

# PROJECT NARRATIVE

January 21, 2022

Melanie A. Bachman  
Executive Director  
Connecticut Siting Council  
10 Franklin Square  
New Britain, CT 06051

Re: Request of DISH Wireless LLC for an Order to Approve the Shared Use of an Existing Tower  
56 Ruops Road Tolland, CT 06084  
Latitude: 41°52'24.0" / Longitude: -72°20'17.88"

Dear Ms. Bachman:

Pursuant to Connecticut General Statutes ("C.G.S.") §16-50aa, as amended, DISH Wireless LLC ("DISH") hereby requests an order from the Connecticut Siting Council ("Council") to approve the shared use by DISH of an existing telecommunication tower at 56 Ruops Road in Tolland (the "Property"). The existing 165-foot monopole tower is owned by American Tower Corporation ("ATC"). The underlying property is owned by The Town of Tolland. DISH requests that the Council find that the proposed shared use of the ATC tower satisfies the criteria of C.G.S. §16-50aa and issue an order approving the proposed shared use. A copy of this filing is being sent to Tammy Nuccio, Chair for the Town of Tolland Town Council, James Paquin, Town of Tolland Building Official & The Town of Tolland as the property owner.

## **Background**

This facility was approved by the Council under Docket No. 100 on January 5, 1989. A copy of the Decision and Order is included in the filing attachments. The existing ATC facility consists of a 165-foot monopole tower located within an existing leased area. T-Mobile currently maintains antennas at the 162-foot level, 105-foot level and 81-foot level. AT&T Mobility currently maintains antennas at the 149-foot level. Verizon Wireless currently maintains antennas at the 140-foot level. Sprint/Nextel currently maintains antennas at the 133-foot level, 121-foot level and 50-foot level. Equipment associated with these antennas are located at various positions within the tower and compound.

DISH is licensed by the Federal Communications Commission ("FCC") to provide wireless services throughout the State of Connecticut. DISH and Crown Castle have agreed to the proposed shared use of the 56 Ruops Road tower pursuant to mutually acceptable terms and conditions. Likewise, DISH and ATC have agreed to the proposed installation of equipment cabinets on the ground on the south side of the tower within the existing compound. ATC has authorized DISH to apply for all necessary permits and approvals that may be required to share the existing tower. (See attached Letter of Authorization)

DISH proposes to install three (3) antennas, (1) Tower platform mount, (6) Remote radio units at the 93-foot level along with, (1) over voltage protection device (OVP) and (1) Hybrid cable. DISH will install an equipment cabinet on a 5'x7' equipment platform. DISH's Construction Drawings provide project specifications for all proposed site improvement locations. The construction drawings also include specifications for DISH's proposed antenna and groundwork.

C.G.S. § 16-50aa(c)(1) provides that, upon written request for approval of a proposed shared use, "if the Council finds that the proposed shared use of the facility is technically, legally, environmentally and economically feasible and meets public safety concerns, the council shall issue an order approving such a shared use." DISH respectfully submits that the shared use of the tower satisfies these criteria.

**A. Technical Feasibility.** The existing ATC tower is structurally capable of supporting DISH's proposed improvements. The proposed shared use of this tower is, therefore, technically feasible. A Feasibility Structural Analysis Report ("Structural Report") prepared for this project confirms that this tower can support DISH's proposed loading. A copy of the Structural Report has been included in this application. The Structural Report was also reviewed by the State Building Inspector for compliance with the 2018 Connecticut State Building Code. The proposed additions comply with the structural requirements of the 2018 Connecticut State Building Code. A copy of this review has been included in this application.

**B. Legal Feasibility.** Under C.G.S. § 16-50aa, the Council has been authorized to issue order approving the shared use of an existing tower such as the ATC tower. This authority complements the Council's prior-existing authority under C.G.S. § 16-50p to issue orders approving the construction of new towers that are subject to the Council's jurisdiction. In addition, § 16-50x(a) directs the Council to "give such consideration to the other state laws and municipal regulations as it shall deem appropriate" in ruling on requests for the shared use of existing tower facilities. Under the statutory authority vested in the Council, an order by the Council approving the requested shared use would permit the Applicant to obtain a building permit for the proposed installations.

**C. Environmental Feasibility.** The proposed shared use of the ATC tower would have a minimal environmental effect for the following reasons:

1. The proposed installation will have no visual impact on the area of the tower. DISH's equipment cabinet would be installed within the existing facility compound. DISH's shared use of this tower therefore will not cause any significant change or alteration in the physical or environmental characteristics of the existing site.
2. Operation of DISH's antennas at this site would not exceed the RF emissions standard adopted by the Federal Communications Commission ("FCC"). Included in the EME report of this filing are the approximation tables that demonstrate that DISH's proposed facility will operate well within the FCC RF emissions safety standards.
3. Under ordinary operating conditions, the proposed installation would not require the use of any water or sanitary facilities and would not generate air emissions or discharges to water bodies or sanitary facilities. After construction is complete the proposed installations would not generate any increased traffic to the ATC facility other than periodic maintenance. The proposed shared use of the ATC tower, would, therefore, have a minimal environmental effect, and is environmentally feasible.

D. **Economic Feasibility.** As previously mentioned, DISH has entered into an agreement with ATC for the shared use of the existing facility subject to mutually agreeable terms. The proposed tower sharing is, therefore, economically feasible.

E. **Public Safety Concerns.** As discussed above, the tower is structurally capable of supporting DISH's full array of three (3) antennas, (1) Tower platform mount, (6) Remote radio units, (1) over voltage protection device (OVP) and (1) Hybrid cable and all related equipment. DISH is not aware of any public safety concerns relative to the proposed sharing of the existing ATC tower

### **Conclusion**

For the reasons discussed above, the proposed shared use of the existing ATC tower at 56 Ruops Road satisfies the criteria stated in C.G.S. §16-50aa and advances the Council's goal of preventing the unnecessary proliferation of towers in Connecticut. The Applicant, therefore, respectfully requests that the Council issue an order approving the proposed shared use.

Sincerely,

*David Hoogasian*

**David Hoogasian**  
*Project Manager*



# LETTER OF AUTHORIZATION



**AMERICAN TOWER®**  
CORPORATION

**LETTER OF AUTHORIZATION**  
**LICENSEE: DISH WIRELESS L.L.C.**

I, Margaret Robinson, Senior Counsel for American Tower\*, owner/operator of the tower facility located at the address identified above (the "Tower Facility"), do hereby authorize DISH WIRELESS L.L.C., its successors and assigns, and/or its agent, (collectively, the "Licensee") to act as American Tower's non-exclusive agent for the sole purpose of filing and consummating any land-use or building permit application(s) as may be required by the applicable permitting authorities for Licensee's telecommunications' installation.

We understand that this application may be denied, modified or approved with conditions. The above authorization is limited to the acceptance by Licensee only of conditions related to Licensee's installation and any such conditions of approval or modifications will be Licensee's sole responsibility.

\*American Tower includes all affiliates and subsidiaries of American Tower Corporation.

Project #	ATC Site #	ATC Site Name	ATC Site Address
13688133	208450	Enfield	1A Ecology Drive, Enfield CT
13700322	209115	Ridgefield 2	320 Old Stagecoach Road, Ridgefield, CT
13688136	209185	Burlington 2	87 Monce Road, Burlington CT
13700320	209271	Brookfield 2	100 Pocono Road, Brookfield CT
13693702	243036	WEST HAVEN & RT 162 CT	668 Jones Hill Road, West Haven CT
13693677	280501	ROXBURY CT	377 Southbury Road, Roxbury CT
13685406	281416	WILLINGTON CT	196 Tolland Turnpike, Willington CT
13709418	281862	BRIDGEWATER CT	111 SECOND HILL RD, Bridgewater CT
13693659	283418	NORTH HAVEN CT	50 Devine Street, North Haven CT
13694329	283419	PINE ORCHARD BRANFORD CT	123 Pine Orchard Road, Branford CT
13694332	283422	SHORT BEACH BRANFORD CT	171 Short Beach Road, Branford CT
13698427	283423	NAUGATUCK CT	880 Andrew Mountain Road, Naugatuck CT
13685464	283563	MANSFIELD CT	343 Daleville Road, Willington CT
13692735	284983	OLD LYME CT	61-1 Buttonball Road, Old Lyme CT
13693120	284984	PAWCATUCK CT	166 Pawcatuck Ave, Pawcatuck CT
13693144	284988	GUILFORD CT	Moose Hill Road, Guilford CT
13694582	302465	Colchester CT 6	355 Route 85, Colchester CT
13683501	302468	Petro Lock	99 Meadow St, Hartford CT
13685427	302469	Bridgeport CT 2	1069 Connecticut Avenue, Bridgeport CT
13683503	302472	Andover-bunker Hill Road	104 Bunker Hill Road, Andover CT
13683507	302473	E H F R - Prestige Park	310 Prestige Park Road, East Hartford CT



**AMERICAN TOWER®**  
CORPORATION

Project #	ATC Site #	ATC Site Name	ATC Site Address
13683510	302474	South Windsor	391 Niederwerfer Road, South Windsor CT
13683513	302483	Brln - Berlin	286 Beckley Road, Berlin CT
13692185	302488	Cntn - Canton	4 Hoffmann Road, Canton CT
13692173	302495	Tolland CT	56 Ruops Road, Tolland CT
13694579	302496	Clch - Colchester	Chestnut Hill Road, Colchester CT
13701212	302501	Plymouth CT 3	297 North Street, Plymouth CT
13685414	302515	SMFR - North	5 High Ridge Park Road, Stamford CT
13702496	302516	Mlfd - Milford	438 Bridgeport Ave, Milford CT
13688395	302518	Newtown CT 3	25 Meridian Ridge Drive, Newton CT
13692174	302529	Vernon CT 6	777 Talcotville Road, Vernon Rockville CT
13693124	311014	NORWICH CT	202 N Wawecus Hill Rd, Norwich CT
13702522	311305	GLFD-GUILFORD REBUILD CT	10 Tanner Marsh Road, Guilford CT
13693127	370623	MONTVILLE CT	139 Sharp Hill Road, Uncasville CT
13681964	370625	Old Saybrook	77 Springbrook Road, Old Saybrook CT
13702535	383660	North Madison Volunteer FD	864 Opening Hill Road, Madison CT
13702538	411180	Good Hill CT	481 GOOD HILL ROAD, Woodbury CT
13693709	411182	Nepaug CT	20 Antolini Road, New Hartford CT
13693131	411183	WATERFORD CT	53 Dayton Rd., Waterford CT
13693135	411184	SALEM CT SQA	399 West Road, Salem CT
13692177	411186	West Granby, CT CT	207 West Granby Road, Granby CT
13692178	411187	Hartford North 2 CT	811 Blue Hills Avenue, Bloomfield CT
13693705	411188	Southbury CT	111 Upper Fishrock Road, Southbury CT
13692179	411256	CANTON CT	14 CANTON SPRINGS ROAD, Canton CT
13681988	411257	Middle Haddam Road-CROWN CT	191 Middle Haddam Rd, Portland CT
13692180	411258	Farmington North 2 CT	199 Town Farm Road, Farmington CT
13692182	411259	CT Collinsville CAC 802816 CT	650 Albany Turnpike, Collinsville CT
13692184	416862	SUFFIELD SW CT CT	106 South Grand St., West Suffield CT
13694578	6260	NORTH STONINGTON CT	118C Wintechog Hill Rd., off of Rt. 2, North Stonington CT
13681397	88013	Killingworth	131 Little City Road, Killingworth CT

Signature:

Print Name: Margaret Robinson  
Senior Counsel  
American Tower\*



**AMERICAN TOWER®**  
CORPORATION

**LETTER OF AUTHORIZATION  
LICENSEE: DISH WIRELESS L.L.C.**

**NOTARY BLOCK**

Commonwealth of MASSACHUSETTS  
County of Middlesex

This instrument was acknowledged before me by Margaret Robinson, Senior Counsel for American Tower\*, personally known to me (or proved to me on the basis of satisfactory evidence) to be the person whose name is subscribed to the within instrument and acknowledged to me that he executed the same.

WITNESS my hand and official seal, this 10<sup>th</sup> day of September 2021.

**NOTARY SEAL**

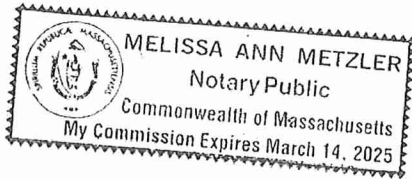

Notary Public   
My Commission Expires: March 14, 2025

# ORIGINAL FACILITY APPROVAL

DOCKET NO. 100 - An application of SNET : CONNECTICUT SITING  
Cellular, Inc., for a Certificate of :  
Environmental Compatibility and Public : COUNCIL  
Need for cellular telephone antennas : January 5, 1989  
and associated equipment in the Town of :  
Tolland, Connecticut.

DECISION AND ORDER

Pursuant to the foregoing Opinion, the Connecticut Siting Council finds that the effects associated with the construction and operation of a cellular telephone monopole structure at the proposed Tolland site, including effects on the natural environment; ecological integrity and balance; public health and safety; scenic, historic, and recreational values; forests and parks; air and water purity; and fish and wildlife; are not significant either alone or cumulatively with other effects, are not in conflict with the policies of the State concerning such effects, and are not sufficient reason to deny the application, and therefore directs that a Certificate of Environmental Compatibility and Public Need, as provided by Section 16-50k of the General Statutes of Connecticut (CGS), be issued to SNET Cellular, Inc., for the construction, operation, and maintenance of a cellular telephone tower site and associated equipment at the proposed Tolland site in Tolland, Connecticut.

The alternative Tolland site is hereby denied.

The facility shall be constructed, operated, and maintained as specified in the Council's record in this matter, and subject to the following conditions:

1. The tower shall be constructed as a monopole tower no taller than necessary to provide the proposed service, and in no event shall the tower structure exceed a total height of 167 feet, including antennas.
2. The facility shall be constructed in accordance with the State of Connecticut Basic Building Code.
3. Unless necessary to comply with future requirements of the Federal Aviation Administration, no lights shall be installed on this tower.



4. The Certificate Holder shall prepare a development and management (D&M) plan for this site in compliance with Sections 16-50j-75 through 16-50j-77 of the Regulations of State Agencies. The D&M plan shall include detailed plans for erosion and sediment control along the access road and at the tower site, plans for permanent evergreen screening along the outside perimeter of the eight-foot fence surrounding the site, and plans for loaming and seeding the site and sides of the access road following completion of construction. The access road shall be constructed in a manner to minimize erosion and tree clearing as much as possible.
5. The Certificate Holder or its successor shall notify the Council if and when directional antennas or any equipment other than that listed in this application are added to this facility.
6. The Certificate Holder or its successor shall permit public or private entities to share space on the tower for fair consideration, or shall provide any requesting entity with specific legal, technical, environmental, or economic reasons precluding such tower sharing.
7. If this facility does not provide, or permanently ceases to provide, cellular service following the completion of construction, this Decision and Order shall be void, and the tower and all associated equipment in this application shall be dismantled and removed or reapplication for any new use shall be made to the Council and a Certificate granted before such new use is made.
8. The Certificate Holder shall comply with any future radio frequency (RF) standard, promulgated by State or federal regulatory agencies. Upon the establishment of any new governmental RF standards, the facility granted in this Decision and Order shall be brought into compliance with such standards.
9. Unless otherwise approved by the Council, this Decision and Order shall be void if all construction authorized herein is not completed within three years of the issuance of this Decision and Order, or within three years of the completion of any appeal taken in this Decision and Order.

Pursuant to Section 16-50p, we hereby direct that a copy of the Decision and Order be served on each person listed below. A notice of issuance shall be published in the Manchester Journal Enquirer.

By this Decision and Order, the Council disposes of the legal rights, duties, and privileges of each party named or admitted to the proceeding in accordance with section 16-50j-17 of the Regulations of State Agencies.

The parties or intervenors to this proceeding are:

	<b>STATUS HOLDER</b>	<b>REPRESENTATIVE</b>
Party  <input checked="" type="checkbox"/>	SNET Cellular, Inc. 555 Long Wharf Drive New Haven, CT 06506	SNET Cellular, Inc. c/o Peter J. Tyrrell Senior Attorney 227 Church Street Room 1021 New Haven, CT 06506 (203) 771-7381
Party  <input type="checkbox"/>  Intervenor  <input checked="" type="checkbox"/>	Metro Mobile CTS of Hartford, Inc.	Jennifer Young Gaudet Byrne, Slater, Sandler Shulman & Rouse, P.C. 330 Main Street P.O. Box 3216 Hartford, CT 06103 (203) 525-4700



CERTIFICATION

The undersigned members of the Connecticut Siting Council hereby certify that they have heard this case in Docket No. 100 or read the record thereof, and that we voted as follows:

Dated at New Britain, Connecticut the 5th day of January, 1989.

<u>Council Members</u>	<u>Vote Cast</u>
<u><i>Gloria Dibble Pond</i></u> Gloria Dibble Pond Chairperson	Yes
<u><i>Patricia A. Austin</i></u> Commissioner Peter Boucher Designee: Patricia Austin	Abstain
<u><i>Brian J. Emerick</i></u> Commissioner Leslie Carothers Designee: Brian Emerick	Yes
<u><i>Mortimer A. Gelston</i></u> Mortimer A. Gelston	Yes
<u><i>Harry E. Covey</i></u> Harry E. Covey	Abstain
<u><i>Daniel P. Lynch, Jr.</i></u> Daniel P. Lynch, Jr.	Yes
<u>Paulann H. Sheets</u>	Absent
<u><i>William H. Smith</i></u> William H. Smith	Yes
<u><i>Colin C. Tait</i></u> Colin C. Tait	Abstain

# ENGINEERING DRAWINGS



DISH Wireless L.L.C. SITE ID:

**BOBDL00015A**

DISH Wireless L.L.C. SITE ADDRESS:

**56 RUOPS ROAD  
TOLLAND, CT 06084**

SCOPE OF WORK	
THIS IS NOT AN ALL INCLUSIVE LIST. CONTRACTOR SHALL UTILIZE SPECIFIED EQUIPMENT PART OR ENGINEER APPROVED EQUIVALENT. CONTRACTOR SHALL VERIFY ALL NEEDED EQUIPMENT TO PROVIDE A FUNCTIONAL SITE. THE PROJECT GENERALLY CONSISTS OF THE FOLLOWING:	
<b>TOWER SCOPE OF WORK:</b>	
<ul style="list-style-type: none"> <li>• INSTALL (3) PROPOSED PANEL ANTENNAS (1 PER SECTOR)</li> <li>• INSTALL (1) PROPOSED TOWER PLATFORM MOUNT</li> <li>• INSTALL PROPOSED JUMPERS</li> <li>• INSTALL (6) PROPOSED RRUs (2 PER SECTOR)</li> <li>• INSTALL (1) PROPOSED OVER VOLTAGE PROTECTION DEVICE (OVP)</li> <li>• INSTALL (1) PROPOSED HYBRID CABLE</li> </ul>	
<b>GROUND SCOPE OF WORK:</b>	
<ul style="list-style-type: none"> <li>• INSTALL (1) PROPOSED METAL PLATFORM</li> <li>• INSTALL (1) PROPOSED ICE BRIDGE</li> <li>• INSTALL (1) PROPOSED PPC CABINET</li> <li>• INSTALL (1) PROPOSED EQUIPMENT CABINET</li> <li>• INSTALL (1) PROPOSED POWER CONDUIT</li> <li>• INSTALL (1) PROPOSED TELCO CONDUIT</li> <li>• INSTALL (1) PROPOSED TELCO-FIBER BOX</li> <li>• INSTALL (1) PROPOSED GPS UNIT</li> <li>• INSTALL (1) PROPOSED FIBER NID (IF REQUIRED)</li> <li>• INSTALL (1) PROPOSED METER CANISTER</li> <li>• INSTALL (1) PROPOSED FIBER HAND HOLE</li> </ul>	

SITE INFORMATION	PROJECT DIRECTORY
PROPERTY OWNER: TOWN OF TOLLAND	APPLICANT: DISH Wireless L.L.C. 5701 SOUTH SANTA FE DRIVE LITTLETON, CO 80120
TOWER TYPE: MONOPOLE	TOWER OWNER: AMERICAN TOWER CORPORATION 10 PRESIDENTIAL WAY WOBURN, MA 01801 (781) 926-4500
TOWER CO SITE ID: 302495	SITE DESIGNER: B+T GROUP 1717 S. BOULDER AVE, SUITE 300 TULSA, OK 74119 (918) 587-4630
TOWER APP NUMBER: 13692173	SITE ACQUISITION: KENNETH R. BRADBURY II (781) 926-4770
COUNTY: TOLLAND	CONSTRUCTION MANAGER: JAVIER SOTO javier.soto@dish.com
LATITUDE (NAD 83): 41° 52' 24" N 41.87333333 N	RF ENGINEER: BOSSENER CHARLES bossener.charles@dish.com
LONGITUDE (NAD 83): 72° 20' 17.88" W 72.3383 W	
ZONING JURISDICTION: TOLLAND COUNTY	
ZONING DISTRICT: 300V	
PARCEL NUMBER: 09013142-23/E/051	
OCCUPANCY GROUP: U	
CONSTRUCTION TYPE: II-B	
POWER COMPANY: T.B.D.	
TELEPHONE COMPANY: CROWN CASTLE	



5701 SOUTH SANTA FE DRIVE  
LITTLETON, CO 80120



**B&T ENGINEERING, INC.**  
PEC.0001564  
Expires 2/10/22

IT IS A VIOLATION OF LAW FOR ANY PERSON, UNLESS THEY ARE ACTING UNDER THE DIRECTION OF A LICENSED PROFESSIONAL ENGINEER, TO ALTER THIS DOCUMENT.

DRAWN BY: DAS    CHECKED BY: DAS    APPROVED BY: RCM

RFDS REV #: 2

**CONSTRUCTION DOCUMENTS**

SUBMITTALS		
REV	DATE	DESCRIPTION
A	7/26/21	ISSUED FOR REVIEW
0	9/8/21	ISSUED FOR CONSTRUCTION

A&E PROJECT NUMBER  
153473.001.01

DISH Wireless L.L.C.  
PROJECT INFORMATION  
**BOBDL00015A**  
56 RUOPS ROAD  
TOLLAND, CT 06084

SHEET TITLE  
TITLE SHEET

SHEET NUMBER  
**T-1**

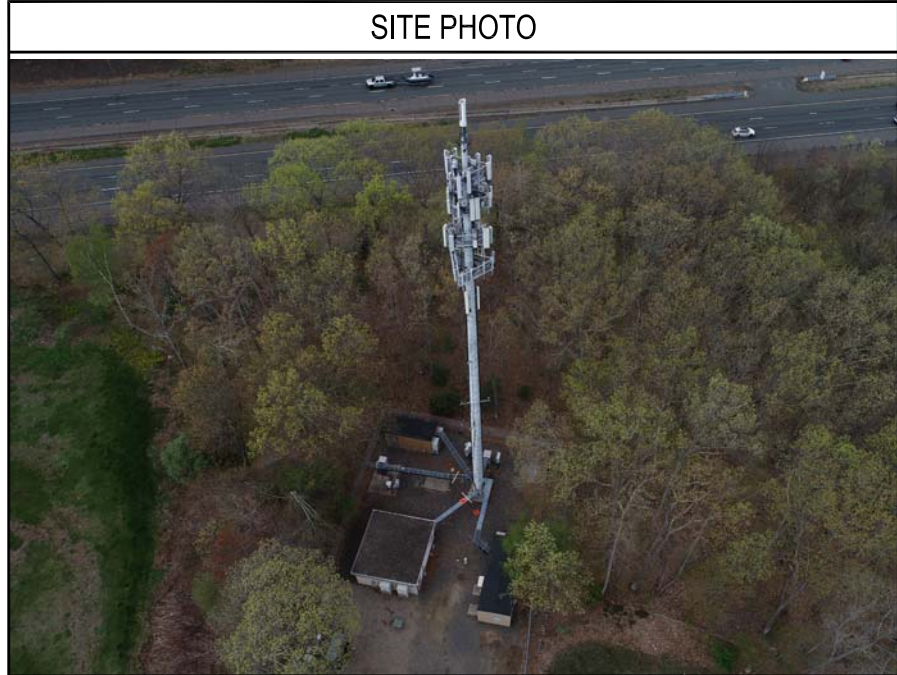

UNDERGROUND SERVICE ALERT CBYD 811  
UTILITY NOTIFICATION CENTER OF CONNECTICUT  
(800) 922-4455  
WWW.CBYD.COM  
CALL 2 WORKING DAYS UTILITY NOTIFICATION PRIOR TO CONSTRUCTION

**GENERAL NOTES**

THE FACILITY IS UNMANNED AND NOT FOR HUMAN HABITATION. A TECHNICIAN WILL VISIT THE SITE AS REQUIRED FOR ROUTINE MAINTENANCE. THE PROJECT WILL NOT RESULT IN ANY SIGNIFICANT DISTURBANCE OR EFFECT ON DRAINAGE, NO SANITARY SEWER SERVICE, POTABLE WATER, OR TRASH DISPOSAL IS REQUIRED AND NO COMMERCIAL SIGNAGE IS PROPOSED.

11"x17" PLOT WILL BE HALF SCALE UNLESS OTHERWISE NOTED

CONTRACTOR SHALL VERIFY ALL PLANS, EXISTING DIMENSIONS, AND CONDITIONS ON THE JOB SITE, AND SHALL IMMEDIATELY NOTIFY THE ENGINEER IN WRITING OF ANY DISCREPANCIES BEFORE PROCEEDING WITH THE WORK.

**DIRECTIONS**

DIRECTIONS FROM BRADLEY INTERNATIONAL AIRPORT:  
CONTINUE TO BRADLEY INTERNATIONAL AIRPORT CON, HEAD NORTH TOWARD BRADLEY INTERNATIONAL AIRPORT, SLIGHT LEFT ONTO BRADLEY INTERNATIONAL AIRPORT, SLIGHT LEFT, TAKE I-91 S, I-291 E AND I-84 E TO CT-195 S IN TOLLAND. TAKE EXIT 68 FROM I-84 E, CONTINUE ONTO BRADLEY INTERNATIONAL AIRPORT CON, CONTINUE ONTO CT-20 E/BRADLEY INTERNATIONAL AIRPORT CON, USE THE RIGHT 2 LANES TO MERGE WITH I-91 S TOWARD HARTFORD, TAKE EXIT 35A FOR I-291 TOWARD MANCHESTER, CONTINUE ONTO I-291 E, USE THE LEFT LANE TO MERGE WITH I-84 E TOWARD BOSTON, TAKE EXIT 68 FOR CT-195 TOWARD TOLLAND/MANSFIELD, FOLLOW CT-195 S, ANTHONY RD AND KATE LN TO RUOPS RD, USE THE RIGHT 2 LANES TO TURN RIGHT ONTO CT-195 S, TURN LEFT ONTO ANTHONY RD, TURN RIGHT TO STAY ON ANTHONY RD, TURN LEFT ONTO KATE LN, TURN LEFT ONTO RUOPS RD, ARRIVING AT BOBDL00015A.

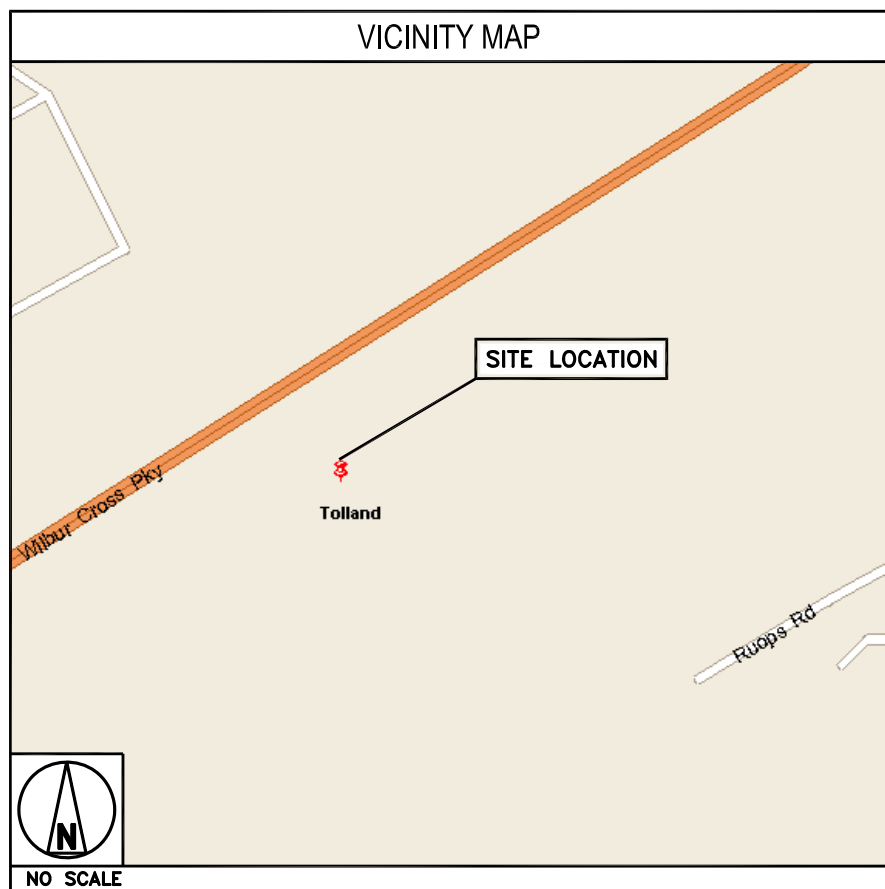

**CONNECTICUT CODE COMPLIANCE**

ALL WORK SHALL BE PERFORMED AND MATERIALS INSTALLED IN ACCORDANCE WITH THE CURRENT EDITIONS OF THE FOLLOWING CODES AS ADOPTED BY THE LOCAL GOVERNING AUTHORITIES. NOTHING IN THESE PLANS IS TO BE CONSTRUED TO PERMIT WORK NOT CONFORMING TO THESE CODES:

CODE TYPE	CODE
BUILDING	2018 CT STATE BUILDING CODE/2015 IBC W/ CT AMENDMENTS
MECHANICAL	2018 CT STATE BUILDING CODE/2015 IMC W/ CT AMENDMENTS
ELECTRICAL	2018 CT STATE BUILDING CODE/2017 NEC W/ CT AMENDMENTS

**SHEET INDEX**

SHEET NO.	SHEET TITLE
T-1	TITLE SHEET
A-1	OVERALL AND ENLARGED SITE PLAN
A-2	ELEVATION, ANTENNA LAYOUT AND SCHEDULE
A-3	EQUIPMENT PLATFORM AND H-FRAME DETAILS
A-4	EQUIPMENT DETAILS
A-5	EQUIPMENT DETAILS
A-6	EQUIPMENT DETAILS
E-1	ELECTRICAL/FIBER ROUTE PLAN AND NOTES
E-2	ELECTRICAL DETAILS
E-3	ELECTRICAL ONE-LINE, FAULT CALCS & PANEL SCHEDULE
G-1	GROUNDING PLANS AND NOTES
G-2	GROUNDING DETAILS
G-3	GROUNDING DETAILS
RF-1	RF CABLE COLOR CODE
GN-1	LEGEND AND ABBREVIATIONS
GN-2	GENERAL NOTES
GN-3	GENERAL NOTES
GN-4	GENERAL NOTES

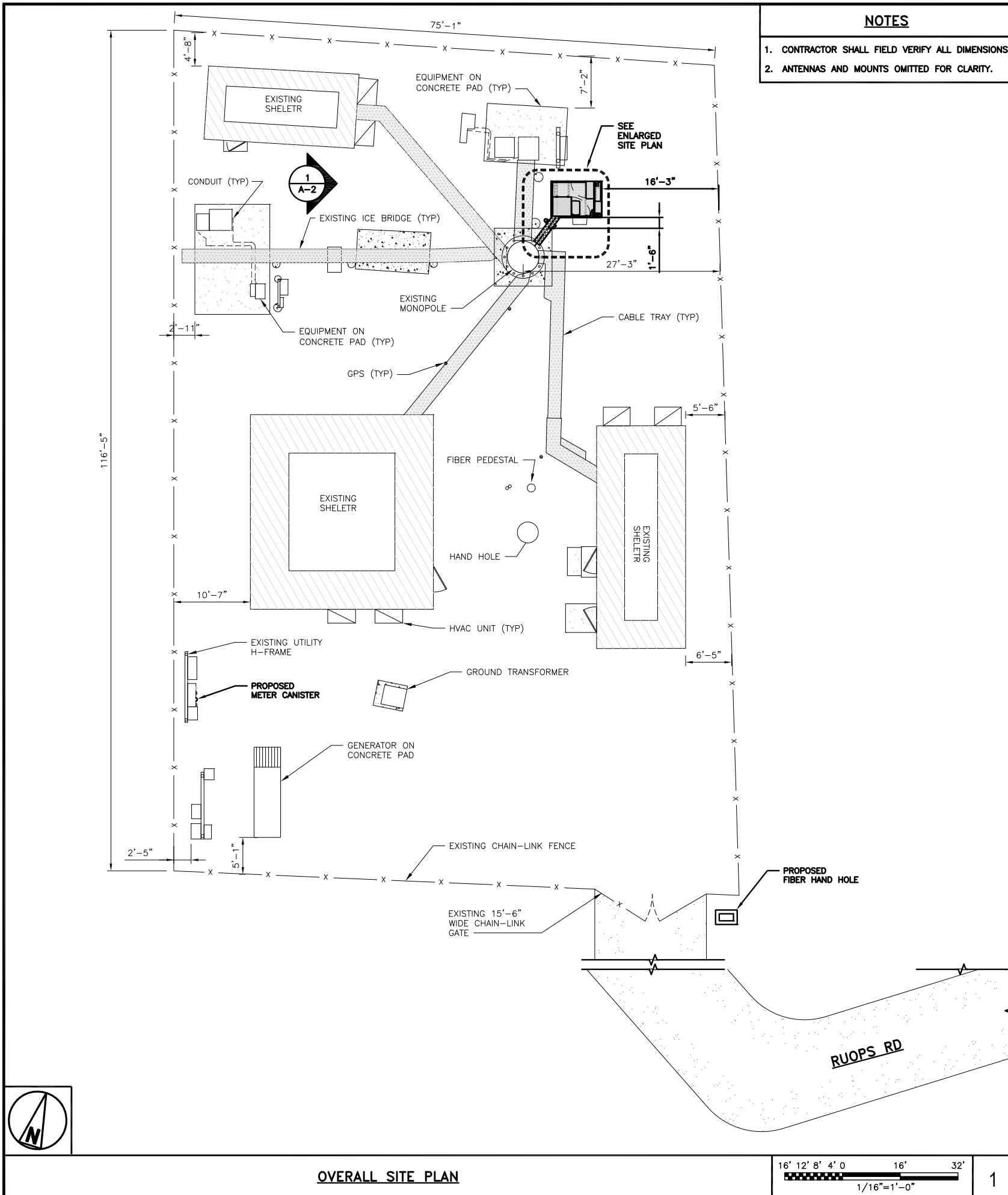

- NOTES**
1. CONTRACTOR SHALL FIELD VERIFY ALL DIMENSIONS.
  2. ANTENNAS AND MOUNTS OMITTED FOR CLARITY.

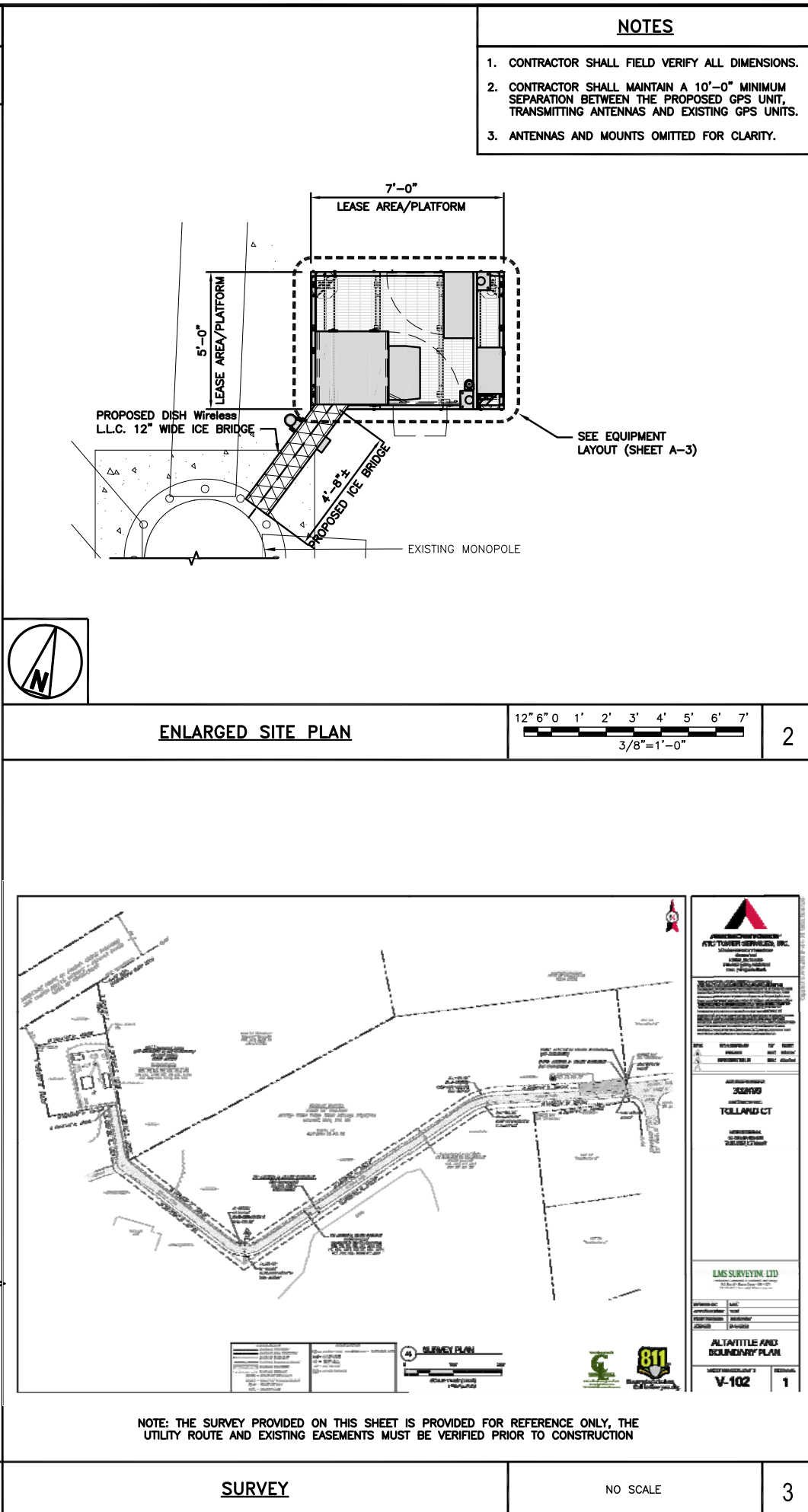

- NOTES**
1. CONTRACTOR SHALL FIELD VERIFY ALL DIMENSIONS.
  2. CONTRACTOR SHALL MAINTAIN A 10'-0" MINIMUM SEPARATION BETWEEN THE PROPOSED GPS UNIT, TRANSMITTING ANTENNAS AND EXISTING GPS UNITS.
  3. ANTENNAS AND MOUNTS OMITTED FOR CLARITY.

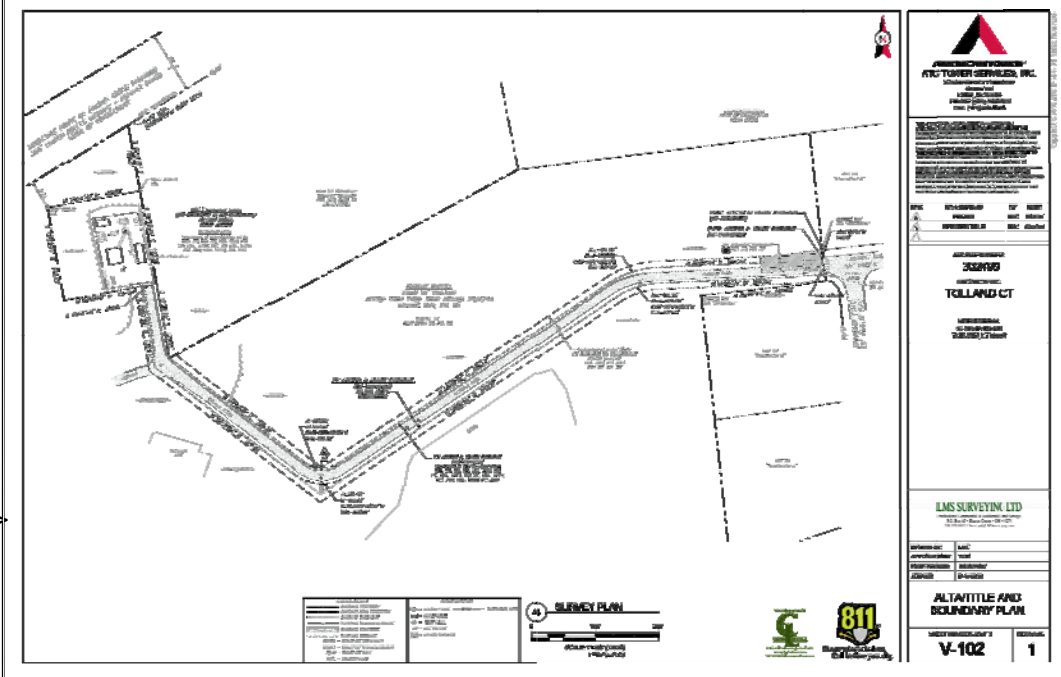

NOTE: THE SURVEY PROVIDED ON THIS SHEET IS PROVIDED FOR REFERENCE ONLY, THE UTILITY ROUTE AND EXISTING EASEMENTS MUST BE VERIFIED PRIOR TO CONSTRUCTION



5701 SOUTH SANTA FE DRIVE  
LITTLETON, CO 80120



**B&T ENGINEERING, INC.**  
PEC.0001564  
Expires 2/10/22

IT IS A VIOLATION OF LAW FOR ANY PERSON, UNLESS THEY ARE ACTING UNDER THE DIRECTION OF A LICENSED PROFESSIONAL ENGINEER, TO ALTER THIS DOCUMENT.

DRAWN BY: CHECKED BY: APPROVED BY:  
DAS DAS RCM

RFDS REV #: 2

**CONSTRUCTION DOCUMENTS**

SUBMITTALS		
REV	DATE	DESCRIPTION
A	7/26/21	ISSUED FOR REVIEW
D	9/8/21	ISSUED FOR CONSTRUCTION

A&E PROJECT NUMBER  
153473.001.01

DISH Wireless L.L.C.  
PROJECT INFORMATION  
BOBDL0015A  
56 RUOPS ROAD  
TOLLAND, CT 06084

SHEET TITLE  
OVERALL AND ENLARGED  
SITE PLAN

SHEET NUMBER  
**A-1**



**NOTES**

1. CONTRACTOR SHALL FIELD VERIFY ALL DIMENSIONS.
2. ANTENNA AND MW DISH SPECIFICATIONS REFER TO ANTENNA SCHEDULE AND TO FINAL CONSTRUCTION RFDS FOR ALL RF DETAILS
3. EXISTING EQUIPMENT AND FENCE OMITTED FOR CLARITY.

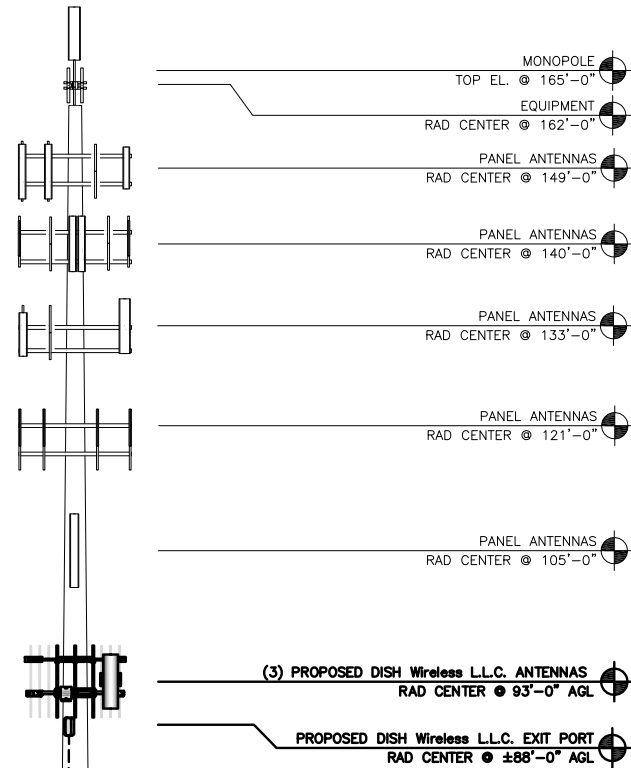

(1) PROPOSED DISH Wireless L.L.C. HYBRID CABLE ROUTED INSIDE POLE

PROPOSED DISH Wireless L.L.C. ICE BRIDGE

PROPOSED DISH Wireless L.L.C. GPS UNIT

PROPOSED DISH Wireless L.L.C. EQUIPMENT ON PROPOSED STEEL PLATFORM

EXISTING MONOPOLE

EXISTING ENTRY PORT

BOTTOM OF BASE PLATE  
0'-0"

**PROPOSED WEST ELEVATION**

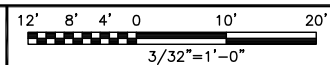

1

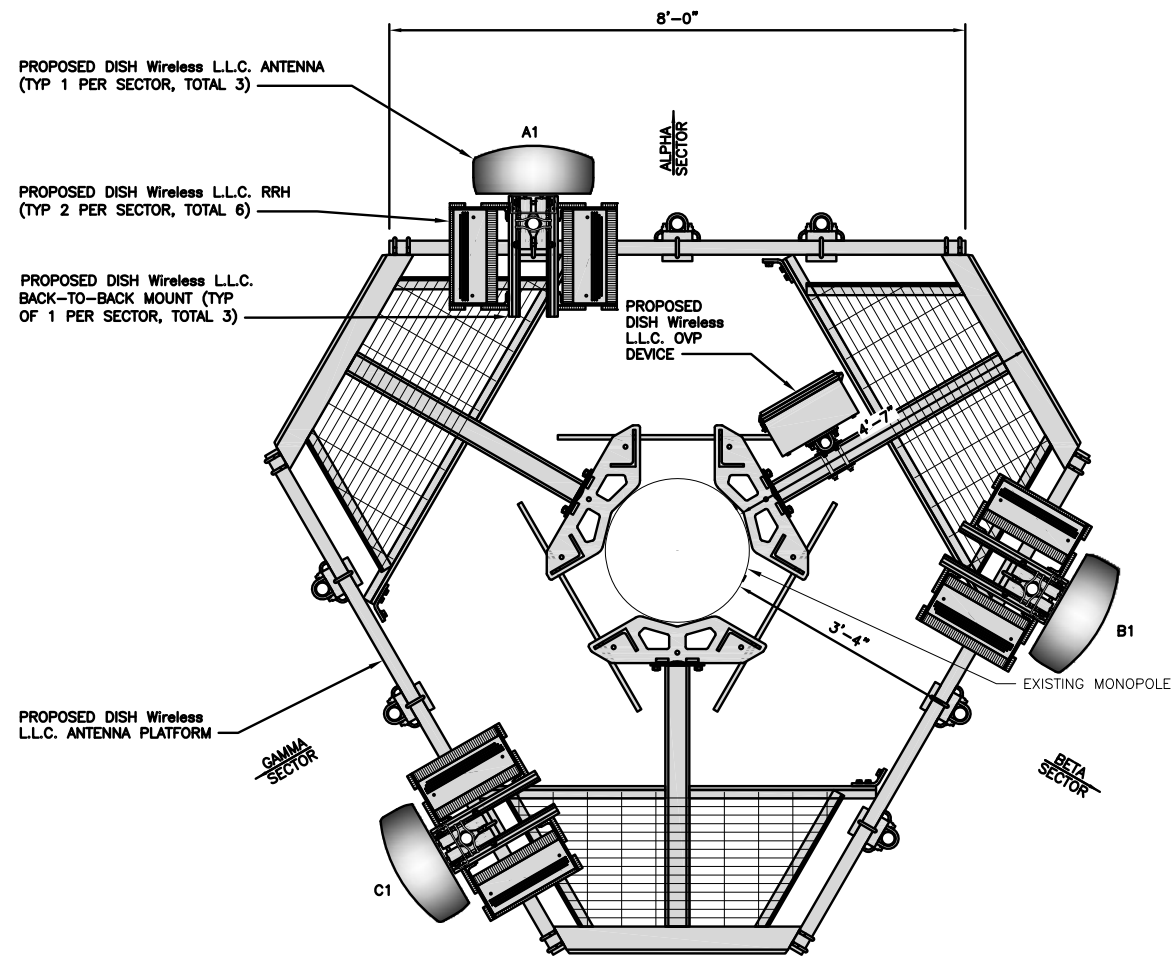

**ANTENNA LAYOUT**

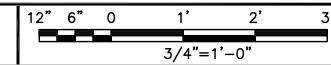

2

SECTOR	POSITION	ANTENNA					TRANSMISSION CABLE	
		EXISTING OR PROPOSED	MANUFACTURER - MODEL NUMBER	TECHNOLOGY	SIZE (HxW)	AZIMUTH	RAD CENTER	FEED LINE TYPE AND LENGTH
ALPHA	A1	PROPOSED	JMA - MX08FR0665-21	5G	72.0" x 20.0"	0°	93'-0"	(1) HIGH-CAPACITY HYBRID CABLE (125' LONG)
BETA	B1	PROPOSED	JMA - MX08FR0665-21	5G	72.0" x 20.0"	120°	93'-0"	
GAMMA	C1	PROPOSED	JMA - MX08FR0665-21	5G	72.0" x 20.0"	240°	93'-0"	

SECTOR	POSITION	RRH		NOTES
		MANUFACTURER - MODEL NUMBER	TECHNOLOGY	
ALPHA	A1	FUJITSU - TA08025-B604	5G	1. CONTRACTOR TO REFER TO FINAL CONSTRUCTION RFDS FOR ALL RF DETAILS. 2. ANTENNA AND RRH MODELS MAY CHANGE DUE TO EQUIPMENT AVAILABILITY. ALL EQUIPMENT CHANGES MUST BE APPROVED AND REMAIN IN COMPLIANCE WITH THE PROPOSED DESIGN AND STRUCTURAL ANALYSES.
	A1	FUJITSU - TA08025-B605	5G	
BETA	B1	FUJITSU - TA08025-B604	5G	
	B1	FUJITSU - TA08025-B605	5G	
GAMMA	C1	FUJITSU - TA08025-B604	5G	
	C1	FUJITSU - TA08025-B605	5G	

OVP		
EXISTING OR PROPOSED	MANUFACTURER - MODEL NUMBER	SIZE (HxWxD)
PROPOSED	RAYCAP-RDIDC-9181-PF-48	16"x14"x8"

**ANTENNA SCHEDULE**

NO SCALE

3



5701 SOUTH SANTA FE DRIVE  
LITTLETON, CO 80120



**B&T ENGINEERING, INC.**  
PEC.0001564  
Expires 2/10/22

IT IS A VIOLATION OF LAW FOR ANY PERSON, UNLESS THEY ARE ACTING UNDER THE DIRECTION OF A LICENSED PROFESSIONAL ENGINEER, TO ALTER THIS DOCUMENT.

DRAWN BY: CHECKED BY: APPROVED BY:  
DAS DAS RCM

RFDS REV #: 2

**CONSTRUCTION DOCUMENTS**

SUBMITTALS		
REV	DATE	DESCRIPTION
A	7/26/21	ISSUED FOR REVIEW
0	9/8/21	ISSUED FOR CONSTRUCTION

A&E PROJECT NUMBER  
153473.001.01

DISH Wireless L.L.C.  
PROJECT INFORMATION  
BOBDL00015A  
56 RUOPS ROAD  
TOLLAND, CT 06084

SHEET TITLE  
ELEVATION, ANTENNA  
LAYOUT AND SCHEDULE

SHEET NUMBER

**A-2**



5701 SOUTH SANTA FE DRIVE  
LITTLETON, CO 80120



**B&T ENGINEERING, INC.**  
PEC.0001564  
Expires 2/10/22

IT IS A VIOLATION OF LAW FOR ANY PERSON, UNLESS THEY ARE ACTING UNDER THE DIRECTION OF A LICENSED PROFESSIONAL ENGINEER, TO ALTER THIS DOCUMENT.

DRAWN BY: CHECKED BY: APPROVED BY:  
DAS DAS RCM

RFDS REV #: 2

**CONSTRUCTION DOCUMENTS**

SUBMITTALS		
REV	DATE	DESCRIPTION
A	7/26/21	ISSUED FOR REVIEW
0	9/8/21	ISSUED FOR CONSTRUCTION

A&E PROJECT NUMBER  
153473.001.01

DISH Wireless L.L.C.  
PROJECT INFORMATION

BOBDL0015A  
56 RUOPS ROAD  
TOLLAND, CT 06084

SHEET TITLE  
EQUIPMENT PLATFORM AND  
H-FRAME DETAILS

SHEET NUMBER

**A-3**

**NOTES**

1. CONTRACTOR TO BURY PLATFORM FEET WITH A MINIMUM OF 2" OF FILL PER EXISTING SITE SURFACE
2. WEED BARRIER FABRIC TO BE ADDED AT DISCRETION OF DISH Wireless L.L.C. CONSTRUCTION MANAGER AT TIME OF CONSTRUCTION. ONE SHEET 8'x8' INSTALLED UNDER ALL FOUR FEET OF THE PLATFORM (4 MIL BLACK PLASTIC)
3. EQUIPMENT CABINET OMITTED FOR CLARITY

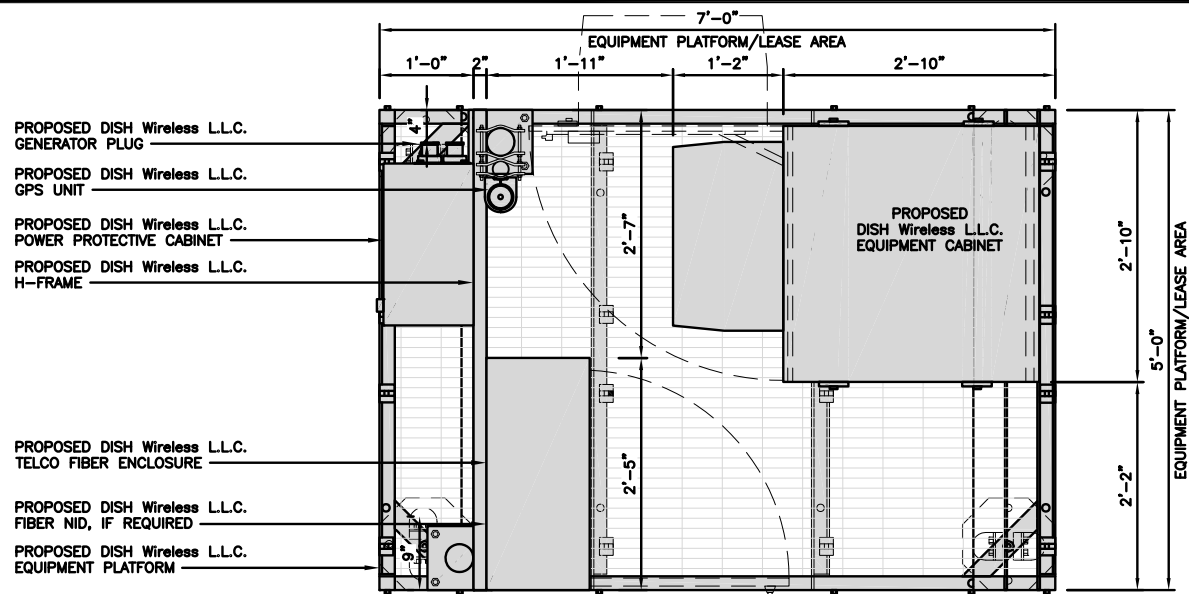

PLATFORM EQUIPMENT PLAN

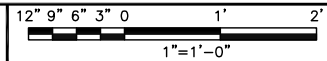

1

<b>COMMSCOPE MTC4045LP 5X7 PLATFORM</b>	
DIMENSIONS (HxWxD)	16"x84"x60"
TOTAL WEIGHT	423 LBS

NOTE:  
GC TO PROVIDE EXTENDED  
THREAD FOR PLATFORM IF  
REQUIRED HEIGHT EXCEEDS 17"

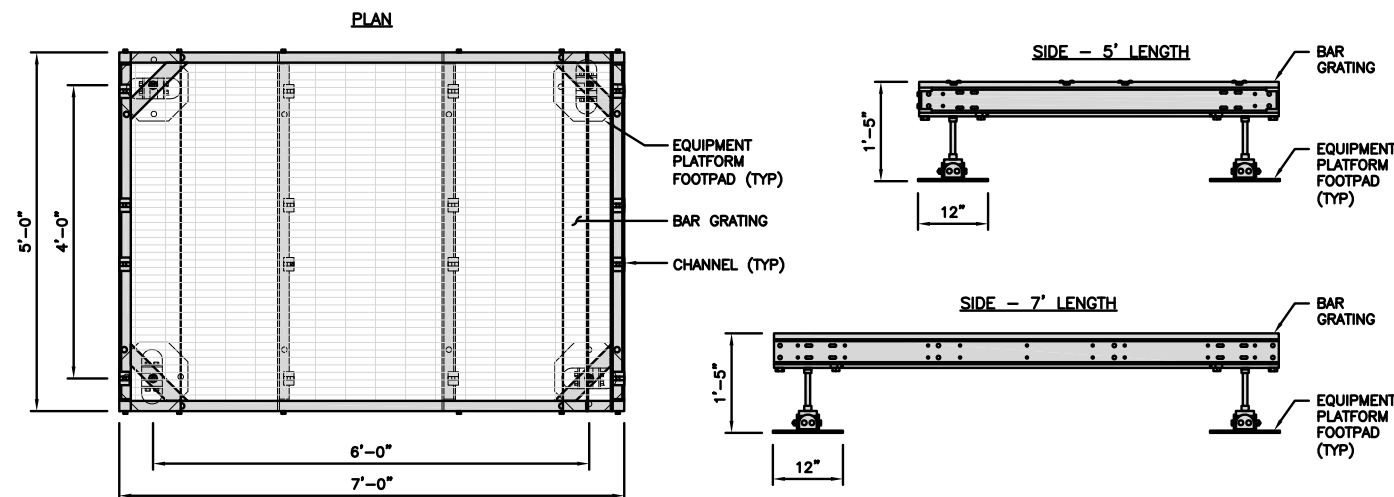

PLATFORM DETAIL

NO SCALE

2

<b>COMMSCOPE MTC4045HFLD H-FRAME</b>	
UNISTRUT/SUPPORT RAILS QTY	5
WEIGHT	59.74 lbs

NOTE:  
OR DISH Wireless L.L.C.  
APPROVED EQUIVALENT

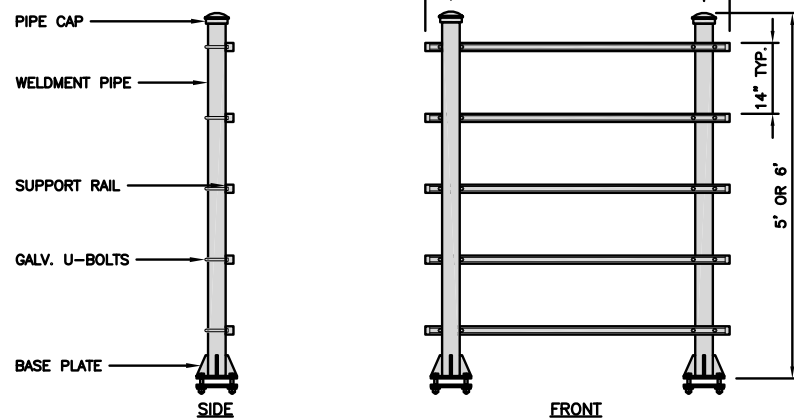

H-FRAME DETAIL

NO SCALE

3

NOT USED

NO SCALE

4

H-FRAME EQUIPMENT ELEVATION

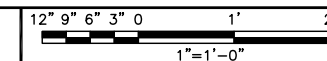

5

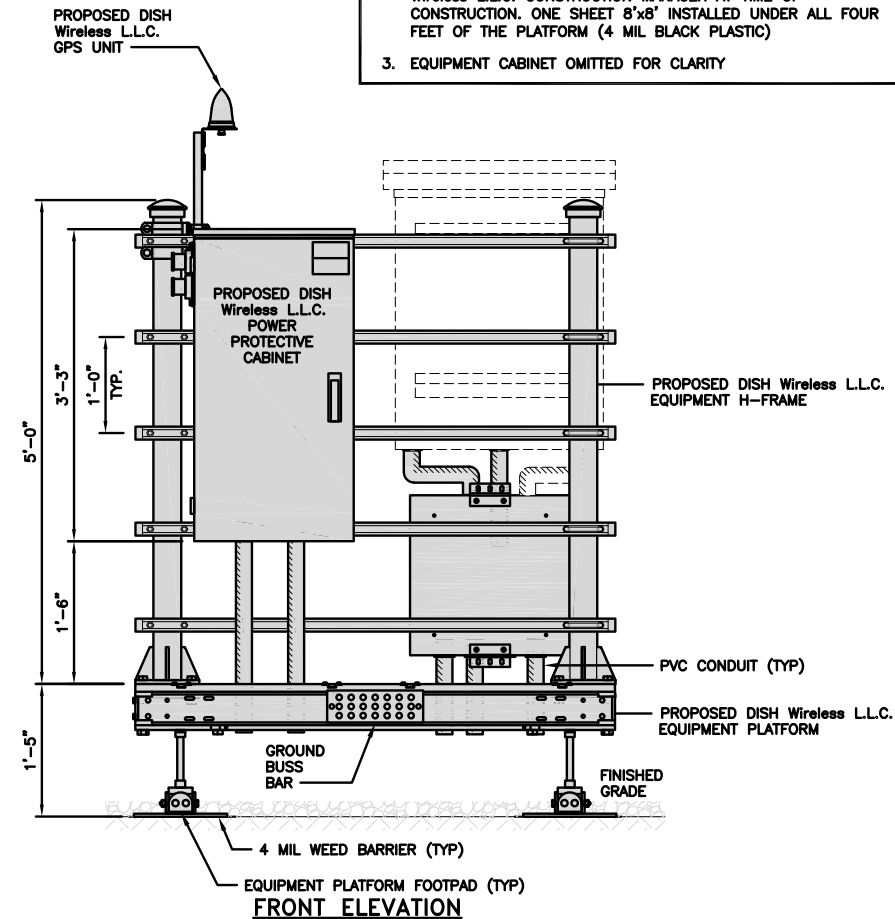

FRONT ELEVATION

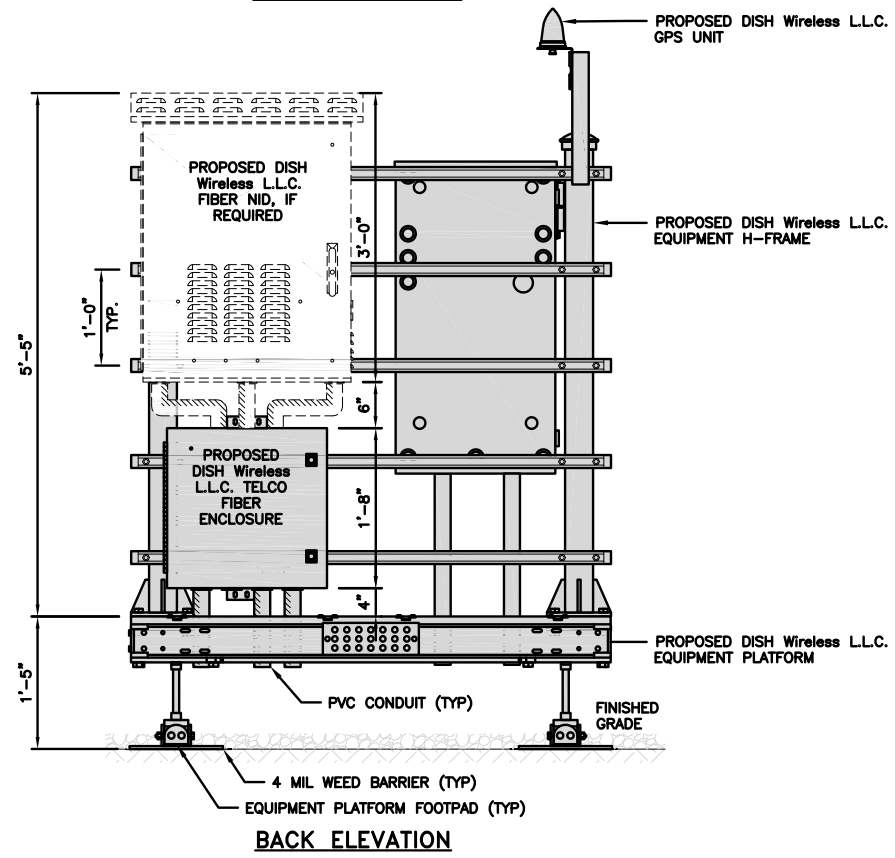

BACK ELEVATION

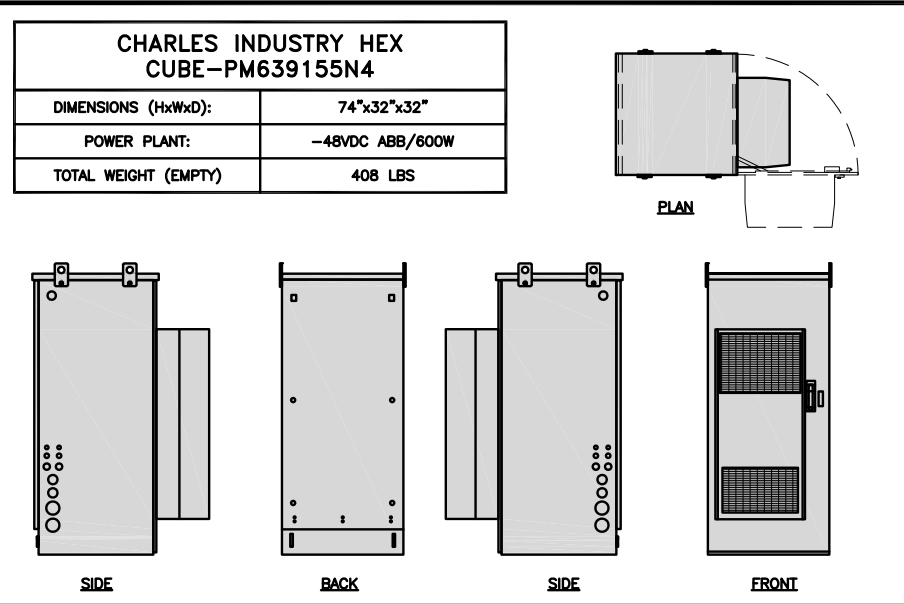

**CABINET DETAIL**      NO SCALE      1

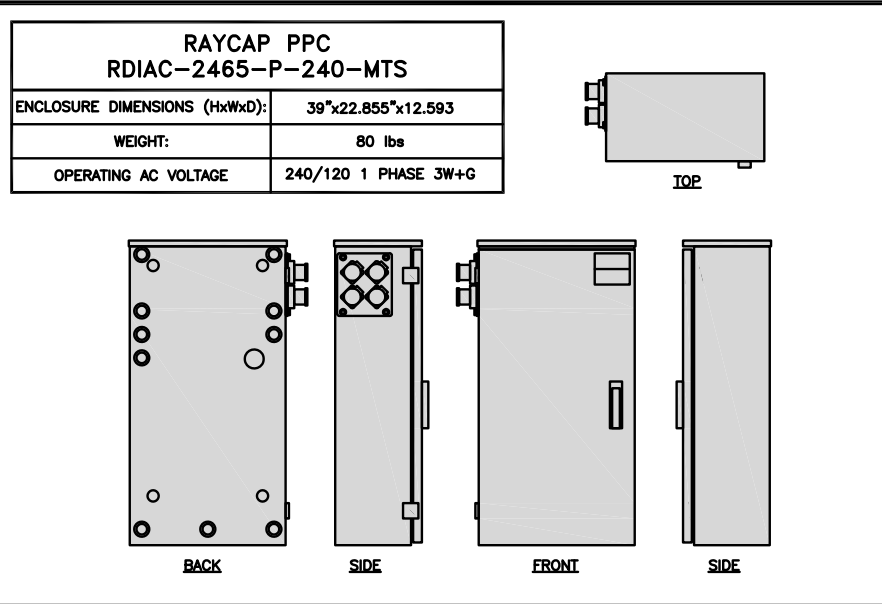

**POWER PROTECTION CABINET (PPC) DETAIL**      NO SCALE      2

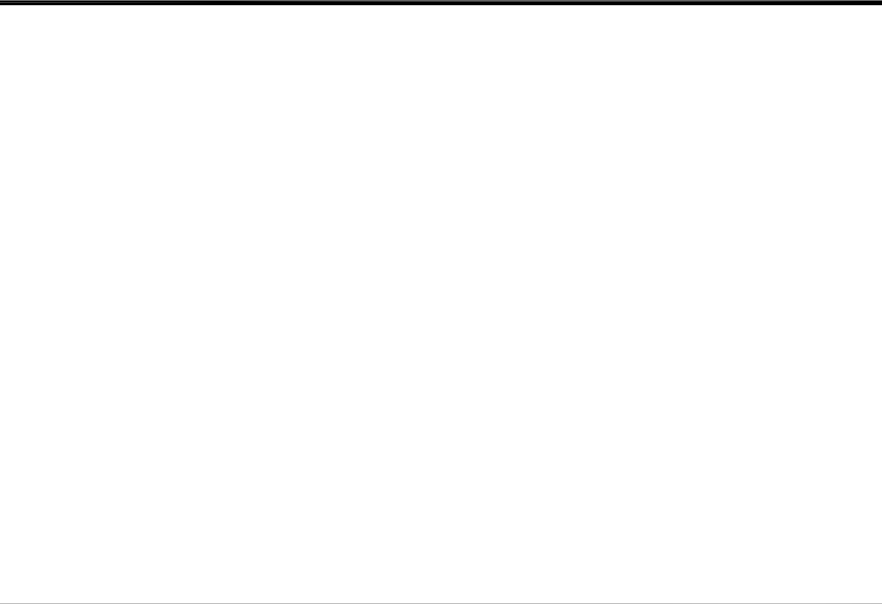

**NOT USED**      NO SCALE      3



**NOT USED**      NO SCALE      4

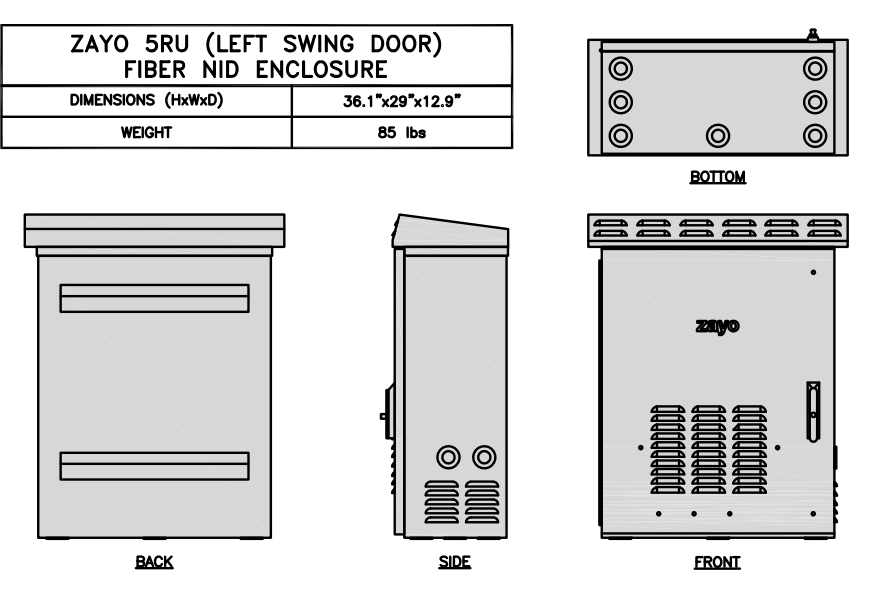

**FIBER NID ENCLOSURE DETAIL**      NO SCALE      5

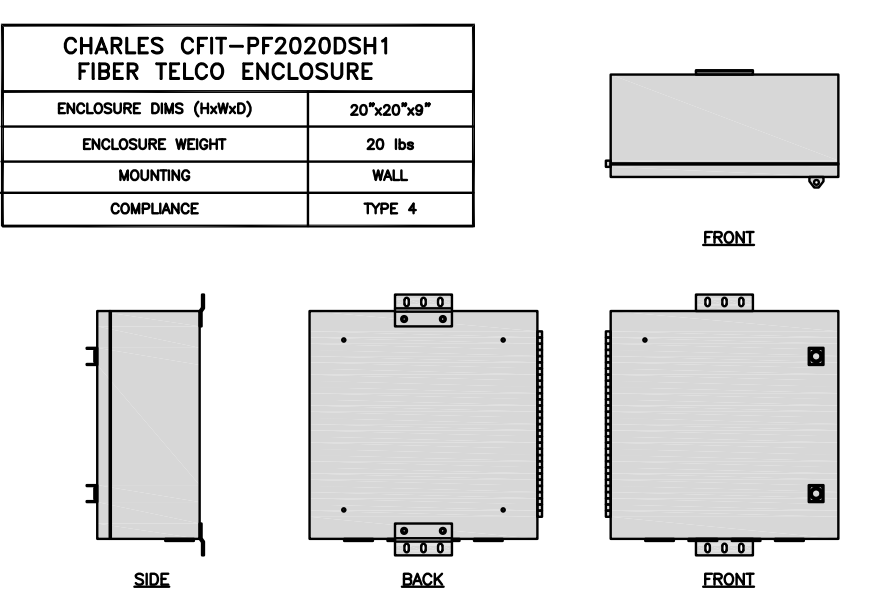

**FIBER TELCO ENCLOSURE DETAIL**      NO SCALE      6

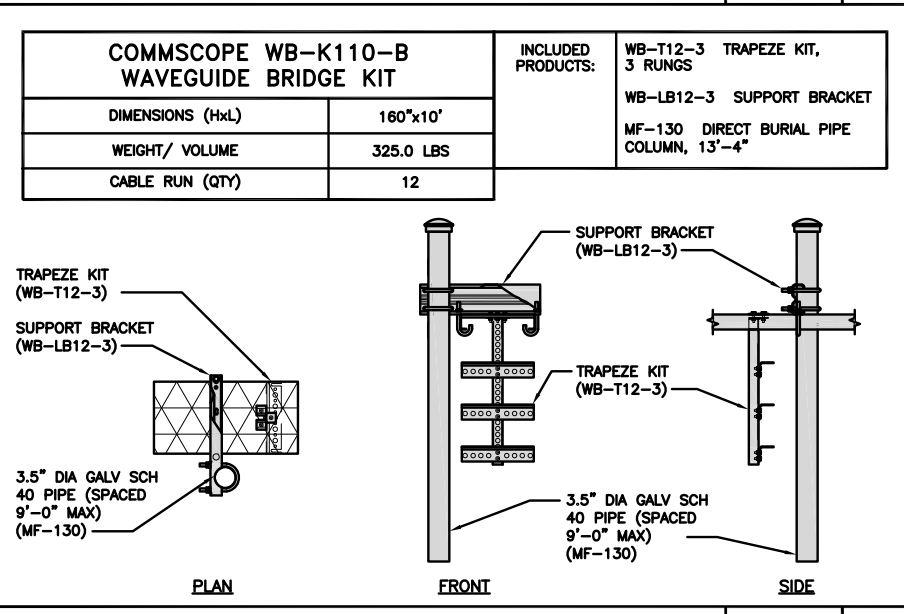

**ICE BRIDGE DETAIL**      NO SCALE      7

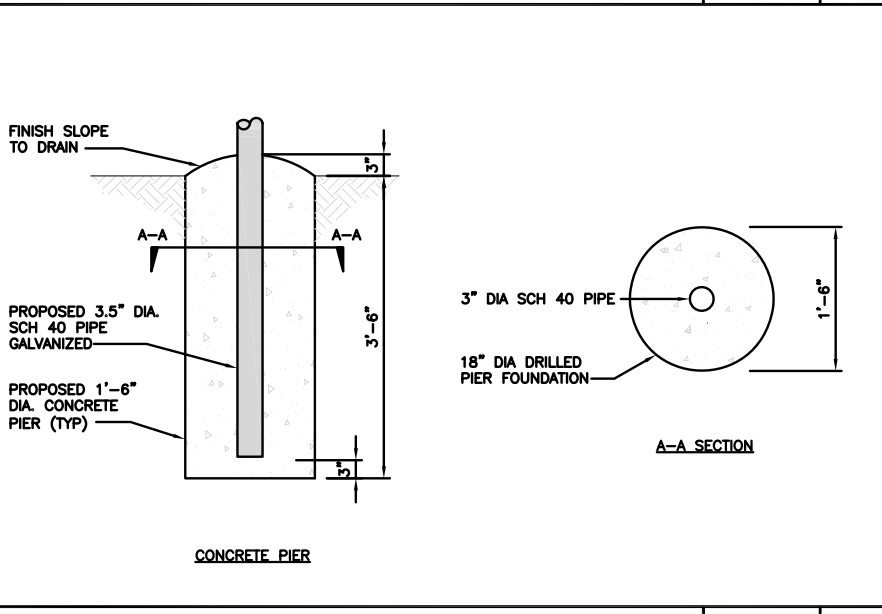

**TYPICAL ICE BRIDGE CONCRETE PIER DETAIL**      NO SCALE      8

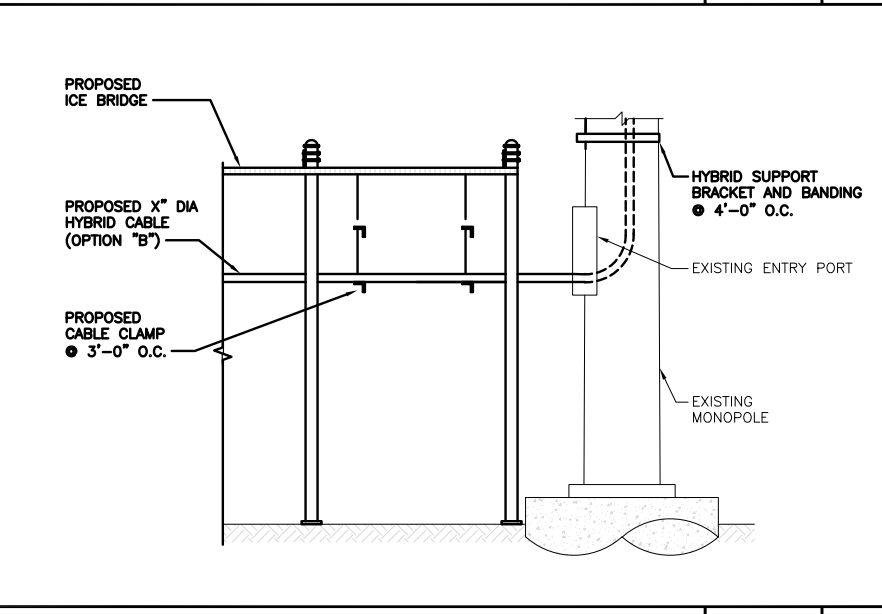

**HYBRID CABLE RUN**      NO SCALE      9

**dish wireless.**

5701 SOUTH SANTA FE DRIVE  
LITTLETON, CO 80120

**AMERICAN TOWER**  
10 PRESIDENTIAL WAY  
WOBURN, MA 01801

**B+T GRP**  
1717 S. BOULDER SUITE 300  
TULSA, OK 74119  
PH: (918) 587-4630  
www.btgrp.com

**B&T ENGINEERING, INC.**  
PEC.0001564  
Expires 2/10/22

IT IS A VIOLATION OF LAW FOR ANY PERSON, UNLESS THEY ARE ACTING UNDER THE DIRECTION OF A LICENSED PROFESSIONAL ENGINEER, TO ALTER THIS DOCUMENT.

DRAWN BY:	CHECKED BY:	APPROVED BY:
DAS	DAS	RCM
RFDS REV #:		2

**CONSTRUCTION DOCUMENTS**

SUBMITTALS		
REV	DATE	DESCRIPTION
A	7/26/21	ISSUED FOR REVIEW
0	9/8/21	ISSUED FOR CONSTRUCTION

A&E PROJECT NUMBER  
**153473.001.01**

DISH Wireless L.L.C.  
PROJECT INFORMATION

**BOBDL0015A**  
56 RUOPS ROAD  
TOLLAND, CT 06084

SHEET TITLE  
**EQUIPMENT DETAILS**

SHEET NUMBER  
**A-4**

PCTEL GPSGL-TMG-SPI-40NCB	
DIMENSIONS (DIAxH) MM/INCH	81x184mm 3.2"x7.25"
WEIGHT W/ACCESSORIES	075 lbs
CONNECTOR	N-FEMALE
FREQUENCY RANGE	1590 ± 30MHz

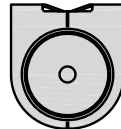

TOP

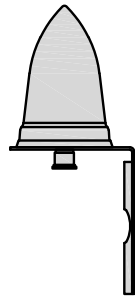

BACK

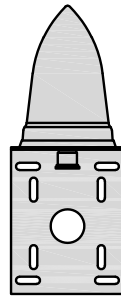

SIDE

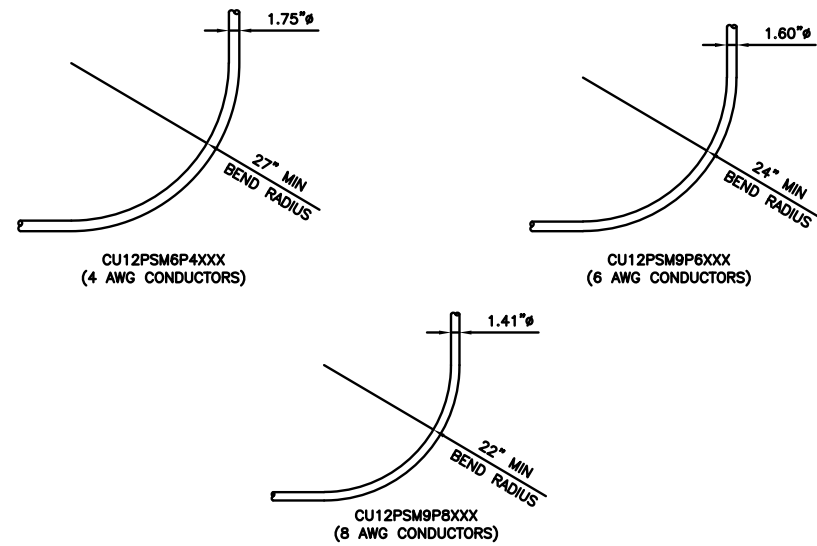
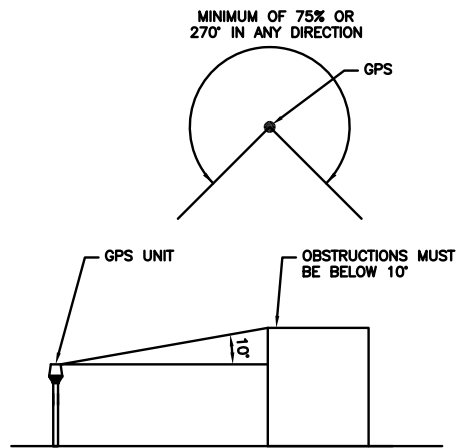

GPS DETAIL

NO SCALE

1

GPS MINIMUM SKY VIEW REQUIREMENTS

NO SCALE

2

CABLES UNLIMITED HYBRID CABLE  
MINIMUM BEND RADIUSES

NO SCALE

3

NOT USED

NO SCALE

4

NOT USED

NO SCALE

5

NOT USED

NO SCALE

6

NOT USED

NO SCALE

7

NOT USED

NO SCALE

8

NOT USED

NO SCALE

9



5701 SOUTH SANTA FE DRIVE  
LITTLETON, CO 80120



B&T ENGINEERING, INC.  
PEC.0001564  
Expires 2/10/22

IT IS A VIOLATION OF LAW FOR ANY PERSON,  
UNLESS THEY ARE ACTING UNDER THE DIRECTION  
OF A LICENSED PROFESSIONAL ENGINEER,  
TO ALTER THIS DOCUMENT.

DRAWN BY: CHECKED BY: APPROVED BY:  
DAS DAS RCM

RFDS REV #: 2

CONSTRUCTION DOCUMENTS

SUBMITTALS		
REV	DATE	DESCRIPTION
A	7/28/21	ISSUED FOR REVIEW
0	9/8/21	ISSUED FOR CONSTRUCTION

A&E PROJECT NUMBER  
153473.001.01

DISH Wireless L.L.C.  
PROJECT INFORMATION  
BOBDL00015A  
56 RUOPS ROAD  
TOLLAND, CT 06084

SHEET TITLE  
EQUIPMENT DETAILS

SHEET NUMBER  
**A-5**



FUJITSU TRIPLE BAND TA08025-B605	
DIMENSIONS (HxWxD)	14.9"x15.7"x9"
WEIGHT	74.95 lbs
CONNECTOR TYPE	4.3-10 RF CONNECTOR
POWER SUPPLY	DC -58~-36V

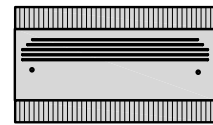

PLAN

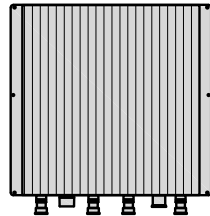

BACK



SIDE

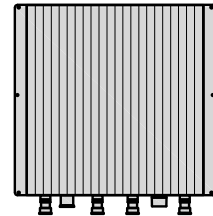

FRONT

RRH DETAIL

NO SCALE

1

FUJITSU DUAL BAND TA08025-B604	
DIMENSIONS (HxWxD)	14.9"x15.7"x7.8"
WEIGHT	63.9 lbs
CONNECTOR TYPE	4.3-10 RF CONNECTOR
POWER SUPPLY	DC -58~-36V

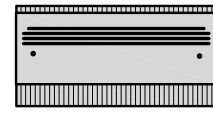

PLAN

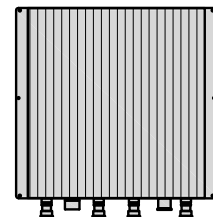

BACK

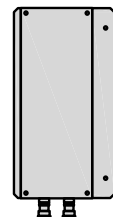

SIDE

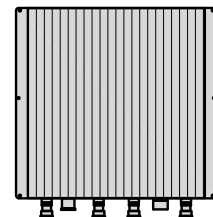

FRONT

RRH DETAIL

NO SCALE

2

SABRE DOUBLE Z-BRACKET C10123155	
DIMENSIONS (HxWxD) (1 BRACKET)	5"x20"x1-13/16"
WEIGHT (FULL ASSEMBLY)	35.79 lbs
PACKAGE QUANTITY	4

#	DESCRIPTION
1	PLATE, CHANNEL BRACKET
2	RRH Z BRACKET, 3/16"
3	THREADED ROD ASSEMBLY 1/2"x12"

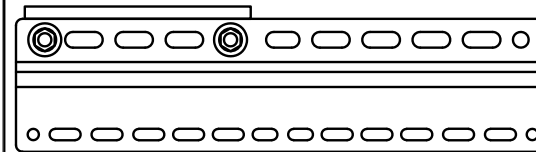

NOTE:  
OR DISH Wireless L.L.C.  
APPROVED EQUIVALENT

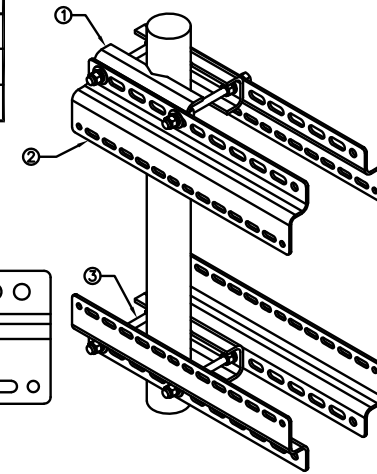

RRH MOUNT DETAIL

NO SCALE

3

JMA MX08FRO665-21	
DIMENSIONS (HxWxD)	72"x20.0"x8.0"
RF PORTS, CONNECTOR TYPE	8 x 4.3-10 FEMALE
WEIGHT	64.5 lbs
WEIGHT WITH BRACKETS	82.5 lbs

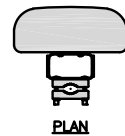

PLAN

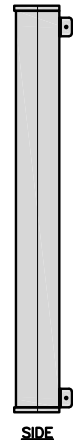

SIDE

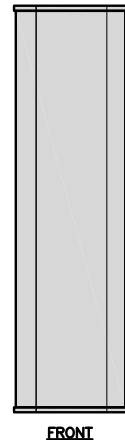

FRONT

ANTENNA DETAIL

NO SCALE

4

JMA ANTENNA MOUNT BRACKET #91900318	
TOTAL WEIGHT (WITH BRACKETS)	18 lbs (8.18 Kg)
POLE DIAMETER RANGE	2.5" TO 4.5"

NOTE:  
KIT #91900318: TOP AND BOTTOM BRACKETS  
FOR 4-, 6-, AND 8-FOOT ANTENNAS  
ANTENNA BRACKET NOT PART OF KIT

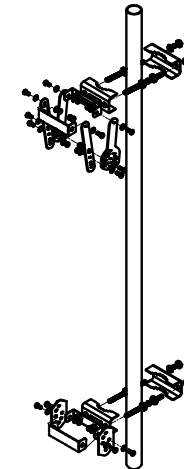

NOTE:  
OR DISH Wireless L.L.C.  
APPROVED EQUIVALENT

ANTENNA BRACKET DETAIL

NO SCALE

6

RAYCAP RDIDC-9181-PF-48 DC SURGE PROTECTION (OVP)	
DIMENSIONS (HxWxD)	18.98"x14.39"x8.15"
WEIGHT	21.82 LBS

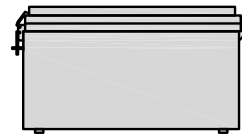

PLAN

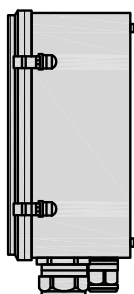

SIDE

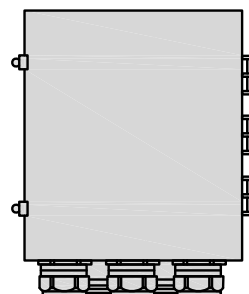

BACK

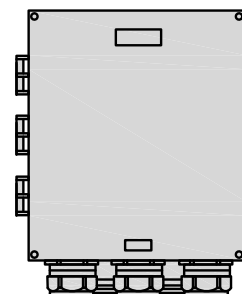

FRONT

SURGE SUPPRESSION DETAIL (OVP)

NO SCALE

7

COMMSCOPE XP-2040 CROSSOVER PLATE	
DIMENSIONS (HxW)	10"x12"
WEIGHT	11 lbs

NOTE:  
OR DISH Wireless L.L.C.  
APPROVED EQUIVALENT

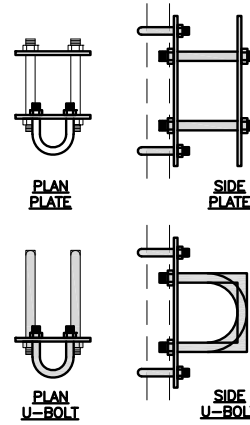

PLAN  
U-BOLT

SIDE  
U-BOLT

RRH/OVP MOUNT DETAIL

NO SCALE

8

COMMSCOPE MC-PK8-DSH	
FACE WIDTH	96"
WEIGHT	1373.08 lbs
NOTE: 15" TO 38" O.D.	

NOTE:  
OR DISH Wireless L.L.C.  
APPROVED EQUIVALENT

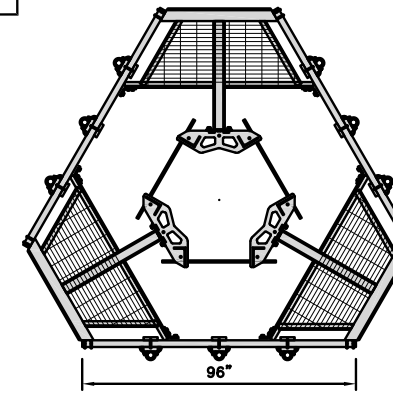
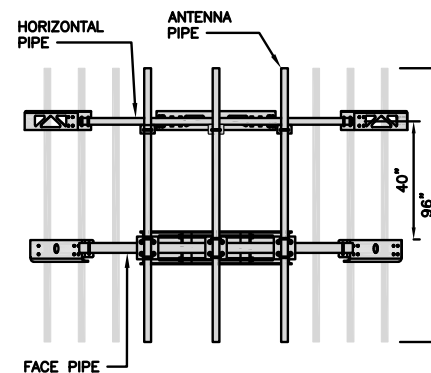

ANTENNA PLATFORM DETAIL

NO SCALE

9

**dish**  
wireless.

5701 SOUTH SANTA FE DRIVE  
LITTLETON, CO 80120

**AMERICAN TOWER**  
10 PRESIDENTIAL WAY  
WOBURN, MA 01801

**B+T GRP**  
1717 S. BOULDER  
SUITE 300  
TULSA, OK 74119  
PH: (918) 587-4630  
www.btgrp.com



**B&T ENGINEERING, INC.**  
PEC.0001564  
Expires 2/10/22

IT IS A VIOLATION OF LAW FOR ANY PERSON,  
UNLESS THEY ARE ACTING UNDER THE DIRECTION  
OF A LICENSED PROFESSIONAL ENGINEER,  
TO ALTER THIS DOCUMENT.

DRAWN BY: CHECKED BY: APPROVED BY:  
DAS DAS RCM

RFDS REV #: 2

**CONSTRUCTION  
DOCUMENTS**

SUBMITTALS		
REV	DATE	DESCRIPTION
A	7/26/21	ISSUED FOR REVIEW
0	9/8/21	ISSUED FOR CONSTRUCTION

A&E PROJECT NUMBER  
153473.001.01

DISH Wireless L.L.C.  
PROJECT INFORMATION  
BOBDL0015A  
56 RUOPS ROAD  
TOLLAND, CT 06084

SHEET TITLE  
EQUIPMENT DETAILS

SHEET NUMBER  
**A-6**



**CARLON EXPANSION FITTINGS**

COUPLING END PART#	MALE TERMINAL ADAPTER END PART#	SIZE	STD CTN QTY.	TRAVEL LENGTH
E945D	E945DX	1/2"	20	4"
E945E	E945EX	3/4"	15	4"
E945F	E945FX	1"	10	4"
E945G	E945GX	1 1/4"	5	4"
E945H	E945HX	1 1/2"	5	4"
E945J	E945JX	2"	15	8"
E945K	E945KX	2 1/2"	10	8"
E945L	E945LX	3"	10	8"
E945M	E945MX	3 1/2"	5	8"
E945N	E945NX	4"	5	8"
E945P	E945PX	5"	1	8"
E945R	E945RX	6"	1	8"

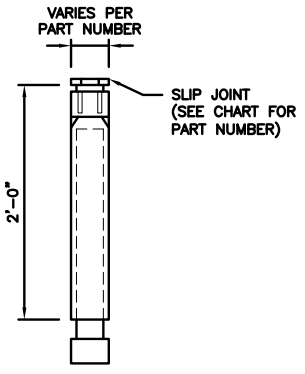

NOTE: CONTRACTOR TO INSTALL EXPANSION FITTING SLIP JOINT AT METER CENTER CONDUIT TERMINATION, AS PER LOCAL UTILITY POLICY, ORDINANCE AND/OR SPECIFIED REQUIREMENT.

**TRENCHING NOTES**

- CONTRACTOR SHALL RESTORE THE TRENCH TO ITS ORIGINAL CONDITIONS BY EITHER SEEDING OR SODDING GRASS AREAS, OR REPLACING ASPHALT OR CONCRETE AREAS TO ITS ORIGINAL CROSS SECTION.
- TRENCHING SAFETY; INCLUDING, BUT NOT LIMITED TO SOIL CLASSIFICATION, SLOPING, AND SHORING, SHALL BE GOVERNED BY THE CURRENT OSHA TRENCHING AND EXCAVATION SAFETY STANDARDS.
- ALL CONDUITS SHALL BE INSTALLED IN COMPLIANCE WITH THE CURRENT NATIONAL ELECTRIC CODE (NEC) OR AS REQUIRED BY THE LOCAL JURISDICTION, WHICHEVER IS THE MOST STRINGENT.

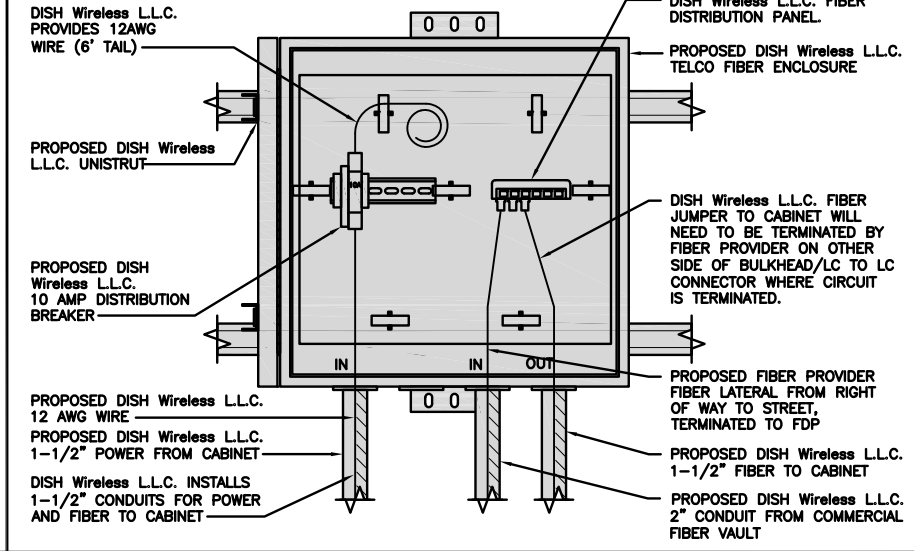
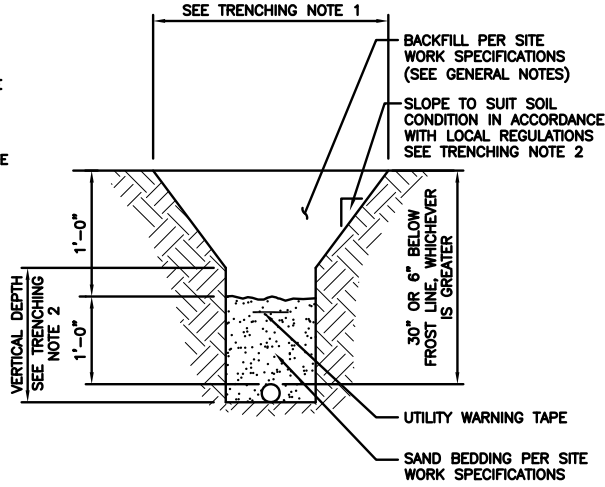

5701 SOUTH SANTA FE DRIVE  
LITTLETON, CO 80120



**B+T GRP**  
1717 S. BOULDER SUITE 300  
TULSA, OK 74119  
PH: (918) 587-4630  
www.btgrp.com



**B&T ENGINEERING, INC.**  
PEC.0001564  
Expires 2/10/22

IT IS A VIOLATION OF LAW FOR ANY PERSON, UNLESS THEY ARE ACTING UNDER THE DIRECTION OF A LICENSED PROFESSIONAL ENGINEER, TO ALTER THIS DOCUMENT.

DRAWN BY: CHECKED BY: APPROVED BY:  
DAS DAS RCM

RFDS REV #: 2

**CONSTRUCTION DOCUMENTS**

SUBMITTALS		
REV	DATE	DESCRIPTION
A	7/26/21	ISSUED FOR REVIEW
0	9/8/21	ISSUED FOR CONSTRUCTION

A&E PROJECT NUMBER  
153473.001.01

DISH Wireless L.L.C.  
PROJECT INFORMATION  
BOBDL0015A  
56 RUOPS ROAD  
TOLLAND, CT 06084

SHEET TITLE  
ELECTRICAL  
DETAILS

SHEET NUMBER  
**E-2**

EXPANSION JOINT DETAIL NO SCALE 1

TYPICAL UNDERGROUND TRENCH DETAIL NO SCALE 2

DARK TELCO BOX – INTERIOR WIRING LAYOUT NO SCALE 3

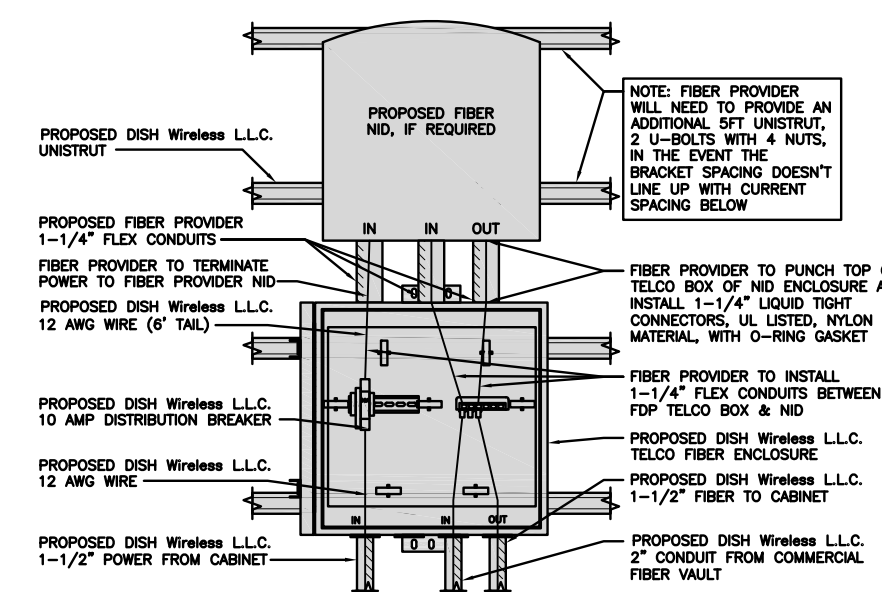

LIT TELCO BOX – INTERIOR WIRING LAYOUT (OPTIONAL) NO SCALE 4

NOT USED NO SCALE 5

NOT USED NO SCALE 6

NOT USED NO SCALE 7

NOT USED NO SCALE 8

NOT USED NO SCALE 9



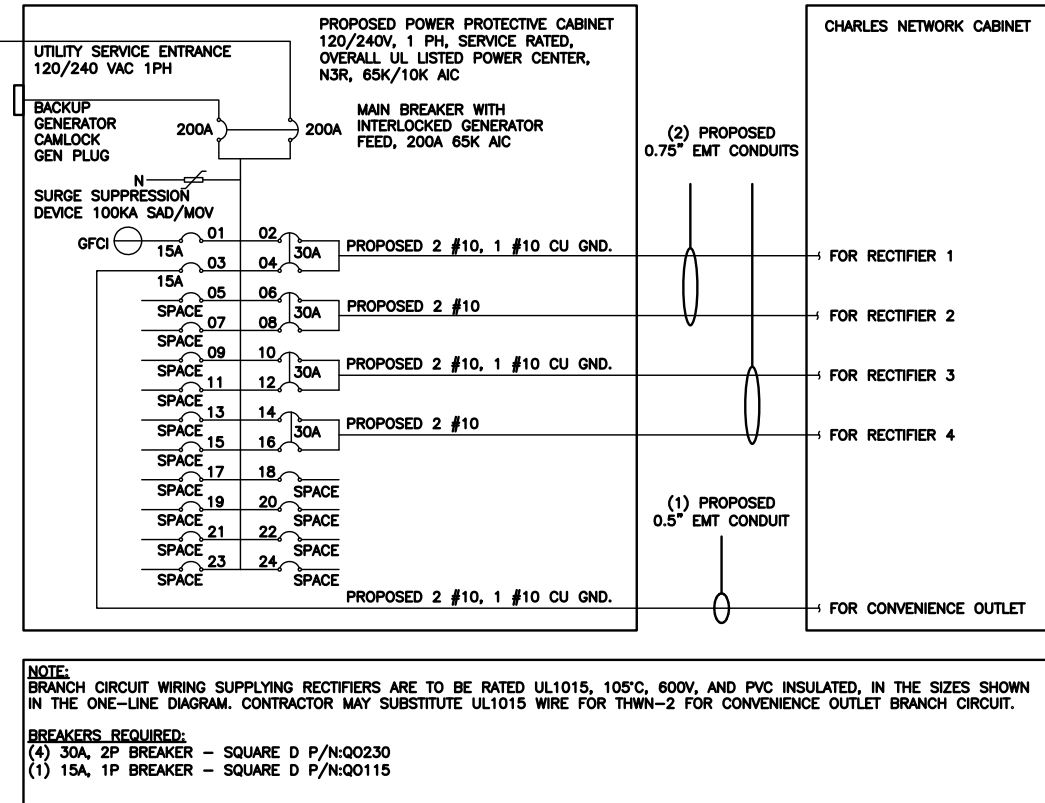
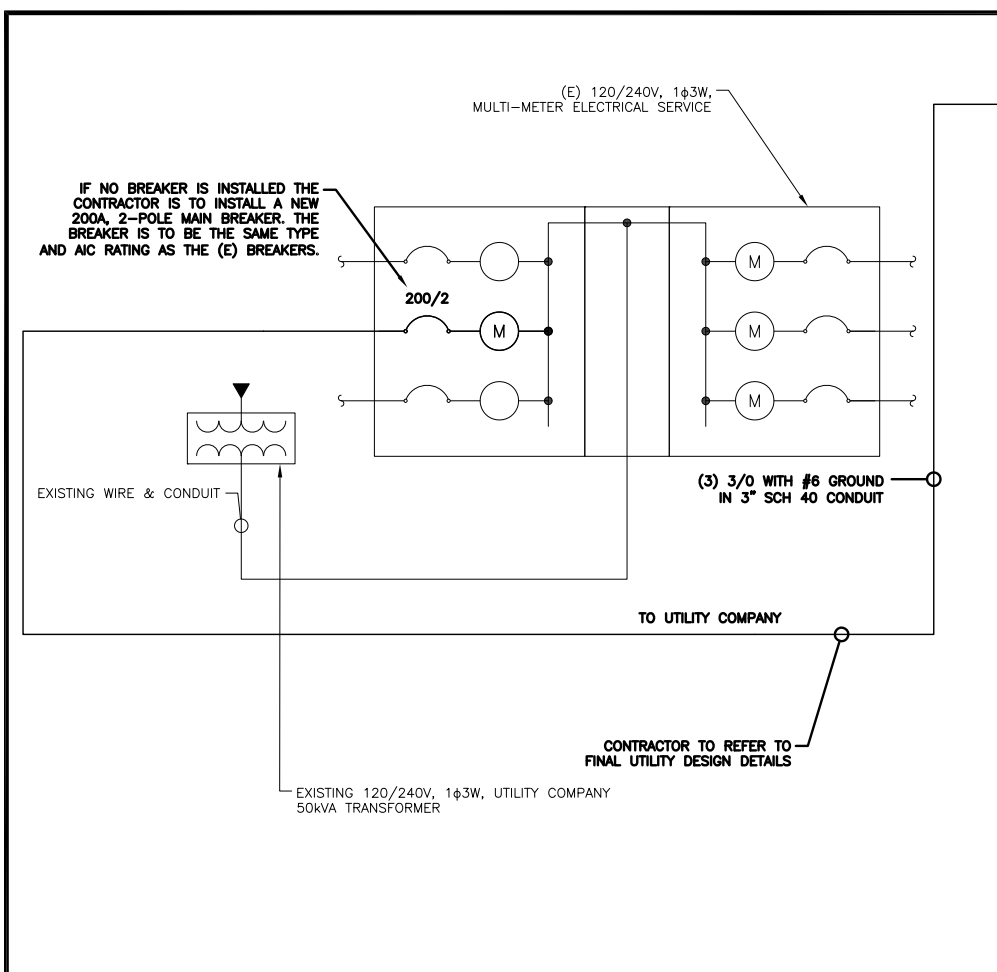

**NOTES**

THE (2) CONDUITS WITH (4) CURRENT CARRYING CONDUCTORS EACH, SHALL APPLY THE ADJUSTMENT FACTOR OF 80% PER 2014/17 NEC TABLE 310.15(B)(3)(g) OR 2020 NEC TABLE 310.15(C)(1) FOR UL1015 WIRE.

#12 FOR 15A-20A/1P BREAKER: 0.8 x 30A = 24.0A  
 #10 FOR 25A-30A/2P BREAKER: 0.8 x 40A = 32.0A  
 #8 FOR 35A-40A/2P BREAKER: 0.8 x 55A = 44.0A  
 #6 FOR 45A-60A/2P BREAKER: 0.8 x 75A = 60.0A

CONDUIT SIZING: AT 40% FILL PER NEC CHAPTER 9, TABLE 4, ARTICLE 358.  
 0.5" CONDUIT - 0.122 SQ. IN AREA  
 0.75" CONDUIT - 0.213 SQ. IN AREA  
 2.0" CONDUIT - 1.316 SQ. IN AREA  
 3.0" CONDUIT - 2.907 SQ. IN AREA

CABINET CONVENIENCE OUTLET CONDUCTORS (1 CONDUIT): USING THWN-2, CU.  
 #10 - 0.0211 SQ. IN X 2 = 0.0422 SQ. IN  
 #10 - 0.0211 SQ. IN X 1 = 0.0211 SQ. IN <GROUND  
 TOTAL = 0.0633 SQ. IN

0.5" EMT CONDUIT IS ADEQUATE TO HANDLE THE TOTAL OF (3) WIRES, INCLUDING GROUND WIRE, AS INDICATED ABOVE.

RECTIFIER CONDUCTORS (2 CONDUITS): USING UL1015, CU.  
 #10 - 0.0266 SQ. IN X 4 = 0.1064 SQ. IN  
 #10 - 0.0082 SQ. IN X 1 = 0.0082 SQ. IN <BARE GROUND  
 TOTAL = 0.1146 SQ. IN

0.75" EMT CONDUIT IS ADEQUATE TO HANDLE THE TOTAL OF (5) WIRES, INCLUDING GROUND WIRE, AS INDICATED ABOVE.

PPC FEED CONDUCTORS (1 CONDUIT): USING THWN, CU.  
 3/0 - 0.2679 SQ. IN X 3 = 0.8037 SQ. IN  
 #6 - 0.0507 SQ. IN X 1 = 0.0507 SQ. IN <GROUND  
 TOTAL = 0.8544 SQ. IN

3.0" SCH 40 PVC CONDUIT IS ADEQUATE TO HANDLE THE TOTAL OF (4) WIRES, INCLUDING GROUND WIRE, AS INDICATED ABOVE.

PPC ONE-LINE DIAGRAM

NO SCALE 1

PROPOSED CHARLES PANEL SCHEDULE										
LOAD SERVED	VOLT AMPS (WATTS)		TRIP	CKT #	PHASE	CKT #	TRIP	VOLT AMPS (WATTS)		LOAD SERVED
	L1	L2						L1	L2	
PPC GFCI OUTLET	180	180	15A	1	A	2	30A	2880	2880	ABB/GE INFINITY RECTIFIER 1
CHARLES GFCI OUTLET			15A	3	B	4	30A	2880	2880	ABB/GE INFINITY RECTIFIER 1
-SPACE-				5	A	6	30A	2880	2880	ABB/GE INFINITY RECTIFIER 2
-SPACE-				7	B	8	30A	2880	2880	ABB/GE INFINITY RECTIFIER 2
-SPACE-				9	A	10	30A	2880	2880	ABB/GE INFINITY RECTIFIER 3
-SPACE-				11	B	12	30A	2880	2880	ABB/GE INFINITY RECTIFIER 3
-SPACE-				13	A	14	30A	2880	2880	ABB/GE INFINITY RECTIFIER 4
-SPACE-				15	B	16	30A	2880	2880	ABB/GE INFINITY RECTIFIER 4
-SPACE-				17	A	18				-SPACE-
-SPACE-				19	B	20				-SPACE-
-SPACE-				21	A	22				-SPACE-
-SPACE-				23	B	24				-SPACE-
VOLTAGE AMPS		180	180					11520	11520	
200A MCB, 1φ, 24 SPACE, 120/240V				L1	L2					
MB RATING: 65,000 AIC				11700	11700					
				98	98					
				98						
				123						

PANEL SCHEDULE

NO SCALE 2

NOT USED

NO SCALE 3



5701 SOUTH SANTA FE DRIVE  
LITTLETON, CO 80120



B&T ENGINEERING, INC.  
PEC.0001564  
Expires 2/10/22

IT IS A VIOLATION OF LAW FOR ANY PERSON, UNLESS THEY ARE ACTING UNDER THE DIRECTION OF A LICENSED PROFESSIONAL ENGINEER, TO ALTER THIS DOCUMENT.

DRAWN BY: CHECKED BY: APPROVED BY:  
DAS DAS RCM

RFDS REV #: 2

CONSTRUCTION DOCUMENTS

SUBMITTALS		
REV	DATE	DESCRIPTION
A	7/26/21	ISSUED FOR REVIEW
0	9/8/21	ISSUED FOR CONSTRUCTION

A&E PROJECT NUMBER  
153473.001.01

DISH Wireless L.L.C.  
PROJECT INFORMATION  
BOBDL00015A  
56 RUOPS ROAD  
TOLLAND, CT 06084

SHEET TITLE  
ELECTRICAL ONE-LINE, FAULT  
CALCS & PANEL SCHEDULE

SHEET NUMBER  
**E-3**

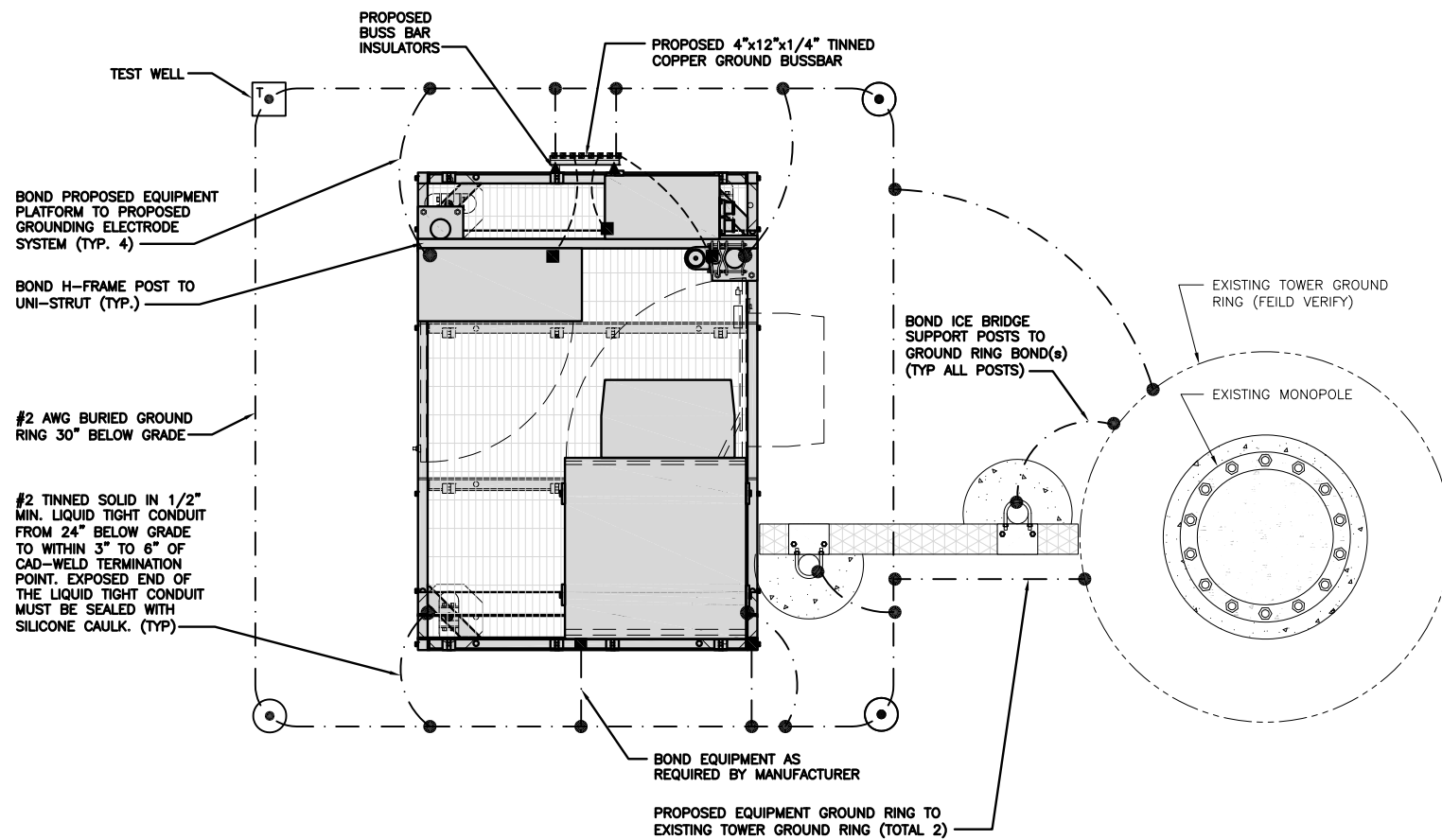

TYPICAL EQUIPMENT GROUNDING PLAN

NO SCALE 1

NOTES

1. ANTENNAS AND OVP SHOWN ARE GENERIC AND NOT REFERENCING TO A SPECIFIC MANUFACTURER. THIS LAYOUT IS FOR REFERENCE ONLY

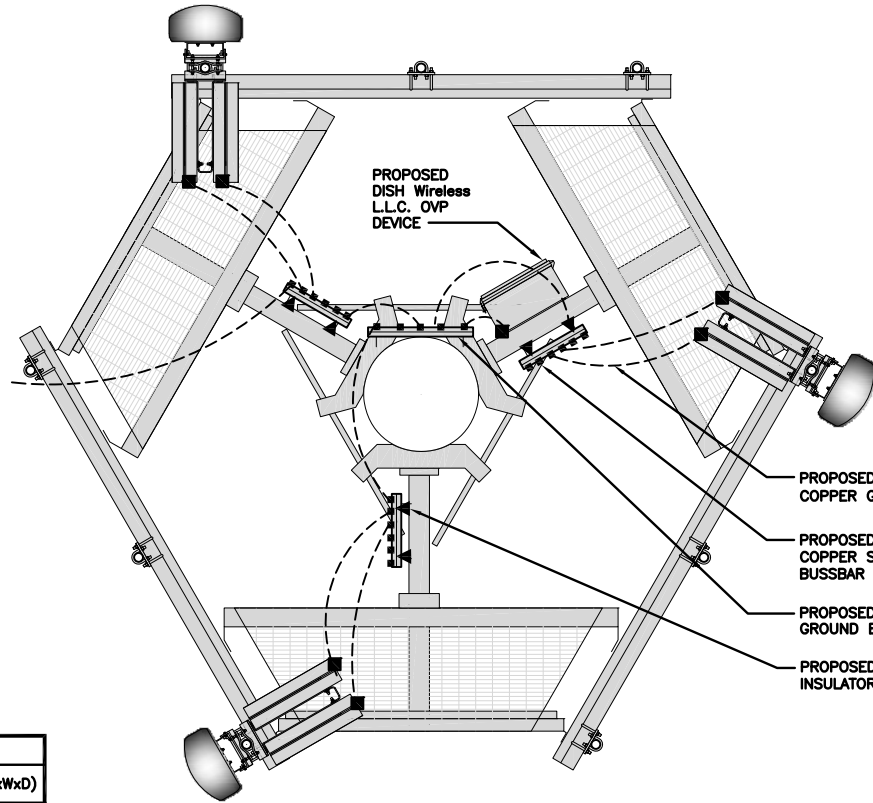

TYPICAL ANTENNA GROUNDING PLAN

NO SCALE 2

- EXOTHERMIC CONNECTION
- MECHANICAL CONNECTION
- ▬ GROUND BUS BAR
- GROUND ROD
- TEST GROUND ROD WITH INSPECTION SLEEVE
- #6 AWG STRANDED & INSULATED
- - - #2 AWG SOLID COPPER TINNED
- ▲ BUSS BAR INSULATOR

GROUNDING LEGEND

1. GROUNDING IS SHOWN DIAGRAMMATICALLY ONLY.
2. CONTRACTOR SHALL GROUND ALL EQUIPMENT AS A COMPLETE SYSTEM. GROUNDING SHALL BE IN COMPLIANCE WITH NEC SECTION 250 AND DISH Wireless L.L.C. GROUNDING AND BONDING REQUIREMENTS AND MANUFACTURER'S SPECIFICATIONS.
3. ALL GROUND CONDUCTORS SHALL BE COPPER; NO ALUMINUM CONDUCTORS SHALL BE USED.

GROUNDING KEY NOTES

- (A) EXTERIOR GROUND RING: #2 AWG SOLID COPPER, BURIED AT A DEPTH OF AT LEAST 30 INCHES BELOW GRADE, OR 6 INCHES BELOW THE FROST LINE AND APPROXIMATELY 24 INCHES FROM THE EXTERIOR WALL OR FOOTING.
- (B) TOWER GROUND RING: THE GROUND RING SYSTEM SHALL BE INSTALLED AROUND AN ANTENNA TOWER'S LEGS, AND/OR GUY ANCHORS. WHERE SEPARATE SYSTEMS HAVE BEEN PROVIDED FOR THE TOWER AND THE BUILDING, AT LEAST TWO BONDS SHALL BE MADE BETWEEN THE TOWER RING GROUND SYSTEM AND THE BUILDING RING GROUND SYSTEM USING MINIMUM #2 AWG SOLID COPPER CONDUCTORS.
- (C) INTERIOR GROUND RING: #2 AWG STRANDED GREEN INSULATED COPPER CONDUCTOR EXTENDED AROUND THE PERIMETER OF THE EQUIPMENT AREA. ALL NON-TELECOMMUNICATIONS RELATED METALLIC OBJECTS FOUND WITHIN A SITE SHALL BE GROUND TO THE INTERIOR GROUND RING WITH #6 AWG STRANDED GREEN INSULATED CONDUCTOR.
- (D) BOND TO INTERIOR GROUND RING: #2 AWG SOLID TINNED COPPER WIRE PRIMARY BONDS SHALL BE PROVIDED AT LEAST AT FOUR POINTS ON THE INTERIOR GROUND RING, LOCATED AT THE CORNERS OF THE BUILDING.
- (E) GROUND ROD: UL LISTED COPPER CLAD STEEL MINIMUM 1/2" DIAMETER BY EIGHT FEET LONG. GROUND RODS SHALL BE INSTALLED WITH INSPECTION SLEEVES. GROUND RODS SHALL BE DRIVEN TO THE DEPTH OF GROUND RING CONDUCTOR.
- (F) CELL REFERENCE GROUND BAR: POINT OF GROUND REFERENCE FOR ALL COMMUNICATIONS EQUIPMENT FRAMES. ALL BONDS ARE MADE WITH #2 AWG UNLESS NOTED OTHERWISE STRANDED GREEN INSULATED COPPER CONDUCTORS. BOND TO GROUND RING WITH (2) #2 SOLID TINNED COPPER CONDUCTORS.
- (G) HATCH PLATE GROUND BAR: BOND TO THE INTERIOR GROUND RING WITH TWO #2 AWG STRANDED GREEN INSULATED COPPER CONDUCTORS. WHEN A HATCH-PLATE AND A CELL REFERENCE GROUND BAR ARE BOTH PRESENT, THE CRGB MUST BE CONNECTED TO THE HATCH-PLATE AND TO THE INTERIOR GROUND RING USING (2) TWO #2 AWG STRANDED GREEN INSULATED COPPER CONDUCTORS EACH.
- (H) EXTERIOR CABLE ENTRY PORT GROUND BARS: LOCATED AT THE ENTRANCE TO THE CELL SITE BUILDING. BOND TO GROUND RING WITH A #2 AWG SOLID TINNED COPPER CONDUCTORS WITH AN EXOTHERMIC WELD AND INSPECTION SLEEVE.
- (I) TELCO GROUND BAR: BOND TO BOTH CELL REFERENCE GROUND BAR OR EXTERIOR GROUND RING.
- (J) FRAME BONDING: THE BONDING POINT FOR TELECOM EQUIPMENT FRAMES SHALL BE THE GROUND BUS THAT IS NOT ISOLATED FROM THE EQUIPMENTS METAL FRAMEWORK.
- (K) INTERIOR UNIT BONDS: METAL FRAMES, CABINETS AND INDIVIDUAL METALLIC UNITS LOCATED WITH THE AREA OF THE INTERIOR GROUND RING REQUIRE A #6 AWG STRANDED GREEN INSULATED COPPER BOND TO THE INTERIOR GROUND RING.
- (L) FENCE AND GATE GROUNDING: METAL FENCES WITHIN 7 FEET OF THE EXTERIOR GROUND RING OR OBJECTS BONDED TO THE EXTERIOR GROUND RING SHALL BE BONDED TO THE GROUND RING WITH A #2 AWG SOLID TINNED COPPER CONDUCTOR AT AN INTERVAL NOT EXCEEDING 25 FEET. BONDS SHALL BE MADE AT EACH GATE POST AND ACROSS GATE OPENINGS.
- (M) EXTERIOR UNIT BONDS: METALLIC OBJECTS, EXTERNAL TO OR MOUNTED TO THE BUILDING, SHALL BE BONDED TO THE EXTERIOR GROUND RING. USING #2 TINNED SOLID COPPER WIRE
- (N) ICE BRIDGE SUPPORTS: EACH ICE BRIDGE LEG SHALL BE BONDED TO THE GROUND RING WITH #2 AWG BARE TINNED COPPER CONDUCTOR. PROVIDE EXOTHERMIC WELDS AT BOTH THE ICE BRIDGE LEG AND BURIED GROUND RING.
- (O) DURING ALL DC POWER SYSTEM CHANGES INCLUDING DC SYSTEM CHANGE OUTS, RECTIFIER REPLACEMENTS OR ADDITIONS, BREAKER DISTRIBUTION CHANGES, BATTERY ADDITIONS, BATTERY REPLACEMENTS AND INSTALLATIONS OR CHANGES TO DC CONVERTER SYSTEMS IT SHALL BE REQUIRED THAT SERVICE CONTRACTORS VERIFY ALL DC POWER SYSTEMS ARE EQUIPPED WITH A MASTER DC SYSTEM RETURN GROUND CONDUCTOR FROM THE DC POWER SYSTEM COMMON RETURN BUS DIRECTLY CONNECTED TO THE CELL SITE REFERENCE GROUND BAR
- (P) TOWER TOP COLLECTOR BUSS BAR IS TO BE MECHANICALLY BONDED TO PROPOSED ANTENNA MOUNT COLLAR. REFER TO DISH Wireless L.L.C. GROUNDING NOTES.

GROUNDING KEY NOTES

NO SCALE 3



5701 SOUTH SANTA FE DRIVE  
LITTLETON, CO 80120



B&T ENGINEERING, INC.  
PEC.0001564  
Expires 2/10/22

IT IS A VIOLATION OF LAW FOR ANY PERSON, UNLESS THEY ARE ACTING UNDER THE DIRECTION OF A LICENSED PROFESSIONAL ENGINEER, TO ALTER THIS DOCUMENT.

DRAWN BY:	CHECKED BY:	APPROVED BY:
DAS	DAS	RCM

RFDS REV #: 2

CONSTRUCTION DOCUMENTS

SUBMITTALS		
REV	DATE	DESCRIPTION
A	7/26/21	ISSUED FOR REVIEW
0	9/8/21	ISSUED FOR CONSTRUCTION

A&E PROJECT NUMBER  
153473.001.01

DISH Wireless L.L.C.  
PROJECT INFORMATION

BOBDL0015A  
56 RUOPS ROAD  
TOLLAND, CT 06084

SHEET TITLE  
GROUNDING PLANS  
AND NOTES

SHEET NUMBER

G-1

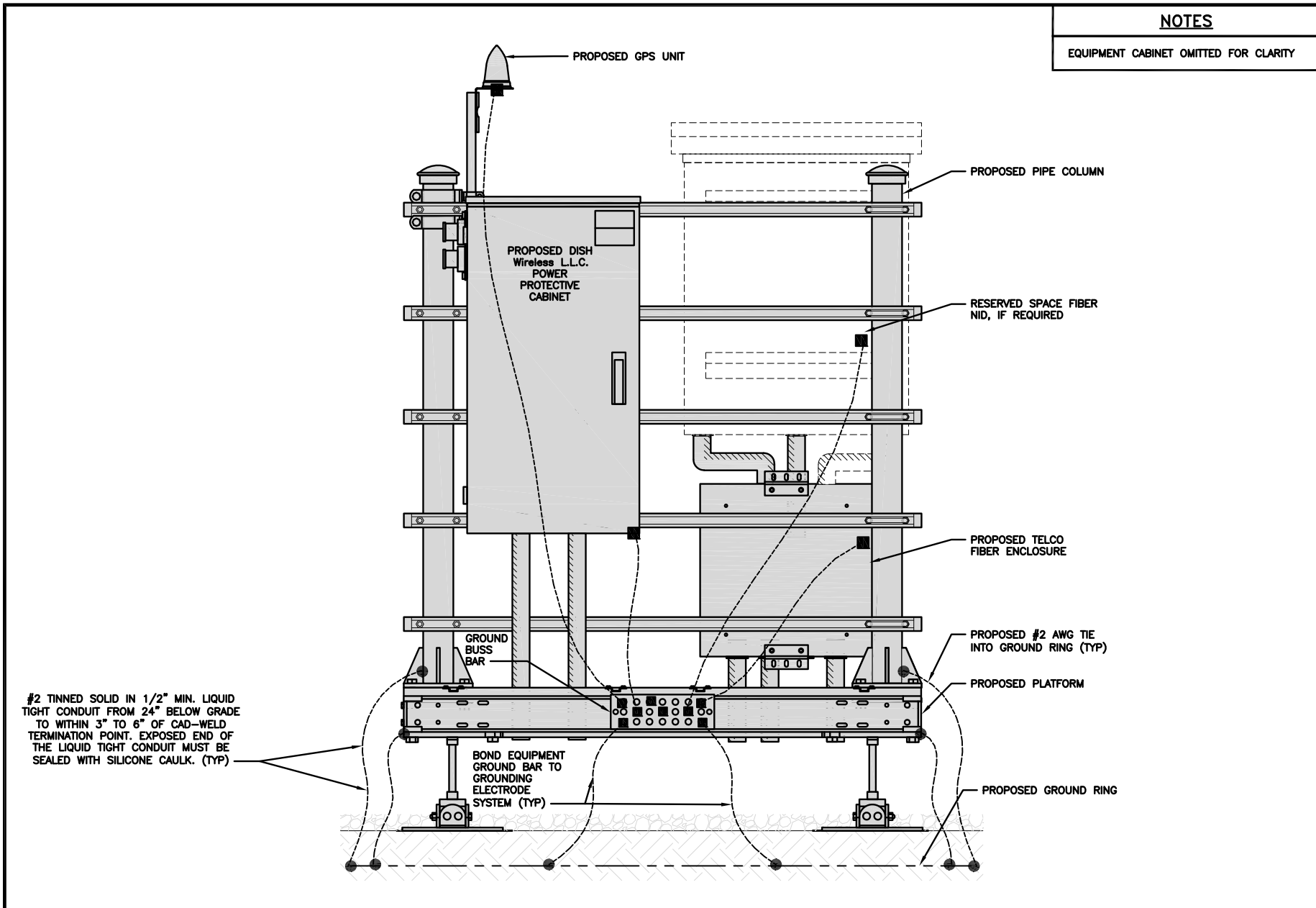

**H-FRAME GROUNDING DETAIL**

NO SCALE 1

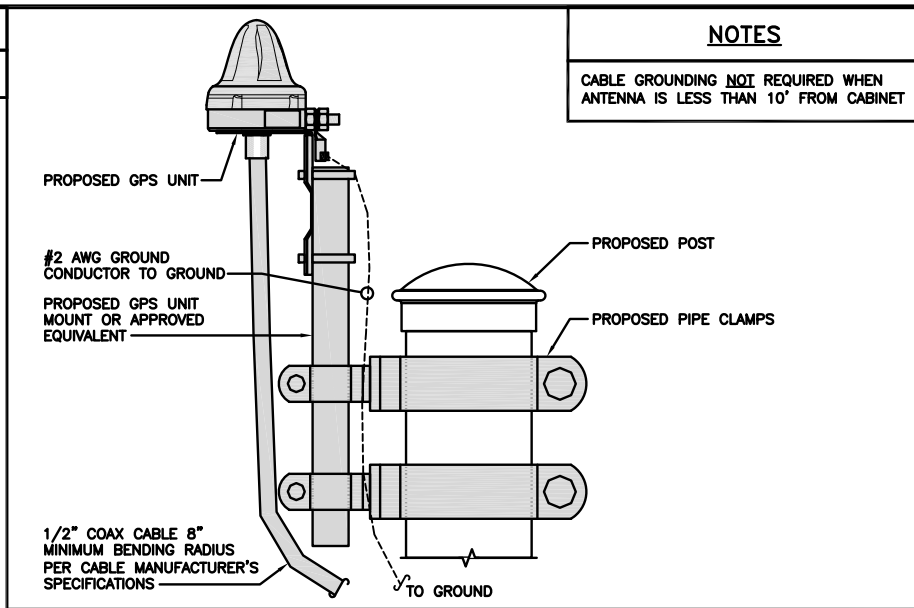

**TYPICAL GPS UNIT GROUNDING**

NO SCALE 2

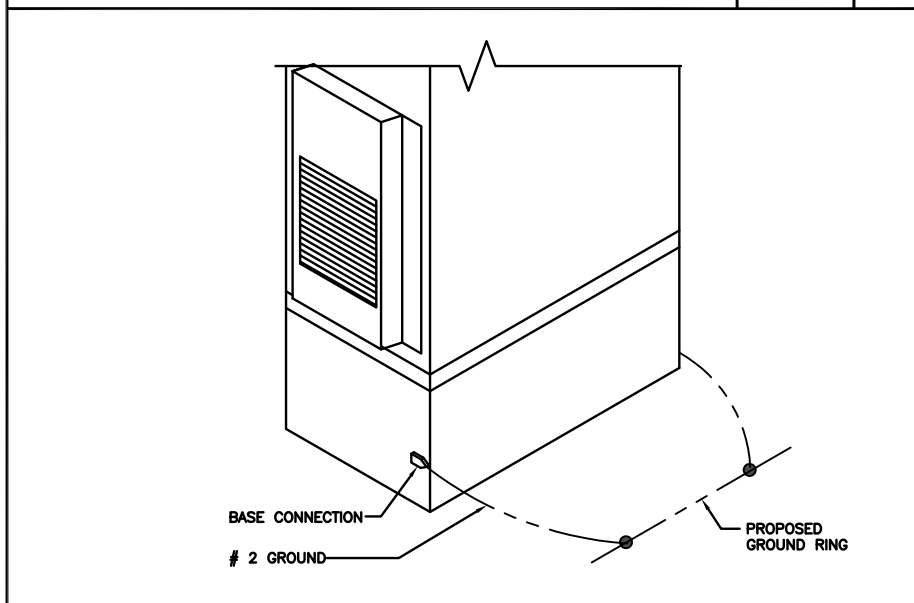

**OUTDOOR CABINET GROUNDING**

NO SCALE 3

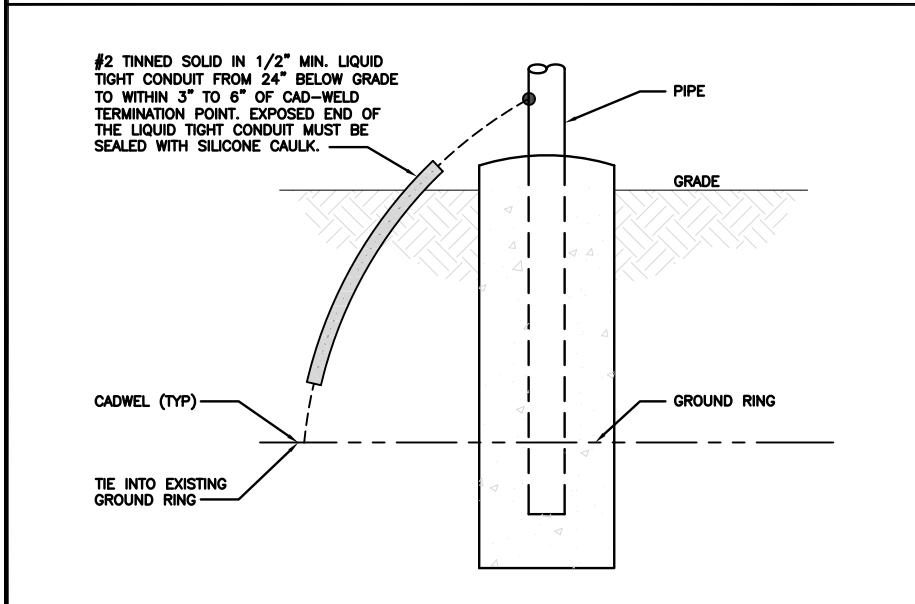

**TRANSITIONING GROUND DETAIL**

NO SCALE 4

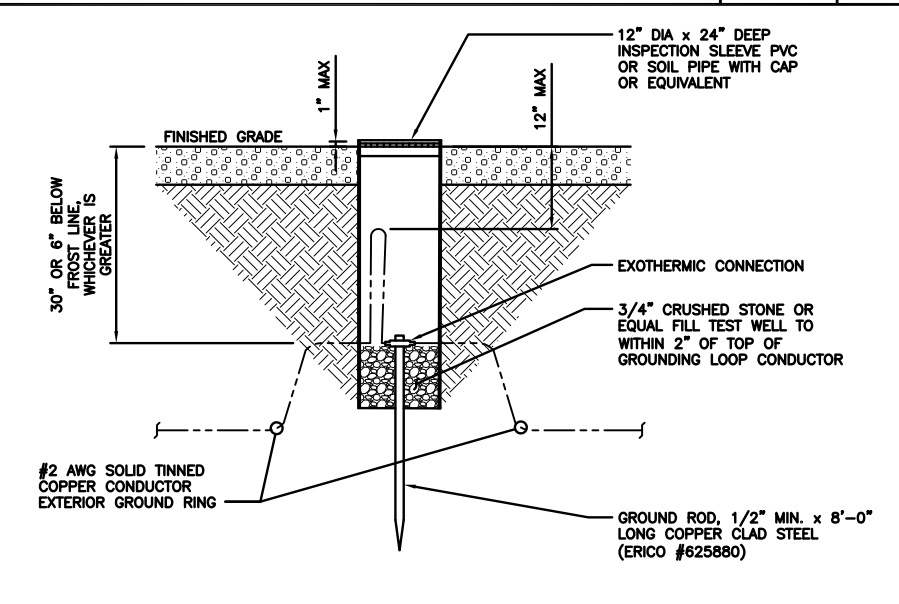

**TYPICAL TEST GROUND ROD WITH INSPECTION SLEEVE**

NO SCALE 5

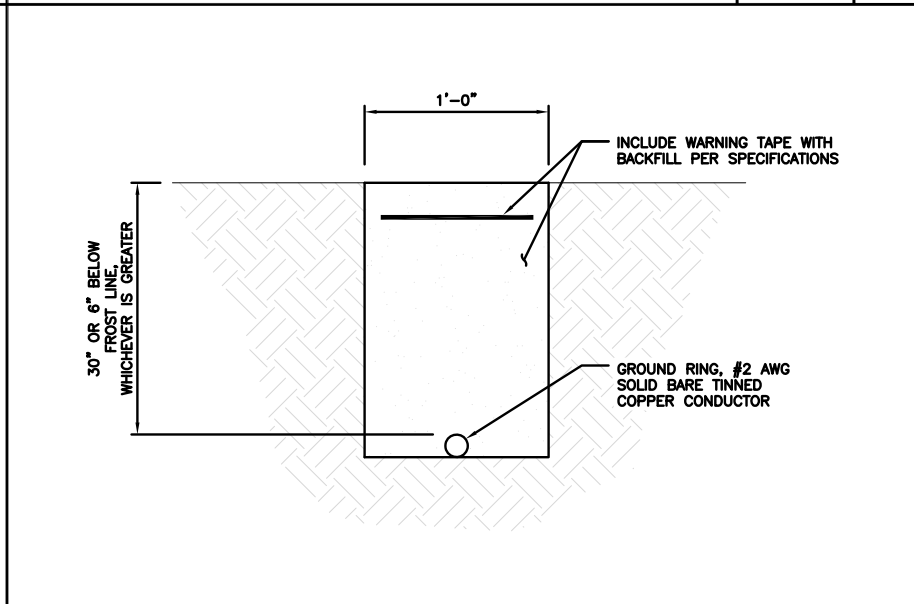

**TYPICAL GROUND RING TRENCH**

NO SCALE 6



5701 SOUTH SANTA FE DRIVE  
LITTLETON, CO 80120



**B&T ENGINEERING, INC.**  
PEC.0001564  
Expires 2/10/22

IT IS A VIOLATION OF LAW FOR ANY PERSON, UNLESS THEY ARE ACTING UNDER THE DIRECTION OF A LICENSED PROFESSIONAL ENGINEER, TO ALTER THIS DOCUMENT.

DRAWN BY: CHECKED BY: APPROVED BY:  
DAS DAS RCM

RFDS REV #: 2

**CONSTRUCTION DOCUMENTS**

SUBMITTALS		
REV	DATE	DESCRIPTION
A	7/26/21	ISSUED FOR REVIEW
0	9/8/21	ISSUED FOR CONSTRUCTION

A&E PROJECT NUMBER  
153473.001.01

DISH Wireless L.L.C.  
PROJECT INFORMATION

BOBDL0015A  
56 RUOPS ROAD  
TOLLAND, CT 06084

SHEET TITLE  
GROUNDING DETAILS

SHEET NUMBER  
**G-2**



1. EXOTHERMIC WELD (2) TWO, #2 AWG BARE TINNED SOLID COPPER CONDUCTORS TO GROUND BAR. ROUTE CONDUCTORS TO BURIED GROUND RING AND PROVIDE PARALLEL EXOTHERMIC WELD.
2. ALL EXTERIOR GROUNDING HARDWARE SHALL BE STAINLESS STEEL 3/8" DIAMETER OR LARGER. ALL HARDWARE 18-8 STAINLESS STEEL INCLUDING LOCK WASHERS, COAT ALL SURFACES WITH AN ANTI-OXIDANT COMPOUND BEFORE MATING.
3. FOR GROUND BOND TO STEEL ONLY: COAT ALL SURFACES WITH AN ANTI-OXIDANT COMPOUND BEFORE MATING.
4. DO NOT INSTALL CABLE GROUNDING KIT AT A BEND AND ALWAYS DIRECT GROUND CONDUCTOR DOWN TO GROUNDING BUS.
5. NUT & WASHER SHALL BE PLACED ON THE FRONT SIDE OF THE GROUND BAR AND BOLTED ON THE BACK SIDE.
6. ALL GROUNDING PARTS AND EQUIPMENT TO BE SUPPLIED AND INSTALLED BY CONTRACTOR.
7. THE CONTRACTOR SHALL BE RESPONSIBLE FOR INSTALLING ADDITIONAL GROUND BAR AS REQUIRED.
8. ENSURE THE WIRE INSULATION TERMINATION IS WITHIN 1/8" OF THE BARREL (NO SHINERS).

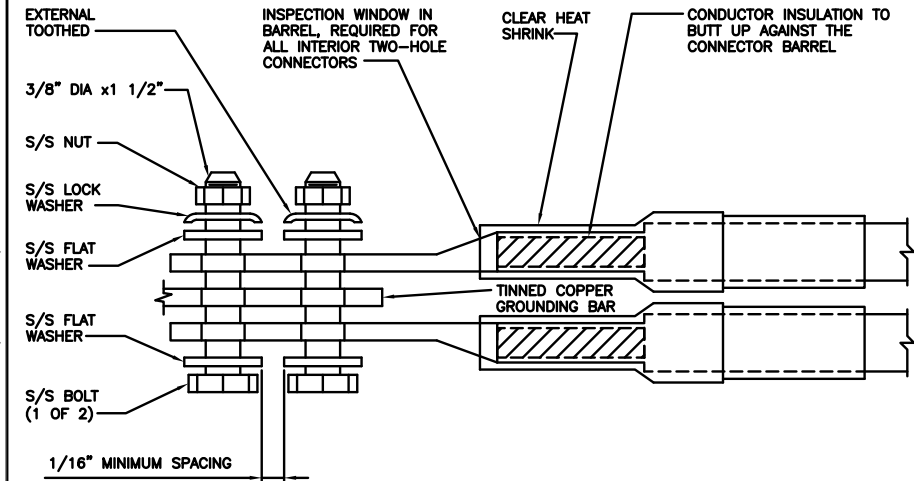
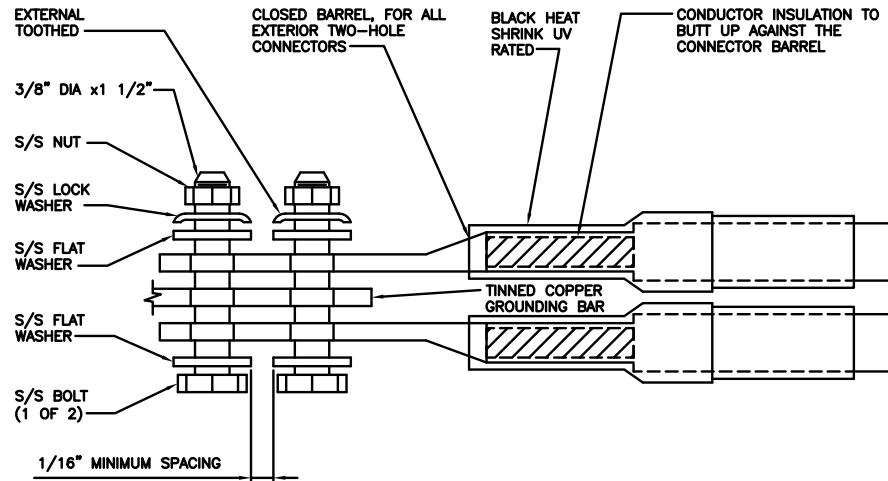

TYPICAL GROUNDING NOTES

NO SCALE 1

TYPICAL EXTERIOR TWO HOLE LUG

NO SCALE 2

TYPICAL INTERIOR TWO HOLE LUG

NO SCALE 3

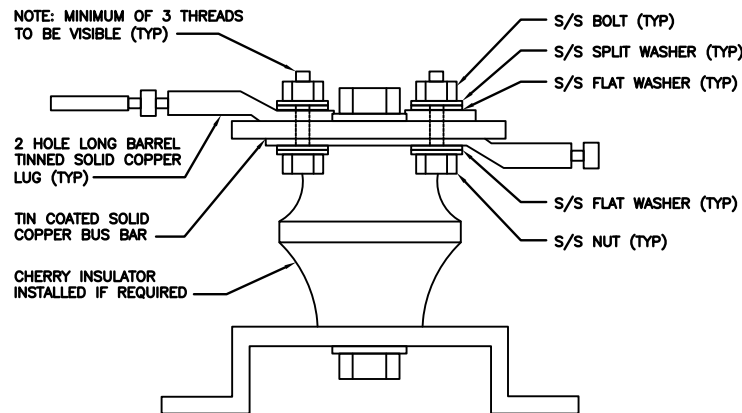

LUG DETAIL

NO SCALE 4

NOT USED

NO SCALE 5

NOT USED

NO SCALE 6

NOT USED

NO SCALE 7

NOT USED

NO SCALE 8

NOT USED

NO SCALE 9

**dish**  
wireless.

5701 SOUTH SANTA FE DRIVE  
LITTLETON, CO 80120

**AMERICAN TOWER**  
10 PRESIDENTIAL WAY  
WOBURN, MA 01801

**B+T GRP**  
1717 S. BOULDER  
SUITE 300  
TULSA, OK 74119  
PH: (918) 587-4630  
www.btgrp.com



**B&T ENGINEERING, INC.**  
PEC.0001564  
Expires 2/10/22

IT IS A VIOLATION OF LAW FOR ANY PERSON, UNLESS THEY ARE ACTING UNDER THE DIRECTION OF A LICENSED PROFESSIONAL ENGINEER, TO ALTER THIS DOCUMENT.

DRAWN BY: CHECKED BY: APPROVED BY:  
DAS DAS RCM

RFDS REV #: 2

**CONSTRUCTION DOCUMENTS**

SUBMITTALS		
REV	DATE	DESCRIPTION
A	7/26/21	ISSUED FOR REVIEW
D	9/8/21	ISSUED FOR CONSTRUCTION

A&E PROJECT NUMBER  
153473.001.01

DISH Wireless L.L.C.  
PROJECT INFORMATION  
BOBDL0015A  
56 RUOPS ROAD  
TOLLAND, CT 06084

SHEET TITLE  
GROUNDING DETAILS

SHEET NUMBER  
**G-3**

**RF JUMPER COLOR CODING**

3/4" TAPE WIDTHS WITH 3/4" SPACING

LOW-BAND RRH -  
(600MHz N71 BASEBAND) +  
(850MHz N26 BAND) +  
(700MHz N29 BAND) - OPTIONAL PER MARKET

ADD FREQUENCY COLOR TO SECTOR BAND  
(CBRS WILL USE YELLOW BANDS)

ALPHA RRH				BETA RRH				GAMMA RRH			
PORT 1 + SLANT	PORT 2 - SLANT	PORT 3 + SLANT	PORT 4 - SLANT	PORT 1 + SLANT	PORT 2 - SLANT	PORT 3 + SLANT	PORT 4 - SLANT	PORT 1 + SLANT	PORT 2 - SLANT	PORT 3 + SLANT	PORT 4 - SLANT
RED	RED	RED	RED	BLUE	BLUE	BLUE	BLUE	GREEN	GREEN	GREEN	GREEN
ORANGE	ORANGE	RED	RED	ORANGE	ORANGE	BLUE	BLUE	ORANGE	ORANGE	GREEN	GREEN
	WHITE (-) PORT	ORANGE	ORANGE		WHITE (-) PORT	ORANGE	ORANGE		WHITE (-) PORT	ORANGE	ORANGE
			WHITE (-) PORT				WHITE (-) PORT				WHITE (-) PORT

MID-BAND RRH -  
(AWS BANDS N66+N70)

ADD FREQUENCY COLOR TO SECTOR BAND  
(CBRS WILL USE YELLOW BANDS)

RED	RED	RED	RED	BLUE	BLUE	BLUE	BLUE	GREEN	GREEN	GREEN	GREEN
PURPLE	PURPLE	RED	RED	PURPLE	PURPLE	BLUE	BLUE	PURPLE	PURPLE	GREEN	GREEN
	WHITE (-) PORT	PURPLE	PURPLE		WHITE (-) PORT	PURPLE	PURPLE		WHITE (-) PORT	PURPLE	PURPLE
			WHITE (-) PORT				WHITE (-) PORT				WHITE (-) PORT

**HYBRID/DISCREET CABLES**

INCLUDE SECTOR BANDS BEING SUPPORTED  
ALONG WITH FREQUENCY BANDS

EXAMPLE 1 - HYBRID, OR DISCREET, SUPPORTS  
ALL SECTORS, BOTH LOW-BANDS AND MID-BANDS

EXAMPLE 2 - HYBRID, OR DISCREET, SUPPORTS  
CBRS ONLY, ALL SECTORS

EXAMPLE 1	EXAMPLE 2	EXAMPLE 3
RED	RED	RED
BLUE	BLUE	
GREEN	GREEN	ORANGE
ORANGE	YELLOW	PURPLE
PURPLE		

**FIBER JUMPERS TO RRHs**

LOW-BAND RRH FIBER CABLES HAVE SECTOR  
STRIPE ONLY

LOW BAND RRH	HIGH BAND RRH	LOW BAND RRH	HIGH BAND RRH	LOW BAND RRH	HIGH BAND RRH
RED	RED	BLUE	BLUE	GREEN	GREEN
	PURPLE		PURPLE		PURPLE

**POWER CABLES TO RRHs**

LOW-BAND RRH POWER CABLES HAVE SECTOR  
STRIPE ONLY

LOW BAND RRH	HIGH BAND RRH	LOW BAND RRH	HIGH BAND RRH	LOW BAND RRH	HIGH BAND RRH
RED	RED	BLUE	BLUE	GREEN	GREEN
	PURPLE		PURPLE		PURPLE

**RET MOTORS AT ANTENNAS**

ANTENNA 1 LOW BAND/ "IN"	ANTENNA 1 HIGH BAND/ "IN"	ANTENNA 1 LOW BAND/ "IN"	ANTENNA 1 HIGH BAND/ "IN"	ANTENNA 1 LOW BAND/ "IN"	ANTENNA 1 HIGH BAND/ "IN"
RED	RED	BLUE	BLUE	GREEN	GREEN
	PURPLE		PURPLE		PURPLE

**MICROWAVE RADIO LINKS**

LINKS WILL HAVE A 1.5-2 INCH WHITE WRAP WITH  
THE AZIMUTH COLOR OVERLAPPING IN THE MIDDLE.  
ADD ADDITIONAL SECTOR COLOR BANDS FOR EACH  
ADDITIONAL MW RADIO.

MICROWAVE CABLES WILL REQUIRE P-TOUCH  
LABELS INSIDE THE CABINET TO IDENTIFY THE  
LOCAL AND REMOTE SITE ID'S

FORWARD AZIMUTH OF 0-120 DEGREES		FORWARD AZIMUTH OF 120-240 DEGREES		FORWARD AZIMUTH OF 240-360 DEGREES	
PRIMARY	SECONDARY	PRIMARY	SECONDARY	PRIMARY	SECONDARY
WHITE	WHITE	WHITE	WHITE	WHITE	WHITE
RED	RED	BLUE	BLUE	GREEN	GREEN
WHITE	WHITE	WHITE	WHITE	WHITE	WHITE
	RED		BLUE		GREEN
	WHITE		WHITE		WHITE

**RF CABLE COLOR CODES**

NO SCALE

1

LOW BANDS (N71+N26)  
OPTIONAL - (N29)



CBRS TECH  
(3 GHz)

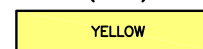

AWS  
(N66+N70+H-BLOCK)



NEGATIVE SLANT PORT  
ON ANT/RRH

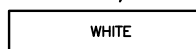

ALPHA SECTOR



BETA SECTOR



GAMMA SECTOR



COLOR IDENTIFIER

NO SCALE

2

NOT USED

NO SCALE

3

NOT USED

NO SCALE

4



5701 SOUTH SANTA FE DRIVE  
LITTLETON, CO 80120



**B&T ENGINEERING, INC.**  
PEC.0001564  
Expires 2/10/22

IT IS A VIOLATION OF LAW FOR ANY PERSON,  
UNLESS THEY ARE ACTING UNDER THE DIRECTION  
OF A LICENSED PROFESSIONAL ENGINEER,  
TO ALTER THIS DOCUMENT.

DRAWN BY:	CHECKED BY:	APPROVED BY:
DAS	DAS	RCM

RFDS REV #: 2

**CONSTRUCTION DOCUMENTS**

SUBMITTALS		
REV	DATE	DESCRIPTION
A	7/26/21	ISSUED FOR REVIEW
D	9/8/21	ISSUED FOR CONSTRUCTION

A&E PROJECT NUMBER  
153473.001.01

DISH Wireless L.L.C.  
PROJECT INFORMATION

BOBDL00015A  
56 RUOPS ROAD  
TOLLAND, CT 06084

SHEET TITLE  
RF  
CABLE COLOR CODES

SHEET NUMBER

**RF-1**



EXOTHERMIC CONNECTION  
 MECHANICAL CONNECTION  
 BUSS BAR INSULATOR  
 CHEMICAL ELECTROLYTIC GROUNDING SYSTEM  
 TEST CHEMICAL ELECTROLYTIC GROUNDING SYSTEM  
 EXOTHERMIC WITH INSPECTION SLEEVE  
 GROUNDING BAR  
 GROUND ROD  
 TEST GROUND ROD WITH INSPECTION SLEEVE  
 SINGLE POLE SWITCH  
 DUPLEX RECEPTACLE  
 DUPLEX GFCI RECEPTACLE  
 FLUORESCENT LIGHTING FIXTURE (2) TWO LAMPS 48-T8  
 SMOKE DETECTION (DC)  
 EMERGENCY LIGHTING (DC)  
 SECURITY LIGHT W/PHOTOCELL LITHONIA ALXW  
 LED-1-25A400/51K-SR4-120-PE-DOBXTD  
 CHAIN LINK FENCE  
 WOOD/WROUGHT IRON FENCE  
 WALL STRUCTURE  
 LEASE AREA  
 PROPERTY LINE (PL)  
 SETBACKS  
 ICE BRIDGE  
 CABLE TRAY  
 WATER LINE  
 UNDERGROUND POWER  
 UNDERGROUND TELCO  
 OVERHEAD POWER  
 OVERHEAD TELCO  
 UNDERGROUND TELCO/POWER  
 ABOVE GROUND POWER  
 ABOVE GROUND TELCO  
 ABOVE GROUND TELCO/POWER  
 WORKPOINT

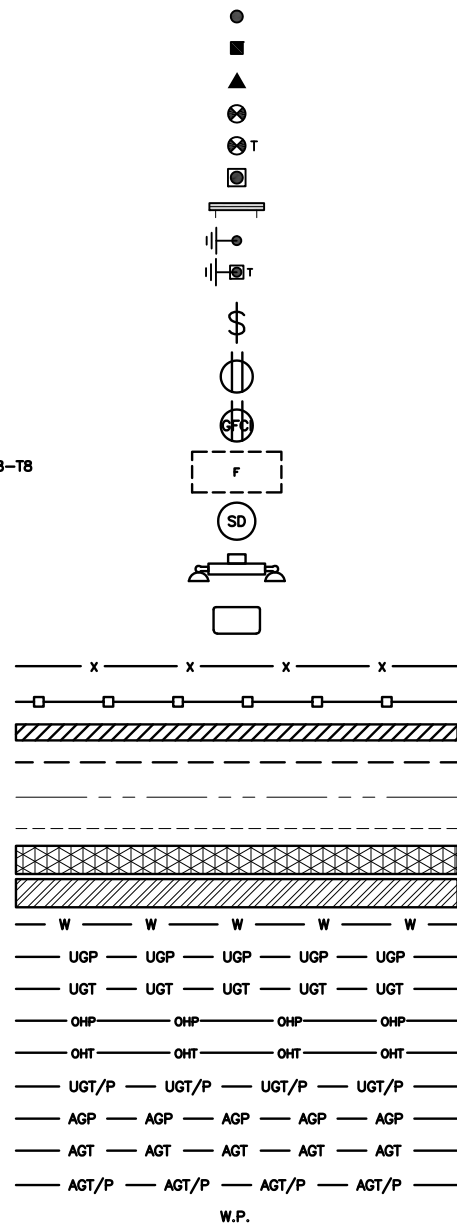

SECTION REFERENCE  
 DETAIL REFERENCE

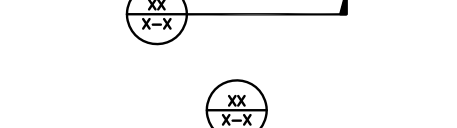

**LEGEND**

AB ANCHOR BOLT  
 ABV ABOVE  
 AC ALTERNATING CURRENT  
 ADDL ADDITIONAL  
 AFF ABOVE FINISHED FLOOR  
 AFG ABOVE FINISHED GRADE  
 AGL ABOVE GROUND LEVEL  
 AIC AMPERAGE INTERRUPTION CAPACITY  
 ALUM ALUMINUM  
 ALT ALTERNATE  
 ANT ANTENNA  
 APPROX APPROXIMATE  
 ARCH ARCHITECTURAL  
 ATS AUTOMATIC TRANSFER SWITCH  
 AWG AMERICAN WIRE GAUGE  
 BATT BATTERY  
 BLDG BUILDING  
 BLK BLOCK  
 BLKG BLOCKING  
 BM BEAM  
 BTC BARE TINNED COPPER CONDUCTOR  
 BOF BOTTOM OF FOOTING  
 CAB CABINET  
 CANT CANTILEVERED  
 CHG CHARGING  
 CLG CEILING  
 CLR CLEAR  
 COL COLUMN  
 COMM COMMON  
 CONC CONCRETE  
 CONSTR CONSTRUCTION  
 DBL DOUBLE  
 DC DIRECT CURRENT  
 DEPT DEPARTMENT  
 DF DOUGLAS FIR  
 DIA DIAMETER  
 DIAG DIAGONAL  
 DIM DIMENSION  
 DWG DRAWING  
 DWL DOWEL  
 EA EACH  
 EC ELECTRICAL CONDUCTOR  
 EL ELEVATION  
 ELEC ELECTRICAL  
 EMT ELECTRICAL METALLIC TUBING  
 ENG ENGINEER  
 EQ EQUAL  
 EXP EXPANSION  
 EXT EXTERIOR  
 EW EACH WAY  
 FAB FABRICATION  
 FF FINISH FLOOR  
 FG FINISH GRADE  
 FIF FACILITY INTERFACE FRAME  
 FIN FINISH(ED)  
 FLR FLOOR  
 FDN FOUNDATION  
 FOC FACE OF CONCRETE  
 FOM FACE OF MASONRY  
 FOS FACE OF STUD  
 FOW FACE OF WALL  
 FS FINISH SURFACE  
 FT FOOT  
 FTG FOOTING  
 GA GAUGE  
 GEN GENERATOR  
 GFCI GROUND FAULT CIRCUIT INTERRUPTER  
 GLB GLUE LAMINATED BEAM  
 GLV GALVANIZED  
 GPS GLOBAL POSITIONING SYSTEM  
 GND GROUND  
 GSM GLOBAL SYSTEM FOR MOBILE  
 HDG HOT DIPPED GALVANIZED  
 HDR HEADER  
 HGR HANGER  
 HVAC HEAT/VENTILATION/AIR CONDITIONING  
 HT HEIGHT  
 IGR INTERIOR GROUND RING

IN INCH  
 INT INTERIOR  
 LB(S) POUND(S)  
 LF LINEAR FEET  
 LTE LONG TERM EVOLUTION  
 MAS MASONRY  
 MAX MAXIMUM  
 MB MACHINE BOLT  
 MECH MECHANICAL  
 MFR MANUFACTURER  
 MGB MASTER GROUND BAR  
 MIN MINIMUM  
 MISC MISCELLANEOUS  
 MTL METAL  
 MTS MANUAL TRANSFER SWITCH  
 MW MICROWAVE  
 NEC NATIONAL ELECTRIC CODE  
 NM NEWTON METERS  
 NO. NUMBER  
 # NUMBER  
 NTS NOT TO SCALE  
 OC ON-CENTER  
 OSHA OCCUPATIONAL SAFETY AND HEALTH ADMINISTRATION  
 OPNG OPENING  
 P/C PRECAST CONCRETE  
 PCS PERSONAL COMMUNICATION SERVICES  
 PCU PRIMARY CONTROL UNIT  
 PRC PRIMARY RADIO CABINET  
 PP POLARIZING PRESERVING  
 PSF POUNDS PER SQUARE FOOT  
 PSI POUNDS PER SQUARE INCH  
 PT PRESSURE TREATED  
 PWR POWER CABINET  
 QTY QUANTITY  
 RAD RADIUS  
 RECT RECTIFIER  
 REF REFERENCE  
 REINF REINFORCEMENT  
 REQ'D REQUIRED  
 RET REMOTE ELECTRIC TILT  
 RF RADIO FREQUENCY  
 RMC RIGID METALLIC CONDUIT  
 RRH REMOTE RADIO HEAD  
 RRU REMOTE RADIO UNIT  
 RWY RACEWAY  
 SCH SCHEDULE  
 SHT SHEET  
 SIAD SMART INTEGRATED ACCESS DEVICE  
 SIM SIMILAR  
 SPEC SPECIFICATION  
 SQ SQUARE  
 SS STAINLESS STEEL  
 STD STANDARD  
 STL STEEL  
 TEMP TEMPORARY  
 THK THICKNESS  
 TMA TOWER MOUNTED AMPLIFIER  
 TN TOE NAIL  
 TOA TOP OF ANTENNA  
 TOC TOP OF CURB  
 TOF TOP OF FOUNDATION  
 TOP TOP OF PLATE (PARAPET)  
 TOS TOP OF STEEL  
 TOW TOP OF WALL  
 TVSS TRANSIENT VOLTAGE SURGE SUPPRESSION  
 TYP TYPICAL  
 UG UNDERGROUND  
 UL UNDERWRITERS LABORATORY  
 UNO UNLESS NOTED OTHERWISE  
 UMTS UNIVERSAL MOBILE TELECOMMUNICATIONS SYSTEM  
 UPS UNINTERRUPTIBLE POWER SYSTEM (DC POWER PLANT)  
 VIF VERIFIED IN FIELD  
 W WIDE  
 W/ WITH  
 WD WOOD  
 WP WEATHERPROOF  
 WT WEIGHT

**ABBREVIATIONS**



5701 SOUTH SANTA FE DRIVE  
 LITTLETON, CO 80120



**B&T ENGINEERING, INC.**  
 PEC.0001564  
 Expires 2/10/22

IT IS A VIOLATION OF LAW FOR ANY PERSON,  
 UNLESS THEY ARE ACTING UNDER THE DIRECTION  
 OF A LICENSED PROFESSIONAL ENGINEER,  
 TO ALTER THIS DOCUMENT.

DRAWN BY: CHECKED BY: APPROVED BY:  
 DAS DAS RCM

RFDS REV #: 2

**CONSTRUCTION DOCUMENTS**

SUBMITTALS		
REV	DATE	DESCRIPTION
A	7/26/21	ISSUED FOR REVIEW
0	9/8/21	ISSUED FOR CONSTRUCTION

A&E PROJECT NUMBER  
 153473.001.01

DISH Wireless L.L.C.  
 PROJECT INFORMATION  
 BOBDL00015A  
 56 RUOPS ROAD  
 TOLLAND, CT 06084

SHEET TITLE  
 LEGEND AND ABBREVIATIONS

SHEET NUMBER  
**GN-1**

**SITE ACTIVITY REQUIREMENTS:**

1. NOTICE TO PROCEED – NO WORK SHALL COMMENCE PRIOR TO CONTRACTOR RECEIVING A WRITTEN NOTICE TO PROCEED (NTP) AND THE ISSUANCE OF A PURCHASE ORDER. PRIOR TO ACCESSING/ENTERING THE SITE YOU MUST CONTACT THE DISH Wireless L.L.C. AND TOWER OWNER NOC & THE DISH Wireless L.L.C. AND TOWER OWNER CONSTRUCTION MANAGER.
2. "LOOK UP" – DISH Wireless L.L.C. AND TOWER OWNER SAFETY CLIMB REQUIREMENT:  
THE INTEGRITY OF THE SAFETY CLIMB AND ALL COMPONENTS OF THE CLIMBING FACILITY SHALL BE CONSIDERED DURING ALL STAGES OF DESIGN, INSTALLATION, AND INSPECTION. TOWER MODIFICATION, MOUNT REINFORCEMENTS, AND/OR EQUIPMENT INSTALLATIONS SHALL NOT COMPROMISE THE INTEGRITY OR FUNCTIONAL USE OF THE SAFETY CLIMB OR ANY COMPONENTS OF THE CLIMBING FACILITY ON THE STRUCTURE. THIS SHALL INCLUDE, BUT NOT BE LIMITED TO: PINCHING OF THE WIRE ROPE, BENDING OF THE WIRE ROPE FROM ITS SUPPORTS, DIRECT CONTACT OR CLOSE PROXIMITY TO THE WIRE ROPE WHICH MAY CAUSE FRICTIONAL WEAR, IMPACT TO THE ANCHORAGE POINTS IN ANY WAY, OR TO IMPEDE/BLOCK ITS INTENDED USE. ANY COMPROMISED SAFETY CLIMB, INCLUDING EXISTING CONDITIONS MUST BE TAGGED OUT AND REPORTED TO YOUR DISH Wireless L.L.C. AND DISH Wireless L.L.C. AND TOWER OWNER POC OR CALL THE NOC TO GENERATE A SAFETY CLIMB MAINTENANCE AND CONTRACTOR NOTICE TICKET.
3. PRIOR TO THE START OF CONSTRUCTION, ALL REQUIRED JURISDICTIONAL PERMITS SHALL BE OBTAINED. THIS INCLUDES, BUT IS NOT LIMITED TO, BUILDING, ELECTRICAL, MECHANICAL, FIRE, FLOOD ZONE, ENVIRONMENTAL, AND ZONING. AFTER ONSITE ACTIVITIES AND CONSTRUCTION ARE COMPLETED, ALL REQUIRED PERMITS SHALL BE SATISFIED AND CLOSED OUT ACCORDING TO LOCAL JURISDICTIONAL REQUIREMENTS.
4. ALL CONSTRUCTION MEANS AND METHODS; INCLUDING BUT NOT LIMITED TO, ERECTION PLANS, RIGGING PLANS, CLIMBING PLANS, AND RESCUE PLANS SHALL BE THE RESPONSIBILITY OF THE GENERAL CONTRACTOR RESPONSIBLE FOR THE EXECUTION OF THE WORK CONTAINED HEREIN, AND SHALL MEET ANSI/ASSE A10.48 (LATEST EDITION); FEDERAL, STATE, AND LOCAL REGULATIONS; AND ANY APPLICABLE INDUSTRY CONSENSUS STANDARDS RELATED TO THE CONSTRUCTION ACTIVITIES BEING PERFORMED. ALL RIGGING PLANS SHALL ADHERE TO ANSI/ASSE A10.48 (LATEST EDITION) AND DISH Wireless L.L.C. AND TOWER OWNER STANDARDS, INCLUDING THE REQUIRED INVOLVEMENT OF A QUALIFIED ENGINEER FOR CLASS IV CONSTRUCTION, TO CERTIFY THE SUPPORTING STRUCTURE(S) IN ACCORDANCE WITH ANSI/TIA-322 (LATEST EDITION).
5. ALL SITE WORK TO COMPLY WITH DISH Wireless L.L.C. AND TOWER OWNER INSTALLATION STANDARDS FOR CONSTRUCTION ACTIVITIES ON DISH Wireless L.L.C. AND TOWER OWNER TOWER SITE AND LATEST VERSION OF ANSI/TIA-1019-A-2012 "STANDARD FOR INSTALLATION, ALTERATION, AND MAINTENANCE OF ANTENNA SUPPORTING STRUCTURES AND ANTENNAS."
6. IF THE SPECIFIED EQUIPMENT CAN NOT BE INSTALLED AS SHOWN ON THESE DRAWINGS, THE CONTRACTOR SHALL PROPOSE AN ALTERNATIVE INSTALLATION FOR APPROVAL BY DISH Wireless L.L.C. AND TOWER OWNER PRIOR TO PROCEEDING WITH ANY SUCH CHANGE OF INSTALLATION.
7. ALL MATERIALS FURNISHED AND INSTALLED SHALL BE IN STRICT ACCORDANCE WITH ALL APPLICABLE CODES, REGULATIONS AND ORDINANCES. CONTRACTOR SHALL ISSUE ALL APPROPRIATE NOTICES AND COMPLY WITH ALL LAWS, ORDINANCES, RULES, REGULATIONS AND LAWFUL ORDERS OF ANY PUBLIC AUTHORITY REGARDING THE PERFORMANCE OF THE WORK. ALL WORK CARRIED OUT SHALL COMPLY WITH ALL APPLICABLE MUNICIPAL AND UTILITY COMPANY SPECIFICATIONS AND LOCAL JURISDICTIONAL CODES, ORDINANCES AND APPLICABLE REGULATIONS.
8. THE CONTRACTOR SHALL INSTALL ALL EQUIPMENT AND MATERIALS IN ACCORDANCE WITH MANUFACTURER'S RECOMMENDATIONS UNLESS SPECIFICALLY STATED OTHERWISE.
9. THE CONTRACTOR SHALL CONTACT UTILITY LOCATING SERVICES INCLUDING PRIVATE LOCATES SERVICES PRIOR TO THE START OF CONSTRUCTION.
10. ALL EXISTING ACTIVE SEWER, WATER, GAS, ELECTRIC AND OTHER UTILITIES WHERE ENCOUNTERED IN THE WORK, SHALL BE PROTECTED AT ALL TIMES AND WHERE REQUIRED FOR THE PROPER EXECUTION OF THE WORK, SHALL BE RELOCATED AS DIRECTED BY CONTRACTOR. EXTREME CAUTION SHOULD BE USED BY THE CONTRACTOR WHEN EXCAVATING OR DRILLING PIERS AROUND OR NEAR UTILITIES. CONTRACTOR SHALL PROVIDE SAFETY TRAINING FOR THE WORKING CREW. THIS WILL INCLUDE BUT NOT BE LIMITED TO A) FALL PROTECTION B) CONFINED SPACE C) ELECTRICAL SAFETY D) TRENCHING AND EXCAVATION E) CONSTRUCTION SAFETY PROCEDURES.
11. ALL SITE WORK SHALL BE AS INDICATED ON THE STAMPED CONSTRUCTION DRAWINGS AND DISH PROJECT SPECIFICATIONS, LATEST APPROVED REVISION.
12. CONTRACTOR SHALL KEEP THE SITE FREE FROM ACCUMULATING WASTE MATERIAL, DEBRIS, AND TRASH AT THE COMPLETION OF THE WORK. IF NECESSARY, RUBBISH, STUMPS, DEBRIS, STICKS, STONES AND OTHER REFUSE SHALL BE REMOVED FROM THE SITE AND DISPOSED OF LEGALLY.
13. ALL EXISTING INACTIVE SEWER, WATER, GAS, ELECTRIC AND OTHER UTILITIES, WHICH INTERFERE WITH THE EXECUTION OF THE WORK, SHALL BE REMOVED AND/OR CAPPED, PLUGGED OR OTHERWISE DISCONTINUED AT POINTS WHICH WILL NOT INTERFERE WITH THE EXECUTION OF THE WORK, SUBJECT TO THE APPROVAL OF DISH Wireless L.L.C. AND TOWER OWNER, AND/OR LOCAL UTILITIES.
14. THE CONTRACTOR SHALL PROVIDE SITE SIGNAGE IN ACCORDANCE WITH THE TECHNICAL SPECIFICATION FOR SITE SIGNAGE REQUIRED BY LOCAL JURISDICTION AND SIGNAGE REQUIRED ON INDIVIDUAL PIECES OF EQUIPMENT, ROOMS, AND SHELTERS.
15. THE SITE SHALL BE GRADED TO CAUSE SURFACE WATER TO FLOW AWAY FROM THE CARRIER'S EQUIPMENT AND TOWER AREAS.
16. THE SUB GRADE SHALL BE COMPACTED AND BROUGHT TO A SMOOTH UNIFORM GRADE PRIOR TO FINISHED SURFACE APPLICATION.
17. THE AREAS OF THE OWNERS PROPERTY DISTURBED BY THE WORK AND NOT COVERED BY THE TOWER, EQUIPMENT OR DRIVEWAY, SHALL BE GRADED TO A UNIFORM SLOPE, AND STABILIZED TO PREVENT EROSION AS SPECIFIED ON THE CONSTRUCTION DRAWINGS AND/OR PROJECT SPECIFICATIONS.
18. CONTRACTOR SHALL MINIMIZE DISTURBANCE TO EXISTING SITE DURING CONSTRUCTION. EROSION CONTROL MEASURES, IF REQUIRED DURING CONSTRUCTION, SHALL BE IN CONFORMANCE WITH THE LOCAL GUIDELINES FOR EROSION AND SEDIMENT CONTROL.
19. THE CONTRACTOR SHALL PROTECT EXISTING IMPROVEMENTS, PAVEMENTS, CURBS, LANDSCAPING AND STRUCTURES. ANY DAMAGED PART SHALL BE REPAIRED AT CONTRACTOR'S EXPENSE TO THE SATISFACTION OF OWNER.
20. CONTRACTOR SHALL LEGALLY AND PROPERLY DISPOSE OF ALL SCRAP MATERIALS SUCH AS COAXIAL CABLES AND OTHER ITEMS REMOVED FROM THE EXISTING FACILITY. ANTENNAS AND RADIOS REMOVED SHALL BE RETURNED TO THE OWNER'S DESIGNATED LOCATION.
21. CONTRACTOR SHALL LEAVE PREMISES IN CLEAN CONDITION. TRASH AND DEBRIS SHOULD BE REMOVED FROM SITE ON A DAILY BASIS.
22. NO FILL OR EMBANKMENT MATERIAL SHALL BE PLACED ON FROZEN GROUND. FROZEN MATERIALS, SNOW OR ICE SHALL NOT BE PLACED IN ANY FILL OR EMBANKMENT.

**GENERAL NOTES:**

1. FOR THE PURPOSE OF CONSTRUCTION DRAWING, THE FOLLOWING DEFINITIONS SHALL APPLY:  
CONTRACTOR: GENERAL CONTRACTOR RESPONSIBLE FOR CONSTRUCTION  
CARRIER: DISH Wireless L.L.C.  
TOWER OWNER: TOWER OWNER
2. THESE DRAWINGS HAVE BEEN PREPARED USING STANDARDS OF PROFESSIONAL CARE AND COMPLETENESS NORMALLY EXERCISED UNDER SIMILAR CIRCUMSTANCES BY REPUTABLE ENGINEERS IN THIS OR SIMILAR LOCALITIES. IT IS ASSUMED THAT THE WORK DEPICTED WILL BE PERFORMED BY AN EXPERIENCED CONTRACTOR AND/OR WORKPEOPLE WHO HAVE A WORKING KNOWLEDGE OF THE APPLICABLE CODE STANDARDS AND REQUIREMENTS AND OF INDUSTRY ACCEPTED STANDARD GOOD PRACTICE. AS NOT EVERY CONDITION OR ELEMENT IS (OR CAN BE) EXPLICITLY SHOWN ON THESE DRAWINGS, THE CONTRACTOR SHALL USE INDUSTRY ACCEPTED STANDARD GOOD PRACTICE FOR MISCELLANEOUS WORK NOT EXPLICITLY SHOWN.
3. THESE DRAWINGS REPRESENT THE FINISHED STRUCTURE. THEY DO NOT INDICATE THE MEANS OR METHODS OF CONSTRUCTION. THE CONTRACTOR SHALL BE SOLELY RESPONSIBLE FOR THE CONSTRUCTION MEANS, METHODS, TECHNIQUES, SEQUENCES, AND PROCEDURES. THE CONTRACTOR SHALL PROVIDE ALL MEASURES NECESSARY FOR PROTECTION OF LIFE AND PROPERTY DURING CONSTRUCTION. SUCH MEASURES SHALL INCLUDE, BUT NOT BE LIMITED TO, BRACING, FORMWORK, SHORING, ETC. SITE VISITS BY THE ENGINEER OR HIS REPRESENTATIVE WILL NOT INCLUDE INSPECTION OF THESE ITEMS AND IS FOR STRUCTURAL OBSERVATION OF THE FINISHED STRUCTURE ONLY.
4. NOTES AND DETAILS IN THE CONSTRUCTION DRAWINGS SHALL TAKE PRECEDENCE OVER GENERAL NOTES AND TYPICAL DETAILS. WHERE NO DETAILS ARE SHOWN, CONSTRUCTION SHALL CONFORM TO SIMILAR WORK ON THE PROJECT, AND/OR AS PROVIDED FOR IN THE CONTRACT DOCUMENTS. WHERE DISCREPANCIES OCCUR BETWEEN PLANS, DETAILS, GENERAL NOTES, AND SPECIFICATIONS, THE GREATER, MORE STRICT REQUIREMENTS, SHALL GOVERN. IF FURTHER CLARIFICATION IS REQUIRED CONTACT THE ENGINEER OF RECORD.
5. SUBSTANTIAL EFFORT HAS BEEN MADE TO PROVIDE ACCURATE DIMENSIONS AND MEASUREMENTS ON THE DRAWINGS TO ASSIST IN THE FABRICATION AND/OR PLACEMENT OF CONSTRUCTION ELEMENTS BUT IT IS THE SOLE RESPONSIBILITY OF THE CONTRACTOR TO FIELD VERIFY THE DIMENSIONS, MEASUREMENTS, AND/OR CLEARANCES SHOWN IN THE CONSTRUCTION DRAWINGS PRIOR TO FABRICATION OR CUTTING OF ANY NEW OR EXISTING CONSTRUCTION ELEMENTS. IF IT IS DETERMINED THAT THERE ARE DISCREPANCIES AND/OR CONFLICTS WITH THE CONSTRUCTION DRAWINGS THE ENGINEER OF RECORD IS TO BE NOTIFIED AS SOON AS POSSIBLE.
6. PRIOR TO THE SUBMISSION OF BIDS, THE BIDDING CONTRACTOR SHALL VISIT THE CELL SITE TO FAMILIARIZE WITH THE EXISTING CONDITIONS AND TO CONFIRM THAT THE WORK CAN BE ACCOMPLISHED AS SHOWN ON THE CONSTRUCTION DRAWINGS. ANY DISCREPANCY FOUND SHALL BE BROUGHT TO THE ATTENTION OF CARRIER POC AND TOWER OWNER.
7. ALL MATERIALS FURNISHED AND INSTALLED SHALL BE IN STRICT ACCORDANCE WITH ALL APPLICABLE CODES, REGULATIONS AND ORDINANCES. CONTRACTOR SHALL ISSUE ALL APPROPRIATE NOTICES AND COMPLY WITH ALL LAWS, ORDINANCES, RULES, REGULATIONS AND LAWFUL ORDERS OF ANY PUBLIC AUTHORITY REGARDING THE PERFORMANCE OF THE WORK. ALL WORK CARRIED OUT SHALL COMPLY WITH ALL APPLICABLE MUNICIPAL AND UTILITY COMPANY SPECIFICATIONS AND LOCAL JURISDICTIONAL CODES, ORDINANCES AND APPLICABLE REGULATIONS.
8. UNLESS NOTED OTHERWISE, THE WORK SHALL INCLUDE FURNISHING MATERIALS, EQUIPMENT, APPURTENANCES AND LABOR NECESSARY TO COMPLETE ALL INSTALLATIONS AS INDICATED ON THE DRAWINGS.
9. THE CONTRACTOR SHALL INSTALL ALL EQUIPMENT AND MATERIALS IN ACCORDANCE WITH MANUFACTURER'S RECOMMENDATIONS UNLESS SPECIFICALLY STATED OTHERWISE.
10. IF THE SPECIFIED EQUIPMENT CAN NOT BE INSTALLED AS SHOWN ON THESE DRAWINGS, THE CONTRACTOR SHALL PROPOSE AN ALTERNATIVE INSTALLATION FOR APPROVAL BY THE CARRIER AND TOWER OWNER PRIOR TO PROCEEDING WITH ANY SUCH CHANGE OF INSTALLATION.
11. CONTRACTOR IS TO PERFORM A SITE INVESTIGATION, BEFORE SUBMITTING BIDS, TO DETERMINE THE BEST ROUTING OF ALL CONDUITS FOR POWER, AND TELCO AND FOR GROUNDING CABLES AS SHOWN IN THE POWER, TELCO, AND GROUNDING PLAN DRAWINGS.
12. THE CONTRACTOR SHALL PROTECT EXISTING IMPROVEMENTS, PAVEMENTS, CURBS, LANDSCAPING AND STRUCTURES. ANY DAMAGED PART SHALL BE REPAIRED AT CONTRACTOR'S EXPENSE TO THE SATISFACTION OF DISH Wireless L.L.C. AND TOWER OWNER
13. CONTRACTOR SHALL LEGALLY AND PROPERLY DISPOSE OF ALL SCRAP MATERIALS SUCH AS COAXIAL CABLES AND OTHER ITEMS REMOVED FROM THE EXISTING FACILITY. ANTENNAS REMOVED SHALL BE RETURNED TO THE OWNER'S DESIGNATED LOCATION.
14. CONTRACTOR SHALL LEAVE PREMISES IN CLEAN CONDITION. TRASH AND DEBRIS SHOULD BE REMOVED FROM SITE ON A DAILY BASIS.



5701 SOUTH SANTA FE DRIVE  
LITTLETON, CO 80120



**B&T ENGINEERING, INC.**  
PEC.0001564  
Expires 2/10/22

IT IS A VIOLATION OF LAW FOR ANY PERSON, UNLESS THEY ARE ACTING UNDER THE DIRECTION OF A LICENSED PROFESSIONAL ENGINEER, TO ALTER THIS DOCUMENT.

DRAWN BY:	CHECKED BY:	APPROVED BY:
DAS	DAS	RCM

RFDS REV #: 2

**CONSTRUCTION DOCUMENTS**

SUBMITTALS		
REV	DATE	DESCRIPTION
A	7/26/21	ISSUED FOR REVIEW
0	9/8/21	ISSUED FOR CONSTRUCTION

A&E PROJECT NUMBER  
153473.001.01

DISH Wireless L.L.C.  
PROJECT INFORMATION  
  
BOBDL0015A  
56 RUOPS ROAD  
TOLLAND, CT 06084

SHEET TITLE  
GENERAL NOTES

SHEET NUMBER  
**GN-2**

**CONCRETE, FOUNDATIONS, AND REINFORCING STEEL:**

1. ALL CONCRETE WORK SHALL BE IN ACCORDANCE WITH THE ACI 301, ACI 318, ACI 336, ASTM A184, ASTM A185 AND THE DESIGN AND CONSTRUCTION SPECIFICATION FOR CAST-IN-PLACE CONCRETE.
2. UNLESS NOTED OTHERWISE, SOIL BEARING PRESSURE USED FOR DESIGN OF SLABS AND FOUNDATIONS IS ASSUMED TO BE 1000 psf.
3. ALL CONCRETE SHALL HAVE A MINIMUM COMPRESSIVE STRENGTH (f'c) OF 3000 psi AT 28 DAYS, UNLESS NOTED OTHERWISE. NO MORE THAN 90 MINUTES SHALL ELAPSE FROM BATCH TIME TO TIME OF PLACEMENT UNLESS APPROVED BY THE ENGINEER OF RECORD. TEMPERATURE OF CONCRETE SHALL NOT EXCEED 90°f AT TIME OF PLACEMENT.
4. CONCRETE EXPOSED TO FREEZE-THAW CYCLES SHALL CONTAIN AIR ENTRAINING ADMIXTURES. AMOUNT OF AIR ENTRAINMENT TO BE BASED ON SIZE OF AGGREGATE AND F3 CLASS EXPOSURE (VERY SEVERE). CEMENT USED TO BE TYPE II PORTLAND CEMENT WITH A MAXIMUM WATER-TO-CEMENT RATIO (W/C) OF 0.45.
5. ALL STEEL REINFORCING SHALL CONFORM TO ASTM A615. ALL WELDED WIRE FABRIC (WWF) SHALL CONFORM TO ASTM A185. ALL SPLICES SHALL BE CLASS "B" TENSION SPLICES, UNLESS NOTED OTHERWISE. ALL HOOKS SHALL BE STANDARD 90 DEGREE HOOKS, UNLESS NOTED OTHERWISE. YIELD STRENGTH (Fy) OF STANDARD DEFORMED BARS ARE AS FOLLOWS:  
 #4 BARS AND SMALLER 40 ksi  
 #5 BARS AND LARGER 60 ksi
6. THE FOLLOWING MINIMUM CONCRETE COVER SHALL BE PROVIDED FOR REINFORCING STEEL UNLESS SHOWN OTHERWISE ON DRAWINGS:
  - CONCRETE CAST AGAINST AND PERMANENTLY EXPOSED TO EARTH 3"
  - CONCRETE EXPOSED TO EARTH OR WEATHER:
    - #6 BARS AND LARGER 2"
    - #5 BARS AND SMALLER 1-1/2"
  - CONCRETE NOT EXPOSED TO EARTH OR WEATHER:
    - SLAB AND WALLS 3/4"
    - BEAMS AND COLUMNS 1-1/2"
7. A TOOLED EDGE OR A 3/4" CHAMFER SHALL BE PROVIDED AT ALL EXPOSED EDGES OF CONCRETE, UNLESS NOTED OTHERWISE, IN ACCORDANCE WITH ACI 301 SECTION 4.2.4.

**ELECTRICAL INSTALLATION NOTES:**

1. ALL ELECTRICAL WORK SHALL BE PERFORMED IN ACCORDANCE WITH THE PROJECT SPECIFICATIONS, NEC AND ALL APPLICABLE FEDERAL, STATE, AND LOCAL CODES/ORDINANCES.
2. CONDUIT ROUTINGS ARE SCHEMATIC. CONTRACTOR SHALL INSTALL CONDUITS SO THAT ACCESS TO EQUIPMENT IS NOT BLOCKED AND TRIP HAZARDS ARE ELIMINATED.
3. WIRING, RACEWAY AND SUPPORT METHODS AND MATERIALS SHALL COMPLY WITH THE REQUIREMENTS OF THE NEC.
4. ALL CIRCUITS SHALL BE SEGREGATED AND MAINTAIN MINIMUM CABLE SEPARATION AS REQUIRED BY THE NEC.
- 4.1. ALL EQUIPMENT SHALL BEAR THE UNDERWRITERS LABORATORIES LABEL OF APPROVAL, AND SHALL CONFORM TO REQUIREMENT OF THE NATIONAL ELECTRICAL CODE.
- 4.2. ALL OVERCURRENT DEVICES SHALL HAVE AN INTERRUPTING CURRENT RATING THAT SHALL BE GREATER THAN THE SHORT CIRCUIT CURRENT TO WHICH THEY ARE SUBJECTED, 22,000 AIC MINIMUM. VERIFY AVAILABLE SHORT CIRCUIT CURRENT DOES NOT EXCEED THE RATING OF ELECTRICAL EQUIPMENT IN ACCORDANCE WITH ARTICLE 110.24 NEC OR THE MOST CURRENT ADOPTED CODE PRE THE GOVERNING JURISDICTION.
5. EACH END OF EVERY POWER PHASE CONDUCTOR, GROUNDING CONDUCTOR, AND TELCO CONDUCTOR OR CABLE SHALL BE LABELED WITH COLOR-CODED INSULATION OR ELECTRICAL TAPE (3M BRAND, 1/2" PLASTIC ELECTRICAL TAPE WITH UV PROTECTION, OR EQUAL). THE IDENTIFICATION METHOD SHALL CONFORM WITH NEC AND OSHA.
6. ALL ELECTRICAL COMPONENTS SHALL BE CLEARLY LABELED WITH LAMICOID TAGS SHOWING THEIR RATED VOLTAGE, PHASE CONFIGURATION, WIRE CONFIGURATION, POWER OR AMPACITY RATING AND BRANCH CIRCUIT ID NUMBERS (i.e. PANEL BOARD AND CIRCUIT ID'S).
7. PANEL BOARDS (ID NUMBERS) SHALL BE CLEARLY LABELED WITH PLASTIC LABELS.
8. TIE WRAPS ARE NOT ALLOWED.
9. ALL POWER AND EQUIPMENT GROUND WIRING IN TUBING OR CONDUIT SHALL BE SINGLE COPPER CONDUCTOR (#14 OR LARGER) WITH TYPE THHW, THWN, THWN-2, XHHW, XHHW-2, THW, THW-2, RHW, OR RHW-2 INSULATION UNLESS OTHERWISE SPECIFIED.
10. SUPPLEMENTAL EQUIPMENT GROUND WIRING LOCATED INDOORS SHALL BE SINGLE COPPER CONDUCTOR (#6 OR LARGER) WITH TYPE THHW, THWN, THWN-2, XHHW, XHHW-2, THW, THW-2, RHW, OR RHW-2 INSULATION UNLESS OTHERWISE SPECIFIED.
11. POWER AND CONTROL WIRING IN FLEXIBLE CORD SHALL BE MULTI-CONDUCTOR, TYPE SOOW CORD (#14 OR LARGER) UNLESS OTHERWISE SPECIFIED.
12. POWER AND CONTROL WIRING FOR USE IN CABLE TRAY SHALL BE MULTI-CONDUCTOR, TYPE TC CABLE (#14 OR LARGER), WITH TYPE THHW, THWN, THWN-2, XHHW, XHHW-2, THW, THW-2, RHW, OR RHW-2 INSULATION UNLESS OTHERWISE SPECIFIED.
13. ALL POWER AND GROUNDING CONNECTIONS SHALL BE CRIMP-STYLE, COMPRESSION WIRE LUGS AND WIRE NUTS BY THOMAS AND BETTS (OR EQUAL). LUGS AND WIRE NUTS SHALL BE RATED FOR OPERATION NOT LESS THAN 75° C (90° C IF AVAILABLE).
14. RACEWAY AND CABLE TRAY SHALL BE LISTED OR LABELED FOR ELECTRICAL USE IN ACCORDANCE WITH NEMA, UL, ANSI/IEEE AND NEC.
15. ELECTRICAL METALLIC TUBING (EMT), INTERMEDIATE METAL CONDUIT (IMC), OR RIGID METAL CONDUIT (RMC) SHALL BE USED FOR EXPOSED INDOOR LOCATIONS.

16. ELECTRICAL METALLIC TUBING (EMT) OR METAL-CLAD CABLE (MC) SHALL BE USED FOR CONCEALED INDOOR LOCATIONS.
17. SCHEDULE 40 PVC UNDERGROUND ON STRAIGHTS AND SCHEDULE 80 PVC FOR ALL ELBOWS/90s AND ALL APPROVED ABOVE GRADE PVC CONDUIT.
18. LIQUID-TIGHT FLEXIBLE METALLIC CONDUIT (LIQUID-TITE FLEX) SHALL BE USED INDOORS AND OUTDOORS, WHERE VIBRATION OCCURS OR FLEXIBILITY IS NEEDED.
19. CONDUIT AND TUBING FITTINGS SHALL BE THREADED OR COMPRESSION-TYPE AND APPROVED FOR THE LOCATION USED. SET SCREW FITTINGS ARE NOT ACCEPTABLE.
20. CABINETS, BOXES AND WIRE WAYS SHALL BE LABELED FOR ELECTRICAL USE IN ACCORDANCE WITH NEMA, UL, ANSI/IEEE AND THE NEC.
21. WIREWAYS SHALL BE METAL WITH AN ENAMEL FINISH AND INCLUDE A HINGED COVER, DESIGNED TO SWING OPEN DOWNWARDS (WIREMOLD SPECMATE WIREWAY).
22. SLOTTED WIRING DUCT SHALL BE PVC AND INCLUDE COVER (PANDUIT TYPE E OR EQUAL).
23. CONDUITS SHALL BE FASTENED SECURELY IN PLACE WITH APPROVED NON-PERFORATED STRAPS AND HANGERS. EXPLOSIVE DEVICES (i.e. POWDER-ACTUATED) FOR ATTACHING HANGERS TO STRUCTURE WILL NOT BE PERMITTED. CLOSELY FOLLOW THE LINES OF THE STRUCTURE, MAINTAIN CLOSE PROXIMITY TO THE STRUCTURE AND KEEP CONDUITS IN TIGHT ENVELOPES. CHANGES IN DIRECTION TO ROUTE AROUND OBSTACLES SHALL BE MADE WITH CONDUIT OUTLET BODIES. CONDUIT SHALL BE INSTALLED IN A NEAT AND WORKMANLIKE MANNER. PARALLEL AND PERPENDICULAR TO STRUCTURE WALL AND CEILING LINES. ALL CONDUIT SHALL BE FISHED TO CLEAR OBSTRUCTIONS. ENDS OF CONDUITS SHALL BE TEMPORARILY CAPPED FLUSH TO FINISH GRADE TO PREVENT CONCRETE, PLASTER OR DIRT FROM ENTERING. CONDUITS SHALL BE RIGIDLY CLAMPED TO BOXES BY GALVANIZED MALLEABLE IRON BUSHING ON INSIDE AND GALVANIZED MALLEABLE IRON LOCKNUT ON OUTSIDE AND INSIDE.
24. EQUIPMENT CABINETS, TERMINAL BOXES, JUNCTION BOXES AND PULL BOXES SHALL BE GALVANIZED OR EPOXY-COATED SHEET STEEL SHALL MEET OR EXCEED UL 50 AND BE RATED NEMA 1 (OR BETTER) FOR INTERIOR LOCATIONS AND NEMA 3 (OR BETTER) FOR EXTERIOR LOCATIONS.
25. METAL RECEPTACLE, SWITCH AND DEVICE BOXES SHALL BE GALVANIZED, EPOXY-COATED OR NON-CORRODING; SHALL MEET OR EXCEED UL 514A AND NEMA OS 1 AND BE RATED NEMA 1 (OR BETTER) FOR INTERIOR LOCATIONS AND WEATHER PROTECTED (WP OR BETTER) FOR EXTERIOR LOCATIONS.
26. NONMETALLIC RECEPTACLE, SWITCH AND DEVICE BOXES SHALL MEET OR EXCEED NEMA OS 2 (NEWEST REVISION) AND BE RATED NEMA 1 (OR BETTER) FOR INTERIOR LOCATIONS AND WEATHER PROTECTED (WP OR BETTER) FOR EXTERIOR LOCATIONS.
27. THE CONTRACTOR SHALL NOTIFY AND OBTAIN NECESSARY AUTHORIZATION FROM THE CARRIER AND/OR DISH Wireless L.L.C. AND TOWER OWNER BEFORE COMMENCING WORK ON THE AC POWER DISTRIBUTION PANELS.
28. THE CONTRACTOR SHALL PROVIDE NECESSARY TAGGING ON THE BREAKERS, CABLES AND DISTRIBUTION PANELS IN ACCORDANCE WITH THE APPLICABLE CODES AND STANDARDS TO SAFEGUARD LIFE AND PROPERTY.
29. INSTALL LAMICOID LABEL ON THE METER CENTER TO SHOW "DISH Wireless L.L.C.".
30. ALL EMPTY/SPARE CONDUITS THAT ARE INSTALLED ARE TO HAVE A METERED MULE TAPE PULL CORD INSTALLED.



5701 SOUTH SANTA FE DRIVE  
LITTLETON, CO 80120



**B&T ENGINEERING, INC.**  
PEC.0001564  
Expires 2/10/22

IT IS A VIOLATION OF LAW FOR ANY PERSON, UNLESS THEY ARE ACTING UNDER THE DIRECTION OF A LICENSED PROFESSIONAL ENGINEER, TO ALTER THIS DOCUMENT.

DRAWN BY:	CHECKED BY:	APPROVED BY:
DAS	DAS	RCM

RFDS REV #: 2

**CONSTRUCTION DOCUMENTS**

SUBMITTALS		
REV	DATE	DESCRIPTION
A	7/26/21	ISSUED FOR REVIEW
0	9/8/21	ISSUED FOR CONSTRUCTION

A&E PROJECT NUMBER  
153473.001.01

DISH Wireless L.L.C.  
PROJECT INFORMATION  
  
BOBDL00015A  
56 RUOPS ROAD  
TOLLAND, CT 06084

SHEET TITLE  
GENERAL NOTES

SHEET NUMBER  
**GN-3**



**GROUNDING NOTES:**

1. ALL GROUND ELECTRODE SYSTEMS (INCLUDING TELECOMMUNICATION, RADIO, LIGHTNING PROTECTION AND AC POWER GES'S) SHALL BE BONDED TOGETHER AT OR BELOW GRADE, BY TWO OR MORE COPPER BONDING CONDUCTORS IN ACCORDANCE WITH THE NEC.
2. THE CONTRACTOR SHALL PERFORM IEEE FALL-OF-POTENTIAL RESISTANCE TO EARTH TESTING (PER IEEE 1100 AND 81) FOR GROUND ELECTRODE SYSTEMS, THE CONTRACTOR SHALL FURNISH AND INSTALL SUPPLEMENTAL GROUND ELECTRODES AS NEEDED TO ACHIEVE A TEST RESULT OF 5 OHMS OR LESS.
3. THE CONTRACTOR IS RESPONSIBLE FOR PROPERLY SEQUENCING GROUNDING AND UNDERGROUND CONDUIT INSTALLATION AS TO PREVENT ANY LOSS OF CONTINUITY IN THE GROUNDING SYSTEM OR DAMAGE TO THE CONDUIT AND PROVIDE TESTING RESULTS.
4. METAL CONDUIT AND TRAY SHALL BE GROUNDED AND MADE ELECTRICALLY CONTINUOUS WITH LISTED BONDING FITTINGS OR BY BONDING ACROSS THE DISCONTINUITY WITH #6 COPPER WIRE UL APPROVED GROUNDING TYPE CONDUIT CLAMPS.
5. METAL RACEWAY SHALL NOT BE USED AS THE NEC REQUIRED EQUIPMENT GROUND CONDUCTOR. STRANDED COPPER CONDUCTORS WITH GREEN INSULATION, SIZED IN ACCORDANCE WITH THE NEC, SHALL BE FURNISHED AND INSTALLED WITH THE POWER CIRCUITS TO BTS EQUIPMENT.
6. EACH CABINET FRAME SHALL BE DIRECTLY CONNECTED TO THE MASTER GROUND BAR WITH GREEN INSULATED SUPPLEMENTAL EQUIPMENT GROUND WIRES, #6 STRANDED COPPER OR LARGER FOR INDOOR BTS; #2 BARE SOLID TINNED COPPER FOR OUTDOOR BTS.
7. CONNECTIONS TO THE GROUND BUS SHALL NOT BE DOUBLED UP OR STACKED BACK TO BACK CONNECTIONS ON OPPOSITE SIDE OF THE GROUND BUS ARE PERMITTED.
8. ALL EXTERIOR GROUND CONDUCTORS BETWEEN EQUIPMENT/GROUND BARS AND THE GROUND RING SHALL BE #2 SOLID TINNED COPPER UNLESS OTHERWISE INDICATED.
9. ALUMINUM CONDUCTOR OR COPPER CLAD STEEL CONDUCTOR SHALL NOT BE USED FOR GROUNDING CONNECTIONS.
10. USE OF 90° BENDS IN THE PROTECTION GROUNDING CONDUCTORS SHALL BE AVOIDED WHEN 45° BENDS CAN BE ADEQUATELY SUPPORTED.
11. EXOTHERMIC WELDS SHALL BE USED FOR ALL GROUNDING CONNECTIONS BELOW GRADE.
12. ALL GROUND CONNECTIONS ABOVE GRADE (INTERIOR AND EXTERIOR) SHALL BE FORMED USING HIGH PRESS CRIMPS.
13. COMPRESSION GROUND CONNECTIONS MAY BE REPLACED BY EXOTHERMIC WELD CONNECTIONS.
14. ICE BRIDGE BONDING CONDUCTORS SHALL BE EXOTHERMICALLY BONDED OR BOLTED TO THE BRIDGE AND THE TOWER GROUND BAR.
15. APPROVED ANTIOXIDANT COATINGS (i.e. CONDUCTIVE GEL OR PASTE) SHALL BE USED ON ALL COMPRESSION AND BOLTED GROUND CONNECTIONS.
16. ALL EXTERIOR GROUND CONNECTIONS SHALL BE COATED WITH A CORROSION RESISTANT MATERIAL.
17. MISCELLANEOUS ELECTRICAL AND NON-ELECTRICAL METAL BOXES, FRAMES AND SUPPORTS SHALL BE BONDED TO THE GROUND RING, IN ACCORDANCE WITH THE NEC.
18. BOND ALL METALLIC OBJECTS WITHIN 6 ft OF MAIN GROUND RING WITH (1) #2 BARE SOLID TINNED COPPER GROUND CONDUCTOR.
19. GROUND CONDUCTORS USED FOR THE FACILITY GROUNDING AND LIGHTNING PROTECTION SYSTEMS SHALL NOT BE ROUTED THROUGH METALLIC OBJECTS THAT FORM A RING AROUND THE CONDUCTOR, SUCH AS METALLIC CONDUITS, METAL SUPPORT CLIPS OR SLEEVES THROUGH WALLS OR FLOORS. WHEN IT IS REQUIRED TO BE HOUSED IN CONDUIT TO MEET CODE REQUIREMENTS OR LOCAL CONDITIONS, NON-METALLIC MATERIAL SUCH AS PVC CONDUIT SHALL BE USED. WHERE USE OF METAL CONDUIT IS UNAVOIDABLE (i.e., NONMETALLIC CONDUIT PROHIBITED BY LOCAL CODE) THE GROUND CONDUCTOR SHALL BE BONDED TO EACH END OF THE METAL CONDUIT.
20. ALL GROUNDS THAT TRANSITION FROM BELOW GRADE TO ABOVE GRADE MUST BE #2 BARE SOLID TINNED COPPER IN 3/4" NON-METALLIC, FLEXIBLE CONDUIT FROM 24" BELOW GRADE TO WITHIN 3" TO 6" OF CAD-WELD TERMINATION POINT. THE EXPOSED END OF THE CONDUIT MUST BE SEALED WITH SILICONE CAULK. (ADD TRANSITIONING GROUND STANDARD DETAIL AS WELL).
21. BUILDINGS WHERE THE MAIN GROUNDING CONDUCTORS ARE REQUIRED TO BE ROUTED TO GRADE, THE CONTRACTOR SHALL ROUTE TWO GROUNDING CONDUCTORS FROM THE ROOFTOP, TOWERS, AND WATER TOWERS GROUNDING RING, TO THE EXISTING GROUNDING SYSTEM, THE GROUNDING CONDUCTORS SHALL NOT BE SMALLER THAN 2/0 COPPER. ROOFTOP GROUNDING RING SHALL BE BONDED TO THE EXISTING GROUNDING SYSTEM, THE BUILDING STEEL COLUMNS, LIGHTNING PROTECTION SYSTEM, AND BUILDING MAIN WATER LINE (FERROUS OR NONFERROUS METAL PIPING ONLY). DO NOT ATTACH GROUNDING TO FIRE SPRINKLER SYSTEM PIPES.



5701 SOUTH SANTA FE DRIVE  
LITTLETON, CO 80120



**AMERICAN TOWER®**  
10 PRESIDENTIAL WAY  
WOBBURN, MA 01801



1717 S. BOULDER  
SUITE 300  
TULSA, OK 74119  
PH: (918) 587-4630  
www.blgrp.com



**B&T ENGINEERING, INC.**  
PEC.0001564  
Expires 2/10/22

IT IS A VIOLATION OF LAW FOR ANY PERSON, UNLESS THEY ARE ACTING UNDER THE DIRECTION OF A LICENSED PROFESSIONAL ENGINEER, TO ALTER THIS DOCUMENT.

DRAWN BY:	CHECKED BY:	APPROVED BY:
DAS	DAS	RCM

RFDS REV #: 2

**CONSTRUCTION DOCUMENTS**

SUBMITTALS		
REV	DATE	DESCRIPTION
A	7/26/21	ISSUED FOR REVIEW
0	9/8/21	ISSUED FOR CONSTRUCTION

A&E PROJECT NUMBER  
153473.001.01

DISH Wireless L.L.C.  
PROJECT INFORMATION  
  
BOBDL00015A  
56 RUOPS ROAD  
TOLLAND, CT 06084

SHEET TITLE  
GENERAL NOTES

SHEET NUMBER  
**GN-4**

ENGINEERING:  
STRUCTURAL ANALYSIS  
MOUNT ANALYSIS



DEPARTMENT OF ADMINISTRATIVE SERVICES

---

January 18, 2022

David Hoogasian  
Network Building & Consulting  
100 Apollo Drive Suite 303  
Chelmsford, MA 01824

Re: Structural Analysis Report for Site # BOBDL00015A - 302495  
56 Ruops Road, Tolland

Mr. Hoogasian,

Based on the Structural Analysis Report by A.T. Engineering Services PLLC, dated July 8, 2021, the proposed additions to this tower comply with the structural requirements of the 2018 Connecticut State Building Code.

If you have any questions you may contact me as 860-713-5900.

Sincerely,

A handwritten signature in blue ink that reads "Joseph V. Cassidy".

Joseph V. Cassidy, P.E.  
State Building Inspector



**AMERICAN TOWER®**  
CORPORATION

---

## Structural Analysis Report

**Structure** : 165 ft Monopole  
**ATC Site Name** : Tolland CT, CT  
**ATC Asset Number** : 302495  
**Engineering Number** : 13692173\_C3\_03  
**Proposed Carrier** : DISH WIRELESS L.L.C.  
**Carrier Site Name** : BOBDL00015A  
**Carrier Site Number** : BOBDL00015A  
**Site Location** : 56 Ruops Road  
Tolland, CT 06084-3116  
41.873300,-72.338300  
**County** : Tolland  
**Date** : July 8, 2021  
**Max Usage** : 101%  
**Result** : Pass



Prepared By:  
Brian Davies, E.I.  
Structural Engineer II

Reviewed By:

**COA: PEC.0001553**



**Table of Contents**

Introduction ..... 1

Supporting Documents..... 1

Analysis..... 1

Conclusion..... 1

Existing and Reserved Equipment..... 2

Equipment to be Removed ..... 2

Proposed Equipment..... 2

Structure Usages .....3

Foundations .....3

Deflection, Twist, and Sway .....3

Standard Conditions .....4

Calculations..... Attached





## Introduction

The purpose of this report is to summarize results of a structural analysis performed on the 165 ft monopole to reflect the change in loading by DISH WIRELESS L.L.C..

## Supporting Documents

<b>Tower Drawings</b>	EI Drawing #GS50842 Rev 1, dated June 24, 1998 Mapping by Delta Oaks Group Project #AGI19-04721-03, dated August 1, 2019
<b>Foundation Drawing</b>	EI Drawing #F3503-150.N, dated March 2, 1998
<b>Geotechnical Report</b>	ASR Project #12-06077, dated December 1, 2006
<b>Modifications</b>	Spectrasite Drawing #CT-0031-M1, dated November 15, 2004

## Analysis

The tower was analyzed using American Tower Corporation's tower analysis software. This program considers an elastic three-dimensional model and second-order effects per ANSI/TIA-222.

<b>Basic Wind Speed:</b>	118 mph (3-Second Gust)
<b>Basic Wind Speed w/ Ice:</b>	50 mph (3-Second Gust) w/ 1"1/2 radial ice concurrent
<b>Code:</b>	ANSI/TIA-222-H / 2015 IBC / 2018 Connecticut State Building Code
<b>Exposure Category:</b>	B
<b>Risk Category:</b>	II
<b>Topographic Factor Procedure:</b>	Method 1
<b>Topographic Category:</b>	1
<b>Crest Height (H):</b>	0 ft
<b>Spectral Response:</b>	$S_s = 0.18, S_1 = 0.05$
<b>Site Class:</b>	D - Stiff Soil

## Conclusion

Based on the analysis results, the structure meets the requirements per the applicable codes listed above. The tower and foundation can support the equipment as described in this report.

If you have any questions or require additional information, please contact American Tower via email at [Engineering@americantower.com](mailto:Engineering@americantower.com). Please include the American Tower site name, site number, and engineering number in the subject line for any questions.



**Existing and Reserved Equipment**

Elev. <sup>1</sup> (ft)	Qty	Equipment	Mount Type	Lines	Carrier
162.0	3	EMS RR90-17-02DP	Flush	(6) 1 5/8" Coax	T-MOBILE
	6	Ericsson KRY 112 71/x (12.8"x5.9")			
149.0	6	Kathrein Scala 782-10250	Triangular Platform with Handrails	(1) 0.39" (10mm) Fiber Trunk (2) 0.78" (19.7mm) 8 AWG 6 (24) 1 1/4" Coax (1) 3" conduit (1) 3/8" (0.38"-9.5mm) RET Control Cable	AT&T MOBILITY
	3	Powerwave Allgon 7020.00 Dual Band RET			
	3	Ericsson RRUS-12 800 MHz			
	3	Powerwave Allgon 7770.00			
	6	KMW AM-X-CD-16-65-00T-RET			
	6	CCI DTMABP7819VG12A			
	1	Raycap DC6-48-60-18-8F ("Squid")			
	3	Ericsson RRUS 11 (Band 12)			
	1	Andrew ABT-DMDF-ADBH			
140.0	6	Decibel DB844G90A-XY	Triangular Platform with Handrails	(14) 1 5/8" Coax (2) 1 5/8" Hybriflex	VERIZON WIRELESS
	6	Commscope JAHH-65B-R3B			
	2	RFS DB-T1-6Z-8AB-OZ			
	3	Samsung MT6407-77A			
	6	Swedcom SC 9012			
	3	Samsung B2/B66A RRH-BR049			
	3	Samsung B5/B13 RRH-BR04C			
	3	Samsung Outdoor CBRS 20W RRH			
	6	RFS FDJ85020D7-S			
	3	Samsung CBRS 64T64R MMU			
133.0	3	Alcatel-Lucent 1900 MHz 4X45 RRH	Triangular Platform with Handrails	(4) 1 1/4" Hybriflex Cable (6) 1 5/8" Coax	SPRINT NEXTEL
	3	Alcatel-Lucent TD-RRH8x20-25 w/ Solar Shield			
	3	RFS APXVTM14-ALU-I20			
	3	Commscope NNVV-65B-R4			
	6	Alcatel-Lucent 800 MHz 2X50W RRH w/ Filter			
121.0	2	Andrew DB844H90E-A	Platform with Handrails	-	SPRINT NEXTEL
	1	Andrew DB844H90E-A			
	1	Andrew DB844H90E-A			
	6	Andrew DB844H90E-A			
	2	Andrew DB844H90E-A			
105.0	3	Commscope LNX-6515DS-VTM	Flush	-	T-MOBILE
	3	Kathrein Scala Smart Bias Tee			
81.0	1	Generic GPS	Flush	(1) 1/2" Coax	
50.0	1	Generic 2" x 4" GPS	Flush	-	SPRINT NEXTEL

**Equipment to be Removed**

Elev. <sup>1</sup> (ft)	Qty	Equipment	Mount Type	Lines	Carrier
No loading was considered as removed as part of this analysis.					



**Proposed Equipment**

Elev. <sup>1</sup> (ft)	Qty	Equipment	Mount Type	Lines	Carrier
93.0	1	Commscope RDIDC-9181-PF-48	Triangular Platform with Handrails	(1) 1.60" (40.6mm) Hybrid	DISH WIRELESS L.L.C.
	3	Fujitsu TA08025-B605			
	3	Fujitsu TA08025-B604			
	3	JMA Wireless MX08FRO665-21			

<sup>1</sup> Contracted elevations are shown for appurtenances within contracted installation tolerances. Appurtenances outside of contract limits are shown at installed elevations.

Install proposed coax inside the pole shaft.



**Structure Usages**

Structural Component	Controlling Usage	Pass/Fail
Anchor Bolts	101%	Pass
Shaft	98%	Pass
Base Plate	56%	Pass

**Foundations**

Reaction Component	Analysis Reactions	% of Usage
Moment (Kips-Ft)	4,530.5	95%
Axial (Kips)	94.1	4%
Shear (Kips)	43.6	54%

The structure base reactions resulting from this analysis were found to be acceptable through analysis based on geotechnical and foundation information, therefore no modification or reinforcement of the foundation will be required.

**Deflection and Sway\***

Antenna Elevation (ft)	Antenna	Carrier	Deflection (ft)	Sway (Rotation) (°)
93.0	Commscope RDIDC-9181-PF-48	DISH WIRELESS L.L.C.	1.093	1.395
	Fujitsu TA08025-B605			
	Fujitsu TA08025-B604			
	JMA Wireless MX08FRO665-21			

\*Deflection and Sway was evaluated considering a design wind speed of 60 mph (3-Second Gust) per ANSI/TIA-222-H



## Standard Conditions

All engineering services performed by A.T. Engineering Service, PLLC are prepared on the basis that the information used is current and correct. This information may consist of, but is not limited to the following:

- Information supplied by the client regarding antenna, mounts and feed line loading
- Information from drawings, design and analysis documents, and field notes in the possession of A.T. Engineering Service, PLLC

It is the responsibility of the client to ensure that the information provided to A.T. Engineering Service, PLLC and used in the performance of our engineering services is correct and complete.

All assets of American Tower Corporation, its affiliates and subsidiaries (collectively "American Tower") are inspected at regular intervals. Based upon these inspections and in the absence of information to the contrary, American Tower assumes that all structures were constructed in accordance with the drawings and specifications.

Unless explicitly agreed by both the client and A.T. Engineering Service, PLLC, all services will be performed in accordance with the current revision of ANSI/TIA-222.

All services are performed, results obtained, and recommendations made in accordance with generally accepted engineering principles and practices. A.T. Engineering Service, PLLC is not responsible for the conclusions, opinions and recommendations made by others based on the information supplied herein.

Job Information	
Client : DISH WIRELESS L.L.C.	
Pole : 302495	Code: ANSI/TIA-222-H
Location : Tolland CT, CT	
Description : EEI 155' Monopole - Model 125112	Risk Category: 1/25
Shape : 12 Sides	Exposure : B
Height : 165.00 (ft)	Topo Method : Method 1
Base Elev (ft): 0.00	Topographic Category : 1
Taper: 0.21061 (in/ft)	

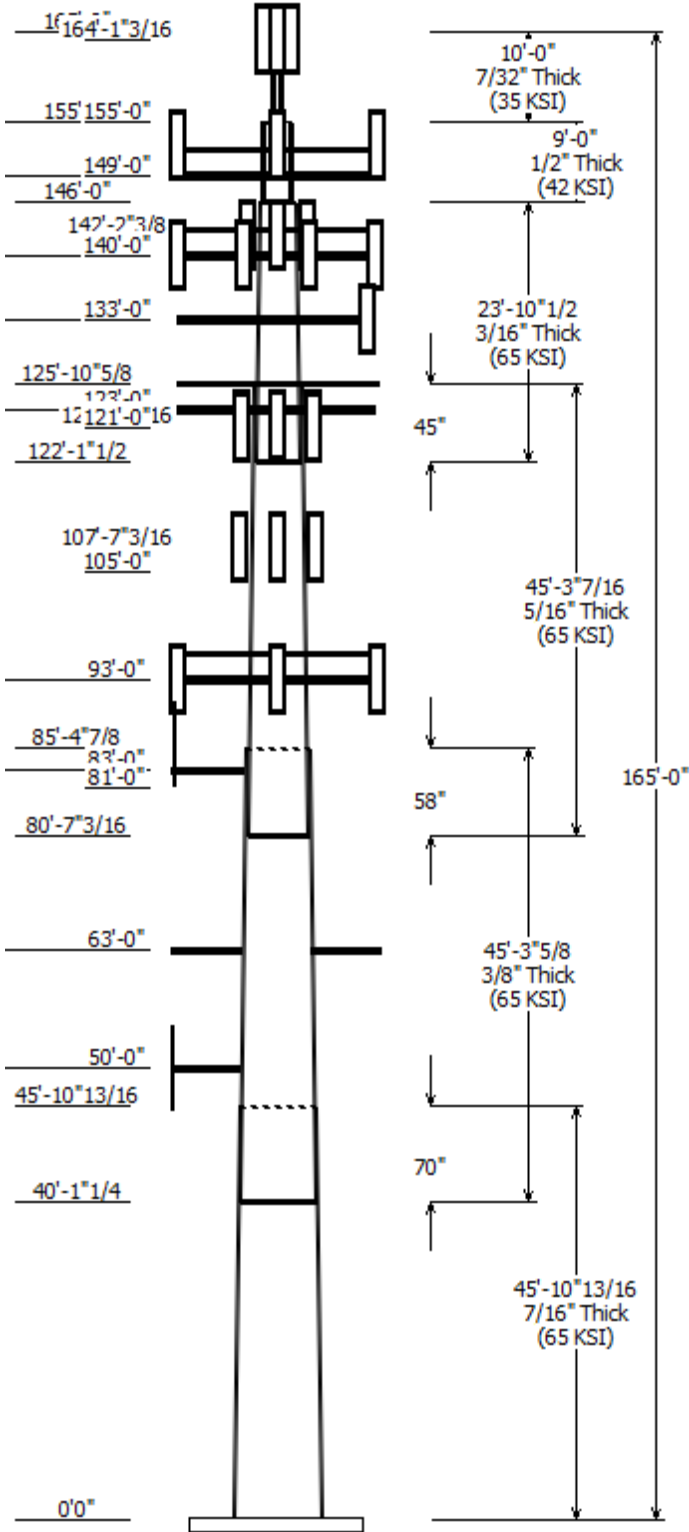

Sections Properties						
Shaft Section	Length (ft)	Diameter (in)		Thick Joint (in)	Overlap Length (in)	Steel Grade
		Across Flats Top	Across Flats Bottom			
1	45.898	40.33	50.00	0.438	0.000	12 Sides 65
2	45.302	32.76	42.30	0.375	69.531	12 Sides 65
3	45.286	24.86	34.40	0.313	57.688	12 Sides 65
4	23.878	21.00	26.02	0.188	45.156	12 Sides 65
5	9.000	16.00	16.00	0.500	0.000	Round 42
6	10.000	3.500	3.500	0.218	0.000	Round 35

Discrete Appurtenance			
Attach Elev (ft)	Force Elev (ft)	Qty	Description
164.100	164.100	3	EMS RR90-17-02DP
155.000	155.000	1	Canister
155.000	157.000	6	Ericsson KRY 112 71/x (12.8"x5)
149.000	149.000	1	Generic Flat Platform with Han
149.000	151.000	6	KMW AM-X-CD-16-65-00T-RET
149.000	151.000	3	Powerwave Allgon 7770.00
149.000	151.000	3	Ericsson RRUS-12 800 MHz
149.000	151.000	1	Raycap DC6-48-60-18-8F
149.000	151.000	6	CCI DTMABP7819VG12A
149.000	151.000	6	Kathrein Scala 782-10250
149.000	151.000	3	Ericsson RRUS 11 (Band 12)
149.000	151.000	3	Powerwave Allgon 7020.00
149.000	149.000	1	Andrew ABT-DMDF-ADBH
142.200	142.200	6	Decibel DB844G90A-XY
140.000	140.000	1	Generic Flat Platform with Han
140.000	140.000	6	Commscope JAHH-65B-R3B
140.000	140.000	2	RFS DB-T1-6Z-8AB-0Z
140.000	140.000	3	Samsung MT6407-77A
140.000	140.000	3	Samsung CBRS 64T64R MMU
140.000	140.000	6	Swedcom SC 9012
140.000	140.000	3	Samsung B2/B66A RRH-BR049
140.000	140.000	3	Samsung B5/B13 RRH-BR04C
140.000	140.000	3	Samsung Outdoor CBRS 20W
140.000	140.000	6	RFS FDJ85020D7-S
133.000	133.000	1	Modified Platform w/ Handrails
133.000	133.000	3	Commscope NNVV-65B-R4
133.000	133.000	3	RFS APXVTM14-ALU-I20
133.000	133.000	3	Alcatel-Lucent 1900 MHz 4X45
133.000	133.000	3	Alcatel-Lucent TD-RRH8x20-25
133.000	133.000	6	Alcatel-Lucent 800 MHz 2X50W
123.000	123.000	1	Generic Flat Platform with Han
121.300	121.300	2	Andrew DB844H90E-A
121.200	121.200	1	Andrew DB844H90E-A
121.200	121.200	1	Andrew DB844H90E-A
121.100	121.100	6	Andrew DB844H90E-A
121.000	121.000	2	Andrew DB844H90E-A
107.600	107.600	3	Commscope LNX-6515DS-VTM
105.000	105.000	3	Kathrein Scala Smart Bias Tee
93.000	93.000	3	JMA Wireless MX08FRO665-21
93.000	93.000	3	Fujitsu TA08025-B604
93.000	93.000	3	Fujitsu TA08025-B605

93.000	93.000	1	Commscope RDIDC-9181-PF-48
93.000	93.000	1	Generic Flat Platform with Han
83.000	83.000	1	Stand-Off
81.000	83.000	1	Generic GPS
63.000	63.000	2	Stand-Off
50.000	50.000	1	Stand-Off
50.000	50.000	1	Generic 2" x 4" GPS

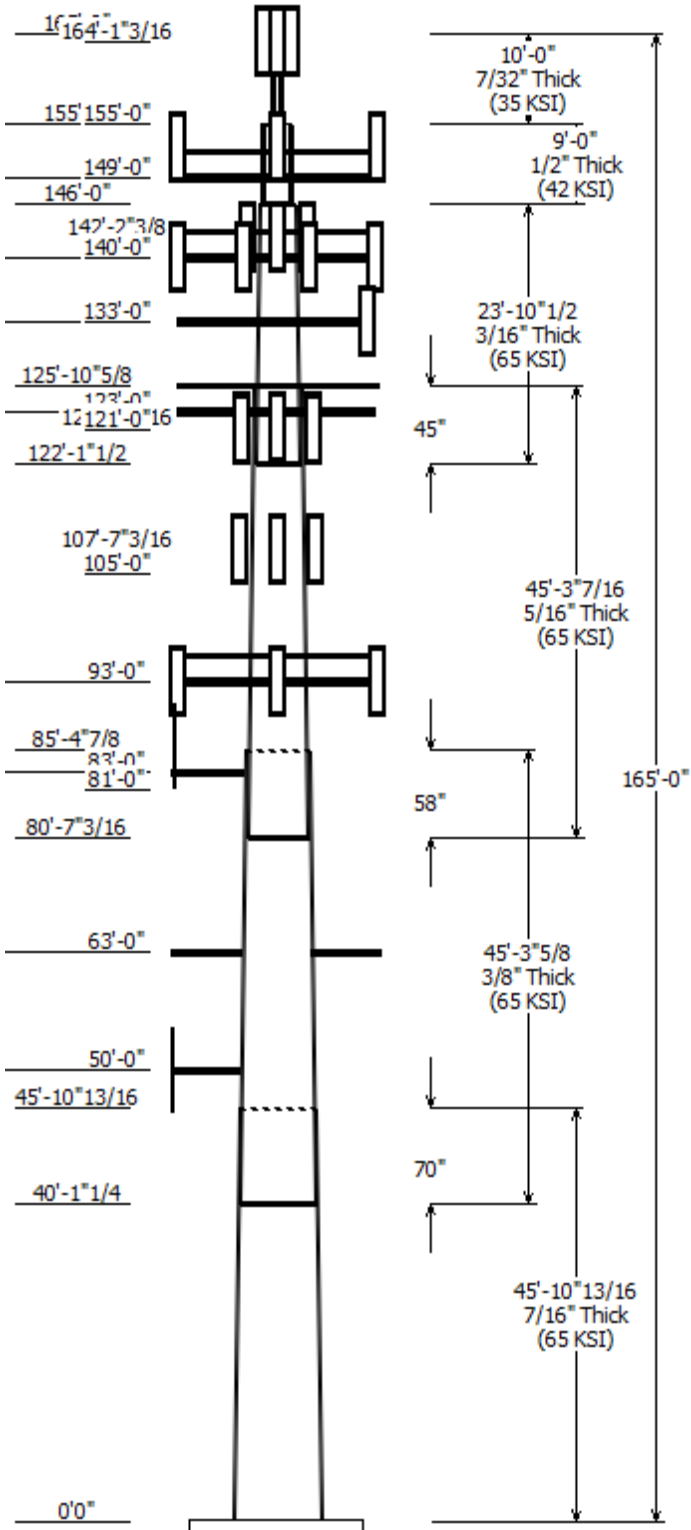

Linear Appurtenance			
Elev (ft)		Description	Exposed To Wind
From	To		
120.0	149.0	Climbing Ladder	Yes
0.000	162.0	1 5/8" Coax	No
0.000	81.000	1/2" Coax	No
0.000	93.000	1.60" (40.6mm)	No
0.000	133.0	1 1/4" Hybriflex	No
0.000	133.0	1 5/8" Coax	No
0.000	140.0	1 5/8" Coax	Yes
0.000	140.0	1 5/8" Hybriflex	Yes
0.000	149.0	0.39" (10mm)	No
0.000	149.0	0.78" (19.7mm) 8	No
0.000	149.0	1 1/4" Coax	No
0.000	149.0	1 1/4" Coax	No
0.000	149.0	1 1/4" Coax	Yes
0.000	149.0	3" conduit	No
0.000	149.0	3/8" (0.38"-	No

Load Cases	
1.2D + 1.0W	118 mph with No Ice
0.9D + 1.0W	118 mph with No Ice (Reduced DL)
1.2D + 1.0Di + 1.0Wi	50 mph with 1.50 in Radial Ice
1.2D + 1.0Ev + 1.0Eh	Seismic
0.9D - 1.0Ev + 1.0Eh	Seismic (Reduced DL)
1.0D + 1.0W	Serviceability 60 mph

Reactions			
Load Case	Moment (kip-ft)	Shear (kip)	Axial (kip)
1.2D + 1.0W	4530.52	43.60	59.16
0.9D + 1.0W	4442.87	43.58	44.35
1.2D + 1.0Di + 1.0Wi	1030.64	8.46	94.14
1.2D + 1.0Ev + 1.0Eh	199.58	1.48	60.05
0.9D - 1.0Ev + 1.0Eh	194.28	1.48	41.76
1.0D + 1.0W	1037.37	10.08	49.35

Dish Deflections			
Load Case	Attach Elev (ft)	Deflection (in)	Rotation (deg)
	0.00	0.000	0.000

Load Case : 1.2D + 1.0W  
Max Ratio 97.59% at 0.0 ft

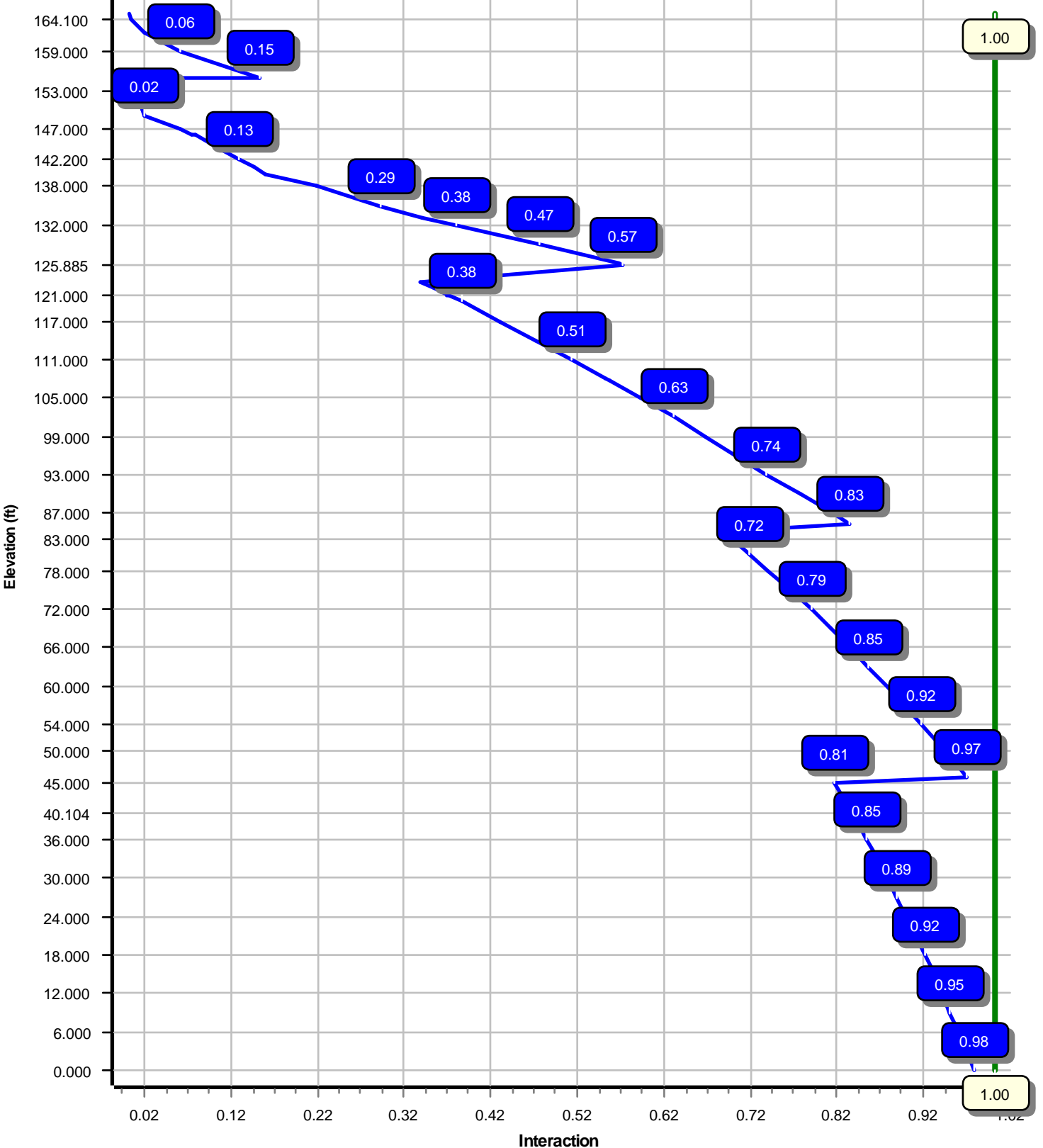



Site Number: 302495

Code: ANSI/TIA-222-H

© 2007 - 2021 by ATC IP LLC. All rights reserved.

Site Name: Tolland CT, CT

Engineering Number: 13692173\_C3\_03

7/8/2021 6:22:46 PM

Customer: DISH WIRELESS L.L.C.

Analysis Parameters

Location :	Tolland County, CT	Height (ft) :	165
Code :	ANSI/TIA-222-H	Base Diameter (in) :	50.00
Shape :	12 Sides. Sect 5: Round. Sect 6: Round	Top Diameter (in) :	3.50
Pole Type :	Custom	Taper (in/ft) :	0.211
Pole Manufacturer :	EEI	Rotation (deg) :	0.00
Kd (non-service) :	0.95	Ke :	0.98

Ice & Wind Parameters

Exposure Category:	B	Design Wind Speed Without Ice:	118 mph
Risk Category:	II	Design Wind Speed With Ice:	50 mph
Topographic Factor Procedure:	Method 1	Operational Wind Speed:	60 mph
Topographic Category:	1	Design Ice Thickness:	1.50 in
Crest Height:	0 ft	HMSL:	695.00 ft

Seismic Parameters

Analysis Method:	Equivalent Lateral Force Method		
Site Class:	D - Stiff Soil		
Period Based on Rayleigh Method (sec):	3.15		
T <sub>L</sub> (sec):	6	p:	1
S <sub>s</sub> :	0.181	S <sub>1</sub> :	0.055
F <sub>a</sub> :	1.600	F <sub>v</sub> :	2.400
S <sub>ds</sub> :	0.193	S <sub>d1</sub> :	0.088
		C <sub>s</sub> :	0.030
		C <sub>s</sub> Max:	0.030
		C <sub>s</sub> Min:	0.030

Load Cases

1.2D + 1.0W	118 mph with No Ice
0.9D + 1.0W	118 mph with No Ice (Reduced DL)
1.2D + 1.0Di + 1.0Wi	50 mph with 1.50 in Radial Ice
1.2D + 1.0Ev + 1.0Eh	Seismic
0.9D - 1.0Ev + 1.0Eh	Seismic (Reduced DL)
1.0D + 1.0W	Serviceability 60 mph

Site Number: 302495

Code: ANSI/TIA-222-H

© 2007 - 2021 by ATC IP LLC. All rights reserved.

Site Name: Tolland CT, CT

Engineering Number: 13692173\_C3\_03

7/8/2021 6:22:46 PM

Customer: DISH WIRELESS L.L.C.

**Shaft Section Properties**

Sect Info	Length (ft)	Thick (in)	Fy (ksi)	Joint Type	Slip Joint Len (in)	Weight (lb)	Bottom						Top							
							Dia (in)	Elev (ft)	Area (in <sup>2</sup> )	Ix (in <sup>4</sup> )	W/t Ratio	D/t Ratio	Dia (in)	Elev (ft)	Area (in <sup>2</sup> )	Ix (in <sup>4</sup> )	W/t Ratio	D/t Ratio	Taper (in/ft)	
1-12	45.898	0.4375	65		0.00	9,841	50.00	0.00	69.82	21891.7	27.94	114.29	40.33	45.90	56.20	11418.1	22.02	92.19	0.210616	
2-12	45.302	0.3750	65	Slip	69.53	6,917	42.30	40.10	50.63	11360.5	27.55	112.81	32.76	85.41	39.11	5235.8	20.73	87.37	0.210616	
3-12	45.286	0.3125	65	Slip	57.69	4,546	34.40	80.60	34.30	5087.0	26.82	110.08	24.86	125.89	24.70	1900.2	18.64	79.56	0.210616	
4-12	23.878	0.1875	65	Slip	45.16	1,144	26.02	122.12	15.60	1329.8	34.52	138.82	21.00	146.00	12.57	694.7	27.33	112.00	0.210616	
5-R	9.000	0.5000	42	Butt	0.00	746	16.00	146.00	24.35	731.7	0.00	32.00	16.00	155.00	24.35	731.7	0.00	32.00	0.000000	
6-R	10.000	0.2180	35	Butt	0.00	76	3.500	155.00	2.25	3.0	0.00	16.06	3.500	165.00	2.25	3.0	0.00	16.06	0.000000	
Shaft Weight						23,270														

**Discrete Appurtenance Properties**

Attach Elev (ft)	Description	Qty	Ka	Vert Ecc (ft)	Weight (lb)	No Ice EPAa (sf)	Orientation Factor	Weight (lb)	Ice EPAa (sf)	Orientation Factor
164.10	EMS RR90-17-02DP	3	1.00	0.000	13.50	4.356	0.01	113.27	5.355	0.01
155.00	Ericsson KRY 112 71/x	6	1.00	2.000	13.20	0.629	0.01	31.85	1.203	0.01
155.00	Canister	1	1.00	0.000	500.00	9.800	1.00	798.17	12.331	1.00
149.00	Andrew ABT-DMDF-ADBH	1	0.75	0.000	1.10	0.045	1.00	3.33	0.218	1.00
149.00	Powerwave Allgon 7020.00 Dual	3	0.75	2.000	2.20	0.339	0.50	12.42	0.749	0.50
149.00	Kathrein Scala 782-10250	6	0.75	2.000	6.40	0.449	0.50	19.17	0.940	0.50
149.00	CCI DTMABP7819VG12A	6	0.75	2.000	19.20	0.972	0.50	44.69	1.627	0.50
149.00	Raycap DC6-48-60-18-8F	1	0.75	2.000	31.80	1.470	1.00	93.54	2.169	1.00
149.00	Ericsson RRUS 11 (Band 12)	3	0.75	2.000	50.00	2.566	0.67	118.22	3.614	0.67
149.00	Ericsson RRUS-12 800 MHz	3	0.75	2.000	60.00	2.700	0.67	134.20	3.775	0.67
149.00	Powerwave Allgon 7770.00	3	0.75	2.000	35.00	5.508	0.65	169.95	6.564	0.65
149.00	KMW AM-X-CD-16-65-00T-RET	6	0.75	2.000	48.50	8.024	0.67	210.56	10.815	0.67
149.00	Generic Flat Platform with	1	1.00	0.000	2,500.00	42.400	1.00	4,277.73	63.387	1.00
142.20	Decibel DB844G90A-XY	6	0.75	0.000	14.00	3.615	0.73	123.87	3.917	0.73
140.00	RFS FDJ85020D7-S	6	0.75	0.000	11.70	0.425	0.50	29.79	0.867	0.50
140.00	Samsung Outdoor CBRS 20W	3	0.75	0.000	18.60	0.857	0.50	42.46	1.480	0.50
140.00	Samsung B5/B13 RRH-BR04C	3	0.75	0.000	70.30	1.875	0.50	127.19	2.773	0.50
140.00	Samsung B2/B66A RRH-BR049	3	0.75	0.000	84.40	1.875	0.50	147.84	2.773	0.50
140.00	Swedcom SC 9012	6	0.75	0.000	10.00	3.172	0.73	109.54	3.469	0.73
140.00	Samsung CBRS 64T64R MMU	3	0.75	0.000	75.00	4.496	0.58	167.59	5.895	0.58
140.00	Samsung MT6407-77A	3	0.75	0.000	81.60	4.709	0.61	182.96	6.219	0.61
140.00	RFS DB-T1-6Z-8AB-OZ	2	0.75	0.000	44.00	4.800	0.72	169.16	6.213	0.72
140.00	Commscope JAHH-65B-R3B	6	0.75	0.000	60.60	9.113	0.69	261.78	11.872	0.69
140.00	Generic Flat Platform with	1	1.00	0.000	2,500.00	42.400	1.00	4,266.61	63.256	1.00
133.00	Alcatel-Lucent 800 MHz 2X50W	6	0.75	0.000	64.00	2.058	0.67	140.25	3.006	0.67
133.00	Alcatel-Lucent 1900 MHz 4X45	3	0.75	0.000	60.00	2.322	0.67	139.76	3.391	0.67
133.00	Alcatel-Lucent TD-RRH8x20-25	3	0.75	0.000	70.00	4.046	0.61	163.53	5.360	0.61
133.00	RFS APXVTM14-ALU-I20	3	0.75	0.000	56.20	6.342	0.66	192.48	8.498	0.66
133.00	Commscope NNVV-65B-R4	3	0.75	0.000	77.40	12.271	0.64	326.08	15.046	0.64
133.00	Modified Platform w/ Handrails	1	1.00	0.000	2,500.00	47.400	1.00	4,258.17	70.604	1.00
123.00	Generic Flat Platform with	1	1.00	0.000	2,500.00	42.400	1.00	4,244.52	62.995	1.00
121.30	Andrew DB844H90E-A	2	0.75	0.000	10.00	3.796	0.78	117.66	3.706	0.78
121.20	Andrew DB844H90E-A	1	0.75	0.000	10.00	3.796	1.00	117.65	3.706	1.00
121.20	Andrew DB844H90E-A	1	0.75	0.000	10.00	3.796	1.00	117.65	3.706	1.00
121.10	Andrew DB844H90E-A	6	0.75	0.000	10.00	3.796	0.70	117.64	3.706	0.70
121.00	Andrew DB844H90E-A	2	0.75	0.000	10.00	3.796	0.78	117.58	3.706	0.78
107.60	Commscope LNX-6515DS-VTM	3	1.00	0.000	50.30	11.440	0.70	272.41	14.573	0.70
105.00	Kathrein Scala Smart Bias Tee	3	1.00	0.000	3.30	0.080	0.50	6.48	0.281	0.50
93.00	Commscope RDIDC-9181-PF-48	1	0.75	0.000	21.90	1.867	1.00	76.17	2.725	1.00
93.00	Fujitsu TA08025-B605	3	0.75	0.000	75.00	1.962	0.50	134.75	2.839	0.50
93.00	Fujitsu TA08025-B604	3	0.75	0.000	63.90	1.962	0.50	119.52	2.839	0.50
93.00	JMA Wireless MX08FRO665-21	3	0.75	0.000	64.50	12.489	0.64	309.63	15.169	0.64
93.00	Generic Flat Platform with	1	1.00	0.000	2,500.00	42.400	1.00	4,194.27	62.402	1.00
83.00	Stand-Off	1	1.00	0.000	75.00	2.500	1.00	124.29	4.143	1.00
81.00	Generic GPS	1	1.00	2.000	10.00	0.900	1.00	37.56	1.502	1.00

Site Number: 302495

Code: ANSI/TIA-222-H

© 2007 - 2021 by ATC IP LLC. All rights reserved.

Site Name: Tolland CT, CT

Engineering Number: 13692173\_C3\_03

7/8/2021 6:22:46 PM

Customer: DISH WIRELESS L.L.C.

63.00	Stand-Off	2	0.90	0.000	75.00	2.500	0.90	122.89	4.096	0.90
50.00	Generic 2" x 4" GPS	1	1.00	0.000	5.00	0.040	1.00	7.30	0.149	1.00
50.00	Stand-Off	1	1.00	0.000	75.00	2.500	1.00	121.81	4.060	1.00
Totals	Num Loadings:48	140			18,097.00			38,970.43		

Linear Appurtenance Properties Load Case Azimuth (deg) :

Elev From (ft)	Elev To (ft)	Qty	Description	Coax Dia (in)	Coax Wt (lb/ft)	Max Coax / Flat Row	Dist Between Rows (in)	Dist Between Cols (in)	Azimuth (deg)	Dist From Face (in)	Exposed To Wind Carrier
0.00	162.00	6	1 5/8" Coax	1.98	0.82	N	0	0.00	0.00	0	N T-MOBILE
0.00	149.00	1	0.39" (10mm) Fiber	0.39	0.06	N	0	0.00	0.00	0	N AT&T MOBILITY
0.00	149.00	2	0.78" (19.7mm) 8 AWG	0.78	0.59	N	0	0.00	0.00	0	N AT&T MOBILITY
0.00	149.00	12	1 1/4" Coax	1.55	0.63	N	0	0.00	0.00	0	N AT&T MOBILITY
0.00	149.00	9	1 1/4" Coax	1.55	0.63	N	0	0.00	0.00	0	N AT&T MOBILITY
0.00	149.00	3	1 1/4" Coax	1.55	0.63	N	3	0.00	0.00	180	Y AT&T MOBILITY
0.00	149.00	1	3" conduit	3.50	7.58	N	0	0.00	0.00	0	N AT&T MOBILITY
0.00	149.00	1	3/8" (0.38"- 9.5mm)	0.38	0.23	N	0	0.00	0.00	0	N AT&T MOBILITY
120.00	149.00	1	Climbing Ladder	2.00	6.90	Y	1	0.00	0.00	90	Y
0.00	140.00	14	1 5/8" Coax	1.98	0.82	N	3	0.00	0.00	270	Y VERIZON WIRELESS
0.00	140.00	2	1 5/8" Hybriflex	1.98	1.30	N	2	0.00	0.00	285	Y VERIZON WIRELESS
0.00	133.00	4	1 1/4" Hybriflex Cable	1.54	1.00	N	0	0.00	0.00	0	N SPRINT NEXTEL
0.00	133.00	6	1 5/8" Coax	1.98	0.82	N	0	0.00	0.00	0	N SPRINT NEXTEL
0.00	93.00	1	1.60" (40.6mm) Hybrid	1.60	2.34	N	0	0.00	0.00	0	N DISH WIRELESS
0.00	81.00	1	1/2" Coax	0.63	0.15	N	0	0.00	0.00	0	N T-MOBILE

Segment Properties (Max Len : 3. ft)

Seg Top Elev (ft)	Description	Thick (in)	Flat Dia (in)	Area (in <sup>2</sup> )	Ix (in <sup>4</sup> )	W/t Ratio	D/t Ratio	F'y (ksi)	S (in <sup>3</sup> )	Z (in <sup>3</sup> )	Weight (lb)
0.00		0.4375	50.000	69.821	21,891.7	27.94	114.29	74.2	845.8	0.0	0.0
3.00		0.4375	49.368	68.931	21,065.1	27.56	112.84	74.7	824.3	0.0	708.2
6.00		0.4375	48.736	68.041	20,259.5	27.17	111.40	75.1	803.1	0.0	699.1
9.00		0.4375	48.104	67.151	19,474.8	26.78	109.95	75.5	782.1	0.0	690.0
12.00		0.4375	47.473	66.261	18,710.5	26.40	108.51	75.9	761.4	0.0	681.0
15.00		0.4375	46.841	65.371	17,966.6	26.01	107.06	76.3	741.0	0.0	671.9
18.00		0.4375	46.209	64.480	17,242.6	25.62	105.62	76.8	720.9	0.0	662.8
21.00		0.4375	45.577	63.590	16,538.3	25.23	104.18	77.2	701.0	0.0	653.7
24.00		0.4375	44.945	62.700	15,853.5	24.85	102.73	77.6	681.4	0.0	644.6
27.00		0.4375	44.313	61.810	15,187.9	24.46	101.29	78.0	662.1	0.0	635.5
30.00		0.4375	43.682	60.920	14,541.1	24.07	99.84	78.5	643.1	0.0	626.4
33.00		0.4375	43.050	60.030	13,913.0	23.69	98.40	78.9	624.3	0.0	617.3
36.00		0.4375	42.418	59.140	13,303.2	23.30	96.95	79.3	605.9	0.0	608.3
39.00		0.4375	41.786	58.250	12,711.5	22.91	95.51	79.7	587.7	0.0	599.2
40.10	Bot - Section 2	0.4375	41.553	57.922	12,498.3	22.77	94.98	79.9	581.1	0.0	218.2
42.00		0.4375	41.154	57.360	12,137.7	22.53	94.07	80.1	569.8	0.0	696.9
45.00		0.4375	40.522	56.469	11,581.3	22.14	92.62	80.6	552.1	0.0	1,089.0
45.90	Top - Section 1	0.3750	41.083	49.155	10,397.1	26.68	109.55	75.6	488.9	0.0	322.9
48.00		0.3750	40.640	48.620	10,061.7	26.36	108.37	76.0	478.3	0.0	349.6
50.00		0.3750	40.219	48.112	9,749.2	26.06	107.25	76.3	468.3	0.0	329.2
51.00		0.3750	40.009	47.858	9,595.4	25.91	106.69	76.5	463.3	0.0	163.3
54.00		0.3750	39.377	47.095	9,143.7	25.46	105.00	77.0	448.6	0.0	484.7
57.00		0.3750	38.745	46.332	8,706.5	25.00	103.32	77.4	434.1	0.0	476.9
60.00		0.3750	38.113	45.569	8,283.4	24.55	101.63	77.9	419.9	0.0	469.1
63.00		0.3750	37.481	44.806	7,874.3	24.10	99.95	78.4	405.9	0.0	461.3
66.00		0.3750	36.849	44.043	7,478.8	23.65	98.26	78.9	392.1	0.0	453.5
69.00		0.3750	36.217	43.280	7,096.9	23.20	96.58	79.4	378.5	0.0	445.7
72.00		0.3750	35.586	42.517	6,728.1	22.75	94.89	79.9	365.3	0.0	437.9
75.00		0.3750	34.954	41.754	6,372.4	22.30	93.21	80.4	352.2	0.0	430.1
78.00		0.3750	34.322	40.991	6,029.4	21.84	91.53	80.9	339.4	0.0	422.3
80.60	Bot - Section 3	0.3750	33.775	40.330	5,742.4	21.45	90.07	81.3	328.5	0.0	359.6
81.00		0.3750	33.690	40.228	5,699.0	21.39	89.84	81.4	326.8	0.0	101.7
83.00		0.3750	33.269	39.719	5,485.5	21.09	88.72	81.7	318.5	0.0	503.5
84.00		0.3750	33.058	39.465	5,380.8	20.94	88.16	81.9	314.4	0.0	249.3
85.41	Top - Section 2	0.3125	33.387	33.281	4,647.0	25.95	106.84	76.4	268.9	0.0	348.0
87.00		0.3125	33.051	32.943	4,507.0	25.66	105.76	76.7	263.4	0.0	179.6
90.00		0.3125	32.420	32.308	4,251.0	25.12	103.74	77.3	253.3	0.0	333.1
93.00		0.3125	31.788	31.672	4,004.9	24.58	101.72	77.9	243.4	0.0	326.6
96.00		0.3125	31.156	31.036	3,768.6	24.03	99.70	78.5	233.7	0.0	320.1
99.00		0.3125	30.524	30.400	3,541.7	23.49	97.68	79.1	224.2	0.0	313.6
102.0		0.3125	29.892	29.765	3,324.1	22.95	95.65	79.7	214.8	0.0	307.1
105.0		0.3125	29.260	29.129	3,115.6	22.41	93.63	80.3	205.7	0.0	300.6
107.6		0.3125	28.713	28.578	2,942.1	21.94	91.88	80.8	197.9	0.0	255.3
108.0		0.3125	28.628	28.493	2,916.0	21.87	91.61	80.9	196.8	0.0	38.8
111.0		0.3125	27.997	27.857	2,725.1	21.33	89.59	81.5	188.0	0.0	287.6
114.0		0.3125	27.365	27.221	2,542.7	20.78	87.57	81.9	179.5	0.0	281.1
117.0		0.3125	26.733	26.586	2,368.7	20.24	85.55	81.9	171.2	0.0	274.6
120.0		0.3125	26.101	25.950	2,202.8	19.70	83.52	81.9	163.0	0.0	268.1
121.0		0.3125	25.890	25.738	2,149.3	19.52	82.85	81.9	160.4	0.0	87.9
121.1		0.3125	25.869	25.717	2,143.9	19.50	82.78	81.9	160.1	0.0	8.8
121.2		0.3125	25.848	25.695	2,138.7	19.48	82.71	81.9	159.8	0.0	8.7
121.3		0.3125	25.827	25.674	2,133.4	19.47	82.65	81.9	159.6	0.0	8.7
122.1	Bot - Section 4	0.3125	25.654	25.500	2,090.2	19.32	82.09	81.9	157.4	0.0	71.6
123.0		0.3125	25.469	25.314	2,044.8	19.16	81.50	81.9	155.1	0.0	122.3
125.8	Top - Section 3	0.1875	25.236	15.123	1,211.2	33.38	134.59	68.3	92.7	0.0	395.8
126.0		0.1875	25.212	15.109	1,207.7	33.35	134.47	68.3	92.5	0.0	5.9
129.0		0.1875	24.580	14.727	1,118.5	32.45	131.10	69.3	87.9	0.0	152.3
132.0		0.1875	23.949	14.346	1,033.8	31.54	127.73	70.3	83.4	0.0	148.4

Site Number: 302495

Code: ANSI/TIA-222-H

© 2007 - 2021 by ATC IP LLC. All rights reserved.

Site Name: Tolland CT, CT

Engineering Number: 13692173\_C3\_03

7/8/2021 6:22:46 PM

Customer: DISH WIRELESS L.L.C.

133.0		0.1875	23.738	14.219	1,006.6	31.24	126.60	70.6	81.9	0.0	48.6
135.0		0.1875	23.317	13.964	953.5	30.64	124.36	71.3	79.0	0.0	95.9
138.0		0.1875	22.685	13.583	877.5	29.74	120.99	72.3	74.7	0.0	140.6
140.0		0.1875	22.264	13.329	829.1	29.14	118.74	72.9	71.9	0.0	91.6
141.0		0.1875	22.053	13.201	805.6	28.84	117.62	73.3	70.6	0.0	45.1
142.2		0.1875	21.800	13.049	778.0	28.47	116.27	73.7	68.9	0.0	53.6
144.0		0.1875	21.421	12.820	737.8	27.93	114.25	74.2	66.5	0.0	79.2
146.0	Top - Section 4	0.1875	21.000	12.566	694.7	27.33	112.00	74.9	63.9	0.0	86.4
146.0	Bot - Section 5	0.5000	16.000	24.347	731.7	0.00	32.00	42.0	91.5	120.2	
147.0		0.5000	16.000	24.347	731.7	0.00	32.00	42.0	91.5	120.2	82.8
149.0		0.5000	16.000	24.347	731.7	0.00	32.00	42.0	91.5	120.2	165.7
150.0		0.5000	16.000	24.347	731.7	0.00	32.00	42.0	91.5	120.2	82.8
153.0		0.5000	16.000	24.347	731.7	0.00	32.00	42.0	91.5	120.2	248.5
155.0	Top - Section 5	0.5000	16.000	24.347	731.7	0.00	32.00	42.0	91.5	120.2	165.7
155.0	Bot - Section 6	0.2180	3.500	2.248	3.0	0.00	16.06	35.0	1.7	2.4	
156.0		0.2180	3.500	2.248	3.0	0.00	16.06	35.0	1.7	2.4	7.6
159.0		0.2180	3.500	2.248	3.0	0.00	16.06	35.0	1.7	2.4	22.9
162.0		0.2180	3.500	2.248	3.0	0.00	16.06	35.0	1.7	2.4	22.9
164.1		0.2180	3.500	2.248	3.0	0.00	16.06	35.0	1.7	2.4	16.1
165.0		0.2180	3.500	2.248	3.0	0.00	16.06	35.0	1.7	2.4	6.9

23,270.4

<b>Load Case:</b> 1.2D + 1.0W	118 mph with No Ice	32 Iterations
Gust Response Factor : 1.10		
Dead Load Factor : 1.20		
Wind Load Factor : 1.00		

**Applied Segment Forces Summary**

Seg Elev (ft)	Description	Shaft Forces		Discrete Forces			Linear Forces		Sum of Forces				
		Wind FX (lb)	Dead Load (lb)	Wind FX (lb)	Torsion MY (lb-ft)	Moment MZ (lb-ft)	Dead Load (lb)	Wind FX (lb)	Dead Load (lb)	Wind FX (lb)	Dead Load (lb)	Torsion MY (lb-ft)	Moment MZ (lb)
0.00		255.0	0.0					0.0	0.0	255.0	0.0	0.0	0.0
3.00		506.8	849.9					0.2	196.5	506.9	1,046.3	0.0	0.0
6.00		500.3	839.0					0.3	196.5	500.7	1,035.4	0.0	0.0
9.00		493.8	828.0					0.5	196.5	494.4	1,024.5	0.0	0.0
12.00		487.4	817.1					0.7	196.5	488.1	1,013.6	0.0	0.0
15.00		480.9	806.2					0.9	196.5	481.7	1,002.7	0.0	0.0
18.00		474.4	795.3					1.0	196.5	475.4	991.8	0.0	0.0
21.00		467.9	784.4					1.2	196.5	469.1	980.9	0.0	0.0
24.00		461.4	773.5					1.37	196.5	461.4	970.0	0.0	0.0
27.00		454.9	762.6					1.5	196.5	456.5	959.1	0.0	0.0
30.00		451.8	751.7					1.7	196.5	453.5	948.2	0.0	0.0
33.00		454.4	740.8					1.9	196.5	456.3	937.3	0.0	0.0
36.00		459.0	729.9					2.1	196.5	461.1	926.4	0.0	0.0
39.00		315.8	719.0					2.3	196.5	318.1	915.5	0.0	0.0
40.10	Bot - Section 2	234.7	261.9					0.9	72.3	235.6	334.2	0.0	0.0
42.00		387.0	836.3					1.6	124.2	388.6	960.4	0.0	0.0
45.00		308.8	1,306.8					2.8	196.5	311.6	1,503.3	0.0	0.0
45.90	Top - Section 1	238.4	387.4					36.7	58.8	275.1	446.3	0.0	0.0
48.00		326.4	419.5					2.0	137.6	328.3	557.2	0.0	0.0
50.00	Appurtenance(s)	239.0	395.0	74.8	0.0	0.0	96.0	83.4	131.0	397.2	622.0	0.0	0.0
51.00		319.0	195.9					42.1	65.5	361.0	261.4	0.0	0.0
54.00		478.5	581.6					127.6	196.5	606.1	778.1	0.0	0.0
57.00		478.2	572.2					129.6	196.5	607.7	768.7	0.0	0.0
60.00		477.3	562.9					131.5	196.5	608.8	759.4	0.0	0.0
63.00	Appurtenance(s)	476.0	553.5	127.4	0.0	0.0	180.0	133.4	196.5	736.8	930.0	0.0	0.0
66.00		474.2	544.2					135.2	196.5	609.4	740.7	0.0	0.0
69.00		472.1	534.9					136.9	196.5	609.0	731.3	0.0	0.0
72.00		469.5	525.5					138.6	196.5	608.1	722.0	0.0	0.0
75.00		466.6	516.2					140.3	196.5	606.8	712.6	0.0	0.0
78.00		432.6	506.8					141.8	196.5	574.4	703.3	0.0	0.0
80.60	Bot - Section 3	231.4	431.5					124.1	170.2	355.5	601.7	0.0	0.0
81.00	Appurtenance(s)	187.0	122.1	30.6	0.0	61.3	12.0	19.3	26.3	236.9	160.3	0.0	0.0
83.00	Appurtenance(s)	233.2	604.1	85.1	0.0	0.0	90.0	96.4	130.6	414.7	824.8	0.0	0.0
84.00		186.2	299.2					48.5	65.3	234.6	364.5	0.0	0.0
85.41	Top - Section 2	231.2	417.6					68.4	91.9	299.6	509.4	0.0	0.0
87.00		351.7	215.5					77.9	104.1	429.6	319.6	0.0	0.0
90.00		455.9	399.7					147.8	195.9	603.7	595.6	0.0	0.0
93.00	Appurtenance(s)	451.2	391.9	2,327.5	0.0	0.0	3,758.5	149.1	195.9	2,927.9	4,346.3	0.0	0.0
96.00		446.3	384.1					150.5	187.5	596.8	571.6	0.0	0.0
99.00		441.1	376.3					109.8	187.5	550.9	563.8	0.0	0.0
102.00		435.7	368.5					110.7	187.5	546.4	556.0	0.0	0.0
105.00	Appurtenance(s)	401.7	360.7	4.4	0.0	0.0	11.9	111.6	187.5	517.7	560.1	0.0	0.0
107.60		213.6	306.3					97.4	162.5	311.0	468.8	0.0	0.0
108.00		238.9	46.6					15.0	25.0	253.9	71.6	0.0	0.0
111.00		418.0	345.1					113.3	187.5	531.4	532.7	0.0	0.0
114.00		411.7	337.4					114.2	187.5	525.9	524.9	0.0	0.0
117.00		405.2	329.6					115.0	187.5	520.2	517.1	0.0	0.0
120.00		251.9	321.8					115.8	187.5	367.7	509.3	0.0	0.0



Site Number: 302495

Code: ANSI/TIA-222-H

© 2007 - 2021 by ATC IP LLC. All rights reserved.

Site Name: Tolland CT, CT

Engineering Number: 13692173\_C3\_03

7/8/2021 6:22:52 PM

Customer: DISH WIRELESS L.L.C.

Load Case: 1.2D + 1.0W		118 mph with No Ice										32 Iterations	
Gust Response Factor : 1.10													
Dead Load Factor : 1.20													
Wind Load Factor : 1.00													
121.00	Appurtenance(s)	56.0	105.5	168.4	0.0	0.0	24.0	44.4	70.8	268.8	200.3	0.0	0.0
121.10		10.2	10.5					4.4	7.1	14.6	17.6	0.0	0.0
121.20		10.1	10.5					4.4	7.1	14.6	17.6	0.0	0.0
121.30		46.7	10.5					4.4	7.1	51.1	17.6	0.0	0.0
122.12	Bot - Section 4	86.4	85.9					36.6	58.2	123.0	144.1	0.0	0.0
123.00	Appurtenance(s)	190.6	146.8	1,614.8	0.0	0.0	3,000.0	39.1	62.1	1,844.5	3,208.9	0.0	0.0
125.89	Top - Section 3	151.5	475.0					129.3	204.3	280.8	679.2	0.0	0.0
126.00		154.5	7.1					5.2	8.1	159.6	15.2	0.0	0.0
129.00		294.7	182.7					135.3	212.4	430.0	395.1	0.0	0.0
132.00		194.0	178.1					136.2	212.4	330.2	390.4	0.0	0.0
133.00	Appurtenance(s)	143.1	58.3	3,495.1	0.0	0.0	4,409.8	52.8	70.8	3,690.9	4,538.9	0.0	0.0
135.00		235.2	115.1					105.8	120.2	341.0	235.2	0.0	0.0
138.00		231.9	168.7					159.5	180.3	391.4	349.0	0.0	0.0
140.00	Appurtenance(s)	127.7	109.9	4,140.4	0.0	0.0	4,885.8	106.9	120.2	4,374.9	5,115.9	0.0	0.0
141.00		78.7	54.2					0.0	43.2	78.7	97.4	0.0	0.0
142.20		106.1	64.3					0.0	51.8	106.1	116.1	0.0	0.0
144.00		132.8	95.1					0.0	77.7	132.8	172.8	0.0	0.0
146.00	Top - Section 4	87.9	103.7					0.0	86.4	87.9	190.0	0.0	0.0
147.00		55.6	99.4					0.0	43.2	55.6	142.6	0.0	0.0
149.00	Appurtenance(s)	53.2	198.8	3,518.9	0.0	3,623.7	4,102.9	0.0	86.4	3,572.1	4,388.1	0.0	0.0
150.00		64.6	99.4					0.0	5.9	64.6	105.3	0.0	0.0
153.00		81.0	298.3					0.0	17.7	81.0	316.0	0.0	0.0
155.00	Top - Section 5	39.6	198.8	400.3	0.0	3.1	695.0	0.0	11.8	439.9	905.7	0.0	0.0
156.00		28.6	9.2					0.0	5.9	28.6	15.1	0.0	0.0
159.00		43.0	27.5					0.0	17.7	43.0	45.2	0.0	0.0
162.00		35.5	27.5					0.0	17.7	35.5	45.2	0.0	0.0
164.10		19.9	19.3					0.0	0.0	19.9	19.3	0.0	0.0
165.00		6.0	8.3					0.0	0.0	6.0	8.3	0.0	0.0
Totals:										41,571.5	58,773.4	0.00	0.00

Site Number: 302495

Code: ANSI/TIA-222-H

© 2007 - 2021 by ATC IP LLC. All rights reserved.

Site Name: Tolland CT, CT

Engineering Number: 13692173\_C3\_03

7/8/2021 6:22:52 PM

Customer: DISH WIRELESS L.L.C.

Load Case: 1.2D + 1.0W

118 mph with No Ice

32 Iterations

Gust Response Factor : 1.10

Dead Load Factor : 1.20

Wind Load Factor : 1.00

Calculated Forces

Seg Elev (ft)	Pu FY (-) (kips)	Vu FX (-) (kips)	Tu MY (ft-kips)	Mu MZ (ft-kips)	Mu MX (ft-kips)	Resultant Moment (ft-kips)	phi Pn (kips)	phi Vn (kips)	phi Tn (ft-kips)	phi Mn (ft-kips)	Total Deflect (in)	Rotation (deg)	Ratio
0.00	-59.16	-43.60	0.00	-4,530.52	0.00	4,530.52	4,665.07	1,225.36	5,729.16	4,709.48	0.00	0.00	0.976
3.00	-57.98	-43.27	0.00	-4,399.71	0.00	4,399.71	4,631.78	1,209.74	5,584.06	4,615.74	0.06	-0.17	0.967
6.00	-56.81	-42.94	0.00	-4,269.89	0.00	4,269.89	4,597.82	1,194.12	5,440.82	4,522.21	0.22	-0.35	0.958
9.00	-55.66	-42.61	0.00	-4,141.07	0.00	4,141.07	4,563.18	1,178.50	5,299.44	4,428.89	0.50	-0.53	0.949
12.00	-54.52	-42.28	0.00	-4,013.24	0.00	4,013.24	4,527.86	1,162.88	5,159.92	4,335.83	0.89	-0.71	0.939
15.00	-53.39	-41.96	0.00	-3,886.38	0.00	3,886.38	4,491.86	1,147.25	5,022.26	4,243.05	1.39	-0.89	0.929
18.00	-52.28	-41.63	0.00	-3,760.51	0.00	3,760.51	4,455.19	1,131.63	4,886.46	4,150.57	2.01	-1.07	0.919
21.00	-51.17	-41.31	0.00	-3,635.62	0.00	3,635.62	4,417.85	1,116.01	4,752.53	4,058.43	2.74	-1.25	0.909
24.00	-50.08	-40.85	0.00	-3,511.70	0.00	3,511.70	4,379.82	1,100.39	4,620.45	3,966.64	3.58	-1.43	0.898
27.00	-49.01	-40.53	0.00	-3,389.16	0.00	3,389.16	4,341.13	1,084.77	4,490.24	3,875.23	4.54	-1.62	0.887
30.00	-47.94	-40.20	0.00	-3,267.58	0.00	3,267.58	4,301.75	1,069.15	4,361.89	3,784.23	5.62	-1.81	0.876
33.00	-46.89	-39.87	0.00	-3,146.98	0.00	3,146.98	4,261.70	1,053.52	4,235.40	3,693.68	6.82	-2.00	0.864
36.00	-45.85	-39.53	0.00	-3,027.37	0.00	3,027.37	4,220.97	1,037.90	4,110.77	3,603.58	8.13	-2.19	0.852
39.00	-44.86	-39.27	0.00	-2,908.80	0.00	2,908.80	4,179.57	1,022.28	3,988.00	3,513.97	9.57	-2.38	0.840
40.10	-44.47	-39.10	0.00	-2,865.43	0.00	2,865.43	4,164.16	1,016.53	3,943.28	3,481.12	10.13	-2.45	0.835
42.00	-43.42	-38.79	0.00	-2,791.31	0.00	2,791.31	4,137.49	1,006.66	3,867.09	3,424.88	11.12	-2.57	0.827
45.00	-41.85	-38.50	0.00	-2,674.94	0.00	2,674.94	4,094.73	991.04	3,748.05	3,336.33	12.80	-2.76	0.813
45.90	-41.35	-38.27	0.00	-2,640.35	0.00	2,640.35	3,345.43	862.67	3,312.91	2,772.86	13.33	-2.82	0.967
48.00	-40.72	-38.02	0.00	-2,559.92	0.00	2,559.92	3,324.15	853.29	3,241.28	2,724.99	14.60	-2.96	0.954
50.00	-40.05	-37.66	0.00	-2,483.88	0.00	2,483.88	3,303.59	844.36	3,173.84	2,679.55	15.87	-3.10	0.941
51.00	-39.71	-37.39	0.00	-2,446.22	0.00	2,446.22	3,293.20	839.90	3,140.39	2,656.86	16.52	-3.17	0.935
54.00	-38.83	-36.88	0.00	-2,334.07	0.00	2,334.07	3,261.57	826.51	3,041.08	2,589.00	18.58	-3.38	0.915
57.00	-37.97	-36.37	0.00	-2,223.42	0.00	2,223.42	3,229.26	813.12	2,943.38	2,521.44	20.78	-3.60	0.896
60.00	-37.12	-35.85	0.00	-2,114.32	0.00	2,114.32	3,196.28	799.73	2,847.27	2,454.19	23.10	-3.81	0.875
63.00	-36.11	-35.19	0.00	-2,006.77	0.00	2,006.77	3,162.62	786.34	2,752.76	2,387.28	25.56	-4.02	0.854
66.00	-35.29	-34.66	0.00	-1,901.21	0.00	1,901.21	3,128.28	772.95	2,659.84	2,320.75	28.16	-4.23	0.833
69.00	-34.48	-34.12	0.00	-1,797.25	0.00	1,797.25	3,093.27	759.56	2,568.51	2,254.62	30.88	-4.44	0.810
72.00	-33.69	-33.58	0.00	-1,694.89	0.00	1,694.89	3,057.58	746.17	2,478.79	2,188.92	33.74	-4.65	0.787
75.00	-32.91	-33.04	0.00	-1,594.15	0.00	1,594.15	3,021.22	732.78	2,390.65	2,123.66	36.73	-4.86	0.764
78.00	-32.15	-32.51	0.00	-1,495.05	0.00	1,495.05	2,984.18	719.39	2,304.12	2,058.89	39.85	-5.07	0.739
80.60	-31.52	-32.16	0.00	-1,410.56	0.00	1,410.56	2,951.54	707.79	2,230.44	2,003.18	42.65	-5.25	0.717
81.00	-31.34	-31.95	0.00	-1,397.60	0.00	1,397.60	2,946.46	706.00	2,219.17	1,994.61	43.10	-5.28	0.713
83.00	-30.50	-31.52	0.00	-1,333.70	0.00	1,333.70	2,920.94	697.07	2,163.43	1,952.06	45.33	-5.41	0.696
84.00	-30.11	-31.29	0.00	-1,302.18	0.00	1,302.18	2,908.96	692.61	2,135.83	1,931.47	46.47	-5.48	0.687
85.41	-29.58	-31.00	0.00	-1,258.18	0.00	1,258.18	2,288.86	584.09	1,822.48	1,541.02	48.10	-5.58	0.832
87.00	-29.22	-30.62	0.00	-1,208.78	0.00	1,208.78	2,274.94	578.16	1,785.69	1,515.96	49.98	-5.68	0.813
90.00	-28.57	-30.07	0.00	-1,116.91	0.00	1,116.91	2,248.22	567.00	1,717.45	1,468.96	53.61	-5.90	0.776
93.00	-24.46	-26.79	0.00	-1,026.70	0.00	1,026.70	2,220.81	555.84	1,650.54	1,422.23	57.38	-6.12	0.735
96.00	-23.86	-26.23	0.00	-946.32	0.00	946.32	2,192.74	544.68	1,584.96	1,375.78	61.29	-6.33	0.701
99.00	-23.27	-25.70	0.00	-867.65	0.00	867.65	2,163.98	533.53	1,520.71	1,329.64	65.32	-6.53	0.666
102.00	-22.69	-25.17	0.00	-790.55	0.00	790.55	2,134.56	522.37	1,457.78	1,283.85	69.49	-6.73	0.629
105.00	-22.12	-24.66	0.00	-715.05	0.00	715.05	2,104.45	511.21	1,396.19	1,238.42	73.77	-6.93	0.590
107.60	-21.59	-23.43	0.00	-650.94	0.00	650.94	2,077.81	501.54	1,343.89	1,199.37	77.58	-7.09	0.555

<b>Load Case:</b> 1.2D + 1.0W	118 mph with No Ice											32 Iterations
Gust Response Factor :	1.10											
Dead Load Factor :	1.20											
Wind Load Factor :	1.00											

108.00	-21.50	-23.21	0.00	-641.57	0.00	641.57	2,073.67	500.05	1,335.93	1,193.39	78.17	-7.11	0.550
111.00	-20.97	-22.68	0.00	-571.95	0.00	571.95	2,042.21	488.89	1,277.00	1,148.77	82.69	-7.29	0.510
114.00	-20.46	-22.15	0.00	-503.92	0.00	503.92	2,006.48	477.73	1,219.39	1,102.63	87.31	-7.46	0.469
117.00	-19.96	-21.62	0.00	-437.49	0.00	437.49	1,959.62	466.58	1,163.12	1,051.43	92.04	-7.62	0.428
120.00	-19.47	-21.22	0.00	-372.64	0.00	372.64	1,912.75	455.42	1,108.17	1,001.46	96.86	-7.76	0.384
121.00	-19.29	-20.93	0.00	-351.43	0.00	351.43	1,897.13	451.70	1,090.15	985.07	98.48	-7.81	0.369
121.10	-19.27	-20.46	0.00	-349.33	0.00	349.33	1,895.57	451.33	1,088.36	983.44	98.65	-7.81	0.367
121.20	-19.26	-20.22	0.00	-347.29	0.00	347.29	1,894.01	450.95	1,086.57	981.81	98.81	-7.82	0.366
121.30	-19.24	-20.01	0.00	-345.26	0.00	345.26	1,892.45	450.58	1,084.78	980.18	98.97	-7.82	0.364
122.12	-19.10	-19.88	0.00	-328.81	0.00	328.81	1,879.60	447.52	1,070.10	966.84	100.32	-7.86	0.352
123.00	-16.15	-17.63	0.00	-311.37	0.00	311.37	1,865.89	444.26	1,054.56	952.70	101.77	-7.90	0.337
125.89	-15.50	-17.28	0.00	-260.49	0.00	260.49	929.68	265.41	627.12	474.96	106.56	-8.01	0.569
126.00	-15.48	-17.14	0.00	-258.51	0.00	258.51	929.29	265.16	625.91	474.31	106.75	-8.02	0.566
129.00	-15.10	-16.70	0.00	-207.09	0.00	207.09	918.88	258.46	594.71	457.06	111.83	-8.18	0.474
132.00	-14.74	-16.34	0.00	-156.99	0.00	156.99	907.79	251.77	564.31	439.76	117.00	-8.32	0.377
133.00	-10.77	-12.04	0.00	-140.65	0.00	140.65	903.95	249.54	554.35	433.99	118.74	-8.36	0.338
135.00	-10.57	-11.68	0.00	-116.57	0.00	116.57	896.03	245.07	534.70	422.43	122.25	-8.44	0.290
138.00	-10.27	-11.26	0.00	-81.53	0.00	81.53	883.59	238.38	505.89	405.10	127.56	-8.52	0.215
140.00	-5.86	-6.17	0.00	-59.02	0.00	59.02	874.92	233.92	487.13	393.55	131.13	-8.57	0.157
141.00	-5.77	-6.08	0.00	-52.84	0.00	52.84	870.48	231.68	477.88	387.78	132.92	-8.59	0.144
142.20	-5.64	-5.48	0.00	-45.55	0.00	45.55	865.04	229.01	466.90	380.87	135.08	-8.61	0.127
144.00	-5.49	-5.33	0.00	-35.68	0.00	35.68	856.69	224.99	450.67	370.52	138.32	-8.64	0.103
146.00	-5.31	-5.21	0.00	-25.03	0.00	25.03	847.12	220.53	432.97	359.05	141.93	-8.66	0.077
146.00	-5.31	-5.21	0.00	-25.03	0.00	25.03	920.33	276.10	376.25	378.52	141.93	-8.66	0.072
147.00	-5.18	-5.14	0.00	-19.82	0.00	19.82	920.33	276.10	376.25	378.52	143.73	-8.67	0.058
149.00	-1.38	-0.94	0.00	-5.92	0.00	5.92	920.33	276.10	376.25	378.52	147.36	-8.68	0.017
150.00	-1.29	-0.86	0.00	-4.98	0.00	4.98	920.33	276.10	376.25	378.52	149.17	-8.68	0.015
153.00	-0.99	-0.74	0.00	-2.39	0.00	2.39	920.33	276.10	376.25	378.52	154.60	-8.69	0.007
155.00	-0.16	-0.16	0.00	-0.92	0.00	0.92	920.33	276.10	376.25	378.52	158.23	-8.69	0.003
155.00	-0.16	-0.16	0.00	-0.92	0.00	0.92	70.80	21.24	6.13	6.17	158.23	-8.69	0.151
156.00	-0.15	-0.13	0.00	-0.75	0.00	0.75	70.80	21.24	6.13	6.17	160.04	-8.69	0.124
159.00	-0.11	-0.08	0.00	-0.35	0.00	0.35	70.80	21.24	6.13	6.17	165.53	-8.84	0.058
162.00	-0.07	-0.04	0.00	-0.10	0.00	0.10	70.80	21.24	6.13	6.17	171.09	-8.91	0.017
164.10	-0.01	-0.01	0.00	-0.01	0.00	0.01	70.80	21.24	6.13	6.17	175.00	-8.92	0.001
165.00	0.00	-0.01	0.00	0.00	0.00	0.00	70.80	21.24	6.13	6.17	176.67	-8.92	0.000

Site Number: 302495

Code: ANSI/TIA-222-H

© 2007 - 2021 by ATC IP LLC. All rights reserved.

Site Name: Tolland CT, CT

Engineering Number: 13692173\_C3\_03

7/8/2021 6:22:53 PM

Customer: DISH WIRELESS L.L.C.

**Load Case:** 0.9D + 1.0W

118 mph with No Ice (Reduced DL)

32 Iterations

Gust Response Factor : 1.10

Dead Load Factor : 0.90

Wind Load Factor : 1.00

### Applied Segment Forces Summary

Seg Elev (ft)	Description	Shaft Forces		Discrete Forces			Linear Forces		Sum of Forces				
		Wind FX (lb)	Dead Load (lb)	Wind FX (lb)	Torsion MY (lb-ft)	Moment MZ (lb-ft)	Dead Load (lb)	Wind FX (lb)	Dead Load (lb)	Wind FX (lb)	Dead Load (lb)	Torsion MY (lb-ft)	Moment MZ (lb)
0.00		255.0	0.0					0.0	0.0	255.0	0.0	0.0	0.0
3.00		506.8	637.4					0.2	147.4	506.9	784.8	0.0	0.0
6.00		500.3	629.2					0.3	147.4	500.7	776.6	0.0	0.0
9.00		493.8	621.0					0.5	147.4	494.4	768.4	0.0	0.0
12.00		487.4	612.9					0.7	147.4	488.1	760.2	0.0	0.0
15.00		480.9	604.7					0.9	147.4	481.7	752.0	0.0	0.0
18.00		474.4	596.5					1.0	147.4	475.4	743.9	0.0	0.0
21.00		467.9	588.3					1.2	147.4	469.1	735.7	0.0	0.0
24.00		461.4	580.1					1.3	147.4	462.8	727.5	0.0	0.0
27.00		454.9	572.0					1.5	147.4	456.5	719.3	0.0	0.0
30.00		451.8	563.8					1.7	147.4	453.5	711.2	0.0	0.0
33.00		454.4	555.6					1.9	147.4	456.3	703.0	0.0	0.0
36.00		459.0	547.4					2.1	147.4	461.1	694.8	0.0	0.0
39.00		315.8	539.3					2.3	147.4	318.1	686.6	0.0	0.0
40.10	Bot - Section 2	234.7	196.4					0.9	54.2	235.6	250.7	0.0	0.0
42.00		387.0	627.2					1.6	93.1	388.6	720.3	0.0	0.0
45.00		308.8	980.1					2.8	147.4	311.6	1,127.5	0.0	0.0
45.90	Top - Section 1	238.4	290.6					36.7	44.1	275.1	334.7	0.0	0.0
48.00		326.4	314.6					2.0	103.2	328.3	417.9	0.0	0.0
50.00	Appurtenance(s)	239.0	296.2	74.8	0.0	0.0	72.0	83.4	98.2	397.2	466.5	0.0	0.0
51.00		319.0	147.0					42.1	49.1	361.0	196.1	0.0	0.0
54.00		478.5	436.2					127.6	147.4	606.1	583.6	0.0	0.0
57.00		478.2	429.2					129.6	147.4	607.7	576.5	0.0	0.0
60.00		477.3	422.2					131.5	147.4	608.8	569.5	0.0	0.0
63.00	Appurtenance(s)	476.0	415.2	127.4	0.0	0.0	135.0	133.4	147.4	736.8	697.5	0.0	0.0
66.00		474.2	408.1					135.2	147.4	609.4	555.5	0.0	0.0
69.00		472.1	401.1					136.9	147.4	609.0	548.5	0.0	0.0
72.00		469.5	394.1					138.6	147.4	608.1	541.5	0.0	0.0
75.00		466.6	387.1					140.3	147.4	606.8	534.5	0.0	0.0
78.00		432.6	380.1					141.8	147.4	574.4	527.5	0.0	0.0
80.60	Bot - Section 3	231.4	323.6					124.1	127.7	355.5	451.3	0.0	0.0
81.00	Appurtenance(s)	187.0	91.5	30.6	0.0	61.3	9.0	19.3	19.7	236.9	120.2	0.0	0.0
83.00	Appurtenance(s)	233.2	453.1	85.1	0.0	0.0	67.5	96.4	98.0	414.7	618.6	0.0	0.0
84.00		186.2	224.4					48.5	49.0	234.6	273.4	0.0	0.0
85.41	Top - Section 2	231.2	313.2					68.4	68.9	299.6	382.1	0.0	0.0
87.00		351.7	161.6					77.9	78.1	429.6	239.7	0.0	0.0
90.00		455.9	299.7					147.8	147.0	603.7	446.7	0.0	0.0
93.00	Appurtenance(s)	451.2	293.9	2,327.5	0.0	0.0	2,818.9	149.1	147.0	2,927.9	3,259.8	0.0	0.0
96.00		446.3	288.1					150.5	140.6	596.8	428.7	0.0	0.0
99.00		441.1	282.2					109.8	140.6	550.9	422.9	0.0	0.0
102.00		435.7	276.4					110.7	140.6	546.4	417.0	0.0	0.0
105.00	Appurtenance(s)	401.7	270.5	4.4	0.0	0.0	8.9	111.6	140.6	517.7	420.1	0.0	0.0
107.60		213.6	229.7					97.4	121.9	311.0	351.6	0.0	0.0
108.00		238.9	35.0					15.0	18.8	253.9	53.7	0.0	0.0
111.00		418.0	258.9					113.3	140.6	531.4	399.5	0.0	0.0
114.00		411.7	253.0					114.2	140.6	525.9	393.7	0.0	0.0
117.00		405.2	247.2					115.0	140.6	520.2	387.8	0.0	0.0
120.00		251.9	241.3					115.8	140.6	367.7	382.0	0.0	0.0

Site Number: 302495

Code: ANSI/TIA-222-H

© 2007 - 2021 by ATC IP LLC. All rights reserved.

Site Name: Tolland CT, CT

Engineering Number: 13692173\_C3\_03

7/8/2021 6:22:59 PM

Customer: DISH WIRELESS L.L.C.

<b>Load Case:</b> 0.9D + 1.0W	118 mph with No Ice (Reduced DL)	32 Iterations
Gust Response Factor : 1.10		
Dead Load Factor : 0.90		
Wind Load Factor : 1.00		

121.00	Appurtenance(s)	56.0	79.1	168.4	0.0	0.0	18.0	44.4	53.1	268.8	150.2	0.0	0.0
121.10		10.2	7.9					4.4	5.3	14.6	13.2	0.0	0.0
121.20		10.1	7.9					4.4	5.3	14.6	13.2	0.0	0.0
121.30		46.7	7.9					4.4	5.3	51.1	13.2	0.0	0.0
122.12	Bot - Section 4	86.4	64.4					36.6	43.7	123.0	108.1	0.0	0.0
123.00	Appurtenance(s)	190.6	110.1	1,614.8	0.0	0.0	2,250.0	39.1	46.6	1,844.5	2,406.7	0.0	0.0
125.89	Top - Section 3	151.5	356.2					129.3	153.2	280.8	509.4	0.0	0.0
126.00		154.5	5.3					5.2	6.1	159.6	11.4	0.0	0.0
129.00		294.7	137.1					135.3	159.3	430.0	296.3	0.0	0.0
132.00		194.0	133.6					136.2	159.3	330.2	292.8	0.0	0.0
133.00	Appurtenance(s)	143.1	43.7	3,495.1	0.0	0.0	3,307.3	52.8	53.1	3,690.9	3,404.2	0.0	0.0
135.00		235.2	86.3					105.8	90.1	341.0	176.4	0.0	0.0
138.00		231.9	126.5					159.5	135.2	391.4	261.7	0.0	0.0
140.00	Appurtenance(s)	127.7	82.4	4,140.4	0.0	0.0	3,664.3	106.9	90.1	4,374.9	3,836.9	0.0	0.0
141.00		78.7	40.6					0.0	32.4	78.7	73.0	0.0	0.0
142.20		106.1	48.2					0.0	38.9	106.1	87.1	0.0	0.0
144.00		132.8	71.3					0.0	58.3	132.8	129.6	0.0	0.0
146.00	Top - Section 4	87.9	77.7					0.0	64.8	87.9	142.5	0.0	0.0
147.00		55.6	74.6					0.0	32.4	55.6	107.0	0.0	0.0
149.00	Appurtenance(s)	53.2	149.1	3,518.9	0.0	3,623.7	3,077.2	0.0	64.8	3,572.1	3,291.1	0.0	0.0
150.00		64.6	74.6					0.0	4.4	64.6	79.0	0.0	0.0
153.00		81.0	223.7					0.0	13.3	81.0	237.0	0.0	0.0
155.00	Top - Section 5	39.6	149.1	400.3	0.0	3.1	521.3	0.0	8.9	439.9	679.3	0.0	0.0
156.00		28.6	6.9					0.0	4.4	28.6	11.3	0.0	0.0
159.00		43.0	20.7					0.0	13.3	43.0	33.9	0.0	0.0
162.00		35.5	20.7					0.0	13.3	35.5	33.9	0.0	0.0
164.10		19.9	14.5					0.0	0.0	19.9	14.5	0.0	0.0
165.00		6.0	6.2					0.0	0.0	6.0	6.2	0.0	0.0
<b>Totals:</b>										41,571.5	44,080.0	0.00	0.00

Site Number: 302495

Code: ANSI/TIA-222-H

© 2007 - 2021 by ATC IP LLC. All rights reserved.

Site Name: Tolland CT, CT

Engineering Number: 13692173\_C3\_03

7/8/2021 6:22:59 PM

Customer: DISH WIRELESS L.L.C.

Load Case: 0.9D + 1.0W

118 mph with No Ice (Reduced DL)

32 Iterations

Gust Response Factor : 1.10

Dead Load Factor : 0.90

Wind Load Factor : 1.00

Calculated Forces

Seg Elev (ft)	Pu FY (-) (kips)	Vu FX (-) (kips)	Tu MY (ft-kips)	Mu MZ (ft-kips)	Mu MX (ft-kips)	Resultant Moment (ft-kips)	phi Pn (kips)	phi Vn (kips)	phi Tn (ft-kips)	phi Mn (ft-kips)	Total Deflect (in)	Rotation (deg)	Ratio
0.00	-44.35	-43.58	0.00	-4,442.87	0.00	4,442.87	4,665.07	1,225.36	5,729.16	4,709.48	0.00	0.00	0.954
3.00	-43.44	-43.20	0.00	-4,312.14	0.00	4,312.14	4,631.78	1,209.74	5,584.06	4,615.74	0.06	-0.17	0.945
6.00	-42.53	-42.83	0.00	-4,182.54	0.00	4,182.54	4,597.82	1,194.12	5,440.82	4,522.21	0.22	-0.34	0.935
9.00	-41.64	-42.45	0.00	-4,054.06	0.00	4,054.06	4,563.18	1,178.50	5,299.44	4,428.89	0.49	-0.52	0.926
12.00	-40.76	-42.08	0.00	-3,926.71	0.00	3,926.71	4,527.86	1,162.88	5,159.92	4,335.83	0.87	-0.69	0.916
15.00	-39.88	-41.71	0.00	-3,800.47	0.00	3,800.47	4,491.86	1,147.25	5,022.26	4,243.05	1.36	-0.87	0.906
18.00	-39.02	-41.35	0.00	-3,675.33	0.00	3,675.33	4,455.19	1,131.63	4,886.46	4,150.57	1.97	-1.04	0.896
21.00	-38.16	-40.98	0.00	-3,551.29	0.00	3,551.29	4,417.85	1,116.01	4,752.53	4,058.43	2.68	-1.22	0.885
24.00	-37.32	-40.49	0.00	-3,428.35	0.00	3,428.35	4,379.82	1,100.39	4,620.45	3,966.64	3.51	-1.40	0.874
27.00	-36.49	-40.13	0.00	-3,306.89	0.00	3,306.89	4,341.13	1,084.77	4,490.24	3,875.23	4.45	-1.59	0.863
30.00	-35.66	-39.77	0.00	-3,186.52	0.00	3,186.52	4,301.75	1,069.15	4,361.89	3,784.23	5.50	-1.77	0.852
33.00	-34.85	-39.40	0.00	-3,067.22	0.00	3,067.22	4,261.70	1,053.52	4,235.40	3,693.68	6.67	-1.95	0.840
36.00	-34.05	-39.02	0.00	-2,949.02	0.00	2,949.02	4,220.97	1,037.90	4,110.77	3,603.58	7.96	-2.14	0.828
39.00	-33.29	-38.75	0.00	-2,831.95	0.00	2,831.95	4,179.57	1,022.28	3,988.00	3,513.97	9.36	-2.32	0.815
40.10	-32.98	-38.56	0.00	-2,789.16	0.00	2,789.16	4,164.16	1,016.53	3,943.28	3,481.12	9.91	-2.39	0.811
42.00	-32.18	-38.23	0.00	-2,716.06	0.00	2,716.06	4,137.49	1,006.66	3,867.09	3,424.88	10.88	-2.51	0.802
45.00	-30.99	-37.93	0.00	-2,601.37	0.00	2,601.37	4,094.73	991.04	3,748.05	3,336.33	12.52	-2.70	0.789
45.90	-30.60	-37.69	0.00	-2,567.29	0.00	2,567.29	3,345.43	862.67	3,312.91	2,772.86	13.03	-2.75	0.937
48.00	-30.11	-37.42	0.00	-2,488.08	0.00	2,488.08	3,324.15	853.29	3,241.28	2,724.99	14.27	-2.89	0.924
50.00	-29.60	-37.05	0.00	-2,413.25	0.00	2,413.25	3,303.59	844.36	3,173.84	2,679.55	15.51	-3.02	0.912
51.00	-29.33	-36.75	0.00	-2,376.21	0.00	2,376.21	3,293.20	839.90	3,140.39	2,656.86	16.15	-3.09	0.905
54.00	-28.65	-36.21	0.00	-2,265.96	0.00	2,265.96	3,261.57	826.51	3,041.08	2,589.00	18.16	-3.30	0.886
57.00	-27.99	-35.67	0.00	-2,157.32	0.00	2,157.32	3,229.26	813.12	2,943.38	2,521.44	20.30	-3.51	0.866
60.00	-27.33	-35.13	0.00	-2,050.30	0.00	2,050.30	3,196.28	799.73	2,847.27	2,454.19	22.57	-3.71	0.846
63.00	-26.56	-34.44	0.00	-1,944.91	0.00	1,944.91	3,162.62	786.34	2,752.76	2,387.28	24.97	-3.92	0.825
66.00	-25.93	-33.89	0.00	-1,841.58	0.00	1,841.58	3,128.28	772.95	2,659.84	2,320.75	27.50	-4.12	0.804
69.00	-25.31	-33.33	0.00	-1,739.92	0.00	1,739.92	3,093.27	759.56	2,568.51	2,254.62	30.15	-4.33	0.782
72.00	-24.70	-32.77	0.00	-1,639.92	0.00	1,639.92	3,057.58	746.17	2,478.79	2,188.92	32.94	-4.53	0.759
75.00	-24.10	-32.21	0.00	-1,541.61	0.00	1,541.61	3,021.22	732.78	2,390.65	2,123.66	35.85	-4.73	0.736
78.00	-23.52	-31.67	0.00	-1,444.99	0.00	1,444.99	2,984.18	719.39	2,304.12	2,058.89	38.88	-4.93	0.712
80.60	-23.05	-31.31	0.00	-1,362.69	0.00	1,362.69	2,951.54	707.79	2,230.44	2,003.18	41.61	-5.11	0.690
81.00	-22.91	-31.10	0.00	-1,350.07	0.00	1,350.07	2,946.46	706.00	2,219.17	1,994.61	42.04	-5.13	0.687
83.00	-22.28	-30.67	0.00	-1,287.87	0.00	1,287.87	2,920.94	697.07	2,163.43	1,952.06	44.22	-5.26	0.669
84.00	-21.99	-30.44	0.00	-1,257.21	0.00	1,257.21	2,908.96	692.61	2,135.83	1,931.47	45.33	-5.33	0.660
85.41	-21.58	-30.14	0.00	-1,214.40	0.00	1,214.40	2,288.86	584.09	1,822.48	1,541.02	46.91	-5.42	0.800
87.00	-21.30	-29.75	0.00	-1,166.36	0.00	1,166.36	2,274.94	578.16	1,785.69	1,515.96	48.74	-5.53	0.781
90.00	-20.81	-29.18	0.00	-1,077.11	0.00	1,077.11	2,248.22	567.00	1,717.45	1,468.96	52.27	-5.74	0.745
93.00	-17.77	-26.00	0.00	-989.56	0.00	989.56	2,220.81	555.84	1,650.54	1,422.23	55.94	-5.95	0.706
96.00	-17.32	-25.42	0.00	-911.56	0.00	911.56	2,192.74	544.68	1,584.96	1,375.78	59.73	-6.15	0.673
99.00	-16.87	-24.89	0.00	-835.29	0.00	835.29	2,163.98	533.53	1,520.71	1,329.64	63.65	-6.35	0.638
102.00	-16.44	-24.35	0.00	-760.63	0.00	760.63	2,134.56	522.37	1,457.78	1,283.85	67.70	-6.54	0.602
105.00	-16.01	-23.84	0.00	-687.57	0.00	687.57	2,104.45	511.21	1,396.19	1,238.42	71.86	-6.72	0.565
107.60	-15.64	-22.62	0.00	-625.59	0.00	625.59	2,077.81	501.54	1,343.89	1,199.37	75.55	-6.88	0.531



<b>Load Case:</b> 0.9D + 1.0W	118 mph with No Ice (Reduced DL)											32 Iterations
Gust Response Factor :	1.10											
Dead Load Factor :	0.90											
Wind Load Factor :	1.00											

108.00	-15.57	-22.39	0.00	-616.54	0.00	616.54	2,073.67	500.05	1,335.93	1,193.39	76.13	-6.90	0.526
111.00	-15.18	-21.86	0.00	-549.38	0.00	549.38	2,042.21	488.89	1,277.00	1,148.77	80.51	-7.07	0.488
114.00	-14.80	-21.33	0.00	-483.81	0.00	483.81	2,006.48	477.73	1,219.39	1,102.63	85.00	-7.24	0.448
117.00	-14.42	-20.80	0.00	-419.83	0.00	419.83	1,959.62	466.58	1,163.12	1,051.43	89.59	-7.39	0.409
120.00	-14.06	-20.41	0.00	-357.43	0.00	357.43	1,912.75	455.42	1,108.17	1,001.46	94.26	-7.53	0.366
121.00	-13.94	-20.13	0.00	-337.02	0.00	337.02	1,897.13	451.70	1,090.15	985.07	95.84	-7.57	0.351
121.10	-13.93	-19.65	0.00	-335.01	0.00	335.01	1,895.57	451.33	1,088.36	983.44	96.00	-7.58	0.350
121.20	-13.93	-19.42	0.00	-333.05	0.00	333.05	1,894.01	450.95	1,086.57	981.81	96.16	-7.58	0.348
121.30	-13.92	-19.21	0.00	-331.10	0.00	331.10	1,892.45	450.58	1,084.78	980.18	96.31	-7.59	0.347
122.12	-13.82	-19.08	0.00	-315.31	0.00	315.31	1,879.60	447.52	1,070.10	966.84	97.62	-7.62	0.335
123.00	-11.66	-16.95	0.00	-298.57	0.00	298.57	1,865.89	444.26	1,054.56	952.70	99.02	-7.66	0.321
125.89	-11.17	-16.61	0.00	-249.67	0.00	249.67	929.68	265.41	627.12	474.96	103.67	-7.77	0.542
126.00	-11.16	-16.47	0.00	-247.77	0.00	247.77	929.29	265.16	625.91	474.31	103.86	-7.77	0.538
129.00	-10.88	-16.03	0.00	-198.37	0.00	198.37	918.88	258.46	594.71	457.06	108.78	-7.93	0.450
132.00	-10.62	-15.68	0.00	-150.28	0.00	150.28	907.79	251.77	564.31	439.76	113.79	-8.06	0.357
133.00	-7.75	-11.55	0.00	-134.61	0.00	134.61	903.95	249.54	554.35	433.99	115.48	-8.10	0.321
135.00	-7.61	-11.20	0.00	-111.51	0.00	111.51	896.03	245.07	534.70	422.43	118.88	-8.17	0.275
138.00	-7.40	-10.78	0.00	-77.91	0.00	77.91	883.59	238.38	505.89	405.10	124.03	-8.26	0.203
140.00	-4.23	-5.90	0.00	-56.35	0.00	56.35	874.92	233.92	487.13	393.55	127.48	-8.30	0.149
141.00	-4.17	-5.81	0.00	-50.45	0.00	50.45	870.48	231.68	477.88	387.78	129.22	-8.32	0.136
142.20	-4.09	-5.22	0.00	-43.47	0.00	43.47	865.04	229.01	466.90	380.87	131.31	-8.34	0.119
144.00	-3.98	-5.07	0.00	-34.08	0.00	34.08	856.69	224.99	450.67	370.52	134.44	-8.36	0.097
146.00	-3.85	-4.97	0.00	-23.93	0.00	23.93	847.12	220.53	432.97	359.05	137.94	-8.39	0.072
146.00	-3.85	-4.97	0.00	-23.93	0.00	23.93	920.33	276.10	376.25	378.52	137.94	-8.39	0.068
147.00	-3.75	-4.90	0.00	-18.97	0.00	18.97	920.33	276.10	376.25	378.52	139.69	-8.40	0.054
149.00	-1.01	-0.88	0.00	-5.55	0.00	5.55	920.33	276.10	376.25	378.52	143.20	-8.41	0.016
150.00	-0.94	-0.81	0.00	-4.67	0.00	4.67	920.33	276.10	376.25	378.52	144.95	-8.41	0.013
153.00	-0.72	-0.69	0.00	-2.25	0.00	2.25	920.33	276.10	376.25	378.52	150.22	-8.41	0.007
155.00	-0.11	-0.16	0.00	-0.87	0.00	0.87	920.33	276.10	376.25	378.52	153.73	-8.41	0.002
155.00	-0.11	-0.16	0.00	-0.87	0.00	0.87	70.80	21.24	6.13	6.17	153.73	-8.41	0.142
156.00	-0.11	-0.13	0.00	-0.71	0.00	0.71	70.80	21.24	6.13	6.17	155.49	-8.41	0.116
159.00	-0.08	-0.08	0.00	-0.33	0.00	0.33	70.80	21.24	6.13	6.17	160.80	-8.56	0.054
162.00	-0.05	-0.04	0.00	-0.09	0.00	0.09	70.80	21.24	6.13	6.17	166.18	-8.62	0.015
164.10	-0.01	-0.01	0.00	-0.01	0.00	0.01	70.80	21.24	6.13	6.17	169.96	-8.63	0.001
165.00	0.00	-0.01	0.00	0.00	0.00	0.00	70.80	21.24	6.13	6.17	171.58	-8.63	0.000

<b>Load Case:</b> 1.2D + 1.0Di + 1.0Wi	50 mph with 1.50 in Radial Ice	31 Iterations
Gust Response Factor : 1.10	Ice Dead Load Factor : 1.00	
Dead Load Factor : 1.20		Ice Importance Factor : 1.00
Wind Load Factor : 1.00		

**Applied Segment Forces Summary**

Seg Elev (ft)	Description	Shaft Forces		Discrete Forces			Linear Forces		Sum of Forces				
		Wind FX (lb)	Dead Load (lb)	Wind FX (lb)	Torsion MY (lb-ft)	Moment MZ (lb-ft)	Dead Load (lb)	Wind FX (lb)	Dead Load (lb)	Wind FX (lb)	Dead Load (lb)	Torsion MY (lb-ft)	Moment MZ (lb)
0.00		36.7	0.0					0.0	0.0	36.7	0.0	0.0	0.0
3.00		73.2	1,065.8					2.1	275.7	75.3	1,341.5	0.0	0.0
6.00		72.6	1,077.6					2.5	283.9	75.1	1,361.5	0.0	0.0
9.00		71.8	1,076.3					2.9	288.2	74.7	1,364.5	0.0	0.0
12.00		71.0	1,070.8					3.2	291.1	74.2	1,362.0	0.0	0.0
15.00		70.2	1,063.2					3.4	293.4	73.6	1,356.6	0.0	0.0
18.00		69.4	1,054.2					3.7	295.3	73.1	1,349.5	0.0	0.0
21.00		68.5	1,044.3					4.0	296.9	72.5	1,341.2	0.0	0.0
24.00		67.7	1,033.7					4.2	298.3	71.9	1,332.0	0.0	0.0
27.00		66.9	1,022.6					4.5	299.6	71.3	1,322.2	0.0	0.0
30.00		66.5	1,011.0					4.7	300.7	71.2	1,311.8	0.0	0.0
33.00		67.0	999.2					5.1	301.7	72.0	1,300.9	0.0	0.0
36.00		67.8	987.0					5.5	302.7	73.2	1,289.7	0.0	0.0
39.00		46.7	974.6					5.8	303.6	52.5	1,278.1	0.0	0.0
40.10	Bot - Section 2	34.7	356.0					2.3	111.9	37.0	467.9	0.0	0.0
42.00		57.3	999.8					4.0	192.4	61.3	1,192.2	0.0	0.0
45.00		45.7	1,563.3					6.6	305.1	52.4	1,868.4	0.0	0.0
45.90	Top - Section 1	35.3	464.2					2.1	91.5	37.4	555.8	0.0	0.0
48.00		48.4	597.9					4.8	214.3	53.2	812.3	0.0	0.0
50.00	Appurtenance(s)	35.5	563.8	22.3	0.0	0.0	137.2	4.7	204.3	62.5	905.4	0.0	0.0
51.00		47.4	280.2					2.4	102.3	49.8	382.4	0.0	0.0
54.00		71.2	831.5					7.5	307.2	78.7	1,138.7	0.0	0.0
57.00		71.3	819.7					8.0	307.8	79.2	1,127.5	0.0	0.0
60.00		71.2	807.8					8.4	308.4	79.6	1,116.2	0.0	0.0
63.00	Appurtenance(s)	71.2	795.8	37.5	0.0	0.0	260.8	8.8	309.0	117.4	1,365.6	0.0	0.0
66.00		71.0	783.7					9.2	309.5	80.2	1,093.2	0.0	0.0
69.00		70.8	771.6					9.6	310.0	80.4	1,081.6	0.0	0.0
72.00		70.6	759.3					10.0	310.5	80.6	1,069.8	0.0	0.0
75.00		70.2	747.0					10.5	311.0	80.7	1,058.0	0.0	0.0
78.00		65.2	734.6					10.9	311.5	76.1	1,046.1	0.0	0.0
80.60	Bot - Section 3	34.9	626.6					9.8	270.2	44.7	896.7	0.0	0.0
81.00	Appurtenance(s)	28.2	152.7	9.2	0.0	18.4	35.4	1.5	41.7	38.9	229.8	0.0	0.0
83.00	Appurtenance(s)	35.2	755.3	25.3	0.0	0.0	131.8	7.8	207.8	68.3	1,094.9	0.0	0.0
84.00		28.1	374.5					4.0	104.0	32.1	478.5	0.0	0.0
85.41	Top - Section 2	35.0	522.7					5.7	146.3	40.6	669.0	0.0	0.0
87.00		53.3	333.7					6.4	165.9	59.7	499.6	0.0	0.0
90.00		69.2	618.7					12.3	312.6	81.5	931.3	0.0	0.0
93.00	Appurtenance(s)	68.6	607.6	585.1	0.0	0.0	6,162.6	12.8	313.0	666.4	7,083.2	0.0	0.0
96.00		68.0	596.4					13.2	305.0	81.2	901.4	0.0	0.0
99.00		67.4	585.2					13.6	305.4	81.0	890.6	0.0	0.0
102.00		66.7	574.0					14.1	305.7	80.8	879.7	0.0	0.0
105.00	Appurtenance(s)	61.6	562.7	2.8	0.0	0.0	20.0	14.5	306.1	78.9	888.8	0.0	0.0
107.60		32.8	478.8					13.0	265.5	45.8	744.3	0.0	0.0
108.00		36.8	73.1					2.0	40.9	38.8	114.0	0.0	0.0
111.00		64.5	540.0					15.5	306.8	79.9	846.8	0.0	0.0
114.00		63.7	528.6					15.9	307.1	79.6	835.7	0.0	0.0
117.00		62.8	517.2					16.4	307.4	79.2	824.6	0.0	0.0
120.00		42.3	505.7					16.8	307.7	59.1	813.4	0.0	0.0

Site Number: 302495

Code: ANSI/TIA-222-H

© 2007 - 2021 by ATC IP LLC. All rights reserved.

Site Name: Tolland CT, CT

Engineering Number: 13692173\_C3\_03

7/8/2021 6:23:05 PM

Customer: DISH WIRELESS L.L.C.

<b>Load Case:</b> 1.2D + 1.0Di + 1.0Wi	50 mph with 1.50 in Radial Ice	31 Iterations
Gust Response Factor : 1.10	Ice Dead Load Factor : 1.00	
Dead Load Factor : 1.20		Ice Importance Factor : 1.00
Wind Load Factor : 1.00		

121.00	Appurtenance(s)	12.2	166.5	29.5	0.0	0.0	239.2	5.7	113.9	47.4	519.5	0.0	0.0
121.10		2.2	16.6					0.6	11.4	2.8	28.0	0.0	0.0
121.20		2.2	16.6					0.6	11.4	2.8	28.0	0.0	0.0
121.30		10.2	16.6					0.6	11.4	10.7	28.0	0.0	0.0
122.12	Bot - Section 4	18.8	135.7					4.8	93.7	23.6	229.4	0.0	0.0
123.00	Appurtenance(s)	41.6	200.3	430.7	0.0	0.0	4,489.5	5.1	100.0	477.4	4,789.8	0.0	0.0
125.89	Top - Section 3	33.1	647.3					17.1	329.1	50.2	976.4	0.0	0.0
126.00		33.9	13.9					0.7	13.1	34.6	27.0	0.0	0.0
129.00		64.8	358.0					18.0	342.5	82.8	700.4	0.0	0.0
132.00		42.8	349.5					18.5	342.8	61.3	692.3	0.0	0.0
133.00	Appurtenance(s)	31.7	115.1	884.0	0.0	0.0	7,736.0	6.3	114.3	921.9	7,965.4	0.0	0.0
135.00		52.3	226.9					12.7	207.4	65.0	434.2	0.0	0.0
138.00		51.8	332.5					19.5	311.3	71.2	643.8	0.0	0.0
140.00	Appurtenance(s)	29.9	217.4	1,023.9	0.0	0.0	9,202.6	13.2	207.7	1,067.1	9,627.6	0.0	0.0
141.00		20.6	107.5					0.0	54.4	20.6	161.9	0.0	0.0
142.20		27.8	127.7					0.0	65.3	27.8	193.0	0.0	0.0
144.00		34.8	188.7					0.0	97.9	34.8	286.6	0.0	0.0
146.00	Top - Section 4	25.2	205.9					0.0	108.9	25.2	314.8	0.0	0.0
147.00		21.0	137.1					7.3	54.4	28.4	191.6	0.0	0.0
149.00	Appurtenance(s)	21.1	274.4	905.6	0.0	893.1	7,507.0	14.7	108.9	941.3	7,890.3	0.0	0.0
150.00		28.3	137.2					0.0	5.9	28.3	143.1	0.0	0.0
153.00		35.4	411.8					0.0	17.7	35.4	429.5	0.0	0.0
155.00	Top - Section 5	16.8	274.7	90.6	0.0	1.1	1,046.5	0.0	11.8	107.4	1,333.0	0.0	0.0
156.00		10.3	20.4					0.0	5.9	10.3	26.3	0.0	0.0
159.00		15.5	61.3					0.0	17.7	15.5	79.0	0.0	0.0
162.00		12.8	61.4					0.0	17.7	12.8	79.1	0.0	0.0
164.10		7.2	43.0					0.0	0.0	7.2	43.0	0.0	0.0
165.00		2.2	18.4					0.0	0.0	2.2	18.4	0.0	0.0
<b>Totals:</b>										<b>8,026.58</b>	<b>91,094.3</b>	<b>0.00</b>	<b>0.00</b>

Site Number: 302495

Code: ANSI/TIA-222-H

© 2007 - 2021 by ATC IP LLC. All rights reserved.

Site Name: Tolland CT, CT

Engineering Number: 13692173\_C3\_03

7/8/2021 6:23:05 PM

Customer: DISH WIRELESS L.L.C.

**Load Case:** 1.2D + 1.0Di + 1.0Wi

50 mph with 1.50 in Radial Ice

31 Iterations

Gust Response Factor : 1.10

Ice Dead Load Factor : 1.00

Dead Load Factor : 1.20

Ice Importance Factor : 1.00

Wind Load Factor : 1.00

**Calculated Forces**

Seg Elev (ft)	Pu FY (-) (kips)	Vu FX (-) (kips)	Tu MY (ft-kips)	Mu MZ (ft-kips)	Mu MX (ft-kips)	Resultant Moment (ft-kips)	phi Pn (kips)	phi Vn (kips)	phi Tn (ft-kips)	phi Mn (ft-kips)	Total Deflect (in)	Rotation (deg)	Ratio
0.00	-94.14	-8.46	0.00	-1,030.64	0.00	1,030.64	4,665.07	1,225.36	5,729.16	4,709.48	0.00	0.00	0.239
3.00	-92.80	-8.45	0.00	-1,005.25	0.00	1,005.25	4,631.78	1,209.74	5,584.06	4,615.74	0.01	-0.04	0.238
6.00	-91.43	-8.44	0.00	-979.89	0.00	979.89	4,597.82	1,194.12	5,440.82	4,522.21	0.05	-0.08	0.237
9.00	-90.06	-8.43	0.00	-954.57	0.00	954.57	4,563.18	1,178.50	5,299.44	4,428.89	0.11	-0.12	0.235
12.00	-88.69	-8.42	0.00	-929.29	0.00	929.29	4,527.86	1,162.88	5,159.92	4,335.83	0.20	-0.16	0.234
15.00	-87.33	-8.40	0.00	-904.04	0.00	904.04	4,491.86	1,147.25	5,022.26	4,243.05	0.32	-0.20	0.233
18.00	-85.97	-8.39	0.00	-878.84	0.00	878.84	4,455.19	1,131.63	4,886.46	4,150.57	0.46	-0.25	0.231
21.00	-84.63	-8.37	0.00	-853.68	0.00	853.68	4,417.85	1,116.01	4,752.53	4,058.43	0.63	-0.29	0.230
24.00	-83.29	-8.36	0.00	-828.57	0.00	828.57	4,379.82	1,100.39	4,620.45	3,966.64	0.82	-0.33	0.228
27.00	-81.96	-8.34	0.00	-803.50	0.00	803.50	4,341.13	1,084.77	4,490.24	3,875.23	1.05	-0.38	0.226
30.00	-80.64	-8.32	0.00	-778.48	0.00	778.48	4,301.75	1,069.15	4,361.89	3,784.23	1.30	-0.42	0.225
33.00	-79.34	-8.30	0.00	-753.52	0.00	753.52	4,261.70	1,053.52	4,235.40	3,693.68	1.58	-0.47	0.223
36.00	-78.04	-8.28	0.00	-728.61	0.00	728.61	4,220.97	1,037.90	4,110.77	3,603.58	1.88	-0.51	0.221
39.00	-76.76	-8.26	0.00	-703.77	0.00	703.77	4,179.57	1,022.28	3,988.00	3,513.97	2.22	-0.56	0.219
40.10	-76.29	-8.25	0.00	-694.65	0.00	694.65	4,164.16	1,016.53	3,943.28	3,481.12	2.35	-0.57	0.218
42.00	-75.09	-8.23	0.00	-679.01	0.00	679.01	4,137.49	1,006.66	3,867.09	3,424.88	2.59	-0.60	0.216
45.00	-73.22	-8.19	0.00	-654.34	0.00	654.34	4,094.73	991.04	3,748.05	3,336.33	2.98	-0.65	0.214
45.90	-72.66	-8.18	0.00	-646.98	0.00	646.98	3,345.43	862.67	3,312.91	2,772.86	3.10	-0.67	0.255
48.00	-71.84	-8.16	0.00	-629.80	0.00	629.80	3,324.15	853.29	3,241.28	2,724.99	3.40	-0.70	0.253
50.00	-70.93	-8.12	0.00	-613.48	0.00	613.48	3,303.59	844.36	3,173.84	2,679.55	3.70	-0.73	0.251
51.00	-70.55	-8.11	0.00	-605.37	0.00	605.37	3,293.20	839.90	3,140.39	2,656.86	3.86	-0.75	0.249
54.00	-69.40	-8.08	0.00	-581.05	0.00	581.05	3,261.57	826.51	3,041.08	2,589.00	4.35	-0.80	0.246
57.00	-68.27	-8.04	0.00	-556.82	0.00	556.82	3,229.26	813.12	2,943.38	2,521.44	4.87	-0.86	0.242
60.00	-67.15	-8.01	0.00	-532.69	0.00	532.69	3,196.28	799.73	2,847.27	2,454.19	5.43	-0.91	0.238
63.00	-65.78	-7.93	0.00	-508.67	0.00	508.67	3,162.62	786.34	2,752.76	2,387.28	6.02	-0.96	0.234
66.00	-64.68	-7.89	0.00	-484.87	0.00	484.87	3,128.28	772.95	2,659.84	2,320.75	6.64	-1.02	0.230
69.00	-63.59	-7.85	0.00	-461.20	0.00	461.20	3,093.27	759.56	2,568.51	2,254.62	7.30	-1.07	0.225
72.00	-62.51	-7.81	0.00	-437.64	0.00	437.64	3,057.58	746.17	2,478.79	2,188.92	7.99	-1.13	0.220
75.00	-61.45	-7.77	0.00	-414.21	0.00	414.21	3,021.22	732.78	2,390.65	2,123.66	8.72	-1.18	0.215
78.00	-60.40	-7.72	0.00	-390.91	0.00	390.91	2,984.18	719.39	2,304.12	2,058.89	9.48	-1.23	0.210
80.60	-59.50	-7.69	0.00	-370.84	0.00	370.84	2,951.54	707.79	2,230.44	2,003.18	10.16	-1.28	0.205
81.00	-59.27	-7.66	0.00	-367.74	0.00	367.74	2,946.46	706.00	2,219.17	1,994.61	10.27	-1.29	0.205
83.00	-58.17	-7.60	0.00	-352.41	0.00	352.41	2,920.94	697.07	2,163.43	1,952.06	10.82	-1.32	0.201
84.00	-57.69	-7.58	0.00	-344.82	0.00	344.82	2,908.96	692.61	2,135.83	1,931.47	11.10	-1.34	0.198
85.41	-57.02	-7.55	0.00	-334.16	0.00	334.16	2,288.86	584.09	1,822.48	1,541.02	11.49	-1.37	0.242
87.00	-56.52	-7.52	0.00	-322.13	0.00	322.13	2,274.94	578.16	1,785.69	1,515.96	11.96	-1.40	0.238
90.00	-55.58	-7.47	0.00	-299.58	0.00	299.58	2,248.22	567.00	1,717.45	1,468.96	12.85	-1.46	0.229
93.00	-48.51	-6.67	0.00	-277.17	0.00	277.17	2,220.81	555.84	1,650.54	1,422.23	13.79	-1.51	0.217
96.00	-47.60	-6.61	0.00	-257.17	0.00	257.17	2,192.74	544.68	1,584.96	1,375.78	14.75	-1.57	0.209
99.00	-46.71	-6.55	0.00	-237.33	0.00	237.33	2,163.98	533.53	1,520.71	1,329.64	15.76	-1.63	0.200
102.00	-45.83	-6.49	0.00	-217.69	0.00	217.69	2,134.56	522.37	1,457.78	1,283.85	16.80	-1.68	0.191
105.00	-44.94	-6.42	0.00	-198.23	0.00	198.23	2,104.45	511.21	1,396.19	1,238.42	17.87	-1.73	0.182
107.60	-43.45	-6.15	0.00	-181.53	0.00	181.53	2,077.81	501.54	1,343.89	1,199.37	18.83	-1.78	0.172

<b>Load Case:</b> 1.2D + 1.0Di + 1.0Wi				50 mph with 1.50 in Radial Ice				31 Iterations				
Gust Response Factor : 1.10				Ice Dead Load Factor : 1.00				Ice Importance Factor : 1.00				
Dead Load Factor : 1.20												
Wind Load Factor : 1.00												

108.00	-43.33	-6.13	0.00	-179.07	0.00	179.07	2,073.67	500.05	1,335.93	1,193.39	18.98	-1.79	0.171
111.00	-42.48	-6.06	0.00	-160.70	0.00	160.70	2,042.21	488.89	1,277.00	1,148.77	20.12	-1.84	0.161
114.00	-41.65	-5.98	0.00	-142.53	0.00	142.53	2,006.48	477.73	1,219.39	1,102.63	21.29	-1.88	0.150
117.00	-40.82	-5.91	0.00	-124.58	0.00	124.58	1,959.62	466.58	1,163.12	1,051.43	22.48	-1.93	0.139
120.00	-40.01	-5.84	0.00	-106.86	0.00	106.86	1,912.75	455.42	1,108.17	1,001.46	23.71	-1.97	0.128
121.00	-39.49	-5.78	0.00	-101.02	0.00	101.02	1,897.13	451.70	1,090.15	985.07	24.12	-1.98	0.124
121.10	-38.75	-5.67	0.00	-100.45	0.00	100.45	1,895.57	451.33	1,088.36	983.44	24.16	-1.98	0.123
121.20	-38.48	-5.62	0.00	-99.88	0.00	99.88	1,894.01	450.95	1,086.57	981.81	24.21	-1.99	0.122
121.30	-38.21	-5.58	0.00	-99.32	0.00	99.32	1,892.45	450.58	1,084.78	980.18	24.25	-1.99	0.122
122.12	-37.98	-5.55	0.00	-94.73	0.00	94.73	1,879.60	447.52	1,070.10	966.84	24.59	-2.00	0.118
123.00	-33.21	-4.92	0.00	-89.86	0.00	89.86	1,865.89	444.26	1,054.56	952.70	24.96	-2.01	0.112
125.89	-32.24	-4.85	0.00	-75.66	0.00	75.66	929.68	265.41	627.12	474.96	26.18	-2.04	0.194
126.00	-32.21	-4.83	0.00	-75.10	0.00	75.10	929.29	265.16	625.91	474.31	26.23	-2.04	0.193
129.00	-31.51	-4.74	0.00	-60.63	0.00	60.63	918.88	258.46	594.71	457.06	27.53	-2.09	0.167
132.00	-30.82	-4.67	0.00	-46.41	0.00	46.41	907.79	251.77	564.31	439.76	28.86	-2.13	0.140
133.00	-22.89	-3.46	0.00	-41.74	0.00	41.74	903.95	249.54	554.35	433.99	29.31	-2.14	0.122
135.00	-22.46	-3.39	0.00	-34.82	0.00	34.82	896.03	245.07	534.70	422.43	30.21	-2.17	0.108
138.00	-21.81	-3.30	0.00	-24.67	0.00	24.67	883.59	238.38	505.89	405.10	31.58	-2.19	0.086
140.00	-12.23	-1.86	0.00	-18.08	0.00	18.08	874.92	233.92	487.13	393.55	32.50	-2.21	0.060
141.00	-12.07	-1.84	0.00	-16.21	0.00	16.21	870.48	231.68	477.88	387.78	32.97	-2.21	0.056
142.20	-11.13	-1.68	0.00	-14.01	0.00	14.01	865.04	229.01	466.90	380.87	33.52	-2.22	0.050
144.00	-10.84	-1.64	0.00	-10.98	0.00	10.98	856.69	224.99	450.67	370.52	34.36	-2.23	0.042
146.00	-10.53	-1.60	0.00	-7.70	0.00	7.70	847.12	220.53	432.97	359.05	35.30	-2.23	0.034
146.00	-10.53	-1.60	0.00	-7.70	0.00	7.70	920.33	276.10	376.25	378.52	35.30	-2.23	0.032
147.00	-10.34	-1.57	0.00	-6.10	0.00	6.10	920.33	276.10	376.25	378.52	35.76	-2.24	0.027
149.00	-2.49	-0.32	0.00	-2.08	0.00	2.08	920.33	276.10	376.25	378.52	36.70	-2.24	0.008
150.00	-2.35	-0.28	0.00	-1.76	0.00	1.76	920.33	276.10	376.25	378.52	37.17	-2.24	0.007
153.00	-1.92	-0.23	0.00	-0.91	0.00	0.91	920.33	276.10	376.25	378.52	38.58	-2.24	0.004
155.00	-0.59	-0.07	0.00	-0.45	0.00	0.45	920.33	276.10	376.25	378.52	39.52	-2.24	0.002
155.00	-0.59	-0.07	0.00	-0.45	0.00	0.45	70.80	21.24	6.13	6.17	39.52	-2.24	0.080
156.00	-0.57	-0.06	0.00	-0.37	0.00	0.37	70.80	21.24	6.13	6.17	39.99	-2.24	0.068
159.00	-0.49	-0.04	0.00	-0.19	0.00	0.19	70.80	21.24	6.13	6.17	41.43	-2.32	0.038
162.00	-0.41	-0.03	0.00	-0.06	0.00	0.06	70.80	21.24	6.13	6.17	42.90	-2.36	0.015
164.10	-0.02	0.00	0.00	0.00	0.00	0.00	70.80	21.24	6.13	6.17	43.94	-2.36	0.001
165.00	0.00	0.00	0.00	0.00	0.00	0.00	70.80	21.24	6.13	6.17	44.38	-2.36	0.000

<b>Load Case:</b> 1.0D + 1.0W	Serviceability 60 mph	30 Iterations
Gust Response Factor : 1.10		
Dead Load Factor : 1.00		
Wind Load Factor : 1.00		

**Applied Segment Forces Summary**

Seg Elev (ft)	Description	Shaft Forces		Discrete Forces			Linear Forces		Sum of Forces				
		Wind FX (lb)	Dead Load (lb)	Wind FX (lb)	Torsion MY (lb-ft)	Moment MZ (lb-ft)	Dead Load (lb)	Wind FX (lb)	Dead Load (lb)	Wind FX (lb)	Dead Load (lb)	Torsion MY (lb-ft)	Moment MZ (lb)
0.00		59.0	0.0					0.0	0.0	59.0	0.0	0.0	0.0
3.00		117.2	708.2					0.0	163.7	117.3	872.0	0.0	0.0
6.00		115.7	699.1					0.1	163.7	115.8	862.9	0.0	0.0
9.00		114.2	690.0					0.1	163.7	114.4	853.8	0.0	0.0
12.00		112.7	681.0					0.2	163.7	112.9	844.7	0.0	0.0
15.00		111.2	671.9					0.2	163.7	111.4	835.6	0.0	0.0
18.00		109.7	662.8					0.2	163.7	110.0	826.5	0.0	0.0
21.00		108.2	653.7					0.3	163.7	108.5	817.4	0.0	0.0
24.00		106.7	644.6					31.8	163.7	138.5	808.3	0.0	0.0
27.00		105.2	635.5					0.4	163.7	105.6	799.3	0.0	0.0
30.00		104.5	626.4					0.4	163.7	104.9	790.2	0.0	0.0
33.00		105.1	617.3					0.4	163.7	105.6	781.1	0.0	0.0
36.00		106.2	608.3					0.5	163.7	106.7	772.0	0.0	0.0
39.00		73.0	599.2					0.5	163.7	73.6	762.9	0.0	0.0
40.10	Bot - Section 2	54.3	218.2					0.2	60.3	54.5	278.5	0.0	0.0
42.00		89.5	696.9					0.4	103.5	89.9	800.4	0.0	0.0
45.00		71.4	1,089.0					0.6	163.7	72.1	1,252.8	0.0	0.0
45.90	Top - Section 1	55.1	322.9					8.5	49.0	63.6	371.9	0.0	0.0
48.00		75.5	349.6					0.5	114.7	76.0	464.3	0.0	0.0
50.00	Appurtenance(s)	55.3	329.2	17.3	0.0	0.0	80.0	19.3	109.2	91.9	518.3	0.0	0.0
51.00		73.8	163.3					9.7	54.6	83.5	217.9	0.0	0.0
54.00		110.7	484.7					29.5	163.7	140.2	648.4	0.0	0.0
57.00		110.6	476.9					30.0	163.7	140.6	640.6	0.0	0.0
60.00		110.4	469.1					30.4	163.7	140.8	632.8	0.0	0.0
63.00	Appurtenance(s)	110.1	461.3	29.5	0.0	0.0	150.0	30.9	163.7	170.4	775.0	0.0	0.0
66.00		109.7	453.5					31.3	163.7	141.0	617.2	0.0	0.0
69.00		109.2	445.7					31.7	163.7	140.9	609.4	0.0	0.0
72.00		108.6	437.9					32.1	163.7	140.7	601.7	0.0	0.0
75.00		107.9	430.1					32.4	163.7	140.4	593.9	0.0	0.0
78.00		100.1	422.3					32.8	163.7	132.9	586.1	0.0	0.0
80.60	Bot - Section 3	53.5	359.6					28.7	141.9	82.2	501.4	0.0	0.0
81.00	Appurtenance(s)	43.3	101.7	7.1	0.0	14.2	10.0	4.5	21.9	54.8	133.6	0.0	0.0
83.00	Appurtenance(s)	53.9	503.5	19.7	0.0	0.0	75.0	22.3	108.9	95.9	687.3	0.0	0.0
84.00		43.1	249.3					11.2	54.4	54.3	303.8	0.0	0.0
85.41	Top - Section 2	53.5	348.0					15.8	76.5	69.3	424.5	0.0	0.0
87.00		81.4	179.6					18.0	86.7	99.4	266.3	0.0	0.0
90.00		105.5	333.1					34.2	163.3	139.6	496.3	0.0	0.0
93.00	Appurtenance(s)	104.4	326.6	538.4	0.0	0.0	3,132.1	34.5	163.3	677.3	3,622.0	0.0	0.0
96.00		103.2	320.1					34.8	156.3	138.1	476.3	0.0	0.0
99.00		102.0	313.6					25.4	156.3	127.4	469.9	0.0	0.0
102.00		100.8	307.1					25.6	156.3	126.4	463.4	0.0	0.0
105.00	Appurtenance(s)	92.9	300.6	1.0	0.0	0.0	9.9	25.8	156.3	119.8	466.8	0.0	0.0
107.60		49.4	255.3					22.5	135.4	71.9	390.7	0.0	0.0
108.00		55.3	38.8					3.5	20.8	58.7	59.7	0.0	0.0
111.00		96.7	287.6					26.2	156.3	122.9	443.9	0.0	0.0
114.00		95.2	281.1					26.4	156.3	121.7	437.4	0.0	0.0
117.00		93.7	274.6					26.6	156.3	120.3	430.9	0.0	0.0
120.00		58.3	268.1					26.8	156.3	85.1	424.4	0.0	0.0

Site Number: 302495

Code: ANSI/TIA-222-H

© 2007 - 2021 by ATC IP LLC. All rights reserved.

Site Name: Tolland CT, CT

Engineering Number: 13692173\_C3\_03

7/8/2021 6:23:11 PM

Customer: DISH WIRELESS L.L.C.

Load Case: 1.0D + 1.0W		Serviceability 60 mph										30 Iterations	
Gust Response Factor : 1.10													
Dead Load Factor : 1.00													
Wind Load Factor : 1.00													
121.00	Appurtenance(s)	13.0	87.9	38.9	0.0	0.0	20.0	10.3	59.0	62.2	166.9	0.0	0.0
121.10		2.3	8.8					1.0	5.9	3.4	14.7	0.0	0.0
121.20		2.3	8.7					1.0	5.9	3.4	14.6	0.0	0.0
121.30		10.8	8.7					1.0	5.9	11.8	14.6	0.0	0.0
122.12	Bot - Section 4	20.0	71.6					8.5	48.5	28.5	120.1	0.0	0.0
123.00	Appurtenance(s)	44.1	122.3	373.5	0.0	0.0	2,500.0	9.1	51.8	426.7	2,674.1	0.0	0.0
125.89	Top - Section 3	35.0	395.8					29.9	170.2	65.0	566.0	0.0	0.0
126.00		35.7	5.9					1.2	6.8	36.9	12.7	0.0	0.0
129.00		68.2	152.3					31.3	177.0	99.5	329.3	0.0	0.0
132.00		44.9	148.4					31.5	177.0	76.4	325.4	0.0	0.0
133.00	Appurtenance(s)	33.1	48.6	808.5	0.0	0.0	3,674.8	12.2	59.0	853.8	3,782.4	0.0	0.0
135.00		54.4	95.9					24.5	100.1	78.9	196.0	0.0	0.0
138.00		53.6	140.6					36.9	150.2	90.6	290.8	0.0	0.0
140.00	Appurtenance(s)	29.5	91.6	957.8	0.0	0.0	4,071.5	24.7	100.1	1,012.1	4,263.2	0.0	0.0
141.00		18.2	45.1					0.0	36.0	18.2	81.1	0.0	0.0
142.20		24.6	53.6					0.0	43.2	24.6	96.8	0.0	0.0
144.00		30.7	79.2					0.0	64.8	30.7	144.0	0.0	0.0
146.00	Top - Section 4	20.3	86.4					0.0	72.0	20.3	158.4	0.0	0.0
147.00		12.9	82.8					0.0	36.0	12.9	118.8	0.0	0.0
149.00	Appurtenance(s)	12.3	165.7	814.0	0.0	838.3	3,419.1	0.0	72.0	826.3	3,656.8	0.0	0.0
150.00		14.9	82.8					0.0	4.9	14.9	87.8	0.0	0.0
153.00		18.7	248.5					0.0	14.8	18.7	263.3	0.0	0.0
155.00	Top - Section 5	9.2	165.7	92.6	0.0	0.7	579.2	0.0	9.8	101.8	754.7	0.0	0.0
156.00		6.6	7.6					0.0	4.9	6.6	12.6	0.0	0.0
159.00		10.0	22.9					0.0	14.8	10.0	37.7	0.0	0.0
162.00		8.2	22.9					0.0	14.8	8.2	37.7	0.0	0.0
164.10		4.6	16.1					0.0	0.0	4.6	16.1	0.0	0.0
165.00		1.4	6.9					0.0	0.0	1.4	6.9	0.0	0.0
Totals:									9,616.79	48,977.8	0.00	0.00	



Site Number: 302495

Code: ANSI/TIA-222-H

© 2007 - 2021 by ATC IP LLC. All rights reserved.

Site Name: Tolland CT, CT

Engineering Number: 13692173\_C3\_03

7/8/2021 6:23:11 PM

Customer: DISH WIRELESS L.L.C.

Load Case: 1.0D + 1.0W

Serviceability 60 mph

30 Iterations

Gust Response Factor : 1.10

Dead Load Factor : 1.00

Wind Load Factor : 1.00

Calculated Forces

Seg Elev (ft)	Pu FY (-) (kips)	Vu FX (-) (kips)	Tu MY (ft-kips)	Mu MZ (ft-kips)	Mu MX (ft-kips)	Resultant Moment (ft-kips)	phi Pn (kips)	phi Vn (kips)	phi Tn (ft-kips)	phi Mn (ft-kips)	Total Deflect (in)	Rotation (deg)	Ratio
0.00	-49.35	-10.08	0.00	-1,037.37	0.00	1,037.37	4,665.07	1,225.36	5,729.16	4,709.48	0.00	0.00	0.231
3.00	-48.47	-10.00	0.00	-1,007.12	0.00	1,007.12	4,631.78	1,209.74	5,584.06	4,615.74	0.01	-0.04	0.229
6.00	-47.60	-9.92	0.00	-977.13	0.00	977.13	4,597.82	1,194.12	5,440.82	4,522.21	0.05	-0.08	0.226
9.00	-46.74	-9.83	0.00	-947.38	0.00	947.38	4,563.18	1,178.50	5,299.44	4,428.89	0.11	-0.12	0.224
12.00	-45.89	-9.75	0.00	-917.88	0.00	917.88	4,527.86	1,162.88	5,159.92	4,335.83	0.20	-0.16	0.222
15.00	-45.05	-9.67	0.00	-888.63	0.00	888.63	4,491.86	1,147.25	5,022.26	4,243.05	0.32	-0.20	0.220
18.00	-44.21	-9.59	0.00	-859.63	0.00	859.63	4,455.19	1,131.63	4,886.46	4,150.57	0.46	-0.24	0.217
21.00	-43.39	-9.51	0.00	-830.86	0.00	830.86	4,417.85	1,116.01	4,752.53	4,058.43	0.63	-0.29	0.215
24.00	-42.58	-9.40	0.00	-802.34	0.00	802.34	4,379.82	1,100.39	4,620.45	3,966.64	0.82	-0.33	0.212
27.00	-41.77	-9.32	0.00	-774.15	0.00	774.15	4,341.13	1,084.77	4,490.24	3,875.23	1.04	-0.37	0.209
30.00	-40.97	-9.24	0.00	-746.20	0.00	746.20	4,301.75	1,069.15	4,361.89	3,784.23	1.29	-0.41	0.207
33.00	-40.19	-9.16	0.00	-718.49	0.00	718.49	4,261.70	1,053.52	4,235.40	3,693.68	1.56	-0.46	0.204
36.00	-39.41	-9.07	0.00	-691.03	0.00	691.03	4,220.97	1,037.90	4,110.77	3,603.58	1.86	-0.50	0.201
39.00	-38.64	-9.01	0.00	-663.81	0.00	663.81	4,179.57	1,022.28	3,988.00	3,513.97	2.19	-0.54	0.198
40.10	-38.36	-8.97	0.00	-653.86	0.00	653.86	4,164.16	1,016.53	3,943.28	3,481.12	2.32	-0.56	0.197
42.00	-37.56	-8.90	0.00	-636.86	0.00	636.86	4,137.49	1,006.66	3,867.09	3,424.88	2.54	-0.59	0.195
45.00	-36.30	-8.83	0.00	-610.17	0.00	610.17	4,094.73	991.04	3,748.05	3,336.33	2.93	-0.63	0.192
45.90	-35.92	-8.77	0.00	-602.24	0.00	602.24	3,345.43	862.67	3,312.91	2,772.86	3.05	-0.64	0.228
48.00	-35.46	-8.71	0.00	-583.80	0.00	583.80	3,324.15	853.29	3,241.28	2,724.99	3.34	-0.68	0.225
50.00	-34.94	-8.63	0.00	-566.38	0.00	566.38	3,303.59	844.36	3,173.84	2,679.55	3.63	-0.71	0.222
51.00	-34.71	-8.56	0.00	-557.75	0.00	557.75	3,293.20	839.90	3,140.39	2,656.86	3.78	-0.72	0.221
54.00	-34.06	-8.44	0.00	-532.06	0.00	532.06	3,261.57	826.51	3,041.08	2,589.00	4.25	-0.77	0.216
57.00	-33.41	-8.32	0.00	-506.73	0.00	506.73	3,229.26	813.12	2,943.38	2,521.44	4.75	-0.82	0.211
60.00	-32.78	-8.20	0.00	-481.77	0.00	481.77	3,196.28	799.73	2,847.27	2,454.19	5.28	-0.87	0.207
63.00	-32.00	-8.04	0.00	-457.17	0.00	457.17	3,162.62	786.34	2,752.76	2,387.28	5.84	-0.92	0.202
66.00	-31.38	-7.92	0.00	-433.04	0.00	433.04	3,128.28	772.95	2,659.84	2,320.75	6.44	-0.97	0.197
69.00	-30.76	-7.79	0.00	-409.28	0.00	409.28	3,093.27	759.56	2,568.51	2,254.62	7.06	-1.01	0.192
72.00	-30.16	-7.67	0.00	-385.90	0.00	385.90	3,057.58	746.17	2,478.79	2,188.92	7.71	-1.06	0.186
75.00	-29.56	-7.54	0.00	-362.90	0.00	362.90	3,021.22	732.78	2,390.65	2,123.66	8.40	-1.11	0.181
78.00	-28.97	-7.42	0.00	-340.28	0.00	340.28	2,984.18	719.39	2,304.12	2,058.89	9.11	-1.16	0.175
80.60	-28.47	-7.34	0.00	-321.01	0.00	321.01	2,951.54	707.79	2,230.44	2,003.18	9.75	-1.20	0.170
81.00	-28.33	-7.29	0.00	-318.05	0.00	318.05	2,946.46	706.00	2,219.17	1,994.61	9.85	-1.20	0.169
83.00	-27.65	-7.19	0.00	-303.47	0.00	303.47	2,920.94	697.07	2,163.43	1,952.06	10.36	-1.23	0.165
84.00	-27.34	-7.14	0.00	-296.29	0.00	296.29	2,908.96	692.61	2,135.83	1,931.47	10.62	-1.25	0.163
85.41	-26.92	-7.07	0.00	-286.25	0.00	286.25	2,288.86	584.09	1,822.48	1,541.02	10.99	-1.27	0.198
87.00	-26.65	-6.98	0.00	-274.98	0.00	274.98	2,274.94	578.16	1,785.69	1,515.96	11.42	-1.30	0.193
90.00	-26.15	-6.85	0.00	-254.04	0.00	254.04	2,248.22	567.00	1,717.45	1,468.96	12.25	-1.35	0.185
93.00	-22.54	-6.11	0.00	-233.48	0.00	233.48	2,220.81	555.84	1,650.54	1,422.23	13.12	-1.40	0.174
96.00	-22.06	-5.98	0.00	-215.16	0.00	215.16	2,192.74	544.68	1,584.96	1,375.78	14.01	-1.44	0.167
99.00	-21.59	-5.85	0.00	-197.23	0.00	197.23	2,163.98	533.53	1,520.71	1,329.64	14.93	-1.49	0.158
102.00	-21.12	-5.73	0.00	-179.67	0.00	179.67	2,134.56	522.37	1,457.78	1,283.85	15.88	-1.54	0.150
105.00	-20.66	-5.61	0.00	-162.47	0.00	162.47	2,104.45	511.21	1,396.19	1,238.42	16.86	-1.58	0.141
107.60	-20.12	-5.33	0.00	-147.88	0.00	147.88	2,077.81	501.54	1,343.89	1,199.37	17.73	-1.62	0.133

<b>Load Case:</b> 1.0D + 1.0W				<b>Serviceability</b> 60 mph				<b>30 Iterations</b>				
Gust Response Factor : 1.10												
Dead Load Factor : 1.00												
Wind Load Factor : 1.00												

108.00	-20.06	-5.28	0.00	-145.75	0.00	145.75	2,073.67	500.05	1,335.93	1,193.39	17.87	-1.62	0.132
111.00	-19.62	-5.16	0.00	-129.91	0.00	129.91	2,042.21	488.89	1,277.00	1,148.77	18.90	-1.66	0.123
114.00	-19.18	-5.03	0.00	-114.44	0.00	114.44	2,006.48	477.73	1,219.39	1,102.63	19.95	-1.70	0.113
117.00	-18.75	-4.91	0.00	-99.34	0.00	99.34	1,959.62	466.58	1,163.12	1,051.43	21.03	-1.74	0.104
120.00	-18.33	-4.82	0.00	-84.60	0.00	84.60	1,912.75	455.42	1,108.17	1,001.46	22.14	-1.77	0.094
121.00	-18.16	-4.76	0.00	-79.78	0.00	79.78	1,897.13	451.70	1,090.15	985.07	22.51	-1.78	0.091
121.10	-18.09	-4.65	0.00	-79.30	0.00	79.30	1,895.57	451.33	1,088.36	983.44	22.55	-1.78	0.090
121.20	-18.06	-4.59	0.00	-78.84	0.00	78.84	1,894.01	450.95	1,086.57	981.81	22.58	-1.78	0.090
121.30	-18.02	-4.54	0.00	-78.38	0.00	78.38	1,892.45	450.58	1,084.78	980.18	22.62	-1.78	0.090
122.12	-17.90	-4.51	0.00	-74.64	0.00	74.64	1,879.60	447.52	1,070.10	966.84	22.93	-1.79	0.087
123.00	-15.24	-4.01	0.00	-70.68	0.00	70.68	1,865.89	444.26	1,054.56	952.70	23.26	-1.80	0.082
125.89	-14.68	-3.93	0.00	-59.12	0.00	59.12	929.68	265.41	627.12	474.96	24.35	-1.83	0.140
126.00	-14.67	-3.89	0.00	-58.67	0.00	58.67	929.29	265.16	625.91	474.31	24.40	-1.83	0.140
129.00	-14.34	-3.79	0.00	-46.99	0.00	46.99	918.88	258.46	594.71	457.06	25.56	-1.86	0.119
132.00	-14.01	-3.71	0.00	-35.61	0.00	35.61	907.79	251.77	564.31	439.76	26.74	-1.90	0.097
133.00	-10.26	-2.73	0.00	-31.90	0.00	31.90	903.95	249.54	554.35	433.99	27.14	-1.91	0.085
135.00	-10.07	-2.65	0.00	-26.43	0.00	26.43	896.03	245.07	534.70	422.43	27.94	-1.92	0.074
138.00	-9.78	-2.56	0.00	-18.47	0.00	18.47	883.59	238.38	505.89	405.10	29.16	-1.94	0.057
140.00	-5.55	-1.40	0.00	-13.36	0.00	13.36	874.92	233.92	487.13	393.55	29.97	-1.95	0.040
141.00	-5.47	-1.38	0.00	-11.96	0.00	11.96	870.48	231.68	477.88	387.78	30.38	-1.96	0.037
142.20	-5.30	-1.24	0.00	-10.31	0.00	10.31	865.04	229.01	466.90	380.87	30.87	-1.96	0.033
144.00	-5.15	-1.20	0.00	-8.07	0.00	8.07	856.69	224.99	450.67	370.52	31.61	-1.97	0.028
146.00	-5.00	-1.18	0.00	-5.67	0.00	5.67	847.12	220.53	432.97	359.05	32.44	-1.97	0.022
146.00	-5.00	-1.18	0.00	-5.67	0.00	5.67	920.33	276.10	376.25	378.52	32.44	-1.97	0.020
147.00	-4.88	-1.16	0.00	-4.49	0.00	4.49	920.33	276.10	376.25	378.52	32.85	-1.97	0.017
149.00	-1.25	-0.21	0.00	-1.32	0.00	1.32	920.33	276.10	376.25	378.52	33.68	-1.98	0.005
150.00	-1.16	-0.19	0.00	-1.11	0.00	1.11	920.33	276.10	376.25	378.52	34.09	-1.98	0.004
153.00	-0.90	-0.16	0.00	-0.54	0.00	0.54	920.33	276.10	376.25	378.52	35.34	-1.98	0.002
155.00	-0.15	-0.04	0.00	-0.21	0.00	0.21	920.33	276.10	376.25	378.52	36.17	-1.98	0.001
155.00	-0.15	-0.04	0.00	-0.21	0.00	0.21	70.80	21.24	6.13	6.17	36.17	-1.98	0.035
156.00	-0.14	-0.03	0.00	-0.17	0.00	0.17	70.80	21.24	6.13	6.17	36.58	-1.98	0.029
159.00	-0.10	-0.02	0.00	-0.08	0.00	0.08	70.80	21.24	6.13	6.17	37.84	-2.01	0.014
162.00	-0.06	-0.01	0.00	-0.02	0.00	0.02	70.80	21.24	6.13	6.17	39.11	-2.03	0.004
164.10	-0.01	0.00	0.00	0.00	0.00	0.00	70.80	21.24	6.13	6.17	40.00	-2.03	0.000
165.00	0.00	0.00	0.00	0.00	0.00	0.00	70.80	21.24	6.13	6.17	40.38	-2.03	0.000

Site Number: 302495

Code: ANSI/TIA-222-H

© 2007 - 2021 by ATC IP LLC. All rights reserved.

Site Name: Tolland CT, CT

Engineering Number: 13692173\_C3\_03

7/8/2021 6:23:12 PM

Customer: DISH WIRELESS L.L.C.

### Equivalent Lateral Forces Method Analysis

Spectral Response Acceleration for Short Period ( $S_s$ ):	0.18
Spectral Response Acceleration at 1.0 Second Period ( $S_{d1}$ ):	0.05
Long-Period Transition Period ( $T_L$ ):	6
Importance Factor ( $I_E$ ):	1.00
Site Coefficient $F_a$ :	1.60
Site Coefficient $F_v$ :	2.40
Response Modification Coefficient (R):	1.50
Design Spectral Response Acceleration at Short Period ( $S_{ds}$ ):	0.19
Design Spectral Response Acceleration at 1.0 Second Period ( $S_{d1}$ ):	0.09
Seismic Response Coefficient ( $C_s$ ):	0.03
Upper Limit $C_s$	0.03
Lower Limit $C_s$	0.03
Period based on Rayleigh Method (sec):	3.15
Redundancy Factor (p):	1.00
Seismic Force Distribution Exponent (k):	2.00
Total Unfactored Dead Load:	49.35 k
Seismic Base Shear (E):	1.48 k

**Load Case** 1.2D + 1.0Ev + 1.0Eh

**Seismic**

Segment	Height Above Base (ft)	Weight (lb)	$W_z$ (lb-ft)	$C_{vx}$	Horizontal Force (lb)	Vertical Force (lb)
75	164.55	7	186	0.000	1	9
74	163.05	16	427	0.001	1	20
73	160.50	38	971	0.002	3	47
72	157.50	38	935	0.002	3	47
71	155.50	13	304	0.001	1	16
70	154.00	176	4,163	0.009	13	217
69	151.50	263	6,043	0.012	18	326
68	149.50	88	1,962	0.004	6	109
67	148.00	238	5,206	0.011	16	294
66	146.50	119	2,551	0.005	8	147
65	145.00	158	3,330	0.007	10	196
64	143.10	144	2,949	0.006	9	178
63	141.60	97	1,941	0.004	6	120
62	140.50	81	1,601	0.003	5	100
61	139.00	192	3,704	0.008	11	237
60	136.50	291	5,419	0.011	16	360
59	134.00	196	3,520	0.007	11	243
58	132.50	108	1,889	0.004	6	133
57	130.50	325	5,541	0.011	17	403
56	127.50	329	5,353	0.011	16	408
55	125.94	13	201	0.000	1	16
54	124.44	566	8,766	0.018	27	701
53	122.56	174	2,615	0.005	8	216
52	121.71	120	1,779	0.004	5	149
51	121.25	15	215	0.000	1	18

Site Number: 302495

Code: ANSI/TIA-222-H

© 2007 - 2021 by ATC IP LLC. All rights reserved.

Site Name: Tolland CT, CT

Engineering Number: 13692173\_C3\_03

7/8/2021 6:23:12 PM

Customer: DISH WIRELESS L.L.C.

50	121.15	15	215	0.000	1	18
49	121.05	15	215	0.000	1	18
48	120.50	147	2,133	0.004	6	182
47	118.50	424	5,960	0.012	18	526
46	115.50	431	5,748	0.012	17	534
45	112.50	437	5,536	0.011	17	542
44	109.50	444	5,322	0.011	16	550
43	107.80	60	693	0.001	2	74
42	106.30	391	4,415	0.009	13	484
41	103.50	457	4,894	0.010	15	566
40	100.50	463	4,680	0.010	14	574
39	97.50	470	4,467	0.009	14	582
38	94.50	476	4,254	0.009	13	590
37	91.50	490	4,101	0.008	12	607
36	88.50	496	3,887	0.008	12	615
35	86.20	266	1,979	0.004	6	330
34	84.70	425	3,046	0.006	9	526
33	83.50	304	2,118	0.004	6	376
32	82.00	612	4,117	0.008	13	758
31	80.80	124	807	0.002	2	153
30	79.30	501	3,153	0.006	10	621
29	76.50	586	3,430	0.007	10	726
28	73.50	594	3,208	0.007	10	736
27	70.50	602	2,990	0.006	9	745
26	67.50	609	2,777	0.006	8	755
25	64.50	617	2,568	0.005	8	765
24	61.50	625	2,364	0.005	7	774
23	58.50	633	2,166	0.004	7	784
22	55.50	641	1,973	0.004	6	793
21	52.50	648	1,787	0.004	5	803
20	50.50	218	556	0.001	2	270
19	49.00	438	1,052	0.002	3	543
18	46.95	464	1,023	0.002	3	575
17	45.45	372	768	0.002	2	461
16	43.50	1,253	2,371	0.005	7	1,552
15	41.05	800	1,349	0.003	4	991
14	39.55	279	436	0.001	1	345
13	37.50	763	1,073	0.002	3	945
12	34.50	772	919	0.002	3	956
11	31.50	781	775	0.002	2	967
10	28.50	790	642	0.001	2	979
9	25.50	799	520	0.001	2	990
8	22.50	808	409	0.001	1	1,001
7	19.50	817	311	0.001	1	1,012
6	16.50	827	225	0.000	1	1,024
5	13.50	836	152	0.000	0	1,035
4	10.50	845	93	0.000	0	1,046
3	7.50	854	48	0.000	0	1,058
2	4.50	863	17	0.000	0	1,069
1	1.50	872	2	0.000	0	1,080
EMS RR90-17-02DP	164.10	41	1,091	0.002	3	50
Ericsson KRY 112 71/ Canister	155.00	79	1,903	0.004	6	98
	155.00	500	12,013	0.025	37	619
Andrew ABT-D MDF-ADBH	149.00	1	24	0.000	0	1
Powerwave Allgon 702	149.00	7	147	0.000	0	8
Kathrein Scala 782-1	149.00	38	853	0.002	3	48
CCI DTMAP7819VG12A	149.00	115	2,558	0.005	8	143
Raycap DC6-48-60-18-	149.00	32	706	0.001	2	39
Ericsson RRUS 11 (Ba	149.00	150	3,330	0.007	10	186
Ericsson RRUS-12 800	149.00	180	3,996	0.008	12	223
Powerwave Allgon 777	149.00	105	2,331	0.005	7	130
KMW AM-X-CD-16-65-00	149.00	291	6,460	0.013	20	360
Generic Flat Platfor	149.00	2,500	55,503	0.114	169	3,097
Decibel DB844G90A-XY	142.20	84	1,699	0.003	5	104

Site Number: 302495

Code: ANSI/TIA-222-H

© 2007 - 2021 by ATC IP LLC. All rights reserved.

Site Name: Tolland CT, CT

Engineering Number: 13692173\_C3\_03

7/8/2021 6:23:12 PM

Customer: DISH WIRELESS L.L.C.

RFS FDJ85020D7-S	140.00	70	1,376	0.003	4	87
Samsung Outdoor CBRS	140.00	56	1,094	0.002	3	69
Samsung B5/B13 RRH-B	140.00	211	4,134	0.008	13	261
Samsung B2/B66A RRH-	140.00	253	4,963	0.010	15	314
Swedcom SC 9012	140.00	60	1,176	0.002	4	74
Samsung CBRS 64T64R	140.00	225	4,410	0.009	13	279
Samsung MT6407-77A	140.00	245	4,798	0.010	15	303
RFS DB-T1-6Z-8AB-0Z	140.00	88	1,725	0.004	5	109
Commscope JAHH-65B-R	140.00	364	7,127	0.015	22	450
Generic Flat Platfor	140.00	2,500	49,000	0.101	149	3,097
Alcatel-Lucent 800 M	133.00	384	6,793	0.014	21	476
Alcatel-Lucent 1900	133.00	180	3,184	0.007	10	223
Alcatel-Lucent TD-RR	133.00	210	3,715	0.008	11	260
RFS APXVTM14-ALU-I20	133.00	169	2,982	0.006	9	209
Commscope NNVV-65B-R	133.00	232	4,107	0.008	12	288
Modified Platform w/	133.00	2,500	44,223	0.091	135	3,097
Generic Flat Platfor	123.00	2,500	37,823	0.078	115	3,097
Andrew DB844H90E-A	121.30	20	294	0.001	1	25
Andrew DB844H90E-A	121.20	10	147	0.000	0	12
Andrew DB844H90E-A	121.20	10	147	0.000	0	12
Andrew DB844H90E-A	121.10	60	880	0.002	3	74
Andrew DB844H90E-A	121.00	20	293	0.001	1	25
Commscope LNX-6515DS	107.60	151	1,747	0.004	5	187
Kathrein Scala Smart	105.00	10	109	0.000	0	12
Commscope RDIDC-9181	93.00	22	189	0.000	1	27
Fujitsu TA08025-B605	93.00	225	1,946	0.004	6	279
Fujitsu TA08025-B604	93.00	192	1,658	0.003	5	237
JMA Wireless MX08FRO	93.00	193	1,674	0.003	5	240
Generic Flat Platfor	93.00	2,500	21,623	0.044	66	3,097
Stand-Off	83.00	75	517	0.001	2	93
Generic GPS	81.00	10	66	0.000	0	12
Stand-Off	63.00	150	595	0.001	2	186
Generic 2" x 4" GPS	50.00	5	13	0.000	0	6
Stand-Off	50.00	75	188	0.000	1	93
		49,353	486,639	1.000	1,481	61,130

Load Case 0.9D - 1.0Ev + 1.0Eh

Seismic (Reduced DL)

Segment	Height Above Base (ft)	Weight (lb)	W <sub>z</sub> (lb-ft)	C <sub>vx</sub>	Horizontal Force (lb)	Vertical Force (lb)
75	164.55	7	186	0.000	1	6
74	163.05	16	427	0.001	1	14
73	160.50	38	971	0.002	3	32
72	157.50	38	935	0.002	3	32
71	155.50	13	304	0.001	1	11
70	154.00	176	4,163	0.009	13	151
69	151.50	263	6,043	0.012	18	227
68	149.50	88	1,962	0.004	6	76
67	148.00	238	5,206	0.011	16	205
66	146.50	119	2,551	0.005	8	102
65	145.00	158	3,330	0.007	10	136
64	143.10	144	2,949	0.006	9	124
63	141.60	97	1,941	0.004	6	83
62	140.50	81	1,601	0.003	5	70
61	139.00	192	3,704	0.008	11	165
60	136.50	291	5,419	0.011	16	251
59	134.00	196	3,520	0.007	11	169
58	132.50	108	1,889	0.004	6	93
57	130.50	325	5,541	0.011	17	280
56	127.50	329	5,353	0.011	16	284
55	125.94	13	201	0.000	1	11

Site Number: 302495

Code: ANSI/TIA-222-H

© 2007 - 2021 by ATC IP LLC. All rights reserved.

Site Name: Tolland CT, CT

Engineering Number: 13692173\_C3\_03

7/8/2021 6:23:12 PM

Customer: DISH WIRELESS L.L.C.

54	124.44	566	8,766	0.018	27	488
53	122.56	174	2,615	0.005	8	150
52	121.71	120	1,779	0.004	5	103
51	121.25	15	215	0.000	1	13
50	121.15	15	215	0.000	1	13
49	121.05	15	215	0.000	1	13
48	120.50	147	2,133	0.004	6	127
47	118.50	424	5,960	0.012	18	366
46	115.50	431	5,748	0.012	17	371
45	112.50	437	5,536	0.011	17	377
44	109.50	444	5,322	0.011	16	382
43	107.80	60	693	0.001	2	51
42	106.30	391	4,415	0.009	13	337
41	103.50	457	4,894	0.010	15	394
40	100.50	463	4,680	0.010	14	399
39	97.50	470	4,467	0.009	14	405
38	94.50	476	4,254	0.009	13	410
37	91.50	490	4,101	0.008	12	422
36	88.50	496	3,887	0.008	12	428
35	86.20	266	1,979	0.004	6	229
34	84.70	425	3,046	0.006	9	366
33	83.50	304	2,118	0.004	6	262
32	82.00	612	4,117	0.008	13	527
31	80.80	124	807	0.002	2	106
30	79.30	501	3,153	0.006	10	432
29	76.50	586	3,430	0.007	10	505
28	73.50	594	3,208	0.007	10	512
27	70.50	602	2,990	0.006	9	518
26	67.50	609	2,777	0.006	8	525
25	64.50	617	2,568	0.005	8	532
24	61.50	625	2,364	0.005	7	538
23	58.50	633	2,166	0.004	7	545
22	55.50	641	1,973	0.004	6	552
21	52.50	648	1,787	0.004	5	559
20	50.50	218	556	0.001	2	188
19	49.00	438	1,052	0.002	3	378
18	46.95	464	1,023	0.002	3	400
17	45.45	372	768	0.002	2	320
16	43.50	1,253	2,371	0.005	7	1,079
15	41.05	800	1,349	0.003	4	689
14	39.55	279	436	0.001	1	240
13	37.50	763	1,073	0.002	3	657
12	34.50	772	919	0.002	3	665
11	31.50	781	775	0.002	2	673
10	28.50	790	642	0.001	2	681
9	25.50	799	520	0.001	2	688
8	22.50	808	409	0.001	1	696
7	19.50	817	311	0.001	1	704
6	16.50	827	225	0.000	1	712
5	13.50	836	152	0.000	0	720
4	10.50	845	93	0.000	0	728
3	7.50	854	48	0.000	0	735
2	4.50	863	17	0.000	0	743
1	1.50	872	2	0.000	0	751
EMS RR90-17-02DP	164.10	41	1,091	0.002	3	35
Ericsson KRY 112 71/	155.00	79	1,903	0.004	6	68
Canister	155.00	500	12,013	0.025	37	431
Andrew ABT-DMDF-ADBH	149.00	1	24	0.000	0	1
Powerwave Allgon 702	149.00	7	147	0.000	0	6
Kathrein Scala 782-1	149.00	38	853	0.002	3	33
CCI DTMAPB7819VG12A	149.00	115	2,558	0.005	8	99
Raycap DC6-48-60-18-	149.00	32	706	0.001	2	27
Ericsson RRUS 11 (Ba	149.00	150	3,330	0.007	10	129
Ericsson RRUS-12 800	149.00	180	3,996	0.008	12	155

Site Number: 302495

Code: ANSI/TIA-222-H

© 2007 - 2021 by ATC IP LLC. All rights reserved.

Site Name: Tolland CT, CT

Engineering Number: 13692173\_C3\_03

7/8/2021 6:23:12 PM

Customer: DISH WIRELESS L.L.C.

Powerwave Allgon 777	149.00	105	2,331	0.005	7	90
KMW AM-X-CD-16-65-00	149.00	291	6,460	0.013	20	251
Generic Flat Platfor	149.00	2,500	55,503	0.114	169	2,153
Decibel DB844G90A-XY	142.20	84	1,699	0.003	5	72
RFS FDJ85020D7-S	140.00	70	1,376	0.003	4	60
Samsung Outdoor CBRS	140.00	56	1,094	0.002	3	48
Samsung B5/B13 RRH-B	140.00	211	4,134	0.008	13	182
Samsung B2/B66A RRH-	140.00	253	4,963	0.010	15	218
Swedcom SC 9012	140.00	60	1,176	0.002	4	52
Samsung CBRS 64T64R	140.00	225	4,410	0.009	13	194
Samsung MT6407-77A	140.00	245	4,798	0.010	15	211
RFS DB-T1-6Z-8AB-0Z	140.00	88	1,725	0.004	5	76
Commscope JAHH-65B-R	140.00	364	7,127	0.015	22	313
Generic Flat Platfor	140.00	2,500	49,000	0.101	149	2,153
Alcatel-Lucent 800 M	133.00	384	6,793	0.014	21	331
Alcatel-Lucent 1900	133.00	180	3,184	0.007	10	155
Alcatel-Lucent TD-RR	133.00	210	3,715	0.008	11	181
RFS APXVTM14-ALU-I20	133.00	169	2,982	0.006	9	145
Commscope NNVV-65B-R	133.00	232	4,107	0.008	12	200
Modified Platform w/	133.00	2,500	44,223	0.091	135	2,153
Generic Flat Platfor	123.00	2,500	37,823	0.078	115	2,153
Andrew DB844H90E-A	121.30	20	294	0.001	1	17
Andrew DB844H90E-A	121.20	10	147	0.000	0	9
Andrew DB844H90E-A	121.20	10	147	0.000	0	9
Andrew DB844H90E-A	121.10	60	880	0.002	3	52
Andrew DB844H90E-A	121.00	20	293	0.001	1	17
Commscope LNX-6515DS	107.60	151	1,747	0.004	5	130
Kathrein Scala Smart	105.00	10	109	0.000	0	9
Commscope RDIDC-9181	93.00	22	189	0.000	1	19
Fujitsu TA08025-B605	93.00	225	1,946	0.004	6	194
Fujitsu TA08025-B604	93.00	192	1,658	0.003	5	165
JMA Wireless MX08FRO	93.00	193	1,674	0.003	5	167
Generic Flat Platfor	93.00	2,500	21,623	0.044	66	2,153
Stand-Off	83.00	75	517	0.001	2	65
Generic GPS	81.00	10	66	0.000	0	9
Stand-Off	63.00	150	595	0.001	2	129
Generic 2" x 4" GPS	50.00	5	13	0.000	0	4
Stand-Off	50.00	75	188	0.000	1	65
		49,353	486,639	1.000	1,481	42,512



Load Case 1.2D + 1.0Ev + 1.0Eh

Seismic

Calculated Forces

Seg	Pu	Vu	Tu	Mu	Mu	Resultant	phi	phi	phi	phi	Total	Rotation	Ratio
Elev	FY (-)	FX (-)	MY	MZ	MX	Moment	Pn	Vn	Tn	Mn	Deflect	(deg)	
(ft)	(kips)	(kips)	(ft-kips)	(ft-kips)	(ft-kips)	(ft-kips)	(kips)	(kips)	(ft-kips)	(ft-kips)	(in)		
0.00	-60.05	-1.48	0.00	-199.58	0.00	199.58	4,665.07	1,225.36	5,729.16	4,709.48	0.00	0.00	0.055
3.00	-58.98	-1.49	0.00	-195.13	0.00	195.13	4,631.78	1,209.74	5,584.06	4,615.74	0.00	-0.01	0.055
6.00	-57.92	-1.50	0.00	-190.66	0.00	190.66	4,597.82	1,194.12	5,440.82	4,522.21	0.01	-0.02	0.055
9.00	-56.88	-1.51	0.00	-186.16	0.00	186.16	4,563.18	1,178.50	5,299.44	4,428.89	0.02	-0.02	0.054
12.00	-55.84	-1.51	0.00	-181.64	0.00	181.64	4,527.86	1,162.88	5,159.92	4,335.83	0.04	-0.03	0.054
15.00	-54.82	-1.52	0.00	-177.10	0.00	177.10	4,491.86	1,147.25	5,022.26	4,243.05	0.06	-0.04	0.054
18.00	-53.80	-1.53	0.00	-172.55	0.00	172.55	4,455.19	1,131.63	4,886.46	4,150.57	0.09	-0.05	0.054
21.00	-52.80	-1.53	0.00	-167.97	0.00	167.97	4,417.85	1,116.01	4,752.53	4,058.43	0.12	-0.06	0.053
24.00	-51.81	-1.54	0.00	-163.38	0.00	163.38	4,379.82	1,100.39	4,620.45	3,966.64	0.16	-0.06	0.053
27.00	-50.83	-1.54	0.00	-158.77	0.00	158.77	4,341.13	1,084.77	4,490.24	3,875.23	0.20	-0.07	0.053
30.00	-49.87	-1.55	0.00	-154.14	0.00	154.14	4,301.75	1,069.15	4,361.89	3,784.23	0.25	-0.08	0.052
33.00	-48.91	-1.55	0.00	-149.51	0.00	149.51	4,261.70	1,053.52	4,235.40	3,693.68	0.31	-0.09	0.052
36.00	-47.96	-1.55	0.00	-144.86	0.00	144.86	4,220.97	1,037.90	4,110.77	3,603.58	0.37	-0.10	0.052
39.00	-47.62	-1.55	0.00	-140.21	0.00	140.21	4,179.57	1,022.28	3,988.00	3,513.97	0.43	-0.11	0.051
40.10	-46.63	-1.55	0.00	-138.49	0.00	138.49	4,164.16	1,016.53	3,943.28	3,481.12	0.46	-0.11	0.051
42.00	-45.08	-1.55	0.00	-135.55	0.00	135.55	4,137.49	1,006.66	3,867.09	3,424.88	0.51	-0.12	0.050
45.00	-44.62	-1.55	0.00	-130.90	0.00	130.90	4,094.73	991.04	3,748.05	3,336.33	0.58	-0.13	0.050
45.90	-44.04	-1.55	0.00	-129.51	0.00	129.51	3,345.43	862.67	3,312.91	2,772.86	0.61	-0.13	0.060
48.00	-43.50	-1.55	0.00	-126.26	0.00	126.26	3,324.15	853.29	3,241.28	2,724.99	0.67	-0.14	0.059
50.00	-43.13	-1.55	0.00	-123.16	0.00	123.16	3,303.59	844.36	3,173.84	2,679.55	0.73	-0.14	0.059
51.00	-42.32	-1.55	0.00	-121.61	0.00	121.61	3,293.20	839.90	3,140.39	2,656.86	0.76	-0.15	0.059
54.00	-41.53	-1.55	0.00	-116.97	0.00	116.97	3,261.57	826.51	3,041.08	2,589.00	0.85	-0.16	0.058
57.00	-40.75	-1.55	0.00	-112.32	0.00	112.32	3,229.26	813.12	2,943.38	2,521.44	0.96	-0.17	0.057
60.00	-39.97	-1.54	0.00	-107.68	0.00	107.68	3,196.28	799.73	2,847.27	2,454.19	1.07	-0.18	0.056
63.00	-39.02	-1.54	0.00	-103.05	0.00	103.05	3,162.62	786.34	2,752.76	2,387.28	1.18	-0.19	0.056
66.00	-38.27	-1.54	0.00	-98.43	0.00	98.43	3,128.28	772.95	2,659.84	2,320.75	1.31	-0.20	0.055
69.00	-37.52	-1.53	0.00	-93.83	0.00	93.83	3,093.27	759.56	2,568.51	2,254.62	1.44	-0.21	0.054
72.00	-36.79	-1.53	0.00	-89.23	0.00	89.23	3,057.58	746.17	2,478.79	2,188.92	1.58	-0.22	0.053
75.00	-36.06	-1.52	0.00	-84.66	0.00	84.66	3,021.22	732.78	2,390.65	2,123.66	1.72	-0.24	0.052
78.00	-35.44	-1.51	0.00	-80.10	0.00	80.10	2,984.18	719.39	2,304.12	2,058.89	1.87	-0.25	0.051
80.60	-35.28	-1.51	0.00	-76.17	0.00	76.17	2,951.54	707.79	2,230.44	2,003.18	2.01	-0.26	0.050
81.00	-34.51	-1.50	0.00	-75.56	0.00	75.56	2,946.46	706.00	2,219.17	1,994.61	2.03	-0.26	0.050
83.00	-34.04	-1.49	0.00	-72.56	0.00	72.56	2,920.94	697.07	2,163.43	1,952.06	2.14	-0.26	0.049
84.00	-33.52	-1.48	0.00	-71.07	0.00	71.07	2,908.96	692.61	2,135.83	1,931.47	2.20	-0.27	0.048
85.41	-33.19	-1.48	0.00	-68.98	0.00	68.98	2,288.86	584.09	1,822.48	1,541.02	2.28	-0.27	0.059
87.00	-32.57	-1.47	0.00	-66.62	0.00	66.62	2,274.94	578.16	1,785.69	1,515.96	2.37	-0.28	0.058
90.00	-31.97	-1.46	0.00	-62.21	0.00	62.21	2,248.22	567.00	1,717.45	1,468.96	2.55	-0.29	0.057
93.00	-27.50	-1.35	0.00	-57.83	0.00	57.83	2,220.81	555.84	1,650.54	1,422.23	2.74	-0.30	0.053
96.00	-26.92	-1.34	0.00	-53.79	0.00	53.79	2,192.74	544.68	1,584.96	1,375.78	2.93	-0.32	0.051
99.00	-26.34	-1.33	0.00	-49.77	0.00	49.77	2,163.98	533.53	1,520.71	1,329.64	3.13	-0.33	0.050
102.00	-25.78	-1.31	0.00	-45.80	0.00	45.80	2,134.56	522.37	1,457.78	1,283.85	3.34	-0.34	0.048
105.00	-25.28	-1.30	0.00	-41.86	0.00	41.86	2,104.45	511.21	1,396.19	1,238.42	3.56	-0.35	0.046
107.60	-25.02	-1.29	0.00	-38.48	0.00	38.48	2,077.81	501.54	1,343.89	1,199.37	3.75	-0.36	0.044
108.00	-24.47	-1.28	0.00	-37.97	0.00	37.97	2,073.67	500.05	1,335.93	1,193.39	3.78	-0.36	0.044
111.00	-23.93	-1.26	0.00	-34.14	0.00	34.14	2,042.21	488.89	1,277.00	1,148.77	4.01	-0.37	0.041
114.00	-23.39	-1.24	0.00	-30.36	0.00	30.36	2,006.48	477.73	1,219.39	1,102.63	4.25	-0.38	0.039
117.00	-22.87	-1.23	0.00	-26.63	0.00	26.63	1,959.62	466.58	1,163.12	1,051.43	4.49	-0.39	0.037

Site Number: 302495

Code: ANSI/TIA-222-H

© 2007 - 2021 by ATC IP LLC. All rights reserved.

Site Name: Tolland CT, CT

Engineering Number: 13692173\_C3\_03

7/8/2021 6:23:12 PM

Customer: DISH WIRELESS L.L.C.

120.00	-22.68	-1.22	0.00	-22.95	0.00	22.95	1,912.75	455.42	1,108.17	1,001.46	4.74	-0.40	0.035
121.00	-22.52	-1.21	0.00	-21.73	0.00	21.73	1,897.13	451.70	1,090.15	985.07	4.83	-0.40	0.034
121.10	-22.50	-1.21	0.00	-21.61	0.00	21.61	1,895.57	451.33	1,088.36	983.44	4.84	-0.40	0.034
121.20	-22.48	-1.21	0.00	-21.49	0.00	21.49	1,894.01	450.95	1,086.57	981.81	4.84	-0.40	0.034
121.30	-22.33	-1.21	0.00	-21.37	0.00	21.37	1,892.45	450.58	1,084.78	980.18	4.85	-0.40	0.034
122.12	-22.12	-1.20	0.00	-20.37	0.00	20.37	1,879.60	447.52	1,070.10	966.84	4.92	-0.41	0.033
123.00	-18.32	-1.03	0.00	-19.32	0.00	19.32	1,865.89	444.26	1,054.56	952.70	5.00	-0.41	0.030
125.89	-18.30	-1.03	0.00	-16.35	0.00	16.35	929.68	265.41	627.12	474.96	5.25	-0.42	0.054
126.00	-17.90	-1.01	0.00	-16.23	0.00	16.23	929.29	265.16	625.91	474.31	5.26	-0.42	0.053
129.00	-17.49	-1.00	0.00	-13.19	0.00	13.19	918.88	258.46	594.71	457.06	5.52	-0.43	0.048
132.00	-17.36	-0.99	0.00	-10.20	0.00	10.20	907.79	251.77	564.31	439.76	5.79	-0.44	0.042
133.00	-12.57	-0.75	0.00	-9.21	0.00	9.21	903.95	249.54	554.35	433.99	5.88	-0.44	0.035
135.00	-12.21	-0.73	0.00	-7.71	0.00	7.71	896.03	245.07	534.70	422.43	6.07	-0.44	0.032
138.00	-11.97	-0.72	0.00	-5.53	0.00	5.53	883.59	238.38	505.89	405.10	6.35	-0.45	0.027
140.00	-6.83	-0.43	0.00	-4.09	0.00	4.09	874.92	233.92	487.13	393.55	6.54	-0.45	0.018
141.00	-6.71	-0.42	0.00	-3.66	0.00	3.66	870.48	231.68	477.88	387.78	6.63	-0.45	0.017
142.20	-6.43	-0.41	0.00	-3.16	0.00	3.16	865.04	229.01	466.90	380.87	6.75	-0.45	0.016
144.00	-6.23	-0.40	0.00	-2.42	0.00	2.42	856.69	224.99	450.67	370.52	6.92	-0.46	0.014
146.00	-6.08	-0.39	0.00	-1.63	0.00	1.63	847.12	220.53	432.97	359.05	7.11	-0.46	0.012
146.00	-6.08	-0.39	0.00	-1.63	0.00	1.63	920.33	276.10	376.25	378.52	7.11	-0.46	0.011
147.00	-5.79	-0.37	0.00	-1.25	0.00	1.25	920.33	276.10	376.25	378.52	7.21	-0.46	0.010
149.00	-1.45	-0.10	0.00	-0.51	0.00	0.51	920.33	276.10	376.25	378.52	7.40	-0.46	0.003
150.00	-1.12	-0.08	0.00	-0.41	0.00	0.41	920.33	276.10	376.25	378.52	7.50	-0.46	0.002
153.00	-0.90	-0.06	0.00	-0.19	0.00	0.19	920.33	276.10	376.25	378.52	7.78	-0.46	0.001
155.00	-0.17	-0.01	0.00	-0.06	0.00	0.06	920.33	276.10	376.25	378.52	7.98	-0.46	0.000
155.00	-0.17	-0.01	0.00	-0.06	0.00	0.06	70.80	21.24	6.13	6.17	7.98	-0.46	0.013
156.00	-0.13	-0.01	0.00	-0.05	0.00	0.05	70.80	21.24	6.13	6.17	8.07	-0.46	0.010
159.00	-0.08	-0.01	0.00	-0.03	0.00	0.03	70.80	21.24	6.13	6.17	8.37	-0.47	0.005
162.00	-0.06	0.00	0.00	-0.01	0.00	0.01	70.80	21.24	6.13	6.17	8.66	-0.48	0.002
164.10	0.00	0.00	0.00	0.00	0.00	0.00	70.80	21.24	6.13	6.17	8.87	-0.48	0.000
165.00	0.00	0.00	0.00	0.00	0.00	0.00	70.80	21.24	6.13	6.17	8.96	-0.48	0.000

Load Case 0.9D - 1.0Ev + 1.0Eh

Seismic (Reduced DL)

Calculated Forces

Seg	Pu	Vu	Tu	Mu	Mu	Resultant	phi	phi	phi	phi	Total	Rotation	Ratio
Elev	FY (-)	FX (-)	MY	MZ	MX	Moment	Pn	Vn	Tn	Mn	Deflect	(deg)	
(ft)	(kips)	(kips)	(ft-kips)	(ft-kips)	(ft-kips)	(ft-kips)	(kips)	(kips)	(ft-kips)	(ft-kips)	(in)		
0.00	-41.76	-1.48	0.00	-194.28	0.00	194.28	4,665.07	1,225.36	5,729.16	4,709.48	0.00	0.00	0.050
3.00	-41.02	-1.49	0.00	-189.83	0.00	189.83	4,631.78	1,209.74	5,584.06	4,615.74	0.00	-0.01	0.050
6.00	-40.28	-1.49	0.00	-185.37	0.00	185.37	4,597.82	1,194.12	5,440.82	4,522.21	0.01	-0.02	0.050
9.00	-39.55	-1.50	0.00	-180.89	0.00	180.89	4,563.18	1,178.50	5,299.44	4,428.89	0.02	-0.02	0.050
12.00	-38.83	-1.50	0.00	-176.40	0.00	176.40	4,527.86	1,162.88	5,159.92	4,335.83	0.04	-0.03	0.049
15.00	-38.12	-1.51	0.00	-171.90	0.00	171.90	4,491.86	1,147.25	5,022.26	4,243.05	0.06	-0.04	0.049
18.00	-37.42	-1.51	0.00	-167.38	0.00	167.38	4,455.19	1,131.63	4,886.46	4,150.57	0.09	-0.05	0.049
21.00	-36.72	-1.51	0.00	-162.85	0.00	162.85	4,417.85	1,116.01	4,752.53	4,058.43	0.12	-0.05	0.048
24.00	-36.03	-1.52	0.00	-158.31	0.00	158.31	4,379.82	1,100.39	4,620.45	3,966.64	0.16	-0.06	0.048
27.00	-35.35	-1.52	0.00	-153.76	0.00	153.76	4,341.13	1,084.77	4,490.24	3,875.23	0.20	-0.07	0.048
30.00	-34.68	-1.52	0.00	-149.20	0.00	149.20	4,301.75	1,069.15	4,361.89	3,784.23	0.25	-0.08	0.047
33.00	-34.01	-1.52	0.00	-144.64	0.00	144.64	4,261.70	1,053.52	4,235.40	3,693.68	0.30	-0.09	0.047
36.00	-33.36	-1.52	0.00	-140.07	0.00	140.07	4,220.97	1,037.90	4,110.77	3,603.58	0.36	-0.10	0.047
39.00	-33.12	-1.52	0.00	-135.51	0.00	135.51	4,179.57	1,022.28	3,988.00	3,513.97	0.42	-0.11	0.046
40.10	-32.43	-1.52	0.00	-133.82	0.00	133.82	4,164.16	1,016.53	3,943.28	3,481.12	0.45	-0.11	0.046
42.00	-31.35	-1.52	0.00	-130.94	0.00	130.94	4,137.49	1,006.66	3,867.09	3,424.88	0.49	-0.12	0.046
45.00	-31.03	-1.52	0.00	-126.39	0.00	126.39	4,094.73	991.04	3,748.05	3,336.33	0.57	-0.12	0.045
45.90	-30.63	-1.52	0.00	-125.02	0.00	125.02	3,345.43	862.67	3,312.91	2,772.86	0.59	-0.13	0.054
48.00	-30.25	-1.51	0.00	-121.84	0.00	121.84	3,324.15	853.29	3,241.28	2,724.99	0.65	-0.13	0.054
50.00	-29.99	-1.51	0.00	-118.81	0.00	118.81	3,303.59	844.36	3,173.84	2,679.55	0.71	-0.14	0.053
51.00	-29.43	-1.51	0.00	-117.30	0.00	117.30	3,293.20	839.90	3,140.39	2,656.86	0.73	-0.14	0.053
54.00	-28.88	-1.51	0.00	-112.76	0.00	112.76	3,261.57	826.51	3,041.08	2,589.00	0.83	-0.15	0.052
57.00	-28.34	-1.51	0.00	-108.24	0.00	108.24	3,229.26	813.12	2,943.38	2,521.44	0.93	-0.16	0.052
60.00	-27.80	-1.50	0.00	-103.72	0.00	103.72	3,196.28	799.73	2,847.27	2,454.19	1.04	-0.17	0.051
63.00	-27.14	-1.50	0.00	-99.21	0.00	99.21	3,162.62	786.34	2,752.76	2,387.28	1.15	-0.19	0.050
66.00	-26.61	-1.49	0.00	-94.73	0.00	94.73	3,128.28	772.95	2,659.84	2,320.75	1.27	-0.20	0.049
69.00	-26.09	-1.48	0.00	-90.25	0.00	90.25	3,093.27	759.56	2,568.51	2,254.62	1.39	-0.21	0.048
72.00	-25.58	-1.48	0.00	-85.80	0.00	85.80	3,057.58	746.17	2,478.79	2,188.92	1.53	-0.22	0.048
75.00	-25.08	-1.47	0.00	-81.37	0.00	81.37	3,021.22	732.78	2,390.65	2,123.66	1.67	-0.23	0.047
78.00	-24.64	-1.46	0.00	-76.96	0.00	76.96	2,984.18	719.39	2,304.12	2,058.89	1.81	-0.24	0.046
80.60	-24.54	-1.46	0.00	-73.16	0.00	73.16	2,951.54	707.79	2,230.44	2,003.18	1.95	-0.25	0.045
81.00	-24.00	-1.45	0.00	-72.58	0.00	72.58	2,946.46	706.00	2,219.17	1,994.61	1.97	-0.25	0.045
83.00	-23.67	-1.44	0.00	-69.68	0.00	69.68	2,920.94	697.07	2,163.43	1,952.06	2.07	-0.26	0.044
84.00	-23.31	-1.43	0.00	-68.24	0.00	68.24	2,908.96	692.61	2,135.83	1,931.47	2.13	-0.26	0.043
85.41	-23.08	-1.43	0.00	-66.22	0.00	66.22	2,288.86	584.09	1,822.48	1,541.02	2.20	-0.26	0.053
87.00	-22.65	-1.42	0.00	-63.95	0.00	63.95	2,274.94	578.16	1,785.69	1,515.96	2.29	-0.27	0.052
90.00	-22.23	-1.41	0.00	-59.70	0.00	59.70	2,248.22	567.00	1,717.45	1,468.96	2.47	-0.28	0.051
93.00	-19.12	-1.30	0.00	-55.48	0.00	55.48	2,220.81	555.84	1,650.54	1,422.23	2.65	-0.29	0.048
96.00	-18.72	-1.29	0.00	-51.58	0.00	51.58	2,192.74	544.68	1,584.96	1,375.78	2.84	-0.30	0.046
99.00	-18.32	-1.27	0.00	-47.72	0.00	47.72	2,163.98	533.53	1,520.71	1,329.64	3.03	-0.32	0.044
102.00	-17.92	-1.26	0.00	-43.89	0.00	43.89	2,134.56	522.37	1,457.78	1,283.85	3.23	-0.33	0.043
105.00	-17.58	-1.25	0.00	-40.11	0.00	40.11	2,104.45	511.21	1,396.19	1,238.42	3.44	-0.34	0.041
107.60	-17.40	-1.24	0.00	-36.86	0.00	36.86	2,077.81	501.54	1,343.89	1,199.37	3.63	-0.35	0.039
108.00	-17.01	-1.22	0.00	-36.37	0.00	36.37	2,073.67	500.05	1,335.93	1,193.39	3.66	-0.35	0.039
111.00	-16.64	-1.21	0.00	-32.69	0.00	32.69	2,042.21	488.89	1,277.00	1,148.77	3.88	-0.36	0.037
114.00	-16.27	-1.19	0.00	-29.07	0.00	29.07	2,006.48	477.73	1,219.39	1,102.63	4.11	-0.37	0.034
117.00	-15.90	-1.17	0.00	-25.49	0.00	25.49	1,959.62	466.58	1,163.12	1,051.43	4.34	-0.38	0.032

Site Number: 302495

Code: ANSI/TIA-222-H

© 2007 - 2021 by ATC IP LLC. All rights reserved.

Site Name: Tolland CT, CT

Engineering Number: 13692173\_C3\_03

7/8/2021 6:23:12 PM

Customer: DISH WIRELESS L.L.C.

120.00	-15.77	-1.17	0.00	-21.97	0.00	21.97	1,912.75	455.42	1,108.17	1,001.46	4.58	-0.39	0.030
121.00	-15.66	-1.16	0.00	-20.80	0.00	20.80	1,897.13	451.70	1,090.15	985.07	4.66	-0.39	0.029
121.10	-15.65	-1.16	0.00	-20.69	0.00	20.69	1,895.57	451.33	1,088.36	983.44	4.67	-0.39	0.029
121.20	-15.63	-1.16	0.00	-20.57	0.00	20.57	1,894.01	450.95	1,086.57	981.81	4.68	-0.39	0.029
121.30	-15.53	-1.15	0.00	-20.46	0.00	20.46	1,892.45	450.58	1,084.78	980.18	4.69	-0.39	0.029
122.12	-15.38	-1.15	0.00	-19.51	0.00	19.51	1,879.60	447.52	1,070.10	966.84	4.75	-0.39	0.028
123.00	-12.74	-0.99	0.00	-18.50	0.00	18.50	1,865.89	444.26	1,054.56	952.70	4.83	-0.39	0.026
125.89	-12.73	-0.99	0.00	-15.65	0.00	15.65	929.68	265.41	627.12	474.96	5.07	-0.40	0.047
126.00	-12.44	-0.97	0.00	-15.54	0.00	15.54	929.29	265.16	625.91	474.31	5.08	-0.40	0.046
129.00	-12.16	-0.95	0.00	-12.63	0.00	12.63	918.88	258.46	594.71	457.06	5.33	-0.41	0.041
132.00	-12.07	-0.95	0.00	-9.77	0.00	9.77	907.79	251.77	564.31	439.76	5.59	-0.42	0.036
133.00	-8.74	-0.72	0.00	-8.82	0.00	8.82	903.95	249.54	554.35	433.99	5.68	-0.42	0.030
135.00	-8.49	-0.70	0.00	-7.39	0.00	7.39	896.03	245.07	534.70	422.43	5.86	-0.43	0.027
138.00	-8.32	-0.69	0.00	-5.30	0.00	5.30	883.59	238.38	505.89	405.10	6.13	-0.43	0.023
140.00	-4.75	-0.41	0.00	-3.92	0.00	3.92	874.92	233.92	487.13	393.55	6.31	-0.44	0.015
141.00	-4.67	-0.41	0.00	-3.51	0.00	3.51	870.48	231.68	477.88	387.78	6.40	-0.44	0.014
142.20	-4.47	-0.39	0.00	-3.03	0.00	3.03	865.04	229.01	466.90	380.87	6.51	-0.44	0.013
144.00	-4.33	-0.38	0.00	-2.32	0.00	2.32	856.69	224.99	450.67	370.52	6.68	-0.44	0.011
146.00	-4.23	-0.37	0.00	-1.57	0.00	1.57	847.12	220.53	432.97	359.05	6.86	-0.44	0.009
146.00	-4.23	-0.37	0.00	-1.57	0.00	1.57	920.33	276.10	376.25	378.52	6.86	-0.44	0.009
147.00	-4.03	-0.35	0.00	-1.20	0.00	1.20	920.33	276.10	376.25	378.52	6.95	-0.44	0.008
149.00	-1.01	-0.09	0.00	-0.49	0.00	0.49	920.33	276.10	376.25	378.52	7.14	-0.44	0.002
150.00	-0.78	-0.07	0.00	-0.40	0.00	0.40	920.33	276.10	376.25	378.52	7.23	-0.44	0.002
153.00	-0.63	-0.06	0.00	-0.18	0.00	0.18	920.33	276.10	376.25	378.52	7.51	-0.44	0.001
155.00	-0.12	-0.01	0.00	-0.06	0.00	0.06	920.33	276.10	376.25	378.52	7.70	-0.44	0.000
155.00	-0.12	-0.01	0.00	-0.06	0.00	0.06	70.80	21.24	6.13	6.17	7.70	-0.44	0.012
156.00	-0.09	-0.01	0.00	-0.05	0.00	0.05	70.80	21.24	6.13	6.17	7.79	-0.44	0.009
159.00	-0.05	-0.01	0.00	-0.03	0.00	0.03	70.80	21.24	6.13	6.17	8.07	-0.45	0.005
162.00	-0.04	0.00	0.00	-0.01	0.00	0.01	70.80	21.24	6.13	6.17	8.36	-0.46	0.002
164.10	0.00	0.00	0.00	0.00	0.00	0.00	70.80	21.24	6.13	6.17	8.56	-0.46	0.000
165.00	0.00	0.00	0.00	0.00	0.00	0.00	70.80	21.24	6.13	6.17	8.65	-0.46	0.000

Site Number: 302495

Code: ANSI/TIA-222-H

© 2007 - 2021 by ATC IP LLC. All rights reserved.

Site Name: Tolland CT, CT

Engineering Number: 13692173\_C3\_03

7/8/2021 6:23:12 PM

Customer: DISH WIRELESS L.L.C.

### Analysis Summary

Load Case	Reactions						Max Usage	
	Shear FX (kips)	Shear FZ (kips)	Axial FY (kips)	Moment MX (ft-kips)	Moment MY (ft-kips)	Moment MZ (ft-kips)	Elev (ft)	Interaction Ratio
1.2D + 1.0W	43.60	0.00	59.16	0.00	0.00	4530.52	0.00	0.98
0.9D + 1.0W	43.58	0.00	44.35	0.00	0.00	4442.87	0.00	0.95
1.2D + 1.0Di + 1.0Wi	8.46	0.00	94.14	0.00	0.00	1030.64	45.90	0.26
1.2D + 1.0Ev + 1.0Eh	1.48	0.00	60.05	0.00	0.00	199.58	45.90	0.06
0.9D - 1.0Ev + 1.0Eh	1.48	0.00	41.76	0.00	0.00	194.28	45.90	0.05
1.0D + 1.0W	10.08	0.00	49.35	0.00	0.00	1037.37	0.00	0.23

**Site Name:** Tolland, CT  
**Site Number:** 302495  
**Tower Type:** MP  
**Design Base Loads (Factored) - Analysis per TIA-222-H Standards**

## Pier Foundation Analysis

Foundation Analysis Parameters		
Analyze or Design a Foundation?	Analyze	-
Foundation Mapped:	N	-
Moment (M):	4,530.5	k-ft
Shear/Leg (V):	43.6	k
Axial Load (P):	59.2	k
Uplift/Leg (U):		k
Diameter of Caisson (d):	7	ft
Caisson Embedment (L-h):	30	ft
Caisson Height Above Ground (h):	1	ft
Depth Below Ground Surface to Water Table (w):	3	ft
Unit Weight of Concrete:	150	pcf
Unit Weight of Water:	62.4	pcf
Tension/Compression Skin Friction Factor:	1	-
Pullout Angle:	30	°

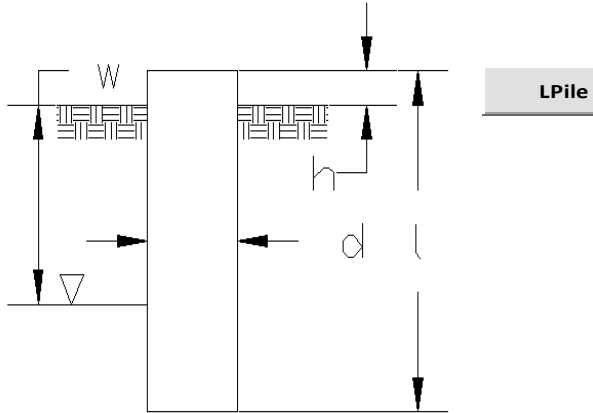

Depth (ft)		$\gamma_{soil}$ (pcf)	Cu (psf)	$\phi$ (degree)	Ultimate Skin Friction (psf)	Ultimate Bearing Pressure (psf)
Top	Bottom					
0	3	105	0	0	0	0
3	5	127	0	37	0	0
5	10	133	0	40	832	0
10	31	137	0	40	1,668	57,156

Soil Strength Capacities		
Required Embedment:	23.0	ft
Volume of Concrete:	1193.0	ft <sup>3</sup>
Buoyant Weight of Concrete:	114.1	k
Average Soil Unit Weight:	76.3	pcf
Skin Friction Resistance:	825.1	k
Compressive Bearing Resistance:	2199.6	k
Pullout Weight (Minus Concrete Weight):	1155.1	k
Nominal Uplift Capacity per Leg ( $f_s T_n$ ):	618.8	k
Nominal Compressive Capacity per Leg ( $f_s P_n$ ):	2268.5	k
$T_u$ :	0.00	k
$T_u/f_s T_n$ :	0%	Pass
$P_u$ :	83.5	k
$P_u/f_s P_n$ :	4%	Pass
Total Lateral Resistance:	2862.3	k
Inflection Point (Below Ground Surface):	21.1	ft
Moment At Inflection Point ( $M_D$ ):	5494.7	k-ft
Nominal Moment Capacity ( $f_s M_n$ ):	12424.5	k-ft
$f_s$ :	0.75	-
$M_D/f_s M_n$ :	44%	Pass

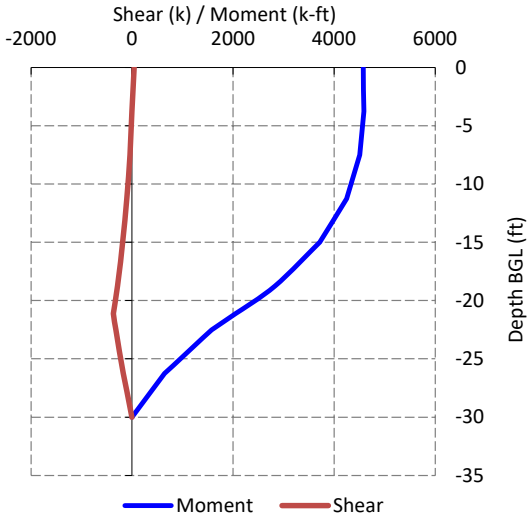



### Caisson Strength Capacities

Concrete Compressive Strength ( $f'_c$ ):	4,000	psi	
Vertical Steel Rebar Size #:	11	-	
Vertical Steel Rebar Area:	1.56	in <sup>2</sup>	
# of Vertical Steel Rebars:	18	-	
Vertical Steel Rebar Yield Strength ( $F_y$ ):	60	ksi	
Horizontal Tie / Stirrup Size #:	5	-	
Horizontal Tie / Stirrup Area:	0.31	in <sup>2</sup>	
Vertical Rebar Clear Cover:	3	in	
Design Horizontal Tie / Stirrup Spacing:	12	in	
Horizontal Tie / Stirrup Steel Yield Strength ( $F_y$ ):	60	ksi	
Rebar Cage Diameter:	78.0	in	
Strength Bending/Tension Reduction Factor ( $f_b$ ):	0.9	-	ACI 318-14 - 21.2.1 [Table 21.2.1 (a)]
Strength Shear Reduction Factor ( $f_v$ ):	0.75	-	ACI 318-14 - 21.2.1 [Table 21.2.1 (b)]
Strength Compression Reduction Factor ( $f_c$ ):	0.65	-	ACI 318-14 - 21.2.1 [Table 21.2.1 (a)]
Steel Elastic Modulus:	29000	ksi	
Design Moment ( $M_u$ ):	4588.8	k-ft	
Nominal Moment Capacity ( $f_b M_n$ ):	4824.4	k-ft	ACI 318-14 - 9.5.2/22.3
$M_u/f_b M_n$ :	95%	Pass	
Design Shear ( $V_u$ ):	369.1	k	
Nominal Shear Capacity ( $f_v V_n$ ):	684.79	k	ACI 318-14 - 22.5
$V_u/f_v V_n$ :	54%	Pass	
Design Tension ( $T_u$ ):	0.0	k	
Nominal Tension Capacity ( $f_t T_n$ ):	1516.3	k	
$T_u/f_t T_n$ :	0%	Pass	
Design Compression ( $P_u$ ):	83.5	k	
Nominal Compression Capacity ( $f_p P_n$ ):	10624.3	k	ACI 318-14 - 22.4
$P_u/f_p P_n$ :	1%	Pass	
Bending Reinforcement Ratio:	0.005	-	
$M_u/f_b M_n + T_u/f_t T_n$ :	95%	Pass	ACI 318-14 - 10.6.1 & TIA-222-H - 9.4.1

### Nominal and Factored Moment Capacity and Factored Design Loads

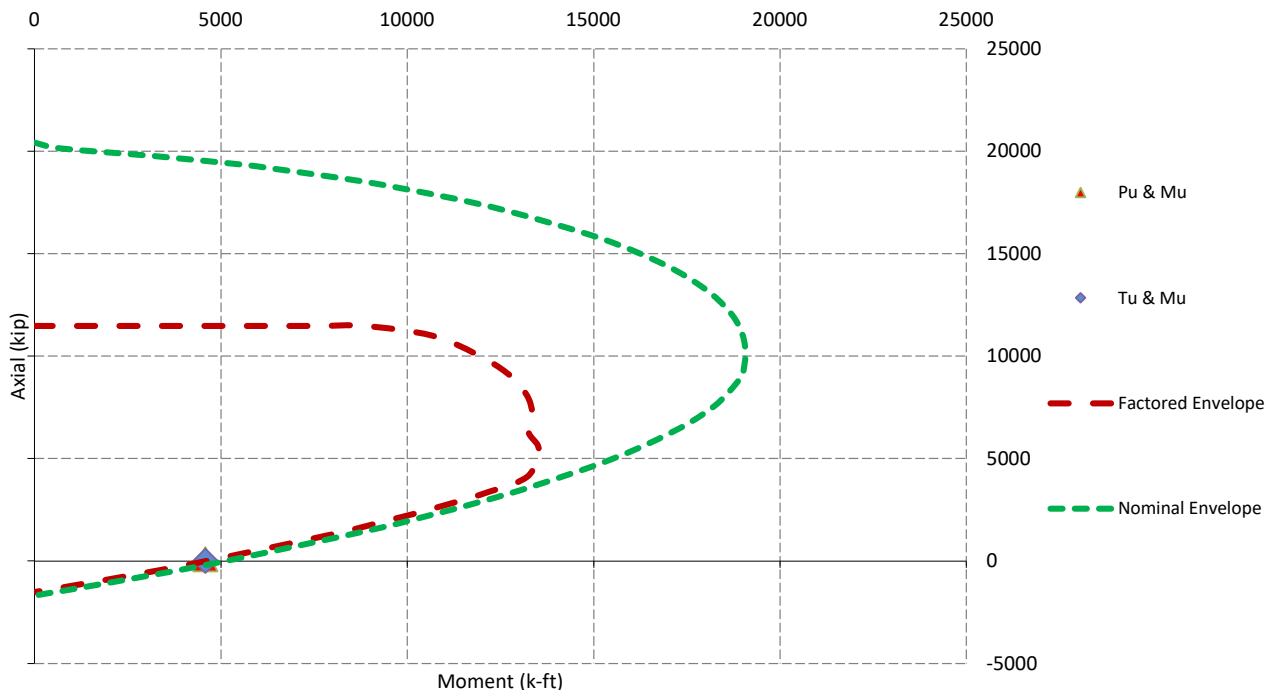

## Base Plate & Anchor Rod Analysis

Pole Dimensions		
Number of Sides	12	-
Diameter	50	in
Thickness	0.4375	in
Orientation Offset	0	°

Base Reactions		
Moment, Mu	4530.5	k-ft
Axial, Pu	59.2	k
Shear, Vu	43.6	k
Neutral Axis	235	°

Report Capacities		
Component	Capacity	Result
Base Plate	56%	Pass
Anchor Rods	101%	Pass
Dwyidag	-	-

Base Plate		
Shape	Round	-
Diameter, $\phi$	65	in
Thickness	2	in
Grade	A572-60	
Yield Strength, Fy	60	ksi
Tensile Strength, Fu	75	ksi
Clip	N/A	in
Orientation Offset	0	°
Anchor Rod Detail	c	$\eta=0.55$
Clear Distance	N/A	in
Applied Moment, Mu	1285.0	k
Bending Stress, $\phi Mn$	2304.2	k

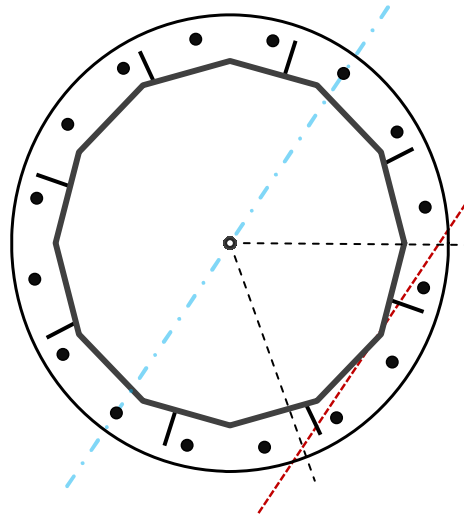

Original Anchor Rods		
Arrangement	Radial	-
Quantity	16	-
Diameter, $\phi$	2 1/4	in
Bolt Circle	59	in
Grade	A615-75	
Yield Strength, Fy	75	ksi
Tensile Strength, Fu	100	ksi
Spacing	11.6	in
Orientation Offset	10	°
Applied Force, Pu	243.6	k
Anchor Rods, $\phi Pn$	243.6	k

Stiffeners		
Arrangement	Radial	-
Quantity	8	-
Height	12	in
Width	5	in
Effective Width	5.000	in
Thickness	3/4	in
Effective Thickness	0.360	in
Notch	1	in
Flat Edge	0.5	in
Grade	A36	-
Yield Strength, Fy	36	ksi
Tensile Strength, Fu	58	ksi
Horizontal Weld	Fillet	
Horizontal Fillet Size	5/16	in
Bevel Depth	0	in
Vertical Weld	Fillet	
Vertical Fillet Size	1/4	in
Weld Strength	70	ksi
Electrode Coefficient	1	-
Orientation Offset	3.75	°
Vertical Weld, $\phi Rn$	133.9	k
Horz. Weld, $\phi Rn$	73.9	k
Ten. Capacity, $\phi Tn$	97.2	k
Comp. Capacity, $\phi Pn$	141.2	k

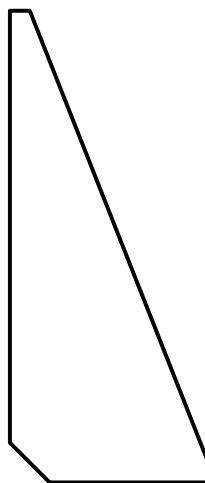

# Flange Plate Analysis

<b>Flange Plate</b>	Plate Type	<b>Flange</b>	<b>@ 146 ft</b>
	Pole Diameter	16	in
	Pole Thickness	0.5	in
	Plate Diameter	28.5	in
	Plate Thickness	1.5	in
	Plate Fy	60	ksi
	Weld Length	0.3125	in
	f <sub>s</sub> Resistance	127.23	k-in
	Applied	13.77	k-in

Code Rev.	<b>H</b>
Moment	25.0 k-ft
Axial	5.3 k

Date	7/8/2021
Engineer	DAVI
Site #	302495
Carrier	Verizon Wireless

Required Flange Thickness:  
0.49 in OK

<b>Stiffeners</b>	#	
-------------------	---	--

<b>Bolts</b>	#	<b>12</b>	
	Bolt Circle (R)adial / (S)quare	25.75	in
	Bolt Gap	6	in
	Diameter	1	in
	Hole Diameter	1.125	in
	Type	A325	
	Fy	92	ksi
	Fu	120	ksi
	f <sub>s</sub> Resistance	54.52	k
	Applied	3.44	k

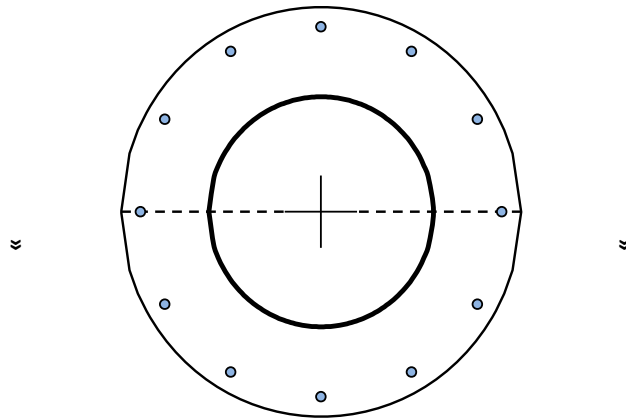

<b>Reinforcement</b>	#	
----------------------	---	--

**Plate Stress Ratio:**  
11% Pass

**Bolt Stress Ratio:**  
6% Pass

<b>Extra Bolts</b>	#	
--------------------	---	--

# Flange Plate Analysis

<b>Flange Plate</b>	Plate Type	<b>Flange</b>	<b>@ 155 ft</b>
	Pole Diameter	3.5	in
	Pole Thickness	0.218	in
	Plate Diameter	16	in
	Plate Thickness	0.75	in
	Plate Fy	36	ksi
	Weld Length	0.1875	in
	f <sub>s</sub> Resistance	174.52	k-in
	Applied	3.24	k-in

Code Rev.	<b>H</b>
Moment	0.9 k-ft
Axial	0.2 k

Date	7/8/2021
Engineer	DAVI
Site #	302495
Carrier	Verizon Wireless

<b>Stiffeners</b>	#	<b>4</b>	<b>Show</b>
	Thickness	0.5	in
	Length	3	in
	Height	6	in
	Chamfer	0.5	in
	Offset Angle	45	°
	Fy	36	ksi

<b>Bolts</b>	#	<b>4</b>	
	Bolt Circle (R)adial / (S)quare	12	in
	Bolt Gap	R	
	Diameter	6	in
	Hole Diameter	0.625	in
	Type	0.75	in
	Fy	A325	
	Fu	92	ksi
	f <sub>s</sub> Resistance	120	ksi
	Applied	20.34	k
	0.88	k	

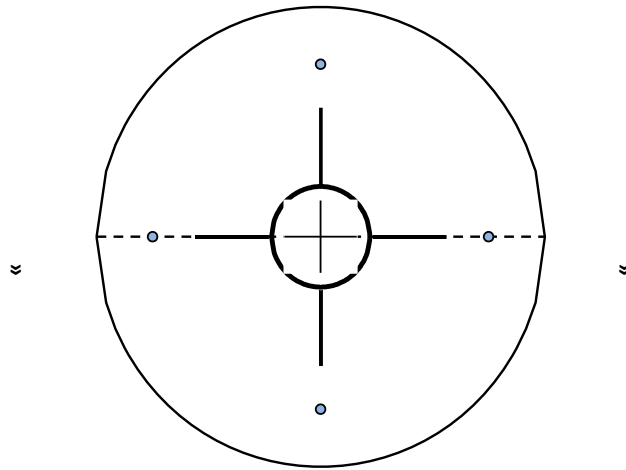

<b>Reinforcement</b>	#		
----------------------	---	--	--

**Plate Stress Ratio:**  
2% Pass

**Bolt Stress Ratio:**  
4% Pass

<b>Extra Bolts</b>	#		
--------------------	---	--	--

# INFINIGY

---

## MOUNT ANALYSIS REPORT

August 30, 2021

Dish Wireless Site Name	BOBDL00015A
Dish Wireless Site Number	BOBDL00015A
ATC Site Name	Tolland CT, CT
ATC Site Number	302495
Infinigy Job Number	1197-F0001-B
Client	ATC
Carrier	Dish Wireless
Site Location	56 Ruops Road Tolland, CT 06084 Tolland County 41.873333 N NAD83 72.3383 W NAD83
Mount Type	8.0 ft Platform
Mount Elevation	93.0 ft AGL
Structural Usage Ratio	<b>41.4%</b>
<b>Overall Result</b>	<b>Pass</b>

The enclosed mount structural analysis has been performed in accordance with the 2018 Connecticut State Building Code (2015 IBC) based on an ultimate 3-second gust wind speed of 125 mph. The evaluation criteria and applicable codes are presented in the next section of this report.

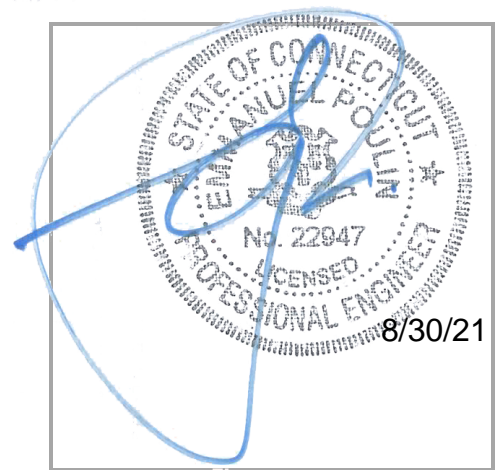

**CONTENTS**

1. Introduction
2. Design/Analysis Parameters
3. Proposed Loading Configuration
4. Supporting Documentation
5. Results
6. Recommendations
7. Assumptions
8. Liability Waiver and Limitations
9. Calculations



**1. INTRODUCTION**

Infinigy performed a structural analysis on the Dish Wireless proposed telecommunication equipment supporting Platform mounted to the existing structure located at the aforementioned address. All referenced supporting documents have been obtained from the client and are assumed to be accurate and applicable to this site. The mount was analyzed using Risa-3D version 17.0.4 analysis software.

**2. DESIGN/ANALYSIS PARAMETERS**

Wind Speed	125 mph (3-Second Gust)
Wind Speed w/ ice	50 mph (3-Second Gust) w/ 2" ice
Code / Standard	TIA-222-H
Adopted Code	2018 Connecticut State Building Code (2015 IBC)
Risk Category	II
Exposure Category	B
Topographic Category	1
Calculated Crest Height	0 ft.
Seismic Spectral Response	$S_s = 0.175 \text{ g} / S_1 = 0.064 \text{ g}$
Live Load Wind Speed	60 mph
Man Live Load at Mid/End Points	250 lbs
Man Live Load at Mount Pipes	500 lbs

**3. PROPOSED LOADING CONFIGURATION - 93.0 ft. AGL Platform**

Antenna Centerline (ft)	Qty.	Appurtenance Manufacturers	Appurtenance Models
93.0	3	JMA WIRELESS	MX08FRO665-21
	3	FUJITSU	TA08025-B605
	3	FUJITSU	TA08025-B604
	1	RAYCAP	RDIDC-9181-PF-48

**4. SUPPORTING DOCUMENTATION**

Proposed Loading	Dish Wireless Asset ID CT-ATC-T-302495 Rev 2, Site #BOBDL00015A, dated July 09, 2021
Mount Manufacturer Drawings	Commscope Document # MC-PK8-DSH, dated March 08, 2021
Structural Analysis Report	ATC, Asset #302495, dated July 8, 2021

## 5. RESULTS

<b>Components</b>	<b>Capacity</b>	<b>Pass/Fail</b>
Mount Pipes	17.8%	Pass
Horizontals	10.7%	Pass
Standoffs	31.8%	Pass
Handrails	21.3%	Pass
Connections	41.4%	Pass
<b>MOUNT RATING =</b>	<b>41.4%</b>	<b>Pass</b>

Notes:

1. See additional documentation in Appendix for calculations supporting the capacity consumed and detailed mount connection calculations.

## 6. RECOMMENDATIONS

Infinigy recommends installing Dish Wireless's proposed equipment loading configuration on the mount at 93.0 ft. The installation shall be performed in accordance with the construction documents issued for this site.

Binita Yadav  
Project Engineer I | **INFINIGY**

**7. ASSUMPTIONS**

The antenna mounting system was properly fabricated, installed and maintained in accordance with its original design and manufacturer's specifications.	
The configuration of antennas, mounts, and other appurtenances are as specified in the proposed loading configuration table.	
All member connections are assumed to have been designed to meet or exceed the load carrying capacity of the connected member unless otherwise specified in this report.	
The analysis will require revisions if the existing conditions in the field differ from those shown in the above-referenced documents or assumed in this analysis. No allowance was made for any damaged, missing, or rusted members.	
Steel grades have been assumed as follows, unless noted otherwise:	
Channel, Solid Round, Plate, Built-up Angle	ASTM A1011 36 KSI
Structural Angle	ASTM A529 Gr. 50
HSS (Rectangular)	ASTM A500-B GR 46
HSS (Circular)	ASTM A500-B GR 42
Pipe	ASTM A500 Gr C
Connection Bolts	ASTM A325
U-Bolts	ASTM A307
All bolted connections are pretensioned in accordance with Table 8.2 of the RCSC 2014 Standard	

**8. LIABILITY WAIVER AND LIMITATIONS**

Our structural calculations are completed assuming all information provided to Infinigy is accurate and applicable to this site. For the purposes of calculations, we assume an overall structure condition as erected and all members and connections to be free of corrosion and/or structural defects. The structure owner and/or contractor shall verify the structure's condition prior to installation of any proposed equipment. If actual conditions differ from those described in this report, Infinigy should be notified immediately to assess the impact on the results of this report.

Our evaluation is completed using industry standard methods and procedures. The structural results, conclusions and recommendations contained in this report are proprietary and should not be used by others as their own. Infinigy is not responsible for decisions made by others that are or are not based on the stated assumptions and conclusions in this report.

This report is an evaluation of the mount structure only and does not determine the adequacy of the supporting structure, other carrier mounts or cable mounting attachments. The analysis of these elements is outside the scope of this analysis, are assumed to be adequate for the purpose of this report and to have been installed per their manufacturer requirements. This document is not for construction purposes.

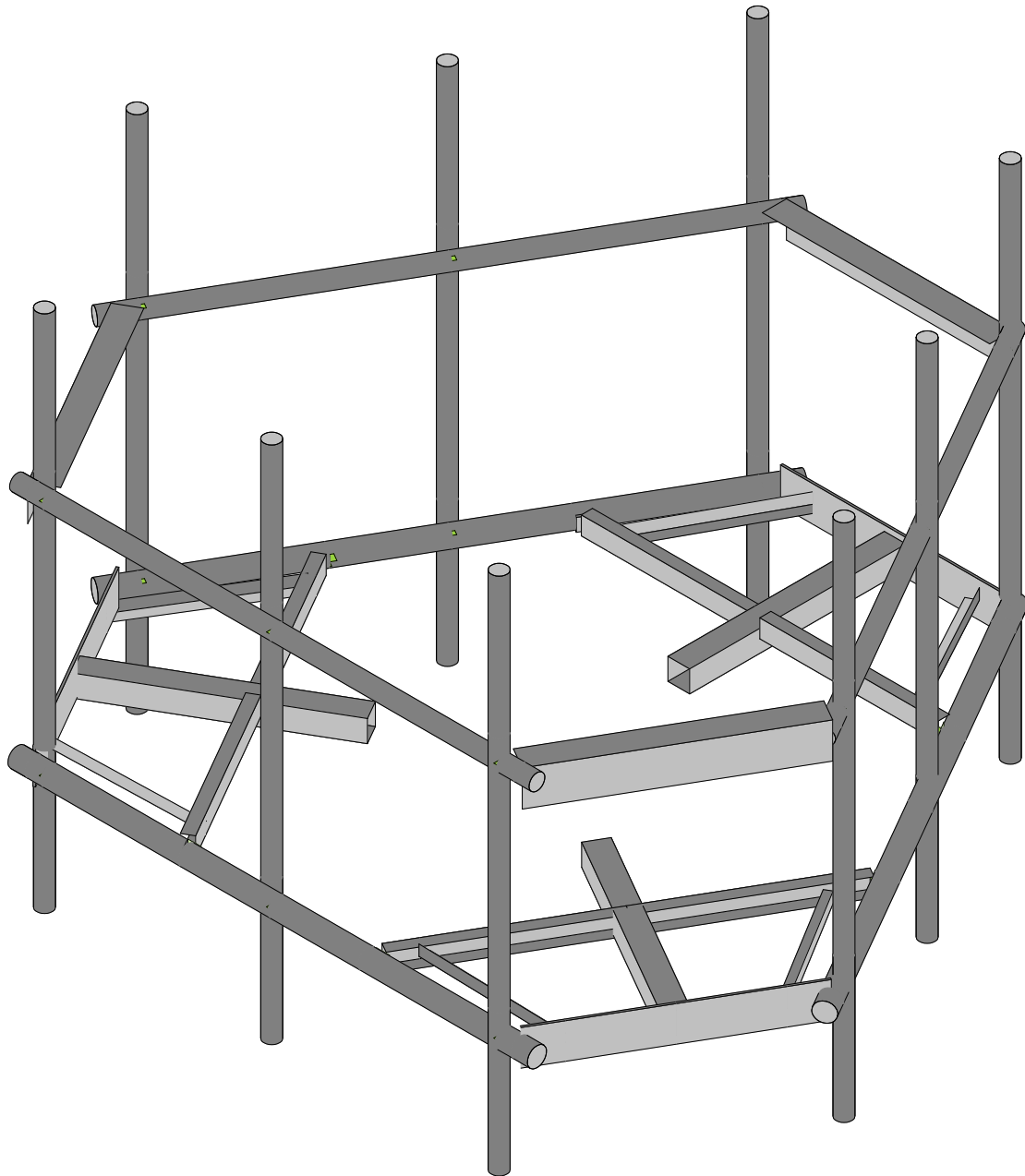
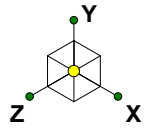

Envelope Only Solution

Infinigy Engineering, PLLC

BY

1197-F0001-B

BOBDL00015A

Rendered

Aug 30, 2021 at 11:11 AM

BOBDL00015A\_loaded.r3d

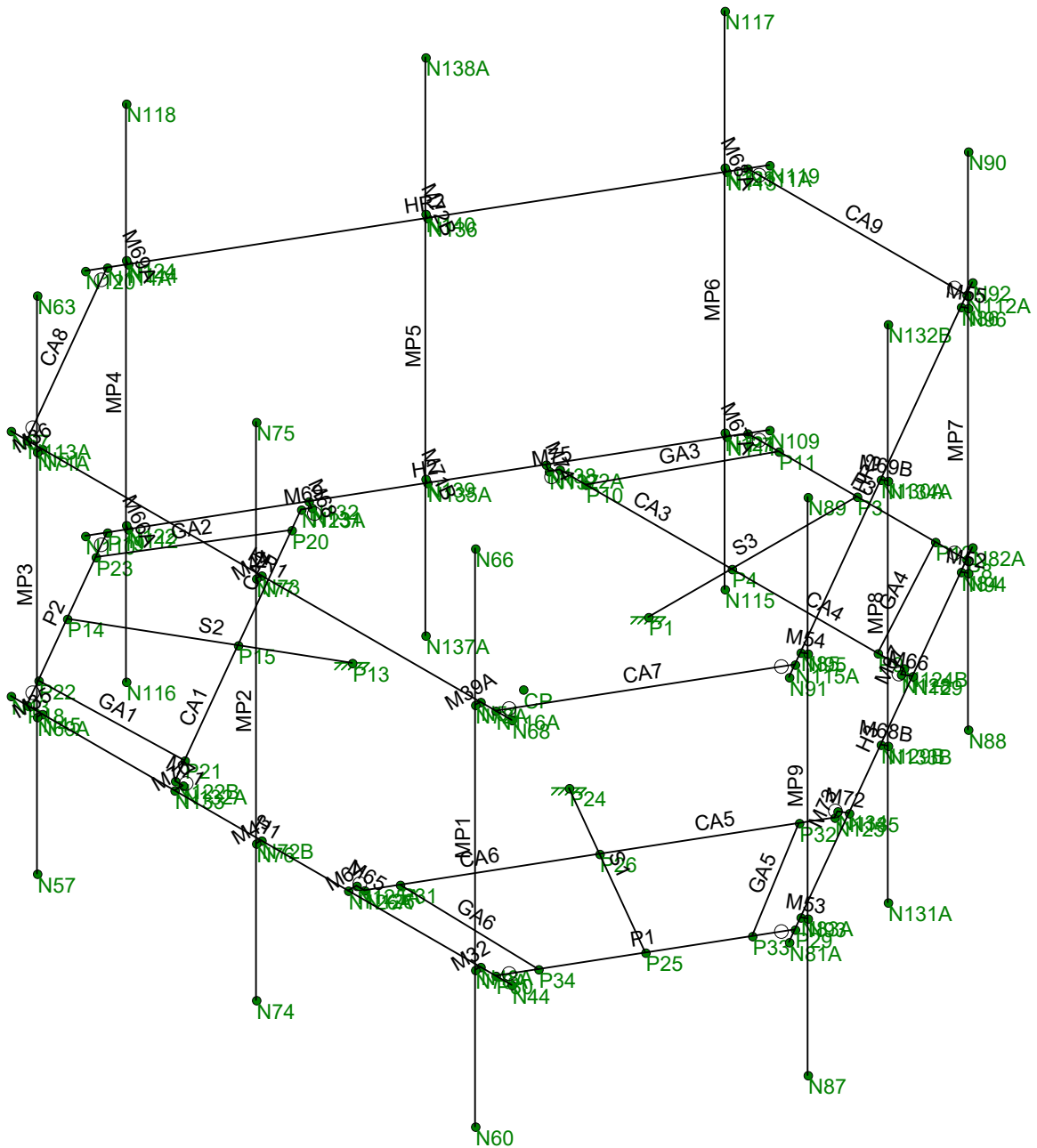
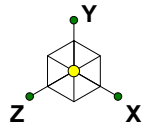

Envelope Only Solution

Infinigy Engineering, PLLC

BY

1197-F0001-B

BOBDL00015A

Wire Frame

Aug 30, 2021 at 11:11 AM

BOBDL00015A\_loaded.r3d



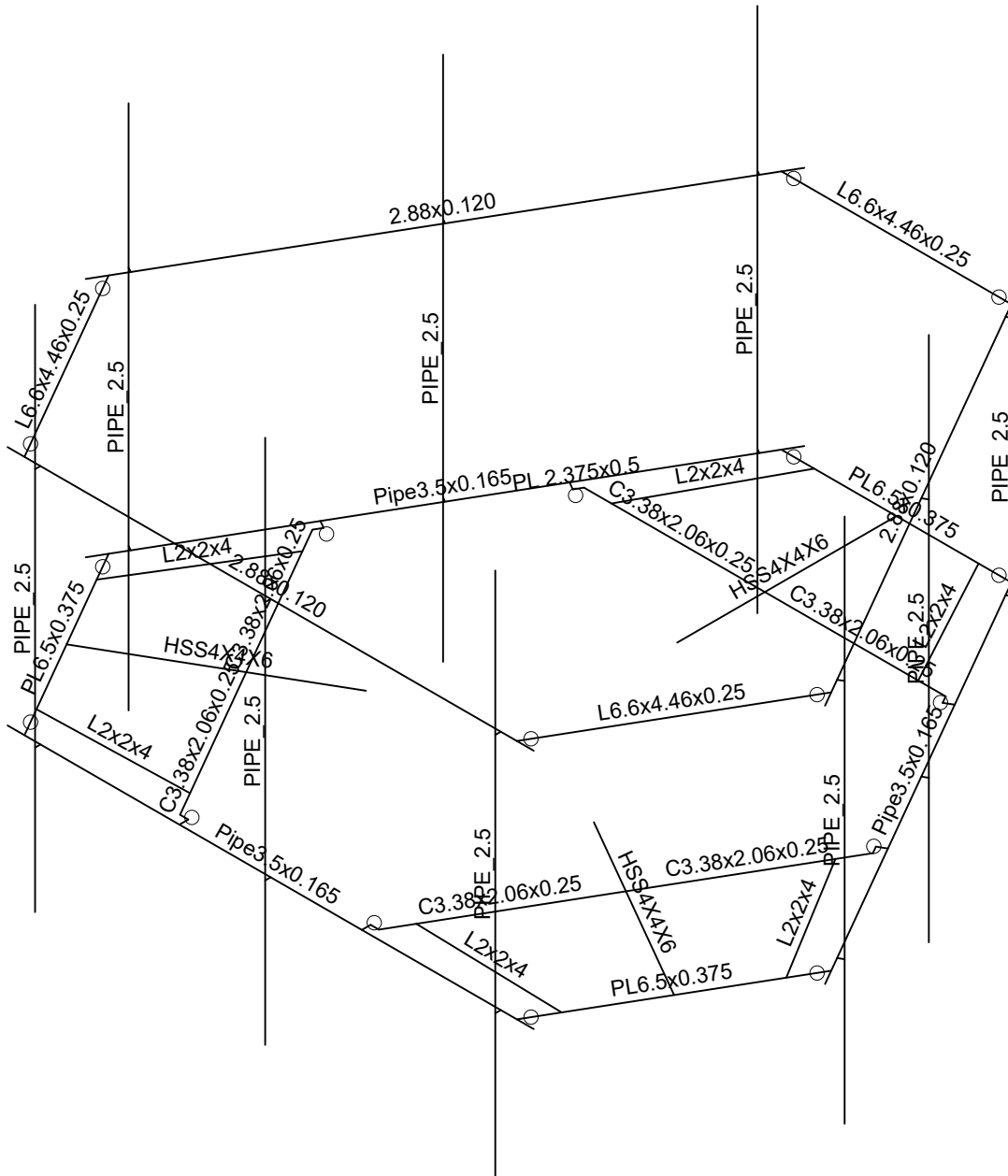
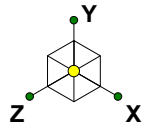

Envelope Only Solution

Infinigy Engineering, PLLC

BY

1197-F0001-B

BOBDL00015A

Member Shape

Aug 30, 2021 at 11:13 AM

BOBDL00015A\_loaded.r3d



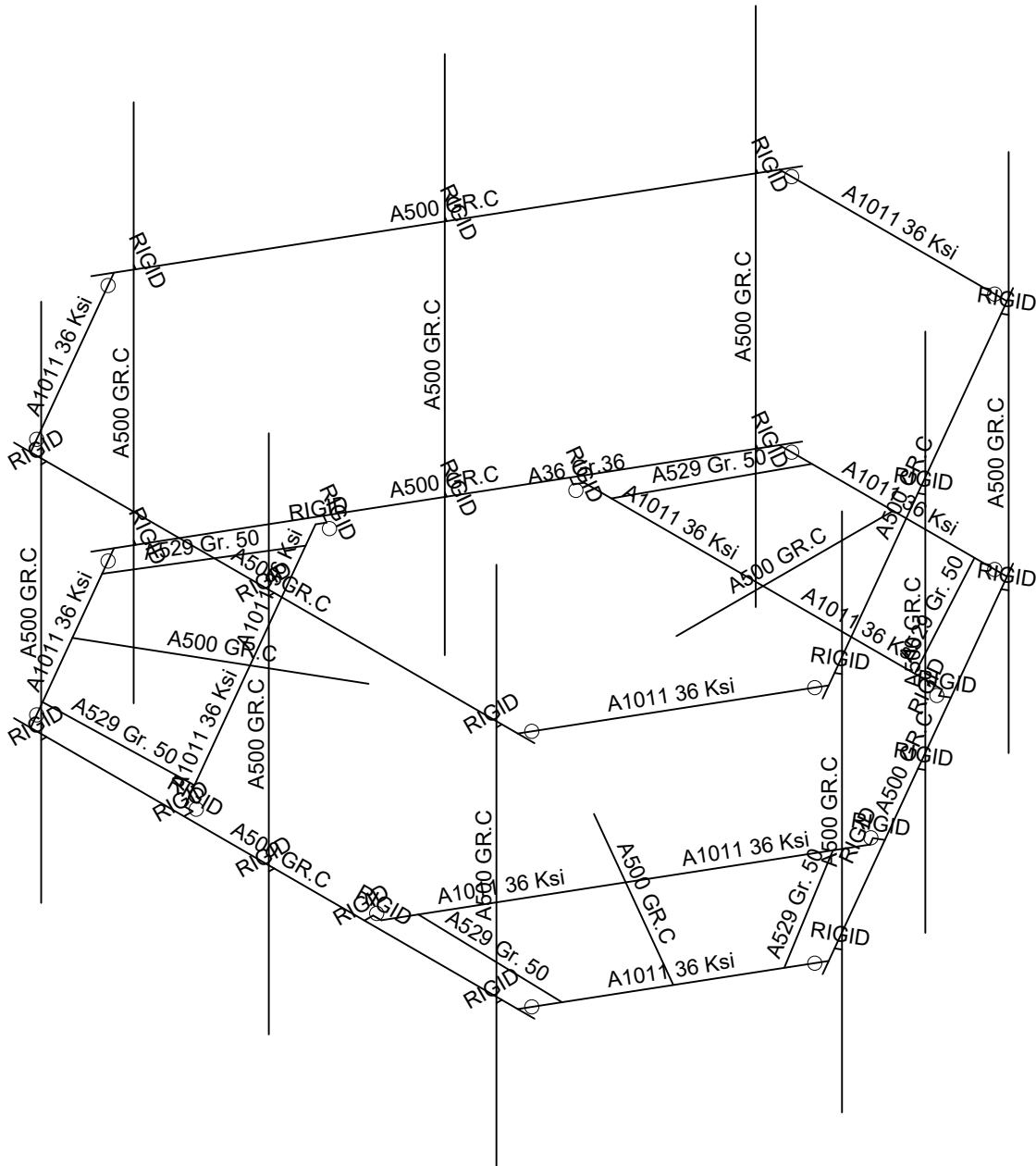
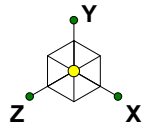

Envelope Only Solution

Infinigy Engineering, PLLC

BY

1197-F0001-B

BOBDL00015A

Material Sets

Aug 30, 2021 at 11:14 AM

BOBDL00015A\_loaded.r3d

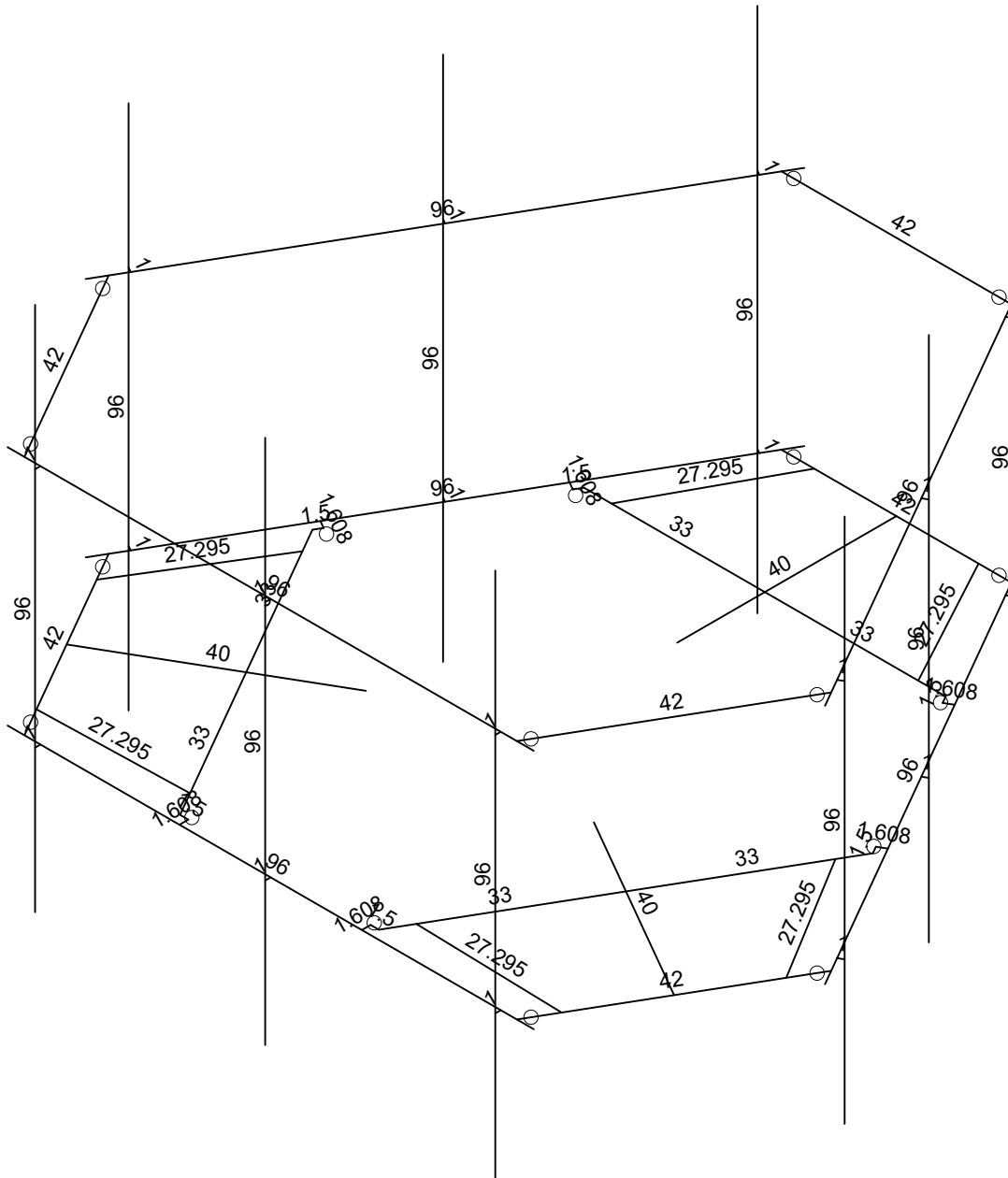
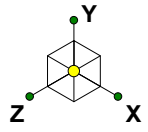

Member Length (in) Displayed  
Envelope Only Solution

Infinigy Engineering, PLLC	BOBDL00015A	Member Length
BY		Aug 30, 2021 at 11:14 AM
1197-F0001-B		BOBDL00015A_loaded.r3d

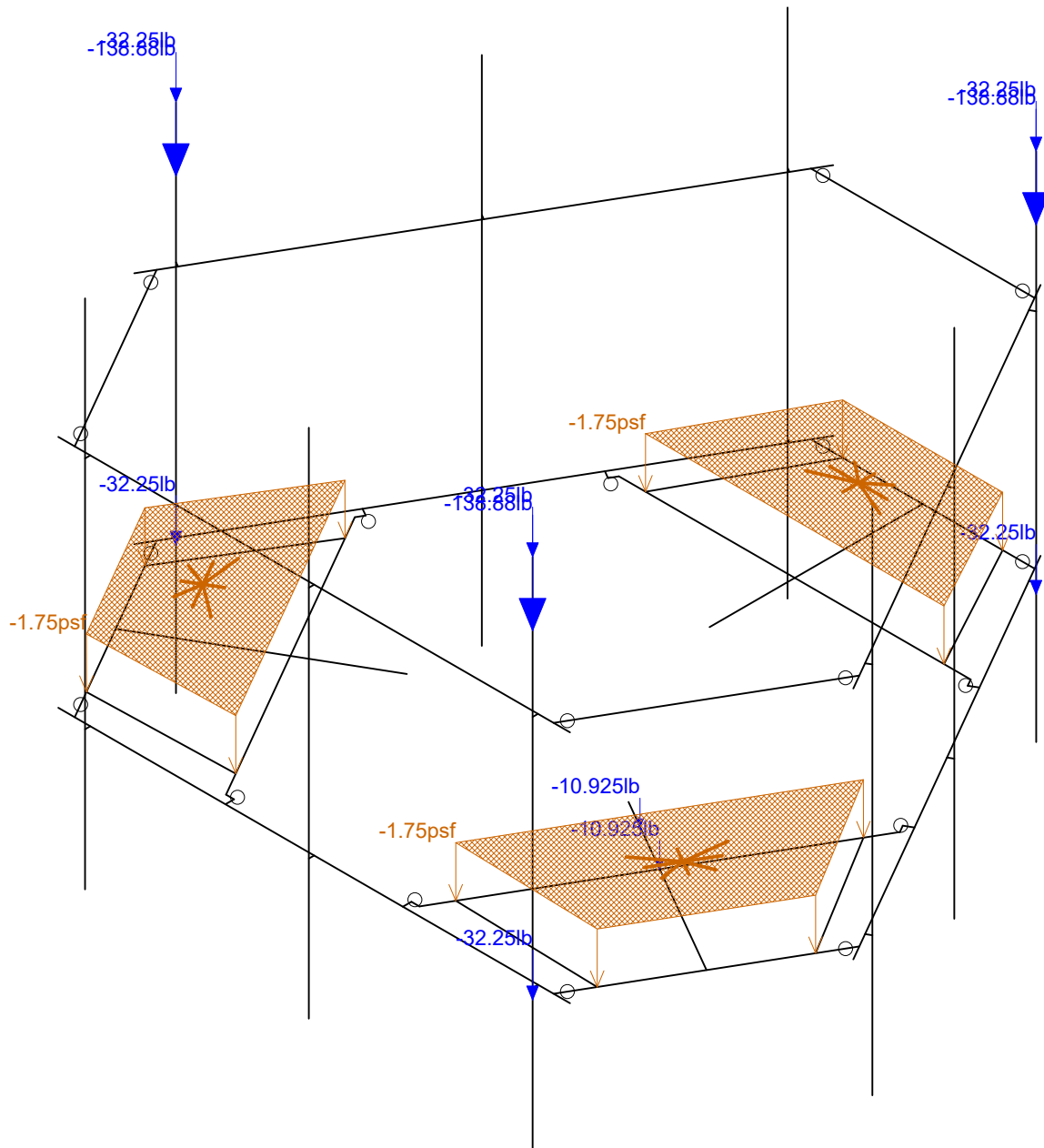
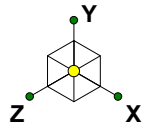

Loads: BLC 1, Self Weight  
Envelope Only Solution

Infinigy Engineering, PLLC  
BY  
1197-F0001-B

BOBDL00015A

Self-Weight

Aug 30, 2021 at 11:24 AM

BOBDL00015A\_loaded.r3d

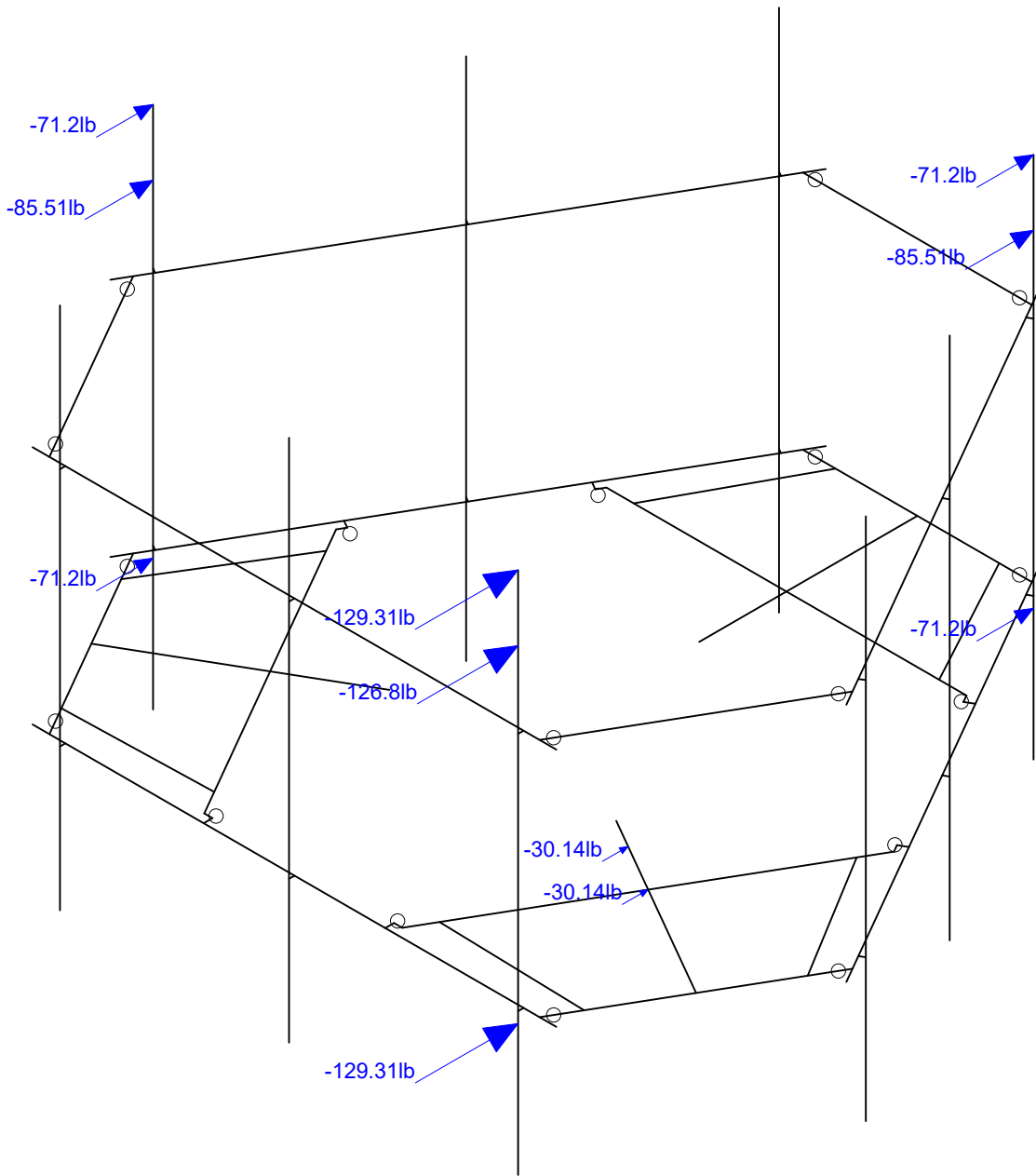
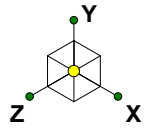

Loads: BLC 2, Wind Load AZI 0  
Envelope Only Solution

Infinigy Engineering, PLLC	BOBDL00015A	Wind Load AZI 000
BY		Aug 30, 2021 at 11:25 AM
1197-F0001-B		BOBDL00015A_loaded.r3d

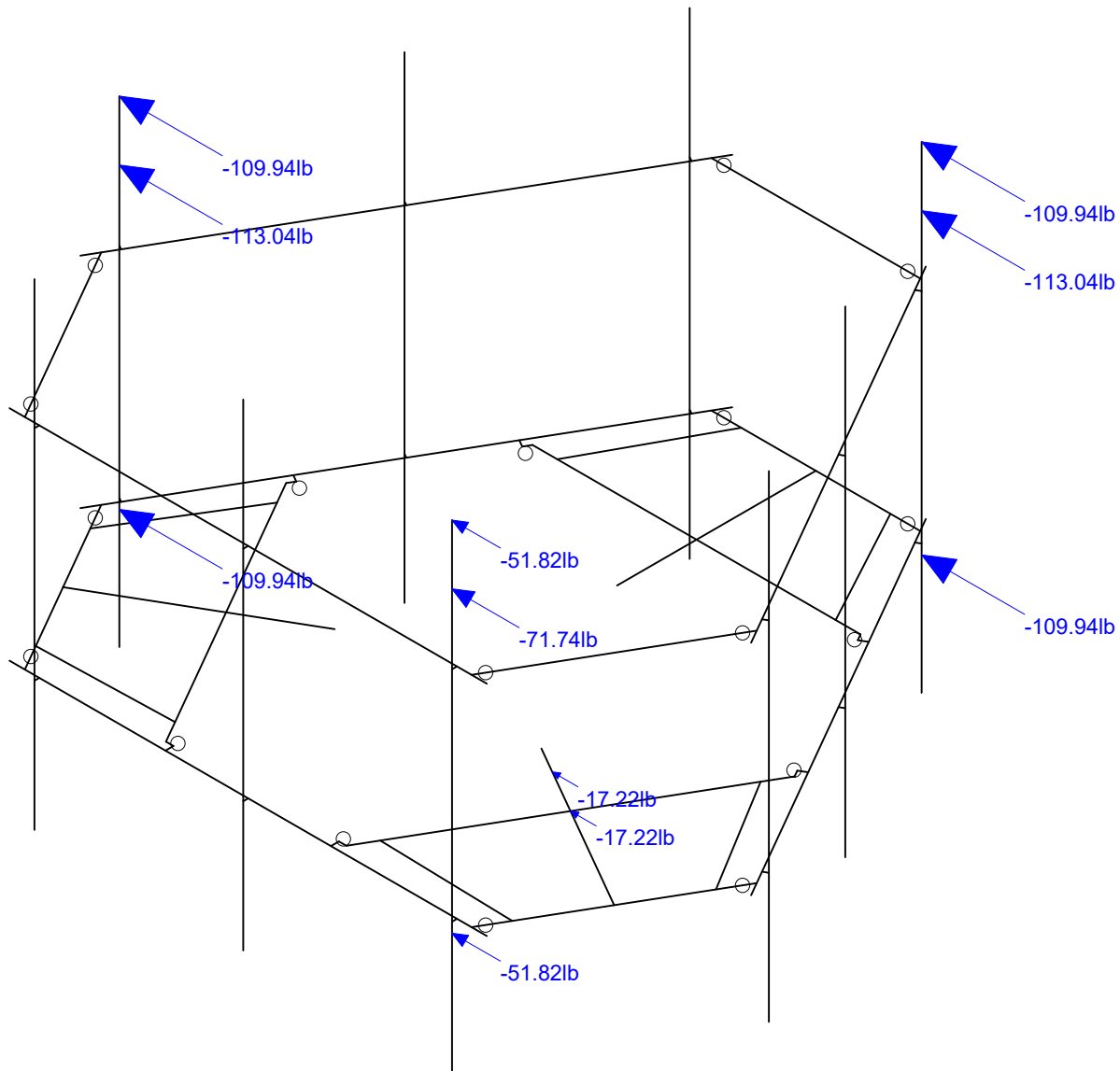
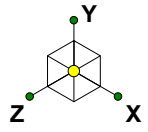

Loads: BLC 5, Wind Load AZI 90  
Envelope Only Solution

Infinigy Engineering, PLLC	BOBDL00015A	Wind Load AZI 090
BY		Aug 30, 2021 at 11:28 AM
1197-F0001-B		BOBDL00015A_loaded.r3d

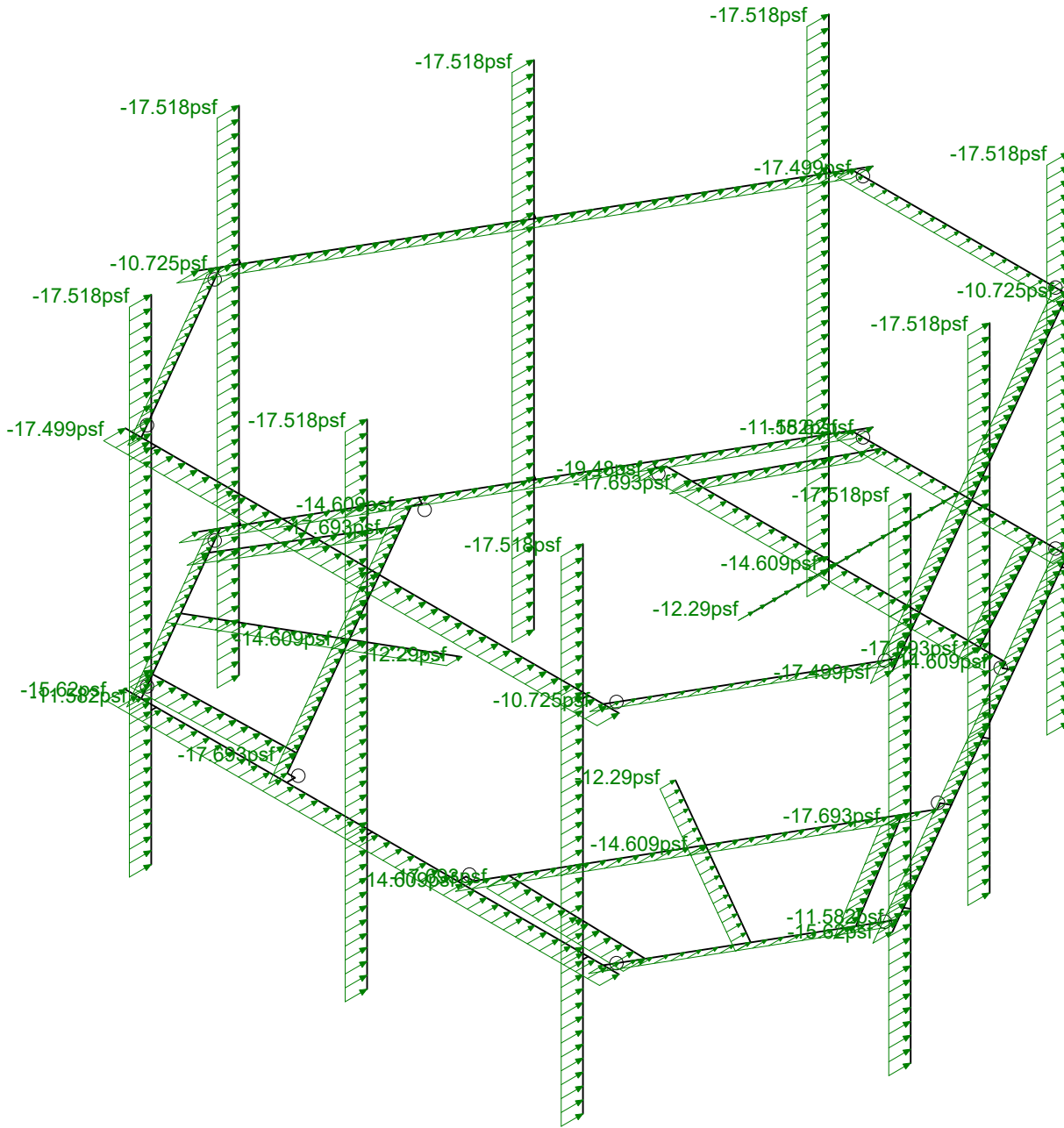
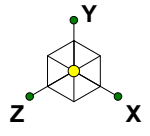

Loads: BLC 29, Distr. Ice Wind Load Z  
Envelope Only Solution

Infinigy Engineering, PLLC	BOBDL00015A	Distr.Wind Load AZI 000
BY		Aug 30, 2021 at 11:34 AM
1197-F0001-B		BOBDL00015A_loaded.r3d

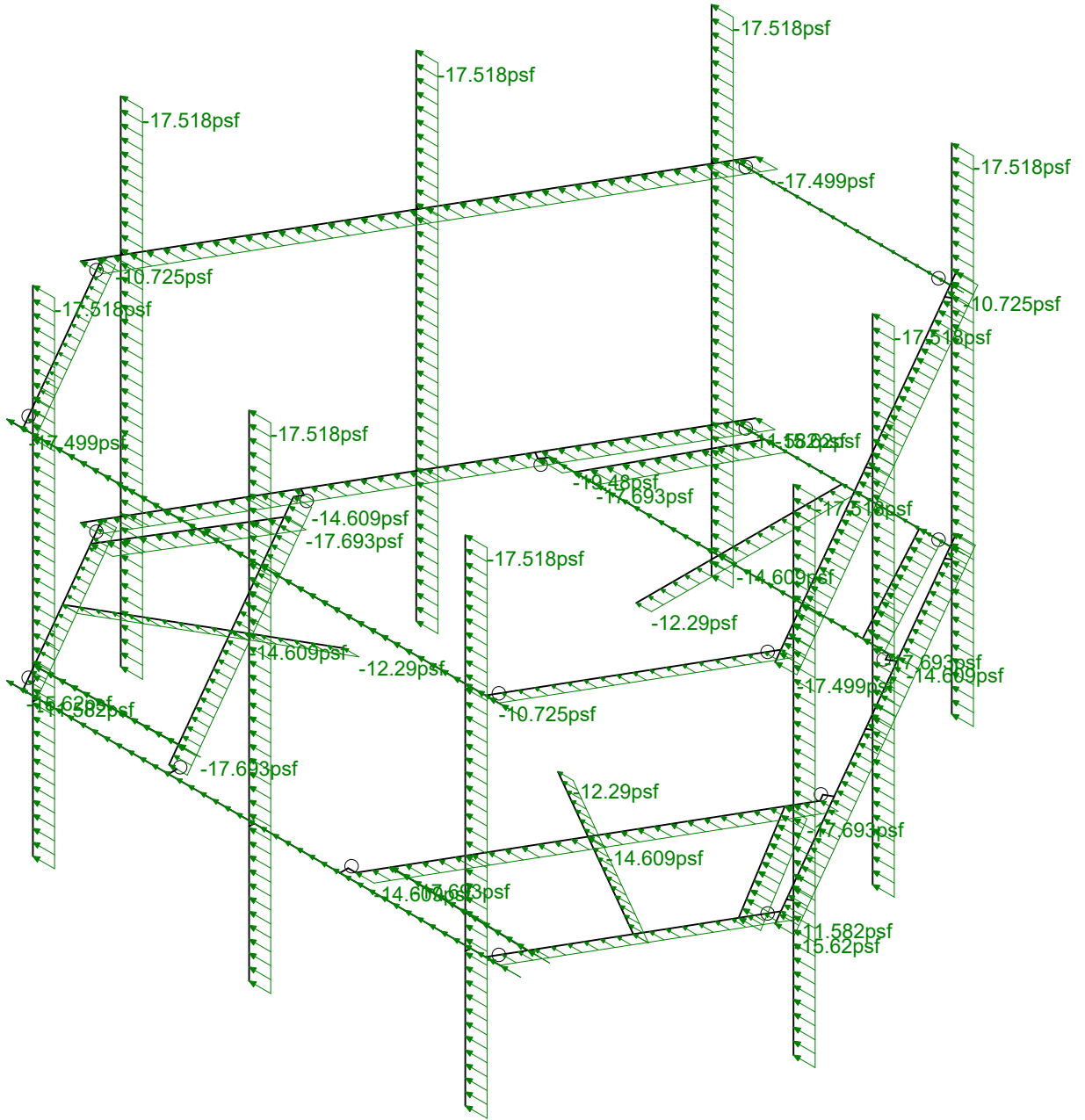
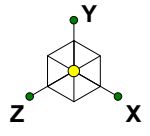

Loads: BLC 30, Distr. Ice Wind Load X  
Envelope Only Solution

Infinigy Engineering, PLLC	BOBDL00015A	Distr. Wind Load AZI 090
BY		Aug 30, 2021 at 11:34 AM
1197-F0001-B		BOBDL00015A_loaded.r3d



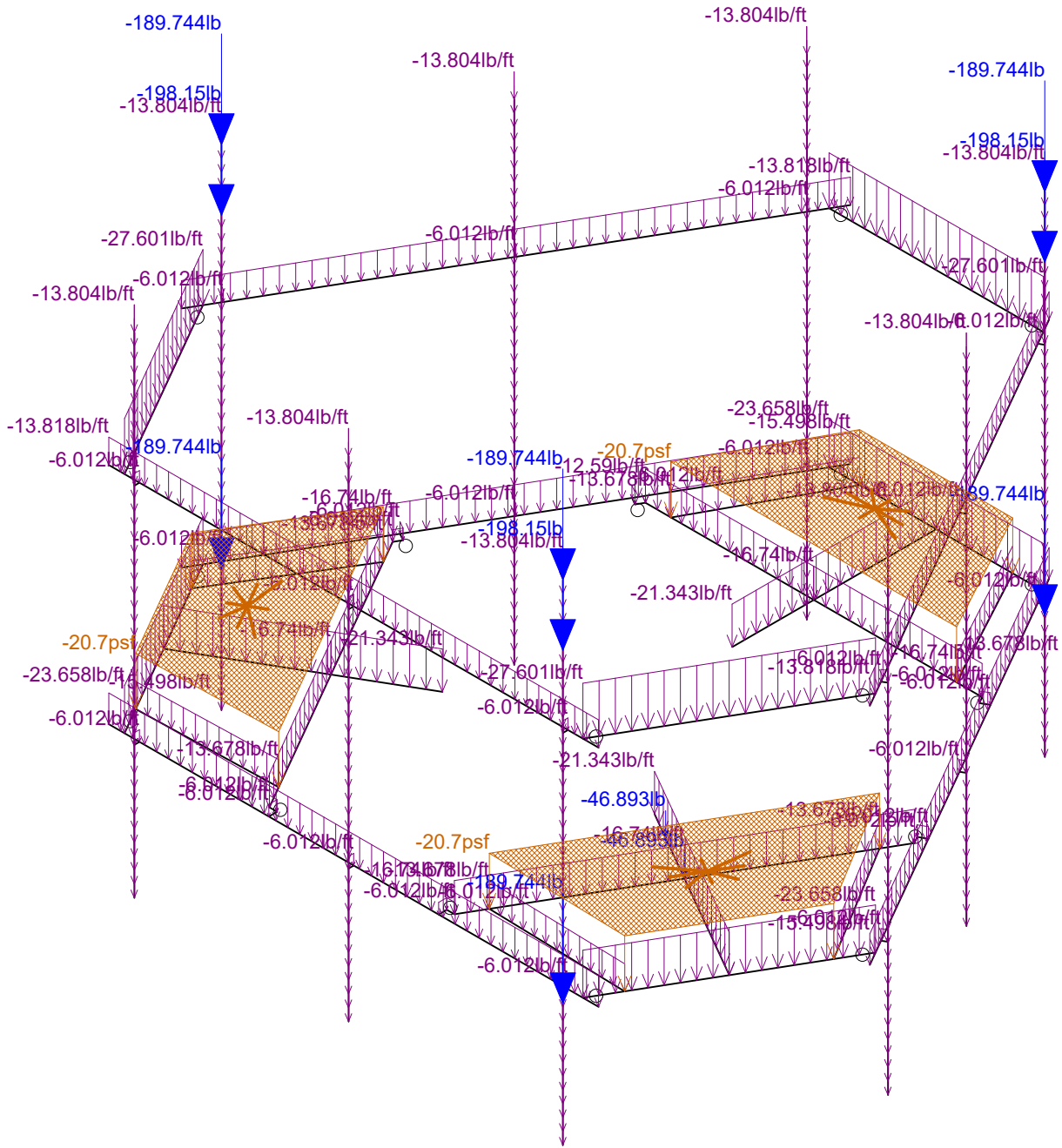
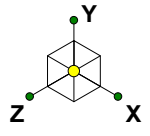

Loads: BLC 16, Ice Weight  
Envelope Only Solution

Infinigy Engineering, PLLC	BOBDL00015A	Ice Weight
BY		Aug 30, 2021 at 11:40 AM
1197-F0001-B		BOBDL00015A_loaded.r3d

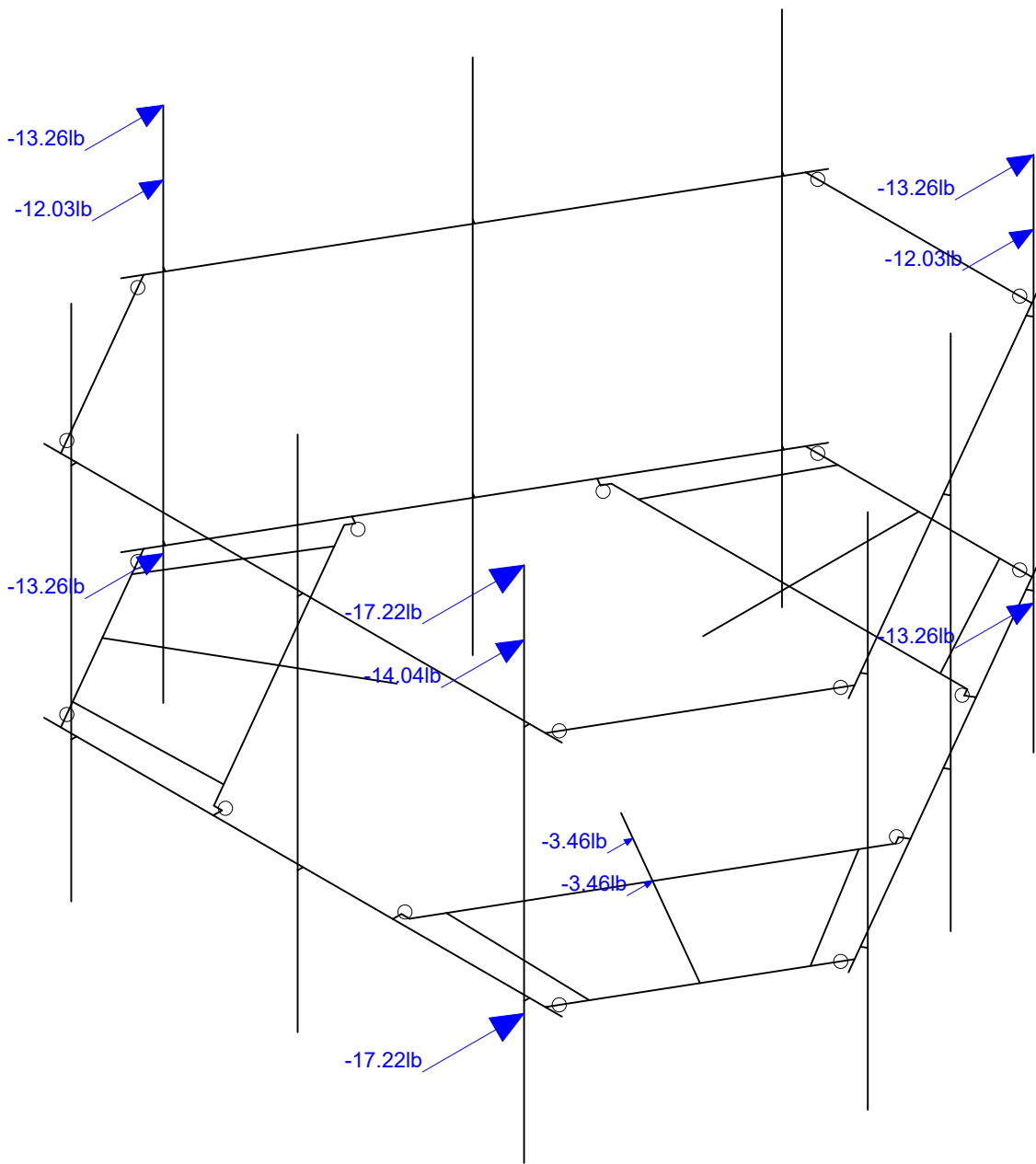
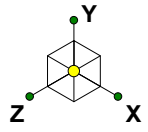

Loads: BLC 17, Ice Wind Load AZI 0  
Envelope Only Solution

Infinigy Engineering, PLLC  
BY  
1197-F0001-B

BOBDL00015A

Ice Wind Load AZI 000  
Aug 30, 2021 at 11:41 AM  
BOBDL00015A\_loaded.r3d

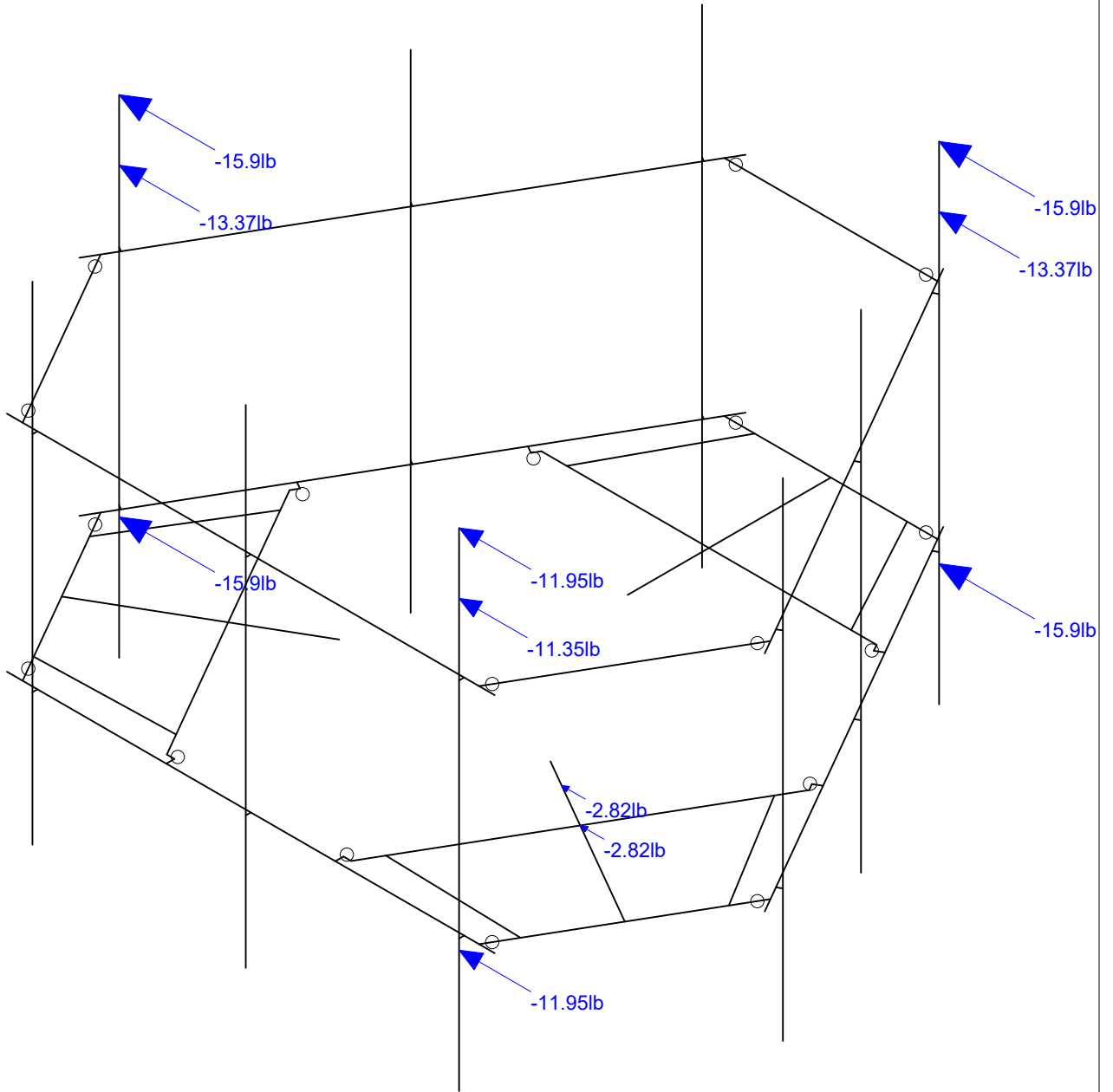
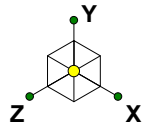

Loads: BLC 20, Ice Wind Load AZI 90  
Envelope Only Solution

Infinigy Engineering, PLLC	BOBDL00015A	Ice Wind Load AZI 090
BY		Aug 30, 2021 at 11:41 AM
1197-F0001-B		BOBDL00015A_loaded.r3d

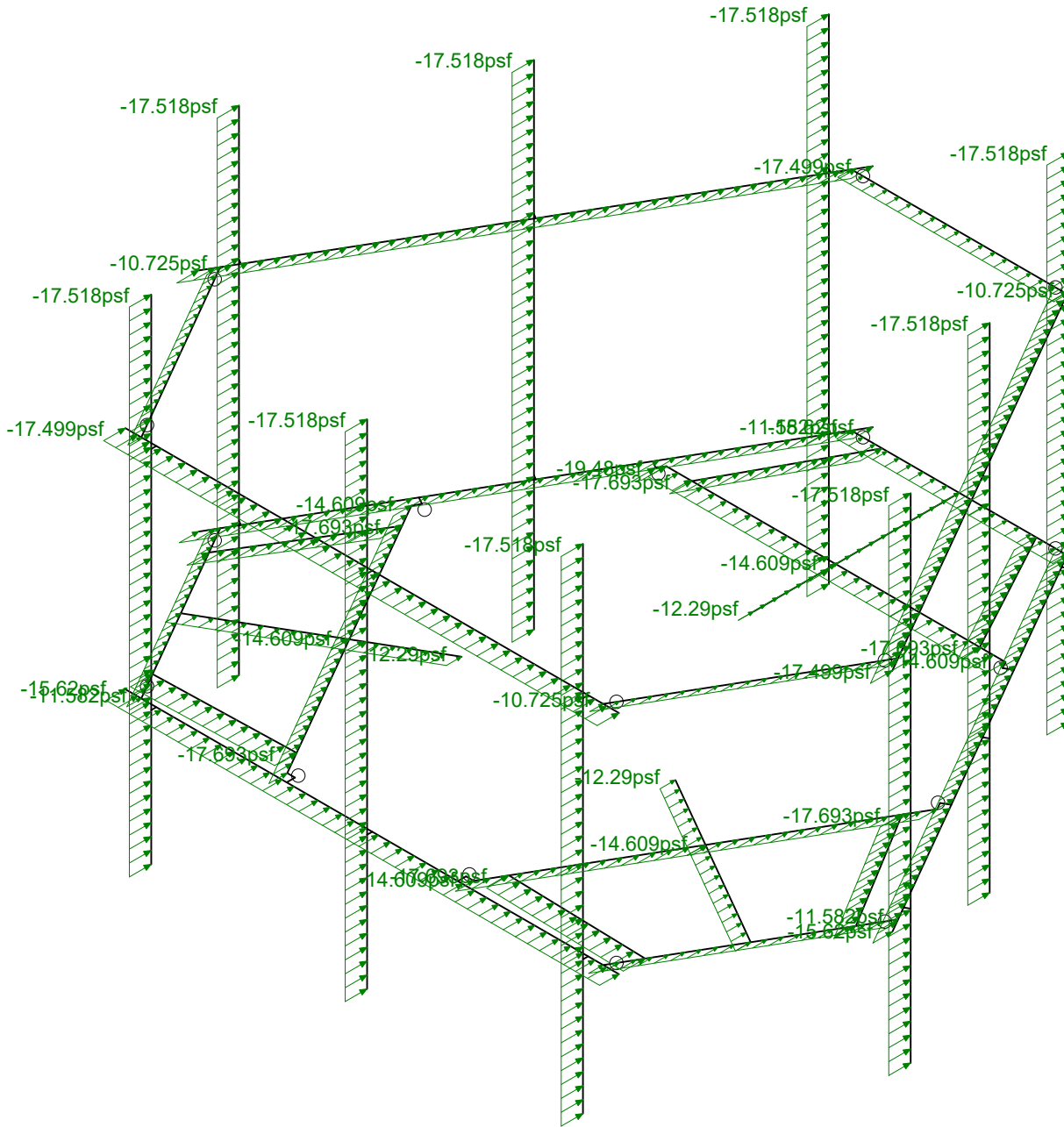
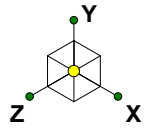

Loads: BLC 29, Distr. Ice Wind Load Z  
Envelope Only Solution

Infinigy Engineering, PLLC	BOBDL00015A	Distr. Ice Wind Load AZI000
BY		Aug 30, 2021 at 11:43 AM
1197-F0001-B		BOBDL00015A_loaded.r3d

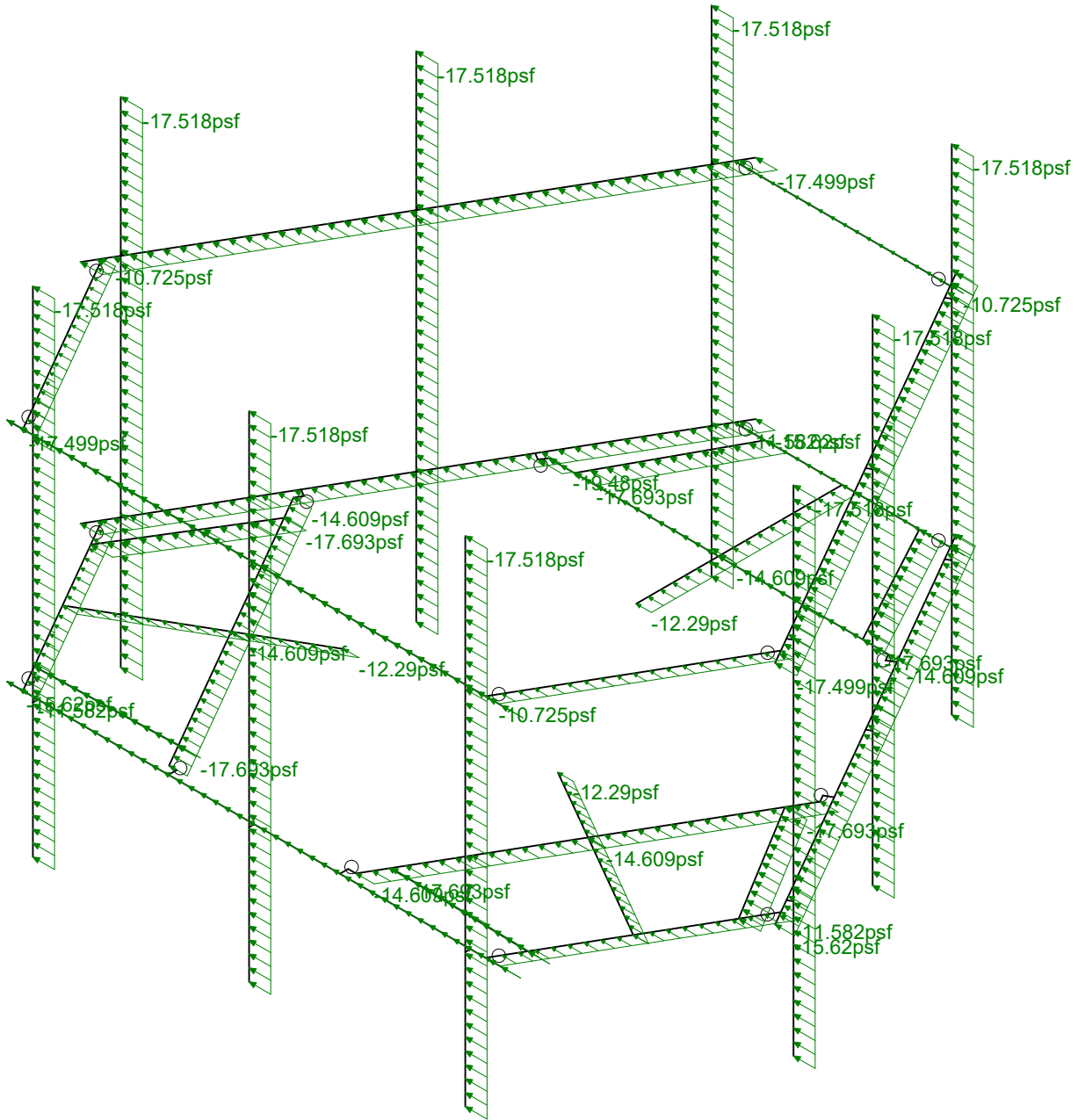
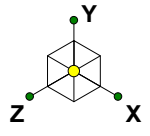

Loads: BLC 30, Distr. Ice Wind Load X  
Envelope Only Solution

Infinigy Engineering, PLLC

BY

1197-F0001-B

BOBDL00015A

Distr. Ice Wind Load AZI090

Aug 30, 2021 at 11:44 AM

BOBDL00015A\_loaded.r3d

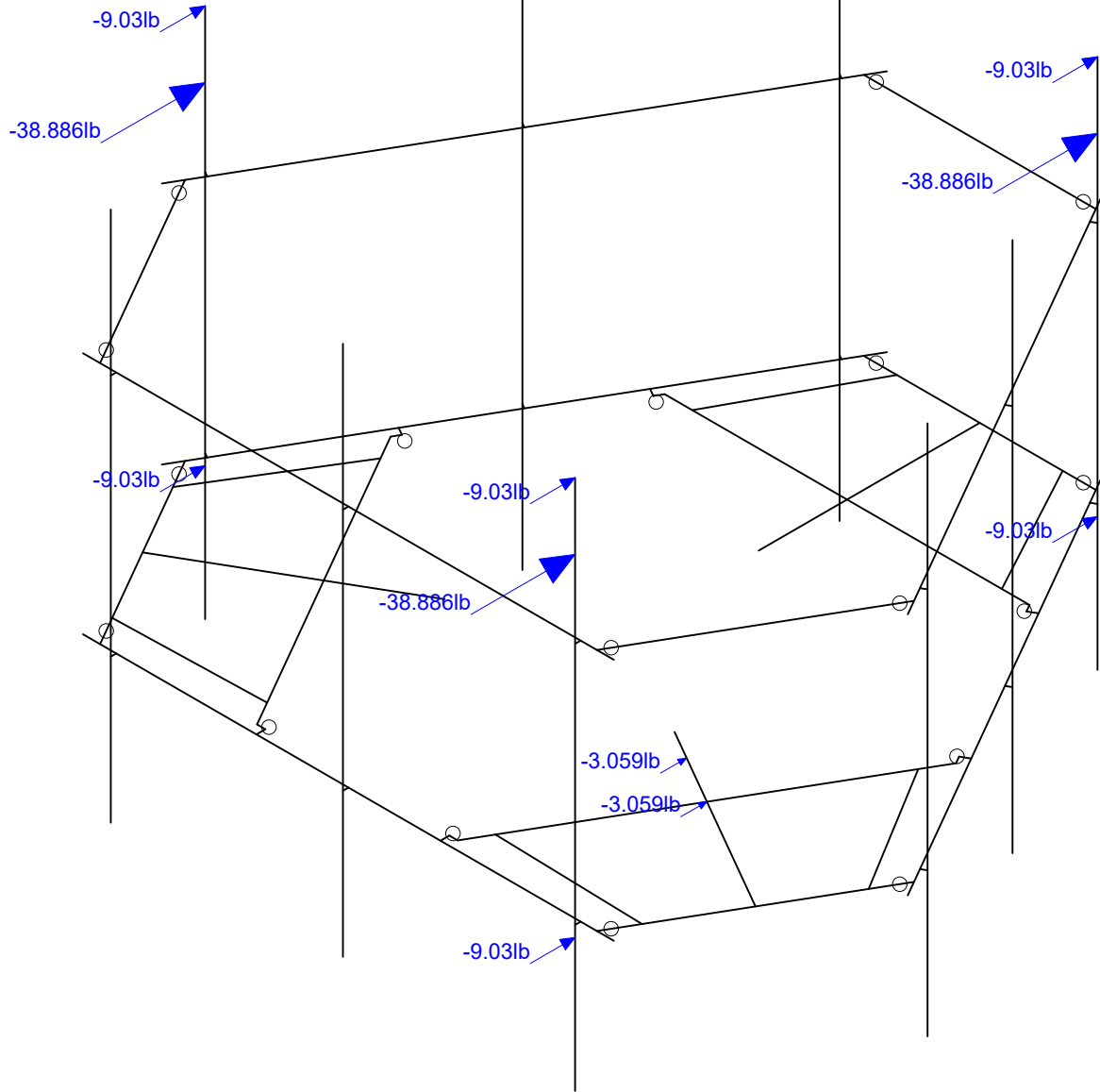
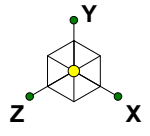

Loads: BLC 31, Seismic Load Z  
Envelope Only Solution

Infinigy Engineering, PLLC

BY

1197-F0001-B

BOBDL00015A

Seismic Load AZI 000

Aug 30, 2021 at 11:45 AM

BOBDL00015A\_loaded.r3d

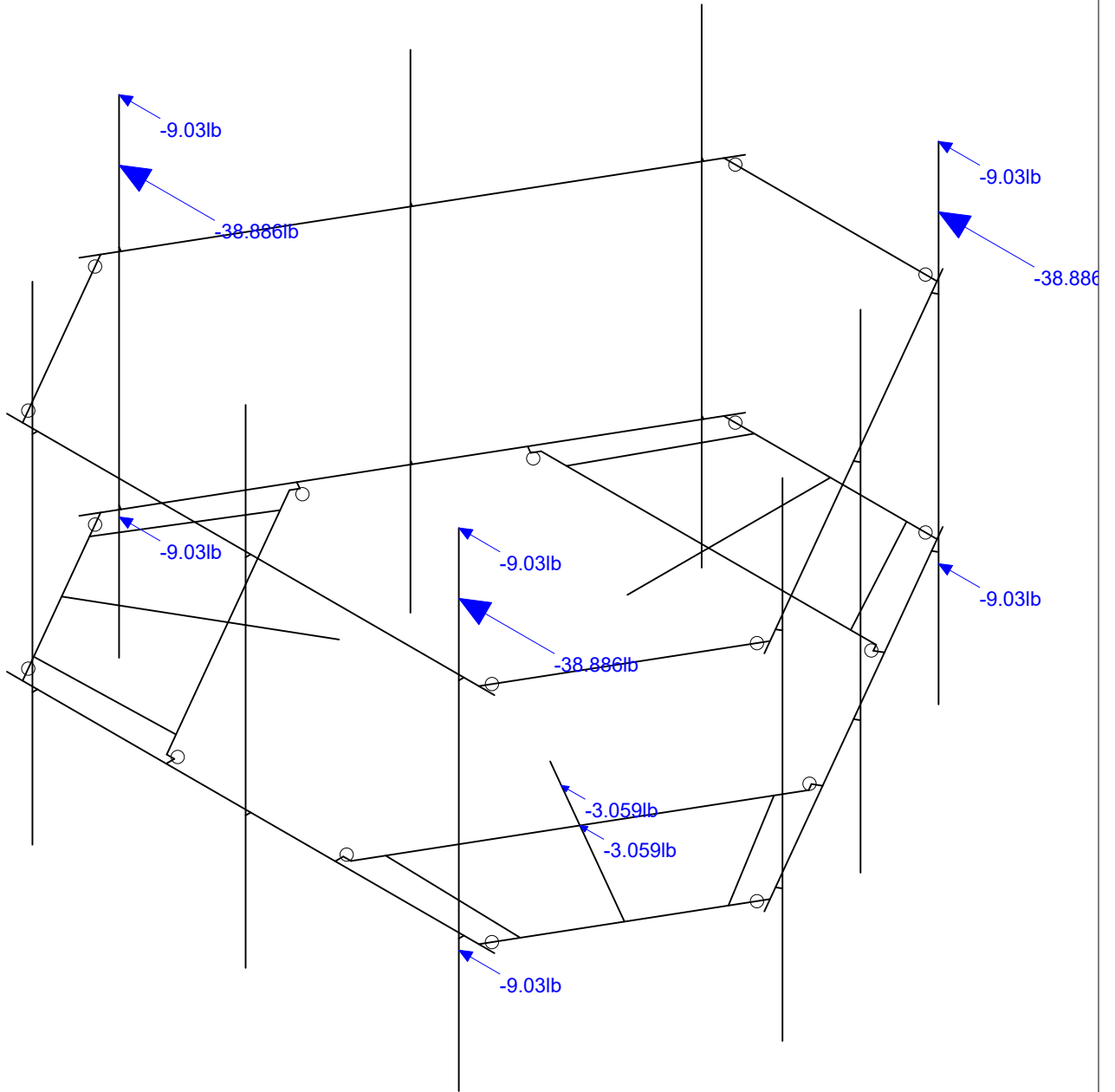
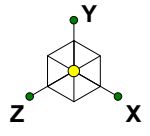

Loads: BLC 32, Seismic Load X  
Envelope Only Solution

Infinigy Engineering, PLLC  
BY  
1197-F0001-B

BOBDL00015A

Seismic Load AZI 090  
Aug 30, 2021 at 11:45 AM  
BOBDL00015A\_loaded.r3d

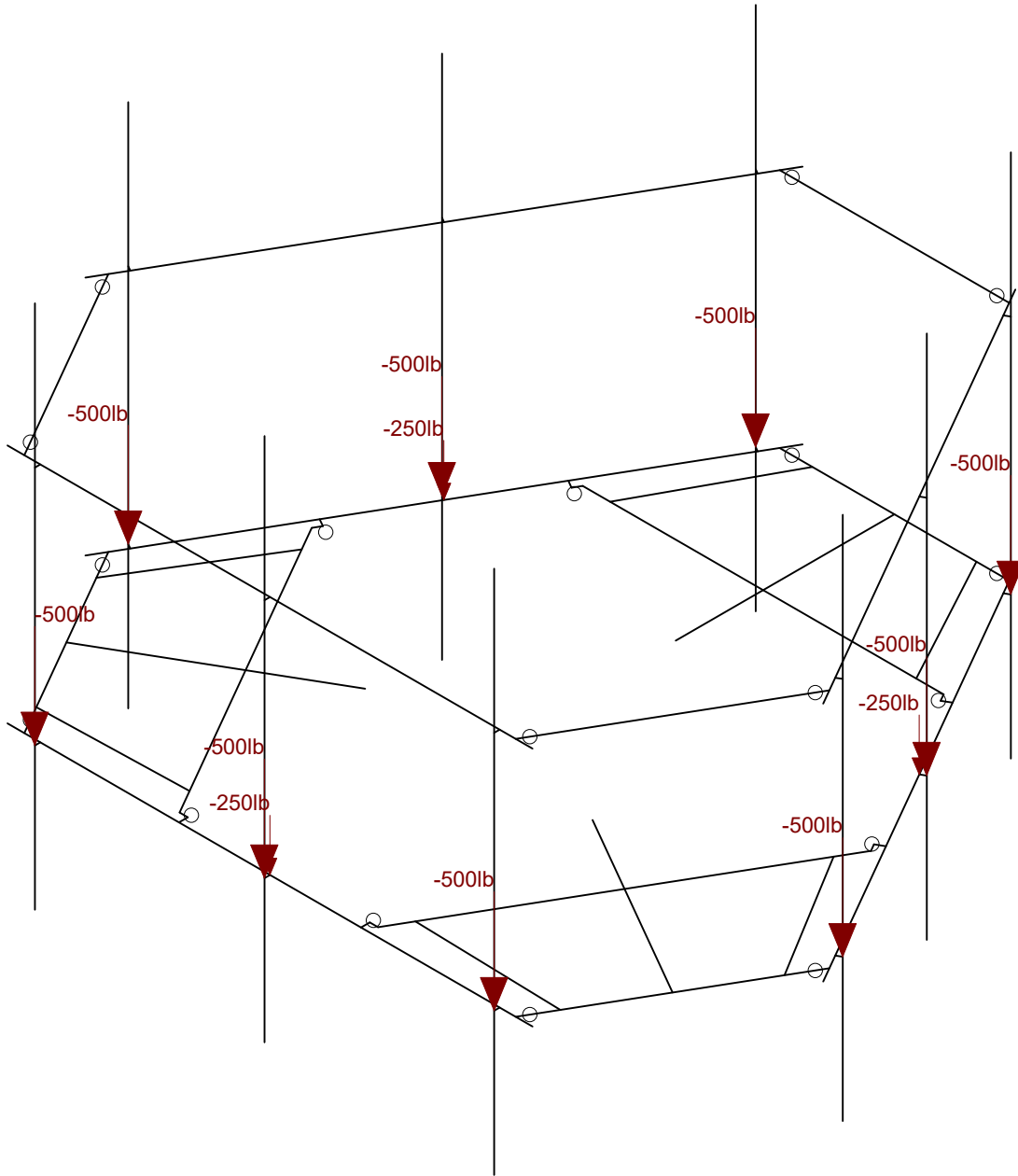
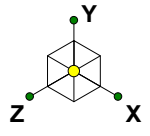

Loads: LL - Live Load  
Envelope Only Solution

Infinigy Engineering, PLLC  
BY  
1197-F0001-B

BOBDL00015A

Non-concurrent Live Loads  
Aug 30, 2021 at 11:46 AM  
BOBDL00015A\_loaded.r3d



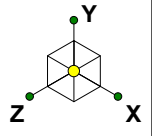

Code Check ( Env )	
Black	No Calc
Red	> 1.0
Magenta	.90-1.0
Green	.75-.90
Cyan	.50-.75
Blue	0-.50

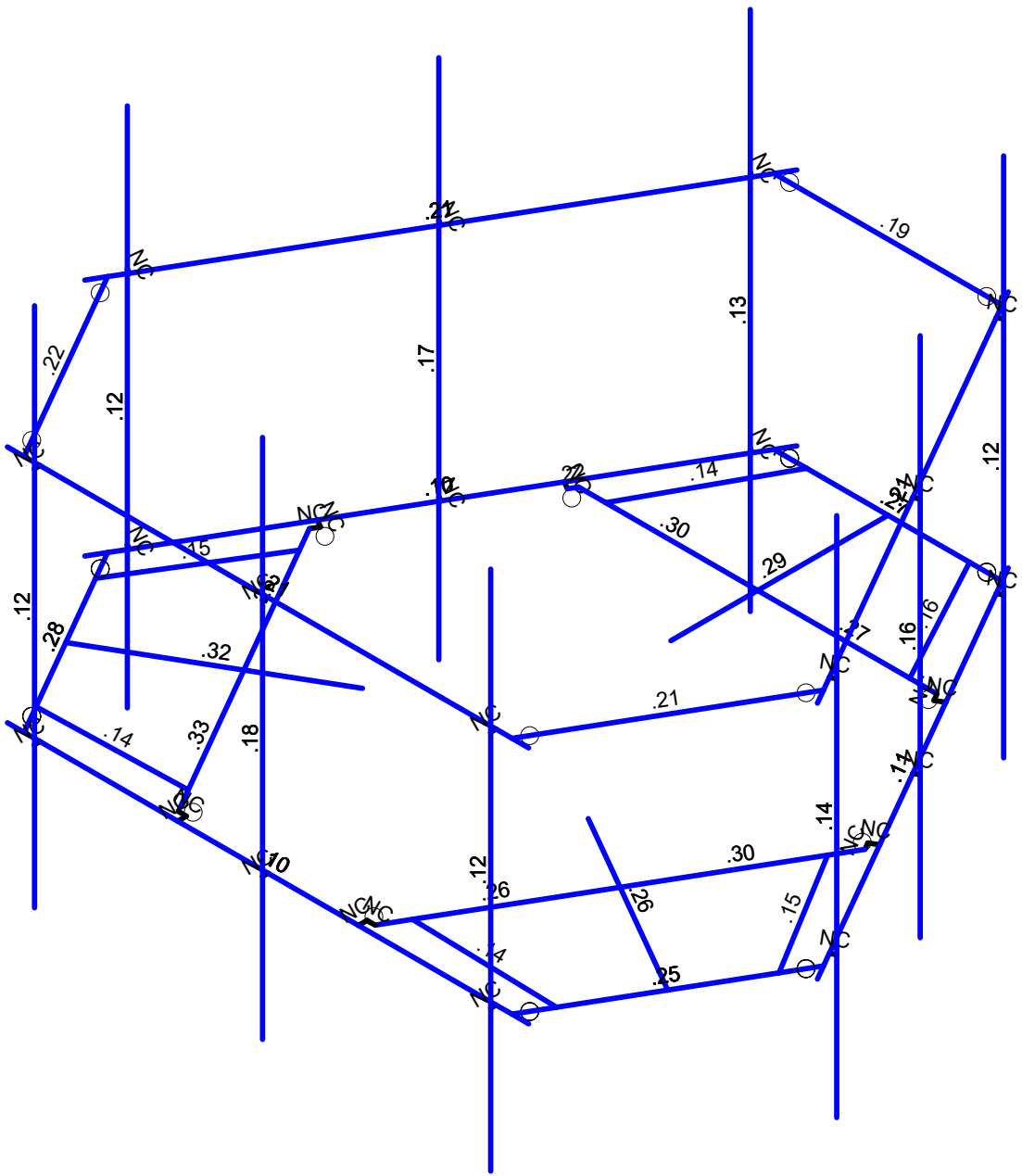

Member Code Checks Displayed (Enveloped)  
Envelope Only Solution

Infinigy Engineering, PLLC	BOBDL00015A	Bending Check
BY		Aug 30, 2021 at 11:47 AM
1197-F0001-B		BOBDL00015A_loaded.r3d

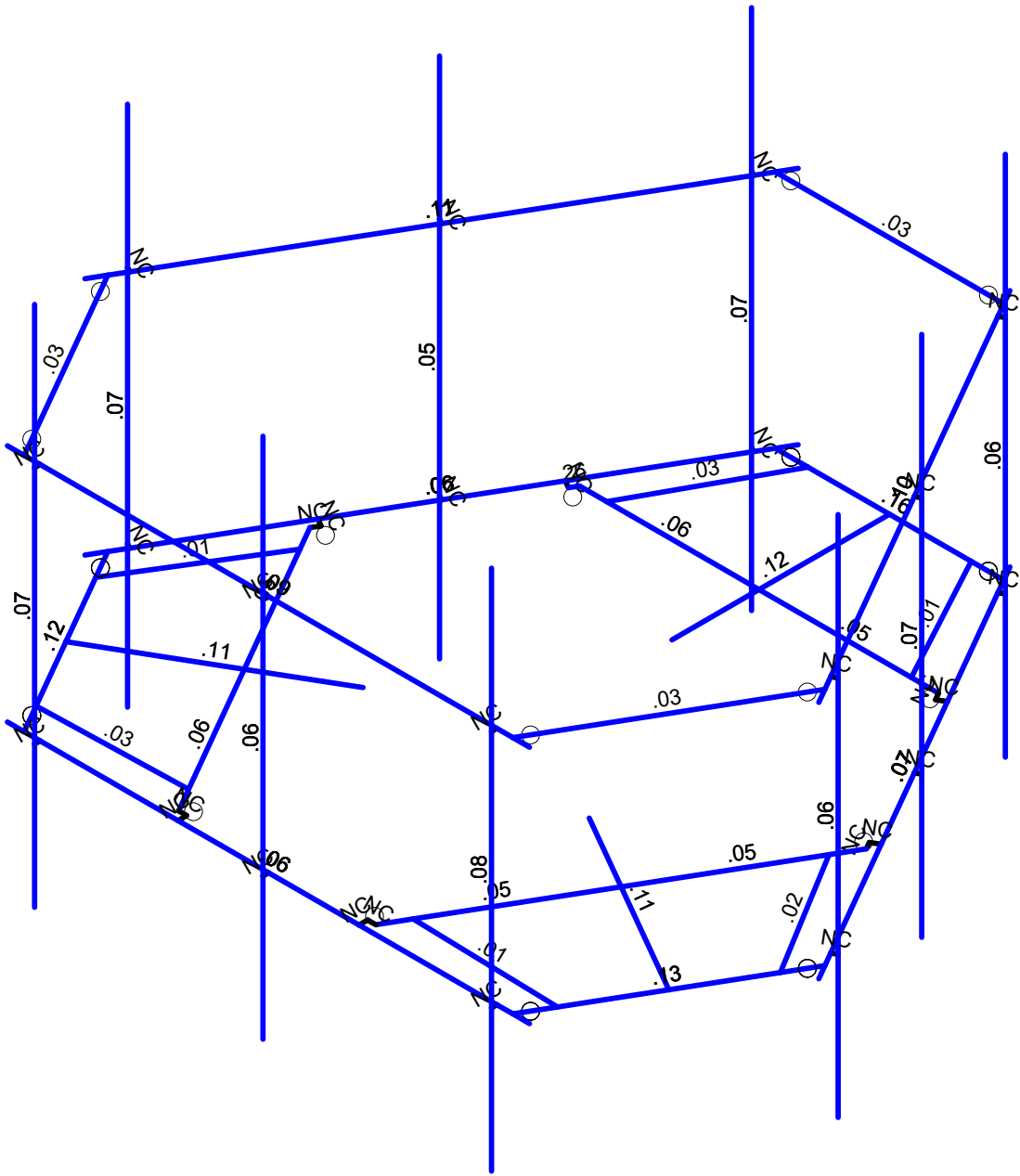
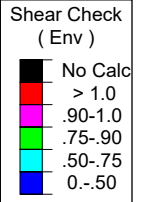
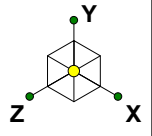

Member Shear Checks Displayed (Enveloped)  
Envelope Only Solution

Infinigy Engineering, PLLC	BOBDL00015A	Shear Check
BY		Aug 30, 2021 at 11:47 AM
1197-F0001-B		BOBDL00015A_loaded.r3d

## Program Inputs

PROJECT INFORMATION		
Client:	ATC	
Carrier:	Dish Wireless	
Engineer:	Binita Yadav	

SITE INFORMATION		
Risk Category:	II	
Exposure Category:	B	
Topo Factor Procedure:	Method 1, Category 1	
Site Class:	D - Stiff Soil (Assumed)	
Ground Elevation:	689.31	ft *Rev H

MOUNT INFORMATION		
Mount Type:	Platform	
Num Sectors:	3	
Centerline AGL:	93.00	ft
Tower Height AGL:	165.00	ft

TOPOGRAPHIC DATA		
Topo Feature:	N/A	
Slope Distance:	N/A	ft
Crest Distance:	N/A	ft
Crest Height:	N/A	ft

FACTORS		
Directionality Fact. ( $K_d$ ):	0.950	
Ground Ele. Factor ( $K_e$ ):	0.975	*Rev H Only
Rooftop Speed-Up ( $K_s$ ):	1.000	*Rev H Only
Topographic Factor ( $K_{zt}$ ):	1.000	
Gust Effect Factor ( $G_h$ ):	1.000	

CODE STANDARDS		
Building Code:	2015 IBC	
TIA Standard:	TIA-222-H	
ASCE Standard:	ASCE 7-10	

WIND AND ICE DATA		
Ultimate Wind ( $V_{ult}$ ):	125	mph
Design Wind ( $V$ ):	N/A	mph
Ice Wind ( $V_{ice}$ ):	50	mph
Base Ice Thickness ( $t_i$ ):	2	in
Flat Pressure:	71.751	psf
Round Pressure:	43.051	psf
Ice Wind Pressure:	6.888	psf

SEISMIC DATA		
Short-Period Accel. ( $S_s$ ):	0.175	g
1-Second Accel. ( $S_1$ ):	0.064	g
Short-Period Design ( $S_{DS}$ ):	0.187	
1-Second Design ( $S_{D1}$ ):	0.102	
Short-Period Coeff. ( $F_a$ ):	1.600	
1-Second Coeff. ( $F_v$ ):	2.400	
Amplification Factor ( $A_s$ ):	3.000	
Response Mod. Coeff. ( $R$ ):	2.000	



Infinigy Load Calculator V2.1.7



# ASCE 7 Hazards Report

**Address:**  
No Address at This Location

**Standard:** ASCE/SEI 7-10  
**Risk Category:** II  
**Soil Class:** D - Stiff Soil

**Elevation:** 689.31 ft (NAVD 88)  
**Latitude:** 41.873333  
**Longitude:** -72.3383

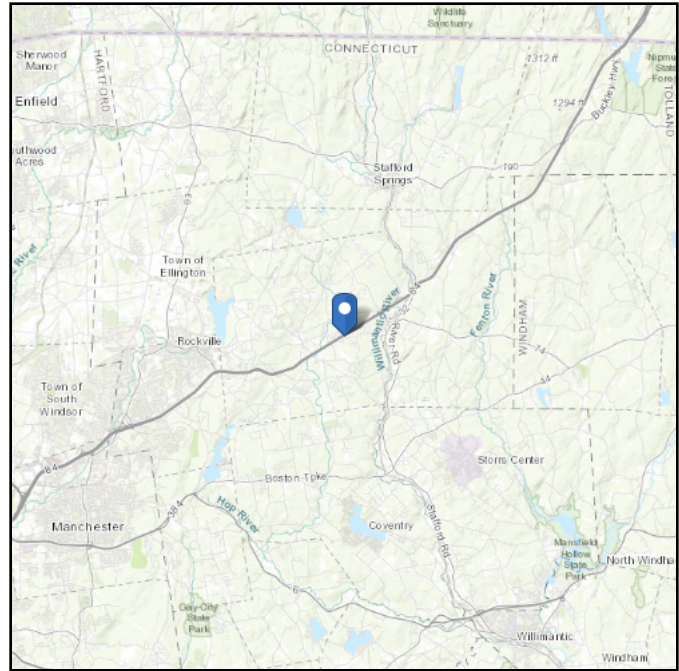

## Wind

### Results:

Wind Speed:	125 mph per Tolland City Requirements in WSEL
10-year MRI	77 Vmph
25-year MRI	87 Vmph
50-year MRI	94 Vmph
100-year MRI	101 Vmph

**Data Source:** ASCE/SEI 7-10, Fig. 26.5-1A and Figs. CC-1–CC-4, and Section 26.5.2, incorporating errata of March 12, 2014

Value provided is 3-second gust wind speeds at 33 ft above ground for Exposure C Category, based on linear interpolation between contours. Wind speeds are interpolated in accordance with the 7-10 Standard. Wind speeds correspond to approximately a 7% probability of exceedance in 50 years (annual exceedance probability = 0.00143, MRI = 700 years).

Site is in a hurricane-prone region as defined in ASCE/SEI 7-10 Section 26.2. Glazed openings need not be protected against wind-borne debris.

**Site Soil Class:** D - Stiff Soil

**Results:**

$S_S$ :	0.175	$S_{DS}$ :	0.187
$S_1$ :	0.064	$S_{D1}$ :	0.102
$F_a$ :	1.6	$T_L$ :	6
$F_v$ :	2.4	PGA :	0.087
$S_{MS}$ :	0.28	PGA <sub>M</sub> :	0.139
$S_{M1}$ :	0.152	F <sub>PGA</sub> :	1.6
		$I_e$ :	1

**Seismic Design Category** B

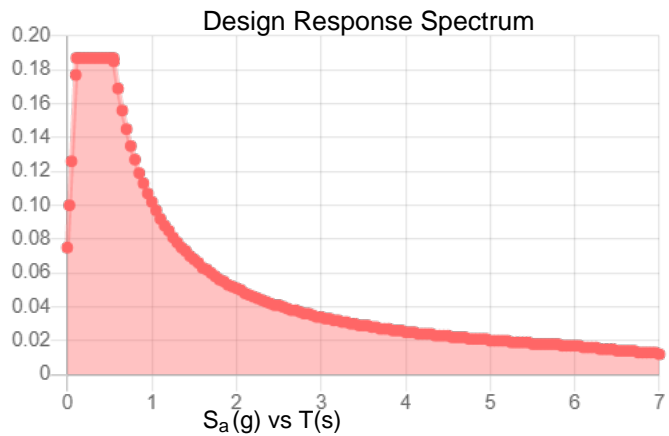
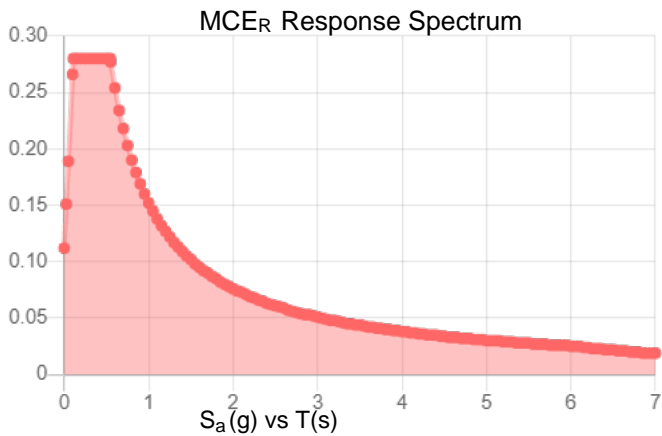

**Data Accessed:**

Fri Aug 27 2021

**Date Source:**

USGS Seismic Design Maps based on ASCE/SEI 7-10, incorporating Supplement 1 and errata of March 31, 2013, and ASCE/SEI 7-10 Table 1.5-2. Additional data for site-specific ground motion procedures in accordance with ASCE/SEI 7-10 Ch. 21 are available from USGS.





























**A Ya Vyf'DcJbh@UXg f6 @ '% 'GYZK YJ | H**

	T ^ ( ä ˆ ˆ ä ˆ )	Ö ä ˆ ä )	T ä ) ä ä ˆ ä ˆ ä ˆ ä	Š ˆ ä ) ˆ ä ä
F	T ÜF	Y	È HGG	€
G	T ÜF	Y	È HGG	Ì G
H	T ÜF	Y	È I ÈI	FG
I	T ÜF	Y	È HÈH	FG
Í	ÜF	Y	È ÈG	Í
Î	ÜF	Y	È ÈG	FÌ
Ï	T ÜI	Y	È HGG	€
Ì	T ÜI	Y	È HGG	Ì G
J	T ÜI	Y	È I ÈI	FG
F€	T ÜI	Y	È HÈH	FG
FF	T ÜI	Y	È HGG	€
FG	T ÜI	Y	È HGG	Ì G
FH	T ÜI	Y	È I ÈI	FG
FI	T ÜI	Y	È HÈH	FG

**A Ya Vyf'DcJbh@UXg f6 @ '& : 'K jX' @UX'5 N=' \$L**

	T ^ ( ä ˆ ˆ ä ˆ )	Ö ä ˆ ä )	T ä ) ä ä ˆ ä ˆ ä ˆ ä	Š ˆ ä ) ˆ ä ä
F	T ÜF	Y	€	€
G	T ÜF	Z	È G ÈF	€
H	T ÜF	Y	€	Ì G
I	T ÜF	Z	È G ÈF	Ì G
Í	T ÜF	Y	€	FG
Î	T ÜF	Z	È H È	FG
Ï	T ÜF	Y	€	FG
Ì	T ÜF	Z	È H È	FG
J	ÜF	Y	€	Í
F€	ÜF	Z	È H È	Í
FF	ÜF	Y	€	FÌ
FG	ÜF	Z	È H È	FÌ
FH	T ÜI	Y	€	€
FI	T ÜI	Z	È FÈG	€
FÍ	T ÜI	Y	€	Ì G
FÎ	T ÜI	Z	È FÈG	Ì G
FÏ	T ÜI	Y	€	FG
FÌ	T ÜI	Z	È I ÈI	FG
FJ	T ÜI	Y	€	FG
G€	T ÜI	Z	È ÈI	FG
G€	T ÜI	Y	€	€
GG	T ÜI	Z	È FÈG	€
GH	T ÜI	Y	€	Ì G
G	T ÜI	Z	È FÈG	Ì G
G	T ÜI	Y	€	FG
G	T ÜI	Z	È I ÈI	FG
G	T ÜI	Y	€	FG
G	T ÜI	Z	È ÈI	FG

**A Ya Vyf'DcJbh@UXg f6 @ ' : 'K jX' @UX'5 N=' \$L**

	T ^ ( ä ˆ ˆ ä ˆ )	Ö ä ˆ ä )	T ä ) ä ä ˆ ä ˆ ä ˆ ä	Š ˆ ä ) ˆ ä ä
F	T ÜF	Y	È I ÈI	€
G	T ÜF	Z	È I ÈF	€























**A Ya Vyf Dc Jbh @ UXg f6 @ '&': W'K JbX' @ UX'5 N='%' \$L'f' cbtjbi YXL**

	T ^ ( ä ^ ) S e e ^ ^	Ö ä ^ & c ä }	T a e ) ä a ^ Z a B a E c ä	Š ( & e ä ) Z ä B ä á
G	T ÚF	Z	F H É I	€
H	T ÚF	Y	H É I	I G
I	T ÚF	Z	F H É I	I G
Í	T ÚF	Y	H É I	FG
Ī	T ÚF	Z	I É G	FG
İ	T ÚF	Y	H É H	FG
Ĭ	T ÚF	Z	I É I	FG
J	ÚF	Y	H É I	I
F€	ÚF	Z	G É I	I
FF	ÚF	Y	H É I	F I
FG	ÚF	Z	G É I	F I
FH	T ÚI	Y	H É I	€
FI	T ÚI	Z	F H É I	€
FĪ	T ÚI	Y	H É I	I G
FĬ	T ÚI	Z	F H É I	I G
Fİ	T ÚI	Y	G É F	FG
FĪ	T ÚI	Z	I É H	FG
FJ	T ÚI	Y	G É I	FG
G€	T ÚI	Z	I É	FG
GF	T ÚI	Y	H É I	€
GG	T ÚI	Z	F H É I	€
GH	T ÚI	Y	H É I	I G
G	T ÚI	Z	F H É I	I G
Ḡ	T ÚI	Y	H É I	FG
Ġ	T ÚI	Z	I É G	FG
G̈	T ÚI	Y	H É H	FG
G̉	T ÚI	Z	I É I	FG

**A Ya Vyf Dc Jbh @ UXg f6 @ '&': W'K JbX' @ UX'5 N='%' \$L**

	T ^ ( ä ^ ) S e e ^ ^	Ö ä ^ & c ä }	T a e ) ä a ^ Z a B a E c ä	Š ( & e ä ) Z ä B ä á
F	T ÚF	Y	€	€
G	T ÚF	Z	F I É G	€
H	T ÚF	Y	€	I G
I	T ÚF	Z	F I É G	I G
Í	T ÚF	Y	€	FG
Ī	T ÚF	Z	I É G	FG
İ	T ÚF	Y	€	FG
Ĭ	T ÚF	Z	I É G	FG
J	ÚF	Y	€	I
F€	ÚF	Z	H É I	I
FF	ÚF	Y	€	F I
FG	ÚF	Z	H É I	F I
FH	T ÚI	Y	€	€
FI	T ÚI	Z	F H É I	€
FĪ	T ÚI	Y	€	I G
FĬ	T ÚI	Z	F H É I	I G
Fİ	T ÚI	Y	€	FG
FĪ	T ÚI	Z	I É G	FG
FJ	T ÚI	Y	€	FG
G€	T ÚI	Z	I É F	FG
GF	T ÚI	Y	€	€













**A Ya Vyf'8 jgh'vi hYX @ UXq'f6 @ '% : '8 jgh'"K jbx' @ UK'NL'f' c bhpí YXL**

	T \ ( á! ^áé ^)	Óá ^áé ^)	Úcáo Á áé ) á á ^áé ^éééééééé - á	Ó) á Á áé ) á á ^áé ^éééééééé - á	Úcáo Á áé ) á á ^áé ^éééééééé - á	Úcáo Á áé ) á á ^áé ^éééééééé - á
Í G	T Í Í	Ú Z	€	€	€	Á FEE
Í H	P G	Ú Z	€ HÉ F	€ HÉ F	€	Á FEE
Í I	T Ú Í	Ú Z	€ HÉ F	€ HÉ F	€	Á FEE
Í J	T Ú Í	Ú Z	€ HÉ F	€ HÉ F	€	Á FEE
Í K	P Ú G	Ú Z	€ HÉ F	€ HÉ F	€	Á FEE
Í L	T Í Í É	Ú Z	€	€	€	Á FEE
Í M	T Í Í É	Ú Z	€	€	€	Á FEE
Í N	T Í Í É	Ú Z	€	€	€	Á FEE
Í O	T Í J É	Ú Z	€	€	€	Á FEE
Í P	T Ú Í	Ú Z	€ HÉ F	€ HÉ F	€	Á FEE
Í Q	T Í Í Ó	Ú Z	€	€	€	Á FEE
Í R	T Í J Ó	Ú Z	€	€	€	Á FEE
Í S	T Ú Í	Ú Z	€ HÉ F	€ HÉ F	€	Á FEE
Í T	T Í F Ó	Ú Z	€	€	€	Á FEE
Í U	T Í G Ó	Ú Z	€	€	€	Á FEE

**A Ya Vyf'8 jgh'vi hYX @ UXq'f6 @ '% : '8 jgh'"K jbx' @ UK'LL**

	T \ ( á! ^áé ^)	Óá ^áé ^)	Úcáo Á áé ) á á ^áé ^éééééééé - á	Ó) á Á áé ) á á ^áé ^éééééééé - á	Úcáo Á áé ) á á ^áé ^éééééééé - á	Úcáo Á áé ) á á ^áé ^éééééééé - á
F	Ú H	Ú Y	€ FÉ Í F	€ FÉ Í F	€	Á FEE
G	Ó Ó É	Ú Y	€ FÉ Í F	€ FÉ Í F	€	Á FEE
H	Ó Ó H	Ú Y	€ FÉ Í F	€ FÉ Í F	€	Á FEE
I	Ú H	Ú Y	€ FÉ Í F	€ FÉ Í F	€	Á FEE
J	Ú G	Ú Y	€ FÉ Í F	€ FÉ Í F	€	Á FEE
K	Ó Ó G	Ú Y	€ FÉ Í F	€ FÉ Í F	€	Á FEE
L	Ó Ó F	Ú Y	€ FÉ Í F	€ FÉ Í F	€	Á FEE
M	Ú G	Ú Y	€ FÉ Í F	€ FÉ Í F	€	Á FEE
N	Ú F	Ú Y	€ FÉ Í F	€ FÉ Í F	€	Á FEE
O	Ó Ó É	Ú Y	€ FÉ Í F	€ FÉ Í F	€	Á FEE
P	Ó Ó É	Ú Y	€ FÉ Í F	€ FÉ Í F	€	Á FEE
Q	Ú F	Ú Y	€ FÉ Í F	€ FÉ Í F	€	Á FEE
R	P F	Ú Y	€ HÉ F	€ HÉ F	€	Á FEE
S	T Ú F	Ú Y	€ HÉ F	€ HÉ F	€	Á FEE
T	T Ú H	Ú Y	€ HÉ F	€ HÉ F	€	Á FEE
U	P Ú F	Ú Y	€ HÉ F	€ HÉ F	€	Á FEE
V	Ó Ó É	Ú Y	€ FÉ Í F	€ FÉ Í F	€	Á FEE
W	Ó Ó É	Ú Y	€ FÉ Í F	€ FÉ Í F	€	Á FEE
X	Ó Ó É	Ú Y	€ FÉ Í F	€ FÉ Í F	€	Á FEE
Y	Ó Ó É	Ú Y	€ FÉ Í F	€ FÉ Í F	€	Á FEE
Z	Ó Ó É	Ú Y	€ FÉ Í F	€ FÉ Í F	€	Á FEE
AA	T H G	Ú Y	€	€	€	Á FEE
AB	T H	Ú Y	€	€	€	Á FEE
AC	T H	Ú Y	€	€	€	Á FEE
AD	T H J É	Ú Y	€	€	€	Á FEE
AE	Ó Ó H	Ú Y	€ FÉ Í F	€ FÉ Í F	€	Á FEE
AF	Ó Ó É	Ú Y	€ FÉ Í F	€ FÉ Í F	€	Á FEE
AG	Ó Ó F	Ú Y	€ FÉ Í F	€ FÉ Í F	€	Á FEE
AH	Ó Ó G	Ú Y	€ FÉ Í F	€ FÉ Í F	€	Á FEE
AI	Ó Ó É	Ú Y	€ FÉ Í F	€ FÉ Í F	€	Á FEE
AJ	Ó Ó É	Ú Y	€ FÉ Í F	€ FÉ Í F	€	Á FEE
AK	T Í Í	Ú Y	€	€	€	Á FEE
AL	T Í Í	Ú Y	€	€	€	Á FEE
AM	T Í Í	Ú Y	€	€	€	Á FEE
AN	T Í Í	Ú Y	€	€	€	Á FEE

















## Ice

---

**Results:**

Ice Thickness: 1.00 in.

Concurrent Temperature: 5 F

Gust Speed: 50 mph

**Data Source:** Standard ASCE/SEI 7-10, Figs. 10-2 through 10-8

**Date Accessed:** Fri Aug 27 2021

Ice thicknesses on structures in exposed locations at elevations higher than the surrounding terrain and in valleys and gorges may exceed the mapped values.

Values provided are equivalent radial ice thicknesses due to freezing rain with concurrent 3-second gust speeds, for a 50-year mean recurrence interval, and temperatures concurrent with ice thicknesses due to freezing rain. Thicknesses for ice accretions caused by other sources shall be obtained from local meteorological studies. Ice thicknesses in exposed locations at elevations higher than the surrounding terrain and in valleys and gorges may exceed the mapped values.

---

The ASCE 7 Hazard Tool is provided for your convenience, for informational purposes only, and is provided “as is” and without warranties of any kind. The location data included herein has been obtained from information developed, produced, and maintained by third party providers; or has been extrapolated from maps incorporated in the ASCE 7 standard. While ASCE has made every effort to use data obtained from reliable sources or methodologies, ASCE does not make any representations or warranties as to the accuracy, completeness, reliability, currency, or quality of any data provided herein. Any third-party links provided by this Tool should not be construed as an endorsement, affiliation, relationship, or sponsorship of such third-party content by or from ASCE.

ASCE does not intend, nor should anyone interpret, the results provided by this Tool to replace the sound judgment of a competent professional, having knowledge and experience in the appropriate field(s) of practice, nor to substitute for the standard of care required of such professionals in interpreting and applying the contents of this Tool or the ASCE 7 standard.

In using this Tool, you expressly assume all risks associated with your use. Under no circumstances shall ASCE or its officers, directors, employees, members, affiliates, or agents be liable to you or any other person for any direct, indirect, special, incidental, or consequential damages arising from or related to your use of, or reliance on, the Tool or any information obtained therein. To the fullest extent permitted by law, you agree to release and hold harmless ASCE from any and all liability of any nature arising out of or resulting from any use of data provided by the ASCE 7 Hazard Tool.

## Bolt Calculation Tool, V1.5.1

PROJECT DATA	
Site Name:	BOBDL00015A
Site Number:	BOBDL00015A
Connection Description:	Platform to Monopole

MAXIMUM BOLT LOADS		
Bolt Tension:	8428.05	lbs
Bolt Shear:	1627.54	lbs

WORST CASE BOLT LOADS <sup>1</sup>		
Bolt Tension:	8428.05	lbs
Bolt Shear:	1505.57	lbs

BOLT PROPERTIES		
Bolt Type:	Bolt	-
Bolt Diameter:	0.625	in
Bolt Grade:	A325	-
# of Bolts:	4	-
Threads Excluded?	No	-

<sup>1</sup> Worst case bolt loads correspond to Load combination #32 on member S2 in RISA-3D, which causes the maximum demand on the bolts.

Member Information
I nodes of S3, S2, S1

BOLT CHECK		
Tensile Strength	20340.15	
Shear Strength	13805.83	
Max Tensile Usage	41.4%	
Max Shear Usage	11.8%	
Interaction Check (Worst Case)	0.18	≤1.05
Result	Pass	

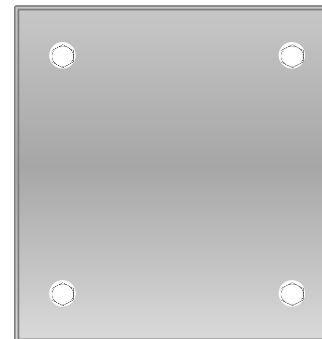

# POWER DENSITY STUDY

RADIO FREQUENCY EMISSIONS ANALYSIS REPORT  
EVALUATION OF HUMAN EXPOSURE POTENTIAL  
TO NON-IONIZING EMISSIONS

Dish Wireless Existing Facility

Site ID: BOBDL00015A

BOBDL00015A  
56 Ruops Road  
Tolland, Connecticut 06084

**October 4, 2021**

**EBI Project Number: 6221003974**

Site Compliance Summary	
Compliance Status:	<b>COMPLIANT</b>
Site total MPE% of FCC general population allowable limit:	<b>16.90%</b>

October 4, 2021

Dish Wireless

Emissions Analysis for Site: BOBDL00015A - BOBDL00015A

EBI Consulting was directed to analyze the proposed Dish Wireless facility located at **56 Ruops Road in Tolland, Connecticut** for the purpose of determining whether the emissions from the Proposed Dish Wireless Antenna Installation located on this property are within specified federal limits.

All information used in this report was analyzed as a percentage of current Maximum Permissible Exposure (% MPE) as listed in the FCC OET Bulletin 65 Edition 97-01 and ANSI/IEEE Std C95.1. The FCC regulates Maximum Permissible Exposure in units of microwatts per square centimeter ( $\mu\text{W}/\text{cm}^2$ ). The number of  $\mu\text{W}/\text{cm}^2$  calculated at each sample point is called the power density. The exposure limit for power density varies depending upon the frequencies being utilized. Wireless Carriers and Paging Services use different frequency bands each with different exposure limits; therefore, it is necessary to report results and limits in terms of percent MPE rather than power density.

All results were compared to the FCC (Federal Communications Commission) radio frequency exposure rules, 47 CFR 1.1307(b)(1) – (b)(3), to determine compliance with the Maximum Permissible Exposure (MPE) limits for General Population/Uncontrolled environments as defined below.

General population/uncontrolled exposure limits apply to situations in which the general population may be exposed or in which persons who are exposed as a consequence of their employment may not be made fully aware of the potential for exposure or cannot exercise control over their exposure. Therefore, members of the general population would always be considered under this category when exposure is not employment related, for example, in the case of a telecommunications tower that exposes persons in a nearby residential area.

Public exposure to radio frequencies is regulated and enforced in units of microwatts per square centimeter ( $\mu\text{W}/\text{cm}^2$ ). The general population exposure limits for the 600 MHz and 700 MHz frequency bands are approximately  $400 \mu\text{W}/\text{cm}^2$  and  $467 \mu\text{W}/\text{cm}^2$ , respectively. The general population exposure limit for the 1900 MHz (PCS), 2100 MHz (AWS) and 11 GHz frequency bands is  $1000 \mu\text{W}/\text{cm}^2$ . Because each carrier will be using different frequency bands, and each frequency band has different exposure limits, it is necessary to report percent of MPE rather than power density.

Occupational/controlled exposure limits apply to situations in which persons are exposed as a consequence of their employment and in which those persons who are exposed have been made fully aware of the potential for exposure and can exercise control over their exposure.

Occupational/controlled exposure limits also apply where exposure is of a transient nature as a result of incidental passage through a location where exposure levels may be above general population/uncontrolled limits (see below), as long as the exposed person has been made fully aware of the potential for exposure and can exercise control over his or her exposure by leaving the area or by some other appropriate means.

Additional details can be found in FCC OET 65.

## **CALCULATIONS**

Calculations were done for the proposed Dish Wireless antenna facility located at 56 Ruops Road in Tolland, Connecticut using the equipment information listed below. All calculations were performed per the specifications under FCC OET 65. Since Dish Wireless is proposing highly focused directional panel antennas, which project most of the emitted energy out toward the horizon, all calculations were performed assuming a lobe representing the maximum gain of the antenna per the antenna manufacturer's supplied specifications, minus 20 dB for directional panel antennas and 20 dB for highly focused parabolic microwave dishes, was focused at the base of the tower. For this report, the sample point is the top of a 6-foot person standing at the base of the tower.

For all calculations, all equipment was calculated using the following assumptions:

- 1) 4 n71 channels (600 MHz Band) were considered for each sector of the proposed installation. These Channels have a transmit power of 30 Watts per Channel.
- 2) 4 n70 channels (PCS Band - 1900 MHz) were considered for each sector of the proposed installation. These Channels have a transmit power of 40 Watts per Channel.
- 3) 4 n66 channels (AWS Band - 2190 MHz) were considered for each sector of the proposed installation. These Channels have a transmit power of 40 Watts per Channel.
- 4) All radios at the proposed installation were considered to be running at full power and were uncombined in their RF transmissions paths per carrier prescribed configuration. Per FCC OET Bulletin No. 65 - Edition 97-01 recommendations to achieve the maximum anticipated value at each sample point, all power levels emitting from the proposed antenna installation are increased by a factor of 2.56 to account for possible in-phase reflections from the surrounding environment. This is rarely the case, and if so, is never continuous.
- 5) For the following calculations, the sample point was the top of a 6-foot person standing at the base of the tower. The maximum gain of the antenna per the antenna manufacturer's supplied specifications, minus 20 dB for directional panel antennas and 20 dB for highly focused parabolic microwave dishes, was used in this direction. This value is a very conservative

estimate as gain reductions for these particular antennas are typically much higher in this direction.

- 6) The antennas used in this modeling are the JMA MX08FRO665-21 for the 600 MHz / 1900 MHz / 2190 MHz channel(s) in Sector A, the JMA MX08FRO665-21 for the 600 MHz / 1900 MHz / 2190 MHz channel(s) in Sector B, the JMA MX08FRO665-21 for the 600 MHz / 1900 MHz / 2190 MHz channel(s) in Sector C. This is based on feedback from the carrier with regard to anticipated antenna selection. All Antenna gain values and associated transmit power levels are shown in the Site Inventory and Power Data table below. The maximum gain of the antenna per the antenna manufacturer's supplied specifications, minus 20 dB for directional panel antennas and 20 dB for highly focused parabolic microwave dishes, was used for all calculations. This value is a very conservative estimate as gain reductions for these particular antennas are typically much higher in this direction.
- 7) The antenna mounting height centerline of the proposed antennas is 93 feet above ground level (AGL).
- 8) Emissions values for additional carriers were taken from the Connecticut Siting Council active database. Values in this database are provided by the individual carriers themselves.
- 9) All calculations were done with respect to uncontrolled / general population threshold limits.



## Dish Wireless Site Inventory and Power Data

Sector:	A	Sector:	B	Sector:	C
Antenna #:	1	Antenna #:	1	Antenna #:	1
Make / Model:	JMA MX08FRO665-21	Make / Model:	JMA MX08FRO665-21	Make / Model:	JMA MX08FRO665-21
Frequency Bands:	600 MHz / 1900 MHz / 2190 MHz	Frequency Bands:	600 MHz / 1900 MHz / 2190 MHz	Frequency Bands:	600 MHz / 1900 MHz / 2190 MHz
Gain:	17.45 dBd / 22.65 dBd / 22.65 dBd	Gain:	17.45 dBd / 22.65 dBd / 22.65 dBd	Gain:	17.45 dBd / 22.65 dBd / 22.65 dBd
Height (AGL):	93 feet	Height (AGL):	93 feet	Height (AGL):	93 feet
Channel Count:	12	Channel Count:	12	Channel Count:	12
Total TX Power (W):	440 Watts	Total TX Power (W):	440 Watts	Total TX Power (W):	440 Watts
ERP (W):	5,236.31	ERP (W):	5,236.31	ERP (W):	5,236.31
Antenna AI MPE %:	<b>3.12%</b>	Antenna BI MPE %:	<b>3.12%</b>	Antenna CI MPE %:	<b>3.12%</b>

Site Composite MPE %	
Carrier	MPE %
Dish Wireless (Max at Sector A):	3.12%
T-Mobile	1.75%
AT&T	2.98%
Verizon	5.19%
Sprint	3.42%
Nextel	0.44%
<b>Site Total MPE % :</b>	<b>16.90%</b>

Dish Wireless MPE % Per Sector	
Dish Wireless Sector A Total:	3.12%
Dish Wireless Sector B Total:	3.12%
Dish Wireless Sector C Total:	3.12%
<b>Site Total MPE % :</b>	<b>16.90%</b>

Dish Wireless Maximum MPE Power Values (Sector A)							
Dish Wireless Frequency Band / Technology (Sector A)	# Channels	Watts ERP (Per Channel)	Height (feet)	Total Power Density ( $\mu\text{W}/\text{cm}^2$ )	Frequency (MHz)	Allowable MPE ( $\mu\text{W}/\text{cm}^2$ )	Calculated % MPE
Dish Wireless 600 MHz n71	4	223.68	93.0	4.25	600 MHz n71	400	1.06%
Dish Wireless 1900 MHz n70	4	542.70	93.0	10.31	1900 MHz n70	1000	1.03%
Dish Wireless 2190 MHz n66	4	542.70	93.0	10.31	2190 MHz n66	1000	1.03%
						<b>Total:</b>	<b>3.12%</b>

• NOTE: Totals may vary by approximately 0.01% due to summation of remainders in calculations.

## Summary

All calculations performed for this analysis yielded results that were **within** the allowable limits for general population exposure to RF Emissions.

The anticipated maximum composite contributions from the Dish Wireless facility as well as the site composite emissions value with regards to compliance with FCC's allowable limits for general population exposure to RF Emissions are shown here:

Dish Wireless Sector	Power Density Value (%)
Sector A:	3.12%
Sector B:	3.12%
Sector C:	3.12%
Dish Wireless Maximum MPE % (Sector A):	3.12%
Site Total:	16.90%
Site Compliance Status:	<b>COMPLIANT</b>

The anticipated composite MPE value for this site assuming all carriers present is **16.90%** of the allowable FCC established general population limit sampled at the ground level. This is based upon values listed in the Connecticut Siting Council database for existing carrier emissions.

FCC guidelines state that if a site is found to be out of compliance (over allowable thresholds), that carriers over a 5% contribution to the composite value will require measures to bring the site into compliance. For this facility, the composite values calculated were well within the allowable 100% threshold standard per the federal government.

## UNDERLYING PROPERTY INFORMATION

# 1 EAGLE HILL

**Location** 1 EAGLE HILL

**Mblu** 23/ E/ 51/00 /

**Acct#** 6783

**Owner** TOWN OF TOLLAND

**Assessment** \$47,410,700

**Appraisal** \$67,729,400

**PID** 3893

**Building Count** 1

## Current Value

Appraisal			
Valuation Year	Improvements	Land	Total
2019	\$64,952,400	\$2,777,000	\$67,729,400

Assessment			
Valuation Year	Improvements	Land	Total
2019	\$45,466,800	\$1,943,900	\$47,410,700

## Owner of Record

**Owner** TOWN OF TOLLAND  
**Co-Owner**  
**Address** 21 TOLLAND GREEN  
TOLLAND, CT 06084-0000

**Sale Price** \$850,000  
**Certificate**  
**Book & Page** 0819/0081  
**Sale Date** 04/24/2003  
**Instrument** 15

## Ownership History

Ownership History					
Owner	Sale Price	Certificate	Book & Page	Instrument	Sale Date
TOWN OF TOLLAND	\$850,000		0819/0081	15	04/24/2003
RUOPS ALBERT J TRUSTEE U TR	\$0		0396/0288	29	06/16/1960

## Building Information

### Building 1 : Section 1

**Year Built:** 2005  
**Living Area:** 258,330  
**Replacement Cost:** \$69,099,782  
**Building Percent Good:** 90

Replacement Cost  
Less Depreciation:

\$62,189,800

**Building Attributes**

Field	Description
Style:	Schools-Public
Model	Commercial
Grade	Excellent
Stories:	2
Occupancy	1.00
Ext Wall 1	Brick Veneer
Exterior Wall 2	Reinforc Concr
Roof Structure	Flat
Roof Cover	Tar & Gravel
Interior Wall 1	Minim/Masonry
Interior Wall 2	Drywall/Sheet
Interior Floor 1	Vinyl/Asphalt
Interior Floor 2	
Heating Fuel	Oil
Heating Type	Hot Water
AC Type	Vapor Cooler
Struct Class	
Bldg Use	Municipal
Total Rooms	70
Total Bedrms	0
Total Baths	0
Solar	
1st Floor Use:	901C
Heat/AC	Heat/AC Split
Frame Type	Fireprf Steel
Baths/Plumbing	Average
Ceiling/Wall	Sus Ceil Min W
Rooms/Prtns	Above Average
Wall Height	16.00
% Comn Wall	

**Building Photo**



(<http://images.vgsi.com/photos/TollandCTPhotos/\A00\00\69\90.jpg>)

**Building Layout**

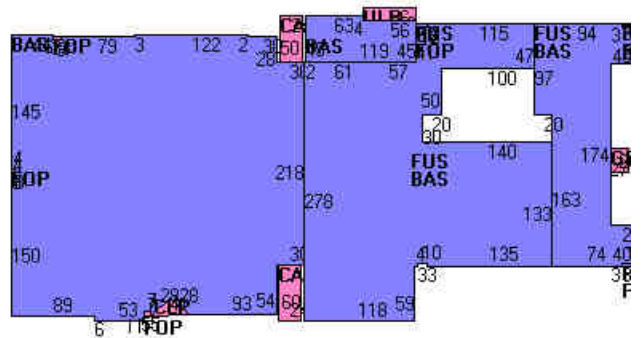

([http://images.vgsi.com/photos/TollandCTPhotos//Sketches/3893\\_3931.jpg](http://images.vgsi.com/photos/TollandCTPhotos//Sketches/3893_3931.jpg))

Building Sub-Areas (sq ft)			Legend
Code	Description	Gross Area	Living Area
BAS	Main Floor	177,914	177,914
FUS	Finished Upper Story	80,416	80,416
CAN	Canopy	2,640	0
CLP	Covered Loading Platform	380	0
FOP	Open Porch	202	0
GRN	Green House	540	0
ULP	Loading Platform	728	0
		262,820	258,330

**Extra Features**

Extra Features				Legend
Code	Description	Size	Value	Bldg #
SPR1	SPRINKLERS-WET	248306.00 S.F.	\$178,800	1

ELV	ELEVATOR	1.00 UNITS	\$24,300	1
-----	----------	------------	----------	---

## Land

### Land Use

**Use Code** 901C  
**Description** Municipal  
**Zone** RDD  
**Neighborhood** 350C  
**Alt Land Appr** No  
**Category**

### Land Line Valuation

**Size (Acres)** 68.5  
**Frontage** 1351  
**Depth**  
**Assessed Value** \$1,943,900  
**Appraised Value** \$2,777,000

## Outbuildings

Outbuildings						<u>Legend</u>
Code	Description	Sub Code	Sub Description	Size	Value	Bldg #
PAV	PAVING	A	Asphalt	480000.00 S.F.	\$645,100	1
FN	FENCE	CL4	4' Chain Link	7500.00 L.F.	\$50,400	1
PLS	POLES	L1	Lighting	48.00 UNITS	\$121,000	1
BALL	FIELD HARD		TYPICAL	1.00 UNITS	\$702,000	1
TRL1	TRAILER	A	Storage	640.00 S.F.	\$9,600	1
FGR	GARAGE	1F	1Story Frame	720.00 S.F.	\$16,800	1
FGR	GARAGE	1F	1Story Frame	720.00 S.F.	\$16,800	1
SHD	SHED	1LT	1 Stry Lean To	1024.00 S.F.	\$9,200	1
BALL	FIELD HARD		TYPICAL	2.00 UNITS	\$650,000	1
AF	ATHLETIC FLD	FB	Football	1.00 UNITS	\$126,000	1
AF	ATHLETIC FLD	RT	Running Trck	1.00 UNITS	\$210,000	1
SHD	SHED	1F	1 Stry Frame	160.00 S.F.	\$2,600	1

## Valuation History

Appraisal			
Valuation Year	Improvements	Land	Total
4000	\$64,952,400	\$2,777,000	\$67,729,400
2020	\$64,952,400	\$2,777,000	\$67,729,400
2019	\$64,952,400	\$2,777,000	\$67,729,400

Assessment			
Valuation Year	Improvements	Land	Total
4000	\$45,466,800	\$1,943,900	\$47,410,700
2020	\$45,466,800	\$1,943,900	\$47,410,700
2019	\$45,466,800	\$1,943,900	\$47,410,700





# 56 RUOPS ROAD

**Location** 56 RUOPS ROAD

**Mblu** 23/ E/ 51/ /

**Acct#** 5384

**Owner** TOWN OF TOLLAND

**Assessment** \$1,347,600

**Appraisal** \$1,925,000

**PID** 3892

**Building Count** 1

## Current Value

Appraisal			
Valuation Year	Improvements	Land	Total
2019	\$191,700	\$1,733,300	\$1,925,000

Assessment			
Valuation Year	Improvements	Land	Total
2019	\$134,300	\$1,213,300	\$1,347,600

## Owner of Record

**Owner** TOWN OF TOLLAND  
**Co-Owner** C/O SPECTRASITE COMMUNICATIONS  
**Address** PO BOX 723597  
ATLANTA, GA 31139

**Sale Price** \$0  
**Certificate**  
**Book & Page** 0819/0081  
**Sale Date** 04/24/2003  
**Instrument** 15

## Ownership History

Ownership History					
Owner	Sale Price	Certificate	Book & Page	Instrument	Sale Date
TOWN OF TOLLAND	\$0		0819/0081	15	04/24/2003

## Building Information

### Building 1 : Section 1

**Year Built:**  
**Living Area:** 0  
**Replacement Cost:** \$0  
**Building Percent Good:**  
**Replacement Cost**  
**Less Depreciation:** \$0

**Building Attributes**

Field	Description
Style:	Outbuildings
Model	
Grade:	
Stories:	
Occupancy	
Exterior Wall 1	
Exterior Wall 2	
Roof Structure:	
Roof Cover	
Interior Wall 1	
Interior Wall 2	
Interior Flr 1	
Interior Flr 2	
Heat Fuel	
Heat Type:	
AC Type:	
Total Bedrooms:	
Total Bthrms:	
Total Half Baths:	
Total Xtra Fixtrs:	
Total Rooms:	
Bath Style:	
Kitchen Style:	
Num Kitchens	
Cndtn	
Func Code	
Econ Code	
Num Park	
Fireplaces	
Solar	
Solar Type	
Fndtn Cndtn	
Basement	

### Building Photo



(<http://images.vgsi.com/photos/TollandCTPhotos/\00\00\63\46.jpg>)

### Building Layout

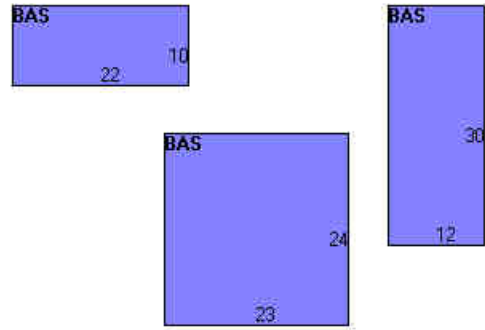

([http://images.vgsi.com/photos/TollandCTPhotos//Sketches/3892\\_3930.jpg](http://images.vgsi.com/photos/TollandCTPhotos//Sketches/3892_3930.jpg))

Building Sub-Areas (sq ft)	Legend
No Data for Building Sub-Areas	

### Extra Features

Extra Features	Legend
No Data for Extra Features	

**Land****Land Use**

**Use Code** 300V  
**Description** Industrial  
**Zone** RDD  
**Neighborhood** 350C  
**Alt Land Appr** No  
**Category**

**Land Line Valuation**

**Size (Acres)** 0.78  
**Frontage** 2973  
**Depth**  
**Assessed Value** \$1,213,300  
**Appraised Value** \$1,733,300

**Outbuildings**

Outbuildings						<u>Legend</u>
Code	Description	Sub Code	Sub Description	Size	Value	Bldg #
FN	FENCE	CL8	8' Chain Link	380.00 L.F.	\$3,800	1
SHD	SHED	CL	Cell Shed	220.00 S.F.	\$35,800	1
SHD	SHED	CL	Cell Shed	576.00 S.F.	\$93,600	1
SHD	SHED	CL	Cell Shed	360.00 S.F.	\$58,500	1

**Valuation History**

Appraisal			
Valuation Year	Improvements	Land	Total
4000	\$191,700	\$1,733,300	\$1,925,000
2020	\$191,700	\$1,733,300	\$1,925,000
2019	\$191,700	\$1,733,300	\$1,925,000

Assessment			
Valuation Year	Improvements	Land	Total
4000	\$134,300	\$1,213,300	\$1,347,600
2020	\$134,300	\$1,213,300	\$1,347,600
2019	\$134,300	\$1,213,300	\$1,347,600

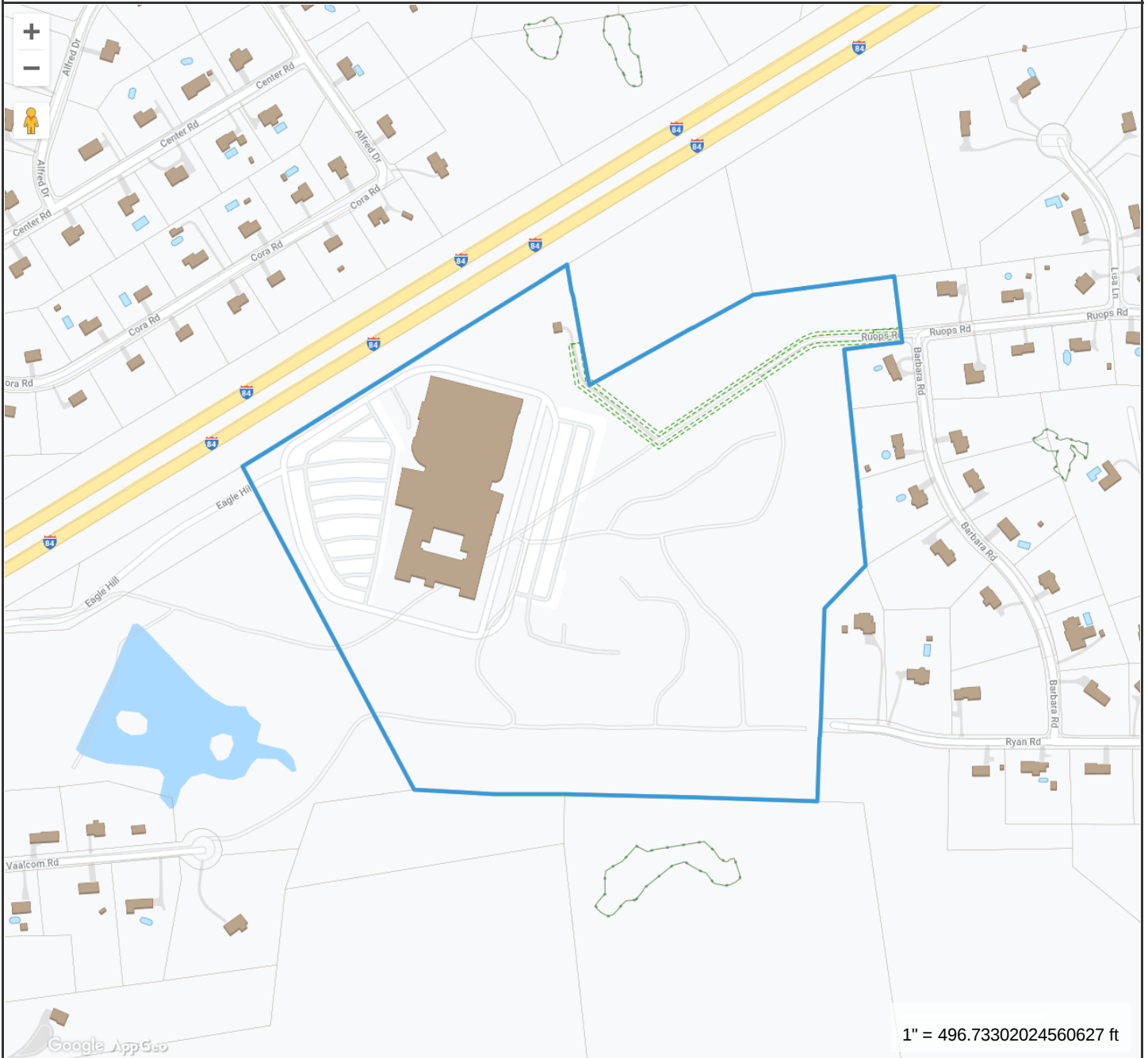

**Property Information**

**Property ID** 23/E/051  
**Location** 1 EAGLE HILL  
**Owner** TOWN OF TOLLAND



**MAP FOR REFERENCE ONLY  
NOT A LEGAL DOCUMENT**

Town of Tolland, CT makes no claims and no warranties, expressed or implied, concerning the validity or accuracy of the GIS data presented on this map.

Geometry updated October 25, 2021  
Data updated daily

Print map scale is approximate. Critical layout or measurement activities should not be done using this resource.



January 28, 2022

Dear Customer,

The following is the proof-of-delivery for tracking number: 775824466148

---

**Delivery Information:**

---

<b>Status:</b>	Delivered	<b>Delivered To:</b>	Shipping/Receiving
<b>Signed for by:</b>	S.IGNATURE ON FILE	<b>Delivery Location:</b>	21 TOLLAND GRN
<b>Service type:</b>	FedEx 2Day		
<b>Special Handling:</b>	Deliver Weekday		TOLLAND, CT, 06084
		<b>Delivery date:</b>	Jan 25, 2022 12:11

---

**Shipping Information:**

---

<b>Tracking number:</b>	775824466148	<b>Ship Date:</b>	Jan 21, 2022
		<b>Weight:</b>	0.5 LB/0.23 KG

**Recipient:**  
Tammy Nuccio - Town Council Chair,  
21 Tolland Green  
TOLLAND, CT, US, 06084

**Shipper:**  
Corey Milan, NB+C  
100 Apollo Dr.  
Suite 303  
CHELMSFORD, MA, US, 01824

**Reference** 100814

Thank you for choosing FedEx



January 28, 2022

Dear Customer,

The following is the proof-of-delivery for tracking number: 775824442806

---

**Delivery Information:**

---

<b>Status:</b>	Delivered	<b>Delivered To:</b>	Shipping/Receiving
<b>Signed for by:</b>	S.IGNATURE ON FILE	<b>Delivery Location:</b>	21 TOLLAND GRN
<b>Service type:</b>	FedEx 2Day		
<b>Special Handling:</b>	Deliver Weekday		TOLLAND, CT, 06084
		<b>Delivery date:</b>	Jan 24, 2022 10:07

---

**Shipping Information:**

---

<b>Tracking number:</b>	775824442806	<b>Ship Date:</b>	Jan 21, 2022
		<b>Weight:</b>	0.5 LB/0.23 KG

**Recipient:**  
James Paquin - Building Official,  
21 Tolland Green  
3rd Level  
TOLLAND, CT, US, 06084

**Shipper:**  
Corey Milan, NB+C  
100 Apollo Dr.  
Suite 303  
CHELMSFORD, MA, US, 01824

**Reference** 100814

Thank you for choosing FedEx



January 28, 2022

Dear Customer,

The following is the proof-of-delivery for tracking number: 775824410535

---

**Delivery Information:**

---

<b>Status:</b>	Delivered	<b>Delivered To:</b>	Shipping/Receiving
<b>Signed for by:</b>	S.IGNATURE ON FILE	<b>Delivery Location:</b>	21 TOLLAND GRN
<b>Service type:</b>	FedEx 2Day		
<b>Special Handling:</b>	Deliver Weekday		TOLLAND, CT, 06084
		<b>Delivery date:</b>	Jan 24, 2022 10:07

---

**Shipping Information:**

---

<b>Tracking number:</b>	775824410535	<b>Ship Date:</b>	Jan 21, 2022
		<b>Weight:</b>	0.5 LB/0.23 KG

**Recipient:**  
The Town of Tolland - Owner,  
21 Tolland Green  
TOLLAND, CT, US, 06084

**Shipper:**  
Corey Milan, NB+C  
100 Apollo Dr.  
Suite 303  
CHELMSFORD, MA, US, 01824

**Reference** 100814

Thank you for choosing FedEx