

September 8, 2015

VIA EMAIL AND OVERNIGHT DELIVERY

Ms. Melanie A. Bachman
Acting Executive Director
Connecticut Siting Council
Ten Franklin Square
New Britain, CT 06051

EM-T-MOBILE-141-150909

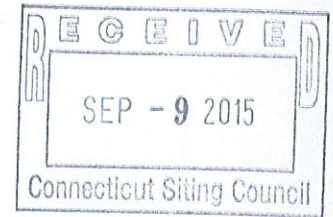

RE: T-Mobile Northeast LLC – Notice of Exempt Modification
720 Thompson Road, Thompson, CT

Dear Ms. Bachman:

ORIGINAL

This letter and attachments are submitted on behalf of T-Mobile Northeast LLC ("T-Mobile"). T-Mobile is undertaking modifications to certain existing sites in its Connecticut network in order to implement updated technology. In order to do so, T-Mobile will modify antenna and equipment configurations at a number of existing sites. Please accept this letter and attachments as notification, pursuant to R.C.S.A. Section 16-50j-73, of construction which constitutes an exempt modification pursuant to R.C.S.A. Section 16-50j-72(b)(2). In compliance with R.C.S.A. Section 16-50j-73, a copy of this letter and attachments is being sent to the First Selectman of the Town of Thompson, and the property owner, Crown Castle.

T-Mobile plans to modify the existing facility at 720 Thompson Road owned by Crown Castle (coordinates 41-58-39.74/-71-50-47.55). Attached are drawings depicting the planned changes, and documentation of the structural sufficiency of the tower to accommodate the revised antenna configuration with proposed modifications as shown in the attached Monopole Reinforcement Drawings prepared by Aero Solutions LLC. Also included is a power density calculation reflecting the modification to T-Mobile's operations at the site.

The changes to the facility do not constitute a modification as defined in Connecticut General Statutes ("C.G.S.") Section 16-50i(d) because the general physical characteristics of the facility will not be significantly changed. Rather, the planned changes to the facility fall squarely within those activities explicitly provided for in R.C.S.A. Section 16-50j-72(b)(2).

1. The height of the overall structure will be unaffected. T-Mobile proposes to replace six (6) existing antennas at a centerline height of 143' AGL.
2. The proposed changes will not extend the site boundaries. T-Mobile does

not propose to replace or install any equipment at grade. Thus, there will be no effect on the site compound or T-Mobile's leased area.

3. The proposed changes will not increase the noise level at the existing facility by six decibels or more. The incremental effect of the proposed changes will be negligible.

4. The changes to the facility will not increase the calculated "worst case" power density for the combined operations at the site to a level at or above the applicable standard for uncontrolled environments as calculated for a mixed frequency site. As indicated in the attached power density calculations, T-Mobile's operations at the site will result in a power density of 6.45%; the combined site operations will result in a total power density of 9.93%.

Please feel free to call me with any questions or concerns regarding this matter. Thank you for your consideration.

Respectfully submitted,

By: 
Eric Dahl, Agent for T-Mobile
edahl@comcast.net
860-227-1975

Attachments

cc: First Selectman Paul A. Lenky, Town of Thompson
Crown Castle
Melrose Associates Limited Partnership

T-MOBILE PROJECT NO.	0644-CT11608	ISSUED BY	
T-MOBILE PROJECT NAME		DATE	
T-MOBILE PROJECT LOCATION		SCALE	
T-MOBILE PROJECT COMMENTS		DATE	

ISSUED BY	
DATE	

CT111608
 THOMPSON/A-395 X99_1
 720 THOMPSON RD
 THOMPSON, CT 06277

SHEET TITLE
SITE PLAN & EQUIPMENT PLAN

SHEET NUMBER
A-1

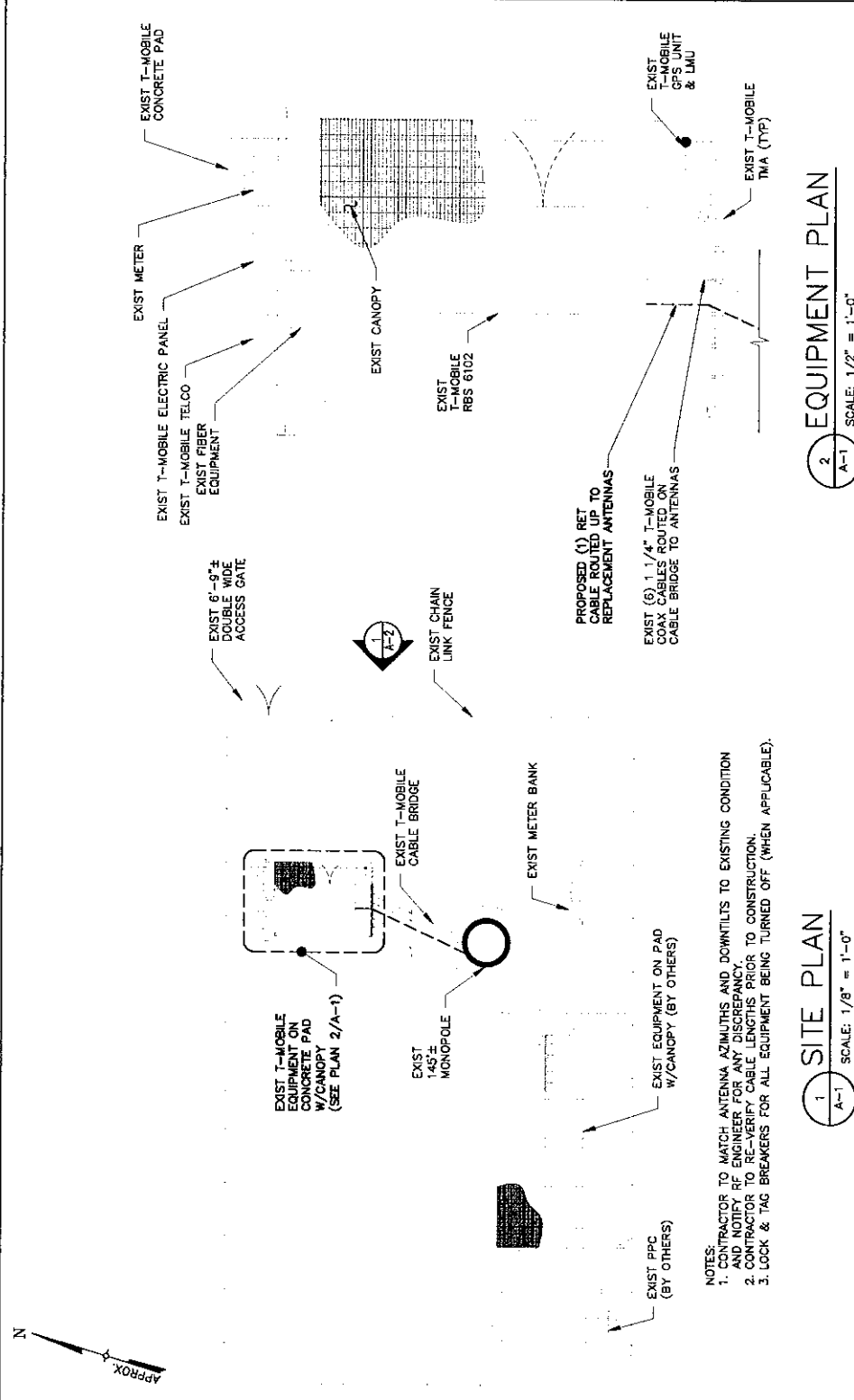

2
 EQUIPMENT PLAN
 SCALE: 1/2" = 1'-0"

CONFIGURATION
4B
 REFER TO LATEST T-MOBILE RF DATA SHEET FOR FINAL RF DESIGN & BON.

ORIGINAL SIZE IN INCHES

1
 SITE PLAN
 SCALE: 1/8" = 1'-0"

- NOTES:
 1. CONTRACTOR TO MATCH ANTENNA AZIMUTHS AND DOWNTILTS TO EXISTING CONDITION AND NOTIFY RF ENGINEER FOR ANY DISCREPANCY PRIOR TO CONSTRUCTION.
 2. CONTRACTOR TO RE-VERIFY CABLE LENGTHS PRIOR TO CONSTRUCTION.
 3. LOCK & TAG BREAKERS FOR ALL EQUIPMENT BEING TURNED OFF (WHEN APPLICABLE).

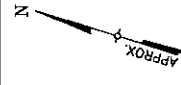

T-MOBILE ENCLOSURE CONSTRUCTION	APPROVALS
PROJECT NUMBER 6441511160B	DESIGNED BY AS
REV. DATE REVISION 12/17/12 FOR COMMENT	DRAWN BY AP
ISSUED BY	DATE

CT11160B THOMPSON/-395 X99_1 720 THOMPSON RD THOMPSON, CT 06277
--

ELEVATION

CONFIGURATION 4B
REFER TO LATEST T-MOBILE RF DATA SHEET FOR FINAL RF DESIGN & BOM.

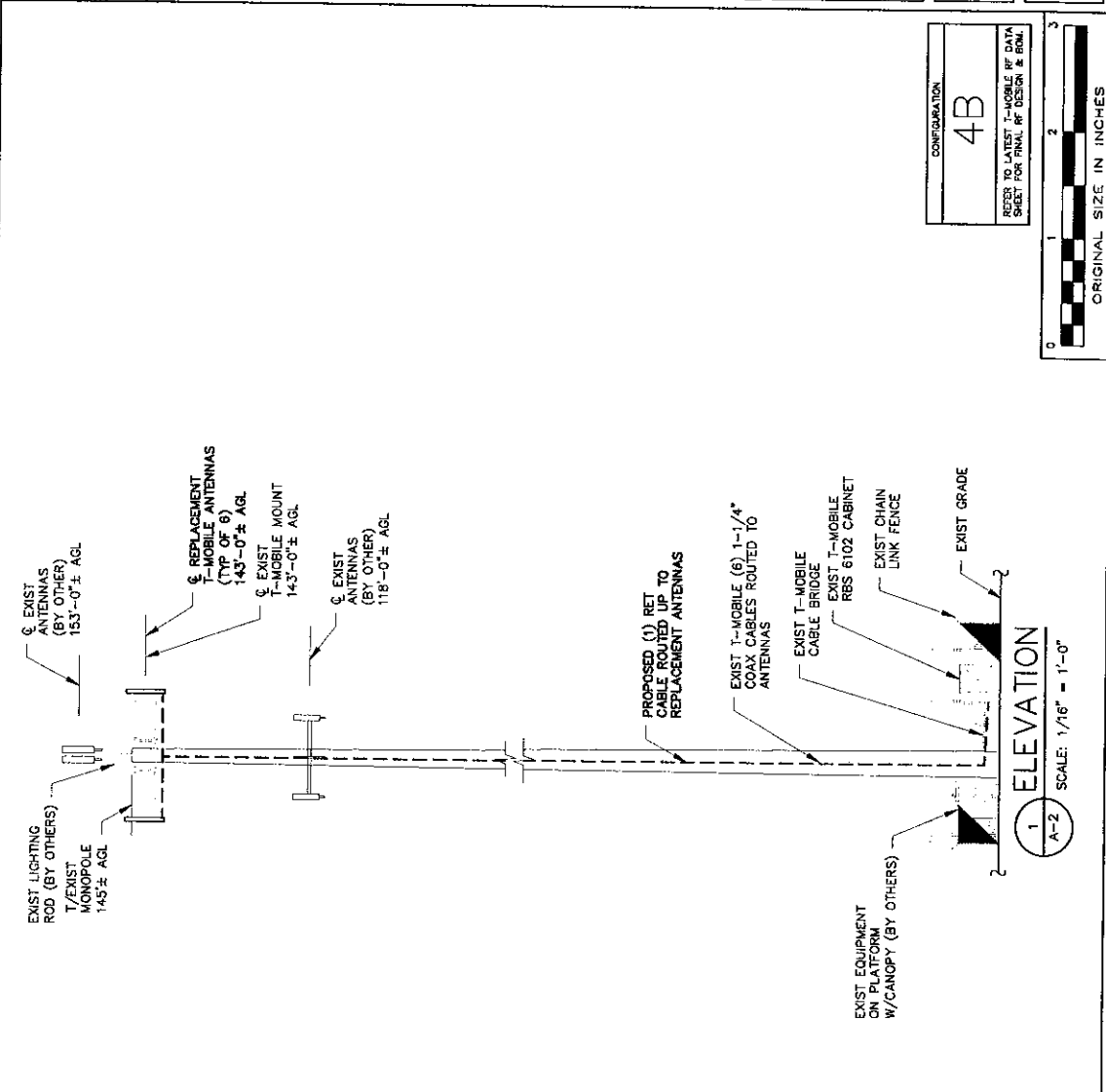
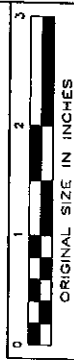

THE EXISTING MONOPOLE AND EXISTING MOUNT SHALL BE STRUCTURALLY ANALYZED BY A PROFESSIONAL ENGINEER LICENSED IN THE STATE OF CONNECTICUT (TO BE COORDINATED BY OTHERS)

ELEVATION NOTE:
 ELEVATION OF EXIST MONOPOLE HAS BEEN ARBITRARILY ASSIGNED AS EL 776'-0"±. THIS IS APPROXIMATELY 145'-0"± ABOVE GRADE WHICH WAS ESTIMATED AS EL 531'-0"± TAKEN FROM U.S.G.S. QUAD MAP, AND DOES NOT NECESSARILY CORRESPOND TO ACTUAL ELEVATION ABOVE SEA LEVEL. ALL OTHER ELEVATIONS INDICATED WERE DETERMINED ON THIS BASIS.

Date: **May 29, 2015**

Mitchell Abbott
Crown Castle
3530 Toringdon Way, Suite 300
Charlotte, NC 28277



Aero Solutions, LLC
5500 Flatiron Parkway, Suite 100
Boulder, CO 80301
720-304-6882

Subject: Structural Analysis Report

Carrier Designation:

T-Mobile Co-Locate
Carrier Site Number:
Carrier Site Name:

CT11160B
Thompson

Crown Castle Designation:

Crown Castle BU Number:
Crown Castle Site Name:
Crown Castle JDE Job Number:
Crown Castle Work Order Number:
Crown Castle Application Number:

828402
Thompson/ I-395 X99_1
322407
1066929
282339 Rev. 1

Engineering Firm Designation:

Aero Solutions, LLC Project Number:

003-15-0429

Site Data:

720 Thompson Rd, Thompson, Windham County, CT
Latitude 41° 58' 39.74", Longitude -71° 50' 47.55"
156 Foot - Monopole Tower

Dear Mitchell Abbott,

Aero Solutions, LLC is pleased to submit this "**Structural Modification Report**" to determine the structural integrity of the above mentioned tower. This analysis has been performed in accordance with the Crown Castle Structural 'Statement of Work' and the terms of Crown Castle Purchase Order Number 791176, in accordance with application 282339, revision 1.

The purpose of the analysis is to determine acceptability of the tower stress level. Based on our analysis we have determined the tower stress level for the structure and foundation, under the following load case, to be:

LC4.5: Modified Structure w/ Existing + Proposed

Note: See Table I and Table II for the proposed and existing loading, respectively.

Sufficient Capacity

The analysis has been performed in accordance with the TIA/EIA-222-F standard and the 2005 CT State Building Code with 2009 amendment based upon a wind speed of 85 mph fastest mile.

All modifications and equipment proposed in this report shall be installed in accordance with the attached drawings for the determined available structural capacity to be effective.

We at Aero Solutions, LLC appreciate the opportunity of providing our continuing professional services to you and Crown Castle. If you have any questions or need further assistance on this or any other projects please give us a call.

Structural analysis prepared by: Marcus Benson, E.I.

Respectfully submitted by:

Shraddha Dharia, P.E.
Structural Engineer
CT PE# PEN0028187
Expires: 01/31/2016



6.3.2015

TABLE OF CONTENTS

- 1) INTRODUCTION
- 2) ANALYSIS CRITERIA
 - Table 1 - Proposed Antenna and Cable Information
 - Table 2 - Existing Antenna and Cable Information
 - Table 3 - Design Antenna and Cable Information
- 3) ANALYSIS PROCEDURE
 - Table 4 - Documents Provided
 - 3.1) Analysis Method
 - 3.2) Assumptions
- 4) ANALYSIS RESULTS
 - Table 5 - Section Capacity (Summary)
 - Table 6 - Tower Components vs. Capacity
 - 4.1) Recommendations
- 5) APPENDIX A
 - tnxTower Output
- 6) APPENDIX B
 - Base Level Drawing
- 7) APPENDIX C
 - Additional Calculations
- 8) APPENDIX D
 - Modification Drawings

1) INTRODUCTION

This tower is a 156 ft Monopole tower designed by FRED A. NUDD CORPORATION in April of 1998. The tower was originally designed for a wind speed of 85 mph per TIA/EIA-222-E.

The tower has been modified per reinforcement drawings prepared by All-Points Technology Corp, P.C., in May of 2005. Reinforcement consists of the addition of base plate stiffeners.

This analysis considers the proposed modifications in "Appendix D - Modification Drawings".

2) ANALYSIS CRITERIA

The structural analysis was performed for this tower in accordance with the requirements of TIA/EIA-222-F Structural Standards for Steel Antenna Towers and Antenna Supporting Structures using a fastest mile wind speed of 85 mph with no ice, 37.6 mph with 1 inch ice thickness and 50 mph under service loads.

Table 1 - Proposed Antenna and Cable Information

Mounting Level (ft)	Center Line Elevation (ft)	Number of Antennas	Antenna Manufacturer	Antenna Model	Number of Feed Lines	Feed Line Size (in)	Note
143.0	143.0	6	rfs celwave	APXV18-206517S-C-ACU w/ Mount Pipe	6	1-1/4"	

Table 2 - Existing Antenna and Cable Information

Mounting Level (ft)	Center Line Elevation (ft)	Number of Antennas	Antenna Manufacturer	Antenna Model	Number of Feed Lines	Feed Line Size (in)	Note
154.0	154.0	2	andrew	RR90-17-VDPL2	4	1-5/8"	1
143.0	143.0	6	andrew	RR90-17-VDPL2 w/ Mount Pipe	6	1-1/4"	2
		6	remec	G20045A1			
		1	tower mounts	Side Arm Mount [SO 201-3]			1
		1	tower mounts	Side Arm Mount [SO 308-3]			
120.0	120.0	1	tower mounts	LP 1201-1	2	1-5/8"	1
		2	decibel	DB844H90 w/ Mount Pipe			

Notes:

- 1) Existing Equipment
- 2) Equipment To Be Removed

Table 3 - Design Antenna and Cable Information

Mounting Level (ft)	Center Line Elevation (ft)	Number of Antennas	Antenna Manufacturer	Antenna Model	Number of Feed Lines	Feed Line Size (in)
140.0	140.0	3	ems wireless	RR901700DP		
		6	unknown	FE15801P72		
130.0	130.0	12	dapa	58000		
120.0	120.0	12	dapa	58000		

3) ANALYSIS PROCEDURE

Table 4 - Documents Provided

Document	Remarks	Reference	Source
4-TOWER FOUNDATION DRAWINGS/DESIGN/SPECS	Fred A. Nudd Corporation	3918434	CCISITES
4-TOWER MANUFACTURER DRAWINGS	FDH Engineering, Inc.(Mapped)	3508519	CCISITES
4-TOWER REINFORCEMENT DESIGN/DRAWINGS/DATA	All-Points Technology Corp., P.C.	3675126	CCISITES
4-GEOTECHNICAL REPORTS	FDH Engineering, Inc. (Mapped)	4726392	CCISITES
4-POST-MODIFICATION INSPECTION	DYCO Industries, Inc.	3675131	CCISITES

3.1) Analysis Method

tnxTower (version 6.1.4.1), a commercially available analysis software package, was used to create a three-dimensional model of the tower and calculate member stresses for various loading cases. Selected output from the analysis is included in Appendix A.

3.2) Assumptions

- 1) Tower and structures were built in accordance with the manufacturer's specifications.
- 2) The tower and structures have been maintained in accordance with the manufacturer's specification.
- 3) The configuration of antennas, transmission cables, mounts and other appurtenances are as specified in Tables 1 and 2 and the referenced drawings.
- 4) When applicable, transmission cables are considered as structural components for calculating wind loads as allowed by TIA/EIA-222-F.

This analysis may be affected if any assumptions are not valid or have been made in error. Aero Solutions, LLC should be notified to determine the effect on the structural integrity of the tower.

4) ANALYSIS RESULTS

Table 5 - Section Capacity (Summary)

Section No.	Elevation (ft)	Component Type	Size	Critical Element	P (K)	SF*P_allow (K)	% Capacity	Pass / Fail
L1	156 - 144	Pole	TP6.69x6.69x0.365	1	-0.29	203.03	20.4	Pass
L2	144 - 94	Pole	TP27.08x18x0.25	2	-6.63	710.78	79.1	Pass
L3	94 - 83	Pole	TP28.845x25.3566x0.25	3	-8.10	773.24	98.7	Pass
L4	83 - 77	Pole	TP30.34x28.845x0.3511	4	-8.85	1139.14	73.8	Pass
L5	77 - 75	Pole	TP30.761x30.34x0.4131	5	-9.14	1358.46	64.1	Pass
L6	75 - 57	Pole	TP34.55x30.761x0.3125	6	-11.05	1135.93	93.3	Pass
L7	57 - 40	Pole	TP36.55x33.2935x0.3954	7	-14.71	1548.44	89.3	Pass
L8	40 - 35.5	Pole	TP37.378x36.55x0.4565	8	-15.61	1827.49	79.4	Pass
L9	35.5 - 10	Pole	TP42.07x37.378x0.4486	9	-19.69	1970.28	87.6	Pass
L10	10 - 0	Pole	TP43.1875x40.216x0.4445	10	-24.41	2058.74	96.5	Pass
							Summary	
						Pole (L3)	98.7	Pass
						Rating =	98.7	Pass

Table 6 - Tower Component Stresses vs. Capacity - LC4.5

Notes	Component	Elevation (ft)	% Capacity	Pass / Fail
1	Anchor Rods	0	95.4	Pass
1	Base Plate	0	91.0	Pass
1	Base Foundation	0	65.6	Pass
1	Base Foundation Soil Interaction	0	23.7	Pass

Structure Rating (max from all components) =	98.7%
---	--------------

Notes:

- 1) See additional documentation in "Appendix C – Additional Calculations" for calculations supporting the % capacity consumed.

4.1) Recommendations

The tower and its foundation have sufficient capacity to carry the existing and proposed loads once the proposed modifications are installed.

APPENDIX A
TNXTOWER OUTPUT

Section	1	2	3	4	5	6	7	8	9	10
Length (ft)	12.00	50.00	14.00	6.00	2.00	18.00	20.00	4.50	25.50	16.00
Number of Sides	1	12	12	12	12	12	12	12	12	12
Thickness (in)	0.3650	0.2500	0.2500	0.4130	0.3511	0.3125	0.3954	0.4585	0.4486	0.4445
Socket Length (ft)		3.00				3.00			6.00	
Top Dia (in)				30.34	30.088	30.7610	33.2935	36.5500	37.3780	40.2160
Bot Dia (in)				30.761	30.3400	34.5500	36.5500	37.3780	42.0700	43.1875
Grade				42.07654	42.01432	42.062508	42.09071	42.102576	42.09071	42.079706
Weight (K)	0.3	3.1	1.0	0.7	0.3	2.0	2.9	0.8	4.9	3.2

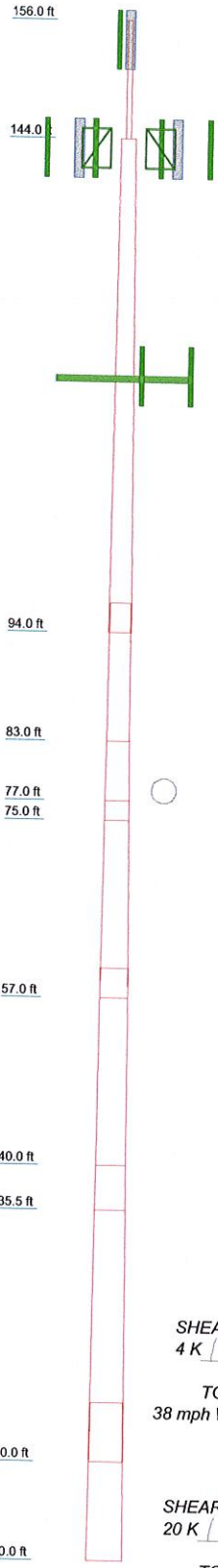

DESIGNED APPURTENANCE LOADING

TYPE	ELEVATION	TYPE	ELEVATION
RR90-17-VDPL2	154	12' horizontal x 2" Pipe Mount	143
RR90-17-VDPL2	154	12' horizontal x 2" Pipe Mount	143
(2) G20045A1	143	6' x 2" Mount Pipe	143
(2) G20045A1	143	Lighting Rod 3/4" x 5'	143
(2) G20045A1	143	Side Arm Mount [SO 308-3]	143
(2) APXV18-206517S-C-ACU w/ Mount Pipe	143	Side Arm Mount [SO 201-3]	143
(2) APXV18-206517S-C-ACU w/ Mount Pipe	143	(2) DB844H90 w/ Mount Pipe	120
(2) APXV18-206517S-C-ACU w/ Mount Pipe	143	(3) 6' x 2" Mount Pipe	120
(2) APXV18-206517S-C-ACU w/ Mount Pipe	143	6' x 2" Mount Pipe	120
(2) APXV18-206517S-C-ACU w/ Mount Pipe	143	(3) 6' x 2" Mount Pipe	120
12' horizontal x 2" Pipe Mount	143	LP 1201-1	120

MATERIAL STRENGTH

GRADE	Fy	Fu	GRADE	Fy	Fu
A53-B-35	35 ksi	63 ksi	42.062508ksi	42 ksi	57 ksi
A36M-42	42 ksi	60 ksi	42.102576ksi	42 ksi	57 ksi
42.01432ksi	42 ksi	57 ksi	42.09071ksi	42 ksi	57 ksi
42.07654ksi	42 ksi	57 ksi	42.079706ksi	42 ksi	57 ksi

TOWER DESIGN NOTES

1. Tower is located in Windham County, Connecticut.
2. Tower designed for a 85 mph basic wind in accordance with the TIA/EIA-222-F Standard.
3. Tower is also designed for a 38 mph basic wind with 1.00 in ice.
4. Deflections are based upon a 50 mph wind.
5. TOWER RATING: 98.7%

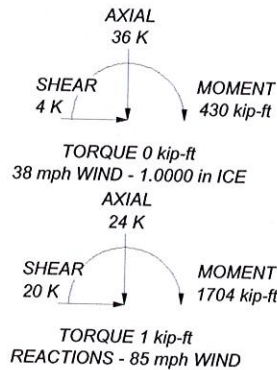

Aero Solutions, LLC 5500 Flatiron Parkway, Suite 100 Boulder, CO 80301 Phone: 720-304-6882 FAX:	Job: BU#828402 Thompson-I-395 XX99_1		
	Project: Existing 156 ft. Monopole		
	Client: Crown Castle	Drawn by: MBenson	App'd:
	Code: TIA/EIA-222-F	Date: 05/29/15	Scale: NTS
	Path:		Dwg No. E-1

Tower Input Data

There is a pole section.

This tower is designed using the TIA/EIA-222-F standard.

The following design criteria apply:

- 3) Tower is located in Windham County, Connecticut.
- 4) Basic wind speed of 85 mph.
- 5) Nominal ice thickness of 1.0000 in.
- 6) Ice density of 56 pcf.
- 7) A wind speed of 38 mph is used in combination with ice.
- 8) Temperature drop of 50 °F.
- 9) Deflections calculated using a wind speed of 50 mph.
- 10) A non-linear (P-delta) analysis was used.
- 11) Pressures are calculated at each section.
- 12) Stress ratio used in pole design is 1.333.
- 13) Local bending stresses due to climbing loads, feed line supports, and appurtenance mounts are not considered.

Options

- | | | |
|--|--|---|
| <ul style="list-style-type: none"> Consider Moments - Legs Consider Moments - Horizontals Consider Moments - Diagonals Use Moment Magnification √ Use Code Stress Ratios √ Use Code Safety Factors - Guys Escalate Ice Always Use Max Kz Use Special Wind Profile Include Bolts In Member Capacity Leg Bolts Are At Top Of Section Secondary Horizontal Braces Leg Use Diamond Inner Bracing (4 Sided) Add IBC .6D+W Combination | <ul style="list-style-type: none"> Distribute Leg Loads As Uniform Assume Legs Pinned √ Assume Rigid Index Plate √ Use Clear Spans For Wind Area Use Clear Spans For KL/r Retention Guys To Initial Tension √ Bypass Mast Stability Checks √ Use Azimuth Dish Coefficients √ Project Wind Area of Appurt. Autocalc Torque Arm Areas SR Members Have Cut Ends Sort Capacity Reports By Component Triangulate Diamond Inner Bracing Use TIA-222-G Tension Splice Capacity Exemption | <ul style="list-style-type: none"> Treat Feedline Bundles As Cylinder Use ASCE 10 X-Brace Ly Rules Calculate Redundant Bracing Forces Ignore Redundant Members in FEA SR Leg Bolts Resist Compression All Leg Panels Have Same Allowable Offset Girt At Foundation √ Consider Feedline Torque Include Angle Block Shear Check <li style="padding-left: 20px;">Poles √ Include Shear-Torsion Interaction Always Use Sub-Critical Flow Use Top Mounted Sockets |
|--|--|---|

Tapered Pole Section Geometry

Section	Elevation ft	Section Length ft	Splice Length ft	Number of Sides	Top Diameter in	Bottom Diameter in	Wall Thickness in	Bend Radius in	Pole Grade
L1	156.00-144.00	12.00	0.00	Round	6.6900	6.6900	0.3650		A53-B-35 (35 ksi)
L2	144.00-94.00	50.00	3.00	12	18.0000	27.0800	0.2500	1.0000	A36M-42 (42 ksi)
L3	94.00-83.00	14.00	0.00	12	25.3566	28.8450	0.2500	1.0000	A36M-42 (42 ksi)
L4	83.00-77.00	6.00	0.00	12	28.8450	30.3400	0.3511	1.4042	42.01432ksi (42 ksi)
L5	77.00-75.00	2.00	0.00	12	30.3400	30.7610	0.4131	1.6523	42.07654ksi (42 ksi)
L6	75.00-57.00	18.00	3.00	12	30.7610	34.5500	0.3125	1.2500	A36M-42 (42 ksi)
L7	57.00-40.00	20.00	0.00	12	33.2935	36.5500	0.3954	1.5815	42.062508ksi (42 ksi)
L8	40.00-35.50	4.50	0.00	12	36.5500	37.3780	0.4565	1.8259	42.102576ksi (42 ksi)
L9	35.50-10.00	25.50	6.00	12	37.3780	42.0700	0.4486	1.7944	42.09071ksi (42 ksi)
L10	10.00-0.00	16.00		12	40.2160	43.1875	0.4445	1.7778	42.079706ksi (42 ksi)

Section	Elevation ft	Section Length ft	Splice Length ft	Number of Sides	Top Diameter in	Bottom Diameter in	Wall Thickness in	Bend Radius in	Pole Grade
---------	-----------------	-------------------------	------------------------	-----------------------	-----------------------	--------------------------	-------------------------	----------------------	------------

(42 ksi)

Tapered Pole Properties

Section	Tip Dia. in	Area in ²	I in ⁴	r in	C in	I/C in ³	J in ⁴	I/Q in ²	w in	w/t
L1	6.6900	7.2528	36.3897	2.2399	3.3450	10.8788	72.7794	3.6242	0.0000	0
L2	6.6900	7.2528	36.3897	2.2399	3.3450	10.8788	72.7794	3.6242	0.0000	0
	28.0353	21.5982	1984.4669	9.6051	9.3240	61.6275	1164.3256	7.0325	4.1540	16.616
L3	27.0250	20.2108	1626.0936	8.9882	14.0274	141.4704	4021.0679	10.6300	6.5874	26.35
	29.8625	23.0190	2402.4327	10.2370	13.1347	123.8012	3294.9065	9.9471	6.1256	24.502
L4	29.8625	32.2100	3337.9587	10.2008	14.9417	160.7871	4867.9799	11.3292	7.0605	28.242
	31.4103	33.9000	3891.4164	10.7360	14.9417	223.3989	6763.6094	15.8528	6.7896	19.34
L5	31.4103	39.8070	4550.6047	10.7138	15.7161	247.6067	7885.0647	16.6845	7.1903	20.482
	31.8461	40.3670	4745.3674	10.8646	15.9342	289.5501	9220.7589	19.5918	7.0240	17.004
L6	31.8461	30.6388	3625.6807	10.9006	15.9342	297.8102	9615.4009	19.8674	7.1369	17.277
	35.7688	34.4515	5154.6357	12.2570	17.8969	288.0184	10444.689	16.9560	7.4064	23.701
L7	34.9737	41.8817	5785.6588	11.7775	17.2460	335.4777	11723.313	20.6129	8.4219	26.95
	37.8393	46.0275	7679.4643	12.9434	18.9329	405.6148	15560.676	22.6533	7.8631	19.888
L8	37.8393	53.0534	8821.8100	12.9215	18.9329	465.9513	17875.378	26.1113	8.7358	22.096
	38.6966	54.2705	9442.9721	13.2179	19.3618	487.7114	19134.021	26.7103	8.5720	18.778
L9	38.6966	53.3448	9285.8681	13.2207	19.3618	479.5973	18815.686	26.2547	8.7939	19.264
	43.5541	60.1224	13294.004	14.9005	21.7923	610.0333	26937.257	29.5904	8.8150	19.65
L10	42.7883	56.9185	11491.697	14.2382	20.8319	551.6397	23285.294	28.0135	10.0725	22.453
	44.7110	61.1711	14264.716	15.3020	22.3711	637.6397	28904.183	30.1066	9.5868	21.57
									10.3831	23.362

Tower Elevation ft	Gusset Area (per face) ft ²	Gusset Thickness in	Gusset Grade	Adjust. Factor A _r	Adjust. Factor A _r	Weight Mult.	Double Angle Stitch Bolt Spacing Diagonals in	Double Angle Stitch Bolt Spacing Horizontal in
L1 156.00- 144.00				1	1	1		
L2 144.00- 94.00				1	1	1		
L3 94.00- 83.00				1	1	1		
L4 83.00- 77.00				1	1	0.977767		
L5 77.00- 75.00				1	1	0.979269		
L6 75.00- 57.00				1	1	1		
L7 57.00- 40.00				1	1	0.985216		
L8 40.00- 35.50				1	1	0.98624		
L9 35.50- 10.00				1	1	0.988423		
L10 10.00- 0.00				1	1	0.989499		

Feed Line/Linear Appurtenances - Entered As Area

Description	Face or Leg	Allow Shield	Component Type	Placement ft	Total Number	C _A A _A		Weight
						ft ² /ft	plf	
LDF7-50A(1-5/8")	C	No	Inside Pole	144.00 - 0.00	4	No Ice	0.00	0.82
						1/2" Ice	0.00	0.82
						1" Ice	0.00	0.82
LDF7-50A(1-5/8")	C	No	CaAa (Out Of Face)	154.00 - 144.00	3	No Ice	0.00	0.82
						1/2" Ice	0.00	2.33
						1" Ice	0.00	4.46
LDF7-50A(1-5/8")	C	No	CaAa (Out Of Face)	154.00 - 144.00	1	No Ice	0.20	0.82
						1/2" Ice	0.30	2.33
						1" Ice	0.40	4.46

LDF6-50A(1-1/4")	A	No	Inside Pole	143.00 - 0.00	6	No Ice	0.00	0.66
						1/2" Ice	0.00	0.66
						1" Ice	0.00	0.66
LDF6-50A(1-1/4")	A	No	Inside Pole	143.00 - 0.00	6	No Ice	0.00	0.66
						1/2" Ice	0.00	0.66
						1" Ice	0.00	0.66

LDF7-50A(1-5/8")	C	No	Inside Pole	120.00 - 0.00	2	No Ice	0.00	0.82
						1/2" Ice	0.00	0.82
						1" Ice	0.00	0.82

CCI-XFP-040075	A	No	CaAa (Out Of Face)	60.50 - 0.00	1	No Ice	0.13	0.00
						1/2" Ice	0.00	0.00
						1" Ice	0.00	0.00
CCI-XFP-040075	A	No	CaAa (Out Of Face)	84.00 - 74.00	1	No Ice	0.13	0.00
						1/2" Ice	0.00	0.00
						1" Ice	0.00	0.00

Feed Line/Linear Appurtenances Section Areas

Tower Section n	Tower Elevation ft	Face	A _R	A _F	C _A A _A In Face	C _A A _A Out Face	Weight
			ft ²	ft ²	ft ²	ft ²	K
L1	156.00-144.00	A	0.000	0.000	0.000	0.000	0.00
		B	0.000	0.000	0.000	0.000	0.00
		C	0.000	0.000	0.000	1.980	0.03
L2	144.00-94.00	A	0.000	0.000	0.000	0.000	0.39
		B	0.000	0.000	0.000	0.000	0.00
		C	0.000	0.000	0.000	0.000	0.21
L3	94.00-83.00	A	0.000	0.000	0.000	0.125	0.09
		B	0.000	0.000	0.000	0.000	0.00
		C	0.000	0.000	0.000	0.000	0.05
L4	83.00-77.00	A	0.000	0.000	0.000	0.750	0.05
		B	0.000	0.000	0.000	0.000	0.00
		C	0.000	0.000	0.000	0.000	0.03
L5	77.00-75.00	A	0.000	0.000	0.000	0.250	0.02
		B	0.000	0.000	0.000	0.000	0.00
		C	0.000	0.000	0.000	0.000	0.01
L6	75.00-57.00	A	0.000	0.000	0.000	0.563	0.14
		B	0.000	0.000	0.000	0.000	0.00
		C	0.000	0.000	0.000	0.000	0.09
L7	57.00-40.00	A	0.000	0.000	0.000	2.125	0.13
		B	0.000	0.000	0.000	0.000	0.00
		C	0.000	0.000	0.000	0.000	0.08
L8	40.00-35.50	A	0.000	0.000	0.000	0.563	0.04
		B	0.000	0.000	0.000	0.000	0.00
		C	0.000	0.000	0.000	0.000	0.02
L9	35.50-10.00	A	0.000	0.000	0.000	3.188	0.20
		B	0.000	0.000	0.000	0.000	0.00
		C	0.000	0.000	0.000	0.000	0.13
L10	10.00-0.00	A	0.000	0.000	0.000	1.250	0.08
		B	0.000	0.000	0.000	0.000	0.00

Tower Section n	Tower Elevation ft	Face	A _R ft ²	A _F ft ²	C _A A _A In Face ft ²	C _A A _A Out Face ft ²	Weight K
		C	0.000	0.000	0.000	0.000	0.05

Feed Line/Linear Appurtenances Section Areas - With Ice

Tower Section n	Tower Elevation ft	Face or Leg	Ice Thickness in	A _R ft ²	A _F ft ²	C _A A _A In Face ft ²	C _A A _A Out Face ft ²	Weight K
L1	156.00-144.00	A	1.000	0.000	0.000	0.000	0.000	0.00
		B		0.000	0.000	0.000	0.000	0.00
		C		0.000	0.000	0.000	0.000	0.00
L2	144.00-94.00	A	1.000	0.000	0.000	0.000	3.980	0.18
		B		0.000	0.000	0.000	0.000	0.39
		C		0.000	0.000	0.000	0.000	0.00
L3	94.00-83.00	A	1.000	0.000	0.000	0.000	0.000	0.21
		B		0.000	0.000	0.000	0.000	0.09
		C		0.000	0.000	0.000	0.000	0.00
L4	83.00-77.00	A	1.000	0.000	0.000	0.000	0.000	0.05
		B		0.000	0.000	0.000	0.000	0.05
		C		0.000	0.000	0.000	0.000	0.00
L5	77.00-75.00	A	1.000	0.000	0.000	0.000	0.000	0.03
		B		0.000	0.000	0.000	0.000	0.02
		C		0.000	0.000	0.000	0.000	0.00
L6	75.00-57.00	A	1.000	0.000	0.000	0.000	0.000	0.01
		B		0.000	0.000	0.000	0.000	0.14
		C		0.000	0.000	0.000	0.000	0.00
L7	57.00-40.00	A	1.000	0.000	0.000	0.000	0.000	0.09
		B		0.000	0.000	0.000	0.000	0.13
		C		0.000	0.000	0.000	0.000	0.00
L8	40.00-35.50	A	1.000	0.000	0.000	0.000	0.000	0.08
		B		0.000	0.000	0.000	0.000	0.04
		C		0.000	0.000	0.000	0.000	0.00
L9	35.50-10.00	A	1.000	0.000	0.000	0.000	0.000	0.02
		B		0.000	0.000	0.000	0.000	0.20
		C		0.000	0.000	0.000	0.000	0.00
L10	10.00-0.00	A	1.000	0.000	0.000	0.000	0.000	0.13
		B		0.000	0.000	0.000	0.000	0.08
		C		0.000	0.000	0.000	0.000	0.00
				0.000	0.000	0.000	0.000	0.05

Feed Line Center of Pressure

Section	Elevation ft	CP _x in	CP _z in	CP _x Ice in	CP _z Ice in
L1	156.00-144.00	-0.1654	0.0955	-0.2275	0.1313
L2	144.00-94.00	0.0000	0.0000	0.0000	0.0000
L3	94.00-83.00	0.0000	-0.0177	0.0000	0.0000
L4	83.00-77.00	0.0000	-0.1785	0.0000	0.0000
L5	77.00-75.00	0.0000	-0.1787	0.0000	0.0000
L6	75.00-57.00	0.0000	-0.0475	0.0000	0.0000
L7	57.00-40.00	0.0000	-0.1798	0.0000	0.0000
L8	40.00-35.50	0.0000	-0.1802	0.0000	0.0000
L9	35.50-10.00	0.0000	-0.1807	0.0000	0.0000
L10	10.00-0.00	0.0000	-0.1811	0.0000	0.0000

Discrete Tower Loads

Description	Face or Leg	Offset Type	Offsets:		Azimuth Adjustment	Placement	C _A A _A Front	C _A A _A Side	Weight
			Horz	Lateral					

RR90-17-VDPL2	A	From Leg	1.00	0.0000	154.00	No Ice	4.36	2.00	0.01
			0.00			1/2"	4.77	2.33	0.04
			0.00			Ice	5.20	2.68	0.06
RR90-17-VDPL2	C	From Leg	1.00	0.0000	154.00	1" Ice			
			0.00			No Ice	4.36	2.00	0.01
			0.00			1/2"	4.77	2.33	0.04
						Ice	5.20	2.68	0.06
						1" Ice			

(2) G20045A1	A	From Leg	4.00	-30.0000	143.00	No Ice	0.75	0.48	0.01
			0.00			1/2"	0.87	0.59	0.02
			0.00			Ice	1.00	0.71	0.03
(2) G20045A1	B	From Leg	4.00	-30.0000	143.00	1" Ice			
			0.00			No Ice	0.75	0.48	0.01
			0.00			1/2"	0.87	0.59	0.02
						Ice	1.00	0.71	0.03
(2) G20045A1	C	From Leg	4.00	-30.0000	143.00	1" Ice			
			0.00			No Ice	0.75	0.48	0.01
			0.00			1/2"	0.87	0.59	0.02
						Ice	1.00	0.71	0.03
(2) APXV18-206517S-C-ACU w/ Mount Pipe	A	From Leg	6.00	-30.0000	143.00	1" Ice			
			0.00			No Ice	5.40	4.70	0.05
			0.00			1/2"	5.96	5.86	0.10
						Ice	6.48	6.73	0.15
(2) APXV18-206517S-C-ACU w/ Mount Pipe	B	From Leg	6.00	-30.0000	143.00	1" Ice			
			0.00			No Ice	5.40	4.70	0.05
			0.00			1/2"	5.96	5.86	0.10
						Ice	6.48	6.73	0.15
(2) APXV18-206517S-C-ACU w/ Mount Pipe	C	From Leg	6.00	-30.0000	143.00	1" Ice			
			0.00			No Ice	5.40	4.70	0.05
			0.00			1/2"	5.96	5.86	0.10
						Ice	6.48	6.73	0.15
12' horizontal x 2" Pipe Mount	A	From Leg	3.00	0.0000	143.00	1" Ice			
			0.00			No Ice	1.60	1.60	0.10
			0.00			1/2"	2.42	2.42	0.65
						Ice	3.24	3.24	1.21
12' horizontal x 2" Pipe Mount	B	From Leg	3.00	0.0000	143.00	1" Ice			
			0.00			No Ice	1.60	1.60	0.10
			0.00			1/2"	2.42	2.42	0.65
						Ice	3.24	3.24	1.21
12' horizontal x 2" Pipe Mount	C	From Leg	3.00	0.0000	143.00	1" Ice			
			0.00			No Ice	1.60	1.60	0.10
			0.00			1/2"	2.42	2.42	0.65
						Ice	3.24	3.24	1.21
6' x 2" Mount Pipe	A	From Leg	1.00	0.0000	143.00	1" Ice			
			0.00			No Ice	1.43	1.43	0.02
			3.00			1/2"	1.92	1.92	0.03
						Ice	2.29	2.29	0.05
Lighting Rod 3/4" x 5'	C	From Leg	1.00	0.0000	143.00	1" Ice			
			0.00			No Ice	0.38	0.38	0.03
			5.00			1/2"	0.89	0.89	0.03
						Ice	1.36	1.36	0.04
Side Arm Mount [SO 308-3]	C	None		0.0000	143.00	1" Ice			
						No Ice	4.51	4.51	0.16
						1/2"	7.78	7.78	0.24
						Ice	11.05	11.05	0.31
Side Arm Mount [SO 201-3]	C	None		0.0000	143.00	1" Ice			
						No Ice	5.71	5.71	0.29
						1/2"	7.91	7.91	0.35
						Ice	10.11	10.11	0.41
						1" Ice			

(2) DB844H90 w/ Mount Pipe	B	From Leg	4.00	0.0000	120.00	No Ice	3.30	4.92	0.03
			0.00			1/2"	3.69	5.60	0.07

Description	Face or Leg	Offset Type	Offsets:			Azimuth Adjustment	Placement	C _A A _{Front}	C _A A _{Side}	Weight
			Horz	Lateral	Vert					
(3) 6' x 2" Mount Pipe	A	From Leg	4.00	0.0000	120.00	Ice	4.12	6.28	0.11	
			0.00			1" Ice				
			0.00			No Ice	1.43	1.43	0.02	
			0.00			1/2"	1.92	1.92	0.03	
6' x 2" Mount Pipe	B	From Leg	4.00	0.0000	120.00	Ice	2.29	2.29	0.05	
			0.00			1" Ice				
			0.00			No Ice	1.43	1.43	0.02	
			0.00			1/2"	1.92	1.92	0.03	
(3) 6' x 2" Mount Pipe	C	From Leg	4.00	0.0000	120.00	Ice	2.29	2.29	0.05	
			0.00			1" Ice				
			0.00			No Ice	1.43	1.43	0.02	
			0.00			1/2"	1.92	1.92	0.03	
LP 1201-1	C	None		0.0000	120.00	Ice	2.29	2.29	0.05	
						1" Ice				
						No Ice	23.10	23.10	2.10	
						1/2"	26.80	26.80	2.50	
						Ice	30.50	30.50	2.90	
						1" Ice				

Load Combinations

Comb. No.	Description
1	Dead Only
2	Dead+Wind 0 deg - No Ice
3	Dead+Wind 30 deg - No Ice
4	Dead+Wind 60 deg - No Ice
5	Dead+Wind 90 deg - No Ice
6	Dead+Wind 120 deg - No Ice
7	Dead+Wind 150 deg - No Ice
8	Dead+Wind 180 deg - No Ice
9	Dead+Wind 210 deg - No Ice
10	Dead+Wind 240 deg - No Ice
11	Dead+Wind 270 deg - No Ice
12	Dead+Wind 300 deg - No Ice
13	Dead+Wind 330 deg - No Ice
14	Dead+Ice+Temp
15	Dead+Wind 0 deg+Ice+Temp
16	Dead+Wind 30 deg+Ice+Temp
17	Dead+Wind 60 deg+Ice+Temp
18	Dead+Wind 90 deg+Ice+Temp
19	Dead+Wind 120 deg+Ice+Temp
20	Dead+Wind 150 deg+Ice+Temp
21	Dead+Wind 180 deg+Ice+Temp
22	Dead+Wind 210 deg+Ice+Temp
23	Dead+Wind 240 deg+Ice+Temp
24	Dead+Wind 270 deg+Ice+Temp
25	Dead+Wind 300 deg+Ice+Temp
26	Dead+Wind 330 deg+Ice+Temp
27	Dead+Wind 0 deg - Service
28	Dead+Wind 30 deg - Service
29	Dead+Wind 60 deg - Service
30	Dead+Wind 90 deg - Service
31	Dead+Wind 120 deg - Service
32	Dead+Wind 150 deg - Service
33	Dead+Wind 180 deg - Service
34	Dead+Wind 210 deg - Service
35	Dead+Wind 240 deg - Service

Comb. No.	Description
36	Dead+Wind 270 deg - Service
37	Dead+Wind 300 deg - Service
38	Dead+Wind 330 deg - Service

Maximum Member Forces

Section No.	Elevation ft	Component Type	Condition	Gov. Load Comb.	Force K	Major Axis Moment kip-ft	Minor Axis Moment kip-ft
L1	156 - 144	Pole	Max Tension	11	0.00	-0.00	0.00
			Max. Compression	14	-0.71	0.11	0.02
			Max. Mx	11	-0.30	4.81	-0.50
			Max. My	2	-0.30	-0.49	5.37
			Max. Vy	5	0.61	-4.77	0.49
			Max. Vx	8	0.67	0.51	-5.36
L2	144 - 94	Pole	Max. Torque	9			-0.13
			Max Tension	1	0.00	0.00	0.00
			Max. Compression	14	-14.45	-0.38	-0.26
			Max. Mx	5	-6.65	-289.15	4.44
			Max. My	8	-6.64	4.47	-294.29
			Max. Vy	5	9.29	-289.15	4.44
L3	94 - 83	Pole	Max. Vx	8	9.42	4.47	-294.29
			Max. Torque	3			-1.35
			Max Tension	1	0.00	0.00	0.00
			Max. Compression	14	-16.37	-0.38	-0.26
			Max. Mx	5	-8.12	-428.77	6.08
			Max. My	8	-8.10	6.11	-435.82
L4	83 - 77	Pole	Max. Vy	5	10.66	-428.77	6.08
			Max. Vx	8	10.79	6.11	-435.82
			Max. Torque	3			-1.35
			Max Tension	1	0.00	0.00	0.00
			Max. Compression	14	-17.34	-0.38	-0.26
			Max. Mx	5	-8.86	-494.61	6.79
L5	77 - 75	Pole	Max. My	8	-8.85	6.82	-502.47
			Max. Vy	5	11.30	-494.61	6.79
			Max. Vx	8	11.44	6.82	-502.47
			Max. Torque	3			-1.35
			Max Tension	1	0.00	0.00	0.00
			Max. Compression	14	-17.71	-0.38	-0.26
L6	75 - 57	Pole	Max. Mx	5	-9.16	-517.43	7.02
			Max. My	8	-9.15	7.05	-525.56
			Max. Vy	5	11.52	-517.43	7.02
			Max. Vx	8	11.66	7.05	-525.56
			Max. Torque	3			-1.34
			Max Tension	1	0.00	0.00	0.00
L7	57 - 40	Pole	Max. Compression	14	-20.17	-0.38	-0.26
			Max. Mx	5	-11.07	-701.79	8.78
			Max. My	8	-11.06	8.81	-711.95
			Max. Vy	5	13.09	-701.79	8.78
			Max. Vx	8	13.22	8.81	-711.95
			Max. Torque	3			-1.34
L8	40 - 35.5	Pole	Max Tension	1	0.00	0.00	0.00
			Max. Compression	14	-24.63	-0.38	-0.26
			Max. Mx	5	-14.72	-985.12	11.12
			Max. My	8	-14.72	11.14	-997.98
			Max. Vy	5	15.24	-985.12	11.12
			Max. Vx	8	15.37	11.14	-997.98
L9	35.5 - 10	Pole	Max. Torque	3			-1.34
			Max Tension	1	0.00	0.00	0.00
			Max. Compression	14	-25.71	-0.38	-0.26
			Max. Mx	5	-15.62	-1054.69	11.64
			Max. My	8	-15.61	11.66	-1068.15
			Max. Vy	5	15.70	-1054.69	11.64
L9	35.5 - 10	Pole	Max. Vx	8	15.83	11.66	-1068.15
			Max. Torque	3			-1.32
			Max Tension	1	0.00	0.00	0.00
			Max. Compression	14	-30.61	-0.38	-0.26

Section No.	Elevation ft	Component Type	Condition	Gov. Load Comb.	Force K	Major Axis Moment kip-ft	Minor Axis Moment kip-ft
L10	10 - 0	Pole	Max. Mx	5	-19.69	-1379.82	13.89
			Max. My	8	-19.69	13.91	-1395.88
			Max. Vy	5	17.68	-1379.82	13.89
			Max. Vx	8	17.81	13.91	-1395.88
			Max. Torque	3			-1.32
			Max Tension	1	0.00	0.00	0.00
			Max. Compression	14	-36.06	-0.38	-0.26
			Max. Mx	5	-24.41	-1676.54	15.71
			Max. My	8	-24.41	15.73	-1694.70
			Max. Vy	5	19.40	-1676.54	15.71
			Max. Vx	8	19.53	15.73	-1694.70
			Max. Torque	3			-1.30

Maximum Reactions

Location	Condition	Gov. Load Comb.	Vertical K	Horizontal, X K	Horizontal, Z K
Pole	Max. Vert	14	36.06	0.00	0.00
	Max. H _x	11	24.41	19.39	-0.11
	Max. H _z	2	24.41	-0.11	19.52
	Max. M _x	2	1694.62	-0.11	19.52
	Max. M _z	5	1676.54	-19.39	0.11
	Max. Torsion	9	1.29	9.79	-16.96
	Min. Vert	1	24.41	0.00	0.00
	Min. H _x	5	24.41	-19.39	0.11
	Min. H _z	8	24.41	0.11	-19.52
	Min. M _x	8	-1694.70	0.11	-19.52
	Min. M _z	11	-1676.50	19.39	-0.11
	Min. Torsion	3	-1.29	-9.79	16.96

Tower Mast Reaction Summary

Load Combination	Vertical K	Shear _x K	Shear _z K	Overturing Moment, M _x kip-ft	Overturing Moment, M _z kip-ft	Torque kip-ft
Dead Only	24.41	0.00	0.00	0.04	-0.02	0.00
Dead+Wind 0 deg - No Ice	24.41	0.11	-19.52	-1694.62	-15.76	1.20
Dead+Wind 30 deg - No Ice	24.41	9.79	-16.96	-1475.44	-851.88	1.29
Dead+Wind 60 deg - No Ice	24.41	16.85	-9.86	-860.94	-1459.77	1.03
Dead+Wind 90 deg - No Ice	24.41	19.39	-0.11	-15.71	-1676.54	0.49
Dead+Wind 120 deg - No Ice	24.41	16.74	9.66	833.76	-1444.07	-0.17
Dead+Wind 150 deg - No Ice	24.41	9.60	16.85	1459.83	-824.64	-0.79
Dead+Wind 180 deg - No Ice	24.41	-0.11	19.52	1694.70	15.73	-1.20
Dead+Wind 210 deg - No Ice	24.41	-9.79	16.96	1475.52	851.85	-1.29
Dead+Wind 240 deg - No Ice	24.41	-16.85	9.86	861.01	1459.73	-1.03
Dead+Wind 270 deg - No Ice	24.41	-19.39	0.11	15.79	1676.50	-0.49
Dead+Wind 300 deg - No Ice	24.41	-16.74	-9.66	-833.68	1444.03	0.17
Dead+Wind 330 deg - No Ice	24.41	-9.60	-16.85	-1459.74	824.60	0.80
Dead+Ice+Temp	36.06	0.00	0.00	0.26	-0.38	0.00
Dead+Wind 0 deg+Ice+Temp	36.06	0.03	-4.45	-427.05	-4.27	0.25
Dead+Wind 30 deg+Ice+Temp	36.06	2.23	-3.86	-371.72	-215.21	0.28
Dead+Wind 60 deg+Ice+Temp	36.06	3.84	-2.25	-216.70	-368.60	0.24
Dead+Wind 90 deg+Ice+Temp	36.06	4.41	-0.03	-3.54	-423.35	0.13
Dead+Wind 120 deg+Ice+Temp	36.06	3.81	2.20	210.64	-364.77	-0.01
Dead+Wind 150 deg+Ice+Temp	36.06	2.18	3.84	368.47	-208.57	-0.15

Load Combination	Vertical	Shear _x	Shear _y	Overturing Moment, M _x	Overturing Moment, M _y	Torque
	K	K	K	kip-ft	kip-ft	kip-ft
deg+Ice+Temp						
Dead+Wind 180	36.06	-0.03	4.45	427.64	3.40	-0.25
deg+Ice+Temp						
Dead+Wind 210	36.06	-2.23	3.86	372.30	214.35	-0.28
deg+Ice+Temp						
Dead+Wind 240	36.06	-3.84	2.25	217.29	367.74	-0.24
deg+Ice+Temp						
Dead+Wind 270	36.06	-4.41	0.03	4.13	422.49	-0.13
deg+Ice+Temp						
Dead+Wind 300	36.06	-3.81	-2.20	-210.06	363.91	0.01
deg+Ice+Temp						
Dead+Wind 330	36.06	-2.18	-3.84	-367.88	207.71	0.15
deg+Ice+Temp						
Dead+Wind 0 deg - Service	24.41	0.04	-6.82	-596.29	-5.48	0.42
Dead+Wind 30 deg - Service	24.41	3.42	-5.92	-519.12	-299.76	0.45
Dead+Wind 60 deg - Service	24.41	5.88	-3.44	-302.85	-513.73	0.36
Dead+Wind 90 deg - Service	24.41	6.77	-0.04	-5.41	-590.05	0.17
Dead+Wind 120 deg - Service	24.41	5.84	3.37	293.48	-508.28	-0.06
Dead+Wind 150 deg - Service	24.41	3.35	5.88	513.75	-290.31	-0.28
Dead+Wind 180 deg - Service	24.41	-0.04	6.82	596.37	5.43	-0.42
Dead+Wind 210 deg - Service	24.41	-3.42	5.92	519.20	299.72	-0.45
Dead+Wind 240 deg - Service	24.41	-5.88	3.44	302.93	513.69	-0.36
Dead+Wind 270 deg - Service	24.41	-6.77	0.04	5.50	590.01	-0.17
Dead+Wind 300 deg - Service	24.41	-5.84	-3.37	-293.40	508.23	0.06
Dead+Wind 330 deg - Service	24.41	-3.35	-5.88	-513.67	290.27	0.28

Solution Summary

Load Comb.	Sum of Applied Forces			Sum of Reactions			% Error
	PX K	PY K	PZ K	PX K	PY K	PZ K	
1	0.00	-24.41	0.00	0.00	24.41	0.00	0.000%
2	0.11	-24.41	-19.52	-0.11	24.41	19.52	0.000%
3	9.79	-24.41	-16.96	-9.79	24.41	16.96	0.000%
4	16.85	-24.41	-9.86	-16.85	24.41	9.86	0.000%
5	19.39	-24.41	-0.11	-19.39	24.41	0.11	0.000%
6	16.74	-24.41	9.66	-16.74	24.41	-9.66	0.000%
7	9.60	-24.41	16.85	-9.60	24.41	16.85	0.000%
8	-0.11	-24.41	19.52	0.11	24.41	-19.52	0.000%
9	-9.79	-24.41	16.96	9.79	24.41	-16.96	0.000%
10	-16.85	-24.41	9.86	16.85	24.41	-9.86	0.000%
11	-19.39	-24.41	0.11	19.39	24.41	-0.11	0.000%
12	-16.74	-24.41	-9.66	16.74	24.41	9.66	0.000%
13	-9.60	-24.41	-16.85	9.60	24.41	16.85	0.000%
14	0.00	-36.06	0.00	0.00	36.06	0.00	0.000%
15	0.03	-36.06	-4.45	-0.03	36.06	4.45	0.000%
16	2.23	-36.06	-3.86	-2.23	36.06	3.86	0.000%
17	3.84	-36.06	-2.25	-3.84	36.06	2.25	0.000%
18	4.41	-36.06	-0.03	-4.41	36.06	0.03	0.000%
19	3.81	-36.06	2.20	-3.81	36.06	-2.20	0.000%
20	2.18	-36.06	3.84	-2.18	36.06	-3.84	0.000%
21	-0.03	-36.06	4.45	0.03	36.06	-4.45	0.000%
22	-2.23	-36.06	3.86	2.23	36.06	-3.86	0.000%
23	-3.84	-36.06	2.25	3.84	36.06	-2.25	0.000%
24	-4.41	-36.06	0.03	4.41	36.06	-0.03	0.000%
25	-3.81	-36.06	-2.20	3.81	36.06	2.20	0.000%
26	-2.18	-36.06	-3.84	2.18	36.06	3.84	0.000%
27	0.04	-24.41	-6.82	-0.04	24.41	6.82	0.000%

Load Comb.	Sum of Applied Forces			Sum of Reactions			% Error
	PX K	PY K	PZ K	PX K	PY K	PZ K	
28	3.42	-24.41	-5.92	-3.42	24.41	5.92	0.000%
29	5.88	-24.41	-3.44	-5.88	24.41	3.44	0.000%
30	6.77	-24.41	-0.04	-6.77	24.41	0.04	0.000%
31	5.84	-24.41	3.37	-5.84	24.41	-3.37	0.000%
32	3.35	-24.41	5.88	-3.35	24.41	-5.88	0.000%
33	-0.04	-24.41	6.82	0.04	24.41	-6.82	0.000%
34	-3.42	-24.41	5.92	3.42	24.41	-5.92	0.000%
35	-5.88	-24.41	3.44	5.88	24.41	-3.44	0.000%
36	-6.77	-24.41	0.04	6.77	24.41	-0.04	0.000%
37	-5.84	-24.41	-3.37	5.84	24.41	3.37	0.000%
38	-3.35	-24.41	-5.88	3.35	24.41	5.88	0.000%

Non-Linear Convergence Results

Load Combination	Converged?	Number of Cycles	Displacement Tolerance	Force Tolerance
1	Yes	4	0.00000001	0.00000001
2	Yes	5	0.00000001	0.00005080
3	Yes	5	0.00000001	0.00046662
4	Yes	5	0.00000001	0.00040324
5	Yes	4	0.00000001	0.00029531
6	Yes	5	0.00000001	0.00039648
7	Yes	5	0.00000001	0.00041412
8	Yes	4	0.00000001	0.00083604
9	Yes	5	0.00000001	0.00040057
10	Yes	5	0.00000001	0.00043961
11	Yes	4	0.00000001	0.00084650
12	Yes	5	0.00000001	0.00040010
13	Yes	5	0.00000001	0.00038677
14	Yes	4	0.00000001	0.00000001
15	Yes	5	0.00000001	0.00052637
16	Yes	5	0.00000001	0.00059014
17	Yes	5	0.00000001	0.00058478
18	Yes	5	0.00000001	0.00052154
19	Yes	5	0.00000001	0.00057282
20	Yes	5	0.00000001	0.00057669
21	Yes	5	0.00000001	0.00052790
22	Yes	5	0.00000001	0.00058691
23	Yes	5	0.00000001	0.00058612
24	Yes	5	0.00000001	0.00051921
25	Yes	5	0.00000001	0.00056911
26	Yes	5	0.00000001	0.00057149
27	Yes	4	0.00000001	0.00023291
28	Yes	4	0.00000001	0.00097868
29	Yes	4	0.00000001	0.00079138
30	Yes	4	0.00000001	0.00011554
31	Yes	4	0.00000001	0.00079159
32	Yes	4	0.00000001	0.00086901
33	Yes	4	0.00000001	0.00019870
34	Yes	4	0.00000001	0.00078310
35	Yes	4	0.00000001	0.00094656
36	Yes	4	0.00000001	0.00014190
37	Yes	4	0.00000001	0.00080639
38	Yes	4	0.00000001	0.00075267

Maximum Tower Deflections - Service Wind

Section No.	Elevation ft	Horz. Deflection in	Gov. Load Comb.	Tilt °	Twist °

Section No.	Elevation ft	Horz. Deflection in	Gov. Load Comb.	Tilt °	Twist °
L1	156 - 144	30.749	34	1.7628	0.0006
L2	144 - 94	26.376	34	1.6796	0.0050
L3	97 - 83	11.477	34	1.2291	0.0030
L4	83 - 77	8.179	34	0.9977	0.0020
L5	77 - 75	6.975	34	0.9181	0.0017
L6	75 - 57	6.596	34	0.8956	0.0016
L7	60 - 40	4.132	34	0.6729	0.0010
L8	40 - 35.5	1.780	34	0.4330	0.0005
L9	35.5 - 10	1.396	34	0.3815	0.0005
L10	16 - 0	0.300	34	0.1559	0.0002

Critical Deflections and Radius of Curvature - Service Wind

Elevation ft	Appurtenance	Gov. Load Comb.	Deflection in	Tilt °	Twist °	Radius of Curvature ft
154.00	RR90-17-VDPL2	34	30.016	1.7488	0.0017	24543
143.00	(2) G20045A1	34	26.017	1.6728	0.0053	10081
120.00	(2) DB844H90 w/ Mount Pipe	34	18.175	1.5030	0.0062	5555

Maximum Tower Deflections - Design Wind

Section No.	Elevation ft	Horz. Deflection in	Gov. Load Comb.	Tilt °	Twist °
L1	156 - 144	86.458	9	4.9116	0.0028
L2	144 - 94	74.279	9	4.7058	0.0144
L3	97 - 83	32.464	9	3.4674	0.0087
L4	83 - 77	23.159	9	2.8196	0.0057
L5	77 - 75	19.759	9	2.5961	0.0049
L6	75 - 57	18.685	9	2.5327	0.0046
L7	60 - 40	11.715	9	1.9059	0.0029
L8	40 - 35.5	5.052	9	1.2280	0.0016
L9	35.5 - 10	3.964	9	1.0822	0.0013
L10	16 - 0	0.852	9	0.4428	0.0005

Critical Deflections and Radius of Curvature - Design Wind

Elevation ft	Appurtenance	Gov. Load Comb.	Deflection in	Tilt °	Twist °	Radius of Curvature ft
154.00	RR90-17-VDPL2	9	84.417	4.8773	0.0062	10054
143.00	(2) G20045A1	9	73.277	4.6886	0.0152	4084
120.00	(2) DB844H90 w/ Mount Pipe	9	51.318	4.2342	0.0179	2061

Compression Checks

Pole Design Data

Section No.	Elevation ft	Size	L ft	L _u ft	Kl/r	F _a ksi	A in ²	Actual P K	Allow. P _a K	Ratio P P _a
L1	156 - 144 (1)	TP6.69x6.69x0.365	12.00	0.00	0.0	21.000	7.2528	-0.29	152.31	0.002
L2	144 - 94 (2)	TP27.08x18x0.25	50.00	0.00	0.0	25.200	21.1596	-6.63	533.22	0.012
L3	94 - 83 (3)	TP28.845x25.3566x0.25	14.00	0.00	0.0	25.200	23.0190	-8.10	580.08	0.014
L4	83 - 77 (4)	TP30.34x28.845x0.3511	6.00	0.00	0.0	25.209	33.9000	-8.85	854.57	0.010
L5	77 - 75 (5)	TP30.761x30.34x0.4131	2.00	0.00	0.0	25.246	40.3670	-9.14	1019.10	0.009
L6	75 - 57 (6)	TP34.55x30.761x0.3125	18.00	0.00	0.0	25.200	33.8160	-11.05	852.16	0.013
L7	57 - 40 (7)	TP36.55x33.2935x0.3954	20.00	0.00	0.0	25.238	46.0275	-14.71	1161.62	0.013
L8	40 - 35.5 (8)	TP37.378x36.55x0.4565	4.50	0.00	0.0	25.262	54.2705	-15.61	1370.96	0.011
L9	35.5 - 10 (9)	TP42.07x37.378x0.4486	25.50	0.00	0.0	25.254	58.5277	-19.69	1478.08	0.013
L10	10 - 0 (10)	TP43.1875x40.216x0.4445	16.00	0.00	0.0	25.248	61.1711	-24.41	1544.44	0.016

Pole Bending Design Data

Section No.	Elevation ft	Size	Actual M _x kip-ft	Actual f _{bx} ksi	Allow. F _{bx} ksi	Ratio f _{bx} F _{bx}	Actual M _y kip-ft	Actual f _{by} ksi	Allow. F _{by} ksi	Ratio f _{by} F _{by}
L1	156 - 144 (1)	TP6.69x6.69x0.365	5.66	6.241	23.100	0.270	0.00	0.000	23.100	0.000
L2	144 - 94 (2)	TP27.08x18x0.25	296.84	26.238	25.200	1.041	0.00	0.000	25.200	0.000
L3	94 - 83 (3)	TP28.845x25.3566x0.25	439.32	32.788	25.200	1.301	0.00	0.000	25.200	0.000
L4	83 - 77 (4)	TP30.34x28.845x0.3511	506.38	24.541	25.209	0.974	0.00	0.000	25.209	0.000
L5	77 - 75 (5)	TP30.761x30.34x0.4131	529.60	21.340	25.246	0.845	0.00	0.000	25.246	0.000
L6	75 - 57 (6)	TP34.55x30.761x0.3125	717.01	31.012	25.200	1.231	0.00	0.000	25.200	0.000
L7	57 - 40 (7)	TP36.55x33.2935x0.3954	1004.3	29.714	25.238	1.177	0.00	0.000	25.238	0.000
L8	40 - 35.5 (8)	TP37.378x36.55x0.4565	1074.8	26.447	25.262	1.047	0.00	0.000	25.262	0.000
L9	35.5 - 10 (9)	TP42.07x37.378x0.4486	1403.8	29.150	25.254	1.154	0.00	0.000	25.254	0.000
L10	10 - 0 (10)	TP43.1875x40.216x0.444	1703.7	32.064	25.248	1.270	0.00	0.000	25.248	0.000

Pole Shear Design Data

Section No.	Elevation ft	Size	Actual V K	Actual f _v ksi	Allow. F _v ksi	Ratio f _v F _v	Actual T kip-ft	Actual f _t ksi	Allow. F _t ksi	Ratio f _t F _t
L1	156 - 144 (1)	TP6.69x6.69x0.365	0.70	0.096	14.000	0.014	0.13	0.066	14.000	0.005
L2	144 - 94 (2)	TP27.08x18x0.25	9.49	0.449	16.800	0.054	1.35	0.056	16.800	0.003
L3	94 - 83 (3)	TP28.845x25.3566x0.25	10.86	0.472	16.800	0.057	1.35	0.047	16.800	0.003
L4	83 - 77 (4)	TP30.34x28.845x0.3511	11.51	0.339	16.806	0.041	1.34	0.031	16.806	0.002
L5	77 - 75 (5)	TP30.761x30.34x0.4131	11.73	0.290	16.831	0.035	1.34	0.025	16.831	0.002
L6	75 - 57 (6)	TP34.55x30.761x0.3125	13.29	0.393	16.800	0.048	1.34	0.027	16.800	0.002
L7	57 - 40 (7)	TP36.55x33.2935x0.3954	15.44	0.335	16.825	0.041	1.32	0.018	16.825	0.001
L8	40 - 35.5 (8)	TP37.378x36.55x0.4565	15.90	0.293	16.841	0.035	1.32	0.015	16.841	0.001
L9	35.5 - 10 (9)	TP42.07x37.378x0.4486	17.88	0.305	16.836	0.037	1.30	0.013	16.836	0.001
L10	10 - 0 (10)	TP43.1875x40.216x0.444	19.59	0.320	16.832	0.039	1.29	0.011	16.832	0.001

Pole Interaction Design Data

Section No.	Elevation ft	Ratio P P _a	Ratio f _{bx} F _{bx}	Ratio f _{by} F _{by}	Ratio f _v F _v	Ratio f _t F _t	Comb. Stress Ratio	Allow. Stress Ratio	Criteria
L1	156 - 144 (1)	0.002	0.270	0.000	0.014	0.005	0.272	1.333	H1-3+VT

Section No.	Elevation ft	Ratio $\frac{P}{P_a}$	Ratio $\frac{f_{bx}}{F_{bx}}$	Ratio $\frac{f_{by}}{F_{by}}$	Ratio $\frac{f_v}{F_v}$	Ratio $\frac{f_{vt}}{F_{vt}}$	Comb. Stress Ratio	Allow. Stress Ratio	Criteria
L2	144 - 94 (2)	0.012	1.041	0.000	0.054	0.003	1.055	1.333	H1-3+VT
L3	94 - 83 (3)	0.014	1.301	0.000	0.057	0.003	1.316	1.333	H1-3+VT
L4	83 - 77 (4)	0.010	0.974	0.000	0.041	0.002	0.984	1.333	H1-3+VT
L5	77 - 75 (5)	0.009	0.845	0.000	0.035	0.002	0.855	1.333	H1-3+VT
L6	75 - 57 (6)	0.013	1.231	0.000	0.048	0.002	1.244	1.333	H1-3+VT
L7	57 - 40 (7)	0.013	1.177	0.000	0.041	0.001	1.190	1.333	H1-3+VT
L8	40 - 35.5 (8)	0.011	1.047	0.000	0.035	0.001	1.059	1.333	H1-3+VT
L9	35.5 - 10 (9)	0.013	1.154	0.000	0.037	0.001	1.168	1.333	H1-3+VT
L10	10 - 0 (10)	0.016	1.270	0.000	0.039	0.001	1.286	1.333	H1-3+VT

Section Capacity Table

Section No.	Elevation ft	Component Type	Size	Critical Element	P K	SF*P _{allow} K	% Capacity	Pass Fail
L1	156 - 144	Pole	TP6.69x6.69x0.365	1	-0.29	203.03	20.4	Pass
L2	144 - 94	Pole	TP27.08x18x0.25	2	-6.63	710.78	79.1	Pass
L3	94 - 83	Pole	TP28.845x25.3566x0.25	3	-8.10	773.24	98.7	Pass
L4	83 - 77	Pole	TP30.34x28.845x0.3511	4	-8.85	1139.14	73.8	Pass
L5	77 - 75	Pole	TP30.761x30.34x0.4131	5	-9.14	1358.46	64.1	Pass
L6	75 - 57	Pole	TP34.55x30.761x0.3125	6	-11.05	1135.93	93.3	Pass
L7	57 - 40	Pole	TP36.55x33.2935x0.3954	7	-14.71	1548.44	89.3	Pass
L8	40 - 35.5	Pole	TP37.378x36.55x0.4565	8	-15.61	1827.49	79.4	Pass
L9	35.5 - 10	Pole	TP42.07x37.378x0.4486	9	-19.69	1970.28	87.6	Pass
L10	10 - 0	Pole	TP43.1875x40.216x0.4445	10	-24.41	2058.74	96.5	Pass
Summary								
Pole (L3)							98.7	Pass
RATING =							98.7	Pass

APPENDIX B
BASE LEVEL DRAWING

(PROPOSED)
(6) 1-1/4" TO 143 FT LEVEL
(INSTALLED)
(6) 1-1/4" TO 143 FT LEVEL

(INSTALLED)
(2) 1-5/8" TO 120 FT LEVEL
(4) 1-5/8" TO 154 FT LEVEL

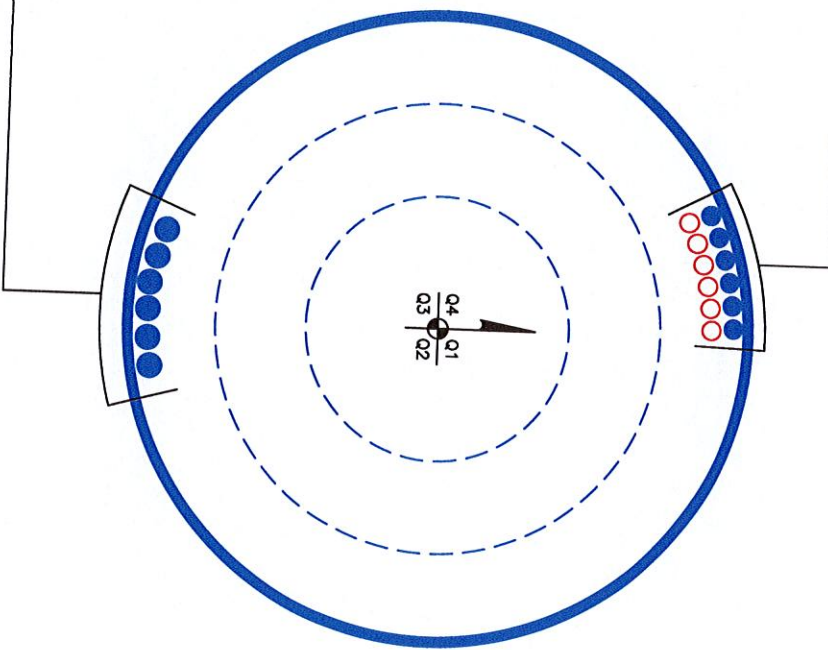

APPENDIX C
ADDITIONAL CALCULATIONS

Reinforced Pole Stress and Effective Thickness Check

Section	Material Properties		Design Parameters		Geometric Properties		Stress Analysis		Strength Check		Effective Thickness		Final Results	
	Area (in ²)	Modulus (ksi)	Yield (ksi)	Ultimate (ksi)	Radius (in)	Thickness (in)	Stress (ksi)	Strain	Factor	Allowable (ksi)	Effective Thickness (in)	Required Thickness (in)	Stress (ksi)	Strain
1	1.04	29	48	68	1.1	0.125	10.5	0.001	1.0	48	0.125	0.125	10.5	0.001
2	1.04	29	48	68	1.1	0.125	10.5	0.001	1.0	48	0.125	0.125	10.5	0.001
3	1.04	29	48	68	1.1	0.125	10.5	0.001	1.0	48	0.125	0.125	10.5	0.001
4	1.04	29	48	68	1.1	0.125	10.5	0.001	1.0	48	0.125	0.125	10.5	0.001
5	1.04	29	48	68	1.1	0.125	10.5	0.001	1.0	48	0.125	0.125	10.5	0.001
6	1.04	29	48	68	1.1	0.125	10.5	0.001	1.0	48	0.125	0.125	10.5	0.001
7	1.04	29	48	68	1.1	0.125	10.5	0.001	1.0	48	0.125	0.125	10.5	0.001
8	1.04	29	48	68	1.1	0.125	10.5	0.001	1.0	48	0.125	0.125	10.5	0.001
9	1.04	29	48	68	1.1	0.125	10.5	0.001	1.0	48	0.125	0.125	10.5	0.001
10	1.04	29	48	68	1.1	0.125	10.5	0.001	1.0	48	0.125	0.125	10.5	0.001
11	1.04	29	48	68	1.1	0.125	10.5	0.001	1.0	48	0.125	0.125	10.5	0.001
12	1.04	29	48	68	1.1	0.125	10.5	0.001	1.0	48	0.125	0.125	10.5	0.001
13	1.04	29	48	68	1.1	0.125	10.5	0.001	1.0	48	0.125	0.125	10.5	0.001
14	1.04	29	48	68	1.1	0.125	10.5	0.001	1.0	48	0.125	0.125	10.5	0.001
15	1.04	29	48	68	1.1	0.125	10.5	0.001	1.0	48	0.125	0.125	10.5	0.001

Reinforcement Capacity



Dimensions and Properties										Compression		Axial		ASD-9		LRFD								
Model	Weight (lb/ft)	Area (in ²)	Moment of Inertia (in ⁴)	Moment of Inertia (in ⁴)	Centroid from Bolt Hole Center (in)	Centroid from Bolt Hole Center (in)	Web Thickness (in)	Width (in)	Flange Width (in)	Flange Thickness (in)	Hole Diameter (in)	Yield Stress (ksi)	Ultimate Stress (ksi)	Slender. Ratio Coefficient	Unbraced Length (in)	Slender. Ratio Coefficient	Unbraced Length (in)	Allowable Axial (kip)	Allowable Axial w/ increase (kip)	Governing Axial	Rupture	Design Axial Strength (kip)	Governing Axial	Rupture
CC-XFP-040075	10.2	3.00	0.14	4.00	0.375	0	0.75	4	0	0	1.1875	65	80	0.80	16	1.00	16	82.5	110.0	Rupture	Rupture	123.8	Rupture	Rupture

Rein1

Bottom	Top	Qty	Model	Position	T or T&C
0	35.5	35.5	3-FP-040075	F	T&C
35.5	59.5	59.5	3-FP-040075	F	T&C
75	83	83	3-FP-040075	F	T&C
				F	T&C
				F	T&C
				F	T&C
				F	T&C
				F	T&C
				F	T&C

Flats (Used for relative orientation only. Actual flat numbers may vary.)

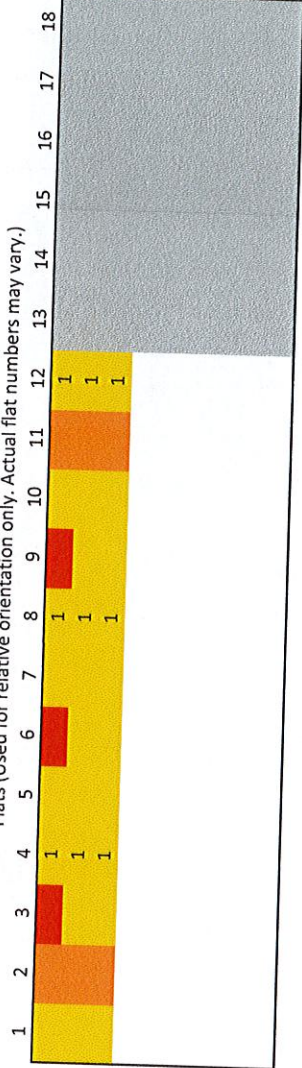

Rein2

Bottom	Top	Qty	Model	Position	T or T&C
0				F	T&C
				F	T&C
				F	T&C
				F	T&C
				F	T&C
				F	T&C
				F	T&C
				F	T&C
				F	T&C

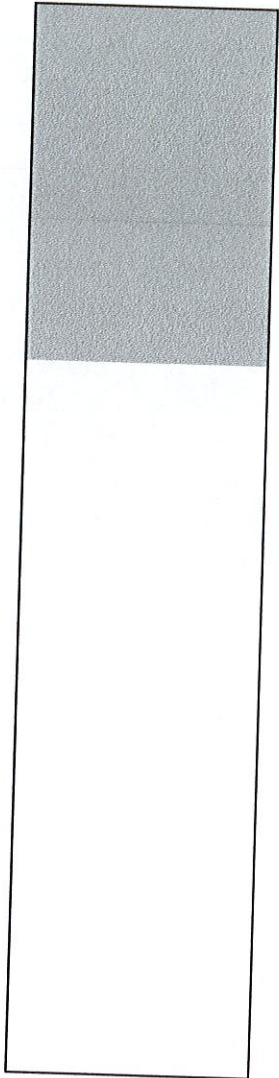

Rein3

Bottom	Top	Qty	Model	Position	T or T&C
0				F	T&C
				F	T&C
				F	T&C
				F	T&C
				F	T&C
				F	T&C
				F	T&C
				F	T&C
				F	T&C

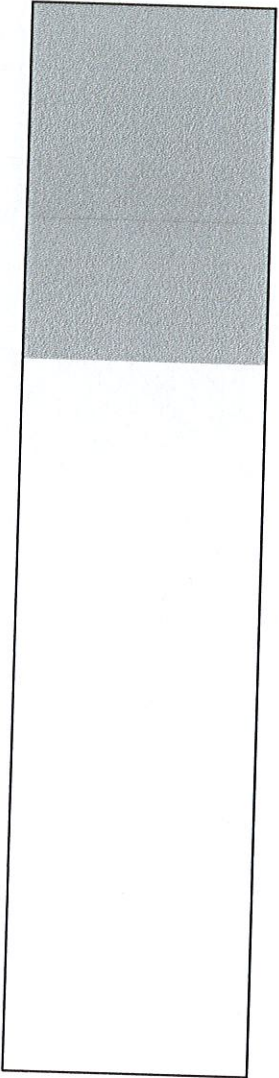

Anchor Rod Information for TIA/EIA-222-F and TIA-222-G-2



Site Information	
ID:	828402
Name:	Thompson- I-395 X99_1
App. #:	282339 R1

Design Information	
TIA Code:	F
ASIF:	1.333
Failure:	100%
eta Factor:	0.50

Base Reactions	
Moment:	1704 ft-kip
Axial:	24 kip
Shear:	20 kip
Base Plate Type:	Circular

Original Anchor Rod Data	
Quantity:	18
Diameter:	2.00 in
Material:	A36
Bolt Circle:	51.0 in
Bolt Spacing:	56.55 in
Bolt Group Area:	18385 in ²
Bolt Group MOIx:	in ⁴

Reactions Seen by Original AR Group

Moment:	1338.6 kip-ft
Axial:	24.4 kip
Shear:	19.6 kip

Original AR Capacity Check

Tension Load:	68.6 kip
Allowable load:	71.9 kip
AR Capacity:	95.4% Pass

First Added Anchor Rod Data	
Quantity:	3
Diameter:	2.25 in
Material:	A193 B7
Bolt Circle:	58.0 in
Bolt Group Area:	11.93 in ²
Bolt Group MOIx:	5016 in ⁴

Reactions Seen by First Added AR Group

Moment:	365.2 kip-ft
Axial:	0.0 kip
Shear:	0.0 kip

First Added AR Capacity Check

Tension Load:	100.7 kip
Allowable load:	218.6 kip
AR Capacity:	46.1% Pass

Second Added Anchor Rod Data	
Quantity:	
Diameter:	in
Material:	in
Bolt Circle:	in
Bolt Group Area:	0.00 in ²
Bolt Group MOIx:	0 in ⁴

Reactions Seen by Second Added AR Group

Moment:	0.0 kip-ft
Axial:	0.0 kip
Shear:	0.0 kip

Second Added AR Capacity Check

Tension Load:	0.0 kip
Allowable load:	0.0 kip
AR Capacity:	0.0%

Third Added Anchor Rod Data	
Quantity:	
Diameter:	in
Material:	in
Bolt Circle:	in
Bolt Group Area:	0.00 in ²
Bolt Group MOIx:	0 in ⁴

Reactions Seen by Second Added AR Group

Moment:	0.0 kip-ft
Axial:	0.0 kip
Shear:	0.0 kip

Second Added AR Capacity Check

Tension Load:	0.0 kip
Allowable load:	0.0 kip
AR Capacity:	0.0%

Anchor Rod Embedment (v1.2)

Analysis Standard

TIA Code:	TIACode	F
Allowable Stress Increase:	ASIF	1.333

Dimensions and Properties

Pier Diameter:	PierDia	72 in
Concrete Strength:	Fc	3000 psi
Clear Cover, Side:	cc.side	3 in
Clear Cover, Top:	cc.top	3 in
Rebar Yield Strength:	BarFy	60 ksi
Rebar Tie Size:	TieSize	4
Rebar Tie Diameter:	TieDia	0.50 in
Vertical Bar Quantity:	BarQty	34
Vertical Bar Size:	BarSize	8
Vertical Bar Diameter:	BarDia	1.000 in
Vertical Bar Area:	BarArea	0.79 in
Vertical Bar Circle Diameter:	BarBC	64.0 in
Vertical Bar Spacing:	BarSp	5.9 in
Vertical Bar Radial Angle Between:	BarAngle	10.6 deg
Anchor Rod Type:	RodType	Other
Anchor Rod Diameter:	RodDia	2.25 in
Anchor Rod Threads per Inch:	RodThreads	4.5
Anchor Rod Net Area Through Threads:	RodArea	3.25 sq in
Anchor Rod Circle Diameter:	RodBC	58 in
Anchor Rod Material:	RodMatl	A193 B7
Anchor Rod Yield Strength:	RodFy	105 ksi
Anchor Rod Ultimate Strength:	RodFu	125 ksi

Anchor Rod Loading

Anchor Rod Tensile Requirement:	RodP	324.8 kip	*LRFD capacity is used for designs.
Anchor Rod Design Criteria:	DesCrit	Design	

Development Length of Vertical Rebar

Reinforcement Location Factor ⁽¹⁾ :	Alpha	1.0	ACI 12.2.4
Coating Factor ⁽¹⁾ :	Beta	1.0	ACI 12.2.4
Lightweight Aggregate Concrete Factor ⁽¹⁾ :	Lambda	1.0	ACI 12.2.4
Reinforcement Size Factor ⁽¹⁾ :	Gamma	1.0	ACI 12.2.4
Transverse Reinforcement Ratio ⁽²⁾ :	Ktr	0.0 in	ACI 12.2.4
Maximum Spacing or Cover Dimension:	Cover	2.95 in	ACI 12.2.4
Development Length:	Ld	32.9 in	ACI 12.2.3
Reinforcement Stress Ratio ⁽³⁾ :	SR	0.66	
Reduced Development Length:	Ld.red	21.6 in	ACI 12.2.5 Used only if DesCrit = "Analysis"

Force Transfer Length

Angle to Vertical Bar:	Angle	5.3 deg
Distance to Farthest Bar:	BarDist	4.1 in

Epoxy Bond

Epoxy Ultimate Bond Stress:	EpoxyBond	1800 psi	
Factor of Safety:	EpoxyFS	3	
Strength Resistance Factor:	EpoxyPhi	0.5	*LRFD capacity is used for designs.
Bond Length Required:	EpoxyL	51.1 in	

Embedment Length

Total Required Embedment Length:	EmbedIn	57 in	Epoxy Length Controls
	EmbedFt	4.7 ft	
Actual Embedment length:	ActEmbed	6.0 ft	
Embedment Capacity	EmbedCap	78.9%	

Notes:

- (1) These factors are typically 1.0 for most tower foundations.
- (2) This factor is typically 0 inches for most tower foundations.
- (3) Stress ratio of reinforcement can be entered to reduce required development length. Only to be used in already installed desperate situations.
- (4) This is consistent with on CCI Foundations Criteria Item AC-1, dated 06/01/2010.

Stiffened or Unstiffened, Ungrouted, Circular Base Plate - Any Rod Material

TIA Rev F

Site Data

BU#: 828402
Site Name: Thompson- I-395 X99_1
App #: 282339 R1
Pole Manufacturer: Other

Reactions	
Moment: 1338.5777	ft-kips
Axial: 24.4092	kips
Shear: 19.592473	kips

Anchor Rod Data	
Qty: 18	
Diam: 2	in
Rod Material: Other	
Strength (Fu): 58	ksi
Yield (Fy): 36	ksi
Bolt Circle: 51	in

If No stiffeners, Criteria: **AISC ASD** <-Only Applicable to Unstiffened Cases

Stiffened
Service, ASD
Fty*ASIF

Plate Data	
Diam: 58	in
Thick: 1.5	in
Grade: 36	ksi
Single-Rod B-eff: 7.71	in

Base Plate Results

Base Plate Stress:
 Allowable Plate Stress:
 Base Plate Stress Ratio:

Flexural Check
 32.7 ksi
 36.0 ksi
 91.0% **Pass**

Stiffened
Service, ASD
0.75*Fy*ASIF
Y.L. Length: N/A, Roark

Stiffener Data (Welding at both sides)	
Config: 1	*
Weld Type: Fillet	
Groove Depth:	<-- Disregard
Groove Angle:	<-- Disregard
Fillet H. Weld: 0.625	in
Fillet V. Weld: 0.375	in
Width: 5	in
Height: 18	in
Thick: 1	in
Notch: 1	in
Grade: 50	ksi
Weld str.: 70	ksi

Stiffener Results

Horizontal Weld : 49.3% **Pass**
 Vertical Weld: 20.8% **Pass**
 Plate Flex+Shear, fb/Fb+(fv/Fv)^2: 4.4% **Pass**
 Plate Tension+Shear, ft/Ft+(fv/Fv)^2: 30.8% **Pass**
 Plate Comp. (AISC Bracket): 27.2% **Pass**

Pole Results

Pole Punching Shear Check: 7.8% **Pass**

Pole Data	
Diam: 43.1875	in
Thick: 0.375	in
Grade: 42	ksi
# of Sides: 12	"0" IF Round
Fu: 57	ksi
Reinf. Fillet Weld: 0	"0" if None

Stress Increase Factor	
ASIF: 1.333	

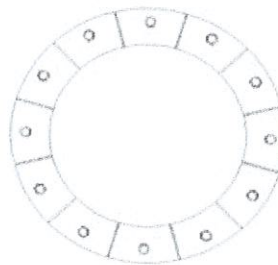

* 0 = none, 1 = every bolt, 2 = every 2 bolts, 3 = 2 per bolt

** Note: for complete joint penetration groove welds the groove depth must be exactly 1/2 the stiffener thickness for calculation purposes



Site Number	828402
Site Name	Thompson- I-395 X99_1

Caisson Analysis

Pier Properties		Analysis Properties	
Moment	1704 kip-ft	TIA Code	F
Shear	20 kip	Soil Safety Factor	2.00
Pier Diameter	6.0 ft	Water Table Depth	99.0 ft
Height Above Grade	0.25 ft	Ignored Soil Depth	4.0 ft
Depth Below Grade	25.25 ft	Cohesion Based on	PLS Caisson
Donut Diameter	ft	Max Soil Capacity	100%
Donut Depth	ft		

Soil Properties						
Layer	Top of Soil Layer (ft)	Layer Thickness (ft)	Bottom of Soil Layer (ft)	Soil Unit Weight (pcf)	Cohesion (psf)	Friction Angle (degrees)
Soil.Layer	Soil.Top	Soil.Thick	Soil.Bottom	Soil.Weight	Soil.Cohesion	Soil.Phi
1	0.00	4	4.00	140	0	42
2	4.00	4	8.00	130	0	38
3	8.00	24	32.00	140	0	42
4						
5						
6						
7						
8						
9						
10						

Critical Depths Below Grade		Results	
Rotation Axis	18.58 ft	Soil Capacity	23.7% OK
Zero Shear	6.92 ft	Max Pier Moment	1818 kip-ft

Moment At User Defined Depths Below Grade	
	kip-ft
	kip-ft
	kip-ft

Moment Capacity of Drilled Concrete Shaft (Caisson) for TIA Rev F or G

Note: Shaft assumed to have ties, not spiral, transverse reinforcing

Site Data

BU#: 828402
 Site Name: Thompson- I-395 X99_1
 App #: 282339 R1

Enter Load Factors Below:

For M (WL)	1.3	<---- Enter Factor
For P (DL)	1.3	<---- Enter Factor

Pier Properties

Concrete:

Pier Diameter = 6.0 ft
 Concrete Area = 4071.5 in²

Reinforcement:

Clear Cover to Tie = 3.00 in
 Horiz. Tie Bar Size = 4
 Vert. Cage Diameter = 5.33 ft
 Vert. Cage Diameter = 64.00 in
Vertical Bar Size = 8
 Bar Diameter = 1.00 in
 Bar Area = 0.79 in²
 Number of Bars = 34
 As Total = 26.86 in²
 A s/ Aconc, Rho: 0.0066 0.66%

ACI 10.5, ACI 21.10.4, and IBC 1810.

Min As for Flexural, Tension Controlled, Shafts:

(3)*(Sqrt(f'c)/Fy: 0.0027
 200 / Fy: 0.0033

Minimum Rho Check:

Actual Req'd Min. Rho:	0.33%	Flexural
Provided Rho:	0.66%	OK

Ref. Shaft Max Axial Capacities, ϕ Max(Pn or Tn):		
Max Pu = ($\phi=0.65$) Pn.		
Pn per ACI 318 (10-2)	6201.23	kips
at Mu=($\phi=0.65$)Mn=	3230.15	ft-kips
Max Tu, ($\phi=0.9$) Tn =	1450.44	kips
at Mu= $\phi=(0.90)$ Mn=	0.00	ft-kips

Maximum Shaft Superimposed Forces

TIA Revision:	F	
Max. Service Shaft M:	1818.01	ft-kips (* Note)
Max. Service Shaft P:	24.4092	kips
Max Axial Force Type:	Comp.	

(* Note: Max Shaft Superimposed Moment does not necessarily equal to the shaft top reaction moment

Load Factor	Shaft Factored Loads	
1.30	Mu:	2363.412 ft-kips
1.30	Pu:	31.73196 kips

Material Properties

Concrete Comp. strength, f'c =	3000	psi
Reinforcement yield strength, Fy =	60	ksi
Reinforcing Modulus of Elasticity, E =	29000	ksi
Reinforcement yield strain =	0.00207	
Limiting compressive strain =	0.003	

ACI 318 Code

Select Analysis ACI Code= 2002

Seismic Properties

Seismic Design Category = D
 Seismic Risk = High

Solve
(Run)

<-- Press Upon Completing All Input

Results:

Governing Orientation Case: 2

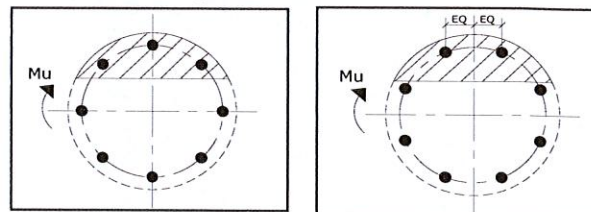

Case 1

Case 2

Dist. From Edge to Neutral Axis: 12.40 in

Extreme Steel Strain, ϵ_t : 0.0134

$\epsilon_t > 0.0050$, Tension Controlled

Reduction Factor, ϕ : 0.900

Output Note: Negative Pu=Tension

For Axial Compression, ϕ Pn = Pu: 31.73 kips
 Drilled Shaft Moment Capacity, ϕ Mn: 3604.04 ft-kips
 Drilled Shaft Superimposed Mu: 2363.41 ft-kips

(Mu/ ϕ Mn, Drilled Shaft Flexure CSR: 65.6%

APPENDIX D
MODIFICATION DRAWINGS

PREPARED FOR CROWN CASTLE MONOPOLE REINFORCEMENT DRAWINGS

SITE NAME: THOMPSON/ I-395 X99_1
BU NUMBER: 828402

SITE ADDRESS:
720 THOMPSON RD
THOMPSON, CT 6277
WINDHAM COUNTY

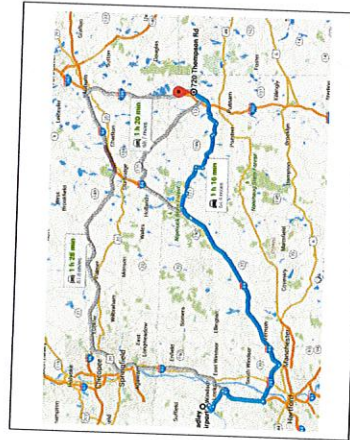

Boulder International's Vision
Schephoester Road, Windsor Locks, CT 06096

Continue to Schephoester Rd 4 min (0.8 mi)
Take I-91 S, I-291 E and exit 73 to CT-171 E in Union. Take exit 73 from I-84 E
38 min (41.3 mi) E and I-91 E to CT-171 E/Somers Turnpike to W Thompson Rd
in Thompson E and CT-171 E/Somers Turnpike to W Thompson Rd
in Thompson 16 min (24.2 mi)

720 Thompson Rd
Thompson, CT 06277

PROJECT CONTACTS

- CROWN PROJECT MANAGER**
John McGee
704-877-8397
John.McGee@crowncastle.com
- CROWN CONSTRUCTION MANAGER**
Jason D'Amico
860-209-0104
Jason.D'Amico.Vendor@crowncastle.com
- AERO DESIGN ENGINEER (EOR)**
Aero Solutions, LLC
720-304-6882
cmrp@aerosolutionsllc.com
5500 Flatiron Parkway, Suite 100
Boulder, CO 80301

DRAWINGS INCLUDED

SHEET NUMBER	DESCRIPTION
S-1	TITLE PAGE
S-2	MODIFICATION INSPECTION CHECKLIST
S-3	NOTES
S-4A	NEXGEN2 BLIND BOLT SPECIFICATIONS AND TIGHTENING PROCEDURE
S-4B	FORGBOLT™ BOLT SPECIFICATIONS AND TIGHTENING PROCEDURE
S-5	ELEVATION
S-6	DETAILS
S-7	FAB DETAILS

TOWER INFORMATION	
TOWER MANUFACTURER:	FRED A. NUDD CORPORATION
TOWER HEIGHT/TYPE:	156 FT MONOPOLE TOWER
TOWER LOCATION:	LAT: 41.9777 LONG: -71.8465
AERO ID:	003-15-0429
APPLICATION ID:	282339 R1

CODE COMPLIANCE
THIS REINFORCEMENT DESIGN IS BASED ON THE REQUIREMENTS OF TIA STRUCTURAL STANDARDS FOR STEEL ANTENNA TOWERS AND ANTENNA SUPPORTING STRUCTURES USING TIA CODE: TIA/EIA-222-F
WIND SPEED NO ICE: 85 MPH FASTEST MILE WIND SPEED
ICE THICKNESS: 1"
WIND SPEED WITH ICE: 38 MPH
SERVICE LOADS: 50 MPH

ATTENTION ALL CONTRACTORS: ANYTIME YOU ACCESS A CROWN SITE FOR ANY REASON, YOU ARE TO CALL THE CROWN NOC UPON ARRIVAL AND DEPARTURE. DAILY AT 800-788-7011.

NO.	DATE	DESCRIPTION	BY
00	05/29/15	INITIAL RELEASE	
REVISIONS			

PREPARED FOR CROWN CASTLE
SITE NAME: THOMPSON/ I-395 X99_1
BU NUMBER: 828402
WO NUMBER: 104922
SITE ADDRESS:
720 THOMPSON RD
THOMPSON, CT 0277
WINDHAM COUNTY



6.3.2015

ENG/CA BY:	MB	DATE:	05/29/2015
DFT BY:	MB	DATE:	05/29/2015
DFT/CA BY:	RS	DATE:	05/29/2015
APRVD BY:	SD	DATE:	05/29/2015
SCALE: N.T.S.			
TITLE PAGE			
S-1	REV.	00	

AeroSolutions LLC
Simplifying Your Tower Construction
THIS DRAWING IS COPYRIGHTED AND IS THE PROPERTY OF AEROSOLUTIONS LLC. IT IS PRODUCED SOLELY FOR CROWN CASTLE. IT IS NOT TO BE REPRODUCED OR TRANSMITTED IN ANY FORM OR BY ANY MEANS, ELECTRONIC OR MECHANICAL, INCLUDING PHOTOCOPYING, RECORDING, OR BY ANY INFORMATION SYSTEMS WITHOUT THE EXPRESS WRITTEN PERMISSION OF CROWN CASTLE.

MODIFICATION INSPECTION NOTES

MI CHECKLIST	
CONSTRUCTION / INSTALLATION INSPECTIONS AND TESTING REQUIRED (COMPLETED BY EOR)	REPORT ITEM
PRE-CONSTRUCTION	
X	MI CHECKLIST DRAWING
X	EOA APPROVAL
X	FABRICATION INSPECTION
X	FABRICATOR CERTIFIED WELD INSPECTION
X	MATERIAL TEST REPORT (MTR)
NA	FABRICATOR NDE INSPECTION
NA	NDE REPORT OF MONOPOLE BASE PLATE PER ENG-SOW-0033
X	PACKING SLIPS
ADDITIONAL TESTING AND INSPECTIONS	
None	
CONSTRUCTION	
X	CONSTRUCTION INSPECTIONS
NA	FOUNDATION INSPECTIONS
NA	CONCRETE COMP. STRENGTH-HAND SLUMP TESTS
X	POST INSTALLED ANCHOR ROD VERIFICATION
NA	BASE PLATE GROUT VERIFICATION
X	CONTRACTORS CERTIFIED WELD INSPECTION AND NDE REPORTS
NA	EARTHWORK/LIFT AND DENSITY
X	ON SITE COLD GALVANIZING VERIFICATION
NA	GUY WIRE TENSION REPORT
X	GC AS BUILT DOCUMENTS
ADDITIONAL TESTING AND INSPECTIONS	
None	
POST CONSTRUCTION	
X	MI INSPECTOR REDLINE OR RECORD DRAWING (S)
X	POST INSTALLED ANCHOR ROD PULL OUT TESTING
X	PHOTOGRAPHS
ADDITIONAL TESTING AND INSPECTIONS	
None	

GENERAL

THE MODIFICATION INSPECTION (MI) IS A VISUAL INSPECTION OF TOWER MODIFICATIONS AND A REVIEW OF CONSTRUCTION WITH THE CONTRACT DOCUMENTS, NAMELY THE MODIFICATION DRAWINGS, AS DESIGNED BY THE ENGINEER OF RECORD (EOR).

THE MI IS TO CONFIRM INSTALLATION CONFIGURATION AND WORKMANSHIP ONLY AND IS NOT A REVIEW OF THE MODIFICATION DESIGN ITSELF. THE MI INSPECTOR TAKE OWNERSHIP OF THE MODIFICATION DESIGN FROM THE EOR AT ALL TIMES.

ALL MTS SHALL BE CONDUCTED BY A CROWN ENGINEERING VENDOR (AEV) OR ENGINEERING SERVICE VENDOR (AESV) THAT IS APPROVED TO PERFORM ELEVATED WORK FOR CROWN. SEE CROWN ENG-SUB-10173.

TO ENSURE THAT THE REQUIREMENTS OF THE MI ARE MET, IT IS VITAL THAT THE GENERAL CONTRACTOR (GC) AND THE MI INSPECTOR BEGIN COMMUNICATIONS EARLY IN THE PROJECT AS A PURCHASE ORDER (PO) IS RECEIVED. IT IS EXPECTED THAT EACH PARTY WILL BE PRODUCTIVE IN RESOLVING ANY DISCREPANCIES. IF CONTACT INFORMATION IS NOT KNOWN, CONTACT YOUR CROWN POINT OF CONTACT (POC).

REFER TO CROWN ENG-SOW-10007, "MODIFICATION INSPECTION SOW", FOR FURTHER DETAILS AND REQUIREMENTS.

MI INSPECTOR

THE MI INSPECTOR IS REQUIRED TO CONTACT THE GC AS SOON AS RECEIVING A PO FOR THE MI TO, AT A MINIMUM:

- REVIEW THE REQUIREMENTS OF THE MI CHECKLIST
- WORK WITH THE GC TO DEVELOP A SCHEDULE TO CONDUCT ON-SITE INSPECTIONS, INCLUDING FOUNDATION INSPECTIONS

THE MI INSPECTOR IS RESPONSIBLE FOR COLLECTING ALL GC INSPECTION AND TEST REPORTS, REVIEWING THE REQUIREMENTS FOR ADHERENCE TO THE CONTRACT DOCUMENTS, CONDUCTING THE IN-FIELD INSPECTIONS, AND SUBMITTING THE MI REPORT TO CROWN.

REQUIRED PHOTOS

BETWEEN THE GC AND THE MI INSPECTOR THE FOLLOWING PHOTOGRAPHS, AT A MINIMUM, ARE TO BE TAKEN AND INCLUDED IN THE MI REPORT:

- PRE-CONSTRUCTION GENERAL SITE CONDITION
- PHOTOGRAPHS DURING THE REINFORCEMENT/ MODIFICATION CONSTRUCTION/ RESECTION AND INSPECTION
- RAW MATERIALS
- FOUND OF ALL CRITICAL DETAILS
- WELD PREPARATION
- BOLT INSTALLATION
- FINAL INSTALLED CONDITION
- FINAL INSTALLED CONDITION WITH CORRECTING REPAIR PHOTOGRAPHS
- POST CONSTRUCTION CONDITION
- FINAL IN-FIELD CONDITION

PHOTOS OF ELEVATED MODIFICATIONS TAKEN ONLY FROM THE GROUND SHALL BE CONSIDERED INADEQUATE. THIS IS NOT A COMPLETE LIST OF REQUIRED PHOTOS. PLEASE REFER TO CROWN ENG-SOW-10007.

GENERAL CONTRACTOR

THE GC IS REQUIRED TO CONTACT THE MI INSPECTOR AS SOON AS RECEIVING A PO FOR THE MODIFICATION INSTALLATION OR TURNKEY PROJECT TO, AT A MINIMUM:

- REVIEW THE REQUIREMENTS OF THE MI CHECKLIST
- WORK WITH THE MI INSPECTOR TO DEVELOP A SCHEDULE TO CONDUCT ON-SITE MI INSPECTIONS, INCLUDING FOUNDATION INSPECTIONS
- BETTER UNDERSTAND ALL INSPECTION AND TESTING REQUIREMENTS

THE GC SHALL PERFORM AND RECORD THE TEST AND INSPECTION RESULTS IN ACCORDANCE WITH THE REQUIREMENTS OF THE MI CHECKLIST AND CROWN ENG-SOW-10007.

RECOMMENDATIONS

THE FOLLOWING RECOMMENDATIONS AND SUGGESTIONS ARE OFFERED TO ENHANCE THE EFFICIENCY AND EFFECTIVENESS OF DELIVERING AN MI REPORT:

- IT IS SUGGESTED THAT THE GC PROVIDE A MINIMUM OF 5 BUSINESS DAYS NOTICE, PREFERABLY 10, TO THE MI INSPECTOR AS TO WHEN THE SITE WILL BE READY FOR THE GC AND MI INSPECTOR ON-SITE SMALL TOWER MODIFICATIONS.
- THE GC AND MI INSPECTOR COORDINATE CLOSELY THROUGHOUT THE ENTIRE PROJECT.
- ANY GUY WIRE TENSIONING OPERATIONS SHALL BE CONDUCTED PRIOR TO CONDUCTING THE FOUNDATION INSPECTIONS TO ALLOW THE FOUNDATION AND MI INSPECTION(S) TO COMMENCE.
- IF ANY DEFICIENCIES ARE IDENTIFIED, THE GC AND MI INSPECTOR ON-SITE DURING THE MI TO HAVE COORDINATE THE MI CAREFULLY TO ENSURE ALL CONSTRUCTION FACILITIES ARE AT THEIR DISPOSAL WHEN THE MI INSPECTOR IS ON SITE.

CANCELLATION OR DELAYS IN SCHEDULED MI

IF THE GC AND MI INSPECTOR AGREE TO A DATE ON WHICH THE MI WILL BE CONDUCTED, AND EITHER PARTY CANCELS OR DELAYS THE MI, THE OTHER PARTY SHALL BE RESPONSIBLE FOR THE COSTS OF DEPOSITS AND/OR OTHER FEES RELATED TO THE CANCELLATION OR DELAY. THE MI INSPECTOR SHALL BE RESPONSIBLE FOR A THIRD PARTY MI, EXCEPTS MAY BE THE EQUIPMENT ON-SITE, ETC., IF CROWN CONTRACTS DIRECTLY. WEATHER OR OTHER CONDITIONS THAT MAY COMPROMISE THE SAFETY OF THE PARTIES INVOLVED.

MI VERIFICATION INSPECTIONS

CROWN RESERVES THE RIGHT TO CONDUCT AN MI VERIFICATION INSPECTION TO VERIFY THE ACCURACY AND COMPLETENESS OF PREVIOUSLY COMPLETED MI INSPECTIONS ON TOWER MODIFICATION PROJECTS. ALL VERIFICATION INSPECTIONS SHALL BE HELD TO THE SAME SPECIFICATIONS AND REQUIREMENTS IN THE CONTRACT DOCUMENTS AND IN ACCORDANCE WITH CROWN ENG-SOW-10007.

VERIFICATION INSPECTION MAY BE CONDUCTED BY AN INDEPENDENT AEA/ESV FIRM AFTER A MODIFICATION PROJECT, AS MARKED BY THE DATE OF AN ACCEPTED CLASS, NG, J, OR PASS, AS NOTED, J.M. REPORT FOR THE ORIGINAL PROJECT.

CORRECTION OF FAILING MTS

IF THE MODIFICATION INSTALLATION WOULD FAIL THE MI (FAILED MI), THE GC SHALL WORK WITH CROWN TO COORDINATE A REMEDIATION PLAN IN ONE OF TWO WAYS:

- CORRECT FAILING ISSUES TO COMPLY WITH THE SPECIFICATIONS CONTAINED IN THE ORIGINAL CONTRACT DOCUMENTS AND COORDINATE A SUPPLEMENT MI.
- WITH CROWN'S APPROVAL, THE GC MAY WORK WITH THE EOR TO RE-ANALYZE THE MODIFICATION/REINFORCEMENT USING THE AS-BUILT CONDITION.

REQUIRED PHOTOS

BETWEEN THE GC AND THE MI INSPECTOR THE FOLLOWING PHOTOGRAPHS, AT A MINIMUM, ARE TO BE TAKEN AND INCLUDED IN THE MI REPORT:

- PRE-CONSTRUCTION GENERAL SITE CONDITION
- PHOTOGRAPHS DURING THE REINFORCEMENT/ MODIFICATION CONSTRUCTION/ RESECTION AND INSPECTION
- RAW MATERIALS
- FOUND OF ALL CRITICAL DETAILS
- WELD PREPARATION
- BOLT INSTALLATION
- FINAL INSTALLED CONDITION
- FINAL INSTALLED CONDITION WITH CORRECTING REPAIR PHOTOGRAPHS
- POST CONSTRUCTION CONDITION
- FINAL IN-FIELD CONDITION

PHOTOS OF ELEVATED MODIFICATIONS TAKEN ONLY FROM THE GROUND SHALL BE CONSIDERED INADEQUATE. THIS IS NOT A COMPLETE LIST OF REQUIRED PHOTOS. PLEASE REFER TO CROWN ENG-SOW-10007.

NO.	DATE	DESCRIPTION	BY	REVISIONS	
				NO.	DATE
00	05/29/15	INITIAL RELEASE	MB		
PREPARED FOR CROWN CASTLE					



AeroSolutions LLC
Enhancing Your Tower Operations

THE DRAWING IS COPYRIGHTED AND IS NOT TO BE REPRODUCED OR TRANSMITTED IN ANY FORM OR BY ANY MEANS, ELECTRONIC OR MECHANICAL, INCLUDING PHOTOCOPYING, RECORDING, OR BY ANY INFORMATION STORAGE AND RETRIEVAL SYSTEM, WITHOUT THE WRITTEN PERMISSION OF AERO SOLUTIONS LLC.

SITE NAME: THOMPSON / 1363 XYT_1
 BU NUMBER: 628402
 WO NUMBER: 1049727
 SITE ADDRESS:
 720 THOMPSON RD
 HARTFORD, CT 06177
 WINDHAM COUNTY

ENG/CA BY: MB DATE: 05/29/2015
 DFT BY: MB DATE: 05/29/2015
 DFT/CA BY: RB DATE: 05/29/2015
 APRVD BY: SD DATE: 05/29/2015
 SCALE: N.T.S.

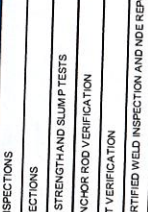

6.3.2015

MODIFICATION INSPECTION CHECKLIST

REV	00
S-2	

NOTE: X DENOTES A DOCUMENT REQUIRED FOR THE MI REPORT
 NA DENOTES A DOCUMENT THAT IS NOT REQUIRED FOR THE MI REPORT

GENERAL NOTES

1. ALL WORK PRESENTED ON THESE DRAWINGS MUST BE COMPLETED BY THE CONTRACTOR UNLESS NOTED OTHERWISE. THE CONTRACTOR MUST BE EXPERIENCED IN THE PERFORMANCE OF THE WORK AS DESCRIBED HEREIN. BY ACCEPTANCE OF THIS ASSIGNMENT, THE CONTRACTOR IS ATTESTING THAT HE DOES HAVE SUFFICIENT EXPERIENCE TO PERFORM THE WORK AND THAT HE IS KNOWLEDGEABLE OF THE WORK TO BE PERFORMED, WHICH IT IS TO BE PERFORMED.
2. THE GENERAL NOTES AND TYPICAL DETAILS ARE APPLICABLE TO ALL PARTS OF THE STRUCTURE AND SHALL BE READ IN CONJUNCTION WITH THE STRUCTURAL DRAWINGS AND PROJECT SPECIFICATIONS.
3. THE CONTRACTOR IS RESPONSIBLE FOR OBTAINING APPROVALS FROM ALL AUTHORITIES HAVING JURISDICTION FOR THIS PROJECT AND SHALL NOTIFY THE APPLICABLE JURISDICTIONAL STATE, COUNTY, OR CITY ENGINEER 24 HOURS PRIOR TO THE BEGINNING OF CONSTRUCTION.
4. THE CONTRACTOR SHALL BE RESPONSIBLE FOR ABIDING BY ALL CONDITIONS AND REQUIREMENTS OF THE PERMITS.
5. ERECT GUARDS AND BARRIERS PER APPLICABLE LABOR AND CONSTRUCTION SAFETY REGULATIONS.
6. THE CONTRACTOR SHALL FIELD VERIFY ALL EXISTING CONDITIONS, POSSIBLE INTERFERENCES, AND DIMENSIONS BEFORE PROCEEDING WITH THE WORK. REPORT ANY AND ALL DISCREPANCIES TO THE ENGINEER OF RECORD (EOR) AND FIELD PERSONNEL IMMEDIATELY. ANY AND ALL FIELD CHANGES SHALL BE APPROVED AND DOCUMENTED BY THE EOR PRIOR TO FIELD IMPLEMENTATION.
7. ALL MATERIALS AND WORKMANSHIP SHALL BE WARRANTED FOR TWO (2) YEARS FROM THE DATE OF COMPLETED CONSTRUCTION SPECIFICATIONS, UNO.
8. USE ONLY THE LATEST ISSUES OF ANY APPLICABLE CODES, STANDARDS, OR REGULATIONS MENTIONED IN THE FOLLOWING NOTES AND SPECIFICATIONS, UNO.
9. ALL WORKMANSHIP SHALL BE IN ACCORDANCE WITH ANSI, ASTM, AISC, TIA, AND AISC STANDARDS AS REFERENCED IN THE APPLICABLE CODE CONSTRUCTION. EXCEPT WHERE NOTED OTHERWISE, SHALL COMPLY WITH THOSE CODES/STANDARDS.
10. STRUCTURAL ELEMENTS SHOWN ON THESE DRAWINGS ARE DESIGNED IN ACCORDANCE WITH APPLICABLE BUILDING CODES/STANDARDS. ALL CONSTRUCTION, EXCEPT WHERE NOTED OTHERWISE, SHALL COMPLY WITH THOSE CODES/STANDARDS.
11. ALL MATERIALS AND EQUIPMENT FURNISHED SHALL BE NEW AND OF GOOD QUALITY, FREE FROM FAULTS AND DEFECTS, AND IN CONFORMANCE WITH THE DRAWINGS. ANY AND ALL SUBSTITUTIONS MUST BE APPROVED AND AUTHORIZED IN WRITING BY THE OWNER AND ENGINEER OF RECORD PRIOR TO FABRICATION AND INSTALLATION. THE CONTRACTOR SHALL FURNISH SATISFACTORY EVIDENCE AS TO THE KIND AND QUALITY OF THE MATERIALS AND EQUIPMENT BEING SUBSTITUTED.
12. ALL MANUFACTURER'S HARDWARE ASSEMBLY INSTRUCTIONS SHALL BE FOLLOWED EXACTLY AND SHALL SUPERSEDE ANY CONFLICTING NOTES ENCLOSED HEREIN.
13. THE CONTRACTOR SHALL BE RESPONSIBLE FOR INITIATING, MAINTAINING, AND SUPERVISING ALL SAFETY PRECAUTIONS AND PROGRAMS IN CONNECTION WITH THE WORK. THE CONTRACTOR SHALL BE RESPONSIBLE FOR ENSURING THAT ALL CONSTRUCTION PROCEDURES MEET THE REQUIREMENTS OF OSHA, THE OWNER, AND ALL OTHER APPLICABLE LOCAL, STATE, AND FEDERAL SAFETY REGULATIONS.
14. ACCESS TO THE PROPOSED WORK SITE MAY BE RESTRICTED. THE CONTRACTOR SHALL COORDINATE INTENDED CONSTRUCTION ACTIVITY, INCLUDING WORK SCHEDULE AND MATERIAL ACCESS, WITH THE RESIDENT LEASING AGENT.
15. IT SHALL BE THE RESPONSIBILITY OF THE CONTRACTOR TO SAFEGUARD ALL EXISTING STRUCTURES OR BURIED SERVICES AFFECTED BY THIS CONSTRUCTION. THE CONTRACTOR IS ALSO RESPONSIBLE FOR TEMPORARILY RELOCATING ANY LINES OR STRUCTS AS NECESSARY TO COMPLETE THE REQUIRED WORK.
16. STRUCTURAL DESIGN IS FOR THE COMPLETE CONDITION ONLY. THE CONTRACTOR MUST BE COGNIZANT THAT THE REMOVAL OF ANY STRUCTURAL MEMBER FROM AN EXISTING TOWER HAS THE POTENTIAL TO CAUSE THE PARTIAL OR TOTAL COLLAPSE OF THE STRUCTURE. ALL NECESSARY PRECAUTIONS MUST BE TAKEN TO ENSURE STRUCTURAL INTEGRITY, INCLUDING BUT NOT LIMITED TO, THE USE OF SHORING, ASSESSMENT OF CONSTRUCTION STRESSES WITH INSTALLATION MAXIMUM WIND SPEED AND/OR TEMPORARY BRACING AND SHORING.
17. DO NOT SCALE DRAWINGS.
18. FOR THIS ANALYSIS AND MODIFICATION, THE TOWER HAS BEEN ASSUMED TO BE IN GOOD CONDITION WITHOUT ANY DEFECTS. IF THE CONTRACTOR DISCOVERS ANY INDICATION OF AN EXISTING STRUCTURAL DEFECT, CONTACT THE ENGINEER OF RECORD IMMEDIATELY.
19. MODIFICATION WORK SHALL BE COMPLETED IN CALM WIND CONDITIONS / OR APPROPRIATE WIND SPEED FOR THE TYPE OF MODIFICATION WORK TO BE INSTALLED.
20. THE CLIMBING FACILITIES, SAFETY CLIMB AND ALL PARTS THEREOF SHALL NOT BE IMPEDED, MODIFIED OR ALTERED WITHOUT THE EXPRESS APPROVAL OF THE ENGINEER OF RECORD.

STRUCTURAL STEEL NOTES

1. DESIGN, FABRICATION, ERECTION, ALTERATION, AND MAINTENANCE SHALL CONFORM TO THE FOLLOWING, UNLESS NOTED OTHERWISE (UNO).
 - A. TIA-222, STRUCTURAL STANDARD FOR ANTENNA SUPPORTS AND ANTENNAS
 - B. AISC, MANUAL OF STEEL CONSTRUCTION
 - C. AISC, MANUAL OF STEEL CONSTRUCTION
2. ALL STRUCTURAL ELEMENTS SHALL CONFORM TO THE FOLLOWING REQUIREMENTS, UNO.
 - A. ALL BOLTS SHALL BE ASTM A572 GRADE 65 (FY = 65KSI).
 - B. ALL BOLTS SHALL BE GALVANIZED HIGH STRENGTH BOLTS.
 - C. ALL NUTS SHALL BE ASTM A533 CARBON STEEL NUTS.
 - D. ALL WASHERS, ASTM F436 HARDENED STEEL WASHERS.
3. HOLES SHALL NOT BE FLAME CUT THRU STEEL UNLESS APPROVED BY THE ENGINEER OF RECORD.
4. ALL FASTENERS SHALL NOT BE REUSED.
5. A NUT LOCKING DEVICE SHALL BE INSTALLED ON ALL PROPOSED AND/OR REPLACED ASTM A325 BOLTS.
6. ALL PROPOSED AND/OR REPLACED BOLTS SHALL BE OF SUFFICIENT LENGTH SUCH THAT THE END OF THE BOLT BE AT LEAST FLUSH WITH THE FACE OF THE NUT. IT IS NOT PERMITTED FOR THE BOLT END TO BE BELOW THE FACE OF THE NUT AFTER TIGHTENING IS COMPLETED.
7. HOT-DIP GALVANIZE ALL ITEMS, UNO. GALVANIZE PER ASTM A123, ASTM A153M/153M OR ASTM A653 GR. AS APPLICABLE.
8. FOR A LIST OF CROWN APPROVED COLD GALVANIZING COMPOUNDS, REFER TO CROWN ENG-BUL-10149, "TOWER PROTECTIVE COATINGS BULLETIN", AND AFTER FINAL INSPECTION, ALL EXPOSED STRUCTURAL STEEL AS THE RESULT OF THIS SCOPE OF WORK INCLUDING WELDS, FIELD DRILLED HOLES, ENG-BUL-10149, "TOWER PROTECTIVE COATINGS BULLETIN". PHOTO DOCUMENTATION IS REQUIRED TO BE SUBMITTED TO THE MI INSPECTOR.

WELDING NOTES

1. ALL WELDING SHALL BE IN ACCORDANCE WITH THE AWS D1.101.1M, "STRUCTURAL WELDING CODE-STEEL".
2. ALL WELDING SHALL BE PERFORMED BY AWS CERTIFIED WELDERS.
3. ALL AWS WELDING ON CROWN STRUCTURES SHALL BE DONE IN ACCORDANCE WITH THE CROWN, ENG-PEM-10015, "CUTTING AND WELDING SAFETY PLAN" AND AWS D1. PREWELDING POST WELD TREATMENT. THIS SHALL INCLUDE A CERTIFIED WELDING INSPECTOR (CWI) FOR ACCEPTANCE AND INSPECTION OF ALL WELDING OPERATIONS. PREWELDING POST WELD TREATMENT SHALL BE IN ACCORDANCE WITH THE CROWN, ENG-PEM-10015, "CUTTING AND WELDING SAFETY PLAN". THE CWI SHALL WORK WITH THE GC ON THE LEVEL OF INTERACTION NEEDED TO CONDUCT THE WELDING INSPECTION. THE CERTIFIED WELDING INSPECTION IS THE RESPONSIBILITY OF THE GC.
4. FOR ALL WELDING, USE E60XX ELECTRODES FOR SMAW PROCESS AND E80T-XX ELECTRODES FOR FCAW PROCESS, UNO.
5. SURFACES TO BE WELDED SHALL BE FREE FROM SCALE, SLAG, RUST, MORTAR, OR OTHER FOREIGN MATERIAL THAT WOULD PREVENT PROPER WELDING. OTHER FOREIGN MATERIAL THAT WOULD WELD FOR A DISTANCE OF 2" MINIMUM ALL AROUND. ENSURE BOTH AREAS ARE 100% FREE OF ALL GALVANIZING.
6. DO NOT WELD IF THE TEMPERATURE OF THE STEEL IN THE VICINITY OF THE WELD AREA IS BELOW 0° F. WHEN THE TEMPERATURE IS BETWEEN 0° F AND 32° F, PREHEAT AND MAINTAIN THE STEEL IN THE VICINITY OF THE WELD AREA AT 70° F DURING THE WELDING PROCESS.
7. DO NOT WELD ON WET OR FROST-COVERED SURFACES & PROVIDE ADEQUATE PROTECTION FROM HIGH WINDS.
8. FULL PENETRATION WELDS IN THE VICINITY OF THE BASE OF THE TOWER ARE REQUIRED TO BE 100% NDE INSPECTED BY UT IN ACCORDANCE WITH AWS D1.1.
9. PARTIAL PENETRATION AND FILLET WELDS IN THE VICINITY OF THE BASE OF THE TOWER ARE REQUIRED TO BE 50% NDE INSPECTED BY MP IN ACCORDANCE WITH AWS D1.1.

DETAIL DRAWINGS SHALL GOVERN OVER ANY VARIANCE FROM THIS SHEET

	
THE DRAWING IS COPYRIGHTED AND IS THE PROPERTY OF AEROSOLUTIONS LLC. IT IS PRODUCED SOLELY FOR THE PROJECT AND IS NOT TO BE REPRODUCED OR TRANSMITTED IN ANY FORM OR BY ANY MEANS, ELECTRONIC OR MECHANICAL, INCLUDING PHOTOCOPYING, RECORDING, OR BY ANY INFORMATION CONTAINED IN THE DRAWING. PERMISSION OF CROWN CASTLE.	
SITE NAME: THOMPSON / 1395 XTY_1 BU NUMBER: 134602 WO NUMBER: 1044727 SITE ADDRESS: 720 THOMPSON RD THOMPSON, CT 0377 WINDHAM COUNTY	
ENG/DA BY: MB DATE: 05/29/2015	DATE: 05/29/2015
DFT BY: MB DATE: 05/29/2015	DATE: 05/29/2015
OFF/DA BY: RS DATE: 05/29/2015	DATE: 05/29/2015
APRVD BY: SD DATE: 05/29/2015	DATE: 05/29/2015
SCALE: N.T.S.	
NOTES	
	
6.3.2015	
PREPARED FOR CROWN CASTLE	
NO.	DATE
00	05/29/15
INITIAL RELEASE	BY
DESCRIPTION	REVISIONS

REV 00
S-3



NEXGEN2
BLIND BOLT ASSEMBLY

- PATENT PENDING -

INTERIOR OF POLE SHAFT

EXTERIOR OF POLE SHAFT

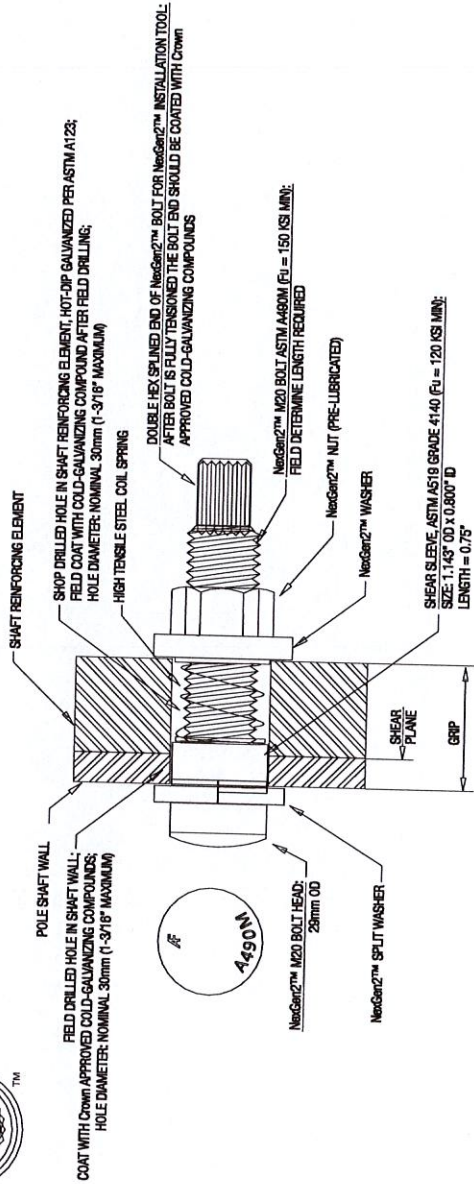

TYPICAL NEXGEN2™ BOLT DETAIL

NOTE: ALL SHOP AND FIELD DRILLED HOLES SHALL BE NOMINAL 30mm DIAMETER. THE MAXIMUM HOLE DIAMETER PERMITTED IS 1-3/16".

NOTE: NEXGEN2™ COMPLETE ASSEMBLY SHALL BE MAGNI 565 COATED PER ASTM F2833 AS APPROPRIATE.

NOTE: INSTALL PER MANUFACTURERS INSTRUCTIONS.

AeroSolutions LLC
"Sustaining Your Vision" www.aerosolutions.com

THE DRAWINGS, COPYRIGHTED AND NOT TO BE REPRODUCED OR TRANSMITTED IN ANY FORM OR BY ANY MEANS, ELECTRONIC OR MECHANICAL, INCLUDING PHOTOCOPYING, RECORDING, OR BY ANY INFORMATION STORAGE AND RETRIEVAL SYSTEM, WITHOUT THE WRITTEN PERMISSION OF CROWN CASTLE.

NO.	DATE	DESCRIPTION	BY
00	05/29/15	INITIAL RELEASE	MB
REVISIONS			

PREPARED FOR CROWN CASTLE

SITE NAME: THOMPSON/1-315 X99.1
BU NUMBER: 328402
WO NUMBER: 1044929
SITE ADDRESS:
720 THOMPSON RD
THOMPSON, CT 0427
WINDHAM COUNTY

ENGCQA BY: MB DATE: 05/29/2015
DFT BY: MB DATE: 05/29/2015
DFT/QA BY: RS DATE: 05/29/2015
APRVD BY: SD DATE: 05/29/2015

SCALE: N.T.S.

NEXGEN2 BLIND BOLT SPECIFICATIONS AND TIGHTENING PROCEDURE

6.3.2015

S-4A REV 00

FORGBOIT™ NOTE SHEET: A325/PC8.8 LANDSCAPE VERSION DATE 01/29/2015; Rev. 1.0 04/23/2015

NOTES:

- ALL STRUCTURAL BOLTS SHALL BE INSTALLED AND TIGHTENED TO THE PRETENSIONED CONDITION ACCORDING TO THE REQUIREMENTS OF THE AISC SPECIFICATION FOR STRUCTURAL JOINTS USING HIGH-STRENGTH BOLTS, DEC. 31, 2009.
- ALL STRUCTURAL BOLTS SHALL BE INSPECTED ACCORDING TO THE REQUIREMENTS OF THE AISC SPECIFICATION FOR STRUCTURAL JOINTS USING HIGH-STRENGTH BOLTS, DEC. 31, 2009.

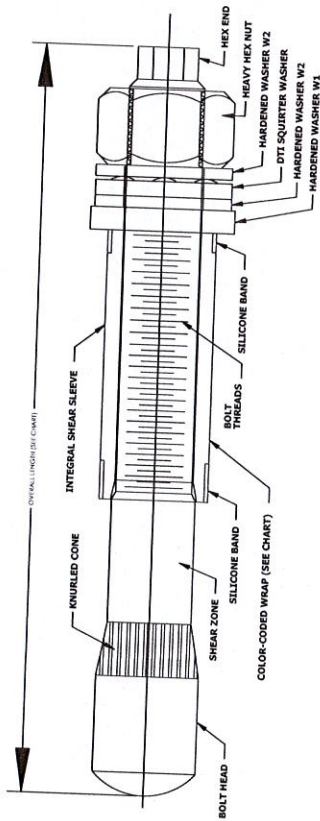

PRE-INSTALLED FORGBOIT™ ASSEMBLY DETAIL 1

BOLT HOLE NOTES:

- ALL SHOP-DRILLED HOLES SHALL BE NOMINAL 30 MM DIAMETER. THE MAXIMUM SHOP-DRILLED HOLE DIAMETER PERMITTED IS 1-3/16".
- ALL FIELD-DRILLED HOLES SHALL BE NOMINAL 30 MM DIAMETER. THE MAXIMUM FIELD-DRILLED HOLE DIAMETER PERMITTED IS 30 MM.

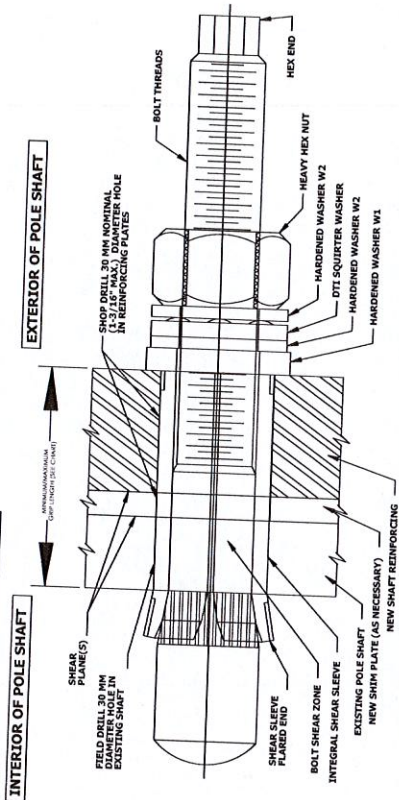

INSTALLED FORGBOIT™ ASSEMBLY DETAIL 2

DISTRIBUTOR CONTACT:
PRECISION TOWER PRODUCTS
 PHONE: 888-926-4857
 EMAIL: info@precisiontowerproducts.com
 WEB: www.precisiontowerproducts.com

CONTAINS PROPRIETARY INFORMATION PATENT PENDING
 © Copyright 2012 to 2015 by PTP, all rights reserved.

FORGBOIT™		AISC Group A Material: ASTM A325 and PC8.8 (Tensile Stress, Fu = 120 ksi minimum)			
GROUP	FORGBOIT™ Size (mm)	Overall Length (inches)	Estimated Weight Each (lbs)	Grip Range (inch)	Color Code
A	135	5.31	1.3	3/8" to 1"	RED
	160	6.30	1.6	3/4" to 1-1/2"	GREEN
	195	7.68	1.9	1-1/4" to 2-1/4"	BLUE
	260	10.24	2.6	2" to 3-1/2"	YELLOW
	365	14.37	3.6	3-1/2" to 5-1/2"	ORANGE
	440	17.32	4.3	5-1/2" to 8-1/2"	BLACK
DTI Note		Each Group A (A325/PC8.8) FORGBOIT™ assembly shall have a 'Squitter' DTI that is compatible with a M20-PC8.8 bolt.			

FORGBOIT™ Installation

Follow all Manufacturer/Distributor Recommendations, and Inspection, Tightening, and Inspection.

- FIELD DRILL HOLES TO 30 MM DIAMETER.
- SELECT CORRECT BOLT SIZE FOR INSTALLATION GRIP (REFER TO PLANS).
- INSERT BOLT ASSEMBLY THROUGH HOLES IN SHAFT REINFORCING PLATES AND SEAT THE HARDENED WASHER W1 FLUSH AGAINST OUTSIDE OF PLATE.
- HAND TIGHTEN NUT TO FINGER TIGHT.
- TIGHTEN NUT TO PRETENSIONED CONDITION AND UNTIL DTI SHOWS PROPER INDICATION.
- PROPERLY DOCUMENT AND INSPECT BOLT TIGHTENING PER PLAN REQUIREMENTS.

AeroSolutions LLC
 220 Main Street, Suite 100
 Thompson, CT 06255

THE DRAWING IS COPYRIGHTED AND IS THE PROPERTY OF CROWN CASTLE. IT IS TO BE USED ONLY FOR THE PROJECT AND ITS AFFILIATES. REPRODUCTION OR INFORMATION CONTAINED HEREIN WITHOUT THE WRITTEN PERMISSION OF CROWN CASTLE.

SITE NAME: THOMPSON / 1-385 XFF.1
 BU NUMBER: 826402
 WO NUMBER: 104429
 SITE ADDRESS:
 720 THOMPSON RD
 THOMPSON, CT 06277
 WINDHAM COUNTY

ENG'G BY: MB DATE: 05/29/2015
 DFT BY: MB DATE: 05/29/2015
 DFT/QA BY: RS DATE: 05/29/2015
 APPR'D BY: SD DATE: 05/29/2015
 SCALE: N.T.S.

6.3.2015

FORGBOIT™ BOLT SPECIFICATIONS AND TIGHTENING PROCEDURE

REV 00

S-4B



PREPARED FOR CROWN CASTLE

POLE SPECIFICATIONS
 POLE SHAPE TYPE: 12 SIDED POLYGON
 TAPER: 0.24917 IN/FT
 SHAFT STEEL: A36M-42
 BASE PL STEEL: 36 KSI YIELD STRENGTH
 ANCHOR RODS: 2 INCH A36

SHAFT SECTION	SECTION LENGTH (FT)	PLATE THICKNESS (IN)	LAP SPICE (FT)	DIAMETER ACROSS FLATS (IN)
1	12.00	0.3650	0.00	6.690
2	50.00	0.2500	3.00	18.000
3	20.00	0.2500	0.00	23.357
4	20.00	0.3125	3.00	30.340
5	30.00	0.3125	0.00	33.294
6	30.00	0.3750	6.00	36.550
7	16.00	0.3750	0.00	40.216
				43.188

POLE MODIFICATION SCHEDULE

ELEVATION (FT)	MODIFICATION	REFERENCE SHEET
A	Anchor Rods	S-6
B	Shaft Reinforcement	S-5
C	Shaft Reinforcement	S-5

CCI FLAT PLATE (65 KSI) REINFORCING SCHEDULE

BOTTOM ELEVATION (FT)	TOP ELEVATION (FT)	PART NUMBER	FLAT/DEGREE (I)	TERMINATION BOLTS (BOTTOM)	TERMINATION BOLTS (TOP)	MAX INTERMEDIATE BOLT SPACING	BOLT QUANTITY PER PLATE	STEEL WEIGHT PER PLATE (BLACK)	TOTAL BOLT QUANTITY	TOTAL STEEL WEIGHT (BLACK)
0.5	35.5	CCI-SFP-04007535	4,8.12	4	4	1'-4"	32	357	96	1071
35.5	60.5	CCI-SFP-04007525	4,8.12	4	4	1'-4"	25	255	75	765
74	84	CCI-SFP-04007510	4,8.12	4	4	1'-4"	13	102	39	306
									210	2142

NOTES FOR CROWN REINFORCING (65 KSI) MATERIAL:

- DO NOT WELD WITHOUT APPROVAL FROM THE EOR.
- SHIMS FOR MONOPOLE REINFORCEMENT MEMBER SHALL BE REQUIRED WHERE GAPS BETWEEN THE POLE SHAFT AND REINFORCEMENT MEMBER EXIST AT FASTENER LOCATIONS. FOR INTERMEDIATE CONNECTIONS, THE MINIMUM SHIM LENGTH AND WIDTH SHALL BE THE WIDTH OF THE REINFORCEMENT MEMBER. FOR TERMINATION CONNECTIONS, A CONTINUOUS SHIM PLATE (PREFERRED) OR EQUIVALENT INDIVIDUAL SHIM PLATES THE WIDTH OF THE REINFORCEMENT MEMBER MAY BE USED. SHIM THICKNESS SHALL BE NO LESS THAN 1/16". STACKING OF SHIMS IS PERMITTED.
- ALL FLAT PLATE REINFORCEMENTS IS TO BE INSTALLED CENTERED ON ITS DESIGNATED FLAT, UNO.
- SEE CWP 65 KSI PARTS CATALOG 2nd EDITION FOR PART DETAILS.
- ON MULTISIDED POLES, EXISTING SAFETY CLIMB IS CONSIDERED FLAT 1. THEN FLATS ARE NUMBERED COUNTER CLOCKWISE.
- CLIMBING PEGS TO BE RELOCATED AS REQUIRED.

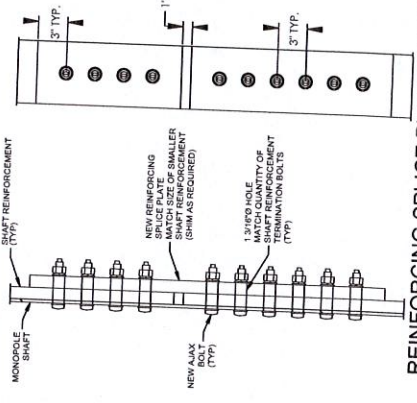
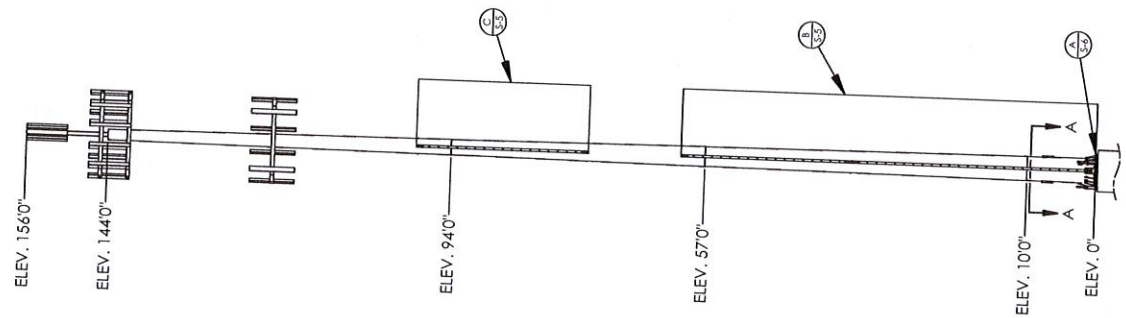

REINFORCING SPLICE PLATE DETAIL

AeroSolutions LLC
 14000 Airport Blvd., Suite 100, Dallas, TX 75243
 TEL: 972.344.0000 FAX: 972.344.0001
 WWW.AEROSOLUTIONS.COM

THE DRAWING IS COPYRIGHTED AND IS THE PROPERTY OF AEROSOLUTIONS LLC. IT IS PRODUCED SOLELY FOR THE PROJECT AND IS NOT TO BE REPRODUCED OR TRANSMITTED IN ANY FORM OR BY ANY MEANS, ELECTRONIC OR MECHANICAL, WITHOUT THE EXPRESS WRITTEN PERMISSION OF AEROSOLUTIONS LLC.

SITE NAME: THOMPSON / 1395 XYP_1
 BU NUMBER: 828602
 WO NUMBER: 1044729
 SITE ADDRESS:
 720 THOMPSON RD
 THOMPSON, CT 0377
 WINDHAM COUNTY

ENGLCA BY MB DATE: 05/29/2015
 DFT BY MB DATE: 05/29/2015
 DFT/DA BY RS DATE: 05/29/2015
 APPROV BY SD DATE: 05/29/2015
 SCALE: N.T.S.

DATE: 6.3.2015

PREPARED FOR CROWN CASTLE

NO.	DATE	DESCRIPTION	BY
00	05/29/15	INITIAL RELEASE	MB

REVISIONS

ELEVATION	REV
S-5	00

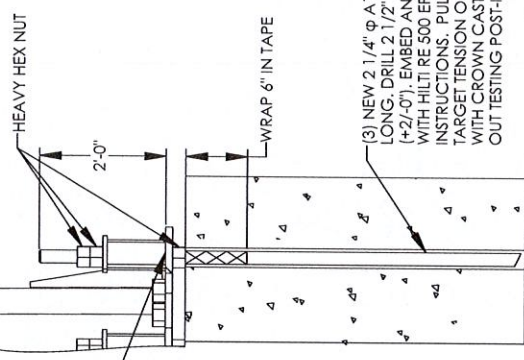
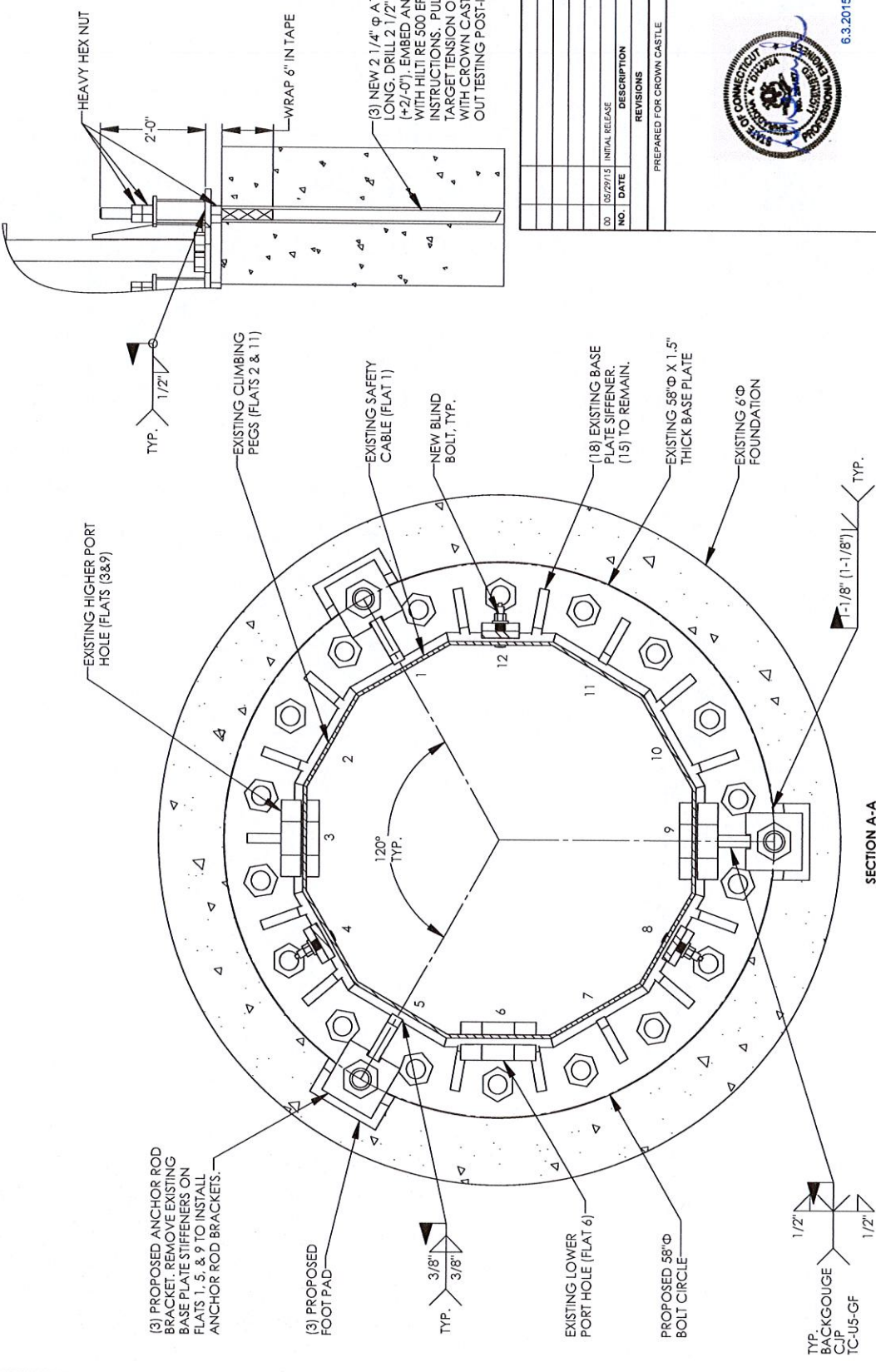

(3) NEW 2 1/4" ϕ A193 B7 THREADED ROD X 9'-0" LONG. DRILL 2 1/2" TO 2 3/4" ϕ HOLE 6'-0" LONG (+2/-0). EMBED ANCHORS 6'-0" DEEP MINIMUM WITH HILT RE 500 EPOXY PER MANUFACTURER'S INSTRUCTIONS. PULL TEST ANCHOR RODS TO A TARGET TENSION OF 190 KIPS IN ACCORDANCE WITH CROWN CASTLE ENG-PRC-10119 "PULL-OUT TESTING POST-INSTALLED ANCHOR RODS."

AeroSolutions LLC
2010 WINDING ROAD / SUITE 200 / WINDHAM, CT 06258

THIS DRAWING IS COPYRIGHTED AND IS THE SOLE PROPERTY OF CROWN CASTLE. IT AND ITS AFFILIATES, REPRESENTATIVES OR AGENTS, SHALL NOT BE REPRODUCED OR TRANSMITTED IN ANY FORM OR BY ANY MEANS, ELECTRONIC OR MECHANICAL, INCLUDING PHOTOCOPYING, RECORDING, OR BY ANY INFORMATION CONTAINED HEREIN, WITHOUT THE WRITTEN PERMISSION OF CROWN CASTLE.

PREPARED FOR CROWN CASTLE

SITE NAME: THOMPSON / 1395 XFF_1
 BU NUMBER: 828462
 WO NUMBER: 1044929
 SITE ADDRESS:
 730 THOMPSON RD
 THOMPSON, CT 04277
 WINDHAM COUNTY

ENG/OA BY: MB DATE: 05/29/2015
 DFT BY: MB DATE: 05/29/2015
 DFT/OA BY: RS DATE: 05/29/2015
 APRVD BY: SD DATE: 05/29/2015
 SCALE: N.T.S.

6.3.2015

STATE OF CONNECTICUT
 REGISTERED PROFESSIONAL ENGINEER
 STATE OF CONNECTICUT
 LICENSE NO. 10000

NO.	DATE	DESCRIPTION	BY
00	05/29/15	INITIAL RELEASE	MB

REVISIONS

DETAILS

S-6 00

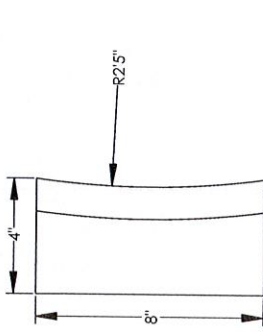
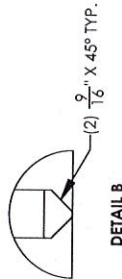
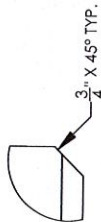
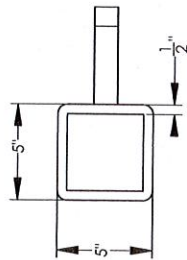

MATCH BASE PLATE THICKNESS. ACTUAL THICKNESS MAY VARY FROM DESIGN THICKNESS SHOWN ON S-6.

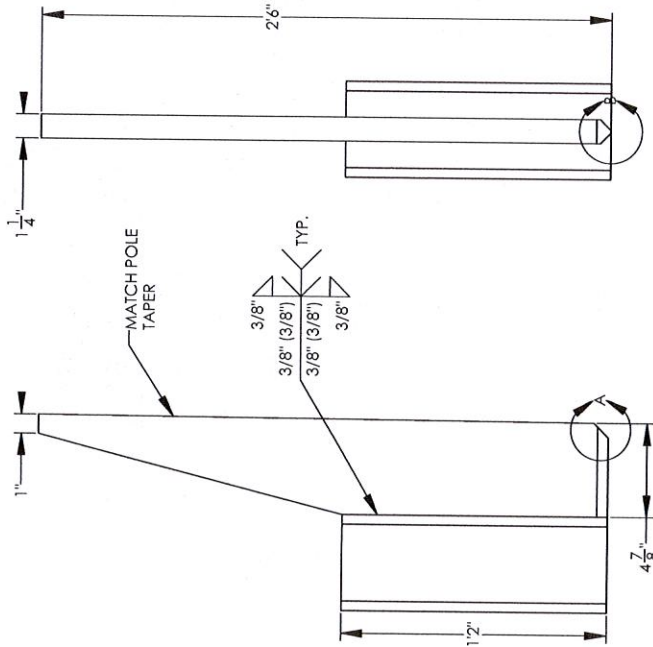
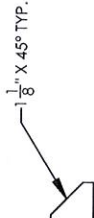

ANCHOR ROD BRACKET (828402-ARB1-0429)
(3) REQUIRED (STIFFENER FY=65 KSI, TUBE FY = 46 KSI)

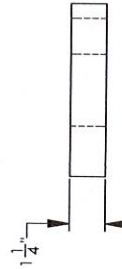
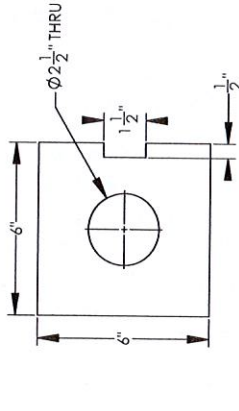

ANCHOR ROD WASHER (828402-ARW1-0429)
(3) REQUIRED (FY=65 KSI)

FOOT PAD (828402-FP1-0429)
(3) REQUIRED (FY=36 KSI)

<small>THESE DRAWINGS ARE CONSIDERED TO BE THE SOLE PROPERTY OF CROWN CASTLE. IT IS NOT TO BE REPRODUCED OR TRANSMITTED IN ANY FORM OR BY ANY MEANS, ELECTRONIC OR MECHANICAL, INCLUDING PHOTOCOPYING, RECORDING, OR BY ANY INFORMATION STORAGE AND RETRIEVAL SYSTEM, WITHOUT THE WRITTEN PERMISSION OF CROWN CASTLE.</small>			
NO. 00	DATE 05/29/15	DESCRIPTION INITIAL RELEASE	BY M8
REVISIONS			
PREPARED FOR CROWN CASTLE			
SITE NAME: THOMPSON / 395 XFF 1			
BU NUMBER: 828402			
WO NUMBER: 106429			
SITE ADDRESS: 770 WINDMILL ROAD THOMPSON, CT 0429 WINDHAM COUNTY			
ENGINEER BY: MB	DATE: 05/29/2015		
DFT BY: MB	DATE: 05/29/2015		
DFT/QA BY: RS	DATE: 05/29/2015		
APPR'D BY: SD	DATE: 05/29/2015		
SCALE: N.T.S.			
6.3.2015			
FAB DETAILS			
			REV 00
			S-7

**RADIO FREQUENCY EMISSIONS ANALYSIS REPORT
EVALUATION OF HUMAN EXPOSURE POTENTIAL
TO NON-IONIZING EMISSIONS**

T-Mobile Existing Facility

Site ID: CT11160B

**Thompson Road / I-395 / X 99_1
720 Thompson Road
Thompson, CT 06277**

August 11, 2015

EBI Project Number: 6215004393

Site Compliance Summary	
Compliance Status:	COMPLIANT
Site total MPE% of FCC general public allowable limit:	9.93 %

August 11, 2015

T-Mobile USA
Attn: Jason Overbey, RF Manager
35 Griffin Road South
Bloomfield, CT 06002

Emissions Analysis for Site: **CT11160B – Thompson Road / I-395 / X 99_1**

EBI Consulting was directed to analyze the proposed T-Mobile facility located at **720 Thompson Road, Thompson, CT**, for the purpose of determining whether the emissions from the Proposed T-Mobile Antenna Installation located on this property are within specified federal limits.

All information used in this report was analyzed as a percentage of current Maximum Permissible Exposure (% MPE) as listed in the FCC OET Bulletin 65 Edition 97-01 and ANSI/IEEE Std C95.1. The FCC regulates Maximum Permissible Exposure in units of microwatts per square centimeter ($\mu\text{W}/\text{cm}^2$). The number of $\mu\text{W}/\text{cm}^2$ calculated at each sample point is called the power density. The exposure limit for power density varies depending upon the frequencies being utilized. Wireless Carriers and Paging Services use different frequency bands each with different exposure limits, therefore it is necessary to report results and limits in terms of percent MPE rather than power density.

All results were compared to the FCC (Federal Communications Commission) radio frequency exposure rules, 47 CFR 1.1307(b)(1) – (b)(3), to determine compliance with the Maximum Permissible Exposure (MPE) limits for General Population/Uncontrolled environments as defined below.

General population/uncontrolled exposure limits apply to situations in which the general public may be exposed or in which persons who are exposed as a consequence of their employment may not be made fully aware of the potential for exposure or cannot exercise control over their exposure. Therefore, members of the general public would always be considered under this category when exposure is not employment related, for example, in the case of a telecommunications tower that exposes persons in a nearby residential area.

Public exposure to radio frequencies is regulated and enforced in units of microwatts per square centimeter ($\mu\text{W}/\text{cm}^2$). The general population exposure limit for the PCS and AWS bands is $1000 \mu\text{W}/\text{cm}^2$. Because each carrier will be using different frequency bands, and each frequency band has different exposure limits, it is necessary to report percent of MPE rather than power density.

Occupational/controlled exposure limits apply to situations in which persons are exposed as a consequence of their employment and in which those persons who are exposed have been made fully aware of the potential for exposure and can exercise control over their exposure. Occupational/controlled exposure limits also apply where exposure is of a transient nature as a result of incidental passage through a location where exposure levels may be above general population/uncontrolled limits (see below), as long as the exposed person has been made fully aware of the potential for exposure and can exercise control over his or her exposure by leaving the area or by some other appropriate means.

Additional details can be found in FCC OET 65.

CALCULATIONS

Calculations were done for the proposed T-Mobile Wireless antenna facility located at **720 Thompson Road, Thompson, CT**, using the equipment information listed below. All calculations were performed per the specifications under FCC OET 65. Since T-Mobile is proposing highly focused directional panel antennas, which project most of the emitted energy out toward the horizon, all calculations were performed assuming a lobe representing the maximum gain of the antenna per the antenna manufactures supplied specifications, minus 10 dB, was focused at the base of the tower. For this report the sample point is the top of a 6 foot person standing at the base of the tower.

For all calculations, all equipment was calculated using the following assumptions:

- 1) 2 GSM channels (PCS Band - 1900 MHz) were considered for each sector of the proposed installation. These Channels have a transmit power of 30 Watts per Channel
- 2) 2 UMTS channels (AWS Band – 2100 MHz) were considered for each sector of the proposed installation. These Channels have a transmit power of 30 Watts per Channel.
- 3) 2 LTE channels (AWS Band – 2100 MHz) were considered for each sector of the proposed installation. These Channels have a transmit power of 60 Watts per Channel.
- 4) All radios at the proposed installation were considered to be running at full power and were uncombined in their RF transmissions paths per carrier prescribed configuration. Per FCC OET Bulletin No. 65 - Edition 97-01 recommendations to achieve the maximum anticipated value at each sample point, all power levels emitting from the proposed antenna installation are increased by a factor of 2.56 to account for possible in-phase reflections from the surrounding environment. This is rarely the case, and if so, is never continuous.

- 5) For the following calculations the sample point was the top of a six foot person standing at the base of the tower. The maximum gain of the antenna per the antenna manufactures supplied specifications minus 10 dB was used in this direction. This value is a very conservative estimate as gain reductions for these particular antennas are typically much higher in this direction.
- 6) The antennas used in this modeling are the **RFS APXV18-206517S-C-A20** for 1900 MHz (PCS) and 2100 MHz (AWS). This is based on feedback from the carrier with regards to anticipated antenna selection. The **RFS APXV18-206517S-C-A20** has a maximum gain of **16.7 dBd** at its main lobe. The maximum gain of the antenna per the antenna manufactures supplied specifications, minus 10 dB, was used for all calculations. This value is a very conservative estimate as gain reductions for these particular antennas are typically much higher in this direction.
- 7) The antenna mounting height centerline of the proposed antennas is **143 feet** above ground level (AGL).
- 8) Emissions values for additional carriers were taken from the Connecticut Siting Council active database. Values in this database are provided by the individual carriers themselves.

All calculations were done with respect to uncontrolled / general public threshold limits.

T-Mobile Site Inventory and Power Data

Sector:	A	Sector:	B	Sector:	C
Antenna #:	1	Antenna #:	1	Antenna #:	1
Make / Model:	RFS APXV18-206517S-C-A20	Make / Model:	RFS APXV18-206517S-C-A20	Make / Model:	RFS APXV18-206517S-C-A20
Gain:	16.7 dBd	Gain:	16.7 dBd	Gain:	16.7 dBd
Height (AGL):	143	Height (AGL):	143	Height (AGL):	143
Frequency Bands	1900 MHz(PCS) / 2100 MHz (AWS)	Frequency Bands	1900 MHz(PCS) / 2100 MHz (AWS)	Frequency Bands	1900 MHz(PCS) / 2100 MHz (AWS)
Channel Count	2	Channel Count	2	# PCS Channels:	2
Total TX Power:	120	Total TX Power:	120	# AWS Channels:	120
ERP (W):	5,612.82	ERP (W):	5,612.82	ERP (W):	5,612.82
Antenna A1 MPE%	1.08	Antenna B1 MPE%	1.08	Antenna C1 MPE%	1.08
Antenna #:	2	Antenna #:	2	Antenna #:	2
Make / Model:	RFS APXV18-206517S-C-A20	Make / Model:	RFS APXV18-206517S-C-A20	Make / Model:	RFS APXV18-206517S-C-A20
Gain:	16.7 dBd	Gain:	16.7 dBd	Gain:	16.7 dBd
Height (AGL):	143	Height (AGL):	143	Height (AGL):	143
Frequency Bands	1900 MHz(PCS) / 2100 MHz (AWS)	Frequency Bands	1900 MHz(PCS) / 2100 MHz (AWS)	Frequency Bands	1900 MHz(PCS) / 2100 MHz (AWS)
Channel Count	4	Channel Count	4	Channel Count	4
Total TX Power:	120	Total TX Power:	120	Total TX Power:	120
ERP (W):	5,612.82	ERP (W):	5,612.82	ERP (W):	5,612.82
Antenna A2 MPE%	1.08	Antenna B2 MPE%	1.08	Antenna C2 MPE%	1.08

Site Composite MPE%	
Carrier	MPE%
T-Mobile	6.45
Nextel	3.48 %
Site Total MPE %:	9.93 %

T-Mobile Sector 1 Total:	2.15 %
T-Mobile Sector 2 Total:	2.15 %
T-Mobile Sector 3 Total:	2.15 %
Site Total:	9.93 %

Summary

All calculations performed for this analysis yielded results that were **within** the allowable limits for general public exposure to RF Emissions.

The anticipated maximum composite contributions from the T-Mobile facility as well as the site composite emissions value with regards to compliance with FCC's allowable limits for general public exposure to RF Emissions are shown here:

T-Mobile Sector	Power Density Value (%)
Sector 1:	2.15 %
Sector 2:	2.15 %
Sector 3 :	2.15 %
T-Mobile Total:	6.45 %
Site Total:	9.93 %
Site Compliance Status:	COMPLIANT

The anticipated composite MPE value for this site assuming all carriers present is **9.93%** of the allowable FCC established general public limit sampled at the ground level. This is based upon values listed in the Connecticut Siting Council database for existing carrier emissions.

FCC guidelines state that if a site is found to be out of compliance (over allowable thresholds), that carriers over a 5% contribution to the composite value will require measures to bring the site into compliance. For this facility, the composite values calculated were well within the allowable 100% threshold standard per the federal government.



Scott Heffernan
RF Engineering Director

EBI Consulting
21 B Street
Burlington, MA 01803