

PROJECT NARRATIVE

October 26, 2021

Melanie A. Bachman
Executive Director
Connecticut Siting Council
10 Franklin Square
New Britain, CT 06051

Re: Request of DISH Wireless LLC for an Order to Approve the Shared Use of an Existing Tower
106 South Grand Street West Suffield, CT 06093
Latitude: 41°59'13.300" / Longitude: -72°42'7.500"

Dear Ms. Bachman:

Pursuant to Connecticut General Statutes ("C.G.S.") §16-50aa, as amended, DISH Wireless LLC ("DISH") hereby requests an order from the Connecticut Siting Council ("Council") to approve the shared use by DISH of an existing telecommunication tower at 106 South Grand Street in West Suffield (the "Property"). The existing 139-foot monopole tower is owned by American Tower Corporation ("ATC"). The underlying property is owned by Robert G. Paganelli. DISH requests that the Council find that the proposed shared use of the ATC tower satisfies the criteria of C.G.S. §16-50aa and issue an order approving the proposed shared use. A copy of this filing is being sent to Melissa M. Mack, First Selectwoman for the Town of Suffield, Edward Flanders, Town of Suffield Building Official and Robert G. Paganelli as the property owner.

Background

The existing ATC facility consists of a 139-foot monopole tower located within an existing leased area. AT&T Mobility currently maintains antennas at the 135-foot level. Verizon Wireless currently maintains antennas at the 120-foot level. Equipment associated with these antennas are located at various positions within the tower and compound.

DISH is licensed by the Federal Communications Commission ("FCC") to provide wireless services throughout the State of Connecticut. DISH and Crown Castle have agreed to the proposed shared use of the 106 South Grand Street tower pursuant to mutually acceptable terms and conditions. Likewise, DISH and ATC have agreed to the proposed installation of equipment cabinets on the ground on the south side of the tower within the existing compound. ATC has authorized DISH to apply for all necessary permits and approvals that may be required to share the existing tower. (See attached Letter of Authorization)

DISH proposes to install three (3) antennas, (1) Tower platform mount, (6) Remote radio units at the 110-foot level along with, (1) over voltage protection device (OVP) and (1) Hybrid cable. DISH will install an equipment cabinet on a 5'x7' equipment platform. DISH's Construction Drawings provide project specifications for all proposed site improvement locations.

The construction drawings also include specifications for DISH's proposed antenna and groundwork.

C.G.S. § 16-50aa(c)(1) provides that, upon written request for approval of a proposed shared use, "if the Council finds that the proposed shared use of the facility is technically, legally, environmentally and economically feasible and meets public safety concerns, the council shall issue an order approving such a shared use." DISH respectfully submits that the shared use of the tower satisfies these criteria.

A. Technical Feasibility. The existing ATC tower is structurally capable of supporting DISH's proposed improvements. The proposed shared use of this tower is, therefore, technically feasible. A Feasibility Structural Analysis Report ("Structural Report") prepared for this project confirms that this tower can support DISH's proposed loading. A copy of the Structural Report has been included in this application.

B. Legal Feasibility. Under C.G.S. § 16-50aa, the Council has been authorized to issue order approving the shared use of an existing tower such as the ATC tower. This authority complements the Council's prior-existing authority under C.G.S. § 16-50p to issue orders approving the construction of new towers that are subject to the Council's jurisdiction. In addition, § 16-50x(a) directs the Council to "give such consideration to the other state laws and municipal regulations as it shall deem appropriate" in ruling on requests for the shared use of existing tower facilities. Under the statutory authority vested in the Council, an order by the Council approving the requested shared use would permit the Applicant to obtain a building permit for the proposed installations.

C. Environmental Feasibility. The proposed shared use of the ATC tower would have a minimal environmental effect for the following reasons:

1. The proposed installation will have no visual impact on the area of the tower. DISH's equipment cabinet would be installed within the existing facility compound. DISH's shared use of this tower therefore will not cause any significant change or alteration in the physical or environmental characteristics of the existing site.
2. Operation of DISH's antennas at this site would not exceed the RF emissions standard adopted by the Federal Communications Commission ("FCC"). Included in the EME report of this filing are the approximation tables that demonstrate that DISH's proposed facility will operate well within the FCC RF emissions safety standards.
3. Under ordinary operating conditions, the proposed installation would not require the use of any water or sanitary facilities and would not generate air emissions or discharges to water bodies or sanitary facilities. After construction is complete the proposed installations would not generate any increased traffic to the ATC facility other than periodic maintenance. The proposed shared use of the ATC tower, would, therefore, have a minimal environmental effect, and is environmentally feasible.

D. **Economic Feasibility.** As previously mentioned, DISH has entered into an agreement with ATC for the shared use of the existing facility subject to mutually agreeable terms. The proposed tower sharing is, therefore, economically feasible.

E. **Public Safety Concerns.** As discussed above, the tower is structurally capable of supporting DISH's full array of three (3) antennas, (1) Tower platform mount, (6) Remote radio units, (1) over voltage protection device (OVP) and (1) Hybrid cable and all related equipment. DISH is not aware of any public safety concerns relative to the proposed sharing of the existing ATC tower.

Conclusion

For the reasons discussed above, the proposed shared use of the existing ATC tower at 106 South Grand Street satisfies the criteria stated in C.G.S. §16-50aa and advances the Council's goal of preventing the unnecessary proliferation of towers in Connecticut. The Applicant, therefore, respectfully requests that the Council issue an order approving the proposed shared use.

Sincerely,

David Hoogasian

David Hoogasian

Project Manager

LETTER OF AUTHORIZATION



AMERICAN TOWER®
CORPORATION

LETTER OF AUTHORIZATION
LICENSEE: DISH WIRELESS L.L.C.

I, Margaret Robinson, Senior Counsel for American Tower*, owner/operator of the tower facility located at the address identified above (the "Tower Facility"), do hereby authorize DISH WIRELESS L.L.C., its successors and assigns, and/or its agent, (collectively, the "Licensee") to act as American Tower's non-exclusive agent for the sole purpose of filing and consummating any land-use or building permit application(s) as may be required by the applicable permitting authorities for Licensee's telecommunications' installation.

We understand that this application may be denied, modified or approved with conditions. The above authorization is limited to the acceptance by Licensee only of conditions related to Licensee's installation and any such conditions of approval or modifications will be Licensee's sole responsibility.

*American Tower includes all affiliates and subsidiaries of American Tower Corporation.

Project #	ATC Site #	ATC Site Name	ATC Site Address
13688133	208450	Enfield	1A Ecology Drive, Enfield CT
13700322	209115	Ridgefield 2	320 Old Stagecoach Road, Ridgefield, CT
13688136	209185	Burlington 2	87 Monce Road, Burlington CT
13700320	209271	Brookfield 2	100 Pocono Road, Brookfield CT
13693702	243036	WEST HAVEN & RT 162 CT	668 Jones Hill Road, West Haven CT
13693677	280501	ROXBURY CT	377 Southbury Road, Roxbury CT
13685406	281416	WILLINGTON CT	196 Tolland Turnpike, Willington CT
13709418	281862	BRIDGEWATER CT	111 SECOND HILL RD, Bridgewater CT
13693659	283418	NORTH HAVEN CT	50 Devine Street, North Haven CT
13694329	283419	PINE ORCHARD BRANFORD CT	123 Pine Orchard Road, Branford CT
13694332	283422	SHORT BEACH BRANFORD CT	171 Short Beach Road, Branford CT
13698427	283423	NAUGATUCK CT	880 Andrew Mountain Road, Naugatuck CT
13685464	283563	MANSFIELD CT	343 Daleville Road, Willington CT
13692735	284983	OLD LYME CT	61-1 Buttonball Road, Old Lyme CT
13693120	284984	PAWCATUCK CT	166 Pawcatuck Ave, Pawcatuck CT
13693144	284988	GUILFORD CT	Moose Hill Road, Guilford CT
13694582	302465	Colchester CT 6	355 Route 85, Colchester CT
13683501	302468	Petro Lock	99 Meadow St, Hartford CT
13685427	302469	Bridgeport CT 2	1069 Connecticut Avenue, Bridgeport CT
13683503	302472	Andover-bunker Hill Road	104 Bunker Hill Road, Andover CT
13683507	302473	E H F R - Prestige Park	310 Prestige Park Road, East Hartford CT



AMERICAN TOWER®
CORPORATION

Project #	ATC Site #	ATC Site Name	ATC Site Address
13683510	302474	South Windsor	391 Niederwerfer Road, South Windsor CT
13683513	302483	Brln - Berlin	286 Beckley Road, Berlin CT
13692185	302488	Cntn - Canton	4 Hoffmann Road, Canton CT
13692173	302495	Tolland CT	56 Ruops Road, Tolland CT
13694579	302496	Clch - Colchester	Chestnut Hill Road, Colchester CT
13701212	302501	Plymouth CT 3	297 North Street, Plymouth CT
13685414	302515	SMFR - North	5 High Ridge Park Road, Stamford CT
13702496	302516	Mlfd - Milford	438 Bridgeport Ave, Milford CT
13688395	302518	Newtown CT 3	25 Meridian Ridge Drive, Newton CT
13692174	302529	Vernon CT 6	777 Talcotville Road, Vernon Rockville CT
13693124	311014	NORWICH CT	202 N Wawecus Hill Rd, Norwich CT
13702522	311305	GLFD-GUILFORD REBUILD CT	10 Tanner Marsh Road, Guilford CT
13693127	370623	MONTVILLE CT	139 Sharp Hill Road, Uncasville CT
13681964	370625	Old Saybrook	77 Springbrook Road, Old Saybrook CT
13702535	383660	North Madison Volunteer FD	864 Opening Hill Road, Madison CT
13702538	411180	Good Hill CT	481 GOOD HILL ROAD, Woodbury CT
13693709	411182	Nepaug CT	20 Antolini Road, New Hartford CT
13693131	411183	WATERFORD CT	53 Dayton Rd., Waterford CT
13693135	411184	SALEM CT SQA	399 West Road, Salem CT
13692177	411186	West Granby, CT CT	207 West Granby Road, Granby CT
13692178	411187	Hartford North 2 CT	811 Blue Hills Avenue, Bloomfield CT
13693705	411188	Southbury CT	111 Upper Fishrock Road, Southbury CT
13692179	411256	CANTON CT	14 CANTON SPRINGS ROAD, Canton CT
13681988	411257	Middle Haddam Road-CROWN CT	191 Middle Haddam Rd, Portland CT
13692180	411258	Farmington North 2 CT	199 Town Farm Road, Farmington CT
13692182	411259	CT Collinsville CAC 802816 CT	650 Albany Turnpike, Collinsville CT
13692184	416862	SUFFIELD SW CT CT	106 South Grand St., West Suffield CT
13694578	6260	NORTH STONINGTON CT	118C Wintechog Hill Rd., off of Rt. 2, North Stonington CT
13681397	88013	Killingworth	131 Little City Road, Killingworth CT

Signature:

Print Name: Margaret Robinson
Senior Counsel
American Tower*



AMERICAN TOWER®
CORPORATION

LETTER OF AUTHORIZATION
LICENSEE: DISH WIRELESS L.L.C.

NOTARY BLOCK

Commonwealth of MASSACHUSETTS
County of Middlesex

This instrument was acknowledged before me by Margaret Robinson, Senior Counsel for American Tower*, personally known to me (or proved to me on the basis of satisfactory evidence) to be the person whose name is subscribed to the within instrument and acknowledged to me that he executed the same.

WITNESS my hand and official seal, this 10th day of September 2021.

NOTARY SEAL

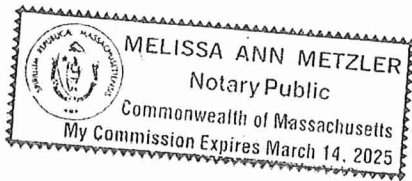

Notary Public 
My Commission Expires: March 14, 2025

ENGINEERING DRAWINGS



DISH WIRELESS, L.L.C. SITE ID:

BOBDL00027A

DISH WIRELESS, L.L.C. SITE ADDRESS:

**106 SOUTH GRAND ST.
WEST SUFFIELD, CT 06093**

SCOPE OF WORK
THIS IS NOT AN ALL INCLUSIVE LIST. CONTRACTOR SHALL UTILIZE SPECIFIED EQUIPMENT PART OR ENGINEER APPROVED EQUIVALENT. CONTRACTOR SHALL VERIFY ALL NEEDED EQUIPMENT TO PROVIDE A FUNCTIONAL SITE. THE PROJECT GENERALLY CONSISTS OF THE FOLLOWING:
TOWER SCOPE OF WORK: <ul style="list-style-type: none"> • INSTALL (3) PROPOSED PANEL ANTENNAS (1 PER SECTOR) • INSTALL (1) PROPOSED ANTENNA PLATFORM MOUNT • INSTALL PROPOSED JUMPERS • INSTALL (6) PROPOSED RRRHS (2 PER SECTOR) • INSTALL (1) PROPOSED OVER VOLTAGE PROTECTION DEVICE (OVP) • INSTALL (1) PROPOSED HYBRID CABLE
GROUND SCOPE OF WORK: <ul style="list-style-type: none"> • INSTALL (1) PROPOSED METAL PLATFORM • INSTALL (1) PROPOSED ICE BRIDGE • INSTALL (1) PROPOSED PPC CABINET • INSTALL (1) PROPOSED EQUIPMENT CABINET • INSTALL (1) PROPOSED POWER CONDUIT • INSTALL (1) PROPOSED TELCO CONDUIT • INSTALL (1) PROPOSED TELCO-FIBER BOX • INSTALL (1) PROPOSED GPS UNIT • INSTALL (1) PROPOSED SAFETY SWITCH (IF REQUIRED) • INSTALL (1) PROPOSED CIENA BOX (IF REQUIRED)

SITE INFORMATION	PROJECT DIRECTORY
PROPERTY OWNER: ROBERT G PAGANELLI ADDRESS: 174 SOUTH GRAND ST. WEST SUFFIELD, CT 06093	APPLICANT: DISH WIRELESS, L.L.C. 5701 SOUTH SANTA FE DRIVE LITTLETON, CO 80120 (303) 706-5008
TOWER TYPE: MONOPOLE	TOWER OWNER: AMERICAN TOWER 10 PRESIDENTIAL WAY WOBURN, MA 01801
TOWER CO SITE ID: 416862	ENGINEER: NB+C ENGINEERING SERVICES, LLC. 8601 SIX FORKS ROAD, SUITE 540 RALEIGH, NC 27615
TOWER APP NUMBER: 13692184	SITE ACQUISITION: APRIL PARROTT APRIL.PARROTT@DISH.COM
COUNTY: HARTFORD	CONSTRUCTION MANAGER: JAVIER SOTO JAVIER.SOTO@DISH.COM
LATITUDE (NAD 83): 41° 59' 13.300" N 41.98702777	RF ENGINEER: BOSSENER CHARLES BOSSENER.CHARLES@DISH.COM
LONGITUDE (NAD 83): 72° 42' 7.500" W 72.70208333	
ZONING JURISDICTION: CONNECTICUT SITING COUNCIL	
ZONING DISTRICT: X	
PARCEL NUMBER: 16H-24-51-A	
OCCUPANCY GROUP: U	
CONSTRUCTION TYPE: V-B	
POWER COMPANY: EVERSOURCE/NORTHEAST UTILITIES	
TELEPHONE COMPANY: TBD	



5701 SOUTH SANTA FE DRIVE
LITTLETON, CO 80120



NB+C ENGINEERING SERVICES, LLC.
8601 SIX FORKS ROAD, SUITE 540
RALEIGH, NC 27615
(919) 657-9131

DRAWN BY:	CHECKED BY:	APPROVED BY:
PRI	BIW	BIW

RFDS REV #: 1

CONSTRUCTION DOCUMENTS

SUBMITTALS		
REV	DATE	DESCRIPTION
A	08/13/2021	ISSUED FOR REVIEW
D	09/13/2021	ISSUED FOR CONSTRUCTION



UNDERGROUND SERVICE ALERT CBYD 811
UTILITY NOTIFICATION CENTER OF CONNECTICUT
 (800) 922-4455
 WWW.CBYD.COM

CALL 2 WORKING DAYS UTILITY NOTIFICATION PRIOR TO CONSTRUCTION

GENERAL NOTES

THE FACILITY IS UNMANNED AND NOT FOR HUMAN HABITATION. A TECHNICIAN WILL VISIT THE SITE AS REQUIRED FOR ROUTINE MAINTENANCE. THE PROJECT WILL NOT RESULT IN ANY SIGNIFICANT DISTURBANCE OR EFFECT ON DRAINAGE. NO SANITARY SEWER SERVICE, POTABLE WATER, OR TRASH DISPOSAL IS REQUIRED AND NO COMMERCIAL SIGNAGE IS PROPOSED.

THE PROJECT DEPICTED IN THESE PLANS QUALIFIES AS AN ELIGIBLE FACILITIES REQUEST ENTITLED TO EXPEDITED REVIEW UNDER 47 U.S.C. § 1455(A) AS A MODIFICATION OF AN EXISTING WIRELESS TOWER THAT INVOLVES THE COLLOCATION, REMOVAL, AND/OR REPLACEMENT OF TRANSMISSION EQUIPMENT THAT IS NOT A SUBSTANTIAL CHANGE UNDER CFR § 1.61000 (B)(7).

11"x17" PLOT WILL BE HALF SCALE UNLESS OTHERWISE NOTED

CONTRACTOR SHALL VERIFY ALL PLANS, EXISTING DIMENSIONS, AND CONDITIONS ON THE JOB SITE, AND SHALL IMMEDIATELY NOTIFY THE ENGINEER IN WRITING OF ANY DISCREPANCIES BEFORE PROCEEDING WITH THE WORK.

DIRECTIONS

TAKE I-91 N AND CT-190 W TO THRALL AVE IN SUFFIELD, HEAD NORTH ON I-91 N, TAKE EXIT 47W TO MERGE ONTO CT-190 W TOWARD SUFFIELD, USE THE LEFT 2 LANES TO TURN LEFT ONTO CT-159 S, TURN RIGHT ONTO THRALL AVE, TAKE CT-168 W/MOUNTAIN RD TO CT-187 S, TURN RIGHT ONTO BRIDGE ST, TURN RIGHT ONTO N MAIN ST, TURN LEFT ONTO CT-168 W/MOUNTAIN RD, TURN LEFT ONTO CT-187 S, DESTINATION WILL BE ON THE LEFT

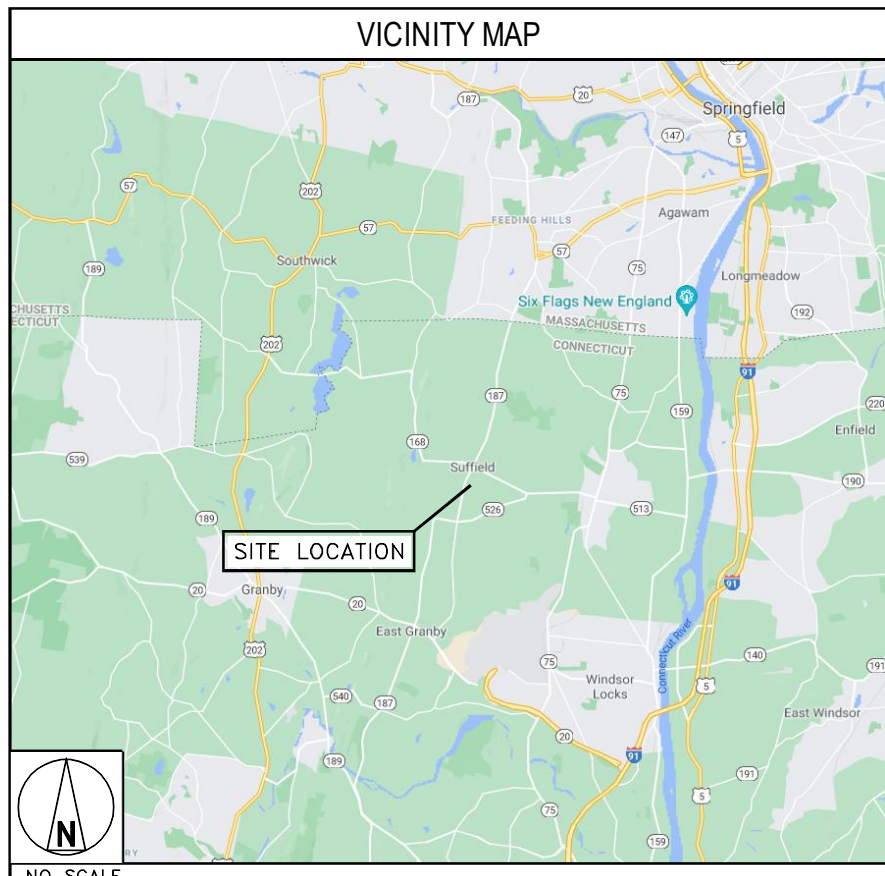

CONNECTICUT CODE COMPLIANCE

ALL WORK SHALL BE PERFORMED AND MATERIALS INSTALLED IN ACCORDANCE WITH THE CURRENT EDITIONS OF THE FOLLOWING CODES AS ADOPTED BY THE LOCAL GOVERNING AUTHORITIES. NOTHING IN THESE PLANS IS TO BE CONSTRUED TO PERMIT WORK NOT CONFORMING TO THESE CODES:

CODE TYPE	CODE
BUILDING	2018 CT STATE BUILDING CODE/2015 IBC W/ CT AMENDMENTS
MECHANICAL	2018 CT STATE BUILDING CODE/2015 IMC W/ CT AMENDMENTS
ELECTRICAL	2018 CT STATE BUILDING CODE/2017 NEC W/ CT AMENDMENTS

SHEET INDEX	
SHEET NO.	SHEET TITLE
T-1	TITLE SHEET
A-1	OVERALL AND ENLARGED SITE PLAN
A-2	ELEVATION, ANTENNA LAYOUT AND SCHEDULE
A-3	EQUIPMENT PLATFORM AND H-FRAME DETAILS
A-4	EQUIPMENT DETAILS
A-5	EQUIPMENT DETAILS
A-6	EQUIPMENT DETAILS
E-1	ELECTRICAL/FIBER ROUTE PLAN AND NOTES
E-2	ELECTRICAL DETAILS
E-3	ELECTRICAL ONE-LINE, FAULT CALCS & PANEL SCHEDULE
G-1	GROUNDING PLANS AND NOTES
G-2	GROUNDING DETAILS
G-3	GROUNDING DETAILS
RF-1	RF CABLE COLOR CODE
RF-2	RF PLUMBING DIAGRAM
GN-1	LEGEND AND ABBREVIATIONS
GN-2	GENERAL NOTES
GN-3	GENERAL NOTES
GN-4	GENERAL NOTES



IT IS A VIOLATION OF LAW FOR ANY PERSON, UNLESS THEY ARE ACTING UNDER THE DIRECTION OF A LICENSED PROFESSIONAL ENGINEER, TO ALTER THIS DOCUMENT.

A&E PROJECT NUMBER
416862-13692184

DISH WIRELESS, L.L.C.
PROJECT INFORMATION
BOBDL00027A
**106 SOUTH GRAND ST.
WEST SUFFIELD, CT 06093**

SHEET TITLE
TITLE SHEET

SHEET NUMBER
T-1

NOTES

1. CONTRACTOR SHALL FIELD VERIFY ALL DIMENSIONS.
2. ANTENNAS AND MOUNTS OMITTED FOR CLARITY.

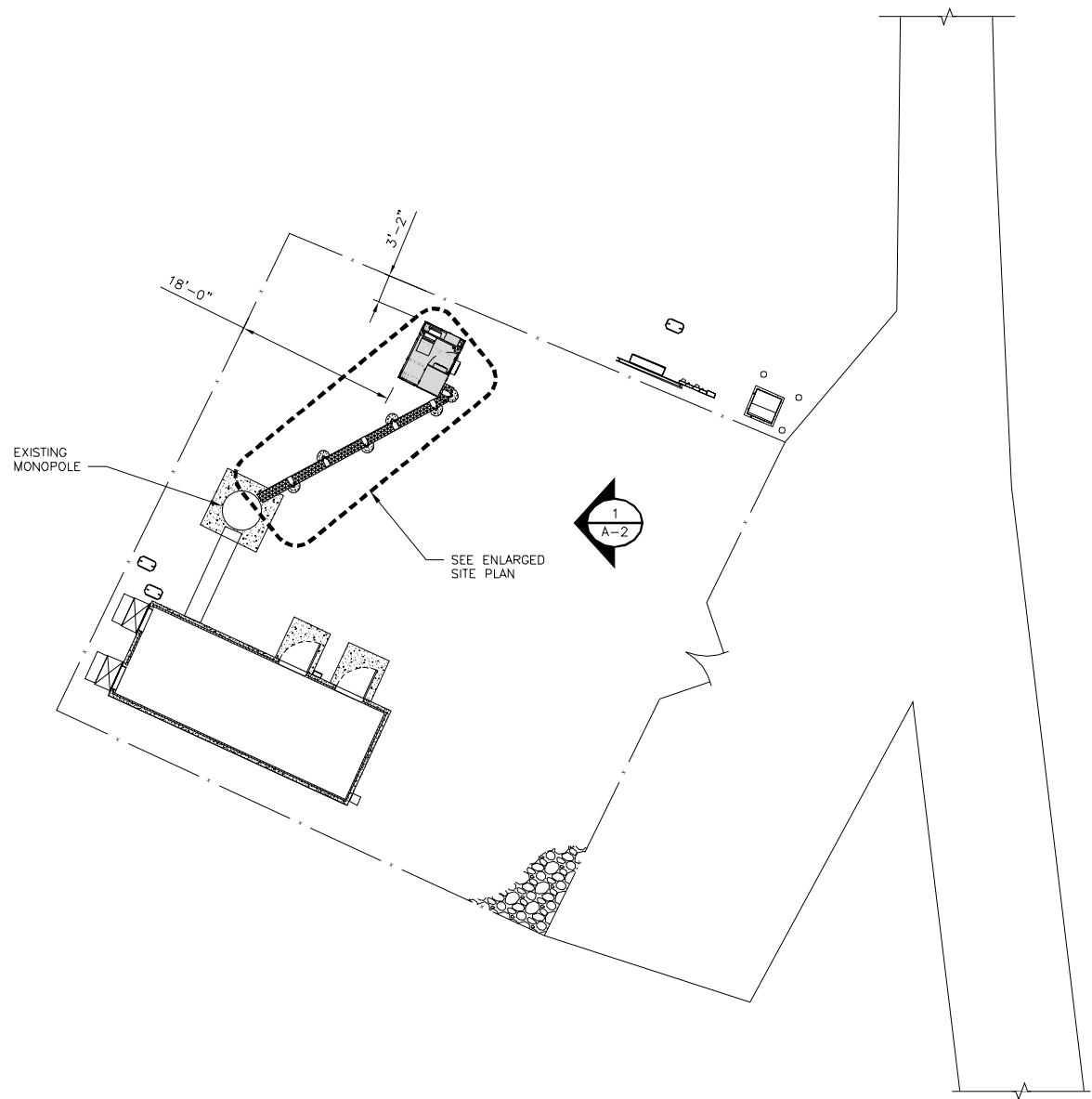

OVERALL SITE PLAN

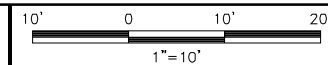

1

NOTES

1. CONTRACTOR SHALL FIELD VERIFY ALL DIMENSIONS.
2. CONTRACTOR SHALL MAINTAIN A 10'-0" MINIMUM SEPARATION BETWEEN THE PROPOSED GPS UNIT, TRANSMITTING ANTENNAS AND EXISTING GPS UNITS.
3. ANTENNAS AND MOUNTS OMITTED FOR CLARITY.

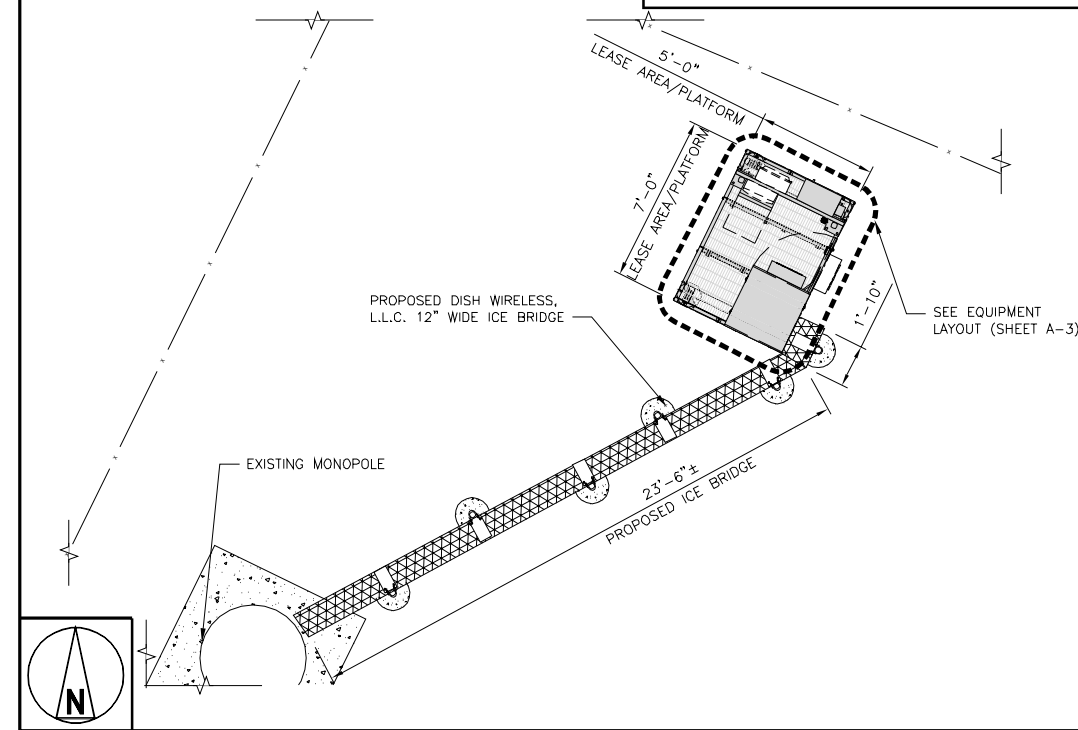

ENLARGED SITE PLAN

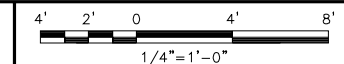

2

NOTES

1. THE SURVEY PROVIDED ON THIS SHEET IS PROVIDED FOR REFERENCE ONLY. THE UTILITY ROUTE AND EXISTING EASEMENTS MUST BE VERIFIED PRIOR TO CONSTRUCTION.

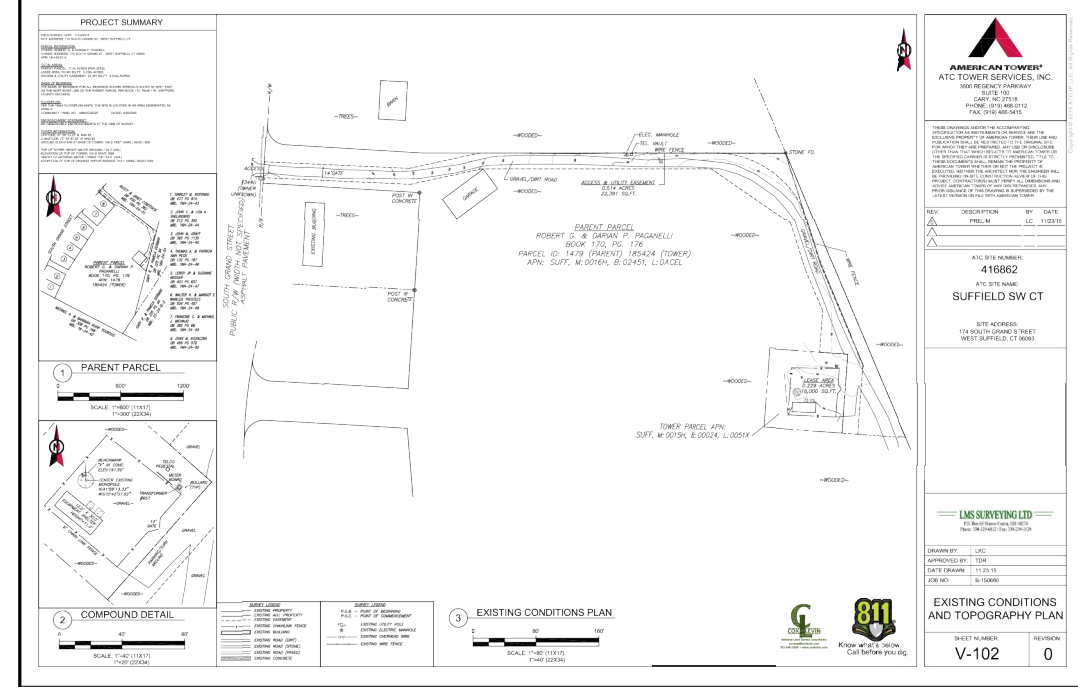

EXISTING SURVEY (BY OTHERS)

NO SCALE

3



5701 SOUTH SANTA FE DRIVE
LITTLETON, CO 80120



NB+C ENGINEERING SERVICES, LLC.
8601 SIX FORKS ROAD, SUITE 540
RALEIGH, NC 27615
(919) 657-9131

DRAWN BY:	CHECKED BY:	APPROVED BY:
PRI	BIW	BIW

RFDS REV #: 1

CONSTRUCTION DOCUMENTS

SUBMITTALS		
REV	DATE	DESCRIPTION
A	08/13/2021	ISSUED FOR REVIEW
D	09/13/2021	ISSUED FOR CONSTRUCTION



09/13/2021

IT IS A VIOLATION OF LAW FOR ANY PERSON, UNLESS THEY ARE ACTING UNDER THE DIRECTION OF A LICENSED PROFESSIONAL ENGINEER, TO ALTER THIS DOCUMENT.

A&E PROJECT NUMBER
416862-13692184

DISH WIRELESS, L.L.C.
PROJECT INFORMATION
BOBDL0027A
106 SOUTH GRAND ST.
WEST SUFFIELD, CT 06093

SHEET TITLE
OVERALL AND ENLARGED
SITE PLAN

SHEET NUMBER
A-1

NOTES

1. CONTRACTOR SHALL FIELD VERIFY ALL DIMENSIONS.
2. ANTENNA AND MW DISH SPECIFICATIONS REFER TO ANTENNA SCHEDULE AND TO FINAL CONSTRUCTION RFDS FOR ALL RF DETAILS
3. EXISTING EQUIPMENT AND FENCE OMITTED FOR CLARITY.

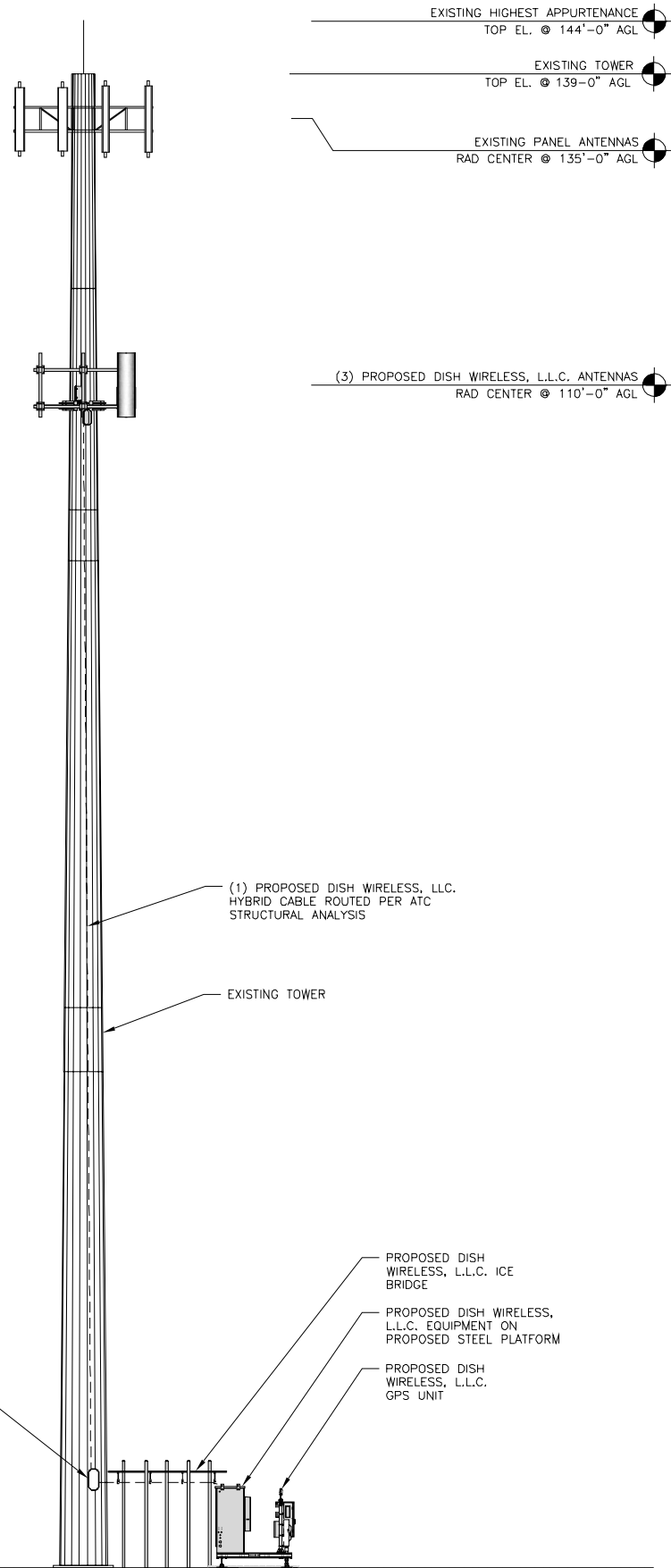

PROPOSED EAST ELEVATION

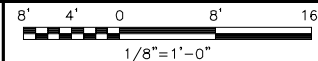

1

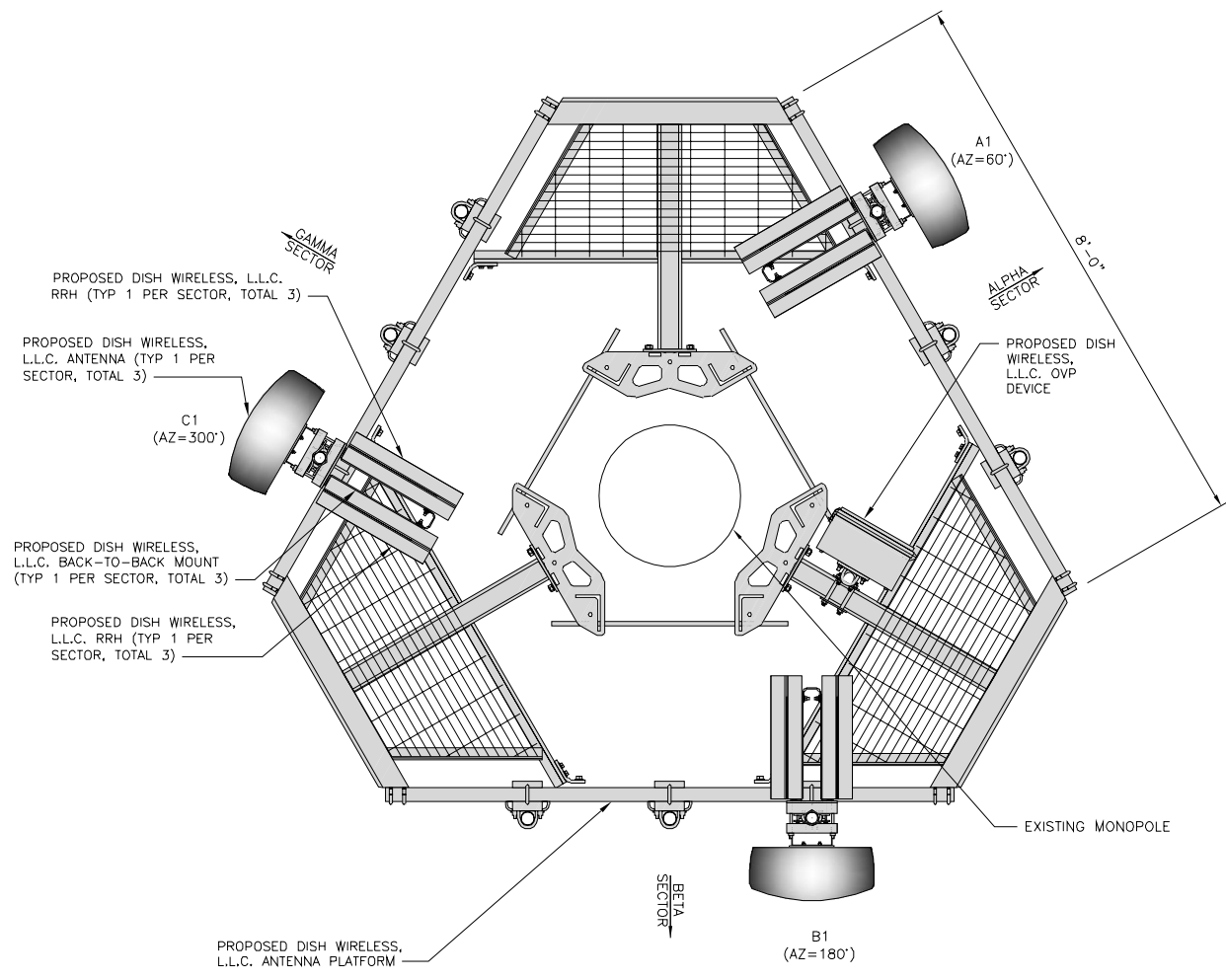

ANTENNA LAYOUT

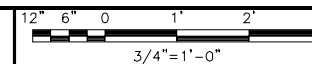

2

SECTOR	POSITION	ANTENNA					TRANSMISSION CABLE	
		EXISTING OR PROPOSED	MANUFACTURER - MODEL NUMBER	TECHNOLOGY	SIZE (HxW)	AZIMUTH	RAD CENTER	FEED LINE TYPE AND LENGTH
ALPHA	A1	PROPOSED	JMA - MX08FRO665-21	5G	72.0" x 20.0"	60'	110'-0"	(1) HIGH-CAPACITY HYBRID CABLE (153' LONG)
BETA	B1	PROPOSED	JMA - MX08FRO665-21	5G	72.0" x 20.0"	180'	110'-0"	
GAMMA	C1	PROPOSED	JMA - MX08FRO665-21	5G	72.0" x 20.0"	300'	110'-0"	
SECTOR	POSITION	RRH		NOTES				
		MANUFACTURER - MODEL NUMBER	TECHNOLOGY					
ALPHA	A1	FUJITSU - TA08025-B604	N29,N71	1. CONTRACTOR TO REFER TO FINAL CONSTRUCTION RFDS FOR ALL RF DETAILS. 2. ANTENNA AND RRH MODELS MAY CHANGE DUE TO EQUIPMENT AVAILABILITY. ALL EQUIPMENT CHANGES MUST BE APPROVED AND REMAIN IN COMPLIANCE WITH THE PROPOSED DESIGN AND STRUCTURAL ANALYSES.				
	A1	FUJITSU - TA08025-B605	N66,N70					
BETA	B1	FUJITSU - TA08025-B604	N29,N71					
	B1	FUJITSU - TA08025-B605	N66,N70					
GAMMA	C1	FUJITSU - TA08025-B604	N29,N71					
	C1	FUJITSU - TA08025-B605	N66,N70					

ANTENNA SCHEDULE

NO SCALE

3



5701 SOUTH SANTA FE DRIVE
LITTLETON, CO 80120



NB+C ENGINEERING SERVICES, LLC.
8601 SIX FORKS ROAD, SUITE 540
RALEIGH, NC 27615
(919) 657-9131

DRAWN BY:	CHECKED BY:	APPROVED BY:
PRI	BIW	BIW

RFDS REV #: 1

CONSTRUCTION DOCUMENTS

SUBMITTALS		
REV	DATE	DESCRIPTION
A	08/13/2021	ISSUED FOR REVIEW
D	09/13/2021	ISSUED FOR CONSTRUCTION



IT IS A VIOLATION OF LAW FOR ANY PERSON, UNLESS THEY ARE ACTING UNDER THE DIRECTION OF A LICENSED PROFESSIONAL ENGINEER, TO ALTER THIS DOCUMENT.

A&E PROJECT NUMBER
416862-13692184

DISH WIRELESS, L.L.C.
PROJECT INFORMATION
BOBDL00027A
106 SOUTH GRAND ST.
WEST SUFFIELD, CT 06093

SHEET TITLE
ELEVATION, ANTENNA LAYOUT AND SCHEDULE

SHEET NUMBER
A-2

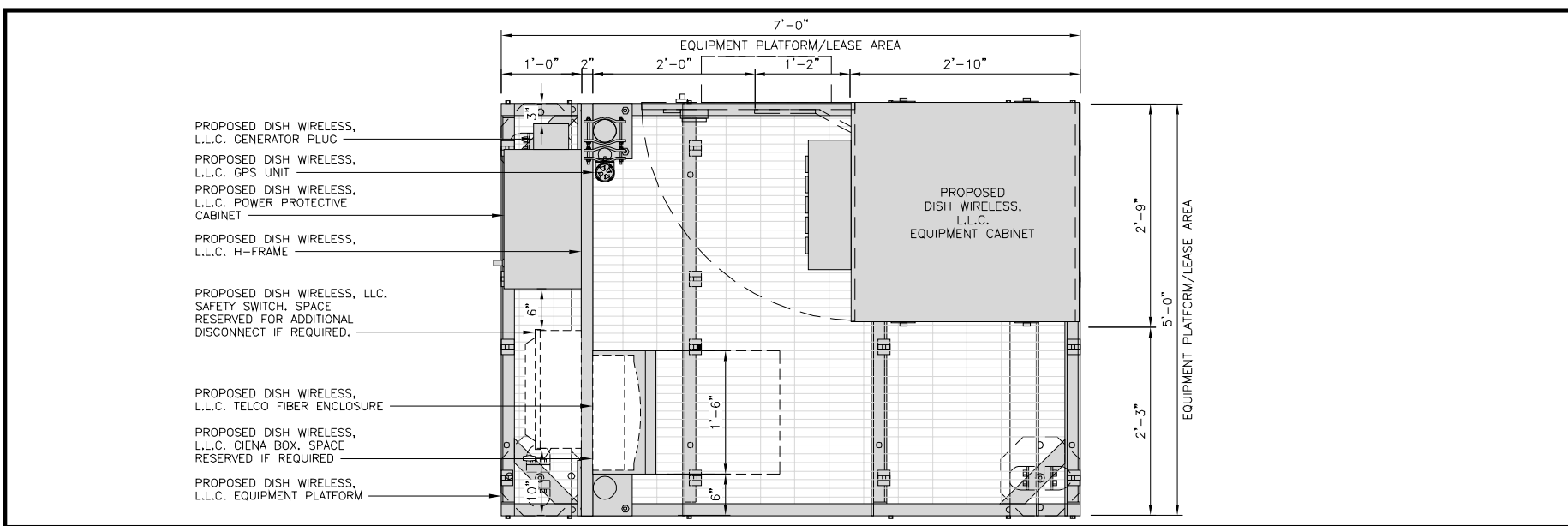

PLATFORM EQUIPMENT PLAN

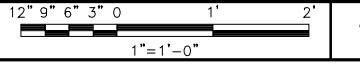

1

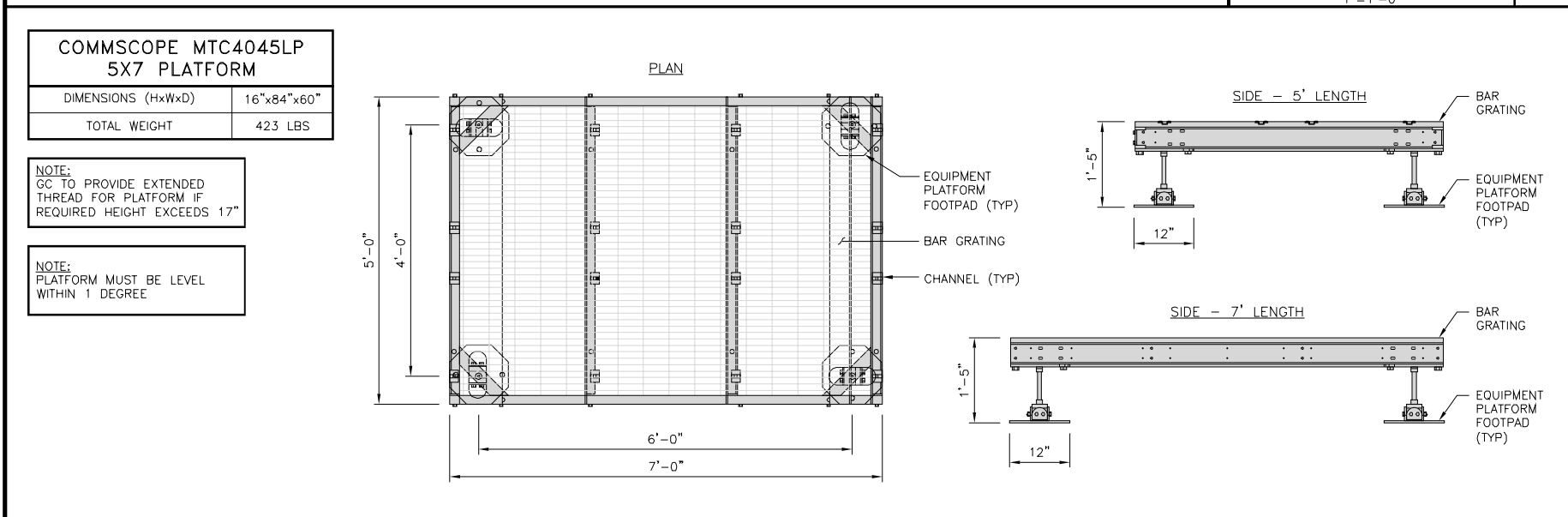

PLATFORM DETAIL

NO SCALE 2

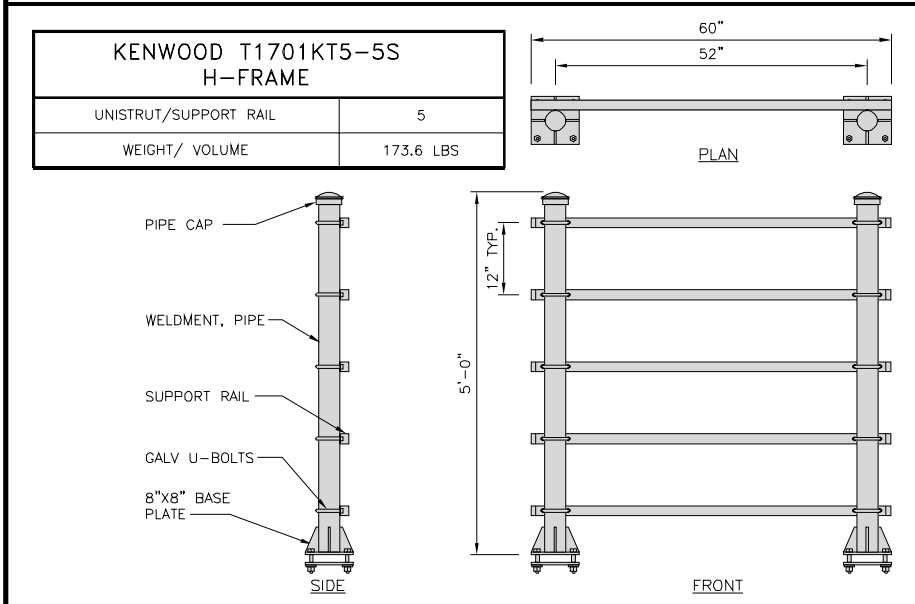

H-FRAME DETAIL

NO SCALE 3

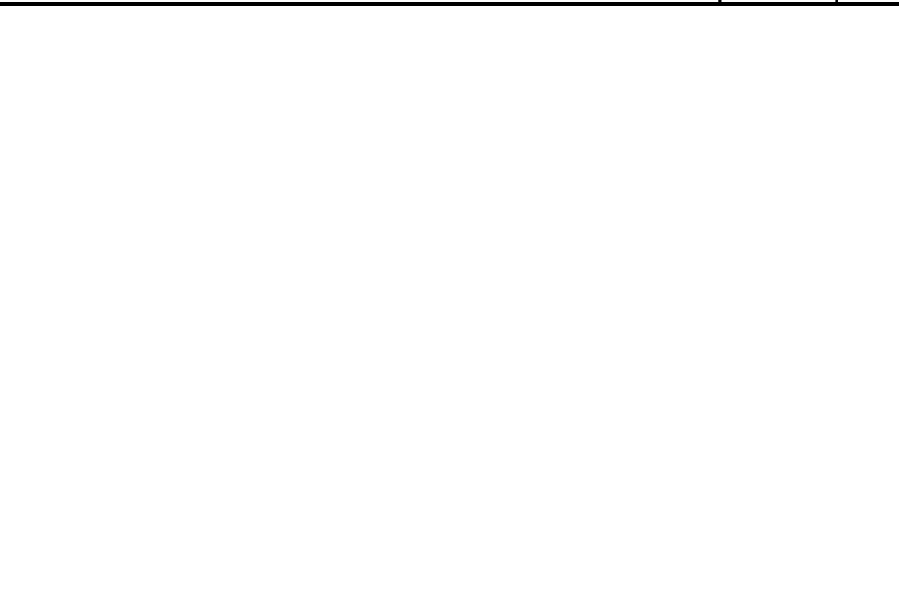

NOT USED

NO SCALE 4

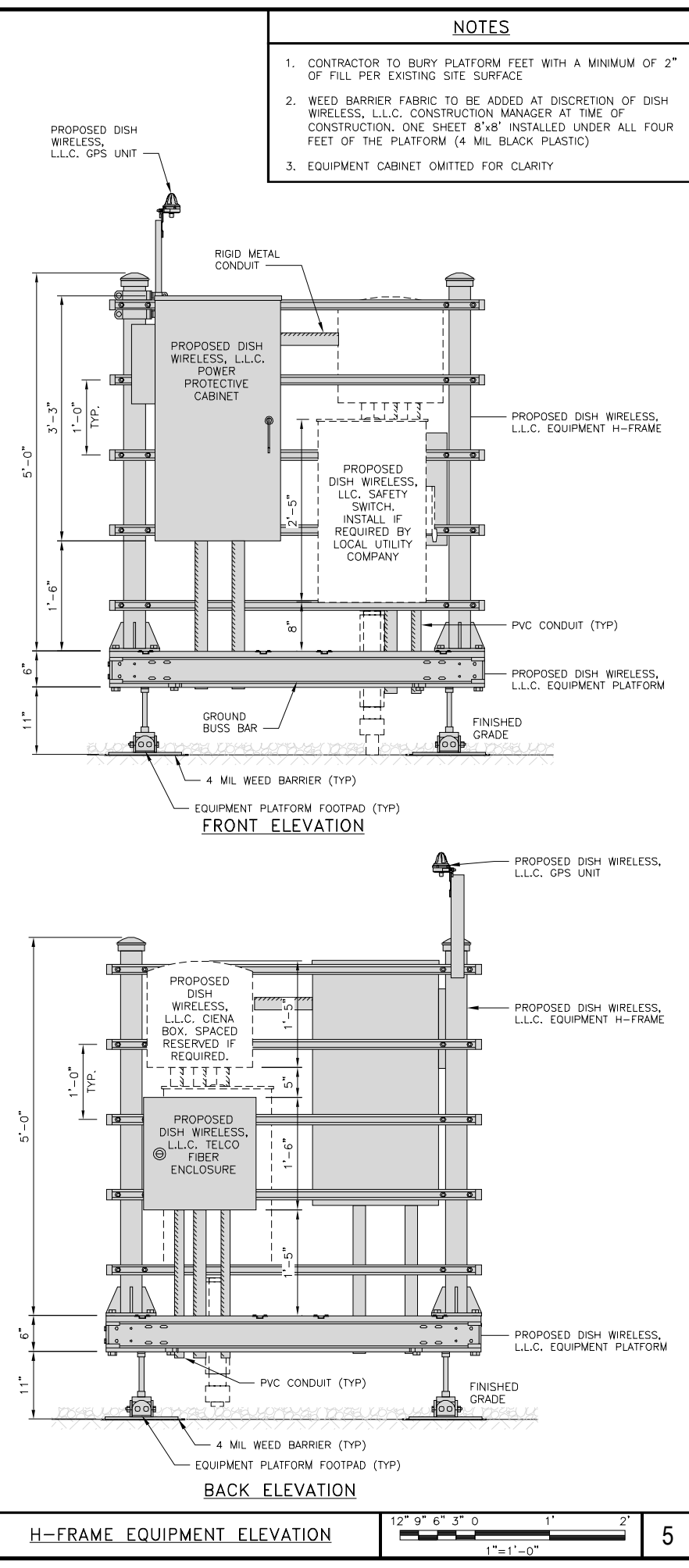

H-FRAME EQUIPMENT ELEVATION

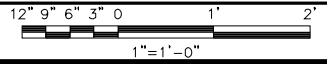

5

- NOTES**
- CONTRACTOR TO BURY PLATFORM FEET WITH A MINIMUM OF 2" OF FILL PER EXISTING SITE SURFACE
 - WEED BARRIER FABRIC TO BE ADDED AT DISCRETION OF DISH WIRELESS, L.L.C. CONSTRUCTION MANAGER AT TIME OF CONSTRUCTION. ONE SHEET 8'x8' INSTALLED UNDER ALL FOUR FEET OF THE PLATFORM (4 MIL BLACK PLASTIC)
 - EQUIPMENT CABINET OMITTED FOR CLARITY

5701 SOUTH SANTA FE DRIVE
LITTLETON, CO 80120

TOTALLY COMMITTED.
NB+C ENGINEERING SERVICES, L.L.C.
8601 SIX FORKS ROAD, SUITE 540
RALEIGH, NC 27615
(919) 657-9131

DRAWN BY:	CHECKED BY:	APPROVED BY:
PRI	BIW	BIW
RFDS REV #:		1

CONSTRUCTION DOCUMENTS

SUBMITTALS		
REV	DATE	DESCRIPTION
A	08/13/2021	ISSUED FOR REVIEW
D	09/13/2021	ISSUED FOR CONSTRUCTION

IT IS A VIOLATION OF LAW FOR ANY PERSON, UNLESS THEY ARE ACTING UNDER THE DIRECTION OF A LICENSED PROFESSIONAL ENGINEER, TO ALTER THIS DOCUMENT.

A&E PROJECT NUMBER
416862-13692184

DISH WIRELESS, L.L.C. PROJECT INFORMATION
BOBDL0027A
106 SOUTH GRAND ST.
WEST SUFFIELD, CT 06093

SHEET TITLE
EQUIPMENT PLATFORM AND H-FRAME DETAILS

SHEET NUMBER
A-3

CHARLES INDUSTRY HEX CUBE-PM639155N4	
DIMENSIONS (HxWxD):	74"x32"x32"
POWER PLANT:	-48VDC ABB/600W
TOTAL WEIGHT (EMPTY)	408 LBS

CABINET DETAIL NO SCALE 1

RAYCAP RDIAC-6512-P-240-MTS POWER & TELCO PROTECTION CABINET	
DIMENSIONS (HxWxD):	40"x20"x10"
WEIGHT/ VOLUME	124 LBS
MANUAL TRANSFER SWITCH	200A
LOAD CENTER	30 POSITION
MAIN BREAKER	200A, 65kA AIC
GENERATOR RECEPTACLE	CAMLOCK
NEMA RATING	3R POWDER COATED ALUMINUM
SURGE PROTECTION DEVICE	UL 1449 4TH EDITION LISTED

POWER PROTECTION CABINET (PPC) DETAIL NO SCALE 2

SQUARE D SAFETY SWITCH D324NRB	
ENCLOSURE DIM (HxWxD)	29.25"x17.25"x8.25"
TOTAL WEIGHT (EMPTY)	45.33 LBS
MAX VOLTAGE/AMPS/WATT	240V/200A/48000W
ENCLOSURE RATING	OUTDOOR NEMA 3R

SAFETY SWITCH NO SCALE 3

NOT USED NO SCALE 4

CIENA 3931 SERVICE DELIVERY SWITCH	
DIMENSIONS (HxWxD)	17.0"x16.8"x7.0" 431x427x178mm
WEIGHT	28.6 LBS/13.0 KG
POWER INPUT	60W MAX

CIENA DETAIL NO SCALE 5

CHARLES FIBER TELCO ENCLOSURE CUBE-MP1818WB-A	
ENCLOSURE DIM (HxWxD)	18.0"x18.0"x9.25"
NEMA RATING	4X
THERMAL	SEALED
MOUNTING BACKBOARD	WOOD

FIBER TELCO ENCLOSURE DETAIL NO SCALE 6

COMMSCOPE WB-K110-B WAVEGUIDE BRIDGE KIT	
DIMENSIONS (HxL)	160"x10"
WEIGHT/ VOLUME	325.0 LBS
CABLE RUN (QTY)	12

INCLUDED PRODUCTS:

- WB-T12-3 TRAPEZE KIT, 3 RUNGS
- WB-LB12-3 SUPPORT BRACKET
- MF-130 DIRECT BURIAL PIPE COLUMN, 13'-4"

ICE BRIDGE DETAIL NO SCALE 7

FINISH SLOPE TO DRAIN

PROPOSED 3.5" DIA. SCH 40 PIPE GALVANIZED

PROPOSED 1'-6" DIA. CONCRETE PIER (TYP)

CONCRETE PIER

3" DIA SCH 40 PIPE

18" DIA DRILLED PIER FOUNDATION

A-A SECTION

TYPICAL ICE BRIDGE CONCRETE PIER DETAIL NO SCALE 8

PROPOSED ICE BRIDGE

PROPOSED X" DIA HYBRID CABLE (OPTION "A")

PROPOSED X" DIA HYBRID CABLE (OPTION "B")

PROPOSED CABLE CLAMP @ 3'-0" O.C.

HYBRID SUPPORT BRACKET AND BANDING @ 10'-0" O.C.

EXISTING ENTRY PORT

EXISTING MONOPOLE

HYBRID CABLE RUN NO SCALE 9

5701 SOUTH SANTA FE DRIVE
LITTLETON, CO 80120

TOTALLY COMMITTED.

NB+C ENGINEERING SERVICES, LLC.
8601 SIX FORKS ROAD, SUITE 540
RALEIGH, NC 27615
(919) 657-9131

DRAWN BY:	CHECKED BY:	APPROVED BY:
PRI	BIW	BIW

RFDS REV #:	1
-------------	---

CONSTRUCTION DOCUMENTS

SUBMITTALS		
REV	DATE	DESCRIPTION
A	08/13/2021	ISSUED FOR REVIEW
D	09/13/2021	ISSUED FOR CONSTRUCTION

IT IS A VIOLATION OF LAW FOR ANY PERSON, UNLESS THEY ARE ACTING UNDER THE DIRECTION OF A LICENSED PROFESSIONAL ENGINEER, TO ALTER THIS DOCUMENT.

A&E PROJECT NUMBER
416862-13692184

DISH WIRELESS, L.L.C.
PROJECT INFORMATION
BOBDL00027A
106 SOUTH GRAND ST.
WEST SUFFIELD, CT 06093

SHEET TITLE
EQUIPMENT DETAILS

SHEET NUMBER
A-4

PCTEL GPSGL-TMG-SPI-40NCB	
DIMENSIONS (DIAxH) MM/INCH	81x184mm 3.2"x7.25"
WEIGHT W/ACCESSORIES	075 lbs
CONNECTOR	N-FEMALE
FREQUENCY RANGE	1590 ± 30MHz

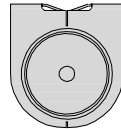

TOP

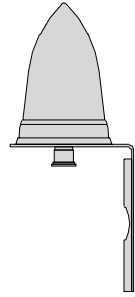

BACK

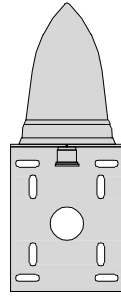

SIDE

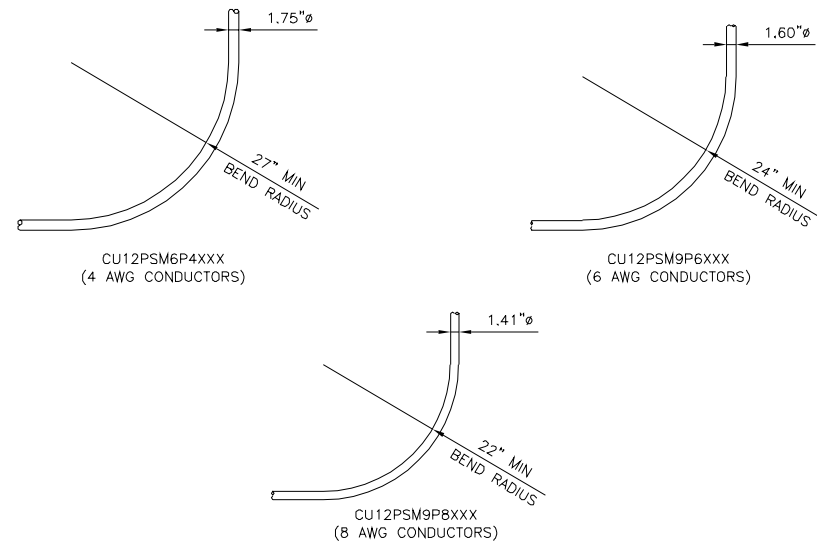
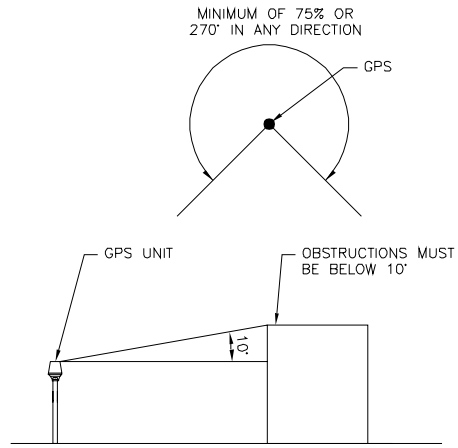

GPS DETAIL

NO SCALE

1

GPS MINIMUM SKY VIEW REQUIREMENTS

NO SCALE

2

CABLES UNLIMITED HYBRID CABLE
MINIMUM BEND RADIUSES

NO SCALE

3

NOT USED

NO SCALE

4

NOT USED

NO SCALE

5

NOT USED

NO SCALE

6

NOT USED

NO SCALE

7

NOT USED

NO SCALE

8

NOT USED

NO SCALE

9

dish
wireless.

5701 SOUTH SANTA FE DRIVE
LITTLETON, CO 80120

NB+C
TOTALLY COMMITTED.

NB+C ENGINEERING SERVICES, LLC.
8601 SIX FORKS ROAD, SUITE 540
RALEIGH, NC 27615
(919) 657-9131

DRAWN BY: CHECKED BY: APPROVED BY:
PRI BIW BIW

RFDS REV #: 1

CONSTRUCTION
DOCUMENTS

SUBMITTALS		
REV	DATE	DESCRIPTION
A	08/13/2021	ISSUED FOR REVIEW
D	09/13/2021	ISSUED FOR CONSTRUCTION



IT IS A VIOLATION OF LAW FOR ANY PERSON,
UNLESS THEY ARE ACTING UNDER THE DIRECTION
OF A LICENSED PROFESSIONAL ENGINEER,
TO ALTER THIS DOCUMENT.

A&E PROJECT NUMBER
416862-13692184

DISH WIRELESS, L.L.C.
PROJECT INFORMATION
BOBDL00027A
106 SOUTH GRAND ST.
WEST SUFFIELD, CT 06093

SHEET TITLE
EQUIPMENT DETAILS

SHEET NUMBER
A-5

FUJITSU TA08025-B604 RRH	
DIMENSIONS (HxWxD) (KG/IN)	380x400x200/14.9"x15.7"x7.8"
WEIGHT(KG,LB)/ VOLUME	29kg,63.9lb/ 30L
POWER SUPPLY	DC-58~-36V

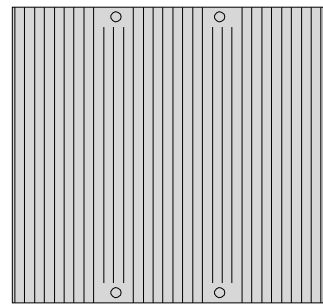
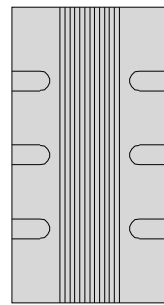
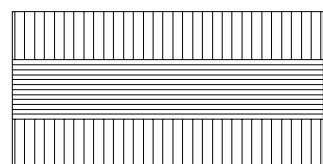

FUJITSU TA08025-B605 RRH	
DIMENSIONS (HxWxD) (KG/IN)	380x400x230/14.9"x15.7"x9.0"
WEIGHT(KG,LB)/ VOLUME	34kg,74.9lb/ 35L
POWER SUPPLY	DC-58~-36V

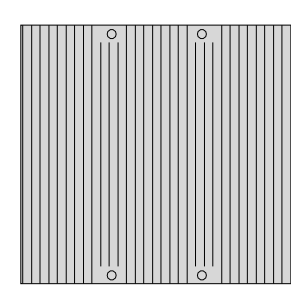
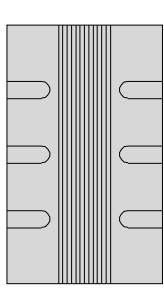
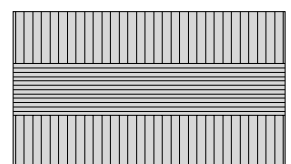

SABRE DOUBLE Z-BRACKET C10123155	
DIMENSIONS (HxWxD) (1 BRACKET)	5"x20"x1-13/16"
WEIGHT (FULL ASSEMBLY)	35.79 lbs
PACKAGE QUANTITY	4

#	DESCRIPTION
1	PLATE, CHANNEL BRACKET
2	RRH Z BRACKET, 3/16"
3	THREADED ROD ASSEMBLY 1/2"x12"

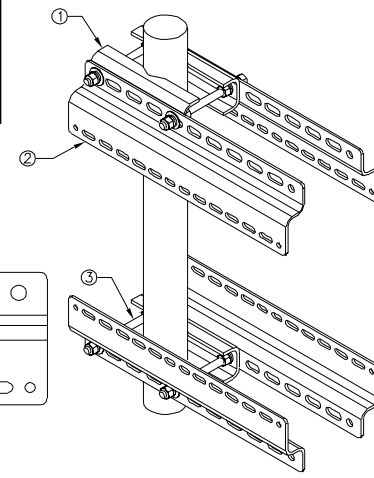
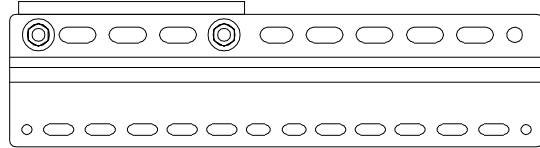

NOTE:
OR DISH Wireless L.L.C.
APPROVED EQUIVALENT

dish
wireless.

5701 SOUTH SANTA FE DRIVE
LITTLETON, CO 80120

NB+C
TOTALLY COMMITTED.

NB+C ENGINEERING SERVICES, L.L.C.
8601 SIX FORKS ROAD, SUITE 540
RALEIGH, NC 27615
(919) 657-9131

REMOTE RADIO HEAD DETAIL

NO SCALE

1

REMOTE RADIO HEAD DETAIL

NO SCALE

2

RRH MOUNT DETAIL

NO SCALE

3

JMA WIRELESS MX08FRO665-21 ANTENNA	
DIMENSIONS (HxWxD)	72.0"x20.0"x8.0"
TOTAL WEIGHT	64.5 LB
RF PORTS, CONNECTOR TYPE	8 x 4.3-10 FEMALE

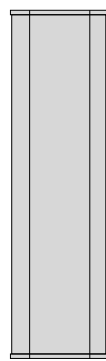
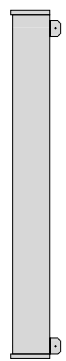
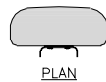

ANTENNA DETAIL

NO SCALE

1

RAYCAP RDIDC-9181-PF-48 DC SURGE PROTECTION (OVP)	
DIMENSIONS (HxWxD)	18.98"x14.39"x8.15"
WEIGHT	21.82 LBS

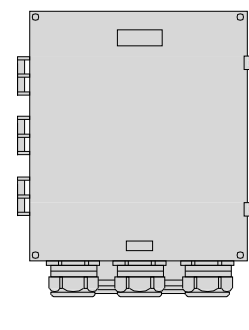
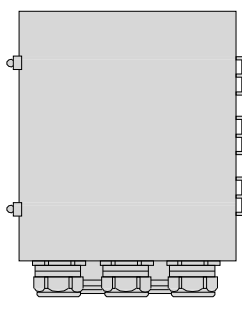
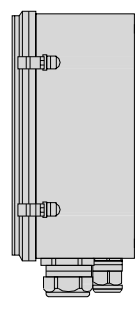

SURGE SUPPRESSION DETAIL (OVP)

NO SCALE

4

JMA ANTENNA MOUNTING BRACKET #91900318	
TOTAL WEIGHT (WITH BRACKETS)	18 lbs (8.18 Kg)
POLE DIAMETER RANGE	2.5 TO 4.5 INCHES

NOTE:
KIT #91900318: TOP AND BOTTOM BRACKETS
FOR 4-, 6-, AND 8-FOOT ANTENNAS
ANTENNA BRACKET NOT PART OF KIT

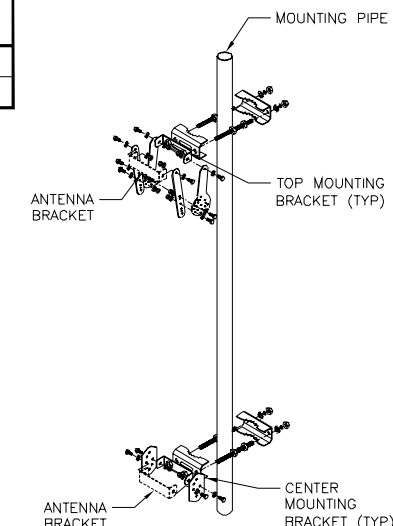

ANTENNA BRACKET DETAIL

NO SCALE

5

COMMSCOPE XP-2040 CROSSOVER PLATE	
DIMENSIONS (HxW)	10"x12"
WEIGHT	11.023 LBS

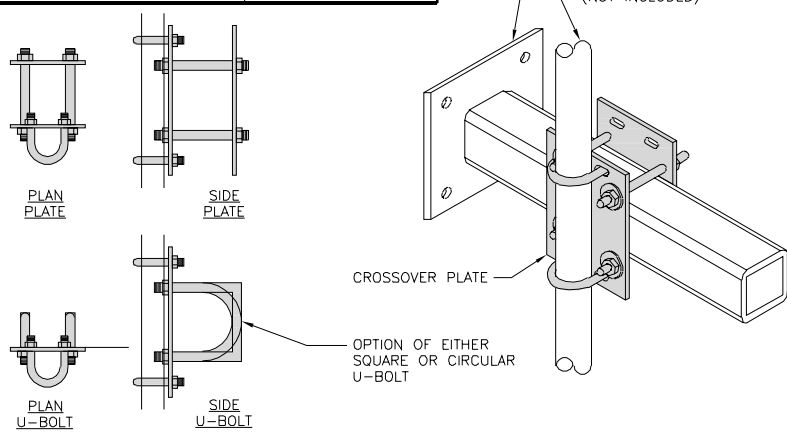

RRH/OVP MOUNT DETAIL

NO SCALE

6

COMMSCOPE MC-PK8-DSH	
FACE WIDTH	96"
WEIGHT	1373.08 lbs
NOTE: 15" TO 38" O.D.	

NOTE:
OR DISH Wireless L.L.C.
APPROVED EQUIVALENT

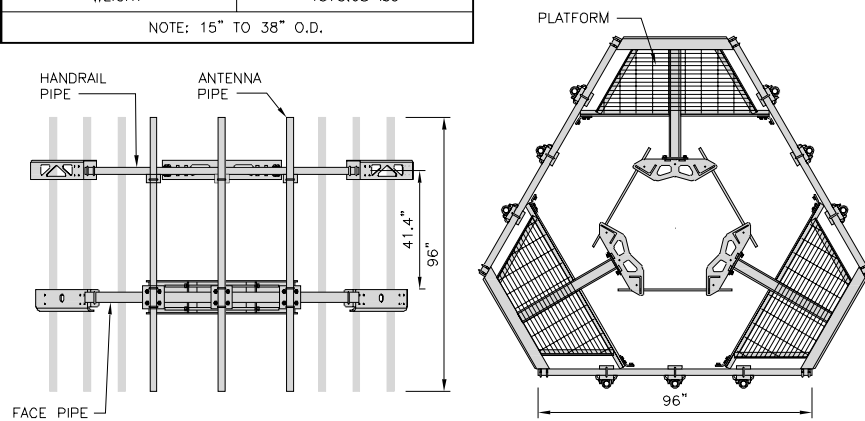

ANTENNA PLATFORM DETAIL

NO SCALE

7

DRAWN BY: CHECKED BY: APPROVED BY:

PRI BIW BIW

RFDS REV #: 1

CONSTRUCTION
DOCUMENTS

SUBMITTALS		
REV	DATE	DESCRIPTION
A	08/13/2021	ISSUED FOR REVIEW
D	09/13/2021	ISSUED FOR CONSTRUCTION



IT IS A VIOLATION OF LAW FOR ANY PERSON,
UNLESS THEY ARE ACTING UNDER THE DIRECTION
OF A LICENSED PROFESSIONAL ENGINEER,
TO ALTER THIS DOCUMENT.

A&E PROJECT NUMBER
416862-13692184

DISH WIRELESS, L.L.C.
PROJECT INFORMATION
BOBDL00027A
106 SOUTH GRAND ST.
WEST SUFFIELD, CT 06093

SHEET TITLE
EQUIPMENT DETAILS

SHEET NUMBER
A-6

NOTES

1. CONTRACTOR SHALL FIELD VERIFY ALL PROPOSED UNDERGROUND UTILITY CONDUIT ROUTE.
2. ANTENNAS AND MOUNTS OMITTED FOR CLARITY.

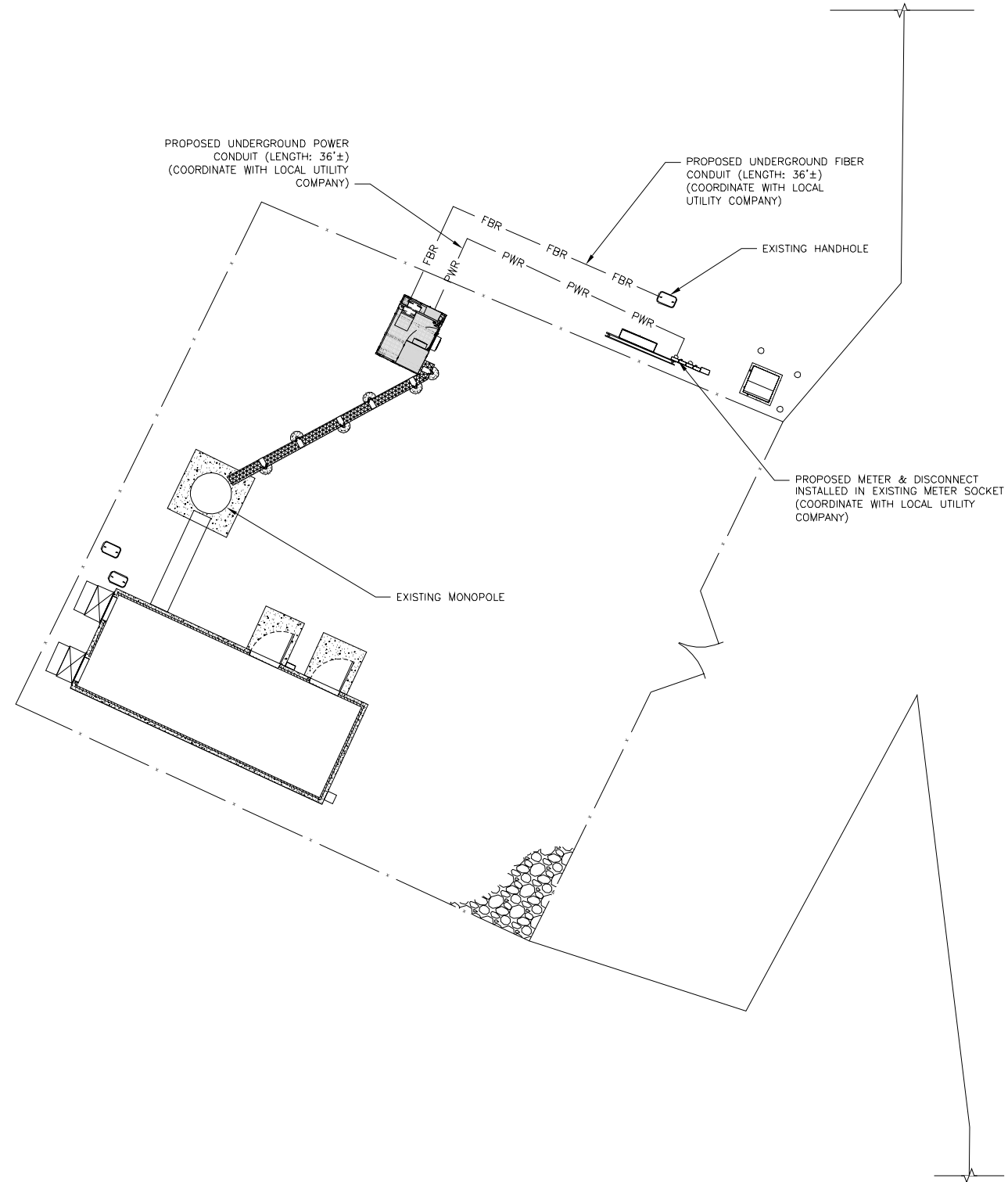

DC POWER WIRING SHALL BE COLOR CODED AT EACH END FOR IDENTIFYING +24V AND -48V CONDUCTORS. RED MARKINGS SHALL IDENTIFY +24V AND BLUE MARKINGS SHALL IDENTIFY -48V.

1. CONTRACTOR SHALL INSPECT THE EXISTING CONDITIONS PRIOR TO SUBMITTING A BID. ANY QUESTIONS ARISING DURING THE BID PERIOD IN REGARDS TO THE CONTRACTOR'S FUNCTIONS, THE SCOPE OF WORK, OR ANY OTHER ISSUE RELATED TO THIS PROJECT SHALL BE BROUGHT UP DURING THE BID PERIOD WITH THE PROJECT MANAGER FOR CLARIFICATION, NOT AFTER THE CONTRACT HAS BEEN AWARDED.
2. ALL ELECTRICAL WORK SHALL BE DONE IN ACCORDANCE WITH CURRENT NATIONAL ELECTRICAL CODES AND ALL STATE AND LOCAL CODES, LAWS, AND ORDINANCES. PROVIDE ALL COMPONENTS AND WIRING SIZES AS REQUIRED TO MEET NEC STANDARDS.
3. LOCATION OF EQUIPMENT, CONDUIT AND DEVICES SHOWN ON THE DRAWINGS ARE APPROXIMATE AND SHALL BE COORDINATED WITH FIELD CONDITIONS PRIOR TO CONSTRUCTION.
4. CONDUIT ROUGH-IN SHALL BE COORDINATED WITH THE MECHANICAL EQUIPMENT TO AVOID LOCATION CONFLICTS. VERIFY WITH THE MECHANICAL EQUIPMENT CONTRACTOR AND COMPLY AS REQUIRED.
5. CONTRACTOR SHALL PROVIDE ALL BREAKERS, CONDUITS AND CIRCUITS AS REQUIRED FOR A COMPLETE SYSTEM.
6. CONTRACTOR SHALL PROVIDE PULL BOXES AND JUNCTION BOXES AS REQUIRED BY THE NEC ARTICLE 314.
7. CONTRACTOR SHALL PROVIDE ALL STRAIN RELIEF AND CABLE SUPPORTS FOR ALL CABLE ASSEMBLIES. INSTALLATION SHALL BE IN ACCORDANCE WITH MANUFACTURER'S SPECIFICATIONS AND RECOMMENDATIONS.
8. ALL DISCONNECTS AND CONTROLLING DEVICES SHALL BE PROVIDED WITH ENGRAVED PHENOLIC NAMEPLATES INDICATING EQUIPMENT CONTROLLED, BRANCH CIRCUITS INSTALLED ON, AND PANEL FIELD LOCATIONS FED FROM.
9. INSTALL AN EQUIPMENT GROUNDING CONDUCTOR IN ALL CONDUITS PER THE SPECIFICATIONS AND NEC 250. THE EQUIPMENT GROUNDING CONDUCTORS SHALL BE BONDED AT ALL JUNCTION BOXES, PULL BOXES, AND ALL DISCONNECT SWITCHES, AND EQUIPMENT CABINETS.
10. ALL NEW MATERIAL SHALL HAVE A U.L. LABEL.
11. PANEL SCHEDULE LOADING AND CIRCUIT ARRANGEMENTS REFLECT POST-CONSTRUCTION EQUIPMENT.
12. CONTRACTOR SHALL BE RESPONSIBLE FOR AS-BUILT PANEL SCHEDULE AND SITE DRAWINGS.
13. ALL TRENCHES IN COMPOUND TO BE HAND DUG

ELECTRICAL NOTES

NO SCALE

2

NOTES

1. THE SURVEY PROVIDED ON THIS SHEET IS PROVIDED FOR REFERENCE ONLY. THE UTILITY ROUTE AND EXISTING EASEMENTS MUST BE VERIFIED PRIOR TO CONSTRUCTION.

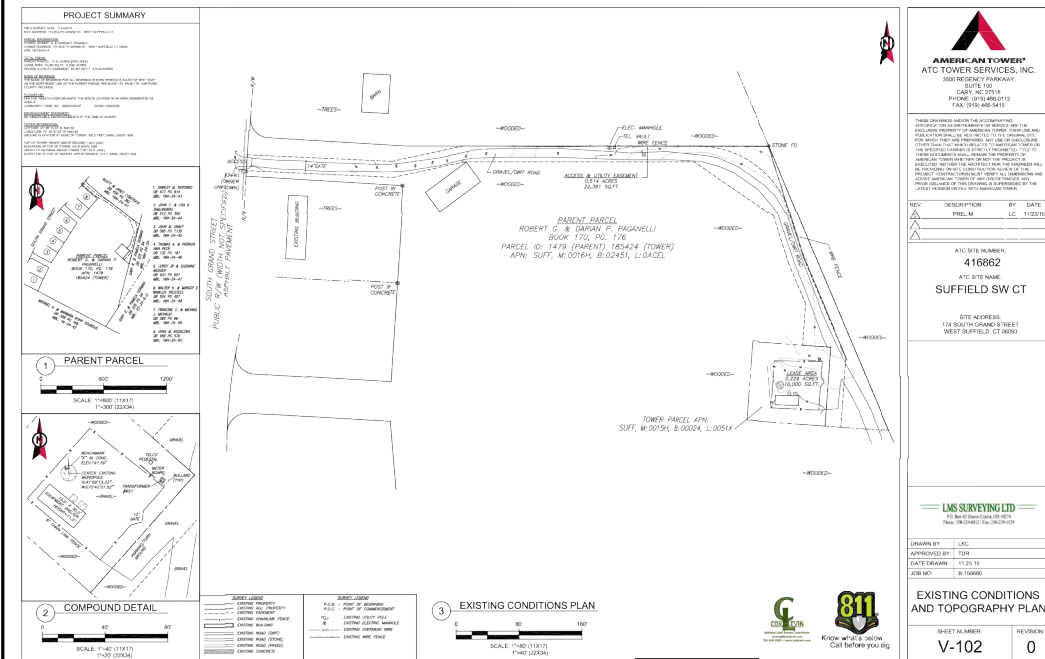

IT IS A VIOLATION OF LAW FOR ANY PERSON, UNLESS THEY ARE ACTING UNDER THE DIRECTION OF A LICENSED PROFESSIONAL ENGINEER, TO ALTER THIS DOCUMENT.

A&E PROJECT NUMBER
416862-13692184

DISH WIRELESS, L.L.C.
PROJECT INFORMATION
BOBDL0027A
106 SOUTH GRAND ST.
WEST SUFFIELD, CT 06093

SHEET TITLE
ELECTRICAL/FIBER ROUTE
PLAN AND NOTES

SHEET NUMBER
E-1

UTILITY ROUTE PLAN

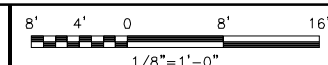

1

EXISTING SURVEY (BY OTHERS)

NO SCALE

3

CARLON EXPANSION FITTINGS

COUPLING END PART#	MALE TERMINAL ADAPTER END PART#	SIZE	STD CTN QTY.	TRAVEL LENGTH
E945D	E945DX	1/2"	20	4"
E945E	E945EX	3/4"	15	4"
E945F	E945FX	1"	10	4"
E945G	E945GX	1 1/4"	5	4"
E945H	E945HX	1 1/2"	5	4"
E945J	E945JX	2"	15	8"
E945K	E945KX	2 1/2"	10	8"
E945L	E945LX	3"	10	8"
E945M	E945MX	3 1/2"	5	8"
E945N	E945NX	4"	5	8"
E945P	E945PX	5"	1	8"
E945R	E945RX	6"	1	8"

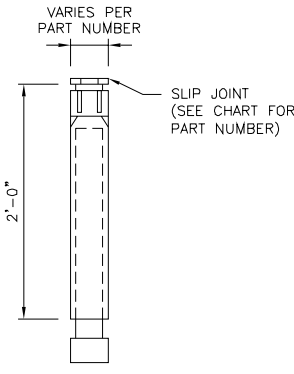

NOTE: CONTRACTOR TO INSTALL EXPANSION FITTING SLIP JOINT AT METER CENTER CONDUIT TERMINATION, AS PER LOCAL UTILITY POLICY, ORDINANCE AND/OR SPECIFIED REQUIREMENT.

TRENCHING NOTES

- CONTRACTOR SHALL RESTORE THE TRENCH TO ITS ORIGINAL CONDITIONS BY EITHER SEEDING OR SODDING GRASS AREAS, OR REPLACING ASPHALT OR CONCRETE AREAS TO ITS ORIGINAL CROSS SECTION.
- TRENCHING SAFETY; INCLUDING, BUT NOT LIMITED TO SOIL CLASSIFICATION, SLOPING, AND SHORING, SHALL BE GOVERNED BY THE CURRENT OSHA TRENCHING AND EXCAVATION SAFETY STANDARDS.
- ALL CONDUITS SHALL BE INSTALLED IN COMPLIANCE WITH THE CURRENT NATIONAL ELECTRIC CODE (NEC) OR AS REQUIRED BY THE LOCAL JURISDICTION, WHICHEVER IS THE MOST STRINGENT.

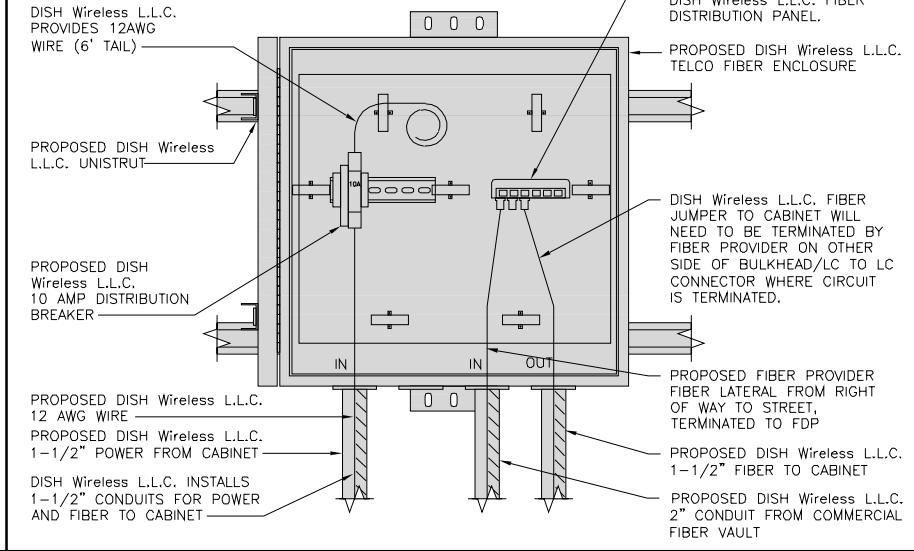
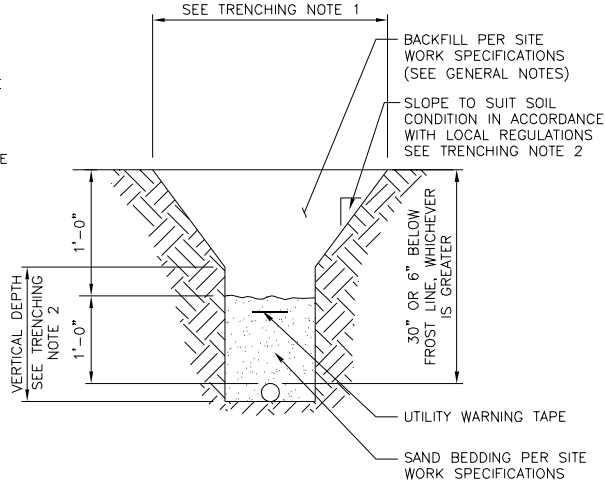

5701 SOUTH SANTA FE DRIVE
LITTLETON, CO 80120



NB+C ENGINEERING SERVICES, LLC.
8601 SIX FORKS ROAD, SUITE 540
RALEIGH, NC 27615
(919) 657-9131

EXPANSION JOINT DETAIL NO SCALE 1

TYPICAL UNDERGROUND TRENCH DETAIL NO SCALE 2

DARK TELCO BOX - INTERIOR WIRING LAYOUT NO SCALE 3

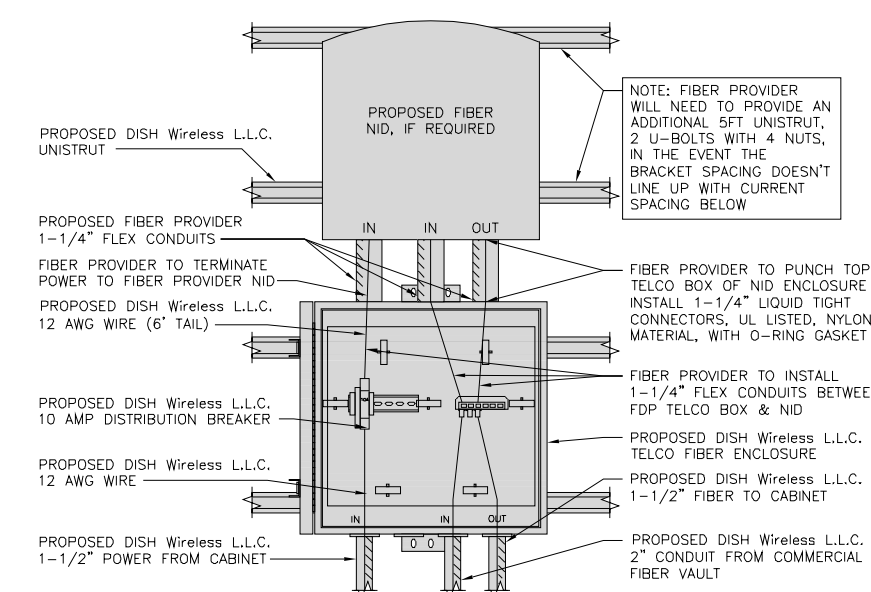

NOT USED

NOT USED

LIT TELCO BOX - INTERIOR WIRING LAYOUT (OPTIONAL) NO SCALE 4

NOT USED NO SCALE 5

NOT USED NO SCALE 6

NOT USED

NOT USED

NOT USED

DRAWN BY: CHECKED BY: APPROVED BY:

PRI BIW BIW

RFDS REV #: 1

CONSTRUCTION DOCUMENTS

SUBMITTALS		
REV	DATE	DESCRIPTION
A	08/13/2021	ISSUED FOR REVIEW
D	09/13/2021	ISSUED FOR CONSTRUCTION



IT IS A VIOLATION OF LAW FOR ANY PERSON, UNLESS THEY ARE ACTING UNDER THE DIRECTION OF A LICENSED PROFESSIONAL ENGINEER, TO ALTER THIS DOCUMENT.

A&E PROJECT NUMBER
416862-13692184

DISH WIRELESS, L.L.C.
PROJECT INFORMATION
BOBDL00027A
106 SOUTH GRAND ST.
WEST SUFFIELD, CT 06093

SHEET TITLE
ELECTRICAL
DETAILS

SHEET NUMBER
E-2

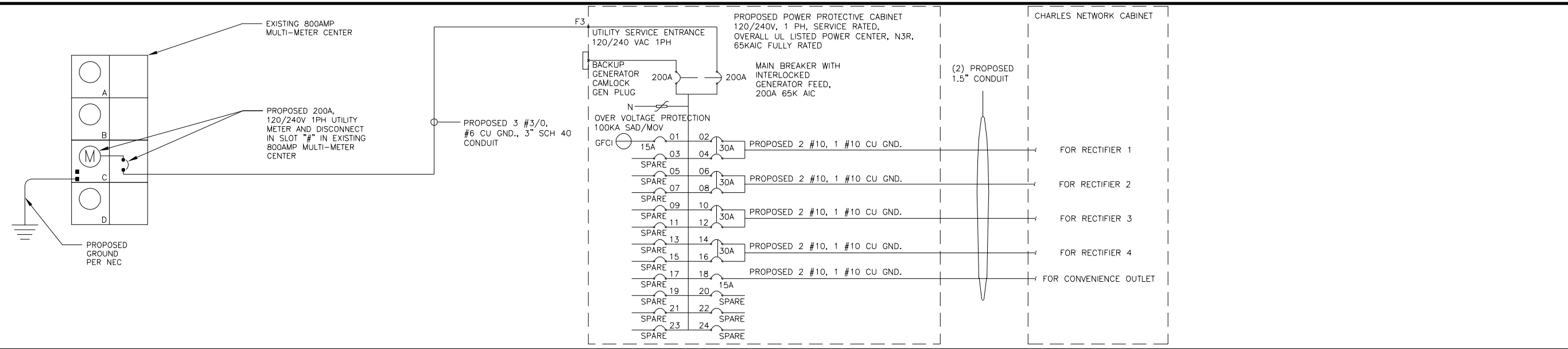

(CHARLES ABB GE INFINITY DC PLANT) WITH MULTI-METER CENTER 120V240V 1PH SOURCE

NO SCALE 1

PROPOSED PANEL SCHEDULE											
LOAD SERVED	VOLT AMPS (WATTS)		TRIP	CKT #	PHASE	CKT #	TRIP	VOLT AMPS (WATTS)		LOAD SERVED	
	L1	L2						L1	L2		
GFCI IN PPC CAB.	1440		15A	1	A	2	30A	2880	2880	ABB/GE INFINITY RECTIFIER 1	
-SPARE-				3	B	4	30A	2880	2880	ABB/GE INFINITY RECTIFIER 2	
-SPARE-				5	A	6	30A	2880	2880	ABB/GE INFINITY RECTIFIER 3	
-SPARE-				7	B	8	30A	2880	2880	ABB/GE INFINITY RECTIFIER 4	
-SPARE-				9	A	10	30A	2880	2880	CHARLES GFCI OUTLET	
-SPARE-				11	B	12	30A	2880	2880	-SPARE-	
-SPARE-				13	A	14	30A	2880	2880	-SPARE-	
-SPARE-				15	B	16	30A	2880	2880	-SPARE-	
-SPARE-				17	A	18	15A	1440A	11520	-SPARE-	
-SPARE-				19	B	20				-SPARE-	
-SPARE-				21	A	22				-SPARE-	
-SPARE-				23	B	24				-SPARE-	
VOLT AMPS	1440							12960A	11520		
200A MCB, 1φ, 3W, 120/240V				L1	L2						
MB RATING: 65,000 AIC	14400			120	96			VOLT AMPS			
				120				AMPS			
				150				MAX AMPS			
								MAX 125%			

PANEL SCHEDULE

(CHARLES ABB GE INFINITY DC PLANT) WITH MULTI-METER CENTER 120V240V 1PH SOURCE

NO SCALE 2

NOT USED

NO SCALE 3

NOT USED

NO SCALE 4



5701 SOUTH SANTA FE DRIVE
LITTLETON, CO 80120



NB+C ENGINEERING SERVICES, LLC.
8601 SIX FORKS ROAD, SUITE 540
RALEIGH, NC 27615
(919) 657-9131

DRAWN BY: CHECKED BY: APPROVED BY:
PRI BIW BIW

RFDS REV #: 1

CONSTRUCTION DOCUMENTS

SUBMITTALS		
REV	DATE	DESCRIPTION
A	08/13/2021	ISSUED FOR REVIEW
D	09/13/2021	ISSUED FOR CONSTRUCTION



IT IS A VIOLATION OF LAW FOR ANY PERSON, UNLESS THEY ARE ACTING UNDER THE DIRECTION OF A LICENSED PROFESSIONAL ENGINEER, TO ALTER THIS DOCUMENT.

A&E PROJECT NUMBER
416862-13692184

DISH WIRELESS, L.L.C.
PROJECT INFORMATION
BOBDL00027A
106 SOUTH GRAND ST.
WEST SUFFIELD, CT 06093

SHEET TITLE
ELECTRICAL ONE-LINE, FAULT
CALCS & PANEL SCHEDULE

SHEET NUMBER
E-3

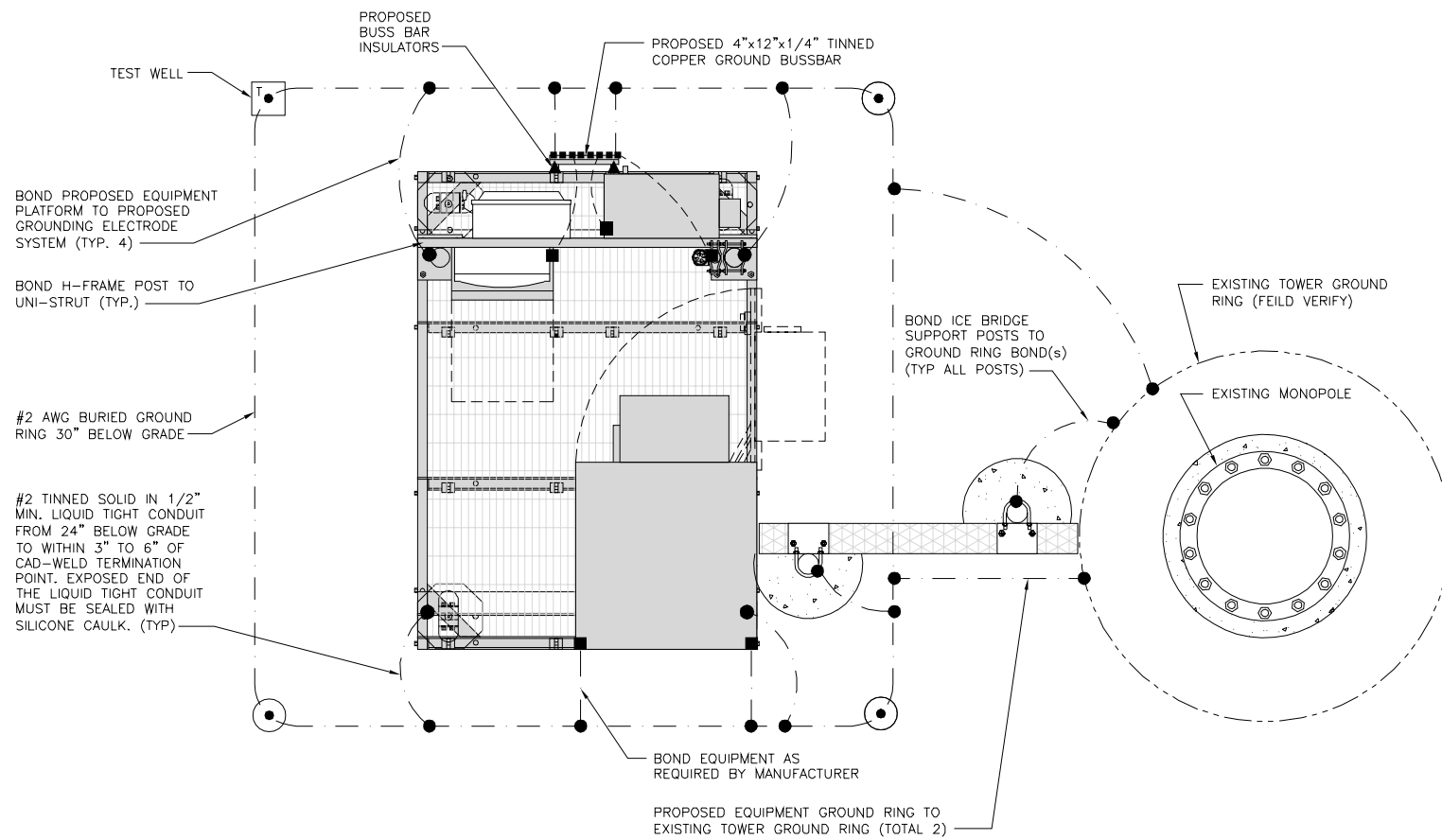

TYPICAL EQUIPMENT GROUNDING PLAN

NO SCALE 1

NOTES

1. ANTENNAS AND OVP SHOWN ARE GENERIC AND NOT REFERENCING TO A SPECIFIC MANUFACTURER. THIS LAYOUT IS FOR REFERENCE ONLY

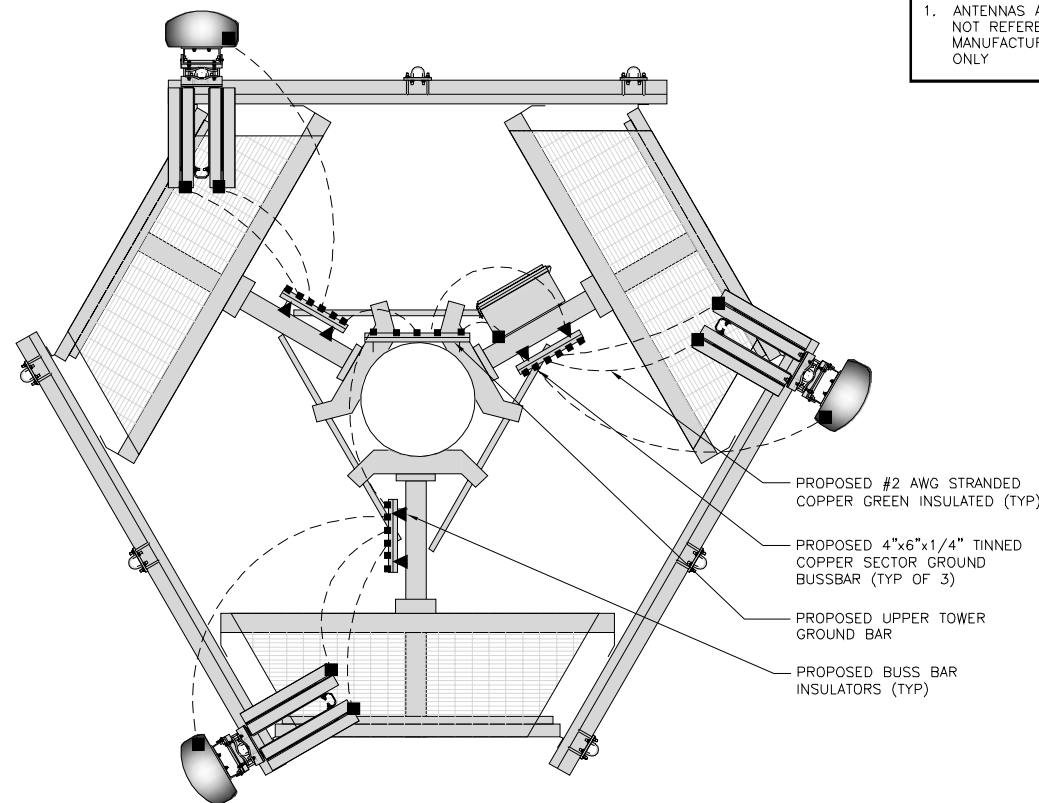

TYPICAL ANTENNA GROUNDING PLAN

NO SCALE 2

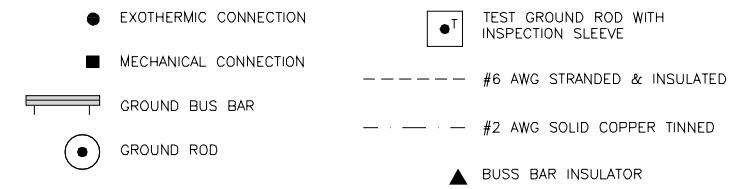

GROUNDING LEGEND

1. GROUNDING IS SHOWN DIAGRAMMATICALLY ONLY.
2. CONTRACTOR SHALL GROUND ALL EQUIPMENT AS A COMPLETE SYSTEM. GROUNDING SHALL BE IN COMPLIANCE WITH NEC SECTION 250 AND DISH WIRELESS, L.L.C. GROUNDING AND BONDING REQUIREMENTS AND MANUFACTURER'S SPECIFICATIONS.
3. ALL GROUND CONDUCTORS SHALL BE COPPER; NO ALUMINUM CONDUCTORS SHALL BE USED.

GROUNDING KEY NOTES

- EXTERIOR GROUND RING:** #2 AWG SOLID COPPER, BURIED AT A DEPTH OF AT LEAST 30 INCHES BELOW GRADE, OR 6 INCHES BELOW THE FROST LINE AND APPROXIMATELY 24 INCHES FROM THE EXTERIOR WALL OR FOOTING.
- TOWER GROUND RING:** THE GROUND RING SYSTEM SHALL BE INSTALLED AROUND AN ANTENNA TOWER'S LEGS, AND/OR GUY ANCHORS. WHERE SEPARATE SYSTEMS HAVE BEEN PROVIDED FOR THE TOWER AND THE BUILDING, AT LEAST TWO BONDS SHALL BE MADE BETWEEN THE TOWER RING GROUND SYSTEM AND THE BUILDING RING GROUND SYSTEM USING MINIMUM #2 AWG SOLID COPPER CONDUCTORS.
- INTERIOR GROUND RING:** #2 AWG STRANDED GREEN INSULATED COPPER CONDUCTOR EXTENDED AROUND THE PERIMETER OF THE EQUIPMENT AREA. ALL NON-TELECOMMUNICATIONS RELATED METALLIC OBJECTS FOUND WITHIN A SITE SHALL BE GROUNDED TO THE INTERIOR GROUND RING WITH #6 AWG STRANDED GREEN INSULATED CONDUCTOR.
- BOND TO INTERIOR GROUND RING:** #2 AWG SOLID TINNED COPPER WIRE PRIMARY BONDS SHALL BE PROVIDED AT LEAST AT FOUR POINTS ON THE INTERIOR GROUND RING, LOCATED AT THE CORNERS OF THE BUILDING.
- GROUND ROD:** UL LISTED COPPER CLAD STEEL, MINIMUM 5/8" DIAMETER BY EIGHT FEET LONG. GROUND RODS SHALL BE INSTALLED WITH INSPECTION SLEEVES. GROUND RODS SHALL BE DRIVEN TO THE DEPTH OF GROUND RING CONDUCTOR.
- CELL REFERENCE GROUND BAR:** POINT OF GROUND REFERENCE FOR ALL COMMUNICATIONS EQUIPMENT FRAMES. ALL BONDS ARE MADE WITH #2 AWG UNLESS NOTED OTHERWISE STRANDED GREEN INSULATED COPPER CONDUCTORS. BOND TO GROUND RING WITH (2) #2 SOLID TINNED COPPER CONDUCTORS.
- HATCH PLATE GROUND BAR:** BOND TO THE INTERIOR GROUND RING WITH TWO #2 AWG STRANDED GREEN INSULATED COPPER CONDUCTORS. WHEN A HATCH-PLATE AND A CELL REFERENCE GROUND BAR ARE BOTH PRESENT, THE CRGB MUST BE CONNECTED TO THE HATCH-PLATE AND TO THE INTERIOR GROUND RING USING (2) TWO #2 AWG STRANDED GREEN INSULATED COPPER CONDUCTORS EACH.
- EXTERIOR CABLE ENTRY PORT GROUND BARS:** LOCATED AT THE ENTRANCE TO THE CELL SITE BUILDING. BOND TO GROUND RING WITH A #2 AWG SOLID TINNED COPPER CONDUCTORS WITH AN EXOTHERMIC WELD AND INSPECTION SLEEVE.
- TELCO GROUND BAR:** BOND TO BOTH CELL REFERENCE GROUND BAR OR EXTERIOR GROUND RING.
- FRAME BONDING:** THE BONDING POINT FOR TELECOM EQUIPMENT FRAMES SHALL BE THE GROUND BUS THAT IS NOT ISOLATED FROM THE EQUIPMENTS METAL FRAMEWORK.
- INTERIOR UNIT BONDS:** METAL FRAMES, CABINETS AND INDIVIDUAL METALLIC UNITS LOCATED WITH THE AREA OF THE INTERIOR GROUND RING REQUIRE A #6 AWG STRANDED GREEN INSULATED COPPER BOND TO THE INTERIOR GROUND RING.
- FENCE AND GATE GROUNDING:** METAL FENCES WITHIN 7 FEET OF THE EXTERIOR GROUND RING OR OBJECTS BONDED TO THE EXTERIOR GROUND RING SHALL BE BONDED TO THE GROUND RING WITH A #2 AWG SOLID TINNED COPPER CONDUCTOR AT AN INTERVAL NOT EXCEEDING 25 FEET. BONDS SHALL BE MADE AT EACH GATE POST AND ACROSS GATE OPENINGS.
- EXTERIOR UNIT BONDS:** METALLIC OBJECTS, EXTERNAL TO OR MOUNTED TO THE BUILDING, SHALL BE BONDED TO THE EXTERIOR GROUND RING. USING #2 TINNED SOLID COPPER WIRE
- ICE BRIDGE SUPPORTS:** EACH ICE BRIDGE LEG SHALL BE BONDED TO THE GROUND RING WITH #2 AWG BARE TINNED COPPER CONDUCTOR. PROVIDE EXOTHERMIC WELDS AT BOTH THE ICE BRIDGE LEG AND BURIED GROUND RING.
- DURING ALL DC POWER SYSTEM CHANGES INCLUDING DC SYSTEM CHANGE OUTS, RECTIFIER REPLACEMENTS OR ADDITIONS, BREAKER DISTRIBUTION CHANGES, BATTERY ADDITIONS, BATTERY REPLACEMENTS AND INSTALLATIONS OR CHANGES TO DC CONVERTER SYSTEMS IT SHALL BE REQUIRED THAT SERVICE CONTRACTORS VERIFY ALL DC POWER SYSTEMS ARE EQUIPPED WITH A MASTER DC SYSTEM RETURN GROUND CONDUCTOR FROM THE DC POWER SYSTEM COMMON RETURN BUS DIRECTLY CONNECTED TO THE CELL SITE REFERENCE GROUND BAR**
- TOWER TOP COLLECTOR BUSS BAR IS TO BE MECHANICALLY BONDED TO PROPOSED ANTENNA MOUNT COLLAR. REFER TO DISH WIRELESS, L.L.C. GROUNDING NOTES.**

GROUNDING KEY NOTES

NO SCALE 3



5701 SOUTH SANTA FE DRIVE
LITTLETON, CO 80120



NB+C ENGINEERING SERVICES, L.L.C.
8601 SIX FORKS ROAD, SUITE 540
RALEIGH, NC 27615
(919) 657-9131

DRAWN BY:	CHECKED BY:	APPROVED BY:
PRI	BIW	BIW

RFDS REV #: 1

CONSTRUCTION DOCUMENTS

SUBMITTALS		
REV	DATE	DESCRIPTION
A	08/13/2021	ISSUED FOR REVIEW
D	09/13/2021	ISSUED FOR CONSTRUCTION



IT IS A VIOLATION OF LAW FOR ANY PERSON, UNLESS THEY ARE ACTING UNDER THE DIRECTION OF A LICENSED PROFESSIONAL ENGINEER, TO ALTER THIS DOCUMENT.

A&E PROJECT NUMBER
416862-13692184

DISH WIRELESS, L.L.C.
PROJECT INFORMATION
BOBDL0027A
106 SOUTH GRAND ST.
WEST SUFFIELD, CT 06093

SHEET TITLE
GROUNDING PLANS
AND NOTES

SHEET NUMBER

G-1

NOTES

EQUIPMENT CABINET OMITTED FOR CLARITY

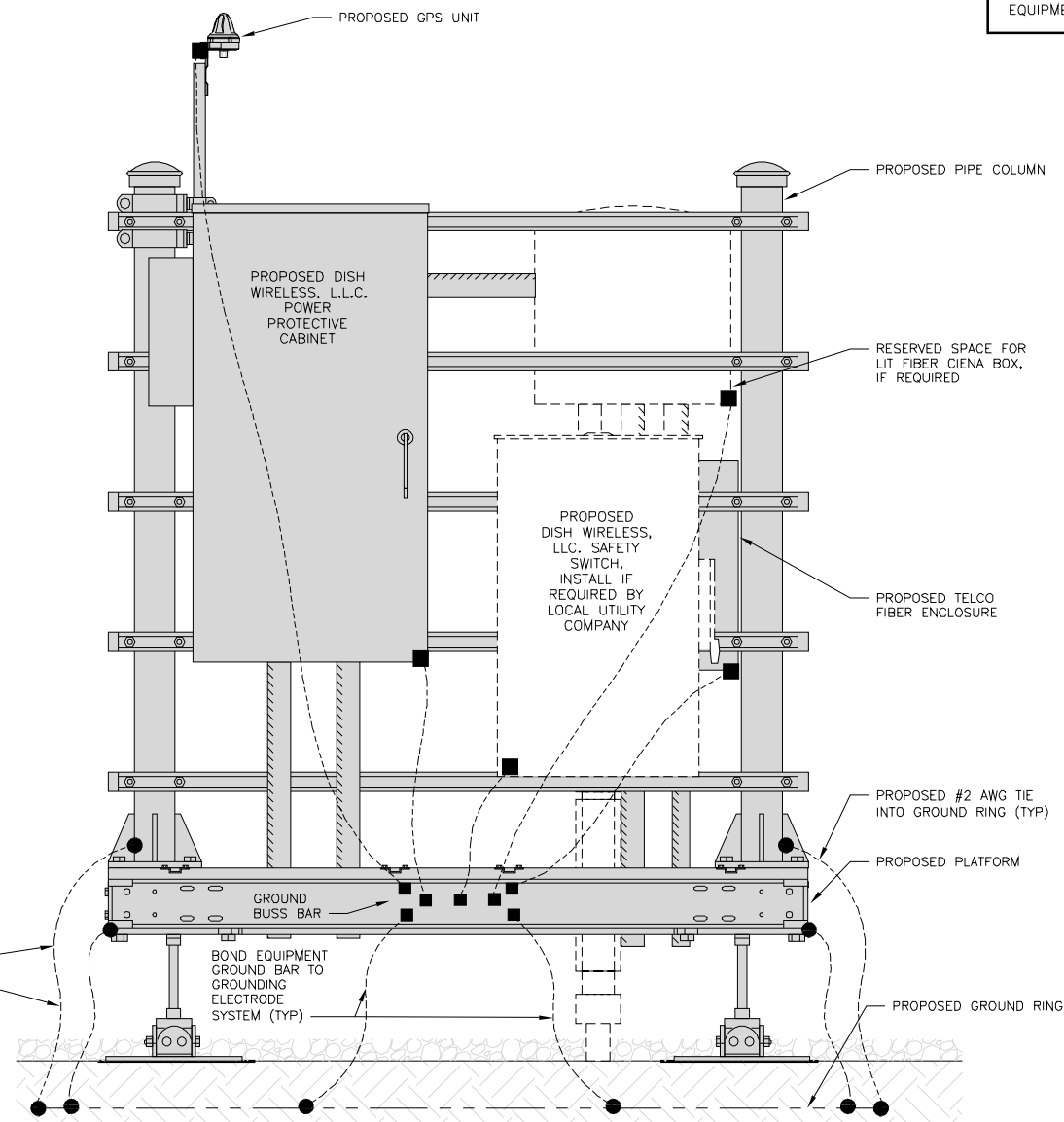

#2 TINNED SOLID IN 1/2" MIN. LIQUID TIGHT CONDUIT FROM 24" BELOW GRADE TO WITHIN 3" TO 6" OF CAD-WELD TERMINATION POINT. EXPOSED END OF THE LIQUID TIGHT CONDUIT MUST BE SEALED WITH SILICONE CAULK. (TYP)

H-FRAME GROUNDING DETAIL

NO SCALE 1

NOTES

CABLE GROUNDING NOT REQUIRED WHEN ANTENNA IS LESS THAN 10' FROM CABINET

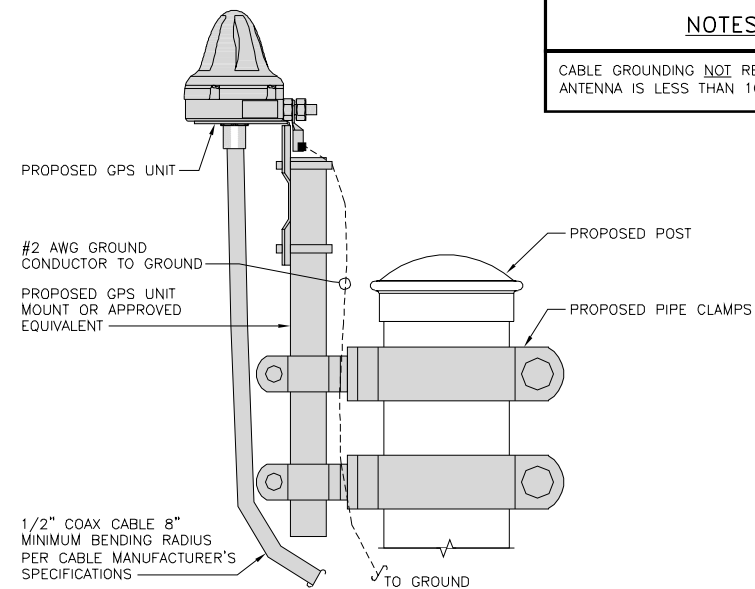

TYPICAL GPS UNIT GROUNDING

NO SCALE 2

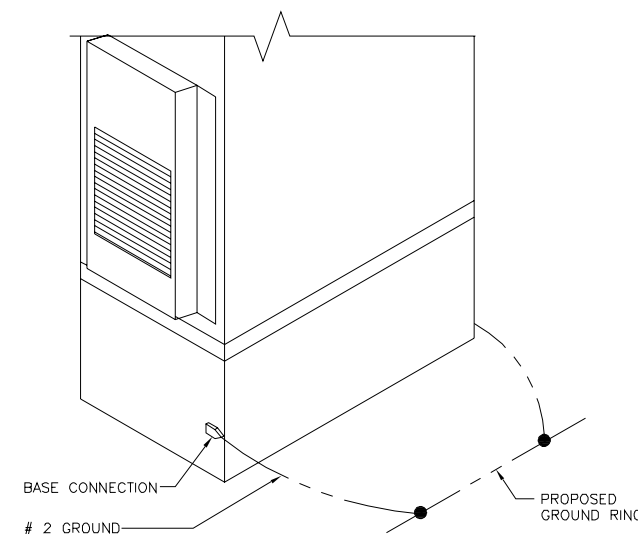

OUTDOOR CABINET GROUNDING

NO SCALE 3

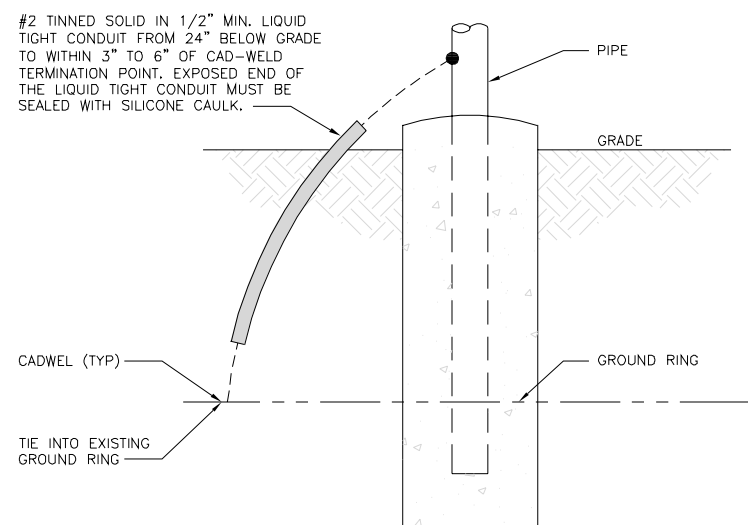

#2 TINNED SOLID IN 1/2" MIN. LIQUID TIGHT CONDUIT FROM 24" BELOW GRADE TO WITHIN 3" TO 6" OF CAD-WELD TERMINATION POINT. EXPOSED END OF THE LIQUID TIGHT CONDUIT MUST BE SEALED WITH SILICONE CAULK.

TRANSITIONING GROUND DETAIL

NO SCALE 4

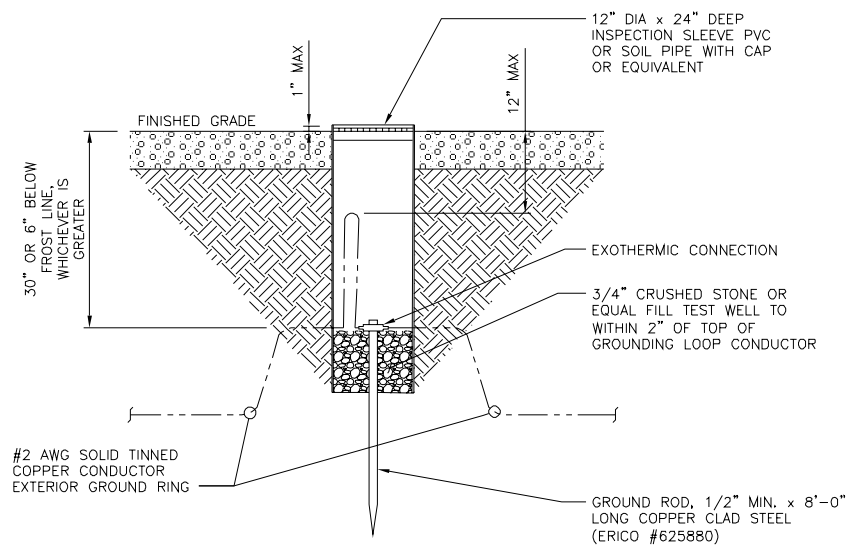

TYPICAL TEST GROUND ROD WITH INSPECTION SLEEVE

NO SCALE 5

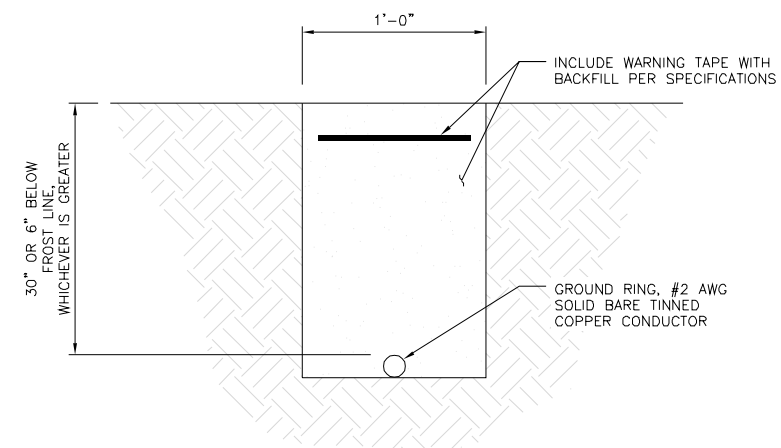

TYPICAL GROUND RING TRENCH

NO SCALE 6

dish
wireless.

5701 SOUTH SANTA FE DRIVE
LITTLETON, CO 80120

NB+C
TOTALLY COMMITTED.

NB+C ENGINEERING SERVICES, LLC.
8601 SIX FORKS ROAD, SUITE 540
RALEIGH, NC 27615
(919) 657-9131

DRAWN BY: CHECKED BY: APPROVED BY:
PRI BIW BIW

RFDS REV #: 1

CONSTRUCTION DOCUMENTS

SUBMITTALS		
REV	DATE	DESCRIPTION
A	08/13/2021	ISSUED FOR REVIEW
D	09/13/2021	ISSUED FOR CONSTRUCTION



IT IS A VIOLATION OF LAW FOR ANY PERSON, UNLESS THEY ARE ACTING UNDER THE DIRECTION OF A LICENSED PROFESSIONAL ENGINEER, TO ALTER THIS DOCUMENT.

A&E PROJECT NUMBER
416862-13692184

DISH WIRELESS, L.L.C.
PROJECT INFORMATION
BOBDL00027A
106 SOUTH GRAND ST.
WEST SUFFIELD, CT 06093

SHEET TITLE
GROUNDING DETAILS

SHEET NUMBER
G-2

1. EXOTHERMIC WELD (2) TWO, #2 AWG BARE TINNED SOLID COPPER CONDUCTORS TO GROUND BAR. ROUTE CONDUCTORS TO BURIED GROUND RING AND PROVIDE PARALLEL EXOTHERMIC WELD.
2. ALL EXTERIOR GROUNDING HARDWARE SHALL BE STAINLESS STEEL 3/8" DIAMETER OR LARGER. ALL HARDWARE 18-8 STAINLESS STEEL INCLUDING LOCK WASHERS, COAT ALL SURFACES WITH AN ANTI-OXIDANT COMPOUND BEFORE MATING.
3. FOR GROUND BOND TO STEEL ONLY: COAT ALL SURFACES WITH AN ANTI-OXIDANT COMPOUND BEFORE MATING.
4. DO NOT INSTALL CABLE GROUNDING KIT AT A BEND AND ALWAYS DIRECT GROUND CONDUCTOR DOWN TO GROUNDING BUS.
5. NUT & WASHER SHALL BE PLACED ON THE FRONT SIDE OF THE GROUND BAR AND BOLTED ON THE BACK SIDE.
6. ALL GROUNDING PARTS AND EQUIPMENT TO BE SUPPLIED AND INSTALLED BY CONTRACTOR.
7. THE CONTRACTOR SHALL BE RESPONSIBLE FOR INSTALLING ADDITIONAL GROUND BAR AS REQUIRED.
9. ENSURE THE WIRE INSULATION TERMINATION IS WITHIN 1/8" OF THE BARREL (NO SHINERS).

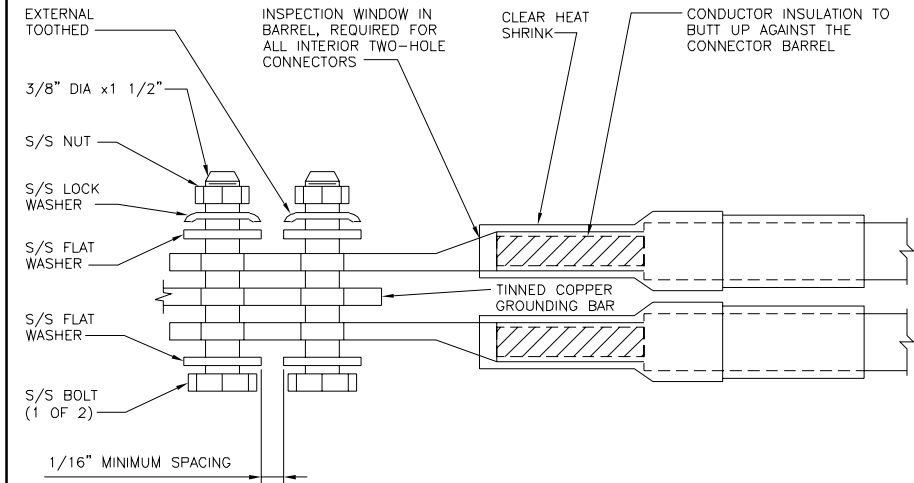
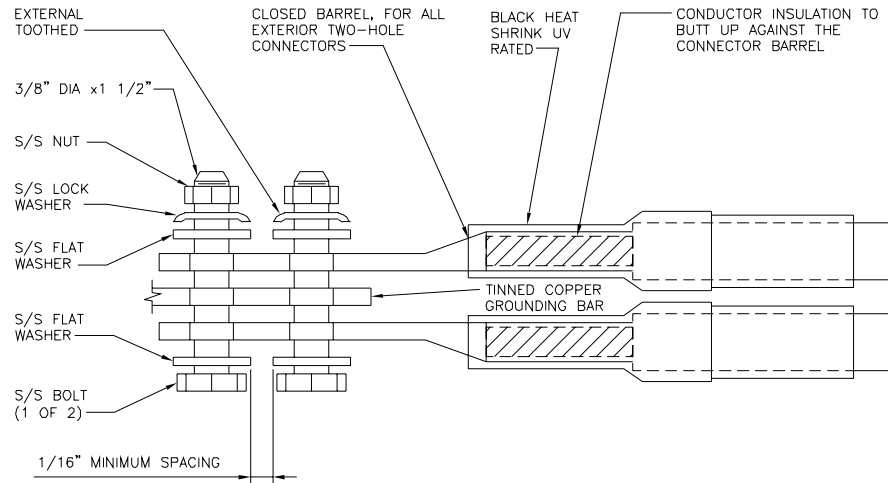

5701 SOUTH SANTA FE DRIVE
LITTLETON, CO 80120



NB+C ENGINEERING SERVICES, LLC.
8601 SIX FORKS ROAD, SUITE 540
RALEIGH, NC 27615
(919) 657-9131

DRAWN BY: CHECKED BY: APPROVED BY:
PRI BIW BIW

RFDS REV #: 1

CONSTRUCTION DOCUMENTS

SUBMITTALS		
REV	DATE	DESCRIPTION
A	08/13/2021	ISSUED FOR REVIEW
D	09/13/2021	ISSUED FOR CONSTRUCTION



IT IS A VIOLATION OF LAW FOR ANY PERSON, UNLESS THEY ARE ACTING UNDER THE DIRECTION OF A LICENSED PROFESSIONAL ENGINEER, TO ALTER THIS DOCUMENT.

A&E PROJECT NUMBER
416862-13692184

DISH WIRELESS, L.L.C.
PROJECT INFORMATION
BOBDL00027A
106 SOUTH GRAND ST.
WEST SUFFIELD, CT 06093

SHEET TITLE
GROUNDING DETAILS

SHEET NUMBER
G-3

TYPICAL GROUNDING NOTES

NO SCALE

1

TYPICAL EXTERIOR TWO HOLE LUG

NO SCALE

2

TYPICAL INTERIOR TWO HOLE LUG

NO SCALE

3

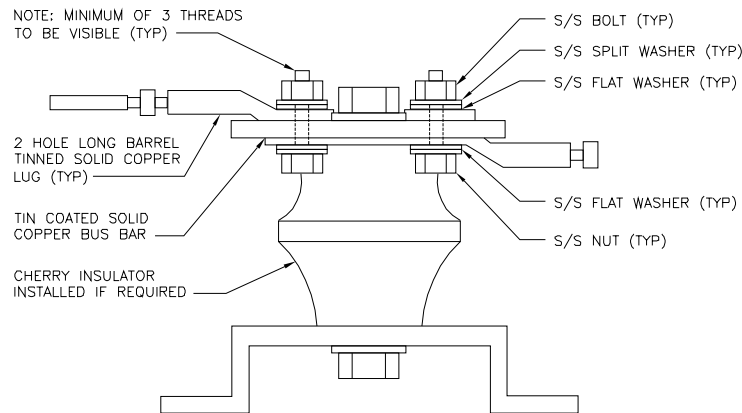

LUG DETAIL

NO SCALE

4

NOT USED

NO SCALE

5

NOT USED

NO SCALE

6

NOT USED

NO SCALE

7

NOT USED

NO SCALE

8

NOT USED

NO SCALE

9

RF JUMPER COLOR CODING

3/4" TAPE WIDTHS WITH 3/4" SPACING

LOW-BAND RRH -
(600MHz N71 BASEBAND) +
(850MHz N26 BAND) +
(700MHz N29 BAND) - OPTIONAL PER MARKET

ADD FREQUENCY COLOR TO SECTOR BAND
(CBRS WILL USE YELLOW BANDS)

ALPHA RRH				BETA RRH				GAMMA RRH			
PORT 1 + SLANT	PORT 2 - SLANT	PORT 3 + SLANT	PORT 4 - SLANT	PORT 1 + SLANT	PORT 2 - SLANT	PORT 3 + SLANT	PORT 4 - SLANT	PORT 1 + SLANT	PORT 2 - SLANT	PORT 3 + SLANT	PORT 4 - SLANT
RED	RED	RED	RED	BLUE	BLUE	BLUE	BLUE	GREEN	GREEN	GREEN	GREEN
ORANGE	ORANGE	RED	RED	ORANGE	ORANGE	BLUE	BLUE	ORANGE	ORANGE	GREEN	GREEN
	WHITE (-) PORT	ORANGE	ORANGE		WHITE (-) PORT	ORANGE	ORANGE		WHITE (-) PORT	ORANGE	ORANGE
			WHITE (-) PORT				WHITE (-) PORT				WHITE (-) PORT

MID-BAND RRH -
(AWS BANDS N66+N70)

ADD FREQUENCY COLOR TO SECTOR BAND
(CBRS WILL USE YELLOW BANDS)

RED	RED	RED	RED	BLUE	BLUE	BLUE	BLUE	GREEN	GREEN	GREEN	GREEN
PURPLE	PURPLE	RED	RED	PURPLE	PURPLE	BLUE	BLUE	PURPLE	PURPLE	GREEN	GREEN
	WHITE (-) PORT	PURPLE	PURPLE		WHITE (-) PORT	PURPLE	PURPLE		WHITE (-) PORT	PURPLE	PURPLE
			WHITE (-) PORT				WHITE (-) PORT				WHITE (-) PORT

HYBRID/DISCREET CABLES

INCLUDE SECTOR BANDS BEING SUPPORTED
ALONG WITH FREQUENCY BANDS

EXAMPLE 1 - HYBRID, OR DISCREET, SUPPORTS
ALL SECTORS, BOTH LOW-BANDS AND MID-BANDS

EXAMPLE 2 - HYBRID, OR DISCREET, SUPPORTS
CBRS ONLY, ALL SECTORS

EXAMPLE 1	EXAMPLE 2	EXAMPLE 3
RED	RED	RED
BLUE	BLUE	
GREEN	GREEN	
ORANGE	YELLOW	ORANGE
PURPLE		PURPLE

FIBER JUMPERS TO RRHs

LOW-BAND RRH FIBER CABLES HAVE SECTOR
STRIPE ONLY

LOW BAND RRH	HIGH BAND RRH	LOW BAND RRH	HIGH BAND RRH	LOW BAND RRH	HIGH BAND RRH
RED	RED	BLUE	BLUE	GREEN	GREEN
	PURPLE		PURPLE		PURPLE

POWER CABLES TO RRHs

LOW-BAND RRH POWER CABLES HAVE SECTOR
STRIPE ONLY

LOW BAND RRH	HIGH BAND RRH	LOW BAND RRH	HIGH BAND RRH	LOW BAND RRH	HIGH BAND RRH
RED	RED	BLUE	BLUE	GREEN	GREEN
	PURPLE		PURPLE		PURPLE

RET MOTORS AT ANTENNAS

ANTENNA 1 LOW BAND/ "IN"	ANTENNA 1 HIGH BAND/ "IN"	ANTENNA 1 LOW BAND/ "IN"	ANTENNA 1 HIGH BAND/ "IN"	ANTENNA 1 LOW BAND/ "IN"	ANTENNA 1 HIGH BAND/ "IN"
RED	RED	BLUE	BLUE	GREEN	GREEN
	PURPLE		PURPLE		PURPLE

MICROWAVE RADIO LINKS

LINKS WILL HAVE A 1.5-2 INCH WHITE WRAP WITH
THE AZIMUTH COLOR OVERLAPPING IN THE MIDDLE.
ADD ADDITIONAL SECTOR COLOR BANDS FOR EACH
ADDITIONAL MW RADIO.

MICROWAVE CABLES WILL REQUIRE P-TOUCH
LABELS INSIDE THE CABINET TO IDENTIFY THE
LOCAL AND REMOTE SITE ID'S

FORWARD AZIMUTH OF 0-120 DEGREES		FORWARD AZIMUTH OF 120-240 DEGREES		FORWARD AZIMUTH OF 240-360 DEGREES	
PRIMARY	SECONDARY	PRIMARY	SECONDARY	PRIMARY	SECONDARY
WHITE	WHITE	WHITE	WHITE	WHITE	WHITE
RED	RED	BLUE	BLUE	GREEN	GREEN
WHITE	WHITE	WHITE	WHITE	WHITE	WHITE
	RED		BLUE		GREEN
	WHITE		WHITE		WHITE

RF CABLE COLOR CODES

NO SCALE

1

LOW BANDS (N71+N26)
OPTIONAL - (N29)



CBRS TECH
(3 GHz)



AWS
(N66+N70+H-BLOCK)



NEGATIVE SLANT PORT
ON ANT/RRH



ALPHA SECTOR

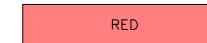

BETA SECTOR



GAMMA SECTOR



COLOR IDENTIFIER

NO SCALE

2

NOT USED

NO SCALE

3

NOT USED

NO SCALE

4



5701 SOUTH SANTA FE DRIVE
LITTLETON, CO 80120



NB+C ENGINEERING SERVICES, LLC.
8601 SIX FORKS ROAD, SUITE 540
RALEIGH, NC 27615
(919) 657-9131

DRAWN BY: CHECKED BY: APPROVED BY:
PRI BIW BIW

RFDS REV #: 1

CONSTRUCTION DOCUMENTS

SUBMITTALS		
REV	DATE	DESCRIPTION
A	08/13/2021	ISSUED FOR REVIEW
D	09/13/2021	ISSUED FOR CONSTRUCTION



IT IS A VIOLATION OF LAW FOR ANY PERSON,
UNLESS THEY ARE ACTING UNDER THE DIRECTION
OF A LICENSED PROFESSIONAL ENGINEER,
TO ALTER THIS DOCUMENT.

A&E PROJECT NUMBER
416862-13692184

DISH WIRELESS, L.L.C.
PROJECT INFORMATION
BOBDL00027A
106 SOUTH GRAND ST.
WEST SUFFIELD, CT 06093

SHEET TITLE
RF
CABLE COLOR CODES

SHEET NUMBER

RF-1

DRAWN BY: CHECKED BY: APPROVED BY:

PRI BIW BIW

RFDS REV #: 1

CONSTRUCTION DOCUMENTS

SUBMITTALS

REV	DATE	DESCRIPTION
A	08/13/2021	ISSUED FOR REVIEW
D	09/13/2021	ISSUED FOR CONSTRUCTION



IT IS A VIOLATION OF LAW FOR ANY PERSON, UNLESS THEY ARE ACTING UNDER THE DIRECTION OF A LICENSED PROFESSIONAL ENGINEER, TO ALTER THIS DOCUMENT.

A&E PROJECT NUMBER
416862-13692184

DISH WIRELESS, L.L.C.
PROJECT INFORMATION
BOBDL0027A
106 SOUTH GRAND ST.
WEST SUFFIELD, CT 06093

SHEET TITLE
RF
PLUMBING DIAGRAM

SHEET NUMBER

RF-2

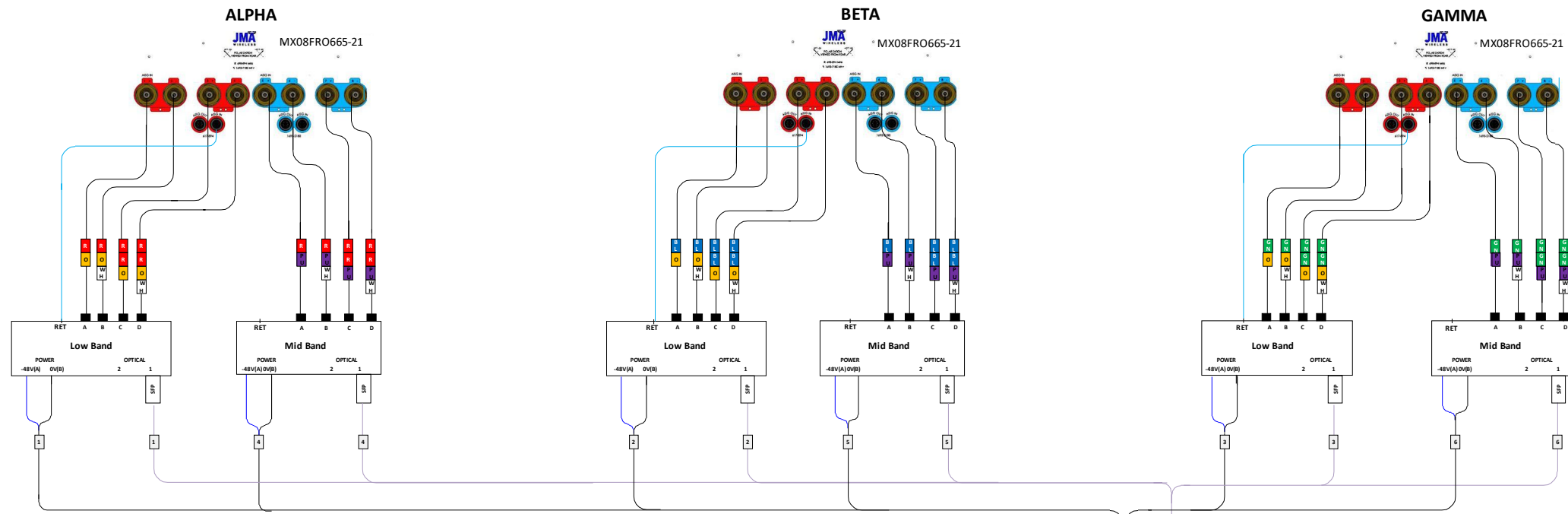

Fiber Patch Panel

Bottom Row	Pair 1	Pair 2	Pair 3	Pair 10	Open	Open
Middle Row	Pair 4	Pair 5	Pair 6	Pair 11	Open	Open
Top Row	Pair 7	Pair 8	Pair 9	Pair 12	Open	Open

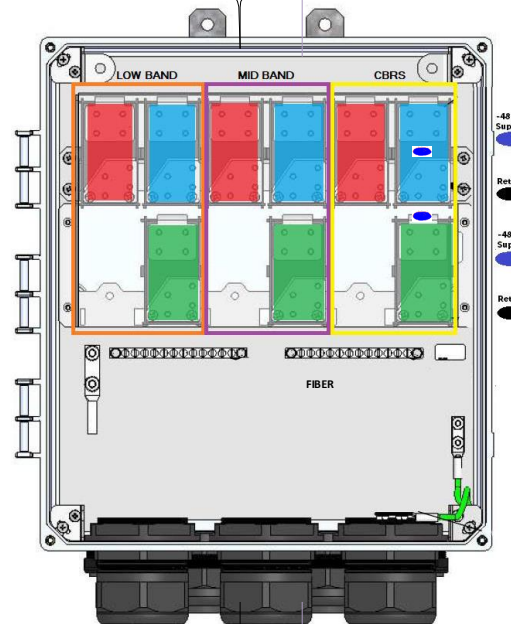

CSR NCS540

Port	Interface	Description
0	Gi0/0/0	SiteBoss
1	Gi0/0/1	CBRS - Alpha
2	Gi0/0/2	CBRS - Beta
3	Gi0/0/3	CBRS - Gamma
4	Te0/0/4	Fujitsu Low-Band RU - Alpha
5	Te0/0/5	Fujitsu Mid-Band RU - Alpha
6	Te0/0/6	Fujitsu Low-Band RU - Beta
7	Te0/0/7	Fujitsu Mid-Band RU - Beta
8	Te0/0/8	Fujitsu Low-Band RU - Gamma
9	Te0/0/9	Fujitsu Mid-Band RU - Gamma
10	Te0/0/10	Fixed Wifi
11	Te0/0/11	Fixed Wifi
12	Te0/0/12	Fixed Wifi
13	Te0/0/13	Fixed Wifi
14	Te0/0/14	CBRS1
15	Te0/0/15	CBRS2
16	Te0/0/16	CBRS3
17	Gi0/0/17	SM1 - BMC
18	Gi0/0/18	SM2 - BMC
19	Te0/0/19	SM1 - Data 1
20	Te0/0/20	SM1 - Data 2
21	Te0/0/21	SM2 - Data 1
22	Te0/0/22	SM2 - Data 2
23	Te0/0/23	Reserved Uplink (EDC, LDC)
24	Te0/0/24	Blank/Future
25	Te0/0/25	Blank/Future
26	Te0/0/26	Fiber NIU
27	Te0/0/27	Fiber NIU
28	Te0/0/28	Blank/Future
29	Te0/0/29	Blank/Future

top

bottom

Bottom OVP Layout

Circuit 1	Alpha Low Band
Circuit 2	Beta Low Band
Circuit 3	Gamma Low Band
Circuit 4	Alpha Mid Band
Circuit 5	Beta Mid Band
Circuit 6	Gamma Mid Band
Circuit 7	Alpha CBRS
Circuit 8	Beta CBRS
Circuit 9	Gamma CBRS
Circuit 10	Open
Circuit 11	Open
Circuit 12	Open

Bottom OVP
Specific OVP model
number detailed in
RFDS

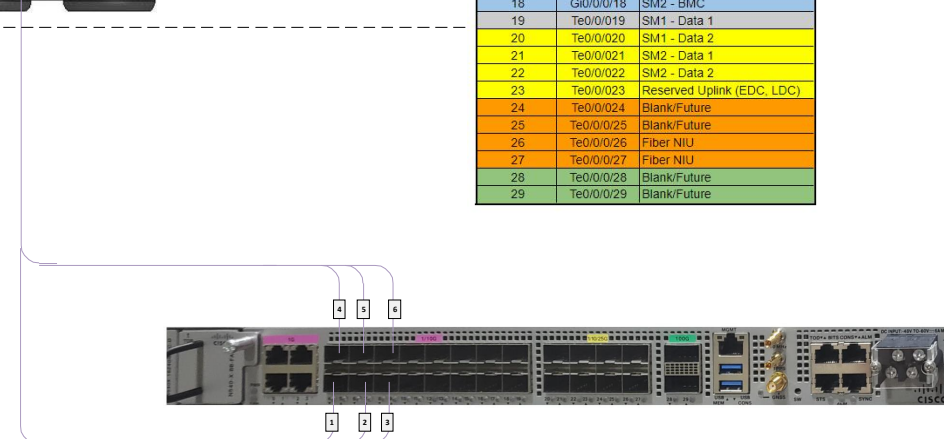
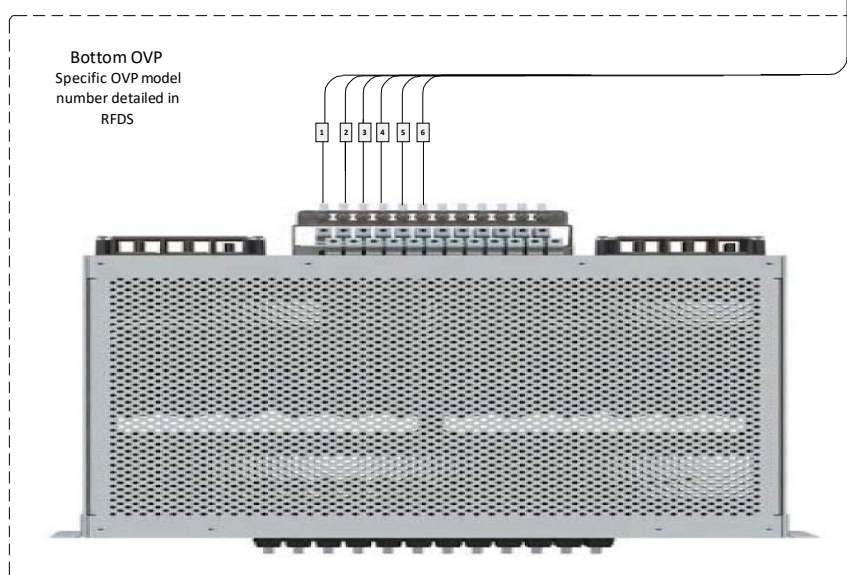

	5G plumbing diagram JMA MX08FRO665-21 2-2-2(LB+MB)			
	SIZE	FSCM NO	DWG NO	REV
Quan Liu				3
5-Jan-2021	SCALE: None		SHEET	

EXOTHERMIC CONNECTION
 MECHANICAL CONNECTION
 BUSS BAR INSULATOR
 CHEMICAL ELECTROLYTIC GROUNDING SYSTEM
 TEST CHEMICAL ELECTROLYTIC GROUNDING SYSTEM
 EXOTHERMIC WITH INSPECTION SLEEVE
 GROUNDING BAR
 GROUND ROD
 TEST GROUND ROD WITH INSPECTION SLEEVE
 SINGLE POLE SWITCH
 DUPLEX RECEPTACLE
 DUPLEX GFCI RECEPTACLE
 FLUORESCENT LIGHTING FIXTURE
 (2) TWO LAMPS 48-T8
 SMOKE DETECTION (DC)
 EMERGENCY LIGHTING (DC)
 SECURITY LIGHT W/PHOTOCELL LITHONIA ALXW
 LED-1-25A400/51K-SR4-120-PE-DEBTD

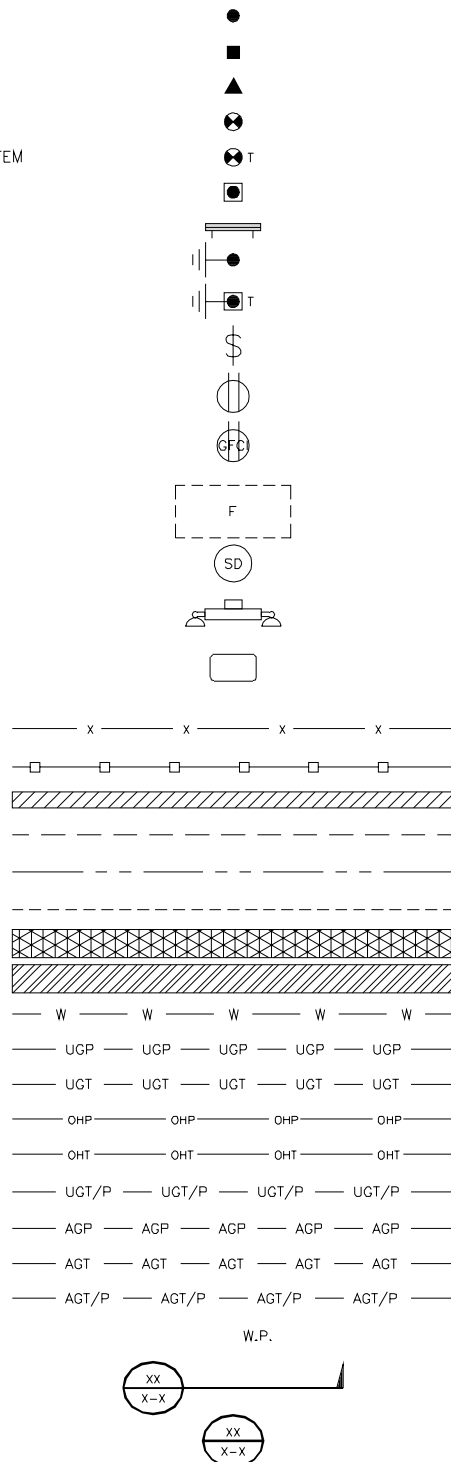

SECTION REFERENCE
 DETAIL REFERENCE

LEGEND

AB ANCHOR BOLT	IN INCH
ABV ABOVE	INT INTERIOR
AC ALTERNATING CURRENT	LB(S) POUND(S)
ADDL ADDITIONAL	LF LINEAR FEET
AFF ABOVE FINISHED FLOOR	LTE LONG TERM EVOLUTION
AFG ABOVE FINISHED GRADE	MAS MASONRY
AGL ABOVE GROUND LEVEL	MAX MAXIMUM
AIC AMPERAGE INTERRUPTION CAPACITY	MB MACHINE BOLT
ALUM ALUMINUM	MECH MECHANICAL
ALT ALTERNATE	MFR MANUFACTURER
ANT ANTENNA	MGB MASTER GROUND BAR
APPROX APPROXIMATE	MIN MINIMUM
ARCH ARCHITECTURAL	MISC MISCELLANEOUS
ATS AUTOMATIC TRANSFER SWITCH	MTL METAL
AWG AMERICAN WIRE GAUGE	MTS MANUAL TRANSFER SWITCH
BATT BATTERY	MW MICROWAVE
BLDG BUILDING	NEC NATIONAL ELECTRIC CODE
BLK BLOCK	NM NEWTON METERS
BLKG BLOCKING	NO. NUMBER
BM BEAM	# NUMBER
BTC BARE TINNED COPPER CONDUCTOR	NTS NOT TO SCALE
BOF BOTTOM OF FOOTING	OC ON-CENTER
CAB CABINET	OSHA OCCUPATIONAL SAFETY AND HEALTH ADMINISTRATION
CANT CANTILEVERED	OPNG OPENING
CHG CHARGING	P/C PRECAST CONCRETE
CLG CEILING	PCS PERSONAL COMMUNICATION SERVICES
CLR CLEAR	PCU PRIMARY CONTROL UNIT
COL COLUMN	PRC PRIMARY RADIO CABINET
COMM COMMON	PP POLARIZING PRESERVING
CONC CONCRETE	PSF POUNDS PER SQUARE FOOT
CONSTR CONSTRUCTION	PSI POUNDS PER SQUARE INCH
DBL DOUBLE	PT PRESSURE TREATED
DC DIRECT CURRENT	PWR POWER CABINET
DEPT DEPARTMENT	QTY QUANTITY
DF DOUGLAS FIR	RAD RADIUS
DIA DIAMETER	RECT RECTIFIER
DIAG DIAGONAL	REF REFERENCE
DIM DIMENSION	REINF REINFORCEMENT
DWG DRAWING	REQ'D REQUIRED
DWL DOWEL	RET REMOTE ELECTRIC TILT
EA EACH	RF RADIO FREQUENCY
EC ELECTRICAL CONDUCTOR	RMC RIGID METALLIC CONDUIT
EL ELEVATION	RRH REMOTE RADIO HEAD
ELEC ELECTRICAL	RRU REMOTE RADIO UNIT
EMT ELECTRICAL METALLIC TUBING	RWY RACEWAY
ENG ENGINEER	SCH SCHEDULE
EQ EQUAL	SHT SHEET
EXP EXPANSION	SIAD SMART INTEGRATED ACCESS DEVICE
EXT EXTERIOR	SIM SIMILAR
EW EACH WAY	SPEC SPECIFICATION
FAB FABRICATION	SQ SQUARE
FF FINISH FLOOR	SS STAINLESS STEEL
FG FINISH GRADE	STD STANDARD
FIF FACILITY INTERFACE FRAME	STL STEEL
FIN FINISH(ED)	TEMP TEMPORARY
FLR FLOOR	THK THICKNESS
FDN FOUNDATION	TMA TOWER MOUNTED AMPLIFIER
FOC FACE OF CONCRETE	TN TOE NAIL
FOM FACE OF MASONRY	TOA TOP OF ANTENNA
FOS FACE OF STUD	TOC TOP OF CURB
FOW FACE OF WALL	TOF TOP OF FOUNDATION
FS FINISH SURFACE	TOP TOP OF PLATE (PARAPET)
FT FOOT	TOS TOP OF STEEL
FTG FOOTING	TOW TOP OF WALL
GA GAUGE	TVSS TRANSIENT VOLTAGE SURGE SUPPRESSION
GEN GENERATOR	TYP TYPICAL
GFCI GROUND FAULT CIRCUIT INTERRUPTER	UG UNDERGROUND
GLB GLUE LAMINATED BEAM	UL UNDERWRITERS LABORATORY
GLV GALVANIZED	UNO UNLESS NOTED OTHERWISE
GPS GLOBAL POSITIONING SYSTEM	UMTS UNIVERSAL MOBILE TELECOMMUNICATIONS SYSTEM
GND GROUND	UPS UNINTERRUPTIBLE POWER SYSTEM (DC POWER PLANT)
GSM GLOBAL SYSTEM FOR MOBILE	VIF VERIFIED IN FIELD
HDG HOT DIPPED GALVANIZED	W WIDE
HDR HEADER	W/ WITH
HGR HANGER	WD WOOD
HVAC HEAT/VENTILATION/AIR CONDITIONING	WP WEATHERPROOF
HT HEIGHT	WT WEIGHT
IGR INTERIOR GROUND RING	

ABBREVIATIONS



5701 SOUTH SANTA FE DRIVE
 LITTLETON, CO 80120



NB+C ENGINEERING SERVICES, LLC.
 8601 SIX FORKS ROAD, SUITE 540
 RALEIGH, NC 27615
 (919) 657-9131

DRAWN BY:	CHECKED BY:	APPROVED BY:
PRI	BIW	BIW

RFDS REV #: 1

CONSTRUCTION DOCUMENTS

SUBMITTALS		
REV	DATE	DESCRIPTION
A	08/13/2021	ISSUED FOR REVIEW
D	09/13/2021	ISSUED FOR CONSTRUCTION



IT IS A VIOLATION OF LAW FOR ANY PERSON, UNLESS THEY ARE ACTING UNDER THE DIRECTION OF A LICENSED PROFESSIONAL ENGINEER, TO ALTER THIS DOCUMENT.

A&E PROJECT NUMBER
416862-13692184

DISH WIRELESS, L.L.C.
 PROJECT INFORMATION
BOBDL0027A
 106 SOUTH GRAND ST.
 WEST SUFFIELD, CT 06093

SHEET TITLE
LEGEND AND ABBREVIATIONS

SHEET NUMBER
GN-1

SITE ACTIVITY REQUIREMENTS:

1. NOTICE TO PROCEED – NO WORK SHALL COMMENCE PRIOR TO CONTRACTOR RECEIVING A WRITTEN NOTICE TO PROCEED (NTP) AND THE ISSUANCE OF A PURCHASE ORDER. PRIOR TO ACCESSING/ENTERING THE SITE YOU MUST CONTACT THE DISH WIRELESS, L.L.C. AND TOWER OWNER NOC & THE DISH WIRELESS, L.L.C. AND TOWER OWNER CONSTRUCTION MANAGER.
2. "LOOK UP" – DISH WIRELESS, L.L.C. AND TOWER OWNER SAFETY CLIMB REQUIREMENT:
THE INTEGRITY OF THE SAFETY CLIMB AND ALL COMPONENTS OF THE CLIMBING FACILITY SHALL BE CONSIDERED DURING ALL STAGES OF DESIGN, INSTALLATION, AND INSPECTION. TOWER MODIFICATION, MOUNT REINFORCEMENTS, AND/OR EQUIPMENT INSTALLATIONS SHALL NOT COMPROMISE THE INTEGRITY OR FUNCTIONAL USE OF THE SAFETY CLIMB OR ANY COMPONENTS OF THE CLIMBING FACILITY ON THE STRUCTURE. THIS SHALL INCLUDE, BUT NOT BE LIMITED TO: PINCHING OF THE WIRE ROPE, BENDING OF THE WIRE ROPE FROM ITS SUPPORTS, DIRECT CONTACT OR CLOSE PROXIMITY TO THE WIRE ROPE WHICH MAY CAUSE FRICTIONAL WEAR, IMPACT TO THE ANCHORAGE POINTS IN ANY WAY, OR TO IMPEDE/BLOCK ITS INTENDED USE. ANY COMPROMISED SAFETY CLIMB, INCLUDING EXISTING CONDITIONS MUST BE TAGGED OUT AND REPORTED TO YOUR DISH WIRELESS, L.L.C. AND DISH WIRELESS, L.L.C. AND TOWER OWNER POC OR CALL THE NOC TO GENERATE A SAFETY CLIMB MAINTENANCE AND CONTRACTOR NOTICE TICKET.
3. PRIOR TO THE START OF CONSTRUCTION, ALL REQUIRED JURISDICTIONAL PERMITS SHALL BE OBTAINED. THIS INCLUDES, BUT IS NOT LIMITED TO, BUILDING, ELECTRICAL, MECHANICAL, FIRE, FLOOD ZONE, ENVIRONMENTAL, AND ZONING. AFTER ONSITE ACTIVITIES AND CONSTRUCTION ARE COMPLETED, ALL REQUIRED PERMITS SHALL BE SATISFIED AND CLOSED OUT ACCORDING TO LOCAL JURISDICTIONAL REQUIREMENTS.
4. ALL CONSTRUCTION MEANS AND METHODS; INCLUDING BUT NOT LIMITED TO, ERECTION PLANS, RIGGING PLANS, CLIMBING PLANS, AND RESCUE PLANS SHALL BE THE RESPONSIBILITY OF THE GENERAL CONTRACTOR RESPONSIBLE FOR THE EXECUTION OF THE WORK CONTAINED HEREIN, AND SHALL MEET ANSI/ASSE A10.48 (LATEST EDITION); FEDERAL, STATE, AND LOCAL REGULATIONS; AND ANY APPLICABLE INDUSTRY CONSENSUS STANDARDS RELATED TO THE CONSTRUCTION ACTIVITIES BEING PERFORMED. ALL RIGGING PLANS SHALL ADHERE TO ANSI/ASSE A10.48 (LATEST EDITION) AND DISH WIRELESS, L.L.C. AND TOWER OWNER STANDARDS, INCLUDING THE REQUIRED INVOLVEMENT OF A QUALIFIED ENGINEER FOR CLASS IV CONSTRUCTION, TO CERTIFY THE SUPPORTING STRUCTURE(S) IN ACCORDANCE WITH ANSI/TIA-322 (LATEST EDITION).
5. ALL SITE WORK TO COMPLY WITH DISH WIRELESS, L.L.C. AND TOWER OWNER INSTALLATION STANDARDS FOR CONSTRUCTION ACTIVITIES ON DISH WIRELESS, L.L.C. AND TOWER OWNER TOWER SITE AND LATEST VERSION OF ANSI/TIA-1019-A-2012 "STANDARD FOR INSTALLATION, ALTERATION, AND MAINTENANCE OF ANTENNA SUPPORTING STRUCTURES AND ANTENNAS."
6. IF THE SPECIFIED EQUIPMENT CAN NOT BE INSTALLED AS SHOWN ON THESE DRAWINGS, THE CONTRACTOR SHALL PROPOSE AN ALTERNATIVE INSTALLATION FOR APPROVAL BY DISH WIRELESS, L.L.C. AND TOWER OWNER PRIOR TO PROCEEDING WITH ANY SUCH CHANGE OF INSTALLATION.
7. ALL MATERIALS FURNISHED AND INSTALLED SHALL BE IN STRICT ACCORDANCE WITH ALL APPLICABLE CODES, REGULATIONS AND ORDINANCES. CONTRACTOR SHALL ISSUE ALL APPROPRIATE NOTICES AND COMPLY WITH ALL LAWS, ORDINANCES, RULES, REGULATIONS AND LAWFUL ORDERS OF ANY PUBLIC AUTHORITY REGARDING THE PERFORMANCE OF THE WORK. ALL WORK CARRIED OUT SHALL COMPLY WITH ALL APPLICABLE MUNICIPAL AND UTILITY COMPANY SPECIFICATIONS AND LOCAL JURISDICTIONAL CODES, ORDINANCES AND APPLICABLE REGULATIONS.
8. THE CONTRACTOR SHALL INSTALL ALL EQUIPMENT AND MATERIALS IN ACCORDANCE WITH MANUFACTURER'S RECOMMENDATIONS UNLESS SPECIFICALLY STATED OTHERWISE.
9. THE CONTRACTOR SHALL CONTACT UTILITY LOCATING SERVICES INCLUDING PRIVATE LOCATES SERVICES PRIOR TO THE START OF CONSTRUCTION.
10. ALL EXISTING ACTIVE SEWER, WATER, GAS, ELECTRIC AND OTHER UTILITIES WHERE ENCOUNTERED IN THE WORK, SHALL BE PROTECTED AT ALL TIMES AND WHERE REQUIRED FOR THE PROPER EXECUTION OF THE WORK, SHALL BE RELOCATED AS DIRECTED BY CONTRACTOR. EXTREME CAUTION SHOULD BE USED BY THE CONTRACTOR WHEN EXCAVATING OR DRILLING PIERS AROUND OR NEAR UTILITIES. CONTRACTOR SHALL PROVIDE SAFETY TRAINING FOR THE WORKING CREW. THIS WILL INCLUDE BUT NOT BE LIMITED TO A) FALL PROTECTION B) CONFINED SPACE C) ELECTRICAL SAFETY D) TRENCHING AND EXCAVATION E) CONSTRUCTION SAFETY PROCEDURES.
11. ALL SITE WORK SHALL BE AS INDICATED ON THE STAMPED CONSTRUCTION DRAWINGS AND DISH PROJECT SPECIFICATIONS, LATEST APPROVED REVISION.
12. CONTRACTOR SHALL KEEP THE SITE FREE FROM ACCUMULATING WASTE MATERIAL, DEBRIS, AND TRASH AT THE COMPLETION OF THE WORK. IF NECESSARY, RUBBISH, STUMPS, DEBRIS, STICKS, STONES AND OTHER REFUSE SHALL BE REMOVED FROM THE SITE AND DISPOSED OF LEGALLY.
13. ALL EXISTING INACTIVE SEWER, WATER, GAS, ELECTRIC AND OTHER UTILITIES, WHICH INTERFERE WITH THE EXECUTION OF THE WORK, SHALL BE REMOVED AND/OR CAPPED, PLUGGED OR OTHERWISE DISCONTINUED AT POINTS WHICH WILL NOT INTERFERE WITH THE EXECUTION OF THE WORK, SUBJECT TO THE APPROVAL OF DISH WIRELESS, L.L.C. AND TOWER OWNER, AND/OR LOCAL UTILITIES.
14. THE CONTRACTOR SHALL PROVIDE SITE SIGNAGE IN ACCORDANCE WITH THE TECHNICAL SPECIFICATION FOR SITE SIGNAGE REQUIRED BY LOCAL JURISDICTION AND SIGNAGE REQUIRED ON INDIVIDUAL PIECES OF EQUIPMENT, ROOMS, AND SHELTERS.
15. THE SITE SHALL BE GRADED TO CAUSE SURFACE WATER TO FLOW AWAY FROM THE CARRIER'S EQUIPMENT AND TOWER AREAS.
16. THE SUB GRADE SHALL BE COMPACTED AND BROUGHT TO A SMOOTH UNIFORM GRADE PRIOR TO FINISHED SURFACE APPLICATION.
17. THE AREAS OF THE OWNERS PROPERTY DISTURBED BY THE WORK AND NOT COVERED BY THE TOWER, EQUIPMENT OR DRIVEWAY, SHALL BE GRADED TO A UNIFORM SLOPE, AND STABILIZED TO PREVENT EROSION AS SPECIFIED ON THE CONSTRUCTION DRAWINGS AND/OR PROJECT SPECIFICATIONS.
18. CONTRACTOR SHALL MINIMIZE DISTURBANCE TO EXISTING SITE DURING CONSTRUCTION. EROSION CONTROL MEASURES, IF REQUIRED DURING CONSTRUCTION, SHALL BE IN CONFORMANCE WITH THE LOCAL GUIDELINES FOR EROSION AND SEDIMENT CONTROL.
19. THE CONTRACTOR SHALL PROTECT EXISTING IMPROVEMENTS, PAVEMENTS, CURBS, LANDSCAPING AND STRUCTURES. ANY DAMAGED PART SHALL BE REPAIRED AT CONTRACTOR'S EXPENSE TO THE SATISFACTION OF OWNER.
20. CONTRACTOR SHALL LEGALLY AND PROPERLY DISPOSE OF ALL SCRAP MATERIALS SUCH AS COAXIAL CABLES AND OTHER ITEMS REMOVED FROM THE EXISTING FACILITY. ANTENNAS AND RADIOS REMOVED SHALL BE RETURNED TO THE OWNER'S DESIGNATED LOCATION.
21. CONTRACTOR SHALL LEAVE PREMISES IN CLEAN CONDITION. TRASH AND DEBRIS SHOULD BE REMOVED FROM SITE ON A DAILY BASIS.
22. NO FILL OR EMBANKMENT MATERIAL SHALL BE PLACED ON FROZEN GROUND. FROZEN MATERIALS, SNOW OR ICE SHALL NOT BE PLACED IN ANY FILL OR EMBANKMENT.

GENERAL NOTES:

1. FOR THE PURPOSE OF CONSTRUCTION DRAWING, THE FOLLOWING DEFINITIONS SHALL APPLY:
CONTRACTOR: GENERAL CONTRACTOR RESPONSIBLE FOR CONSTRUCTION
CARRIER: DISH WIRELESS, L.L.C.
TOWER OWNER: TOWER OWNER
2. THESE DRAWINGS HAVE BEEN PREPARED USING STANDARDS OF PROFESSIONAL CARE AND COMPLETENESS NORMALLY EXERCISED UNDER SIMILAR CIRCUMSTANCES BY REPUTABLE ENGINEERS IN THIS OR SIMILAR LOCALITIES. IT IS ASSUMED THAT THE WORK DEPICTED WILL BE PERFORMED BY AN EXPERIENCED CONTRACTOR AND/OR WORKPEOPLE WHO HAVE A WORKING KNOWLEDGE OF THE APPLICABLE CODE STANDARDS AND REQUIREMENTS AND OF INDUSTRY ACCEPTED STANDARD GOOD PRACTICE. AS NOT EVERY CONDITION OR ELEMENT IS (OR CAN BE) EXPLICITLY SHOWN ON THESE DRAWINGS, THE CONTRACTOR SHALL USE INDUSTRY ACCEPTED STANDARD GOOD PRACTICE FOR MISCELLANEOUS WORK NOT EXPLICITLY SHOWN.
3. THESE DRAWINGS REPRESENT THE FINISHED STRUCTURE. THEY DO NOT INDICATE THE MEANS OR METHODS OF CONSTRUCTION. THE CONTRACTOR SHALL BE SOLELY RESPONSIBLE FOR THE CONSTRUCTION MEANS, METHODS, TECHNIQUES, SEQUENCES, AND PROCEDURES. THE CONTRACTOR SHALL PROVIDE ALL MEASURES NECESSARY FOR PROTECTION OF LIFE AND PROPERTY DURING CONSTRUCTION. SUCH MEASURES SHALL INCLUDE, BUT NOT BE LIMITED TO, BRACING, FORMWORK, SHORING, ETC. SITE VISITS BY THE ENGINEER OR HIS REPRESENTATIVE WILL NOT INCLUDE INSPECTION OF THESE ITEMS AND IS FOR STRUCTURAL OBSERVATION OF THE FINISHED STRUCTURE ONLY.
4. NOTES AND DETAILS IN THE CONSTRUCTION DRAWINGS SHALL TAKE PRECEDENCE OVER GENERAL NOTES AND TYPICAL DETAILS. WHERE NO DETAILS ARE SHOWN, CONSTRUCTION SHALL CONFORM TO SIMILAR WORK ON THE PROJECT, AND/OR AS PROVIDED FOR IN THE CONTRACT DOCUMENTS. WHERE DISCREPANCIES OCCUR BETWEEN PLANS, DETAILS, GENERAL NOTES, AND SPECIFICATIONS, THE GREATER, MORE STRICT REQUIREMENTS, SHALL GOVERN. IF FURTHER CLARIFICATION IS REQUIRED CONTACT THE ENGINEER OF RECORD.
5. SUBSTANTIAL EFFORT HAS BEEN MADE TO PROVIDE ACCURATE DIMENSIONS AND MEASUREMENTS ON THE DRAWINGS TO ASSIST IN THE FABRICATION AND/OR PLACEMENT OF CONSTRUCTION ELEMENTS BUT IT IS THE SOLE RESPONSIBILITY OF THE CONTRACTOR TO FIELD VERIFY THE DIMENSIONS, MEASUREMENTS, AND/OR CLEARANCES SHOWN IN THE CONSTRUCTION DRAWINGS PRIOR TO FABRICATION OR CUTTING OF ANY NEW OR EXISTING CONSTRUCTION ELEMENTS. IF IT IS DETERMINED THAT THERE ARE DISCREPANCIES AND/OR CONFLICTS WITH THE CONSTRUCTION DRAWINGS THE ENGINEER OF RECORD IS TO BE NOTIFIED AS SOON AS POSSIBLE.
6. PRIOR TO THE SUBMISSION OF BIDS, THE BIDDING CONTRACTOR SHALL VISIT THE CELL SITE TO FAMILIARIZE WITH THE EXISTING CONDITIONS AND TO CONFIRM THAT THE WORK CAN BE ACCOMPLISHED AS SHOWN ON THE CONSTRUCTION DRAWINGS. ANY DISCREPANCY FOUND SHALL BE BROUGHT TO THE ATTENTION OF CARRIER POC AND TOWER OWNER.
7. ALL MATERIALS FURNISHED AND INSTALLED SHALL BE IN STRICT ACCORDANCE WITH ALL APPLICABLE CODES, REGULATIONS AND ORDINANCES. CONTRACTOR SHALL ISSUE ALL APPROPRIATE NOTICES AND COMPLY WITH ALL LAWS, ORDINANCES, RULES, REGULATIONS AND LAWFUL ORDERS OF ANY PUBLIC AUTHORITY REGARDING THE PERFORMANCE OF THE WORK. ALL WORK CARRIED OUT SHALL COMPLY WITH ALL APPLICABLE MUNICIPAL AND UTILITY COMPANY SPECIFICATIONS AND LOCAL JURISDICTIONAL CODES, ORDINANCES AND APPLICABLE REGULATIONS.
8. UNLESS NOTED OTHERWISE, THE WORK SHALL INCLUDE FURNISHING MATERIALS, EQUIPMENT, APPURTENANCES AND LABOR NECESSARY TO COMPLETE ALL INSTALLATIONS AS INDICATED ON THE DRAWINGS.
9. THE CONTRACTOR SHALL INSTALL ALL EQUIPMENT AND MATERIALS IN ACCORDANCE WITH MANUFACTURER'S RECOMMENDATIONS UNLESS SPECIFICALLY STATED OTHERWISE.
10. IF THE SPECIFIED EQUIPMENT CAN NOT BE INSTALLED AS SHOWN ON THESE DRAWINGS, THE CONTRACTOR SHALL PROPOSE AN ALTERNATIVE INSTALLATION FOR APPROVAL BY THE CARRIER AND TOWER OWNER PRIOR TO PROCEEDING WITH ANY SUCH CHANGE OF INSTALLATION.
11. CONTRACTOR IS TO PERFORM A SITE INVESTIGATION, BEFORE SUBMITTING BIDS, TO DETERMINE THE BEST ROUTING OF ALL CONDUITS FOR POWER, AND TELCO AND FOR GROUNDING CABLES AS SHOWN IN THE POWER, TELCO, AND GROUNDING PLAN DRAWINGS.
12. THE CONTRACTOR SHALL PROTECT EXISTING IMPROVEMENTS, PAVEMENTS, CURBS, LANDSCAPING AND STRUCTURES. ANY DAMAGED PART SHALL BE REPAIRED AT CONTRACTOR'S EXPENSE TO THE SATISFACTION OF DISH WIRELESS, L.L.C. AND TOWER OWNER
13. CONTRACTOR SHALL LEGALLY AND PROPERLY DISPOSE OF ALL SCRAP MATERIALS SUCH AS COAXIAL CABLES AND OTHER ITEMS REMOVED FROM THE EXISTING FACILITY. ANTENNAS REMOVED SHALL BE RETURNED TO THE OWNER'S DESIGNATED LOCATION.
14. CONTRACTOR SHALL LEAVE PREMISES IN CLEAN CONDITION. TRASH AND DEBRIS SHOULD BE REMOVED FROM SITE ON A DAILY BASIS.



5701 SOUTH SANTA FE DRIVE
LITTLETON, CO 80120



NB+C ENGINEERING SERVICES, LLC.
8601 SIX FORKS ROAD, SUITE 540
RALEIGH, NC 27615
(919) 657-9131

DRAWN BY:	CHECKED BY:	APPROVED BY:
PRI	BIW	BIW

RFDS REV #: 1

CONSTRUCTION DOCUMENTS

SUBMITTALS		
REV	DATE	DESCRIPTION
A	08/13/2021	ISSUED FOR REVIEW
D	09/13/2021	ISSUED FOR CONSTRUCTION



IT IS A VIOLATION OF LAW FOR ANY PERSON, UNLESS THEY ARE ACTING UNDER THE DIRECTION OF A LICENSED PROFESSIONAL ENGINEER, TO ALTER THIS DOCUMENT.

A&E PROJECT NUMBER
416862-13692184

DISH WIRELESS, L.L.C.
PROJECT INFORMATION
BOBDL0027A
106 SOUTH GRAND ST.
WEST SUFFIELD, CT 06093

SHEET TITLE
GENERAL NOTES

SHEET NUMBER
GN-2

CONCRETE, FOUNDATIONS, AND REINFORCING STEEL:

1. ALL CONCRETE WORK SHALL BE IN ACCORDANCE WITH THE ACI 301, ACI 318, ACI 336, ASTM A184, ASTM A185 AND THE DESIGN AND CONSTRUCTION SPECIFICATION FOR CAST-IN-PLACE CONCRETE.
2. UNLESS NOTED OTHERWISE, SOIL BEARING PRESSURE USED FOR DESIGN OF SLABS AND FOUNDATIONS IS ASSUMED TO BE 1000 psf.
3. ALL CONCRETE SHALL HAVE A MINIMUM COMPRESSIVE STRENGTH (f'c) OF 3000 psi AT 28 DAYS, UNLESS NOTED OTHERWISE. NO MORE THAN 90 MINUTES SHALL ELAPSE FROM BATCH TIME TO TIME OF PLACEMENT UNLESS APPROVED BY THE ENGINEER OF RECORD. TEMPERATURE OF CONCRETE SHALL NOT EXCEED 90°f AT TIME OF PLACEMENT.
4. CONCRETE EXPOSED TO FREEZE-THAW CYCLES SHALL CONTAIN AIR ENTRAINING ADMIXTURES. AMOUNT OF AIR ENTRAINMENT TO BE BASED ON SIZE OF AGGREGATE AND F3 CLASS EXPOSURE (VERY SEVERE). CEMENT USED TO BE TYPE II PORTLAND CEMENT WITH A MAXIMUM WATER-TO-CEMENT RATIO (W/C) OF 0.45.
5. ALL STEEL REINFORCING SHALL CONFORM TO ASTM A615. ALL WELDED WIRE FABRIC (WWF) SHALL CONFORM TO ASTM A185. ALL SPLICES SHALL BE CLASS "B" TENSION SPLICES, UNLESS NOTED OTHERWISE. ALL HOOKS SHALL BE STANDARD 90 DEGREE HOOKS, UNLESS NOTED OTHERWISE. YIELD STRENGTH (Fy) OF STANDARD DEFORMED BARS ARE AS FOLLOWS:
 - #4 BARS AND SMALLER 40 ksi
 - #5 BARS AND LARGER 60 ksi
6. THE FOLLOWING MINIMUM CONCRETE COVER SHALL BE PROVIDED FOR REINFORCING STEEL UNLESS SHOWN OTHERWISE ON DRAWINGS:
 - CONCRETE CAST AGAINST AND PERMANENTLY EXPOSED TO EARTH 3"
 - CONCRETE EXPOSED TO EARTH OR WEATHER:
 - #6 BARS AND LARGER 2"
 - #5 BARS AND SMALLER 1-1/2"
 - CONCRETE NOT EXPOSED TO EARTH OR WEATHER:
 - SLAB AND WALLS 3/4"
 - BEAMS AND COLUMNS 1-1/2"
7. A TOOLED EDGE OR A 3/4" CHAMFER SHALL BE PROVIDED AT ALL EXPOSED EDGES OF CONCRETE, UNLESS NOTED OTHERWISE, IN ACCORDANCE WITH ACI 301 SECTION 4.2.4.

ELECTRICAL INSTALLATION NOTES:

1. ALL ELECTRICAL WORK SHALL BE PERFORMED IN ACCORDANCE WITH THE PROJECT SPECIFICATIONS, NEC AND ALL APPLICABLE FEDERAL, STATE, AND LOCAL CODES/ORDINANCES.
2. CONDUIT ROUTINGS ARE SCHEMATIC. CONTRACTOR SHALL INSTALL CONDUITS SO THAT ACCESS TO EQUIPMENT IS NOT BLOCKED AND TRIP HAZARDS ARE ELIMINATED.
3. WIRING, RACEWAY AND SUPPORT METHODS AND MATERIALS SHALL COMPLY WITH THE REQUIREMENTS OF THE NEC.
4. ALL CIRCUITS SHALL BE SEGREGATED AND MAINTAIN MINIMUM CABLE SEPARATION AS REQUIRED BY THE NEC.
 - 4.1. ALL EQUIPMENT SHALL BEAR THE UNDERWRITERS LABORATORIES LABEL OF APPROVAL, AND SHALL CONFORM TO REQUIREMENT OF THE NATIONAL ELECTRICAL CODE.
 - 4.2. ALL OVERCURRENT DEVICES SHALL HAVE AN INTERRUPTING CURRENT RATING THAT SHALL BE GREATER THAN THE SHORT CIRCUIT CURRENT TO WHICH THEY ARE SUBJECTED, 22,000 AIC MINIMUM. VERIFY AVAILABLE SHORT CIRCUIT CURRENT DOES NOT EXCEED THE RATING OF ELECTRICAL EQUIPMENT IN ACCORDANCE WITH ARTICLE 110.24 NEC OR THE MOST CURRENT ADOPTED CODE PRE THE GOVERNING JURISDICTION.
5. EACH END OF EVERY POWER PHASE CONDUCTOR, GROUNDING CONDUCTOR, AND TELCO CONDUCTOR OR CABLE SHALL BE LABELED WITH COLOR-CODED INSULATION OR ELECTRICAL TAPE (3M BRAND, 1/2" PLASTIC ELECTRICAL TAPE WITH UV PROTECTION, OR EQUAL). THE IDENTIFICATION METHOD SHALL CONFORM WITH NEC AND OSHA.
6. ALL ELECTRICAL COMPONENTS SHALL BE CLEARLY LABELED WITH LAMICOID TAGS SHOWING THEIR RATED VOLTAGE, PHASE CONFIGURATION, WIRE CONFIGURATION, POWER OR AMPACITY RATING AND BRANCH CIRCUIT ID NUMBERS (i.e. PANEL BOARD AND CIRCUIT ID'S).
7. PANEL BOARDS (ID NUMBERS) SHALL BE CLEARLY LABELED WITH PLASTIC LABELS.
8. TIE WRAPS ARE NOT ALLOWED.
9. ALL POWER AND EQUIPMENT GROUND WIRING IN TUBING OR CONDUIT SHALL BE SINGLE COPPER CONDUCTOR (#14 OR LARGER) WITH TYPE THHW, THWN, THWN-2, XHHW, XHHW-2, THW, THW-2, RHW, OR RHW-2 INSULATION UNLESS OTHERWISE SPECIFIED.
10. SUPPLEMENTAL EQUIPMENT GROUND WIRING LOCATED INDOORS SHALL BE SINGLE COPPER CONDUCTOR (#6 OR LARGER) WITH TYPE THHW, THWN, THWN-2, XHHW, XHHW-2, THW, THW-2, RHW, OR RHW-2 INSULATION UNLESS OTHERWISE SPECIFIED.
11. POWER AND CONTROL WIRING IN FLEXIBLE CORD SHALL BE MULTI-CONDUCTOR, TYPE SOOW CORD (#14 OR LARGER) UNLESS OTHERWISE SPECIFIED.
12. POWER AND CONTROL WIRING FOR USE IN CABLE TRAY SHALL BE MULTI-CONDUCTOR, TYPE TC CABLE (#14 OR LARGER), WITH TYPE THHW, THWN, THWN-2, XHHW, XHHW-2, THW, THW-2, RHW, OR RHW-2 INSULATION UNLESS OTHERWISE SPECIFIED.
13. ALL POWER AND GROUNDING CONNECTIONS SHALL BE CRIMP-STYLE, COMPRESSION WIRE LUGS AND WIRE NUTS BY THOMAS AND BETTS (OR EQUAL). LUGS AND WIRE NUTS SHALL BE RATED FOR OPERATION NOT LESS THAN 75° C (90° C IF AVAILABLE).
14. RACEWAY AND CABLE TRAY SHALL BE LISTED OR LABELED FOR ELECTRICAL USE IN ACCORDANCE WITH NEMA, UL, ANSI/IEEE AND NEC.
15. ELECTRICAL METALLIC TUBING (EMT), INTERMEDIATE METAL CONDUIT (IMC), OR RIGID METAL CONDUIT (RMC) SHALL BE USED FOR EXPOSED INDOOR LOCATIONS.

16. ELECTRICAL METALLIC TUBING (EMT) OR METAL-CLAD CABLE (MC) SHALL BE USED FOR CONCEALED INDOOR LOCATIONS.
17. SCHEDULE 40 PVC UNDERGROUND ON STRAIGHTS AND SCHEDULE 80 PVC FOR ALL ELBOWS/90s AND ALL APPROVED ABOVE GRADE PVC CONDUIT.
18. LIQUID-TIGHT FLEXIBLE METALLIC CONDUIT (LIQUID-TITE FLEX) SHALL BE USED INDOORS AND OUTDOORS, WHERE VIBRATION OCCURS OR FLEXIBILITY IS NEEDED.
19. CONDUIT AND TUBING FITTINGS SHALL BE THREADED OR COMPRESSION-TYPE AND APPROVED FOR THE LOCATION USED. SET SCREW FITTINGS ARE NOT ACCEPTABLE.
20. CABINETS, BOXES AND WIRE WAYS SHALL BE LABELED FOR ELECTRICAL USE IN ACCORDANCE WITH NEMA, UL, ANSI/IEEE AND THE NEC.
21. WIREWAYS SHALL BE METAL WITH AN ENAMEL FINISH AND INCLUDE A HINGED COVER, DESIGNED TO SWING OPEN DOWNWARDS (WIREMOLD SPECMATE WIREWAY).
22. SLOTTED WIRING DUCT SHALL BE PVC AND INCLUDE COVER (PANDUIT TYPE E OR EQUAL).
23. CONDUITS SHALL BE FASTENED SECURELY IN PLACE WITH APPROVED NON-PERFORATED STRAPS AND HANGERS. EXPLOSIVE DEVICES (i.e. POWDER-ACTUATED) FOR ATTACHING HANGERS TO STRUCTURE WILL NOT BE PERMITTED. CLOSELY FOLLOW THE LINES OF THE STRUCTURE, MAINTAIN CLOSE PROXIMITY TO THE STRUCTURE AND KEEP CONDUITS IN TIGHT ENVELOPES. CHANGES IN DIRECTION TO ROUTE AROUND OBSTACLES SHALL BE MADE WITH CONDUIT OUTLET BODIES. CONDUIT SHALL BE INSTALLED IN A NEAT AND WORKMANLIKE MANNER. PARALLEL AND PERPENDICULAR TO STRUCTURE WALL AND CEILING LINES. ALL CONDUIT SHALL BE FISHED TO CLEAR OBSTRUCTIONS. ENDS OF CONDUITS SHALL BE TEMPORARILY CAPPED FLUSH TO FINISH GRADE TO PREVENT CONCRETE, PLASTER OR DIRT FROM ENTERING. CONDUITS SHALL BE RIGIDLY CLAMPED TO BOXES BY GALVANIZED MALLEABLE IRON BUSHING ON INSIDE AND GALVANIZED MALLEABLE IRON LOCKNUT ON OUTSIDE AND INSIDE.
24. EQUIPMENT CABINETS, TERMINAL BOXES, JUNCTION BOXES AND PULL BOXES SHALL BE GALVANIZED OR EPOXY-COATED SHEET STEEL. SHALL MEET OR EXCEED UL 50 AND BE RATED NEMA 1 (OR BETTER) FOR INTERIOR LOCATIONS AND NEMA 3 (OR BETTER) FOR EXTERIOR LOCATIONS.
25. METAL RECEPTACLE, SWITCH AND DEVICE BOXES SHALL BE GALVANIZED, EPOXY-COATED OR NON-CORRODING; SHALL MEET OR EXCEED UL 514A AND NEMA OS 1 AND BE RATED NEMA 1 (OR BETTER) FOR INTERIOR LOCATIONS AND WEATHER PROTECTED (WP OR BETTER) FOR EXTERIOR LOCATIONS.
26. NONMETALLIC RECEPTACLE, SWITCH AND DEVICE BOXES SHALL MEET OR EXCEED NEMA OS 2 (NEWEST REVISION) AND BE RATED NEMA 1 (OR BETTER) FOR INTERIOR LOCATIONS AND WEATHER PROTECTED (WP OR BETTER) FOR EXTERIOR LOCATIONS.
27. THE CONTRACTOR SHALL NOTIFY AND OBTAIN NECESSARY AUTHORIZATION FROM THE CARRIER AND/OR DISH WIRELESS, L.L.C. AND TOWER OWNER BEFORE COMMENCING WORK ON THE AC POWER DISTRIBUTION PANELS.
28. THE CONTRACTOR SHALL PROVIDE NECESSARY TAGGING ON THE BREAKERS, CABLES AND DISTRIBUTION PANELS IN ACCORDANCE WITH THE APPLICABLE CODES AND STANDARDS TO SAFEGUARD LIFE AND PROPERTY.
29. INSTALL LAMICOID LABEL ON THE METER CENTER TO SHOW "DISH WIRELESS, L.L.C."
30. ALL EMPTY/SPARE CONDUITS THAT ARE INSTALLED ARE TO HAVE A METERED MULE TAPE PULL CORD INSTALLED.



5701 SOUTH SANTA FE DRIVE
LITTLETON, CO 80120



NB+C ENGINEERING SERVICES, LLC.
8601 SIX FORKS ROAD, SUITE 540
RALEIGH, NC 27615
(919) 657-9131

DRAWN BY:	CHECKED BY:	APPROVED BY:
PRI	BIW	BIW

RFDS REV #: 1

CONSTRUCTION DOCUMENTS

SUBMITTALS		
REV	DATE	DESCRIPTION
A	08/13/2021	ISSUED FOR REVIEW
D	09/13/2021	ISSUED FOR CONSTRUCTION



IT IS A VIOLATION OF LAW FOR ANY PERSON, UNLESS THEY ARE ACTING UNDER THE DIRECTION OF A LICENSED PROFESSIONAL ENGINEER, TO ALTER THIS DOCUMENT.

A&E PROJECT NUMBER
416862-13692184

DISH WIRELESS, L.L.C.
PROJECT INFORMATION
BOBDL0027A
106 SOUTH GRAND ST.
WEST SUFFIELD, CT 06093

SHEET TITLE
GENERAL NOTES

SHEET NUMBER
GN-3

GROUNDING NOTES:

1. ALL GROUND ELECTRODE SYSTEMS (INCLUDING TELECOMMUNICATION, RADIO, LIGHTNING PROTECTION AND AC POWER GES'S) SHALL BE BONDED TOGETHER AT OR BELOW GRADE, BY TWO OR MORE COPPER BONDING CONDUCTORS IN ACCORDANCE WITH THE NEC.
2. THE CONTRACTOR SHALL PERFORM IEEE FALL-OF-POTENTIAL RESISTANCE TO EARTH TESTING (PER IEEE 1100 AND 81) FOR GROUND ELECTRODE SYSTEMS, THE CONTRACTOR SHALL FURNISH AND INSTALL SUPPLEMENTAL GROUND ELECTRODES AS NEEDED TO ACHIEVE A TEST RESULT OF 5 OHMS OR LESS.
3. THE CONTRACTOR IS RESPONSIBLE FOR PROPERLY SEQUENCING GROUNDING AND UNDERGROUND CONDUIT INSTALLATION AS TO PREVENT ANY LOSS OF CONTINUITY IN THE GROUNDING SYSTEM OR DAMAGE TO THE CONDUIT AND PROVIDE TESTING RESULTS.
4. METAL CONDUIT AND TRAY SHALL BE GROUND AND MADE ELECTRICALLY CONTINUOUS WITH LISTED BONDING FITTINGS OR BY BONDING ACROSS THE DISCONTINUITY WITH #6 COPPER WIRE UL APPROVED GROUNDING TYPE CONDUIT CLAMPS.
5. METAL RACEWAY SHALL NOT BE USED AS THE NEC REQUIRED EQUIPMENT GROUND CONDUCTOR. STRANDED COPPER CONDUCTORS WITH GREEN INSULATION, SIZED IN ACCORDANCE WITH THE NEC, SHALL BE FURNISHED AND INSTALLED WITH THE POWER CIRCUITS TO BTS EQUIPMENT.
6. EACH CABINET FRAME SHALL BE DIRECTLY CONNECTED TO THE MASTER GROUND BAR WITH GREEN INSULATED SUPPLEMENTAL EQUIPMENT GROUND WIRES, #6 STRANDED COPPER OR LARGER FOR INDOOR BTS; #2 BARE SOLID TINNED COPPER FOR OUTDOOR BTS.
7. CONNECTIONS TO THE GROUND BUS SHALL NOT BE DOUBLED UP OR STACKED BACK TO BACK CONNECTIONS ON OPPOSITE SIDE OF THE GROUND BUS ARE PERMITTED.
8. ALL EXTERIOR GROUND CONDUCTORS BETWEEN EQUIPMENT/GROUND BARS AND THE GROUND RING SHALL BE #2 SOLID TINNED COPPER UNLESS OTHERWISE INDICATED.
9. ALUMINUM CONDUCTOR OR COPPER CLAD STEEL CONDUCTOR SHALL NOT BE USED FOR GROUNDING CONNECTIONS.
10. USE OF 90° BENDS IN THE PROTECTION GROUNDING CONDUCTORS SHALL BE AVOIDED WHEN 45° BENDS CAN BE ADEQUATELY SUPPORTED.
11. EXOTHERMIC WELDS SHALL BE USED FOR ALL GROUNDING CONNECTIONS BELOW GRADE.
12. ALL GROUND CONNECTIONS ABOVE GRADE (INTERIOR AND EXTERIOR) SHALL BE FORMED USING HIGH PRESS CRIMPS.
13. COMPRESSION GROUND CONNECTIONS MAY BE REPLACED BY EXOTHERMIC WELD CONNECTIONS.
14. ICE BRIDGE BONDING CONDUCTORS SHALL BE EXOTHERMICALLY BONDED OR BOLTED TO THE BRIDGE AND THE TOWER GROUND BAR.
15. APPROVED ANTIOXIDANT COATINGS (i.e. CONDUCTIVE GEL OR PASTE) SHALL BE USED ON ALL COMPRESSION AND BOLTED GROUND CONNECTIONS.
16. ALL EXTERIOR GROUND CONNECTIONS SHALL BE COATED WITH A CORROSION RESISTANT MATERIAL.
17. MISCELLANEOUS ELECTRICAL AND NON-ELECTRICAL METAL BOXES, FRAMES AND SUPPORTS SHALL BE BONDED TO THE GROUND RING, IN ACCORDANCE WITH THE NEC.
18. BOND ALL METALLIC OBJECTS WITHIN 6 ft OF MAIN GROUND RING WITH (1) #2 BARE SOLID TINNED COPPER GROUND CONDUCTOR.
19. GROUND CONDUCTORS USED FOR THE FACILITY GROUNDING AND LIGHTNING PROTECTION SYSTEMS SHALL NOT BE ROUTED THROUGH METALLIC OBJECTS THAT FORM A RING AROUND THE CONDUCTOR, SUCH AS METALLIC CONDUITS, METAL SUPPORT CLIPS OR SLEEVES THROUGH WALLS OR FLOORS. WHEN IT IS REQUIRED TO BE HOUSED IN CONDUIT TO MEET CODE REQUIREMENTS OR LOCAL CONDITIONS, NON-METALLIC MATERIAL SUCH AS PVC CONDUIT SHALL BE USED. WHERE USE OF METAL CONDUIT IS UNAVOIDABLE (i.e., NONMETALLIC CONDUIT PROHIBITED BY LOCAL CODE) THE GROUND CONDUCTOR SHALL BE BONDED TO EACH END OF THE METAL CONDUIT.
20. ALL GROUNDS THAT TRANSITION FROM BELOW GRADE TO ABOVE GRADE MUST BE #2 BARE SOLID TINNED COPPER IN 3/4" NON-METALLIC, FLEXIBLE CONDUIT FROM 24" BELOW GRADE TO WITHIN 3" TO 6" OF CAD-WELD TERMINATION POINT. THE EXPOSED END OF THE CONDUIT MUST BE SEALED WITH SILICONE CAULK. (ADD TRANSITIONING GROUND STANDARD DETAIL AS WELL).
21. BUILDINGS WHERE THE MAIN GROUNDING CONDUCTORS ARE REQUIRED TO BE ROUTED TO GRADE, THE CONTRACTOR SHALL ROUTE TWO GROUNDING CONDUCTORS FROM THE ROOFTOP, TOWERS, AND WATER TOWERS GROUNDING RING, TO THE EXISTING GROUNDING SYSTEM, THE GROUNDING CONDUCTORS SHALL NOT BE SMALLER THAN 2/0 COPPER. ROOFTOP GROUNDING RING SHALL BE BONDED TO THE EXISTING GROUNDING SYSTEM, THE BUILDING STEEL COLUMNS, LIGHTNING PROTECTION SYSTEM, AND BUILDING MAIN WATER LINE (FERROUS OR NONFERROUS METAL PIPING ONLY). DO NOT ATTACH GROUNDING TO FIRE SPRINKLER SYSTEM PIPES.

STRUCTURAL STEEL NOTES:

1. STRUCTURAL STEEL SHALL CONFORM TO THE LATEST EDITION OF THE AISC "SPECIFICATION FOR THE DESIGN, FABRICATION AND ERECTION OF STRUCTURAL STEEL FOR BUILDINGS."
2. STRUCTURAL STEEL ROLLED SHAPES, PLATES AND BARS SHALL CONFORM TO THE FOLLOWING ASTM DESIGNATIONS:
 - A. ASTM A-572, GRADE 50 – ALL W SHAPES, UNLESS NOTED OR A992 OTHERWISE
 - B. ASTM A-36 – ALL OTHER ROLLED SHAPES, PLATES AND BARS UNLESS NOTED OTHERWISE.
 - C. ASTM A-500, GRADE B – HSS SECTION (SQUARE, RECTANGULAR, AND ROUND)
 - D. ASTM A-325, TYPE SC OR N – ALL BOLTS FOR CONNECTING STRUCTURAL MEMBERS
 - E. ASTM F-1554 07 – ALL ANCHOR BOLTS, UNLESS NOTED OTHERWISE
3. ALL EXPOSED STRUCTURAL STEEL MEMBERS SHALL BE HOT-DIPPED GALVANIZED AFTER FABRICATION PER ASTM A123. EXPOSED STEEL HARDWARE AND ANCHOR BOLTS SHALL BE GALVANIZED PER ASTM A153 OR B695.
4. ALL FIELD CUT SURFACES, FIELD DRILLED HOLES AND GROUND SURFACES WHERE EXISTING PAINT OR GALVANIZATION REMOVAL WAS REQUIRED SHALL BE REPAIRED WITH (2) BRUSHED COATS OF ZRC GALVILITE COLD GALVANIZING COMPOUND PER ASTM A780 AND MANUFACTURER'S RECOMMENDATIONS.
5. DO NOT DRILL HOLES THROUGH STRUCTURAL STEEL MEMBERS EXCEPT AS SHOWN AND DETAILED ON STRUCTURAL DRAWINGS.
6. CONNECTIONS:
 - A. ALL WELDING TO BE PERFORMED BY AWS CERTIFIED WELDERS AND CONDUCTED IN ACCORDANCE WITH THE LATEST EDITION OF THE AWS WELDING CODE D1.1.
 - B. ALL WELDS SHALL BE INSPECTED VISUALLY. 25% OF WELDS SHALL BE INSPECTED WITH DYE PENETRANT OR MAGNETIC PARTICLE TO MEET THE ACCEPTANCE CRITERIA OF AWS D1.1. REPAIR ALL WELDS AS NECESSARY.
 - C. INSPECTION SHALL BE PERFORMED BY AN AWS CERTIFIED WELD INSPECTOR.
 - D. IT IS THE CONTRACTORS RESPONSIBILITY TO PROVIDE BURNING/WELDING PERMITS AS REQUIRED BY LOCAL GOVERNING AUTHORITY AND IF REQUIRED SHALL HAVE FIRE DEPARTMENT DETAIL FOR ANY WELDING ACTIVITY.
 - E. ALL ELECTRODES TO BE LOW HYDROGEN, MATCHING FILLER METAL, PER AWS D1.1, UNLESS NOTED OTHERWISE.
 - F. MINIMUM WELD SIZE TO BE 0.1875 INCH FILLET WELDS, UNLESS NOTED OTHERWISE.
 - G. PRIOR TO FIELD WELDING GALVANIZING MATERIAL, CONTRACTOR SHALL GRIND OFF GALVANIZING 1/2" BEYOND ALL FIELD WELD SURFACES. AFTER WELD AND WELD INSPECTION IS COMPLETE, REPAIR ALL GROUND AND WELDED SURFACES WITH ZRC GALVILITE COLD GALVANIZING COMPOUND PER ASTM A780 AND MANUFACTURERS RECOMMENDATIONS.
 - H. THE CONTRACTOR SHALL PROVIDE ADEQUATE SHORING AND/OR BRACING WHERE REQUIRED DURING CONSTRUCTION UNTIL ALL CONNECTIONS ARE COMPLETE.
 - I. ANY FIELD CHANGES OR SUBSTITUTIONS SHALL HAVE PRIOR APPROVAL FROM THE ENGINEER, AND DISH WIRELESS L.L.C. PROJECT MANAGER IN WRITING



5701 SOUTH SANTA FE DRIVE
LITTLETON, CO 80120



NB+C ENGINEERING SERVICES, LLC.
8601 SIX FORKS ROAD, SUITE 540
RALEIGH, NC 27615
(919) 657-9131

DRAWN BY:	CHECKED BY:	APPROVED BY:
PRI	BIW	BIW

RFDS REV #: 1

CONSTRUCTION DOCUMENTS

SUBMITTALS		
REV	DATE	DESCRIPTION
A	08/13/2021	ISSUED FOR REVIEW
D	09/13/2021	ISSUED FOR CONSTRUCTION



IT IS A VIOLATION OF LAW FOR ANY PERSON, UNLESS THEY ARE ACTING UNDER THE DIRECTION OF A LICENSED PROFESSIONAL ENGINEER, TO ALTER THIS DOCUMENT.

A&E PROJECT NUMBER
416862-13692184

DISH WIRELESS, L.L.C.
PROJECT INFORMATION
BOBDL0027A
106 SOUTH GRAND ST.
WEST SUFFIELD, CT 06093

SHEET TITLE
GENERAL NOTES

SHEET NUMBER
GN-4

ENGINEERING:
STRUCTURAL ANALYSIS
MOUNT ANALYSIS



AMERICAN TOWER®
CORPORATION

Structural Analysis Report

Structure : 139 ft Monopole
ATC Site Name : SUFFIELD SW CT CT, CT
ATC Asset Number : 416862
Engineering Number : 13692184_C3_02
Proposed Carrier : DISH WIRELESS L.L.C.
Carrier Site Name : BOBDL00027A
Carrier Site Number : BOBDL00027A
Site Location : 106 South Grand St.
West Suffield, CT 06093-3412
41.987000,-72.702100
County : Hartford
Date : July 14, 2021
Max Usage : 49%
Result : Pass



Prepared By:
Rebecca Malz
Structural Engineer

Rebecca Malz

Reviewed By:

COA: PEC.0001553



Table of Contents

Introduction	1
Supporting Documents	1
Analysis	1
Conclusion.....	1
Existing and Reserved Equipment.....	2
Equipment to be Removed.....	2
Proposed Equipment	2
Structure Usages	3
Foundations	3
Deflection and Sway	3
Standard Conditions	4
Calculations	Attached



Introduction

The purpose of this report is to summarize results of a structural analysis performed on the 139 ft monopole to reflect the change in loading by DISH WIRELESS L.L.C..

Supporting Documents

Tower Drawings	EEI Job #16937, dated August 31, 2012
Foundation Drawing	EEI Job #16937, dated March 18, 2013
Geotechnical Report	DET Job #2011.01, dated July 21, 2012
Modifications	ATC Job #OAA760209_C6_04, dated November 19, 2020

Analysis

The tower was analyzed using American Tower Corporation's tower analysis software. This program considers an elastic three-dimensional model and second-order effects per ANSI/TIA-222.

Basic Wind Speed:	115 mph (3-Second Gust)
Basic Wind Speed w/ Ice:	50 mph (3-Second Gust) w/ 1.5" radial ice concurrent
Code:	ANSI/TIA-222-H / 2015 IBC / 2018 Connecticut State Building Code
Exposure Category:	B
Risk Category:	II
Topographic Factor Procedure:	Method 1
Topographic Category:	1
Crest Height (H):	0 ft
Spectral Response:	$S_s = 0.17, S_1 = 0.05$
Site Class:	D - Stiff Soil

Conclusion

Based on the analysis results, the structure meets the requirements per the applicable codes listed above. The tower and foundation can support the equipment as described in this report.

If you have any questions or require additional information, please contact American Tower via email at Engineering@americantower.com. Please include the American Tower site name, site number, and engineering number in the subject line for any questions.



Existing and Reserved Equipment

Elev. ¹ (ft)	Qty	Equipment	Mount Type	Lines	Carrier
135.0	1	Raycap DC6-48-60-0-8F	Sector Frame	(1) 0.40" (10.3mm) Fiber (2) 0.82" (20.8mm) 8 AWG 6 (2) 0.92" (23.4mm) Cable (2) 2" conduit	AT&T MOBILITY
	3	Ericsson RRUS 8843 B2, B66A			
	3	Ericsson RRUS 4415 B30			
	3	Ericsson RRUS 4449 B5, B12			
	3	Ericsson RRUS 4478 B14			
	1	Raycap DC9-48-60-24-8C-EV			
	3	CCI DMP65R-BU8D			
	3	CCI TPA65R-BU8D			
121.0	3	Alcatel-Lucent RRH2x40-07-U	Triangular Low Profile Platform	(2) 1 1/4" Hybriflex Cable	VERIZON WIRELESS
	3	Alcatel-Lucent RRH2x40-AWS			
	2	RFS DB-T1-6Z-8AB-0Z			
120.0	6	Amphenol Antel LPA-171063-12CF-EDIN-X			
	6	Antel BXA-70063/6CF_			
	1	VZW Unused Reserve (19060.68 sqin)			

Equipment to be Removed

Elev. ¹ (ft)	Qty	Equipment	Mount Type	Lines	Carrier
No loading was considered as removed as part of this analysis.					

Proposed Equipment

Elev. ¹ (ft)	Qty	Equipment	Mount Type	Lines	Carrier
110.0	1	Commscope RDIDC-9181-PF-48	Triangular Platform with Handrails	(1) 1.60" (40.6mm) Hybrid	DISH WIRELESS L.L.C.
	3	Fujitsu TA08025-B605			
	3	Fujitsu TA08025-B604			
	3	JMA Wireless MX08FRO665-21			

¹ Contracted elevations are shown for appurtenances within contracted installation tolerances. Appurtenances outside of contract limits are shown at installed elevations.

Install proposed coax inside the pole shaft.



Structure Usages

Structural Component	Controlling Usage	Pass/Fail
Anchor Bolts	40%	Pass
Shaft	49%	Pass
Base Plate	19%	Pass
Flanges	12%	Pass

Foundations

Reaction Component	Analysis Reactions	% of Usage
Moment (Kips-Ft)	2,237.5	42%
Axial (Kips)	42.0	39%
Shear (Kips)	22.0	20%

The structure base reactions resulting from this analysis were found to be acceptable through analysis based on geotechnical and foundation information, therefore no modification or reinforcement of the foundation will be required.

Deflection and Sway*

Antenna Elevation (ft)	Antenna	Carrier	Deflection (ft)	Sway (Rotation) (°)
110.0	Commscope RDIDC-9181-PF-48	DISH WIRELESS L.L.C.	0.665	0.707
	Fujitsu TA08025-B605			
	Fujitsu TA08025-B604			
	JMA Wireless MX08FRO665-21			

*Deflection and Sway was evaluated considering a design wind speed of 60 mph (3-Second Gust) per ANSI/TIA-222-H



Standard Conditions

All engineering services performed by A.T. Engineering Service, PLLC are prepared on the basis that the information used is current and correct. This information may consist of, but is not limited to the following:

- Information supplied by the client regarding antenna, mounts and feed line loading
- Information from drawings, design and analysis documents, and field notes in the possession of A.T. Engineering Service, PLLC

It is the responsibility of the client to ensure that the information provided to A.T. Engineering Service, PLLC and used in the performance of our engineering services is correct and complete.

All assets of American Tower Corporation, its affiliates and subsidiaries (collectively "American Tower") are inspected at regular intervals. Based upon these inspections and in the absence of information to the contrary, American Tower assumes that all structures were constructed in accordance with the drawings and specifications.

Unless explicitly agreed by both the client and A.T. Engineering Service, PLLC, all services will be performed in accordance with the current revision of ANSI/TIA-222.

All services are performed, results obtained, and recommendations made in accordance with generally accepted engineering principles and practices. A.T. Engineering Service, PLLC is not responsible for the conclusions, opinions and recommendations made by others based on the information supplied herein.

Job Information	
Client : DISH WIRELESS L.L.C.	
Pole : 416862	Code: ANSI/TIA-222-H
Location : SUFFIELD SW CT CT, CT	
Description : 119 ft EEI MP w/ Proposed 20 ft Extension	Risk Category : II
Shape : 18 Sides	Exposure : B
Height : 139.00 (ft)	Topo Method : Method 1
Base Elev (ft): 0.00	Topographic Category : 1
Taper: 0.221214 (in/ft)	

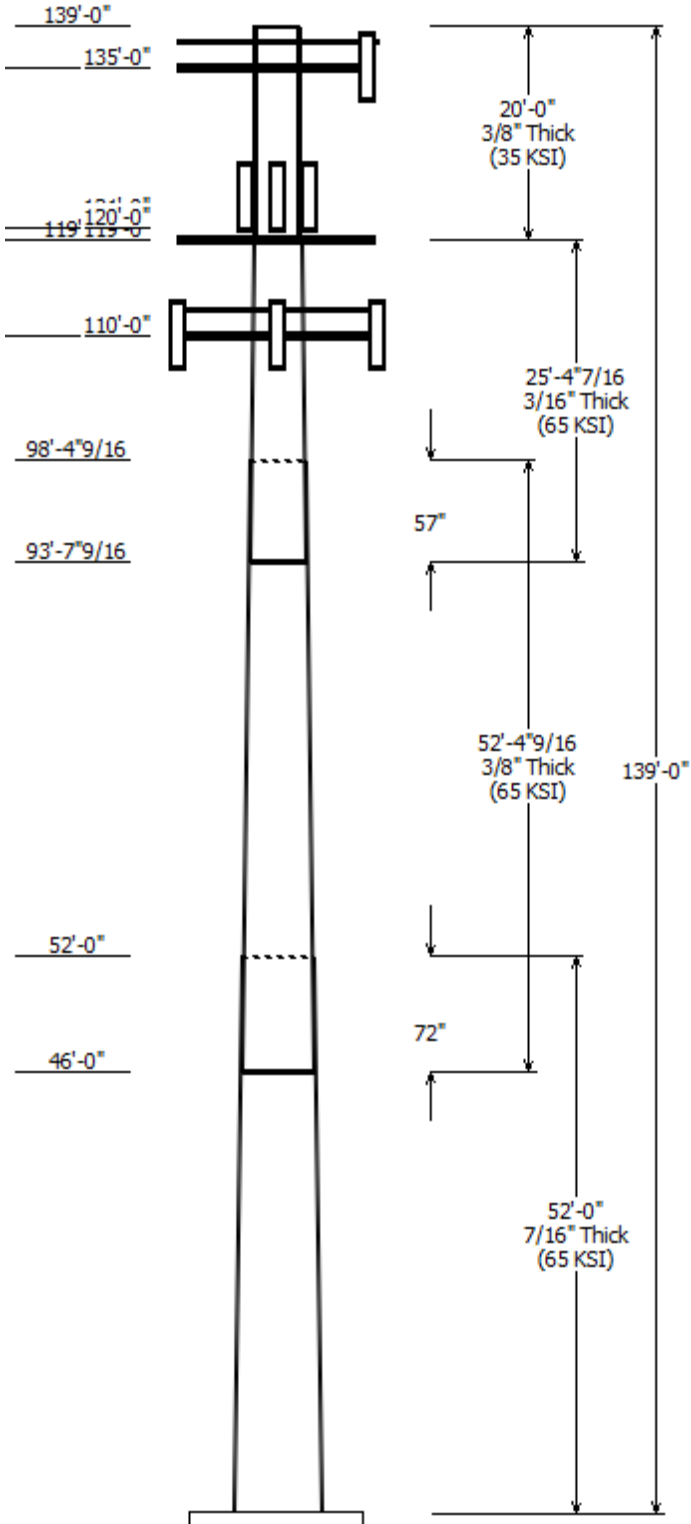

Sections Properties						
Shaft Section	Length (ft)	Diameter (in)		Thick Joint (in)	Overlap Length (in)	Steel Grade (ksi)
		Across Top	Across Bottom			
1	52.000	41.49	53.00	0.438	0.000	18 Sides 65
2	52.380	31.98	43.57	0.375	72.000	18 Sides 65
3	25.370	27.80	33.41	0.188	57.000	18 Sides 65
4	20.000	26.00	26.00	0.375	0.000	Round 35

Discrete Appurtenance			
Attach Elev (ft)	Force Elev (ft)	Qty	Description
135.000	135.000	3	Generic Flat Light Sector Fram
135.000	135.000	3	CCI DMP65R-BU8D
135.000	135.000	1	Raycap DC9-48-60-24-8C-EV
135.000	135.000	3	Ericsson RRUS 4478 B14
135.000	135.000	3	CCI TPA65R-BU8D
135.000	135.000	3	Ericsson RRUS 4449 B5, B12
135.000	135.000	3	Ericsson RRUS 4415 B30
135.000	135.000	3	Ericsson RRUS 8843 B2, B66A
135.000	135.000	1	Raycap DC6-48-60-0-8F
121.000	122.000	2	RFS DB-T1-6Z-8AB-0Z
121.000	122.000	3	Alcatel-Lucent RRH2x40-AWS
121.000	122.000	3	Alcatel-Lucent RRH2x40-07-U
120.000	120.000	1	VZW Unused Reserve
120.000	122.000	6	Antel BXA-70063/6CF_
120.000	122.000	6	Amphenol Antel LPA-171063-
119.000	119.000	1	Generic Flat Low Profile Platf
110.000	110.000	1	Generic Flat Platform with Han
110.000	110.000	3	JMA Wireless MX08FRO665-21
110.000	110.000	3	Fujitsu TA08025-B604
110.000	110.000	3	Fujitsu TA08025-B605
110.000	110.000	1	Commscope RDIDC-9181-PF-48

Linear Appurtenance			
From Elev (ft)	To Elev (ft)	Description	Exposed To Wind
0.000	110.0	1.60" (40.6mm)	No
0.000	121.0	1 1/4" Hybriflex	No
0.000	135.0	0.40" (10.3mm)	No
0.000	135.0	0.82" (20.8mm) 8	No
0.000	135.0	0.92" (23.4mm)	No
0.000	135.0	2" conduit	No

Load Cases	
1.2D + 1.0W	115 mph with No Ice
0.9D + 1.0W	115 mph with No Ice (Reduced DL)
1.2D + 1.0Di + 1.0Wi	50 mph with 1.50 in Radial Ice
1.2D + 1.0Ev + 1.0Eh	Seismic
0.9D - 1.0Ev + 1.0Eh	Seismic (Reduced DL)
1.0D + 1.0W	Serviceability 60 mph

Reactions			
Load Case	Moment (kip-ft)	Shear (kip)	Axial (kip)
1.2D + 1.0W	2237.48	21.99	41.97
0.9D + 1.0W	2218.85	21.98	31.47
1.2D + 1.0Di + 1.0Wi	700.11	6.85	62.10
1.2D + 1.0Ev + 1.0Eh	116.27	1.05	41.66
0.9D - 1.0Ev + 1.0Eh	115.11	1.05	29.09
1.0D + 1.0W	542.06	5.35	34.99

Dish Deflections			
Load Case	Attach Elev (ft)	Deflection (in)	Rotation (deg)
	0.00	0.000	0.000

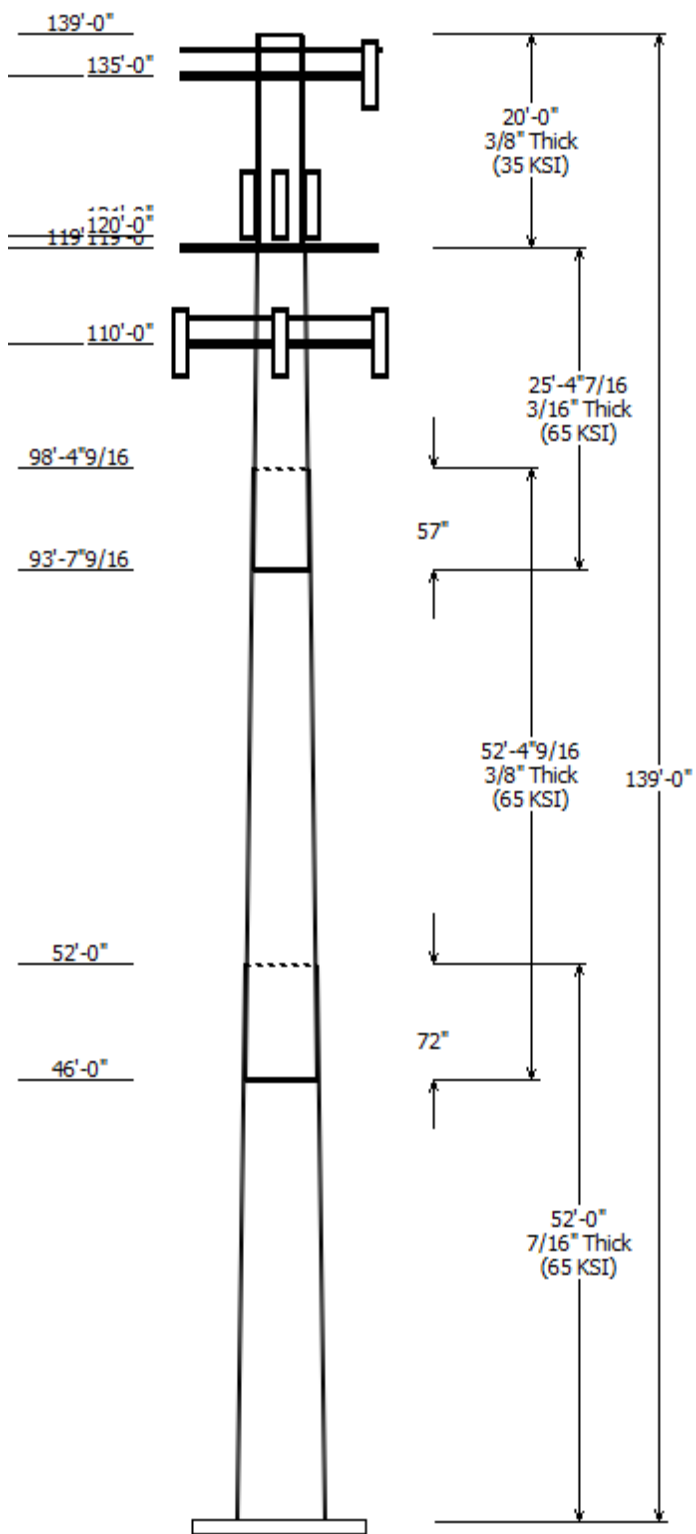

Load Case : 1.2D + 1.0W
Max Ratio 49.42% at 98.4 ft

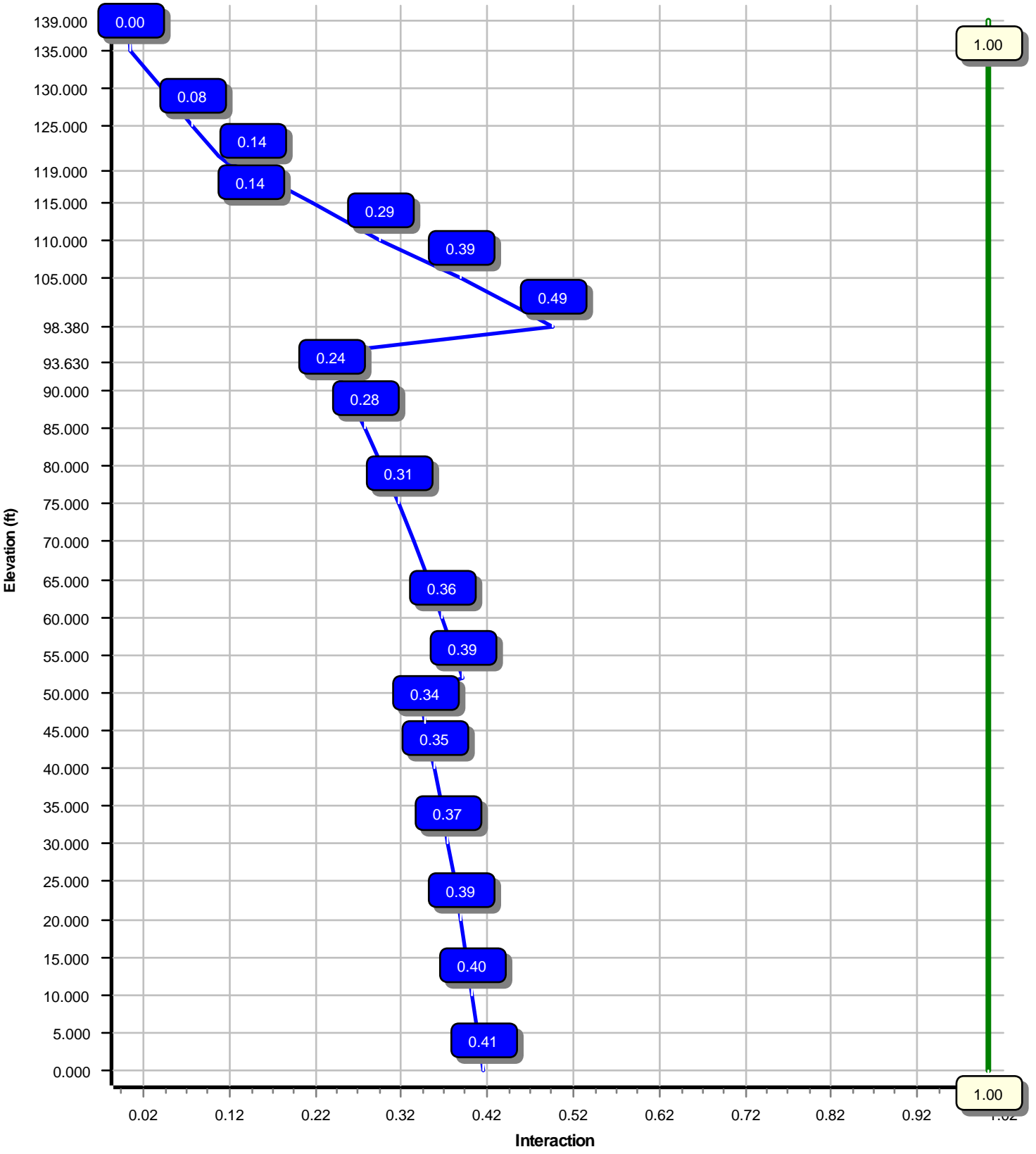

Site Number: 416862

Code: ANSI/TIA-222-H

© 2007 - 2021 by ATC IP LLC. All rights reserved.

Site Name: SUFFIELD SW CT CT, CT

Engineering Number: 13692184_C3_02

7/14/2021 11:04:57 AM

Customer: DISH WIRELESS L.L.C.

Analysis Parameters

Location :	Hartford County, CT	Height (ft) :	139
Code :	ANSI/TIA-222-H	Base Diameter (in) :	53.00
Shape :	18 Sides, Sect 4: Round	Top Diameter (in) :	26.00
Pole Type :	Custom	Taper (in/ft) :	0.221
Pole Manufacturer :	EEI	Rotation (deg) :	0.00
Kd (non-service) :	0.95	Ke :	0.99

Ice & Wind Parameters

Exposure Category:	B	Design Wind Speed Without Ice:	115 mph
Risk Category:	II	Design Wind Speed With Ice:	50 mph
Topographic Factor Procedure:	Method 1	Operational Wind Speed:	60 mph
Topographic Category:	1	Design Ice Thickness:	1.50 in
Crest Height:	0 ft	HMSL:	190.00 ft

Seismic Parameters

Analysis Method:	Equivalent Lateral Force Method		
Site Class:	D - Stiff Soil		
Period Based on Rayleigh Method (sec):	1.92		
T_L (sec):	6	p :	1
S_s :	0.171	S_1 :	0.054
F_a :	1.600	F_v :	2.400
S_{ds} :	0.182	S_{d1} :	0.086
		C_s :	0.030
		C_s Max:	0.030
		C_s Min:	0.030

Load Cases

1.2D + 1.0W	115 mph with No Ice
0.9D + 1.0W	115 mph with No Ice (Reduced DL)
1.2D + 1.0Di + 1.0Wi	50 mph with 1.50 in Radial Ice
1.2D + 1.0Ev + 1.0Eh	Seismic
0.9D - 1.0Ev + 1.0Eh	Seismic (Reduced DL)
1.0D + 1.0W	Serviceability 60 mph

Site Number: 416862

Code: ANSI/TIA-222-H

© 2007 - 2021 by ATC IP LLC. All rights reserved.

Site Name: SUFFIELD SW CT CT, CT

Engineering Number: 13692184_C3_02

7/14/2021 11:04:57 AM

Customer: DISH WIRELESS L.L.C.

Shaft Section Properties

Sect Info	Length (ft)	Thick (in)	Fy (ksi)	Joint Type	Joint Len (in)	Weight (lb)	Bottom						Top						
							Dia (in)	Elev (ft)	Area (in ²)	Ix (in ⁴)	W/t Ratio	D/t Ratio	Dia (in)	Elev (ft)	Area (in ²)	Ix (in ⁴)	W/t Ratio	D/t Ratio	Taper (in/ft)
1-18	52.000	0.4375	65		0.00	11,501	53.00	0.00	72.99	25477.1	19.95	121.14	41.49	52.00	57.01	12143.7	15.31	94.85	0.221218
2-18	52.380	0.3750	65	Slip	72.00	7,935	43.57	46.00	51.42	12122.6	19.08	116.20	31.98	98.38	37.62	4750.2	13.63	85.30	0.221218
3-18	25.370	0.1875	65	Slip	57.00	1,563	33.41	93.63	19.77	2757.6	30.01	178.20	27.80	119.00	16.43	1582.9	24.73	148.27	0.221218
4-R	20.000	0.3750	35	Butt	0.00	2,055	26.00	119.00	30.19	2479.8	0.00	69.33	26.00	139.00	30.19	2479.8	0.00	69.33	0.000000
Shaft Weight						23,054													

Discrete Appurtenance Properties

Attach Elev (ft)	Description	Qty	Ka	Vert Ecc (ft)	Weight (lb)	No Ice EPAa (sf)	Orientation Factor	Weight (lb)	Ice EPAa (sf)	Orientation Factor
135.00	Raycap DC6-48-60-0-8F	1	0.80	0.000	32.80	1.360	0.50	90.33	2.016	0.50
135.00	Ericsson RRUS 8843 B2, B66A	3	0.80	0.000	72.00	1.639	0.50	132.66	2.475	0.50
135.00	Ericsson RRUS 4415 B30	3	0.80	0.000	46.00	1.842	0.50	94.53	2.730	0.50
135.00	Ericsson RRUS 4449 B5, B12	3	0.80	0.000	71.00	1.969	0.50	134.79	2.892	0.50
135.00	Ericsson RRUS 4478 B14	3	0.80	0.000	59.40	2.021	0.67	120.14	2.955	0.67
135.00	Raycap DC9-48-60-24-8C-EV	1	0.80	0.000	16.00	4.788	0.67	143.77	6.244	0.67
135.00	CCI DMP65R-BU8D	3	0.80	0.000	95.70	17.871	0.63	432.08	21.518	0.63
135.00	Generic Flat Light Sector Frame	3	0.75	0.000	400.00	17.900	0.75	697.86	32.833	0.75
135.00	CCI TPA65R-BU8D	3	0.80	0.000	82.50	18.089	0.63	423.74	21.743	0.63
121.00	Alcatel-Lucent RRH2x40-07-U	3	0.80	1.000	50.70	1.925	0.50	108.21	2.822	0.50
121.00	Alcatel-Lucent RRH2x40-AWS	3	0.80	1.000	44.00	2.155	0.67	103.41	3.178	0.67
121.00	RFS DB-T1-6Z-8AB-0Z	2	0.80	1.000	44.00	4.800	0.72	167.39	6.193	0.72
120.00	Amphenol Antel LPA-171063-	6	0.80	2.000	11.50	6.050	0.78	158.45	8.457	0.78
120.00	Antel BXA-70063/6CF_	6	0.80	2.000	17.00	7.569	0.65	155.52	10.270	0.65
120.00	VZW Unused Reserve (19060.68	1	0.80	0.000	1,956.90	132.366	0.90	3,292.28	222.692	0.90
119.00	Generic Flat Low Profile Platform	1	1.00	0.000	1,875.00	26.100	1.00	2,666.61	44.762	1.00
110.00	Commscope RDIDC-9181-PF-48	1	0.75	0.000	21.90	1.867	1.00	77.06	2.739	1.00
110.00	Fujitsu TA08025-B605	3	0.75	0.000	75.00	1.962	0.50	135.72	2.854	0.50
110.00	Fujitsu TA08025-B604	3	0.75	0.000	63.90	1.962	0.50	120.42	2.854	0.50
110.00	JMA Wireless MX08FRO665-21	3	0.75	0.000	64.50	12.489	0.64	313.61	15.213	0.64
110.00	Generic Flat Platform with	1	1.00	0.000	2,500.00	42.400	1.00	4,221.79	62.727	1.00
Totals	Num Loadings:21	56			10,035.70			21,161.97		

Linear Appurtenance Properties

Load Case Azimuth (deg) :

Elev From (ft)	Elev To (ft)	Qty	Description	Coax Dia (in)	Coax Wt (lb/ft)	Max Coax / Row	Dist Between Rows (in)	Dist Between Cols (in)	Azimuth (deg)	Dist From Face (in)	Dist To Wind Carrier	Exposed
0.00	135.00	1	0.40" (10.3mm) Fiber	0.40	0.09	N	0	0.00	0.00	0	0.00	N AT&T MOBILITY
0.00	135.00	2	0.82" (20.8mm) 8 AWG	0.82	0.62	N	0	0.00	0.00	0	0.00	N AT&T MOBILITY
0.00	135.00	2	0.92" (23.4mm) Cable	0.92	0.89	N	0	0.00	0.00	0	0.00	N AT&T MOBILITY
0.00	135.00	2	2" conduit	2.38	3.65	N	0	0.00	0.00	0	0.00	N AT&T MOBILITY
0.00	121.00	2	1 1/4" Hybriflex Cable	1.54	1.00	N	0	0.00	0.00	0	0.00	N VERIZON WIRELESS
0.00	110.00	1	1.60" (40.6mm) Hybrid	1.60	2.34	N	0	0.00	0.00	0	0.00	N DISH WIRELESS

Segment Properties (Max Len : 5. ft)

Seg Top Elev (ft)	Description	Thick (in)	Flat Dia (in)	Area (in ²)	Ix (in ⁴)	W/t Ratio	D/t Ratio	F'y (ksi)	S (in ³)	Z (in ³)	Weight (lb)
0.00		0.4375	53.000	72.987	25,477.1	19.95	121.14	77.9	946.8	0.0	0.0
5.00		0.4375	51.894	71.451	23,902.4	19.50	118.61	78.5	907.2	0.0	1,228.7
10.00		0.4375	50.788	69.915	22,393.9	19.06	116.09	79.0	868.5	0.0	1,202.6
15.00		0.4375	49.682	68.379	20,950.2	18.61	113.56	79.5	830.6	0.0	1,176.5
20.00		0.4375	48.576	66.843	19,570.0	18.17	111.03	80.0	793.5	0.0	1,150.3
25.00		0.4375	47.470	65.308	18,251.7	17.72	108.50	80.6	757.3	0.0	1,124.2
30.00		0.4375	46.363	63.772	16,994.0	17.28	105.97	81.1	721.9	0.0	1,098.1
35.00		0.4375	45.257	62.236	15,795.5	16.83	103.45	81.6	687.4	0.0	1,071.9
40.00		0.4375	44.151	60.700	14,654.7	16.38	100.92	82.1	653.8	0.0	1,045.8
45.00		0.4375	43.045	59.164	13,570.2	15.94	98.39	82.6	620.9	0.0	1,019.7
46.00	Bot - Section 2	0.4375	42.824	58.857	13,359.9	15.85	97.88	82.6	614.5	0.0	200.8
50.00		0.4375	41.939	57.628	12,540.5	15.49	95.86	82.6	589.0	0.0	1,485.4
52.00	Top - Section 1	0.3750	42.247	49.836	11,039.2	18.45	112.66	79.7	514.7	0.0	731.1
55.00		0.3750	41.583	49.046	10,522.5	18.14	110.89	80.1	498.4	0.0	504.7
60.00		0.3750	40.477	47.730	9,697.7	17.62	107.94	80.7	471.9	0.0	823.3
65.00		0.3750	39.371	46.413	8,917.2	17.10	104.99	81.3	446.1	0.0	800.9
70.00		0.3750	38.265	45.097	8,179.7	16.58	102.04	81.9	421.0	0.0	778.5
75.00		0.3750	37.159	43.780	7,484.1	16.06	99.09	82.5	396.7	0.0	756.1
80.00		0.3750	36.053	42.464	6,829.0	15.54	96.14	82.6	373.1	0.0	733.7
85.00		0.3750	34.946	41.147	6,213.4	15.02	93.19	82.6	350.2	0.0	711.3
90.00		0.3750	33.840	39.831	5,635.9	14.50	90.24	82.6	328.0	0.0	688.9
93.63	Bot - Section 3	0.3750	33.037	38.875	5,239.8	14.12	88.10	82.6	312.4	0.0	486.1
95.00		0.3750	32.734	38.514	5,095.3	13.98	87.29	82.6	306.6	0.0	272.1
98.38	Top - Section 2	0.1875	32.362	19.147	2,504.2	29.02	172.59	67.3	152.4	0.0	660.6
100.0		0.1875	32.003	18.934	2,421.4	28.69	170.68	67.7	149.0	0.0	105.0
105.0		0.1875	30.897	18.275	2,177.5	27.65	164.78	68.9	138.8	0.0	316.5
110.0		0.1875	29.791	17.617	1,950.6	26.61	158.89	70.1	129.0	0.0	305.3
115.0		0.1875	28.685	16.959	1,740.0	25.56	152.99	71.3	119.5	0.0	294.1
119.0	Top - Section 3	0.1875	27.800	16.432	1,582.9	24.73	148.27	72.3	112.2	0.0	227.2
119.0	Bot - Section 4	0.3750	26.000	30.189	2,479.8	0.00	69.33	35.0	190.8	246.3	
120.0		0.3750	26.000	30.189	2,479.8	0.00	69.33	35.0	190.8	246.3	102.7
121.0		0.3750	26.000	30.189	2,479.8	0.00	69.33	35.0	190.8	246.3	102.7
125.0		0.3750	26.000	30.189	2,479.8	0.00	69.33	35.0	190.8	246.3	410.9
130.0		0.3750	26.000	30.189	2,479.8	0.00	69.33	35.0	190.8	246.3	513.6
135.0		0.3750	26.000	30.189	2,479.8	0.00	69.33	35.0	190.8	246.3	513.6
139.0		0.3750	26.000	30.189	2,479.8	0.00	69.33	35.0	190.8	246.3	410.9
23,053.8											

Load Case: 1.2D + 1.0W	115 mph with No Ice	21 Iterations
Gust Response Factor :1.10		
Dead Load Factor :1.20		
Wind Load Factor :1.00		

Applied Segment Forces Summary

Seg Elev (ft)	Description	Shaft Forces		Discrete Forces			Linear Forces		Sum of Forces				
		Wind FX (lb)	Dead Load (lb)	Wind FX (lb)	Torsion MY (lb-ft)	Moment MZ (lb-ft)	Dead Load (lb)	Wind FX (lb)	Dead Load (lb)	Wind FX (lb)	Dead Load (lb)	Torsion MY (lb-ft)	Moment MZ (lb)
0.00		199.2	0.0					0.0	0.0	199.2	0.0	0.0	0.0
5.00		394.2	1,474.5					0.0	88.5	394.2	1,563.0	0.0	0.0
10.00		385.8	1,443.1					0.0	88.5	385.8	1,531.6	0.0	0.0
15.00		377.4	1,411.8					0.0	88.5	377.4	1,500.3	0.0	0.0
20.00		369.0	1,380.4					0.0	88.5	369.0	1,468.9	0.0	0.0
25.00		360.6	1,349.0					0.0	88.5	360.6	1,437.5	0.0	0.0
30.00		356.4	1,317.7					0.0	88.5	356.4	1,406.2	0.0	0.0
35.00		359.3	1,286.3					0.0	88.5	359.3	1,374.8	0.0	0.0
40.00		364.2	1,255.0					0.0	88.5	364.2	1,343.5	0.0	0.0
45.00		219.9	1,223.6					0.0	88.5	219.9	1,312.1	0.0	0.0
46.00	Bot - Section 2	186.8	241.0					0.0	17.7	186.8	258.7	0.0	0.0
50.00		225.2	1,782.5					0.0	70.8	225.2	1,853.3	0.0	0.0
52.00	Top - Section 1	187.9	877.3					0.0	35.4	187.9	912.7	0.0	0.0
55.00		300.6	605.7					0.0	53.1	300.6	658.8	0.0	0.0
60.00		375.0	987.9					0.0	88.5	375.0	1,076.4	0.0	0.0
65.00		373.2	961.0					0.0	88.5	373.2	1,049.5	0.0	0.0
70.00		370.5	934.2					0.0	88.5	370.5	1,022.7	0.0	0.0
75.00		367.0	907.3					0.0	88.5	367.0	995.8	0.0	0.0
80.00		362.7	880.4					0.0	88.5	362.7	968.9	0.0	0.0
85.00		357.7	853.5					0.0	88.5	357.7	942.0	0.0	0.0
90.00		304.6	826.6					0.0	88.5	304.6	915.1	0.0	0.0
93.63	Bot - Section 3	175.1	583.3					0.0	64.3	175.1	647.6	0.0	0.0
95.00		165.6	326.6					0.0	24.2	165.6	350.8	0.0	0.0
98.38	Top - Section 2	173.3	792.7					0.0	59.8	173.3	852.6	0.0	0.0
100.00		225.6	126.0					0.0	28.7	225.6	154.6	0.0	0.0
105.00		336.0	379.8					0.0	88.5	336.0	468.3	0.0	0.0
110.00	Appurtenance(s)	328.3	366.4	2,362.1	0.0	0.0	3,758.5	0.0	88.5	2,690.4	4,213.4	0.0	0.0
115.00		288.9	353.0					0.0	74.5	288.9	427.4	0.0	0.0
119.00	Top - Section 3	150.5	272.7					0.0	59.6	150.5	332.3	0.0	0.0
120.00	Appurtenance(s)	47.6	123.3	5,186.7	0.0	3,400.9	2,553.5	0.0	14.9	5,234.2	2,691.6	0.0	0.0
121.00	Appurtenance(s)	119.6	123.3	415.5	0.0	415.5	446.5	0.0	14.9	535.1	584.7	0.0	0.0
125.00		216.7	493.1					0.0	50.0	216.7	543.1	0.0	0.0
130.00		243.3	616.4					0.0	62.5	243.3	678.8	0.0	0.0
135.00	Appurtenance(s)	196.4	616.4	3,687.8	0.0	0.0	3,034.3	0.0	62.5	3,884.2	3,713.1	0.0	0.0
139.00		74.1	493.1					0.0	0.0	74.1	493.1	0.0	0.0
Totals:										21,190.1	39,743.1	0.00	0.00

Site Number: 416862

Code: ANSI/TIA-222-H

© 2007 - 2021 by ATC IP LLC. All rights reserved.

Site Name: SUFFIELD SW CT CT, CT

Engineering Number: 13692184_C3_02

7/14/2021 11:04:58 AM

Customer: DISH WIRELESS L.L.C.

Load Case: 1.2D + 1.0W

115 mph with No Ice

21 Iterations

Gust Response Factor :1.10

Dead Load Factor :1.20

Wind Load Factor :1.00

Calculated Forces

Seg Elev (ft)	Pu FY (-) (kips)	Vu FX (-) (kips)	Tu MY (ft-kips)	Mu MZ (ft-kips)	Mu MX (ft-kips)	Resultant Moment (ft-kips)	phi Pn (kips)	phi Vn (kips)	phi Tn (ft-kips)	phi Mn (ft-kips)	Total Deflect (in)	Rotation (deg)	Ratio
0.00	-41.97	-21.99	0.00	-2,237.48	0.00	2,237.48	5,119.46	1,280.92	6,081.36	5,534.19	0.00	0.00	0.413
5.00	-40.36	-21.68	0.00	-2,127.54	0.00	2,127.54	5,045.45	1,253.97	5,828.14	5,338.45	0.07	-0.12	0.407
10.00	-38.78	-21.37	0.00	-2,019.15	0.00	2,019.15	4,969.98	1,227.01	5,580.31	5,144.62	0.26	-0.25	0.401
15.00	-37.24	-21.07	0.00	-1,912.30	0.00	1,912.30	4,893.07	1,200.06	5,337.86	4,952.78	0.58	-0.37	0.394
20.00	-35.73	-20.77	0.00	-1,806.96	0.00	1,806.96	4,814.71	1,173.10	5,100.79	4,763.03	1.04	-0.50	0.387
25.00	-34.25	-20.47	0.00	-1,703.13	0.00	1,703.13	4,734.90	1,146.15	4,869.11	4,575.48	1.63	-0.62	0.380
30.00	-32.80	-20.17	0.00	-1,600.78	0.00	1,600.78	4,653.63	1,119.19	4,642.81	4,390.22	2.35	-0.75	0.372
35.00	-31.39	-19.86	0.00	-1,499.93	0.00	1,499.93	4,570.92	1,092.24	4,421.90	4,207.35	3.21	-0.88	0.364
40.00	-30.00	-19.54	0.00	-1,400.63	0.00	1,400.63	4,486.76	1,065.28	4,206.37	4,026.98	4.20	-1.01	0.355
45.00	-28.67	-19.34	0.00	-1,302.90	0.00	1,302.90	4,395.58	1,038.33	3,996.23	3,844.33	5.34	-1.14	0.346
46.00	-28.39	-19.18	0.00	-1,283.57	0.00	1,283.57	4,372.76	1,032.94	3,954.84	3,804.32	5.58	-1.17	0.344
50.00	-26.52	-18.95	0.00	-1,206.84	0.00	1,206.84	4,281.48	1,011.37	3,791.47	3,646.34	6.61	-1.28	0.338
52.00	-25.59	-18.77	0.00	-1,168.94	0.00	1,168.94	3,574.52	874.62	3,307.89	3,076.23	7.15	-1.33	0.388
55.00	-24.90	-18.51	0.00	-1,112.62	0.00	1,112.62	3,534.07	860.76	3,203.87	2,992.79	8.01	-1.41	0.379
60.00	-23.79	-18.16	0.00	-1,020.09	0.00	1,020.09	3,465.49	837.65	3,034.21	2,855.22	9.57	-1.56	0.365
65.00	-22.71	-17.82	0.00	-929.27	0.00	929.27	3,395.45	814.55	2,869.16	2,719.65	11.28	-1.70	0.349
70.00	-21.65	-17.47	0.00	-840.19	0.00	840.19	3,323.97	791.45	2,708.73	2,586.16	13.13	-1.84	0.332
75.00	-20.63	-17.12	0.00	-752.85	0.00	752.85	3,251.04	768.34	2,552.91	2,454.85	15.13	-1.98	0.314
80.00	-19.63	-16.77	0.00	-667.26	0.00	667.26	3,154.84	745.24	2,401.71	2,309.85	17.28	-2.11	0.296
85.00	-18.67	-16.41	0.00	-583.43	0.00	583.43	3,057.03	722.13	2,255.12	2,168.13	19.56	-2.24	0.276
90.00	-17.74	-16.11	0.00	-501.36	0.00	501.36	2,959.22	699.03	2,113.15	2,030.89	21.98	-2.37	0.253
93.63	-17.08	-15.92	0.00	-442.90	0.00	442.90	2,888.21	682.25	2,012.97	1,934.07	23.81	-2.45	0.235
95.00	-16.72	-15.76	0.00	-421.09	0.00	421.09	2,861.41	675.92	1,975.80	1,898.14	24.52	-2.49	0.228
98.38	-15.87	-15.56	0.00	-367.83	0.00	367.83	1,159.13	336.03	976.45	768.89	26.31	-2.56	0.494
100.00	-15.69	-15.36	0.00	-342.62	0.00	342.62	1,152.97	332.28	954.82	756.24	27.19	-2.60	0.469
105.00	-15.20	-15.04	0.00	-265.83	0.00	265.83	1,133.01	320.73	889.59	717.16	30.00	-2.77	0.386
110.00	-11.09	-12.17	0.00	-190.61	0.00	190.61	1,111.60	309.18	826.67	678.11	32.99	-2.92	0.293
115.00	-10.66	-11.88	0.00	-129.74	0.00	129.74	1,088.74	297.63	766.05	639.20	36.12	-3.04	0.214
119.00	-8.14	-10.65	0.00	-82.22	0.00	82.22	1,069.41	288.39	719.22	608.22	38.70	-3.11	0.144
119.00	-8.14	-10.65	0.00	-82.22	0.00	82.22	950.95	285.28	642.72	624.60	38.70	-3.11	0.142
120.00	-5.73	-5.27	0.00	-68.18	0.00	68.18	950.95	285.28	642.72	624.60	39.35	-3.12	0.116
121.00	-5.18	-4.71	0.00	-62.49	0.00	62.49	950.95	285.28	642.72	624.60	40.01	-3.13	0.106
125.00	-4.65	-4.46	0.00	-43.65	0.00	43.65	950.95	285.28	642.72	624.60	42.64	-3.15	0.075
130.00	-3.98	-4.19	0.00	-21.33	0.00	21.33	950.95	285.28	642.72	624.60	45.95	-3.17	0.039
135.00	-0.49	-0.10	0.00	-0.40	0.00	0.40	950.95	285.28	642.72	624.60	49.28	-3.18	0.001
139.00	0.00	-0.07	0.00	0.00	0.00	0.00	950.95	285.28	642.72	624.60	51.94	-3.18	0.000

Load Case: 0.9D + 1.0W

115 mph with No Ice (Reduced DL)

21 Iterations

Gust Response Factor :1.10

Dead Load Factor :0.90

Wind Load Factor :1.00

Applied Segment Forces Summary

Seg Elev (ft)	Description	Shaft Forces		Discrete Forces			Linear Forces		Sum of Forces				
		Wind FX (lb)	Dead Load (lb)	Wind FX (lb)	Torsion MY (lb-ft)	Moment MZ (lb-ft)	Dead Load (lb)	Wind FX (lb)	Dead Load (lb)	Wind FX (lb)	Dead Load (lb)	Torsion MY (lb-ft)	Moment MZ (lb)
0.00		199.2	0.0					0.0	0.0	199.2	0.0	0.0	0.0
5.00		394.2	1,105.9					0.0	66.4	394.2	1,172.2	0.0	0.0
10.00		385.8	1,082.3					0.0	66.4	385.8	1,148.7	0.0	0.0
15.00		377.4	1,058.8					0.0	66.4	377.4	1,125.2	0.0	0.0
20.00		369.0	1,035.3					0.0	66.4	369.0	1,101.7	0.0	0.0
25.00		360.6	1,011.8					0.0	66.4	360.6	1,078.2	0.0	0.0
30.00		356.4	988.3					0.0	66.4	356.4	1,054.6	0.0	0.0
35.00		359.3	964.7					0.0	66.4	359.3	1,031.1	0.0	0.0
40.00		364.2	941.2					0.0	66.4	364.2	1,007.6	0.0	0.0
45.00		219.9	917.7					0.0	66.4	219.9	984.1	0.0	0.0
46.00	Bot - Section 2	186.8	180.7					0.0	13.3	186.8	194.0	0.0	0.0
50.00		225.2	1,336.9					0.0	53.1	225.2	1,390.0	0.0	0.0
52.00	Top - Section 1	187.9	657.9					0.0	26.5	187.9	684.5	0.0	0.0
55.00		300.6	454.2					0.0	39.8	300.6	494.1	0.0	0.0
60.00		375.0	740.9					0.0	66.4	375.0	807.3	0.0	0.0
65.00		373.2	720.8					0.0	66.4	373.2	787.2	0.0	0.0
70.00		370.5	700.6					0.0	66.4	370.5	767.0	0.0	0.0
75.00		367.0	680.5					0.0	66.4	367.0	746.8	0.0	0.0
80.00		362.7	660.3					0.0	66.4	362.7	726.7	0.0	0.0
85.00		357.7	640.1					0.0	66.4	357.7	706.5	0.0	0.0
90.00		304.6	620.0					0.0	66.4	304.6	686.4	0.0	0.0
93.63	Bot - Section 3	175.1	437.5					0.0	48.2	175.1	485.7	0.0	0.0
95.00		165.6	244.9					0.0	18.2	165.6	263.1	0.0	0.0
98.38	Top - Section 2	173.3	594.6					0.0	44.9	173.3	639.4	0.0	0.0
100.00		225.6	94.5					0.0	21.5	225.6	116.0	0.0	0.0
105.00		336.0	284.9					0.0	66.4	336.0	351.3	0.0	0.0
110.00	Appurtenance(s)	328.3	274.8	2,362.1	0.0	0.0	2,818.9	0.0	66.4	2,690.4	3,160.1	0.0	0.0
115.00		288.9	264.7					0.0	55.8	288.9	320.6	0.0	0.0
119.00	Top - Section 3	150.5	204.5					0.0	44.7	150.5	249.2	0.0	0.0
120.00	Appurtenance(s)	47.6	92.5	5,186.7	0.0	3,400.9	1,915.1	0.0	11.2	5,234.2	2,018.7	0.0	0.0
121.00	Appurtenance(s)	119.6	92.5	415.5	0.0	415.5	334.9	0.0	11.2	535.1	438.5	0.0	0.0
125.00		216.7	369.8					0.0	37.5	216.7	407.3	0.0	0.0
130.00		243.3	462.3					0.0	46.8	243.3	509.1	0.0	0.0
135.00	Appurtenance(s)	196.4	462.3	3,687.8	0.0	0.0	2,275.7	0.0	46.8	3,884.2	2,784.9	0.0	0.0
139.00		74.1	369.8					0.0	0.0	74.1	369.8	0.0	0.0
Totals:										21,190.1	29,807.3	0.00	0.00

Load Case: 0.9D + 1.0W

115 mph with No Ice (Reduced DL)

21 Iterations

Gust Response Factor :1.10

Dead Load Factor :0.90

Wind Load Factor :1.00

Calculated Forces

Seg Elev (ft)	Pu FY (-) (kips)	Vu FX (-) (kips)	Tu MY (ft-kips)	Mu MZ (ft-kips)	Mu MX (ft-kips)	Resultant Moment (ft-kips)	phi Pn (kips)	phi Vn (kips)	phi Tn (ft-kips)	phi Mn (ft-kips)	Total Deflect (in)	Rotation (deg)	Ratio
0.00	-31.47	-21.98	0.00	-2,218.85	0.00	2,218.85	5,119.46	1,280.92	6,081.36	5,534.19	0.00	0.00	0.407
5.00	-30.25	-21.65	0.00	-2,108.97	0.00	2,108.97	5,045.45	1,253.97	5,828.14	5,338.45	0.07	-0.12	0.401
10.00	-29.06	-21.32	0.00	-2,000.75	0.00	2,000.75	4,969.98	1,227.01	5,580.31	5,144.62	0.26	-0.24	0.395
15.00	-27.89	-21.00	0.00	-1,894.16	0.00	1,894.16	4,893.07	1,200.06	5,337.86	4,952.78	0.58	-0.37	0.388
20.00	-26.75	-20.68	0.00	-1,789.18	0.00	1,789.18	4,814.71	1,173.10	5,100.79	4,763.03	1.03	-0.49	0.382
25.00	-25.63	-20.36	0.00	-1,685.80	0.00	1,685.80	4,734.90	1,146.15	4,869.11	4,575.48	1.61	-0.62	0.374
30.00	-24.53	-20.05	0.00	-1,583.99	0.00	1,583.99	4,653.63	1,119.19	4,642.81	4,390.22	2.33	-0.75	0.366
35.00	-23.46	-19.73	0.00	-1,483.75	0.00	1,483.75	4,570.92	1,092.24	4,421.90	4,207.35	3.18	-0.87	0.358
40.00	-22.42	-19.40	0.00	-1,385.12	0.00	1,385.12	4,486.76	1,065.28	4,206.37	4,026.98	4.16	-1.00	0.349
45.00	-21.41	-19.19	0.00	-1,288.13	0.00	1,288.13	4,395.58	1,038.33	3,996.23	3,844.33	5.28	-1.13	0.340
46.00	-21.20	-19.02	0.00	-1,268.95	0.00	1,268.95	4,372.76	1,032.94	3,954.84	3,804.32	5.53	-1.16	0.339
50.00	-19.79	-18.79	0.00	-1,192.86	0.00	1,192.86	4,281.48	1,011.37	3,791.47	3,646.34	6.54	-1.26	0.332
52.00	-19.09	-18.61	0.00	-1,155.27	0.00	1,155.27	3,574.52	874.62	3,307.89	3,076.23	7.08	-1.32	0.381
55.00	-18.56	-18.34	0.00	-1,099.43	0.00	1,099.43	3,534.07	860.76	3,203.87	2,992.79	7.94	-1.40	0.373
60.00	-17.72	-17.99	0.00	-1,007.74	0.00	1,007.74	3,465.49	837.65	3,034.21	2,855.22	9.48	-1.54	0.359
65.00	-16.90	-17.63	0.00	-917.82	0.00	917.82	3,395.45	814.55	2,869.16	2,719.65	11.17	-1.68	0.343
70.00	-16.11	-17.28	0.00	-829.66	0.00	829.66	3,323.97	791.45	2,708.73	2,586.16	13.00	-1.82	0.326
75.00	-15.33	-16.92	0.00	-743.27	0.00	743.27	3,251.04	768.34	2,552.91	2,454.85	14.98	-1.96	0.308
80.00	-14.58	-16.57	0.00	-658.67	0.00	658.67	3,154.84	745.24	2,401.71	2,309.85	17.10	-2.09	0.290
85.00	-13.85	-16.21	0.00	-575.83	0.00	575.83	3,057.03	722.13	2,255.12	2,168.13	19.36	-2.22	0.271
90.00	-13.15	-15.91	0.00	-494.76	0.00	494.76	2,959.22	699.03	2,113.15	2,030.89	21.75	-2.34	0.249
93.63	-12.66	-15.72	0.00	-437.03	0.00	437.03	2,888.21	682.25	2,012.97	1,934.07	23.57	-2.43	0.231
95.00	-12.39	-15.56	0.00	-415.49	0.00	415.49	2,861.41	675.92	1,975.80	1,898.14	24.27	-2.46	0.224
98.38	-11.74	-15.37	0.00	-362.90	0.00	362.90	1,159.13	336.03	976.45	768.89	26.03	-2.53	0.484
100.00	-11.61	-15.16	0.00	-338.00	0.00	338.00	1,152.97	332.28	954.82	756.24	26.90	-2.57	0.459
105.00	-11.23	-14.84	0.00	-262.20	0.00	262.20	1,133.01	320.73	889.59	717.16	29.68	-2.74	0.378
110.00	-8.18	-12.02	0.00	-188.00	0.00	188.00	1,111.60	309.18	826.67	678.11	32.64	-2.89	0.286
115.00	-7.85	-11.72	0.00	-127.93	0.00	127.93	1,088.74	297.63	766.05	639.20	35.73	-3.00	0.209
119.00	-5.97	-10.52	0.00	-81.03	0.00	81.03	1,069.41	288.39	719.22	608.22	38.28	-3.07	0.140
119.00	-5.97	-10.52	0.00	-81.03	0.00	81.03	950.95	285.28	642.72	624.60	38.28	-3.07	0.137
120.00	-4.24	-5.19	0.00	-67.11	0.00	67.11	950.95	285.28	642.72	624.60	38.92	-3.09	0.112
121.00	-3.83	-4.63	0.00	-61.50	0.00	61.50	950.95	285.28	642.72	624.60	39.57	-3.09	0.103
125.00	-3.43	-4.39	0.00	-42.98	0.00	42.98	950.95	285.28	642.72	624.60	42.17	-3.12	0.073
130.00	-2.93	-4.12	0.00	-21.00	0.00	21.00	950.95	285.28	642.72	624.60	45.45	-3.14	0.037
135.00	-0.37	-0.09	0.00	-0.38	0.00	0.38	950.95	285.28	642.72	624.60	48.73	-3.14	0.001
139.00	0.00	-0.07	0.00	0.00	0.00	0.00	950.95	285.28	642.72	624.60	51.37	-3.14	0.000

Site Number: 416862

Code: ANSI/TIA-222-H

© 2007 - 2021 by ATC IP LLC. All rights reserved.

Site Name: SUFFIELD SW CT CT, CT

Engineering Number: 13692184_C3_02

7/14/2021 11:05:00 AM

Customer: DISH WIRELESS L.L.C.

Load Case: 1.2D + 1.0Di + 1.0Wi

50 mph with 1.50 in Radial Ice

21 Iterations

Gust Response Factor :1.10

Ice Dead Load Factor :1.00

Dead Load Factor :1.20

Ice Importance Factor :1.00

Wind Load Factor :1.00

Applied Segment Forces Summary

Seg Elev (ft)	Description	Shaft Forces		Discrete Forces			Linear Forces		Sum of Forces				
		Wind FX (lb)	Dead Load (lb)	Wind FX (lb)	Torsion MY (lb-ft)	Moment MZ (lb-ft)	Dead Load (lb)	Wind FX (lb)	Dead Load (lb)	Wind FX (lb)	Dead Load (lb)	Torsion MY (lb-ft)	Moment MZ (lb)
0.00		64.6	0.0					0.0	0.0	64.6	0.0	0.0	0.0
5.00		128.2	1,859.6					0.0	88.5	128.2	1,948.1	0.0	0.0
10.00		126.1	1,865.1					0.0	88.5	126.1	1,953.6	0.0	0.0
15.00		123.7	1,847.0					0.0	88.5	123.7	1,935.5	0.0	0.0
20.00		121.3	1,821.2					0.0	88.5	121.3	1,909.7	0.0	0.0
25.00		118.8	1,791.3					0.0	88.5	118.8	1,879.8	0.0	0.0
30.00		117.7	1,759.0					0.0	88.5	117.7	1,847.5	0.0	0.0
35.00		119.0	1,724.9					0.0	88.5	119.0	1,813.4	0.0	0.0
40.00		120.9	1,689.6					0.0	88.5	120.9	1,778.1	0.0	0.0
45.00		73.1	1,653.2					0.0	88.5	73.1	1,741.7	0.0	0.0
46.00	Bot - Section 2	62.2	327.1					0.0	17.7	62.2	344.8	0.0	0.0
50.00		75.0	2,127.7					0.0	70.8	75.0	2,198.5	0.0	0.0
52.00	Top - Section 1	62.7	1,049.2					0.0	35.4	62.7	1,084.6	0.0	0.0
55.00		100.5	861.0					0.0	53.1	100.5	914.1	0.0	0.0
60.00		125.6	1,405.6					0.0	88.5	125.6	1,494.1	0.0	0.0
65.00		125.3	1,371.3					0.0	88.5	125.3	1,459.8	0.0	0.0
70.00		124.7	1,336.6					0.0	88.5	124.7	1,425.1	0.0	0.0
75.00		123.9	1,301.4					0.0	88.5	123.9	1,389.9	0.0	0.0
80.00		122.8	1,266.0					0.0	88.5	122.8	1,354.5	0.0	0.0
85.00		121.5	1,230.2					0.0	88.5	121.5	1,318.7	0.0	0.0
90.00		103.7	1,194.2					0.0	88.5	103.7	1,282.7	0.0	0.0
93.63	Bot - Section 3	59.7	845.4					0.0	64.3	59.7	909.7	0.0	0.0
95.00		56.6	426.0					0.0	24.2	56.6	450.2	0.0	0.0
98.38	Top - Section 2	59.3	1,033.4					0.0	59.8	59.3	1,093.2	0.0	0.0
100.00		77.4	240.4					0.0	28.7	77.4	269.0	0.0	0.0
105.00		115.6	722.5					0.0	88.5	115.6	811.0	0.0	0.0
110.00	Appurtenance(s)	113.4	699.1	628.0	0.0	0.0	6,208.6	0.0	88.5	741.4	6,996.2	0.0	0.0
115.00		100.2	675.5					0.0	74.5	100.2	750.0	0.0	0.0
119.00	Top - Section 3	54.2	524.3					0.0	59.6	54.2	583.8	0.0	0.0
120.00	Appurtenance(s)	20.3	181.0	1,551.3	0.0	885.2	5,155.0	0.0	14.9	1,571.7	5,350.9	0.0	0.0
121.00	Appurtenance(s)	51.2	181.0	108.6	0.0	108.6	956.6	0.0	14.9	159.8	1,152.5	0.0	0.0
125.00		92.8	724.7					0.0	50.0	92.8	774.6	0.0	0.0
130.00		104.1	906.9					0.0	62.5	104.1	969.4	0.0	0.0
135.00	Appurtenance(s)	91.2	908.1	997.2	0.0	0.0	6,294.2	0.0	62.5	1,088.4	7,264.8	0.0	0.0
139.00		38.8	727.3					0.0	0.0	38.8	727.3	0.0	0.0
Totals:										6,581.23	59,177.0	0.00	0.00

Site Number: 416862

Code: ANSI/TIA-222-H

© 2007 - 2021 by ATC IP LLC. All rights reserved.

Site Name: SUFFIELD SW CT CT, CT

Engineering Number: 13692184_C3_02

7/14/2021 11:05:01 AM

Customer: DISH WIRELESS L.L.C.

Load Case: 1.2D + 1.0Di + 1.0Wi

50 mph with 1.50 in Radial Ice

21 Iterations

Gust Response Factor :1.10

Ice Dead Load Factor :1.00

Dead Load Factor :1.20

Ice Importance Factor :1.00

Wind Load Factor :1.00

Calculated Forces

Seg Elev (ft)	Pu FY (-) (kips)	Vu FX (-) (kips)	Tu MY (ft-kips)	Mu MZ (ft-kips)	Mu MX (ft-kips)	Resultant Moment (ft-kips)	phi Pn (kips)	phi Vn (kips)	phi Tn (ft-kips)	phi Mn (ft-kips)	Total Deflect (in)	Rotation (deg)	Ratio
0.00	-62.10	-6.85	0.00	-700.11	0.00	700.11	5,119.46	1,280.92	6,081.36	5,534.19	0.00	0.00	0.139
5.00	-60.15	-6.76	0.00	-665.88	0.00	665.88	5,045.45	1,253.97	5,828.14	5,338.45	0.02	-0.04	0.137
10.00	-58.19	-6.67	0.00	-632.09	0.00	632.09	4,969.98	1,227.01	5,580.31	5,144.62	0.08	-0.08	0.135
15.00	-56.25	-6.58	0.00	-598.75	0.00	598.75	4,893.07	1,200.06	5,337.86	4,952.78	0.18	-0.12	0.132
20.00	-54.34	-6.49	0.00	-565.85	0.00	565.85	4,814.71	1,173.10	5,100.79	4,763.03	0.33	-0.16	0.130
25.00	-52.45	-6.40	0.00	-533.39	0.00	533.39	4,734.90	1,146.15	4,869.11	4,575.48	0.51	-0.20	0.128
30.00	-50.60	-6.32	0.00	-501.36	0.00	501.36	4,653.63	1,119.19	4,642.81	4,390.22	0.74	-0.24	0.125
35.00	-48.78	-6.22	0.00	-469.79	0.00	469.79	4,570.92	1,092.24	4,421.90	4,207.35	1.00	-0.28	0.122
40.00	-47.00	-6.13	0.00	-438.67	0.00	438.67	4,486.76	1,065.28	4,206.37	4,026.98	1.32	-0.32	0.119
45.00	-45.26	-6.06	0.00	-408.04	0.00	408.04	4,395.58	1,038.33	3,996.23	3,844.33	1.67	-0.36	0.116
46.00	-44.91	-6.02	0.00	-401.97	0.00	401.97	4,372.76	1,032.94	3,954.84	3,804.32	1.75	-0.37	0.116
50.00	-42.71	-5.94	0.00	-377.91	0.00	377.91	4,281.48	1,011.37	3,791.47	3,646.34	2.07	-0.40	0.114
52.00	-41.62	-5.89	0.00	-366.03	0.00	366.03	3,574.52	874.62	3,307.89	3,076.23	2.24	-0.42	0.131
55.00	-40.71	-5.81	0.00	-348.36	0.00	348.36	3,534.07	860.76	3,203.87	2,992.79	2.51	-0.44	0.128
60.00	-39.21	-5.70	0.00	-319.33	0.00	319.33	3,465.49	837.65	3,034.21	2,855.22	3.00	-0.49	0.123
65.00	-37.75	-5.59	0.00	-290.83	0.00	290.83	3,395.45	814.55	2,869.16	2,719.65	3.53	-0.53	0.118
70.00	-36.32	-5.48	0.00	-262.88	0.00	262.88	3,323.97	791.45	2,708.73	2,586.16	4.11	-0.58	0.113
75.00	-34.93	-5.37	0.00	-235.48	0.00	235.48	3,251.04	768.34	2,552.91	2,454.85	4.74	-0.62	0.107
80.00	-33.57	-5.25	0.00	-208.64	0.00	208.64	3,154.84	745.24	2,401.71	2,309.85	5.41	-0.66	0.101
85.00	-32.25	-5.14	0.00	-182.37	0.00	182.37	3,057.03	722.13	2,255.12	2,168.13	6.13	-0.70	0.095
90.00	-30.96	-5.04	0.00	-156.67	0.00	156.67	2,959.22	699.03	2,113.15	2,030.89	6.88	-0.74	0.088
93.63	-30.05	-4.98	0.00	-138.39	0.00	138.39	2,888.21	682.25	2,012.97	1,934.07	7.46	-0.77	0.082
95.00	-29.60	-4.92	0.00	-131.57	0.00	131.57	2,861.41	675.92	1,975.80	1,898.14	7.68	-0.78	0.080
98.38	-28.51	-4.86	0.00	-114.94	0.00	114.94	1,159.13	336.03	976.45	768.89	8.24	-0.80	0.174
100.00	-28.24	-4.79	0.00	-107.08	0.00	107.08	1,152.97	332.28	954.82	756.24	8.51	-0.81	0.166
105.00	-27.43	-4.69	0.00	-83.12	0.00	83.12	1,133.01	320.73	889.59	717.16	9.39	-0.87	0.140
110.00	-20.44	-3.85	0.00	-59.68	0.00	59.68	1,111.60	309.18	826.67	678.11	10.33	-0.91	0.107
115.00	-19.69	-3.75	0.00	-40.42	0.00	40.42	1,088.74	297.63	766.05	639.20	11.31	-0.95	0.081
119.00	-16.19	-3.33	0.00	-25.42	0.00	25.42	1,069.41	288.39	719.22	608.22	12.12	-0.97	0.057
119.00	-16.19	-3.33	0.00	-25.42	0.00	25.42	950.95	285.28	642.72	624.60	12.12	-0.97	0.058
120.00	-10.86	-1.67	0.00	-21.20	0.00	21.20	950.95	285.28	642.72	624.60	12.32	-0.98	0.045
121.00	-9.71	-1.49	0.00	-19.43	0.00	19.43	950.95	285.28	642.72	624.60	12.53	-0.98	0.041
125.00	-8.94	-1.39	0.00	-13.46	0.00	13.46	950.95	285.28	642.72	624.60	13.35	-0.99	0.031
130.00	-7.97	-1.27	0.00	-6.53	0.00	6.53	950.95	285.28	642.72	624.60	14.39	-0.99	0.019
135.00	-0.73	-0.05	0.00	-0.21	0.00	0.21	950.95	285.28	642.72	624.60	15.43	-0.99	0.001
139.00	0.00	-0.04	0.00	0.00	0.00	0.00	950.95	285.28	642.72	624.60	16.26	-0.99	0.000

Site Number: 416862

Code: ANSI/TIA-222-H

© 2007 - 2021 by ATC IP LLC. All rights reserved.

Site Name: SUFFIELD SW CT CT, CT

Engineering Number: 13692184_C3_02

7/14/2021 11:05:01 AM

Customer: DISH WIRELESS L.L.C.

Load Case: 1.0D + 1.0W	Serviceability 60 mph	20 Iterations
Gust Response Factor :1.10		
Dead Load Factor :1.00		
Wind Load Factor :1.00		

Applied Segment Forces Summary

Seg Elev (ft)	Description	Shaft Forces		Discrete Forces			Linear Forces		Sum of Forces				
		Wind FX (lb)	Dead Load (lb)	Wind FX (lb)	Torsion MY (lb-ft)	Moment MZ (lb-ft)	Dead Load (lb)	Wind FX (lb)	Dead Load (lb)	Wind FX (lb)	Dead Load (lb)	Torsion MY (lb-ft)	Moment MZ (lb)
0.00		48.5	0.0					0.0	0.0	48.5	0.0	0.0	0.0
5.00		96.0	1,228.7					0.0	73.7	96.0	1,302.5	0.0	0.0
10.00		94.0	1,202.6					0.0	73.7	94.0	1,276.3	0.0	0.0
15.00		91.9	1,176.5					0.0	73.7	91.9	1,250.2	0.0	0.0
20.00		89.9	1,150.3					0.0	73.7	89.9	1,224.1	0.0	0.0
25.00		87.8	1,124.2					0.0	73.7	87.8	1,198.0	0.0	0.0
30.00		86.8	1,098.1					0.0	73.7	86.8	1,171.8	0.0	0.0
35.00		87.5	1,071.9					0.0	73.7	87.5	1,145.7	0.0	0.0
40.00		88.7	1,045.8					0.0	73.7	88.7	1,119.6	0.0	0.0
45.00		53.5	1,019.7					0.0	73.7	53.5	1,093.4	0.0	0.0
46.00	Bot - Section 2	45.5	200.8					0.0	14.8	45.5	215.5	0.0	0.0
50.00		54.8	1,485.4					0.0	59.0	54.8	1,544.4	0.0	0.0
52.00	Top - Section 1	45.8	731.1					0.0	29.5	45.8	760.6	0.0	0.0
55.00		73.2	504.7					0.0	44.3	73.2	549.0	0.0	0.0
60.00		91.3	823.3					0.0	73.7	91.3	897.0	0.0	0.0
65.00		90.9	800.9					0.0	73.7	90.9	874.6	0.0	0.0
70.00		90.2	778.5					0.0	73.7	90.2	852.2	0.0	0.0
75.00		89.4	756.1					0.0	73.7	89.4	829.8	0.0	0.0
80.00		88.3	733.7					0.0	73.7	88.3	807.4	0.0	0.0
85.00		87.1	711.3					0.0	73.7	87.1	785.0	0.0	0.0
90.00		74.2	688.9					0.0	73.7	74.2	762.6	0.0	0.0
93.63	Bot - Section 3	42.6	486.1					0.0	53.5	42.6	539.6	0.0	0.0
95.00		40.3	272.1					0.0	20.2	40.3	292.3	0.0	0.0
98.38	Top - Section 2	42.2	660.6					0.0	49.9	42.2	710.5	0.0	0.0
100.00		55.0	105.0					0.0	23.9	55.0	128.9	0.0	0.0
105.00		81.8	316.5					0.0	73.7	81.8	390.3	0.0	0.0
110.00	Appurtenance(s)	80.0	305.3	575.3	0.0	0.0	3,132.1	0.0	73.7	655.3	3,511.2	0.0	0.0
115.00		70.4	294.1					0.0	62.0	70.4	356.2	0.0	0.0
119.00	Top - Section 3	36.6	227.2					0.0	49.6	36.6	276.9	0.0	0.0
120.00	Appurtenance(s)	11.6	102.7	1,263.3	0.0	828.3	2,127.9	0.0	12.4	1,274.8	2,243.0	0.0	0.0
121.00	Appurtenance(s)	29.1	102.7	101.2	0.0	101.2	372.1	0.0	12.4	130.3	487.2	0.0	0.0
125.00		52.8	410.9					0.0	41.6	52.8	452.5	0.0	0.0
130.00		59.2	513.6					0.0	52.0	59.2	565.7	0.0	0.0
135.00	Appurtenance(s)	47.8	513.6	898.2	0.0	0.0	2,528.6	0.0	52.0	946.0	3,094.3	0.0	0.0
139.00		18.0	410.9					0.0	0.0	18.0	410.9	0.0	0.0
Totals:										5,161.02	33,119.2	0.00	0.00

Site Number: 416862

Code: ANSI/TIA-222-H

© 2007 - 2021 by ATC IP LLC. All rights reserved.

Site Name: SUFFIELD SW CT CT, CT

Engineering Number: 13692184_C3_02

7/14/2021 11:05:03 AM

Customer: DISH WIRELESS L.L.C.

Load Case: 1.0D + 1.0W

Serviceability 60 mph

20 Iterations

Gust Response Factor :1.10

Dead Load Factor :1.00

Wind Load Factor :1.00

Calculated Forces

Seg Elev (ft)	Pu FY (-) (kips)	Vu FX (-) (kips)	Tu MY (ft-kips)	Mu MZ (ft-kips)	Mu MX (ft-kips)	Resultant Moment (ft-kips)	phi Pn (kips)	phi Vn (kips)	phi Tn (ft-kips)	phi Mn (ft-kips)	Total Deflect (in)	Rotation (deg)	Ratio
0.00	-34.99	-5.35	0.00	-542.06	0.00	542.06	5,119.46	1,280.92	6,081.36	5,534.19	0.00	0.00	0.105
5.00	-33.69	-5.27	0.00	-515.30	0.00	515.30	5,045.45	1,253.97	5,828.14	5,338.45	0.02	-0.03	0.103
10.00	-32.41	-5.20	0.00	-488.93	0.00	488.93	4,969.98	1,227.01	5,580.31	5,144.62	0.06	-0.06	0.102
15.00	-31.16	-5.12	0.00	-462.96	0.00	462.96	4,893.07	1,200.06	5,337.86	4,952.78	0.14	-0.09	0.100
20.00	-29.93	-5.04	0.00	-437.36	0.00	437.36	4,814.71	1,173.10	5,100.79	4,763.03	0.25	-0.12	0.098
25.00	-28.73	-4.97	0.00	-412.15	0.00	412.15	4,734.90	1,146.15	4,869.11	4,575.48	0.39	-0.15	0.096
30.00	-27.55	-4.89	0.00	-387.31	0.00	387.31	4,653.63	1,119.19	4,642.81	4,390.22	0.57	-0.18	0.094
35.00	-26.41	-4.82	0.00	-362.85	0.00	362.85	4,570.92	1,092.24	4,421.90	4,207.35	0.78	-0.21	0.092
40.00	-25.28	-4.74	0.00	-338.77	0.00	338.77	4,486.76	1,065.28	4,206.37	4,026.98	1.02	-0.25	0.090
45.00	-24.19	-4.69	0.00	-315.09	0.00	315.09	4,395.58	1,038.33	3,996.23	3,844.33	1.29	-0.28	0.087
46.00	-23.97	-4.65	0.00	-310.41	0.00	310.41	4,372.76	1,032.94	3,954.84	3,804.32	1.35	-0.28	0.087
50.00	-22.43	-4.59	0.00	-291.82	0.00	291.82	4,281.48	1,011.37	3,791.47	3,646.34	1.60	-0.31	0.085
52.00	-21.67	-4.55	0.00	-282.64	0.00	282.64	3,574.52	874.62	3,307.89	3,076.23	1.73	-0.32	0.098
55.00	-21.12	-4.48	0.00	-269.00	0.00	269.00	3,534.07	860.76	3,203.87	2,992.79	1.94	-0.34	0.096
60.00	-20.22	-4.40	0.00	-246.60	0.00	246.60	3,465.49	837.65	3,034.21	2,855.22	2.32	-0.38	0.092
65.00	-19.34	-4.31	0.00	-224.62	0.00	224.62	3,395.45	814.55	2,869.16	2,719.65	2.73	-0.41	0.088
70.00	-18.49	-4.22	0.00	-203.07	0.00	203.07	3,323.97	791.45	2,708.73	2,586.16	3.18	-0.45	0.084
75.00	-17.65	-4.14	0.00	-181.95	0.00	181.95	3,251.04	768.34	2,552.91	2,454.85	3.66	-0.48	0.080
80.00	-16.85	-4.05	0.00	-161.25	0.00	161.25	3,154.84	745.24	2,401.71	2,309.85	4.18	-0.51	0.075
85.00	-16.06	-3.97	0.00	-140.99	0.00	140.99	3,057.03	722.13	2,255.12	2,168.13	4.73	-0.54	0.070
90.00	-15.30	-3.89	0.00	-121.15	0.00	121.15	2,959.22	699.03	2,113.15	2,030.89	5.32	-0.57	0.065
93.63	-14.76	-3.85	0.00	-107.02	0.00	107.02	2,888.21	682.25	2,012.97	1,934.07	5.76	-0.59	0.060
95.00	-14.46	-3.81	0.00	-101.75	0.00	101.75	2,861.41	675.92	1,975.80	1,898.14	5.93	-0.60	0.059
98.38	-13.75	-3.76	0.00	-88.88	0.00	88.88	1,159.13	336.03	976.45	768.89	6.37	-0.62	0.128
100.00	-13.62	-3.71	0.00	-82.78	0.00	82.78	1,152.97	332.28	954.82	756.24	6.58	-0.63	0.121
105.00	-13.23	-3.63	0.00	-64.23	0.00	64.23	1,133.01	320.73	889.59	717.16	7.26	-0.67	0.101
110.00	-9.73	-2.94	0.00	-46.05	0.00	46.05	1,111.60	309.18	826.67	678.11	7.98	-0.71	0.077
115.00	-9.37	-2.87	0.00	-31.34	0.00	31.34	1,088.74	297.63	766.05	639.20	8.74	-0.74	0.058
119.00	-7.22	-2.58	0.00	-19.85	0.00	19.85	1,069.41	288.39	719.22	608.22	9.36	-0.75	0.039
119.00	-7.22	-2.58	0.00	-19.85	0.00	19.85	950.95	285.28	642.72	624.60	9.36	-0.75	0.039
120.00	-4.99	-1.27	0.00	-16.45	0.00	16.45	950.95	285.28	642.72	624.60	9.52	-0.76	0.032
121.00	-4.51	-1.14	0.00	-15.08	0.00	15.08	950.95	285.28	642.72	624.60	9.68	-0.76	0.029
125.00	-4.06	-1.08	0.00	-10.53	0.00	10.53	950.95	285.28	642.72	624.60	10.32	-0.76	0.021
130.00	-3.49	-1.01	0.00	-5.15	0.00	5.15	950.95	285.28	642.72	624.60	11.12	-0.77	0.012
135.00	-0.41	-0.02	0.00	-0.09	0.00	0.09	950.95	285.28	642.72	624.60	11.92	-0.77	0.001
139.00	0.00	-0.02	0.00	0.00	0.00	0.00	950.95	285.28	642.72	624.60	12.57	-0.77	0.000

Equivalent Lateral Forces Method Analysis

Spectral Response Acceleration for Short Period (S_s):	0.17
Spectral Response Acceleration at 1.0 Second Period (S_{d1}):	0.05
Long-Period Transition Period (T_L):	6
Importance Factor (I_E):	1.00
Site Coefficient F_a :	1.60
Site Coefficient F_v :	2.40
Response Modification Coefficient (R):	1.50
Design Spectral Response Acceleration at Short Period (S_{ds}):	0.18
Design Spectral Response Acceleration at 1.0 Second Period (S_{d1}):	0.09
Seismic Response Coefficient (C_s):	0.03
Upper Limit C_s	0.03
Lower Limit C_s	0.03
Period based on Rayleigh Method (sec):	1.92
Redundancy Factor (p):	1.00
Seismic Force Distribution Exponent (k):	1.71
Total Unfactored Dead Load:	34.99 k
Seismic Base Shear (E):	1.05 k

Load Case 1.2D + 1.0Ev + 1.0Eh

Seismic

Segment	Height Above Base (ft)	Weight (lb)	W_z (lb-ft)	C_{vx}	Horizontal Force (lb)	Vertical Force (lb)
34	137.00	411	1,869	0.027	29	508
33	132.50	566	2,430	0.036	37	699
32	127.50	566	2,275	0.033	35	699
31	123.00	453	1,711	0.025	26	560
30	120.50	115	420	0.006	6	142
29	119.50	115	414	0.006	6	142
28	117.00	277	961	0.014	15	342
27	112.50	356	1,156	0.017	18	440
26	107.50	379	1,138	0.017	18	469
25	102.50	390	1,080	0.016	17	483
24	99.19	129	337	0.005	5	159
23	96.69	710	1,779	0.026	27	878
22	94.32	292	702	0.010	11	361
21	91.82	540	1,237	0.018	19	667
20	87.50	763	1,610	0.024	25	943
19	82.50	785	1,498	0.022	23	971
18	77.50	807	1,385	0.020	21	998
17	72.50	830	1,270	0.019	20	1,026
16	67.50	852	1,154	0.017	18	1,054
15	62.50	875	1,038	0.015	16	1,081
14	57.50	897	923	0.014	14	1,109
13	53.50	549	499	0.007	8	679
12	51.00	761	637	0.009	10	940
11	48.00	1,544	1,166	0.017	18	1,910
10	45.50	216	149	0.002	2	267

Site Number: 416862

Code: ANSI/TIA-222-H

© 2007 - 2021 by ATC IP LLC. All rights reserved.

Site Name: SUFFIELD SW CT CT, CT

Engineering Number: 13692184_C3_02

7/14/2021 11:05:03 AM

Customer: DISH WIRELESS L.L.C.

9	42.50	1,093	670	0.010	10	1,352
8	37.50	1,120	554	0.008	9	1,384
7	32.50	1,146	444	0.007	7	1,417
6	27.50	1,172	341	0.005	5	1,449
5	22.50	1,198	247	0.004	4	1,481
4	17.50	1,224	164	0.002	3	1,514
3	12.50	1,250	94	0.001	1	1,546
2	7.50	1,276	40	0.001	1	1,578
1	2.50	1,302	6	0.000	0	1,610
Raycap DC6-48-60-0-8	135.00	33	145	0.002	2	41
Ericsson RRUS 8843 B	135.00	216	958	0.014	15	267
Ericsson RRUS 4415 B	135.00	138	612	0.009	9	171
Ericsson RRUS 4449 B	135.00	213	945	0.014	15	263
Ericsson RRUS 4478 B	135.00	178	790	0.012	12	220
Raycap DC9-48-60-24-	135.00	16	71	0.001	1	20
CCI DMP65R-BU8D	135.00	287	1,273	0.019	20	355
Generic Flat Light S	135.00	1,200	5,322	0.078	82	1,484
CCI TPA65R-BU8D	135.00	248	1,098	0.016	17	306
Alcatel-Lucent RRH2x	121.00	152	559	0.008	9	188
Alcatel-Lucent RRH2x	121.00	132	485	0.007	7	163
RFS DB-T1-6Z-8AB-0Z	121.00	88	324	0.005	5	109
Amphenol Antel LPA-1	120.00	69	250	0.004	4	85
Antel BXA-70063/6CF_	120.00	102	370	0.005	6	126
VZW Unused Reserve (120.00	1,957	7,094	0.104	109	2,420
Generic Flat Low Pro	119.00	1,875	6,700	0.098	103	2,318
Commscope RDIDC-9181	110.00	22	68	0.001	1	27
Fujitsu TA08025-B605	110.00	225	703	0.010	11	278
Fujitsu TA08025-B604	110.00	192	599	0.009	9	237
JMA Wireless MX08FRO	110.00	193	604	0.009	9	239
Generic Flat Platfor	110.00	2,500	7,808	0.115	120	3,091
		34,994	68,177	1.000	1,050	43,270

Load Case 0.9D - 1.0Ev + 1.0Eh

Seismic (Reduced DL)

Segment	Height Above Base (ft)	Weight (lb)	W _z (lb-ft)	C _{vx}	Horizontal Force (lb)	Vertical Force (lb)
34	137.00	411	1,869	0.027	29	355
33	132.50	566	2,430	0.036	37	488
32	127.50	566	2,275	0.033	35	488
31	123.00	453	1,711	0.025	26	391
30	120.50	115	420	0.006	6	99
29	119.50	115	414	0.006	6	99
28	117.00	277	961	0.014	15	239
27	112.50	356	1,156	0.017	18	308
26	107.50	379	1,138	0.017	18	327
25	102.50	390	1,080	0.016	17	337
24	99.19	129	337	0.005	5	111
23	96.69	710	1,779	0.026	27	614
22	94.32	292	702	0.010	11	252
21	91.82	540	1,237	0.018	19	466
20	87.50	763	1,610	0.024	25	659
19	82.50	785	1,498	0.022	23	678
18	77.50	807	1,385	0.020	21	697
17	72.50	830	1,270	0.019	20	717
16	67.50	852	1,154	0.017	18	736
15	62.50	875	1,038	0.015	16	755
14	57.50	897	923	0.014	14	775
13	53.50	549	499	0.007	8	474
12	51.00	761	637	0.009	10	657
11	48.00	1,544	1,166	0.017	18	1,334
10	45.50	216	149	0.002	2	186

Site Number: 416862

Code: ANSI/TIA-222-H

© 2007 - 2021 by ATC IP LLC. All rights reserved.

Site Name: SUFFIELD SW CT CT, CT

Engineering Number: 13692184_C3_02

7/14/2021 11:05:03 AM

Customer: DISH WIRELESS L.L.C.

9	42.50	1,093	670	0.010	10	944
8	37.50	1,120	554	0.008	9	967
7	32.50	1,146	444	0.007	7	989
6	27.50	1,172	341	0.005	5	1,012
5	22.50	1,198	247	0.004	4	1,034
4	17.50	1,224	164	0.002	3	1,057
3	12.50	1,250	94	0.001	1	1,080
2	7.50	1,276	40	0.001	1	1,102
1	2.50	1,302	6	0.000	0	1,125
Raycap DC6-48-60-0-8	135.00	33	145	0.002	2	28
Ericsson RRUS 8843 B	135.00	216	958	0.014	15	187
Ericsson RRUS 4415 B	135.00	138	612	0.009	9	119
Ericsson RRUS 4449 B	135.00	213	945	0.014	15	184
Ericsson RRUS 4478 B	135.00	178	790	0.012	12	154
Raycap DC9-48-60-24-	135.00	16	71	0.001	1	14
CCI DMP65R-BU8D	135.00	287	1,273	0.019	20	248
Generic Flat Light S	135.00	1,200	5,322	0.078	82	1,036
CCI TPA65R-BU8D	135.00	248	1,098	0.016	17	214
Alcatel-Lucent RRH2x	121.00	152	559	0.008	9	131
Alcatel-Lucent RRH2x	121.00	132	485	0.007	7	114
RFS DB-T1-6Z-8AB-0Z	121.00	88	324	0.005	5	76
Amphenol Antel LPA-1	120.00	69	250	0.004	4	60
Antel BXA-70063/6CF_	120.00	102	370	0.005	6	88
VZW Unused Reserve (120.00	1,957	7,094	0.104	109	1,690
Generic Flat Low Pro	119.00	1,875	6,700	0.098	103	1,619
Commscope RDIDC-9181	110.00	22	68	0.001	1	19
Fujitsu TA08025-B605	110.00	225	703	0.010	11	194
Fujitsu TA08025-B604	110.00	192	599	0.009	9	166
JMA Wireless MX08FRO	110.00	193	604	0.009	9	167
Generic Flat Platfor	110.00	2,500	7,808	0.115	120	2,159
		34,994	68,177	1.000	1,050	30,218

Load Case 1.2D + 1.0Ev + 1.0Eh

Seismic

Calculated Forces

Seg Elev (ft)	Pu FY (-) (kips)	Vu FX (-) (kips)	Tu MY (ft-kips)	Mu MZ (ft-kips)	Mu MX (ft-kips)	Resultant Moment (ft-kips)	phi Pn (kips)	phi Vn (kips)	phi Tn (ft-kips)	phi Mn (ft-kips)	Total Deflect (in)	Rotation (deg)	Ratio
0.00	-41.66	-1.05	0.00	-116.27	0.00	116.27	5,119.46	1,280.92	6,081.36	5,534.19	0.00	0.00	0.029
5.00	-40.08	-1.05	0.00	-111.01	0.00	111.01	5,045.45	1,253.97	5,828.14	5,338.45	0.00	-0.01	0.029
10.00	-38.53	-1.06	0.00	-105.74	0.00	105.74	4,969.98	1,227.01	5,580.31	5,144.62	0.01	-0.01	0.028
15.00	-37.02	-1.06	0.00	-100.45	0.00	100.45	4,893.07	1,200.06	5,337.86	4,952.78	0.03	-0.02	0.028
20.00	-35.54	-1.06	0.00	-95.15	0.00	95.15	4,814.71	1,173.10	5,100.79	4,763.03	0.05	-0.03	0.027
25.00	-34.09	-1.06	0.00	-89.86	0.00	89.86	4,734.90	1,146.15	4,869.11	4,575.48	0.09	-0.03	0.027
30.00	-32.67	-1.05	0.00	-84.58	0.00	84.58	4,653.63	1,119.19	4,642.81	4,390.22	0.12	-0.04	0.026
35.00	-31.29	-1.05	0.00	-79.31	0.00	79.31	4,570.92	1,092.24	4,421.90	4,207.35	0.17	-0.05	0.026
40.00	-29.94	-1.04	0.00	-74.08	0.00	74.08	4,486.76	1,065.28	4,206.37	4,026.98	0.22	-0.05	0.025
45.00	-29.67	-1.04	0.00	-68.88	0.00	68.88	4,395.58	1,038.33	3,996.23	3,844.33	0.28	-0.06	0.025
46.00	-27.76	-1.02	0.00	-67.84	0.00	67.84	4,372.76	1,032.94	3,954.84	3,804.32	0.29	-0.06	0.024
50.00	-26.82	-1.01	0.00	-63.76	0.00	63.76	4,281.48	1,011.37	3,791.47	3,646.34	0.35	-0.07	0.024
52.00	-26.14	-1.00	0.00	-61.74	0.00	61.74	3,574.52	874.62	3,307.89	3,076.23	0.38	-0.07	0.027
55.00	-25.03	-0.99	0.00	-58.72	0.00	58.72	3,534.07	860.76	3,203.87	2,992.79	0.42	-0.07	0.027
60.00	-23.95	-0.98	0.00	-53.76	0.00	53.76	3,465.49	837.65	3,034.21	2,855.22	0.50	-0.08	0.026
65.00	-22.90	-0.96	0.00	-48.88	0.00	48.88	3,395.45	814.55	2,869.16	2,719.65	0.59	-0.09	0.025
70.00	-21.87	-0.94	0.00	-44.07	0.00	44.07	3,323.97	791.45	2,708.73	2,586.16	0.69	-0.10	0.024
75.00	-20.87	-0.92	0.00	-39.36	0.00	39.36	3,251.04	768.34	2,552.91	2,454.85	0.80	-0.10	0.022
80.00	-19.90	-0.90	0.00	-34.75	0.00	34.75	3,154.84	745.24	2,401.71	2,309.85	0.91	-0.11	0.021
85.00	-18.96	-0.88	0.00	-30.25	0.00	30.25	3,057.03	722.13	2,255.12	2,168.13	1.03	-0.12	0.020
90.00	-18.29	-0.86	0.00	-25.87	0.00	25.87	2,959.22	699.03	2,113.15	2,030.89	1.16	-0.12	0.019
93.63	-17.93	-0.85	0.00	-22.76	0.00	22.76	2,888.21	682.25	2,012.97	1,934.07	1.25	-0.13	0.018
95.00	-17.05	-0.82	0.00	-21.60	0.00	21.60	2,861.41	675.92	1,975.80	1,898.14	1.29	-0.13	0.017
98.38	-16.89	-0.81	0.00	-18.84	0.00	18.84	1,159.13	336.03	976.45	768.89	1.38	-0.13	0.039
100.00	-16.41	-0.80	0.00	-17.52	0.00	17.52	1,152.97	332.28	954.82	756.24	1.43	-0.14	0.037
105.00	-15.94	-0.78	0.00	-13.54	0.00	13.54	1,133.01	320.73	889.59	717.16	1.58	-0.15	0.033
110.00	-11.63	-0.60	0.00	-9.64	0.00	9.64	1,111.60	309.18	826.67	678.11	1.73	-0.15	0.025
115.00	-11.29	-0.59	0.00	-6.63	0.00	6.63	1,088.74	297.63	766.05	639.20	1.90	-0.16	0.021
119.00	-8.83	-0.47	0.00	-4.28	0.00	4.28	1,069.41	288.39	719.22	608.22	2.03	-0.16	0.015
119.00	-8.83	-0.47	0.00	-4.28	0.00	4.28	950.95	285.28	642.72	624.60	2.03	-0.16	0.016
120.00	-6.05	-0.34	0.00	-3.81	0.00	3.81	950.95	285.28	642.72	624.60	2.07	-0.16	0.012
121.00	-5.03	-0.29	0.00	-3.47	0.00	3.47	950.95	285.28	642.72	624.60	2.10	-0.16	0.011
125.00	-4.33	-0.25	0.00	-2.31	0.00	2.31	950.95	285.28	642.72	624.60	2.24	-0.16	0.008
130.00	-3.63	-0.21	0.00	-1.06	0.00	1.06	950.95	285.28	642.72	624.60	2.41	-0.17	0.006
135.00	0.00	0.00	0.00	0.00	0.00	0.00	950.95	285.28	642.72	624.60	2.58	-0.17	0.000
139.00	0.00	0.00	0.00	0.00	0.00	0.00	950.95	285.28	642.72	624.60	2.72	-0.17	0.000

Load Case 0.9D - 1.0Ev + 1.0Eh

Seismic (Reduced DL)

Calculated Forces

Seg Elev (ft)	Pu FY (-) (kips)	Vu FX (-) (kips)	Tu MY (ft-kips)	Mu MZ (ft-kips)	Mu MX (ft-kips)	Resultant Moment (ft-kips)	phi Pn (kips)	phi Vn (kips)	phi Tn (ft-kips)	phi Mn (ft-kips)	Total Deflect (in)	Rotation (deg)	Ratio
0.00	-29.09	-1.05	0.00	-115.11	0.00	115.11	5,119.46	1,280.92	6,081.36	5,534.19	0.00	0.00	0.026
5.00	-27.99	-1.05	0.00	-109.86	0.00	109.86	5,045.45	1,253.97	5,828.14	5,338.45	0.00	-0.01	0.026
10.00	-26.91	-1.05	0.00	-104.60	0.00	104.60	4,969.98	1,227.01	5,580.31	5,144.62	0.01	-0.01	0.026
15.00	-25.85	-1.05	0.00	-99.33	0.00	99.33	4,893.07	1,200.06	5,337.86	4,952.78	0.03	-0.02	0.025
20.00	-24.82	-1.05	0.00	-94.05	0.00	94.05	4,814.71	1,173.10	5,100.79	4,763.03	0.05	-0.03	0.025
25.00	-23.81	-1.05	0.00	-88.79	0.00	88.79	4,734.90	1,146.15	4,869.11	4,575.48	0.08	-0.03	0.024
30.00	-22.82	-1.05	0.00	-83.54	0.00	83.54	4,653.63	1,119.19	4,642.81	4,390.22	0.12	-0.04	0.024
35.00	-21.85	-1.04	0.00	-78.31	0.00	78.31	4,570.92	1,092.24	4,421.90	4,207.35	0.17	-0.05	0.023
40.00	-20.91	-1.03	0.00	-73.12	0.00	73.12	4,486.76	1,065.28	4,206.37	4,026.98	0.22	-0.05	0.023
45.00	-20.72	-1.03	0.00	-67.97	0.00	67.97	4,395.58	1,038.33	3,996.23	3,844.33	0.28	-0.06	0.022
46.00	-19.39	-1.01	0.00	-66.94	0.00	66.94	4,372.76	1,032.94	3,954.84	3,804.32	0.29	-0.06	0.022
50.00	-18.73	-1.00	0.00	-62.89	0.00	62.89	4,281.48	1,011.37	3,791.47	3,646.34	0.34	-0.07	0.022
52.00	-18.26	-0.99	0.00	-60.89	0.00	60.89	3,574.52	874.62	3,307.89	3,076.23	0.37	-0.07	0.025
55.00	-17.48	-0.98	0.00	-57.91	0.00	57.91	3,534.07	860.76	3,203.87	2,992.79	0.42	-0.07	0.024
60.00	-16.73	-0.97	0.00	-53.00	0.00	53.00	3,465.49	837.65	3,034.21	2,855.22	0.50	-0.08	0.023
65.00	-15.99	-0.95	0.00	-48.17	0.00	48.17	3,395.45	814.55	2,869.16	2,719.65	0.59	-0.09	0.022
70.00	-15.27	-0.93	0.00	-43.42	0.00	43.42	3,323.97	791.45	2,708.73	2,586.16	0.68	-0.10	0.021
75.00	-14.58	-0.91	0.00	-38.77	0.00	38.77	3,251.04	768.34	2,552.91	2,454.85	0.79	-0.10	0.020
80.00	-13.90	-0.89	0.00	-34.22	0.00	34.22	3,154.84	745.24	2,401.71	2,309.85	0.90	-0.11	0.019
85.00	-13.24	-0.86	0.00	-29.78	0.00	29.78	3,057.03	722.13	2,255.12	2,168.13	1.02	-0.12	0.018
90.00	-12.77	-0.84	0.00	-25.46	0.00	25.46	2,959.22	699.03	2,113.15	2,030.89	1.14	-0.12	0.017
93.63	-12.52	-0.83	0.00	-22.40	0.00	22.40	2,888.21	682.25	2,012.97	1,934.07	1.24	-0.13	0.016
95.00	-11.91	-0.81	0.00	-21.26	0.00	21.26	2,861.41	675.92	1,975.80	1,898.14	1.27	-0.13	0.015
98.38	-11.80	-0.80	0.00	-18.54	0.00	18.54	1,159.13	336.03	976.45	768.89	1.37	-0.13	0.034
100.00	-11.46	-0.78	0.00	-17.24	0.00	17.24	1,152.97	332.28	954.82	756.24	1.41	-0.13	0.033
105.00	-11.13	-0.77	0.00	-13.32	0.00	13.32	1,133.01	320.73	889.59	717.16	1.56	-0.14	0.028
110.00	-8.12	-0.59	0.00	-9.48	0.00	9.48	1,111.60	309.18	826.67	678.11	1.71	-0.15	0.021
115.00	-7.88	-0.58	0.00	-6.52	0.00	6.52	1,088.74	297.63	766.05	639.20	1.87	-0.16	0.017
119.00	-6.16	-0.46	0.00	-4.21	0.00	4.21	1,069.41	288.39	719.22	608.22	2.01	-0.16	0.013
119.00	-6.16	-0.46	0.00	-4.21	0.00	4.21	950.95	285.28	642.72	624.60	2.01	-0.16	0.013
120.00	-4.23	-0.33	0.00	-3.75	0.00	3.75	950.95	285.28	642.72	624.60	2.04	-0.16	0.010
121.00	-3.51	-0.28	0.00	-3.41	0.00	3.41	950.95	285.28	642.72	624.60	2.07	-0.16	0.009
125.00	-3.03	-0.25	0.00	-2.28	0.00	2.28	950.95	285.28	642.72	624.60	2.21	-0.16	0.007
130.00	-2.54	-0.21	0.00	-1.04	0.00	1.04	950.95	285.28	642.72	624.60	2.38	-0.16	0.004
135.00	0.00	0.00	0.00	0.00	0.00	0.00	950.95	285.28	642.72	624.60	2.55	-0.16	0.000
139.00	0.00	0.00	0.00	0.00	0.00	0.00	950.95	285.28	642.72	624.60	2.69	-0.16	0.000

Site Number: 416862

Code: ANSI/TIA-222-H

© 2007 - 2021 by ATC IP LLC. All rights reserved.

Site Name: SUFFIELD SW CT CT, CT

Engineering Number: 13692184_C3_02

7/14/2021 11:05:03 AM

Customer: DISH WIRELESS L.L.C.

Analysis Summary

Load Case	Reactions						Max Usage	
	Shear FX (kips)	Shear FZ (kips)	Axial FY (kips)	Moment MX (ft-kips)	Moment MY (ft-kips)	Moment MZ (ft-kips)	Elev (ft)	Interaction Ratio
1.2D + 1.0W	21.99	0.00	41.97	0.00	0.00	2237.48	98.38	0.49
0.9D + 1.0W	21.98	0.00	31.47	0.00	0.00	2218.85	98.38	0.48
1.2D + 1.0Di + 1.0Wi	6.85	0.00	62.10	0.00	0.00	700.11	98.38	0.17
1.2D + 1.0Ev + 1.0Eh	1.05	0.00	41.66	0.00	0.00	116.27	98.38	0.04
0.9D - 1.0Ev + 1.0Eh	1.05	0.00	29.09	0.00	0.00	115.11	98.38	0.03
1.0D + 1.0W	5.35	0.00	34.99	0.00	0.00	542.06	98.38	0.13

Site Name: SUFFIELD SW CT CT, CT
Site Number: 416862
Tower Type: MP
Design Loads (Factored) - Analysis per TIA-222-H Standards

Monolithic Mat & Pier Foundation Analysis

Foundation Analysis Parameters		
Design / Analysis / Mapping:	Analysis	-
Compression/Leg:	42.0	k
Uplift/Leg:	0.0	k
Total Shear:	22.0	k
Moment:	2,237.5	k-ft
Tower + Appurtenance Weight:	42.0	k
Depth to Base of Foundation (l + t - h):	5	ft
Diameter of Pier (d):	7	ft
Length of Pier (l):	3	ft
Height of Pier above Ground (h):	1	ft
Width of Pad (W):	26	ft
Length of Pad (L):	26	ft
Thickness of Pad (t):	3	ft
Tower Leg Center to Center:	0	ft
Number of Tower Legs:	1	-
Tower Center from Mat Center:	0	ft
Depth Below Ground Surface to Water Table:	10	ft
Unit Weight of Concrete:	150	pcf
Unit Weight of Soil Above Water Table:	127	pcf
Unit Weight of Water:	62.4	pcf
Unit Weight of Soil Below Water Table:	64.6	pcf
Friction Angle of Uplift:	15	°
Coefficient of Shear Friction:	0.3	-
Ultimate Compressive Bearing Pressure:	6,376	psf
Ultimate Passive Pressure on Pad Face:	926	psf
$f_{\text{Soil and Concrete Weight}}$:	0.9	-
f_{Soil} :	0.75	-

Foundation Steel Parameters		
Shear/Leg (Compression):	14.7	k
Shear/Leg (Uplift):	12.1	k
Concrete Strength (f'_c):	4,000	psi
Pad Tension Steel Depth:	32.44	in
Dead Load Factor:	0.9	-
f_{Shear} :	0.75	-
$f_{\text{Flexure / Tension}}$:	0.9	-
$f_{\text{Compression}}$:	0.65	-
b:	0.85	-
Bottom Pad Rebar Size #:	9	-
# of Bottom Pad Rebar:	36	-
Pad Bottom Steel Area:	36.00	in ²
Pad Steel F_y :	60,000	psi
Top Pad Rebar Size #:	9	-
# of Top Pad Rebar:	18	-
Pad Top Steel Area:	18.00	in ²
Pier Rebar Size #:	9	-
Pier Steel Area (Single Bar):	1.00	in ²
# of Pier Rebar:	35	-
Pier Steel F_y :	60,000	psi
Pier Cage Diameter:	75.9	in
Rebar Strain Limit:	0.008	-
Steel Elastic Modulus:	29,000	ksi
Tie Rebar Size #:	4	-
Tie Steel Area (Single Bar):	0.20	in ²
Tie Spacing:	6	in
Tie Steel F_y :	60,000	psi
Clear Cover:	3	in

Overturning Moment Usage		
Design OTM:	2369.4	k-ft
OTM Resistance:	6304.9	k-ft
Design OTM / OTM Resistance:	38%	Pass

Soil Bearing Pressure Usage		
Net Bearing Pressure:	1864	psf
Factored Nominal Bearing Pressure:	4782	psf
Factored Nominal (Net) Bearing Pressure:	39%	Pass
Load Direction Controlling Design Bearing Pressure:	Diagonal to Pad Edge	

Sliding Factor of Safety		
Ultimate Friction Resistance:	155.5	k
Ultimate Passive Pressure Resistance:	54.2	k
Total Factored Sliding Resistance:	157.3	k
Sliding Design / Sliding Resistance:	14%	Pass

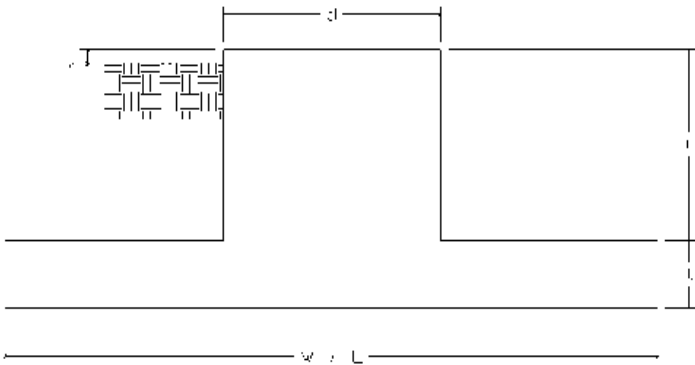

Pad Strength Capacity			
Factored One Way Shear (V_u):	192.7	k	
One Way Shear Capacity (fV_c):	960.1	k	ACI 318-14 25.5.5.1
V_u / fV_c :	20%	Pass	
Load Direction Controlling Shear Capacity:	Parallel to Pad Edge		
Lower Steel Pad Factored Moment (M_u):	1302.5	k-ft	
Lower Steel Pad Moment Capacity (fM_n):	5114.7	k-ft	ACI 318-14 22.3.1.1
M_u / fM_n :	25%	Pass	
Load Direction Controlling Flexural Capacity:	Parallel to Pad Edge		
Upper Steel Pad Factored Moment (M_u):	685.0	k-ft	
Upper Steel Pad Moment Capacity (fM_n):	2592.4	k-ft	
M_u / fM_n :	26%	Pass	
Lower Pad Flexural Reinforcement Ratio:	0.0036		OK - ACI 318-14 7.6.1.1 & 8.6.1.1
Upper Pad Flexural Reinforcement Ratio:	0.0018		OK - ACI 318-14 7.6.1.1 & 8.6.1.1
Pad Shrinkage Reinforcement Ratio:	0.0053		OK - ACI 318-14 24.4.3.2
Lower Pad Reinforcement Spacing:	8.7	in	OK - ACI 318-14 7.7.2.3, 8.7.2.2, & 24.4.3.3
Upper Pad Reinforcement Spacing:	18.0	in	OK - ACI 318-14 7.7.2.3, 8.7.2.2, & 24.4.3.3
Ultimate Punching Shear Stress, v_u :	24.53	psi	ACI 318-14 R8.4.4.2.3
Nominal Punching Shear Capacity ($f_c v_c$):	189.7	psi	ACI 318-14 22.6.5.2
$v_u / f_c v_c$:	13%	Pass	
Pier Moment Pad Flexure Transfer Ratio, γ_f :	0.60		TIA-222-H 9.4.2
Moment Transfer Effective Flexural Width, B_{eff} :	16.00	ft	TIA-222-H 9.4.2
Moment Transfer Through Pad Flexure:	16584.84	k-in	TIA-222-H 9.4.2
Moment Transfer Flexural Capacity ($fM_{sc,f}$):	39173.55	k-in	
$g_f M_{sc} / fM_{sc,f}$:	0%	Pass	

Pier Strength Capacity			
Factored Moment in Pier (M_u):	2303.5	k-ft	
Pier Moment Capacity (fM_n):	5507.0	k-ft	
M_u / fM_n :	42%	Pass	
Factored Shear in Pier (V_u):	22.0	k	
Pier Shear Capacity (fV_n):	729.3	k	ACI 318-14 22.5.1.1
V_u / fV_c :	3%	Pass	
Pier Shear Reinforcement Ratio:	0.0004		OK - No Ties Necessary for Shear - ACI11.5.6.1
Factored Tension in Pier (T_u):	0.0	k	
Pier Tension Capacity (fT_n):	1890.0	k	
T_u / fT_n :	0%	Pass	
Factored Compression in Pier (P_u):	42.0	k	
Pier Compression Capacity (fP_n):	9767.2	k	ACI 318-14 22.4.2.1
P_u / fP_n :	0%	Pass	
Pier Compression Reinforcement Ratio:	0.006		OK - TIA-222-H 9.4.1
Minimum Depth to Develop Vertical Rebar:	37	in	ACI 318-14 25.4.2.3
Minimum Hook Development Length:	22	in	ACI 318-14 25.4.3.1
Minimum Mat Thickness / Edge Distance from Pier:	25.0	in	
Minimum Foundation Depth:	4.93	ft	
$M_u / f_B M_n + T_u / f_T T_n$:	42%	Pass	



Base Plate & Anchor Rod Analysis

Pole Dimensions		
Number of Sides	18	-
Diameter	53	in
Thickness	7/16	in
Orientation Offset	0	°

Base Reactions		
Moment, Mu	2,237.5	k-ft
Axial, Pu	42.0	k
Shear, Vu	22.0	k
Neutral Axis	10	°

Report Capacities		
Component	Capacity	Result
Base Plate	19%	Pass
Anchor Rods	43%	Pass
Dwyidag	-	-

Base Plate		
Shape	Round	-
Diameter, ϕ	67	in
Thickness	2 1/2	in
Grade	A572-50	
Yield Strength, Fy	50	ksi
Tensile Strength, Fu	65	ksi
Clip	N/A	in
Orientation Offset	0	°
Anchor Rod Detail	d	$\eta=0.5$
Clear Distance	3	in
Applied Moment, Mu	478.5	k
Bending Stress, ϕMn	2458.4	k

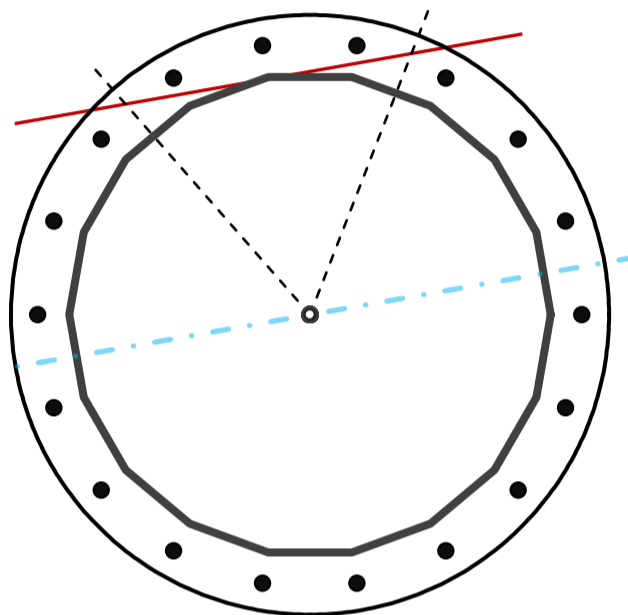

Original Anchor Rods		
Arrangement	Radial	-
Quantity	18	-
Diameter, ϕ	2 1/4	in
Bolt Circle	61	in
Grade	A615-75	
Yield Strength, Fy	75	ksi
Tensile Strength, Fu	100	ksi
Spacing	10.6	in
Orientation Offset	0	°
Applied Force, Pu	104.0	k
Anchor Rods, ϕPn	243.6	k

Calculations for Monopole Base Plate & Anchor Rod Analysis

Reaction Distribution

Reaction	Shear Vu	Moment Mu	Factor
-	k	k-ft	-
Base Forces	22.0	2237.5	1.00
Anchor Rod Forces	22.0	2237.5	1.00
Additional Bolt (Grp1) Forces	0.0	0.0	0.00
Additional Bolt (Grp2) Forces	0.0	0.0	0.00
Dywidag Forces	0.0	0.0	0.00
Stiffener Forces	0.0	0.0	0.00

Geometric Properties

Section	Gross Area	Net Area	Individual Inertia	Threads per Inch	Moment of Inertia
-	in ²	in ²	in ⁴	#	in ⁴
Pole	71.8781	3.9932	0.2558		24827.87
Bolt	3.9761	3.2477	0.8393	4.5	25129.50
Bolt1	0.0000	0.0000	0.0000	0	0.00
Bolt2	0.0000	0.0000	0.0000	0	0.00
Dywidag	0.0000	0.0000	0.0000		0.00
Stiffener	0.0000	0.0000	0.0000		0.00

Base Plate

Shape	Round	-
Diameter, D	67	in
Thickness, t	2.5	in
Yield Strength, Fy	50	ksi
Tensile Strength, Fu	65	ksi
Base Plate Chord	40.988	in
Detail Type	d	-
Detail Factor	0.50	-
Clear Distance	3	-

Anchor Rods

Anchor Rod Quantity, N	18	-
Rod Diameter, d	2.25	in
Bolt Circle, BC	61	in
Yield Strength, Fy	75	ksi
Tensile Strength, Fu	100	ksi
Applied Axial, Pu	104.0	k
Applied Shear, Vu	0.3	k
Compressive Capacity, ϕP_n	243.6	k
Tensile Capacity, ϕR_n	0.427	OK
Interaction Capacity	0.430	OK

External Base Plate

Chord Length AA	34.785	in
Additional AA	5.000	in
Section Modulus, Z	62.164	in ³
Applied Moment, Mu	478.5	k-ft
Bending Capacity, ϕM_n	2797.4	k-ft
Capacity, Mu/ ϕM_n	0.171	OK

Chord Length AB	33.500	in
Additional AB	5.000	in
Section Modulus, Z	60.156	in ³
Applied Moment, Mu	355.6	k-ft
Bending Capacity, ϕM_n	2707.0	k-ft
Capacity, Mu/ ϕM_n	0.131	OK

Bend Line Length	34.964	in
Additional Bend Line	0.000	in
Section Modulus, Z	54.631	in ³
Applied Moment, Mu	478.5	k-ft
Bending Capacity, ϕM_n	2458.4	k-ft
Capacity, Mu/ ϕM_n	0.195	OK

Internal Base Plate

Arc Length	0.000	in
Section Modulus, Z	0.000	in ³
Moment Arm	0.000	in
Applied Moment, Mu	0.0	k-ft
Bending Capacity, ϕM_n	0.0	k-ft
Capacity, Mu/ ϕM_n		

Flange Plate Analysis

Flange Plate	Plate Type	Flange	@ 119 ft
	Pole Diameter	26	in
	Pole Thickness	0.375	in
	Plate Diameter	36	in
	Plate Thickness	1 1/2	in
	Plate Fy	50	ksi
	Weld Length	7/16	in
	f _s Resistance	114.86	k-in
	Applied	12.84	k-in

Code Rev. **H**

Date	7/14/2021
Engineer	RM
Site #	416862
Carrier	DISH WIRELESS L.L.C.

Moment **81.0 k-ft**
Axial **6.0 k**

Required Flange Thickness:
0.50 in OK

Stiffeners	#	
------------	---	--

Bolts	#	18	
	Bolt Circle	32	in
	(R)adial / (S)quare	R	
	Diameter	1	in
	Hole Diameter	1 1/8	in
	Type	A325	
	Fy	92	ksi
	Fu	120	ksi
	f _s Resistance	54.52	k
	Applied	6.42	k

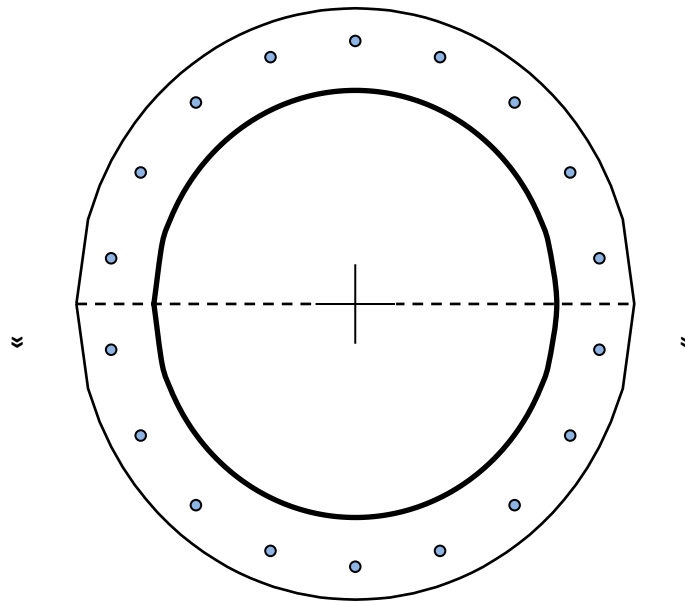

Reinforcement	#	
---------------	---	--

Plate Stress Ratio:
11% Pass

Bolt Stress Ratio:
12% Pass

Extra Bolts O	#	
---------------	---	--

INFINIGY

MOUNT ANALYSIS REPORT

August 27, 2021

Dish Wireless Site Name	BOBDL00027A
Dish Wireless Site Number	BOBDL00027A
ATC Site Name	Suffield SW CT CT, CT
ATC Site Number	416862
Infinigy Job Number	1197-F0001-C
Client	ATC
Carrier	Dish Wireless
Site Location	106 South Grand St. Suffield, CT 06078 Hartford County 41.987028 N NAD83 72.702083 W NAD83
Mount Type	8.0 ft Platform
Mount Elevation	110.0 ft AGL
Structural Usage Ratio	43.1
Overall Result	Pass

The enclosed mount structural analysis has been performed in accordance with the 2018 Connecticut State Building Code (2015 IBC) based on an ultimate 3-second gust wind speed of 120 mph. The evaluation criteria and applicable codes are presented in the next section of this report.

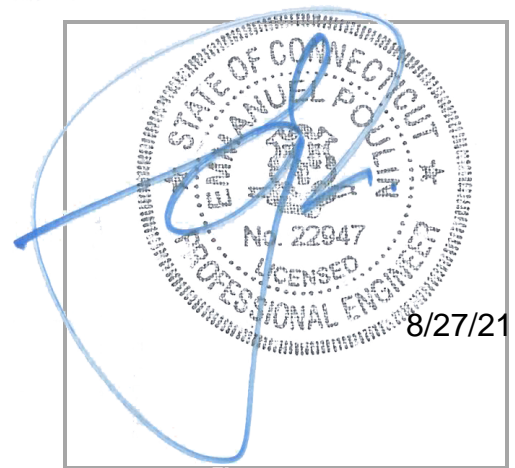

CONTENTS

1. Introduction
2. Design/Analysis Parameters
3. Proposed Loading Configuration
4. Supporting Documentation
5. Results
6. Recommendations
7. Assumptions
8. Liability Waiver and Limitations
9. Calculations

August 27, 2021

1. INTRODUCTION

Infinigy performed a structural analysis on the Dish Wireless proposed telecommunication equipment supporting Platform mounted to the existing structure located at the aforementioned address. All referenced supporting documents have been obtained from the client and are assumed to be accurate and applicable to this site. The mount was analyzed using Risa-3D version 17.0.4 analysis software.

2. DESIGN/ANALYSIS PARAMETERS

Wind Speed	120 mph (3-Second Gust)
Wind Speed w/ ice	50 mph (3-Second Gust) w/ 2.0" ice
Code / Standard	TIA-222-H
Adopted Code	2018 Connecticut State Building Code (2015 IBC)
Risk Category	II
Exposure Category	B
Topographic Category	1
Calculated Crest Height	0 ft.
Seismic Spectral Response	$S_s = 0.176 \text{ g} / S_1 = 0.065 \text{ g}$
Live Load Wind Speed	60 mph
Man Live Load at Mid/End Points	250 lbs
Man Live Load at Mount Pipes	500 lbs

3. PROPOSED LOADING CONFIGURATION - 110.0 ft. AGL Platform

Antenna Centerline (ft)	Qty.	Appurtenance Manufacturers	Appurtenance Models
110.0	3	JMA WIRELESS	MX08FRO665-21
	3	FUJITSU	TA08025-B605
	3	FUJITSU	TA08025-B604
	1	RAYCAP	RDIDC-9181-PF-48

4. SUPPORTING DOCUMENTATION

Proposed Loading	Dish Wireless Asset ID CT-ATC-T-416862 Rev 1, Site #BOBDL00027A, dated June 14, 2021
Mount Manufacturer Drawings	Commscope Document # MC-PK8-DSH, dated March 08, 2021
Structural Analysis Report	ATC, Asset #416862, dated July 14, 2021

5. RESULTS

Components	Capacity	Pass/Fail
Mount Pipes	17.6%	Pass
Horizontals	10.5%	Pass
Standoffs	33.4%	Pass
Handrails	21.0%	Pass
Connections	43.1%	Pass
MOUNT RATING =	43.1 %	Pass

Notes:

1. See additional documentation in Appendix for calculations supporting the capacity consumed and detailed mount connection calculations.

6. RECOMMENDATIONS

Infinigy recommends installing Dish Wireless’s proposed equipment loading configuration on the mount at 110.0 ft. The installation shall be performed in accordance with the construction documents issued for this site.

Pradin Suinyal Magar
 Project Engineer II | **INFINIGY**

7. ASSUMPTIONS

The antenna mounting system was properly fabricated, installed and maintained in accordance with its original design and manufacturer's specifications.	
The configuration of antennas, mounts, and other appurtenances are as specified in the proposed loading configuration table.	
All member connections are assumed to have been designed to meet or exceed the load carrying capacity of the connected member unless otherwise specified in this report.	
The analysis will require revisions if the existing conditions in the field differ from those shown in the above-referenced documents or assumed in this analysis. No allowance was made for any damaged, missing, or rusted members.	
Steel grades have been assumed as follows, unless noted otherwise:	
Channel, Solid Round, Plate, Built-up Angle	ASTM A1011 36 KSI
Structural Angle	ASTM A529 Gr. 50
HSS (Rectangular)	ASTM A500-B GR 46
HSS (Circular)	ASTM A500-B GR 42
Pipe	ASTM A500 Gr C
Connection Bolts	ASTM A325
U-Bolts	ASTM A307
All bolted connections are pretensioned in accordance with Table 8.2 of the RCSC 2014 Standard	

8. LIABILITY WAIVER AND LIMITATIONS

Our structural calculations are completed assuming all information provided to Infinigy is accurate and applicable to this site. For the purposes of calculations, we assume an overall structure condition as erected and all members and connections to be free of corrosion and/or structural defects. The structure owner and/or contractor shall verify the structure's condition prior to installation of any proposed equipment. If actual conditions differ from those described in this report, Infinigy should be notified immediately to assess the impact on the results of this report.

Our evaluation is completed using industry standard methods and procedures. The structural results, conclusions and recommendations contained in this report are proprietary and should not be used by others as their own. Infinigy is not responsible for decisions made by others that are or are not based on the stated assumptions and conclusions in this report.

This report is an evaluation of the mount structure only and does not determine the adequacy of the supporting structure, other carrier mounts or cable mounting attachments. The analysis of these elements is outside the scope of this analysis, are assumed to be adequate for the purpose of this report and to have been installed per their manufacturer requirements. This document is not for construction purposes.

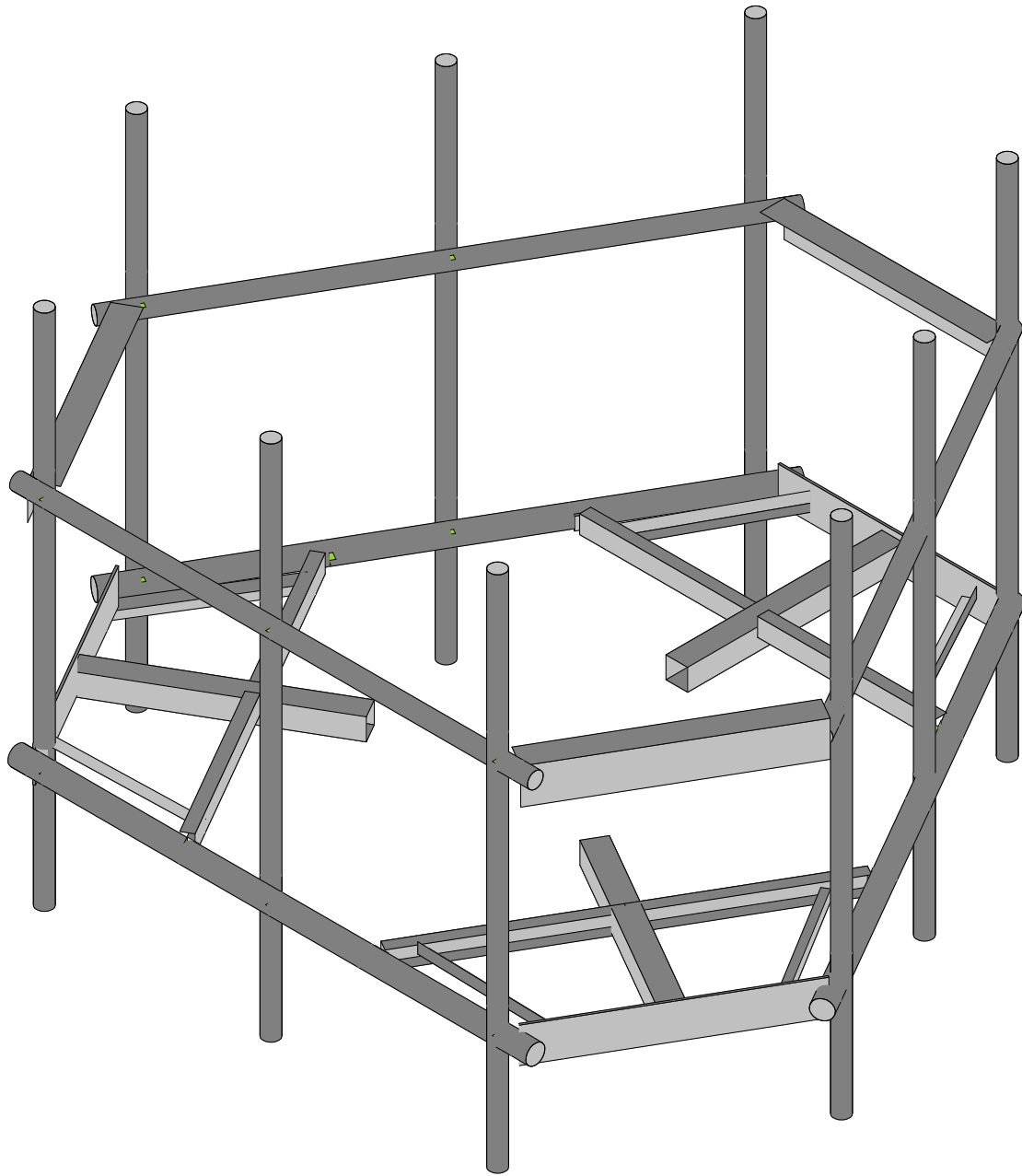
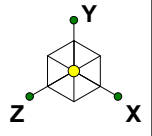

Envelope Only Solution

Infinigy Engineering, PLLC
PSM
1197-F0001-C

BOBDL00027A

Rendered

Aug 27, 2021 at 10:39 AM

BOBDL00027A_loaded.r3d

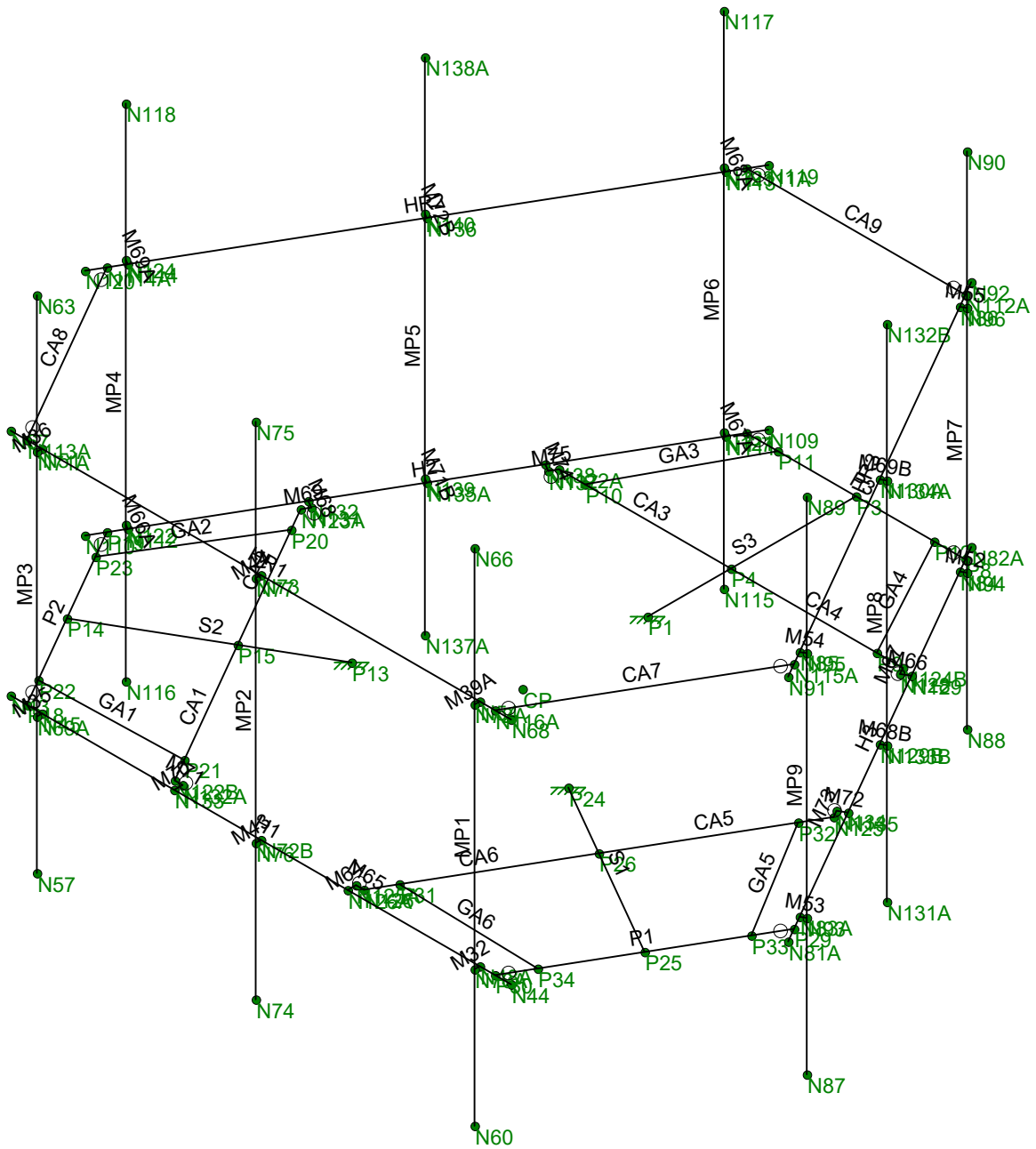
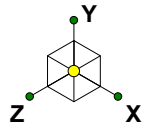

Envelope Only Solution

Infinigy Engineering, PLLC

PSM

1197-F0001-C

BOBDL00027A

WireFrame

Aug 27, 2021 at 10:39 AM

BOBDL00027A_loaded.r3d

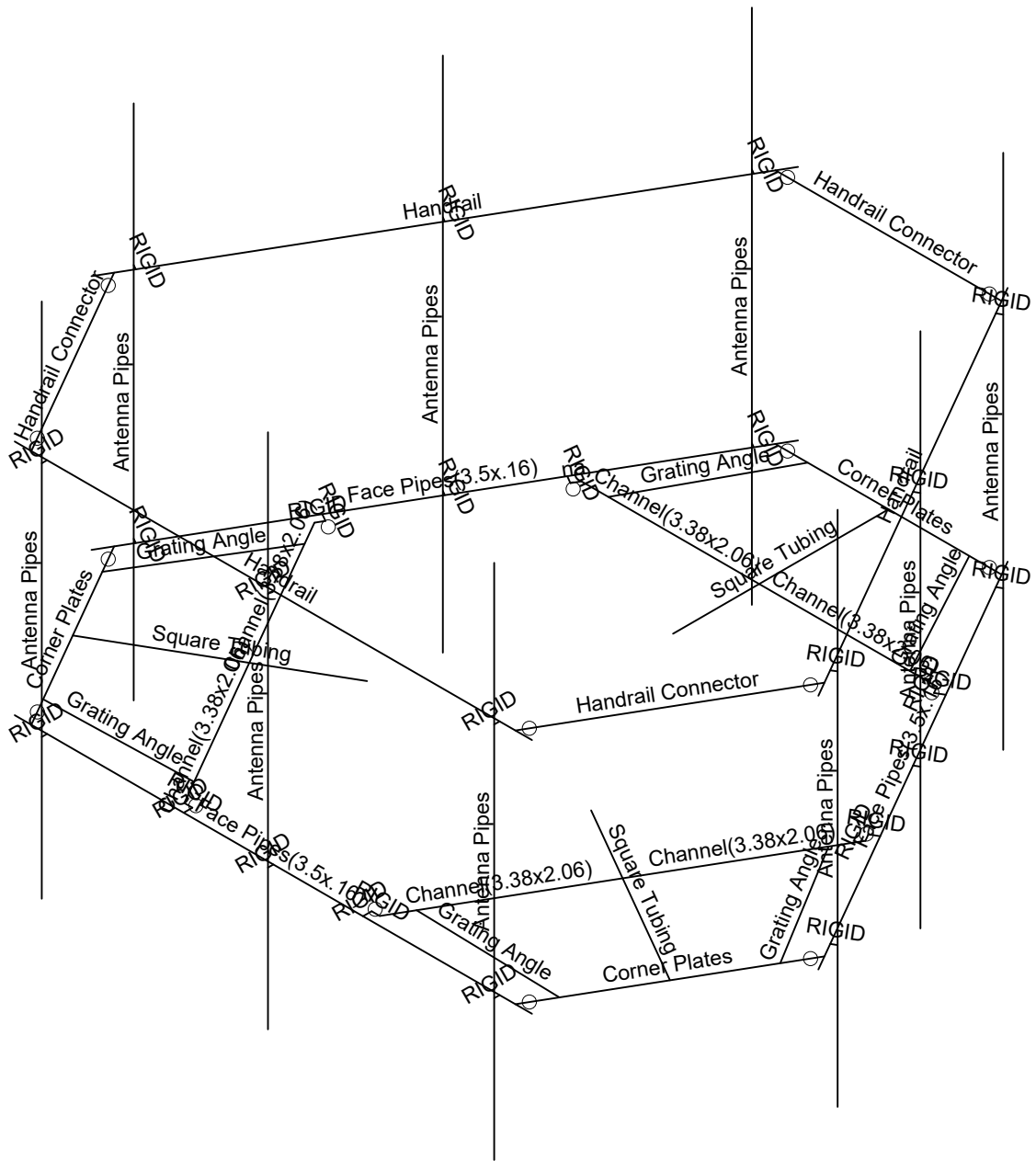
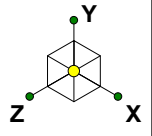

Envelope Only Solution

Infinigy Engineering, PLLC

PSM

1197-F0001-C

BOBDL00027A

Section Sets

Aug 27, 2021 at 10:40 AM

BOBDL00027A_loaded.r3d

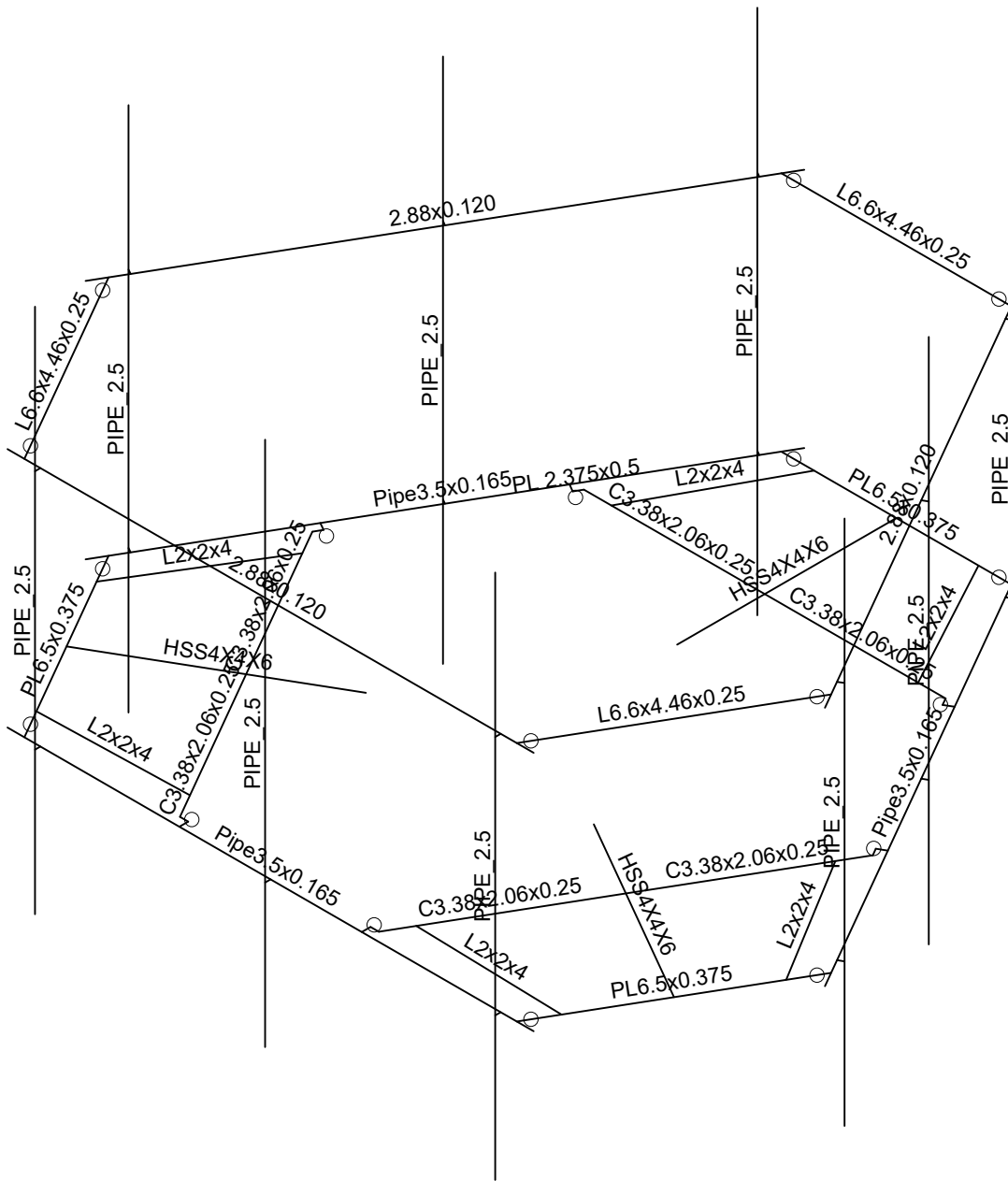
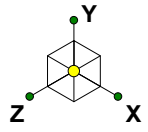

Envelope Only Solution

Infinigy Engineering, PLLC

PSM

1197-F0001-C

BOBDL00027A

Member Shapes

Aug 27, 2021 at 10:40 AM

BOBDL00027A_loaded.r3d

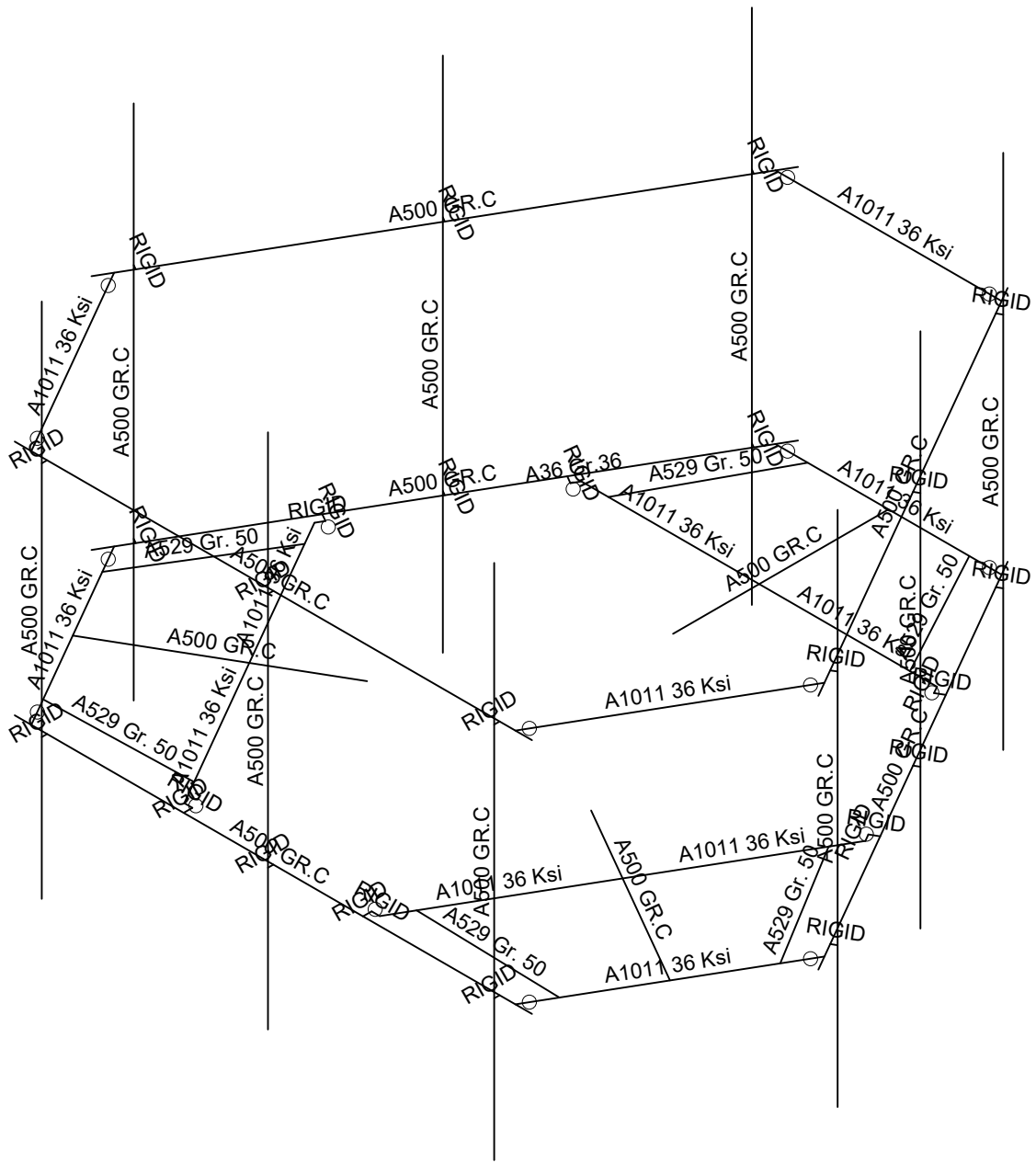
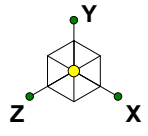

Envelope Only Solution

Infinigy Engineering, PLLC

PSM

1197-F0001-C

BOBDL00027A

Material Sets

Aug 27, 2021 at 10:40 AM

BOBDL00027A_loaded.r3d

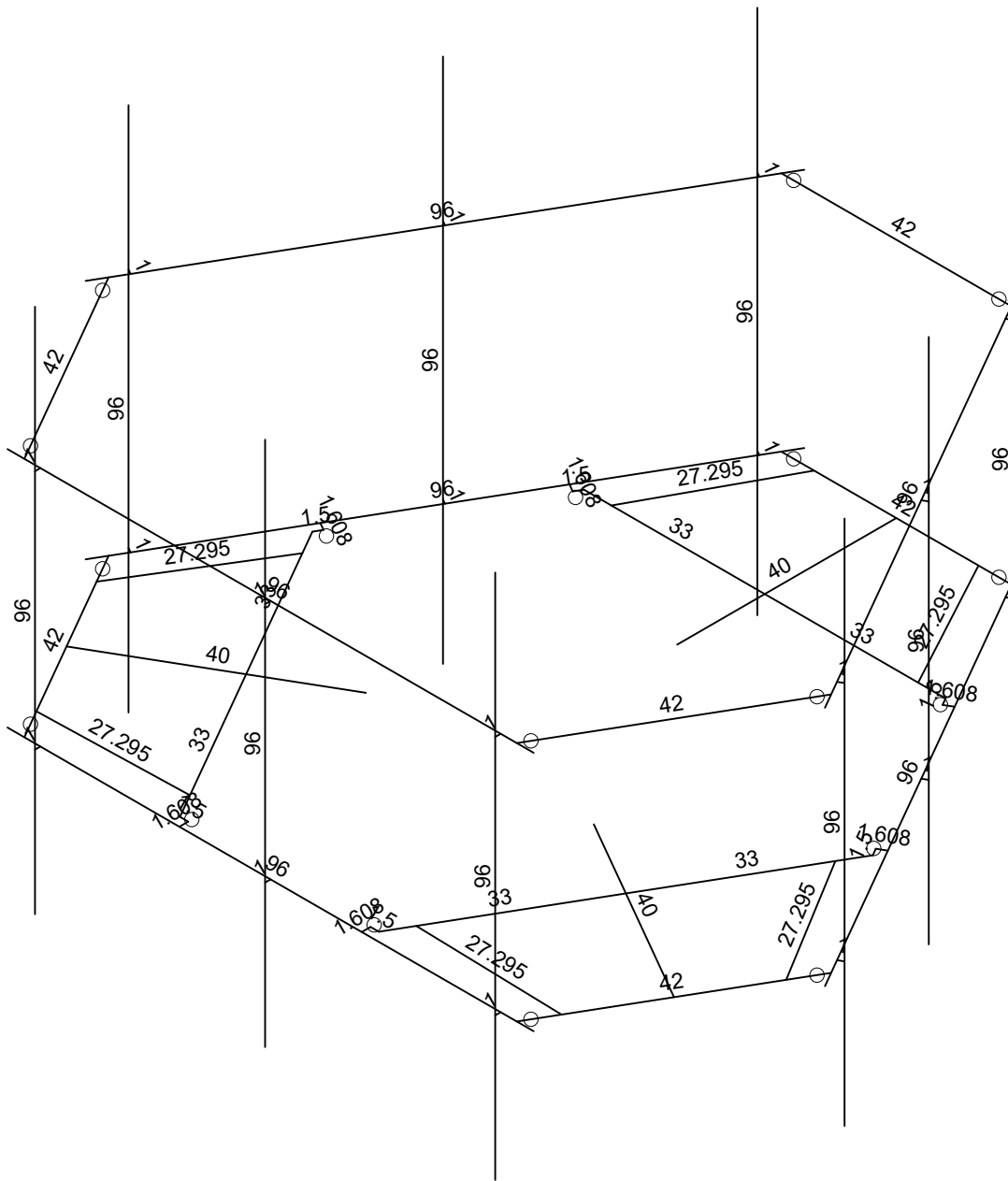
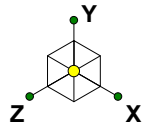

Member Length (in) Displayed
Envelope Only Solution

Infinigy Engineering, PLLC	BOBDL00027A	Member Lengths
PSM		Aug 27, 2021 at 10:41 AM
1197-F0001-C		BOBDL00027A_loaded.r3d

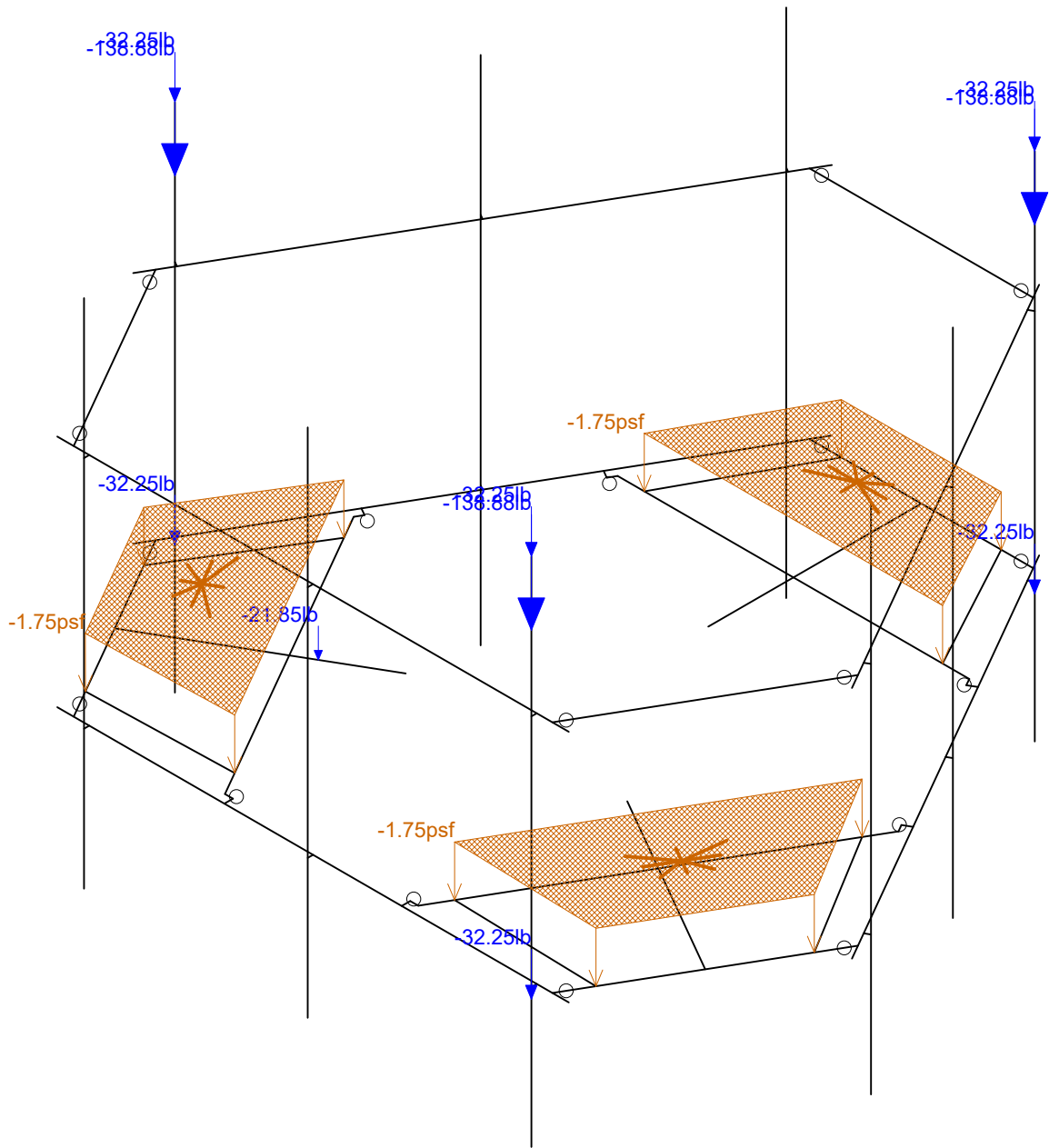
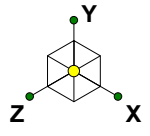

Loads: BLC 1, Self Weight
Envelope Only Solution

Infinigy Engineering, PLLC
PSM
1197-F0001-C

BOBDL00027A

Self Weight
Aug 27, 2021 at 10:41 AM
BOBDL00027A_loaded.r3d

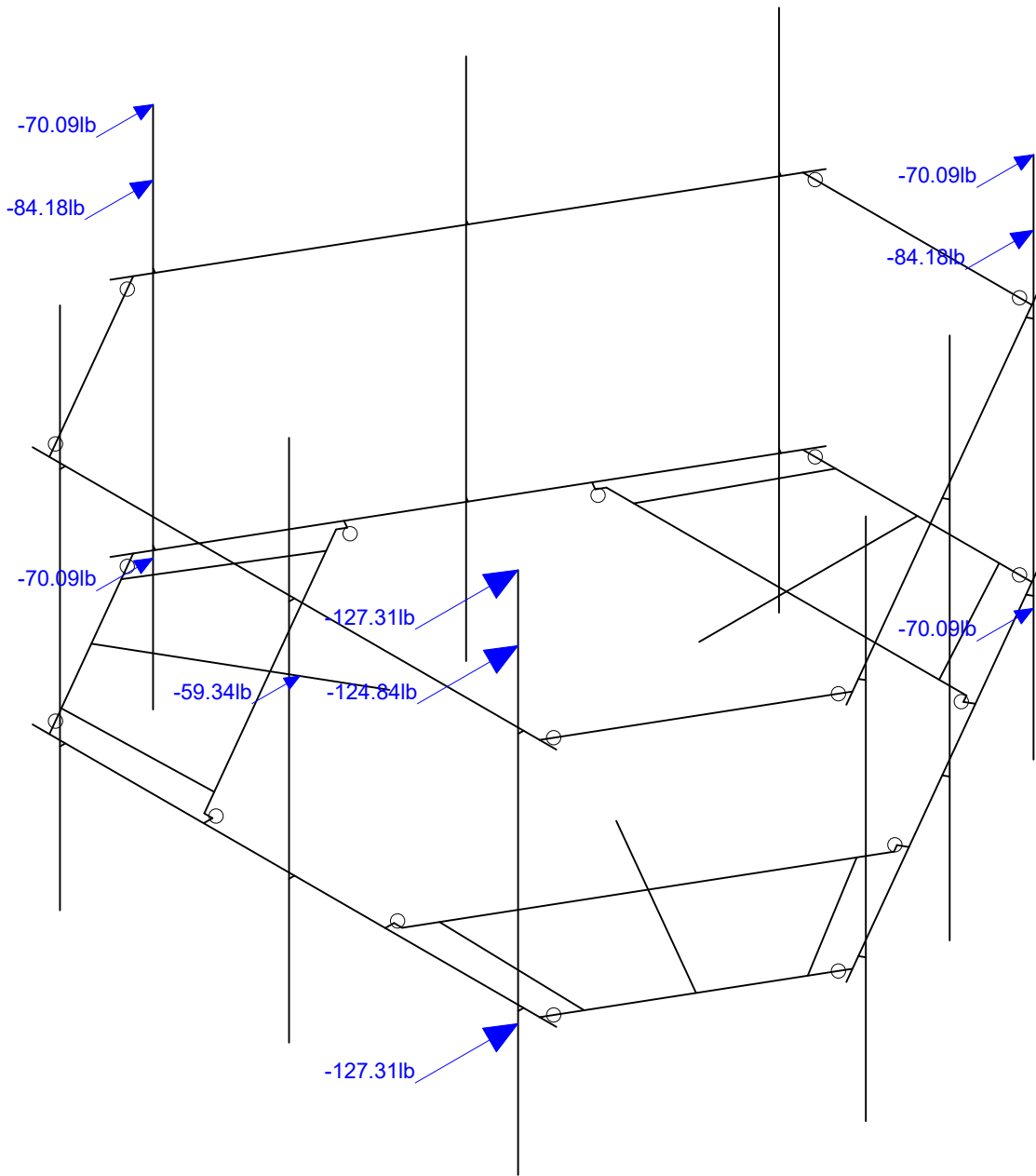
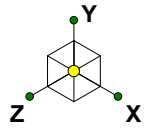

Loads: BLC 2, Wind Load AZI 0
Envelope Only Solution

Infinigy Engineering, PLLC
PSM
1197-F0001-C

BOBDL00027A

Wind Load AZI 000
Aug 27, 2021 at 10:41 AM
BOBDL00027A_loaded.r3d

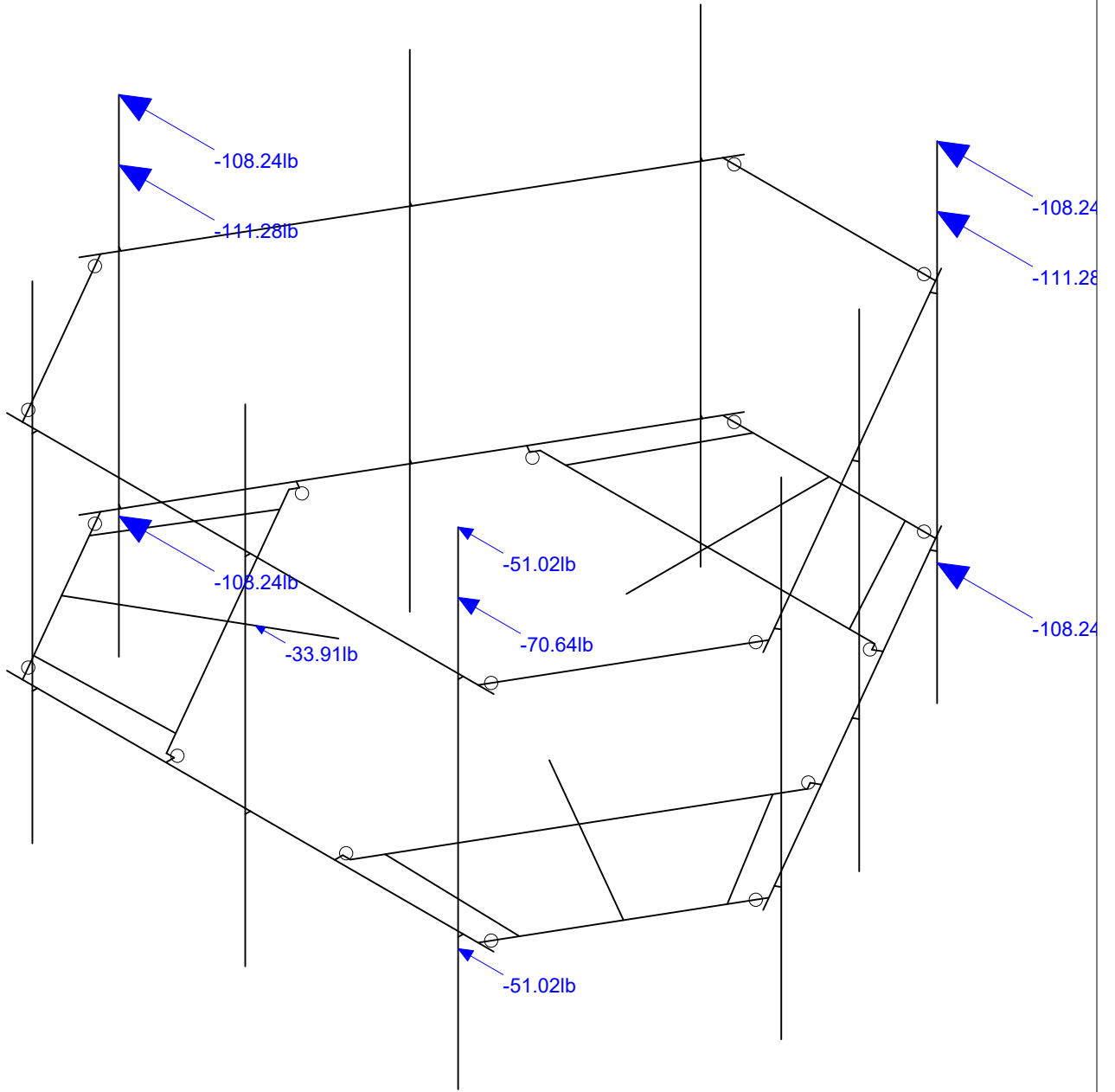
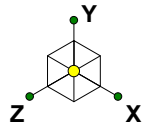

Loads: BLC 5, Wind Load AZI 90
Envelope Only Solution

Infinigy Engineering, PLLC	BOBDL00027A	Wind Load AZI 090
PSM		Aug 27, 2021 at 10:41 AM
1197-F0001-C		BOBDL00027A_loaded.r3d

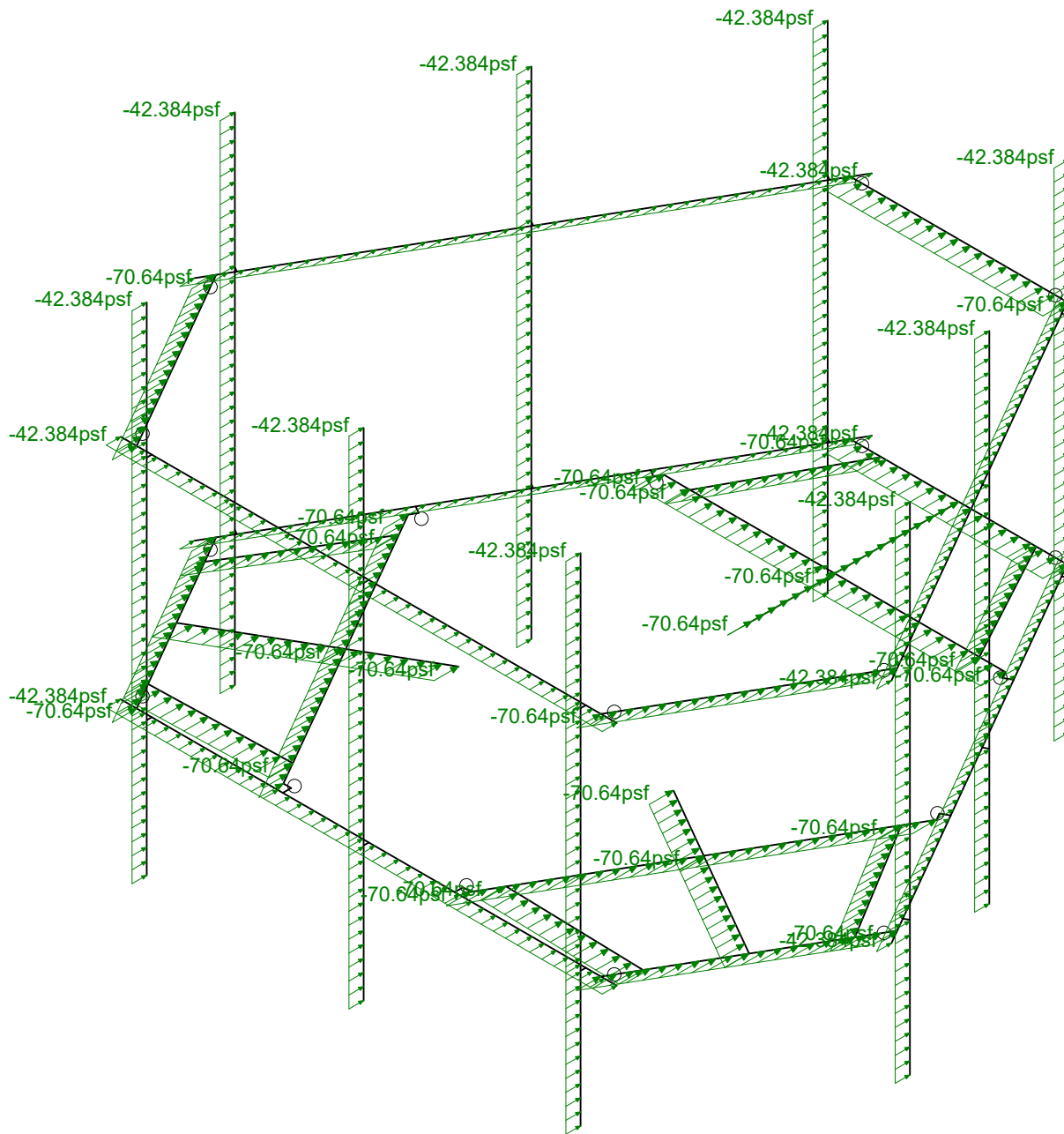
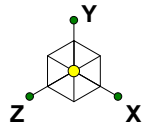

Loads: BLC 14, Distr. Wind Load Z
Envelope Only Solution

Infinigy Engineering, PLLC
PSM
1197-F0001-C

BOBDL00027A

Distr Wind Load AZI 000
Aug 27, 2021 at 10:42 AM
BOBDL00027A_loaded.r3d

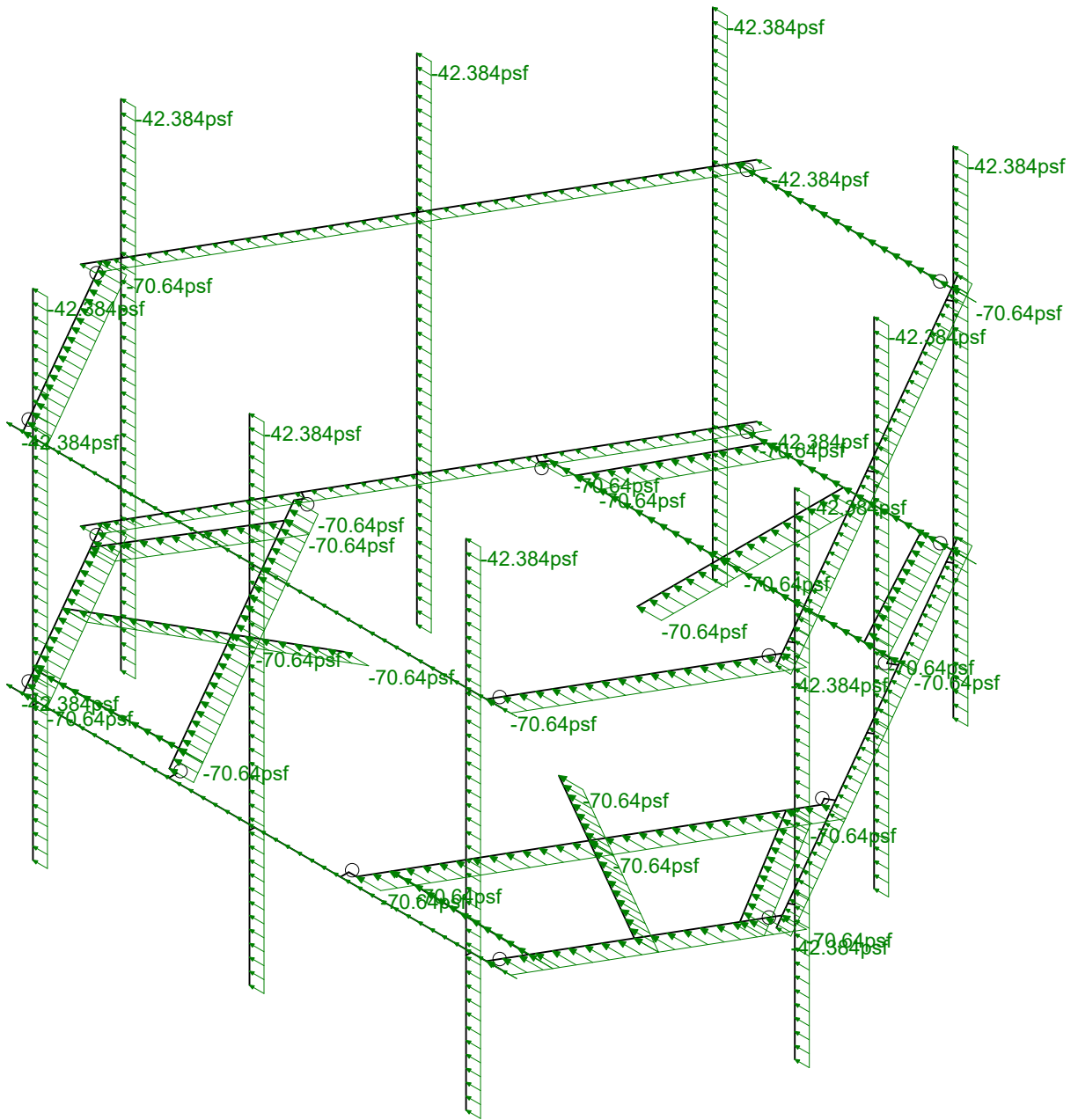
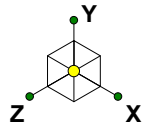

Loads: BLC 15, Distr. Wind Load X
Envelope Only Solution

Infinigy Engineering, PLLC	BOBDL00027A	Distr Wind Load AZI 090
PSM		Aug 27, 2021 at 10:42 AM
1197-F0001-C		BOBDL00027A_loaded.r3d

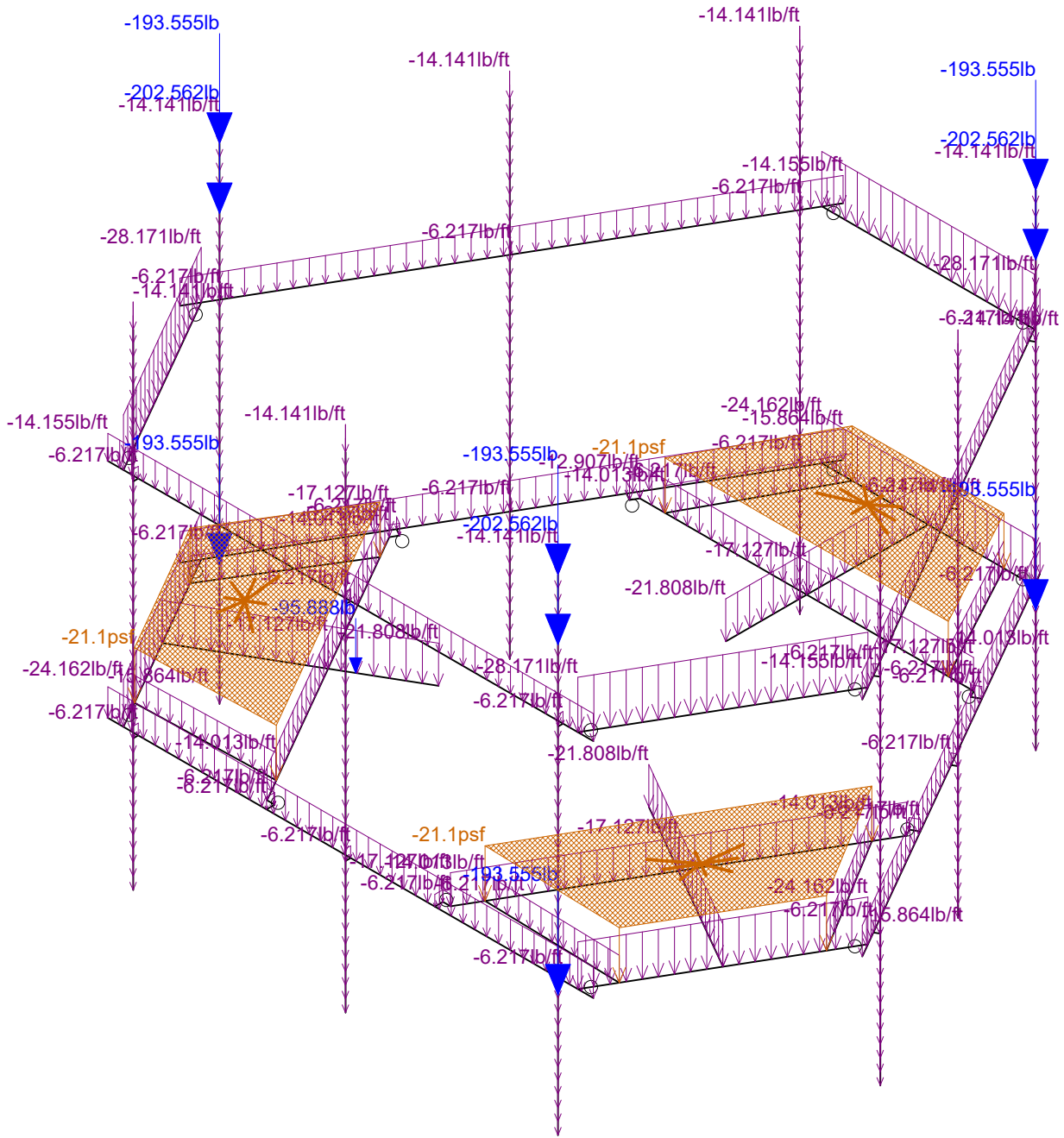
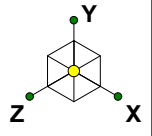

Loads: BLC 16, Ice Weight
Envelope Only Solution

Infinigy Engineering, PLLC	BOBDL00027A	Ice Weight
PSM		Aug 27, 2021 at 10:42 AM
1197-F0001-C		BOBDL00027A_loaded.r3d

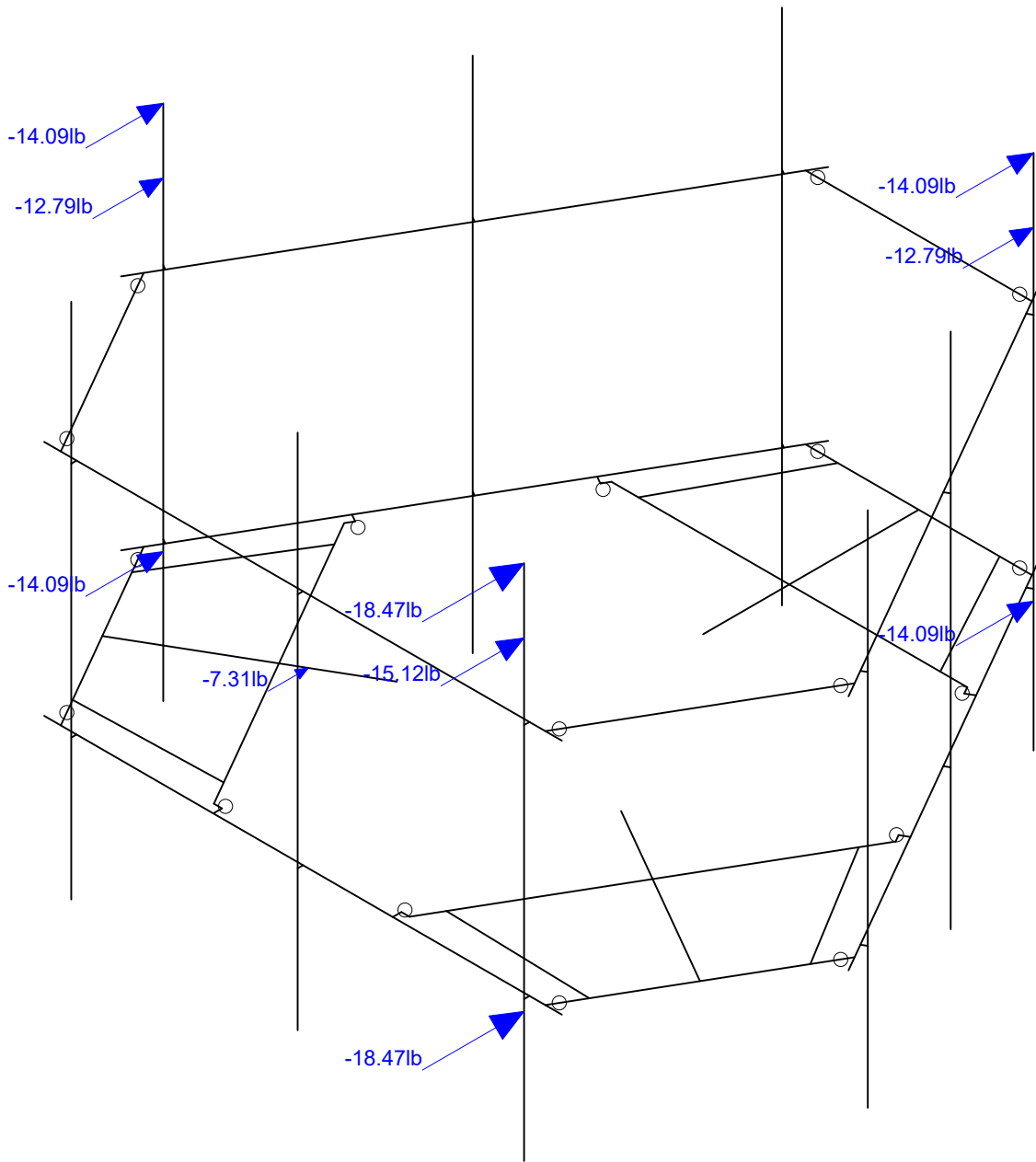
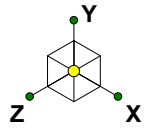

Loads: BLC 17, Ice Wind Load AZI 0
Envelope Only Solution

Infinigy Engineering, PLLC	BOBDL00027A	Ice + Wind Load AZI 000
PSM		Aug 27, 2021 at 10:42 AM
1197-F0001-C		BOBDL00027A_loaded.r3d

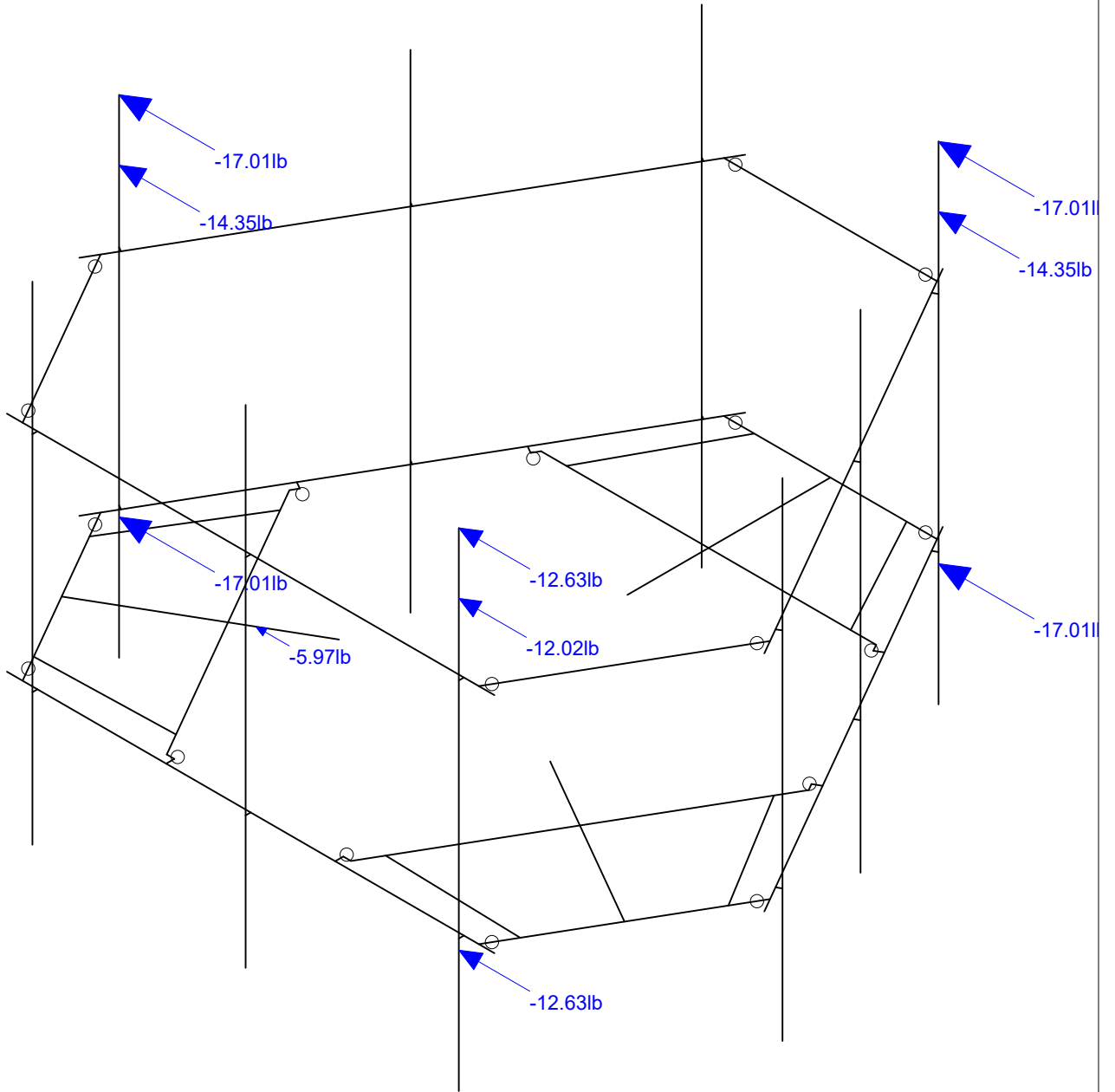
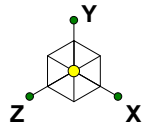

Loads: BLC 20, Ice Wind Load AZI 90
Envelope Only Solution

Infinigy Engineering, PLLC	BOBDL00027A	Ice + Wind Load AZI 090
PSM		Aug 27, 2021 at 10:44 AM
1197-F0001-C		BOBDL00027A_loaded.r3d

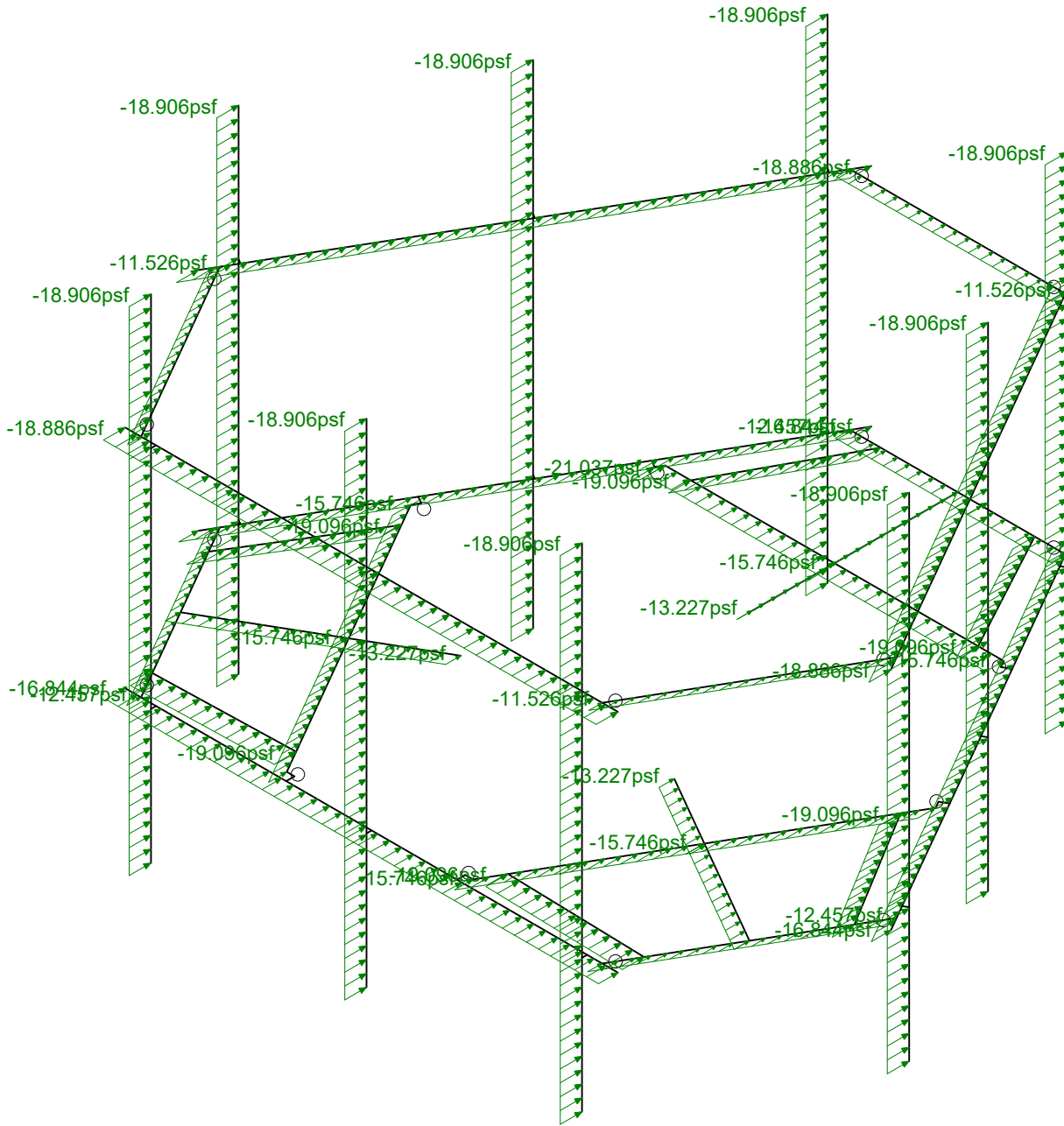
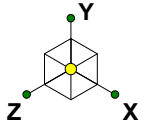

Loads: BLC 29, Distr. Ice Wind Load Z
Envelope Only Solution

Infinigy Engineering, PLLC
PSM
1197-F0001-C

BOBDL00027A

Distr Ice + Wind Load AZI 000
Aug 27, 2021 at 10:43 AM
BOBDL00027A_loaded.r3d

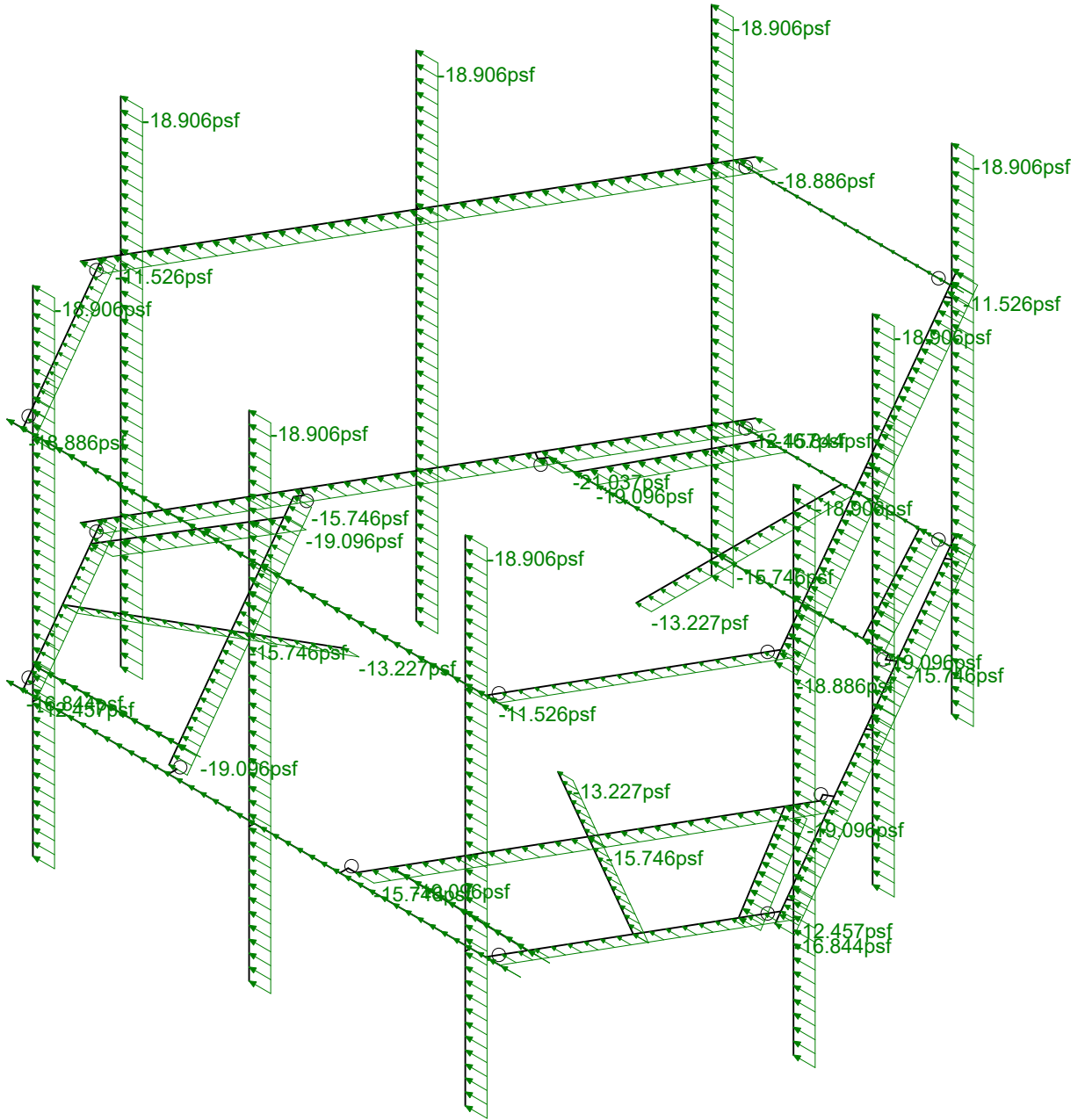
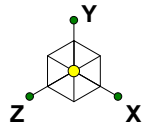

Loads: BLC 30, Distr. Ice Wind Load X
Envelope Only Solution

Infinigy Engineering, PLLC	BOBDL00027A	Distr Ice + Wind Load AZI 090
PSM		Aug 27, 2021 at 10:43 AM
1197-F0001-C		BOBDL00027A_loaded.r3d

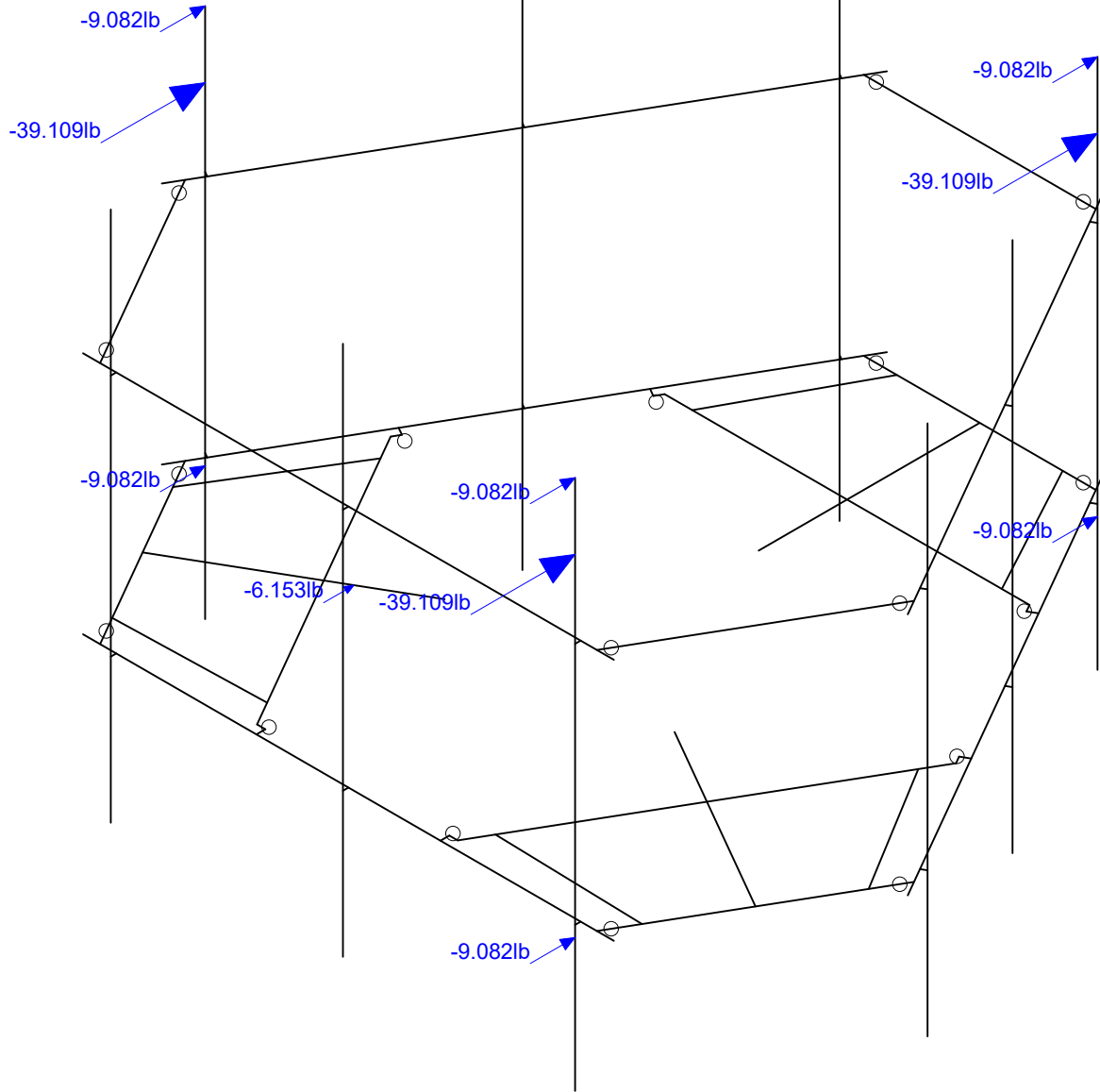
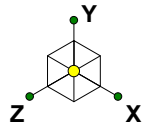

Loads: BLC 31, Seismic Load Z
Envelope Only Solution

Infinigy Engineering, PLLC

PSM

1197-F0001-C

BOBDL00027A

Seismic Load AZI 000

Aug 27, 2021 at 10:45 AM

BOBDL00027A_loaded.r3d

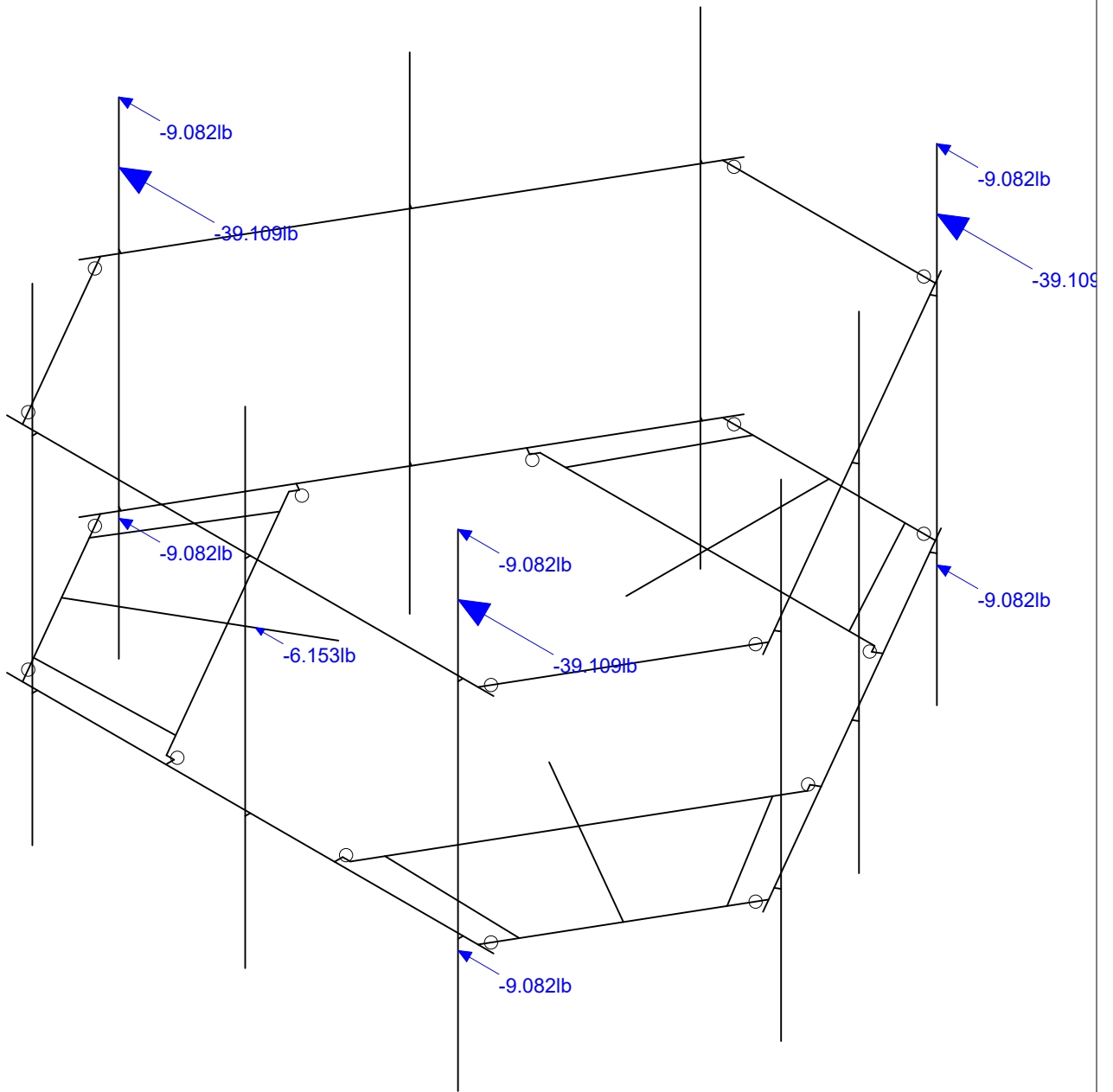
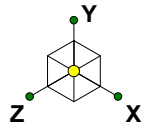

Loads: BLC 32, Seismic Load X
Envelope Only Solution

Infinigy Engineering, PLLC
PSM
1197-F0001-C

BOBDL00027A

Seismic Load AZI 090
Aug 27, 2021 at 10:45 AM
BOBDL00027A_loaded.r3d

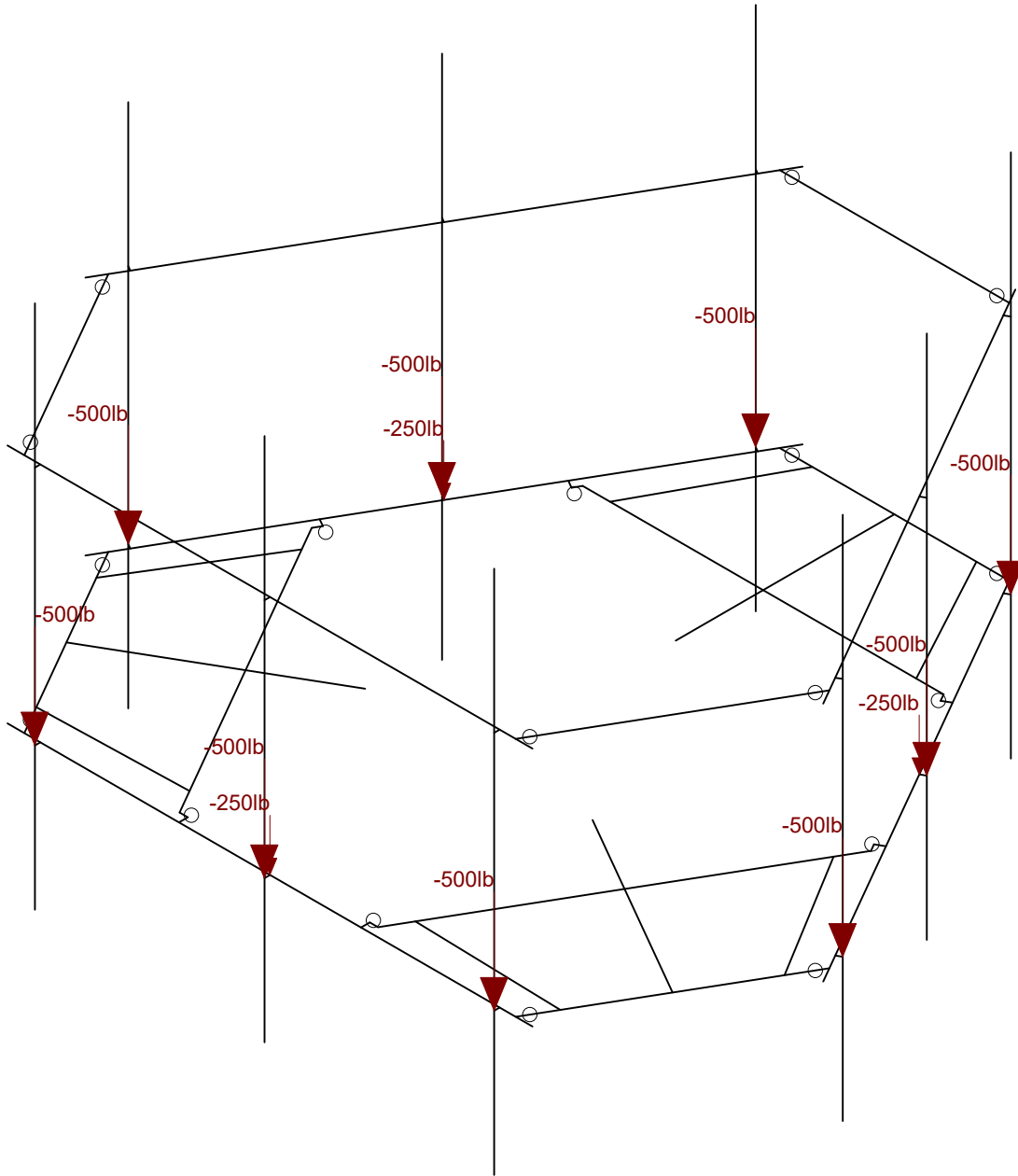
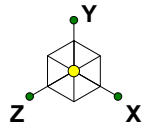

Loads: LL - Live Load
Envelope Only Solution

Infinigy Engineering, PLLC
PSM
1197-F0001-C

BOBDL00027A

Non-concurrent Live Loads
Aug 27, 2021 at 10:45 AM
BOBDL00027A_loaded.r3d

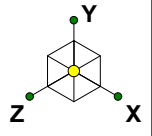

Code Check (Env)	
	No Calc
	> 1.0
	.90-1.0
	.75-.90
	.50-.75
	0-.50

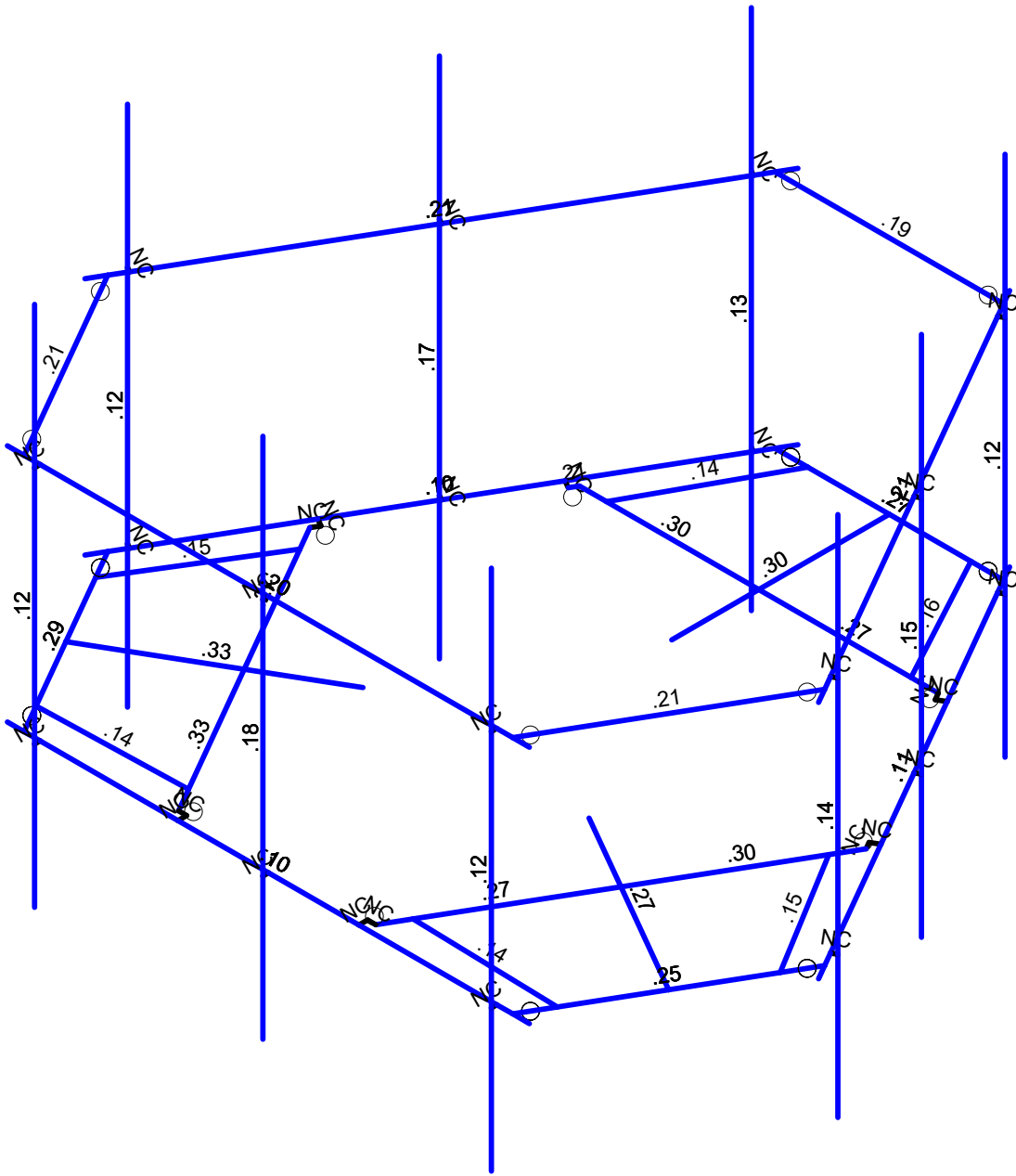

Member Code Checks Displayed (Enveloped)
Envelope Only Solution

Infinigy Engineering, PLLC	BOBDL00027A	Bending Check
PSM		Aug 27, 2021 at 10:45 AM
1197-F0001-C		BOBDL00027A_loaded.r3d

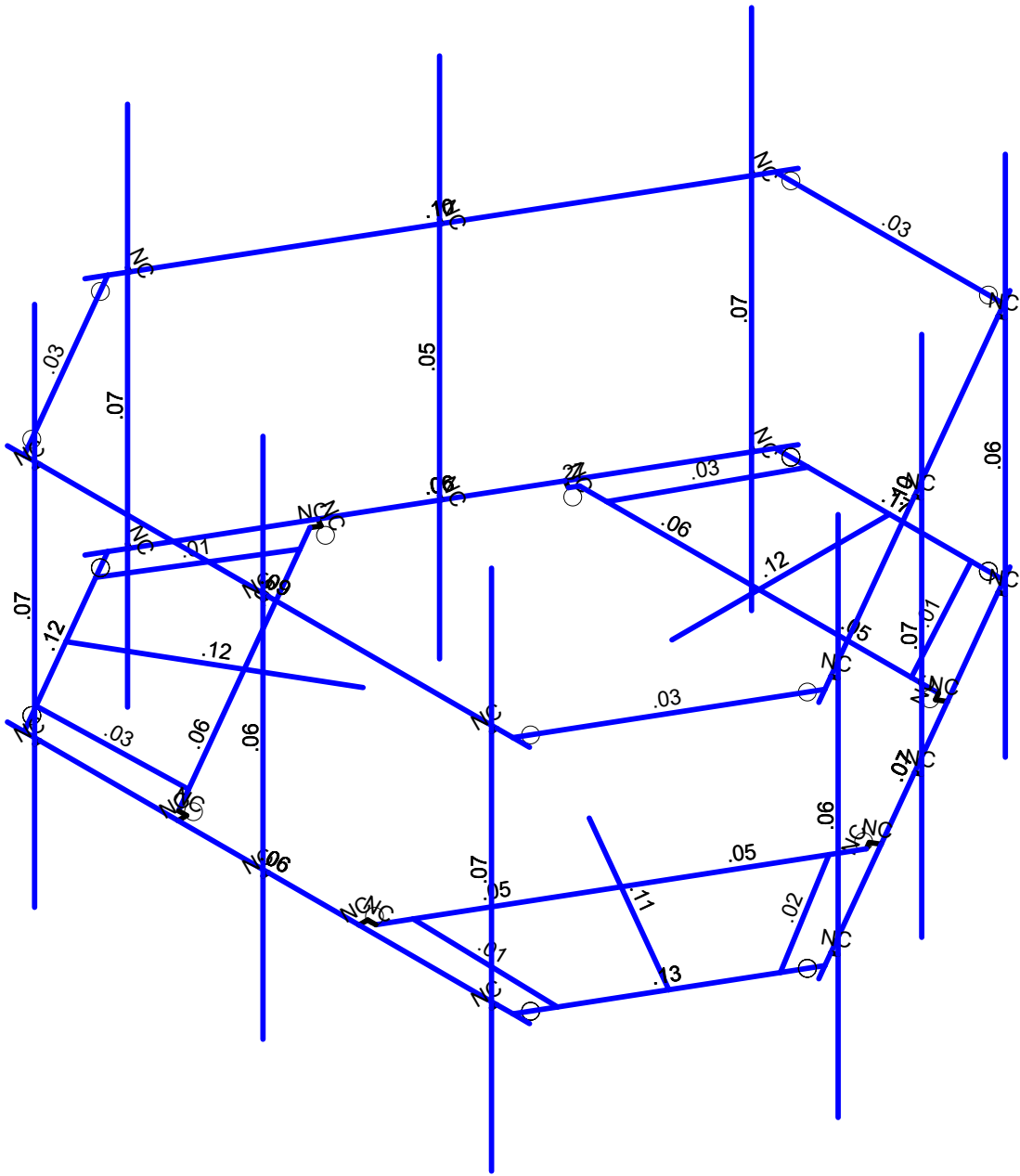
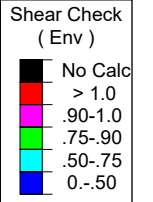
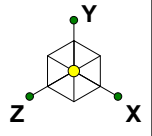

Member Shear Checks Displayed (Enveloped)
Envelope Only Solution

Infinigy Engineering, PLLC	BOBDL00027A	Shear Check
PSM		Aug 27, 2021 at 10:46 AM
1197-F0001-C		BOBDL00027A_loaded.r3d

Program Inputs

PROJECT INFORMATION		
Client:	ATC	
Carrier:	Dish Wireless	
Engineer:	Pradin Suinyal Magar, M.S	

SITE INFORMATION		
Risk Category:	II	
Exposure Category:	B	
Topo Factor Procedure:	Method 1, Category 1	
Site Class:	D - Stiff Soil (Assumed)	
Ground Elevation:	190.05	ft *Rev H

MOUNT INFORMATION		
Mount Type:	Platform	
Num Sectors:	3	
Centerline AGL:	110.00	ft
Tower Height AGL:	139.00	ft

TOPOGRAPHIC DATA		
Topo Feature:	N/A	
Slope Distance:	N/A	ft
Crest Distance:	N/A	ft
Crest Height:	N/A	ft

FACTORS		
Directionality Fact. (K_d):	0.950	
Ground Ele. Factor (K_e):	0.993	*Rev H Only
Rooftop Speed-Up (K_s):	1.000	*Rev H Only
Topographic Factor (K_{zt}):	1.000	
Gust Effect Factor (G_h):	1.000	

CODE STANDARDS		
Building Code:	2015 IBC	
TIA Standard:	TIA-222-H	
ASCE Standard:	ASCE 7-10	

WIND AND ICE DATA		
Ultimate Wind (V_{ult}):	120	mph
Design Wind (V):	N/A	mph
Ice Wind (V_{ice}):	50	mph
Base Ice Thickness (t_i):	2	in
Flat Pressure:	70.640	psf
Round Pressure:	42.384	psf
Ice Wind Pressure:	7.358	psf

SEISMIC DATA		
Short-Period Accel. (S_s):	0.176	g
1-Second Accel. (S_1):	0.065	g
Short-Period Design (S_{DS}):	0.188	
1-Second Design (S_{D1}):	0.104	
Short-Period Coeff. (F_a):	1.600	
1-Second Coeff. (F_v):	2.400	
Amplification Factor (A_s):	3.000	
Response Mod. Coeff. (R):	2.000	



Infinigy Load Calculator V2.1.7

Program Inputs

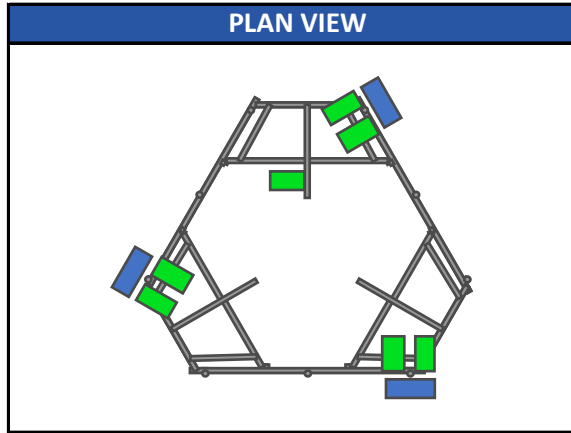
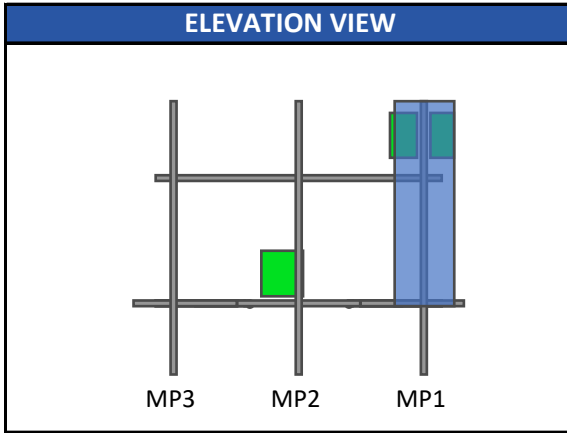

Infinigy Load Calculator V2.1.7

APPURTENANCE INFORMATION											
Appurtenance Name	Elevation	Qty.	K_a	q_z (psf)	EPA_N (ft ²)	EPA_T (ft ²)	Wind F_z (lbs)	Wind F_x (lbs)	Weight (lbs)	Seismic F (lbs)	Member (α sector)
JMA WIRELESS MX08FRO665-21	110.0	3	0.90	35.32	8.01	3.21	254.62	102.04	64.50	18.16	MP1
FUJITSU TA08025-B605	110.0	3	0.90	35.32	1.96	1.19	62.42	37.80	74.95	21.11	MP1
FUJITSU TA08025-B604	110.0	3	0.90	35.32	1.96	1.03	62.42	32.84	63.93	18.00	MP1
RAYCAP RDIDC-9181-PF-48	110.0	1	0.90	35.32	1.87	1.07	59.34	33.91	21.85	6.15	S2

ASCE 7 Hazards Report

Address:
No Address at This Location

Standard: ASCE/SEI 7-10
Risk Category: II
Soil Class: D - Stiff Soil

Elevation: 190.05 ft (NAVD 88)
Latitude: 41.987028
Longitude: -72.702083

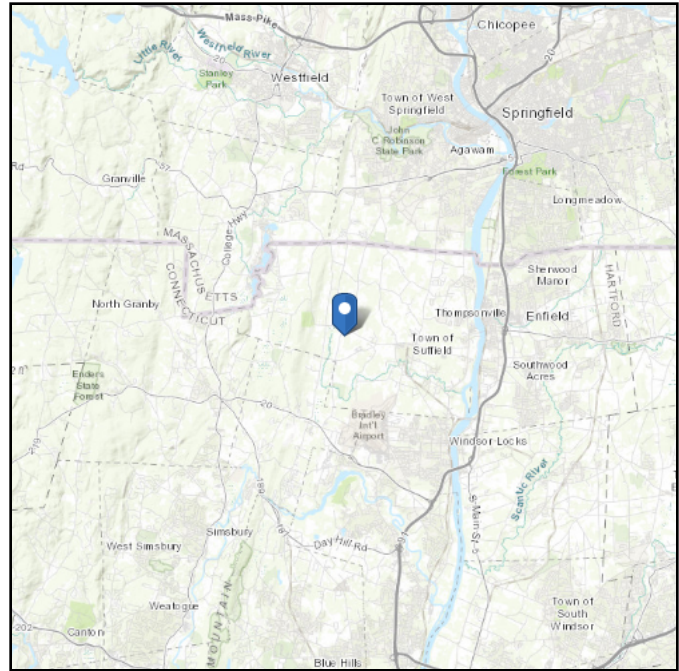
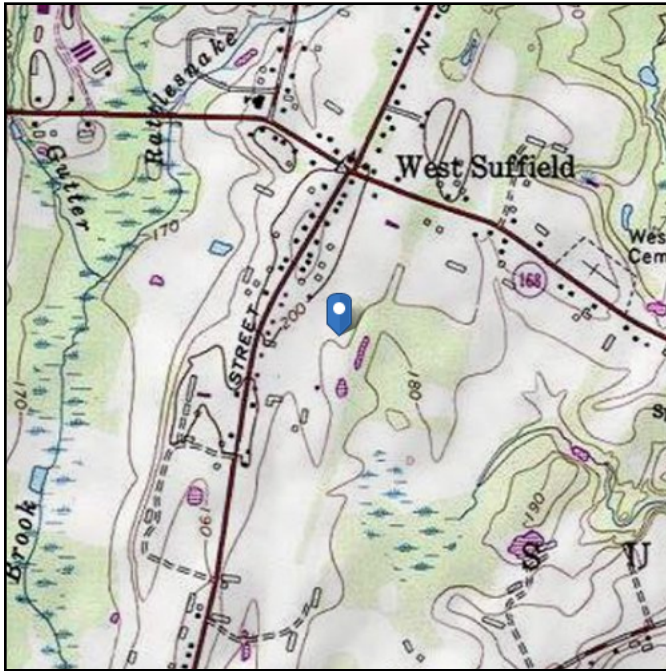

Wind

Results:

Wind Speed:	120 mph per Suffield City Requirements in WSEL
10-year MRI	76 Vmph
25-year MRI	86 Vmph
50-year MRI	91 Vmph
100-year MRI	98 Vmph

Data Source: ASCE/SEI 7-10, Fig. 26.5-1A and Figs. CC-1–CC-4, and Section 26.5.2, incorporating errata of March 12, 2014

Value provided is 3-second gust wind speeds at 33 ft above ground for Exposure C Category, based on linear interpolation between contours. Wind speeds are interpolated in accordance with the 7-10 Standard. Wind speeds correspond to approximately a 7% probability of exceedance in 50 years (annual exceedance probability = 0.00143, MRI = 700 years).

Site is in a hurricane-prone region as defined in ASCE/SEI 7-10 Section 26.2. Glazed openings need not be protected against wind-borne debris.

Site Soil Class: D - Stiff Soil

Results:

S_S :	0.176	S_{DS} :	0.187
S_1 :	0.065	S_{D1} :	0.104
F_a :	1.6	T_L :	6
F_v :	2.4	PGA :	0.086
S_{MS} :	0.281	PGA _M :	0.138
S_{M1} :	0.155	F _{PGA} :	1.6
		I_e :	1

Seismic Design Category B

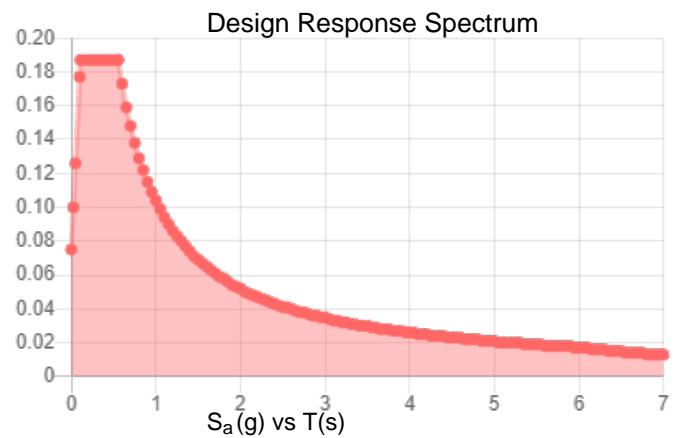
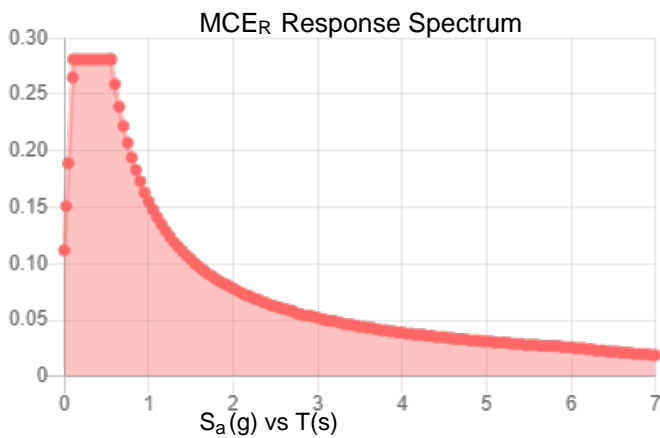

Data Accessed:

Fri Aug 27 2021

Date Source:

USGS Seismic Design Maps based on ASCE/SEI 7-10, incorporating Supplement 1 and errata of March 31, 2013, and ASCE/SEI 7-10 Table 1.5-2. Additional data for site-specific ground motion procedures in accordance with ASCE/SEI 7-10 Ch. 21 are available from USGS.

Ice

Results:

Ice Thickness: 1.00 in.

Concurrent Temperature: 5 F

Gust Speed: 50 mph

Data Source: Standard ASCE/SEI 7-10, Figs. 10-2 through 10-8

Date Accessed: Fri Aug 27 2021

Ice thicknesses on structures in exposed locations at elevations higher than the surrounding terrain and in valleys and gorges may exceed the mapped values.

Values provided are equivalent radial ice thicknesses due to freezing rain with concurrent 3-second gust speeds, for a 50-year mean recurrence interval, and temperatures concurrent with ice thicknesses due to freezing rain. Thicknesses for ice accretions caused by other sources shall be obtained from local meteorological studies. Ice thicknesses in exposed locations at elevations higher than the surrounding terrain and in valleys and gorges may exceed the mapped values.

The ASCE 7 Hazard Tool is provided for your convenience, for informational purposes only, and is provided “as is” and without warranties of any kind. The location data included herein has been obtained from information developed, produced, and maintained by third party providers; or has been extrapolated from maps incorporated in the ASCE 7 standard. While ASCE has made every effort to use data obtained from reliable sources or methodologies, ASCE does not make any representations or warranties as to the accuracy, completeness, reliability, currency, or quality of any data provided herein. Any third-party links provided by this Tool should not be construed as an endorsement, affiliation, relationship, or sponsorship of such third-party content by or from ASCE.

ASCE does not intend, nor should anyone interpret, the results provided by this Tool to replace the sound judgment of a competent professional, having knowledge and experience in the appropriate field(s) of practice, nor to substitute for the standard of care required of such professionals in interpreting and applying the contents of this Tool or the ASCE 7 standard.

In using this Tool, you expressly assume all risks associated with your use. Under no circumstances shall ASCE or its officers, directors, employees, members, affiliates, or agents be liable to you or any other person for any direct, indirect, special, incidental, or consequential damages arising from or related to your use of, or reliance on, the Tool or any information obtained therein. To the fullest extent permitted by law, you agree to release and hold harmless ASCE from any and all liability of any nature arising out of or resulting from any use of data provided by the ASCE 7 Hazard Tool.

Member Primary Data

	Label	I Joint	J Joint	K Joint	Rotate(...)	Section/Shape	Type	Design List	Material	Design Rules
1	S3	P1	P3			Square Tubing	Beam	None	A500 GR.C	Typical
2	GA4	P9	P12		270	Grating Angle	Beam	None	A529 Gr. 50	Typical
3	GA3	P10	P11			Grating Angle	Beam	None	A529 Gr. 50	Typical
4	P3	P7	P8			Corner Plates	Beam	None	A1011 36 Ksi	Typical
5	S2	P13	P14			Square Tubing	Beam	None	A500 GR.C	Typical
6	GA2	P20	P23		270	Grating Angle	Beam	None	A529 Gr. 50	Typical
7	GA1	P21	P22			Grating Angle	Beam	None	A529 Gr. 50	Typical
8	P2	P18	P19			Corner Plates	Beam	None	A1011 36 Ksi	Typical
9	S1	P24	P25			Square Tubing	Beam	None	A500 GR.C	Typical
10	GA6	P31	P34		270	Grating Angle	Beam	None	A529 Gr. 50	Typical
11	GA5	P32	P33			Grating Angle	Beam	None	A529 Gr. 50	Typical
12	P1	P29	P30			Corner Plates	Beam	None	A1011 36 Ksi	Typical
13	H1	N43	N44			Face Pipes(3.5x.16)	Beam	None	A500 GR.C	Typical
14	MP1	N66	N60			Antenna Pipes	Beam	None	A500 GR.C	Typical
15	MP3	N63	N57			Antenna Pipes	Beam	None	A500 GR.C	Typical
16	HR1	N67	N68			Handrail	Beam	None	A500 GR.C	Typical
17	CA8	N114A	N113A		180	Handrail Connector	Beam	None	A1011 36 Ksi	Typical
18	CA9	N112A	N111A		180	Handrail Connector	Beam	None	A1011 36 Ksi	Typical
19	CA7	N116A	N115A		180	Handrail Connector	Beam	None	A1011 36 Ksi	Typical
20	M32	N48A	N70A			RIGID	None	None	RIGID	Typical
21	M35	N45	N69A			RIGID	None	None	RIGID	Typical
22	M36	N51	N71A			RIGID	None	None	RIGID	Typical
23	M39A	N54	N72A			RIGID	None	None	RIGID	Typical
24	CA3	P4	N122A			Channel(3.38x2.06)	Beam	None	A1011 36 Ksi	Typical
25	CA4	N124B	P4			Channel(3.38x2.06)	Beam	None	A1011 36 Ksi	Typical
26	CA1	P15	N122B			Channel(3.38x2.06)	Beam	None	A1011 36 Ksi	Typical
27	CA2	N123A	P15			Channel(3.38x2.06)	Beam	None	A1011 36 Ksi	Typical
28	CA5	P26	N125			Channel(3.38x2.06)	Beam	None	A1011 36 Ksi	Typical
29	CA6	N126	P26			Channel(3.38x2.06)	Beam	None	A1011 36 Ksi	Typical
30	M64	N126A	N125A			RIGID	None	None	RIGID	Typical
31	M65	N126	N125A			RIGID	None	None	RIGID	Typical
32	M66	N129	N128			RIGID	None	None	RIGID	Typical
33	M67	N124B	N128			RIGID	None	None	RIGID	Typical
34	M68	N132	N131			RIGID	None	None	RIGID	Typical
35	M69	N123A	N131			RIGID	None	None	RIGID	Typical
36	M70	N133	N132A			RIGID	None	None	RIGID	Typical
37	M71	N122B	N132A			RIGID	None	None	RIGID	Typical
38	M72	N135	N134			RIGID	None	None	RIGID	Typical
39	M73	N125	N134			RIGID	None	None	RIGID	Typical
40	M74	N138	N137			RIGID	None	None	RIGID	Typical
41	M75	N122A	N137			PL 2.375x0.5	None	None	A36 Gr.36	Typical

Member Primary Data (Continued)

	Label	I Joint	J Joint	K Joint	Rotate(...)	Section/Shape	Type	Design List	Material	Design Rules
42	MP2	N75	N74			Antenna Pipes	Beam	None	A500 GR.C	Typical
43	M43	N72B	N76			RIGID	None	None	RIGID	Typical
44	M44	N73	N77			RIGID	None	None	RIGID	Typical
45	H3	N81A	N82A			Face Pipes(3.5x.16)	Beam	None	A500 GR.C	Typical
46	MP7	N90	N88			Antenna Pipes	Beam	None	A500 GR.C	Typical
47	MP9	N89	N87			Antenna Pipes	Beam	None	A500 GR.C	Typical
48	HR3	N91	N92			Handrail	Beam	None	A500 GR.C	Typical
49	M52	N84	N94			RIGID	None	None	RIGID	Typical
50	M53	N83A	N93			RIGID	None	None	RIGID	Typical
51	M54	N85	N95			RIGID	None	None	RIGID	Typical
52	M55	N86	N96			RIGID	None	None	RIGID	Typical
53	H2	N109	N110			Face Pipes(3.5x.16)	Beam	None	A500 GR.C	Typical
54	MP4	N118	N116			Antenna Pipes	Beam	None	A500 GR.C	Typical
55	MP6	N117	N115			Antenna Pipes	Beam	None	A500 GR.C	Typical
56	HR2	N119	N120			Handrail	Beam	None	A500 GR.C	Typical
57	M66A	N112	N122			RIGID	None	None	RIGID	Typical
58	M67A	N111	N121			RIGID	None	None	RIGID	Typical
59	M68A	N113	N123			RIGID	None	None	RIGID	Typical
60	M69A	N114	N124			RIGID	None	None	RIGID	Typical
61	MP8	N132B	N131A			Antenna Pipes	Beam	None	A500 GR.C	Typical
62	M68B	N129B	N133B			RIGID	None	None	RIGID	Typical
63	M69B	N130A	N134A			RIGID	None	None	RIGID	Typical
64	MP5	N138A	N137A			Antenna Pipes	Beam	None	A500 GR.C	Typical
65	M71B	N135A	N139			RIGID	None	None	RIGID	Typical
66	M72B	N136	N140			RIGID	None	None	RIGID	Typical

Hot Rolled Steel Design Parameters

	Label	Shape	Lengt...	Lbyy[in]	Lbzz[in]	Lcomp t...	Lcomp b...	L-tor...	Kyy	Kzz	Cb	Func...
1	S3	Square Tubing	40			Lbyy						Late...
2	GA4	Grating Angle	27.295			Lbyy						Late...
3	GA3	Grating Angle	27.295			Lbyy						Late...
4	P3	Corner Plates	42			Lbyy						Late...
5	S2	Square Tubing	40			Lbyy						Late...
6	GA2	Grating Angle	27.295			Lbyy						Late...
7	GA1	Grating Angle	27.295			Lbyy						Late...
8	P2	Corner Plates	42			Lbyy						Late...
9	S1	Square Tubing	40			Lbyy						Late...
10	GA6	Grating Angle	27.295			Lbyy						Late...
11	GA5	Grating Angle	27.295			Lbyy						Late...
12	P1	Corner Plates	42			Lbyy						Late...
13	H1	Face Pipes(3.5x.16)	96			Lbyy						Late...



Hot Rolled Steel Design Parameters (Continued)

	Label	Shape	Lengt...	Lbyy[in]	Lbzz[in]	Lcomp t...	Lcomp b...	L-tor...	Kyy	Kzz	Cb	Func...
14	MP1	Antenna Pipes	96			Lbyy						Late...
15	MP3	Antenna Pipes	96			Lbyy						Late...
16	HR1	Handrail	96			Lbyy						Late...
17	CA8	Handrail Connector	42			Lbyy						Late...
18	CA9	Handrail Connector	42			Lbyy						Late...
19	CA7	Handrail Connector	42			Lbyy						Late...
20	CA3	Channel(3.38x2.06)	33			Lbyy						Late...
21	CA4	Channel(3.38x2.06)	33			Lbyy						Late...
22	CA1	Channel(3.38x2.06)	33			Lbyy						Late...
23	CA2	Channel(3.38x2.06)	33			Lbyy						Late...
24	CA5	Channel(3.38x2.06)	33			Lbyy						Late...
25	CA6	Channel(3.38x2.06)	33			Lbyy						Late...
26	M75	PL 2.375x0.5	1.5			Lbyy						Late...
27	MP2	Antenna Pipes	96			Lbyy						Late...
28	H3	Face Pipes(3.5x.16)	96			Lbyy						Late...
29	MP7	Antenna Pipes	96			Lbyy						Late...
30	MP9	Antenna Pipes	96			Lbyy						Late...
31	HR3	Handrail	96			Lbyy						Late...
32	H2	Face Pipes(3.5x.16)	96			Lbyy						Late...
33	MP4	Antenna Pipes	96			Lbyy						Late...
34	MP6	Antenna Pipes	96			Lbyy						Late...
35	HR2	Handrail	96			Lbyy						Late...
36	MP8	Antenna Pipes	96			Lbyy						Late...
37	MP5	Antenna Pipes	96			Lbyy						Late...

Member Advanced Data

	Label	I Release	J Release	I Offset[in]	J Offset[in]	T/C Only	Physical Defl Ra..	Analysis ...	Inactive	Seismi...
1	S3						Yes			None
2	GA4						Yes			None
3	GA3						Yes			None
4	P3	BenPIN	BenPIN				Yes	Default		None
5	S2						Yes			None
6	GA2						Yes			None
7	GA1						Yes			None
8	P2	BenPIN	BenPIN				Yes	Default		None
9	S1						Yes	Default		None
10	GA6						Yes			None
11	GA5						Yes			None
12	P1	BenPIN	BenPIN				Yes	Default		None
13	H1						Yes			None
14	MP1						Yes	+y+3		None



Member Advanced Data (Continued)

	Label	I Release	J Release	I Offset[in]	J Offset[in]	T/C Only	Physical	Defl Ra..	Analysis ...	Inactive	Seismi...
15	MP3						Yes		+y+3		None
16	HR1						Yes				None
17	CA8	00000X	00000X				Yes				None
18	CA9	00000X	00000X				Yes				None
19	CA7	00000X	00000X				Yes	Default			None
20	M32						Yes	** NA **			None
21	M35						Yes	** NA **			None
22	M36						Yes	** NA **			None
23	M39A						Yes	** NA **			None
24	CA3						Yes	Default			None
25	CA4						Yes	Default			None
26	CA1						Yes	Default			None
27	CA2						Yes	Default			None
28	CA5						Yes	Default			None
29	CA6						Yes	Default			None
30	M64	BenPIN					Yes	** NA **			None
31	M65						Yes	** NA **			None
32	M66	BenPIN					Yes	** NA **			None
33	M67						Yes	** NA **			None
34	M68	BenPIN					Yes	** NA **			None
35	M69						Yes	** NA **			None
36	M70	BenPIN					Yes	** NA **			None
37	M71						Yes	** NA **			None
38	M72	BenPIN					Yes	** NA **			None
39	M73						Yes	** NA **			None
40	M74	BenPIN					Yes	** NA **			None
41	M75						Yes	** NA **			None
42	MP2						Yes		+y+3		None
43	M43						Yes	** NA **			None
44	M44						Yes	** NA **			None
45	H3						Yes				None
46	MP7						Yes		+y+3		None
47	MP9						Yes		+y+3		None
48	HR3						Yes				None
49	M52						Yes	** NA **			None
50	M53						Yes	** NA **			None
51	M54						Yes	** NA **			None
52	M55						Yes	** NA **			None
53	H2						Yes				None
54	MP4						Yes		+y+3		None
55	MP6						Yes		+y+3		None
56	HR2						Yes				None

Member Advanced Data (Continued)

	Label	I Release	J Release	I Offset[in]	J Offset[in]	T/C Only	Physical Defl Ra..	Analysis ...	Inactive	Seismi...
57	M66A						Yes ** NA **			None
58	M67A						Yes ** NA **			None
59	M68A						Yes ** NA **			None
60	M69A						Yes ** NA **			None
61	MP8						Yes	+y+3		None
62	M68B						Yes ** NA **			None
63	M69B						Yes ** NA **			None
64	MP5						Yes	+y+3		None
65	M71B						Yes ** NA **			None
66	M72B						Yes ** NA **			None

Material Takeoff

	Material	Size	Pieces	Length[in]	Weight[LB]
1	General				
2	RIGID		29	35.1	0
3	Total General		29	35.1	0
4					
5	Hot Rolled Steel				
6	A1011 36 Ksi	C3.38x2.06x0.25	6	198	98.255
7	A1011 36 Ksi	PL6.5x0.375	3	126	87.09
8	A1011 36 Ksi	L6.6x4.46x0.25	3	126	96.558
9	A36 Gr.36	PL 2.375x0.5	1	1.5	.505
10	A500 GR.C	2.88x0.120	3	288	84.974
11	A500 GR.C	HSS4X4X6	3	120	162.653
12	A500 GR.C	Pipe3.5x0.165	3	288	141.202
13	A500 GR.C	PIPE 2.5	9	864	394.45
14	A529 Gr. 50	L2x2x4	6	163.8	43.838
15	Total HR Steel		37	2175.3	1109.525

Hot Rolled Steel Section Sets

	Label	Shape	Type	Design List	Material	Design... A [in2]	Iyy [in...lzz [in... J [in4]
1	Corner Plates	PL6.5x0.375	Beam	None	A1011 ...	Typical 2.438	.029 8.582 .11
2	6"x0.37" Plate	Plate 6x.37	Beam	None	A1011 ...	Typical 2.22	.025 6.66 .097
3	Grating Angle	L2x2x4	Beam	None	A529 G...	Typical .944	.346 .346 .021
4	Face Pipes(3.5x.1...	Pipe3.5x0.165	Beam	None	A500 G...	Typical 1.729	2.409 2.409 4.819
5	Antenna Pipes	PIPE 2.5	Beam	None	A500 G...	Typical 1.61	1.45 1.45 2.89
6	Channel(3.38x2.06)	C3.38x2.06x0.25	Beam	None	A1011 ...	Typical 1.75	.715 3.026 .034
7	Square Tubing	HSS4X4X6	Beam	None	A500 G...	Typical 4.78	10.3 10.3 17.5
8	Handrail Connector	L6.6x4.46x0.25	Beam	None	A1011 ...	Typical 2.703	4.759 12.473 .055



Hot Rolled Steel Section Sets (Continued)

	Label	Shape	Type	Design List	Material	Design... A [in2]	Iyy [in...lzz [in... J [in4]
9	Handrail	2.88x0.120	Beam	None	A500 G...	Typical 1.04	.993 .993 1.985

Basic Load Cases

	BLC Description	Category	X Gr...	Y Gr...	Z Gr...	Joint	Point	Distributed	Area(Memb...	Surface(Plate/Wall)
1	Self Weight	DL		-1			13		3	
2	Wind Load AZI 0	WLZ					26			
3	Wind Load AZI 30	None					26			
4	Wind Load AZI 60	None					26			
5	Wind Load AZI 90	WLX					26			
6	Wind Load AZI 1...	None					26			
7	Wind Load AZI 1...	None					26			
8	Wind Load AZI 1...	None					26			
9	Wind Load AZI 2...	None					26			
10	Wind Load AZI 2...	None					26			
11	Wind Load AZI 2...	None					26			
12	Wind Load AZI 3...	None					26			
13	Wind Load AZI 3...	None					26			
14	Distr. Wind Load Z	WLZ						66		
15	Distr. Wind Load X	WLX						66		
16	Ice Weight	OL1					13	66	3	
17	Ice Wind Load A...	OL2					26			
18	Ice Wind Load A...	None					26			
19	Ice Wind Load A...	None					26			
20	Ice Wind Load A...	OL3					26			
21	Ice Wind Load A...	None					26			
22	Ice Wind Load A...	None					26			
23	Ice Wind Load A...	None					26			
24	Ice Wind Load A...	None					26			
25	Ice Wind Load A...	None					26			
26	Ice Wind Load A...	None					26			
27	Ice Wind Load A...	None					26			
28	Ice Wind Load A...	None					26			
29	Distr. Ice Wind L...	OL2						66		
30	Distr. Ice Wind L...	OL3						66		
31	Seismic Load Z	ELZ			-.282		13			
32	Seismic Load X	ELX	-.282				13			
33	Service Live Loa...	LL					3			
34	Maintenance Loa...	LL					1			
35	Maintenance Loa...	LL					1			
36	Maintenance Loa...	LL					1			
37	Maintenance Loa...	LL					1			

Basic Load Cases (Continued)

	BLC Description	Category	X Gr...	Y Gr...	Z Gr...	Joint	Point	Distributed	Area(Memb...	Surface(Plate/Wall)
38	Maintenance Loa...	LL				1				
39	Maintenance Loa...	LL				1				
40	Maintenance Loa...	LL				1				
41	Maintenance Loa...	LL				1				
42	Maintenance Loa...	LL				1				
43	BLC 1 Transient ...	None						9		
44	BLC 16 Transien...	None						9		

Load Combinations

	Description	S...	P...	S...B...	Fa...B...	Fa...B...	Fa...B...	Fa...B...	Fa...B...	Fa...B...	Fa...B...	Fa...B...	Fa...B...	Fa...B...	Fa...B...	Fa...B...	Fa...B...	Fa...B...
1	1.4DL	Y...Y		1	1.4													
2	1.2DL + 1WL AZI 0	Y...Y		1	1.2	2	1	14	1	15								
3	1.2DL + 1WL AZI 30	Y...Y		1	1.2	3	1	14	.866	15	.5							
4	1.2DL + 1WL AZI 60	Y...Y		1	1.2	4	1	14	.5	15	.866							
5	1.2DL + 1WL AZI 90	Y...Y		1	1.2	5	1	14		15	1							
6	1.2DL + 1WL AZI 120	Y...Y		1	1.2	6	1	14	-.5	15	.866							
7	1.2DL + 1WL AZI 150	Y...Y		1	1.2	7	1	14	-.8...	15	.5							
8	1.2DL + 1WL AZI 180	Y...Y		1	1.2	8	1	14	-1	15								
9	1.2DL + 1WL AZI 210	Y...Y		1	1.2	9	1	14	-.8...	15	-.5							
10	1.2DL + 1WL AZI 240	Y...Y		1	1.2	10	1	14	-.5	15	-.8...							
11	1.2DL + 1WL AZI 270	Y...Y		1	1.2	11	1	14		15	-1							
12	1.2DL + 1WL AZI 300	Y...Y		1	1.2	12	1	14	.5	15	-.8...							
13	1.2DL + 1WL AZI 330	Y...Y		1	1.2	13	1	14	.866	15	-.5							
14	0.9DL + 1WL AZI 0	Y...Y		1	.9	2	1	14	1	15								
15	0.9DL + 1WL AZI 30	Y...Y		1	.9	3	1	14	.866	15	.5							
16	0.9DL + 1WL AZI 60	Y...Y		1	.9	4	1	14	.5	15	.866							
17	0.9DL + 1WL AZI 90	Y...Y		1	.9	5	1	14		15	1							
18	0.9DL + 1WL AZI 120	Y...Y		1	.9	6	1	14	-.5	15	.866							
19	0.9DL + 1WL AZI 150	Y...Y		1	.9	7	1	14	-.8...	15	.5							
20	0.9DL + 1WL AZI 180	Y...Y		1	.9	8	1	14	-1	15								
21	0.9DL + 1WL AZI 210	Y...Y		1	.9	9	1	14	-.8...	15	-.5							
22	0.9DL + 1WL AZI 240	Y...Y		1	.9	10	1	14	-.5	15	-.8...							
23	0.9DL + 1WL AZI 270	Y...Y		1	.9	11	1	14		15	-1							
24	0.9DL + 1WL AZI 300	Y...Y		1	.9	12	1	14	.5	15	-.8...							
25	0.9DL + 1WL AZI 330	Y...Y		1	.9	13	1	14	.866	15	-.5							
26	1.2D + 1.0Di	Y...Y		1	1.2	16	1											
27	1.2D + 1.0Di +1.0Wi AZI 0	Y...Y		1	1.2	16	1	17	1	29	1	30						
28	1.2D + 1.0Di +1.0Wi AZI 30	Y...Y		1	1.2	16	1	18	1	29	.866	30	.5					
29	1.2D + 1.0Di +1.0Wi AZI 60	Y...Y		1	1.2	16	1	19	1	29	.5	30	.866					
30	1.2D + 1.0Di +1.0Wi AZI 90	Y...Y		1	1.2	16	1	20	1	29		30	1					
31	1.2D + 1.0Di +1.0Wi AZI 120	Y...Y		1	1.2	16	1	21	1	29	-.5	30	.866					



Load Combinations (Continued)

	Description	S...	P...	S...B...	Fa...B...	Fa...B...	Fa...B...	Fa...B...	Fa...B...	Fa...B...	Fa...B...	Fa...B...	Fa...B...	Fa...B...	Fa...B...	Fa...B...	Fa...B...	Fa...B...	Fa...B...
32	1.2D + 1.0Di + 1.0Wi AZI 150	Y...	Y	1	1.2	16	1	22	1	29	-8...	30	.5						
33	1.2D + 1.0Di + 1.0Wi AZI 180	Y...	Y	1	1.2	16	1	23	1	29	-1	30							
34	1.2D + 1.0Di + 1.0Wi AZI 210	Y...	Y	1	1.2	16	1	24	1	29	-8...	30	-.5						
35	1.2D + 1.0Di + 1.0Wi AZI 240	Y...	Y	1	1.2	16	1	25	1	29	-.5	30	-8...						
36	1.2D + 1.0Di + 1.0Wi AZI 270	Y...	Y	1	1.2	16	1	26	1	29		30	-1						
37	1.2D + 1.0Di + 1.0Wi AZI 300	Y...	Y	1	1.2	16	1	27	1	29	.5	30	-8...						
38	1.2D + 1.0Di + 1.0Wi AZI 330	Y...	Y	1	1.2	16	1	28	1	29	.866	30	-.5						
39	(1.2 + 0.2Sds)DL + 1.0E AZI 0	Y...	Y	1	1.2	.31	1	32											
40	(1.2 + 0.2Sds)DL + 1.0E AZI 30	Y...	Y	1	1.2	.31	.866	32	.5										
41	(1.2 + 0.2Sds)DL + 1.0E AZI 60	Y...	Y	1	1.2	.31	.5	32	.866										
42	(1.2 + 0.2Sds)DL + 1.0E AZI 90	Y...	Y	1	1.2	.31		32	1										
43	(1.2 + 0.2Sds)DL + 1.0E AZI 1..	Y...	Y	1	1.2	.31	-.5	32	.866										
44	(1.2 + 0.2Sds)DL + 1.0E AZI 1..	Y...	Y	1	1.2	.31	-8...	32	.5										
45	(1.2 + 0.2Sds)DL + 1.0E AZI 1..	Y...	Y	1	1.2	.31	-1	32											
46	(1.2 + 0.2Sds)DL + 1.0E AZI 2..	Y...	Y	1	1.2	.31	-8...	32	-.5										
47	(1.2 + 0.2Sds)DL + 1.0E AZI 2..	Y...	Y	1	1.2	.31	-.5	32	-8...										
48	(1.2 + 0.2Sds)DL + 1.0E AZI 2..	Y...	Y	1	1.2	.31		32	-1										
49	(1.2 + 0.2Sds)DL + 1.0E AZI 3..	Y...	Y	1	1.2	.31	.5	32	-8...										
50	(1.2 + 0.2Sds)DL + 1.0E AZI 3..	Y...	Y	1	1.2	.31	.866	32	-.5										
51	(0.9 - 0.2Sds)DL + 1.0E AZI 0	Y...	Y	1	.862	31	1	32											
52	(0.9 - 0.2Sds)DL + 1.0E AZI 30	Y...	Y	1	.862	31	.866	32	.5										
53	(0.9 - 0.2Sds)DL + 1.0E AZI 60	Y...	Y	1	.862	31	.5	32	.866										
54	(0.9 - 0.2Sds)DL + 1.0E AZI 90	Y...	Y	1	.862	31		32	1										
55	(0.9 - 0.2Sds)DL + 1.0E AZI 1..	Y...	Y	1	.862	31	-.5	32	.866										
56	(0.9 - 0.2Sds)DL + 1.0E AZI 1..	Y...	Y	1	.862	31	-8...	32	.5										
57	(0.9 - 0.2Sds)DL + 1.0E AZI 1..	Y...	Y	1	.862	31	-1	32											
58	(0.9 - 0.2Sds)DL + 1.0E AZI 2..	Y...	Y	1	.862	31	-8...	32	-.5										
59	(0.9 - 0.2Sds)DL + 1.0E AZI 2..	Y...	Y	1	.862	31	-.5	32	-8...										
60	(0.9 - 0.2Sds)DL + 1.0E AZI 2..	Y...	Y	1	.862	31		32	-1										
61	(0.9 - 0.2Sds)DL + 1.0E AZI 3..	Y...	Y	1	.862	31	.5	32	-8...										
62	(0.9 - 0.2Sds)DL + 1.0E AZI 3..	Y...	Y	1	.862	31	.866	32	-.5										
63	1.0DL + 1.5LL + 1.0SWL (60 ...	Y...	Y	1	1	2	.25	14	.25	15		33	1.5						
64	1.0DL + 1.5LL + 1.0SWL (60 ...	Y...	Y	1	1	3	.25	14	.216	15	.125	33	1.5						
65	1.0DL + 1.5LL + 1.0SWL (60 ...	Y...	Y	1	1	4	.25	14	.125	15	.216	33	1.5						
66	1.0DL + 1.5LL + 1.0SWL (60 ...	Y...	Y	1	1	5	.25	14		15	.25	33	1.5						
67	1.0DL + 1.5LL + 1.0SWL (60 ...	Y...	Y	1	1	6	.25	14	-.1...	15	.216	33	1.5						
68	1.0DL + 1.5LL + 1.0SWL (60 ...	Y...	Y	1	1	7	.25	14	-.2...	15	.125	33	1.5						
69	1.0DL + 1.5LL + 1.0SWL (60 ...	Y...	Y	1	1	8	.25	14	-.25	15		33	1.5						
70	1.0DL + 1.5LL + 1.0SWL (60 ...	Y...	Y	1	1	9	.25	14	-.2...	15	-.1...	33	1.5						
71	1.0DL + 1.5LL + 1.0SWL (60 ...	Y...	Y	1	1	10	.25	14	-.1...	15	-.2...	33	1.5						
72	1.0DL + 1.5LL + 1.0SWL (60 ...	Y...	Y	1	1	11	.25	14		15	-.25	33	1.5						
73	1.0DL + 1.5LL + 1.0SWL (60 ...	Y...	Y	1	1	12	.25	14	.125	15	-.2...	33	1.5						



Load Combinations (Continued)

Description	S...	P...	S...B...	Fa...B...	Fa...B...	Fa...B...	Fa...B...	Fa...B...	Fa...B...	Fa...B...	Fa...B...	Fa...B...	Fa...B...	Fa...B...	Fa...B...	Fa...B...	Fa...B...	Fa...B...	Fa...B...
74	1.0DL + 1.5LL + 1.0SWL (60 ...	Y...	Y	1	1	13	.25	14	.216	15	-1...	33	1.5						
75	1.2DL + 1.5LL	Y...	Y	1	1	2	33	1.5											
76	1.2DL + 1.5LM-MP1 + 1SWL (...)	Y...	Y	1	1	2	34	1.5	2	.063	14	.063	15						
77	1.2DL + 1.5LM-MP1 + 1SWL (...)	Y...	Y	1	1	2	34	1.5	3	.063	14	.054	15	.031					
78	1.2DL + 1.5LM-MP1 + 1SWL (...)	Y...	Y	1	1	2	34	1.5	4	.063	14	.031	15	.054					
79	1.2DL + 1.5LM-MP1 + 1SWL (...)	Y...	Y	1	1	2	34	1.5	5	.063	14		15	.063					
80	1.2DL + 1.5LM-MP1 + 1SWL (...)	Y...	Y	1	1	2	34	1.5	6	.063	14	-0...	15	.054					
81	1.2DL + 1.5LM-MP1 + 1SWL (...)	Y...	Y	1	1	2	34	1.5	7	.063	14	-0...	15	.031					
82	1.2DL + 1.5LM-MP1 + 1SWL (...)	Y...	Y	1	1	2	34	1.5	8	.063	14	-0...	15						
83	1.2DL + 1.5LM-MP1 + 1SWL (...)	Y...	Y	1	1	2	34	1.5	9	.063	14	-0...	15	-0...					
84	1.2DL + 1.5LM-MP1 + 1SWL (...)	Y...	Y	1	1	2	34	1.5	10	.063	14	-0...	15	-0...					
85	1.2DL + 1.5LM-MP1 + 1SWL (...)	Y...	Y	1	1	2	34	1.5	11	.063	14		15	-0...					
86	1.2DL + 1.5LM-MP1 + 1SWL (...)	Y...	Y	1	1	2	34	1.5	12	.063	14	.031	15	-0...					
87	1.2DL + 1.5LM-MP1 + 1SWL (...)	Y...	Y	1	1	2	34	1.5	13	.063	14	.054	15	-0...					
88	1.2DL + 1.5LM-MP2 + 1SWL (...)	Y...	Y	1	1	2	35	1.5	2	.063	14	.063	15						
89	1.2DL + 1.5LM-MP2 + 1SWL (...)	Y...	Y	1	1	2	35	1.5	3	.063	14	.054	15	.031					
90	1.2DL + 1.5LM-MP2 + 1SWL (...)	Y...	Y	1	1	2	35	1.5	4	.063	14	.031	15	.054					
91	1.2DL + 1.5LM-MP2 + 1SWL (...)	Y...	Y	1	1	2	35	1.5	5	.063	14		15	.063					
92	1.2DL + 1.5LM-MP2 + 1SWL (...)	Y...	Y	1	1	2	35	1.5	6	.063	14	-0...	15	.054					
93	1.2DL + 1.5LM-MP2 + 1SWL (...)	Y...	Y	1	1	2	35	1.5	7	.063	14	-0...	15	.031					
94	1.2DL + 1.5LM-MP2 + 1SWL (...)	Y...	Y	1	1	2	35	1.5	8	.063	14	-0...	15						
95	1.2DL + 1.5LM-MP2 + 1SWL (...)	Y...	Y	1	1	2	35	1.5	9	.063	14	-0...	15	-0...					
96	1.2DL + 1.5LM-MP2 + 1SWL (...)	Y...	Y	1	1	2	35	1.5	10	.063	14	-0...	15	-0...					
97	1.2DL + 1.5LM-MP2 + 1SWL (...)	Y...	Y	1	1	2	35	1.5	11	.063	14		15	-0...					
98	1.2DL + 1.5LM-MP2 + 1SWL (...)	Y...	Y	1	1	2	35	1.5	12	.063	14	.031	15	-0...					
99	1.2DL + 1.5LM-MP2 + 1SWL (...)	Y...	Y	1	1	2	35	1.5	13	.063	14	.054	15	-0...					
100	1.2DL + 1.5LM-MP3 + 1SWL (...)	Y...	Y	1	1	2	36	1.5	2	.063	14	.063	15						
101	1.2DL + 1.5LM-MP3 + 1SWL (...)	Y...	Y	1	1	2	36	1.5	3	.063	14	.054	15	.031					
102	1.2DL + 1.5LM-MP3 + 1SWL (...)	Y...	Y	1	1	2	36	1.5	4	.063	14	.031	15	.054					
103	1.2DL + 1.5LM-MP3 + 1SWL (...)	Y...	Y	1	1	2	36	1.5	5	.063	14		15	.063					
104	1.2DL + 1.5LM-MP3 + 1SWL (...)	Y...	Y	1	1	2	36	1.5	6	.063	14	-0...	15	.054					
105	1.2DL + 1.5LM-MP3 + 1SWL (...)	Y...	Y	1	1	2	36	1.5	7	.063	14	-0...	15	.031					
106	1.2DL + 1.5LM-MP3 + 1SWL (...)	Y...	Y	1	1	2	36	1.5	8	.063	14	-0...	15						
107	1.2DL + 1.5LM-MP3 + 1SWL (...)	Y...	Y	1	1	2	36	1.5	9	.063	14	-0...	15	-0...					
108	1.2DL + 1.5LM-MP3 + 1SWL (...)	Y...	Y	1	1	2	36	1.5	10	.063	14	-0...	15	-0...					
109	1.2DL + 1.5LM-MP3 + 1SWL (...)	Y...	Y	1	1	2	36	1.5	11	.063	14		15	-0...					
110	1.2DL + 1.5LM-MP3 + 1SWL (...)	Y...	Y	1	1	2	36	1.5	12	.063	14	.031	15	-0...					
111	1.2DL + 1.5LM-MP3 + 1SWL (...)	Y...	Y	1	1	2	36	1.5	13	.063	14	.054	15	-0...					
112	1.2DL + 1.5LM-MP4 + 1SWL (...)	Y...	Y	1	1	2	37	1.5	2	.063	14	.063	15						
113	1.2DL + 1.5LM-MP4 + 1SWL (...)	Y...	Y	1	1	2	37	1.5	3	.063	14	.054	15	.031					
114	1.2DL + 1.5LM-MP4 + 1SWL (...)	Y...	Y	1	1	2	37	1.5	4	.063	14	.031	15	.054					
115	1.2DL + 1.5LM-MP4 + 1SWL (...)	Y...	Y	1	1	2	37	1.5	5	.063	14		15	.063					



Load Combinations (Continued)

	Description	S...	P...	S...B...	Fa...B...	Fa...B...	Fa...B...	Fa...B...	Fa...B...	Fa...B...	Fa...B...	Fa...B...	Fa...B...	Fa...B...	Fa...B...	Fa...B...	Fa...B...	Fa...B...	Fa...B...
116	1.2DL + 1.5LM-MP4 + 1SWL (...Y...)	Y		1	1.2	37	1.5	6	.063	14	-0...	15	.054						
117	1.2DL + 1.5LM-MP4 + 1SWL (...Y...)	Y		1	1.2	37	1.5	7	.063	14	-0...	15	.031						
118	1.2DL + 1.5LM-MP4 + 1SWL (...Y...)	Y		1	1.2	37	1.5	8	.063	14	-0...	15							
119	1.2DL + 1.5LM-MP4 + 1SWL (...Y...)	Y		1	1.2	37	1.5	9	.063	14	-0...	15	-0...						
120	1.2DL + 1.5LM-MP4 + 1SWL (...Y...)	Y		1	1.2	37	1.5	10	.063	14	-0...	15	-0...						
121	1.2DL + 1.5LM-MP4 + 1SWL (...Y...)	Y		1	1.2	37	1.5	11	.063	14		15	-0...						
122	1.2DL + 1.5LM-MP4 + 1SWL (...Y...)	Y		1	1.2	37	1.5	12	.063	14	.031	15	-0...						
123	1.2DL + 1.5LM-MP4 + 1SWL (...Y...)	Y		1	1.2	37	1.5	13	.063	14	.054	15	-0...						
124	1.2DL + 1.5LM-MP5 + 1SWL (...Y...)	Y		1	1.2	38	1.5	2	.063	14	.063	15							
125	1.2DL + 1.5LM-MP5 + 1SWL (...Y...)	Y		1	1.2	38	1.5	3	.063	14	.054	15	.031						
126	1.2DL + 1.5LM-MP5 + 1SWL (...Y...)	Y		1	1.2	38	1.5	4	.063	14	.031	15	.054						
127	1.2DL + 1.5LM-MP5 + 1SWL (...Y...)	Y		1	1.2	38	1.5	5	.063	14		15	.063						
128	1.2DL + 1.5LM-MP5 + 1SWL (...Y...)	Y		1	1.2	38	1.5	6	.063	14	-0...	15	.054						
129	1.2DL + 1.5LM-MP5 + 1SWL (...Y...)	Y		1	1.2	38	1.5	7	.063	14	-0...	15	.031						
130	1.2DL + 1.5LM-MP5 + 1SWL (...Y...)	Y		1	1.2	38	1.5	8	.063	14	-0...	15							
131	1.2DL + 1.5LM-MP5 + 1SWL (...Y...)	Y		1	1.2	38	1.5	9	.063	14	-0...	15	-0...						
132	1.2DL + 1.5LM-MP5 + 1SWL (...Y...)	Y		1	1.2	38	1.5	10	.063	14	-0...	15	-0...						
133	1.2DL + 1.5LM-MP5 + 1SWL (...Y...)	Y		1	1.2	38	1.5	11	.063	14		15	-0...						
134	1.2DL + 1.5LM-MP5 + 1SWL (...Y...)	Y		1	1.2	38	1.5	12	.063	14	.031	15	-0...						
135	1.2DL + 1.5LM-MP5 + 1SWL (...Y...)	Y		1	1.2	38	1.5	13	.063	14	.054	15	-0...						
136	1.2DL + 1.5LM-MP6 + 1SWL (...Y...)	Y		1	1.2	39	1.5	2	.063	14	.063	15							
137	1.2DL + 1.5LM-MP6 + 1SWL (...Y...)	Y		1	1.2	39	1.5	3	.063	14	.054	15	.031						
138	1.2DL + 1.5LM-MP6 + 1SWL (...Y...)	Y		1	1.2	39	1.5	4	.063	14	.031	15	.054						
139	1.2DL + 1.5LM-MP6 + 1SWL (...Y...)	Y		1	1.2	39	1.5	5	.063	14		15	.063						
140	1.2DL + 1.5LM-MP6 + 1SWL (...Y...)	Y		1	1.2	39	1.5	6	.063	14	-0...	15	.054						
141	1.2DL + 1.5LM-MP6 + 1SWL (...Y...)	Y		1	1.2	39	1.5	7	.063	14	-0...	15	.031						
142	1.2DL + 1.5LM-MP6 + 1SWL (...Y...)	Y		1	1.2	39	1.5	8	.063	14	-0...	15							
143	1.2DL + 1.5LM-MP6 + 1SWL (...Y...)	Y		1	1.2	39	1.5	9	.063	14	-0...	15	-0...						
144	1.2DL + 1.5LM-MP6 + 1SWL (...Y...)	Y		1	1.2	39	1.5	10	.063	14	-0...	15	-0...						
145	1.2DL + 1.5LM-MP6 + 1SWL (...Y...)	Y		1	1.2	39	1.5	11	.063	14		15	-0...						
146	1.2DL + 1.5LM-MP6 + 1SWL (...Y...)	Y		1	1.2	39	1.5	12	.063	14	.031	15	-0...						
147	1.2DL + 1.5LM-MP6 + 1SWL (...Y...)	Y		1	1.2	39	1.5	13	.063	14	.054	15	-0...						
148	1.2DL + 1.5LM-MP7 + 1SWL (...Y...)	Y		1	1.2	40	1.5	2	.063	14	.063	15							
149	1.2DL + 1.5LM-MP7 + 1SWL (...Y...)	Y		1	1.2	40	1.5	3	.063	14	.054	15	.031						
150	1.2DL + 1.5LM-MP7 + 1SWL (...Y...)	Y		1	1.2	40	1.5	4	.063	14	.031	15	.054						
151	1.2DL + 1.5LM-MP7 + 1SWL (...Y...)	Y		1	1.2	40	1.5	5	.063	14		15	.063						
152	1.2DL + 1.5LM-MP7 + 1SWL (...Y...)	Y		1	1.2	40	1.5	6	.063	14	-0...	15	.054						
153	1.2DL + 1.5LM-MP7 + 1SWL (...Y...)	Y		1	1.2	40	1.5	7	.063	14	-0...	15	.031						
154	1.2DL + 1.5LM-MP7 + 1SWL (...Y...)	Y		1	1.2	40	1.5	8	.063	14	-0...	15							
155	1.2DL + 1.5LM-MP7 + 1SWL (...Y...)	Y		1	1.2	40	1.5	9	.063	14	-0...	15	-0...						
156	1.2DL + 1.5LM-MP7 + 1SWL (...Y...)	Y		1	1.2	40	1.5	10	.063	14	-0...	15	-0...						
157	1.2DL + 1.5LM-MP7 + 1SWL (...Y...)	Y		1	1.2	40	1.5	11	.063	14		15	-0...						

Load Combinations (Continued)

	Description	S...	P...	S...B...	Fa...B...	Fa...B...	Fa...B...	Fa...B...	Fa...B...	Fa...B...	Fa...B...	Fa...B...	Fa...B...	Fa...B...	Fa...B...	Fa...B...	Fa...B...	Fa...B...	Fa...B...
158	1.2DL + 1.5LM-MP7 + 1SWL (...Y...)	Y		1	1.2	40	1.5	12	.063	14	.031	15	-0...						
159	1.2DL + 1.5LM-MP7 + 1SWL (...Y...)	Y		1	1.2	40	1.5	13	.063	14	.054	15	-0...						
160	1.2DL + 1.5LM-MP8 + 1SWL (...Y...)	Y		1	1.2	41	1.5	2	.063	14	.063	15							
161	1.2DL + 1.5LM-MP8 + 1SWL (...Y...)	Y		1	1.2	41	1.5	3	.063	14	.054	15	.031						
162	1.2DL + 1.5LM-MP8 + 1SWL (...Y...)	Y		1	1.2	41	1.5	4	.063	14	.031	15	.054						
163	1.2DL + 1.5LM-MP8 + 1SWL (...Y...)	Y		1	1.2	41	1.5	5	.063	14		15	.063						
164	1.2DL + 1.5LM-MP8 + 1SWL (...Y...)	Y		1	1.2	41	1.5	6	.063	14	-0...	15	.054						
165	1.2DL + 1.5LM-MP8 + 1SWL (...Y...)	Y		1	1.2	41	1.5	7	.063	14	-0...	15	.031						
166	1.2DL + 1.5LM-MP8 + 1SWL (...Y...)	Y		1	1.2	41	1.5	8	.063	14	-0...	15							
167	1.2DL + 1.5LM-MP8 + 1SWL (...Y...)	Y		1	1.2	41	1.5	9	.063	14	-0...	15	-0...						
168	1.2DL + 1.5LM-MP8 + 1SWL (...Y...)	Y		1	1.2	41	1.5	10	.063	14	-0...	15	-0...						
169	1.2DL + 1.5LM-MP8 + 1SWL (...Y...)	Y		1	1.2	41	1.5	11	.063	14		15	-0...						
170	1.2DL + 1.5LM-MP8 + 1SWL (...Y...)	Y		1	1.2	41	1.5	12	.063	14	.031	15	-0...						
171	1.2DL + 1.5LM-MP8 + 1SWL (...Y...)	Y		1	1.2	41	1.5	13	.063	14	.054	15	-0...						
172	1.2DL + 1.5LM-MP9 + 1SWL (...Y...)	Y		1	1.2	42	1.5	2	.063	14	.063	15							
173	1.2DL + 1.5LM-MP9 + 1SWL (...Y...)	Y		1	1.2	42	1.5	3	.063	14	.054	15	.031						
174	1.2DL + 1.5LM-MP9 + 1SWL (...Y...)	Y		1	1.2	42	1.5	4	.063	14	.031	15	.054						
175	1.2DL + 1.5LM-MP9 + 1SWL (...Y...)	Y		1	1.2	42	1.5	5	.063	14		15	.063						
176	1.2DL + 1.5LM-MP9 + 1SWL (...Y...)	Y		1	1.2	42	1.5	6	.063	14	-0...	15	.054						
177	1.2DL + 1.5LM-MP9 + 1SWL (...Y...)	Y		1	1.2	42	1.5	7	.063	14	-0...	15	.031						
178	1.2DL + 1.5LM-MP9 + 1SWL (...Y...)	Y		1	1.2	42	1.5	8	.063	14	-0...	15							
179	1.2DL + 1.5LM-MP9 + 1SWL (...Y...)	Y		1	1.2	42	1.5	9	.063	14	-0...	15	-0...						
180	1.2DL + 1.5LM-MP9 + 1SWL (...Y...)	Y		1	1.2	42	1.5	10	.063	14	-0...	15	-0...						
181	1.2DL + 1.5LM-MP9 + 1SWL (...Y...)	Y		1	1.2	42	1.5	11	.063	14		15	-0...						
182	1.2DL + 1.5LM-MP9 + 1SWL (...Y...)	Y		1	1.2	42	1.5	12	.063	14	.031	15	-0...						

Joint Boundary Conditions

	Joint Label	X [k/in]	Y [k/in]	Z [k/in]	X Rot.[k-ft/rad]	Y Rot.[k-ft/rad]	Z Rot.[k-ft/rad]
1	P24	Reaction	Reaction	Reaction	Reaction	Reaction	Reaction
2	P13	Reaction	Reaction	Reaction	Reaction	Reaction	Reaction
3	P1	Reaction	Reaction	Reaction	Reaction	Reaction	Reaction

Envelope Joint Reactions

Joint	X [lb]	LC	Y [lb]	LC	Z [lb]	LC	MX [lb-ft]	LC	MY [lb-ft]	LC	MZ [lb-ft]	LC		
1	P24	...	780.437	6	2476.1...	35	1187.7...	13	647.047	16	1499.103	19	4415.679	35
2		...	-764.765	24	-335.4...	16	-1179.6...	19	-3803.7...	35	-1517.147	13	-1231.886	16
3	P13	...	952.768	4	2965.0...	31	1256.2...	15	654.459	24	1684.987	15	984.326	24
4		...	-950.228	22	-240.4...	24	-1264.4...	9	-2807.4...	92	-1732.334	9	-6640.683	31
5	P1	...	1223.716	17	2651.5...	27	633.623	2	6351.3...	27	1397.858	11	1578.453	115

Envelope Joint Reactions (Continued)

Joint	X [lb]	LC	Y [lb]	LC	Z [lb]	LC	MX [lb-ft]	LC	MY [lb-ft]	LC	MZ [lb-ft]	LC
6	-1241.998	11	-321.6...	20	-636.873	20	-1355.2...	20	-1346.671	17	-857.209	157
7	Totals: 2815.268	5	7453.1...	34	2981.8...	14						
8	-2815.26	23	1534.3...	53	-2981.8...	8						

Member Point Loads (BLC 1 : Self Weight)

	Member Label	Direction	Magnitude[lb,lb-ft]	Location[in, %]
1	MP1	Y	-32.25	0
2	MP1	Y	-32.25	72
3	MP1	Y	-74.95	12
4	MP1	Y	-63.93	12
5	S2	Y	-21.85	12
6	MP4	Y	-32.25	0
7	MP4	Y	-32.25	72
8	MP4	Y	-74.95	12
9	MP4	Y	-63.93	12
10	MP7	Y	-32.25	0
11	MP7	Y	-32.25	72
12	MP7	Y	-74.95	12
13	MP7	Y	-63.93	12

Member Point Loads (BLC 2 : Wind Load AZI 0)

	Member Label	Direction	Magnitude[lb,lb-ft]	Location[in, %]
1	MP1	X	0	0
2	MP1	Z	-127.31	0
3	MP1	X	0	72
4	MP1	Z	-127.31	72
5	MP1	X	0	12
6	MP1	Z	-62.42	12
7	MP1	X	0	12
8	MP1	Z	-62.42	12
9	S2	X	0	12
10	S2	Z	-59.34	12
11	MP4	X	0	0
12	MP4	Z	-70.09	0
13	MP4	X	0	72
14	MP4	Z	-70.09	72
15	MP4	X	0	12
16	MP4	Z	-43.95	12
17	MP4	X	0	12
18	MP4	Z	-40.23	12



Member Point Loads (BLC 2 : Wind Load AZI 0) (Continued)

	Member Label	Direction	Magnitude[lb,lb-ft]	Location[in,%]
19	MP7	X	0	0
20	MP7	Z	-70.09	0
21	MP7	X	0	72
22	MP7	Z	-70.09	72
23	MP7	X	0	12
24	MP7	Z	-43.95	12
25	MP7	X	0	12
26	MP7	Z	-40.23	12

Member Point Loads (BLC 3 : Wind Load AZI 30)

	Member Label	Direction	Magnitude[lb,lb-ft]	Location[in,%]
1	MP1	X	-54.12	0
2	MP1	Z	-93.74	0
3	MP1	X	-54.12	72
4	MP1	Z	-93.74	72
5	MP1	X	-28.13	12
6	MP1	Z	-48.72	12
7	MP1	X	-27.51	12
8	MP1	Z	-47.65	12
9	S2	X	-26.49	12
10	S2	Z	-45.88	12
11	MP4	X	-54.12	0
12	MP4	Z	-93.74	0
13	MP4	X	-54.12	72
14	MP4	Z	-93.74	72
15	MP4	X	-28.13	12
16	MP4	Z	-48.72	12
17	MP4	X	-27.51	12
18	MP4	Z	-47.65	12
19	MP7	X	-25.51	0
20	MP7	Z	-44.18	0
21	MP7	X	-25.51	72
22	MP7	Z	-44.18	72
23	MP7	X	-18.9	12
24	MP7	Z	-32.74	12
25	MP7	X	-16.42	12
26	MP7	Z	-28.44	12

Member Point Loads (BLC 4 : Wind Load AZI 60)

	Member Label	Direction	Magnitude[lb,lb-ft]	Location[in,%]
1	MP1	X	-60.7	0



Member Point Loads (BLC 4 : Wind Load AZI 60) (Continued)

	Member Label	Direction	Magnitude[lb,lb-ft]	Location[in,%]
2	MP1	Z	-35.05	0
3	MP1	X	-60.7	72
4	MP1	Z	-35.05	72
5	MP1	X	-38.07	12
6	MP1	Z	-21.98	12
7	MP1	X	-34.84	12
8	MP1	Z	-20.12	12
9	S2	X	-34.87	12
10	S2	Z	-20.13	12
11	MP4	X	-110.26	0
12	MP4	Z	-63.66	0
13	MP4	X	-110.26	72
14	MP4	Z	-63.66	72
15	MP4	X	-54.05	12
16	MP4	Z	-31.21	12
17	MP4	X	-54.05	12
18	MP4	Z	-31.21	12
19	MP7	X	-60.7	0
20	MP7	Z	-35.05	0
21	MP7	X	-60.7	72
22	MP7	Z	-35.05	72
23	MP7	X	-38.07	12
24	MP7	Z	-21.98	12
25	MP7	X	-34.84	12
26	MP7	Z	-20.12	12

Member Point Loads (BLC 5 : Wind Load AZI 90)

	Member Label	Direction	Magnitude[lb,lb-ft]	Location[in,%]
1	MP1	X	-51.02	0
2	MP1	Z	0	0
3	MP1	X	-51.02	72
4	MP1	Z	0	72
5	MP1	X	-37.8	12
6	MP1	Z	0	12
7	MP1	X	-32.84	12
8	MP1	Z	0	12
9	S2	X	-33.91	12
10	S2	Z	0	12
11	MP4	X	-108.24	0
12	MP4	Z	0	0
13	MP4	X	-108.24	72
14	MP4	Z	0	72



Member Point Loads (BLC 5 : Wind Load AZI 90) (Continued)

	Member Label	Direction	Magnitude[lb,lb-ft]	Location[in,%]
15	MP4	X	-56.26	12
16	MP4	Z	0	12
17	MP4	X	-55.02	12
18	MP4	Z	0	12
19	MP7	X	-108.24	0
20	MP7	Z	0	0
21	MP7	X	-108.24	72
22	MP7	Z	0	72
23	MP7	X	-56.26	12
24	MP7	Z	0	12
25	MP7	X	-55.02	12
26	MP7	Z	0	12

Member Point Loads (BLC 6 : Wind Load AZI 120)

	Member Label	Direction	Magnitude[lb,lb-ft]	Location[in,%]
1	MP1	X	-60.7	0
2	MP1	Z	35.05	0
3	MP1	X	-60.7	72
4	MP1	Z	35.05	72
5	MP1	X	-38.07	12
6	MP1	Z	21.98	12
7	MP1	X	-34.84	12
8	MP1	Z	20.12	12
9	S2	X	-34.87	12
10	S2	Z	20.13	12
11	MP4	X	-60.7	0
12	MP4	Z	35.05	0
13	MP4	X	-60.7	72
14	MP4	Z	35.05	72
15	MP4	X	-38.07	12
16	MP4	Z	21.98	12
17	MP4	X	-34.84	12
18	MP4	Z	20.12	12
19	MP7	X	-110.26	0
20	MP7	Z	63.66	0
21	MP7	X	-110.26	72
22	MP7	Z	63.66	72
23	MP7	X	-54.05	12
24	MP7	Z	31.21	12
25	MP7	X	-54.05	12
26	MP7	Z	31.21	12



Member Point Loads (BLC 7 : Wind Load AZI 150)

	Member Label	Direction	Magnitude[lb,lb-ft]	Location[in,%]
1	MP1	X	-54.12	0
2	MP1	Z	93.74	0
3	MP1	X	-54.12	72
4	MP1	Z	93.74	72
5	MP1	X	-28.13	12
6	MP1	Z	48.72	12
7	MP1	X	-27.51	12
8	MP1	Z	47.65	12
9	S2	X	-26.49	12
10	S2	Z	45.88	12
11	MP4	X	-25.51	0
12	MP4	Z	44.18	0
13	MP4	X	-25.51	72
14	MP4	Z	44.18	72
15	MP4	X	-18.9	12
16	MP4	Z	32.74	12
17	MP4	X	-16.42	12
18	MP4	Z	28.44	12
19	MP7	X	-54.12	0
20	MP7	Z	93.74	0
21	MP7	X	-54.12	72
22	MP7	Z	93.74	72
23	MP7	X	-28.13	12
24	MP7	Z	48.72	12
25	MP7	X	-27.51	12
26	MP7	Z	47.65	12

Member Point Loads (BLC 8 : Wind Load AZI 180)

	Member Label	Direction	Magnitude[lb,lb-ft]	Location[in,%]
1	MP1	X	0	0
2	MP1	Z	127.31	0
3	MP1	X	0	72
4	MP1	Z	127.31	72
5	MP1	X	0	12
6	MP1	Z	62.42	12
7	MP1	X	0	12
8	MP1	Z	62.42	12
9	S2	X	0	12
10	S2	Z	59.34	12
11	MP4	X	0	0
12	MP4	Z	70.09	0
13	MP4	X	0	72



Member Point Loads (BLC 8 : Wind Load AZI 180) (Continued)

	Member Label	Direction	Magnitude[lb,lb-ft]	Location[in,%]
14	MP4	Z	70.09	72
15	MP4	X	0	12
16	MP4	Z	43.95	12
17	MP4	X	0	12
18	MP4	Z	40.23	12
19	MP7	X	0	0
20	MP7	Z	70.09	0
21	MP7	X	0	72
22	MP7	Z	70.09	72
23	MP7	X	0	12
24	MP7	Z	43.95	12
25	MP7	X	0	12
26	MP7	Z	40.23	12

Member Point Loads (BLC 9 : Wind Load AZI 210)

	Member Label	Direction	Magnitude[lb,lb-ft]	Location[in,%]
1	MP1	X	54.12	0
2	MP1	Z	93.74	0
3	MP1	X	54.12	72
4	MP1	Z	93.74	72
5	MP1	X	28.13	12
6	MP1	Z	48.72	12
7	MP1	X	27.51	12
8	MP1	Z	47.65	12
9	S2	X	26.49	12
10	S2	Z	45.88	12
11	MP4	X	54.12	0
12	MP4	Z	93.74	0
13	MP4	X	54.12	72
14	MP4	Z	93.74	72
15	MP4	X	28.13	12
16	MP4	Z	48.72	12
17	MP4	X	27.51	12
18	MP4	Z	47.65	12
19	MP7	X	25.51	0
20	MP7	Z	44.18	0
21	MP7	X	25.51	72
22	MP7	Z	44.18	72
23	MP7	X	18.9	12
24	MP7	Z	32.74	12
25	MP7	X	16.42	12
26	MP7	Z	28.44	12



Member Point Loads (BLC 10 : Wind Load AZI 240)

	Member Label	Direction	Magnitude[lb,lb-ft]	Location[in,%]
1	MP1	X	60.7	0
2	MP1	Z	35.05	0
3	MP1	X	60.7	72
4	MP1	Z	35.05	72
5	MP1	X	38.07	12
6	MP1	Z	21.98	12
7	MP1	X	34.84	12
8	MP1	Z	20.12	12
9	S2	X	34.87	12
10	S2	Z	20.13	12
11	MP4	X	110.26	0
12	MP4	Z	63.66	0
13	MP4	X	110.26	72
14	MP4	Z	63.66	72
15	MP4	X	54.05	12
16	MP4	Z	31.21	12
17	MP4	X	54.05	12
18	MP4	Z	31.21	12
19	MP7	X	60.7	0
20	MP7	Z	35.05	0
21	MP7	X	60.7	72
22	MP7	Z	35.05	72
23	MP7	X	38.07	12
24	MP7	Z	21.98	12
25	MP7	X	34.84	12
26	MP7	Z	20.12	12

Member Point Loads (BLC 11 : Wind Load AZI 270)

	Member Label	Direction	Magnitude[lb,lb-ft]	Location[in,%]
1	MP1	X	51.02	0
2	MP1	Z	0	0
3	MP1	X	51.02	72
4	MP1	Z	0	72
5	MP1	X	37.8	12
6	MP1	Z	0	12
7	MP1	X	32.84	12
8	MP1	Z	0	12
9	S2	X	33.91	12
10	S2	Z	0	12
11	MP4	X	108.24	0
12	MP4	Z	0	0
13	MP4	X	108.24	72



Member Point Loads (BLC 11 : Wind Load AZI 270) (Continued)

	Member Label	Direction	Magnitude[lb,lb-ft]	Location[in,%]
14	MP4	Z	0	72
15	MP4	X	56.26	12
16	MP4	Z	0	12
17	MP4	X	55.02	12
18	MP4	Z	0	12
19	MP7	X	108.24	0
20	MP7	Z	0	0
21	MP7	X	108.24	72
22	MP7	Z	0	72
23	MP7	X	56.26	12
24	MP7	Z	0	12
25	MP7	X	55.02	12
26	MP7	Z	0	12

Member Point Loads (BLC 12 : Wind Load AZI 300)

	Member Label	Direction	Magnitude[lb,lb-ft]	Location[in,%]
1	MP1	X	60.7	0
2	MP1	Z	-35.05	0
3	MP1	X	60.7	72
4	MP1	Z	-35.05	72
5	MP1	X	38.07	12
6	MP1	Z	-21.98	12
7	MP1	X	34.84	12
8	MP1	Z	-20.12	12
9	S2	X	34.87	12
10	S2	Z	-20.13	12
11	MP4	X	60.7	0
12	MP4	Z	-35.05	0
13	MP4	X	60.7	72
14	MP4	Z	-35.05	72
15	MP4	X	38.07	12
16	MP4	Z	-21.98	12
17	MP4	X	34.84	12
18	MP4	Z	-20.12	12
19	MP7	X	110.26	0
20	MP7	Z	-63.66	0
21	MP7	X	110.26	72
22	MP7	Z	-63.66	72
23	MP7	X	54.05	12
24	MP7	Z	-31.21	12
25	MP7	X	54.05	12
26	MP7	Z	-31.21	12



Member Point Loads (BLC 13 : Wind Load AZI 330)

	Member Label	Direction	Magnitude[lb,lb-ft]	Location[in,%]
1	MP1	X	54.12	0
2	MP1	Z	-93.74	0
3	MP1	X	54.12	72
4	MP1	Z	-93.74	72
5	MP1	X	28.13	12
6	MP1	Z	-48.72	12
7	MP1	X	27.51	12
8	MP1	Z	-47.65	12
9	S2	X	26.49	12
10	S2	Z	-45.88	12
11	MP4	X	25.51	0
12	MP4	Z	-44.18	0
13	MP4	X	25.51	72
14	MP4	Z	-44.18	72
15	MP4	X	18.9	12
16	MP4	Z	-32.74	12
17	MP4	X	16.42	12
18	MP4	Z	-28.44	12
19	MP7	X	54.12	0
20	MP7	Z	-93.74	0
21	MP7	X	54.12	72
22	MP7	Z	-93.74	72
23	MP7	X	28.13	12
24	MP7	Z	-48.72	12
25	MP7	X	27.51	12
26	MP7	Z	-47.65	12

Member Point Loads (BLC 16 : Ice Weight)

	Member Label	Direction	Magnitude[lb,lb-ft]	Location[in,%]
1	MP1	Y	-193.555	0
2	MP1	Y	-193.555	72
3	MP1	Y	-104.345	12
4	MP1	Y	-98.217	12
5	S2	Y	-95.888	12
6	MP4	Y	-193.555	0
7	MP4	Y	-193.555	72
8	MP4	Y	-104.345	12
9	MP4	Y	-98.217	12
10	MP7	Y	-193.555	0
11	MP7	Y	-193.555	72
12	MP7	Y	-104.345	12
13	MP7	Y	-98.217	12



Member Point Loads (BLC 17 : Ice Wind Load AZI 0)

	Member Label	Direction	Magnitude[lb,lb-ft]	Location[in,%]
1	MP1	X	0	0
2	MP1	Z	-18.47	0
3	MP1	X	0	72
4	MP1	Z	-18.47	72
5	MP1	X	0	12
6	MP1	Z	-7.56	12
7	MP1	X	0	12
8	MP1	Z	-7.56	12
9	S2	X	0	12
10	S2	Z	-7.31	12
11	MP4	X	0	0
12	MP4	Z	-14.09	0
13	MP4	X	0	72
14	MP4	Z	-14.09	72
15	MP4	X	0	12
16	MP4	Z	-6.5	12
17	MP4	X	0	12
18	MP4	Z	-6.29	12
19	MP7	X	0	0
20	MP7	Z	-14.09	0
21	MP7	X	0	72
22	MP7	Z	-14.09	72
23	MP7	X	0	12
24	MP7	Z	-6.5	12
25	MP7	X	0	12
26	MP7	Z	-6.29	12

Member Point Loads (BLC 18 : Ice Wind Load AZI 30)

	Member Label	Direction	Magnitude[lb,lb-ft]	Location[in,%]
1	MP1	X	-8.5	0
2	MP1	Z	-14.73	0
3	MP1	X	-8.5	72
4	MP1	Z	-14.73	72
5	MP1	X	-3.6	12
6	MP1	Z	-6.24	12
7	MP1	X	-3.57	12
8	MP1	Z	-6.18	12
9	S2	X	-3.49	12
10	S2	Z	-6.04	12
11	MP4	X	-8.5	0
12	MP4	Z	-14.73	0
13	MP4	X	-8.5	72



Member Point Loads (BLC 18 : Ice Wind Load AZI 30) (Continued)

	Member Label	Direction	Magnitude[lb,lb-ft]	Location[in,%]
14	MP4	Z	-14.73	72
15	MP4	X	-3.6	12
16	MP4	Z	-6.24	12
17	MP4	X	-3.57	12
18	MP4	Z	-6.18	12
19	MP7	X	-6.31	0
20	MP7	Z	-10.93	0
21	MP7	X	-6.31	72
22	MP7	Z	-10.93	72
23	MP7	X	-3.08	12
24	MP7	Z	-5.33	12
25	MP7	X	-2.93	12
26	MP7	Z	-5.08	12

Member Point Loads (BLC 19 : Ice Wind Load AZI 60)

	Member Label	Direction	Magnitude[lb,lb-ft]	Location[in,%]
1	MP1	X	-12.2	0
2	MP1	Z	-7.04	0
3	MP1	X	-12.2	72
4	MP1	Z	-7.04	72
5	MP1	X	-5.63	12
6	MP1	Z	-3.25	12
7	MP1	X	-5.45	12
8	MP1	Z	-3.15	12
9	S2	X	-5.46	12
10	S2	Z	-3.15	12
11	MP4	X	-15.99	0
12	MP4	Z	-9.23	0
13	MP4	X	-15.99	72
14	MP4	Z	-9.23	72
15	MP4	X	-6.55	12
16	MP4	Z	-3.78	12
17	MP4	X	-6.55	12
18	MP4	Z	-3.78	12
19	MP7	X	-12.2	0
20	MP7	Z	-7.04	0
21	MP7	X	-12.2	72
22	MP7	Z	-7.04	72
23	MP7	X	-5.63	12
24	MP7	Z	-3.25	12
25	MP7	X	-5.45	12
26	MP7	Z	-3.15	12

Member Point Loads (BLC 20 : Ice Wind Load AZI 90)

	Member Label	Direction	Magnitude[lb,lb-ft]	Location[in, %]
1	MP1	X	-12.63	0
2	MP1	Z	0	0
3	MP1	X	-12.63	72
4	MP1	Z	0	72
5	MP1	X	-6.15	12
6	MP1	Z	0	12
7	MP1	X	-5.87	12
8	MP1	Z	0	12
9	S2	X	-5.97	12
10	S2	Z	0	12
11	MP4	X	-17.01	0
12	MP4	Z	0	0
13	MP4	X	-17.01	72
14	MP4	Z	0	72
15	MP4	X	-7.21	12
16	MP4	Z	0	12
17	MP4	X	-7.14	12
18	MP4	Z	0	12
19	MP7	X	-17.01	0
20	MP7	Z	0	0
21	MP7	X	-17.01	72
22	MP7	Z	0	72
23	MP7	X	-7.21	12
24	MP7	Z	0	12
25	MP7	X	-7.14	12
26	MP7	Z	0	12

Member Point Loads (BLC 21 : Ice Wind Load AZI 120)

	Member Label	Direction	Magnitude[lb,lb-ft]	Location[in, %]
1	MP1	X	-12.2	0
2	MP1	Z	7.04	0
3	MP1	X	-12.2	72
4	MP1	Z	7.04	72
5	MP1	X	-5.63	12
6	MP1	Z	3.25	12
7	MP1	X	-5.45	12
8	MP1	Z	3.15	12
9	S2	X	-5.46	12
10	S2	Z	3.15	12
11	MP4	X	-12.2	0
12	MP4	Z	7.04	0
13	MP4	X	-12.2	72



Member Point Loads (BLC 21 : Ice Wind Load AZI 120) (Continued)

	Member Label	Direction	Magnitude[lb,lb-ft]	Location[in,%]
14	MP4	Z	7.04	72
15	MP4	X	-5.63	12
16	MP4	Z	3.25	12
17	MP4	X	-5.45	12
18	MP4	Z	3.15	12
19	MP7	X	-15.99	0
20	MP7	Z	9.23	0
21	MP7	X	-15.99	72
22	MP7	Z	9.23	72
23	MP7	X	-6.55	12
24	MP7	Z	3.78	12
25	MP7	X	-6.55	12
26	MP7	Z	3.78	12

Member Point Loads (BLC 22 : Ice Wind Load AZI 150)

	Member Label	Direction	Magnitude[lb,lb-ft]	Location[in,%]
1	MP1	X	-8.5	0
2	MP1	Z	14.73	0
3	MP1	X	-8.5	72
4	MP1	Z	14.73	72
5	MP1	X	-3.6	12
6	MP1	Z	6.24	12
7	MP1	X	-3.57	12
8	MP1	Z	6.18	12
9	S2	X	-3.49	12
10	S2	Z	6.04	12
11	MP4	X	-6.31	0
12	MP4	Z	10.93	0
13	MP4	X	-6.31	72
14	MP4	Z	10.93	72
15	MP4	X	-3.08	12
16	MP4	Z	5.33	12
17	MP4	X	-2.93	12
18	MP4	Z	5.08	12
19	MP7	X	-8.5	0
20	MP7	Z	14.73	0
21	MP7	X	-8.5	72
22	MP7	Z	14.73	72
23	MP7	X	-3.6	12
24	MP7	Z	6.24	12
25	MP7	X	-3.57	12
26	MP7	Z	6.18	12



Member Point Loads (BLC 23 : Ice Wind Load AZI 180)

	Member Label	Direction	Magnitude[lb,lb-ft]	Location[in,%]
1	MP1	X	0	0
2	MP1	Z	18.47	0
3	MP1	X	0	72
4	MP1	Z	18.47	72
5	MP1	X	0	12
6	MP1	Z	7.56	12
7	MP1	X	0	12
8	MP1	Z	7.56	12
9	S2	X	0	12
10	S2	Z	7.31	12
11	MP4	X	0	0
12	MP4	Z	14.09	0
13	MP4	X	0	72
14	MP4	Z	14.09	72
15	MP4	X	0	12
16	MP4	Z	6.5	12
17	MP4	X	0	12
18	MP4	Z	6.29	12
19	MP7	X	0	0
20	MP7	Z	14.09	0
21	MP7	X	0	72
22	MP7	Z	14.09	72
23	MP7	X	0	12
24	MP7	Z	6.5	12
25	MP7	X	0	12
26	MP7	Z	6.29	12

Member Point Loads (BLC 24 : Ice Wind Load AZI 210)

	Member Label	Direction	Magnitude[lb,lb-ft]	Location[in,%]
1	MP1	X	8.5	0
2	MP1	Z	14.73	0
3	MP1	X	8.5	72
4	MP1	Z	14.73	72
5	MP1	X	3.6	12
6	MP1	Z	6.24	12
7	MP1	X	3.57	12
8	MP1	Z	6.18	12
9	S2	X	3.49	12
10	S2	Z	6.04	12
11	MP4	X	8.5	0
12	MP4	Z	14.73	0
13	MP4	X	8.5	72



Member Point Loads (BLC 24 : Ice Wind Load AZI 210) (Continued)

	Member Label	Direction	Magnitude[lb,lb-ft]	Location[in,%]
14	MP4	Z	14.73	72
15	MP4	X	3.6	12
16	MP4	Z	6.24	12
17	MP4	X	3.57	12
18	MP4	Z	6.18	12
19	MP7	X	6.31	0
20	MP7	Z	10.93	0
21	MP7	X	6.31	72
22	MP7	Z	10.93	72
23	MP7	X	3.08	12
24	MP7	Z	5.33	12
25	MP7	X	2.93	12
26	MP7	Z	5.08	12

Member Point Loads (BLC 25 : Ice Wind Load AZI 240)

	Member Label	Direction	Magnitude[lb,lb-ft]	Location[in,%]
1	MP1	X	12.2	0
2	MP1	Z	7.04	0
3	MP1	X	12.2	72
4	MP1	Z	7.04	72
5	MP1	X	5.63	12
6	MP1	Z	3.25	12
7	MP1	X	5.45	12
8	MP1	Z	3.15	12
9	S2	X	5.46	12
10	S2	Z	3.15	12
11	MP4	X	15.99	0
12	MP4	Z	9.23	0
13	MP4	X	15.99	72
14	MP4	Z	9.23	72
15	MP4	X	6.55	12
16	MP4	Z	3.78	12
17	MP4	X	6.55	12
18	MP4	Z	3.78	12
19	MP7	X	12.2	0
20	MP7	Z	7.04	0
21	MP7	X	12.2	72
22	MP7	Z	7.04	72
23	MP7	X	5.63	12
24	MP7	Z	3.25	12
25	MP7	X	5.45	12
26	MP7	Z	3.15	12



Member Point Loads (BLC 26 : Ice Wind Load AZI 270)

	Member Label	Direction	Magnitude[lb,lb-ft]	Location[in,%]
1	MP1	X	12.63	0
2	MP1	Z	0	0
3	MP1	X	12.63	72
4	MP1	Z	0	72
5	MP1	X	6.15	12
6	MP1	Z	0	12
7	MP1	X	5.87	12
8	MP1	Z	0	12
9	S2	X	5.97	12
10	S2	Z	0	12
11	MP4	X	17.01	0
12	MP4	Z	0	0
13	MP4	X	17.01	72
14	MP4	Z	0	72
15	MP4	X	7.21	12
16	MP4	Z	0	12
17	MP4	X	7.14	12
18	MP4	Z	0	12
19	MP7	X	17.01	0
20	MP7	Z	0	0
21	MP7	X	17.01	72
22	MP7	Z	0	72
23	MP7	X	7.21	12
24	MP7	Z	0	12
25	MP7	X	7.14	12
26	MP7	Z	0	12

Member Point Loads (BLC 27 : Ice Wind Load AZI 300)

	Member Label	Direction	Magnitude[lb,lb-ft]	Location[in,%]
1	MP1	X	12.2	0
2	MP1	Z	-7.04	0
3	MP1	X	12.2	72
4	MP1	Z	-7.04	72
5	MP1	X	5.63	12
6	MP1	Z	-3.25	12
7	MP1	X	5.45	12
8	MP1	Z	-3.15	12
9	S2	X	5.46	12
10	S2	Z	-3.15	12
11	MP4	X	12.2	0
12	MP4	Z	-7.04	0
13	MP4	X	12.2	72



Member Point Loads (BLC 27 : Ice Wind Load AZI 300) (Continued)

	Member Label	Direction	Magnitude[lb,lb-ft]	Location[in,%]
14	MP4	Z	-7.04	72
15	MP4	X	5.63	12
16	MP4	Z	-3.25	12
17	MP4	X	5.45	12
18	MP4	Z	-3.15	12
19	MP7	X	15.99	0
20	MP7	Z	-9.23	0
21	MP7	X	15.99	72
22	MP7	Z	-9.23	72
23	MP7	X	6.55	12
24	MP7	Z	-3.78	12
25	MP7	X	6.55	12
26	MP7	Z	-3.78	12

Member Point Loads (BLC 28 : Ice Wind Load AZI 330)

	Member Label	Direction	Magnitude[lb,lb-ft]	Location[in,%]
1	MP1	X	8.5	0
2	MP1	Z	-14.73	0
3	MP1	X	8.5	72
4	MP1	Z	-14.73	72
5	MP1	X	3.6	12
6	MP1	Z	-6.24	12
7	MP1	X	3.57	12
8	MP1	Z	-6.18	12
9	S2	X	3.49	12
10	S2	Z	-6.04	12
11	MP4	X	6.31	0
12	MP4	Z	-10.93	0
13	MP4	X	6.31	72
14	MP4	Z	-10.93	72
15	MP4	X	3.08	12
16	MP4	Z	-5.33	12
17	MP4	X	2.93	12
18	MP4	Z	-5.08	12
19	MP7	X	8.5	0
20	MP7	Z	-14.73	0
21	MP7	X	8.5	72
22	MP7	Z	-14.73	72
23	MP7	X	3.6	12
24	MP7	Z	-6.24	12
25	MP7	X	3.57	12
26	MP7	Z	-6.18	12

Member Point Loads (BLC 31 : Seismic Load Z)

	Member Label	Direction	Magnitude[lb,lb-ft]	Location[in,%]
1	MP1	Z	-9.082	0
2	MP1	Z	-9.082	72
3	MP1	Z	-21.106	12
4	MP1	Z	-18.003	12
5	S2	Z	-6.153	12
6	MP4	Z	-9.082	0
7	MP4	Z	-9.082	72
8	MP4	Z	-21.106	12
9	MP4	Z	-18.003	12
10	MP7	Z	-9.082	0
11	MP7	Z	-9.082	72
12	MP7	Z	-21.106	12
13	MP7	Z	-18.003	12

Member Point Loads (BLC 32 : Seismic Load X)

	Member Label	Direction	Magnitude[lb,lb-ft]	Location[in,%]
1	MP1	X	-9.082	0
2	MP1	X	-9.082	72
3	MP1	X	-21.106	12
4	MP1	X	-18.003	12
5	S2	X	-6.153	12
6	MP4	X	-9.082	0
7	MP4	X	-9.082	72
8	MP4	X	-21.106	12
9	MP4	X	-18.003	12
10	MP7	X	-9.082	0
11	MP7	X	-9.082	72
12	MP7	X	-21.106	12
13	MP7	X	-18.003	12

Joint Loads and Enforced Displacements (BLC 33 : Service Live Loads)

	Joint Label	L,D,M	Direction	Magnitude[(lb,lb-ft), (in,rad), (lb*s^2/in, lb*s^2*in)]
1	N72B	L	Y	-250
2	N135A	L	Y	-250
3	N129B	L	Y	-250

Joint Loads and Enforced Displacements (BLC 34 : Maintenance Load 1)

	Joint Label	L,D,M	Direction	Magnitude[(lb,lb-ft), (in,rad), (lb*s^2/in, lb*s^2*in)]
1	N70A	L	Y	-500



Joint Loads and Enforced Displacements (BLC 35 : Maintenance Load 2)

	Joint Label	L,D,M	Direction	Magnitude[(lb,lb-ft), (in,rad), (lb*s^2/in, lb*s^2*in)]
1	N69A	L	Y	-500

Joint Loads and Enforced Displacements (BLC 36 : Maintenance Load 3)

	Joint Label	L,D,M	Direction	Magnitude[(lb,lb-ft), (in,rad), (lb*s^2/in, lb*s^2*in)]
1	N76	L	Y	-500

Joint Loads and Enforced Displacements (BLC 37 : Maintenance Load 4)

	Joint Label	L,D,M	Direction	Magnitude[(lb,lb-ft), (in,rad), (lb*s^2/in, lb*s^2*in)]
1	N94	L	Y	-500

Joint Loads and Enforced Displacements (BLC 38 : Maintenance Load 5)

	Joint Label	L,D,M	Direction	Magnitude[(lb,lb-ft), (in,rad), (lb*s^2/in, lb*s^2*in)]
1	N93	L	Y	-500

Joint Loads and Enforced Displacements (BLC 39 : Maintenance Load 6)

	Joint Label	L,D,M	Direction	Magnitude[(lb,lb-ft), (in,rad), (lb*s^2/in, lb*s^2*in)]
1	N122	L	Y	-500

Joint Loads and Enforced Displacements (BLC 40 : Maintenance Load 7)

	Joint Label	L,D,M	Direction	Magnitude[(lb,lb-ft), (in,rad), (lb*s^2/in, lb*s^2*in)]
1	N121	L	Y	-500

Joint Loads and Enforced Displacements (BLC 41 : Maintenance Load 8)

	Joint Label	L,D,M	Direction	Magnitude[(lb,lb-ft), (in,rad), (lb*s^2/in, lb*s^2*in)]
1	N133B	L	Y	-500

Joint Loads and Enforced Displacements (BLC 42 : Maintenance Load 9)

	Joint Label	L,D,M	Direction	Magnitude[(lb,lb-ft), (in,rad), (lb*s^2/in, lb*s^2*in)]
1	N139	L	Y	-500

Member Distributed Loads (BLC 14 : Distr. Wind Load Z)

	Member Label	Direction	Start Magnitude[lb/ft,...	End Magn...	Start Location...	End Location[in,%]
1	S3	SZ	-70.64	-70.64	0	%100
2	GA4	SZ	-70.64	-70.64	0	%100
3	GA3	SZ	-70.64	-70.64	0	%100
4	P3	SZ	-70.64	-70.64	0	%100
5	S2	SZ	-70.64	-70.64	0	%100
6	GA2	SZ	-70.64	-70.64	0	%100



Member Distributed Loads (BLC 14 : Distr. Wind Load Z) (Continued)

	Member Label	Direction	Start Magnitude[lb/ft,...	End Magn...	Start Location...	End Location[in,%]
7	GA1	SZ	-70.64	-70.64	0	%100
8	P2	SZ	-70.64	-70.64	0	%100
9	S1	SZ	-70.64	-70.64	0	%100
10	GA6	SZ	-70.64	-70.64	0	%100
11	GA5	SZ	-70.64	-70.64	0	%100
12	P1	SZ	-70.64	-70.64	0	%100
13	H1	SZ	-42.384	-42.384	0	%100
14	MP1	SZ	-42.384	-42.384	0	%100
15	MP3	SZ	-42.384	-42.384	0	%100
16	HR1	SZ	-42.384	-42.384	0	%100
17	CA8	SZ	-70.64	-70.64	0	%100
18	CA9	SZ	-70.64	-70.64	0	%100
19	CA7	SZ	-70.64	-70.64	0	%100
20	M32	SZ	0	0	0	%100
21	M35	SZ	0	0	0	%100
22	M36	SZ	0	0	0	%100
23	M39A	SZ	0	0	0	%100
24	CA3	SZ	-70.64	-70.64	0	%100
25	CA4	SZ	-70.64	-70.64	0	%100
26	CA1	SZ	-70.64	-70.64	0	%100
27	CA2	SZ	-70.64	-70.64	0	%100
28	CA5	SZ	-70.64	-70.64	0	%100
29	CA6	SZ	-70.64	-70.64	0	%100
30	M64	SZ	0	0	0	%100
31	M65	SZ	0	0	0	%100
32	M66	SZ	0	0	0	%100
33	M67	SZ	0	0	0	%100
34	M68	SZ	0	0	0	%100
35	M69	SZ	0	0	0	%100
36	M70	SZ	0	0	0	%100
37	M71	SZ	0	0	0	%100
38	M72	SZ	0	0	0	%100
39	M73	SZ	0	0	0	%100
40	M74	SZ	0	0	0	%100
41	M75	SZ	-70.64	-70.64	0	%100
42	MP2	SZ	-42.384	-42.384	0	%100
43	M43	SZ	0	0	0	%100
44	M44	SZ	0	0	0	%100
45	H3	SZ	-42.384	-42.384	0	%100
46	MP7	SZ	-42.384	-42.384	0	%100
47	MP9	SZ	-42.384	-42.384	0	%100
48	HR3	SZ	-42.384	-42.384	0	%100

Member Distributed Loads (BLC 14 : Distr. Wind Load Z) (Continued)

	Member Label	Direction	Start Magnitude[lb/ft,...	End Magn...	Start Location...	End Location[in, %]
49	M52	SZ	0	0	0	%100
50	M53	SZ	0	0	0	%100
51	M54	SZ	0	0	0	%100
52	M55	SZ	0	0	0	%100
53	H2	SZ	-42.384	-42.384	0	%100
54	MP4	SZ	-42.384	-42.384	0	%100
55	MP6	SZ	-42.384	-42.384	0	%100
56	HR2	SZ	-42.384	-42.384	0	%100
57	M66A	SZ	0	0	0	%100
58	M67A	SZ	0	0	0	%100
59	M68A	SZ	0	0	0	%100
60	M69A	SZ	0	0	0	%100
61	MP8	SZ	-42.384	-42.384	0	%100
62	M68B	SZ	0	0	0	%100
63	M69B	SZ	0	0	0	%100
64	MP5	SZ	-42.384	-42.384	0	%100
65	M71B	SZ	0	0	0	%100
66	M72B	SZ	0	0	0	%100

Member Distributed Loads (BLC 15 : Distr. Wind Load X)

	Member Label	Direction	Start Magnitude[lb/ft,...	End Magn...	Start Location...	End Location[in, %]
1	S3	SX	-70.64	-70.64	0	%100
2	GA4	SX	-70.64	-70.64	0	%100
3	GA3	SX	-70.64	-70.64	0	%100
4	P3	SX	-70.64	-70.64	0	%100
5	S2	SX	-70.64	-70.64	0	%100
6	GA2	SX	-70.64	-70.64	0	%100
7	GA1	SX	-70.64	-70.64	0	%100
8	P2	SX	-70.64	-70.64	0	%100
9	S1	SX	-70.64	-70.64	0	%100
10	GA6	SX	-70.64	-70.64	0	%100
11	GA5	SX	-70.64	-70.64	0	%100
12	P1	SX	-70.64	-70.64	0	%100
13	H1	SX	-42.384	-42.384	0	%100
14	MP1	SX	-42.384	-42.384	0	%100
15	MP3	SX	-42.384	-42.384	0	%100
16	HR1	SX	-42.384	-42.384	0	%100
17	CA8	SX	-70.64	-70.64	0	%100
18	CA9	SX	-70.64	-70.64	0	%100
19	CA7	SX	-70.64	-70.64	0	%100
20	M32	SX	0	0	0	%100
21	M35	SX	0	0	0	%100

Member Distributed Loads (BLC 15 : Distr. Wind Load X) (Continued)

	Member Label	Direction	Start Magnitude[lb/ft,...	End Magn...	Start Location...	End Location[in,%]
22	M36	SX	0	0	0	%100
23	M39A	SX	0	0	0	%100
24	CA3	SX	-70.64	-70.64	0	%100
25	CA4	SX	-70.64	-70.64	0	%100
26	CA1	SX	-70.64	-70.64	0	%100
27	CA2	SX	-70.64	-70.64	0	%100
28	CA5	SX	-70.64	-70.64	0	%100
29	CA6	SX	-70.64	-70.64	0	%100
30	M64	SX	0	0	0	%100
31	M65	SX	0	0	0	%100
32	M66	SX	0	0	0	%100
33	M67	SX	0	0	0	%100
34	M68	SX	0	0	0	%100
35	M69	SX	0	0	0	%100
36	M70	SX	0	0	0	%100
37	M71	SX	0	0	0	%100
38	M72	SX	0	0	0	%100
39	M73	SX	0	0	0	%100
40	M74	SX	0	0	0	%100
41	M75	SX	-70.64	-70.64	0	%100
42	MP2	SX	-42.384	-42.384	0	%100
43	M43	SX	0	0	0	%100
44	M44	SX	0	0	0	%100
45	H3	SX	-42.384	-42.384	0	%100
46	MP7	SX	-42.384	-42.384	0	%100
47	MP9	SX	-42.384	-42.384	0	%100
48	HR3	SX	-42.384	-42.384	0	%100
49	M52	SX	0	0	0	%100
50	M53	SX	0	0	0	%100
51	M54	SX	0	0	0	%100
52	M55	SX	0	0	0	%100
53	H2	SX	-42.384	-42.384	0	%100
54	MP4	SX	-42.384	-42.384	0	%100
55	MP6	SX	-42.384	-42.384	0	%100
56	HR2	SX	-42.384	-42.384	0	%100
57	M66A	SX	0	0	0	%100
58	M67A	SX	0	0	0	%100
59	M68A	SX	0	0	0	%100
60	M69A	SX	0	0	0	%100
61	MP8	SX	-42.384	-42.384	0	%100
62	M68B	SX	0	0	0	%100
63	M69B	SX	0	0	0	%100



Member Distributed Loads (BLC 15 : Distr. Wind Load X) (Continued)

	Member Label	Direction	Start Magnitude[lb/ft,...	End Magn...	Start Location...	End Location[in,%]
64	MP5	SX	-42.384	-42.384	0	%100
65	M71B	SX	0	0	0	%100
66	M72B	SX	0	0	0	%100

Member Distributed Loads (BLC 16 : Ice Weight)

	Member Label	Direction	Start Magnitude[lb/ft,...	End Magn...	Start Location...	End Location[in,%]
1	S3	Y	-21.808	-21.808	0	%100
2	GA4	Y	-14.013	-14.013	0	%100
3	GA3	Y	-14.013	-14.013	0	%100
4	P3	Y	-24.162	-24.162	0	%100
5	S2	Y	-21.808	-21.808	0	%100
6	GA2	Y	-14.013	-14.013	0	%100
7	GA1	Y	-14.013	-14.013	0	%100
8	P2	Y	-24.162	-24.162	0	%100
9	S1	Y	-21.808	-21.808	0	%100
10	GA6	Y	-14.013	-14.013	0	%100
11	GA5	Y	-14.013	-14.013	0	%100
12	P1	Y	-24.162	-24.162	0	%100
13	H1	Y	-15.864	-15.864	0	%100
14	MP1	Y	-14.141	-14.141	0	%100
15	MP3	Y	-14.141	-14.141	0	%100
16	HR1	Y	-14.155	-14.155	0	%100
17	CA8	Y	-28.171	-28.171	0	%100
18	CA9	Y	-28.171	-28.171	0	%100
19	CA7	Y	-28.171	-28.171	0	%100
20	M32	Y	-6.217	-6.217	0	%100
21	M35	Y	-6.217	-6.217	0	%100
22	M36	Y	-6.217	-6.217	0	%100
23	M39A	Y	-6.217	-6.217	0	%100
24	CA3	Y	-17.127	-17.127	0	%100
25	CA4	Y	-17.127	-17.127	0	%100
26	CA1	Y	-17.127	-17.127	0	%100
27	CA2	Y	-17.127	-17.127	0	%100
28	CA5	Y	-17.127	-17.127	0	%100
29	CA6	Y	-17.127	-17.127	0	%100
30	M64	Y	-6.217	-6.217	0	%100
31	M65	Y	-6.217	-6.217	0	%100
32	M66	Y	-6.217	-6.217	0	%100
33	M67	Y	-6.217	-6.217	0	%100
34	M68	Y	-6.217	-6.217	0	%100
35	M69	Y	-6.217	-6.217	0	%100
36	M70	Y	-6.217	-6.217	0	%100



Member Distributed Loads (BLC 16 : Ice Weight) (Continued)

	Member Label	Direction	Start Magnitude[lb/ft,...	End Magn...	Start Location...	End Location[in,%]
37	M71	Y	-6.217	-6.217	0	%100
38	M72	Y	-6.217	-6.217	0	%100
39	M73	Y	-6.217	-6.217	0	%100
40	M74	Y	-6.217	-6.217	0	%100
41	M75	Y	-12.907	-12.907	0	%100
42	MP2	Y	-14.141	-14.141	0	%100
43	M43	Y	-6.217	-6.217	0	%100
44	M44	Y	-6.217	-6.217	0	%100
45	H3	Y	-15.864	-15.864	0	%100
46	MP7	Y	-14.141	-14.141	0	%100
47	MP9	Y	-14.141	-14.141	0	%100
48	HR3	Y	-14.155	-14.155	0	%100
49	M52	Y	-6.217	-6.217	0	%100
50	M53	Y	-6.217	-6.217	0	%100
51	M54	Y	-6.217	-6.217	0	%100
52	M55	Y	-6.217	-6.217	0	%100
53	H2	Y	-15.864	-15.864	0	%100
54	MP4	Y	-14.141	-14.141	0	%100
55	MP6	Y	-14.141	-14.141	0	%100
56	HR2	Y	-14.155	-14.155	0	%100
57	M66A	Y	-6.217	-6.217	0	%100
58	M67A	Y	-6.217	-6.217	0	%100
59	M68A	Y	-6.217	-6.217	0	%100
60	M69A	Y	-6.217	-6.217	0	%100
61	MP8	Y	-14.141	-14.141	0	%100
62	M68B	Y	-6.217	-6.217	0	%100
63	M69B	Y	-6.217	-6.217	0	%100
64	MP5	Y	-14.141	-14.141	0	%100
65	M71B	Y	-6.217	-6.217	0	%100
66	M72B	Y	-6.217	-6.217	0	%100

Member Distributed Loads (BLC 29 : Distr. Ice Wind Load Z)

	Member Label	Direction	Start Magnitude[lb/ft,...	End Magn...	Start Location...	End Location[in,%]
1	S3	SZ	-13.227	-13.227	0	%100
2	GA4	SZ	-19.096	-19.096	0	%100
3	GA3	SZ	-19.096	-19.096	0	%100
4	P3	SZ	-12.457	-12.457	0	%100
5	S2	SZ	-13.227	-13.227	0	%100
6	GA2	SZ	-19.096	-19.096	0	%100
7	GA1	SZ	-19.096	-19.096	0	%100
8	P2	SZ	-12.457	-12.457	0	%100
9	S1	SZ	-13.227	-13.227	0	%100

Member Distributed Loads (BLC 29 : Distr. Ice Wind Load Z) (Continued)

	Member Label	Direction	Start Magnitude[lb/ft,...	End Magn...	Start Location...	End Location[in, %]
10	GA6	SZ	-19.096	-19.096	0	%100
11	GA5	SZ	-19.096	-19.096	0	%100
12	P1	SZ	-12.457	-12.457	0	%100
13	H1	SZ	-16.844	-16.844	0	%100
14	MP1	SZ	-18.906	-18.906	0	%100
15	MP3	SZ	-18.906	-18.906	0	%100
16	HR1	SZ	-18.886	-18.886	0	%100
17	CA8	SZ	-11.526	-11.526	0	%100
18	CA9	SZ	-11.526	-11.526	0	%100
19	CA7	SZ	-11.526	-11.526	0	%100
20	M32	SZ	0	0	0	%100
21	M35	SZ	0	0	0	%100
22	M36	SZ	0	0	0	%100
23	M39A	SZ	0	0	0	%100
24	CA3	SZ	-15.746	-15.746	0	%100
25	CA4	SZ	-15.746	-15.746	0	%100
26	CA1	SZ	-15.746	-15.746	0	%100
27	CA2	SZ	-15.746	-15.746	0	%100
28	CA5	SZ	-15.746	-15.746	0	%100
29	CA6	SZ	-15.746	-15.746	0	%100
30	M64	SZ	0	0	0	%100
31	M65	SZ	0	0	0	%100
32	M66	SZ	0	0	0	%100
33	M67	SZ	0	0	0	%100
34	M68	SZ	0	0	0	%100
35	M69	SZ	0	0	0	%100
36	M70	SZ	0	0	0	%100
37	M71	SZ	0	0	0	%100
38	M72	SZ	0	0	0	%100
39	M73	SZ	0	0	0	%100
40	M74	SZ	0	0	0	%100
41	M75	SZ	-21.037	-21.037	0	%100
42	MP2	SZ	-18.906	-18.906	0	%100
43	M43	SZ	0	0	0	%100
44	M44	SZ	0	0	0	%100
45	H3	SZ	-16.844	-16.844	0	%100
46	MP7	SZ	-18.906	-18.906	0	%100
47	MP9	SZ	-18.906	-18.906	0	%100
48	HR3	SZ	-18.886	-18.886	0	%100
49	M52	SZ	0	0	0	%100
50	M53	SZ	0	0	0	%100
51	M54	SZ	0	0	0	%100



Member Distributed Loads (BLC 29 : Distr. Ice Wind Load Z) (Continued)

	Member Label	Direction	Start Magnitude[lb/ft,...	End Magn...	Start Location...	End Location[in,%]
52	M55	SZ	0	0	0	%100
53	H2	SZ	-16.844	-16.844	0	%100
54	MP4	SZ	-18.906	-18.906	0	%100
55	MP6	SZ	-18.906	-18.906	0	%100
56	HR2	SZ	-18.886	-18.886	0	%100
57	M66A	SZ	0	0	0	%100
58	M67A	SZ	0	0	0	%100
59	M68A	SZ	0	0	0	%100
60	M69A	SZ	0	0	0	%100
61	MP8	SZ	-18.906	-18.906	0	%100
62	M68B	SZ	0	0	0	%100
63	M69B	SZ	0	0	0	%100
64	MP5	SZ	-18.906	-18.906	0	%100
65	M71B	SZ	0	0	0	%100
66	M72B	SZ	0	0	0	%100

Member Distributed Loads (BLC 30 : Distr. Ice Wind Load X)

	Member Label	Direction	Start Magnitude[lb/ft,...	End Magn...	Start Location...	End Location[in,%]
1	S3	SX	-13.227	-13.227	0	%100
2	GA4	SX	-19.096	-19.096	0	%100
3	GA3	SX	-19.096	-19.096	0	%100
4	P3	SX	-12.457	-12.457	0	%100
5	S2	SX	-13.227	-13.227	0	%100
6	GA2	SX	-19.096	-19.096	0	%100
7	GA1	SX	-19.096	-19.096	0	%100
8	P2	SX	-12.457	-12.457	0	%100
9	S1	SX	-13.227	-13.227	0	%100
10	GA6	SX	-19.096	-19.096	0	%100
11	GA5	SX	-19.096	-19.096	0	%100
12	P1	SX	-12.457	-12.457	0	%100
13	H1	SX	-16.844	-16.844	0	%100
14	MP1	SX	-18.906	-18.906	0	%100
15	MP3	SX	-18.906	-18.906	0	%100
16	HR1	SX	-18.886	-18.886	0	%100
17	CA8	SX	-11.526	-11.526	0	%100
18	CA9	SX	-11.526	-11.526	0	%100
19	CA7	SX	-11.526	-11.526	0	%100
20	M32	SX	0	0	0	%100
21	M35	SX	0	0	0	%100
22	M36	SX	0	0	0	%100
23	M39A	SX	0	0	0	%100
24	CA3	SX	-15.746	-15.746	0	%100



Member Distributed Loads (BLC 30 : Distr. Ice Wind Load X) (Continued)

	Member Label	Direction	Start Magnitude[lb/ft,...	End Magn...	Start Location...	End Location[in, %]
25	CA4	SX	-15.746	-15.746	0	%100
26	CA1	SX	-15.746	-15.746	0	%100
27	CA2	SX	-15.746	-15.746	0	%100
28	CA5	SX	-15.746	-15.746	0	%100
29	CA6	SX	-15.746	-15.746	0	%100
30	M64	SX	0	0	0	%100
31	M65	SX	0	0	0	%100
32	M66	SX	0	0	0	%100
33	M67	SX	0	0	0	%100
34	M68	SX	0	0	0	%100
35	M69	SX	0	0	0	%100
36	M70	SX	0	0	0	%100
37	M71	SX	0	0	0	%100
38	M72	SX	0	0	0	%100
39	M73	SX	0	0	0	%100
40	M74	SX	0	0	0	%100
41	M75	SX	-21.037	-21.037	0	%100
42	MP2	SX	-18.906	-18.906	0	%100
43	M43	SX	0	0	0	%100
44	M44	SX	0	0	0	%100
45	H3	SX	-16.844	-16.844	0	%100
46	MP7	SX	-18.906	-18.906	0	%100
47	MP9	SX	-18.906	-18.906	0	%100
48	HR3	SX	-18.886	-18.886	0	%100
49	M52	SX	0	0	0	%100
50	M53	SX	0	0	0	%100
51	M54	SX	0	0	0	%100
52	M55	SX	0	0	0	%100
53	H2	SX	-16.844	-16.844	0	%100
54	MP4	SX	-18.906	-18.906	0	%100
55	MP6	SX	-18.906	-18.906	0	%100
56	HR2	SX	-18.886	-18.886	0	%100
57	M66A	SX	0	0	0	%100
58	M67A	SX	0	0	0	%100
59	M68A	SX	0	0	0	%100
60	M69A	SX	0	0	0	%100
61	MP8	SX	-18.906	-18.906	0	%100
62	M68B	SX	0	0	0	%100
63	M69B	SX	0	0	0	%100
64	MP5	SX	-18.906	-18.906	0	%100
65	M71B	SX	0	0	0	%100
66	M72B	SX	0	0	0	%100

Member Distributed Loads (BLC 43 : BLC 1 Transient Area Loads)

	Member Label	Direction	Start Magnitude[lb/ft,...	End Magn...	Start Location...	End Location[in, %]
1	S2	Y	-3.185	-3.185	16.404	40
2	GA2	Y	-1.605	-1.605	3.828	27.295
3	GA1	Y	-1.605	-1.605	3.828	27.295
4	S3	Y	-3.185	-3.185	16.404	40
5	GA4	Y	-1.605	-1.605	3.828	27.295
6	GA3	Y	-1.605	-1.605	3.828	27.295
7	S1	Y	-3.185	-3.185	16.404	40
8	GA6	Y	-1.605	-1.605	3.828	27.295
9	GA5	Y	-1.605	-1.605	3.828	27.295

Member Distributed Loads (BLC 44 : BLC 16 Transient Area Loads)

	Member Label	Direction	Start Magnitude[lb/ft,...	End Magn...	Start Location...	End Location[in, %]
1	S2	Y	-38.406	-38.406	16.404	40
2	GA2	Y	-19.354	-19.354	3.828	27.295
3	GA1	Y	-19.354	-19.354	3.828	27.295
4	S3	Y	-38.406	-38.406	16.404	40
5	GA4	Y	-19.354	-19.354	3.828	27.295
6	GA3	Y	-19.354	-19.354	3.828	27.295
7	S1	Y	-38.406	-38.406	16.404	40
8	GA6	Y	-19.354	-19.354	3.828	27.295
9	GA5	Y	-19.354	-19.354	3.828	27.295

Member Area Loads (BLC 1 : Self Weight)

	Joint A	Joint B	Joint C	Joint D	Direction	Distribution	Magnitude[psf]
1	P22	P21	P20	P23	Y	Two Way	-1.75
2	P10	P11	P12	P9	Y	Two Way	-1.75
3	P31	P34	P33	P32	Y	Two Way	-1.75

Member Area Loads (BLC 16 : Ice Weight)

	Joint A	Joint B	Joint C	Joint D	Direction	Distribution	Magnitude[psf]
1	P22	P21	P20	P23	Y	Two Way	-21.1
2	P10	P11	P12	P9	Y	Two Way	-21.1
3	P31	P34	P33	P32	Y	Two Way	-21.1

Envelope AISC 15th(360-16): LRFD Steel Code Checks

	Member	Shape	Code Check	Loc[in]	LC	She...Loc[in]	Dir	LC	phi*P...	phi*P...	phi*M...	phi*Mn z-z [lb...Cb	Eqn
1	CA1	C3.38x2.06...	.334	0	31	.058 28.188	y	36	4776...	56700	2202...	5751.945	1.... H1-1b
2	S2	HSS4X4X6	.330	0	32	.117 0	y	32	1882...	1978...	2204...	22045.5	1.... H1-1b
3	CA3	C3.38x2.06...	.304	0	27	.057 28.188	y	32	4776...	56700	2202...	5751.945	1.... H1-1b

Envelope AISC 15th(360-16): LRFD Steel Code Checks (Continued)

Member	Shape	Code Check	Loc[in]	LC	She...	Loc[in]	Dir	LC	phi*P...	phi*P...	phi*M...	phi*Mn z-z	lb...	Cb	Eqn
4	CA5	C3.38x2.06...	.303	0	35	.055	28.187	y	28	4776...	56700	2202...	5751.945	1...	H1-1b
5	S3	HSS4X4X6	.299	0	38	.117	0	y	29	1882...	1978...	2204...	22045.5	1...	H1-1b
6	P2	PL6.5x0.375	.291	21	31	.117	21	y	31	3658...	78975	616.9...	8386.646	1...	H1-1b
7	CA4	C3.38x2.06...	.272	33	27	.047	33	y	31	4776...	56700	2202...	5751.945	1...	H1-1b
8	CA6	C3.38x2.06...	.270	33	30	.047	33	y	38	4776...	56700	2202...	5751.945	1...	H1-1b
9	P3	PL6.5x0.375	.268	21	2	.168	36.312	y	30	3658...	78975	616.9...	8003.178	1...	H1-1b
10	CA2	C3.38x2.06...	.268	33	31	.048	33	y	34	4776...	56700	2202...	5751.945	1...	H1-1b
11	S1	HSS4X4X6	.266	0	36	.107	0	y	86	1882...	1978...	2204...	22045.5	1...	H1-1b
12	P1	PL6.5x0.375	.245	21	10	.132	36.312	y	27	3658...	78975	616.9...	8001.871	1...	H1-1b
13	CA8	L6.6x4.46x0...	.214	41.562	22	.031	42	z	4	5117...	87561	2464...	7125.374	1...	H2-1
14	M75	PL 2.375x0.5	.213	1.5	12	.270	0	y	28	3825...	38475	400.7...	1903.711	2...	H1-1b
15	HR2	2.88x0.120	.210	90	3	.105	92		4	2249...	4307...	3155...	3155.674	1...	H1-1b
16	CA7	L6.6x4.46x0...	.209	41.562	3	.029	42	z	8	5117...	87561	2464...	7125.374	1...	H2-1
17	HR3	2.88x0.120	.207	6	2	.098	92		6	2249...	4307...	3155...	3155.674	1...	H1-1b
18	HR1	2.88x0.120	.202	6	4	.092	6		4	2249...	4307...	3155...	3155.674	1...	H1-1b
19	CA9	L6.6x4.46x0...	.191	41.562	18	.027	42	z	12	5117...	87561	2464...	7125.374	1...	H2-1
20	MP2	PIPE 2.5	.176	70	5	.063	70		5	3348...	66654	4726.5	4726.5	4...	H1-1b
21	MP5	PIPE 2.5	.171	70	7	.053	70		7	3348...	66654	4726.5	4726.5	4...	H1-1b
22	GA4	L2x2x4	.162	0	2	.011	27.295	y	9	2952...	42480	959.63	2190.068	2...	H2-1
23	MP8	PIPE 2.5	.153	70	9	.066	70		3	3348...	66654	4726.5	4726.5	4...	H1-1b
24	GA5	L2x2x4	.153	0	9	.025	27.295	y	38	2952...	42480	959.63	2190.068	2.19	H2-1
25	GA2	L2x2x4	.148	0	12	.012	0	y	12	2952...	42480	959.63	2190.068	2...	H2-1
26	GA1	L2x2x4	.139	0	6	.026	27.295	y	34	2952...	42480	959.63	2190.068	2...	H2-1
27	GA3	L2x2x4	.138	0	7	.027	27.295	y	30	2952...	42480	959.63	2190.068	2...	H2-1
28	MP9	PIPE 2.5	.138	70	2	.062	70		7	3348...	66654	4726.5	4726.5	3...	H1-1b
29	GA6	L2x2x4	.137	0	4	.012	0	y	4	2952...	42480	959.63	2190.068	2...	H2-1
30	MP6	PIPE 2.5	.126	70	7	.067	70		6	3348...	66654	4726.5	4726.5	4...	H1-1b
31	MP1	PIPE 2.5	.122	70	11	.075	26		8	3348...	66654	4726.5	4726.5	2...	H1-1b
32	MP3	PIPE 2.5	.120	70	5	.068	70		3	3348...	66654	4726.5	4726.5	4...	H1-1b
33	MP4	PIPE 2.5	.119	70	7	.069	26		4	3348...	66654	4726.5	4726.5	1...	H1-1b
34	MP7	PIPE 2.5	.116	70	9	.061	26		6	3348...	66654	4726.5	4726.5	3...	H1-1b
35	H3	Pipe3.5x0.1...	.105	31	2	.067	90		27	4587...	7158...	6337...	6337.65	1...	H1-1b
36	H1	Pipe3.5x0.1...	.105	90	31	.059	48		4	4587...	7158...	6337...	6337.65	2...	H1-1b
37	H2	Pipe3.5x0.1...	.100	31	6	.057	90		34	4587...	7158...	6337...	6337.65	1...	H1-1b

Bolt Calculation Tool, V1.5.1

PROJECT DATA	
Site Name:	BOBDL00027A
Site Number:	BOBDL00027A
Connection Description:	Platform to Monopole

MAXIMUM BOLT LOADS		
Bolt Tension:	8764.87	lbs
Bolt Shear:	1652.82	lbs

WORST CASE BOLT LOADS ¹		
Bolt Tension:	8764.87	lbs
Bolt Shear:	1560.50	lbs

BOLT PROPERTIES		
Bolt Type:	Bolt	-
Bolt Diameter:	0.625	in
Bolt Grade:	A325	-
# of Bolts:	4	-
Threads Excluded?	No	-

¹ Worst case bolt loads correspond to Load combination #32 on member S2 in RISA-3D, which causes the maximum demand on the bolts.

Member Information
I nodes of S3, S2, S1

BOLT CHECK		
Tensile Strength	20340.15	
Shear Strength	13805.83	
Max Tensile Usage	43.1%	
Max Shear Usage	12.0%	
Interaction Check (Worst Case)	0.20	≤1.05
Result	Pass	

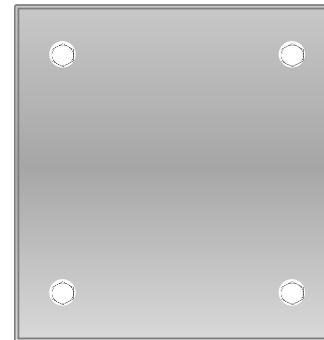

POWER DENSITY STUDY

RADIO FREQUENCY EMISSIONS ANALYSIS REPORT
EVALUATION OF HUMAN EXPOSURE POTENTIAL
TO NON-IONIZING EMISSIONS

Dish Wireless Existing Facility

Site ID: BOBDL00027A

BOBDL00027A
106 South Grand Street
Suffield, Connecticut 06078

October 5, 2021

EBI Project Number: 6221003983

Site Compliance Summary	
Compliance Status:	COMPLIANT
Site total MPE% of FCC general population allowable limit:	9.48%

October 5, 2021

Dish Wireless

Emissions Analysis for Site: BOBDL00027A - BOBDL00027A

EBI Consulting was directed to analyze the proposed Dish Wireless facility located at **106 South Grand Street** in **Suffield, Connecticut** for the purpose of determining whether the emissions from the Proposed Dish Wireless Antenna Installation located on this property are within specified federal limits.

All information used in this report was analyzed as a percentage of current Maximum Permissible Exposure (% MPE) as listed in the FCC OET Bulletin 65 Edition 97-01 and ANSI/IEEE Std C95.1. The FCC regulates Maximum Permissible Exposure in units of microwatts per square centimeter ($\mu\text{W}/\text{cm}^2$). The number of $\mu\text{W}/\text{cm}^2$ calculated at each sample point is called the power density. The exposure limit for power density varies depending upon the frequencies being utilized. Wireless Carriers and Paging Services use different frequency bands each with different exposure limits; therefore, it is necessary to report results and limits in terms of percent MPE rather than power density.

All results were compared to the FCC (Federal Communications Commission) radio frequency exposure rules, 47 CFR 1.1307(b)(1) – (b)(3), to determine compliance with the Maximum Permissible Exposure (MPE) limits for General Population/Uncontrolled environments as defined below.

General population/uncontrolled exposure limits apply to situations in which the general population may be exposed or in which persons who are exposed as a consequence of their employment may not be made fully aware of the potential for exposure or cannot exercise control over their exposure. Therefore, members of the general population would always be considered under this category when exposure is not employment related, for example, in the case of a telecommunications tower that exposes persons in a nearby residential area.

Public exposure to radio frequencies is regulated and enforced in units of microwatts per square centimeter ($\mu\text{W}/\text{cm}^2$). The general population exposure limits for the 600 MHz and 700 MHz frequency bands are approximately $400 \mu\text{W}/\text{cm}^2$ and $467 \mu\text{W}/\text{cm}^2$, respectively. The general population exposure limit for the 1900 MHz (PCS), 2100 MHz (AWS) and 11 GHz frequency bands is $1000 \mu\text{W}/\text{cm}^2$. Because each carrier will be using different frequency bands, and each frequency band has different exposure limits, it is necessary to report percent of MPE rather than power density.

Occupational/controlled exposure limits apply to situations in which persons are exposed as a consequence of their employment and in which those persons who are exposed have been made fully aware of the potential for exposure and can exercise control over their exposure.

Occupational/controlled exposure limits also apply where exposure is of a transient nature as a result of incidental passage through a location where exposure levels may be above general population/uncontrolled limits (see below), as long as the exposed person has been made fully aware of the potential for exposure and can exercise control over his or her exposure by leaving the area or by some other appropriate means.

Additional details can be found in FCC OET 65.

CALCULATIONS

Calculations were done for the proposed Dish Wireless Wireless antenna facility located at 106 South Grand Street in Suffield, Connecticut using the equipment information listed below. All calculations were performed per the specifications under FCC OET 65. Since Dish Wireless is proposing highly focused directional panel antennas, which project most of the emitted energy out toward the horizon, all calculations were performed assuming a lobe representing the maximum gain of the antenna per the antenna manufacturer's supplied specifications, minus 20 dB for directional panel antennas and 20 dB for highly focused parabolic microwave dishes, was focused at the base of the tower. For this report, the sample point is the top of a 6-foot person standing at the base of the tower.

For all calculations, all equipment was calculated using the following assumptions:

- 1) 4 n71 channels (600 MHz Band) were considered for each sector of the proposed installation. These Channels have a transmit power of 30 Watts per Channel.
- 2) 4 n70 channels (PCS Band - 1900 MHz) were considered for each sector of the proposed installation. These Channels have a transmit power of 40 Watts per Channel.
- 3) 4 n66 channels (AWS Band - 2190 MHz) were considered for each sector of the proposed installation. These Channels have a transmit power of 40 Watts per Channel.
- 4) All radios at the proposed installation were considered to be running at full power and were uncombined in their RF transmissions paths per carrier prescribed configuration. Per FCC OET Bulletin No. 65 - Edition 97-01 recommendations to achieve the maximum anticipated value at each sample point, all power levels emitting from the proposed antenna installation are increased by a factor of 2.56 to account for possible in-phase reflections from the surrounding environment. This is rarely the case, and if so, is never continuous.
- 5) For the following calculations, the sample point was the top of a 6-foot person standing at the base of the tower. The maximum gain of the antenna per the antenna manufacturer's supplied specifications, minus 20 dB for directional panel antennas and 20 dB for highly focused parabolic microwave dishes, was used in this direction. This value is a very conservative

estimate as gain reductions for these particular antennas are typically much higher in this direction.

- 6) The antennas used in this modeling are the JMA MX08FRO665-21 for the 600 MHz / 1900 MHz / 2190 MHz channel(s) in Sector A, the JMA MX08FRO665-21 for the 600 MHz / 1900 MHz / 2190 MHz channel(s) in Sector B, the JMA MX08FRO665-21 for the 600 MHz / 1900 MHz / 2190 MHz channel(s) in Sector C. This is based on feedback from the carrier with regard to anticipated antenna selection. All Antenna gain values and associated transmit power levels are shown in the Site Inventory and Power Data table below. The maximum gain of the antenna per the antenna manufacturer's supplied specifications, minus 20 dB for directional panel antennas and 20 dB for highly focused parabolic microwave dishes, was used for all calculations. This value is a very conservative estimate as gain reductions for these particular antennas are typically much higher in this direction.
- 7) The antenna mounting height centerline of the proposed antennas is 110 feet above ground level (AGL).
- 8) Emissions values for additional carriers were taken from the Connecticut Siting Council active database. Values in this database are provided by the individual carriers themselves.
- 9) All calculations were done with respect to uncontrolled / general population threshold limits.

Dish Wireless Site Inventory and Power Data

Sector:	A	Sector:	B	Sector:	C
Antenna #:	1	Antenna #:	1	Antenna #:	1
Make / Model:	JMA MX08FRO665-21	Make / Model:	JMA MX08FRO665-21	Make / Model:	JMA MX08FRO665-21
Frequency Bands:	600 MHz / 1900 MHz / 2190 MHz	Frequency Bands:	600 MHz / 1900 MHz / 2190 MHz	Frequency Bands:	600 MHz / 1900 MHz / 2190 MHz
Gain:	17.45 dBd / 22.65 dBd / 22.65 dBd	Gain:	17.45 dBd / 22.65 dBd / 22.65 dBd	Gain:	17.45 dBd / 22.65 dBd / 22.65 dBd
Height (AGL):	110 feet	Height (AGL):	110 feet	Height (AGL):	110 feet
Channel Count:	12	Channel Count:	12	Channel Count:	12
Total TX Power (W):	440 Watts	Total TX Power (W):	440 Watts	Total TX Power (W):	440 Watts
ERP (W):	5,236.31	ERP (W):	5,236.31	ERP (W):	5,236.31
Antenna AI MPE %:	2.19%	Antenna BI MPE %:	2.19%	Antenna CI MPE %:	2.19%

Site Composite MPE %	
Carrier	MPE %
Dish Wireless (Max at Sector A):	2.19%
AT&T	4.4%
Verizon	2.89%
Site Total MPE % :	9.48%

Dish Wireless MPE % Per Sector	
Dish Wireless Sector A Total:	2.19%
Dish Wireless Sector B Total:	2.19%
Dish Wireless Sector C Total:	2.19%
Site Total MPE % :	9.48%

Dish Wireless Maximum MPE Power Values (Sector A)							
Dish Wireless Frequency Band / Technology (Sector A)	# Channels	Watts ERP (Per Channel)	Height (feet)	Total Power Density ($\mu\text{W}/\text{cm}^2$)	Frequency (MHz)	Allowable MPE ($\mu\text{W}/\text{cm}^2$)	Calculated % MPE
Dish Wireless 600 MHz n71	4	223.68	110.0	2.97	600 MHz n71	400	0.74%
Dish Wireless 1900 MHz n70	4	542.70	110.0	7.22	1900 MHz n70	1000	0.72%
Dish Wireless 2190 MHz n66	4	542.70	110.0	7.22	2190 MHz n66	1000	0.72%
						Total:	2.19%

• NOTE: Totals may vary by approximately 0.01% due to summation of remainders in calculations.

Summary

All calculations performed for this analysis yielded results that were **within** the allowable limits for general population exposure to RF Emissions.

The anticipated maximum composite contributions from the Dish Wireless facility as well as the site composite emissions value with regards to compliance with FCC's allowable limits for general population exposure to RF Emissions are shown here:

Dish Wireless Sector	Power Density Value (%)
Sector A:	2.19%
Sector B:	2.19%
Sector C:	2.19%
Dish Wireless Maximum MPE % (Sector A):	2.19%
Site Total:	9.48%
Site Compliance Status:	COMPLIANT

The anticipated composite MPE value for this site assuming all carriers present is **9.48%** of the allowable FCC established general population limit sampled at the ground level. This is based upon values listed in the Connecticut Siting Council database for existing carrier emissions.

FCC guidelines state that if a site is found to be out of compliance (over allowable thresholds), that carriers over a 5% contribution to the composite value will require measures to bring the site into compliance. For this facility, the composite values calculated were well within the allowable 100% threshold standard per the federal government.