

May 31, 2016

Melanie A. Bachman
Acting Executive Director
Connecticut Siting Council
10 Franklin Square
New Britain, CT 06051

Re: **Notice of Exempt Modification – Facility Modification
44 Fyler Place, Suffield, Connecticut**

Dear Ms. Bachman:

Cellco Partnership d/b/a Verizon Wireless (“Cellco”) currently maintains fifteen (15) wireless telecommunications antennas at the 91-foot level on an existing 109-foot tower at 44 Fyler Place in Suffield, Connecticut (the “Property”). The tower is owned by Crown Castle (“Crown”). Cellco’s use of the tower was approved by the Council in 2001. Cellco now intends to modify its facility by removing six (6) 1900 MHz antennas and two (2) 700 MHz antennas and replacing them with three (3) model 742 213V01, 1900 MHz antennas; two (2) model BXA-70063-6CF, 700 MHz antennas; and three (3) model 742 213V01, 2100 MHz antennas, all at the same 91-foot level on the tower. Cellco also intends to install three (3) remote radio heads (“RRHs”) behind its 2100 MHz antennas and one (1) HYBRIFLEX™ antenna cable attached to the outside of the monopole. Included in Attachment 1 are specifications for Cellco’s replacement antennas, RRHs and HYBRIFLEX™ cable.

Please accept this letter as notification pursuant to R.C.S.A. § 16-50j-73, for construction that constitutes an exempt modification pursuant to R.C.S.A. § 16-50j-72(b)(2). In accordance with R.C.S.A. § 16-50j-73, a copy of this notice is being sent to Melissa Mack, Suffield’s First Selectman. The Property is owned by the Town of Suffield. A copy of this letter is also being sent to Crown, the tower owner.

The planned modifications to the facility fall squarely within those activities explicitly provided for in R.C.S.A. § 16-50j-72(b)(2).

14812352-v1

Melanie A. Bachman

May 31, 2016

Page 2

1. The proposed modifications will not result in an increase in the height of the existing tower. Cellco's replacement antennas and RRHs will be installed at the 91-foot level on the existing 109-foot tower.
2. The proposed modifications will not involve any change to ground-mounted equipment and, therefore, will not require the extension of the site boundary.
3. The proposed modifications will not increase noise levels at the facility by six decibels or more, or to levels that exceed state and local criteria.
4. The operation of the replacement antennas will not increase radio frequency (RF) emissions at the facility to a level at or above the Federal Communications Commission (FCC) safety standard. Far Field Approximation tables for each of Cellco's operating frequencies are included in Attachment 2. The Far Field calculations demonstrate that Cellco's modified facility will operate well within the RF emissions safety limits established by the FCC.
5. The proposed modifications will not cause a change or alteration in the physical or environmental characteristics of the site.
6. The tower and its foundation can support Cellco's proposed modifications. (See Structural Analysis Report included in Attachment 3).

A copy of the Town's Assessment Parcel Map and property owner information is included in Attachment 4.

For the foregoing reasons, Cellco respectfully submits that the proposed modifications to the above-referenced telecommunications facility constitutes an exempt modification under R.C.S.A. § 16-50j-72(b)(2).

Sincerely,



Kenneth C. Baldwin

Enclosures

Copy to:

Melissa Mack, Suffield First Selectman
Crown Castle
Tim Parks

ATTACHMENT 1

BXA-70063-6CF-EDIN-X

X-Pol | FET Panel | 63° | 14.5 dBd

Replace "X" with desired electrical downtilt.

Antenna is also available with NE connector(s). Replace "EDIN" with "NE" in the model number when ordering.

Electrical Characteristics	696-900 MHz			
Frequency bands	696-806 MHz		806-900 MHz	
Polarization	±45°			
Horizontal beamwidth	65°		63°	
Vertical beamwidth	13°		11°	
Gain	14.0 dBd (16.1 dBi)		14.5 dBd (16.6 dBi)	
Electrical downtilt (X)	0, 2, 3, 4, 5, 6, 8, 10			
Impedance	50Ω			
VSWR	≤1.35:1			
Upper sidelobe suppression (0°)	-18.3 dB		-18.2 dB	
Front-to-back ratio (+/-30°)	-33.4 dB		-36.3 dB	
Null fill	5% (-26.02 dB)			
Isolation between ports	< -25 dB			
Input power with EDIN connectors	500 W			
Input power with NE connectors	300 W			
IM3 (2x20W carriers)	< -153 dBc			
Lightning protection	Direct Ground			
Connector(s)	2 Ports / EDIN or NE / Female / Center (Back)			
Mechanical Characteristics				
Dimensions Length x Width x Depth	1804 x 285 x 132 mm		71.0 x 11.2 x 5.2 in	
Depth with z-brackets	172 mm		6.8 in	
Weight: without mounting brackets	7.9 kg		17 lbs	
Survival wind speed	> 201 km/hr		> 125 mph	
Wind area	Front: 0.51 m ²	Side: 0.24 m ²	Front: 5.5 ft ²	Side: 2.6 ft ²
Wind load @ 161 km/hr (100 mph)	Front: 759 N	Side: 391 N	Front: 169 lbf	Side: 89 lbf
Mounting Options	Part Number	Fits Pipe Diameter	Weight	
3-Point Mounting & Downtilt Bracket Kit	36210008	40-115 mm 1.57-4.5 in	6.9 kg	15.2 lbs
Concealment Configurations	For concealment configurations, order BXA-70063-6CF-EDIN-X-FP			



BXA-70063-6CF-EDIN-X

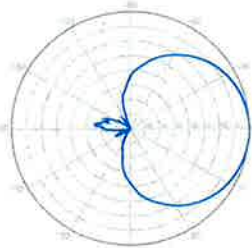

Horizontal | 750 MHz

BXA-70063-6CF-EDIN-0

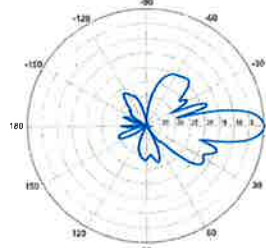

0° | Vertical | 750 MHz

BXA-70063-6CF-EDIN-2

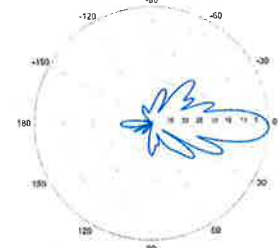

2° | Vertical | 750 MHz

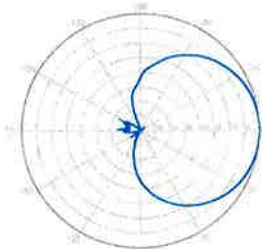

Horizontal | 850 MHz

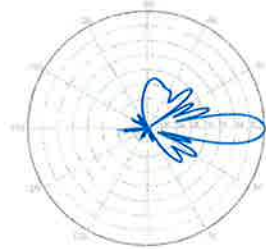

0° | Vertical | 850 MHz

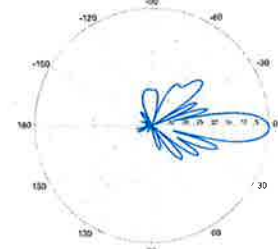

2° | Vertical | 850 MHz

Quoted performance parameters are provided to offer typical or range values only and may vary as a result of normal manufacturing and operational conditions. Extreme operational conditions and/or stress on structural supports is beyond our control. Such conditions may result in damage to this product. Improvements to product may be made without notice.

BXA-70063-6CF-EDIN-X

X-Pol | FET Panel | 63° | 14.5 dBd

BXA-70063-6CF-EDIN-3

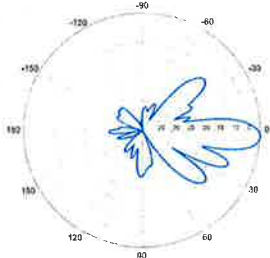

3° | Vertical | 750 MHz

BXA-70063-6CF-EDIN-4

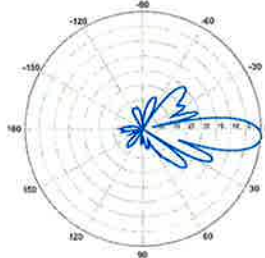

4° | Vertical | 750 MHz

BXA-70063-6CF-EDIN-5

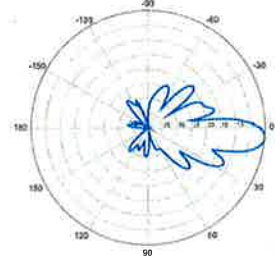

5° | Vertical | 750 MHz

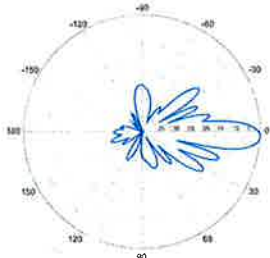

3° | Vertical | 850 MHz

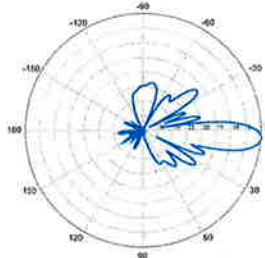

4° | Vertical | 850 MHz

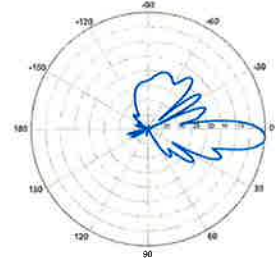

5° | Vertical | 850 MHz

BXA-70063-6CF-EDIN-6

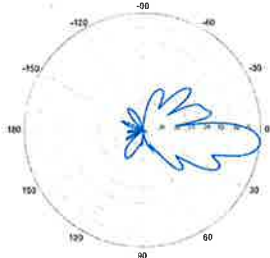

6° | Vertical | 750 MHz

BXA-70063-6CF-EDIN-8

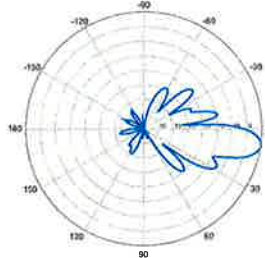

8° | Vertical | 750 MHz

BXA-70063-6CF-EDIN-10

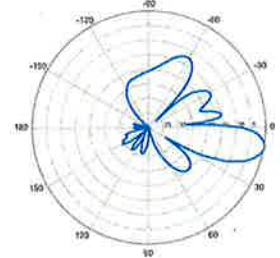

10° | Vertical | 750 MHz

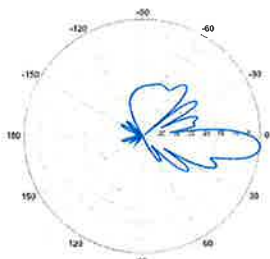

6° | Vertical | 850 MHz

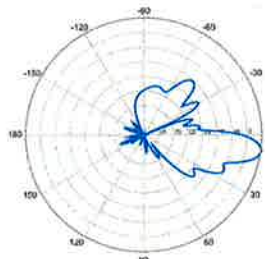

8° | Vertical | 850 MHz

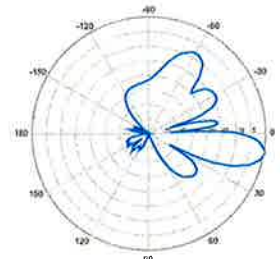

10° | Vertical | 850 MHz

Quoted performance parameters are provided to offer typical or range values only and may vary as a result of normal manufacturing and operational conditions. Extreme operational conditions and/or stress on structural supports is beyond our control. Such conditions may result in damage to this product. Improvements to product may be made without notice.

KATHREIN SCALA DIVISION

742 213V01

65° Panel Antenna

Kathrein's X-polarized adjustable electrical downtilt antennas offer the wireless carrier the ability to tailor polarization diversity sites for optimum performance. Using variable downtilt, only a few models need be procured to accommodate the needs of widely varying conditions. Remotely controlled downtilt is available as a retrofitable option.

- 0-6° downtilt range.
- UV resistant pulltruded fiberglass radome.
- DC Grounded metallic parts for impulse suppression.
- No moving electrical connections.
- Wideband vector dipole technology.
- Optional remote downtilt Control.
- Will accommodate future 3G / UMTS applications.

General specifications:

Frequency range	1710–2200 MHz	
VSWR	< 1.5:1	
Impedance	50 ohms	
Intermodulation (2x20w)	IM3: <-150 dBc	
Polarization	+45° and -45°	
Front-to-back ratio (180°±30°)	>30 dB (co-polar) >25 dB (total power)	
Maximum input power	300 watts per input (at 50°C)	
Electrical downtilt continuously adjustable	0–6 degrees	
Connector	2 x 7-16 DIN female	
Isolation	>30 dB	
Cross polar ratio		
Main direction 0°	25 dB (typical)	
Sector ±60°	>10 dB	
Tracking, average	0.5 dB	
Squint	±2.0°	
Weight	19.8 lb (9 kg) 24.3 lb (11 kg) clamps included	
Dimensions	76.9 x 6.1 x 2.8 inches (1954 x 155 x 70 mm)	
Wind load	at 93 mph (150kph)	
Front/Side/Rear	115 lbf / 32 lbf / 115 lbf (510 N) / (140 N) / (510 N)	
Mounting category	M (Medium)	
Wind survival rating*	120 mph (200 kph)	
Shipping dimensions	88 x 6.8 x 3.6 inches (2235 x 172 x 92 mm)	
Shipping weight	28.7 lb (13 kg)	
Mounting	Fixed mounts for 2 to 4.6 inch (50 to 115 mm) OD masts are included and tilt options are available.	

See reverse for order information.

Specifications:	1710–1880 MHz	1850–1990 MHz	1920–2200 MHz
Gain	19 dBi	19.2 dBi	19.5 dBi
+45° and -45° polarization horizontal beamwidth	67° (half-power)	65° (half-power)	63° (half-power)
+45° and -45° polarization vertical beamwidth	4.7° (half-power)	4.5° (half-power)	4.3° (half-power)
Sidelobe suppression for first sidelobe above main beam	0° 2° 4° 6° T 18 18 16 15 dB	0° 2° 4° 6° T 18 18 17 16 dB	0° 2° 4° 6° T 18 18 18 18 dB

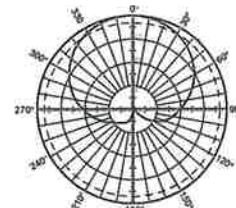

Horizontal pattern
±45°- polarization

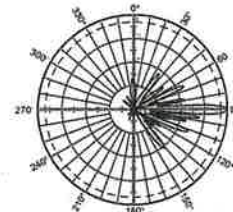

Vertical pattern
±45°- polarization
0°–6° electrical downtilt



11271-B
936.3740/b



* Mechanical design is based on environmental conditions as stipulated in TIA-222-G-2 (December 2009) and/or ETS 300 019-1-4 which include the static mechanical load imposed on an antenna by wind at maximum velocity. See the Engineering Section of the catalog for further details.

Alcatel-Lucent RRH2x40-AWS

REMOTE RADIO HEAD

The Alcatel-Lucent RRH2x40-AWS is a high-power, small form-factor Remote Radio Head (RRH) operating in the AWS frequency band (1700/2100MHz - 3GPP Band 4). The Alcatel-Lucent RRH2x40-AWS is designed with an eco-efficient approach, providing operators with the means to achieve high quality and capacity coverage with minimum site requirements.

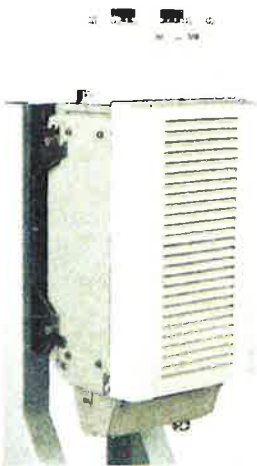

A distributed eNodeB expands deployment options by using two components, a Base Band Unit (BBU) containing the digital assets and a separate RRH containing the radio-frequency (RF) elements. This modular design optimizes available space and allows the main components of an eNodeB to be installed separately, within the same site or several kilometres apart.

The Alcatel-Lucent RRH2x40-AWS is linked to the BBU by an optical-fiber connection carrying downlink and uplink digital radio signals along with operations, administration and maintenance (OA&M) information. The Alcatel-Lucent RRH2x40-AWS has two transmit RF paths, 40 W RF output power per transmit path, and is designed to manage up to four-way receive diversity. The device is ideally suited to support macro coverage, with multiple-input multiple-output (MIMO) 2x2 operation in up to 20 MHz of bandwidth.

The Alcatel-Lucent RRH2x40-AWS is designed to make available all the benefits of a distributed eNodeB, with excellent RF characteristics, with low

capital expenditures (CAPEX) and low operating expenditures (OPEX). The limited space available in some sites may prevent the installation of traditional single-cabinet BTS equipment or require costly cranes to be employed, leaving coverage holes. However, many of these sites can host an Alcatel-Lucent RRH2x40-AWS installation, providing more flexible site selection and improved network quality along with greatly reduced installation time and costs.

Fast, low-cost installation and deployment

The Alcatel-Lucent RRH2x40-AWS is a zero-footprint solution and operates noise-free, simplifying negotiations with site property owners and minimizing environmental impacts. Installation can easily be done by a single person because the Alcatel-Lucent RRH2x40-AWS is compact and weighs less than 20 kg (44 lb), eliminating the need for a crane to hoist the BTS cabinet to the rooftop. A site can be in operation in less than one day — a fraction of the time required for a traditional BTS.

Excellent RF performance

Because of its small size and weight, the Alcatel-Lucent RRH2x40-AWS can be installed close to the antenna. Operators can therefore locate the Alcatel-Lucent RRH2x40-AWS where RF engineering is deemed ideal, minimizing trade-offs between available sites and RF optimum sites. The RF feeder cost and installation costs are reduced or eliminated, and there is no need for a Tower Mounted Amplifier (TMA) because losses introduced by the RF feeder are greatly reduced. The Alcatel-Lucent RRH2x40-AWS provides more RF power while at the same time consuming less electricity.

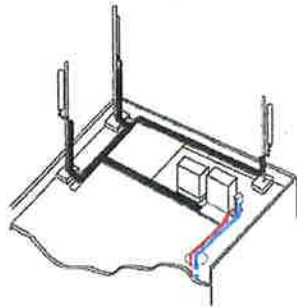

Macro

Features

- Zero-footprint deployment
- Easy installation, with a lightweight unit can be carried and set up by one person
- Optimized RF power, with flexible site selection and elimination of a TMA
- Convection-cooled (fanless)
- Noise-free
- Best-in-class power efficiency, with significantly reduced energy consumption

Benefits

- Leverages existing real estate with lower site costs
- Reduces installation costs, with fewer installation materials and simplified logistics
- Decreases power costs and minimizes environmental impacts, with the potential for eco-sustainable power options
- Improves RF performance and adds flexibility to network planning

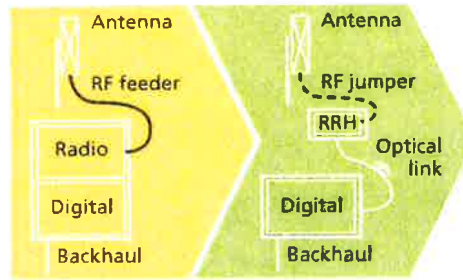

RRH for space-constrained cell sites

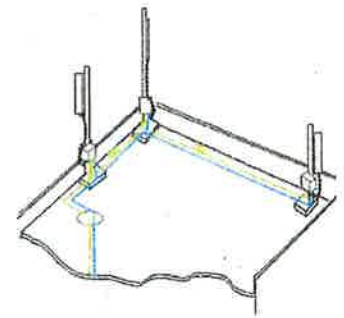

Distributed

Technical specifications

Physical dimensions

- Height: 620 mm (24.4 in.)
- Width: 270 mm (10.63 in.)
- Depth: 170mm (6.7 in.)
- Weight (without mounting kit): less than 20 kg (44 lb)

Power

- Power supply: -48VDC

Operating environment

- Outdoor temperature range:
 - With solar load: -40°C to +50°C (-40°F to +122°F)
 - Without solar load: -40°C to +55°C (-40°F to +131°F)

- Passive convection cooling (no fans)
- Enclosure protection
 - IP65 (International Protection rating)

RF characteristics

- Frequency band: 1700/2100 MHz (AWS); 3GPP Band 4
- Bandwidth: up to 20 MHz
- RF output power at antenna port: 40 W nominal RF power for each Tx port
- Rx diversity: 2-way or 4-way with optional Rx Diversity module
- Noise figure: below 2.0 dB typical
- Antenna Line Device features
 - TMA and Remote electrical tilt (RET) support via AISG v2.0

Optical characteristics

Type/number of fibers

- Single-mode variant
 - One Single Mode Single Fiber per RRH2x, carrying UL and DL using CWDM
 - Single mode dual fiber (SM/DF)
- Multi-mode variant
 - Two Multi-mode fibers per RRH2x: one carrying UL, the other carrying DL

Optical fiber length

- Up to 500 m (0.31 mi), using MM fiber
- Up to 20 km (12.43 mi), using SM fiber

Digital Ports and Alarms

- Two optical ports to support daisy-chaining
- Six external alarms

www.alcatel-lucent.com Alcatel, Lucent, Alcatel-Lucent and the Alcatel-Lucent logo are trademarks of Alcatel-Lucent. All other trademarks are the property of their respective owners. The information presented is subject to change without notice. Alcatel-Lucent assumes no responsibility for inaccuracies contained herein. Copyright © 2010 Alcatel-Lucent. All rights reserved. CPG2809100912 (09)



HYBRIFLEX™ RRH Hybrid Feeder Cabling Solution, 1-5/8", Single-Mode Fiber

Product Description

RFS' HYBRIFLEX Remote Radio Head (RRH) hybrid feeder cabling solution combines optical fiber and DC power for RRHs in a single lightweight aluminum corrugated cable, making it the world's most innovative solution for RRH deployments.

It was developed to reduce installation complexity and costs at cellular sites. HYBRIFLEX allows mobile operators deploying an RRH architecture to standardize the RRH installation process and eliminate the need for and cost of cable grounding. HYBRIFLEX combines optical fiber (multi-mode or single-mode) and power in a single corrugated cable. It eliminates the need for junction boxes and can connect multiple RRHs with a single feeder. Standard RFS CELLFLEX® accessories can be used with HYBRIFLEX cable. Both pre-connectorized and on-site options are available.

Features/Benefits

- Aluminum corrugated armor with outstanding bending characteristics - minimizes installation time and enables mechanical protection and shielding
- Same accessories as 1 5/8" coaxial cable
- Outer conductor grounding - Eliminates typical grounding requirements and saves on installation costs
- Lightweight solution and compact design - Decreases tower loading
- Robust cabling - Eliminates need for expensive cable trays and ducts
- Installation of tight bundled fiber optic cable pairs directly to the RRH - Reduces CAPEX and wind load by eliminating need for interconnection
- Optical fiber and power cables housed in single corrugated cable - Saves CAPEX by standardizing RRH cable installation and reducing installation requirements
- Outdoor polyethylene jacket - Ensures long-lasting cable protection

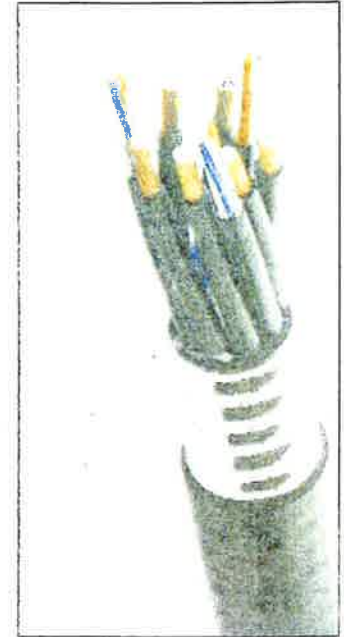

Figure 1: HYBRIFLEX Series

Technical Specifications

Outer Conductor Armor	Corrugated Aluminum	(mm (in))	46.5 (1.83)
Jacket	Polyethylene, PE	(mm (in))	50.3 (1.98)
UV-Protection	Individual and External Jacket		Yes
Weight, Approximate		(kg/m (lb/ft))	1.9 (1.30)
Minimum Bending Radius, Single Bending		(mm (in))	200 (8)
Minimum Bending Radius, Repeated Bending		(mm (in))	500 (20)
Recommended/Maximum Clamp Spacing		(m (ft))	1.0 / 1.2 (3.25 / 4.0)
DC-Resistance Outer Conductor Armor		(Ω/km (Ω/1000ft))	068 (0.255)
DC-Resistance Power Cable, 8 4mm ² (8AWG)		(Ω/km (Ω/1000ft))	2.1 (0.307)
Version	Single-mode OM3		
Quantity, Fiber Count	16 (8 pairs)		
Core/Clad	(μm)	50/125	
Primary Coating (Acrylate)	(μm)	245	
Buffer Diameter, Nominal	(μm)	900	
Secondary Protection, Jacket, Nominal	(mm (in))	2.0 (0.08)	
Minimum Bending Radius	(mm (in))	104 (4.1)	
Insertion Loss @ wavelength 850nm	dB/km	3.0	
Insertion Loss @ wavelength 1310nm	dB/km	1.0	
Standards (Meets or exceeds)	UL34-V0, UL1666 RoHS Compliant		
Size (Power)	(mm (AWG))	8.4 (8)	
Quantity, Wire Count (Power)	16 (8 pairs)		
Size (Alarm)	(mm (AWG))	0.8 (18)	
Quantity, Wire Count (Alarm)	4 (2 pairs)		
Type	UV protected		
Strands	19		
Primary Jacket Diameter, Nominal	(mm (in))	6.8 (0.27)	
Standards (Meets or exceeds)	NFPA 130, ICEA S-95-658 UL Type XHHV-2, UL 44 UL-LS Limited Smoke, UL VW-1 IEEE-383 (1974), IEEE1202/FT4 RoHS Compliant		
Installation Temperature	(°C (°F))	-40 to +65 (-40 to 149)	
Operation Temperature	(°C (°F))	-40 to +65 (-40 to 149)	

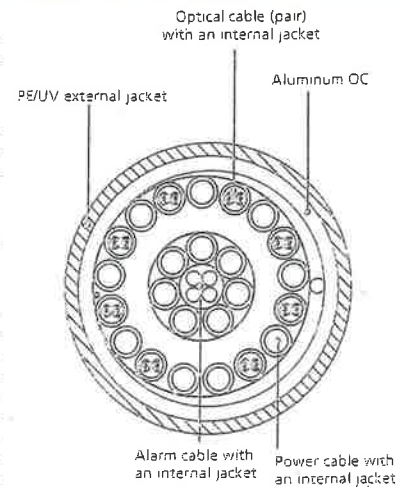

Figure 2: Construction Detail

All information contained in the present datasheet is subject to confirmation at time of ordering.

ATTACHMENT 2

Far Field Approximation
with downtilt variation

**Estimated Radiated Emission
Single Emitter Far Field Model
Dipole / Wire/ Yagi Antenna Types**



Location:	Suffield, CT
Site #:	
Date:	04/22/14
Name:	Mark Brauer
File Name:	Suffield, CT - FF Power

Operating Freq. (MHz)	869.0
Antenna Height (ft)	90.0
Antenna Gain (dBi)	14.2
Antenna Size (in.)	48.0
Downtilt (degrees)	0.0
Feedline Loss (dB)	0.0
Power @ J4 (w)	3795.0

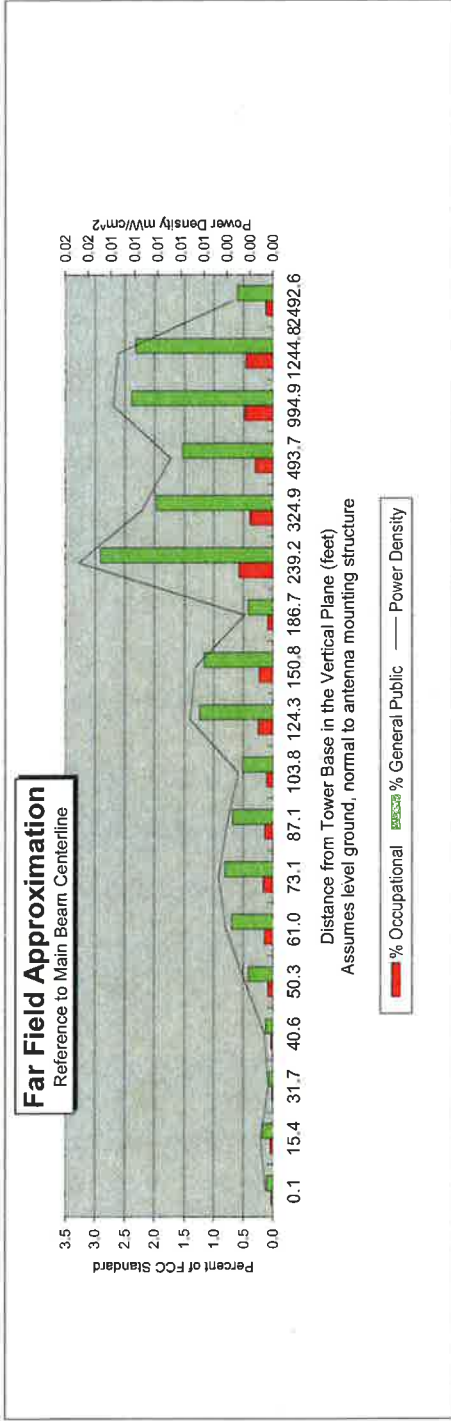

Calc. Angle	90.0	80.0	70.0	65.0	60.0	55.0	50.0	45.0	40.0	35.0	30.0	25.0	20.0	15.0	10.0	5.0	4.0	2.0
Solve for r, dx to antenna	87.0	88.4	92.6	96.0	100.5	106.2	113.6	123.1	135.4	151.7	174.1	206.0	254.5	336.3	501.3	998.7	1247.8	2494.1
Distance from Antenna Structure Base in Horizontal plane	0.1	15.4	31.7	40.6	50.3	61.0	73.1	87.1	103.8	124.3	150.8	186.7	239.2	324.9	493.7	994.9	1244.8	2492.6
Angle from Main Beam (reference to horizontal plane)	90	80	70	65	60	55	50	45	40	35	30	25	20	15	10	5	4	2
dB down from centerline (referenced to centerline)	36.76	34.35	38.52	35.34	29.54	26.8	25.59	25.63	25.99	21.21	20.29	23.24	13.03	12.3	9.92	2	0.2	0
Reflection Coefficient (1 to 4, 2.56 typical)	2.56	2.56	2.56	2.56	2.56	2.56	2.56	2.56	2.56	2.56	2.56	2.56	2.56	2.56	2.56	2.56	2.56	2.56
Power Density (mW/cm²)	0.00	0.00	0.00	0.00	0.00	0.00	0.00	0.00	0.00	0.01	0.01	0.00	0.02	0.01	0.01	0.01	0.01	0.00
Percent of Occupational Standard	0.0	0.0	0.0	0.0	0.1	0.1	0.2	0.1	0.1	0.2	0.2	0.1	0.6	0.4	0.3	0.5	0.5	0.1
Percent of General Population Standard	0.1	0.2	0.1	0.1	0.4	0.7	0.8	0.7	0.5	1.2	1.2	0.4	2.9	2.0	1.5	2.4	2.3	0.6

Antenna Type LPA-80080-4CF
Max% 2.90%

Instructions:

- 1) Fill in Site Location, Site number, Date, Name of Person Responsible for Date, and enter File Name to be saved as.
- 2) References to J4 refer to a point where the transmission line exits the equipment shelter and proceeds to the antenna(s). There is typically a connector located here where power measurements are made.
- 3) Enter Antenna Height (in feet to bottom of antenna), Antenna Gain (expressed as dBi, add 2.17 to dBd to obtain dBi), Antenna Size (vertical size in inches), Downtilt (in Degrees, enter zero if none), Feedline loss from J4 to Antenna, and J4 Po
- 4) From manufacturer's plots, or data sheet, input Angle from mainbeam and dB below mainbeam centerline.
- 5) Enter Reflection coefficient (2.56 would be typical, 1 for free space)
- 6) Spreadsheet calculates actual power density, then relates as Occupational or General Population percentage of FCC Standard.
- 7) An odd distance may be entered in the rightmost column of the lower table.

Far Field Approximation
with downtilt variation

**Estimated Radiated Emission
Single Emitter Far Field Model
Dipole / Wire/ Yagi Antenna Types**



Location:	Suffield, CT
Site #:	
Date:	04/22/14
Name:	Mark Brauer
File Name:	Suffield, CT - FF Power

Operating Freq. (MHz)	1970.0
Antenna Height (ft):	90.0
Antenna Gain (dBi):	19.7
Antenna Size (in.):	77.0
Downtilt (degrees):	0.0
Feedline Loss (dB):	0.0
Power @ J4 (w):	5173.0

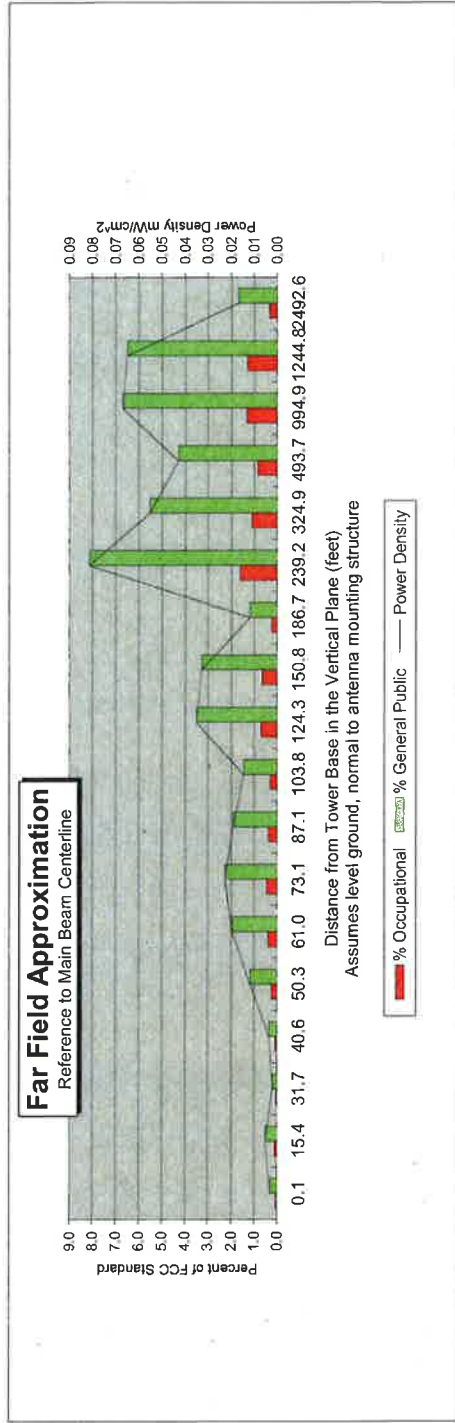

Calc Angle	90.0	80.0	70.0	65.0	60.0	55.0	50.0	45.0	40.0	35.0	30.0	25.0	20.0	15.0	10.0	5.0	4.0	2.0
Solve for r, dx to antenna	87.0	88.4	92.6	96.0	100.5	106.2	113.6	123.1	135.4	151.7	174.1	206.0	254.5	336.3	501.3	998.7	1247.8	2494.1
Distance from Antenna Structure Base in Horizontal plane	0.1	15.4	31.7	40.6	50.3	61.0	73.1	87.1	103.8	124.3	150.8	186.7	239.2	324.9	493.7	994.9	1244.8	2492.6
Angle from Main Beam (reference to horizontal plane)	90	80	70	65	60	55	50	45	40	35	30	25	20	15	10	5	4	2
dB down from centerline (referenced to centerline)	36.76	34.35	38.52	35.34	29.54	26.8	25.59	25.63	25.99	21.21	20.29	23.24	13.03	12.3	9.92	2	0.2	0
Reflection Coefficient (1 to 4, 2.56 typical)	2.56	2.56	2.56	2.56	2.56	2.56	2.56	2.56	2.56	2.56	2.56	2.56	2.56	2.56	2.56	2.56	2.56	2.56
Power Density (mW/cm²)	0.00	0.00	0.00	0.00	0.01	0.02	0.02	0.02	0.01	0.03	0.03	0.01	0.08	0.06	0.04	0.07	0.06	0.02
Percent of Occupational Standard	0.1	0.1	0.0	0.1	0.2	0.4	0.5	0.4	0.3	0.7	0.7	0.2	1.6	1.1	0.9	1.3	1.3	0.3
Percent of General Population Standard	0.3	0.5	0.2	0.3	1.2	2.0	2.3	1.9	1.5	3.5	3.3	1.2	8.1	5.5	4.3	6.7	6.5	1.7

Antenna Type 742213
Max% 8.14%

Instructions:

- 1) Fill in Site Location, Site number, Date, Name of Person Responsible for Date, and enter File Name to be saved as.
- 2) References to J4 refer to a point where the transmission line exits the equipment shelter and proceeds to the antenna(s). There is typically a connector located here where power measurements are made.
- 3) Enter Antenna Height (in feet to bottom of antenna), Antenna Gain (expressed as dBi, add 2.17 to dBd to obtain dBi), Antenna Size (vertical size in inches), Downtilt (in Degrees, enter zero if none), Feedline loss from J4 to Antenna, and J4 Power.
- 4) From manufacturer's plots, or data sheet, input Angle from mainbeam and dB below mainbeam centerline.
- 5) Enter Reflection coefficient (2.56 would be typical, 1 for free space)
- 6) Spreadsheet calculates actual power density, then relates as Occupational or General Population percentage of FCC Standard.
- 7) An odd distance may be entered in the rightmost column of the lower table.

Far Field Approximation
with downtilt variation

**Estimated Radiated Emission
Single Emitter Far Field Model
Dipole / Wire/ Yagi Antenna Types**



Location:	Suffield, CT
Site #:	
Date:	04/22/14
Name:	Mark Brauer
File Name:	Suffield, CT - FF Power
Operating Freq. (MHz)	746.0
Antenna Height (ft):	90.0
Antenna Gain (dBi):	15.2
Antenna Size (ft.):	48.0
Downtilt (degrees):	0.0
Feedline Loss (dB):	0.0
Power @ J4 (w):	1050.0

Far Field Approximation
Reference to Main Beam Centerline

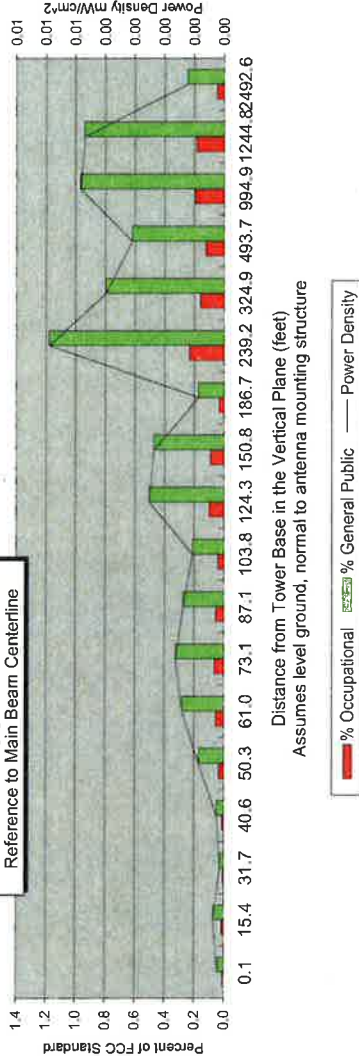

Distance from Tower Base in the Vertical Plane (feet)
Assumes level ground, normal to antenna mounting structure

■ Occupational ■ General Public — Power Density

Calc Angle	90.0	80.0	70.0	65.0	60.0	55.0	50.0	45.0	40.0	35.0	30.0	25.0	20.0	15.0	10.0	5.0	4.0	2.0
Solve for r, dx to antenna	87.0	88.4	92.6	96.0	100.5	106.2	113.6	123.1	135.4	151.7	174.1	206.0	254.5	336.3	501.3	998.7	1247.8	2494.1
Distance from Antenna Structure Base in Horizontal plane	0.1	15.4	31.7	40.6	50.3	61.0	73.1	87.1	103.8	124.3	150.8	186.7	239.2	324.9	493.7	994.9	1244.8	2492.6
Angle from Main Beam (reference to horizontal plane)	90	80	70	65	60	55	50	45	40	35	30	25	20	15	10	5	4	2
dB down from centerline (referenced to centerline)	36.76	34.35	38.52	35.34	29.54	26.8	25.59	25.63	25.99	21.21	20.29	23.24	13.03	12.3	9.92	2	0.2	0
Reflection Coefficient (1 to 4, 2.56 typical)	2.56	2.56	2.56	2.56	2.56	2.56	2.56	2.56	2.56	2.56	2.56	2.56	2.56	2.56	2.56	2.56	2.56	2.56
Power Density (mW/cm ²)	0.00	0.00	0.00	0.00	0.00	0.00	0.00	0.00	0.00	0.00	0.00	0.00	0.00	0.00	0.00	0.00	0.00	0.00
Percent of Occupational Standard	0.0	0.0	0.0	0.0	0.0	0.1	0.1	0.1	0.0	0.1	0.1	0.0	0.2	0.2	0.1	0.2	0.2	0.0
Percent of General Population Standard	0.0	0.1	0.0	0.0	0.2	0.3	0.3	0.3	0.2	0.5	0.5	0.2	1.2	0.8	0.6	1.0	0.9	0.2

Antenna Type BXA-70063-4CF
Max% 1.18%

Instructions:

- 1) Fill in Site Location, Site number, Date, Name of Person Responsible for Date, and enter File Name to be saved as.
- 2) References to J4 refer to a point where the transmission line exits the equipment shelter and proceeds to the antenna(s). There is typically a connector located here where power measurements are made.
- 3) Enter Antenna Height (in feet to bottom of antenna), Antenna Gain (expressed as dBi, add 2.17 to dBi to obtain dBi), Antenna Size (vertical size in inches), Downtilt (in Degrees, enter zero if none), Feedline loss from J4 to Antenna, and J4 Pc
- 4) From manufacturer's plots, or data sheet, input Angle from mainbeam and dB below mainbeam centerline.
- 5) Enter Reflection coefficient (2.56 would be typical, 1 for free space)
- 6) Spreadsheet calculates actual power density, then relates as Occupational or General Population percentage of FCC Standard.
- 7) An odd distance may be entered in the rightmost column of the lower table.

Far Field Approximation
with downtilt variation

Estimated Radiated Emission
Single Emitter Far Field Model
Dipole / Wire/ Yagi Antenna Types



Location:	Suffield, CT
Site #:	
Date:	04/22/14
Name:	Mark Brauer
File Name:	Suffield, CT - FF Power

Operating Freq. (MHz)	2145.0
Antenna Height (ft)	90.0
Antenna Gain (dBi)	19.9
Antenna Size (in.)	77.0
Downtilt (degrees)	0.0
Feedline Loss (dB)	0.0
Power @ J4 (w)	1750.0

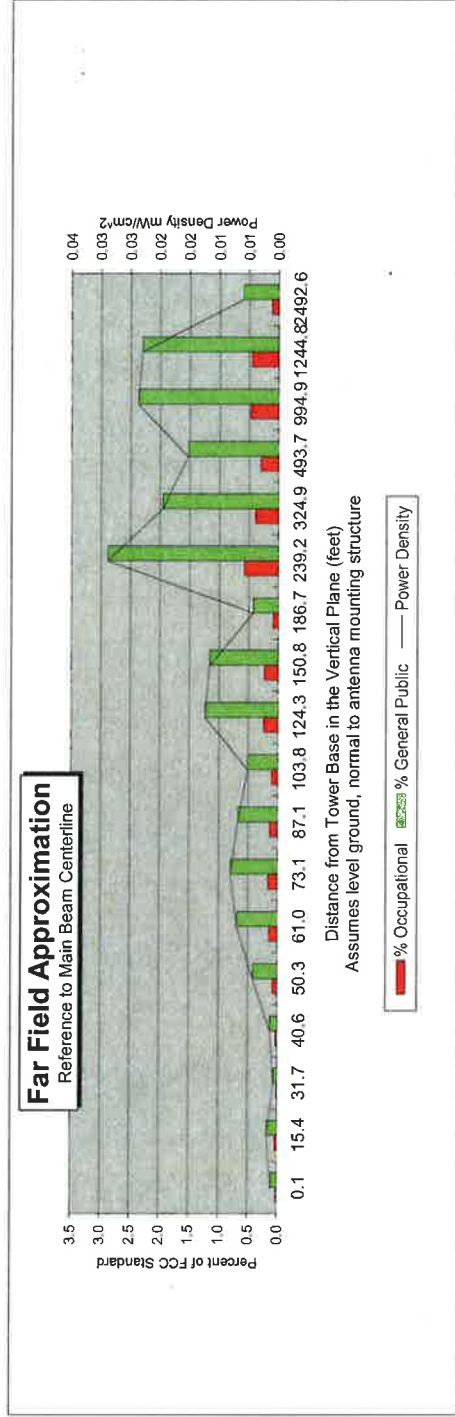

Calc Angle	90.0	80.0	70.0	65.0	60.0	55.0	50.0	45.0	40.0	35.0	30.0	25.0	20.0	15.0	10.0	5.0	4.0	2.0
Solve for r, dx to antenna	87.0	88.4	92.6	96.0	100.5	106.2	113.6	123.1	135.4	151.7	174.1	206.0	254.5	336.3	501.3	998.7	1247.8	2494.1
Distance from Antenna Structure Base in Horizontal plane	0.1	15.4	31.7	40.6	50.3	61.0	73.1	87.1	103.8	124.3	150.8	186.7	239.2	324.9	493.7	994.9	1244.8	2492.6
Angle from Main Beam (reference to horizontal plane)	90	80	70	65	60	55	50	45	40	35	30	25	20	15	10	5	4	2
dB down from centerline (referenced to centerline)	36.76	34.35	38.52	35.34	29.54	26.8	25.59	25.63	25.99	21.21	20.29	23.24	13.03	12.3	9.92	2	0.2	0
Reflection Coefficient (1 to 4, 2.56 typical)	2.56	2.56	2.56	2.56	2.56	2.56	2.56	2.56	2.56	2.56	2.56	2.56	2.56	2.56	2.56	2.56	2.56	2.56
Power Density (mW/cm²)	0.00	0.00	0.00	0.00	0.00	0.01	0.01	0.01	0.01	0.01	0.01	0.00	0.03	0.02	0.02	0.02	0.02	0.01
Percent of Occupational Standard	0.0	0.0	0.0	0.0	0.1	0.1	0.2	0.1	0.1	0.2	0.2	0.1	0.6	0.4	0.3	0.5	0.5	0.1
Percent of General Population Standard	0.1	0.2	0.1	0.1	0.4	0.7	0.8	0.7	0.5	1.2	1.2	0.4	2.9	2.0	1.5	2.4	2.3	0.6

Antenna Type 742213
Max% 2.88%

Instructions:

- 1) Fill in Site Location, Site number, Date, Name of Person Responsible for Date, and enter File Name to be saved as.
- 2) References to J4 refer to a point where the transmission line exits the equipment shelter and proceeds to the antenna(s). There is typically a connector located here where power measurements are made.
- 3) Enter Antenna Height (in feet to bottom of antenna), Antenna Gain (expressed as dBi, add 2.17 to dBd to obtain dBi), Antenna Size (vertical size in inches), Downtilt (in Degrees, enter zero if none), Feedline loss from J4 to Antenna, and J4 Po
- 4) From manufacturer's plots, or data sheet, input Angle from mainbeam and dB below mainbeam centerline.
- 5) Enter Reflection coefficient (2.56 would be typical, 1 for free space)
- 6) Spreadsheet calculates actual power density, then relates as Occupational or General Population percentage of FCC Standard.
- 7) An odd distance may be entered in the rightmost column of the lower table.

ATTACHMENT 3

Date: **March 14, 2014**

Darcy Tarr
Crown Castle
3530 Toringdon Way Suite 300
Charlotte, NC 28277

TECTONIC

Practical Solutions, Exceptional Service

Tectonic
1279 Route 300
Newburgh, NY
(845) 567-6656

Subject: Structural Analysis Report

Carrier Designation:	Verizon Wireless Co-Locate	
	Carrier Site Number:	N/A
	Carrier Site Name:	suffield
Crown Castle Designation:	Crown Castle BU Number:	801486
	Crown Castle Site Name:	CT SUFFIELD 2 CAC 801486
	Crown Castle JDE Job Number:	264262
	Crown Castle Work Order Number:	723734
	Crown Castle Application Number:	213949 Rev. 1
Engineering Firm Designation:	Tectonic Project Number:	6500.801486, Phase 2
Site Data:	44 Fyler Place, Suffield, Hartford County, CT	
	Latitude 41° 58' 49.7"; Longitude -72° 39' 26.2"	
	109 Foot - Monopole Tower	

Dear Darcy Tarr,

Tectonic is pleased to submit this "**Structural Analysis Report**" to determine the structural integrity of the above mentioned tower. This analysis has been performed in accordance with the Crown Castle Structural 'Statement of Work' and the terms of Crown Castle Purchase Order Number 625294, in accordance with application 213949, revision 1.

The purpose of the analysis is to determine acceptability of the tower stress level. Based on our analysis we have determined the tower stress level for the structure and foundation, under the following load case, to be:

LC7: Existing + Reserved + Proposed Equipment

Sufficient Capacity

Note: See Table I and Table II for the proposed and existing/reserved loading, respectively.

The analysis has been performed in accordance with the TIA/EIA-222-F standard and 2005 Connecticut State Building Code with 2009 amendment based upon a wind speed of 80 mph fastest mile.

All modifications and equipment proposed in this report shall be installed in accordance with the attached drawings for the determined available structural capacity to be effective.

We at Tectonic appreciate the opportunity of providing our continuing professional services to you and Crown Castle. If you have any questions or need further assistance on this or any other projects please give us a call.

Structural analysis prepared by: Veronica Elson / KS

Respectfully submitted by:



Antonio A. Gualtieri, P.E.
Sr. Vice President



TABLE OF CONTENTS

1) INTRODUCTION

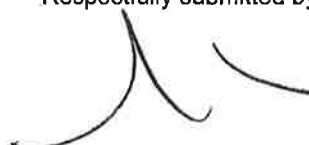
2) ANALYSIS CRITERIA

- Table 1 - Proposed Antenna and Cable Information
- Table 2 - Existing and Reserved Antenna and Cable Information
- Table 3 - Design Antenna and Cable Information

3) ANALYSIS PROCEDURE

- Table 4 - Documents Provided
- 3.1) Analysis Method
- 3.2) Assumptions

4) ANALYSIS RESULTS

- Table 5 - Section Capacity (Summary)
- Table 6 – Tower Components vs. Capacity
- 4.1) Recommendations

5) APPENDIX A

- tnxTower Output

6) APPENDIX B

- Base Level Drawing

7) APPENDIX C

- Additional Calculations

1) INTRODUCTION

This tower is a 109 ft Monopole tower designed by FWT INC. in February of 2002. The tower was originally designed for a wind speed of 80 mph per TIA/EIA-222-F.

2) ANALYSIS CRITERIA

The structural analysis was performed for this tower in accordance with the requirements of TIA/EIA-222-F Structural Standards for Steel Antenna Towers and Antenna Supporting Structures using a fastest mile wind speed of 80 mph with no ice, 37.6 mph with 1 inch ice thickness and 50 mph under service loads.

Table 1 - Proposed Antenna and Cable Information

Mounting Level (ft)	Center Line Elevation (ft)	Number of Antennas	Antenna Manufacturer	Antenna Model	Number of Feed Lines	Feed Line Size (in)	Note
90.0	91.0	3	alcatel lucent	RRH2x40-AWS	1	1-5/8	-
		2	antel	BXA-70063-6CF-EDIN-0 w/ Mount Pipe			
		6	kathrein	742 213 w/ Mount Pipe			
		1	rfs celwave	DB-B1-6C-8AB-0Z			
		6	rfs celwave	FD9R6004/2C-3L			

Table 2 - Existing and Reserved Antenna and Cable Information

Mounting Level (ft)	Center Line Elevation (ft)	Number of Antennas	Antenna Manufacturer	Antenna Model	Number of Feed Lines	Feed Line Size (in)	Note
107.0	109.0	4	andrew	SBNH-1D6565C w/ Mount Pipe	12 1 2	1-5/8 3/8 3/4	1
		3	communication components inc.	DTMABP7819VG12A			
		6	ericsson	RRUS-11			
		3	kathrein	800 10121 w/ Mount Pipe			
		6	kathrein	860 10025			
		3	powerwave technologies	7020.00			
		6	powerwave technologies	LGP13519			
		2	powerwave technologies	P65-17-XLH-RR w/ Mount Pipe			
		6	powerwave technologies	TT19-08BP111-001			
		1	raycap	DC6-48-60-18-8F			
	107.0	1	tower mounts	Platform Mount [LP 712-1]			

Mounting Level (ft)	Center Line Elevation (ft)	Number of Antennas	Antenna Manufacturer	Antenna Model	Number of Feed Lines	Feed Line Size (in)	Note
90.0	91.0	1	antel	BXA-70063-4CF-EDIN-4 w/ Mount Pipe	6	1-1/4	3
		1	antel	BXA-70080/4CF w/ Mount Pipe			
		6	antel	LPA-171080/8CFx2 w/ Mount Pipe			
		1	antel	BXA-70063-4CF-EDIN-X w/ Mount Pipe	12	1-1/4	1
		2	antel	LPA-80080-4CF-EDIN-0 w/ Mount Pipe			
	4	swedcom	SC 9012 REV2 w/Mount Pipe				
90.0	1	tower mounts	Platform Mount [LP 712-1]				
80.0	81.0	12	decibel	DB844H90-XY w/ Mount Pipe	12	7/8	1
	80.0	1	tower mounts	Platform Mount [LP 712-1]			
74.0	74.0	3	alcatel lucent	800MHz 2X50W RRH W/FILTER	-	-	1
		3	alcatel lucent	PCS 1900MHz 4x45W-65MHz			
		1	tower mounts	Side Arm Mount [SO 102-3]			
72.0	74.0	2	rfs celwave	APXV9ERR18-C-A20 w/ Mount Pipe	3	1-1/4	1
		1	rfs celwave	APXVSP18-C-A20 w/ Mount Pipe			
		3	alcatel lucent	TD-RRH8x20-25	1	5/8	2
		3	rfs celwave	APXVTM14-C-120 w/ Mount Pipe			
	72.0	1	tower mounts	Platform Mount [LP 712-1]	-	-	1
62.0	62.0	3	rfs celwave	APX18-206516L	6	1-5/8	1
		1	tower mounts	Pipe Mount [PM 501-3]			
47.0	47.0	1	tower mounts	Side Arm Mount [SO 701-1]	1	1/2	1
		1	unknown	GPS			

Notes:

- 1) Existing equipment
- 2) Reserved Equipment
- 3) Equipment to be removed

Table 3 - Design Antenna and Cable Information

Mounting Level (ft)	Center Line Elevation (ft)	Number of Antennas	Antenna Manufacturer	Antenna Model	Number of Feed Lines	Feed Line Size (in)
110	110	12	swedcom	ALP-9212-N	-	-
102	102	12	swedcom	ALP-9212-N		
92	92	12	swedcom	ALP-9212-N		
82	82	12	swedcom	ALP-9212-N		
72	72	12	swedcom	ALP-9212-N		

3) ANALYSIS PROCEDURE

Table 4 - Documents Provided

Document	Remarks	Reference	Source
4-GEOTECHNICAL REPORTS	Clough, Harbour & Associates, LLP	2294830	CCSITES
4-TOWER FOUNDATION DRAWINGS/DESIGN/SPECS	FWT, Inc.	821489	CCSITES
4-TOWER MANUFACTURER DRAWINGS	FWT, Inc.	823124	CCSITES

3.1) Analysis Method

tnxTower (version 6.1.4.1), a commercially available analysis software package, was used to create a three-dimensional model of the tower and calculate member stresses for various loading cases. Selected output from the analysis is included in Appendix A.

3.2) Assumptions

- 1) Tower and structures were built in accordance with the manufacturer's specifications.
- 2) The tower and structures have been maintained in accordance with the manufacturer's specification.
- 3) The configuration of antennas, transmission cables, mounts and other appurtenances are as specified in Tables 1 and 2 and the referenced drawings.
- 4) When applicable, transmission cables are considered as structural components for calculating wind loads as allowed by TIA/EIA-222-F.

This analysis may be affected if any assumptions are not valid or have been made in error. Tectonic should be notified to determine the effect on the structural integrity of the tower.

4) ANALYSIS RESULTS

Table 5 - Section Capacity (Summary)

Section No.	Elevation (ft)	Component Type	Size	Critical Element	P (K)	SF*P_allow (K)	% Capacity	Pass / Fail
L1	109 - 95	Pole	TP26.715x23.476x0.1875	1	-3.26	820.73	17.8	Pass
L2	95 - 48.0833	Pole	TP37.573x26.715x0.3125	2	-15.20	1862.65	51.7	Pass
L3	48.0833 - 0	Pole	TP48.075x35.8101x0.375	3	-26.86	2951.56	65.2	Pass
							Summary	
						Pole (L3)	65.2	Pass
						Rating =	65.2	Pass

Table 6 - Tower Component Stresses vs. Capacity – LC7

Notes	Component	Elevation (ft)	% Capacity	Pass / Fail
1	Anchor Rods	0	51.2	Pass
1	Base Plate	0	30.6	Pass
1	Base Foundation	0	82.6	Pass
1	Flange Plate	95	4.9	Pass
1	Flange Bolts	95	12.0	Pass

Structure Rating (max from all components) =	82.6%
---	--------------

Notes:

- 1) See additional documentation in "Appendix C – Additional Calculations" for calculations supporting the % capacity consumed.

4.1) Recommendations

The tower and its foundation have sufficient capacity to carry the existing, reserved and proposed loads. No modifications are required at this time.

APPENDIX A
TNXTOWER OUTPUT

Section	1	2	3
Length (ft)	14'	46'-1 1/32"	53'
Number of Sides	18	18	18
Thickness (in)	0.1875	0.3125	0.3750
Socket Length (ft)		4'-11 1/32"	
Top Dia (in)	23.4760	26.7150	35.8101
Bot Dia (in)	26.7150	37.5730	48.0750
Grade		A572-65	
Weight (K)	0.7	5.0	8.9
			14.7

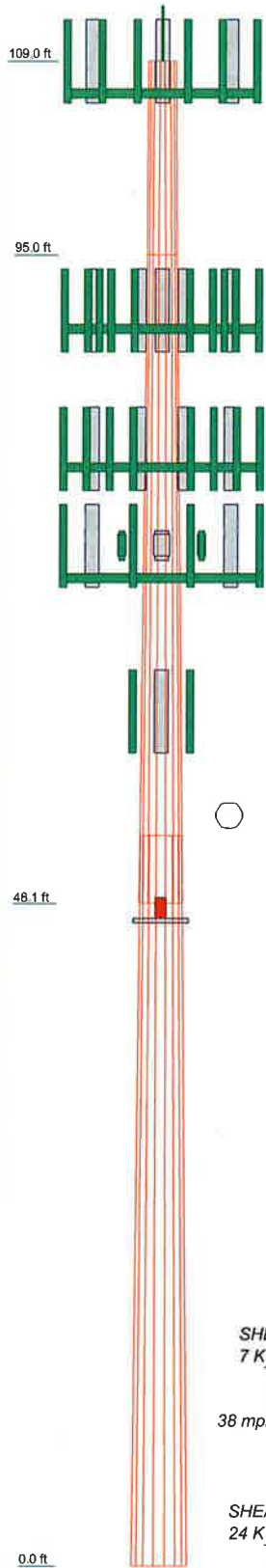

DESIGNED APPURTENANCE LOADING

TYPE	ELEVATION	TYPE	ELEVATION
Lighting Rod 3/4" x 4"	111	(2) FD9R6004/2C-3L	90
800 10121 w/ Mount Pipe	107	(2) FD9R6004/2C-3L	90
800 10121 w/ Mount Pipe	107	(2) FD9R6004/2C-3L	90
800 10121 w/ Mount Pipe	107	RRH2x40-AWS	90
SBNH-1D6565C w/ Mount Pipe	107	RRH2x40-AWS	90
(2) SBNH-1D6565C w/ Mount Pipe	107	RRH2x40-AWS	90
SBNH-1D6565C w/ Mount Pipe	107	DB-B1-6C-8AB-0Z	90
P65-17-XLH-RR w/ Mount Pipe	107	Platform Mount [LP 712-1]	90
P65-17-XLH-RR w/ Mount Pipe	107	(4) DB844H90-XY w/ Mount Pipe	80
(2) 860 10025	107	(4) DB844H90-XY w/ Mount Pipe	80
(2) 860 10025	107	(4) DB844H90-XY w/ Mount Pipe	80
(2) 860 10025	107	Platform Mount [LP 712-1]	80
(2) LGP13519	107	PCS 1900MHz 4x45W-65MHz	74
(2) LGP13519	107	PCS 1900MHz 4x45W-65MHz	74
(2) LGP13519	107	PCS 1900MHz 4x45W-65MHz	74
7020.00	107	800MHz 2X50W RRH W/FILTER	74
7020.00	107	800MHz 2X50W RRH W/FILTER	74
7020.00	107	800MHz 2X50W RRH W/FILTER	74
(2) TT19-08BP111-001	107	Side Arm Mount [SO 102-3]	74
(2) TT19-08BP111-001	107	(2) 5x2 1/2" Pipe Mount	74
(2) TT19-08BP111-001	107	(2) 5x2 1/2" Pipe Mount	74
(4) RRUS-11	107	(2) 5x2 1/2" Pipe Mount	74
(2) RRUS-11	107	APXV9ERR18-C-A20 w/ Mount Pipe	72
DTMABP7819VG12A	107	APXVSP18-C-A20 w/ Mount Pipe	72
(2) DTMABP7819VG12A	107	APXV9ERR18-C-A20 w/ Mount Pipe	72
DCB-48-60-18-8F	107	APXVTM14-C-120 w/ Mount Pipe	72
8x2.375" Pipe Mount	107	APXVTM14-C-120 w/ Mount Pipe	72
8x2.375" Pipe Mount	107	APXVTM14-C-120 w/ Mount Pipe	72
8x2.375" Pipe Mount	107	TD-RRH8x20-25	72
Platform Mount [LP 712-1]	107	TD-RRH8x20-25	72
BXA-70063-4CF-EDIN-X w/ Mount Pipe	90	TD-RRH8x20-25	72
Pipe		Platform Mount [LP 712-1]	72
(2) LPA-80080-4CF-EDIN-0 w/ Mount Pipe	90	5' x 2' Pipe Mount	72
Pipe		5' x 2' Pipe Mount	72
(2) SC 9012 REV2 w/ Mount Pipe	90	5' x 2' Pipe Mount	72
(2) SC 9012 REV2 w/ Mount Pipe	90	APX18-206516L	62
(2) 742 213 w/ Mount Pipe	90	APX18-206516L	62
(2) 742 213 w/ Mount Pipe	90	APX18-206516L	62
(2) 742 213 w/ Mount Pipe	90	Pipe Mount [PM 501-3]	62
BXA-70063-6CF-EDIN-0 w/ Mount Pipe	90	GPS	47
Pipe		Side Arm Mount [SO 701-1]	47
BXA-70063-6CF-EDIN-0 w/ Mount Pipe	90		

MATERIAL STRENGTH

GRADE	Fy	Fu	GRADE	Fy	Fu
A572-65	65 ksi	80 ksi			

TOWER DESIGN NOTES

1. Tower is located in Hartford County, Connecticut.
2. Tower designed for a 80 mph basic wind in accordance with the TIA/EIA-222-F Standard.
3. Tower is also designed for a 38 mph basic wind with 1.00 in ice. Ice is considered to increase in thickness with height.
4. Deflections are based upon a 50 mph wind.
5. TOWER RATING: 65.2%

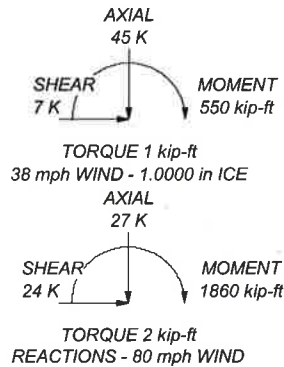

 Physical Solutions, Exceptional Service	TECTONIC 1279 Route 300 Newburgh, NY 12550 Phone: (845) 567-6656 FAX: (845) 557-8703		Job: BU# 801486
	Project: Client: Crown Castle Code: TIA/EIA-222-F Path:	Drawn by: Kelly Schuman Date: 03/14/14	App'd: Scale: NTS Dwg No. E-1

Tower Input Data

There is a pole section.

This tower is designed using the TIA/EIA-222-F standard.

The following design criteria apply:

- 4) Tower is located in Hartford County, Connecticut.
- 5) Basic wind speed of 80 mph.
- 6) Nominal ice thickness of 1.0000 in.
- 7) Ice thickness is considered to increase with height.
- 8) Ice density of 56 pcf.
- 9) A wind speed of 38 mph is used in combination with ice.
- 10) Temperature drop of 50 °F.
- 11) Deflections calculated using a wind speed of 50 mph.
- 12) A non-linear (P-delta) analysis was used.
- 13) Pressures are calculated at each section.
- 14) Stress ratio used in pole design is 1.333.
- 15) Local bending stresses due to climbing loads, feed line supports, and appurtenance mounts are not considered.

Options

Consider Moments - Legs Consider Moments - Horizontals Consider Moments - Diagonals Use Moment Magnification ✓ Use Code Stress Ratios ✓ Use Code Safety Factors - Guys ✓ Escalate Ice Always Use Max Kz Use Special Wind Profile Include Bolts In Member Capacity Leg Bolts Are At Top Of Section Secondary Horizontal Braces Leg Use Diamond Inner Bracing (4 Sided) Add IBC .6D+W Combination	Distribute Leg Loads As Uniform Assume Legs Pinned ✓ Assume Rigid Index Plate ✓ Use Clear Spans For Wind Area ✓ Use Clear Spans For KL/r Retension Guys To Initial Tension ✓ Bypass Mast Stability Checks ✓ Use Azimuth Dish Coefficients ✓ Project Wind Area of Appurt. Autocalc Torque Arm Areas SR Members Have Cut Ends ✓ Sort Capacity Reports By Component Triangulate Diamond Inner Bracing Use TIA-222-G Tension Splice Capacity Exemption	Treat Feedline Bundles As Cylinder Use ASCE 10 X-Brace Ly Rules Calculate Redundant Bracing Forces Ignore Redundant Members in FEA SR Leg Bolts Resist Compression All Leg Panels Have Same Allowable Offset Girt At Foundation ✓ Consider Feedline Torque Include Angle Block Shear Check Poles ✓ Include Shear-Torsion Interaction Always Use Sub-Critical Flow Use Top Mounted Sockets
--	--	---

Tapered Pole Section Geometry

Section	Elevation ft	Section Length ft	Splice Length ft	Number of Sides	Top Diameter in	Bottom Diameter in	Wall Thickness in	Bend Radius in	Pole Grade
L1	109'-95'	14'	0'	18	23.4760	26.7150	0.1875	0.7500	A572-65 (65 ksi)
L2	95'-48'31/32"	46'11-1/32"	4'11-1/32"	18	26.7150	37.5730	0.3125	1.2500	A572-65 (65 ksi)
L3	48'31/32"-0'	53'		18	35.8101	48.0750	0.3750	1.5000	A572-65 (65 ksi)

Tapered Pole Properties

Section	Tip Dia. in	Area in ²	I in ⁴	r in	C in	I/C in ³	J in ⁴	It/Q in ²	w in	w/t
L1	23.8382 27.1271	13.8596 15.7872	949.6645 1403.5717	8.2674 9.4173	11.9258 13.5712	79.6310 103.4227	1900.5786 2808.9903	6.9311 7.8951	3.8018 4.3718	20.276 23.316

Section	Tip Dia. in	Area in ²	I in ⁴	r in	C in	I/C in ³	J in ⁴	I/Q in ²	w in	w/t
L2	27.1271	26.1880	2306.3730	9.3729	13.5712	169.9459	4615.7808	13.0965	4.1518	13.286
	38.1526	36.9578	6482.4687	13.2275	19.0871	339.6259	12973.4672	18.4824	6.0628	19.401
L3	37.5179	42.1767	6690.7939	12.5795	18.1915	367.7969	13390.3918	21.0923	5.6426	15.047
	48.8166	56.7749	16320.3992	16.9335	24.4221	668.2635	32662.2732	28.3929	7.8012	20.803

Tower Elevation ft	Gusset Area (per face) ft ²	Gusset Thickness in	Gusset Grade	Adjust. Factor A _r	Adjust. Factor A _r	Weight Mult.	Double Angle Stitch Bolt Spacing Diagonals in	Double Angle Stitch Bolt Spacing Horizontals in
L1 109'-95'				1	1	1		
L2 95'-48'31/32"				1	1	1		
L3 48'31/32"-0'				1	1	1		

Feed Line/Linear Appurtenances - Entered As Area

Description	Face or Leg	Allow Shield	Component Type	Placement ft	Total Number	C _A A _A ft ² /ft	Weight plf
LDF7-50A(1-5/8")	B	No	Inside Pole	107' - 0'	12	No Ice	0.82
						1/2" Ice	0.82
						1" Ice	0.82
						2" Ice	0.82
						4" Ice	0.82
						No Ice	0.06
FB-L98B-002-75000(3/8")	B	No	Inside Pole	107' - 0'	1	1/2" Ice	0.06
						1" Ice	0.06
						2" Ice	0.06
						4" Ice	0.06
						No Ice	0.58
						1/2" Ice	0.58
WR-VG86ST-BRD(3/4)	B	No	Inside Pole	107' - 0'	2	1" Ice	0.58
						2" Ice	0.58
						4" Ice	0.58
						No Ice	0.58
						1/2" Ice	0.58
						1" Ice	0.58
*** LDF6-50A(1-1/4")	A	No	Inside Pole	90' - 0'	12	No Ice	0.66
						1/2" Ice	0.66
						1" Ice	0.66
						2" Ice	0.66
						4" Ice	0.66
						No Ice	1.30
HB158-1-08U8-S8J18(1-5/8)	A	No	CaAa (Out Of Face)	90' - 0'	1	1/2" Ice	2.81
						1" Ice	4.94
						2" Ice	11.03
						4" Ice	30.52
						No Ice	0.33
						1/2" Ice	0.33
*** LDF5-50A(7/8")	A	No	Inside Pole	80' - 0'	12	1" Ice	0.33
						2" Ice	0.33
						4" Ice	0.33
						No Ice	1.08
						1/2" Ice	1.08
						1" Ice	1.08
*** HB114-1-08U4-M5J(1 1/4")	A	No	Inside Pole	72' - 0'	3	2" Ice	1.08
						4" Ice	1.08
						No Ice	0.24
						1/2" Ice	0.24
						1" Ice	0.24
						2" Ice	0.24
HB058-M12-XXXX(5/8")	A	No	Inside Pole	72' - 0'	1	No Ice	0.24
						1/2" Ice	0.24
						1" Ice	0.24
						2" Ice	0.24
						No Ice	0.24
						1/2" Ice	0.24

Description	Face or Leg	Allow Shield	Component Type	Placement ft	Total Number	C _A A _A		Weight
						ft ² /ft	plf	
LDF4-50A(1/2")	A	No	CaAa (Out Of Face)	47' - 0'	1	4" Ice	0.00	0.24
						No Ice	0.06	0.15
						1/2" Ice	0.16	0.84
						1" Ice	0.26	2.14
						2" Ice	0.46	6.58
						4" Ice	0.86	22.78

CR 50 1873(1-5/8")	C	No	CaAa (Out Of Face)	62' - 0'	1	No Ice	0.20	0.83
						1/2" Ice	0.30	2.34
						1" Ice	0.40	4.47
						2" Ice	0.60	10.55
						4" Ice	1.00	30.05
CR 50 1873(1-5/8")	C	No	CaAa (Out Of Face)	62' - 0'	5	No Ice	0.00	0.00
						1/2" Ice	0.00	2.34
						1" Ice	0.00	4.47
						2" Ice	0.00	10.55
						4" Ice	0.00	30.05

Feed Line/Linear Appurtenances Section Areas

Tower Section n	Tower Elevation ft	Face	A _R	A _F	C _A A _A In Face	C _A A _A Out Face	Weight
			ft ²	ft ²	ft ²	ft ²	K
L1	109'-95'	A	0.000	0.000	0.000	0.000	0.00
		B	0.000	0.000	0.000	0.000	0.13
		C	0.000	0.000	0.000	0.000	0.00
L2	95'-48'31/32"	A	0.000	0.000	0.000	8.300	0.60
		B	0.000	0.000	0.000	0.000	0.52
		C	0.000	0.000	0.000	2.756	0.01
L3	48'31/32"-0'	A	0.000	0.000	0.000	12.482	0.81
		B	0.000	0.000	0.000	0.000	0.53
		C	0.000	0.000	0.000	9.521	0.04

Feed Line/Linear Appurtenances Section Areas - With Ice

Tower Section n	Tower Elevation ft	Face or Leg	Ice Thickness in	A _R	A _F	C _A A _A In Face	C _A A _A Out Face	Weight
				ft ²	ft ²	ft ²	ft ²	K
L1	109'-95'	A	1.145	0.000	0.000	0.000	0.000	0.00
		B		0.000	0.000	0.000	0.000	0.13
		C		0.000	0.000	0.000	0.000	0.00
L2	95'-48'31/32"	A	1.096	0.000	0.000	0.000	17.487	0.77
		B		0.000	0.000	0.000	0.000	0.52
		C		0.000	0.000	0.000	5.806	0.42
L3	48'31/32"-0'	A	1.000	0.000	0.000	0.000	33.322	1.12
		B		0.000	0.000	0.000	0.000	0.53
		C		0.000	0.000	0.000	20.059	1.46

Feed Line Center of Pressure

Section	Elevation ft	CP _x	CP _z	CP _x Ice	CP _z Ice
		in	in	in	in
L1	109'-95'	0.0000	0.0000	0.0000	0.0000
L2	95'-48'31/32"	-0.0785	-0.2030	-0.1435	-0.3712
L3	48'31/32"-0'	-0.2278	-0.2136	-0.3970	-0.5332

Discrete Tower Loads

Description	Face or Leg	Offset Type	Offsets: Horz Lateral Vert ft ft ft	Azimuth Adjustmen t	Placement ft	C _A A _A Front	C _A A _A Side	Weight	
						ft ²	ft ²	K	
Lighting Rod 3/4" x 4'	C	None		0.0000	111'	No Ice	0.30	0.30	0.03
						1/2" Ice	0.71	0.71	0.03
						Ice	1.00	1.00	0.04
						1" Ice	1.52	1.52	0.06
						2" Ice	2.72	2.72	0.14

800 10121 w/ Mount Pipe	A	From Leg	4.00 0' 2'	0.0000	107'	No Ice	5.46	3.35	0.05
						1/2" Ice	5.88	3.74	0.08
						Ice	6.31	4.15	0.12
						1" Ice	7.21	5.06	0.22
						2" Ice	9.09	7.26	0.49
800 10121 w/ Mount Pipe	B	From Leg	4.00 0' 2'	0.0000	107'	No Ice	5.46	3.35	0.05
						1/2" Ice	5.88	3.74	0.08
						Ice	6.31	4.15	0.12
						1" Ice	7.21	5.06	0.22
						2" Ice	9.09	7.26	0.49
800 10121 w/ Mount Pipe	C	From Leg	4.00 0' 2'	0.0000	107'	No Ice	5.46	3.35	0.05
						1/2" Ice	5.88	3.74	0.08
						Ice	6.31	4.15	0.12
						1" Ice	7.21	5.06	0.22
						2" Ice	9.09	7.26	0.49
SBNH-1D6565C w/ Mount Pipe	A	From Leg	4.00 0' 2'	0.0000	107'	No Ice	11.68	9.84	0.09
						1/2" Ice	12.40	11.37	0.18
						Ice	13.14	12.91	0.28
						1" Ice	14.60	15.27	0.52
						2" Ice	17.87	20.14	1.16
(2) SBNH-1D6565C w/ Mount Pipe	B	From Leg	4.00 0' 2'	0.0000	107'	No Ice	11.68	9.84	0.09
						1/2" Ice	12.40	11.37	0.18
						Ice	13.14	12.91	0.28
						1" Ice	14.60	15.27	0.52
						2" Ice	17.87	20.14	1.16
SBNH-1D6565C w/ Mount Pipe	C	From Leg	4.00 0' 2'	0.0000	107'	No Ice	11.68	9.84	0.09
						1/2" Ice	12.40	11.37	0.18
						Ice	13.14	12.91	0.28
						1" Ice	14.60	15.27	0.52
						2" Ice	17.87	20.14	1.16
P65-17-XLH-RR w/ Mount Pipe	A	From Leg	4.00 0' 2'	0.0000	107'	No Ice	11.70	8.94	0.09
						1/2" Ice	12.42	10.45	0.18
						Ice	13.15	11.99	0.27
						1" Ice	14.64	14.31	0.50
						2" Ice	17.91	19.14	1.13
P65-17-XLH-RR w/ Mount Pipe	C	From Leg	4.00 0' 2'	0.0000	107'	No Ice	11.70	8.94	0.09
						1/2" Ice	12.42	10.45	0.18
						Ice	13.15	11.99	0.27
						1" Ice	14.64	14.31	0.50
						2" Ice	17.91	19.14	1.13
(2) 860 10025	A	From Leg	4.00 0' 2'	0.0000	107'	No Ice	0.16	0.14	0.00
						1/2" Ice	0.23	0.20	0.00
						Ice	0.30	0.27	0.01
						1" Ice	0.48	0.44	0.01
						2" Ice	0.93	0.88	0.05
						4" Ice			

Description	Face or Leg	Offset Type	Offsets:		Azimuth Adjustment	Placement	C _A A _A Front	C _A A _A Side	Weight
			Horz	Lateral					
			ft	ft	°	ft	ft ²	ft ²	K
(2) 860 10025	B	From Leg	4.00	0.0000	107'	No Ice	0.16	0.14	0.00
			0'			1/2"	0.23	0.20	0.00
			2'			Ice	0.30	0.27	0.01
						1" Ice	0.48	0.44	0.01
						2" Ice	0.93	0.88	0.05
					4" Ice				
(2) 860 10025	C	From Leg	4.00	0.0000	107'	No Ice	0.16	0.14	0.00
			0'			1/2"	0.23	0.20	0.00
			2'			Ice	0.30	0.27	0.01
						1" Ice	0.48	0.44	0.01
						2" Ice	0.93	0.88	0.05
					4" Ice				
(2) LGP13519	A	From Leg	4.00	0.0000	107'	No Ice	0.34	0.21	0.01
			0'			1/2"	0.42	0.28	0.01
			2'			Ice	0.51	0.36	0.01
						1" Ice	0.73	0.55	0.02
						2" Ice	1.25	1.03	0.07
					4" Ice				
(2) LGP13519	B	From Leg	4.00	0.0000	107'	No Ice	0.34	0.21	0.01
			0'			1/2"	0.42	0.28	0.01
			2'			Ice	0.51	0.36	0.01
						1" Ice	0.73	0.55	0.02
						2" Ice	1.25	1.03	0.07
					4" Ice				
(2) LGP13519	C	From Leg	4.00	0.0000	107'	No Ice	0.34	0.21	0.01
			0'			1/2"	0.42	0.28	0.01
			2'			Ice	0.51	0.36	0.01
						1" Ice	0.73	0.55	0.02
						2" Ice	1.25	1.03	0.07
					4" Ice				
7020.00	A	From Leg	4.00	0.0000	107'	No Ice	0.12	0.20	0.00
			0'			1/2"	0.17	0.28	0.01
			2'			Ice	0.23	0.36	0.01
						1" Ice	0.38	0.56	0.02
						2" Ice	0.78	1.05	0.07
					4" Ice				
7020.00	B	From Leg	4.00	0.0000	107'	No Ice	0.12	0.20	0.00
			0'			1/2"	0.17	0.28	0.01
			2'			Ice	0.23	0.36	0.01
						1" Ice	0.38	0.56	0.02
						2" Ice	0.78	1.05	0.07
					4" Ice				
7020.00	C	From Leg	4.00	0.0000	107'	No Ice	0.12	0.20	0.00
			0'			1/2"	0.17	0.28	0.01
			2'			Ice	0.23	0.36	0.01
						1" Ice	0.38	0.56	0.02
						2" Ice	0.78	1.05	0.07
					4" Ice				
(2) TT19-08BP111-001	A	From Leg	4.00	0.0000	107'	No Ice	0.64	0.52	0.02
			0'			1/2"	0.76	0.62	0.02
			2'			Ice	0.88	0.74	0.03
						1" Ice	1.14	0.99	0.05
						2" Ice	1.78	1.59	0.12
					4" Ice				
(2) TT19-08BP111-001	B	From Leg	4.00	0.0000	107'	No Ice	0.64	0.52	0.02
			0'			1/2"	0.76	0.62	0.02
			2'			Ice	0.88	0.74	0.03
						1" Ice	1.14	0.99	0.05
						2" Ice	1.78	1.59	0.12
					4" Ice				
(2) TT19-08BP111-001	C	From Leg	4.00	0.0000	107'	No Ice	0.64	0.52	0.02
			0'			1/2"	0.76	0.62	0.02
			2'			Ice	0.88	0.74	0.03
						1" Ice	1.14	0.99	0.05
						2" Ice	1.78	1.59	0.12
					4" Ice				

Description	Face or Leg	Offset Type	Offsets:		Azimuth Adjustment	Placement	C _A A _A Front	C _A A _A Side	Weight	
			Horz	Vert						
			ft	ft	°	ft	ft ²	ft ²	K	
(4) RRUS-11	A	From Leg	4.00	0'	0.0000	107'	4" Ice			
							No Ice	3.25	1.37	0.05
							1/2" Ice	3.49	1.55	0.07
							1" Ice	3.74	1.74	0.09
							2" Ice	4.27	2.14	0.15
(2) RRUS-11	B	From Leg	4.00	0'	0.0000	107'	4" Ice			
							No Ice	3.25	1.37	0.05
							1/2" Ice	3.49	1.55	0.07
							1" Ice	3.74	1.74	0.09
							2" Ice	4.27	2.14	0.15
DTMABP7819VG12A	B	From Leg	4.00	0'	0.0000	107'	4" Ice			
							No Ice	1.14	0.39	0.02
							1/2" Ice	1.28	0.49	0.03
							1" Ice	1.44	0.59	0.04
							2" Ice	1.77	0.83	0.06
(2) DTMABP7819VG12A	C	From Leg	4.00	0'	0.0000	107'	4" Ice			
							No Ice	1.14	0.39	0.02
							1/2" Ice	1.28	0.49	0.03
							1" Ice	1.44	0.59	0.04
							2" Ice	1.77	0.83	0.06
DC6-48-60-18-8F	A	From Leg	4.00	0'	0.0000	107'	4" Ice			
							No Ice	1.47	1.47	0.02
							1/2" Ice	1.67	1.67	0.04
							1" Ice	1.88	1.88	0.06
							2" Ice	2.33	2.33	0.11
8'x2.375" Pipe Mount	A	From Leg	4.00	0'	0.0000	107'	4" Ice			
							No Ice	1.90	1.90	0.03
							1/2" Ice	2.73	2.73	0.04
							1" Ice	3.40	3.40	0.06
							2" Ice	4.40	4.40	0.12
8'x2.375" Pipe Mount	B	From Leg	4.00	0'	0.0000	107'	4" Ice			
							No Ice	1.90	1.90	0.03
							1/2" Ice	2.73	2.73	0.04
							1" Ice	3.40	3.40	0.06
							2" Ice	4.40	4.40	0.12
8'x2.375" Pipe Mount	C	From Leg	4.00	0'	0.0000	107'	4" Ice			
							No Ice	1.90	1.90	0.03
							1/2" Ice	2.73	2.73	0.04
							1" Ice	3.40	3.40	0.06
							2" Ice	4.40	4.40	0.12
Platform Mount [LP 712-1]	C	None			0.0000	107'	4" Ice			
							No Ice	24.53	24.53	1.34
							1/2" Ice	29.94	29.94	1.65
							1" Ice	35.35	35.35	1.96
							2" Ice	46.17	46.17	2.58
*** BXA-70063-4CF-EDIN-X w/ Mount Pipe	A	From Leg	4.00	0'	0.0000	90'	4" Ice			
							No Ice	5.40	3.69	0.03
							1/2" Ice	5.84	4.29	0.07
							1" Ice	6.30	4.91	0.12
							2" Ice	7.24	6.26	0.23
(2) LPA-80080-4CF-EDIN-0 w/ Mount Pipe	A	From Leg	4.00	0'	0.0000	90'	4" Ice			
							No Ice	2.86	7.23	0.03
							1/2" Ice	3.22	7.92	0.08
			1'				Ice	3.59	8.63	0.13

Description	Face or Leg	Offset Type	Offsets:		Azimuth Adjustment	Placement	C _A A _{Front}	C _A A _{Side}	Weight
			Horz Lateral	Vert					
(2) SC 9012 REV2 w/ Mount Pipe	B	From Leg	4.00	0.0000	90'	1" Ice	4.45	10.11	0.25
						2" Ice	6.32	13.34	0.61
						4" Ice			
						No Ice	2.95	4.40	0.03
						1/2" Ice	3.33	5.01	0.06
						Ice	3.73	5.64	0.10
(2) SC 9012 REV2 w/ Mount Pipe	C	From Leg	4.00	0.0000	90'	1" Ice	4.55	6.96	0.21
						2" Ice	6.35	9.90	0.51
						4" Ice			
						No Ice	2.95	4.40	0.03
						1/2" Ice	3.33	5.01	0.06
						Ice	3.73	5.64	0.10
(2) 742 213 w/ Mount Pipe	A	From Leg	4.00	0.0000	90'	1" Ice	4.55	6.96	0.21
						2" Ice	6.35	9.90	0.51
						4" Ice			
						No Ice	5.37	4.62	0.05
						1/2" Ice	5.95	6.00	0.09
						Ice	6.50	6.98	0.15
(2) 742 213 w/ Mount Pipe	B	From Leg	4.00	0.0000	90'	1" Ice	7.61	8.85	0.28
						2" Ice	9.93	12.79	0.68
						4" Ice			
						No Ice	5.37	4.62	0.05
						1/2" Ice	5.95	6.00	0.09
						Ice	6.50	6.98	0.15
(2) 742 213 w/ Mount Pipe	C	From Leg	4.00	0.0000	90'	1" Ice	7.61	8.85	0.28
						2" Ice	9.93	12.79	0.68
						4" Ice			
						No Ice	5.37	4.62	0.05
						1/2" Ice	5.95	6.00	0.09
						Ice	6.50	6.98	0.15
BXA-70063-6CF-EDIN-0 w/ Mount Pipe	B	From Leg	4.00	0.0000	90'	1" Ice	7.61	8.85	0.28
						2" Ice	9.93	12.79	0.68
						4" Ice			
						No Ice	7.97	5.80	0.06
						1/2" Ice	8.61	6.95	0.12
						Ice	9.22	7.82	0.19
BXA-70063-6CF-EDIN-0 w/ Mount Pipe	C	From Leg	4.00	0.0000	90'	1" Ice	10.46	9.60	0.35
						2" Ice	13.07	13.37	0.82
						4" Ice			
						No Ice	7.97	5.80	0.06
						1/2" Ice	8.61	6.95	0.12
						Ice	9.22	7.82	0.19
(2) FD9R6004/2C-3L	A	From Leg	4.00	0.0000	90'	1" Ice	10.46	9.60	0.35
						2" Ice	13.07	13.37	0.82
						4" Ice			
						No Ice	0.37	0.08	0.00
						1/2" Ice	0.45	0.14	0.01
						Ice	0.54	0.20	0.01
(2) FD9R6004/2C-3L	B	From Leg	4.00	0.0000	90'	1" Ice	0.75	0.34	0.02
						2" Ice	1.28	0.74	0.06
						4" Ice			
						No Ice	0.37	0.08	0.00
						1/2" Ice	0.45	0.14	0.01
						Ice	0.54	0.20	0.01
(2) FD9R6004/2C-3L	C	From Leg	4.00	0.0000	90'	1" Ice	0.75	0.34	0.02
						2" Ice	1.28	0.74	0.06
						4" Ice			
						No Ice	0.37	0.08	0.00
						1/2" Ice	0.45	0.14	0.01
						Ice	0.54	0.20	0.01
RRH2x40-AWS	A	From Leg	4.00	0.0000	90'	No Ice	2.52	1.59	0.04
						1/2" Ice	2.75	1.80	0.06

Description	Face or Leg	Offset Type	Offsets: Horz Lateral Vert ft ft ft	Azimuth Adjustment °	Placement ft	C _A A _A Front ft ²	C _A A _A Side ft ²	Weight K	
			1'			Ice	2.99	2.01	0.08
						1" Ice	3.50	2.46	0.13
						2" Ice	4.61	3.48	0.28
						4" Ice			
RRH2x40-AWS	B	From Leg	4.00	0.0000	90'	No Ice	2.52	1.59	0.04
			0'			1/2"	2.75	1.80	0.06
			1'			Ice	2.99	2.01	0.08
						1" Ice	3.50	2.46	0.13
						2" Ice	4.61	3.48	0.28
						4" Ice			
RRH2x40-AWS	C	From Leg	4.00	0.0000	90'	No Ice	2.52	1.59	0.04
			0'			1/2"	2.75	1.80	0.06
			1'			Ice	2.99	2.01	0.08
						1" Ice	3.50	2.46	0.13
						2" Ice	4.61	3.48	0.28
						4" Ice			
DB-B1-6C-8AB-0Z	A	From Leg	4.00	0.0000	90'	No Ice	5.60	2.33	0.04
			0'			1/2"	5.92	2.56	0.08
			1'			Ice	6.24	2.79	0.12
						1" Ice	6.91	3.28	0.21
						2" Ice	8.37	4.37	0.45
						4" Ice			
Platform Mount [LP 712-1]	C	None		0.0000	90'	No Ice	24.53	24.53	1.34
						1/2"	29.94	29.94	1.65
						Ice	35.35	35.35	1.96
						1" Ice	46.17	46.17	2.58
						2" Ice	67.81	67.81	3.82
						4" Ice			

(4) DB844H90-XY w/ Mount Pipe	A	From Leg	4.00	0.0000	80'	No Ice	3.10	5.15	0.03
			0'			1/2"	3.48	5.83	0.07
			1'			Ice	3.88	6.52	0.11
						1" Ice	4.76	7.96	0.22
						2" Ice	6.66	11.09	0.55
						4" Ice			
(4) DB844H90-XY w/ Mount Pipe	B	From Leg	4.00	0.0000	80'	No Ice	3.10	5.15	0.03
			0'			1/2"	3.48	5.83	0.07
			1'			Ice	3.88	6.52	0.11
						1" Ice	4.76	7.96	0.22
						2" Ice	6.66	11.09	0.55
						4" Ice			
(4) DB844H90-XY w/ Mount Pipe	C	From Leg	4.00	0.0000	80'	No Ice	3.10	5.15	0.03
			0'			1/2"	3.48	5.83	0.07
			1'			Ice	3.88	6.52	0.11
						1" Ice	4.76	7.96	0.22
						2" Ice	6.66	11.09	0.55
						4" Ice			
Platform Mount [LP 712-1]	C	None		0.0000	80'	No Ice	24.53	24.53	1.34
						1/2"	29.94	29.94	1.65
						Ice	35.35	35.35	1.96
						1" Ice	46.17	46.17	2.58
						2" Ice	67.81	67.81	3.82
						4" Ice			

PCS 1900MHz 4x45W-65MHz	A	From Leg	2.00	0.0000	74'	No Ice	2.71	2.61	0.06
			0'			1/2"	2.95	2.85	0.08
			0'			Ice	3.20	3.09	0.11
						1" Ice	3.72	3.61	0.17
						2" Ice	4.86	4.74	0.35
						4" Ice			
PCS 1900MHz 4x45W-65MHz	B	From Leg	2.00	0.0000	74'	No Ice	2.71	2.61	0.06
			0'			1/2"	2.95	2.85	0.08
			0'			Ice	3.20	3.09	0.11
						1" Ice	3.72	3.61	0.17
						2" Ice	4.86	4.74	0.35
						4" Ice			

Description	Face or Leg	Offset Type	Offsets:		Azimuth Adjustment	Placement	C _A A _A Front	C _A A _A Side	Weight	
			Horz	Lateral						ft
							ft ²	ft ²	K	
PCS 1900MHz 4x45W-65MHz	C	From Leg	2.00	0'	0.0000	74'	4" Ice			
							No Ice	2.71	2.61	0.06
							1/2" Ice	2.95	2.85	0.08
							1" Ice	3.20	3.09	0.11
							2" Ice	3.72	3.61	0.17
800MHz 2X50W RRH W/FILTER	A	From Leg	2.00	0'	0.0000	74'	4" Ice			
							No Ice	2.40	2.25	0.06
							1/2" Ice	2.61	2.46	0.09
							1" Ice	2.83	2.68	0.11
							2" Ice	3.30	3.13	0.17
800MHz 2X50W RRH W/FILTER	B	From Leg	2.00	0'	0.0000	74'	4" Ice			
							No Ice	2.40	2.25	0.06
							1/2" Ice	2.61	2.46	0.09
							1" Ice	2.83	2.68	0.11
							2" Ice	3.30	3.13	0.17
800MHz 2X50W RRH W/FILTER	C	From Leg	2.00	0'	0.0000	74'	4" Ice			
							No Ice	2.40	2.25	0.06
							1/2" Ice	2.61	2.46	0.09
							1" Ice	2.83	2.68	0.11
							2" Ice	3.30	3.13	0.17
Side Arm Mount [SO 102-3]	C	None			0.0000	74'	4" Ice			
							No Ice	3.00	3.00	0.08
							1/2" Ice	3.48	3.48	0.11
							1" Ice	3.96	3.96	0.14
							2" Ice	4.92	4.92	0.20
(2) 5'x2 1/2" Pipe Mount	A	From Leg	2.00	0'	0.0000	74'	4" Ice			
							No Ice	1.33	1.33	0.03
							1/2" Ice	1.63	1.63	0.04
							1" Ice	1.95	1.95	0.05
							2" Ice	2.60	2.60	0.09
(2) 5'x2 1/2" Pipe Mount	B	From Leg	2.00	0'	0.0000	74'	4" Ice			
							No Ice	1.33	1.33	0.03
							1/2" Ice	1.63	1.63	0.04
							1" Ice	1.95	1.95	0.05
							2" Ice	2.60	2.60	0.09
(2) 5'x2 1/2" Pipe Mount	C	From Leg	2.00	0'	0.0000	74'	4" Ice			
							No Ice	1.33	1.33	0.03
							1/2" Ice	1.63	1.63	0.04
							1" Ice	1.95	1.95	0.05
							2" Ice	2.60	2.60	0.09

APXV9ERR18-C-A20 w/ Mount Pipe	A	From Leg	4.00	0'	0.0000	72'	4" Ice			
							No Ice	8.50	7.47	0.09
							1/2" Ice	9.15	8.66	0.16
							1" Ice	9.77	9.56	0.24
							2" Ice	11.03	11.39	0.42
APXVSP18-C-A20 w/ Mount Pipe	B	From Leg	4.00	0'	0.0000	72'	4" Ice			
							No Ice	8.50	6.95	0.08
							1/2" Ice	9.15	8.13	0.15
							1" Ice	9.77	9.02	0.23
							2" Ice	11.03	10.84	0.41
APXV9ERR18-C-A20 w/ Mount Pipe	C	From Leg	4.00	0'	0.0000	72'	4" Ice			
							No Ice	8.50	7.47	0.09
							1/2" Ice	9.15	8.66	0.16
							1" Ice	9.77	9.56	0.24
							2" Ice	11.03	11.39	0.42

Description	Face or Leg	Offset Type	Offsets: Horz Lateral Vert ft ft ft	Azimuth Adjustment	Placement ft	C _A A _A Front ft ²	C _A A _A Side ft ²	Weight K	
						1" Ice	11.03	11.39	0.42
						2" Ice	13.68	15.53	0.94
						4" Ice			
APXVTM14-C-120 w/ Mount Pipe	A	From Leg	4.00 0' 2'	0.0000	72'	No Ice	7.13	4.96	0.08
						1/2"	7.66	5.75	0.13
						Ice	8.18	6.47	0.19
						1" Ice	9.26	8.01	0.34
						2" Ice	11.53	11.41	0.75
						4" Ice			
APXVTM14-C-120 w/ Mount Pipe	B	From Leg	4.00 0' 2'	0.0000	72'	No Ice	7.13	4.96	0.08
						1/2"	7.66	5.75	0.13
						Ice	8.18	6.47	0.19
						1" Ice	9.26	8.01	0.34
						2" Ice	11.53	11.41	0.75
						4" Ice			
APXVTM14-C-120 w/ Mount Pipe	C	From Leg	4.00 0' 2'	0.0000	72'	No Ice	7.13	4.96	0.08
						1/2"	7.66	5.75	0.13
						Ice	8.18	6.47	0.19
						1" Ice	9.26	8.01	0.34
						2" Ice	11.53	11.41	0.75
						4" Ice			
TD-RRH8x20-25	A	From Leg	4.00 0' 2'	0.0000	72'	No Ice	4.72	1.70	0.07
						1/2"	5.01	1.92	0.10
						Ice	5.32	2.15	0.13
						1" Ice	5.95	2.62	0.20
						2" Ice	7.31	3.68	0.40
						4" Ice			
TD-RRH8x20-25	B	From Leg	4.00 0' 2'	0.0000	72'	No Ice	4.72	1.70	0.07
						1/2"	5.01	1.92	0.10
						Ice	5.32	2.15	0.13
						1" Ice	5.95	2.62	0.20
						2" Ice	7.31	3.68	0.40
						4" Ice			
TD-RRH8x20-25	C	From Leg	4.00 0' 2'	0.0000	72'	No Ice	4.72	1.70	0.07
						1/2"	5.01	1.92	0.10
						Ice	5.32	2.15	0.13
						1" Ice	5.95	2.62	0.20
						2" Ice	7.31	3.68	0.40
						4" Ice			
Platform Mount [LP 712-1]	C	None		0.0000	72'	No Ice	24.53	24.53	1.34
						1/2"	29.94	29.94	1.65
						Ice	35.35	35.35	1.96
						1" Ice	46.17	46.17	2.58
						2" Ice	67.81	67.81	3.82
						4" Ice			
5' x 2' Pipe Mount	A	From Leg	4.00 0' 2'	0.0000	72'	No Ice	1.00	1.00	0.03
						1/2"	1.39	1.39	0.04
						Ice	1.70	1.70	0.05
						1" Ice	2.35	2.35	0.08
						2" Ice	3.78	3.78	0.20
						4" Ice			
5' x 2' Pipe Mount	B	From Leg	4.00 0' 2'	0.0000	72'	No Ice	1.00	1.00	0.03
						1/2"	1.39	1.39	0.04
						Ice	1.70	1.70	0.05
						1" Ice	2.35	2.35	0.08
						2" Ice	3.78	3.78	0.20
						4" Ice			
5' x 2' Pipe Mount	C	From Leg	4.00 0' 2'	0.0000	72'	No Ice	1.00	1.00	0.03
						1/2"	1.39	1.39	0.04
						Ice	1.70	1.70	0.05
						1" Ice	2.35	2.35	0.08
						2" Ice	3.78	3.78	0.20
						4" Ice			

APX18-206516L	A	From Leg	1.00	0.0000	62'	No Ice	3.51	2.00	0.02

Description	Face or Leg	Offset Type	Offsets: Horz Lateral Vert ft ft ft	Azimuth Adjustment °	Placement ft	C _A A _A Front ft ²	C _A A _A Side ft ²	Weight K	
			0'		1/2"	3.85	2.33	0.04	
			0'		Ice	4.22	2.66	0.06	
					1" Ice	5.04	3.34	0.12	
					2" Ice	6.80	4.81	0.31	
					4" Ice				
APX18-206516L	B	From Leg	1.00	0.0000	62'	No Ice	3.51	2.00	0.02
			0'		1/2"	3.85	2.33	0.04	
			0'		Ice	4.22	2.66	0.06	
					1" Ice	5.04	3.34	0.12	
					2" Ice	6.80	4.81	0.31	
					4" Ice				
APX18-206516L	C	From Leg	1.00	0.0000	62'	No Ice	3.51	2.00	0.02
			0'		1/2"	3.85	2.33	0.04	
			0'		Ice	4.22	2.66	0.06	
					1" Ice	5.04	3.34	0.12	
					2" Ice	6.80	4.81	0.31	
					4" Ice				
Pipe Mount [PM 501-3]	C	None		0.0000	62'	No Ice	5.78	5.78	0.16
					1/2"	7.37	7.37	0.18	
					Ice	8.96	8.96	0.20	
					1" Ice	12.14	12.14	0.24	
					2" Ice	18.50	18.50	0.32	
					4" Ice				

GPS	A	From Leg	3.00	0.0000	47'	No Ice	0.17	0.17	0.00
			0'		1/2"	0.24	0.24	0.00	
			0'		Ice	0.31	0.31	0.00	
					1" Ice	0.48	0.48	0.01	
					2" Ice	0.92	0.92	0.05	
					4" Ice				
Side Arm Mount [SO 701-1]	A	From Leg	1.50	0.0000	47'	No Ice	0.85	1.67	0.07
			0'		1/2"	1.14	2.34	0.08	
			0'		Ice	1.43	3.01	0.09	
					1" Ice	2.01	4.35	0.12	
					2" Ice	3.17	7.03	0.18	
					4" Ice				

Load Combinations

Comb. No.	Description
1	Dead Only
2	Dead+Wind 0 deg - No Ice
3	Dead+Wind 30 deg - No Ice
4	Dead+Wind 60 deg - No Ice
5	Dead+Wind 90 deg - No Ice
6	Dead+Wind 120 deg - No Ice
7	Dead+Wind 150 deg - No Ice
8	Dead+Wind 180 deg - No Ice
9	Dead+Wind 210 deg - No Ice
10	Dead+Wind 240 deg - No Ice
11	Dead+Wind 270 deg - No Ice
12	Dead+Wind 300 deg - No Ice
13	Dead+Wind 330 deg - No Ice
14	Dead+Ice+Temp
15	Dead+Wind 0 deg+Ice+Temp
16	Dead+Wind 30 deg+Ice+Temp
17	Dead+Wind 60 deg+Ice+Temp
18	Dead+Wind 90 deg+Ice+Temp

Comb. No.	Description
19	Dead+Wind 120 deg+Ice+Temp
20	Dead+Wind 150 deg+Ice+Temp
21	Dead+Wind 180 deg+Ice+Temp
22	Dead+Wind 210 deg+Ice+Temp
23	Dead+Wind 240 deg+Ice+Temp
24	Dead+Wind 270 deg+Ice+Temp
25	Dead+Wind 300 deg+Ice+Temp
26	Dead+Wind 330 deg+Ice+Temp
27	Dead+Wind 0 deg - Service
28	Dead+Wind 30 deg - Service
29	Dead+Wind 60 deg - Service
30	Dead+Wind 90 deg - Service
31	Dead+Wind 120 deg - Service
32	Dead+Wind 150 deg - Service
33	Dead+Wind 180 deg - Service
34	Dead+Wind 210 deg - Service
35	Dead+Wind 240 deg - Service
36	Dead+Wind 270 deg - Service
37	Dead+Wind 300 deg - Service
38	Dead+Wind 330 deg - Service

Maximum Member Forces

Section No.	Elevation ft	Component Type	Condition	Gov. Load Comb.	Force K	Major Axis Moment kip-ft	Minor Axis Moment kip-ft
L1	109 - 95	Pole	Max Tension	15	0.00	0.00	-0.00
			Max. Compression	14	-7.10	-0.75	1.53
			Max. Mx	5	-3.27	-75.01	0.18
			Max. My	2	-3.26	0.17	78.09
			Max. Vy	5	5.90	-75.01	0.18
			Max. Vx	2	-6.10	0.17	78.09
			Max. Torque	12			-1.08
L2	95 - 48.0833	Pole	Max Tension	1	0.00	0.00	0.00
			Max. Compression	14	-28.80	-0.21	2.19
			Max. Mx	5	-15.21	-696.46	-1.34
			Max. My	2	-15.20	1.89	703.53
			Max. Vy	5	19.88	-696.46	-1.34
			Max. Vx	2	-19.95	1.89	703.53
			Max. Torque	11			-2.14
L3	48.0833 - 0	Pole	Max Tension	1	0.00	0.00	0.00
			Max. Compression	14	-44.80	2.08	1.89
			Max. Mx	5	-26.86	-1848.28	-3.34
			Max. My	2	-26.86	4.27	1858.43
			Max. Vy	5	23.58	-1848.28	-3.34
			Max. Vx	2	-23.62	4.27	1858.43
			Max. Torque	11			-2.38

Maximum Reactions

Location	Condition	Gov. Load Comb.	Vertical K	Horizontal, X K	Horizontal, Z K
Pole	Max. Vert	26	44.80	3.41	5.91
	Max. H _x	11	26.88	23.56	0.04
	Max. H _z	2	26.88	0.04	23.61
	Max. M _x	2	1858.43	0.04	23.61
	Max. M _z	5	1848.28	-23.56	-0.04
	Max. Torsion	5	2.38	-23.56	-0.04
	Min. Vert	1	26.88	0.00	0.00
	Min. H _x	5	26.88	-23.56	-0.04
	Min. H _z	8	26.88	-0.04	-23.61
	Min. M _x	8	-1856.11	-0.04	-23.61

Location	Condition	Gov. Load Comb.	Vertical K	Horizontal, X K	Horizontal, Z K
	Min. M _z	11	-1847.81	23.56	0.04
	Min. Torsion	11	-2.38	23.56	0.04

Tower Mast Reaction Summary

Load Combination	Vertical K	Shear _x K	Shear _z K	Overtuning Moment, M _x kip-ft	Overtuning Moment, M _z kip-ft	Torque kip-ft
Dead Only	26.88	0.00	0.00	-1.13	-0.22	0.00
Dead+Wind 0 deg - No Ice	26.88	-0.04	-23.61	-1858.43	4.27	0.39
Dead+Wind 30 deg - No Ice	26.88	11.74	-20.42	-1607.36	-920.36	-0.86
Dead+Wind 60 deg - No Ice	26.88	20.38	-11.77	-925.90	-1598.44	-1.87
Dead+Wind 90 deg - No Ice	26.88	23.56	0.04	3.34	-1848.28	-2.38
Dead+Wind 120 deg - No Ice	26.88	20.42	11.84	931.37	-1602.93	-2.25
Dead+Wind 150 deg - No Ice	26.88	11.82	20.46	1609.53	-928.14	-1.52
Dead+Wind 180 deg - No Ice	26.88	0.04	23.61	1856.11	-4.73	-0.39
Dead+Wind 210 deg - No Ice	26.88	-11.74	20.42	1605.04	919.89	0.85
Dead+Wind 240 deg - No Ice	26.88	-20.38	11.77	923.58	1597.97	1.86
Dead+Wind 270 deg - No Ice	26.88	-23.56	-0.04	-5.66	1847.81	2.38
Dead+Wind 300 deg - No Ice	26.88	-20.42	-11.84	-933.69	1602.46	2.27
Dead+Wind 330 deg - No Ice	26.88	-11.82	-20.46	-1611.85	927.68	1.53
Dead+Ice+Temp	44.80	0.00	-0.00	-1.89	2.08	0.00
Dead+Wind 0 deg+Ice+Temp	44.80	-0.01	-6.81	-549.12	3.19	0.09
Dead+Wind 30 deg+Ice+Temp	44.80	3.39	-5.90	-475.28	-269.39	-0.26
Dead+Wind 60 deg+Ice+Temp	44.80	5.89	-3.40	-274.61	-469.22	-0.54
Dead+Wind 90 deg+Ice+Temp	44.80	6.80	0.01	-0.89	-542.76	-0.68
Dead+Wind 120 deg+Ice+Temp	44.80	5.90	3.42	272.54	-470.30	-0.63
Dead+Wind 150 deg+Ice+Temp	44.80	3.41	5.91	472.42	-271.26	-0.42
Dead+Wind 180 deg+Ice+Temp	44.80	0.01	6.81	545.18	1.03	-0.09
Dead+Wind 210 deg+Ice+Temp	44.80	-3.39	5.90	471.33	273.61	0.26
Dead+Wind 240 deg+Ice+Temp	44.80	-5.89	3.40	270.67	473.44	0.54
Dead+Wind 270 deg+Ice+Temp	44.80	-6.80	-0.01	-3.05	546.98	0.68
Dead+Wind 300 deg+Ice+Temp	44.80	-5.90	-3.42	-276.49	474.52	0.64
Dead+Wind 330 deg+Ice+Temp	44.80	-3.41	-5.91	-476.36	275.48	0.42
Dead+Wind 0 deg - Service	26.88	-0.02	-9.22	-726.89	1.52	0.15
Dead+Wind 30 deg - Service	26.88	4.59	-7.98	-628.78	-359.77	-0.34
Dead+Wind 60 deg - Service	26.88	7.96	-4.60	-362.50	-624.73	-0.73
Dead+Wind 90 deg - Service	26.88	9.20	0.02	0.60	-722.35	-0.93
Dead+Wind 120 deg - Service	26.88	7.98	4.62	363.22	-626.48	-0.88
Dead+Wind 150 deg - Service	26.88	4.62	7.99	628.21	-362.81	-0.60
Dead+Wind 180 deg - Service	26.88	0.02	9.22	724.56	-1.99	-0.15
Dead+Wind 210 deg - Service	26.88	-4.59	7.98	626.46	359.30	0.33
Dead+Wind 240 deg - Service	26.88	-7.96	4.60	360.18	624.26	0.73
Dead+Wind 270 deg - Service	26.88	-9.20	-0.02	-2.92	721.88	0.93
Dead+Wind 300 deg - Service	26.88	-7.98	-4.62	-365.55	626.02	0.88
Dead+Wind 330 deg - Service	26.88	-4.62	-7.99	-630.54	362.35	0.60

Load Combination	Vertical	Shear _x	Shear _z	Overturning Moment, M _x	Overturning Moment, M _z	Torque
	K	K	K	kip-ft	kip-ft	kip-ft
Service						

Solution Summary

Load Comb.	Sum of Applied Forces			Sum of Reactions			% Error
	PX K	PY K	PZ K	PX K	PY K	PZ K	
1	0.00	-26.88	0.00	0.00	26.88	0.00	0.000%
2	-0.04	-26.88	-23.61	0.04	26.88	23.61	0.000%
3	11.74	-26.88	-20.42	-11.74	26.88	20.42	0.000%
4	20.38	-26.88	-11.77	-20.38	26.88	11.77	0.000%
5	23.56	-26.88	0.04	-23.56	26.88	-0.04	0.000%
6	20.42	-26.88	11.84	-20.42	26.88	-11.84	0.000%
7	11.82	-26.88	20.46	-11.82	26.88	-20.46	0.000%
8	0.04	-26.88	23.61	-0.04	26.88	-23.61	0.000%
9	-11.74	-26.88	20.42	11.74	26.88	-20.42	0.000%
10	-20.38	-26.88	11.77	20.38	26.88	-11.77	0.000%
11	-23.56	-26.88	-0.04	23.56	26.88	0.04	0.000%
12	-20.42	-26.88	-11.84	20.42	26.88	11.84	0.000%
13	-11.82	-26.88	-20.46	11.82	26.88	20.46	0.000%
14	0.00	-44.80	0.00	0.00	44.80	0.00	0.000%
15	-0.01	-44.80	-6.81	0.01	44.80	6.81	0.000%
16	3.39	-44.80	-5.90	-3.39	44.80	5.90	0.000%
17	5.89	-44.80	-3.40	-5.89	44.80	3.40	0.000%
18	6.80	-44.80	0.01	-6.80	44.80	-0.01	0.000%
19	5.90	-44.80	3.42	-5.90	44.80	-3.42	0.000%
20	3.41	-44.80	5.91	-3.41	44.80	-5.91	0.000%
21	0.01	-44.80	6.81	-0.01	44.80	-6.81	0.000%
22	-3.39	-44.80	5.90	3.39	44.80	-5.90	0.000%
23	-5.89	-44.80	3.40	5.89	44.80	-3.40	0.000%
24	-6.80	-44.80	-0.01	6.80	44.80	0.01	0.000%
25	-5.90	-44.80	-3.42	5.90	44.80	3.42	0.000%
26	-3.41	-44.80	-5.91	3.41	44.80	5.91	0.000%
27	-0.02	-26.88	-9.22	0.02	26.88	9.22	0.000%
28	4.59	-26.88	-7.98	-4.59	26.88	7.98	0.000%
29	7.96	-26.88	-4.60	-7.96	26.88	4.60	0.000%
30	9.20	-26.88	0.02	-9.20	26.88	-0.02	0.000%
31	7.98	-26.88	4.62	-7.98	26.88	-4.62	0.000%
32	4.62	-26.88	7.99	-4.62	26.88	-7.99	0.000%
33	0.02	-26.88	9.22	-0.02	26.88	-9.22	0.000%
34	-4.59	-26.88	7.98	4.59	26.88	-7.98	0.000%
35	-7.96	-26.88	4.60	7.96	26.88	-4.60	0.000%
36	-9.20	-26.88	-0.02	9.20	26.88	0.02	0.000%
37	-7.98	-26.88	-4.62	7.98	26.88	4.62	0.000%
38	-4.62	-26.88	-7.99	4.62	26.88	7.99	0.000%

Non-Linear Convergence Results

Load Combination	Converged?	Number of Cycles	Displacement Tolerance	Force Tolerance
1	Yes	4	0.00000001	0.00000001
2	Yes	4	0.00000001	0.00010230
3	Yes	5	0.00000001	0.00003013
4	Yes	5	0.00000001	0.00003464
5	Yes	4	0.00000001	0.00037543
6	Yes	5	0.00000001	0.00002807
7	Yes	5	0.00000001	0.00003520
8	Yes	4	0.00000001	0.00012210
9	Yes	5	0.00000001	0.00003214
10	Yes	5	0.00000001	0.00002820
11	Yes	4	0.00000001	0.00039532
12	Yes	5	0.00000001	0.00003657

13	Yes	5	0.00000001	0.00002885
14	Yes	4	0.00000001	0.00000611
15	Yes	4	0.00000001	0.00057037
16	Yes	4	0.00000001	0.00066620
17	Yes	4	0.00000001	0.00067511
18	Yes	4	0.00000001	0.00056843
19	Yes	4	0.00000001	0.00065590
20	Yes	4	0.00000001	0.00066870
21	Yes	4	0.00000001	0.00056065
22	Yes	4	0.00000001	0.00065812
23	Yes	4	0.00000001	0.00065178
24	Yes	4	0.00000001	0.00056986
25	Yes	4	0.00000001	0.00068504
26	Yes	4	0.00000001	0.00066948
27	Yes	4	0.00000001	0.00002454
28	Yes	4	0.00000001	0.00012533
29	Yes	4	0.00000001	0.00017081
30	Yes	4	0.00000001	0.00008326
31	Yes	4	0.00000001	0.00011964
32	Yes	4	0.00000001	0.00017351
33	Yes	4	0.00000001	0.00002605
34	Yes	4	0.00000001	0.00014303
35	Yes	4	0.00000001	0.00011473
36	Yes	4	0.00000001	0.00008482
37	Yes	4	0.00000001	0.00018989
38	Yes	4	0.00000001	0.00011890

Maximum Tower Deflections - Service Wind

Section No.	Elevation ft	Horz. Deflection in	Gov. Load Comb.	Tilt °	Twist °
L1	109 - 95	14.480	27	1.0666	0.0061
L2	95 - 48.0833	11.399	27	1.0193	0.0047
L3	53 - 0	3.764	38	0.6464	0.0016

Critical Deflections and Radius of Curvature - Service Wind

Elevation ft	Appurtenance	Gov. Load Comb.	Deflection in	Tilt °	Twist °	Radius of Curvature ft
111'	Lighting Rod 3/4" x 4"	27	14.480	1.0666	0.0062	41872
107'	800 10121 w/ Mount Pipe	27	14.036	1.0611	0.0060	41872
90'	BXA-70063-4CF-EDIN-X w/ Mount Pipe	27	10.329	0.9926	0.0043	10887
80'	(4) DB844H90-XY w/ Mount Pipe	38	8.279	0.9209	0.0034	7051
74'	PCS 1900MHz 4x45W-65MHz	38	7.127	0.8683	0.0029	5821
72'	APXV9ERR18-C-A20 w/ Mount Pipe	38	6.759	0.8494	0.0028	5500
62'	APX18-206516L	38	5.058	0.7468	0.0021	4314
47'	GPS	38	3.043	0.5770	0.0013	4074

Maximum Tower Deflections - Design Wind

Section No.	Elevation ft	Horz. Deflection in	Gov. Load Comb.	Tilt °	Twist °
L1	109 - 95	36.970	2	2.7195	0.0156
L2	95 - 48.0833	29.118	13	2.6017	0.0119
L3	53 - 0	9.621	13	1.6522	0.0041

Section No.	Elevation ft	Horz. Deflection in	Gov. Load Comb.	Tilt °	Twist °
-------------	-----------------	------------------------	-----------------	-----------	------------

Critical Deflections and Radius of Curvature - Design Wind

Elevation ft	Appurtenance	Gov. Load Comb.	Deflection in	Tilt °	Twist °	Radius of Curvature ft
111'	Lighting Rod 3/4" x 4'	2	36.970	2.7195	0.0159	16776
107'	800 10121 w/ Mount Pipe	2	35.839	2.7059	0.0154	16776
90'	BXA-70063-4CF-EDIN-X w/ Mount Pipe	13	26.389	2.5341	0.0109	4329
80'	(4) DB844H90-XY w/ Mount Pipe	13	21.157	2.3525	0.0087	2783
74'	PCS 1900MHz 4x45W-65MHz	13	18.215	2.2186	0.0075	2292
72'	APXV9ERR18-C-A20 w/ Mount Pipe	13	17.274	2.1704	0.0072	2165
62'	APX18-206516L	13	12.929	1.9088	0.0054	1693
47'	GPS	13	7.779	1.4751	0.0034	1596

Compression Checks

Pole Design Data

Section No.	Elevation ft	Size	L ft	L _u ft	Kl/r	F _a ksi	A in ²	Actual P K	Allow. P _a K	Ratio P P _a
L1	109 - 95 (1)	TP26.715x23.476x0.1875	14'	0'	0.0	39.000	15.7872	-3.26	615.70	0.005
L2	95 - 48.0833 (2)	TP37.573x26.715x0.3125	46'11-1/32"	0'	0.0	39.000	35.8291	-15.20	1397.34	0.011
L3	48.0833 - 0 (3)	TP48.075x35.8101x0.375	53'	0'	0.0	39.000	56.7749	-26.86	2214.22	0.012

Pole Bending Design Data

Section No.	Elevation ft	Size	Actual M _x kip-ft	Actual f _{bx} ksi	Allow. F _{bx} ksi	Ratio f _{bx} F _{bx}	Actual M _y kip-ft	Actual f _{by} ksi	Allow. F _{by} ksi	Ratio f _{by} F _{by}
L1	109 - 95 (1)	TP26.715x23.476x0.1875	78.09	9.061	39.000	0.232	0.00	0.000	39.000	0.000
L2	95 - 48.0833 (2)	TP37.573x26.715x0.3125	703.53	26.456	39.000	0.678	0.00	0.000	39.000	0.000
L3	48.0833 - 0 (3)	TP48.075x35.8101x0.375	1859.74	33.395	39.000	0.856	0.00	0.000	39.000	0.000

Pole Shear Design Data

Section No.	Elevation ft	Size	Actual V K	Actual f _v ksi	Allow. F _v ksi	Ratio f _v F _v	Actual T kip-ft	Actual f _{vt} ksi	Allow. F _{vt} ksi	Ratio f _{vt} F _{vt}
L1	109 - 95 (1)	TP26.715x23.476x0.1875	6.10	0.386	26.000	0.030	0.56	0.032	26.000	0.001
L2	95 - 48.0833 (2)	TP37.573x26.715x0.3125	19.97	0.557	26.000	0.043	1.47	0.027	26.000	0.001
L3	48.0833 - 0 (3)	TP48.075x35.8101x0.375	23.65	0.417	26.000	0.032	1.54	0.013	26.000	0.001

Section No.	Elevation ft	Size	Actual V K	Actual f_v ksi	Allow. F_v ksi	Ratio $\frac{f_v}{F_v}$	Actual T kip-ft	Actual f_{vt} ksi	Allow. F_{vt} ksi	Ratio $\frac{f_{vt}}{F_{vt}}$
-------------	-----------------	------	---------------	---------------------	---------------------	-------------------------	--------------------	------------------------	------------------------	-------------------------------

Pole Interaction Design Data

Section No.	Elevation ft	Ratio $\frac{P}{P_a}$	Ratio $\frac{f_{bx}}{F_{bx}}$	Ratio $\frac{f_{by}}{F_{by}}$	Ratio $\frac{f_v}{F_v}$	Ratio $\frac{f_{vt}}{F_{vt}}$	Comb. Stress Ratio	Allow. Stress Ratio	Criteria
L1	109 - 95 (1)	0.005	0.232	0.000	0.030	0.001	0.238	1.333	H1-3+VT ✓
L2	95 - 48.0833 (2)	0.011	0.678	0.000	0.043	0.001	0.690	1.333	H1-3+VT ✓
L3	48.0833 - 0 (3)	0.012	0.856	0.000	0.032	0.001	0.869	1.333	H1-3+VT ✓

Section Capacity Table

Section No.	Elevation ft	Component Type	Size	Critical Element	P K	SF* P_{allow} K	% Capacity	Pass Fail	
L1	109 - 95	Pole	TP26.715x23.476x0.1875	1	-3.26	820.73	17.8	Pass	
L2	95 - 48.0833	Pole	TP37.573x26.715x0.3125	2	-15.20	1862.65	51.7	Pass	
L3	48.0833 - 0	Pole	TP48.075x35.8101x0.375	3	-26.86	2951.56	65.2	Pass	
							Summary		
							Pole (L3)	65.2	Pass
							RATING =	65.2	Pass

APPENDIX B
BASE LEVEL DRAWING



(INSTALLED)
(1) 5/8" TO 107 FT LEVEL
(2) 3/4" TO 107 FT LEVEL
(12) 1-5/8" TO 107 FT LEVEL

(PROPOSED)
(1) 1-5/8" TO 90 FT LEVEL
(INSTALLED-TO BE REMOVED)
(6) 1-1/4" TO 90 FT LEVEL
(INSTALLED)
(12) 1-1/4" TO 90 FT LEVEL

(INSTALLED)
(12) 7/8" TO 80 FT LEVEL

(RESERVED)
(1) 5/8" TO 72 FT LEVEL
(INSTALLED)
(1) 1/2" TO 47 FT LEVEL
(3) 1-1/4" TO 72 FT LEVEL

(INSTALLED)
(9) 1-5/8" TO 82 FT LEVEL

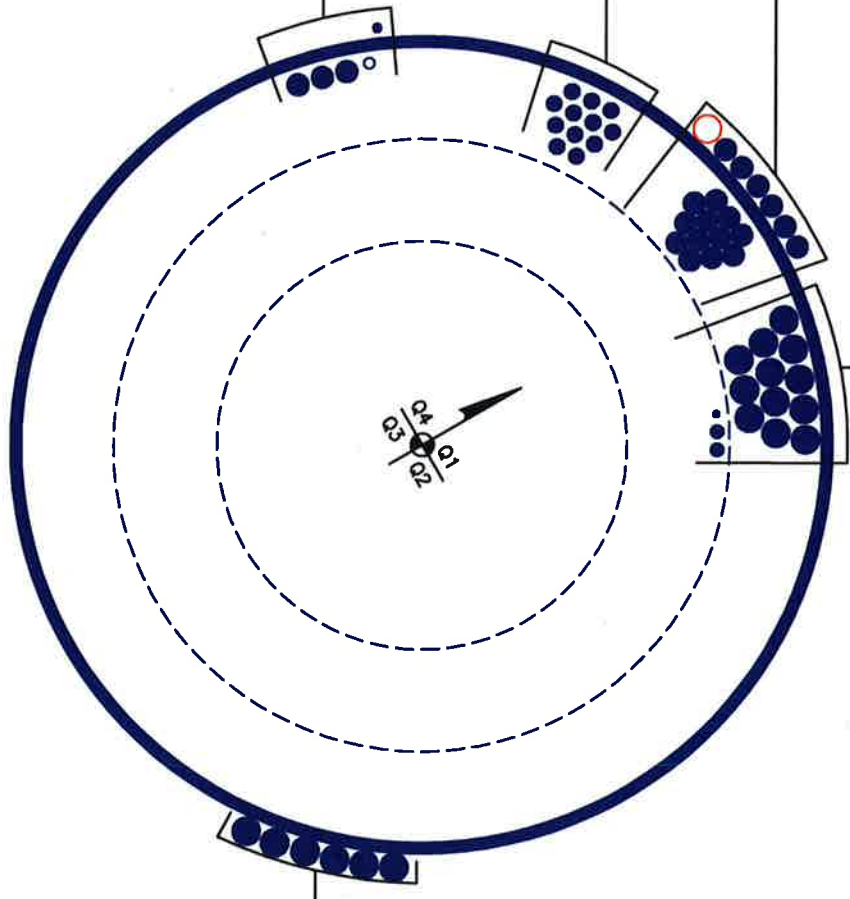

APPENDIX C
ADDITIONAL CALCULATIONS

Stiffened or Unstiffened, UngROUTed, Circular Base Plate - Any Rod Material

TIA Rev F

Site Data	
BU#:	801486
Site Name:	CT Suffield 2 CAC 801486
App #:	213949 Rev 1
Pole Manufacturer:	Other

Reactions		
Moment:	1860	ft-kips
Axial:	27	kips
Shear:	24	kips

Anchor Rod Data		
Qty:	16	
Diam:	2.25	in
Rod Material:	A615-J	
Strength (Fu):	100	ksi
Yield (Fy):	75	ksi
Bolt Circle:	55	in

If No stiffeners, Criteria: **AISC ASD** <-Only Applicable to Unstiffened Cases

Anchor Rod Results

Maximum Rod Tension: 99.8 Kips
 Allowable Tension: 195.0 Kips
 Anchor Rod Stress Ratio: 51.2% **Pass**

Rigid
Service, ASD
Fty*ASIF

Plate Data		
Diam:	61	in
Thick:	2.75	in
Grade:	60	ksi
Single-Rod B-eff:	9.54	in

Base Plate Results

Base Plate Stress: 18.4 ksi
 Allowable Plate Stress: 60.0 ksi
 Base Plate Stress Ratio: 30.6% **Pass**

Flexural Check

Rigid
Service ASD
0.75*Fy*ASIF
Y.L. Length: 26.72

Stiffener Data (Welding at both sides)		
Config:	0	*
Weld Type:		
Groove Depth:		in **
Groove Angle:		degrees
Fillet H. Weld:		<-- Disregard
Fillet V. Weld:		in
Width:		in
Height:		in
Thick:		in
Notch:		in
Grade:		ksi
Weld str.:		ksi

n/a

Stiffener Results

Horizontal Weld : n/a
 Vertical Weld: n/a
 Plate Flex+Shear, fb/Fb+(fv/Fv)^2: n/a
 Plate Tension+Shear, ft/Ft+(fv/Fv)^2: n/a
 Plate Comp. (AISC Bracket): n/a

Pole Results

Pole Punching Shear Check: n/a

Pole Data		
Diam:	48.075	in
Thick:	0.375	in
Grade:	65	ksi
# of Sides:	18	"0" IF Round
Fu	80	ksi
Reinf. Fillet Weld	0	"0" if None

Stress Increase Factor	
ASIF:	1.333

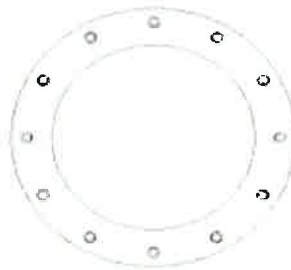

* 0 = none, 1 = every bolt, 2 = every 2 bolts, 3 = 2 per bolt

** Note: for complete joint penetration groove welds the groove depth must be exactly 1/2 the stiffener thickness for calculation purposes

Stiffened or Unstiffened, Exterior Flange Plate - Any Bolt Material TIA Rev F

Site Data

BU#: 801486
 Site Name: CT Suffield 2 CAC 801486
 App #: 213949 Rev 1

Reactions		
Moment:	78.1	ft-kips
Axial:	3.3	kips
Shear:	6.1	kips
Elevation:	95	feet

Pole Manufacturer:	Other
--------------------	-------

Bolt Data			
Qty:	20		
Diameter (in.):	1	Bolt Fu:	120
Bolt Material:	A325	Bolt Fy:	92
N/A:	75	<-- Disregard	Bolt Fty:
N/A:	55	<-- Disregard	44.00
Circle (in.):	33		

Plate Data		
Diam:	36	in
Thick, t:	2.25	in
Grade (Fy):	60	ksi
Strength, Fu:	70	ksi
Single-Rod B-eff:	4.24	in

Stiffener Data (Welding at Both Sides)		
Config:	0	*
Weld Type:		
Groove Depth:		in **
Groove Angle:		degrees
Fillet H. Weld:		<-- Disregard
Fillet V. Weld:		in
Width:		in
Height:		in
Thick:		in
Notch:		in
Grade:		ksi
Weld str.:		ksi

Pole Data		
Diam:	26.715	in
Thick:	0.1875	in
Grade:	65	ksi
# of Sides:	18	"0" IF Round
Fu	80	ksi
Reinf. Fillet Weld	0	"0" if None

Stress Increase Factor	
ASIF:	1.333

If No stiffeners, Criteria: **AISC ASD** <-Only Applicable to Unstiffened Cases

Flange Bolt Results

Bolt Tension Capacity, **B**: 46.07 kips
 Max Bolt directly applied T: 5.52 Kips
 Min. PL "tc" for **B cap. w/o Pry**: 1.703 in
 Min PL "treq" for actual **T w/ Pry**: 0.446 in
 Min PL "t1" for actual **T w/o Pry**: 0.589 in
 T allowable w/o Prying: 46.07 kips
 Prying Force, Q: 0.00 kips
 Total Bolt Tension=T+Q: 5.52 kips
 Non-Prying Bolt Stress Ratio, T/B: 12.0% **Pass**

Rigid
Service, ASD
Fty*ASIF

$\alpha' < 0$ case

Exterior Flange Plate Results

Flexural Check
 Compression Side Plate Stress: 2.9 ksi
 Allowable Plate Stress: 60.0 ksi
 Compression Plate Stress Ratio: 4.9% **Pass**
No Prying
 Tension Side Stress Ratio, (treq/t)^2: 3.9% **Pass**

Rigid
Service ASD
0.75*Fy*ASIF
Comp. Y.L. Length:
19.37

n/a

Stiffener Results

Horizontal Weld : n/a
 Vertical Weld: n/a
 Plate Flex+Shear, fb/Fb+(fv/Fv)^2: n/a
 Plate Tension+Shear, ft/Ft+(fv/Fv)^2: n/a
 Plate Comp. (AISC Bracket): n/a

Pole Results

Pole Punching Shear Check: n/a

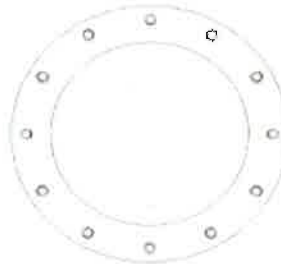

* 0 = none, 1 = every bolt, 2 = every 2 bolts, 3 = 2 per bolt

** Note: for complete joint penetration groove welds the groove depth must be exactly 1/2 the stiffener thickness for calculation purposes

(Bearing and Stability Checks) Tool for TIA Rev F or G - Application (MP, SST with unitbase)

Site Data

BU#: 801486
Site Name: CT Suffield 2 CAC 801486
App #: 213949 Rev 1

Monopole Base Reaction Forces		
TIA Revision:	F	<--Pull Down
Unfactored DL Axial, PD:	27	kips
Unfactored WL Axial, PW:	0	kips
Unfactored WL Shear, V:	24	kips
Unfactored WL Moment, M:	1860	ft-kips

Enter Load Factors Below:		
For P (DL)	1.2	<---- Enter Factor
For P,V, and M (WL)	1.35	<---- Enter Factor

Load Factor	Shaft Factored Loads		
1.20	1.2D+1.6W, Pu:	32.4	kips
0.90	0.9D+1.6W, Pu:	24.3	kips
1.35	Vu:	32.4	kips
	Mu:	2511	ft-kips

Pad & Pier Data		
Base PL Dist. Above Pier:	6	in
Pier Dist. Above Grade:	6	in
Pad Bearing Depth, D:	6.5	ft
Pad Thickness, T:	2.5	ft
Pad Width=Length, L:	26	ft
Pier Cross Section Shape:	Round	<--Pull Down
Enter Pier Diameter:	6.5	ft
Concrete Density:	150.0	pcf
Pier Cross Section Area:	33.18	ft^2
Pier Height:	4.50	ft
Soil (above pad) Height:	4.00	ft

1.2D+1.6W Load Combination, Bearing Results:

(No Soil Wedges) [Reaction+Conc+Soil]	733.74	P1="1.2D+1.6W" (Kips)
Factored "1.6W" Overturning Moment (MW-Msoil), M1	2714.19	ft-kips

Orthogonal Direction:

ecc1 = M1/P1 = 3.70 ft
 Orthogonal qu = 1.70 ksf
 qu/φ*qn Ratio = **28.39% Pass**

Soil Parameters		
Unit Weight, γ:	120.0	pcf
Ultimate Bearing Capacity, qn:	8.00	ksf
Strength Reduct. factor, φ:	0.75	
Angle of Friction, Φ:	0.0	degrees
Undrained Shear Strength, Cu:	1.15	ksf
Allowable Bearing: φ*qn:	6.00	ksf
Passive Pres. Coeff., Kp	1.00	

Diagonal Direction:

ecc2 = (0.707M1)/P1 = 2.62 ft
 Diagonal qu = 1.70 ksf
 qu/φ*qn Ratio = **28.35% Pass**

<-- Press Upon Completing All Input

Forces/Moments due to Wind and Lateral Soil		
Minimum of (φ*Ultimate Pad Passive Force, Vu):	32.4	kips
Pad Force Location Above D:	1.23	ft
φ(Passive Pressure Moment):	39.81	ft-kips
Factored O.T. M(WL), "1.6W":	2754.0	ft-kips
Factored OT (MW-Msoil), M1	2714.19	ft-kips

Overturning Stability Check

0.9D+1.6W Load Combination, Bearing Results:

(w/ Soil Wedges) [Reaction+Conc+Soil]	550.31	P2="0.9D+1.6W" (Kips)
Factored "1.6W" Overturning Moment (MW-Msoil) - 0.9(M of Wedge + M of Cohesion), M2	1999.56	ft-kips

Resistance due to Foundation Gravity		
Soil Wedge Projection grade, a:	0.00	ft
Sum of Soil Wedges Wt:	0.00	kips
Soil Wedges ecc, K1:	0.00	ft
Ftg+Soil above Pad wt:	584.5	kips
Unfactored (Total ftg-soil Wt):	584.45	kips
1.2D. No Soil Wedges.	733.74	kips
0.9D. With Soil Wedges	550.31	kips

Orthogonal ecc3 = M2/P2 = 3.63 ft
 Ortho Non Bearing Length, NBL = 7.27 ft
 Orthogonal qu = 1.27 ksf
 Diagonal qu = 1.26 ksf

Resistance due to Cohesion (Vertical)		
φ*(1/2*Cu)(Total Vert. Planes)	66.13	kips
Cohesion Force Eccentricity, K2	12.01	ft

Max Reaction Moment (ft-kips) so that qu=φ*qn = 100% Capacity Rating

Actual M:	1860.00		
M Orthogonal:	4909.61	37.88%	Pass
M Diagonal:	4909.61	37.88%	Pass

Spread Footing Reinforcement Design		
Concrete Parameters		
Unit weight (γ):	0.150	kcf
Comp.strength (f_c'):	3	ksi (assumed)
Phi:	0.90	Moment
Phi:	0.75	Shear
Steel Parameters		
Yield strength (f_y):	60	ksi
Bar Size:	9	
Bar Spacing:	14	in OC
Concrete Cover:	3	in
As:	0.86	in ² /ft
Foundation Dimensions		
Pier Size	6.5	ft
Footing Depth	26	ft
Footing Width	26	ft
Footing Thickness	2.5	ft
Bearing Depth	6.5	ft
Edge of footing to face of pier	9.75	ft
One Way Shear		
Critical Section Distance	7.25	ft
Shear at Critical Section	12.66	kips
Shear Stress at Critical Section	5.07	ksf
Allowable Shear Stress	15.77	ksf
FS	2.34	O.K.
Moment Capacity of Footing		
T	51.4	kips/ft
d	26.4	in
a	1.681	in
Mn	2852.1	kip-ft
Phi*Mn	2566.9	kip-ft
Calculation of Applied Moment		
q_{max} (conservative):	1.70	ksf
Mu at pier:	2120.96	kip-ft
FS	1.21	O.K.

ATTACHMENT 4

Town of Suffield, Connecticut - Assessment Parcel Map

Parcel: 34H-32-4

Address: 44 FFYLER PL

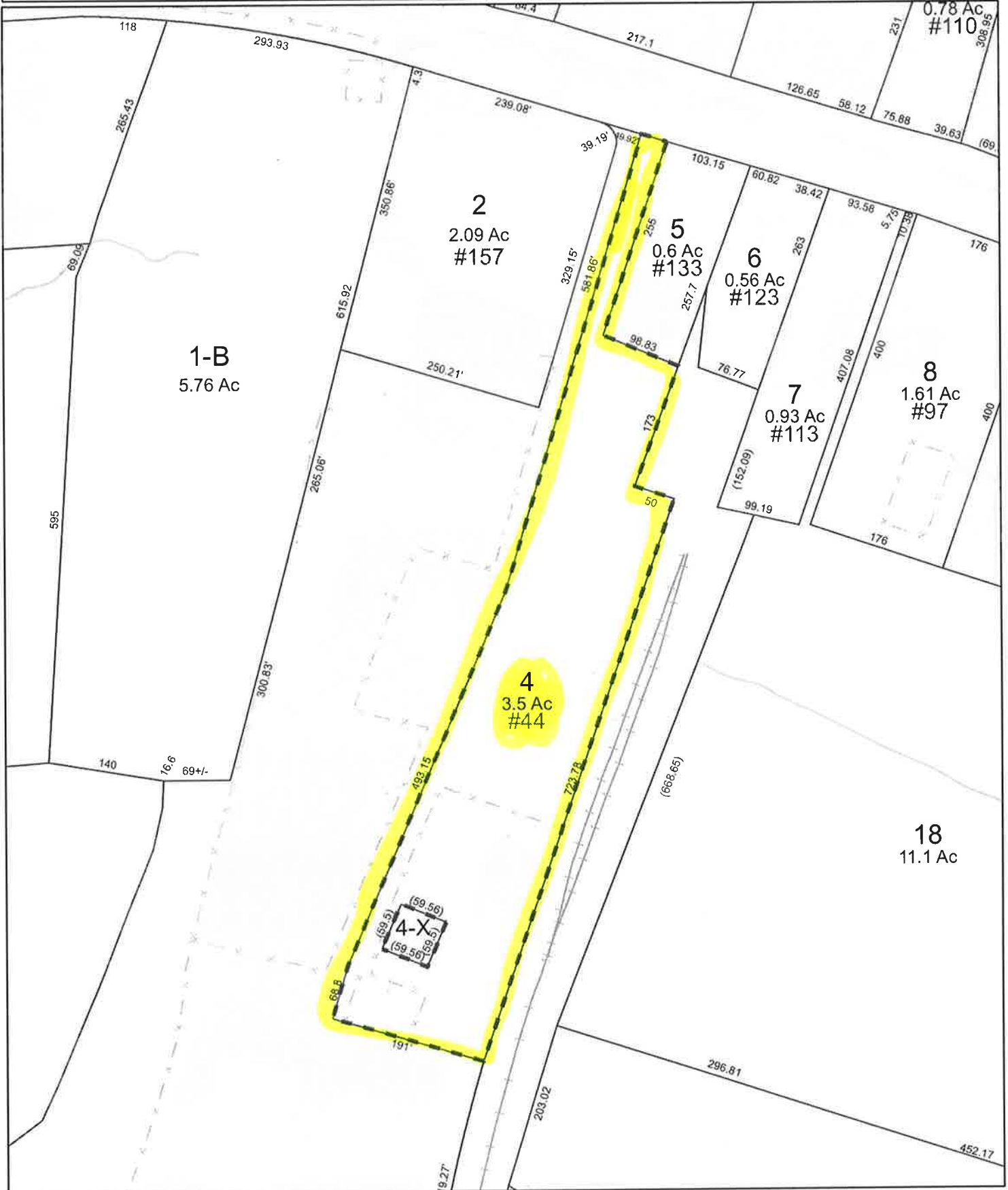

Scale
1:1,800

Map Produced: March 2016
Grand List: October 2015

Disclaimer: This map is for informational purposes only. All information is subject to verification by any user. The Town of Suffield and its mapping contractors assume no legal responsibility for the information contained herein.



Town of Suffield, CT

Property Listing Report

Map Block Lot

34H-32-4

Account

34522

Property Information

Property Location	44 FFYLER PL
Owner	SUFFIELD TOWN OF
Co-Owner	
Mailing Address	83 MOUNTAIN RD SUFFIELD CT 06078
Land Use	903I Municipal MDL-96
Land Class	E
Zoning Code	TCV
Census Tract	4771.01

Neighborhood	D
Acreage	3.5
Utilities	
Lot Setting/Desc	
Additional Info	

Photo



Sketch

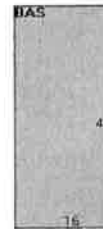

Primary Construction Details

Year Built	2000
Stories	1
Building Style	Pre-Eng Garage
Building Use	Industrial
Building Condition	02
Floors	Concrete
Total Rooms	

Bedrooms	
Full Bathrooms	
Half Bathrooms	
Bath Style	
Kitchen Style	
Roof Style	Gable
Roof Cover	Asphalt

Exterior Walls	MASONRY
Interior Walls	Minimum
Heating Type	Hot Air-No Duc
Heating Fuel	Oil
AC Type	None
Gross Bldg Area	736
Total Living Area	736



Valuation Summary (Assessed value = 70% of Appraised Value)

Item	Appraised	Assessed
Buildings	531800	372260
Extras	34200	23940
Improvements	619500	433650
Outbuildings	53500	37450
Land	229000	160300
Total	848500	593950

Sub Areas

Subarea Type	Gross Area (sq ft)	Living Area (sq ft)
First Floor	736	736
Total Area	6000	6000

Outbuilding and Extra Items

Type	Description
Kennel - Ave	640.00 S.F.
Shed	1920.00 S.F.
Paving - Asphalt	880.00 S.F.
Mezzanine Unfinished	837.00 S.F.
Canopy Ave	1600.00 S.F.
Shed	360.00 S.F.
Fence - 6' Chain	142.00 L.F.
Paving - Asphalt	14000.00 S.F.
Garage - Ave	2408.00 S.F.

Sales History

Owner of Record	Book/ Page	Sale Date	Sale Price
SUFFIELD TOWN OF	134/ 430	6/8/1973	0
SUFFIELD TOWN OF	53/ 210	12/22/1920	0
SUFFIELD TOWN OF	53/ 151	4/15/1920	0
SUFFIELD TOWN OF	53/ 141	3/11/1920	0

