

April 9, 2014

David Martin and  
Members of the Siting Council  
Connecticut Siting Council  
Ten Franklin Square  
New Britain, CT 06051

RE: Notice of Exempt Modification  
72 Jerry Browne Road, Stonington, CT 06378  
N 41° 22' 31.72"  
W -71° 57' 12.14"  
*T-Mobile #: CT11045D*

Dear Mr. Martin and Members of the Siting Council:

On behalf of T-Mobile, SBA Communications is submitting an exempt modification application to the Connecticut Siting council for modification of existing equipment at a tower facility located at 72 Jerry Browne Road, Stonington, CT 06378.

The 72 Jerry Browne Road facility consists of a 160' Flagpole owned and operated by SBA Towers, LLC. In order to accommodate technological changes and enhance system performance in the State of Connecticut, T-Mobile plans to modify the equipment configurations at many of its existing cell sites. Please accept this letter and attachments as notification, pursuant to R.C.S.A. Section 16-50j-73, of construction which constitutes an exempt modification pursuant to R.C.S.A. Section 16-50j-72(b)(2). In compliance with R.C.S.A. Section 16-50j-73, a copy of this letter and attachments is being sent to the chief elected official of the municipality in which the affected cell site is located.

As part of T-Mobile's modernization project, T-Mobile desires to upgrade their equipment to meet the new standards of 4G technology. The new equipment will allow customers to download files and browse the internet at a high rate of speed while also allowing their phones to be compatible with the latest 4G technology.

Attached is a summary of the planned modifications, including power density calculations reflecting the change in T-Mobile's operations at the site along with the required fee of \$625.

The changes to the facility do not constitute modifications as defined in Connecticut General Statutes ("C.G.S.") Section 16-50i(d) because the general physical characteristics of the facility will not be

significantly changed or altered. Rather, the planned changes to the facility fall squarely within those activities explicitly provided for in R.C.S.A. Section 16-50j-72(b)(2).

1. The overall height of the structure will be unaffected.
2. The proposed changes will not extend the site boundaries. There will be no effect on the site compound other than the new equipment cabinets.
3. The proposed changes will not increase the noise level at the existing facility by six decibels or more.
4. The changes in radio frequency power density will not increase the calculated "worst case" power density for the combined operations at the site to a level at or above the applicable standard for uncontrolled environments as calculated for a mixed frequency site.

For the foregoing reasons, SBA Communications on behalf of T-Mobile, respectfully submits that he proposed changes at the referenced site constitute exempt modifications under R.C.S.A. Section 16-50j-72(b)(2).

Please feel free to call me at 508.251.0720 x 3804 with any questions you may have concerning this matter.

Thank you,



Kri Pelletier  
SBA Communications Corporation  
33 Boston Post Road West Suite 320  
Marlborough, MA 01752  
508-251-0720 x 3804 + T  
508-251-1755 + F  
203-446-7700 + C  
[kpelletier@sbsite.com](mailto:kpelletier@sbsite.com)



## T-Mobile Equipment Modification

72 Jerry Browne Road, Stonington, CT 06378  
Site number CT11045D

**Tower Owner:** SBA Towers, LLC

**Equipment Configuration:** Monopole

**Current and/or approved:**

- (3) EMS DR65-18-XXDPL2Q

**Planned Modifications:**

- (3) RFS APXV18-206516S
- (6) Ericsson KRY 112 144/1 TMAs
- (6) 1-5/8" Feed Lines
- (6) 7/8" Feed Lines

**Structural Information:**

The attached structural analysis demonstrates that the tower and foundation will have adequate structural capacity to accommodate the proposed modifications.

**Power Density:**

The anticipated Maximum Composite contributions from the T-Mobile facility are 0.512% of the allowable FCC established general public limit. The anticipated composite MPE value for this site assuming all carriers present is 18.442% of the allowable FCC established general public limit sampled at the ground level.

Site Composite MPE %	
Carrier	MPE %
T-Mobile	0.512%
AT&T	12.840%
Nextel	5.090%
Total Site MPE %	18.442%

April 9, 2014

Mr. Edward Haberek, Jr.  
First Selectman  
Town of Stonington  
152 Elm Street  
Stonington, CT 06378

RE: Telecommunications Facility @ 72 Jerry Browne Road, Stonington, CT 06378

Dear Mr. Haberek,

In order to accommodate technological changes and enhance system performance in the State of Connecticut, T-Mobile will be changing its equipment configuration at certain cell sites.

As required by Regulations of Connecticut State Agencies (R.C.S.A.) Section 16-50j-73, the Connecticut Siting Council has been notified of the changes and will review T-Mobile's proposal. Please accept this letter as notification under Section 16-50j-73 of construction which constitutes an exempt modification pursuant to R.C.S.A. Section 16-50j-72(b)(2).

The accompanying letter to the Siting Council fully describes T-Mobile's proposal for the referenced cell site. However, if you have any questions or require any further information on our plans or the Siting Council's procedures, please call me at 508.251.0720 x 3804.

Thank you,



Kri Pelletier  
SBA Communications Company  
33 Boston Post Road West Suite 320  
Marlborough, MA 01752  
508-251-0720 x 3804 + T  
508-251-1755 + F  
203-446-7700 + C  
[kpelletier@sbsite.com](mailto:kpelletier@sbsite.com)

RADIO FREQUENCY EMISSIONS ANALYSIS REPORT  
EVALUATION OF HUMAN EXPOSURE POTENTIAL  
TO NON-IONIZING EMISSIONS

T-Mobile Existing Facility

Site ID: CT11045D

Stonington / I-95 / X90 / JE

72 Jerry Brown Road  
Stonington, CT 06378

**April 7, 2014**

**EBI Project Number: 62142261**

April 7, 2014

T-Mobile USA  
Attn: Jason Overbey, RF Manager  
35 Griffin Road South  
Bloomfield, CT 06002

Re: Emissions Values for Site: **CT11045D - Stonington / I-95 / X90 / JE**

EBI Consulting was directed to analyze the proposed T-Mobile facility located at 72 Jerry Brown Road, Stonington, CT, for the purpose of determining whether the emissions from the Proposed T-Mobile Antenna Installation located on this property are within specified federal limits.

All information used in this report was analyzed as a percentage of current Maximum Permissible Exposure (% MPE) as listed in the FCC OET Bulletin 65 Edition 97-01 and ANSI/IEEE Std C95.1. The FCC regulates Maximum Permissible Exposure in units of microwatts per square centimeter ( $\mu\text{W}/\text{cm}^2$ ). The number of  $\mu\text{W}/\text{cm}^2$  calculated at each sample point is called the power density. The exposure limit for power density varies depending upon the frequencies being utilized. Wireless Carriers and Paging Services use different frequency bands each with different exposure limits, therefore it is necessary to report results and limits in terms of percent MPE rather than power density.

All results were compared to the FCC (Federal Communications Commission) radio frequency exposure rules, 47 CFR 1.1307(b)(1) – (b)(3), to determine compliance with the Maximum Permissible Exposure (MPE) limits for General Population/Uncontrolled environments as defined below.

General population/uncontrolled exposure limits apply to situations in which the general public may be exposed or in which persons who are exposed as a consequence of their employment may not be made fully aware of the potential for exposure or cannot exercise control over their exposure. Therefore, members of the general public would always be considered under this category when exposure is not employment related, for example, in the case of a telecommunications tower that exposes persons in a nearby residential area.

Public exposure to radio frequencies is regulated and enforced in units of microwatts per square centimeter ( $\mu\text{W}/\text{cm}^2$ ). The general population exposure limit for the cellular band is  $567 \mu\text{W}/\text{cm}^2$ , and the general population exposure limit for the PCS and AWS bands is  $1000 \mu\text{W}/\text{cm}^2$ . Because each carrier will be using different frequency bands, and each frequency band has different exposure limits, it is necessary to report percent of MPE rather than power density.

Occupational/controlled exposure limits apply to situations in which persons are exposed as a consequence of their employment and in which those persons who are exposed have been made fully aware of the potential for exposure and can exercise control over their exposure. Occupational/controlled exposure limits also apply where exposure is of a transient nature as a result of incidental passage through a location where exposure levels may be above general population/uncontrolled limits (see below), as long as the exposed person has been made fully aware of the potential for exposure and can exercise control over his or her exposure by leaving the area or by some other appropriate means.

Additional details can be found in FCC OET 65.

## **CALCULATIONS**

Calculations were done for the proposed T-Mobile Wireless antenna facility located at 72 Jerry Brown Road, Stonington, CT, using the equipment information listed below. All calculations were performed per the specifications under FCC OET 65. Since T-Mobile is proposing highly focused directional panel antennas, which project most of the emitted energy out toward the horizon, the actual antenna pattern gain value in the direction of the sample area was used. For this report the sample point is a 6 foot person standing at the base of the tower

For all calculations, all equipment was calculated using the following assumptions:

- 1) 2 GSM / UMTS channels (1935.000 MHz to 1945.000 MHz / 1983.000 MHz to 1984.000 MHz ) were considered for each sector of the proposed installation.
- 2) 4 UMTS / LTE channels (2110.000 to 2120.000 MHz / 2140.000 MHz to 2145.000 MHz) were considered for each sector of the proposed installation
- 3) All radios at the proposed installation were considered to be running at full power and were uncombined in their RF transmissions paths per carrier prescribed configuration. Per FCC OET Bulletin No. 65 - Edition 97-01 recommendations to achieve the maximum anticipated value at each sample point, all power levels emitting from the proposed antenna installation are increased by a factor of 2.56 to account for possible in-phase reflections from the surrounding environment. This is rarely the case, and if so, is never continuous.
- 4) For the following calculations the sample point was the top of a six foot person standing at the base of the tower. The actual gain in this direction was used per the manufactures supplied specifications.
- 5) The antenna used in this modeling is the RFS APXV18-206516S-A20 for LTE, UMTS and GSM. This is based on feedback from the carrier with regards to anticipated antenna selection. This antenna has a 16.3 dBi gain value at its main lobe. Actual antenna gain values were used for all calculations as per the manufacturers specifications

- 6) The antenna mounting height centerline of the proposed antennas is **135 feet** above ground level (AGL)
- 7) Emissions values for additional carriers were taken from the Connecticut Siting Council active database. Values in this database are provided by the individual carriers themselves.

All calculation were done with respect to uncontrolled / general public threshold limits



Site ID	CT11045D - Stonington / I-95 / X90 / JE
Site Address	72 Jerry Brown Road, Stonington, CT 06378
Site Type	Monopole

Sector 1																	
Antenna Number	Antenna Make	Antenna Model	Status	Frequency Band	Technology	Power Out Per Channel (Watts)	Number of Channels	Composite Power	Antenna Gain in direction of sample point (dBi)	Antenna Height (ft)	analysis height	Cable Size	Cable Loss (dB)	Additional Loss	ERP	Power Density Value	Power Density Percentage
1a	RFS	APXV18-206516S-A20	Passive	PCS - 1950 MHz	GSM / UMTS	30	2	60	-3.25	135	129	7/8"	1.2	0	21.535316	0.465241	0.04652%
1B	RFS	APXV18-206516S-A20	Passive	AWS - 2100 MHz	UMTS/LTE	40	4	160	-3.25	135	129	7/8"	1.2	0	57.42751	1.240642	0.12406%
															Sector total Power Density Value: 0.171%		
Sector 2																	
Antenna Number	Antenna Make	Antenna Model	Status	Frequency Band	Technology	Power Out Per Channel (Watts)	Number of Channels	Composite Power	Antenna Gain in direction of sample point (dBi)	Antenna Height (ft)	analysis height	Cable Size	Cable Loss (dB)	Additional Loss	ERP	Power Density Value	Power Density Percentage
1a	RFS	APXV18-206516S-A20	Passive	PCS - 1950 MHz	GSM / UMTS	30	2	60	-3.25	135	129	7/8"	1.2	0	21.535316	0.465241	0.04652%
1B	RFS	APXV18-206516S-A20	Passive	AWS - 2100 MHz	UMTS/LTE	40	4	160	-3.25	135	129	1-5/8"	1.2	0	57.42751	1.240642	0.12406%
															Sector total Power Density Value: 0.171%		
Sector 3																	
Antenna Number	Antenna Make	Antenna Model	Status	Frequency Band	Technology	Power Out Per Channel (Watts)	Number of Channels	Composite Power	Antenna Gain in direction of sample point (dBi)	Antenna Height (ft)	analysis height	Cable Size	Cable Loss (dB)	Additional Loss	ERP	Power Density Value	Power Density Percentage
1a	Ericsson	AIR21 B4A/B2P	Passive	PCS - 1950 MHz	GSM / UMTS	30	2	60	-3.25	135	129	7/8"	1.2	0	21.535316	0.465241	0.04652%
1B	Ericsson	AIR21 B4A/B2P	Passive	AWS - 2100 MHz	UMTS/LTE	40	4	160	-3.25	135	129	1-5/8"	1.2	0	57.42751	1.240642	0.12406%
															Sector total Power Density Value: 0.171%		

Site Composite MPE %	
Carrier	MPE %
T-Mobile	0.512%
AT&T	12.840%
Nextel	5.090%
<b>Total Site MPE %</b>	<b>18.442%</b>

## Summary

All calculations performed for this analysis yielded results that were well within the allowable limits for general public exposure to RF Emissions.

The anticipated Maximum Composite contributions from the T-Mobile facility are **0.512% (0.171% from each sector)** of the allowable FCC established general public limit considering all three sectors simultaneously sampled at the ground level.

The anticipated composite MPE value for this site assuming all carriers present is **18.442%** of the allowable FCC established general public limit sampled at the ground level. This is based upon values listed in the Connecticut Siting Council database for existing carrier emissions.

FCC guidelines state that if a site is found to be out of compliance (over allowable thresholds), that carriers over a 5% contribution to the composite value will require measures to bring the site into compliance. For this facility, the composite values calculated were well within the allowable 100% threshold standard per the federal government.



Scott Heffernan  
RF Engineering Director

**EBI Consulting**  
21 B Street  
Burlington, MA 01803



FDH Engineering, Inc., 6521 Meriden Drive Raleigh, NC 27616, Ph. 919.755.1012

**Structural Analysis for  
SBA Network Services, Inc.**

**159.25' Monopole Tower**

**SBA Site Name: Mystic  
SBA Site ID: CT00799-S-02  
T-Mobile Site ID: CT11045D  
Site Address: 72 Jerry Brown Road, Mystic, CT 06355**

FDH Project Number 1424PR1400

**Analysis Results**

Tower Components	83.4%	Sufficient
Foundation	83.7%	Sufficient

Prepared By:

Luis A Mendoza, EIT  
Project Engineer

Reviewed By:

J. Darrin Holt, PhD, PE  
Principal  
CT PE License No. 22988

**FDH Engineering, Inc.**  
6521 Meriden Drive  
Raleigh, NC 27616  
(919) 755-1012  
info@fdh-inc.com

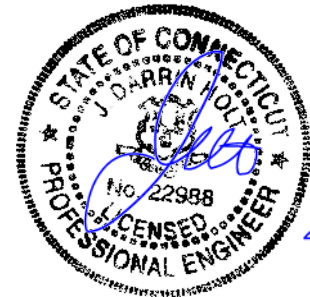

April 1, 2014

*Prepared pursuant to TIA/EIA-222-F Structural Standards for Steel Antenna Towers and Antenna Supporting Structures and 2005 Connecticut State Building Code*

**TABLE OF CONTENTS**

EXECUTIVE SUMMARY .....3

    Conclusions.....3

    Recommendation .....3

APPURTENANCE LISTING .....4

RESULTS .....5

GENERAL COMMENTS .....6

LIMITATIONS .....6

APPENDIX .....7

---

## EXECUTIVE SUMMARY

At the request of SBA Network Services, Inc., FDH Engineering, Inc. performed a structural analysis of the monopole located in Mystic, CT to determine whether the tower is structurally adequate to support both the existing and proposed loads pursuant to the *Structural Standards for Steel Antenna Towers and Antenna Supporting Structures, TIA/EIA-222-F* and *2005 Connecticut State Building Code*. Information pertaining to the existing/proposed antenna loading, current tower geometry, geotechnical data, foundation dimensions, and member sizes was obtained from:

- Summit Manufacturing, LLC. (Job No. 4252) original design drawings dated December 10, 1998
- FDH Engineering, Inc. (Project No. 1424W51600) Geotechnical Evaluation of Subsurface Conditions dated March 26, 2014
- Stealth Concealment Solutions, Inc. (Job No. FOUR-4C-100-40) fabrication drawings dated March 17, 2003
- SBA Network Services, Inc.

The *basic design wind speed* per the *TIA/EIA-222-F* standards is 100 mph without ice and 50 mph with 3/4" radial ice. Ice is considered to increase in thickness with height.

## Conclusions

With the existing and proposed antennas from T-Mobile in place at 135 ft, the tower meets the requirements of the *TIA/222-F* standards and *2005 Connecticut State Building Code* provided the **Recommendation** listed below is satisfied. Furthermore, provided the foundation was designed and constructed to support the original design reactions (see Summit Manufacturing, Job No. 4252), the foundation should have the necessary capacity to support the existing and proposed loading. For a more detailed description of the analysis of the tower, see the **Results** section of this report.

Our structural analysis has been performed assuming all information provided to FDH Engineering, Inc. is accurate (i.e., the steel data, tower layout, existing antenna loading, and proposed antenna loading) and that the tower has been properly erected and maintained per the original design drawings.

## Recommendation

To ensure the requirements of the *TIA/EIA-222-F* standards and *2005 Connecticut State Building Code* are met with the existing and proposed loading in place, we have the following recommendation:

1. The proposed feed lines should be installed inside of the pole's shaft.

## APPURTENANCE LISTING

The proposed and existing antennas with their corresponding cables/coax lines are shown in **Table 1**. *If the actual layout determined in the field deviates from the layout, FDH Engineering, Inc. should be contacted to perform a revised analysis.*

**Table 1 - Appurtenance Loading**

### Existing Loading:

Antenna Elevation (ft)	Description	Feed Lines <sup>1</sup>	Carrier	Mount Elevation (ft)	Mount Type
155	(3) EMS RS90-10-00A-2	(6) 1-1/4"	Nextel	155	Inside Concealment
145	(3) EMS RS90-10-00A-2	(6) 1-1/4"		145	
135	(3) EMS DR65-18-XXDPL2Q	---	T-Mobile	135	
125	(3) Powerwave 7770.00	(12) 1-5/8"	AT&T	125	

1. Feed lines installed inside the pole's shaft unless otherwise noted.

### Proposed Loading:

Antenna Elevation (ft)	Description	Feed Lines	Carrier	Mount Elevation (ft)	Mount Type
135	(3) RFS APXV18-206516S (6) Ericsson KRY 112 144/1 TMAs	(6) 1-5/8" (6) 7/8"	T-Mobile	135	Inside Concealment

## RESULTS

The following yield strength of steel for individual members was used for analysis:

**Table 2 - Material Strength**

Member Type	Yield Strength
Tower Shaft Sections	35 ksi & 60 ksi
Flange Plate	50 ksi
Flange Bolts	F <sub>U</sub> = 105 ksi
Base Plate	50 ksi
Anchor Bolts	75 ksi

**Table 3** displays the summary of the ratio (as a percentage) of force in the member to their capacities. Values greater than 100% indicate locations where the maximum force in the member exceeds its capacity. *Note: Capacities up to 105% are considered acceptable.* **Table 4** displays the maximum foundation reactions.

If the assumptions outlined in this report differ from actual field conditions, FDH Engineering, Inc. should be contacted to perform a revised analysis. Furthermore, as no information pertaining to the allowable twist and sway requirements for the existing or proposed appurtenances was provided, deflection and rotation were not taken into consideration when performing this analysis.

See the **Appendix** for detailed modeling information

**Table 3 - Summary of Working Percentage of Structural Components**

Section No.	Elevation ft	Component Type	Size	% Capacity	Pass Fail
L1	159.3 – 139.8	Concealment Spline	P5x0.625" (5" OD)	36.9	Pass
	139.8	Spoked Flange	PL 27.625"Ø x 3" Thick	6.2	Pass
	139.8	Flange Bolts	(6) 1.125"Ø w/ BC = 21.5"	14.3	Pass
L2	139.8 - 120	Concealment Spline	P8x0.5" (8" OD)	83.4	Pass
	120	Spoked Flange	PL 29.625"Ø x 3" Thick	13.1	Pass
	120	Flange Bolts	(6) 1.5"Ø w/ BC = 23.5"	27.3	Pass
L3	120 - 76	Pole	TP36.6x30x0.25	33.5	Pass
L4	76 - 36.75	Pole	TP41.99x35.3875x0.3125	45.4	Pass
L5	36.75 - 0	Pole	TP46.88x40.5772x0.375	53.7	Pass
		Anchor Bolts	PL 52" SQ. x 2.75" Thick	74.9	Pass
		Base Plate	(8) 2.25"Ø w/ BC = 54"	64.4	Pass

\*Capacities include 1/3 allowable stress increase for wind per the TIA/EIA-222-F standards.

**Table 4 - Maximum Base Reactions**

Base Reactions	Current Analysis (TIA/EIA-222-F)	Original Design (TIA/EIA-222-F)
Axial	24 k	20 k
Shear	17 k	17 k
Moment	1,341 k-ft	1,602 k-ft

## **GENERAL COMMENTS**

This engineering analysis is based upon the theoretical capacity of the structure. It is not a condition assessment of the tower and its foundation. It is the responsibility of SBA Network Services, Inc. to verify that the tower modeled and analyzed is the correct structure (with accurate antenna loading information) modeled. If there are substantial modifications to be made or the assumptions made in this analysis are not accurate, FDH Engineering, Inc. should be notified immediately to perform a revised analysis.

## **LIMITATIONS**

All opinions and conclusions are considered accurate to a reasonable degree of engineering certainty based upon the evidence available at the time of this report. All opinions and conclusions are subject to revision based upon receipt of new or additional/updated information. All services are provided exercising a level of care and diligence equivalent to the standard and care of our profession. No other warranty or guarantee, expressed or implied, is offered. Our services are confidential in nature and we will not release this report to any other party without the client's consent. The use of this engineering work is limited to the express purpose for which it was commissioned and it may not be reused, copied, or distributed for any other purpose without the written consent of FDH Engineering, Inc.



## **APPENDIX**

Section	10	9	8	7	6	5	4	3	2	1
Length (ft)	42.00	44.00	44.00	9.50	0.50	9.25	0.50	9.50	0.50	9.50
Number of Sides	18	18	18	1	1	1	1	1	1	1
Thickness (in)	0.3750	0.3125	0.2500	0.1875	0.1875	0.1875	0.1875	0.1875	0.1875	0.1875
Socket Length (ft)		5.25	4.75							
Top Dia (in)	40.5772	35.3875	30.0000	30.0000	30.0000	30.0000	30.0000	30.0000	30.0000	30.0000
Bot Dia (in)	46.8800	41.9900	36.6000	30.0000	30.0000	30.0000	30.0000	30.0000	30.0000	30.0000
Grade	A607-60	A607-60	A53	A53	A53	A53	A53	A53	A53	A53
Weight (K)	19.2	5.7	3.9	0.6	0.0	0.5	0.0	0.5	0.0	0.5

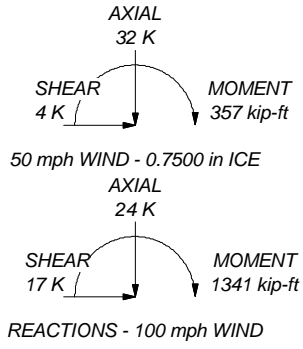
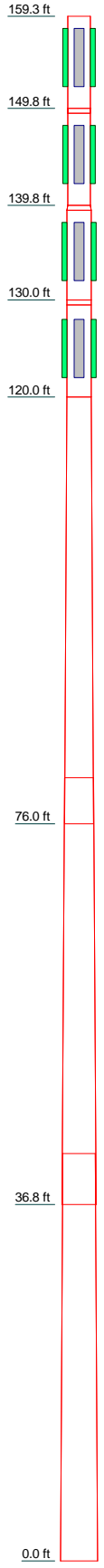

**DESIGNED APPURTENANCE LOADING**

TYPE	ELEVATION	TYPE	ELEVATION
RS90-10-00A-2 w/Mount Pipe	155	APXV18-206516S w/Mount Pipe	135
RS90-10-00A-2 w/Mount Pipe	155	APXV18-206516S w/Mount Pipe	135
RS90-10-00A-2 w/Mount Pipe	155	(2) KRY 112 144/1	135
10' x 15' American Flag	155	(2) KRY 112 144/1	135
RS90-10-00A-2 w/Mount Pipe	145	(2) KRY 112 144/1	135
RS90-10-00A-2 w/Mount Pipe	145	7770.00 w/Mount Pipe	125
RS90-10-00A-2 w/Mount Pipe	145	7770.00 w/Mount Pipe	125
APXV18-206516S w/Mount Pipe	135	7770.00 w/Mount Pipe	125

**MATERIAL STRENGTH**

GRADE	Fy	Fu	GRADE	Fy	Fu
A53	35 ksi	60 ksi	A607-60	60 ksi	75 ksi

**TOWER DESIGN NOTES**

1. Tower is located in New London County, Connecticut.
2. Tower designed for a 100 mph basic wind in accordance with the TIA/EIA-222-F Standard.
3. Tower is also designed for a 50 mph basic wind with 0.75 in ice. Ice is considered to increase in thickness with height.
4. Deflections are based upon a 50 mph wind.
5. TOWER RATING: 53.7%

<p><b>FDH Engineering, Inc.</b> 6521 Meridien Drive Raleigh, North Carolina Phone: 9197551012 FAX: 9197551031</p>	<p>Job: <b>Mystic, CT00799-S-02</b></p>
	<p>Project: <b>1424PR1400</b></p>
	<p>Client: SBA Network Services, Inc. Drawn by: LMendoza App'd:</p>
	<p>Code: TIA/EIA-222-F Date: 04/01/14 Scale: NTS</p>
	<p>Path: Dwg No. E-1</p>

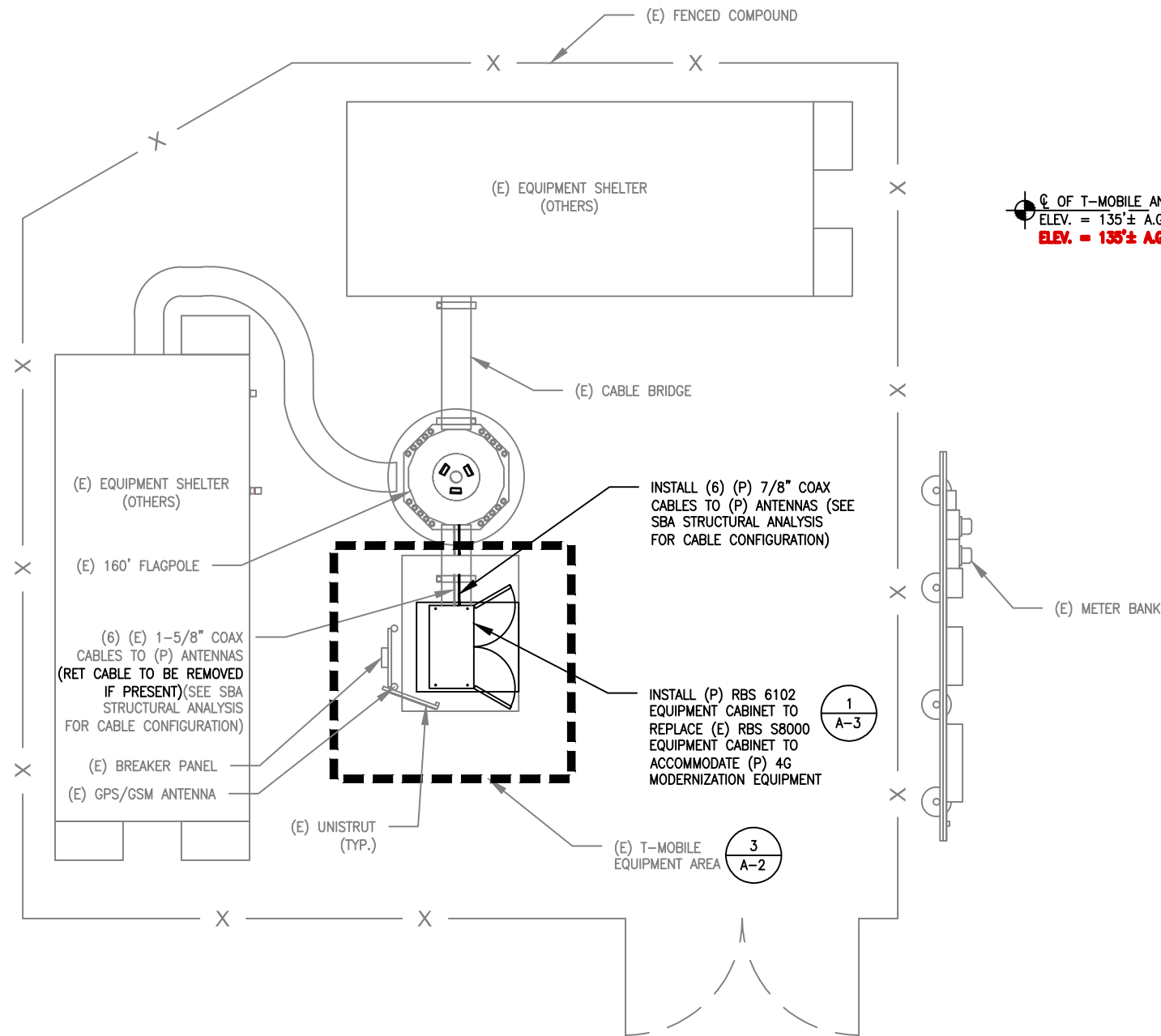

◉ OF T-MOBILE ANTENNAS  
 ELEV. = 135'± A.G.L. (T-MOBILE)\*  
**ELEV. = 135'± A.G.L. (SBA)\***

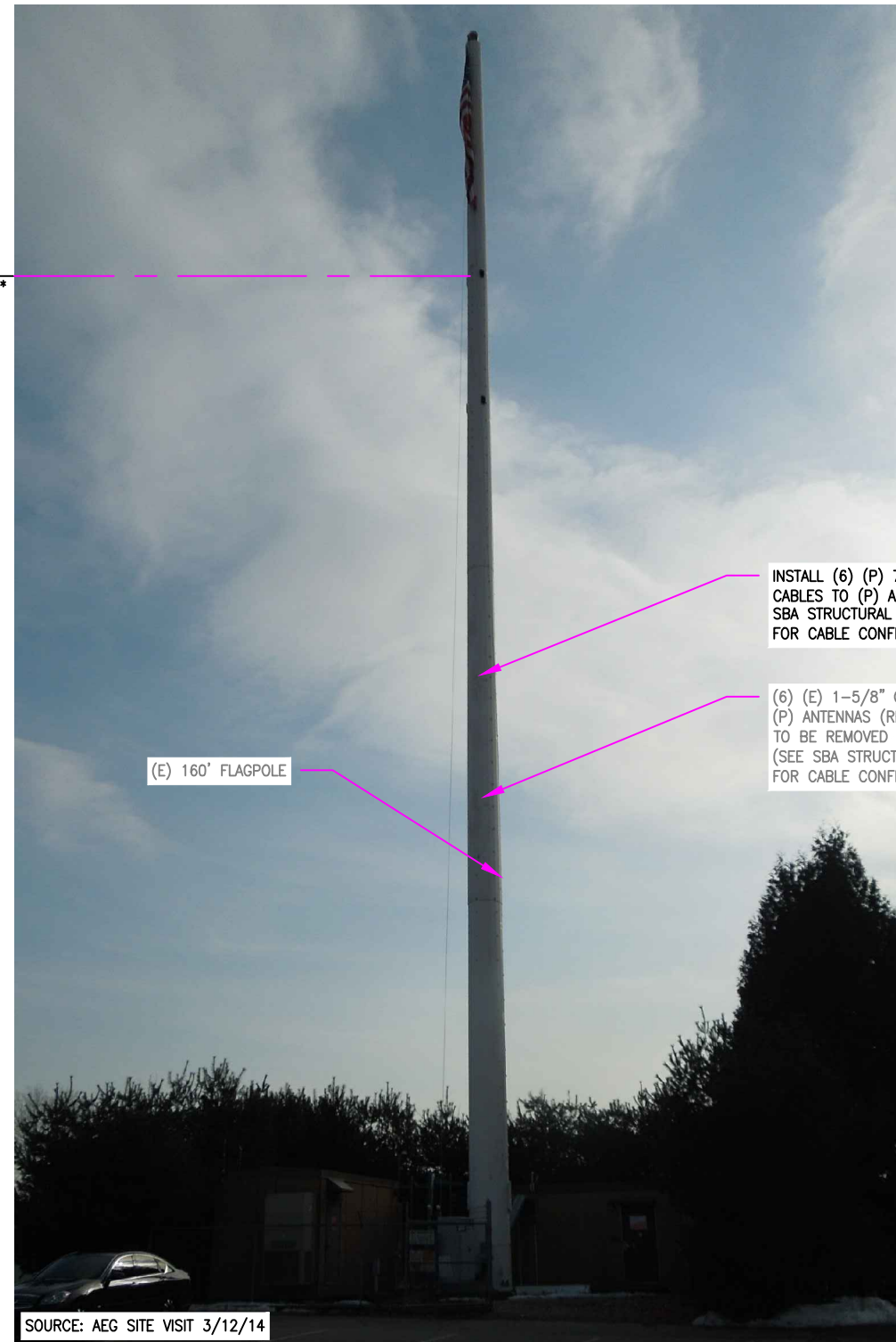

INSTALL (6) (P) 7/8" COAX CABLES TO (P) ANTENNAS (SEE SBA STRUCTURAL ANALYSIS FOR CABLE CONFIGURATION)

(6) (E) 1-5/8" COAX CABLES TO (P) ANTENNAS (RET CABLE TO BE REMOVED IF PRESENT) (SEE SBA STRUCTURAL ANALYSIS FOR CABLE CONFIGURATION)

(E) 160' FLAGPOLE

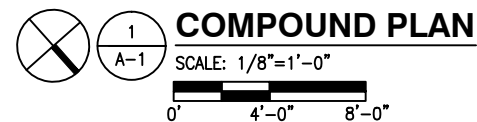

NOTE:  
GROUND EQUIPMENT NOT SHOWN FOR CLARITY

◉ EXISTING ELEVATION  
 A-1 SCALE: NTS

\*NOTE:  
 ANTENNA ELEVATION BASED ON CLIENT-PROVIDED INFORMATION

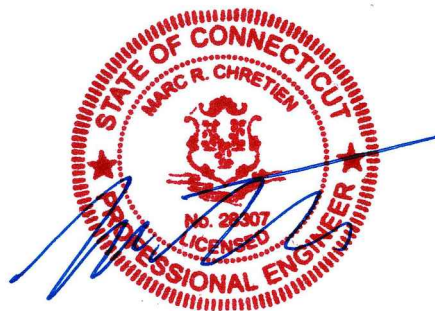

**ADVANCED ENGINEERING GROUP, P.C.**  
 Civil Engineering - Site Development Surveying - Telecommunications  
 500 NORTH BROADWAY EAST PROVIDENCE, RI 02914  
 PH: (401) 354-2403 FAX: (401) 633-6354



**SBA COMMUNICATIONS CORPORATION**  
 33 BOSTON POST ROAD WEST, SUITE 320  
 MARLBOROUGH, MA 01752  
 PHONE: 508-251-0720

**SITE NUMBER: CT11045D**  
**SITE NAME: STONINGTON / I-95 / X90 / JE**  
 72 JERRY BROWNE ROAD  
 STONINGTON, CT 06378

**T-MOBILE NORTHEAST LLC**  
 15 COMMERCE WAY, SUITE B  
 NORTON, MA 02766  
 OFFICE: (508) 286-2700  
 FAX: (508) 286-2893

				T-MOBILE				
				COMPOUND PLAN AND ELEVATION				
NO.	DATE	REVISIONS	BY	CHK	APP'D	JOB NUMBER	DRAWING NUMBER	REV
1	03/25/14	CONSTRUCTION REVISED	AAB	SB	MRC	CT11045D	A-1	1
0	03/20/14	CONSTRUCTION	AAB	SB	MRC			
SCALE: AS SHOWN			DESIGNED BY: MRC		DRAWN BY: AAB			

**EXISTING ANTENNA SCHEDULE**

SECTOR	MAKE	MODEL#	SIZE (INCHES)
SECTOR A:	DAPA	59212X\59212X	9x3x67
SECTOR B:	DAPA	59212X\59212X	9x3x67
SECTOR C:	DAPA	59212X\59212X	9x3x67

**PROPOSED ANTENNA SCHEDULE**

SECTOR	MAKE	MODEL#	SIZE (INCHES)
SECTOR A:	RFS	APXV18-206516S-A2	6.9x3.15x53.1
SECTOR B:	RFS	APXV18-206516S-A2	6.9x3.15x53.1
SECTOR C:	RFS	APXV18-206516S-A2	6.9x3.15x53.1

**NOTE:**  
1. REFER TO FINAL RF DATA SHEET FOR FINAL ANTENNA SETTINGS.

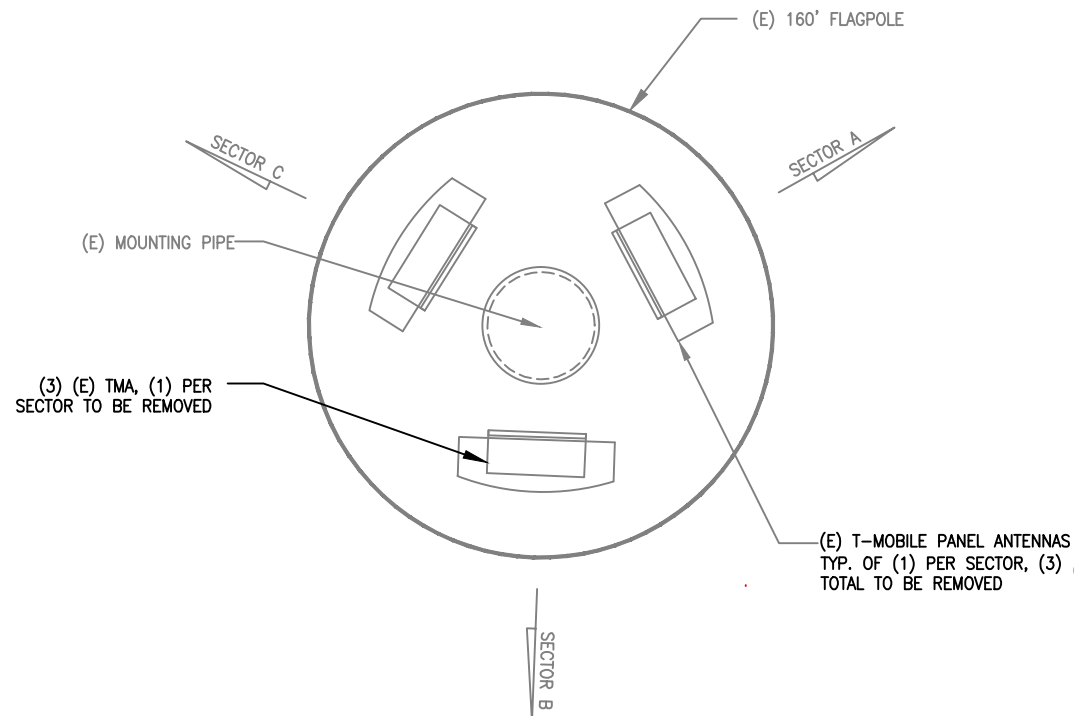

**EXISTING ANTENNA PLAN**  
SCALE: 1"=1'-0"  
0' 0-6" 1'-0"

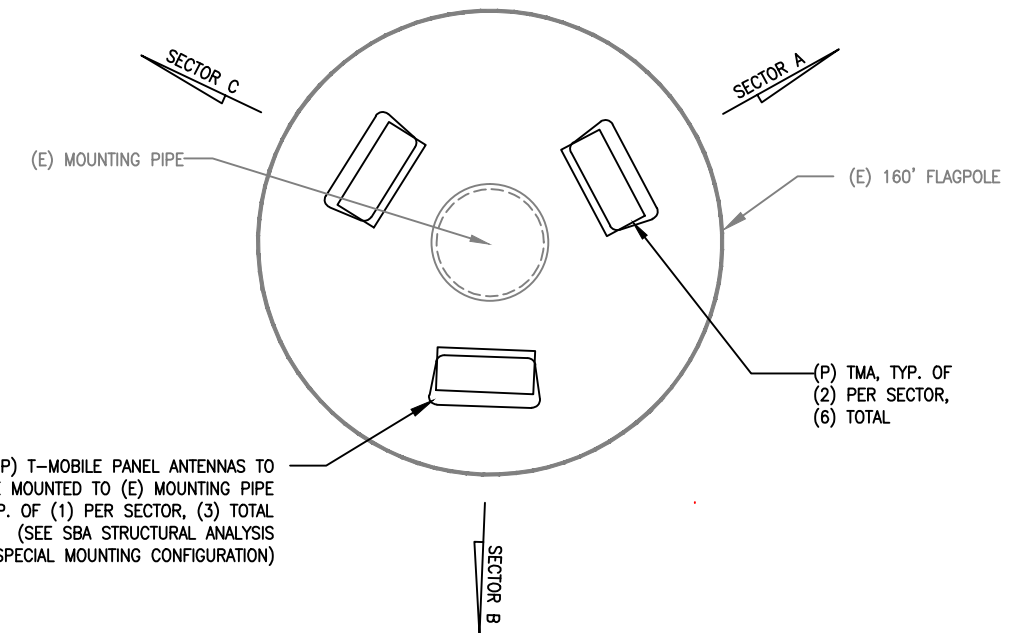

**PROPOSED ANTENNA PLAN**  
SCALE: 1"=1'-0"  
0' 0-6" 1'-0"

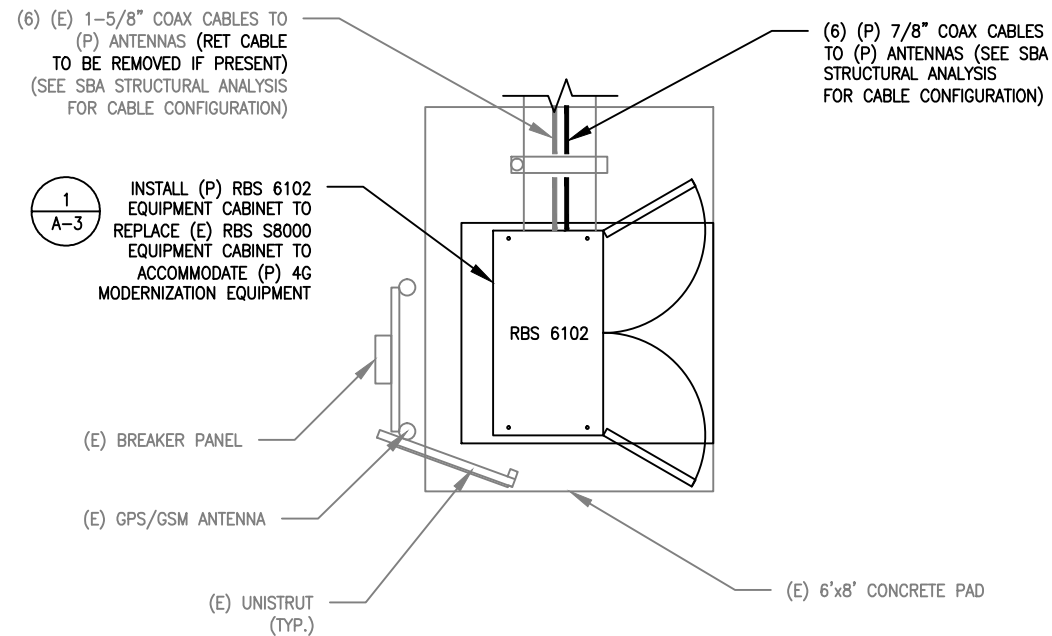

**EQUIPMENT PLAN**  
SCALE: 1/4"=1'-0"  
0' 2'-0" 4'-0"

(E) 2G EQUIPMENT CABINET (E) GPS/GSM ANTENNA

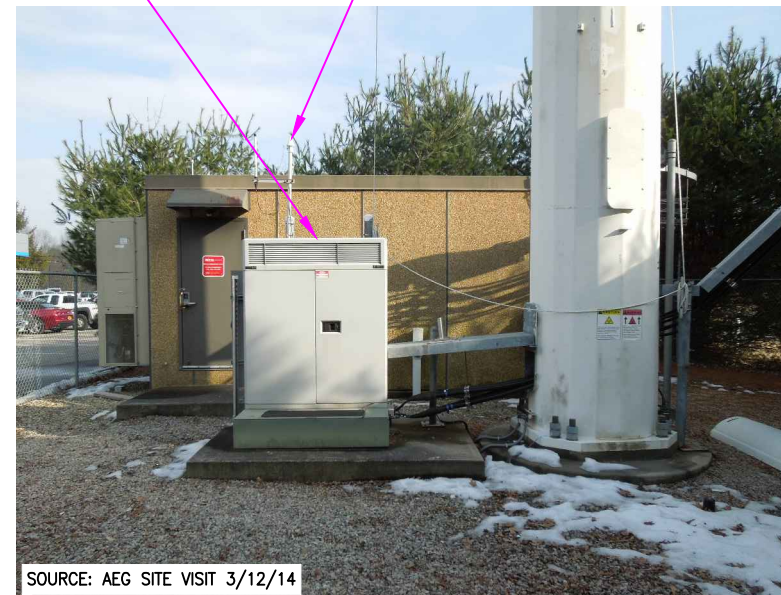

**EXISTING EQUIPMENT AREA.**  
N.T.S.



REVISIONS				BY	CHK	APP'D	JOB NUMBER	DRAWING NUMBER	REV
1	03/25/14	CONSTRUCTION REVISED		AAB	SB	MRC	CT11045D	A-2	1
0	03/20/14	CONSTRUCTION		AAB	SB	MRC			
SCALE: AS SHOWN		DESIGNED BY: MRC	DRAWN BY: AAB						

RBS 6102 OUTDOOR DIMENSIONS		
CABINET	DEPTH x WIDTH x HEIGHT	
OUTDOOR RBS 6102	27.5" x 51.125" x 57"	
RBS 6102 OUTDOOR WEIGHT		
CABINET	APPROX. MAX WEIGHT	MAX. FLOOR LOADING
OUTDOOR RBS 6102	1028 LBS.	
RBS 6102 MINIMUM CLEARANCE		
DIRECTION	MINIMUM CLEARANCE	
CABINET REAR	8"	
CABINET SIDES	4"	
ABOVE THE CABINET	20"	
IN FRONT OF THE CABINET	28"	

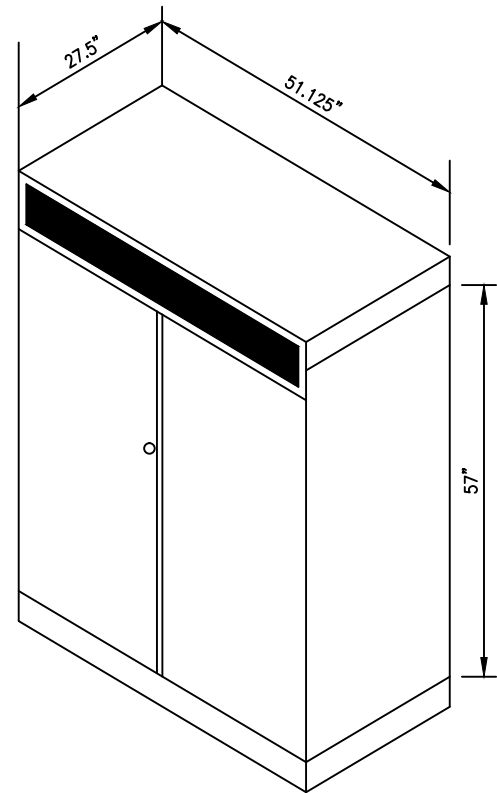

**1**  
A-3 **RBS 6102 CABINET**  
SCALE: N.T.S.

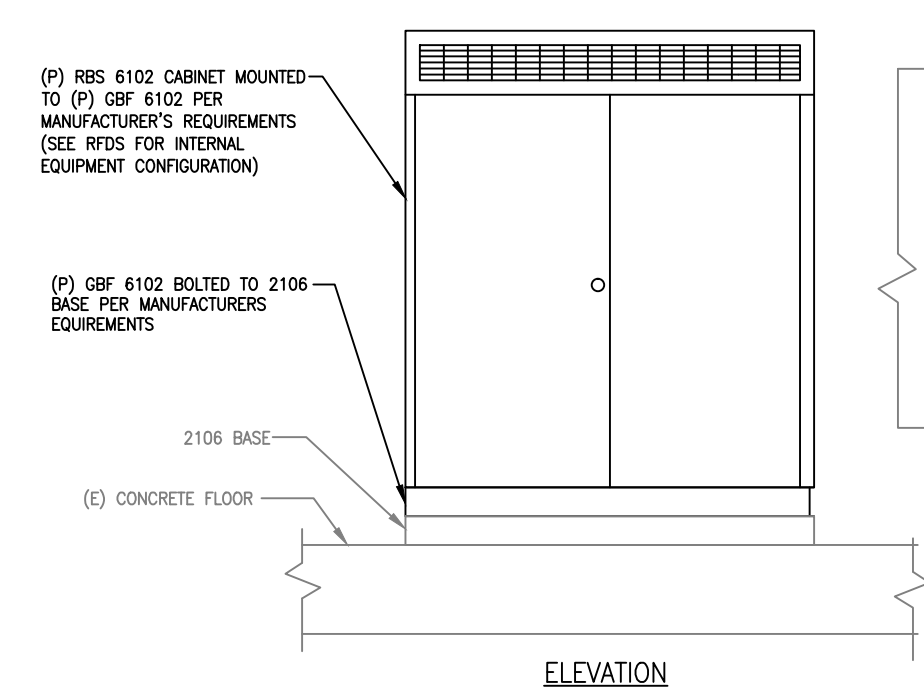

ELEVATION

**2**  
A-3 **RBS 6102 MOUNTING DETAIL**  
SCALE: 1"=2'-0"

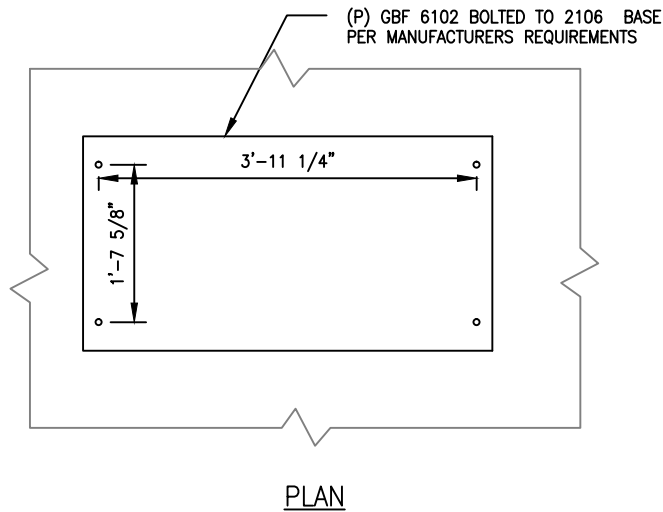

PLAN

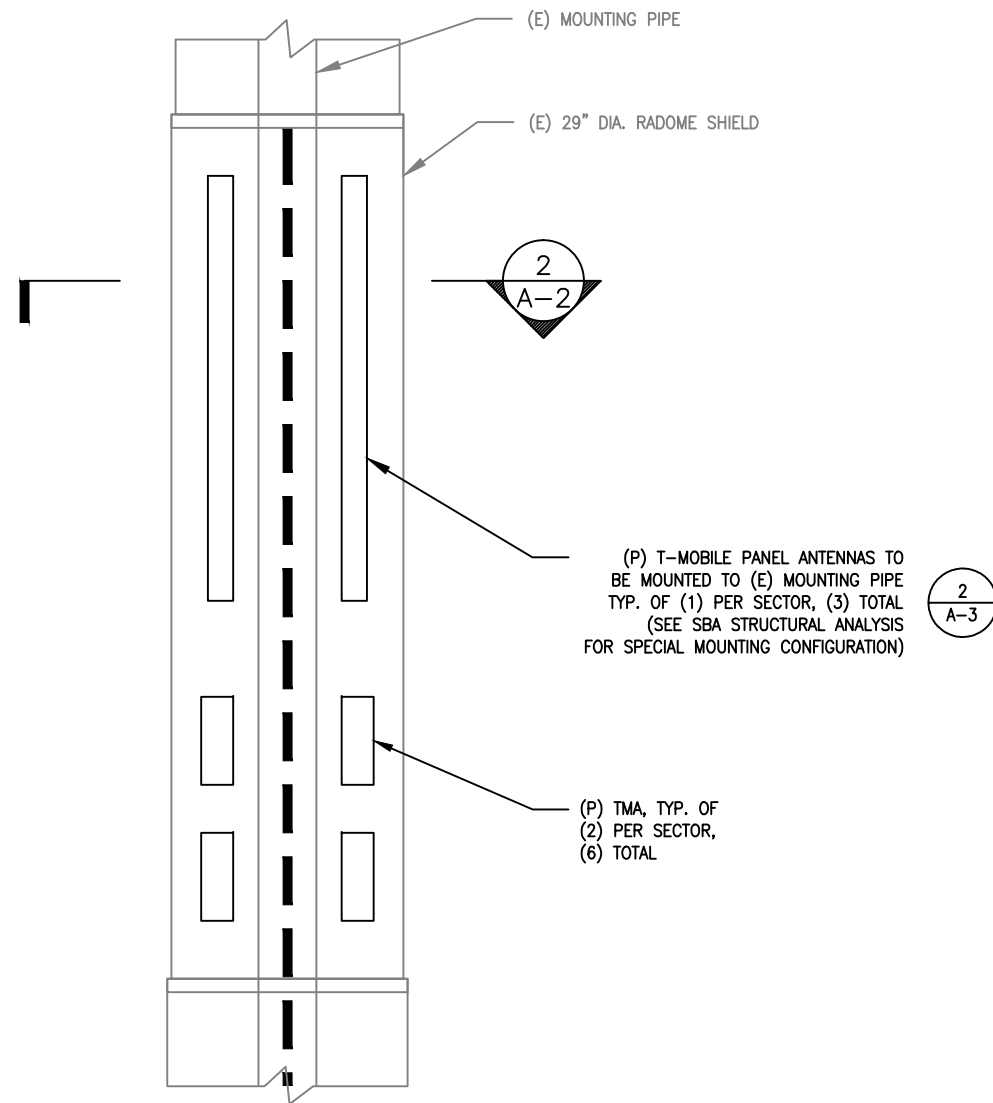

**3**  
A-3 **ANTENNA CONFIGURATION**  
SCALE: N.T.S.



				T-MOBILE		
				DETAILS		
1	03/25/14	CONSTRUCTION REVISED	AAB	SB	MRC	
0	03/20/14	CONSTRUCTION	AAB	SB	MRC	
NO.	DATE	REVISIONS	BY	CHK	APP'D	
SCALE: AS SHOWN		DESIGNED BY: MRC	DRAWN BY: AAB		JOB NUMBER	DRAWING NUMBER
					CT11045D	A-3
						REV
						1