



10 INDUSTRIAL AVE,
SUITE 3
MAHWAH NJ 07430

PHONE: 201.684.0055
FAX: 201.684.0066

July 30, 2018

Melanie Bachman
Executive Director
Connecticut Siting Council
10 Franklin Square
New Britain, CT 06051

Notice of Exempt Modification
652 Glenbrook Road, Stamford, CT 06906
Latitude- 41.0754840000
Longitude- -73.519140000

Dear Ms. Bachman,

T-Mobile currently maintains (9) existing antennas 85' level of the existing 108' water tower at 652 Glenbrook Road in Stamford. The structure and property are owned by Glenbrook Industrial Park LLC. T-Mobile now intends to remove (6) of the existing antennas and replace with (6) new 600/700/1900/2100 MHz antennas. These antennas would be installed at the same 85' level of the water tower. T-Mobile also intends to swap (3) remote radio heads and add (3) hybrid cables.

Please accept this letter as notification pursuant to Regulations of Connecticut State Agencies 16-50j-73, for construction that constitutes an exempt modification pursuant to R.C.S.A. 16-50j-72(b)(2). In accordance with R.C.S.A. 16-50j-73, a copy of this letter is being sent to David Martin, Mayor of the City of Stamford, David Woods, Principle Planner of the City of Stamford, as well as the owner.

The planned modifications to the facility fall squarely within those activities explicitly provided for in R.C.S.A. 16-50j-72(b)(2).

1. The proposed modification will not result in an increase in the height of the existing structure
2. The proposed modifications will not require the extension of the site boundary.
3. The proposed modifications will not increase noise levels at the facility by six decibels or more, or to levels that exceed state and local criteria.
4. The operation of the replacement antennas will not increase radio frequency emissions at the facility to a level at or above the Federal Communications Commission safety standard.
5. The proposed modification will not cause a change or alteration in the physical or environmental characteristics of the site.
6. The existing structure and its foundation can support the proposed loading.

For the foregoing reasons, T-Mobile respectfully submits that the proposed modifications to the above-referenced telecommunications facility constitute an exempt modification under R.C.S.A. 16-50j-72(b)(2).

Sincerely,

Kyle Richers

Kyle Richers
Transcend Wireless
10 Industrial Ave., Suite 3
Mahwah, New Jersey 07430
908-447-4716
krichers@transcendwireless.com

cc: David Martin- as elected official
David Woods- as zoning official
Glenbrook Industrial Park LLC- as owner

Stamford, CT Tax Maps

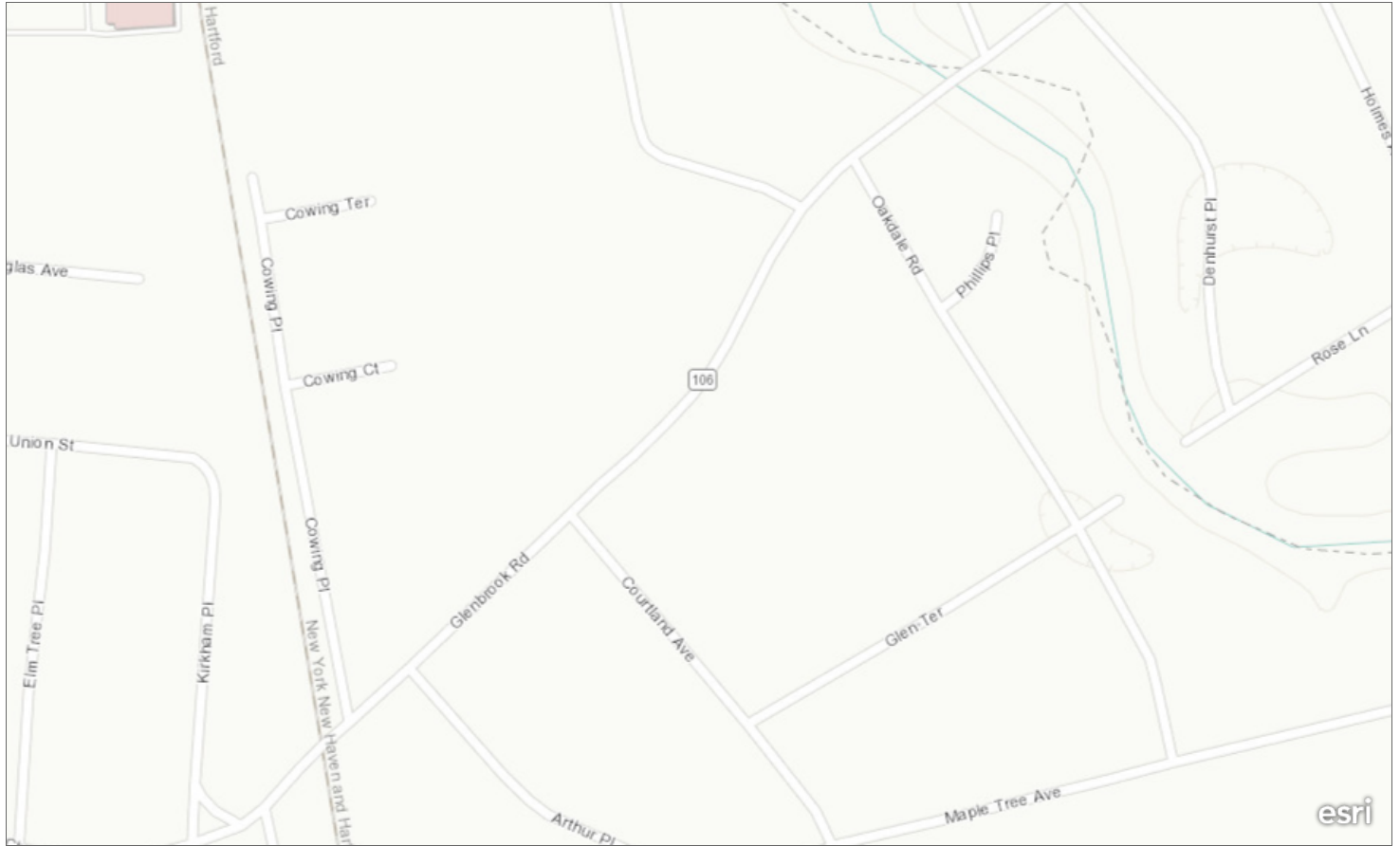

County of Westchester, Esri, HERE, Garmin, INCREMENT P, USGS, EPA, USDA

650 GLENBROOK ROAD

Location 650 GLENBROOK ROAD

Mblu 003/ 8507/ / /

Acct# 003-8507

Owner GLENBROOK INDUSTRIAL
PARK LLC

Assessment \$7,641,150

Appraisal \$10,915,890

PID 35719

Building Count 5

Current Value

Appraisal			
Valuation Year	Improvements	Land	Total
2017	\$5,175,490	\$5,740,400	\$10,915,890

Assessment			
Valuation Year	Improvements	Land	Total
2017	\$3,622,870	\$4,018,280	\$7,641,150

Owner of Record

Owner GLENBROOK INDUSTRIAL PARK LLC
Co-Owner C/O SPINNAKER RE PARTNERS
Address 1 N WATER STREET
SUITE 100
NORWALK, CT 06854

Sale Price \$0
Book & Page 7365/ 192
Sale Date 01/29/2004
Instrument 25

Ownership History

Ownership History				
Owner	Sale Price	Book & Page	Instrument	Sale Date
GLENBROOK INDUSTRIAL PARK LLC	\$0	7365/ 192	25	01/29/2004
GLENBROOK INDUSTRIAL PARK ASC	\$0	5077/ 267		09/01/1998
GLENBROOK INDUSTRIAL PARK ASC	\$0	5077/ 267		08/31/1998
GLENBROOK INDUSTRIAL PARK ASC	\$0	1691/ 178	25	11/04/1997

Building Information

Building 1 : Section 1

Year Built: 1943
Living Area: 134,160

Building Attributes	
Field	Description

STYLE	Industry Light
Stories:	2
Occupancy	29
Exterior Wall 1	Brick
Exterior Wall 2	Stucco Mas
Roof Structure	Flat
Roof Cover	T&G/Rubber
Interior Wall 1	Drywall/Plaste
Interior Wall 2	
Interior Floor 1	Concrete Slab
Interior Floor 2	
Heating Fuel	Gas/LP
Heating Type	Forced Air-Duc
AC Type	None
Bldg Use	Industrial MDL-96
Total Rooms	
Total Bedrms	00
Total Baths	0
1st Floor Use:	300
Heat/AC	None
Frame Type	Steel
Baths/Plumbing	Average
Ceiling/Wall	Sus-Ceil/Mn WL
Rooms/Prtns	Average
Wall Height	14
% Comn Wall	

Building Photo



(<http://images.vgsi.com/photos/StamfordCTPhotos//\00\11\45\0>)

Building Layout

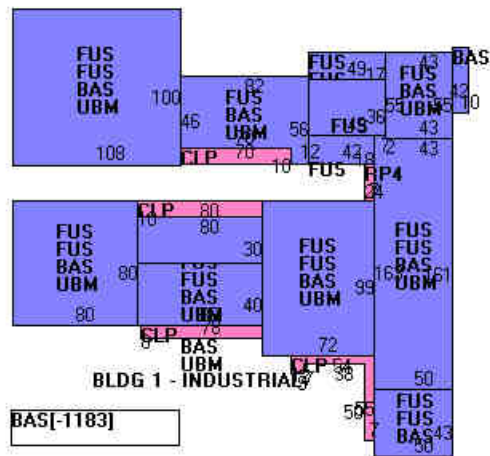

(<http://images.vgsi.com/photos/StamfordCTPhotos//Sketches/35>)

Building Sub-Areas (sq ft)			Legend
Code	Description	Gross Area	Living Area
FUS	Upper Story, Finished	85,927	85,927
BAS	First Floor	48,233	48,233
CLP	Loading Platform	2,807	0
RP4	Porch Enclosed	0	0
UBM	Basement, Unfinished	44,249	0
		181,216	134,160

Building 2 : Section 1

Year Built: 1958
Living Area: 2,555

Building Attributes : Bldg 2 of 5	
Field	Description
STYLE	Industry Light
Stories:	3

Occupancy	1
Exterior Wall 1	Brick
Exterior Wall 2	
Roof Structure	Flat
Roof Cover	T&G/Rubber
Interior Wall 1	Drywall/Plaste
Interior Wall 2	
Interior Floor 1	Hardwood
Interior Floor 2	
Heating Fuel	Gas/LP
Heating Type	Hot Wtr Bbd
AC Type	Unit/AC
Bldg Use	Commercial MDL-94
Total Rooms	
Total Bedrms	00
Total Baths	0
1st Floor Use:	200
Heat/AC	None
Frame Type	Steel
Baths/Plumbing	Average
Ceiling/Wall	Sus-Ceil&Wall
Rooms/Prtns	Average
Wall Height	14
% Comn Wall	

Building Photo



(<http://images.vgsi.com/photos/StamfordCTPhotos//\00\11\45\0>)

Building Layout

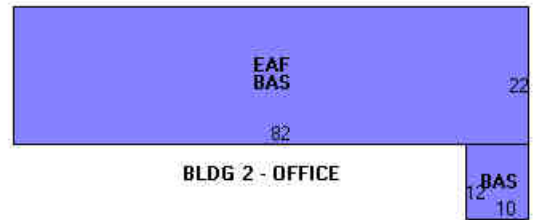

(<http://images.vgsi.com/photos/StamfordCTPhotos//Sketches/35>)

Building Sub-Areas (sq ft)		Legend	
Code	Description	Gross Area	Living Area
BAS	First Floor	1,924	1,924
EAF	Attic, Expansion, Finished	1,804	631
		3,728	2,555

Building 3 : Section 1

Year Built: 1950
Living Area: 2,238

Building Attributes : Bldg 3 of 5	
Field	Description
STYLE	Industry Light
Stories:	3
Occupancy	1
Exterior Wall 1	Brick
Exterior Wall 2	

Roof Structure	Flat
Roof Cover	T&G/Rubber
Interior Wall 1	Minimum
Interior Wall 2	
Interior Floor 1	Concrete Slab
Interior Floor 2	
Heating Fuel	Gas/LP
Heating Type	Hot Air-no Duc
AC Type	None
Bldg Use	Industrial MDL-96
Total Rooms	
Total Bedrms	00
Total Baths	0
1st Floor Use:	300
Heat/AC	None
Frame Type	Steel
Baths/Plumbing	Average
Ceiling/Wall	Ceiling Only
Rooms/Prtns	Average
Wall Height	20
% Comn Wall	

Building Photo



(<http://images.vgsi.com/photos/StamfordCTPhotos//\00\11\45\0>)

Building Layout

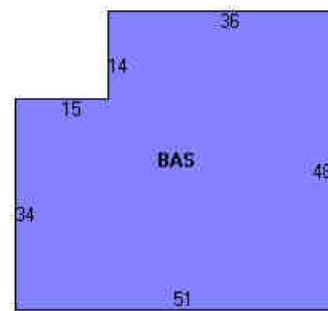

BLDG 3 - BOILER ROOM

(<http://images.vgsi.com/photos/StamfordCTPhotos//Sketches/35>)

Building Sub-Areas (sq ft)			<u>Legend</u>
Code	Description	Gross Area	Living Area
BAS	First Floor	2,238	2,238
		2,238	2,238

Building 4 : Section 1

Year Built: 1950
Living Area: 2,040

Building Attributes : Bldg 4 of 5	
Field	Description
STYLE	Auto Repair
Stories:	3
Occupancy	1
Exterior Wall 1	Concr/Cinder
Exterior Wall 2	
Roof Structure	Flat

Roof Cover	T&G/Rubber
Interior Wall 1	Minimum
Interior Wall 2	
Interior Floor 1	Concrete Slab
Interior Floor 2	
Heating Fuel	Gas/LP
Heating Type	Hot Air-no Duc
AC Type	None
Bldg Use	Industrial MDL-96
Total Rooms	
Total Bedrms	00
Total Baths	0
1st Floor Use:	300
Heat/AC	None
Frame Type	Masonry
Baths/Plumbing	Average
Ceiling/Wall	Sus-Ceil/Mn WL
Rooms/Prtns	Average
Wall Height	14
% Comn Wall	

Building Photo



(<http://images.vgsi.com/photos/StamfordCTPhotos//\00\11\45\0>)

Building Layout



BLDG 4 - AUTO BODY SHOP

(<http://images.vgsi.com/photos/StamfordCTPhotos//Sketches/35>)

Building Sub-Areas (sq ft)			<u>Legend</u>
Code	Description	Gross Area	Living Area
BAS	First Floor	2,040	2,040
		2,040	2,040

Building 5 : Section 1

Year Built: 1950
Living Area: 1,368

Building Attributes : Bldg 5 of 5	
Field	Description
STYLE	Auto Repair
Stories:	3
Occupancy	1
Exterior Wall 1	Concr/Cinder
Exterior Wall 2	
Roof Structure	Flat

Roof Cover	Rolled Compos
Interior Wall 1	Minimum
Interior Wall 2	Drywall/Plaste
Interior Floor 1	Concrete Slab
Interior Floor 2	
Heating Fuel	Gas/LP
Heating Type	Hot Air-no Duc
AC Type	None
Bldg Use	Industrial MDL-96
Total Rooms	
Total Bedrms	
Total Baths	
1st Floor Use:	
Heat/AC	None
Frame Type	Masonry
Baths/Plumbing	None
Ceiling/Wall	Ceiling Only
Rooms/Prtns	Average
Wall Height	8
% Comn Wall	

Building Photo



(<http://images.vgsi.com/photos/StamfordCTPhotos//\00\11\45\1>)

Building Layout

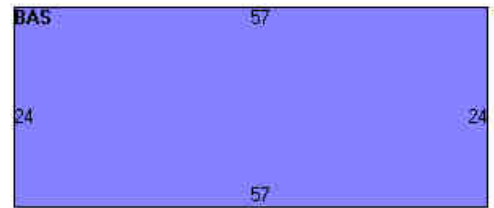

BLDG 5 - GARAGE

(<http://images.vgsi.com/photos/StamfordCTPhotos//Sketches/35>)

Building Sub-Areas (sq ft)			<u>Legend</u>
Code	Description	Gross Area	Living Area
BAS	First Floor	1,368	1,368
		1,368	1,368

Extra Features

Extra Features				<u>Legend</u>
Code	Description	Size	Value	Bldg #
OH1	Door Overhd Co	1 UNITS	\$2,590	4
OH2	Door Overhd Re	3 UNITS	\$7,770	5
SPR1	Sprinklers - Wet	1804 S.F.	\$2,160	2
SPR1	Sprinklers - Wet	132518 S.F.	\$86,930	1
H04	Air Con/Sfla	32000 S.F	\$32,800	1
EL1	Elev Frght	3 STOPS	\$67,650	1
EL1	Elev Frght	3 STOPS	\$67,650	1

EL1	Elev Frght	3 STOPS	\$67,650	1
EL1	Elev Frght	3 STOPS	\$67,650	1
HL1	Hydro Lift Com	3 UNITS	\$11,070	1

Land

Land Use

Use Code	300
Description	Industrial MDL-96
Zone	MZN
Neighborhood	0400
Alt Land Appr Category	No

Land Line Valuation

Size (Acres)	4.28
Depth	
Assessed Value	\$4,018,280
Appraised Value	\$5,740,400

Outbuildings

Outbuildings						Legend
Code	Description	Sub Code	Sub Description	Size	Value	Bldg #
AP1	Fence Chn Lk			1800 L.F.	\$15,530	1
CEL1	Cell Tower			1 SITES	\$146,250	3
AP1	Fence Chn Lk			3636 L.F.	\$31,360	1
CSHD	Cell Equipment			330 S.F.	\$8,980	3
FC4	Shed Finishd			128 S.F.	\$2,740	1
LP4	Pavng Asphlt			80000 S.F.	\$96,000	1

Valuation History

Appraisal			
Valuation Year	Improvements	Land	Total
2017	\$5,175,490	\$5,740,400	\$10,915,890
2016	\$4,580,430	\$5,218,370	\$9,798,800
2015	\$4,580,430	\$5,218,370	\$9,798,800

Assessment			
Valuation Year	Improvements	Land	Total
2017	\$3,622,870	\$4,018,280	\$7,641,150
2016	\$3,206,310	\$3,652,860	\$6,859,170
2015	\$3,206,310	\$3,652,860	\$6,859,170

(c) 2016 Vision Government Solutions, Inc. All rights reserved.



RADIO FREQUENCY EMISSIONS ANALYSIS REPORT EVALUATION OF HUMAN EXPOSURE POTENTIAL TO NON-IONIZING EMISSIONS

T-Mobile Existing Facility

Site ID: CT11334A

Stamford-3/ Hope St.
652 Glenbrook Road
Stamford, CT 06906

July 26, 2018

EBI Project Number: 6218005252

Site Compliance Summary	
Compliance Status:	COMPLIANT
Site total MPE% of FCC general population allowable limit:	19.10 %



July 26, 2018

T-Mobile USA
Attn: Jason Overbey, RF Manager
35 Griffin Road South
Bloomfield, CT 06002

Emissions Analysis for Site: **CT11334A – Stamford-3/ Hope St.**

EBI Consulting was directed to analyze the proposed T-Mobile facility located at **652 Glenbrook Road, Stamford, CT**, for the purpose of determining whether the emissions from the Proposed T-Mobile Antenna Installation located on this property are within specified federal limits.

All information used in this report was analyzed as a percentage of current Maximum Permissible Exposure (% MPE) as listed in the FCC OET Bulletin 65 Edition 97-01 and ANSI/IEEE Std C95.1. The FCC regulates Maximum Permissible Exposure in units of microwatts per square centimeter ($\mu\text{W}/\text{cm}^2$). The number of $\mu\text{W}/\text{cm}^2$ calculated at each sample point is called the power density. The exposure limit for power density varies depending upon the frequencies being utilized. Wireless Carriers and Paging Services use different frequency bands each with different exposure limits, therefore it is necessary to report results and limits in terms of percent MPE rather than power density.

All results were compared to the FCC (Federal Communications Commission) radio frequency exposure rules, 47 CFR 1.1307(b)(1) – (b)(3), to determine compliance with the Maximum Permissible Exposure (MPE) limits for General Population/Uncontrolled environments as defined below.

General population/uncontrolled exposure limits apply to situations in which the general population may be exposed or in which persons who are exposed as a consequence of their employment may not be made fully aware of the potential for exposure or cannot exercise control over their exposure. Therefore, members of the general population would always be considered under this category when exposure is not employment related, for example, in the case of a telecommunications tower that exposes persons in a nearby residential area.

Public exposure to radio frequencies is regulated and enforced in units of microwatts per square centimeter ($\mu\text{W}/\text{cm}^2$). The general population exposure limits for the 600 MHz and 700 MHz Band are approximately $400 \mu\text{W}/\text{cm}^2$ and $467 \mu\text{W}/\text{cm}^2$ respectively. The general population exposure limit for the 1900 MHz (PCS) and 2100 MHz (AWS) bands is $1000 \mu\text{W}/\text{cm}^2$. Because each carrier will be using different frequency bands, and each frequency band has different exposure limits, it is necessary to report percent of MPE rather than power density.



Occupational/controlled exposure limits apply to situations in which persons are exposed as a consequence of their employment and in which those persons who are exposed have been made fully aware of the potential for exposure and can exercise control over their exposure. Occupational/controlled exposure limits also apply where exposure is of a transient nature as a result of incidental passage through a location where exposure levels may be above general population/uncontrolled limits (see below), as long as the exposed person has been made fully aware of the potential for exposure and can exercise control over his or her exposure by leaving the area or by some other appropriate means.

Additional details can be found in FCC OET 65.

CALCULATIONS

Calculations were done for the proposed T-Mobile Wireless antenna facility located at **652 Glenbrook Road, Stamford, CT**, using the equipment information listed below. All calculations were performed per the specifications under FCC OET 65. Since T-Mobile is proposing highly focused directional panel antennas, which project most of the emitted energy out toward the horizon, all calculations were performed assuming a lobe representing the maximum gain of the antenna per the antenna manufactures supplied specifications, minus 10 dB for directional panel antennas, was focused at the base of the tower. For this report the sample point is the top of a 6-foot person standing at the base of the tower.

For all calculations, all equipment was calculated using the following assumptions:

- 1) 2 GSM channels (PCS Band - 1900 MHz) were considered for each sector of the proposed installation. These Channels have a transmit power of 30 Watts per Channel.
- 2) 2 UMTS channels (AWS Band – 2100 MHz) were considered for each sector of the proposed installation. These Channels have a transmit power of 30 Watts per Channel.
- 3) 2 LTE channels (PCS Band - 1900 MHz) were considered for each sector of the proposed installation. These Channels have a transmit power of 60 Watts per Channel.
- 4) 2 LTE channels (AWS Band – 2100 MHz) were considered for each sector of the proposed installation. These Channels have a transmit power of 60 Watts per Channel.
- 5) 2 LTE channels (600 MHz Band) were considered for each sector of the proposed installation. These Channels have a transmit power of 30 Watts per Channel.
- 6) 2 LTE channels (700 MHz Band) were considered for each sector of the proposed installation. These Channels have a transmit power of 30 Watts per Channel.



- 7) All radios at the proposed installation were considered to be running at full power and were uncombined in their RF transmissions paths per carrier prescribed configuration. Per FCC OET Bulletin No. 65 - Edition 97-01 recommendations to achieve the maximum anticipated value at each sample point, all power levels emitting from the proposed antenna installation are increased by a factor of 2.56 to account for possible in-phase reflections from the surrounding environment. This is rarely the case, and if so, is never continuous.
- 8) For the following calculations the sample point was the top of a 6-foot person standing at the base of the tower. The maximum gain of the antenna per the antenna manufactures supplied specifications, minus 10 dB for directional panel antennas, was used in this direction. This value is a very conservative estimate as gain reductions for these particular antennas are typically much higher in this direction.
- 9) The antennas used in this modeling are the **Ericsson AIR32 B66A/B2A & Ericsson AIR21 B2A/B4P** for 1900 MHz (PCS) and 2100 MHz (AWS) channels, the **RFS APXVAARR24_43-U-NA20** for 600 MHz and 700 MHz channels. This is based on feedback from the carrier with regard to anticipated antenna selection. All Antenna gain values and associated transmit power levels are shown in the Site Inventory and Power Data table below. The maximum gain of the antenna per the antenna manufactures supplied specifications, minus 10 dB for directional panel antennas, was used for all calculations. This value is a very conservative estimate as gain reductions for these particular antennas are typically much higher in this direction.
- 10) The antenna mounting height centerline of the proposed antennas is **85 feet** above ground level (AGL).
- 11) Emissions values for additional carriers were taken from the Connecticut Siting Council active database. Values in this database are provided by the individual carriers themselves.
- 12) All calculations were done with respect to uncontrolled / general population threshold limits.



T-Mobile Site Inventory and Power Data

Sector:	A	Sector:	B	Sector:	C
Antenna #:	1	Antenna #:	1	Antenna #:	1
Make / Model:	Ericsson AIR32 B66A/B2A	Make / Model:	Ericsson AIR32 B66A/B2A	Make / Model:	Ericsson AIR32 B66A/B2A
Gain:	15.9 dBd	Gain:	15.9 dBd	Gain:	15.9 dBd
Height (AGL):	85	Height (AGL):	85	Height (AGL):	85
Frequency Bands	1900 MHz (PCS) / 2100 MHz (AWS)	Frequency Bands	1900 MHz (PCS) / 2100 MHz (AWS)	Frequency Bands	1900 MHz (PCS) / 2100 MHz (AWS)
Channel Count	4	Channel Count	4	Channel Count	4
Total TX Power(W):	240	Total TX Power(W):	240	Total TX Power(W):	240
ERP (W):	9,337.08	ERP (W):	9,337.08	ERP (W):	9,337.08
Antenna A1 MPE%	5.38	Antenna B1 MPE%	5.38	Antenna C1 MPE%	5.38
Antenna #:	2	Antenna #:	2	Antenna #:	2
Make / Model:	Ericsson AIR21 B2A/B4P	Make / Model:	Ericsson AIR21 B2A/B4P	Make / Model:	Ericsson AIR21 B2A/B4P
Gain:	15.9 dBd	Gain:	15.9 dBd	Gain:	15.9 dBd
Height (AGL):	85	Height (AGL):	85	Height (AGL):	85
Frequency Bands	1900 MHz (PCS) / 2100 MHz (AWS)	Frequency Bands	1900 MHz (PCS) / 2100 MHz (AWS)	Frequency Bands	1900 MHz (PCS) / 2100 MHz (AWS)
Channel Count	4	Channel Count	4	Channel Count	4
Total TX Power(W):	120	Total TX Power(W):	120	Total TX Power(W):	120
ERP (W):	4,668.54	ERP (W):	4,668.54	ERP (W):	4,668.54
Antenna A2 MPE%	2.69	Antenna B2 MPE%	2.69	Antenna C2 MPE%	2.69
Antenna #:	3	Antenna #:	3	Antenna #:	3
Make / Model:	RFS APXVAARR24_43-U-NA20	Make / Model:	RFS APXVAARR24_43-U-NA20	Make / Model:	RFS APXVAARR24_43-U-NA20
Gain:	12.95 / 13.35 dBd	Gain:	12.95 / 13.35 dBd	Gain:	12.95 / 13.35 dBd
Height (AGL):	85	Height (AGL):	85	Height (AGL):	85
Frequency Bands	600 MHz / 700 MHz	Frequency Bands	600 MHz / 700 MHz	Frequency Bands	600 MHz / 700 MHz
Channel Count	4	Channel Count	4	Channel Count	4
Total TX Power(W):	120	Total TX Power(W):	120	Total TX Power(W):	120
ERP (W):	2,481.08	ERP (W):	2,481.08	ERP (W):	2,481.08
Antenna A3 MPE%	3.30	Antenna B3 MPE%	3.30	Antenna C3 MPE%	3.30

Site Composite MPE%	
Carrier	MPE%
T-Mobile (Per Sector Max)	11.37 %
MetroPCS	2.41
Clearwire	0.24
Nextel	0.76
AT&T	4.32
Site Total MPE %:	19.10 %

T-Mobile Sector A Total:	11.37 %
T-Mobile Sector B Total:	11.37 %
T-Mobile Sector C Total:	11.37 %
<hr/>	
Site Total:	19.10 %



T-Mobile Max Power Values (Per Sector)

T-Mobile Max Power Values (Per Sector)	# Channels	Watts ERP (Per Channel)	Height (feet)	Total Power Density ($\mu\text{W}/\text{cm}^2$)	Frequency (MHz)	Allowable MPE ($\mu\text{W}/\text{cm}^2$)	Calculated % MPE
T-Mobile PCS - 1900 MHz LTE	2	2,334.27	85	26.89	PCS - 1900 MHz	1000.00	2.69%
T-Mobile AWS - 2100 MHz LTE	2	2,334.27	85	26.89	AWS - 2100 MHz	1000.00	2.69%
T-Mobile PCS - 1900 MHz GSM	2	1,167.14	85	13.45	PCS - 1900 MHz	1000.00	1.34%
T-Mobile AWS - 2100 MHz UMTS	2	1,167.14	85	13.45	AWS - 2100 MHz	1000.00	1.34%
T-Mobile 600 MHz LTE	2	591.73	85	6.82	600 MHz	400.00	1.70%
T-Mobile 700 MHz LTE	2	648.82	85	7.47	700 MHz	467.00	1.61%
						Total:	11.37%

Summary

All calculations performed for this analysis yielded results that were **within** the allowable limits for general population exposure to RF Emissions.

The anticipated maximum composite contributions from the T-Mobile facility as well as the site composite emissions value with regards to compliance with FCC's allowable limits for general population exposure to RF Emissions are shown here:

T-Mobile Sector	Power Density Value (%)
Sector A:	11.37 %
Sector B:	11.37 %
Sector C:	11.37 %
T-Mobile Maximum MPE % (Per Sector):	11.37 %
Site Total:	19.10 %
Site Compliance Status:	COMPLIANT

The anticipated composite MPE value for this site assuming all carriers present is **19.10%** of the allowable FCC established general population limit sampled at the ground level. This is based upon values listed in the Connecticut Siting Council database for existing carrier emissions.

FCC guidelines state that if a site is found to be out of compliance (over allowable thresholds), that carriers over a 5% contribution to the composite value will require measures to bring the site into compliance. For this facility, the composite values calculated were well within the allowable 100% threshold standard per the federal government.

July 2, 2018

Mr. Dan Reid
Transcend Wireless
10 Industrial Ave
Mahwah, NJ 07430

Re: *Structural Evaluation Letter ~ Antenna Upgrade*
T-Mobile Site Ref ~ CT11334A
652 Glenbrook Road
Stamford, CT 06906

Centek Project No. 18058.59

Dear Mr. Reid,

Centek Engineering, Inc. has reviewed the proposed T-Mobile antenna upgrade at the above referenced site. The purpose of the review is to determine the structural adequacy of the existing mounts and host water tank to support the proposed modified antenna configuration. The existing installation consists of three (3) antenna sectors mounted on steel frames attached to the handrail/façade of the water tank. The review considered the effects of wind load, dead load, ice load and seismic forces in accordance with the 2012 International Building Code as amended by the 2016 CT State Building Code (CSBC).

The existing and proposed T-Mobile loads considered in this analysis consist of the following:

- T-Mobile (Existing to Remain):
Antennas: Three (3) Ericsson AIR21 panel antennas and three (3) TMAs mounted on steel frames attached to the handrail/façade of the water tank with a rad center antenna elevation of +/- 85-ft AGL.
- T-Mobile (Existing to Remove):
Antennas: Three (3) Ericsson AIR21 panel antennas, three (3) Andrew LNX6515DS panel antennas and three (3) Ericsson RRUS-11 remote radio units mounted on steel frames attached to the handrail/façade of the water tank with a rad center antenna elevation of +/- 85-ft AGL.
- T-Mobile (Proposed):
Antennas: Three (3) Ericsson AIR32 panel antennas, three (3) RFS APXVAARR24-43-AN20 panel antennas and three (3) Ericsson 4449 B71_B12 remote radio units mounted on steel frames attached to the handrail/façade of the water tank with a rad center antenna elevation of +/- 85-ft AGL.

The proposed antenna installation meets the requirements of 2012 International Building Code as amended by the 2016 CT State Building Code considering the ultimate design wind speed of 120 mph as required in Appendix N of the CSBC. Our findings are based on the assumption that the hosting structure, all structural members and appurtenances were properly designed, detailed, fabricated, installed and have been properly maintained since erection.

In conclusion, the proposed T-Mobile antenna upgrade will not negatively impact the structural integrity of the existing host structure. If there are any questions regarding this matter, please feel free to call.

Respectfully Submitted by:

Timothy J. Lynn, PE
Structural Engineer

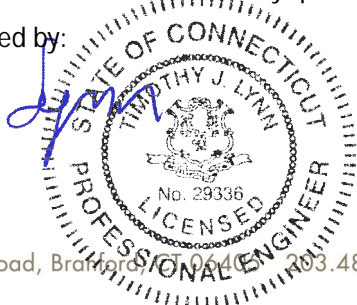



WIRELESS COMMUNICATIONS FACILITY

STAMFORD-3/ HOPE ST.

SITE ID: CT11334A

652 GLENBROOK ROAD STAMFORD, CT 06906

GENERAL NOTES

- ALL WORK SHALL BE IN ACCORDANCE WITH THE 2012 INTERNATIONAL BUILDING CODE AS MODIFIED BY THE 2016 CONNECTICUT SUPPLEMENT, INCLUDING THE TIA/EIA-222 REVISION "G" "STRUCTURAL STANDARDS FOR STEEL ANTENNA TOWERS AND SUPPORTING STRUCTURES." 2016 CONNECTICUT FIRE SAFETY CODE, NATIONAL ELECTRICAL CODE AND LOCAL CODES.
- CONTRACTOR SHALL REVIEW ALL DRAWINGS AND SPECIFICATIONS IN THE CONTRACT DOCUMENT SET. CONTRACTOR SHALL COORDINATE ALL WORK SHOWN IN THE SET OF DRAWINGS. THE CONTRACTOR SHALL PROVIDE A COMPLETE SET OF DRAWINGS TO ALL SUBCONTRACTORS AND ALL RELATED PARTIES. THE SUBCONTRACTORS SHALL EXAMINE ALL THE DRAWINGS AND SPECIFICATIONS FOR THE INFORMATION THAT AFFECTS THEIR WORK.
- CONTRACTOR SHALL PROVIDE A COMPLETE BUILD-OUT WITH ALL FINISHES, STRUCTURAL, MECHANICAL, AND ELECTRICAL COMPONENTS AND PROVIDE ALL ITEMS AS SHOWN OR INDICATED ON THE DRAWINGS OR IN THE WRITTEN SPECIFICATIONS.
- CONTRACTOR SHALL FURNISH ALL MATERIAL, LABOR AND EQUIPMENT TO COMPLETE THE WORK AND FURNISH A COMPLETED JOB ALL IN ACCORDANCE WITH LOCAL AND STATE GOVERNING AUTHORITIES AND OTHER AUTHORITIES HAVING LAWFUL JURISDICTION OVER THE WORK.
- CONTRACTOR SHALL SECURE AND PAY FOR ALL PERMITS AND ALL INSPECTIONS REQUIRED AND SHALL ALSO PAY FEES REQUIRED FOR THE GENERAL CONSTRUCTION, PLUMBING, ELECTRICAL AND HVAC. PERMITS SHALL BE PAID FOR BY THE RESPECTIVE SUBCONTRACTORS.
- CONTRACTOR SHALL MAINTAIN A CURRENT SET OF DRAWINGS AND SPECIFICATIONS ON SITE AT ALL TIMES AND INSURE DISTRIBUTION OF NEW DRAWINGS TO SUBCONTRACTORS AND OTHER RELEVANT PARTIES AS SOON AS THEY ARE MADE AVAILABLE. ALL OLD DRAWINGS SHALL BE MARKED VOID AND REMOVED FROM THE CONTRACT AREA. THE CONTRACTOR SHALL FURNISH AN "AS-BUILT" SET OF DRAWINGS TO OWNER UPON COMPLETION OF PROJECT.
- LOCATION OF EQUIPMENT, AND WORK SUPPLIED BY OTHERS THAT IS DIAGRAMMATICALLY INDICATED ON THE DRAWINGS SHALL BE DETERMINED BY THE CONTRACTOR. THE CONTRACTOR SHALL DETERMINE LOCATIONS AND DIMENSIONS SUBJECT TO STRUCTURAL CONDITIONS AND WORK OF THE SUBCONTRACTORS.
- THE CONTRACTOR IS SOLELY RESPONSIBLE TO DETERMINE CONSTRUCTION PROCEDURE AND SEQUENCE, AND TO ENSURE THE SAFETY OF THE EXISTING STRUCTURES AND ITS COMPONENT PARTS DURING CONSTRUCTION. THIS INCLUDES THE ADDITION OF WHATEVER SHORING, BRACING, UNDERPINNING, ETC. THAT MAY BE NECESSARY.
- DRAWINGS INDICATE THE MINIMUM STANDARDS, BUT IF ANY WORK SHOULD BE INDICATED TO BE SUBSTANDARD TO ANY ORDINANCES, LAWS, CODES, RULES, OR REGULATIONS BEARING ON THE WORK, THE CONTRACTOR SHALL INCLUDE IN HIS WORK AND SHALL EXECUTE THE WORK CORRECTLY IN ACCORDANCE WITH SUCH ORDINANCES, LAWS, CODES, RULES OR REGULATIONS WITH NO INCREASE IN COSTS.
- ALL UTILITY WORK SHALL BE IN ACCORDANCE WITH LOCAL UTILITY COMPANY REQUIREMENTS AND SPECIFICATIONS.
- ALL EQUIPMENT AND PRODUCTS PURCHASED ARE TO BE REVIEWED BY CONTRACTOR AND ALL APPLICABLE SUBCONTRACTORS FOR ANY CONDITION PER MFR.'S RECOMMENDATIONS. CONTRACTOR TO SUPPLY THESE ITEMS AT NO COST TO OWNER OR CONSTRUCTION MANAGER.
- ANY AND ALL ERRORS, DISCREPANCIES, AND "MISSED" ITEMS ARE TO BE BROUGHT TO THE ATTENTION OF THE T-MOBILE CONSTRUCTION MANAGER DURING THE BIDDING PROCESS. BY THE CONTRACTOR. ALL THESE ITEMS ARE TO BE INCLUDED IN THE BID. NO "EXTRA" WILL BE ALLOWED FOR MISSED ITEMS.
- CONTRACTOR SHALL BE RESPONSIBLE FOR ALL ON-SITE SAFETY FROM THE TIME THE JOB IS AWARDED UNTIL ALL WORK IS COMPLETE AND ACCEPTED BY THE OWNER.
- CONTRACTOR TO REVIEW ALL SHOP DRAWINGS AND SUBMIT COPY TO ENGINEER FOR APPROVAL. DRAWINGS MUST BEAR THE CHECKER'S INITIALS BEFORE SUBMITTING TO THE CONSTRUCTION MANAGER FOR REVIEW.
- THE CONTRACTOR SHALL FIELD VERIFY ALL DIMENSIONS, ELEVATIONS, ANGLES, AND EXISTING CONDITIONS AT THE SITE, PRIOR TO FABRICATION AND/OR INSTALLATION OF ANY WORK IN THE CONTRACT AREA.
- COORDINATION, LAYOUT, FURNISHING AND INSTALLATION OF CONDUIT AND ALL APPURTENANCES REQUIRED FOR PROPER INSTALLATION OF ELECTRICAL AND TELECOMMUNICATION SERVICE SHALL BE THE SOLE RESPONSIBILITY OF THE CONTRACTOR.
- ALL DAMAGE CAUSED TO ANY EXISTING STRUCTURE SHALL BE THE SOLE RESPONSIBILITY OF THE CONTRACTOR. THE CONTRACTOR WILL BE HELD LIABLE FOR ALL REPAIRS REQUIRED FOR EXISTING STRUCTURES IF DAMAGED DURING CONSTRUCTION ACTIVITIES.
- THE CONTRACTOR SHALL CONTACT "CALL BEFORE YOU DIG" AT LEAST 48 HOURS PRIOR TO ANY EXCAVATIONS AT 1-800-922-4455. ALL UTILITIES SHALL BE IDENTIFIED AND CLEARLY MARKED. CONTRACTOR SHALL MAINTAIN AND PROTECT MARKED UTILITIES THROUGHOUT PROJECT COMPLETION.
- CONTRACTOR SHALL COMPLY WITH OWNERS ENVIRONMENTAL ENGINEER ON ALL METHODS AND PROVISIONS FOR ALL EXCAVATION ACTIVITIES INCLUDING SOIL DISPOSAL. ALL BACKFILL MATERIALS TO BE PROVIDED BY THE CONTRACTOR.

SITE DIRECTIONS

FROM: 35 GRIFFIN ROAD SOUTH
BLOOMFIELD, CT 06002

TO: 652 GLENBROOK ROAD
STAMFORD, CT 06906

- HEAD NORTH ON GRIFFIN ROAD S. TOWARD HARTMAN RD. 0.21 MI.
- TAKE THE 2ND RIGHT ONTO DAY HILL RD. 0.14 MI.
- TAKE THE 1ST RIGHT ONTO BLUE HILLS AVENUE EXT/CT-187 1.89 MI.
- TURN LEFT ONTO CT-305/OLD WINDSOR RD. 2.32 MI.
- STAY STRAIGHT TO GO ONTO BLOOMFIELD AVE/CT-305. 0.01 MI.
- MERGE ONTO I-91 S 27.74 MI.
- MERGE ONTO CT-15 S VIA EXIT 17 TOWARD E MAIN ST 51.60 MI.
- TAKE THE CT-106/OLD STAMFORD RD EXIT, EXIT 36 0.11 MI.
- TURN RIGHT ONTO OLD STAMFORD RD/CT-106. CONTINUE TO FOLLOW CT-106 3.03 MI.
- SLIGHT RIGHT ONTO MIDDLESEX RD/CT-106. CONTINUE TO FOLLOW CT-106 0.34 MI.

VICINITY MAP

SCALE: 1" = 1000'

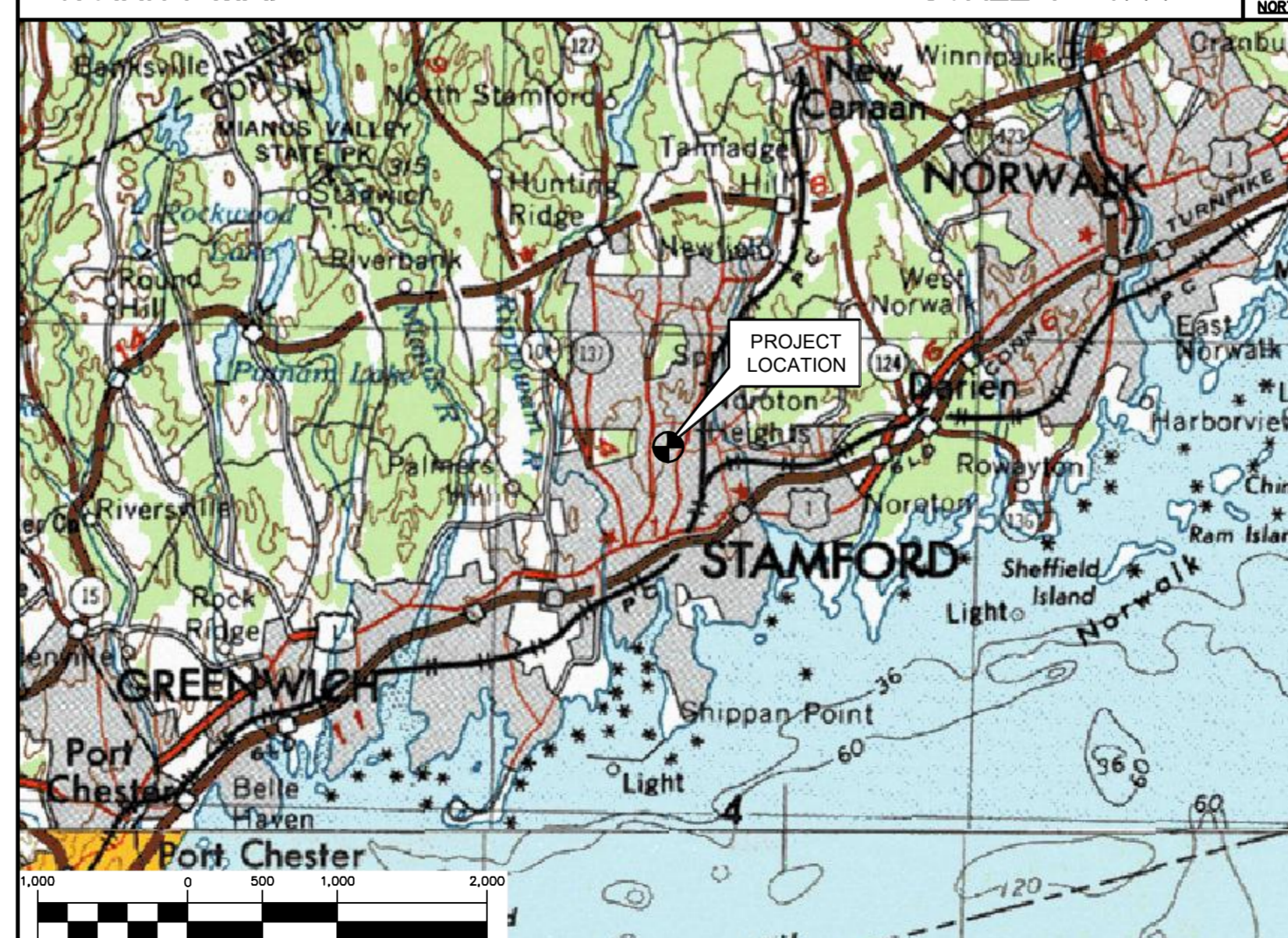

T-MOBILE RF CONFIGURATION

67D92DB_2xAIR+1OP

PROJECT SUMMARY

- THE PROPOSED SCOPE OF WORK CONSISTS OF A MODIFICATION TO THE EXISTING UNMANNED TELECOMMUNICATIONS FACILITY INCLUDING THE FOLLOWING:
 - REMOVE (6) EXISTING ANTENNAS, (2) PER SECTOR
 - INSTALL (6) PROPOSED ANTENNAS, (2) PER SECTOR
 - REMOVE (3) EXISTING RRUS11 B12, (1) PER SECTOR
 - INSTALL (3) NEW RADIO 4449 B71+B12'S, (1) PER SECTOR
 - INSTALL (3) NEW HYBRID CABLES, (1) PER SECTOR. ALL EXISTING AND PROPOSED CABLES TO BE INSTALLED WITHIN CABLE TRAYS.

PROJECT INFORMATION

SITE NAME: STAMFORD-3/ HOPE ST.

SITE ID: CT11334A

SITE ADDRESS: 652 GLENBROOK ROAD
STAMFORD, CT 06906

APPLICANT: T-MOBILE NORTHEAST, LLC
35 GRIFFIN ROAD SOUTH
BLOOMFIELD, CT 06002

CONTACT PERSON: DAN REID (PROJECT MANAGER)
TRANSCEND WIRELESS, LLC
(203) 592-8291

ENGINEER: CENTEK ENGINEERING, INC.
63-2 NORTH BRANFORD RD.
BRANFORD, CT 06405

PROJECT COORDINATES: LATITUDE: 41°-4'-31.10" N
LONGITUDE: 73°-31'-9.08" W
GROUND ELEVATION: 54'± AMSL

SITE COORDINATES AND GROUND ELEVATION REFERENCED FROM GOOGLE EARTH.

SHEET INDEX

SHT. NO.	DESCRIPTION	REV.
T-1	TITLE SHEET	0
N-1	DESIGN BASIS AND SITE NOTES	0
C-1	SITE LOCATION PLAN	0
C-2	COMPOUND PLAN AND ELEVATION	0
C-3	ANTENNA MOUNTING CONFIGURATION	0
E-1	TYPICAL ELECTRICAL DETAILS	0

REV.	DATE	TITLE	BY	CHK'D BY	CAG	ISSUED FOR CONSTRUCTION
0	07/18/18					

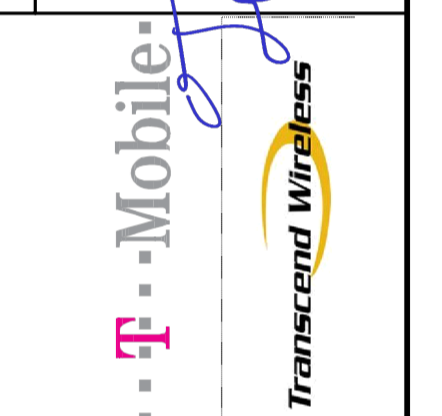
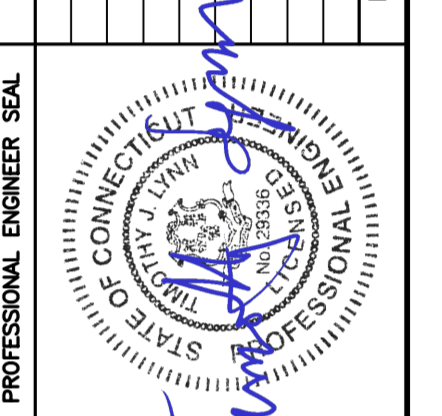

CEN TEK engineering
Centek on Solutions
(203) 498-0390
(203) 498-3897 Fax
652 North Branford Road
Branford, CT 06405
www.CentekEng.com

T-MOBILE NORTHEAST LLC
WIRELESS COMMUNICATIONS FACILITY
STAMFORD-3/HOPE ST.
SITE ID: CT11334A
652 GLENBROOK ROAD
STAMFORD, CT 06906

DATE: 06/19/18
SCALE: AS NOTED
JOB NO. 18058.59

TITLE SHEET

T-1

DESIGN BASIS:

GOVERNING CODE: 2012 INTERNATIONAL BUILDING (IBC) AS MODIFIED BY THE 2016 CT STATE BUILDING CODE AND AMENDMENTS.

- 1. DESIGN CRITERIA:
• RISK CATEGORY: II (BASED ON IBC TABLE 1604.5)
• ULTIMATE DESIGN SPEED (OTHER STRUCTURE): 120 MPH (VuIt) (EXPOSURE B)/IMPORTANCE FACTOR 1.0 BASED ON ASCE 7-10 PER 2012 INTERNATIONAL BUILDING CODE (IBC) AS MODIFIED BY THE 2016 CONNECTICUT STATE BUILDING CODE.
• SEISMIC LOAD (DOES NOT CONTROL): PER ASCE 7-10 MINIMUM DESIGN LOADS FOR BUILDING AND OTHER STRUCTURES.

GENERAL NOTES:

- 1. ALL CONSTRUCTION SHALL BE IN COMPLIANCE WITH THE GOVERNING BUILDING CODE.
2. DRAWINGS INDICATE THE MINIMUM STANDARDS, BUT IF ANY WORK SHOULD BE INDICATED TO BE SUBSTANDARD TO ANY ORDINANCES, LAWS, CODES, RULES, OR REGULATIONS BEARING ON THE WORK, THE CONTRACTOR SHALL INCLUDE IN HIS WORK AND SHALL EXECUTE THE WORK CORRECTLY IN ACCORDANCE WITH SUCH ORDINANCES, LAWS, CODES, RULES OR REGULATIONS WITH NO INCREASE IN COSTS.
3. BEFORE BEGINNING THE WORK, THE CONTRACTOR IS RESPONSIBLE FOR MAKING SUCH INVESTIGATIONS CONCERNING PHYSICAL CONDITIONS (SURFACE AND SUBSURFACE) AT OR CONTIGUOUS TO THE SITE WHICH MAY AFFECT PERFORMANCE AND COST OF THE WORK.
4. DIMENSIONS AND DETAILS SHALL BE CHECKED AGAINST EXISTING FIELD CONDITIONS.
5. THE CONTRACTOR SHALL VERIFY AND COORDINATE THE SIZE AND LOCATION OF ALL OPENINGS, SLEEVES AND ANCHOR BOLTS AS REQUIRED BY ALL TRADES.
6. ALL DIMENSIONS, ELEVATIONS, AND OTHER REFERENCES TO EXISTING STRUCTURES, SURFACE, AND SUBSURFACE CONDITIONS ARE APPROXIMATE. NO GUARANTEE IS MADE FOR THE ACCURACY OR COMPLETENESS OF THE INFORMATION SHOWN. THE CONTRACTOR SHALL VERIFY AND COORDINATE ALL DIMENSIONS, ELEVATIONS, ANGLES WITH EXISTING CONDITIONS AND WITH ARCHITECTURAL AND SITE DRAWINGS BEFORE PROCEEDING WITH ANY WORK.
7. AS THE WORK PROGRESSES, THE CONTRACTOR SHALL NOTIFY THE OWNER OF ANY CONDITIONS WHICH ARE IN CONFLICT OR OTHERWISE NOT CONSISTENT WITH THE CONSTRUCTION DOCUMENTS AND SHALL NOT PROCEED WITH SUCH WORK UNTIL THE CONFLICT IS SATISFACTORILY RESOLVED.
8. THE CONTRACTOR SHALL COMPLY WITH ALL APPLICABLE SAFETY CODES AND REGULATIONS DURING ALL PHASES OF CONSTRUCTION. THE CONTRACTOR IS SOLELY RESPONSIBLE FOR PROVIDING AND MAINTAINING ADEQUATE SHORING, BRACING, AND BARRICADES AS MAY BE REQUIRED FOR THE PROTECTION OF EXISTING PROPERTY, CONSTRUCTION WORKERS, AND FOR PUBLIC SAFETY.
9. THE CONTRACTOR IS SOLELY RESPONSIBLE TO DETERMINE CONSTRUCTION PROCEDURE AND SEQUENCE, AND TO ENSURE THE SAFETY OF THE EXISTING STRUCTURES AND ITS COMPONENT PARTS DURING CONSTRUCTION. THIS INCLUDES THE ADDITION OF WHATEVER SHORING, BRACING, UNDERPINNING, ETC. THAT MAY BE NECESSARY. MAINTAIN EXISTING SITE OPERATIONS, COORDINATE WORK WITH NORTHEAST UTILITIES
10. THE STRUCTURE IS DESIGNED TO BE SELF-SUPPORTING AND STABLE AFTER FOUNDATION REMEDIATION WORK IS COMPLETE. IT IS THE CONTRACTOR'S SOLE RESPONSIBILITY TO DETERMINE ERECTION PROCEDURE AND SEQUENCE AND TO ENSURE THE SAFETY OF THE STRUCTURE AND ITS COMPONENT PARTS DURING ERECTION. THIS INCLUDES THE ADDITION OF WHATEVER SHORING, TEMPORARY BRACING, GUYS OR TIEDOWNS, WHICH MIGHT BE NECESSARY.
11. ALL DAMAGE CAUSED TO ANY EXISTING STRUCTURE SHALL BE THE SOLE RESPONSIBILITY OF THE CONTRACTOR. THE CONTRACTOR WILL BE HELD LIABLE FOR ALL REPAIRS REQUIRED FOR EXISTING STRUCTURES IF DAMAGED DURING CONSTRUCTION ACTIVITIES.
12. SHOP DRAWINGS, CONCRETE MIX DESIGNS, TEST REPORTS, AND OTHER SUBMITTALS PERTAINING TO STRUCTURAL WORK SHALL BE FORWARDED TO THE OWNER FOR REVIEW BEFORE FABRICATION AND/OR INSTALLATION IS MADE. SHOP DRAWINGS SHALL INCLUDE ERECTION DRAWINGS AND COMPLETE DETAILS OF CONNECTIONS AS WELL AS MANUFACTURER'S SPECIFICATION DATA WHERE APPROPRIATE. SHOP DRAWINGS SHALL BE CHECKED BY THE CONTRACTOR AND BEAR THE CHECKER'S INITIALS BEFORE BEING SUBMITTED FOR REVIEW.
13. NO DRILLING WELDING OR TAPING ON EVERSOURCE OWNED EQUIPMENT.
14. REFER TO DRAWING T1 FOR ADDITIONAL NOTES AND REQUIREMENTS.

STRUCTURAL STEEL

- 1. ALL STRUCTURAL STEEL IS DESIGNED BY ALLOWABLE STRESS DESIGN (ASD)
A. STRUCTURAL STEEL (W SHAPES)---ASTM A992 (FY = 50 KSI)
B. STRUCTURAL STEEL (OTHER SHAPES)---ASTM A36 (FY = 36 KSI)
C. STRUCTURAL HSS (RECTANGULAR SHAPES)---ASTM A500 GRADE B, (FY = 46 KSI)
D. STRUCTURAL HSS (ROUND SHAPES)---ASTM A500 GRADE B, (FY = 42 KSI)
E. PIPE---ASTM A53 (FY = 35 KSI)
F. CONNECTION BOLTS---ASTM A325-N
G. U-BOLTS---ASTM A36
H. ANCHOR RODS---ASTM F 1554
I. WELDING ELECTRODE---ASTM E 70XX
2. CONTRACTOR TO REVIEW ALL SHOP DRAWINGS AND SUBMIT COPY TO ENGINEER FOR APPROVAL. DRAWINGS MUST BEAR THE CHECKER'S INITIALS BEFORE SUBMITTING TO THE ENGINEER FOR REVIEW. SHOP DRAWINGS SHALL INCLUDE THE FOLLOWING: SECTION PROFILES, SIZES, CONNECTION ATTACHMENTS, REINFORCING, ANCHORAGE, SIZE AND TYPE OF FASTENERS AND ACCESSORIES. INCLUDE ERECTION DRAWINGS, ELEVATIONS AND DETAILS.
3. STRUCTURAL STEEL SHALL BE DETAILED, FABRICATED AND ERECTED IN ACCORDANCE WITH THE LATEST PROVISIONS OF AISC MANUAL OF STEEL CONSTRUCTION.
4. PROVIDE ALL PLATES, CLIP ANGLES, CLOSURE PIECES, STRAP ANCHORS, MISCELLANEOUS PIECES AND HOLES REQUIRED TO COMPLETE THE STRUCTURE.
5. FIT AND SHOP ASSEMBLE FABRICATIONS IN THE LARGEST PRACTICAL SECTIONS FOR DELIVERY TO SITE.
6. INSTALL FABRICATIONS PLUMB AND LEVEL, ACCURATELY FITTED, AND FREE FROM DISTORTIONS OR DEFECTS.
7. AFTER ERECTION OF STRUCTURES, TOUCHUP ALL WELDS, ABRASIONS AND NON-GALVANIZED SURFACES WITH A 95% ORGANIC ZINC RICH PAINT IN ACCORDANCE WITH ASTM 780.
8. ALL STEEL MATERIAL (EXPOSED TO WEATHER) SHALL BE GALVANIZED AFTER FABRICATION IN ACCORDANCE WITH ASTM A123 "ZINC (HOT DIPPED GALVANIZED) COATINGS" ON IRONS AND STEEL PRODUCTS.
9. ALL BOLTS, ANCHORS AND MISCELLANEOUS HARDWARE SHALL BE GALVANIZED IN ACCORDANCE WITH ASTM A153 "ZINC COATING (HOT-DIP) ON IRON AND STEEL HARDWARE".
10. THE ENGINEER SHALL BE NOTIFIED OF ANY INCORRECTLY FABRICATED, DAMAGED OR OTHERWISE MISFITTING OR NON CONFORMING MATERIALS OR CONDITIONS TO REMEDIAL OR CORRECTIVE ACTION. ANY SUCH ACTION SHALL REQUIRE ENGINEER REVIEW.
11. CONNECTION ANGLES SHALL HAVE A MINIMUM THICKNESS OF 1/4 INCHES.
12. STRUCTURAL CONNECTION BOLTS SHALL CONFORM TO ASTM A325. ALL BOLTS SHALL BE 3/4" DIAMETER MINIMUM AND SHALL HAVE A MINIMUM OF TWO BOLTS, UNLESS OTHERWISE ON THE DRAWINGS.
13. LOCK WASHER ARE NOT PERMITTED FOR A325 STEEL ASSEMBLIES.
14. SHOP CONNECTIONS SHALL BE WELDED OR HIGH STRENGTH BOLTED.
15. MILL BEARING ENDS OF COLUMNS, STIFFENERS, AND OTHER BEARING SURFACES TO TRANSFER LOAD OVER ENTIRE CROSS SECTION.
16. FABRICATE BEAMS WITH MILL CAMBER UP.
17. LEVEL AND PLUMB INDIVIDUAL MEMBERS OF THE STRUCTURE TO AN ACCURACY OF 1:500, BUT NOT TO EXCEED 1/4" IN THE FULL HEIGHT OF THE COLUMN.
18. COMMENCEMENT OF STRUCTURAL STEEL WORK WITHOUT NOTIFYING THE ENGINEER OF ANY DISCREPANCIES WILL BE CONSIDERED ACCEPTANCE OF PRECEDING WORK.
19. INSPECTION AND TESTING OF ALL WELDING AND HIGH STRENGTH BOLTING SHALL BE PERFORMED BY AN INDEPENDENT TESTING LABORATORY.
20. FOUR COPIES OF ALL INSPECTION TEST REPORTS SHALL BE SUBMITTED TO THE ENGINEER WITHIN TEN (10) WORKING DAYS OF THE DATE OF INSPECTION.

Table with columns for REV., DATE, T.J.L. DRAWN BY, C.A.G. CHECK'D BY, and DESCRIPTION.

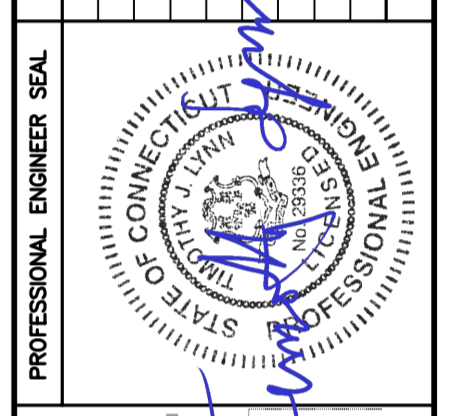

CENTEK engineering
Centered on Solutions
(203) 498-0390
(203) 498-3397 Fax
652 North Branford Road
Branford, CT 06405
www.CentekEng.com

T-MOBILE NORTHEAST LLC
WIRELESS COMMUNICATIONS FACILITY
STAMFORD-3/HOPE ST.
SITE ID: CT11334A
652 GLENBROOK ROAD
STAMFORD, CT 06906

DATE: 06/19/18
SCALE: AS NOTED
JOB NO. 18058.59

DESIGN BASIS AND SITE NOTES

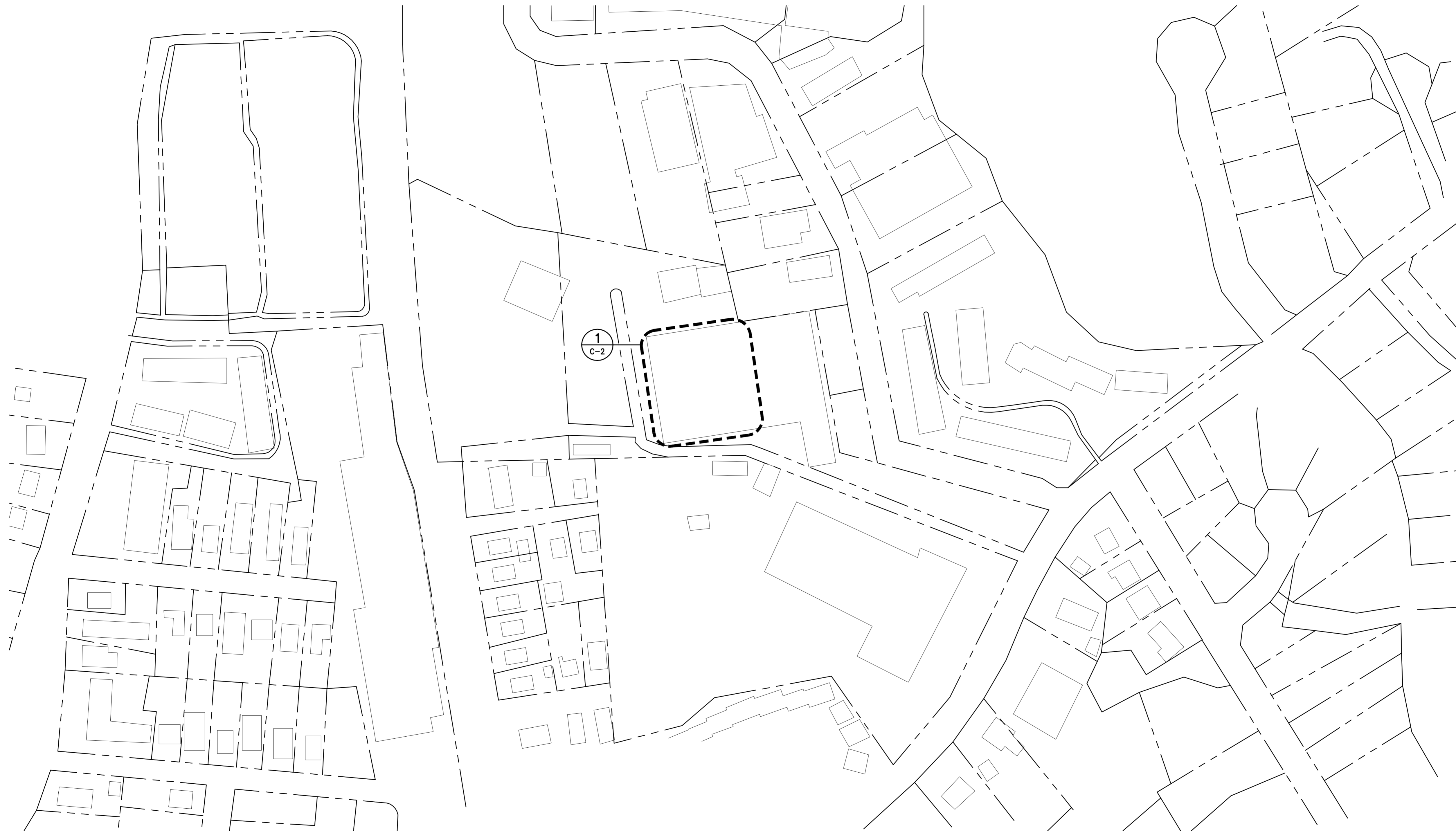

1 SITE LOCATION PLAN
 C-1 SCALE: 1" = 100'

APPROXIMATE NORTH

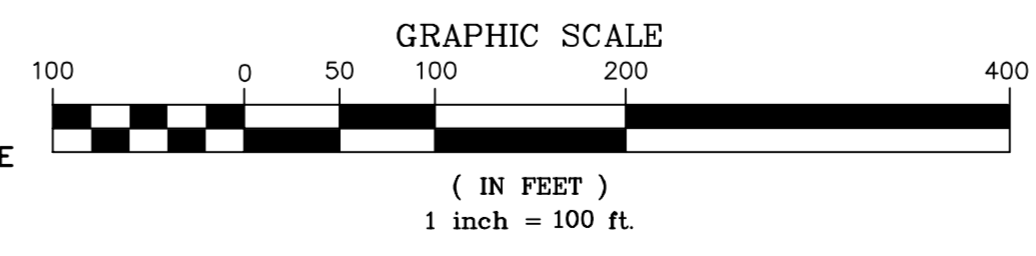

REV.	DATE	TITLE	CHK'D BY	CAC	ISSUED FOR CONSTRUCTION
0	07/18/18				

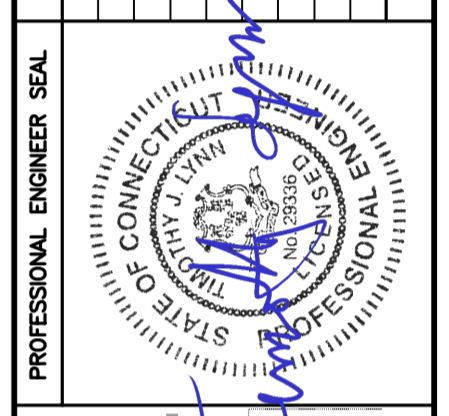

CEN TEK engineering
 Centered on Solutions
 (203) 488-0380 Fax
 (203) 488-3387 For
 652 North Branford Road
 Branford, CT 06405
 www.CenTekEng.com

T-MOBILE NORTHEAST LLC
 WIRELESS COMMUNICATIONS FACILITY
STAMFORD-3/HOPE ST.
SITE ID: CT11334A
 652 GLENBROOK ROAD
 STAMFORD, CT 06906

DATE: 06/19/18
 SCALE: AS NOTED
 JOB NO. 18058.59

SITE LOCATION PLAN

C-1
 Sheet No. 3 of 6

STRUCTURAL NOTE:
 REFER TO STRUCTURAL LETTER
 AS PREPARED BY CENTEK
 ENGINEERING INC.,
 DATED: 07/02/18
 PROJECT NUMBER: 18058.59

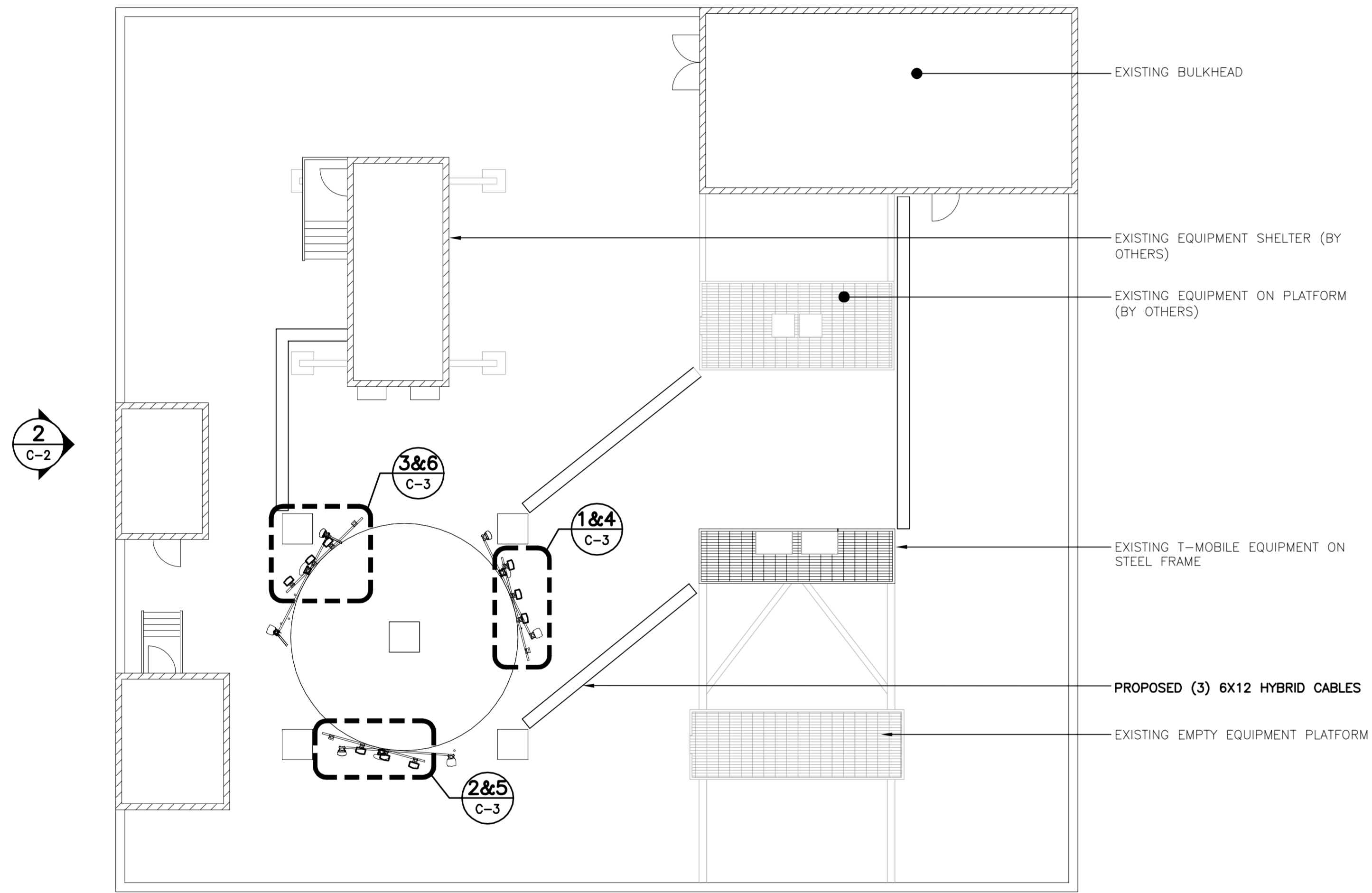

1 **COMPOUND PLAN**
 C-2 SCALE: 1" = 10'
 APPROXIMATE NORTH

GRAPHIC SCALE
 (IN FEET)
 1 inch = 10 ft.

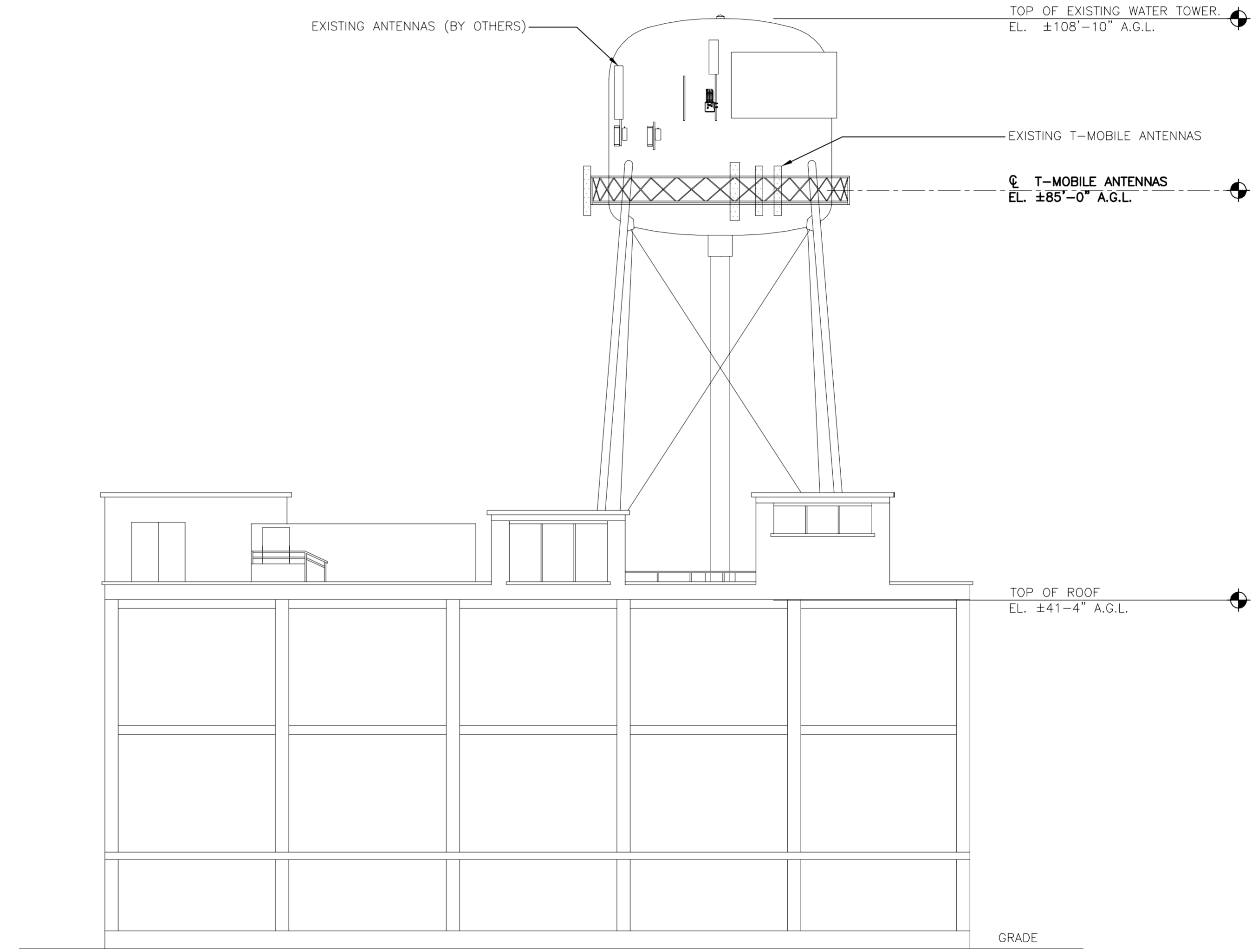

2 **ELEVATION**
 C-2 SCALE: 1" = 10'

GRAPHIC SCALE
 (IN FEET)
 1 inch = 10 ft.

REV.	DATE	TITLE	BY	CHK'D BY	ISSUED FOR CONSTRUCTION
0	07/18/18	DATE			

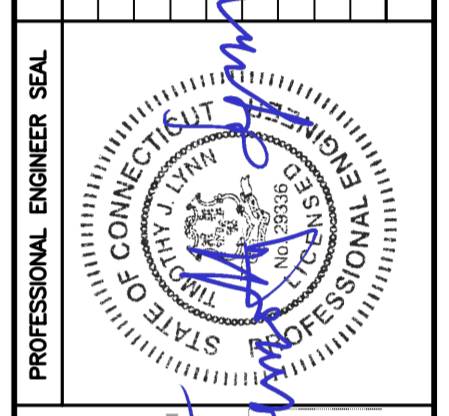

CEN TEK engineering
 Centered on Solutions
 (203) 488-0380 Fax
 (203) 488-3387
 652 North Branford Road
 Branford, CT 06405
 www.CentekEng.com

T-MOBILE NORTHEAST LLC
 WIRELESS COMMUNICATIONS FACILITY
STAMFORD-3/HOPE ST.
SITE ID: CT11334A
 652 GLENBROOK ROAD
 STAMFORD, CT 06906

DATE: 06/19/18
 SCALE: AS NOTED
 JOB NO. 18058.59

COMPOUND PLAN,
 AND ELEVATION

C-2
 Sheet No. 4 of 6

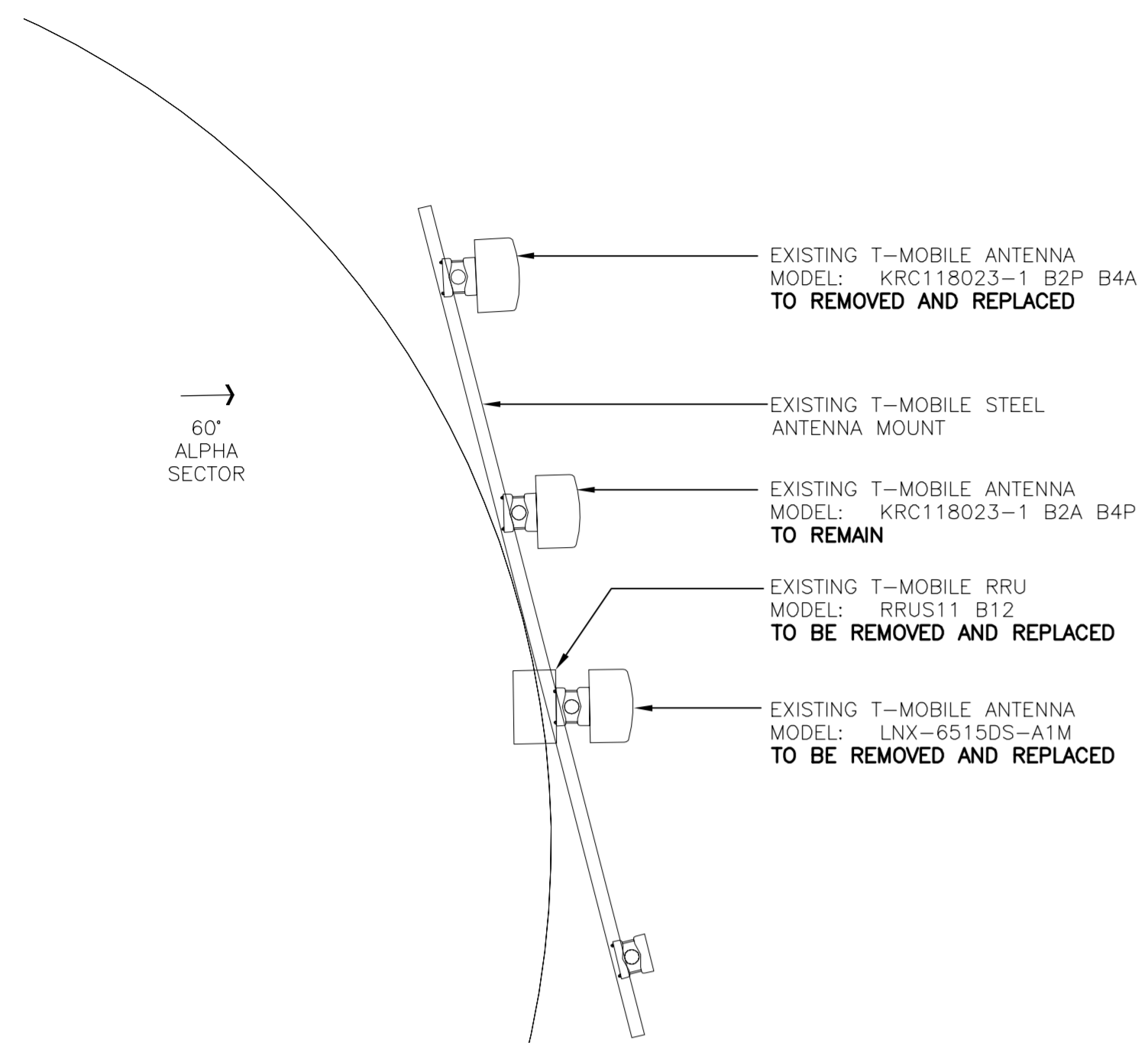

1 EXISTING ANTENNA MOUNTING CONFIGURATION (ALPHA SECTOR) 85° ELEVATION
 C-3 SCALE: 1/2" = 1' APPROXIMATE NORTH

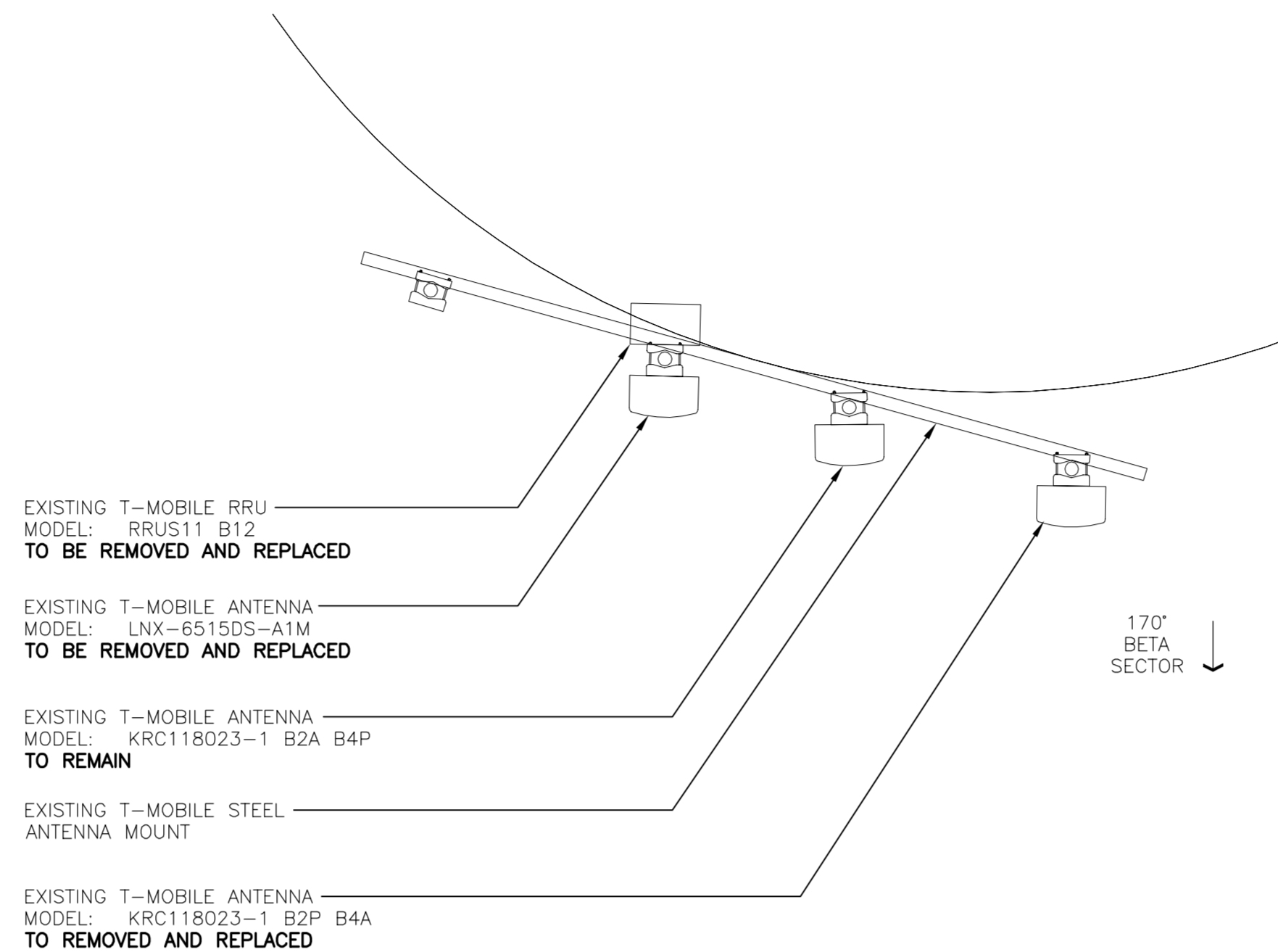

2 EXISTING ANTENNA MOUNTING CONFIGURATION (BETA SECTOR) 85° ELEVATION
 C-3 SCALE: 1/2" = 1' APPROXIMATE NORTH

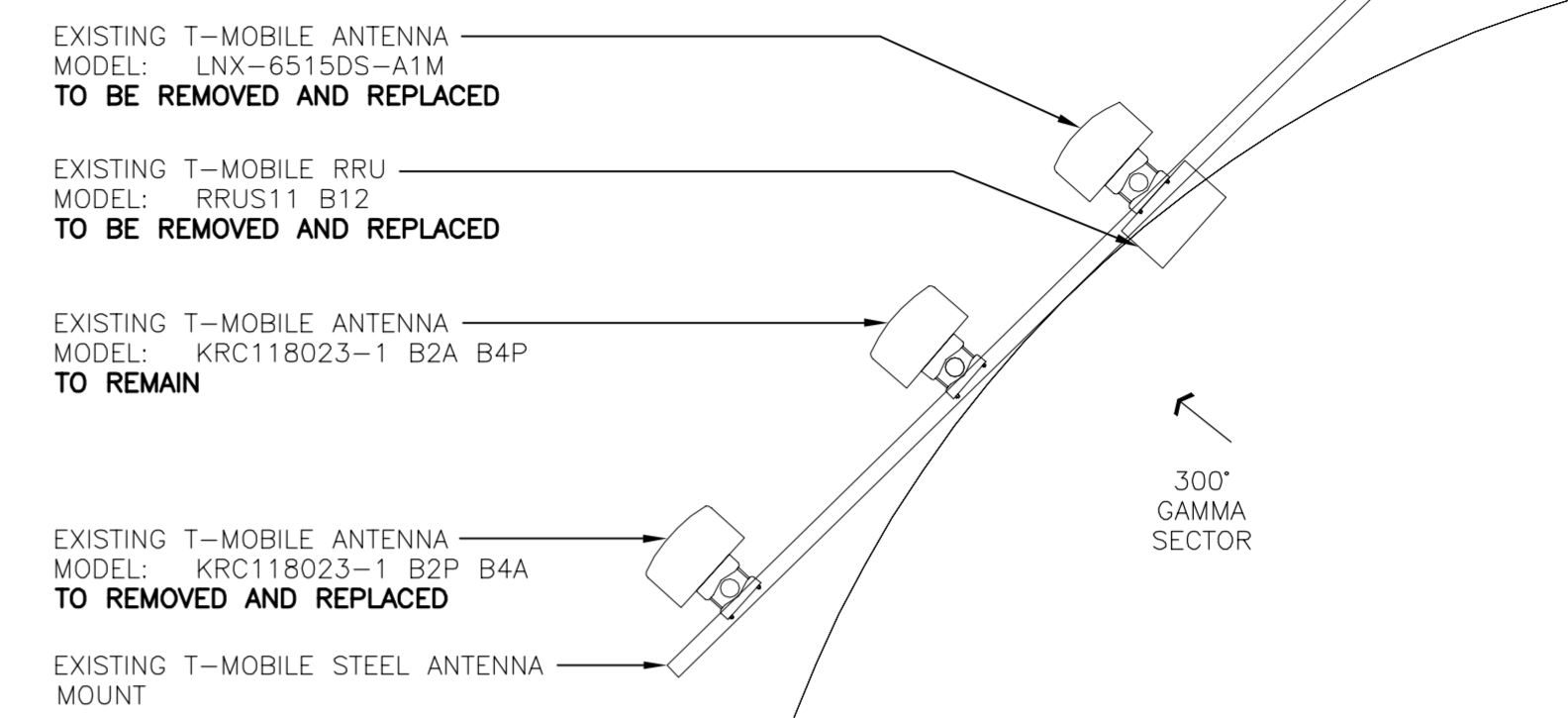

3 EXISTING ANTENNA MOUNTING CONFIGURATION (GAMMA SECTOR) 85° ELEVATION
 C-3 SCALE: 1/2" = 1' APPROXIMATE NORTH

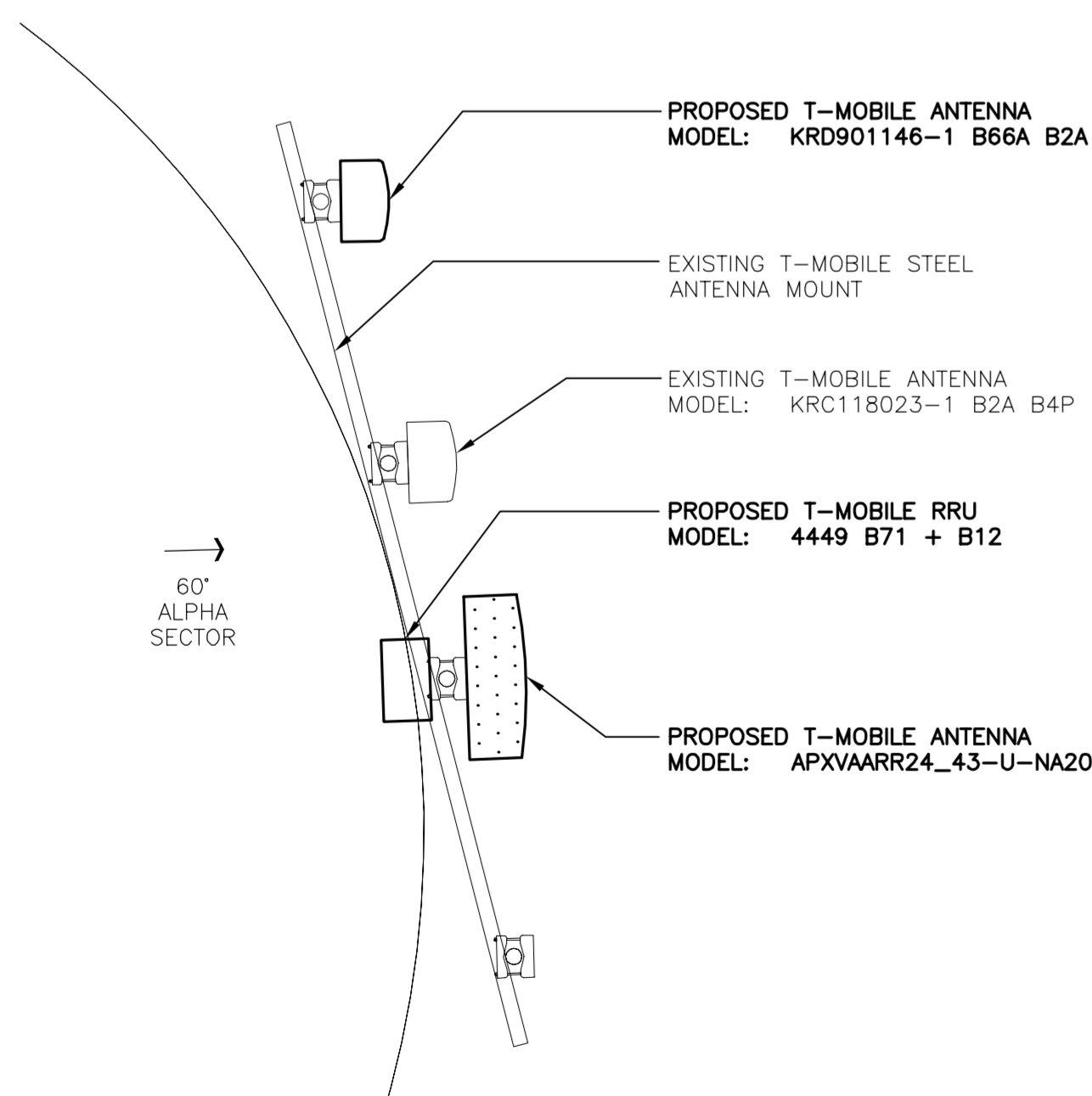

4 PROPOSED ANTENNA MOUNTING CONFIGURATION (ALPHA SECTOR) 85° ELEVATION
 C-3 SCALE: 1/2" = 1' APPROXIMATE NORTH

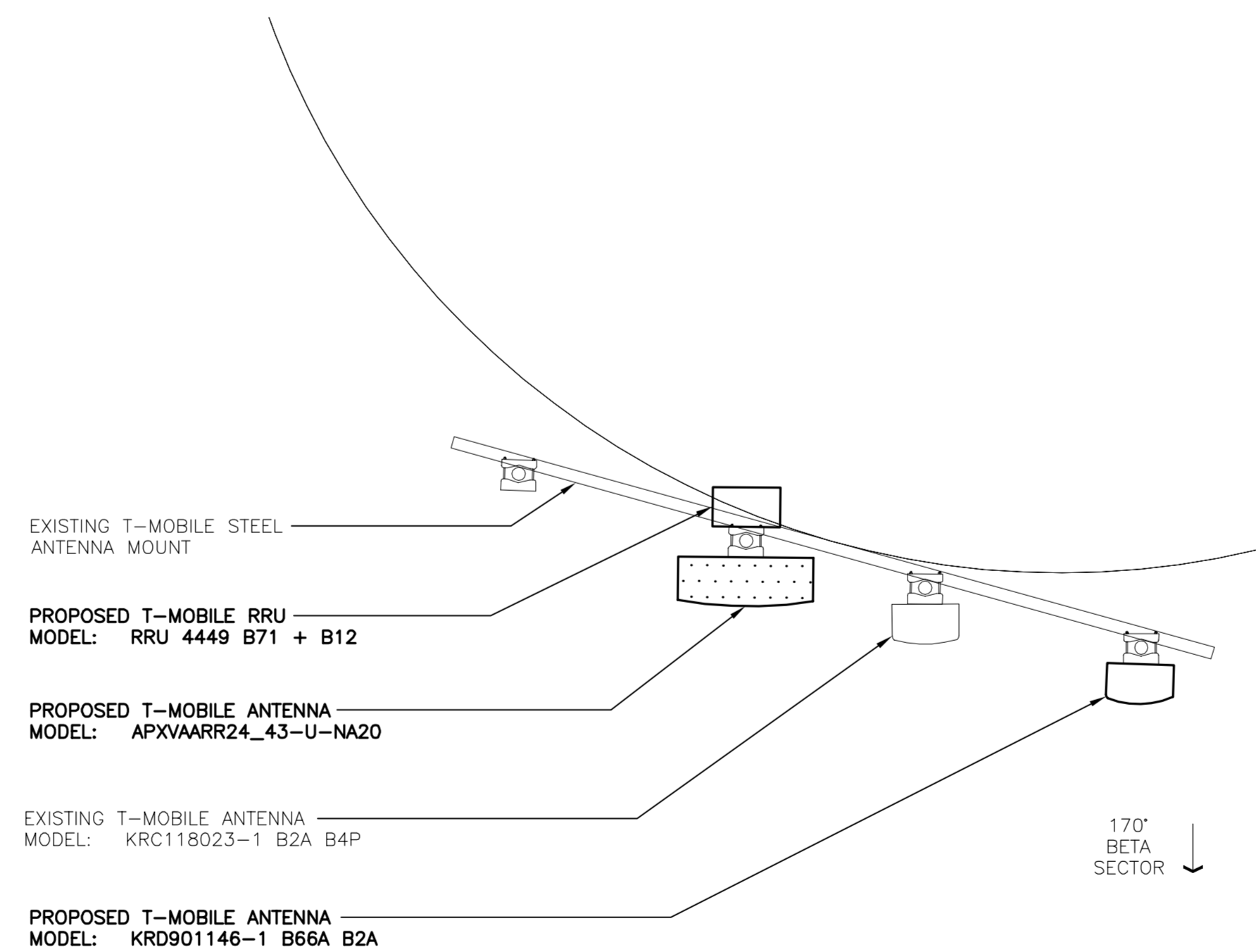

5 PROPOSED ANTENNA MOUNTING CONFIGURATION (BETA SECTOR) 85° ELEVATION
 C-3 SCALE: 1/2" = 1' APPROXIMATE NORTH

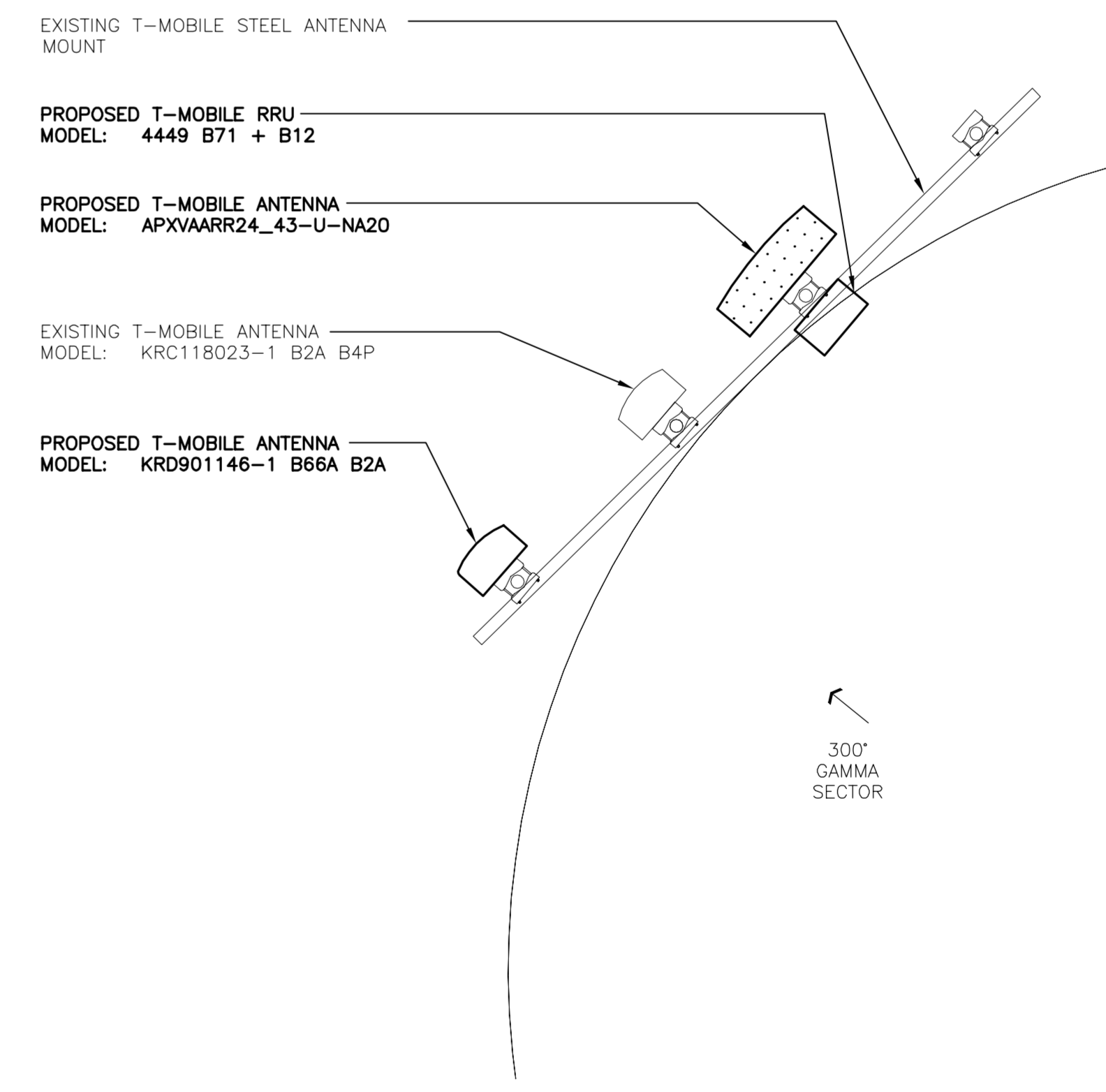

6 PROPOSED ANTENNA MOUNTING CONFIGURATION (GAMMA SECTOR) 85° ELEVATION
 C-3 SCALE: 1/2" = 1' APPROXIMATE NORTH

REV.	DATE	TITLE	BY	CHK'D BY	ISSUED FOR CONSTRUCTION
0	07/18/18				

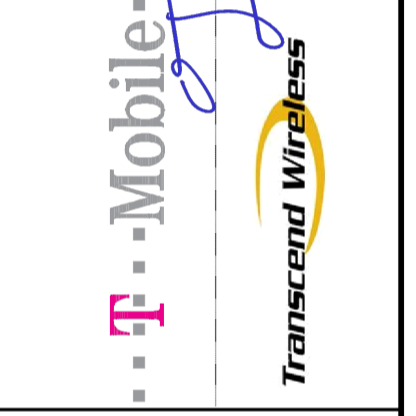
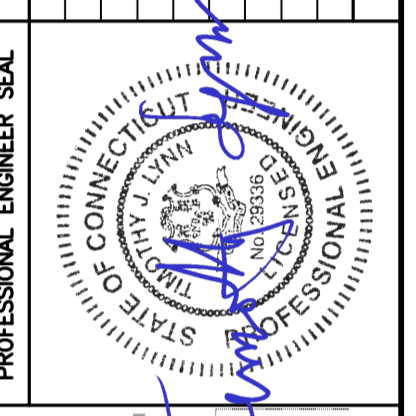

CEN TEK engineering
 Centered on Solutions
 (203) 498-0390
 (203) 498-3897 Fax
 652 North Branford Road
 Branford, CT 06405
 www.CenTekEng.com

T-MOBILE NORTHEAST LLC
 WIRELESS COMMUNICATIONS FACILITY
STAMFORD-3/HOPE ST.
 SITE ID: CT11334A
 652 GLENBROOK ROAD
 STAMFORD, CT 06906

DATE: 06/19/18
 SCALE: AS NOTED
 JOB NO. 18058.59

ANTENNA MOUNTING CONFIGURATION

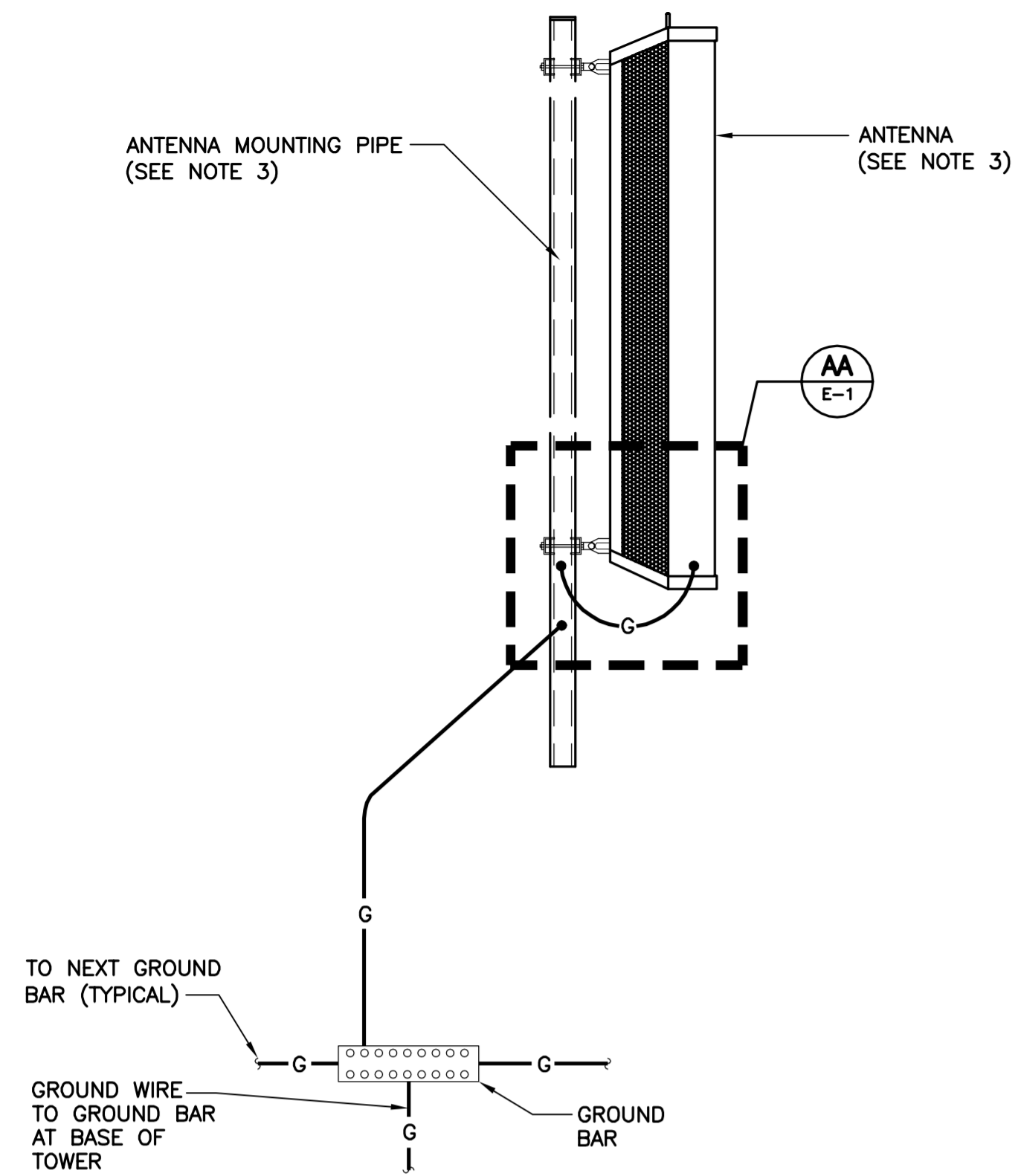

NOTES:

1. BOND COAXIAL CABLE GROUND KITS TO EACH OWNER'S GROUND BAR ALONG ENTIRE COAX RUN FROM ANTENNA TO SHELTER.
2. BOND ALL EQUIPMENT TO GROUND PER NEC AND MANUFACTURERS SPECIFICATIONS.
3. DETAIL IS TYPICAL FOR ALL ANTENNA SECTORS, INCLUDING GPS ANTENNA.

1 TYPICAL ANTENNA GROUNDING DETAIL
E-1 SCALE: NONE

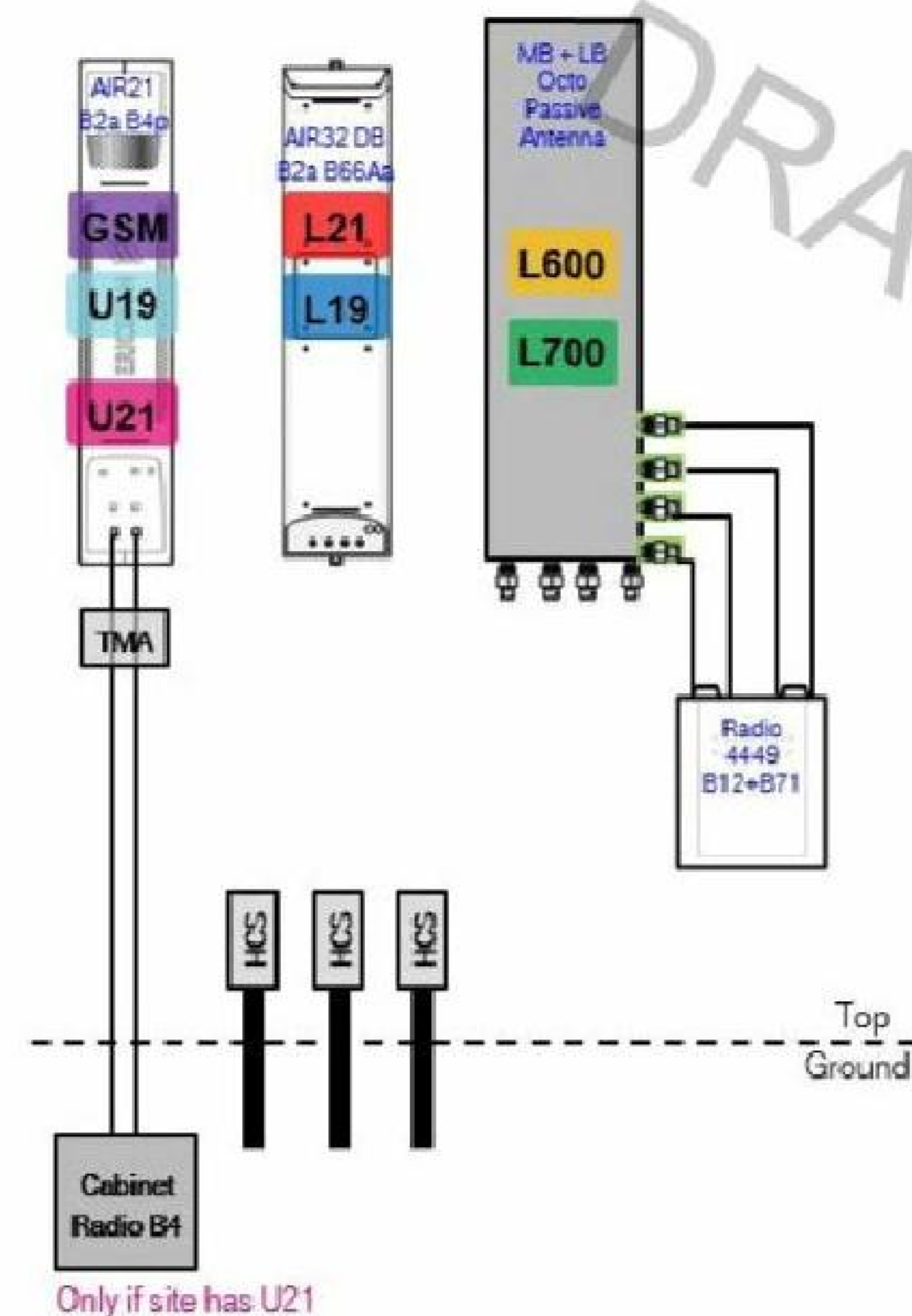

2 PROPOSED PLUMBING DIAGRAM
E-1 SCALE: NONE

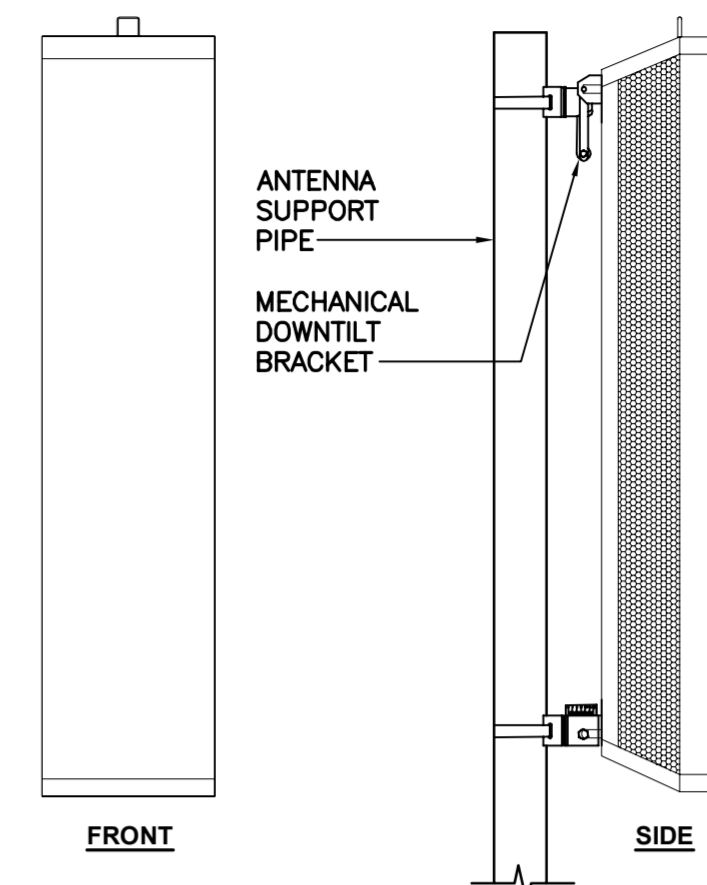

ALPHA/BETA/GAMMA ANTENNA		
EQUIPMENT	DIMENSIONS	WEIGHT
MAKE: ERICSSON MODEL: KR901146-1_B66A_B2A	56.65"L x 12.87"W x 8.66"D	132.2 LBS.
MAKE: RFS MODEL: APXVAARR24_43-U-NA20	95.9"L x 24.0"W x 8.7"D	128 LBS.

3 PROPOSED ANTENNA DETAIL
E-1 SCALE: NONE

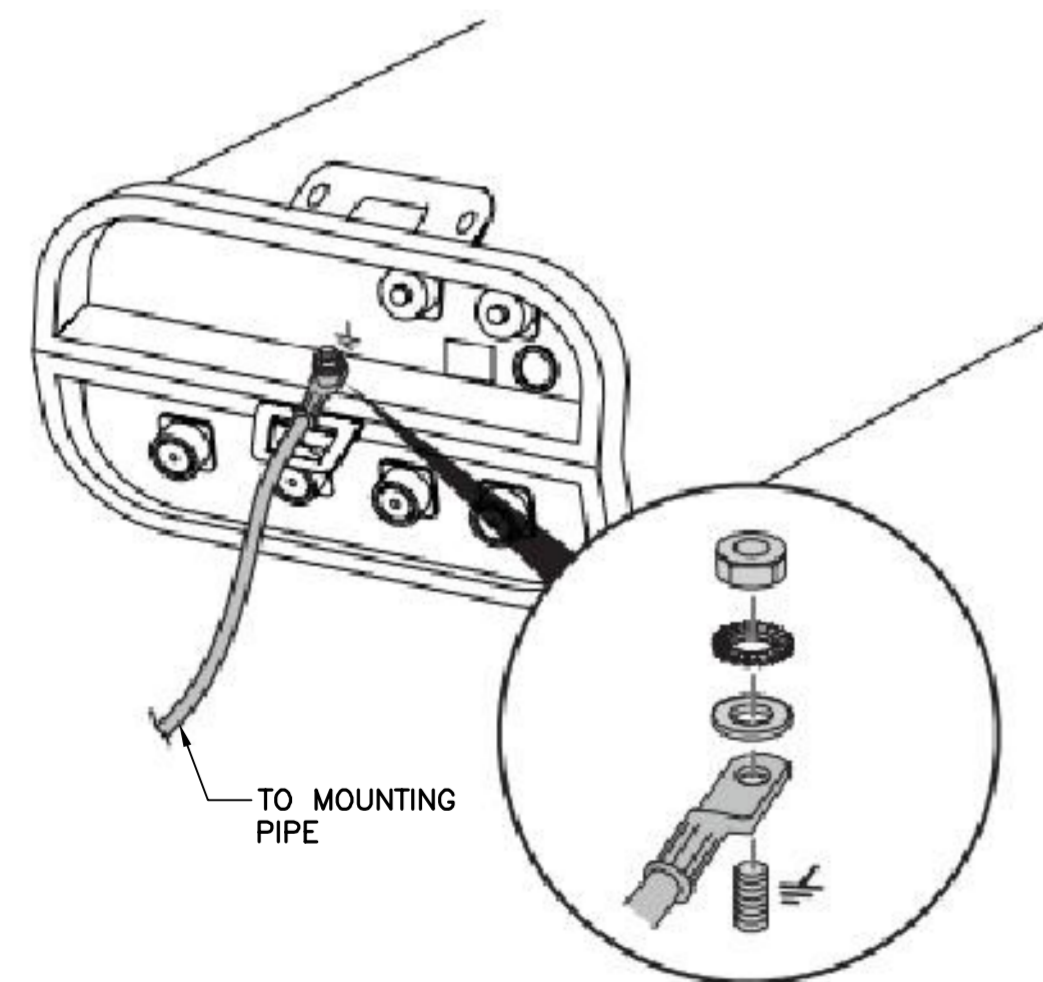

AA TYPICAL ANTENNA GROUNDING DETAIL
E-1 SCALE: NONE

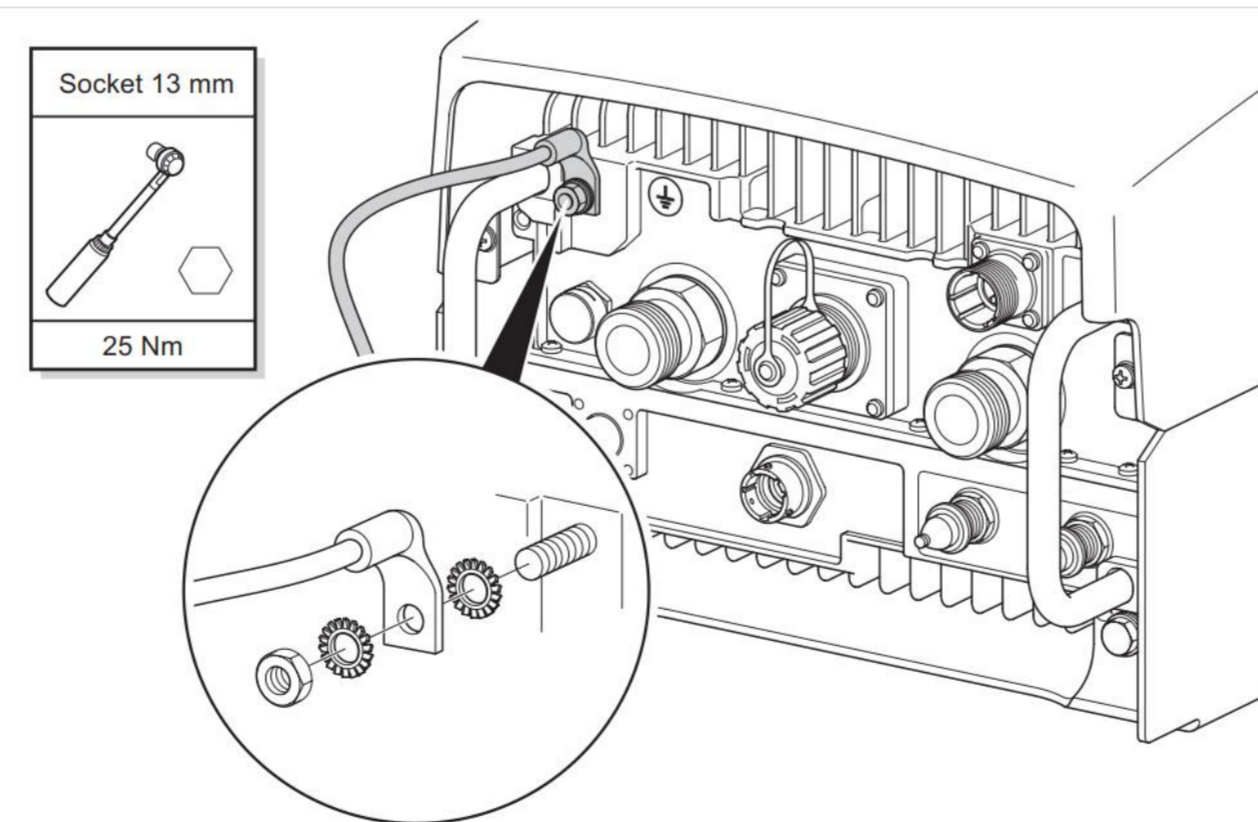

4 TYPICAL RRU GROUNDING DETAIL
E-1 NOT TO SCALE



RRU (REMOTE RADIO UNIT)			
EQUIPMENT	DIMENSIONS	WEIGHT	CLEARANCES
MAKE: ERICSSON MODEL: RADIO 4449 B71B12	14.9"L x 13.2"W x 10.4"D	74 LBS.	ABOVE: 16" MIN. BELOW: 12" MIN. FRONT: 36" MIN.

NOTES:
1. CONTRACTOR TO COORDINATE FINAL EQUIPMENT MODEL SELECTION WITH T-MOBILE CONSTRUCTION MANAGER PRIOR TO ORDERING.

5 PROPOSED RRU DETAIL
E-1 SCALE: NONE

ISSUED FOR CONSTRUCTION
CAG
DRAWN BY CHK'D BY
T.J.L.
DATE
07/18/18
REV.

PROFESSIONAL ENGINEER SEAL
STATE OF CONNECTICUT
JULY 18, 2018
JULY 18, 2018
PROFESSIONAL ENGINEER

T-Mobile
Transcend Wireless

CEN TEK engineering
Centered on Solutions
(203) 498-0390
(203) 498-3397 Fax
652 North Branford Road
Branford, CT 06405
www.CenTekEng.com

T-MOBILE NORTHEAST LLC
WIRELESS COMMUNICATIONS FACILITY
STAMFORD-3/HOPE ST.
SITE ID: CT11334A
652 GLENBROOK ROAD
STAMFORD, CT 06906

DATE: 06/19/18
SCALE: AS NOTED
JOB NO. 18058.59

TYPICAL ELECTRICAL DETAILS

E-1

Sheet No. 6 of 6

Kyle Richers

From: UPS Quantum View <pkginfo@ups.com>
Sent: Wednesday, August 1, 2018 11:33 AM
To: krichers@transcendwireless.com
Subject: UPS Delivery Notification, Reference Number 1: CT11334A owner CSC



Your package has been delivered.

Delivery Date: Wednesday, 08/01/2018
Delivery Time: 11:27 AM



[Set Delivery Instructions](#)

[Get Free Alerts](#)

[View Delivery Planner](#)

At the request of TRANSCEND WIRELESS this notice alerts you that the status of the shipment listed below has changed.

Shipment Detail

Tracking Number:	1ZV257424292193129
Ship To:	Glenbrook Industrial Park LLC 1 N WATER ST NORWALK, CT 06854 US
UPS Service:	UPS GROUND
Number of Packages:	1
Package Weight:	1.0 LBS
Delivery Location:	OFFICE
Signed by:	MCCORMICK

Kyle Richers

From: UPS Quantum View <pkginfo@ups.com>
Sent: Wednesday, August 1, 2018 12:28 PM
To: krichers@transcendwireless.com
Subject: UPS Delivery Notification, Reference Number 1: CT11334A zoning CSC



Your package has been delivered.

Delivery Date: Wednesday, 08/01/2018
Delivery Time: 12:23 PM

At the request of TRANSCEND WIRELESS this notice alerts you that the status of the shipment listed below has changed.

Shipment Detail

Tracking Number:	<u>1ZV257424294943118</u>
Ship To:	David Woods City of Stamford 888 WASHINGTON BLVD STAMFORD, CT 06901 US
UPS Service:	UPS GROUND
Number of Packages:	1
Weight:	1.0 LBS
Delivery Location:	MAIL ROOM CRUZ
Signature Required:	A signature is required for package delivery
Reference Number 1:	CT11334A zoning CSC



[Download the UPS mobile app](#)

Kyle Richers

From: UPS Quantum View <pkginfo@ups.com>
Sent: Wednesday, August 1, 2018 12:28 PM
To: krichers@transcendwireless.com
Subject: UPS Delivery Notification, Reference Number 1: CT11334A elected CSC



Your package has been delivered.

Delivery Date: Wednesday, 08/01/2018
Delivery Time: 12:23 PM

At the request of TRANSCEND WIRELESS this notice alerts you that the status of the shipment listed below has changed.

Shipment Detail

Tracking Number:	1ZV257424291097100
Ship To:	David Martin City of Stamford 888 WASHINGTON BLVD STAMFORD, CT 06901 US
UPS Service:	UPS GROUND
Number of Packages:	1
Weight:	1.0 LBS
Delivery Location:	MAIL ROOM CRUZ
Signature Required:	A signature is required for package delivery
Reference Number 1:	CT11334A elected CSC



[Download the UPS mobile app](#)