



August 05, 2014

David Martin and
Members of the Siting Council
Connecticut Siting Council
Ten Franklin Square
New Britain, CT 06051

RE: Notice of Exempt Modification
30 Old Country Road
Stafford Springs, CT 06076
T-Mobile #: CTHA526A
N 41° 56' 24.1"
W -72° 14' 14.9"

Dear Mr. Martin and Members of the Siting Council:

On behalf of T-Mobile Northeast LLC, SBA Communications is submitting an exempt modification application to the Connecticut Siting council for modification of existing equipment at a tower facility located at 30 Old Country Road, Stafford Springs, CT.

The 30 Old Country Road facility consists of a 180' MONOPOLE Tower owned and operated by SBA Towers, LLC. In order to accommodate technological changes and enhance system performance in the State of Connecticut, T-Mobile Northeast LLC plans to modify the equipment configurations at many of its existing cell sites. Please accept this letter and attachments as notification, pursuant to R.C.S.A. Section 16-50j-73, of construction which constitutes an exempt modification pursuant to R.C.S.A. Section 16-50j-72(b)(2). In compliance with R.C.S.A. Section 16-50j-73, a copy of this letter and attachments is being sent to the chief elected official of the municipality in which the affected cell site is located.

T-Mobile Northeast LLC wishes to upgrade their equipment to meet the new standards of 4G technology. The new equipment will allow customers to download files and browse the internet at a high rate of speed while also allowing their phones to be compatible with the latest 4G technology.

Attached is a summary of the planned modifications, including power density calculations reflecting the change in Sprint's operations at the site along with the required fee of \$625.

The changes to the facility do not constitute modifications as defined in Connecticut General Statutes ("C.G.S.") Section 16-50i(d) because the general physical characteristics of the facility will not be

significantly changed or altered. Rather, the planned changes to the facility fall squarely within those activities explicitly provided for in R.C.S.A. Section 16-50j-72(b)(2).

1. The overall height of the structure will be unaffected.
2. The proposed changes will not extend the site boundaries. There will be no effect on the site compound other than the new equipment cabinets.
3. The proposed changes will not increase the noise level at the existing facility by six decibels or more.
4. The changes in radio frequency power density will not increase the calculated "worst case" power density for the combined operations at the site to a level at or above the applicable standard for uncontrolled environments as calculated for a mixed frequency site.

For the foregoing reasons, SBA Communications on behalf of T-Mobile Northeast LLC, respectfully submits that the proposed changes at the referenced site constitute exempt modifications under R.C.S.A. Section 16-50j-72(b)(2).

Please feel free to call me at (508) 251-0720 x 3807 with any questions you may have concerning this matter.

Thank you,



Peter Nute
SBA Communications Corporation
33 Boston Post Road West Suite 320
Marlborough, MA 01752
508-251-0720 x 3807 + T
508-251-1755 + F
Pnute@sbsite.com



**T-Mobile Northeast LLC
Equipment Modification**

30 Old Country Road, Stafford Springs, CT
Site number CTHA526A

Tower Owner: SBA Towers, LLC

Equipment Configuration: MONOPOLE Tower

Current and/or approved:

- (3) RFS APXV18-206517LS-C
- (6) 1-5/8" feed lines

Planned Modifications:

- (3) RFS APX16DWV-16DWVS-C
- (3) RFS ATMAA1412D-1A20
- (3) Double TMA 17/21
- (12) 1-5/8" feed lines

Structural Information:

The attached structural analysis demonstrates that the tower and foundation will have adequate structural capacity to accommodate the proposed modifications.

Power Density:

The anticipated Maximum Composite contributions from the T-Mobile facility are 0.329% of the allowable FCC established general public limit. The anticipated composite MPE value for this site assuming all carriers present is 10.409% of the allowable FCC established general public limit sampled at the ground level.

Site Composite MPE %	
Carrier	MPE %
Metro MobilePCS	0.329%
Verizon Wireless	5.350%
AT&T	4.730%
Total Site MPE %	10.409%



August 05, 2014

Richard Shuck
First Selectman
Town of Stafford
Town Hall
1 Main Street
Stafford Springs, CT 06076

RE: Telecommunications Facility @ 30 Old Country Road, Stafford Springs, CT

Dear Mr. Shuck,

In order to accommodate technological changes and enhance system performance in the State of Connecticut, T-Mobile Northeast LLC will be changing its equipment configuration at certain cell sites.

As required by Regulations of Connecticut State Agencies (R.C.S.A.) Section 16-50j-73, the Connecticut Siting Council has been notified of the changes and will review T-Mobile's proposal. Please accept this letter as notification under Section 16-50j-73 of construction which constitutes an exempt modification pursuant to R.C.S.A. Section 16-50j-72(b)(2).

The accompanying letter to the Siting Council fully describes Sprint's proposal for the referenced cell site. However, if you have any questions or require any further information on our plans or the Siting Council's procedures, please call me at (508) 251-0720 x 3807.

Thank you,

A handwritten signature in blue ink, appearing to read "Peter Nute", is written over a light blue horizontal line.

Peter Nute
SBA Communications Corporation
33 Boston Post Road West Suite 320
Marlborough, MA 01752
508-251-0720 x 3807 + T
508-251-1755 + F
Pnute@sbsite.com



August 05, 2014

Lisa Kenderdine
7 Doratzak Rd.
Willington CT 06279-2405

RE: Telecommunications Facility @ 30 Old Country Road, Stafford Springs, CT

Dear Ms. Kenderdine,

In order to accommodate technological changes and enhance system performance in the State of Connecticut, T-Mobile Northeast LLC will be changing its equipment configuration at certain cell sites.

As required by Regulations of Connecticut State Agencies (R.C.S.A.) Section 16-50j-73, the Connecticut Siting Council has been notified of the changes and will review T-Mobile's proposal. Please accept this letter as notification under Section 16-50j-73 of construction which constitutes an exempt modification pursuant to R.C.S.A. Section 16-50j-72(b)(2).

The accompanying letter to the Siting Council fully describes Sprint's proposal for the referenced cell site. However, if you have any questions or require any further information on our plans or the Siting Council's procedures, please call me at (508) 251-0720 x 3807.

Thank you,

A handwritten signature in blue ink, appearing to read "Peter Nute", is positioned below the "Thank you," text. The signature is fluid and cursive.

Peter Nute
SBA Communications Corporation
33 Boston Post Road West Suite 320
Marlborough, MA 01752
508-251-0720 x 3807 + T
508-251-1755 + F
Pnute@sbsite.com

RADIO FREQUENCY EMISSIONS ANALYSIS REPORT
EVALUATION OF HUMAN EXPOSURE POTENTIAL
TO NON-IONIZING EMISSIONS

Metro MobilePCS Existing Facility

Site ID: CTHA526A

SBA Stafford Monopole
30 Old Country Road
Stafford Springs, CT 06076

July 22, 2014

EBI Project Number: 62143997

July 22, 2014

Metro MobilePCS USA
Attn: Jason Overbey, RF Manager
35 Griffin Road South
Bloomfield, CT 06002

Re: Emissions Values for Site: **CTHA526A - SBA Stafford Monopole**

EBI Consulting was directed to analyze the proposed Metro MobilePCS facility located at 30 Old Country Road, Stafford Springs, CT, for the purpose of determining whether the emissions from the Proposed Metro MobilePCS Antenna Installation located on this property are within specified federal limits.

All information used in this report was analyzed as a percentage of current Maximum Permissible Exposure (% MPE) as listed in the FCC OET Bulletin 65 Edition 97-01 and ANSI/IEEE Std C95.1. The FCC regulates Maximum Permissible Exposure in units of microwatts per square centimeter ($\mu\text{W}/\text{cm}^2$). The number of $\mu\text{W}/\text{cm}^2$ calculated at each sample point is called the power density. The exposure limit for power density varies depending upon the frequencies being utilized. Wireless Carriers and Paging Services use different frequency bands each with different exposure limits, therefore it is necessary to report results and limits in terms of percent MPE rather than power density.

All results were compared to the FCC (Federal Communications Commission) radio frequency exposure rules, 47 CFR 1.1307(b)(1) – (b)(3), to determine compliance with the Maximum Permissible Exposure (MPE) limits for General Population/Uncontrolled environments as defined below.

General population/uncontrolled exposure limits apply to situations in which the general public may be exposed or in which persons who are exposed as a consequence of their employment may not be made fully aware of the potential for exposure or cannot exercise control over their exposure. Therefore, members of the general public would always be considered under this category when exposure is not employment related, for example, in the case of a telecommunications tower that exposes persons in a nearby residential area.

Public exposure to radio frequencies is regulated and enforced in units of microwatts per square centimeter ($\mu\text{W}/\text{cm}^2$). The general population exposure limit for the cellular band is $567 \mu\text{W}/\text{cm}^2$, and the general population exposure limit for the PCS and AWS bands is $1000 \mu\text{W}/\text{cm}^2$. Because each carrier

will be using different frequency bands, and each frequency band has different exposure limits, it is necessary to report percent of MPE rather than power density.

Occupational/controlled exposure limits apply to situations in which persons are exposed as a consequence of their employment and in which those persons who are exposed have been made fully aware of the potential for exposure and can exercise control over their exposure. Occupational/controlled exposure limits also apply where exposure is of a transient nature as a result of incidental passage through a location where exposure levels may be above general population/uncontrolled limits (see below), as long as the exposed person has been made fully aware of the potential for exposure and can exercise control over his or her exposure by leaving the area or by some other appropriate means.

Additional details can be found in FCC OET 65.

CALCULATIONS

Calculations were done for the proposed Metro MobilePCS Wireless antenna facility located at 30 Old Country Road, Stafford Springs, CT, using the equipment information listed below. All calculations were performed per the specifications under FCC OET 65. Since Metro MobilePCS is proposing highly focused directional panel antennas, which project most of the emitted energy out toward the horizon, the actual antenna pattern gain value in the direction of the sample area was used. For this report the sample point is a 6 foot person standing at the base of the tower

For all calculations, all equipment was calculated using the following assumptions:

- 1) 2 GSM channels (1935.000 MHz—to 1945.000 MHz) were considered for each sector of the proposed installation.
- 2) 2 UMTS channels (2110.000 MHz to 2120.000 MHz / 2140.000 MHz to 2145.000 MHz) were considered for each sector of the proposed installation.
- 3) 2 LTE channels (2110.000 MHz to 2120.000 MHz / 2140.000 MHz to 2145.000 MHz) were considered for each sector of the proposed installation.
- 4) All radios at the proposed installation were considered to be running at full power and were uncombined in their RF transmissions paths per carrier prescribed configuration. Per FCC OET Bulletin No. 65 - Edition 97-01 recommendations to achieve the maximum anticipated value at each sample point, all power levels emitting from the proposed antenna installation are increased by a factor of 2.56 to account for possible in-phase reflections from the surrounding environment. This is rarely the case, and if so, is never continuous.
- 5) For the following calculations the sample point was the top of a six foot person standing at the base of the tower. The actual gain in this direction was used per the manufactures supplied specifications.
- 6) The antenna used in this modeling is the RFS APX16DWV-16DWVS-E-A20 for LTE, UMTS and GSM. This is based on feedback from the carrier with regards to anticipated

antenna selection. This antenna has a 16.3 dBd gain value at its main lobe. Actual antenna gain values were used for all calculations as per the manufacturers specifications.

- 7) The antenna mounting height centerline of the proposed antennas is **167 feet** above ground level (AGL).
- 8) Emissions values for additional carriers were taken from the Connecticut Siting Council active database. Values in this database are provided by the individual carriers themselves.

All calculations were done with respect to uncontrolled / general public threshold limits.

Site ID	CTHA526A - SBA Stafford Monopole
Site Address	30 Old Country Road, Stafford Springs, CT 06076
Site Type	Monopole

Sector 1

Antenna Number	Antenna Make	Antenna Model	Status	Frequency Band	Technology	Power Out Per Channel (Watts)	Number of Channels	Composite Power	Antenna Gain in direction of sample point (dBd)	Antenna Height (ft)	analysis height	Cable Size	Cable Loss (dB)	Additional Loss	ERP	Power Density Value	Power Density Percentage
1a	RFS	APX16DWV-16DWVS-E-A20	Passive	PCS - 1950 MHz	GSM / UMTS	30	2	60	-3.25	167	161	7/8"	1.2	0	21.535316	0.29868	0.02987%
1B	RFS	APX16DWV-16DWVS-E-A20	Passive	AWS - 2100 MHz	UMTS/LTE	40	4	160	-3.25	167	161	7/8"	1.2	0	57.42751	0.796479	0.07965%
Sector total Power Density Value: 0.110%																	

Sector 2

Antenna Number	Antenna Make	Antenna Model	Status	Frequency Band	Technology	Power Out Per Channel (Watts)	Number of Channels	Composite Power	Antenna Gain in direction of sample point (dBd)	Antenna Height (ft)	analysis height	Cable Size	Cable Loss (dB)	Additional Loss	ERP	Power Density Value	Power Density Percentage
1a	RFS	APX16DWV-16DWVS-E-A20	Passive	PCS - 1950 MHz	GSM / UMTS	30	2	60	-3.25	167	161	7/8"	1.2	0	21.535316	0.29868	0.02987%
1B	RFS	APX16DWV-16DWVS-E-A20	Passive	AWS - 2100 MHz	UMTS/LTE	40	4	160	-3.25	167	161	1-5/8"	1.2	0	57.42751	0.796479	0.07965%
Sector total Power Density Value: 0.110%																	

Sector 3

Antenna Number	Antenna Make	Antenna Model	Status	Frequency Band	Technology	Power Out Per Channel (Watts)	Number of Channels	Composite Power	Antenna Gain in direction of sample point (dBd)	Antenna Height (ft)	analysis height	Cable Size	Cable Loss (dB)	Additional Loss	ERP	Power Density Value	Power Density Percentage
1a	RFS	APX16DWV-16DWVS-E-A20	Passive	PCS - 1950 MHz	GSM / UMTS	30	2	60	-3.25	167	161	7/8"	1.2	0	21.535316	0.29868	0.02987%
1B	RFS	APX16DWV-16DWVS-E-A20	Passive	AWS - 2100 MHz	UMTS/LTE	40	4	160	-3.25	167	161	1-5/8"	1.2	0	57.42751	0.796479	0.07965%
Sector total Power Density Value: 0.110%																	

Site Composite MPE %	
Carrier	MPE %
Metro MobilePCS	0.329%
Verizon Wireless	5.350%
AT&T	4.730%
Total Site MPE %	10.409%

Summary

All calculations performed for this analysis yielded results that were well within the allowable limits for general public exposure to RF Emissions.

The anticipated Maximum Composite contributions from the Metro MobilePCS facility are **0.110%** (**0.329% from each sector**) of the allowable FCC established general public limit considering all three sectors simultaneously sampled at the ground level.

The anticipated composite MPE value for this site assuming all carriers present is **10.409%** of the allowable FCC established general public limit sampled at the ground level. This is based upon values listed in the Connecticut Siting Council database for existing carrier emissions.

FCC guidelines state that if a site is found to be out of compliance (over allowable thresholds), that carriers over a 5% contribution to the composite value will require measures to bring the site into compliance. For this facility, the composite values calculated were well within the allowable 100% threshold standard per the federal government.



Scott Heffernan
RF Engineering Director

EBI Consulting
21 B Street
Burlington, MA 01803



FDH Engineering, Inc., 6521 Meriden Drive Raleigh, NC 27616, Ph. 919.755.1012

**Structural Analysis for
SBA Network Services, Inc.**

180' Monopole Tower

**SBA Site Name: Stafford Springs
SBA Site ID: CT03111-S-04
T-Mobile Site ID: CTHA526A**

FDH Project Number 1466XR1400

Analysis Results

Tower Components	80.1%	Sufficient
Foundation	82.2%	Sufficient

Prepared By:

Virginia Chriscoe
Project Engineer

Reviewed By:

Bradley R. Newman, PE
Senior Project Engineer
CT PE License No. 29630

FDH Engineering, Inc.
6521 Meriden Drive
Raleigh, NC 27616
(919) 755-1012
info@fdh-inc.com



June 11, 2014

Prepared pursuant to TIA/EIA-222-F Structural Standards for Steel Antenna Towers and Antenna Supporting Structures and the 2005 Connecticut State Building Code

TABLE OF CONTENTS

EXECUTIVE SUMMARY3

 Conclusions.....3

 Recommendations3

APPURTENANCE LISTING4

RESULTS5

GENERAL COMMENTS6

LIMITATIONS6

APPENDIX7

EXECUTIVE SUMMARY

At the request of SBA Network Services, Inc., FDH Engineering, Inc. performed a structural analysis of the monopole located in Stafford Springs, CT to determine whether the tower is structurally adequate to support both the existing and proposed loads pursuant to the *Structural Standards for Steel Antenna Towers and Antenna Supporting Structures, TIA/EIA-222-F and the 2005 Connecticut State Building Code*. Information pertaining to the existing/proposed antenna loading, current tower geometry, foundation dimensions, and member sizes was obtained from:

- Valmont Microflex (Order No. 12303-00) Communication Pole Design Calculations dated August 16, 2000
- Valmont Microflex (Drawing No. 3304-F) foundation design dated August 29, 2000
- SBA Network Services, Inc.

The *basic design wind speed* per the *TIA/EIA-222-F standards and the 2005 Connecticut State Building Code* is 85 mph without ice and 38 mph with 1" radial ice. Ice is considered to increase in thickness with height.

Conclusions

With the existing and proposed antennas from T-Mobile in place at 167 ft, the tower meets the requirements of the *TIA/EIA-222-F standards and the 2005 Connecticut State Building Code* provided the **Recommendations** listed below are satisfied. Furthermore, provided the foundations were designed and constructed to support the original design reactions (see Valmont Microflex Drawing No. 3304-F), the foundation should have the necessary capacity to support the existing and proposed loading. For a more detailed description of the analysis of the tower, see the **Results** section of this report.

Our structural analysis has been performed assuming all information provided to FDH Engineering, Inc. is accurate (i.e., the steel data, tower layout, existing antenna loading, and proposed antenna loading) and that the tower has been properly erected and maintained per the original design drawings.

Recommendations

To ensure the requirements of the *TIA/EIA-222-F standards and the 2005 Connecticut State Building Code* are met with the existing and proposed loading in place, we have the following recommendations:

1. Proposed coax must be installed inside the monopole's shaft
2. The proposed TMAs should be installed directly behind the proposed panel antennas.

APPURTENANCE LISTING

The proposed and existing antennas with their corresponding cables/coax lines are shown in **Table 1**. *If the actual layout determined in the field deviates from the layout, FDH Engineering, Inc. should be contacted to perform a revised analysis.*

Table 1 - Appurtenance Loading

Existing Loading:

Antenna Elevation (ft)	Description	Coax and Lines ¹	Carrier	Mount Elevation (ft)	Mount Type
177	(6) Decibel DB844G90A-XC (3) Antel BXA-185063/12CF (3) Powerwave P65-16-XL-2	(12) 1-5/8"	Verizon	177	(1) Platform w/ Handrails
167	(3) RFS APXV18-206517LS-C	(6) 1-5/8"	T-Mobile	167	(1) Low Profile Platform
157	(9) Powerwave P65-17-XLH (3) KMW AM-X-CW-16-6500T (3) ADC Cleargain TMAs (3) CCI DTMABP 7819VG12A (6) Kathrein 860 10025 (6) Ericsson RRUS-11 (3) Powerwave LGP13519 (3) CSS DBC-750	(12) 1-5/8"	AT&T	157	(1) Low Profile Platform

1. Coax are installed inside the monopole's shaft unless otherwise noted.

Proposed Carrier Final Loading:

Antenna Elevation (ft)	Description	Coax and Lines	Carrier	Mount Elevation (ft)	Mount Type
167	(3) RFS APX16DWV-16DWVS-C (3) RFS ATMAA1412D-1A20 (3) Double TMA 17/21	(12) 1-5/8"	T-Mobile	167	(1) Low Profile Platform

RESULTS

The following yield strength of steel for individual members was used for analysis:

Table 2 - Material Strength

Member Type	Yield Strength
Tower Shaft Sections	65 ksi
Base Plate	60 ksi
Anchor Bolts	75 ksi

Table 3 displays the summary of the ratio (as a percentage) of force in the member to their capacities. Values greater than 100% indicate locations where the maximum force in the member exceeds its capacity. *Note: Capacities up to 100% are considered acceptable.* **Table 4** displays the maximum foundation reactions.

If the assumptions outlined in this report differ from actual field conditions, FDH Engineering, Inc. should be contacted to perform a revised analysis. Furthermore, as no information pertaining to the allowable twist and sway requirements for the existing or proposed appurtenances was provided, deflection and rotation were not taken into consideration when performing this analysis.

See the **Appendix** for detailed modeling information

Table 3 - Summary of Working Percentage of Structural Components

Section No.	Elevation ft	Component Type	Size	% Capacity*	Pass Fail
L1	180 - 131.667	Pole	TP36.322x26.9x0.25	52.5	Pass
L2	131.667 - 91.667	Pole	TP43.623x34.7824x0.3125	78.5	Pass
L3	91.667 - 45.4167	Pole	TP52.015x41.763x0.4375	76.3	Pass
L4	45.4167 - 0	Pole	TP60x49.7103x0.5	80.1	Pass
		Anchor Bolts	(24) 2.5" Ø x 68.62" BC	70.0	Pass
		Base Plate	74.62" Ø x 3" tk. PL	52.1	Pass

* Capacities include a 1/3 allowable increase for wind per TIA/EIA-222-F Standards.

Table 4 - Maximum Base Reactions

Base Reactions	Current Analysis (TIA/EIA-222-F)	Original Design (TIA/EIA-222-F)
Axial	51 k	66 k
Shear	40 k	45 k
Moment	4,753 k-ft	5,785 k-ft

GENERAL COMMENTS

This engineering analysis is based upon the theoretical capacity of the structure. It is not a condition assessment of the tower and its foundation. It is the responsibility of SBA Network Services, Inc. to verify that the tower modeled and analyzed is the correct structure (with accurate antenna loading information) modeled. If there are substantial modifications to be made or the assumptions made in this analysis are not accurate, FDH Engineering, Inc. should be notified immediately to perform a revised analysis.

LIMITATIONS

All opinions and conclusions are considered accurate to a reasonable degree of engineering certainty based upon the evidence available at the time of this report. All opinions and conclusions are subject to revision based upon receipt of new or additional/updated information. All services are provided exercising a level of care and diligence equivalent to the standard and care of our profession. No other warranty or guarantee, expressed or implied, is offered. Our services are confidential in nature and we will not release this report to any other party without the client's consent. The use of this engineering work is limited to the express purpose for which it was commissioned and it may not be reused, copied, or distributed for any other purpose without the written consent of FDH Engineering, Inc.

APPENDIX

Section	1	2	3	4	
Length (ft)	48.33	45.33	52.58	52.75	
Number of Sides	16	16	16	16	
Thickness (in)	0.2500	0.3125	0.4375	0.5000	
Socket Length (ft)	5.33	6.33	7.33		
Top Dia (in)	26.9000	34.7824	41.7630	49.7103	
Bot Dia (in)	36.3220	43.6230	52.0150	60.0000	
Grade			A572-65		
Weight (K)	4.1	6.0	11.6	15.6	37.3

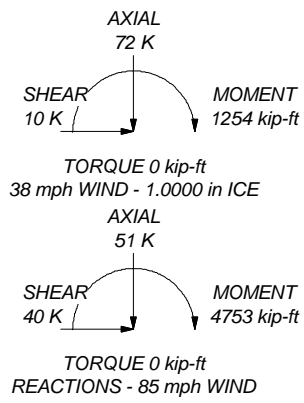
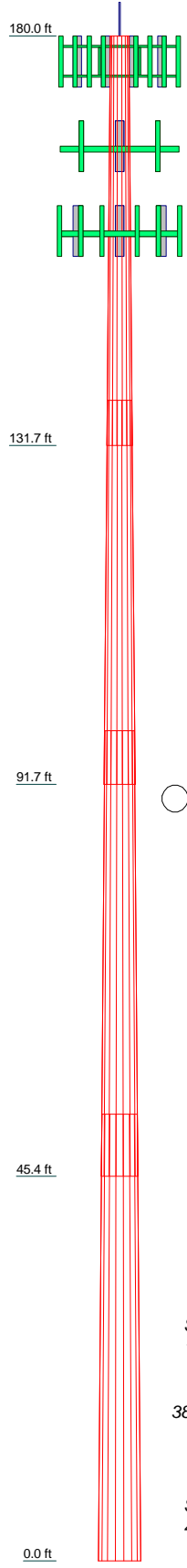

DESIGNED APPURTENANCE LOADING

TYPE	ELEVATION	TYPE	ELEVATION
Lightning Rod	180	Low Profile Platform	167
(2) DB844G90A-XC w/ Mount Pipe	177	Low Profile Platform	157
(2) DB844G90A-XC w/ Mount Pipe	177	(3) P65-17-XLH w/ Mount Pipe	157
(2) DB844G90A-XC w/ Mount Pipe	177	(3) P65-17-XLH w/ Mount Pipe	157
BXA-185063/12CF w/ Mount Pipe	177	(3) P65-17-XLH w/ Mount Pipe	157
BXA-185063/12CF w/ Mount Pipe	177	AM-X-CW-16-6500T w/ Mount Pipe	157
BXA-185063/12CF w/ Mount Pipe	177	AM-X-CW-16-6500T w/ Mount Pipe	157
Powerwave P65-16-XL-2 w/ Mount Pipe	177	AM-X-CW-16-6500T w/ Mount Pipe	157
Powerwave P65-16-XL-2 w/ Mount Pipe	177	Cleargain TMA	157
Powerwave P65-16-XL-2 w/ Mount Pipe	177	Cleargain TMA	157
Powerwave P65-16-XL-2 w/ Mount Pipe	177	Cleargain TMA	157
Platform w/ Handrails	177	DTMAPB 7819VG12A TMA	157
APX16DWV-16DWVS-C w/ Mount Pipe	167	DTMAPB 7819VG12A TMA	157
APX16DWV-16DWVS-C w/ Mount Pipe	167	(2) 860 10025 RET	157
APX16DWV-16DWVS-C w/ Mount Pipe	167	(2) 860 10025 RET	157
APX16DWV-16DWVS-C w/ Mount Pipe	167	(2) 860 10025 RET	157
APX16DWV-16DWVS-C w/ Mount Pipe	167	(2) RRUS-11	157
APX16DWV-16DWVS-C w/ Mount Pipe	167	(2) RRUS-11	157
ATMAA1412D-1A20 TMA	167	(2) RRUS-11	157
ATMAA1412D-1A20 TMA	167	LGP13519 TMA	157
ATMAA1412D-1A20 TMA	167	LGP13519 TMA	157
ATMAA1412D-1A20 TMA	167	LGP13519 TMA	157
Double TMA 17/21	167	LGP13519 TMA	157
Double TMA 17/21	167	DBC-750 Diplexer	157
Double TMA 17/21	167	DBC-750 Diplexer	157
Double TMA 17/21	167	DBC-750 Diplexer	157

MATERIAL STRENGTH

GRADE	Fy	Fu	GRADE	Fy	Fu
A572-65	65 ksi	80 ksi			

TOWER DESIGN NOTES

1. Tower is located in Tolland County, Connecticut.
2. Tower designed for a 85 mph basic wind in accordance with the TIA/EIA-222-F Standard.
3. Tower is also designed for a 38 mph basic wind with 1.00 in ice. Ice is considered to increase in thickness with height.
4. Deflections are based upon a 50 mph wind.
5. TOWER RATING: 80.1%

 FDH Engineering, Inc. 6521 Meridian Drive, Suite 107 Raleigh, North Carolina 27616 Phone: 9197551012 FAX: 9197551031	Job: Stafford Springs-CT03111-S-04		
	Project: 1466XR1400		
Tower Analysis	Client: SBA	Drawn by: VChriscoe	App'd:
	Code: TIA/EIA-222-F	Date: 06/11/14	Scale: NTS
	Path:		Dwg No. E-1

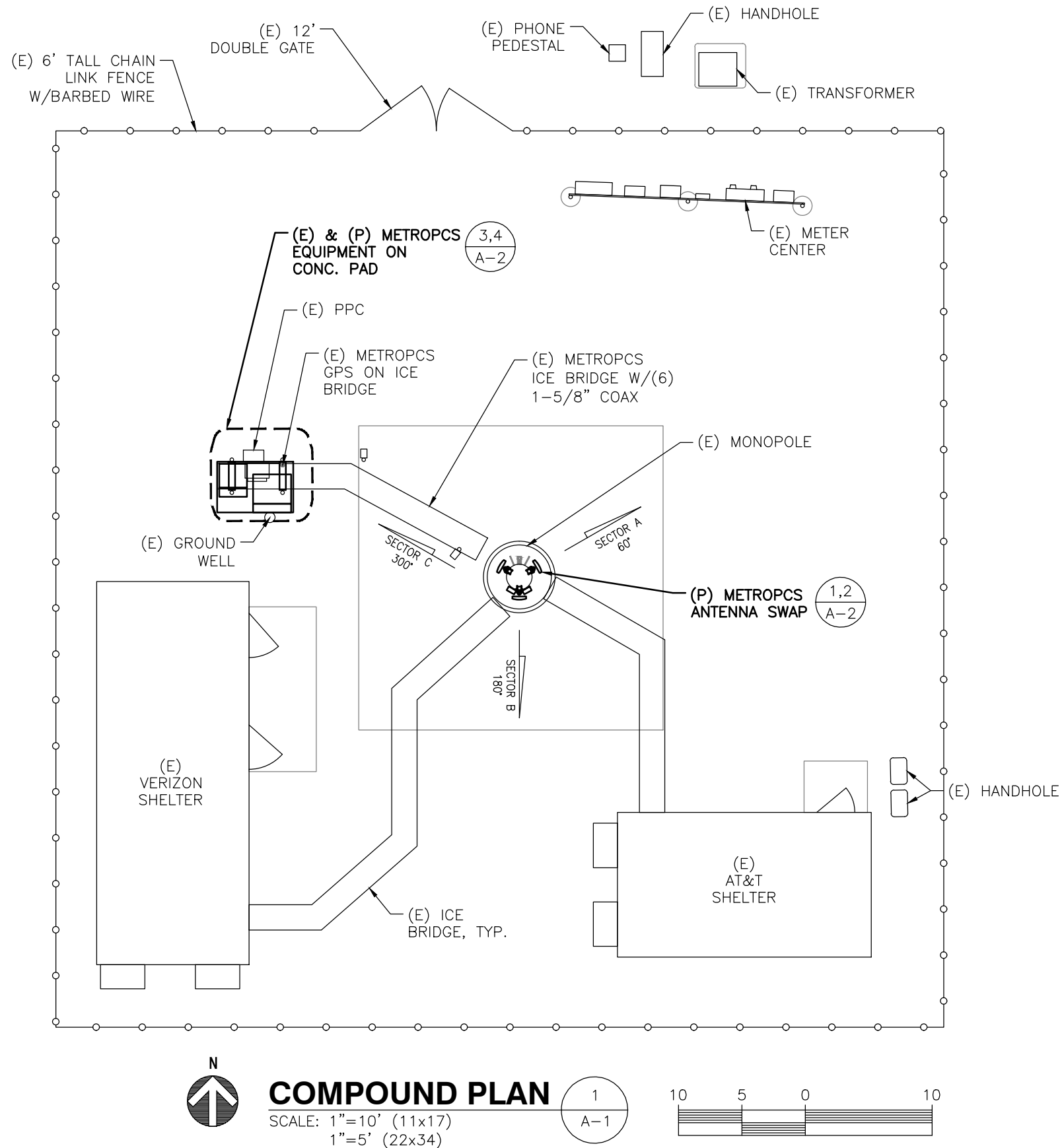

COMPOUND PLAN
 SCALE: 1"=10' (11x17)
 1"=5' (22x34)

1
A-1



(E) ANTENNAS, TYP. (OTHERS)

CL OF METROPCS ANTENNAS
 ELEV.= 167'± A.G.L.

REMOVE (E) (6) 1-5/8" COAX AND ADD (P) (12) 7/8" COAX IN ACCORDANCE W/RFDS ACROSS (E) ICE BRIDGE & UP INSIDE MONOPOLE.

(E) MONOPOLE

NOTE:
 GROUND EQUIPMENT NOT SHOWN FOR CLARITY

* NOTE:
 ANTENNA ELEVATION BASED ON CLIENT-PROVIDED INFORMATION

IMAGE SOURCE: PROTERRA 05/29/14

EXISTING ELEVATION

SCALE: N.T.S.

2
A-1

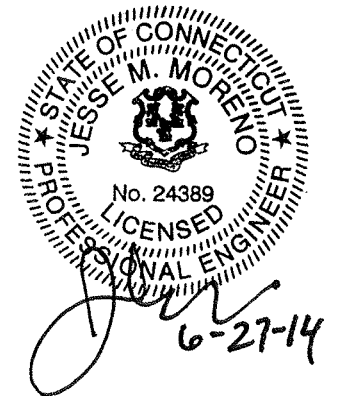

ProTerra
 DESIGN GROUP, LLC
 1 Short Street
 Suite 3
 Northampton, MA 01060
 Ph: (413)320-4918
 Fax: (413)320-4917

SBA
 SBA COMMUNICATIONS CORPORATION
 33 BOSTON POST ROAD WEST, SUITE 320
 MARLBOROUGH, MA 01752
 PHONE: 508-251-0720

SITE NUMBER: CTHA526A
SITE NAME: SBA STAFFORD MONOPOLE
 30 OLD COUNTRY ROAD, STAFFORD SPRINGS, CT 06076

metroPCS
 Unlimit Yourself.
 35 GRIFFIN ROAD
 SOUTH BLOOMFIELD, CT 06002

NO.	DATE	REVISIONS	BY	CHK	APP'D
1	06/27/14	CONSTRUCTION FINAL	BLM	TEJ	JMM
0	06/13/14	CONSTRUCTION	BLM	TEJ	JMM

SCALE: AS SHOWN DESIGNED BY: JMM/TEJ DRAWN BY: BLM

METROPCS

COMPOUND PLAN AND ELEVATION

JOB NUMBER	SHEET	REV
#13-062	A-1	0

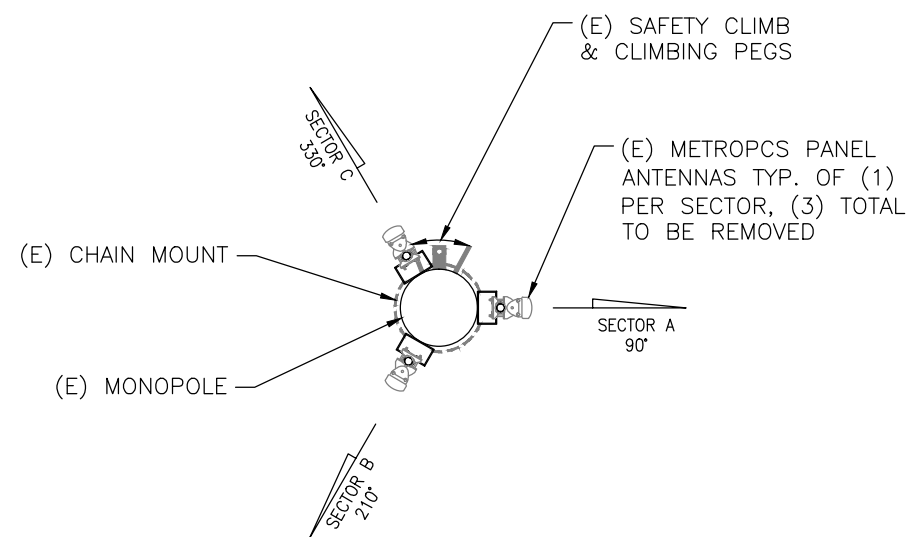

EXISTING ANTENNA SCHEDULE			
SECTOR	MAKE	MODEL#	SIZE (INCHES)
SECTOR A:	RFS	APXV18-206517LS-C	6.6x3.2x71.7
SECTOR B:	RFS	APXV18-206517LS-C	6.6x3.2x71.7
SECTOR C:	RFS	APXV18-206517LS-C	6.6x3.2x71.7

PROPOSED ANTENNA SCHEDULE			
SECTOR	MAKE	MODEL#	SIZE (INCHES)
SECTOR A:	RFS	APX16DWV-16DWVS-C	13x3.2x55.9
SECTOR B:	RFS	APX16DWV-16DWVS-C	13x3.2x55.9
SECTOR C:	RFS	APX16DWV-16DWVS-C	13x3.2x55.9

NOTE:
1. REFER TO FINAL RF DATA SHEET FOR FINAL ANTENNA SETTINGS.

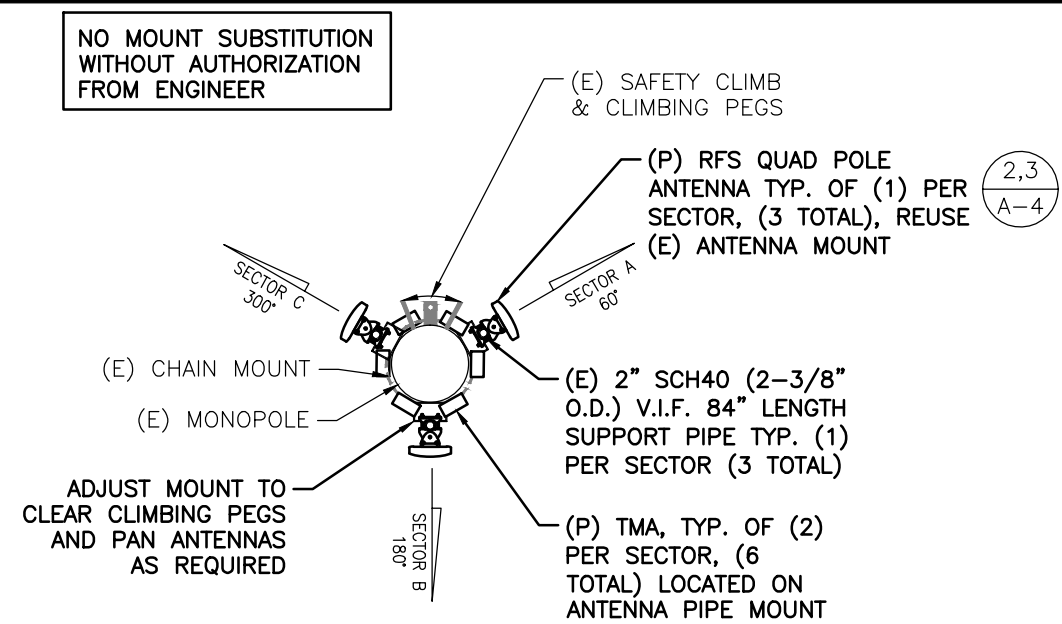

EXISTING ANTENNA PLAN
SCALE: 1"=5' (11x17)
1"=2.5' (22x34)

PROPOSED ANTENNA PLAN
SCALE: 1"=5' (11x17)
1"=2.5' (22x34)

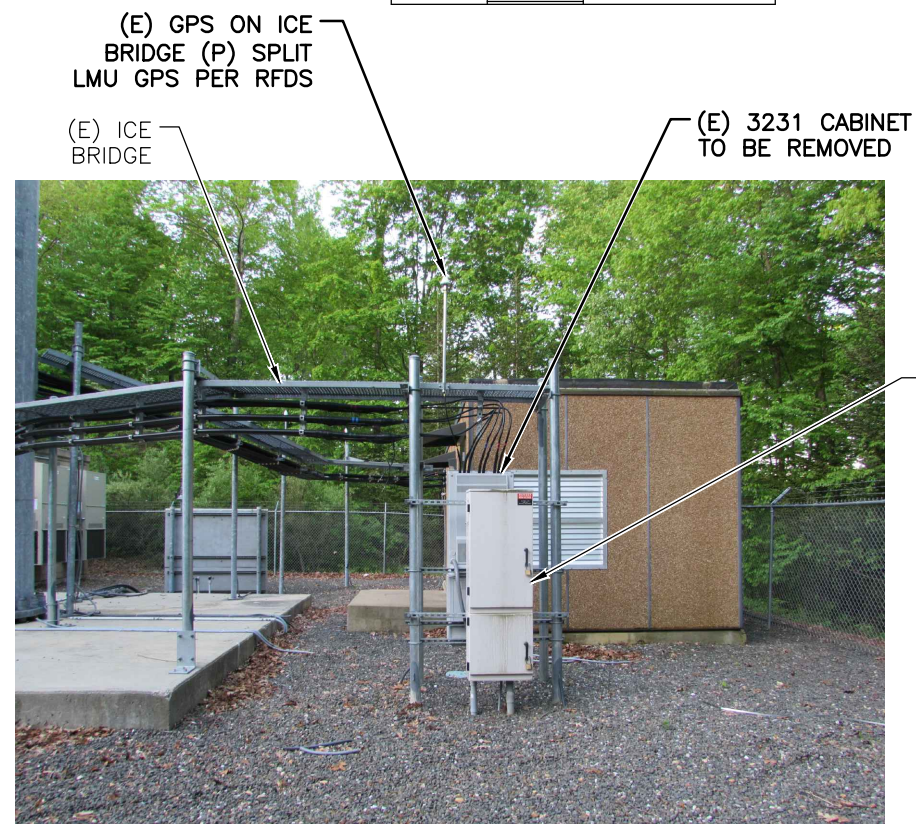
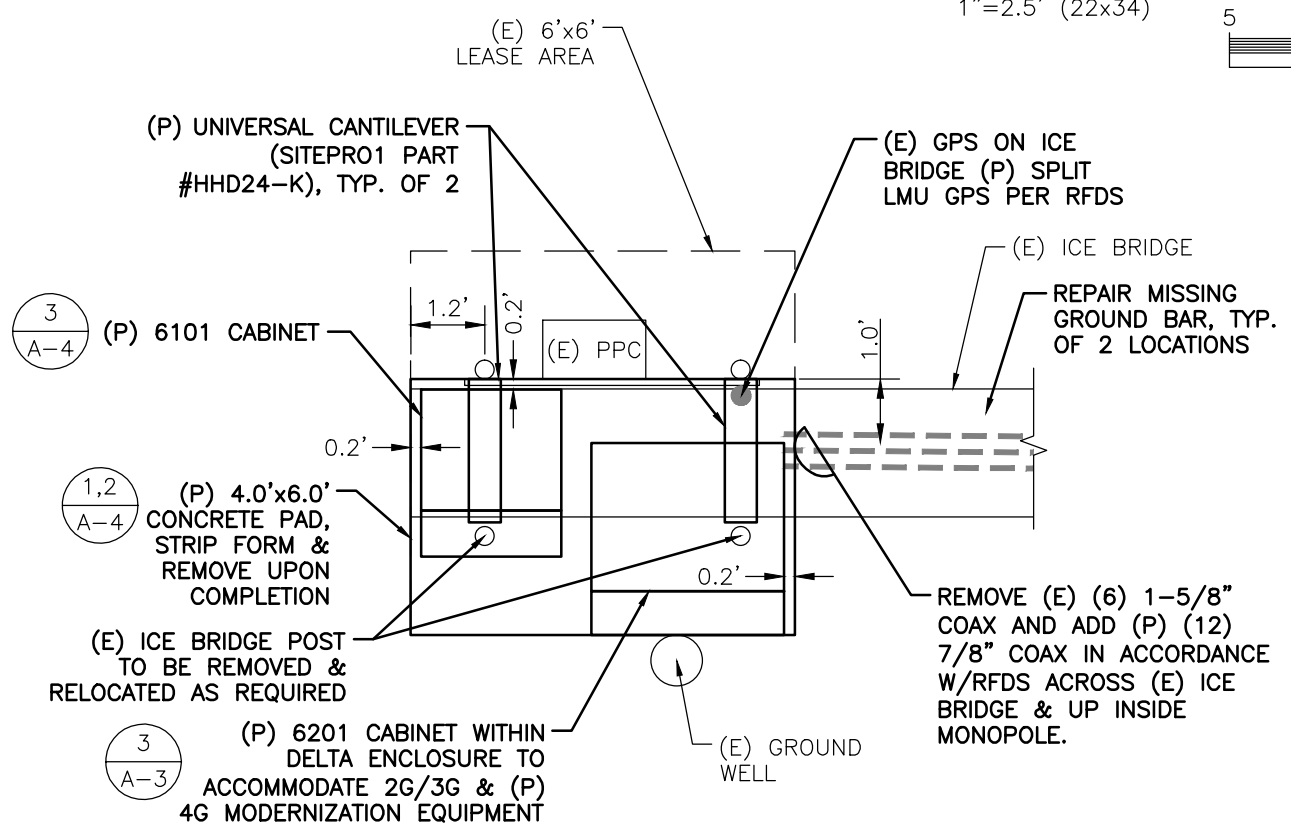
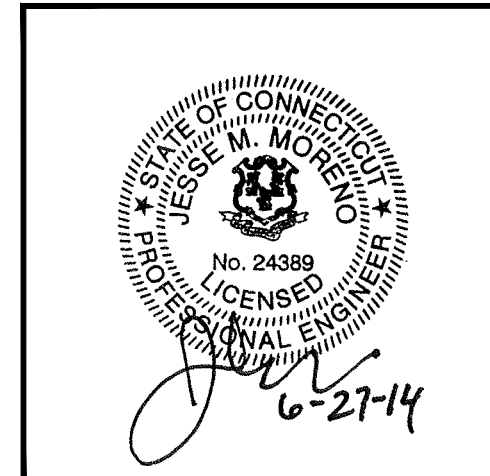

IMAGE SOURCE: PROTERRA 05/29/14
EXISTING EQUIPMENT AREA
SCALE: N.T.S.



PROPOSED EQUIPMENT AREA
SCALE: 1"=3' (11x17)
1"=1.5' (22x34)



NO.	DATE	REVISIONS	BY	CHK	APP'D
1	06/27/14	CONSTRUCTION FINAL	BLM	TEJ	JMM
0	06/13/14	CONSTRUCTION	BLM	TEJ	JMM

SCALE: AS SHOWN DESIGNED BY: JMM/TEJ DRAWN BY: BLM