

JULIE D. KOHLER

Please Reply To: Bridgeport
Writer's Direct Dial: (203) 337-4157
E-Mail: jkohler@cohenandwolf.com

September 25, 2014

Attorney Melanie Bachman
Acting Executive Director
Connecticut Siting Council
Ten Franklin Square
New Britain, CT 06501

**Re: Notice of Exempt Modification
CL&P/T-Mobile co-location
Site ID CT11734B
437 Hobart Street, Southington, CT**

Dear Attorney Bachman:

This office represents T-Mobile Northeast LLC ("T-Mobile") and has been retained to file exempt modification filings with the Connecticut Siting Council on its behalf.

In this case, Connecticut Light and Power ("CL&P") owns the existing lattice transmissions tower and related facility at 437 Hobart Street, Southington Connecticut (-72.86280/41.60839). T-Mobile intends to replace three (3) existing antennas with three (3) new antennas and related equipment at this existing telecommunications facility in Southington ("Southington Facility"). Please accept this letter as notification, pursuant to R.C.S.A. §16-50j-73, of construction which constitutes an exempt modification pursuant to R.C.S.A. § 16-50j-72(b)(2). In accordance with R. C.S.A. § 16-50j-73, a copy of this letter is being sent to the Town Manager, Garry Brumback, and the property owner, CL&P. Please also see the letter of authorization from CL&P attached hereto as **Exhibit A**.

The existing Southington Facility consists of an 86-foot lattice transmission tower.¹ T-Mobile plans to replace three (3) existing antennas flush mounted to the existing PCS mast with three (3) new antennas flush mounted to the existing PCS mast at a centerline of 97 feet. T-Mobile will also install coax cables running on a leg of the existing tower, reuse existing coax cable, turn off existing tower mounted amplifiers ("TMAs"), and remove diplexers. (See the plans revised to August 18, 2014 attached hereto as **Exhibit B**). The existing Southington Facility is structurally capable of supporting T-Mobile's proposed modifications, as indicated in the structural analysis dated January 29, 2014, and attached hereto as **Exhibit C**.

The planned modifications to the Southington Facility fall squarely within those activities explicitly provided for in R.C.S.A. § 16-50j-72(b)(2).

¹ The Southington Facility was approved at a height of 100 feet, inclusive of antennas (Petition No. 764), consistent with this filing. The 86-foot height cited in this application includes only the tower, not the antennas mounted atop the tower. With the antennas (mounted at a centerline of 97 feet), the tower is approximately 100 feet.

1. The proposed modification will not increase the height of the tower. T-Mobile's existing antennas are at a centerline of 97 feet; the replacement antennas will be installed at the same 97 foot level. The enclosed tower drawing confirms that the proposed modification will not increase the height of the tower.

2. The proposed modifications will not require an extension on the site boundaries or lease area, as depicted on Sheet 3 of Exhibit A. T-Mobile's equipment will be located entirely within the existing compound area.

3. The proposed modification to the Facility will not increase the noise levels at the existing facility by six decibels or more.

4. The operation of the replacement antennas and equipment will not increase the total radio frequency (RF) power density, measured at the base of the tower, to a level at or above the applicable standard. According to a Radio Frequency Emissions Analysis Report prepared by EBI dated March 24, 2014, T-Mobile's operations would add 1.028% of the FCC Standard. Therefore, the calculated "worst case" power density for the planned combined operation at the site including all of the proposed antennas would be 1.028% of the FCC Standard as calculated for a mixed frequency site as evidenced by the engineering exhibit attached hereto as **Exhibit D**.

For the foregoing reasons, T-Mobile respectfully submits that the proposed replacement antennas and equipment at the Southington Facility constitutes an exempt modification under R.C.S.A. § 16-50j-72(b)(2). Upon acknowledgement of this exempt modification, T-Mobile shall commence construction approximately sixty days from the receipt of the Council's decision.

Sincerely,



Julie D. Kohler

cc: Town Manager Garry Brumback, Town of Southington
CL&P
Halene Fujimoto, HPC Wireless Services

EXHIBIT A



**Northeast
Utilities System**

56 Prospect Street, Hartford, CT 06103

Northeast Utilities Service Company
P.O. Box 270
Hartford, CT 06141-0270
(203) 665-5000

August 19, 2014

Mr. Mark Richard
T-Mobile
35 Griffin Rd.
Bloomfield, CT 06002

RE: T-Mobile Antenna Site, CT-11 734B, 437 Hobart St., Southington CT, structure 1814.

Dear Mr. Richard:

Based on our reviews of the site drawings, the structural analysis and foundation review provided by Centek Engineering, along with a third party review performed by Commonwealth Associates we have reviewed for acceptance this modification.

Since there are no outstanding structural or site related issues to resolve at this time, construction at these locations may begin as soon as scheduling allows. You may contact Mr. O'Brien (860-665-6987); once the lease issues are secured you may then contact Mr. John Landry directly (860-665-5425) to begin the construction arrangements

Sincerely,

A handwritten signature in black ink, appearing to read "Robert Gray", written over a horizontal line.

Robert Gray
Transmission Line Engineering

Ref: CT11734B_CD_Rev A_06.18.14.pdf

Ref: 14005.000 - CT11734B Structural Anlaysis Rev0 14-01-30.pdf

EXHIBIT B

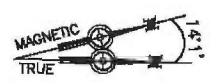
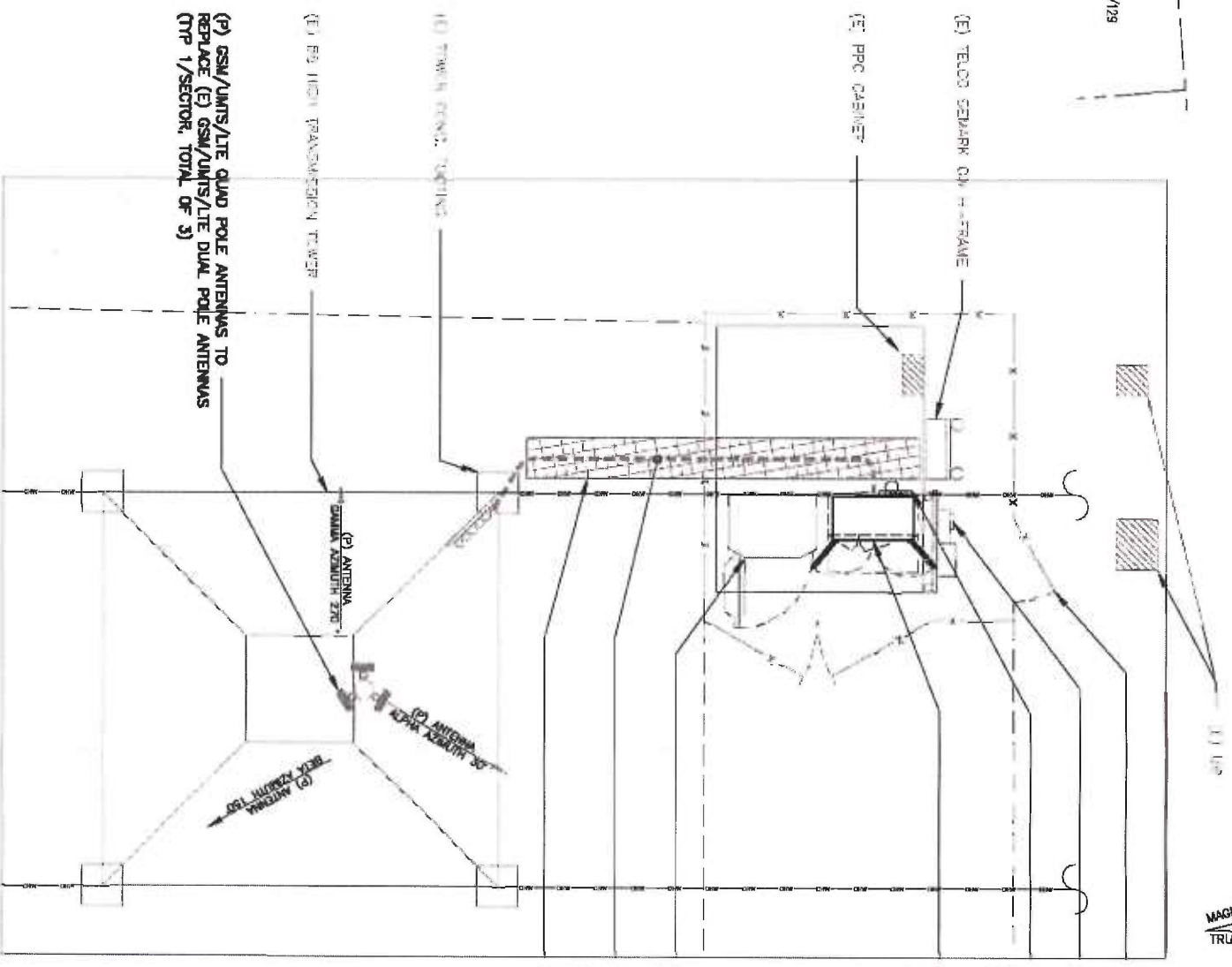
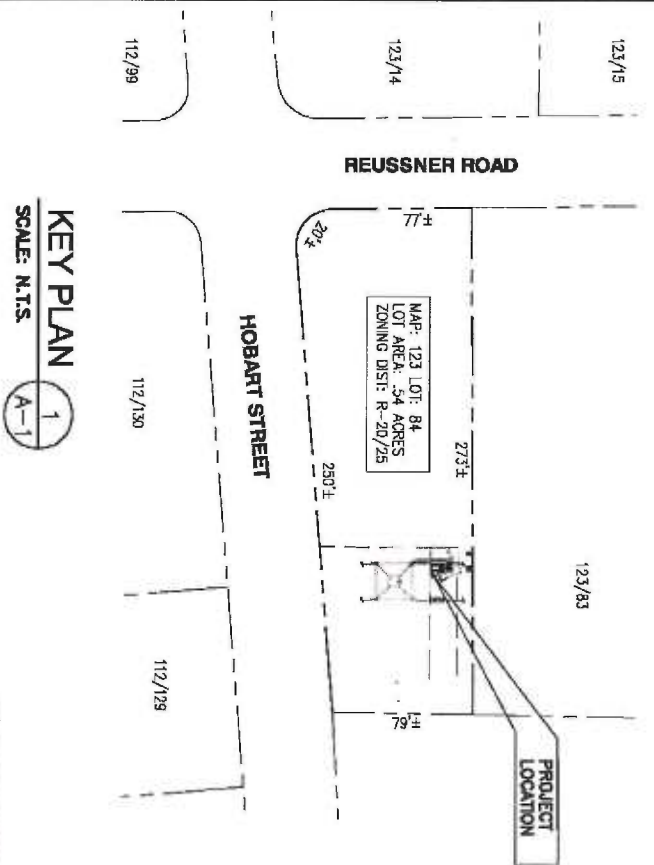

- (F) 4 WIDE GATE
- (B) 2-RANG WELER ON H-FRAME
- (E) (B) 4 B2/B4 TMA'S TO REMAIN AND TURNED OFF (E) (B) DIPLEXERS TO BE REMOVED
- (C) GSM/LITE/LTE EXCESSION RES 412' CABINET ON CONG. PAD TO REMAIN
- (E) ICE SERVICE
- (E) EXCESSION RES FOR LITE CABINET ON CONG. PAD TO REMAIN
- (P) (B) 7/8" COAX CABLES TO REMAIN
- (E) (B) 7/8" COAX CABLES TO REMAIN
- (E) ICE SERVICE



SITE PLAN
SCALE: 1" = 8'-0" (11x17)



- GENERAL SITE NOTES:**
1. SITE INFORMATION WAS OBTAINED FROM A FIELD INVESTIGATION PERFORMED BY ATLANTIS GROUP, INC. CONTRACTOR TO FIELD VERIFY DIMENSIONS AS NECESSARY BEFORE CONSTRUCTION.
 2. THE PROPOSED DEVELOPMENT DOES NOT INCLUDE SIGNS OF ADVERTISING.
 3. THE PROPOSED DEVELOPMENT IS UNMANNED AND THEREFORE DOES NOT REQUIRE A MEANS OF WATER SUPPLY OR SEWAGE DISPOSAL.
 4. NO LANDSCAPING WORK IS PROPOSED IN CONJUNCTION WITH THIS DEVELOPMENT OTHER THAN THAT WHICH IS SHOWN.
 5. THE PROPOSED DEVELOPMENT DOES NOT INCLUDE OUTDOOR STORAGE OR ANY SOLID WASTE RECEPTACLES.
 6. UTILITIES SHOWN ON PLAN ARE TAKEN FROM OWNERS RECORDS AND FIELD LOCATION OF VISIBLE SURFACE FEATURES. THE EXISTENCE, EXTENT AND EXACT HORIZONTAL AND VERTICAL LOCATIONS OF UTILITIES HAS NOT BEEN VERIFIED. ANY CONTRACTOR PERFORMING WORK ON THIS SITE MUST CONTACT CALL BEFORE YOU DIG THREE WORKING DAYS PRIOR TO COMMENCING WORK.
 7. ALL OBSOLETE OR UNUSED FACILITIES SHALL BE REMOVED WITHIN 12 MONTHS OF CESSATION OF OPERATIONS.

SITE LEGEND

(---)	SITE PROPERTY LINE
(---)	STREET OR ROAD
(---)	CHAIN LINK FENCE
(---)	OPAQUE WOODEN FENCE
(---)	BOARD ON BOARD FENCE
(---)	DECIDUOUS TREES/SHRUBS
(---)	EVERGREEN TREES/SHRUBS
(---)	TREE LINE
(---)	UTILITY POLE
(E)	EXISTING
(N)	NEW
(P)	PROPOSED
(F)	FUTURE
(P)	PROP. LTE ANTENNA
(P)	PROP. UMTS/GSM ANTENNA
(P)	EX. GSM ANTENNA
(P)	EX. UMTS ANTENNA

ATLANTIS GROUP
1340 Centre Street, Suite 212
Newton Center, MA 02459
Office: 617-965-0789
Fax: 617-213-5056

T-Mobile
T-MOBILE NORTHEAST, LLC
35 GREENWOOD STREET
BLOOMFIELD, CT 06002
OFFICE: (860) 862-7100
FAX: (860) 862-7159

DATE	DESCRIPTION	REVISION
04/07/14	ISSUED FOR REVIEW	A

PROJECT NO:	CT11734B
DRAWN BY:	MB
CHECKED BY:	SM

PROFESSIONAL SEAL

THIS DOCUMENT IS THE CREATION, DESIGN, PROPERTY AND COPYRIGHTED WORK OF T-MOBILE. ANY DUPLICATION OR USE WITHOUT EXPRESS WRITTEN CONSENT IS STRICTLY PROHIBITED.

SITE NAME
CT11734B
CT734/CL&P
STANCHION
437 HOBART STREET
SOUTHINGTON, CT 06489

SHEET TITLE
KEY PLAN
AND
SITE PLAN

SHEET NUMBER
A-1

CENTER OF EXISTING ANTENNAS
ELEV. = 87 ± (AGL)

TOP OF EXISTING TOWER
ELEV. = 86 ± (AGL)

(P) GSM/UMTS/LTE DUAL POLE ANTENNAS TO REPLACE (E) GSM/UMTS/LTE DUAL POLE ANTENNAS (TYP 1/SECTOR, TOTAL OF 3)

(P) (8) 7/8" COAX CABLES TO REMAIN
(E) (8) 7/8" COAX CABLES TO REMAIN

(E) NEW BRIDGE

(E) EPICORON P385 3 PR UNITS CABLE TO REMAIN ON (E) CONC. PAD

(E) CONDUIT AT EPICORON P385 BLVD CONC. TO REMAIN ON (E) CONC. PAD

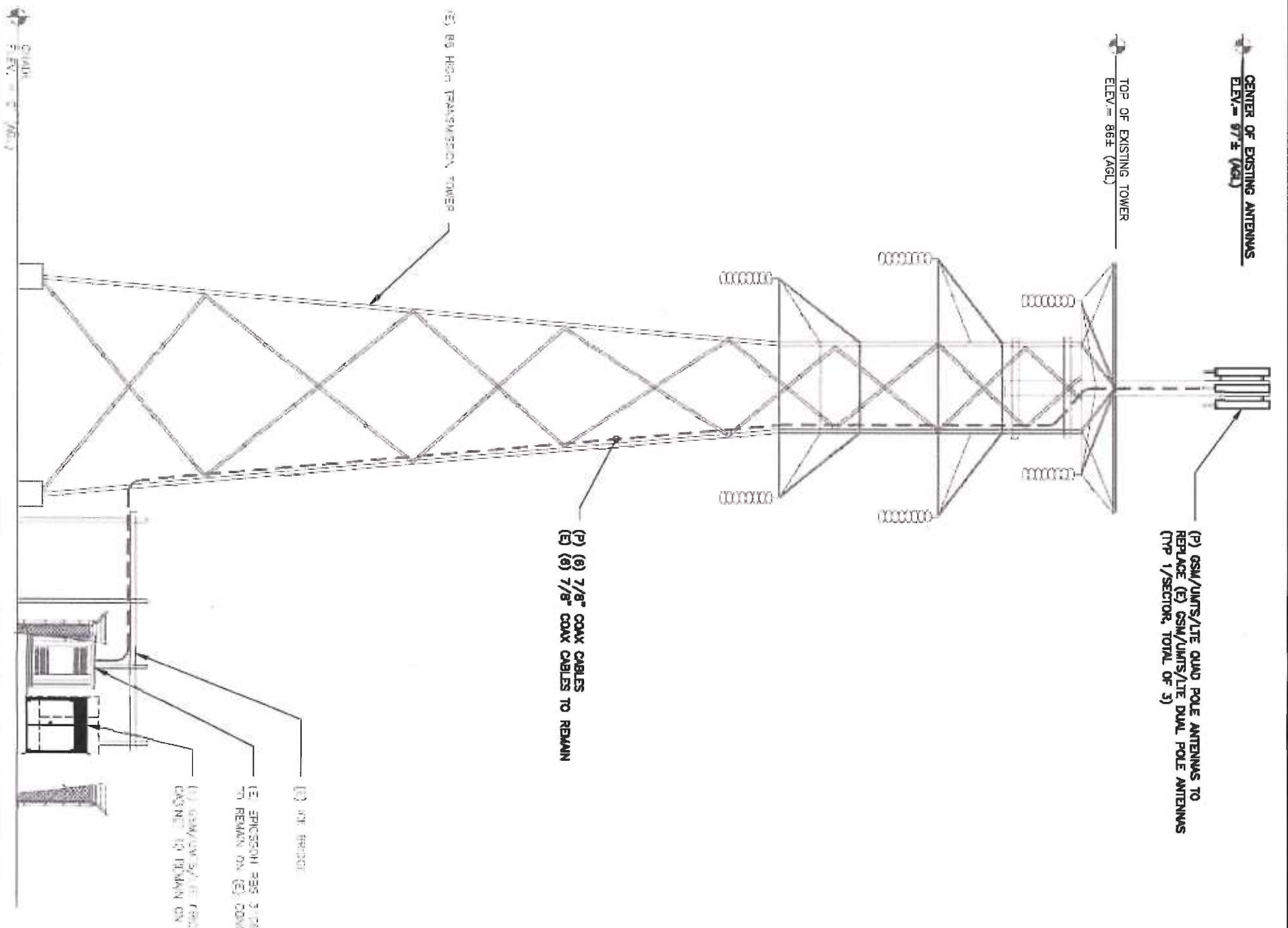

ELEVATION

SCALE: 1" = 10'-0" (11x17)

2
A-2



Mobile
1-MOBILE NORTHEAST, LLC
35 GREENFIELD, CT 06030
PHONE: (860) 262-7100
FAX: (860) 262-7159

ATLANTIS
G R O U P
1340 Centre Street, Suite 212
Newton Centre, MA 02459
Office: 617-965-0789
Fax: 617-213-5056

SUBMITTALS

DATE	DESCRIPTION	REVISION
08/14/14	ISSUED FOR PERMIT	A

REV.	DATE	BY	REVISIONS

PROJECT NO.: CT11734B
DRAWN BY: MB
CHECKED BY: SM

PROFESSIONAL SEAL

THIS DOCUMENT IS THE CREATION, DESIGN, PROPERTY AND COPYRIGHTED WORK OF T-MOBILE. ANY DUPLICATION OR USE WITHOUT EXPRESS WRITTEN CONSENT IS STRICTLY PROHIBITED.

SITE NAME
CT11734B
CT1734/CL&P
STANCHION
437 HOBART STREET
SOUTHINGTON, CT 06489

SHEET TITLE
ELEVATION

SHEET NUMBER
A-2

SUBMITTALS

DATE	DESCRIPTION	REVISION
04/14/14	ISSUE FOR REVIEW	A

DATE	REV'S	REVISIONS

PROJECT NO: CT11734B
 DRAWN BY: MB
 CHECKED BY: SM

PROFESSIONAL SEAL

THIS DOCUMENT IS THE CREATION,
 DESIGN, PROPERTY AND COPYRIGHTED
 WORK OF T-MOBILE & ANY DUBLICATION
 OR USE WITHOUT EXPRESS WRITTEN
 CONSENT IS STRICTLY PROHIBITED.

SITE NAME
CT11734B
CT734/CL&P
STANCHION
437 HOBART STREET
SOUTHINGTON, CT 06489

SHEET TITLE
ANTENNA
DETAILS

SHEET NUMBER
A-3

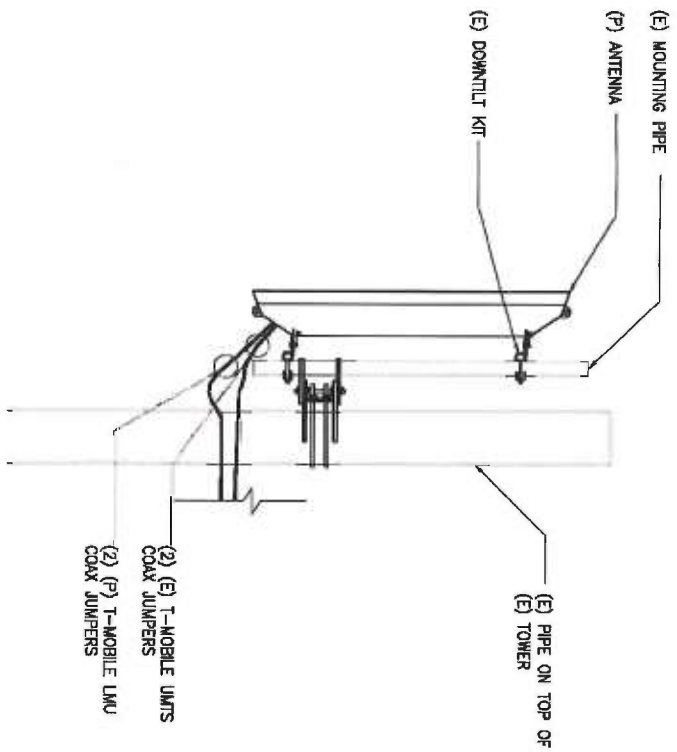

ANTENNA MOUNTING DETAILS

SCALE: N.T.S

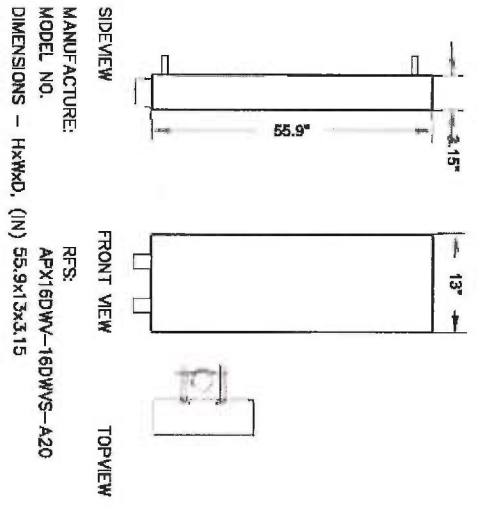

ANTENNA DETAILS

SCALE: N.T.S



EXHIBIT C

**Structural Analysis of PCS
Mast and CL&P Tower**

T-Mobile Site Ref: CT11734B

*CL&P Structure No. 1814
86' Electric Transmission Lattice Tower*

*437 Hobart Street
Southington, CT*

CEN TEK Project No. 14005.000

Date: January 29, 2014



Prepared for:
*T-Mobile Towers
4 Sylvan Way
Parsippany, NJ 07054*

Table of Contents

SECTION 1 - REPORT

- INTRODUCTION
- PRIMARY ASSUMPTIONS USED IN THE ANALYSIS
- ANALYSIS
- DESIGN BASIS
- RESULTS
- CONCLUSION

SECTION 2 - CONDITIONS & SOFTWARE

- STANDARD ENGINEERING CONDITIONS
- GENERAL DESCRIPTION OF STRUCTURAL ANALYSIS PROGRAMS
 - RISA 3-D
 - PLS TOWER

SECTION 3 - DESIGN CRITERIA

- CRITERIA FOR DESIGN OF PCS FACILITIES ON OR EXTENDING ABOVE METAL ELECTRIC TRANSMISSION TOWERS
- NU DESIGN CRITERIA TABLE
- PCS SHAPE FACTOR CRITERIA
- WIRE LOADS SHEET

SECTION 4 - DRAWINGS

- EL-1 TOWER AND MAST ELEVATION
- FP-1 FEEDLINE PLAN

SECTION 5 - EIA/TIA-222-F LOAD CALCULATIONS FOR PCS MAST ANALYSIS

- PCS MAST WIND & ICE LOAD

SECTION 6 - PCS MAST ANALYSIS PER EIA/TIA-222F

- LOAD CASES AND COMBINATIONS (TIA/EIA LOADING)
- RISA 3-D ANALYSIS REPORT
- MAST CONNECTION ANALYSIS

SECTION 7 - NECS/NU LOAD CALCULATIONS FOR OBTAINING REACTIONS APPLIED TO UTILITY STRUCTURE

- PCS MAST WIND LOAD

SECTION 8 - PCS MAST ANALYSIS PER NESC/NU FOR OBTAINING REACTIONS APPLIED TO UTILITY STRUCTURE

- LOAD CASES AND COMBINATIONS (NESC/NU LOADING)
- RISA 3-D ANALYSIS REPORT

SECTION 9 - PLS TOWER RESULTS FROM PCS MAST REACTIONS CALCULATED IN RISA WITH NESC/NU CRITERIA

- COAX CABLE LOAD ON CL&P TOWER CALCULATION
- PLS REPORT
- FOUNDATION ANALYSIS

SECTION 10 - REFERENCE MATERIAL

- RFDS SHEET
- EQUIPMENT CUT SHEETS

Introduction

The purpose of this report is to analyze the existing PCS mast and 86' CL&P tower located at 437 Hobart Street in Southington, CT for the proposed T-Mobile antenna upgrade.

The existing and proposed loads consist of the following:

- **T-MOBILE (Existing to be Removed):**
Antennas: Three (3) RFS APXV18-209014-C-A20 panel antennas flush mounted to the existing PCS mast with a RAD center elevation of 97-ft above grade.
- **T-MOBILE (Existing to Remain):**
Coax Cables: Six (6) 7/8" \varnothing coax cables running on a leg of the existing tower as indicated in section 4 of this report.
Mast: Pipe 12" Sch. 40 (O.D. = 12.75").
- **T-MOBILE (Proposed):**
Antennas: Three (3) RFS APX16DWV-16DWVS-E-A20 panel antennas flush mounted to the existing PCS mast with a RAD center elevation of 97-ft above grade.
Coax Cables: Six (6) 7/8" \varnothing coax cables running on a leg of the existing tower as indicated in section 4 of this report.

Primary assumptions used in the analysis

- Allowable steel stresses are defined by AISC-ASD 9th edition for design of the PCS Mast and antenna supporting elements.
- ASCE Manual No. 10-97, "Design of Latticed Steel Transmission Structures", defines allowable steel stresses for evaluation of the CL&P utility tower.
- All utility tower members are adequately protected to prevent corrosion of steel members.
- All proposed antenna mounts are modeled as listed above.
- All coaxial cable will be installed as indicated in Section 4 of this report.
- PCS Mast will be properly installed and maintained.
- No residual stresses exist due to incorrect tower erection.
- All bolts are appropriately tightened providing the necessary connection continuity.
- All welds conform to the requirements of AWS D1.1.
- PCS Mast and utility tower will be in plumb condition.
- Utility tower was properly installed and maintained and all members were properly designed, detailed, fabricated, and installed and have been properly maintained since erection.
- Any deviation from the analyzed loading will require a new analysis for verification of structural adequacy.
- PCS mast was designed and installed per sketches prepared by Clough Harbour and Associates project no; 10585-1054-1601 dated April 5, 2005.

A n a l y s i s

Structural analysis of the existing PCS Mast was independently completed using the current version of RISA-3D computer program licensed to CENTEK Engineering, Inc.

The PCS mast consisting of a 12" Sch. 40 pipe conforming to ASTM A53 Grade B ($F_y = 35\text{ksi}$) connected at four points to the existing tower was analyzed for its ability to resist loads prescribed by the TIA/EIA standard. Section 5 of this report details these gravity and lateral wind loads. NESC prescribed loads were also applied to the PCS Mast in order to obtain reactions needed for analyzing the CL&P tower structure. These loads are developed in Section 7 of this report. Load cases and combinations used in RISA-3D for TIA/EIA loading and for NESC/NU loading are listed in report Sections 6 and 8, respectively.

An envelope solution was first made to determine maximum and minimum forces, stresses, and deflections to confirm the selected section as adequate. Additional analyses were then made to determine the NESC forces to be applied to the CL&P tower structure.

The RISA-3D program contains a library of all AISC shapes and corresponding section properties are computed and applied directly within the program. The program's Steel Code Check option was also utilized. The forces calculated in RISA-3D using NESC guidelines were then applied to the CL&P tower using PLS-Tower. Maximum usage for the tower was calculated considering the additional forces from the mast and associated appurtenances.

D e s i g n B a s i s

Our analysis was performed in accordance with EIA-222-F-1996, ASCE Manual No. 10-97, "Design of Latticed Steel Transmission Structures", NESC C2-2007 and Northeast Utilities Design Criteria.

The CL&P tower structure, considering existing and future conductor and shield wire loading, with the proposed antenna mast was analyzed under two conditions:

▪ UTILITY TOWER ANALYSIS

The purpose of this analysis is to determine the adequacy of the existing utility structure to support the proposed antenna loads. The loading and design requirements were analyzed in accordance with the NU Design Criteria Table, NESC C2-2007 ~ Construction Grade B, and ASCE Manual No. 10-97, "Design of Latticed Steel Transmission Structures".

Load cases considered:

Load Case 1: NESC Heavy

Wind Pressure.....	4.0 psf
Radial Ice Thickness.....	0.5"
Vertical Overload Capacity Factor.....	1.50
Wind Overload Capacity Factor.....	2.50
Wire Tension Overload Capacity Factor.....	1.65

Load Case 2: NESC Extreme

Wind Speed.....	110 mph ⁽¹⁾
Radial Ice Thickness.....	0"

Note 1: NESC C2-2007, Section 25, Rule 250C: Extreme Wind Loading, 1.25 x Gust Response Factor (wind speed: 3-second gust)

▪ PCS MAST ANALYSIS

PCS mast, appurtenances and connections to the utility tower were analyzed and designed in accordance with the NU Design Criteria Table, TIA/EIA-222-F, and AISC-ASD standards.

Load cases considered:

Load Case 1:

Wind Speed..... 85 mph ⁽²⁾
 Radial Ice Thickness..... 0"

Load Case 2:

Wind Pressure..... 75% of 85 mph wind pressure
 Radial Ice Thickness..... 0.5"

| Note 2: Per NU Mast Design Criteria Exception 1.

Results

▪ MAST ASSEMBLY

The existing mast was determined to be structurally **adequate**.

Member	Stress Ratio (% of capacity)	Result
12" Sch. 40 Mast	20.8%	PASS
HSS 5x5x1/4 Brace	37.4%	PASS
Mast Connection to CL&P Tower	23.2% ⁽¹⁾	PASS

Note 1 – 1/3 increase in allowable stress not used for connection to tower per OTRM 059.

▪ UTILITY TOWER

This analysis finds that the subject utility structure is adequate to support the existing PCS mast and related appurtenances. The tower stresses meet the requirements set forth by the ASCE Manual No. 10-97, "Design of Latticed Steel Transmission Structures", for the applied NESC Heavy and Hi-Wind load cases. The detailed analysis results are provided in Section 9 of this report. The analysis results are summarized as follows:

A maximum usage of **68.28%** occurs in the utility tower under the **NESC Extreme** loading condition.

TOWER SECTION:

The utility structure was found to be within allowable limits.

Tower Member	Stress Ratio (% of capacity)	Result
Angle g35Y	68.28%	PASS

▪ FOUNDATION AND ANCHORS

The existing foundation consists of four (4) 2-ft square tapering to 4-ft square x 7-ft long reinforced concrete piers on four (4) 6.5-ft square x 2.5-ft thick reinforced concrete pads. The base of the tower is connected to the foundation by one (1) anchor stub angle per leg embedded into the concrete foundation. Foundation information was obtained from NUSCO drawing # 01099-60003.

BASE REACTIONS:

From PLS-Tower analysis of CL&P tower based on NESC/NU prescribed loads.

Load Case	Shear	Uplift	Compression
NESC Heavy Wind	7.52 kips	9.57 kips	32.71 kips
NESC Extreme Wind	12.61 kips	39.24 kips	51.81 kips

Note 1 – 10% increase to be applied to the above tower base reactions for foundation verification per OTRM 051

FOUNDATION:

The foundation was found to be within allowable limits.

Foundation	Design Limit	Allowable Limit	Proposed Loading ⁽²⁾	Result
Reinforced Conc. Pad and Pier	Uplift	1.0 FS ⁽¹⁾	1.33 FS ⁽¹⁾	PASS

Note 1: FS denotes Factor of Safety

Note 2: 10% increase to PLS base reactions used in foundation analysis per OTRM 051.

Conclusions and Recommendations

This analysis shows that the subject utility tower **is adequate** to support the proposed T-Mobile equipment upgrade.

The analysis is based, in part on the information provided to this office by Northeast Utilities and T-Mobile. If the existing conditions are different than the information in this report, CENTEK engineering, Inc. must be contacted for resolution of any potential issues.

Please feel free to call with any questions or comments.

Respectfully Submitted by:



Carlo F. Centore, PE
 Principal ~ Structural Engineer



Prepared by:



Timothy J. Lynn, PE
 Structural Engineer

EXHIBIT D

RADIO FREQUENCY EMISSIONS ANALYSIS REPORT
EVALUATION OF HUMAN EXPOSURE POTENTIAL
TO NON-IONIZING EMISSIONS

T-Mobile Existing Facility

Site ID: CT11734B

CL&P Stanchion #1814

437 Hobart Street
Southington, CT 06489

March 24, 2014

EBI Project Number: 62141760

March 24, 2014

T-Mobile USA
Attn: Jason Overbey, RF Manager
35 Griffin Road South
Bloomfield, CT 06002

Re: Emissions Values for Site: **CT11734B - CL&P Stanchion #1814**

EBI Consulting was directed to analyze the proposed T-Mobile facility located at 437 Hobart Street, Southington, CT, for the purpose of determining whether the emissions from the Proposed T-Mobile Antenna Installation located on this property are within specified federal limits.

All information used in this report was analyzed as a percentage of current Maximum Permissible Exposure (% MPE) as listed in the FCC OET Bulletin 65 Edition 97-01 and ANSI/IEEE Std C95.1. The FCC regulates Maximum Permissible Exposure in units of microwatts per square centimeter ($\mu\text{W}/\text{cm}^2$). The number of $\mu\text{W}/\text{cm}^2$ calculated at each sample point is called the power density. The exposure limit for power density varies depending upon the frequencies being utilized. Wireless Carriers and Paging Services use different frequency bands each with different exposure limits, therefore it is necessary to report results and limits in terms of percent MPE rather than power density.

All results were compared to the FCC (Federal Communications Commission) radio frequency exposure rules, 47 CFR 1.1307(b)(1) – (b)(3), to determine compliance with the Maximum Permissible Exposure (MPE) limits for General Population/Uncontrolled environments as defined below.

General population/uncontrolled exposure limits apply to situations in which the general public may be exposed or in which persons who are exposed as a consequence of their employment may not be made fully aware of the potential for exposure or cannot exercise control over their exposure. Therefore, members of the general public would always be considered under this category when exposure is not employment related, for example, in the case of a telecommunications tower that exposes persons in a nearby residential area.

Public exposure to radio frequencies is regulated and enforced in units of microwatts per square centimeter ($\mu\text{W}/\text{cm}^2$). The general population exposure limit for the cellular band is $567 \mu\text{W}/\text{cm}^2$, and the general population exposure limit for the PCS band is $1000 \mu\text{W}/\text{cm}^2$. Because each carrier will be using different frequency bands, and each frequency band has different exposure limits, it is necessary to report percent of MPE rather than power density.

Occupational/controlled exposure limits apply to situations in which persons are exposed as a consequence of their employment and in which those persons who are exposed have been made fully aware of the potential for exposure and can exercise control over their exposure. Occupational/controlled exposure limits also apply where exposure is of a transient nature as a result of incidental passage through a location where exposure levels may be above general population/uncontrolled limits (see below), as long as the exposed person has been made fully aware of the potential for exposure and can exercise control over his or her exposure by leaving the area or by some other appropriate means.

Additional details can be found in FCC OET 65.

CALCULATIONS

Calculations were done for the proposed T-Mobile Wireless antenna facility located at 437 Hobart Street, Southington, CT, using the equipment information listed below. All calculations were performed per the specifications under FCC OET 65. Since T-Mobile is proposing highly focused directional panel antennas, which project most of the emitted energy out toward the horizon, the actual antenna pattern gain value in the direction of the sample area was used. For this report the sample point is a 6 foot person standing at the base of the tower

For all calculations, all equipment was calculated using the following assumptions:

- 1) 2 GSM channels (1935.000 MHz—to 1945.000 MHz) were considered for each sector of the proposed installation.
- 2) 2 UMTS channels (2110.000 MHz to 2120.000 MHz / 2140.000 MHz to 2145.000 MHz) were considered for each sector of the proposed installation
- 3) 2 LTE channels (2110.000 MHz to 2120.000 MHz / 2140.000 MHz to 2145.000 MHz) were considered for each sector of the proposed installation
- 4) All radios at the proposed installation were considered to be running at full power and were uncombined in their RF transmissions paths per carrier prescribed configuration. Per FCC OET Bulletin No. 65 - Edition 97-01 recommendations to achieve the maximum anticipated value at each sample point, all power levels emitting from the proposed antenna installation are increased by a factor of 2.56 to account for possible in-phase reflections from the surrounding environment. This is rarely the case, and if so, is never continuous.
- 5) For the following calculations the sample point was the top of a six foot person standing at the base of the tower. The actual gain in this direction was used per the manufactures supplied specifications.
- 6) The antenna used in this modeling is the RFS APX16DWV-16DWVS-A20 for LTE, UMTS and GSM. This is based on feedback from the carrier with regards to anticipated antenna selection. This antenna has a 16.3 dBd gain value at its main lobe. Actual antenna gain values were used for all calculations as per the manufacturers specifications

-
- 7) The antenna mounting height centerline of the proposed antennas is **97 feet** above ground level (AGL)
 - 8) Emissions values for additional carriers were taken from the Connecticut Siting Council active database. Values in this database are provided by the individual carriers themselves.

All calculation were done with respect to uncontrolled / general public threshold limits

Site ID	CT11734B - CI&P Stanchion #1814
Site Address	437 Hobart Street, Southington, CT 06489
Site Type	Transmission Tower

Sector 1																	
Antenna Number	Antenna Make	Antenna Model	Status	Frequency Band	Technology	Power Out Per Channel (Watts)	Number of Channels	Composite Power	Antenna Gain in direction of sample point (dbd)	Antenna Height (ft)	analysis height	Cable Size	Cable Loss (dB)	Additional Loss	ERP	Power Density Value	Power Density Percentage
1a	RFS	APX16DWV-16DWVS-A20	Passive	PCS - 1950 MHz	GSM / UMTS	30	2	60	-3.25	97	91	7/8"	1.2	0	21.535316	0.93492	0.09349%
1B	RFS	APX16DWV-16DWVS-A20	Passive	AWS - 2100 MHz	UMTS/LTE	40	4	160	-3.25	97	91	7/8"	1.2	0	57.42751	2.49312	0.24931%
Sector total Power Density Value:													0.343%				
Sector 2																	
Antenna Number	Antenna Make	Antenna Model	Status	Frequency Band	Technology	Power Out Per Channel (Watts)	Number of Channels	Composite Power	Antenna Gain in direction of sample point (dbd)	Antenna Height (ft)	analysis height	Cable Size	Cable Loss (dB)	Additional Loss	ERP	Power Density Value	Power Density Percentage
1a	RFS	APX16DWV-16DWVS-A20	Passive	PCS - 1950 MHz	GSM / UMTS	30	2	60	-3.25	97	91	7/8"	1.2	0	21.535316	0.93492	0.09349%
1B	RFS	APX16DWV-16DWVS-A20	Passive	AWS - 2100 MHz	UMTS/LTE	40	4	160	-3.25	97	91	7/8"	1.2	0	57.42751	2.49312	0.24931%
Sector total Power Density Value:													0.343%				
Sector 3																	
Antenna Number	Antenna Make	Antenna Model	Status	Frequency Band	Technology	Power Out Per Channel (Watts)	Number of Channels	Composite Power	Antenna Gain in direction of sample point (dbd)	Antenna Height (ft)	analysis height	Cable Size	Cable Loss (dB)	Additional Loss	ERP	Power Density Value	Power Density Percentage
1a	RFS	APX16DWV-16DWVS-A20	Passive	PCS - 1950 MHz	GSM / UMTS	30	2	60	-3.25	97	91	7/8"	1.2	0	21.535316	0.93492	0.09349%
1B	RFS	APX16DWV-16DWVS-A20	Passive	AWS - 2100 MHz	UMTS/LTE	40	4	160	-3.25	97	91	7/8"	1.2	0	57.42751	2.49312	0.24931%
Sector total Power Density Value:													0.343%				

Site Composite MPE %	
Carrier	MPE %
T-Mobile	1.028%
Total Site MPE %	1.028%

Summary

All calculations performed for this analysis yielded results that were well within the allowable limits for general public exposure to RF Emissions.

The anticipated Maximum Composite contributions from the T-Mobile facility are **1.028% (0.343% from each sector)** of the allowable FCC established general public limit considering all three sectors simultaneously sampled at the ground level.

The anticipated composite MPE value for this site assuming all carriers present is **1.028%** of the allowable FCC established general public limit sampled at the ground level. This is based upon values listed in the Connecticut Siting Council database for existing carrier emissions.

FCC guidelines state that if a site is found to be out of compliance (over allowable thresholds), that carriers over a 5% contribution to the composite value will require measures to bring the site into compliance. For this facility, the composite values calculated were well within the allowable 100% threshold standard per the federal government.



Scott Heffernan
RF Engineering Director

EBI Consulting

21 B Street
Burlington, MA 01803