

January 30, 2017

Melanie A. Bachman
Acting Executive Director
Connecticut Siting Council
10 Franklin Square
New Britain, CT 06051

RE: Notice of Exempt Modification for T-Mobile / L700 Crown Site BU: 806358
T-Mobile Site ID: CT11127A
Located at: 1432 Old Waterbury Road, Southbury, CT 06488
Latitude: 41° 29' 36.92" / Longitude: -73° 9' 54.98"

Dear Ms. Bachman,

T-Mobile currently maintains six (6) antennas at the 207-foot level of the existing 226-foot monopole at 1432 Old Waterbury Road, Southbury, CT. The tower and the property is owned by Crown Castle. T-Mobile now intends to remove and replace the six (6) existing antennas with six (6) new antennas at the same 207-foot level, and add three (3) BiasTs and six (6) lines of coaxial to the tower. They propose to add one equipment cabinet to the existing ground space.

This facility was approved by the Connecticut Siting Council, Docket Number 88 on March 3, 1988. This approval included the condition(s) that:

1. The monopole tower at the Southbury site shall be no taller than necessary to provide the proposed service, and in no event shall exceed a total height of 243 feet, including antennas and associated equipment, or violate the air space of Oxford Airport as determined by the Federal Aviation Administration (FAA).
2. The facility shall be constructed in accordance with all applicable federal, state, and municipal laws and regulations.
3. Unless necessary to comply with condition number 2 above, no lights shall be installed on this tower.

4. The Certificate holder shall prepare a development and management (D&M) plan for the Southbury site in compliance with sections 16-50j-75 through 16-50j-77 of the Regulations of State Agencies. The D&M plan shall provide for permanent evergreen screening around the outside perimeter of the eight-foot chain link fence which will surround this site. The D&M shall also document the final height of the tower as approved by the FAA.
5. The Certificate Holder or its successor shall notify the Council if and when directional antennas or any equipment other than that listed in this application is added to this facility.
6. The Certificate Holder or its successor shall permit public or private entities to share space on the Southbury tower for due consideration, or shall provide any requesting entity with specific legal, technical, environmental, or economic reasons precluding such tower sharing.
7. If this facility does not provide or permanently ceases to provide cellular service following completion of construction, this Decision and Order shall be void, and the tower and all associated equipment in this application shall be dismantled and removed or reapplication for any new use shall be made to the Council before any such new use is made.
8. The Certificate Holder shall comply with any future radio frequency (RF) standard promulgated by State or federal regulatory agencies. Upon the establishment of any new governmental RF standards, the facility granted in this Decision and Order shall be brought into compliance with such standards.
9. Unless otherwise approved by the Council, this Decision and Order shall be void if all construction authorized herein is not completed within three years of the issuance of this Decision and Order, or within three years of the completion of any appeal taken in this Decision and Order.

This modification complies with the aforementioned condition(s).

Please accept this letter as notification pursuant to Regulations of Connecticut State Agencies §16-50j-73, for construction that constitutes an exempt modification pursuant to R.C.S.A. §16-50j-72(b)(2). In

accordance with R.S.C.A. § 16-50j-73, a copy of this letter is being sent to First Selectman Jeff Manville, the Planning Department for the Town of Southbury, the property owner and the tower owner.

1. The proposed modifications will not result in an increase in the height of the existing tower.
2. The proposed modification will not require the extension of the site boundary.
3. The proposed modification will not increase noise levels at the facility by six decibels or more, or to levels that exceed state and local criteria.
4. The operation of the replacement antennas will not increase radio frequency emissions at the facility to a level at or above the Federal Communication Commission safety standard.
5. The proposed modifications will not cause a change or alteration in the physical or environmental characteristics of the site.
6. The existing structure and its foundation can support the proposed loading.

For the foregoing reasons, T-Mobile respectfully submits that the proposed modifications to the above-referenced telecommunications facility constitutes an exempt modification under R.C.S.A. § 16-50j-72(b)(2). Please send approval/rejection letter to Attn: Amanda Goodall.

Sincerely,

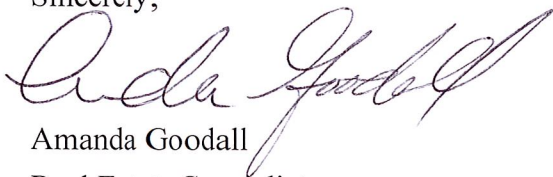

Amanda Goodall

Real Estate Specialist

12 Gill Street, Suite 5800, Woburn, MA 01801

339-205-7017

Amanda.Goodall@crowncastle.com

Melanie A. Bachman

January 30, 2017

Page 4

Attachments:

Tab 1: Exhibit-1: Compound plan and elevation depicting the planned changes

Tab 2: Exhibit-2: Structural Modification Report

Tab 3: Exhibit-3: General Power Density Table report (RF Emissions Analysis Report)

cc: First Selectman Jeff Manville

Town of Southbury

501 Main Street South

Southbury, CT 06488

DeLoris Curtis, AICP, Land Use Administrator

Planning Department

501 Main Street South

Southbury, CT 06488

Crown Castle (Tower Owner & Property Owner)

12 Gill Street, Suite 5800

Woburn, Ma 01801

DOCKET NO. 88 - AN APPLICATION OF : CONNECTICUT SITING
METRO MOBILE CTS OF NEW HAVEN, INC.,
FOR A CERTIFICATE OF ENVIRONMENTAL :
COMPATIBILITY AND PUBLIC NEED FOR : COUNCIL
CELLULAR TELEPHONE ANTENNAS AND
ASSOCIATED EQUIPMENT IN THE TOWN OF :
SOUTHBURY, CONNECTICUT : MARCH 3, 1988

D E C I S I O N A N D O R D E R

Pursuant to the forgoing opinion, the Connecticut Siting Council hereby directs that a Certificate of Environmental Compatibility and Public Need as provided by Section 16-50k of the General Statutes of Connecticut (CGS) be issued to Metro Mobile CTS of New Haven, Inc. for the construction, operation, and maintenance of a cellular telephone tower site and associated equipment at the "M/A-Southbury" alternative site on Old Waterbury Road in the Town of Southbury, Connecticut. The "M-Southbury" site on Luther Drive is hereby denied.

The facility shall be constructed, operated, and maintained as specified in the Council's record in this matter, and subject to the following conditions:

1. The monopole tower at the Southbury site shall be no taller than necessary to provide the proposed service, and in no event shall exceed a total height of 243 feet, including antennas and associated equipment, or violate the air space of Oxford Airport as determined by the Federal Aviation Administration (FAA).
2. The facility shall be constructed in accordance with all applicable federal, state, and municipal laws and regulations.
3. Unless necessary to comply with condition number 2, above, no lights shall be installed on this tower.

4. The Certificate Holder shall prepare a development and management (D&M) plan for the Southbury site in compliance with sections 16-50j-75 through 16-50j-77 of the Regulations of State Agencies. The D&M plan shall provide for permanent evergreen screening around the outside perimeter of the eight-foot chain link fence which will surround the site. The D&M shall also document the final height of the tower as approved by the FAA.
5. The Certificate Holder or its successor shall notify the Council if and when directional antennas or any equipment other than that listed in this application is added to this facility.
6. The Certificate Holder or its successor shall permit public or private entities to share space on the Southbury tower for due consideration, or shall provide any requesting entity with specific legal, technical, environmental, or economic reasons precluding such tower sharing.
7. If this facility does not provide or permanently ceases to provide cellular service following completion of construction, this Decision and Order shall be void, and the tower and all associated equipment in this application shall be dismantled and removed or reapplication for any new use shall be made to the Council before any such new use is made.

8. The Certificate Holder shall comply with any future radio frequency (RF) standards promulgated by State or federal regulatory agencies. Upon the establishment of any new governmental RF standards, the facility granted in this Decision and Order shall be brought into compliance with such standards.
9. Unless otherwise approved by the Council, this Decision and Order shall be void if all construction authorized herein is not completed within three years of the issuance of this Decision and Order, or within three years of the completion of any appeal taken in this Decision and Order.

Pursuant to CGS Section 16-50p, we hereby direct that a copy of this Decision and Order be served on each person listed below. A notice of the issuance shall be published in the Waterbury Republican and Newtown Bee.

By this Decision and Order, the Council disposes of the legal rights, duties, and privileges of each party named or admitted to the proceeding in accordance with Section 16-50j-17 of the Regulations of State Agencies.

The parties or intervenors to this proceeding are:

Metro Mobile CTS of
New Haven, Inc.
50 Rockland Road
South Norwalk, CT 06854

(applicant)

Mr. Howard L. Slater, Esq. (its representative)
Ms. Jennifer Young Gaudet
Byrne, Slater, Sandler,
Shulman & Rouse, P.C.
330 Main Street
P.O. Box 3216
Hartford, CT 06103

Fleishman and Walsh, P.C. (party)
1725 N Street, N.W.
Washington, D.C. 20036

SNET Cellular, Inc. (intervenor)
Peter J. Tyrrell, Esq.
227 Church Street
New Haven, CT 06506

Dennis Roberts (intervenor)
Martha J. Roberts
306 Luther Drive
Southbury, CT 06488

Carol A. Herskowitz (intervenor)
First Selectman
Town of Southbury
Town Hall
501 Main Street South
Southbury, CT 06488

Duncan M. Graham (party)
Executive Director
Council of Governments
Of The Central Naugatuck Valley
20 East Main Street
Waterbury, CT 06702

CERTIFICATION

The undersigned members of the Connecticut Siting Council hereby certify that they have heard this case in Docket 88 or read the record thereof, and that we voted as follows:

Dated at New Britain, Connecticut the 3rd day of March, 1988.

<u>Council Members</u>	<u>Vote Cast</u>
<u>Gloria Dibble Pond</u> Gloria Dibble Pond Chairperson	Yes
<u>Roland A. Miller</u> Commissioner Peter Boucher Designee: Roland Miller	Yes
<u>Brian J. Emerick</u> Commissioner Leslie Carothers Designee: Brian Emerick	Yes
<u>Owen L. Clark</u>	Absent
<u>Fred J. Doocy</u> Fred J. Doocy	Yes
<u>Mortimer A. Gelston</u> Mortimer A. Gelston	Yes
<u>James G. Horsfall</u> James G. Horsfall	Yes
<u>William H. Smith</u> William H. Smith	Yes
<u>Colin C. Tait</u>	Absent

Property Detail Report

For Property Located At :

1432 OLD WATERBURY RD, SOUTHURY, CT 06488-3905



Owner Information

Owner Name: **CROWN ATLANTIC CO LLC**
 Mailing Address: **PO BOX 353, MCMURRAY PA 15317 B003**
 Vesting Codes: **//**

Location Information

Legal Description:

County:	NEW HAVEN, CT	APN:	SBUR-000046-000008-A000010-537702
Census Tract / Block:	3481.22 / 2	Alternate APN:	1332381
Township-Range-Sect:		Subdivision:	
Legal Book/Page:		Map Reference:	/
Legal Lot:		Tract #:	
Legal Block:		School District:	
Market Area:		School District Name:	
Neighbor Code:		Munic/Township:	SOUTHBURY

Owner Transfer Information

Recording/Sale Date:	/	Deed Type:	
Sale Price:		1st Mtg Document #:	
Document #:			

Last Market Sale Information

Recording/Sale Date:	/	1st Mtg Amount/Type:	/
Sale Price:		1st Mtg Int. Rate/Type:	/
Sale Type:		1st Mtg Document #:	
Document #:		2nd Mtg Amount/Type:	/
Deed Type:		2nd Mtg Int. Rate/Type:	/
Transfer Document #:		Price Per SqFt:	
New Construction:		Multi/Split Sale:	
Title Company:			
Lender:			
Seller Name:			

Prior Sale Information

Prior Rec/Sale Date:	/	Prior Lender:	
Prior Sale Price:		Prior 1st Mtg Amt/Type:	/
Prior Doc Number:		Prior 1st Mtg Rate/Type:	/
Prior Deed Type:			

Property Characteristics

Year Built / Eff:	/	Total Rooms/Offices:		Garage Area:	
Gross Area:		Total Restrooms:		Garage Capacity:	
Building Area:		Roof Type:		Parking Spaces:	
Tot Adj Area:		Roof Material:		Heat Type:	
Above Grade:		Construction:		Air Cond:	YES

of Stories:
Other Improvements:

Foundation:
Exterior wall:
Basement Area:

Pool:
Quality:
Condition:

Site Information

Zoning: **M-2**
Lot Area: **3,576**
Land Use: **INDUSTRIAL (NEC)**
Site Influence:

Acres: **0.08**
Lot Width/Depth: **x**
Commercial Units: **8**
Sewer Type:

County Use:
State Use: **MIXED USE-PRIM INDUST & RES (041)**
Water Type:
Building Class:

Tax Information

Total Value: **\$66,080**
Land Value: **\$56,000**
Improvement Value: **\$10,080**
Total Taxable Value:

Assessed Year: **2016**
Improved %: **15%**
Tax Year: **2016**

Property Tax: **\$1,903.00**
Tax Area: **308**
Tax Exemption:

Town of Southbury

Geographic Information System (GIS)

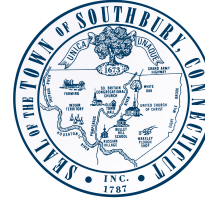

Date Printed: 12/29/2016

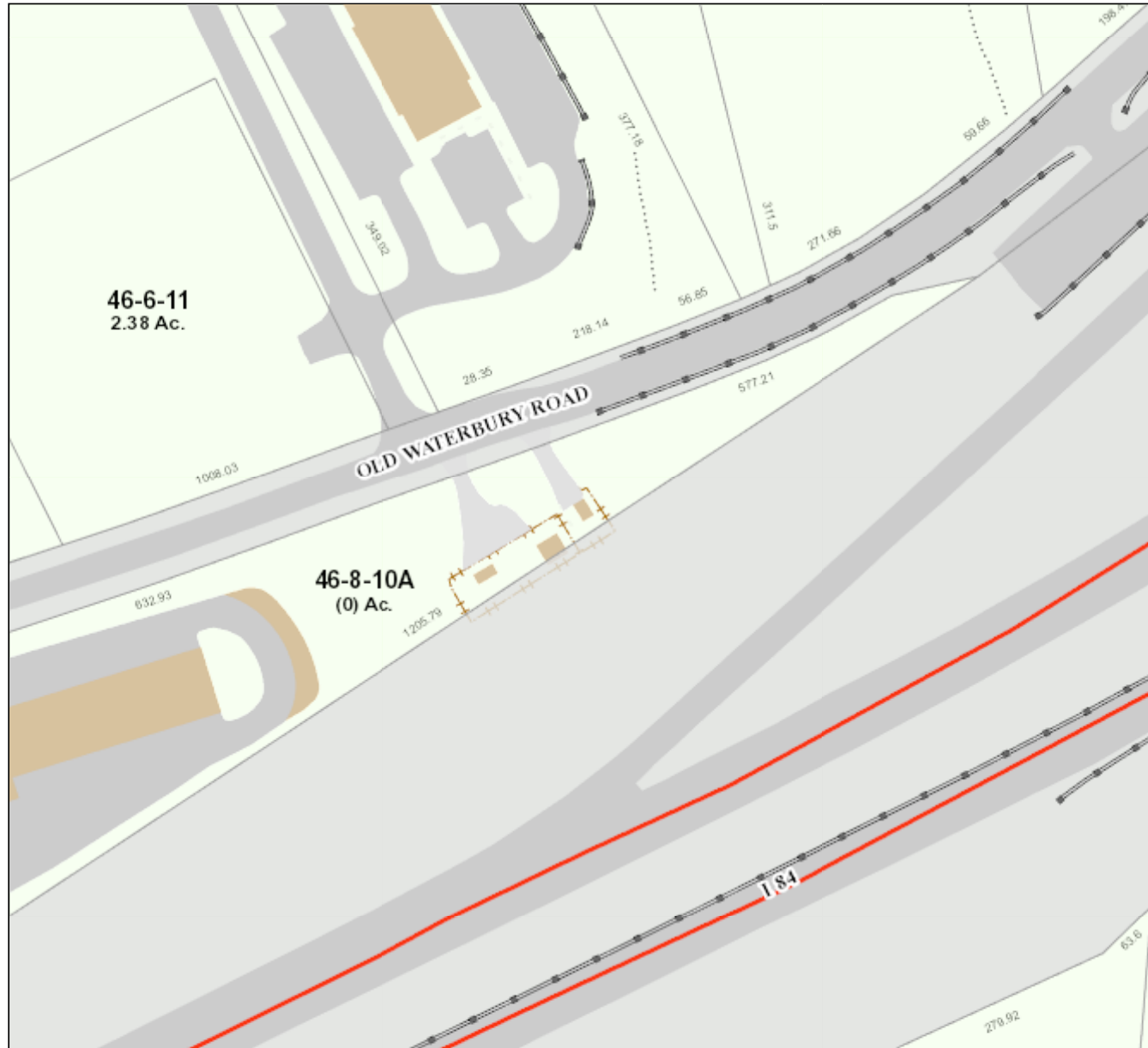



MAP DISCLAIMER - NOTICE OF LIABILITY

This map is for informational purposes only. It is not for legal description or conveyances. All information is subject to verification by any user. The Town of Southbury and its mapping contractors assume no legal responsibility for the information contained herein.

Approximate Scale: 1 inch = 150 feet

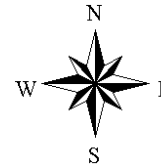



T-MOBILE SITE NUMBER: CT11127A
T-MOBILE SITE NAME: MIDDLEBURY/I-84 X 16
SITE TYPE: MONOPOLE
TOWER HEIGHT: 226'-0"

CROWN CASTLE BU #: 806358
SITE ADDRESS: 1432 OLD WATERBURY ROAD
 SOUTHURY, CT 06488
COUNTY: NEW HAVEN
JURISDICTION: CONNECTICUT
SITING COUNCIL

T-MOBILE L700_704G CONFIGURATION



510 VIRGINIA DRIVE,
 FT WASHINGTON, PA 19034



3 CORPORATE PARK DRIVE, SUITE 101
 CLIFTON PARK, NY 12065

T-MOBILE SITE NUMBER:
CT11127A

BU #: **806358**
 NHV 109 943107

1432 OLD WATERBURY ROAD
 SOUTHURY, CT 06488

EXISTING 226'-0" MONOPOLE

ISSUED FOR:

REV	DATE	DRWN	DESCRIPTION	DES./QA
A	12/14/16	NJH	PRELIMINARY	CTR
B	01/09/17	NJH	PRELIMINARY	CTR
C	01/13/17	NJH	PRELIMINARY	CTR
D	01/24/17	NJH	PRELIMINARY	LMR
0	01/30/17	JRM	CONSTRUCTION	JL

SITE INFORMATION

CROWN CASTLE SITE NAME: NHV 109 943107
 SITE ADDRESS: 1432 OLD WATERBURY ROAD
 SOUTHURY, CT 06488
 COUNTY: NEW HAVEN
 MAP/PARCEL #: SBUR-537700-000000
 AREA OF CONSTRUCTION: EXISTING
 LATITUDE: 41° 29' 36.92"
 LONGITUDE: -73° 9' 54.98"
 LAT/LONG TYPE: NAD83
 GROUND ELEVATION: 667'-0" FT.
 CURRENT ZONING: M-2
 JURISDICTION: CONNECTICUT SITING COUNCIL
 OCCUPANCY CLASSIFICATION: U
 TYPE OF CONSTRUCTION: VB
 A.D.A. COMPLIANCE: FACILITY IS UNMANNED AND NOT FOR
 HUMAN HABITATION
 PROPERTY OWNER: VOLPE BUILDERS INC RM
 8313 HERITAGE GRAND PL
 BRADENTON, FL 34212-3278
 TOWER OWNER: CROWN ATLANTIC COMPANY LLC
 2000 CORPORATE DRIVE
 CANONSBURG, PA 15317
 CARRIER/APPLICANT: T-MOBILE
 510 VIRGINIA DRIVE,
 FT WASHINGTON, PA 19034
 CROWN CASTLE
 APPLICATION ID: 369852
 ELECTRIC PROVIDER: NORTHEAST UTILITIES
 (800) 286-2000
 TELCO PROVIDER: AT&T
 (866) 620-6900

DRAWING INDEX

SHEET #	SHEET DESCRIPTION
T-1	TITLE SHEET
T-2	GENERAL NOTES
C-1	OVERALL SITE PLAN
C-2	ENLARGED EXISTING & FINAL SITE PLAN
C-3	FINAL ELEVATION AND ANTENNA PLANS
C-4	ANTENNA AND CABLE SCHEDULE
C-5	EQUIPMENT SPECIFICATIONS
G-1	ANTENNA AND UTILITY FRAME GROUNDING DETAILS
G-2	GROUNDING DETAILS
G-3	GROUNDING DETAILS

ALL DRAWINGS CONTAINED HEREIN ARE FORMATTED FOR 11X17.
 CONTRACTOR SHALL VERIFY ALL PLANS AND EXISTING DIMENSIONS
 AND CONDITIONS ON THE JOB SITE AND SHALL IMMEDIATELY NOTIFY
 THE ENGINEER IN WRITING OF ANY DISCREPANCIES BEFORE
 PROCEEDING WITH THE WORK OR BE RESPONSIBLE FOR SAME.

**APPLICABLE CODES/REFERENCE
 DOCUMENTS**

ALL WORK SHALL BE PERFORMED AND MATERIALS INSTALLED IN
 ACCORDANCE WITH THE CURRENT EDITIONS OF THE FOLLOWING
 CODES AS ADOPTED BY THE LOCAL GOVERNING AUTHORITIES.
 NOTHING IN THESE PLANS IS TO BE CONSTRUED TO PERMIT WORK
 NOT CONFORMING TO THESE CODES:

CODE TYPE	CODE
BUILDING	2016 CT STATE BUILDING CODE/2012 IBC W/ CT AMENDMENTS
MECHANICAL	2016 CT STATE BUILDING CODE/2012 IMC W/ CT AMENDMENTS
ELECTRICAL	2016 CT STATE BUILDING CODE/2014 NEC W/ CT AMENDMENTS

REFERENCE DOCUMENTS:
 STRUCTURAL ANALYSIS: PAUL J. FORD & COMPANY
 DATED JANUARY 9, 2017

MOUNT ANALYSIS: BY OTHERS

LOCATION MAP

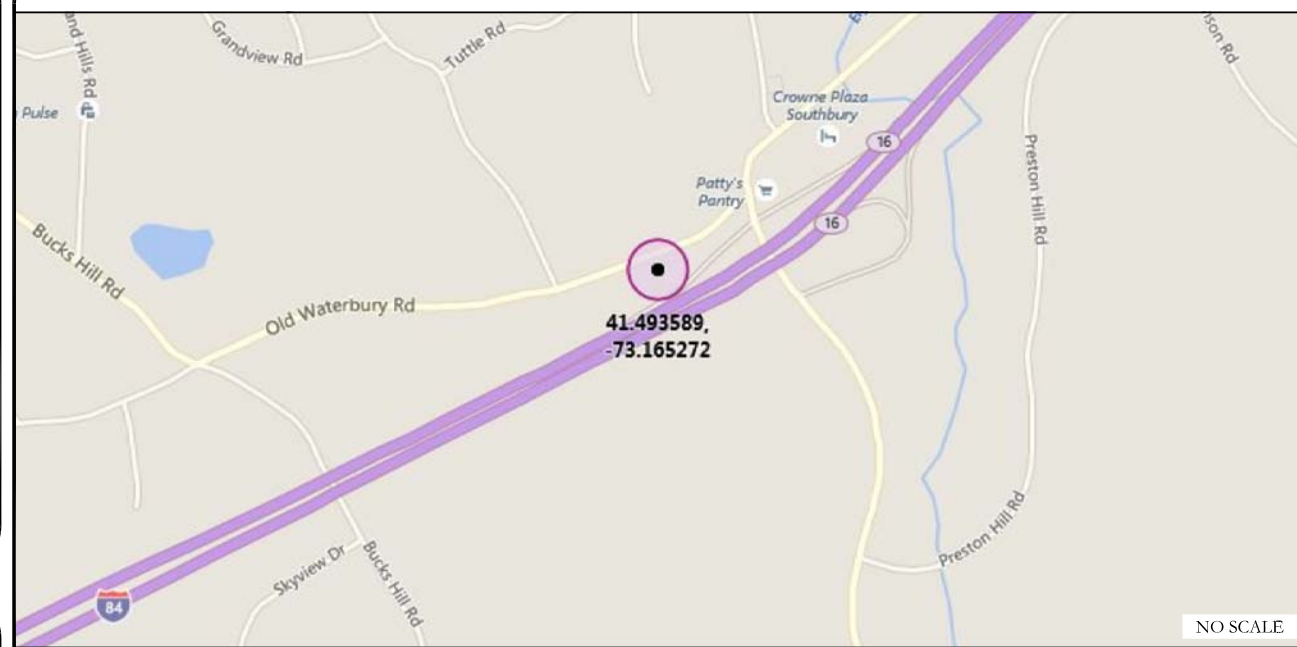

APPROVALS

APPROVAL	SIGNATURE	DATE
PROPERTY OWNER OR REP.	_____	_____
LAND USE PLANNER	_____	_____
T-MOBILE	_____	_____
OPERATIONS	_____	_____
RF	_____	_____
NETWORK	_____	_____
BACKHAUL	_____	_____
CONSTRUCTION MANAGER	_____	_____

THE PARTIES ABOVE HEREBY APPROVE AND ACCEPT THESE
 DOCUMENTS AND AUTHORIZE THE CONTRACTOR TO PROCEED WITH
 THE CONSTRUCTION DESCRIBED HEREIN. ALL CONSTRUCTION
 DOCUMENTS ARE SUBJECT TO REVIEW BY THE LOCAL BUILDING
 DEPARTMENT AND ANY CHANGES AND MODIFICATIONS THEY MAY
 IMPOSE.

PROJECT DESCRIPTION

THE PURPOSE OF THIS PROJECT IS TO ENHANCE BROADBAND
 CONNECTIVITY AND CAPACITY TO THE EXISTING ELIGIBLE WIRELESS
 FACILITY.

- REMOVE (6) ANTENNAS
- REMOVE (6) TMAs
- INSTALL (6) ANTENNAS
- INSTALL (3) BLAS TEE
- REMOVE (6) 1-5/8" COAX CABLES
- INSTALL (6) 1-5/8" COAX CABLES
- INSTALL (1) CABINET ON (E) PAD

DESIGN PACKAGE BASED ON RF DATA SHEET
 VERSION: 1.1
 ISSUED: 10/27/16

DESIGN PACKAGE BASED ON THE APPLICATION
 ID: 369852
 REVISION: 4

NOTE:
 PRIOR TO ACCESSING/ENTERING THE SITE YOU MUST CONTACT THE
 CROWN NOC AT (800) 788-7011 & CROWN CONSTRUCTION MANAGER



CALL CONNECTICUT ONE CALL
 (800) 922-4455
 CALL 3 WORKING DAYS
 BEFORE YOU DIG!



PROJECT TEAM

CROWN CASTLE
 A&E FIRM: CROWN CASTLE
 2000 CORPORATE DRIVE
 CANONSBURG, PA 15317
 CROWN.AE.APPROVAL@CROWNCastle.COM
 CROWN CASTLE
 CONTACTS: 3 CORPORATE PARK DRIVE, SUITE 101
 CLIFTON PARK, NY 12065
 TRICIA PELON - PROJECT MANAGER
 (518) 373-3507
 JASON D'AMICO - CONSTRUCTION MANAGER
 (860) 209-0104
 WILLIAM STONE - A&E PROJECT MANAGER
 WILLIAM.STONE@CROWNCastle.COM
 (518) 373-3543

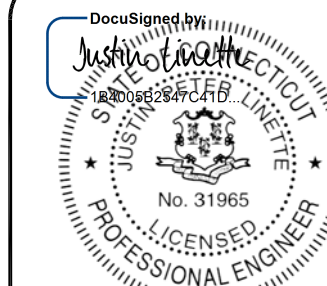

1/30/2017 10:25:26 AM EST

Justin Peter Linette, P.E.
 Professional Engineer License: #31965
 Crown Castle USA, Inc. Certificate of Registration
 #PEC.0001101

IT IS A VIOLATION OF LAW FOR ANY PERSON,
 UNLESS THEY ARE ACTING UNDER THE DIRECTION
 OF A LICENSED PROFESSIONAL ENGINEER,
 TO ALTER THIS DOCUMENT.

SHEET NUMBER: REVISION:

T-1

0

SITE WORK GENERAL NOTES:

- THE SUBCONTRACTOR SHALL CONTACT UTILITY LOCATING SERVICES PRIOR TO THE START OF CONSTRUCTION.
- ALL EXISTING ACTIVE SEWER, WATER, GAS, ELECTRIC AND OTHER UTILITIES WHERE ENCOUNTERED IN THE WORK, SHALL BE PROTECTED AT ALL TIMES AND WHERE REQUIRED FOR THE PROPER EXECUTION OF THE WORK, SHALL BE RELOCATED AS DIRECTED BY CONTRACTOR. EXTREME CAUTION SHOULD BE USED BY THE SUBCONTRACTOR WHEN EXCAVATING OR DRILLING PIERS AROUND OR NEAR UTILITIES. SUBCONTRACTOR SHALL PROVIDE SAFETY TRAINING FOR THE WORKING CREW. THIS WILL INCLUDE BUT NOT BE LIMITED TO A) FALL PROTECTION B) CONFINED SPACE C) ELECTRICAL SAFETY D) TRENCHING AND EXCAVATION.
- ALL SITE WORK TO COMPLY WITH QAS-STD-10068 "INSTALLATION STANDARDS FOR CONSTRUCTION ACTIVITIES ON CROWN CASTLE TOWER SITE" AND LATEST VERSION OF TIA 1019 "STANDARD FOR INSTALLATION, ALTERATION, AND MAINTENANCE OF ANTENNA SUPPORTING STRUCTURES AND ANTENNAS."
- ALL SITE WORK SHALL BE AS INDICATED ON THE STAMPED CONSTRUCTION DRAWINGS AND PROJECT SPECIFICATIONS.
- IF NECESSARY, RUBBISH, STUMPS, DEBRIS, STICKS, STONES AND OTHER REFUSE SHALL BE REMOVED FROM THE SITE AND DISPOSED OF LEGALLY.
- ALL EXISTING INACTIVE SEWER, WATER, GAS, ELECTRIC AND OTHER UTILITIES, WHICH INTERFERE WITH THE EXECUTION OF THE WORK, SHALL BE REMOVED AND/OR CAPPED, PLUGGED OR OTHERWISE DISCONTINUED AT POINTS WHICH WILL NOT INTERFERE WITH THE EXECUTION OF THE WORK, SUBJECT TO THE APPROVAL OF CONTRACTOR, OWNER AND/OR LOCAL UTILITIES.
- THE SUBCONTRACTOR SHALL PROVIDE SITE SIGNAGE IN ACCORDANCE WITH THE TECHNICAL SPECIFICATION FOR SITE SIGNAGE.
- THE SITE SHALL BE GRADED TO CAUSE SURFACE WATER TO FLOW AWAY FROM THE BTS EQUIPMENT AND TOWER AREAS.
- NO FILL OR EMBANKMENT MATERIAL SHALL BE PLACED ON FROZEN GROUND. FROZEN MATERIALS, SNOW OR ICE SHALL NOT BE PLACED IN ANY FILL OR EMBANKMENT.
- THE SUB GRADE SHALL BE COMPACTED AND BROUGHT TO A SMOOTH UNIFORM GRADE PRIOR TO FINISHED SURFACE APPLICATION.
- THE AREAS OF THE OWNERS PROPERTY DISTURBED BY THE WORK AND NOT COVERED BY THE TOWER, EQUIPMENT OR DRIVEWAY, SHALL BE GRADED TO A UNIFORM SLOPE, AND STABILIZED TO PREVENT EROSION AS SPECIFIED ON THE PROJECT SPECIFICATIONS.
- SUBCONTRACTOR SHALL MINIMIZE DISTURBANCE TO EXISTING SITE DURING CONSTRUCTION. EROSION CONTROL MEASURES, IF REQUIRED DURING CONSTRUCTION, SHALL BE IN CONFORMANCE WITH THE LOCAL GUIDELINES FOR EROSION AND SEDIMENT CONTROL.
- NOTICE TO PROCEED- NO WORK TO COMMENCE PRIOR TO COMPANY'S WRITTEN NOTICE TO PROCEED AND THE ISSUANCE OF A PURCHASE ORDER.
- ALL CONSTRUCTION MEANS AND METHODS; INCLUDING BUT NOT LIMITED TO, ERECTION PLANS, RIGGING PLANS, CLIMBING PLANS, AND RESCUE PLANS SHALL BE THE RESPONSIBILITY OF THE GENERAL CONTRACTOR RESPONSIBLE FOR THE EXECUTION OF THE WORK CONTAINED HEREIN AND SHALL MEET ANSI/TIA 1019 (LATEST EDITION), OSHA, AND GENERAL INDUSTRY STANDARDS. ALL RIGGING PLANS SHALL ADHERE TO ANSI/TIA-1019 (LATEST EDITION) INCLUDING THE REQUIRED INVOLVEMENT OF A QUALIFIED ENGINEER FOR CLASS IV CONSTRUCTION.

STRUCTURAL STEEL NOTES:

- ALL STEEL WORK SHALL BE PAINTED IN ACCORDANCE WITH THE PROJECT SPECIFICATIONS AND IN ACCORDANCE WITH ASTM A36 UNLESS OTHERWISE NOTED.
- BOLTED CONNECTIONS SHALL BE ASTM A325 BEARING TYPE (3/4") CONNECTIONS AND SHALL HAVE MINIMUM OF TWO BOLTS UNLESS NOTED OTHERWISE.
- NON-STRUCTURAL CONNECTIONS FOR STEEL GRATING MAY USE 5/8" ASTM A307 BOLTS UNLESS NOTED OTHERWISE.
- INSTALLATION OF CONCRETE EXPANSION/WEDGE ANCHOR, SHALL BE PER MANUFACTURER'S RECOMMENDED PROCEDURE. THE ANCHOR BOLT, DOWEL OR ROD SHALL CONFORM TO MANUFACTURER'S RECOMMENDATION FOR EMBEDMENT DEPTH OR AS SHOWN ON THE DRAWINGS. NO REBAR SHALL BE CUT WITHOUT PRIOR CONTRACTOR APPROVAL WHEN DRILLING HOLES IN CONCRETE. SPECIAL INSPECTIONS, REQUIRED BY GOVERNING CODES, SHALL BE PERFORMED IN ORDER TO MAINTAIN MANUFACTURER'S MAXIMUM ALLOWABLE LOADS.

CONCRETE AND REINFORCING STEEL NOTES:

- ALL CONCRETE WORK SHALL BE IN ACCORDANCE WITH THE ACI 301, ACI 318, ACI 336, ASTM A184, ASTM A185 AND THE DESIGN AND CONSTRUCTION SPECIFICATION FOR CAST-IN-PLACE CONCRETE.
- ALL CONCRETE SHALL HAVE A MINIMUM COMPRESSIVE STRENGTH OF 3000 PSI AT 28 DAYS, UNLESS NOTED OTHERWISE. SLAB FOUNDATION DESIGN ASSUMING ALLOWABLE SOIL BEARING PRESSURE OF 2000 PSF.
- REINFORCING STEEL SHALL CONFORM TO ASTM A615, GRADE 60, DEFORMED UNLESS NOTED OTHERWISE. WELDED WIRE FABRIC SHALL CONFORM TO ASTM A185 WELDED STEEL WIRE FABRIC UNLESS NOTED OTHERWISE. SPLICES SHALL BE CLASS "B" AND ALL HOOKS SHALL BE STANDARD, UNO.
- THE FOLLOWING MINIMUM CONCRETE COVER SHALL BE PROVIDED FOR REINFORCING STEEL UNLESS SHOWN OTHERWISE ON DRAWINGS:
 CONCRETE CAST AGAINST EARTH.....3 IN.
 CONCRETE EXPOSED TO EARTH OR WEATHER:
 #6 AND LARGER.....2 IN.
 #5 AND SMALLER & WWF.....1 1/2 IN.
 CONCRETE NOT EXPOSED TO EARTH OR WEATHER OR NOT CAST AGAINST THE GROUND:
 SLAB AND WALLS.....3/4 IN.
 BEAMS AND COLUMNS.....1 1/2 IN.
- A CHAMFER 3/4" SHALL BE PROVIDED AT ALL EXPOSED EDGES OF CONCRETE, UNLESS NOTED OTHERWISE. IN ACCORDANCE WITH ACI 301 SECTION 4.2.4.

MASONRY NOTES:

- HOLLOW CONCRETE MASONRY UNITS SHALL MEET A.S.T.M. SPECIFICATION C90, GRADE N. TYPE 1. THE SPECIFIED DESIGN COMPRESSIVE STRENGTH OF CONCRETE MASONRY (F'm) SHALL BE 1500 PSI.
- MORTAR SHALL MEET THE PROPERTY SPECIFICATION OF A.S.T.M. C270 TYP. "S" MORTAR AND SHALL HAVE A MINIMUM COMPRESSIVE STRENGTH OF 2000 PSI.
- GROUT SHALL MEET A.S.T.M. SPECIFICATION C475 AND HAVE A MINIMUM 28 DAY COMPRESSIVE STRENGTH OF 2000 PSI.
- CONCRETE MASONRY SHALL BE LAID IN RUNNING (COMMON) BOND.
- WALL SHALL RECEIVE TEMPORARY BRACING. TEMPORARY BRACING SHALL NOT BE REMOVED UNTIL GROUT IS FULLY CURED.

GENERAL NOTES:

- FOR THE PURPOSE OF CONSTRUCTION DRAWING, THE FOLLOWING DEFINITIONS SHALL APPLY:
 CONTRACTOR- GENERAL CONTRACTOR (CONSTRUCTION)
 SUBCONTRACTOR- T-MOBILE
 CARRIER- T-MOBILE
 TOWER OWNER- CROWN CASTLE
 OEM- ORIGINAL EQUIPMENT MANUFACTURER
- PRIOR TO THE SUBMISSION OF BIDS, THE BIDDING SUBCONTRACTOR SHALL VISIT THE CELL SITE TO FAMILIARIZE WITH THE EXISTING CONDITIONS AND TO CONFIRM THAT THE WORK CAN BE ACCOMPLISHED AS SHOWN ON THE CONSTRUCTION DRAWINGS. ANY DISCREPANCY FOUND SHALL BE BROUGHT TO THE ATTENTION OF CONTRACTOR AND CROWN CASTLE.
- ALL MATERIALS FURNISHED AND INSTALLED SHALL BE IN STRICT ACCORDANCE WITH ALL APPLICABLE CODES, REGULATIONS AND ORDINANCES. SUBCONTRACTOR SHALL ISSUE ALL APPROPRIATE NOTICES AND COMPLY WITH ALL LAWS, ORDINANCES, RULES, REGULATIONS AND LAWFUL ORDERS OF ANY PUBLIC AUTHORITY REGARDING THE PERFORMANCE OF THE WORK. ALL WORK CARRIED OUT SHALL COMPLY WITH ALL APPLICABLE MUNICIPAL AND UTILITY COMPANY SPECIFICATIONS AND LOCAL JURISDICTIONAL CODES, ORDINANCES AND APPLICABLE REGULATIONS.
- DRAWINGS PROVIDED HERE ARE NOT TO SCALE AND ARE INTENDED TO SHOW OUTLINE ONLY.
- UNLESS NOTED OTHERWISE, THE WORK SHALL INCLUDE FURNISHING MATERIALS, EQUIPMENT, APPURTENANCES AND LABOR NECESSARY TO COMPLETE ALL INSTALLATIONS AS INDICATED ON THE DRAWINGS.
- "KITTING LIST" SUPPLIED WITH THE BID PACKAGE IDENTIFIES ITEMS THAT WILL BE SUPPLIED BY CONTRACTOR. ITEMS NOT INCLUDED IN THE BILL OF MATERIALS AND KITTING LIST SHALL BE SUPPLIED BY THE SUBCONTRACTOR.
- THE SUBCONTRACTOR SHALL INSTALL ALL EQUIPMENT AND MATERIALS IN ACCORDANCE WITH MANUFACTURER'S RECOMMENDATIONS UNLESS SPECIFICALLY STATED OTHERWISE.
- IF THE SPECIFIED EQUIPMENT CAN NOT BE INSTALLED AS SHOWN ON THESE DRAWINGS, THE SUBCONTRACTOR SHALL PROVIDE AN ALTERNATIVE INSTALLATION FOR APPROVAL BY THE CONTRACTOR AND CROWN CASTLE PRIOR TO PROCEEDING WITH ANY SUCH CHANGE OF INSTALLATION.
- SUBCONTRACTOR SHALL DETERMINE ACTUAL ROUTING OF CONDUIT, POWER AND T1 CABLES, GROUNDING CABLES AS SHOWN ON THE POWER, GROUNDING AND TELCO PLAN DRAWINGS.
- THE SUBCONTRACTOR SHALL PROTECT EXISTING IMPROVEMENTS, PAVEMENTS, CURBS, LANDSCAPING AND STRUCTURES. ANY DAMAGED PART SHALL BE REPAIRED AT SUBCONTRACTOR'S EXPENSE TO THE SATISFACTION OF OWNER.
- SUBCONTRACTOR SHALL LEGALLY AND PROPERLY DISPOSE OF ALL SCRAP MATERIALS SUCH AS COAXIAL CABLES AND OTHER ITEMS REMOVED FROM THE EXISTING FACILITY. ANTENNAS REMOVED SHALL BE RETURNED TO THE OWNER'S DESIGNATED LOCATION.
- SUBCONTRACTOR SHALL LEAVE PREMISES IN CLEAN CONDITION. TRASH AND DEBRIS SHOULD BE REMOVED FROM SITE ON A DAILY BASIS.

ABBREVIATIONS AND SYMBOLS:

ABBREVIATIONS:

- AGL ABOVE GRADE LEVEL
- BTS BASE TRANSCIVER STATION
- (E) EXISTING
- MIN. MINIMUM
- REF REFERENCE
- RF RADIO FREQUENCY
- T.B.D. TO BE DETERMINED
- T.B.R. TO BE RESOLVED
- TYP TYPICAL
- REQ REQUIRED
- EGR EQUIPMENT GROUND RING
- AWG AMERICAN WIRE GAUGE
- MGB MASTER GROUND BAR
- EG EQUIPMENT GROUND
- BCW BARE COPPER WIRE
- SIAD SMART INTEGRATED ACCESS DEVICE
- GEN GENERATOR
- IGR INTERIOR GROUND RING (HALO)
- RBS RADIO BASE STATION

SYMBOLS:

- SOLID GROUND BUS BAR
- SOLID NEUTRAL BUS BAR
- SUPPLEMENTAL GROUND CONDUCTOR
- 2-POLE THERMAL-MAGNETIC CIRCUIT BREAKER
- SINGLE-POLE THERMAL-MAGNETIC CIRCUIT BREAKER
- CHEMICAL GROUND ROD
- TEST WELL
- DISCONNECT SWITCH
- METER
- EXOTHERMIC WELD (CADWELD) (UNLESS OTHERWISE NOTED)
- MECHANICAL CONNECTION
- GROUNDING WIRE

ELECTRICAL INSTALLATION NOTES:

- ALL ELECTRICAL WORK SHALL BE PERFORMED IN ACCORDANCE WITH THE PROJECT SPECIFICATIONS, NEC AND ALL APPLICABLE FEDERAL, STATE, AND LOCAL CODES/ORDINANCES.
- CONDUIT ROUTINGS ARE SCHEMATIC. SUBCONTRACTOR SHALL INSTALL CONDUITS SO THAT ACCESS TO EQUIPMENT IS NOT BLOCKED AND TRIP HAZARDS ARE ELIMINATED.
- WIRING, RACEWAY AND SUPPORT METHODS AND MATERIALS SHALL COMPLY WITH THE REQUIREMENTS OF THE NEC. HILTI EPOXY ANCHORS ARE REQUIRED BY CROWN CASTLE.
- ALL CIRCUITS SHALL BE SEGREGATED AND MAINTAIN MINIMUM CABLE SEPARATION AS REQUIRED BY THE NEC.
- CABLES SHALL NOT BE ROUTED THROUGH LADDER-STYLE CABLE TRAY RUNGS.
- EACH END OF EVERY POWER, POWER PHASE CONDUCTOR (I.E., HOTS), GROUNDING AND T1 CONDUCTOR AND CABLE SHALL BE LABELED WITH COLOR-CODED INSULATION OR ELECTRICAL TAPE (3M BRAND, 1/2" PLASTIC ELECTRICAL TAPE WITH UV PROTECTION, OR EQUAL). THE IDENTIFICATION METHOD SHALL CONFORM WITH NEC AND OSHA.
- ALL ELECTRICAL COMPONENTS SHALL BE CLEARLY LABELED WITH PLASTIC TAPE PER COLOR SCHEDULE. ALL EQUIPMENT SHALL BE LABELED WITH THEIR VOLTAGE RATING, PHASE CONFIGURATION, WIRE CONFIGURATION, POWER OR AMPACITY RATING AND BRANCH CIRCUIT ID NUMBERS (I.E. PANEL BOARD AND CIRCUIT ID'S).
- PANEL BOARDS (ID NUMBERS) AND INTERNAL CIRCUIT BREAKERS (CIRCUIT ID NUMBERS) SHALL BE CLEARLY LABELED WITH PLASTIC LABELS.
- ALL TIE WRAPS SHALL BE CUT FLUSH WITH APPROVED CUTTING TOOL TO REMOVE SHARP EDGES.
- POWER, CONTROL AND EQUIPMENT GROUND WIRING IN TUBING OR CONDUIT SHALL BE SINGLE CONDUCTOR (#14 AWG OR LARGER), 600 V, OIL RESISTANT THHN OR THWN-2, CLASS B STRANDED COPPER CABLE RATED FOR 90° C (WET AND DRY) OPERATION LISTED OR LABELED FOR THE LOCATION AND RACEWAY SYSTEM USED UNLESS OTHERWISE SPECIFIED.
- SUPPLEMENTAL EQUIPMENT GROUND WIRING LOCATED INDOORS SHALL BE SINGLE CONDUCTOR (#6 AWG OR LARGER), 600V, OIL RESISTANT THHN OR THWN-2 GREEN INSULATION CLASS B STRANDED COPPER CABLE RATED FOR 90° C (WET AND DRY) OPERATION LISTED OR LABELED FOR THE LOCATION AND RACEWAY SYSTEM USED UNLESS OTHERWISE SPECIFIED.
- POWER AND CONTROL WIRING, NOT IN TUBING OR CONDUIT, SHALL BE MULTI-CONDUCTOR, TYPE TC CABLE (#14 AWG OR LARGER), 600 V, OIL RESISTANT THHN OR THWN-2, CLASS B STRANDED COPPER CABLE RATED FOR 90° C (WET AND DRY) OPERATION WITH OUTER JACKET LISTED OR LABELED FOR THE LOCATION USED UNLESS OTHERWISE SPECIFIED.
- ALL POWER AND GROUNDING CONNECTIONS SHALL BE CRIMP-STYLE, COMPRESSION WIRE LUGS AND WIRE NUTS BY THOMAS AND BETTS (OR EQUAL). LUGS AND WIRE NUTS SHALL BE RATED FOR OPERATION AT NO LESS THAN 75° C (90° C IF AVAILABLE).
- RACEWAY AND CABLE TRAY SHALL BE LISTED OR LABELED FOR ELECTRICAL USE IN ACCORDANCE WITH NEMA, UL, ANSI/IEEE AND NEC.
- ELECTRICAL METALLIC TUBING (EMT) OR RIGID NONMETALLIC CONDUIT (I.E. RIGID PVC SCHEDULE 40 OR RIGID PVC SCHEDULE 80 FOR LOCATIONS SUBJECT TO PHYSICAL DAMAGE) SHALL BE USED FOR EXPOSED INDOOR LOCATIONS.
- ELECTRICAL METALLIC TUBING (EMT), ELECTRICAL NONMETALLIC TUBING (ENT) OR RIGID NONMETALLIC CONDUIT (RIGID PVC, SCHEDULE 40) SHALL BE USED FOR CONCEALED INDOOR LOCATIONS.
- SCHEDULE 40 PVC UNDERGROUND ON STRAIGHTS AND SCHEDULE 80 PVC FOR ALL ELBOWS/90s AND ALL APPROVED ABOVE GRADE PVC CONDUIT.
- LIQUID-TIGHT FLEXIBLE METALLIC CONDUIT (LIQUID-TITE FLEX) SHALL BE USED INDOORS AND OUTDOORS, WHERE VIBRATION OCCURS OR FLEXIBILITY IS NEEDED.
- CONDUIT AND TUBING FITTINGS SHALL BE THREADED OR COMPRESSION-TYPE AND APPROVED FOR THE LOCATION USED. SET SCREW FITTINGS ARE NOT ACCEPTABLE.
- CABINETS, BOXES AND WIRE WAYS SHALL BE LABELED FOR ELECTRICAL USE IN ACCORDANCE WITH NEMA, UL, ANSI/IEEE AND NEC.
- WIREWAYS SHALL BE EPOXY-COATED (GRAY) AND INCLUDE A HINGED COVER, DESIGNED TO SWING OPEN DOWNWARDS; SHALL BE PANDUIT TYPE E (OR EQUAL); AND RATED NEMA 1 (OR BETTER).
- CONDUITS SHALL BE FASTENED SECURELY IN PLACE WITH APPROVED NON-PERFORATED STRAPS AND HANGERS. EXPLOSIVE DEVICES FOR ATTACHING HANGERS TO STRUCTURE WILL NOT BE PERMITTED. CLOSELY FOLLOW THE LINES OF THE STRUCTURE, MAINTAIN CLOSE PROXIMITY TO THE STRUCTURE AND KEEP CONDUITS IN TIGHT ENVELOPES. CHANGES IN DIRECTION TO ROUTE AROUND OBSTACLES SHALL BE MADE WITH CONDUIT OUTLET BODIES. CONDUIT SHALL BE INSTALLED IN A NEAT AND WORKMANLIKE MANNER. PARALLEL AND PERPENDICULAR TO STRUCTURE WALL AND CEILING LINES. ALL CONDUIT SHALL BE FISHED TO CLEAR OBSTRUCTIONS. ENDS OF CONDUITS SHALL BE TEMPORARILY CAPPED FLUSH TO FINISH GRADE TO PREVENT CONCRETE, PLASTER OR DIRT FROM ENTERING. CONDUITS SHALL BE RIGIDLY CLAMPED TO BOXES BY GALVANIZED MALLEABLE IRON BUSHIN ON INSIDE AND GALVANIZED MALLEABLE IRON LOCKNUT ON OUTSIDE AND INSIDE.
- EQUIPMENT CABINETS, TERMINAL BOXES, JUNCTION BOXES AND PULL BOXES SHALL BE GALVANIZED OR EPOXY-COATED SHEET STEEL; SHALL MEET OR EXCEED UL 50 AND RATED NEMA 1 (OR BETTER) INDOORS OR NEMA 3R (OR BETTER) OUTDOORS.
- METAL RECEPTACLE, SWITCH AND DEVICE BOXES SHALL BE GALVANIZED, EPOXY-COATED OR NON-CORRODING; SHALL MEET OR EXCEED UL 514A AND NEMA OS 1; AND RATED NEMA 1 (OR BETTER) INDOORS OR WEATHER PROTECTED (WP OR BETTER) OUTDOORS.
- NONMETALLIC RECEPTACLE, SWITCH AND DEVICE BOXES SHALL MEET OR EXCEED NEMA OS 2; AND RATED NEMA 1 (OR BETTER) INDOORS OR WEATHER PROTECTED (WP OR BETTER) OUTDOORS.
- THE SUBCONTRACTOR SHALL NOTIFY AND OBTAIN NECESSARY AUTHORIZATION FROM THE CONTRACTOR BEFORE COMMENCING WORK ON THE AC POWER DISTRIBUTION PANELS.
- THE SUBCONTRACTOR SHALL PROVIDE NECESSARY TAGGING ON THE BREAKERS, CABLES AND DISTRIBUTION PANELS IN ACCORDANCE WITH THE APPLICABLE CODES AND STANDARDS TO SAFEGUARD LIFE AND PROPERTY.
- INSTALL PLASTIC LABEL ON THE METER CENTER TO SHOW "T-MOBILE".
- ALL CONDUITS THAT ARE INSTALLED ARE TO HAVE A METERED MULE TAPE PULL CORD INSTALLED.

GREENFIELD GROUNDING NOTES:

- ALL GROUND ELECTRODE SYSTEMS (INCLUDING TELECOMMUNICATION, RADIO, LIGHTNING PROTECTION AND AC POWER GES'S) SHALL BE BONDED TOGETHER AT OR BELOW GRADE, BY TWO OR MORE COPPER BONDING CONDUCTORS IN ACCORDANCE WITH THE NEC.
- THE SUBCONTRACTOR SHALL PERFORM IEEE FALL-OF-POTENTIAL RESISTANCE TO EARTH TESTING (PER IEEE 1100 AND 81) FOR GROUND ELECTRODE SYSTEMS. THE SUBCONTRACTOR SHALL FURNISH AND INSTALL SUPPLEMENTAL GROUND ELECTRODES AS NEEDED TO ACHIEVE A TEST RESULT OF 5 OHMS OR LESS.
- THE SUBCONTRACTOR IS RESPONSIBLE FOR PROPERLY SEQUENCING GROUNDING AND UNDERGROUND CONDUIT INSTALLATION AS TO PREVENT ANY LOSS OF CONTINUITY IN THE GROUNDING SYSTEM OR DAMAGE TO THE CONDUIT AND PROVIDE TESTING RESULTS.
- METAL CONDUIT AND TRAY SHALL BE GROUNDING AND MADE ELECTRICALLY CONTINUOUS WITH LISTED BONDING FITTINGS OR BY BONDING ACROSS THE DISCONTINUITY WITH #6 AWG COPPER WIRE UL APPROVED GROUNDING TYPE CONDUIT CLAMPS.
- METAL RACEWAY SHALL NOT BE USED AS THE NEC REQUIRED EQUIPMENT GROUND CONDUCTOR. STRANDED COPPER CONDUCTORS WITH GREEN INSULATION, SIZED IN ACCORDANCE WITH THE NEC, SHALL BE FURNISHED AND INSTALLED WITH THE POWER CIRCUITS TO BTS EQUIPMENT.
- EACH CABINET FRAME SHALL BE DIRECTLY CONNECTED TO THE MASTER GROUND BAR WITH GREEN INSULATED SUPPLEMENTAL EQUIPMENT GROUND WIRES, 6 AWG STRANDED COPPER OR LARGER FOR INDOOR BTS; #2 AWG SOLID TINNED COPPER FOR OUTDOOR BTS.
- CONNECTIONS TO THE GROUND BUS SHALL NOT BE DOUBLED UP OR STACKED BACK TO BACK CONNECTIONS ON OPPOSITE SIDE OF THE GROUND BUS ARE PERMITTED.
- ALL EXTERIOR GROUND CONDUCTORS BETWEEN EQUIPMENT/GROUND BARS AND THE GROUND RING SHALL BE #2 AWG SOLID TINNED COPPER UNLESS OTHERWISE INDICATED.
- ALUMINUM CONDUCTOR OR COPPER CLAD STEEL CONDUCTOR SHALL NOT BE USED FOR GROUNDING CONNECTIONS.
- USE OF 90° BENDS IN THE PROTECTION GROUNDING CONDUCTORS SHALL BE AVOIDED WHEN 45° BENDS CAN BE ADEQUATELY SUPPORTED.
- EXOTHERMIC WELDS SHALL BE USED FOR ALL GROUNDING CONNECTIONS BELOW GRADE.
- ALL GROUND CONNECTIONS ABOVE GRADE (INTERIOR AND EXTERIOR) SHALL BE FORMED USING HIGH PRESS CRIMPS.
- COMPRESSION GROUND CONNECTIONS MAY BE REPLACED BY EXOTHERMIC WELD CONNECTIONS.
- ICE BRIDGE BONDING CONDUCTORS SHALL BE EXOTHERMICALLY BONDED OR BOLTED TO THE BRIDGE AND THE TOWER GROUND BAR.
- APPROVED ANTIOXIDANT COATINGS (I.E. CONDUCTIVE GEL OR PASTE) SHALL BE USED ON ALL COMPRESSION AND BOLTED GROUND CONNECTIONS.
- ALL EXTERIOR GROUND CONNECTIONS SHALL BE COATED WITH A CORROSION RESISTANT MATERIAL.
- MISCELLANEOUS ELECTRICAL AND NON-ELECTRICAL METAL BOXES, FRAMES AND SUPPORTS SHALL BE BONDED TO THE GROUND RING, IN ACCORDANCE WITH THE NEC.
- BOND ALL METALLIC OBJECTS WITHIN 6 FT. OF MAIN GROUND WIRES WITH 1-#2 AWG TIN-PLATED COPPER GROUND CONDUCTOR.
- GROUND CONDUCTORS USED IN THE FACILITY GROUND AND LIGHTNING PROTECTION SYSTEMS SHALL NOT BE ROUTED THROUGH METALLIC OBJECTS THAT FORM A RING AROUND THE CONDUCTOR, SUCH AS METALLIC CONDUITS, METAL SUPPORT CLIPS OR SLEEVES THROUGH WALLS OR FLOORS, WHEN IT IS REQUIRED TO BE HOUSED IN CONDUIT TO MEET CODE REQUIREMENTS OR LOCAL CONDITIONS, NON-METALLIC MATERIAL SUCH AS PVC PLASTIC CONDUIT SHALL BE USED. WHERE USE OF METAL CONDUIT IS UNAVOIDABLE (E.G., NONMETALLIC CONDUIT PROHIBITED BY LOCAL CODE) THE GROUND CONDUCTOR SHALL BE BONDED TO EACH END OF THE METAL CONDUIT.
- ALL GROUNDS THAT TRANSITION FROM BELOW GRADE TO ABOVE GRADE MUST BE #2 TINNED SOLID IN 3/4" LIQUID TIGHT CONDUIT FROM 24" BELOW GRADE TO WITHIN 3" TO 6" OF CAD-WELD TERMINATION POINT. THE EXPOSED END OF THE LIQUID TIGHT CONDUIT MUST BE SEALED WITH SILICONE CAULK. (ADD TRANSITIONING GROUND STANDARD DETAIL AS WELL).

NEC INSULATOR COLOR CODE		
DESCRIPTION	PHASE/CODE LETTER	WIRE COLOR
240/120 1Ø	LEG 1	BLACK
	LEG 2	RED
AC NEUTRAL	N	WHITE
GROUND (EGC)	G	GREEN
VDC POS	+	*RED-POLARITY MARK AT TERMINATION
VDC NEG	-	*BLACK-POLARITY MARK AT TERMINATION
240V OR 208V, 3Ø	PHASE A	BLACK
	PHASE B	RED(ORG. IF HI LEG)
	PHASE C	BLUE
480V, 3Ø	PHASE A	BROWN
	PHASE B	ORANGE
	PHASE C	YELLOW

* SEE NEC 210.5(C)(1) AND (2)



510 VIRGINIA DRIVE,
FT WASHINGTON, PA 19034



3 CORPORATE PARK DRIVE, SUITE 101
CLIFTON PARK, NY 12065

T-MOBILE SITE NUMBER:
CT11127A

BU #: **806358**
NHV **109 943107**

1432 OLD WATERBURY ROAD
SOUTHURY, CT 06488

EXISTING 226'-0" MONOPOLE

ISSUED FOR:

REV	DATE	DRWN	DESCRIPTION	DES./QA
A	12/14/16	NJH	PRELIMINARY	CTR
B	01/09/17	NJH	PRELIMINARY	CTR
C	01/13/17	NJH	PRELIMINARY	CTR
D	01/24/17	NJH	PRELIMINARY	LMR
0	01/30/17	JRM	CONSTRUCTION	JL

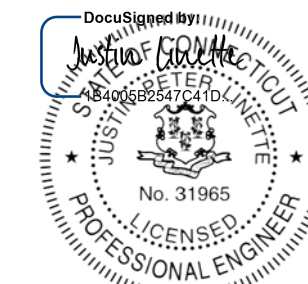

1/30/2017 | 10:25:26 AM EST

Justin Peter Linette, P.E.
Professional Engineer License: #31965
Crown Castle USA, Inc. Certificate of Registration
#PEC.0001101

IT IS A VIOLATION OF LAW FOR ANY PERSON,
UNLESS THEY ARE ACTING UNDER THE DIRECTION
OF A LICENSED PROFESSIONAL ENGINEER,
TO ALTER THIS DOCUMENT.

SHEET NUMBER: **T-2** REVISION: **0**

T-Mobile
 510 VIRGINIA DRIVE,
 FT WASHINGTON, PA 19034

CROWN CASTLE
 3 CORPORATE PARK DRIVE, SUITE 101
 CLIFTON PARK, NY 12065

T-MOBILE SITE NUMBER:
CT11127A

BU #: **806358**
 NHV **109 943107**

1432 OLD WATERBURY ROAD
 SOUTHURY, CT 06488

EXISTING 226'-0" MONOPOLE

ISSUED FOR:

REV	DATE	DRWN	DESCRIPTION	DES./QA
A	12/14/16	NJH	PRELIMINARY	CTR
B	01/09/17	NJH	PRELIMINARY	CTR
C	01/13/17	NJH	PRELIMINARY	CTR
D	01/24/17	NJH	PRELIMINARY	LMR
0	01/30/17	JRM	CONSTRUCTION	JL

DocuSigned by:
JUSTIN PETER LINETTE
 No. 31965
 LICENSED PROFESSIONAL ENGINEER

1/30/2017 | 10:25:26 AM EST

Justin Peter Linette, P.E.
 Professional Engineer License: #31965
 Crown Castle USA, Inc. Certificate of Registration
 #PEC.0001101

IT IS A VIOLATION OF LAW FOR ANY PERSON,
 UNLESS THEY ARE ACTING UNDER THE DIRECTION
 OF A LICENSED PROFESSIONAL ENGINEER,
 TO ALTER THIS DOCUMENT.

SHEET NUMBER: **C-1** REVISION: **0**

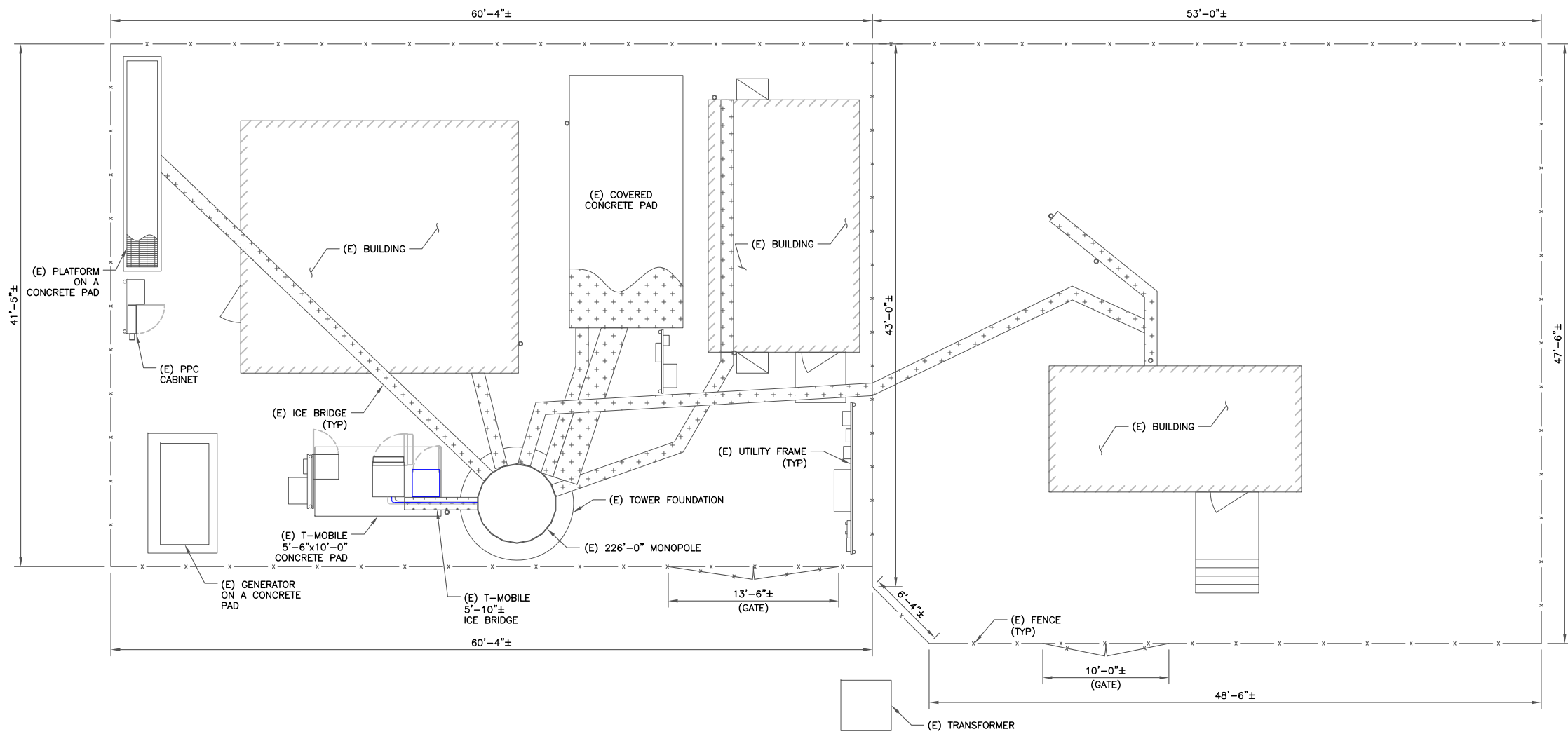

1 OVERALL SITE PLAN
 SCALE: 3/16"=1'-0" (FULL SIZE)
 3/32"=1'-0" (11x17)

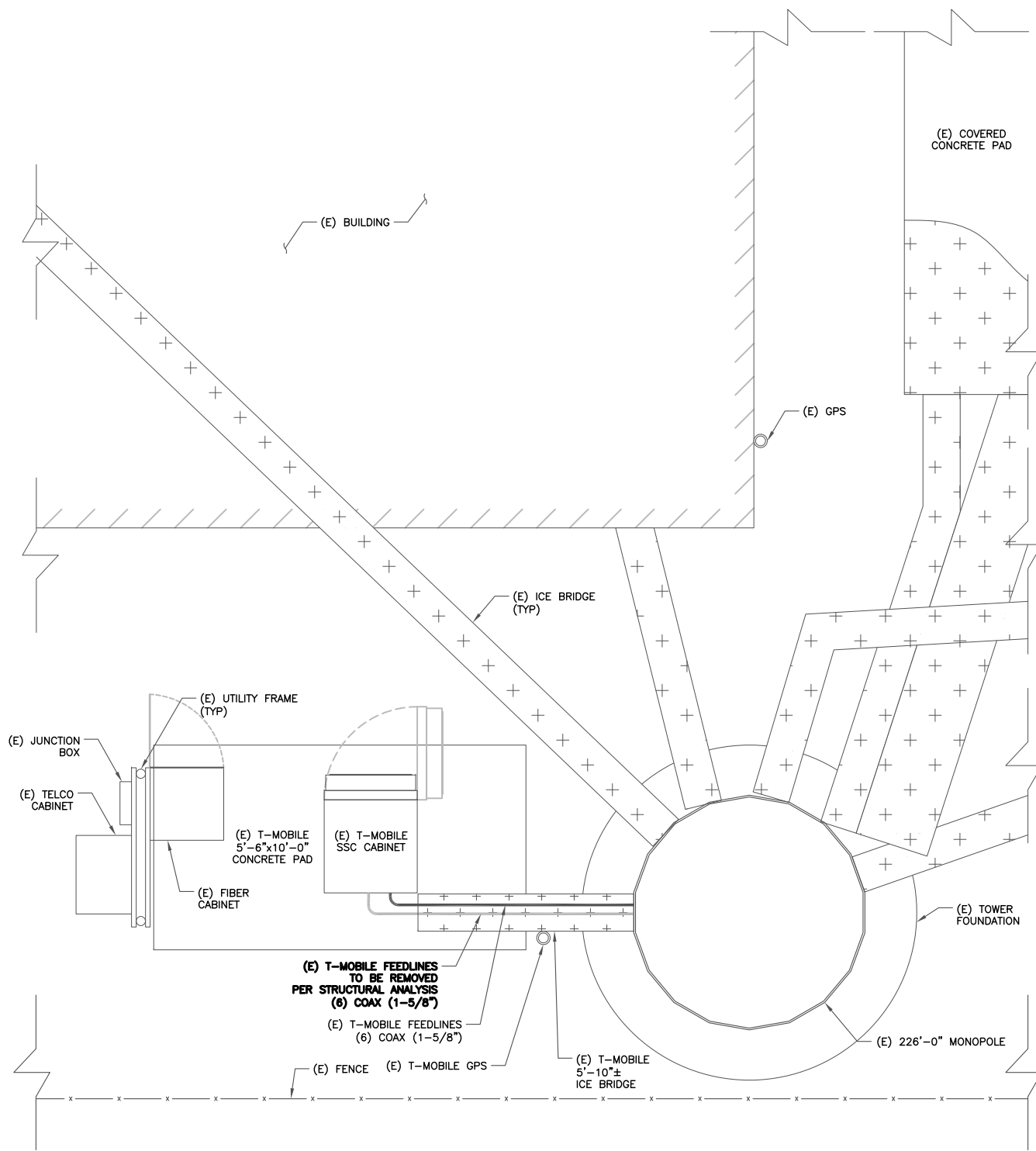

1 EXISTING ENLARGED SITE PLAN
SCALE: 1/2"=1'-0" (FULL SIZE)
1/4"=1'-0" (11x17)

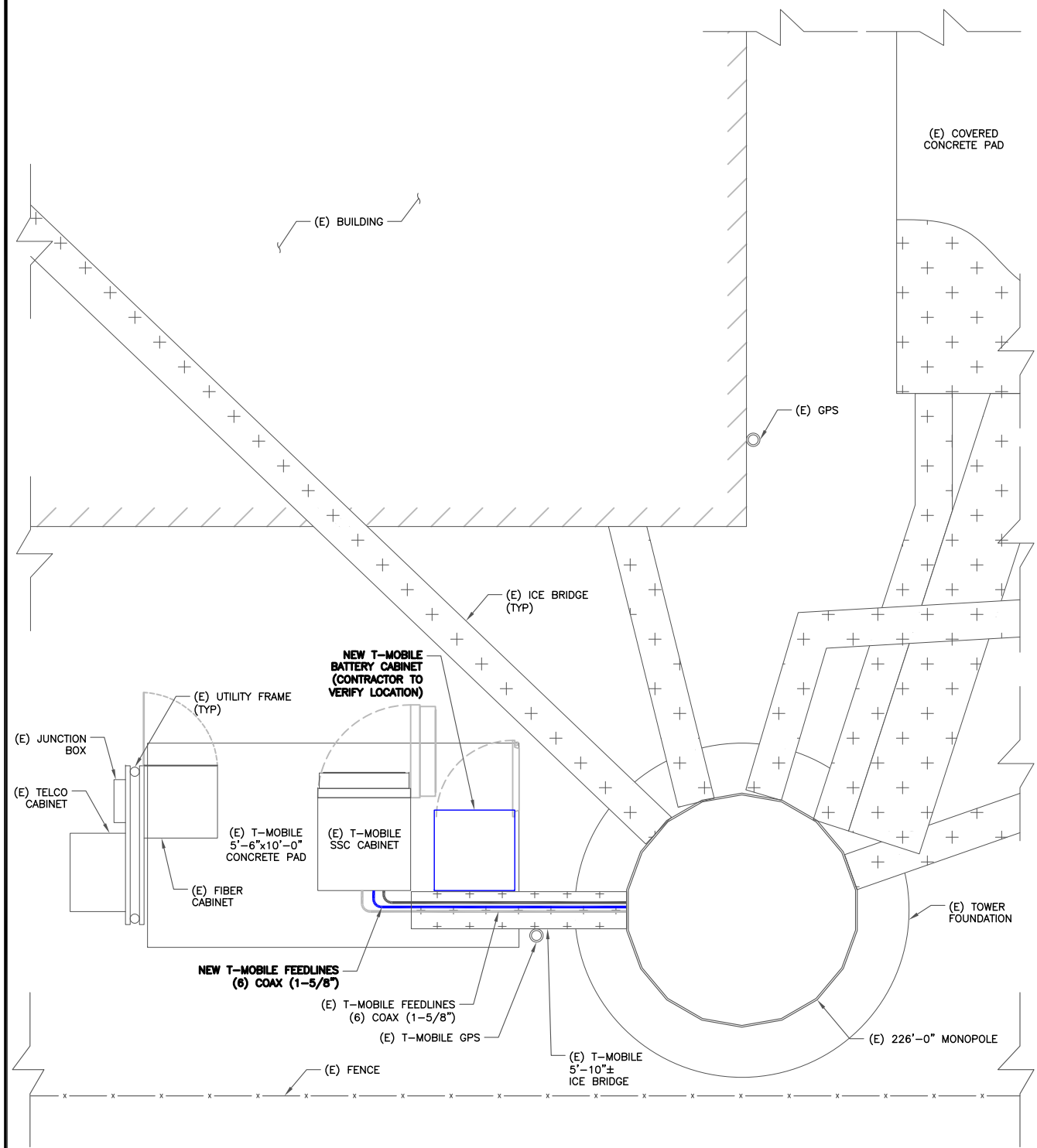

2 FINAL ENLARGED SITE PLAN
SCALE: 1/2"=1'-0" (FULL SIZE)
1/4"=1'-0" (11x17)

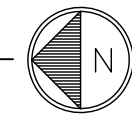

T-Mobile
510 VIRGINIA DRIVE,
FT WASHINGTON, PA 19034

CROWN CASTLE
3 CORPORATE PARK DRIVE, SUITE 101
CLIFTON PARK, NY 12065

T-MOBILE SITE NUMBER:
CT11127A

BU #: 806358
NHV 109 943107

1432 OLD WATERBURY ROAD
SOUTHURY, CT 06488

EXISTING 226'-0" MONOPOLE

ISSUED FOR:

REV	DATE	DRWN	DESCRIPTION	DES./QA
A	12/14/16	NJH	PRELIMINARY	CTR
B	01/09/17	NJH	PRELIMINARY	CTR
C	01/13/17	NJH	PRELIMINARY	CTR
D	01/24/17	NJH	PRELIMINARY	LMR
0	01/30/17	JRM	CONSTRUCTION	JL

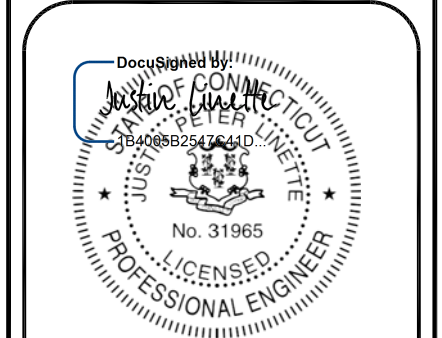

1/30/2017 | 10:25:26 AM EST

Justin Peter Linette, P.E.
Professional Engineer License: #31965
Crown Castle USA, Inc. Certificate of Registration
#PEC.0001101

IT IS A VIOLATION OF LAW FOR ANY PERSON,
UNLESS THEY ARE ACTING UNDER THE DIRECTION
OF A LICENSED PROFESSIONAL ENGINEER,
TO ALTER THIS DOCUMENT.

SHEET NUMBER: **C-2** REVISION: **0**

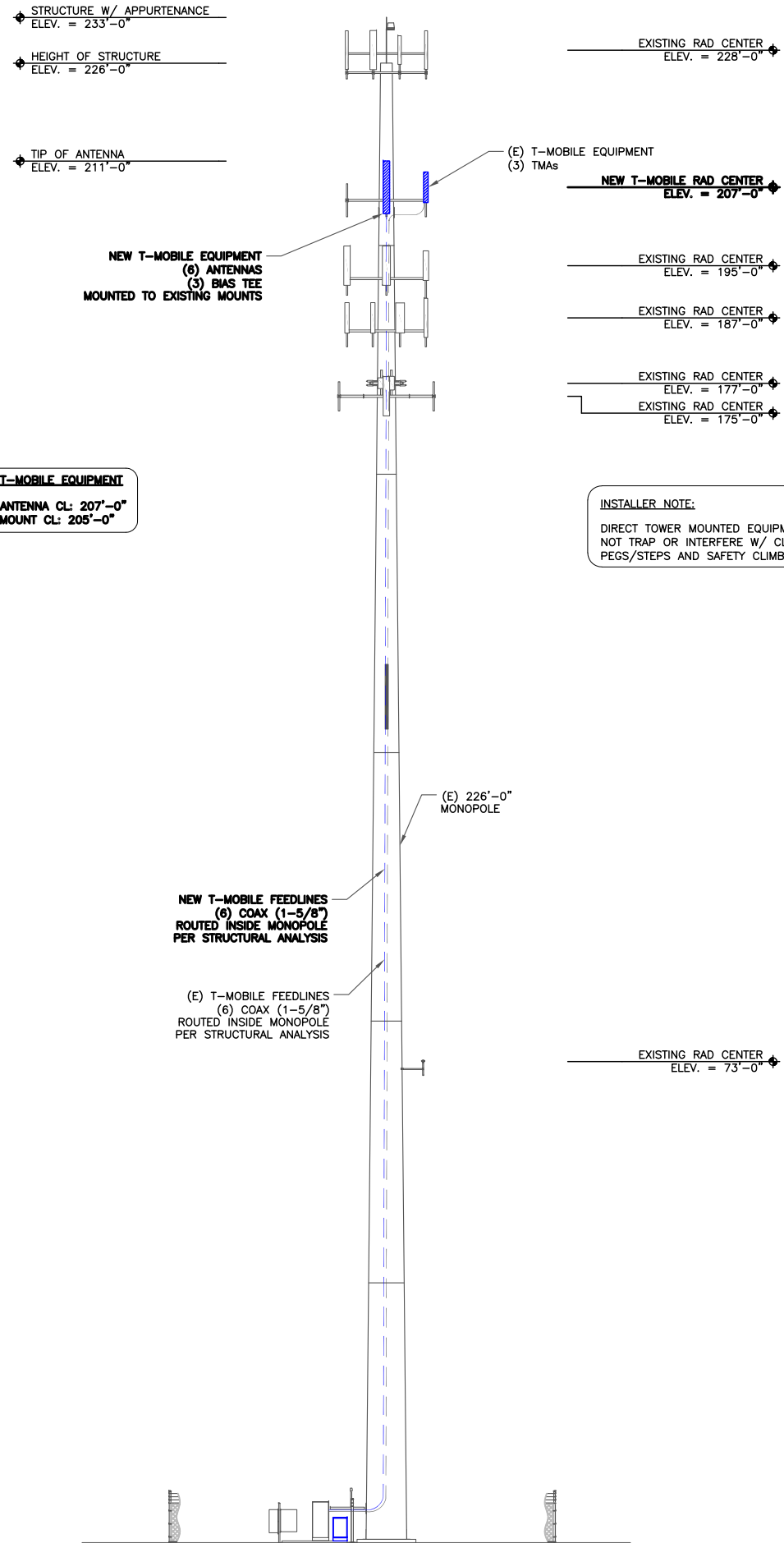

T-MOBILE EQUIPMENT
ANTENNA CL: 207'-0"
MOUNT CL: 205'-0"

INSTALLER NOTE:
DIRECT TOWER MOUNTED EQUIPMENT MUST NOT TRAP OR INTERFERE W/ CLIMBING PEGS/STEPS AND SAFETY CLIMB.

1 FINAL ELEVATION
SCALE: NOT TO SCALE

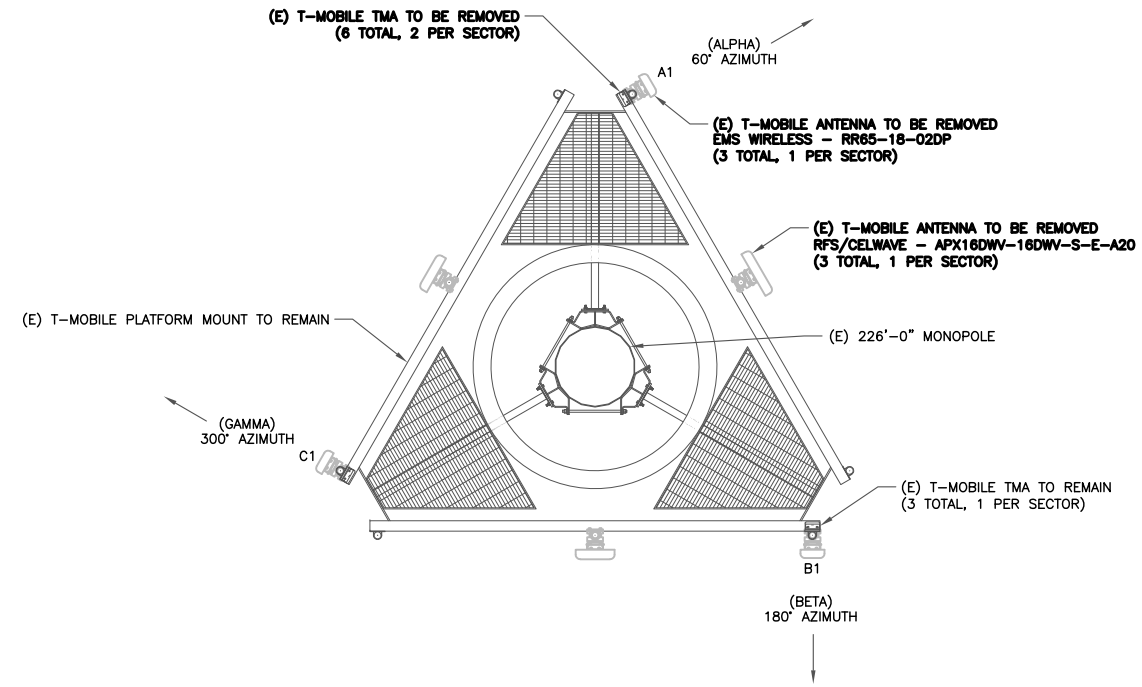

2 EXISTING ANTENNA LAYOUT
SCALE: NOT TO SCALE

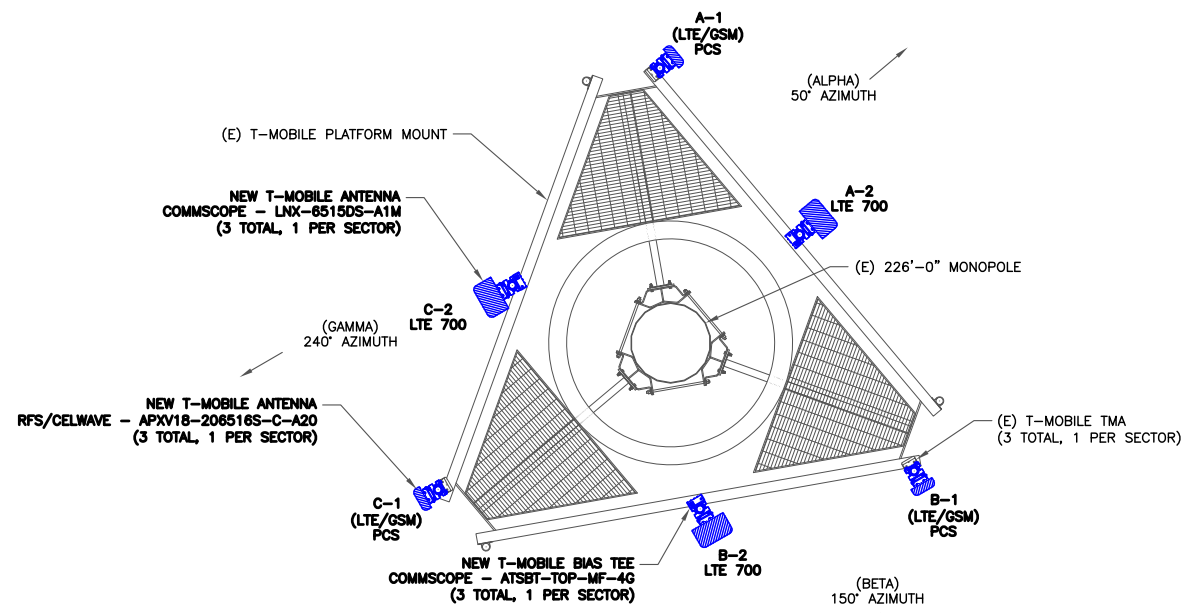

INSTALLER NOTE:
REPLACE EXISTING PIPE MOUNTS WITH NEW 2-1/2" STD (2-7/8" O.D.) GALV. SCH 40 PIPE AS REQ'D.

3 FINAL ANTENNA LAYOUT
SCALE: NOT TO SCALE



T-Mobile
510 VIRGINIA DRIVE,
FT WASHINGTON, PA 19034

CROWN CASTLE
3 CORPORATE PARK DRIVE, SUITE 101
CLIFTON PARK, NY 12065

T-MOBILE SITE NUMBER:
CT11127A

BU #: 806358
NHV 109 943107

1432 OLD WATERBURY ROAD
SOUTHBURY, CT 06488

EXISTING 226'-0" MONOPOLE

ISSUED FOR:

REV	DATE	DRWN	DESCRIPTION	DES./QA
A	12/14/16	NJH	PRELIMINARY	CTR
B	01/09/17	NJH	PRELIMINARY	CTR
C	01/13/17	NJH	PRELIMINARY	CTR
D	01/24/17	NJH	PRELIMINARY	LMR
0	01/30/17	JRM	CONSTRUCTION	JL

DocuSigned by:
Justin Peter Linette
No. 31965
PROFESSIONAL ENGINEER

1/30/2017 | 10:25:26 AM EST

Justin Peter Linette, P.E.
Professional Engineer License: #31965
Crown Castle USA, Inc. Certificate of Registration
#PEC.0001101

IT IS A VIOLATION OF LAW FOR ANY PERSON,
UNLESS THEY ARE ACTING UNDER THE DIRECTION
OF A LICENSED PROFESSIONAL ENGINEER,
TO ALTER THIS DOCUMENT.

SHEET NUMBER: **C-3** REVISION: **0**

ANTENNA SCHEDULE										
SECTOR	POS.	TECHNOLOGY	RAD CENTER	AZIMUTH	ANTENNA MANUFACTURER	ANTENNA MODEL	MECH. TILT	ELECT. TILT	TOWER MOUNTED EQUIPMENT	FEEDLINE TYPE
ALPHA	A1	(LTE/GSM) PCS	207'-0"	50'	RFS/CELWAVE	APXV18-206516S-C-A20	0'	2'	(1) RFS/CELWAVE - ATMPP1412D-1CWA	COAX
ALPHA	A2	LTE 700	207'-0"	50'	COMMSCOPE	LNK-6515DS-A1M	0'	2'	(1) COMMSCOPE - ATSBT-TOP-MF-4G	COAX
BETA	B1	(LTE/GSM) PCS	207'-0"	150'	RFS/CELWAVE	APXV18-206516S-C-A20	0'	2'	(1) RFS/CELWAVE - ATMPP1412D-1CWA	COAX
BETA	B2	LTE 700	207'-0"	150'	COMMSCOPE	LNK-6515DS-A1M	0'	2'	(1) COMMSCOPE - ATSBT-TOP-MF-4G	COAX
GAMMA	C1	(LTE/GSM) PCS	207'-0"	240'	RFS/CELWAVE	APXV18-206516S-C-A20	0'	2'	(1) RFS/CELWAVE - ATMPP1412D-1CWA	COAX
GAMMA	C2	LTE 700	207'-0"	240'	COMMSCOPE	LNK-6515DS-A1M	0'	2'	(1) COMMSCOPE - ATSBT-TOP-MF-4G	COAX

CABLE SCHEDULE			
STATUS	CABLE TYPE	SIZE	QUANTITY
EXISTING	COAX	1-5/8"	6
NEW	COAX	1-5/8"	6
FINAL CABLE QUANTITY			12

1 ANTENNA AND CABLE SCHEDULE
SCALE: NOT TO SCALE

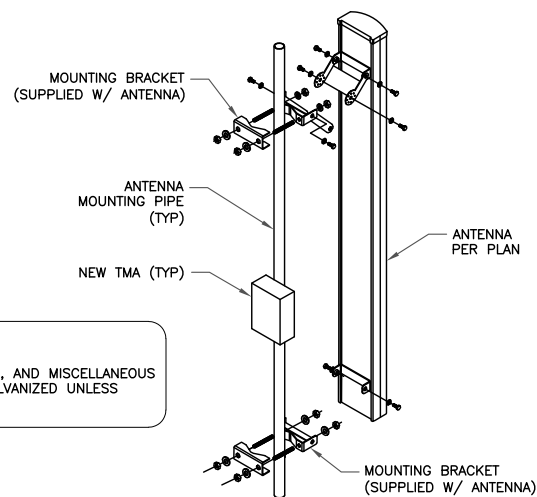

INSTALLER NOTES:
1. ALL PIPES, BRACKETS, AND MISCELLANEOUS HARDWARE TO BE GALVANIZED UNLESS NOTED OTHERWISE.

2 MOUNTING DETAIL
SCALE: NOT TO SCALE



T-MOBILE SITE NUMBER:
CT11127A

BU #: 806358
NHV 109 943107

1432 OLD WATERBURY ROAD
SOUTHURY, CT 06488

EXISTING 226'-0" MONOPOLE

ISSUED FOR:

REV	DATE	DRWN	DESCRIPTION	DES./QA
A	12/14/16	NJH	PRELIMINARY	CTR
B	01/09/17	NJH	PRELIMINARY	CTR
C	01/13/17	NJH	PRELIMINARY	CTR
D	01/24/17	NJH	PRELIMINARY	LMR
0	01/30/17	JRM	CONSTRUCTION	JL

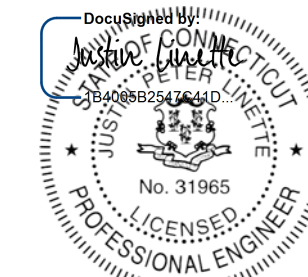

1/30/2017 | 10:25:26 AM EST

Justin Peter Linette, P.E.
Professional Engineer License: #31965
Crown Castle USA, Inc. Certificate of Registration
#PEC.0001101

IT IS A VIOLATION OF LAW FOR ANY PERSON, UNLESS THEY ARE ACTING UNDER THE DIRECTION OF A LICENSED PROFESSIONAL ENGINEER, TO ALTER THIS DOCUMENT.

SHEET NUMBER: **C-4** REVISION: **0**

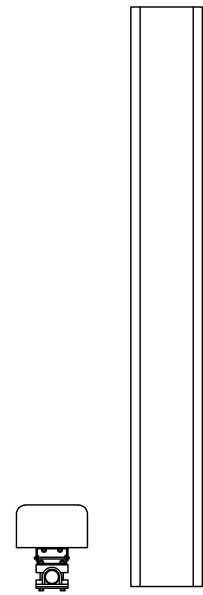

ANDREW - LNX-6515DS-A1M
 WEIGHT (WITHOUT MOUNTING HARDWARE): 43.7 LBS
 SIZE (HxWxD): 96.60x11.90x7.10 IN.
 MOUNTING HARDWARE P/N: DB380-3 & DB5083D
 RATED WIND VELOCITY: 149.8 MPH

1 ANDREW - LNX-6515DS-A1M
 SCALE: NOT TO SCALE

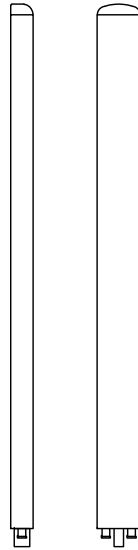

RFS/CELWAVE - APXV18-206516S-C-A20
 WEIGHT (WITHOUT MOUNTING HARDWARE): 18.7 LBS
 SIZE (HxWxD): 53.1x6.9x3.15 IN.
 MOUNTING HARDWARE P/N: APM40-2
 RATED WIND VELOCITY: 160 MPH

2 RFS/CELWAVE - APXV18-206516S-C-A20
 SCALE: NOT TO SCALE

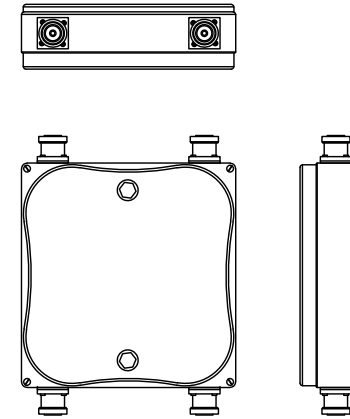

RFS/CELWAVE - ATMP1412D-1CWA
 WEIGHT (WITHOUT MOUNTING HARDWARE): 12.5LBS
 SIZE (HxWxD): 13.8x8.7x3.1 IN.

3 RFS/CELWAVE - ATMP1412D-1CWA
 SCALE: NOT TO SCALE

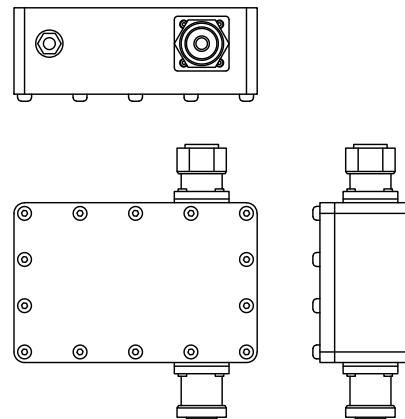

COMMSCOPE - ATSBT-TOP-MF-4G
 WEIGHT: 1.8 LBS
 SIZE (HxWxD): 5.63x3.7x2.0 IN.

4 COMMSCOPE - ATSBT-TOP-MF-4G
 SCALE: NOT TO SCALE

5 NOT USED
 SCALE: NOT TO SCALE

6 NOT USED
 SCALE: NOT TO SCALE

T-Mobile
 510 VIRGINIA DRIVE,
 FT WASHINGTON, PA 19034

CROWN CASTLE
 3 CORPORATE PARK DRIVE, SUITE 101
 CLIFTON PARK, NY 12065

T-MOBILE SITE NUMBER:
CT11127A

BU #: **806358**
 NHV **109 943107**

1432 OLD WATERBURY ROAD
 SOUTHURY, CT 06488

EXISTING 226'-0" MONOPOLE

ISSUED FOR:

REV	DATE	DRWN	DESCRIPTION	DES./QA
A	12/14/16	NJH	PRELIMINARY	CTR
B	01/09/17	NJH	PRELIMINARY	CTR
C	01/13/17	NJH	PRELIMINARY	CTR
D	01/24/17	NJH	PRELIMINARY	LMR
0	01/30/17	JRM	CONSTRUCTION	JL

DocuSigned by:
 Justin Peter Linette
 No. 31965
 LICENSED PROFESSIONAL ENGINEER

1/30/2017 | 10:25:26 AM EST

Justin Peter Linette, P.E.
 Professional Engineer License: #31965
 Crown Castle USA, Inc. Certificate of Registration
 #PEC.0001101

IT IS A VIOLATION OF LAW FOR ANY PERSON,
 UNLESS THEY ARE ACTING UNDER THE DIRECTION
 OF A LICENSED PROFESSIONAL ENGINEER,
 TO ALTER THIS DOCUMENT.

SHEET NUMBER: **C-5** REVISION: **0**



T-MOBILE SITE NUMBER:
CT11127A

BU #: **806358**
NHV 109 943107

1432 OLD WATERBURY ROAD
SOUTHURY, CT 06488

EXISTING 226'-0" MONOPOLE

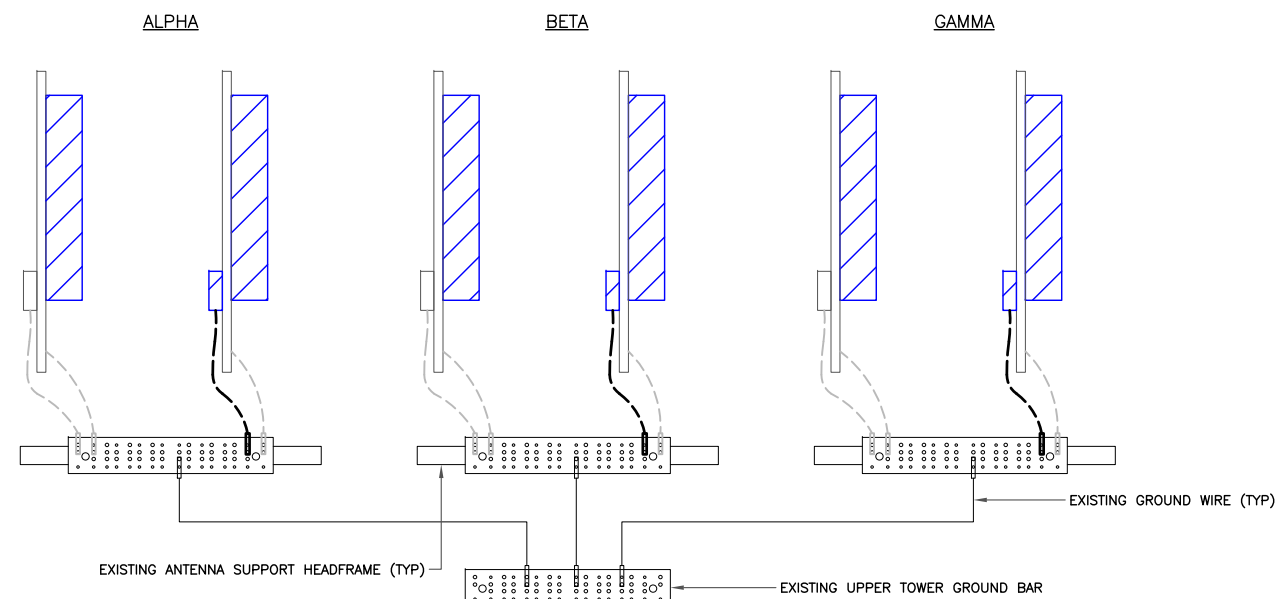

1 ANTENNA GROUND DIAGRAM
SCALE: NOT TO SCALE

ISSUED FOR:

REV	DATE	DRWN	DESCRIPTION	DES./QA
A	12/14/16	NJH	PRELIMINARY	CTR
B	01/09/17	NJH	PRELIMINARY	CTR
C	01/13/17	NJH	PRELIMINARY	CTR
D	01/24/17	NJH	PRELIMINARY	LMR
0	01/30/17	JRM	CONSTRUCTION	JL

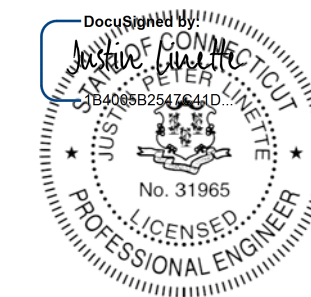

1/30/2017 | 10:25:26 AM EST

Justin Peter Linette, P.E.
Professional Engineer License: #31965
Crown Castle USA, Inc. Certificate of Registration
#PEC.0001101

IT IS A VIOLATION OF LAW FOR ANY PERSON,
UNLESS THEY ARE ACTING UNDER THE DIRECTION
OF A LICENSED PROFESSIONAL ENGINEER,
TO ALTER THIS DOCUMENT.

SHEET NUMBER: **G-1** REVISION: **0**

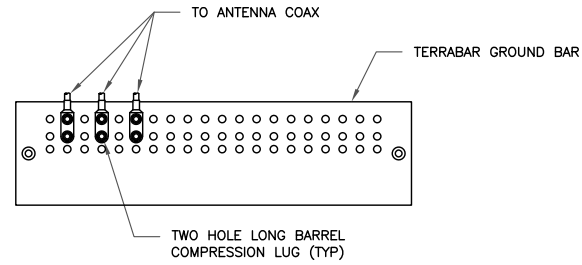

NOTES:

1. DOUBLING UP "OR STACKING" OF CONNECTIONS IS NOT PERMITTED.
2. EXTERIOR ANTIOXIDANT JOINT COMPOUND TO BE USED ON ALL EXTERIOR CONNECTIONS.
3. GROUND BAR SHALL NOT BE ISOLATED FROM TOWER. MOUNT DIRECTLY TO TOWER STEEL.

1 ANTENNA GROUND BAR DETAIL
SCALE: NOT TO SCALE

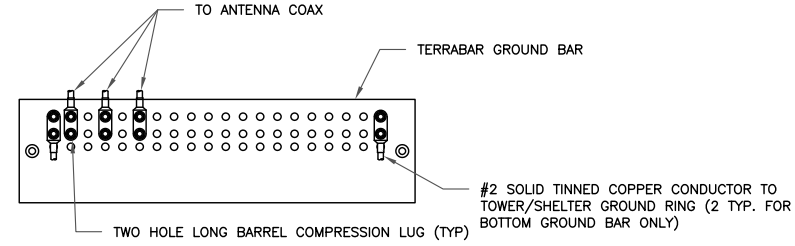

NOTES:

1. EXTERIOR ANTIOXIDANT JOINT COMPOUND TO BE USED ON ALL EXTERIOR CONNECTIONS.
2. GROUND BAR SHALL NOT BE ISOLATED FROM TOWER. MOUNT DIRECTLY TO TOWER STEEL (TOWER ONLY).
3. INSTALL GROUND BARS AT 75 FT. INTERVAL MAXIMUM.
4. GROUND BAR SHALL BE ISOLATED FROM BUILDING OR SHELTER.

2 TOWER/SHELTER GROUND BAR DETAIL
SCALE: NOT TO SCALE

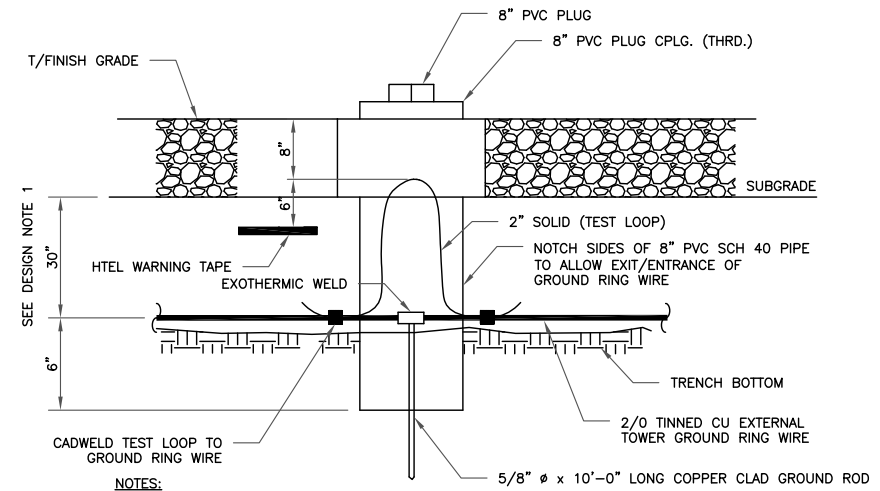

NOTES:

1. GROUND ROD SHALL BE DRIVEN VERTICALLY, NOT TO EXCEED 45 DEGREES FROM THE VERTICAL.
2. GROUND WIRE SHALL BE MIN. 30" BELOW GRADE OR 6" BELOW FROST LINE. (WHICH EVER IS GREATER) AS PER N.E.C. ARTICLE 250-50(D)

3 INSPECTION PORT DETAIL
SCALE: NOT TO SCALE

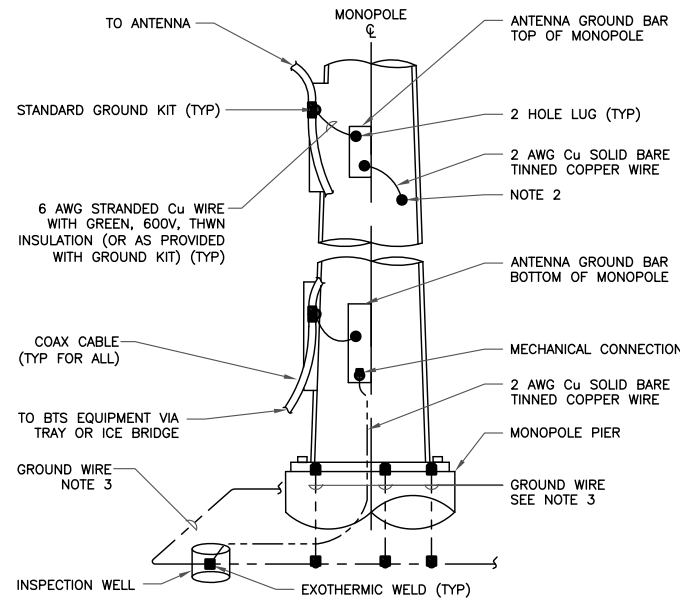

NOTES:

1. NUMBER OF GROUND BARS MAY VARY DEPENDING ON THE TYPE OF MONOPOLE, ANTENNA LOCATION AND CONNECTION ORIENTATION. COAXIAL CABLES EXCEEDING 200 FEET IN/ON THE POLE SHALL HAVE GROUND KITS AT THE MIDPOINT. PROVIDE AS REQUIRED.
2. ONLY MECHANICAL CONNECTIONS ARE ALLOWED TO BE MADE TO CROWN CASTLE TOWERS. ALL MECHANICAL CONNECTIONS SHALL BE TREATED WITH AN ANTI-OXIDANT COATING.
3. ALL TOWER GROUNDING SYSTEMS SHALL COMPLY WITH THE REQUIREMENTS OF ANSI/TIA 222. FOR TOWERS BEING BUILT TO REV G OF THE STANDARD, THE WIRE SIZE OF THE BURIED GROUND RING AND CONNECTIONS BETWEEN THE TOWER AND THE BURIED GROUND RING SHALL BE 2/0 AWG. STRANDED IN ADDITION, THE MINIMUM LENGTH OF THE GROUND RODS SHALL BE INCREASED FROM 8 FEET TO 10 FEET.

4 TYPICAL ANTENNA CABLE GROUNDING
SCALE: NOT TO SCALE

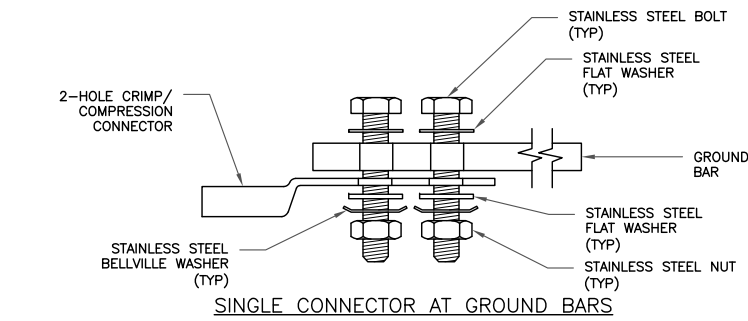

SINGLE CONNECTOR AT GROUND BARS

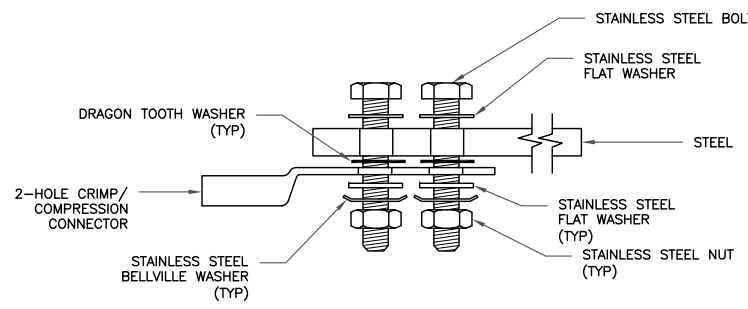

SINGLE CONNECTOR AT STEEL OBJECTS

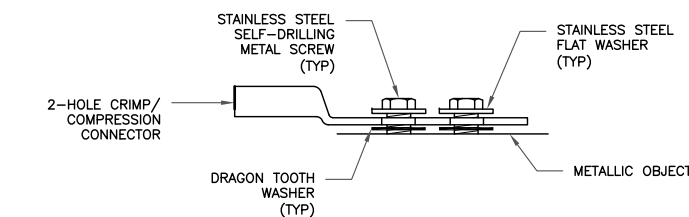

SINGLE CONNECTOR AT METALLIC/STEEL OBJECTS

5 HARDWARE DETAIL FOR EXTERIOR CONNECTIONS
SCALE: NOT TO SCALE

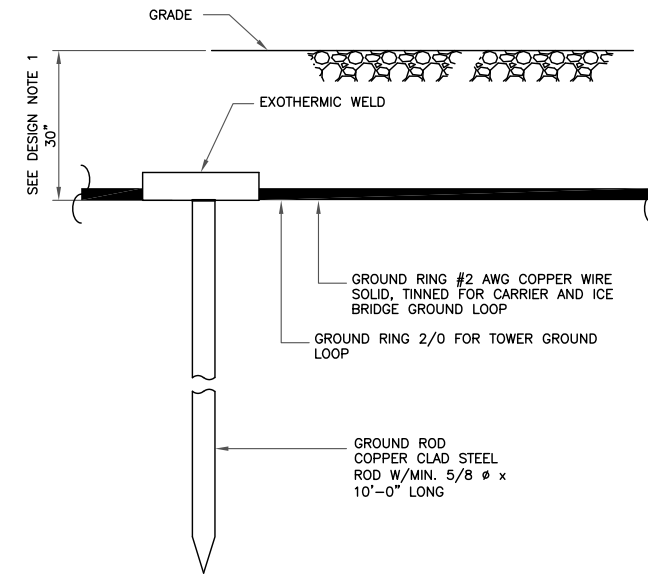

NOTES:

1. GROUND ROD SHALL BE DRIVEN VERTICALLY, NOT TO EXCEED 45 DEGREES FROM THE VERTICAL.
2. GROUND WIRE SHALL BE MIN. 30" BELOW GRADE OR 6" BELOW FROST LINE. (WHICH EVER IS GREATER) AS PER N.E.C. ARTICLE 250-50(D)

6 GROUND ROD DETAIL
SCALE: NOT TO SCALE



T-MOBILE SITE NUMBER:
CT11127A

BU #: **806358**
NHV **109 943107**

1432 OLD WATERBURY ROAD
SOUTHURY, CT 06488

EXISTING 226'-0" MONOPOLE

ISSUED FOR:

REV	DATE	DRWN	DESCRIPTION	DES./QA
A	12/14/16	NJH	PRELIMINARY	CTR
B	01/09/17	NJH	PRELIMINARY	CTR
C	01/13/17	NJH	PRELIMINARY	CTR
D	01/24/17	NJH	PRELIMINARY	LMR
0	01/30/17	JRM	CONSTRUCTION	JL

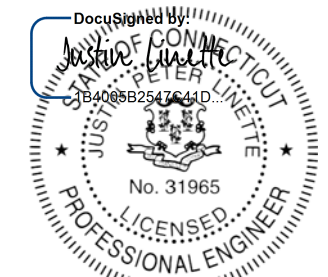

1/30/2017 | 10:25:26 AM EST

Justin Peter Linette, P.E.
Professional Engineer License: #31965
Crown Castle USA, Inc. Certificate of Registration
#PEC.0001101

IT IS A VIOLATION OF LAW FOR ANY PERSON, UNLESS THEY ARE ACTING UNDER THE DIRECTION OF A LICENSED PROFESSIONAL ENGINEER, TO ALTER THIS DOCUMENT.

SHEET NUMBER:

G-2

REVISION:

0

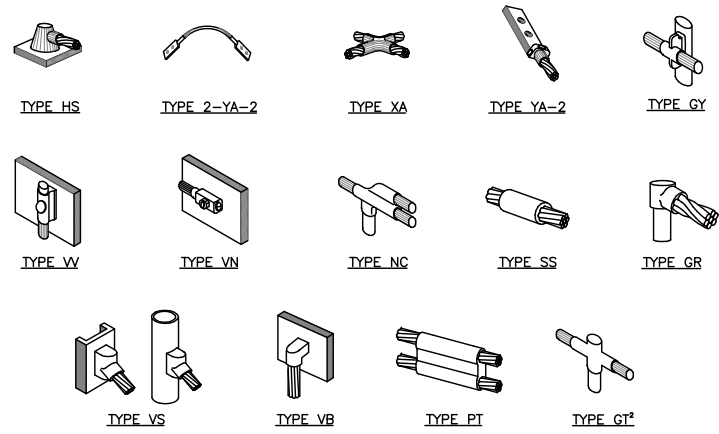

NOTE:
 1. ERICO EXOTHERMIC "MOLD TYPES" SHOWN HERE ARE EXAMPLES. CONSULT WITH CONSTRUCTION MANAGER FOR SPECIFIC MOLDS TO BE USED FOR THIS PROJECT.
 2. MOLD TYPE ONLY TO BE USED BELOW GRADE WHEN CONNECTING GROUND RING TO GROUND ROD.

1 CADWELD GROUNDING CONNECTIONS
 SCALE: NOT TO SCALE

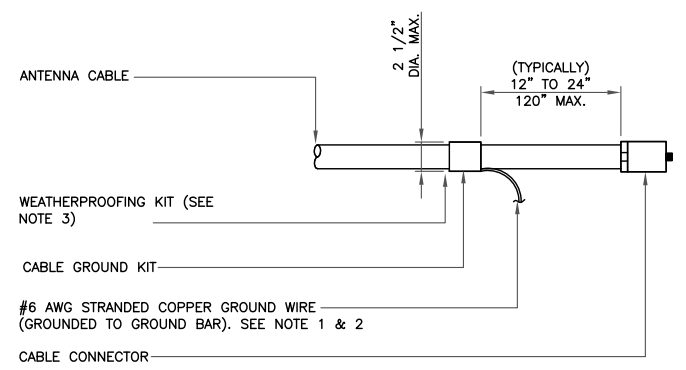

NOTES:
 1. DO NOT INSTALL CABLE GROUND KIT AT A BEND AND ALWAYS DIRECT GROUND WIRE DOWN TO GROUND BAR.
 2. GROUNDING KIT SHALL BE TYPE AND PART NUMBER AS SUPPLIED OR RECOMMENDED BY CABLE MANUFACTURER.
 3. WEATHER PROOFING SHALL BE TWO-PART TAPE KIT. COLD SHRINK SHALL NOT BE USED.

3 CABLE GROUND KIT CONNECTION
 SCALE: NOT TO SCALE

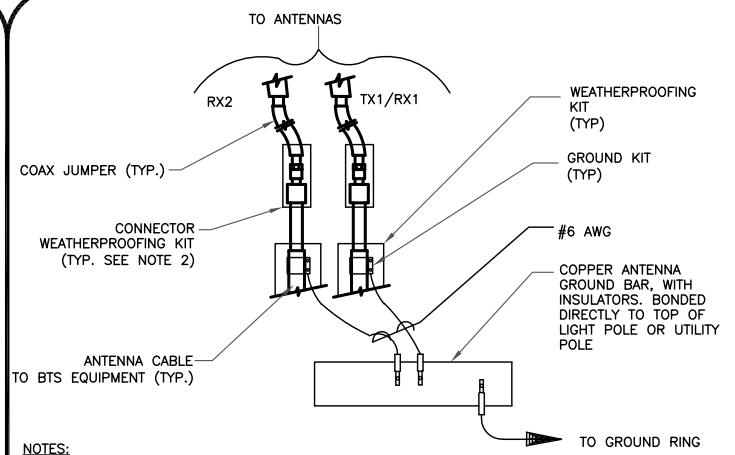

NOTES:
 1. DO NOT INSTALL CABLE GROUND KIT AT A BEND AND ALWAYS DIRECT GROUND WIRE DOWN TO ANTENNA GROUND BAR.
 2. WEATHER PROOFING SHALL BE TWO-PART TAPE KIT. COLD SHRINK SHALL NOT BE USED.

4 GROUND CABLE CONNECTION
 SCALE: NOT TO SCALE

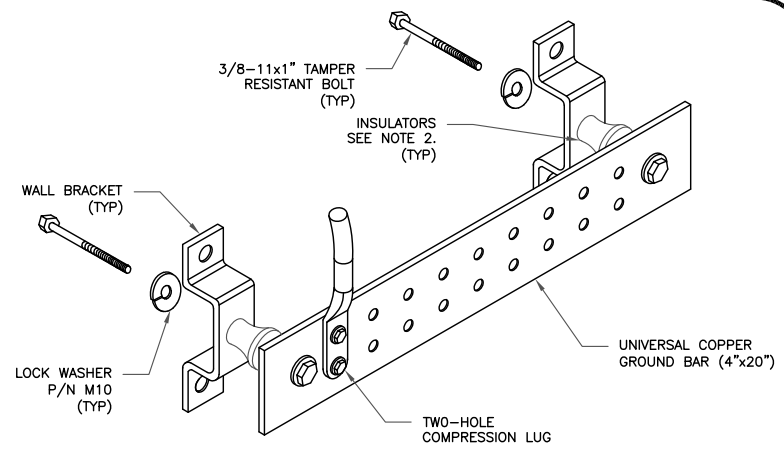

NOTES:
 1. DOWN LEAD (HOME RUN) CONDUCTORS ARE NOT TO BE INSTALLED ON CROWN CASTLE TOWER. PER THE GROUNDING DOWN CONDUCTOR POLICY QAS-STD-10091. NO MODIFICATION OR DRILLING TO TOWER STEEL IS ALLOWED IN ANY FORM OR FASHION. CAD-WELDING ON THE TOWER AND/OR IN THE AIR ARE NOT PERMITTED.
 2. OMIT INSULATOR WHEN MOUNTING TO TOWER STEEL OR PLATFORM STEEL. USE INSULATORS WHEN ATTACHING TO BUILDING OR SHELTERS.

6 GROUND BAR DETAIL
 SCALE: NOT TO SCALE

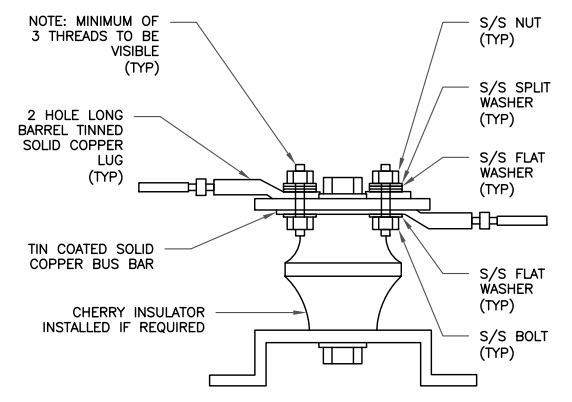

NOTE: MINIMUM OF 3 THREADS TO BE VISIBLE (TYP)
 S/S NUT (TYP)
 S/S SPLIT WASHER (TYP)
 S/S FLAT WASHER (TYP)
 S/S FLAT WASHER (TYP)
 S/S BOLT (TYP)
 CHERRY INSULATOR INSTALLED IF REQUIRED

7 LUG DETAIL
 SCALE: NOT TO SCALE

WIRE SIZE	BURNDY LUG	BOLT SIZE
#6 AWG GREEN INSULATED	YA6C-2TC38	3/8" - 16 NC S 2 BOLT
#2 AWG SOLID TINNED	YA3C-2TC38	3/8" - 16 NC S 2 BOLT
#2 AWG STRANDED	YA2C-2TC38	3/8" - 16 NC S 2 BOLT
#2/0 AWG STRANDED	YA26-2TC38	3/8" - 16 NC S 2 BOLT
#4/0 AWG STRANDED	YA28-2N	1/2" - 16 NC S 2 BOLT

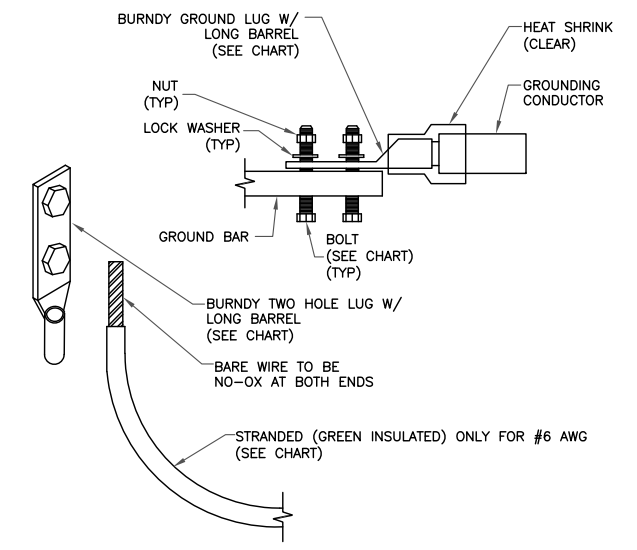

NOTES:
 1. ALL GROUNDING LUGS ARE TO BE INSTALLED PER MANUFACTURER'S SPECIFICATIONS. ALL HARDWARE BOLTS, NUTS, LOCK WASHERS SHALL BE STAINLESS STEEL. ALL HARDWARE ARE TO BE AS FOLLOWS: BOLT, FLAT WASHER, GROUND BAR, GROUND LUG, FLAT WASHER AND NUT.
 STRANDED (GREEN INSULATED) ONLY FOR #6 AWG (SEE CHART)

2 MECHANICAL LUG CONNECTION
 SCALE: NOT TO SCALE

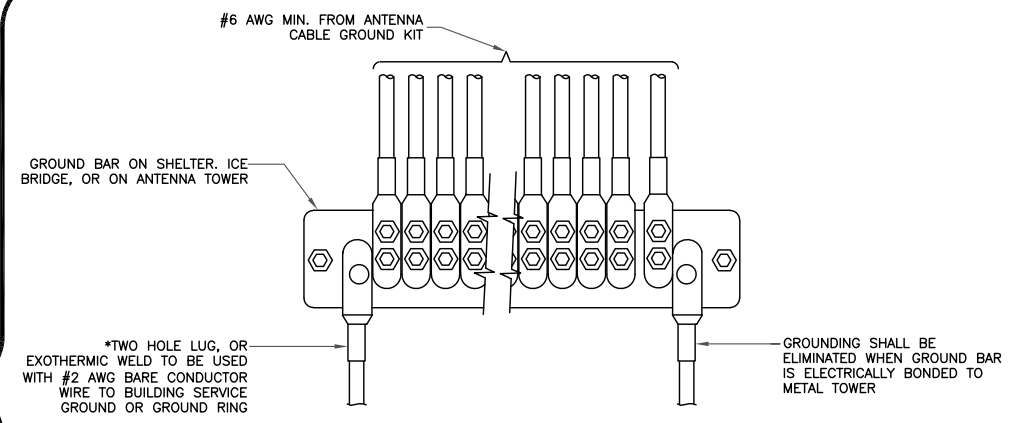

*TWO HOLE LUG, OR EXOTHERMIC WELD TO BE USED WITH #2 AWG BARE CONDUCTOR WIRE TO BUILDING SERVICE GROUND OR GROUND RING
 GROUNDING SHALL BE ELIMINATED WHEN GROUND BAR IS ELECTRICALLY BONDED TO METAL TOWER

5 GROUNDWIRE INSTALLATION
 SCALE: NOT TO SCALE

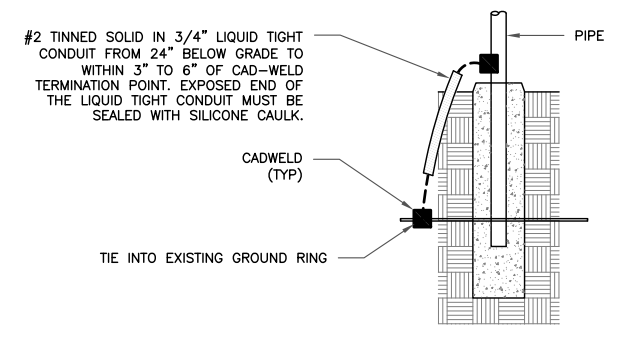

#2 TINNED SOLID IN 3/4" LIQUID TIGHT CONDUIT FROM 24" BELOW GRADE TO WITHIN 3" TO 6" OF CAD-WELD TERMINATION POINT. EXPOSED END OF THE LIQUID TIGHT CONDUIT MUST BE SEALED WITH SILICONE CAULK.

8 TRANSITIONING GROUND DETAIL
 SCALE: NOT TO SCALE



T-MOBILE SITE NUMBER:
CT11127A
 BU #: 806358
 NHV 109 943107
 1432 OLD WATERBURY ROAD
 SOUTHURY, CT 06488
 EXISTING 226'-0" MONOPOLE

ISSUED FOR:

REV	DATE	DRWN	DESCRIPTION	DES./QA
A	12/14/16	NJH	PRELIMINARY	CTR
B	01/09/17	NJH	PRELIMINARY	CTR
C	01/13/17	NJH	PRELIMINARY	CTR
D	01/24/17	NJH	PRELIMINARY	LMR
0	01/30/17	JRM	CONSTRUCTION	JL

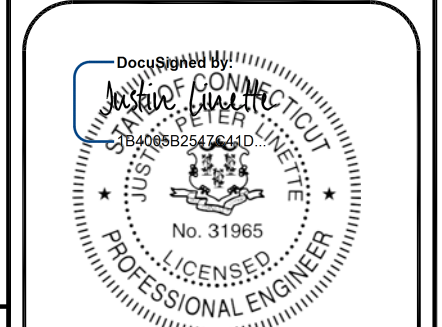

1/30/2017 | 10:25:26 AM EST

Justin Peter Linette, P.E.
 Professional Engineer License: #31965
 Crown Castle USA, Inc. Certificate of Registration #PEC.0001101
 IT IS A VIOLATION OF LAW FOR ANY PERSON, UNLESS THEY ARE ACTING UNDER THE DIRECTION OF A LICENSED PROFESSIONAL ENGINEER, TO ALTER THIS DOCUMENT.

SHEET NUMBER: **G-3** REVISION: **0**



Date: January 09, 2017

Charles McGuirt
Crown Castle
3530 Toringdon Way, Suite 300
Charlotte, NC 28277
704.405.6607

Paul J. Ford and Company
250 E. Broad Street, Suite 600
Columbus, OH 43215
614.221.6679
jmeinerding@pjfweb.com

Subject: Structural Analysis Report

Carrier Designation: T-Mobile Co-Locate
Carrier Site Number: CT11127A
Carrier Site Name: Middlebury/I-84 x 16

Crown Castle Designation: **Crown Castle BU Number:** 806358
Crown Castle Site Name: NHV 109 943107
Crown Castle JDE Job Number: 410222
Crown Castle Work Order Number: 1345140
Crown Castle Application Number: 369852 Rev. 4

Engineering Firm Designation: Paul J. Ford and Company Project Number: 37517-0065.001.7805

Site Data: 1432 Old Waterbury Road, SOUTHBURY, New Haven County, CT
Latitude 41° 29' 36.92", Longitude -73° 9' 54.98"
226 Foot - Monopole Tower

Dear Charles McGuirt,

Paul J. Ford and Company is pleased to submit this "Structural Analysis Report" to determine the structural integrity of the above mentioned tower. This analysis has been performed in accordance with the Crown Castle Structural 'Statement of Work' and the terms of Crown Castle Purchase Order Number 987563, in accordance with application 369852, revision 4.

The purpose of the analysis is to determine acceptability of the tower stress level. Based on our analysis we have determined the tower stress level for the structure and foundation, under the following load case, to be:

LC7: Existing + Reserved + Proposed Equipment **Sufficient Capacity**
Note: See Table I and Table II for the proposed and existing/reserved loading, respectively.

This analysis has been performed in accordance with the 2016 Connecticut State Building Code based upon an ultimate 3-second gust wind speed of 120 mph converted to a nominal 3-second gust wind speed of 93 mph per Section 1609.3 and Appendix N as required for use in the TIA-222-G Standard per Exception #5 of Section 1609.1.1. Exposure Category B with a maximum topographic factor, Kzt, of 1.000 and Risk Category II were used in this analysis.

We at Paul J. Ford and Company appreciate the opportunity of providing our continuing professional services to you and Crown Castle. If you have any questions or need further assistance on this or any other projects please give us a call.

Respectfully submitted by:

Joey Meinerding, E.I.
Structural Designer

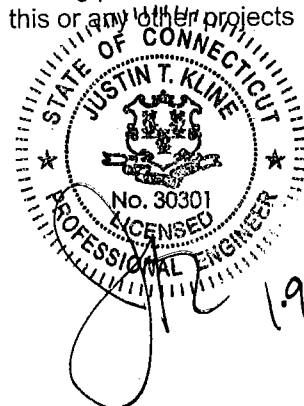

Date: **January 09, 2017**

Charles McGuirt
Crown Castle
3530 Toringdon Way, Suite 300
Charlotte, NC 28277
704.405.6607

Paul J. Ford and Company
250 E. Broad Street, Suite 600
Columbus, OH 43215
614.221.6679
jmeinerding@pjfweb.com

Subject: Structural Analysis Report

Carrier Designation: *T-Mobile Co-Locate*
Carrier Site Number: CT11127A
Carrier Site Name: Middlebury/I-84 x 16

Crown Castle Designation: **Crown Castle BU Number:** 806358
Crown Castle Site Name: NHV 109 943107
Crown Castle JDE Job Number: 410222
Crown Castle Work Order Number: 1345140
Crown Castle Application Number: 369852 Rev. 4

Engineering Firm Designation: **Paul J. Ford and Company Project Number:** 37517-0065.001.7805

Site Data: **1432 Old Waterbury Road, SOUTHURY, New Haven County, CT**
Latitude 41° 29' 36.92", Longitude -73° 9' 54.98"
226 Foot - Monopole Tower

Dear Charles McGuirt,

Paul J. Ford and Company is pleased to submit this "**Structural Analysis Report**" to determine the structural integrity of the above mentioned tower. This analysis has been performed in accordance with the Crown Castle Structural 'Statement of Work' and the terms of Crown Castle Purchase Order Number 987563, in accordance with application 369852, revision 4.

The purpose of the analysis is to determine acceptability of the tower stress level. Based on our analysis we have determined the tower stress level for the structure and foundation, under the following load case, to be:

LC7: Existing + Reserved + Proposed Equipment

Sufficient Capacity

Note: See Table I and Table II for the proposed and existing/reserved loading, respectively.

This analysis has been performed in accordance with the 2016 Connecticut State Building Code based upon an ultimate 3-second gust wind speed of 120 mph converted to a nominal 3-second gust wind speed of 93 mph per Section 1609.3 and Appendix N as required for use in the TIA-222-G Standard per Exception #5 of Section 1609.1.1. Exposure Category B with a maximum topographic factor, Kzt, of 1.000 and Risk Category II were used in this analysis.

We at *Paul J. Ford and Company* appreciate the opportunity of providing our continuing professional services to you and Crown Castle. If you have any questions or need further assistance on this or any other projects please give us a call.

Respectfully submitted by:

Joey Meinerding, E.I.
Structural Designer

TABLE OF CONTENTS

1) INTRODUCTION

2) ANALYSIS CRITERIA

Table 1 - Proposed Antenna and Cable Information

Table 2 - Existing and Reserved Antenna and Cable Information

3) ANALYSIS PROCEDURE

Table 3 - Documents Provided

3.1) Analysis Method

3.2) Assumptions

4) ANALYSIS RESULTS

Table 4 – Section Capacity (Summary)

Table 5 – Tower Component Stresses vs. Capacity

4.1) Recommendations

5) APPENDIX A

tnxTower Output

6) APPENDIX B

Base Level Drawing

7) APPENDIX C

Additional Calculations

1) INTRODUCTION

This tower is a 226 ft. monopole tower designed by Engineered Endeavors, Inc. in July of 1999. The tower was originally designed for a wind speed of 85 mph per TIA/EIA-222-F.

2) ANALYSIS CRITERIA

This analysis has been performed in accordance with the 2016 Connecticut State Building Code based upon an ultimate 3-second gust wind speed of 120 mph converted to a nominal 3-second gust wind speed of 93 mph per Section 1609.3 and Appendix N as required for use in the TIA-222-G Standard per Exception #5 of Section 1609.1.1. Exposure Category B with a maximum topographic factor, Kzt, of 1.000 and Risk Category II were used in this analysis.

Table 1 - Proposed Antenna and Cable Information

Mounting Level (ft)	Center Line Elevation (ft)	Number of Antennas	Antenna Manufacturer	Antenna Model	Number of Feed Lines	Feed Line Size (in)	Note
205.0	207.0	3	commscope	ATSBT-TOP-MF-4G	6	1-5/8	--
		3	commscope	LNx-6515DS-A1M w/ Mount Pipe			
		3	rfs celwave	APXV18-206516S-C-A20 w/ Mount Pipe			

Table 2 - Existing and Reserved Antenna and Cable Information

Mounting Level (ft)	Center Line Elevation (ft)	Number of Antennas	Antenna Manufacturer	Antenna Model	Number of Feed Lines	Feed Line Size (in)	Note
226.0	228.0	3	alcatel lucent	RRH2X60-1900	2	1-5/8	2
		3	alcatel lucent	RRH2x60-700			
		3	alcatel lucent	RRH4X45-AWS4 B66			
		6	commscope	SBNHH-1D65B w/ Mount Pipe			
		2	rfs celwave	DB-T1-6Z-8AB-0Z			
	226.0	6	antel	LPA-80080/6CF w/ Mount Pipe	10	1-5/8	1
		6	rfs celwave	FD9R6004/2C-3L			
		1	tower mounts	Platform Mount [LP 602-1]			
205.0	207.0	1	tower mounts	Side Arm Mount [SO 203-3]	6	1-5/8	3
		3	ems wireless	RR65-18-02DP w/ Mount Pipe			
		6	nokia	CS72993.07			
	3	rfs celwave	ATMPP1412D-1CWA				
205.0	205.0	1	tower mounts	Platform Mount [LP 601-1]	6	1-5/8	1

Mounting Level (ft)	Center Line Elevation (ft)	Number of Antennas	Antenna Manufacturer	Antenna Model	Number of Feed Lines	Feed Line Size (in)	Note
193.0	195.0	6	cci antennas	DTMABP7819VG12A	2 2 12	3/8 5/8 1-1/4	1
		3	cci antennas	OPA-65R-LCUU-H6 w/ Mount Pipe			
		3	ericsson	RRUS 11			
		3	ericsson	RRUS 12-B2			
		3	ericsson	RRUS A2 MODULE			
		3	kathrein	800 10121 w/ Mount Pipe			
		6	kathrein	860 10025			
		3	kmw communications	AM-X-CD-16-65-00T-RET w/ Mount Pipe			
	1	raycap	DC6-48-60-18-8F				
	193.0	1	tower mounts	Platform Mount [LP 601-1]			
185.0	187.0	3	decibel	978QNB120E-M w/ Mount Pipe	1 12	1/2 1-5/8	1
		6	ems wireless	FV90-16-02DP w/ Mount Pipe			
		3	nokia	CS72993.07			
	3	rfs celwave	APXV18-206517S-C w/ Mount Pipe				
	185.0	1	tower mounts	Platform Mount [LP 601-1]			
177.0	177.0	3	alcatel lucent	TME-1900MHz RRH (65 MHz)	--	--	1
		3	alcatel lucent	TME-800MHZ RRH			
		1	tower mounts	Side Arm Mount [SO 102-3]			
175.0	175.0	3	alcatel lucent	800 EXTERNAL NOTCH FILTER	3	1-1/4	1
		9	rfs celwave	ACU-A20-N			
		3	rfs celwave	APXVSP18-C-A20 w/ Mount Pipe			
		1	tower mounts	Platform Mount [LP 1201-1]			
72.0	73.0	1	gps	GPS_A	1	1/2	1
	72.0	1	tower mounts	Side Arm Mount [SO 701-1]			

- Notes:
 1) Existing Equipment
 2) Reserved Equipment
 3) Equipment To Be Removed

3) ANALYSIS PROCEDURE

Table 3 - Documents Provided

Document	Remarks	Reference	Source
4-GEOTECHNICAL REPORTS	East Coast Drilling & Boring, 88268, 05/18/1988	217688	CCISITES
4-POST-MODIFICATION INSPECTION	Vertical Structures, 2007-209-001, 01/22/2007	1863184	CCISITES
4-POST-MODIFICATION INSPECTION	TEP, 128360, 03/12/2013	4062849	CCISITES
4-TOWER FOUNDATION DRAWINGS/DESIGN/SPECS	EEI, 5262, 08/23/1999	821496	CCISITES
4-TOWER STRUCTURAL ANALYSIS REPORTS	EEI, 5262, 07/09/1999	821492	CCISITES
4-TOWER MANUFACTURER DRAWINGS	EEI, 5262, 07/09/1999	821494	CCISITES

3.1) Analysis Method

tnxTower (version 7.0.5.1), a commercially available analysis software package, was used to create a three-dimensional model of the tower and calculate member stresses for various loading cases. Selected output from the analysis is included in Appendix A.

3.2) Assumptions

- 1) Tower and structures were built in accordance with the manufacturer's specifications.
- 2) The tower and structures have been maintained in accordance with the manufacturer's specification.
- 3) The configuration of antennas, transmission cables, mounts and other appurtenances are as specified in Tables 1 and 2 and the referenced drawings.
- 4) At the time of analysis the referenced geotechnical report did not provide definitive values for the soil properties. The soil properties were estimated off the boring logs.
- 5) The existing monopole shaft has been reinforced using a Crown-approved system in accordance with the above referenced documents. However, in this analysis we found that the existing pole shaft without modifications has adequate capacity according to TIA-222-G-2 (addendum 2) and therefore, we did not consider the existing reinforcing elements in the strength calculations.

This analysis may be affected if any assumptions are not valid or have been made in error. Paul J. Ford and Company should be notified to determine the effect on the structural integrity of the tower.

4) ANALYSIS RESULTS

Table 4 - Section Capacity (Summary)

Section No.	Elevation (ft)	Component Type	Size	Critical Element	P (K)	SF*P_allow (K)	% Capacity	Pass / Fail
L1	226 - 197.96	Pole	TP28.67x21.5x0.1875	1	-6.25	1072.42	40.5	Pass
L2	197.96 - 162.91	Pole	TP37.12x27.2517x0.375	2	-20.82	3134.05	43.0	Pass
L3	162.91 - 120.29	Pole	TP47.14x35.0662x0.4375	3	-34.03	4616.12	52.8	Pass
L4	120.29 - 79.21	Pole	TP56.63x44.643x0.5	4	-51.27	6258.12	52.7	Pass
L5	79.21 - 39.13	Pole	TP65.75x53.7146x0.5625	5	-73.30	8104.46	49.8	Pass
L6	39.13 - 0	Pole	TP74.5x62.4159x0.5625	6	-104.56	9035.61	53.3	Pass
							Summary	
						Pole (L6)	53.3	Pass
						Rating =	53.3	Pass

Table 5 - Tower Component Stresses vs. Capacity

Notes	Component	Elevation (ft)	% Capacity	Pass / Fail
1	Anchor Rods	0	58.9	Pass
1	Base Plate	0	41.4	Pass
1	Base Foundation Structural Steel	0	56.9	Pass
1	Base Foundation Soil Interaction	0	18.6	Pass

Structure Rating (max from all components) =	58.9%
---	--------------

Notes:

- 1) See additional documentation in "Appendix C – Additional Calculations" for calculations supporting the % capacity consumed.

4.1) Recommendations

The monopole and its foundation have sufficient capacity to carry the proposed loading configuration. No modifications are required at this time.

APPENDIX A
TNXTOWER OUTPUT

Tower Input Data

There is a pole section.
 This tower is designed using the TIA-222-G standard.
 The following design criteria apply:

- 1) Tower is located in New Haven County, Connecticut.
- 2) ASCE 7-10 Wind Data is used (wind speeds converted to nominal values).
- 3) Basic wind speed of 93.00 mph.
- 4) Structure Class II.
- 5) Exposure Category B.
- 6) Topographic Category 1.
- 7) Crest Height 0.0000 ft.
- 8) Nominal ice thickness of 0.7500 in.
- 9) Ice thickness is considered to increase with height.
- 10) Ice density of 56.00 pcf.
- 11) A wind speed of 50.00 mph is used in combination with ice.
- 12) Temperature drop of 50.00 °F.
- 13) Deflections calculated using a wind speed of 60.00 mph.
- 14) A non-linear (P-delta) analysis was used.
- 15) Pressures are calculated at each section.
- 16) Stress ratio used in pole design is 1.
- 17) Local bending stresses due to climbing loads, feed line supports, and appurtenance mounts are not considered.

Options

- | | | |
|--|--|---|
| Consider Moments - Legs
Consider Moments - Horizontals
Consider Moments - Diagonals
Use Moment Magnification
✓ Use Code Stress Ratios
✓ Use Code Safety Factors - Guys
Escalate Ice
Always Use Max Kz
Use Special Wind Profile

Include Bolts In Member Capacity

Leg Bolts Are At Top Of Section
Secondary Horizontal Braces Leg
Use Diamond Inner Bracing (4 Sided)
SR Members Have Cut Ends
SR Members Are Concentric | Distribute Leg Loads As Uniform
Assume Legs Pinned
✓ Assume Rigid Index Plate
✓ Use Clear Spans For Wind Area
Use Clear Spans For KL/r
Retension Guys To Initial Tension
✓ Bypass Mast Stability Checks
✓ Use Azimuth Dish Coefficients
✓ Project Wind Area of Appurt.

Autocalc Torque Arm Areas

Add IBC .6D+W Combination
Sort Capacity Reports By Component
Triangulate Diamond Inner Bracing
Treat Feed Line Bundles As Cylinder | Use ASCE 10 X-Brace Ly Rules
Calculate Redundant Bracing Forces
Ignore Redundant Members in FEA
SR Leg Bolts Resist Compression
All Leg Panels Have Same Allowable
Offset Girt At Foundation
✓ Consider Feed Line Torque
Include Angle Block Shear Check
Use TIA-222-G Bracing Resist.
Exemption
Use TIA-222-G Tension Splice
Exemption

<div style="text-align: center; background-color: #e0e0e0; padding: 2px;">Poles</div> ✓ Include Shear-Torsion Interaction
Always Use Sub-Critical Flow
Use Top Mounted Sockets |
|--|--|---|

Tapered Pole Section Geometry

Section	Elevation ft	Section Length ft	Splice Length ft	Number of Sides	Top Diameter in	Bottom Diameter in	Wall Thickness in	Bend Radius in	Pole Grade
L1	226.0000- 197.9600	28.0400	4.08	18	21.5000	28.6700	0.1875	0.7500	A572-65 (65 ksi)
L2	197.9600- 162.9100	39.1300	5.17	18	27.2517	37.1200	0.3750	1.5000	A572-65 (65 ksi)
L3	162.9100- 120.2900	47.7900	6.42	18	35.0662	47.1400	0.4375	1.7500	A572-65 (65 ksi)
L4	120.2900- 79.2100	47.5000	7.59	18	44.6430	56.6300	0.5000	2.0000	A572-65 (65 ksi)
L5	79.2100-	47.6700	8.75	18	53.7146	65.7500	0.5625	2.2500	A572-65

Section	Elevation ft	Section Length ft	Splice Length ft	Number of Sides	Top Diameter in	Bottom Diameter in	Wall Thickness in	Bend Radius in	Pole Grade
L6	39.1300 39.1300-0.0000	47.8800		18	62.4159	74.5000	0.5625	2.2500	(65 ksi) A572-65 (65 ksi)

Tapered Pole Properties

Section	Tip Dia. in	Area in ²	I in ⁴	r in	C in	I/C in ³	J in ⁴	It/Q in ²	w in	w/t
L1	21.8317	12.6836	727.8616	7.5659	10.9220	66.6418	1456.6810	6.3430	3.4540	18.421
	29.1123	16.9506	1737.3206	10.1113	14.5644	119.2857	3476.9272	8.4769	4.7159	25.152
L2	28.7169	31.9900	2919.4725	9.5412	13.8439	210.8855	5842.7866	15.9980	4.1363	11.03
	37.6926	43.7357	7460.5423	13.0445	18.8570	395.6387	14930.9013	21.8720	5.8731	15.662
L3	36.9334	48.0862	7285.0027	12.2932	17.8136	408.9571	14579.5911	24.0477	5.4016	12.347
	47.8672	64.8523	17870.7516	16.5794	23.9471	746.2589	35765.0179	32.4323	7.5266	17.204
L4	46.9768	70.0550	17246.4919	15.6708	22.6787	760.4723	34515.6771	35.0341	6.9772	13.954
	57.5036	89.0783	35456.7972	19.9262	28.7680	1232.5065	70960.2494	44.5476	9.0869	18.174
L5	56.4891	94.8964	33871.0281	18.8690	27.2870	1241.2871	67786.6246	47.4572	8.4638	15.047
	66.7643	116.3841	62482.7128	23.1416	33.4010	1870.6839	125047.6419	58.2031	10.5820	18.812
L6	65.6212	110.4314	53377.3255	21.9579	31.7073	1683.4419	106824.8863	55.2262	9.9952	17.769
	75.6493	132.0062	91171.9378	26.2478	37.8460	2409.0244	182463.8419	66.0156	12.1220	21.55

Tower Elevation ft	Gusset Area (per face) ft ²	Gusset Thickness in	Gusset Grade	Adjust. Factor A _r	Adjust. Factor A _r	Weight Mult.	Double Angle Stitch Bolt Spacing Diagonals in	Double Angle Stitch Bolt Spacing Horizontals in	Double Angle Stitch Bolt Spacing Redundants in
L1 226.0000-197.9600				1	1	1			
L2 197.9600-162.9100				1	1	1			
L3 162.9100-120.2900				1	1	1			
L4 120.2900-79.2100				1	1	1			
L5 79.2100-39.1300				1	1	1			
L6 39.1300-0.0000				1	1	1			

Feed Line/Linear Appurtenances - Entered As Area

Description	Face or Shield Leg	Allow Shield	Component Type	Placement ft	Total Number	C _A A _A ft ² /ft	Weight plf
561(1-5/8)	C	No	Inside Pole	226.0000 - 0.0000	10	No Ice	0.0000
						1/2" Ice	0.0000
						1" Ice	0.0000
HB158-1-08U8-S8J18(1-5/8)	C	No	Inside Pole	226.0000 - 0.0000	2	No Ice	0.0000
						1/2" Ice	0.0000
						1" Ice	0.0000

Description	Face or Leg	Allow Shield	Component Type	Placement ft	Total Number	C _A A _A		Weight
						No Ice	ft ² /ft	plf
LDF7-50A(1-5/8)	C	No	Inside Pole	205.0000 - 0.0000	6	No Ice	0.0000	0.82
						1/2" Ice	0.0000	0.82
						1" Ice	0.0000	0.82
AVA7-50(1-5/8)	C	No	Inside Pole	205.0000 - 0.0000	6	No Ice	0.0000	0.70
						1/2" Ice	0.0000	0.70
						1" Ice	0.0000	0.70

FB-L98B-034-XXX(3/8)	C	No	Inside Pole	193.0000 - 0.0000	2	No Ice	0.0000	0.06
						1/2" Ice	0.0000	0.06
						1" Ice	0.0000	0.06
WR-VG82ST-BRDA(5/8)	C	No	Inside Pole	193.0000 - 0.0000	2	No Ice	0.0000	0.31
						1/2" Ice	0.0000	0.31
						1" Ice	0.0000	0.31
2" (Nominal) Conduit	C	No	Inside Pole	193.0000 - 0.0000	1	No Ice	0.0000	0.72
						1/2" Ice	0.0000	0.72
						1" Ice	0.0000	0.72
LDF6-50A(1-1/4)	C	No	Inside Pole	193.0000 - 0.0000	9	No Ice	0.0000	0.60
						1/2" Ice	0.0000	0.60
						1" Ice	0.0000	0.60
LDF6-50A(1-1/4)	C	No	CaAa (Out Of Face)	193.0000 - 0.0000	2	No Ice	0.0000	0.60
						1/2" Ice	0.0000	1.85
						1" Ice	0.0000	3.72
LDF6-50A(1-1/4)	C	No	CaAa (Out Of Face)	185.0000 - 0.0000	1	No Ice	0.0000	0.60
						1/2" Ice	0.0000	1.85
						1" Ice	0.0000	3.72
LDF6-50A(1-1/4)	C	No	CaAa (Out Of Face)	193.0000 - 185.0000	1	No Ice	0.1550	0.60
						1/2" Ice	0.2550	1.85
						1" Ice	0.3550	3.72

LDF7-50A(1-5/8)	C	No	Inside Pole	185.0000 - 0.0000	6	No Ice	0.0000	0.82
						1/2" Ice	0.0000	0.82
						1" Ice	0.0000	0.82
LDF4-50A(1/2)	C	No	CaAa (Out Of Face)	185.0000 - 0.0000	1	No Ice	0.0000	0.15
						1/2" Ice	0.0000	0.84
						1" Ice	0.0000	2.14
LDF7-50A(1-5/8)	C	No	CaAa (Out Of Face)	185.0000 - 0.0000	5	No Ice	0.0000	0.82
						1/2" Ice	0.0000	2.33
						1" Ice	0.0000	4.46
LDF7-50A(1-5/8)	C	No	CaAa (Out Of Face)	185.0000 - 0.0000	1	No Ice	0.1980	0.82
						1/2" Ice	0.2980	2.33
						1" Ice	0.3980	4.46

HB114-1-0813U4-M5J(1-1/4)	C	No	Inside Pole	175.0000 - 0.0000	3	No Ice	0.0000	1.20
						1/2" Ice	0.0000	1.20
						1" Ice	0.0000	1.20

LDF4-50A(1/2)	C	No	Inside Pole	72.0000 - 0.0000	1	No Ice	0.0000	0.15
						1/2" Ice	0.0000	0.15
						1" Ice	0.0000	0.15

1" Flat Reinforcement	C	No	CaAa (Out Of Face)	134.0000 - 124.0000	1	No Ice	0.1667	15.00
						1/2" Ice	0.2778	15.69
						1" Ice	0.3889	16.73

Feed Line/Linear Appurtenances Section Areas

Tower Section	Tower Elevation ft	Face	A _R ft ²	A _F ft ²	C _A A _A In Face ft ²	C _A A _A Out Face ft ²	Weight K
L1	226.0000- 197.9600	A	0.000	0.000	0.000	0.000	0.00
		B	0.000	0.000	0.000	0.000	0.00
		C	0.000	0.000	0.000	0.000	0.52
L2	197.9600- 162.9100	A	0.000	0.000	0.000	0.000	0.00
		B	0.000	0.000	0.000	0.000	0.00
		C	0.000	0.000	0.000	5.614	1.41
L3	162.9100-	A	0.000	0.000	0.000	0.000	0.00

Tower Section n	Tower Elevation ft	Face	A _R ft ²	A _F ft ²	C _A A _A In Face ft ²	C _A A _A Out Face ft ²	Weight K
L4	120.2900-79.2100	B	0.000	0.000	0.000	0.000	0.00
		C	0.000	0.000	0.000	10.105	2.17
		A	0.000	0.000	0.000	0.000	0.00
L5	79.2100-39.1300	B	0.000	0.000	0.000	0.000	0.00
		C	0.000	0.000	0.000	8.134	1.95
		A	0.000	0.000	0.000	0.000	0.00
L6	39.1300-0.0000	B	0.000	0.000	0.000	0.000	0.00
		C	0.000	0.000	0.000	7.936	1.91
		A	0.000	0.000	0.000	0.000	0.00
		C	0.000	0.000	0.000	7.748	1.86

Feed Line/Linear Appurtenances Section Areas - With Ice

Tower Section n	Tower Elevation ft	Face or Leg	Ice Thickness in	A _R ft ²	A _F ft ²	C _A A _A In Face ft ²	C _A A _A Out Face ft ²	Weight K
L1	226.0000-197.9600	A	1.806	0.000	0.000	0.000	0.000	0.00
		B		0.000	0.000	0.000	0.000	0.00
		C		0.000	0.000	0.000	0.000	0.52
L2	197.9600-162.9100	A	1.777	0.000	0.000	0.000	0.000	0.00
		B		0.000	0.000	0.000	0.000	0.00
		C		0.000	0.000	0.000	16.483	3.35
L3	162.9100-120.2900	A	1.734	0.000	0.000	0.000	0.000	0.00
		B		0.000	0.000	0.000	0.000	0.00
		C		0.000	0.000	0.000	29.202	5.54
L4	120.2900-79.2100	A	1.675	0.000	0.000	0.000	0.000	0.00
		B		0.000	0.000	0.000	0.000	0.00
		C		0.000	0.000	0.000	22.383	5.05
L5	79.2100-39.1300	A	1.590	0.000	0.000	0.000	0.000	0.00
		B		0.000	0.000	0.000	0.000	0.00
		C		0.000	0.000	0.000	21.361	4.79
L6	39.1300-0.0000	A	1.420	0.000	0.000	0.000	0.000	0.00
		B		0.000	0.000	0.000	0.000	0.00
		C		0.000	0.000	0.000	20.191	4.49

Feed Line Center of Pressure

Section	Elevation ft	CP _x in	CP _z in	CP _x Ice in	CP _z Ice in
L1	226.0000-197.9600	0.0000	0.0000	0.0000	0.0000
L2	197.9600-162.9100	-0.1984	0.1145	-0.4803	0.2773
L3	162.9100-120.2900	-0.2878	0.1662	-0.6961	0.4019
L4	120.2900-79.2100	-0.2423	0.1399	-0.5850	0.3377
L5	79.2100-39.1300	-0.2439	0.1408	-0.5887	0.3399
L6	39.1300-0.0000	-0.2451	0.1415	-0.5828	0.3365

Shielding Factor Ka

Tower Section	Feed Line Record No.	Description	Feed Line Segment Elev.	K _s No Ice	K _s Ice

Discrete Tower Loads

Description	Face or Leg	Offset Type	Offsets: Horz Lateral Vert ft ft ft	Azimuth Adjustmen t °	Placement ft	C _A A _A Front ft ²	C _A A _A Side ft ²	Weight K	
Beacon	C	From Leg	0.0000	0.0000	226.0000	No Ice	3.6000	3.6000	0.10
			0.00			1/2"	4.0000	4.0000	0.15
			1.00			Ice	4.4000	4.4000	0.20
						1" Ice			

(2) LPA-80080/6CF w/ Mount Pipe	A	From Leg	4.0000	0.0000	226.0000	No Ice	4.5639	10.2588	0.05
			0.00			1/2"	5.1051	11.4274	0.11
			2.00			Ice	5.6116	12.3118	0.19
						1" Ice			
(2) LPA-80080/6CF w/ Mount Pipe	B	From Leg	4.0000	0.0000	226.0000	No Ice	4.5639	10.2588	0.05
			0.00			1/2"	5.1051	11.4274	0.11
			2.00			Ice	5.6116	12.3118	0.19
						1" Ice			
(2) LPA-80080/6CF w/ Mount Pipe	C	From Leg	4.0000	0.0000	226.0000	No Ice	4.5639	10.2588	0.05
			0.00			1/2"	5.1051	11.4274	0.11
			2.00			Ice	5.6116	12.3118	0.19
						1" Ice			
(2) FD9R6004/2C-3L	A	From Leg	4.0000	0.0000	226.0000	No Ice	0.3142	0.0762	0.00
			0.00			1/2"	0.3862	0.1189	0.01
			2.00			Ice	0.4656	0.1685	0.01
						1" Ice			
(2) FD9R6004/2C-3L	B	From Leg	4.0000	0.0000	226.0000	No Ice	0.3142	0.0762	0.00
			0.00			1/2"	0.3862	0.1189	0.01
			2.00			Ice	0.4656	0.1685	0.01
						1" Ice			
(2) FD9R6004/2C-3L	C	From Leg	4.0000	0.0000	226.0000	No Ice	0.3142	0.0762	0.00
			0.00			1/2"	0.3862	0.1189	0.01
			2.00			Ice	0.4656	0.1685	0.01
						1" Ice			
(2) SBNHH-1D65B w/ Mount Pipe	A	From Leg	4.0000	0.0000	226.0000	No Ice	8.3995	7.0730	0.07
			0.00			1/2"	8.9639	8.2637	0.14
			2.00			Ice	9.4943	9.1753	0.21
						1" Ice			
(2) SBNHH-1D65B w/ Mount Pipe	B	From Leg	4.0000	0.0000	226.0000	No Ice	8.3995	7.0730	0.07
			0.00			1/2"	8.9639	8.2637	0.14
			2.00			Ice	9.4943	9.1753	0.21
						1" Ice			
(2) SBNHH-1D65B w/ Mount Pipe	C	From Leg	4.0000	0.0000	226.0000	No Ice	8.3995	7.0730	0.07
			0.00			1/2"	8.9639	8.2637	0.14
			2.00			Ice	9.4943	9.1753	0.21
						1" Ice			
RRH4X45-AWS4 B66	A	From Leg	4.0000	0.0000	226.0000	No Ice	2.6600	1.5861	0.06
			0.00			1/2"	2.8781	1.7690	0.08
			2.00			Ice	3.1037	1.9588	0.11
						1" Ice			
RRH4X45-AWS4 B66	B	From Leg	4.0000	0.0000	226.0000	No Ice	2.6600	1.5861	0.06
			0.00			1/2"	2.8781	1.7690	0.08
			2.00			Ice	3.1037	1.9588	0.11
						1" Ice			
RRH4X45-AWS4 B66	C	From Leg	4.0000	0.0000	226.0000	No Ice	2.6600	1.5861	0.06
			0.00			1/2"	2.8781	1.7690	0.08
			2.00			Ice	3.1037	1.9588	0.11
						1" Ice			
RRH2X60-1900	A	From Leg	4.0000	0.0000	226.0000	No Ice	1.8741	1.2177	0.04
			0.00			1/2"	2.0516	1.3670	0.06
			2.00			Ice	2.2365	1.5233	0.08
						1" Ice			
RRH2X60-1900	B	From Leg	4.0000	0.0000	226.0000	No Ice	1.8741	1.2177	0.04
			0.00			1/2"	2.0516	1.3670	0.06
			2.00			Ice	2.2365	1.5233	0.08
						1" Ice			

Description	Face or Leg	Offset Type	Offsets: Horz Lateral Vert ft ft ft	Azimuth Adjustment t °	Placement ft		C _{AA} Front ft ²	C _{AA} Side ft ²	Weight K
RRH2X60-1900	C	From Leg	4.0000	0.0000	226.0000	No Ice	1.8741	1.2177	0.04
			0.00			1/2"	2.0516	1.3670	0.06
			2.00			Ice	2.2365	1.5233	0.08
RRH2x60-700	A	From Leg	4.0000	0.0000	226.0000	1" Ice	3.5002	1.8157	0.06
			0.00			1/2"	3.7609	2.0519	0.08
			2.00			Ice	4.0285	2.2894	0.11
RRH2x60-700	B	From Leg	4.0000	0.0000	226.0000	1" Ice	3.5002	1.8157	0.06
			0.00			1/2"	3.7609	2.0519	0.08
			2.00			Ice	4.0285	2.2894	0.11
RRH2x60-700	C	From Leg	4.0000	0.0000	226.0000	1" Ice	3.5002	1.8157	0.06
			0.00			1/2"	3.7609	2.0519	0.08
			2.00			Ice	4.0285	2.2894	0.11
(2) DB-T1-6Z-8AB-OZ	C	From Leg	4.0000	0.0000	226.0000	No Ice	4.8000	2.0000	0.04
			0.00			1/2"	5.0704	2.1926	0.08
			2.00			Ice	5.3481	2.3926	0.12
8-ft Ladder	C	From Leg	2.0000	0.0000	226.0000	1" Ice	7.0700	7.0700	0.04
			0.00			1/2"	9.7300	9.7300	0.07
			-2.00			Ice	11.1900	11.1900	0.08
Side Arm Mount [SO 203-3]	C	None		0.0000	226.0000	1" Ice	7.1200	7.1200	0.38
						1/2"	9.8800	9.8800	0.46
						Ice	12.6400	12.6400	0.55
Platform Mount [LP 602-1]	C	None		0.0000	226.0000	1" Ice	32.0300	32.0300	1.34
						1/2"	38.7100	38.7100	1.80
						Ice	45.3900	45.3900	2.26

ATMPP1412D-1CWA	A	From Leg	4.0000	0.0000	205.0000	No Ice	1.0005	0.3823	0.01
			0.00			1/2"	1.1292	0.4766	0.02
			2.00			Ice	1.2653	0.5780	0.03
ATMPP1412D-1CWA	B	From Leg	4.0000	0.0000	205.0000	1" Ice	1.0005	0.3823	0.01
			0.00			1/2"	1.1292	0.4766	0.02
			2.00			Ice	1.2653	0.5780	0.03
ATMPP1412D-1CWA	C	From Leg	4.0000	0.0000	205.0000	1" Ice	1.0005	0.3823	0.01
			0.00			1/2"	1.1292	0.4766	0.02
			2.00			Ice	1.2653	0.5780	0.03
APXV18-206516S-C-A20 w/ Mount Pipe	A	From Leg	4.0000	0.0000	205.0000	1" Ice	3.8586	3.2963	0.04
			0.00			1/2"	4.2736	4.0044	0.07
			2.00			Ice	4.6737	4.6717	0.11
APXV18-206516S-C-A20 w/ Mount Pipe	B	From Leg	4.0000	0.0000	205.0000	1" Ice	3.8586	3.2963	0.04
			0.00			1/2"	4.2736	4.0044	0.07
			2.00			Ice	4.6737	4.6717	0.11
APXV18-206516S-C-A20 w/ Mount Pipe	C	From Leg	4.0000	0.0000	205.0000	1" Ice	3.8586	3.2963	0.04
			0.00			1/2"	4.2736	4.0044	0.07
			2.00			Ice	4.6737	4.6717	0.11
LNX-6515DS-A1M w/ Mount Pipe	A	From Leg	4.0000	0.0000	205.0000	1" Ice	11.6828	9.8418	0.08
			0.00			1/2"	12.4043	11.3657	0.17
			2.00			Ice	13.1351	12.9138	0.27
LNX-6515DS-A1M w/ Mount Pipe	B	From Leg	4.0000	0.0000	205.0000	1" Ice	11.6828	9.8418	0.08
			0.00			1/2"	12.4043	11.3657	0.17
			2.00			Ice	13.1351	12.9138	0.27

Description	Face or Leg	Offset Type	Offsets:		Azimuth Adjustment	Placement	C _{AA}		Weight	
			Horz	Lateral			Front	Side		
			ft	ft	°	ft	ft ²	ft ²	K	
LNX-6515DS-A1M w/ Mount Pipe	C	From Leg	4.0000	0.0000	0.0000	205.0000	No Ice	11.6828	9.8418	0.08
			0.00				1/2"	12.4043	11.3657	0.17
			2.00				Ice	13.1351	12.9138	0.27
							1" Ice			
ATSBT-TOP-MF-4G	A	From Leg	4.0000	0.0000	0.0000	205.0000	No Ice	0.1736	0.0949	0.00
			0.00				1/2"	0.2291	0.1399	0.00
			2.00				Ice	0.2921	0.1934	0.01
							1" Ice			
ATSBT-TOP-MF-4G	B	From Leg	4.0000	0.0000	0.0000	205.0000	No Ice	0.1736	0.0949	0.00
			0.00				1/2"	0.2291	0.1399	0.00
			2.00				Ice	0.2921	0.1934	0.01
							1" Ice			
ATSBT-TOP-MF-4G	C	From Leg	4.0000	0.0000	0.0000	205.0000	No Ice	0.1736	0.0949	0.00
			0.00				1/2"	0.2291	0.1399	0.00
			2.00				Ice	0.2921	0.1934	0.01
							1" Ice			
8-ft Ladder	C	From Leg	2.0000	0.0000	0.0000	205.0000	No Ice	7.0700	7.0700	0.04
			0.00				1/2"	9.7300	9.7300	0.07
			-2.00				Ice	11.1900	11.1900	0.08
							1" Ice			
Platform Mount [LP 601-1]	C	None			0.0000	205.0000	No Ice	28.4700	28.4700	1.12
							1/2"	33.5900	33.5900	1.51
							Ice	38.7100	38.7100	1.91
							1" Ice			

AM-X-CD-16-65-00T-RET w/ Mount Pipe	A	From Leg	4.0000	0.0000	0.0000	193.0000	No Ice	8.2619	6.3042	0.07
			0.00				1/2"	8.8215	7.4790	0.14
			2.00				Ice	9.3462	8.3676	0.21
							1" Ice			
AM-X-CD-16-65-00T-RET w/ Mount Pipe	B	From Leg	4.0000	0.0000	0.0000	193.0000	No Ice	8.2619	6.3042	0.07
			0.00				1/2"	8.8215	7.4790	0.14
			2.00				Ice	9.3462	8.3676	0.21
							1" Ice			
AM-X-CD-16-65-00T-RET w/ Mount Pipe	C	From Leg	4.0000	0.0000	0.0000	193.0000	No Ice	8.2619	6.3042	0.07
			0.00				1/2"	8.8215	7.4790	0.14
			2.00				Ice	9.3462	8.3676	0.21
							1" Ice			
OPA-65R-LCUU-H6 w/ Mount Pipe	A	From Leg	4.0000	0.0000	0.0000	193.0000	No Ice	9.8953	7.1792	0.10
			0.00				1/2"	10.4700	8.3621	0.18
			2.00				Ice	11.0098	9.2588	0.26
							1" Ice			
OPA-65R-LCUU-H6 w/ Mount Pipe	B	From Leg	4.0000	0.0000	0.0000	193.0000	No Ice	9.8953	7.1792	0.10
			0.00				1/2"	10.4700	8.3621	0.18
			2.00				Ice	11.0098	9.2588	0.26
							1" Ice			
OPA-65R-LCUU-H6 w/ Mount Pipe	C	From Leg	4.0000	0.0000	0.0000	193.0000	No Ice	9.8953	7.1792	0.10
			0.00				1/2"	10.4700	8.3621	0.18
			2.00				Ice	11.0098	9.2588	0.26
							1" Ice			
800 10121 w/ Mount Pipe	A	From Leg	4.0000	0.0000	0.0000	193.0000	No Ice	5.7362	4.9479	0.07
			0.00				1/2"	6.3448	6.0222	0.12
			2.00				Ice	6.8570	6.8104	0.18
							1" Ice			
800 10121 w/ Mount Pipe	B	From Leg	4.0000	0.0000	0.0000	193.0000	No Ice	5.7362	4.9479	0.07
			0.00				1/2"	6.3448	6.0222	0.12
			2.00				Ice	6.8570	6.8104	0.18
							1" Ice			
800 10121 w/ Mount Pipe	C	From Leg	4.0000	0.0000	0.0000	193.0000	No Ice	5.7362	4.9479	0.07
			0.00				1/2"	6.3448	6.0222	0.12
			2.00				Ice	6.8570	6.8104	0.18
							1" Ice			
(2) DTMABP7819VG12A	A	From Leg	4.0000	0.0000	0.0000	193.0000	No Ice	0.9762	0.3387	0.02
			0.00				1/2"	1.1002	0.4192	0.03
			2.00				Ice	1.2316	0.5098	0.04
							1" Ice			

Description	Face or Leg	Offset Type	Offsets:		Azimuth Adjustment	Placement	C _{AA} Front	C _{AA} Side	Weight
			Horz	Lateral					
			ft	ft	°	ft	ft ²	ft ²	K
(2) DTMABP7819VG12A	B	From Leg	4.0000	0.0000	193.0000	No Ice	0.9762	0.3387	0.02
			0.00			1/2"	1.1002	0.4192	0.03
			2.00			Ice	1.2316	0.5098	0.04
(2) DTMABP7819VG12A	C	From Leg	4.0000	0.0000	193.0000	No Ice	0.9762	0.3387	0.02
			0.00			1/2"	1.1002	0.4192	0.03
			2.00			Ice	1.2316	0.5098	0.04
RRUS A2 MODULE	A	From Leg	4.0000	0.0000	193.0000	No Ice	1.6000	0.3797	0.02
			0.00			1/2"	1.7581	0.4701	0.03
			2.00			Ice	1.9237	0.5675	0.04
RRUS A2 MODULE	B	From Leg	4.0000	0.0000	193.0000	No Ice	1.6000	0.3797	0.02
			0.00			1/2"	1.7581	0.4701	0.03
			2.00			Ice	1.9237	0.5675	0.04
RRUS A2 MODULE	C	From Leg	4.0000	0.0000	193.0000	No Ice	1.6000	0.3797	0.02
			0.00			1/2"	1.7581	0.4701	0.03
			2.00			Ice	1.9237	0.5675	0.04
RRUS 12-B2	A	From Leg	4.0000	0.0000	193.0000	No Ice	3.1435	1.2816	0.06
			0.00			1/2"	3.3632	1.4340	0.08
			2.00			Ice	3.5904	1.5955	0.11
RRUS 12-B2	B	From Leg	4.0000	0.0000	193.0000	No Ice	3.1435	1.2816	0.06
			0.00			1/2"	3.3632	1.4340	0.08
			2.00			Ice	3.5904	1.5955	0.11
RRUS 12-B2	C	From Leg	4.0000	0.0000	193.0000	No Ice	3.1435	1.2816	0.06
			0.00			1/2"	3.3632	1.4340	0.08
			2.00			Ice	3.5904	1.5955	0.11
(2) 860 10025	A	From Leg	4.0000	0.0000	193.0000	No Ice	0.1369	0.1157	0.00
			0.00			1/2"	0.1901	0.1669	0.00
			2.00			Ice	0.2523	0.2252	0.01
(2) 860 10025	B	From Leg	4.0000	0.0000	193.0000	No Ice	0.1369	0.1157	0.00
			0.00			1/2"	0.1901	0.1669	0.00
			2.00			Ice	0.2523	0.2252	0.01
(2) 860 10025	C	From Leg	4.0000	0.0000	193.0000	No Ice	0.1369	0.1157	0.00
			0.00			1/2"	0.1901	0.1669	0.00
			2.00			Ice	0.2523	0.2252	0.01
RRUS 11	A	From Leg	4.0000	0.0000	193.0000	No Ice	2.7908	1.1923	0.05
			0.00			1/2"	2.9984	1.3395	0.07
			2.00			Ice	3.2134	1.4957	0.10
RRUS 11	B	From Leg	4.0000	0.0000	193.0000	No Ice	2.7908	1.1923	0.05
			0.00			1/2"	2.9984	1.3395	0.07
			2.00			Ice	3.2134	1.4957	0.10
RRUS 11	C	From Leg	4.0000	0.0000	193.0000	No Ice	2.7908	1.1923	0.05
			0.00			1/2"	2.9984	1.3395	0.07
			2.00			Ice	3.2134	1.4957	0.10
DC6-48-60-18-8F	B	From Leg	4.0000	0.0000	193.0000	No Ice	0.9167	0.9167	0.02
			0.00			1/2"	1.4583	1.4583	0.04
			2.00			Ice	1.6431	1.6431	0.06
8-ft Ladder	C	From Leg	2.0000	0.0000	193.0000	No Ice	7.0700	7.0700	0.04
			0.00			1/2"	9.7300	9.7300	0.07
			-2.00			Ice	11.1900	11.1900	0.08
Platform Mount [LP 601-1]	C	None		0.0000	193.0000	No Ice	28.4700	28.4700	1.12

Description	Face or Leg	Offset Type	Offsets: Horz Lateral Vert ft ft ft	Azimuth Adjustment t °	Placement ft	C _{AA} Front ft ²	C _{AA} Side ft ²	Weight K	
						1/2"	33.5900	33.5900	1.51
						Ice	38.7100	38.7100	1.91
						1" Ice			

APXV18-206517S-C w/ Mount Pipe	A	From Leg	4.0000 0.00 2.00	0.0000	185.0000	No Ice	5.4042	4.7000	0.05
						1/2"	5.9597	5.8600	0.10
						Ice	6.4808	6.7338	0.15
						1" Ice			
APXV18-206517S-C w/ Mount Pipe	B	From Leg	4.0000 0.00 2.00	0.0000	185.0000	No Ice	5.4042	4.7000	0.05
						1/2"	5.9597	5.8600	0.10
						Ice	6.4808	6.7338	0.15
						1" Ice			
APXV18-206517S-C w/ Mount Pipe	C	From Leg	4.0000 0.00 2.00	0.0000	185.0000	No Ice	5.4042	4.7000	0.05
						1/2"	5.9597	5.8600	0.10
						Ice	6.4808	6.7338	0.15
						1" Ice			
978QNB120E-M w/ Mount Pipe	A	From Leg	4.0000 0.00 2.00	0.0000	185.0000	No Ice	7.8255	5.1455	0.06
						1/2"	8.2838	5.9157	0.12
						Ice	8.7366	6.6150	0.19
						1" Ice			
978QNB120E-M w/ Mount Pipe	B	From Leg	4.0000 0.00 2.00	0.0000	185.0000	No Ice	7.8255	5.1455	0.06
						1/2"	8.2838	5.9157	0.12
						Ice	8.7366	6.6150	0.19
						1" Ice			
978QNB120E-M w/ Mount Pipe	C	From Leg	4.0000 0.00 2.00	0.0000	185.0000	No Ice	7.8255	5.1455	0.06
						1/2"	8.2838	5.9157	0.12
						Ice	8.7366	6.6150	0.19
						1" Ice			
(2) FV90-16-02DP w/ Mount Pipe	A	From Leg	4.0000 0.00 2.00	0.0000	185.0000	No Ice	4.5931	3.3194	0.04
						1/2"	5.0183	4.0888	0.08
						Ice	5.4362	4.7844	0.12
						1" Ice			
(2) FV90-16-02DP w/ Mount Pipe	B	From Leg	4.0000 0.00 2.00	0.0000	185.0000	No Ice	4.5931	3.3194	0.04
						1/2"	5.0183	4.0888	0.08
						Ice	5.4362	4.7844	0.12
						1" Ice			
(2) FV90-16-02DP w/ Mount Pipe	C	From Leg	4.0000 0.00 2.00	0.0000	185.0000	No Ice	4.5931	3.3194	0.04
						1/2"	5.0183	4.0888	0.08
						Ice	5.4362	4.7844	0.12
						1" Ice			
CS72993.07	A	From Leg	4.0000 0.00 2.00	0.0000	185.0000	No Ice	1.2250	0.3887	0.02
						1/2"	1.3648	0.4841	0.03
						Ice	1.5120	0.5866	0.04
						1" Ice			
CS72993.07	B	From Leg	4.0000 0.00 2.00	0.0000	185.0000	No Ice	1.2250	0.3887	0.02
						1/2"	1.3648	0.4841	0.03
						Ice	1.5120	0.5866	0.04
						1" Ice			
CS72993.07	C	From Leg	4.0000 0.00 2.00	0.0000	185.0000	No Ice	1.2250	0.3887	0.02
						1/2"	1.3648	0.4841	0.03
						Ice	1.5120	0.5866	0.04
						1" Ice			
8-ft Ladder	C	From Leg	2.0000 0.00 -2.00	0.0000	185.0000	No Ice	7.0700	7.0700	0.04
						1/2"	9.7300	9.7300	0.07
						Ice	11.1900	11.1900	0.08
						1" Ice			
Platform Mount [LP 601-1]	C	None		0.0000	185.0000	No Ice	28.4700	28.4700	1.12
						1/2"	33.5900	33.5900	1.51
						Ice	38.7100	38.7100	1.91
						1" Ice			

TME-800MHZ RRH	A	From Leg	2.0000 0.00 0.00	0.0000	177.0000	No Ice	2.1342	1.7730	0.05
						1/2"	2.3195	1.9461	0.07
						Ice	2.5123	2.1267	0.10
						1" Ice			

Description	Face or Leg	Offset Type	Offsets: Horz Lateral Vert ft ft ft	Azimuth Adjustment t °	Placement ft		C _{AA} Front ft ²	C _{AA} Side ft ²	Weight K
TME-800MHZ RRH	B	From Leg	2.0000	0.0000	177.0000	No Ice	2.1342	1.7730	0.05
			0.00			1/2"	2.3195	1.9461	0.07
			0.00			Ice	2.5123	2.1267	0.10
TME-800MHZ RRH	C	From Leg	2.0000	0.0000	177.0000	No Ice	2.1342	1.7730	0.05
			0.00			1/2"	2.3195	1.9461	0.07
			0.00			Ice	2.5123	2.1267	0.10
TME-1900MHz RRH (65 MHz)	A	From Leg	2.0000	0.0000	177.0000	No Ice	2.3125	2.3750	0.06
			0.00			1/2"	2.5168	2.5809	0.08
			0.00			Ice	2.7284	2.7943	0.11
TME-1900MHz RRH (65 MHz)	B	From Leg	2.0000	0.0000	177.0000	No Ice	2.3125	2.3750	0.06
			0.00			1/2"	2.5168	2.5809	0.08
			0.00			Ice	2.7284	2.7943	0.11
TME-1900MHz RRH (65 MHz)	C	From Leg	2.0000	0.0000	177.0000	No Ice	2.3125	2.3750	0.06
			0.00			1/2"	2.5168	2.5809	0.08
			0.00			Ice	2.7284	2.7943	0.11
Side Arm Mount [SO 102-3]	C	None		0.0000	177.0000	No Ice	3.0000	3.0000	0.08
						1/2"	3.4800	3.4800	0.11
						Ice	3.9600	3.9600	0.14

APXVSP18-C-A20 w/ Mount Pipe	A	From Leg	4.0000	0.0000	175.0000	No Ice	8.2619	6.9458	0.08
			0.00			1/2"	8.8215	8.1266	0.15
			0.00			Ice	9.3462	9.0212	0.23
APXVSP18-C-A20 w/ Mount Pipe	B	From Leg	4.0000	0.0000	175.0000	No Ice	8.2619	6.9458	0.08
			0.00			1/2"	8.8215	8.1266	0.15
			0.00			Ice	9.3462	9.0212	0.23
APXVSP18-C-A20 w/ Mount Pipe	C	From Leg	4.0000	0.0000	175.0000	No Ice	8.2619	6.9458	0.08
			0.00			1/2"	8.8215	8.1266	0.15
			0.00			Ice	9.3462	9.0212	0.23
800 EXTERNAL NOTCH FILTER	A	From Leg	4.0000	0.0000	175.0000	No Ice	0.6601	0.3211	0.01
			0.00			1/2"	0.7627	0.3983	0.02
			0.00			Ice	0.8727	0.4830	0.02
800 EXTERNAL NOTCH FILTER	B	From Leg	4.0000	0.0000	175.0000	No Ice	0.6601	0.3211	0.01
			0.00			1/2"	0.7627	0.3983	0.02
			0.00			Ice	0.8727	0.4830	0.02
800 EXTERNAL NOTCH FILTER	C	From Leg	4.0000	0.0000	175.0000	No Ice	0.6601	0.3211	0.01
			0.00			1/2"	0.7627	0.3983	0.02
			0.00			Ice	0.8727	0.4830	0.02
(3) ACU-A20-N	A	From Leg	4.0000	0.0000	175.0000	No Ice	0.0667	0.1167	0.00
			0.00			1/2"	0.1037	0.1620	0.00
			0.00			Ice	0.1481	0.2148	0.00
(3) ACU-A20-N	B	From Leg	4.0000	0.0000	175.0000	No Ice	0.0667	0.1167	0.00
			0.00			1/2"	0.1037	0.1620	0.00
			0.00			Ice	0.1481	0.2148	0.00
(3) ACU-A20-N	C	From Leg	4.0000	0.0000	175.0000	No Ice	0.0667	0.1167	0.00
			0.00			1/2"	0.1037	0.1620	0.00
			0.00			Ice	0.1481	0.2148	0.00
(2) 2.375" OD x 6' Mount Pipe	A	From Leg	4.0000	0.0000	175.0000	No Ice	1.4250	1.4250	0.03
			0.00			1/2"	1.9250	1.9250	0.04
			0.00			Ice	2.2939	2.2939	0.05

Description	Face or Leg	Offset Type	Offsets: Horz Lateral Vert ft ft ft	Azimuth Adjustment t °	Placement ft	C _{AA} Front ft ²	C _{AA} Side ft ²	Weight K	
(2) 2.375" OD x 6' Mount Pipe	B	From Leg	4.0000 0.00 0.00	0.0000	175.0000	No Ice	1.4250	1.4250	0.03
						1/2"	1.9250	1.9250	0.04
						Ice	2.2939	2.2939	0.05
(2) 2.375" OD x 6' Mount Pipe	C	From Leg	4.0000 0.00 0.00	0.0000	175.0000	No Ice	1.4250	1.4250	0.03
						1/2"	1.9250	1.9250	0.04
						Ice	2.2939	2.2939	0.05
Platform Mount [LP 1201-1]	C	None		0.0000	175.0000	No Ice	23.1000	23.1000	2.10
						1/2"	26.8000	26.8000	2.50
						Ice	30.5000	30.5000	2.90
*** GPS_A	A	From Leg	3.0000 0.00 1.00	0.0000	72.0000	No Ice	0.2550	0.2550	0.00
						1/2"	0.3205	0.3205	0.00
						Ice	0.3934	0.3934	0.01
Side Arm Mount [SO 701-1]	A	None		0.0000	72.0000	No Ice	0.8500	1.6700	0.07
						1/2"	1.1400	2.3400	0.08
						Ice	1.4300	3.0100	0.09
						1" Ice			

Tower Pressures - No Ice

$G_H = 1.100$

Section Elevation ft	z ft	K _z	q _z psf	A _G ft ²	F a c e	A _F ft ²	A _R ft ²	A _{leg} ft ²	Leg %	C _{AA} In Face ft ²	C _{AA} Out Face ft ²
L1 226.0000-197.9600	211.3121	1.224	26	59.520	A	0.000	59.520	59.520	100.00	0.000	0.000
					B	0.000	59.520	100.00	0.000	0.000	
					C	0.000	59.520	100.00	0.000	0.000	
L2 197.9600-162.9100	179.7664	1.169	25	96.986	A	0.000	96.986	96.986	100.00	0.000	0.000
					B	0.000	96.986	100.00	0.000	0.000	
					C	0.000	96.986	100.00	0.000	5.614	
L3 162.9100-120.2900	140.9127	1.09	23	150.59 2	A	0.000	150.592	150.592	100.00	0.000	0.000
					B	0.000	150.592	100.00	0.000	0.000	
					C	0.000	150.592	100.00	0.000	10.105	
L4 120.2900-79.2100	99.3630	0.986	21	178.83 6	A	0.000	178.836	178.836	100.00	0.000	0.000
					B	0.000	178.836	100.00	0.000	0.000	
					C	0.000	178.836	100.00	0.000	8.134	
L5 79.2100-39.1300	59.1030	0.85	18	205.83 3	A	0.000	205.833	205.833	100.00	0.000	0.000
					B	0.000	205.833	100.00	0.000	0.000	
					C	0.000	205.833	100.00	0.000	7.936	
L6 39.1300-0.0000	19.1021	0.7	15	230.33 0	A	0.000	230.330	230.330	100.00	0.000	0.000
					B	0.000	230.330	100.00	0.000	0.000	
					C	0.000	230.330	100.00	0.000	7.748	

Tower Pressure - With Ice

$G_H = 1.100$

Section Elevation ft	z ft	K _z	q _z psf	t _z in	A _G ft ²	F a c e	A _F ft ²	A _R ft ²	A _{leg} ft ²	Leg %	C _A A _A In Face ft ²	C _A A _A Out Face ft ²
L1 226.0000-197.9600	211.3121	1.224	7	1.8061	67.960	A	0.000	67.960	67.960	100.00	0.000	0.000
						B	0.000	67.960		100.00	0.000	0.000
						C	0.000	67.960		100.00	0.000	0.000
L2 197.9600-162.9100	179.7664	1.169	7	1.7771	107.536	A	0.000	107.536	107.536	100.00	0.000	0.000
						B	0.000	107.536		100.00	0.000	0.000
						C	0.000	107.536		100.00	0.000	16.483
L3 162.9100-120.2900	140.9127	1.09	7	1.7343	163.215	A	0.000	163.215	163.215	100.00	0.000	0.000
						B	0.000	163.215		100.00	0.000	0.000
						C	0.000	163.215		100.00	0.000	29.202
L4 120.2900-79.2100	99.3630	0.986	6	1.6748	190.710	A	0.000	190.710	190.710	100.00	0.000	0.000
						B	0.000	190.710		100.00	0.000	0.000
						C	0.000	190.710		100.00	0.000	22.383
L5 79.2100-39.1300	59.1030	0.85	5	1.5900	217.021	A	0.000	217.021	217.021	100.00	0.000	0.000
						B	0.000	217.021		100.00	0.000	0.000
						C	0.000	217.021		100.00	0.000	21.361
L6 39.1300-0.0000	19.1021	0.7	4	1.4202	240.699	A	0.000	240.699	240.699	100.00	0.000	0.000
						B	0.000	240.699		100.00	0.000	0.000
						C	0.000	240.699		100.00	0.000	20.191

Tower Pressure - Service

$G_H = 1.100$

Section Elevation ft	z ft	K _z	q _z psf	A _G ft ²	F a c e	A _F ft ²	A _R ft ²	A _{leg} ft ²	Leg %	C _A A _A In Face ft ²	C _A A _A Out Face ft ²
L1 226.0000-197.9600	211.3121	1.224	10	59.520	A	0.000	59.520	59.520	100.00	0.000	0.000
					B	0.000	59.520		100.00	0.000	0.000
					C	0.000	59.520		100.00	0.000	0.000
L2 197.9600-162.9100	179.7664	1.169	9	96.986	A	0.000	96.986	96.986	100.00	0.000	0.000
					B	0.000	96.986		100.00	0.000	0.000
					C	0.000	96.986		100.00	0.000	5.614
L3 162.9100-120.2900	140.9127	1.09	9	150.59	A	0.000	150.592	150.592	100.00	0.000	0.000
				2	B	0.000	150.592		100.00	0.000	0.000
					C	0.000	150.592		100.00	0.000	10.105
L4 120.2900-79.2100	99.3630	0.986	8	178.83	A	0.000	178.836	178.836	100.00	0.000	0.000
				6	B	0.000	178.836		100.00	0.000	0.000
					C	0.000	178.836		100.00	0.000	8.134
L5 79.2100-39.1300	59.1030	0.85	7	205.83	A	0.000	205.833	205.833	100.00	0.000	0.000
				3	B	0.000	205.833		100.00	0.000	0.000
					C	0.000	205.833		100.00	0.000	7.936
L6 39.1300-0.0000	19.1021	0.7	5	230.33	A	0.000	230.330	230.330	100.00	0.000	0.000
				0	B	0.000	230.330		100.00	0.000	0.000
					C	0.000	230.330		100.00	0.000	7.748

Load Combinations

Comb. No.	Description
1	Dead Only
2	1.2 Dead+1.6 Wind 0 deg - No Ice
3	0.9 Dead+1.6 Wind 0 deg - No Ice
4	1.2 Dead+1.6 Wind 30 deg - No Ice
5	0.9 Dead+1.6 Wind 30 deg - No Ice
6	1.2 Dead+1.6 Wind 60 deg - No Ice
7	0.9 Dead+1.6 Wind 60 deg - No Ice
8	1.2 Dead+1.6 Wind 90 deg - No Ice
9	0.9 Dead+1.6 Wind 90 deg - No Ice
10	1.2 Dead+1.6 Wind 120 deg - No Ice
11	0.9 Dead+1.6 Wind 120 deg - No Ice

Comb. No.	Description
12	1.2 Dead+1.6 Wind 150 deg - No Ice
13	0.9 Dead+1.6 Wind 150 deg - No Ice
14	1.2 Dead+1.6 Wind 180 deg - No Ice
15	0.9 Dead+1.6 Wind 180 deg - No Ice
16	1.2 Dead+1.6 Wind 210 deg - No Ice
17	0.9 Dead+1.6 Wind 210 deg - No Ice
18	1.2 Dead+1.6 Wind 240 deg - No Ice
19	0.9 Dead+1.6 Wind 240 deg - No Ice
20	1.2 Dead+1.6 Wind 270 deg - No Ice
21	0.9 Dead+1.6 Wind 270 deg - No Ice
22	1.2 Dead+1.6 Wind 300 deg - No Ice
23	0.9 Dead+1.6 Wind 300 deg - No Ice
24	1.2 Dead+1.6 Wind 330 deg - No Ice
25	0.9 Dead+1.6 Wind 330 deg - No Ice
26	1.2 Dead+1.0 Ice+1.0 Temp
27	1.2 Dead+1.0 Wind 0 deg+1.0 Ice+1.0 Temp
28	1.2 Dead+1.0 Wind 30 deg+1.0 Ice+1.0 Temp
29	1.2 Dead+1.0 Wind 60 deg+1.0 Ice+1.0 Temp
30	1.2 Dead+1.0 Wind 90 deg+1.0 Ice+1.0 Temp
31	1.2 Dead+1.0 Wind 120 deg+1.0 Ice+1.0 Temp
32	1.2 Dead+1.0 Wind 150 deg+1.0 Ice+1.0 Temp
33	1.2 Dead+1.0 Wind 180 deg+1.0 Ice+1.0 Temp
34	1.2 Dead+1.0 Wind 210 deg+1.0 Ice+1.0 Temp
35	1.2 Dead+1.0 Wind 240 deg+1.0 Ice+1.0 Temp
36	1.2 Dead+1.0 Wind 270 deg+1.0 Ice+1.0 Temp
37	1.2 Dead+1.0 Wind 300 deg+1.0 Ice+1.0 Temp
38	1.2 Dead+1.0 Wind 330 deg+1.0 Ice+1.0 Temp
39	Dead+Wind 0 deg - Service
40	Dead+Wind 30 deg - Service
41	Dead+Wind 60 deg - Service
42	Dead+Wind 90 deg - Service
43	Dead+Wind 120 deg - Service
44	Dead+Wind 150 deg - Service
45	Dead+Wind 180 deg - Service
46	Dead+Wind 210 deg - Service
47	Dead+Wind 240 deg - Service
48	Dead+Wind 270 deg - Service
49	Dead+Wind 300 deg - Service
50	Dead+Wind 330 deg - Service

Maximum Member Forces

Section No.	Elevation ft	Component Type	Condition	Gov. Load Comb.	Axial K	Major Axis Moment kip-ft	Minor Axis Moment kip-ft
L1	226 - 197.96	Pole	Max Tension	26	0.00	-0.00	0.00
			Max. Compression	26	-19.13	2.77	-1.61
			Max. Mx	20	-6.26	239.40	-3.31
			Max. My	14	-6.28	3.55	-235.67
			Max. Vy	20	-13.24	239.40	-3.31
			Max. Vx	14	13.11	3.55	-235.67
			Max. Torque	12			-3.04
			Max Tension	1	0.00	0.00	0.00
L2	197.96 - 162.91	Pole	Max. Compression	26	-51.54	5.79	-3.90
			Max. Mx	20	-20.84	959.93	-7.70
			Max. My	14	-20.86	7.98	-951.52
			Max. Vy	20	-28.21	959.93	-7.70
			Max. Vx	14	28.07	7.98	-951.52
			Max. Torque	24			5.25
			Max Tension	1	0.00	0.00	0.00
			L3	162.91 - 120.29	Pole	Max. Compression	26
Max. Mx	20	-34.04				2216.68	-13.27
Max. My	14	-34.06				13.92	-2202.15
Max. Vy	20	-32.49				2216.68	-13.27
Max. Vx	14	32.35				13.92	-2202.15

Section No.	Elevation ft	Component Type	Condition	Gov. Load Comb.	Axial K	Major Axis Moment kip-ft	Minor Axis Moment kip-ft
L4	120.29 - 79.21	Pole	Max. Torque	24			5.89
			Max Tension	1	0.00	0.00	0.00
			Max. Compression	26	-96.35	19.02	-11.59
			Max. Mx	20	-51.28	3600.55	-18.53
			Max. My	14	-51.29	19.49	-3580.16
			Max. Vy	20	-36.70	3600.55	-18.53
			Max. Vx	14	36.56	19.49	-3580.16
L5	79.21 - 39.13	Pole	Max. Torque	24			6.50
			Max Tension	1	0.00	0.00	0.00
			Max. Compression	26	-126.33	26.30	-15.70
			Max. Mx	20	-73.30	5109.97	-23.60
			Max. My	14	-73.31	24.86	-5083.92
			Max. Vy	20	-40.62	5109.97	-23.60
			Max. Vx	14	40.48	24.86	-5083.92
L6	39.13 - 0	Pole	Max. Torque	24			7.09
			Max Tension	1	0.00	0.00	0.00
			Max. Compression	26	-167.13	35.32	-20.91
			Max. Mx	20	-104.56	7149.36	-29.69
			Max. My	14	-104.56	31.37	-7116.51
			Max. Vy	20	-44.32	7149.36	-29.69
			Max. Vx	14	44.19	31.37	-7116.51
		Max. Torque	24			7.81	

Maximum Reactions

Location	Condition	Gov. Load Comb.	Vertical K	Horizontal, X K	Horizontal, Z K
Pole	Max. Vert	26	167.13	-0.00	0.00
	Max. H _x	21	78.44	44.28	-0.11
	Max. H _z	3	78.44	-0.11	44.15
	Max. M _x	2	7111.25	-0.11	44.15
	Max. M _z	8	7139.97	-44.27	0.11
	Max. Torsion	24	7.81	22.04	38.18
	Min. Vert	9	78.43	-44.28	0.11
	Min. H _x	9	78.43	-44.28	0.11
	Min. H _z	15	78.44	0.11	-44.15
	Min. M _x	14	-7116.51	0.11	-44.15
	Min. M _z	20	-7149.36	44.28	-0.11
	Min. Torsion	12	-7.81	-22.04	-38.18

Tower Mast Reaction Summary

Load Combination	Vertical K	Shear _x K	Shear _z K	Overtuning Moment, M _x kip-ft	Overtuning Moment, M _z kip-ft	Torque kip-ft
Dead Only	87.15	0.00	-0.00	2.07	3.41	-0.00
1.2 Dead+1.6 Wind 0 deg - No Ice	104.58	0.11	-44.15	-7111.25	-22.81	-6.68
0.9 Dead+1.6 Wind 0 deg - No Ice	78.44	0.11	-44.15	-7024.59	-23.52	-6.67
1.2 Dead+1.6 Wind 30 deg - No Ice	104.58	22.24	-38.29	-6172.21	-3592.03	-3.78
0.9 Dead+1.6 Wind 30 deg - No Ice	78.44	22.24	-38.29	-6096.82	-3548.76	-3.77
1.2 Dead+1.6 Wind 60 deg - No Ice	104.58	38.40	-22.17	-3578.04	-6197.57	0.12
0.9 Dead+1.6 Wind 60 deg - No Ice	78.44	38.40	-22.17	-3534.57	-6122.21	0.12

Load Combination	Vertical K	Shear _x K	Shear _z K	Overturning Moment, M _x kip-ft	Overturning Moment, M _z kip-ft	Torque kip-ft
1.2 Dead+1.6 Wind 90 deg - No Ice	104.58	44.27	-0.11	-24.48	-7139.97	3.99
0.9 Dead+1.6 Wind 90 deg - No Ice	78.43	44.28	-0.11	-24.76	-7053.54	3.98
1.2 Dead+1.6 Wind 120 deg - No Ice	104.58	38.29	21.98	3536.42	-6170.66	6.81
0.9 Dead+1.6 Wind 120 deg - No Ice	78.44	38.29	21.98	3492.29	-6095.71	6.79
1.2 Dead+1.6 Wind 150 deg - No Ice	104.58	22.04	38.18	6150.52	-3545.22	7.81
0.9 Dead+1.6 Wind 150 deg - No Ice	78.44	22.04	38.18	6074.15	-3502.64	7.79
1.2 Dead+1.6 Wind 180 deg - No Ice	104.58	-0.11	44.15	7116.51	31.37	6.71
0.9 Dead+1.6 Wind 180 deg - No Ice	78.44	-0.11	44.15	7028.47	29.85	6.70
1.2 Dead+1.6 Wind 210 deg - No Ice	104.58	-22.24	38.29	6177.50	3600.64	3.81
0.9 Dead+1.6 Wind 210 deg - No Ice	78.44	-22.24	38.29	6100.75	3555.14	3.80
1.2 Dead+1.6 Wind 240 deg - No Ice	104.58	-38.40	22.17	3583.29	6206.22	-0.12
0.9 Dead+1.6 Wind 240 deg - No Ice	78.44	-38.40	22.17	3538.45	6128.60	-0.12
1.2 Dead+1.6 Wind 270 deg - No Ice	104.58	-44.28	0.11	29.69	7149.36	-4.03
0.9 Dead+1.6 Wind 270 deg - No Ice	78.44	-44.28	0.11	28.61	7060.43	-4.01
1.2 Dead+1.6 Wind 300 deg - No Ice	104.58	-38.29	-21.98	-3531.25	6179.26	-6.84
0.9 Dead+1.6 Wind 300 deg - No Ice	78.44	-38.29	-21.98	-3488.46	6102.05	-6.82
1.2 Dead+1.6 Wind 330 deg - No Ice	104.58	-22.04	-38.18	-6145.32	3553.78	-7.81
0.9 Dead+1.6 Wind 330 deg - No Ice	78.44	-22.04	-38.18	-6070.33	3508.98	-7.79
1.2 Dead+1.0 Ice+1.0 Temp	167.13	0.00	-0.00	20.91	35.32	-0.00
1.2 Dead+1.0 Wind 0 deg+1.0 Ice+1.0 Temp	167.13	0.02	-14.75	-2405.26	29.86	-2.66
1.2 Dead+1.0 Wind 30 deg+1.0 Ice+1.0 Temp	167.13	7.41	-12.79	-2083.06	-1185.86	-1.49
1.2 Dead+1.0 Wind 60 deg+1.0 Ice+1.0 Temp	167.13	12.81	-7.40	-1197.07	-2074.29	0.07
1.2 Dead+1.0 Wind 90 deg+1.0 Ice+1.0 Temp	167.13	14.78	-0.02	15.33	-2397.37	1.61
1.2 Dead+1.0 Wind 120 deg+1.0 Ice+1.0 Temp	167.13	12.79	7.36	1229.40	-2068.74	2.73
1.2 Dead+1.0 Wind 150 deg+1.0 Ice+1.0 Temp	167.13	7.37	12.76	2119.49	-1175.89	3.11
1.2 Dead+1.0 Wind 180 deg+1.0 Ice+1.0 Temp	167.13	-0.02	14.75	2447.44	41.38	2.66
1.2 Dead+1.0 Wind 210 deg+1.0 Ice+1.0 Temp	167.13	-7.41	12.79	2125.47	1257.24	1.49
1.2 Dead+1.0 Wind 240 deg+1.0 Ice+1.0 Temp	167.13	-12.81	7.40	1239.38	2145.76	-0.07
1.2 Dead+1.0 Wind 270 deg+1.0 Ice+1.0 Temp	167.13	-14.78	0.02	26.85	2468.62	-1.62
1.2 Dead+1.0 Wind 300 deg+1.0 Ice+1.0 Temp	167.13	-12.79	-7.36	-1187.10	2139.79	-2.73
1.2 Dead+1.0 Wind 330 deg+1.0 Ice+1.0 Temp	167.13	-7.37	-12.77	-2077.52	1247.26	-3.11
Dead+Wind 0 deg - Service	87.15	0.03	-10.28	-1642.04	-2.67	-0.99
Dead+Wind 30 deg - Service	87.15	5.18	-8.91	-1424.89	-827.55	-0.55
Dead+Wind 60 deg - Service	87.15	8.94	-5.16	-825.35	-1429.73	0.03
Dead+Wind 90 deg - Service	87.15	10.31	-0.03	-4.08	-1647.86	0.60
Dead+Wind 120 deg - Service	87.15	8.91	5.12	818.87	-1423.48	1.02
Dead+Wind 150 deg - Service	87.15	5.13	8.89	1422.99	-816.72	1.16

Load Combination	Vertical	Shear _x	Shear _z	Overturning Moment, M _x	Overturning Moment, M _z	Torque
	K	K	K	kip-ft	kip-ft	kip-ft
Dead+Wind 180 deg - Service	87.15	-0.03	10.28	1646.40	9.84	0.99
Dead+Wind 210 deg - Service	87.15	-5.18	8.91	1429.24	834.72	0.55
Dead+Wind 240 deg - Service	87.15	-8.94	5.16	829.71	1436.90	-0.03
Dead+Wind 270 deg - Service	87.15	-10.31	0.03	8.43	1655.03	-0.60
Dead+Wind 300 deg - Service	87.15	-8.91	-5.12	-814.52	1430.65	-1.02
Dead+Wind 330 deg - Service	87.15	-5.13	-8.89	-1418.64	823.89	-1.16

Solution Summary

Load Comb.	Sum of Applied Forces			Sum of Reactions			% Error
	PX K	PY K	PZ K	PX K	PY K	PZ K	
1	0.00	-87.15	0.00	-0.00	87.15	0.00	0.000%
2	0.11	-104.58	-44.15	-0.11	104.58	44.15	0.003%
3	0.11	-78.44	-44.15	-0.11	78.44	44.15	0.003%
4	22.24	-104.58	-38.29	-22.24	104.58	38.29	0.000%
5	22.24	-78.44	-38.29	-22.24	78.44	38.29	0.000%
6	38.41	-104.58	-22.17	-38.40	104.58	22.17	0.000%
7	38.41	-78.44	-22.17	-38.40	78.44	22.17	0.000%
8	44.28	-104.58	-0.11	-44.27	104.58	0.11	0.007%
9	44.28	-78.44	-0.11	-44.28	78.43	0.11	0.006%
10	38.29	-104.58	21.98	-38.29	104.58	-21.98	0.000%
11	38.29	-78.44	21.98	-38.29	78.44	-21.98	0.000%
12	22.04	-104.58	38.18	-22.04	104.58	-38.18	0.000%
13	22.04	-78.44	38.18	-22.04	78.44	-38.18	0.000%
14	-0.11	-104.58	44.15	0.11	104.58	-44.15	0.003%
15	-0.11	-78.44	44.15	0.11	78.44	-44.15	0.003%
16	-22.24	-104.58	38.29	22.24	104.58	-38.29	0.000%
17	-22.24	-78.44	38.29	22.24	78.44	-38.29	0.000%
18	-38.41	-104.58	22.17	38.40	104.58	-22.17	0.000%
19	-38.41	-78.44	22.17	38.40	78.44	-22.17	0.000%
20	-44.28	-104.58	0.11	44.28	104.58	-0.11	0.003%
21	-44.28	-78.44	0.11	44.28	78.44	-0.11	0.003%
22	-38.29	-104.58	-21.98	38.29	104.58	21.98	0.000%
23	-38.29	-78.44	-21.98	38.29	78.44	21.98	0.000%
24	-22.04	-104.58	-38.18	22.04	104.58	38.18	0.000%
25	-22.04	-78.44	-38.18	22.04	78.44	38.18	0.000%
26	0.00	-167.13	0.00	-0.00	167.13	0.00	0.000%
27	0.02	-167.13	-14.75	-0.02	167.13	14.75	0.001%
28	7.41	-167.13	-12.79	-7.41	167.13	12.79	0.001%
29	12.81	-167.13	-7.40	-12.81	167.13	7.40	0.001%
30	14.78	-167.13	-0.02	-14.78	167.13	0.02	0.001%
31	12.79	-167.13	7.36	-12.79	167.13	-7.36	0.001%
32	7.37	-167.13	12.77	-7.37	167.13	-12.76	0.001%
33	-0.02	-167.13	14.75	0.02	167.13	-14.75	0.001%
34	-7.41	-167.13	12.79	7.41	167.13	-12.79	0.001%
35	-12.81	-167.13	7.40	12.81	167.13	-7.40	0.001%
36	-14.78	-167.13	0.02	14.78	167.13	-0.02	0.001%
37	-12.79	-167.13	-7.36	12.79	167.13	7.36	0.001%
38	-7.37	-167.13	-12.77	7.37	167.13	12.77	0.001%
39	0.03	-87.15	-10.28	-0.03	87.15	10.28	0.002%
40	5.18	-87.15	-8.91	-5.18	87.15	8.91	0.002%
41	8.94	-87.15	-5.16	-8.94	87.15	5.16	0.002%
42	10.31	-87.15	-0.03	-10.31	87.15	0.03	0.002%
43	8.91	-87.15	5.12	-8.91	87.15	-5.12	0.002%
44	5.13	-87.15	8.89	-5.13	87.15	-8.89	0.002%
45	-0.03	-87.15	10.28	0.03	87.15	-10.28	0.002%
46	-5.18	-87.15	8.91	5.18	87.15	-8.91	0.002%
47	-8.94	-87.15	5.16	8.94	87.15	-5.16	0.002%
48	-10.31	-87.15	0.03	10.31	87.15	-0.03	0.002%

Load Comb.	Sum of Applied Forces			Sum of Reactions			% Error
	PX K	PY K	PZ K	PX K	PY K	PZ K	
49	-8.91	-87.15	-5.12	8.91	87.15	5.12	0.002%
50	-5.13	-87.15	-8.89	5.13	87.15	8.89	0.002%

Non-Linear Convergence Results

Load Combination	Converged?	Number of Cycles	Displacement Tolerance	Force Tolerance
1	Yes	6	0.00000001	0.00000001
2	Yes	17	0.00005501	0.00010878
3	Yes	17	0.00003650	0.00009117
4	Yes	21	0.00000001	0.00009494
5	Yes	20	0.00000001	0.00014504
6	Yes	21	0.00000001	0.00009731
7	Yes	20	0.00000001	0.00014873
8	Yes	16	0.00010781	0.00012767
9	Yes	16	0.00007265	0.00011042
10	Yes	21	0.00000001	0.00009954
11	Yes	21	0.00000001	0.00007533
12	Yes	21	0.00000001	0.00009019
13	Yes	20	0.00000001	0.00013772
14	Yes	17	0.00005500	0.00013845
15	Yes	17	0.00003650	0.00011493
16	Yes	21	0.00000001	0.00010010
17	Yes	21	0.00000001	0.00007556
18	Yes	21	0.00000001	0.00009809
19	Yes	20	0.00000001	0.00014972
20	Yes	17	0.00005496	0.00009545
21	Yes	17	0.00003647	0.00007963
22	Yes	21	0.00000001	0.00009098
23	Yes	20	0.00000001	0.00013885
24	Yes	21	0.00000001	0.00010000
25	Yes	21	0.00000001	0.00007569
26	Yes	14	0.00000001	0.00001665
27	Yes	18	0.00010913	0.00010685
28	Yes	18	0.00010892	0.00014565
29	Yes	18	0.00010892	0.00014739
30	Yes	18	0.00010914	0.00010564
31	Yes	19	0.00005847	0.00008556
32	Yes	18	0.00010892	0.00014608
33	Yes	18	0.00010915	0.00010915
34	Yes	19	0.00005847	0.00008855
35	Yes	19	0.00005848	0.00008749
36	Yes	18	0.00010915	0.00010916
37	Yes	18	0.00010892	0.00014869
38	Yes	19	0.00005847	0.00008710
39	Yes	16	0.00008861	0.00002287
40	Yes	16	0.00008850	0.00002729
41	Yes	16	0.00008850	0.00003053
42	Yes	16	0.00008861	0.00002123
43	Yes	16	0.00008850	0.00003818
44	Yes	16	0.00008850	0.00002421
45	Yes	16	0.00008861	0.00002334
46	Yes	16	0.00008850	0.00003534
47	Yes	16	0.00008850	0.00003168
48	Yes	16	0.00008862	0.00002161
49	Yes	16	0.00008850	0.00002479
50	Yes	16	0.00008850	0.00003925

Maximum Tower Deflections - Service Wind

Section No.	Elevation ft	Horz. Deflection in	Gov. Load Comb.	Tilt °	Twist °
L1	226 - 197.96	34.185	47	1.5333	0.0094
L2	202.04 - 162.91	26.804	47	1.3750	0.0053
L3	168.08 - 120.29	17.808	47	1.1241	0.0028
L4	126.71 - 79.21	9.530	47	0.7656	0.0013
L5	86.8 - 39.13	4.291	47	0.4730	0.0006
L6	47.88 - 0	1.303	47	0.2461	0.0003

Critical Deflections and Radius of Curvature - Service Wind

Elevation ft	Appurtenance	Gov. Load Comb.	Deflection in	Tilt °	Twist °	Radius of Curvature ft
226.0000	Beacon	47	34.185	1.5333	0.0094	33125
205.0000	ATMPP1412D-1CWA	47	27.682	1.3950	0.0057	7908
193.0000	AM-X-CD-16-65-00T-RET w/ Mount Pipe	47	24.215	1.3126	0.0043	6956
185.0000	APXV18-206517S-C w/ Mount Pipe	47	22.042	1.2551	0.0037	6996
177.0000	TME-800MHZ RRH	47	19.979	1.1950	0.0032	7037
175.0000	APXVSPP18-C-A20 w/ Mount Pipe	47	19.481	1.1795	0.0031	7047
72.0000	GPS_A	47	2.916	0.3817	0.0005	9038

Maximum Tower Deflections - Design Wind

Section No.	Elevation ft	Horz. Deflection in	Gov. Load Comb.	Tilt °	Twist °
L1	226 - 197.96	147.389	18	6.6061	0.0430
L2	202.04 - 162.91	115.663	18	5.9357	0.0254
L3	168.08 - 120.29	76.907	18	4.8579	0.0143
L4	126.71 - 79.21	41.179	18	3.3100	0.0071
L5	86.8 - 39.13	18.544	18	2.0450	0.0036
L6	47.88 - 0	5.632	18	1.0636	0.0017

Critical Deflections and Radius of Curvature - Design Wind

Elevation ft	Appurtenance	Gov. Load Comb.	Deflection in	Tilt °	Twist °	Radius of Curvature ft
226.0000	Beacon	18	147.389	6.6061	0.0430	7985
205.0000	ATMPP1412D-1CWA	18	119.440	6.0208	0.0272	1903
193.0000	AM-X-CD-16-65-00T-RET w/ Mount Pipe	18	104.523	5.6690	0.0211	1664
185.0000	APXV18-206517S-C w/ Mount Pipe	18	95.163	5.4224	0.0183	1665
177.0000	TME-800MHZ RRH	18	86.271	5.1636	0.0162	1666
175.0000	APXVSPP18-C-A20 w/ Mount Pipe	18	84.121	5.0967	0.0157	1666
72.0000	GPS_A	18	12.600	1.6500	0.0028	2094

Compression Checks

Pole Design Data

Section No.	Elevation ft	Size	L ft	L_u ft	KI/r	A in^2	P_u K	ϕP_n K	Ratio $\frac{P_u}{\phi P_n}$
L1	226 - 197.96 (1)	TP28.67x21.5x0.1875	28.040	0.0000	0.0	16.329	-6.25	1072.42	0.006
L2	197.96 - 162.91 (2)	TP37.12x27.2517x0.375	39.130	0.0000	0.0	42.183	-20.82	3134.05	0.007
L3	162.91 - 120.29 (3)	TP47.14x35.0662x0.4375	47.790	0.0000	0.0	62.599	-34.03	4616.12	0.007
L4	120.29 - 79.21 (4)	TP56.63x44.643x0.5	47.500	0.0000	0.0	86.038	-51.27	6258.12	0.008
L5	79.21 - 39.13 (5)	TP65.75x53.7146x0.5625	47.670	0.0000	0.0	112.44	-73.30	8104.46	0.009
L6	39.13 - 0 (6)	TP74.5x62.4159x0.5625	47.880	0.0000	0.0	132.00	-104.56	9035.61	0.012

Pole Bending Design Data

Section No.	Elevation ft	Size	M_{ux} kip-ft	ϕM_{nx} kip-ft	Ratio $\frac{M_{ux}}{\phi M_{nx}}$	M_{uy} kip-ft	ϕM_{ny} kip-ft	Ratio $\frac{M_{uy}}{\phi M_{ny}}$
L1	226 - 197.96 (1)	TP28.67x21.5x0.1875	241.25	605.72	0.398	0.00	605.72	0.000
L2	197.96 - 162.91 (2)	TP37.12x27.2517x0.375	964.30	2277.90	0.423	0.00	2277.90	0.000
L3	162.91 - 120.29 (3)	TP47.14x35.0662x0.4375	2224.20	4271.34	0.521	0.00	4271.34	0.000
L4	120.29 - 79.21 (4)	TP56.63x44.643x0.5	3611.11	6967.32	0.518	0.00	6967.32	0.000
L5	79.21 - 39.13 (5)	TP65.75x53.7146x0.5625	5123.47	10484.50	0.489	0.00	10484.50	0.000
L6	39.13 - 0 (6)	TP74.5x62.4159x0.5625	7166.39	13741.17	0.522	0.00	13741.17	0.000

Pole Shear Design Data

Section No.	Elevation ft	Size	Actual V_u K	ϕV_n K	Ratio $\frac{V_u}{\phi V_n}$	Actual T_u kip-ft	ϕT_n kip-ft	Ratio $\frac{T_u}{\phi T_n}$
L1	226 - 197.96 (1)	TP28.67x21.5x0.1875	13.31	536.21	0.025	0.00	1212.93	0.000
L2	197.96 - 162.91 (2)	TP37.12x27.2517x0.375	28.29	1567.02	0.018	0.16	4561.38	0.000
L3	162.91 - 120.29 (3)	TP47.14x35.0662x0.4375	32.57	2308.06	0.014	0.16	8553.08	0.000
L4	120.29 - 79.21 (4)	TP56.63x44.643x0.5	36.77	3129.06	0.012	0.16	13951.67	0.000
L5	79.21 - 39.13 (5)	TP65.75x53.7146x0.5625	40.69	4052.23	0.010	0.12	20994.58	0.000
L6	39.13 - 0 (6)	TP74.5x62.4159x0.5625	44.39	4517.80	0.010	0.12	27515.92	0.000

Pole Interaction Design Data

Section No.	Elevation ft	Ratio P_u	Ratio M_{ux}	Ratio M_{uy}	Ratio V_u	Ratio T_u	Comb. Stress Ratio	Allow. Stress Ratio	Criteria
		ϕP_n	ϕM_{nx}	ϕM_{ny}	ϕV_n	ϕT_n			
L1	226 - 197.96 (1)	0.006	0.398	0.000	0.025	0.000	0.405 ✓	1.000	4.8.2 ✓
L2	197.96 - 162.91 (2)	0.007	0.423	0.000	0.018	0.000	0.430 ✓	1.000	4.8.2 ✓
L3	162.91 - 120.29 (3)	0.007	0.521	0.000	0.014	0.000	0.528 ✓	1.000	4.8.2 ✓
L4	120.29 - 79.21 (4)	0.008	0.518	0.000	0.012	0.000	0.527 ✓	1.000	4.8.2 ✓
L5	79.21 - 39.13 (5)	0.009	0.489	0.000	0.010	0.000	0.498 ✓	1.000	4.8.2 ✓
L6	39.13 - 0 (6)	0.012	0.522	0.000	0.010	0.000	0.533 ✓	1.000	4.8.2 ✓

Section Capacity Table

Section No.	Elevation ft	Component Type	Size	Critical Element	P K	ϕP_{allow} K	% Capacity	Pass Fail	
L1	226 - 197.96	Pole	TP28.67x21.5x0.1875	1	-6.25	1072.42	40.5	Pass	
L2	197.96 - 162.91	Pole	TP37.12x27.2517x0.375	2	-20.82	3134.05	43.0	Pass	
L3	162.91 - 120.29	Pole	TP47.14x35.0662x0.4375	3	-34.03	4616.12	52.8	Pass	
L4	120.29 - 79.21	Pole	TP56.63x44.643x0.5	4	-51.27	6258.12	52.7	Pass	
L5	79.21 - 39.13	Pole	TP65.75x53.7146x0.5625	5	-73.30	8104.46	49.8	Pass	
L6	39.13 - 0	Pole	TP74.5x62.4159x0.5625	6	-104.56	9035.61	53.3	Pass	
							Summary		
							Pole (L6)	53.3	Pass
							RATING =	53.3	Pass

APPENDIX B
BASE LEVEL DRAWING

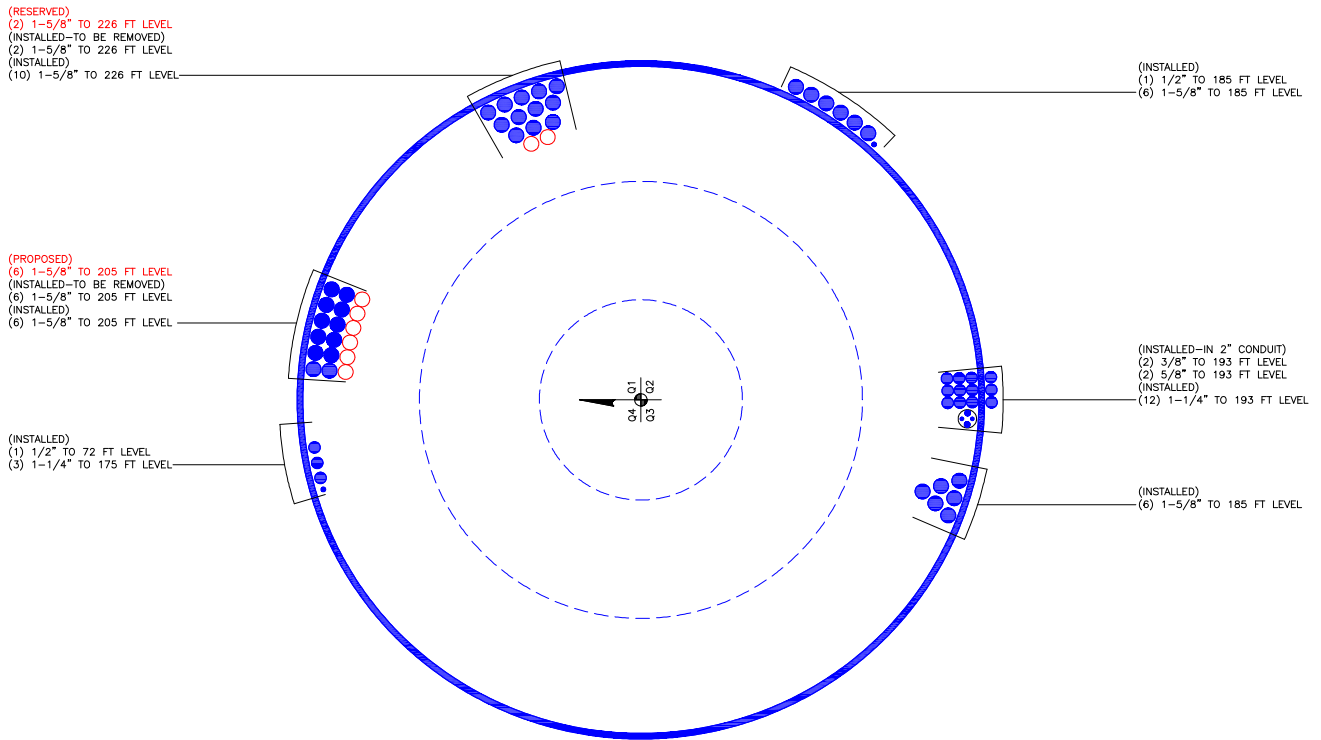

APPENDIX C
ADDITIONAL CALCULATIONS

DESIGNED APPURTENANCE LOADING

TYPE	ELEVATION	TYPE	ELEVATION
Beacon	226	(2) DTMAPB7819VG12A	193
(2) LPA-80080/6CF w/ Mount Pipe	226	(2) DTMAPB7819VG12A	193
(2) LPA-80080/6CF w/ Mount Pipe	226	RRUS A2 MODULE	193
(2) LPA-80080/6CF w/ Mount Pipe	226	RRUS A2 MODULE	193
(2) FD9R6004/2C-3L	226	RRUS A2 MODULE	193
(2) FD9R6004/2C-3L	226	RRUS 12-B2	193
(2) FD9R6004/2C-3L	226	RRUS 12-B2	193
(2) SBNHH-1D65B w/ Mount Pipe	226	RRUS 12-B2	193
(2) SBNHH-1D65B w/ Mount Pipe	226	(2) 860 10025	193
(2) SBNHH-1D65B w/ Mount Pipe	226	(2) 860 10025	193
RRH4X45-AWS4 B66	226	(2) 860 10025	193
RRH4X45-AWS4 B66	226	RRUS 11	193
RRH4X45-AWS4 B66	226	RRUS 11	193
RRH2X60-1900	226	RRUS 11	193
RRH2X60-1900	226	DC6-48-60-18-8F	193
RRH2X60-1900	226	8-ft Ladder	193
RRH2X60-700	226	Platform Mount [LP 601-1]	193
RRH2X60-700	226	APXV18-206517S-C w/ Mount Pipe	185
RRH2X60-700	226	APXV18-206517S-C w/ Mount Pipe	185
(2) DB-T1-6Z-8AB-OZ	226	APXV18-206517S-C w/ Mount Pipe	185
8-ft Ladder	226	978QNB120E-M w/ Mount Pipe	185
Side Arm Mount [SO 203-3]	226	978QNB120E-M w/ Mount Pipe	185
Platform Mount [LP 602-1]	226	978QNB120E-M w/ Mount Pipe	185
ATMPP1412D-1CWA	205	(2) FV90-16-02DP w/ Mount Pipe	185
ATMPP1412D-1CWA	205	(2) FV90-16-02DP w/ Mount Pipe	185
ATMPP1412D-1CWA	205	(2) FV90-16-02DP w/ Mount Pipe	185
APXV18-206516S-C-A20 w/ Mount Pipe	205	CS72993.07	185
APXV18-206516S-C-A20 w/ Mount Pipe	205	CS72993.07	185
APXV18-206516S-C-A20 w/ Mount Pipe	205	CS72993.07	185
APXV18-206516S-C-A20 w/ Mount Pipe	205	8-ft Ladder	185
APXV18-206516S-C-A20 w/ Mount Pipe	205	Platform Mount [LP 601-1]	185
LNX-6515DS-A1M w/ Mount Pipe	205	TME-800MHZ RRH	177
LNX-6515DS-A1M w/ Mount Pipe	205	TME-800MHZ RRH	177
LNX-6515DS-A1M w/ Mount Pipe	205	TME-800MHZ RRH	177
ATSBT-TOP-MF-4G	205	TME-1900MHZ RRH (65 MHz)	177
ATSBT-TOP-MF-4G	205	TME-1900MHZ RRH (65 MHz)	177
ATSBT-TOP-MF-4G	205	TME-1900MHZ RRH (65 MHz)	177
8-ft Ladder	205	Side Arm Mount [SO 102-3]	177
Platform Mount [LP 601-1]	205	APXVSPP18-C-A20 w/ Mount Pipe	175
AM-X-CD-16-65-00T-RET w/ Mount Pipe	193	APXVSPP18-C-A20 w/ Mount Pipe	175
AM-X-CD-16-65-00T-RET w/ Mount Pipe	193	APXVSPP18-C-A20 w/ Mount Pipe	175
AM-X-CD-16-65-00T-RET w/ Mount Pipe	193	800 EXTERNAL NOTCH FILTER	175
AM-X-CD-16-65-00T-RET w/ Mount Pipe	193	800 EXTERNAL NOTCH FILTER	175
AM-X-CD-16-65-00T-RET w/ Mount Pipe	193	800 EXTERNAL NOTCH FILTER	175
OPA-65R-LCUU-H6 w/ Mount Pipe	193	(3) ACU-A20-N	175
OPA-65R-LCUU-H6 w/ Mount Pipe	193	(3) ACU-A20-N	175
OPA-65R-LCUU-H6 w/ Mount Pipe	193	(3) ACU-A20-N	175
800 10121 w/ Mount Pipe	193	(2) 2.375" OD x 6' Mount Pipe	175
800 10121 w/ Mount Pipe	193	(2) 2.375" OD x 6' Mount Pipe	175
800 10121 w/ Mount Pipe	193	(2) 2.375" OD x 6' Mount Pipe	175
800 10121 w/ Mount Pipe	193	Platform Mount [LP 1201-1]	175
(2) DTMAPB7819VG12A	193	GPS_A	72
		Side Arm Mount [SO 701-1]	72

MATERIAL STRENGTH					
GRADE	Fy	Fu	GRADE	Fy	Fu
A572-65	65 ksi	80 ksi			

TOWER DESIGN NOTES

1. Tower is located in New Haven County, Connecticut.
2. Tower designed for Exposure B to the TIA-222-G Standard.
3. Tower designed for a 93.00 mph basic wind in accordance with the TIA-222-G Standard.
4. Tower is also designed for a 50.00 mph basic wind with 0.75 in ice. Ice is considered to increase in thickness with height.
5. Deflections are based upon a 60.00 mph wind.
6. Tower Structure Class II.
7. Topographic Category 1 with Crest Height of 0.0000 ft
8. TOWER RATING: 53.3%

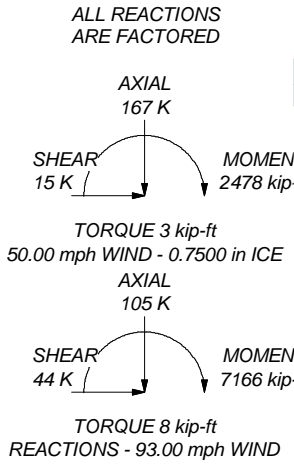

Section	Length (ft)	Number of Sides	Thickness (in)	Socket Length (ft)	Top Dia (in)	Bot Dia (in)	Grade	Weight (K)
1	28.0400	18	0.1875	4.0800	21.5000	28.6700	1.4	
2	39.1300	18	0.3750	5.1700	27.2517	37.1200	5.0	
3	47.7900	18	0.4375	6.4200	35.0662	47.1400	9.2	
4	47.5000	18	0.5000	7.5900	44.6430	56.6300	12.9	A572-65
5	47.6700	18	0.5625	8.7500	53.7146	65.7500	17.1	
6	47.8800	18	0.5625	62.4159	74.5000		19.7	
							65.4	

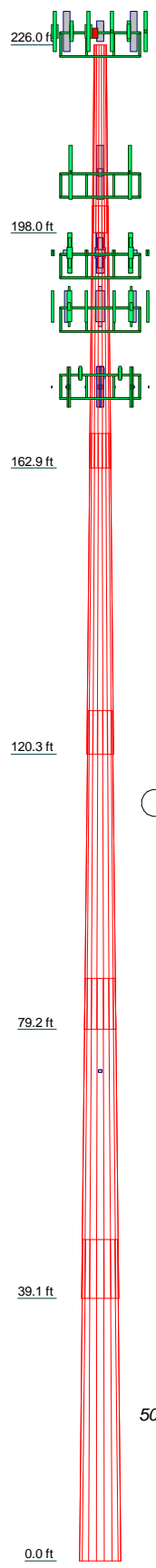

Paul J. Ford and Company
 250 E. Broad Street, Suite 600
 Columbus, OH 43215
 Phone: 614.221.6679
 FAX: 614.448.4105

Job: **226 ft Monopole / NHV 109 943107**
 Project: **PJF 37517-0065 / BU 806358**
 Client: Crown Castle | Drawn by: Joey Meinering | App'd:
 Code: TIA-222-G | Date: 01/09/17 | Scale: NTS
 Path: | Dwg No. E-1

Stiffened or Unstiffened, UngROUTED, Circular Base Plate - Any Rod Material

TIA Rev G

Assumption: Clear space between bottom of leveling nut and top of concrete **not** exceeding (1)*(Rod Diameter)

Site Data

BU#: 806358
Site Name: NHV 109 943107
App #:
Pole Manufacturer: <i>Other</i>

Anchor Rod Data

Qty:	28	
Diam:	2.25	in
Rod Material:	A615-J	
Strength (Fu):	100	ksi
Yield (Fy):	75	ksi
Bolt Circle:	84	in

Plate Data

Diam:	90	in
Thick:	2.5	in
Grade:	60	ksi
Single-Rod B-eff:	8.44	in

Stiffener Data (Welding at both sides)

Config:	1	*
Weld Type:	Groove	
Groove Depth:	0.5	in **
Groove Angle:	45	degrees
Fillet H. Weld:		<-- Disregard
Fillet V. Weld:	0.5	in
Width:	6	in
Height:	18	in
Thick:	1	in
Notch:	0.75	in
Grade:	50	ksi
Weld str.:	70	ksi

Pole Data

Diam:	74.5	in
Thick:	0.5625	in
Grade:	65	ksi
# of Sides:	18	"0" IF Round
Fu	80	ksi
Reinf. Fillet Weld	0	"0" if None

Reactions

Mu:	7166	ft-kips
Axial, Pu:	105	kips
Shear, Vu:	44	kips
Eta Factor, η	0.5	TIA G (Fig. 4-4)

If No stiffeners, Criteria: **AISC LRFD** <-Only Applicable to Unstiffened Cases

Anchor Rod Results

Max Rod (Cu+ Vu/η): 153.1 Kips
 Allowable Axial, Φ*Fu*Anet: 260.0 Kips
 Anchor Rod Stress Ratio: 58.9% **Pass**

Stiffened
AISC LRFD
φ*Tn

Base Plate Results

Base Plate Stress: 19.7 ksi
 Allowable Plate Stress: 54.0 ksi
 Base Plate Stress Ratio: 36.5% **Pass**

Flexural Check

Stiffened
AISC LRFD
φ*Fy
Y.L. Length: N/A, Roark

Stiffener Results

Horizontal Weld : 39.6% **Pass**
 Vertical Weld: 26.1% **Pass**
 Plate Flex+Shear, fb/Fb+(fv/Fv)^2: 9.7% **Pass**
 Plate Tension+Shear, ft/Ft+(fv/Fv)^2: 40.4% **Pass**
 Plate Comp. (AISC Bracket): 41.4% **Pass**

Pole Results

Pole Punching Shear Check: 7.0% **Pass**

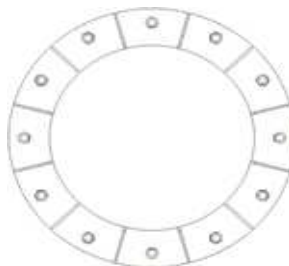

* 0 = none, 1 = every bolt, 2 = every 2 bolts, 3 = 2 per bolt

** Note: for complete joint penetration groove welds the groove depth must be exactly 1/2 the stiffener thickness for calculation purposes

DRILLED PIER SOIL AND STEEL ANALYSIS - TIA-222-G

Factored Base Reactions from RISAs

	Comp. (+)	Tension (-)	
Moment, Mu =	7166.0		k-ft
Shear, Vu =	44.0		kips
Axial Load, Pu1 =	105.0		kips (from 1.2D + 1.6W)*
Axial Load, Pu2 =	78.8	0.0	kips (from 0.9D + 1.6W)**
OTMu =	7210.0	0.0	k-ft @ Ground

*Axial Load, Pu1 will be used for Soil Compression Analysis.

**Axial Load, Pu2 will be used for Steel Analysis.

Drilled Pier Parameters

Diameter =	9	ft
Height Above Grade =	1	ft
Depth Below Grade =	36	ft
fc' =	4	ksi
εc =	0.003	in/in
L / D Ratio =	4.11	

Mat Ftdn. Cap Width =		ft
Mat Ftdn. Cap Length =		ft
Depth Below Grade =		ft

Steel Parameters

Number of Bars =	40	
Rebar Size =	#11	
Rebar Fy =	60	ksi
Rebar MOE =	29000	ksi
Tie Size =	#5	
Side Clear Cover to Ties =	4	in

Direct Embed Pole Shaft Parameters

Dia @ Grade =		in
Dia @ Depth Below Grade =		in
Number of Sides =		
Thickness =		in
Fy =		ksi
Backfill Condition =		

Define Soil Layers

Note: Cohesion = Undrained Shear Strength = Unconfined Compressive Strength / 2

Layer	Thickness ft	Unit Weight pcf	Cohesion psf	Friction Angle degrees	Soil Type	Ultimate End Bearing psf	Comp. Ult. Skin Friction psf	Tension Ult. Skin Friction psf	Depth ft
1	4	100	0	28	Sand				4
2	5	110	0	35	Sand				9
3	5	120	0	40	Sand				14
4	5	125	0	40	Sand				19
5	20	130	0	40	Sand	10000			39
6									
7									
8									
9									
10									
11									
12									

Soil Results: Overturning

Depth to COR =	26.54	ft, from Grade
Bending Moment, Mu =	8377.83	k-ft, from COR
Resisting Moment, ΦMn =	45023.60	k-ft, from COR

MOMENT RATIO = 18.6% OK

Shear, Vu =	44.00	kips
Resisting Shear, ΦVn =	236.46	kips

SHEAR RATIO = 18.6% OK

Soil Results: Uplift

Uplift, Tu =	0.00	kips
Uplift Capacity, ΦTn =	317.77	kips

UPLIFT RATIO = 0.0% OK

Soil Results: Compression

Compression, Cu =	105.00	kips
Comp. Capacity, ΦCn =	388.19	kips

COMPRESSION RATIO = 27.0% OK

Steel Results (ACI 318-05):

Minimum Steel Area =	30.54	sq in
Actual Steel Area =	62.40	sq in

Axial, ΦPn (min) =	-3369.60	kips, Where ΦMn = 0 k-ft
Axial, ΦPn (max) =	18033.00	kips, Where ΦMn = 0 k-ft

Axial Load, Pu =	153.90	kips @ 7.75 ft Below Grade
Moment, Mu =	7508.84	k-ft @ 7.75 ft Below Grade
Moment, ΦMn =	13198.26	k-ft

MOMENT RATIO = 56.9% OK

Safety Factors / Load Factors / Φ Factors

Tower Type =	Monopole DP
ACI Code =	ACI 318-05
Seismic Design Category =	D
Reference Standard =	TIA-222-G
Use 1.3 Load Factor?	No
Load Factor =	1.00

	Safety Factor	Φ Factor
Soil Lateral Resistance =	2.00	0.75
Skin Friction =	2.00	0.75
End Bearing =	2.00	0.75
Concrete Wt. Resist Uplift =	1.25	

Load Combinations Checked per TIA-222-G

- (0.75) Ult. Skin Friction + (0.75) Ult. End Bearing + (1.2) Effective Soil Wt. - (1.2) Buoyant Conc. Wt. ≥ Comp.
- (0.75) Ult. Skin Friction + (0.9) Buoyant Conc. Wt. ≥ Uplift

Soil Parameters

Water Table Depth =	99.00	ft
Depth to Ignore Soil =	4.50	ft
Depth to Full Cohesion =	0	ft
Full Cohesion Starts at?*	Ground	

Above Full Cohesion Lateral Resistance = 4(Cohesion)(Dia)(H)
 Below Full Cohesion Lateral Resistance = 8(Cohesion)(Dia)(H)

Maximum Capacity Ratios

Maximum Soil Ratio =	110.0%
Maximum Steel Ratio =	105.0%

*Note: The drilled pier foundation was analyzed using the methodology in the software 'PLS-Caisson' (Version 8.10, or newer, by Power Line Systems, Inc.). Per the methods in PLS-Caisson, the soil reactions of cohesive soils are calculated using 8CD independent of the depth of the soil layer. The depth of soil to be ignored at the top of the drilled pier is based on the recommendations of the site specific geotechnical report. In the absence of any recommendations, the frost depth at the site or one half of the drilled pier diameter (whichever is greater) shall be ignored.

Moment Capacity of Drilled Concrete Shaft (Caisson) for TIA Rev F or G

Note: Shaft assumed to have ties, not spiral, transverse reinforcing

Site Data

BU#: 806358
Site Name: NHV 109 943107
App #:

Loads Already Factored		
For M (WL)	1	<----Disregard
For P (DL)	1	<----Disregard

Pier Properties	
Concrete:	
Pier Diameter =	9.0 ft
Concrete Area =	9160.9 in ²
Reinforcement:	
Clear Cover to Tie=	4.00 in
Horiz. Tie Bar Size=	5
Vert. Cage Diameter =	8.11 ft
Vert. Cage Diameter =	97.34 in
Vertical Bar Size =	11
Bar Diameter =	1.41 in
Bar Area =	1.56 in ²
Number of Bars =	40
As Total=	62.4 in ²
A s/ Aconc, Rho:	0.0068 0.68%

ACI 10.5 , ACI 21.10.4, and IBC 1810.

Min As for Flexural, Tension Controlled, Shafts:

$$(3) * (\text{Sqrt}(f'c) / Fy) = 0.0032$$

$$200 / Fy = 0.0033$$

Minimum Rho Check:

Actual Req'd Min. Rho:	0.33%	Flexural
Provided Rho:	0.68%	OK

Ref. Shaft Max Axial Capacities, ϕ Max(Pn or Tn):		
Max Pu = ($\phi=0.65$) Pn.		
Pn per ACI 318 (10-2)	18033.00	kips
at Mu=($\phi=0.65$)Mn=	14169.12	ft-kips
Max Tu, ($\phi=0.9$) Tn =	3369.6	kips
at Mu= $\phi=(0.90)$ Mn=	0.00	ft-kips

Maximum Shaft Superimposed Forces		
TIA Revision:	G	
Max. Factored Shaft Mu:	7508.84	ft-kips (* Note)
Max. Factored Shaft Pu:	153.9	kips
Max Axial Force Type:	Comp.	

(* Note: Max Shaft Superimposed Moment does not necessarily equal to the shaft top reaction moment

Load Factor	Shaft Factored Loads	
1.00	Mu:	7508.84 ft-kips
1.00	Pu:	153.9 kips

Material Properties		
Concrete Comp. strength, f'c =	4000	psi
Reinforcement yield strength, Fy =	60	ksi
Reinforcing Modulus of Elasticity, E =	29000	ksi
Reinforcement yield strain =	0.00207	
Limiting compressive strain =	0.003	
ACI 318 Code		
Select Analysis ACI Code=	2005	
Seismic Properties		
Seismic Design Category =	D	
Seismic Risk =	High	

Solve (Run) <-- Press Upon Completing All Input

Results:

Governing Orientation Case: 1

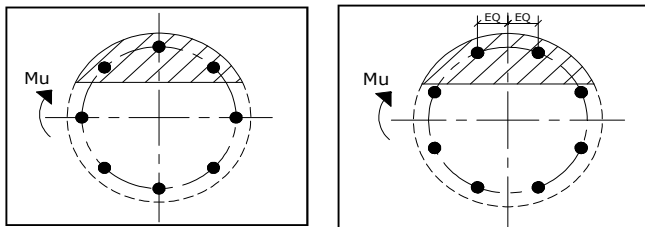

Case 1

Case 2

Dist. From Edge to Neutral Axis: 16.56 in

Extreme Steel Strain, ϵ_t : 0.0156

$\epsilon_t > 0.0050$, Tension Controlled

Reduction Factor, ϕ : 0.90

Output Note: Negative Pu=Tension
 For Axial Compression, ϕ Pn = Pu: 153.90 kips
 Drilled Shaft Moment Capacity, ϕ Mn: 13198.27 ft-kips
 Drilled Shaft Superimposed Mu: 7508.84 ft-kips

(Mu/ ϕ Mn, Drilled Shaft Flexure CSR: 56.9%)

RADIO FREQUENCY EMISSIONS ANALYSIS REPORT
EVALUATION OF HUMAN EXPOSURE POTENTIAL
TO NON-IONIZING EMISSIONS

T-Mobile Existing Facility

Site ID: CT11127A

Middlebury /I-84 X16
1432 Old Waterbury Road
Southbury, CT 06488

January 26, 2017

EBI Project Number: 6217000270

Site Compliance Summary	
Compliance Status:	COMPLIANT
Site total MPE% of FCC general public allowable limit:	2.57 %

January 26, 2017

T-Mobile USA
Attn: Jason Overbey, RF Manager
35 Griffin Road South
Bloomfield, CT 06002

Emissions Analysis for Site: **CT11127A – Middlebury /I-84 X16**

EBI Consulting was directed to analyze the proposed T-Mobile facility located at **1432 Old Waterbury Road, Southbury, CT**, for the purpose of determining whether the emissions from the Proposed T-Mobile Antenna Installation located on this property are within specified federal limits.

All information used in this report was analyzed as a percentage of current Maximum Permissible Exposure (% MPE) as listed in the FCC OET Bulletin 65 Edition 97-01 and ANSI/IEEE Std C95.1. The FCC regulates Maximum Permissible Exposure in units of microwatts per square centimeter ($\mu\text{W}/\text{cm}^2$). The number of $\mu\text{W}/\text{cm}^2$ calculated at each sample point is called the power density. The exposure limit for power density varies depending upon the frequencies being utilized. Wireless Carriers and Paging Services use different frequency bands each with different exposure limits, therefore it is necessary to report results and limits in terms of percent MPE rather than power density.

All results were compared to the FCC (Federal Communications Commission) radio frequency exposure rules, 47 CFR 1.1307(b)(1) – (b)(3), to determine compliance with the Maximum Permissible Exposure (MPE) limits for General Population/Uncontrolled environments as defined below.

General population/uncontrolled exposure limits apply to situations in which the general public may be exposed or in which persons who are exposed as a consequence of their employment may not be made fully aware of the potential for exposure or cannot exercise control over their exposure. Therefore, members of the general public would always be considered under this category when exposure is not employment related, for example, in the case of a telecommunications tower that exposes persons in a nearby residential area.

Public exposure to radio frequencies is regulated and enforced in units of microwatts per square centimeter ($\mu\text{W}/\text{cm}^2$). The general population exposure limit for the 700 MHz Band is approximately 467 $\mu\text{W}/\text{cm}^2$, and the general population exposure limit for the 1900 MHz (PCS) and 2100 MHz (AWS) bands is 1000 $\mu\text{W}/\text{cm}^2$. Because each carrier will be using different frequency bands, and each frequency band has different exposure limits, it is necessary to report percent of MPE rather than power density.

Occupational/controlled exposure limits apply to situations in which persons are exposed as a consequence of their employment and in which those persons who are exposed have been made fully aware of the potential for exposure and can exercise control over their exposure. Occupational/controlled exposure limits also apply where exposure is of a transient nature as a result of incidental passage through a location where exposure levels may be above general population/uncontrolled limits (see below), as long as the exposed person has been made fully aware of the potential for exposure and can exercise control over his or her exposure by leaving the area or by some other appropriate means.

Additional details can be found in FCC OET 65.

CALCULATIONS

Calculations were done for the proposed T-Mobile Wireless antenna facility located at **1432 Old Waterbury Road, Southbury, CT**, using the equipment information listed below. All calculations were performed per the specifications under FCC OET 65. Since T-Mobile is proposing highly focused directional panel antennas, which project most of the emitted energy out toward the horizon, all calculations were performed assuming a lobe representing the maximum gain of the antenna per the antenna manufactures supplied specifications, minus 10 dB, was focused at the base of the tower. For this report the sample point is the top of a 6-foot person standing at the base of the tower.

For all calculations, all equipment was calculated using the following assumptions:

- 1) 2 GSM channels (PCS Band - 1900 MHz) were considered for each sector of the proposed installation. These Channels have a transmit power of 30 Watts per Channel.
- 2) 2 LTE channels (PCS Band - 1900 MHz) were considered for each sector of the proposed installation. These Channels have a transmit power of 60 Watts per Channel.
- 3) 1 LTE channel (700 MHz Band) was considered for each sector of the proposed installation. This channel has a transmit power of 30 Watts.
- 4) Since all radios are ground mounted there are additional cabling losses accounted for. For each ground mounted RF path the following losses were calculated. 1.40 dB of additional cable loss for all ground mounted 700 MHz Channels and 2.58 dB of additional cable loss for all ground mounted 1900 MHz channels was factored into the calculations. This is based on manufacturers Specifications for 250 feet of 1-5/8" coax cable on each path.

- 5) All radios at the proposed installation were considered to be running at full power and were uncombined in their RF transmissions paths per carrier prescribed configuration. Per FCC OET Bulletin No. 65 - Edition 97-01 recommendations to achieve the maximum anticipated value at each sample point, all power levels emitting from the proposed antenna installation are increased by a factor of 2.56 to account for possible in-phase reflections from the surrounding environment. This is rarely the case, and if so, is never continuous.
- 6) For the following calculations the sample point was the top of a 6-foot person standing at the base of the tower. The maximum gain of the antenna per the antenna manufactures supplied specifications minus 10 dB was used in this direction. This value is a very conservative estimate as gain reductions for these particular antennas are typically much higher in this direction.
- 7) The antennas used in this modeling are the **RFS APXV18-206516S-C-A20** for 1900 MHz (PCS) channels and the **Commscope LNX-6515DS-A1M** for 700 MHz channels. This is based on feedback from the carrier with regards to anticipated antenna selection. The **RFS APXV18-206516S-C-A20** has a maximum gain of **16.3 dBd** at its main lobe at 1900 MHz. The **Commscope LNX-6515DS-A1M** has a maximum gain of **14.6 dBd** at its main lobe. The maximum gain of the antenna per the antenna manufactures supplied specifications, minus 10 dB, was used for all calculations. This value is a very conservative estimate as gain reductions for these particular antennas are typically much higher in this direction.
- 8) The antenna mounting height centerline of the proposed antennas is **207 feet** above ground level (AGL).
- 9) Emissions values for additional carriers were taken from the Connecticut Siting Council active database. Values in this database are provided by the individual carriers themselves.
- 10) All calculations were done with respect to uncontrolled / general public threshold limits.

T-Mobile Site Inventory and Power Data

Sector:	A	Sector:	B	Sector:	C
Antenna #:	1	Antenna #:	1	Antenna #:	1
Make / Model:	RFS APXV18-206516S- C-A20	Make / Model:	RFS APXV18-206516S- C-A20	Make / Model:	RFS APXV18-206516S- C-A20
Gain:	16.3 dBd	Gain:	16.3 dBd	Gain:	16.3 dBd
Height (AGL):	207	Height (AGL):	207	Height (AGL):	207
Frequency Bands	1900 MHz (PCS)	Frequency Bands	1900 MHz (PCS)	Frequency Bands	1900 MHz (PCS)
Channel Count	4	Channel Count	4	Channel Count	4
Total TX Power(W):	180	Total TX Power(W):	180	Total TX Power(W):	180
ERP (W):	4,239.09	ERP (W):	4,239.09	ERP (W):	4,239.09
Antenna A1 MPE%	0.38	Antenna B1 MPE%	0.38	Antenna C1 MPE%	0.38
Antenna #:	2	Antenna #:	2	Antenna #:	2
Make / Model:	Commscope LNX-6515DS-A1M	Make / Model:	Commscope LNX-6515DS-A1M	Make / Model:	Commscope LNX-6515DS-A1M
Gain:	14.6 dBd	Gain:	14.6 dBd	Gain:	14.6 dBd
Height (AGL):	207	Height (AGL):	207	Height (AGL):	207
Frequency Bands	700 MHz	Frequency Bands	700 MHz	Frequency Bands	700 MHz
Channel Count	1	Channel Count	1	Channel Count	1
Total TX Power(W):	30	Total TX Power(W):	30	Total TX Power(W):	30
ERP (W):	626.79	ERP (W):	626.79	ERP (W):	626.79
Antenna A2 MPE%	0.12	Antenna B2 MPE%	0.12	Antenna C2 MPE%	0.12

Site Composite MPE%	
Carrier	MPE%
T-Mobile (Per Sector Max)	0.50 %
AT&T	0.44 %
MetroPCS	0.27 %
Sprint	0.44 %
Verizon Wireless	0.92 %
Site Total MPE %:	2.57 %

T-Mobile Sector A Total:	0.50 %
T-Mobile Sector B Total:	0.50 %
T-Mobile Sector C Total:	0.50 %
Site Total:	2.57 %

T-Mobile_Max Values per sector	# Channels	Watts ERP (Per Channel)	Height (feet)	Total Power Density ($\mu\text{W}/\text{cm}^2$)	Frequency (MHz)	Allowable MPE ($\mu\text{W}/\text{cm}^2$)	Calculated % MPE
T-Mobile PCS - 1950 MHz LTE	2	1,413.03	207	2.51	PCS - 1950 MHz	1000	0.25%
T-Mobile PCS - 1950 MHz GSM	2	706.51	207	1.26	PCS - 1950 MHz	1000	0.13%
T-Mobile 700 MHz LTE	1	626.79	207	0.56	700 MHz	467	0.12%
						Total:	0.50%

Summary

All calculations performed for this analysis yielded results that were **within** the allowable limits for general public exposure to RF Emissions.

The anticipated maximum composite contributions from the T-Mobile facility as well as the site composite emissions value with regards to compliance with FCC's allowable limits for general public exposure to RF Emissions are shown here:

T-Mobile Sector	Power Density Value (%)
Sector A:	0.50 %
Sector B:	0.50 %
Sector C:	0.50 %
T-Mobile Per Sector Maximum:	0.50 %
Site Total:	2.57 %
Site Compliance Status:	COMPLIANT

The anticipated composite MPE value for this site assuming all carriers present is **2.57%** of the allowable FCC established general public limit sampled at the ground level. This is based upon values listed in the Connecticut Siting Council database for existing carrier emissions.

FCC guidelines state that if a site is found to be out of compliance (over allowable thresholds), that carriers over a 5% contribution to the composite value will require measures to bring the site into compliance. For this facility, the composite values calculated were well within the allowable 100% threshold standard per the federal government.