



**Crown Castle**  
3 Corporate Park Drive, Suite 101  
Clifton Park, NY 12065

October 7, 2016

Melanie A. Bachman  
Acting Executive Director  
Connecticut Siting Council  
10 Franklin Square  
New Britain, CT 06051

**RE: Request of T-Mobile for an Order to Approve the Shared Use of an Existing Tower at 22 Wayside Lane, Redding, CT 06896**

Dear Ms. Bachman:

Pursuant to Connecticut General Statutes (“C.G.S.”) §16-50aa, as amended, T-Mobile hereby requests an order from the Connecticut Siting Council (“Council”) to approve the shared use by T-Mobile of an existing telecommunication tower at 22 Wayside Lane in Redding, Connecticut (the “Property”). The existing 109-foot stealth monopole is owned by Crown Castle International Corp. (“Crown Castle”), the underlying property is owned by Nancy Enright. T-Mobile requests that the Council find that the proposed shared use of the Crown Castle tower satisfies the criteria of C.G.S. §16-50aa and issue an order approving the proposed shared use. A copy of this filing is being sent to First Selectman Julia Pemberton.

### **Background**

The existing Crown Castle facility consists of a 109-foot monopole tower on a 70’x70’ foot parcel along the northeast side of Wayside Lane. AT&T maintains antennas at the 94-foot level and 104-foot level. Equipment associated with the AT&T antennas is located south of the tower.

T-Mobile is licensed by the Federal Communications Commission (“FCC”) to provide wireless services throughout the State of Connecticut. T-Mobile and Crown Castle have agreed to the proposed shared use of the Wayside Lane tower pursuant to mutually acceptable terms and conditions. Likewise, T-Mobile and Crown Castle have agreed to the proposed installation of equipment cabinets on the ground on the west side of the tower. Crown Castle has authorized T-Mobile to apply for all necessary permits and approvals that may be required to share the existing tower. (See Owner’s authorization letter).

T-Mobile proposes to install three (3) antennas, three (3) TMA units, three (3) diplexers, and three (3) Bias-Ts installed at a height of 84 feet above ground level. T-Mobile will also install twelve (12) lines of coaxial cable to run inside the existing monopole and an 8’x13” concrete pad with a four (4) equipment cabinet. Included in the Construction Drawings are T-Mobile’s project specifications for locations of all proposed site improvements.

C.G.S. § 16-50aa(c)(1) provides that, upon written request for approval of a proposed shared use, “if the Council finds that the proposed shared use of the facility is technically, legally, environmentally and economically feasible and meets public safety concerns, the council shall issue an order approving such a shared use.” T-Mobile respectfully submits that the shared use of the tower satisfies these criteria.

**A. Technical Feasibility.** The existing Crown Castle tower is structurally capable of supporting T-Mobile’s proposed improvements. The proposed shared use of this tower is, therefore, technically feasible. A Feasibility Structural Analysis Report (“Structural Report”) prepared for this project confirms that this tower can support T-Mobile’s proposed loading. A copy of the Structural Report has been included in this application.

**B. Legal Feasibility.** Under C.G.S. § 16-50aa, the Council has been authorized to issue order approving the shared use of an existing tower such as the Crown Castle tower. This authority complements the Council’s prior-existing authority under C.G.S. § 16-50p to issue orders approving the construction of new towers that are subject to the Council’s jurisdiction. In addition, § 16-50x(a) directs the Council to “give such consideration to the other state laws and municipal regulations as it shall deem appropriate” in ruling on requests for the shared use of existing tower facilities. Under the statutory authority vested in the Council, an order by the Council approving the requested shared use would permit the Applicant to obtain a building permit for the proposed installations.

**C. Environmental Feasibility.** The proposed shared use of the Crown Castle tower would have a minimal environmental effect for the following reasons:

1. The proposed installation of three (3) antennas, three (3) TMA units, three (3) diplexers, and three (3) Bias-Ts installed at the 84 foot-level on the existing 109-foot tower would have no visual impact on the area of the tower. All equipment would be installed within the stealth enclosures. T-Mobile’s cabinets would be installed within the facility compound. T-Mobile’s shared use of this tower therefore, does not cause any significant change or alteration in the physical or environmental characteristics of the existing site.
2. Operation of T-Mobile’s antennas at this site would not exceed the RF emissions standard adopted by the Federal Communications Commission (“FCC”). Included in the EME report of this filing are the approximation tables that demonstrate that T-Mobile’s proposed facility will operate well within the FCC RF emissions safety standards.
3. Under ordinary operating conditions, the proposed installation would not require the use of any water or sanitary facilities and would not generate air emissions or discharges to water bodies or sanitary facilities. After construction is complete the proposed installations would not generate any increased traffic to the Crown Castle

facility other than periodic maintenance. The proposed shared use of the Crown Castle tower, would, therefore, have a minimal environmental effect, and is environmentally feasible.

- D. Economic Feasibility.** As previously mentioned, T-Mobile has entered into an agreement with Crown Castle for the shared use of the existing facility subject to mutually agreeable terms. The proposed tower sharing is, therefore, economically feasible. (Please see included authorization.)
- E. Public Safety Concerns.** As discussed above, the tower is structurally capable of supporting T-Mobile's full array of three (3) antennas, three (3) TMA units, three (3) diplexers, three (3) Bias-Ts, twelve (12) coaxial cables and all related equipment. T-Mobile is not aware of any public safety concerns relative to the proposed sharing of the existing Crown Castle tower.

### **Conclusion**

For the reasons discussed above, the proposed shared use of the existing Crown Castle tower at 22 Wayside Lane satisfies the criteria state in C.G.S. §16-50aa and advances the General Assembly's and the Council's goal of preventing the unnecessary proliferation of towers in Connecticut. The Applicant, therefore, respectfully requests that the Council issue an order approving the proposed shared use.

Sincerely,



Amanda Goodall  
Real Estate Specialist  
12 Gill Street, Suite 5800,  
Woburn, MA 01801  
339-205-7017  
Amanda.Goodall@crowncastle.com

Attachments:

- Tab 1: Exhibit-1: Compound plan and elevation depicting the planned changes  
Tab 2: Exhibit-2: Structural Modification Report  
Tab 4: Exhibit-3: General Power Density Table report (RF Emissions Analysis Report)

Melanie A. Bachman

October 7, 2016

Page 4

Copies to:

First Selectman Julia Pemberton  
100 Hill Road  
P.O. Box 1028  
Redding, CT 06875

Nancy Enright  
22 Wayside Lane  
Redding, CT 06875  
(Property Owner)

Crown Castle  
12 Gill St., Suite 5800  
Woburn, MA 01801  
(Tower Owner)

# Connecticut Siting Council

## Decisions

<b>DOCKET NO. 284</b> – AT&T Wireless PCS, LLC d/b/a AT&T Wireless application for a Certificate of Environmental Compatibility and Public need for the construction, maintenance and operation of a wireless telecommunications facility at 259 Redding Road or 22 Wayside Lane in Redding, Connecticut.	}	Connecticut
	}	Siting
	}	Council
		October 7, 2004

### Decision and Order

Pursuant to the foregoing Findings of Fact and Opinion, the Connecticut Siting Council (Council) finds that the effects associated with the construction, operation, and maintenance of a telecommunications facility including effects on the natural environment; ecological integrity and balance; public health and safety; scenic, historic, and recreational values; forests and parks; air and water purity; and fish and wildlife are not disproportionate either alone or cumulatively with other effects when compared to need, are not in conflict with the policies of the State concerning such effects, and are not sufficient reason to deny the application and therefore directs that a Certificate of Environmental Compatibility and Public Need, as provided by General Statutes § 16-50k, be issued to AT&T Wireless PCS, LLC d/b/a AT&T Wireless at Site B, located at 22 Wayside Lane, Redding, Connecticut. The Council denies certification of Site A, located at 259 Redding Road, Redding, Connecticut.

The facility shall be constructed, operated, and maintained substantially as specified in the Council's record in this matter, and subject to the following conditions:

1. The tower shall be constructed as a flagpole approximately 50 feet to the north of the proposed site, no taller than necessary to provide the proposed telecommunications services, sufficient to accommodate the antennas of AT&T Wireless and other entities, both public and private, but such tower shall not exceed a height of 120 feet above ground level, including appurtenances. The tower shall not be lit.
2. The Certificate Holder shall prepare a Development and Management (D&M) Plan for this site in compliance with Sections 16-50j-75 through 16-50j-77 of the Regulations of Connecticut State Agencies. The D&M Plan shall be served on the Town of Redding, and all parties and intervenors as listed in the service list for the purpose of seeking comments, and submitted to and approved by the Council prior to the commencement of facility construction and shall include:
  - a. color options for the flagpole, with the preferred option of the Town of Redding;
  - b. a final site plan(s) of site development to include specifications for the tower, tower foundation, antennas, equipment building, access road, utility line, and landscaping; and
  - c. construction plans for site clearing, water drainage, and erosion and sedimentation control consistent with the 2002 Connecticut Guidelines for Soil Erosion and Sediment Control, as amended.
3. The Certificate Holder shall, prior to the commencement of operation, provide the Council worst-case modeling of electromagnetic radio frequency power density of all proposed entities' antennas at the closest point of uncontrolled access to the tower base, consistent with Federal Communications Commission, Office of Engineering and Technology, Bulletin No. 65, August 1997. The Certificate Holder shall ensure a recalculated report of electromagnetic radio frequency power density is submitted to the Council if and when circumstances in operation cause a change in power density above the levels calculated and provided pursuant to this Decision and Order.

4. Upon the establishment of any new State or federal radio frequency standards applicable to frequencies of this facility, the facility granted herein shall be brought into compliance with such standards.
5. The Certificate Holder shall permit public or private entities to share space on the proposed tower for fair consideration, or shall provide any requesting entity with specific legal, technical, environmental, or economic reasons precluding such tower sharing.
6. The Certificate Holder shall provide reasonable space on the tower for no compensation for any municipal antennas, provided such antennas are compatible with the structural integrity of the tower.
7. If the facility does not initially provide wireless services within one year of completion of construction or ceases to provide wireless services for a period of one year, this Decision and Order shall be void, and the Certificate Holder shall dismantle the tower and remove all associated equipment or reapply for any continued or new use to the Council before any such use is made.
8. Any antenna that becomes obsolete and ceases to function shall be removed within 60 days after such antennas become obsolete and cease to function.
9. Unless otherwise approved by the Council, this Decision and Order shall be void if the facility authorized herein is not operational within one year of the effective date of this Decision and Order or within one year after all appeals to this Decision and Order have been resolved. Any request for extension of this period shall be filed with the Council not later than sixty days prior to expiration date of this Certificate and shall be served on all parties and intervenors and the Town of Redding, as listed in the service list. Any proposed modifications to this Decision and Order shall likewise be so served.

Pursuant to General Statutes § 16-50p, we hereby direct that a copy of the Findings of Fact, Opinion, and Decision and Order be served on each person listed below, and notice of issuance shall be published in the Danbury New Times, The Hour (Norwalk) and the Redding Pilot.

By this Decision and Order, the Council disposes of the legal rights, duties, and privileges of each party named or admitted to the proceeding in accordance with Section 16-50j-17 of the Regulations of Connecticut State Agencies.

The parties and intervenors to this proceeding are:

<p><b><u>Applicant</u></b></p> <p>AT&amp;T Wireless PCS, LLC d/b/a AT&amp;T Wireless</p>	<p><b><u>Its Representative</u></b></p> <p>Christopher B. Fisher, Esq. Cuddy &amp; Feder LLP 90 Maple Avenue White Plains, NY 10601</p>
<p><b><u>Party</u></b></p> <p>Fred and Susan Baker</p>	<p><b><u>Its Representative</u></b></p>
<p><b><u>Intervenor</u></b></p> <p>Representative Hank Bielawa, 59<sup>th</sup> District</p>	<p><b><u>Its Representative</u></b></p>
<p><b><u>Party</u></b></p> <p>Lee Shull</p>	<p><b><u>Its Representative</u></b></p> <p>Ira W. Bloom, Esq. 27 Imperial Avenue Westport, CT 06880</p>
<p><b><u>Party</u></b></p>	<p><b><u>Its Representative</u></b></p>

Town of Redding	Monte E. Frank, Esq. Cohen & Wolf, P.C. 158 Deer Hill Avenue Danbury, CT 06810
<b><u>Party</u></b>  William F. King and Jose E. Pereyra	<b><u>Its Representative</u></b>  Douglas I. Bayer Paul & Bayer, P.C. P.O. Box 459 Wilton, CT 06897-0459

Content Last Modified on 10/13/2004 11:18:59 AM



-73.404221, 41.283693

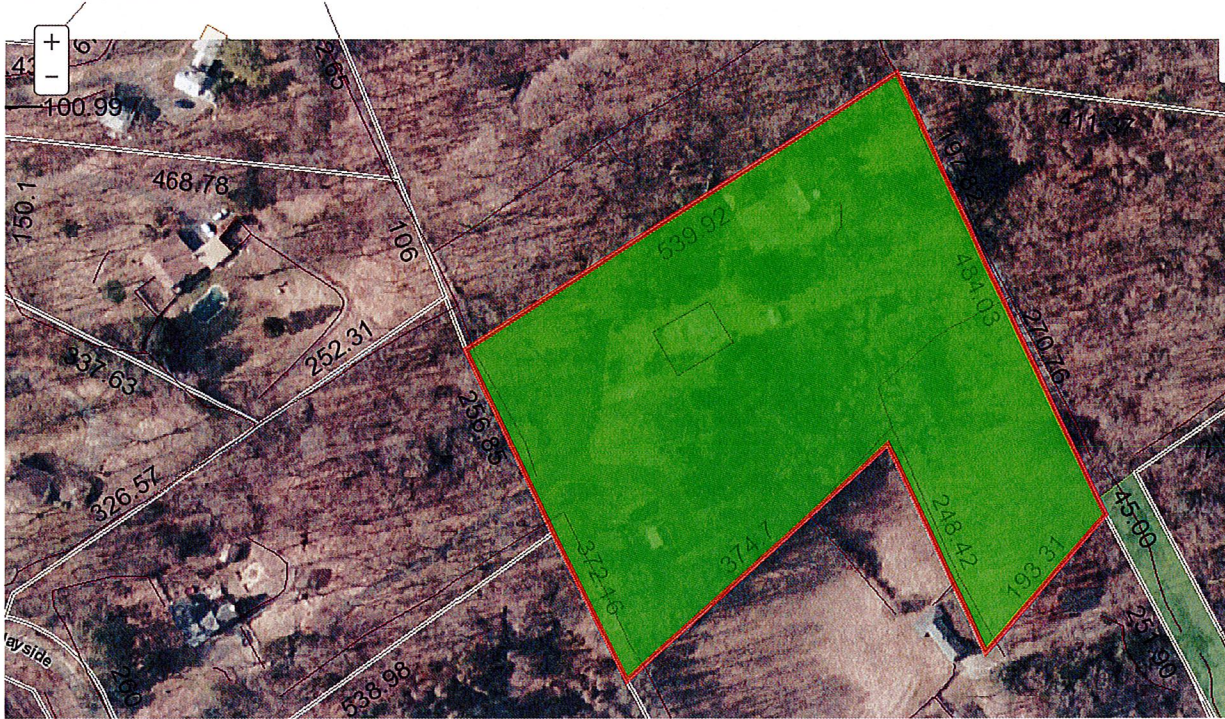

M:	00256000
	22 WAYSIDE LN
	ENRIGHT
IE:	EDWARD D & NANCY
N/A	
Assessment	Sales
REDDING, CT	
06896-2803	
2497	



Redding, CT GIS Data Portal

### Town of Redding, CT GIS Portal

The The Town of Redding GIS Portal provides the general public and other interested parties local government property tax and assessment information.

Information presented is provided "as is." The Town of Redding, CT disclaims all representations or warranties regarding GIS information, including but not limited to, all express or implied warranties, representations or conditions of merchantability, fitness for a particular purpose, non-infringement of intellectual property, non-infringement of third party rights, freedom of computer virus, or warranties of any other nature.

The user agrees that the Town of Redding, CT shall be held harmless from all actions, claims, damages or judgments arising out of the use of GIS data. GIS data is representative data only. GIS information is supplied upon the condition that the user will make a determination as to its suitability for the user's purposes. In no event will the Town of Redding be responsible for damages of any nature whatsoever resulting from use of or reliance upon GIS information.

Please contact the appropriate department with any questions you may have concerning the data provided herein.



Close tool tray to resume operation

Source Sites  
 Transportation  
 Road Names

wayside

Roads  
 Utilities

\*Advanced Search

Trails - Fire Hill to Picketts Ridge  
 Land Use Landcover  
 Dam  
 Cultural Features

Clear

#### QUICKMAPS

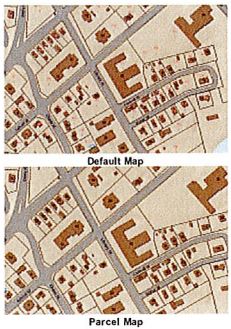



## 22 WAYSIDE LN

**Location** 22 WAYSIDE LN

**Mblu** 36/ / 10/ C/

**Acct#** 3610C

**Owner** ENRIGHT NANCY

**Assessment** \$252,000

**Appraisal** \$360,000

**PID** 100626

**Building Count** 1

### Assessing Distr...

### Current Value

Appraisal			
Valuation Year	Improvements	Land	Total
2013	\$0	\$360,000	\$360,000

Assessment			
Valuation Year	Improvements	Land	Total
2013	\$0	\$252,000	\$252,000

### Owner of Record

**Owner** ENRIGHT NANCY

**Sale Price** \$0

**Co-Owner**

**Certificate**

**Address** 22 WAYSIDE LN

**Book & Page** 393/1028

REDDING, CT 06896-2603

**Sale Date** 08/07/2014

**Instrument** 04

### Ownership History

Ownership History					
Owner	Sale Price	Certificate	Book & Page	Instrument	Sale Date
ENRIGHT NANCY	\$0		393/1028	04	08/07/2014
ENRIGHT EDWARD D & NANCY	\$0		389/1117	25	10/15/2013
ENRIGHT EDWARD D & NANCY	\$0		104/965X	XX	05/22/1979

### Building Information

#### Building 1 : Section 1

**Year Built:**

**Living Area:** 0

**Replacement Cost:** \$0

**Building Percent****Good:****Replacement Cost****Less Depreciation:** \$0**Building Photo**

(http://images.vgsi.com/photos/ReddingCTPhotos//default.jpg)

Building Attributes	
Field	Description
Style	Bungalow
Model	
Grade:	
Stories	
Occupancy	
Exterior Wall 1	
Exterior Wall 2	
Roof Structure	
Roof Cover	
Interior Wall 1	
Interior Wall 2	
Interior Flr 1	
Interior Flr 2	
Heat Fuel	
Heat Type:	
AC Type:	
Total Bedrooms	
Full Bathrooms	
Half Bathrooms	
Total Xtra Fixtrs	
Total Rooms	
Bath Style:	
Kitchen Style:	
Fireplaces	
Whirlpool Tubs	
Fin Bsmt Area	
Fin Bsmt Qual	
Bsmt Garages	

**Building Layout**
 Building Layout

Building Sub-Areas (sq ft)	Legend
No Data for Building Sub-Areas	

**Extra Features**

Extra Features	Legend
No Data for Extra Features	

**Land**

**Land Use**

**Use Code** 435  
**Description** Cell Site Vac Lnd  
**Zone** R-2  
**Neighborhood**  
**Alt Land Appr Category** No

**Land Line Valuation**

**Size (Acres)** 0  
**Frontage**  
**Depth**  
**Assessed Value** \$252,000  
**Appraised Value** \$360,000

**Outbuildings**

Outbuildings	<u>Legend</u>
No Data for Outbuildings	

**Valuation History**

Appraisal			
Valuation Year	Improvements	Land	Total
2013	\$0	\$360,000	\$360,000
2012	\$0	\$360,000	\$360,000

Assessment			
Valuation Year	Improvements	Land	Total
2013	\$0	\$252,000	\$252,000
2012	\$0	\$252,000	\$252,000



Crown Castle  
3530 Toringdon Way, Suite 300  
Charlotte, NC 28277

Crown Castle, does hereby authorize T-Mobile and its authorized contractors/agents to act as “Applicant” in the processing of all applications, permits, research and other related activities associated with the processing, planning, design review, permitting, entitlement and construction of additional equipment, antennas and site improvements for the Crown Castle existing wireless communications facility described as follows:

Customer Site Name:	ATT Wayside Lane	Crown Castle Site ID Number:	857144
Site Address:	22 Wayside Lane – Redding, CT 06896	Crown Castle Site Name:	Redding Wayside Lane

This authorization is fully contingent upon T-Mobile authorized contractors/agents’ compliance with the following conditions:

1. Crown Castle must review the application prior to submittal. Crown Castle must be provided all applications, narratives, drawings and attachments at least 72 hours in advance of their submittal to the locality. Use of email and electronic attachments is encouraged. A Crown Castle Zoning Subject Matter Expert (SME) will review and provide written comment to the customer within 48 hours of receipt of a complete set of application materials. If Crown Castle indicates that changes are required, submissions shall be altered in accordance with Crown Castle comments prior to submission to the locality. Verification of corrections should also be accomplished via emails and attachments.
2. In no event may T-Mobile encourage, suggest, participate in, or permit the imposition of any restrictions or additional obligations whatsoever on the tower site or Crown Castle’s current or future use or ability to license space at the tower site as part of or in exchange for obtaining any approval, permit, exception or variance.
3. A copy of the final permit and/or a written summary of the zoning/entitlement decision rendered by the locality and any/all conditions placed on that decision shall be communicated in detail to Crown Castle well within the appeal period provided by the locality (typically 10-15 days).
4. All conditions of approval pertinent to the construction of the proposed project must be included in the construction drawings for the project. The conditions of approval pertinent to the construction of the project shall be copied verbatim from the zoning permit approval language, and shall be present in the drawings prior to submission for building permits and contractor bidding. Crown Castle shall verify the inclusion of appropriate conditions of approval in the construction drawing redline process.
5. Crown Castle will provide a Notice To Proceed (NTP) to construction to the customer upon receipt of the final approved zoning permit and the approved Building Permit.

By Crown Castle:

Signature:   
Printed Name: Collin Thompson

Title: Real Estate Specialist Intern – East Area

Date: October 5, 2016

# SITE NAME: CTFF575B

22 WAYSIDE LANE  
REDDING, CT 06896  
FAIRFIELD COUNTY

## T-MOBILE SITE NUMBER: CTFF575B

CROWN BU NUMBER: 857144

### RF DESIGN GUIDELINE: 707C\_TOWER

#### T-MOBILE TECHNICIAN SITE SAFETY NOTES

LOCATION	SPECIAL RESTRICTIONS
SECTOR A: ANTENNA/TMA RRH	ACCESS NOT PERMITTED UNRESTRICTED
SECTOR B: ANTENNA/TMA RRH	ACCESS NOT PERMITTED UNRESTRICTED
SECTOR C: ANTENNA/TMA RRH	ACCESS NOT PERMITTED UNRESTRICTED CAUTION: OSHA-APPROVED PORTABLE 10' STEP-LADDER REQUIRED
GPS/LMU:	UNRESTRICTED
RADIO CABINETS:	UNRESTRICTED
PPC DISCONNECT:	UNRESTRICTED
MAIN CIRCUIT D/C:	UNRESTRICTED
NIU/T DEMARC:	UNRESTRICTED
OTHER/SPECIAL:	NONE

#### T-MOBILE NORTHEAST LLC

35 GRIFFIN ROAD SOUTH  
BLOOMFIELD, CT 06002  
OFFICE: (860) 648-1116



CROWN CASTLE  
12 GILL STREET, SUITE 5800  
WOBBURN, MA 01801



1600 OSGOOD STREET  
BUILDING 20 NORTH, SUITE 3090 N. ANDOVER, MA 01845  
TEL: (978) 557-5553  
FAX: (978) 336-5586

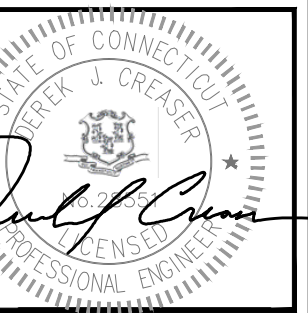

CHECKED BY: BB

APPROVED BY: DJC

#### SUBMITTALS

REV.	DATE	DESCRIPTION	BY
0	10/07/16	ISSUED FOR CONSTRUCTION	DJM

SITE NUMBER:  
CTFF575B  
CROWN CASTLE SITE ID:  
857144  
SITE NAME:  
CTFF575B

SITE ADDRESS:  
22 WAYSIDE LANE  
REDDING, CT 06896  
FAIRFIELD COUNTY

SHEET TITLE

TITLE SHEET

SHEET NUMBER

T-1

#### GENERAL NOTES

THIS DOCUMENT IS THE CREATION, DESIGN, PROPERTY AND COPYRIGHTED WORK OF T-MOBILE. ANY DUPLICATION OR USE WITHOUT EXPRESS WRITTEN CONSENT IS STRICTLY PROHIBITED. DUPLICATION AND USE BY GOVERNMENT AGENCIES FOR THE PURPOSES OF CONDUCTING THEIR LAWFULLY AUTHORIZED REGULATORY AND ADMINISTRATIVE FUNCTIONS IS SPECIFICALLY ALLOWED.

THE FACILITY IS AN UNMANNED PRIVATE AND SECURED EQUIPMENT INSTALLATION. IT IS ONLY ACCESSED BY TRAINED TECHNICIANS FOR PERIODIC ROUTINE MAINTENANCE AND THEREFORE DOES NOT REQUIRE ANY WATER OR SANITARY SEWER SERVICE. THE FACILITY IS NOT GOVERNED BY REGULATIONS REQUIRING PUBLIC ACCESS PER ADA REQUIREMENTS.

CONTRACTOR SHALL VERIFY ALL PLANS AND EXISTING DIMENSIONS AND CONDITIONS ON THE JOB SITE AND SHALL IMMEDIATELY NOTIFY THE T-MOBILE NORTHEAST, LLC REPRESENTATIVE IN WRITING OF DISCREPANCIES BEFORE PROCEEDING WITH THE WORK OR BE RESPONSIBLE FOR SAME.

#### SPECIAL STRUCTURAL NOTES

CONTRACTOR SCOPE OF WORK SHALL INCLUDE ALL REQUIRED STRUCTURAL MODIFICATIONS, RE-BUNDLING OF COAXIAL CABLES OR OTHER SPECIAL MODIFICATIONS AS OUTLINED THEREIN.

STRUCTURAL DESIGNS AND DETAILS FOR ANTENNA MOUNTS AND GLOBAL STRUCTURAL STABILITY ANALYSIS COMPLETED ON BEHALF OF T-MOBILE ARE INCLUSIVE OF THE ENTIRE SUPPORT STRUCTURE, EXISTING ANTENNA MOUNTS AND ALL OTHER ASPECTS OF THE STRUCTURE THAT WILL SUPPORT THE T-MOBILE G700 EQUIPMENT DEPLOYMENT AS DEPICTED HEREIN.

HUDSON DESIGN ASSUMES THAT THE EQUIPMENT IS PROPERLY CONSTRUCTED AND MAINTAINED. ALL STRUCTURAL MEMBERS AND THEIR CONNECTION ARE ASSUMED TO BE IN GOOD CONDITION AND ARE FREE FROM DEFECTS WITH NO DETERIORATION TO ITS MEMBER CAPACITIES

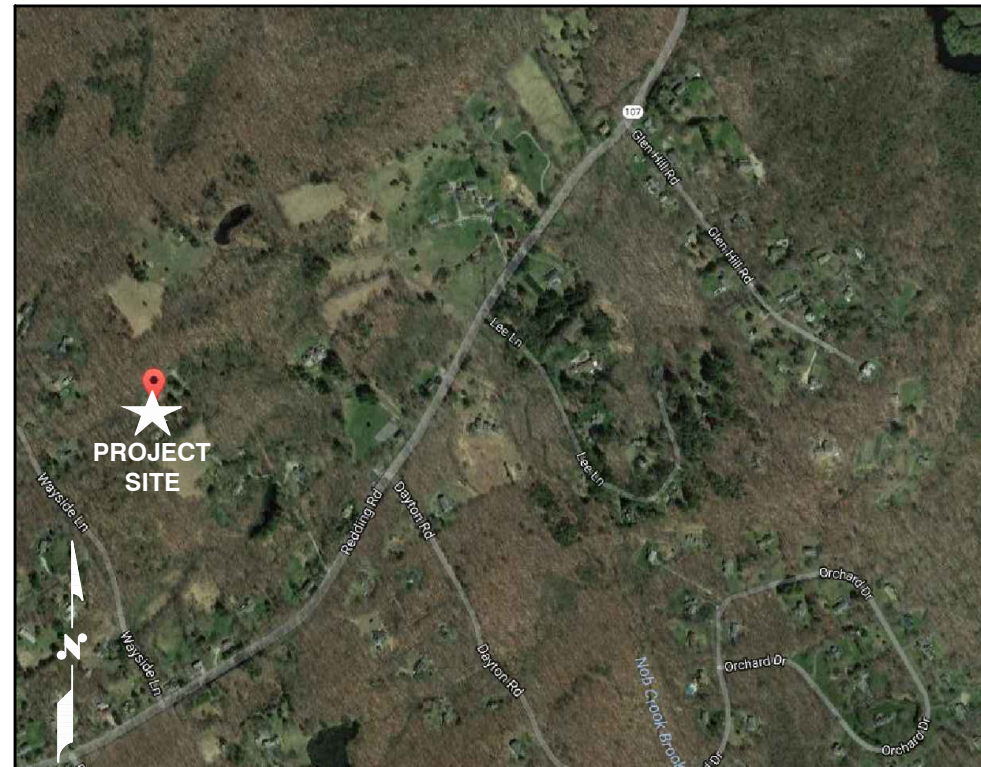

#### PROJECT SUMMARY

SCOPE OF WORK: UNMANNED TELECOMMUNICATIONS FACILITY T-MOBILE EQUIPMENT MODERNIZATION

ZONING JURISDICTION: (TOWN OF REDDING) BASED ON INFORMATION PROVIDED BY T-MOBILE, THIS TELECOMMUNICATIONS EQUIPMENT DEPLOYMENT IS AN ELIGIBLE FACILITY UNDER THE TAX RELIEF ACT OF 2012, 47 USC 1455(A), AND IS SUBJECT TO AN EXPEDITED ELIGIBLE FACILITIES REQUEST/REVIEW AND ZONING PRE-EMPTION FOR LOCAL DISCRETIONARY PERMITS (VARIANCE, SPECIAL PERMIT, SITE PLAN REVIEW).

SITE ADDRESS: 22 WAYSIDE LANE  
REDDING, CT 06896

LATITUDE: 41.28265889

LONGITUDE: -73.40749889

JURISDICTION: NATIONAL, STATE & LOCAL CODES OR ORDINANCES

CURRENT USE: TELECOMMUNICATIONS FACILITY

PROPOSED USE: TELECOMMUNICATIONS FACILITY

CROWN CASTLE  
SITE NAME: REDDING WAYSIDE LANE

CROWN CASTLE  
SITE ID: 857144

#### APPROVALS

PROJECT MANAGER	DATE
CONSTRUCTION	DATE
RF ENGINEERING	DATE
ZONING / SITE ACQ.	DATE
OPERATIONS	DATE
TOWER OWNER	DATE

72 HOURS



CALL  
BEFORE YOU DIG



CALL TOLL FREE 1-800-962-7962

OR CALL 811

UNDERGROUND SERVICE ALERT

#### DRAWING INDEX

SHEET NO.	DESCRIPTION	REV.
T-1	TITLE SHEET	0
GN-1	GENERAL NOTES	0
A-1	COMPOUND AND EQUIPMENT PLAN	0
A-2	ANTENNA LAYOUT & ELEVATION	0
A-3	TOWER EQUIPMENT DETAILS	0
A-4	GROUND EQUIPMENT DETAILS	0
A-5	GROUND EQUIPMENT DETAILS	0
S-1	RAISED EQUIPMENT FRAME DETAILS	0
E-1	ELECTRICAL DETAILS AND NOTES	0
G-1	GROUNDING SCHEMATIC AND RISER DIAGRAM	0
G-2	GROUNDING DETAILS AND NOTES	0



**GROUNDING NOTES**

1. THE SUBCONTRACTOR SHALL REVIEW AND INSPECT THE EXISTING FACILITY GROUNDING SYSTEM AND LIGHTNING PROTECTION SYSTEM (AS DESIGNED AND INSTALLED) FOR STRICT COMPLIANCE WITH THE NEC (AS ADOPTED BY THE AHJ), THE SITE-SPECIFIC (UL, LPI, OR NFPA) LIGHTING PROTECTION CODE, AND GENERAL COMPLIANCE WITH TELCORDIA AND TIA GROUNDING STANDARDS. THE SUBCONTRACTOR SHALL REPORT ANY VIOLATIONS OR ADVERSE FINDINGS TO THE CONTRACTOR FOR RESOLUTION.
2. ALL GROUND ELECTRODE SYSTEMS (INCLUDING TELECOMMUNICATION, RADIO, LIGHTNING PROTECTION, AND AC POWER GES'S) SHALL BE BONDED TOGETHER, AT OR BELOW GRADE, BY TWO OR MORE COPPER BONDING CONDUCTORS IN ACCORDANCE WITH THE NEC.
3. THE SUBCONTRACTOR SHALL PERFORM IEEE FALL-OF-POTENTIAL RESISTANCE TO EARTH TESTING (PER IEEE 1100 AND 81) FOR NEW GROUND ELECTRODE SYSTEMS. THE SUBCONTRACTOR SHALL FURNISH AND INSTALL SUPPLEMENTAL GROUND ELECTRODES AS NEEDED TO ACHIEVE A TEST RESULT OF 5 OHMS OR LESS.
4. METAL RACEWAY SHALL NOT BE USED AS THE NEC REQUIRED EQUIPMENT GROUND CONDUCTOR. STRANDED COPPER CONDUCTORS WITH GREEN INSULATION, SIZED IN ACCORDANCE WITH THE NEC, SHALL BE FURNISHED AND INSTALLED WITH THE POWER CIRCUITS TO BTS EQUIPMENT.
5. EACH BTS CABINET FRAME SHALL BE DIRECTLY CONNECTED TO THE MASTER GROUND BAR WITH GREEN INSULATED SUPPLEMENTAL EQUIPMENT GROUND WIRES, 6 AWG STRANDED COPPER OR LARGER FOR INDOOR BTS 2 AWG STRANDED COPPER FOR OUTDOOR BTS.
6. EXOTHERMIC WELDS SHALL BE USED FOR ALL GROUNDING CONNECTIONS BELOW GRADE.
7. APPROVED ANTIOXIDANT COATINGS (I.E., CONDUCTIVE GEL OR PASTE) SHALL BE USED ON ALL COMPRESSION AND BOLTED GROUND CONNECTIONS.
8. ICE BRIDGE BONDING CONDUCTORS SHALL BE EXOTHERMICALLY BONDED OR BOLTED TO GROUND BAR.
9. ALUMINUM CONDUCTOR OR COPPER CLAD STEEL CONDUCTOR SHALL NOT BE USED FOR GROUNDING CONNECTIONS.
10. MISCELLANEOUS ELECTRICAL AND NON-ELECTRICAL METAL BOXES, FRAMES AND SUPPORTS SHALL BE BONDED TO THE GROUND RING, IN ACCORDANCE WITH THE NEC.
11. METAL CONDUIT SHALL BE MADE ELECTRICALLY CONTINUOUS WITH LISTED BONDING FITTINGS OR BY BONDING ACROSS THE DISCONTINUITY WITH 6 AWS COPPER WIRE UL APPROVED GROUNDING TYPE CONDUIT CLAMPS.
12. ALL NEW STRUCTURES WITH A FOUNDATION AND/OR FOOTING HAVING 20 FT. OR MORE OF 1/2 IN. OR GREATER ELECTRICALLY CONDUCTIVE REINFORCING STEEL MUST HAVE IT BONDED TO THE GROUND RING USING AN EXOTHERMIC WELD CONNECTION USING #2 AWG SOLID BARE TINNED COPPER GROUND WIRE, PER NEC 250.50

**GENERAL NOTES**

1. FOR THE PURPOSE OF CONSTRUCTION DRAWING, THE FOLLOWING DEFINITIONS SHALL APPLY:  
 CONTRACTOR – CROWN CASTLE  
 SUBCONTRACTOR – GENERAL CONTRACTOR (CONSTRUCTION)  
 OWNER – T-MOBILE
2. PRIOR TO THE SUBMISSION OF BIDS, THE BIDDING SUBCONTRACTOR SHALL VISIT THE CELL SITE TO FAMILIARIZE WITH THE EXISTING CONDITIONS AND TO CONFIRM THAT THE WORK CAN BE ACCOMPLISHED AS SHOWN ON THE CONSTRUCTION DRAWINGS. ANY DISCREPANCY FOUND SHALL BE BROUGHT TO THE ATTENTION OF CONTRACTOR.
3. ALL MATERIALS FURNISHED AND INSTALLED SHALL BE IN STRICT ACCORDANCE WITH ALL APPLICABLE CODES, REGULATIONS, AND ORDINANCES. SUBCONTRACTOR SHALL ISSUE ALL APPROPRIATE NOTICES AND COMPLY WITH ALL LAWS, ORDINANCES, RULES, REGULATIONS, AND LAWFUL ORDERS OF ANY PUBLIC AUTHORITY REGARDING THE PERFORMANCE OF THE WORK. ALL WORK CARRIED OUT SHALL COMPLY WITH ALL APPLICABLE MUNICIPAL AND UTILITY COMPANY SPECIFICATIONS AND LOCAL JURISDICTIONAL CODES, ORDINANCES AND APPLICABLE REGULATIONS.
4. DRAWINGS PROVIDED HERE ARE NOT TO BE SCALED AND ARE INTENDED TO SHOW OUTLINE ONLY.
5. UNLESS NOTED OTHERWISE, THE WORK SHALL INCLUDE FURNISHING MATERIALS, EQUIPMENT, APPURTENANCES, AND LABOR NECESSARY TO COMPLETE ALL INSTALLATIONS AS INDICATED ON THE DRAWINGS.
6. "KITTING LIST" SUPPLIED WITH THE BID PACKAGE IDENTIFIES ITEMS THAT WILL BE SUPPLIED BY CONTRACTOR. ITEMS NOT INCLUDED IN THE BILL OF MATERIALS AND KITTING LIST SHALL BE SUPPLIED BY THE SUBCONTRACTOR.
7. THE SUBCONTRACTOR SHALL INSTALL ALL EQUIPMENT AND MATERIALS IN ACCORDANCE WITH MANUFACTURER'S RECOMMENDATIONS UNLESS SPECIFICALLY STATED OTHERWISE.
8. IF THE SPECIFIED EQUIPMENT CANNOT BE INSTALLED AS SHOWN ON THESE DRAWINGS, THE SUBCONTRACTOR SHALL PROPOSE AN ALTERNATIVE INSTALLATION SPACE FOR APPROVAL BY THE CONTRACTOR.
9. SUBCONTRACTOR SHALL DETERMINE ACTUAL ROUTING OF CONDUIT, POWER AND T1 CABLES, GROUNDING CABLES AS SHOWN ON THE POWER, GROUNDING AND TELCO PLAN DRAWING. SUBCONTRACTOR SHALL UTILIZE EXISTING TRAYS AND/OR SHALL ADD NEW TRAYS AS NECESSARY. SUBCONTRACTOR SHALL CONFIRM THE ACTUAL ROUTING WITH THE CONTRACTOR.
10. THE SUBCONTRACTOR SHALL PROTECT EXISTING IMPROVEMENTS, PAVEMENTS, CURBS, LANDSCAPING AND STRUCTURES. ANY DAMAGED PART SHALL BE REPAIRED AT SUBCONTRACTOR'S EXPENSE TO THE SATISFACTION OF OWNER.
11. SUBCONTRACTOR SHALL LEGALLY AND PROPERLY DISPOSE OF ALL SCRAP MATERIALS SUCH AS COAXIAL CABLES AND OTHER ITEMS REMOVED FROM THE EXISTING FACILITY. ANTENNAS REMOVED SHALL BE RETURNED TO THE OWNER'S DESIGNATED LOCATION.
12. SUBCONTRACTOR SHALL LEAVE PREMISES IN CLEAN CONDITION.
13. ALL CONCRETE REPAIR WORK SHALL BE DONE IN ACCORDANCE WITH AMERICAN CONCRETE INSTITUTE (ACI) 301.

14. ANY NEW CONCRETE NEEDED FOR THE CONSTRUCTION SHALL BE AIR-ENTRAINED AND SHALL HAVE 4000 PSI STRENGTH AT 28 DAYS. ALL CONCRETE WORK SHALL BE DONE IN ACCORDANCE WITH ACI 318 CODE REQUIREMENTS.
15. ALL STRUCTURAL STEEL WORK SHALL BE DETAILED, FABRICATED AND ERECTED IN ACCORDANCE WITH AISC SPECIFICATIONS. ALL STRUCTURAL STEEL SHALL BE ASTM A36 (Fy = 36 ksi) UNLESS OTHERWISE NOTED. PIPES SHALL BE ASTM A53 TYPE E (Fy = 36 ksi). ALL STEEL EXPOSED TO WEATHER SHALL BE HOT DIPPED GALVANIZED. TOUCHUP ALL SCRATCHES AND OTHER MARKS IN THE FIELD AFTER STEEL IS ERECTED USING A COMPATIBLE ZINC RICH PAINT.
16. CONSTRUCTION SHALL COMPLY WITH G700 SPECIFICATIONS AND "GENERAL CONSTRUCTION SERVICES FOR CONSTRUCTION OF T-MOBILE SITES."
17. SUBCONTRACTOR SHALL VERIFY ALL EXISTING DIMENSIONS AND CONDITIONS PRIOR TO COMMENCING ANY WORK. ALL DIMENSIONS OF EXISTING CONSTRUCTION SHOWN ON THE DRAWINGS MUST BE VERIFIED. SUBCONTRACTOR SHALL NOTIFY THE CONTRACTOR OF ANY DISCREPANCIES PRIOR TO ORDERING MATERIAL OR PROCEEDING WITH CONSTRUCTION.
18. THE EXISTING CELL SITE IS IN FULL COMMERCIAL OPERATION. ANY CONSTRUCTION WORK BY SUBCONTRACTOR SHALL NOT DISRUPT THE EXISTING NORMAL OPERATION. ANY WORK ON EXISTING EQUIPMENT MUST BE COORDINATED WITH CONTRACTOR. ALSO, WORK SHOULD BE SCHEDULED FOR AN APPROPRIATE MAINTENANCE WINDOW USUALLY IN LOW TRAFFIC PERIODS AFTER MIDNIGHT.
19. SINCE THE CELL SITE IS ACTIVE, ALL SAFETY PRECAUTIONS MUST BE TAKEN WHEN WORKING AROUND HIGH LEVELS OF ELECTROMAGNETIC RADIATION. EQUIPMENT SHOULD BE SHUTDOWN PRIOR TO PERFORMING ANY WORK THAT COULD EXPOSE THE WORKERS TO DANGER. PERSONAL RF EXPOSURE MONITORS ARE ADVISED TO BE WORN TO ALERT OF ANY DANGEROUS EXPOSURE LEVELS.
20. APPLICABLE BUILDING CODES:  
 SUBCONTRACTOR'S WORK SHALL COMPLY WITH ALL APPLICABLE NATIONAL, STATE, AND LOCAL CODES AS ADOPTED BY THE LOCAL AUTHORITY HAVING JURISDICTION (AHJ) FOR THE LOCATION. THE EDITION OF THE AHJ ADOPTED CODES AND STANDARDS IN EFFECT ON THE DATE OF CONTRACT AWARD SHALL GOVERN THE DESIGN.  
 IBC 2012 WITH 2016 CT STATE BUILDING CODE AMENDMENTS  
 2014 NEC  
  
 SUBCONTRACTOR'S WORK SHALL COMPLY WITH THE LATEST EDITION OF THE FOLLOWING STANDARDS:  
  
 AMERICAN CONCRETE INSTITUTE (ACI) 318; BUILDING CODE REQUIREMENTS FOR STRUCTURAL CONCRETE;  
  
 AMERICAN INSTITUTE OF STEEL CONSTRUCTION (AISC)  
  
 MANUAL OF STEEL CONSTRUCTION, ASD, FOURTEENTH EDITION;  
  
 TELECOMMUNICATIONS INDUSTRY ASSOCIATION (TIA) 222-G,  
 STRUCTURAL STANDARDS FOR STEEL  
  
 EQUIPMENT AND ANTENNA SUPPORTING STRUCTURES; REFER TO ELECTRICAL DRAWINGS FOR SPECIFIC ELECTRICAL STANDARDS.  
  
 FOR ANY CONFLICTS BETWEEN SECTIONS OF LISTED CODES AND STANDARDS REGARDING MATERIAL, METHODS OF CONSTRUCTION, OR OTHER REQUIREMENTS, THE MOST RESTRICTIVE REQUIREMENT SHALL GOVERN. WHERE THERE IS CONFLICT BETWEEN A GENERAL REQUIREMENT AND A SPECIFIC REQUIREMENT, THE SPECIFIC REQUIREMENT SHALL GOVERN.

ABBREVIATIONS					
AGL	ABOVE GRADE LEVEL	EQ	EQUAL	REQ	REQUIRED
AWG	AMERICAN WIRE GAUGE	GC	GENERAL CONTRACTOR	RF	RADIO FREQUENCY
BBU	BATTERY BACKUP UNIT	GRC	GALVANIZED RIGID CONDUIT	TBD	TO BE DETERMINED
BTCW	BARE TINNED SOLID COPPER WIRE	MGB	MASTER GROUND BAR	TBR	TO BE REMOVED
BGR	BURIED GROUND RING	MIN	MINIMUM	TBRR	TO BE REMOVED AND REPLACED
BTS	BASE TRANSCEIVER STATION	P	PROPOSED	TYP	TYPICAL
E	EXISTING	NTS	NOT TO SCALE	UG	UNDER GROUND
EGB	EQUIPMENT GROUND BAR	RAD	RADIATION CENTER LINE (ANTENNA)	VIF	VERIFY IN FIELD
EGR	EQUIPMENT GROUND RING	REF	REFERENCE		

**T-MOBILE  
NORTHEAST LLC**

35 GRIFFIN ROAD SOUTH  
 BLOOMFIELD, CT 06002  
 OFFICE: (860) 448-1116



CROWN CASTLE  
 12 GILL STREET, SUITE 5800  
 WOBURN, MA 01801



1600 OSGOOD STREET  
 BUILDING 20 NORTH, SUITE 3090  
 N. ANDOVER, MA 01845  
 TEL: (978) 557-5553  
 FAX: (978) 336-5586

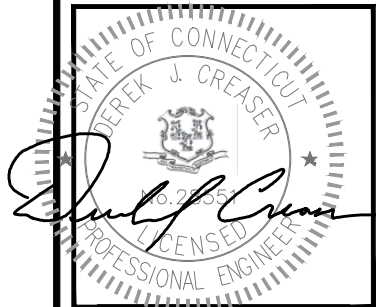

CHECKED BY: BB

APPROVED BY: DJC

**SUBMITTALS**

REV.	DATE	DESCRIPTION	BY
0	10/07/16	ISSUED FOR CONSTRUCTION	DJM

SITE NUMBER:  
 CTFF575B  
 CROWN CASTLE SITE ID:  
 857144  
 SITE NAME:  
 CTFF575B

SITE ADDRESS:  
 22 WAYSIDE LANE  
 REDDING, CT 06896  
 FAIRFIELD COUNTY

SHEET TITLE

GENERAL NOTES

SHEET NUMBER

**GN-1**



**T-MOBILE  
NORTHEAST LLC**

35 GRIFFIN ROAD SOUTH  
BLOOMFIELD, CT 06002  
OFFICE: (860) 448-1116



CROWN CASTLE  
12 GILL STREET, SUITE 5800  
WOBURN, MA 01801



1600 OSGOOD STREET  
BUILDING 20 NORTH, SUITE 3090 TEL: (978) 557-5553  
N. ANDOVER, MA 01845 FAX: (978) 336-5586

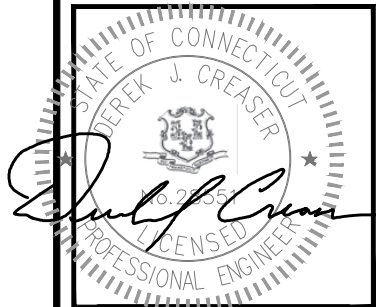

CHECKED BY: BB

APPROVED BY: DJC

**SUBMITTALS**

REV.	DATE	DESCRIPTION	BY
0	10/07/16	ISSUED FOR CONSTRUCTION	DJM

SITE NUMBER:

CTFF575B

CROWN CASTLE SITE ID:

857144

SITE NAME:

CTFF575B

SITE ADDRESS:

22 WAYSIDE LANE

REDDING, CT 06896

FAIRFIELD COUNTY

SHEET TITLE

**COMPOUND &  
EQUIPMENT PLAN**

SHEET NUMBER

**A-1**

**NOTE:**  
REFER TO FINAL RF DATA SHEET  
FOR FINAL ANTENNA SETTINGS

**STRUCTURAL NOTE:**  
REFER TO STRUCTURAL ANALYSIS REPORT AND  
MOD DESIGN BY: PAUL J. FORD & COMPANY,  
DATED: SEPTEMBER 26, 2016 FOR AN ANALYSIS  
OF THE CAPACITY OF THE EXISTING STRUCTURES  
TO SUPPORT THE PROPOSED EQUIPMENT PRIOR  
TO COMMENCING CONSTRUCTION.

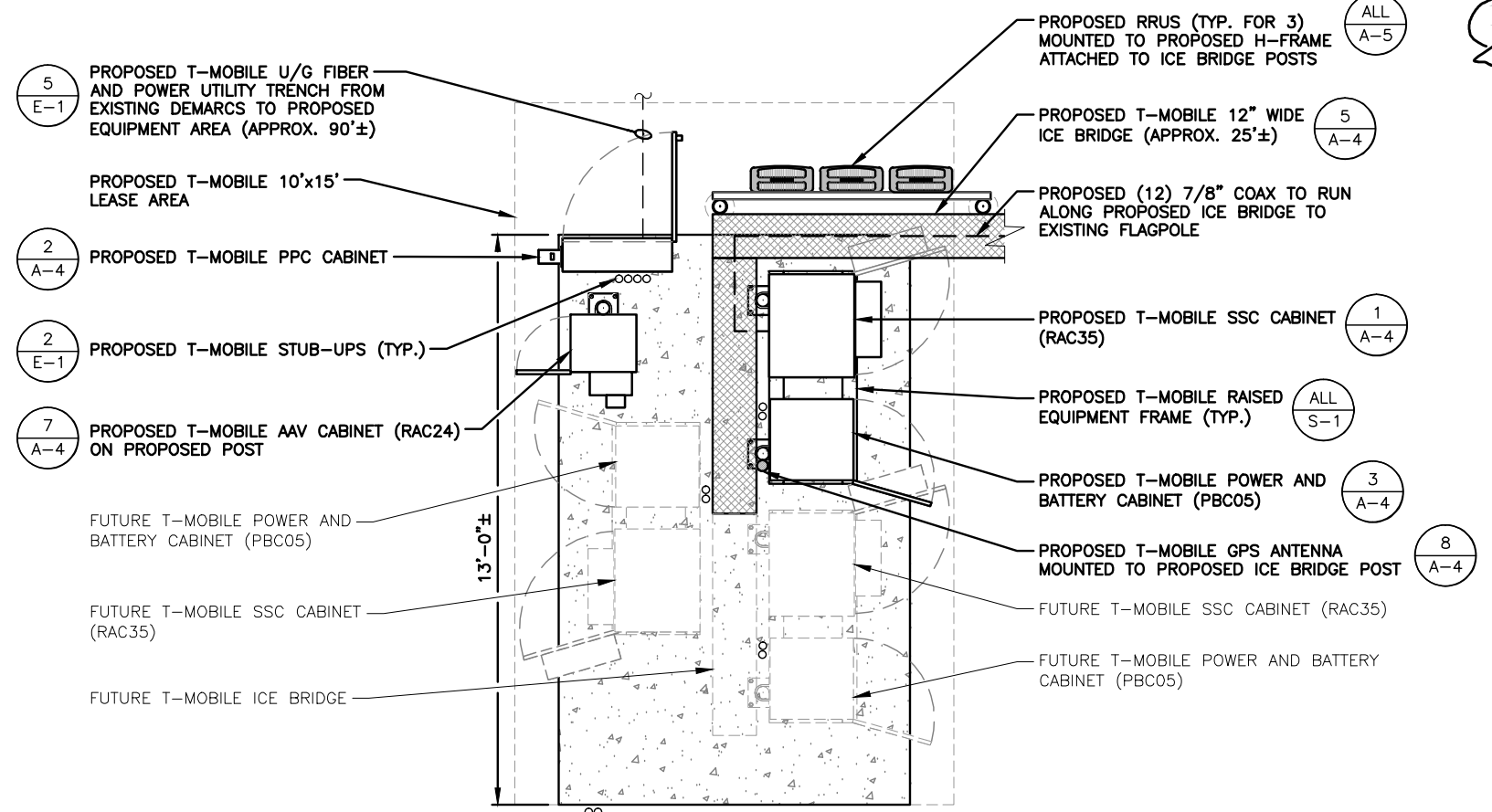
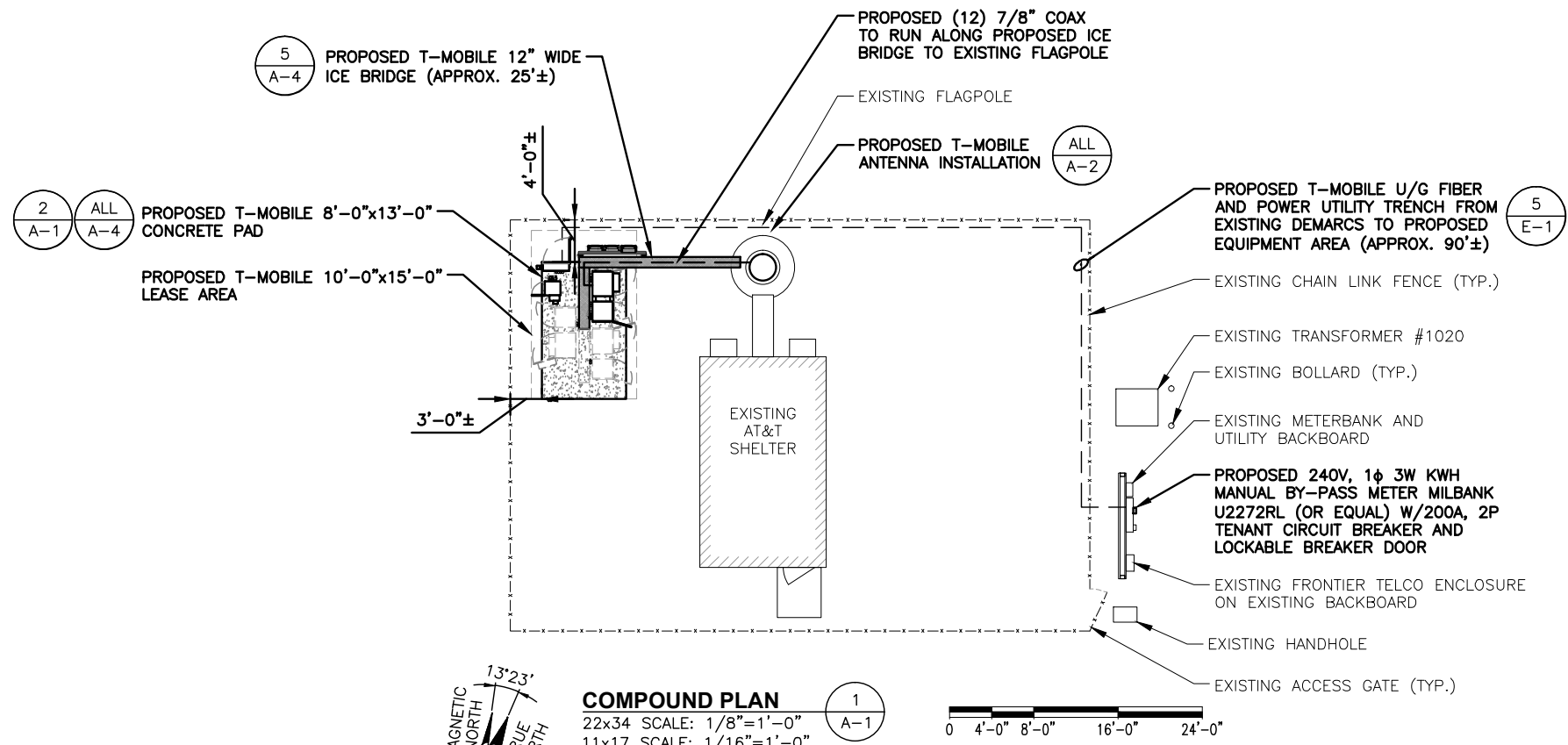

**NOTE:**  
SEE CONDUIT PLAN 3/E-1

**STRUCTURAL NOTE:**  
REFER TO STRUCTURAL ANALYSIS REPORT AND MOD DESIGN BY: PAUL J. FORD & COMPANY, DATED: SEPTEMBER 26, 2016 FOR AN ANALYSIS OF THE CAPACITY OF THE EXISTING STRUCTURES TO SUPPORT THE PROPOSED EQUIPMENT PRIOR TO COMMENCING CONSTRUCTION.

**NOTE:**  
REFER TO FINAL RF DATA SHEET FOR FINAL ANTENNA SETTINGS

**T-MOBILE  
NORTHEAST LLC**

35 GRIFFIN ROAD SOUTH  
BLOOMFIELD, CT 06002  
OFFICE: (860) 648-1116



CROWN CASTLE  
12 GILL STREET, SUITE 5800  
WOBURN, MA 01801



1600 OSGOOD STREET  
BUILDING 20 NORTH, SUITE 3090  
N. ANDOVER, MA 01845  
TEL: (978) 557-5553  
FAX: (978) 336-5586

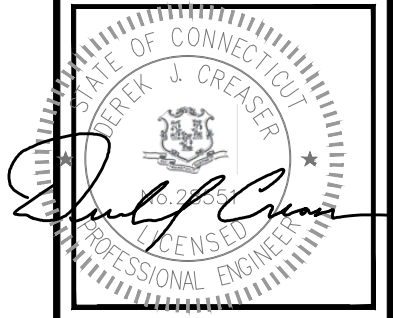

CHECKED BY: BB

APPROVED BY: DJC

**SUBMITTALS**

REV.	DATE	DESCRIPTION	BY
0	10/07/16	ISSUED FOR CONSTRUCTION	DJM

SITE NUMBER:  
CTFF575B

CROWN CASTLE SITE ID:  
857144

SITE NAME:  
CTFF575B

SITE ADDRESS:  
22 WAYSIDE LANE  
REDDING, CT 06896  
FAIRFIELD COUNTY

SHEET TITLE

ANTENNA LAYOUT  
& ELEVATION

SHEET NUMBER

**A-2**

TOP OF EXISTING FLAGPOLE  
ELEV. = 109.0'± A.G.L.

CL OF PROPOSED T-MOBILE ANTENNAS  
ELEV. = 87.0'± A.G.L.

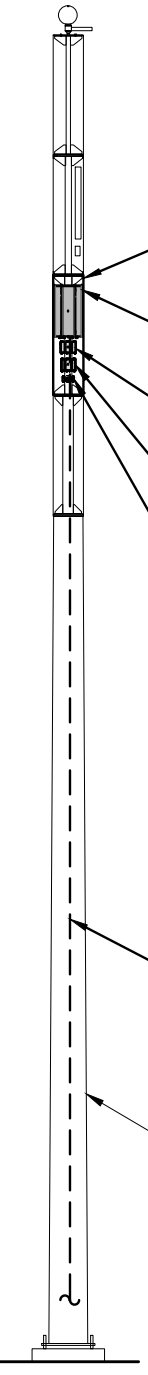

PROPOSED 2'-6"Ø SHROUD (ENLARGEMENT PER STRUCTURAL AND MOD DESIGN BY PAUL J. FORD - SEE NOTE) (SHROUD TO BE PAINTED TO MATCH EXISTING POLE)

PROPOSED T-MOBILE DBXNH-6565A-A2M ANTENNA MOUNTED TO PROPOSED CLUSTER MOUNT (TYP. OF 1 PER SECTOR, TOTAL OF 3)

PROPOSED T-MOBILE STYLE 4 TMA (TYP. OF 1 PER SECTOR, TOTAL OF 3) BANDED TO SPINE

PROPOSED T-MOBILE DIPLEXER (TYP. OF 1 PER SECTOR, TOTAL OF 3) BANDED TO SPINE

PROPOSED T-MOBILE SMART BIAS-T (TYP. OF 1 PER SECTOR, TOTAL OF 3) BANDED TO SPINE

- 1,2  
A-3
- 5  
A-3
- 6  
A-3
- 4  
A-3

PROPOSED (12) 7/8" COAX TO RUN ALONG PROPOSED ICE BRIDGE THEN UP INTERIOR OF EXISTING FLAGPOLE

EXISTING FLAGPOLE

GROUND LEVEL  
ELEV. = 0.0'± A.G.L.

**TOWER ELEVATION**

22x34 SCALE: 3/32"=1'-0"  
11x17 SCALE: 3/64"=1'-0"

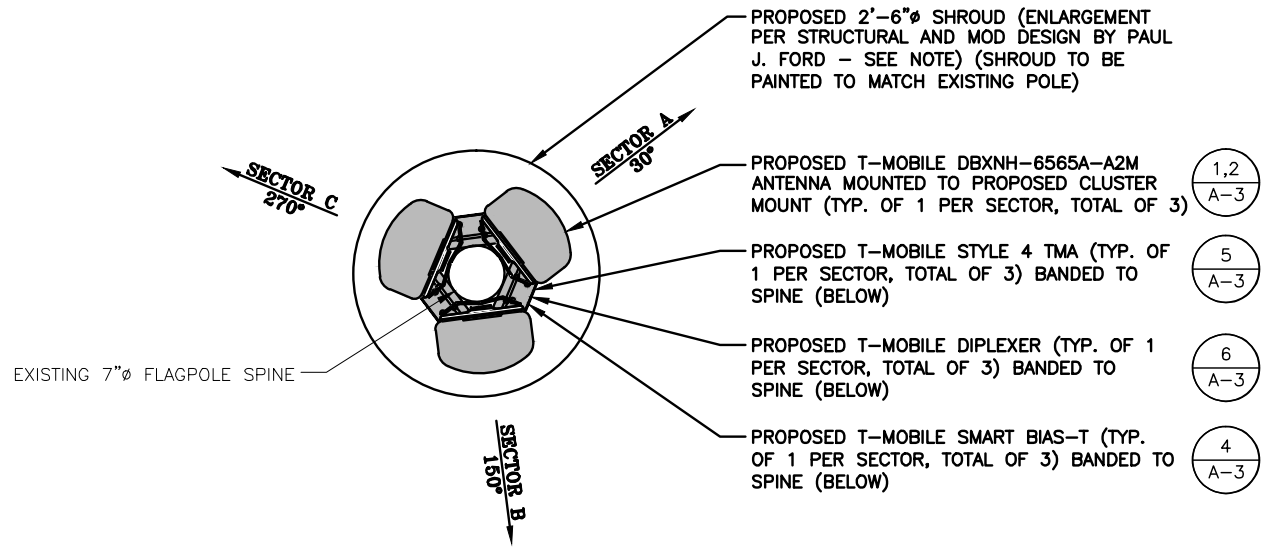
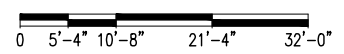

**PROPOSED ANTENNA LAYOUT**

SCALE: N.T.S.

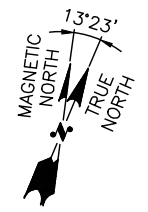

1  
A-2

2  
A-2

**STRUCTURAL NOTE:**  
REFER TO STRUCTURAL ANALYSIS REPORT AND MOD DESIGN BY: PAUL J. FORD & COMPANY, DATED: SEPTEMBER 26, 2016 FOR AN ANALYSIS OF THE CAPACITY OF THE EXISTING STRUCTURES TO SUPPORT THE PROPOSED EQUIPMENT PRIOR TO COMMENCING CONSTRUCTION.

**NOTE:**  
REFER TO FINAL RF DATA SHEET FOR FINAL ANTENNA SETTINGS

U19/L21 ANTENNA DIMENSIONS	
MODEL #	DBXNH-6565A-A2M (QUAD)
MANUF.	ANDREW
HEIGHT	50.9"
WIDTH	11.9"
DEPTH	7.1"
WEIGHT	34.2 LBS

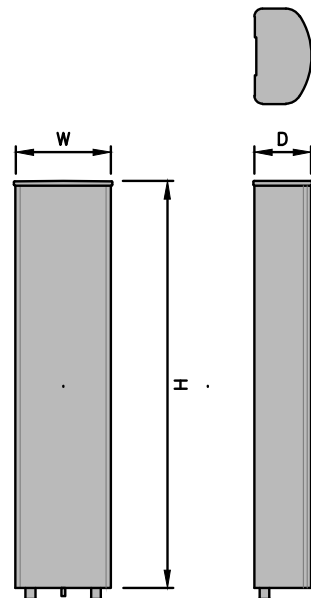

**ANTENNA DETAIL** (1/A-3)  
SCALE: N.T.S.

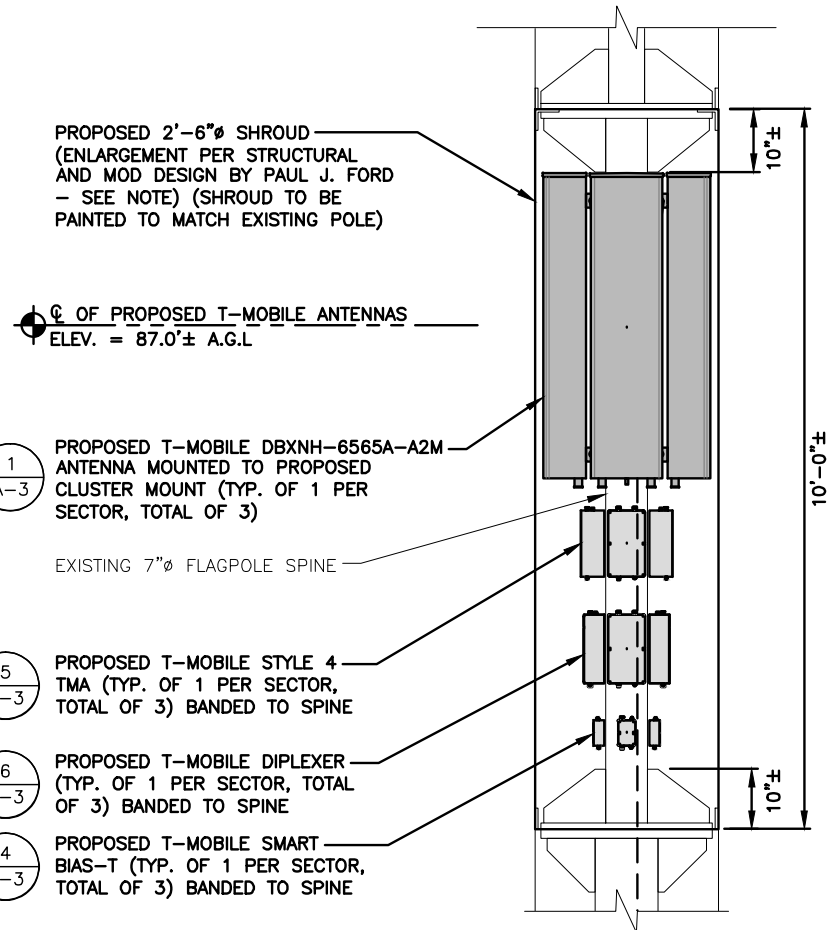

**PROPOSED ELEVATION VIEW** (2/A-3)  
SCALE: N.T.S.

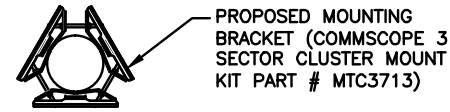

**PROPOSED CLUSTER MOUNT** (3/A-3)  
SCALE: N.T.S.

SMART BIAS-T DIMENSIONS	
MODEL #	ATSBT-BOTTOM-24V
MANUF.	ANDREW
HEIGHT	4.3"
WIDTH	2.9"
DEPTH	1.8"
WEIGHT	2.87 LBS

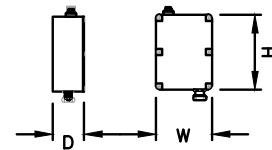

**SMART BIAS-TEE** (4/A-3)  
SCALE: N.T.S.

TMA DIMENSIONS	
MODEL #	KRY 112 489/2
MANUF.	ERICSSON
HEIGHT	11"
WIDTH	6.1"
DEPTH	3.94"
WEIGHT	15.4 LBS

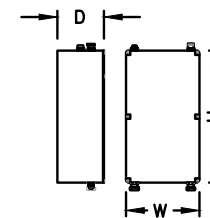

**STYLE 4 TMA** (5/A-3)  
SCALE: N.T.S.

DIPLEXER DIMENSIONS	
MODEL #	KRF 102 267/1
MANUF.	ERICSSON
HEIGHT	11.46"
WIDTH	5.75"
DEPTH	3.39"
WEIGHT	6.6 LBS

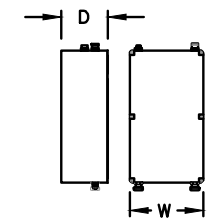

**DIPLEXER** (6/A-3)  
SCALE: N.T.S.

PROPOSED 2'-6" SHROUD (ENLARGEMENT PER STRUCTURAL AND MOD DESIGN BY PAUL J. FORD - SEE NOTE) (SHROUD TO BE PAINTED TO MATCH EXISTING POLE)

☉ OF PROPOSED T-MOBILE ANTENNAS  
ELEV. = 87.0'± A.G.L.

(1/A-2) (1/A-3) PROPOSED T-MOBILE DBXNH-6565A-A2M ANTENNA MOUNTED TO PROPOSED CLUSTER MOUNT (TYP. OF 1 PER SECTOR, TOTAL OF 3)

EXISTING 7" FLAGPOLE SPINE

(5/A-3) PROPOSED T-MOBILE STYLE 4 TMA (TYP. OF 1 PER SECTOR, TOTAL OF 3) BANDED TO SPINE

(6/A-3) PROPOSED T-MOBILE DIPLEXER (TYP. OF 1 PER SECTOR, TOTAL OF 3) BANDED TO SPINE

(4/A-3) PROPOSED T-MOBILE SMART BIAS-T (TYP. OF 1 PER SECTOR, TOTAL OF 3) BANDED TO SPINE

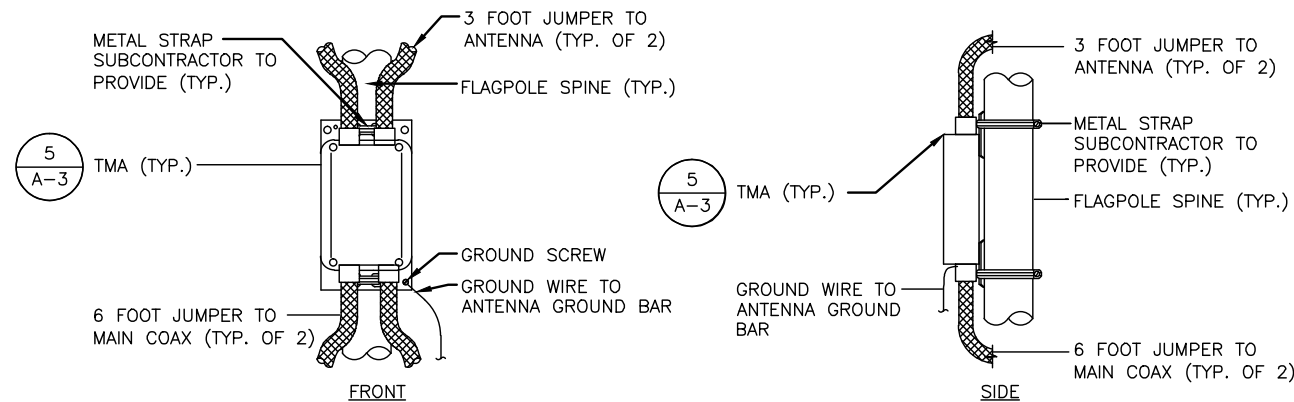

**TMA MOUNTING DETAIL** (7/A-3)  
SCALE: N.T.S.

**T-MOBILE NORTHEAST LLC**

35 GRIFFIN ROAD SOUTH  
BLOOMFIELD, CT 06002  
OFFICE: (860) 648-1116

**CROWN CASTLE**

CROWN CASTLE  
12 GILL STREET, SUITE 5800  
WOBURN, MA 01801

**Hudson Design Group**

1600 OSGOOD STREET  
BUILDING 20 NORTH, SUITE 3090  
N. ANDOVER, MA 01845  
TEL: (978) 557-5553  
FAX: (978) 336-5586

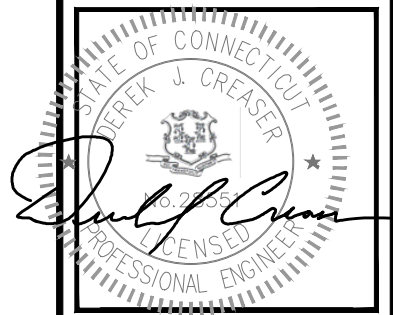

CHECKED BY: BB

APPROVED BY: DJC

**SUBMITTALS**

REV.	DATE	DESCRIPTION	BY
0	10/07/16	ISSUED FOR CONSTRUCTION	DJM

SITE NUMBER:  
CTFF575B  
CROWN CASTLE SITE ID:  
857144  
SITE NAME:  
CTFF575B

SITE ADDRESS:  
22 WAYSIDE LANE  
REDDING, CT 06896  
FAIRFIELD COUNTY

SHEET TITLE  
**TOWER EQUIPMENT DETAILS**

SHEET NUMBER

**A-3**

NOTE:  
INSTALL CABINET ANCHORS AND FLOOR MOUNT KIT ANCHORS PER MANUFACTURER'S INSTALLATION GUIDELINES

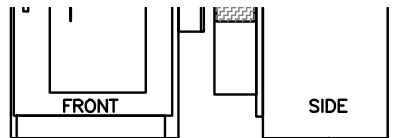

**SITE SUPPORT CABINET (SSC)**  
SCALE: N.T.S.

1  
A-4

PPC DIMENSIONS	
MODEL #	CS2S2-W736
MANUF.	EMERSON
WIDTH	30"
DEPTH	10"
HEIGHT	66"
WEIGHT	150 LBS

NOTE:  
INSTALL CABINET ANCHORS PER MANUFACTURER'S INSTALLATION GUIDELINES

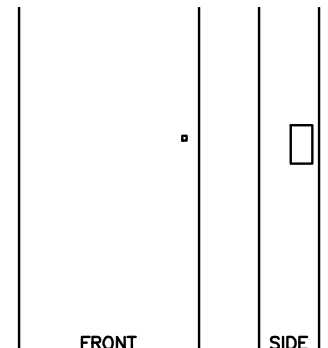

**POWER PROTECTION CABINET (PPC)**  
SCALE: N.T.S.

2  
A-4

INSTALL CABINET ANCHORS AND FLOOR MOUNT KIT ANCHORS PER MANUFACTURER'S INSTALLATION GUIDELINES

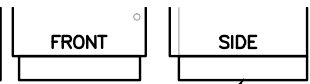

**POWER AND BATTERY CABINET (PBC)**  
SCALE: N.T.S.

3  
A-4

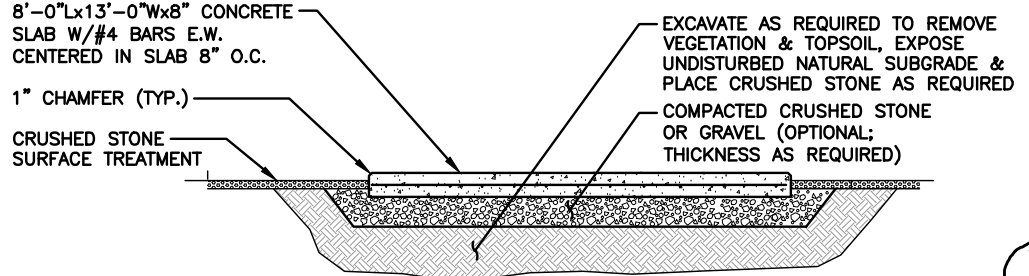

**NEW CONC. PAD NOTES:**  
- REINF. W/ #4's @ 8" O.C. EA. WAY (MID-DEPTH).  
- REINF. SHALL BE ASTM A615-GRADE 60. SECURE IN PLACE.  
- REINFORCEMENT IN EQUIPMENT SLAB TO BE WELDED AND BONDED TO GROUND RING

**CONCRETE PAD DETAIL**  
SCALE: N.T.S.

4  
A-4

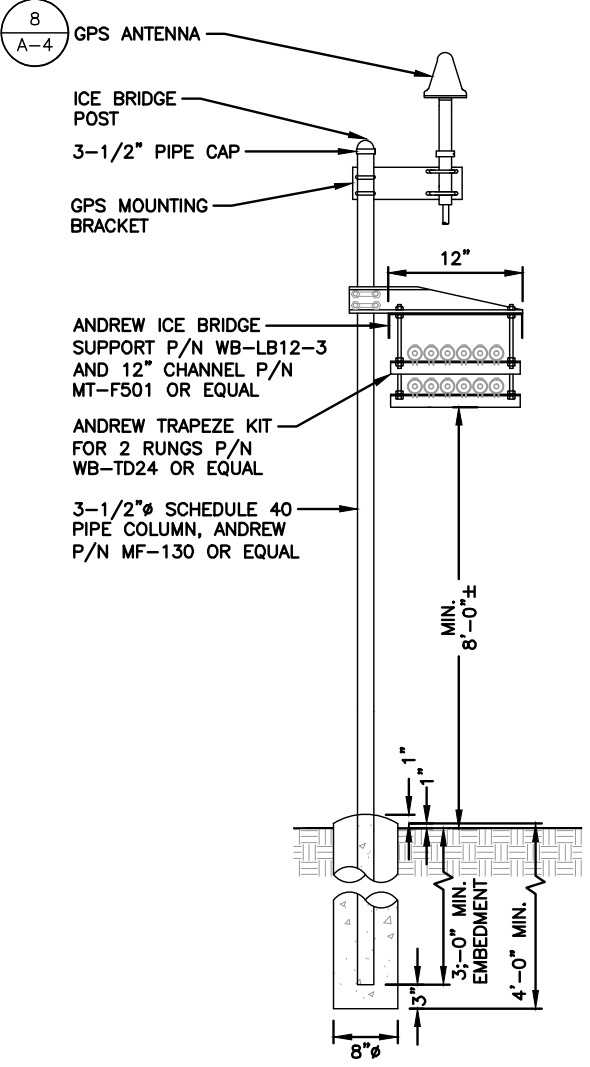

**COAX ICE BRIDGE DETAIL**  
SCALE: N.T.S.

5  
A-4

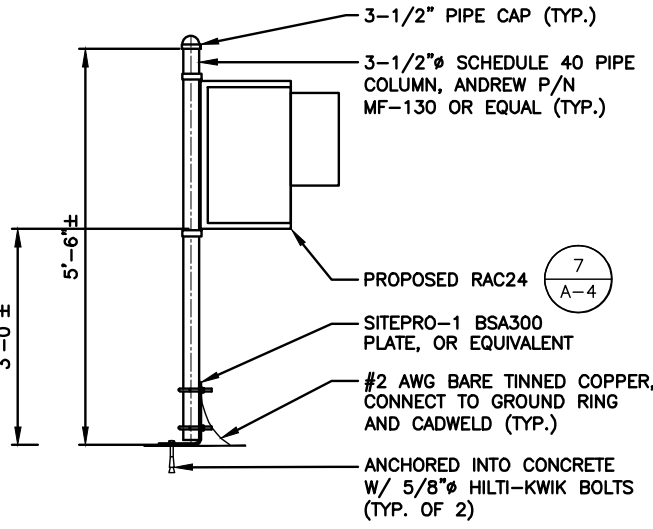
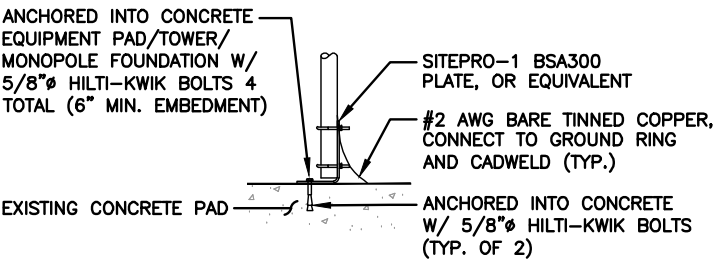

**RAC24 MOUNTING DETAIL**  
SCALE: N.T.S.

6  
A-4

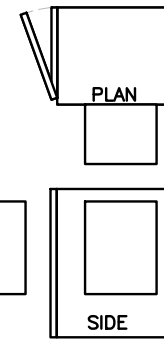

RAC24 DIMENSIONS	
MODEL #	RAC24
MANUF.	PURCELL
WIDTH	15.7"
DEPTH	20"
HEIGHT	24"
WEIGHT W/O BATTERIES	DEPENDANT ON OPTIONS

NOTE:  
INSTALL CABINET ANCHORS PER MANUFACTURER'S INSTALLATION GUIDELINES

**RAC24 CABINET**  
SCALE: N.T.S.

7  
A-4

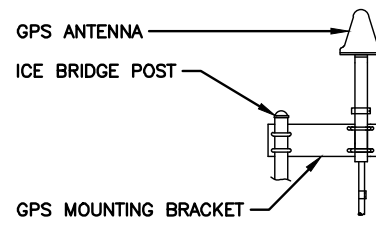

GPS DIMENSIONS	
MODEL #	CCAH32ST03
MANUF.	NAIS
HEIGHT	3.9"
WIDTH	3.5"

**GPS ANTENNA MOUNTING DETAIL**  
SCALE: N.T.S.

8  
A-4

**CROWN CASTLE**  
12 GILL STREET, SUITE 5800  
WORURN, MA 01801

**Hudson Design Group, Inc.**  
1600 OSGOOD STREET  
BUILDING 20 NORTH, SUITE 3090  
N. ANDOVER, MA 01845  
TEL: (978) 557-5553  
FAX: (978) 336-5586

STATE OF CONNECTICUT  
Derek J. Creaser  
Professional Engineer  
No. 22355

CHECKED BY: BB

APPROVED BY: DJC

SUBMITTALS			
REV.	DATE	DESCRIPTION	BY
0	10/07/16	ISSUED FOR CONSTRUCTION	DJM

SITE NUMBER:  
CTFF575B  
CROWN CASTLE SITE ID:  
857144  
SITE NAME:  
CTFF575B  
SITE ADDRESS:  
22 WAYSIDE LANE  
REDDING, CT 06896  
FAIRFIELD COUNTY

SHEET TITLE  
**GROUND EQUIPMENT DETAILS**

SHEET NUMBER  
**A-4**

**T-MOBILE  
NORTHEAST LLC**

35 GRIFFIN ROAD SOUTH  
BLOOMFIELD, CT 06002  
OFFICE: (860) 648-1116



CROWN CASTLE  
12 GILL STREET, SUITE 5800  
WOBURN, MA 01801



1600 OSGOOD STREET  
BUILDING 20 NORTH, SUITE 3090  
N. ANDOVER, MA 01845  
TEL: (978) 557-5553  
FAX: (978) 336-5586

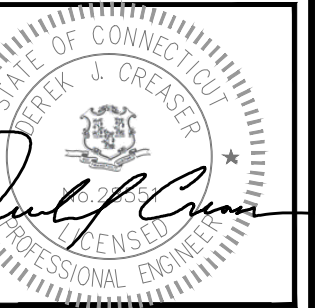

CHECKED BY: BB

APPROVED BY: DJC

**SUBMITTALS**

REV.	DATE	DESCRIPTION	BY
0	10/07/16	ISSUED FOR CONSTRUCTION	DJM

SITE NUMBER:

CTFF575B

CROWN CASTLE SITE ID:

857144

SITE NAME:

CTFF575B

SITE ADDRESS:

22 WAYSIDE LANE  
REDDING, CT 06896  
FAIRFIELD COUNTY

SHEET TITLE

GROUND EQUIPMENT  
DETAILS

SHEET NUMBER

**A-5**

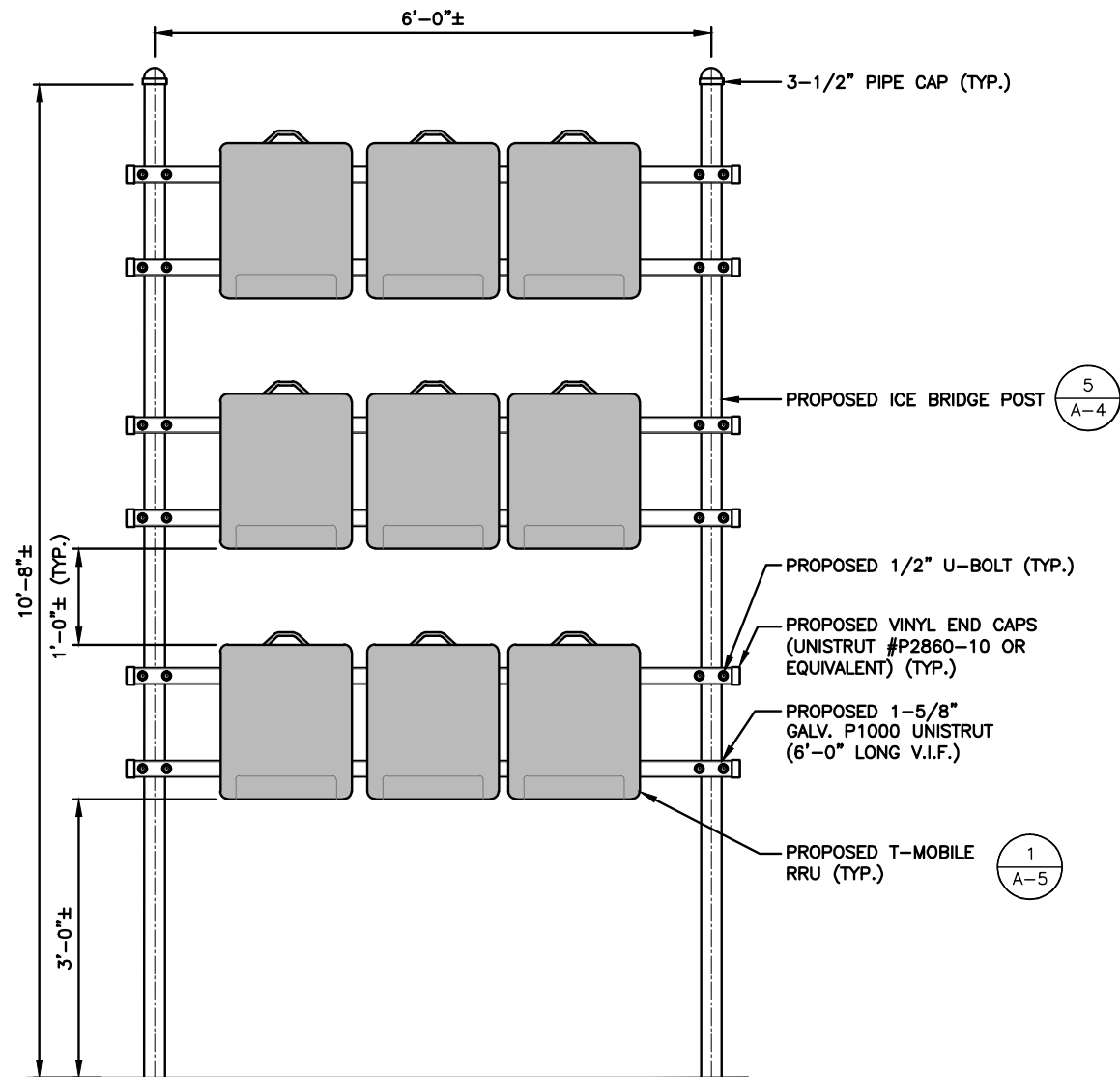

RRU DIMENSIONS	
MODEL #	RRUS11 B2
MODEL #	RRUS11 B4
MODEL #	RRUS11 B12
MANUF.	ERICSSON
WIDTH	17"
DEPTH	7"
HEIGHT	20"
WEIGHT	50.6 LBS

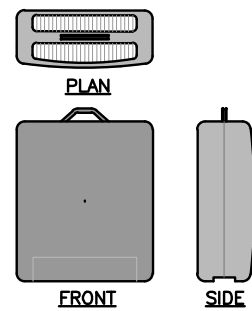

**PROPOSED RRU DETAIL** 1/A-5  
SCALE: N.T.S.

NOTE:  
SEE DETAIL 2/E-1 FOR  
H-FRAME GROUNDING

**RRU H-FRAME DETAIL** 2/A-5  
SCALE: N.T.S.



**T-MOBILE  
NORTHEAST LLC**

35 GRIFFIN ROAD SOUTH  
BLOOMFIELD, CT 06002  
OFFICE: (860) 648-1116



CROWN CASTLE  
12 GILL STREET, SUITE 5800  
WOBURN, MA 01801



1600 OSGOOD STREET  
BUILDING 20 NORTH, SUITE 3090  
N. ANDOVER, MA 01845  
TEL: (978) 557-5553  
FAX: (978) 336-5586

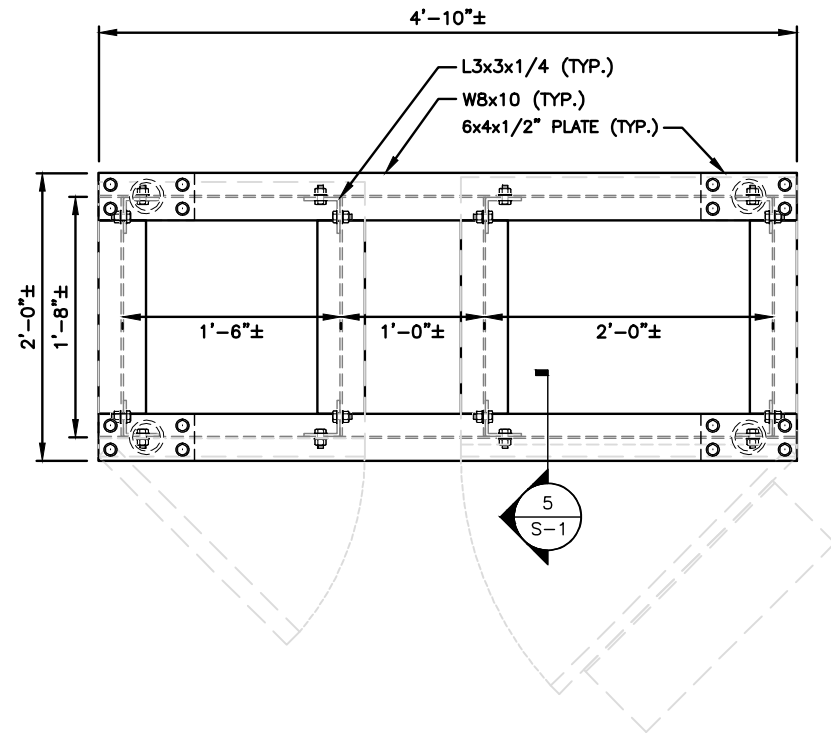
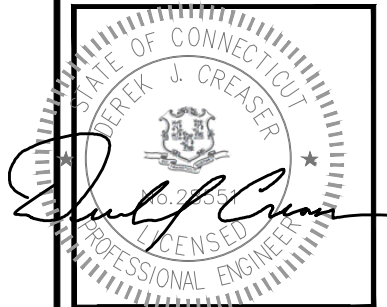

**PLATFORM FRAME PLAN**

22x34 SCALE: 1-1/2"=1'-0"  
11x17 SCALE: 3/4"=1'-0"



0 16'-0" 32'-0" 64'-0" 96'-0"

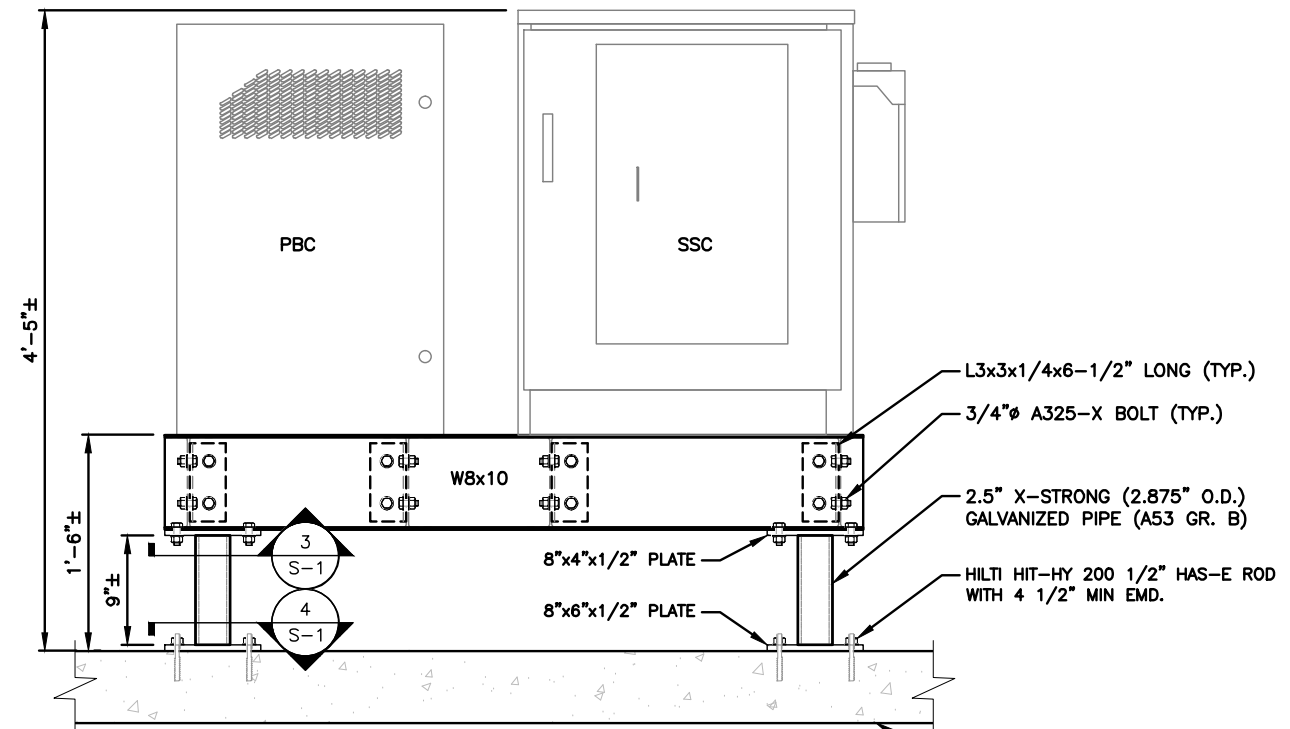

**PLATFORM FRAME ELEVATION**

22x34 SCALE: 1-1/2"=1'-0"  
11x17 SCALE: 3/4"=1'-0"



0 16'-0" 32'-0" 64'-0" 96'-0"

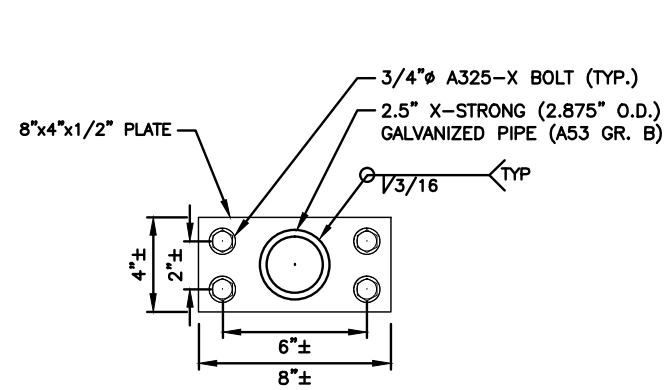

**PLATFORM FRAME TOP PLATE DETAIL**

22x34 SCALE: 3"=1'-0"  
11x17 SCALE: 1-1/2"=1'-0"



0 16'-0" 32'-0" 64'-0" 96'-0"

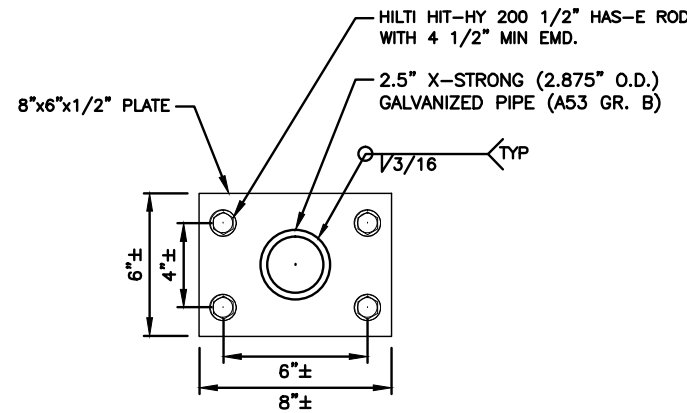

**PLATFORM FRAME BOTTOM PLATE DETAIL**

22x34 SCALE: 3"=1'-0"  
11x17 SCALE: 1-1/2"=1'-0"



0 16'-0" 32'-0" 64'-0" 96'-0"

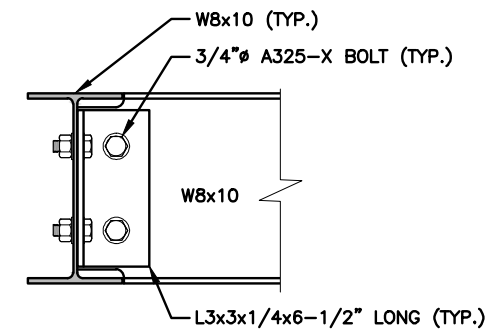

**PLATFORM FRAME SECTION DETAIL**

22x34 SCALE: 3"=1'-0"  
11x17 SCALE: 1-1/2"=1'-0"



0 16'-0" 32'-0" 64'-0" 96'-0"

CHECKED BY: BB

APPROVED BY: DJC

**SUBMITTALS**

REV.	DATE	DESCRIPTION	BY
0	10/07/16	ISSUED FOR CONSTRUCTION	DJM

SITE NUMBER:  
CTFF575B  
CROWN CASTLE SITE ID:  
857144  
SITE NAME:  
CTFF575B

SITE ADDRESS:  
22 WAYSIDE LANE  
REDDING, CT 06896  
FAIRFIELD COUNTY

SHEET TITLE  
**RAISED EQUIPMENT  
FRAME DETAILS**

SHEET NUMBER

**S-1**



**ELECTRICAL NOTES**

- ALL ELECTRICAL WORK SHALL CONFORM TO THE REQUIREMENTS OF THE NATIONAL ELECTRICAL CODE (NEC) AS WELL AS APPLICABLE STATE AND LOCAL CODES.
- ALL ELECTRICAL ITEMS SHALL BE U.L. APPROVED OR LISTED AND PROCURED PER SPECIFICATION REQUIREMENTS.
- THE ELECTRICAL WORK INCLUDES ALL LABOR AND MATERIAL DESCRIBED BY DRAWINGS AND SPECIFICATION INCLUDING INCIDENTAL WORK TO PROVIDE COMPLETE OPERATING AND APPROVED ELECTRICAL SYSTEM.
- GENERAL CONTRACTOR SHALL PAY FEES FOR PERMITS, AND IS RESPONSIBLE FOR OBTAINING SAID PERMITS AND COORDINATION OF INSPECTIONS.
- ELECTRICAL AND TELCO WIRING EXPOSED TO WEATHER SHALL BE IN WATER TIGHT GALVANIZED RIGID STEEL CONDUITS OR SCHEDULE 80 PVC (AS PERMITTED BY CODE) AND WHERE REQUIRED IN LIQUID TIGHT FLEXIBLE METAL OR NONMETALLIC CONDUITS. RIGID STEEL CONDUITS SHALL BE GROUNDED AT BOTH ENDS.
- ELECTRICAL WIRING SHALL BE COPPER WITH TYPE XHHW, THWN, OR THIN INSULATION.
- RUN ELECTRICAL CONDUIT OR CABLE BETWEEN ELECTRICAL METER BANK AND PROPOSED CELL SITE POWER PEDESTAL AS INDICATED ON THIS DRAWING. PROVIDE FULL LENGTH PULL ROPE. COORDINATE INSTALLATION WITH UTILITY COMPANY.
- RUN TELCO CONDUIT OR CABLE BETWEEN TELEPHONE UTILITY DEMARCATION POINT AND PROPOSED CELL SITE TELCO CABINET AND BTS CABINET AS INDICATED ON DRAWING A-1. PROVIDE FULL LENGTH PULL ROPE IN INSTALLED TELCO CONDUIT. PROVIDE GREENLEE CONDUIT MEASURING TAPE AT EACH END.
- ALL EQUIPMENT LOCATED OUTSIDE SHALL HAVE NEMA 3R ENCLOSURE.

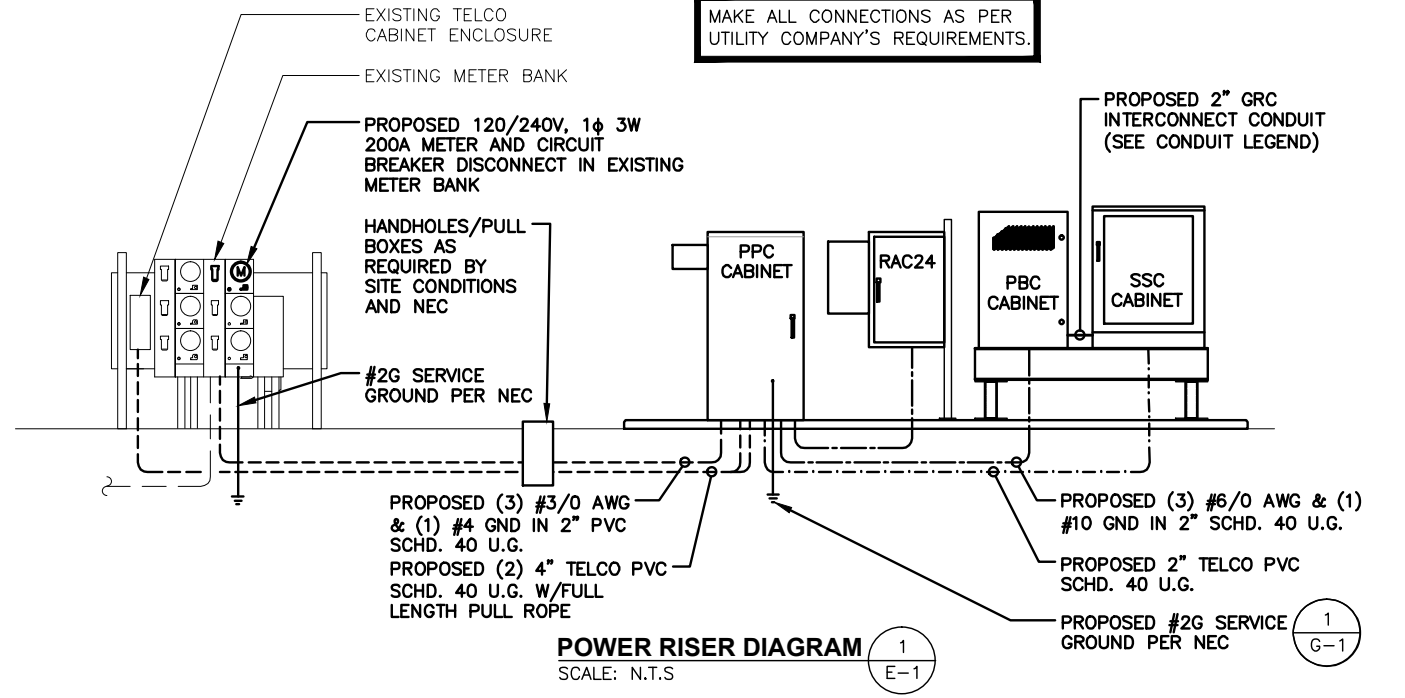

**CONDUIT LEGEND**

	2" $\phi$ GRC INTERCONNECT KIT, -48V DC, ON CONCRETE PAD, (1) CONDUIT PBC TO SSC AND (1) CONDUIT PBC TO FUTURE BBU, ANCHOR AT 3' INTERVALS, GROUNDING BOND AT EACH END
	2" $\phi$ PVC SCHD. 40 CONDUIT, AC-POWER, BELOW CONCRETE PAD, (1) CONDUIT PPC TO PBC, (2) CONDUIT PPC TO FUTURE PBC
	2" $\phi$ PVC SCHD. 40 CONDUIT, TELCO, BELOW CONCRETE PAD, (1) CONDUIT PPC TO SSC AND (1) CONDUIT SSC FOR DAISY CHAIN TO FUTURE SSC

**LEGEND**

A	AMPERE
V	VOLT
KWH	KILOWATT - HOUR
C	CONDUIT
GRC	GALVANIZED RIGID CONDUIT
BGR	BURIED GROUND RING
BTCW	BARE TINNED SOLID COPPER WIRE
G	GROUND
$\perp$	GROUND
MGB	MASTER GROUND BAR
	MECHANICAL CONNECTION
	CADWELD CONNECTION
EGB	EQUIPMENT GROUND BAR
	GROUND COPPER WIRE, SIZE AS NOTED
	EXPOSED WIRING
	#6G AWG INSULATED STRANDED
	COAXIAL CABLE/HYBRID CABLE
	5/8" x 8" COPPER CLAD STAINLESS STEEL GROUND ROD
	GROUND ROD WITH TEST WELL
	EXOTHERMIC (CAD WELD) OR MECHANICAL (COMPRESSION TYPE) CONNECTION
PPC	POWER PROTECTION CABINET
	OMNI-DIRECTIONAL ELECTRONIC MARKER SYSTEM (EMS) BALL

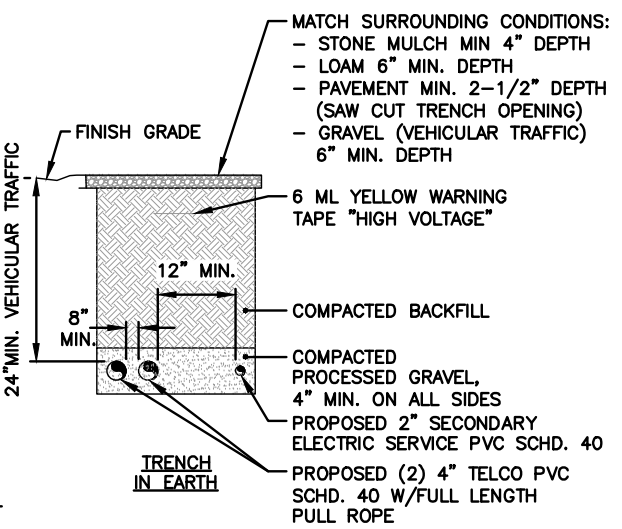
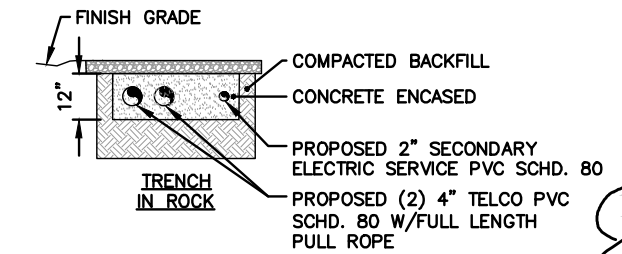
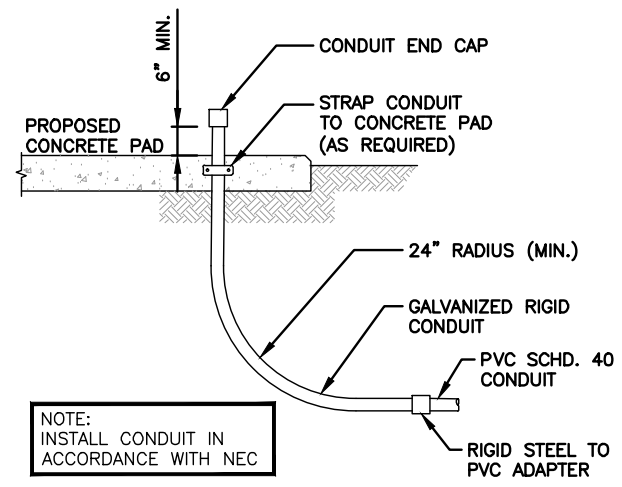
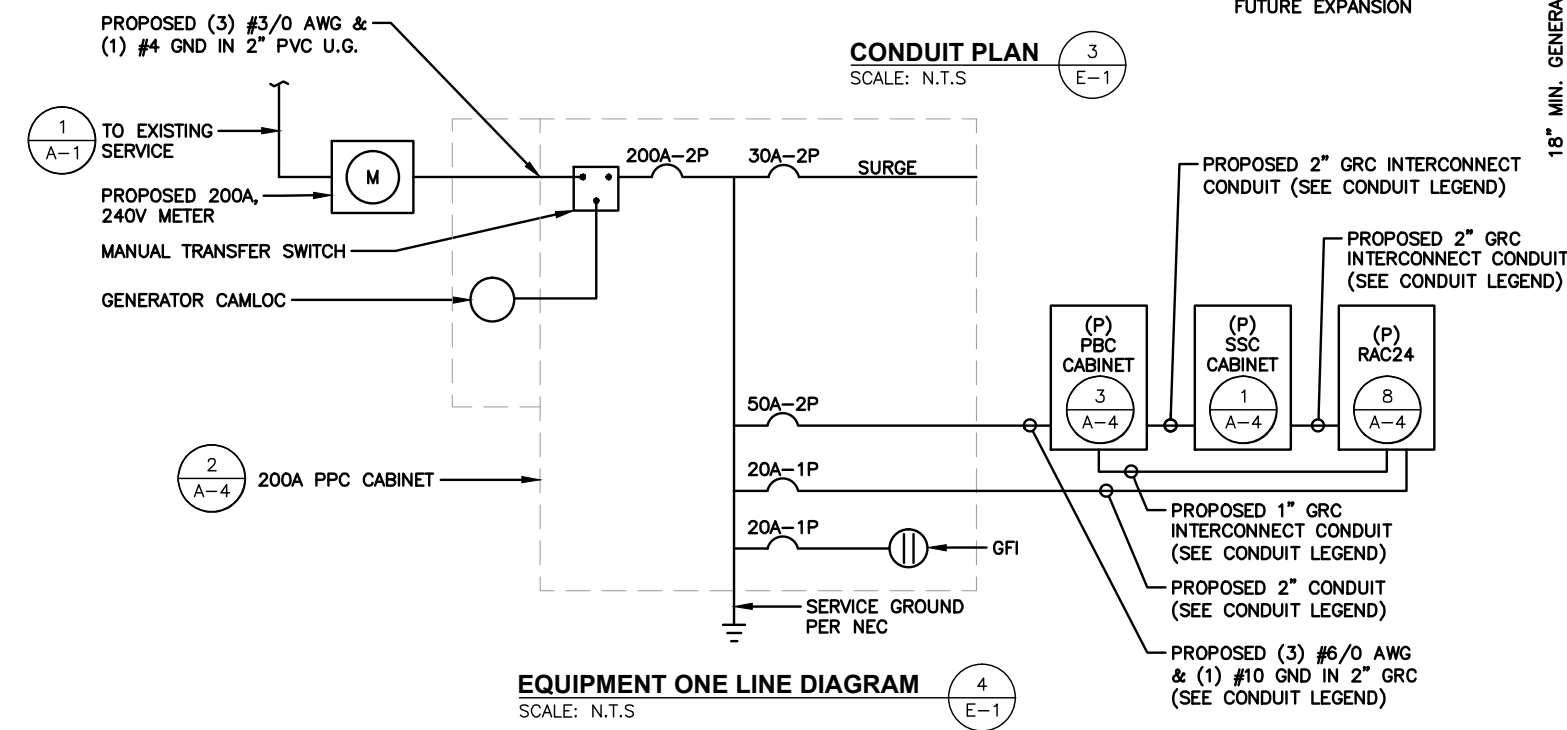

**SPECIAL WORK NOTE:**  
EXISTING UNDERGROUND UTILITY LOCATIONS ARE UNKNOWN. WHERE DIRECTED OR REQUIRED, HAND-EXCAVATE PROPOSED UTILITY TRENCHING

**BURIED CONDUIT DETAIL** 5  
SCALE: N.T.S. E-1

**T-MOBILE NORTHEAST LLC**  
35 GRIFFIN ROAD SOUTH  
BLOOMFIELD, CT 06002  
OFFICE: (860) 648-1116

**CROWN CASTLE**  
CROWN CASTLE  
12 GILL STREET, SUITE 5800  
WOBURN, MA 01801

**Hudson Design Group**  
1600 OSGOOD STREET  
BUILDING 20 NORTH, SUITE 3090  
N. ANDOVER, MA 01845  
TEL: (978) 557-5553  
FAX: (978) 336-5586

STATE OF CONNECTICUT  
BEREK J. CREASER  
LICENSED PROFESSIONAL ENGINEER  
No. 20355

CHECKED BY: BB

APPROVED BY: DJC

**SUBMITTALS**

REV.	DATE	DESCRIPTION	BY
0	10/07/16	ISSUED FOR CONSTRUCTION	DJM

SITE NUMBER:  
CTFF575B  
CROWN CASTLE SITE ID:  
857144  
SITE NAME:  
CTFF575B  
SITE ADDRESS:  
22 WAYSIDE LANE  
REDDING, CT 06896  
FAIRFIELD COUNTY

SHEET TITLE  
**ELECTRICAL DETAILS AND NOTES**

SHEET NUMBER  
**E-1**

**ELECTRICAL NOTES**

1. ALL ELECTRICAL WORK SHALL CONFORM TO THE REQUIREMENTS OF THE NATIONAL ELECTRICAL CODE (NEC) AS WELL AS APPLICABLE STATE AND LOCAL CODES.
2. ALL ELECTRICAL ITEMS SHALL BE U.L. APPROVED OR LISTED AND PROCURED PER SPECIFICATION REQUIREMENTS.
3. THE ELECTRICAL WORK INCLUDES ALL LABOR AND MATERIAL DESCRIBED BY DRAWINGS AND SPECIFICATION INCLUDING INCIDENTAL WORK TO PROVIDE COMPLETE OPERATING AND APPROVED ELECTRICAL SYSTEM.
4. GENERAL CONTRACTOR SHALL PAY FEES FOR PERMITS, AND IS RESPONSIBLE FOR OBTAINING SAID PERMITS AND COORDINATION OF INSPECTIONS.
5. ELECTRICAL AND TELCO WIRING EXPOSED TO WEATHER SHALL BE IN WATER TIGHT GALVANIZED RIGID STEEL CONDUITS OR SCHEDULE 80 PVC (AS PERMITTED BY CODE) AND WHERE REQUIRED IN LIQUID TIGHT FLEXIBLE METAL OR NONMETALLIC CONDUITS. RIGID STEEL CONDUITS SHALL BE GROUNDED AT BOTH ENDS.
6. ELECTRICAL WIRING SHALL BE COPPER WITH TYPE XHHW, THWN, OR THIN INSULATION.
7. RUN ELECTRICAL CONDUIT OR CABLE BETWEEN ELECTRICAL METER BANK AND PROPOSED CELL SITE POWER PEDESTAL AS INDICATED ON THIS DRAWING. PROVIDE FULL LENGTH PULL ROPE. COORDINATE INSTALLATION WITH UTILITY COMPANY.
8. RUN TELCO CONDUIT OR CABLE BETWEEN TELEPHONE UTILITY DEMARCATION POINT AND PROPOSED CELL SITE TELCO CABINET AND BTS CABINET AS INDICATED ON DRAWING A-1. PROVIDE FULL LENGTH PULL ROPE IN INSTALLED TELCO CONDUIT. PROVIDE GREENLEE CONDUIT MEASURING TAPE AT EACH END.
9. ALL EQUIPMENT LOCATED OUTSIDE SHALL HAVE NEMA 3R ENCLOSURE.

- NOTE:**
1. BASE BID TO INCLUDE INSTALLATION OF A BURIED GROUND RING AND (6) GROUND RODS OR SINGLE XIT HORIZONTAL CHEMICAL ROD AS DETERMINED BY FIELD CONDITIONS. ADDITIONAL RODS AS REQUIRED TO ACHIEVE 5 OHMS RESISTANCE.
  2. MAXIMUM VERTICAL/HORIZONTAL DISTANCE BETWEEN CABLE GROUNDING KITS SHALL NOT EXCEED 100 FEET. INSTALL ADDITIONAL KITS AS REQUIRED BY FIELD CONDITIONS.
  3. ALL CONNECTIONS TO EQUIPMENT PER MANUFACTURER'S GUIDELINES.
  4. ALL ABOVE-GRADE DOWNLEADS TO BGR SHALL BE INSTALLED IN 1" NON-METALLIC CONDUIT SECURED EVERY 2' WITH NON-METALLIC CLIPS.

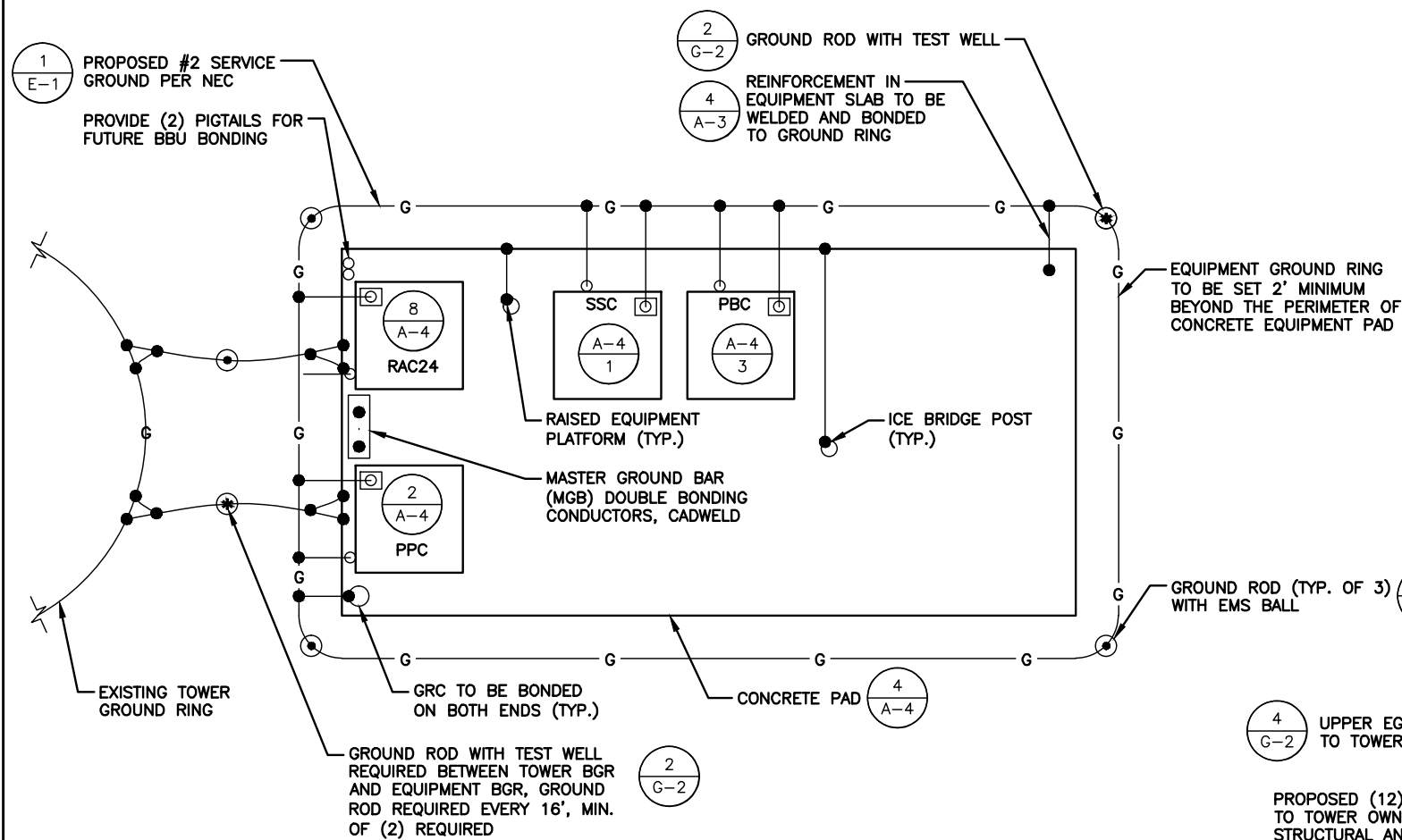

**EQUIPMENT PLAN GROUNDING RING SCHEMATIC**  
SCALE: N.T.S.

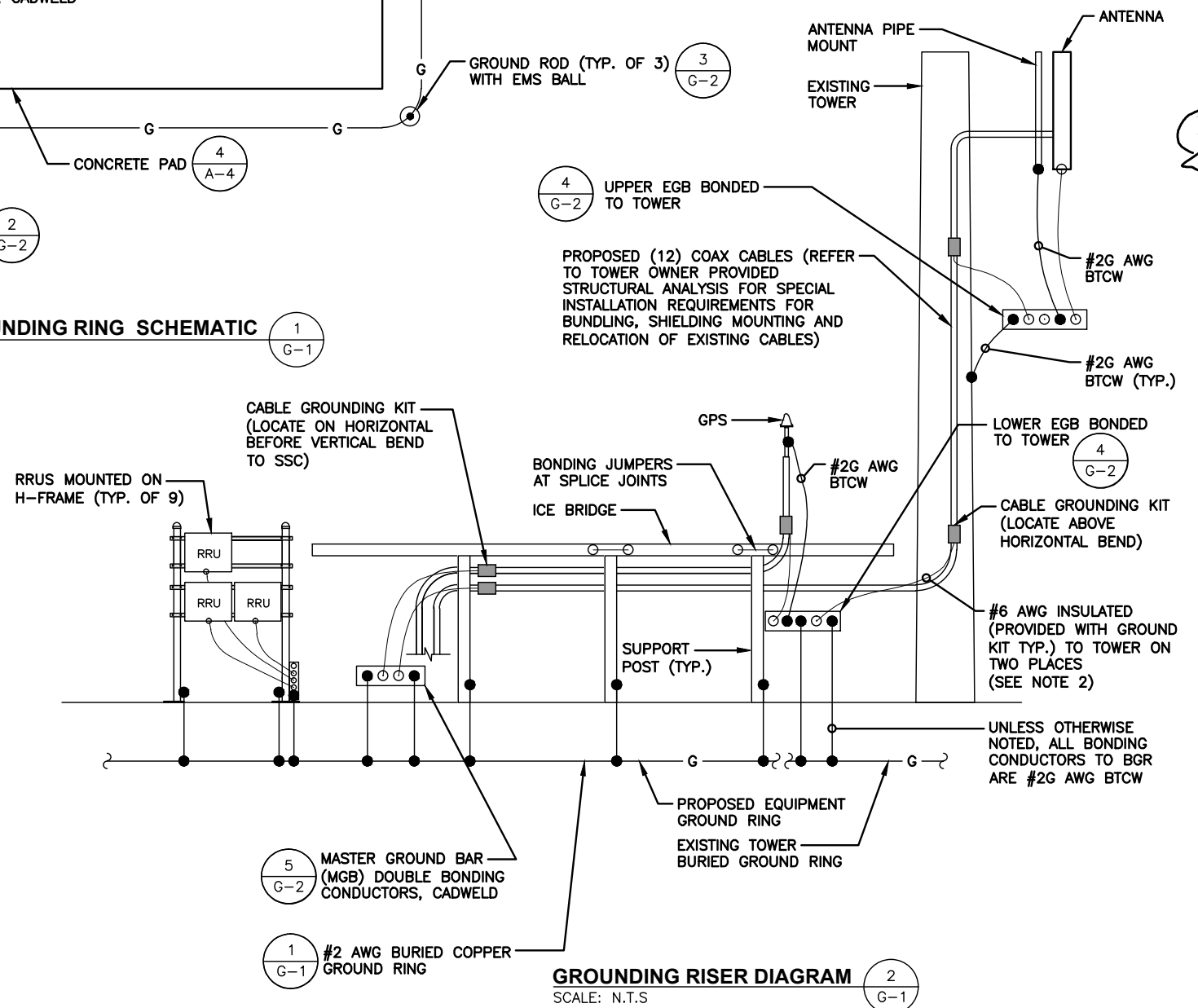

**GROUNDING RISER DIAGRAM**  
SCALE: N.T.S.

**LEGEND**

A	AMPERE
V	VOLT
KWH	KILOWATT - HOUR
C	CONDUIT
GRC	GALVANIZED RIGID CONDUIT
BGR	BURIED GROUND RING
BTCW	BARE TINNED SOLID COPPER WIRE
G	GROUND
⊥	GROUND
MGB	MASTER GROUND BAR
○	MECHANICAL CONNECTION
●	CADWELD CONNECTION
EGB	EQUIPMENT GROUND BAR
—G—	GROUND COPPER WIRE, SIZE AS NOTED
—	EXPOSED WIRING
—	#6G AWG INSULATED STRANDED
—	COAXIAL CABLE/HYBRID CABLE
⊙	5/8"x8' COPPER CLAD STAINLESS STEEL GROUND ROD
⊕	GROUND ROD WITH TEST WELL
⊖	EXOTHERMIC (CAD WELD) OR MECHANICAL (COMPRESSION TYPE) CONNECTION
PPC	POWER PROTECTION CABINET
⊗	OMNI-DIRECTIONAL ELECTRONIC MARKER SYSTEM (EMS) BALL

**T-MOBILE  
NORTHEAST LLC**

35 GRIFFIN ROAD SOUTH  
BLOOMFIELD, CT 06002  
OFFICE: (860) 648-1116

**CROWN  
CASTLE**

CROWN CASTLE  
12 GILL STREET, SUITE 5800  
WOBBURN, MA 01801

**Hudson  
Design Group, Inc.**

1600 OSGOOD STREET  
BUILDING 20 NORTH, SUITE 3090  
N. ANDOVER, MA 01845

TEL: (978) 557-5553  
FAX: (978) 336-5586

STATE OF CONNECTICUT  
Derek J. Creaser  
Professional Engineer  
No. 22355

CHECKED BY: BB

APPROVED BY: DJC

**SUBMITTALS**

REV.	DATE	DESCRIPTION	BY
0	10/07/16	ISSUED FOR CONSTRUCTION	DJM

SITE NUMBER:  
CTFF575B  
CROWN CASTLE SITE ID:  
857144  
SITE NAME:  
CTFF575B  
SITE ADDRESS:  
22 WAYSIDE LANE  
REDDING, CT 06896  
FAIRFIELD COUNTY

SHEET TITLE  
**GROUNDING  
SCHEMATIC AND  
RISER DIAGRAM**

SHEET NUMBER  
**G-1**

**ELECTRICAL NOTES**

1. ALL ELECTRICAL WORK SHALL CONFORM TO THE REQUIREMENTS OF THE NATIONAL ELECTRICAL CODE (NEC) AS WELL AS APPLICABLE STATE AND LOCAL CODES.
2. ALL ELECTRICAL ITEMS SHALL BE U.L. APPROVED OR LISTED AND PROCURED PER SPECIFICATION REQUIREMENTS.
3. THE ELECTRICAL WORK INCLUDES ALL LABOR AND MATERIAL DESCRIBED BY DRAWINGS AND SPECIFICATION INCLUDING INCIDENTAL WORK TO PROVIDE COMPLETE OPERATING AND APPROVED ELECTRICAL SYSTEM.
4. GENERAL CONTRACTOR SHALL PAY FEES FOR PERMITS, AND IS RESPONSIBLE FOR OBTAINING SAID PERMITS AND COORDINATION OF INSPECTIONS.
5. ELECTRICAL AND TELCO WIRING EXPOSED TO WEATHER SHALL BE IN WATER TIGHT GALVANIZED RIGID STEEL CONDUITS OR SCHEDULE 80 PVC (AS PERMITTED BY CODE) AND WHERE REQUIRED IN LIQUID TIGHT FLEXIBLE METAL OR NONMETALLIC CONDUITS. RIGID STEEL CONDUITS SHALL BE GROUNDED AT BOTH ENDS.
6. ELECTRICAL WIRING SHALL BE COPPER WITH TYPE XHHW, THWN, OR THIN INSULATION.
7. RUN ELECTRICAL CONDUIT OR CABLE BETWEEN ELECTRICAL METER BANK AND PROPOSED CELL SITE POWER PEDESTAL AS INDICATED ON THIS DRAWING. PROVIDE FULL LENGTH PULL ROPE. COORDINATE INSTALLATION WITH UTILITY COMPANY.
8. RUN TELCO CONDUIT OR CABLE BETWEEN TELEPHONE UTILITY DEMARCATION POINT AND PROPOSED CELL SITE TELCO CABINET AND BTS CABINET AS INDICATED ON DRAWING A-1. PROVIDE FULL LENGTH PULL ROPE IN INSTALLED TELCO CONDUIT. PROVIDE GREENLEE CONDUIT MEASURING TAPE AT EACH END.
9. ALL EQUIPMENT LOCATED OUTSIDE SHALL HAVE NEMA 3R ENCLOSURE.

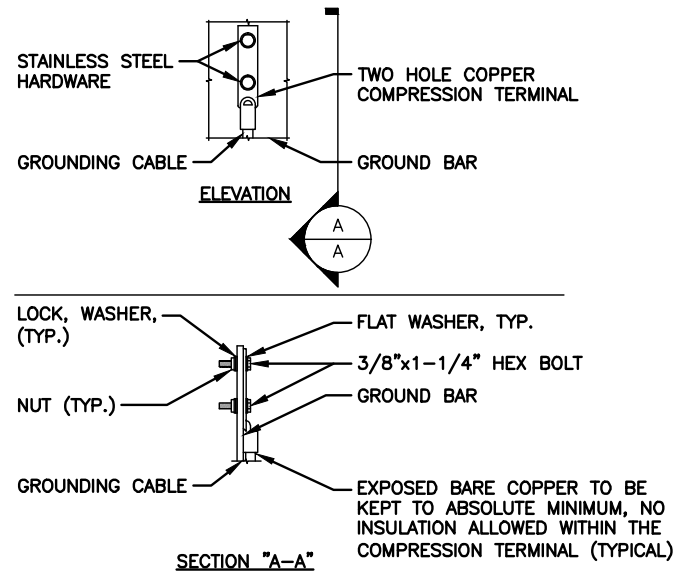

NOTE:  
 1. "DOUBLING UP" OR "STACKING" OF CONNECTION IS NOT PERMITTED.  
 2. OXIDE INHIBITING COMPOUND TO BE USED AT ALL LOCATIONS.  
 3. CADWELD DOWNLEADS FROM UPPER EGB, LOWER EGB, AND MGB.

**TYPICAL GROUND BAR CONNECTION DETAIL**  
 SCALE: N.T.S.

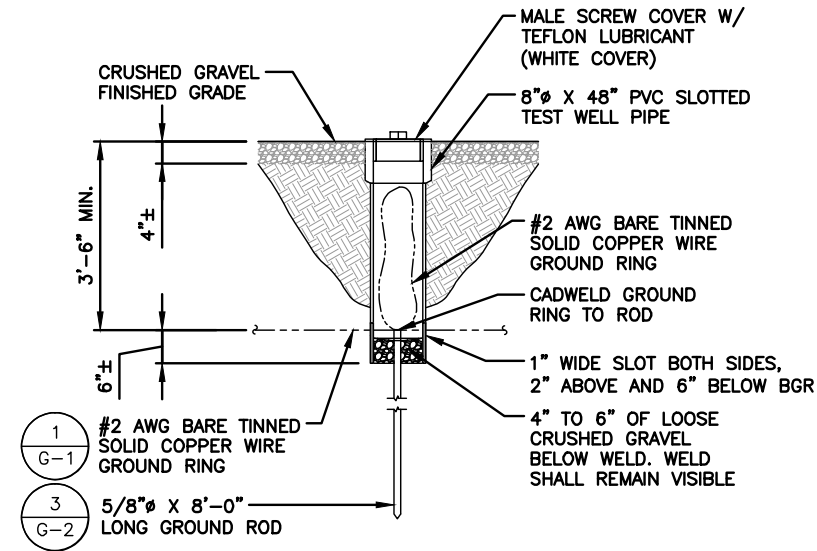

NOTE:  
 1. PROPOSED BGR TO BE INSTALLED 3'-6" MIN. BELOW GRADE OR BELOW LOCAL FROST DEPTH, WHICHEVER IS GREATER.  
 2. ONE TEST WELL SHALL BE PROVIDED BETWEEN THE TOWER GROUND LOOP AND TWO ON THE EQUIPMENT GROUND LOOP

**GROUND ROD TEST WELL DETAIL**  
 SCALE: N.T.S.

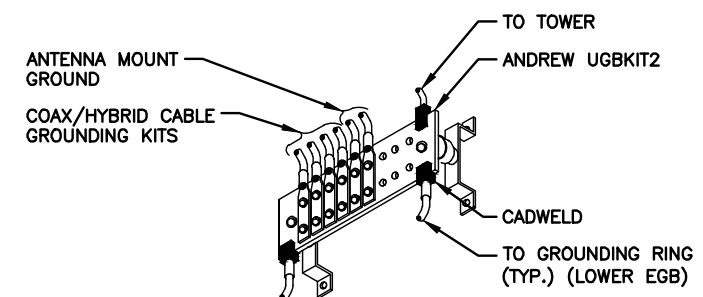

**EQUIPMENT GROUND BAR (EGB)**  
 SCALE: N.T.S.

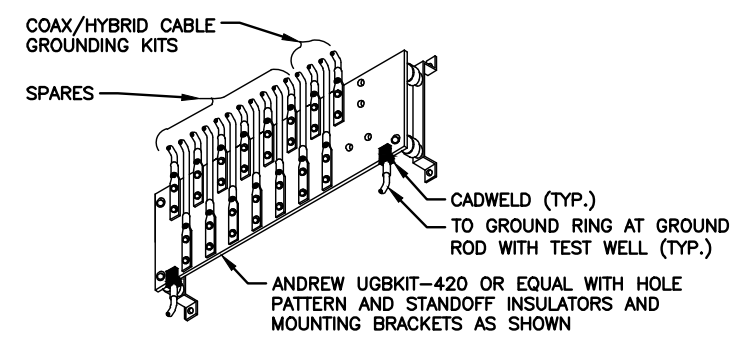

**MASTER GROUND BAR (MGB)**  
 SCALE: N.T.S.

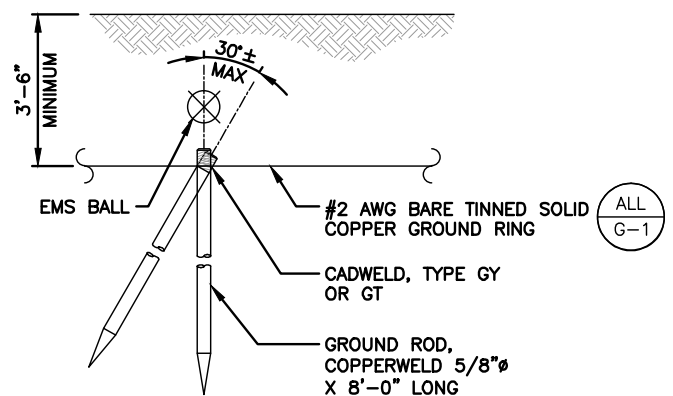

NOTE:  
 1. PROPOSED BGR TO BE INSTALLED 3'-6" MIN. BELOW GRADE OR BELOW LOCAL FROST DEPTH, WHICHEVER IS GREATER.  
 2. GROUND ROD SHALL BE DRIVEN VERTICALLY, NOT TO EXCEED 30 DEGREES FROM THE VERTICAL.

**GROUND ROD DETAIL**  
 SCALE: N.T.S.

LEGEND	
A	AMPERE
V	VOLT
KWH	KILOWATT - HOUR
C	CONDUIT
GRC	GALVANIZED RIGID CONDUIT
BGR	BURIED GROUND RING
BTCW	BARE TINNED SOLID COPPER WIRE
G	GROUND
⊥	GROUND
MGB	MASTER GROUND BAR
○	MECHANICAL CONNECTION
●	CADWELD CONNECTION
EGB	EQUIPMENT GROUND BAR
—G—	GROUND COPPER WIRE, SIZE AS NOTED
—	EXPOSED WIRING
—	#6G AWG INSULATED STRANDED
—	COAXIAL CABLE/HYBRID CABLE
⊙	5/8"x8' COPPER CLAD STAINLESS STEEL GROUND ROD
⊕	GROUND ROD WITH TEST WELL
⊖	EXOTHERMIC (CAD WELD) OR MECHANICAL (COMPRESSION TYPE) CONNECTION
PPC	POWER PROTECTION CABINET
⊗	OMNI-DIRECTIONAL ELECTRONIC MARKER SYSTEM (EMS) BALL

**T-MOBILE NORTHEAST LLC**  
 35 GRIFFIN ROAD SOUTH  
 BLOOMFIELD, CT 06002  
 OFFICE: (860) 648-1116

**CROWN CASTLE**  
 CROWN CASTLE  
 12 GILL STREET, SUITE 5800  
 WOBURN, MA 01801

**Hudson Design Group**  
 1600 OSGOOD STREET  
 BUILDING 20 NORTH, SUITE 3090  
 N. ANDOVER, MA 01845  
 TEL: (978) 557-5553  
 FAX: (978) 336-5586

STATE OF CONNECTICUT  
 BREK J. CREASER  
 LICENSED PROFESSIONAL ENGINEER  
 No. 20351

CHECKED BY: BB

APPROVED BY: DJC

SUBMITTALS			
REV.	DATE	DESCRIPTION	BY
0	10/07/16	ISSUED FOR CONSTRUCTION	DJM

SITE NUMBER:  
 CTFF575B  
 CROWN CASTLE SITE ID:  
 857144  
 SITE NAME:  
 CTFF575B  
 SITE ADDRESS:  
 22 WAYSIDE LANE  
 REDDING, CT 06896  
 FAIRFIELD COUNTY

SHEET TITLE  
**GROUNDING DETAILS AND NOTES**

SHEET NUMBER  
**G-2**





Date: September 26, 2016

Andrew Bazinet  
Crown Castle  
3 Corporate Park Drive, Suite 101  
Clifton Park, NY 12065  
585.370.4766

Paul J. Ford and Company  
250 E. Broad Street, Suite 600  
Columbus, OH 43215  
614.221.6679  
jmeinerding@pjfweb.com

**Subject: Structural Modification Report**

**Carrier Designation:** T-Mobile Co-Locate  
**Carrier Site Number:** CTFF575B  
**Carrier Site Name:** ATT Wayside Lane

**Crown Castle Designation:**  
**Crown Castle BU Number:** 857144  
**Crown Castle Site Name:** REDDING WAYSIDE LANE  
**Crown Castle JDE Job Number:** 380605  
**Crown Castle Work Order Number:** 1301248  
**Crown Castle Application Number:** 345878 Rev. 14

**Engineering Firm Designation:** Paul J. Ford and Company Project Number: 37516-3037.002.7700

**Site Data:** 22 WAYSIDE LANE, REDDING, Fairfield County, CT  
Latitude 41° 16' 56.3", Longitude -73° 24' 26.9"  
109 Foot - Monopole Tower

Dear Andrew Bazinet,

Paul J. Ford and Company is pleased to submit this "Structural Modification Report" to determine the structural integrity of the above mentioned tower. This analysis has been performed in accordance with the Crown Castle Structural 'Statement of Work' and the terms of Crown Castle Purchase Order Number 948676, in accordance with application 345878, revision 14.

The purpose of the analysis is to determine acceptability of the tower stress level. Based on our analysis we have determined the tower stress level for the structure and foundation, under the following load case, to be:

LC4.5: Modified Structure w/ Existing + Proposed Equipment **Sufficient Capacity**  
Note: See Table I and Table II for the proposed and existing loading, respectively.

This analysis has been performed in accordance with the 2016 Connecticut State Building Code based upon an ultimate 3-second gust wind speed of 120 mph converted to a nominal 3-second gust wind speed of 93 mph per Section 1609.3 and Appendix N as required for use in the ANSI/TIA-222-G-2005 Standard, "Structural Standard for Antenna Supporting Structures and Antennas", with ANSI/TIA-222-G-1-2007 and ANSI/TIA-222-G-2-2009 Addenda per Exception #5 of Section 1609.1.1. Risk Category II and Exposure Category C were used in this analysis.

All modifications and equipment proposed in this report shall be installed in accordance with the attached drawings for the determined available structural capacity to be effective.

We at Paul J. Ford and Company appreciate the opportunity of providing our continuing professional services to you and Crown Castle. If you have any questions or need further assistance on this or other projects please give us a call.

Respectfully submitted by:

Joey Meinerding, E.I.  
Structural Designer

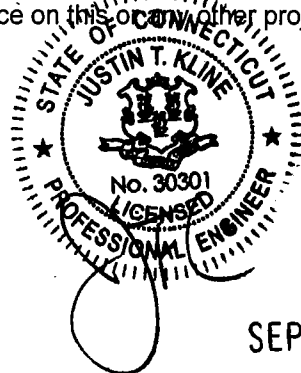

SEP 28 2016

Date: **September 26, 2016**

Andrew Bazinet  
Crown Castle  
3 Corporate Park Drive, Suite 101  
Clifton Park, NY 12065  
585.370.4766

Paul J. Ford and Company  
250 E. Broad Street, Suite 600  
Columbus, OH 43215  
614.221.6679  
jmeinerding@pjfweb.com

**Subject: Structural Modification Report**

**Carrier Designation:** *T-Mobile Co-Locate*  
**Carrier Site Number:** CTFF575B  
**Carrier Site Name:** ATT Wayside Lane

**Crown Castle Designation:** **Crown Castle BU Number:** 857144  
**Crown Castle Site Name:** REDDING WAYSIDE LANE  
**Crown Castle JDE Job Number:** 380605  
**Crown Castle Work Order Number:** 1301248  
**Crown Castle Application Number:** 345878 Rev. 14

**Engineering Firm Designation:** **Paul J. Ford and Company Project Number:** 37516-3037.002.7700

**Site Data:** **22 WAYSIDE LANE, REDDING, Fairfield County, CT**  
**Latitude 41° 16' 56.3", Longitude -73° 24' 26.9"**  
**109 Foot - Monopole Tower**

Dear Andrew Bazinet,

*Paul J. Ford and Company* is pleased to submit this “**Structural Modification Report**” to determine the structural integrity of the above mentioned tower. This analysis has been performed in accordance with the Crown Castle Structural ‘Statement of Work’ and the terms of Crown Castle Purchase Order Number 948676, in accordance with application 345878, revision 14.

The purpose of the analysis is to determine acceptability of the tower stress level. Based on our analysis we have determined the tower stress level for the structure and foundation, under the following load case, to be:

LC4.5: Modified Structure w/ Existing + Proposed Equipment **Sufficient Capacity**  
Note: See Table I and Table II for the proposed and existing loading, respectively.

This analysis has been performed in accordance with the 2016 Connecticut State Building Code based upon an ultimate 3-second gust wind speed of 120 mph converted to a nominal 3-second gust wind speed of 93 mph per Section 1609.3 and Appendix N as required for use in the ANSI/TIA-222-G-2005 Standard, “Structural Standard for Antenna Supporting Structures and Antennas”, with ANSI/TIA-222-G-1-2007 and ANSI/TIA-222-G-2-2009 Addenda per Exception #5 of Section 1609.1.1. Risk Category II and Exposure Category C were used in this analysis.

All modifications and equipment proposed in this report shall be installed in accordance with the attached drawings for the determined available structural capacity to be effective.

We at *Paul J. Ford and Company* appreciate the opportunity of providing our continuing professional services to you and Crown Castle. If you have any questions or need further assistance on this or any other projects please give us a call.

Respectfully submitted by:

Joey Meinerding, E.I.  
Structural Designer

## TABLE OF CONTENTS

### 1) INTRODUCTION

### 2) ANALYSIS CRITERIA

Table 1 - Proposed Antenna and Cable Information

Table 2 - Existing Antenna and Cable Information

### 3) ANALYSIS PROCEDURE

Table 3 - Documents Provided

3.1) Analysis Method

3.2) Assumptions

### 4) ANALYSIS RESULTS

Table 4 – Section Capacity (Summary)

Table 5 – Tower Component Stresses vs. Capacity

4.1) Recommendations

### 5) APPENDIX A

tnxTower Output

### 6) APPENDIX B

Base Level Drawing

### 7) APPENDIX C

Additional Calculations



**1) INTRODUCTION**

This tower is a 109 ft. monopole tower designed by Engineered Endeavors, Inc. in March of 2006. The tower was originally designed for a wind speed of 85 mph per TIA/EIA-222-F.

**2) ANALYSIS CRITERIA**

This analysis has been performed in accordance with the 2016 Connecticut State Building Code based upon an ultimate 3-second gust wind speed of 120 mph converted to a nominal 3-second gust wind speed of 93 mph per Section 1609.3 and Appendix N as required for use in the ANSI/TIA-222-G-2005 Standard, "Structural Standard for Antenna Supporting Structures and Antennas", with ANSI/TIA-222-G-1-2007 and ANSI/TIA-222-G-2-2009 Addenda per Exception #5 of Section 1609.1.1. Risk Category II and Exposure Category C were used in this analysis.

**Table 1 - Proposed Antenna and Cable Information**

Mounting Level (ft)	Center Line Elevation (ft)	Number of Antennas	Antenna Manufacturer	Antenna Model	Number of Feed Lines	Feed Line Size (in)	Note
94.0	94.0	1	generic	30.75"Ø x 10' Concealment Shroud	12	7/8	--
84.0	86.0	3	andrew	DBXNH-6565A-A2M			
	84.0	1	generic	30.75"Ø x 10' Concealment Shroud			
	83.0	3	ericsson	KRF 102 267/1			
	82.0	3	ericsson	KRY 112 489/2			
	81.0	3	commscope	ATBT-BOTTOM-24V			

**Table 2 - Existing Antenna and Cable Information**

Mounting Level (ft)	Center Line Elevation (ft)	Number of Antennas	Antenna Manufacturer	Antenna Model	Number of Feed Lines	Feed Line Size (in)	Note
104.0	106.0	3	powerwave technologies	7770.00	1 6	5/16 1-5/8	1
		6	powerwave technologies	LGP21401			
	104.0	1	generic	30.75"Ø x 10' Concealment Shroud			
94.0	96.0	3	powerwave technologies	P65-16-XLH-RR	6	1-5/8	1
		6	powerwave technologies	TTAW-07BP111-001			
74.0	74.0	1	generic	30.75"Ø x 10' Concealment Shroud	--	--	1

Notes:  
 1) Existing Equipment

### 3) ANALYSIS PROCEDURE

**Table 3 - Documents Provided**

Document	Remarks	Reference	Source
4-GEOTECHNICAL REPORTS	FDH Velocitel, 16BBRX1600, 02/16/2016	6109301	CCISITES
4-TOWER FOUNDATION DRAWINGS/DESIGN/SPECS	EEl, 13999, 03/27/2006	4568119	CCISITES
4-TOWER MANUFACTURER DRAWINGS	EEl, 13999, 03/27/2006 & TEP, 69664_84692, 06/10/2016 (Mapping)	5171985	CCISITES

#### 3.1) Analysis Method

tnxTower (version 7.0.5.1), a commercially available analysis software package, was used to create a three-dimensional model of the tower and calculate member stresses for various loading cases. Selected output from the analysis is included in Appendix A.

#### 3.2) Assumptions

- 1) Tower and structures were built in accordance with the manufacturer's specifications.
- 2) The tower and structures have been maintained in accordance with the manufacturer's specification.
- 3) The configuration of antennas, transmission cables, mounts and other appurtenances are as specified in Tables 1 and 2 and the referenced drawings.
- 4) The concealment manufacturer drawings are not available at the time of this analysis. Therefore, we have assumed concealment spine and concealment flange plate steel yield strength(s) ( $F_y$ ) as shown in the attached calculations.

This analysis may be affected if any assumptions are not valid or have been made in error. Paul J. Ford and Company should be notified to determine the effect on the structural integrity of the tower.

**4) ANALYSIS RESULTS**

**Table 4 - Section Capacity (Summary)**

Section No.	Elevation (ft)	Component Type	Size	Critical Element	P (K)	SF*P_allow (K)	% Capacity	Pass / Fail
L1	109 - 99	Pole	TP4.5x4.5x2.25	1	-1.03	715.69	17.8	Pass
L2	99 - 89	Pole	TP6x6x3	2	-3.00	1272.35	21.1	Pass
L3	89 - 79	Pole	TP7x7x3.5	3	-5.41	1731.80	25.4	Pass
L4	79 - 69	Pole	TP10.75x10.75x1	4	-7.31	964.86	35.2	Pass
L5	69 - 48.21	Pole	TP32.36x29.5x0.1875	5	-9.20	1156.26	21.2	Pass
L6	48.21 - 0	Pole	TP38.5x31.3549x0.25	6	-16.42	1955.62	33.0	Pass
							Summary	
						Pole (L4)	35.2	Pass
						RATING =	35.2	Pass

**Table 5 - Tower Component Stresses vs. Capacity**

Notes	Component	Elevation (ft)	% Capacity	Pass / Fail
1	Anchor Rods	0	45.6	Pass
1	Base Plate	0	32.4	Pass
1	Base Foundation Structural Steel	0	13.4	Pass
1	Base Foundation Soil Interaction	0	5.1	Pass
1	Flange Connection	69	81.3	Pass
1	Flange Connection	79	72.2	Pass
1	Flange Connection	89	84.1	Pass
1	Flange Connection	99	53.3	Pass

<b>Structure Rating (max from all components) =</b>	<b>84.1%</b>
-----------------------------------------------------	--------------

Notes:

- 1) See additional documentation in "Appendix C – Additional Calculations" for calculations supporting the % capacity consumed.

**4.1) Recommendations**

Install the proposed modifications per the attached drawings.

**APPENDIX A**  
**TNXTOWER OUTPUT**

## Tower Input Data

There is a pole section.  
 This tower is designed using the TIA-222-G standard.  
 The following design criteria apply:

- 1) Tower is located in Fairfield County, Connecticut.
- 2) ASCE 7-10 Wind Data is used (wind speeds converted to nominal values).
- 3) Basic wind speed of 93 mph.
- 4) Structure Class II.
- 5) Exposure Category C.
- 6) Topographic Category 1.
- 7) Crest Height 0.0000 ft.
- 8) Nominal ice thickness of 0.7500 in.
- 9) Ice thickness is considered to increase with height.
- 10) Ice density of 56.00 pcf.
- 11) A wind speed of 50 mph is used in combination with ice.
- 12) Temperature drop of 50 °F.
- 13) Deflections calculated using a wind speed of 60 mph.
- 14) A non-linear (P-delta) analysis was used.
- 15) Pressures are calculated at each section.
- 16) Stress ratio used in pole design is 1.
- 17) Local bending stresses due to climbing loads, feed line supports, and appurtenance mounts are not considered.

## Options

Consider Moments - Legs Consider Moments - Horizontals Consider Moments - Diagonals Use Moment Magnification ✓ Use Code Stress Ratios ✓ Use Code Safety Factors - Guys Escalate Ice Always Use Max Kz Use Special Wind Profile  Include Bolts In Member Capacity  Leg Bolts Are At Top Of Section Secondary Horizontal Braces Leg Use Diamond Inner Bracing (4 Sided) SR Members Have Cut Ends SR Members Are Concentric	Distribute Leg Loads As Uniform Assume Legs Pinned ✓ Assume Rigid Index Plate ✓ Use Clear Spans For Wind Area Use Clear Spans For KL/r Retension Guys To Initial Tension ✓ Bypass Mast Stability Checks ✓ Use Azimuth Dish Coefficients ✓ Project Wind Area of Appurt.  Autocalc Torque Arm Areas  Add IBC .6D+W Combination Sort Capacity Reports By Component Triangulate Diamond Inner Bracing Treat Feed Line Bundles As Cylinder	Use ASCE 10 X-Brace Ly Rules Calculate Redundant Bracing Forces Ignore Redundant Members in FEA SR Leg Bolts Resist Compression All Leg Panels Have Same Allowable Offset Girt At Foundation ✓ Consider Feed Line Torque Include Angle Block Shear Check Use TIA-222-G Bracing Resist. Exemption Use TIA-222-G Tension Splice Exemption  <div style="text-align: center; background-color: #e0e0e0; padding: 2px;"><b>Poles</b></div> ✓ Include Shear-Torsion Interaction Always Use Sub-Critical Flow Use Top Mounted Sockets
--------------------------------------------------------------------------------------------------------------------------------------------------------------------------------------------------------------------------------------------------------------------------------------------------------------------------------------------------------------------------------------------------------------------------------------------------------------------------	------------------------------------------------------------------------------------------------------------------------------------------------------------------------------------------------------------------------------------------------------------------------------------------------------------------------------------------------------------------------------------------------------------------------------------------------------------------------------------	-----------------------------------------------------------------------------------------------------------------------------------------------------------------------------------------------------------------------------------------------------------------------------------------------------------------------------------------------------------------------------------------------------------------------------------------------------------------------------------------------------------------------------------------------------------------------------

## Tapered Pole Section Geometry

Section	Elevation <small>ft</small>	Section Length <small>ft</small>	Splice Length <small>ft</small>	Number of Sides	Top Diameter <small>in</small>	Bottom Diameter <small>in</small>	Wall Thickness <small>in</small>	Bend Radius <small>in</small>	Pole Grade
L1	109.0000- 99.0000	10.0000	0.00	Round	4.5000	4.5000	2.2500		A572-50 (50 ksi)
L2	99.0000- 89.0000	10.0000	0.00	Round	6.0000	6.0000	3.0000		A572-50 (50 ksi)
L3	89.0000- 79.0000	10.0000	0.00	Round	7.0000	7.0000	3.5000		A572-50 (50 ksi)
L4	79.0000- 69.0000	10.0000	0.00	Round	10.7500	10.7500	1.0000		A53-B-35 (35 ksi)
L5	69.0000-	20.7900	4.58	18	29.5000	32.3600	0.1875	0.7500	A572-65

Section	Elevation ft	Section Length ft	Splice Length ft	Number of Sides	Top Diameter in	Bottom Diameter in	Wall Thickness in	Bend Radius in	Pole Grade
L6	48.2100-0.0000	52.7900		18	31.3549	38.5000	0.2500	1.0000	(65 ksi) A572-65 (65 ksi)

**Tapered Pole Properties**

Section	Tip Dia. in	Area in <sup>2</sup>	I in <sup>4</sup>	r in	C in	I/C in <sup>3</sup>	J in <sup>4</sup>	It/Q in <sup>2</sup>	w in	w/t
L1	4.5000	15.9043	20.1289	1.1250	2.2500	8.9462	40.2578	7.9474	0.0000	0
L2	6.0000	28.2743	63.6173	1.5000	3.0000	21.2058	127.2345	14.1287	0.0000	0
L3	7.0000	38.4845	117.8588	1.7500	3.5000	33.6739	235.7176	19.2308	0.0000	0
L4	10.7500	30.6305	367.8056	3.4652	5.3750	68.4290	735.6113	15.3061	0.0000	0
L5	29.9551	17.4446	1893.6697	10.4059	14.9860	126.3626	3789.8311	8.7240	4.8620	25.931
L6	32.4681	19.1467	2503.8025	11.4212	16.4389	152.3098	5010.8996	9.5751	5.3654	28.615
	39.0939	30.3514	5610.2046	13.5787	19.5580	286.8496	11227.791	15.1786	6.3360	25.344

Tower Elevation ft	Gusset Area (per face) ft <sup>2</sup>	Gusset Thickness in	Gusset Grade	Adjust. Factor A <sub>r</sub>	Adjust. Factor A <sub>r</sub>	Weight Mult.	Double Angle Stitch Bolt Spacing Diagonals in	Double Angle Stitch Bolt Spacing Horizontals in	Double Angle Stitch Bolt Spacing Redundants in
L1 109.0000-99.0000				1	0	1			
L2 99.0000-89.0000				1	0	1			
L3 89.0000-79.0000				1	0	1			
L4 79.0000-69.0000				1	0	1			
L5 69.0000-48.2100				1	1	1			
L6 48.2100-0.0000				1	1	1			

**Feed Line/Linear Appurtenances - Entered As Area**

Description	Face or Shield Leg	Allow Shield	Component Type	Placement ft	Total Number	C <sub>A</sub> A <sub>A</sub> ft <sup>2</sup> /ft	Weight plf
7085.05(5/16")	C	No	Inside Pole	104.0000 - 0.0000	1	No Ice 1/2" Ice 1" Ice	0.0000 0.0000 0.09
LDF7-50A(1-5/8")	C	No	Inside Pole	104.0000 - 0.0000	6	No Ice 1/2" Ice 1" Ice	0.0000 0.0000 0.82
***							
LDF7-50A(1-5/8")	C	No	Inside Pole	94.0000 - 0.0000	6	No Ice 1/2" Ice 1" Ice	0.0000 0.0000 0.82
***							
AVA5-50( 7/8)	C	No	Inside Pole	84.0000 - 0.0000	12	No Ice 1/2" Ice 1" Ice	0.0000 0.0000 0.30



**Feed Line/Linear Appurtenances Section Areas**

Tower Section n	Tower Elevation ft	Face	A <sub>R</sub> ft <sup>2</sup>	A <sub>F</sub> ft <sup>2</sup>	C <sub>A</sub> A <sub>A</sub> In Face ft <sup>2</sup>	C <sub>A</sub> A <sub>A</sub> Out Face ft <sup>2</sup>	Weight K
L1	109.0000-99.0000	A	0.000	0.000	0.000	0.000	0.00
		B	0.000	0.000	0.000	0.000	0.00
		C	0.000	0.000	0.000	0.000	0.03
L2	99.0000-89.0000	A	0.000	0.000	0.000	0.000	0.00
		B	0.000	0.000	0.000	0.000	0.00
		C	0.000	0.000	0.000	0.000	0.07
L3	89.0000-79.0000	A	0.000	0.000	0.000	0.000	0.00
		B	0.000	0.000	0.000	0.000	0.00
		C	0.000	0.000	0.000	0.000	0.12
L4	79.0000-69.0000	A	0.000	0.000	0.000	0.000	0.00
		B	0.000	0.000	0.000	0.000	0.00
		C	0.000	0.000	0.000	0.000	0.14
L5	69.0000-48.2100	A	0.000	0.000	0.000	0.000	0.00
		B	0.000	0.000	0.000	0.000	0.00
		C	0.000	0.000	0.000	0.000	0.28
L6	48.2100-0.0000	A	0.000	0.000	0.000	0.000	0.00
		B	0.000	0.000	0.000	0.000	0.00
		C	0.000	0.000	0.000	0.000	0.65

**Feed Line/Linear Appurtenances Section Areas - With Ice**

Tower Section n	Tower Elevation ft	Face or Leg	Ice Thickness in	A <sub>R</sub> ft <sup>2</sup>	A <sub>F</sub> ft <sup>2</sup>	C <sub>A</sub> A <sub>A</sub> In Face ft <sup>2</sup>	C <sub>A</sub> A <sub>A</sub> Out Face ft <sup>2</sup>	Weight K
L1	109.0000-99.0000	A	1.682	0.000	0.000	0.000	0.000	0.00
		B		0.000	0.000	0.000	0.000	0.00
		C		0.000	0.000	0.000	0.000	0.03
L2	99.0000-89.0000	A	1.666	0.000	0.000	0.000	0.000	0.00
		B		0.000	0.000	0.000	0.000	0.00
		C		0.000	0.000	0.000	0.000	0.07
L3	89.0000-79.0000	A	1.647	0.000	0.000	0.000	0.000	0.00
		B		0.000	0.000	0.000	0.000	0.00
		C		0.000	0.000	0.000	0.000	0.12
L4	79.0000-69.0000	A	1.626	0.000	0.000	0.000	0.000	0.00
		B		0.000	0.000	0.000	0.000	0.00
		C		0.000	0.000	0.000	0.000	0.14
L5	69.0000-48.2100	A	1.588	0.000	0.000	0.000	0.000	0.00
		B		0.000	0.000	0.000	0.000	0.00
		C		0.000	0.000	0.000	0.000	0.28
L6	48.2100-0.0000	A	1.456	0.000	0.000	0.000	0.000	0.00
		B		0.000	0.000	0.000	0.000	0.00
		C		0.000	0.000	0.000	0.000	0.65

**Feed Line Center of Pressure**

Section	Elevation ft	CP <sub>x</sub> in	CP <sub>z</sub> in	CP <sub>x</sub> Ice in	CP <sub>z</sub> Ice in
L1	109.0000-99.0000	0.0000	0.0000	0.0000	0.0000
L2	99.0000-89.0000	0.0000	0.0000	0.0000	0.0000
L3	89.0000-79.0000	0.0000	0.0000	0.0000	0.0000
L4	79.0000-69.0000	0.0000	0.0000	0.0000	0.0000
L5	69.0000-48.2100	0.0000	0.0000	0.0000	0.0000
L6	48.2100-0.0000	0.0000	0.0000	0.0000	0.0000

**Shielding Factor Ka**

Tower Section	Feed Line Record No.	Description	Feed Line Segment Elev.	K <sub>a</sub> No Ice	K <sub>a</sub> Ice
---------------	----------------------	-------------	-------------------------	-----------------------	--------------------

**User Defined Loads**

Description	Elevation	Offset From Centroid	Azimuth Angle	Weight	F <sub>x</sub>	F <sub>z</sub>	Wind Force	C <sub>A</sub> A <sub>c</sub>	
	ft	ft	°	K	K	K	K	ft <sup>2</sup>	
Flag	109.0000	0.00	0.00	No Ice	0.04	0.00	0.00	0.34	<b>11.5529</b>
				Ice	0.63	0.00	0.00	0.10	<b>11.7264</b>
				Service	0.04	0.00	0.00	0.14	<b>12.9121</b>

**Discrete Tower Loads**

Description	Face or Leg	Offset Type	Offsets: Horz Lateral Vert	Azimuth Adjustment	Placement	C <sub>A</sub> A <sub>A</sub> Front	C <sub>A</sub> A <sub>A</sub> Side	Weight
			ft ft ft	°	ft	ft <sup>2</sup>	ft <sup>2</sup>	K
*** *** *****								
7770.00	A	From Leg	0.5000 0.00 2.00	0.00	104.0000	No Ice 1/2" Ice 1" Ice	0.0000 0.0000 0.0000 0.0000	0.04 0.07 0.11
7770.00	B	From Leg	0.5000 0.00 2.00	0.00	104.0000	No Ice 1/2" Ice 1" Ice	0.0000 0.0000 0.0000 0.0000	0.04 0.07 0.11
7770.00	C	From Leg	0.5000 0.00 2.00	0.00	104.0000	No Ice 1/2" Ice 1" Ice	0.0000 0.0000 0.0000 0.0000	0.04 0.07 0.11
(2) LGP21401	A	From Leg	0.5000 0.00 2.00	0.00	104.0000	No Ice 1/2" Ice 1" Ice	0.0000 0.0000 0.0000 0.0000	0.01 0.02 0.03
(2) LGP21401	B	From Leg	0.5000 0.00 2.00	0.00	104.0000	No Ice 1/2" Ice 1" Ice	0.0000 0.0000 0.0000 0.0000	0.01 0.02 0.03
(2) LGP21401	C	From Leg	0.5000 0.00 2.00	0.00	104.0000	No Ice 1/2" Ice 1" Ice	0.0000 0.0000 0.0000 0.0000	0.01 0.02 0.03
***								
P65-16-XLH-RR	A	From Leg	0.5000 0.00 2.00	0.00	94.0000	No Ice 1/2" Ice 1" Ice	0.0000 0.0000 0.0000 0.0000	0.05 0.10 0.15
P65-16-XLH-RR	B	From Leg	0.5000 0.00 2.00	0.00	94.0000	No Ice 1/2" Ice 1" Ice	0.0000 0.0000 0.0000 0.0000	0.05 0.10 0.15
P65-16-XLH-RR	C	From Leg	0.5000 0.00	0.00	94.0000	No Ice 1/2"	0.0000 0.0000	0.05 0.10

Description	Face or Leg	Offset Type	Offsets:		Azimuth Adjustment	Placement	C <sub>A</sub> A <sub>A</sub> Front	C <sub>A</sub> A <sub>A</sub> Side	Weight
			Horz	Lateral					
			ft	ft	°	ft	ft <sup>2</sup>	ft <sup>2</sup>	K
				2.00					
(2) TTAW-07BP111-001	A	From Leg	0.5000	0.00	0.00	94.0000	No Ice	0.0000	0.02
			0.00				1/2"	0.0000	0.02
			2.00				Ice	0.0000	0.03
							1" Ice		
(2) TTAW-07BP111-001	B	From Leg	0.5000	0.00	0.00	94.0000	No Ice	0.0000	0.02
			0.00				1/2"	0.0000	0.02
			2.00				Ice	0.0000	0.03
							1" Ice		
(2) TTAW-07BP111-001	C	From Leg	0.5000	0.00	0.00	94.0000	No Ice	0.0000	0.02
			0.00				1/2"	0.0000	0.02
			2.00				Ice	0.0000	0.03
							1" Ice		
***									
DBXNH-6565A-A2M	A	From Leg	0.5000	0.00	0.00	84.0000	No Ice	0.0000	0.03
			0.00				1/2"	0.0000	0.07
			2.00				Ice	0.0000	0.11
							1" Ice		
DBXNH-6565A-A2M	B	From Leg	0.5000	0.00	0.00	84.0000	No Ice	0.0000	0.03
			0.00				1/2"	0.0000	0.07
			2.00				Ice	0.0000	0.11
							1" Ice		
DBXNH-6565A-A2M	C	From Leg	0.5000	0.00	0.00	84.0000	No Ice	0.0000	0.03
			0.00				1/2"	0.0000	0.07
			2.00				Ice	0.0000	0.11
							1" Ice		
ATBT-BOTTOM-24V	A	From Leg	0.5000	0.00	0.00	84.0000	No Ice	0.0000	0.00
			0.00				1/2"	0.0000	0.00
			-3.00				Ice	0.0000	0.01
							1" Ice		
ATBT-BOTTOM-24V	B	From Leg	0.5000	0.00	0.00	84.0000	No Ice	0.0000	0.00
			0.00				1/2"	0.0000	0.00
			-3.00				Ice	0.0000	0.01
							1" Ice		
ATBT-BOTTOM-24V	C	From Leg	0.5000	0.00	0.00	84.0000	No Ice	0.0000	0.00
			0.00				1/2"	0.0000	0.00
			-3.00				Ice	0.0000	0.01
							1" Ice		
KRY 112 489/2	A	From Leg	0.5000	0.00	0.00	84.0000	No Ice	0.0000	0.02
			0.00				1/2"	0.0000	0.02
			-2.00				Ice	0.0000	0.03
							1" Ice		
KRY 112 489/2	B	From Leg	0.5000	0.00	0.00	84.0000	No Ice	0.0000	0.02
			0.00				1/2"	0.0000	0.02
			-2.00				Ice	0.0000	0.03
							1" Ice		
KRY 112 489/2	C	From Leg	0.5000	0.00	0.00	84.0000	No Ice	0.0000	0.02
			0.00				1/2"	0.0000	0.02
			-2.00				Ice	0.0000	0.03
							1" Ice		
KRF 102 267/1	A	From Leg	0.5000	0.00	0.00	84.0000	No Ice	0.0000	0.01
			0.00				1/2"	0.0000	0.01
			-1.00				Ice	0.0000	0.02
							1" Ice		
KRF 102 267/1	B	From Leg	0.5000	0.00	0.00	84.0000	No Ice	0.0000	0.01
			0.00				1/2"	0.0000	0.01
			-1.00				Ice	0.0000	0.02
							1" Ice		
KRF 102 267/1	C	From Leg	0.5000	0.00	0.00	84.0000	No Ice	0.0000	0.01
			0.00				1/2"	0.0000	0.01
			-1.00				Ice	0.0000	0.02
							1" Ice		
***									
Canister Load1	C	None		0.00		109.0000	No Ice	7.6875	0.08

Description	Face or Leg	Offset Type	Offsets: Horz Lateral Vert ft ft ft	Azimuth Adjustment °	Placement ft	C <sub>A</sub> A <sub>A</sub> Front ft <sup>2</sup>	C <sub>A</sub> A <sub>A</sub> Side ft <sup>2</sup>	Weight K	
Canister Load2	C	None		0.00	99.0000	1/2" Ice	15.8750	15.8750	0.18
						1" Ice	16.3750	16.3750	0.27
						No Ice	15.3750	15.3750	0.35
						1/2" Ice	31.7500	31.7500	0.54
Canister Load3	C	None		0.00	89.0000	1" Ice	32.7500	32.7500	0.74
						No Ice	15.3750	15.3750	0.40
						1/2" Ice	31.7500	31.7500	0.59
						1" Ice	32.7500	32.7500	0.79
Canister Load4	C	None		0.00	79.0000	No Ice	15.3750	15.3750	0.40
						1/2" Ice	31.7500	31.7500	0.59
						1" Ice	32.7500	32.7500	0.79
						No Ice	15.3750	15.3750	0.40
Canister Load5	C	None		0.00	69.0000	No Ice	7.6875	7.6875	0.36
						1/2" Ice	15.8750	15.8750	0.46
						1" Ice	16.3750	16.3750	0.56
						No Ice	7.6875	7.6875	0.36
Truck Ball	C	None		0.00	109.7500	No Ice	0.8836	0.8836	0.05
						1/2" Ice	1.3783	1.3783	0.07
						1" Ice	1.5272	1.5272	0.09
						No Ice	0.8836	0.8836	0.05

**Tower Pressures - No Ice**

$G_H = 1.100$

Section Elevation ft	z ft	K <sub>z</sub>	q <sub>z</sub> psf	A <sub>G</sub> ft <sup>2</sup>	F a c e	A <sub>F</sub> ft <sup>2</sup>	A <sub>R</sub> ft <sup>2</sup>	A <sub>leg</sub> ft <sup>2</sup>	Leg %	C <sub>A</sub> A <sub>A</sub> In Face ft <sup>2</sup>	C <sub>A</sub> A <sub>A</sub> Out Face ft <sup>2</sup>
L1 109.0000-99.0000	104.0000	1.276	26.842	3.750	A	0.000	0.000	0.000	0.00	0.000	0.000
					B	0.000	0.000	0.00	0.000	0.000	
					C	0.000	0.000	0.00	0.000	0.000	
L2 99.0000-89.0000	94.0000	1.249	26.277	5.000	A	0.000	0.000	0.000	0.00	0.000	0.000
					B	0.000	0.000	0.00	0.000	0.000	
					C	0.000	0.000	0.00	0.000	0.000	
L3 89.0000-79.0000	84.0000	1.22	25.662	5.833	A	0.000	0.000	0.000	0.00	0.000	0.000
					B	0.000	0.000	0.00	0.000	0.000	
					C	0.000	0.000	0.00	0.000	0.000	
L4 79.0000-69.0000	74.0000	1.188	24.986	8.958	A	0.000	0.000	0.000	0.00	0.000	0.000
					B	0.000	0.000	0.00	0.000	0.000	
					C	0.000	0.000	0.00	0.000	0.000	
L5 69.0000-48.2100	58.4448	1.13	23.775	54.413	A	0.000	54.413	54.413	100.00	0.000	0.000
					B	0.000	54.413	100.00	0.000	0.000	
					C	0.000	54.413	100.00	0.000	0.000	
L6 48.2100-0.0000	24.4610	0.941	19.589	143.750	A	0.000	143.750	143.750	100.00	0.000	0.000
					B	0.000	143.750	100.00	0.000	0.000	
					C	0.000	143.750	100.00	0.000	0.000	

**Tower Pressure - With Ice**

$G_H = 1.100$

Section Elevation ft	z ft	K <sub>Z</sub>	q <sub>z</sub> psf	l <sub>z</sub> in	A <sub>G</sub> ft <sup>2</sup>	F a c e	A <sub>F</sub> ft <sup>2</sup>	A <sub>R</sub> ft <sup>2</sup>	A <sub>leg</sub> ft <sup>2</sup>	Leg %	C <sub>A</sub> A <sub>A</sub> In Face ft <sup>2</sup>	C <sub>A</sub> A <sub>A</sub> Out Face ft <sup>2</sup>
L1 109.0000-99.0000	104.0000	1.276	7.759	1.6825	6.554	A	0.000	0.000	0.000	0.00	0.000	0.000
						B	0.000	0.000	0.00	0.000	0.000	
						C	0.000	0.000	0.00	0.000	0.000	
L2 99.0000-89.0000	94.0000	1.249	7.595	1.6655	7.776	A	0.000	0.000	0.000	0.00	0.000	0.000
						B	0.000	0.000	0.00	0.000	0.000	
						C	0.000	0.000	0.00	0.000	0.000	
L3 89.0000-79.0000	84.0000	1.22	7.418	1.6469	8.578	A	0.000	0.000	0.000	0.00	0.000	0.000
						B	0.000	0.000	0.00	0.000	0.000	
						C	0.000	0.000	0.00	0.000	0.000	
L4 79.0000-69.0000	74.0000	1.188	7.222	1.6262	11.669	A	0.000	0.000	0.000	0.00	0.000	0.000
						B	0.000	0.000	0.00	0.000	0.000	
						C	0.000	0.000	0.00	0.000	0.000	
L5 69.0000-48.2100	58.4448	1.13	6.872	1.5882	59.916	A	0.000	59.916	59.916	100.00	0.000	0.000
						B	0.000	59.916	100.00	0.000	0.000	
						C	0.000	59.916	100.00	0.000	0.000	
L6 48.2100-0.0000	24.4610	0.941	5.662	1.4558	156.512	A	0.000	156.512	156.512	100.00	0.000	0.000
						B	0.000	156.512	100.00	0.000	0.000	
						C	0.000	156.512	100.00	0.000	0.000	

**Tower Pressure - Service**

$G_H = 1.100$

Section Elevation ft	z ft	K <sub>Z</sub>	q <sub>z</sub> psf	A <sub>G</sub> ft <sup>2</sup>	F a c e	A <sub>F</sub> ft <sup>2</sup>	A <sub>R</sub> ft <sup>2</sup>	A <sub>leg</sub> ft <sup>2</sup>	Leg %	C <sub>A</sub> A <sub>A</sub> In Face ft <sup>2</sup>	C <sub>A</sub> A <sub>A</sub> Out Face ft <sup>2</sup>
L1 109.0000-99.0000	104.0000	1.276	9.997	3.750	A	0.000	0.000	0.000	0.00	0.000	0.000
					B	0.000	0.000	0.00	0.000	0.000	
					C	0.000	0.000	0.00	0.000	0.000	
L2 99.0000-89.0000	94.0000	1.249	9.786	5.000	A	0.000	0.000	0.000	0.00	0.000	0.000
					B	0.000	0.000	0.00	0.000	0.000	
					C	0.000	0.000	0.00	0.000	0.000	
L3 89.0000-79.0000	84.0000	1.22	9.557	5.833	A	0.000	0.000	0.000	0.00	0.000	0.000
					B	0.000	0.000	0.00	0.000	0.000	
					C	0.000	0.000	0.00	0.000	0.000	
L4 79.0000-69.0000	74.0000	1.188	9.305	8.958	A	0.000	0.000	0.000	0.00	0.000	0.000
					B	0.000	0.000	0.00	0.000	0.000	
					C	0.000	0.000	0.00	0.000	0.000	
L5 69.0000-48.2100	58.4448	1.13	8.854	54.413	A	0.000	54.413	54.413	100.00	0.000	0.000
					B	0.000	54.413	100.00	0.000	0.000	
					C	0.000	54.413	100.00	0.000	0.000	
L6 48.2100-0.0000	24.4610	0.941	7.295	143.750	A	0.000	143.750	143.750	100.00	0.000	0.000
					B	0.000	143.750	100.00	0.000	0.000	
					C	0.000	143.750	100.00	0.000	0.000	

**Load Combinations**

Comb. No.	Description
1	Dead Only
2	1.2 Dead+1.6 Wind 0 deg - No Ice
3	0.9 Dead+1.6 Wind 0 deg - No Ice
4	1.2 Dead+1.6 Wind 30 deg - No Ice
5	0.9 Dead+1.6 Wind 30 deg - No Ice
6	1.2 Dead+1.6 Wind 60 deg - No Ice
7	0.9 Dead+1.6 Wind 60 deg - No Ice
8	1.2 Dead+1.6 Wind 90 deg - No Ice
9	0.9 Dead+1.6 Wind 90 deg - No Ice
10	1.2 Dead+1.6 Wind 120 deg - No Ice
11	0.9 Dead+1.6 Wind 120 deg - No Ice

Comb. No.	Description
12	1.2 Dead+1.6 Wind 150 deg - No Ice
13	0.9 Dead+1.6 Wind 150 deg - No Ice
14	1.2 Dead+1.6 Wind 180 deg - No Ice
15	0.9 Dead+1.6 Wind 180 deg - No Ice
16	1.2 Dead+1.6 Wind 210 deg - No Ice
17	0.9 Dead+1.6 Wind 210 deg - No Ice
18	1.2 Dead+1.6 Wind 240 deg - No Ice
19	0.9 Dead+1.6 Wind 240 deg - No Ice
20	1.2 Dead+1.6 Wind 270 deg - No Ice
21	0.9 Dead+1.6 Wind 270 deg - No Ice
22	1.2 Dead+1.6 Wind 300 deg - No Ice
23	0.9 Dead+1.6 Wind 300 deg - No Ice
24	1.2 Dead+1.6 Wind 330 deg - No Ice
25	0.9 Dead+1.6 Wind 330 deg - No Ice
26	1.2 Dead+1.0 Ice+1.0 Temp
27	1.2 Dead+1.0 Wind 0 deg+1.0 Ice+1.0 Temp
28	1.2 Dead+1.0 Wind 30 deg+1.0 Ice+1.0 Temp
29	1.2 Dead+1.0 Wind 60 deg+1.0 Ice+1.0 Temp
30	1.2 Dead+1.0 Wind 90 deg+1.0 Ice+1.0 Temp
31	1.2 Dead+1.0 Wind 120 deg+1.0 Ice+1.0 Temp
32	1.2 Dead+1.0 Wind 150 deg+1.0 Ice+1.0 Temp
33	1.2 Dead+1.0 Wind 180 deg+1.0 Ice+1.0 Temp
34	1.2 Dead+1.0 Wind 210 deg+1.0 Ice+1.0 Temp
35	1.2 Dead+1.0 Wind 240 deg+1.0 Ice+1.0 Temp
36	1.2 Dead+1.0 Wind 270 deg+1.0 Ice+1.0 Temp
37	1.2 Dead+1.0 Wind 300 deg+1.0 Ice+1.0 Temp
38	1.2 Dead+1.0 Wind 330 deg+1.0 Ice+1.0 Temp
39	Dead+Wind 0 deg - Service
40	Dead+Wind 30 deg - Service
41	Dead+Wind 60 deg - Service
42	Dead+Wind 90 deg - Service
43	Dead+Wind 120 deg - Service
44	Dead+Wind 150 deg - Service
45	Dead+Wind 180 deg - Service
46	Dead+Wind 210 deg - Service
47	Dead+Wind 240 deg - Service
48	Dead+Wind 270 deg - Service
49	Dead+Wind 300 deg - Service
50	Dead+Wind 330 deg - Service

**Maximum Member Forces**

Section No.	Elevation ft	Component Type	Condition	Gov. Load Comb.	Axial K	Major Axis Moment kip-ft	Minor Axis Moment kip-ft
L1	109 - 99	Pole	Max Tension	9	0.00	0.00	0.00
			Max. Compression	26	-2.82	0.00	0.00
			Max. Mx	8	-1.03	-10.07	0.00
			Max. My	2	-1.03	0.00	10.07
			Max. Vy	8	1.03	-10.07	0.00
			Max. Vx	2	-1.03	0.00	10.07
			Max. Torque	12			0.00
			Max Tension	1	0.00	0.00	0.00
L2	99 - 89	Pole	Max. Compression	26	-6.34	0.00	0.00
			Max. Mx	8	-3.00	-28.14	0.00
			Max. My	2	-3.00	0.00	28.14
			Max. Vy	8	1.83	-28.14	0.00
			Max. Vx	2	-1.83	0.00	28.14
			Max. Torque	12			0.00
			Max Tension	1	0.00	0.00	0.00
			Max. Compression	26	-10.16	0.00	0.00
L3	89 - 79	Pole	Max. Mx	8	-5.41	-53.79	0.00
			Max. My	2	-5.41	0.00	53.79
			Max. Vy	8	2.58	-43.52	0.00
			Max. Vx	2	-2.58	0.00	43.52
			Max. Torque	12			0.00
			Max Tension	1	0.00	0.00	0.00
			Max. Compression	26	-10.16	0.00	0.00
			Max Tension	1	0.00	0.00	0.00
L4	79 - 69	Pole	Max Tension	1	0.00	0.00	0.00
			Max. Compression	26	-10.16	0.00	0.00

Section No.	Elevation ft	Component Type	Condition	Gov. Load Comb.	Axial K	Major Axis Moment kip-ft	Minor Axis Moment kip-ft
L5	69 - 48.21	Pole	Max. Compression	26	-12.95	0.00	0.00
			Max. Mx	8	-7.31	-86.28	0.00
			Max. My	2	-7.31	0.00	86.28
			Max. Vy	8	3.26	-57.04	0.00
			Max. Vx	2	-3.26	0.00	57.04
			Max. Torque	12			0.00
			Max Tension	1	0.00	0.00	0.00
			Max. Compression	26	-16.20	0.00	0.00
			Max. Mx	8	-9.20	-153.36	0.00
			Max. My	2	-9.20	0.00	153.36
L6	48.21 - 0	Pole	Max. Vy	8	4.71	-153.36	0.00
			Max. Vx	2	-4.71	0.00	153.36
			Max. Torque	12			0.00
			Max Tension	1	0.00	0.00	0.00
			Max. Compression	26	-27.12	0.00	0.00
			Max. Mx	8	-16.42	-495.31	0.00
			Max. My	2	-16.42	0.00	495.31
			Max. Vy	8	8.11	-495.31	0.00
			Max. Vx	2	-8.11	0.00	495.31
			Max. Torque	12			0.00

### Maximum Reactions

Location	Condition	Gov. Load Comb.	Vertical K	Horizontal, X K	Horizontal, Z K
Pole	Max. Vert	26	27.12	0.00	0.00
	Max. H <sub>x</sub>	20	16.42	8.10	0.00
	Max. H <sub>z</sub>	2	16.42	0.00	8.10
	Max. M <sub>x</sub>	2	495.31	0.00	8.10
	Max. M <sub>z</sub>	8	495.31	-8.10	0.00
	Max. Torsion	12	0.00	-4.05	-7.02
	Min. Vert	3	12.32	0.00	8.10
	Min. H <sub>x</sub>	8	16.42	-8.10	0.00
	Min. H <sub>z</sub>	14	16.42	0.00	-8.10
	Min. M <sub>x</sub>	14	-495.31	0.00	-8.10
	Min. M <sub>z</sub>	20	-495.31	8.10	0.00
	Min. Torsion	16	-0.00	4.05	-7.02

### Tower Mast Reaction Summary

Load Combination	Vertical K	Shear <sub>x</sub> K	Shear <sub>z</sub> K	Overturning Moment, M <sub>x</sub> kip-ft	Overturning Moment, M <sub>z</sub> kip-ft	Torque kip-ft
Dead Only	13.69	0.00	0.00	0.00	0.00	0.00
1.2 Dead+1.6 Wind 0 deg - No Ice	16.42	0.00	-8.10	-495.31	0.00	0.00
0.9 Dead+1.6 Wind 0 deg - No Ice	12.32	0.00	-8.10	-491.50	0.00	0.00
1.2 Dead+1.6 Wind 30 deg - No Ice	16.42	4.05	-7.02	-428.95	-247.65	0.00
0.9 Dead+1.6 Wind 30 deg - No Ice	12.32	4.05	-7.02	-425.69	-245.78	0.00
1.2 Dead+1.6 Wind 60 deg - No Ice	16.42	7.02	-4.05	-247.65	-428.95	-0.00
0.9 Dead+1.6 Wind 60 deg - No Ice	12.32	7.02	-4.05	-245.78	-425.69	-0.00
1.2 Dead+1.6 Wind 90 deg - No Ice	16.42	8.10	0.00	0.00	-495.31	0.00
0.9 Dead+1.6 Wind 90 deg - No Ice	12.32	8.10	0.00	0.00	-491.50	0.00

Load Combination	Vertical K	Shear <sub>x</sub> K	Shear <sub>z</sub> K	Overturning Moment, M <sub>x</sub> kip-ft	Overturning Moment, M <sub>z</sub> kip-ft	Torque kip-ft
1.2 Dead+1.6 Wind 120 deg - No Ice	16.42	7.02	4.05	247.65	-428.95	0.00
0.9 Dead+1.6 Wind 120 deg - No Ice	12.32	7.02	4.05	245.78	-425.69	0.00
1.2 Dead+1.6 Wind 150 deg - No Ice	16.42	4.05	7.02	428.95	-247.65	-0.00
0.9 Dead+1.6 Wind 150 deg - No Ice	12.32	4.05	7.02	425.69	-245.78	-0.00
1.2 Dead+1.6 Wind 180 deg - No Ice	16.42	0.00	8.10	495.31	0.00	0.00
0.9 Dead+1.6 Wind 180 deg - No Ice	12.32	0.00	8.10	491.50	0.00	0.00
1.2 Dead+1.6 Wind 210 deg - No Ice	16.42	-4.05	7.02	428.95	247.65	0.00
0.9 Dead+1.6 Wind 210 deg - No Ice	12.32	-4.05	7.02	425.69	245.78	0.00
1.2 Dead+1.6 Wind 240 deg - No Ice	16.42	-7.02	4.05	247.65	428.95	-0.00
0.9 Dead+1.6 Wind 240 deg - No Ice	12.32	-7.02	4.05	245.78	425.69	-0.00
1.2 Dead+1.6 Wind 270 deg - No Ice	16.42	-8.10	0.00	0.00	495.31	0.00
0.9 Dead+1.6 Wind 270 deg - No Ice	12.32	-8.10	0.00	0.00	491.50	0.00
1.2 Dead+1.6 Wind 300 deg - No Ice	16.42	-7.02	-4.05	-247.65	428.95	0.00
0.9 Dead+1.6 Wind 300 deg - No Ice	12.32	-7.02	-4.05	-245.78	425.69	0.00
1.2 Dead+1.6 Wind 330 deg - No Ice	16.42	-4.05	-7.02	-428.95	247.65	-0.00
0.9 Dead+1.6 Wind 330 deg - No Ice	12.32	-4.05	-7.02	-425.69	245.78	-0.00
1.2 Dead+1.0 Ice+1.0 Temp	27.12	0.00	0.00	0.00	0.00	0.00
1.2 Dead+1.0 Wind 0 deg+1.0 Ice+1.0 Temp	27.12	0.00	-2.95	-183.42	0.00	0.00
1.2 Dead+1.0 Wind 30 deg+1.0 Ice+1.0 Temp	27.12	1.48	-2.56	-158.85	-91.71	0.00
1.2 Dead+1.0 Wind 60 deg+1.0 Ice+1.0 Temp	27.12	2.56	-1.48	-91.71	-158.85	-0.00
1.2 Dead+1.0 Wind 90 deg+1.0 Ice+1.0 Temp	27.12	2.95	0.00	0.00	-183.42	0.00
1.2 Dead+1.0 Wind 120 deg+1.0 Ice+1.0 Temp	27.12	2.56	1.48	91.71	-158.85	0.00
1.2 Dead+1.0 Wind 150 deg+1.0 Ice+1.0 Temp	27.12	1.48	2.56	158.85	-91.71	-0.00
1.2 Dead+1.0 Wind 180 deg+1.0 Ice+1.0 Temp	27.12	0.00	2.95	183.42	0.00	0.00
1.2 Dead+1.0 Wind 210 deg+1.0 Ice+1.0 Temp	27.12	-1.48	2.56	158.85	91.71	0.00
1.2 Dead+1.0 Wind 240 deg+1.0 Ice+1.0 Temp	27.12	-2.56	1.48	91.71	158.85	-0.00
1.2 Dead+1.0 Wind 270 deg+1.0 Ice+1.0 Temp	27.12	-2.95	0.00	0.00	183.42	0.00
1.2 Dead+1.0 Wind 300 deg+1.0 Ice+1.0 Temp	27.12	-2.56	-1.48	-91.71	158.85	0.00
1.2 Dead+1.0 Wind 330 deg+1.0 Ice+1.0 Temp	27.12	-1.48	-2.56	-158.85	91.71	-0.00
Dead+Wind 0 deg - Service	13.69	0.00	-1.90	-116.40	0.00	0.00
Dead+Wind 30 deg - Service	13.69	0.95	-1.65	-100.80	-58.20	0.00
Dead+Wind 60 deg - Service	13.69	1.65	-0.95	-58.20	-100.80	-0.00
Dead+Wind 90 deg - Service	13.69	1.90	0.00	0.00	-116.40	0.00
Dead+Wind 120 deg - Service	13.69	1.65	0.95	58.20	-100.80	0.00
Dead+Wind 150 deg - Service	13.69	0.95	1.65	100.80	-58.20	-0.00
Dead+Wind 180 deg - Service	13.69	0.00	1.90	116.40	0.00	0.00
Dead+Wind 210 deg - Service	13.69	-0.95	1.65	100.80	58.20	0.00



Load Combination	Vertical	Shear <sub>x</sub>	Shear <sub>z</sub>	Overturning Moment, M <sub>x</sub>	Overturning Moment, M <sub>z</sub>	Torque
	K	K	K	kip-ft	kip-ft	kip-ft
Dead+Wind 240 deg - Service	13.69	-1.65	0.95	58.20	100.80	-0.00
Dead+Wind 270 deg - Service	13.69	-1.90	0.00	0.00	116.40	0.00
Dead+Wind 300 deg - Service	13.69	-1.65	-0.95	-58.20	100.80	0.00
Dead+Wind 330 deg - Service	13.69	-0.95	-1.65	-100.80	58.20	-0.00

## Solution Summary

Load Comb.	Sum of Applied Forces			Sum of Reactions			% Error
	PX K	PY K	PZ K	PX K	PY K	PZ K	
1	0.00	-13.69	0.00	0.00	13.69	0.00	0.000%
2	0.00	-16.43	-8.10	0.00	16.42	8.10	0.006%
3	0.00	-12.32	-8.10	0.00	12.32	8.10	0.009%
4	4.05	-16.43	-7.02	-4.05	16.42	7.02	0.006%
5	4.05	-12.32	-7.02	-4.05	12.32	7.02	0.005%
6	7.02	-16.43	-4.05	-7.02	16.42	4.05	0.006%
7	7.02	-12.32	-4.05	-7.02	12.32	4.05	0.005%
8	8.10	-16.43	0.00	-8.10	16.42	0.00	0.006%
9	8.10	-12.32	0.00	-8.10	12.32	0.00	0.009%
10	7.02	-16.43	4.05	-7.02	16.42	-4.05	0.006%
11	7.02	-12.32	4.05	-7.02	12.32	-4.05	0.005%
12	4.05	-16.43	7.02	-4.05	16.42	-7.02	0.006%
13	4.05	-12.32	7.02	-4.05	12.32	-7.02	0.005%
14	0.00	-16.43	8.10	0.00	16.42	-8.10	0.006%
15	0.00	-12.32	8.10	0.00	12.32	-8.10	0.009%
16	-4.05	-16.43	7.02	4.05	16.42	-7.02	0.006%
17	-4.05	-12.32	7.02	4.05	12.32	-7.02	0.005%
18	-7.02	-16.43	4.05	7.02	16.42	-4.05	0.006%
19	-7.02	-12.32	4.05	7.02	12.32	-4.05	0.005%
20	-8.10	-16.43	0.00	8.10	16.42	0.00	0.006%
21	-8.10	-12.32	0.00	8.10	12.32	0.00	0.009%
22	-7.02	-16.43	-4.05	7.02	16.42	4.05	0.006%
23	-7.02	-12.32	-4.05	7.02	12.32	4.05	0.005%
24	-4.05	-16.43	-7.02	4.05	16.42	7.02	0.006%
25	-4.05	-12.32	-7.02	4.05	12.32	7.02	0.005%
26	0.00	-27.12	0.00	0.00	27.12	0.00	0.000%
27	0.00	-27.12	-2.95	0.00	27.12	2.95	0.002%
28	1.48	-27.12	-2.56	-1.48	27.12	2.56	0.002%
29	2.56	-27.12	-1.48	-2.56	27.12	1.48	0.002%
30	2.95	-27.12	0.00	-2.95	27.12	0.00	0.002%
31	2.56	-27.12	1.48	-2.56	27.12	-1.48	0.002%
32	1.48	-27.12	2.56	-1.48	27.12	-2.56	0.002%
33	0.00	-27.12	2.95	0.00	27.12	-2.95	0.002%
34	-1.48	-27.12	2.56	1.48	27.12	-2.56	0.002%
35	-2.56	-27.12	1.48	2.56	27.12	-1.48	0.002%
36	-2.95	-27.12	0.00	2.95	27.12	0.00	0.002%
37	-2.56	-27.12	-1.48	2.56	27.12	1.48	0.002%
38	-1.48	-27.12	-2.56	1.48	27.12	2.56	0.002%
39	0.00	-13.69	-1.90	0.00	13.69	1.90	0.005%
40	0.95	-13.69	-1.65	-0.95	13.69	1.65	0.005%
41	1.65	-13.69	-0.95	-1.65	13.69	0.95	0.005%
42	1.90	-13.69	0.00	-1.90	13.69	0.00	0.005%
43	1.65	-13.69	0.95	-1.65	13.69	-0.95	0.005%
44	0.95	-13.69	1.65	-0.95	13.69	-1.65	0.005%
45	0.00	-13.69	1.90	0.00	13.69	-1.90	0.005%
46	-0.95	-13.69	1.65	0.95	13.69	-1.65	0.005%
47	-1.65	-13.69	0.95	1.65	13.69	-0.95	0.005%
48	-1.90	-13.69	0.00	1.90	13.69	0.00	0.005%
49	-1.65	-13.69	-0.95	1.65	13.69	0.95	0.005%
50	-0.95	-13.69	-1.65	0.95	13.69	1.65	0.005%

### Non-Linear Convergence Results

Load Combination	Converged?	Number of Cycles	Displacement Tolerance	Force Tolerance
1	Yes	6	0.00000001	0.00000001
2	Yes	17	0.00010264	0.00006531
3	Yes	16	0.00012809	0.00010290
4	Yes	17	0.00010194	0.00014169
5	Yes	17	0.00000001	0.00012096
6	Yes	17	0.00010194	0.00014169
7	Yes	17	0.00000001	0.00012096
8	Yes	17	0.00010264	0.00006531
9	Yes	16	0.00012809	0.00010290
10	Yes	17	0.00010194	0.00014169
11	Yes	17	0.00000001	0.00012096
12	Yes	17	0.00010194	0.00014169
13	Yes	17	0.00000001	0.00012096
14	Yes	17	0.00010264	0.00006531
15	Yes	16	0.00012809	0.00010290
16	Yes	17	0.00010194	0.00014169
17	Yes	17	0.00000001	0.00012096
18	Yes	17	0.00010194	0.00014169
19	Yes	17	0.00000001	0.00012096
20	Yes	17	0.00010264	0.00006531
21	Yes	16	0.00012809	0.00010290
22	Yes	17	0.00010194	0.00014169
23	Yes	17	0.00000001	0.00012096
24	Yes	17	0.00010194	0.00014169
25	Yes	17	0.00000001	0.00012096
26	Yes	6	0.00000001	0.00000001
27	Yes	18	0.00000001	0.00006648
28	Yes	18	0.00000001	0.00007175
29	Yes	18	0.00000001	0.00007175
30	Yes	18	0.00000001	0.00006648
31	Yes	18	0.00000001	0.00007175
32	Yes	18	0.00000001	0.00007175
33	Yes	18	0.00000001	0.00006648
34	Yes	18	0.00000001	0.00007175
35	Yes	18	0.00000001	0.00007175
36	Yes	18	0.00000001	0.00006648
37	Yes	18	0.00000001	0.00007175
38	Yes	18	0.00000001	0.00007175
39	Yes	15	0.00000001	0.00005173
40	Yes	15	0.00000001	0.00004802
41	Yes	15	0.00000001	0.00004802
42	Yes	15	0.00000001	0.00005173
43	Yes	15	0.00000001	0.00004802
44	Yes	15	0.00000001	0.00004802
45	Yes	15	0.00000001	0.00005173
46	Yes	15	0.00000001	0.00004802
47	Yes	15	0.00000001	0.00004802
48	Yes	15	0.00000001	0.00005173
49	Yes	15	0.00000001	0.00004802
50	Yes	15	0.00000001	0.00004802

### Maximum Tower Deflections - Service Wind

Section No.	Elevation  ft	Horz. Deflection in	Gov. Load Comb.	Tilt  °	Twist  °
L1	109 - 99	8.17	42	1.05	0.00
L2	99 - 89	6.08	42	0.88	0.00
L3	89 - 79	4.42	42	0.67	0.00
L4	79 - 69	3.24	42	0.43	0.00

Section No.	Elevation ft	Horz. Deflection in	Gov. Load Comb.	Tilt °	Twist °
L5	69 - 48.21	2.45	42	0.31	0.00
L6	52.79 - 0	1.51	42	0.25	0.00

**Critical Deflections and Radius of Curvature - Service Wind**

Elevation ft	Appurtenance	Gov. Load Comb.	Deflection in	Tilt °	Twist °	Radius of Curvature ft
109.7500	Truck Ball	42	8.17	1.05	0.00	4579
109.0000	Canister Load1	42	8.17	1.05	0.00	4579
104.0000	7770.00	42	7.09	0.97	0.00	4579
99.0000	Canister Load2	42	6.08	0.88	0.00	2523
94.0000	P65-16-XLH-RR	42	5.19	0.78	0.00	2424
89.0000	Canister Load3	42	4.42	0.67	0.00	2555
84.0000	DBXNH-6565A-A2M	42	3.77	0.55	0.00	2610
79.0000	Canister Load4	42	3.24	0.43	0.00	2815
69.0000	Canister Load5	42	2.45	0.31	0.00	8482

**Maximum Tower Deflections - Design Wind**

Section No.	Elevation ft	Horz. Deflection in	Gov. Load Comb.	Tilt °	Twist °
L1	109 - 99	34.38	2	4.39	0.00
L2	99 - 89	25.70	2	3.68	0.00
L3	89 - 79	18.75	2	2.83	0.00
L4	79 - 69	13.75	2	1.84	0.00
L5	69 - 48.21	10.42	2	1.30	0.00
L6	52.79 - 0	6.43	2	1.04	0.00

**Critical Deflections and Radius of Curvature - Design Wind**

Elevation ft	Appurtenance	Gov. Load Comb.	Deflection in	Tilt °	Twist °	Radius of Curvature ft
109.7500	Truck Ball	2	34.38	4.39	0.00	1142
109.0000	Canister Load1	2	34.38	4.39	0.00	1142
104.0000	7770.00	2	29.91	4.04	0.00	1142
99.0000	Canister Load2	2	25.70	3.68	0.00	627
94.0000	P65-16-XLH-RR	2	21.97	3.28	0.00	595
89.0000	Canister Load3	2	18.75	2.83	0.00	619
84.0000	DBXNH-6565A-A2M	2	16.01	2.31	0.00	628
79.0000	Canister Load4	2	13.75	1.84	0.00	675
69.0000	Canister Load5	2	10.42	1.30	0.00	2019

**Compression Checks**

**Pole Design Data**

Section No.	Elevation ft	Size	L ft	L <sub>u</sub> ft	Kl/r	A in <sup>2</sup>	P <sub>u</sub> K	φP <sub>n</sub> K	Ratio P <sub>u</sub> / φP <sub>n</sub>
L1	109 - 99 (1)	TP4.5x4.5x2.25	10.000 0	0.0000	0.0	15.904 3	-1.03	715.69	0.001
L2	99 - 89 (2)	TP6x6x3	10.000 0	0.0000	0.0	28.274 3	-3.00	1272.35	0.002
L3	89 - 79 (3)	TP7x7x3.5	10.000 0	0.0000	0.0	38.484 5	-5.41	1731.80	0.003
L4	79 - 69 (4)	TP10.75x10.75x1	10.000 0	0.0000	0.0	30.630 5	-7.31	964.86	0.008
L5	69 - 48.21 (5)	TP32.36x29.5x0.1875	20.790 0	0.0000	0.0	18.771 7	-9.20	1156.26	0.008
L6	48.21 - 0 (6)	TP38.5x31.3549x0.25	52.790 0	0.0000	0.0	30.351 4	-16.42	1955.62	0.008

### Pole Bending Design Data

Section No.	Elevation ft	Size	M <sub>ux</sub> kip-ft	φM <sub>nx</sub> kip-ft	Ratio M <sub>ux</sub> / φM <sub>nx</sub>	M <sub>uy</sub> kip-ft	φM <sub>ny</sub> kip-ft	Ratio M <sub>uy</sub> / φM <sub>ny</sub>
L1	109 - 99 (1)	TP4.5x4.5x2.25	10.07	56.95	0.177	0.00	56.95	0.000
L2	99 - 89 (2)	TP6x6x3	28.14	135.00	0.208	0.00	135.00	0.000
L3	89 - 79 (3)	TP7x7x3.5	53.79	214.38	0.251	0.00	214.38	0.000
L4	79 - 69 (4)	TP10.75x10.75x1	86.28	250.41	0.345	0.00	250.41	0.000
L5	69 - 48.21 (5)	TP32.36x29.5x0.1875	153.36	751.40	0.204	0.00	751.40	0.000
L6	48.21 - 0 (6)	TP38.5x31.3549x0.25	495.31	1540.21	0.322	0.00	1540.21	0.000

### Pole Shear Design Data

Section No.	Elevation ft	Size	Actual V <sub>u</sub> K	φV <sub>n</sub> K	Ratio V <sub>u</sub> / φV <sub>n</sub>	Actual T <sub>u</sub> kip-ft	φT <sub>n</sub> kip-ft	Ratio T <sub>u</sub> / φT <sub>n</sub>
L1	109 - 99 (1)	TP4.5x4.5x2.25	1.03	357.85	0.003	0.00	67.10	0.000
L2	99 - 89 (2)	TP6x6x3	1.83	636.17	0.003	0.00	159.04	0.000
L3	89 - 79 (3)	TP7x7x3.5	2.56	865.90	0.003	0.00	252.56	0.000
L4	79 - 69 (4)	TP10.75x10.75x1	3.24	482.43	0.007	0.00	359.25	0.000
L5	69 - 48.21 (5)	TP32.36x29.5x0.1875	4.71	578.13	0.008	0.00	1504.63	0.000
L6	48.21 - 0 (6)	TP38.5x31.3549x0.25	8.11	977.81	0.008	0.00	3084.18	0.000

### Pole Interaction Design Data

Section No.	Elevation ft	Ratio P <sub>u</sub> / φP <sub>n</sub>	Ratio M <sub>ux</sub> / φM <sub>nx</sub>	Ratio M <sub>uy</sub> / φM <sub>ny</sub>	Ratio V <sub>u</sub> / φV <sub>n</sub>	Ratio T <sub>u</sub> / φT <sub>n</sub>	Comb. Stress Ratio	Allow. Stress Ratio	Criteria
L1	109 - 99 (1)	0.001	0.177	0.000	0.003	0.000	0.178	1.000	4.8.2 ✓
L2	99 - 89 (2)	0.002	0.208	0.000	0.003	0.000	0.211	1.000	4.8.2 ✓
L3	89 - 79 (3)	0.003	0.251	0.000	0.003	0.000	0.254	1.000	4.8.2 ✓
L4	79 - 69 (4)	0.008	0.345	0.000	0.007	0.000	0.352	1.000	4.8.2 ✓
L5	69 - 48.21 (5)	0.008	0.204	0.000	0.008	0.000	0.212	1.000	4.8.2 ✓
L6	48.21 - 0 (6)	0.008	0.322	0.000	0.008	0.000	0.330	1.000	4.8.2 ✓

Section No.	Elevation ft	Ratio $\frac{P_u}{\phi P_n}$	Ratio $\frac{M_{ux}}{\phi M_{nx}}$	Ratio $\frac{M_{uy}}{\phi M_{ny}}$	Ratio $\frac{V_u}{\phi V_n}$	Ratio $\frac{T_u}{\phi T_n}$	Comb. Stress Ratio	Allow. Stress Ratio	Criteria
							✓		

### Section Capacity Table

Section No.	Elevation ft	Component Type	Size	Critical Element	P K	$\phi P_{allow}$ K	% Capacity	Pass Fail
L1	109 - 99	Pole	TP4.5x4.5x2.25	1	-1.03	715.69	17.8	Pass
L2	99 - 89	Pole	TP6x6x3	2	-3.00	1272.35	21.1	Pass
L3	89 - 79	Pole	TP7x7x3.5	3	-5.41	1731.80	25.4	Pass
L4	79 - 69	Pole	TP10.75x10.75x1	4	-7.31	964.86	35.2	Pass
L5	69 - 48.21	Pole	TP32.36x29.5x0.1875	5	-9.20	1156.26	21.2	Pass
L6	48.21 - 0	Pole	TP38.5x31.3549x0.25	6	-16.42	1955.62	33.0	Pass
Summary								
Pole (L4)							35.2	Pass
<b>RATING =</b>							<b>35.2</b>	<b>Pass</b>

**APPENDIX B**  
**BASE LEVEL DRAWING**

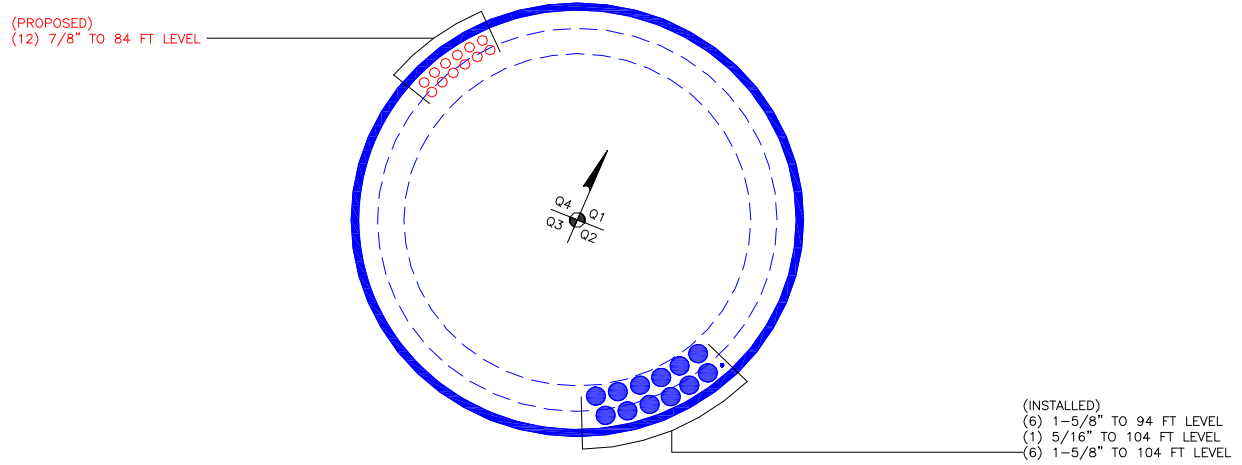

**APPENDIX C**  
**ADDITIONAL CALCULATIONS**



Section	1	2	3	4	5	6
Length (ft)	10.0000	10.0000	10.0000	10.0000	20.7500	52.7500
Number of Sides	0	0	0	0	18	18
Thickness (in)	0	0	0	1.0000	0.1875	0.2500
Socket Length (ft)	2.2500	3.0000	3.5000	1.0000	4.5800	
Top Dia (in)	4.5000	6.0000	7.0000	10.7500	29.5000	31.3549
Bot Dia (in)	4.5000	6.0000	7.0000	10.7500	32.3600	38.5000
Grade	A572-50			A53-B-35		A572-65
Weight (K)	0.5	1.0	1.3	1.0	1.3	4.9

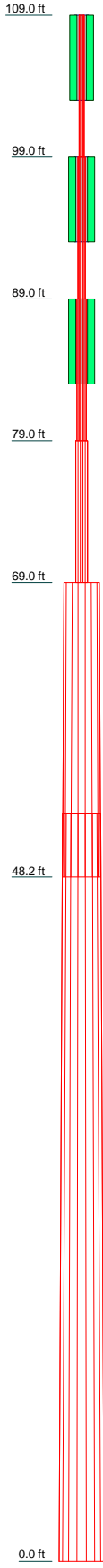

### DESIGNED APPURTENANCE LOADING

TYPE	ELEVATION	TYPE	ELEVATION
Truck Ball	109.75	Canister Load3	89
Canister Load1	109	ATBT-BOTTOM-24V	84
Flag	109	KRY 112 489/2	84
(2) LGP21401	104	KRY 112 489/2	84
(2) LGP21401	104	KRY 112 489/2	84
(2) LGP21401	104	KRF 102 267/1	84
7770.00	104	KRF 102 267/1	84
7770.00	104	KRF 102 267/1	84
7770.00	104	DBXNH-6565A-A2M	84
Canister Load2	99	DBXNH-6565A-A2M	84
(2) TTAW-07BP111-001	94	ATBT-BOTTOM-24V	84
(2) TTAW-07BP111-001	94	DBXNH-6565A-A2M	84
P65-16-XLH-RR	94	ATBT-BOTTOM-24V	84
(2) TTAW-07BP111-001	94	Canister Load4	79
P65-16-XLH-RR	94	Canister Load5	69
P65-16-XLH-RR	94		

### MATERIAL STRENGTH

GRADE	Fy	Fu	GRADE	Fy	Fu
A572-50	50 ksi	65 ksi	A572-65	65 ksi	80 ksi
A53-B-35	35 ksi	60 ksi			

### TOWER DESIGN NOTES

1. Tower is located in Fairfield County, Connecticut.
2. Tower designed for Exposure C to the TIA-222-G Standard.
3. Tower designed for a 93 mph basic wind in accordance with the TIA-222-G Standard.
4. Tower is also designed for a 50 mph basic wind with 0.75 in ice. Ice is considered to increase in thickness with height.
5. Deflections are based upon a 60 mph wind.
6. Tower Structure Class II.
7. Topographic Category 1 with Crest Height of 0.0000 ft
8. TOWER RATING: 35.2%

ALL REACTIONS  
ARE FACTORED

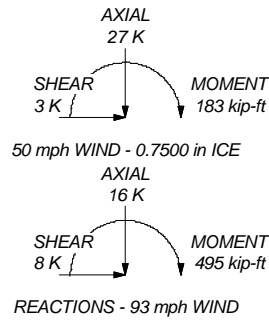

**Paul J. Ford and Company**  
 250 E. Broad Street, Suite 600  
 Columbus, OH 43215  
 Phone: 614.221.6679  
 FAX: 614.448.4105

Job: **109 ft Monopole / Redding Wayside Lane**  
 Project: **PJF 37516-3037 / BU 857144**  
 Client: Crown Castle | Drawn by: Joey Meinering | App'd:  
 Code: TIA-222-G | Date: 09/23/16 | Scale: NTS  
 Path: | Dwg No. E-1

# CCI Flagpole Tool



Site Data	
BU#:	857144
Site Name:	Redding Wayside Lane
App #:	345878 Rev. 14

Code	
Code:	TIA-222-G
Ice Thickness:	0.75 in
Windspeed (V):	93 mph
Ice Wind Speed (V):	50 mph
Exposure Category:	C
Topographic Feature:	N/A
Structure Class:	II

Tower Information	
Total Tower Height:	109 ft
Base Tower Height:	69 ft
Total Canister Length:	40 ft
Number of Canister Assembly Sections:	4

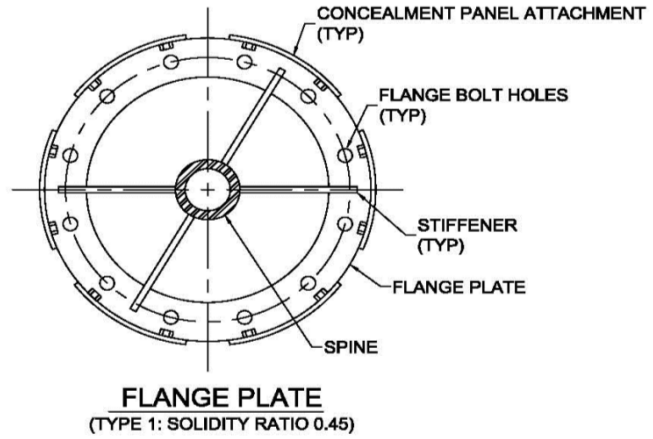

Canister Section Number *:	Canister Assembly Length (ft):	Canister Assembly Diameter (in):	Number of Sides Canister Section	Plate Type:	Mating Flange Plate Thickness (in)**:	Mating Flange Plate Diameter (in):	Solidity Ratio	Plate Weight (Kip):	Canister Weight (Kip)
1	10	30.75	Round	1	1.00	30.75	0.45	0.190	0.161
2	10	30.75	Round	1	1.25	30.75	0.45	0.237	0.161
3	10	30.75	Round	1	1.25	30.75	0.45	0.237	0.161
4	10	30.75	Round	1	1.50	30.75	0.45	0.284	0.161

\* Sections are numbered from the top of the tower down

\*\* Mating Flange Plate Thickness at the bottom of canister section

Flag on Tower:	Yes
Flag Width:	25 ft
Flag Height:	15 ft
Flag Elevation(z):	109 ft

Truck Ball on Tower:	Yes
Diameter of Ball:	18 in

Geometry : Base Tower + Spine				No Concealment.eri (last saved 09/22 2:44 pm)				
Pole Height Above Base (ft)	Section Length (ft)	Lap Splice Length (ft)	Number of Sides	Top Diameter (in)	Bottom Diameter (in)	Wall Thickness (in)	Bend Radius (in)	Pole Material
109	10	0	0	4.5	4.5	2.25	n/a	A572-50
99	10	0	0	6	6	3	n/a	A572-50
89	10	0	0	7	7	3.5	n/a	A572-50
79	10	0	0	10.75	10.75	1	n/a	A53-B-35

Delete  
[x]  
[x]  
[x]  
[x]

69	20.79	4.58	18	29.5	32.36	0.1875	0.75	A572-65	[x]
52.79	52.79	0	18	31.354947	38.5	0.25	1	A572-65	[x]

Discrete Loads: Truck Ball	Apply $C_a A_A$ at Elevation(z) (ft)	$C_a A_A$ No Ice (ft <sup>2</sup> )	$C_a A_A$ 1/2" Ice (ft <sup>2</sup> )	$C_a A_A$ 1" Ice (ft <sup>2</sup> )	$C_a A_A$ 2" Ice (ft <sup>2</sup> )	$C_a A_A$ 4" Ice (ft <sup>2</sup> )	Weight No Ice (Kip)	Weight 1/2" Ice (Kip)
		109.75	0.884	1.378	1.527	1.848	2.581	0.05

Discrete Loads : $C_f A_F$ for Canister Assembly								
Canister Loading	Apply $C_f A_F$ at Elevation(z) (ft)	$C_f A_F$ No Ice (ft <sup>2</sup> )	$C_f A_F$ 1/2" Ice (ft <sup>2</sup> )	$C_f A_F$ 1" Ice (ft <sup>2</sup> )	$C_f A_F$ 2" Ice (ft <sup>2</sup> )	$C_f A_F$ 4" Ice (ft <sup>2</sup> )	Canister Assembly Weight No Ice (Kip)	Canister Assembly Weight 1/2" Ice (Kip)
Canister Load 1	109	7.688	15.875	16.375	17.375	19.375	0.081	0.176
Canister Load 2	99	15.375	31.750	32.750	34.750	38.750	0.351	0.541
Canister Load 3	89	15.375	31.750	32.750	34.750	38.750	0.398	0.589
Canister Load 4	79	15.375	31.750	32.750	34.750	38.750	0.398	0.589
Canister Load 5	69	7.688	15.875	16.375	17.375	19.375	0.365	0.460

User Forces: Flag Force Calculation Per ANSI/NAAMM FP 1001-07	
Wind <sub>FORCE</sub> =	0.345 Kip
Weight=	0.039 Kip
Wind <sub>FORCE, ICE</sub> =	0.101 Kip
Weight <sub>ICE</sub> =	0.631 Kip
W <sub>FORCE, SERVICE WIND</sub> =	0.143 Kip
Weight=	0.039 Kip

← Flag force should be included at the top of the flag attachment elevation. If the attachment of the flag to the halyard distributes forces equally to the pole, apply flag forces accordingly in tnx file.

Deflection Check Required:	Yes	<a href="#">Import Deflection Results</a>
3% Spine Deflection Check		
Allowable (3%) Horizontal Spine Deflection (inches)	Actual Deflection *** (inches)	Sufficient/ Insufficient
14.400	5.715	Sufficient

\*\*\* Relative deflection under service level wind speed

© Copyright 2016 by Paul J. Ford & Company, all rights reserved.

**EEI FLANGE CONCEALMENT CALCULATIONS (99 Ft)**

EEI Kit Number	<b>Custom</b>
Flange Elevation	<b>99.00</b> ft

**STIFFENER INFORMATION**

		Overrides
Stiffener Quantity	4	<b>4</b>
Width (in)	11.5	<b>11.50</b>
Height (in)	9	<b>9.00</b>
Thickness (in)	0.75	<b>0.75</b>
Horizontal Fillet Weld	0.375	<b>0.375</b>
Vertical Fillet Weld	0.375	<b>0.375</b>
Stiffener Grade (ksi)	36	<b>36</b>

**RING PLATE INFORMATION**

Thickness (in)	1	<b>1.00</b>
ID (in)	23.5	<b>23.50</b>
OD (in)	28.5	<b>28.50</b>
Ring Plate Grade (ksi)	36	<b>36</b>

**BOLT INFORMATION**

Bolt Quantity	12	<b>12</b>
Size (in)	1	<b>1.00</b>
Bolt Circle (in)	26	<b>26.0</b>
Bolt Specification	A325	<b>A325</b>

**SPINE INFORMATION**

Size	4.5 S.R.	<b>4.5 S.R.</b>
Pipe Grade	A572-50	<b>A572-50</b>
Fy (ksi)	50	<b>50</b>
Fu (ksi)	65	<b>65</b>
Pipe OD (in)	4.5	<b>4.50</b>
Pipe Thickness (in)	2.25	<b>2.250</b>

**FLANGE CONNECTION REACTIONS**

Moment	<b>10.07</b>	kip*ft
Shear	<b>1.03</b>	kips
Axial	<b>1.03</b>	kips

Max Allowable Capacity	<b>105%</b>
Electrode (ksi)	<b>E70</b>

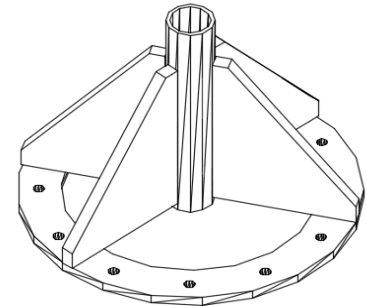

**FLANGE CONNECTION RESULTS**

<b>Bolts</b>	<b>4.7% Passing</b>
<b>Ring Plate</b>	<b>42.9% Passing</b>
<b>Weld - Stiffener &amp; Ring Plate</b>	<b>11.1% Passing</b>
<b>Weld - Spine &amp; Stiffener</b>	<b>13.7% Passing</b>
<b>Spine Wall Tear Out / Punching Shear</b>	N/a
<b>Max Tension In Stiffeners</b>	5.1 kips
<b>Max Compression in Stiffeners</b>	5.6 kips
<b>Stiffener Bending</b>	<b>13.5% Passing</b>
<b>Stiffener Shear</b>	<b>24.6% Passing</b>
<b>Stiffener Combined Shear &amp; Bending</b>	<b>53.3% Passing</b>

© Copyright 2016 by Paul J. Ford & Company, all rights reserved.

**EEI FLANGE CONCEALMENT CALCULATIONS (89 Ft)**

EEI Kit Number	Custom
Flange Elevation	89.00 ft

**STIFFENER INFORMATION**

		Overrides
Stiffener Quantity	4	4
Width (in)	11	11.00
Height (in)	9	9.00
Thickness (in)	1	1.00
Horizontal Fillet Weld	0.5	0.500
Vertical Fillet Weld	0.5	0.500
Stiffener Grade (ksi)	36	36

**RING PLATE INFORMATION**

Thickness (in)	1.25	1.25
ID (in)	23.5	23.50
OD (in)	28.5	28.50
Ring Plate Grade (ksi)	36	36

**BOLT INFORMATION**

Bolt Quantity	12	12
Size (in)	1	1.00
Bolt Circle (in)	26	26.0
Bolt Specification	A325	A325

**SPINE INFORMATION**

Size	6 S.R.	6 S.R.
Pipe Grade	A572-50	A572-50
Fy (ksi)	50	50
Fu (ksi)	65	65
Pipe OD (in)	6	6.00
Pipe Thickness (in)	3	3.000

**FLANGE CONNECTION REACTIONS**

Moment	28.14	kip*ft
Shear	1.83	kips
Axial	3.00	kips

Max Allowable Capacity	105%
Electrode (ksi)	E70

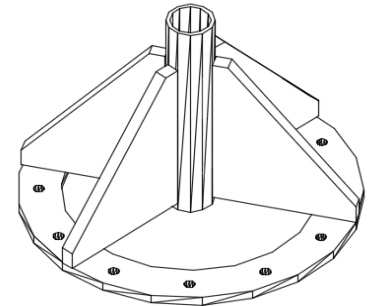

**FLANGE CONNECTION RESULTS**

Bolts	13.1% Passing
Ring Plate	76.6% Passing
Weld - Stiffener & Ring Plate	19.7% Passing
Weld - Spine & Stiffener	27.7% Passing
Spine Wall Tear Out / Punching Shear	N/a
Max Tension In Stiffeners	14.2 kips
Max Compression in Stiffeners	15.7 kips
Stiffener Bending	26.6% Passing
Stiffener Shear	44.0% Passing
Stiffener Combined Shear & Bending	84.1% Passing

© Copyright 2016 by Paul J. Ford & Company, all rights reserved.

**EEI FLANGE CONCEALMENT CALCULATIONS (79 Ft)**

EEI Kit Number	Custom
Flange Elevation	79.00 ft

**STIFFENER INFORMATION**

Overrides

Stiffener Quantity	6	6
Width (in)	10	10.00
Height (in)	9	9.00
Thickness (in)	0.75	0.75
Horizontal Fillet Weld	0.625	0.625
Vertical Fillet Weld	0.625	0.625
Stiffener Grade (ksi)	36	36

**RING PLATE INFORMATION**

Thickness (in)	1.25	1.25
ID (in)	23.5	23.50
OD (in)	28.5	28.50
Ring Plate Grade (ksi)	36	36

**BOLT INFORMATION**

Bolt Quantity	12	12
Size (in)	1	1.00
Bolt Circle (in)	26	26.0
Bolt Specification	A325	A325

**SPINE INFORMATION**

Size	7 S.R.	7 S.R.
Pipe Grade	A572-50	A572-50
Fy (ksi)	50	50
Fu (ksi)	65	65
Pipe OD (in)	7	7.00
Pipe Thickness (in)	3.5	3.500

**FLANGE CONNECTION REACTIONS**

Moment	53.79	kip*ft
Shear	2.56	kips
Axial	5.41	kips

Max Allowable Capacity	105%
Electrode (ksi)	E70

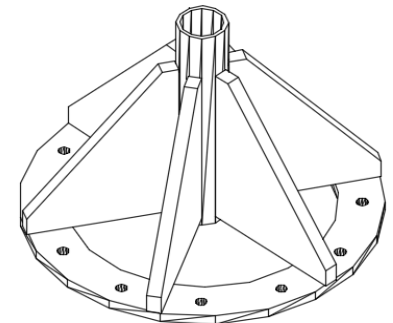

**FLANGE CONNECTION RESULTS**

Bolts	12.3% Passing
Ring Plate	72.2% Passing
Weld - Stiffener & Ring Plate	19.3% Passing
Weld - Spine & Stiffener	19.4% Passing
Spine Wall Tear Out / Punching Shear	N/a
Max Tension In Stiffeners	13.4 kips
Max Compression in Stiffeners	15.2 kips
Stiffener Bending	31.7% Passing
Stiffener Shear	29.2% Passing
Stiffener Combined Shear & Bending	38.2% Passing

NOTE: Toe Height has been considered in Stiffener Checks

© Copyright 2016 by Paul J. Ford & Company, all rights reserved.

**EEI FLANGE CONCEALMENT CALCULATIONS (69 Ft)**

EEI Kit Number	<b>Custom</b>
Flange Elevation	<b>69.00</b> ft

**STIFFENER INFORMATION**

		Overrides
Stiffener Quantity	6	<b>6</b>
Width (in)	8	<b>8.00</b>
Height (in)	9	<b>9.00</b>
Thickness (in)	1	<b>1.00</b>
Horizontal Fillet Weld	0.75	<b>0.750</b>
Vertical Fillet Weld	0.75	<b>0.750</b>
Stiffener Grade (ksi)	36	<b>36</b>

**RING PLATE INFORMATION**

Thickness (in)	1.5	<b>1.50</b>
ID (in)	23.5	<b>23.50</b>
OD (in)	28.5	<b>28.50</b>
Ring Plate Grade (ksi)	36	<b>36</b>

**BOLT INFORMATION**

Bolt Quantity	12	<b>12</b>
Size (in)	1	<b>1.00</b>
Bolt Circle (in)	26	<b>26.0</b>
Bolt Specification	A325	<b>A325</b>

**SPINE INFORMATION**

Size	10 XXS	<b>10 XXS</b>
Pipe Grade	A53-B-35	<b>A53-B-35</b>
Fy (ksi)	35	<b>35</b>
Fu (ksi)	60	<b>60</b>
Pipe OD (in)	10.75	<b>10.75</b>
Pipe Thickness (in)	1	<b>1.000</b>

**FLANGE CONNECTION REACTIONS**

Moment	<b>86.28</b>	kip*ft
Shear	<b>3.24</b>	kips
Axial	<b>7.31</b>	kips

Max Allowable Capacity	<b>105%</b>
Electrode (ksi)	<b>E70</b>

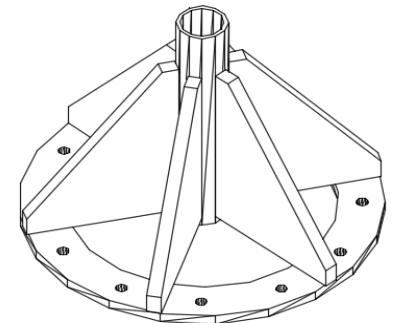

**FLANGE CONNECTION RESULTS**

<b>Bolts</b>	<b>20.0% Passing</b>
<b>Ring Plate</b>	<b>81.3% Passing</b>
<b>Weld - Stiffener &amp; Ring Plate</b>	<b>24.8% Passing</b>
<b>Weld - Spine &amp; Stiffener</b>	<b>20.9% Passing</b>
<b>Spine Wall Tear Out / Punching Shear</b>	<b>12.4% Passing</b>
<b>Max Tension In Stiffeners</b>	21.8 kips
<b>Max Compression in Stiffeners</b>	24.2 kips
<b>Stiffener Bending</b>	<b>29.6% Passing</b>
<b>Stiffener Shear</b>	<b>35.0% Passing</b>
<b>Stiffener Combined Shear &amp; Bending</b>	<b>45.8% Passing</b>

NOTE: Toe Height has been considered in Stiffener Checks

# Stiffened or Unstiffened, Interior Flange Plate - Any Bolt Material TIA Rev G

## Site Data

BU#: 857144  
 Site Name: Redding Wayside Lane  
 App #:

Manufacturer: Other

## Bolt Data

Qty:	12		
Diam:	1	Bolt Fu:	120
Bolt Material:	A325	Bolt Fy:	92
N/A:		<-- Disregard	
N/A:		<-- Disregard	
Circle:	26	in	

## Plate Data

Plate Outer Diam:	29.125	in
Plate Inner Diam:	23.5	in (Hole @ Ctr)
Thick:	1.5	in
Grade:	60	ksi
<b>Effective Width:</b>	7.25	in

## Stiffener Data (Welding at Both Sides)

Config:	0	*
Weld Type:		
Groove Depth:		in **
Groove Angle:		degrees
Fillet H. Weld:		<-- Disregard
Fillet V. Weld:		in
Width:		in
Height:		in
Thick:		in
Notch:		in
Grade:		ksi
Weld str.:		ksi

## Pole Data

Pole OuterDiam:	29.5	in
Thick:	0.1875	in
Pole Inner Diam:	29.125	in
Grade:	65	ksi
# of Sides:	18	"0" IF Round
Fu	80	ksi

## Reactions

Moment:	86.28	ft-kips
Axial:	7.31	kips
Shear:	3.24	kips
Exterior Flange Run, T+q:	0	kips

## Bolt Threads:

X-Excluded
$\phi V_n = \phi(0.55 A_b F_u)$
$\phi = 0.75, \phi V_n$ (kips):
38.88

Elevation: 69 feet

## Interior Flange Bolt Results

Maximum Bolt Tension, Tu: 12.7 Kips, Ext. Tu=Interior Tu  
 Adjusted  $\phi T_n$  (due to  $V_u = V_u / Q_t$ ), I: 54.5 Kips  
 Bolt Stress Ratio: 23.2% **Pass**

## Interior Flange Plate Results

Controlling Bolt Axial Force: 13.9 Kips, Ext. Cu=Interior Cu  
 Plate Stress: 5.3 ksi  
 Allowable Plate Stress,  $\phi F_y$ : 54.0 ksi  
 Plate Stress Ratio: 9.9% **Pass**

n/a

## Stiffener Results

Horizontal Weld : n/a  
 Vertical Weld: n/a  
 Plate Flex+Shear,  $f_b / F_b + (f_v / F_v)^2$ : n/a  
 Plate Tension+Shear,  $f_t / F_t + (f_v / F_v)^2$ : n/a  
 Plate Comp. (AISC Bracket): n/a

## Pole Results

Pole Punching Shear Check: n/a

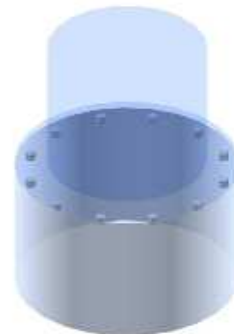
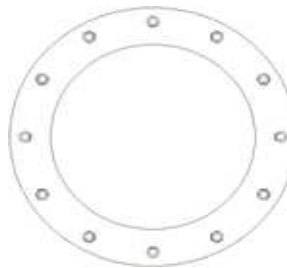

\* 0 = none, 1 = every bolt, 2 = every 2 bolts, 3 = 2 per bolt

\*\* Note: for complete joint penetration groove welds the groove depth must be exactly 1/2 the stiffener thickness for calculation purposes



## Square, Stiffened / Unstiffened Base Plate, Any Rod Material - Rev. F /G

- Assumptions: 1) Rod groups at corners. Total # rods divisible by 4. Maximum total # of rods = 48 (12 per Corner).  
 2) Rod Spacing = Straight Center-to-Center distance between any (2) adjacent rods (same corner)  
 3) Clear space between bottom of leveling nut and top of concrete **not** exceeding (1)\*(Rod Diameter)

Site Data		
BU#:	857144	
Site Name:	Redding Wayside Lane	
App #:		
Anchor Rod Data		
Eta Factor, $\eta$	0.5	TIA G (Fig. 4-4)
Qty:	8	
Diam:	1.75	in
Rod Material:	A615-J	
Yield, Fy:	75	ksi
Strength, Fu:	100	ksi
Bolt Circle:	45.5	in
Anchor Spacing:	6	in

Plate Data		
W=Side:	45	in
Thick:	2	in
Grade:	60	ksi
Clip Distance:	9.47	in

Stiffener Data (Welding at both sides)		
Configuration:	Unstiffened	
Weld Type:		**
Groove Depth:		in **
Groove Angle:		degrees
Fillet H. Weld:		<-- Disregard
Fillet V. Weld:		
Width:		in
Height:		in
Thick:		in
Notch:		in
Grade:		ksi
Weld str.:		ksi

Pole Data		
Diam:	38.5	in
Thick:	0.25	in
Grade:	65	ksi
# of Sides:	18	"0" IF Round

Base Reactions		
TIA Revision:	G	
Factored Moment, Mu:	495	ft-kips
Factored Axial, Pu:	16	kips
Factored Shear, Vu:	8	kips

### Anchor Rod Results

TIA G --> Max Rod (Cu+ Vu/ $\eta$ ): 69.3 Kips  
 Axial Design Strength,  $\Phi * F_u * A_{net}$ : 152.0 Kips  
 Anchor Rod Stress Ratio: 45.6% **Pass**

### Base Plate Results

Base Plate Stress: 17.5 ksi  
 PL Design Bending Strength,  $\Phi * F_y$ : 54.0 ksi  
 Base Plate Stress Ratio: 32.4% **Pass**

### Flexural Check

PL Ref. Data	
Yield Line (in):	25.14
Max PL Length:	25.14

### N/A - Unstiffened

### Stiffener Results

Horizontal Weld : N/A  
 Vertical Weld: N/A  
 Plate Flex+Shear,  $f_b/F_b + (f_v/F_v)^2$ : N/A  
 Plate Tension+Shear,  $f_t/F_t + (f_v/F_v)^2$ : N/A  
 Plate Comp. (AISC Bracket): N/A

### Pole Results

Pole Punching Shear Check: N/A

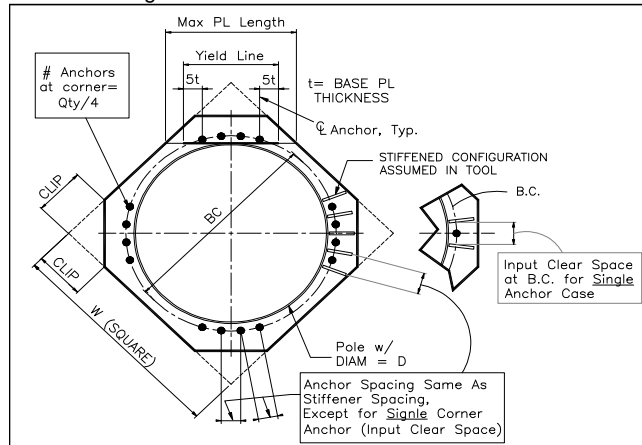

\*\* Note: for complete joint penetration groove welds the groove depth must be exactly 1/2 the stiffener thickness for calculation purposes

**Factored Foundation Loads:**

	LC1	LC2	
Factored Axial Load (+Comp, -Ten) =	<b>16</b>	<b>12</b>	kips
Factored Horiz. Load at Top of Pier =	<b>8</b>	<b>8</b>	kips
Factored OTM at Top of Pier =	<b>495</b>	<b>495</b>	kips

**LRFD Resistance and Load Factors:**

	$\Phi$	Dead Load Factors	
Soil Bearing =	<b>0.75</b>		
Soil Weight =	<b>0.75</b>	1.2	0.9
Concrete Weight =	<b>0.75</b>	1.2	0.9

**Soil Properties:**

Depth to Water Table =	<b>22</b> ft
Uplift Cone from	<b>Top</b> of footing

Layer Thk ft	Soil Density pcf	Cohesion ksf	Friction Angle degrees	Ult Bearing ksf	Depth ft
<b>6.5</b>	<b>130</b>	<b>0</b>	<b>38</b>	<b>30</b>	<b>6.50</b>

**Dimensions:**

Pier Shape =	<b>Square</b>
Pier Width =	<b>6</b> ft Square
Pier Height above Grade =	<b>1</b> ft
Depth to Bottom of Footing =	<b>6.5</b> ft
Footing Thickness =	<b>3</b> ft
Footing Width, B =	<b>13.5</b> ft
Footing Length, L =	<b>13.5</b> ft

**Concrete:**

Concrete Strength =	<b>3</b> ksi
Rebar Strength =	<b>60</b> ksi

**Summary Results:**

	Required	Available
Maximum Net Soil Bearing =	<b>1.156</b> ksf	<b>22.500</b> ksf
Uplift =	<b>0.0</b> kips	<b>158.2</b> kips
Punching Shear Stress =	<b>0.007</b> ksi	<b>0.164</b> ksi
Bending Shear Stress =	<b>22.2</b> kips	<b>419.3</b> kips
Bending Moment =	<b>0.004</b> in / in	<b>0.0</b> in / in
Conc Pier Reinforcing Steel =	<b>531.0</b> k-ft	<b>3959.8</b> k-ft

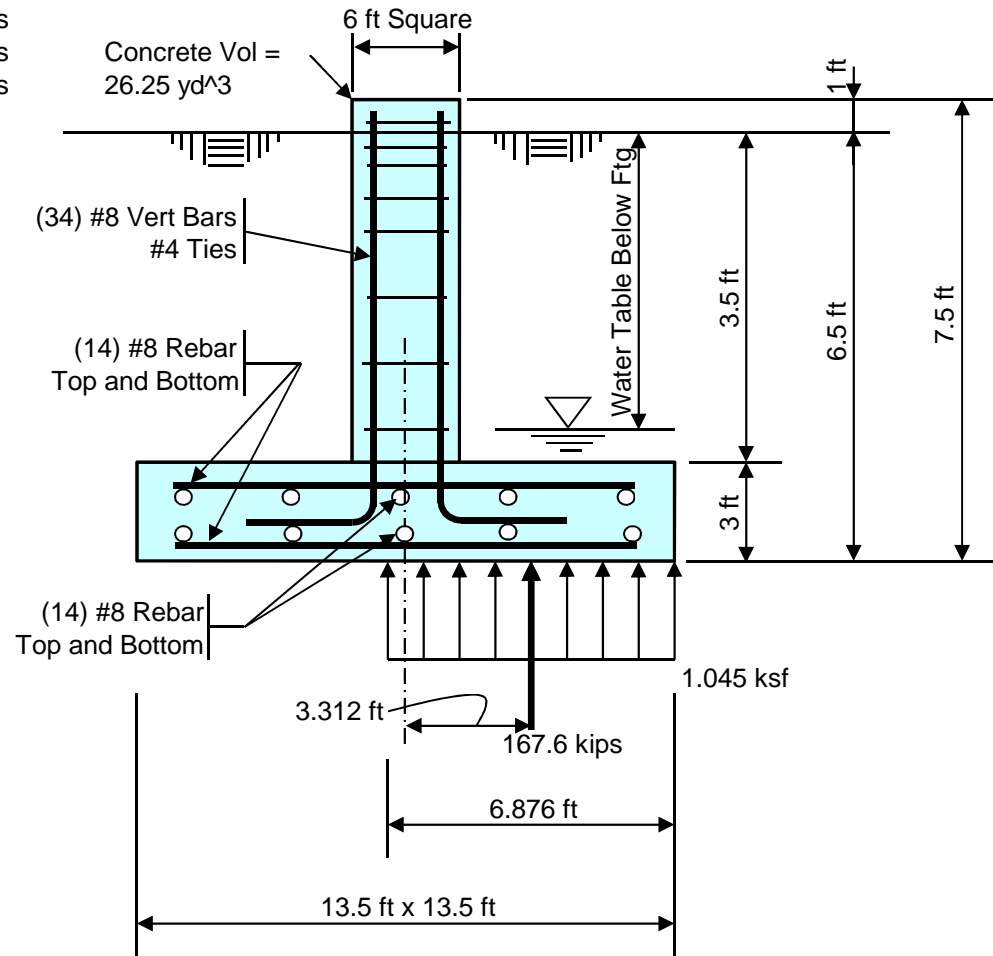

Total Pad Reinf Stl = **22.12** in<sup>2</sup> >= 10.5 in<sup>2</sup> = Min Stl, OK  
 Total Pier Reinf Stl = **26.86** in<sup>2</sup> >= 25.92 in<sup>2</sup> = Min Stl, OK  
 Footing Thickness = **3.00** ft >= 1.53 ft = Min Ftg Thk, OK

Stress Ratio = **5.1%** in Soil Bearing  
 Stress Ratio = **0.0%** in Uplift  
 Stress Ratio = **4.2%** in Punching Shear  
 Stress Ratio = **5.3%** in Bending Shear  
 Stress Ratio = **8.5%** in Bending Moment  
 Stress Ratio = **13.4%** in Pier Rebar

# MODIFICATION OF AN EXISTING 109'-0" MONOPOLE TOWER MAPPING CCI DOC ID #5171985 BU #857144; REDDING WAYSIDE LANE

22 WAYSIDE LANE  
REDDING, CONNECTICUT 06896  
FAIRFIELD COUNTY  
LAT: 41° 16' 56.3"; LONG: -73° 24' 26.9"  
APP: 345878 REV. 14; WO: 1301248

## PROJECT CONTACTS

STRUCTURE OWNER:  
CROWN CASTLE  
MOD PM: DAN VADNEY AT DAN.VADNEY@CROWNCastle.COM  
PH: (518) 373-3510  
MOD CM: JASON D'AMICO AT JASON.D'AMICO@CROWNCastle.COM  
PH: (860) 209-0104

ENGINEER OF RECORD:  
PJFMOD@PJFWEB.COM

## THIS PROJECT INCLUDES THE FOLLOWING ITEMS

INSTALLATION OF NEW CONCEALMENT SHROUDS  
PAINT MODIFICATIONS TO MATCH EXISTING POLE  
INSTALL CONCEALMENT REINFORCING SOLUTIONS PER CROWN CASTLE  
DOC OPS-PRC-10127 AND OPS-SOW-10127

## SHEET INDEX

SHEET NUMBER	DESCRIPTION
T-1	TITLE SHEET
T-2	MI CHECKLIST
S-1	GENERAL NOTES
S-2	MONOPOLE PROFILE
S-3	CONCEALMENT ELEVATION DETAILS

## WIND DESIGN DATA

REFERENCE STANDARD	ANSI/TIA-222-G-2-2009
LOCAL CODE	2016 CONNECTICUT BUILDING CODE
ULTIMATE WIND SPEED (3-SECOND GUST)	120 MPH
CONVERTED NOMINAL WIND SPEED (3-SECOND GUST)	93 MPH
ICE THICKNESS	0.75 IN
ICE WIND SPEED	50 MPH
SERVICE WIND SPEED	60 MPH
RISK CATEGORY	II
EXPOSURE CATEGORY	C
Kzt	1.0

QUALIFIED ENGINEERING SERVICES ARE AVAILABLE FROM PAUL J. FORD & COMPANY TO ASSIST CONTRACTORS IN CLASS IV RIGGING PLAN REVIEWS. FOR REQUESTED QUALIFIED ENGINEERING SERVICES, PLEASE CONTACT RIGGING@PJFWEB.COM.

THE ASSOCIATED FAILING SA WO NUMBER FOR THIS PROJECT IS 1295471

ATTENTION ALL CONTRACTORS, ANYTIME YOU ACCESS A CROWN SITE FOR ANY REASON YOU ARE TO CALL THE CROWN NOC UPON ARRIVAL AND DEPARTURE, DAILY AT (800) 788-7011.

© Copyright 2016, by Paul J. Ford and Company, All Rights Reserved. This document and the data contained herein, is proprietary to Paul J. Ford and Company, issued in strict confidence and shall not, without the prior written permission of Paul J. Ford and Company, be reproduced, copied or used for any purpose other than the intended use for this specific project.

**PJF**  
**PAUL J. FORD & COMPANY**  
250 E Broad St, Ste 600 Columbus, OH 43215  
Phone 614.221.6679 www.pauljford.com

**CROWN CASTLE**  
3 CORPORATE PARK DRIVE, SUITE 101, CLIFTON PARK, NY 12065  
PH: (585) 370-4766

MODIFICATION OF AN EXISTING  
109'-0" MONOPOLE  
BU #857144; REDDING WAYSIDE LANE  
REDDING, CONNECTICUT

PROJECT No: 37516-3037.002.7700  
DRAWN BY: B.M.S.  
DESIGNED BY: J.W.M.  
CHECKED BY:  
DATE: 9-26-2016

TITLE SHEET

T-1

**MODIFICATION INSPECTION NOTES:**

- 1. GENERAL**
  - 1.1. THE MODIFICATION INSPECTION (MI) IS A VISUAL INSPECTION OF TOWER MODIFICATIONS AND A REVIEW OF CONSTRUCTION INSPECTIONS AND OTHER REPORTS TO ENSURE THE INSTALLATION WAS CONSTRUCTED IN ACCORDANCE WITH THE CONTRACT DOCUMENTS, NAMELY THE MODIFICATION DRAWINGS, AS DESIGNED BY THE EOR.
  - 1.2. THE MI IS TO CONFIRM INSTALLATION CONFIGURATION AND WORKMANSHIP ONLY AND IS NOT A REVIEW OF THE MODIFICATION DESIGN ITSELF, NOR DOES THE MI INSPECTOR TAKE OWNERSHIP OF THE MODIFICATION DESIGN. OWNERSHIP OF THE STRUCTURAL MODIFICATION DESIGN EFFECTIVENESS AND INTEGRITY RESIDES WITH THE EOR AT ALL TIMES.
  - 1.3. ALL MI'S SHALL BE CONDUCTED BY A CROWN CASTLE ENGINEERING VENDOR (AEV) OR ENGINEERING SERVICE VENDOR (AESV) THAT IS APPROVED TO PERFORM ELEVATED WORK FOR CROWN CASTLE.
  - 1.4. TO ENSURE THAT THE REQUIREMENTS OF THE MI ARE MET, IT IS VITAL THAT THE GENERAL CONTRACTOR (GC) AND THE MI INSPECTOR BEGIN COMMUNICATING AND COORDINATING AS SOON AS A PO IS RECEIVED. IT IS EXPECTED THAT EACH PARTY WILL BE PROACTIVE IN REACHING OUT TO THE OTHER PARTY. IF CONTACT INFORMATION IS NOT KNOWN, CONTACT YOUR CROWN CASTLE POINT OF CONTACT (POC).
  - 1.5. REFER TO ENG-SOW-10007: MODIFICATION INSPECTION SOW FOR FURTHER DETAILS AND REQUIREMENTS.
- 2. MI INSPECTOR**
  - 2.1. THE MI INSPECTOR IS REQUIRED TO CONTACT THE GC AS SOON AS RECEIVING A PO FOR THE MI TO, AT A MINIMUM:
    - 2.1.1. REVIEW THE REQUIREMENTS OF THE MI CHECKLIST.
    - 2.1.2. WORK WITH THE GC TO DEVELOP A SCHEDULE TO CONDUCT ON-SITE INSPECTIONS, INCLUDING FOUNDATION INSPECTIONS.
    - 2.1.3. THE MI INSPECTOR IS RESPONSIBLE FOR COLLECTING ALL GC INSPECTION AND TEST REPORTS, REVIEWING THE DOCUMENTS FOR ADHERENCE TO THE CONTRACT DOCUMENTS, CONDUCTING THE IN-FIELD INSPECTIONS, AND SUBMITTING THE MI REPORT TO CROWN CASTLE.
- 3. GENERAL CONTRACTOR**
  - 3.1. THE GC IS REQUIRED TO CONTACT THE MI INSPECTOR AS SOON AS RECEIVING A PO FOR THE MODIFICATION INSTALLATION OR TURNKEY PROJECT TO, AT A MINIMUM:
    - 3.1.1. REVIEW THE REQUIREMENTS OF THE MI CHECKLIST.
    - 3.1.2. WORK WITH THE MI INSPECTOR TO DEVELOP A SCHEDULE TO CONDUCT ON-SITE INSPECTIONS, INCLUDING FOUNDATION INSPECTIONS.
    - 3.1.3. BETTER UNDERSTAND ALL INSPECTION AND TESTING REQUIREMENTS.
    - 3.1.4. THE GC SHALL PERFORM AND RECORD THE TEST AND INSPECTION RESULTS IN ACCORDANCE WITH THE REQUIREMENTS OF THE MI CHECKLIST AND ENG-SOW-10007.
- 4. RECOMMENDATIONS**
  - 4.1. THE FOLLOWING RECOMMENDATIONS AND SUGGESTIONS ARE OFFERED TO ENHANCE THE EFFICIENCY AND EFFECTIVENESS OF DELIVERING AN MI REPORT:
    - 4.1.1. IT IS SUGGESTED THAT THE GC PROVIDE A MINIMUM OF 5 BUSINESS DAYS NOTICE, PREFERABLE 10, TO THE MI INSPECTOR AS TO WHEN THE SITE WILL BE READY FOR THE MI TO BE CONDUCTED.
    - 4.1.2. THE GC AND MI INSPECTOR COORDINATE CLOSELY THROUGHOUT THE ENTIRE PROJECT.
    - 4.1.3. WHEN POSSIBLE, IT IS PREFERRED TO HAVE THE GC AND MI INSPECTOR ON-SITE SIMULTANEOUSLY FOR ANY GUY WIRE TENSIONING OR RE-TENSIONING OPERATIONS.
    - 4.1.4. IT MAY BE BENEFICIAL TO INSTALL ALL TOWER MODIFICATIONS PRIOR TO CONDUCTING THE FOUNDATION INSPECTIONS TO ALLOW FOUNDATION AND MI INSPECTION(S) TO COMMENCE WITH ONE SITE VISIT.
    - 4.1.5. WHEN POSSIBLE, IT IS PREFERRED TO HAVE THE GC AND MI INSPECTOR ON-SITE DURING THE MI TO HAVE ANY DEFICIENCIES CORRECTED DURING THE INITIAL MI. THEREFORE, THE GC MAY CHOOSE TO COORDINATE THE MI CAREFULLY TO ENSURE ALL CONSTRUCTION FACILITIES ARE AT THEIR DISPOSAL WHEN THE MI INSPECTOR IS ON SITE.
- 5. CANCELLATION OR DELAYS IN SCHEDULED MI**
  - 5.1. IF THE GC AND MI INSPECTOR AGREE TO A DATE ON WHICH THE MI WILL BE CONDUCTED, AND EITHER PARTY CANCELS OR DELAYS, CROWN CASTLE SHALL NOT BE RESPONSIBLE FOR ANY COSTS, FEES, LOSS OF DEPOSITS AND/OR OTHER PENALTIES RELATED TO THE CANCELLATION OR DELAY INCURRED BY EITHER PARTY FOR ANY TIME (E.G. TRAVEL AND LODGING, COSTS OF KEEPING EQUIPMENT ON-SITE, ETC.). IF CROWN CASTLE CONTRACTS DIRECTLY FOR A THIRD PARTY MI, EXCEPTIONS MAY BE MADE IN THE EVENT THAT THE DELAY/CANCELLATION IS CAUSED BY WEATHER OR OTHER CONDITIONS THAT MAY COMPROMISE THE SAFETY OF THE PARTIES INVOLVED.
- 6. CORRECTION OF FAILING MI'S**
  - 6.1. IF THE MODIFICATION INSTALLATION WOULD FAIL THE MI ("FAILED MI"), THE GC SHALL WORK WITH CROWN CASTLE TO COORDINATE A REMEDIATION PLAN IN ONE OF TWO WAYS:
    - 6.1.1. CORRECT FAILING ISSUES TO COMPLY WITH THE SPECIFICATIONS CONTAINED IN THE ORIGINAL CONTRACT DOCUMENTS AND COORDINATE A SUPPLEMENT MI.
    - 6.1.2. OR, WITH CROWN CASTLE'S APPROVAL, THE GC MAY WORK WITH THE EOR TO RE-ANALYZE THE MODIFICATION/REINFORCEMENT USING THE AS-BUILT CONDITION.
- 7. MI VERIFICATION INSPECTIONS**
  - 7.1. CROWN CASTLE RESERVES THE RIGHT TO CONDUCT A MI VERIFICATION INSPECTION TO VERIFY THE ACCURACY AND COMPLETENESS OF PREVIOUSLY COMPLETED MI INSPECTION(S) ON TOWER MODIFICATION PROJECTS.
  - 7.2. ALL VERIFICATION INSPECTIONS SHALL BE HELD TO THE SAME SPECIFICATIONS AND REQUIREMENTS IN THE CONTRACT DOCUMENTS AND IN ACCORDANCE WITH ENG-SOW-10007.
  - 7.3. VERIFICATION INSPECTION MAY BE CONDUCTED BY AN INDEPENDENT AEV/AESV FIRM AFTER A MODIFICATION PROJECT IS COMPLETED, AS MARKED BY THE DATE OF AN ACCEPTED "PASSING MI" OR "PASS AS NOTED MI" REPORT FOR THE ORIGINAL PROJECT.
- 8. PHOTOGRAPHS**
  - 8.1. BETWEEN THE GC AND THE MI INSPECTOR THE FOLLOWING PHOTOGRAPHS, AT A MINIMUM, ARE TO BE TAKEN AND INCLUDED IN THE MI REPORT:
    - 8.1.1. PRECONSTRUCTION GENERAL SITE CONDITION
    - 8.1.2. PHOTOGRAPHS DURING THE REINFORCEMENT MODIFICATION CONSTRUCTION/ERECTION AND INSPECTION
    - 8.1.3. RAW MATERIALS
    - 8.1.4. PHOTOS OF ALL CRITICAL DETAILS
    - 8.1.5. FOUNDATION MODIFICATIONS
    - 8.1.6. WELD PREPARATION
    - 8.1.7. BOLT INSTALLATION AND TORQUE
    - 8.1.8. FINAL INSTALLED CONDITION
    - 8.1.9. SURFACE COATING REPAIR
    - 8.1.10. POST CONSTRUCTION PHOTOGRAPHS
    - 8.1.11. FINAL INFIELD CONDITION
    - 8.1.12. PHOTOS OF ELEVATED MODIFICATIONS TAKEN FROM THE GROUND SHALL BE CONSIDERED INADEQUATE.
    - 8.1.13. THIS IS NOT A COMPLETE LIST OF REQUIRED PHOTOS, PLEASE REFER TO ENG-SOW-10007.

**9. INSPECTION AND TESTING**

- 9.1. ALL WORK SHALL BE SUBJECT TO REVIEW AND OBSERVATION BY CROWN CASTLE'S REPRESENTATIVE AND CROWN CASTLE'S AUTHORIZED INDEPENDENT INSPECTION AND TESTING AGENCY.
- 9.2. INSPECTION SERVICES WHICH ARE FURNISHED BY OTHERS ARE STILL REQUIRED WHEN THE EOR PERFORMS SUPPORT SERVICES DURING CONSTRUCTION.
- 9.3. OBSERVED DISCREPANCIES BETWEEN THE WORK AND THE CONTRACT DOCUMENTS SHALL BE CORRECTED BY THE CONTRACTOR AT NO ADDITIONAL COST.
- 9.4. AN INDEPENDENT QUALIFIED INSPECTION/TESTING AGENCY SHALL BE SELECTED AND RETAINED FOR THE SOLE PURPOSE OF INSPECTING, TESTING, DOCUMENTING, AND APPROVING ALL WELDING AND FIELD WORK PERFORMED BY THE CONTRACTOR.
  - 9.4.1. ACCESS TO ANY PLACE WHERE WORK IS BEING DONE SHALL BE PERMITTED AT ALL TIMES.
  - 9.4.2. THE INSPECTION AGENCY SHALL SO SCHEDULE THIS WORK AS TO CAUSE A MINIMUM OF INTERRUPTION TO, AND COORDINATE WITH, THE WORK IN PROGRESS. IT IS THE CONTRACTOR'S RESPONSIBILITY TO COORDINATE THE WORK SCHEDULE WITH THE TESTING AGENCY. THE CONTRACTOR SHALL ALLOW FOR ADEQUATE TIME AND ACCESS FOR THE TESTING AGENCY TO PERFORM THEIR DUTIES.
- 9.5. THE INSPECTION AND TESTING AGENCY SHALL BE RESPONSIBLE TO PERFORM THE FOLLOWING SERVICES AND INSPECT THE FOLLOWING ITEMS IN ACCORDANCE WITH THE CONSTRUCTION DRAWINGS. THE TESTING AGENCY SHALL INSPECT ITEMS ON THIS LIST AND OTHER ITEMS AS NECESSARY TO FULFILL THEIR RESPONSIBILITY. THE TESTING AGENCY SHALL UTILIZE EXPERIENCED, TRAINED INSPECTORS INCLUDING AWS CERTIFIED WELDING INSPECTORS (CWI). INSPECTORS SHALL HAVE THE TRAINING, CREDENTIALS, AND EXPERIENCE APPROPRIATE FOR AND COMMENSURATE WITH THE SCOPE AND TYPE OF INSPECTION WORK TO BE PERFORMED.
- 9.6. **GENERAL**
  - 9.6.1. PERFORM PERIODIC ON-SITE OBSERVATION, INSPECTION, VERIFICATION, AND TESTING DURING THE TIME THE CONTRACTOR IS WORKING ON-SITE. AGENCY SHALL NOTIFY CROWN CASTLE AND THE EOR IMMEDIATELY WHEN FIELD PROBLEMS OR DISCREPANCIES OCCUR.
- 9.7. FOUNDATIONS AND SOIL PREPARATION - (NOT REQUIRED)
- 9.8. CONCRETE TESTING PER ACI - (NOT REQUIRED)
- 9.9. STRUCTURAL STEEL
  - 9.9.1. CHECK STEEL ON THE JOB WITH THE PLANS.
  - 9.9.2. CHECK MILL CERTIFICATIONS. CALL FOR LABORATORY TEST REPORTS WHEN MILL CERTIFICATION IS IN QUESTION.
  - 9.9.3. CHECK GRADE OF STEEL MEMBERS, AND BOLTS FOR CONFORMANCE WITH DRAWINGS.
  - 9.9.4. INSPECT ALL STRUCTURAL BOLTS SHALL BE FIELD INSPECTED ACCORDING TO THE REQUIREMENTS OF THE AISC 'SPECIFICATION FOR STRUCTURAL JOINTS USING HIGH-STRENGTH BOLTS', DEC. 31, 2009.
  - 9.9.5. INSPECT STEEL MEMBERS FOR DISTORTION, EXCESSIVE RUST, FLAWS AND BURNED HOLES.
  - 9.9.6. CHECK STEEL MEMBERS FOR SIZES, SWEEP AND DIMENSIONAL TOLERANCES.
  - 9.9.7. CHECK FOR SURFACE FINISH SPECIFIED, GALVANIZED.
  - 9.9.8. CHECK THAT BOLTS HAVE BEEN TIGHTENED PROPERLY.
  - 9.9.9. PRIOR TO ANY FIELD CUTTING THE CONTRACTOR SHALL MARK THE CUTOUT LINES ON THE STEEL AND THE INSPECTION/TESTING AGENCY SHALL VERIFY PROPOSED LAYOUT, LOCATION, AND DIMENSIONS. THE INSPECTION/TESTING AGENCY SHALL CLOSELY AND CONTINUOUSLY MONITOR THIS ACTIVITY.
- 9.10. WELDING:
  - 9.10.1. VERIFY FIELD WELDING PROCEDURES, WELDERS, AND WELDING OPERATORS, NOT DEEMED PREQUALIFIED, IN ACCORDANCE WITH AWS D1.1.
  - 9.10.2. INSPECT FIELD WELDED CONNECTIONS IN ACCORDANCE WITH THE REQUIREMENTS SPECIFIED AND WITH AWS D1.1.
  - 9.10.3. APPROVE FIELD WELDING SEQUENCE.
  - 9.10.4. A PROGRAM OF THE APPROVED SEQUENCES SHALL BE SUBMITTED TO CROWN CASTLE BEFORE WELDING BEGINS. NO CHANGE IN APPROVED SEQUENCES MAY BE MADE WITHOUT PERMISSION FROM CROWN CASTLE.
  - 9.10.5. INSPECT WELDED CONNECTIONS AS FOLLOWS AND IN ACCORDANCE WITH AWS D1.1:
    - 9.10.5.1. INSPECT WELDING EQUIPMENT FOR CAPACITY, MAINTENANCE, AND WORKING CONDITIONS.
    - 9.10.5.2. VERIFY SPECIFIED ELECTRODES AND HANDLING AND STORAGE OF ELECTRODES FOR CONFORMANCE TO SPECIFICATIONS.
    - 9.10.5.3. INSPECT PREHEATING AND INTERPASS TEMPERATURES FOR CONFORMANCE WITH AWS D1.1.
    - 9.10.5.4. VISUALLY INSPECT ALL WELDS AND VERIFY THAT QUALITY OF WELDS MEETS THE REQUIREMENTS OF AWS D1.1. OTHER TESTS MAY ALSO BE PERFORMED ON THE WELDS BY THE TESTING AGENCY IN ORDER FOR THEM TO PERFORM THEIR DUTIES FOR THIS PROJECT.
    - 9.10.5.5. SPOT TEST AT LEAST ONE FILLET WELD OF EACH MEMBER USING MAGNETIC PARTICLE.
    - 9.10.5.6. INSPECT FOR SIZE, SPACING, TYPE AND LOCATION AS PER APPROVED DRAWINGS.
    - 9.10.5.7. VERIFY THAT THE BASE METAL CONFORMS TO THE DRAWINGS.
    - 9.10.5.8. REVIEW THE REPORTS BY TESTING LABS.
    - 9.10.5.9. CHECK TO SEE THAT WELDS ARE CLEAN AND FREE FROM SLAG.
    - 9.10.5.10. INSPECT RUST PROTECTION OF WELDS AS PER SPECIFICATIONS.
    - 9.10.5.11. CHECK THAT DEFECTIVE WELDS ARE CLEARLY MARKED AND HAVE BEEN ADEQUATELY REPAIRED.
- 9.11. **REPORTS:**
  - 9.11.1. COMPILE AND PERIODICALLY SUBMIT DAILY INSPECTION REPORTS TO CROWN CASTLE.
  - 9.11.2. THE INSPECTION PLAN OUTLINED HEREIN IS INTENDED AS A DESCRIPTION OF GENERAL AND SPECIFIC ITEMS OF CONCERN. IT IS NOT INTENDED TO BE ALL-INCLUSIVE. IT DOES NOT LIMIT THE TESTING AND INSPECTION AGENCY TO THE ITEMS LISTED. ADDITIONAL TESTING, INSPECTION, AND CHECKING MAY BE REQUIRED AND SHOULD BE ANTICIPATED. THE TESTING AGENCY SHALL USE THEIR PROFESSIONAL JUDGMENT AND KNOWLEDGE OF THE JOB SITE CONDITIONS AND THE CONTRACTOR'S PERFORMANCE TO DECIDE WHAT OTHER ITEMS REQUIRE ADDITIONAL ATTENTION. THE TESTING AGENCY'S JUDGMENT MUST PREVAIL ON ITEMS NOT SPECIFICALLY COVERED. ANY DISCREPANCIES OR PROBLEMS SHALL BE BROUGHT IMMEDIATELY TO CROWN CASTLE'S ATTENTION. RESOLUTIONS ARE NOT TO BE MADE WITHOUT CROWN CASTLE'S REVIEW AND SPECIFIC WRITTEN CONSENT. CROWN CASTLE RESERVES THE RIGHT TO DETERMINE WHETHER OR NOT A RESOLUTION IS ACCEPTABLE.
  - 9.11.3. AFTER EACH INSPECTION, THE TESTING AGENCY WILL PREPARE A WRITTEN ACCEPTANCE OR REJECTION WHICH WILL BE GIVEN TO THE CONTRACTOR AND FILED AS DAILY REPORTS TO CROWN CASTLE. THIS WRITTEN ACTION WILL GIVE THE CONTRACTOR A LIST OF ITEMS TO BE CORRECTED, PRIOR TO CONTINUING CONSTRUCTION, AND/OR LOADING OF STRUCTURAL ITEMS.
  - 9.11.4. THE TESTING AGENCY DOES NOT RELIEVE THE CONTRACTOR'S CONTRACTUAL OR STATUTORY OBLIGATIONS. THE CONTRACTOR HAS THE SOLE RESPONSIBILITY FOR ANY DEVIATIONS FROM THE OFFICIAL CONTRACT DOCUMENTS. THE TESTING AGENCY WILL NOT REPLACE THE CONTRACTOR'S QUALITY CONTROL PERSONNEL.

MI CHECKLIST	
CONSTRUCTION/INSTALLATION INSPECTIONS AND TESTING REQUIRED (COMPLETED BY EOR)	REPORT ITEM
<b>PRE-CONSTRUCTION</b>	
X	MI CHECKLIST DRAWINGS
X	EOR REVIEW
X	FABRICATION INSPECTION
NA	FABRICATOR CERTIFIED WELD INSPECTION
NA	MATERIAL TEST REPORT (MTR)
NA	FABRICATOR NDE INSPECTION
NA	NDE REPORT OF MONOPOLE BASE PLATE (AS REQUIRED)
X	PACKING SLIPS
ADDITIONAL TESTING AND INSPECTIONS: _____	
<b>CONSTRUCTION</b>	
X	CONSTRUCTION INSPECTIONS
NA	FOUNDATION INSPECTIONS
NA	CONCRETE COMP. STRENGTH AND SLUMP TESTS
NA	POST INSTALLED ANCHOR ROD VERIFICATION
NA	BASE PLATE GROUT VERIFICATION
NA	CONTRACTOR'S CERTIFIED WELD INSPECTION
NA	EARTHWORK: PROVIDE PHOTO DOCUMENTATION OF EXCAVATION QUALITY AND COMPACTION
NA	ON SITE COLD GALVANIZING VERIFICATION
NA	GUY WIRE TENSION REPORT
X	GC AS-BUILT DOCUMENTS
NA	MICROPILE/ROCK ANCHOR INSTALLER'S DRILLING AND INSTALLATION LOGS AND QA/QC DOCUMENTS
ADDITIONAL TESTING AND INSPECTIONS: _____	
<b>POST-CONSTRUCTION</b>	
X	MI INSPECTOR REDLINE OR RECORD DRAWING(S)
NA	POST INSTALLED ANCHOR ROD TARGET TENSION LOAD TESTING
NA	REFER TO MICROPILE/ROCK ANCHOR NOTES FOR SPECIAL INSPECTION AND TESTING REQUIREMENTS.
X	PHOTOGRAPHS
ADDITIONAL TESTING AND INSPECTIONS: FACT TIA INSPECTION PER CROWN CASTLE DOC OPS-SOW-10127. INSTALL CONCEALMENT REINFORCING PER CROWN CASTLE DOC OPS-SOW-10127 AND OPS-PBC-10127.	

NOTE: X DENOTES A DOCUMENT NEEDED FOR THE PMI REPORT  
 NA DENOTES A DOCUMENT THAT IS NOT REQUIRED FOR THE PMI REPORT

© Copyright 2016, by Paul J. Ford and Company, All Rights Reserved. This document and the data contained herein, is proprietary to Paul J. Ford and Company, issued in strict confidence and shall not, without the prior written permission of Paul J. Ford and Company, be reproduced, copied or used for any purpose other than the intended use for this specific project.

**PAUL J. FORD & COMPANY**  
 250 E Broad St, Ste 600, Columbus, OH 43215  
 Phone 614.221.6679 www.pauljford.com

**CROWN CASTLE**  
 3 CORPORATE PARK DRIVE, SUITE 101, CLIFTON PARK, NY 12065  
 PH: (585) 370-4766

**MODIFICATION OF AN EXISTING  
 109'-0" MONOPOLE  
 BU #857144; REDDING WAYSIDE LANE  
 REDDING, CONNECTICUT**

PROJECT No:	37516-3037.002.7700
DRAWN BY:	B.M.S.
DESIGNED BY:	J.W.M.
CHECKED BY:	
DATE:	9-26-2016

MI CHECKLIST

T-2

**1. GENERAL NOTES**

- 1.1. THE MONOPOLE STRUCTURE IN ITS EXISTING CONDITION DOES NOT HAVE THE STRUCTURAL CAPACITY TO CARRY ALL OF THE PROPOSED AND EXISTING LOADS FROM THE ATTACHED STRUCTURAL MODIFICATION REPORT AT THE REQUIRED MINIMUM WIND SPEEDS. DO NOT INSTALL ANY NEW LOADS UNTIL THE MONOPOLE REINFORCING SYSTEM IS COMPLETELY AND SUCCESSFULLY INSTALLED.
- 1.2. THESE DRAWINGS WERE PREPARED FROM INFORMATION PROVIDED BY CROWN CASTLE. THE INFORMATION PROVIDED HAS NOT BEEN FIELD VERIFIED BY THE ENGINEER OF RECORD (EOR) FOR ACCURACY AND THEREFORE DISCREPANCIES BETWEEN THESE DRAWINGS AND ACTUAL SITE CONDITIONS SHOULD BE ANTICIPATED. PRIOR TO FABRICATION AND INSTALLATION CONTRACTOR SHALL VERIFY ALL LENGTHS AND QUANTITIES GIVEN. LENGTH AND QUANTITIES PROVIDED ARE FOR QUOTING PURPOSES ONLY AND SHALL NOT BE USED FOR FABRICATION. THE CONTRACTOR SHALL COORDINATE WITH THE PROJECT DRAWINGS AND THEIR FIELD VERIFIED CONDITIONS AND DIMENSIONS BEFORE PROCEEDING WITH THE WORK. THE CONTRACTOR SHALL IMMEDIATELY REPORT ANY AND ALL DISCREPANCIES TO THE EOR AND CROWN CASTLE BEFORE PROCEEDING WITH THE WORK. ANY WORK PERFORMED WITHOUT A PREFABRICATION MAPPING IS DONE AT THE RISK OF THE GENERAL CONTRACTOR AND/OR THE FABRICATOR
- 1.3. IF MATERIALS, QUANTITIES, STRENGTHS OR SIZES INDICATED BY THE DRAWINGS OR SPECIFICATIONS ARE NOT IN AGREEMENT WITH THESE NOTES, THE BETTER QUALITY AND/OR GREATER QUANTITY, STRENGTH OR SIZE INDICATED, SPECIFIED OR NOTED SHALL BE PROVIDED.
- 1.4. THIS STRUCTURE IS DESIGNED TO BE SELF-SUPPORTING AND STABLE AFTER THE INSTALLATION OF THE REINFORCING REPAIR SYSTEM HAS BEEN SUCCESSFULLY COMPLETED. IT IS THE CONTRACTOR'S SOLE RESPONSIBILITY TO ENSURE THE SAFETY AND STABILITY OF THE MONOPOLE AND ITS COMPONENT PARTS DURING FIELD MODIFICATIONS. THIS INCLUDES, BUT IS NOT LIMITED TO, THE ADDITION OF WHATEVER TEMPORARY BRACING, GUYS OR TIE DOWNS THAT MAY BE NECESSARY. SUCH MATERIAL SHALL BE REMOVED AND SHALL REMAIN THE PROPERTY OF THE CONTRACTOR AFTER THE COMPLETION OF THE PROJECT.
- 1.5. ALL CONSTRUCTION MEANS AND METHODS; INCLUDING BUT NOT LIMITED TO, ERECTION PLANS, RIGGING PLANS, CLIMBING PLANS AND RESCUE PLANS SHALL BE THE RESPONSIBILITY OF THE GENERAL CONTRACTOR RESPONSIBLE FOR THE EXECUTION OF THE WORK CONTAINED HEREIN AND SHALL MEET ANSITIA-1019 (LATEST EDITION), OSHA AND GENERAL INDUSTRY STANDARDS. ALL RIGGING PLANS SHALL ADHERE TO ANSITIA-1019 (LATEST EDITION) INCLUDING THE REQUIRED INVOLVEMENT OF A QUALIFIED ENGINEER FOR CLASS IV CONSTRUCTION.
- 1.6. OBSERVATION VISITS TO THE SITE BY CROWN CASTLE AND/OR THE EOR SHALL NOT INCLUDE INSPECTIONS OF THE PROTECTIVE MEASURES OR THE CONSTRUCTION PROCEDURES. ANY SUPPORT SERVICES PERFORMED BY THE EOR DURING CONSTRUCTION ARE SOLELY FOR THE PURPOSE OF ACHIEVING GENERAL CONFORMANCE WITH THE CONTRACT DOCUMENTS. THEY DO NOT GUARANTEE THE CONTRACTOR'S PERFORMANCE AND SHALL NOT BE CONSTRUED AS SUPERVISION OF CONSTRUCTION.
- 1.7. ALL MATERIALS AND EQUIPMENT FURNISHED SHALL BE NEW AND OF GOOD QUALITY, FREE FROM FAULTS AND DEFECTS AND IN CONFORMANCE WITH THE CONTRACT DOCUMENTS. ANY AND ALL SUBSTITUTIONS MUST BE PROPERLY APPROVED AND AUTHORIZED IN WRITING BY CROWN CASTLE AND EOR PRIOR TO INSTALLATION. THE CONTRACTOR SHALL FURNISH SATISFACTORY EVIDENCE AS TO THE KIND AND QUALITY OF MATERIALS AND EQUIPMENT BEING SUBSTITUTED.
- 1.8. THE CONTRACTOR SHALL BE RESPONSIBLE FOR INITIATING, MAINTAINING, AND SUPERVISING ALL SAFETY PRECAUTIONS AND PROGRAMS IN CONNECTION WITH THE WORK. THE CONTRACTOR IS RESPONSIBLE TO ENSURE THAT THIS PROJECT AND RELATED WORK COMPLIES WITH ALL APPLICABLE LOCAL, STATE, AND FEDERAL SAFETY CODES AND REGULATIONS GOVERNING THIS WORK AS WELL AS CROWN CASTLE SAFETY GUIDELINES.
- 1.9. THE CONTRACTOR SHALL BE RESPONSIBLE FOR PROTECTING ALL EXISTING AND NEW COAXIAL CABLES AND OTHER EQUIPMENT DURING CONSTRUCTION.
- 1.10. ANY EXISTING ATTACHMENTS AND/OR PROJECTIONS ON THE POLE THAT MAY INTERFERE WITH THE INSTALLATION OF THE REINFORCING SYSTEM WILL HAVE TO BE REMOVED AND RELOCATED, REPLACED, OR RE-INSTALLED AS REQUIRED AFTER THE REINFORCING IS SUCCESSFULLY COMPLETED. THE CONTRACTOR SHALL IDENTIFY AND COORDINATE THESE ITEMS PRIOR TO CONSTRUCTION WITH CROWN CASTLE, TESTING AGENCY, AND EOR.
- 1.11. ANY AND ALL EXISTING PLATFORMS THAT ARE LOCATED IN AREAS OF THE POLE SHAFT WHERE SHAFT REINFORCING MUST BE APPLIED SHALL BE TEMPORARILY REMOVED OR OTHERWISE SUPPORTED TO PERMIT NEW CONTINUOUS REINFORCEMENT TO BE ATTACHED. AFTER THE CONTRACTOR HAS SUCCESSFULLY INSTALLED THE MONOPOLE REINFORCEMENT SYSTEM, THE CONTRACTOR SHALL RE-INSTALL THE PLATFORMS.
- 1.12. THE CLIMBING FACILITIES, SAFETY CLIMB AND ALL PARTS THEREOF SHALL NOT BE IMPEDDED, MODIFIED OR ALTERED WITHOUT THE EXPRESS APPROVAL OF THE EOR.
- 1.13. FOR STANDARD CROWN PARTS SEE THE MOST RECENT VERSION OF THE "CCI APPROVED REINFORCEMENT COMPONENTS" CATALOG.
- 1.14. ALL SOLUTIONS FOR THE REPLACEMENT, RELOCATION OR MODIFICATION OF THE SAFETY CLIMB AND/OR ANY OF THE MONOPOLE CLIMBING FACILITIES SHALL BE COORDINATED WITH TUF-TUG PRODUCTS. CONTACT DETAILS:  
3434 ENCRETE LANE, MORAIN, OHIO 45439  
PHONE: 937-299-1213 EMAIL: TUFTUG@AOL.COM

**2. STRUCTURAL STEEL**

- 2.1. STRUCTURAL STEEL MATERIALS, FABRICATION, DETAILING, AND WORKMANSHIP SHALL CONFORM TO THE LATEST EDITION OF THE FOLLOWING REFERENCE STANDARDS:
  - 2.1.1. BY THE AMERICAN INSTITUTE OF STEEL CONSTRUCTION (AISC):
    - 2.1.1.1. "SPECIFICATION FOR STRUCTURAL STEEL BUILDINGS."
    - 2.1.1.2. "SPECIFICATION FOR STRUCTURAL JOINTS USING ASTM HIGH STRENGTH BOLTS," AS APPROVED BY THE RESEARCH COUNCIL ON STRUCTURAL CONNECTIONS.
    - 2.1.1.3. "CODE OF STANDARD PRACTICE FOR STEEL BUILDINGS AND BRIDGES"
  - 2.1.2. BY THE AMERICAN WELDING SOCIETY (AWS):
    - 2.1.2.1. "STRUCTURAL WELDING CODE – STEEL D1.1."
    - 2.1.2.2. "STANDARD SYMBOLS FOR WELDING, BRAZING, AND NONDESTRUCTIVE EXAMINATION"
- 2.2. ALL STRUCTURAL BOLTS SHALL BE INSTALLED AND TIGHTENED TO THE PRETENSIONED CONDITION ACCORDING TO THE REQUIREMENTS OF THE AISC 'SPECIFICATION FOR STRUCTURAL JOINTS USING ASTM HIGH STRENGTH BOLTS', DEC. 31, 2009.
- 2.3. ANY MATERIAL OR WORKMANSHIP WHICH IS OBSERVED TO BE DEFECTIVE OR INCONSISTENT WITH THE CONTRACT DOCUMENTS SHALL BE CORRECTED, MODIFIED, OR REPLACED AT THE CONTRACTOR'S EXPENSE.
- 2.4. WELDED CONNECTIONS SHALL CONFORM TO THE LATEST REVISED CODE OF THE AMERICAN WELDING SOCIETY, AWS D1.1. ALL WELD ELECTRODES SHALL BE E80XX UNLESS NOTED OTHERWISE ON THE DRAWINGS.
- 2.5. ALL WELDED CONNECTIONS SHALL BE MADE BY WELDERS CERTIFIED BY AWS. CONTRACTOR SHALL SUBMIT WELDERS' CERTIFICATION AND QUALIFICATION DOCUMENTATION TO CROWN CASTLE'S TESTING AGENCY FOR REVIEW AND APPROVAL PRIOR TO CONSTRUCTION.
- 2.6. STRUCTURAL STEEL PLATES SHALL CONFORM TO ASTM A572 GRADE 65(FY = 65 KSI MIN.) UNLESS NOTED OTHERWISE ON THE DRAWINGS.
- 2.7. SURFACES OF EXISTING STEEL SHALL BE PREPARED AS REQUIRED FOR FIELD WELDING PER AWS. SEE SECTION I NOTES REGARDING TOUCH UP OF GALVANIZED SURFACES DAMAGED DURING TRANSPORTATION OR ERECTION AND ASSEMBLY AS WELL AS FIELD WELDING.
- 2.8. NO WELDING SHALL BE DONE TO THE EXISTING STRUCTURE WITHOUT THE PRIOR APPROVAL AND SUPERVISION OF THE TESTING AGENCY.
- 2.9. FIELD CUTTING OF STEEL:
  - 2.9.1. IMPORTANT CUTTING AND WELDING SAFETY GUIDELINES: THE CONTRACTOR SHALL FOLLOW ALL CROWN CASTLE CUTTING, WELDING, FIRE PREVENTION AND SAFETY GUIDELINES. PRIOR TO CONSTRUCTION, THE CONTRACTOR SHALL OBTAIN A COPY OF THE CURRENT CROWN CASTLE GUIDELINES. PER THE 12-01-2005 CROWN CASTLE DIRECTIVE: "ALL CUTTING AND WELDING ACTIVITIES SHALL BE CONDUCTED IN ACCORDANCE WITH CROWN CASTLE POLICY 'CUTTING AND WELDING SAFETY PLAN' (DOC # ENG-PLN-10015) ON AN ONGOING BASIS THROUGHOUT THE ENTIRE LIFE OF THE PROJECT". ANY DAMAGE TO THE COAX CABLES, AND/OR OTHER EQUIPMENT AND/OR THE STRUCTURE, RESULTING FROM THE CONTRACTOR'S ACTIVITIES SHALL BE REPAIRED AT THE CONTRACTOR'S EXPENSE. THE INSPECTION/TESTING AGENCY SHALL CLOSELY AND CONTINUOUSLY MONITOR THIS ACTIVITY.
  - 2.9.2. ALL REQUIRED CUTS SHALL BE CUT WITHIN THE DIMENSIONS SHOWN ON THE DRAWINGS. NO CUTS SHALL EXTEND BEYOND THE OUTLINE OF THE DIMENSIONS SHOWN ON THE DRAWINGS. ALL CUT EDGES SHALL BE GROUND SMOOTH AND DE-BURRED. CUT EDGES THAT ARE TO BE FIELD WELDED SHALL BE PREPARED FOR FIELD WELDING PER AWS D1.1 AND AS SHOWN ON THE DRAWINGS. CONTRACTOR TO AVOID 90 DEGREE CORNERS. IT MAY BE NECESSARY TO DRILL STARTER HOLES AS REQUIRED TO MAKE THE CUTS.

**3. BASE PLATE GROUT - (NOT REQUIRED)**

**4. FOUNDATION WORK - (NOT REQUIRED)**

**5. CAST-IN-PLACE CONCRETE - (NOT REQUIRED)**

**6. EPOXY GROUTED REINFORCING ANCHOR RODS - (NOT REQUIRED)**

**7. TOUCH UP OF GALVANIZING**

- 7.1. THE CONTRACTOR SHALL TOUCH UP ANY AND ALL AREAS OF GALVANIZING ON THE EXISTING STRUCTURE OR NEW COMPONENTS THAT ARE DAMAGED OR ABRADED DURING CONSTRUCTION. GALVANIZED SURFACES DAMAGED DURING TRANSPORTATION OR ERECTION AND ASSEMBLY AS WELL AS ANY AND ALL ABRASIONS, CUTS, FIELD DRILLING, AND ALL FIELD WELDING SHALL BE TOUCHED UP WITH TWO (2) COATS OF ZRC COLD GALVANIZING COMPOUND. FILM THICKNESS PER COAT SHALL BE: WET 3.0 MILS; DRY 1.5 MILS. APPLY PER ZRC (MANUFACTURER) RECOMMENDED PROCEDURES. CONTACT ZRC AT 1-800-831-3275 FOR PRODUCT INFORMATION.
- 7.2. CONTRACTOR SHALL CLEAN AND PREPARE ALL FIELD WELDS ON GALVANIZED AND PRIME PAINTED SURFACES FOR TOUCH-UP COATING IN ACCORDANCE WITH AWS D1.1. CROWN CASTLE'S TESTING AGENCY SHALL VERIFY THE PREPARED SURFACE PRIOR TO APPLICATION OF THE TOUCH-UP COATING.
- 7.3. CROWN CASTLE'S TESTING AGENCY SHALL TEST AND VERIFY THE COATING THICKNESS AFTER THE CONTRACTOR HAS APPLIED THE ZRC COLD GALVANIZING COMPOUND AND IT HAS SUFFICIENTLY DRIED. AREAS FOUND TO BE ADEQUATELY COATED, SHALL BE RE-COATED BY THE CONTRACTOR AND RE-TESTED BY THE TESTING AGENCY.

**8. HOT-DIP GALVANIZING**

- 8.1. HOT-DIP GALVANIZE ALL STRUCTURAL STEEL MEMBERS AND ALL STEEL ACCESSORIES, BOLTS, WASHERS, ETC. PER ASTM A123 OR PER ASTM A153, AS APPROPRIATE.
- 8.2. PROPERLY PREPARE STEEL ITEMS FOR GALVANIZING. DRILL OR PUNCH WEEP AND/OR DRAINAGE HOLES WITH EOR APPROVAL OF LOCATIONS.
- 8.3. ALL GALVANIZING SHALL BE DONE AFTER FABRICATION IS COMPLETED AND PRIOR TO FIELD INSTALLATION.

**9. PERPETUAL INSPECTION AND MAINTENANCE BY THE OWNER**

- 9.1. AFTER THE CONTRACTOR HAS SUCCESSFULLY COMPLETED THE INSTALLATION OF THE MONOPOLE REINFORCING SYSTEM AND THE WORK HAS BEEN ACCEPTED BY CROWN CASTLE, CROWN CASTLE WILL BE RESPONSIBLE FOR THE LONG TERM AND PERPETUAL INSPECTION AND MAINTENANCE OF THE POLE AND REINFORCING SYSTEM.
- 9.2. ANY FIELD WELDED CONNECTIONS ARE SUBJECT TO CORROSION DAMAGE AND DETERIORATION IF THEY ARE NOT PROPERLY MAINTAINED AND COVERED WITH CORROSION PREVENTIVE COATING SUCH AS THE ZRC GALVANIZING COMPOUND SPECIFIED PREVIOUSLY. THE STRUCTURAL LOAD CARRYING CAPACITY OF THE REINFORCED POLE SYSTEM IS DEPENDENT UPON THE INSTALLED SIZE AND QUALITY, MAINTAINED SOUND CONDITION AND STRENGTH OF THESE FIELD WELDED CONNECTIONS. ANY CORROSION OF, DAMAGE TO, FATIGUE, FRACTURE, AND/OR DETERIORATION OF THESE WELDS AND/OR THE EXISTING GALVANIZED STEEL POLE STRUCTURE AND THE WELDED COMPONENTS WILL RESULT IN THE LOSS OF STRUCTURAL LOAD CARRYING CAPACITY AND MAY LEAD TO FAILURE OF THE STRUCTURAL SYSTEM. THEREFORE, IT IS IMPERATIVE THAT CROWN CASTLE REGULARLY INSPECTS, MAINTAINS, AND REPAIRS AS NECESSARY, ALL OF THESE WELDS, CONNECTIONS, AND COMPONENTS FOR THE LIFE OF THE STRUCTURE.
- 9.3. CROWN CASTLE SHALL REFER TO ANSITIA-222-G-2-2009, SECTION 14 AND ANNEX J FOR RECOMMENDATIONS FOR MAINTENANCE AND INSPECTION. THE FREQUENCY OF THE INSPECTION AND MAINTENANCE INTERVALS IS TO BE DETERMINED BY CROWN CASTLE BASED UPON ACTUAL SITE AND ENVIRONMENTAL CONDITIONS. THE EOR RECOMMENDS THAT A COMPLETE AND THOROUGH INSPECTION OF THE ENTIRE REINFORCED MONOPOLE STRUCTURAL SYSTEM BE PERFORMED YEARLY AND/OR AS FREQUENTLY AS CONDITIONS WARRANT. ACCORDING TO ANSITIA-222-G-2-2009 SECTION 14.2: "IT IS RECOMMENDED THAT THE STRUCTURE BE INSPECTED AFTER SEVERE WIND AND/OR ICE STORMS OR OTHER EXTREME LOADING CONDITIONS".

**10. FIELD NDE MINIMUM REQUIREMENTS**

- 10.1. ALL NDE SHALL BE IN ACCORDANCE WITH AWS D1.1.
- 10.2. FOR NEW BASE STIFFENERS (INCLUSIVE OF TRANSITION STIFFENERS) AND ANCHOR ROD BRACKETS, COMPLETE JOINT PENETRATION WELDS SHALL BE 100% INSPECTED BY UT. ALL PARTIAL JOINT PENETRATION AND FILLET WELDS SHALL BE 100% INSPECTED BY MT.
- 10.3. FOR NEW FLAT PLATE REINFORCEMENT AT THE BASE OF THE TOWER, COMPLETE JOINT PENETRATION WELDS SHALL BE 100% INSPECTED BY UT. ALL PARTIAL JOINT PENETRATION AND FILLET WELDS SHALL BE 100% INSPECTED BY MT, BUT MAY BE LIMITED TO A HEIGHT OF 10'-0".
- 10.4. FOR NDE OF THE EXISTING BASE PLATE CIRCUMFERENTIAL WELD, GC SHALL REFERENCE THE MI CHECKLIST FOR APPLICABILITY. PLEASE SEE ENG-SOW-10033: TOWER BASE PLATE NDE, AND ENG-BUL-10051: NDE REQUIREMENTS FOR MONOPOLE BASE PLATE TO PREVENT CONNECTION FAILURE. NOTIFY THE EOR AND CROWN ENGINEERING IMMEDIATELY IF ANY CRACKS ARE SUSPECTED OR HAVE BEEN IDENTIFIED. THE NDE SHALL INCLUDE ALL EXISTING MODIFICATIONS THAT HAVE BEEN WELDED TO THE BASE PLATE.
- 10.5. ALL TESTING LIMITATIONS SHALL BE DETAILED IN THE NDE REPORT.

© Copyright 2016, by Paul J. Ford and Company, All Rights Reserved. This document and the data contained herein, is proprietary to Paul J. Ford and Company, issued in strict confidence and shall not, without the prior written permission of Paul J. Ford and Company, be reproduced, copied or used for any purpose other than the intended use for this specific project.

**PAUL J. FORD & COMPANY**  
250 E Broad St, Ste 600, Columbus, OH 43215  
Phone 614.221.6679 www.pauljford.com

**CROWN CASTLE**  
3 CORPORATE PARK DRIVE, SUITE 101, CLIFTON PARK, NY 12065  
PH: (585) 370-4766

**MODIFICATION OF AN EXISTING  
109'-0" MONOPOLE  
BU #857144; REDDING WAYSIDE LANE  
REDDING, CONNECTICUT**

PROJECT No:	37516-3037.002.7700
DRAWN BY:	B.M.S.
DESIGNED BY:	J.W.M.
CHECKED BY:	
DATE:	9-26-2016

**GENERAL NOTES**

**S-1**

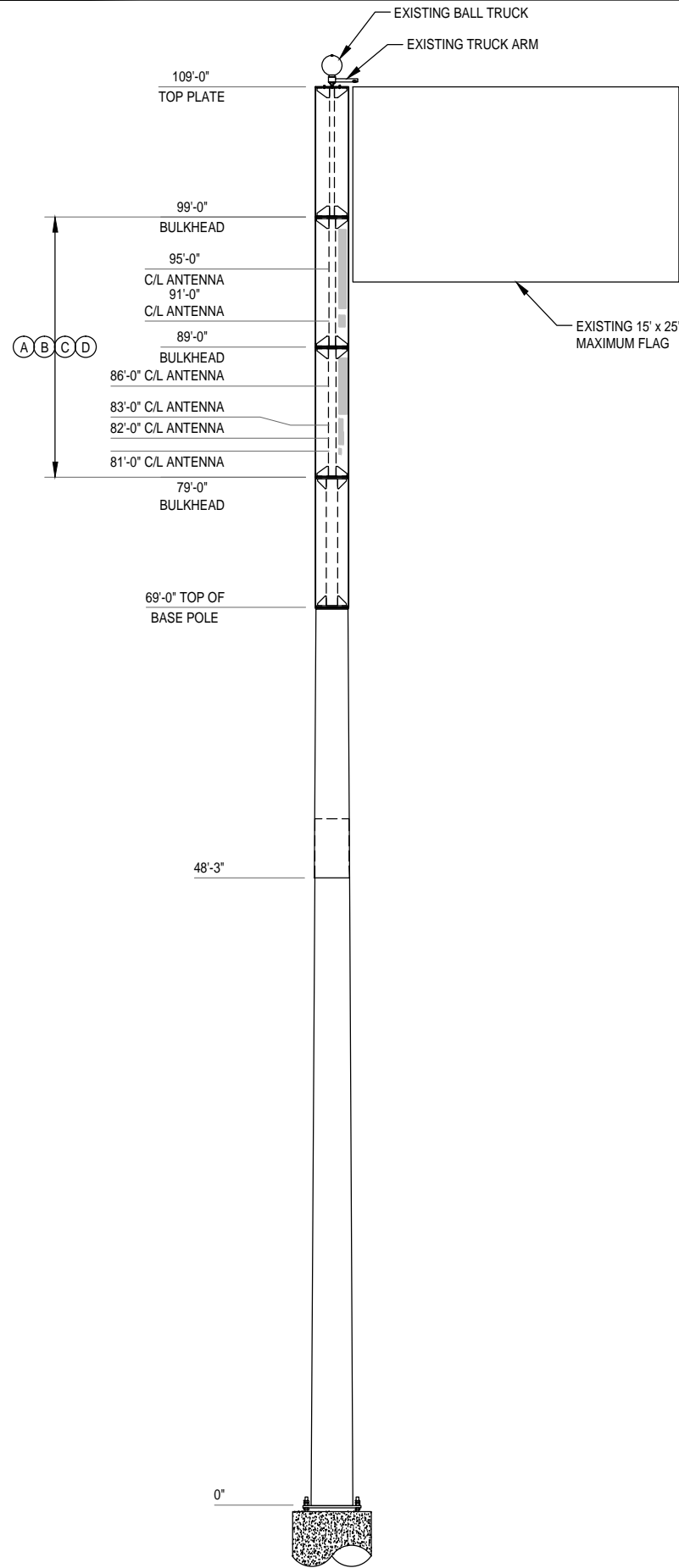

POLE ELEVATION 1  
S-2

SHAFT SECTION DATA							
SHAFT SECTION	SECTION LENGTH (FT)	PLATE THICKNESS (IN)	LAP SPLICE (IN)	DIAMETER ACROSS FLATS (IN)		POLE GRADE (ksi)	POLE SHAPE
				@ TOP	@ BOTTOM		
1	10.00	SOLID		4.500	4.500	50	ROUND
2	10.00	SOLID		6.000	6.000	50	ROUND
3	10.00	SOLID		7.000	7.000	50	ROUND
4	10.00	1.0000		10.750	10.750	35	ROUND
5	20.79	0.1875	55.00	29.500	32.360	65	18-SIDED
6	52.79	0.2500		31.355	38.500	65	18-SIDED

NOTE: DIMENSIONS SHOWN DO NOT INCLUDE GALVANIZING TOLERANCES

TOWER MODIFICATION SCHEDULE			
	ELEVATION	TOWER MODIFICATION DESCRIPTION	REFERENCE SHEETS
(A)	69' TO 109'	REMOVE EXISTING CONCEALMENT SHROUDS	S-2
(B)	69' TO 109'	INSTALL NEW CONCEALMENT SHROUDS	S-3
(C)	69' TO 109'	PAINT MODIFICATIONS TO MATCH EXISTING POLE	S-2
(D)	69' TO 109'	INSTALL CONCEALMENT REINFORCING SOLUTION PER CROWN CASTLE DOC OPS-PRC-10127	S-2

- EXISTING CONCEALMENT SHROUDS TO BE REMOVED AND REPLACED WITH THE NEW CONCEALMENT SHROUDS.
- CONTRACTOR SHALL SEND PAUL J. FORD & COMPANY THE FABRICATION DRAWINGS FOR APPROVAL PRIOR TO MANUFACTURING.

© Copyright 2016, by Paul J. Ford and Company, All Rights Reserved. This document and the data contained herein, is proprietary to Paul J. Ford and Company, issued in strict confidence and shall not, without the prior written permission of Paul J. Ford and Company, be reproduced, copied or used for any purpose other than the intended use for this specific project.

**PJF PAUL J. FORD & COMPANY**  
 250 E Broad St, Ste 600, Columbus, OH 43215  
 Phone 614.221.6679 www.pauljford.com

**CROWN CASTLE**  
 3 CORPORATE PARK DRIVE, SUITE 101, CLIFTON PARK, NY 12065  
 PH: (585) 370-4766

MODIFICATION OF AN EXISTING  
 109'-0" MONOPOLE  
 BU #857144; REDDING WAYSIDE LANE  
 REDDING, CONNECTICUT

PROJECT No: 37516-3037.002.7700  
 DRAWN BY: B.M.S.  
 DESIGNED BY: J.W.M.  
 CHECKED BY:  
 DATE: 9-26-2016

MONOPOLE  
 PROFILE

S-2

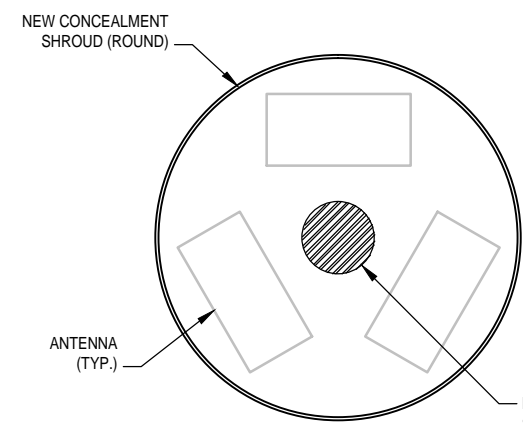
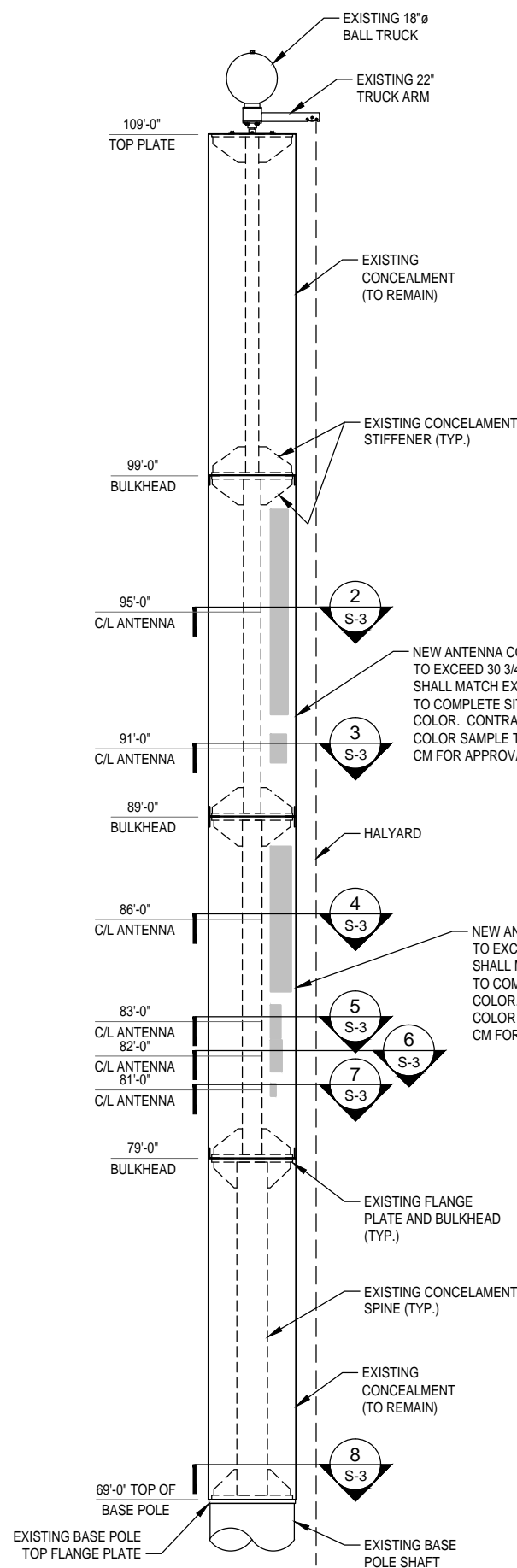

**SECTION 2**  
(PROPOSED ANTENNA FIT)  
S-3

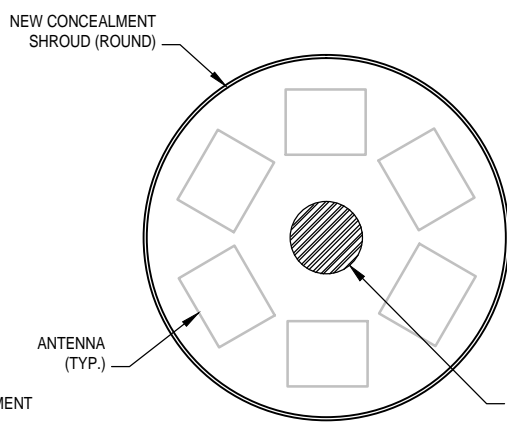

**SECTION 3**  
(PROPOSED ANTENNA FIT)  
S-3

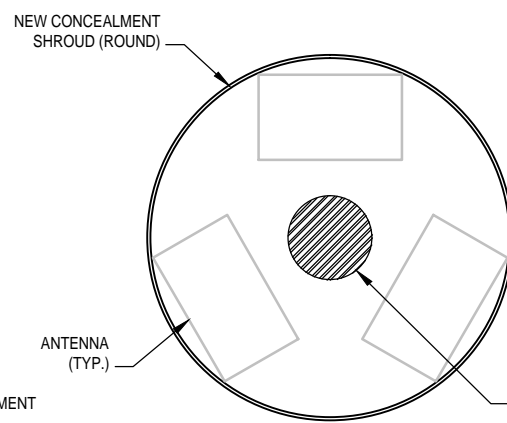

**SECTION 4**  
(PROPOSED ANTENNA FIT)  
S-3

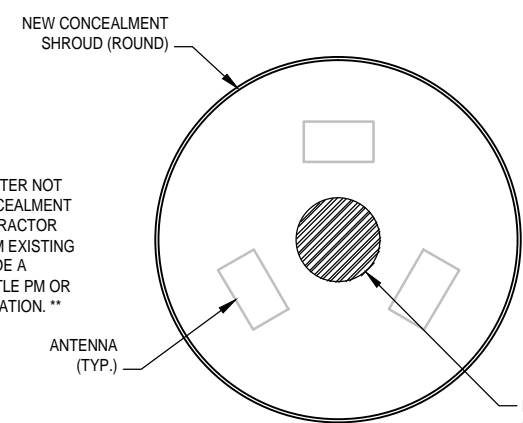

**SECTION 5**  
(PROPOSED ANTENNA FIT)  
S-3

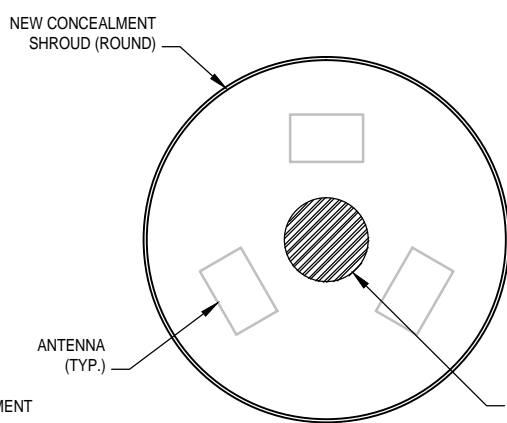

**SECTION 6**  
(PROPOSED ANTENNA FIT)  
S-3

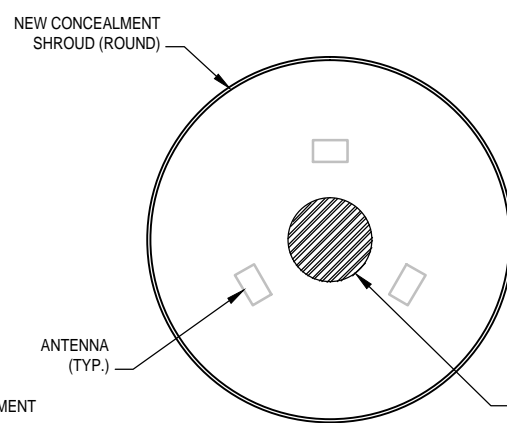

**SECTION 7**  
(PROPOSED ANTENNA FIT)  
S-3

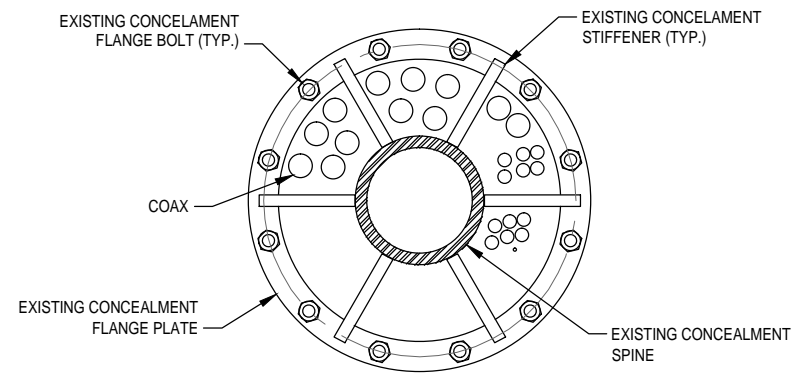

**SECTION 8**  
S-3

NEW ANTENNA CONCEALMENT DIAMETER NOT TO EXCEED 30 3/4". COLOR OF CONCEALMENT SHALL MATCH EXISTING POLE. CONTRACTOR TO COMPLETE SITE VISIT TO CONFIRM EXISTING COLOR. CONTRACTOR SHALL PROVIDE A COLOR SAMPLE TO THE CROWN CASTLE PM OR CM FOR APPROVAL PRIOR TO FABRICATION. \*\*

NEW ANTENNA CONCEALMENT DIAMETER NOT TO EXCEED 30 3/4". COLOR OF CONCEALMENT SHALL MATCH EXISTING POLE. CONTRACTOR TO COMPLETE SITE VISIT TO CONFIRM EXISTING COLOR. CONTRACTOR SHALL PROVIDE A COLOR SAMPLE TO THE CROWN CASTLE PM OR CM FOR APPROVAL PRIOR TO FABRICATION. \*\*

\*\* CONTRACTOR SHALL FIELD VERIFY SIZE OF EXISTING BULKHEADS AND CONCEALMENT ATTACHMENT DETAILS PRIOR TO FABRICATING 30 3/4"Ø CONCEALMENT

Antenna Model	QUANTITY	Antenna Centerline Elevation, ft	Height, in	Depth, in	Width, in
P65-16-XLH-RR	3	95	72	6	12
TTAW-07BP111-001	6	91	9.9	5.4	6.7
DBXNH-6565A-A2M	3	86	50.9	7.1	11.9
ATBT-BOTTOM-24V	3	81	4.3	1.8	2.9
KRY 112 489/2	3	82	11	3.94	6.1
KRF 102 267/1	3	83	11.46	3.39	5.75

Coax Model	QUANTITY	Elevation, ft	Nominal Diameter, in	Actual Diameter, in
7085.05	1	104	5/16	0.315
LDF7-50A	6	104	1 5/8	1.98
LDF7-50A	6	94	1 5/8	1.98
AVA5-50	12	84	7/8	1.09

NOTE: COAX LAYOUT AND FIT IS THEORETICAL. ACTUAL LAYOUT AND FIT MAY VARY PENDING EXISTING CONDITIONS.

NOTE: ALL ANTENNA DIMENSIONS HAVE BEEN PROVIDED BY CROWN CASTLE. A 3" SPACING BETWEEN THE SPINE AND ANTENNA HAS BEEN ASSUMED.

**PARTIAL ELEVATION 1**  
S-3

© Copyright 2016, by Paul J. Ford and Company, All Rights Reserved. This document and the data contained herein, is proprietary to Paul J. Ford and Company, issued in strict confidence and shall not, without the prior written permission of Paul J. Ford and Company, be reproduced, copied or used for any purpose other than the intended use for this specific project.

**PAUL J. FORD & COMPANY**  
250 E Broad St, Ste 600 Columbus, OH 43215  
Phone 614.221.6679 www.pauljford.com

**CROWN CASTLE**  
3 CORPORATE PARK DRIVE, SUITE 101, CLIFTON PARK, NY 12065  
PH: (585) 370-4766

**MODIFICATION OF AN EXISTING 109'-0" MONOPOLE**  
BU #857144; REDDING WAYSIDE LANE  
REDDING, CONNECTICUT

PROJECT No: 37516-3037.002.7700  
DRAWN BY: B.M.S.  
DESIGNED BY: J.W.M.  
CHECKED BY:  
DATE: 9-26-2016

**CONCEALMENT ELEVATION DETAILS**

**S-3**

# MODIFICATION OF AN EXISTING 109'-0" MONOPOLE TOWER MAPPING CCI DOC ID #5171985 BU #857144; REDDING WAYSIDE LANE

22 WAYSIDE LANE  
REDDING, CONNECTICUT 06896  
FAIRFIELD COUNTY  
LAT: 41° 16' 56.3"; LONG: -73° 24' 26.9"  
APP: 345878 REV. 14; WO: 1301248

## PROJECT CONTACTS

**STRUCTURE OWNER:**  
CROWN CASTLE  
MOD PM: DAN VADNEY AT DAN.VADNEY@CROWNCastle.COM  
PH: (518) 373-3510  
MOD CM: JASON D'AMICO AT JASON.D'AMICO@CROWNCastle.COM  
PH: (860) 209-0104

**ENGINEER OF RECORD:**  
PJFMOD@PJFWEB.COM

## THIS PROJECT INCLUDES THE FOLLOWING ITEMS

INSTALLATION OF NEW CONCEALMENT SHROUDS  
PAINT MODIFICATIONS TO MATCH EXISTING POLE  
INSTALL CONCEALMENT REINFORCING SOLUTIONS PER CROWN CASTLE  
DOC OPS-PRC-10127 AND OPS-SOW-10127

## SHEET INDEX

SHEET NUMBER	DESCRIPTION
T-1	TITLE SHEET
T-2	MI CHECKLIST
S-1	GENERAL NOTES
S-2	MONOPOLE PROFILE
S-3	CONCEALMENT ELEVATION DETAILS

## WIND DESIGN DATA

REFERENCE STANDARD	ANSI/TIA-222-G-2-2009
LOCAL CODE	2016 CONNECTICUT BUILDING CODE
ULTIMATE WIND SPEED (3-SECOND GUST)	120 MPH
CONVERTED NOMINAL WIND SPEED (3-SECOND GUST)	93 MPH
ICE THICKNESS	0.75 IN
ICE WIND SPEED	50 MPH
SERVICE WIND SPEED	60 MPH
RISK CATEGORY	II
EXPOSURE CATEGORY	C
Kzt	1.0

QUALIFIED ENGINEERING SERVICES ARE AVAILABLE FROM PAUL J. FORD & COMPANY TO ASSIST CONTRACTORS IN CLASS IV RIGGING PLAN REVIEWS. FOR REQUESTED QUALIFIED ENGINEERING SERVICES, PLEASE CONTACT RIGGING@PJFWEB.COM.

THE ASSOCIATED FAILING SA WO NUMBER FOR THIS PROJECT IS 1295471

ATTENTION ALL CONTRACTORS, ANYTIME YOU ACCESS A CROWN SITE FOR ANY REASON YOU ARE TO CALL THE CROWN NOC UPON ARRIVAL AND DEPARTURE, DAILY AT (800) 788-7011.

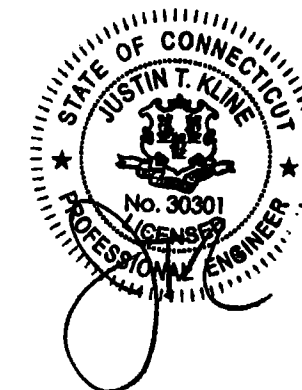

SEP 28 2016

© Copyright 2016, by Paul J. Ford and Company. All Rights Reserved. This document and the data contained herein, is proprietary to Paul J. Ford and Company, issued in strict confidence and shall not, without the prior written permission of Paul J. Ford and Company, be reproduced, copied or used for any purpose other than the intended use for this specific project.

**PJF PAUL J. FORD & COMPANY**  
250 E Broad St, Ste 600, Columbus, OH 43215  
Phone 614.221.6679 www.pauljford.com

**CROWN CASTLE**  
3 CORPORATE PARK DRIVE, SUITE 101, CLIFTON PARK, NY 12065  
PH: (860) 370-4766

MODIFICATION OF AN EXISTING  
109'-0" MONOPOLE  
BU #857144; REDDING WAYSIDE LANE  
REDDING, CONNECTICUT

PROJECT No: 37516-3037.002.7700  
DRAWN BY: B.M.S.  
DESIGNED BY: J.W.M.  
CHECKED BY: J.W.M.  
DATE: 9-26-2016

TITLE SHEET

T-1



**MODIFICATION INSPECTION NOTES:**

**1. GENERAL**

- 1.1. THE MODIFICATION INSPECTION (MI) IS A VISUAL INSPECTION OF TOWER MODIFICATIONS AND A REVIEW OF CONSTRUCTION INSPECTIONS AND OTHER REPORTS TO ENSURE THE INSTALLATION WAS CONSTRUCTED IN ACCORDANCE WITH THE CONTRACT DOCUMENTS, NAMELY THE MODIFICATION DRAWINGS, AS DESIGNED BY THE EOR. THE MI IS TO CONFIRM INSTALLATION CONFIGURATION AND WORKMANSHIP ONLY AND IS NOT A REVIEW OF THE MODIFICATION DESIGN ITSELF, NOR DOES THE MI INSPECTOR TAKE OWNERSHIP OF THE MODIFICATION DESIGN. OWNERSHIP OF THE STRUCTURAL MODIFICATION DESIGN EFFECTIVENESS AND INTEGRITY RESIDES WITH THE EOR AT ALL TIMES.
- 1.3. ALL MIs SHALL BE CONDUCTED BY A CROWN CASTLE ENGINEERING VENDOR (AEV) OR ENGINEERING SERVICE VENDOR (AESV) THAT IS APPROVED TO PERFORM ELEVATED WORK FOR CROWN CASTLE.
- 1.4. TO ENSURE THAT THE REQUIREMENTS OF THE MI ARE MET, IT IS VITAL THAT THE GENERAL CONTRACTOR (GC) AND THE MI INSPECTOR BEGIN COMMUNICATING AND COORDINATING AS SOON AS A PO IS RECEIVED. IT IS EXPECTED THAT EACH PARTY WILL BE PROACTIVE IN REACHING OUT TO THE OTHER PARTY. IF CONTACT INFORMATION IS NOT KNOWN, CONTACT YOUR CROWN CASTLE POINT OF CONTACT (POC). REFER TO ENG-SOW-10007: MODIFICATION INSPECTION SOW FOR FURTHER DETAILS AND REQUIREMENTS.

**2. MI INSPECTOR**

- 2.1. THE MI INSPECTOR IS REQUIRED TO CONTACT THE GC AS SOON AS RECEIVING A PO FOR THE MI TO, AT A MINIMUM:
  - 2.1.1. REVIEW THE REQUIREMENTS OF THE MI CHECKLIST.
  - 2.1.2. WORK WITH THE GC TO DEVELOP A SCHEDULE TO CONDUCT ON-SITE INSPECTIONS, INCLUDING FOUNDATION INSPECTIONS.
  - 2.1.3. THE MI INSPECTOR IS RESPONSIBLE FOR COLLECTING ALL GC INSPECTION AND TEST REPORTS, REVIEWING THE DOCUMENTS FOR ADHERENCE TO THE CONTRACT DOCUMENTS, CONDUCTING THE IN-FIELD INSPECTIONS, AND SUBMITTING THE MI REPORT TO CROWN CASTLE.

**3. GENERAL CONTRACTOR**

- 3.1. THE GC IS REQUIRED TO CONTACT THE MI INSPECTOR AS SOON AS RECEIVING A PO FOR THE MODIFICATION INSTALLATION OR TURNKEY PROJECT TO, AT A MINIMUM:
  - 3.1.1. REVIEW THE REQUIREMENTS OF THE MI CHECKLIST.
  - 3.1.2. WORK WITH THE MI INSPECTOR TO DEVELOP A SCHEDULE TO CONDUCT ON-SITE INSPECTIONS, INCLUDING FOUNDATION INSPECTIONS.
  - 3.1.3. BETTER UNDERSTAND ALL INSPECTION AND TESTING REQUIREMENTS.
  - 3.1.4. THE GC SHALL PERFORM AND RECORD THE TEST AND INSPECTION RESULTS IN ACCORDANCE WITH THE REQUIREMENTS OF THE MI CHECKLIST AND ENG-SOW-10007.

**4. RECOMMENDATIONS**

- 4.1. THE FOLLOWING RECOMMENDATIONS AND SUGGESTIONS ARE OFFERED TO ENHANCE THE EFFICIENCY AND EFFECTIVENESS OF DELIVERING AN MI REPORT:
  - 4.1.1. IT IS SUGGESTED THAT THE GC PROVIDE A MINIMUM OF 5 BUSINESS DAYS NOTICE, PREFERABLE 10, TO THE MI INSPECTOR AS TO WHEN THE SITE WILL BE READY FOR THE MI TO BE CONDUCTED.
  - 4.1.2. THE GC AND MI INSPECTOR COORDINATE CLOSELY THROUGHOUT THE ENTIRE PROJECT.
  - 4.1.3. WHEN POSSIBLE, IT IS PREFERRED TO HAVE THE GC AND MI INSPECTOR ON-SITE SIMULTANEOUSLY FOR ANY GUY WIRE TENSIONING OR RE-TENSIONING OPERATIONS.
  - 4.1.4. IT MAY BE BENEFICIAL TO INSTALL ALL TOWER MODIFICATIONS PRIOR TO CONDUCTING THE FOUNDATION INSPECTIONS TO ALLOW FOUNDATION AND MI INSPECTION(S) TO COMMENCE WITH ONE SITE VISIT.
  - 4.1.5. WHEN POSSIBLE, IT IS PREFERRED TO HAVE THE GC AND MI INSPECTOR ON-SITE DURING THE MI TO HAVE ANY DEFICIENCIES CORRECTED DURING THE INITIAL MI. THEREFORE, THE GC MAY CHOOSE TO COORDINATE THE MI CAREFULLY TO ENSURE ALL CONSTRUCTION FACILITIES ARE AT THEIR DISPOSAL WHEN THE MI INSPECTOR IS ON SITE.

**5. CANCELLATION OR DELAYS IN SCHEDULED MI**

- 5.1. IF THE GC AND MI INSPECTOR AGREE TO A DATE ON WHICH THE MI WILL BE CONDUCTED, AND EITHER PARTY CANCELS OR DELAYS, CROWN CASTLE SHALL NOT BE RESPONSIBLE FOR ANY COSTS, FEES, LOSS OF DEPOSITS AND/OR OTHER PENALTIES RELATED TO THE CANCELLATION OR DELAY INCURRED BY EITHER PARTY FOR ANY TIME (E.G. TRAVEL AND LODGING, COSTS OF KEEPING EQUIPMENT ON-SITE, ETC.). IF CROWN CASTLE CONTRACTS DIRECTLY FOR A THIRD PARTY MI, EXCEPTIONS MAY BE MADE IN THE EVENT THAT THE DELAY/CANCELLATION IS CAUSED BY WEATHER OR OTHER CONDITIONS THAT MAY COMPROMISE THE SAFETY OF THE PARTIES INVOLVED.

**6. CORRECTION OF FAILING MIs**

- 6.1. IF THE MODIFICATION INSTALLATION WOULD FAIL THE MI ("FAILED MI"), THE GC SHALL WORK WITH CROWN CASTLE TO COORDINATE A REMEDIATION PLAN IN ONE OF TWO WAYS:
  - 6.1.1. CORRECT FAILING ISSUES TO COMPLY WITH THE SPECIFICATIONS CONTAINED IN THE ORIGINAL CONTRACT DOCUMENTS AND COORDINATE A SUPPLEMENT MI.
  - 6.1.2. OR, WITH CROWN CASTLE'S APPROVAL, THE GC MAY WORK WITH THE EOR TO RE-ANALYZE THE MODIFICATION/REINFORCEMENT USING THE AS-BUILT CONDITION.

**7. MI VERIFICATION INSPECTIONS**

- 7.1. CROWN CASTLE RESERVES THE RIGHT TO CONDUCT A MI VERIFICATION INSPECTION TO VERIFY THE ACCURACY AND COMPLETENESS OF PREVIOUSLY COMPLETED MI INSPECTION(S) ON TOWER MODIFICATION PROJECTS.
- 7.2. ALL VERIFICATION INSPECTIONS SHALL BE HELD TO THE SAME SPECIFICATIONS AND REQUIREMENTS IN THE CONTRACT DOCUMENTS AND IN ACCORDANCE WITH ENG-SOW-10007.
- 7.3. VERIFICATION INSPECTION MAY BE CONDUCTED BY AN INDEPENDENT AEA/AESV FIRM AFTER A MODIFICATION PROJECT IS COMPLETED, AS MARKED BY THE DATE OF AN ACCEPTED "PASSING MI" OR "PASS AS NOTED MI" REPORT FOR THE ORIGINAL PROJECT.

**8. PHOTOGRAPHS**

- 8.1. BETWEEN THE GC AND THE MI INSPECTOR THE FOLLOWING PHOTOGRAPHS, AT A MINIMUM, ARE TO BE TAKEN AND INCLUDED IN THE MI REPORT:
  - 8.1.1. PRECONSTRUCTION GENERAL SITE CONDITION
  - 8.1.2. PHOTOGRAPHS DURING THE REINFORCEMENT MODIFICATION CONSTRUCTION/ERECTION AND INSPECTION
  - 8.1.3. RAW MATERIALS
  - 8.1.4. PHOTOS OF ALL CRITICAL DETAILS
  - 8.1.5. FOUNDATION MODIFICATIONS
  - 8.1.6. WELD PREPARATION
  - 8.1.7. BOLT INSTALLATION AND TORQUE
  - 8.1.8. FINAL INSTALLED CONDITION
  - 8.1.9. SURFACE COATING REPAIR
  - 8.1.10. POST CONSTRUCTION PHOTOGRAPHS
  - 8.1.11. FINAL INFIELD CONDITION
  - 8.1.12. PHOTOS OF ELEVATED MODIFICATIONS TAKEN FROM THE GROUND SHALL BE CONSIDERED INADEQUATE.
  - 8.1.13. THIS IS NOT A COMPLETE LIST OF REQUIRED PHOTOS, PLEASE REFER TO ENG-SOW-10007.

**9. INSPECTION AND TESTING**

- 9.1. ALL WORK SHALL BE SUBJECT TO REVIEW AND OBSERVATION BY CROWN CASTLE'S REPRESENTATIVE AND CROWN CASTLE'S AUTHORIZED INDEPENDENT INSPECTION AND TESTING AGENCY.
- 9.2. INSPECTION SERVICES WHICH ARE FURNISHED BY OTHERS ARE STILL REQUIRED WHEN THE EOR PERFORMS SUPPORT SERVICES DURING CONSTRUCTION.
- 9.3. OBSERVED DISCREPANCIES BETWEEN THE WORK AND THE CONTRACT DOCUMENTS SHALL BE CORRECTED BY THE CONTRACTOR AT NO ADDITIONAL COST.
- 9.4. AN INDEPENDENT QUALIFIED INSPECTION/TESTING AGENCY SHALL BE SELECTED AND RETAINED FOR THE SOLE PURPOSE OF INSPECTING, TESTING, DOCUMENTING, AND APPROVING ALL WELDING AND FIELD WORK PERFORMED BY THE CONTRACTOR.
  - 9.4.1. ACCESS TO ANY PLACE WHERE WORK IS BEING DONE SHALL BE PERMITTED AT ALL TIMES.
  - 9.4.2. THE INSPECTION AGENCY SHALL SO SCHEDULE THIS WORK AS TO CAUSE A MINIMUM OF INTERRUPTION TO, AND COORDINATE WITH, THE WORK IN PROGRESS. IT IS THE CONTRACTOR'S RESPONSIBILITY TO COORDINATE THE WORK SCHEDULE WITH THE TESTING AGENCY. THE CONTRACTOR SHALL ALLOW FOR ADEQUATE TIME AND ACCESS FOR THE TESTING AGENCY TO PERFORM THEIR DUTIES.
- 9.5. THE INSPECTION AND TESTING AGENCY SHALL BE RESPONSIBLE TO PERFORM THE FOLLOWING SERVICES AND INSPECT THE FOLLOWING ITEMS IN ACCORDANCE WITH THE CONSTRUCTION DRAWINGS. THE TESTING AGENCY SHALL INSPECT ITEMS ON THIS LIST AND OTHER ITEMS AS NECESSARY TO FULFILL THEIR RESPONSIBILITY. THE TESTING AGENCY SHALL UTILIZE EXPERIENCED, TRAINED INSPECTORS INCLUDING AWS CERTIFIED WELDING INSPECTORS (CWI). INSPECTORS SHALL HAVE THE TRAINING, CREDENTIALS, AND EXPERIENCE APPROPRIATE FOR AND COMMENSURATE WITH THE SCOPE AND TYPE OF INSPECTION WORK TO BE PERFORMED.
- 9.6. **GENERAL**
  - 9.6.1. PERFORM PERIODIC ON-SITE OBSERVATION, INSPECTION, VERIFICATION, AND TESTING DURING THE TIME THE CONTRACTOR IS WORKING ON-SITE. AGENCY SHALL NOTIFY CROWN CASTLE AND THE EOR IMMEDIATELY WHEN FIELD PROBLEMS OR DISCREPANCIES OCCUR.
- 9.7. **FOUNDATIONS AND SOIL PREPARATION - (NOT REQUIRED)**
- 9.8. **CONCRETE TESTING PER ACI - (NOT REQUIRED)**
- 9.9. **STRUCTURAL STEEL**
  - 9.9.1. CHECK STEEL ON THE JOB WITH THE PLANS.
  - 9.9.2. CHECK MILL CERTIFICATIONS. CALL FOR LABORATORY TEST REPORTS WHEN MILL CERTIFICATION IS IN QUESTION.
  - 9.9.3. CHECK GRADE OF STEEL MEMBERS, AND BOLTS FOR CONFORMANCE WITH DRAWINGS.
  - 9.9.4. INSPECT ALL STRUCTURAL BOLTS SHALL BE FIELD INSPECTED ACCORDING TO THE REQUIREMENTS OF THE AISC 'SPECIFICATION FOR STRUCTURAL JOINTS USING HIGH-STRENGTH BOLTS', DEC. 31, 2009.
  - 9.9.5. INSPECT STEEL MEMBERS FOR DISTORTION, EXCESSIVE RUST, FLAWS AND BURNED HOLES.
  - 9.9.6. CHECK STEEL MEMBERS FOR SIZES, SWEEP AND DIMENSIONAL TOLERANCES.
  - 9.9.7. CHECK FOR SURFACE FINISH SPECIFIED, GALVANIZED.
  - 9.9.8. CHECK THAT BOLTS HAVE BEEN TIGHTENED PROPERLY.
  - 9.9.9. PRIOR TO ANY FIELD CUTTING THE CONTRACTOR SHALL MARK THE CUTOUT LINES ON THE STEEL AND THE INSPECTION/TESTING AGENCY SHALL VERIFY PROPOSED LAYOUT, LOCATION, AND DIMENSIONS. THE INSPECTION/TESTING AGENCY SHALL CLOSELY AND CONTINUOUSLY MONITOR THIS ACTIVITY.
- 9.10. **WELDING:**
  - 9.10.1. VERIFY FIELD WELDING PROCEDURES, WELDERS, AND WELDING OPERATORS, NOT DEEMED PREQUALIFIED, IN ACCORDANCE WITH AWS D1.1.
  - 9.10.2. INSPECT FIELD WELDED CONNECTIONS IN ACCORDANCE WITH THE REQUIREMENTS SPECIFIED AND WITH AWS D1.1.
  - 9.10.3. APPROVE FIELD WELDING SEQUENCE.
  - 9.10.4. A PROGRAM OF THE APPROVED SEQUENCES SHALL BE SUBMITTED TO CROWN CASTLE BEFORE WELDING BEGINS. NO CHANGE IN APPROVED SEQUENCES MAY BE MADE WITHOUT PERMISSION FROM CROWN CASTLE.
  - 9.10.5. INSPECT WELDED CONNECTIONS AS FOLLOWS AND IN ACCORDANCE WITH AWS D1.1:
    - 9.10.5.1. INSPECT WELDING EQUIPMENT FOR CAPACITY, MAINTENANCE, AND WORKING CONDITIONS.
    - 9.10.5.2. VERIFY SPECIFIED ELECTRODES AND HANDLING AND STORAGE OF ELECTRODES FOR CONFORMANCE TO SPECIFICATIONS.
    - 9.10.5.3. INSPECT PREHEATING AND INTERPASS TEMPERATURES FOR CONFORMANCE WITH AWS D1.1.
    - 9.10.5.4. VISUALLY INSPECT ALL WELDS AND VERIFY THAT QUALITY OF WELDS MEETS THE REQUIREMENTS OF AWS D1.1. OTHER TESTS MAY ALSO BE PERFORMED ON THE WELDS BY THE TESTING AGENCY IN ORDER FOR THEM TO PERFORM THEIR DUTIES FOR THIS PROJECT.
    - 9.10.5.5. SPOT TEST AT LEAST ONE FILLET WELD OF EACH MEMBER USING MAGNETIC PARTICLE.
    - 9.10.5.6. INSPECT FOR SIZE, SPACING, TYPE AND LOCATION AS PER APPROVED DRAWINGS.
    - 9.10.5.7. VERIFY THAT THE BASE METAL CONFORMS TO THE DRAWINGS.
    - 9.10.5.8. REVIEW THE REPORTS BY TESTING LABS.
    - 9.10.5.9. CHECK TO SEE THAT WELDS ARE CLEAN AND FREE FROM SLAG.
    - 9.10.5.10. INSPECT RUST PROTECTION OF WELDS AS PER SPECIFICATIONS.
    - 9.10.5.11. CHECK THAT DEFECTIVE WELDS ARE CLEARLY MARKED AND HAVE BEEN ADEQUATELY REPAIRED.
- 9.11. **REPORTS:**
  - 9.11.1. COMPILER AND PERIODICALLY SUBMIT DAILY INSPECTION REPORTS TO CROWN CASTLE.
  - 9.11.2. THE INSPECTION PLAN OUTLINED HEREIN IS INTENDED AS A DESCRIPTION OF GENERAL AND SPECIFIC ITEMS OF CONCERN. IT IS NOT INTENDED TO BE ALL-INCLUSIVE. IT DOES NOT LIMIT THE TESTING AND INSPECTION AGENCY TO THE ITEMS LISTED. ADDITIONAL TESTING, INSPECTION, AND CHECKING MAY BE REQUIRED AND SHOULD BE ANTICIPATED. THE TESTING AGENCY SHALL USE THEIR PROFESSIONAL JUDGMENT AND KNOWLEDGE OF THE JOB SITE CONDITIONS AND THE CONTRACTOR'S PERFORMANCE TO DECIDE WHAT OTHER ITEMS REQUIRE ADDITIONAL ATTENTION. THE TESTING AGENCY'S JUDGMENT MUST PREVAIL ON ITEMS NOT SPECIFICALLY COVERED. ANY DISCREPANCIES OR PROBLEMS SHALL BE BROUGHT IMMEDIATELY TO CROWN CASTLE'S ATTENTION. RESOLUTIONS ARE NOT TO BE MADE WITHOUT CROWN CASTLE'S REVIEW AND SPECIFIC WRITTEN CONSENT. CROWN CASTLE RESERVES THE RIGHT TO DETERMINE WHETHER OR NOT A RESOLUTION IS ACCEPTABLE.
  - 9.11.3. AFTER EACH INSPECTION, THE TESTING AGENCY WILL PREPARE A WRITTEN ACCEPTANCE OR REJECTION WHICH WILL BE GIVEN TO THE CONTRACTOR AND FILED AS DAILY REPORTS TO CROWN CASTLE. THIS WRITTEN ACTION WILL GIVE THE CONTRACTOR A LIST OF ITEMS TO BE CORRECTED, PRIOR TO CONTINUING CONSTRUCTION, AND/OR LOADING OF STRUCTURAL ITEMS.
  - 9.11.4. THE TESTING AGENCY DOES NOT RELIEVE THE CONTRACTOR'S CONTRACTUAL OR STATUTORY OBLIGATIONS. THE CONTRACTOR HAS THE SOLE RESPONSIBILITY FOR ANY DEVIATIONS FROM THE OFFICIAL CONTRACT DOCUMENTS. THE TESTING AGENCY WILL NOT REPLACE THE CONTRACTOR'S QUALITY CONTROL PERSONNEL.

MI CHECKLIST	
CONSTRUCTION/INSTALLATION INSPECTIONS AND TESTING REQUIRED (COMPLETED BY EOR)	REPORT ITEM
<b>PRE-CONSTRUCTION</b>	
X	MI CHECKLIST DRAWINGS
X	EOB REVIEW
X	FABRICATION INSPECTION
NA	FABRICATOR CERTIFIED WELD INSPECTION
NA	MATERIAL TEST REPORT (MTR)
NA	FABRICATOR NDE INSPECTION
NA	NDE REPORT OF MONOPOLE BASE PLATE (AS REQUIRED)
X	PACKING SLIPS
ADDITIONAL TESTING AND INSPECTIONS: _____	
<b>CONSTRUCTION</b>	
X	CONSTRUCTION INSPECTIONS
NA	FOUNDATION INSPECTIONS
NA	CONCRETE COMP. STRENGTH AND SLUMP TESTS
NA	POST INSTALLED ANCHOR ROD VERIFICATION
NA	BASE PLATE GROUT VERIFICATION
NA	CONTRACTOR'S CERTIFIED WELD INSPECTION
NA	EARTHWORK: PROVIDE PHOTO DOCUMENTATION OF EXCAVATION QUALITY AND COMPACTION
NA	ON SITE COLD GALVANIZING VERIFICATION
NA	GUY WIRE TENSION REPORT
X	GC AS-BUILT DOCUMENTS
NA	MICROPILE/ROCK ANCHOR INSTALLER'S DRILLING AND INSTALLATION LOGS AND QA/QC DOCUMENTS
ADDITIONAL TESTING AND INSPECTIONS: _____	
<b>POST-CONSTRUCTION</b>	
X	MI INSPECTOR REDLINE OR RECORD DRAWING(S)
NA	POST INSTALLED ANCHOR ROD TARGET TENSION LOAD TESTING
NA	REFER TO MICROPILE/ROCK ANCHOR NOTES FOR SPECIAL INSPECTION AND TESTING REQUIREMENTS.
X	PHOTOGRAPHS
ADDITIONAL TESTING AND INSPECTIONS: FACT TIA INSPECTION PER CROWN CASTLE DOC OPS-SOW-10127. INSTALL CONCEALMENT REINFORCING PER CROWN CASTLE DOC OPS-SOW-10127 AND OPS-PBC-10127.	

NOTE: X DENOTES A DOCUMENT NEEDED FOR THE PMI REPORT  
NA DENOTES A DOCUMENT THAT IS NOT REQUIRED FOR THE PMI REPORT

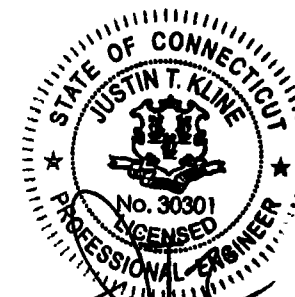

SEP 28 2016

© Copyright 2016, by Paul J. Ford and Company, All Rights Reserved. This document and the data contained herein, is proprietary to Paul J. Ford and Company, issued in strict confidence and shall not, without the prior written permission of Paul J. Ford and Company, be reproduced, copied or used for any purpose other than the intended use for this specific project.

**PAUL J. FORD & COMPANY**  
250 E Broad St, Ste 600, Columbus, OH 43215  
Phone 614.221.6679 www.pauljford.com

**CROWN CASTLE**  
3 CORPORATE PARK DRIVE, SUITE 101, CLIFTON PARK, NY 12065  
PH: (885) 370-4766

**MODIFICATION OF AN EXISTING  
109'-0" MONOPOLE  
BU #857144; REDDING WAYSIDE LANE  
REDDING, CONNECTICUT**

PROJECT No: 37516-3037.002.7700  
DRAWN BY: B.M.S.  
DESIGNED BY: J.W.M.  
CHECKED BY: TSD  
DATE: 9-26-2016

MI CHECKLIST

T-2

**1. GENERAL NOTES**

- 1.1. THE MONOPOLE STRUCTURE IN ITS EXISTING CONDITION DOES NOT HAVE THE STRUCTURAL CAPACITY TO CARRY ALL OF THE PROPOSED AND EXISTING LOADS FROM THE ATTACHED STRUCTURAL MODIFICATION REPORT AT THE REQUIRED MINIMUM WIND SPEEDS. DO NOT INSTALL ANY NEW LOADS UNTIL THE MONOPOLE REINFORCING SYSTEM IS COMPLETELY AND SUCCESSFULLY INSTALLED.
- 1.2. THESE DRAWINGS WERE PREPARED FROM INFORMATION PROVIDED BY CROWN CASTLE. THE INFORMATION PROVIDED HAS NOT BEEN FIELD VERIFIED BY THE ENGINEER OF RECORD (EOR) FOR ACCURACY AND THEREFORE DISCREPANCIES BETWEEN THESE DRAWINGS AND ACTUAL SITE CONDITIONS SHOULD BE ANTICIPATED. PRIOR TO FABRICATION AND INSTALLATION CONTRACTOR SHALL VERIFY ALL LENGTHS AND QUANTITIES GIVEN. LENGTH AND QUANTITIES PROVIDED ARE FOR QUOTING PURPOSES ONLY AND SHALL NOT BE USED FOR FABRICATION. THE CONTRACTOR SHALL COORDINATE WITH THE PROJECT DRAWINGS AND THEIR FIELD VERIFIED CONDITIONS AND DIMENSIONS BEFORE PROCEEDING WITH THE WORK. THE CONTRACTOR SHALL IMMEDIATELY REPORT ANY AND ALL DISCREPANCIES TO THE EOR AND CROWN CASTLE BEFORE PROCEEDING WITH THE WORK. ANY WORK PERFORMED WITHOUT A PREFABRICATION MAPPING IS DONE AT THE RISK OF THE GENERAL CONTRACTOR AND/OR THE FABRICATOR
- 1.3. IF MATERIALS, QUANTITIES, STRENGTHS OR SIZES INDICATED BY THE DRAWINGS OR SPECIFICATIONS ARE NOT IN AGREEMENT WITH THESE NOTES, THE BETTER QUALITY AND/OR GREATER QUANTITY, STRENGTH OR SIZE INDICATED, SPECIFIED OR NOTED SHALL BE PROVIDED.
- 1.4. THIS STRUCTURE IS DESIGNED TO BE SELF-SUPPORTING AND STABLE AFTER THE INSTALLATION OF THE REINFORCING REPAIR SYSTEM HAS BEEN SUCCESSFULLY COMPLETED. IT IS THE CONTRACTOR'S SOLE RESPONSIBILITY TO ENSURE THE SAFETY AND STABILITY OF THE MONOPOLE AND ITS COMPONENT PARTS DURING FIELD MODIFICATIONS. THIS INCLUDES, BUT IS NOT LIMITED TO, THE ADDITION OF WHATEVER TEMPORARY BRACING, GUYS OR TIE DOWNS THAT MAY BE NECESSARY. SUCH MATERIAL SHALL BE REMOVED AND SHALL REMAIN THE PROPERTY OF THE CONTRACTOR AFTER THE COMPLETION OF THE PROJECT.
- 1.5. ALL CONSTRUCTION MEANS AND METHODS; INCLUDING BUT NOT LIMITED TO, ERECTION PLANS, RIGGING PLANS, CLIMBING PLANS AND RESCUE PLANS SHALL BE THE RESPONSIBILITY OF THE GENERAL CONTRACTOR RESPONSIBLE FOR THE EXECUTION OF THE WORK CONTAINED HEREIN AND SHALL MEET ANSII/A-1019 (LATEST EDITION), OSHA AND GENERAL INDUSTRY STANDARDS. ALL RIGGING PLANS SHALL ADHERE TO ANSII/A-1019 (LATEST EDITION) INCLUDING THE REQUIRED INVOLVEMENT OF A QUALIFIED ENGINEER FOR CLASS IV CONSTRUCTION.
- 1.6. OBSERVATION VISITS TO THE SITE BY CROWN CASTLE AND/OR THE EOR SHALL NOT INCLUDE INSPECTIONS OF THE PROTECTIVE MEASURES OR THE CONSTRUCTION PROCEDURES. ANY SUPPORT SERVICES PERFORMED BY THE EOR DURING CONSTRUCTION ARE SOLELY FOR THE PURPOSE OF ACHIEVING GENERAL CONFORMANCE WITH THE CONTRACT DOCUMENTS. THEY DO NOT GUARANTEE THE CONTRACTOR'S PERFORMANCE AND SHALL NOT BE CONSTRUED AS SUPERVISION OF CONSTRUCTION.
- 1.7. ALL MATERIALS AND EQUIPMENT FURNISHED SHALL BE NEW AND OF GOOD QUALITY, FREE FROM FAULTS AND DEFECTS AND IN CONFORMANCE WITH THE CONTRACT DOCUMENTS. ANY AND ALL SUBSTITUTIONS MUST BE PROPERLY APPROVED AND AUTHORIZED IN WRITING BY CROWN CASTLE AND EOR PRIOR TO INSTALLATION. THE CONTRACTOR SHALL FURNISH SATISFACTORY EVIDENCE AS TO THE KIND AND QUALITY OF MATERIALS AND EQUIPMENT BEING SUBSTITUTED.
- 1.8. THE CONTRACTOR SHALL BE RESPONSIBLE FOR INITIATING, MAINTAINING, AND SUPERVISING ALL SAFETY PRECAUTIONS AND PROGRAMS IN CONNECTION WITH THE WORK. THE CONTRACTOR IS RESPONSIBLE TO ENSURE THAT THIS PROJECT AND RELATED WORK COMPLIES WITH ALL APPLICABLE LOCAL, STATE, AND FEDERAL SAFETY CODES AND REGULATIONS GOVERNING THIS WORK AS WELL AS CROWN CASTLE SAFETY GUIDELINES.
- 1.9. THE CONTRACTOR SHALL BE RESPONSIBLE FOR PROTECTING ALL EXISTING AND NEW COAXIAL CABLES AND OTHER EQUIPMENT DURING CONSTRUCTION.
- 1.10. ANY EXISTING ATTACHMENTS AND/OR PROJECTIONS ON THE POLE THAT MAY INTERFERE WITH THE INSTALLATION OF THE REINFORCING SYSTEM HAVE TO BE REMOVED AND RELOCATED, REPLACED, OR RE-INSTALLED AS REQUIRED AFTER THE REINFORCING IS SUCCESSFULLY COMPLETED. THE CONTRACTOR SHALL IDENTIFY AND COORDINATE THESE ITEMS PRIOR TO CONSTRUCTION WITH CROWN CASTLE, TESTING AGENCY, AND EOR.
- 1.11. ANY AND ALL EXISTING PLATFORMS THAT ARE LOCATED IN AREAS OF THE POLE SHAFT WHERE SHAFT REINFORCING MUST BE APPLIED SHALL BE TEMPORARILY REMOVED OR OTHERWISE SUPPORTED TO PERMIT NEW CONTINUOUS REINFORCEMENT TO BE ATTACHED. AFTER THE CONTRACTOR HAS SUCCESSFULLY INSTALLED THE MONOPOLE REINFORCEMENT SYSTEM, THE CONTRACTOR SHALL RE-INSTALL THE PLATFORMS.
- 1.12. THE CLIMBING FACILITIES, SAFETY CLIMB AND ALL PARTS THEREOF SHALL NOT BE IMPEDED, MODIFIED OR ALTERED WITHOUT THE EXPRESS APPROVAL OF THE EOR.
- 1.13. FOR STANDARD CROWN PARTS SEE THE MOST RECENT VERSION OF THE "CCI APPROVED REINFORCEMENT COMPONENTS" CATALOG.
- 1.14. ALL SOLUTIONS FOR THE REPLACEMENT, RELOCATION OR MODIFICATION OF THE SAFETY CLIMB AND/OR ANY OF THE MONOPOLE CLIMBING FACILITIES SHALL BE COORDINATED WITH TUF-TUG PRODUCTS. CONTACT DETAILS:  
3434 ENCRETE LANE, MORAINNE, OHIO 45439  
PHONE: 937-299-1213 EMAIL: TUFUG@AOL.COM

**2. STRUCTURAL STEEL**

- 2.1. STRUCTURAL STEEL MATERIALS, FABRICATION, DETAILING, AND WORKMANSHIP SHALL CONFORM TO THE LATEST EDITION OF THE FOLLOWING REFERENCE STANDARDS:
  - 2.1.1. BY THE AMERICAN INSTITUTE OF STEEL CONSTRUCTION (AISC):
    - 2.1.1.1. "SPECIFICATION FOR STRUCTURAL STEEL BUILDINGS."
    - 2.1.1.2. "SPECIFICATION FOR STRUCTURAL JOINTS USING ASTM HIGH STRENGTH BOLTS," AS APPROVED BY THE RESEARCH COUNCIL ON STRUCTURAL CONNECTIONS.
    - 2.1.1.3. "CODE OF STANDARD PRACTICE FOR STEEL BUILDINGS AND BRIDGES"
  - 2.1.2. BY THE AMERICAN WELDING SOCIETY (AWS):
    - 2.1.2.1. "STRUCTURAL WELDING CODE - STEEL D1.1."
    - 2.1.2.2. "STANDARD SYMBOLS FOR WELDING, BRAZING, AND NONDESTRUCTIVE EXAMINATION"
- 2.2. ALL STRUCTURAL BOLTS SHALL BE INSTALLED AND TIGHTENED TO THE PRETENSIONED CONDITION ACCORDING TO THE REQUIREMENTS OF THE AISC "SPECIFICATION FOR STRUCTURAL JOINTS USING ASTM HIGH STRENGTH BOLTS", DEC. 31, 2009.
- 2.3. ANY MATERIAL OR WORKMANSHIP WHICH IS OBSERVED TO BE DEFECTIVE OR INCONSISTENT WITH THE CONTRACT DOCUMENTS SHALL BE CORRECTED, MODIFIED, OR REPLACED AT THE CONTRACTOR'S EXPENSE.
- 2.4. WELDED CONNECTIONS SHALL CONFORM TO THE LATEST REVISED CODE OF THE AMERICAN WELDING SOCIETY, AWS D1.1. ALL WELD ELECTRODES SHALL BE E80XX UNLESS NOTED OTHERWISE ON THE DRAWINGS.
- 2.5. ALL WELDED CONNECTIONS SHALL BE MADE BY WELDERS CERTIFIED BY AWS. CONTRACTOR SHALL SUBMIT WELDERS' CERTIFICATION AND QUALIFICATION DOCUMENTATION TO CROWN CASTLE'S TESTING AGENCY FOR REVIEW AND APPROVAL PRIOR TO CONSTRUCTION.
- 2.6. STRUCTURAL STEEL PLATES SHALL CONFORM TO ASTM A572 GRADE 65 (FY = 65 KSI MIN.) UNLESS NOTED OTHERWISE ON THE DRAWINGS.
- 2.7. SURFACES OF EXISTING STEEL SHALL BE PREPARED AS REQUIRED FOR FIELD WELDING PER AWS. SEE SECTION I NOTES REGARDING TOUCH UP OF GALVANIZED SURFACES DAMAGED DURING TRANSPORTATION OR ERECTION AND ASSEMBLY AS WELL AS FIELD WELDING.
- 2.8. NO WELDING SHALL BE DONE TO THE EXISTING STRUCTURE WITHOUT THE PRIOR APPROVAL AND SUPERVISION OF THE TESTING AGENCY.
- 2.9. FIELD CUTTING OF STEEL:
  - 2.9.1. IMPORTANT CUTTING AND WELDING SAFETY GUIDELINES: THE CONTRACTOR SHALL FOLLOW ALL CROWN CASTLE CUTTING, WELDING, FIRE PREVENTION AND SAFETY GUIDELINES. PRIOR TO CONSTRUCTION, THE CONTRACTOR SHALL OBTAIN A COPY OF THE CURRENT CROWN CASTLE GUIDELINES. PER THE 12-01-2005 CROWN CASTLE DIRECTIVE: "ALL CUTTING AND WELDING ACTIVITIES SHALL BE CONDUCTED IN ACCORDANCE WITH CROWN CASTLE POLICY 'CUTTING AND WELDING SAFETY PLAN' (DOC # ENG-PLN-10015) ON AN ONGOING BASIS THROUGHOUT THE ENTIRE LIFE OF THE PROJECT". ANY DAMAGE TO THE COAX CABLES, AND/OR OTHER EQUIPMENT AND/OR THE STRUCTURE, RESULTING FROM THE CONTRACTOR'S ACTIVITIES SHALL BE REPAIRED AT THE CONTRACTOR'S EXPENSE. THE INSPECTION/TESTING AGENCY SHALL CLOSELY AND CONTINUOUSLY MONITOR THIS ACTIVITY.
  - 2.9.2. ALL REQUIRED CUTS SHALL BE CUT WITHIN THE DIMENSIONS SHOWN ON THE DRAWINGS. NO CUTS SHALL EXTEND BEYOND THE OUTLINE OF THE DIMENSIONS SHOWN ON THE DRAWINGS. ALL CUT EDGES SHALL BE GROUND SMOOTH AND DE-BURRED. CUT EDGES THAT ARE TO BE FIELD WELDED SHALL BE PREPARED FOR FIELD WELDING PER AWS D1.1 AND AS SHOWN ON THE DRAWINGS. CONTRACTOR TO AVOID 90 DEGREE CORNERS. IT MAY BE NECESSARY TO DRILL STARTER HOLES AS REQUIRED TO MAKE THE CUTS.

**3. BASE PLATE GROUT - (NOT REQUIRED)**

**4. FOUNDATION WORK - (NOT REQUIRED)**

**5. CAST-IN-PLACE CONCRETE - (NOT REQUIRED)**

**6. EPOXY GROUTED REINFORCING ANCHOR RODS - (NOT REQUIRED)**

**7. TOUCH UP OF GALVANIZING**

- 7.1. THE CONTRACTOR SHALL TOUCH UP ANY AND ALL AREAS OF GALVANIZING ON THE EXISTING STRUCTURE OR NEW COMPONENTS THAT ARE DAMAGED OR ABRADED DURING CONSTRUCTION. GALVANIZED SURFACES DAMAGED DURING TRANSPORTATION OR ERECTION AND ASSEMBLY AS WELL AS ANY AND ALL ABRASIONS, CUTS, FIELD DRILLING, AND ALL FIELD WELDING SHALL BE TOUCHED UP WITH TWO (2) COATS OF ZRC COLD GALVANIZING COMPOUND. FILM THICKNESS PER COAT SHALL BE: WET 3.0 MILS; DRY 1.5 MILS. APPLY PER ZRC (MANUFACTURER) RECOMMENDED PROCEDURES. CONTACT ZRC AT 1-800-831-3275 FOR PRODUCT INFORMATION.
- 7.2. CONTRACTOR SHALL CLEAN AND PREPARE ALL FIELD WELDS ON GALVANIZED AND PRIME PAINTED SURFACES FOR TOUCH-UP COATING IN ACCORDANCE WITH AWS D1.1. CROWN CASTLE'S TESTING AGENCY SHALL VERIFY THE PREPARED SURFACE PRIOR TO APPLICATION OF THE TOUCH-UP COATING.
- 7.3. CROWN CASTLE'S TESTING AGENCY SHALL TEST AND VERIFY THE COATING THICKNESS AFTER THE CONTRACTOR HAS APPLIED THE ZRC COLD GALVANIZING COMPOUND AND IT HAS SUFFICIENTLY DRIED. AREAS FOUND TO BE ADEQUATELY COATED, SHALL BE RE-COATED BY THE CONTRACTOR AND RE-TESTED BY THE TESTING AGENCY.

**8. HOT-DIP GALVANIZING**

- 8.1. HOT-DIP GALVANIZE ALL STRUCTURAL STEEL MEMBERS AND ALL STEEL ACCESSORIES, BOLTS, WASHERS, ETC. PER ASTM A123 OR PER ASTM A153, AS APPROPRIATE.
- 8.2. PROPERLY PREPARE STEEL ITEMS FOR GALVANIZING. DRILL OR PUNCH WEEP AND/OR DRAINAGE HOLES WITH EOR APPROVAL OF LOCATIONS.
- 8.3. ALL GALVANIZING SHALL BE DONE AFTER FABRICATION IS COMPLETED AND PRIOR TO FIELD INSTALLATION.

**9. PERPETUAL INSPECTION AND MAINTENANCE BY THE OWNER**

- 9.1. AFTER THE CONTRACTOR HAS SUCCESSFULLY COMPLETED THE INSTALLATION OF THE MONOPOLE REINFORCING SYSTEM AND THE WORK HAS BEEN ACCEPTED BY CROWN CASTLE, CROWN CASTLE WILL BE RESPONSIBLE FOR THE LONG TERM AND PERPETUAL INSPECTION AND MAINTENANCE OF THE POLE AND REINFORCING SYSTEM.
- 9.2. ANY FIELD WELDED CONNECTIONS ARE SUBJECT TO CORROSION DAMAGE AND DETERIORATION IF THEY ARE NOT PROPERLY MAINTAINED AND COVERED WITH CORROSION PREVENTIVE COATING SUCH AS THE ZRC GALVANIZING COMPOUND SPECIFIED PREVIOUSLY. THE STRUCTURAL LOAD CARRYING CAPACITY OF THE REINFORCED POLE SYSTEM IS DEPENDENT UPON THE INSTALLED SIZE AND QUALITY, MAINTAINED SOUND CONDITION AND STRENGTH OF THESE FIELD WELDED CONNECTIONS. ANY CORROSION OF, DAMAGE TO, FATIGUE, FRACTURE, AND/OR DETERIORATION OF THESE WELDS AND/OR THE EXISTING GALVANIZED STEEL POLE STRUCTURE AND THE WELDED COMPONENTS WILL RESULT IN THE LOSS OF STRUCTURAL LOAD CARRYING CAPACITY AND MAY LEAD TO FAILURE OF THE STRUCTURAL SYSTEM. THEREFORE, IT IS IMPERATIVE THAT CROWN CASTLE REGULARLY INSPECTS, MAINTAINS, AND REPAIRS AS NECESSARY, ALL OF THESE WELDS, CONNECTIONS, AND COMPONENTS FOR THE LIFE OF THE STRUCTURE.
- 9.3. CROWN CASTLE SHALL REFER TO ANSII/A-222-G-2-2009, SECTION 14 AND ANNEX J FOR RECOMMENDATIONS FOR MAINTENANCE AND INSPECTION. THE FREQUENCY OF THE INSPECTION AND MAINTENANCE INTERVALS IS TO BE DETERMINED BY CROWN CASTLE BASED UPON ACTUAL SITE AND ENVIRONMENTAL CONDITIONS. THE EOR RECOMMENDS THAT A COMPLETE AND THOROUGH INSPECTION OF THE ENTIRE REINFORCED MONOPOLE STRUCTURAL SYSTEM BE PERFORMED YEARLY AND/OR AS FREQUENTLY AS CONDITIONS WARRANT. ACCORDING TO ANSII/A-222-G-2-2009 SECTION 14.2: "IT IS RECOMMENDED THAT THE STRUCTURE BE INSPECTED AFTER SEVERE WIND AND/OR ICE STORMS OR OTHER EXTREME LOADING CONDITIONS".

**10. FIELD NDE MINIMUM REQUIREMENTS**

- 10.1. ALL NDE SHALL BE IN ACCORDANCE WITH AWS D1.1.
- 10.2. FOR NEW BASE STIFFENERS (INCLUSIVE OF TRANSITION STIFFENERS) AND ANCHOR ROD BRACKETS, COMPLETE JOINT PENETRATION WELDS SHALL BE 100% INSPECTED BY UT. ALL PARTIAL JOINT PENETRATION AND FILLET WELDS SHALL BE 100% INSPECTED BY MT.
- 10.3. FOR NEW FLAT PLATE REINFORCEMENT AT THE BASE OF THE TOWER, COMPLETE JOINT PENETRATION WELDS SHALL BE 100% INSPECTED BY UT. ALL PARTIAL JOINT PENETRATION AND FILLET WELDS SHALL BE 100% INSPECTED BY MT, BUT MAY BE LIMITED TO A HEIGHT OF 10'-0".
- 10.4. FOR NDE OF THE EXISTING BASE PLATE CIRCUMFERENTIAL WELD, GC SHALL REFERENCE THE MI CHECKLIST FOR APPLICABILITY. PLEASE SEE ENG-SOW-10033: 'TOWER BASE PLATE NDE, AND ENG-BUL-10051: 'NDE REQUIREMENTS FOR MONOPOLE BASE PLATE TO PREVENT CONNECTION FAILURE'. NOTIFY THE EOR AND CROWN ENGINEERING IMMEDIATELY IF ANY CRACKS ARE SUSPECTED OR HAVE BEEN IDENTIFIED. THE NDE SHALL INCLUDE ALL EXISTING MODIFICATIONS THAT HAVE BEEN WELDED TO THE BASE PLATE.
- 10.5. ALL TESTING LIMITATIONS SHALL BE DETAILED IN THE NDE REPORT.

© Copyright 2016, by Paul J. Ford and Company, All Rights Reserved. This document and the data contained herein, is proprietary to Paul J. Ford and Company, issued in strict confidence and shall not, without the prior written permission of Paul J. Ford and Company, be reproduced, copied or used for any purpose other than the intended use for this specific project.

**RJF PAUL J. FORD & COMPANY**  
250 E Broad St, Ste 600- Columbus, OH 43215  
Phone 614.221.6679 www.pauljford.com

**CROWN CASTLE**  
3 CORPORATE PARK DRIVE, SUITE 101, CLIFTON PARK, NY 12065  
PH: (609) 370-4786

MODIFICATION OF AN EXISTING  
109'-0" MONOPOLE  
BU #857144; REDDING WAYSIDE LANE  
REDDING, CONNECTICUT

PROJECT No: 37516-3037.002.7700  
DRAWN BY: B.M.S.  
DESIGNED BY: J.W.M.  
CHECKED BY: TSD  
DATE: 9-26-2016

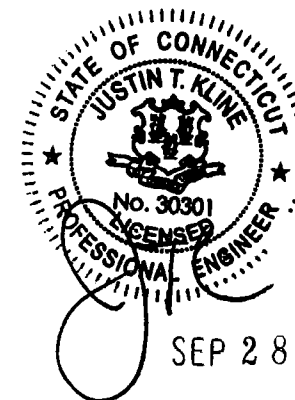

GENERAL NOTES

S-1

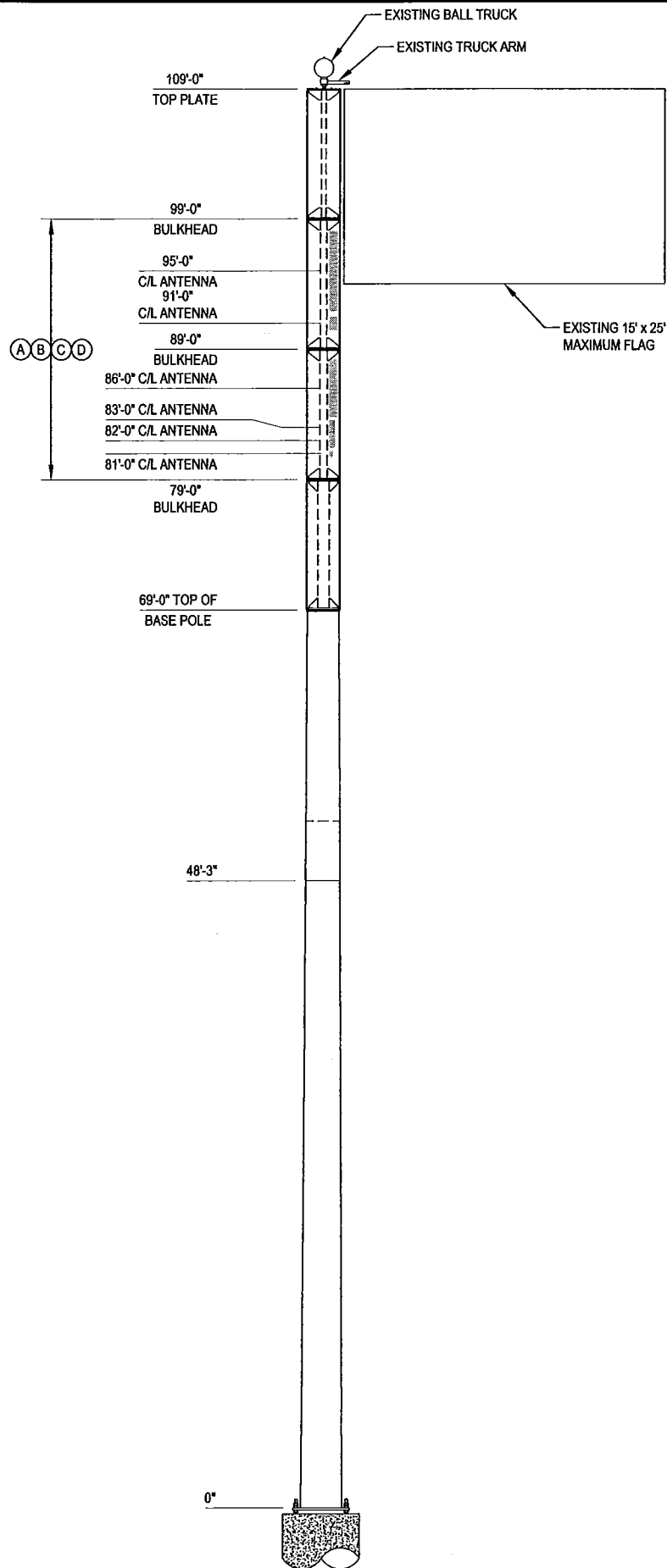

POLE ELEVATION 1  
S-2

SHAFT SECTION DATA							
SHAFT SECTION	SECTION LENGTH (FT)	PLATE THICKNESS (IN)	LAP SPLICE (IN)	DIAMETER ACROSS FLATS (IN)		POLE GRADE (ksi)	POLE SHAPE
				@ TOP	@ BOTTOM		
1	10.00	SOLID		4.500	4.500	50	ROUND
2	10.00	SOLID		6.000	6.000	50	ROUND
3	10.00	SOLID		7.000	7.000	50	ROUND
4	10.00	1.0000		10.750	10.750	35	ROUND
5	20.79	0.1875	55.00	29.500	32.360	65	18-SIDED
6	52.79	0.2500		31.355	38.500	65	18-SIDED

NOTE: DIMENSIONS SHOWN DO NOT INCLUDE GALVANIZING TOLERANCES

TOWER MODIFICATION SCHEDULE			
	ELEVATION	TOWER MODIFICATION DESCRIPTION	REFERENCE SHEETS
(A)	69' TO 109'	REMOVE EXISTING CONCEALMENT SHROUDS	S-2
(B)	69' TO 109'	INSTALL NEW CONCEALMENT SHROUDS	S-3
(C)	69' TO 109'	PAINT MODIFICATIONS TO MATCH EXISTING POLE	S-2
(D)	69' TO 109'	INSTALL CONCEALMENT REINFORCING SOLUTION PER CROWN CASTLE DOC OPS-PRC-10127	S-2

- EXISTING CONCEALMENT SHROUDS TO BE REMOVED AND REPLACED WITH THE NEW CONCEALMENT SHROUDS.
- CONTRACTOR SHALL SEND PAUL J. FORD & COMPANY THE FABRICATION DRAWINGS FOR APPROVAL PRIOR TO MANUFACTURING.

© Copyright 2016, by Paul J. Ford and Company. All Rights Reserved. This document and the data contained herein, is proprietary to Paul J. Ford and Company, issued in strict confidence and shall not, without the prior written permission of Paul J. Ford and Company, be reproduced, copied or used for any purpose other than the intended use for this specific project.

**PJF PAUL J. FORD & COMPANY**  
 250 E Broad St, Ste 600, Columbus, OH 43215  
 Phone 614.221.6679 www.pauljford.com

**CROWN CASTLE**  
 3 CORPORATE PARK DRIVE, SUITE 101, CLIFTON PARK, NY 12065  
 PH: (688) 370-4766

MODIFICATION OF AN EXISTING  
 109'-0" MONOPOLE  
 BU #857144; REDDING WAYSIDE LANE  
 REDDING, CONNECTICUT

PROJECT No:	37516-3037.002.7700
DRAWN BY:	B.M.S.
DESIGNED BY:	J.W.M.
CHECKED BY:	TSD
DATE:	9-26-2016

MONOPOLE  
 PROFILE

S-2



© Copyright 2016, by Paul J. Ford and Company, All Rights Reserved. This document and the data contained herein, is proprietary to Paul J. Ford and Company, issued in strict confidence and shall not, without the prior written permission of Paul J. Ford and Company, be reproduced, copied or used for any purpose other than the intended use for this specific project.

**PAUL J. FORD & COMPANY**  
 250 E Broad St, Ste 600, Columbus, OH 43215  
 Phone 614.221.6679 www.pauljford.com

**CROWN CASTLE**  
 3 CORPORATE PARK DRIVE, SUITE 101, CLIFTON PARK, NY 12065  
 PH: (885) 370-4766

**MODIFICATION OF AN EXISTING 109'-0" MONOPOLE**  
 BU #857144; REDDING WAYSIDE LANE  
 REDDING, CONNECTICUT

PROJECT No: 37516-3037.002.7700  
 DRAWN BY: B.M.S.  
 DESIGNED BY: J.W.M.  
 CHECKED BY: T.S.S.  
 DATE: 9-28-2016

**CONCEALMENT ELEVATION DETAILS**

**S-3**

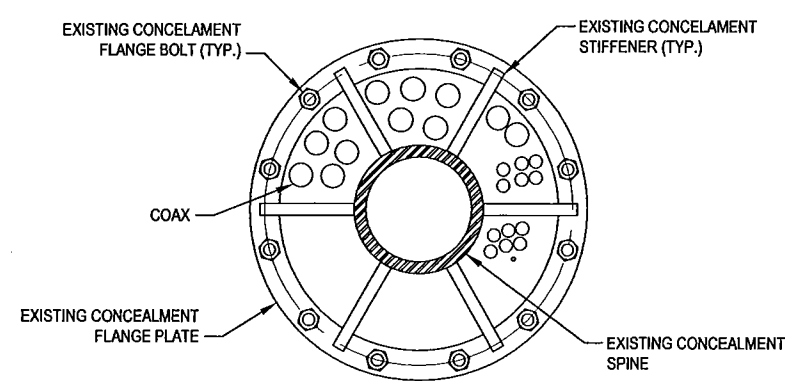
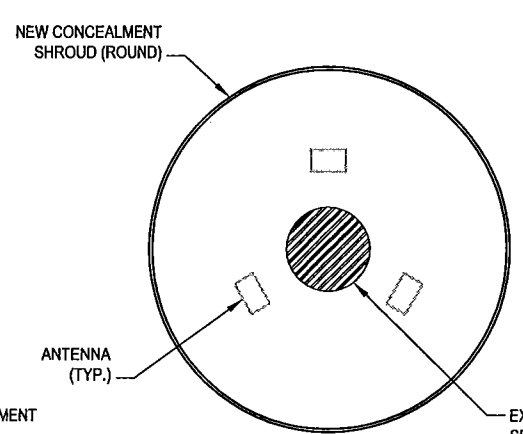
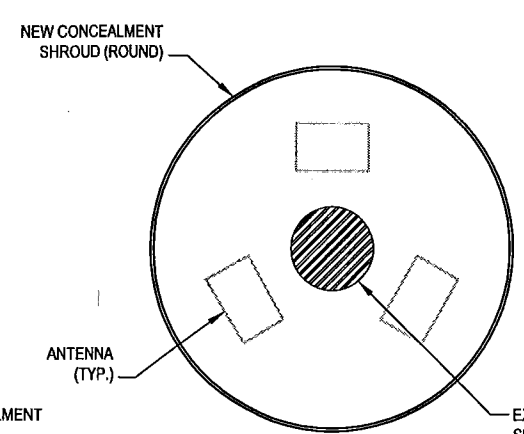
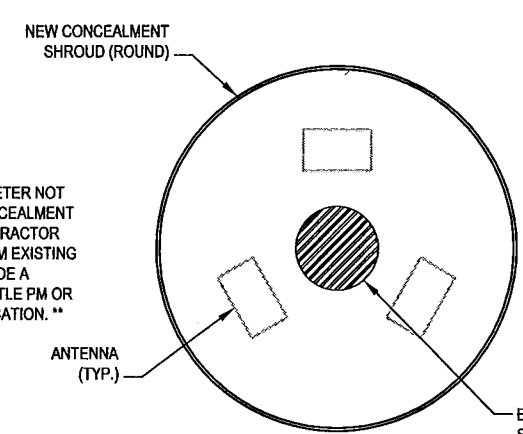
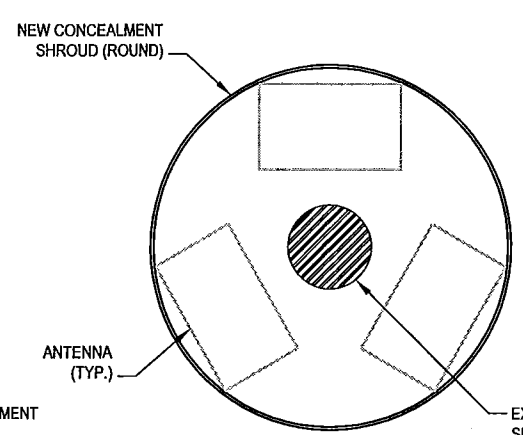
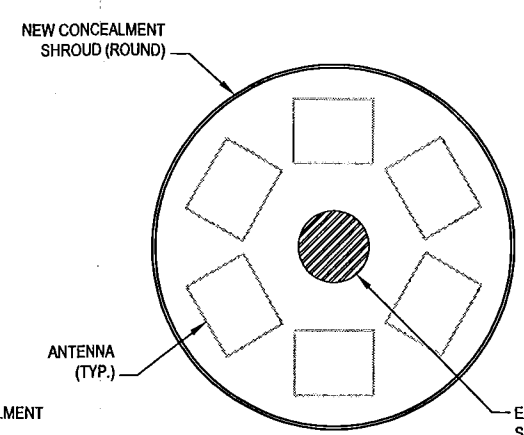
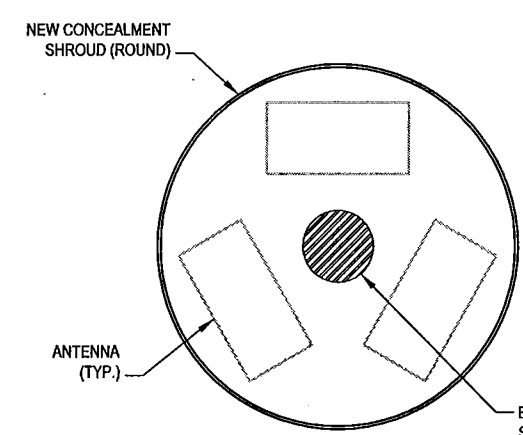
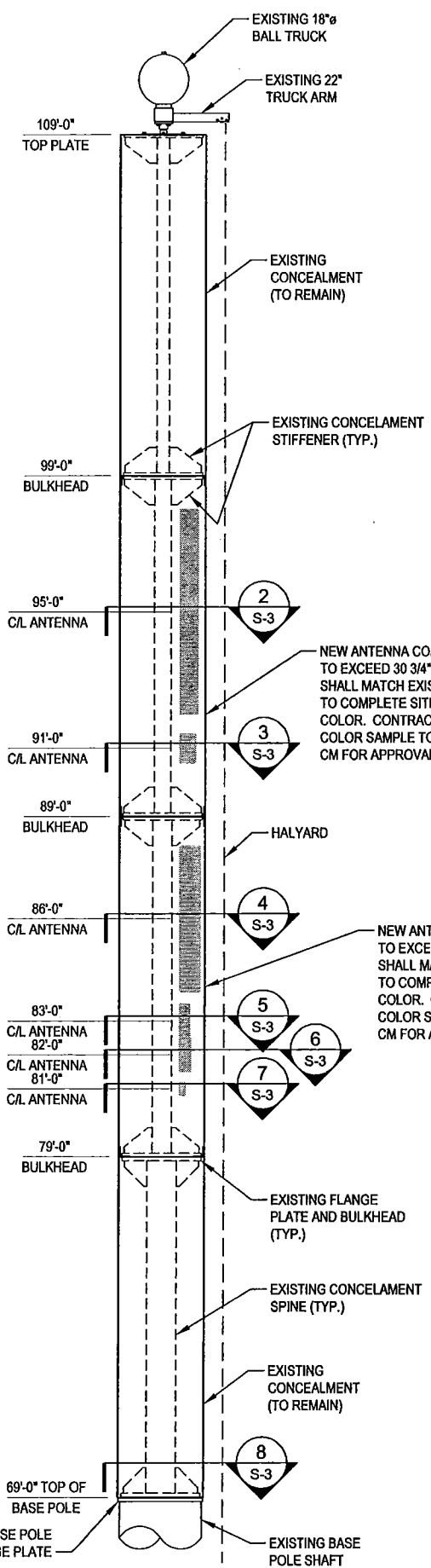

NEW ANTENNA CONCEALMENT DIAMETER NOT TO EXCEED 30 3/4". COLOR OF CONCEALMENT SHALL MATCH EXISTING POLE. CONTRACTOR TO COMPLETE SITE VISIT TO CONFIRM EXISTING COLOR. CONTRACTOR SHALL PROVIDE A COLOR SAMPLE TO THE CROWN CASTLE PM OR CM FOR APPROVAL PRIOR TO FABRICATION. \*\*

\*\* CONTRACTOR SHALL FIELD VERIFY SIZE OF EXISTING BULKHEADS AND CONCEALMENT ATTACHMENT DETAILS PRIOR TO FABRICATING 30 3/4"Ø CONCEALMENT

Antenna Model	QUANTITY	Antenna Centerline Elevation, ft	Height, in	Depth, in	Width, in
P65-16-XLH-RR	3	95	72	6	12
TTAW-07BP111-001	6	91	9.9	5.4	6.7
DBXNH-6565A-A2M	3	86	50.9	7.1	11.9
ATBT-BOTTOM-24V	3	81	4.3	1.8	2.9
KRY 112 489/2	3	82	11	3.94	6.1
KRF 102 267/1	3	83	11.46	3.39	5.75

Coax Model	QUANTITY	Elevation, ft	Nominal Diameter, in	Actual Diameter, in
7085.05	1	104	5/16	0.315
LDF7-50A	6	104	1 5/8	1.98
LDF7-50A	6	94	1 5/8	1.98
AVA5-50	12	84	7/8	1.09

NOTE: COAX LAYOUT AND FIT IS THEORETICAL. ACTUAL LAYOUT AND FIT MAY VARY PENDING EXISTING CONDITIONS.

NOTE: ALL ANTENNA DIMENSIONS HAVE BEEN PROVIDED BY CROWN CASTLE. A 3" SPACING BETWEEN THE SPINE AND ANTENNA HAS BEEN ASSUMED.

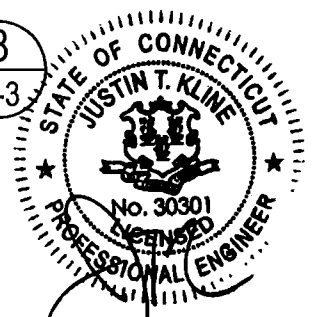

37516-3037.002.DWG



## RADIO FREQUENCY EMISSIONS ANALYSIS REPORT EVALUATION OF HUMAN EXPOSURE POTENTIAL TO NON-IONIZING EMISSIONS

T-Mobile Existing Facility

Site ID: CTFF575A

ATT Wayside Lane  
22 Wayside Lane  
Redding, CT 06896

**August 3, 2016**

**EBI Project Number: 6216003497**

Site Compliance Summary	
Compliance Status:	<b>COMPLIANT</b>
Site total MPE% of FCC general public allowable limit:	<b>7.12 %</b>

August 3, 2016

T-Mobile USA  
Attn: Jason Overbey, RF Manager  
35 Griffin Road South  
Bloomfield, CT 06002

Emissions Analysis for Site: **CTFF575A – ATT Wayside Lane**

EBI Consulting was directed to analyze the proposed T-Mobile facility located at **22 Wayside Lane, Redding, CT**, for the purpose of determining whether the emissions from the Proposed T-Mobile Antenna Installation located on this property are within specified federal limits.

All information used in this report was analyzed as a percentage of current Maximum Permissible Exposure (% MPE) as listed in the FCC OET Bulletin 65 Edition 97-01 and ANSI/IEEE Std C95.1. The FCC regulates Maximum Permissible Exposure in units of microwatts per square centimeter ( $\mu\text{W}/\text{cm}^2$ ). The number of  $\mu\text{W}/\text{cm}^2$  calculated at each sample point is called the power density. The exposure limit for power density varies depending upon the frequencies being utilized. Wireless Carriers and Paging Services use different frequency bands each with different exposure limits, therefore it is necessary to report results and limits in terms of percent MPE rather than power density.

All results were compared to the FCC (Federal Communications Commission) radio frequency exposure rules, 47 CFR 1.1307(b)(1) – (b)(3), to determine compliance with the Maximum Permissible Exposure (MPE) limits for General Population/Uncontrolled environments as defined below.

General population/uncontrolled exposure limits apply to situations in which the general public may be exposed or in which persons who are exposed as a consequence of their employment may not be made fully aware of the potential for exposure or cannot exercise control over their exposure. Therefore, members of the general public would always be considered under this category when exposure is not employment related, for example, in the case of a telecommunications tower that exposes persons in a nearby residential area.

Public exposure to radio frequencies is regulated and enforced in units of microwatts per square centimeter ( $\mu\text{W}/\text{cm}^2$ ). The general population exposure limit for the 700 MHz Band is approximately 467  $\mu\text{W}/\text{cm}^2$ , and the general population exposure limit for the 1900 MHz (PCS) and 2100 MHz (AWS) bands is 1000  $\mu\text{W}/\text{cm}^2$ . Because each carrier will be using different frequency bands, and each frequency band has different exposure limits, it is necessary to report percent of MPE rather than power density.





Occupational/controlled exposure limits apply to situations in which persons are exposed as a consequence of their employment and in which those persons who are exposed have been made fully aware of the potential for exposure and can exercise control over their exposure. Occupational/controlled exposure limits also apply where exposure is of a transient nature as a result of incidental passage through a location where exposure levels may be above general population/uncontrolled limits (see below), as long as the exposed person has been made fully aware of the potential for exposure and can exercise control over his or her exposure by leaving the area or by some other appropriate means.

Additional details can be found in FCC OET 65.

## CALCULATIONS

Calculations were done for the proposed T-Mobile Wireless antenna facility located at **22 Wayside Lane, Redding, CT**, using the equipment information listed below. All calculations were performed per the specifications under FCC OET 65. Since T-Mobile is proposing highly focused directional panel antennas, which project most of the emitted energy out toward the horizon, all calculations were performed assuming a lobe representing the maximum gain of the antenna per the antenna manufactures supplied specifications, minus 10 dB, was focused at the base of the tower. For this report the sample point is the top of a 6-foot person standing at the base of the tower.

For all calculations, all equipment was calculated using the following assumptions:

- 1) 2 UMTS channels (AWS Band – 2100 MHz) were considered for each sector of the proposed installation. These Channels have a transmit power of 30 Watts per Channel.
- 2) 2 LTE channels (AWS Band – 2100 MHz) were considered for each sector of the proposed installation. These Channels have a transmit power of 60 Watts per Channel
- 3) 1 LTE channel (700 MHz Band) was considered for each sector of the proposed installation. This channel has a transmit power of 30 Watts.
- 4) All radios at the proposed installation were considered to be running at full power and were uncombined in their RF transmissions paths per carrier prescribed configuration. Per FCC OET Bulletin No. 65 - Edition 97-01 recommendations to achieve the maximum anticipated value at each sample point, all power levels emitting from the proposed antenna installation are increased by a factor of 2.56 to account for possible in-phase reflections from the surrounding environment. This is rarely the case, and if so, is never continuous.



- 5) For the following calculations the sample point was the top of a 6-foot person standing at the base of the tower. The maximum gain of the antenna per the antenna manufactures supplied specifications minus 10 dB was used in this direction. This value is a very conservative estimate as gain reductions for these particular antennas are typically much higher in this direction.
- 6) The antennas used in this modeling are the **RFS APXV18-206516S-C-A20** for 2100 MHz (AWS) channels and the **Commscope LNX-6515DS-VTM** for 700 MHz channels. This is based on feedback from the carrier with regards to anticipated antenna selection. The **RFS APXV18-206516S-C-A20** has a maximum gain of **16.3 dBd** at its main lobe at 2100 MHz. The **Commscope LNX-6515DS-VTM** has a maximum gain of **14.6 dBd** at its main lobe at 700 MHz. The maximum gain of the antenna per the antenna manufactures supplied specifications, minus 10 dB, was used for all calculations. This value is a very conservative estimate as gain reductions for these particular antennas are typically much higher in this direction.
- 7) The antenna mounting height centerline of the proposed antennas is **87 feet** above ground level (AGL).
- 8) Emissions values for additional carriers were taken from the Connecticut Siting Council active database. Values in this database are provided by the individual carriers themselves.
- 9) All calculations were done with respect to uncontrolled / general public threshold limits.





## T-Mobile Site Inventory and Power Data

Sector:	A	Sector:	B	Sector:	C
Antenna #:	1	Antenna #:	1	Antenna #:	1
Make / Model:	RFS APXV18-206516S-C-A20	Make / Model:	RFS APXV18-206516S-C-A20	Make / Model:	RFS APXV18-206516S-C-A20
Gain:	16.3 dBd	Gain:	16.3 dBd	Gain:	16.3 dBd
Height (AGL):	87	Height (AGL):	87	Height (AGL):	87
Frequency Bands	2100 MHz (AWS)	Frequency Bands	2100 MHz (AWS)	Frequency Bands	2100 MHz (AWS)
Channel Count	2	Channel Count	4	Channel Count	4
Total TX Power(W):	90	Total TX Power(W):	180	Total TX Power(W):	180
ERP (W):	3,839.22	ERP (W):	7,678.43	ERP (W):	7,678.43
Antenna A1 MPE%	2.10	Antenna B1 MPE%	4.21	Antenna C1 MPE%	4.21
Antenna #:	2	Antenna #:	2	Antenna #:	2
Make / Model:	Commscope LNX-6515DS-VTM	Make / Model:	Commscope LNX-6515DS-VTM	Make / Model:	Commscope LNX-6515DS-VTM
Gain:	14.6 dBd	Gain:	14.6 dBd	Gain:	14.6 dBd
Height (AGL):	87	Height (AGL):	87	Height (AGL):	87
Frequency Bands	700 MHz	Frequency Bands	700 MHz	Frequency Bands	700 MHz
Channel Count	1	Channel Count	1	Channel Count	1
Total TX Power(W):	30	Total TX Power(W):	30	Total TX Power(W):	30
ERP (W):	865.21	ERP (W):	865.21	ERP (W):	865.21
Antenna A3 MPE%	1.02	Antenna B3 MPE%	1.02	Antenna C3 MPE%	1.02

Site Composite MPE%	
Carrier	MPE%
T-Mobile (Per Sector Max)	5.22 %
AT&T	1.90 %
<b>Site Total MPE %:</b>	<b>7.12 %</b>

T-Mobile Sector A Total:	3.12 %
T-Mobile Sector B Total:	5.22 %
T-Mobile Sector C Total:	5.22 %
<b>Site Total:</b>	<b>7.12 %</b>

T-Mobile _per sector	# Channels	Watts ERP (Per Channel)	Height (feet)	Total Power Density ( $\mu\text{W}/\text{cm}^2$ )	Frequency (MHz)	Allowable MPE ( $\mu\text{W}/\text{cm}^2$ )	Calculated % MPE
T-Mobile 2100 MHz (AWS) LTE	2	2559.74	87	28.05	2100	1000	2.80 %
T-Mobile 2100 MHz (AWS) UMTS	2	1279.48	87	14.02	2100	1000	1.40 %
T-Mobile 700 MHz LTE	1	865.21	87	4.74	700	467	1.02 %
						<b>Total*:</b>	<b>5.22 %</b>

\*NOTE: Totals may vary by .01% due to summing of remainders



## Summary

All calculations performed for this analysis yielded results that were **within** the allowable limits for general public exposure to RF Emissions.

The anticipated maximum composite contributions from the T-Mobile facility as well as the site composite emissions value with regards to compliance with FCC's allowable limits for general public exposure to RF Emissions are shown here:

T-Mobile Sector	Power Density Value (%)
Sector A:	3.12 %
Sector B:	5.22 %
Sector C:	5.22 %
T-Mobile Per Sector Maximum:	5.22 %
Site Total:	7.12 %
Site Compliance Status:	<b>COMPLIANT</b>

The anticipated composite MPE value for this site assuming all carriers present is **7.12%** of the allowable FCC established general public limit sampled at the ground level. This is based upon values listed in the Connecticut Siting Council database for existing carrier emissions.

FCC guidelines state that if a site is found to be out of compliance (over allowable thresholds), that carriers over a 5% contribution to the composite value will require measures to bring the site into compliance. For this facility, the composite values calculated were well within the allowable 100% threshold standard per the federal government.