



10 INDUSTRIAL AVE,
SUITE 3
MAHWAH NJ 07430
PHONE: 201.684.0055

May 19, 2017

Melanie A. Bachman
Acting Executive Director
Connecticut Siting Council
10 Franklin Square
New Britain, CT 06051

Notice of Exempt Modification
74 Goodrich Lane, Portland, CT 06840
Latitude- 41.60826900
Longitude- -72.59157400

Dear Ms. Bachman,

T-Mobile currently maintains (6) existing antennas at the 137' level of the existing 160' monopole located at 74 Goodrich Lane in Portland, CT. The tower is owned by Crown Castle. The property is owned by Joan Hale. T-Mobile now intends to add (3) TMAs and (6) coax. T-Mobile is not changing its current antenna configuration.

The facility was approved by the Connecticut Siting Council in Docket No. 58 on July 11, 1986. This modification complies with this original approval.

Please accept this letter as notification pursuant to Regulations of Connecticut State Agencies 16-50j-73, for construction that constitutes an exempt modification pursuant to R.C.S.A. 16-50j-72(b)(2). In accordance with R.C.S.A. 16-50j-73, a copy of this letter is being sent to Susan S. Bransfield, First Selectwoman for the Town of Portland, as well as the property owner and tower owner.

The planned modifications to the facility fall squarely within those activities explicitly provided for in R.C.S.A. 16-50j-72(b)(2).

1. The proposed modification will not result in an increase in the height of the existing structure
2. The proposed modifications will not require the extension of the site boundary.
3. The proposed modifications will not increase noise levels at the facility by six decibels or more, or to levels that exceed state and local criteria.
4. The operation of the replacement antennas will not increase radio frequency emissions at the facility to a level at or above the Federal Communications Commission safety standard.
5. The proposed modification will not cause a change or alteration in the physical or environmental characteristics of the site.

6. The existing structure and its foundation can support the proposed loading.

For the foregoing reasons, T-Mobile respectfully submits that the proposed modifications to the above-referenced telecommunications facility constitute an exempt modification under R.C.S.A. 16-50j-72(b)(2).

Sincerely,

Kyle Richers

Kyle Richers
Transcend Wireless
10 Industrial Ave., Suite 3
Mahwah, New Jersey 07430
908-447-4716
krichers@transcendwireless.com

cc: Susan S. Bransfield- as elected official
Crown Castle- as tower owner
Joan Hale- as property owner
Dan Bourret- as zoning official

Portland, CT : Assessor Database

Property Search:

Parcel ID:	Alternate ID:	Owner 1 Name:	Street Number:	Street Name:
<input type="text"/>	<input type="text"/>	<input type="text"/>	74	GOODRICH LANE ▼

Property Detail:

Parcel ID:	Alternate ID/Map Block Lot:	Card:	Card:	Street Name:	Street Number:	Zoning:	LUC:	Acres:
084-0009	00354100			GOODRICH LANE	74	R25	Communication Towers	0.08

Owner Information:

Owner 1 Name:	HALE JOAN J
Owner 2 Name:	CROWN ATLANTIC LLC
Street 1:	PMB 353
Street 2:	4017 WASHINGTON RD
City:	MCMURRAY
State:	PA
Zip:	15317
Volume:	284
Page:	47

Property Images:

Picture:

There is no picture available.

Sketch:

There is no sketch available.

Valuation:

Appraised Land:	\$74,900.00
Appraised Bldg:	\$139,200.00
Appraised Total:	\$214,100.00
Total Assessment:	\$149,870.00

Out-Buildings:

Code:	Description:	Units:	Year Built:	Size1:	Size2:	Area:	Grade:	Condition:
FN1	FENCE CHAIN	3	1996	8	260	0	2	
TT4	TOWER CELLULAR	4	1978	1	160	0	1	
SH1	FRAME MACHINERY SHED	4	1978	1	200	0	2	
SH1	FRAME MACHINERY SHED	4	2000	1	96	0	9	
PC3	PAVING CONCRETE MAT/SLAB	3	1996	1	2640	0	2	

The information delivered through this on-line database is provided in the spirit of open access to government information and is intended as an enhanced service and convenience for citizens of Portland, CT.

The providers of this database: Tyler CLT, Big Room Studios, and Portland, CT assume no liability for any error or omission in the information provided here.

Comments regarding this service should be directed to: assessor@portlandct.org

Google Maps 74 Goodrich Ln



Imagery ©2017 Google, Map data ©2017 Google 100 ft 

RADIO FREQUENCY EMISSIONS ANALYSIS REPORT
EVALUATION OF HUMAN EXPOSURE POTENTIAL
TO NON-IONIZING EMISSIONS

T-Mobile Existing Facility

Site ID: CT11252A

Portland Rt. 66/Rt. 151
74 Goodrich Lane
Portland, CT 06480

May 10, 2017

EBI Project Number: 6217002017

Site Compliance Summary	
Compliance Status:	COMPLIANT
Site total MPE% of FCC general public allowable limit:	10.61 %

May 10, 2017

T-Mobile USA
Attn: Jason Overbey, RF Manager
35 Griffin Road South
Bloomfield, CT 06002

Emissions Analysis for Site: **CT11252A – Portland Rt. 66/Rt. 151**

EBI Consulting was directed to analyze the proposed T-Mobile facility located at **74 Goodrich Lane, Portland, CT**, for the purpose of determining whether the emissions from the Proposed T-Mobile Antenna Installation located on this property are within specified federal limits.

All information used in this report was analyzed as a percentage of current Maximum Permissible Exposure (% MPE) as listed in the FCC OET Bulletin 65 Edition 97-01 and ANSI/IEEE Std C95.1. The FCC regulates Maximum Permissible Exposure in units of microwatts per square centimeter ($\mu\text{W}/\text{cm}^2$). The number of $\mu\text{W}/\text{cm}^2$ calculated at each sample point is called the power density. The exposure limit for power density varies depending upon the frequencies being utilized. Wireless Carriers and Paging Services use different frequency bands each with different exposure limits, therefore it is necessary to report results and limits in terms of percent MPE rather than power density.

All results were compared to the FCC (Federal Communications Commission) radio frequency exposure rules, 47 CFR 1.1307(b)(1) – (b)(3), to determine compliance with the Maximum Permissible Exposure (MPE) limits for General Population/Uncontrolled environments as defined below.

General population/uncontrolled exposure limits apply to situations in which the general public may be exposed or in which persons who are exposed as a consequence of their employment may not be made fully aware of the potential for exposure or cannot exercise control over their exposure. Therefore, members of the general public would always be considered under this category when exposure is not employment related, for example, in the case of a telecommunications tower that exposes persons in a nearby residential area.

Public exposure to radio frequencies is regulated and enforced in units of microwatts per square centimeter ($\mu\text{W}/\text{cm}^2$). The general population exposure limit for the 700 MHz Band is approximately 467 $\mu\text{W}/\text{cm}^2$, and the general population exposure limit for the 1900 MHz (PCS) and 2100 MHz (AWS) bands is 1000 $\mu\text{W}/\text{cm}^2$. Because each carrier will be using different frequency bands, and each frequency band has different exposure limits, it is necessary to report percent of MPE rather than power density.

Occupational/controlled exposure limits apply to situations in which persons are exposed as a consequence of their employment and in which those persons who are exposed have been made fully aware of the potential for exposure and can exercise control over their exposure. Occupational/controlled exposure limits also apply where exposure is of a transient nature as a result of incidental passage through a location where exposure levels may be above general population/uncontrolled limits (see below), as long as the exposed person has been made fully aware of the potential for exposure and can exercise control over his or her exposure by leaving the area or by some other appropriate means.

Additional details can be found in FCC OET 65.

CALCULATIONS

Calculations were done for the proposed T-Mobile Wireless antenna facility located at **74 Goodrich Lane, Portland, CT**, using the equipment information listed below. All calculations were performed per the specifications under FCC OET 65. Since T-Mobile is proposing highly focused directional panel antennas, which project most of the emitted energy out toward the horizon, all calculations were performed assuming a lobe representing the maximum gain of the antenna per the antenna manufactures supplied specifications, minus 10 dB, was focused at the base of the tower. For this report the sample point is the top of a 6-foot person standing at the base of the tower.

For all calculations, all equipment was calculated using the following assumptions:

- 1) 2 UMTS channels (AWS Band – 2100 MHz) were considered for each sector of the proposed installation. These Channels have a transmit power of 30 Watts per Channel.
- 2) 2 LTE channels (PCS Band - 1900 MHz) were considered for each sector of the proposed installation. These Channels have a transmit power of 60 Watts per Channel.
- 3) 2 LTE channels (AWS Band – 2100 MHz) were considered for each sector of the proposed installation. These Channels have a transmit power of 60 Watts per Channel
- 4) 1 LTE channel (700 MHz Band) was considered for each sector of the proposed installation. This channel has a transmit power of 30 Watts.
- 5) Since the 2100 MHz UMTS radios are ground mounted there are additional cabling losses accounted for. For each ground mounted 2100 MHz UMTS RF path an additional 1.58 dB of loss was factored into the calculations used for this analysis. This is based on manufacturers Specifications for 150 feet of 1-5/8” coax cable on each path.

- 6) All radios at the proposed installation were considered to be running at full power and were uncombined in their RF transmissions paths per carrier prescribed configuration. Per FCC OET Bulletin No. 65 - Edition 97-01 recommendations to achieve the maximum anticipated value at each sample point, all power levels emitting from the proposed antenna installation are increased by a factor of 2.56 to account for possible in-phase reflections from the surrounding environment. This is rarely the case, and if so, is never continuous.
- 7) For the following calculations the sample point was the top of a 6-foot person standing at the base of the tower. The maximum gain of the antenna per the antenna manufactures supplied specifications minus 10 dB was used in this direction. This value is a very conservative estimate as gain reductions for these particular antennas are typically much higher in this direction.
- 8) The antennas used in this modeling are the **Ericsson AIR21 B4A/B2P** for 1900 MHz (PCS) and 2100 MHz (AWS) channels and the **Commscope SBNH-1D65C-SR** for 2100 MHz (AWS) and 700 MHz channels. This is based on feedback from the carrier with regards to anticipated antenna selection. The **Ericsson AIR21 B4A/B2P** has a maximum gain of **15.9 dBd** at its main lobe at 1900 MHz and 2100 MHz. The **Commscope SBNH-1D65C-SR** has a maximum gain of **16.15 dBd** at its main lobe 2100 MHz and a maximum gain of **13.95 dBd** at its main lobe at 700 MHz. The maximum gain of the antenna per the antenna manufactures supplied specifications, minus 10 dB, was used for all calculations. This value is a very conservative estimate as gain reductions for these particular antennas are typically much higher in this direction.
- 9) The antenna mounting height centerline of the proposed antennas is **137 feet** above ground level (AGL).
- 10) Emissions values for additional carriers were taken from the Connecticut Siting Council active database. Values in this database are provided by the individual carriers themselves.
- 11) All calculations were done with respect to uncontrolled / general public threshold limits.

T-Mobile Site Inventory and Power Data

Sector:	A	Sector:	B	Sector:	C
Antenna #:	1	Antenna #:	1	Antenna #:	1
Make / Model:	Ericsson AIR21 B4A/B2P	Make / Model:	Ericsson AIR21 B4A/B2P	Make / Model:	Ericsson AIR21 B4A/B2P
Gain:	15.9 dBd	Gain:	15.9 dBd	Gain:	15.9 dBd
Height (AGL):	137	Height (AGL):	137	Height (AGL):	137
Frequency Bands	1900 MHz (PCS) / 2100 MHz (AWS)	Frequency Bands	1900 MHz (PCS) / 2100 MHz (AWS)	Frequency Bands	1900 MHz (PCS) / 2100 MHz (AWS)
Channel Count	4	Channel Count	4	Channel Count	4
Total TX Power(W):	240	Total TX Power(W):	240	Total TX Power(W):	240
ERP (W):	9,337.08	ERP (W):	9,337.08	ERP (W):	9,337.08
Antenna A1 MPE%	1.96	Antenna B1 MPE%	1.96	Antenna C1 MPE%	1.96
Antenna #:	2	Antenna #:	2	Antenna #:	2
Make / Model:	Commscope SBNH-1D65C-SR	Make / Model:	Commscope SBNH-1D65C-SR	Make / Model:	Commscope SBNH-1D65C-SR
Gain:	16.15 / 13.95 dBd	Gain:	16.15 / 13.95 dBd	Gain:	16.15 / 13.95 dBd
Height (AGL):	137	Height (AGL):	137	Height (AGL):	137
Frequency Bands	2100 MHz (AWS) / 700 MHz	Frequency Bands	2100 MHz (AWS) / 700 MHz	Frequency Bands	2100 MHz (AWS) / 700 MHz
Channel Count	4	Channel Count	4	Channel Count	4
Total TX Power(W):	120	Total TX Power(W):	120	Total TX Power(W):	120
ERP (W):	3,204.43	ERP (W):	3,204.43	ERP (W):	3,204.43
Antenna A2 MPE%	1.03	Antenna B2 MPE%	1.03	Antenna C2 MPE%	1.03

Site Composite MPE%	
Carrier	MPE%
T-Mobile (Per Sector Max)	2.98 %
AT&T	4.19 %
Verizon Wireless	1.94 %
Clearwire	0.10 %
Sprint	1.40 %
Site Total MPE %:	10.61 %

T-Mobile Sector A Total:	2.98 %
T-Mobile Sector B Total:	2.98 %
T-Mobile Sector C Total:	2.98 %
Site Total*:	10.61 %

T-Mobile_Max Values per sector	# Channels	Watts ERP (Per Channel)	Height (feet)	Total Power Density ($\mu\text{W}/\text{cm}^2$)	Frequency (MHz)	Allowable MPE ($\mu\text{W}/\text{cm}^2$)	Calculated % MPE
T-Mobile AWS - 2100 MHz LTE	2	2,334.27	137	9.78	AWS - 2100 MHz	1000	0.98%
T-Mobile PCS - 1900 MHz LTE	2	2,334.27	137	9.78	PCS - 1900 MHz	1000	0.98%
T-Mobile AWS - 2100 MHz UMTS	2	857.28	137	3.59	AWS - 2100 MHz	1000	0.36%
T-Mobile 700 MHz LTE	2	744.94	137	3.12	700 MHz	467	0.67%
						Total*	2.98%

*NOTE: Totals may vary by 0.01% due to summing of remainders

Summary

All calculations performed for this analysis yielded results that were **within** the allowable limits for general public exposure to RF Emissions.

The anticipated maximum composite contributions from the T-Mobile facility as well as the site composite emissions value with regards to compliance with FCC's allowable limits for general public exposure to RF Emissions are shown here:

T-Mobile Sector	Power Density Value (%)
Sector A:	2.98 %
Sector B:	2.98 %
Sector C:	2.98 %
T-Mobile Per Sector Maximum:	2.98 %
Site Total:	10.61 %
Site Compliance Status:	COMPLIANT

The anticipated composite MPE value for this site assuming all carriers present is **10.61%** of the allowable FCC established general public limit sampled at the ground level. This is based upon values listed in the Connecticut Siting Council database for existing carrier emissions.

FCC guidelines state that if a site is found to be out of compliance (over allowable thresholds), that carriers over a 5% contribution to the composite value will require measures to bring the site into compliance. For this facility, the composite values calculated were well within the allowable 100% threshold standard per the federal government.

Date: **April 18, 2017**



Sean Dempsey
Crown Castle
3530 Toringdon Way Suite 300
Charlotte, NC 28277

Black & Veatch Corp.
6800 W. 115th St., Suite 2292
Overland Park, KS 66211
(913) 458-8145

Subject: Structural Analysis Report

Carrier Designation: *T-Mobile Co-Locate*
Carrier Site Number: CT11252A
Carrier Site Name: Portland Rt. 66/Rt. 151

Crown Castle Designation:
Crown Castle BU Number: 806382
Crown Castle Site Name: HRT 082 943274
Crown Castle JDE Job Number: 434834
Crown Castle Work Order Number: 1391529
Crown Castle Application Number: 387889 Rev. 0

Engineering Firm Designation: **Black & Veatch Corp. Project Number:** 194393

Site Data: **74 Goodrich Lane, Portland, Middlesex County, CT**
Latitude 41° 36' 29.9", Longitude -72° 35' 29.56"
160 Foot - Monopole Tower

Dear Sean Dempsey,

Black & Veatch Corp. is pleased to submit this "**Structural Analysis Report**" to determine the structural integrity of the above mentioned tower. This analysis has been performed in accordance with the Crown Castle Structural 'Statement of Work' and the terms of Crown Castle Purchase Order Number 1025919, in accordance with application 387889, revision 0.

The purpose of the analysis is to determine acceptability of the tower stress level. Based on our analysis we have determined the tower stress level for the structure and foundation, under the following load case, to be:

LC7: Existing + Reserved + Proposed Equipment **Sufficient Capacity**
Note: See Table I and Table II for the proposed and existing/reserved loading, respectively.

This analysis has been performed in accordance with the 2016 Connecticut State Building Code based upon an ultimate 3-second gust wind speed of 130 mph converted to a nominal 3-second gust wind speed of 101 mph per Section 1609.3 and Appendix N as required for use in the TIA-222-G Standard per Exception #5 of Section 1609.1.1. Exposure Category B with a maximum topographic factor, Kzt, of 1.0 and Risk Category II were used in this analysis. Seismic forces have been evaluated based on Site Class D with spectral response factors S_s of 0.180g and S₁ of 0.063g.

We at *Black & Veatch Corp.* appreciate the opportunity of providing our continuing professional services to you and Crown Castle. If you have any questions or need further assistance on this or any other projects please give us a call.

Structural analysis prepared by: Patdanai Chongcharoenkamon/ Sheetal Ajgaonkar

Respectfully submitted by:

Ping Jiang, P.E.
Professional Engineer



TABLE OF CONTENTS

1) INTRODUCTION

2) ANALYSIS CRITERIA

Table 1 - Proposed Antenna and Cable Information

Table 2 - Existing and Reserved Antenna and Cable Information

Table 3 - Design Antenna and Cable Information

3) ANALYSIS PROCEDURE

Table 4 - Documents Provided

3.1) Analysis Method

3.2) Assumptions

4) ANALYSIS RESULTS

4.1) Wind Results

Table 5 - Section Capacity (Summary)

Table 6 – Tower Components vs. Capacity

4.2) Seismic Results

4.3) Recommendations

5) APPENDIX A

tnxTower Output

6) APPENDIX B

Base Level Drawing

7) APPENDIX C

Additional Calculations

1) INTRODUCTION

This tower is a 160 ft Monopole tower designed by Valmont in January of 1998. The tower was originally designed for a wind speed of 85 mph per TIA/EIA-222-F.

The tower has been modified per reinforcement drawing prepared by B+T Group in May of 2013. Reinforcement consists of installation of reinforcement flat plates from elevation 42.5' to 52.5'. Refer to Modification Inspection Report prepared by Tower Engineering Professionals in September of 2013. The reinforcement was found out to be ineffective as per the analysis.

2) ANALYSIS CRITERIA

The structural analysis was performed for this tower in accordance with the requirements of TIA-222-G Structural Standards for Antenna Supporting Structures and Antennas using a 3-second gust wind speed of 101 mph with no ice, 50 mph with 0.75 inch ice thickness and 60 mph under service loads, exposure category B with topographic category 1 and crest height of 0 feet. Seismic forces have been evaluated based on Site Class D with spectral response factors S_S of 0.180g and S_1 of 0.063g.

Table 1 - Proposed Antenna and Cable Information

Mounting Level (ft)	Center Line Elevation (ft)	Number of Antennas	Antenna Manufacturer	Antenna Model	Number of Feed Lines	Feed Line Size (in)	Note
134.0	137.0	3	commscope	TMAT1921B78-21A	6	1-5/8	1

Notes:

- 1) See Appendix B for proposed coax configuration

Table 2 - Existing and Reserved Antenna and Cable Information

Mounting Level (ft)	Center Line Elevation (ft)	Number of Antennas	Antenna Manufacturer	Antenna Model	Number of Feed Lines	Feed Line Size (in)	Note
158.0	160.0	3	alcatel lucent	RRH2X60-AWS	1 2 11	1/2 1-1/4 1-5/8	1
		3	alcatel lucent	RRH2X60-PCS			
		3	alcatel lucent	RRH2x60-700			
		3	andrew	HBXX-6517DS-A2M w/ Mount Pipe			
		6	andrew	SBNHH-1D65B w/ Mount Pipe			
		2	decibel	DB846F65ZAXY w/ Mount Pipe			
		4	decibel	DB846H80E-SX w/ Mount Pipe			
		1	rfs celwave	DB-B1-6C-8AB-0Z			
		1	rfs celwave	DB-T1-6Z-8AB-0Z			
	2	rfs celwave	FD9R6004/2C-3L				
	158.0	1	cci tower mounts	Platform Mount 13' [LP 713-1]			
150.0	152.0	3	alcatel lucent	1900MHZ RRH	2	1	2
		3	alcatel lucent	800MHZ RRH	3	1-1/4	

Mounting Level (ft)	Center Line Elevation (ft)	Number of Antennas	Antenna Manufacturer	Antenna Model	Number of Feed Lines	Feed Line Size (in)	Note
		3	argus technologies	LLPX310R-V1 w/ Mount Pipe			
		1	box enclosures and assembly	BEN-92P			
		3	nokia	FWHR			
		3	rfs celwave	APXVSPP18-C-A20 w/ Mount Pipe			
	150.0	1	cci tower mounts	Platform Mount 13' [LP 713-1]	-	-	1
142.0	144.0	2	radiowaves	HP3-11	2	1/2	1
	142.0	1	cci tower mounts	Side Arm Mount [SO 101-3]			
134.0	137.0	3	commscope	SBNH-1D65C-SR w/ Mount Pipe	1	1-5/8	1
		3	ericsson	ERICSSON AIR 21 B4A B2P w/ Mount Pipe			
		3	ericsson	RRUS 11 B12			
	3	ericsson	RRUS 11 B2				
	134.0	1	cci tower mounts	T-Arm Mount [TA 602-3]			
116.0	120.0	3	ericsson	RRUS 11	-	-	2
		3	ericsson	RRUS 12			
		3	powerwave technologies	1001983			
		12	powerwave technologies	7020.00			
		6	powerwave technologies	LGP13519			
		3	kmw communications	AM-X-CD-16-65-00T-RET w/ Mount Pipe			
		6	powerwave technologies	7770.00 w/ Mount Pipe			
		6	powerwave technologies	LGP21401			
	1	raycap	DC6-48-60-18-8F				
	116.0	1	cci tower mounts	Platform Mount [LP 303-1]	1 2 12	3/8 3/4 1-1/4	1
61.0	61.0	2	lucent	KS24019-L112A	2	1/2	1
		2	tower mounts	Side Arm Mount [SO 701-1]			
50.0	50.0	2	tower mounts	Side Arm Mount [SO 701-1]	-	-	1

Notes:

- 1) Existing Equipment
- 2) Reserved Equipment

Table 3 - Design Antenna and Cable Information

Mounting Level (ft)	Center Line Elevation (ft)	Number of Antennas	Antenna Manufacturer	Antenna Model	Number of Feed Lines	Feed Line Size (in)
157	157	12	swedcom	ALP 9212-N	-	-
148	148	12	swedcom	ALP 9212-N	-	-
138	138	12	swedcom	ALP 9212-N	-	-
128	128	12	swedcom	ALP 9212-N	-	-
60	60	2	generic	GPS	-	-
50	50	2	generic	GPS	-	-

3) ANALYSIS PROCEDURE

Table 4 - Documents Provided

Document	Remarks	Reference	Source
4-GEOTECHNICAL REPORTS	Timmerman Geotechnical Group, Inc.	1041653	CCISITES
4-POST-MODIFICATION INSPECTION	Tower Engineering Professionals	3996803	CCISITES
4-TOWER FOUNDATION DRAWINGS/DESIGN/SPECS	Valmont	301226	CCISITES
4-TOWER MANUFACTURER DRAWINGS	Valmont	255193	CCISITES
4-TOWER REINFORCEMENT DESIGN/DRAWINGS/DATA	B+T Group	3865159	CCISITES
4-TOWER STRUCTURAL ANALYSIS REPORTS	B+T Group	6591190	CCISITES
4-EXPOSURE CATEGORY/TOPOGRAPHIC FACTOR	Crown Castle	6139551	CCISITES

3.1) Analysis Method

tnxTower (version 7.0.5.1), a commercially available analysis software package, was used to create a three-dimensional model of the tower and calculate member stresses for various loading cases. Selected output from the analysis is included in Appendix A.

3.2) Assumptions

- 1) Tower and structures were built in accordance with the manufacturer's specifications.
- 2) The tower and structures have been maintained in accordance with the manufacturer's specification.
- 3) The configuration of antennas, transmission cables, mounts and other appurtenances are as specified in Tables 1 and 2 and the referenced drawings.
- 4) The wind loading Exposure Category / Topographic Category for this site have been analyzed and determined by the tower owner. Black & Veatch does not assume any responsibility for its accuracy.
- 5) This analysis was performed under the assumption that all information provided to Black & Veatch is current and correct. This is to include site data, existing/proposed appurtenance loading, tower/foundation details, and geotechnical data. The existing/proposed loading on the structure is based on CAD level drawings and carrier applications provided by the owner. If any

of this information is not current and correct, this report should be considered obsolete and further analysis will be required.

This analysis may be affected if any assumptions are not valid or have been made in error. Black & Veatch Corp. should be notified to determine the effect on the structural integrity of the tower.

4) ANALYSIS RESULTS

4.1) Wind Results

Table 5 - Section Capacity (Summary)

Elevation (ft)	Component Type	Size	Critical Element	% Capacity	Pass / Fail
160 - 158.1	Pole	TP19.402x18.87x0.1875	Pole	0.1%	Pass
158.1 - 153.1	Pole	TP20.803x19.402x0.1875	Pole	16.2%	Pass
153.1 - 148.1	Pole	TP22.204x20.803x0.1875	Pole	29.9%	Pass
148.1 - 143.1	Pole	TP23.605x22.204x0.1875	Pole	43.9%	Pass
143.1 - 138.1	Pole	TP25.006x23.605x0.1875	Pole	57.6%	Pass
138.1 - 133.1	Pole	TP26.407x25.006x0.1875	Pole	72.1%	Pass
133.1 - 128.1	Pole	TP27.808x26.407x0.1875	Pole	86.0%	Pass
128.1 - 128	Pole	TP29.05x27.808x0.1875	Pole	86.3%	Pass
128 - 123	Pole	TP28.861x27.461x0.3125	Pole	47.5%	Pass
123 - 118	Pole	TP30.261x28.861x0.3125	Pole	52.2%	Pass
118 - 113	Pole	TP31.661x30.261x0.3125	Pole	58.0%	Pass
113 - 108	Pole	TP33.061x31.661x0.3125	Pole	62.8%	Pass
108 - 103	Pole	TP34.46x33.061x0.3125	Pole	67.2%	Pass
103 - 98	Pole	TP35.86x34.46x0.3125	Pole	71.1%	Pass
98 - 93	Pole	TP37.26x35.86x0.3125	Pole	74.8%	Pass
93 - 88	Pole	TP38.66x37.26x0.3125	Pole	78.2%	Pass
88 - 83	Pole	TP40.06x38.66x0.3125	Pole	81.5%	Pass
83 - 82	Pole	TP41.95x40.06x0.3125	Pole	82.1%	Pass
82 - 75.25	Pole	TP41.606x39.715x0.3438	Pole	76.3%	Pass
75.25 - 70.25	Pole	TP43.006x41.606x0.3438	Pole	78.6%	Pass
70.25 - 65.25	Pole	TP44.407x43.006x0.3438	Pole	80.8%	Pass
65.25 - 60.25	Pole	TP45.807x44.407x0.3438	Pole	83.0%	Pass
60.25 - 55.25	Pole	TP47.208x45.807x0.3438	Pole	85.1%	Pass
55.25 - 51	Pole	TP48.398x47.208x0.3438	Pole	86.8%	Pass
51 - 50.75	Pole	TP48.469x48.398x0.3438	Pole	87.0%	Pass
50.75 - 45.75	Pole	TP49.869x48.469x0.3438	Pole	89.0%	Pass
45.75 - 44	Pole	TP52.32x49.869x0.3438	Pole	89.7%	Pass
44 - 36	Pole	TP51.913x49.672x0.4063	Pole	72.6%	Pass
36 - 31	Pole	TP53.314x51.913x0.4063	Pole	73.8%	Pass
31 - 26	Pole	TP54.715x53.314x0.4063	Pole	75.0%	Pass
26 - 21	Pole	TP56.116x54.715x0.4063	Pole	76.2%	Pass
21 - 16	Pole	TP57.517x56.116x0.4063	Pole	77.4%	Pass
16 - 11	Pole	TP58.918x57.517x0.4063	Pole	78.6%	Pass
11 - 6	Pole	TP60.319x58.918x0.4063	Pole	79.8%	Pass

Elevation (ft)	Component Type	Size	Critical Element	% Capacity	Pass / Fail
6 - 1	Pole	TP61.72x60.319x0.4063	Pole	81.0%	Pass
1 - 0	Pole	TP62x61.72x0.4063	Pole	81.3%	Pass
				Summary	
			Pole	89.7%	Pass
			Reinforcement	0.0%	Pass
			Overall	89.7%	Pass

Table 6 - Tower Component Stresses vs. Capacity – LC7

Notes	Component	Elevation (ft)	% Capacity	Pass / Fail
1	Anchor Rods	0	78.5	Pass
1	Base Plate	0	42.5	Pass
1	Base Foundation	0	50.6	Pass
1	Base Foundation Soil Interaction	0	70.8	Pass

4.2) Seismic Results

Tower and foundation have been analyzed based on the seismic criteria outlined in section 2 of this report. Based on the analysis, seismic loading is not governing the tower and foundation stress. Wind loading is governing the tower and foundation stress.

Structure Rating (max from all components) =	89.7%
---	--------------

Notes:

- 1) See additional documentation in "Appendix C – Additional Calculations" for calculations supporting the % capacity consumed.

4.3) Recommendations

The tower, its base plate, anchor rods and foundation have sufficient capacity to carry the existing, reserved, and proposed loads. No modifications are required at this time.

APPENDIX A
TNXTOWER OUTPUT

Section	Length (ft)	Number of Sides	Thickness (in)	Socket Length (ft)	Top Dia (in)	Bot Dia (in)	Grade	Weight (K)
1	1.90	12	0.1875	4.33	19.4024	20.8033	A572-65	0.1
2	5.00	12	0.1875	4.33	22.2042	23.6051	A572-65	0.2
3	5.00	12	0.1875	4.33	25.0061	26.4070	A572-65	0.2
4	5.00	12	0.1875	4.33	27.8079	28.2098	A572-65	0.2
5	5.00	12	0.1875	4.33	30.6097	31.4126	A572-65	0.2
6	5.00	12	0.1875	4.33	33.4115	34.2144	A572-65	0.2
7	5.00	12	0.1875	4.33	36.2133	37.0162	A572-65	0.2
8	5.00	12	0.1875	4.33	39.0151	39.8180	A572-65	0.2
9	5.00	12	0.1875	4.33	41.8169	42.6198	A572-65	0.2
10	5.00	12	0.1875	4.33	44.6187	45.4216	A572-65	0.2
11	5.00	12	0.1875	4.33	47.4205	48.2234	A572-65	0.2
12	5.00	12	0.1875	4.33	50.2223	51.0252	A572-65	0.2
13	5.00	12	0.1875	4.33	53.0241	53.8270	A572-65	0.2
14	5.00	12	0.1875	4.33	55.8259	56.6288	A572-65	0.2
15	5.00	12	0.1875	4.33	58.6277	59.4306	A572-65	0.2
16	5.00	12	0.1875	4.33	61.4295	62.2324	A572-65	0.2
17	5.00	12	0.1875	4.33	64.2313	65.0342	A572-65	0.2
18	5.00	12	0.1875	4.33	67.0331	67.8360	A572-65	0.2
19	5.00	12	0.1875	4.33	69.8349	70.6378	A572-65	0.2
20	5.00	12	0.1875	4.33	72.6367	73.4396	A572-65	0.2
21	5.00	12	0.1875	4.33	75.4385	76.2414	A572-65	0.2
22	5.00	12	0.1875	4.33	78.2403	79.0432	A572-65	0.2
23	5.00	12	0.1875	4.33	81.0421	81.8450	A572-65	0.2
24	5.00	12	0.1875	4.33	83.8439	84.6468	A572-65	0.2
25	5.00	12	0.1875	4.33	86.6457	87.4486	A572-65	0.2
26	5.00	12	0.1875	4.33	89.4475	90.2504	A572-65	0.2
27	5.00	12	0.1875	4.33	92.2493	93.0522	A572-65	0.2
28	5.00	12	0.1875	4.33	95.0511	95.8540	A572-65	0.2
29	5.00	12	0.1875	4.33	97.8529	98.6558	A572-65	0.2
30	5.00	12	0.1875	4.33	100.6547	101.4576	A572-65	0.2
31	5.00	12	0.1875	4.33	103.4565	104.2594	A572-65	0.2
32	5.00	12	0.1875	4.33	106.2583	107.0612	A572-65	0.2
33	5.00	12	0.1875	4.33	109.0601	109.8630	A572-65	0.2
34	5.00	12	0.1875	4.33	111.8619	112.6648	A572-65	0.2
35	5.00	12	0.1875	4.33	114.6637	115.4666	A572-65	0.2
36	1.00	12	0.1875	4.33	117.4655	118.2684	A572-65	0.1

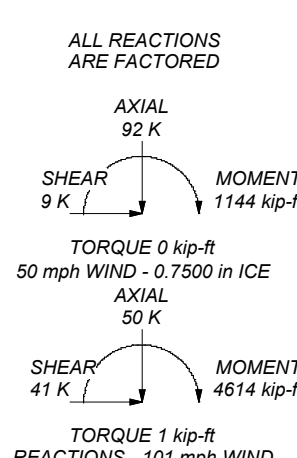
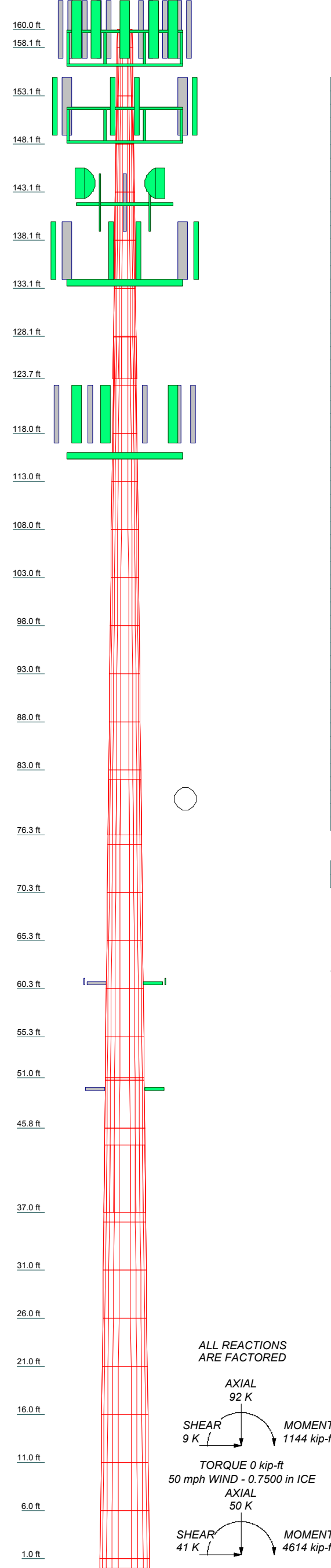

DESIGNED APPURTENANCE LOADING

TYPE	ELEVATION	TYPE	ELEVATION
Platform Mount 13' [LP 713-1]	158	HP3-11	142
(2) DB846H80E-SX w/ Mount Pipe	158	HP3-11	142
(2) DB846H80E-SX w/ Mount Pipe	158	ERICSSON AIR 21 B4A B2P w/ Mount Pipe	134
(2) DB846F65ZAXY w/ Mount Pipe	158	ERICSSON AIR 21 B4A B2P w/ Mount Pipe	134
SBNHH-1D65B w/ Mount Pipe	158	SBNHH-1D65C-SR w/ Mount Pipe	134
SBNHH-1D65B w/ Mount Pipe	158	SBNHH-1D65C-SR w/ Mount Pipe	134
SBNHH-1D65B w/ Mount Pipe	158	TMAT1921B78-21A	134
SBNHH-1D65B w/ Mount Pipe	158	TMAT1921B78-21A	134
SBNHH-1D65B w/ Mount Pipe	158	TMAT1921B78-21A	134
HBXX-6517DS-A2M w/ Mount Pipe	158	RRUS 11 B2	134
HBXX-6517DS-A2M w/ Mount Pipe	158	RRUS 11 B2	134
RRH2x60-700	158	RRUS 11 B12	134
RRH2x60-700	158	RRUS 11 B12	134
RRH2x60-700	158	RRUS 11 B12	134
RRH2X60-PCS	158	T-Arm Mount [TA 602-3]	134
RRH2X60-PCS	158	ERICSSON AIR 21 B4A B2P w/ Mount Pipe	134
RRH2X60-PCS	158	(2) 7770.00 w/ Mount Pipe	116
RRH2X60-AWS	158	(2) 7770.00 w/ Mount Pipe	116
RRH2X60-AWS	158	AM-X-CD-16-65-00T-RET w/ Mount Pipe	116
RRH2X60-AWS	158	AM-X-CD-16-65-00T-RET w/ Mount Pipe	116
DB-B1-6C-8AB-0Z	158	AM-X-CD-16-65-00T-RET w/ Mount Pipe	116
DB-T1-6Z-8AB-0Z	158	(2) LGP13519	116
(2) FD9R6004/2C-3L	158	(2) LGP13519	116
Platform Mount 13' [LP 713-1]	150	(2) LGP13519	116
6' x 2" Mount Pipe	150	(4) 7020.00	116
6' x 2" Mount Pipe	150	(4) 7020.00	116
6' x 2" Mount Pipe	150	RRUS 11	116
6' x 2" Mount Pipe	150	RRUS 11	116
6' x 2" Mount Pipe	150	RRUS 11	116
6' x 2" Mount Pipe	150	RRUS 11	116
APXVSP18-C-A20 w/ Mount Pipe	150	RRUS 12	116
APXVSP18-C-A20 w/ Mount Pipe	150	RRUS 12	116
APXVSP18-C-A20 w/ Mount Pipe	150	RRUS 12	116
LLPX310R-V1 w/ Mount Pipe	150	1001983	116
LLPX310R-V1 w/ Mount Pipe	150	1001983	116
LLPX310R-V1 w/ Mount Pipe	150	1001983	116
800MHZ RRH	150	(2) LGP21401	116
800MHZ RRH	150	(2) LGP21401	116
800MHZ RRH	150	(2) LGP21401	116
1900MHz RRH	150	DC6-48-60-18-8F	116
1900MHz RRH	150	Platform Mount [LP 303-1]	116
1900MHz RRH	150	(2) 7770.00 w/ Mount Pipe	116
FWHR	150	KS24019-L112A	61
FWHR	150	KS24019-L112A	61
BEN-92P	150	2' x 2" Pipe Mount	61
4' x 2" Horizontal Face Mount Pipe	145	Side Arm Mount [SO 701-1]	61
4' x 2" Horizontal Face Mount Pipe	145	Side Arm Mount [SO 701-1]	61
J-Box - 1' x 1' x 4"	145	2' x 2" Pipe Mount	50
(2) 6' x 3" Mount Pipe	142	2' x 2" Pipe Mount	50
Side Arm Mount [SO 101-3]	142	Side Arm Mount [SO 701-1]	50
(2) 6' x 3" Mount Pipe	142	Side Arm Mount [SO 701-1]	50
(2) 6' x 3" Mount Pipe	142	Side Arm Mount [SO 701-1]	50

MATERIAL STRENGTH

GRADE	Fy	Fu	GRADE	Fy	Fu
A572-65	65 ksi	80 ksi			

TOWER DESIGN NOTES

1. Tower is located in Middlesex County, Connecticut.
2. Tower designed for Exposure B to the TIA-222-G Standard.
3. Tower designed for a 101 mph basic wind in accordance with the TIA-222-G Standard.
4. Tower is also designed for a 50 mph basic wind with 0.75 in ice. Ice is considered to increase in thickness with height.
5. Deflections are based upon a 60 mph wind.
6. Tower Structure Class II.
7. Topographic Category 1 with Crest Height of 0.00 ft

Tower Input Data

There is a pole section.

This tower is designed using the TIA-222-G standard.

The following design criteria apply:

Tower is located in Middlesex County, Connecticut.

Basic wind speed of 101 mph.

Structure Class II.

Exposure Category B.

Topographic Category 1.

Crest Height 0.00 ft.

Nominal ice thickness of 0.7500 in.

Ice thickness is considered to increase with height.

Ice density of 56 pcf.

A wind speed of 50 mph is used in combination with ice.

Temperature drop of 50 °F.

Deflections calculated using a wind speed of 60 mph.

A non-linear (P-delta) analysis was used.

Pressures are calculated at each section.

Stress ratio used in pole design is 1.

Local bending stresses due to climbing loads, feed line supports, and appurtenance mounts are not considered.

Options

Consider Moments - Legs Consider Moments - Horizontals Consider Moments - Diagonals Use Moment Magnification ✓ Use Code Stress Ratios ✓ Use Code Safety Factors - Guys Escalate Ice Always Use Max Kz Use Special Wind Profile Include Bolts In Member Capacity Leg Bolts Are At Top Of Section Secondary Horizontal Braces Leg Use Diamond Inner Bracing (4 Sided) SR Members Have Cut Ends SR Members Are Concentric	Distribute Leg Loads As Uniform Assume Legs Pinned ✓ Assume Rigid Index Plate ✓ Use Clear Spans For Wind Area Use Clear Spans For KL/r Retension Guys To Initial Tension ✓ Bypass Mast Stability Checks ✓ Use Azimuth Dish Coefficients ✓ Project Wind Area of Appurt. Autocalc Torque Arm Areas Add IBC .6D+W Combination Sort Capacity Reports By Component Triangulate Diamond Inner Bracing Treat Feed Line Bundles As Cylinder	Use ASCE 10 X-Brace Ly Rules Calculate Redundant Bracing Forces Ignore Redundant Members in FEA SR Leg Bolts Resist Compression All Leg Panels Have Same Allowable Offset Girt At Foundation ✓ Consider Feed Line Torque Include Angle Block Shear Check Use TIA-222-G Bracing Resist. Exemption Use TIA-222-G Tension Splice Exemption <div style="text-align: center; background-color: #e0e0e0; padding: 2px;">Poles</div> ✓ Include Shear-Torsion Interaction Always Use Sub-Critical Flow Use Top Mounted Sockets
--	--	---

Tapered Pole Section Geometry

Section	Elevation ft	Section Length ft	Splice Length ft	Number of Sides	Top Diameter in	Bottom Diameter in	Wall Thickness in	Bend Radius in	Pole Grade
L1	160.00-158.10	1.90	0.00	12	18.8700	19.4024	0.1875	0.7500	A572-65 (65 ksi)
L2	158.10-153.10	5.00	0.00	12	19.4024	20.8033	0.1875	0.7500	A572-65 (65 ksi)
L3	153.10-148.10	5.00	0.00	12	20.8033	22.2042	0.1875	0.7500	A572-65 (65 ksi)
L4	148.10-143.10	5.00	0.00	12	22.2042	23.6051	0.1875	0.7500	A572-65 (65 ksi)
L5	143.10-138.10	5.00	0.00	12	23.6051	25.0061	0.1875	0.7500	A572-65 (65 ksi)
L6	138.10-133.10	5.00	0.00	12	25.0061	26.4070	0.1875	0.7500	A572-65 (65 ksi)
L7	133.10-128.10	5.00	0.00	12	26.4070	27.8079	0.1875	0.7500	A572-65

Section	Elevation ft	Section Length ft	Splice Length ft	Number of Sides	Top Diameter in	Bottom Diameter in	Wall Thickness in	Bend Radius in	Pole Grade
L8	128.10-123.67	4.43	4.33	12	27.8079	29.0500	0.1875	0.7500	(65 ksi) A572-65
L9	123.67-123.00	5.00	0.00	12	27.4610	28.8609	0.3125	1.2500	(65 ksi) A572-65
L10	123.00-118.00	5.00	0.00	12	28.8609	30.2608	0.3125	1.2500	(65 ksi) A572-65
L11	118.00-113.00	5.00	0.00	12	30.2608	31.6607	0.3125	1.2500	(65 ksi) A572-65
L12	113.00-108.00	5.00	0.00	12	31.6607	33.0606	0.3125	1.2500	(65 ksi) A572-65
L13	108.00-103.00	5.00	0.00	12	33.0606	34.4605	0.3125	1.2500	(65 ksi) A572-65
L14	103.00-98.00	5.00	0.00	12	34.4605	35.8604	0.3125	1.2500	(65 ksi) A572-65
L15	98.00-93.00	5.00	0.00	12	35.8604	37.2603	0.3125	1.2500	(65 ksi) A572-65
L16	93.00-88.00	5.00	0.00	12	37.2603	38.6602	0.3125	1.2500	(65 ksi) A572-65
L17	88.00-83.00	5.00	0.00	12	38.6602	40.0601	0.3125	1.2500	(65 ksi) A572-65
L18	83.00-76.25	6.75	5.75	12	40.0601	41.9500	0.3125	1.2500	(65 ksi) A572-65
L19	76.25-75.25	6.75	0.00	12	39.7151	41.6058	0.3438	1.3750	(65 ksi) A572-65
L20	75.25-70.25	5.00	0.00	12	41.6058	43.0064	0.3438	1.3750	(65 ksi) A572-65
L21	70.25-65.25	5.00	0.00	12	43.0064	44.4069	0.3438	1.3750	(65 ksi) A572-65
L22	65.25-60.25	5.00	0.00	12	44.4069	45.8075	0.3438	1.3750	(65 ksi) A572-65
L23	60.25-55.25	5.00	0.00	12	45.8075	47.2080	0.3438	1.3750	(65 ksi) A572-65
L24	55.25-51.00	4.25	0.00	12	47.2080	48.3985	0.3438	1.3750	(65 ksi) A572-65
L25	51.00-50.75	0.25	0.00	12	48.3985	48.4685	0.3438	1.3750	(65 ksi) A572-65
L26	50.75-45.75	5.00	0.00	12	48.4685	49.8690	0.3438	1.3750	(65 ksi) A572-65
L27	45.75-37.00	8.75	7.00	12	49.8690	52.3200	0.3438	1.3750	(65 ksi) A572-65
L28	37.00-36.00	8.00	0.00	12	49.6717	51.9132	0.4063	1.6250	(65 ksi) A572-65
L29	36.00-31.00	5.00	0.00	12	51.9132	53.3142	0.4063	1.6250	(65 ksi) A572-65
L30	31.00-26.00	5.00	0.00	12	53.3142	54.7151	0.4063	1.6250	(65 ksi) A572-65
L31	26.00-21.00	5.00	0.00	12	54.7151	56.1161	0.4063	1.6250	(65 ksi) A572-65
L32	21.00-16.00	5.00	0.00	12	56.1161	57.5170	0.4063	1.6250	(65 ksi) A572-65
L33	16.00-11.00	5.00	0.00	12	57.5170	58.9179	0.4063	1.6250	(65 ksi) A572-65
L34	11.00-6.00	5.00	0.00	12	58.9179	60.3189	0.4063	1.6250	(65 ksi) A572-65
L35	6.00-1.00	5.00	0.00	12	60.3189	61.7198	0.4063	1.6250	(65 ksi) A572-65
L36	1.00-0.00	1.00		12	61.7198	62.0000	0.4063	1.6250	(65 ksi) A572-65

Tapered Pole Properties

Section	Tip Dia. in	Area in ²	I in ⁴	r in	C in	I/C in ³	J in ⁴	It/Q in ²	w in	w/t
L1	19.5357	11.2796	502.5139	6.6883	9.7747	51.4099	1018.2294	5.5515	4.5547	24.292

Section	Tip Dia. in	Area in ²	I in ⁴	r in	C in	I/C in ³	J in ⁴	It/Q in ²	w in	w/t
L2	20.0868	11.6010	546.7066	6.8789	10.0504	54.3964	1107.7758	5.7096	4.6973	25.052
	20.0868	11.6010	546.7066	6.8789	10.0504	54.3964	1107.7758	5.7096	4.6973	25.052
L3	21.5371	12.4468	675.2159	7.3805	10.7761	62.6586	1368.1704	6.1259	5.0728	27.055
	21.5371	12.4468	675.2159	7.3805	10.7761	62.6586	1368.1704	6.1259	5.0728	27.055
L4	22.9875	13.2926	822.4331	7.8820	11.5018	71.5048	1666.4725	6.5422	5.4482	29.057
	22.9875	13.2926	822.4331	7.8820	11.5018	71.5048	1666.4725	6.5422	5.4482	29.057
L5	24.4378	14.1384	989.6297	8.3835	12.2275	80.9350	2005.2580	6.9585	5.8237	31.06
	24.4378	14.1384	989.6297	8.3835	12.2275	80.9350	2005.2580	6.9585	5.8237	31.06
L6	25.8882	14.9842	1178.0768	8.8850	12.9531	90.9491	2387.1030	7.3748	6.1991	33.062
	25.8882	14.9842	1178.0768	8.8850	12.9531	90.9491	2387.1030	7.3748	6.1991	33.062
L7	27.3385	15.8300	1389.0458	9.3866	13.6788	101.5471	2814.5833	7.7911	6.5746	35.064
	27.3385	15.8300	1389.0458	9.3866	13.6788	101.5471	2814.5833	7.7911	6.5746	35.064
L8	28.7889	16.6758	1623.8079	9.8881	14.4045	112.7291	3290.2750	8.2073	6.9500	37.067
	28.7889	16.6758	1623.8079	9.8881	14.4045	112.7291	3290.2750	8.2073	6.9500	37.067
L9	30.0748	17.4257	1852.8699	10.3328	15.0479	123.1315	3754.4168	8.5764	7.2829	38.842
	29.6856	27.3181	2569.9646	9.7191	14.2248	180.6682	5207.4451	13.4452	6.5220	20.871
L10	29.8790	28.7268	2988.3772	10.2203	14.9499	199.8924	6055.2624	14.1385	6.8972	22.071
	29.8790	28.7268	2988.3772	10.2203	14.9499	199.8924	6055.2624	14.1385	6.8972	22.071
L11	31.3283	30.1354	3449.9042	10.7215	15.6751	220.0885	6990.4413	14.8317	7.2724	23.272
	31.3283	30.1354	3449.9042	10.7215	15.6751	220.0885	6990.4413	14.8317	7.2724	23.272
L12	32.7775	31.5441	3956.6600	11.2226	16.4002	241.2564	8017.2658	15.5250	7.6476	24.472
	32.7775	31.5441	3956.6600	11.2226	16.4002	241.2564	8017.2658	15.5250	7.6476	24.472
L13	34.2268	32.9528	4510.7585	11.7238	17.1254	263.3961	9140.0197	16.2183	8.0227	25.673
	34.2268	32.9528	4510.7585	11.7238	17.1254	263.3961	9140.0197	16.2183	8.0227	25.673
L14	35.6761	34.3614	5114.3141	12.2250	17.8505	286.5076	10362.9869	16.9116	8.3979	26.873
	35.6761	34.3614	5114.3141	12.2250	17.8505	286.5076	10362.9869	16.9116	8.3979	26.873
L15	37.1254	35.7701	5769.4408	12.7261	18.5757	310.5910	11690.4513	17.6049	8.7731	28.074
	37.1254	35.7701	5769.4408	12.7261	18.5757	310.5910	11690.4513	17.6049	8.7731	28.074
L16	38.5747	37.1787	6478.2530	13.2273	19.3008	335.6462	13126.6969	18.2982	9.1483	29.274
	38.5747	37.1787	6478.2530	13.2273	19.3008	335.6462	13126.6969	18.2982	9.1483	29.274
L17	40.0240	38.5874	7242.8647	13.7285	20.0260	361.6732	14676.0074	18.9915	9.5234	30.475
	40.0240	38.5874	7242.8647	13.7285	20.0260	361.6732	14676.0074	18.9915	9.5234	30.475
L18	41.4733	39.9960	8065.3901	14.2296	20.7511	388.6721	16342.6669	19.6848	9.8986	31.676
	41.4733	39.9960	8065.3901	14.2296	20.7511	388.6721	16342.6669	19.6848	9.8986	31.676
L19	43.4298	41.8977	9271.4099	14.9062	21.7301	426.6621	18786.3900	20.6208	10.4051	33.296
	42.7835	43.5792	8622.3500	14.0949	20.5724	419.1217	17471.2180	21.4483	9.7224	28.283
L20	43.0735	45.6720	9925.1756	14.7718	21.5518	460.5260	20111.0967	22.4784	10.2291	29.757
	43.0735	45.6720	9925.1756	14.7718	21.5518	460.5260	20111.0967	22.4784	10.2291	29.757
L21	44.5235	47.2222	10970.5278	15.2732	22.2773	492.4531	22229.2635	23.2413	10.6045	30.849
	44.5235	47.2222	10970.5278	15.2732	22.2773	492.4531	22229.2635	23.2413	10.6045	30.849
L22	45.9734	48.7724	12086.8176	15.7746	23.0028	525.4501	24491.1694	24.0043	10.9798	31.941
	45.9734	48.7724	12086.8176	15.7746	23.0028	525.4501	24491.1694	24.0043	10.9798	31.941
L23	47.4234	50.3227	13276.3739	16.2760	23.7283	559.5171	26901.5329	24.7673	11.3552	33.033
	47.4234	50.3227	13276.3739	16.2760	23.7283	559.5171	26901.5329	24.7673	11.3552	33.033
L24	48.8733	51.8729	14541.5253	16.7774	24.4538	594.6542	29465.0728	25.5303	11.7305	34.125
	48.8733	51.8729	14541.5253	16.7774	24.4538	594.6542	29465.0728	25.5303	11.7305	34.125
	50.1058	53.1906	15678.0802	17.2036	25.0704	625.3619	31768.0411	26.1788	12.0495	35.053

Section	Tip Dia. in	Area in ²	I in ⁴	r in	C in	I/C in ³	J in ⁴	It/Q in ²	w in	w/t
L25	50.1058	53.1906	15678.080 2	17.2036	25.0704	625.3619	31768.041 1	26.1788	12.0495	35.053
	50.1783	53.2681	15746.720 3	17.2287	25.1067	627.1923	31907.124 4	26.2169	12.0683	35.108
L26	50.1783	53.2681	15746.720 3	17.2287	25.1067	627.1923	31907.124 4	26.2169	12.0683	35.108
	51.6282	54.8183	17161.918 3	17.7301	25.8322	664.3623	34774.699 4	26.9799	12.4437	36.2
L27	51.6282	54.8183	17161.918 3	17.7301	25.8322	664.3623	34774.699 4	26.9799	12.4437	36.2
	54.1656	57.5312	19838.067 2	18.6075	27.1018	731.9845	40197.302 5	28.3151	13.1005	38.111
L28	53.4545	64.4454	19964.736 5	17.6370	25.7300	775.9334	40453.968 8	31.7181	12.2233	30.088
	53.7445	67.3776	22815.696 3	18.4395	26.8911	848.4492	46230.786 4	33.1612	12.8240	31.567
L29	53.7445	67.3776	22815.696 3	18.4395	26.8911	848.4492	46230.786 4	33.1612	12.8240	31.567
	55.1949	69.2102	24728.484 2	18.9410	27.6167	895.4163	50106.613 2	34.0631	13.1995	32.491
L30	55.1949	69.2102	24728.484 2	18.9410	27.6167	895.4163	50106.613 2	34.0631	13.1995	32.491
	56.6453	71.0428	26745.298 9	19.4426	28.3424	943.6487	54193.226 5	34.9651	13.5749	33.415
L31	56.6453	71.0428	26745.298 9	19.4426	28.3424	943.6487	54193.226 5	34.9651	13.5749	33.415
	58.0956	72.8754	28868.894 9	19.9441	29.0681	993.1464	58496.207 9	35.8671	13.9504	34.339
L32	58.0956	72.8754	28868.894 9	19.9441	29.0681	993.1464	58496.207 9	35.8671	13.9504	34.339
	59.5460	74.7080	31102.026 9	20.4456	29.7938	1043.9092	63021.138 7	36.7690	14.3258	35.264
L33	59.5460	74.7080	31102.026 9	20.4456	29.7938	1043.9092	63021.138 7	36.7690	14.3258	35.264
	60.9963	76.5406	33447.449 3	20.9472	30.5195	1095.9374	67773.600 3	37.6710	14.7013	36.188
L34	60.9963	76.5406	33447.449 3	20.9472	30.5195	1095.9374	67773.600 3	37.6710	14.7013	36.188
	62.4467	78.3732	35907.916 5	21.4487	31.2452	1149.2307	72759.174 0	38.5729	15.0767	37.112
L35	62.4467	78.3732	35907.916 5	21.4487	31.2452	1149.2307	72759.174 0	38.5729	15.0767	37.112
	63.8971	80.2058	38486.183 2	21.9503	31.9709	1203.7893	77983.441 2	39.4749	15.4522	38.036
L36	63.8971	80.2058	38486.183 2	21.9503	31.9709	1203.7893	77983.441 2	39.4749	15.4522	38.036
	64.1871	80.5723	39016.214 8	22.0506	32.1160	1214.8529	79057.429 0	39.6552	15.5273	38.221

Tower Elevation	Gusset Area (per face)	Gusset Thickness	Gusset Grade	Adjust. Factor A _r	Adjust. Factor A _r	Weight Mult.	Double Angle Stitch Bolt Spacing Diagonals	Double Angle Stitch Bolt Spacing Horizontals	Double Angle Stitch Bolt Spacing Redundants
ft	ft ²	in					in	in	in
L1 160.00-158.10				1	1	1			
L2 158.10-153.10				1	1	1			
L3 153.10-148.10				1	1	1			
L4 148.10-143.10				1	1	1			
L5 143.10-138.10				1	1	1			
L6 138.10-133.10				1	1	1			
L7 133.10-128.10				1	1	1			
L8 128.10-				1	1	1			

Tower Elevation	Gusset Area (per face)	Gusset Thickness	Gusset Grade	Adjust. Factor A_r	Adjust. Factor A_r	Weight Mult.	Double Angle Stitch Bolt Spacing Diagonals in	Double Angle Stitch Bolt Spacing Horizontals in	Double Angle Stitch Bolt Spacing Redundants in
ft	ft ²	in							
123.67									
L9 123.67-123.00				1	1	1			
L10 123.00-118.00				1	1	1			
L11 118.00-113.00				1	1	1			
L12 113.00-108.00				1	1	1			
L13 108.00-103.00				1	1	1			
L14 103.00-98.00				1	1	1			
L15 98.00-93.00				1	1	1			
L16 93.00-88.00				1	1	1			
L17 88.00-83.00				1	1	1			
L18 83.00-76.25				1	1	1			
L19 76.25-75.25				1	1	1			
L20 75.25-70.25				1	1	1			
L21 70.25-65.25				1	1	1			
L22 65.25-60.25				1	1	1			
L23 60.25-55.25				1	1	1			
L24 55.25-51.00				1	1	1			
L25 51.00-50.75				1	1	1			
L26 50.75-45.75				1	1	1			
L27 45.75-37.00				1	1	1			
L28 37.00-36.00				1	1	1			
L29 36.00-31.00				1	1	1			
L30 31.00-26.00				1	1	1			
L31 26.00-21.00				1	1	1			
L32 21.00-16.00				1	1	1			
L33 16.00-11.00				1	1	1			
L34 11.00-6.00				1	1	1			
L35 6.00-1.00				1	1	1			
L36 1.00-0.00				1	1	1			

Feed Line/Linear Appurtenances - Entered As Round Or Flat

Description	Sector	Component Type	Placement	Total Number	Number Per Row	Start/End Position	Width or Diameter in	Perimeter in	Weight plf
Safety Line 3/8	B	Surface Ar	160.00 - 8.00	1	1	0.000	0.3750		0.22

Description	Sector	Component Type	Placement ft	Total Number	Number Per Row	Start/End Position	Width or Diameter in	Perimeter in	Weight plf
150		(CaAa)				0.000			
CORRUGATED 1 IN(1)	B	Surface Ar (CaAa)	150.00 - 6.00	2	2	0.000 0.062	1.3300		0.12
HB114-1-08U4-M5F(1-1/4)	B	Surface Ar (CaAa)	150.00 - 6.00	3	3	-0.108 0.000	1.5400		1.30
142									
HJ4-50(1/2)	C	Surface Ar (CaAa)	142.00 - 6.00	2	2	-0.400 -0.374	0.5800		0.25
2" innerduct conduit	C	Surface Ar (CaAa)	142.00 - 6.00	2	2	-0.500 -0.409	2.0000		0.20
LDF6-50A(1-1/4)	C	Surface Ar (CaAa)	116.00 - 6.00	6	6	0.105 0.300	1.5500		0.60

CCI-SFP-045100	A	Surface Af (CaAa)	52.50 - 42.50	1	1	0.000 0.000	4.5000	11.0000	0.00
CCI-SFP-045100	B	Surface Af (CaAa)	52.50 - 42.50	1	1	0.000 0.000	4.5000	11.0000	0.00
CCI-SFP-045100	C	Surface Af (CaAa)	52.50 - 42.50	1	1	0.000 0.000	4.5000	11.0000	0.00

Feed Line/Linear Appurtenances - Entered As Area

Description	Face or Leg	Allow Shield	Component Type	Placement ft	Total Number	C _A A _A ft ² /ft	Weight plf	
158								
LDF4-50A(1/2)	A	No	Inside Pole	158.00 - 6.00	1	No Ice 1/2" Ice 1" Ice	0.00 0.00 0.00	0.15 0.15 0.15
LDF6-50A(1-1/4)	A	No	Inside Pole	158.00 - 6.00	2	No Ice 1/2" Ice 1" Ice	0.00 0.00 0.00	0.60 0.60 0.60
561(1-5/8)	A	No	Inside Pole	158.00 - 6.00	9	No Ice 1/2" Ice 1" Ice	0.00 0.00 0.00	1.35 1.35 1.35
HB158-1-08U8-S8J18(1-5/8)	A	No	Inside Pole	158.00 - 6.00	2	No Ice 1/2" Ice 1" Ice	0.00 0.00 0.00	1.30 1.30 1.30
134								
LCF158-50J(1-5/8)	B	No	Inside Pole	134.00 - 6.00	6	No Ice 1/2" Ice 1" Ice	0.00 0.00 0.00	0.92 0.92 0.92
MLE Hybrid 9Power/18Fiber RL 2(1-5/8)	B	No	Inside Pole	134.00 - 6.00	1	No Ice 1/2" Ice 1" Ice	0.00 0.00 0.00	1.07 1.07 1.07
116								
2" innerduct conduit	C	No	Inside Pole	116.00 - 6.00	1	No Ice 1/2" Ice 1" Ice	0.00 0.00 0.00	0.20 0.20 0.20
FB-L98B-002-75000(3/8)	C	No	Inside Pole	116.00 - 6.00	1	No Ice 1/2" Ice 1" Ice	0.00 0.00 0.00	0.06 0.06 0.06
WR-VG86ST-BRD(3/4)	C	No	Inside Pole	116.00 - 6.00	2	No Ice 1/2" Ice 1" Ice	0.00 0.00 0.00	0.58 0.58 0.58
LDF6-50A(1-1/4)	C	No	Inside Pole	116.00 - 6.00	6	No Ice 1/2" Ice 1" Ice	0.00 0.00 0.00	0.60 0.60 0.60
61								
LDF4-50A(1/2)	C	No	Inside Pole	61.00 - 6.00	2	No Ice 1/2" Ice 1" Ice	0.00 0.00 0.00	0.15 0.15 0.15

Feed Line/Linear Appurtenances Section Areas

Tower Sectio n	Tower Elevation ft	Face	A_R ft ²	A_F ft ²	$C_A A_A$ In Face ft ²	$C_A A_A$ Out Face ft ²	Weight K
L1	160.00-158.10	A	0.000	0.000	0.000	0.000	0.00
		B	0.000	0.000	0.071	0.000	0.00
		C	0.000	0.000	0.000	0.000	0.00
L2	158.10-153.10	A	0.000	0.000	0.000	0.000	0.08
		B	0.000	0.000	0.188	0.000	0.00
		C	0.000	0.000	0.000	0.000	0.00
L3	153.10-148.10	A	0.000	0.000	0.000	0.000	0.08
		B	0.000	0.000	1.571	0.000	0.01
		C	0.000	0.000	0.000	0.000	0.00
L4	148.10-143.10	A	0.000	0.000	0.000	0.000	0.08
		B	0.000	0.000	3.827	0.000	0.02
		C	0.000	0.000	0.000	0.000	0.00
L5	143.10-138.10	A	0.000	0.000	0.000	0.000	0.08
		B	0.000	0.000	3.827	0.000	0.02
		C	0.000	0.000	2.012	0.000	0.00
L6	138.10-133.10	A	0.000	0.000	0.000	0.000	0.08
		B	0.000	0.000	3.827	0.000	0.03
		C	0.000	0.000	2.580	0.000	0.00
L7	133.10-128.10	A	0.000	0.000	0.000	0.000	0.08
		B	0.000	0.000	3.827	0.000	0.05
		C	0.000	0.000	2.580	0.000	0.00
L8	128.10-123.67	A	0.000	0.000	0.000	0.000	0.07
		B	0.000	0.000	3.393	0.000	0.05
		C	0.000	0.000	2.287	0.000	0.00
L9	123.67-123.00	A	0.000	0.000	0.000	0.000	0.01
		B	0.000	0.000	0.511	0.000	0.01
		C	0.000	0.000	0.344	0.000	0.00
L10	123.00-118.00	A	0.000	0.000	0.000	0.000	0.08
		B	0.000	0.000	3.827	0.000	0.05
		C	0.000	0.000	2.580	0.000	0.00
L11	118.00-113.00	A	0.000	0.000	0.000	0.000	0.08
		B	0.000	0.000	3.827	0.000	0.05
		C	0.000	0.000	5.370	0.000	0.03
L12	113.00-108.00	A	0.000	0.000	0.000	0.000	0.08
		B	0.000	0.000	3.827	0.000	0.05
		C	0.000	0.000	7.230	0.000	0.05
L13	108.00-103.00	A	0.000	0.000	0.000	0.000	0.08
		B	0.000	0.000	3.827	0.000	0.05
		C	0.000	0.000	7.230	0.000	0.05
L14	103.00-98.00	A	0.000	0.000	0.000	0.000	0.08
		B	0.000	0.000	3.827	0.000	0.05
		C	0.000	0.000	7.230	0.000	0.05
L15	98.00-93.00	A	0.000	0.000	0.000	0.000	0.08
		B	0.000	0.000	3.827	0.000	0.05
		C	0.000	0.000	7.230	0.000	0.05
L16	93.00-88.00	A	0.000	0.000	0.000	0.000	0.08
		B	0.000	0.000	3.827	0.000	0.05
		C	0.000	0.000	7.230	0.000	0.05
L17	88.00-83.00	A	0.000	0.000	0.000	0.000	0.08
		B	0.000	0.000	3.827	0.000	0.05
		C	0.000	0.000	7.230	0.000	0.05
L18	83.00-76.25	A	0.000	0.000	0.000	0.000	0.11
		B	0.000	0.000	5.167	0.000	0.07
		C	0.000	0.000	9.761	0.000	0.06
L19	76.25-75.25	A	0.000	0.000	0.000	0.000	0.02
		B	0.000	0.000	0.765	0.000	0.01
		C	0.000	0.000	1.446	0.000	0.01
L20	75.25-70.25	A	0.000	0.000	0.000	0.000	0.08
		B	0.000	0.000	3.827	0.000	0.05
		C	0.000	0.000	7.230	0.000	0.05
L21	70.25-65.25	A	0.000	0.000	0.000	0.000	0.08
		B	0.000	0.000	3.827	0.000	0.05
		C	0.000	0.000	7.230	0.000	0.05
L22	65.25-60.25	A	0.000	0.000	0.000	0.000	0.08

Tower Section n	Tower Elevation ft	Face	A _R ft ²	A _F ft ²	C _A A _A In Face ft ²	C _A A _A Out Face ft ²	Weight K
		B	0.000	0.000	3.827	0.000	0.05
		C	0.000	0.000	7.230	0.000	0.05
L23	60.25-55.25	A	0.000	0.000	0.000	0.000	0.08
		B	0.000	0.000	3.827	0.000	0.05
		C	0.000	0.000	7.230	0.000	0.05
L24	55.25-51.00	A	0.000	0.000	1.125	0.000	0.07
		B	0.000	0.000	4.378	0.000	0.05
		C	0.000	0.000	7.271	0.000	0.04
L25	51.00-50.75	A	0.000	0.000	0.188	0.000	0.00
		B	0.000	0.000	0.379	0.000	0.00
		C	0.000	0.000	0.549	0.000	0.00
L26	50.75-45.75	A	0.000	0.000	3.750	0.000	0.08
		B	0.000	0.000	7.577	0.000	0.05
		C	0.000	0.000	10.980	0.000	0.05
L27	45.75-37.00	A	0.000	0.000	2.438	0.000	0.14
		B	0.000	0.000	9.136	0.000	0.10
		C	0.000	0.000	15.090	0.000	0.09
L28	37.00-36.00	A	0.000	0.000	0.000	0.000	0.02
		B	0.000	0.000	0.765	0.000	0.01
		C	0.000	0.000	1.446	0.000	0.01
L29	36.00-31.00	A	0.000	0.000	0.000	0.000	0.08
		B	0.000	0.000	3.827	0.000	0.05
		C	0.000	0.000	7.230	0.000	0.05
L30	31.00-26.00	A	0.000	0.000	0.000	0.000	0.08
		B	0.000	0.000	3.827	0.000	0.05
		C	0.000	0.000	7.230	0.000	0.05
L31	26.00-21.00	A	0.000	0.000	0.000	0.000	0.08
		B	0.000	0.000	3.827	0.000	0.05
		C	0.000	0.000	7.230	0.000	0.05
L32	21.00-16.00	A	0.000	0.000	0.000	0.000	0.08
		B	0.000	0.000	3.827	0.000	0.05
		C	0.000	0.000	7.230	0.000	0.05
L33	16.00-11.00	A	0.000	0.000	0.000	0.000	0.08
		B	0.000	0.000	3.827	0.000	0.05
		C	0.000	0.000	7.230	0.000	0.05
L34	11.00-6.00	A	0.000	0.000	0.000	0.000	0.08
		B	0.000	0.000	3.752	0.000	0.05
		C	0.000	0.000	7.230	0.000	0.05
L35	6.00-1.00	A	0.000	0.000	0.000	0.000	0.00
		B	0.000	0.000	0.000	0.000	0.00
		C	0.000	0.000	0.000	0.000	0.00
L36	1.00-0.00	A	0.000	0.000	0.000	0.000	0.00
		B	0.000	0.000	0.000	0.000	0.00
		C	0.000	0.000	0.000	0.000	0.00

Feed Line/Linear Appurtenances Section Areas - With Ice

Tower Section n	Tower Elevation ft	Face or Leg	Ice Thickness in	A _R ft ²	A _F ft ²	C _A A _A In Face ft ²	C _A A _A Out Face ft ²	Weight K
L1	160.00-158.10	A	1.755	0.000	0.000	0.000	0.000	0.00
		B		0.000	0.000	0.738	0.000	0.01
		C		0.000	0.000	0.000	0.000	0.00
L2	158.10-153.10	A	1.752	0.000	0.000	0.000	0.000	0.08
		B		0.000	0.000	1.939	0.000	0.02
		C		0.000	0.000	0.000	0.000	0.00
L3	153.10-148.10	A	1.746	0.000	0.000	0.000	0.000	0.08
		B		0.000	0.000	5.321	0.000	0.07
		C		0.000	0.000	0.000	0.000	0.00
L4	148.10-143.10	A	1.740	0.000	0.000	0.000	0.000	0.08
		B		0.000	0.000	10.827	0.000	0.14
		C		0.000	0.000	0.000	0.000	0.00
L5	143.10-138.10	A	1.734	0.000	0.000	0.000	0.000	0.08
		B		0.000	0.000	10.806	0.000	0.14
		C		0.000	0.000	5.897	0.000	0.07
L6	138.10-133.10	A	1.728	0.000	0.000	0.000	0.000	0.08

Tower Section	Tower Elevation ft	Face or Leg	Ice Thickness in	A_R ft ²	A_F ft ²	C_{AA} In Face ft ²	C_{AA} Out Face ft ²	Weight K
		B		0.000	0.000	10.784	0.000	0.15
		C		0.000	0.000	7.544	0.000	0.09
L7	133.10-128.10	A	1.721	0.000	0.000	0.000	0.000	0.08
		B		0.000	0.000	10.762	0.000	0.18
		C		0.000	0.000	7.528	0.000	0.09
L8	128.10-123.67	A	1.715	0.000	0.000	0.000	0.000	0.07
		B		0.000	0.000	9.522	0.000	0.15
		C		0.000	0.000	6.660	0.000	0.08
L9	123.67-123.00	A	1.711	0.000	0.000	0.000	0.000	0.01
		B		0.000	0.000	1.433	0.000	0.02
		C		0.000	0.000	1.002	0.000	0.01
L10	123.00-118.00	A	1.707	0.000	0.000	0.000	0.000	0.08
		B		0.000	0.000	10.713	0.000	0.17
		C		0.000	0.000	7.493	0.000	0.09
L11	118.00-113.00	A	1.700	0.000	0.000	0.000	0.000	0.08
		B		0.000	0.000	10.688	0.000	0.17
		C		0.000	0.000	12.238	0.000	0.17
L12	113.00-108.00	A	1.693	0.000	0.000	0.000	0.000	0.08
		B		0.000	0.000	10.662	0.000	0.17
		C		0.000	0.000	15.385	0.000	0.22
L13	108.00-103.00	A	1.685	0.000	0.000	0.000	0.000	0.08
		B		0.000	0.000	10.634	0.000	0.17
		C		0.000	0.000	15.356	0.000	0.22
L14	103.00-98.00	A	1.677	0.000	0.000	0.000	0.000	0.08
		B		0.000	0.000	10.606	0.000	0.17
		C		0.000	0.000	15.325	0.000	0.22
L15	98.00-93.00	A	1.668	0.000	0.000	0.000	0.000	0.08
		B		0.000	0.000	10.576	0.000	0.17
		C		0.000	0.000	15.293	0.000	0.21
L16	93.00-88.00	A	1.659	0.000	0.000	0.000	0.000	0.08
		B		0.000	0.000	10.545	0.000	0.17
		C		0.000	0.000	15.259	0.000	0.21
L17	88.00-83.00	A	1.650	0.000	0.000	0.000	0.000	0.08
		B		0.000	0.000	10.512	0.000	0.17
		C		0.000	0.000	15.224	0.000	0.21
L18	83.00-76.25	A	1.638	0.000	0.000	0.000	0.000	0.11
		B		0.000	0.000	14.135	0.000	0.23
		C		0.000	0.000	20.493	0.000	0.28
L19	76.25-75.25	A	1.630	0.000	0.000	0.000	0.000	0.02
		B		0.000	0.000	2.094	0.000	0.03
		C		0.000	0.000	3.036	0.000	0.04
L20	75.25-70.25	A	1.623	0.000	0.000	0.000	0.000	0.08
		B		0.000	0.000	10.419	0.000	0.17
		C		0.000	0.000	15.125	0.000	0.21
L21	70.25-65.25	A	1.612	0.000	0.000	0.000	0.000	0.08
		B		0.000	0.000	10.379	0.000	0.16
		C		0.000	0.000	15.082	0.000	0.21
L22	65.25-60.25	A	1.600	0.000	0.000	0.000	0.000	0.08
		B		0.000	0.000	10.336	0.000	0.16
		C		0.000	0.000	15.036	0.000	0.21
L23	60.25-55.25	A	1.586	0.000	0.000	0.000	0.000	0.08
		B		0.000	0.000	10.290	0.000	0.16
		C		0.000	0.000	14.986	0.000	0.21
L24	55.25-51.00	A	1.573	0.000	0.000	1.397	0.000	0.08
		B		0.000	0.000	10.104	0.000	0.15
		C		0.000	0.000	14.094	0.000	0.19
L25	51.00-50.75	A	1.566	0.000	0.000	0.233	0.000	0.01
		B		0.000	0.000	0.744	0.000	0.01
		C		0.000	0.000	0.978	0.000	0.01
L26	50.75-45.75	A	1.558	0.000	0.000	4.651	0.000	0.13
		B		0.000	0.000	14.841	0.000	0.21
		C		0.000	0.000	19.531	0.000	0.25
L27	45.75-37.00	A	1.534	0.000	0.000	3.015	0.000	0.17
		B		0.000	0.000	20.703	0.000	0.31
		C		0.000	0.000	28.899	0.000	0.38
L28	37.00-36.00	A	1.515	0.000	0.000	0.000	0.000	0.02
		B		0.000	0.000	2.021	0.000	0.03
		C		0.000	0.000	2.958	0.000	0.04
L29	36.00-31.00	A	1.502	0.000	0.000	0.000	0.000	0.08

Tower Section	Tower Elevation ft	Face or Leg	Ice Thickness in	A_R ft ²	A_F ft ²	C_{AA} In Face ft ²	C_{AA} Out Face ft ²	Weight K
L30	31.00-26.00	B	1.478	0.000	0.000	9.995	0.000	0.15
		C		0.000	0.000	14.671	0.000	0.20
		A		0.000	0.000	0.000	0.000	0.08
L31	26.00-21.00	B	1.450	0.000	0.000	9.911	0.000	0.15
		C		0.000	0.000	14.580	0.000	0.19
		A		0.000	0.000	0.000	0.000	0.08
L32	21.00-16.00	B	1.416	0.000	0.000	9.812	0.000	0.15
		C		0.000	0.000	14.474	0.000	0.19
		A		0.000	0.000	0.000	0.000	0.08
L33	16.00-11.00	B	1.372	0.000	0.000	9.692	0.000	0.15
		C		0.000	0.000	14.346	0.000	0.19
		A		0.000	0.000	0.000	0.000	0.08
L34	11.00-6.00	B	1.310	0.000	0.000	9.538	0.000	0.14
		C		0.000	0.000	14.181	0.000	0.18
		A		0.000	0.000	0.000	0.000	0.08
L35	6.00-1.00	B	1.198	0.000	0.000	8.722	0.000	0.13
		C		0.000	0.000	13.948	0.000	0.17
		A		0.000	0.000	0.000	0.000	0.00
L36	1.00-0.00	B	0.987	0.000	0.000	0.000	0.000	0.00
		C		0.000	0.000	0.000	0.000	0.00
		A		0.000	0.000	0.000	0.000	0.00

Feed Line Center of Pressure

Section	Elevation ft	CP_x in	CP_z in	CP_x Ice in	CP_z Ice in
L1	160.00-158.10	0.0469	-0.0271	0.3519	-0.2032
L2	158.10-153.10	0.0469	-0.0271	0.3561	-0.2056
L3	153.10-148.10	0.3535	-0.2248	0.7034	-0.4287
L4	148.10-143.10	0.7121	-0.4560	0.9795	-0.6058
L5	143.10-138.10	0.9528	-0.1619	1.1217	-0.1587
L6	138.10-133.10	1.0237	-0.0937	1.1847	-0.0737
L7	133.10-128.10	1.0404	-0.0954	1.2283	-0.0766
L8	128.10-123.67	1.0552	-0.0969	1.2683	-0.0792
L9	123.67-123.00	1.0588	-0.0972	1.2784	-0.0799
L10	123.00-118.00	1.0672	-0.0981	1.3014	-0.0814
L11	118.00-113.00	0.7387	0.3750	1.0128	0.2725
L12	113.00-108.00	0.5666	0.6360	0.8652	0.4736
L13	108.00-103.00	0.5761	0.6466	0.8908	0.4883
L14	103.00-98.00	0.5852	0.6567	0.9157	0.5027
L15	98.00-93.00	0.5939	0.6663	0.9398	0.5168
L16	93.00-88.00	0.6022	0.6755	0.9634	0.5306
L17	88.00-83.00	0.6101	0.6843	0.9862	0.5442
L18	83.00-76.25	0.6190	0.6942	1.0121	0.5598
L19	76.25-75.25	0.6214	0.6969	1.0197	0.5640
L20	75.25-70.25	0.6257	0.7017	1.0312	0.5723
L21	70.25-65.25	0.6327	0.7094	1.0519	0.5852
L22	65.25-60.25	0.6394	0.7168	1.0718	0.5978
L23	60.25-55.25	0.6458	0.7240	1.0909	0.6103
L24	55.25-51.00	0.5789	0.6490	1.0254	0.5754
L25	51.00-50.75	0.4838	0.5424	0.9094	0.5111
L26	50.75-45.75	0.4874	0.5463	0.9176	0.5167
L27	45.75-37.00	0.5906	0.6620	1.0597	0.6002
L28	37.00-36.00	0.6678	0.7485	1.1572	0.6553
L29	36.00-31.00	0.6711	0.7521	1.1622	0.6634
L30	31.00-26.00	0.6764	0.7579	1.1758	0.6752
L31	26.00-21.00	0.6814	0.7636	1.1877	0.6870
L32	21.00-16.00	0.6863	0.7690	1.1975	0.6989
L33	16.00-11.00	0.6911	0.7743	1.2040	0.7111
L34	11.00-6.00	0.6837	0.7887	1.1534	0.7674
L35	6.00-1.00	0.0000	0.0000	0.0000	0.0000
L36	1.00-0.00	0.0000	0.0000	0.0000	0.0000

Shielding Factor Ka

Tower Section	Feed Line Record No.	Description	Feed Line Segment Elev.	K_a No Ice	K_a Ice
L1	1	Safety Line 3/8	158.10 - 160.00	1.0000	1.0000
L2	1	Safety Line 3/8	153.10 - 158.10	1.0000	1.0000
L3	1	Safety Line 3/8	148.10 - 153.10	1.0000	1.0000
L3	8	CORRUGATED 1 IN(1)	148.10 - 150.00	1.0000	1.0000
L3	9	HB114-1-08U4-M5F(1-1/4)	148.10 - 150.00	1.0000	1.0000
L4	1	Safety Line 3/8	143.10 - 148.10	1.0000	1.0000
L4	8	CORRUGATED 1 IN(1)	143.10 - 148.10	1.0000	1.0000
L4	9	HB114-1-08U4-M5F(1-1/4)	143.10 - 148.10	1.0000	1.0000
L5	1	Safety Line 3/8	138.10 - 143.10	1.0000	1.0000
L5	8	CORRUGATED 1 IN(1)	138.10 - 143.10	1.0000	1.0000
L5	9	HB114-1-08U4-M5F(1-1/4)	138.10 - 143.10	1.0000	1.0000
L5	13	HJ4-50(1/2)	138.10 - 142.00	1.0000	1.0000
L5	14	2" innerduct conduit	138.10 - 142.00	1.0000	1.0000
L6	1	Safety Line 3/8	133.10 - 138.10	1.0000	1.0000
L6	8	CORRUGATED 1 IN(1)	133.10 - 138.10	1.0000	1.0000
L6	9	HB114-1-08U4-M5F(1-1/4)	133.10 - 138.10	1.0000	1.0000
L6	13	HJ4-50(1/2)	133.10 - 138.10	1.0000	1.0000
L6	14	2" innerduct conduit	133.10 - 138.10	1.0000	1.0000
L7	1	Safety Line 3/8	128.10 - 133.10	1.0000	1.0000
L7	8	CORRUGATED 1 IN(1)	128.10 - 133.10	1.0000	1.0000
L7	9	HB114-1-08U4-M5F(1-1/4)	128.10 - 133.10	1.0000	1.0000
L7	13	HJ4-50(1/2)	128.10 - 133.10	1.0000	1.0000
L7	14	2" innerduct conduit	128.10 - 133.10	1.0000	1.0000
L8	1	Safety Line 3/8	123.67 - 128.10	1.0000	1.0000
L8	8	CORRUGATED 1 IN(1)	123.67 - 128.10	1.0000	1.0000
L8	9	HB114-1-08U4-M5F(1-1/4)	123.67 - 128.10	1.0000	1.0000
L8	13	HJ4-50(1/2)	123.67 - 128.10	1.0000	1.0000
L8	14	2" innerduct conduit	123.67 - 128.10	1.0000	1.0000
L10	1	Safety Line 3/8	118.00 - 123.00	1.0000	1.0000
L10	8	CORRUGATED 1 IN(1)	118.00 - 123.00	1.0000	1.0000
L10	9	HB114-1-08U4-M5F(1-1/4)	118.00 -	1.0000	1.0000

Tower Section	Feed Line Record No.	Description	Feed Line Segment Elev.	K _a No Ice	K _a Ice
			123.00		
L10	13	HJ4-50(1/2)	118.00 -	1.0000	1.0000
			123.00		
L10	14	2" innerduct conduit	118.00 -	1.0000	1.0000
			123.00		
L11	1	Safety Line 3/8	113.00 -	1.0000	1.0000
			118.00		
L11	8	CORRUGATED 1 IN(1)	113.00 -	1.0000	1.0000
			118.00		
L11	9	HB114-1-08U4-M5F(1-1/4)	113.00 -	1.0000	1.0000
			118.00		
L11	13	HJ4-50(1/2)	113.00 -	1.0000	1.0000
			118.00		
L11	14	2" innerduct conduit	113.00 -	1.0000	1.0000
			118.00		
L11	23	LDF6-50A(1-1/4)	113.00 -	1.0000	1.0000
			116.00		
L12	1	Safety Line 3/8	108.00 -	1.0000	1.0000
			113.00		
L12	8	CORRUGATED 1 IN(1)	108.00 -	1.0000	1.0000
			113.00		
L12	9	HB114-1-08U4-M5F(1-1/4)	108.00 -	1.0000	1.0000
			113.00		
L12	13	HJ4-50(1/2)	108.00 -	1.0000	1.0000
			113.00		
L12	14	2" innerduct conduit	108.00 -	1.0000	1.0000
			113.00		
L12	23	LDF6-50A(1-1/4)	108.00 -	1.0000	1.0000
			113.00		
L13	1	Safety Line 3/8	103.00 -	1.0000	1.0000
			108.00		
L13	8	CORRUGATED 1 IN(1)	103.00 -	1.0000	1.0000
			108.00		
L13	9	HB114-1-08U4-M5F(1-1/4)	103.00 -	1.0000	1.0000
			108.00		
L13	13	HJ4-50(1/2)	103.00 -	1.0000	1.0000
			108.00		
L13	14	2" innerduct conduit	103.00 -	1.0000	1.0000
			108.00		
L13	23	LDF6-50A(1-1/4)	103.00 -	1.0000	1.0000
			108.00		
L14	1	Safety Line 3/8	98.00 -	1.0000	1.0000
			103.00		
L14	8	CORRUGATED 1 IN(1)	98.00 -	1.0000	1.0000
			103.00		
L14	9	HB114-1-08U4-M5F(1-1/4)	98.00 -	1.0000	1.0000
			103.00		
L14	13	HJ4-50(1/2)	98.00 -	1.0000	1.0000
			103.00		
L14	14	2" innerduct conduit	98.00 -	1.0000	1.0000
			103.00		
L14	23	LDF6-50A(1-1/4)	98.00 -	1.0000	1.0000
			103.00		
L15	1	Safety Line 3/8	93.00 -	1.0000	1.0000
			98.00		
L15	8	CORRUGATED 1 IN(1)	93.00 -	1.0000	1.0000
			98.00		
L15	9	HB114-1-08U4-M5F(1-1/4)	93.00 -	1.0000	1.0000
			98.00		
L15	13	HJ4-50(1/2)	93.00 -	1.0000	1.0000
			98.00		
L15	14	2" innerduct conduit	93.00 -	1.0000	1.0000
			98.00		
L15	23	LDF6-50A(1-1/4)	93.00 -	1.0000	1.0000
			98.00		
L16	1	Safety Line 3/8	88.00 -	1.0000	1.0000
			93.00		
L16	8	CORRUGATED 1 IN(1)	88.00 -	1.0000	1.0000
			93.00		

Tower Section	Feed Line Record No.	Description	Feed Line Segment Elev.	K _a No Ice	K _a Ice
L16	9	HB114-1-08U4-M5F(1-1/4)	88.00 - 93.00	1.0000	1.0000
L16	13	HJ4-50(1/2)	88.00 - 93.00	1.0000	1.0000
L16	14	2" innerduct conduit	88.00 - 93.00	1.0000	1.0000
L16	23	LDF6-50A(1-1/4)	88.00 - 93.00	1.0000	1.0000
L17	1	Safety Line 3/8	83.00 - 88.00	1.0000	1.0000
L17	8	CORRUGATED 1 IN(1)	83.00 - 88.00	1.0000	1.0000
L17	9	HB114-1-08U4-M5F(1-1/4)	83.00 - 88.00	1.0000	1.0000
L17	13	HJ4-50(1/2)	83.00 - 88.00	1.0000	1.0000
L17	14	2" innerduct conduit	83.00 - 88.00	1.0000	1.0000
L17	23	LDF6-50A(1-1/4)	83.00 - 88.00	1.0000	1.0000
L18	1	Safety Line 3/8	76.25 - 83.00	1.0000	1.0000
L18	8	CORRUGATED 1 IN(1)	76.25 - 83.00	1.0000	1.0000
L18	9	HB114-1-08U4-M5F(1-1/4)	76.25 - 83.00	1.0000	1.0000
L18	13	HJ4-50(1/2)	76.25 - 83.00	1.0000	1.0000
L18	14	2" innerduct conduit	76.25 - 83.00	1.0000	1.0000
L18	23	LDF6-50A(1-1/4)	76.25 - 83.00	1.0000	1.0000
L20	1	Safety Line 3/8	70.25 - 75.25	1.0000	1.0000
L20	8	CORRUGATED 1 IN(1)	70.25 - 75.25	1.0000	1.0000
L20	9	HB114-1-08U4-M5F(1-1/4)	70.25 - 75.25	1.0000	1.0000
L20	13	HJ4-50(1/2)	70.25 - 75.25	1.0000	1.0000
L20	14	2" innerduct conduit	70.25 - 75.25	1.0000	1.0000
L20	23	LDF6-50A(1-1/4)	70.25 - 75.25	1.0000	1.0000
L21	1	Safety Line 3/8	65.25 - 70.25	1.0000	1.0000
L21	8	CORRUGATED 1 IN(1)	65.25 - 70.25	1.0000	1.0000
L21	9	HB114-1-08U4-M5F(1-1/4)	65.25 - 70.25	1.0000	1.0000
L21	13	HJ4-50(1/2)	65.25 - 70.25	1.0000	1.0000
L21	14	2" innerduct conduit	65.25 - 70.25	1.0000	1.0000
L21	23	LDF6-50A(1-1/4)	65.25 - 70.25	1.0000	1.0000
L22	1	Safety Line 3/8	60.25 - 65.25	1.0000	1.0000
L22	8	CORRUGATED 1 IN(1)	60.25 - 65.25	1.0000	1.0000
L22	9	HB114-1-08U4-M5F(1-1/4)	60.25 - 65.25	1.0000	1.0000
L22	13	HJ4-50(1/2)	60.25 - 65.25	1.0000	1.0000
L22	14	2" innerduct conduit	60.25 - 65.25	1.0000	1.0000
L22	23	LDF6-50A(1-1/4)	60.25 - 65.25	1.0000	1.0000
L23	1	Safety Line 3/8	55.25 -	1.0000	1.0000

Tower Section	Feed Line Record No.	Description	Feed Line Segment Elev.	K _a No Ice	K _a Ice
			60.25		
L23	8	CORRUGATED 1 IN(1)	55.25 -	1.0000	1.0000
			60.25		
L23	9	HB114-1-08U4-M5F(1-1/4)	55.25 -	1.0000	1.0000
			60.25		
L23	13	HJ4-50(1/2)	55.25 -	1.0000	1.0000
			60.25		
L23	14	2" innerduct conduit	55.25 -	1.0000	1.0000
			60.25		
L23	23	LDF6-50A(1-1/4)	55.25 -	1.0000	1.0000
			60.25		
L24	1	Safety Line 3/8	51.00 -	1.0000	1.0000
			55.25		
L24	8	CORRUGATED 1 IN(1)	51.00 -	1.0000	1.0000
			55.25		
L24	9	HB114-1-08U4-M5F(1-1/4)	51.00 -	1.0000	1.0000
			55.25		
L24	13	HJ4-50(1/2)	51.00 -	1.0000	1.0000
			55.25		
L24	14	2" innerduct conduit	51.00 -	1.0000	1.0000
			55.25		
L24	23	LDF6-50A(1-1/4)	51.00 -	1.0000	1.0000
			55.25		
L24	27	CCI-SFP-045100	51.00 -	1.0000	1.0000
			52.50		
L24	28	CCI-SFP-045100	51.00 -	1.0000	1.0000
			52.50		
L24	29	CCI-SFP-045100	51.00 -	1.0000	1.0000
			52.50		
L25	1	Safety Line 3/8	50.75 -	1.0000	1.0000
			51.00		
L25	8	CORRUGATED 1 IN(1)	50.75 -	1.0000	1.0000
			51.00		
L25	9	HB114-1-08U4-M5F(1-1/4)	50.75 -	1.0000	1.0000
			51.00		
L25	13	HJ4-50(1/2)	50.75 -	1.0000	1.0000
			51.00		
L25	14	2" innerduct conduit	50.75 -	1.0000	1.0000
			51.00		
L25	23	LDF6-50A(1-1/4)	50.75 -	1.0000	1.0000
			51.00		
L25	27	CCI-SFP-045100	50.75 -	1.0000	1.0000
			51.00		
L25	28	CCI-SFP-045100	50.75 -	1.0000	1.0000
			51.00		
L25	29	CCI-SFP-045100	50.75 -	1.0000	1.0000
			51.00		
L26	1	Safety Line 3/8	45.75 -	1.0000	1.0000
			50.75		
L26	8	CORRUGATED 1 IN(1)	45.75 -	1.0000	1.0000
			50.75		
L26	9	HB114-1-08U4-M5F(1-1/4)	45.75 -	1.0000	1.0000
			50.75		
L26	13	HJ4-50(1/2)	45.75 -	1.0000	1.0000
			50.75		
L26	14	2" innerduct conduit	45.75 -	1.0000	1.0000
			50.75		
L26	23	LDF6-50A(1-1/4)	45.75 -	1.0000	1.0000
			50.75		
L26	27	CCI-SFP-045100	45.75 -	1.0000	1.0000
			50.75		
L26	28	CCI-SFP-045100	45.75 -	1.0000	1.0000
			50.75		
L26	29	CCI-SFP-045100	45.75 -	1.0000	1.0000
			50.75		
L27	1	Safety Line 3/8	37.00 -	1.0000	1.0000
			45.75		
L27	8	CORRUGATED 1 IN(1)	37.00 -	1.0000	1.0000
			45.75		

Tower Section	Feed Line Record No.	Description	Feed Line Segment Elev.	K _a No Ice	K _a Ice
L27	9	HB114-1-08U4-M5F(1-1/4)	37.00 - 45.75	1.0000	1.0000
L27	13	HJ4-50(1/2)	37.00 - 45.75	1.0000	1.0000
L27	14	2" innerduct conduit	37.00 - 45.75	1.0000	1.0000
L27	23	LDF6-50A(1-1/4)	37.00 - 45.75	1.0000	1.0000
L27	27	CCI-SFP-045100	42.50 - 45.75	1.0000	1.0000
L27	28	CCI-SFP-045100	42.50 - 45.75	1.0000	1.0000
L27	29	CCI-SFP-045100	42.50 - 45.75	1.0000	1.0000
L29	1	Safety Line 3/8	31.00 - 36.00	1.0000	1.0000
L29	8	CORRUGATED 1 IN(1)	31.00 - 36.00	1.0000	1.0000
L29	9	HB114-1-08U4-M5F(1-1/4)	31.00 - 36.00	1.0000	1.0000
L29	13	HJ4-50(1/2)	31.00 - 36.00	1.0000	1.0000
L29	14	2" innerduct conduit	31.00 - 36.00	1.0000	1.0000
L29	23	LDF6-50A(1-1/4)	31.00 - 36.00	1.0000	1.0000
L30	1	Safety Line 3/8	26.00 - 31.00	1.0000	1.0000
L30	8	CORRUGATED 1 IN(1)	26.00 - 31.00	1.0000	1.0000
L30	9	HB114-1-08U4-M5F(1-1/4)	26.00 - 31.00	1.0000	1.0000
L30	13	HJ4-50(1/2)	26.00 - 31.00	1.0000	1.0000
L30	14	2" innerduct conduit	26.00 - 31.00	1.0000	1.0000
L30	23	LDF6-50A(1-1/4)	26.00 - 31.00	1.0000	1.0000
L31	1	Safety Line 3/8	21.00 - 26.00	1.0000	1.0000
L31	8	CORRUGATED 1 IN(1)	21.00 - 26.00	1.0000	1.0000
L31	9	HB114-1-08U4-M5F(1-1/4)	21.00 - 26.00	1.0000	1.0000
L31	13	HJ4-50(1/2)	21.00 - 26.00	1.0000	1.0000
L31	14	2" innerduct conduit	21.00 - 26.00	1.0000	1.0000
L31	23	LDF6-50A(1-1/4)	21.00 - 26.00	1.0000	1.0000
L32	1	Safety Line 3/8	16.00 - 21.00	1.0000	1.0000
L32	8	CORRUGATED 1 IN(1)	16.00 - 21.00	1.0000	1.0000
L32	9	HB114-1-08U4-M5F(1-1/4)	16.00 - 21.00	1.0000	1.0000
L32	13	HJ4-50(1/2)	16.00 - 21.00	1.0000	1.0000
L32	14	2" innerduct conduit	16.00 - 21.00	1.0000	1.0000
L32	23	LDF6-50A(1-1/4)	16.00 - 21.00	1.0000	1.0000
L33	1	Safety Line 3/8	11.00 - 16.00	1.0000	1.0000
L33	8	CORRUGATED 1 IN(1)	11.00 - 16.00	1.0000	1.0000
L33	9	HB114-1-08U4-M5F(1-1/4)	11.00 - 16.00	1.0000	1.0000
L33	13	HJ4-50(1/2)	11.00 -	1.0000	1.0000

Tower Section	Feed Line Record No.	Description	Feed Line Segment Elev.	K_a No Ice	K_a Ice
L33	14	2" innerduct conduit	16.00 11.00 - 16.00	1.0000	1.0000
L33	23	LDF6-50A(1-1/4)	11.00 - 16.00	1.0000	1.0000
L34	1	Safety Line 3/8	8.00 - 11.00	1.0000	1.0000
L34	8	CORRUGATED 1 IN(1)	6.00 - 11.00	1.0000	1.0000
L34	9	HB114-1-08U4-M5F(1-1/4)	6.00 - 11.00	1.0000	1.0000
L34	13	HJ4-50(1/2)	6.00 - 11.00	1.0000	1.0000
L34	14	2" innerduct conduit	6.00 - 11.00	1.0000	1.0000
L34	23	LDF6-50A(1-1/4)	6.00 - 11.00	1.0000	1.0000

Discrete Tower Loads

Description	Face or Leg	Offset Type	Offsets:			Azimuth Adjustment t	Placement ft	C_{AA} Front ft ²	C_{AA} Side ft ²	Weight K
			Horz Lateral ft	Vert ft						
Platform Mount 13' [LP 713-1]	C	None			0.00	158.00	No Ice	33.88	33.88	1.64
							1/2" Ice	42.99	42.99	2.09
							1" Ice	52.10	52.10	2.54
(2) DB846H80E-SX w/ Mount Pipe	A	From Face	4.00	-20.00	158.00	No Ice	5.33	7.74	0.04	
						1/2" Ice	5.89	8.93	0.10	
						1" Ice	6.41	9.84	0.16	
(2) DB846H80E-SX w/ Mount Pipe	B	From Face	4.00	-20.00	158.00	No Ice	5.33	7.74	0.04	
						1/2" Ice	5.89	8.93	0.10	
						1" Ice	6.41	9.84	0.16	
(2) DB846F65ZAXY w/ Mount Pipe	C	From Face	4.00	-40.00	158.00	No Ice	7.27	7.82	0.05	
						1/2" Ice	7.83	9.01	0.11	
						1" Ice	8.35	9.91	0.19	
SBNHH-1D65B w/ Mount Pipe	A	From Face	4.00	-20.00	158.00	No Ice	8.43	7.10	0.07	
						1/2" Ice	8.99	8.29	0.14	
						1" Ice	9.52	9.20	0.22	
SBNHH-1D65B w/ Mount Pipe	B	From Face	4.00	-20.00	158.00	No Ice	8.43	7.10	0.07	
						1/2" Ice	8.99	8.29	0.14	
						1" Ice	9.52	9.20	0.22	
SBNHH-1D65B w/ Mount Pipe	C	From Face	4.00	-40.00	158.00	No Ice	8.43	7.10	0.07	
						1/2" Ice	8.99	8.29	0.14	
						1" Ice	9.52	9.20	0.22	
SBNHH-1D65B w/ Mount Pipe	A	From Face	4.00	-20.00	158.00	No Ice	8.43	7.10	0.07	
						1/2" Ice	8.99	8.29	0.14	
						1" Ice	9.52	9.20	0.22	
SBNHH-1D65B w/ Mount Pipe	B	From Face	4.00	-20.00	158.00	No Ice	8.43	7.10	0.07	
						1/2" Ice	8.99	8.29	0.14	
						1" Ice	9.52	9.20	0.22	
SBNHH-1D65B w/ Mount Pipe	C	From Face	4.00	-40.00	158.00	No Ice	8.43	7.10	0.07	
						1/2" Ice	8.99	8.29	0.14	
						1" Ice	9.52	9.20	0.22	
HBXX-6517DS-A2M w/	A	From Face	4.00	-20.00	158.00	No Ice	8.77	6.96	0.07	

Description	Face or Leg	Offset Type	Offsets: Horz Lateral Vert ft ft ft	Azimuth Adjustment t °	Placement ft	C _{AA} Front ft ²	C _{AA} Side ft ²	Weight K
Mount Pipe			0.00 2.00			1/2" Ice 9.34 9.89	8.18 9.14	0.14 0.21
HBXX-6517DS-A2M w/ Mount Pipe	B	From Face	4.00 0.00 2.00	-20.00	158.00	1" Ice No Ice 1/2" Ice 9.89	6.96 8.18 9.14	0.07 0.14 0.21
HBXX-6517DS-A2M w/ Mount Pipe	C	From Face	4.00 0.00 2.00	-40.00	158.00	1" Ice No Ice 1/2" Ice 9.89	6.96 8.18 9.14	0.07 0.14 0.21
RRH2x60-700	A	From Face	4.00 0.00 2.00	0.00	158.00	1" Ice No Ice 1/2" Ice 4.03	1.82 2.05 2.29	0.06 0.08 0.11
RRH2x60-700	B	From Face	4.00 0.00 2.00	0.00	158.00	1" Ice No Ice 1/2" Ice 4.03	1.82 2.05 2.29	0.06 0.08 0.11
RRH2x60-700	C	From Face	4.00 0.00 2.00	0.00	158.00	1" Ice No Ice 1/2" Ice 4.03	1.82 2.05 2.29	0.06 0.08 0.11
RRH2X60-PCS	A	From Face	4.00 0.00 2.00	0.00	158.00	1" Ice No Ice 1/2" Ice 2.59	1.72 1.90 2.09	0.06 0.08 0.10
RRH2X60-PCS	B	From Face	4.00 0.00 2.00	0.00	158.00	1" Ice No Ice 1/2" Ice 2.59	1.72 1.90 2.09	0.06 0.08 0.10
RRH2X60-PCS	C	From Face	4.00 0.00 2.00	0.00	158.00	1" Ice No Ice 1/2" Ice 2.59	1.72 1.90 2.09	0.06 0.08 0.10
RRH2X60-AWS	A	From Face	4.00 0.00 2.00	0.00	158.00	1" Ice No Ice 1/2" Ice 4.03	2.10 2.34 2.58	0.06 0.08 0.11
RRH2X60-AWS	B	From Face	4.00 0.00 2.00	0.00	158.00	1" Ice No Ice 1/2" Ice 4.03	2.10 2.34 2.58	0.06 0.08 0.11
RRH2X60-AWS	C	From Face	4.00 0.00 2.00	0.00	158.00	1" Ice No Ice 1/2" Ice 4.03	2.10 2.34 2.58	0.06 0.08 0.11
DB-B1-6C-8AB-0Z	A	From Face	4.00 0.00 2.00	0.00	158.00	1" Ice No Ice 1/2" Ice 5.35	2.00 2.19 2.39	0.04 0.08 0.12
DB-T1-6Z-8AB-0Z	B	From Face	4.00 0.00 2.00	0.00	158.00	1" Ice No Ice 1/2" Ice 5.35	2.00 2.19 2.39	0.04 0.08 0.12
(2) FD9R6004/2C-3L	B	From Face	4.00 0.00 2.00	0.00	158.00	1" Ice No Ice 1/2" Ice 0.47	0.08 0.12 0.17	0.00 0.01 0.01
***** Platform Mount 13' [LP 713-1]	C	None		0.00	150.00	No Ice 1/2" Ice 52.10	33.88 42.99 52.10	1.64 2.09 2.54
6' x 2" Mount Pipe	A	From Leg	4.00	0.00	150.00	1" Ice No Ice	1.43	0.02

Description	Face or Leg	Offset Type	Offsets:		Azimuth Adjustment	Placement	C _{AA} Front	C _{AA} Side	Weight
			Horz	Lateral					
			ft	ft	°	ft	ft ²	ft ²	K
			2.00			1/2"	1.92	1.92	0.03
			0.00			Ice	2.29	2.29	0.05
6' x 2" Mount Pipe	B	From Leg	4.00		0.00	150.00	1.43	1.43	0.02
			2.00			1/2"	1.92	1.92	0.03
			0.00			Ice	2.29	2.29	0.05
						1" Ice			
6' x 2" Mount Pipe	C	From Leg	4.00		0.00	150.00	1.43	1.43	0.02
			2.00			1/2"	1.92	1.92	0.03
			0.00			Ice	2.29	2.29	0.05
						1" Ice			
6' x 2" Mount Pipe	A	From Leg	4.00		0.00	150.00	1.43	1.43	0.02
			-2.00			1/2"	1.92	1.92	0.03
			0.00			Ice	2.29	2.29	0.05
						1" Ice			
6' x 2" Mount Pipe	B	From Leg	4.00		0.00	150.00	1.43	1.43	0.02
			-2.00			1/2"	1.92	1.92	0.03
			0.00			Ice	2.29	2.29	0.05
						1" Ice			
6' x 2" Mount Pipe	C	From Leg	4.00		0.00	150.00	1.43	1.43	0.02
			-2.00			1/2"	1.92	1.92	0.03
			0.00			Ice	2.29	2.29	0.05
						1" Ice			
APX/SPP18-C-A20 w/ Mount Pipe	A	From Leg	4.00		30.00	150.00	8.26	6.95	0.08
			-6.00			1/2"	8.82	8.13	0.15
			2.00			Ice	9.35	9.02	0.23
						1" Ice			
APX/SPP18-C-A20 w/ Mount Pipe	B	From Leg	4.00		0.00	150.00	8.26	6.95	0.08
			-6.00			1/2"	8.82	8.13	0.15
			2.00			Ice	9.35	9.02	0.23
						1" Ice			
APX/SPP18-C-A20 w/ Mount Pipe	C	From Leg	4.00		-30.00	150.00	8.26	6.95	0.08
			-6.00			1/2"	8.82	8.13	0.15
			2.00			Ice	9.35	9.02	0.23
						1" Ice			
LLPX310R-V1 w/ Mount Pipe	A	From Leg	4.00		30.00	150.00	4.54	2.98	0.05
			6.00			1/2"	4.89	3.53	0.08
			2.00			Ice	5.25	4.09	0.13
						1" Ice			
LLPX310R-V1 w/ Mount Pipe	B	From Leg	4.00		0.00	150.00	4.54	2.98	0.05
			6.00			1/2"	4.89	3.53	0.08
			2.00			Ice	5.25	4.09	0.13
						1" Ice			
LLPX310R-V1 w/ Mount Pipe	C	From Leg	4.00		-30.00	150.00	4.54	2.98	0.05
			6.00			1/2"	4.89	3.53	0.08
			2.00			Ice	5.25	4.09	0.13
						1" Ice			
800MHZ RRH	A	From Leg	4.00		0.00	150.00	2.13	1.77	0.05
			0.00			1/2"	2.32	1.95	0.07
			2.00			Ice	2.51	2.13	0.10
						1" Ice			
800MHZ RRH	B	From Leg	4.00		0.00	150.00	2.13	1.77	0.05
			0.00			1/2"	2.32	1.95	0.07
			2.00			Ice	2.51	2.13	0.10
						1" Ice			
800MHZ RRH	C	From Leg	4.00		0.00	150.00	2.13	1.77	0.05
			0.00			1/2"	2.32	1.95	0.07
			2.00			Ice	2.51	2.13	0.10
						1" Ice			
1900MHz RRH	A	From Leg	4.00		0.00	150.00	2.49	3.26	0.04
			0.00			1/2"	2.70	3.48	0.08
			2.00			Ice	2.91	3.72	0.11
						1" Ice			
1900MHz RRH	B	From Leg	4.00		0.00	150.00	2.49	3.26	0.04
			0.00			1/2"	2.70	3.48	0.08

Description	Face or Leg	Offset Type	Offsets: Horz Lateral Vert ft ft ft	Azimuth Adjustment t °	Placement ft	C _{AA} Front ft ²	C _{AA} Side ft ²	Weight K
			2.00			Ice 2.91	3.72	0.11
1900MHz RRH	C	From Leg	4.00 0.00 2.00	0.00	150.00	1" Ice No Ice 1/2" Ice 2.49 2.70 2.91	3.26 3.48 3.72	0.04 0.08 0.11
FWHR	A	From Leg	4.00 0.00 2.00	0.00	150.00	1" Ice No Ice 1/2" Ice 1.03 1.16 1.30	0.51 0.60 0.70	0.03 0.04 0.05
FWHR	B	From Leg	4.00 0.00 2.00	0.00	150.00	1" Ice No Ice 1/2" Ice 1.03 1.16 1.30	0.51 0.60 0.70	0.03 0.04 0.05
FWHR	C	From Leg	4.00 0.00 2.00	0.00	150.00	1" Ice No Ice 1/2" Ice 1.03 1.16 1.30	0.51 0.60 0.70	0.03 0.04 0.05
BEN-92P	A	From Leg	4.00 0.00 2.00	0.00	150.00	1" Ice No Ice 1/2" Ice 0.65 0.75 0.86	0.42 0.51 0.60	0.00 0.01 0.02

Side Arm Mount [SO 101-3]	C	None		0.00	142.00	No Ice 1/2" Ice 7.50 8.90 10.30	7.50 8.90 10.30	0.25 0.33 0.41
(2) 6' x 3" Mount Pipe	A	From Leg	2.00 0.00 0.00	0.00	142.00	1" Ice No Ice 1/2" Ice 1.77 2.13 2.50	1.77 2.13 2.50	0.03 0.04 0.06
(2) 6' x 3" Mount Pipe	B	From Leg	2.00 0.00 0.00	0.00	142.00	1" Ice No Ice 1/2" Ice 1.77 2.13 2.50	1.77 2.13 2.50	0.03 0.04 0.06
(2) 6' x 3" Mount Pipe	C	From Leg	2.00 0.00 0.00	0.00	142.00	1" Ice No Ice 1/2" Ice 1.77 2.13 2.50	1.77 2.13 2.50	0.03 0.04 0.06
4' x 2" Horizontal Face Mount Pipe	B	From Leg	0.50 0.00 0.00	0.00	145.00	1" Ice No Ice 1/2" Ice 0.87 1.11 1.36	0.04 0.09 0.13	0.01 0.02 0.03
4' x 2" Horizontal Face Mount Pipe	C	From Leg	0.50 0.00 0.00	0.00	145.00	1" Ice No Ice 1/2" Ice 0.87 1.11 1.36	0.04 0.09 0.13	0.01 0.02 0.03
J-Box - 1' x 1' x 4"	C	From Leg	0.50 0.00 0.00	0.00	145.00	1" Ice No Ice 1/2" Ice 2.13 2.31 2.50	1.20 1.34 1.49	0.02 0.04 0.06

T-Arm Mount [TA 602-3]	C	None		0.00	134.00	No Ice 1/2" Ice 11.59 15.44 19.29	11.59 15.44 19.29	0.77 0.99 1.21
ERICSSON AIR 21 B4A B2P w/ Mount Pipe	A	From Leg	4.00 -6.00 3.00	15.00	134.00	1" Ice No Ice 1/2" Ice 6.32 6.76 7.20	5.63 6.41 7.12	0.11 0.17 0.23
ERICSSON AIR 21 B4A B2P w/ Mount Pipe	B	From Leg	4.00 -6.00 3.00	70.00	134.00	1" Ice No Ice 1/2" Ice 6.32 6.76 7.20	5.63 6.41 7.12	0.11 0.17 0.23
ERICSSON AIR 21 B4A	C	From Leg	4.00	15.00	134.00	1" Ice No Ice 6.32	5.63	0.11

Description	Face or Leg	Offset Type	Offsets: Horz Lateral Vert ft ft ft	Azimuth Adjustment t °	Placement ft	C _{AA} Front ft ²	C _{AA} Side ft ²	Weight K
B2P w/ Mount Pipe			-6.00 3.00			1/2" Ice 7.20	6.41 7.12	0.17 0.23
SBNH-1D65C-SR w/ Mount Pipe	A	From Leg	4.00 6.00 3.00	15.00	134.00	1" Ice No Ice 1/2" Ice 13.15	9.85 11.38 12.42 12.93	0.08 0.17 0.27
SBNH-1D65C-SR w/ Mount Pipe	B	From Leg	4.00 6.00 3.00	70.00	134.00	1" Ice No Ice 1/2" Ice 13.15	9.85 11.38 12.42 12.93	0.08 0.17 0.27
SBNH-1D65C-SR w/ Mount Pipe	C	From Leg	4.00 6.00 3.00	15.00	134.00	1" Ice No Ice 1/2" Ice 13.15	9.85 11.38 12.42 12.93	0.08 0.17 0.27
TMAT1921B78-21A	A	From Leg	4.00 0.00 3.00	0.00	134.00	1" Ice No Ice 1/2" Ice 0.87	0.31 0.39 0.76 0.87	0.02 0.02 0.03
TMAT1921B78-21A	B	From Leg	4.00 0.00 3.00	0.00	134.00	1" Ice No Ice 1/2" Ice 0.87	0.31 0.39 0.76 0.87	0.02 0.02 0.03
TMAT1921B78-21A	C	From Leg	4.00 0.00 3.00	0.00	134.00	1" Ice No Ice 1/2" Ice 0.87	0.31 0.39 0.76 0.87	0.02 0.02 0.03
RRUS 11 B2	A	From Leg	4.00 0.00 3.00	0.00	134.00	1" Ice No Ice 1/2" Ice 3.26	1.18 1.33 3.04 3.26	0.05 0.07 0.10
RRUS 11 B2	B	From Leg	4.00 0.00 3.00	0.00	134.00	1" Ice No Ice 1/2" Ice 3.26	1.18 1.33 3.04 3.26	0.05 0.07 0.10
RRUS 11 B2	C	From Leg	4.00 0.00 3.00	0.00	134.00	1" Ice No Ice 1/2" Ice 3.26	1.18 1.33 3.04 3.26	0.05 0.07 0.10
RRUS 11 B12	A	From Leg	4.00 0.00 3.00	0.00	134.00	1" Ice No Ice 1/2" Ice 3.26	1.18 1.33 3.04 3.26	0.05 0.07 0.10
RRUS 11 B12	B	From Leg	4.00 0.00 3.00	0.00	134.00	1" Ice No Ice 1/2" Ice 3.26	1.18 1.33 3.04 3.26	0.05 0.07 0.10
RRUS 11 B12	C	From Leg	4.00 0.00 3.00	0.00	134.00	1" Ice No Ice 1/2" Ice 3.26	1.18 1.33 3.04 3.26	0.05 0.07 0.10

Platform Mount [LP 303-1]	C	None		0.00	116.00	No Ice 1/2" Ice 23.08	14.66 18.87 23.08	1.25 1.48 1.71
(2) 7770.00 w/ Mount Pipe	A	From Face	4.00 0.00 4.00	10.00	116.00	1" Ice No Ice 1/2" Ice 6.61	4.25 5.01 6.18 5.71	0.06 0.10 0.16
(2) 7770.00 w/ Mount Pipe	B	From Face	4.00 0.00 4.00	20.00	116.00	1" Ice No Ice 1/2" Ice 6.61	4.25 5.01 6.18 5.71	0.06 0.10 0.16
(2) 7770.00 w/ Mount Pipe	C	From Face	4.00	20.00	116.00	1" Ice No Ice	4.25	0.06

Description	Face or Leg	Offset Type	Offsets:		Azimuth Adjustment	Placement	C _{AA} _{Front}	C _{AA} _{Side}	Weight	
			Horz	Lateral						Vert
			ft	ft	°	ft	ft ²	ft ²	K	
				0.00			1/2"	6.18	5.01	0.10
				4.00			Ice	6.61	5.71	0.16
							1" Ice			
AM-X-CD-16-65-00T-RET w/ Mount Pipe	A	From Face	4.00	10.00	116.00	No Ice	8.26	6.30	0.07	
			2.00			1/2"	8.82	7.48	0.14	
			4.00			Ice	9.35	8.37	0.21	
						1" Ice				
AM-X-CD-16-65-00T-RET w/ Mount Pipe	B	From Face	4.00	20.00	116.00	No Ice	8.26	6.30	0.07	
			2.00			1/2"	8.82	7.48	0.14	
			4.00			Ice	9.35	8.37	0.21	
						1" Ice				
AM-X-CD-16-65-00T-RET w/ Mount Pipe	C	From Face	4.00	20.00	116.00	No Ice	8.26	6.30	0.07	
			2.00			1/2"	8.82	7.48	0.14	
			4.00			Ice	9.35	8.37	0.21	
						1" Ice				
(2) LGP13519	A	From Leg	4.00	0.00	116.00	No Ice	0.29	0.18	0.01	
			0.00			1/2"	0.36	0.24	0.01	
			4.00			Ice	0.44	0.31	0.01	
						1" Ice				
(2) LGP13519	B	From Leg	4.00	0.00	116.00	No Ice	0.29	0.18	0.01	
			0.00			1/2"	0.36	0.24	0.01	
			4.00			Ice	0.44	0.31	0.01	
						1" Ice				
(2) LGP13519	C	From Leg	4.00	0.00	116.00	No Ice	0.29	0.18	0.01	
			0.00			1/2"	0.36	0.24	0.01	
			4.00			Ice	0.44	0.31	0.01	
						1" Ice				
(4) 7020.00	A	From Leg	4.00	0.00	116.00	No Ice	0.10	0.17	0.00	
			0.00			1/2"	0.15	0.24	0.01	
			4.00			Ice	0.20	0.31	0.01	
						1" Ice				
(4) 7020.00	B	From Leg	4.00	0.00	116.00	No Ice	0.10	0.17	0.00	
			0.00			1/2"	0.15	0.24	0.01	
			4.00			Ice	0.20	0.31	0.01	
						1" Ice				
(4) 7020.00	C	From Leg	4.00	0.00	116.00	No Ice	0.10	0.17	0.00	
			0.00			1/2"	0.15	0.24	0.01	
			4.00			Ice	0.20	0.31	0.01	
						1" Ice				
RRUS 11	A	From Leg	4.00	0.00	116.00	No Ice	2.78	1.19	0.05	
			0.00			1/2"	2.99	1.33	0.07	
			4.00			Ice	3.21	1.49	0.10	
						1" Ice				
RRUS 11	B	From Leg	4.00	0.00	116.00	No Ice	2.78	1.19	0.05	
			0.00			1/2"	2.99	1.33	0.07	
			4.00			Ice	3.21	1.49	0.10	
						1" Ice				
RRUS 11	C	From Leg	4.00	0.00	116.00	No Ice	2.78	1.19	0.05	
			0.00			1/2"	2.99	1.33	0.07	
			4.00			Ice	3.21	1.49	0.10	
						1" Ice				
RRUS 12	A	From Leg	4.00	0.00	116.00	No Ice	3.15	1.29	0.06	
			0.00			1/2"	3.36	1.44	0.08	
			4.00			Ice	3.59	1.60	0.11	
						1" Ice				
RRUS 12	B	From Leg	4.00	0.00	116.00	No Ice	3.15	1.29	0.06	
			0.00			1/2"	3.36	1.44	0.08	
			4.00			Ice	3.59	1.60	0.11	
						1" Ice				
RRUS 12	C	From Leg	4.00	0.00	116.00	No Ice	3.15	1.29	0.06	
			0.00			1/2"	3.36	1.44	0.08	
			4.00			Ice	3.59	1.60	0.11	
						1" Ice				
1001983	A	From Leg	4.00	0.00	116.00	No Ice	0.18	0.08	0.00	
			0.00			1/2"	0.23	0.13	0.00	

Description	Face or Leg	Offset Type	Offsets:			Azimuth Adjustment	Placement	C _{AA} Front	C _{AA} Side	Weight
			Horz	Lateral	Vert					
			ft	ft	ft	°	ft	ft ²	ft ²	K
			4.00				Ice	0.30	0.18	0.01
1001983	B	From Leg	4.00	0.00	116.00		1" Ice	0.18	0.08	0.00
			0.00				No Ice	0.23	0.13	0.00
			4.00				1/2"	0.30	0.18	0.01
							Ice			
1001983	C	From Leg	4.00	0.00	116.00		1" Ice	0.18	0.08	0.00
			0.00				No Ice	0.23	0.13	0.00
			4.00				1/2"	0.30	0.18	0.01
							Ice			
(2) LGP21401	A	From Leg	4.00	0.00	116.00		1" Ice	1.10	0.35	0.01
			0.00				No Ice	1.24	0.44	0.02
			4.00				1/2"	1.38	0.54	0.03
							Ice			
(2) LGP21401	B	From Leg	4.00	0.00	116.00		1" Ice	1.10	0.35	0.01
			0.00				No Ice	1.24	0.44	0.02
			4.00				1/2"	1.38	0.54	0.03
							Ice			
(2) LGP21401	C	From Leg	4.00	0.00	116.00		1" Ice	1.10	0.35	0.01
			0.00				No Ice	1.24	0.44	0.02
			4.00				1/2"	1.38	0.54	0.03
							Ice			
DC6-48-60-18-8F	C	From Leg	1.00	0.00	116.00		1" Ice	0.92	0.92	0.02
			0.00				No Ice	1.46	1.46	0.04
			4.00				1/2"	1.64	1.64	0.06
							Ice			
							1" Ice			

Side Arm Mount [SO 701-1]	A	From Face	1.50	0.00	61.00		No Ice	0.85	1.67	0.07
			0.00				1/2"	1.14	2.34	0.08
			0.00				Ice	1.43	3.01	0.09
							1" Ice			
Side Arm Mount [SO 701-1]	B	From Leg	1.50	0.00	61.00		No Ice	0.85	1.67	0.07
			0.00				1/2"	1.14	2.34	0.08
			0.00				Ice	1.43	3.01	0.09
							1" Ice			
KS24019-L112A	A	From Face	3.00	0.00	61.00		No Ice	0.14	0.14	0.01
			0.00				1/2"	0.20	0.20	0.01
			0.00				Ice	0.26	0.26	0.01
							1" Ice			
KS24019-L112A	B	From Leg	3.00	0.00	61.00		No Ice	0.14	0.14	0.01
			0.00				1/2"	0.20	0.20	0.01
			0.00				Ice	0.26	0.26	0.01
							1" Ice			
2' x 2" Pipe Mount	A	From Face	3.00	0.00	61.00		No Ice	0.02	0.02	0.01
			0.00				1/2"	0.05	0.05	0.01
			0.00				Ice	0.09	0.09	0.01
							1" Ice			
2' x 2" Pipe Mount	B	From Leg	3.00	0.00	61.00		No Ice	0.02	0.02	0.01
			0.00				1/2"	0.05	0.05	0.01
			0.00				Ice	0.09	0.09	0.01
							1" Ice			

Side Arm Mount [SO 701-1]	A	From Face	1.50	0.00	50.00		No Ice	0.85	1.67	0.07
			0.00				1/2"	1.14	2.34	0.08
			0.00				Ice	1.43	3.01	0.09
							1" Ice			
Side Arm Mount [SO 701-1]	B	From Leg	1.50	0.00	50.00		No Ice	0.85	1.67	0.07
			0.00				1/2"	1.14	2.34	0.08
			0.00				Ice	1.43	3.01	0.09
							1" Ice			
2' x 2" Pipe Mount	A	From Face	3.00	0.00	50.00		No Ice	0.02	0.02	0.01
			0.00				1/2"	0.05	0.05	0.01
			0.00				Ice	0.09	0.09	0.01
							1" Ice			
2' x 2" Pipe Mount	B	From Leg	3.00	0.00	50.00		No Ice	0.02	0.02	0.01

Description	Face or Leg	Offset Type	Offsets: Horz Lateral Vert ft ft ft	Azimuth Adjustment t °	Placement ft	C _{AA} Front ft ²	C _{AA} Side ft ²	Weight K
			0.00		1/2"	0.05	0.05	0.01
			0.00		Ice	0.09	0.09	0.01
					1" Ice			

Dishes

Description	Face or Leg	Dish Type	Offset Type	Offsets: Horz Lateral Vert ft	Azimuth Adjustment °	3 dB Beam Width °	Elevation ft	Outside Diameter ft	Aperture Area ft ²	Weight K	
HP3-11	B	Paraboloid w/Shroud (HP)	From Leg	2.00 1.00 2.00	10.00		142.00	3.17	No Ice 1/2" Ice 1" Ice	7.88 8.30 8.72	0.05 0.09 0.14
HP3-11	C	Paraboloid w/Shroud (HP)	From Leg	2.00 1.00 2.00	18.00		142.00	3.17	No Ice 1/2" Ice 1" Ice	7.88 8.30 8.72	0.05 0.09 0.14

Load Combinations

Comb. No.	Description
1	Dead Only
2	1.2 Dead+1.6 Wind 0 deg - No Ice
3	0.9 Dead+1.6 Wind 0 deg - No Ice
4	1.2 Dead+1.6 Wind 30 deg - No Ice
5	0.9 Dead+1.6 Wind 30 deg - No Ice
6	1.2 Dead+1.6 Wind 60 deg - No Ice
7	0.9 Dead+1.6 Wind 60 deg - No Ice
8	1.2 Dead+1.6 Wind 90 deg - No Ice
9	0.9 Dead+1.6 Wind 90 deg - No Ice
10	1.2 Dead+1.6 Wind 120 deg - No Ice
11	0.9 Dead+1.6 Wind 120 deg - No Ice
12	1.2 Dead+1.6 Wind 150 deg - No Ice
13	0.9 Dead+1.6 Wind 150 deg - No Ice
14	1.2 Dead+1.6 Wind 180 deg - No Ice
15	0.9 Dead+1.6 Wind 180 deg - No Ice
16	1.2 Dead+1.6 Wind 210 deg - No Ice
17	0.9 Dead+1.6 Wind 210 deg - No Ice
18	1.2 Dead+1.6 Wind 240 deg - No Ice
19	0.9 Dead+1.6 Wind 240 deg - No Ice
20	1.2 Dead+1.6 Wind 270 deg - No Ice
21	0.9 Dead+1.6 Wind 270 deg - No Ice
22	1.2 Dead+1.6 Wind 300 deg - No Ice
23	0.9 Dead+1.6 Wind 300 deg - No Ice
24	1.2 Dead+1.6 Wind 330 deg - No Ice
25	0.9 Dead+1.6 Wind 330 deg - No Ice
26	1.2 Dead+1.0 Ice+1.0 Temp
27	1.2 Dead+1.0 Wind 0 deg+1.0 Ice+1.0 Temp
28	1.2 Dead+1.0 Wind 30 deg+1.0 Ice+1.0 Temp
29	1.2 Dead+1.0 Wind 60 deg+1.0 Ice+1.0 Temp
30	1.2 Dead+1.0 Wind 90 deg+1.0 Ice+1.0 Temp
31	1.2 Dead+1.0 Wind 120 deg+1.0 Ice+1.0 Temp
32	1.2 Dead+1.0 Wind 150 deg+1.0 Ice+1.0 Temp

Comb. No.	Description
33	1.2 Dead+1.0 Wind 180 deg+1.0 Ice+1.0 Temp
34	1.2 Dead+1.0 Wind 210 deg+1.0 Ice+1.0 Temp
35	1.2 Dead+1.0 Wind 240 deg+1.0 Ice+1.0 Temp
36	1.2 Dead+1.0 Wind 270 deg+1.0 Ice+1.0 Temp
37	1.2 Dead+1.0 Wind 300 deg+1.0 Ice+1.0 Temp
38	1.2 Dead+1.0 Wind 330 deg+1.0 Ice+1.0 Temp
39	Dead+Wind 0 deg - Service
40	Dead+Wind 30 deg - Service
41	Dead+Wind 60 deg - Service
42	Dead+Wind 90 deg - Service
43	Dead+Wind 120 deg - Service
44	Dead+Wind 150 deg - Service
45	Dead+Wind 180 deg - Service
46	Dead+Wind 210 deg - Service
47	Dead+Wind 240 deg - Service
48	Dead+Wind 270 deg - Service
49	Dead+Wind 300 deg - Service
50	Dead+Wind 330 deg - Service

Maximum Member Forces

Section No.	Elevation ft	Component Type	Condition	Gov. Load Comb.	Axial K	Major Axis Moment kip-ft	Minor Axis Moment kip-ft
L1	160 - 158.1	Pole	Max Tension	36	0.00	-0.00	-0.00
			Max. Compression	26	-0.19	-0.01	0.00
			Max. Mx	8	-0.07	-0.16	0.00
			Max. My	2	-0.07	-0.00	0.16
			Max. Vy	8	0.16	-0.16	0.00
			Max. Vx	2	-0.16	-0.00	0.16
			Max. Torque	12			-0.00
L2	158.1 - 153.1	Pole	Max Tension	1	0.00	0.00	0.00
			Max. Compression	26	-11.43	-0.18	0.66
			Max. Mx	8	-3.09	-55.82	-0.36
			Max. My	2	-3.12	0.42	55.24
			Max. Vy	8	9.02	-55.82	-0.36
			Max. Vx	2	-8.92	0.42	55.24
			Max. Torque	4			0.36
L3	153.1 - 148.1	Pole	Max Tension	1	0.00	0.00	0.00
			Max. Compression	26	-19.19	-0.25	0.85
			Max. Mx	8	-5.93	-114.18	-0.55
			Max. My	2	-5.95	0.54	113.35
			Max. Vy	8	13.79	-114.18	-0.55
			Max. Vx	2	-13.75	0.54	113.35
			Max. Torque	4			0.94
L4	148.1 - 143.1	Pole	Max Tension	1	0.00	0.00	0.00
			Max. Compression	26	-20.61	-0.06	0.16
			Max. Mx	20	-6.38	185.28	0.88
			Max. My	14	-6.44	-0.91	-183.85
			Max. Vy	8	15.22	-185.25	-0.85
			Max. Vx	2	-14.92	0.77	183.80
			Max. Torque	2			1.51
L5	143.1 - 138.1	Pole	Max Tension	1	0.00	0.00	0.00
			Max. Compression	26	-22.70	-0.27	0.20
			Max. Mx	8	-7.24	-265.84	-1.39
			Max. My	2	-7.30	1.57	262.87
			Max. Vy	8	16.55	-265.84	-1.39
			Max. Vx	2	-16.25	1.57	262.87
			Max. Torque	2			1.51
L6	138.1 - 133.1	Pole	Max Tension	1	0.00	0.00	0.00
			Max. Compression	26	-28.82	-0.51	0.22
			Max. Mx	8	-9.44	-359.77	-1.69

Section No.	Elevation ft	Component Type	Condition	Gov. Load Comb.	Axial K	Major Axis Moment kip-ft	Minor Axis Moment kip-ft
L7	133.1 - 128.1	Pole	Max. My	2	-9.49	2.17	355.62
			Max. Vy	8	20.19	-359.77	-1.69
			Max. Vx	2	-19.98	2.17	355.62
			Max. Torque	2			1.51
			Max Tension	1	0.00	0.00	0.00
			Max. Compression	26	-29.83	-0.77	0.24
			Max. Mx	8	-10.02	-462.05	-1.91
L8	128.1 - 123.667	Pole	Max. My	2	-10.06	2.64	456.80
			Max. Vy	8	20.72	-462.05	-1.91
			Max. Vx	2	-20.51	2.64	456.80
			Max. Torque	2			1.05
			Max Tension	1	0.00	0.00	0.00
			Max. Compression	26	-29.85	-0.77	0.24
			Max. Mx	8	-10.05	-464.12	-1.92
L9	123.667 - 123	Pole	Max. My	2	-10.09	2.65	458.85
			Max. Vy	8	20.73	-464.12	-1.92
			Max. Vx	2	-20.51	2.65	458.85
			Max. Torque	2			1.05
			Max Tension	1	0.00	0.00	0.00
			Max. Compression	26	-31.70	-1.04	0.27
			Max. Mx	8	-11.08	-569.37	-2.14
L10	123 - 118	Pole	Max. My	2	-11.13	3.13	563.01
			Max. Vy	8	21.36	-569.37	-2.14
			Max. Vx	2	-21.15	3.13	563.01
			Max. Torque	2			1.05
			Max Tension	1	0.00	0.00	0.00
			Max. Compression	26	-33.01	-1.31	0.29
			Max. Mx	8	-11.89	-677.69	-2.36
L11	118 - 113	Pole	Max. My	2	-11.93	3.60	670.23
			Max. Vy	8	21.96	-677.69	-2.36
			Max. Vx	2	-21.75	3.60	670.23
			Max. Torque	2			1.05
			Max Tension	1	0.00	0.00	0.00
			Max. Compression	26	-41.03	-1.37	0.13
			Max. Mx	8	-15.21	-810.52	-2.63
L12	113 - 108	Pole	Max. My	2	-15.26	4.13	801.53
			Max. Vy	8	26.16	-810.52	-2.63
			Max. Vx	2	-25.88	4.13	801.53
			Max. Torque	2			1.05
			Max Tension	1	0.00	0.00	0.00
			Max. Compression	26	-42.56	-1.60	0.01
			Max. Mx	8	-16.17	-942.85	-2.88
L13	108 - 103	Pole	Max. My	2	-16.21	4.62	932.42
			Max. Vy	8	26.78	-942.85	-2.88
			Max. Vx	2	-26.50	4.62	932.42
			Max. Torque	2			0.99
			Max Tension	1	0.00	0.00	0.00
			Max. Compression	26	-44.13	-1.83	-0.11
			Max. Mx	8	-17.16	-1078.28	-3.13
L14	103 - 98	Pole	Max. My	2	-17.20	5.10	1066.41
			Max. Vy	8	27.40	-1078.28	-3.13
			Max. Vx	2	-27.12	5.10	1066.41
			Max. Torque	2			0.98
			Max Tension	1	0.00	0.00	0.00
			Max. Compression	26	-45.73	-2.08	-0.24
			Max. Mx	8	-18.19	-1216.84	-3.38
L15	98 - 93	Pole	Max. My	2	-18.23	5.58	1203.53
			Max. Vy	8	28.04	-1216.84	-3.38
			Max. Vx	2	-27.75	5.58	1203.53
			Max. Torque	2			0.98
			Max Tension	1	0.00	0.00	0.00
			Max. Compression	26	-47.38	-2.33	-0.37
			Max. Mx	8	-19.25	-1358.60	-3.62
			Max. My	2	-19.29	6.06	1343.84
			Max. Vy	8	28.68	-1358.60	-3.62
			Max. Vx	2	-28.40	6.06	1343.84

Section No.	Elevation ft	Component Type	Condition	Gov. Load Comb.	Axial K	Major Axis Moment kip-ft	Minor Axis Moment kip-ft
L16	93 - 88	Pole	Max. Torque	2			0.98
			Max Tension	1	0.00	0.00	0.00
			Max. Compression	26	-49.06	-2.58	-0.51
			Max. Mx	8	-20.34	-1503.57	-3.87
			Max. My	2	-20.38	6.54	1487.37
			Max. Vy	8	29.33	-1503.57	-3.87
			Max. Vx	2	-29.05	6.54	1487.37
L17	88 - 83	Pole	Max. Torque	2			0.98
			Max Tension	1	0.00	0.00	0.00
			Max. Compression	26	-50.79	-2.84	-0.64
			Max. Mx	8	-21.47	-1651.81	-4.12
			Max. My	2	-21.50	7.01	1634.17
			Max. Vy	8	29.98	-1651.81	-4.12
			Max. Vx	2	-29.70	7.01	1634.17
L18	83 - 76.25	Pole	Max. Torque	2			0.98
			Max Tension	1	0.00	0.00	0.00
			Max. Compression	26	-51.14	-2.89	-0.67
			Max. Mx	8	-21.70	-1681.85	-4.17
			Max. My	2	-21.73	7.11	1663.92
			Max. Vy	8	30.11	-1681.85	-4.17
			Max. Vx	2	-29.83	7.11	1663.92
L19	76.25 - 75.25	Pole	Max. Torque	2			0.98
			Max Tension	1	0.00	0.00	0.00
			Max. Compression	26	-55.10	-3.22	-0.85
			Max. Mx	8	-24.25	-1888.57	-4.51
			Max. My	2	-24.28	7.74	1868.68
			Max. Vy	8	31.13	-1888.57	-4.51
			Max. Vx	2	-30.85	7.74	1868.68
L20	75.25 - 70.25	Pole	Max. Torque	2			0.98
			Max Tension	1	0.00	0.00	0.00
			Max. Compression	26	-56.98	-3.46	-0.99
			Max. Mx	8	-25.53	-2045.84	-4.75
			Max. My	2	-25.55	8.21	2024.52
			Max. Vy	8	31.79	-2045.84	-4.75
			Max. Vx	2	-31.51	8.21	2024.52
L21	70.25 - 65.25	Pole	Max. Torque	2			0.98
			Max Tension	1	0.00	0.00	0.00
			Max. Compression	26	-58.91	-3.71	-1.13
			Max. Mx	8	-26.84	-2206.43	-5.00
			Max. My	2	-26.86	8.68	2183.66
			Max. Vy	8	32.46	-2206.43	-5.00
			Max. Vx	2	-32.18	8.68	2183.66
L22	65.25 - 60.25	Pole	Max. Torque	2			0.98
			Max Tension	1	0.00	0.00	0.00
			Max. Compression	26	-61.18	-3.97	-1.27
			Max. Mx	8	-28.36	-2370.41	-5.23
			Max. My	2	-28.39	9.12	2346.22
			Max. Vy	8	33.22	-2370.41	-5.23
			Max. Vx	2	-32.97	9.12	2346.22
L23	60.25 - 55.25	Pole	Max. Torque	2			0.98
			Max Tension	1	0.00	0.00	0.00
			Max. Compression	26	-63.19	-4.23	-1.42
			Max. Mx	8	-29.75	-2538.11	-5.34
			Max. My	2	-29.77	9.45	2512.64
			Max. Vy	8	33.88	-2538.11	-5.34
			Max. Vx	2	-33.63	9.45	2512.64
L24	55.25 - 51	Pole	Max. Torque	2			0.98
			Max Tension	1	0.00	0.00	0.00
			Max. Compression	26	-64.97	-4.46	-1.54
			Max. Mx	8	-30.95	-2683.25	-5.44
			Max. My	2	-30.97	9.73	2656.68
			Max. Vy	8	34.44	-2683.25	-5.44
			Max. Vx	2	-34.19	9.73	2656.68
			Max. Torque	2			0.98

Section No.	Elevation ft	Component Type	Condition	Gov. Load Comb.	Axial K	Major Axis Moment kip-ft	Minor Axis Moment kip-ft
L25	51 - 50.75	Pole	Max Tension	1	0.00	0.00	0.00
			Max. Compression	26	-65.08	-4.47	-1.55
			Max. Mx	8	-31.03	-2691.86	-5.44
			Max. My	2	-31.05	9.75	2665.23
			Max. Vy	8	34.46	-2691.86	-5.44
			Max. Vx	2	-34.21	9.75	2665.23
			Max. Torque	2			0.98
L26	50.75 - 45.75	Pole	Max Tension	1	0.00	0.00	0.00
			Max. Compression	26	-67.58	-4.74	-1.70
			Max. Mx	8	-32.64	-2866.13	-5.45
			Max. My	2	-32.65	9.96	2838.34
			Max. Vy	8	35.20	-2866.13	-5.45
			Max. Vx	2	-34.98	9.96	2838.34
			Max. Torque	2			0.98
L27	45.75 - 37	Pole	Max Tension	1	0.00	0.00	0.00
			Max. Compression	26	-68.33	-4.83	-1.76
			Max. Mx	8	-33.14	-2927.91	-5.44
			Max. My	2	-33.16	10.03	2899.72
			Max. Vy	8	35.43	-2927.91	-5.44
			Max. Vx	2	-35.21	10.03	2899.72
			Max. Torque	2			0.98
L28	37 - 36	Pole	Max Tension	1	0.00	0.00	0.00
			Max. Compression	26	-74.45	-5.27	-2.00
			Max. Mx	8	-37.37	-3215.94	-5.42
			Max. My	2	-37.38	10.34	3185.94
			Max. Vy	8	36.58	-3215.94	-5.42
			Max. Vx	2	-36.37	10.34	3185.94
			Max. Torque	2			0.98
L29	36 - 31	Pole	Max Tension	1	0.00	0.00	0.00
			Max. Compression	26	-76.83	-5.55	-2.16
			Max. Mx	8	-39.09	-3400.38	-5.41
			Max. My	2	-39.10	10.53	3369.24
			Max. Vy	8	37.20	-3400.38	-5.41
			Max. Vx	2	-36.99	10.53	3369.24
			Max. Torque	2			0.98
L30	31 - 26	Pole	Max Tension	1	0.00	0.00	0.00
			Max. Compression	26	-79.23	-5.82	-2.32
			Max. Mx	8	-40.86	-3587.88	-5.40
			Max. My	2	-40.87	10.72	3555.61
			Max. Vy	8	37.81	-3587.88	-5.40
			Max. Vx	2	-37.60	10.72	3555.61
			Max. Torque	2			0.98
L31	26 - 21	Pole	Max Tension	1	0.00	0.00	0.00
			Max. Compression	26	-81.67	-6.10	-2.48
			Max. Mx	8	-42.67	-3778.44	-5.38
			Max. My	2	-42.67	10.91	3745.05
			Max. Vy	8	38.43	-3778.44	-5.38
			Max. Vx	2	-38.21	10.91	3745.05
			Max. Torque	2			0.98
L32	21 - 16	Pole	Max Tension	1	0.00	0.00	0.00
			Max. Compression	26	-84.15	-6.37	-2.63
			Max. Mx	8	-44.51	-3972.12	-5.37
			Max. My	2	-44.51	11.09	3937.60
			Max. Vy	8	39.06	-3972.12	-5.37
			Max. Vx	2	-38.84	11.09	3937.60
			Max. Torque	2			0.98
L33	16 - 11	Pole	Max Tension	1	0.00	0.00	0.00
			Max. Compression	26	-86.64	-6.64	-2.79
			Max. Mx	8	-46.39	-4168.97	-5.35
			Max. My	2	-46.40	11.27	4133.34
			Max. Vy	8	39.70	-4168.97	-5.35
			Max. Vx	2	-39.49	11.27	4133.34
			Max. Torque	2			0.98
L34	11 - 6	Pole	Max Tension	1	0.00	0.00	0.00
			Max. Compression	26	-89.15	-6.89	-2.96
			Max. Mx	8	-48.31	-4369.05	-5.34
			Max. My	2	-48.31	11.45	4332.30
			Max. Vy	8	40.35	-4369.05	-5.34

Section No.	Elevation ft	Component Type	Condition	Gov. Load Comb.	Axial K	Major Axis Moment kip-ft	Minor Axis Moment kip-ft
L35	6 - 1	Pole	Max. Vx	2	-40.14	11.45	4332.30
			Max. Torque	2			0.98
			Max Tension	1	0.00	0.00	0.00
			Max. Compression	26	-91.23	-6.89	-2.96
			Max. Mx	8	-50.05	-4572.36	-5.30
			Max. My	2	-50.05	11.67	4534.56
			Max. Vy	8	41.01	-4572.36	-5.30
			Max. Vx	2	-40.80	11.67	4534.56
L36	1 - 0	Pole	Max. Torque	2			0.98
			Max Tension	1	0.00	0.00	0.00
			Max. Compression	26	-91.64	-6.89	-2.96
			Max. Mx	8	-50.40	-4613.42	-5.29
			Max. My	2	-50.40	11.71	4575.42
			Max. Vy	8	41.14	-4613.42	-5.29
			Max. Vx	2	-40.93	11.71	4575.42
			Max. Torque	2			0.98

Maximum Reactions

Location	Condition	Gov. Load Comb.	Vertical K	Horizontal, X K	Horizontal, Z K
Pole	Max. Vert	26	91.64	-0.00	-0.00
	Max. H _x	20	50.42	41.11	0.05
	Max. H _z	2	50.42	0.04	40.92
	Max. M _x	2	4575.42	0.04	40.92
	Max. M _z	8	4613.42	-41.13	0.01
	Max. Torsion	2	0.98	0.04	40.92
	Min. Vert	13	37.81	-20.66	-35.45
	Min. H _x	8	50.42	-41.13	0.01
	Min. H _z	14	50.42	0.03	-40.88
	Min. M _x	14	-4570.07	0.03	-40.88
	Min. M _z	20	-4608.40	41.11	0.05
	Min. Torsion	14	-0.90	0.03	-40.88

Tower Mast Reaction Summary

Load Combination	Vertical K	Shear _x K	Shear _z K	Overturning Moment, M _x kip-ft	Overturning Moment, M _z kip-ft	Torque kip-ft
Dead Only	42.01	0.00	0.00	0.28	-0.67	0.00
1.2 Dead+1.6 Wind 0 deg - No Ice	50.42	-0.04	-40.92	-4575.42	11.71	-0.98
0.9 Dead+1.6 Wind 0 deg - No Ice	37.81	-0.04	-40.92	-4533.43	11.77	-0.98
1.2 Dead+1.6 Wind 30 deg - No Ice	50.42	20.70	-35.42	-3956.18	-2322.94	-0.19
0.9 Dead+1.6 Wind 30 deg - No Ice	37.81	20.70	-35.42	-3919.91	-2301.36	-0.19
1.2 Dead+1.6 Wind 60 deg - No Ice	50.42	35.71	-20.44	-2279.61	-4006.98	0.09
0.9 Dead+1.6 Wind 60 deg - No Ice	37.81	35.71	-20.44	-2258.77	-3969.88	0.08
1.2 Dead+1.6 Wind 90 deg - No Ice	50.42	41.13	-0.01	5.29	-4613.42	0.14
0.9 Dead+1.6 Wind 90 deg - No Ice	37.81	41.13	-0.01	5.12	-4570.74	0.14
1.2 Dead+1.6 Wind 120 deg - No Ice	50.42	35.63	20.30	2269.58	-3999.74	0.39
0.9 Dead+1.6 Wind 120 deg - No Ice	37.81	35.63	20.30	2248.62	-3962.69	0.39

Load Combination	Vertical K	Shear _x K	Shear _z K	Overturning Moment, M _x kip-ft	Overturning Moment, M _z kip-ft	Torque kip-ft
1.2 Dead+1.6 Wind 150 deg - No Ice	50.42	20.66	35.45	3966.89	-2326.72	0.69
0.9 Dead+1.6 Wind 150 deg - No Ice	37.81	20.66	35.45	3930.33	-2305.05	0.69
1.2 Dead+1.6 Wind 180 deg - No Ice	50.42	-0.03	40.88	4570.07	-1.98	0.90
0.9 Dead+1.6 Wind 180 deg - No Ice	37.81	-0.03	40.88	4527.96	-1.72	0.90
1.2 Dead+1.6 Wind 210 deg - No Ice	50.42	-20.61	35.42	3957.44	2306.55	0.26
0.9 Dead+1.6 Wind 210 deg - No Ice	37.81	-20.61	35.42	3920.98	2285.54	0.26
1.2 Dead+1.6 Wind 240 deg - No Ice	50.42	-35.64	20.36	2268.73	3994.22	0.09
0.9 Dead+1.6 Wind 240 deg - No Ice	37.81	-35.64	20.36	2247.82	3957.66	0.09
1.2 Dead+1.6 Wind 270 deg - No Ice	50.42	-41.11	-0.05	-13.32	4608.40	-0.18
0.9 Dead+1.6 Wind 270 deg - No Ice	37.81	-41.11	-0.05	-13.24	4566.17	-0.18
1.2 Dead+1.6 Wind 300 deg - No Ice	50.42	-35.62	-20.37	-2278.99	3996.76	-0.47
0.9 Dead+1.6 Wind 300 deg - No Ice	37.81	-35.62	-20.37	-2258.10	3960.15	-0.47
1.2 Dead+1.6 Wind 330 deg - No Ice	50.42	-20.71	-35.55	-3981.11	2331.49	-0.93
0.9 Dead+1.6 Wind 330 deg - No Ice	37.81	-20.71	-35.55	-3944.57	2310.18	-0.93
1.2 Dead+1.0 Ice+1.0 Temp	91.64	0.00	0.00	2.96	-6.89	0.00
1.2 Dead+1.0 Wind 0 deg+1.0 Ice+1.0 Temp	91.64	-0.01	-8.87	-1072.42	-3.95	-0.20
1.2 Dead+1.0 Wind 30 deg+1.0 Ice+1.0 Temp	91.64	4.47	-7.67	-926.76	-549.51	-0.06
1.2 Dead+1.0 Wind 60 deg+1.0 Ice+1.0 Temp	91.64	7.71	-4.43	-532.50	-944.30	-0.01
1.2 Dead+1.0 Wind 90 deg+1.0 Ice+1.0 Temp	91.64	8.88	-0.00	4.78	-1087.18	0.00
1.2 Dead+1.0 Wind 120 deg+1.0 Ice+1.0 Temp	91.64	7.69	4.40	537.90	-943.69	0.06
1.2 Dead+1.0 Wind 150 deg+1.0 Ice+1.0 Temp	91.64	4.71	8.11	986.17	-580.80	0.13
1.2 Dead+1.0 Wind 180 deg+1.0 Ice+1.0 Temp	91.64	-0.01	8.86	1077.36	-8.14	0.18
1.2 Dead+1.0 Wind 210 deg+1.0 Ice+1.0 Temp	91.64	-4.45	7.67	932.97	532.40	0.07
1.2 Dead+1.0 Wind 240 deg+1.0 Ice+1.0 Temp	91.64	-7.70	4.42	536.37	927.88	0.05
1.2 Dead+1.0 Wind 270 deg+1.0 Ice+1.0 Temp	91.64	-8.88	-0.01	-0.35	1072.25	-0.01
1.2 Dead+1.0 Wind 300 deg+1.0 Ice+1.0 Temp	91.64	-7.69	-4.42	-533.74	929.16	-0.08
1.2 Dead+1.0 Wind 330 deg+1.0 Ice+1.0 Temp	91.64	-4.72	-8.13	-982.94	567.76	-0.18
Dead+Wind 0 deg - Service	42.01	-0.01	-8.08	-898.73	1.78	-0.20
Dead+Wind 30 deg - Service	42.01	4.09	-6.99	-777.07	-456.92	-0.04
Dead+Wind 60 deg - Service	42.01	7.05	-4.03	-447.68	-787.81	0.02
Dead+Wind 90 deg - Service	42.01	8.12	-0.00	1.26	-906.97	0.03
Dead+Wind 120 deg - Service	42.01	7.03	4.01	446.15	-786.38	0.08
Dead+Wind 150 deg - Service	42.01	4.08	7.00	779.63	-457.67	0.14
Dead+Wind 180 deg - Service	42.01	-0.01	8.07	898.12	-0.91	0.18
Dead+Wind 210 deg - Service	42.01	-4.07	6.99	777.76	452.65	0.05
Dead+Wind 240 deg - Service	42.01	-7.03	4.02	445.98	784.25	0.02
Dead+Wind 270 deg - Service	42.01	-8.11	-0.01	-2.39	904.93	-0.03

Load Combination	Vertical	Shear _x	Shear _z	Overturning Moment, M _x	Overturning Moment, M _z	Torque
	K	K	K	kip-ft	kip-ft	kip-ft
Dead+Wind 300 deg - Service	42.01	-7.03	-4.02	-447.55	784.75	-0.10
Dead+Wind 330 deg - Service	42.01	-4.09	-7.02	-781.99	457.57	-0.19

Solution Summary

Load Comb.	Sum of Applied Forces			Sum of Reactions			% Error
	PX K	PY K	PZ K	PX K	PY K	PZ K	
1	0.00	-42.01	0.00	0.00	42.01	0.00	0.000%
2	-0.04	-50.42	-40.92	0.04	50.42	40.92	0.000%
3	-0.04	-37.81	-40.92	0.04	37.81	40.92	0.000%
4	20.70	-50.42	-35.42	-20.70	50.42	35.42	0.000%
5	20.70	-37.81	-35.42	-20.70	37.81	35.42	0.000%
6	35.71	-50.42	-20.44	-35.71	50.42	20.44	0.000%
7	35.71	-37.81	-20.44	-35.71	37.81	20.44	0.000%
8	41.13	-50.42	-0.01	-41.13	50.42	0.01	0.000%
9	41.13	-37.81	-0.01	-41.13	37.81	0.01	0.000%
10	35.63	-50.42	20.30	-35.63	50.42	-20.30	0.000%
11	35.63	-37.81	20.30	-35.63	37.81	-20.30	0.000%
12	20.66	-50.42	35.45	-20.66	50.42	-35.45	0.000%
13	20.66	-37.81	35.45	-20.66	37.81	-35.45	0.000%
14	-0.03	-50.42	40.88	0.03	50.42	-40.88	0.000%
15	-0.03	-37.81	40.88	0.03	37.81	-40.88	0.000%
16	-20.61	-50.42	35.42	20.61	50.42	-35.42	0.000%
17	-20.61	-37.81	35.42	20.61	37.81	-35.42	0.000%
18	-35.64	-50.42	20.36	35.64	50.42	-20.36	0.000%
19	-35.64	-37.81	20.36	35.64	37.81	-20.36	0.000%
20	-41.11	-50.42	-0.05	41.11	50.42	0.05	0.000%
21	-41.11	-37.81	-0.05	41.11	37.81	0.05	0.000%
22	-35.62	-50.42	-20.37	35.62	50.42	20.37	0.000%
23	-35.62	-37.81	-20.37	35.62	37.81	20.37	0.000%
24	-20.71	-50.42	-35.55	20.71	50.42	35.55	0.000%
25	-20.71	-37.81	-35.55	20.71	37.81	35.55	0.000%
26	0.00	-91.64	0.00	-0.00	91.64	-0.00	0.000%
27	-0.01	-91.64	-8.87	0.01	91.64	8.87	0.000%
28	4.47	-91.64	-7.67	-4.47	91.64	7.67	0.000%
29	7.71	-91.64	-4.43	-7.71	91.64	4.43	0.000%
30	8.88	-91.64	-0.00	-8.88	91.64	0.00	0.000%
31	7.69	-91.64	4.40	-7.69	91.64	-4.40	0.000%
32	4.71	-91.64	8.11	-4.71	91.64	-8.11	0.000%
33	-0.01	-91.64	8.86	0.01	91.64	-8.86	0.000%
34	-4.45	-91.64	7.67	4.45	91.64	-7.67	0.000%
35	-7.70	-91.64	4.42	7.70	91.64	-4.42	0.000%
36	-8.88	-91.64	-0.01	8.88	91.64	0.01	0.000%
37	-7.69	-91.64	-4.42	7.69	91.64	4.42	0.000%
38	-4.72	-91.64	-8.13	4.72	91.64	8.13	0.000%
39	-0.01	-42.01	-8.08	0.01	42.01	8.08	0.000%
40	4.09	-42.01	-6.99	-4.09	42.01	6.99	0.000%
41	7.05	-42.01	-4.03	-7.05	42.01	4.03	0.000%
42	8.12	-42.01	-0.00	-8.12	42.01	0.00	0.000%
43	7.03	-42.01	4.01	-7.03	42.01	-4.01	0.000%
44	4.08	-42.01	7.00	-4.08	42.01	-7.00	0.000%
45	-0.01	-42.01	8.07	0.01	42.01	-8.07	0.000%
46	-4.07	-42.01	6.99	4.07	42.01	-6.99	0.000%
47	-7.03	-42.01	4.02	7.03	42.01	-4.02	0.000%
48	-8.11	-42.01	-0.01	8.11	42.01	0.01	0.000%
49	-7.03	-42.01	-4.02	7.03	42.01	4.02	0.000%
50	-4.09	-42.01	-7.02	4.09	42.01	7.02	0.000%

Non-Linear Convergence Results

Load Combination	Converged?	Number of Cycles	Displacement Tolerance	Force Tolerance
1	Yes	4	0.00000001	0.00000001
2	Yes	5	0.00000001	0.00092734
3	Yes	5	0.00000001	0.00039565
4	Yes	7	0.00000001	0.00004762
5	Yes	6	0.00000001	0.00032280
6	Yes	7	0.00000001	0.00004774
7	Yes	6	0.00000001	0.00032377
8	Yes	5	0.00000001	0.00029864
9	Yes	5	0.00000001	0.00011617
10	Yes	7	0.00000001	0.00004808
11	Yes	6	0.00000001	0.00032652
12	Yes	7	0.00000001	0.00004729
13	Yes	6	0.00000001	0.00032011
14	Yes	5	0.00000001	0.00052959
15	Yes	5	0.00000001	0.00022561
16	Yes	7	0.00000001	0.00004792
17	Yes	6	0.00000001	0.00032534
18	Yes	7	0.00000001	0.00004757
19	Yes	6	0.00000001	0.00032295
20	Yes	5	0.00000001	0.00024515
21	Yes	5	0.00000001	0.00009064
22	Yes	7	0.00000001	0.00004734
23	Yes	6	0.00000001	0.00032087
24	Yes	7	0.00000001	0.00004879
25	Yes	6	0.00000001	0.00033099
26	Yes	4	0.00000001	0.00045763
27	Yes	6	0.00000001	0.00094992
28	Yes	7	0.00000001	0.00017967
29	Yes	7	0.00000001	0.00017923
30	Yes	6	0.00000001	0.00096187
31	Yes	7	0.00000001	0.00018054
32	Yes	7	0.00000001	0.00019505
33	Yes	6	0.00000001	0.00095163
34	Yes	7	0.00000001	0.00017654
35	Yes	7	0.00000001	0.00017587
36	Yes	6	0.00000001	0.00094831
37	Yes	7	0.00000001	0.00017668
38	Yes	7	0.00000001	0.00019311
39	Yes	5	0.00000001	0.00005486
40	Yes	5	0.00000001	0.00036395
41	Yes	5	0.00000001	0.00036434
42	Yes	5	0.00000001	0.00004238
43	Yes	5	0.00000001	0.00037166
44	Yes	5	0.00000001	0.00036139
45	Yes	5	0.00000001	0.00005058
46	Yes	5	0.00000001	0.00036678
47	Yes	5	0.00000001	0.00035952
48	Yes	5	0.00000001	0.00004184
49	Yes	5	0.00000001	0.00035821
50	Yes	5	0.00000001	0.00038888

Maximum Tower Deflections - Service Wind

Section No.	Elevation ft	Horz. Deflection in	Gov. Load Comb.	Tilt °	Twist °
L1	160 - 158.1	23.1200	42	1.45	0.00
L2	158.1 - 153.1	22.5422	42	1.45	0.00
L3	153.1 - 148.1	21.0280	42	1.44	0.00
L4	148.1 - 143.1	19.5379	42	1.41	0.00
L5	143.1 - 138.1	18.0881	42	1.36	0.00
L6	138.1 - 133.1	16.6929	42	1.30	0.00
L7	133.1 - 128.1	15.3636	42	1.24	0.00
L8	128.1 - 123.667	14.1095	42	1.16	0.00
L9	128 - 123	14.0853	42	1.16	0.00

Section No.	Elevation ft	Horz. Deflection in	Gov. Load Comb.	Tilt °	Twist °
L10	123 - 118	12.8900	42	1.12	0.00
L11	118 - 113	11.7426	42	1.07	0.00
L12	113 - 108	10.6529	42	1.01	0.00
L13	108 - 103	9.6230	42	0.95	0.00
L14	103 - 98	8.6542	42	0.90	0.00
L15	98 - 93	7.7470	42	0.84	0.00
L16	93 - 88	6.9015	42	0.78	0.00
L17	88 - 83	6.1173	42	0.72	0.00
L18	83 - 76.25	5.3937	42	0.66	0.00
L19	82 - 75.25	5.2563	42	0.65	0.00
L20	75.25 - 70.25	4.3628	42	0.61	0.00
L21	70.25 - 65.25	3.7533	42	0.56	0.00
L22	65.25 - 60.25	3.1984	42	0.50	0.00
L23	60.25 - 55.25	2.6968	42	0.45	0.00
L24	55.25 - 51	2.2475	42	0.40	0.00
L25	51 - 50.75	1.9057	42	0.36	0.00
L26	50.75 - 45.75	1.8867	42	0.36	0.00
L27	45.75 - 37	1.5333	42	0.31	0.00
L28	44 - 36	1.4212	42	0.30	0.00
L29	36 - 31	0.9512	42	0.26	0.00
L30	31 - 26	0.6994	42	0.22	0.00
L31	26 - 21	0.4879	42	0.18	0.00
L32	21 - 16	0.3157	42	0.15	0.00
L33	16 - 11	0.1817	42	0.11	0.00
L34	11 - 6	0.0852	42	0.07	0.00
L35	6 - 1	0.0251	42	0.04	0.00
L36	1 - 0	0.0007	42	0.01	0.00

Critical Deflections and Radius of Curvature - Service Wind

Elevation ft	Appurtenance	Gov. Load Comb.	Deflection in	Tilt °	Twist °	Radius of Curvature ft
158.00	Platform Mount 13' [LP 713-1]	42	22.5118	1.45	0.00	17469
150.00	Platform Mount 13' [LP 713-1]	42	20.1002	1.42	0.00	8711
145.00	4' x 2" Horizontal Face Mount	42	18.6333	1.38	0.00	6053
144.00	Pipe HP3-11	42	18.3454	1.37	0.00	5732
142.00	Side Arm Mount [SO 101-3]	42	17.7760	1.35	0.00	5225
134.00	T-Arm Mount [TA 602-3]	42	15.5975	1.25	0.00	4075
116.00	Platform Mount [LP 303-1]	42	11.2996	1.05	0.00	5095
61.00	Side Arm Mount [SO 701-1]	42	2.7687	0.46	0.00	5732
50.00	Side Arm Mount [SO 701-1]	42	1.8305	0.35	0.00	5999

Maximum Tower Deflections - Design Wind

Section No.	Elevation ft	Horz. Deflection in	Gov. Load Comb.	Tilt °	Twist °
L1	160 - 158.1	117.5370	8	7.39	0.02
L2	158.1 - 153.1	114.6044	8	7.39	0.02
L3	153.1 - 148.1	106.9189	8	7.31	0.01
L4	148.1 - 143.1	99.3541	8	7.16	0.01
L5	143.1 - 138.1	91.9920	8	6.93	0.01
L6	138.1 - 133.1	84.9058	8	6.63	0.01
L7	133.1 - 128.1	78.1521	8	6.29	0.01
L8	128.1 - 123.667	71.7792	8	5.90	0.00
L9	128 - 123	71.6560	8	5.89	0.00
L10	123 - 118	65.5800	8	5.72	0.00
L11	118 - 113	59.7468	8	5.44	0.00
L12	113 - 108	54.2057	8	5.16	0.00

Section No.	Elevation ft	Horz. Deflection in	Gov. Load Comb.	Tilt °	Twist °
L13	108 - 103	48.9678	8	4.86	0.00
L14	103 - 98	44.0398	8	4.56	0.00
L15	98 - 93	39.4248	8	4.26	0.00
L16	93 - 88	35.1228	8	3.96	0.00
L17	88 - 83	31.1324	8	3.67	0.00
L18	83 - 76.25	27.4505	8	3.37	0.00
L19	82 - 75.25	26.7508	8	3.31	0.00
L20	75.25 - 70.25	22.2039	8	3.10	0.00
L21	70.25 - 65.25	19.1019	8	2.83	0.00
L22	65.25 - 60.25	16.2774	8	2.57	0.00
L23	60.25 - 55.25	13.7245	8	2.31	0.00
L24	55.25 - 51	11.4374	8	2.06	0.00
L25	51 - 50.75	9.6978	8	1.85	0.00
L26	50.75 - 45.75	9.6013	8	1.84	0.00
L27	45.75 - 37	7.8027	8	1.60	0.00
L28	44 - 36	7.2322	8	1.52	0.00
L29	36 - 31	4.8399	8	1.32	0.00
L30	31 - 26	3.5588	8	1.12	0.00
L31	26 - 21	2.4826	24	0.93	0.00
L32	21 - 16	1.6061	24	0.74	0.00
L33	16 - 11	0.9246	24	0.56	0.00
L34	11 - 6	0.4334	24	0.38	0.00
L35	6 - 1	0.1278	24	0.20	0.00
L36	1 - 0	0.0035	24	0.03	0.00

Critical Deflections and Radius of Curvature - Design Wind

Elevation ft	Appurtenance	Gov. Load Comb.	Deflection in	Tilt °	Twist °	Radius of Curvature ft
158.00	Platform Mount 13' [LP 713-1]	8	114.4501	7.39	0.02	3582
150.00	Platform Mount 13' [LP 713-1]	8	102.2091	7.23	0.01	1777
145.00	4' x 2" Horizontal Face Mount Pipe	8	94.7608	7.02	0.01	1229
144.00	HP3-11	8	93.2988	6.97	0.01	1162
142.00	Side Arm Mount [SO 101-3]	8	90.4072	6.87	0.01	1058
134.00	T-Arm Mount [TA 602-3]	8	79.3410	6.35	0.01	820
116.00	Platform Mount [LP 303-1]	8	57.4944	5.32	0.00	1018
61.00	Side Arm Mount [SO 701-1]	8	14.0904	2.35	0.00	1129
50.00	Side Arm Mount [SO 701-1]	8	9.3153	1.80	0.00	1180

Compression Checks

Pole Design Data

Section No.	Elevation ft	Size	L ft	L _u ft	KI/r	A in ²	P _u K	φP _n K	Ratio P _u / φP _n
L1	160 - 158.1 (1)	TP19.4024x18.87x0.1875	1.90	0.00	0.0	11.601 0	-0.07	808.03	0.000
L2	158.1 - 153.1 (2)	TP20.8033x19.4024x0.18 75	5.00	0.00	0.0	12.446 8	-3.09	842.48	0.004
L3	153.1 - 148.1 (3)	TP22.2042x20.8033x0.18 75	5.00	0.00	0.0	13.292 6	-5.93	873.60	0.007
L4	148.1 - 143.1 (4)	TP23.6051x22.2042x0.18 75	5.00	0.00	0.0	14.138 4	-6.38	901.40	0.007
L5	143.1 - 138.1 (5)	TP25.0061x23.6051x0.18 75	5.00	0.00	0.0	14.984 2	-7.25	925.88	0.008

Section No.	Elevation ft	Size	L ft	L _u ft	Kl/r	A in ²	P _u K	φP _n K	Ratio P _u / φP _n
L6	138.1 - 133.1 (6)	TP26.407x25.0061x0.187 5	5.00	0.00	0.0	15.830 0	-9.44	947.02	0.010
L7	133.1 - 128.1 (7)	TP27.8079x26.407x0.187 5	5.00	0.00	0.0	16.675 8	-10.02	964.85	0.010
L8	128.1 - 123.667 (8)	TP29.05x27.8079x0.1875	4.43	0.00	0.0	16.692 8	-10.05	965.17	0.010
L9	123.667 - 123 (9)	TP28.8609x27.461x0.312 5	5.00	0.00	0.0	28.726 8	-11.08	2084.95	0.005
L10	123 - 118 (10)	TP30.2608x28.8609x0.31 25	5.00	0.00	0.0	30.135 4	-11.89	2151.68	0.006
L11	118 - 113 (11)	TP31.6607x30.2608x0.31 25	5.00	0.00	0.0	31.544 1	-15.21	2215.08	0.007
L12	113 - 108 (12)	TP33.0606x31.6607x0.31 25	5.00	0.00	0.0	32.952 8	-16.17	2275.17	0.007
L13	108 - 103 (13)	TP34.4605x33.0606x0.31 25	5.00	0.00	0.0	34.361 4	-17.16	2331.93	0.007
L14	103 - 98 (14)	TP35.8604x34.4605x0.31 25	5.00	0.00	0.0	35.770 1	-18.19	2385.38	0.008
L15	98 - 93 (15)	TP37.2603x35.8604x0.31 25	5.00	0.00	0.0	37.178 7	-19.25	2435.50	0.008
L16	93 - 88 (16)	TP38.6602x37.2603x0.31 25	5.00	0.00	0.0	38.587 4	-20.34	2482.30	0.008
L17	88 - 83 (17)	TP40.0601x38.6602x0.31 25	5.00	0.00	0.0	39.996 0	-21.47	2525.79	0.009
L18	83 - 76.25 (18)	TP41.95x40.0601x0.3125	6.75	0.00	0.0	40.277 8	-21.70	2534.09	0.009
L19	76.25 - 75.25 (19)	TP41.6058x39.7151x0.34 38	6.75	0.00	0.0	45.672 0	-24.25	2970.22	0.008
L20	75.25 - 70.25 (20)	TP43.0064x41.6058x0.34 38	5.00	0.00	0.0	47.222 2	-25.52	3020.43	0.008
L21	70.25 - 65.25 (21)	TP44.4069x43.0064x0.34 38	5.00	0.00	0.0	48.772 4	-26.84	3067.31	0.009
L22	65.25 - 60.25 (22)	TP45.8075x44.4069x0.34 38	5.00	0.00	0.0	50.322 7	-28.36	3110.86	0.009
L23	60.25 - 55.25 (23)	TP47.208x45.8075x0.343 8	5.00	0.00	0.0	51.872 9	-29.75	3151.10	0.009
L24	55.25 - 51 (24)	TP48.3985x47.208x0.343 8	4.25	0.00	0.0	53.190 6	-30.95	3182.68	0.010
L25	51 - 50.75 (25)	TP48.4685x48.3985x0.34 38	0.25	0.00	0.0	53.268 1	-31.03	3184.47	0.010
L26	50.75 - 45.75 (26)	TP49.869x48.4685x0.343 8	5.00	0.00	0.0	54.818 3	-32.64	3218.39	0.010
L27	45.75 - 37 (27)	TP52.32x49.869x0.3438	8.75	0.00	0.0	55.360 9	-33.14	3229.47	0.010
L28	37 - 36 (28)	TP51.9132x49.6717x0.40 63	8.00	0.00	0.0	67.377 6	-37.37	4262.16	0.009
L29	36 - 31 (29)	TP53.3142x51.9132x0.40 63	5.00	0.00	0.0	69.210 2	-39.09	4315.30	0.009
L30	31 - 26 (30)	TP54.7151x53.3142x0.40 63	5.00	0.00	0.0	71.042 8	-40.86	4365.11	0.009
L31	26 - 21 (31)	TP56.1161x54.7151x0.40 63	5.00	0.00	0.0	72.875 4	-42.67	4411.60	0.010
L32	21 - 16 (32)	TP57.517x56.1161x0.406 3	5.00	0.00	0.0	74.708 0	-44.51	4454.77	0.010
L33	16 - 11 (33)	TP58.9179x57.517x0.406 3	5.00	0.00	0.0	76.540 6	-46.39	4494.61	0.010
L34	11 - 6 (34)	TP60.3189x58.9179x0.40 63	5.00	0.00	0.0	78.373 2	-48.31	4531.12	0.011
L35	6 - 1 (35)	TP61.7198x60.3189x0.40 63	5.00	0.00	0.0	80.205 8	-50.05	4564.31	0.011
L36	1 - 0 (36)	TP62x61.7198x0.4063	1.00	0.00	0.0	80.572 3	-50.40	4570.55	0.011

Pole Bending Design Data

Section No.	Elevation ft	Size	M_{ux} kip-ft	ϕM_{nx} kip-ft	Ratio $\frac{M_{ux}}{\phi M_{nx}}$	M_{uy} kip-ft	ϕM_{ny} kip-ft	Ratio $\frac{M_{uy}}{\phi M_{ny}}$
L1	160 - 158.1 (1)	TP19.4024x18.87x0.1875	0.16	315.74	0.000	0.00	315.74	0.000
L2	158.1 - 153.1 (2)	TP20.8033x19.4024x0.1875	56.07	353.43	0.159	0.00	353.43	0.000
L3	153.1 - 148.1 (3)	TP22.2042x20.8033x0.1875	114.50	391.62	0.292	0.00	391.62	0.000
L4	148.1 - 143.1 (4)	TP23.6051x22.2042x0.1875	185.59	430.01	0.432	0.00	430.01	0.000
L5	143.1 - 138.1 (5)	TP25.0061x23.6051x0.1875	266.02	468.31	0.568	0.00	468.31	0.000
L6	138.1 - 133.1 (6)	TP26.407x25.0061x0.1875	359.78	506.25	0.711	0.00	506.25	0.000
L7	133.1 - 128.1 (7)	TP27.8079x26.407x0.1875	462.05	543.53	0.850	0.00	543.53	0.000
L8	128.1 - 123.667 (8)	TP29.05x27.8079x0.1875	464.12	544.27	0.853	0.00	544.27	0.000
L9	123.667 - 123 (9)	TP28.8609x27.461x0.3125	569.38	1208.99	0.471	0.00	1208.99	0.000
L10	123 - 118 (10)	TP30.2608x28.8609x0.3125	677.70	1309.53	0.518	0.00	1309.53	0.000
L11	118 - 113 (11)	TP31.6607x30.2608x0.3125	810.53	1411.78	0.574	0.00	1411.78	0.000
L12	113 - 108 (12)	TP33.0606x31.6607x0.3125	942.86	1515.47	0.622	0.00	1515.47	0.000
L13	108 - 103 (13)	TP34.4605x33.0606x0.3125	1078.28	1620.32	0.665	0.00	1620.32	0.000
L14	103 - 98 (14)	TP35.8604x34.4605x0.3125	1216.85	1726.02	0.705	0.00	1726.02	0.000
L15	98 - 93 (15)	TP37.2603x35.8604x0.3125	1358.60	1832.29	0.741	0.00	1832.29	0.000
L16	93 - 88 (16)	TP38.6602x37.2603x0.3125	1503.58	1938.85	0.775	0.00	1938.85	0.000
L17	88 - 83 (17)	TP40.0601x38.6602x0.3125	1651.82	2045.42	0.808	0.00	2045.42	0.000
L18	83 - 76.25 (18)	TP41.95x40.0601x0.3125	1681.86	2066.71	0.814	0.00	2066.71	0.000
L19	76.25 - 75.25 (19)	TP41.6058x39.7151x0.3438	1888.58	2495.82	0.757	0.00	2495.82	0.000
L20	75.25 - 70.25 (20)	TP43.0064x41.6058x0.3438	2045.87	2624.86	0.779	0.00	2624.86	0.000
L21	70.25 - 65.25 (21)	TP44.4069x43.0064x0.3438	2206.47	2753.80	0.801	0.00	2753.80	0.000
L22	65.25 - 60.25 (22)	TP45.8075x44.4069x0.3438	2370.47	2882.37	0.822	0.00	2882.37	0.000
L23	60.25 - 55.25 (23)	TP47.208x45.8075x0.3438	2538.18	3010.27	0.843	0.00	3010.27	0.000
L24	55.25 - 51 (24)	TP48.3985x47.208x0.3438	2683.32	3118.23	0.861	0.00	3118.23	0.000
L25	51 - 50.75 (25)	TP48.4685x48.3985x0.3438	2691.93	3124.56	0.862	0.00	3124.56	0.000
L26	50.75 - 45.75 (26)	TP49.869x48.4685x0.3438	2866.22	3250.40	0.882	0.00	3250.40	0.000
L27	45.75 - 37 (27)	TP52.32x49.869x0.3438	2927.99	3294.10	0.889	0.00	3294.10	0.000
L28	37 - 36 (28)	TP51.9132x49.6717x0.4063	3216.03	4472.58	0.719	0.00	4472.58	0.000
L29	36 - 31 (29)	TP53.3142x51.9132x0.4063	3400.47	4652.48	0.731	0.00	4652.48	0.000
L30	31 - 26 (30)	TP54.7151x53.3142x0.4063	3587.97	4831.75	0.743	0.00	4831.75	0.000
L31	26 - 21 (31)	TP56.1161x54.7151x0.4063	3778.53	5010.11	0.754	0.00	5010.11	0.000
L32	21 - 16 (32)	TP57.517x56.1161x0.4063	3972.20	5187.27	0.766	0.00	5187.27	0.000
L33	16 - 11 (33)	TP58.9179x57.517x0.4063	4169.05	5362.96	0.777	0.00	5362.96	0.000
L34	11 - 6 (34)	TP60.3189x58.9179x0.4063	4369.12	5536.87	0.789	0.00	5536.87	0.000
L35	6 - 1 (35)	TP61.7198x60.3189x0.4063	4572.50	5708.72	0.801	0.00	5708.72	0.000

Section No.	Elevation ft	Size	M_{ux} kip-ft	ϕM_{nx} kip-ft	Ratio $\frac{M_{ux}}{\phi M_{nx}}$	M_{uy} kip-ft	ϕM_{ny} kip-ft	Ratio $\frac{M_{uy}}{\phi M_{ny}}$
L36	1 - 0 (36)	63 TP62x61.7198x0.4063	4613.57	5742.82	0.803	0.00	5742.82	0.000

Pole Shear Design Data

Section No.	Elevation ft	Size	Actual V_u K	ϕV_n K	Ratio $\frac{V_u}{\phi V_n}$	Actual T_u kip-ft	ϕT_n kip-ft	Ratio $\frac{T_u}{\phi T_n}$
L1	160 - 158.1 (1)	TP19.4024x18.87x0.1875	0.16	404.02	0.000	0.00	640.21	0.000
L2	158.1 - 153.1 (2)	TP20.8033x19.4024x0.1875	9.05	421.24	0.021	0.08	716.64	0.000
L3	153.1 - 148.1 (3)	TP22.2042x20.8033x0.1875	13.80	436.80	0.032	0.06	794.07	0.000
L4	148.1 - 143.1 (4)	TP23.6051x22.2042x0.1875	15.20	450.70	0.034	0.81	871.92	0.001
L5	143.1 - 138.1 (5)	TP25.0061x23.6051x0.1875	16.53	462.94	0.036	0.81	949.59	0.001
L6	138.1 - 133.1 (6)	TP26.407x25.0061x0.1875	20.19	473.51	0.043	0.24	1026.52	0.000
L7	133.1 - 128.1 (7)	TP27.8079x26.407x0.1875	20.72	482.42	0.043	0.20	1102.12	0.000
L8	128.1 - 123.667 (8)	TP29.05x27.8079x0.1875	20.73	482.58	0.043	0.20	1103.61	0.000
L9	123.667 - 123 (9)	TP28.8609x27.461x0.3125	21.36	1042.48	0.020	0.20	2451.46	0.000
L10	123 - 118 (10)	TP30.2608x28.8609x0.3125	21.96	1075.84	0.020	0.20	2655.32	0.000
L11	118 - 113 (11)	TP31.6607x30.2608x0.3125	26.16	1107.54	0.024	0.14	2862.67	0.000
L12	113 - 108 (12)	TP33.0606x31.6607x0.3125	26.78	1137.58	0.024	0.14	3072.92	0.000
L13	108 - 103 (13)	TP34.4605x33.0606x0.3125	27.40	1165.97	0.024	0.14	3285.49	0.000
L14	103 - 98 (14)	TP35.8604x34.4605x0.3125	28.04	1192.69	0.024	0.14	3499.82	0.000
L15	98 - 93 (15)	TP37.2603x35.8604x0.3125	28.68	1217.75	0.024	0.14	3715.31	0.000
L16	93 - 88 (16)	TP38.6602x37.2603x0.3125	29.33	1241.15	0.024	0.14	3931.39	0.000
L17	88 - 83 (17)	TP40.0601x38.6602x0.3125	29.98	1262.89	0.024	0.14	4147.47	0.000
L18	83 - 76.25 (18)	TP41.95x40.0601x0.3125	30.11	1267.04	0.024	0.14	4190.63	0.000
L19	76.25 - 75.25 (19)	TP41.6058x39.7151x0.3438	31.15	1485.11	0.021	0.93	5060.73	0.000
L20	75.25 - 70.25 (20)	TP43.0064x41.6058x0.3438	31.81	1510.21	0.021	0.93	5322.39	0.000
L21	70.25 - 65.25 (21)	TP44.4069x43.0064x0.3438	32.47	1533.65	0.021	0.93	5583.85	0.000
L22	65.25 - 60.25 (22)	TP45.8075x44.4069x0.3438	33.23	1555.43	0.021	0.93	5844.54	0.000
L23	60.25 - 55.25 (23)	TP47.208x45.8075x0.3438	33.89	1575.55	0.022	0.93	6103.87	0.000
L24	55.25 - 51 (24)	TP48.3985x47.208x0.3438	34.45	1591.34	0.022	0.93	6322.81	0.000
L25	51 - 50.75 (25)	TP48.4685x48.3985x0.3438	34.47	1592.23	0.022	0.93	6335.63	0.000
L26	50.75 - 45.75 (26)	TP49.869x48.4685x0.3438	35.21	1609.19	0.022	0.93	6590.79	0.000
L27	45.75 - 37 (27)	TP52.32x49.869x0.3438	35.44	1614.74	0.022	0.93	6679.41	0.000
L28	37 - 36 (28)	TP51.9132x49.6717x0.4063	36.60	2131.08	0.017	0.93	9069.00	0.000
L29	36 - 31 (29)	TP53.3142x51.9132x0.4063	37.22	2157.65	0.017	0.93	9433.75	0.000

Section No.	Elevation ft	Size	Actual V_u K	ϕV_n K	Ratio $\frac{V_u}{\phi V_n}$	Actual T_u kip-ft	ϕT_n kip-ft	Ratio $\frac{T_u}{\phi T_n}$
L30	31 - 26 (30)	63 TP54.7151x53.3142x0.40	37.82	2182.56	0.017	0.93	9797.25	0.000
L31	26 - 21 (31)	63 TP56.1161x54.7151x0.40	38.44	2205.80	0.017	0.93	10158.92	0.000
L32	21 - 16 (32)	63 TP57.517x56.1161x0.406	39.07	2227.38	0.018	0.93	10518.17	0.000
L33	16 - 11 (33)	3 TP58.9179x57.517x0.406	39.71	2247.30	0.018	0.93	10874.42	0.000
L34	11 - 6 (34)	3 TP60.3189x58.9179x0.40	40.36	2265.56	0.018	0.93	11227.00	0.000
L35	6 - 1 (35)	63 TP61.7198x60.3189x0.40	41.02	2282.16	0.018	0.93	11575.50	0.000
L36	1 - 0 (36)	63 TP62x61.7198x0.4063	41.16	2285.28	0.018	0.93	11644.67	0.000

Pole Interaction Design Data

Section No.	Elevation ft	Ratio $\frac{P_u}{\phi P_n}$	Ratio $\frac{M_{ux}}{\phi M_{nx}}$	Ratio $\frac{M_{uy}}{\phi M_{ny}}$	Ratio $\frac{V_u}{\phi V_n}$	Ratio $\frac{T_u}{\phi T_n}$	Comb. Stress Ratio	Allow. Stress Ratio	Criteria
L1	160 - 158.1 (1)	0.000	0.000	0.000	0.000	0.000	0.001	1.000	4.8.2 ✓
L2	158.1 - 153.1 (2)	0.004	0.159	0.000	0.021	0.000	0.163	1.000	4.8.2 ✓
L3	153.1 - 148.1 (3)	0.007	0.292	0.000	0.032	0.000	0.300	1.000	4.8.2 ✓
L4	148.1 - 143.1 (4)	0.007	0.432	0.000	0.034	0.001	0.440	1.000	4.8.2 ✓
L5	143.1 - 138.1 (5)	0.008	0.568	0.000	0.036	0.001	0.577	1.000	4.8.2 ✓
L6	138.1 - 133.1 (6)	0.010	0.711	0.000	0.043	0.000	0.722	1.000	4.8.2 ✓
L7	133.1 - 128.1 (7)	0.010	0.850	0.000	0.043	0.000	0.862	1.000	4.8.2 ✓
L8	128.1 - 123.667 (8)	0.010	0.853	0.000	0.043	0.000	0.865	1.000	4.8.2 ✓
L9	123.667 - 123 (9)	0.005	0.471	0.000	0.020	0.000	0.477	1.000	4.8.2 ✓
L10	123 - 118 (10)	0.006	0.518	0.000	0.020	0.000	0.523	1.000	4.8.2 ✓
L11	118 - 113 (11)	0.007	0.574	0.000	0.024	0.000	0.582	1.000	4.8.2 ✓
L12	113 - 108 (12)	0.007	0.622	0.000	0.024	0.000	0.630	1.000	4.8.2 ✓
L13	108 - 103 (13)	0.007	0.665	0.000	0.024	0.000	0.673	1.000	4.8.2 ✓
L14	103 - 98 (14)	0.008	0.705	0.000	0.024	0.000	0.713	1.000	4.8.2 ✓
L15	98 - 93 (15)	0.008	0.741	0.000	0.024	0.000	0.750	1.000	4.8.2 ✓
L16	93 - 88 (16)	0.008	0.775	0.000	0.024	0.000	0.784	1.000	4.8.2 ✓
L17	88 - 83 (17)	0.009	0.808	0.000	0.024	0.000	0.817	1.000	4.8.2 ✓
L18	83 - 76.25 (18)	0.009	0.814	0.000	0.024	0.000	0.823	1.000	4.8.2 ✓
L19	76.25 - 75.25 (19)	0.008	0.757	0.000	0.021	0.000	0.765	1.000	4.8.2 ✓

Section No.	Elevation ft	Ratio	Ratio	Ratio	Ratio	Ratio	Comb. Stress Ratio	Allow. Stress Ratio	Criteria
		P_u ϕP_n	M_{ux} ϕM_{nx}	M_{uy} ϕM_{ny}	V_u ϕV_n	T_u ϕT_n			
L20	75.25 - 70.25 (20)	0.008	0.779	0.000	0.021	0.000	0.788	1.000	4.8.2 ✓
L21	70.25 - 65.25 (21)	0.009	0.801	0.000	0.021	0.000	0.810	1.000	4.8.2 ✓
L22	65.25 - 60.25 (22)	0.009	0.822	0.000	0.021	0.000	0.832	1.000	4.8.2 ✓
L23	60.25 - 55.25 (23)	0.009	0.843	0.000	0.022	0.000	0.853	1.000	4.8.2 ✓
L24	55.25 - 51 (24)	0.010	0.861	0.000	0.022	0.000	0.871	1.000	4.8.2 ✓
L25	51 - 50.75 (25)	0.010	0.862	0.000	0.022	0.000	0.872	1.000	4.8.2 ✓
L26	50.75 - 45.75 (26)	0.010	0.882	0.000	0.022	0.000	0.892	1.000	4.8.2 ✓
L27	45.75 - 37 (27)	0.010	0.889	0.000	0.022	0.000	0.900	1.000	4.8.2 ✓
L28	37 - 36 (28)	0.009	0.719	0.000	0.017	0.000	0.728	1.000	4.8.2 ✓
L29	36 - 31 (29)	0.009	0.731	0.000	0.017	0.000	0.740	1.000	4.8.2 ✓
L30	31 - 26 (30)	0.009	0.743	0.000	0.017	0.000	0.752	1.000	4.8.2 ✓
L31	26 - 21 (31)	0.010	0.754	0.000	0.017	0.000	0.764	1.000	4.8.2 ✓
L32	21 - 16 (32)	0.010	0.766	0.000	0.018	0.000	0.776	1.000	4.8.2 ✓
L33	16 - 11 (33)	0.010	0.777	0.000	0.018	0.000	0.788	1.000	4.8.2 ✓
L34	11 - 6 (34)	0.011	0.789	0.000	0.018	0.000	0.800	1.000	4.8.2 ✓
L35	6 - 1 (35)	0.011	0.801	0.000	0.018	0.000	0.812	1.000	4.8.2 ✓
L36	1 - 0 (36)	0.011	0.803	0.000	0.018	0.000	0.815	1.000	4.8.2 ✓

Section Capacity Table

Section No.	Elevation ft	Component Type	Size	Critical Element	P K	ϕP_{allow} K	% Capacity	Pass Fail
L1	160 - 158.1	Pole	TP19.4024x18.87x0.1875	1	-0.07	808.03	0.1	Pass
L2	158.1 - 153.1	Pole	TP20.8033x19.4024x0.1875	2	-3.09	842.48	16.3	Pass
L3	153.1 - 148.1	Pole	TP22.2042x20.8033x0.1875	3	-5.93	873.60	30.0	Pass
L4	148.1 - 143.1	Pole	TP23.6051x22.2042x0.1875	4	-6.38	901.40	44.0	Pass
L5	143.1 - 138.1	Pole	TP25.0061x23.6051x0.1875	5	-7.25	925.88	57.7	Pass
L6	138.1 - 133.1	Pole	TP26.407x25.0061x0.1875	6	-9.44	947.02	72.2	Pass
L7	133.1 - 128.1	Pole	TP27.8079x26.407x0.1875	7	-10.02	964.85	86.2	Pass
L8	128.1 - 123.667	Pole	TP29.05x27.8079x0.1875	8	-10.05	965.17	86.5	Pass
L9	123.667 - 123	Pole	TP28.8609x27.461x0.3125	9	-11.08	2084.95	47.7	Pass
L10	123 - 118	Pole	TP30.2608x28.8609x0.3125	10	-11.89	2151.68	52.3	Pass
L11	118 - 113	Pole	TP31.6607x30.2608x0.3125	11	-15.21	2215.08	58.2	Pass
L12	113 - 108	Pole	TP33.0606x31.6607x0.3125	12	-16.17	2275.17	63.0	Pass
L13	108 - 103	Pole	TP34.4605x33.0606x0.3125	13	-17.16	2331.93	67.3	Pass
L14	103 - 98	Pole	TP35.8604x34.4605x0.3125	14	-18.19	2385.38	71.3	Pass
L15	98 - 93	Pole	TP37.2603x35.8604x0.3125	15	-19.25	2435.50	75.0	Pass
L16	93 - 88	Pole	TP38.6602x37.2603x0.3125	16	-20.34	2482.30	78.4	Pass

Section No.	Elevation ft	Component Type	Size	Critical Element	P K	σP_{allow} K	% Capacity	Pass Fail	
L17	88 - 83	Pole	TP40.0601x38.6602x0.3125	17	-21.47	2525.79	81.7	Pass	
L18	83 - 76.25	Pole	TP41.95x40.0601x0.3125	18	-21.70	2534.09	82.3	Pass	
L19	76.25 - 75.25	Pole	TP41.6058x39.7151x0.3438	19	-24.25	2970.22	76.5	Pass	
L20	75.25 - 70.25	Pole	TP43.0064x41.6058x0.3438	20	-25.52	3020.43	78.8	Pass	
L21	70.25 - 65.25	Pole	TP44.4069x43.0064x0.3438	21	-26.84	3067.31	81.0	Pass	
L22	65.25 - 60.25	Pole	TP45.8075x44.4069x0.3438	22	-28.36	3110.86	83.2	Pass	
L23	60.25 - 55.25	Pole	TP47.208x45.8075x0.3438	23	-29.75	3151.10	85.3	Pass	
L24	55.25 - 51	Pole	TP48.3985x47.208x0.3438	24	-30.95	3182.68	87.1	Pass	
L25	51 - 50.75	Pole	TP48.4685x48.3985x0.3438	25	-31.03	3184.47	87.2	Pass	
L26	50.75 - 45.75	Pole	TP49.869x48.4685x0.3438	26	-32.64	3218.39	89.2	Pass	
L27	45.75 - 37	Pole	TP52.32x49.869x0.3438	27	-33.14	3229.47	90.0	Pass	
L28	37 - 36	Pole	TP51.9132x49.6717x0.4063	28	-37.37	4262.16	72.8	Pass	
L29	36 - 31	Pole	TP53.3142x51.9132x0.4063	29	-39.09	4315.30	74.0	Pass	
L30	31 - 26	Pole	TP54.7151x53.3142x0.4063	30	-40.86	4365.11	75.2	Pass	
L31	26 - 21	Pole	TP56.1161x54.7151x0.4063	31	-42.67	4411.60	76.4	Pass	
L32	21 - 16	Pole	TP57.517x56.1161x0.4063	32	-44.51	4454.77	77.6	Pass	
L33	16 - 11	Pole	TP58.9179x57.517x0.4063	33	-46.39	4494.61	78.8	Pass	
L34	11 - 6	Pole	TP60.3189x58.9179x0.4063	34	-48.31	4531.12	80.0	Pass	
L35	6 - 1	Pole	TP61.7198x60.3189x0.4063	35	-50.05	4564.31	81.2	Pass	
L36	1 - 0	Pole	TP62x61.7198x0.4063	36	-50.40	4570.55	81.5	Pass	
							Summary		
							Pole (L27)	90.0	Pass
							RATING =	90.0	Pass

Note: Above stress ratio for reinforced sections are approximate. More exact calculations are presented in Appendix C.

APPENDIX B
BASE LEVEL DRAWING

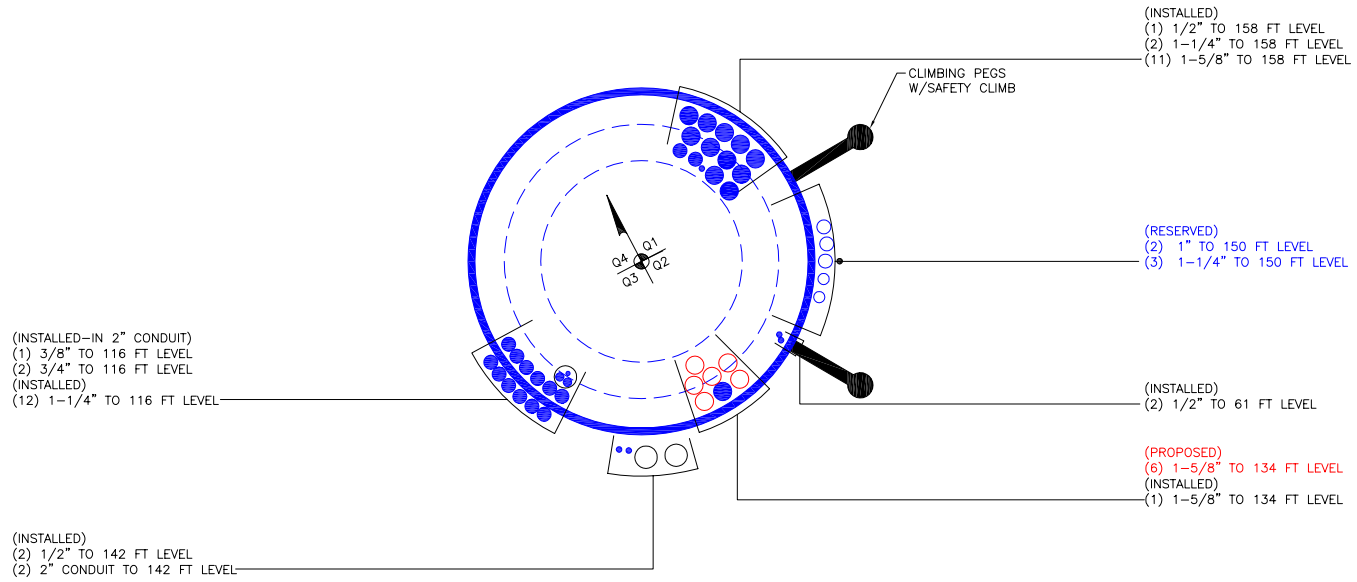

APPENDIX C
ADDITIONAL CALCULATIONS



per TIA-222- G

Site BU: 806382
 Work Order: 1391529



Copyright © 2016 Crown Castle

Pole Geometry

	Pole Height Above Base (ft)	Section Length (ft)	Lap Splice Length (ft)	Number of Sides	Top Diameter (in)	Bottom Diameter (in)	Wall Thickness (in)	Bend Radius (in)	Pole Material
1	160	36.333	4.333	12	18.87	29.05	0.1875	0.75	A572-65
2	128	51.75	5.75	12	27.46	41.95	0.3125	1.25	A572-65
3	82	45	7	12	39.72	52.32	0.34375	1.375	A572-65
4	44	44	0	12	49.67	62	0.40625	1.625	A572-65

Reinforcement Configuration

	Bottom Effective Elevation (ft)	Top Effective Elevation (ft)	Type	Model	Number	1	2	3	4	5	6	7	8	9	10	11	12
1	44	51	plate	CCI-SFP-045100	3			e				e				e	
2																	
3																	
4																	
5																	
6																	
7																	
8																	
9																	
10																	

Reinforcement Details

	B (in)	H (in)	Gross Area (in ²)	Pole Face to Centroid (in)	Bottom Termination Length (in)	Top Termination Length (in)	L _u (in)	Net Area (in ²)	Bolt Hole Size (in)	Reinforcement Material
1	4.5	1	4.5	0.5	18.000	18.000	20.000	3.250	1.1875	A572-65

TNX Geometry Input

Increment (ft): 5

	Section Height (ft)	Section Length (ft)	Lap Splice Length (ft)	Number of Sides	Top Diameter (in)	Bottom Diameter (in)	Wall Thickness (in)	Tapered Pole Grade	Weight Multiplier
1	160 - 158.1	1.9		12	18.870	19.402	0.1875	A572-65	1.000
2	158.1 - 153.1	5		12	19.402	20.803	0.1875	A572-65	1.000
3	153.1 - 148.1	5		12	20.803	22.204	0.1875	A572-65	1.000
4	148.1 - 143.1	5		12	22.204	23.605	0.1875	A572-65	1.000
5	143.1 - 138.1	5		12	23.605	25.006	0.1875	A572-65	1.000
6	138.1 - 133.1	5		12	25.006	26.407	0.1875	A572-65	1.000
7	133.1 - 128.1	5		12	26.407	27.808	0.1875	A572-65	1.000
8	128.1 - 128	4.433	4.333	12	27.808	29.050	0.1875	A572-65	1.000
9	128 - 123	5		12	27.461	28.861	0.3125	A572-65	1.000
10	123 - 118	5		12	28.861	30.261	0.3125	A572-65	1.000
11	118 - 113	5		12	30.261	31.661	0.3125	A572-65	1.000
12	113 - 108	5		12	31.661	33.061	0.3125	A572-65	1.000
13	108 - 103	5		12	33.061	34.460	0.3125	A572-65	1.000
14	103 - 98	5		12	34.460	35.860	0.3125	A572-65	1.000
15	98 - 93	5		12	35.860	37.260	0.3125	A572-65	1.000
16	93 - 88	5		12	37.260	38.660	0.3125	A572-65	1.000
17	88 - 83	5		12	38.660	40.060	0.3125	A572-65	1.000
18	83 - 82	6.75	5.75	12	40.060	41.950	0.3125	A572-65	1.000
19	82 - 75.25	6.75		12	39.715	41.606	0.34375	A572-65	1.000
20	75.25 - 70.25	5		12	41.606	43.006	0.34375	A572-65	1.000
21	70.25 - 65.25	5		12	43.006	44.407	0.34375	A572-65	1.000
22	65.25 - 60.25	5		12	44.407	45.807	0.34375	A572-65	1.000
23	60.25 - 55.25	5		12	45.807	47.208	0.34375	A572-65	1.000
24	55.25 - 51	4.25		12	47.208	48.398	0.34375	A572-65	1.000
25	51 - 50.75	0.25		12	48.398	48.469	0.34375	A572-65	1.000
26	50.75 - 45.75	5		12	48.469	49.869	0.34375	A572-65	1.000
27	45.75 - 44	8.75	7	12	49.869	52.320	0.34375	A572-65	1.000
28	44 - 36	8		12	49.672	51.913	0.40625	A572-65	1.000
29	36 - 31	5		12	51.913	53.314	0.40625	A572-65	1.000
30	31 - 26	5		12	53.314	54.715	0.40625	A572-65	1.000
31	26 - 21	5		12	54.715	56.116	0.40625	A572-65	1.000
32	21 - 16	5		12	56.116	57.517	0.40625	A572-65	1.000
33	16 - 11	5		12	57.517	58.918	0.40625	A572-65	1.000
34	11 - 6	5		12	58.918	60.319	0.40625	A572-65	1.000
35	6 - 1	5		12	60.319	61.720	0.40625	A572-65	1.000
36	1 - 0	1		12	61.720	62.000	0.40625	A572-65	1.000

TNX Section Forces

Increment (ft):		5	TNX Output		
	Section Height (ft)	P _u (K)	M _{ux} (kip-ft)	V _u (K)	
1	160 - 158.1	0.0687	0.1562	0.1647	
2	158.1 - 153.1	3.0911	56.07	9.0527	
3	153.1 - 148.1	5.9281	114.5	13.798	
4	148.1 - 143.1	6.384	185.59	15.202	
5	143.1 - 138.1	7.2512	266.02	16.531	
6	138.1 - 133.1	9.4446	359.78	20.192	
7	133.1 - 128.1	10.02	462.05	20.721	
8	128.1 - 128	10.045	464.12	20.729	
9	128 - 123	11.084	569.38	21.364	
10	123 - 118	11.892	677.7	21.963	
11	118 - 113	15.211	810.53	26.164	
12	113 - 108	16.167	942.86	26.778	
13	108 - 103	17.159	1078.3	27.402	
14	103 - 98	18.186	1216.8	28.036	
15	98 - 93	19.247	1358.6	28.677	
16	93 - 88	20.342	1503.6	29.326	
17	88 - 83	21.471	1651.8	29.981	
18	83 - 82	21.7	1681.9	30.112	
19	82 - 75.25	24.248	1888.6	31.146	
20	75.25 - 70.25	25.525	2045.9	31.808	
21	70.25 - 65.25	26.836	2206.5	32.472	
22	65.25 - 60.25	28.363	2370.5	33.232	
23	60.25 - 55.25	29.746	2538.2	33.892	
24	55.25 - 51	30.947	2683.3	34.451	
25	51 - 50.75	31.031	2691.9	34.473	
26	50.75 - 45.75	32.639	2866.2	35.213	
27	45.75 - 44	33.143	2928	35.443	
28	44 - 36	37.366	3216	36.599	
29	36 - 31	39.094	3400.5	37.218	
30	31 - 26	40.861	3588	37.825	
31	26 - 21	42.666	3778.5	38.443	
32	21 - 16	44.509	3972.2	39.072	
33	16 - 11	46.392	4169	39.712	
34	11 - 6	48.312	4369.1	40.362	
35	6 - 1	50.051	4572.5	41.024	
36	1 - 0	50.403	4613.6	41.157	

Analysis Results

Elevation (ft)	Component Type	Size	Critical Element	% Capacity	Pass / Fail
160 - 158.1	Pole	TP19.402x18.87x0.1875	Pole	0.1%	Pass
158.1 - 153.1	Pole	TP20.803x19.402x0.1875	Pole	16.2%	Pass
153.1 - 148.1	Pole	TP22.204x20.803x0.1875	Pole	29.9%	Pass
148.1 - 143.1	Pole	TP23.605x22.204x0.1875	Pole	43.9%	Pass
143.1 - 138.1	Pole	TP25.006x23.605x0.1875	Pole	57.6%	Pass
138.1 - 133.1	Pole	TP26.407x25.006x0.1875	Pole	72.1%	Pass
133.1 - 128.1	Pole	TP27.808x26.407x0.1875	Pole	86.0%	Pass
128.1 - 128	Pole	TP29.05x27.808x0.1875	Pole	86.3%	Pass
128 - 123	Pole	TP28.861x27.461x0.3125	Pole	47.5%	Pass
123 - 118	Pole	TP30.261x28.861x0.3125	Pole	52.2%	Pass
118 - 113	Pole	TP31.661x30.261x0.3125	Pole	58.0%	Pass
113 - 108	Pole	TP33.061x31.661x0.3125	Pole	62.8%	Pass
108 - 103	Pole	TP34.46x33.061x0.3125	Pole	67.2%	Pass
103 - 98	Pole	TP35.86x34.46x0.3125	Pole	71.1%	Pass
98 - 93	Pole	TP37.26x35.86x0.3125	Pole	74.8%	Pass
93 - 88	Pole	TP38.66x37.26x0.3125	Pole	78.2%	Pass
88 - 83	Pole	TP40.06x38.66x0.3125	Pole	81.5%	Pass
83 - 82	Pole	TP41.95x40.06x0.3125	Pole	82.1%	Pass
82 - 75.25	Pole	TP41.606x39.715x0.3438	Pole	76.3%	Pass
75.25 - 70.25	Pole	TP43.006x41.606x0.3438	Pole	78.6%	Pass
70.25 - 65.25	Pole	TP44.407x43.006x0.3438	Pole	80.8%	Pass
65.25 - 60.25	Pole	TP45.807x44.407x0.3438	Pole	83.0%	Pass
60.25 - 55.25	Pole	TP47.208x45.807x0.3438	Pole	85.1%	Pass
55.25 - 51	Pole	TP48.398x47.208x0.3438	Pole	86.8%	Pass
51 - 50.75	Pole	TP48.469x48.398x0.3438	Pole	87.0%	Pass
50.75 - 45.75	Pole	TP49.869x48.469x0.3438	Pole	89.0%	Pass
45.75 - 44	Pole	TP52.32x49.869x0.3438	Pole	89.7%	Pass
44 - 36	Pole	TP51.913x49.672x0.4063	Pole	72.6%	Pass
36 - 31	Pole	TP53.314x51.913x0.4063	Pole	73.8%	Pass
31 - 26	Pole	TP54.715x53.314x0.4063	Pole	75.0%	Pass
26 - 21	Pole	TP56.116x54.715x0.4063	Pole	76.2%	Pass
21 - 16	Pole	TP57.517x56.116x0.4063	Pole	77.4%	Pass
16 - 11	Pole	TP58.918x57.517x0.4063	Pole	78.6%	Pass
11 - 6	Pole	TP60.319x58.918x0.4063	Pole	79.8%	Pass
6 - 1	Pole	TP61.72x60.319x0.4063	Pole	81.0%	Pass
1 - 0	Pole	TP62x61.72x0.4063	Pole	81.3%	Pass
				Summary	
			Pole	89.7%	Pass
			Reinforcement	0.0%	Pass
			Overall	89.7%	Pass

Additional Calculations

Section Elevation (ft)	Moment of Inertia (in ⁴)			Area (in ²)			% Capacity	
	Pole	Reinf.	Total	Pole	Reinf.	Total	Pole	R1
160 - 158.1	547	n/a	547	11.58	n/a	11.58	0.1%	
158.1 - 153.1	676	n/a	676	12.43	n/a	12.43	16.2%	
153.1 - 148.1	824	n/a	824	13.27	n/a	13.27	29.9%	
148.1 - 143.1	991	n/a	991	14.12	n/a	14.12	43.9%	
143.1 - 138.1	1180	n/a	1180	14.96	n/a	14.96	57.6%	
138.1 - 133.1	1391	n/a	1391	15.81	n/a	15.81	72.1%	
133.1 - 128.1	1626	n/a	1626	16.65	n/a	16.65	86.0%	
128.1 - 128	1631	n/a	1631	16.67	n/a	16.67	86.3%	
128 - 123	2992	n/a	2992	28.69	n/a	28.69	47.5%	
123 - 118	3455	n/a	3455	30.09	n/a	30.09	52.2%	
118 - 113	3962	n/a	3962	31.50	n/a	31.50	58.0%	
113 - 108	4517	n/a	4517	32.91	n/a	32.91	62.8%	
108 - 103	5121	n/a	5121	34.31	n/a	34.31	67.2%	
103 - 98	5777	n/a	5777	35.72	n/a	35.72	71.1%	
98 - 93	6487	n/a	6487	37.13	n/a	37.13	74.8%	
93 - 88	7253	n/a	7253	38.53	n/a	38.53	78.2%	
88 - 83	8076	n/a	8076	39.94	n/a	39.94	81.5%	
83 - 82	8248	n/a	8248	40.22	n/a	40.22	82.1%	
82 - 75.25	9939	n/a	9939	45.61	n/a	45.61	76.3%	
75.25 - 70.25	10985	n/a	10985	47.15	n/a	47.15	78.6%	
70.25 - 65.25	12103	n/a	12103	48.70	n/a	48.70	80.8%	
65.25 - 60.25	13294	n/a	13294	50.25	n/a	50.25	83.0%	
60.25 - 55.25	14561	n/a	14561	51.80	n/a	51.80	85.1%	
55.25 - 51	15699	n/a	15699	53.11	n/a	53.11	86.8%	
51 - 50.75	15768	n/a	15768	53.19	n/a	53.19	87.0%	
50.75 - 45.75	17185	n/a	17185	54.74	n/a	54.74	89.0%	
45.75 - 44	17700	n/a	17700	55.28	n/a	55.28	89.7%	
44 - 36	22846	n/a	22846	67.28	n/a	67.28	72.6%	
36 - 31	24762	n/a	24762	69.11	n/a	69.11	73.8%	
31 - 26	26781	n/a	26781	70.94	n/a	70.94	75.0%	
26 - 21	28908	n/a	28908	72.77	n/a	72.77	76.2%	
21 - 16	31144	n/a	31144	74.60	n/a	74.60	77.4%	
16 - 11	33492	n/a	33492	76.43	n/a	76.43	78.6%	
11 - 6	35956	n/a	35956	78.26	n/a	78.26	79.8%	
6 - 1	38538	n/a	38538	80.09	n/a	80.09	81.0%	
1 - 0	39068	n/a	39068	80.46	n/a	80.46	81.3%	

Note: Section capacity checked in 5 degree increments.

Stiffened or Unstiffened, UngROUTED, Circular Base Plate - Any Rod Material

TIA Rev G Assumption: Clear space between bottom of leveling nut and top of concrete **not** exceeding (1)*(Rod Diameter)

Site Data

BU#: 806382
Site Name: HRT 082 943274
App #: 387889 Rev.0
Pole Manufacturer: Other

Anchor Rod Data

Qty:	16	
Diam:	2.25	in
Rod Material:	A615-J	
Strength (Fu):	100	ksi
Yield (Fy):	75	ksi
Bolt Circle:	70.69	in

Plate Data

Diam:	76.69	in
Thick:	2.75	in
Grade:	60	ksi
Single-Rod B-eff:	12.46	in

Stiffener Data (Welding at both sides)

Config:	0	*
Weld Type:		
Groove Depth:		<-- Disregard
Groove Angle:		<-- Disregard
Fillet H. Weld:		in
Fillet V. Weld:		in
Width:		in
Height:		in
Thick:		in
Notch:		in
Grade:		ksi
Weld str.:		ksi

Pole Data

Diam:	62	in
Thick:	0.40625	in
Grade:	65	ksi
# of Sides:	12	"0" IF Round
Fu	80	ksi
Reinf. Fillet Weld	0	"0" if None

Reactions

Mu:	4614	ft-kips
Axial, Pu:	50	kips
Shear, Vu:	41	kips
Eta Factor, η	0.5	TIA G (Fig. 4-4)

If No stiffeners, Criteria: **AISC LRFD** <-Only Applicable to Unstiffened Cases

Anchor Rod Results

Max Rod (Cu+ Vu/η): 204.1 Kips
 Allowable Axial, Φ*Fu*Anet: 260.0 Kips
 Anchor Rod Stress Ratio: 78.5% **Pass**

Rigid
AISC LRFD
φ*Tn

Base Plate Results

Base Plate Stress: 23.0 ksi
 Allowable Plate Stress: 54.0 ksi
 Base Plate Stress Ratio: 42.5% **Pass**

Flexural Check

Rigid
AISC LRFD
φ*Fy
Y.L. Length:
33.96

n/a

Stiffener Results

Horizontal Weld : n/a
 Vertical Weld: n/a
 Plate Flex+Shear, fb/Fb+(fv/Fv)^2: n/a
 Plate Tension+Shear, ft/Ft+(fv/Fv)^2: n/a
 Plate Comp. (AISC Bracket): n/a

Pole Results

Pole Punching Shear Check: n/a

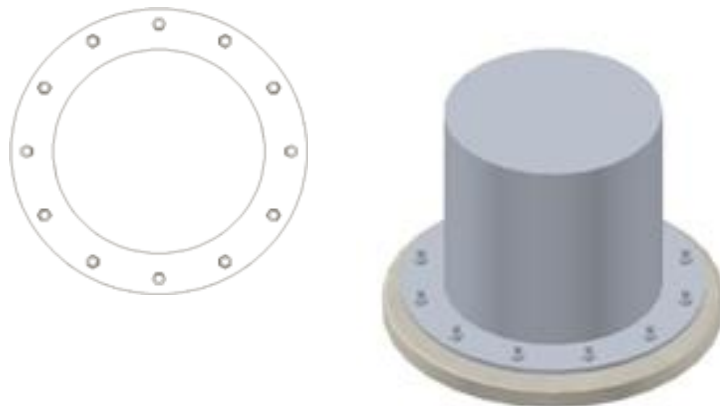

* 0 = none, 1 = every bolt, 2 = every 2 bolts, 3 = 2 per bolt

** Note: for complete joint penetration groove welds the groove depth must be exactly 1/2 the stiffener thickness for calculation purposes

BU:	806382
Site Name:	HRT 082 943274
App Number:	387889 Rev.0
Work Order:	1391529



Monopole Drilled Pier

Input

Criteria	
TIA Revision:	G
ACI 318 Revision:	2008
Seismic Category:	B
Forces	
Compression	50 kips
Shear	41 kips
Moment	4614 k-ft
Swelling Force	0 kips
Foundation Dimensions	
Pier Diameter:	7.5 ft
Ext. above grade:	0.5 ft
Depth below grade:	20 ft
Material Properties	
Number of Rebar:	36
Rebar Size:	11
Tie Size	5
Rebar tensile strength:	60 ksi
Concrete Strength:	4000 psi
Ultimate Concrete Strain	0.003 in/in
Clear Cover to Ties:	4 in

Soil Profile: 806382 Soil

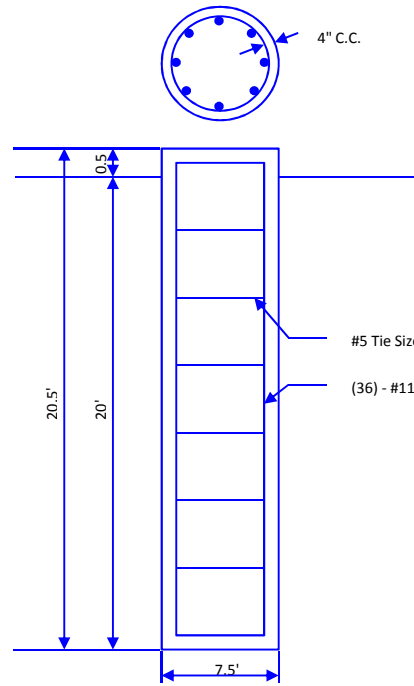

Layer	Thickness (ft)	From (ft)	To (ft)	Unit Weight (pcf)	Cohesion (psf)	Friction Angle (deg)	Ultimate Uplift Friction (ksf)	Ultimate Comp. Friction (ksf)	Ultimate Bearing Capacity (ksf)	SPT 'N' Counts
1	3.33	0	3.33	100	0	28	0	0		
2	2.67	3.33	6	110		34	0	0		
3	3.5	6	9.5	115		38	0	0		
4	10.5	9.5	20	145		45	0	0	32.575	

Analysis Results

Soil Lateral Capacity

Depth to Zero Shear:	4.65 ft
Max Moment, Mu:	4725.63 k-ft
Soil Safety Factor:	1.88
Safety Factor Req'd:	1.33
RATING:	70.8%

Soil Axial Capacity

Skin Friction (k):	0.00 kips
End Bearing (k):	1079.34 kips
Comp. Capacity (k), φCn:	1079.34 kips
Comp. (k), Cu:	50.00 kips
RATING:	4.6%

Concrete/Steel Check

Mu (from soil analysis)	4725.63 k-ft
φMn	9335.02 k-ft
RATING:	50.6%

rho provided	0.88
rho required	0.33 OK

Rebar Spacing	5.51
Spacing required	22.56 OK

Dev. Length required	15.02
Dev. Length provided	53.51 OK

Overall Foundation Rating: 70.8%



WIRELESS COMMUNICATIONS FACILITY

PORTLAND RT. 66/RT. 151

SITE ID: CT11252A - U1900

CROWN CASTLE BU # 806382

74 GOODRICH LANE

PORTLAND, CT 06480

GENERAL NOTES

- ALL WORK SHALL BE IN ACCORDANCE WITH THE 2012 INTERNATIONAL BUILDING CODE AS MODIFIED BY THE 2016 CONNECTICUT SUPPLEMENT, INCLUDING THE TIA/EIA-222 REVISION "G" "STRUCTURAL STANDARDS FOR STEEL ANTENNA TOWERS AND SUPPORTING STRUCTURES." 2016 CONNECTICUT FIRE SAFETY CODE, NATIONAL ELECTRICAL CODE AND LOCAL CODES.
- CONTRACTOR SHALL REVIEW ALL DRAWINGS AND SPECIFICATIONS IN THE CONTRACT DOCUMENT SET. CONTRACTOR SHALL COORDINATE ALL WORK SHOWN IN THE SET OF DRAWINGS. THE CONTRACTOR SHALL PROVIDE A COMPLETE SET OF DRAWINGS TO ALL SUBCONTRACTORS AND ALL RELATED PARTIES. THE SUBCONTRACTORS SHALL EXAMINE ALL THE DRAWINGS AND SPECIFICATIONS FOR THE INFORMATION THAT AFFECTS THEIR WORK.
- CONTRACTOR SHALL PROVIDE A COMPLETE BUILD-OUT WITH ALL FINISHES, STRUCTURAL, MECHANICAL, AND ELECTRICAL COMPONENTS AND PROVIDE ALL ITEMS AS SHOWN OR INDICATED ON THE DRAWINGS OR IN THE WRITTEN SPECIFICATIONS.
- CONTRACTOR SHALL FURNISH ALL MATERIAL, LABOR AND EQUIPMENT TO COMPLETE THE WORK AND FURNISH A COMPLETED JOB ALL IN ACCORDANCE WITH LOCAL AND STATE GOVERNING AUTHORITIES AND OTHER AUTHORITIES HAVING LAWFUL JURISDICTION OVER THE WORK.
- CONTRACTOR SHALL SECURE AND PAY FOR ALL PERMITS AND ALL INSPECTIONS REQUIRED AND SHALL ALSO PAY FEES REQUIRED FOR THE GENERAL CONSTRUCTION, PLUMBING, ELECTRICAL AND HVAC. PERMITS SHALL BE PAID FOR BY THE RESPECTIVE SUBCONTRACTORS.
- CONTRACTOR SHALL MAINTAIN A CURRENT SET OF DRAWINGS AND SPECIFICATIONS ON SITE AT ALL TIMES AND INSURE DISTRIBUTION OF NEW DRAWINGS TO SUBCONTRACTORS AND OTHER RELEVANT PARTIES AS SOON AS THEY ARE MADE AVAILABLE. ALL OLD DRAWINGS SHALL BE MARKED VOID AND REMOVED FROM THE CONTRACT AREA. THE CONTRACTOR SHALL FURNISH AN "AS-BUILT" SET OF DRAWINGS TO OWNER UPON COMPLETION OF PROJECT.
- LOCATION OF EQUIPMENT, AND WORK SUPPLIED BY OTHERS THAT IS DIAGRAMMATICALLY INDICATED ON THE DRAWINGS SHALL BE DETERMINED BY THE CONTRACTOR. THE CONTRACTOR SHALL DETERMINE LOCATIONS AND DIMENSIONS SUBJECT TO STRUCTURAL CONDITIONS AND WORK OF THE SUBCONTRACTORS.
- THE CONTRACTOR IS SOLELY RESPONSIBLE TO DETERMINE CONSTRUCTION PROCEDURE AND SEQUENCE, AND TO ENSURE THE SAFETY OF THE EXISTING STRUCTURES AND ITS COMPONENT PARTS DURING CONSTRUCTION. THIS INCLUDES THE ADDITION OF WHATEVER SHORING, BRACING, UNDERPINNING, ETC. THAT MAY BE NECESSARY.
- DRAWINGS INDICATE THE MINIMUM STANDARDS, BUT IF ANY WORK SHOULD BE INDICATED TO BE SUBSTANDARD TO ANY ORDINANCES, LAWS, CODES, RULES, OR REGULATIONS BEARING ON THE WORK, THE CONTRACTOR SHALL INCLUDE IN HIS WORK AND SHALL EXECUTE THE WORK CORRECTLY IN ACCORDANCE WITH SUCH ORDINANCES, LAWS, CODES, RULES OR REGULATIONS WITH NO INCREASE IN COSTS.
- ALL UTILITY WORK SHALL BE IN ACCORDANCE WITH LOCAL UTILITY COMPANY REQUIREMENTS AND SPECIFICATIONS.
- ALL EQUIPMENT AND PRODUCTS PURCHASED ARE TO BE REVIEWED BY CONTRACTOR AND ALL APPLICABLE SUBCONTRACTORS FOR ANY CONDITION PER MFR.'S RECOMMENDATIONS. CONTRACTOR TO SUPPLY THESE ITEMS AT NO COST TO OWNER OR CONSTRUCTION MANAGER.
- ANY AND ALL ERRORS, DISCREPANCIES, AND "MISSED" ITEMS ARE TO BE BROUGHT TO THE ATTENTION OF THE T-MOBILE CONSTRUCTION MANAGER DURING THE BIDDING PROCESS BY THE CONTRACTOR. ALL THESE ITEMS ARE TO BE INCLUDED IN THE BID. NO "EXTRA" WILL BE ALLOWED FOR MISSED ITEMS.
- CONTRACTOR SHALL BE RESPONSIBLE FOR ALL ON-SITE SAFETY FROM THE TIME THE JOB IS AWARDED UNTIL ALL WORK IS COMPLETE AND ACCEPTED BY THE OWNER.
- CONTRACTOR TO REVIEW ALL SHOP DRAWINGS AND SUBMIT COPY TO ENGINEER FOR APPROVAL. DRAWINGS MUST BEAR THE CHECKER'S INITIALS BEFORE SUBMITTING TO THE CONSTRUCTION MANAGER FOR REVIEW.
- THE CONTRACTOR SHALL FIELD VERIFY ALL DIMENSIONS, ELEVATIONS, ANGLES, AND EXISTING CONDITIONS AT THE SITE, PRIOR TO FABRICATION AND/OR INSTALLATION OF ANY WORK IN THE CONTRACT AREA.
- COORDINATION, LAYOUT, FURNISHING AND INSTALLATION OF CONDUIT AND ALL APPURTENANCES REQUIRED FOR PROPER INSTALLATION OF ELECTRICAL AND TELECOMMUNICATION SERVICE SHALL BE THE SOLE RESPONSIBILITY OF THE CONTRACTOR.
- ALL DAMAGE CAUSED TO ANY EXISTING STRUCTURE SHALL BE THE SOLE RESPONSIBILITY OF THE CONTRACTOR. THE CONTRACTOR WILL BE HELD LIABLE FOR ALL REPAIRS REQUIRED FOR EXISTING STRUCTURES IF DAMAGED DURING CONSTRUCTION ACTIVITIES.
- THE CONTRACTOR SHALL CONTACT "CALL BEFORE YOU DIG" AT LEAST 48 HOURS PRIOR TO ANY EXCAVATIONS AT 1-800-922-4455. ALL UTILITIES SHALL BE IDENTIFIED AND CLEARLY MARKED. CONTRACTOR SHALL MAINTAIN AND PROTECT MARKED UTILITIES THROUGHOUT PROJECT COMPLETION.
- CONTRACTOR SHALL COMPLY WITH OWNERS ENVIRONMENTAL ENGINEER ON ALL METHODS AND PROVISIONS FOR ALL EXCAVATION ACTIVITIES INCLUDING SOIL DISPOSAL. ALL BACKFILL MATERIALS TO BE PROVIDED BY THE CONTRACTOR.

SITE DIRECTIONS

FROM:	TO:
35 GRIFFIN ROAD SOUTH BLOOMFIELD, CT 06002	74 GOODRICH LANE PORTLAND, CT 06480
<ol style="list-style-type: none"> HEAD NORTH ON GRIFFIN ROAD S. TOWARD HARTMAN RD. 0.21 MI. TAKE THE 2ND RIGHT ONTO DAY HILL RD. 0.14 MI. TAKE THE 1ST RIGHT ONTO BLUE HILLS AVENUE EXT/CT-187 1.89 MI. TURN LEFT ONTO CT-305/OLD WINDSOR RD. 2.32 MI. STAY STRAIGHT TO GO ONTO BLOOMFIELD AVE/CT-305. 0.01 MI. MERGE ONTO I-91 S TOWARD HARTFORD 6.04 MI. MERGE ONTO I-84 W via EXIT 30 TOWARD CT-2/E HARTFORD/NEW LONDON 0.61 MI. MERGE ONTO CT-2 E via EXIT 55 TOWARD NORWICH/NEW LONDON 4.42 MI. MERGE ONTO CT-17 S via EXIT 7 ON LEFT TOWARD PORTLAND 8.61 MI. TURN LEFT ONTO SAGE HOLLOW RD. 0.06 MI. TURN SLIGHT LEFT ONTO CORNWALL ST. 0.36 MI. TURN LEFT ONTO OLD MARLBOROUGH TPKE. 0.13 MI. TAKE THE 1ST RIGHT ONTO GOODRICH LN. 0.33 MI. 	
74 GOODRICH RD. IS ON THE LEFT	

VICINITY MAP

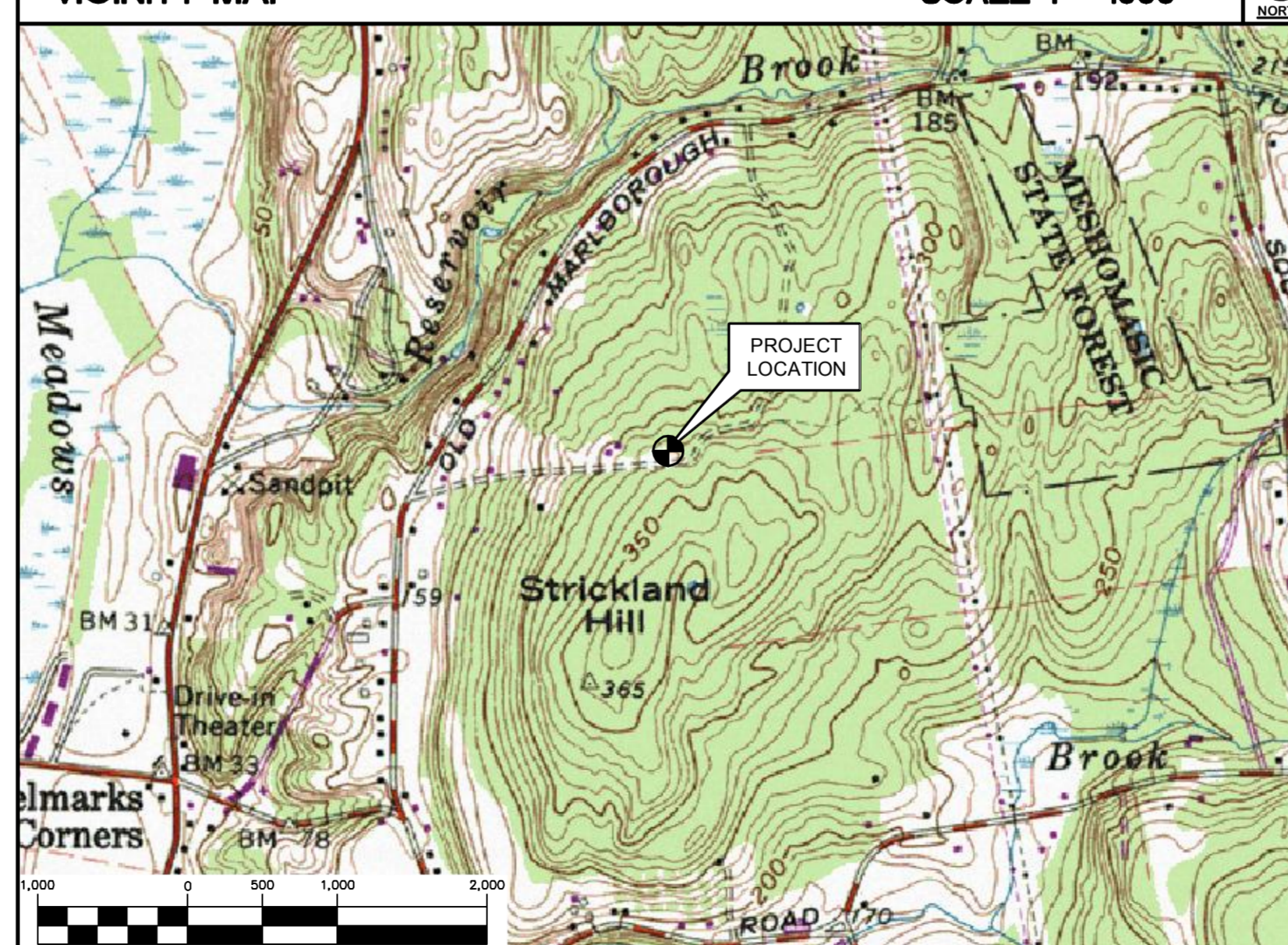

T-MOBILE RF CONFIGURATION

CUSTOM

PROJECT SUMMARY

- THE PROPOSED SCOPE OF WORK CONSISTS OF A MODIFICATION TO THE EXISTING UNMANNED TELECOMMUNICATIONS FACILITY INCLUDING THE FOLLOWING:
 - INSTALL (1) TWIN AWS TMA PER SECTOR FOR A TOTAL OF (3), BEHIND POSITION 2 ANTENNA
 - INSTALL (6) PROPOSED 1-5/8" COAX CABLES FROM THE EXISTING EQUIPMENT TO THE ANTENNA SECTOR LOCATIONS.

PROJECT INFORMATION

SITE NAME:	PORTLAND RT. 66/RT. 151
SITE ID:	CTX11252A - U1900
SITE ADDRESS:	74 GOODRICH LANE PORTLAND, CT 06480
APPLICANT:	T-MOBILE NORTHEAST, LLC 35 GRIFFIN ROAD SOUTH BLOOMFIELD, CT 06002
CONTACT PERSON:	BRIAN PAUL (PROJECT MANAGER) TRANSCEND WIRELESS, LLC (860) 550-5971
ENGINEER:	CENITEK ENGINEERING, INC. 63-2 NORTH BRANFORD RD. BRANFORD, CT 06405
PROJECT COORDINATES:	LATITUDE: 41°-36'-29.76" N LONGITUDE: 72°-35'-29.66" W GROUND ELEVATION: 340± AMSL
	SITE COORDINATES AND GROUND ELEVATION REFERENCED FROM GOOGLE EARTH.

SHEET INDEX

SHT. NO.	DESCRIPTION	REV.
T-1	TITLE SHEET	0
N-1	DESIGN BASIS AND SITE NOTES	0
C-1	SITE LOCATION PLAN	0
C-2	COMPOUND PLAN, ELEVATION AND ANTENNA MOUNTING CONFIG.	0

DATE: 04/03/17
SCALE: AS NOTED
JOB NO. 17012.46

TITLE SHEET

T-1

Sheet No. 1 of 4

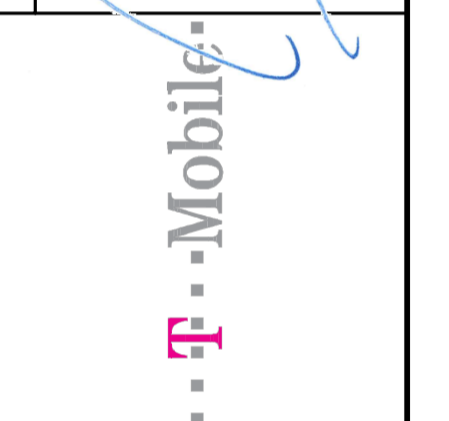

CENITEK engineering
Centered on Solutions
(203) 498-0380
(203) 498-3887
632 North Branford Road
Branford, CT 06405
www.CenitekEng.com

T-MOBILE NORTHEAST LLC
WIRELESS COMMUNICATIONS FACILITY
PORTLAND RT. 66/RT. 151
SITE ID: CT11252A - U1900
74 GOODRICH LANE
PORTLAND CT 06480

REV.	DATE	BY	CHK'D BY	DESCRIPTION
0	05/18/17	KAW	CAG	CONSTRUCTION DRAWINGS - ISSUED FOR CONSTRUCTION

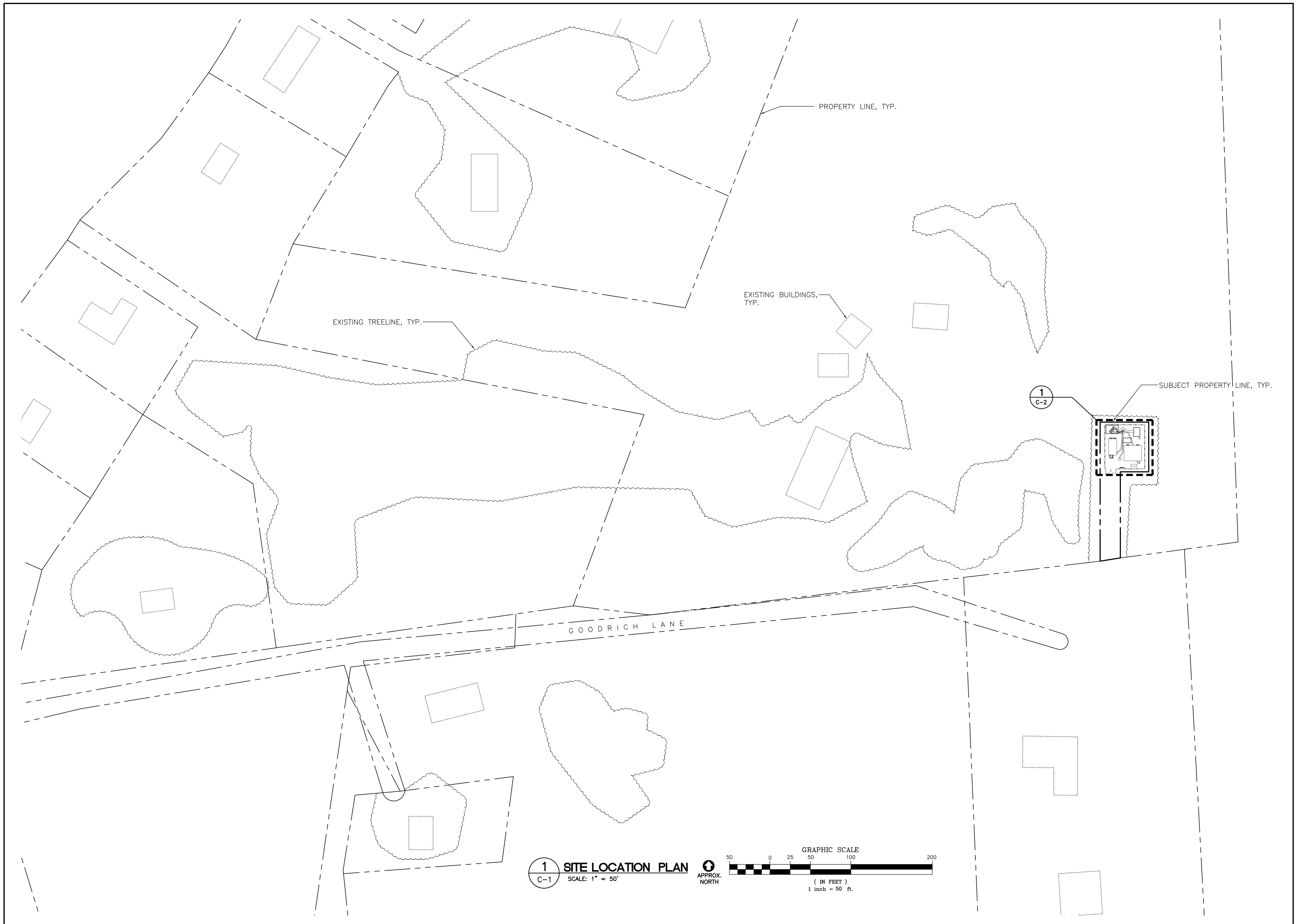

PROFESSIONAL ENGINEER SEAL		CONSTRUCTION DRAWINGS - ISSUED FOR CONSTRUCTION	
		CAG	DESCRIPTION
REV.	DATE	DRAWN BY	CHK'D BY
0	05/18/17	KAW	
T-MOBILE NORTHEAST LLC WIRELESS COMMUNICATIONS FACILITY PORTLAND RT. 66/RT. 151 SITE ID: CT11252A - U1900 74 GOODRICH LANE PORTLAND CT 06480			
CEN TEK engineering <small>Centered on Solutions</small> (203) 498-0390 (203) 498-3397 Fax 632 North Branford Road Branford, CT 06405 www.CenTekEng.com			
DATE: 04/03/17 SCALE: AS NOTED JOB NO. 17012.46			
SITE LOCATION PLAN			
C-1			
Sheet No. 3 of 4			

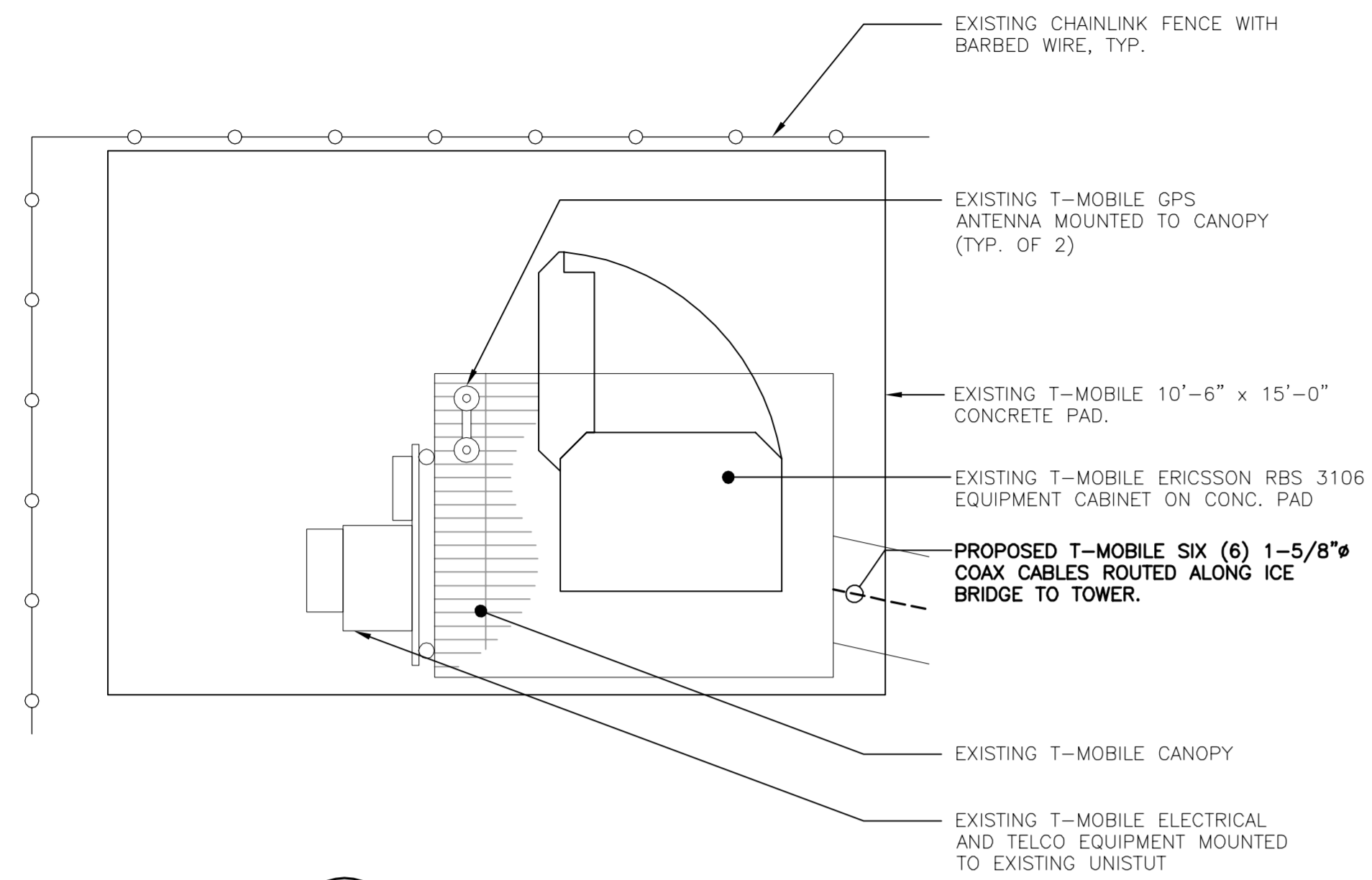

3 EQUIPMENT PLAN
C-2 SCALE: 3/8" = 1' TRUE NORTH

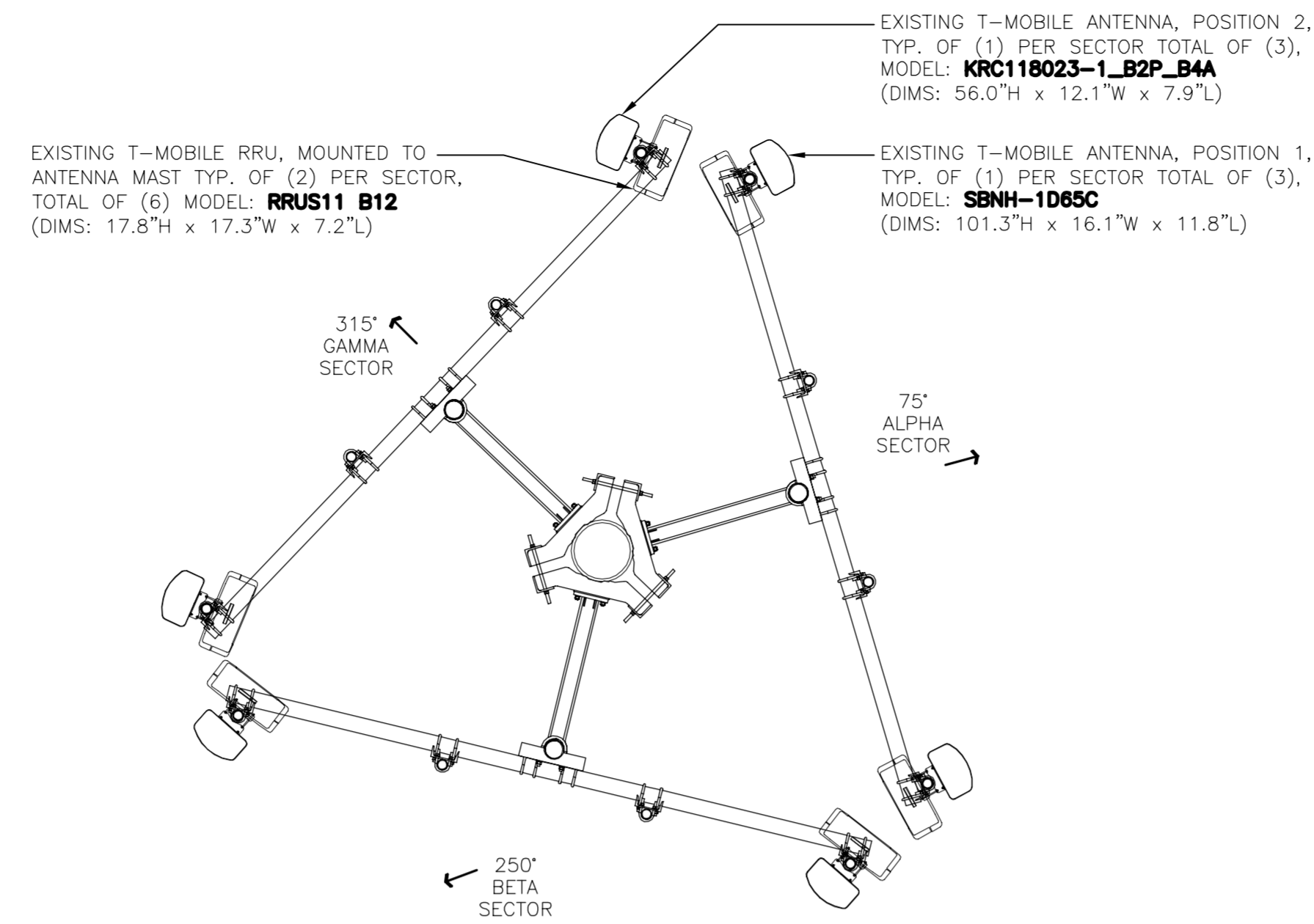

4 EXISTING ANTENNA MOUNTING CONFIGURATION
C-2 SCALE: 3/8" = 1' 83° ELEVATION TRUE NORTH

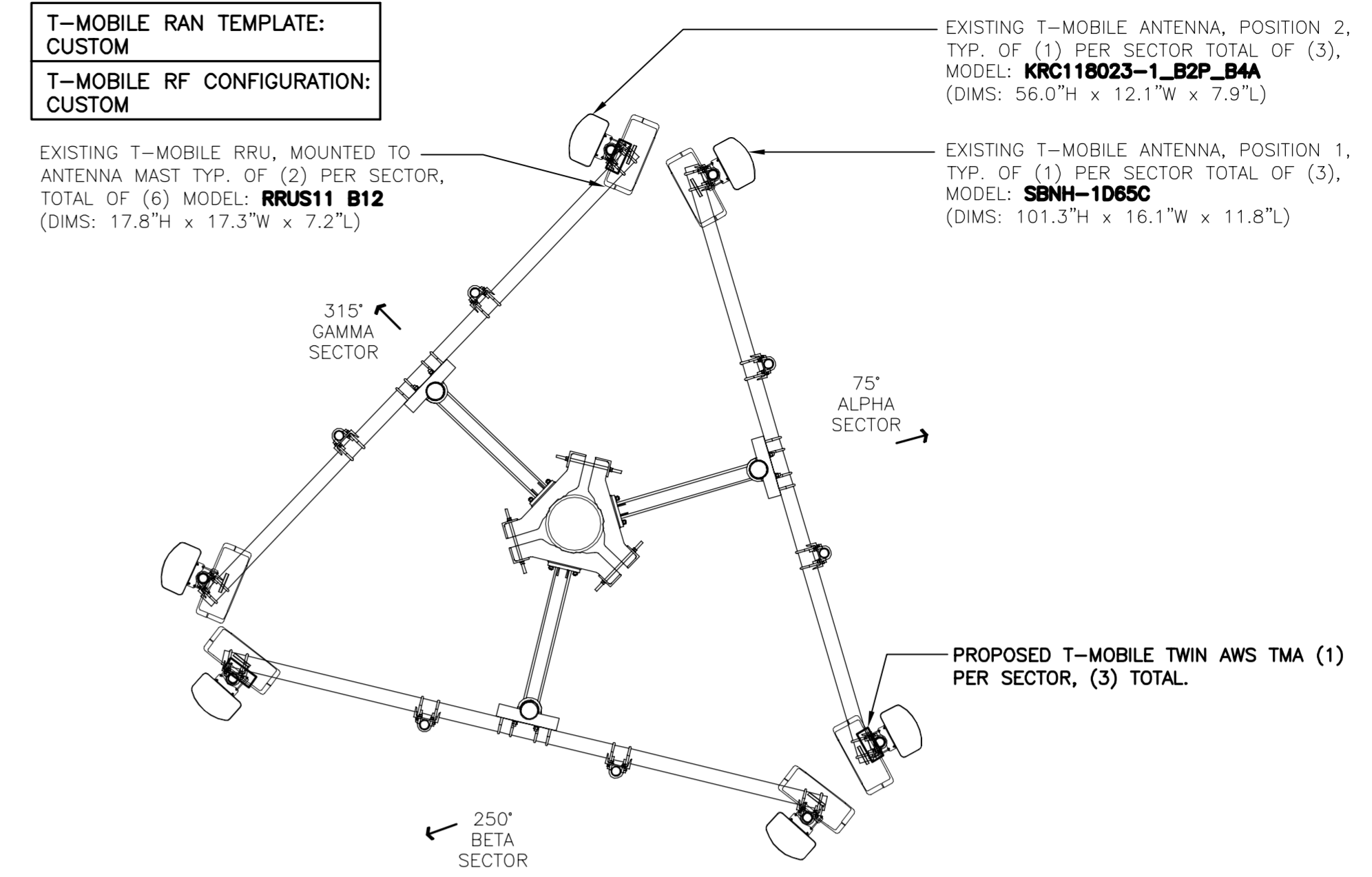

5 PROPOSED ANTENNA MOUNTING CONFIGURATION
C-2 SCALE: 3/8" = 1' 83° ELEVATION TRUE NORTH

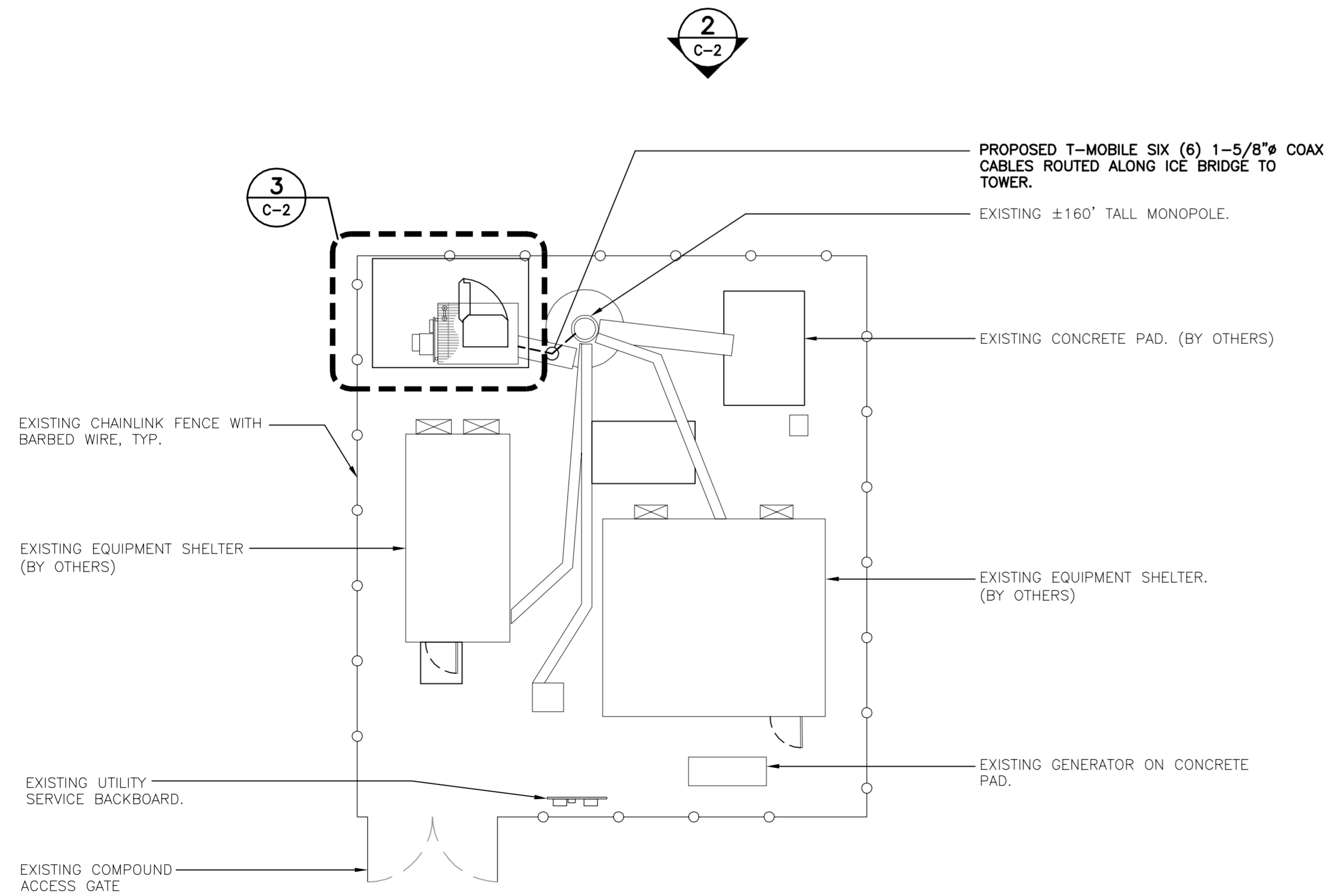

1 COMPOUND PLAN
C-2 SCALE: 1" = 10' TRUE NORTH

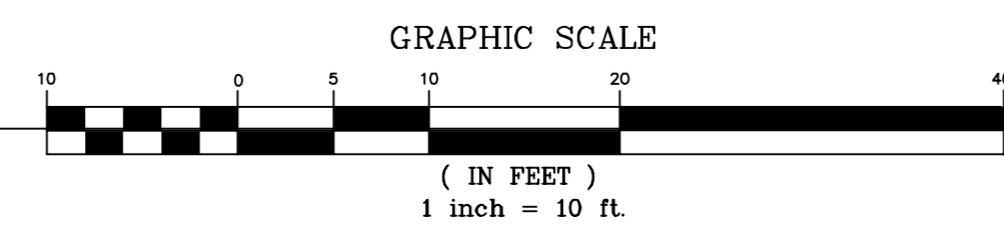

TOWER STRUCTURAL NOTES:

- TOWER STRUCTURAL ANALYSIS SIGNED AND SEALED BY A STRUCTURAL ENGINEER LICENSED IN THE STATE OF CONNECTICUT TO BE PROVIDED PRIOR TO INSTALLATION OF ADDITIONAL TOWER LOADING DEPICTED HEREIN.
- ALL ANTENNAS AND COAX TO BE INSTALLED IN ACCORDANCE WITH STRUCTURAL ANALYSIS PROVIDED BY CROWN CASTLE, INC AND FINAL AT&T RF DATA SHEET.

NOTES:

- OTHER CARRIER EQUIPMENT NOT SHOWN FOR CLARITY.
- A.G.L. = ABOVE GRADE LEVEL

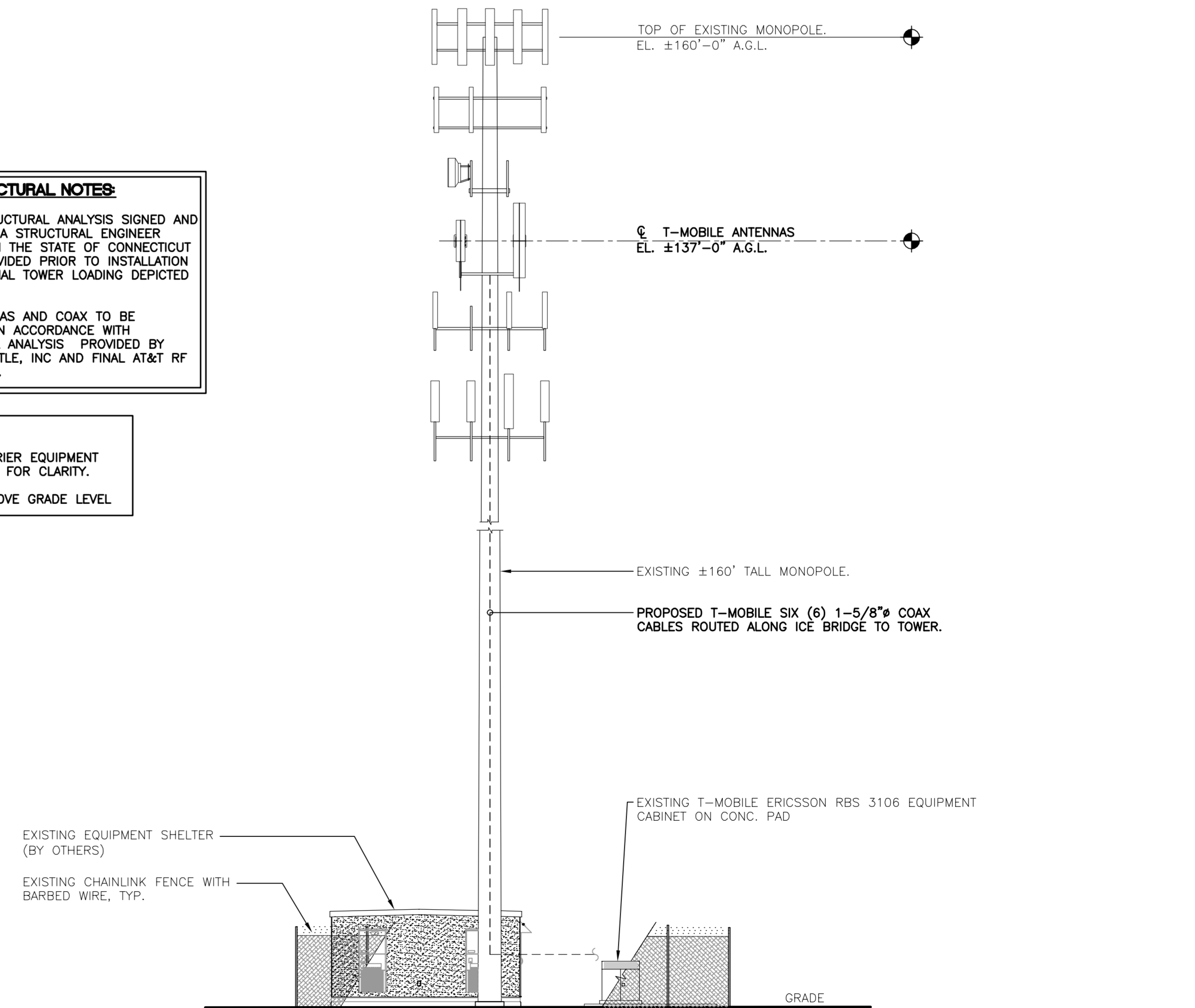

2 SOUTH TOWER ELEVATION
C-2 SCALE: 1" = 10' TRUE NORTH

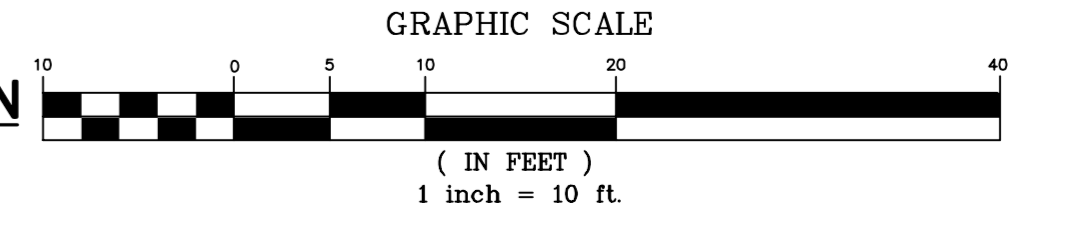

PROFESSIONAL ENGINEER SEAL	CONSTRUCTION DRAWINGS - ISSUED FOR CONSTRUCTION										
	<table border="1"> <tr> <th>REV.</th> <th>DATE</th> <th>BY</th> <th>CHK'D BY</th> <th>DESCRIPTION</th> </tr> <tr> <td>0</td> <td>05/18/17</td> <td>KAW</td> <td></td> <td></td> </tr> </table>	REV.	DATE	BY	CHK'D BY	DESCRIPTION	0	05/18/17	KAW		
REV.	DATE	BY	CHK'D BY	DESCRIPTION							
0	05/18/17	KAW									
CENTEK engineering Centered on Solutions (203) 498-0380 (203) 498-3387 Fax 652 North Branford Road Branford, CT 06480 www.CentekEng.com											
T-MOBILE NORTHEAST LLC WIRELESS COMMUNICATIONS FACILITY PORTLAND RT. 66/RT. 151 SITE ID: CT11252A - U1900 74 GOODRICH LANE PORTLAND CT 06480											
DATE: 04/03/17 SCALE: AS NOTED JOB NO. 17012.46											
COMPOUND PLAN, ELEVATION AND ANTENNA MOUNTING CONFIG.											
C-2											
Sheet No. 4 of 4											