



STATE OF CONNECTICUT  
*CONNECTICUT SITING COUNCIL*

Ten Franklin Square, New Britain, CT 06051

Phone: (860) 827-2935 Fax: (860) 827-2950

E-Mail: [siting.council@ct.gov](mailto:siting.council@ct.gov)

Web Site: [portal.ct.gov/csc](http://portal.ct.gov/csc)

**VIA ELECTRONIC MAIL**

August 9, 2021

Richard Zajac  
Site Acquisition Specialist  
Crown Castle USA  
4545 East River Road, Suite 320  
West Henrietta, NY 14586

RE: **TS-DISH-133-210621** - DISH Wireless LLC request for an order to approve tower sharing at an existing telecommunications facility located at 74 Goodrich Lane, Portland, Connecticut.

Dear Mr. Zajac:

The Connecticut Siting Council (Council) is in receipt of your correspondence of August 2, 2021 submitted in response to the Council's July 2, 2021 notification of an incomplete request for tower sharing with regard to the above-referenced matter.

The submission renders the request for tower sharing complete and the Council will process the request in accordance with the Federal Communications Commission 60-day timeframe.

Thank you for your attention and cooperation.

Sincerely,

*s/Melanie A. Bachman*

Melanie A. Bachman  
Executive Director

MAB/IN/laf

**From:** Zajac, Richard <Richard.Zajac@crowncastle.com>  
**Sent:** Monday, August 2, 2021 12:55 PM  
**To:** Robidoux, Evan <Evan.Robidoux@ct.gov>  
**Cc:** CSC-DL Siting Council <Siting.Council@ct.gov>  
**Subject:** RE: Council Incomplete Letter for TS-DISH-113-210621 (74 Goodrich Lane, Portland)

**EXTERNAL EMAIL:** This email originated from outside of the organization. Do not click any links or open any attachments unless you trust the sender and know the content is safe.

Good afternoon,

Pursuant to the incomplete letter issued for TS-DISH-113-210621, please see the attached mount analysis report. A hard copy of this report will be sent via FedEx to arrive to you tomorrow, 8/3.

If you have any questions/concerns or require additional information in order to resume the review process/issue an approval, please do not hesitate to contact me.

Thank you,

**RICH ZAJAC**

Site Acquisition Specialist

T: (585) 445-5896 M: (607) 346-7212

F: (724) 416-4461

**CROWN CASTLE**

4545 East River Road, Suite 320

West Henrietta, NY 14586

Date: **July 21, 2021**

Darcy Tarr  
Crown Castle  
3530 Toringdon Way, Suite 300  
Charlotte, NC 28277  
704-405-6589



Trylon  
1825 W. Walnut Hill Lane,  
Suite 302  
Irving, TX 75038  
214-930-1730

**Subject:** **Mount Replacement Analysis Report**

**Carrier Designation:** **Dish Network Equipment Change Out**  
**Carrier Site Number:** BOBDL00050A  
**Carrier Site Name:** CT-CCI-T-806382

**Crown Castle Designation:** **Crown Castle BU Number:** 806382  
**Crown Castle Site Name:** HRT 082 943274  
**Crown Castle JDE Job Number:** 645111  
**Crown Castle Order Number:** 553285 Rev. 0

**Engineering Firm Designation:** **Trylon Report Designation:** 188192

**Site Data:** **74 Goodrich Lane, Portland, Middlesex County, CT, 06480**  
**Latitude 41°36'29.90" Longitude -72°35'29.56"**

**Structure Information:** **Tower Height & Type:** **160.0 ft Monopole**  
**Mount Elevation:** **108.0 ft**  
**Mount Type:** **8.0 ft Platform**

Dear Darcy Tarr,

Trylon is pleased to submit this "**Mount Replacement Analysis Report**" to determine the structural integrity of Dish Network's antenna mounting system with the proposed appurtenance and equipment addition on the abovementioned supporting tower structure. Analysis of the existing supporting tower structure is to be completed by others and therefore is not part of this analysis. Analysis of the antenna mounting system as a tie-off point for fall protection or rigging is not part of this document.

The purpose of the analysis is to determine acceptability of the mount stress level. Based on our analysis we have determined the mount stress level to be:

**Platform** **Sufficient**  
**\*Sufficient upon completion of the changes listed in the 'Recommendations' section of this report.**

This analysis utilizes an ultimate 3-second gust wind speed of 130 mph as required by the 2018 Connecticut State Building Code. Applicable Standard references and design criteria are listed in Section 2 - Analysis Criteria.

Mount analysis prepared by: Steve Mustaro, P.E.

Respectfully Submitted by:  
Cliff Abernathy, P.E.

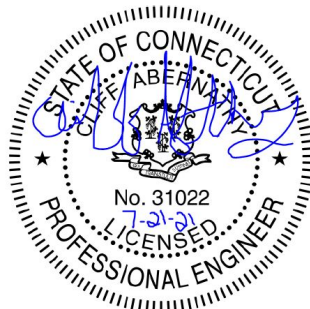

## TABLE OF CONTENTS

### 1) INTRODUCTION

### 2) ANALYSIS CRITERIA

Table 1 - Proposed Equipment Configuration

### 3) ANALYSIS PROCEDURE

Table 2 - Documents Provided

3.1) Analysis Method

3.2) Assumptions

### 4) ANALYSIS RESULTS

Table 3 - Mount Component Stresses vs. Capacity

4.1) Recommendations

### 5) APPENDIX A

Wire Frame and Rendered Models

### 6) APPENDIX B

Software Input Calculations

### 7) APPENDIX C

Software Analysis Output

### 8) APPENDIX D

Additional Calculations

### 9) APPENDIX E

Supplemental Drawings

## 1) INTRODUCTION

This is a proposed three sector 8.0 ft Platform, designed by Commscope.

## 2) ANALYSIS CRITERIA

<b>Building Code:</b>	2015 IBC
<b>TIA-222 Revision:</b>	TIA-222-H
<b>Risk Category:</b>	II
<b>Ultimate Wind Speed:</b>	130 mph
<b>Exposure Category:</b>	B
<b>Topographic Factor at Base:</b>	1.0
<b>Topographic Factor at Mount:</b>	1.0
<b>Ice Thickness:</b>	1.5 in
<b>Wind Speed with Ice:</b>	50 mph
<b>Seismic S<sub>s</sub>:</b>	0.180
<b>Seismic S<sub>1</sub>:</b>	0.063
<b>Live Loading Wind Speed:</b>	30 mph
<b>Man Live Load at Mid/End-Points:</b>	250 lb
<b>Man Live Load at Mount Pipes:</b>	500 lb

**Table 1 - Proposed Equipment Configuration**

Mount Centerline (ft)	Antenna Centerline (ft)	Number of Antennas	Antenna Manufacturer	Antenna Model	Mount / Modification Details
108.0	108.0	3	JMA WIRELESS	MX08FRO665-20	8.0 ft Platform [Commscope MC-PK8-DSH]
		3	FUJITSU	TA08025-B604	
		3	FUJITSU	TA8025-B605	
		1	RAYCAP	RDIDC-9181-PF-48	

## 3) ANALYSIS PROCEDURE

**Table 2 - Documents Provided**

Document	Remarks	Reference	Source
Crown Application	Dish Network Application	553285 Rev. 0	CCI Sites
Construction Drawings	Infinigy	BOBDL00050A	TSA
Mount Manufacturer Drawings	Commscope	MC-PK8-DSH	TSA

### 3.1) Analysis Method

RISA-3D (Version 17.0.4), a commercially available analysis software package, was used to create a three-dimensional model of the antenna mounting system and calculate member stresses for various loading cases.

A tool internally developed, using Microsoft Excel, by Tylon was used to calculate wind loading on all appurtenances, dishes, and mount members for various load cases. Selected output from the analysis is included in Appendix B.

This analysis was performed in accordance with Crown Castle's ENG-SOW-10208 *Tower Mount Analysis* (Revision B).

**3.2) Assumptions**

- 1) The antenna mounting system was properly fabricated, installed and maintained in good condition in accordance with its original design and manufacturer's specifications.
- 2) The configuration of antennas, mounts, and other appurtenances are as specified in Table 1 and the referenced drawings.
- 3) All member connections are assumed to have been designed to meet or exceed the load carrying capacity of the connected member unless otherwise specified in this report.
- 4) The analysis will be required to be revised if the existing conditions in the field differ from those shown in the above-referenced documents or assumed in this analysis. No allowance was made for any damaged, missing, or rusted members.
- 5) Prior structural modifications to the tower mounting system are assumed to be installed as shown per available data.
- 6) Steel grades have been assumed as follows, unless noted otherwise:
 

Channel, Solid Round, Angle, Plate	ASTM A36 (GR 36)
HSS (Rectangular)	ASTM A500 (GR B-46)
Pipe	ASTM A53 (GR 35)
Connection Bolts	ASTM A325

This analysis may be affected if any assumptions are not valid or have been made in error. Tylon should be notified to determine the effect on the structural integrity of the antenna mounting system.

**4) ANALYSIS RESULTS**

**Table 3 - Mount Component Stresses vs. Capacity (Platform, All Sectors)**

Notes	Component	Critical Member	Centerline (ft)	% Capacity	Pass / Fail
1, 2	Mount Pipe(s)	MP1	108.0	27.8	Pass
	Horizontal(s)	H1		10.0	Pass
	Standoff(s)	M12		46.9	Pass
	Bracing(s)	M1		35.1	Pass
	Handrail(s)	M22		11.4	Pass
	Mount Connection(s)	-		16.6	Pass

<b>Structure Rating (max from all components) =</b>	<b>46.9%</b>
-----------------------------------------------------	--------------

Notes:

- 1) See additional documentation in "Appendix C - Software Analysis Output" for calculations supporting the % capacity consumed.
- 2) Rating per TIA-222-H, Section 15.5

**4.1) Recommendations**

The mount has sufficient capacity to carry the proposed loading configuration. In order for the results of the analysis to be considered valid, the proposed mount listed below must be installed.

1. Commscope MC-PK8-DSH.

No structural modifications are required at this time, provided that the above-listed changes are implemented.

**APPENDIX A**  
**WIRE FRAME AND RENDERED MODELS**

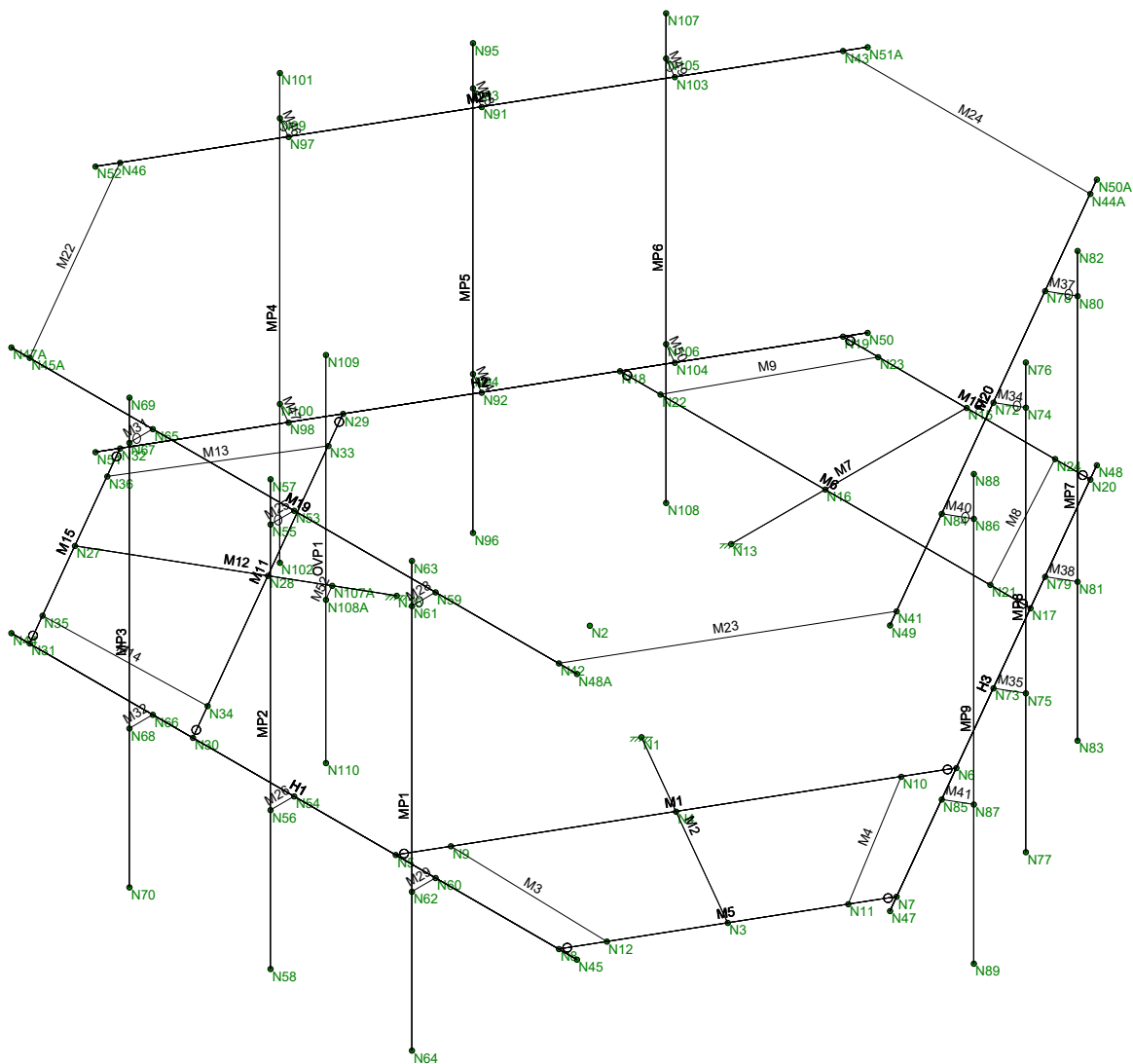

Trylon
SMM
188192

806382
--------

Wireframe
July 21, 2021 at 9:47 AM
806382_loaded.r3d



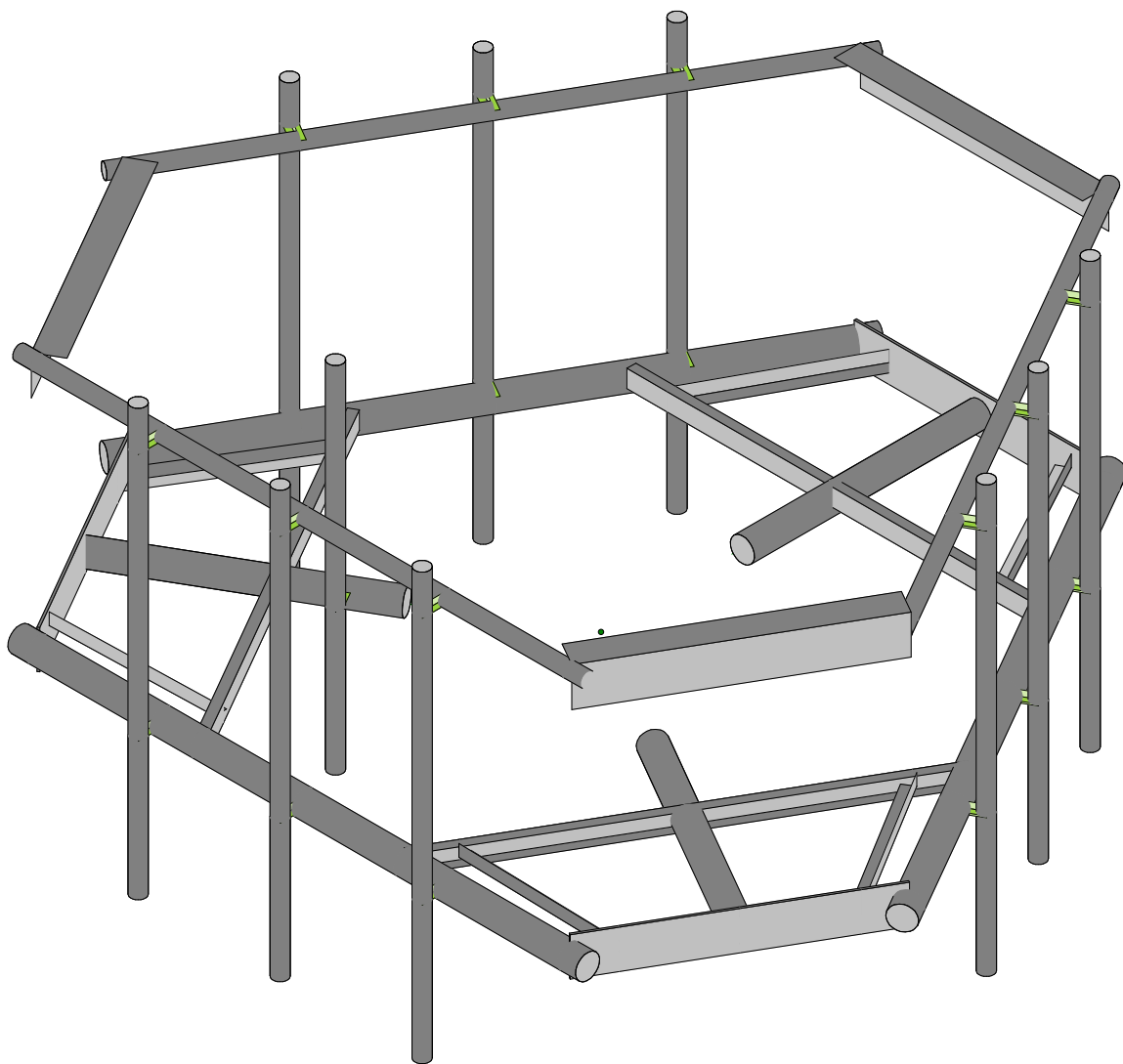

Trylon

SMM

188192

806382

Render

July 21, 2021 at 9:47 AM

806382\_loaded.r3d

**APPENDIX B**  
**SOFTWARE INPUT CALCULATIONS**

# ASCE 7 Hazards Report

**Address:**  
No Address at This  
Location

**Standard:** ASCE/SEI 7-10  
**Risk Category:** II  
**Soil Class:** D - Stiff Soil

**Elevation:** 316.81 ft (NAVD 88)  
**Latitude:** 41.608306  
**Longitude:** -72.591544

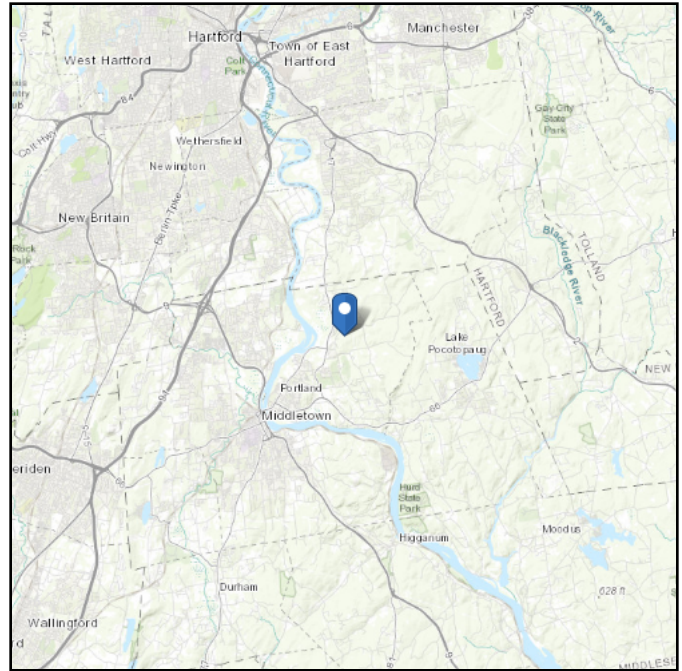

**Site Soil Class:** D - Stiff Soil

**Results:**

$S_s$ :	0.18	$S_{DS}$ :	0.192
$S_1$ :	0.063	$S_{D1}$ :	0.1
$F_a$ :	1.6	$T_L$ :	6
$F_v$ :	2.4	PGA :	0.091
$S_{MS}$ :	0.288	PGA <sub>M</sub> :	0.146
$S_{M1}$ :	0.151	F <sub>PGA</sub> :	1.6
		$I_e$ :	1

**Seismic Design Category** B

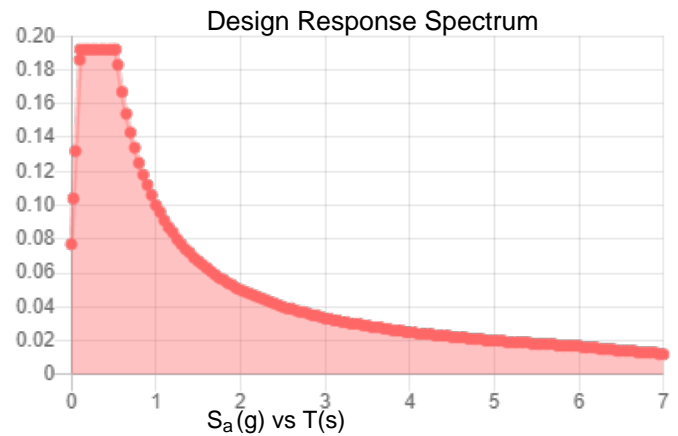
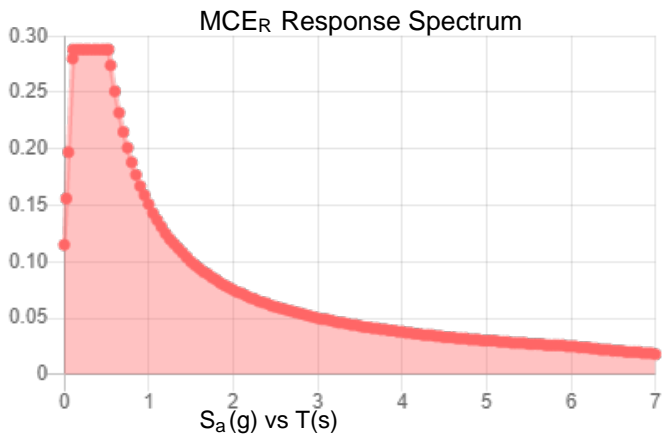

**Data Accessed:**

Wed Jul 21 2021

**Date Source:**

USGS Seismic Design Maps based on ASCE/SEI 7-10, incorporating Supplement 1 and errata of March 31, 2013, and ASCE/SEI 7-10 Table 1.5-2. Additional data for site-specific ground motion procedures in accordance with ASCE/SEI 7-10 Ch. 21 are available from USGS.

## Ice

---

**Results:**

Ice Thickness: 0.75 in.

Concurrent Temperature: 15 F

Gust Speed: 50 mph

**Data Source:** Standard ASCE/SEI 7-10, Figs. 10-2 through 10-8

**Date Accessed:** Wed Jul 21 2021

Ice thicknesses on structures in exposed locations at elevations higher than the surrounding terrain and in valleys and gorges may exceed the mapped values.

Values provided are equivalent radial ice thicknesses due to freezing rain with concurrent 3-second gust speeds, for a 50-year mean recurrence interval, and temperatures concurrent with ice thicknesses due to freezing rain. Thicknesses for ice accretions caused by other sources shall be obtained from local meteorological studies. Ice thicknesses in exposed locations at elevations higher than the surrounding terrain and in valleys and gorges may exceed the mapped values.

---

The ASCE 7 Hazard Tool is provided for your convenience, for informational purposes only, and is provided “as is” and without warranties of any kind. The location data included herein has been obtained from information developed, produced, and maintained by third party providers; or has been extrapolated from maps incorporated in the ASCE 7 standard. While ASCE has made every effort to use data obtained from reliable sources or methodologies, ASCE does not make any representations or warranties as to the accuracy, completeness, reliability, currency, or quality of any data provided herein. Any third-party links provided by this Tool should not be construed as an endorsement, affiliation, relationship, or sponsorship of such third-party content by or from ASCE.

ASCE does not intend, nor should anyone interpret, the results provided by this Tool to replace the sound judgment of a competent professional, having knowledge and experience in the appropriate field(s) of practice, nor to substitute for the standard of care required of such professionals in interpreting and applying the contents of this Tool or the ASCE 7 standard.

In using this Tool, you expressly assume all risks associated with your use. Under no circumstances shall ASCE or its officers, directors, employees, members, affiliates, or agents be liable to you or any other person for any direct, indirect, special, incidental, or consequential damages arising from or related to your use of, or reliance on, the Tool or any information obtained therein. To the fullest extent permitted by law, you agree to release and hold harmless ASCE from any and all liability of any nature arising out of or resulting from any use of data provided by the ASCE 7 Hazard Tool.

**CONNECTICUT DESIGN CRITERIA - STATE**

Revision: R-397 7/2/2021

CT is NOT a Home Rule State; Tab added only for Design Criteria

<b>(APPENDIX N) MUNICIPALITY - SPECIFIC STRUCTURAL DESIGN PARAMETERS</b>												
Municipality	Ground Snow Load	<i>Wind Design Parameters</i>										
		MCE Spectral Accelerations (%g)		Ultimate Design Wind Speeds, $V_{ult}$ (mph)			Nominal Design Wind Speeds, $V_{asd}$ (mph)			Wind-Borne Debris Regions <sup>1</sup>		Hurricane-Prone Regions
		S <sub>s</sub>	S <sub>1</sub>	Risk Cat. I	Risk Cat. II	Risk Cat III-IV	Risk Cat. I	Risk Cat. II	Risk Cat. III-IV	Risk Cat. II & III except Occup I-2	Risk Cat III Occup I-2 & Risk Cat. IV	
Portland	30	0.180	0.063	115	130	135	89	101	105			Yes

1. Wind-Borne Debris Regions:

Type A: Full Municipality.

Type B: Areas south of Interstate 95.

*Exception:* Areas that are more than one mile from the coastal mean high-water line as certified by a registered design professional may be classified as being outside a wind-borne debris region.

Type C: Areas south of Metro North/Amtrak Railroad to the west of the Quinnipiac River and areas south of Interstate 95 to the east of the Quinnipiac River.

*Exception:* Areas that are more than one mile from the coastal mean high-water line as certified by a registered design professional may be classified as being outside a wind-borne debris region.



# Trylon

1825 W. Walnut Hill Lane Suite 120  
Irving, TX 75038

## TIA LOAD CALCULATOR 2.0

PROJECT DATA	
Job Code:	188192
Carrier Site ID:	BU# 806382
Carrier Site Name:	HRT 082 943274

CODES AND STANDARDS	
Building Code:	2015 IBC
Local Building Code:	2018 CSBC
Design Standard:	TIA-222-H

STRUCTURE DETAILS		
Mount Type:	Platform	--
Mount Elevation:	108.0	ft.
Number of Sectors:	3	--
Structure Type:	Monopole	--
Structure Height:	160.0	ft.

ANALYSIS CRITERIA		
Structure Risk Category:	II	--
Exposure Category:	B	--
Site Class:	D - Default	--
Ground Elevation:	316.81	ft.

TOPOGRAPHIC DATA		
Topographic Category:	1.00	--
Topographic Feature:	N/A	--
Crest Point Elevation:	0.00	ft.
Base Point Elevation:	0.00	ft.
Crest to Mid-Height (L/2):	0.00	ft.
Distance from Crest (x):	0.00	ft.
Base Topo Factor ( $K_{zt}$ ):	1.00	--
Mount Topo Factor ( $K_{zt}$ ):	1.00	--

WIND PARAMETERS		
Design Wind Speed:	130	mph
Wind Escalation Factor ( $K_s$ ):	1.00	--
Velocity Coefficient ( $K_z$ ):	1.01	--
Directionality Factor ( $K_d$ ):	0.95	--
Gust Effect Factor (G <sub>h</sub> ):	1.00	--
Shielding Factor ( $K_a$ ):	0.90	--
Velocity Pressure ( $q_z$ ):	41.05	psf

ICE PARAMETERS		
Design Ice Wind Speed:	50	mph
Design Ice Thickness ( $t_i$ ):	1.50	in
Importance Factor ( $I_i$ ):	1.00	--
Ice Velocity Pressure ( $q_{zi}$ ):	41.05	psf
Mount Ice Thickness ( $t_{iz}$ ):	1.69	in

WIND STRUCTURE CALCULATIONS		
Flat Member Pressure:	73.88	psf
Round Member Pressure:	44.33	psf
Ice Wind Pressure:	7.31	psf

SEISMIC PARAMETERS		
Importance Factor ( $I_e$ ):	1.00	--
Short Period Accel. ( $S_s$ ):	0.18	g
1 Second Accel. ( $S_1$ ):	0.06	g
Short Period Des. ( $S_{DS}$ ):	0.19	g
1 Second Des. ( $S_{D1}$ ):	0.10	g
Short Period Coeff. ( $F_a$ ):	1.60	--
1 Second Coeff. ( $F_v$ ):	2.40	--
Response Coefficient ( $C_s$ ):	0.10	--
Amplification Factor ( $A_S$ ):	1.20	--

## LOAD COMBINATIONS [LRFD]

#	Description
1	1.4DL
2	1.2DL + 1WL 0 AZI
3	1.2DL + 1WL 30 AZI
4	1.2DL + 1WL 45 AZI
5	1.2DL + 1WL 60 AZI
6	1.2DL + 1WL 90 AZI
7	1.2DL + 1WL 120 AZI
8	1.2DL + 1WL 135 AZI
9	1.2DL + 1WL 150 AZI
10	1.2DL + 1WL 180 AZI
11	1.2DL + 1WL 210 AZI
12	1.2DL + 1WL 225 AZI
13	1.2DL + 1WL 240 AZI
14	1.2DL + 1WL 270 AZI
15	1.2DL + 1WL 300 AZI
16	1.2DL + 1WL 315 AZI
17	1.2DL + 1WL 330 AZI
18	0.9DL + 1WL 0 AZI
19	0.9DL + 1WL 30 AZI
20	0.9DL + 1WL 45 AZI
21	0.9DL + 1WL 60 AZI
22	0.9DL + 1WL 90 AZI
23	0.9DL + 1WL 120 AZI
24	0.9DL + 1WL 135 AZI
25	0.9DL + 1WL 150 AZI
26	0.9DL + 1WL 180 AZI
27	0.9DL + 1WL 210 AZI
28	0.9DL + 1WL 225 AZI
29	0.9DL + 1WL 240 AZI
30	0.9DL + 1WL 270 AZI
31	0.9DL + 1WL 300 AZI
32	0.9DL + 1WL 315 AZI
33	0.9DL + 1WL 330 AZI
34	1.2DL + 1DLi + 1WLi 0 AZI
35	1.2DL + 1DLi + 1WLi 30 AZI
36	1.2DL + 1DLi + 1WLi 45 AZI
37	1.2DL + 1DLi + 1WLi 60 AZI
38	1.2DL + 1DLi + 1WLi 90 AZI
39	1.2DL + 1DLi + 1WLi 120 AZI
40	1.2DL + 1DLi + 1WLi 135 AZI
41	1.2DL + 1DLi + 1WLi 150 AZI

#	Description
42	1.2DL + 1DLi + 1WLi 180 AZI
43	1.2DL + 1DLi + 1WLi 210 AZI
44	1.2DL + 1DLi + 1WLi 225 AZI
45	1.2DL + 1DLi + 1WLi 240 AZI
46	1.2DL + 1DLi + 1WLi 270 AZI
47	1.2DL + 1DLi + 1WLi 300 AZI
48	1.2DL + 1DLi + 1WLi 315 AZI
49	1.2DL + 1DLi + 1WLi 330 AZI
50	(1.2+0.2Sds) + 1.0E 0 AZI
51	(1.2+0.2Sds) + 1.0E 30 AZI
52	(1.2+0.2Sds) + 1.0E 45 AZI
53	(1.2+0.2Sds) + 1.0E 60 AZI
54	(1.2+0.2Sds) + 1.0E 90 AZI
55	(1.2+0.2Sds) + 1.0E 120 AZI
56	(1.2+0.2Sds) + 1.0E 135 AZI
57	(1.2+0.2Sds) + 1.0E 150 AZI
58	(1.2+0.2Sds) + 1.0E 180 AZI
59	(1.2+0.2Sds) + 1.0E 210 AZI
60	(1.2+0.2Sds) + 1.0E 225 AZI
61	(1.2+0.2Sds) + 1.0E 240 AZI
62	(1.2+0.2Sds) + 1.0E 270 AZI
63	(1.2+0.2Sds) + 1.0E 300 AZI
64	(1.2+0.2Sds) + 1.0E 315 AZI
65	(1.2+0.2Sds) + 1.0E 330 AZI
66	(0.9-0.2Sds) + 1.0E 0 AZI
67	(0.9-0.2Sds) + 1.0E 30 AZI
68	(0.9-0.2Sds) + 1.0E 45 AZI
69	(0.9-0.2Sds) + 1.0E 60 AZI
70	(0.9-0.2Sds) + 1.0E 90 AZI
71	(0.9-0.2Sds) + 1.0E 120 AZI
72	(0.9-0.2Sds) + 1.0E 135 AZI
73	(0.9-0.2Sds) + 1.0E 150 AZI
74	(0.9-0.2Sds) + 1.0E 180 AZI
75	(0.9-0.2Sds) + 1.0E 210 AZI
76	(0.9-0.2Sds) + 1.0E 225 AZI
77	(0.9-0.2Sds) + 1.0E 240 AZI
78	(0.9-0.2Sds) + 1.0E 270 AZI
79	(0.9-0.2Sds) + 1.0E 300 AZI
80	(0.9-0.2Sds) + 1.0E 315 AZI
81	(0.9-0.2Sds) + 1.0E 330 AZI
82-88	1.2D + 1.5 Lv1



#	Description
89	1.2D + 1.5Lm + 1.0Wm 0 AZI - MP1
90	1.2D + 1.5Lm + 1.0Wm 30 AZI - MP1
91	1.2D + 1.5Lm + 1.0Wm 45 AZI - MP1
92	1.2D + 1.5Lm + 1.0Wm 60 AZI - MP1
93	1.2D + 1.5Lm + 1.0Wm 90 AZI - MP1
94	1.2D + 1.5Lm + 1.0Wm 120 AZI - MP1
95	1.2D + 1.5Lm + 1.0Wm 135 AZI - MP1
96	1.2D + 1.5Lm + 1.0Wm 150 AZI - MP1
97	1.2D + 1.5Lm + 1.0Wm 180 AZI - MP1
98	1.2D + 1.5Lm + 1.0Wm 210 AZI - MP1
99	1.2D + 1.5Lm + 1.0Wm 225 AZI - MP1
100	1.2D + 1.5Lm + 1.0Wm 240 AZI - MP1
101	1.2D + 1.5Lm + 1.0Wm 270 AZI - MP1
102	1.2D + 1.5Lm + 1.0Wm 300 AZI - MP1
103	1.2D + 1.5Lm + 1.0Wm 315 AZI - MP1
104	1.2D + 1.5Lm + 1.0Wm 330 AZI - MP1
105	1.2D + 1.5Lm + 1.0Wm 0 AZI - MP2
106	1.2D + 1.5Lm + 1.0Wm 30 AZI - MP2
107	1.2D + 1.5Lm + 1.0Wm 45 AZI - MP2
108	1.2D + 1.5Lm + 1.0Wm 60 AZI - MP2
109	1.2D + 1.5Lm + 1.0Wm 90 AZI - MP2
110	1.2D + 1.5Lm + 1.0Wm 120 AZI - MP2
111	1.2D + 1.5Lm + 1.0Wm 135 AZI - MP2
112	1.2D + 1.5Lm + 1.0Wm 150 AZI - MP2
113	1.2D + 1.5Lm + 1.0Wm 180 AZI - MP2
114	1.2D + 1.5Lm + 1.0Wm 210 AZI - MP2
115	1.2D + 1.5Lm + 1.0Wm 225 AZI - MP2
116	1.2D + 1.5Lm + 1.0Wm 240 AZI - MP2
117	1.2D + 1.5Lm + 1.0Wm 270 AZI - MP2
118	1.2D + 1.5Lm + 1.0Wm 300 AZI - MP2
119	1.2D + 1.5Lm + 1.0Wm 315 AZI - MP2
120	1.2D + 1.5Lm + 1.0Wm 330 AZI - MP2

#	Description
121	1.2D + 1.5Lm + 1.0Wm 0 AZI - MP3
122	1.2D + 1.5Lm + 1.0Wm 30 AZI - MP3
123	1.2D + 1.5Lm + 1.0Wm 45 AZI - MP3
124	1.2D + 1.5Lm + 1.0Wm 60 AZI - MP3
125	1.2D + 1.5Lm + 1.0Wm 90 AZI - MP3
126	1.2D + 1.5Lm + 1.0Wm 120 AZI - MP3
127	1.2D + 1.5Lm + 1.0Wm 135 AZI - MP3
128	1.2D + 1.5Lm + 1.0Wm 150 AZI - MP3
129	1.2D + 1.5Lm + 1.0Wm 180 AZI - MP3
130	1.2D + 1.5Lm + 1.0Wm 210 AZI - MP3
131	1.2D + 1.5Lm + 1.0Wm 225 AZI - MP3
132	1.2D + 1.5Lm + 1.0Wm 240 AZI - MP3
133	1.2D + 1.5Lm + 1.0Wm 270 AZI - MP3
134	1.2D + 1.5Lm + 1.0Wm 300 AZI - MP3
135	1.2D + 1.5Lm + 1.0Wm 315 AZI - MP3
136	1.2D + 1.5Lm + 1.0Wm 330 AZI - MP3
137	1.2D + 1.5Lm + 1.0Wm 0 AZI - MP4
138	1.2D + 1.5Lm + 1.0Wm 30 AZI - MP4
139	1.2D + 1.5Lm + 1.0Wm 45 AZI - MP4
140	1.2D + 1.5Lm + 1.0Wm 60 AZI - MP4
141	1.2D + 1.5Lm + 1.0Wm 90 AZI - MP4
142	1.2D + 1.5Lm + 1.0Wm 120 AZI - MP4
143	1.2D + 1.5Lm + 1.0Wm 135 AZI - MP4
144	1.2D + 1.5Lm + 1.0Wm 150 AZI - MP4
145	1.2D + 1.5Lm + 1.0Wm 180 AZI - MP4
146	1.2D + 1.5Lm + 1.0Wm 210 AZI - MP4
147	1.2D + 1.5Lm + 1.0Wm 225 AZI - MP4
148	1.2D + 1.5Lm + 1.0Wm 240 AZI - MP4
149	1.2D + 1.5Lm + 1.0Wm 270 AZI - MP4
150	1.2D + 1.5Lm + 1.0Wm 300 AZI - MP4
151	1.2D + 1.5Lm + 1.0Wm 315 AZI - MP4
152	1.2D + 1.5Lm + 1.0Wm 330 AZI - MP4

\*This page shows an example of maintenance loads for (4) pipes, the number of mount pipe LCs may vary per site

## EQUIPMENT LOADING

<i>Appurtenance Name/Location</i>	<i>Qty.</i>	<i>Elevation [ft]</i>	<i>--</i>	<i>EPA<sub>N</sub> (ft<sup>2</sup>)</i>	<i>EPA<sub>T</sub> (ft<sup>2</sup>)</i>	<i>Weight (lbs)</i>
MX08FRO665-20	3	108	No Ice	8.01	3.21	82.50
MP1/MP4/MP7, 10/120/270	--	--	w/ Ice	9.63	4.63	279.15
TA08025-B604	3	108	No Ice	1.96	0.98	63.90
MP1/MP4/MP7, 90/210/330	--	--	w/ Ice	2.38	1.30	67.76
TA08025-B605	3	108	No Ice	1.96	1.13	75.00
MP1/MP4/MP7, 90/210/330	--	--	w/ Ice	2.38	1.46	72.20
RDIDC-9181-PF-48	1	108	No Ice	2.01	1.17	21.85
OVP1, 340	--	--	w/ Ice	2.43	1.52	71.15
			No Ice			
--	--	--	w/ Ice			
			No Ice			
--	--	--	w/ Ice			
			No Ice			
--	--	--	w/ Ice			
			No Ice			
--	--	--	w/ Ice			
			No Ice			
--	--	--	w/ Ice			
			No Ice			
--	--	--	w/ Ice			
			No Ice			
--	--	--	w/ Ice			
			No Ice			
--	--	--	w/ Ice			
			No Ice			
--	--	--	w/ Ice			
			No Ice			
--	--	--	w/ Ice			
			No Ice			
--	--	--	w/ Ice			
			No Ice			
--	--	--	w/ Ice			
			No Ice			
--	--	--	w/ Ice			
			No Ice			
--	--	--	w/ Ice			
			No Ice			
--	--	--	w/ Ice			
			No Ice			
--	--	--	w/ Ice			
			No Ice			
--	--	--	w/ Ice			
			No Ice			
--	--	--	w/ Ice			
			No Ice			
--	--	--	w/ Ice			
			No Ice			
--	--	--	w/ Ice			
			No Ice			

# EQUIPMENT WIND CALCULATIONS

<i>Appurtenance Name</i>	<i>Qty.</i>	<i>Elevation [ft]</i>	$K_{zt}$	$K_z$	$K_d$	$t_d$	$q_z$ [psf]	$q_{zi}$ [psf]
MX08FRO665-20	3	108	1.00	1.01	0.95	1.69	41.05	6.07
TA08025-B604	3	108	1.00	1.01	0.95	1.69	41.05	6.07
TA08025-B605	3	108	1.00	1.01	0.95	1.69	41.05	6.07
RDIDC-9181-PF-48	1	108	1.00	1.01	0.95	1.69	41.05	6.07



## **EQUIPMENT SEISMIC FORCE CALCULATIONS**

<i>Appurtenance Name</i>	<i>Qty.</i>	<i>Elevation [ft]</i>	<i>Weight [lbs]</i>	<i>F<sub>p</sub> [lbs]</i>
MX08FRO665-20	3	108	82.5	9.50
TA08025-B604	3	108	63.9	7.36
TA08025-B605	3	108	75	8.64
RDIDC-9181-PF-48	1	108	21.85	2.52

**APPENDIX C**  
**SOFTWARE ANALYSIS OUTPUT**





















**APPENDIX D**  
**ADDITIONAL CALCUATIONS**



**BOLT TOOL 1.5.2**

Project Data	
Job Code:	188192
Carrier Site ID:	BU# 806382
Carrier Site Name:	HRT 082 943274

Code	
Design Standard:	TIA-222-H
Slip Check:	No
Pretension Standard:	TIA-222-H

Bolt Properties		
Connection Type:	Bolt	
Diameter:	0.625	in
Grade:	A325	--
Yield Strength (Fy):	92	ksi
Ultimate Strength (Fu):	120	ksi
Number of Bolts:	4	--
Threads Included:	Yes	--
Double Shear:	No	--
Connection Pipe Size:	-	in

Connection Description
Standoff to Collar Connection

Bolt Check*		
Tensile Capacity ( $\phi T_n$ ):	20340.1	lbs
Shear Capacity ( $\phi V_n$ ):	13805.8	lbs
Tension Force ( $T_u$ ):	3534.7	lbs
Shear Force ( $V_u$ ):	472.5	lbs
Tension Usage:	16.6%	--
Shear Usage:	3.3%	--
Interaction:	16.6%	Pass
Controlling Member:	M12	--
Controlling LC:	42	--

\*Rating per TIA-222-H Section 15.5

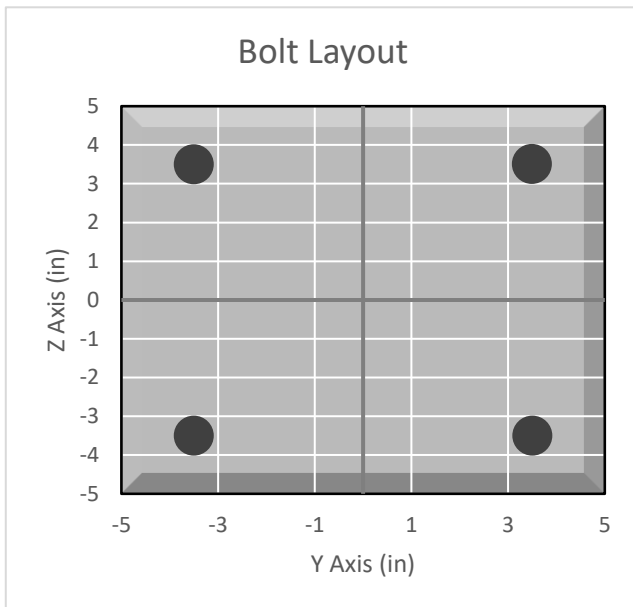

**APPENDIX E**  
**SUPPLEMENTAL DRAWINGS**

ITEM	PART NO.	DESCRIPTION	QTY.	WEIGHT	NOTE NO.
1	MTC3006SB	STEEL BUNDLE FOR SNUB NOSE PLATFORM	1	402.64 LBS	
2	MCPK8CSB	PIPE STEEL BUNDLE FOR MC-PK8-C	1	464.27 LBS	
3	MCPK8CHWK	HARDWARE KIT FOR MC-PK8-C	1	543.22 LBS	



REVISIONS				
REV.	ECN	DESCRIPTION	BY	DATE
A		INITIAL RELEASE	DRR	12/27/11
B	8000005979	CHANGE NOSE CORNER BRKT, ADD GUB-4240	MSM	11/25/14
C	8000007579	NEW RINGMOUNT WELDMENT DESIGN	RJC	04/07/15

FOR BOM ENTRY ONLY

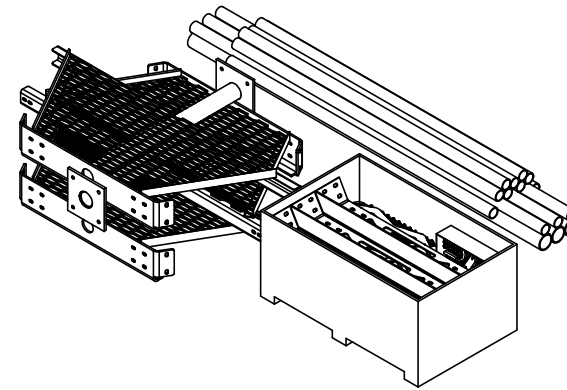

NOTES:  
1. CUSTOMER ASSEMBLY SHEETS 2-3.

<small>These drawings and specifications are the proprietary property of ANDREW CORPORATION and may be used only for the specific purpose authorized in writing by Andrew Corporation.</small>			<small>DRAWN BY:</small> MSM	<small>SHEET:</small> 1 of 3	<small>PART NUMBER:</small> MC-PK8-C
<small>ALL DIMENSIONS ARE IN INCHES U.O.S. TOLERANCES UNLESS OTHERWISE SPECIFIED:</small>			<small>CHECKED BY:</small> TP	<small>SCALE:</small> NTS	<small>DESCRIPTION:</small> LOW PROFILE PLATFORM KIT 8' FACE
<small>.X = ± .12      ANGLES      ±2° .XX = ± .06      FRACTIONS    ±1/32 .XXX = ± .03</small>			<small>DATE:</small> 10/18/11	<small>MATERIAL:</small> A36, A500	<small>DRAWING TYPE:</small> ASSEMBLY DRAWING
<small>REMOVE BURRS AND BREAK EDGES .005</small>			<small>REVISION:</small> C	<small>FINISH:</small> GALV A123	
<small>DO NOT SCALE THIS PRINT</small>				<small>WEIGHT:</small> 1410.14 LBS	

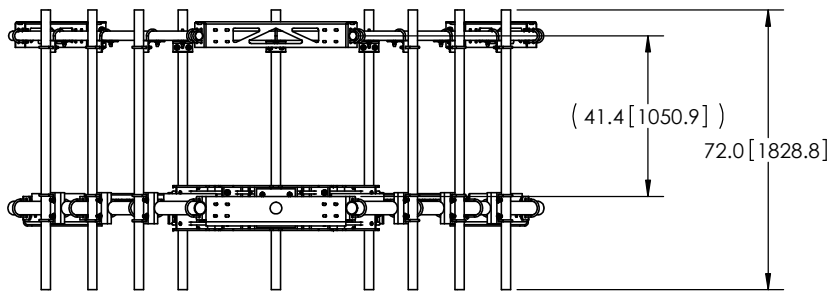
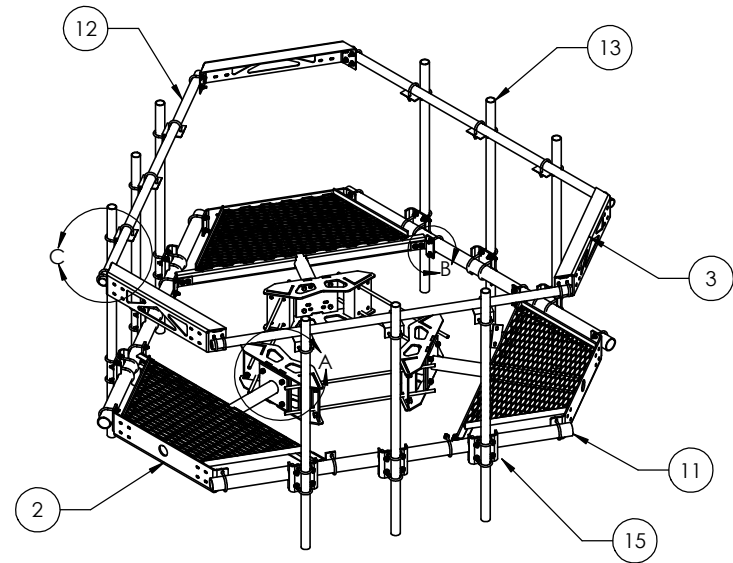
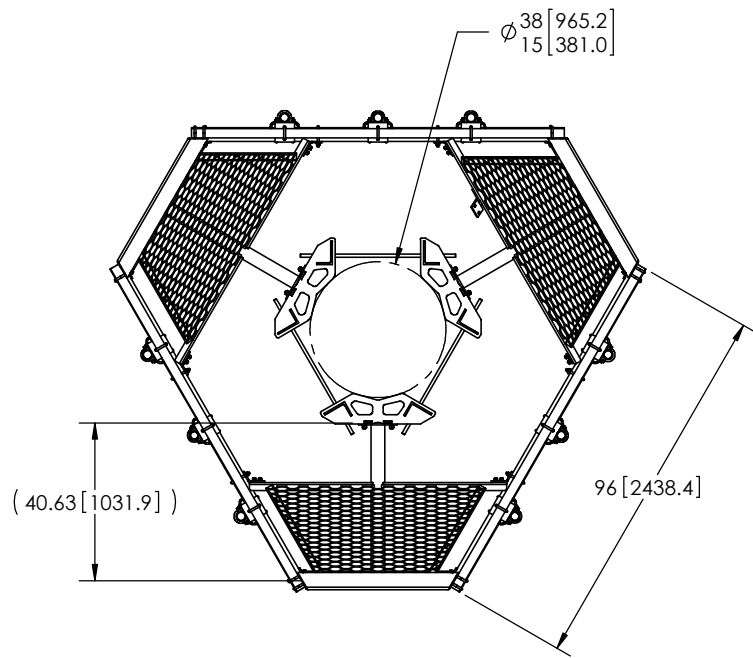

ITEM	PART NO.	DESCRIPTION	QTY.	WEIGHT
1	MC-RM1550-3	12" - 50" OD RINGMOUNT	1	230.42 LBS
2	MTC300601	Low Profile Co-Location Platform Snub Nose	3	134.21 LBS
3	MT195801	Corner Weldment Snub Nose Handrail	3	27.10 LBS
4	XA2020.01	CROSS OVER ANGLE	9	2.65 LBS
5	GUB-4356	1/2" X 3-5/8" X 6" GALV U-BOLT	18	0.82 LBS
6	GUB-4355	1/2" X 3-5/8" X 5" GALV U-BOLT	12	0.71 LBS
7	GUB-4240	1/2" X 2-1/2" X 4" GALV U-BOLT	48	0.56 LBS
8	GB-04145	1/2" X 1-1/2" GALV BOLT KIT	12	0.13 LBS
9	GWF-04	1/2" GALV FLAT WASHER	24	0.03 LBS
10	GB-0520A	5/8" X 2" GALV BOLT KIT (A325)	12	0.27 LBS
11	MT54796	3.50" OD X 96" GALV PIPE	3	60.28 LBS
12	MT-651-96	Ø2.375" OD X 96" PIPE	3	29.07 LBS
13	MT-651	2.375" OD x 72" PIPE	9	21.80 LBS
14	MT19617	MT196 Pipe Mount Plate	6	2.49 LBS
15	MT21701	PIPE MOUNT PLATE	9	7.93 LBS

<small>These drawings and specifications are the proprietary property of ANDREW CORPORATION and may be used only for the specific purpose authorized in writing by Andrew Corporation.</small>			
<small>ALL DIMENSIONS ARE IN INCHES U.O.S. TOLERANCES UNLESS OTHERWISE SPECIFIED:</small> .X = ± .12 ANGLES ±2° .XX = ± .06 FRACTIONS ±1/32 .XXX = ± .03 <small>REMOVE BURRS AND BREAK EDGES .005</small>	<small>DO NOT SCALE THIS PRINT</small>	<small>DRAWN BY:</small> MSM <small>CHECKED BY:</small> TP <small>DATE:</small> 10/18/11 <small>REVISION:</small> C	<small>SHEET:</small> 2 of 3 <small>TITLE:</small> NTS <small>DATE:</small> 10/18/11 <small>REVISION:</small> C <small>WEIGHT:</small> 1361.27 LBS
<small>PROPERTY NO.:</small> 25" OD Snub Nose MT-196 <small>DRAWING TYPE:</small> ASSEMBLY DRAWING		 WESTCHESTER, IL. 60154 U.S.A.	

NOTES:

1. ALL METRIC DIMENSIONS ARE IN BRACKETS.
2. WILL FIT MONOPOLES 15"-38" OD.

8 7 6 5 4 3 2 1

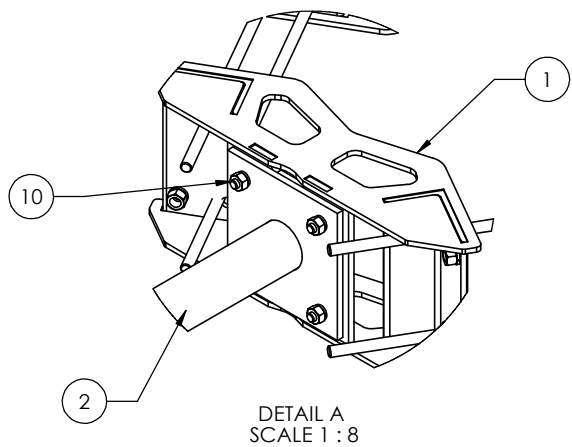

DETAIL A  
SCALE 1 : 8

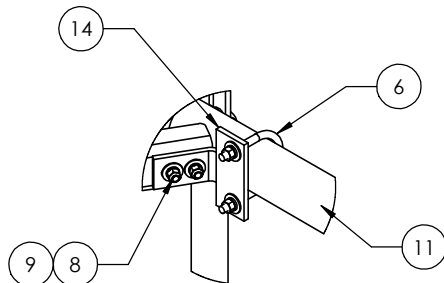

DETAIL B  
SCALE 1 : 8

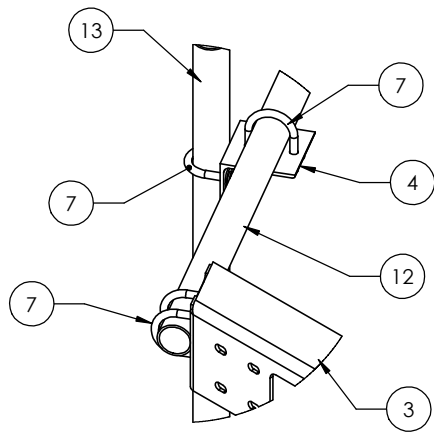

DETAIL C  
SCALE 1 : 8

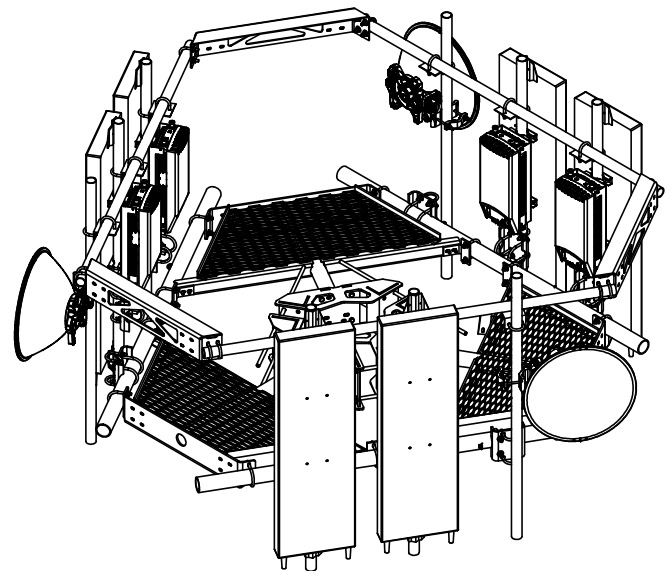

**WITH ANTENNAS**

NOTES:  
1. ALL METRIC DIMENSIONS ARE IN BRACKETS.

<small>These drawings and specifications are the proprietary property of ANDREW CORPORATION and may be used only for the specific purpose authorized in writing by Andrew Corporation.</small>		<small>DRAWN BY:</small> MSM	<small>SHEET:</small> 3 of 3	<small>PART NUMBER:</small> MC-PK8-C
<small>ALL DIMENSIONS ARE IN INCHES U.O.S. TOLERANCES UNLESS OTHERWISE SPECIFIED:</small> .X = ± .12 ANGLES ±2° .XX = ± .06 FRACTIONS ±1/32 .XXX = ± .03 REMOVE BURRS AND BREAK EDGES .005		<small>CHECKED BY:</small> TP	<small>SCALE:</small> NTS	<small>DESCRIPTION:</small> 25" OD Snub Nose MT-196
<small>DO NOT SCALE THIS PRINT</small>		<small>DATE:</small> 10/18/11	<small>MATERIAL:</small> A36, A53	<small>DRAWING TYPE:</small> ASSEMBLY DRAWING
		<small>REVISION:</small> C	<small>FINISH:</small> GALV A123	 WESTCHESTER, IL. 60154 U.S.A.
			<small>WEIGHT:</small> 1361.27 LBS	

8 7 6 5 4 3 2 1