

January 26, 2015

Melanie A. Bachman  
Acting Executive Director  
Connecticut Siting Council  
10 Franklin Square  
New Britain, CT 06051

Re: **Notice of Exempt Modification – Facility Modification  
398 Pomfret Street, Pomfret, Connecticut**

Dear Ms. Bachman:

Cellco Partnership d/b/a Verizon Wireless (“Cellco”) currently maintains twelve (12) antennas at the 157-foot level on the existing 168-foot tower at 398 Pomfret Street in Pomfret (the “Property”). The tower is owned by SBA. Cellco’s shared use of this tower was approved by the Council in 2000. Cellco now intends to modify its facility by replacing all of its existing antennas with three (3) model LNX-6514DS-VTM, 700 MHz antennas; three (3) model LNX-6514DS-VTM, 850 MHz antennas; three (3) model HBXX-6517DS-VTM, 1900 MHz antennas; and three (3) model HBXX-6517DS-VTM, 2100 MHz antennas, all at the same level on the tower. Cellco also intends to install six (6) remote radio heads (“RRHs”) behind its 700 MHz and 2100 MHz antennas and one (1) HYBRIFLEX™ antenna cable, inside the monopole tower. Included in Attachment 1 are specifications for Cellco’s replacement antennas, RRHs and HYBRIFLEX™ cable.

Please accept this letter as notification pursuant to R.C.S.A. § 16-50j-73, for construction that constitutes an exempt modification pursuant to R.C.S.A. § 16-50j-72(b)(2). In accordance with R.C.S.A. § 16-50j-73, a copy of this letter is being sent Maureen Nicholson, First Selectman of the Town of Pomfret. A copy of this letter is also being sent to Pomfret School, Inc., the owner of the Property.

The planned modifications to the facility fall squarely within those activities explicitly provided for in R.C.S.A. § 16-50j-72(b)(2).

# Robinson+Cole

Melanie A. Bachman

January 26, 2015

Page 2

1. The proposed modifications will not result in an increase in the height of the existing tower. Cellco's replacement antennas and RRHs will be installed on its existing antenna platform at the 157-foot level of the 168-foot tower.
2. The proposed modifications will not involve any change to ground-mounted equipment and, therefore, will not require the extension of the site boundary.
3. The proposed modifications will not increase noise levels at the facility by six decibels or more, or to levels that exceed state and local criteria.
4. The operation of the replacement antennas will not increase radio frequency (RF) emissions at the facility to a level at or above the Federal Communications Commission (FCC) safety standard. A cumulative General Power Density table for Cellco's modified facility is included in Attachment 2.
5. The proposed modifications will not cause a change or alteration in the physical or environmental characteristics of the site.
6. The tower and its foundation can support Cellco's proposed modifications. (See Structural Analysis included in Attachment 3).

For the foregoing reasons, Cellco respectfully submits that the proposed modifications to the above-referenced telecommunications facility constitutes an exempt modification under R.C.S.A. § 16-50j-72(b)(2).

Sincerely,

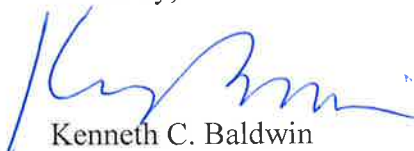

Kenneth C. Baldwin

Enclosures

Copy to:

Maureen Nicholson, Pomfret First Selectman  
Pomfret School, Inc.  
Sandy M. Carter

# **ATTACHMENT 1**

# Product Specifications

COMMSCOPE®

LNX-6514DS-VTM

Andrew® Antenna, 698–896 MHz, 65° horizontal beamwidth, RET compatible

POWERED BY



## Electrical Specifications

Frequency Band, MHz	698–806	806–896
Gain, dBi	15.7	16.3
Beamwidth, Horizontal, degrees	65	65
Beamwidth, Horizontal Tolerance, degrees	±3	±3
Beamwidth, Vertical, degrees	12.5	11.2
Beam Tilt, degrees	0–10	0–10
USLS, typical, dB	17	18
Front-to-Back Ratio at 180°, dB	32	30
CPR at Boresight, dB	20	20
CPR at Sector, dB	10	10
Isolation, dB	30	30
VSWR   Return Loss, dB	1.4   15.6	1.4   15.6
PIM, 3rd Order, 2 x 20 W, dBc	-153	-153
Input Power per Port, maximum, watts	400	400
Polarization	±45°	±45°

## Mechanical Specifications

Color   Radome Material	Light gray   Fiberglass, UV resistant
Connector Interface   Location   Quantity	7-16 DIN Female   Bottom   2
Wind Loading, maximum	617.7 N @ 150 km/h 138.9 lbf @ 150 km/h
Wind Speed, maximum	241.0 km/h   149.8 mph
Antenna Dimensions, L x W x D	1847.0 mm x 301.0 mm x 181.0 mm   72.7 in x 11.9 in x 7.1 in
Net Weight	17.6 kg   38.8 lb
Model with factory installed AISG 2.0 RET	LNX-6514DS-A1M



# Product Specifications

COMMSCOPE®

HBXX-6517DS-VTM

Andrew® Quad Port Teletilt® Antenna, 1710–2180 MHz, 65° horizontal beamwidth, RET compatible

POWERED BY



## Electrical Specifications

Frequency Band, MHz	1710–1880	1850–1990	1920–2180
Gain by all Beam Tilts, average, dBi	18.5	18.6	18.8
Gain by all Beam Tilts Tolerance, dB	±0.4	±0.3	±0.4
	0 °   18.4	0 °   18.4	0 °   18.7
Gain by Beam Tilt, average, dBi	3 °   18.7	3 °   18.7	3 °   18.9
	6 °   18.4	6 °   18.5	6 °   18.6
Beamwidth, Horizontal, degrees	67	66	65
Beamwidth, Horizontal Tolerance, degrees	±2.4	±1.7	±2.9
Beamwidth, Vertical, degrees	5.0	4.7	4.4
Beamwidth, Vertical Tolerance, degrees	±0.3	±0.3	±0.3
Beam Tilt, degrees	0–6	0–6	0–6
USLS, dB	18	19	19
Front-to-Back Total Power at 180° ± 30°, dB	25	26	26
CPR at Boresight, dB	22	23	22
CPR at Sector, dB	10	10	9
Isolation, dB	30	30	30
VSWR   Return Loss, dB	1.4   15.6	1.4   15.6	1.4   15.6
PIM, 3rd Order, 2 x 20 W, dBc	-153	-153	-153
Input Power per Port, maximum, watts	350	350	350
Polarization	±45°	±45°	±45°

\*Values calculated using NGMN Alliance N-P-BASTA v9.6

## Mechanical Specifications

Color   Radome Material	Light gray   PVC, UV resistant
Connector Interface   Location   Quantity	7-16 DIN Female   Bottom   4
Wind Loading, maximum	668.0 N @ 150 km/h 150.2 lbf @ 150 km/h
Wind Speed, maximum	241.0 km/h   149.8 mph
Antenna Dimensions, L x W x D	1903.0 mm x 305.0 mm x 166.0 mm   74.9 in x 12.0 in x 6.5 in
Net Weight	19.5 kg   43.0 lb
Model with factory installed AISG 2.0 RET	HBXX-6517DS-A2M



## Alcatel-Lucent RRH2x40-07-U REMOTE RADIO HEAD

The Alcatel-Lucent RRH2x40-07-U is a high-power, small form-factor Remote Radio Head (RRH) operating in the North American Digital Dividend / 700MHz frequency band (3GPP Band 13). The Alcatel-Lucent RRH2x40-07-U is designed with an eco-efficient approach, providing operators with the means to achieve high quality and capacity coverage with minimum site requirements.



A distributed eNodeB expands deployment options by using two components, a Base Band Unit (BBU) containing the digital assets and a separate RRH containing the radio-frequency (RF) elements. This modular design optimizes available space and allows the main components of an eNodeB to be installed separately, within the same site or several kilometres apart.

The Alcatel-Lucent RRH2x40-07-U is linked to the BBU by an optical-fiber connection carrying downlink and uplink digital radio signals along with operations, administration and maintenance (OA&M) information. The Alcatel-Lucent RRH2x40-07-U has two transmit RF paths, 40 W RF output power per transmit path, and is designed to manage up to two-way receive diversity. The device is ideally suited to support macro coverage, with multiple-input multiple-output (MIMO) 2x2 operation in up to 10 MHz of bandwidth.

The Alcatel-Lucent RRH2x40-07-U is designed to make available all the benefits of a distributed eNodeB, with excellent RF characteristics, with low

capital expenditures (CAPEX) and low operating expenditures (OPEX). The limited space available in some sites may prevent the installation of traditional single-cabinet BTS equipment or require costly cranes to be employed, leaving coverage holes. However, many of these sites can host an Alcatel-Lucent RRH2x40-07-U installation, providing more flexible site selection and improved network quality along with greatly reduced installation time and costs.

### Fast, low-cost installation and deployment

The Alcatel-Lucent RRH2x40-07-U is a zero-footprint solution and operates noise-free, simplifying negotiations with site property owners and minimizing environmental impacts. Installation can easily be done by a single person because the Alcatel-Lucent RRH2x40-07-U is compact and weighs less than 23 kg (50 lb), eliminating the need for a crane to hoist the BTS cabinet to the rooftop. A site can be in operation in less than one day — a fraction of the time required for a traditional BTS.

## Excellent RF performance

Because of its small size and weight, the Alcatel-Lucent RRH2x40-07-U can be installed close to the antenna. Operators can therefore locate the Alcatel-Lucent RRH2x40-07-U where RF engineering is deemed ideal, minimizing trade-offs between available sites and RF optimum sites. The RF feeder cost and installation costs are reduced or eliminated, and there is no need for a Tower Mounted Amplifier (TMA) because losses introduced by the RF feeder are greatly reduced. The Alcatel-Lucent RRH2x40-07-U provides more RF power while at the same time consuming less electricity.

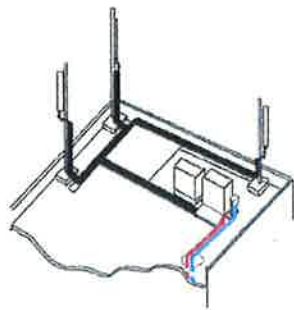

Macro

## Features

- Zero-footprint deployment
- Easy installation, with a lightweight unit can be carried and set up by one person
- Optimized RF power, with flexible site selection and elimination of a TMA
- Convection-cooled (fanless), noise-free, and heaterless unit
- Best-in-class power efficiency, with significantly reduced energy consumption

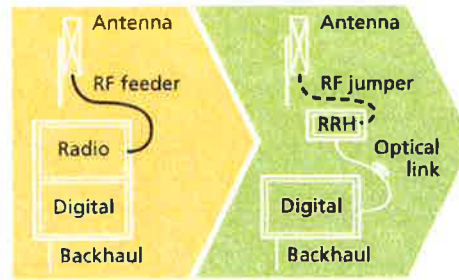

RRH for space-constrained cell sites

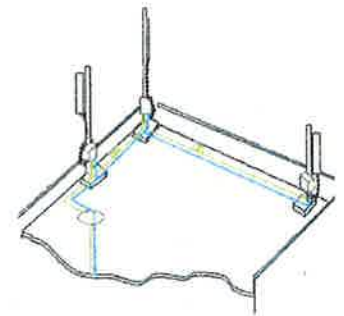

Distributed

## Benefits

- Leverages existing real estate with lower site costs
- Reduces installation costs, with fewer installation materials and simplified logistics
- Decreases power costs and minimizes environmental impacts, with the potential for eco-sustainable power options
- Improves RF performance and adds flexibility to network planning

## Technical specifications

### Physical dimensions

- Height: 390 mm (15.4 in.)
- Width: 380 mm (15 in.)
- Depth: 210 mm (8.2 in.)
- Weight (without mounting kit): less than 23 kg (50 lb)

### Power

- Power supply: -48V

### Operating environment

- Outdoor temperature range:
  - With solar load: -40°C to +50°C (-40°F to +122°F)
  - Without solar load: -40°C to +55°C (-40°F to +131°F)
- Passive convection cooling (no fans)

- Enclosure protection
  - IP65 (International Protection rating)

### RF characteristics

- Frequency band: 700 MHz; 3GPP Band 13
- Bandwidth: up to 10 MHz
- RF output power at antenna port:
  - 40 W nominal RF power for each Tx port
- Rx diversity: 2-way or 4-way
- Noise figure: below 2.5 dB typical
- ALD features
  - TMA
  - Remote electrical tilt (RET) support (AISG v2.0)

### Optical characteristics

#### Type/number of fibers

- Up to 3.12 Gb/s line bit rate
- Single-mode variant
  - One SM fiber (9/125 μm) per RRH2x, carrying UL and DL using CWDM (at 1550/1310 nm)
- Multi-mode variant
  - Two MM fibers (50/125 μm) per RRH2x: one carrying UL, the other carrying DL (at 850 nm)

### Optical fiber length

- Up to 500 m (0.31 mi), using MM fiber
- Up to 20 km (12.43 mi), using SM fiber

### Alarms and ports

- Six external alarms
- Two optical ports to support daisy-chaining

[www.alcatel-lucent.com](http://www.alcatel-lucent.com) Alcatel, Lucent, Alcatel-Lucent and the Alcatel-Lucent logo are trademarks of Alcatel-Lucent. All other trademarks are the property of their respective owners. The information presented is subject to change without notice. Alcatel-Lucent assumes no responsibility for inaccuracies contained herein. Copyright © 2010 Alcatel-Lucent. All rights reserved. CPG2809100913 (09)

# ALCATEL-LUCENT WIRELESS PRODUCT DATASHEET RRH2X60-AWS FOR BAND 4 APPLICATIONS

The Alcatel-Lucent RRH2x60-AWS is a high power, small form factor Remote Radio Head operating in the AWS frequency band (3GPP Band 4) for LTE technology. It is designed with an eco-efficient approach, providing operators with the means to achieve high quality and high capacity coverage with minimum site requirements and efficient operation.

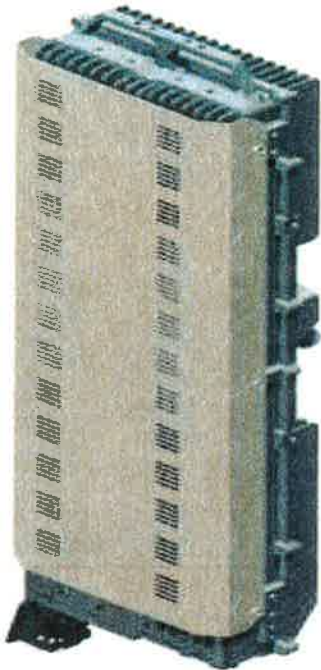

A distributed Node B expands the deployment options by using two components, a Base Band Unit (BBU) containing the digital assets and a separate RRH containing the radio-frequency (RF) elements. This modular design optimizes available space and allows the main components of a Node B to be installed separately, within the same site or several kilometers apart.

The Alcatel-Lucent RRH2x60-AWS is linked to the BBU by an optical-fiber connection carrying downlink and uplink digital radio signals

along with operations, administration and maintenance (OA&M) information.

#### SUPERIOR RF PERFORMANCE

The Alcatel-Lucent RRH2x60-AWS integrates all the latest technologies. This allows to offer best-in-class characteristics.

It delivers an outstanding 120 watts of total RF power thanks to its two transmit RF paths of 60 W each.

It is ideally suited to support multiple-input multiple-output (MIMO) 2x2 operation.

It includes four RF receivers to natively support 4-way uplink reception diversity. This improves the radio uplink coverage and this can be used to extend the cell radius commensurate with 2x2MIMO 2x60 W for the downlink.

It supports multiple discontinuous LTE carriers within an instantaneous bandwidth of 45 MHz corresponding to the entire AWS B4 spectrum.

The latest generation power amplifiers (PA) used in this product achieve high efficiency (>40%), resulting in improved power consumption figures.

#### OPTIMIZED TCO

The Alcatel-Lucent RRH2x60-AWS is designed to make available all the benefits of a distributed Node B, with excellent RF characteristics, with low capital expenditures (CAPEX) and low operating expenditures (OPEX).

The Alcatel-Lucent RRH2x60-AWS is a very cost-effective solution to deploy LTE MIMO.

#### EASY INSTALLATION

The RRH2x60-AWS includes a reversible mounting bracket which allows for ease of installation behind an antenna, or on a rooftop knee wall while providing easy access to the mid body RF connectors.

The limited space available in some sites may prevent the installation of traditional single-cabinet BTS equipment. However, many of these sites can host an Alcatel-Lucent RRH2x60-AWS installation, providing more flexible site selection and improved network quality along with greatly reduced installation time and costs.

The Alcatel-Lucent RRH2x60-AWS is a zero-footprint solution and is convection cooled without fans for silent operation, simplifying negotiations with site property owners and minimizing environmental impacts.

Installation can easily be done by a single person as the Alcatel-Lucent RRH2x60-AWS is compact and weighs about 20 kg, eliminating the need for a crane to hoist the BTS cabinet to the rooftop. A site can be in operation in less than one day.



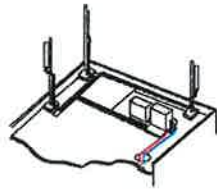

Macro

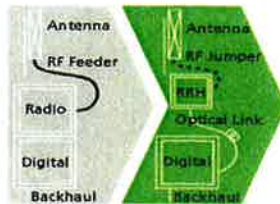

RRH for space-constrained cell sites

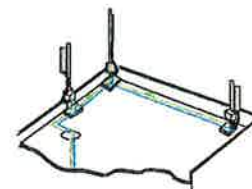

Distributed

## FEATURES

- RRH2x60-AWS integrates two power amplifiers of 60W rating (at each antenna connector)
- Support multiple carriers over the entire 3GPP band 4
- RRH2x60-AWS is optimized for LTE operation
- RRH2x60-AWS is a very compact and lightweight product
- Advanced power management techniques are embedded to provide power savings, such as PA bias control

## BENEFITS

- MIMO LTE operation with only one single unit per sector
- Improved uplink coverage with built-in 4-way receive diversity capability
- RRH can be mounted close to the antenna, eliminating nearly all losses in RF cables and thus reducing power consumption by 50% compared to conventional solutions
- Distributed configurations provide easily deployable and cost-effective solutions, near zero footprint and

silent solutions, with minimum impact on the neighborhood, which ease the deployment

- RETA and TMA support without additional hardware thanks to the AISG v2.0 port and the integrated Bias-Tees. Bias-Tees support AISG DC supply and signaling.

## TECHNICAL SPECIFICATIONS

Specifications listed are hardware capabilities. Some capabilities depend on support in a specific software release or future release.

### Dimensions and weights

- HxWxD : 510x285x186mm (27 l with solar shield)
- Weight : 20 kg (44 lbs)

### Electrical Data

- Power Supply : -48V DC (-40.5 to -57V)
- Power Consumption (ETSI average traffic load reference) : 250W @2x60W

### RF Characteristics

- Frequency band: 1710-1755, UL / 2110-2155 MHz, DL (3GPP band 4)
- Output power: 2x60W at antenna connectors
- Technology supported: LTE
- Instantaneous bandwidth: 45 MHz
- Rx diversity: 2-way and 4-way uplink reception
- Typical sensitivity without Rx diversity: -105 dBm for LTE

### Connectivity

- Two CPRI optical ports for daisy chaining and up to six RRHs per fiber
- Type of optical fiber: Single-Mode (SM) and Multi-Mode (MM) SFPs
- Optical fiber length: up to 500m using MM fiber, up to 20km using SM fiber
- TMA/RETA : AISG 2.0 (RS485 connector and internal Bias-Tee)
- Six external alarms
- Surge protection for all external ports (DC and RF)

### Environmental specifications

- Operating temperature: -40°C to 55°C including solar load
- Operating relative humidity: 8% to 100%
- Environmental Conditions : ETS 300 019-1-4 class 4.1E
- Ingress Protection : IEC 60529 IP65
- Acoustic Noise : Noiseless (natural convection cooling)

### Safety and Regulatory Data

- EMC : 3GPP 25113, EN 301 489-1, EN 301 489-23, GR 1089, GR 3108, OET-65
- Safety : IEC60950-1, EN 60825-1, UL, ANSI/NFPA 70, CAN/CSA-C22.2
- Regulatory : FCC Part 15 Class B, CE Mark – European Directive : 2002/95/EC (ROHS); 2002/96/EC (WEEE); 1999/5/EC (R&TTE)
- Health : EN 50385

www.alcatel-lucent.com Alcatel, Lucent, Alcatel-Lucent and the Alcatel-Lucent logo are trademarks of Alcatel-Lucent. All other trademarks are the property of their respective owners. The information presented is subject to change without notice. Alcatel-Lucent assumes no responsibility for inaccuracies contained herein.

Copyright © 2012 Alcatel-Lucent. All rights reserved. M2012XXXXXX (March)

.....Alcatel-Lucent



AT THE SPEED OF IDEAS™



**HYBRIFLEX™ RRH Hybrid Feeder Cabling Solution, 1-5/8", Single-Mode Fiber**

**Product Description**

RFS' HYBRIFLEX Remote Radio Head (RRH) hybrid feeder cabling solution combines optical fiber and DC power for RRHs in a single lightweight aluminum corrugated cable, making it the world's most innovative solution for RRH deployments.

It was developed to reduce installation complexity and costs at Cellular sites. HYBRIFLEX allows mobile operators deploying an RRH architecture to standardize the RRH installation process and eliminate the need for and cost of cable grounding. HYBRIFLEX combines optical fiber (multi-mode or single-mode) and power in a single corrugated cable. It eliminates the need for junction boxes and can connect multiple RRHs with a single feeder. Standard RFS CELLFLEX® accessories can be used with HYBRIFLEX cable. Both pre-connectorized and on-site options are available.

**Features/Benefits**

- Aluminum corrugated armor with outstanding bending characteristics - minimizes installation time and enables mechanical protection and shielding
- Same accessories as 1 5/8" coaxial cable
- Outer conductor grounding - Eliminates typical grounding requirements and saves on installation costs
- Lightweight solution and compact design - Decreases tower loading
- Robust cabling - Eliminates need for expensive cable trays and ducts
- Installation of tight bundled fiber optic cable pairs directly to the RRH - Reduces CAPEX and wind load by eliminating need for interconnection
- Optical fiber and power cables housed in single corrugated cable - Saves CAPEX by standardizing RRH cable installation and reducing installation requirements
- Outdoor polyethylene jacket - Ensures long-lasting cable protection

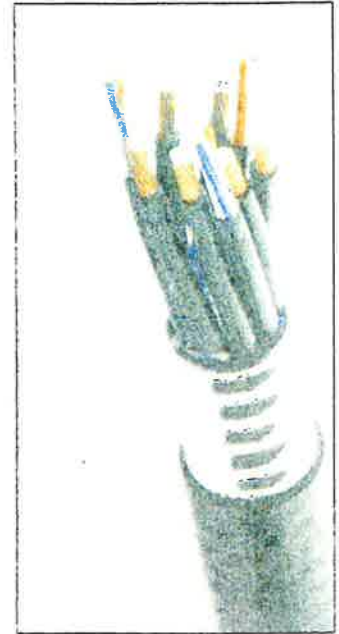

Figure 1: HYBRIFLEX Series

**Technical Specifications**

Outer Conductor Armor	Corrugated Aluminum	(mm (in.))	46.5 (1.83)
Jacket	Polyethylene, PE	(mm (in.))	50.3 (1.98)
UV-Protection	Individual and External Jacket		Yes
Weight, Approximate		(kg/m (lb/ft))	1.9 (1.30)
Minimum Bending Radius, Single Bending		(mm (in.))	200 (8)
Minimum Bending Radius, Repeated Bending		(mm (in.))	500 (20)
Recommended/Maximum Clamp Spacing		(m (ft))	1.0 / 1.2 (3.25 / 4.0)
DC-Resistance Outer Conductor Armor		(Ω/km (Ω/1000ft))	0.68 (0.205)
DC-Resistance Power Cable 8 4mm <sup>2</sup> (8AWG)		(Ω/km (Ω/1000ft))	2.1 (0.307)
Version			Single-mode OM3
Quantity, Fiber Count			16 (8 pairs)
Core/Clad		(μm)	50/125
Primary Coating (Acrylate)		(μm)	245
Buffer Diameter, Nominal		(μm)	900
Secondary Protection, Jacket, Nominal		(mm (in.))	2.0 (0.08)
Minimum Bending Radius		(mm (in.))	104 (4.1)
Insertion Loss @ wavelength 850nm		dB/km	3.0
Insertion Loss @ wavelength 1310nm		dB/km	1.0
Standards (Meets or exceeds)			UL34-V0, UL1666 RoHS Compliant
Size (Power)		(mm (AWG))	8.4 (8)
Quantity, Wire Count (Power)			16 (8 pairs)
Size (Alarm)		(mm (AWG))	0.8 (18)
Quantity, Wire Count (Alarm)			4 (2 pairs)
Type			UV protected
Strands			19
Primary Jacket Diameter, Nominal		(mm (in.))	6.8 (0.27)
Standards (Meets or exceeds)			NFPA 130, ICEA S-95-658 UL Type X-HW-2, UL 44 UL-LS Limited Smoke, UL YW-1 IEEE-383 (1974), IEEE1292/FT4 RoHS Compliant
Installation Temperature		(°C (°F))	-40 to +65 (-40 to 149)
Operation Temperature		(°C (°F))	-40 to +65 (-40 to 149)

\* This data is provisional and subject to change

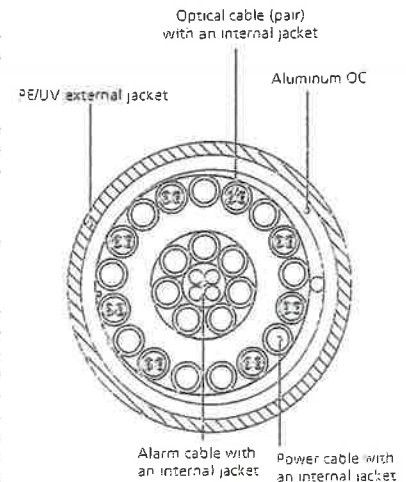

Figure 3: Construction Detail

All information contained in the present datasheet is subject to confirmation at time of ordering

# **ATTACHMENT 2**



# **ATTACHMENT 3**



FDH Engineering, Inc., 2730 Rowland Rd. Raleigh, NC 27615, Ph. 919.755.1012, Fax 919.755.1031

**Structural Analysis for  
SBA Network Services, Inc.**

**168' Monopole Tower**

**SBA Site Name: Pomfret School  
SBA Site ID: CT02217-S-00  
Verizon Site Name: Pomfret East**

FDH Project Number 146GSJ1400

**Analysis Results**

Tower Components	63.3%	Sufficient
Foundation	64.5%	Sufficient

Prepared By:

Colleen Brophy, EI  
Project Engineer

Reviewed By:

Bradley R. Newman, PE  
Senior Project Engineer  
CT PE License No. 29630

**FDH Engineering, Inc.**  
2730 Rowland Rd.  
Raleigh, NC 27615  
(919) 755-1012  
info@fdh-inc.com



November 14, 2014

*Prepared pursuant to TIA/EIA-222-F Structural Standards for Steel Antenna Towers and Antenna Supporting Structures and the 2005 Connecticut Building Code*

**TABLE OF CONTENTS**

EXECUTIVE SUMMARY ..... 3

    Conclusions..... 3

    Recommendation ..... 3

APPURTENANCE LISTING ..... 4

RESULTS ..... 5

GENERAL COMMENTS ..... 6

LIMITATIONS..... 6

APPENDIX ..... 7

## EXECUTIVE SUMMARY

At the request of SBA Network Services, Inc., FDH Engineering, Inc. performed a structural analysis of the monopole located in Pomfret, CT to determine whether the tower is structurally adequate to support both the existing and proposed loads pursuant to the *Structural Standards for Steel Antenna Towers and Antenna Supporting Structures, TIA/EIA-222-F and the 2005 Connecticut Building Code*. Information pertaining to the existing/proposed antenna loading, current tower geometry, foundation dimensions, and member sizes was obtained from:

- Paul J. Ford Structural Engineers (Job No. 29299-802) original design drawings dated November 24, 1999
- SBA Network Services, Inc.

The *basic design wind speed* per the *TIA/EIA-222-F standards and the 2005 Connecticut Building Code* is 85 mph without ice and 38 mph with 1-1/4" radial ice. Ice is considered to increase in thickness with height.

## Conclusions

With the existing and proposed antennas from Verizon in place at 157 ft, the tower meets the requirements of the *TIA/EIA-222-F standards and the 2005 Connecticut Building Code* provided the **Recommendations** listed below are satisfied. Furthermore, provided the foundations were designed and constructed per the original design reactions (see Paul J Ford Structural Engineers Job No. 29299-802), the foundations should have the necessary capacity to support the existing and proposed loading. For a more detailed description of the analysis of the tower, see the **Results** section of this report.

Our structural analysis has been performed assuming all information provided to FDH Engineering, Inc. is accurate (i.e., the steel data, tower layout, existing antenna loading, and proposed antenna loading) and that the tower has been properly erected and maintained per the original design drawings.

## Recommendations

To ensure the requirements of the *TIA/EIA-222-F standards and the 2005 Connecticut Building Code* are met with the existing and proposed loading in place, we have the following recommendations:

1. The proposed feed lines should be installed inside the monopole's shaft.
2. RRU/RRH Stipulation: The proposed equipment may be installed in any arrangement determined by the client.



**APPURTENANCE LISTING**

The proposed and existing antennas with their corresponding cables/coax lines are shown in **Table 1**. *If the actual layout determined in the field deviates from the layout, FDH Engineering, Inc. should be contacted to perform a revised analysis.*

**Table 1 - Appurtenance Loading**

**Existing Loading:**

Antenna Elevation (ft)	Description	Coax and Lines <sup>1</sup>	Carrier	Mount Elevation (ft)	Mount Type
167	(6) Lucent DB908H90E-M w/ Mount Pipe	(6) 1-5/8"	Sprint	167	(1) LP Platform mount
157	(3) Antel BXA-70063-6CF w/Mount Pipe (6) Antel LPA-80080/6CF W/Mount Pipe (3) BXA-171085-8BF w/ Mount Pipe (6) RFS FD9R6004/2C-3L Diplexer	(12) 1-5/8"	Verizon	157	(1) LP Platform mount
147	(6) EMS RR90-17-02DP w/Mount Pipe	(12) 1-5/8"	T-Mobile	147	(1) LP Platform mount

1. Coax installed inside of monopoles shaft unless noted otherwise

**Proposed Carrier Final Loading:**

Antenna Elevation (ft)	Description	Coax and Lines	Carrier	Mount Elevation (ft)	Mount Type
157	(6) Commscope HBXX-6517DS-VTM (6) Commscope LNX-6514DS-VTM (3) ALU RRH 2x40-700U (3) ALU RRH 2x60-AWS (1) RFS DB-T1-6Z-8AB-0Z	(12) 1-5/8" (1) 1-5/8" Hybriflex	Verizon	157	(1) LP Platform mount

## RESULTS

The following yield strength of steel for individual members was used for analysis:

**Table 2 - Material Strength**

Member Type	Yield Strength
Tower Shaft Sections	65 ksi
Base Plate	50 ksi
Anchor Bolts	75 ksi

**Table 3** displays the summary of the ratio (as a percentage) of force in the member to their capacities. Values greater than 100% indicate locations where the maximum force in the member exceeds its capacity. *Note: Capacities up to 100% are considered acceptable.* **Table 4** displays the maximum foundation reactions.

If the assumptions outlined in this report differ from actual field conditions, FDH Engineering, Inc. should be contacted to perform a revised analysis. Furthermore, as no information pertaining to the allowable twist and sway requirements for the existing or proposed appurtenances was provided, deflection and rotation were not taken into consideration when performing this analysis.

See the **Appendix** for detailed modeling information

**Table 3 - Summary of Working Percentage of Structural Components**

Section No.	Elevation ft	Component Type	Size	% Capacity	Pass Fail
L1	168 - 123.25	Pole	TP33.846x24x0.25	47.8	Pass
L2	123.25 - 82.5	Pole	TP42.313x32.4109x0.3125	62.6	Pass
L3	82.5 - 42.75	Pole	TP50.434x40.5328x0.375	63.3	Pass
L4	42.75 - 0	Pole	TP59.09x48.3088x0.4375	60.9	Pass
		Anchor Bolts	(20) 2.25" Ø x 66" BC	56.1	Pass
		Base Plate	65" Sq.x 3" tk PL.	53.4	Pass

\*Capacities include 1/3 allowable increase for wind.

**Table 4 - Maximum Base Reactions**

Base Reactions	Current Analysis* (TIA/EIA-222-F)	Original Design (TIA/EIA-222-F)
Axial	41 k	38 k
Shear	26 k	38 k
Moment	3,063 k-ft	4,750 k-ft

\* Per our experience with foundations of similar type, the axial loading should not control the foundation analysis

## **GENERAL COMMENTS**

This engineering analysis is based upon the theoretical capacity of the structure. It is not a condition assessment of the tower and its foundation. It is the responsibility of SBA Network Services, Inc. to verify that the tower modeled and analyzed is the correct structure (with accurate antenna loading information) modeled. If there are substantial modifications to be made or the assumptions made in this analysis are not accurate, FDH Engineering, Inc. should be notified immediately to perform a revised analysis.

## **LIMITATIONS**

All opinions and conclusions are considered accurate to a reasonable degree of engineering certainty based upon the evidence available at the time of this report. All opinions and conclusions are subject to revision based upon receipt of new or additional/updated information. All services are provided exercising a level of care and diligence equivalent to the standard and care of our profession. No other warranty or guarantee, expressed or implied, is offered. Our services are confidential in nature and we will not release this report to any other party without the client's consent. The use of this engineering work is limited to the express purpose for which it was commissioned and it may not be reused, copied, or distributed for any other purpose without the written consent of FDH Engineering, Inc.

## APPENDIX

Section	1	2	3	4
Length (ft)	44.75	45.00	45.00	49.00
Number of Sides	18	18	18	18
Thickness (in)	0.2500	0.3125	0.3750	0.4375
Socket Length (ft)	4.25	5.25	6.25	48.3088
Top Dia (in)	24.0000	32.4109	40.5328	59.0900
Bot Dia (in)	33.8460	42.3130	50.4340	
Grade			A572-65	
Weight (K)	3.5	5.6	8.2	12.3

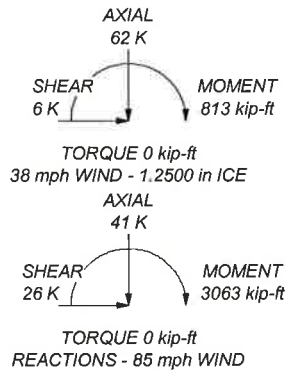
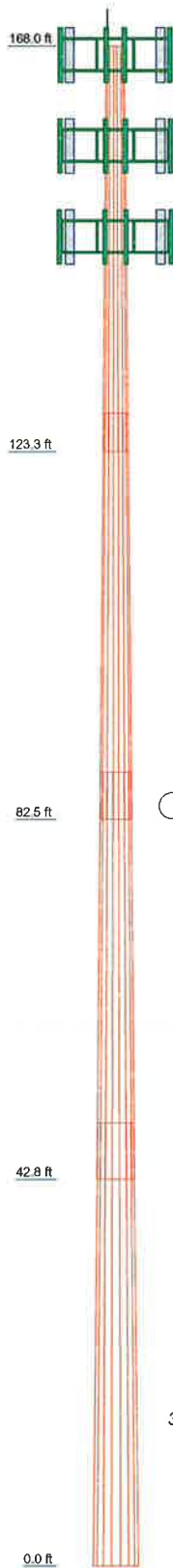

### DESIGNED APPURTENANCE LOADING

TYPE	ELEVATION	TYPE	ELEVATION
Lightning Rod 5/8x4'	168	(2) LNX-6514DS-VTM w/ Mount Pipe	157
(1) Low Profile Platform	167	(2) LNX-6514DS-VTM w/ Mount Pipe	157
(2) Lucent DB908H90E-M W/ Mount Pipe	167	(2) LNX-6514DS-VTM w/ Mount Pipe	157
(2) Lucent DB908H90E-M W/ Mount Pipe	167	RRH2x40-80W-700	157
(2) Lucent DB908H90E-M W/ Mount Pipe	167	RRH2x40-80W-700	157
(2) Lucent DB908H90E-M W/ Mount Pipe	167	RRH2x40-80W-700	157
Pipe Mount	167	RRH2X60-AWS BAND 4	157
Pipe Mount	167	RRH2X60-AWS BAND 4	157
Pipe Mount	167	RRH2X60-AWS BAND 4	157
(1) Low Profile Platform	157	DB-T1-6Z-6AB-0Z	157
(2) HBXX-6517DS-VTM w/ Mount Pipe	157	(2) RR90-17-02DP w/Mount Pipe	147
(2) HBXX-6517DS-VTM w/ Mount Pipe	157	(2) RR90-17-02DP w/Mount Pipe	147
(2) HBXX-6517DS-VTM w/ Mount Pipe	157	(1) Low Profile Platform	147
(2) HBXX-6517DS-VTM w/ Mount Pipe	157	(2) RR90-17-02DP w/Mount Pipe	147

### MATERIAL STRENGTH

GRADE	Fy	Fu	GRADE	Fy	Fu
A572-65	65 ksi	80 ksi			

### TOWER DESIGN NOTES

1. Tower is located in Windham County, Connecticut.
2. Tower designed for a 85 mph basic wind in accordance with the TIA/EIA-222-F Standard.
3. Tower is also designed for a 38 mph basic wind with 1.25 in ice. Ice is considered to increase in thickness with height.
4. Deflections are based upon a 50 mph wind.
5. TOWER RATING: 63.3%

 <b>FDH Engineering, Inc.</b> 6521 Meriden Drive, Suite 107 Raleigh, North Carolina 27616 Phone: 9197551012 FAX: 9197551031 Tower Analysis	<b>Job:</b> Pomfret School, CT02217-S-00 <b>Project:</b> 146GSJ1400	
	<b>Client:</b> SBA <b>Code:</b> TIA/EIA-222-F	<b>Drawn by:</b> CBrophy <b>Date:</b> 11/14/14
	<b>App'd:</b> <b>Scale:</b> NTS	<b>Dwg No:</b> E-1
	<b>Path:</b>	