

October 23, 2015

Members of the Siting Council
Connecticut Siting Council
Ten Franklin Square
New Britain, CT 06051

RE: Notice of Exempt Modification
62 Babbit Hill Rd.,
Pomfret, CT 06259
N 41.87042
W -71.98829
T-Mobile Site #: CT11524A_L700

Members of the Siting Council:

On behalf of T-Mobile, SBA Communications is submitting an exempt modification application to the Connecticut Siting council for modification of existing equipment at a tower facility located at 62 Babbit Hill Rd, Pomfret, CT.

The 62 Babbit Hill Rd facility consists of a 168' Monopole Tower owned and operated by SBA Towers, LLC. In order to accommodate technological changes and enhance system performance in the State of Connecticut, T-Mobile plans to modify the equipment configurations at many of its existing cell sites. Please accept this letter and attachments as notification, pursuant to R.C.S.A. Section 16-50j-73, of construction which constitutes an exempt modification pursuant to R.C.S.A. Section 16-50j-72(b)(2). In compliance with R.C.S.A. Section 16-50j-73, a copy of this letter and attachments is being sent to the chief elected official of the municipality in which the affected cell site is located, First Selectman Maureen Nicholson, as well as the property owners, Joseph and Celile Stoddard.

As part of T-Mobile's L700 project, T-Mobile desires to upgrade their equipment to meet the new standards of 4G technology. The new equipment will allow customers to download files and browse the internet at a high rate of speed while also allowing their phones to be compatible with the latest 4G technology.

Attached is a summary of the planned modifications, including power density calculations reflecting the change in T-Mobile's operations at the site along with the required fee of \$625.

The changes to the facility do not constitute modifications as defined in Connecticut General Statutes ("C.G.S.") Section 16-50i(d) because the general physical characteristics of the facility will not be significantly changed or altered. Rather, the planned changes to the facility fall squarely within those activities explicitly provided for in R.C.S.A. Section 16-50j-72(b)(2).

1. The overall height of the structure will be unaffected.
2. The proposed changes will not extend the site boundaries. There will be no effect on the site compound other than the new equipment cabinet.
3. The proposed changes will not increase the noise level at the existing facility by six decibels or more.
4. The changes in radio frequency power density will not increase the calculated "worst case" power density for the combined operations at the site to a level at or above the applicable standard for uncontrolled environments as calculated for a mixed frequency site.

For the foregoing reasons, SBA Communications on behalf of T-Mobile, respectfully submits that the proposed changes at the referenced site constitute exempt modifications under R.C.S.A. Section 16-50j-72(b)(2).

Please feel free to call me at 508.251.0720 x 3804 with any questions you may have concerning this matter.

Thank you,



Kri Pelletier
SBA Communications Corporation
33 Boston Post Road West Suite 320
Marlborough, MA 01752
508-251-0720 x 3804 + T
508-251-1755 + F
203-446-7700 + C
kpelletier@sbsite.com



T-Mobile

Equipment Modification

62 Babbit Hill Rd, Pomfret, CT 06259
Site number CT11524A_L700

Tower Owner: SBA Towers, LLC

Equipment Configuration: Monopole

Current and/or approved:

- (6) EMS - RR90-17-02DP - Panel
- (6) Allen Telecom - FE15501P77/75 - TMA
- (12) 1-5/8" lines

Final Configuration:

- (3) Kathrein - 782 11056 - Bias T's
- (3) RFS - APXV18-206516S-C-A20 - Panel
- (3) Commscope - LNX-6515DS-VTM - Panel
- (3) Allen Telecom - FE15501P77/75 - TMA
- (3) Ericsson - KRY 112 144/1 - TMA
- (12) 1-5/8" lines

Structural Information:

The attached structural analysis demonstrates that the tower and foundation will have adequate structural capacity to accommodate the proposed modifications.

Power Density:

The anticipated Maximum Composite contributions from the T-Mobile facility are 1.75% of the allowable FCC established general public limit. The anticipated composite MPE value for this site assuming all carriers present is 3.86% of the allowable FCC established general public limit sampled at the ground level.

Site Composite MPE%	
Carrier	MPE%
T-Mobile (Per Sector Max)	1.75 %
Nextel	0.20 %
Sprint	0.27 %
AT&T	1.64 %
Site Total MPE %:	3.86 %

October 23, 2015

Maureen Nicholson
First Selectman
Town of Pomfret
5 Haven Road
Pomfret Center, CT 06259

RE: Telecommunications Facility @ 62 Babbit Hill Rd., Pomfret, CT

Dear Ms. Nicholson,

In order to accommodate technological changes and enhance system performance in the State of Connecticut, T-Mobile will be changing its equipment configuration at certain cell sites.

As required by Regulations of Connecticut State Agencies (R.C.S.A.) Section 16-50j-73, the Connecticut Siting Council has been notified of the changes and will review T-Mobile's proposal. Please accept this letter as notification under Section 16-50j-73 of construction which constitutes an exempt modification pursuant to R.C.S.A. Section 16-50j-72(b)(2).

The accompanying letter to the Siting Council fully describes T-Mobile's proposal for the referenced cell site. However, if you have any questions or require any further information on our plans or the Siting Council's procedures, please call me at 508.251.0720 x 3804.

Thank you,



Kri Pelletier
SBA Communications Company
33 Boston Post Road West Suite 320
Marlborough, MA 01752
508-251-0720 x 3804 + T
508-251-1755 + F
203-446-7700 + C
kpelletier@sbsite.com

October 23, 2015

Joseph & Cecile Stoddard
62 Babbitt Hill Road
Pomfret CT 06259

RE: Telecommunications Facility @ 62 Babbit Hill Rd., Pomfret, CT

Dear Mr. and Mrs. Stoddard:

In order to accommodate technological changes and enhance system performance in the State of Connecticut, T-Mobile will be changing its equipment configuration at certain cell sites.

As required by Regulations of Connecticut State Agencies (R.C.S.A.) Section 16-50j-73, the Connecticut Siting Council has been notified of the changes and will review T-Mobile's proposal. Please accept this letter as notification under Section 16-50j-73 of construction which constitutes an exempt modification pursuant to R.C.S.A. Section 16-50j-72(b)(2).

The accompanying letter to the Siting Council fully describes T-Mobile's proposal for the referenced cell site. However, if you have any questions or require any further information on our plans or the Siting Council's procedures, please call me at 508.251.0720 x 3804.

Thank you,



Kri Pelletier
SBA Communications Company
33 Boston Post Road West Suite 320
Marlborough, MA 01752
508-251-0720 x 3804 + T
508-251-1755 + F
203-446-7700 + C
kpelletier@sbsite.com

RADIO FREQUENCY EMISSIONS ANALYSIS REPORT
EVALUATION OF HUMAN EXPOSURE POTENTIAL
TO NON-IONIZING EMISSIONS

T-Mobile Existing Facility

Site ID: CT11524A

CT524 / SBA Pomfret
62 Babbit Hill Road
Pomfret, CT 06259

October 22, 2015

EBI Project Number: 6215005333

Site Compliance Summary	
Compliance Status:	COMPLIANT
Site total MPE% of FCC general public allowable limit:	3.86 %

October 22, 2015

T-Mobile USA
Attn: Jason Overbey, RF Manager
35 Griffin Road South
Bloomfield, CT 06002

Emissions Analysis for Site: **CT11524A – CT524 / SBA Pomfret**

EBI Consulting was directed to analyze the proposed T-Mobile facility located at **62 Babbit Hill Road, Pomfret, CT**, for the purpose of determining whether the emissions from the Proposed T-Mobile Antenna Installation located on this property are within specified federal limits.

All information used in this report was analyzed as a percentage of current Maximum Permissible Exposure (% MPE) as listed in the FCC OET Bulletin 65 Edition 97-01 and ANSI/IEEE Std C95.1. The FCC regulates Maximum Permissible Exposure in units of microwatts per square centimeter ($\mu\text{W}/\text{cm}^2$). The number of $\mu\text{W}/\text{cm}^2$ calculated at each sample point is called the power density. The exposure limit for power density varies depending upon the frequencies being utilized. Wireless Carriers and Paging Services use different frequency bands each with different exposure limits, therefore it is necessary to report results and limits in terms of percent MPE rather than power density.

All results were compared to the FCC (Federal Communications Commission) radio frequency exposure rules, 47 CFR 1.1307(b)(1) – (b)(3), to determine compliance with the Maximum Permissible Exposure (MPE) limits for General Population/Uncontrolled environments as defined below.

General population/uncontrolled exposure limits apply to situations in which the general public may be exposed or in which persons who are exposed as a consequence of their employment may not be made fully aware of the potential for exposure or cannot exercise control over their exposure. Therefore, members of the general public would always be considered under this category when exposure is not employment related, for example, in the case of a telecommunications tower that exposes persons in a nearby residential area.

Public exposure to radio frequencies is regulated and enforced in units of microwatts per square centimeter ($\mu\text{W}/\text{cm}^2$). The general population exposure limit for the 700 MHz Band is approximately 467 $\mu\text{W}/\text{cm}^2$, and the general population exposure limit for the 1900 MHz (PCS) band is 1000 $\mu\text{W}/\text{cm}^2$. Because each carrier will be using different frequency bands, and each frequency band has different exposure limits, it is necessary to report percent of MPE rather than power density.

Occupational/controlled exposure limits apply to situations in which persons are exposed as a consequence of their employment and in which those persons who are exposed have been made fully aware of the potential for exposure and can exercise control over their exposure. Occupational/controlled exposure limits also apply where exposure is of a transient nature as a result of incidental passage through a location where exposure levels may be above general population/uncontrolled limits (see below), as long as the exposed person has been made fully aware of the potential for exposure and can exercise control over his or her exposure by leaving the area or by some other appropriate means.

Additional details can be found in FCC OET 65.

CALCULATIONS

Calculations were done for the proposed T-Mobile Wireless antenna facility located at **62 Babbit Hill Road, Pomfret, CT**, using the equipment information listed below. All calculations were performed per the specifications under FCC OET 65. Since T-Mobile is proposing highly focused directional panel antennas, which project most of the emitted energy out toward the horizon, all calculations were performed assuming a lobe representing the maximum gain of the antenna per the antenna manufactures supplied specifications, minus 10 dB, was focused at the base of the tower. For this report the sample point is the top of a 6 foot person standing at the base of the tower.

For all calculations, all equipment was calculated using the following assumptions:

- 1) 2 GSM channels (PCS Band - 1900 MHz) were considered for each sector of the proposed installation. These Channels have a transmit power of 30 Watts per Channel
- 2) 2 UMTS channels (PCS Band - 1900 MHz) were considered for each sector of the proposed installation. These Channels have a transmit power of 30 Watts per Channel.
- 3) 2 LTE channels (PCS Band - 1900 MHz) were considered for each sector of the proposed installation. These Channels have a transmit power of 60 Watts per Channel.
- 4) 1 LTE channel (700 MHz Band) was considered for each sector of the proposed installation. This channel has a transmit power of 30 Watts.
- 5) Since the radios are ground mounted there are additional cabling losses accounted for. For each RF path the following losses were calculated. 0.95 dB of additional cable loss at 700 MHz and 1.96 dB of additional cable loss at 1900 MHz. This is based on manufacturers Specifications for 170 feet of 1-5/8" coax cable on each path.

- 6) All radios at the proposed installation were considered to be running at full power and were uncombined in their RF transmissions paths per carrier prescribed configuration. Per FCC OET Bulletin No. 65 - Edition 97-01 recommendations to achieve the maximum anticipated value at each sample point, all power levels emitting from the proposed antenna installation are increased by a factor of 2.56 to account for possible in-phase reflections from the surrounding environment. This is rarely the case, and if so, is never continuous.
- 7) For the following calculations the sample point was the top of a six foot person standing at the base of the tower. The maximum gain of the antenna per the antenna manufactures supplied specifications minus 10 dB was used in this direction. This value is a very conservative estimate as gain reductions for these particular antennas are typically much higher in this direction.
- 8) The antennas used in this modeling are the **RFS APXV18-206516S-C-A20** for 1900 MHz (PCS) channels and the **Commscope LNX-6515DS-VTM** for 700 MHz channels. This is based on feedback from the carrier with regards to anticipated antenna selection. The **RFS APXV18-206516S-C-A20** has a maximum gain of **16.3 dBd** at their main lobe. The **Commscope LNX-6515DS-VTM** has a maximum gain of **14.6 dBd** at its main lobe. The maximum gain of the antenna per the antenna manufactures supplied specifications, minus 10 dB, was used for all calculations. This value is a very conservative estimate as gain reductions for these particular antennas are typically much higher in this direction.
- 9) The antenna mounting height centerline of the proposed antennas is **137 feet** above ground level (AGL).
- 10) Emissions values for additional carriers were taken from the Connecticut Siting Council active database. Values in this database are provided by the individual carriers themselves.

All calculations were done with respect to uncontrolled / general public threshold limits.

T-Mobile Site Inventory and Power Data

Sector:	A	Sector:	B	Sector:	C
Antenna #:	1	Antenna #:	1	Antenna #:	1
Make / Model:	RFS APXV18-206516S-C-A20	Make / Model:	RFS APXV18-206516S-C-A20	Make / Model:	RFS APXV18-206516S-C-A20
Gain:	16.3 dBd	Gain:	16.3 dBd	Gain:	16.3 dBd
Height (AGL):	137	Height (AGL):	137	Height (AGL):	137
Frequency Bands	1900 MHz(PCS) / 2100 MHz (AWS)	Frequency Bands	1900 MHz(PCS) / 2100 MHz (AWS)	Frequency Bands	1900 MHz(PCS) / 2100 MHz (AWS)
Channel Count	8	Channel Count	8	# PCS Channels:	8
Total TX Power:	240	Total TX Power:	240	# AWS Channels:	240
ERP (W):	6,842.44	ERP (W):	6,842.44	ERP (W):	6,842.44
Antenna A1 MPE%	1.43	Antenna B1 MPE%	1.43	Antenna C1 MPE%	1.43
Antenna #:	2	Antenna #:	2	Antenna #:	2
Make / Model:	Commscope LNX-6515DS-VTM	Make / Model:	Commscope LNX-6515DS-VTM	Make / Model:	Commscope LNX-6515DS-VTM
Gain:	14.6 dBd	Gain:	14.6 dBd	Gain:	14.6 dBd
Height (AGL):	137	Height (AGL):	137	Height (AGL):	137
Frequency Bands	700 MHz	Frequency Bands	700 MHz	Frequency Bands	700 MHz
Channel Count	1	Channel Count	1	Channel Count	1
Total TX Power:	30	Total TX Power:	30	Total TX Power:	30
ERP (W):	695.22	ERP (W):	695.22	ERP (W):	695.22
Antenna A2 MPE%	0.31	Antenna B2 MPE%	0.31	Antenna C2 MPE%	0.31

Site Composite MPE%	
Carrier	MPE%
T-Mobile (Per Sector Max)	1.75 %
Nextel	0.20 %
Sprint	0.27 %
AT&T	1.64 %
Site Total MPE %:	3.86 %

T-Mobile Sector 1 Total:	1.75 %
T-Mobile Sector 2 Total:	1.75 %
T-Mobile Sector 3 Total:	1.75 %
Site Total:	3.86 %

T-Mobile_per sector	# Channels	Watts ERP (Per Channel)	Height (feet)	Total Power Density ($\mu\text{W}/\text{cm}^2$)	Frequency (MHz)	Allowable MPE ($\mu\text{W}/\text{cm}^2$)	Calculated % MPE
T-Mobile 1900 MHz (PCS) LTE	2	1710.06	137	7.17	2100	1000	0.72 %
T-Mobile 1900 MHz (PCS) GSM	2	855.31	137	3.58	1900	1000	0.36 %
T-Mobile 1900 MHz (PCS) UMTS	2	855.31	137	3.58	2100	1000	0.36 %
T-Mobile 700 MHz LTE	1	695.22	137	0.31	700	467	0.31 %
						Total:	1.75%

Summary

All calculations performed for this analysis yielded results that were **within** the allowable limits for general public exposure to RF Emissions.

The anticipated maximum composite contributions from the T-Mobile facility as well as the site composite emissions value with regards to compliance with FCC's allowable limits for general public exposure to RF Emissions are shown here:

T-Mobile Sector	Power Density Value (%)
Sector 1:	1.75 %
Sector 2:	1.75 %
Sector 3 :	1.75 %
T-Mobile Per Sector Maximum:	1.75 %
Site Total:	3.86 %
Site Compliance Status:	COMPLIANT

The anticipated composite MPE value for this site assuming all carriers present is **3.86%** of the allowable FCC established general public limit sampled at the ground level. This is based upon values listed in the Connecticut Siting Council database for existing carrier emissions.

FCC guidelines state that if a site is found to be out of compliance (over allowable thresholds), that carriers over a 5% contribution to the composite value will require measures to bring the site into compliance. For this facility, the composite values calculated were well within the allowable 100% threshold standard per the federal government.



Scott Heffernan
RF Engineering Director

EBI Consulting
21 B Street
Burlington, MA 01803



Tower Engineering Solutions

Phone (972) 483-0607, Fax (972) 975-9615
8445 Freeport Parkway, Suite 375, Irving, Texas 75063

Structural Analysis Report

Existing 168 ft. SUMMIT Monopole
Customer Name: SBA Communications Corp
Customer Site Number: CT01364-S
Customer Site Name: Pomfret
Carrier Name: T-Mobile
Carrier Site Number: CT11524A
Carrier Site Name: N/A
Site Location: 62 Babbitt Hill Road
Pomfret, Connecticut
Windham County
Latitude: 41.870258
Longitude: -71.988241

Analysis Result:

Max Structural Usage: 64.0% [Pass]

Max Foundation Usage: 67% [Pass]

Report Prepared By : Stacey Hesselbein



Introduction

The purpose of this report is to summarize the analysis results on the 168 ft. SUMMIT Monopole to support the proposed antennas and transmission lines in addition to those currently installed. Any modification listed under Sources of Information was assumed completed and was included in this analysis.

Sources of Information

Tower Drawings	Tower Drawings prepared by Paul J. Ford and Company, Job # 4728 Dated 04/30/1999
Foundation Drawing	Dispersive Wave Propagation Testing and Rebar Investigation prepared by FDH Engineering, Project #1207133EN1 Dated 08/17/2012
Geotechnical Report	Geotechnical Report prepared by Jaworski Geotech Inc., Project # 99261G Dated 05/21/1999
Modification Drawings	N/A

Analysis Criteria

The rigorous analysis was performed in accordance with the requirements and stipulations of the ANSI/TIA/EIA 222-F. In accordance with this standard, the structure was analyzed using **TESPoles**, a proprietary analysis software. The program considers the structure as an elastic 3-D model with second-order effects and temperature effects incorporated in the analysis. The analysis was performed using multiple wind directions.

Basic Wind Speed Used in the Analysis:	85.0 mph (fastest mile)
Basic Wind Speed with Ice:	74 mph (fastest mile) with 1/2" radial ice concurrent
Operational Wind Speed:	50 mph + 0" Radial ice
Standard/Codes:	ANSI/TIA/EIA 222-F / 2005 Connecticut State Building Code
Exposure Category:	C
Crest Height:	0 ft.

Existing Antennas, Mounts and Transmission Lines

The table below summarizes the antennas, mounts and transmission lines that were considered in the analysis as existing on the tower.

Items	Elevation (ft.)	Qty.	Antenna Descriptions	Mount Type & Qty.	Transmission Lines	Owner
-	167.0	-	Vacant	(1)Low Profile Platform	-	-
1	157.0	6	Decibel - DB980H90E-M - Panel	(1)Low Profile Platform	(6) 1 5/8"	Sprint
2	147.0	6	Powerwave - 7770.00 - Panel	(1)Low Profile Platform	(12) 1 5/8" (2) 3/4" DC (1) 7/16" Fiber	New Cingular
3		3	KMW - AM-X-CD-17-65-00T - Panel			
4		6	Powerwave - LGP21401 - TMA			
5		6	ADC - CG-1900W800 - TMA			
6		6	Ericsson - RRUS 11 - RRU			
7		6	Powerwave - LGP21903 - Diplexer			
8		1	Raycap - DC2-48-60-18-8F - SP			
9		3	CSS - Dual Combiner			
11	137.0	6	EMS - RR90-17-02DP - Panel	(1)Low Profile Platform	(12) 1 5/8"	T-Mobile
14		6	Allen Telecom - FE15501P77/75 - TMA			

Proposed Carrier's Final Configuration of Antennas, Mounts and Transmission Lines

Information pertaining to the proposed carrier's final configuration of antennas and transmission lines was provided by SBA Communications Corp. The proposed antennas and lines are listed below.

Items	Elevation (ft.)	Qty.	Antenna Descriptions	Mount Type & Qty.	Transmission Lines	Owner
10	137.5	3	Kathrein - 782 11056 - Bias T's	(1)Low Profile Platform w/Site Pro P/N PRK-1245	(12) 1 5/8"	T-Mobile
12	137.0	3	RFS - APXV18-206516S-C-A20 - Panel			
13		3	Commscope - LNX-6515DS-VTM - Panel			
14		3	Allen Telecom - FE15501P77/75 - TMA			
15		3	Ericsson - KRY 112 144/1 - TMA			

All transmission lines are considered running inside of the pole shafts.

Analysis Results

The results of the structural analysis, performed for the wind and ice loading and antenna equipment as defined above, are summarized as the following:

	Pole shafts	Anchor Bolts	Base Plate
Max. Usage:	64.0%	57.6%	52.6%
Pass/Fail	Pass	Pass	Pass

Foundations

	Moment (Kip-Ft)	Shear (Kips)	Axial (Kips)
Original Design Reactions	4615.0	37.0	34.0
Analysis Reactions	2931.6	25.5	41.5

The foundation has been investigated using the supplied documents and soils report and was found adequate. Therefore, no modification to the foundation will be required.

Operational Condition (Rigidity):

Operational characteristics of the tower are found to be within the limits prescribed by ANSI/TIA/EIA 222-F for the installed antennas. Maximum twist/sway at the elevation of the proposed equipment is 1.3078 degrees under the operational wind speed as specified in the Analysis Criteria.

Conclusions

Based on the analysis results, the existing structure and its foundation were found to be adequate to safely support the existing and proposed equipment and meet the minimum requirements per the ANSI/TIA/EIA 222-F Standard under the design basic wind speed as specified in the Analysis Criteria.

Standard Conditions

1. This analysis was performed based on the information supplied to **(TES) Tower Engineering Solutions, LLC**. Verification of the information provided was not included in the Scope of Work for **TES**. The accuracy of the analysis is dependent on the accuracy of the information provided.
2. The analysis is based on the presumption that the tower members and components along with any existing reinforcement items have been correctly and properly designed, manufactured, installed and maintained.
3. All the existing structural members were assumed to be in good condition with no physical damage or deterioration associated with corrosion.
4. An initial tension of 10% of the break strength on all the existing guy wires was assumed in all the structural analyses of guyed towers unless different values were provided by the client. **TES** cannot take responsibility for the deviations in the analysis results because of differences in the initial tension forces of the existing guy wires.
5. Secondary component or connection secondary components, welds and bolts are assumed to be able to carry their intended original design loads. **TES** cannot take responsibility for verification of the adequacy on the connections, bolts and welds present in the structure.
6. The analyses will be performed based on the codes as specified by the client or based on the best knowledge of the engineering staff of **TES**. In the absence of information to the contrary, all work will be performed in accordance with the latest relevant revision of ANSI/TIA-222. If wind speed or/and ice loads are different from the minimum values recommended by the EIA/TIA-222 standard or other codes, **TES** should be notified in writing and the applicable minimum values provided by the client.
7. The configuration of the existing mounts, antennas, coax and other appurtenances were supplied by the customer for the current structural analysis. **TES** has not visited the tower site to verify the adequacy of the information provided. If there is any discrepancy found in the report regarding the existing conditions, **TES** should be notified immediately to evaluate the effect of the discrepancy on the analysis results.
8. The client will assume responsibility for rework associated with the differences in initially provided information, including tower and foundation information, existing and/or proposed equipment and transmission lines.
9. If a feasibility analysis was performed, final acceptance of changed conditions shall be based upon a rigorous structural analysis.

Usage Diagram - Max Stress 64.0% at 0.0ft

Structure: CT01364-S-SBA
Site Name: Pomfret
Height: 168.00 (ft)
Base Elev: 0.000 (ft)

Code: EIA/TIA-222-F
Exposure: C
Gh: 1.69

10/14/2015
 Page: 1



Dead Load Factor: 1.00
Wind Load Factor: 1.00

Load Case : 85 mph Wind with 0 in Ice

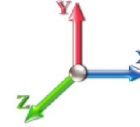

Iterations: 25

52 Allowable Stress
33 Resulting Stress

Copyright © 2015 by Tower Engineering Solutions, LLC. All rights reserved.

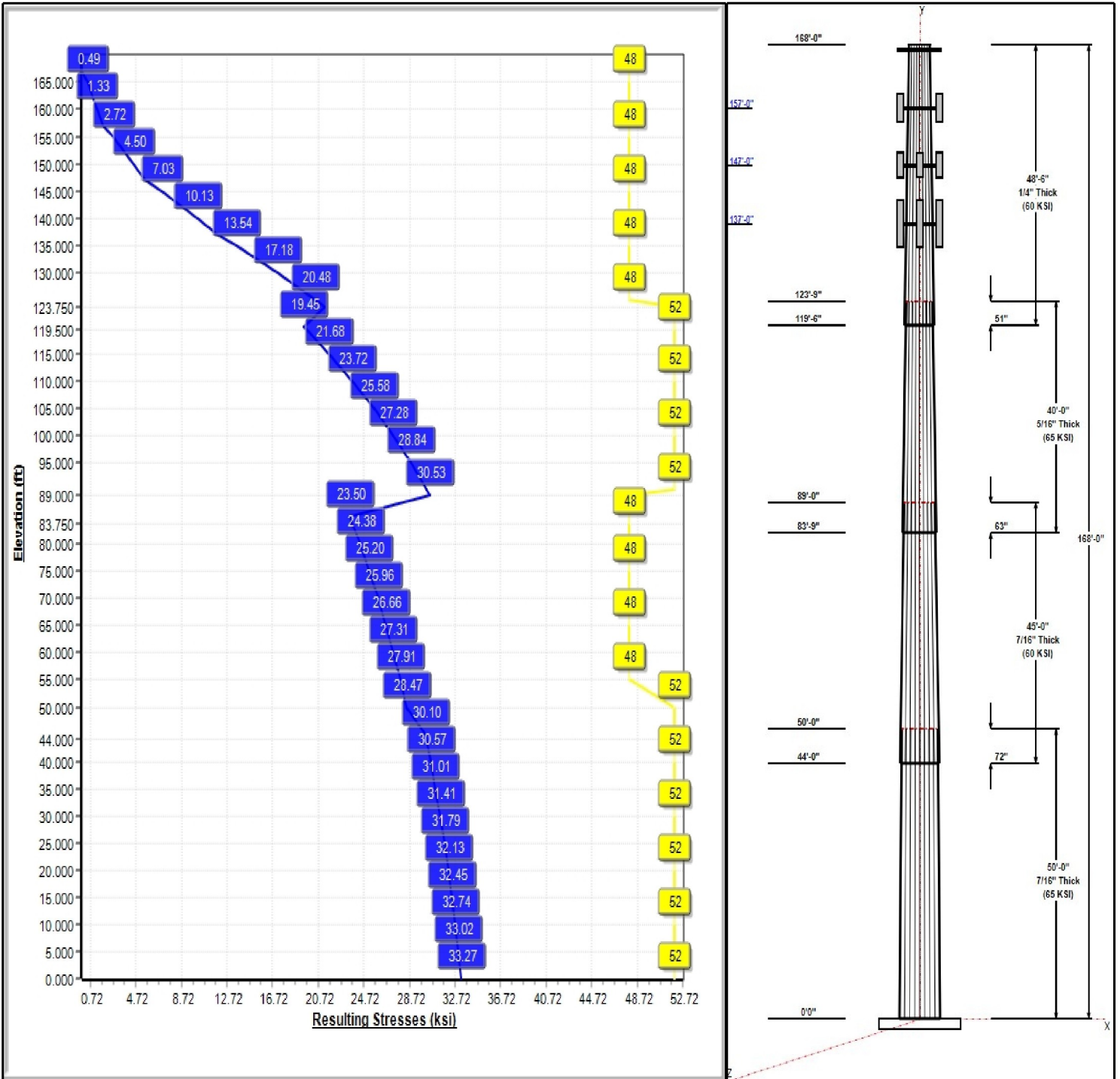

Structure: CT01364-S-SBA

Type: Tapered
Site Name: Pomfret
Height: 168.00 (ft)
Base Elev: 0.00 (ft)

Base Shape: 18 Sided
Taper: 0.20500

10/14/2015



Page: 2

Shaft Properties

Seq	Length (ft)	Top (in)	Bottom (in)	Thick (in)	Joint Type	Taper	Grade (ksi)
1	50.00	46.19	56.44	0.438		0.20500	65
2	45.00	39.07	48.30	0.438	Slip	0.20500	60
3	40.00	32.57	40.77	0.313	Slip	0.20500	65
4	48.50	24.00	33.94	0.250	Slip	0.20500	60

Discrete Appurtenances

Attach Elev (ft)	Force Elev (ft)	Qty	Description	Carrier
168.00	168.00	1	6' Lightning rod	T-Mobile
167.00	167.00	1	Low Profile Platform-flat	Nextel
157.00	157.00	6	DB980H90E-M	Sprint
157.00	157.00	1	Low Profile Platform-flat	Sprint
147.00	147.00	6	7770.00	New Cingular
147.00	147.00	3	AM-X-CD-17-65-00T-RET	New Cingular
147.00	147.00	6	CG-1900W800	New Cingular
147.00	147.00	1	DC2-48-60-18-8F	New Cingular
147.00	147.00	3	Dual Combiner	New Cingular
147.00	147.00	6	LGP21401	New Cingular
147.00	147.00	6	LGP21903	New Cingular
147.00	147.00	1	Low Profile	New Cingular
147.00	147.00	6	RRUS 11	New Cingular
137.50	137.50	3	782 11056	T-Mobile
137.00	137.00	3	APXV18-206516S-C-A20	T-Mobile
137.00	137.00	3	FE15501P77/75	T-Mobile
137.00	137.00	3	KRY 112 144/1	T-Mobile
137.00	137.00	3	LNx-6515DS-VTM	T-Mobile
137.00	137.00	1	Low Profile Platform w/	T-Mobile

Linear Appurtenances

Elev From (ft)	Elev To (ft)	Placement	Description	Carrier
0.00	157.00	Inside	1 5/8" Coax	Sprint
0.00	147.00	Inside	1 5/8" Coax	New Cingular
0.00	147.00	Inside	3/4" DC	New Cingular
0.00	147.00	Inside	7/16" Fiber	New Cingular
0.00	137.00	Inside	1 5/8" Coax	T-Mobile

Anchor Bolts

Qty	Specifications	Grade (ksi)	Arrangement
20	2.25" 18J	75.0	Cluster

Base Plate

Thickness (in)	Specifications (in)	Grade (ksi)	Geometry
3.2500	64.0	50.0	Clipped

Reactions

Load Case	Moment	Shear	Axial
85 mph Wind with 0" Ice	2931.6	25.5	41.5
73.61 mph Wind with 0.5" Ice	2411.0	20.5	47.4
50 mph Wind with 0" Ice	1014.9	8.8	41.5

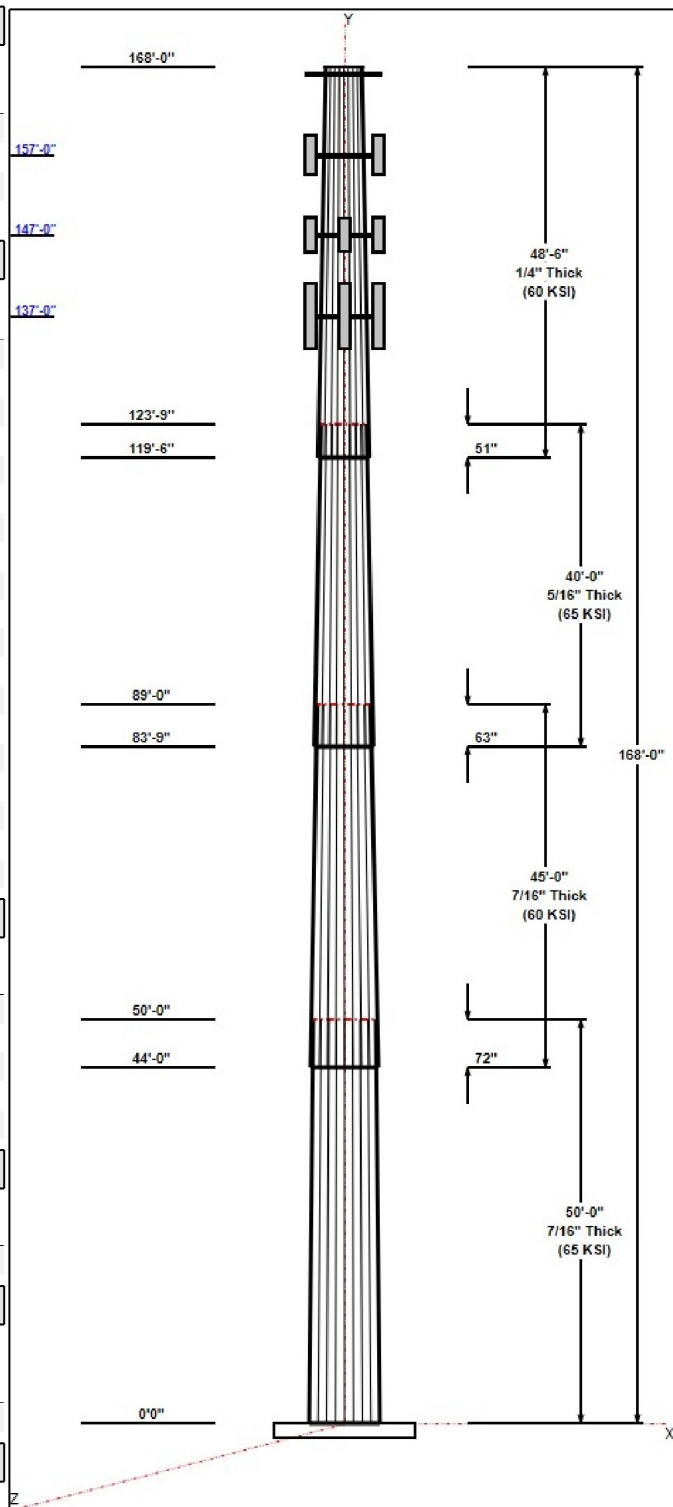

Structure: CT01364-S-SBA - Coax Line Placement

Type: Monopole
Site Name: Pomfret
Height: 168.00 (ft)

10/14/2015



Page: 3

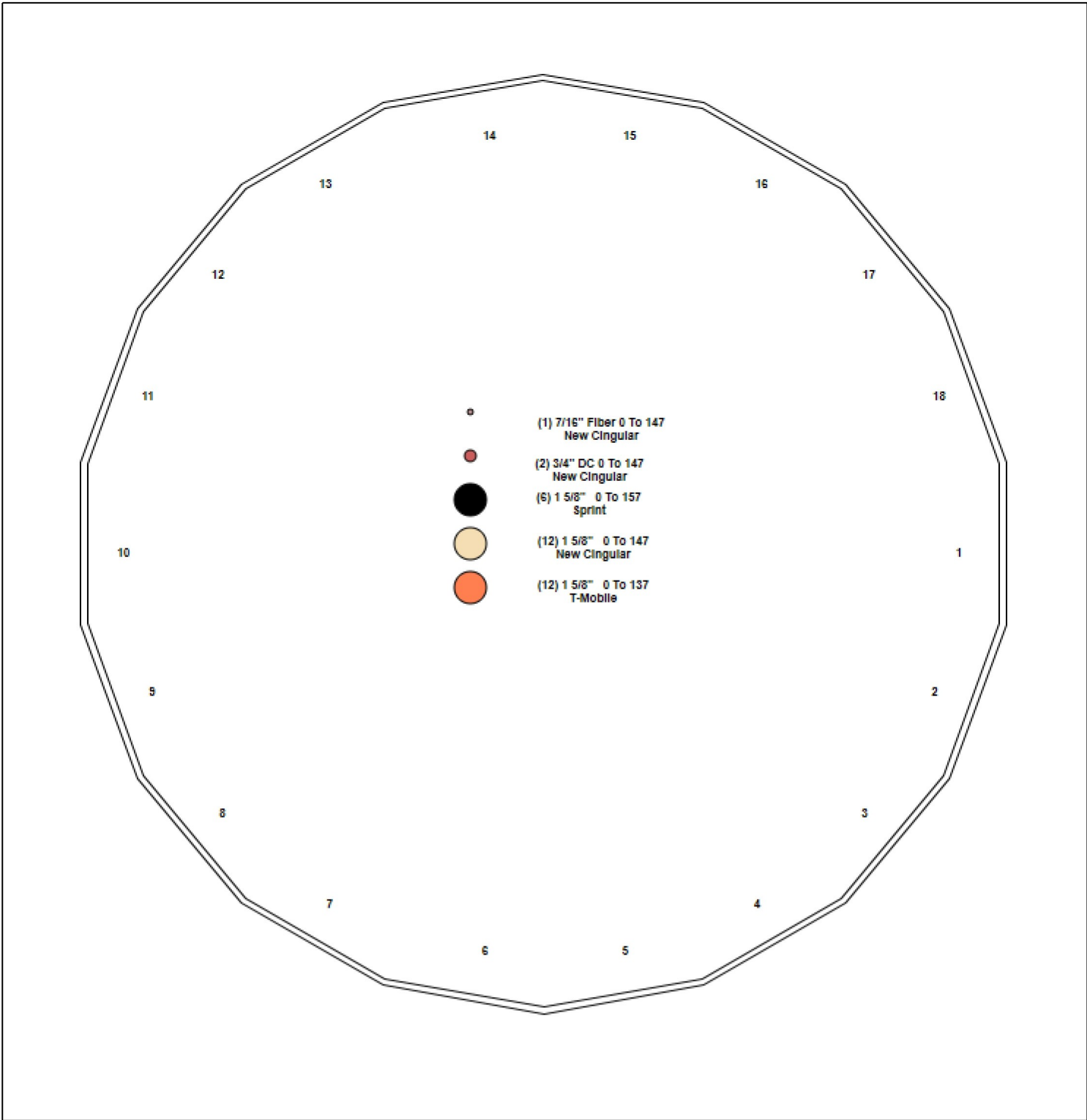

Shaft Properties

Structure: CT01364-S-SBA
Site Name: Pomfret
Height: 168.00 (ft)
Base Elev: 0.000 (ft)

Code: EIA/TIA-222-F
Exposure: C
Gh: 1.69
Struct Class: II

10/14/2015
 Page: 4



Sec. No.	Shape	Length (ft)	Thick (in)	Fy (ksi)	Joint Type	Overlap (in)	Weight (lb)
1	18	50.000	0.4375	65		0.00	12,020
2	18	45.000	0.4375	60	Slip	72.00	9,195
3	18	40.000	0.3125	65	Slip	63.00	4,908
4	18	48.500	0.2500	60	Slip	51.00	3,761
Total Shaft Weight:							29,884

Bottom

Top

Sec. No.	Dia (in)	Elev (ft)	Area (sqin)	Ix (in ⁴)	W/t Ratio	D/t Ratio	Dia (in)	Elev (ft)	Area (sqin)	Ix (in ⁴)	W/t Ratio	D/t Ratio	Taper
1	56.44	0.00	77.76	30813.76	21.33	129.0	46.19	50.00	63.53	16802.2	17.20	105.5	0.205000
2	48.30	44.00	66.45	19229.70	18.05	110.3	39.07	89.00	53.64	10115.3	14.33	89.30	0.205000
3	40.77	83.75	40.13	8299.11	21.59	130.4	32.57	123.7	32.00	4206.66	16.96	104.2	0.205000
4	33.94	119.5	26.73	3834.28	22.52	135.7	24.00	168.0	18.84	1343.00	15.51	96	0.205000

Loading Summary

Structure: CT01364-S-SBA
Site Name: Pomfret
Height: 168.00 (ft)
Base Elev: 0.000 (ft)

Code: EIA/TIA-222-F
Exposure: C
Gh: 1.69
Struct Class: II

10/14/2015
 Page: 5



Discrete Appurtenances

No.	Elev (ft)	Description	Qty	No Ice			Ice			Hor. Ecc. (ft)	Vert Ecc (ft)
				Weight (lb)	CaAa (sf)	CaAa Factor	Weight (lb)	CaAa (sf)	CaAa Factor		
1	168.0	6' Lightning rod	1	6.50	0.38	0.00	11.80	0.980	0.00	0.00	
2	167.0	Low Profile Platform-flat	1	1200.00	25.00	1.00	1500.00	31.00	1.00	0.00	
3	157.0	DB980H90E-M	6	8.50	3.90	0.79	0.00	4.180	0.80	0.00	
4	157.0	Low Profile Platform-flat	1	1200.00	25.00	1.00	1500.00	31.00	1.00	0.00	
5	147.0	7770.00	6	35.00	5.88	0.75	0.00	6.250	0.75	0.00	
6	147.0	AM-X-CD-17-65-00T-RET (48")	3	30.80	5.51	0.76	63.00	5.840	0.77	0.00	
7	147.0	CG-1900W800	6	28.70	1.54	0.76	39.60	1.680	0.77	0.00	
8	147.0	DC2-48-60-18-8F	1	31.80	2.57	1.00	49.50	2.770	1.00	0.00	
9	147.0	Dual Combiner	3	4.80	0.50	0.59	7.70	0.590	0.63	0.00	
10	147.0	LGP21401	6	14.10	1.29	0.64	21.20	1.420	0.66	0.00	
11	147.0	LGP21903	6	5.50	0.27	0.74	7.90	0.330	0.76	0.00	
12	147.0	Low Profile Platform-Round	1	1500.00	22.00	1.00	1800.00	27.00	1.00	0.00	
13	147.0	RRUS 11	6	50.70	2.94	0.76	66.00	3.140	0.77	0.00	
14	137.5	782 11056	3	1.80	0.17	0.78	4.00	0.230	0.82	0.00	
15	137.0	APXV18-206516S-C-A20	3	18.70	3.62	0.78	38.70	3.900	0.79	0.00	
16	137.0	FE15501P77/75	3	17.50	0.63	0.99	16.50	0.730	0.99	0.00	
17	137.0	KRY 112 144/1	3	11.00	0.41	0.72	14.10	0.490	0.75	0.00	
18	137.0	LNx-6515DS-VTM	3	51.30	11.43	0.84	117.10	11.90	0.84	0.00	
19	137.0	Low Profile Platform w/ Kicker	1	1800.00	33.84	1.00	2200.00	36.00	1.00	0.00	
Totals:			63	7,001.00			8,652.80				

Linear Appurtenances

Bottom Elev. (ft)	Top Elev. (ft)	Description	No Ice		Ice		Exposed
			Weight (lb/ft)	CaAa (sf/ft)	Weight (lb/ft)	CaAa (sf/ft)	
0.00	157.0	(6) 1 5/8" Coax	6.24	0.00	6.24	0.00	Inside
0.00	147.0	(12) 1 5/8" Coax	12.48	0.00	12.48	0.00	Inside
0.00	147.0	(2) 3/4" DC	0.80	0.00	0.80	0.00	Inside
0.00	147.0	(1) 7/16" Fiber	0.18	0.00	0.18	0.00	Inside
0.00	137.0	(12) 1 5/8" Coax	12.48	0.00	12.48	0.00	Inside
Totals:			4,668.06		4,668.06		

Shaft Section Properties

Structure: CT01364-S-SBA
Site Name: Pomfret
Height: 168.00 (ft)
Base Elev: 0.000 (ft)

Code: EIA/TIA-222-F
Exposure: C
Gh: 1.69
Struct Class: II

10/14/2015
 Page: 6



Increment Length: 5 (ft)

Elev (ft)	Description	Thick (in)	Dia (in)	Area (in^2)	Ix (in^4)	W/t Ratio	D/t Ratio	Fy (ksi)	Fb (ksi)	Weight (lb)
0.00		0.4375	56.440	77.764	30813.8	21.34	129.01	65	52	0.0
5.00		0.4375	55.415	76.340	29152.6	20.92	126.66	65	52	1311.0
10.00		0.4375	54.390	74.917	27552.3	20.51	124.32	65	52	1286.7
15.00		0.4375	53.365	73.494	26011.6	20.10	121.98	65	52	1262.5
20.00		0.4375	52.340	72.071	24529.4	19.68	119.63	65	52	1238.3
25.00		0.4375	51.315	70.647	23104.7	19.27	117.29	65	52	1214.1
30.00		0.4375	50.290	69.224	21736.2	18.86	114.95	65	52	1189.9
35.00		0.4375	49.265	67.801	20422.8	18.44	112.61	65	52	1165.7
40.00		0.4375	48.240	66.377	19163.5	18.03	110.26	65	52	1141.4
44.00	Bot - Section 2	0.4375	47.420	65.239	18194.1	17.70	108.39	65	52	895.7
45.00		0.4375	47.215	64.954	17957.0	17.62	107.92	65	52	447.2
50.00	Top - Section 1	0.4375	47.065	64.746	17784.8	17.56	107.58	60	52	2206.7
55.00		0.4375	46.040	63.322	16637.5	17.15	105.23	60	48	1089.5
60.00		0.4375	45.015	61.899	15540.7	16.73	102.89	60	48	1065.3
65.00		0.4375	43.990	60.476	14493.1	16.32	100.55	60	48	1041.0
70.00		0.4375	42.965	59.053	13493.7	15.91	98.21	60	48	1016.8
75.00		0.4375	41.940	57.629	12541.4	15.49	95.86	60	48	992.6
80.00		0.4375	40.915	56.206	11634.9	15.08	93.52	60	48	968.4
83.75	Bot - Section 3	0.4375	40.146	55.139	10984.5	14.77	91.76	60	48	710.4
85.00		0.4375	39.890	54.783	10773.2	14.67	91.18	60	48	403.9
89.00	Top - Section 2	0.3125	39.695	39.061	7654.3	20.99	127.02	65	48	1275.1
90.00		0.3125	39.490	38.858	7535.4	20.87	126.37	65	52	132.6
95.00		0.3125	38.465	37.841	6959.3	20.29	123.09	65	52	652.5
100.00		0.3125	37.440	36.825	6413.3	19.71	119.81	65	52	635.2
105.00		0.3125	36.415	35.808	5896.7	19.14	116.53	65	52	617.9
110.00		0.3125	35.390	34.791	5408.5	18.56	113.25	65	52	600.6
115.00		0.3125	34.365	33.775	4948.1	17.98	109.97	65	52	583.3
119.50	Bot - Section 4	0.3125	33.443	32.860	4556.8	17.46	107.02	65	52	510.2
120.00		0.3125	33.340	32.758	4514.6	17.40	106.69	65	52	101.2
123.75	Top - Section 3	0.2500	33.071	26.043	3544.5	21.91	132.28	60	52	749.3
125.00		0.2500	32.815	25.839	3462.1	21.73	131.26	60	48	110.3
130.00		0.2500	31.790	25.026	3145.4	21.01	127.16	60	48	432.7
135.00		0.2500	30.765	24.213	2848.6	20.29	123.06	60	48	418.9
137.00		0.2500	30.355	23.887	2735.3	20.00	121.42	60	48	163.7
137.50		0.2500	30.253	23.806	2707.4	19.93	121.01	60	48	40.6
140.00		0.2500	29.740	23.399	2571.0	19.57	118.96	60	48	200.8
145.00		0.2500	28.715	22.586	2312.2	18.84	114.86	60	48	391.2
147.00		0.2500	28.305	22.261	2213.7	18.55	113.22	60	48	152.6
150.00		0.2500	27.690	21.773	2071.3	18.12	110.76	60	48	224.8
155.00		0.2500	26.665	20.960	1847.7	17.40	106.66	60	48	363.5
157.00		0.2500	26.255	20.634	1763.0	17.11	105.02	60	48	141.5
160.00		0.2500	25.640	20.146	1640.9	16.67	102.56	60	48	208.2
165.00		0.2500	24.615	19.333	1450.1	15.95	98.46	60	48	335.8
167.00		0.2500	24.205	19.008	1378.1	15.66	96.82	60	48	130.5
168.00		0.2500	24.000	18.845	1343.0	15.52	96.00	60	48	64.4

29884.3

Wind Loading - Shaft

Structure: CT01364-S-SBA
Site Name: Pomfret
Height: 168.00 (ft)
Base Elev: 0.000 (ft)

Code: EIA/TIA-222-F
Exposure: C
Gh: 1.69
Struct Class: II

10/14/2015
 Page: 7



Load Case: 85 mph Wind with 0" Ice

Dead Load Factor 1.00
Wind Load Factor 1.00



Iterations: 25

Elev (ft)	Description	Kzt	Kz	qz (psf)	qzGh (psf)	C (mph-ft)	Cf	Ice Thick (in)	Tributary (ft)	Aa (sf)	CfAa (sf)	Wind Force X (lb)	Dead Load Ice (lb)	Tot Dead Load (lb)
0.00		0.00	1.00	18.496	31.26	399.78	0.650	0.000	0.00	0.000	0.00	0.0	0.0	0.0
5.00		0.00	1.00	18.496	31.26	392.52	0.650	0.000	5.00	23.303	15.15	473.5	0.0	1311.0
10.00		0.00	1.00	18.496	31.26	385.26	0.650	0.000	5.00	22.876	14.87	464.8	0.0	1286.7
15.00		0.00	1.00	18.496	31.26	378.00	0.650	0.000	5.00	22.449	14.59	456.1	0.0	1262.5
20.00		0.00	1.00	18.496	31.26	370.74	0.650	0.000	5.00	22.022	14.31	447.4	0.0	1238.3
25.00		0.00	1.00	18.496	31.26	363.48	0.650	0.000	5.00	21.595	14.04	438.8	0.0	1214.1
30.00		0.00	1.00	18.496	31.26	356.22	0.650	0.000	5.00	21.168	13.76	430.1	0.0	1189.9
35.00		0.00	1.02	18.810	31.79	351.91	0.650	0.000	5.00	20.741	13.48	428.5	0.0	1165.7
40.00		0.00	1.06	19.541	33.02	351.22	0.650	0.000	5.00	20.314	13.20	436.0	0.0	1141.4
44.00	Bot - Section 2	0.00	1.09	20.081	33.94	349.98	0.650	0.000	4.00	15.943	10.36	351.7	0.0	895.7
45.00		0.00	1.09	20.210	34.15	349.59	0.650	0.000	1.00	4.016	2.61	89.2	0.0	447.2
50.00	Top - Section 1	0.00	1.13	20.827	35.20	347.19	0.650	0.000	5.00	19.824	12.89	453.6	0.0	2206.7
55.00		0.00	1.16	21.402	36.17	350.80	0.650	0.000	5.00	19.397	12.61	456.0	0.0	1089.5
60.00		0.00	1.19	21.941	37.08	347.28	0.650	0.000	5.00	18.970	12.33	457.2	0.0	1065.3
65.00		0.00	1.21	22.449	37.94	343.28	0.650	0.000	5.00	18.543	12.05	457.3	0.0	1041.0
70.00		0.00	1.24	22.929	38.75	338.85	0.650	0.000	5.00	18.116	11.78	456.3	0.0	1016.8
75.00		0.00	1.26	23.386	39.52	334.04	0.650	0.000	5.00	17.689	11.50	454.4	0.0	992.6
80.00		0.00	1.29	23.821	40.26	328.90	0.650	0.000	5.00	17.261	11.22	451.7	0.0	968.4
83.75	Bot - Section 3	0.00	1.30	24.135	40.79	324.84	0.650	0.000	3.75	12.666	8.23	335.8	0.0	710.4
85.00		0.00	1.31	24.237	40.96	323.45	0.650	0.000	1.25	4.234	2.75	112.7	0.0	403.9
89.00	Top - Section 2	0.00	1.33	24.558	41.50	318.89	0.650	0.000	4.00	13.368	8.69	360.6	0.0	1275.1
90.00		0.00	1.33	24.636	41.63	322.83	0.650	0.000	1.00	3.299	2.14	89.3	0.0	132.6
95.00		0.00	1.35	25.020	42.28	316.89	0.650	0.000	5.00	16.241	10.56	446.4	0.0	652.5
100.00		0.00	1.37	25.389	42.91	310.71	0.650	0.000	5.00	15.814	10.28	441.0	0.0	635.2
105.00		0.00	1.39	25.745	43.51	304.32	0.650	0.000	5.00	15.386	10.00	435.1	0.0	617.9
110.00		0.00	1.41	26.090	44.09	297.72	0.650	0.000	5.00	14.959	9.72	428.7	0.0	600.6
115.00		0.00	1.43	26.423	44.66	290.94	0.650	0.000	5.00	14.532	9.45	421.8	0.0	583.3
119.50	Bot - Section 4	0.00	1.44	26.715	45.15	284.69	0.650	0.000	4.50	12.714	8.26	373.1	0.0	510.2
120.00		0.00	1.45	26.747	45.20	283.99	0.650	0.000	0.50	1.412	0.92	41.5	0.0	101.2
123.75	Top - Section 3	0.00	1.46	26.983	45.60	278.66	0.650	0.000	3.75	10.455	6.80	309.9	0.0	749.3
125.00		0.00	1.46	27.060	45.73	281.15	0.650	0.000	1.25	3.432	2.23	102.0	0.0	110.3
130.00		0.00	1.48	27.365	46.25	273.90	0.650	0.000	5.00	13.459	8.75	404.6	0.0	432.7
135.00		0.00	1.50	27.662	46.75	266.50	0.650	0.000	5.00	13.032	8.47	396.0	0.0	418.9
137.00	Appurtenance(s)	0.00	1.50	27.778	46.95	263.50	0.650	0.000	2.00	5.093	3.31	155.4	0.0	163.7
137.50	Appurtenance(s)	0.00	1.50	27.807	46.99	262.75	0.650	0.000	0.50	1.263	0.82	38.6	0.0	40.6
140.00		0.00	1.51	27.951	47.24	258.96	0.650	0.000	2.50	6.249	4.06	191.9	0.0	200.8
145.00		0.00	1.53	28.233	47.71	251.29	0.650	0.000	5.00	12.178	7.92	377.7	0.0	391.2
147.00	Appurtenance(s)	0.00	1.53	28.343	47.90	248.19	0.650	0.000	2.00	4.752	3.09	147.9	0.0	152.6
150.00		0.00	1.54	28.507	48.18	243.50	0.650	0.000	3.00	6.999	4.55	219.2	0.0	224.8
155.00		0.00	1.56	28.776	48.63	235.59	0.650	0.000	5.00	11.324	7.36	358.0	0.0	363.5
157.00	Appurtenance(s)	0.00	1.56	28.881	48.81	232.39	0.650	0.000	2.00	4.410	2.87	139.9	0.0	141.5
160.00		0.00	1.57	29.038	49.07	227.56	0.650	0.000	3.00	6.487	4.22	206.9	0.0	208.2
165.00		0.00	1.58	29.294	49.51	219.43	0.650	0.000	5.00	10.470	6.81	336.9	0.0	335.8
167.00	Appurtenance(s)	0.00	1.59	29.395	49.68	216.14	0.650	0.000	2.00	4.068	2.64	131.4	0.0	130.5
168.00	Appurtenance(s)	0.00	1.59	29.446	49.76	214.50	0.650	0.000	1.00	2.009	1.31	65.0	0.0	64.4
Totals:									168.00			14,269.9		29,884.3

Discrete Appurtenance Forces

Structure: CT01364-S-SB
Site Name: Pomfret
Height: 168.00 (ft)
Base Elev: 0.000 (ft)

Code: EIA/TIA-222-F
Exposure: C
Gh: 1.69
Struct Class: II

10/14/2015
 Page: 8



Load Case: 85 mph Wind with 0" Ice

Dead Load Factor 1.00
Wind Load Factor 1.00

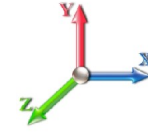

Iterations: 25

No.	Elev (ft)	Description	Qty	qz (psf)	qzGh (psf)	CaAa Factor	Total CaAa (sf)	Dead Load (lb)	Horiz Ecc (ft)	Vert Ecc (ft)	Wind FX (lb)	Mom Y (lb-ft)	Mom Z (lb-ft)
1	168.00	6' Lightning rod	1	29.446	49.763	0.00	0.38	6.50	0.000	0.000	18.91	0.00	0.00
2	167.00	Low Profile Platform-flat	1	29.395	49.678	1.00	25.00	1200.00	0.000	0.000	1241.95	0.00	0.00
3	157.00	Low Profile Platform-flat	1	28.881	48.809	1.00	25.00	1200.00	0.000	0.000	1220.23	0.00	0.00
4	157.00	DB980H90E-M	6	28.881	48.809	0.79	18.49	51.00	0.000	0.000	902.29	0.00	0.00
5	147.00	RRUS 11	6	28.343	47.900	0.76	13.41	304.20	0.000	0.000	642.17	0.00	0.00
6	147.00	Low Profile Platform-Round	1	28.343	47.900	1.00	22.00	1500.00	0.000	0.000	1053.80	0.00	0.00
7	147.00	LGP21903	6	28.343	47.900	0.74	1.20	33.00	0.000	0.000	57.42	0.00	0.00
8	147.00	LGP21401	6	28.343	47.900	0.64	4.95	84.60	0.000	0.000	237.28	0.00	0.00
9	147.00	Dual Combiner	3	28.343	47.900	0.59	0.89	14.40	0.000	0.000	42.39	0.00	0.00
10	147.00	DC2-48-60-18-8F	1	28.343	47.900	1.00	2.57	31.80	0.000	0.000	123.10	0.00	0.00
11	147.00	CG-1900W800	6	28.343	47.900	0.76	7.02	172.20	0.000	0.000	336.37	0.00	0.00
12	147.00	AM-X-CD-17-65-00T-RET	3	28.343	47.900	0.76	12.56	92.40	0.000	0.000	601.76	0.00	0.00
13	147.00	7770.00	6	28.343	47.900	0.75	26.46	210.00	0.000	0.000	1267.44	0.00	0.00
14	137.50	782 11056	3	27.807	46.994	0.78	0.40	5.40	0.000	0.000	18.69	0.00	0.00
15	137.00	Low Profile Platform w/	1	27.778	46.946	1.00	33.84	1800.00	0.000	0.000	1588.64	0.00	0.00
16	137.00	LNx-6515DS-VTM	3	27.778	46.946	0.84	28.80	153.90	0.000	0.000	1352.20	0.00	0.00
17	137.00	KRY 112 144/1	3	27.778	46.946	0.72	0.89	33.00	0.000	0.000	41.58	0.00	0.00
18	137.00	FE15501P77/75	3	27.778	46.946	0.99	1.87	52.50	0.000	0.000	87.84	0.00	0.00
19	137.00	APXV18-206516S-C-A20	3	27.778	46.946	0.78	8.47	56.10	0.000	0.000	397.67	0.00	0.00

Totals: 7,001.00

11,231.75

Total Applied Force Summary

Structure: CT01364-S-SB
Site Name: Pomfret
Height: 168.00 (ft)
Base Elev: 0.000 (ft)

Code: EIA/TIA-222-F
Exposure: C
Gh: 1.69
Struct Class: II

10/14/2015
 Page: 9



Load Case: 85 mph Wind with 0" Ice

Dead Load Factor 1.00
Wind Load Factor 1.00

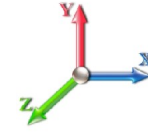

Iterations: 25

Elev (ft)	Description	Lateral FX (-) (lb)	Axial FY (-) (lb)	Torsion MY (lb-ft)	Moment MZ (lb-ft)
0.00		0.00	0.00	0.00	0.00
5.00		473.47	1471.85	0.00	0.00
10.00		464.79	1447.64	0.00	0.00
15.00		456.11	1423.42	0.00	0.00
20.00		447.44	1399.21	0.00	0.00
25.00		438.76	1374.99	0.00	0.00
30.00		430.08	1350.78	0.00	0.00
35.00		428.55	1326.56	0.00	0.00
40.00		436.05	1302.34	0.00	0.00
44.00		351.68	1024.44	0.00	0.00
45.00		89.16	479.33	0.00	0.00
50.00		453.55	2367.60	0.00	0.00
55.00		456.03	1250.37	0.00	0.00
60.00		457.22	1226.15	0.00	0.00
65.00		457.26	1201.94	0.00	0.00
70.00		456.29	1177.72	0.00	0.00
75.00		454.40	1153.51	0.00	0.00
80.00		451.68	1129.29	0.00	0.00
83.75		335.80	831.08	0.00	0.00
85.00		112.72	444.14	0.00	0.00
89.00		360.63	1403.83	0.00	0.00
90.00		89.29	164.75	0.00	0.00
95.00		446.36	813.37	0.00	0.00
100.00		441.04	796.08	0.00	0.00
105.00		435.15	778.78	0.00	0.00
110.00		428.73	761.48	0.00	0.00
115.00		421.81	744.19	0.00	0.00
119.50		373.10	654.98	0.00	0.00
120.00		41.49	117.33	0.00	0.00
123.75		309.89	870.02	0.00	0.00
125.00		102.01	150.56	0.00	0.00
130.00		404.60	593.61	0.00	0.00
135.00		396.01	579.77	0.00	0.00
137.00	(13) appurtenances	3623.35	2323.53	0.00	0.00
137.50	(3) appurtenances	57.26	55.82	0.00	0.00
140.00		191.88	250.04	0.00	0.00
145.00		377.69	489.70	0.00	0.00
147.00	(38) appurtenances	4509.68	2634.60	0.00	0.00
150.00		219.19	243.48	0.00	0.00
155.00		357.95	394.72	0.00	0.00
157.00	(7) appurtenances	2262.44	1405.01	0.00	0.00
160.00		206.92	208.15	0.00	0.00
165.00		336.92	335.85	0.00	0.00
167.00	(1) appurtenances	1373.32	1330.46	0.00	0.00
168.00	(1) appurtenances	83.88	70.90	0.00	0.00
Totals:		25,501.62	41,553.39	0.00	0.00

Resulting Forces and Deflections

Structure: CT01364-S-SB
Site Name: Pomfret
Height: 168.00 (ft)
Base Elev: 0.000 (ft)

Code: EIA/TIA-222-F
Exposure: C
Gh: 1.69
Struct Class: II

10/14/2015
 Page: 10



Load Case: 85 mph Wind with 0" Ice

Dead Load Factor 1.00
Wind Load Factor 1.00

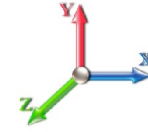

Iterations: 25

Elev (ft)	Lateral FX (-) (kips)	Axial FY (-) (kips)	Lateral FZ (kips)	Moment MX (ft-kips)	Torsion MY (ft-kips)	Moment MZ (ft-kips)	Deflect X (in)	Deflect Z (in)	Deflect Resultant (in)	Rotation Sway (deg)	Rotation Twist (deg)
0.00	-25.550	-41.523	0.000	0.000	0.000	-2931.6	0.000	0.000	0.000	0.000	0.000
5.00	-25.168	-39.993	0.000	0.000	0.000	-2803.8	-0.071	0.000	0.071	-0.132	0.000
10.00	-24.788	-38.489	0.000	0.000	0.000	-2678.0	-0.282	0.000	0.282	-0.266	0.000
15.00	-24.411	-37.011	0.000	0.000	0.000	-2554.0	-0.633	0.000	0.633	-0.401	0.000
20.00	-24.038	-35.558	0.000	0.000	0.000	-2432.0	-1.127	0.000	1.127	-0.538	0.000
25.00	-23.667	-34.131	0.000	0.000	0.000	-2311.8	-1.763	0.000	1.763	-0.675	0.000
30.00	-23.299	-32.729	0.000	0.000	0.000	-2193.5	-2.545	0.000	2.545	-0.814	0.000
35.00	-22.926	-31.353	0.000	0.000	0.000	-2077.0	-3.472	0.000	3.472	-0.954	0.000
40.00	-22.534	-30.009	0.000	0.000	0.000	-1962.4	-4.547	0.000	4.547	-1.094	0.000
44.00	-22.197	-28.965	0.000	0.000	0.000	-1872.2	-5.512	0.000	5.512	-1.208	0.000
45.00	-22.141	-28.454	0.000	0.000	0.000	-1850.0	-5.769	0.000	5.769	-1.237	0.000
50.00	-21.698	-26.043	0.000	0.000	0.000	-1739.3	-7.141	0.000	7.141	-1.379	0.000
55.00	-21.271	-24.754	0.000	0.000	0.000	-1630.8	-8.662	0.000	8.662	-1.522	0.000
60.00	-20.835	-23.492	0.000	0.000	0.000	-1524.5	-10.328	0.000	10.328	-1.657	0.000
65.00	-20.394	-22.256	0.000	0.000	0.000	-1420.3	-12.136	0.000	12.136	-1.792	0.000
70.00	-19.949	-21.047	0.000	0.000	0.000	-1318.3	-14.085	0.000	14.085	-1.926	0.000
75.00	-19.501	-19.865	0.000	0.000	0.000	-1218.6	-16.173	0.000	16.173	-2.060	0.000
80.00	-19.046	-18.715	0.000	0.000	0.000	-1121.1	-18.402	0.000	18.402	-2.193	0.000
83.75	-18.698	-17.876	0.000	0.000	0.000	-1049.7	-20.164	0.000	20.164	-2.292	0.000
85.00	-18.589	-17.414	0.000	0.000	0.000	-1026.3	-20.769	0.000	20.769	-2.326	0.000
89.00	-18.188	-16.006	0.000	0.000	0.000	-951.99	-22.762	0.000	22.762	-2.430	0.000
90.00	-18.119	-15.814	0.000	0.000	0.000	-933.80	-23.274	0.000	23.274	-2.457	0.000
95.00	-17.681	-14.970	0.000	0.000	0.000	-843.21	-25.937	0.000	25.937	-2.624	0.000
100.00	-17.242	-14.147	0.000	0.000	0.000	-754.81	-28.773	0.000	28.773	-2.788	0.000
105.00	-16.805	-13.346	0.000	0.000	0.000	-668.59	-31.777	0.000	31.777	-2.946	0.000
110.00	-16.369	-12.566	0.000	0.000	0.000	-584.57	-34.943	0.000	34.943	-3.097	0.000
115.00	-15.934	-11.810	0.000	0.000	0.000	-502.73	-38.263	0.000	38.263	-3.240	0.000
119.50	-15.536	-11.160	0.000	0.000	0.000	-431.03	-41.375	0.000	41.375	-3.361	0.000
120.00	-15.499	-11.030	0.000	0.000	0.000	-423.26	-41.727	0.000	41.727	-3.374	0.000
123.75	-15.148	-10.164	0.000	0.000	0.000	-365.14	-44.414	0.000	44.414	-3.467	0.000
125.00	-15.051	-9.999	0.000	0.000	0.000	-346.21	-45.326	0.000	45.326	-3.497	0.000
130.00	-14.630	-9.402	0.000	0.000	0.000	-270.95	-49.057	0.000	49.057	-3.624	0.000
135.00	-14.208	-8.832	0.000	0.000	0.000	-197.80	-52.910	0.000	52.910	-3.730	0.000
137.00	-10.443	-6.746	0.000	0.000	0.000	-169.39	-54.480	0.000	54.480	-3.767	0.000
137.50	-10.385	-6.690	0.000	0.000	0.000	-164.16	-54.875	0.000	54.875	-3.775	0.000
140.00	-10.183	-6.444	0.000	0.000	0.000	-138.20	-56.862	0.000	56.862	-3.815	0.000
145.00	-9.778	-5.974	0.000	0.000	0.000	-87.291	-60.891	0.000	60.891	-3.877	0.000
147.00	-5.101	-3.649	0.000	0.000	0.000	-67.736	-62.518	0.000	62.518	-3.896	0.000
150.00	-4.867	-3.419	0.000	0.000	0.000	-52.434	-64.973	0.000	64.973	-3.920	0.000
155.00	-4.484	-3.049	0.000	0.000	0.000	-28.098	-69.091	0.000	69.091	-3.947	0.000
157.00	-2.130	-1.803	0.000	0.000	0.000	-19.130	-70.745	0.000	70.745	-3.955	0.000
160.00	-1.910	-1.609	0.000	0.000	0.000	-12.739	-73.231	0.000	73.231	-3.962	0.000
165.00	-1.551	-1.297	0.000	0.000	0.000	-3.190	-77.381	0.000	77.381	-3.969	0.000
167.00	-0.089	-0.065	0.000	0.000	0.000	-0.089	-79.043	0.000	79.043	-3.970	0.000
168.00	-0.084	0.000	0.000	0.000	0.000	0.000	0.000	0.000	79.874	-3.970	0.000

Resulting Stresses

Structure: CT01364-S-SBA
Site Name: Pomfret
Height: 168.00 (ft)
Base Elev: 0.000 (ft)

Code: EIA/TIA-222-F
Exposure: C
Gh: 1.69
Struct Class: II

10/14/2015
 Page: 11



Load Case: 85 mph Wind with 0" Ice

Dead Load Factor 1.00
Wind Load Factor 1.00

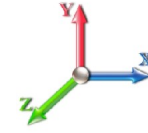

Iterations: 25

Applied Stresses

Elev (ft)	fa Axial (Y) (ksi)	fvx Shear (X) (ksi)	fvz Shear (Z) (ksi)	fvT Torsion (ksi)	fbx Bending (X) (ksi)	fbz Bending (Z) (ksi)	fb Combined (ksi)	Allow Stress (ksi)	f/Fb Stress Ratio
0.00	0.53	0.66	0.00	0.00	0.00	32.72	33.27	52.0	0.640
5.00	0.52	0.66	0.00	0.00	0.00	32.47	33.02	52.0	0.635
10.00	0.51	0.67	0.00	0.00	0.00	32.21	32.74	52.0	0.630
15.00	0.50	0.67	0.00	0.00	0.00	31.92	32.45	52.0	0.624
20.00	0.49	0.67	0.00	0.00	0.00	31.62	32.13	52.0	0.618
25.00	0.48	0.68	0.00	0.00	0.00	31.28	31.79	52.0	0.612
30.00	0.47	0.68	0.00	0.00	0.00	30.92	31.41	52.0	0.604
35.00	0.46	0.68	0.00	0.00	0.00	30.53	31.01	52.0	0.597
40.00	0.45	0.68	0.00	0.00	0.00	30.10	30.57	52.0	0.588
44.00	0.44	0.69	0.00	0.00	0.00	29.73	30.20	52.0	0.581
45.00	0.44	0.69	0.00	0.00	0.00	29.64	30.10	52.0	0.579
50.00	0.40	0.68	0.00	0.00	0.00	28.04	28.47	52.0	0.548
55.00	0.39	0.68	0.00	0.00	0.00	27.50	27.91	48.0	0.582
60.00	0.38	0.68	0.00	0.00	0.00	26.90	27.31	48.0	0.569
65.00	0.37	0.68	0.00	0.00	0.00	26.27	26.66	48.0	0.556
70.00	0.36	0.68	0.00	0.00	0.00	25.58	25.96	48.0	0.541
75.00	0.34	0.68	0.00	0.00	0.00	24.83	25.20	48.0	0.525
80.00	0.33	0.68	0.00	0.00	0.00	24.02	24.38	48.0	0.508
83.75	0.32	0.68	0.00	0.00	0.00	23.37	23.73	48.0	0.495
85.00	0.32	0.68	0.00	0.00	0.00	23.15	23.50	48.0	0.490
89.00	0.41	0.94	0.00	0.00	0.00	30.08	30.53	48.0	0.636
90.00	0.41	0.94	0.00	0.00	0.00	29.82	30.27	52.0	0.582
95.00	0.40	0.94	0.00	0.00	0.00	28.39	28.84	52.0	0.555
100.00	0.38	0.94	0.00	0.00	0.00	26.85	27.28	52.0	0.525
105.00	0.37	0.95	0.00	0.00	0.00	25.16	25.58	52.0	0.492
110.00	0.36	0.95	0.00	0.00	0.00	23.30	23.72	52.0	0.456
115.00	0.35	0.95	0.00	0.00	0.00	21.27	21.68	52.0	0.417
119.50	0.34	0.95	0.00	0.00	0.00	19.27	19.68	52.0	0.379
120.00	0.34	0.95	0.00	0.00	0.00	19.04	19.45	52.0	0.374
123.75	0.39	1.17	0.00	0.00	0.00	20.76	21.24	52.0	0.409
125.00	0.39	1.17	0.00	0.00	0.00	19.99	20.48	48.0	0.427
130.00	0.38	1.18	0.00	0.00	0.00	16.68	17.18	48.0	0.358
135.00	0.36	1.18	0.00	0.00	0.00	13.02	13.54	48.0	0.282
137.00	0.28	0.88	0.00	0.00	0.00	11.45	11.83	48.0	0.247
137.50	0.28	0.88	0.00	0.00	0.00	11.18	11.56	48.0	0.241
140.00	0.28	0.88	0.00	0.00	0.00	9.74	10.13	48.0	0.211
145.00	0.26	0.87	0.00	0.00	0.00	6.60	7.03	48.0	0.147
147.00	0.16	0.46	0.00	0.00	0.00	5.28	5.50	48.0	0.115
150.00	0.16	0.45	0.00	0.00	0.00	4.27	4.50	48.0	0.094
155.00	0.15	0.43	0.00	0.00	0.00	2.47	2.72	48.0	0.057
157.00	0.09	0.21	0.00	0.00	0.00	1.74	1.86	48.0	0.039
160.00	0.08	0.19	0.00	0.00	0.00	1.21	1.33	48.0	0.028
165.00	0.07	0.16	0.00	0.00	0.00	0.33	0.49	48.0	0.010
167.00	0.00	0.01	0.00	0.00	0.00	0.01	0.02	48.0	0.000
168.00	0.00	0.01	0.00	0.00	0.00	0.00	0.02	48.0	0.000

Wind Loading - Shaft

Structure: CT01364-S-SBA
Site Name: Pomfret
Height: 168.00 (ft)
Base Elev: 0.000 (ft)

Code: EIA/TIA-222-F
Exposure: C
Gh: 1.69
Struct Class: II

10/14/2015
 Page: 12



Load Case: 73.61 mph Wind with 0.5" Ice

Dead Load Factor 1.00
Wind Load Factor 1.00



Iterations: 25

Elev (ft)	Description	Kzt	Kz	qz (psf)	qzGh (psf)	C (mph-ft)	Cf	Ice Thick (in)	Tributary (ft)	Aa (sf)	CfAa (sf)	Wind Force X (lb)	Dead Load Ice (lb)	Tot Dead Load (lb)
0.00		0.00	1.00	13.871	23.44	346.21	0.650	0.500	0.00	0.000	0.00	0.0	0.0	0.0
5.00		0.00	1.00	13.871	23.44	339.92	0.650	0.500	5.00	23.720	15.42	361.4	172.5	1483.5
10.00		0.00	1.00	13.871	23.44	333.64	0.650	0.500	5.00	23.293	15.14	354.9	169.4	1456.1
15.00		0.00	1.00	13.871	23.44	327.35	0.650	0.500	5.00	22.866	14.86	348.4	166.2	1428.7
20.00		0.00	1.00	13.871	23.44	321.06	0.650	0.500	5.00	22.439	14.59	341.9	163.0	1401.4
25.00		0.00	1.00	13.871	23.44	314.77	0.650	0.500	5.00	22.011	14.31	335.4	159.9	1374.0
30.00		0.00	1.00	13.871	23.44	308.49	0.650	0.500	5.00	21.584	14.03	328.9	156.7	1346.6
35.00		0.00	1.02	14.106	23.84	304.75	0.650	0.500	5.00	21.157	13.75	327.8	153.6	1319.2
40.00		0.00	1.06	14.655	24.77	304.16	0.650	0.500	5.00	20.730	13.47	333.7	150.4	1291.8
44.00	Bot - Section 2	0.00	1.09	15.059	25.45	303.09	0.650	0.500	4.00	16.277	10.58	269.3	118.3	1014.0
45.00		0.00	1.09	15.156	25.61	302.75	0.650	0.500	1.00	4.099	2.66	68.3	30.0	477.1
50.00	Top - Section 1	0.00	1.13	15.620	26.40	300.67	0.650	0.500	5.00	20.241	13.16	347.3	146.8	2353.5
55.00		0.00	1.16	16.051	27.13	303.80	0.650	0.500	5.00	19.814	12.88	349.4	143.6	1233.1
60.00		0.00	1.19	16.455	27.81	300.75	0.650	0.500	5.00	19.386	12.60	350.4	140.4	1205.7
65.00		0.00	1.21	16.836	28.45	297.28	0.650	0.500	5.00	18.959	12.32	350.6	137.3	1178.3
70.00		0.00	1.24	17.196	29.06	293.44	0.650	0.500	5.00	18.532	12.05	350.1	134.1	1150.9
75.00		0.00	1.26	17.538	29.64	289.28	0.650	0.500	5.00	18.105	11.77	348.8	131.0	1123.6
80.00		0.00	1.29	17.865	30.19	284.82	0.650	0.500	5.00	17.678	11.49	346.9	127.8	1096.2
83.75	Bot - Section 3	0.00	1.30	18.100	30.59	281.31	0.650	0.500	3.75	12.978	8.44	258.0	94.1	804.5
85.00		0.00	1.31	18.177	30.72	280.10	0.650	0.500	1.25	4.338	2.82	86.6	31.6	435.6
89.00	Top - Section 2	0.00	1.33	18.417	31.12	276.15	0.650	0.500	4.00	13.702	8.91	277.2	99.2	1374.3
90.00		0.00	1.33	18.476	31.22	279.57	0.650	0.500	1.00	3.383	2.20	68.7	24.7	157.2
95.00		0.00	1.35	18.764	31.71	274.42	0.650	0.500	5.00	16.657	10.83	343.3	120.2	772.7
100.00		0.00	1.37	19.041	32.18	269.08	0.650	0.500	5.00	16.230	10.55	339.5	117.1	752.2
105.00		0.00	1.39	19.308	32.63	263.54	0.650	0.500	5.00	15.803	10.27	335.2	113.9	731.8
110.00		0.00	1.41	19.566	33.07	257.83	0.650	0.500	5.00	15.376	9.99	330.5	110.7	711.3
115.00		0.00	1.43	19.816	33.49	251.96	0.650	0.500	5.00	14.949	9.72	325.4	107.6	690.9
119.50	Bot - Section 4	0.00	1.44	20.035	33.86	246.54	0.650	0.500	4.50	13.089	8.51	288.1	94.3	604.4
120.00		0.00	1.45	20.059	33.90	245.93	0.650	0.500	0.50	1.454	0.94	32.0	10.6	111.8
123.75	Top - Section 3	0.00	1.46	20.236	34.20	241.32	0.650	0.500	3.75	10.767	7.00	239.3	77.7	827.0
125.00		0.00	1.46	20.294	34.30	243.48	0.650	0.500	1.25	3.536	2.30	78.8	25.7	136.0
130.00		0.00	1.48	20.523	34.68	237.20	0.650	0.500	5.00	13.876	9.02	312.8	99.6	532.3
135.00		0.00	1.50	20.745	35.06	230.79	0.650	0.500	5.00	13.449	8.74	306.5	96.5	515.3
137.00	Appurtenance(s)	0.00	1.50	20.833	35.21	228.19	0.650	0.500	2.00	5.260	3.42	120.4	38.1	201.8
137.50	Appurtenance(s)	0.00	1.50	20.854	35.24	227.54	0.650	0.500	0.50	1.304	0.85	29.9	9.5	50.1
140.00		0.00	1.51	20.962	35.43	224.26	0.650	0.500	2.50	6.458	4.20	148.7	46.7	247.4
145.00		0.00	1.53	21.173	35.78	217.62	0.650	0.500	5.00	12.595	8.19	292.9	90.1	481.3
147.00	Appurtenance(s)	0.00	1.53	21.256	35.92	214.93	0.650	0.500	2.00	4.918	3.20	114.8	35.6	188.2
150.00		0.00	1.54	21.379	36.13	210.87	0.650	0.500	3.00	7.249	4.71	170.3	52.2	276.9
155.00		0.00	1.56	21.581	36.47	204.02	0.650	0.500	5.00	11.741	7.63	278.3	83.8	447.3
157.00	Appurtenance(s)	0.00	1.56	21.660	36.60	201.25	0.650	0.500	2.00	4.577	2.97	108.9	33.0	174.6
160.00		0.00	1.57	21.777	36.80	197.07	0.650	0.500	3.00	6.737	4.38	161.2	48.4	256.5
165.00		0.00	1.58	21.969	37.13	190.02	0.650	0.500	5.00	10.886	7.08	262.7	77.5	413.3
167.00	Appurtenance(s)	0.00	1.59	22.045	37.26	187.18	0.650	0.500	2.00	4.235	2.75	102.6	30.5	161.0
168.00	Appurtenance(s)	0.00	1.59	22.083	37.32	185.75	0.650	0.500	1.00	2.092	1.36	50.7	15.1	79.5
Totals:									168.00			10,976.9	34,069.3	

Discrete Appurtenance Forces

Structure: CT01364-S-SB
Site Name: Pomfret
Height: 168.00 (ft)
Base Elev: 0.000 (ft)

Code: EIA/TIA-222-F
Exposure: C
Gh: 1.69
Struct Class: II

10/14/2015
 Page: 13



Load Case: 73.61 mph Wind with 0.5" Ice

Dead Load Factor 1.00
Wind Load Factor 1.00

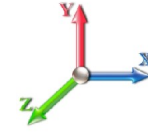

Iterations: 25

No.	Elev (ft)	Description	Qty	qz (psf)	qzGh (psf)	CaAa Factor	Total CaAa (sf)	Dead Load (lb)	Horiz Ecc (ft)	Vert Ecc (ft)	Wind FX (lb)	Mom Y (lb-ft)	Mom Z (lb-ft)
1	168.00	6' Lightning rod	1	22.083	37.320	0.00	0.98	11.80	0.000	0.000	36.57	0.00	0.00
2	167.00	Low Profile Platform-flat	1	22.045	37.256	1.00	31.00	1500.00	0.000	0.000	1154.95	0.00	0.00
3	157.00	Low Profile Platform-flat	1	21.660	36.605	1.00	31.00	1500.00	0.000	0.000	1134.75	0.00	0.00
4	157.00	DB980H90E-M	6	21.660	36.605	0.80	20.06	0.00	0.000	0.000	734.44	0.00	0.00
5	147.00	RRUS 11	6	21.256	35.923	0.77	14.51	396.00	0.000	0.000	521.13	0.00	0.00
6	147.00	Low Profile Platform-Round	1	21.256	35.923	1.00	27.00	1800.00	0.000	0.000	969.92	0.00	0.00
7	147.00	LGP21903	6	21.256	35.923	0.76	1.50	47.40	0.000	0.000	54.06	0.00	0.00
8	147.00	LGP21401	6	21.256	35.923	0.66	5.62	127.20	0.000	0.000	202.00	0.00	0.00
9	147.00	Dual Combiner	3	21.256	35.923	0.63	1.12	23.10	0.000	0.000	40.06	0.00	0.00
10	147.00	DC2-48-60-18-8F	1	21.256	35.923	1.00	2.77	49.50	0.000	0.000	99.51	0.00	0.00
11	147.00	CG-1900W800	6	21.256	35.923	0.77	7.76	237.60	0.000	0.000	278.82	0.00	0.00
12	147.00	AM-X-CD-17-65-00T-RET	3	21.256	35.923	0.77	13.49	189.00	0.000	0.000	484.62	0.00	0.00
13	147.00	7770.00	6	21.256	35.923	0.75	28.13	0.00	0.000	0.000	1010.33	0.00	0.00
14	137.50	782 11056	3	20.854	35.244	0.82	0.57	12.00	0.000	0.000	19.94	0.00	0.00
15	137.00	Low Profile Platform w/	1	20.833	35.207	1.00	36.00	2200.00	0.000	0.000	1267.46	0.00	0.00
16	137.00	LNx-6515DS-VTM	3	20.833	35.207	0.84	29.99	351.30	0.000	0.000	1055.79	0.00	0.00
17	137.00	KRY 112 144/1	3	20.833	35.207	0.75	1.10	42.30	0.000	0.000	38.82	0.00	0.00
18	137.00	FE15501P77/75	3	20.833	35.207	0.99	2.17	49.50	0.000	0.000	76.33	0.00	0.00
19	137.00	APXV18-206516S-C-A20	3	20.833	35.207	0.79	9.24	116.10	0.000	0.000	325.42	0.00	0.00

Totals: 8,652.80

9,504.92

Total Applied Force Summary

Structure: CT01364-S-SB
Site Name: Pomfret
Height: 168.00 (ft)
Base Elev: 0.000 (ft)

Code: EIA/TIA-222-F
Exposure: C
Gh: 1.69
Struct Class: II

10/14/2015
 Page: 14



Load Case: 73.61 mph Wind with 0.5" Ice

Dead Load Factor 1.00
Wind Load Factor 1.00

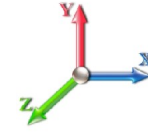

Iterations: 25

Elev (ft)	Description	Lateral FX (-) (lb)	Axial FY (-) (lb)	Torsion MY (lb-ft)	Moment MZ (lb-ft)
0.00		0.00	0.00	0.00	0.00
5.00		361.43	1644.39	0.00	0.00
10.00		354.92	1617.01	0.00	0.00
15.00		348.41	1589.64	0.00	0.00
20.00		341.91	1562.26	0.00	0.00
25.00		335.40	1534.88	0.00	0.00
30.00		328.89	1507.50	0.00	0.00
35.00		327.85	1480.12	0.00	0.00
40.00		333.72	1452.74	0.00	0.00
44.00		269.26	1142.73	0.00	0.00
45.00		68.25	509.32	0.00	0.00
50.00		347.29	2514.37	0.00	0.00
55.00		349.35	1393.98	0.00	0.00
60.00		350.42	1366.60	0.00	0.00
65.00		350.63	1339.22	0.00	0.00
70.00		350.07	1311.84	0.00	0.00
75.00		348.81	1284.46	0.00	0.00
80.00		346.92	1257.09	0.00	0.00
83.75		258.04	925.14	0.00	0.00
85.00		86.61	475.78	0.00	0.00
89.00		277.20	1503.05	0.00	0.00
90.00		68.65	189.43	0.00	0.00
95.00		343.34	933.61	0.00	0.00
100.00		339.47	913.15	0.00	0.00
105.00		335.18	892.69	0.00	0.00
110.00		330.49	872.23	0.00	0.00
115.00		325.41	851.77	0.00	0.00
119.50		288.06	749.24	0.00	0.00
120.00		32.03	127.92	0.00	0.00
123.75		239.35	947.72	0.00	0.00
125.00		78.82	176.26	0.00	0.00
130.00		312.83	693.25	0.00	0.00
135.00		306.48	676.25	0.00	0.00
137.00	(13) appurtenances	2884.19	3025.32	0.00	0.00
137.50	(3) appurtenances	49.82	71.91	0.00	0.00
140.00		148.70	296.69	0.00	0.00
145.00		292.94	579.85	0.00	0.00
147.00	(38) appurtenances	3775.29	3097.36	0.00	0.00
150.00		170.25	295.67	0.00	0.00
155.00		278.33	478.55	0.00	0.00
157.00	(7) appurtenances	1978.09	1687.04	0.00	0.00
160.00		161.16	256.55	0.00	0.00
165.00		262.73	413.35	0.00	0.00
167.00	(1) appurtenances	1257.51	1660.96	0.00	0.00
168.00	(1) appurtenances	87.32	91.32	0.00	0.00
Totals:		20,481.84	47,390.21	0.00	0.00

Resulting Forces and Deflections

Structure: CT01364-S-SB
Site Name: Pomfret
Height: 168.00 (ft)
Base Elev: 0.000 (ft)

Code: EIA/TIA-222-F
Exposure: C
Gh: 1.69
Struct Class: II

10/14/2015
 Page: 15



Load Case: 73.61 mph Wind with 0.5" Ice

Dead Load Factor 1.00
Wind Load Factor 1.00

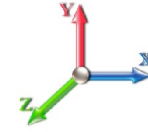

Iterations: 25

Elev (ft)	Lateral FX (-) (kips)	Axial FY (-) (kips)	Lateral FZ (kips)	Moment MX (ft-kips)	Torsion MY (ft-kips)	Moment MZ (ft-kips)	Deflect X (in)	Deflect Z (in)	Deflect Resultant (in)	Rotation Sway (deg)	Rotation Twist (deg)
0.00	-20.527	-47.370	0.000	0.000	0.000	-2410.9	0.000	0.000	0.000	0.000	0.000
5.00	-20.251	-45.687	0.000	0.000	0.000	-2308.3	-0.059	0.000	0.059	-0.109	0.000
10.00	-19.977	-44.033	0.000	0.000	0.000	-2207.0	-0.232	0.000	0.232	-0.219	0.000
15.00	-19.704	-42.407	0.000	0.000	0.000	-2107.2	-0.521	0.000	0.521	-0.330	0.000
20.00	-19.432	-40.808	0.000	0.000	0.000	-2008.6	-0.928	0.000	0.928	-0.443	0.000
25.00	-19.162	-39.238	0.000	0.000	0.000	-1911.5	-1.453	0.000	1.453	-0.557	0.000
30.00	-18.892	-37.697	0.000	0.000	0.000	-1815.7	-2.097	0.000	2.097	-0.671	0.000
35.00	-18.619	-36.183	0.000	0.000	0.000	-1721.2	-2.863	0.000	2.863	-0.787	0.000
40.00	-18.328	-34.702	0.000	0.000	0.000	-1628.1	-3.750	0.000	3.750	-0.904	0.000
44.00	-18.074	-33.545	0.000	0.000	0.000	-1554.8	-4.548	0.000	4.548	-0.998	0.000
45.00	-18.038	-33.014	0.000	0.000	0.000	-1536.7	-4.760	0.000	4.760	-1.023	0.000
50.00	-17.707	-30.471	0.000	0.000	0.000	-1446.5	-5.894	0.000	5.894	-1.141	0.000
55.00	-17.387	-29.049	0.000	0.000	0.000	-1358.0	-7.152	0.000	7.152	-1.259	0.000
60.00	-17.059	-27.658	0.000	0.000	0.000	-1271.1	-8.532	0.000	8.532	-1.372	0.000
65.00	-16.727	-26.295	0.000	0.000	0.000	-1185.8	-10.029	0.000	10.029	-1.484	0.000
70.00	-16.391	-24.961	0.000	0.000	0.000	-1102.2	-11.643	0.000	11.643	-1.597	0.000
75.00	-16.051	-23.656	0.000	0.000	0.000	-1020.2	-13.375	0.000	13.375	-1.708	0.000
80.00	-15.703	-22.383	0.000	0.000	0.000	-940.00	-15.224	0.000	15.224	-1.820	0.000
83.75	-15.436	-21.452	0.000	0.000	0.000	-881.11	-16.687	0.000	16.687	-1.903	0.000
85.00	-15.355	-20.964	0.000	0.000	0.000	-861.82	-17.189	0.000	17.189	-1.931	0.000
89.00	-15.045	-19.457	0.000	0.000	0.000	-800.40	-18.845	0.000	18.845	-2.019	0.000
90.00	-14.997	-19.248	0.000	0.000	0.000	-785.35	-19.270	0.000	19.270	-2.041	0.000
95.00	-14.665	-18.292	0.000	0.000	0.000	-710.37	-21.484	0.000	21.484	-2.183	0.000
100.00	-14.331	-17.359	0.000	0.000	0.000	-637.05	-23.844	0.000	23.844	-2.320	0.000
105.00	-13.996	-16.450	0.000	0.000	0.000	-565.40	-26.346	0.000	26.346	-2.454	0.000
110.00	-13.661	-15.563	0.000	0.000	0.000	-495.42	-28.985	0.000	28.985	-2.582	0.000
115.00	-13.326	-14.701	0.000	0.000	0.000	-427.11	-31.754	0.000	31.754	-2.703	0.000
119.50	-13.016	-13.954	0.000	0.000	0.000	-367.15	-34.351	0.000	34.351	-2.806	0.000
120.00	-12.989	-13.817	0.000	0.000	0.000	-360.64	-34.646	0.000	34.646	-2.817	0.000
123.75	-12.714	-12.871	0.000	0.000	0.000	-311.93	-36.891	0.000	36.891	-2.896	0.000
125.00	-12.642	-12.684	0.000	0.000	0.000	-296.04	-37.652	0.000	37.652	-2.922	0.000
130.00	-12.314	-11.986	0.000	0.000	0.000	-232.83	-40.772	0.000	40.772	-3.031	0.000
135.00	-11.984	-11.315	0.000	0.000	0.000	-171.26	-43.997	0.000	43.997	-3.122	0.000
137.00	-8.941	-8.449	0.000	0.000	0.000	-147.30	-45.312	0.000	45.312	-3.154	0.000
137.50	-8.890	-8.377	0.000	0.000	0.000	-142.83	-45.642	0.000	45.642	-3.162	0.000
140.00	-8.732	-8.082	0.000	0.000	0.000	-120.60	-47.307	0.000	47.307	-3.196	0.000
145.00	-8.411	-7.515	0.000	0.000	0.000	-76.945	-50.684	0.000	50.684	-3.251	0.000
147.00	-4.468	-4.635	0.000	0.000	0.000	-60.122	-52.050	0.000	52.050	-3.268	0.000
150.00	-4.282	-4.348	0.000	0.000	0.000	-46.720	-54.109	0.000	54.109	-3.288	0.000
155.00	-3.978	-3.886	0.000	0.000	0.000	-25.308	-57.565	0.000	57.565	-3.313	0.000
157.00	-1.906	-2.316	0.000	0.000	0.000	-17.351	-58.954	0.000	58.954	-3.320	0.000
160.00	-1.731	-2.069	0.000	0.000	0.000	-11.634	-61.041	0.000	61.041	-3.327	0.000
165.00	-1.444	-1.671	0.000	0.000	0.000	-2.981	-64.527	0.000	64.527	-3.333	0.000
167.00	-0.092	-0.086	0.000	0.000	0.000	-0.092	-65.923	0.000	65.923	-3.334	0.000
168.00	-0.087	0.000	0.000	0.000	0.000	0.000	0.000	0.000	66.621	-3.334	0.000

Resulting Stresses

Structure: CT01364-S-SBA
Site Name: Pomfret
Height: 168.00 (ft)
Base Elev: 0.000 (ft)

Code: EIA/TIA-222-F
Exposure: C
Gh: 1.69
Struct Class: II

10/14/2015
 Page: 16



Load Case: 73.61 mph Wind with 0.5" Ice

Dead Load Factor 1.00
Wind Load Factor 1.00



Iterations: 25

Applied Stresses

Elev (ft)	fa Axial (Y) (ksi)	fvx Shear (X) (ksi)	fvz Shear (Z) (ksi)	fvT Torsion (ksi)	fbx Bending (X) (ksi)	fbz Bending (Z) (ksi)	fb Combined (ksi)	Allow Stress (ksi)	f/Fb Stress Ratio
0.00	0.61	0.53	0.00	0.00	0.00	26.91	27.53	52.0	0.530
5.00	0.60	0.53	0.00	0.00	0.00	26.73	27.35	52.0	0.526
10.00	0.59	0.54	0.00	0.00	0.00	26.54	27.15	52.0	0.522
15.00	0.58	0.54	0.00	0.00	0.00	26.34	26.93	52.0	0.518
20.00	0.57	0.54	0.00	0.00	0.00	26.11	26.70	52.0	0.514
25.00	0.56	0.55	0.00	0.00	0.00	25.87	26.44	52.0	0.509
30.00	0.54	0.55	0.00	0.00	0.00	25.59	26.16	52.0	0.503
35.00	0.53	0.55	0.00	0.00	0.00	25.30	25.85	52.0	0.497
40.00	0.52	0.56	0.00	0.00	0.00	24.97	25.51	52.0	0.491
44.00	0.51	0.56	0.00	0.00	0.00	24.69	25.22	52.0	0.485
45.00	0.51	0.56	0.00	0.00	0.00	24.62	25.15	52.0	0.484
50.00	0.47	0.55	0.00	0.00	0.00	23.32	23.81	52.0	0.458
55.00	0.46	0.55	0.00	0.00	0.00	22.90	23.37	48.0	0.487
60.00	0.45	0.56	0.00	0.00	0.00	22.43	22.90	48.0	0.477
65.00	0.43	0.56	0.00	0.00	0.00	21.93	22.38	48.0	0.467
70.00	0.42	0.56	0.00	0.00	0.00	21.38	21.83	48.0	0.455
75.00	0.41	0.56	0.00	0.00	0.00	20.79	21.22	48.0	0.442
80.00	0.40	0.56	0.00	0.00	0.00	20.14	20.56	48.0	0.429
83.75	0.39	0.56	0.00	0.00	0.00	19.62	20.03	48.0	0.418
85.00	0.38	0.56	0.00	0.00	0.00	19.44	19.85	48.0	0.414
89.00	0.50	0.78	0.00	0.00	0.00	25.29	25.82	48.0	0.538
90.00	0.50	0.78	0.00	0.00	0.00	25.08	25.61	52.0	0.493
95.00	0.48	0.78	0.00	0.00	0.00	23.92	24.44	52.0	0.470
100.00	0.47	0.78	0.00	0.00	0.00	22.66	23.17	52.0	0.446
105.00	0.46	0.79	0.00	0.00	0.00	21.27	21.78	52.0	0.419
110.00	0.45	0.79	0.00	0.00	0.00	19.75	20.24	52.0	0.389
115.00	0.44	0.80	0.00	0.00	0.00	18.07	18.56	52.0	0.357
119.50	0.42	0.80	0.00	0.00	0.00	16.42	16.90	52.0	0.325
120.00	0.42	0.80	0.00	0.00	0.00	16.23	16.71	52.0	0.321
123.75	0.49	0.98	0.00	0.00	0.00	17.73	18.31	52.0	0.352
125.00	0.49	0.99	0.00	0.00	0.00	17.10	17.67	48.0	0.368
130.00	0.48	0.99	0.00	0.00	0.00	14.34	14.92	48.0	0.311
135.00	0.47	1.00	0.00	0.00	0.00	11.27	11.86	48.0	0.247
137.00	0.35	0.75	0.00	0.00	0.00	9.96	10.40	48.0	0.217
137.50	0.35	0.75	0.00	0.00	0.00	9.72	10.16	48.0	0.212
140.00	0.35	0.75	0.00	0.00	0.00	8.50	8.94	48.0	0.186
145.00	0.33	0.75	0.00	0.00	0.00	5.82	6.29	48.0	0.131
147.00	0.21	0.40	0.00	0.00	0.00	4.68	4.94	48.0	0.103
150.00	0.20	0.40	0.00	0.00	0.00	3.81	4.06	48.0	0.085
155.00	0.19	0.38	0.00	0.00	0.00	2.23	2.50	48.0	0.052
157.00	0.11	0.19	0.00	0.00	0.00	1.57	1.72	48.0	0.036
160.00	0.10	0.17	0.00	0.00	0.00	1.11	1.25	48.0	0.026
165.00	0.09	0.15	0.00	0.00	0.00	0.31	0.47	48.0	0.010
167.00	0.00	0.01	0.00	0.00	0.00	0.01	0.02	48.0	0.000
168.00	0.00	0.01	0.00	0.00	0.00	0.00	0.02	48.0	0.000

Wind Loading - Shaft

Structure: CT01364-S-SBA
Site Name: Pomfret
Height: 168.00 (ft)
Base Elev: 0.000 (ft)

Code: EIA/TIA-222-F
Exposure: C
Gh: 1.69
Struct Class: II

10/14/2015
 Page: 17



Load Case: 50 mph Wind with 0" Ice

Dead Load Factor 1.00
Wind Load Factor 1.00



Iterations: 24

Elev (ft)	Description	Kzt	Kz	qz (psf)	qzGh (psf)	C (mph-ft)	Cf	Ice Thick (in)	Tributary (ft)	Aa (sf)	CfAa (sf)	Wind Force X (lb)	Dead Load Ice (lb)	Tot Dead Load (lb)
0.00		0.00	1.00	6.400	10.82	235.17	0.650	0.000	0.00	0.000	0.00	0.0	0.0	0.0
5.00		0.00	1.00	6.400	10.82	230.90	0.650	0.000	5.00	23.303	15.15	163.8	0.0	1311.0
10.00		0.00	1.00	6.400	10.82	226.63	0.650	0.000	5.00	22.876	14.87	160.8	0.0	1286.7
15.00		0.00	1.00	6.400	10.82	222.35	0.650	0.000	5.00	22.449	14.59	157.8	0.0	1262.5
20.00		0.00	1.00	6.400	10.82	218.08	0.650	0.000	5.00	22.022	14.31	154.8	0.0	1238.3
25.00		0.00	1.00	6.400	10.82	213.81	0.650	0.000	5.00	21.595	14.04	151.8	0.0	1214.1
30.00		0.00	1.00	6.400	10.82	209.54	0.650	0.000	5.00	21.168	13.76	148.8	0.0	1189.9
35.00		0.00	1.02	6.509	11.00	207.00	0.650	0.000	5.00	20.741	13.48	148.3	0.0	1165.7
40.00		0.00	1.06	6.762	11.43	206.60	0.650	0.000	5.00	20.314	13.20	150.9	0.0	1141.4
44.00	Bot - Section 2	0.00	1.09	6.948	11.74	205.87	0.650	0.000	4.00	15.943	10.36	121.7	0.0	895.7
45.00		0.00	1.09	6.993	11.82	205.64	0.650	0.000	1.00	4.016	2.61	30.9	0.0	447.2
50.00	Top - Section 1	0.00	1.13	7.207	12.18	204.23	0.650	0.000	5.00	19.824	12.89	156.9	0.0	2206.7
55.00		0.00	1.16	7.406	12.52	206.36	0.650	0.000	5.00	19.397	12.61	157.8	0.0	1089.5
60.00		0.00	1.19	7.592	12.83	204.29	0.650	0.000	5.00	18.970	12.33	158.2	0.0	1065.3
65.00		0.00	1.21	7.768	13.13	201.93	0.650	0.000	5.00	18.543	12.05	158.2	0.0	1041.0
70.00		0.00	1.24	7.934	13.41	199.32	0.650	0.000	5.00	18.116	11.78	157.9	0.0	1016.8
75.00		0.00	1.26	8.092	13.68	196.50	0.650	0.000	5.00	17.689	11.50	157.2	0.0	992.6
80.00		0.00	1.29	8.242	13.93	193.47	0.650	0.000	5.00	17.261	11.22	156.3	0.0	968.4
83.75	Bot - Section 3	0.00	1.30	8.351	14.11	191.08	0.650	0.000	3.75	12.666	8.23	116.2	0.0	710.4
85.00		0.00	1.31	8.387	14.17	190.26	0.650	0.000	1.25	4.234	2.75	39.0	0.0	403.9
89.00	Top - Section 2	0.00	1.33	8.497	14.36	187.58	0.650	0.000	4.00	13.368	8.69	124.8	0.0	1275.1
90.00		0.00	1.33	8.525	14.41	189.90	0.650	0.000	1.00	3.299	2.14	30.9	0.0	132.6
95.00		0.00	1.35	8.657	14.63	186.40	0.650	0.000	5.00	16.241	10.56	154.4	0.0	652.5
100.00		0.00	1.37	8.785	14.85	182.77	0.650	0.000	5.00	15.814	10.28	152.6	0.0	635.2
105.00		0.00	1.39	8.908	15.06	179.01	0.650	0.000	5.00	15.386	10.00	150.6	0.0	617.9
110.00		0.00	1.41	9.028	15.26	175.13	0.650	0.000	5.00	14.959	9.72	148.3	0.0	600.6
115.00		0.00	1.43	9.143	15.45	171.14	0.650	0.000	5.00	14.532	9.45	146.0	0.0	583.3
119.50	Bot - Section 4	0.00	1.44	9.244	15.62	167.46	0.650	0.000	4.50	12.714	8.26	129.1	0.0	510.2
120.00		0.00	1.45	9.255	15.64	167.05	0.650	0.000	0.50	1.412	0.92	14.4	0.0	101.2
123.75	Top - Section 3	0.00	1.46	9.337	15.78	163.92	0.650	0.000	3.75	10.455	6.80	107.2	0.0	749.3
125.00		0.00	1.46	9.363	15.82	165.38	0.650	0.000	1.25	3.432	2.23	35.3	0.0	110.3
130.00		0.00	1.48	9.469	16.00	161.12	0.650	0.000	5.00	13.459	8.75	140.0	0.0	432.7
135.00		0.00	1.50	9.572	16.18	156.76	0.650	0.000	5.00	13.032	8.47	137.0	0.0	418.9
137.00	Appurtenance(s)	0.00	1.50	9.612	16.24	155.00	0.650	0.000	2.00	5.093	3.31	53.8	0.0	163.7
137.50	Appurtenance(s)	0.00	1.50	9.622	16.26	154.56	0.650	0.000	0.50	1.263	0.82	13.3	0.0	40.6
140.00		0.00	1.51	9.672	16.35	152.33	0.650	0.000	2.50	6.249	4.06	66.4	0.0	200.8
145.00		0.00	1.53	9.769	16.51	147.82	0.650	0.000	5.00	12.178	7.92	130.7	0.0	391.2
147.00	Appurtenance(s)	0.00	1.53	9.807	16.57	146.00	0.650	0.000	2.00	4.752	3.09	51.2	0.0	152.6
150.00		0.00	1.54	9.864	16.67	143.24	0.650	0.000	3.00	6.999	4.55	75.8	0.0	224.8
155.00		0.00	1.56	9.957	16.83	138.58	0.650	0.000	5.00	11.324	7.36	123.9	0.0	363.5
157.00	Appurtenance(s)	0.00	1.56	9.994	16.89	136.70	0.650	0.000	2.00	4.410	2.87	48.4	0.0	141.5
160.00		0.00	1.57	10.048	16.98	133.86	0.650	0.000	3.00	6.487	4.22	71.6	0.0	208.2
165.00		0.00	1.58	10.136	17.13	129.07	0.650	0.000	5.00	10.470	6.81	116.6	0.0	335.8
167.00	Appurtenance(s)	0.00	1.59	10.171	17.19	127.14	0.650	0.000	2.00	4.068	2.64	45.5	0.0	130.5
168.00	Appurtenance(s)	0.00	1.59	10.189	17.22	126.17	0.650	0.000	1.00	2.009	1.31	22.5	0.0	64.4
Totals:									168.00			4,937.7		29,884.3

Discrete Appurtenance Forces

Structure: CT01364-S-SB
Site Name: Pomfret
Height: 168.00 (ft)
Base Elev: 0.000 (ft)

Code: EIA/TIA-222-F
Exposure: C
Gh: 1.69
Struct Class: II

10/14/2015
 Page: 18



Load Case: 50 mph Wind with 0" Ice

Dead Load Factor 1.00
Wind Load Factor 1.00

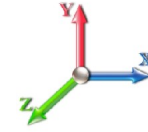

Iterations: 24

No.	Elev (ft)	Description	Qty	qz (psf)	qzGh (psf)	CaAa Factor	Total CaAa (sf)	Dead Load (lb)	Horiz Ecc (ft)	Vert Ecc (ft)	Wind FX (lb)	Mom Y (lb-ft)	Mom Z (lb-ft)
1	168.00	6' Lightning rod	1	10.189	17.219	0.00	0.38	6.50	0.000	0.000	6.54	0.00	0.00
2	167.00	Low Profile Platform-flat	1	10.171	17.190	1.00	25.00	1200.00	0.000	0.000	429.74	0.00	0.00
3	157.00	Low Profile Platform-flat	1	9.994	16.889	1.00	25.00	1200.00	0.000	0.000	422.23	0.00	0.00
4	157.00	DB980H90E-M	6	9.994	16.889	0.79	18.49	51.00	0.000	0.000	312.21	0.00	0.00
5	147.00	RRUS 11	6	9.807	16.574	0.76	13.41	304.20	0.000	0.000	222.20	0.00	0.00
6	147.00	Low Profile Platform-Round	1	9.807	16.574	1.00	22.00	1500.00	0.000	0.000	364.64	0.00	0.00
7	147.00	LGP21903	6	9.807	16.574	0.74	1.20	33.00	0.000	0.000	19.87	0.00	0.00
8	147.00	LGP21401	6	9.807	16.574	0.64	4.95	84.60	0.000	0.000	82.10	0.00	0.00
9	147.00	Dual Combiner	3	9.807	16.574	0.59	0.89	14.40	0.000	0.000	14.67	0.00	0.00
10	147.00	DC2-48-60-18-8F	1	9.807	16.574	1.00	2.57	31.80	0.000	0.000	42.60	0.00	0.00
11	147.00	CG-1900W800	6	9.807	16.574	0.76	7.02	172.20	0.000	0.000	116.39	0.00	0.00
12	147.00	AM-X-CD-17-65-00T-RET	3	9.807	16.574	0.76	12.56	92.40	0.000	0.000	208.22	0.00	0.00
13	147.00	7770.00	6	9.807	16.574	0.75	26.46	210.00	0.000	0.000	438.56	0.00	0.00
14	137.50	782 11056	3	9.622	16.261	0.78	0.40	5.40	0.000	0.000	6.47	0.00	0.00
15	137.00	Low Profile Platform w/	1	9.612	16.244	1.00	33.84	1800.00	0.000	0.000	549.70	0.00	0.00
16	137.00	LNx-6515DS-VTM	3	9.612	16.244	0.84	28.80	153.90	0.000	0.000	467.89	0.00	0.00
17	137.00	KRY 112 144/1	3	9.612	16.244	0.72	0.89	33.00	0.000	0.000	14.39	0.00	0.00
18	137.00	FE15501P77/75	3	9.612	16.244	0.99	1.87	52.50	0.000	0.000	30.39	0.00	0.00
19	137.00	APXV18-206516S-C-A20	3	9.612	16.244	0.78	8.47	56.10	0.000	0.000	137.60	0.00	0.00

Totals: 7,001.00

3,886.42

Total Applied Force Summary

Structure: CT01364-S-SB
Site Name: Pomfret
Height: 168.00 (ft)
Base Elev: 0.000 (ft)

Code: EIA/TIA-222-F
Exposure: C
Gh: 1.69
Struct Class: II

10/14/2015
 Page: 19



Load Case: 50 mph Wind with 0" Ice

Dead Load Factor 1.00
Wind Load Factor 1.00

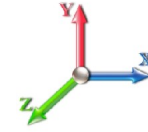

Iterations: 24

Elev (ft)	Description	Lateral FX (-) (lb)	Axial FY (-) (lb)	Torsion MY (lb-ft)	Moment MZ (lb-ft)
0.00		0.00	0.00	0.00	0.00
5.00		163.83	1471.85	0.00	0.00
10.00		160.83	1447.64	0.00	0.00
15.00		157.83	1423.42	0.00	0.00
20.00		154.82	1399.21	0.00	0.00
25.00		151.82	1374.99	0.00	0.00
30.00		148.82	1350.78	0.00	0.00
35.00		148.29	1326.56	0.00	0.00
40.00		150.88	1302.34	0.00	0.00
44.00		121.69	1024.44	0.00	0.00
45.00		30.85	479.33	0.00	0.00
50.00		156.94	2367.60	0.00	0.00
55.00		157.80	1250.37	0.00	0.00
60.00		158.21	1226.15	0.00	0.00
65.00		158.22	1201.94	0.00	0.00
70.00		157.89	1177.72	0.00	0.00
75.00		157.23	1153.51	0.00	0.00
80.00		156.29	1129.29	0.00	0.00
83.75		116.19	831.08	0.00	0.00
85.00		39.00	444.14	0.00	0.00
89.00		124.79	1403.83	0.00	0.00
90.00		30.90	164.75	0.00	0.00
95.00		154.45	813.37	0.00	0.00
100.00		152.61	796.08	0.00	0.00
105.00		150.57	778.78	0.00	0.00
110.00		148.35	761.48	0.00	0.00
115.00		145.96	744.19	0.00	0.00
119.50		129.10	654.98	0.00	0.00
120.00		14.36	117.33	0.00	0.00
123.75		107.23	870.02	0.00	0.00
125.00		35.30	150.56	0.00	0.00
130.00		140.00	593.61	0.00	0.00
135.00		137.03	579.77	0.00	0.00
137.00	(13) appurtenances	1253.75	2323.53	0.00	0.00
137.50	(3) appurtenances	19.81	55.82	0.00	0.00
140.00		66.39	250.04	0.00	0.00
145.00		130.69	489.70	0.00	0.00
147.00	(38) appurtenances	1560.44	2634.60	0.00	0.00
150.00		75.84	243.48	0.00	0.00
155.00		123.86	394.72	0.00	0.00
157.00	(7) appurtenances	782.85	1405.01	0.00	0.00
160.00		71.60	208.15	0.00	0.00
165.00		116.58	335.85	0.00	0.00
167.00	(1) appurtenances	475.20	1330.46	0.00	0.00
168.00	(1) appurtenances	29.02	70.90	0.00	0.00
Totals:		8,824.09	41,553.39	0.00	0.00

Resulting Forces and Deflections

Structure: CT01364-S-SB
Site Name: Pomfret
Height: 168.00 (ft)
Base Elev: 0.000 (ft)

Code: EIA/TIA-222-F
Exposure: C
Gh: 1.69
Struct Class: II

10/14/2015
 Page: 20



Load Case: 50 mph Wind with 0" Ice

Dead Load Factor 1.00
Wind Load Factor 1.00

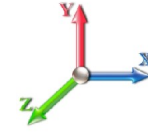

Iterations: 24

Elev (ft)	Lateral FX (-) (kips)	Axial FY (-) (kips)	Lateral FZ (kips)	Moment MX (ft-kips)	Torsion MY (ft-kips)	Moment MZ (ft-kips)	Deflect X (in)	Deflect Z (in)	Deflect Resultant (in)	Rotation Sway (deg)	Rotation Twist (deg)
0.00	-8.840	-41.550	0.000	0.000	0.000	-1014.9	0.000	0.000	0.000	0.000	0.000
5.00	-8.708	-40.071	0.000	0.000	0.000	-970.74	-0.025	0.000	0.025	-0.046	0.000
10.00	-8.577	-38.617	0.000	0.000	0.000	-927.20	-0.098	0.000	0.098	-0.092	0.000
15.00	-8.446	-37.187	0.000	0.000	0.000	-884.32	-0.219	0.000	0.219	-0.139	0.000
20.00	-8.317	-35.781	0.000	0.000	0.000	-842.09	-0.390	0.000	0.390	-0.186	0.000
25.00	-8.189	-34.400	0.000	0.000	0.000	-800.50	-0.611	0.000	0.611	-0.234	0.000
30.00	-8.062	-33.043	0.000	0.000	0.000	-759.56	-0.881	0.000	0.881	-0.282	0.000
35.00	-7.933	-31.710	0.000	0.000	0.000	-719.25	-1.202	0.000	1.202	-0.330	0.000
40.00	-7.798	-30.403	0.000	0.000	0.000	-679.59	-1.574	0.000	1.574	-0.379	0.000
44.00	-7.682	-29.376	0.000	0.000	0.000	-648.39	-1.909	0.000	1.909	-0.418	0.000
45.00	-7.662	-28.893	0.000	0.000	0.000	-640.71	-1.997	0.000	1.997	-0.428	0.000
50.00	-7.509	-26.520	0.000	0.000	0.000	-602.40	-2.473	0.000	2.473	-0.478	0.000
55.00	-7.362	-25.265	0.000	0.000	0.000	-564.86	-2.999	0.000	2.999	-0.527	0.000
60.00	-7.211	-24.035	0.000	0.000	0.000	-528.05	-3.576	0.000	3.576	-0.574	0.000
65.00	-7.059	-22.829	0.000	0.000	0.000	-491.99	-4.202	0.000	4.202	-0.620	0.000
70.00	-6.906	-21.647	0.000	0.000	0.000	-456.69	-4.877	0.000	4.877	-0.667	0.000
75.00	-6.751	-20.490	0.000	0.000	0.000	-422.17	-5.601	0.000	5.601	-0.713	0.000
80.00	-6.594	-19.359	0.000	0.000	0.000	-388.41	-6.373	0.000	6.373	-0.759	0.000
83.75	-6.474	-18.527	0.000	0.000	0.000	-363.68	-6.983	0.000	6.983	-0.794	0.000
85.00	-6.436	-18.080	0.000	0.000	0.000	-355.59	-7.193	0.000	7.193	-0.805	0.000
89.00	-6.298	-16.676	0.000	0.000	0.000	-329.85	-7.883	0.000	7.883	-0.842	0.000
90.00	-6.275	-16.508	0.000	0.000	0.000	-323.55	-8.060	0.000	8.060	-0.851	0.000
95.00	-6.123	-15.691	0.000	0.000	0.000	-292.18	-8.983	0.000	8.983	-0.909	0.000
100.00	-5.972	-14.892	0.000	0.000	0.000	-261.56	-9.965	0.000	9.965	-0.966	0.000
105.00	-5.821	-14.110	0.000	0.000	0.000	-231.70	-11.006	0.000	11.006	-1.020	0.000
110.00	-5.671	-13.346	0.000	0.000	0.000	-202.59	-12.103	0.000	12.103	-1.073	0.000
115.00	-5.521	-12.601	0.000	0.000	0.000	-174.24	-13.254	0.000	13.254	-1.122	0.000
119.50	-5.384	-11.946	0.000	0.000	0.000	-149.40	-14.332	0.000	14.332	-1.164	0.000
120.00	-5.371	-11.828	0.000	0.000	0.000	-146.70	-14.454	0.000	14.454	-1.169	0.000
123.75	-5.250	-10.958	0.000	0.000	0.000	-126.56	-15.386	0.000	15.386	-1.201	0.000
125.00	-5.216	-10.806	0.000	0.000	0.000	-120.00	-15.702	0.000	15.702	-1.211	0.000
130.00	-5.071	-10.212	0.000	0.000	0.000	-93.926	-16.995	0.000	16.995	-1.255	0.000
135.00	-4.925	-9.633	0.000	0.000	0.000	-68.572	-18.330	0.000	18.330	-1.292	0.000
137.00	-3.620	-7.338	0.000	0.000	0.000	-58.722	-18.875	0.000	18.875	-1.305	0.000
137.50	-3.600	-7.282	0.000	0.000	0.000	-56.912	-19.012	0.000	19.012	-1.308	0.000
140.00	-3.530	-7.033	0.000	0.000	0.000	-47.912	-19.700	0.000	19.700	-1.322	0.000
145.00	-3.390	-6.545	0.000	0.000	0.000	-30.262	-21.097	0.000	21.097	-1.343	0.000
147.00	-1.768	-3.948	0.000	0.000	0.000	-23.482	-21.661	0.000	21.661	-1.350	0.000
150.00	-1.687	-3.706	0.000	0.000	0.000	-18.177	-22.512	0.000	22.512	-1.358	0.000
155.00	-1.555	-3.314	0.000	0.000	0.000	-9.741	-23.940	0.000	23.940	-1.367	0.000
157.00	-0.738	-1.928	0.000	0.000	0.000	-6.632	-24.513	0.000	24.513	-1.370	0.000
160.00	-0.662	-1.722	0.000	0.000	0.000	-4.416	-25.375	0.000	25.375	-1.373	0.000
165.00	-0.538	-1.389	0.000	0.000	0.000	-1.106	-26.814	0.000	26.814	-1.375	0.000
167.00	-0.031	-0.070	0.000	0.000	0.000	-0.031	-27.390	0.000	27.390	-1.375	0.000
168.00	-0.029	0.000	0.000	0.000	0.000	0.000	0.000	0.000	27.678	-1.375	0.000

Resulting Stresses

Structure: CT01364-S-SBA
Site Name: Pomfret
Height: 168.00 (ft)
Base Elev: 0.000 (ft)

Code: EIA/TIA-222-F
Exposure: C
Gh: 1.69
Struct Class: II

10/14/2015
 Page: 21



Load Case: 50 mph Wind with 0" Ice

Dead Load Factor 1.00
Wind Load Factor 1.00



Iterations: 24

Applied Stresses

Elev (ft)	fa Axial (Y) (ksi)	fvx Shear (X) (ksi)	fvz Shear (Z) (ksi)	fvT Torsion (ksi)	fbx Bending (X) (ksi)	fbz Bending (Z) (ksi)	fb Combined (ksi)	Allow Stress (ksi)	f/Fb Stress Ratio
0.00	0.53	0.23	0.00	0.00	0.00	11.33	11.87	52.0	0.228
5.00	0.52	0.23	0.00	0.00	0.00	11.24	11.77	52.0	0.227
10.00	0.52	0.23	0.00	0.00	0.00	11.15	11.67	52.0	0.225
15.00	0.51	0.23	0.00	0.00	0.00	11.05	11.57	52.0	0.223
20.00	0.50	0.23	0.00	0.00	0.00	10.95	11.45	52.0	0.220
25.00	0.49	0.23	0.00	0.00	0.00	10.83	11.33	52.0	0.218
30.00	0.48	0.23	0.00	0.00	0.00	10.71	11.19	52.0	0.215
35.00	0.47	0.24	0.00	0.00	0.00	10.57	11.05	52.0	0.213
40.00	0.46	0.24	0.00	0.00	0.00	10.42	10.89	52.0	0.209
44.00	0.45	0.24	0.00	0.00	0.00	10.30	10.75	52.0	0.207
45.00	0.44	0.24	0.00	0.00	0.00	10.26	10.72	52.0	0.206
50.00	0.41	0.23	0.00	0.00	0.00	9.71	10.13	52.0	0.195
55.00	0.40	0.23	0.00	0.00	0.00	9.52	9.93	48.0	0.207
60.00	0.39	0.23	0.00	0.00	0.00	9.32	9.72	48.0	0.202
65.00	0.38	0.24	0.00	0.00	0.00	9.10	9.48	48.0	0.198
70.00	0.37	0.24	0.00	0.00	0.00	8.86	9.24	48.0	0.192
75.00	0.36	0.24	0.00	0.00	0.00	8.60	8.97	48.0	0.187
80.00	0.34	0.24	0.00	0.00	0.00	8.32	8.68	48.0	0.181
83.75	0.34	0.24	0.00	0.00	0.00	8.10	8.44	48.0	0.176
85.00	0.33	0.24	0.00	0.00	0.00	8.02	8.36	48.0	0.174
89.00	0.43	0.32	0.00	0.00	0.00	10.42	10.86	48.0	0.226
90.00	0.42	0.33	0.00	0.00	0.00	10.33	10.77	52.0	0.207
95.00	0.41	0.33	0.00	0.00	0.00	9.84	10.27	52.0	0.198
100.00	0.40	0.33	0.00	0.00	0.00	9.30	9.72	52.0	0.187
105.00	0.39	0.33	0.00	0.00	0.00	8.72	9.13	52.0	0.176
110.00	0.38	0.33	0.00	0.00	0.00	8.08	8.48	52.0	0.163
115.00	0.37	0.33	0.00	0.00	0.00	7.37	7.77	52.0	0.149
119.50	0.36	0.33	0.00	0.00	0.00	6.68	7.07	52.0	0.136
120.00	0.36	0.33	0.00	0.00	0.00	6.60	6.99	52.0	0.134
123.75	0.42	0.41	0.00	0.00	0.00	7.19	7.65	52.0	0.147
125.00	0.42	0.41	0.00	0.00	0.00	6.93	7.38	48.0	0.154
130.00	0.41	0.41	0.00	0.00	0.00	5.78	6.23	48.0	0.130
135.00	0.40	0.41	0.00	0.00	0.00	4.51	4.96	48.0	0.103
137.00	0.31	0.31	0.00	0.00	0.00	3.97	4.31	48.0	0.090
137.50	0.31	0.30	0.00	0.00	0.00	3.87	4.21	48.0	0.088
140.00	0.30	0.30	0.00	0.00	0.00	3.38	3.71	48.0	0.077
145.00	0.29	0.30	0.00	0.00	0.00	2.29	2.63	48.0	0.055
147.00	0.18	0.16	0.00	0.00	0.00	1.83	2.03	48.0	0.042
150.00	0.17	0.16	0.00	0.00	0.00	1.48	1.67	48.0	0.035
155.00	0.16	0.15	0.00	0.00	0.00	0.86	1.05	48.0	0.022
157.00	0.09	0.07	0.00	0.00	0.00	0.60	0.71	48.0	0.015
160.00	0.09	0.07	0.00	0.00	0.00	0.42	0.52	48.0	0.011
165.00	0.07	0.06	0.00	0.00	0.00	0.11	0.21	48.0	0.004
167.00	0.00	0.00	0.00	0.00	0.00	0.00	0.01	48.0	0.000
168.00	0.00	0.00	0.00	0.00	0.00	0.00	0.01	48.0	0.000

Final Analysis Summary

Structure: CT01364-S-SBA
Site Name: Pomfret
Height: 168.00 (ft)
Base Elev: 0.000 (ft)

Code: EIA/TIA-222-F
Exposure: C
Gh: 1.69
Struct Class: II

10/14/2015
 Page: 22



Reactions

Load Case	Shear FX (kips)	Shear FZ (kips)	Axial FY (kips)	Moment MX (ft-kips)	Moment MY (ft-kips)	t MZ (ft-kips)
85 mph Wind with 0" Ice	25.5	0.00	41.52	0.00	0.00	2931.62
73.61 mph Wind with 0.5" Ice	20.5	0.00	47.37	0.00	0.00	2410.98
50 mph Wind with 0" Ice	8.8	0.00	41.55	0.00	0.00	1014.94

Max Stresses

Load Case	fa Axial (Y) (ksi)	fvx Shear (X) (ksi)	fvz Shear (Z) (ksi)	fvT Torsion (ksi)	fbx Bending (X) (ksi)	fbz Bending (Z) (ksi)	Combined Stress (ksi)	Allowable Stress (ksi)	Elev (ft)	Stress Ratio
85 mph Wind with 0" Ice	0.53	0.66	0.00	0.00	0.00	32.72	33.27	52.0	0.00	0.640
73.61 mph Wind with 0.5" Ice	0.50	0.78	0.00	0.00	0.00	25.29	25.82	48.0	89.00	0.538
50 mph Wind with 0" Ice	0.53	0.23	0.00	0.00	0.00	11.33	11.87	52.0	0.00	0.228



Monopole Mat Foundation Design

Date
10/14/2015

Customer Name:	T-Mobile	EIA/TIA Standard:	EIA-222-F
Site Name:	Pomfret	Structure Height (Ft.):	168
Site Number:	CT01364-S-SBA	Engineer Name:	S. Hesselbein
Engr. Number:	17978	Engineer Login ID:	

Foundation Info Obtained from:

Mapping Operation

Structure Type:

Monopole

Analysis or Design?

Analysis

Base Reactions (Unfactored)

Axial Load (Kips):	41.5	Shear Force (Kips):	25.5
Uplift Force (Kips):	0.0	Moment (Kips-ft):	2931.6

Allowable overstress %: 5.0%

Foundation Geometries:

Diameter of Pier (ft.):	9.0	Mods required -Yes/No ?:	No
Pier Height A. G. (ft.):	1.00	Depth of Base BG (ft.):	8.6
Length of Pad (ft.):	23	Thickness of Pad (ft.):	2.00
Final Length of pad (ft)	23.0	Final width of pad (ft):	23.0
Control Value for Cell D18:	0	Control Value for Cell F18:	0

Material Properties and Rebar Info:

Concrete Strength (psi):	3000	Steel Elastic Modulus:	29000	ksi
Vertical bar yield (ksi)	60	Tie steel yield (ksi):	60	
Vertical Rebar Size #:	9	Tie / Stirrup Size #:	4	
Qty. of Vertical Rebars:	46	Tie Spacing (in):	12.0	
Pad Rebar Yield (Ksi):	60	Pad Steel Rebar Size (#):	8	
Concrete Cover (in.):	3	Unit Weight of Concrete:	150.0	pcf
Rebar at the bottom of the concrete pad:				
Qty. of Rebar in Pad (L):	20	Qty. of Rebar in Pad (W):	20	
Rebar at the top of the concrete pad:				
Qty. of Rebar in Pad (L):	20	Qty. of Rebar in Pad (W):	20	

Apply 1.35 factor for e/w Per G: 1.35

Soil Design Parameters:

Soil Unit Weight (pcf):	125.0	Soil Buoyant Weight:	50.0	Pcf
Water Table B.G.S. (ft):	99.0	Unit Weight of Water:	62.4	pcf
Allowable Net Soil Bearing (psf):	9000	Allowable Skin Friction:	0	Psf
Consider Friction for O.T.M. (Y/N):	No	Consider Friction for bearing (Y/N):	No	
Consider soil hori. force for O.T.M.:	No	Reduction factor on the maximum soil bearing pressure:	1.00	
		Angle from Top of Pad:		30
		Angle from Bottom of Pad:		25
		Angle from Bottom of Pad:		25

Foundation Analysis and Design:

Total Dry Soil Volume (cu. Ft.):	3071.53	Total Dry Soil Weight (Kips):	383.94
Total Buoyant Soil Volume (cu. Ft.):	0.00	Total Buoyant Soil Weight (Kips):	0.00
Total Effective Soil Weight (Kips):	383.94	Weight from the Concrete Block at Top (K):	0.00
Total Dry Concrete Volume (cu. Ft.):	1541.49	Total Dry Concrete Weight (Kips):	231.22
Total Buoyant Concrete Volume (cu. Ft.):	0.00	Total Buoyant Concrete Weight (Kips):	0.00
Total Effective Concrete Weight (Kips):	231.22	Total Vertical Load on Base (Kips):	656.68

Check Soil Capacities:

Calculated Maximum Net Soil Pressure under the base (psf):	2506	<	Allowable Soil Bearing (psf):	9000	0.28	OK!
Allowable Foundation Overturning Resistance (SF=1.5, kips-ft.):	5034.6	>	Applied Moment (kips-ft):	3176	0.63	OK!
Factor of Safety Against Overturning (O. R. Moment/Design Moment):	2.38					OK!

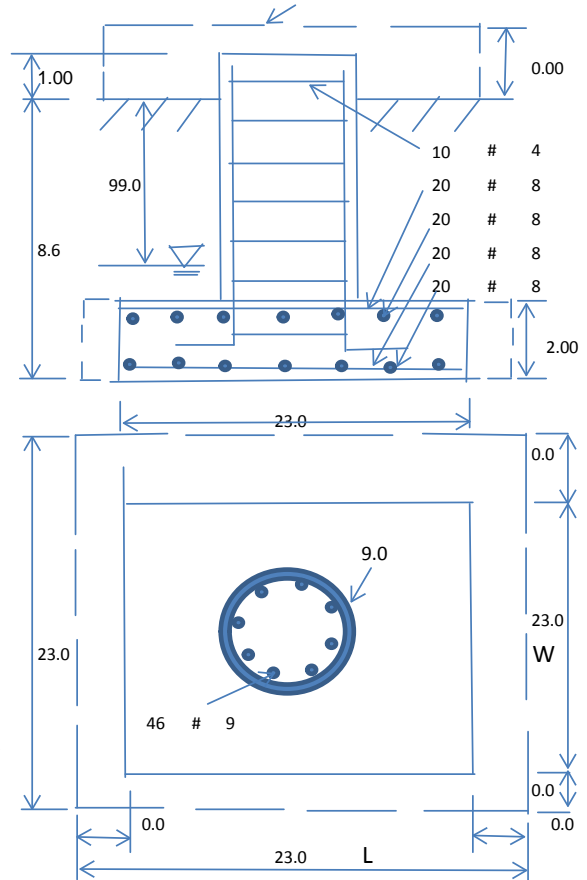

Check the capacities of Reinforcing Concrete:

Strength reduction factor (Flexure and axial tension):	0.90	Strength reduction factor (Shear):	0.75		
Strength reduction factor (Axial compression):	0.65	Wind Load Factor on Concrete Design:	1.30		

(1) Concrete Pier:

				Load/ Capacity Ratio	
Vertical Steel Rebar Area (sq. in./each):	1.00	Tie / Stirrup Area (sq. in./each):	0.20		
Calculated Moment Capacity (Mn,Kips-Ft):	9927.8	> Design Factored Moment (Mu, Kips-Ft)	3125.4	0.31	OK!
Calculated Shear Capacity (Kips):	925.4	> Design Factored Shear (Kips):	33.2	0.04	OK!
Calculated Tension Capacity (Tn, Kips):	2484.0	> Design Factored Tension (Tu Kips):	0.0	0.00	OK!
Calculated Compression Capacity (Pn, Kips):	12086.3	> Design Factored Axial Load (Pu Kips):	54.0	0.00	OK!
Moment & Axial Strength Combination:	0.31	OK! Check Tie Spacing (Design/Required):		1	OK!
Pier Reinforcement Ratio:	0.005	Reinforcement Ratio is satisfied per ACI			

(2).Concrete Pad:

One-Way Design Shear Capacity (L-Direction, Kips):	464.9	> One-Way Factored Shear (L-D. Kips):	222.3	0.48	OK!
One-Way Design Shear Capacity (W-Direction, Kips):	464.9	> One-Way Factored Shear (W-D., Kips):	222.3	0.48	OK!
One-Way Design Shear Capacity (Corner-Corner. Kips):	475.5	> One-Way Factored Shear (C-C, Kips):	319.3	0.67	OK!
Lower Steel Pad Reinforcement Ratio (L-Direct.):	0.0028	OK! Lower Steel Pad Reinf. Ratio (W-Direct.):	0.0028		
Lower Steel Pad Moment Capacity (L-Direction. Kips-ft):	1409.7	> Moment at Bottom (L-Direct. K-Ft):	452.4	0.32	OK!
Lower Steel Pad Moment Capacity (W-Direction. Kips-ft):	1409.7	> Moment at Bottom (W-Direct. K-Ft):	452.4	0.32	OK!
Lower Steel Pad Moment Capacity (Corner-Corner,K-ft):	1967.7	> Moment at Bottom (C-C Dir. K-Ft):	639.8	0.33	OK!
Upper Steel Pad Reinforcement Ratio (L-Direct.):	0.0028	OK! Upper Steel Reinf. Ratio (W-Direct.):	0.0028		
Upper Steel Pad Moment Capacity (L-Direction. Kips-ft):	1409.7	> Moment at the top (L-Dir Kips-Ft):	229.5	0.16	OK!
Upper Steel Pad Moment Capacity (W-Direction. Kips-ft):	1409.7	> Moment at the top (W-Dir Kips-Ft):	229.5	0.16	OK!
Upper Steel Pad Moment Capacity (Corner-Corner. K-ft):	1967.7	> Moment at the top (C-C Direc. K-Ft):	500.7	0.25	OK!

ANTENNA MOUNT STRUCTURAL ASSESSMENT REQUIREMENT:

ENGINEER OF RECORD HAS MADE A VISUAL ASSESSMENT ONLY AND DETERMINED THAT THE EXISTING ANTENNA MOUNT SHALL BE REPLACED OR MODIFIED TO ACCOMMODATE ANY ADDITIONAL EQUIPMENT LOADS. STRUCTURAL DESIGNS AND DETAILS AS SHOWN HEREIN FOR STRUCTURAL MODIFICATIONS OF THE EXISTING ANTENNA MOUNT ARE PRELIMINARY ONLY AND FINAL CONSTRUCTION DETAILS ARE SUBJECT TO CHANGE PENDING THE COMPLETION OF AN ANTENNA MOUNT STRUCTURAL ASSESSMENT.

STRUCTURAL NOTES:

PRIOR TO COMMENCING CONSTRUCTION, GC SHALL REFER TO TOWER STRUCTURAL ANALYSIS PROVIDED BY SBA TO DETERMINE IF THERE ARE ANY SUPPLEMENTAL OR SPECIAL INSTALLATION REQUIREMENTS FOR TOWER TOP EQUIPMENT AND FOR CABLE BUNDLING, SHIELDING, MOUNTING, OR RELOCATION ARRANGEMENTS

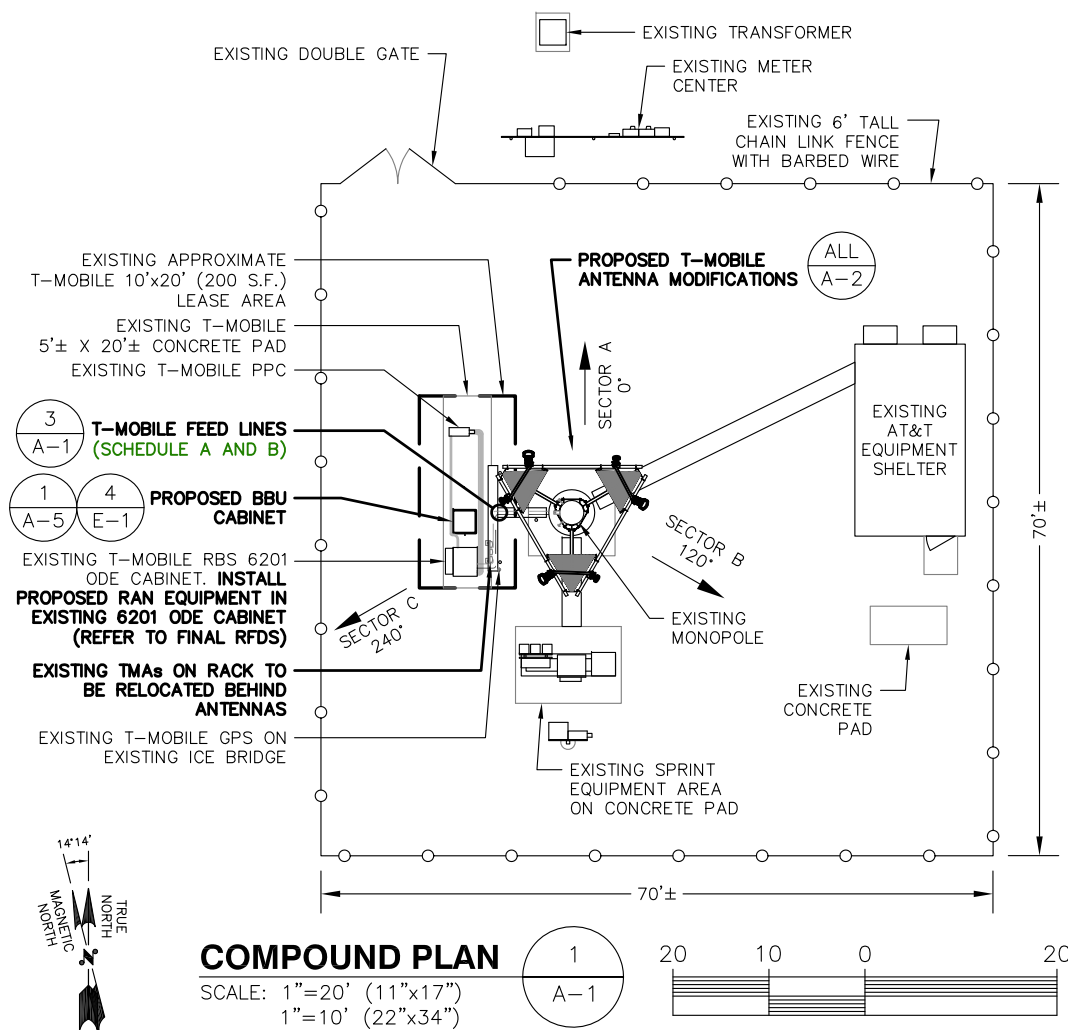

COMPOUND PLAN

SCALE: 1"=20' (11"x17")
1"=10' (22"x34")

FEEDLINE SCHEDULE	FEEDLINE DESCRIPTION	LOCATION
A	EXISTING: TO REMAIN (6) 1-5/8" COAX TO 137' RAD	UP INSIDE MONOPOLE
B	PROPOSED: (6) 1-5/8" COAX TO 137' RAD	UP INSIDE MONOPOLE

NOTE: EXISTING T-MOBILE EQUIPMENT FEEDLINE INVENTORY BASED ON OBSERVED FIELD CONDITIONS. RFDS AND FEEDLINE LEASING ENTITLEMENTS MAY DIFFER.



PARTIAL ELEVATION PHOTO DETAIL

SCALE: N.T.S.

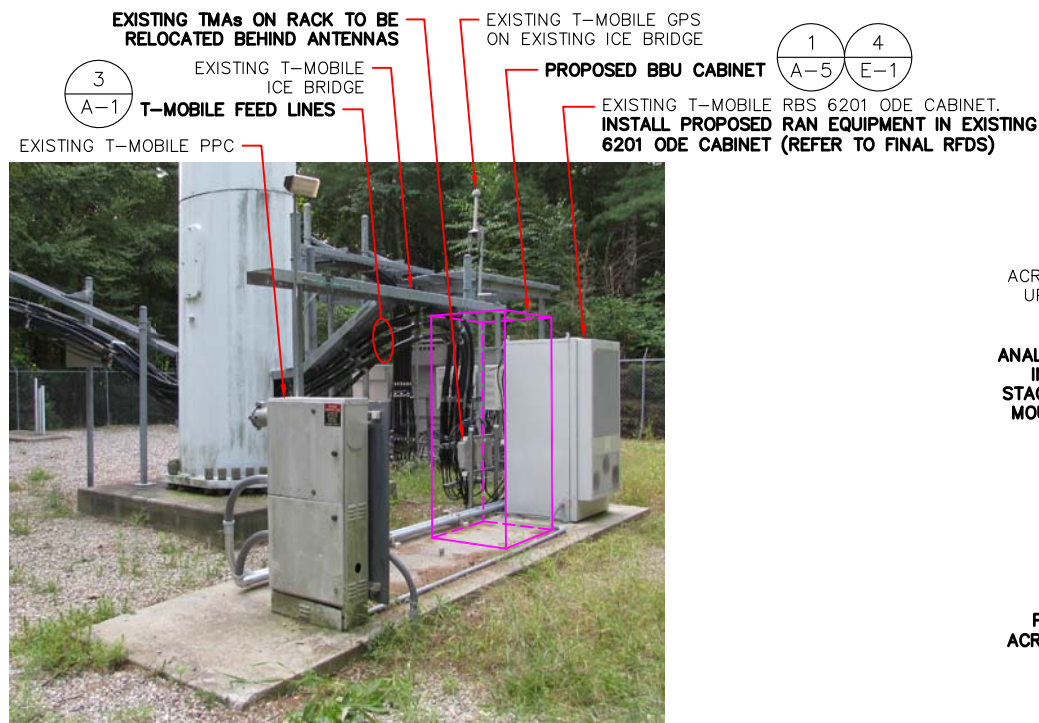

EQUIPMENT PHOTO DETAIL

SCALE: N.T.S.

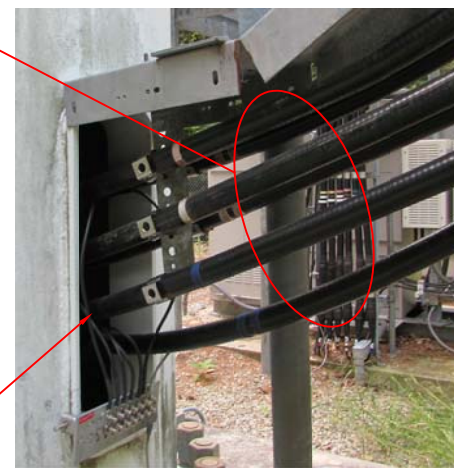

FEEDLINE PHOTO DETAIL AT TOWER BASE

SCALE: N.T.S.

T-Mobile
T-MOBILE NORTHEAST LLC
35 GRIFFIN ROAD SOUTH
BLOOMFIELD, CT 06002
OFFICE: (860) 648-1116

SBA
SBA COMMUNICATIONS CORP.
33 BOSTON POST ROAD WEST, SUITE 320
MARLBOROUGH, MA 01752 TEL: (508) 251-0720

ProTerra
DESIGN GROUP, LLC
4 Bay Road, Building A
Suite 200
Hadley, MA 01035 Ph: (413) 320-4918

STATE OF CONNECTICUT
THOMAS E. JOHNSON
No. 28192
LICENSED PROFESSIONAL ENGINEER
10-13-15

CHECKED BY: JMM/TEJ
APPROVED BY: JMM/TEJ

SUBMITTALS

REV.	DATE	DESCRIPTION	BY
1	10/13/15	CONSTRUCTION REVISED	JEB
0	09/21/15	ISSUED FOR CONSTRUCTION	JEB

SITE NUMBER:
CT11524A
SITE NAME:
CT524 / SBA POMFRET
SITE ADDRESS:
62 BABBIT HILL ROAD
POMFRET, CT 06259
WINDHAM COUNTY

SHEET TITLE
COMPOUND & ELEVATION PLAN

SHEET NUMBER
A-1

ANTENNA MOUNT STRUCTURAL ASSESSMENT REQUIREMENT:
 ENGINEER OF RECORD HAS MADE A VISUAL ASSESSMENT ONLY AND DETERMINED THAT THE EXISTING ANTENNA MOUNT SHALL BE REPLACED OR MODIFIED TO ACCOMMODATE ANY ADDITIONAL EQUIPMENT LOADS. STRUCTURAL DESIGNS AND DETAILS AS SHOWN HEREIN FOR STRUCTURAL MODIFICATIONS OF THE EXISTING ANTENNA MOUNT ARE PRELIMINARY ONLY AND FINAL CONSTRUCTION DETAILS ARE SUBJECT TO CHANGE PENDING THE COMPLETION OF AN ANTENNA MOUNT STRUCTURAL ASSESSMENT.

STRUCTURAL NOTES:
 PRIOR TO COMMENCING CONSTRUCTION, GC SHALL REFER TO TOWER STRUCTURAL ANALYSIS PROVIDED BY SBA TO DETERMINE IF THERE ARE ANY SUPPLEMENTAL OR SPECIAL INSTALLATION REQUIREMENTS FOR TOWER TOP EQUIPMENT AND FOR CABLE BUNDLING, SHIELDING, MOUNTING, OR RELOCATION ARRANGEMENTS

NOTE:
 REFER TO THE FINAL RF DATA SHEET FOR FINAL ANTENNA SETTINGS.

T-Mobile
T-MOBILE NORTHEAST LLC
 35 GRIFFIN ROAD SOUTH
 BLOOMFIELD, CT 06002
 OFFICE: (860) 648-1116

SBA
 SBA COMMUNICATIONS CORP.
 33 BOSTON POST ROAD WEST, SUITE 320
 MARLBOROUGH, MA 01752 TEL: (508) 251-0720

ProTerra
 DESIGN GROUP, LLC
 4 Bay Road, Building A
 Suite 200
 Hadley, MA 01035 Ph: (413) 320-4918

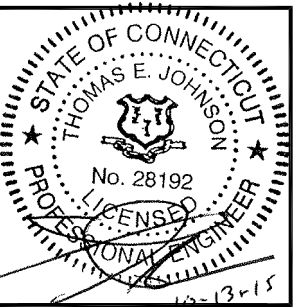

CHECKED BY: JMM/TEJ

APPROVED BY: JMM/TEJ

SUBMITTALS

REV.	DATE	DESCRIPTION	BY
1	10/13/15	CONSTRUCTION REVISED	JEB
0	09/21/15	ISSUED FOR CONSTRUCTION	JEB

SITE NUMBER:
CT11524A
 SITE NAME:
CT524 / SBA POMFRET
 SITE ADDRESS:
 62 BABBIT HILL ROAD
 POMFRET, CT 06259
 WINDHAM COUNTY

SHEET TITLE
EXISTING & PROPOSED ANTENNA PLAN

SHEET NUMBER
A-2

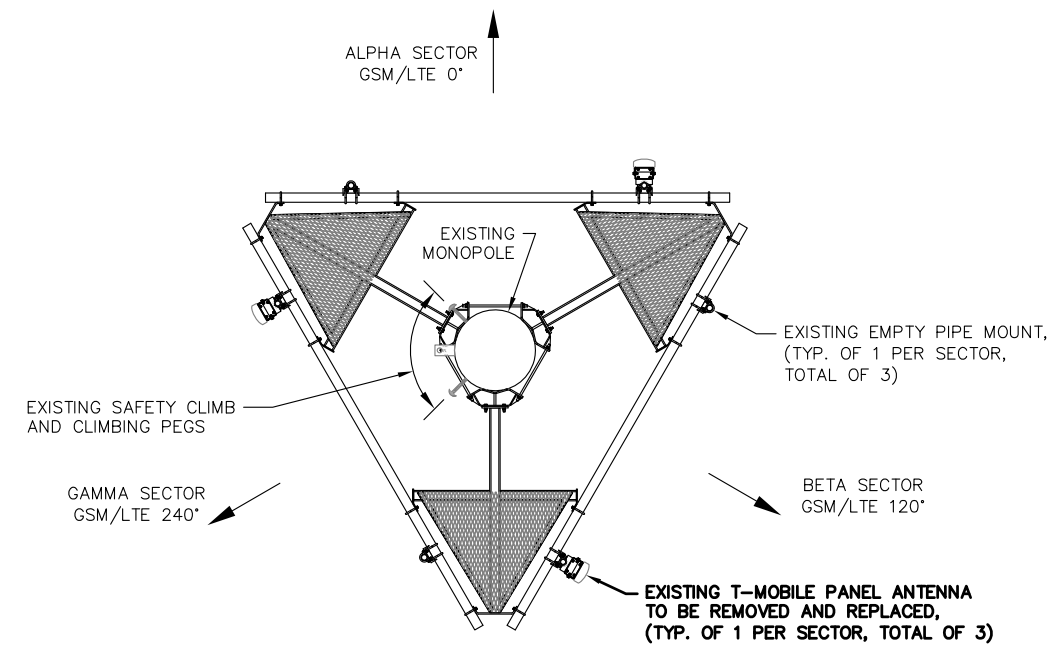

EXISTING ANTENNA PLAN

SCALE: N.T.S.

1
A-2

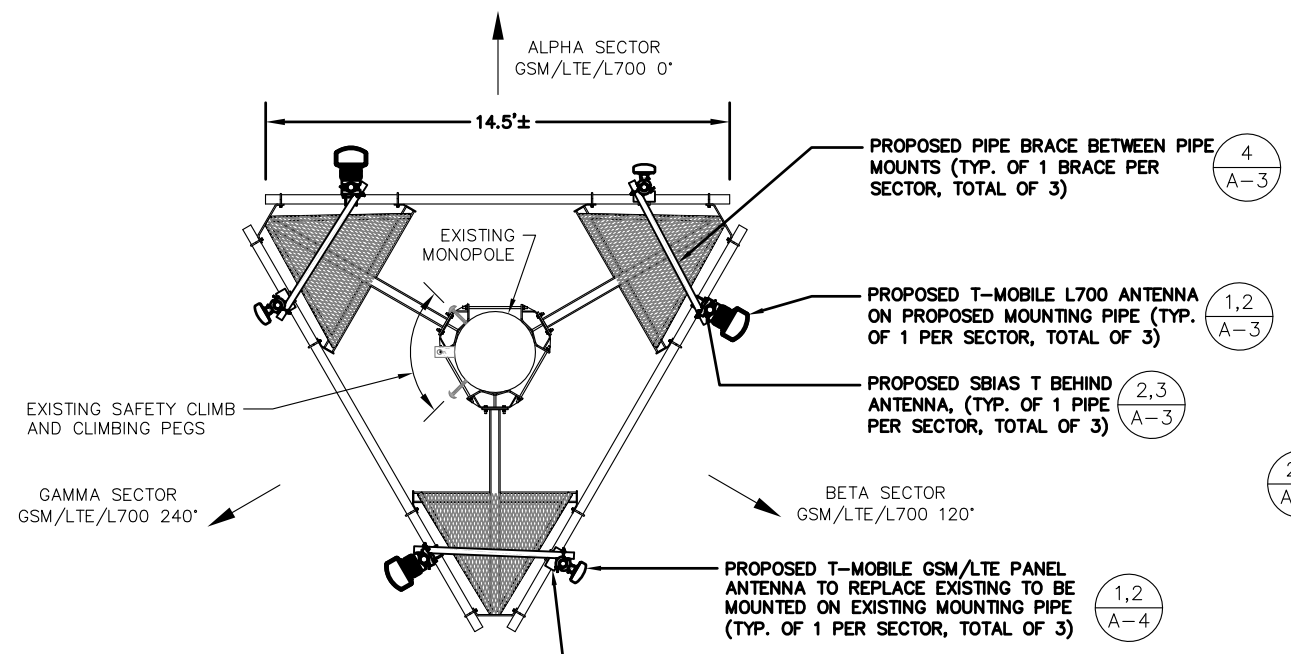
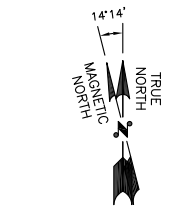

PROPOSED ANTENNA PLAN

SCALE: N.T.S.

2
A-2

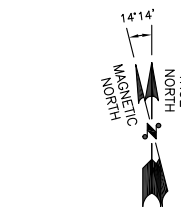

NOTE:
 ALL PIPE TO BE SCH40 GALVANIZED
 ASTM A53 GRADE B (35 KSI)

1,2
A-3
PROPOSED T-MOBILE L700 ANTENNA ON PROPOSED MOUNTING PIPE (TYP. OF 1 PER SECTOR, TOTAL OF 3)

2,3
A-3
PROPOSED SBIAS T BEHIND ANTENNA, (TYP. OF 1 PIPE PER SECTOR, TOTAL OF 3)

EXISTING T-MOBILE PANEL ANTENNA TO BE REMOVED AND REPLACED, (TYP. OF 1 PER SECTOR, TOTAL OF 3)

4
A-3
PROPOSED PIPE BRACE BETWEEN PIPE MOUNTS (TYP. OF 1 BRACE PER SECTOR, TOTAL OF 3)

1,2
A-3
PROPOSED T-MOBILE L700 ANTENNA ON PROPOSED MOUNTING PIPE (TYP. OF 1 PER SECTOR, TOTAL OF 3)

2,3
A-3
PROPOSED SBIAS T BEHIND ANTENNA, (TYP. OF 1 PIPE PER SECTOR, TOTAL OF 3)

2,3
A-4
RELOCATE EXISTING TMA (FROM GROUND RACK) MOUNTED ON BACK OF ANTENNA MOUNTING PIPE BEHIND PROPOSED ANTENNA, (TYP. OF 1 PER SECTOR, TOTAL OF 3)

1,2
A-4
PROPOSED T-MOBILE GSM/LTE PANEL ANTENNA TO REPLACE EXISTING TO BE MOUNTED ON EXISTING MOUNTING PIPE (TYP. OF 1 PER SECTOR, TOTAL OF 3)

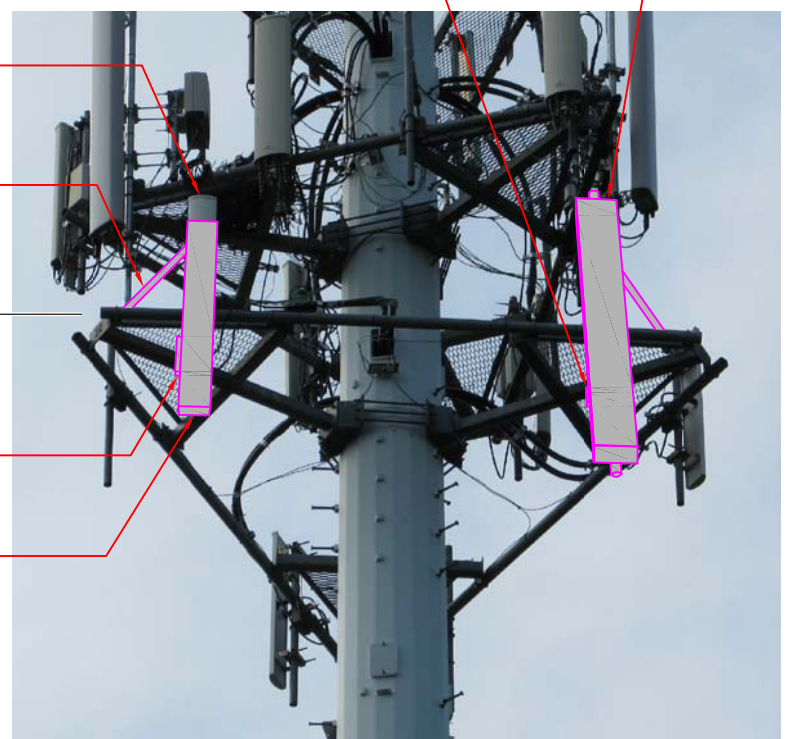
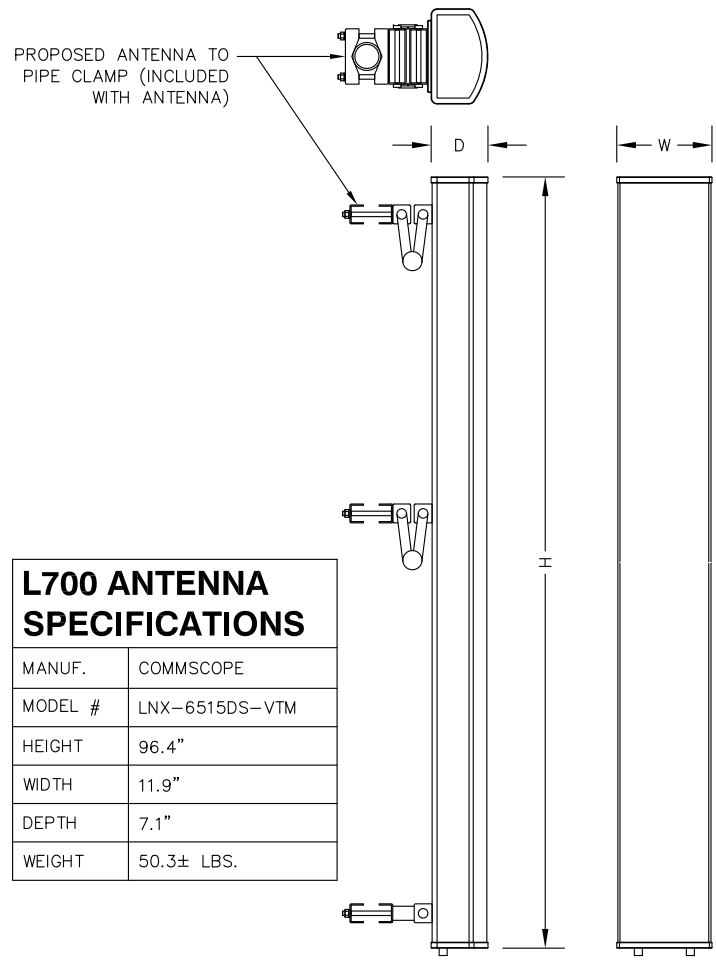

IMAGE SOURCE: PROTERRA 09/04/15
 NOTE: ONE SECTOR SHOWN FOR CLARITY

ANTENNA PHOTO DETAIL

SCALE: N.T.S.

3
A-2



L700 ANTENNA SPECIFICATIONS

MANUF.	COMMSCOPE
MODEL #	LNX-6515DS-VTM
HEIGHT	96.4"
WIDTH	11.9"
DEPTH	7.1"
WEIGHT	50.3± LBS.

L700 ANTENNA DETAIL

SCALE: N.T.S.

1
A-3

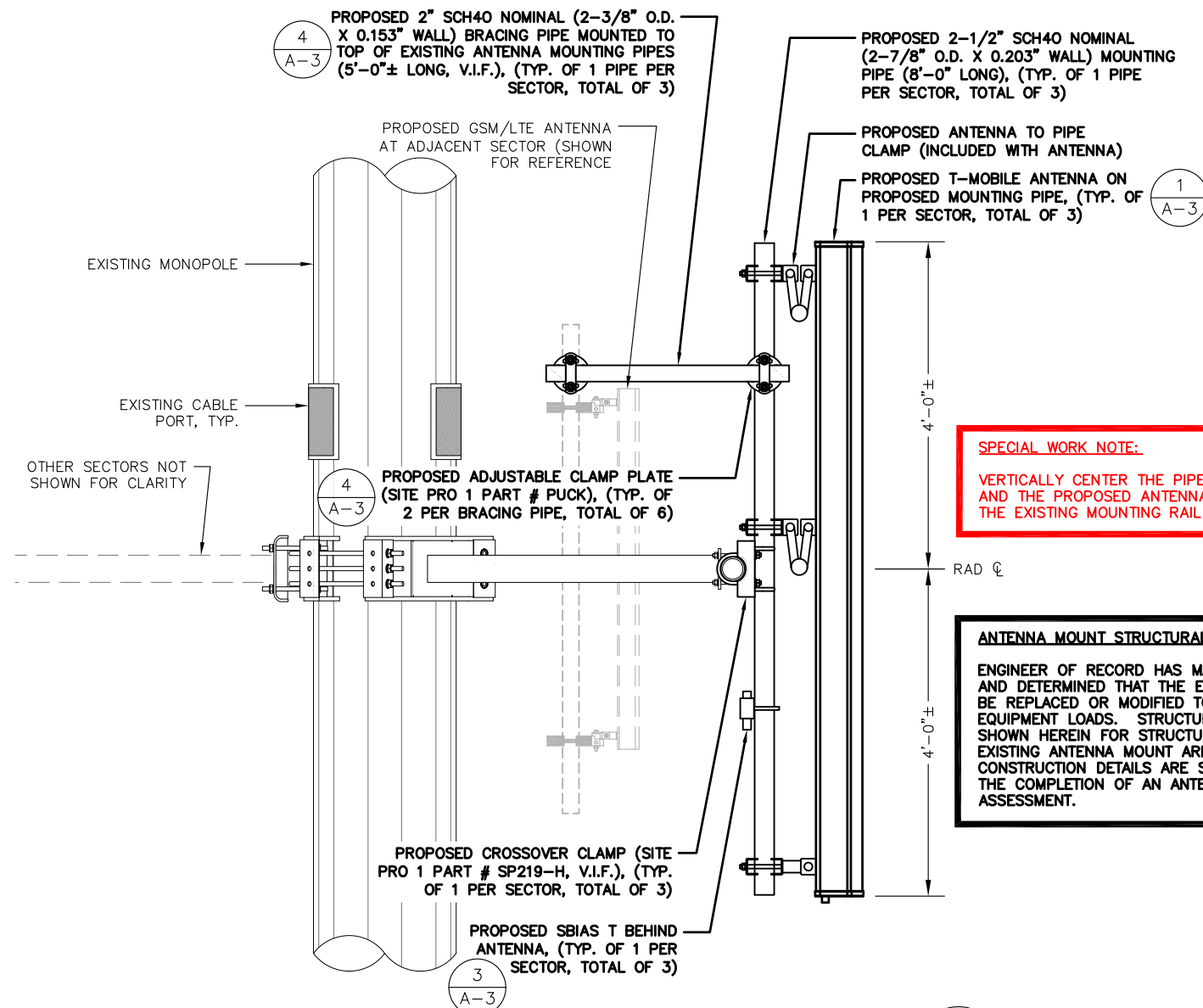

SPECIAL WORK NOTE:
VERTICALLY CENTER THE PIPE MAST AND THE PROPOSED ANTENNAS ON THE EXISTING MOUNTING RAIL

ANTENNA MOUNT STRUCTURAL ASSESSMENT REQUIREMENT:
ENGINEER OF RECORD HAS MADE A VISUAL ASSESSMENT ONLY AND DETERMINED THAT THE EXISTING ANTENNA MOUNT SHALL BE REPLACED OR MODIFIED TO ACCOMMODATE ANY ADDITIONAL EQUIPMENT LOADS. STRUCTURAL DESIGNS AND DETAILS AS SHOWN HEREIN FOR STRUCTURAL MODIFICATIONS OF THE EXISTING ANTENNA MOUNT ARE PRELIMINARY ONLY AND FINAL CONSTRUCTION DETAILS ARE SUBJECT TO CHANGE PENDING THE COMPLETION OF AN ANTENNA MOUNT STRUCTURAL ASSESSMENT.

PROPOSED L700 ANTENNA MOUNTING DETAIL

SCALE: N.T.S.

2
A-3

SBT SPECIFICATIONS

MANUF.	COMMSCOPE
MODEL #	ATSBT-TOP-FM-4G
HEIGHT	5.63"
WIDTH	3.7"
DEPTH	2.0"
WEIGHT	1.8 LBS.

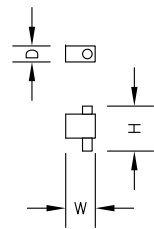

SMART BIAS TEE (SBT)

SCALE: N.T.S.

3
A-3

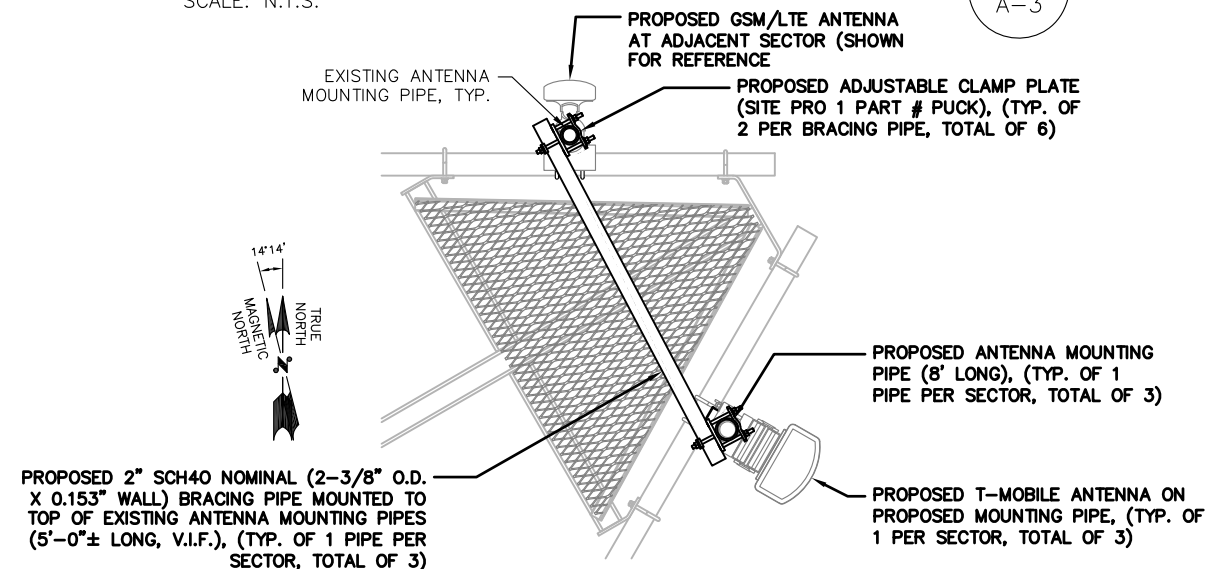

PROPOSED ANTENNA PIPE BRACE DETAIL

SCALE: N.T.S.

4
A-3



T-MOBILE NORTHEAST LLC
35 GRIFFIN ROAD SOUTH
BLOOMFIELD, CT 06002
OFFICE: (860) 648-1116



SBA COMMUNICATIONS CORP.
33 BOSTON POST ROAD WEST, SUITE 320
MARLBOROUGH, MA 01752 TEL: (508) 251-0720



4 Bay Road, Building A
Suite 200
Hadley, MA 01035 Ph: (413) 320-4918

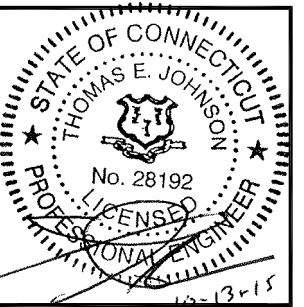

CHECKED BY: JMM/TEJ

APPROVED BY: JMM/TEJ

SUBMITTALS

REV.	DATE	DESCRIPTION	BY
1	10/13/15	CONSTRUCTION REVISED	JEB
0	09/21/15	ISSUED FOR CONSTRUCTION	JEB

SITE NUMBER:
CT11524A
SITE NAME:
CT524 / SBA POMFRET

SITE ADDRESS:
62 BABBIT HILL ROAD
POMFRET, CT 06259
WINDHAM COUNTY

SHEET TITLE
DETAILS

SHEET NUMBER
A-3

GSM/LTE ANTENNA SPECIFICATIONS

MANUF.	RFS
MODEL #	APXV18-206516S-C-A20
HEIGHT	53.1"
WIDTH	6.9"
DEPTH	3.15"
WEIGHT	18.7± LBS.

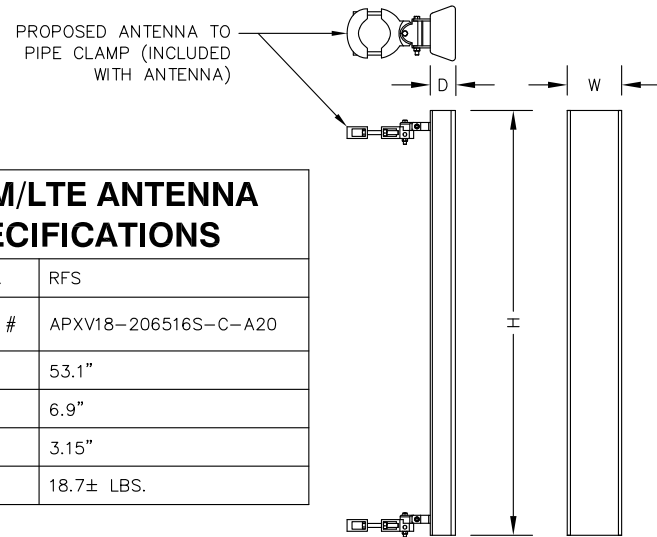

GSM/LTE ANTENNA DETAIL

SCALE: N.T.S.

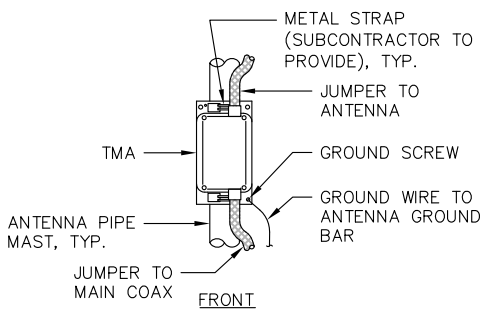
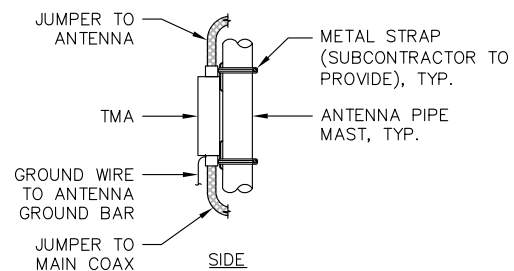
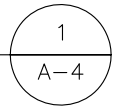

TMA MOUNTING DETAIL

SCALE: N.T.S.

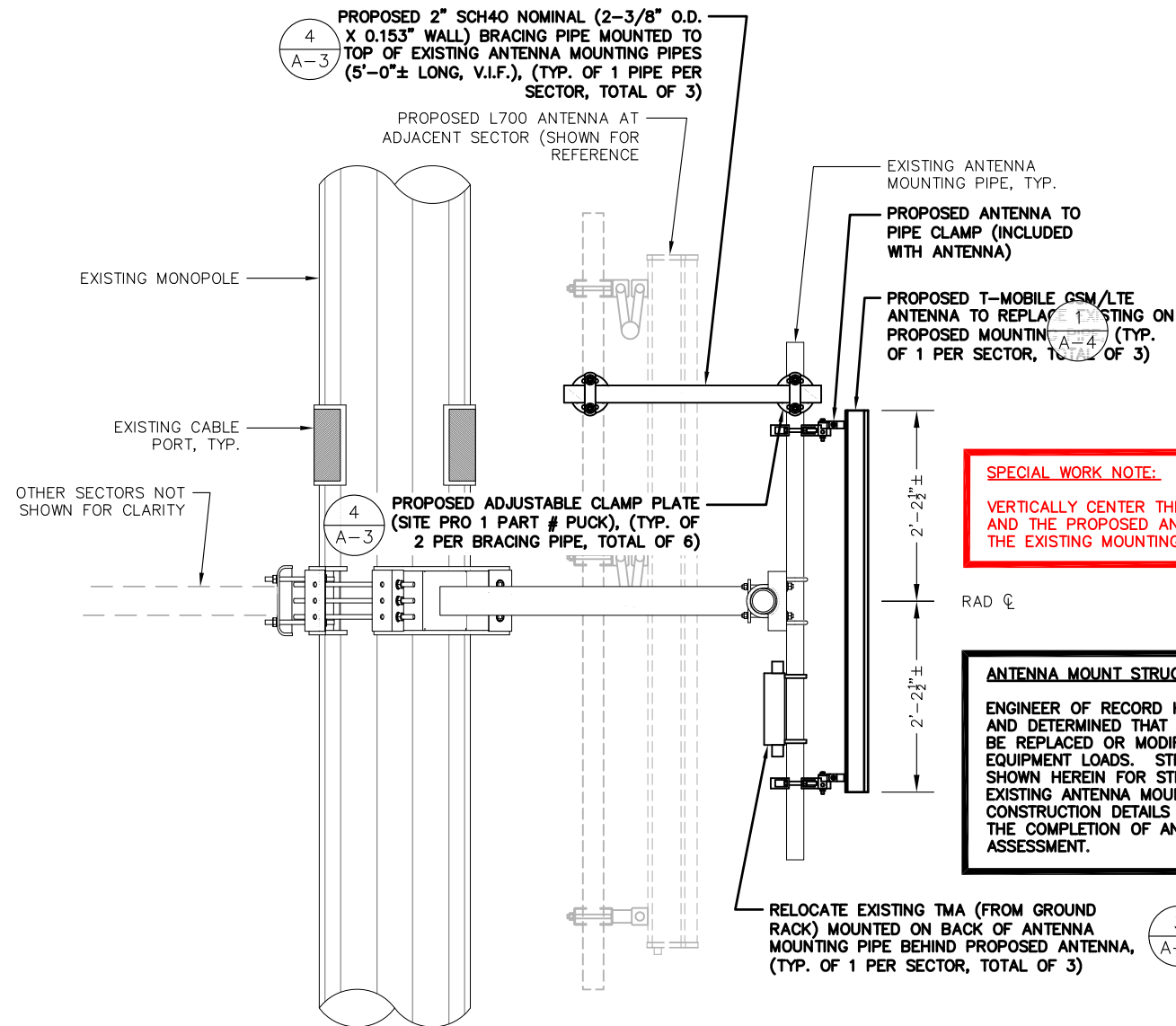
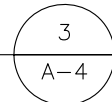

SPECIAL WORK NOTE:
VERTICALLY CENTER THE PIPE MAST AND THE PROPOSED ANTENNAS ON THE EXISTING MOUNTING RAIL

ANTENNA MOUNT STRUCTURAL ASSESSMENT REQUIREMENT:
ENGINEER OF RECORD HAS MADE A VISUAL ASSESSMENT ONLY AND DETERMINED THAT THE EXISTING ANTENNA MOUNT SHALL BE REPLACED OR MODIFIED TO ACCOMMODATE ANY ADDITIONAL EQUIPMENT LOADS. STRUCTURAL DESIGNS AND DETAILS AS SHOWN HEREIN FOR STRUCTURAL MODIFICATIONS OF THE EXISTING ANTENNA MOUNT ARE PRELIMINARY ONLY AND FINAL CONSTRUCTION DETAILS ARE SUBJECT TO CHANGE PENDING THE COMPLETION OF AN ANTENNA MOUNT STRUCTURAL ASSESSMENT.

PROPOSED GSM/LTE ANTENNA MOUNTING DETAIL

SCALE: N.T.S.

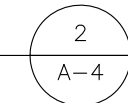

T-Mobile
T-MOBILE NORTHEAST LLC
35 GRIFFIN ROAD SOUTH
BLOOMFIELD, CT 06002
OFFICE: (860) 648-1116



SBA COMMUNICATIONS CORP.
33 BOSTON POST ROAD WEST, SUITE 320
MARLBOROUGH, MA 01752 TEL: (508) 251-0720

ProTerra
DESIGN GROUP, LLC

4 Bay Road, Building A
Suite 200
Hadley, MA 01035 Ph: (413)320-4918

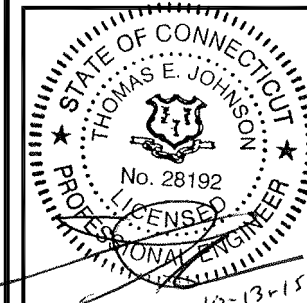

CHECKED BY: JMM/TEJ

APPROVED BY: JMM/TEJ

SUBMITTALS			
REV.	DATE	DESCRIPTION	BY
1	10/13/15	CONSTRUCTION REVISED	JEB
0	09/21/15	ISSUED FOR CONSTRUCTION	JEB

SITE NUMBER:
CT11524A
SITE NAME:
CT524 / SBA POMFRET

SITE ADDRESS:
62 BABBIT HILL ROAD
POMFRET, CT 06259
WINDHAM COUNTY

SHEET TITLE
DETAILS

SHEET NUMBER
A-4