



May 30, 2014

David Martin and
Members of the Siting Council
Connecticut Siting Council
Ten Franklin Square
New Britain, CT 06051

RE: Notice of Exempt Modification
170 Mount Tobe Road
Plymouth, CT 06782
Sprint Site #: NV2.5_CT33XC275
N 41° 37' 48.11"
W -73° 03' 23.59"

Dear Mr. Martin and Members of the Siting Council:

On behalf of Sprint Spectrum, SBA Communications is submitting an exempt modification application to the Connecticut Siting Council for modification of existing equipment at a tower facility located at 170 Mount Tobe Road, Plymouth CT.

The 170 Mount Tobe Road facility consists of a 160' MONOPOLE Tower owned and operated by SBA Properties, LLC. In order to accommodate technological changes and enhance system performance in the State of Connecticut, Sprint Spectrum plans to modify the equipment configurations at many of its existing cell sites. Please accept this letter and attachments as notification, pursuant to R.C.S.A. Section 16-50j-73, of construction which constitutes an exempt modification pursuant to R.C.S.A. Section 16-50j-72(b)(2). In compliance with R.C.S.A. Section 16-50j-73, a copy of this letter and attachments is being sent to the chief elected official of the municipality in which the affected cell site is located.

As part of Sprint's Network Vision modification project, Sprint desires to upgrade their equipment to meet the new standards of 4G technology. The new equipment will allow customers to download files and browse the internet at a high rate of speed while also allowing their phones to be compatible with the latest 4G technology.

Attached is a summary of the planned modifications, including power density calculations reflecting the change in Sprint's operations at the site along with the required fee of \$625.

The changes to the facility do not constitute modifications as defined in Connecticut General Statutes ("C.G.S.") Section 16-50i(d) because the general physical characteristics of the facility will not be



significantly changed or altered. Rather, the planned changes to the facility fall squarely within those activities explicitly provided for in R.C.S.A. Section 16-50j-72(b)(2).

1. The overall height of the structure will be unaffected.
2. The proposed changes will not extend the site boundaries. There will be no effect on the site compound other than the new equipment cabinets.
3. The proposed changes will not increase the noise level at the existing facility by six decibels or more.
4. The changes in radio frequency power density will not increase the calculated "worst case" power density for the combined operations at the site to a level at or above the applicable standard for uncontrolled environments as calculated for a mixed frequency site.

For the foregoing reasons, SBA Communications on behalf of Sprint Spectrum, respectfully submits that the proposed changes at the referenced site constitute exempt modifications under R.C.S.A. Section 16-50j-72(b)(2).

Please feel free to call me at (508) 251-0720 x 3804 with any questions you may have concerning this matter.

Thank you,

Kri Pelletier
SBA Communications Corporation
33 Boston Post Road West Suite 320
Marlborough, MA 01752
508-251-0720 x 3804 + T
508-251-1755 + F
203-446-7700 + C
kpelletier@sbsite.com



**Sprint Spectrum
Equipment Modification**

170 Mount Tobe Road, Plymouth CT
Site number CT33XC275

Tower Owner: SBA Properties, LLC

Equipment Configuration: MONOPOLE Tower

Current and/or approved:

- (3) RFS APXVSP18-C-A20
- (3) Alcatel Lucent 1900 MHz RRHs
- (3) Alcatel Lucent 800 MHz RRHs
- (3) Alcatel Lucent 800 MHz Filters
- (4) RFS ACU-A20-N RETs
- (3) 1-1/4" Hybrid Lines

Planned Modifications:

Elevation 150':

- (3) RFS APXVTM14-C-I20

Elevation 148':

- (3) RFS APXVSP18-C-A20
- (3) Alcatel Lucent 1900 MHz RRHs
- (3) Alcatel Lucent 800 MHz RRHs
- (3) Alcatel Lucent 800 MHz Filters
- (4) RFS ACU-A20-N RETs
- (3) TD-RRH8x20-25 RRHs
- (4) 1-1/4" Hybrid Lines

Structural Information:

The attached structural analysis demonstrates that the tower and foundation will have adequate structural capacity to accommodate the proposed modifications.

Power Density:

The anticipated Maximum Composite contributions from the Sprint facility are 0.50% of the allowable FCC established general public limit. The anticipated composite MPE value for this site assuming all carriers present is 52.51% of the allowable FCC established general public limit sampled at the ground level.

Site Composite MPE %	
Carrier	MPE %
Sprint	0.50%
T-Mobile	0.13%
MetroPCS	4.97%
Nextel	3.54%
Verizon Wireless	15.81%
AT&T	27.56%
Total Site MPE %	52.51%



May 30, 2014

Mayor David V. Merchant
Town of Plymouth
Town Hall
80 Main Street
Terryville, CT 06786

RE: Telecommunications Facility @ 170 Mount Tobe Road, Plymouth CT

Dear Mayor Merchant,

In order to accommodate technological changes and enhance system performance in the State of Connecticut, Sprint Spectrum will be changing its equipment configuration at certain cell sites.

As required by Regulations of Connecticut State Agencies (R.C.S.A.) Section 16-50j-73, the Connecticut Siting Council has been notified of the changes and will review Sprint's proposal. Please accept this letter as notification under Section 16-50j-73 of construction which constitutes an exempt modification pursuant to R.C.S.A. Section 16-50j-72(b)(2).

The accompanying letter to the Siting Council fully describes Sprint's proposal for the referenced cell site. However, if you have any questions or require any further information on our plans or the Siting Council's procedures, please call me at (508) 251-0720 x 3804.

Thank you,

Kri Pelletier
SBA Communications Company
33 Boston Post Road West, Suite 320
Marlborough, MA 01752
508-251-0720 x 3804 + T
508-251-1755 + F
203-446-7700 + C
kpelletier@sbsite.com



May 30, 2014

Mrs. Susan A. and Mr. Walter T. MacDonald
42 South Street
Plymouth CT 06782-2315

RE: Telecommunications Facility @ 170 Mount Tobe Road, Plymouth CT

Dear Mr. & Mrs. MacDonald,

In order to accommodate technological changes and enhance system performance in the State of Connecticut, Sprint Spectrum will be changing its equipment configuration at certain cell sites.

As required by Regulations of Connecticut State Agencies (R.C.S.A.) Section 16-50j-73, the Connecticut Siting Council has been notified of the changes and will review Sprint's proposal. Please accept this letter as notification under Section 16-50j-73 of construction which constitutes an exempt modification pursuant to R.C.S.A. Section 16-50j-72(b)(2).

The accompanying letter to the Siting Council fully describes Sprint's proposal for the referenced cell site. However, if you have any questions or require any further information on our plans or the Siting Council's procedures, please call me at (508) 251-0720 x 3804.

Thank you,

A handwritten signature in black ink, appearing to read "Kri Pelletier".

Kri Pelletier
SBA Communications Company
33 Boston Post Road West, Suite 320
Marlborough, MA 01752
508-251-0720 x 3804 + T
508-251-1755 + F
203-446-7700 + C
kpelletier@sbsite.com

RADIO FREQUENCY FCC REGULATORY COMPLIANCE
MAXIMUM PERMISSIBLE EXPOSURE (MPE) ASSESSMENT

Sprint Existing Facility

Site ID: CT33XC275

Thomaston SBA

170 Mount Tobe Road
Thomaston, CT 06787

May 28, 2014

EBI Project Number: 62143097

May 28, 2014

Sprint
Attn: RF Engineering Manager
1 International Boulevard, Suite 800
Mahwah, NJ 07495

Re: Radio Frequency Maximum Permissible Exposure (MPE) Assessment for Site:
CT33XC275 - Thomaston SBA

Site Total: 52.51% - MPE% in full compliance

EBI Consulting was directed to analyze the proposed upgrades to the existing Sprint facility located at 170 Mount Tobe Road, Thomaston, CT, for the purpose of determining whether the radio frequency (RF) exposure levels from the proposed Sprint equipment upgrades on this property are within specified federal limits.

All information used in this report was analyzed as a percentage of current Maximum Permissible Exposure (% MPE) as listed in the FCC OET Bulletin 65 Edition 97-01 and ANSI/IEEE Std C95.1. The FCC regulates Maximum Permissible Exposure in units of microwatts per square centimeter ($\mu\text{W}/\text{cm}^2$). The number of $\mu\text{W}/\text{cm}^2$ calculated at each sample point is called the power density. The exposure limit for power density varies depending upon the frequencies being utilized. Wireless Carriers and Paging Services use different frequency bands each with different exposure limits, therefore it is necessary to report results and limits in terms of percent MPE rather than power density.

All results were compared to the FCC (Federal Communications Commission) radio frequency exposure rules, 47 CFR 1.1307(b)(1) – (b)(3), to determine compliance with the Maximum Permissible Exposure (MPE) limits for General Population/Uncontrolled environments as defined below.

General population/uncontrolled exposure limits apply to situations in which the general public may be exposed or in which persons who are exposed as a consequence of their employment may not be made fully aware of the potential for exposure or cannot exercise control over their exposure. Therefore, members of the general public would always be considered under this category when exposure is not employment related, for example, in the case of a telecommunications tower that exposes persons in a nearby residential area.

Public exposure to radio frequencies is regulated and enforced in units of microwatts per square centimeter ($\mu\text{W}/\text{cm}^2$). The general population exposure limit for the cellular band (850 MHz Band) is approximately $567 \mu\text{W}/\text{cm}^2$, and the general population exposure limit for the 1900 MHz and 2500 MHz bands is $1000 \mu\text{W}/\text{cm}^2$. Because each carrier will be using different frequency bands, and each frequency band has different exposure limits, it is necessary to report percent of MPE rather than power density.

Occupational/controlled exposure limits apply to situations in which persons are exposed as a consequence of their employment and in which those persons who are exposed have been made fully aware of the potential for exposure and can exercise control over their exposure. Occupational/controlled exposure limits also apply where exposure is of a transient nature as a result of incidental passage through a location where exposure levels may be above general population/uncontrolled limits (see below), as long as the exposed person has been made fully aware of the potential for exposure and can exercise control over his or her exposure by leaving the area or by some other appropriate means.

Additional details can be found in FCC OET 65.

CALCULATIONS

Calculations were done for the proposed upgrades to the existing Sprint Wireless antenna facility located at 170 Mount Tobe Road, Thomaston, CT, using the equipment information listed below. All calculations were performed per the specifications under FCC OET 65. All calculations were performed assuming a lobe representing the maximum gain of the antenna per the antenna manufactures supplied specifications, minus 10 dB, was focused at the base of the tower. For this report the sample point is the top of a 6 foot person standing at the base of the tower.

For all calculations, all emissions were calculated using the following assumptions:

- 1) 2 channels in the 1900 MHz Band were considered for each sector of the proposed installation.
- 2) 1 channel in the 800 MHz Band was considered for each sector of the proposed installation
- 3) 2 channels in the 2500 MHz Band were considered for each sector of the proposed installation.
- 4) All radios at the proposed installation were considered to be running at full power and were uncombined in their RF transmissions paths per carrier prescribed configuration. Per FCC OET Bulletin No. 65 - Edition 97-01 recommendations to achieve the maximum anticipated value at each sample point, all power levels emitting from the proposed antenna installation are increased by a factor of 2.56 to account for possible in-phase reflections from the surrounding environment. This is rarely the case, and if so, is never continuous.
- 5) For the following calculations the sample point was the top of a six foot person standing at the base of the tower. The maximum gain of the antenna per the antenna manufactures supplied specifications minus 10 dB was used in this direction. This value is a very conservative estimate as gain reductions for these particular antennas are typically much higher in this direction.

- 6) The antennas used in this modeling are the RFS APXVSPP18-C-A20 and the RFS APXVTM14-C-I20. This is based on feedback from the carrier with regards to anticipated antenna selection. The RFS APXVSPP18-C-A20 has a 15.9 dBd gain value at its main lobe at 1900 MHz and 13.4 dBd at its main lobe for 850 MHz. The RFS APXVTM14-C-I20 has a 15.9 dBd gain value at its main lobe at 2500 MHz. The maximum gain of the antenna per the antenna manufactures supplied specifications, minus 10 dB, was used for all calculations. This value is a very conservative estimate as gain reductions for these particular antennas are typically much higher in this direction.
- 7) The antenna mounting height centerline for the proposed antennas is **148 feet** above ground level (AGL).
- 8) Emissions values for additional carriers were taken from the Connecticut Siting Council active database. Values in this database are provided by the individual carriers themselves.

All calculation were done with respect to uncontrolled / general public threshold limits

Site ID	CT33XC275 - Thomaston SBA
Site Address	170 Mount Tobe Road, Thomaston, CT, 06787
Site Type	Monopole

Sector 1

Antenna Number	Antenna Make	Antenna Model	Radio Type	Frequency Band	Technology	Power Out Per Channel (Watts)	Number of Channels	Composite Power	Antenna Gain (10 db reduction)	Antenna Height (ft)	analysis height	Cable Size	Cable Loss (dB)	Additional Loss (dB)	ERP	Power Density Percentage
1a	RFS	APXVSP18-C-A20	RRH	1900 MHz	CDMA / LTE	20	2	40	1.59	148	142	1/2 "	0.5	3	25.77	0.05%
1a	RFS	APXVSP18-C-A20	RRH	850 MHz	CDMA / LTE	20	1	20	1.34	148	142	1/2 "	0.5	3	12.16	0.04%
1B	RFS	APXVTMM14-C-120	RRH	2500 MHz	CDMA / LTE	20	2	40	1.59	148	142	1/2 "	0.5	3	25.77	0.08%
Sector total Power Density Value:																0.17%

Sector 2

Antenna Number	Antenna Make	Antenna Model	Radio Type	Frequency Band	Technology	Power Out Per Channel (Watts)	Number of Channels	Composite Power	Antenna Gain (10 db reduction)	Antenna Height (ft)	analysis height	Cable Size	Cable Loss (dB)	Additional Loss (dB)	ERP	Power Density Percentage
2a	RFS	APXVSP18-C-A20	RRH	1900 MHz	CDMA / LTE	20	2	40	1.59	148	142	1/2 "	0.5	3	25.77	0.05%
2a	RFS	APXVSP18-C-A20	RRH	850 MHz	CDMA / LTE	20	1	20	1.34	148	142	1/2 "	0.5	3	12.16	0.04%
2B	RFS	APXVTMM14-C-120	RRH	2500 MHz	CDMA / LTE	20	2	40	1.59	148	142	1/2 "	0.5	3	25.77	0.08%
Sector total Power Density Value:																0.17%

Sector 3

Antenna Number	Antenna Make	Antenna Model	Radio Type	Frequency Band	Technology	Power Out Per Channel (Watts)	Number of Channels	Composite Power	Antenna Gain (10 db reduction)	Antenna Height (ft)	analysis height	Cable Size	Cable Loss (dB)	Additional Loss (dB)	ERP	Power Density Percentage
3a	RFS	APXVSP18-C-A20	RRH	1900 MHz	CDMA / LTE	20	2	40	1.59	148	142	1/2 "	0.5	3	25.77	0.05%
3a	RFS	APXVSP18-C-A20	RRH	850 MHz	CDMA / LTE	20	1	20	1.34	148	142	1/2 "	0.5	3	12.16	0.04%
3B	RFS	APXVTMM14-C-120	RRH	2500 MHz	CDMA / LTE	20	2	40	1.59	148	142	1/2 "	0.5	3	25.77	0.08%
Sector total Power Density Value:																0.17%

Site Composite MPE %	
Carrier	MPE %
Sprint	0.50%
T-Mobile	0.13%
MetroPCS	4.97%
Nextel	3.54%
Verizon Wireless	15.81%
AT&T	27.56%
Total Site MPE %	52.51%

Summary

All calculations performed for this analysis yielded results that were well within the allowable limits for general public Maximum Permissible Exposure (MPE) to radio frequency energy.

The anticipated Maximum Composite contributions from the Sprint facility are **0.50% (0.17% from sector 1, 0.17% from sector 2 and 0.17% from sector 3)** of the allowable FCC established general public limit considering all three sectors simultaneously sampled at the ground level.

The anticipated composite MPE value for this site assuming all carriers present is **52.51%** of the allowable FCC established general public limit sampled at 6 feet above ground level. This total composite site value is based upon MPE values listed in the Connecticut Siting Council database for existing carrier emissions.

FCC guidelines state that if a site is found to be out of compliance (over allowable thresholds), that carriers over a 5% contribution to the composite value will require measures to bring the site into compliance. For this facility, the composite values calculated were well within the allowable 100% threshold standard per the federal government.



Scott Heffernan
RF Engineering Director

EBI Consulting
21 B Street
Burlington, MA 01803



**Structural Analysis for
SBA Network Services, Inc.**

160' Monopole Tower

**SBA Site Name: South Plymouth
SBA Site ID: CT03538-S-02
Sprint Site ID: CT33XC275**

FDH Project Number 1462H11400

Analysis Results

Tower Components	84.6 %	Sufficient
Foundation	84.6 %	Sufficient

Prepared By:

Cary J. Webb, PE
Project Engineer

Reviewed By:

Bradley Newman, PE
Senior Project Engineer
CT License No. 29630

FDH Engineering, Inc.
6521 Meriden Drive
Raleigh, NC 27616
(919) 755-1012
info@fdh-inc.com

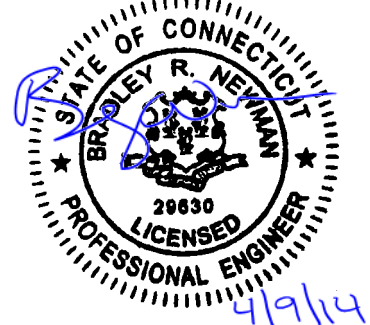

April 9, 2014

TABLE OF CONTENTS

EXECUTIVE SUMMARY3

 Conclusions.....3

 Recommendations3

APPURTENANCE LISTING4

RESULTS5

GENERAL COMMENTS6

LIMITATIONS.....6

APPENDIX7

EXECUTIVE SUMMARY

At the request of SBA Network Services, Inc., FDH Engineering, Inc. performed a structural analysis of the monopole located in Plymouth, CT to determine whether the tower is structurally adequate to support both the existing and proposed loads pursuant to the *Structural Standards for Steel Antenna Towers and Antenna Supporting Structures, TIA/EIA-222-F* and the *2005 Connecticut Building Code (CBC)*. Information pertaining to the existing/proposed antenna loading, current tower geometry, geotechnical data, foundation dimensions, and member sizes was obtained from:

- Paul J. Ford and Company (Job No. 29201-1019) original design drawings dated August 21, 2001
- Jaworski Geotech, Inc. (Project No. 00244G) Geotechnical Evaluation dated July 31, 2001
- SBA Network Services, Inc.

The *basic design wind speed* per the *TIA/EIA-222-F* standards and the *2005 CBC* is 80 mph without ice and 28 mph with 1" radial ice. Ice is considered to increase in thickness with height.

Conclusions

With the existing and proposed antennas from Sprint in place at 148 ft and 150 ft, the tower meets the requirements of the *TIA/EIA-222-F* standards and the *2005 CBC* provided the **Recommendations** listed below are satisfied. Furthermore, provided the foundation was designed and constructed to support the original design reactions (see Paul J. Ford and Company Job No. 29201-1019), the foundation should have the necessary capacity to support the existing and proposed loading. For a more detailed description of the analysis of the tower, see the **Results** section of this report.

Our structural analysis has been performed assuming all information provided to FDH Engineering, Inc. is accurate (i.e., the steel data, tower layout, existing antenna loading, and proposed antenna loading) and that the tower has been properly erected and maintained per the original design drawings.

Recommendations

To ensure the requirements of the *TIA/EIA-222-F* standards and the *2005 CBC* are met with the existing and proposed loading in place, we have the following recommendations:

1. The feed lines should be installed inside the pole's shaft.
2. The proposed TMAs should be installed directly behind the proposed panel antennas.

APPURTENANCE LISTING

The proposed and existing antennas with their corresponding cables/coax lines are shown in **Table 1**. *If the actual layout determined in the field deviates from the layout, FDH Engineering, Inc. should be contacted to perform a revised analysis.*

Table 1 - Appurtenance Loading

Existing Loading:

Antenna Elevation (ft)	Description	Feed Lines ¹	Carrier	Mount Elevation (ft)	Mount Type
160	(3) Ericsson AIR 21 B2A/B4P (3) Ericsson AIR 21 B4A/B2P (3) Ericsson KRY 112 144/1 TMAs	(12) 1-5/8" (1) 1-5/8" Fiber	T-Mobile	160	(1) Low Profile Platform
156.5	(1) Lone Star Electronics Co. LS-230C Omni	(1) 7/8"	Thomaston PD	153	(1) 4' Side-Arm
153	(1) Andrew VHLP-2.6-11 Dish (1) Hutton HPD3.4-4.7 Dish (3) Motorola ODU-A-RF Bands	(2) EW90			(2) Pipe Mounts
134.5	(1) Bird Technologies CSA10-67-DIM Dipole	(1) 7/8"			133
148	(3) RFS APXVSPP18-C-A20 (3) Alcatel Lucent 1900 MHz RRHs (3) Alcatel Lucent 800 MHz RRHs (3) Alcatel Lucent 800 MHz Filters (4) RFS ACU-A20-N RETs	(3) 1-1/4"	Sprint	148	(1) Low Profile Platform
137	(6) Antel LPA-80080/6CF (3) Antel BXA-70063/6CF-2 (3) Antel BXA-171085/8BF- 2 (6) RFS FDR6004/2C-3L Diplexers	(12) 1-5/8"	Verizon	137	(1) Low Profile Platform
127	(12) Decibel DB844H90E-XY	(12) 1-5/8"	Nextel	127	(1) Low Profile Platform
117	(3) RFS APXV18-206515S-C	(6) 1-5/8"	Pocket	117	(3) Pipe Mount
108	(6) Powerwave 7770 (3) CSS DUO1417-8686-40 (3) KMW AM-X-CD-16-65-00T-RET (6) Powerwave LGP21401 TMAs (6) Powerwave LGP21903 Diplexers (6) Ericsson RRUS-11 RRUs (1) Andrew ABT-DFDM-ADBH Surge Arrestor (1) Raycap DC6-48-60-18-8F Surge Arrestor	(12) 1-5/8" (1) 3" Conduit (1) 7/16" Fiber (2) 3/4" DC Power	AT&T	108	(1) Low Profile Platform
75	(1) GPS	(1) 1/2"	T-Mobile	75	(1) Pipe Mount

1. Feed lines installed inside pole's shaft unless otherwise noted

Proposed Loading:

Antenna Elevation (ft)	Description	Feed Lines	Carrier	Mount Elevation (ft)	Mount Type
150	(3) RFS APXVTM14-C-I20	(4) 1-1/4"	Sprint	148	(1) Low Profile Platform
148	(3) RFS APXVSPP18-C-A20 (3) Alcatel Lucent 1900 MHz RRHs (3) Alcatel Lucent 800 MHz RRHs (3) Alcatel Lucent 800 MHz Filters (4) RFS ACU-A20-N RETs (3) TD-RRH8x20-25 RRHs				

RESULTS

The following yield strength of steel for individual members was used for analysis:

Table 2 - Material Strength

Member Type	Yield Strength
Tower Shaft Sections	65 ksi
Base Plate	55 ksi
Anchor Bolts	75 ksi

Table 3 displays the summary of the ratio (as a percentage) of force in the member to their capacities. Values greater than 100% indicate locations where the maximum force in the member exceeds its capacity. *Note: Capacities up to 100% are considered acceptable.* **Table 4** displays the maximum foundation reactions. **Table 5** displays maximum antenna rotations at service wind speeds (dishes only).

If the assumptions outlined in this report differ from actual field conditions, FDH Engineering, Inc. should be contacted to perform a revised analysis. Furthermore, as no information pertaining to the allowable twist and sway requirements for the existing or proposed appurtenances was provided, deflection and rotation were not taken into consideration when performing this analysis.

See the **Appendix** for detailed modeling information.

Table 3 - Summary of Working Percentage of Structural Components

Section No.	Elevation (ft)	Component Type	Size	% Capacity	Pass Fail
L1	160 - 119.25	Pole	TP32.763x24x0.25	43.5	Pass
L2	119.25 - 78.5	Pole	TP41.025x31.3491x0.3125	77.9	Pass
L3	78.5 - 38.75	Pole	TP48.947x39.2711x0.375	84.6	Pass
L4	38.75 - 0	Pole	TP56.53x46.8531x0.4375	81.8	Pass
		Anchor Bolts	(20) 2.25" Ø w/ BC = 64"	71.2	Pass
		Base Plate	PL 64" Square x 3" Thick	65.4	Pass

*Capacities include a 1/3 allowable increase for wind per TIA/EIA-222-F standards.

Table 4 - Maximum Base Reactions

Base Reactions	Current Analysis (TIA/EIA-222-F)	Original Design (TIA/EIA-222-F)
Axial	48 k*	37 k
Shear	32 k	38 k
Moment	3,765 k-ft	4,450 k-ft

*Per our experience with foundations of similar type, the axial loading should not control the foundation analysis

Table 5 - Maximum Dish Rotations at Service Wind Speed (Dishes Only)

Centerline Elevation (ft)	Dish	Tilt* (deg)	Twist* (deg)
153	(1) Andrew VHLP-2.6-11 Dish (1) Hutton HPD3.4-4.7 Dish	1.9682	0.0046

*Allowable tilt and twist values to be determined by the carrier.

GENERAL COMMENTS

This engineering analysis is based upon the theoretical capacity of the structure. It is not a condition assessment of the tower and its foundation. It is the responsibility of SBA Network Services, Inc. to verify that the tower modeled and analyzed is the correct structure (with accurate antenna loading information) modeled. If there are substantial modifications to be made or the assumptions made in this analysis are not accurate, FDH Engineering, Inc. should be notified immediately to perform a revised analysis.

LIMITATIONS

All opinions and conclusions are considered accurate to a reasonable degree of engineering certainty based upon the evidence available at the time of this report. All opinions and conclusions are subject to revision based upon receipt of new or additional/updated information. All services are provided exercising a level of care and diligence equivalent to the standard and care of our profession. No other warranty or guarantee, expressed or implied, is offered. Our services are confidential in nature and we will not release this report to any other party without the client's consent. The use of this engineering work is limited to the express purpose for which it was commissioned and it may not be reused, copied, or distributed for any other purpose without the written consent of FDH Engineering, Inc.

APPENDIX

DESIGNED APPURTENANCE LOADING

TYPE	ELEVATION	TYPE	ELEVATION
AIR 21 B2A/B4P w/Mount Pipe	160	BXA-70063/6CF-2 w/ Mount Pipe	137
AIR 21 B2A/B4P w/Mount Pipe	160	BXA-70063/6CF-2 w/ Mount Pipe	137
AIR 21 B2A/B4P w/Mount Pipe	160	BXA-70063/6CF-2 w/ Mount Pipe	137
AIR 21 B4A/B2P w/Mount Pipe	160	BXA-171085-8BF-2 w/ Mount Pipe	137
AIR 21 B4A/B2P w/Mount Pipe	160	BXA-171085-8BF-2 w/ Mount Pipe	137
AIR 21 B4A/B2P w/Mount Pipe	160	BXA-171085-8BF-2 w/ Mount Pipe	137
KRY 112 144/1 TMA	160	(2) FDR6004/2C-3L	137
KRY 112 144/1 TMA	160	(2) FDR6004/2C-3L	137
KRY 112 144/1 TMA	160	(2) FDR6004/2C-3L	137
Empty Mount Pipe	160	Low Profile Platform	137
Empty Mount Pipe	160	(2) LPA-80080/6CF w/ Mount Pipe	137
Empty Mount Pipe	160	(2) LPA-80080/6CF w/ Mount Pipe	137
Low Profile Platform	160	Bird Technologies CSA10-67-DIM TX Dipole	133
Lone Star LS-230C RX Omni	153		
Motorola ODU-A-RF Bands	153	4' Standoff	133
Motorola ODU-A-RF Bands	153	(4) DB844H90E-XY w/ Mount Pipe	127
Motorola ODU-A-RF Bands	153	Low Profile Platform	127
4' Side-Arm	153	(4) DB844H90E-XY w/ Mount Pipe	127
Pipe Mount	153	(4) DB844H90E-XY w/ Mount Pipe	127
Pipe Mount	153	APXV18-206515S-C w/Mount Pipe	117
VHLP2.6-11	153	APXV18-206515S-C w/Mount Pipe	117
Hutton HPD33.4-4.7	153	APXV18-206515S-C w/Mount Pipe	117
APXVSPP18-C-A20 w/Mount Pipe	148	(2) 7770 w/ Mount Pipe	108
1900 MHz RRH	148	DUO1417-8686-40 w/ Mount Pipe	108
1900 MHz RRH	148	DUO1417-8686-40 w/ Mount Pipe	108
1900 MHz RRH	148	DUO1417-8686-40 w/ Mount Pipe	108
800 MHz RRH	148	AM-X-CD-16-65-00T-RET w/ Mount Pipe	108
800 MHz RRH	148	AM-X-CD-16-65-00T-RET w/ Mount Pipe	108
800 MHz RRH	148	AM-X-CD-16-65-00T-RET w/ Mount Pipe	108
800 MHz External Notch Filter	148	AM-X-CD-16-65-00T-RET w/ Mount Pipe	108
800 MHz External Notch Filter	148	AM-X-CD-16-65-00T-RET w/ Mount Pipe	108
800 MHz External Notch Filter	148	(2) LGP21401 TMA	108
ACU-A20-N RET	148	(2) LGP21401 TMA	108
ACU-A20-N RET	148	(2) LGP21401 TMA	108
(2) ACU-A20-N RET	148	(2) LGP21903 Diplexer	108
(2) Empty Mount Pipe	148	(2) LGP21903 Diplexer	108
(2) Empty Mount Pipe	148	(2) LGP21903 Diplexer	108
(2) Empty Mount Pipe	148	(2) RRUS-11	108
APXVTM14-C-I20 w/ Mount Pipe	148	(2) RRUS-11	108
APXVTM14-C-I20 w/ Mount Pipe	148	(2) RRUS-11	108
APXVTM14-C-I20 w/ Mount Pipe	148	(2) RRUS-11	108
TD-RRH8x20-25	148	ABT-DFDM-ADBH	108
TD-RRH8x20-25	148	DC6-48-60-18-8F Surge Arrestor	108
TD-RRH8x20-25	148	Low Profile Platform	108
Low Profile Platform	148	(2) 7770 w/ Mount Pipe	108
APXVSPP18-C-A20 w/Mount Pipe	148	(2) 7770 w/ Mount Pipe	108
APXVSPP18-C-A20 w/Mount Pipe	148	GPS	75
(2) LPA-80080/6CF w/ Mount Pipe	137	Pipe Mount	75
BXA-70063/6CF-2 w/ Mount Pipe	137		

MATERIAL STRENGTH

GRADE	Fy	Fu	GRADE	Fy	Fu
A607-65	65 ksi	80 ksi			

TOWER DESIGN NOTES

1. Tower is located in Litchfield County, Connecticut.
2. Tower designed for a 80 mph basic wind in accordance with the TIA/EIA-222-F Standard.
3. Tower is also designed for a 28 mph basic wind with 1.00 in ice. Ice is considered to increase in thickness with height.
4. Deflections are based upon a 50 mph wind.
5. TOWER RATING: 84.6%

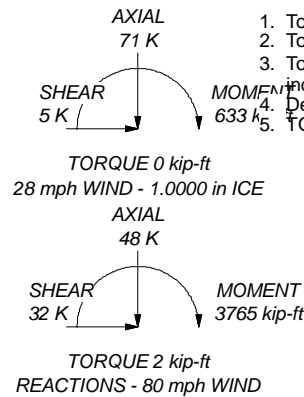

Section	Length (ft)	Number of Sides	Thickness (in)	Socket Length (ft)	Top Dia (in)	Bot Dia (in)	Grade	Weight (K)
1	40.75	18	0.2500	4.25	24.0000	32.7630	A607-65	3.1
2	45.00	18	0.3125	5.25	31.3491	41.0250	A607-65	5.4
3	45.00	18	0.3750	6.25	39.2711	48.9470	A607-65	8.0
4	45.00	18	0.4375	46.8531	56.5300		A607-65	10.9
								27.4

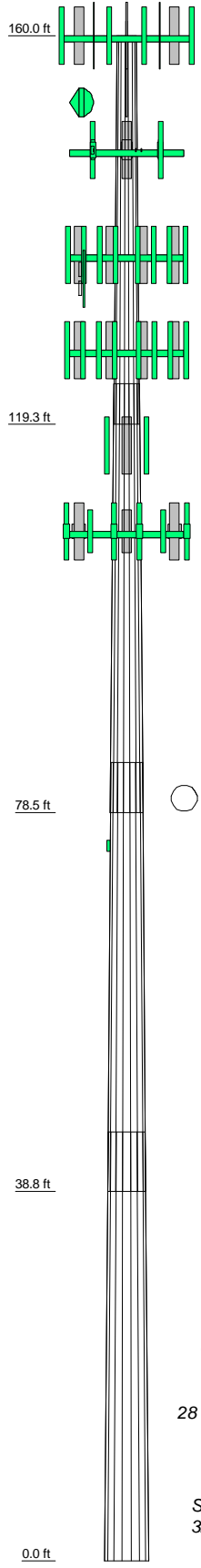

FDH Engineering, Inc.
 6521 Meriden Drive, Suite 107
 Raleigh, NC 27616
 Phone: 9197551012
 FAX: 9197551031

Job: **South Plymouth, CT03538-S-02**
 Project: **1462H11400**
 Client: **SBA Network Services, Inc.** Drawn by: **Cary Webb** App'd:
 Code: **TIA/EIA-222-F** Date: **04/09/14** Scale: **NTS**
 Path: _____ Dwg No. **E-1**

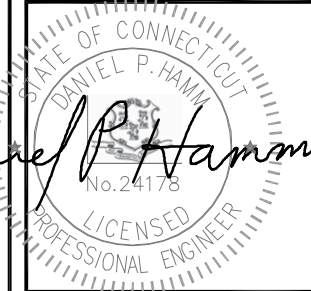

Daniel P. Hamm

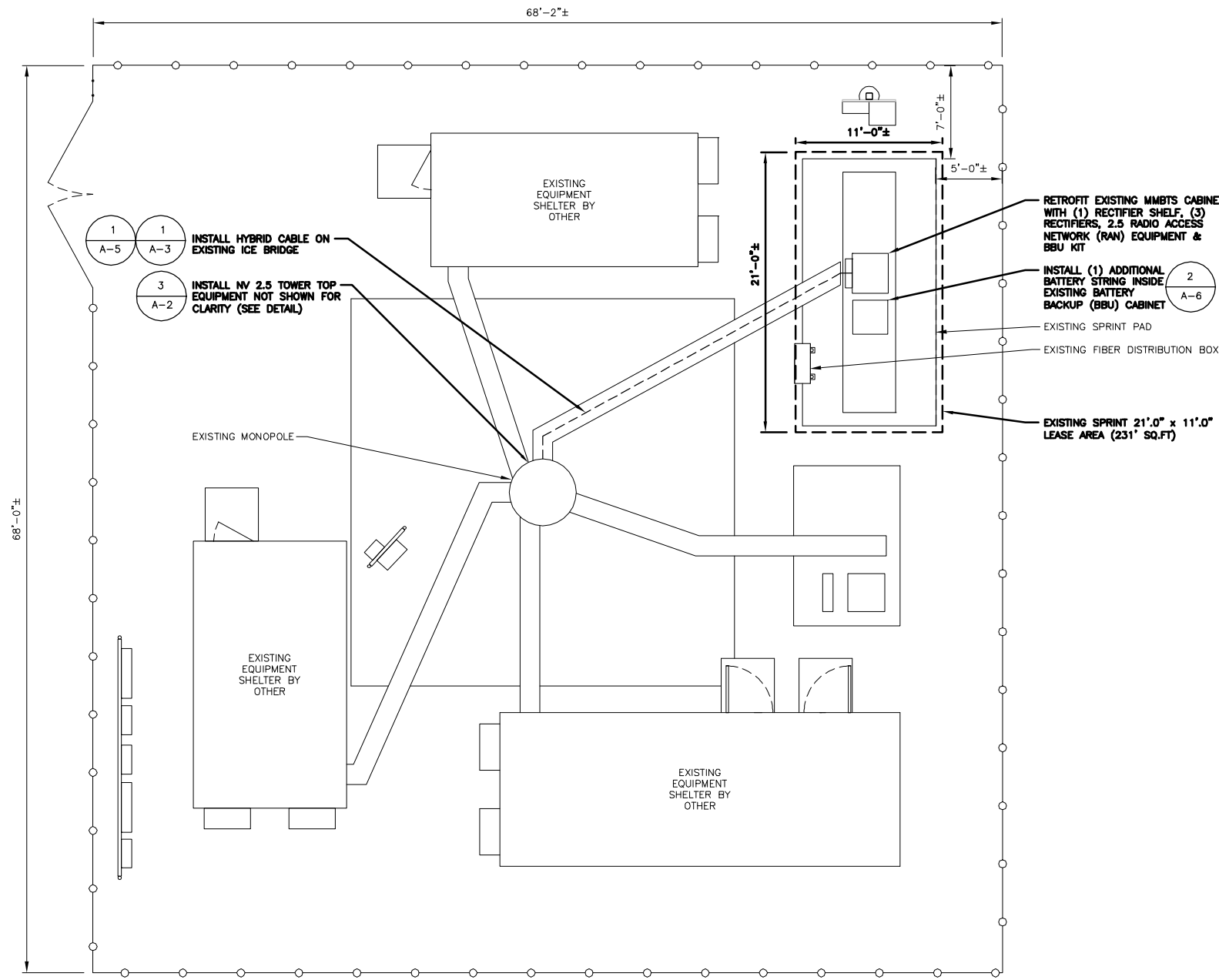

SOURCE: SPRINT SITE AUDIT 09-15-13

RAN EQUIPMENT PHOTO DETAIL
SCALE: N.T.S.

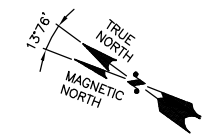

COMPOUND PLAN
SCALE: 3/16"=1'-0"

1
A-1

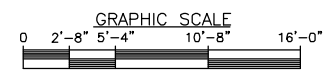

CHECKED BY: KB

APPROVED BY: DPH

SUBMITTALS			
REV.	DATE	DESCRIPTION	BY
0	05/20/14	ISSUED FOR CONSTRUCTION	SF

SITE NUMBER:
CT33XC275-C

SITE NAME:
THOMASTON SBA

SITE ADDRESS:
170 MOUNT TOBE ROAD
PLYMOUTH, CT 06782

SHEET TITLE
COMPOUND PLAN

SHEET NUMBER
A-1

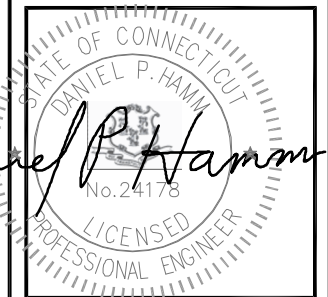

Daniel P. Hamm

SPECIAL CONSTRUCTION NOTE:
SPRINT TOWER TOP WORK IS CONTINGENT ON THE FOLLOWING:
 * COMPLETION OF A GLOBAL STRUCTURAL STABILITY ANALYSIS (PROVIDED BY TOWER OWNER).
 * COMPLETION OF AN ANTENNA/RRH MOUNT STRUCTURAL ASSESSMENT (PROVIDED BY A&E VENDOR).
 * GC SHALL FURNISH, INSTALL AND COMPLETE ALL REQUIRED STRUCTURAL MODIFICATIONS AS INDICATED IN BEFORE-MENTIONED ANALYSIS AND ASSESSMENT.
 * SBA COMMUNICATIONS CORPORATION SHALL PROVIDE WRITTEN ACCEPTANCE/APPROVAL FOR THE COMPLETION OF ALL TOWER/FOUNDATION STRUCTURAL MODIFICATIONS INCLUDING (AS NECESSARY) CONTROLLED CONSTRUCTION INSPECTIONS, SHOP-DRAWING APPROVALS, MATERIALS TEST RESULTS, AND FINAL ENGINEER'S AFFIDAVIT.

NOTE:
EXISTING AZIMUTHS FROM SPRINT
SITE AUDIT DATED 09/15/13

NOTE:
SPRINT RAD CENTER SHOWN IN RED TEXT BASED ON SBA-PROVIDED COLLOCATION APPLICATION, EQUIPMENT DATABASE, AND STRUCTURAL ANALYSIS. THE SBA-PROVIDED ANTENNA RAD CENTER SHALL SUPERSEDE ANY CONFLICTING INFORMATION DERIVED FROM THE SPRINT NV 2.5 RFDS.

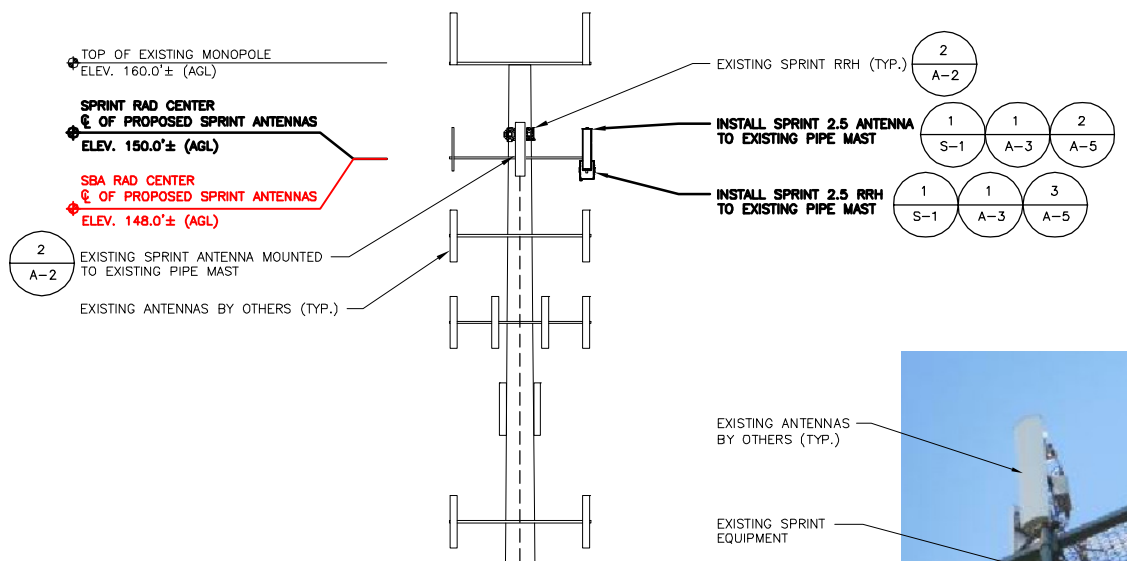

EXISTING PARTIAL ELEVATION PHOTO DETAIL
SCALE: N.T.S.

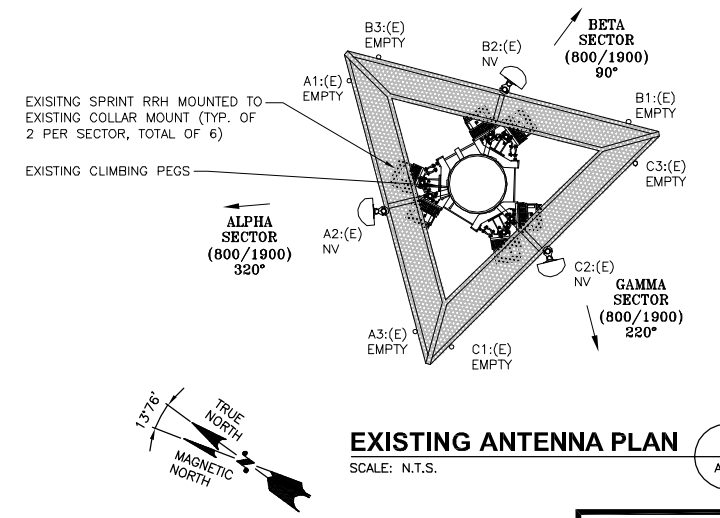

ANTENNA STATUS LEGEND:

EMPTY - EMPTY PIPE
(E) - EXISTING
(P) - INSTALL
NV - SPRINT ANTENNA MODEL APXVSP18-C-A20
2.5 - SPRINT ANTENNA

SPECIAL WORK NOTE:
JUMPERS FROM 2.5 RRH TO 2.5 ANTENNA CAN NOT EXCEED 15'. NOTIFY SPRINT CONSTRUCTION MANAGER OF ANY DISCREPANCY.

NOTE:
VERIFY PROPOSED AZIMUTHS WITH RF ENGINEER PRIOR TO INSTALLATION.

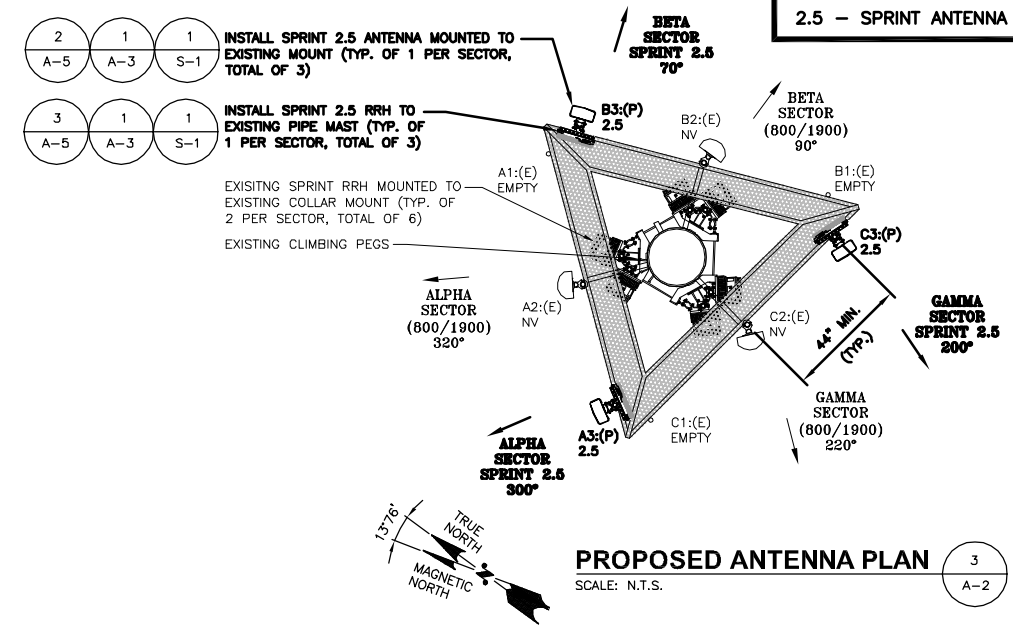
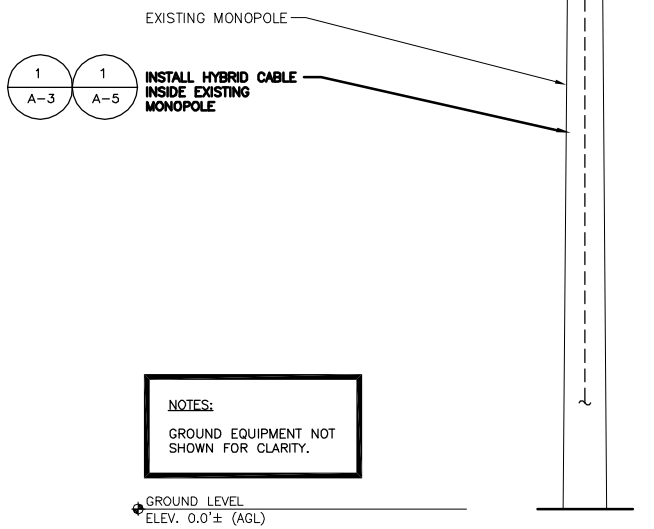

NOTES:
GROUND EQUIPMENT NOT SHOWN FOR CLARITY.

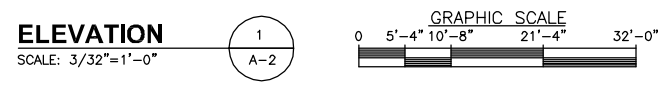

CHECKED BY: KB

APPROVED BY: DPH

SUBMITTALS

REV.	DATE	DESCRIPTION	BY
0	05/20/14	ISSUED FOR CONSTRUCTION	SF

SITE NUMBER:
CT33XC275-C
SITE NAME:
THOMASTON SBA
SITE ADDRESS:
170 MOUNT TOBE ROAD
PLYMOUTH, CT 06782

SHEET TITLE
ELEVATION AND ANTENNA PLANS

SHEET NUMBER
A-2