



10 INDUSTRIAL AVENUE,
SUITE 3
MAHWAH, NJ 07430
PHONE: 201.684.0055
FAX: 201.684.0066

July 23, 2019

Melanie A. Bachman
Acting Executive Director
Connecticut Siting Council
10 Franklin Square
New Britain, CT 06051

Notice of Exempt Modification
125 Mile Creek Road, Old Lyme CT
Latitude 41.30555556
Longitude -72.29736111
T-Mobile site: CTNL802A / L600

Dear Ms. Bachman:

T-Mobile currently maintains (6) antennas at the 170-foot level of the existing 170-foot monopole at 125 Mile Creek Road in Old Lyme, CT. The monopole is owned by American Tower and the property is owned by Todd J. Machnik. T-Mobile now intends to add (3) 600/700 MHz antennas at the 170-foot level of the tower along with mount modifications that are proposed per the attached mount analysis.

Planned Modifications:

Remove:

(3) 1-5/8" coax

Remove and Replace:

TMA's:

(3) Andrew ETW190VS12UB (REMOVE) - (3) Ericsson KRY 112 144/1 (REPLACE)

Existing to Remain:

(3) Ericsson AIR 21, 1.3M B4A B2P

(3) Ericsson AIR 21, 1.3M B2A B4P

(9) 1-5/8" coax

(1) 1-5/8" Hybrid

(1) Generic E-911 GPS

(1) 1/2" coax

Install New:

Antennas:

(3) APXVAARR24_43-U-NA20 - 600 MHz / 700 MHz

Coax Cables:

(3) 1-5/8" Hybrid

This facility was approved by Docket No.202 by the Siting Council September 12, 2001, then extended by means of a petition No. 877 on January 8, 2009 with no record of conditions that would restrict exempt modifications. Therefore, this modification complies with the aforementioned approval. A copy of the approvals are attached.

Please accept this letter as notification pursuant to Regulations of Connecticut State Agencies § 16- SOj-73, for construction that constitutes an exempt modification pursuant to R.C.S.A. § 16-50j-72(b)(2). In accordance with R.C.S.A. § 16-SOj-73, a copy of this letter is being sent to The Honorable Bonnie A. Reemsnyder, First Selectwoman, and Kim Groves, Land Use Administrator.

The planned modifications to the facility fall squarely within those activities explicitly provided for in R.C.S.A. § 16-50j-72(b)(2).

1. The proposed modifications will not result in an increase in the height of the existing structure.
2. The proposed modifications will not require the extension of the site boundary.
3. The proposed modifications will not increase noise levels at the facility by six decibels or more, or to levels that exceed state and local criteria.
4. The operation of the replacement antennas will not increase radio frequency emissions at the facility to a level at or above the Federal Communications Commission safety standard.
5. The proposed modifications will not cause a change or alteration in the physical or environmental characteristics of the site.
6. The existing structure and its foundation can support the proposed loading.

For the foregoing reasons, T-Mobile respectfully submits that the proposed modifications to the above referenced telecommunications facility constitute an exempt modification under R.C.S.A. § 16-50j-72(b)(2).

Sincerely,

Elizabeth Jamieson

Elizabeth Jamieson
Transcend Wireless
10 Industrial Ave., Suite 3
Mahwah, New Jersey 07430
860-605-7808
EJamieson@TranscendWireless.com

cc:

The Honorable Bonnie A. Reemsnyder, First Selectwoman
Kim Groves, Land Use Administrator
American Tower, Tower Owner
Todd J. Machnik, Property Owner

Exhibit A

Original Facility Approval

Connecticut Siting Council

DOCKET NO. 202 - Crown Atlantic Company LLC and Cellco Partnership d/b/a Cellco Wireless application for a Certificate of Environmental Compatibility and Public Need for the construction, maintenance, and operation of a cellular telecommunications facility off of Buttonball Road, located approximately 1,000 feet south of the intersection of Buttonball Road and the Amtrak railroad right-of-way, Old Lyme; or at 125 Mile Creek Road, Old Lyme, Connecticut.	} Connecticut } Siting } Council } September } 12, 2001
---	---

Decision and Order

Pursuant to the foregoing Findings of Fact and Opinion, the Connecticut Siting Council (Council) finds that the effects associated with the construction, operation, and maintenance of a telecommunications facility at the proposed alternate #1 site in Old Lyme, Connecticut, including effects on the natural environment; ecological integrity and balance; public health and safety; scenic, historic, and recreational values; forests and parks; air and water purity; and fish and wildlife are not disproportionate either alone or cumulatively with other effects when compared to need, are not in conflict with the policies of the State concerning such effects, and are not sufficient reason to deny the application and therefore directs that a Certificate of Environmental Compatibility and Public Need, as provided by General Statutes § 16-50k, be issued to Crown Atlantic Company LLC and Cellco Partnership d/b/a Verizon Wireless for the construction, maintenance, and operation of a cellular telecommunications facility located at 125 Mile Creek Road, Old Lyme, Connecticut. We deny certification of the proposed prime site.

The facility shall be constructed, operated, and maintained substantially as specified in the Council's record in this matter, and subject to the following conditions:

1. The tower shall be constructed as a monopole, no taller than necessary to provide the proposed telecommunications services, sufficient to accommodate the antennas of Cellco and at least three other telecommunications entities, both public and private, but such tower shall not exceed a height of 160 feet above ground level (AGL), including appurtenances. The tower and foundation may be designed and constructed capable of being extended from 160 feet AGL to 190 feet AGL, with such extension subject to Council approval by petition for a declaratory ruling, pursuant to Sections 16-50j-38 through 16-50j-40 of the Regulations of Connecticut State Agencies.
2. The Certificate Holder shall prepare a Development and Management (D&M) Plan for this site in compliance with Sections 16-50j-75 through 16-50j-77 of the Regulations of Connecticut State Agencies. The D&M Plan shall be submitted to and approved by the Council prior to the commencement of facility construction and shall include: a final site plan(s) for site development to include the location and specifications for the tower foundation, antennas, equipment building, emergency generator and fuel tank, security fence, access road, and utility line; construction plans for site clearing, tree trimming, water drainage, and erosion and sedimentation controls consistent with the Connecticut Guidelines for Soil Erosion and Sediment Control, as amended; provisions for a single equipment building to accommodate the telecommunications equipment for at least three other telecommunications providers with provisions for expansion of the building and suitable architectural treatment; landscaping; a tower finish that may include painting; and provisions for the prevention and containment of spills and/or other discharge into surface water and groundwater bodies.
3. Upon the establishment of any new State or federal radio frequency standards applicable to frequencies of this facility, the facility granted herein shall be brought into compliance with such standards.
4. The Certificate Holder shall provide the Council with a recalculated report of electromagnetic radio frequency power density if and when circumstances in operation cause a change in power density above the levels originally calculated and provided in the application.
5. The Certificate Holder shall permit public or private entities to share space on the proposed tower for fair consideration, or shall provide any requesting entity with specific legal, technical, environmental, or economic reasons precluding such tower sharing.
6. If the facility does not initially provide, or permanently ceases to provide wireless services following completion of construction, this Decision and Order shall be void, and the Certificate Holder shall dismantle the

tower and remove all associated equipment or reapply for any continued or new use to the Council before any such use is made.

7. Any antenna that becomes obsolete and ceases to function shall be removed within 60 days after such antennas become obsolete and cease to function.

8. Unless otherwise approved by the Council, this Decision and Order shall be void if all construction authorized herein is not completed within three years of the effective date of this Decision and Order or within three years after all appeals to this Decision and Order have been resolved.

Pursuant to General Statutes § 16-50p, we hereby direct that a copy of the Findings of Fact, Opinion, and Decision and Order be served on each person listed below, and notice of issuance shall be published in The Hartford Courant, The Day, and the Pictorial/Gazette.

By this Decision and Order, the Council disposes of the legal rights, duties, and privileges of each party named or admitted to the proceeding in accordance with Section 16-50j-17 of the Regulations of Connecticut State Agencies.

The parties and intervenors to this proceeding are:

Applicant

Crown Atlantic Company LLC
and Cellco Partnership d/b/a
Verizon Wireless

Its Representative

Robert Stanford, Project Manager
Crown Atlantic Company LLC
703 Hebron Avenue
Glastonbury, CT 06033

Kenneth C. Baldwin, Esq.
Robinson & Cole LLP
280 Trumbull Street
Hartford, CT 06103-3597

Intervenor

Town of Old Lyme
Zoning Commission

Its Representative

Eric Knapp, Esq.
Branse & Willis, LLC
41-C New London Turnpike
Glen Lochen East
Glastonbury, CT 06033-2038

Intervenor

James B. Blair
38-1 Buttonball Road
Old Lyme, CT 06371

Party

John P. McCarthy
Judith A. McCarthy
54 Buttonball Road
Old Lyme, CT 06371

I:\siting\dockets\202\dftd&o.doc

Petition No. 877
Omnipoint Communications (T-Mobile)
Old Lyme, Connecticut
Staff Report
January 8, 2009

On November 25, 2008, Omnipoint Communications (T-Mobile) filed a petition for a declaratory ruling that no Certificate of Environmental Compatibility and Public Need is required for the extension of an existing telecommunications tower in Old Lyme, Connecticut. Connecticut Siting Council member Phil Ashton and Council staff member David Martin conducted a field review of the proposed modifications on December 10, 2008. Jennifer Gaudet represented T-Mobile at the field review.

T-Mobile proposes to add a ten-foot extension to an existing 160-foot monopole tower located at 125 Mile Creek Road in Old Lyme. The existing tower is owned by Verizon Wireless and was certificated by the Council in Docket 202, which was approved on June 3, 2002. In this docket, Verizon, and its co-applicant Crown, originally proposed a 190-foot tower. The Council approved a 160-foot tower but allowed for the tower and foundation to be built to accommodate extensions up to 190 feet.

From this location, T-Mobile is seeking to cover an area south of the tower that encompasses a section of the Amtrak rail line that is currently without coverage. T-Mobile's RF engineers have determined that antennas placed at the highest, existing available height of 130 feet would not cover the target area. Consequently, T-Mobile is seeking the extension in order to place its antennas at the 170-foot level to be able to achieve its coverage objectives.

The tower is located on a 62-acre parcel used for the storage of construction and agricultural equipment. The surrounding area consists of sparse single-family residential development. There is a short section on Mile Creek Road where the tower is very clearly visible because the land has been cleared for agricultural and residential purposes. Most of the surrounding area, however, is shielded from views of the tower by existing, mature deciduous trees. The proposed ten-foot extension will not appreciably increase the visible footprint of the existing tower.

The addition of T-Mobile's antennas would bring the cumulative power density of the antenna systems on the tower to 16.6% of the FCC limit.

The tower compound is enclosed by a stockade fence. At the time of the field review, the gate of the fence was open and in poor condition. Council representatives pointed this out to T-Mobile's representative and asked that a request to repair the fence be passed on to the tower owner.

Council representatives also noted that ospreys had built a nest on the tower's highest antenna platform. T-Mobile's representative stated that the proposed modifications could be done at a time when they would not disturb the nesting birds.

Based upon observations made during the field review, T-Mobile's proposed modifications should not create any significant adverse environmental impacts. Staff recommends approval of this petition with the conditions that: 1) the tower owner repair the fence as needed and 2) any work related to the extension of the tower and installation of T-Mobile's antennas be undertaken at a time when it will not disturb any actively nesting ospreys.

View of existing tower



Tower compound



Exhibit B

Property card

125 MILE CREEK RD

Location 125 MILE CREEK RD

Mblu 13 / / 93 / /

Acct# 00044800

Owner MACHNIK TODD & REBECCA
L Q/C/S

Assessment \$407,000

Appraisal \$813,400

PID 474

Building Count 3

Current Value

Appraisal			
Valuation Year	Improvements	Land	Total
2014	\$402,800	\$410,600	\$813,400

Assessment			
Valuation Year	Improvements	Land	Total
2014	\$282,100	\$124,900	\$407,000

Owner of Record

Owner MACHNIK TODD & REBECCA L Q/C/S
Co-Owner
Address 126 MILE CREEK RD
OLD LYME, CT 06371

Sale Price \$0
Certificate
Book & Page 309/ 432
Sale Date 01/06/2004

Ownership History

Ownership History				
Owner	Sale Price	Certificate	Book & Page	Sale Date
MACHNIK TODD & REBECCA L Q/C/S	\$0		309/ 432	01/06/2004
MACHNIK LEON & TODD H & REBECCA L Q/	\$0		291/ 852	01/06/2003
MACHNIK LEON & TODD & REBECCA Q/C/S T	\$0		284/ 764	07/22/2002
MACHNIK LEON & Q/C/S	\$0		267/ 227	01/02/2001
MACHNIK LEON ET AL	\$0		261/ 299	01/19/2000

Building Information

Building 1 : Section 1

Year Built: 1975
Living Area: 678
Replacement Cost: \$75,048

Building Percent 74

Good:

Replacement Cost

Less Depreciation: \$55,500

Building Attributes	
Field	Description
STYLE	Commercial
MODEL	Commercial
Grade	Average
Stories:	1
Occupancy	1
Exterior Wall 1	Vinyl Siding
Exterior Wall 2	
Roof Structure	Gable/Hip
Roof Cover	Asph/F Gls/Cmp
Interior Wall 1	Drywall/Sheet
Interior Wall 2	
Interior Floor 1	Inlaid Sht Gds
Interior Floor 2	
Heating Fuel	Oil
Heating Type	Forced Air-Duc
AC Type	None
Bldg Use	OFFICE BLD MDL-94
Total Rooms	
Total Bedrms	00
Total Baths	0
1st Floor Use:	3400
Heat/AC	NONE
Frame Type	MASONRY
Baths/Plumbing	AVERAGE
Ceiling/Wall	SUS-CEIL & WL
Rooms/Prtns	AVERAGE
Wall Height	8
% Comn Wall	0

Building Photo



(<http://images.vgsi.com/photos/OldLymeCTPhotos//\00\00\43\44>)

Building Layout

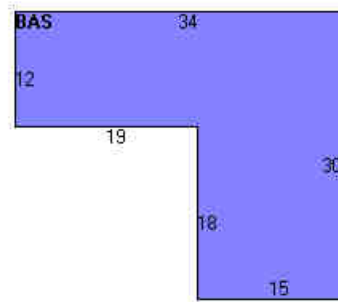

(<http://images.vgsi.com/photos/OldLymeCTPhotos//Sketches/47>)

Building Sub-Areas (sq ft)			Legend
Code	Description	Gross Area	Living Area
BAS	First Floor	678	678
		678	678

Building 2 : Section 1

Year Built: 1994

Living Area: 1,512

Replacement Cost: \$62,842

Building Percent 87

Good:

Replacement Cost

Less Depreciation: \$54,700

Building Attributes : Bldg 2 of 3
--

Field	Description
STYLE	Pre-Eng Gar
MODEL	Ind/Comm
Grade	Below Average
Stories:	1
Occupancy	0
Exterior Wall 1	Pre-finsh Metl
Exterior Wall 2	
Roof Structure	Gable/Hip
Roof Cover	Metal/Tin
Interior Wall 1	Minim/Masonry
Interior Wall 2	
Interior Floor 1	Concr-Finished
Interior Floor 2	
Heating Fuel	Oil
Heating Type	Hot Air-no Duc
AC Type	None
Bldg Use	COM WHS/GAR
Total Rooms	
Total Bedrms	00
Total Baths	0
1st Floor Use:	316I
Heat/AC	NONE
Frame Type	STEEL
Baths/Plumbing	NONE
Ceiling/Wall	NONE
Rooms/Prtns	AVERAGE
Wall Height	12
% Comn Wall	

Building Photo



(<http://images.vgsi.com/photos/OldLymeCTPhotos//\00\00\51\0/>)

Building Layout

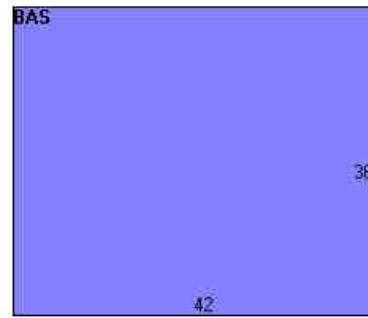

(<http://images.vgsi.com/photos/OldLymeCTPhotos//Sketches/47/>)

Building Sub-Areas (sq ft)			Legend
Code	Description	Gross Area	Living Area
BAS	First Floor	1,512	1,512
		1,512	1,512

Building 3 : Section 1

Year Built: 1975
Living Area: 7,500
Replacement Cost: \$307,125
Building Percent Good: 74
Replacement Cost Less Depreciation: \$227,300

Building Attributes : Bldg 3 of 3	
Field	Description
STYLE	Pre-Eng Gar
MODEL	Ind/Comm

Grade	Average
Stories:	1
Occupancy	1
Exterior Wall 1	Pre-finish Metl
Exterior Wall 2	
Roof Structure	Gable/Hip
Roof Cover	Metal/Tin
Interior Wall 1	Minim/Masonry
Interior Wall 2	
Interior Floor 1	Concr-Finished
Interior Floor 2	
Heating Fuel	Oil
Heating Type	Forced Air-Duc
AC Type	None
Bldg Use	AUTO REPR
Total Rooms	
Total Bedrms	00
Total Baths	0
1st Floor Use:	3320
Heat/AC	HEAT/AC SPLIT
Frame Type	STEEL
Baths/Plumbing	LIGHT
Ceiling/Wall	NONE
Rooms/Prtns	AVERAGE
Wall Height	12
% Conn Wall	

Building Photo



(<http://images.vgsi.com/photos/OldLymeCTPhotos//\00\00\51\10>)

Building Layout

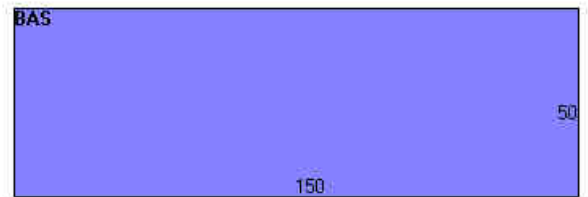

(<http://images.vgsi.com/photos/OldLymeCTPhotos//Sketches/47>)

Building Sub-Areas (sq ft)			<u>Legend</u>
Code	Description	Gross Area	Living Area
BAS	First Floor	7,500	7,500
		7,500	7,500

Extra Features

Extra Features	<u>Legend</u>
No Data for Extra Features	

Land

Land Use

Use Code	3400
Description	OFFICE BLD MDL-94
Zone	RU40

Land Line Valuation

Size (Acres)	62.00
Frontage	0
Depth	0

Neighborhood 0060
Alt Land Appr No
Category

Assessed Value \$124,900
Appraised Value \$410,600

Outbuildings

Outbuildings						Legend
Code	Description	Sub Code	Sub Description	Size	Value	Bldg #
FGR2	GARAGE-GOOD			864 S.F.	\$10,800	1
PAV1	PAVING-ASPHALT			1008 S.F.	\$1,000	2
PAV1	PAVING-ASPHALT			792 S.F.	\$600	3
BRN8	POLE BARN			1092 S.F.	\$7,600	3
BRN8	POLE BARN			792 S.F.	\$4,000	2
SHD2	W/LIGHTS ETC			600 S.F.	\$5,400	1
SHD1	SHED FRAME			100 S.F.	\$800	3
SHD2	W/LIGHTS ETC			572 S.F.	\$5,100	1
PAV1	PAVING-ASPHALT			100 S.F.	\$100	3
LNT	LEAN-TO			300 S.F.	\$600	3
	TOWER			50	\$29,300	3

Valuation History

Appraisal			
Valuation Year	Improvements	Land	Total
2018	\$402,800	\$410,600	\$813,400
2017	\$402,800	\$410,600	\$813,400
2011	\$285,600	\$410,600	\$696,200

Assessment			
Valuation Year	Improvements	Land	Total
2018	\$282,100	\$124,900	\$407,000
2017	\$282,100	\$124,900	\$407,000
2011	\$200,000	\$122,790	\$322,790

(c) 2019 Vision Government Solutions, Inc. All rights reserved.



Town of Old Lyme, CT

Property



125 Mile Creek Rd

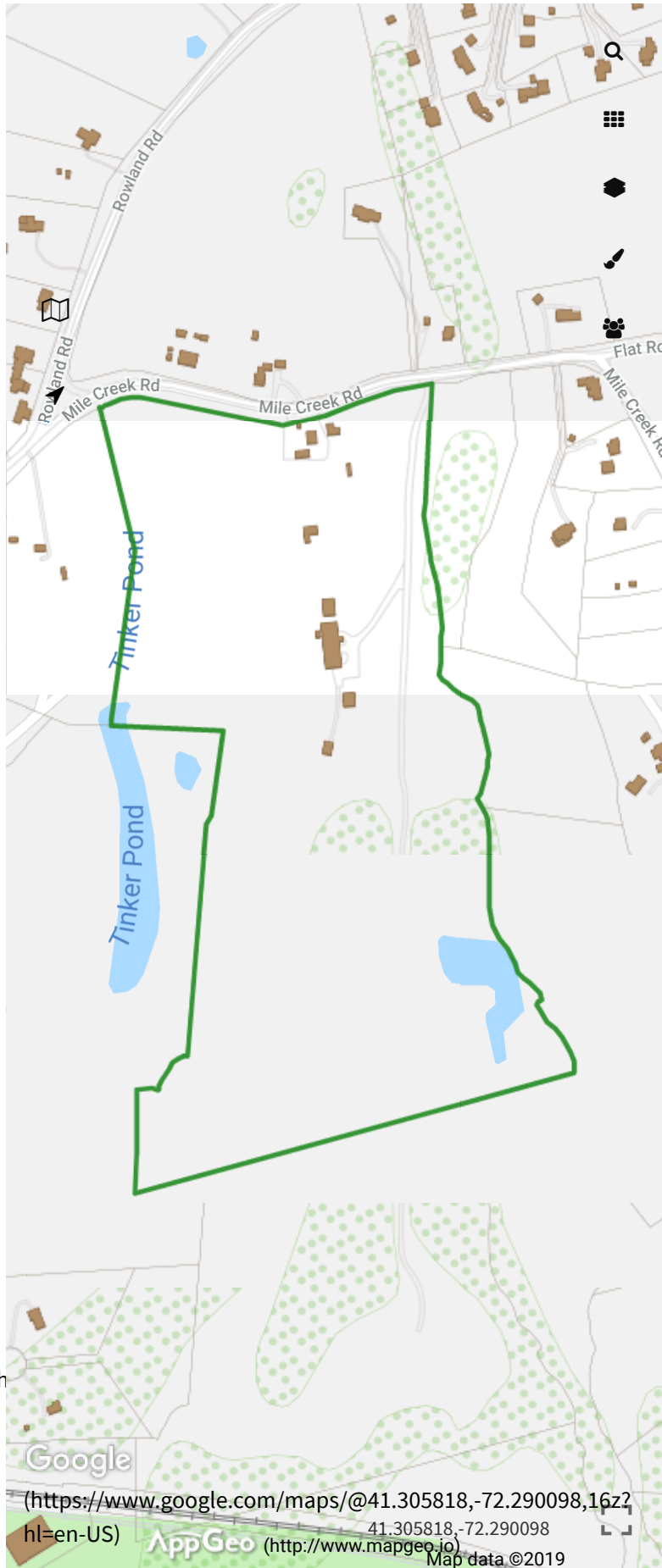

Search

Advanced Search

Clear Results

Zoom To Results

Download Results All Results

Showing 1-1 results. Scroll to see more.



125 MILE CREEK RD
MACHNIK TODD & REBECCA L Q/C/S
13-93



Google

(https://www.google.com/maps/@41.305818,-72.290098,16z?hl=en-US)

AppGeo (http://www.mapgeo.io) 41.305818,-72.290098

Map data ©2019

Exhibit C

Construction Drawings

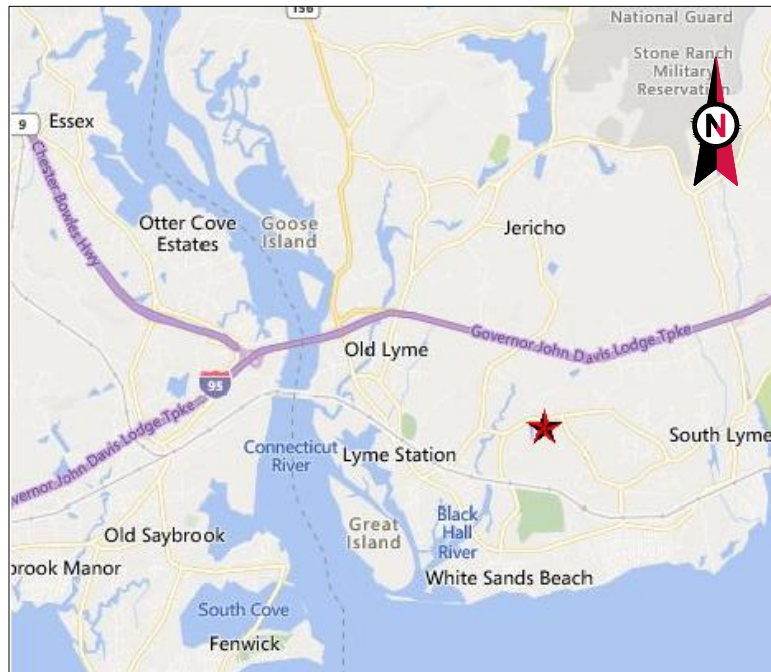

VICINITY MAP



AMERICAN TOWER®

ATC SITE NAME: OLD LYME SOUTH CT
 ATC SITE NUMBER: 411178
 T-MOBILE SITE ID: CTNL802A
 SITE ADDRESS: 125 MILE CREEK ROAD
 OLD LYME, CT 06371



LOCATION MAP

AMERICAN TOWER®
A.T. ENGINEERING SERVICE, PLLC
 3500 REGENCY PARKWAY
 SUITE 100
 CARY, NC 27518
 PHONE: (919) 468-0112
 COA: PEC.0001553

THESE DRAWINGS AND/OR THE ACCOMPANYING SPECIFICATION AS INSTRUMENTS OR SERVICE ARE THE EXCLUSIVE PROPERTY OF AMERICAN TOWER. THEIR USE AND PUBLICATION SHALL BE RESTRICTED TO THE ORIGINAL SITE FOR WHICH THEY ARE PREPARED. ANY USE OR DISCLOSURE OTHER THAN THAT WHICH RELATES TO AMERICAN TOWER OR THE SPECIFIED CARRIER IS STRICTLY PROHIBITED. TITLE TO THESE DOCUMENTS SHALL REMAIN THE PROPERTY OF AMERICAN TOWER WHETHER OR NOT THE PROJECT IS EXECUTED. NEITHER THE ARCHITECT NOR THE ENGINEER WILL BE PROVIDING ON-SITE CONSTRUCTION REVIEW OF THIS PROJECT. CONTRACTOR(S) MUST VERIFY ALL DIMENSIONS AND ADVISE AMERICAN TOWER OF ANY DISCREPANCIES. ANY PRIOR ISSUANCE OF THIS DRAWING IS SUPERSEDED BY THE LATEST VERSION ON FILE WITH AMERICAN TOWER.

REV.	DESCRIPTION	BY	DATE
0	FOR CONSTRUCTION	KC	05/29/19
1	MA UPDATE	LR	07/16/19

**T-MOBILE L600 ANTENNA AMENDMENT
 67D02C OUTDOOR CONFIGURATION**

ATC SITE NUMBER:
411178
 ATC SITE NAME:
OLD LYME SOUTH CT
 SITE ADDRESS:
 125 MILE CREEK ROAD
 OLD LYME, CT 06371

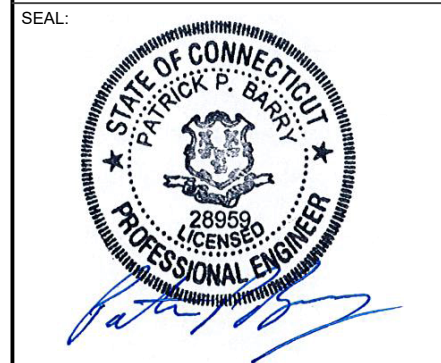

Authorized by "EOR"
 July 16 2019 4:51 PM
P-Mobile design

COMPLIANCE CODE	PROJECT SUMMARY	PROJECT DESCRIPTION	SHEET INDEX				
ALL WORK SHALL BE PERFORMED AND MATERIALS INSTALLED IN ACCORDANCE WITH THE CURRENT EDITIONS OF THE FOLLOWING CODES AS ADOPTED BY THE LOCAL GOVERNMENT AUTHORITIES. NOTHING IN THESE PLANS IS TO BE CONSTRUED TO PERMIT WORK NOT CONFORMING TO THESE CODES. 1. INTERNATIONAL BUILDING CODE (IBC) 2. NATIONAL ELECTRIC CODE (NEC) 3. LOCAL BUILDING CODE 4. CITY/COUNTY ORDINANCES	<u>SITE ADDRESS:</u> 125 MILE CREEK ROAD OLD LYME, CT 06371 COUNTY: NEW LONDON <u>GEOGRAPHIC COORDINATES:</u> LATITUDE: 41° 18' 20.351" N LONGITUDE: 72° 17' 50.5" W GROUND ELEVATION: 40' AMSL	THE PROPOSED PROJECT INCLUDES MODIFYING GROUND BASED AND TOWER MOUNTED EQUIPMENT AS INDICATED PER BELOW: REMOVE (3) TTAs, AND (3) 1-5/8" COAX CABLES INSTALL (3) NEW PANELS, (3) TTAs, (3) RRU's, (3) 1-5/8" HYBRID CABLES, AND MOUNT MODIFICATIONS EXISTING (6) PANELS, (9) 1-5/8" COAX CABLES, AND (1) 1-5/8" HYBRID CABLES TO REMAIN	SHEET NO:	DESCRIPTION:	REV:	DATE:	BY:
	<u>PROJECT TEAM</u> <u>TOWER OWNER:</u> AMERICAN TOWER 10 PRESIDENTIAL WAY WOBURN, MA 01801 <u>ENGINEER:</u> ATC TOWER SERVICES, LLC 3500 REGENCY PKWY STE 100 CARY, NC 27518 <u>PROPERTY OWNER:</u> TODD J MACHNIK 125 MILE CREEK RD OLD LYME, CT 06371	<u>PROJECT NOTES</u> 1. THE FACILITY IS UNMANNED. 2. A TECHNICIAN WILL VISIT THE SITE APPROXIMATELY ONCE A MONTH FOR ROUTINE INSPECTION AND MAINTENANCE. 3. THE PROJECT WILL NOT RESULT IN ANY SIGNIFICANT LAND DISTURBANCE OR EFFECT OF STORM WATER DRAINAGE. 4. NO SANITARY SEWER, POTABLE WATER OR TRASH DISPOSAL IS REQUIRED. 5. HANDICAP ACCESS IS NOT REQUIRED.	G-001 TITLE SHEET G-002 GENERAL NOTES C-101 DETAILED SITE PLAN & TOWER ELEVATION C-501 ANTENNA INFORMATION & SCHEDULE E-501 GROUNDING DETAILS R-601 SUPPLEMENTAL R-602 SUPPLEMENTAL R-603 SUPPLEMENTAL R-604 SUPPLEMENTAL R-605 SUPPLEMENTAL R-606 SUPPLEMENTAL				
<u>UTILITY COMPANIES</u> POWER COMPANY: EVERSOURCE PHONE: (888) 783-6617 TELEPHONE COMPANY: AT&T PHONE: (866) 593-1383		<u>PROJECT LOCATION DIRECTIONS</u> FROM WALLINGFORD, CT: TAKE I-91 N TOWARD HARTFORD. GO TO RT. 9 S TO RT. 95 N TO EXIT 70. TURN RIGHT AT END OF EXIT. TAKE 3RD LEFT ONTO MILL CREEK RD. GO UNDER RAILROAD BRIDGE TO #125 MILE CREEK RD. (1.5 MILES TOTAL) MAIL BOX IS ON LEFT SIDE OF ROAD. TAKE RIGHT INTO THE CONSTRUCTION CO./FARM AND FOLLOW AROUND TO THE BACK.					



DRAWN BY:	KC
APPROVED BY:	PB
DATE DRAWN:	05/29/19
ATC JOB NO:	12951861

TITLE SHEET

SHEET NUMBER:	REVISION:
G-001	1

Copyright © 2019 ATC IP LLC, All Rights Reserved.

GENERAL CONSTRUCTION NOTES:

1. ALL WORK SHALL CONFORM TO ALL CURRENT APPLICABLE FEDERAL, STATE, AND LOCAL CODES, INCLUDING ANSIEIA/TIA-222, AND COMPLY WITH ATC MASTER SPECIFICATIONS.
2. CONTRACTOR SHALL CONTACT LOCAL 811 FOR IDENTIFICATION OF UNDERGROUND UTILITIES PRIOR TO START OF CONSTRUCTION.
3. CONTRACTOR SHALL BE RESPONSIBLE FOR COORDINATING ALL REQUIRED INSPECTIONS.
4. ALL DIMENSIONS TO, OF, AND ON EXISTING BUILDINGS, DRAINAGE STRUCTURES, AND SITE IMPROVEMENTS SHALL BE VERIFIED IN FIELD BY CONTRACTOR WITH ALL DISCREPANCIES REPORTED TO THE ENGINEER.
5. DO NOT CHANGE SIZE OR SPACING OF STRUCTURAL ELEMENTS.
6. DETAILS SHOWN ARE TYPICAL; SIMILAR DETAILS APPLY TO SIMILAR CONDITIONS UNLESS OTHERWISE NOTED.
7. THESE DRAWINGS DO NOT INCLUDE NECESSARY COMPONENTS FOR CONSTRUCTION SAFETY WHICH SHALL BE THE SOLE RESPONSIBILITY OF THE CONTRACTOR.
8. CONTRACTOR SHALL BRACE STRUCTURES UNTIL ALL STRUCTURAL ELEMENTS NEEDED FOR STABILITY ARE INSTALLED. THESE ELEMENTS ARE AS FOLLOWS: LATERAL BRACING, ANCHOR BOLTS, ETC.
9. CONTRACTOR SHALL DETERMINE EXACT LOCATION OF EXISTING UTILITIES, GROUNDS DRAINS, DRAIN PIPES, VENTS, ETC. BEFORE COMMENCING WORK.
10. INCORRECTLY FABRICATED, DAMAGED, OR OTHERWISE MISFITTING OR NONCONFORMING MATERIALS OR CONDITIONS SHALL BE REPORTED TO THE T-MOBILE WIRELESS REP PRIOR TO REMEDIAL OR CORRECTIVE ACTION. ANY SUCH REMEDIAL ACTION SHALL REQUIRE WRITTEN APPROVAL BY THE T-MOBILE WIRELESS REP PRIOR TO PROCEEDING.
11. EACH CONTRACTOR SHALL COOPERATE WITH THE T-MOBILE WIRELESS REP, AND COORDINATE HIS WORK WITH THE WORK OF OTHERS.
12. CONTRACTOR SHALL REPAIR ANY DAMAGE CAUSED BY CONSTRUCTION OF THIS PROJECT TO MATCH EXISTING PRE-CONSTRUCTION CONDITIONS TO THE SATISFACTION OF THE T-MOBILE WIRELESS CONSTRUCTION MANAGER.
13. ALL CABLE/CONDUIT ENTRY/EXIT PORTS SHALL BE WEATHERPROOFED DURING INSTALLATION USING A SILICONE SEALANT.
14. WHERE EXISTING CONDITIONS DO NOT MATCH THOSE SHOWN IN THIS PLAN SET, CONTRACTOR SHALL NOTIFY THE T-MOBILE WIRELESS REP IMMEDIATELY.
15. CONTRACTOR SHALL ENSURE ALL SUBCONTRACTORS ARE PROVIDED WITH A COMPLETE AND CURRENT SET OF DRAWINGS AND SPECIFICATIONS FOR THIS PROJECT.
16. CONTRACTOR SHALL REMOVE ALL RUBBISH AND DEBRIS FROM THE SITE AT THE END OF EACH DAY.
17. CONTRACTOR SHALL COORDINATE WORK SCHEDULE WITH LANDLORD AND TAKE PRECAUTIONS TO MINIMIZE IMPACT AND DISRUPTION OF OTHER OCCUPANTS OF THE FACILITY.
18. CONTRACTOR SHALL FURNISH T-MOBILE WIRELESS WITH A PDF MARKED UP AS-BUILT SET OF DRAWINGS UPON COMPLETION OF WORK.
19. PRIOR TO SUBMISSION OF BID, CONTRACTOR SHALL COORDINATE WITH T-MOBILE WIRELESS REP TO DETERMINE WHAT, IF ANY, ITEMS WILL BE PROVIDED. ALL ITEMS NOT PROVIDED SHALL BE PROVIDED AND INSTALLED BY THE CONTRACTOR. CONTRACTOR WILL INSTALL ALL ITEMS PROVIDED.
20. PRIOR TO SUBMISSION OF BID, CONTRACTOR SHALL COORDINATE WITH T-MOBILE WIRELESS REP TO DETERMINE IF ANY PERMITS WILL BE OBTAINED BY CONTRACTOR. ALL REQUIRED PERMITS NOT OBTAINED BY T-MOBILE WIRELESS MUST BE OBTAINED, AND PAID FOR, BY THE CONTRACTOR.
21. CONTRACTOR SHALL INSTALL ALL SITE SIGNAGE IN ACCORDANCE WITH T-MOBILE WIRELESS SPECIFICATIONS AND REQUIREMENTS.
22. CONTRACTOR SHALL SUBMIT ALL SHOP DRAWINGS TO T-MOBILE WIRELESS FOR REVIEW AND APPROVAL PRIOR TO FABRICATION.
23. ALL EQUIPMENT SHALL BE INSTALLED ACCORDING TO MANUFACTURER'S SPECIFICATIONS AND LOCATED ACCORDING TO T-MOBILE WIRELESS SPECIFICATIONS, AND AS SHOWN IN THESE PLANS.
24. THE CONTRACTOR SHALL SUPERVISE AND DIRECT THE PROJECT DESCRIBED HEREIN. THE CONTRACTOR SHALL BE SOLELY RESPONSIBLE FOR ALL THE CONSTRUCTION MEANS, METHODS, TECHNIQUES, SEQUENCES AND PROCEDURES AND FOR COORDINATING ALL PORTIONS OF THE WORK UNDER THE CONTRACT.
25. CONTRACTOR SHALL NOTIFY T-MOBILE WIRELESS REP A MINIMUM OF 48 HOURS IN ADVANCE OF POURING CONCRETE OR BACKFILLING ANY UNDERGROUND UTILITIES, FOUNDATIONS OR SEALING ANY WALL, FLOOR OR ROOF PENETRATIONS FOR ENGINEERING REVIEW AND APPROVAL.
26. CONTRACTOR SHALL BE RESPONSIBLE FOR SITE SAFETY INCLUDING COMPLIANCE WITH ALL APPLICABLE OSHA STANDARDS AND RECOMMENDATIONS AND SHALL PROVIDE ALL NECESSARY SAFETY DEVICES INCLUDING PPE AND PPM AND CONSTRUCTION DEVICES SUCH AS WELDING AND FIRE PREVENTION, TEMPORARY SHORING, SCAFFOLDING, TRENCH BOXES/SLOPING, BARRIERS, ETC.

27. THE CONTRACTOR SHALL PROTECT AT HIS OWN EXPENSE, ALL EXISTING FACILITIES AND SUCH OF HIS NEW WORK LIABLE TO INJURY DURING THE CONSTRUCTION PERIOD. ANY DAMAGE CAUSED BY NEGLIGENCE ON THE PART OF THIS CONTRACTOR OR HIS REPRESENTATIVES, OR BY THE ELEMENTS DUE TO NEGLIGENCE ON THE PART OF THIS CONTRACTOR OR HIS REPRESENTATIVES, EITHER TO THE EXISTING WORK, OR TO HIS WORK OR THE WORK OF ANY OTHER CONTRACTOR, SHALL BE REPAIRED AT HIS EXPENSE TO THE OWNER'S SATISFACTION.
28. ALL WORK SHALL BE INSTALLED IN A FIRST CLASS, NEAT AND WORKMANLIKE MANNER BY MECHANICS SKILLED IN THE TRADE INVOLVED. THE QUALITY OF WORKMANSHIP SHALL BE SUBJECT TO THE APPROVAL OF THE T-MOBILE WIRELESS REP. ANY WORK FOUND BY THE T-MOBILE WIRELESS REP TO BE OF INFERIOR QUALITY AND/OR WORKMANSHIP SHALL BE REPLACED AND/OR REWORKED AT CONTRACTOR EXPENSE UNTIL APPROVAL IS OBTAINED.
29. IN ORDER TO ESTABLISH STANDARDS OF QUALITY AND PERFORMANCE, ALL TYPES OF MATERIALS LISTED HEREINAFTER BY MANUFACTURER'S NAMES AND/OR MANUFACTURER'S CATALOG NUMBER SHALL BE PROVIDED BY THESE MANUFACTURERS AS SPECIFIED.

STRUCTURAL STEEL NOTES:

1. STRUCTURAL STEEL SHALL CONFORM TO THE LATEST EDITION OF THE AISC "SPECIFICATION FOR THE DESIGN, FABRICATION AND ERECTION OF STRUCTURAL STEEL FOR BUILDINGS."
2. STRUCTURAL STEEL ROLLED SHAPES, PLATES AND BARS SHALL CONFORM TO THE FOLLOWING ASTM DESIGNATIONS:
 - A. ASTM A-572, GRADE 50 - ALL W SHAPES, UNLESS NOTED OR A992 OTHERWISE
 - B. ASTM A-36 - ALL OTHER ROLLED SHAPES, PLATES AND BARS UNLESS NOTED OTHERWISE.
 - C. ASTM A-500, GRADE B - HSS SECTION (SQUARE, RECTANGULAR, AND ROUND)
 - D. ASTM A-325, TYPE SC OR N - ALL BOLTS FOR CONNECTING STRUCTURAL MEMBERS
 - E. ASTM F-1554 07 - ALL ANCHOR BOLTS, UNLESS NOTED OTHERWISE
3. ALL EXPOSED STRUCTURAL STEEL MEMBERS SHALL BE HOT-DIPPED GALVANIZED AFTER FABRICATION PER ASTM A123. EXPOSED STEEL HARDWARE AND ANCHOR BOLTS SHALL BE GALVANIZED PER ASTM A153 OR B695.
4. ALL FIELD CUT SURFACES, FIELD DRILLED HOLES AND GROUND SURFACES WHERE EXISTING PAINT OR GALVANIZATION REMOVAL WAS REQUIRED SHALL BE REPAIRED WITH (2) BRUSHED COATS OF ZRC GALVILITE COLD GALVANIZING COMPOUND PER ASTM A780 AND MANUFACTURER'S RECOMMENDATIONS.
5. DO NOT DRILL HOLES THROUGH STRUCTURAL STEEL MEMBERS EXCEPT AS SHOWN AND DETAILED ON STRUCTURAL DRAWINGS.
6. CONNECTIONS:
 - A. ALL WELDING TO BE PERFORMED BY AWS CERTIFIED WELDERS AND CONDUCTED IN ACCORDANCE WITH THE LATEST EDITION OF THE AWS WELDING CODE D1.1.
 - B. ALL WELDS SHALL BE INSPECTED VISUALLY. 25% OF WELDS SHALL BE INSPECTED WITH DYE PENETRANT OR MAGNETIC PARTICLE TO MEET THE ACCEPTANCE CRITERIA OF AWS D1.1. REPAIR ALL WELDS AS NECESSARY.
 - C. INSPECTION SHALL BE PERFORMED BY AN AWS CERTIFIED WELD INSPECTOR.
 - D. IT IS THE CONTRACTORS RESPONSIBILITY TO PROVIDE BURNING/WELDING PERMITS AS REQUIRED BY LOCAL GOVERNING AUTHORITY AND IF REQUIRED SHALL HAVE FIRE DEPARTMENT DETAIL FOR ANY WELDING ACTIVITY.
 - E. ALL ELECTRODES TO BE LOW HYDROGEN, MATCHING FILLER METAL, PER AWS D1.1, UNLESS NOTED OTHERWISE.
 - F. MINIMUM WELD SIZE TO BE 0.1875 INCH FILLET WELDS, UNLESS NOTED OTHERWISE.
 - G. PRIOR TO FIELD WELDING GALVANIZING MATERIAL, CONTRACTOR SHALL GRIND OFF GALVANIZING 1/2" BEYOND ALL FIELD WELD SURFACES. AFTER WELD AND WELD INSPECTION IS COMPLETE, REPAIR ALL GROUND AND WELDED SURFACES WITH ZRC GALVILITE COLD GALVANIZING COMPOUND PER ASTM A780 AND MANUFACTURERS RECOMMENDATIONS.



THESE DRAWINGS AND/OR THE ACCOMPANYING SPECIFICATION AS INSTRUMENTS OR SERVICE ARE THE EXCLUSIVE PROPERTY OF AMERICAN TOWER. THEIR USE AND PUBLICATION SHALL BE RESTRICTED TO THE ORIGINAL SITE FOR WHICH THEY ARE PREPARED. ANY USE OR DISCLOSURE OTHER THAN THAT WHICH RELATES TO AMERICAN TOWER OR THE SPECIFIED CARRIER IS STRICTLY PROHIBITED. TITLE TO THESE DOCUMENTS SHALL REMAIN THE PROPERTY OF AMERICAN TOWER WHETHER OR NOT THE PROJECT IS EXECUTED. NEITHER THE ARCHITECT NOR THE ENGINEER WILL BE PROVIDING ON-SITE CONSTRUCTION REVIEW OF THIS PROJECT. CONTRACTOR(S) MUST VERIFY ALL DIMENSIONS AND ADVISE AMERICAN TOWER OF ANY DISCREPANCIES. ANY PRIOR ISSUANCE OF THIS DRAWING IS SUPERSEDED BY THE LATEST VERSION ON FILE WITH AMERICAN TOWER.

REV.	DESCRIPTION	BY	DATE
0	FOR CONSTRUCTION	KC	05/29/19

ATC SITE NUMBER:
411178

ATC SITE NAME:
OLD LYME SOUTH CT

SITE ADDRESS:
125 MILE CREEK ROAD
OLD LYME, CT 06371

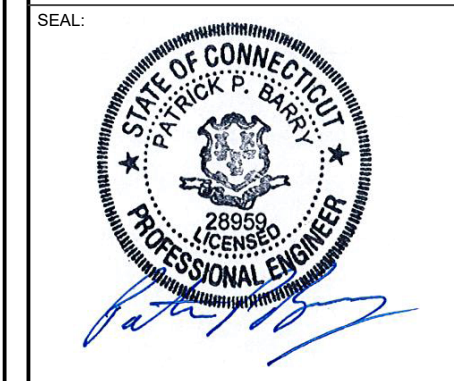

Authorized by "EOR"
Jul 16 2019 4:51 PM
P-Mobileesign

DRAWN BY:	KC
APPROVED BY:	PB
DATE DRAWN:	05/29/19
ATC JOB NO:	12951861

GENERAL NOTES	
SHEET NUMBER: G-002	REVISION: 0

Copyright © 2019 ATC IP LLC, All Rights Reserved.

SITE PLAN NOTES:

1. THIS SITE PLAN REPRESENTS THE BEST PRESENT KNOWLEDGE AVAILABLE TO THE ENGINEER AT THE TIME OF THIS DESIGN. THE CONTRACTOR SHALL VISIT THE SITE PRIOR TO CONSTRUCTION AND VERIFY ALL EXISTING CONDITIONS RELATED TO THE SCOPE OF WORK FOR THIS PROJECT.
2. ICE BRIDGE, CABLE LADDER, COAX PORT, AND COAX CABLE ARE SHOWN FOR REFERENCE ONLY. CONTRACTOR SHALL CONFIRM THE EXACT LOCATION OF ALL PROPOSED AND EXISTING EQUIPMENT AND STRUCTURES DEPICTED ON THIS PLAN. BEFORE UTILIZING EXISTING CABLE SUPPORTS, COAX PORTS, INSTALLING NEW PORTS OR ANY OTHER EQUIPMENT, CONTRACTOR SHALL VERIFY ALL ASPECTS OF THE COMPONENTS MEET THE ATC SPECIFICATIONS.
3. THIS PROJECT INCLUDES NO INSTALL OR MODIFICATION AT GRADE.

TOP OF EXISTING HIGHEST APPURTENANCE
ELEV. 187'

TOP OF EXISTING TOWER
ELEV. 171.5'

EXISTING AND PROPOSED T-MOBILE ANTENNAS
(SEE TOWER NOTE 3)

PER MOUNT ANALYSIS COMPLETED BY CLS ENGINEERING, DATED 07/03/19, THE EXISTING MOUNT CAN NOT ADEQUATELY SUPPORT THE PROPOSED LOADING. THE MOUNT MODIFICATION PROPOSED IN THE MOUNT ANALYSIS, INCLUDED AT THE END OF THIS PLAN SET, MUST BE INSTALLED PRIOR TO THE INSTALLATION OF THE PROPOSED ANTENNAS AND OTHER EQUIPMENT.

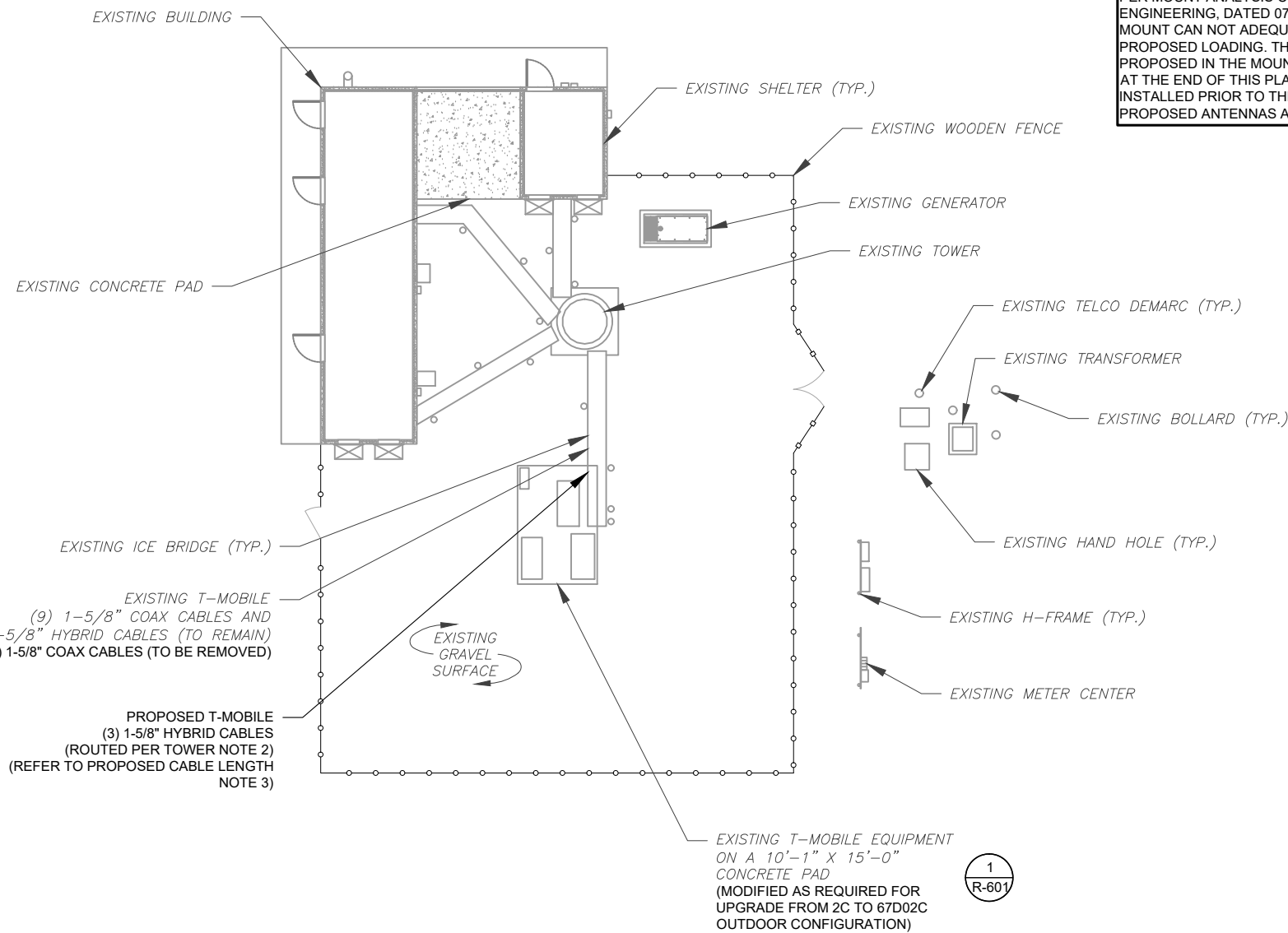

1 DETAILED SITE PLAN

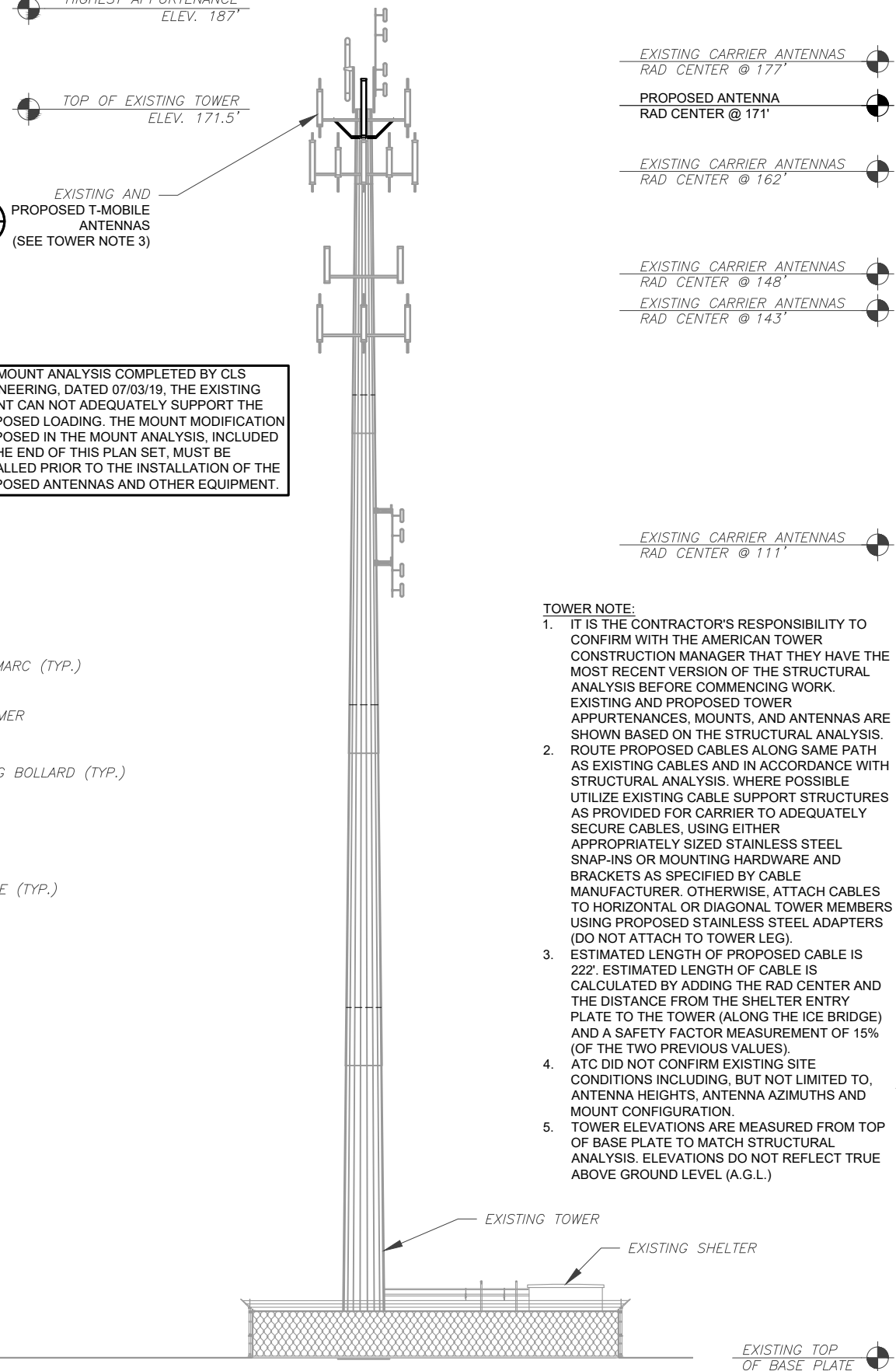
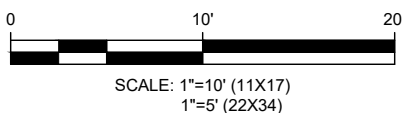

2 TOWER ELEVATION
SCALE: NOT TO SCALE

TOWER NOTE:

1. IT IS THE CONTRACTOR'S RESPONSIBILITY TO CONFIRM WITH THE AMERICAN TOWER CONSTRUCTION MANAGER THAT THEY HAVE THE MOST RECENT VERSION OF THE STRUCTURAL ANALYSIS BEFORE COMMENCING WORK. EXISTING AND PROPOSED TOWER APPURTENANCES, MOUNTS, AND ANTENNAS ARE SHOWN BASED ON THE STRUCTURAL ANALYSIS. ROUTE PROPOSED CABLES ALONG SAME PATH AS EXISTING CABLES AND IN ACCORDANCE WITH STRUCTURAL ANALYSIS. WHERE POSSIBLE UTILIZE EXISTING CABLE SUPPORT STRUCTURES AS PROVIDED FOR CARRIER TO ADEQUATELY SECURE CABLES, USING EITHER APPROPRIATELY SIZED STAINLESS STEEL SNAP-INS OR MOUNTING HARDWARE AND BRACKETS AS SPECIFIED BY CABLE MANUFACTURER. OTHERWISE, ATTACH CABLES TO HORIZONTAL OR DIAGONAL TOWER MEMBERS USING PROPOSED STAINLESS STEEL ADAPTERS (DO NOT ATTACH TO TOWER LEG).
2. ESTIMATED LENGTH OF PROPOSED CABLE IS 222'. ESTIMATED LENGTH OF CABLE IS CALCULATED BY ADDING THE RAD CENTER AND THE DISTANCE FROM THE SHELTER ENTRY PLATE TO THE TOWER (ALONG THE ICE BRIDGE) AND A SAFETY FACTOR MEASUREMENT OF 15% (OF THE TWO PREVIOUS VALUES).
3. ATC DID NOT CONFIRM EXISTING SITE CONDITIONS INCLUDING, BUT NOT LIMITED TO, ANTENNA HEIGHTS, ANTENNA AZIMUTHS AND MOUNT CONFIGURATION.
4. TOWER ELEVATIONS ARE MEASURED FROM TOP OF BASE PLATE TO MATCH STRUCTURAL ANALYSIS. ELEVATIONS DO NOT REFLECT TRUE ABOVE GROUND LEVEL (A.G.L.).



AMERICAN TOWER®
A.T. ENGINEERING SERVICE, PLLC
3500 REGENCY PARKWAY
SUITE 100
CARY, NC 27518
PHONE: (919) 468-0112
COA: PEC.0001553

THESE DRAWINGS AND/OR THE ACCOMPANYING SPECIFICATION AS INSTRUMENTS OR SERVICE ARE THE EXCLUSIVE PROPERTY OF AMERICAN TOWER. THEIR USE AND PUBLICATION SHALL BE RESTRICTED TO THE ORIGINAL SITE FOR WHICH THEY ARE PREPARED. ANY USE OR DISCLOSURE OTHER THAN THAT WHICH RELATES TO AMERICAN TOWER OR THE SPECIFIED CARRIER IS STRICTLY PROHIBITED. TITLE TO THESE DOCUMENTS SHALL REMAIN THE PROPERTY OF AMERICAN TOWER WHETHER OR NOT THE PROJECT IS EXECUTED. NEITHER THE ARCHITECT NOR THE ENGINEER WILL BE PROVIDING ON-SITE CONSTRUCTION REVIEW OF THIS PROJECT. CONTRACTOR(S) MUST VERIFY ALL DIMENSIONS AND ADVISE AMERICAN TOWER OF ANY DISCREPANCIES. ANY PRIOR ISSUANCE OF THIS DRAWING IS SUPERSEDED BY THE LATEST VERSION ON FILE WITH AMERICAN TOWER.

REV.	DESCRIPTION	BY	DATE
0	FOR CONSTRUCTION	KC	05/29/19
1	MA UPDATE	LR	07/16/19

ATC SITE NUMBER:
411178

ATC SITE NAME:
OLD LYME SOUTH CT

SITE ADDRESS:
125 MILE CREEK ROAD
OLD LYME, CT 06371

SEAL:



Authorized by "EOR"
Jul 16 2019 4:51 PM
P. Mobilosign

DRAWN BY:	KC
APPROVED BY:	PB
DATE DRAWN:	05/29/19
ATC JOB NO:	12951861

DETAILED SITE PLAN & TOWER ELEVATION

SHEET NUMBER:	REVISION:
C-101	1

THESE DRAWINGS AND/OR THE ACCOMPANYING SPECIFICATION AS INSTRUMENTS OR SERVICE ARE THE EXCLUSIVE PROPERTY OF AMERICAN TOWER. THEIR USE AND PUBLICATION SHALL BE RESTRICTED TO THE ORIGINAL SITE FOR WHICH THEY ARE PREPARED. ANY USE OR DISCLOSURE OTHER THAN THAT WHICH RELATES TO AMERICAN TOWER OR THE SPECIFIED CARRIER IS STRICTLY PROHIBITED. TITLE TO THESE DOCUMENTS SHALL REMAIN THE PROPERTY OF AMERICAN TOWER WHETHER OR NOT THE PROJECT IS EXECUTED. NEITHER THE ARCHITECT NOR THE ENGINEER WILL BE PROVIDING ON-SITE CONSTRUCTION REVIEW OF THIS PROJECT. CONTRACTOR(S) MUST VERIFY ALL DIMENSIONS AND ADVISE AMERICAN TOWER OF ANY DISCREPANCIES. ANY PRIOR ISSUANCE OF THIS DRAWING IS SUPERSEDED BY THE LATEST VERSION ON FILE WITH AMERICAN TOWER.

REV.	DESCRIPTION	BY	DATE
0	FOR CONSTRUCTION	KC	05/29/19
1	MA UPDATE	LR	07/16/19

ATC SITE NUMBER:
411178

ATC SITE NAME:
OLD LYME SOUTH CT

SITE ADDRESS:
 125 MILE CREEK ROAD
 OLD LYME, CT 06371



Authorized by "EOR"
 July 16, 2019 4:51 PM



DRAWN BY:	KC
APPROVED BY:	PB
DATE DRAWN:	05/29/19
ATC JOB NO:	12951861

ANTENNA INFORMATION & SCHEDULE

SHEET NUMBER:
C-501

REVISION:
1

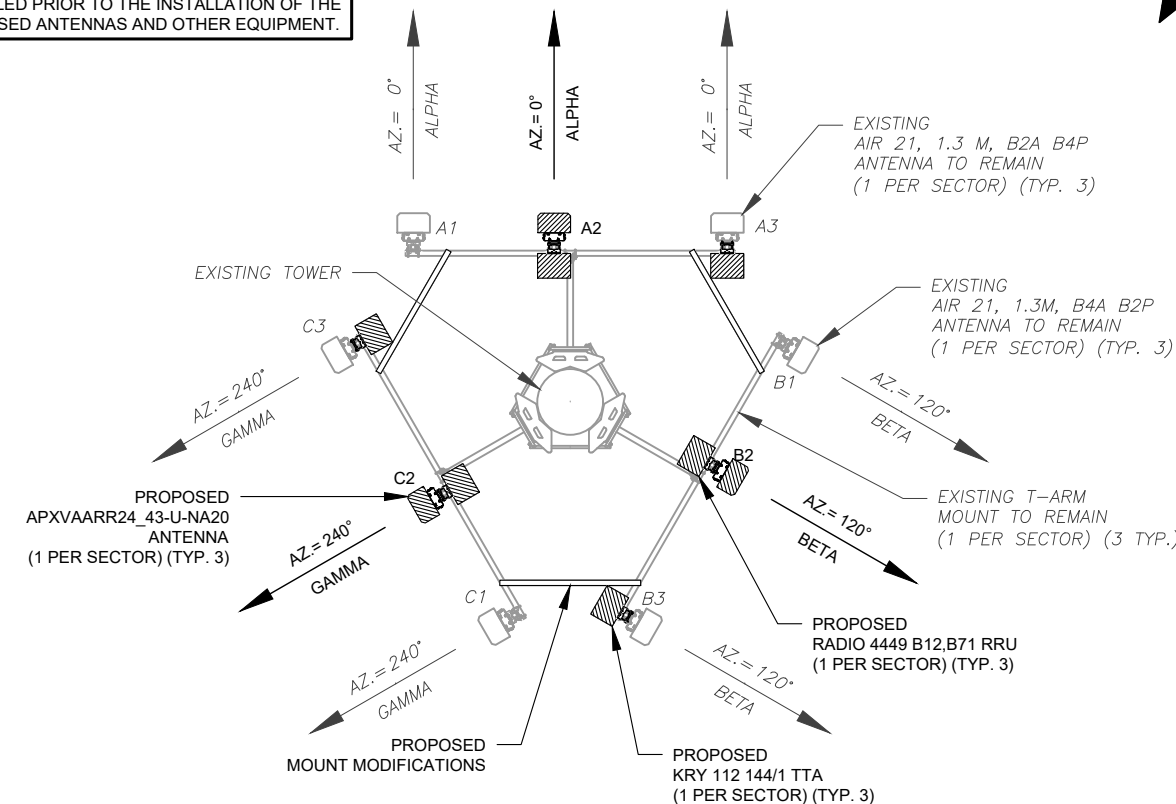
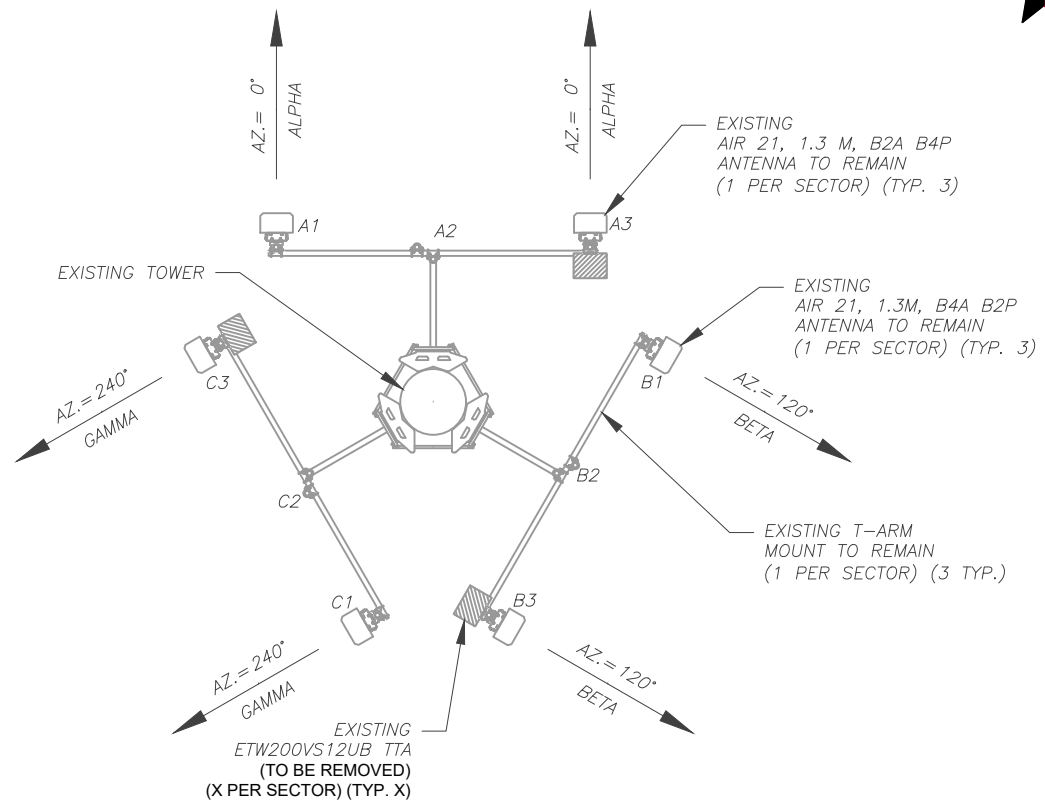
PER MOUNT ANALYSIS COMPLETED BY CLS ENGINEERING, DATED 07/03/19, THE EXISTING MOUNT CAN NOT ADEQUATELY SUPPORT THE PROPOSED LOADING. THE MOUNT MODIFICATION PROPOSED IN THE MOUNT ANALYSIS, INCLUDED AT THE END OF THIS PLAN SET, MUST BE INSTALLED PRIOR TO THE INSTALLATION OF THE PROPOSED ANTENNAS AND OTHER EQUIPMENT.



EXISTING ANTENNA / EQUIPMENT SCHEDULE							
SECTOR	ANT.	MANUFACTURER (MODEL #)	RAD CENTER	AZIMUTH (TN)	MECH. D-TILT	ELEC. D-TILT	ADDITIONAL TOWER MOUNTED EQUIPMENT
ALPHA	A1	AIR 21, 1.3M, B4A B2P	170'-0"	0°	-	2°	-
ALPHA	A2	-	-	-	-	-	-
ALPHA	A3	AIR 21, 1.3 M, B2A B4P	170'-0"	0°	-	2°	ETW200VS12UB
BETA	B1	AIR 21, 1.3M, B4A B2P	170'-0"	120°	-	2°	-
BETA	B2	-	-	-	-	-	-
BETA	B3	AIR 21, 1.3 M, B2A B4P	170'-0"	120°	-	2°	ETW200VS12UB
GAMMA	C1	AIR 21, 1.3M, B4A B2P	170'-0"	240°	-	2°	-
GAMMA	C2	-	-	-	-	-	-
GAMMA	C3	AIR 21, 1.3 M, B2A B4P	170'-0"	240°	-	2°	ETW200VS12UB

- NOTES**
- BASED ON APPROVED ATC APPLICATION 12927156, DATED 04/05/19. CONFIRM WITH T-MOBILE REP FOR APPLICABLE UPDATES/REVISIONS AND MOST RECENT RFDS FOR NSN CONFIGURATION (CONFIG). GC TO CAP ALL UNUSED PORTS.
 - ATC HAS NOT YET VERIFIED ANY EXISTING ANTENNA CONFIG OR MOUNT CONFIG. CONTRACTOR TO VERIFY MOUNT CONFIG HAS SUFFICIENT SPACE FOR PROPOSED LESSEE EQUIPMENT (EQUIP) (I.E. CLEARANCES, MOUNT PIPE, SUFFICIENT LENGTH, ETC.) ATC DID NOT ANALYZE ANTENNA MOUNT TO DETERMINE ADEQUATE STRUCTURAL CAPACITY FOR ANY LESSEE LOADING.
 - ALL PROPOSED EQUIP INCLUDING ANTENNAS, COAX, ETC. SHALL BE MOUNTED IN ACCORDANCE WITH THE TOWER STRUCTURAL ANALYSIS ON FILE WITH ATC'S CM.
 - CONFIRM SPACING OF PROPOSED EQUIP DOES NOT CAUSE TOWER CONFLICTS NOR IMPEDE TOWER CLIMBING PEGS.
 - POSITIONS START WITH FIRST PIPE ON THE LEFT SIDE (AS VIEWED FROM BEHIND THE MOUNT).

FINAL ANTENNA / EQUIPMENT SCHEDULE							
SECTOR	ANT.	MANUFACTURER (MODEL #)	RAD CENTER	AZIMUTH (TN)	MECH. D-TILT	ELEC. D-TILT	ADDITIONAL TOWER MOUNTED EQUIPMENT
ALPHA	A1	AIR 21, 1.3M, B4A B2P	171'-0"	0°	-	2°	-
ALPHA	A2	APXVAARR24_43-U-NA20	171'-0"	0°	-	2°	RADIO 4449 B12,B71
ALPHA	A3	AIR 21, 1.3 M, B2A B4P	171'-0"	0°	-	2°	KRY 112 144/1
BETA	B1	AIR 21, 1.3M, B4A B2P	171'-0"	120°	-	2°	-
BETA	B2	APXVAARR24_43-U-NA20	171'-0"	120°	-	2°	RADIO 4449 B12,B71
BETA	B3	AIR 21, 1.3 M, B2A B4P	171'-0"	120°	-	2°	KRY 112 144/1
GAMMA	C1	AIR 21, 1.3M, B4A B2P	171'-0"	240°	-	2°	-
GAMMA	C2	APXVAARR24_43-U-NA20	171'-0"	240°	-	2°	RADIO 4449 B12,B71
GAMMA	C3	AIR 21, 1.3 M, B2A B4P	171'-0"	240°	-	2°	KRY 112 144/1

CURRENT FIBER DISTRIBUTION/OVP BOX		CURRENT CABLING SUMMARY			STATUS ABBREVIATIONS		
MODEL NUMBER	STATUS	COAX	HYBRID	STATUS	RMV:	REL:	DSC:
-	-	(9) 1-5/8"	(1) 1-5/8"	RMN	TO BE REMOVED	TO BE RELOCATED	TO BE DISCONNECTED & REMAIN
-	-	(3) 1-5/8"	-	RMV	ADD: TO BE ADDED		

3 ANTENNA SCHEDULE

PROPOSED FIBER DISTRIBUTION/OVP BOX		PROPOSED CABLING SUMMARY		
MODEL NUMBER	STATUS	COAX	HYBRID	STATUS
-	-	(9) 1-5/8"	(1) 1-5/8"	RMN
-	-	-	(3) 1-5/8"	ADD

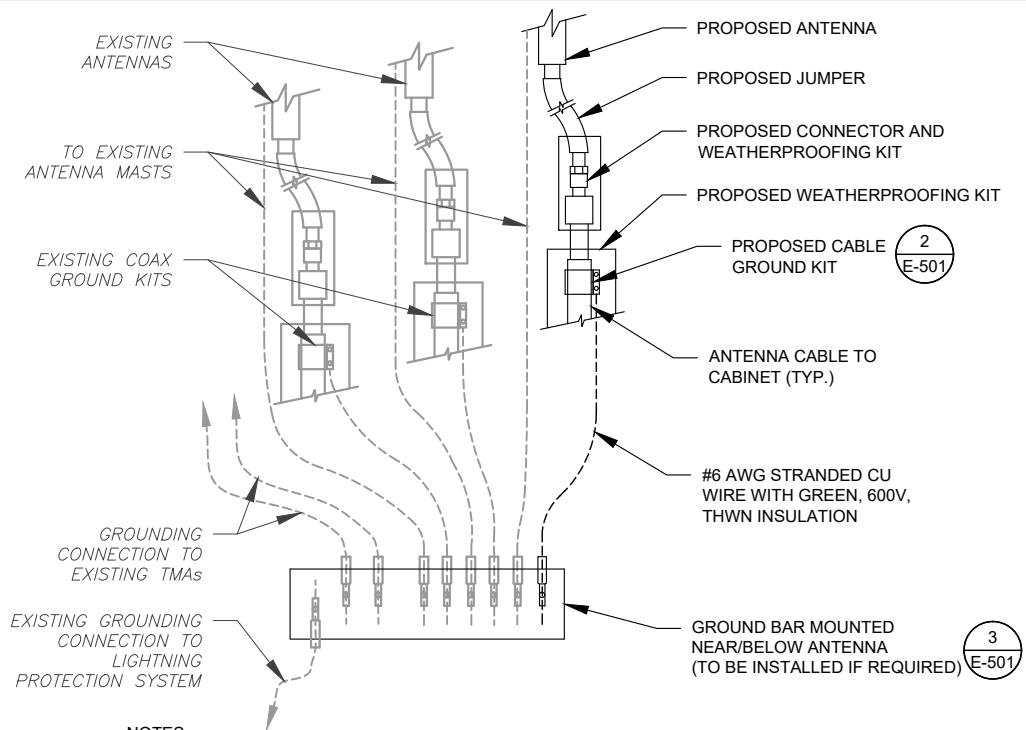

NOTES:

1. THIS DETAIL IS INTENDED TO SHOW THE GENERAL GROUNDING REQUIREMENTS. SLIGHT ADJUSTMENTS MAY BE REQUIRED BASED ON EXISTING SITE CONDITIONS. THE CONTRACTOR SHALL MAKE FIELD ADJUSTMENTS AS NEEDED AND INFORM THE CONSTRUCTION MANAGER OF ANY CONFLICTS.
2. SITE GROUNDING SHALL COMPLY WITH T-MOBILE GROUNDING STANDARDS, LATEST EDITION, AND COMPLY WITH T-MOBILE GROUNDING CHECKLIST, LATEST VERSION. WHEN NATIONAL AND LOCAL GROUNDING CODES ARE MORE STRINGENT THEY SHALL GOVERN.

1 TYPICAL ANTENNA GROUNDING DIAGRAM
SCALE: NOT TO SCALE

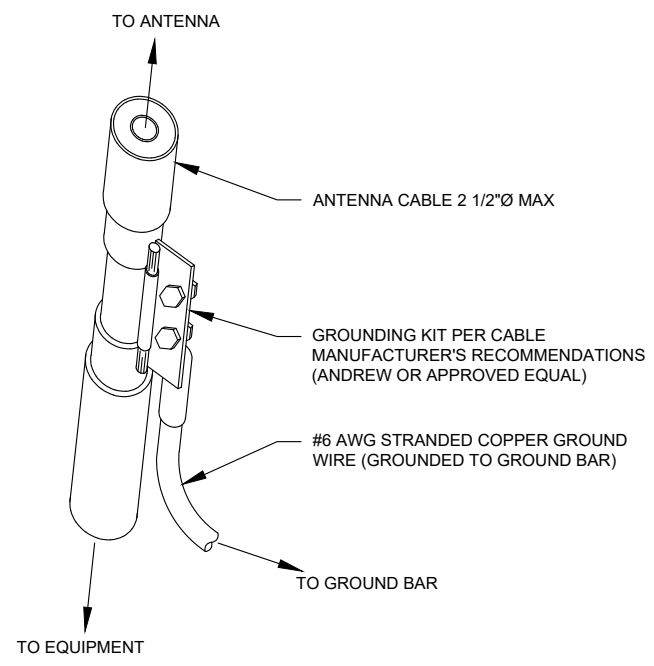

GROUND KIT NOTES:

1. DO NOT INSTALL CABLE GROUND KIT AT A BEND AND ALWAYS DIRECT GROUND WIRE DOWN TO GROUND BAR.
2. CONTRACTOR SHALL PROVIDE WEATHERPROOFING KIT (ANDREW PART NUMBER 221213) AND INSTALL/TAPE PER MANUFACTURER'S SPECIFICATIONS.

2 CABLE GROUND KIT CONNECTION DETAIL
SCALE: NOT TO SCALE

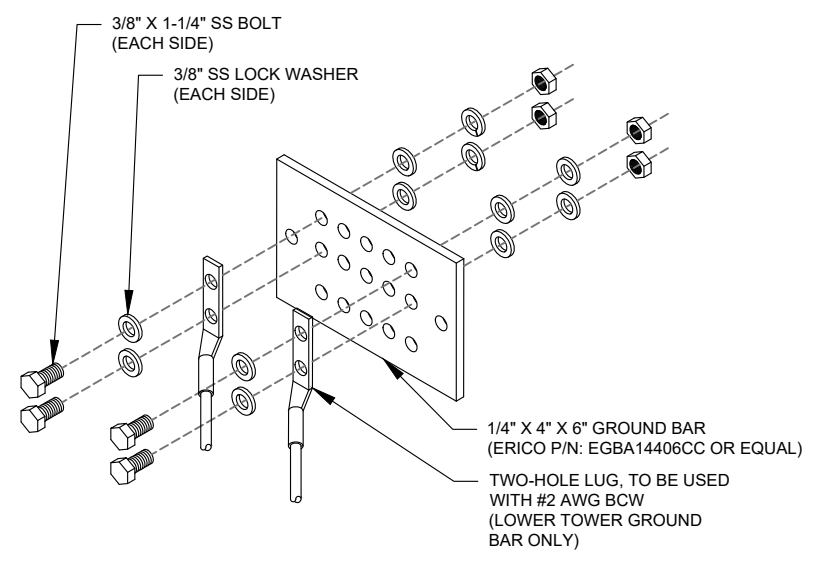

GROUND BAR NOTES:

1. GROUND BAR KITS COME WITH ALL HARDWARE, NUTS, BOLTS, WASHERS, ETC. EXCEPT THE STRUCTURAL MOUNTING MEMBER(S).
2. GROUND BAR TO BE BONDED DIRECTLY TO TOWER.

3 TOWER GROUND BAR DETAIL
SCALE: NOT TO SCALE

AMERICAN TOWER®
A.T. ENGINEERING SERVICE, PLLC
 3500 REGENCY PARKWAY
 SUITE 100
 CARY, NC 27518
 PHONE: (919) 468-0112
 COA: PEC.0001553

THESE DRAWINGS AND/OR THE ACCOMPANYING SPECIFICATION AS INSTRUMENTS OR SERVICE ARE THE EXCLUSIVE PROPERTY OF AMERICAN TOWER. THEIR USE AND PUBLICATION SHALL BE RESTRICTED TO THE ORIGINAL SITE FOR WHICH THEY ARE PREPARED. ANY USE OR DISCLOSURE OTHER THAN THAT WHICH RELATES TO AMERICAN TOWER OR THE SPECIFIED CARRIER IS STRICTLY PROHIBITED. TITLE TO THESE DOCUMENTS SHALL REMAIN THE PROPERTY OF AMERICAN TOWER WHETHER OR NOT THE PROJECT IS EXECUTED. NEITHER THE ARCHITECT NOR THE ENGINEER WILL BE PROVIDING ON-SITE CONSTRUCTION REVIEW OF THIS PROJECT. CONTRACTOR(S) MUST VERIFY ALL DIMENSIONS AND ADVISE AMERICAN TOWER OF ANY DISCREPANCIES. ANY PRIOR ISSUANCE OF THIS DRAWING IS SUPERSEDED BY THE LATEST VERSION ON FILE WITH AMERICAN TOWER.

REV.	DESCRIPTION	BY	DATE
0	FOR CONSTRUCTION	KC	05/29/19

ATC SITE NUMBER:
411178

ATC SITE NAME:
OLD LYME SOUTH CT

SITE ADDRESS:
125 MILE CREEK ROAD
OLD LYME, CT 06371

SEAL:

Patrick P. Barry

Authorized by "EOR"
 Jul 16 2019 4:51 PM
 P-Mobileesign

DRAWN BY:	KC
APPROVED BY:	PB
DATE DRAWN:	05/29/19
ATC JOB NO:	12951861

GROUNDING DETAILS

SHEET NUMBER:	REVISION:
E-501	0

Copyright © 2019 ATC IP, LLC. All Rights Reserved.

Section 5 - RAN Equipment

Existing RAN Equipment		
Template: 2C		
Enclosure	1	2
Enclosure Type	RBS 6131	S8000 Outdoor
Baseband	DUW30 (x2) DUG20 DUS31	
Hybrid Cable System	Ericsson 9x18 HCS 60m	
Radio	RU22 (x6)	

Proposed RAN Equipment		
Template: 67D02C Outdoor		
Enclosure	1	2
Enclosure Type	RBS 6131	S8000 Outdoor
Baseband	DUW30 U2100 DUW30 U1900 DUG20 G1900 BB 6630 L2100 BB 6630 N600 (DARK) L700 L600	
Hybrid Cable System	Ericsson 9x18 HCS 60m	Ericsson 6x12 HCS *Select Length & AWG* (x3)
Radio	RU22 (x6) U2100	

RAN Scope of Work:

Replace (1) DUS31 with (1) BB6630 for LTE.
 Install (1) BB6630 for future 5G N600.

Add (3) 6X12 HCS.
 Existing: (12) 1-5/8"; (1) 9X18 HCS, Remove (3) Coaxial Lines in order to accommodate (3) new 6X12 HCS.

Rad Center: 170 Feet

1 CABINET CONFIGURATION
 SCALE: NOT TO SCALE

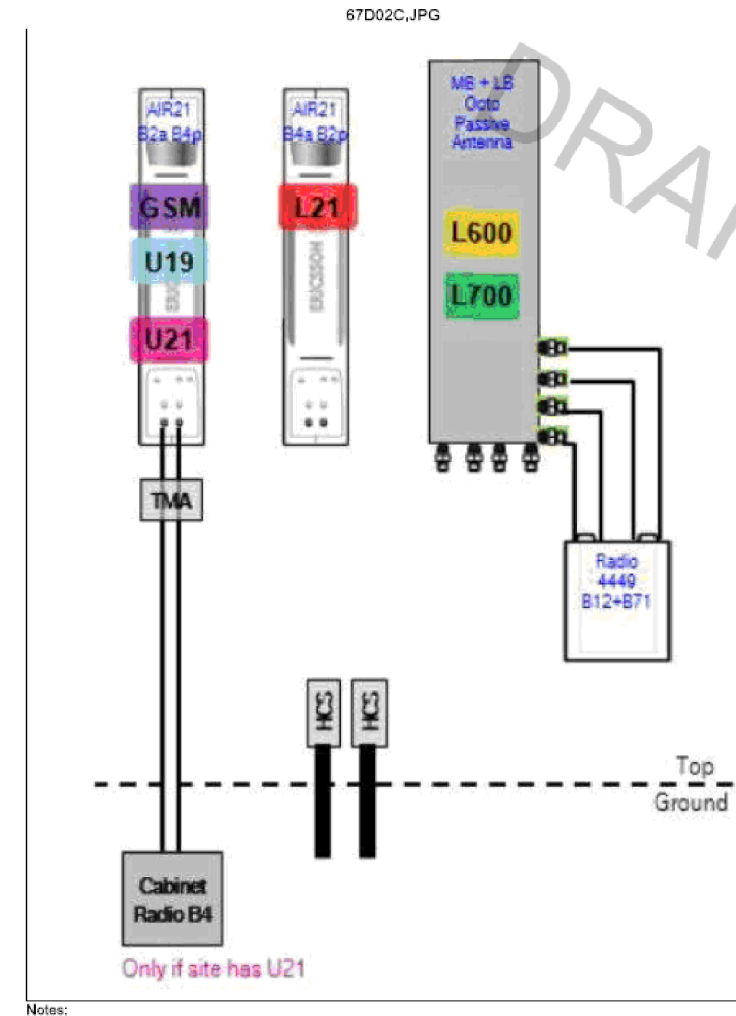

2 ANTENNA CONFIGURATION
 SCALE: NOT TO SCALE

SUPPLEMENTAL

SHEET NUMBER: R-601
 REVISION: 0

NOTE: THIS SHEET CREATED BY OTHERS AND PROVIDED BY REQUEST OF CUSTOMER WITHOUT EDIT.

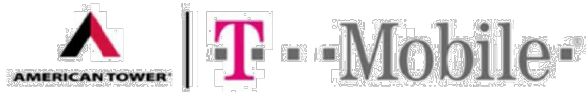

Mount Analysis of Existing T-Arms for American Tower on behalf of T-Mobile
411178 - Old Lyme South CT
Project #: 12927156
T-Mobile Site ID: CTNL802A
Program: L600

CLS Engineering PLLC Project #41124-12927156-01-MA-R1
 July 3, 2019

MOUNT DESCRIPTION	Existing T-Arms at 169 ft AGL
ANTENNA ELEVATION	Nominal Rad. Elevation of 171 ft AGL (Eccentricity of ~2 ft)
SITE DESCRIPTION	170.5 ft Monopole
SITE ADDRESS	129 Mile Creek Road, Old Lyme, CT 06371-1718, New London County
GPS COORDINATES	41.305653, -72.297361
ANALYSIS STANDARD	2015 IBC / 2018 Connecticut State Building Code / TIA-222-G
LOADING CRITERIA	135 mph, V_{ult} / 104.6 mph, V_{sust} (3-Second Gust) w/o ice & 50 mph (3-Second Gust) w/ 0.75"

■ ANALYSIS RESULT: **Pass (Conditional)**

MEMBER USAGE	92%	Pass
--------------	-----	------

Modifications are proposed to bring mounts into compliance; see conclusion for details.

Prepared by:
 Jennifer Soza

Reviewed and Approved by:
 Tyler M. Barker, P.E.



Tyler M. Barker
 CLS Engineering, PLLC
 Director of Engineering
 PE # 32402 Exp. 11/31/2020
 COA # PEC.001833 Exp. 8/14/2019

Digitally signed by Tyler Barker
 DN: c=US, o=Telamon Corporation, ou=A01427E0000 016A4525ADF800 001D17, cn=Tyler Barker
 Date: 2019.07.03 22:00:14 -04'00'

■ RESULTS SUMMARY

Existing Mount Usages:

COMPONENT	PEAK USAGE	RESULT
Collar Usage	136%	Fail
Mount Pipes	125%	Fail
Connections	98%	Pass
Face Horizontals	81%	Pass
Stand-Off Horizontals	58%	Pass

Modified Mount Usages:

COMPONENT	PEAK USAGE	RESULT
Collar Reactions	92%	Pass
Face Horizontals	74%	Pass
Connections	69%	Pass
Mount Pipes	59%	Pass
Stand-Off Horizontals	35%	Pass

■ CONCLUSION AND RECOMMENDATIONS

According to our structural analysis, the mounts have been found to **CONDITIONALLY PASS**. The mounting configuration considered in this analysis will be capable of supporting the referenced loading pursuant to referenced standards once the following scope is executed:

- Install (1) Site Pro 1 PRK-1245 kit at the offset arms on the existing T-Arm mount as shown in the following sketches. Collar to be installed flush with existing monopole at a height of ±1.5 ft. below the centerline of existing T-Arm mount collar. Field-cut proposed angles as required. Maintain minimum bolt edge distance. Do not pinch safety climb.
- Replace existing mount pipe at Position 2 with (1) Site Pro 1 SP219-96H, 2-7/8" Pipe Mount Kit at each sector (3 total).
- Install (3) 8 ft. long Pipe 2 STD, A53 Gr. B, bracing pipes at the existing T-Arm mount. Connect to existing outermost mount pipes of adjacent sectors with Site Pro 1 SCX1-K or equal, as shown in the following sketches. Field-cut proposed pipes as required.

See following sketches and Site Pro 1 assembly drawings for additional details.

NOTE: THIS SHEET WAS CREATED BY OTHERS AND PROVIDED AT THE REQUEST OF THE CUSTOMER WITHOUT EDIT. PLEASE REFERENCE THE MOUNT ANALYSIS REPORT FOR COMPLETE MOUNT ANALYSIS CALCULATIONS AND DETAILS. SUPPLEMENTAL PAGES INCLUDED IN THE CONSTRUCTION DRAWINGS ARE FOR REFERENCE ONLY. GENERAL CONTRACTOR IS TO VERIFY THEY HAVE THE MOST RECENT MOUNT ANALYSIS PRIOR TO CONTRUCTION.

SUPPLEMENTAL

SHEET NUMBER: R-602	REVISION: 0
-------------------------------	-----------------------

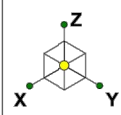

Install (3) 8 ft. long Pipe 2 STD, A53 Gr. B, bracing pipes at the existing T-Arm mount. Connect to existing outermost mount pipes of adjacent sectors with Site Pro 1 SCX1-K or equal, as shown in the following sketches. Field-cut proposed pipes as required.

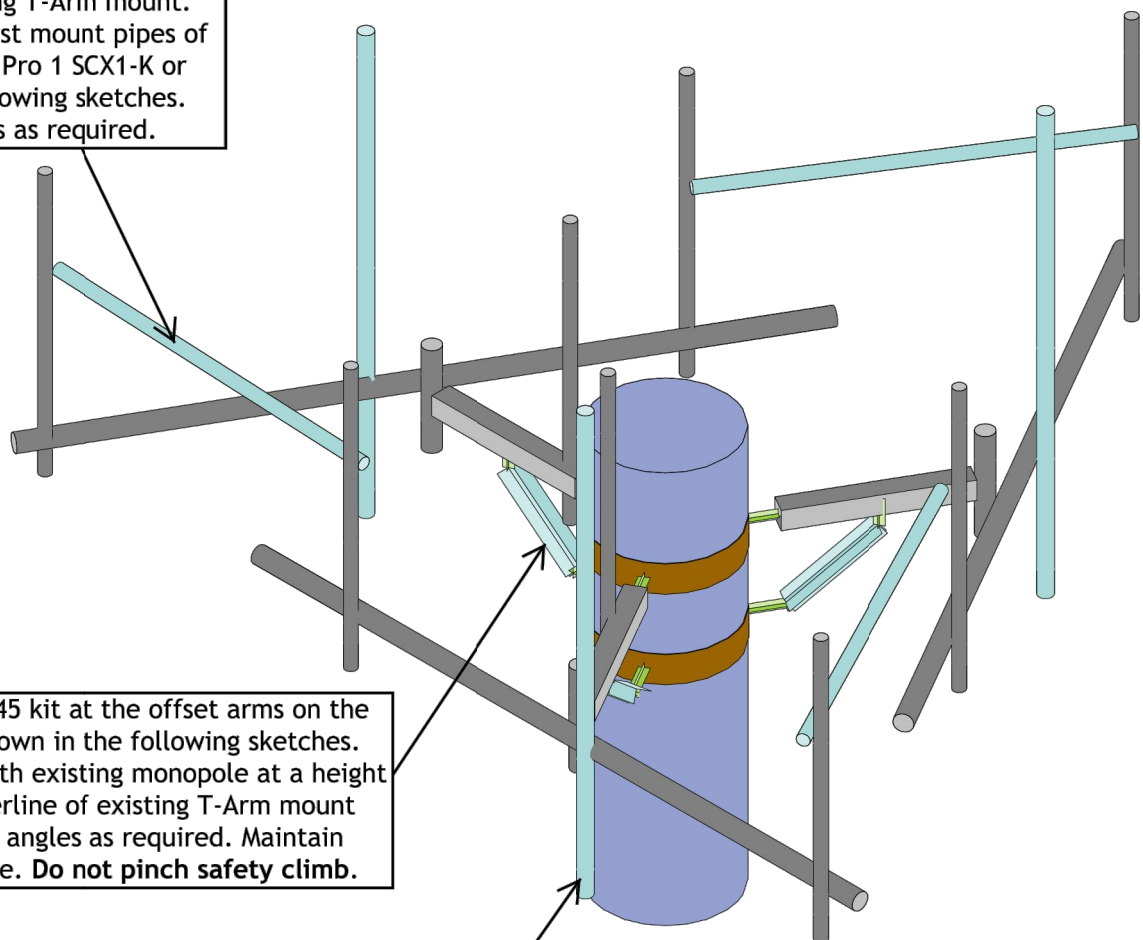

Install (1) Site Pro 1 PRK-1245 kit at the offset arms on the existing T-Arm mount as shown in the following sketches. Collar to be installed flush with existing monopole at a height of ± 1.5 ft. below the centerline of existing T-Arm mount collar. Field-cut proposed angles as required. Maintain minimum bolt edge distance. **Do not pinch safety climb.**

Replace existing mount pipe at Position 2 with (1) Site Pro 1 SP219-96H, 2-7/8" Pipe Mount Kit at each sector (3 total). Attach proposed mount pipe to existing face horizontal pipe using crossover plate and hardware included in the standard kit.

CLS	41124-12927156-Old Lyme South CT Proposed Modification - Rendered	IN - 1
BP		Apr 12, 2019 at 10:24 AM
41124-12927156-01-MA		41124-12927156-01-MA_Sketches.r3d

1 MOUNT ANALYSIS
SCALE: NOT TO SCALE

NOTE: THIS SHEET WAS CREATED BY OTHERS AND PROVIDED AT THE REQUEST OF THE CUSTOMER WITHOUT EDIT. PLEASE REFERENCE THE MOUNT ANALYSIS REPORT FOR COMPLETE MOUNT ANALYSIS CALCULATIONS AND DETAILS. SUPPLEMENTAL PAGES INCLUDED IN THE CONSTRUCTION DRAWINGS ARE FOR REFERENCE ONLY. GENERAL CONTRACTOR IS TO VERIFY THEY HAVE THE MOST RECENT MOUNT ANALYSIS PRIOR TO CONSTRUCTION.

SUPPLEMENTAL	
SHEET NUMBER: R-603	REVISION: 0

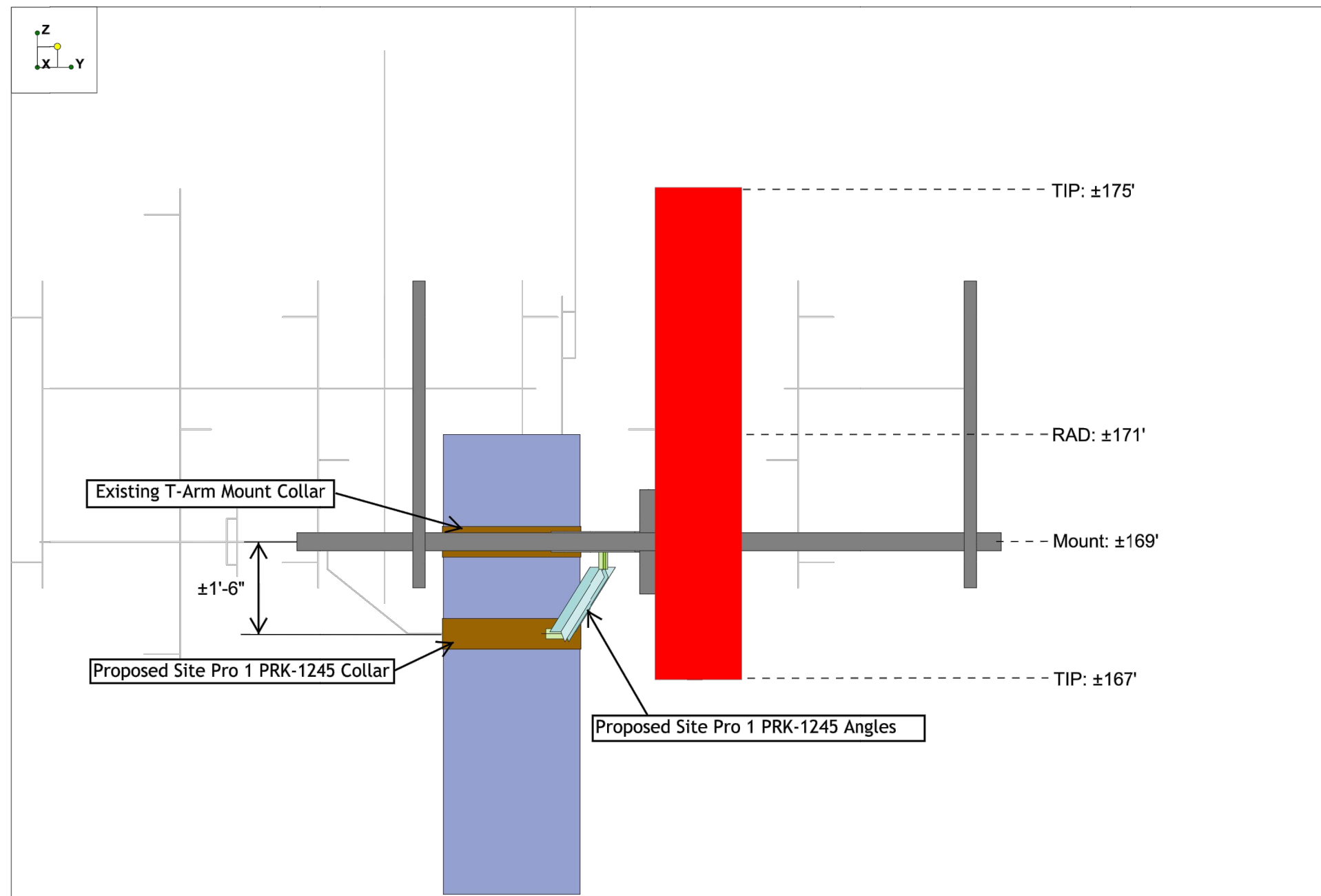

CLS	41124-12927156-Old Lyme South CT Installation Sketch - Front Elevation	IN - 2
BP		Apr 12, 2019 at 10:47 AM
41124-12927156-01-MA		41124-12927156-01-MA_Sketches.r3d

1 MOUNT ANALYSIS
SCALE: NOT TO SCALE

NOTE: THIS SHEET WAS CREATED BY OTHERS AND PROVIDED AT THE REQUEST OF THE CUSTOMER WITHOUT EDIT. PLEASE REFERENCE THE MOUNT ANALYSIS REPORT FOR COMPLETE MOUNT ANALYSIS CALCULATIONS AND DETAILS. SUPPLEMENTAL PAGES INCLUDED IN THE CONSTRUCTION DRAWINGS ARE FOR REFERENCE ONLY. GENERAL CONTRACTOR IS TO VERIFY THEY HAVE THE MOST RECENT MOUNT ANALYSIS PRIOR TO CONSTRUCTION.

SUPPLEMENTAL	
SHEET NUMBER: R-604	REVISION: 0

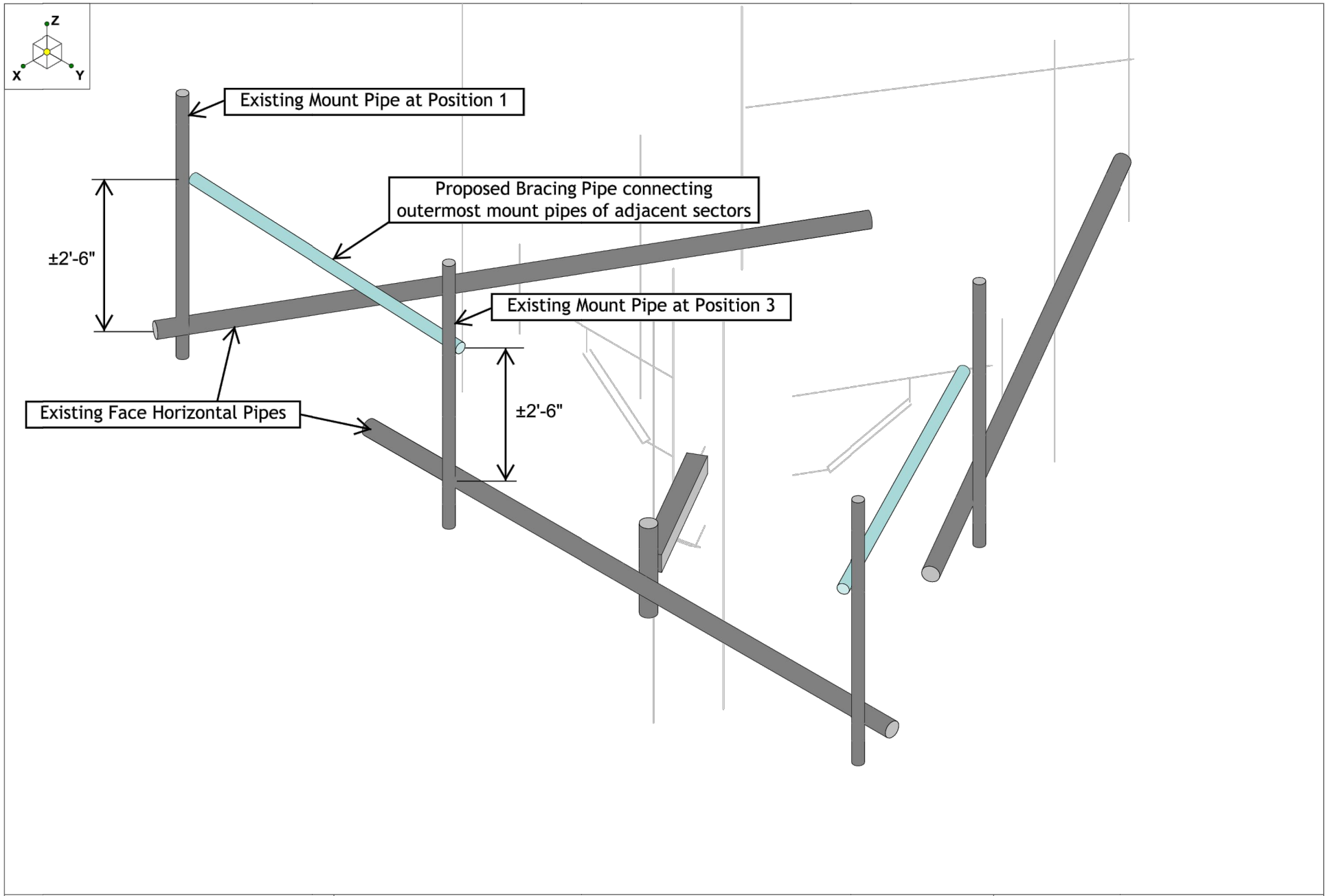

CLS	41124-12927156-Old Lyme South CT Bracing Pipe Installation Sketch - Isometric View	IN - 3
BP		Apr 12, 2019 at 10:27 AM
41124-12927156-01-MA		41124-12927156-01-MA_Sketches.r3d

1 MOUNT ANALYSIS
SCALE: NOT TO SCALE

NOTE: THIS SHEET WAS CREATED BY OTHERS AND PROVIDED AT THE REQUEST OF THE CUSTOMER WITHOUT EDIT. PLEASE REFERENCE THE MOUNT ANALYSIS REPORT FOR COMPLETE MOUNT ANALYSIS CALCULATIONS AND DETAILS. SUPPLEMENTAL PAGES INCLUDED IN THE CONSTRUCTION DRAWINGS ARE FOR REFERENCE ONLY. GENERAL CONTRACTOR IS TO VERIFY THEY HAVE THE MOST RECENT MOUNT ANALYSIS PRIOR TO CONSTRUCTION.

SUPPLEMENTAL	
SHEET NUMBER: R-605	REVISION: 0

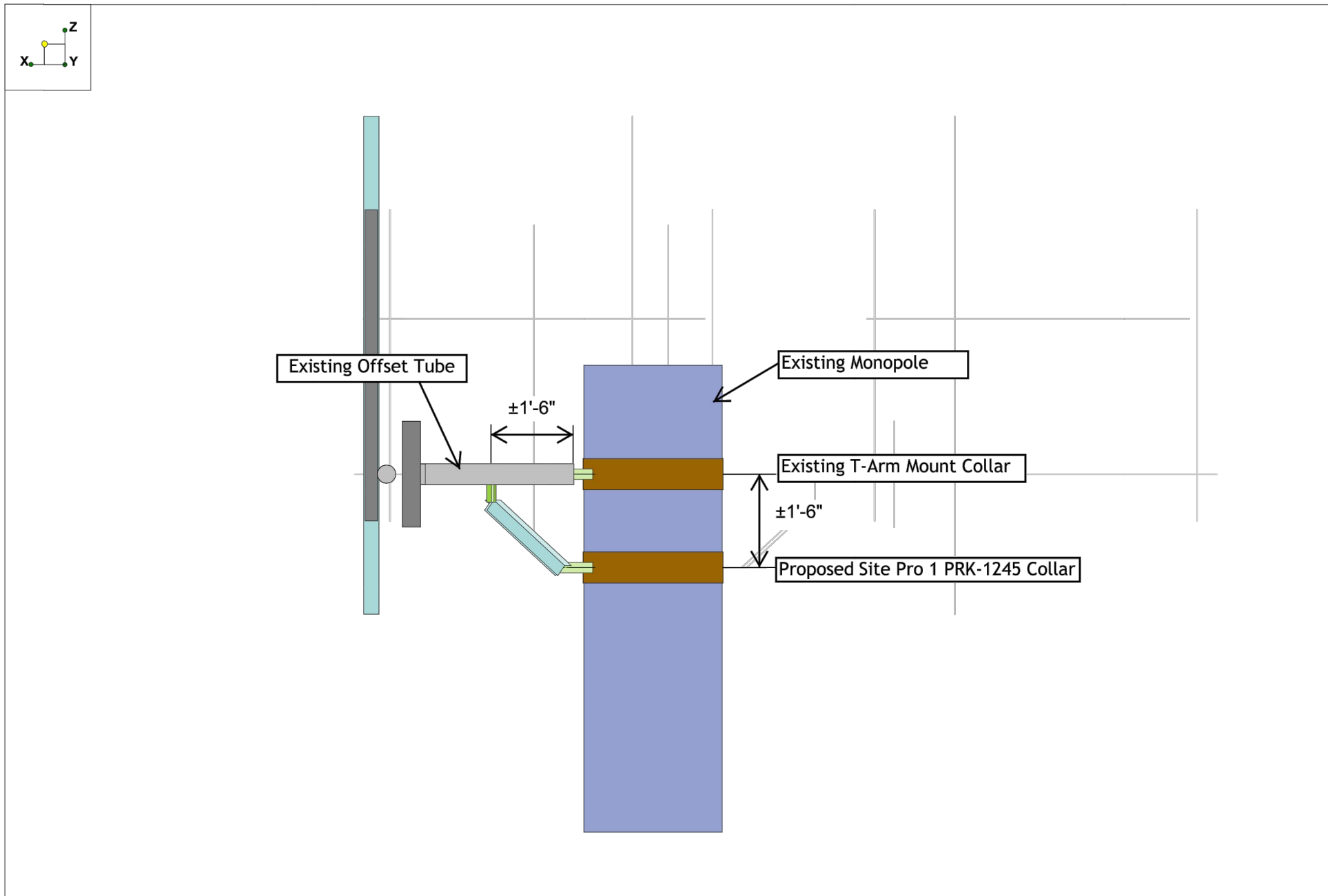

CLS	41124-12927156-Old Lyme South CT Site Pro 1 PRK-1245 Installation Sketch - Side Elevation	IN - 4
BP		Apr 12, 2019 at 10:30 AM
41124-12927156-01-MA		41124-12927156-01-MA_Sketches.r3d

1
MOUNT ANALYSIS
SCALE: NOT TO SCALE

NOTE: THIS SHEET WAS CREATED BY OTHERS AND PROVIDED AT THE REQUEST OF THE CUSTOMER WITHOUT EDIT. PLEASE REFERENCE THE MOUNT ANALYSIS REPORT FOR COMPLETE MOUNT ANALYSIS CALCULATIONS AND DETAILS. SUPPLEMENTAL PAGES INCLUDED IN THE CONSTRUCTION DRAWINGS ARE FOR REFERENCE ONLY. GENERAL CONTRACTOR IS TO VERIFY THEY HAVE THE MOST RECENT MOUNT ANALYSIS PRIOR TO CONSTRUCTION.

SUPPLEMENTAL	
SHEET NUMBER: R-606	REVISION: 0

Exhibit D

Structural Analysis Report



AMERICAN TOWER®
CORPORATION

Structural Analysis Report

Structure : 170.5 ft Monopole
ATC Site Name : Old Lyme South CT, CT
ATC Site Number : 411178
Engineering Number : 12927156_C3_02
Proposed Carrier : T-MOBILE
Carrier Site Name : Amtrak Old Lyme Verizon
Carrier Site Number : CTNL802A
Site Location : 125 Mile Creek Road
OLD LYME, CT 06371-1718
41.305700,-72.297400
County : New London
Date : July 18, 2019
Max Usage : 55%
Result : Pass

Prepared By:
Hussam Al Tahan, E.I.
Structural Engineer I

Hussam Al Tahan

Reviewed By:



Authorized by "EOR"
Jul 19 2019 2:52 PM

cosign

COA: PEC.0001553



Table of Contents

Introduction	1
Supporting Documents	1
Analysis	1
Conclusion.....	1
Existing and Reserved Equipment.....	2
Equipment to be Removed.....	2
Proposed Equipment	3
Structure Usages	3
Foundations	3
Deflection and Sway	3
Standard Conditions	4
Calculations	Attached



Introduction

The purpose of this report is to summarize results of a structural analysis performed on the 170.5 ft monopole to reflect the change in loading by T-MOBILE.

Supporting Documents

Tower Drawings	EEI Project #11723 Rev 1, dated September 19, 2003 Mapping by TEP Job #68269-80551, dated April 25, 2016
Foundation Drawing	EEI Project #11723 Rev 1, dated October 21, 2003
Geotechnical Report	Clarence Welti Site #CT54XC701, dated October 17, 2003
Mount Analysis	CLS Engineering PLLC Project #41124-12927156-01-MA-RA, dated July 3, 2019

Analysis

The tower was analyzed using American Tower Corporation's tower analysis software. This program considers an elastic three-dimensional model and second-order effects per ANSI/TIA-222.

Basic Wind Speed:	105 mph (3-Second Gust, V_{asd}) / 135 mph (3-Second Gust, V_{ult})
Basic Wind Speed w/ Ice:	50 mph (3-Second Gust) w/ 3/4" radial ice concurrent
Code:	ANSI/TIA-222-G / 2015 IBC / 2018 Connecticut State Building Code
Structure Class:	II
Exposure Category:	B
Topographic Category:	1
Crest Height:	0 ft
Spectral Response:	$S_s = 0.16$, $S_1 = 0.06$
Site Class:	D - Stiff Soil

Conclusion

Based on the analysis results, the structure meets the requirements per the applicable codes listed above. The tower and foundation can support the equipment as described in this report.

If you have any questions or require additional information, please contact American Tower via email at Engineering@americantower.com. Please include the American Tower site name, site number, and engineering number in the subject line for any questions.



Existing and Reserved Equipment

Elev. ¹ (ft)	Qty	Antenna	Mount Type	Lines	Carrier
177.0	1	Generic 12' Dipole	Flush	(7) 1/2" Coax	TOWN OF OLD LYME, CT
176.0	1	Decibel DB201-A			
171.0	1	Generic E-911 GPS	T-Arm	(1) 1 5/8" (1.63"-41.3mm) Fiber (9) 1 5/8" Coax (1) 1/2" Coax	T-MOBILE
161.0	1	Antel BXA-70063-4CF-EDIN-10	Low Profile Platform	(18) 1 5/8" Coax (2) 1 5/8" Hybriflex	VERIZON WIRELESS
	4	RFS APL866513-42T0			
	3	Alcatel-Lucent B66 RRH4x45			
	3	Alcatel-Lucent RRH2x60 700			
	2	RFS DB-T1-6Z-8AB-OZ			
	3	Alcatel-Lucent RRH2X60-1900			
	6	Commscope SBNHH-1D65B			
	2	Amphenol Antel LPA-80080-6CF-EDIN-2			
149.0	2	Antel BXA-70063/6CF_	Low Profile Platform	(4) 1 1/4" Hybriflex Cable (6) 1 5/8" Coax (1) 1/2" Coax	SPRINT NEXTEL
	3	Commscope NNVV-65B-R4			
	1	Generic GPS			
	6	Alcatel-Lucent RRH2x50-08			
	3	Alcatel-Lucent 1900 MHz 4X45 RRH			
140.0	3	Alcatel-Lucent TD-RRH8x20-25 w/ Solar Shield	Low Profile Platform	(1) 3" conduit (1) 0.39" (10mm) Fiber Trunk (2) 0.78" (19.7mm) 8 AWG 6 (12) 1 5/8" Coax (1) 2" conduit	AT&T MOBILITY
	3	RFS APXVTM14-ALU-I20			
	3	Powerwave Allgon 7770.00			
	6	KMW AM-X-CD-14-65-00T-RET			
	6	Ericsson RRUS-11			
111.0	1	Raycap DC6-48-60-18-8F ("Squid")	Stand-Off	(2) 1/2" Coax	TOWN OF OLD LYME, CT
	6	Powerwave Allgon TT19-08BP111-001			
74.0	1	Generic 12' Dipole	Stand-Off	(1) 1/2" Coax	SPRINT NEXTEL
	1	Generic GPS			
74.0	1	Generic GPS	Stand-Off	(1) 1/2" Coax	SPRINT NEXTEL
	1	Generic GPS			

Equipment to be Removed

Elev. ¹ (ft)	Qty	Antenna	Mount Type	Lines	Carrier
175.0	3	Andrew ETW200VS12UB	-	(3) 1 5/8" Coax	T-MOBILE
170.0	3	RFS APX16DWV-16DWVS-E-A20			
	6	Ericsson AIR 21			



Proposed Equipment

Elev. ¹ (ft)	Qty	Antenna	Mount Type	Lines	Carrier
171.0	3	Ericsson KRY 112 144/1	T-Arm w/ Reinforcement	(3) 1 5/8" (1.63"-41.3mm) Fiber	T-MOBILE
	3	Ericsson Radio 4449 B12,B71			
	3	Ericsson AIR 21, 1.3 M, B2A B4P			
	3	Ericsson AIR 21, 1.3M, B4A B2P			
	3	RFS APXVAARR24_43-U-NA20			

¹ Contracted elevations are shown for appurtenances within contracted installation tolerances. Appurtenances outside of contract limits are shown at installed elevations.

Install proposed coax inside the pole shaft.

Structure Usages

Structural Component	Controlling Usage	Pass/Fail
Anchor Bolts	43%	Pass
Shaft	51%	Pass
Base Plate	55%	Pass
Flanges	12%	Pass

Foundations

Reaction Component	Analysis Reactions	% of Usage
Moment (Kips-Ft)	4,266.0	41%
Axial (Kips)	69.8	17%
Shear (Kips)	35.2	17%

The structure base reactions resulting from this analysis were found to be acceptable through analysis based on geotechnical and foundation information, therefore no modification or reinforcement of the foundation will be required.

Deflection and Sway*

Antenna Elevation (ft)	Antenna	Carrier	Deflection (ft)	Sway (Rotation) (°)
171.0	Ericsson KRY 112 144/1	T-MOBILE	1.0675	0.67
	Ericsson Radio 4449 B12,B71			
	Ericsson AIR 21, 1.3 M, B2A B4P			
	Ericsson AIR 21, 1.3M, B4A B2P			
	RFS APXVAARR24_43-U-NA20			

*Deflection and Sway was evaluated considering a design wind speed of 60 mph (3-Second Gust) per ANSI/TIA-222-G



Standard Conditions

All engineering services performed by A.T. Engineering Service, PLLC are prepared on the basis that the information used is current and correct. This information may consist of, but is not limited to the following:

- Information supplied by the client regarding antenna, mounts and feed line loading
- Information from drawings, design and analysis documents, and field notes in the possession of A.T. Engineering Service, PLLC

It is the responsibility of the client to ensure that the information provided to A.T. Engineering Service, PLLC and used in the performance of our engineering services is correct and complete.

All assets of American Tower Corporation, its affiliates and subsidiaries (collectively "American Tower") are inspected at regular intervals. Based upon these inspections and in the absence of information to the contrary, American Tower assumes that all structures were constructed in accordance with the drawings and specifications.

Unless explicitly agreed by both the client and A.T. Engineering Service, PLLC, all services will be performed in accordance with the current revision of ANSI/TIA-222.

All services are performed, results obtained, and recommendations made in accordance with generally accepted engineering principles and practices. A.T. Engineering Service, PLLC is not responsible for the conclusions, opinions and recommendations made by others based on the information supplied herein.

© 2007 - 2019 by ATC IP LLC. All rights reserved.

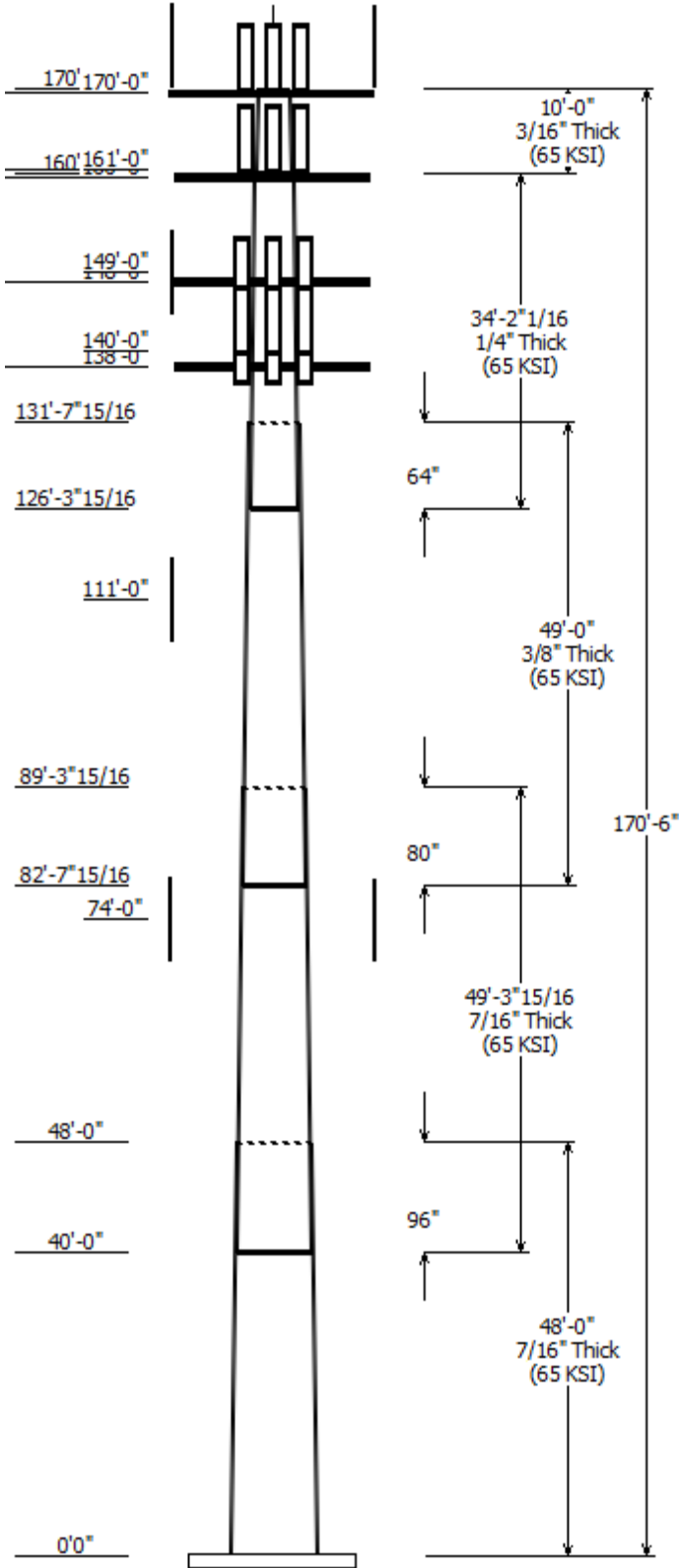

Job Information	
Client : T-MOBILE	Code: ANSI/TIA-222-G
Pole : 411178	
Location : Old Lyme South CT, CT	
Description : 170.5 ft Monopole	Struct Class : II
Shape : 18 Sides	Exposure : B
Height : 170.50 (ft)	Topo : 1
Base Elev (ft): 0.00	
Taper: 0.26246 (in/ft)	

Sections Properties							
Shaft Section	Length (ft)	Diameter (in)		Thick (in)	Joint Type	Overlap Length (in)	Steel Grade
		Top	Bottom				
1	48.000	56.28	69.00	0.438		0.000	18 Sides 65
2	49.330	46.20	59.27	0.438	Slip Joint	96.000	18 Sides 65
3	49.000	35.73	48.71	0.375	Slip Joint	80.000	18 Sides 65
4	34.170	28.59	37.64	0.250	Slip Joint	64.000	18 Sides 65
5	10.000	26.00	27.50	0.188	Butt Joint	0.000	18 Sides 65

Discrete Appurtenance			
Attach Elev (ft)	Force Elev (ft)	Qty	Description
170.500	171.000	3	RFS APXVAARR24_43-U-NA20
170.500	171.000	3	Ericsson AIR 21, 1.3M, B4A B2P
170.500	171.000	3	Ericsson AIR 21, 1.3 M, B2A B4
170.500	171.000	3	Ericsson Radio 4449 B12,B71
170.500	171.000	1	Generic E-911 GPS
170.500	171.000	3	Ericsson KRY 112 144/1
170.500	176.000	1	Decibel DB201-A
170.500	177.000	1	Generic 12' Dipole
170.000	170.000	3	Round T-Arm
161.000	161.000	1	VZW Unused Reserve: 520 sq
161.000	162.000	2	Amphenol Antel LPA-80080-
161.000	162.000	6	Commscope SBNHH-1D65B
161.000	162.000	2	Antel BXA-70063/6CF_
161.000	162.000	2	RFS DB-T1-6Z-8AB-0Z
161.000	162.000	1	Antel BXA-70063-4CF-EDIN-10
161.000	162.000	4	RFS APL866513-42T0
161.000	162.000	3	Alcatel-Lucent B66 RRH4x45
161.000	162.000	3	Alcatel-Lucent RRH2x60 700
161.000	162.000	3	Alcatel-Lucent RRH2X60-1900
160.000	160.000	1	Flat Low Profile Platform
149.000	149.000	3	Commscope NNVV-65B-R4
149.000	149.000	3	RFS APXVTM14-ALU-I20
149.000	149.000	3	Alcatel-Lucent TD-RRH8x20-25
149.000	149.000	3	Alcatel-Lucent 1900 MHz 4X45
149.000	149.000	6	Alcatel-Lucent RRH2x50-08
149.000	149.000	1	Generic GPS
148.000	148.000	1	Flat Low Profile Platform
140.000	143.000	3	Powerwave Allgon 7770.00
140.000	140.000	6	KMW AM-X-CD-14-65-00T-RET
140.000	143.000	6	Ericsson RRUS-11
140.000	143.000	1	Raycap DC6-48-60-18-8F
140.000	143.000	6	Powerwave Allgon TT19-
138.000	138.000	1	Flat Low Profile Platform
111.000	111.000	1	Generic 12' Dipole
74.000	74.000	1	Generic GPS
74.000	74.000	1	Generic GPS

Linear Appurtenance			
From Elev (ft)	To Elev (ft)	Description	Exposed To Wind
0.000	74.000	1/2" Coax	No

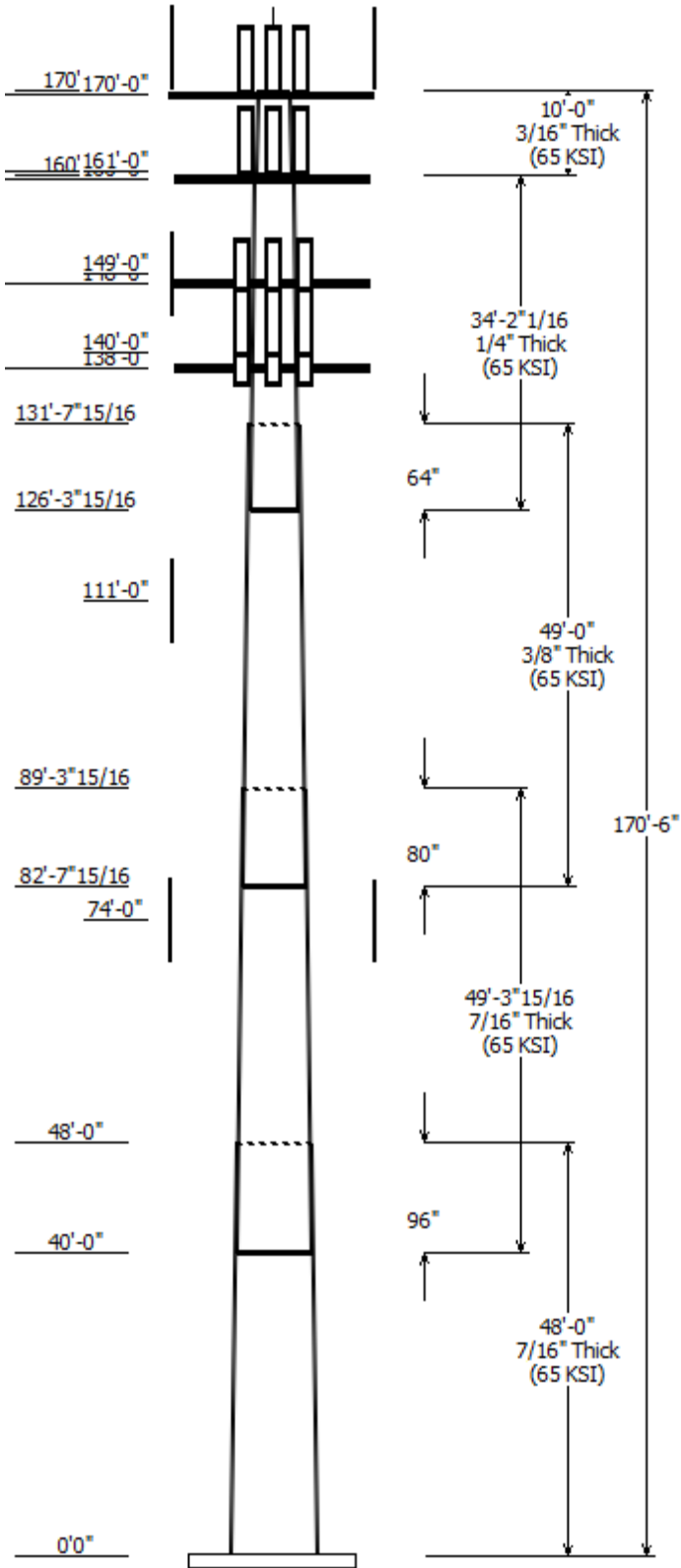

0.000	111.0	1/2" Coax	No
0.000	140.0	0.39" (10mm)	No
0.000	140.0	0.78" (19.7mm) 8	No
0.000	140.0	1 5/8" Coax	No
0.000	140.0	2" conduit	No
0.000	143.0	3" conduit	No
0.000	149.0	1 1/4" Hybriflex	No
0.000	149.0	1 5/8" Coax	No
0.000	149.0	1/2" Coax	No
0.000	161.0	1 5/8" Coax	No
0.000	161.0	1 5/8" Coax	Yes
0.000	161.0	1 5/8" Hybriflex	No
0.000	162.0	1 5/8" Coax	No
0.000	171.0	1 5/8" (1.63"-	No
0.000	171.0	1 5/8" Coax	No
0.000	171.0	1/2" Coax	No
0.000	176.0	1/2" Coax	No
0.000	176.0	1/2" Coax	No
0.000	177.0	1/2" Coax	No

Load Cases

1.2D + 1.6W	105 mph with No Ice
0.9D + 1.6W	105 mph with No Ice (Reduced DL)
1.2D + 1.0Di + 1.0Wi	50 mph with 0.75 in Radial Ice
(1.2 + 0.2Sds) * DL + E	Seismic Equivalent Lateral Forces Method
(1.2 + 0.2Sds) * DL + E	Seismic Equivalent Modal Analysis Method
(0.9 - 0.2Sds) * DL + E	Seismic (Reduced DL) Equivalent Lateral
(0.9 - 0.2Sds) * DL + E	Seismic (Reduced DL) Equivalent Modal
1.0D + 1.0W	Serviceability 60 mph

Reactions

Load Case	Moment (kip-ft)	Shear (kip)	Axial (kip)
1.2D + 1.6W	4266.01	35.24	69.81
0.9D + 1.6W	4230.44	35.22	52.35
1.2D + 1.0Di + 1.0Wi	1107.25	9.44	98.35
(1.2 + 0.2Sds) * DL + E ELFM	229.75	1.75	69.49
(1.2 + 0.2Sds) * DL + E EMAM	272.35	2.16	69.49
(0.9 - 0.2Sds) * DL + E ELFM	227.35	1.75	48.69
(0.9 - 0.2Sds) * DL + E EMAM	269.54	2.16	48.69
1.0D + 1.0W	774.99	6.43	58.20

Dish Deflections

Load Case	Attach Elev (ft)	Deflection (in)	Rotation (deg)
	0.00	0.000	0.000

Load Case : 1.2D + 1.6W
Max Ratio 51.26% at 0.0 ft

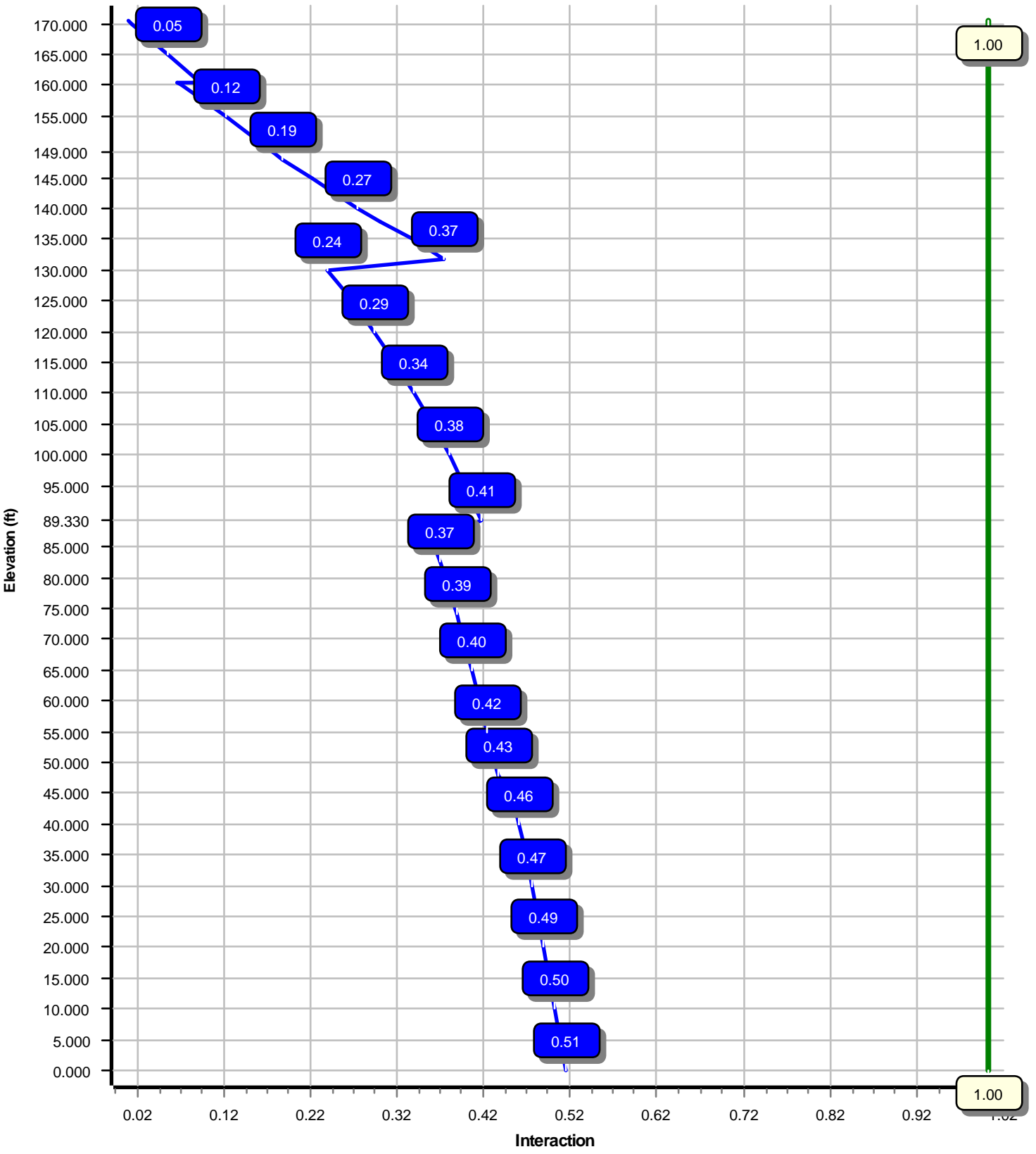

Site Number: 411178

Code: ANSI/TIA-222-G

© 2007 - 2019 by ATC IP LLC. All rights reserved.

Site Name: Old Lyme South CT, CT

Engineering Number: 12927156_C3_02

7/18/2019 8:44:55 PM

Customer: T-MOBILE

Analysis Parameters

Location :	New London County, CT	Height (ft) :	170.5
Code :	ANSI/TIA-222-G	Base Diameter (in) :	69.00
Shape :	18 Sides	Top Diameter (in) :	26.00
Pole Type :	Custom	Taper (in/ft) :	0.262
Pole Manufacturer :	EEl	Rotation (deg) :	0.00

Ice & Wind Parameters

Structure Class:	II	Design Wind Speed Without Ice:	105 mph
Exposure Category:	B	Design Wind Speed With Ice:	50 mph
Topographic Category:	1	Operational Wind Speed:	60 mph
Crest Height:	0 ft	Design Ice Thickness:	0.75 in

Seismic Parameters

Analysis Method: Equivalent Modal Analysis & Equivalent Lateral Force Methods

Site Class: D - Stiff Soil

Period Based on Rayleigh Method (sec): 2.07

T_L (sec):	6	p :	1	C_s :	0.030
S_s :	0.163	S_1 :	0.058	C_s Max:	0.030
F_a :	1.600	F_v :	2.400	C_s Min:	0.030
S_{ds} :	0.174	S_{d1} :	0.093		

Load Cases

1.2D + 1.6W	105 mph with No Ice
0.9D + 1.6W	105 mph with No Ice (Reduced DL)
1.2D + 1.0Di + 1.0Wi	50 mph with 0.75 in Radial Ice
(1.2 + 0.2S _{ds}) * DL + E ELFM	Seismic Equivalent Lateral Forces Method
(1.2 + 0.2S _{ds}) * DL + E EMAM	Seismic Equivalent Modal Analysis Method
(0.9 - 0.2S _{ds}) * DL + E ELFM	Seismic (Reduced DL) Equivalent Lateral Forces Method
(0.9 - 0.2S _{ds}) * DL + E EMAM	Seismic (Reduced DL) Equivalent Modal Analysis Method
1.0D + 1.0W	Serviceability 60 mph

Site Number: 411178

Code: ANSI/TIA-222-G

© 2007 - 2019 by ATC IP LLC. All rights reserved.

Site Name: Old Lyme South CT, CT

Engineering Number: 12927156_C3_02

7/18/2019 8:44:55 PM

Customer: T-MOBILE

Shaft Section Properties

Sect Info	Length (ft)	Thick (in)	Fy (ksi)	Joint Type	Joint Len (in)	Weight (lb)	Bottom						Top						
							Dia (in)	Elev (ft)	Area (in ²)	Ix (in ⁴)	W/t Ratio	D/t Ratio	Dia (in)	Elev (ft)	Area (in ²)	Ix (in ⁴)	W/t Ratio	D/t Ratio	Taper (in/ft)
1-18	48.000	0.4375	65		0.00	14,108	69.00	0.00	95.20	56543.5	26.40	157.71	56.28	48.00	77.54	30550.4	21.27	128.64	0.265000
2-18	49.330	0.4375	65	Slip	96.00	12,191	59.27	40.00	81.70	35734.3	22.48	135.49	46.20	89.33	63.55	16816.1	17.21	105.61	0.265000
3-18	49.000	0.3750	65	Slip	80.00	8,305	48.71	82.66	57.54	16990.6	21.50	129.92	35.73	131.66	42.08	6647.9	15.39	95.29	0.265000
4-18	34.170	0.2500	65	Slip	64.00	3,033	37.64	126.33	29.67	5243.4	25.14	150.59	28.59	160.50	22.49	2282.4	18.76	114.37	0.265000
5-18	10.000	0.1875	65	Butt	0.00	538	27.50	160.50	16.25	1531.9	24.45	146.67	26.00	170.50	15.36	1293.1	23.04	138.67	0.150000
Shaft Weight						38,174													

Discrete Appurtenance Properties

Attach Elev (ft)	Description	Qty	Ka	Vert Ecc (ft)	Weight (lb)	No Ice EPAa (sf)	Orientation Factor	Weight (lb)	Ice EPAa (sf)	Orientation Factor
170.50	Ericsson KRY 112 144/1	3	0.80	0.500	11.00	0.350	0.50	21.92	0.761	0.50
170.50	Generic E-911 GPS	1	0.80	0.500	5.00	0.580	1.00	31.00	1.029	1.00
170.50	Ericsson Radio 4449 B12,B71	3	0.80	0.500	74.00	1.640	0.50	130.82	2.497	0.50
170.50	Decibel DB201-A	1	1.00	5.500	25.00	3.130	1.00	125.74	13.811	1.00
170.50	Generic 12' Dipole	1	1.00	6.500	40.00	4.510	1.00	175.32	11.773	1.00
170.50	Ericsson AIR 21, 1.3 M, B2A B4P	3	0.80	0.500	83.00	6.050	0.71	231.11	8.244	0.71
170.50	Ericsson AIR 21, 1.3M, B4A B2P	3	0.80	0.500	81.50	6.090	0.70	229.06	8.286	0.70
170.50	RFS APXVAARR24_43-U-NA20	3	0.80	0.500	127.90	20.240	0.63	526.30	24.003	0.63
170.00	Round T-Arm w/Reinforcement	3	0.75	0.000	404.97	9.700	0.67	747.98	18.053	0.67
161.00	Alcatel-Lucent RRH2X60-1900	3	0.80	1.000	43.00	1.880	0.50	98.83	2.828	0.50
161.00	Alcatel-Lucent RRH2x60 700	3	0.80	1.000	56.70	2.150	0.67	125.37	3.161	0.67
161.00	Alcatel-Lucent B66 RRH4x45	3	0.80	1.000	67.00	2.580	0.67	138.49	3.717	0.67
161.00	VZW Unused Reserve: 520 sq in	1	0.80	0.000	209.00	3.610	0.90	355.91	6.148	0.90
161.00	RFS APL866513-42T0	4	0.80	1.000	15.70	4.050	0.76	125.66	5.926	0.76
161.00	Antel BXA-70063-4CF-EDIN-10	1	0.80	1.000	9.90	4.710	1.00	112.46	6.567	1.00
161.00	RFS DB-T1-6Z-8AB-OZ	2	0.80	1.000	44.00	4.800	0.72	170.99	6.234	0.72
161.00	Antel BXA-70063/6CF_	2	0.80	1.000	17.00	7.570	0.73	159.69	10.353	0.73
161.00	Commscope SBNHH-1D65B	6	0.80	1.000	50.70	8.170	0.69	227.79	11.024	0.69
161.00	Amphenol Antel LPA-80080-6CF-	2	0.80	1.000	21.00	8.630	0.71	190.60	11.390	0.71
160.00	Flat Low Profile Platform	1	1.00	0.000	1,500.00	26.100	1.00	2,152.40	45.325	1.00
149.00	Generic GPS	1	0.80	0.000	10.00	0.900	1.00	39.29	1.540	1.00
149.00	Alcatel-Lucent RRH2x50-08	6	0.80	0.000	52.90	1.700	0.50	112.22	2.563	0.50
149.00	Alcatel-Lucent 1900 MHz 4X45	3	0.80	0.000	60.00	2.320	0.67	140.67	3.401	0.67
149.00	Alcatel-Lucent TD-RRH8x20-25	3	0.80	0.000	70.00	4.050	0.61	164.61	5.380	0.61
149.00	RFS APXVTM14-ALU-I20	3	0.80	0.000	56.20	6.340	0.66	194.04	8.520	0.66
149.00	Commscope NNVV-65B-R4	3	0.80	0.000	77.40	12.270	0.64	328.94	15.077	0.64
148.00	Flat Low Profile Platform	1	1.00	0.000	1,500.00	26.100	1.00	2,147.69	45.186	1.00
140.00	Powerwave Allgon TT19-	6	0.80	3.000	16.00	0.550	0.50	36.09	1.056	0.50
140.00	Raycap DC6-48-60-18-8F	1	0.80	3.000	31.80	1.470	1.00	93.16	2.165	1.00
140.00	Ericsson RRUS-11	6	0.80	3.000	55.00	3.790	0.61	144.28	5.066	0.61
140.00	KMW AM-X-CD-14-65-00T-RET	6	0.80	0.000	36.40	4.990	0.66	147.08	6.846	0.66
140.00	Powerwave Allgon 7770.00	3	0.80	3.000	35.00	5.510	0.65	168.92	6.556	0.65
138.00	Flat Low Profile Platform	1	1.00	0.000	1,500.00	26.100	1.00	2,143.13	45.051	1.00
111.00	Generic 12' Dipole	1	1.00	0.000	40.00	4.510	1.00	169.59	11.466	1.00
74.00	Generic GPS	1	1.00	0.000	10.00	0.900	1.00	37.24	1.495	1.00
74.00	Generic GPS	1	1.00	0.000	10.00	0.900	1.00	37.24	1.495	1.00
Totals	Num Loadings:36	95			10,126.51			22,911.27		

Linear Appurtenance Properties

Load Case Azimuth (deg) : 90

Elev From (ft)	Elev To (ft)	Qty	Coax Dia (in)	Coax Wt (lb/ft)	Max Coax / Row	Dist Between Rows (in)	Dist Between Cols (in)	Dist Azimuth (deg)	Dist Exposed From Face (in)	Dist Exposed To Wind Carrier				
0.00	177.00	2	1/2"	Coax	0.63	0.15	N	0	0.00	0.00	0	0.00	N	TOWN OF OLD

Site Number: 411178

Code: ANSI/TIA-222-G

© 2007 - 2019 by ATC IP LLC. All rights reserved.

Site Name: Old Lyme South CT, CT

Engineering Number: 12927156_C3_02

7/18/2019 8:44:55 PM

Customer: T-MOBILE

0.00	176.00	4	1/2" Coax	0.63	0.15	N	0	0.00	0.00	0	0.00	N	TOWN OF OLD
0.00	176.00	1	1/2" Coax	0.63	0.15	N	0	0.00	0.00	0	0.00	N	TOWN OF OLD
0.00	171.00	4	1 5/8" (1.63"-41.3mm)	1.63	1.61	N	0	0.00	0.00	0	0.00	N	T-MOBILE
0.00	171.00	9	1 5/8" Coax	1.98	0.82	N	6	0.00	0.50	90	1.00	N	T-MOBILE
0.00	171.00	1	1/2" Coax	0.63	0.15	N	0	0.00	0.00	0	0.00	N	T-MOBILE
0.00	162.00	6	1 5/8" Coax	1.98	0.82	N	0	0.00	0.00	0	0.00	N	VERIZON WIRELESS
0.00	161.00	6	1 5/8" Coax	1.98	0.82	N	0	0.00	0.00	0	0.00	N	VERIZON WIRELESS
0.00	161.00	6	1 5/8" Coax	1.98	0.82	N	6	1.00	1.00	0	1.00	Y	VERIZON WIRELESS
0.00	161.00	2	1 5/8" Hybriflex	1.98	1.30	N	0	0.00	0.00	0	0.00	N	VERIZON WIRELESS
0.00	149.00	4	1 1/4" Hybriflex Cable	1.54	1.00	N	0	0.00	0.00	0	0.00	N	SPRINT NEXTEL
0.00	149.00	6	1 5/8" Coax	1.98	0.82	N	0	0.00	0.00	0	0.00	N	SPRINT NEXTEL
0.00	149.00	1	1/2" Coax	0.63	0.15	N	0	0.00	0.00	0	0.00	N	SPRINT NEXTEL
0.00	143.00	1	3" conduit	3.50	7.58	N	0	0.00	0.00	0	0.00	N	AT&T MOBILITY
0.00	140.00	1	0.39" (10mm) Fiber	0.39	0.06	N	0	0.00	0.00	0	0.00	N	AT&T MOBILITY
0.00	140.00	2	0.78" (19.7mm) 8 AWG	0.78	0.59	N	0	0.00	0.00	0	0.00	N	AT&T MOBILITY
0.00	140.00	12	1 5/8" Coax	1.98	0.82	N	0	0.00	0.00	0	0.00	N	AT&T MOBILITY
0.00	140.00	1	2" conduit	2.38	3.65	N	0	0.00	0.00	0	0.00	N	AT&T MOBILITY
0.00	111.00	2	1/2" Coax	0.63	0.15	N	0	0.00	0.00	0	0.00	N	TOWN OF OLD
0.00	74.00	1	1/2" Coax	0.63	0.15	N	0	0.00	0.00	0	0.00	N	SPRINT NEXTEL

Segment Properties (Max Len : 5. ft)

Seg Top Elev (ft)	Description	Thick (in)	Flat Dia (in)	Area (in ²)	Ix (in ⁴)	W/t Ratio	D/t Ratio	F'y (ksi)	S (in ³)	Z (in ³)	Weight (lb)
0.00		0.4375	69.000	95.204	56,543.5	26.40	157.71	70.4	1614.	0.0	0.0
5.00		0.4375	67.675	93.364	53,328.2	25.86	154.69	71.0	1552.	0.0	1,604.1
10.00		0.4375	66.350	91.524	50,237.2	25.33	151.66	71.6	1491.	0.0	1,572.8
15.00		0.4375	65.025	89.685	47,268.1	24.80	148.63	72.2	1431.	0.0	1,541.5
20.00		0.4375	63.700	87.845	44,418.3	24.26	145.60	72.9	1373.	0.0	1,510.2
25.00		0.4375	62.375	86.005	41,685.3	23.73	142.57	73.5	1316.	0.0	1,478.9
30.00		0.4375	61.050	84.165	39,066.9	23.19	139.54	74.1	1260.	0.0	1,447.6
35.00		0.4375	59.725	82.325	36,560.5	22.66	136.51	74.7	1205.	0.0	1,416.3
40.00	Bot - Section 2	0.4375	58.400	80.485	34,163.6	22.13	133.49	75.4	1152.	0.0	1,385.0
45.00		0.4375	57.075	78.645	31,873.9	21.59	130.46	76.0	1099.	0.0	2,728.1
48.00	Top - Section 1	0.4375	57.155	78.757	32,009.1	21.62	130.64	76.0	1103.	0.0	1,606.8
50.00		0.4375	56.625	78.021	31,120.1	21.41	129.43	76.2	1082.	0.0	533.5
55.00		0.4375	55.300	76.181	28,970.0	20.88	126.40	76.8	1031.	0.0	1,311.8
60.00		0.4375	53.975	74.341	26,921.3	20.34	123.37	77.5	982.4	0.0	1,280.5
65.00		0.4375	52.650	72.501	24,971.6	19.81	120.34	78.1	934.2	0.0	1,249.2
70.00		0.4375	51.325	70.661	23,118.3	19.28	117.31	78.7	887.2	0.0	1,217.9
74.00		0.4375	50.265	69.189	21,703.5	18.85	114.89	79.2	850.4	0.0	951.8
75.00		0.4375	50.000	68.821	21,359.1	18.74	114.29	79.4	841.4	0.0	234.8
80.00		0.4375	48.675	66.981	19,691.4	18.21	111.26	80.0	796.8	0.0	1,155.3
82.66	Bot - Section 3	0.4375	47.969	66.001	18,839.7	17.92	109.64	80.3	773.6	0.0	602.6
85.00		0.4375	47.350	65.142	18,112.9	17.67	108.23	80.6	753.4	0.0	975.9
89.33	Top - Section 2	0.3750	46.953	55.437	15,195.2	20.67	125.21	77.1	637.4	0.0	1,774.9
90.00		0.3750	46.775	55.226	15,022.1	20.58	124.73	77.2	632.6	0.0	126.1
95.00		0.3750	45.450	53.649	13,771.5	19.96	121.20	77.9	596.8	0.0	926.2
100.0		0.3750	44.125	52.072	12,592.4	19.34	117.67	78.7	562.1	0.0	899.4
105.0		0.3750	42.800	50.495	11,482.6	18.71	114.13	79.4	528.4	0.0	872.5
110.0		0.3750	41.475	48.918	10,440.0	18.09	110.60	80.1	495.8	0.0	845.7
111.0		0.3750	41.210	48.602	10,239.4	17.97	109.89	80.3	489.4	0.0	165.9
115.0		0.3750	40.150	47.340	9,462.5	17.47	107.07	80.9	464.2	0.0	652.9
120.0		0.3750	38.825	45.763	8,548.0	16.85	103.53	81.6	433.6	0.0	792.0
125.0		0.3750	37.500	44.186	7,694.4	16.22	100.00	82.3	404.1	0.0	765.2
126.3	Bot - Section 4	0.3750	37.148	43.767	7,477.3	16.06	99.06	82.5	396.5	0.0	199.0
130.0		0.3750	36.175	42.609	6,899.6	15.60	96.47	82.6	375.7	0.0	905.1
131.6	Top - Section 3	0.2500	36.234	28.552	4,671.1	24.15	144.94	73.0	253.9	0.0	402.3
135.0		0.2500	35.350	27.851	4,335.2	23.52	141.40	73.7	241.5	0.0	320.2
138.0		0.2500	34.555	27.220	4,047.2	22.96	138.22	74.4	230.7	0.0	281.1
140.0		0.2500	34.025	26.799	3,862.5	22.59	136.10	74.8	223.6	0.0	183.8
145.0		0.2500	32.700	25.748	3,425.5	21.65	130.80	75.9	206.3	0.0	447.0
148.0		0.2500	31.905	25.117	3,179.9	21.09	127.62	76.6	196.3	0.0	259.6
149.0		0.2500	31.640	24.907	3,100.7	20.91	126.56	76.8	193.0	0.0	85.1
150.0		0.2500	31.375	24.697	3,022.8	20.72	125.50	77.0	189.8	0.0	84.4
155.0		0.2500	30.050	23.645	2,653.0	19.78	120.20	78.1	173.9	0.0	411.2
160.0		0.2500	28.725	22.594	2,314.6	18.85	114.90	79.2	158.7	0.0	393.4
160.5	Top - Section 4	0.2500	28.592	22.489	2,282.4	18.76	114.37	79.3	157.2	0.0	38.4
160.5	Bot - Section 5	0.1875	27.500	16.254	1,531.9	24.45	146.67	72.6	109.7	0.0	
161.0		0.1875	27.425	16.209	1,519.3	24.38	146.27	72.7	109.1	0.0	27.6
165.0		0.1875	26.825	15.852	1,421.1	23.82	143.07	73.4	104.3	0.0	218.2
170.0		0.1875	26.075	15.406	1,304.4	23.11	139.07	74.2	98.5	0.0	265.9
170.5		0.1875	26.000	15.361	1,293.1	23.04	138.67	74.3	98.0	0.0	26.2

38,174.1

Load Case: 1.2D + 1.6W	105 mph with No Ice	23 Iterations
Gust Response Factor :1.10		Wind Importance Factor :1.00
Dead Load Factor :1.20		
Wind Load Factor :1.60		

Applied Segment Forces Summary

Seg Elev (ft)	Description	Shaft Forces		Discrete Forces			Linear Forces		Sum of Forces				
		Wind FX (lb)	Dead Load (lb)	Wind FX (lb)	Torsion MY (lb-ft)	Moment MZ (lb-ft)	Dead Load (lb)	Wind FX (lb)	Dead Load (lb)	Wind FX (lb)	Dead Load (lb)	Torsion MY (lb-ft)	Moment MZ (lb)
0.00		310.4	0.0					0.0	0.0	310.4	0.0	0.0	0.0
5.00		614.8	1,925.0					0.0	385.3	614.8	2,310.2	0.0	0.0
10.00		602.8	1,887.4					0.0	385.3	602.8	2,272.7	0.0	0.0
15.00		590.7	1,849.8					0.0	385.3	590.7	2,235.1	0.0	0.0
20.00		578.7	1,812.3					0.0	385.3	578.7	2,197.5	0.0	0.0
25.00		566.6	1,774.7					0.0	385.3	566.6	2,160.0	0.0	0.0
30.00		561.2	1,737.2					0.0	385.3	561.2	2,122.4	0.0	0.0
35.00		567.1	1,699.6					0.0	385.3	567.1	2,084.8	0.0	0.0
40.00	Bot - Section 2	580.5	1,662.0					0.0	385.3	580.5	2,047.3	0.0	0.0
45.00		472.3	3,273.7					0.0	385.3	472.3	3,659.0	0.0	0.0
48.00	Top - Section 1	296.9	1,928.2					0.0	231.2	296.9	2,159.3	0.0	0.0
50.00		417.5	640.2					0.0	154.1	417.5	794.3	0.0	0.0
55.00		597.7	1,574.1					0.0	385.3	597.7	1,959.4	0.0	0.0
60.00		598.0	1,536.6					0.0	385.3	598.0	1,921.8	0.0	0.0
65.00		596.9	1,499.0					0.0	385.3	596.9	1,884.3	0.0	0.0
70.00		535.2	1,461.4					0.0	385.3	535.2	1,846.7	0.0	0.0
74.00	Appurtenance(s)	296.3	1,142.1	77.0	0.0	0.0	24.0	0.0	308.2	373.4	1,474.3	0.0	0.0
75.00		353.3	281.8					0.0	76.9	353.3	358.6	0.0	0.0
80.00		449.8	1,386.3					0.0	384.4	449.8	1,770.7	0.0	0.0
82.66	Bot - Section 3	293.5	723.1					0.0	204.7	293.5	927.8	0.0	0.0
85.00		391.7	1,171.1					0.0	179.6	391.7	1,350.8	0.0	0.0
89.33	Top - Section 2	292.8	2,129.9					0.0	332.9	292.8	2,462.8	0.0	0.0
90.00		328.2	151.4					0.0	51.5	328.2	202.9	0.0	0.0
95.00		574.3	1,111.4					0.0	384.4	574.3	1,495.8	0.0	0.0
100.00		565.8	1,079.2					0.0	384.4	565.8	1,463.6	0.0	0.0
105.00		556.5	1,047.0					0.0	384.4	556.5	1,431.4	0.0	0.0
110.00		330.4	1,014.8					0.0	384.4	330.4	1,399.2	0.0	0.0
111.00	Appurtenance(s)	270.7	199.1	216.7	0.0	0.0	48.0	0.0	76.9	487.4	324.0	0.0	0.0
115.00		481.3	783.5					0.0	306.0	481.3	1,089.6	0.0	0.0
120.00		524.5	950.4					0.0	382.6	524.5	1,333.0	0.0	0.0
125.00		327.3	918.2					0.0	382.6	327.3	1,300.8	0.0	0.0
126.33	Bot - Section 4	255.7	238.8					0.0	101.8	255.7	340.6	0.0	0.0
130.00		271.7	1,086.1					0.0	280.8	271.7	1,366.9	0.0	0.0
131.66	Top - Section 3	250.3	482.7					0.0	127.3	250.3	610.0	0.0	0.0
135.00		313.3	384.2					0.0	255.3	313.3	639.5	0.0	0.0
138.00	Appurtenance(s)	243.6	337.3	1,334.5	0.0	0.0	1,800.0	0.0	229.5	1,578.1	2,366.8	0.0	0.0
140.00	Appurtenance(s)	333.4	220.6	1,957.7	0.0	3,438.3	937.4	0.0	153.0	2,291.1	1,311.0	0.0	0.0
145.00		375.3	536.4					0.0	276.0	375.3	812.4	0.0	0.0
148.00	Appurtenance(s)	184.2	311.6	1,361.4	0.0	0.0	1,800.0	0.0	149.2	1,545.7	2,260.8	0.0	0.0
149.00	Appurtenance(s)	91.0	102.1	2,265.6	0.0	0.0	1,341.8	0.0	49.7	2,356.5	1,493.7	0.0	0.0
150.00		267.5	101.3					0.0	38.9	267.5	140.1	0.0	0.0
155.00		436.8	493.5					0.0	194.3	436.8	687.8	0.0	0.0
160.00	Appurtenance(s)	235.6	472.0	1,392.1	0.0	0.0	1,800.0	0.0	194.3	1,627.7	2,466.3	0.0	0.0
160.50	Top - Section 4	41.5	46.0					0.0	19.4	41.5	65.5	0.0	0.0
161.00	Appurtenance(s)	180.4	33.1	4,138.1	0.0	3,999.2	1,500.0	0.0	19.4	4,318.5	1,552.6	0.0	0.0
165.00		356.5	261.8					0.0	78.0	356.5	339.8	0.0	0.0
170.00	Appurtenance(s)	216.0	319.1	793.6	0.0	0.0	1,457.9	0.0	90.1	1,009.6	1,867.1	0.0	0.0
170.50	Appurtenance(s)	19.4	31.4	3,354.4	0.0	4,020.5	1,442.6	0.0	9.0	3,373.8	1,483.1	0.0	0.0

Site Number: 411178

Code: ANSI/TIA-222-G

© 2007 - 2019 by ATC IP LLC. All rights reserved.

Site Name: Old Lyme South CT, CT

Engineering Number: 12927156_C3_02

7/18/2019 8:45:06 PM

Customer: T-MOBILE

Load Case: 1.2D + 1.6W

105 mph with No Ice

23 Iterations

Gust Response Factor :1.10

Wind Importance Factor :1.00

Dead Load Factor :1.20

Wind Load Factor :1.60

Totals: 35,487.0 69,844.1 0.00 0.00

Load Case: 1.2D + 1.6W

105 mph with No Ice

23 Iterations

Gust Response Factor :1.10

Wind Importance Factor :1.00

Dead Load Factor :1.20

Wind Load Factor :1.60

Calculated Forces

Seg Elev (ft)	Pu FY (-) (kips)	Vu FX (-) (kips)	Tu MY (ft-kips)	Mu MZ (ft-kips)	Mu MX (ft-kips)	Resultant Moment (ft-kips)	phi Pn (kips)	phi Vn (kips)	phi Tn (ft-kips)	phi Mn (ft-kips)	Total Deflect (in)	Rotation (deg)	Ratio
0.00	-69.81	-35.24	0.00	-4,266.01	0.00	4,266.01	6,027.96	3,013.98	17,007.2	8,516.24	0.00	0.00	0.513
5.00	-67.44	-34.75	0.00	-4,089.80	0.00	4,089.80	5,964.25	2,982.12	16,500.1	8,262.35	0.06	-0.11	0.506
10.00	-65.10	-34.26	0.00	-3,916.06	0.00	3,916.06	5,898.45	2,949.22	15,994.5	8,009.14	0.22	-0.21	0.500
15.00	-62.80	-33.78	0.00	-3,744.75	0.00	3,744.75	5,830.57	2,915.29	15,490.5	7,756.77	0.51	-0.32	0.494
20.00	-60.55	-33.31	0.00	-3,575.84	0.00	3,575.84	5,760.62	2,880.31	14,988.5	7,505.43	0.90	-0.43	0.487
25.00	-58.33	-32.84	0.00	-3,409.32	0.00	3,409.32	5,688.58	2,844.29	14,489.0	7,255.28	1.41	-0.54	0.480
30.00	-56.15	-32.36	0.00	-3,245.14	0.00	3,245.14	5,614.46	2,807.23	13,992.1	7,006.49	2.04	-0.66	0.473
35.00	-54.00	-31.88	0.00	-3,083.32	0.00	3,083.32	5,538.27	2,769.13	13,498.4	6,759.23	2.79	-0.77	0.466
40.00	-51.90	-31.38	0.00	-2,923.92	0.00	2,923.92	5,459.99	2,729.99	13,008.0	6,513.68	3.66	-0.89	0.459
45.00	-48.20	-30.92	0.00	-2,767.04	0.00	2,767.04	5,379.63	2,689.82	12,521.4	6,270.01	4.66	-1.01	0.450
48.00	-46.01	-30.64	0.00	-2,674.27	0.00	2,674.27	5,384.54	2,692.27	12,550.6	6,284.66	5.31	-1.08	0.434
50.00	-45.18	-30.27	0.00	-2,612.99	0.00	2,612.99	5,351.87	2,675.93	12,357.0	6,187.71	5.77	-1.13	0.431
55.00	-43.18	-29.72	0.00	-2,461.64	0.00	2,461.64	5,268.72	2,634.36	11,875.9	5,946.82	7.02	-1.24	0.422
60.00	-41.21	-29.16	0.00	-2,313.05	0.00	2,313.05	5,183.50	2,591.75	11,399.4	5,708.21	8.39	-1.36	0.413
65.00	-39.28	-28.60	0.00	-2,167.23	0.00	2,167.23	5,096.20	2,548.10	10,927.8	5,472.05	9.88	-1.48	0.404
70.00	-37.40	-28.09	0.00	-2,024.23	0.00	2,024.23	5,006.81	2,503.41	10,461.4	5,238.51	11.49	-1.60	0.394
74.00	-35.90	-27.71	0.00	-1,911.88	0.00	1,911.88	4,933.81	2,466.91	10,092.3	5,053.69	12.87	-1.70	0.386
75.00	-35.52	-27.39	0.00	-1,884.17	0.00	1,884.17	4,915.35	2,457.68	10,000.6	5,007.77	13.23	-1.72	0.384
80.00	-33.72	-26.94	0.00	-1,747.22	0.00	1,747.22	4,821.81	2,410.90	9,545.79	4,779.99	15.10	-1.84	0.373
82.66	-32.77	-26.65	0.00	-1,675.46	0.00	1,675.46	4,771.13	2,385.57	9,306.02	4,659.93	16.15	-1.91	0.367
85.00	-31.40	-26.26	0.00	-1,613.19	0.00	1,613.19	4,726.18	2,363.09	9,097.16	4,555.34	17.09	-1.97	0.361
89.33	-28.92	-25.91	0.00	-1,499.48	0.00	1,499.48	3,846.41	1,923.21	7,360.18	3,685.56	18.93	-2.07	0.415
90.00	-28.70	-25.62	0.00	-1,482.12	0.00	1,482.12	3,836.63	1,918.32	7,313.25	3,662.06	19.22	-2.09	0.412
95.00	-27.17	-25.05	0.00	-1,354.04	0.00	1,354.04	3,762.45	1,881.23	6,965.41	3,487.88	21.48	-2.22	0.396
100.00	-25.67	-24.48	0.00	-1,228.80	0.00	1,228.80	3,686.20	1,843.10	6,621.98	3,315.91	23.88	-2.36	0.378
105.00	-24.21	-23.92	0.00	-1,106.38	0.00	1,106.38	3,607.86	1,803.93	6,283.29	3,146.32	26.42	-2.49	0.359
110.00	-22.79	-23.56	0.00	-986.77	0.00	986.77	3,527.44	1,763.72	5,949.70	2,979.27	29.09	-2.62	0.338
111.00	-22.47	-23.09	0.00	-963.21	0.00	963.21	3,511.11	1,755.55	5,883.62	2,946.18	29.65	-2.64	0.334
115.00	-21.36	-22.60	0.00	-870.87	0.00	870.87	3,444.94	1,722.47	5,621.53	2,814.94	31.91	-2.75	0.316
120.00	-20.00	-22.05	0.00	-757.89	0.00	757.89	3,360.36	1,680.18	5,299.14	2,653.51	34.85	-2.87	0.292
125.00	-18.69	-21.68	0.00	-647.66	0.00	647.66	3,273.70	1,636.85	4,982.86	2,495.14	37.92	-2.99	0.265
126.33	-18.35	-21.42	0.00	-618.82	0.00	618.82	3,250.30	1,625.15	4,899.81	2,453.55	38.75	-3.02	0.258
130.00	-16.97	-21.10	0.00	-540.20	0.00	540.20	3,165.67	1,582.83	4,644.73	2,325.82	41.10	-3.10	0.238
131.66	-16.36	-20.83	0.00	-505.11	0.00	505.11	1,875.92	937.96	2,776.25	1,390.19	42.19	-3.13	0.373
135.00	-15.71	-20.50	0.00	-435.62	0.00	435.62	1,848.21	924.11	2,667.57	1,335.77	44.40	-3.20	0.335
138.00	-13.42	-18.81	0.00	-374.12	0.00	374.12	1,822.51	911.25	2,570.47	1,287.14	46.44	-3.28	0.298
140.00	-12.22	-16.46	0.00	-333.07	0.00	333.07	1,804.96	902.48	2,506.10	1,254.91	47.83	-3.33	0.273
145.00	-11.41	-16.05	0.00	-250.77	0.00	250.77	1,759.62	879.81	2,346.60	1,175.04	51.37	-3.44	0.220
148.00	-9.23	-14.38	0.00	-202.61	0.00	202.61	1,731.42	865.71	2,251.99	1,127.67	53.55	-3.49	0.185
149.00	-7.88	-11.94	0.00	-188.23	0.00	188.23	1,721.85	860.93	2,220.65	1,111.98	54.29	-3.51	0.174
150.00	-7.75	-11.67	0.00	-176.29	0.00	176.29	1,712.20	856.10	2,189.41	1,096.33	55.02	-3.53	0.166
155.00	-7.08	-11.20	0.00	-117.95	0.00	117.95	1,662.70	831.35	2,034.89	1,018.96	58.76	-3.60	0.120
160.00	-4.72	-9.42	0.00	-61.96	0.00	61.96	1,611.13	805.56	1,883.37	943.08	62.55	-3.65	0.069

Site Number: 411178

Code: ANSI/TIA-222-G

© 2007 - 2019 by ATC IP LLC. All rights reserved.

Site Name: Old Lyme South CT, CT

Engineering Number: 12927156_C3_02

7/18/2019 8:45:06 PM

Customer: T-MOBILE

Load Case: 1.2D + 1.6W

105 mph with No Ice

23 Iterations

Gust Response Factor :1.10

Wind Importance Factor :1.00

Dead Load Factor :1.20

Wind Load Factor :1.60

160.50	-4.65	-9.37	0.00	-57.25	0.00	57.25	1,605.85	802.93	1,868.39	935.58	62.93	-3.65	0.064
160.50	-4.65	-9.37	0.00	-57.25	0.00	57.25	1,062.64	531.32	1,193.75	597.76	62.93	-3.65	0.100
161.00	-3.38	-4.97	0.00	-48.57	0.00	48.57	1,060.93	530.47	1,188.54	595.15	63.32	-3.65	0.085
165.00	-3.06	-4.59	0.00	-28.70	0.00	28.70	1,047.03	523.52	1,146.95	574.33	66.39	-3.68	0.053
170.00	-1.26	-3.46	0.00	-5.75	0.00	5.75	1,029.05	514.53	1,095.30	548.46	70.26	-3.70	0.012
170.50	0.00	-3.37	0.00	-4.02	0.00	4.02	1,027.22	513.61	1,090.15	545.89	70.64	-3.70	0.007

Load Case: 0.9D + 1.6W	105 mph with No Ice (Reduced DL)	23 Iterations
Gust Response Factor :1.10		Wind Importance Factor :1.00
Dead Load Factor :0.90		
Wind Load Factor :1.60		

Applied Segment Forces Summary

Seg Elev (ft)	Description	Shaft Forces		Discrete Forces			Linear Forces		Sum of Forces				
		Wind FX (lb)	Dead Load (lb)	Wind FX (lb)	Torsion MY (lb-ft)	Moment MZ (lb-ft)	Dead Load (lb)	Wind FX (lb)	Dead Load (lb)	Wind FX (lb)	Dead Load (lb)	Torsion MY (lb-ft)	Moment MZ (lb)
0.00		310.4	0.0					0.0	0.0	310.4	0.0	0.0	0.0
5.00		614.8	1,443.7					0.0	288.9	614.8	1,732.7	0.0	0.0
10.00		602.8	1,415.6					0.0	288.9	602.8	1,704.5	0.0	0.0
15.00		590.7	1,387.4					0.0	288.9	590.7	1,676.3	0.0	0.0
20.00		578.7	1,359.2					0.0	288.9	578.7	1,648.2	0.0	0.0
25.00		566.6	1,331.0					0.0	288.9	566.6	1,620.0	0.0	0.0
30.00		561.2	1,302.9					0.0	288.9	561.2	1,591.8	0.0	0.0
35.00		567.1	1,274.7					0.0	288.9	567.1	1,563.6	0.0	0.0
40.00	Bot - Section 2	580.5	1,246.5					0.0	288.9	580.5	1,535.5	0.0	0.0
45.00		472.3	2,455.3					0.0	288.9	472.3	2,744.2	0.0	0.0
48.00	Top - Section 1	296.9	1,446.1					0.0	173.4	296.9	1,619.5	0.0	0.0
50.00		417.5	480.1					0.0	115.6	417.5	595.7	0.0	0.0
55.00		597.7	1,180.6					0.0	288.9	597.7	1,469.5	0.0	0.0
60.00		598.0	1,152.4					0.0	288.9	598.0	1,441.4	0.0	0.0
65.00		596.9	1,124.3					0.0	288.9	596.9	1,413.2	0.0	0.0
70.00		535.2	1,096.1					0.0	288.9	535.2	1,385.0	0.0	0.0
74.00	Appurtenance(s)	296.3	856.6	77.0	0.0	0.0	18.0	0.0	231.2	373.4	1,105.7	0.0	0.0
75.00		353.3	211.3					0.0	57.7	353.3	269.0	0.0	0.0
80.00		449.8	1,039.7					0.0	288.3	449.8	1,328.0	0.0	0.0
82.66	Bot - Section 3	293.5	542.3					0.0	153.6	293.5	695.9	0.0	0.0
85.00		391.7	878.4					0.0	134.7	391.7	1,013.1	0.0	0.0
89.33	Top - Section 2	292.8	1,597.4					0.0	249.6	292.8	1,847.1	0.0	0.0
90.00		328.2	113.5					0.0	38.6	328.2	152.2	0.0	0.0
95.00		574.3	833.6					0.0	288.3	574.3	1,121.8	0.0	0.0
100.00		565.8	809.4					0.0	288.3	565.8	1,097.7	0.0	0.0
105.00		556.5	785.3					0.0	288.3	556.5	1,073.5	0.0	0.0
110.00		330.4	761.1					0.0	288.3	330.4	1,049.4	0.0	0.0
111.00	Appurtenance(s)	270.7	149.3	216.7	0.0	0.0	36.0	0.0	57.7	487.4	243.0	0.0	0.0
115.00		481.3	587.6					0.0	229.5	481.3	817.2	0.0	0.0
120.00		524.5	712.8					0.0	286.9	524.5	999.7	0.0	0.0
125.00		327.3	688.7					0.0	286.9	327.3	975.6	0.0	0.0
126.33	Bot - Section 4	255.7	179.1					0.0	76.3	255.7	255.4	0.0	0.0
130.00		271.7	814.6					0.0	210.6	271.7	1,025.2	0.0	0.0
131.66	Top - Section 3	250.3	362.0					0.0	95.4	250.3	457.5	0.0	0.0
135.00		313.3	288.2					0.0	191.5	313.3	479.7	0.0	0.0
138.00	Appurtenance(s)	243.6	253.0	1,334.5	0.0	0.0	1,350.0	0.0	172.2	1,578.1	1,775.1	0.0	0.0
140.00	Appurtenance(s)	333.4	165.4	1,957.7	0.0	3,438.3	703.1	0.0	114.8	2,291.1	983.3	0.0	0.0
145.00		375.3	402.3					0.0	207.0	375.3	609.3	0.0	0.0
148.00	Appurtenance(s)	184.2	233.7	1,361.4	0.0	0.0	1,350.0	0.0	111.9	1,545.7	1,695.6	0.0	0.0
149.00	Appurtenance(s)	91.0	76.6	2,265.6	0.0	0.0	1,006.4	0.0	37.3	2,356.5	1,120.3	0.0	0.0
150.00		267.5	76.0					0.0	29.1	267.5	105.1	0.0	0.0
155.00		436.8	370.1					0.0	145.7	436.8	515.8	0.0	0.0
160.00	Appurtenance(s)	235.6	354.0	1,392.1	0.0	0.0	1,350.0	0.0	145.7	1,627.7	1,849.7	0.0	0.0
160.50	Top - Section 4	41.2	34.5					0.0	14.6	41.2	49.1	0.0	0.0
161.00	Appurtenance(s)	180.2	24.9	4,138.1	0.0	3,999.2	1,125.0	0.0	14.6	4,318.3	1,164.4	0.0	0.0
165.00		356.5	196.4					0.0	58.5	356.5	254.9	0.0	0.0
170.00	Appurtenance(s)	216.0	239.3	793.6	0.0	0.0	1,093.4	0.0	67.6	1,009.6	1,400.3	0.0	0.0
170.50	Appurtenance(s)	19.4	23.6	3,354.4	0.0	4,020.5	1,082.0	0.0	6.8	3,373.8	1,112.3	0.0	0.0

Site Number: 411178

Code: ANSI/TIA-222-G

© 2007 - 2019 by ATC IP LLC. All rights reserved.

Site Name: Old Lyme South CT, CT

Engineering Number: 12927156_C3_02

7/18/2019 8:45:16 PM

Customer: T-MOBILE

Load Case: 0.9D + 1.6W

105 mph with No Ice (Reduced DL)

23 Iterations

Gust Response Factor :1.10

Wind Importance Factor :1.00

Dead Load Factor :0.90

Wind Load Factor :1.60

Totals: 35,486.5 52,383.0 0.00 0.00

Load Case: 0.9D + 1.6W

105 mph with No Ice (Reduced DL)

23 Iterations

Gust Response Factor :1.10

Wind Importance Factor :1.00

Dead Load Factor :0.90

Wind Load Factor :1.60

Calculated Forces

Seg Elev (ft)	Pu FY (-) (kips)	Vu FX (-) (kips)	Tu MY (ft-kips)	Mu MZ (ft-kips)	Mu MX (ft-kips)	Resultant Moment (ft-kips)	phi Pn (kips)	phi Vn (kips)	phi Tn (ft-kips)	phi Mn (ft-kips)	Total Deflect (in)	Rotation (deg)	Ratio
0.00	-52.35	-35.22	0.00	-4,230.44	0.00	4,230.44	6,027.96	3,013.98	17,007.2	8,516.24	0.00	0.00	0.506
5.00	-50.55	-34.70	0.00	-4,054.32	0.00	4,054.32	5,964.25	2,982.12	16,500.1	8,262.35	0.06	-0.10	0.499
10.00	-48.79	-34.18	0.00	-3,880.82	0.00	3,880.82	5,898.45	2,949.22	15,994.5	8,009.14	0.22	-0.21	0.493
15.00	-47.05	-33.67	0.00	-3,709.91	0.00	3,709.91	5,830.57	2,915.29	15,490.5	7,756.77	0.50	-0.32	0.486
20.00	-45.34	-33.17	0.00	-3,541.53	0.00	3,541.53	5,760.62	2,880.31	14,988.5	7,505.43	0.89	-0.43	0.480
25.00	-43.66	-32.68	0.00	-3,375.68	0.00	3,375.68	5,688.58	2,844.29	14,489.0	7,255.28	1.40	-0.54	0.473
30.00	-42.01	-32.18	0.00	-3,212.29	0.00	3,212.29	5,614.46	2,807.23	13,992.1	7,006.49	2.02	-0.65	0.466
35.00	-40.39	-31.68	0.00	-3,051.38	0.00	3,051.38	5,538.27	2,769.13	13,498.4	6,759.23	2.77	-0.76	0.459
40.00	-38.80	-31.15	0.00	-2,893.00	0.00	2,893.00	5,459.99	2,729.99	13,008.0	6,513.68	3.63	-0.88	0.451
45.00	-36.02	-30.70	0.00	-2,737.23	0.00	2,737.23	5,379.63	2,689.82	12,521.4	6,270.01	4.61	-1.00	0.443
48.00	-34.37	-30.41	0.00	-2,645.15	0.00	2,645.15	5,384.54	2,692.27	12,550.6	6,284.66	5.26	-1.07	0.427
50.00	-33.74	-30.03	0.00	-2,584.33	0.00	2,584.33	5,351.87	2,675.93	12,357.0	6,187.71	5.72	-1.12	0.424
55.00	-32.23	-29.46	0.00	-2,434.21	0.00	2,434.21	5,268.72	2,634.36	11,875.9	5,946.82	6.95	-1.23	0.416
60.00	-30.74	-28.89	0.00	-2,286.90	0.00	2,286.90	5,183.50	2,591.75	11,399.4	5,708.21	8.31	-1.35	0.407
65.00	-29.28	-28.32	0.00	-2,142.43	0.00	2,142.43	5,096.20	2,548.10	10,927.8	5,472.05	9.78	-1.47	0.397
70.00	-27.86	-27.80	0.00	-2,000.81	0.00	2,000.81	5,006.81	2,503.41	10,461.4	5,238.51	11.38	-1.58	0.388
74.00	-26.74	-27.43	0.00	-1,889.60	0.00	1,889.60	4,933.81	2,466.91	10,092.3	5,053.69	12.75	-1.68	0.379
75.00	-26.44	-27.10	0.00	-1,862.17	0.00	1,862.17	4,915.35	2,457.68	10,000.6	5,007.77	13.10	-1.70	0.377
80.00	-25.09	-26.65	0.00	-1,726.67	0.00	1,726.67	4,821.81	2,410.90	9,545.79	4,779.99	14.95	-1.82	0.367
82.66	-24.37	-26.36	0.00	-1,655.70	0.00	1,655.70	4,771.13	2,385.57	9,306.02	4,659.93	15.99	-1.89	0.361
85.00	-23.34	-25.97	0.00	-1,594.11	0.00	1,594.11	4,726.18	2,363.09	9,097.16	4,555.34	16.92	-1.95	0.355
89.33	-21.48	-25.63	0.00	-1,481.67	0.00	1,481.67	3,846.41	1,923.21	7,360.18	3,685.56	18.74	-2.05	0.408
90.00	-21.30	-25.33	0.00	-1,464.50	0.00	1,464.50	3,836.63	1,918.32	7,313.25	3,662.06	19.03	-2.07	0.406
95.00	-20.15	-24.76	0.00	-1,337.86	0.00	1,337.86	3,762.45	1,881.23	6,965.41	3,487.88	21.26	-2.20	0.389
100.00	-19.02	-24.19	0.00	-1,214.08	0.00	1,214.08	3,686.20	1,843.10	6,621.98	3,315.91	23.64	-2.33	0.371
105.00	-17.91	-23.63	0.00	-1,093.11	0.00	1,093.11	3,607.86	1,803.93	6,283.29	3,146.32	26.15	-2.46	0.353
110.00	-16.85	-23.28	0.00	-974.95	0.00	974.95	3,527.44	1,763.72	5,949.70	2,979.27	28.80	-2.59	0.332
111.00	-16.60	-22.80	0.00	-951.67	0.00	951.67	3,511.11	1,755.55	5,883.62	2,946.18	29.34	-2.62	0.328
115.00	-15.76	-22.31	0.00	-860.48	0.00	860.48	3,444.94	1,722.47	5,621.53	2,814.94	31.58	-2.72	0.310
120.00	-14.75	-21.77	0.00	-748.92	0.00	748.92	3,360.36	1,680.18	5,299.14	2,653.51	34.49	-2.84	0.287
125.00	-13.76	-21.41	0.00	-640.08	0.00	640.08	3,273.70	1,636.85	4,982.86	2,495.14	37.52	-2.95	0.261
126.33	-13.50	-21.16	0.00	-611.60	0.00	611.60	3,250.30	1,625.15	4,899.81	2,453.55	38.35	-2.98	0.254
130.00	-12.47	-20.84	0.00	-533.96	0.00	533.96	3,165.67	1,582.83	4,644.73	2,325.82	40.67	-3.06	0.234
131.66	-12.01	-20.58	0.00	-499.30	0.00	499.30	1,875.92	937.96	2,776.25	1,390.19	41.75	-3.10	0.366
135.00	-11.52	-20.25	0.00	-430.63	0.00	430.63	1,848.21	924.11	2,667.57	1,335.77	43.94	-3.17	0.329
138.00	-9.82	-18.59	0.00	-369.87	0.00	369.87	1,822.51	911.25	2,570.47	1,287.14	45.95	-3.24	0.293
140.00	-8.94	-16.26	0.00	-329.26	0.00	329.26	1,804.96	902.48	2,506.10	1,254.91	47.32	-3.29	0.268
145.00	-8.33	-15.86	0.00	-247.96	0.00	247.96	1,759.62	879.81	2,346.60	1,175.04	50.83	-3.40	0.216
148.00	-6.72	-14.22	0.00	-200.38	0.00	200.38	1,731.42	865.71	2,251.99	1,127.67	52.99	-3.46	0.182
149.00	-5.75	-11.80	0.00	-186.16	0.00	186.16	1,721.85	860.93	2,220.65	1,111.98	53.71	-3.47	0.171
150.00	-5.65	-11.53	0.00	-174.36	0.00	174.36	1,712.20	856.10	2,189.41	1,096.33	54.44	-3.49	0.163
155.00	-5.15	-11.07	0.00	-116.69	0.00	116.69	1,662.70	831.35	2,034.89	1,018.96	58.13	-3.56	0.118
160.00	-3.40	-9.33	0.00	-61.34	0.00	61.34	1,611.13	805.56	1,883.37	943.08	61.89	-3.61	0.067

Site Number: 411178

Code: ANSI/TIA-222-G

© 2007 - 2019 by ATC IP LLC. All rights reserved.

Site Name: Old Lyme South CT, CT

Engineering Number: 12927156_C3_02

7/18/2019 8:45:16 PM

Customer: T-MOBILE

Load Case: 0.9D + 1.6W

105 mph with No Ice (Reduced DL)

23 Iterations

Gust Response Factor :1.10

Wind Importance Factor :1.00

Dead Load Factor :0.90

Wind Load Factor :1.60

160.50	-3.35	-9.29	0.00	-56.68	0.00	56.68	1,605.85	802.93	1,868.39	935.58	62.26	-3.61	0.063
160.50	-3.35	-9.29	0.00	-56.68	0.00	56.68	1,062.64	531.32	1,193.75	597.76	62.26	-3.61	0.098
161.00	-2.46	-4.91	0.00	-48.03	0.00	48.03	1,060.93	530.47	1,188.54	595.15	62.64	-3.61	0.083
165.00	-2.23	-4.53	0.00	-28.41	0.00	28.41	1,047.03	523.52	1,146.95	574.33	65.68	-3.64	0.052
170.00	-0.89	-3.44	0.00	-5.74	0.00	5.74	1,029.05	514.53	1,095.30	548.46	69.50	-3.66	0.011
170.50	0.00	-3.37	0.00	-4.02	0.00	4.02	1,027.22	513.61	1,090.15	545.89	69.89	-3.66	0.007

Load Case: 1.2D + 1.0Di + 1.0Wi	50 mph with 0.75 in Radial Ice	22 Iterations
Gust Response Factor :1.10	Ice Dead Load Factor :1.00	Wind Importance Factor :1.00
Dead Load Factor :1.20		Ice Importance Factor :1.00
Wind Load Factor :1.00		

Applied Segment Forces Summary

Seg Elev (ft)	Description	Shaft Forces		Discrete Forces			Linear Forces		Sum of Forces				
		Wind FX (lb)	Dead Load (lb)	Wind FX (lb)	Torsion MY (lb-ft)	Moment MZ (lb-ft)	Dead Load (lb)	Wind FX (lb)	Dead Load (lb)	Wind FX (lb)	Dead Load (lb)	Torsion MY (lb-ft)	Moment MZ (lb)
0.00		83.9	0.0					0.0	0.0	83.9	0.0	0.0	0.0
5.00		166.6	2,424.7					12.6	466.5	179.2	2,891.2	0.0	0.0
10.00		163.9	2,435.5					13.4	473.2	177.3	2,908.8	0.0	0.0
15.00		161.0	2,416.0					13.8	476.7	174.8	2,892.7	0.0	0.0
20.00		158.1	2,386.5					14.0	479.1	172.1	2,865.6	0.0	0.0
25.00		155.1	2,351.9					14.2	480.9	169.3	2,832.8	0.0	0.0
30.00		153.9	2,314.0					14.4	482.4	168.3	2,796.5	0.0	0.0
35.00		155.8	2,274.0					14.9	483.7	170.7	2,757.7	0.0	0.0
40.00	Bot - Section 2	159.7	2,232.3					15.7	484.9	175.3	2,717.2	0.0	0.0
45.00		130.0	3,847.0					16.4	485.9	146.4	4,332.9	0.0	0.0
48.00	Top - Section 1	81.8	2,270.7					10.1	292.0	92.0	2,562.7	0.0	0.0
50.00		115.2	867.7					6.9	194.8	122.1	1,062.5	0.0	0.0
55.00		165.2	2,133.9					17.6	487.6	182.8	2,621.5	0.0	0.0
60.00		165.6	2,088.4					18.2	488.4	183.7	2,576.8	0.0	0.0
65.00		165.5	2,042.3					18.7	489.1	184.2	2,531.4	0.0	0.0
70.00		148.7	1,995.7					19.2	489.7	167.9	2,485.4	0.0	0.0
74.00	Appurtenance(s)	82.4	1,563.8	18.1	0.0	0.0	61.5	15.7	392.2	116.3	2,017.5	0.0	0.0
75.00		98.4	387.0					4.0	97.9	102.4	484.9	0.0	0.0
80.00		125.4	1,901.1					20.2	490.0	145.6	2,391.1	0.0	0.0
82.66	Bot - Section 3	81.9	994.8					10.9	261.2	92.9	1,256.1	0.0	0.0
85.00		109.5	1,410.9					9.7	229.3	119.1	1,640.2	0.0	0.0
89.33	Top - Section 2	81.9	2,565.7					18.2	425.2	100.1	2,991.0	0.0	0.0
90.00		92.0	218.8					2.8	65.8	94.8	284.6	0.0	0.0
95.00		161.1	1,602.1					21.4	491.6	182.6	2,093.7	0.0	0.0
100.00		159.1	1,558.7					21.8	492.0	180.9	2,050.7	0.0	0.0
105.00		156.9	1,515.0					22.2	492.5	179.1	2,007.5	0.0	0.0
110.00		93.3	1,471.2					22.6	492.9	115.9	1,964.1	0.0	0.0
111.00	Appurtenance(s)	76.6	290.1	78.1	0.0	0.0	151.8	4.6	98.6	159.3	540.5	0.0	0.0
115.00		136.5	1,139.2					18.4	393.3	154.8	1,532.5	0.0	0.0
120.00		149.1	1,382.7					23.3	491.9	172.4	1,874.6	0.0	0.0
125.00		93.2	1,338.2					23.6	492.3	116.9	1,830.5	0.0	0.0
126.33	Bot - Section 4	73.0	349.8					6.3	131.0	79.3	480.8	0.0	0.0
130.00		77.6	1,389.3					17.6	361.7	95.2	1,751.0	0.0	0.0
131.66	Top - Section 3	71.7	618.9					8.0	164.0	79.7	782.8	0.0	0.0
135.00		89.8	651.5					16.2	329.1	106.1	980.5	0.0	0.0
138.00	Appurtenance(s)	70.0	573.0	326.5	0.0	0.0	2,143.1	14.7	296.0	411.2	3,012.1	0.0	0.0
140.00	Appurtenance(s)	96.1	375.7	372.5	0.0	644.1	2,317.1	9.9	197.4	478.5	2,890.2	0.0	0.0
145.00		108.4	910.8					24.9	387.1	133.3	1,298.0	0.0	0.0
148.00	Appurtenance(s)	53.3	531.6	334.0	0.0	0.0	2,147.7	15.1	216.1	402.5	2,895.4	0.0	0.0
149.00	Appurtenance(s)	26.4	175.0	425.0	0.0	0.0	2,824.7	5.1	72.0	456.5	3,071.7	0.0	0.0
150.00		77.8	173.6					5.1	61.2	82.9	234.8	0.0	0.0
155.00		127.4	841.5					25.5	306.1	152.9	1,147.6	0.0	0.0
160.00	Appurtenance(s)	68.9	806.7	342.6	0.0	0.0	2,152.4	25.8	306.4	437.3	3,265.5	0.0	0.0
160.50	Top - Section 4	12.1	79.4					2.6	30.7	14.7	110.1	0.0	0.0
161.00	Appurtenance(s)	53.2	65.2	813.7	0.0	780.2	3,801.6	2.6	30.7	869.5	3,897.5	0.0	0.0
165.00		105.4	513.8					0.0	78.0	105.4	591.8	0.0	0.0
170.00	Appurtenance(s)	63.9	626.6	209.3	0.0	0.0	2,801.8	0.0	90.1	273.3	3,518.6	0.0	0.0
170.50	Appurtenance(s)	5.8	62.1	730.4	0.0	1,451.3	2,562.0	0.0	9.0	736.2	2,633.1	0.0	0.0

Site Number: 411178

Code: ANSI/TIA-222-G

© 2007 - 2019 by ATC IP LLC. All rights reserved.

Site Name: Old Lyme South CT, CT

Engineering Number: 12927156_C3_02

7/18/2019 8:45:26 PM

Customer: T-MOBILE

Load Case: 1.2D + 1.0Di + 1.0Wi

50 mph with 0.75 in Radial Ice

22 Iterations

Gust Response Factor :1.10

Ice Dead Load Factor :1.00

Wind Importance Factor :1.00

Dead Load Factor :1.20

Ice Importance Factor :1.00

Wind Load Factor :1.00

Totals: 9,497.45 98,356.4 0.00 0.00

Load Case: 1.2D + 1.0Di + 1.0Wi

50 mph with 0.75 in Radial Ice

22 Iterations

Gust Response Factor :1.10

Ice Dead Load Factor :1.00

Wind Importance Factor :1.00

Dead Load Factor :1.20

Ice Importance Factor :1.00

Wind Load Factor :1.00

Calculated Forces

Seg Elev (ft)	Pu FY (-) (kips)	Vu FX (-) (kips)	Tu MY (ft-kips)	Mu MZ (ft-kips)	Mu MX (ft-kips)	Resultant Moment (ft-kips)	phi Pn (kips)	phi Vn (kips)	phi Tn (ft-kips)	phi Mn (ft-kips)	Total Deflect (in)	Rotation (deg)	Ratio
0.00	-98.35	-9.44	0.00	-1,107.25	0.00	1,107.25	6,027.96	3,013.98	17,007.2	8,516.24	0.00	0.00	0.146
5.00	-95.46	-9.30	0.00	-1,060.07	0.00	1,060.07	5,964.25	2,982.12	16,500.1	8,262.35	0.01	-0.03	0.144
10.00	-92.55	-9.17	0.00	-1,013.56	0.00	1,013.56	5,898.45	2,949.22	15,994.5	8,009.14	0.06	-0.05	0.142
15.00	-89.65	-9.03	0.00	-967.72	0.00	967.72	5,830.57	2,915.29	15,490.5	7,756.77	0.13	-0.08	0.140
20.00	-86.78	-8.90	0.00	-922.55	0.00	922.55	5,760.62	2,880.31	14,988.5	7,505.43	0.23	-0.11	0.138
25.00	-83.94	-8.77	0.00	-878.05	0.00	878.05	5,688.58	2,844.29	14,489.0	7,255.28	0.37	-0.14	0.136
30.00	-81.14	-8.63	0.00	-834.22	0.00	834.22	5,614.46	2,807.23	13,992.1	7,006.49	0.53	-0.17	0.134
35.00	-78.38	-8.49	0.00	-791.05	0.00	791.05	5,538.27	2,769.13	13,498.4	6,759.23	0.72	-0.20	0.131
40.00	-75.66	-8.35	0.00	-748.58	0.00	748.58	5,459.99	2,729.99	13,008.0	6,513.68	0.95	-0.23	0.129
45.00	-71.32	-8.21	0.00	-706.84	0.00	706.84	5,379.63	2,689.82	12,521.4	6,270.01	1.20	-0.26	0.126
48.00	-68.76	-8.13	0.00	-682.20	0.00	682.20	5,384.54	2,692.27	12,550.6	6,284.66	1.37	-0.28	0.121
50.00	-67.69	-8.03	0.00	-665.94	0.00	665.94	5,351.87	2,675.93	12,357.0	6,187.71	1.49	-0.29	0.120
55.00	-65.07	-7.86	0.00	-625.81	0.00	625.81	5,268.72	2,634.36	11,875.9	5,946.82	1.81	-0.32	0.118
60.00	-62.49	-7.70	0.00	-586.49	0.00	586.49	5,183.50	2,591.75	11,399.4	5,708.21	2.16	-0.35	0.115
65.00	-59.96	-7.53	0.00	-548.01	0.00	548.01	5,096.20	2,548.10	10,927.8	5,472.05	2.55	-0.38	0.112
70.00	-57.47	-7.37	0.00	-510.37	0.00	510.37	5,006.81	2,503.41	10,461.4	5,238.51	2.96	-0.41	0.109
74.00	-55.45	-7.25	0.00	-480.89	0.00	480.89	4,933.81	2,466.91	10,092.3	5,053.69	3.31	-0.43	0.106
75.00	-54.96	-7.17	0.00	-473.63	0.00	473.63	4,915.35	2,457.68	10,000.6	5,007.77	3.40	-0.44	0.106
80.00	-52.57	-7.02	0.00	-437.81	0.00	437.81	4,821.81	2,410.90	9,545.79	4,779.99	3.88	-0.47	0.103
82.66	-51.31	-6.93	0.00	-419.10	0.00	419.10	4,771.13	2,385.57	9,306.02	4,659.93	4.15	-0.49	0.101
85.00	-49.67	-6.82	0.00	-402.91	0.00	402.91	4,726.18	2,363.09	9,097.16	4,555.34	4.39	-0.50	0.099
89.33	-46.68	-6.70	0.00	-373.39	0.00	373.39	3,846.41	1,923.21	7,360.18	3,685.56	4.86	-0.53	0.113
90.00	-46.39	-6.62	0.00	-368.90	0.00	368.90	3,836.63	1,918.32	7,313.25	3,662.06	4.93	-0.53	0.113
95.00	-44.30	-6.44	0.00	-335.79	0.00	335.79	3,762.45	1,881.23	6,965.41	3,487.88	5.51	-0.57	0.108
100.00	-42.25	-6.27	0.00	-303.57	0.00	303.57	3,686.20	1,843.10	6,621.98	3,315.91	6.12	-0.60	0.103
105.00	-40.24	-6.09	0.00	-272.24	0.00	272.24	3,607.86	1,803.93	6,283.29	3,146.32	6.77	-0.63	0.098
110.00	-38.27	-5.96	0.00	-241.80	0.00	241.80	3,527.44	1,763.72	5,949.70	2,979.27	7.44	-0.66	0.092
111.00	-37.73	-5.81	0.00	-235.84	0.00	235.84	3,511.11	1,755.55	5,883.62	2,946.18	7.58	-0.67	0.091
115.00	-36.20	-5.65	0.00	-212.61	0.00	212.61	3,444.94	1,722.47	5,621.53	2,814.94	8.16	-0.69	0.086
120.00	-34.32	-5.47	0.00	-184.35	0.00	184.35	3,360.36	1,680.18	5,299.14	2,653.51	8.90	-0.72	0.080
125.00	-32.49	-5.34	0.00	-156.98	0.00	156.98	3,273.70	1,636.85	4,982.86	2,495.14	9.67	-0.75	0.073
126.33	-32.01	-5.27	0.00	-149.87	0.00	149.87	3,250.30	1,625.15	4,899.81	2,453.55	9.89	-0.76	0.071
130.00	-30.26	-5.15	0.00	-130.55	0.00	130.55	3,165.67	1,582.83	4,644.73	2,325.82	10.48	-0.78	0.066
131.66	-29.48	-5.07	0.00	-121.97	0.00	121.97	1,875.92	937.96	2,776.25	1,390.19	10.75	-0.79	0.103
135.00	-28.50	-4.96	0.00	-105.06	0.00	105.06	1,848.21	924.11	2,667.57	1,335.77	11.31	-0.80	0.094
138.00	-25.49	-4.51	0.00	-90.18	0.00	90.18	1,822.51	911.25	2,570.47	1,287.14	11.82	-0.82	0.084
140.00	-22.61	-4.00	0.00	-80.51	0.00	80.51	1,804.96	902.48	2,506.10	1,254.91	12.17	-0.84	0.077
145.00	-21.31	-3.85	0.00	-60.51	0.00	60.51	1,759.62	879.81	2,346.60	1,175.04	13.06	-0.86	0.064
148.00	-18.42	-3.41	0.00	-48.95	0.00	48.95	1,731.42	865.71	2,251.99	1,127.67	13.61	-0.88	0.054
149.00	-15.36	-2.91	0.00	-45.54	0.00	45.54	1,721.85	860.93	2,220.65	1,111.98	13.79	-0.88	0.050
150.00	-15.12	-2.83	0.00	-42.63	0.00	42.63	1,712.20	856.10	2,189.41	1,096.33	13.97	-0.88	0.048
155.00	-13.98	-2.66	0.00	-28.50	0.00	28.50	1,662.70	831.35	2,034.89	1,018.96	14.91	-0.90	0.036
160.00	-10.72	-2.17	0.00	-15.22	0.00	15.22	1,611.13	805.56	1,883.37	943.08	15.86	-0.91	0.023

Site Number: 411178

Code: ANSI/TIA-222-G

© 2007 - 2019 by ATC IP LLC. All rights reserved.

Site Name: Old Lyme South CT, CT

Engineering Number: 12927156_C3_02

7/18/2019 8:45:26 PM

Customer: T-MOBILE

Load Case: 1.2D + 1.0Di + 1.0Wi

50 mph with 0.75 in Radial Ice

22 Iterations

Gust Response Factor :1.10

Ice Dead Load Factor :1.00

Wind Importance Factor :1.00

Dead Load Factor :1.20

Ice Importance Factor :1.00

Wind Load Factor :1.00

160.50	-10.61	-2.15	0.00	-14.13	0.00	14.13	1,605.85	802.93	1,868.39	935.58	15.96	-0.91	0.022
160.50	-10.61	-2.15	0.00	-14.13	0.00	14.13	1,062.64	531.32	1,193.75	597.76	15.96	-0.91	0.034
161.00	-6.72	-1.22	0.00	-12.27	0.00	12.27	1,060.93	530.47	1,188.54	595.15	16.05	-0.91	0.027
165.00	-6.13	-1.11	0.00	-7.38	0.00	7.38	1,047.03	523.52	1,146.95	574.33	16.82	-0.92	0.019
170.00	-2.62	-0.78	0.00	-1.84	0.00	1.84	1,029.05	514.53	1,095.30	548.46	17.79	-0.93	0.006
170.50	0.00	-0.74	0.00	-1.45	0.00	1.45	1,027.22	513.61	1,090.15	545.89	17.89	-0.93	0.003

Load Case: 1.0D + 1.0W	Serviceability 60 mph	22 Iterations
Gust Response Factor :1.10		Wind Importance Factor :1.00
Dead Load Factor :1.00		
Wind Load Factor :1.00		

Applied Segment Forces Summary

Seg Elev (ft)	Description	Shaft Forces		Discrete Forces			Linear Forces		Sum of Forces				
		Wind FX (lb)	Dead Load (lb)	Wind FX (lb)	Torsion MY (lb-ft)	Moment MZ (lb-ft)	Dead Load (lb)	Wind FX (lb)	Dead Load (lb)	Wind FX (lb)	Dead Load (lb)	Torsion MY (lb-ft)	Moment MZ (lb)
0.00		56.7	0.0					0.0	0.0	56.7	0.0	0.0	0.0
5.00		112.3	1,604.1					0.0	321.1	112.3	1,925.2	0.0	0.0
10.00		110.1	1,572.8					0.0	321.1	110.1	1,893.9	0.0	0.0
15.00		107.9	1,541.5					0.0	321.1	107.9	1,862.6	0.0	0.0
20.00		105.7	1,510.2					0.0	321.1	105.7	1,831.3	0.0	0.0
25.00		103.5	1,478.9					0.0	321.1	103.5	1,800.0	0.0	0.0
30.00		102.5	1,447.6					0.0	321.1	102.5	1,768.7	0.0	0.0
35.00		103.5	1,416.3					0.0	321.1	103.5	1,737.4	0.0	0.0
40.00	Bot - Section 2	106.0	1,385.0					0.0	321.1	106.0	1,706.1	0.0	0.0
45.00		86.2	2,728.1					0.0	321.1	86.2	3,049.2	0.0	0.0
48.00	Top - Section 1	54.2	1,606.8					0.0	192.6	54.2	1,799.4	0.0	0.0
50.00		76.2	533.5					0.0	128.4	76.2	661.9	0.0	0.0
55.00		109.1	1,311.8					0.0	321.1	109.1	1,632.8	0.0	0.0
60.00		109.2	1,280.5					0.0	321.1	109.2	1,601.5	0.0	0.0
65.00		109.0	1,249.2					0.0	321.1	109.0	1,570.2	0.0	0.0
70.00		97.7	1,217.9					0.0	321.1	97.7	1,538.9	0.0	0.0
74.00	Appurtenance(s)	54.1	951.8	14.1	0.0	0.0	20.0	0.0	256.8	68.2	1,228.6	0.0	0.0
75.00		64.5	234.8					0.0	64.1	64.5	298.9	0.0	0.0
80.00		82.1	1,155.3					0.0	320.3	82.1	1,475.6	0.0	0.0
82.66	Bot - Section 3	53.6	602.6					0.0	170.6	53.6	773.2	0.0	0.0
85.00		71.5	975.9					0.0	149.7	71.5	1,125.6	0.0	0.0
89.33	Top - Section 2	53.5	1,774.9					0.0	277.4	53.5	2,052.3	0.0	0.0
90.00		59.9	126.1					0.0	42.9	59.9	169.1	0.0	0.0
95.00		104.9	926.2					0.0	320.3	104.9	1,246.5	0.0	0.0
100.00		103.3	899.4					0.0	320.3	103.3	1,219.7	0.0	0.0
105.00		101.6	872.5					0.0	320.3	101.6	1,192.8	0.0	0.0
110.00		60.3	845.7					0.0	320.3	60.3	1,166.0	0.0	0.0
111.00	Appurtenance(s)	49.4	165.9	39.6	0.0	0.0	40.0	0.0	64.1	89.0	270.0	0.0	0.0
115.00		87.9	652.9					0.0	255.0	87.9	908.0	0.0	0.0
120.00		95.8	792.0					0.0	318.8	95.8	1,110.8	0.0	0.0
125.00		59.8	765.2					0.0	318.8	59.8	1,084.0	0.0	0.0
126.33	Bot - Section 4	46.7	199.0					0.0	84.8	46.7	283.8	0.0	0.0
130.00		49.6	905.1					0.0	234.0	49.6	1,139.1	0.0	0.0
131.66	Top - Section 3	45.7	402.3					0.0	106.1	45.7	508.3	0.0	0.0
135.00		57.2	320.2					0.0	212.7	57.2	532.9	0.0	0.0
138.00	Appurtenance(s)	44.5	281.1	243.7	0.0	0.0	1,500.0	0.0	191.3	288.2	1,972.4	0.0	0.0
140.00	Appurtenance(s)	60.9	183.8	357.5	0.0	627.8	781.2	0.0	127.5	418.4	1,092.5	0.0	0.0
145.00		68.5	447.0					0.0	230.0	68.5	677.0	0.0	0.0
148.00	Appurtenance(s)	33.6	259.6	248.6	0.0	0.0	1,500.0	0.0	124.3	282.2	1,884.0	0.0	0.0
149.00	Appurtenance(s)	16.6	85.1	413.7	0.0	0.0	1,118.2	0.0	41.5	430.3	1,244.8	0.0	0.0
150.00		48.8	84.4					0.0	32.4	48.8	116.8	0.0	0.0
155.00		79.8	411.2					0.0	161.9	79.8	573.1	0.0	0.0
160.00	Appurtenance(s)	43.0	393.4	254.2	0.0	0.0	1,500.0	0.0	161.9	297.2	2,055.3	0.0	0.0
160.50	Top - Section 4	7.5	38.4					0.0	16.2	7.5	54.5	0.0	0.0
161.00	Appurtenance(s)	32.9	27.6	755.6	0.0	730.3	1,250.0	0.0	16.2	788.5	1,293.8	0.0	0.0
165.00		65.1	218.2					0.0	65.0	65.1	283.2	0.0	0.0
170.00	Appurtenance(s)	39.4	265.9	144.9	0.0	0.0	1,214.9	0.0	75.1	184.3	1,555.9	0.0	0.0
170.50	Appurtenance(s)	3.5	26.2	612.5	0.0	734.1	1,202.2	0.0	7.5	616.1	1,235.9	0.0	0.0

Site Number: 411178

Code: ANSI/TIA-222-G

© 2007 - 2019 by ATC IP LLC. All rights reserved.

Site Name: Old Lyme South CT, CT

Engineering Number: 12927156_C3_02

7/18/2019 8:45:35 PM

Customer: T-MOBILE

Load Case: 1.0D + 1.0W

Serviceability 60 mph

22 Iterations

Gust Response Factor :1.10

Wind Importance Factor :1.00

Dead Load Factor :1.00

Wind Load Factor :1.00

Totals: 6,479.81 58,203.4 0.00 0.00

Load Case: 1.0D + 1.0W

Serviceability 60 mph

22 Iterations

Gust Response Factor :1.10

Wind Importance Factor :1.00

Dead Load Factor :1.00

Wind Load Factor :1.00

Calculated Forces

Seg Elev (ft)	Pu FY (-) (kips)	Vu FX (-) (kips)	Tu MY (ft-kips)	Mu MZ (ft-kips)	Mu MX (ft-kips)	Resultant Moment (ft-kips)	phi Pn (kips)	phi Vn (kips)	phi Tn (ft-kips)	phi Mn (ft-kips)	Total Deflect (in)	Rotation (deg)	Ratio
0.00	-58.20	-6.43	0.00	-774.99	0.00	774.99	6,027.96	3,013.98	17,007.2	8,516.24	0.00	0.00	0.101
5.00	-56.28	-6.34	0.00	-742.83	0.00	742.83	5,964.25	2,982.12	16,500.1	8,262.35	0.01	-0.02	0.099
10.00	-54.38	-6.25	0.00	-711.13	0.00	711.13	5,898.45	2,949.22	15,994.5	8,009.14	0.04	-0.04	0.098
15.00	-52.51	-6.16	0.00	-679.90	0.00	679.90	5,830.57	2,915.29	15,490.5	7,756.77	0.09	-0.06	0.097
20.00	-50.68	-6.07	0.00	-649.13	0.00	649.13	5,760.62	2,880.31	14,988.5	7,505.43	0.16	-0.08	0.095
25.00	-48.88	-5.98	0.00	-618.80	0.00	618.80	5,688.58	2,844.29	14,489.0	7,255.28	0.26	-0.10	0.094
30.00	-47.11	-5.89	0.00	-588.92	0.00	588.92	5,614.46	2,807.23	13,992.1	7,006.49	0.37	-0.12	0.092
35.00	-45.37	-5.80	0.00	-559.49	0.00	559.49	5,538.27	2,769.13	13,498.4	6,759.23	0.51	-0.14	0.091
40.00	-43.66	-5.70	0.00	-530.50	0.00	530.50	5,459.99	2,729.99	13,008.0	6,513.68	0.66	-0.16	0.089
45.00	-40.61	-5.62	0.00	-501.99	0.00	501.99	5,379.63	2,689.82	12,521.4	6,270.01	0.85	-0.18	0.088
48.00	-38.81	-5.57	0.00	-485.13	0.00	485.13	5,384.54	2,692.27	12,550.6	6,284.66	0.96	-0.20	0.084
50.00	-38.15	-5.50	0.00	-474.00	0.00	474.00	5,351.87	2,675.93	12,357.0	6,187.71	1.05	-0.20	0.084
55.00	-36.51	-5.40	0.00	-446.51	0.00	446.51	5,268.72	2,634.36	11,875.9	5,946.82	1.27	-0.23	0.082
60.00	-34.91	-5.29	0.00	-419.53	0.00	419.53	5,183.50	2,591.75	11,399.4	5,708.21	1.52	-0.25	0.080
65.00	-33.34	-5.19	0.00	-393.06	0.00	393.06	5,096.20	2,548.10	10,927.8	5,472.05	1.79	-0.27	0.078
70.00	-31.80	-5.10	0.00	-367.11	0.00	367.11	5,006.81	2,503.41	10,461.4	5,238.51	2.09	-0.29	0.076
74.00	-30.57	-5.03	0.00	-346.73	0.00	346.73	4,933.81	2,466.91	10,092.3	5,053.69	2.34	-0.31	0.075
75.00	-30.27	-4.97	0.00	-341.70	0.00	341.70	4,915.35	2,457.68	10,000.6	5,007.77	2.40	-0.31	0.074
80.00	-28.79	-4.89	0.00	-316.86	0.00	316.86	4,821.81	2,410.90	9,545.79	4,779.99	2.74	-0.33	0.072
82.66	-28.02	-4.83	0.00	-303.85	0.00	303.85	4,771.13	2,385.57	9,306.02	4,659.93	2.93	-0.35	0.071
85.00	-26.89	-4.76	0.00	-292.56	0.00	292.56	4,726.18	2,363.09	9,097.16	4,555.34	3.10	-0.36	0.070
89.33	-24.84	-4.70	0.00	-271.94	0.00	271.94	3,846.41	1,923.21	7,360.18	3,685.56	3.44	-0.38	0.080
90.00	-24.67	-4.64	0.00	-268.79	0.00	268.79	3,836.63	1,918.32	7,313.25	3,662.06	3.49	-0.38	0.080
95.00	-23.42	-4.54	0.00	-245.56	0.00	245.56	3,762.45	1,881.23	6,965.41	3,487.88	3.90	-0.40	0.077
100.00	-22.20	-4.44	0.00	-222.86	0.00	222.86	3,686.20	1,843.10	6,621.98	3,315.91	4.33	-0.43	0.073
105.00	-21.01	-4.34	0.00	-200.66	0.00	200.66	3,607.86	1,803.93	6,283.29	3,146.32	4.80	-0.45	0.070
110.00	-19.84	-4.27	0.00	-178.98	0.00	178.98	3,527.44	1,763.72	5,949.70	2,979.27	5.28	-0.47	0.066
111.00	-19.57	-4.18	0.00	-174.71	0.00	174.71	3,511.11	1,755.55	5,883.62	2,946.18	5.38	-0.48	0.065
115.00	-18.66	-4.10	0.00	-157.97	0.00	157.97	3,444.94	1,722.47	5,621.53	2,814.94	5.79	-0.50	0.062
120.00	-17.55	-4.00	0.00	-137.50	0.00	137.50	3,360.36	1,680.18	5,299.14	2,653.51	6.33	-0.52	0.057
125.00	-16.47	-3.93	0.00	-117.51	0.00	117.51	3,273.70	1,636.85	4,982.86	2,495.14	6.88	-0.54	0.052
126.33	-16.18	-3.88	0.00	-112.29	0.00	112.29	3,250.30	1,625.15	4,899.81	2,453.55	7.03	-0.55	0.051
130.00	-15.04	-3.83	0.00	-98.03	0.00	98.03	3,165.67	1,582.83	4,644.73	2,325.82	7.46	-0.56	0.047
131.66	-14.53	-3.78	0.00	-91.67	0.00	91.67	1,875.92	937.96	2,776.25	1,390.19	7.66	-0.57	0.074
135.00	-14.00	-3.72	0.00	-79.06	0.00	79.06	1,848.21	924.11	2,667.57	1,335.77	8.06	-0.58	0.067
138.00	-12.03	-3.41	0.00	-67.91	0.00	67.91	1,822.51	911.25	2,570.47	1,287.14	8.43	-0.60	0.059
140.00	-10.94	-2.99	0.00	-60.45	0.00	60.45	1,804.96	902.48	2,506.10	1,254.91	8.68	-0.60	0.054
145.00	-10.27	-2.91	0.00	-45.53	0.00	45.53	1,759.62	879.81	2,346.60	1,175.04	9.32	-0.62	0.045
148.00	-8.38	-2.61	0.00	-36.79	0.00	36.79	1,731.42	865.71	2,251.99	1,127.67	9.72	-0.63	0.037
149.00	-7.14	-2.17	0.00	-34.18	0.00	34.18	1,721.85	860.93	2,220.65	1,111.98	9.85	-0.64	0.035
150.00	-7.03	-2.12	0.00	-32.01	0.00	32.01	1,712.20	856.10	2,189.41	1,096.33	9.99	-0.64	0.033
155.00	-6.46	-2.03	0.00	-21.42	0.00	21.42	1,662.70	831.35	2,034.89	1,018.96	10.67	-0.65	0.025
160.00	-4.40	-1.71	0.00	-11.26	0.00	11.26	1,611.13	805.56	1,883.37	943.08	11.35	-0.66	0.015

Site Number: 411178

Code: ANSI/TIA-222-G

© 2007 - 2019 by ATC IP LLC. All rights reserved.

Site Name: Old Lyme South CT, CT

Engineering Number: 12927156_C3_02

7/18/2019 8:45:36 PM

Customer: T-MOBILE

Load Case: 1.0D + 1.0W

Serviceability 60 mph

22 Iterations

Gust Response Factor :1.10

Wind Importance Factor :1.00

Dead Load Factor :1.00

Wind Load Factor :1.00

160.50	-4.35	-1.70	0.00	-10.40	0.00	10.40	1,605.85	802.93	1,868.39	935.58	11.42	-0.66	0.014
160.50	-4.35	-1.70	0.00	-10.40	0.00	10.40	1,062.64	531.32	1,193.75	597.76	11.42	-0.66	0.022
161.00	-3.06	-0.90	0.00	-8.82	0.00	8.82	1,060.93	530.47	1,188.54	595.15	11.49	-0.66	0.018
165.00	-2.78	-0.83	0.00	-5.21	0.00	5.21	1,047.03	523.52	1,146.95	574.33	12.05	-0.67	0.012
170.00	-1.23	-0.63	0.00	-1.05	0.00	1.05	1,029.05	514.53	1,095.30	548.46	12.75	-0.67	0.003
170.50	0.00	-0.62	0.00	-0.73	0.00	0.73	1,027.22	513.61	1,090.15	545.89	12.82	-0.67	0.001

Equivalent Lateral Forces Method Analysis

(Based on ASCE7-10 Chapters 11, 12, 15)

Spectral Response Acceleration for Short Period (S_s):	0.16
Spectral Response Acceleration at 1.0 Second Period (S_1):	0.06
Long-Period Transition Period (T_L):	6
Importance Factor (I_E):	1.00
Site Coefficient F_a :	1.60
Site Coefficient F_v :	2.40
Response Modification Coefficient (R):	1.50
Design Spectral Response Acceleration at Short Period (S_{ds}):	0.17
Design Spectral Response Acceleration at 1.0 Second Period (S_{d1}):	0.09
Seismic Response Coefficient (C_s):	0.03
Upper Limit C_s	0.03
Lower Limit C_s	0.03
Period based on Rayleigh Method (sec):	2.07
Redundancy Factor (ρ):	1.00
Seismic Force Distribution Exponent (k):	1.79
Total Unfactored Dead Load:	58.20 k
Seismic Base Shear (E):	1.75 k

Load Case (1.2 + 0.2Sds) * DL + E ELFM

Seismic Equivalent Lateral Forces Method

Segment	Height Above Base (ft)	Weight (lb)	W_z (lb-ft)	C_{vx}	Horizontal Force (lb)	Vertical Force (lb)
47	170.25	34	326	0.002	3	42
46	167.50	341	3,207	0.016	28	421
45	163.00	283	2,537	0.013	22	350
44	160.75	44	383	0.002	3	54
43	160.25	55	474	0.002	4	67
42	157.50	555	4,678	0.023	41	686
41	152.50	573	4,559	0.023	40	708
40	149.50	117	896	0.004	8	144
39	148.50	127	960	0.005	8	156
38	146.50	384	2,843	0.014	25	474
37	142.50	677	4,770	0.024	42	836
36	139.00	311	2,098	0.011	18	384
35	136.50	472	3,082	0.015	27	583
34	133.33	533	3,335	0.017	29	658
33	130.83	508	3,075	0.015	27	628
32	128.17	1,139	6,641	0.033	58	1,407
31	125.67	284	1,598	0.008	14	350
30	122.50	1,084	5,830	0.029	51	1,338
29	117.50	1,111	5,545	0.028	49	1,372
28	113.00	908	4,227	0.021	37	1,121
27	110.50	230	1,029	0.005	9	284
26	107.50	1,166	4,965	0.025	44	1,440
25	102.50	1,193	4,665	0.023	41	1,473

24	97.50	1,220	4,363	0.022	38	1,506
23	92.50	1,246	4,058	0.020	36	1,539
22	89.67	169	521	0.003	5	209
21	87.17	2,052	6,009	0.030	53	2,534
20	83.83	1,126	3,074	0.015	27	1,390
19	81.33	773	2,000	0.010	18	955
18	77.50	1,476	3,502	0.018	31	1,822
17	74.50	299	661	0.003	6	369
16	72.00	1,209	2,515	0.013	22	1,492
15	67.50	1,539	2,854	0.014	25	1,900
14	62.50	1,570	2,538	0.013	22	1,939
13	57.50	1,602	2,230	0.011	20	1,978
12	52.50	1,633	1,933	0.010	17	2,016
11	49.00	662	693	0.003	6	817
10	46.50	1,799	1,715	0.009	15	2,222
9	42.50	3,049	2,474	0.012	22	3,765
8	37.50	1,706	1,107	0.006	10	2,107
7	32.50	1,737	873	0.004	8	2,145
6	27.50	1,769	659	0.003	6	2,184
5	22.50	1,800	469	0.002	4	2,223
4	17.50	1,831	304	0.002	3	2,261
3	12.50	1,863	170	0.001	1	2,300
2	7.50	1,894	69	0.000	1	2,339
1	2.50	1,925	10	0.000	0	2,377
Ericsson KRY 112 144	170.50	33	320	0.002	3	41
Generic E-911 GPS	170.50	5	49	0.000	0	6
Ericsson Radio 4449	170.50	222	2,155	0.011	19	274
Decibel DB201-A	170.50	25	243	0.001	2	31
Generic 12' Dipole	170.50	40	388	0.002	3	49
Ericsson AIR 21, 1.3	170.50	249	2,417	0.012	21	307
Ericsson AIR 21, 1.3	170.50	244	2,374	0.012	21	302
RFS APXVAARR24_43-U-	170.50	384	3,725	0.019	33	474
Round T-Arm w/Reinfo	170.00	1,215	11,733	0.059	103	1,500
Alcatel-Lucent RRH2X	161.00	129	1,130	0.006	10	159
Alcatel-Lucent RRH2x	161.00	170	1,491	0.007	13	210
Alcatel-Lucent B66 R	161.00	201	1,761	0.009	15	248
VZW Unused Reserve:	161.00	209	1,831	0.009	16	258
RFS APL866513-42T0	161.00	63	550	0.003	5	78
Antel BXA-70063-4CF-	161.00	10	87	0.000	1	12
RFS DB-T1-6Z-8AB-0Z	161.00	88	771	0.004	7	109
Antel BXA-70063/6CF_	161.00	34	298	0.001	3	42
Commscope SBNHH-1D65	161.00	304	2,666	0.013	23	376
Amphenol Antel LPA-8	161.00	42	368	0.002	3	52
Flat Low Profile Pla	160.00	1,500	12,999	0.065	114	1,852
Generic GPS	149.00	10	76	0.000	1	12
Alcatel-Lucent RRH2x	149.00	317	2,422	0.012	21	392
Alcatel-Lucent 1900	149.00	180	1,374	0.007	12	222
Alcatel-Lucent TD-RR	149.00	210	1,602	0.008	14	259
RFS APXVTM14-ALU-I20	149.00	169	1,287	0.006	11	208
Commscope NNVV-65B-R	149.00	232	1,772	0.009	16	287
Flat Low Profile Pla	148.00	1,500	11,309	0.057	99	1,852
Powerwave Allgon TT1	140.00	96	655	0.003	6	119
Raycap DC6-48-60-18-	140.00	32	217	0.001	2	39
Ericsson RRUS-11	140.00	330	2,253	0.011	20	407
KMW AM-X-CD-14-65-00	140.00	218	1,491	0.007	13	270
Powerwave Allgon 777	140.00	105	717	0.004	6	130
Flat Low Profile Pla	138.00	1,500	9,980	0.050	87	1,852
Generic 12' Dipole	111.00	40	180	0.001	2	49
Generic GPS	74.00	10	22	0.000	0	12
Generic GPS	74.00	10	22	0.000	0	12
		58,203	199,261	1.000	1,746	71,868

Load Case (0.9 - 0.2Sds) * DL + E ELMF

Seismic (Reduced DL) Equivalent Lateral Forces Method

Segment	Height Above Base (ft)	Weight (lb)	W _z (lb-ft)	C _{vx}	Horizontal Force (lb)	Vertical Force (lb)
47	170.25	34	326	0.002	3	29
46	167.50	341	3,207	0.016	28	295
45	163.00	283	2,537	0.013	22	245
44	160.75	44	383	0.002	3	38
43	160.25	55	474	0.002	4	47
42	157.50	555	4,678	0.023	41	480
41	152.50	573	4,559	0.023	40	496
40	149.50	117	896	0.004	8	101
39	148.50	127	960	0.005	8	110
38	146.50	384	2,843	0.014	25	332
37	142.50	677	4,770	0.024	42	586
36	139.00	311	2,098	0.011	18	269
35	136.50	472	3,082	0.015	27	409
34	133.33	533	3,335	0.017	29	461
33	130.83	508	3,075	0.015	27	440
32	128.17	1,139	6,641	0.033	58	986
31	125.67	284	1,598	0.008	14	246
30	122.50	1,084	5,830	0.029	51	938
29	117.50	1,111	5,545	0.028	49	961
28	113.00	908	4,227	0.021	37	786
27	110.50	230	1,029	0.005	9	199
26	107.50	1,166	4,965	0.025	44	1,009
25	102.50	1,193	4,665	0.023	41	1,032
24	97.50	1,220	4,363	0.022	38	1,055
23	92.50	1,246	4,058	0.020	36	1,078
22	89.67	169	521	0.003	5	146
21	87.17	2,052	6,009	0.030	53	1,776
20	83.83	1,126	3,074	0.015	27	974
19	81.33	773	2,000	0.010	18	669
18	77.50	1,476	3,502	0.018	31	1,277
17	74.50	299	661	0.003	6	259
16	72.00	1,209	2,515	0.013	22	1,046
15	67.50	1,539	2,854	0.014	25	1,332
14	62.50	1,570	2,538	0.013	22	1,359
13	57.50	1,602	2,230	0.011	20	1,386
12	52.50	1,633	1,933	0.010	17	1,413
11	49.00	662	693	0.003	6	573
10	46.50	1,799	1,715	0.009	15	1,557
9	42.50	3,049	2,474	0.012	22	2,638
8	37.50	1,706	1,107	0.006	10	1,476
7	32.50	1,737	873	0.004	8	1,503
6	27.50	1,769	659	0.003	6	1,530
5	22.50	1,800	469	0.002	4	1,557
4	17.50	1,831	304	0.002	3	1,584
3	12.50	1,863	170	0.001	1	1,612
2	7.50	1,894	69	0.000	1	1,639
1	2.50	1,925	10	0.000	0	1,666
Ericsson KRY 112 144	170.50	33	320	0.002	3	29
Generic E-911 GPS	170.50	5	49	0.000	0	4
Ericsson Radio 4449	170.50	222	2,155	0.011	19	192
Decibel DB201-A	170.50	25	243	0.001	2	22
Generic 12' Dipole	170.50	40	388	0.002	3	35
Ericsson AIR 21, 1.3	170.50	249	2,417	0.012	21	215
Ericsson AIR 21, 1.3	170.50	244	2,374	0.012	21	212
RFS APXVAARR24_43-U-	170.50	384	3,725	0.019	33	332
Round T-Arm w/Reinfo	170.00	1,215	11,733	0.059	103	1,051
Alcatel-Lucent RRH2X	161.00	129	1,130	0.006	10	112

Site Number: 411178

Code: ANSI/TIA-222-G

© 2007 - 2019 by ATC IP LLC. All rights reserved.

Site Name: Old Lyme South CT, CT

Engineering Number: 12927156_C3_02

7/18/2019 8:45:36 PM

Customer: T-MOBILE

Alcatel-Lucent RRH2x	161.00	170	1,491	0.007	13	147
Alcatel-Lucent B66 R	161.00	201	1,761	0.009	15	174
VZW Unused Reserve:	161.00	209	1,831	0.009	16	181
RFS APL866513-42T0	161.00	63	550	0.003	5	54
Antel BXA-70063-4CF-	161.00	10	87	0.000	1	9
RFS DB-T1-6Z-8AB-0Z	161.00	88	771	0.004	7	76
Antel BXA-70063/6CF_	161.00	34	298	0.001	3	29
Commscope SBNHH-1D65	161.00	304	2,666	0.013	23	263
Amphenol Antel LPA-8	161.00	42	368	0.002	3	36
Flat Low Profile Pla	160.00	1,500	12,999	0.065	114	1,298
Generic GPS	149.00	10	76	0.000	1	9
Alcatel-Lucent RRH2x	149.00	317	2,422	0.012	21	275
Alcatel-Lucent 1900	149.00	180	1,374	0.007	12	156
Alcatel-Lucent TD-RR	149.00	210	1,602	0.008	14	182
RFS APXVTM14-ALU-I20	149.00	169	1,287	0.006	11	146
Commscope NNVV-65B-R	149.00	232	1,772	0.009	16	201
Flat Low Profile Pla	148.00	1,500	11,309	0.057	99	1,298
Powerwave Allgon TT1	140.00	96	655	0.003	6	83
Raycap DC6-48-60-18-	140.00	32	217	0.001	2	28
Ericsson RRUS-11	140.00	330	2,253	0.011	20	286
KMW AM-X-CD-14-65-00	140.00	218	1,491	0.007	13	189
Powerwave Allgon 777	140.00	105	717	0.004	6	91
Flat Low Profile Pla	138.00	1,500	9,980	0.050	87	1,298
Generic 12' Dipole	111.00	40	180	0.001	2	35
Generic GPS	74.00	10	22	0.000	0	9
Generic GPS	74.00	10	22	0.000	0	9
		58,203	199,261	1.000	1,746	50,359

Load Case (1.2 + 0.2Sds) * DL + E ELFM Seismic Equivalent Lateral Forces Method

Calculated Forces

Seg Elev (ft)	Pu FY (-) (kips)	Vu FX (-) (kips)	Tu MY (ft-kips)	Mu MZ (ft-kips)	Mu MX (ft-kips)	Resultant Moment (ft-kips)	phi Pn (kips)	phi Vn (kips)	phi Tn (ft-kips)	phi Mn (ft-kips)	Total Deflect (in)	Rotation (deg)	Ratio
0.00	-69.49	-1.75	0.00	-229.75	0.00	229.75	6,027.96	3,013.98	17,007.2	8,516.24	0.00	0.00	0.039
5.00	-67.15	-1.75	0.00	-221.00	0.00	221.00	5,964.25	2,982.12	16,500.1	8,262.35	0.00	-0.01	0.038
10.00	-64.85	-1.76	0.00	-212.23	0.00	212.23	5,898.45	2,949.22	15,994.5	8,009.14	0.01	-0.01	0.037
15.00	-62.59	-1.76	0.00	-203.43	0.00	203.43	5,830.57	2,915.29	15,490.5	7,756.77	0.03	-0.02	0.037
20.00	-60.37	-1.76	0.00	-194.62	0.00	194.62	5,760.62	2,880.31	14,988.5	7,505.43	0.05	-0.02	0.036
25.00	-58.18	-1.76	0.00	-185.79	0.00	185.79	5,688.58	2,844.29	14,489.0	7,255.28	0.08	-0.03	0.036
30.00	-56.04	-1.76	0.00	-176.98	0.00	176.98	5,614.46	2,807.23	13,992.1	7,006.49	0.11	-0.04	0.035
35.00	-53.93	-1.76	0.00	-168.17	0.00	168.17	5,538.27	2,769.13	13,498.4	6,759.23	0.15	-0.04	0.035
40.00	-50.17	-1.74	0.00	-159.39	0.00	159.39	5,459.99	2,729.99	13,008.0	6,513.68	0.20	-0.05	0.034
45.00	-47.94	-1.72	0.00	-150.71	0.00	150.71	5,379.63	2,689.82	12,521.4	6,270.01	0.25	-0.05	0.033
48.00	-47.13	-1.72	0.00	-145.53	0.00	145.53	5,384.54	2,692.27	12,550.6	6,284.66	0.29	-0.06	0.032
50.00	-45.11	-1.70	0.00	-142.09	0.00	142.09	5,351.87	2,675.93	12,357.0	6,187.71	0.31	-0.06	0.031
55.00	-43.13	-1.69	0.00	-133.57	0.00	133.57	5,268.72	2,634.36	11,875.9	5,946.82	0.38	-0.07	0.031
60.00	-41.19	-1.67	0.00	-125.13	0.00	125.13	5,183.50	2,591.75	11,399.4	5,708.21	0.46	-0.07	0.030
65.00	-39.29	-1.64	0.00	-116.80	0.00	116.80	5,096.20	2,548.10	10,927.8	5,472.05	0.54	-0.08	0.029
70.00	-37.80	-1.62	0.00	-108.58	0.00	108.58	5,006.81	2,503.41	10,461.4	5,238.51	0.62	-0.09	0.028
74.00	-37.41	-1.62	0.00	-102.08	0.00	102.08	4,933.81	2,466.91	10,092.3	5,053.69	0.70	-0.09	0.028
75.00	-35.59	-1.59	0.00	-100.46	0.00	100.46	4,915.35	2,457.68	10,000.6	5,007.77	0.72	-0.09	0.027
80.00	-34.63	-1.57	0.00	-92.52	0.00	92.52	4,821.81	2,410.90	9,545.79	4,779.99	0.82	-0.10	0.027
82.66	-33.24	-1.54	0.00	-88.33	0.00	88.33	4,771.13	2,385.57	9,306.02	4,659.93	0.88	-0.10	0.026
85.00	-30.71	-1.49	0.00	-84.73	0.00	84.73	4,726.18	2,363.09	9,097.16	4,555.34	0.93	-0.11	0.025
89.33	-30.50	-1.49	0.00	-78.28	0.00	78.28	3,846.41	1,923.21	7,360.18	3,685.56	1.03	-0.11	0.029
90.00	-28.96	-1.45	0.00	-77.28	0.00	77.28	3,836.63	1,918.32	7,313.25	3,662.06	1.04	-0.11	0.029
95.00	-27.45	-1.41	0.00	-70.03	0.00	70.03	3,762.45	1,881.23	6,965.41	3,487.88	1.16	-0.12	0.027
100.00	-25.98	-1.37	0.00	-62.97	0.00	62.97	3,686.20	1,843.10	6,621.98	3,315.91	1.29	-0.13	0.026
105.00	-24.54	-1.33	0.00	-56.12	0.00	56.12	3,607.86	1,803.93	6,283.29	3,146.32	1.43	-0.13	0.025
110.00	-24.26	-1.32	0.00	-49.49	0.00	49.49	3,527.44	1,763.72	5,949.70	2,979.27	1.57	-0.14	0.023
111.00	-23.08	-1.28	0.00	-48.17	0.00	48.17	3,511.11	1,755.55	5,883.62	2,946.18	1.60	-0.14	0.023
115.00	-21.71	-1.23	0.00	-43.05	0.00	43.05	3,444.94	1,722.47	5,621.53	2,814.94	1.72	-0.15	0.022
120.00	-20.37	-1.18	0.00	-36.91	0.00	36.91	3,360.36	1,680.18	5,299.14	2,653.51	1.88	-0.15	0.020
125.00	-20.02	-1.16	0.00	-31.03	0.00	31.03	3,273.70	1,636.85	4,982.86	2,495.14	2.04	-0.16	0.019
126.33	-18.62	-1.10	0.00	-29.48	0.00	29.48	3,250.30	1,625.15	4,899.81	2,453.55	2.09	-0.16	0.018
130.00	-17.99	-1.07	0.00	-25.44	0.00	25.44	3,165.67	1,582.83	4,644.73	2,325.82	2.21	-0.16	0.017
131.66	-17.33	-1.04	0.00	-23.66	0.00	23.66	1,875.92	937.96	2,776.25	1,390.19	2.27	-0.16	0.026
135.00	-16.75	-1.02	0.00	-20.18	0.00	20.18	1,848.21	924.11	2,667.57	1,335.77	2.38	-0.17	0.024
138.00	-14.51	-0.90	0.00	-17.13	0.00	17.13	1,822.51	911.25	2,570.47	1,287.14	2.49	-0.17	0.021
140.00	-12.71	-0.81	0.00	-15.32	0.00	15.32	1,804.96	902.48	2,506.10	1,254.91	2.56	-0.17	0.019
145.00	-12.24	-0.79	0.00	-11.27	0.00	11.27	1,759.62	879.81	2,346.60	1,175.04	2.75	-0.18	0.017
148.00	-10.23	-0.67	0.00	-8.92	0.00	8.92	1,731.42	865.71	2,251.99	1,127.67	2.86	-0.18	0.014
149.00	-8.71	-0.58	0.00	-8.24	0.00	8.24	1,721.85	860.93	2,220.65	1,111.98	2.90	-0.18	0.012
150.00	-8.00	-0.54	0.00	-7.66	0.00	7.66	1,712.20	856.10	2,189.41	1,096.33	2.94	-0.18	0.012
155.00	-7.31	-0.50	0.00	-4.95	0.00	4.95	1,662.70	831.35	2,034.89	1,018.96	3.13	-0.19	0.009
160.00	-5.39	-0.38	0.00	-2.45	0.00	2.45	1,611.13	805.56	1,883.37	943.08	3.33	-0.19	0.006
160.50	-5.34	-0.37	0.00	-2.26	0.00	2.26	1,605.85	802.93	1,868.39	935.58	3.35	-0.19	0.006
160.50	-5.34	-0.37	0.00	-2.26	0.00	2.26	1,062.64	531.32	1,193.75	597.76	3.35	-0.19	0.009
161.00	-3.45	-0.25	0.00	-2.08	0.00	2.08	1,060.93	530.47	1,188.54	595.15	3.37	-0.19	0.007
165.00	-3.03	-0.22	0.00	-1.09	0.00	1.09	1,047.03	523.52	1,146.95	574.33	3.52	-0.19	0.005

Site Number: 411178

Code: ANSI/TIA-222-G

© 2007 - 2019 by ATC IP LLC. All rights reserved.

Site Name: Old Lyme South CT, CT

Engineering Number: 12927156_C3_02

7/18/2019 8:45:36 PM

Customer: T-MOBILE

170.00	0.00	0.00	0.00	0.00	0.00	0.00	1,029.05	514.53	1,095.30	548.46	3.72	-0.19	0.000
170.50	0.00	0.00	0.00	0.00	0.00	0.00	1,027.22	513.61	1,090.15	545.89	3.74	-0.19	0.000

Load Case (0.9 - 0.2Sds) * DL + E ELMF

Seismic (Reduced DL) Equivalent Lateral Forces Method

Calculated Forces

Seg Elev (ft)	Pu FY (-) (kips)	Vu FX (-) (kips)	Tu MY (ft-kips)	Mu MZ (ft-kips)	Mu MX (ft-kips)	Resultant Moment (ft-kips)	phi Pn (kips)	phi Vn (kips)	phi Tn (ft-kips)	phi Mn (ft-kips)	Total Deflect (in)	Rotation (deg)	Ratio
0.00	-48.69	-1.75	0.00	-227.35	0.00	227.35	6,027.96	3,013.98	17,007.2	8,516.24	0.00	0.00	0.035
5.00	-47.05	-1.75	0.00	-218.62	0.00	218.62	5,964.25	2,982.12	16,500.1	8,262.35	0.00	-0.01	0.034
10.00	-45.44	-1.75	0.00	-209.86	0.00	209.86	5,898.45	2,949.22	15,994.5	8,009.14	0.01	-0.01	0.034
15.00	-43.86	-1.75	0.00	-201.10	0.00	201.10	5,830.57	2,915.29	15,490.5	7,756.77	0.03	-0.02	0.033
20.00	-42.30	-1.75	0.00	-192.32	0.00	192.32	5,760.62	2,880.31	14,988.5	7,505.43	0.05	-0.02	0.033
25.00	-40.77	-1.75	0.00	-183.55	0.00	183.55	5,688.58	2,844.29	14,489.0	7,255.28	0.08	-0.03	0.032
30.00	-39.27	-1.75	0.00	-174.79	0.00	174.79	5,614.46	2,807.23	13,992.1	7,006.49	0.11	-0.04	0.032
35.00	-37.79	-1.74	0.00	-166.05	0.00	166.05	5,538.27	2,769.13	13,498.4	6,759.23	0.15	-0.04	0.031
40.00	-35.15	-1.72	0.00	-157.34	0.00	157.34	5,459.99	2,729.99	13,008.0	6,513.68	0.20	-0.05	0.031
45.00	-33.59	-1.71	0.00	-148.73	0.00	148.73	5,379.63	2,689.82	12,521.4	6,270.01	0.25	-0.05	0.030
48.00	-33.02	-1.70	0.00	-143.61	0.00	143.61	5,384.54	2,692.27	12,550.6	6,284.66	0.28	-0.06	0.029
50.00	-31.61	-1.69	0.00	-140.20	0.00	140.20	5,351.87	2,675.93	12,357.0	6,187.71	0.31	-0.06	0.029
55.00	-30.22	-1.67	0.00	-131.76	0.00	131.76	5,268.72	2,634.36	11,875.9	5,946.82	0.38	-0.07	0.028
60.00	-28.86	-1.65	0.00	-123.41	0.00	123.41	5,183.50	2,591.75	11,399.4	5,708.21	0.45	-0.07	0.027
65.00	-27.53	-1.63	0.00	-115.17	0.00	115.17	5,096.20	2,548.10	10,927.8	5,472.05	0.53	-0.08	0.026
70.00	-26.49	-1.60	0.00	-107.04	0.00	107.04	5,006.81	2,503.41	10,461.4	5,238.51	0.62	-0.09	0.026
74.00	-26.21	-1.60	0.00	-100.62	0.00	100.62	4,933.81	2,466.91	10,092.3	5,053.69	0.69	-0.09	0.025
75.00	-24.93	-1.57	0.00	-99.02	0.00	99.02	4,915.35	2,457.68	10,000.6	5,007.77	0.71	-0.09	0.025
80.00	-24.27	-1.55	0.00	-91.18	0.00	91.18	4,821.81	2,410.90	9,545.79	4,779.99	0.81	-0.10	0.024
82.66	-23.29	-1.52	0.00	-87.05	0.00	87.05	4,771.13	2,385.57	9,306.02	4,659.93	0.87	-0.10	0.024
85.00	-21.52	-1.47	0.00	-83.48	0.00	83.48	4,726.18	2,363.09	9,097.16	4,555.34	0.92	-0.10	0.023
89.33	-21.37	-1.47	0.00	-77.12	0.00	77.12	3,846.41	1,923.21	7,360.18	3,685.56	1.01	-0.11	0.026
90.00	-20.29	-1.43	0.00	-76.14	0.00	76.14	3,836.63	1,918.32	7,313.25	3,662.06	1.03	-0.11	0.026
95.00	-19.24	-1.39	0.00	-68.98	0.00	68.98	3,762.45	1,881.23	6,965.41	3,487.88	1.15	-0.12	0.025
100.00	-18.20	-1.35	0.00	-62.02	0.00	62.02	3,686.20	1,843.10	6,621.98	3,315.91	1.28	-0.12	0.024
105.00	-17.19	-1.31	0.00	-55.27	0.00	55.27	3,607.86	1,803.93	6,283.29	3,146.32	1.41	-0.13	0.022
110.00	-17.00	-1.30	0.00	-48.73	0.00	48.73	3,527.44	1,763.72	5,949.70	2,979.27	1.55	-0.14	0.021
111.00	-16.18	-1.26	0.00	-47.43	0.00	47.43	3,511.11	1,755.55	5,883.62	2,946.18	1.58	-0.14	0.021
115.00	-15.21	-1.21	0.00	-42.39	0.00	42.39	3,444.94	1,722.47	5,621.53	2,814.94	1.70	-0.14	0.019
120.00	-14.28	-1.16	0.00	-36.34	0.00	36.34	3,360.36	1,680.18	5,299.14	2,653.51	1.86	-0.15	0.018
125.00	-14.03	-1.14	0.00	-30.55	0.00	30.55	3,273.70	1,636.85	4,982.86	2,495.14	2.02	-0.16	0.017
126.33	-13.05	-1.08	0.00	-29.02	0.00	29.02	3,250.30	1,625.15	4,899.81	2,453.55	2.06	-0.16	0.016
130.00	-12.61	-1.06	0.00	-25.05	0.00	25.05	3,165.67	1,582.83	4,644.73	2,325.82	2.18	-0.16	0.015
131.66	-12.14	-1.03	0.00	-23.29	0.00	23.29	1,875.92	937.96	2,776.25	1,390.19	2.24	-0.16	0.023
135.00	-11.74	-1.00	0.00	-19.86	0.00	19.86	1,848.21	924.11	2,667.57	1,335.77	2.35	-0.17	0.021
138.00	-10.17	-0.89	0.00	-16.86	0.00	16.86	1,822.51	911.25	2,570.47	1,287.14	2.46	-0.17	0.019
140.00	-8.91	-0.80	0.00	-15.09	0.00	15.09	1,804.96	902.48	2,506.10	1,254.91	2.53	-0.17	0.017
145.00	-8.57	-0.77	0.00	-11.10	0.00	11.10	1,759.62	879.81	2,346.60	1,175.04	2.71	-0.18	0.014
148.00	-7.17	-0.66	0.00	-8.78	0.00	8.78	1,731.42	865.71	2,251.99	1,127.67	2.82	-0.18	0.012
149.00	-6.10	-0.58	0.00	-8.12	0.00	8.12	1,721.85	860.93	2,220.65	1,111.98	2.86	-0.18	0.011
150.00	-5.60	-0.53	0.00	-7.54	0.00	7.54	1,712.20	856.10	2,189.41	1,096.33	2.90	-0.18	0.010
155.00	-5.12	-0.49	0.00	-4.87	0.00	4.87	1,662.70	831.35	2,034.89	1,018.96	3.09	-0.18	0.008
160.00	-3.78	-0.37	0.00	-2.42	0.00	2.42	1,611.13	805.56	1,883.37	943.08	3.28	-0.19	0.005
160.50	-3.74	-0.37	0.00	-2.23	0.00	2.23	1,605.85	802.93	1,868.39	935.58	3.30	-0.19	0.005
160.50	-3.74	-0.37	0.00	-2.23	0.00	2.23	1,062.64	531.32	1,193.75	597.76	3.30	-0.19	0.007
161.00	-2.41	-0.24	0.00	-2.05	0.00	2.05	1,060.93	530.47	1,188.54	595.15	3.32	-0.19	0.006
165.00	-2.12	-0.21	0.00	-1.07	0.00	1.07	1,047.03	523.52	1,146.95	574.33	3.48	-0.19	0.004

Site Number: 411178

Code: ANSI/TIA-222-G

© 2007 - 2019 by ATC IP LLC. All rights reserved.

Site Name: Old Lyme South CT, CT

Engineering Number: 12927156_C3_02

7/18/2019 8:45:36 PM

Customer: T-MOBILE

170.00	0.00	0.00	0.00	0.00	0.00	0.00	1,029.05	514.53	1,095.30	548.46	3.67	-0.19	0.000
170.50	0.00	0.00	0.00	0.00	0.00	0.00	1,027.22	513.61	1,090.15	545.89	3.69	-0.19	0.000

Equivalent Modal Analysis Method

(Based on ASCE7-10 Chapters 11, 12 & 15 and ANSI/TIA-G, section 2.7)

Spectral Response Acceleration for Short Period (S_s):	0.16
Spectral Response Acceleration at 1.0 Second Period (S_1):	0.06
Importance Factor (I_E):	1.00
Site Coefficient F_a :	1.60
Site Coefficient F_v :	2.40
Response Modification Coefficient (R):	1.50
Design Spectral Response Acceleration at Short Period (S_{ds}):	0.17
Design Spectral Response Acceleration at 1.0 Second Period (S_{d1}):	0.09
Period Based on Rayleigh Method (sec):	2.07
Redundancy Factor (ρ):	1.00

Load Case (1.2 + 0.2Sds) * DL + E EMAM Seismic Equivalent Modal Analysis Method

Segment	Height Above Base (ft)	Weight (lb)	a	b	c	Saz	Horizontal Force (lb)	Vertical Force (lb)
47	170.25	34	1.884	1.951	1.130	0.330	7	42
46	167.50	341	1.824	1.650	1.019	0.296	67	421
45	163.00	283	1.727	1.229	0.857	0.243	46	350
44	160.75	44	1.680	1.048	0.784	0.219	6	54
43	160.25	55	1.670	1.010	0.769	0.213	8	67
42	157.50	555	1.613	0.819	0.688	0.185	69	686
41	152.50	573	1.512	0.531	0.557	0.139	53	708
40	149.50	117	1.453	0.392	0.489	0.114	9	144
39	148.50	127	1.434	0.351	0.467	0.106	9	156
38	146.50	384	1.395	0.275	0.427	0.091	23	474
37	142.50	677	1.320	0.149	0.354	0.064	29	836
36	139.00	311	1.256	0.064	0.299	0.042	9	384
35	136.50	472	1.211	0.016	0.263	0.029	9	583
34	133.33	533	1.156	-0.033	0.223	0.014	5	658
33	130.83	508	1.113	-0.062	0.195	0.004	1	628
32	128.17	1,139	1.068	-0.086	0.168	-0.006	-4	1,407
31	125.67	284	1.027	-0.102	0.145	-0.013	-2	350
30	122.50	1,084	0.976	-0.115	0.120	-0.020	-15	1,338
29	117.50	1,111	0.898	-0.122	0.086	-0.028	-21	1,372
28	113.00	908	0.830	-0.117	0.063	-0.030	-18	1,121
27	110.50	230	0.794	-0.111	0.052	-0.029	-5	284
26	107.50	1,166	0.751	-0.101	0.041	-0.027	-21	1,440
25	102.50	1,193	0.683	-0.082	0.027	-0.021	-16	1,473
24	97.50	1,220	0.618	-0.059	0.017	-0.011	-9	1,506
23	92.50	1,246	0.556	-0.037	0.010	0.000	0	1,539
22	89.67	169	0.523	-0.024	0.008	0.006	1	209
21	87.17	2,052	0.494	-0.014	0.007	0.012	17	2,534
20	83.83	1,126	0.457	-0.001	0.006	0.019	14	1,390
19	81.33	773	0.430	0.008	0.006	0.024	12	955
18	77.50	1,476	0.390	0.021	0.007	0.030	30	1,822
17	74.50	299	0.361	0.030	0.008	0.034	7	369
16	72.00	1,209	0.337	0.036	0.009	0.037	30	1,492
15	67.50	1,539	0.296	0.046	0.013	0.041	42	1,900
14	62.50	1,570	0.254	0.055	0.017	0.043	45	1,939

13	57.50	1,602	0.215	0.061	0.021	0.044	47	1,978
12	52.50	1,633	0.179	0.065	0.026	0.044	48	2,016
11	49.00	662	0.156	0.067	0.029	0.044	19	817
10	46.50	1,799	0.141	0.069	0.031	0.043	52	2,222
9	42.50	3,049	0.117	0.070	0.035	0.043	87	3,765
8	37.50	1,706	0.091	0.071	0.038	0.042	47	2,107
7	32.50	1,737	0.069	0.072	0.041	0.041	47	2,145
6	27.50	1,769	0.049	0.071	0.042	0.039	46	2,184
5	22.50	1,800	0.033	0.069	0.041	0.038	45	2,223
4	17.50	1,831	0.020	0.064	0.038	0.035	43	2,261
3	12.50	1,863	0.010	0.055	0.032	0.031	38	2,300
2	7.50	1,894	0.004	0.040	0.022	0.024	30	2,339
1	2.50	1,925	0.000	0.016	0.009	0.010	13	2,377
Ericsson KRY 112 144	170.50	33	1.890	1.980	1.140	0.333	7	41
Generic E-911 GPS	170.50	5	1.890	1.980	1.140	0.333	1	6
Ericsson Radio 4449	170.50	222	1.890	1.980	1.140	0.333	49	274
Decibel DB201-A	170.50	25	1.890	1.980	1.140	0.333	6	31
Generic 12' Dipole	170.50	40	1.890	1.980	1.140	0.333	9	49
Ericsson AIR 21, 1.3	170.50	249	1.890	1.980	1.140	0.333	55	307
Ericsson AIR 21, 1.3	170.50	244	1.890	1.980	1.140	0.333	54	302
RFS APXVAARR24_43-U-	170.50	384	1.890	1.980	1.140	0.333	85	474
Round T-Arm w/Reinfo	170.00	1,215	1.879	1.922	1.119	0.327	265	1,500
Alcatel-Lucent RRH2X	161.00	129	1.685	1.067	0.792	0.221	19	159
Alcatel-Lucent RRH2x	161.00	170	1.685	1.067	0.792	0.221	25	210
Alcatel-Lucent B66 R	161.00	201	1.685	1.067	0.792	0.221	30	248
VZW Unused Reserve:	161.00	209	1.685	1.067	0.792	0.221	31	258
RFS APL866513-42T0	161.00	63	1.685	1.067	0.792	0.221	9	78
Antel BXA-70063-4CF-	161.00	10	1.685	1.067	0.792	0.221	1	12
RFS DB-T1-6Z-8AB-0Z	161.00	88	1.685	1.067	0.792	0.221	13	109
Antel BXA-70063/6CF_	161.00	34	1.685	1.067	0.792	0.221	5	42
Commscope SBNHH-	161.00	304	1.685	1.067	0.792	0.221	45	376
Amphenol Antel LPA-8	161.00	42	1.685	1.067	0.792	0.221	6	52
Flat Low Profile Pla	160.00	1,500	1.664	0.992	0.761	0.211	211	1,852
Generic GPS	149.00	10	1.443	0.371	0.478	0.110	1	12
Alcatel-Lucent RRH2x	149.00	317	1.443	0.371	0.478	0.110	23	392
Alcatel-Lucent 1900	149.00	180	1.443	0.371	0.478	0.110	13	222
Alcatel-Lucent TD-RR	149.00	210	1.443	0.371	0.478	0.110	15	259
RFS APXVTM14-ALU-I20	149.00	169	1.443	0.371	0.478	0.110	12	208
Commscope NNVV-	149.00	232	1.443	0.371	0.478	0.110	17	287
Flat Low Profile Pla	148.00	1,500	1.424	0.331	0.457	0.102	102	1,852
Powerwave Allgon TT1	140.00	96	1.274	0.086	0.314	0.048	3	119
Raycap DC6-48-60-18-	140.00	32	1.274	0.086	0.314	0.048	1	39
Ericsson RRUS-11	140.00	330	1.274	0.086	0.314	0.048	11	407
KMW AM-X-CD-14-65-00	140.00	218	1.274	0.086	0.314	0.048	7	270
Powerwave Allgon 777	140.00	105	1.274	0.086	0.314	0.048	3	130
Flat Low Profile Pla	138.00	1,500	1.238	0.044	0.284	0.037	37	1,852
Generic 12' Dipole	111.00	40	0.801	-0.112	0.054	-0.030	-1	49
Generic GPS	74.00	10	0.356	0.031	0.008	0.035	0	12
Generic GPS	74.00	10	0.356	0.031	0.008	0.035	0	12
		58,203	89.799	41.814	33.906	9.124	2,172	71,868

Load Case (0.9 - 0.2Sds) * DL + E EMAM

Seismic (Reduced DL) Equivalent Modal Analysis Method

Segment	Height Above Base (ft)	Weight (lb)	a	b	c	Saz	Horizontal Force (lb)	Vertical Force (lb)
47	170.25	34	1.884	1.951	1.130	0.330	7	29
46	167.50	341	1.824	1.650	1.019	0.296	67	295
45	163.00	283	1.727	1.229	0.857	0.243	46	245
44	160.75	44	1.680	1.048	0.784	0.219	6	38

43	160.25	55	1.670	1.010	0.769	0.213	8	47
42	157.50	555	1.613	0.819	0.688	0.185	69	480
41	152.50	573	1.512	0.531	0.557	0.139	53	496
40	149.50	117	1.453	0.392	0.489	0.114	9	101
39	148.50	127	1.434	0.351	0.467	0.106	9	110
38	146.50	384	1.395	0.275	0.427	0.091	23	332
37	142.50	677	1.320	0.149	0.354	0.064	29	586
36	139.00	311	1.256	0.064	0.299	0.042	9	269
35	136.50	472	1.211	0.016	0.263	0.029	9	409
34	133.33	533	1.156	-0.033	0.223	0.014	5	461
33	130.83	508	1.113	-0.062	0.195	0.004	1	440
32	128.17	1,139	1.068	-0.086	0.168	-0.006	-4	986
31	125.67	284	1.027	-0.102	0.145	-0.013	-2	246
30	122.50	1,084	0.976	-0.115	0.120	-0.020	-15	938
29	117.50	1,111	0.898	-0.122	0.086	-0.028	-21	961
28	113.00	908	0.830	-0.117	0.063	-0.030	-18	786
27	110.50	230	0.794	-0.111	0.052	-0.029	-5	199
26	107.50	1,166	0.751	-0.101	0.041	-0.027	-21	1,009
25	102.50	1,193	0.683	-0.082	0.027	-0.021	-16	1,032
24	97.50	1,220	0.618	-0.059	0.017	-0.011	-9	1,055
23	92.50	1,246	0.556	-0.037	0.010	0.000	0	1,078
22	89.67	169	0.523	-0.024	0.008	0.006	1	146
21	87.17	2,052	0.494	-0.014	0.007	0.012	17	1,776
20	83.83	1,126	0.457	-0.001	0.006	0.019	14	974
19	81.33	773	0.430	0.008	0.006	0.024	12	669
18	77.50	1,476	0.390	0.021	0.007	0.030	30	1,277
17	74.50	299	0.361	0.030	0.008	0.034	7	259
16	72.00	1,209	0.337	0.036	0.009	0.037	30	1,046
15	67.50	1,539	0.296	0.046	0.013	0.041	42	1,332
14	62.50	1,570	0.254	0.055	0.017	0.043	45	1,359
13	57.50	1,602	0.215	0.061	0.021	0.044	47	1,386
12	52.50	1,633	0.179	0.065	0.026	0.044	48	1,413
11	49.00	662	0.156	0.067	0.029	0.044	19	573
10	46.50	1,799	0.141	0.069	0.031	0.043	52	1,557
9	42.50	3,049	0.117	0.070	0.035	0.043	87	2,638
8	37.50	1,706	0.091	0.071	0.038	0.042	47	1,476
7	32.50	1,737	0.069	0.072	0.041	0.041	47	1,503
6	27.50	1,769	0.049	0.071	0.042	0.039	46	1,530
5	22.50	1,800	0.033	0.069	0.041	0.038	45	1,557
4	17.50	1,831	0.020	0.064	0.038	0.035	43	1,584
3	12.50	1,863	0.010	0.055	0.032	0.031	38	1,612
2	7.50	1,894	0.004	0.040	0.022	0.024	30	1,639
1	2.50	1,925	0.000	0.016	0.009	0.010	13	1,666
Ericsson KRY 112 144	170.50	33	1.890	1.980	1.140	0.333	7	29
Generic E-911 GPS	170.50	5	1.890	1.980	1.140	0.333	1	4
Ericsson Radio 4449	170.50	222	1.890	1.980	1.140	0.333	49	192
Decibel DB201-A	170.50	25	1.890	1.980	1.140	0.333	6	22
Generic 12' Dipole	170.50	40	1.890	1.980	1.140	0.333	9	35
Ericsson AIR 21, 1.3	170.50	249	1.890	1.980	1.140	0.333	55	215
Ericsson AIR 21, 1.3	170.50	244	1.890	1.980	1.140	0.333	54	212
RFS APXVAARR24_43-U-	170.50	384	1.890	1.980	1.140	0.333	85	332
Round T-Arm w/Reinfo	170.00	1,215	1.879	1.922	1.119	0.327	265	1,051
Alcatel-Lucent RRH2X	161.00	129	1.685	1.067	0.792	0.221	19	112
Alcatel-Lucent RRH2x	161.00	170	1.685	1.067	0.792	0.221	25	147
Alcatel-Lucent B66 R	161.00	201	1.685	1.067	0.792	0.221	30	174
VZW Unused Reserve:	161.00	209	1.685	1.067	0.792	0.221	31	181
RFS APL866513-42T0	161.00	63	1.685	1.067	0.792	0.221	9	54
Antel BXA-70063-4CF-	161.00	10	1.685	1.067	0.792	0.221	1	9
RFS DB-T1-6Z-8AB-0Z	161.00	88	1.685	1.067	0.792	0.221	13	76
Antel BXA-70063/6CF_	161.00	34	1.685	1.067	0.792	0.221	5	29
Commscope SBNHH-	161.00	304	1.685	1.067	0.792	0.221	45	263
Amphenol Antel LPA-8	161.00	42	1.685	1.067	0.792	0.221	6	36
Flat Low Profile Pla	160.00	1,500	1.664	0.992	0.761	0.211	211	1,298
Generic GPS	149.00	10	1.443	0.371	0.478	0.110	1	9

Site Number: 411178

Code: ANSI/TIA-222-G

© 2007 - 2019 by ATC IP LLC. All rights reserved.

Site Name: Old Lyme South CT, CT

Engineering Number: 12927156_C3_02

7/18/2019 8:45:37 PM

Customer: T-MOBILE

Alcatel-Lucent RRH2x	149.00	317	1.443	0.371	0.478	0.110	23	275
Alcatel-Lucent 1900	149.00	180	1.443	0.371	0.478	0.110	13	156
Alcatel-Lucent TD-RR	149.00	210	1.443	0.371	0.478	0.110	15	182
RFS APXVTM14-ALU-I20	149.00	169	1.443	0.371	0.478	0.110	12	146
Commscope NNVV-	149.00	232	1.443	0.371	0.478	0.110	17	201
Flat Low Profile Pla	148.00	1,500	1.424	0.331	0.457	0.102	102	1,298
Powerwave Allgon TT1	140.00	96	1.274	0.086	0.314	0.048	3	83
Raycap DC6-48-60-18-	140.00	32	1.274	0.086	0.314	0.048	1	28
Ericsson RRUS-11	140.00	330	1.274	0.086	0.314	0.048	11	286
KMW AM-X-CD-14-65-00	140.00	218	1.274	0.086	0.314	0.048	7	189
Powerwave Allgon 777	140.00	105	1.274	0.086	0.314	0.048	3	91
Flat Low Profile Pla	138.00	1,500	1.238	0.044	0.284	0.037	37	1,298
Generic 12' Dipole	111.00	40	0.801	-0.112	0.054	-0.030	-1	35
Generic GPS	74.00	10	0.356	0.031	0.008	0.035	0	9
Generic GPS	74.00	10	0.356	0.031	0.008	0.035	0	9
		58,203	89.799	41.814	33.906	9.124	2,172	50,359

Load Case (1.2 + 0.2Sds) * DL + E EMAM Seismic Equivalent Modal Analysis Method

Calculated Forces

Seg Elev (ft)	Pu FY (-) (kips)	Vu FX (-) (kips)	Tu MY (ft-kips)	Mu MZ (ft-kips)	Mu MX (ft-kips)	Resultant Moment (ft-kips)	phi Pn (kips)	phi Vn (kips)	phi Tn (ft-kips)	phi Mn (ft-kips)	Total Deflect (in)	Rotation (deg)	Ratio
0.00	-69.49	-2.16	0.00	-272.35	0.00	272.35	6,027.96	3,013.98	17,007.20	8,516.24	0.00	0.00	0.044
5.00	-67.15	-2.14	0.00	-261.53	0.00	261.53	5,964.25	2,982.12	16,500.18	8,262.35	0.00	-0.01	0.043
10.00	-64.85	-2.11	0.00	-250.83	0.00	250.83	5,898.45	2,949.22	15,994.50	8,009.14	0.01	-0.01	0.042
15.00	-62.59	-2.07	0.00	-240.28	0.00	240.28	5,830.57	2,915.29	15,490.52	7,756.77	0.03	-0.02	0.042
20.00	-60.37	-2.03	0.00	-229.92	0.00	229.92	5,760.62	2,880.31	14,988.58	7,505.43	0.06	-0.03	0.041
25.00	-58.18	-1.99	0.00	-219.74	0.00	219.74	5,688.58	2,844.29	14,489.01	7,255.28	0.09	-0.03	0.041
30.00	-56.04	-1.95	0.00	-209.77	0.00	209.77	5,614.46	2,807.23	13,992.17	7,006.49	0.13	-0.04	0.040
35.00	-53.93	-1.91	0.00	-200.00	0.00	200.00	5,538.27	2,769.13	13,498.40	6,759.23	0.18	-0.05	0.039
40.00	-50.17	-1.83	0.00	-190.44	0.00	190.44	5,459.99	2,729.99	13,008.03	6,513.68	0.23	-0.06	0.038
45.00	-47.94	-1.78	0.00	-181.30	0.00	181.30	5,379.63	2,689.82	12,521.41	6,270.01	0.30	-0.06	0.038
48.00	-47.13	-1.76	0.00	-175.96	0.00	175.96	5,384.54	2,692.27	12,550.67	6,284.66	0.34	-0.07	0.037
50.00	-45.11	-1.72	0.00	-172.44	0.00	172.44	5,351.87	2,675.93	12,357.05	6,187.71	0.37	-0.07	0.036
55.00	-43.13	-1.67	0.00	-163.86	0.00	163.86	5,268.72	2,634.36	11,875.99	5,946.82	0.45	-0.08	0.036
60.00	-41.19	-1.63	0.00	-155.50	0.00	155.50	5,183.50	2,591.75	11,399.48	5,708.21	0.54	-0.09	0.035
65.00	-39.29	-1.59	0.00	-147.35	0.00	147.35	5,096.20	2,548.10	10,927.86	5,472.05	0.64	-0.10	0.035
70.00	-37.80	-1.56	0.00	-139.40	0.00	139.40	5,006.81	2,503.41	10,461.47	5,238.51	0.74	-0.10	0.034
74.00	-37.41	-1.56	0.00	-133.15	0.00	133.15	4,933.81	2,466.91	10,092.37	5,053.69	0.83	-0.11	0.034
75.00	-35.58	-1.53	0.00	-131.59	0.00	131.59	4,915.35	2,457.68	10,000.67	5,007.77	0.86	-0.11	0.034
80.00	-34.63	-1.52	0.00	-123.95	0.00	123.95	4,821.81	2,410.90	9,545.79	4,779.99	0.98	-0.12	0.033
82.66	-33.24	-1.50	0.00	-119.91	0.00	119.91	4,771.13	2,385.57	9,306.02	4,659.93	1.05	-0.13	0.033
85.00	-30.71	-1.48	0.00	-116.40	0.00	116.40	4,726.18	2,363.09	9,097.16	4,555.34	1.11	-0.13	0.032
89.33	-30.50	-1.48	0.00	-109.98	0.00	109.98	3,846.41	1,923.21	7,360.18	3,685.56	1.23	-0.14	0.038
90.00	-28.96	-1.48	0.00	-108.98	0.00	108.98	3,836.63	1,918.32	7,313.25	3,662.06	1.25	-0.14	0.037
95.00	-27.45	-1.49	0.00	-101.56	0.00	101.56	3,762.45	1,881.23	6,965.41	3,487.88	1.40	-0.15	0.036
100.00	-25.98	-1.51	0.00	-94.09	0.00	94.09	3,686.20	1,843.10	6,621.98	3,315.91	1.57	-0.16	0.035
105.00	-24.54	-1.53	0.00	-86.54	0.00	86.54	3,607.86	1,803.93	6,283.29	3,146.32	1.74	-0.17	0.034
110.00	-24.25	-1.54	0.00	-78.87	0.00	78.87	3,527.44	1,763.72	5,949.70	2,979.27	1.92	-0.18	0.033
111.00	-23.08	-1.56	0.00	-77.33	0.00	77.33	3,511.11	1,755.55	5,883.62	2,946.18	1.96	-0.18	0.033
115.00	-21.71	-1.58	0.00	-71.11	0.00	71.11	3,444.94	1,722.47	5,621.53	2,814.94	2.12	-0.19	0.032
120.00	-20.37	-1.59	0.00	-63.23	0.00	63.23	3,360.36	1,680.18	5,299.14	2,653.51	2.32	-0.20	0.030
125.00	-20.02	-1.59	0.00	-55.28	0.00	55.28	3,273.70	1,636.85	4,982.86	2,495.14	2.54	-0.21	0.028
126.33	-18.62	-1.59	0.00	-53.17	0.00	53.17	3,250.30	1,625.15	4,899.81	2,453.55	2.60	-0.21	0.027
130.00	-17.99	-1.59	0.00	-47.32	0.00	47.32	3,165.67	1,582.83	4,644.73	2,325.82	2.76	-0.22	0.026
131.66	-17.33	-1.59	0.00	-44.67	0.00	44.67	1,875.92	937.96	2,776.25	1,390.19	2.84	-0.22	0.041
135.00	-16.75	-1.58	0.00	-39.38	0.00	39.38	1,848.21	924.11	2,667.57	1,335.77	3.00	-0.23	0.039
138.00	-14.51	-1.52	0.00	-34.66	0.00	34.66	1,822.51	911.25	2,570.47	1,287.14	3.14	-0.24	0.035
140.00	-12.71	-1.46	0.00	-31.61	0.00	31.61	1,804.96	902.48	2,506.10	1,254.91	3.24	-0.24	0.032
145.00	-12.23	-1.44	0.00	-24.30	0.00	24.30	1,759.62	879.81	2,346.60	1,175.04	3.50	-0.25	0.028
148.00	-10.23	-1.32	0.00	-19.98	0.00	19.98	1,731.42	865.71	2,251.99	1,127.67	3.66	-0.26	0.024
149.00	-8.70	-1.22	0.00	-18.66	0.00	18.66	1,721.85	860.93	2,220.65	1,111.98	3.72	-0.26	0.022
150.00	-7.99	-1.17	0.00	-17.44	0.00	17.44	1,712.20	856.10	2,189.41	1,096.33	3.77	-0.26	0.021
155.00	-7.31	-1.10	0.00	-11.60	0.00	11.60	1,662.70	831.35	2,034.89	1,018.96	4.05	-0.27	0.016
160.00	-5.39	-0.87	0.00	-6.13	0.00	6.13	1,611.13	805.56	1,883.37	943.08	4.33	-0.27	0.010
160.50	-5.34	-0.86	0.00	-5.69	0.00	5.69	1,605.85	802.93	1,868.39	935.58	4.36	-0.27	0.009
160.50	-5.34	-0.86	0.00	-5.69	0.00	5.69	1,062.64	531.32	1,193.75	597.76	4.36	-0.27	0.015
161.00	-3.44	-0.62	0.00	-5.26	0.00	5.26	1,060.93	530.47	1,188.54	595.15	4.39	-0.27	0.012
165.00	-3.02	-0.55	0.00	-2.77	0.00	2.77	1,047.03	523.52	1,146.95	574.33	4.62	-0.28	0.008

Site Number: 411178

Code: ANSI/TIA-222-G

© 2007 - 2019 by ATC IP LLC. All rights reserved.

Site Name: Old Lyme South CT, CT

Engineering Number: 12927156_C3_02

7/18/2019 8:45:37 PM

Customer: T-MOBILE

170.00	0.00	0.00	0.00	0.00	0.00	0.00	1,029.05	514.53	1,095.30	548.46	4.91	-0.28	0.000
170.50	0.00	0.00	0.00	0.00	0.00	0.00	1,027.22	513.61	1,090.15	545.89	4.93	-0.28	0.000

Load Case (0.9 - 0.2Sds) * DL + E EMAM Seismic (Reduced DL) Equivalent Modal Analysis Method

Calculated Forces

Seg Elev (ft)	Pu FY (-) (kips)	Vu FX (-) (kips)	Tu MY (ft-kips)	Mu MZ (ft-kips)	Mu MX (ft-kips)	Resultant Moment (ft-kips)	phi Pn (kips)	phi Vn (kips)	phi Tn (ft-kips)	phi Mn (ft-kips)	Total Deflect (in)	Rotation (deg)	Ratio
0.00	-48.69	-2.16	0.00	-269.54	0.00	269.54	6,027.96	3,013.98	17,007.20	8,516.24	0.00	0.00	0.040
5.00	-47.05	-2.14	0.00	-258.74	0.00	258.74	5,964.25	2,982.12	16,500.18	8,262.35	0.00	-0.01	0.039
10.00	-45.44	-2.10	0.00	-248.05	0.00	248.05	5,898.45	2,949.22	15,994.50	8,009.14	0.01	-0.01	0.039
15.00	-43.86	-2.07	0.00	-237.54	0.00	237.54	5,830.57	2,915.29	15,490.52	7,756.77	0.03	-0.02	0.038
20.00	-42.30	-2.02	0.00	-227.21	0.00	227.21	5,760.62	2,880.31	14,988.58	7,505.43	0.06	-0.03	0.038
25.00	-40.77	-1.98	0.00	-217.08	0.00	217.08	5,688.58	2,844.29	14,489.01	7,255.28	0.09	-0.03	0.037
30.00	-39.27	-1.94	0.00	-207.17	0.00	207.17	5,614.46	2,807.23	13,992.17	7,006.49	0.13	-0.04	0.037
35.00	-37.79	-1.90	0.00	-197.47	0.00	197.47	5,538.27	2,769.13	13,498.40	6,759.23	0.18	-0.05	0.036
40.00	-35.15	-1.81	0.00	-187.99	0.00	187.99	5,459.99	2,729.99	13,008.03	6,513.68	0.23	-0.06	0.035
45.00	-33.59	-1.76	0.00	-178.93	0.00	178.93	5,379.63	2,689.82	12,521.41	6,270.01	0.30	-0.06	0.035
48.00	-33.02	-1.74	0.00	-173.65	0.00	173.65	5,384.54	2,692.27	12,550.67	6,284.66	0.34	-0.07	0.034
50.00	-31.61	-1.70	0.00	-170.16	0.00	170.16	5,351.87	2,675.93	12,357.05	6,187.71	0.37	-0.07	0.033
55.00	-30.22	-1.65	0.00	-161.67	0.00	161.67	5,268.72	2,634.36	11,875.99	5,946.82	0.45	-0.08	0.033
60.00	-28.86	-1.61	0.00	-153.41	0.00	153.41	5,183.50	2,591.75	11,399.48	5,708.21	0.53	-0.09	0.032
65.00	-27.53	-1.57	0.00	-145.36	0.00	145.36	5,096.20	2,548.10	10,927.86	5,472.05	0.63	-0.10	0.032
70.00	-26.49	-1.54	0.00	-137.52	0.00	137.52	5,006.81	2,503.41	10,461.47	5,238.51	0.73	-0.10	0.032
74.00	-26.21	-1.54	0.00	-131.35	0.00	131.35	4,933.81	2,466.91	10,092.37	5,053.69	0.82	-0.11	0.031
75.00	-24.93	-1.51	0.00	-129.82	0.00	129.82	4,915.35	2,457.68	10,000.67	5,007.77	0.85	-0.11	0.031
80.00	-24.26	-1.49	0.00	-122.29	0.00	122.29	4,821.81	2,410.90	9,545.79	4,779.99	0.97	-0.12	0.031
82.66	-23.29	-1.48	0.00	-118.31	0.00	118.31	4,771.13	2,385.57	9,306.02	4,659.93	1.04	-0.12	0.030
85.00	-21.51	-1.46	0.00	-114.85	0.00	114.85	4,726.18	2,363.09	9,097.16	4,555.34	1.10	-0.13	0.030
89.33	-21.37	-1.46	0.00	-108.53	0.00	108.53	3,846.41	1,923.21	7,360.18	3,685.56	1.22	-0.14	0.035
90.00	-20.29	-1.46	0.00	-107.55	0.00	107.55	3,836.63	1,918.32	7,313.25	3,662.06	1.24	-0.14	0.035
95.00	-19.23	-1.47	0.00	-100.24	0.00	100.24	3,762.45	1,881.23	6,965.41	3,487.88	1.39	-0.15	0.034
100.00	-18.20	-1.49	0.00	-92.88	0.00	92.88	3,686.20	1,843.10	6,621.98	3,315.91	1.55	-0.16	0.033
105.00	-17.19	-1.51	0.00	-85.44	0.00	85.44	3,607.86	1,803.93	6,283.29	3,146.32	1.72	-0.17	0.032
110.00	-16.99	-1.52	0.00	-77.89	0.00	77.89	3,527.44	1,763.72	5,949.70	2,979.27	1.90	-0.18	0.031
111.00	-16.17	-1.53	0.00	-76.38	0.00	76.38	3,511.11	1,755.55	5,883.62	2,946.18	1.94	-0.18	0.031
115.00	-15.21	-1.55	0.00	-70.25	0.00	70.25	3,444.94	1,722.47	5,621.53	2,814.94	2.09	-0.19	0.029
120.00	-14.27	-1.57	0.00	-62.48	0.00	62.48	3,360.36	1,680.18	5,299.14	2,653.51	2.29	-0.20	0.028
125.00	-14.03	-1.57	0.00	-54.65	0.00	54.65	3,273.70	1,636.85	4,982.86	2,495.14	2.50	-0.21	0.026
126.33	-13.04	-1.57	0.00	-52.56	0.00	52.56	3,250.30	1,625.15	4,899.81	2,453.55	2.56	-0.21	0.025
130.00	-12.60	-1.57	0.00	-46.79	0.00	46.79	3,165.67	1,582.83	4,644.73	2,325.82	2.73	-0.22	0.024
131.66	-12.14	-1.56	0.00	-44.18	0.00	44.18	1,875.92	937.96	2,776.25	1,390.19	2.80	-0.22	0.038
135.00	-11.73	-1.55	0.00	-38.96	0.00	38.96	1,848.21	924.11	2,667.57	1,335.77	2.96	-0.23	0.036
138.00	-10.17	-1.50	0.00	-34.30	0.00	34.30	1,822.51	911.25	2,570.47	1,287.14	3.10	-0.23	0.032
140.00	-8.90	-1.45	0.00	-31.29	0.00	31.29	1,804.96	902.48	2,506.10	1,254.91	3.20	-0.24	0.030
145.00	-8.57	-1.42	0.00	-24.06	0.00	24.06	1,759.62	879.81	2,346.60	1,175.04	3.46	-0.25	0.025
148.00	-7.16	-1.31	0.00	-19.79	0.00	19.79	1,731.42	865.71	2,251.99	1,127.67	3.62	-0.25	0.022
149.00	-6.10	-1.21	0.00	-18.49	0.00	18.49	1,721.85	860.93	2,220.65	1,111.98	3.67	-0.26	0.020
150.00	-5.60	-1.16	0.00	-17.28	0.00	17.28	1,712.20	856.10	2,189.41	1,096.33	3.72	-0.26	0.019
155.00	-5.12	-1.09	0.00	-11.50	0.00	11.50	1,662.70	831.35	2,034.89	1,018.96	4.00	-0.26	0.014
160.00	-3.78	-0.86	0.00	-6.07	0.00	6.07	1,611.13	805.56	1,883.37	943.08	4.28	-0.27	0.009
160.50	-3.74	-0.85	0.00	-5.64	0.00	5.64	1,605.85	802.93	1,868.39	935.58	4.30	-0.27	0.008
160.50	-3.74	-0.85	0.00	-5.64	0.00	5.64	1,062.64	531.32	1,193.75	597.76	4.30	-0.27	0.013
161.00	-2.41	-0.62	0.00	-5.22	0.00	5.22	1,060.93	530.47	1,188.54	595.15	4.33	-0.27	0.011
165.00	-2.12	-0.55	0.00	-2.75	0.00	2.75	1,047.03	523.52	1,146.95	574.33	4.56	-0.27	0.007

Site Number: 411178

Code: ANSI/TIA-222-G

© 2007 - 2019 by ATC IP LLC. All rights reserved.

Site Name: Old Lyme South CT, CT

Engineering Number: 12927156_C3_02

7/18/2019 8:45:37 PM

Customer: T-MOBILE

170.00	0.00	0.00	0.00	0.00	0.00	0.00	1,029.05	514.53	1,095.30	548.46	4.85	-0.27	0.000
170.50	0.00	0.00	0.00	0.00	0.00	0.00	1,027.22	513.61	1,090.15	545.89	4.87	-0.27	0.000

Site Number: 411178

Code: ANSI/TIA-222-G

© 2007 - 2019 by ATC IP LLC. All rights reserved.

Site Name: Old Lyme South CT, CT

Engineering Number: 12927156_C3_02

7/18/2019 8:45:37 PM

Customer: T-MOBILE

Analysis Summary

Load Case	Reactions						Max Usage	
	Shear FX (kips)	Shear FZ (kips)	Axial FY (kips)	Moment MX (ft-kips)	Moment MY (ft-kips)	Moment MZ (ft-kips)	Elev (ft)	Interaction Ratio
1.2D + 1.6W	35.24	0.00	69.81	0.00	0.00	4266.01	0.00	0.51
0.9D + 1.6W	35.22	0.00	52.35	0.00	0.00	4230.44	0.00	0.51
1.2D + 1.0Di + 1.0Wi	9.44	0.00	98.35	0.00	0.00	1107.25	0.00	0.15
(1.2 + 0.2Sds) * DL + E ELFM	1.75	0.00	69.49	0.00	0.00	229.75	0.00	0.04
(1.2 + 0.2Sds) * DL + E EMAM	2.16	0.00	69.49	0.00	0.00	272.35	0.00	0.04
(0.9 - 0.2Sds) * DL + E ELFM	1.75	0.00	48.69	0.00	0.00	227.35	0.00	0.03
(0.9 - 0.2Sds) * DL + E EMAM	2.16	0.00	48.69	0.00	0.00	269.54	0.00	0.04
1.0D + 1.0W	6.43	0.00	58.20	0.00	0.00	774.99	0.00	0.10

Base Plate & Anchor Rod Analysis

Pole Dimensions		
Number of Sides	18	-
Diameter	69	in
Thickness	0.4375	in
Orientation Offset	0	°

Base Reactions		
Moment, Mu	4262.6	k-ft
Axial, Pu	69.3	k
Shear, Vu	35.2	k
Neutral Axis	240	°

Report Capacities		
Component	Capacity	Result
Base Plate	55%	Pass
Anchor Rods	43%	Pass
Dwyidag	-	-

Base Plate		
Shape	Round	-
Diameter, ϕ	85	in
Thickness	2 1/4	in
Grade	A572-60	-
Yield Strength, Fy	60	ksi
Tensile Strength, Fu	75	ksi
Clip	N/A	in
Orientation Offset	0	°
Anchor Rod Detail	d	$\eta=0.5$
Clear Distance	3	in
Applied Moment, Mu	1255.2	k
Bending Stress, ϕMn	2295.6	k

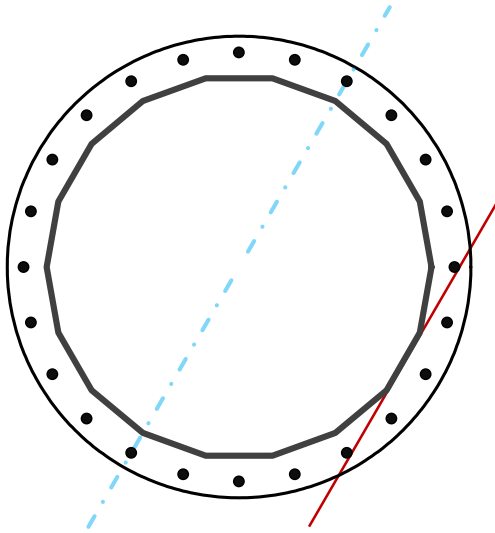

Original Anchor Rods		
Arrangement	Radial	-
Quantity	24	-
Diameter, ϕ	2 1/4	in
Bolt Circle	79	in
Grade	A615-75	-
Yield Strength, Fy	75	ksi
Tensile Strength, Fu	100	ksi
Spacing	10.3	in
Orientation Offset	0	°
Applied Force, Pu	110.8	k
Anchor Rods, ϕPn	259.8	k

Calculations for Monopole Base Plate & Anchor Rod Analysis

Reaction Distribution

Reaction	Shear Vu	Moment Mu	Factor
-	k	k-ft	-
Base Forces	35.2	4262.6	1.00
Anchor Rod Forces	35.2	4262.6	1.00
Additional Bolt (Grp1) Forces	0.0	0.0	0.00
Additional Bolt (Grp2) Forces	0.0	0.0	0.00
Dywidag Forces	0.0	0.0	0.00
Stiffener Forces	0.0	0.0	0.00

Geometric Properties

Section	Gross Area	Net Area	Individual Inertia	Threads per Inch	Moment of Inertia
-	in ²	in ²	in ⁴	#	in ⁴
Pole	93.7578	5.2088	0.3334		55098.28
Bolt	3.9761	3.2477	0.8393	4.5	60826.64
Bolt1	0.0000	0.0000	0.0000	0	0.00
Bolt2	0.0000	0.0000	0.0000	0	0.00
Dywidag	0.0000	0.0000	0.0000		0.00
Stiffener	0.0000	0.0000	0.0000		0.00

Base Plate		
Shape	Round	-
Diameter, D	85	in
Thickness, t	2.25	in
Yield Strength, Fy	60	ksi
Tensile Strength, Fu	75	ksi
Base Plate Chord	49.639	in
Detail Type	d	-
Detail Factor	0.50	-
Clear Distance	3	-

Anchor Rods		
Anchor Rod Quantity, N	24	-
Rod Diameter, d	2.25	in
Bolt Circle, BC	79	in
Yield Strength, Fy	75	ksi
Tensile Strength, Fu	100	ksi
Applied Axial, Pu	110.8	k
Applied Shear, Vu	0.6	k
Compressive Capacity, φPn	259.8	k
Tensile Capacity, φRnt	0.426	OK
Interaction Capacity	0.431	OK

External Base Plate		
Chord Length AA	42.568	in
Additional AA	4.500	in
Section Modulus, Z	59.570	in ³
Applied Moment, Mu	1255.2	k-ft
Bending Capacity, φMn	3216.8	k-ft
Capacity, Mu/φMn	0.390	OK
Chord Length AB	40.765	in
Additional AB	4.500	in
Section Modulus, Z	57.289	in ³
Applied Moment, Mu	1081.0	k-ft
Bending Capacity, φMn	3093.6	k-ft
Capacity, Mu/φMn	0.349	OK
Bend Line Length	33.588	in
Additional Bend Line	0.000	in
Section Modulus, Z	42.510	in ³
Applied Moment, Mu	1255.2	k-ft
Bending Capacity, φMn	2295.6	k-ft
Capacity, Mu/φMn	0.547	OK

Internal Base Plate		
Arc Length	0.000	in
Section Modulus, Z	0.000	in ³
Moment Arm	0.000	in
Applied Moment, Mu	0.0	k-ft
Bending Capacity, φMn	0.0	k-ft
Capacity, Mu/φMn		

Base Plate & Anchor Rod Analysis

Pole Dimensions		
Number of Sides	18	-
Diameter	69	in
Thickness	0.4375	in
Orientation Offset	0	°

Base Reactions		
Moment, Mu	4266.0	k-ft
Axial, Pu	69.8	k
Shear, Vu	35.2	k
Neutral Axis	240	°

Report Capacities		
Component	Capacity	Result
Base Plate	55%	Pass
Anchor Rods	43%	Pass
Dwyidag	-	-

Base Plate		
Shape	Round	-
Diameter, ϕ	85	in
Thickness	2 1/4	in
Grade	A572-60	-
Yield Strength, Fy	60	ksi
Tensile Strength, Fu	75	ksi
Clip	N/A	in
Orientation Offset	0	°
Anchor Rod Detail	d	$\eta=0.5$
Clear Distance	3	in
Applied Moment, Mu	1256.4	k
Bending Stress, ϕMn	2295.6	k

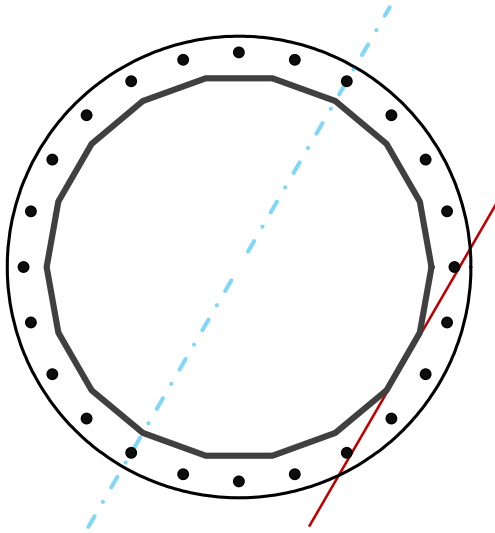

Original Anchor Rods		
Arrangement	Radial	-
Quantity	24	-
Diameter, ϕ	2 1/4	in
Bolt Circle	79	in
Grade	A615-75	-
Yield Strength, Fy	75	ksi
Tensile Strength, Fu	100	ksi
Spacing	10.3	in
Orientation Offset	0	°
Applied Force, Pu	110.9	k
Anchor Rods, ϕPn	259.8	k

Calculations for Monopole Base Plate & Anchor Rod Analysis

Reaction Distribution

Reaction	Shear Vu	Moment Mu	Factor
-	k	k-ft	-
Base Forces	35.2	4266.0	1.00
Anchor Rod Forces	35.2	4266.0	1.00
Additional Bolt (Grp1) Forces	0.0	0.0	0.00
Additional Bolt (Grp2) Forces	0.0	0.0	0.00
Dywidag Forces	0.0	0.0	0.00
Stiffener Forces	0.0	0.0	0.00

Geometric Properties

Section	Gross Area	Net Area	Individual Inertia	Threads per Inch	Moment of Inertia
-	in ²	in ²	in ⁴	#	in ⁴
Pole	93.7578	5.2088	0.3334		55098.28
Bolt	3.9761	3.2477	0.8393	4.5	60826.64
Bolt1	0.0000	0.0000	0.0000	0	0.00
Bolt2	0.0000	0.0000	0.0000	0	0.00
Dywidag	0.0000	0.0000	0.0000		0.00
Stiffener	0.0000	0.0000	0.0000		0.00

Base Plate		
Shape	Round	-
Diameter, D	85	in
Thickness, t	2.25	in
Yield Strength, Fy	60	ksi
Tensile Strength, Fu	75	ksi
Base Plate Chord	49.639	in
Detail Type	d	-
Detail Factor	0.50	-
Clear Distance	3	-

Anchor Rods		
Anchor Rod Quantity, N	24	-
Rod Diameter, d	2.25	in
Bolt Circle, BC	79	in
Yield Strength, Fy	75	ksi
Tensile Strength, Fu	100	ksi
Applied Axial, Pu	110.9	k
Applied Shear, Vu	0.6	k
Compressive Capacity, φPn	259.8	k
Tensile Capacity, φRnt	0.427	OK
Interaction Capacity	0.431	OK

External Base Plate		
Chord Length AA	42.568	in
Additional AA	4.500	in
Section Modulus, Z	59.570	in ³
Applied Moment, Mu	1256.4	k-ft
Bending Capacity, φMn	3216.8	k-ft
Capacity, Mu/φMn	0.391	OK
Chord Length AB	40.765	in
Additional AB	4.500	in
Section Modulus, Z	57.289	in ³
Applied Moment, Mu	1082.1	k-ft
Bending Capacity, φMn	3093.6	k-ft
Capacity, Mu/φMn	0.350	OK
Bend Line Length	33.588	in
Additional Bend Line	0.000	in
Section Modulus, Z	42.510	in ³
Applied Moment, Mu	1256.4	k-ft
Bending Capacity, φMn	2295.6	k-ft
Capacity, Mu/φMn	0.547	OK

Internal Base Plate		
Arc Length	0.000	in
Section Modulus, Z	0.000	in ³
Moment Arm	0.000	in
Applied Moment, Mu	0.0	k-ft
Bending Capacity, φMn	0.0	k-ft
Capacity, Mu/φMn		

Site Name: Old Lyme South CT, CT
 Site Number: 411178
 Engineering Number: 12927156
 Engineer: Hussam.Altahan
 Date: 07/18/19
 Tower Type: MP

Program Last Updated: 11/30/2018

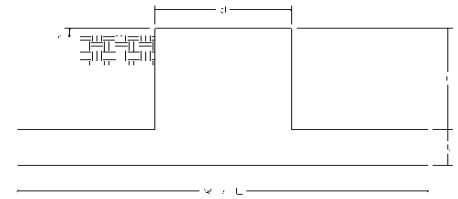

Design Loads (Factored) - Analysis per TIA-222-G Standards

Design / Analysis / Mapping:	Analysis		
Compression/Leg:	69.8 k	Concrete Strength (f'_c):	4000
Uplift/Leg:	0.0 k	Pad Tension Steel Depth:	38.0
Total Shear:	35.2 k	ϕ_{Shear} :	0.75
Moment:	4266.0 k-ft	$\phi_{\text{Flexure / Tension}}$:	0.9
Tower + Appurtenance Weight:	69.8 k	$\phi_{\text{Compression}}$:	0.65
Depth to Base of Foundation (l + t - h):	7 ft	β :	0.85
Diameter of Pier (d):	8.5 ft	Bottom Pad Rebar Size #:	9
Length of Pier (l):	4.5 ft	Dead Load Factor:	0.9
Height of Pier above Ground (h):	1 ft	# of Bottom Pad Rebar:	54
Width of Pad (W):	31 ft	Pad Bottom Steel Area:	54
Length of Pad (L):	31 ft	Pad Steel F_y :	60000
Thickness of Pad (t):	3.5 ft	Top Pad Rebar Size #:	9
Tower Leg Center to Center:	0 ft	# of Top Pad Rebar:	27
Number of Tower Legs:	1 (1 if MP or GT)	Pad Top Steel Area:	27
Tower Center from Mat Center:	0 ft	Pier Rebar Size #:	9
Depth Below Ground Surface to Water Table:	99 ft	Pier Steel Area (Single Bar):	1
Unit Weight of Concrete:	150 pcf	# of Pier Rebar:	52
Unit Weight of Soil Above Water Table:	125 pcf	Pier Steel F_y :	60000
Unit Weight of Water:	62.4 pcf	Pier Cage Diameter:	94.0
Unit Weight of Soil Below Water Table:	62.6 pcf	Rebar Strain Limit:	0.008
Friction Angle of Uplift:	15 Degrees	Steel Elastic Modulus:	29000
Ultimate Coefficient of Shear Friction:	0.6	Tie Rebar Size #:	4
Ultimate Compressive Bearing Pressure:	12000 psf	Tie Steel Area (Single Bar):	0.2
Ultimate Passive Pressure on Pad Face:	0 psf	Tie Spacing:	12
$\phi_{\text{Soil and Concrete Weight}}$:	0.9	Tie Steel F_y :	60000
ϕ_{Soil} :	0.75		

Overturing Moment Usage

Design OTM:	4547.9 k-ft
OTM Resistance:	14626.8 k-ft
Design OTM / OTM Resistance:	0.31 Result: OK

Soil Bearing Pressure Usage

Net Bearing Pressure:	1554 psf
Factored Nominal Bearing Pressure:	9000 psf
Net Bearing Pressure/Factored Nominal Bearing Pressure:	0.17 Result: OK
Load Direction Controlling Design Bearing Pressure:	Diagonal to Pad Edge

Sliding Factor of Safety

Total Factored Sliding Resistance:	448.5 k
Sliding Design / Sliding Resistance:	0.08 Result: OK

One Way Shear, Flexural Capacity, and Punching Shear

Factored One Way Shear (V_u):	231.0 k
One Way Shear Capacity (ϕV_c):	1341.1 k - ACI11.3.1.1
$V_u / \phi V_c$:	0.17 Result: OK
Load Direction Controlling Shear Capacity:	Parallel to Pad Edge
Lower Steel Pad Factored Moment (M_u):	1841.1 k-ft
Lower Steel Pad Moment Capacity (ϕM_n):	8969.4 k-ft - ACI10.3
$M_u / \phi M_n$:	0.21 Result: OK
Load Direction Controlling Flexural Capacity:	Parallel to Pad Edge
Upper Steel Pad Factored Moment (M_u):	1098.5 k-ft
Upper Steel Pad Moment Capacity (ϕM_n):	4550.9 k-ft
$M_u / \phi M_n$:	0.24 Result: OK
Lower Pad Flexural Reinforcement Ratio:	0.0038 OK - Minimum Reinforcement Ratio Met - ACI10.5.1
Upper Pad Flexural Reinforcement Ratio:	0.0019 OK - Minimum Reinforcement Ratio Met - ACI10.5.1
Lower Pad Reinforcement Spacing:	7 in - Pad Reinforcing Spacing OK - ACI7.12.2.2 & 10.5.4
Upper Pad Reinforcement Spacing:	14 in - Pad Reinforcing Spacing OK - ACI7.12.2.2 & 10.5.4
Factored Punching Shear (V_u):	0.0 k
Nominal Punching Shear Capacity ($\phi_c V_n$):	3171.1 k - ACI11.12.2.1
$V_u / \phi V_c$:	0.00 Result: OK
Factored Moment in Pier (M_u):	4424.6 k-ft
Pier Moment Capacity (ϕM_n):	10755.0 k-ft
$M_u / \phi M_n$:	0.41 Result: OK
Factored Shear in Pier (V_u):	35.2 k
Pier Shear Capacity (ϕV_n):	900.9 k
$V_u / \phi V_c$:	0.04 Result: OK
Pier Shear Reinforcement Ratio:	0.0002 No Ties Necessary for Shear - ACI11.5.6.1
Factored Tension in Pier (T_u):	0.0 k
Pier Tension Capacity (ϕT_n):	2808.0 k
$T_u / \phi T_n$:	0.00 Result: OK
Factored Compression in Pier (P_u):	69.8 k
Pier Compression Capacity (ϕP_n):	14354.9 k - ACI10.3.6.2
$P_u / \phi P_n$:	0.00 Result: OK
Pier Compression Reinforcement Ratio:	0.006 OK - Reinforcement Ratio Met - ACI10.9.1 & 10.8.4
$M_u / \phi_B M_n + T_u / \phi_T T_n$:	0.41 Result: OK

Nominal and Design Moment Capacity and Factored Design Loads

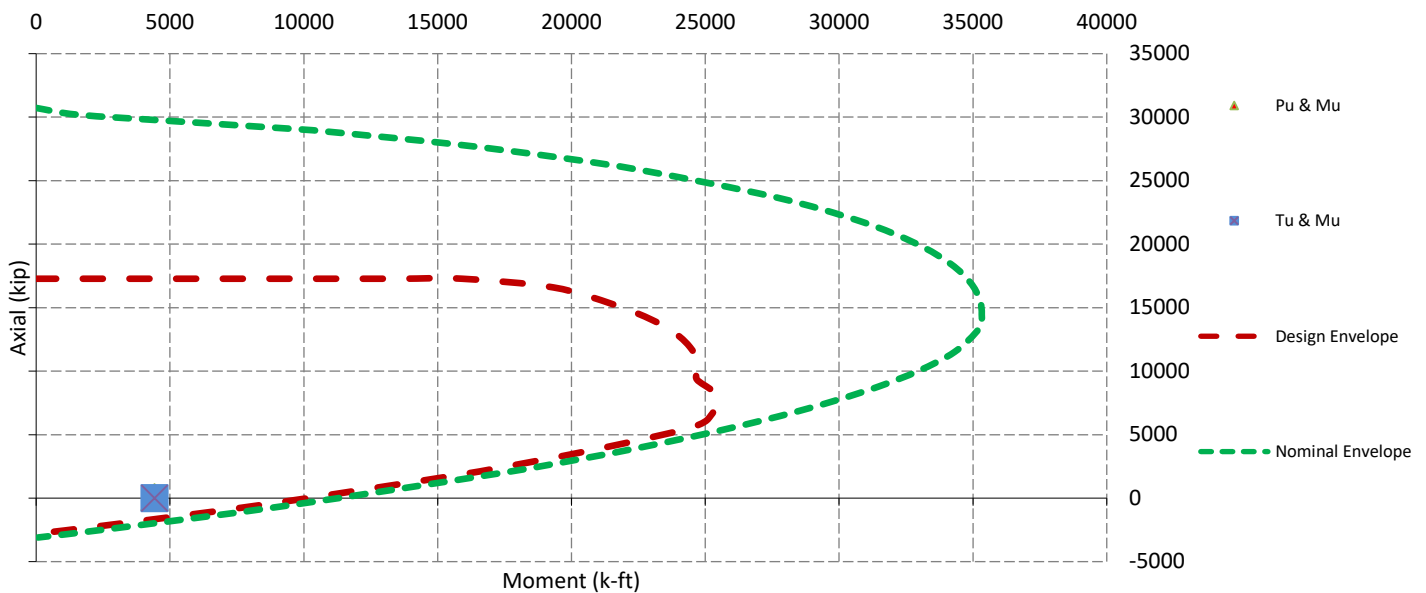

psi
in

in²
psi

in²

in²

psi
in

ksi

in²
in
psi

Exhibit E

Mount Analysis

Mount Analysis of Existing T-Arms for American Tower on behalf of T-Mobile
411178 - Old Lyme South CT
Project #: 12927156
T-Mobile Site ID: CTNL802A
Program: L600

CLS Engineering PLLC Project #41124-12927156-01-MA-R2
 July 17, 2019

MOUNT DESCRIPTION	Existing T-Arms at 169 ft AGL
ANTENNA ELEVATION	Nominal Rad. Elevation of 171 ft AGL (Eccentricity of -2 ft)
SITE DESCRIPTION	170.5 ft Monopole
SITE ADDRESS	125 Mile Creek Road, Old Lyme, CT 06371-1718, New London County
GPS COORDINATES	41.305653, -72.297361
ANALYSIS STANDARD	2015 IBC / 2018 Connecticut State Building Code / TIA-222-G
LOADING CRITERIA	135 mph, V_{ult} / 104.6 mph, V_{asd} (3-Second Gust) w/o ice & 50 mph (3-Second Gust) w/ 0.75"

■ ANALYSIS RESULT: **Pass (Conditional)**

MEMBER USAGE	92%	Pass
--------------	-----	------

Modifications are proposed to bring mounts into compliance; see conclusion for details.

Prepared by:
Jennifer Soza

Reviewed and Approved by:
Tyler M. Barker, P.E.

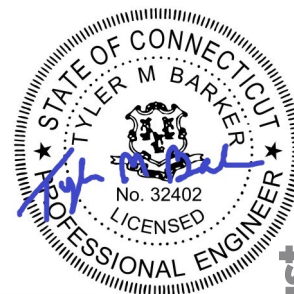

Tyler M. Barker
 CLS Engineering, PLLC
 Director of Engineering
 PE # 32402 Exp. 1/31/2020
 COA # PEC.001833 Exp. 8/14/2019



Digitally signed by
 Tyler Barker
 DN: c=US,
 o=Telamon
 Corporation,
 ou=A01427E000001
 6A4525ADF800001
 D17, cn=Tyler Barker
 Date: 2019.07.17
 17:54:26 -04'00'

■ INTRODUCTION

The proposed equipment is to be mounted to the existing T-Arms. This proposed mounting configuration was analyzed using RISA-3D, a commercially available finite element analysis software package. A selection of input and output from our analysis is attached to the end of this report.

■ STRUCTURAL DOCUMENTS PROVIDED

STRUCTURAL DATA	Site photos, dated August 1, 2017 Tower Mapping Report by TEP, Project #68269, dated April 25, 2016 Site Pro 1 Drawing No. PRK-1245, dated April 10, 2014 Site Pro 1 Drawing No. SP219-xxxH, dated February 2, 2016 Site Pro 1 Drawing No. SCX1-K, Rev A, dated July 5, 2012
PREVIOUS ANALYSES	Structural Analysis by ATC, Engineering #OAA710430_C3_03, dated March 23, 2018
LOADING DATA	ATC Application, Project #12927156, dated April 5, 2019

■ ANALYSIS CRITERIA

STANDARD	2015 IBC / 2018 Connecticut State Building Code / TIA-222-G
BASIC WIND SPEED	135 mph, V_{ult} / 104.6 mph, V_{asd} (3-Second Gust)
BASIC WIND SPEED W/ ICE	50 mph (3-Second Gust) w/ 0.75" Radial Ice (Escalating)
EXPOSURE CATEGORY	B
MAX. TOPOGRAPHIC FACTOR, K_{zt}	1.00
RISK CATEGORY	II
MAINTENANCE LIVE LOAD	L_M : 500 lb

■ FINAL EQUIPMENT

ELEVATION (ft)		ANTENNAS	
MOUNT	RAD.	#	NAME
169.0	171.0	3	RFS Celwave APXVAARR24_43-U-NA20
		3	Ericsson AIR 21, 1.3M, B4A B2P
		3	Ericsson AIR 21, 1.3M, B2A B4P
		3	Ericsson RADIO 4449 B12/B71
		3	Ericsson KRY 112 144/1
		1	E-911 GPS

■ RESULTS SUMMARY

Existing Mount Usages:

COMPONENT	PEAK USAGE	RESULT
Collar Usage	136%	Fail
Mount Pipes	125%	Fail
Connections	98%	Pass
Face Horizontals	81%	Pass
Stand-Off Horizontals	58%	Pass

Modified Mount Usages:

COMPONENT	PEAK USAGE	RESULT
Collar Reactions	92%	Pass
Face Horizontals	74%	Pass
Connections	69%	Pass
Mount Pipes	59%	Pass
Stand-Off Horizontals	35%	Pass

■ CONCLUSION AND RECOMMENDATIONS

According to our structural analysis, the mounts have been found to **CONDITIONALLY PASS**. The mounting configuration considered in this analysis will be capable of supporting the referenced loading pursuant to referenced standards once the following scope is executed:

- Install (1) Site Pro 1 PRK-1245 kit at the offset arms on the existing T-Arm mount as shown in the following sketches. Collar to be installed flush with existing monopole at a height of ± 1.5 ft. below the centerline of existing T-Arm mount collar. Field-cut proposed angles as required. Maintain minimum bolt edge distance. Do not pinch safety climb.
- Replace existing mount pipe at Position 2 with (1) Site Pro 1 SP219-96H, 2-7/8" Pipe Mount Kit at each sector (3 total).
- Install (3) 8 ft. long Pipe 2 STD, A53 Gr. B, bracing pipes at the existing T-Arm mount. Connect to existing outermost mount pipes of adjacent sectors with Site Pro 1 SCX1-K or equal, as shown in the following sketches. Field-cut proposed pipes as required.

See following sketches and Site Pro 1 assembly drawings for additional details.

■ ASSUMPTIONS AND CONDITIONS

This analysis is inclusive of the antenna supporting frames/mounts and all recorded connections that will support the equipment listed in this report. It considers only the theoretical capacity of structural components and it is not a condition assessment. The validity of the analysis may be dependent on the accuracy of structural information supplied by others. The client is responsible for verifying this information. If any provided information is revised after completion of this analysis, CLS Engineering PLLC should be notified immediately to revise results.

This analysis assumes the following:

1. The tower or other superstructure and mounts (if existing) were properly constructed as per the original design and have been properly maintained in accordance with applicable code standards.
2. Member sizes and strengths are accurate as supplied or are assumed as stated in the calculations.
3. In the absence of sufficient design information, all welds and connections are assumed to develop at least the capacity of the connected member, unless otherwise stated in this analysis.
4. All prior structural modifications, if any, are assumed to be correctly installed and fully effective.
5. The loading configuration is complete and accurate as supplied and/or as modeled in the previous analysis. All appurtenances are assumed to be properly installed and supported as per manufacturer requirements.
6. Some conservative assumptions may be used regarding appurtenances and their projected areas based on careful interpretation of data supplied, previous experience and standard industry practice.

All opinions and conclusions are considered accurate to a reasonable degree of engineering certainty based upon the evidence available at the time of the report. All opinions and conclusions contained herein are subject to revision based upon receipt of new or updated information. All services are provided exercising a level of care and diligence equivalent to the standard of our profession. No warranty or guarantee, either expressed or implied, is offered. All services are confidential in nature and this report will not be released to any other party without the client's consent. The use of this analysis is limited to the expressed purpose for which it was commissioned and it may not be reused, copied or disseminated for any other purpose without consent from CLS Engineering PLLC.

All services were performed, results obtained and recommendations made in accordance with generally accepted engineering principles and practices. CLS Engineering PLLC is not responsible for the conclusions, opinions or recommendations made by others based on the information supplied in this analysis.

It is not possible to have the fully detailed information necessary to perform a complete and thorough analysis of every structural sub-component of an existing structure. The structural analysis by CLS Engineering PLLC verifies the adequacy of the primary members of the structure. CLS Engineering PLLC provides a limited scope of service in that we cannot verify the adequacy of every weld, bolt, gusset, etc.

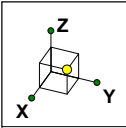

Existing Mount - To Be Modified

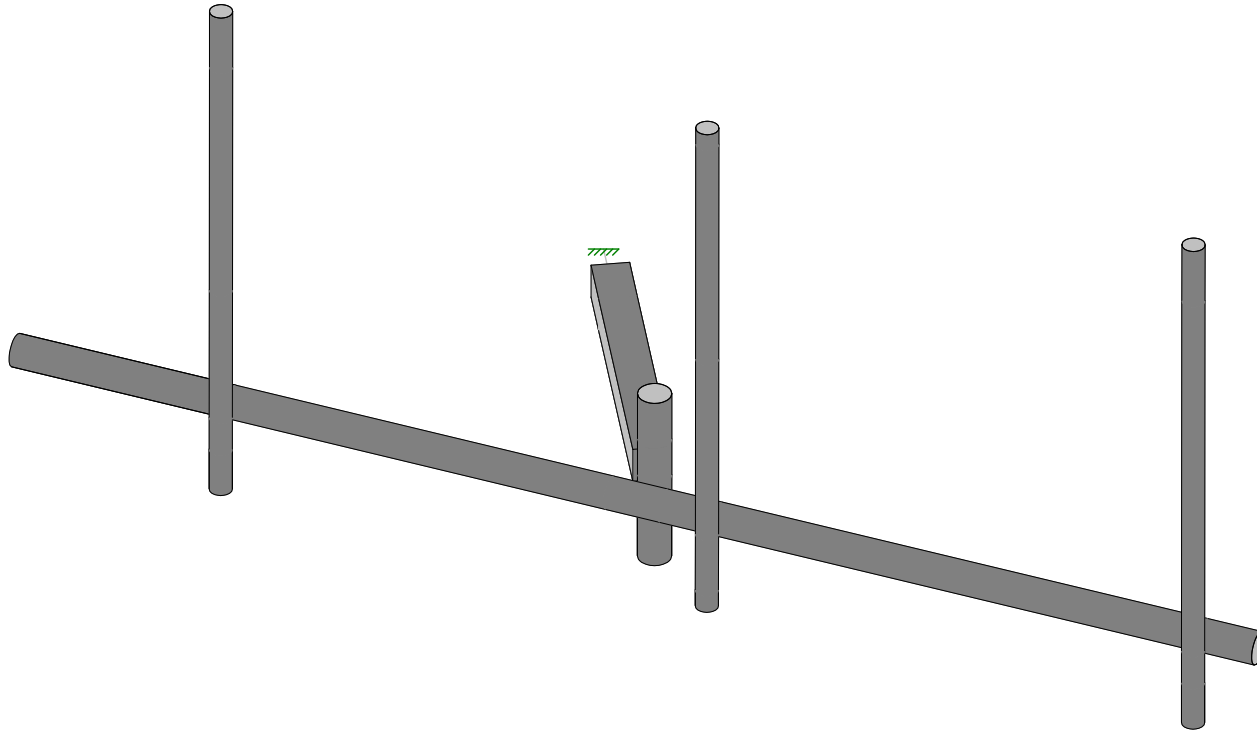

Envelope Only Solution

CLS
BP
41124-12927156-01-MA

41124-12927156-Old Lyme South CT
Existing Mount - Rendered

EX - 1
Apr 12, 2019 at 10:38 AM
41124-12927156-01-MA.r3d

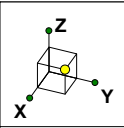

Existing Mount - To Be Modified

Code Check (Env)	
	No Calc
	> 1.0
	.90-1.0
	.75-.90
	.50-.75
	0-.50

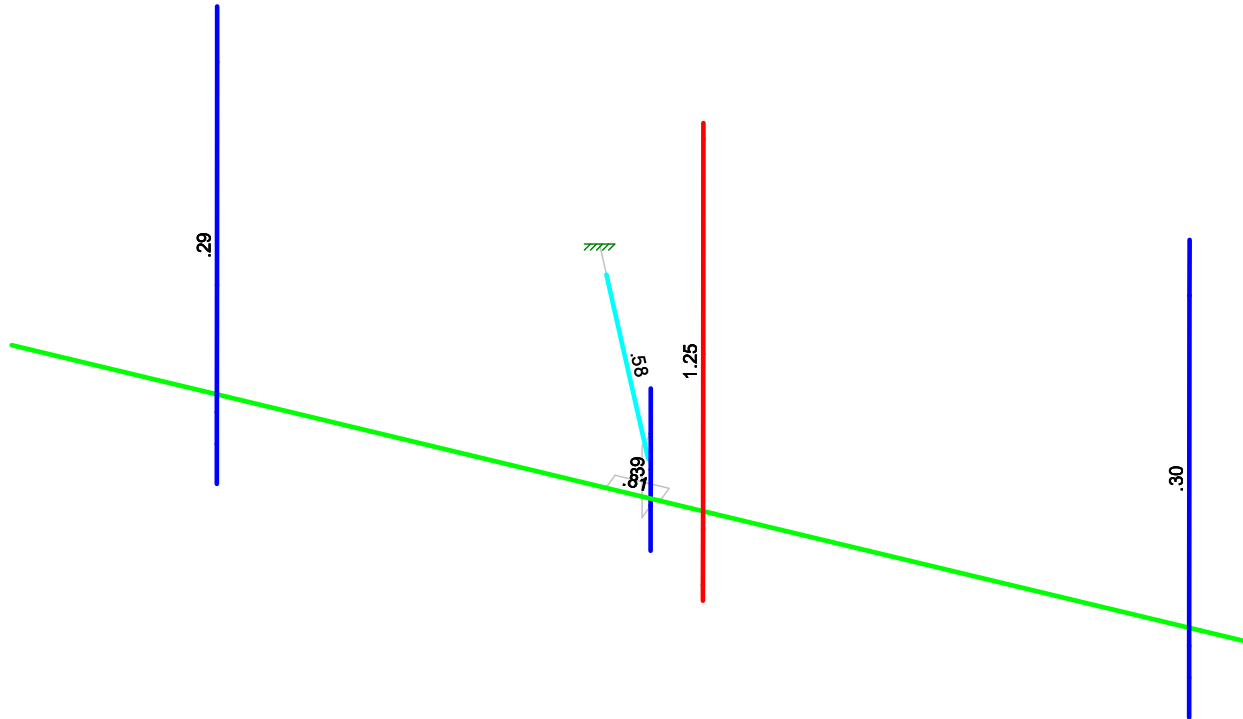

Member Code Checks Displayed (Enveloped)
Envelope Only Solution

CLS	41124-12927156-Old Lyme South CT Existing Mount - Envelope Member Unity Check Results - Bending	EX - 2
BP		Apr 12, 2019 at 10:37 AM
41124-12927156-01-MA		41124-12927156-01-MA.r3d

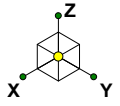

Install (3) 8 ft. long Pipe 2 STD, A53 Gr. B, bracing pipes at the existing T-Arm mount. Connect to existing outermost mount pipes of adjacent sectors with Site Pro 1 SCX1-K or equal, as shown in the following sketches. Field-cut proposed pipes as required.

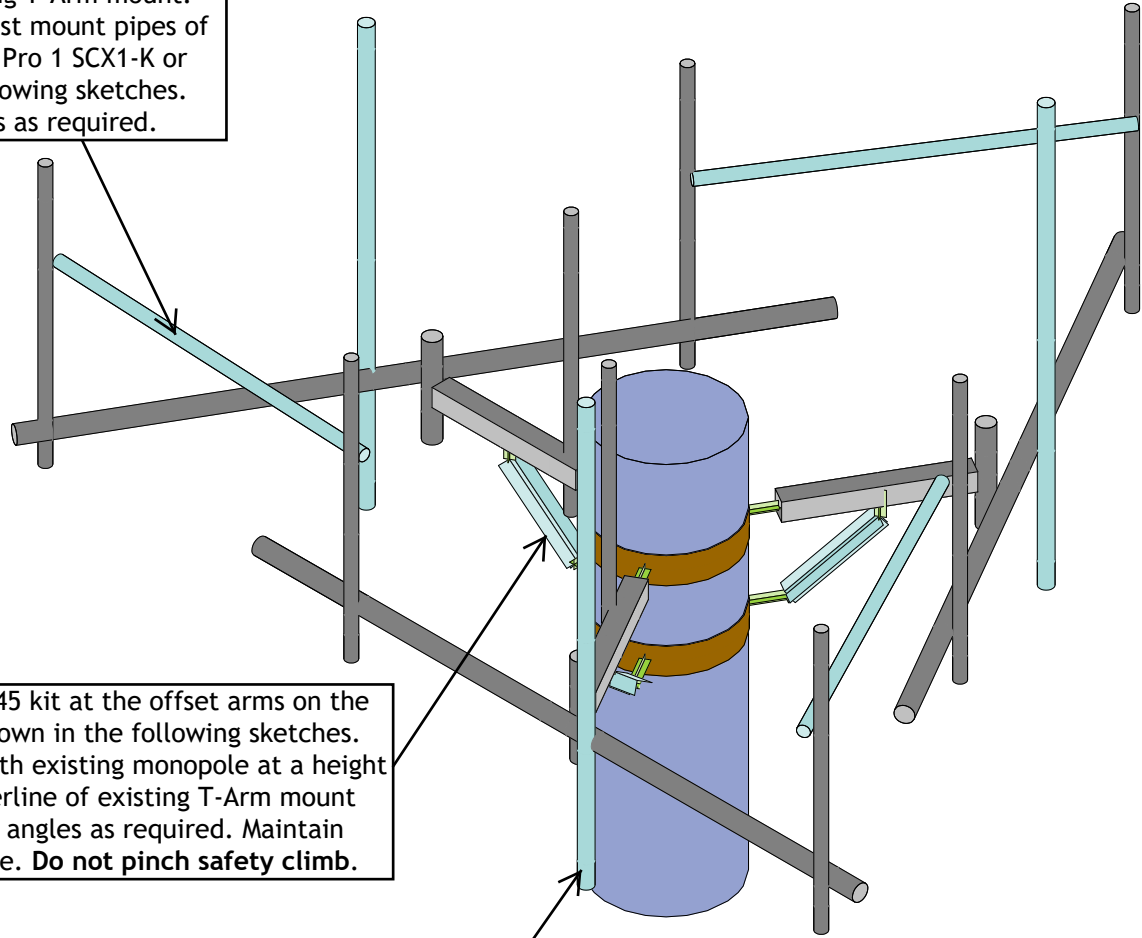

Install (1) Site Pro 1 PRK-1245 kit at the offset arms on the existing T-Arm mount as shown in the following sketches. Collar to be installed flush with existing monopole at a height of ± 1.5 ft. below the centerline of existing T-Arm mount collar. Field-cut proposed angles as required. Maintain minimum bolt edge distance. **Do not pinch safety climb.**

Replace existing mount pipe at Position 2 with (1) Site Pro 1 SP219-96H, 2-7/8" Pipe Mount Kit at each sector (3 total). Attach proposed mount pipe to existing face horizontal pipe using crossover plate and hardware included in the standard kit.

CLS
BP
41124-12927156-01-MA

41124-12927156-Old Lyme South CT
Proposed Modification - Rendered

IN - 1
Apr 12, 2019 at 10:24 AM
41124-12927156-01-MA_Sketches.r3d

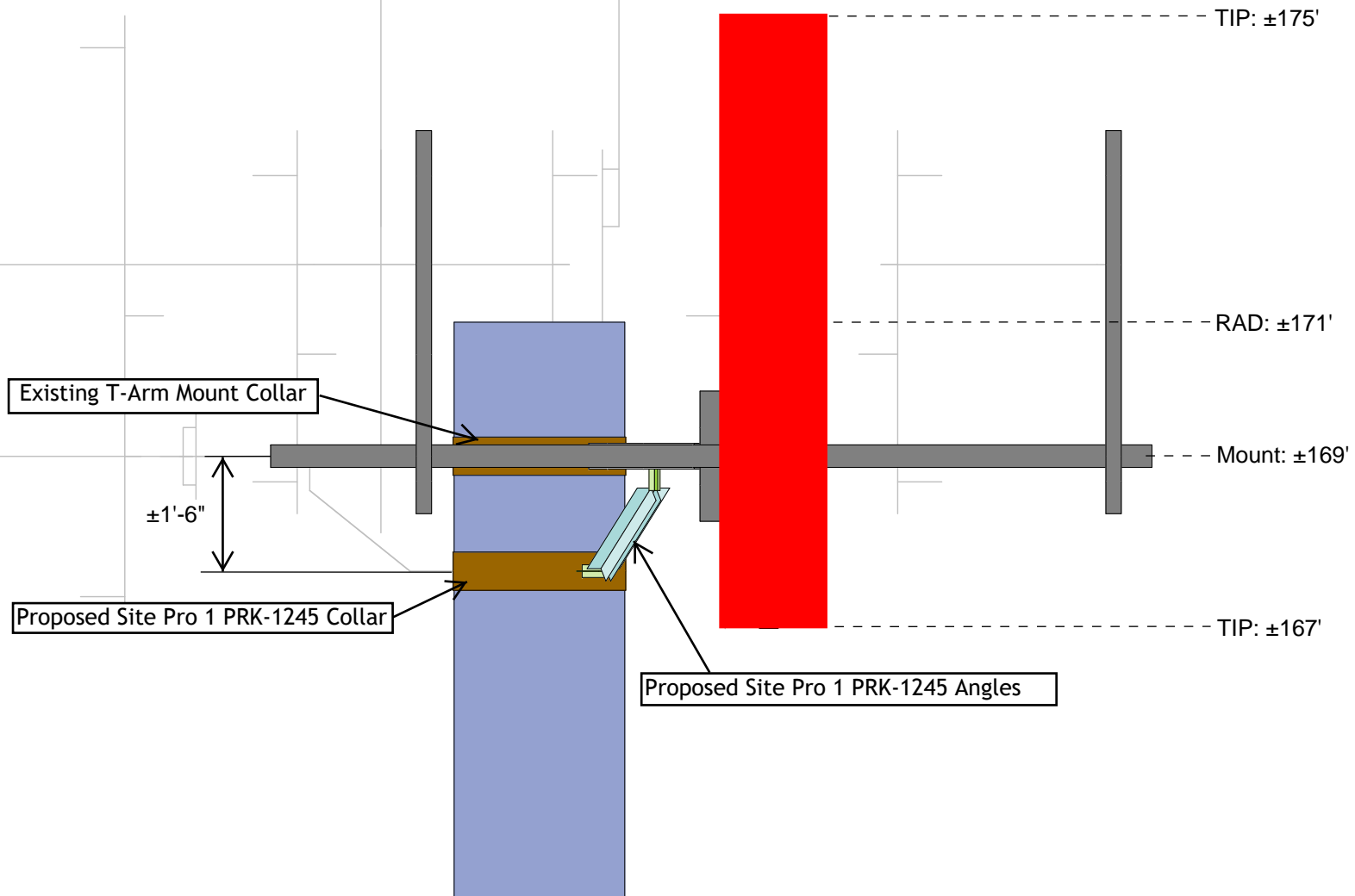

CLS
BP
41124-12927156-01-MA

41124-12927156-Old Lyme South CT
Installation Sketch - Front Elevation

IN - 2
Apr 12, 2019 at 10:47 AM
41124-12927156-01-MA_Sketches.r3d

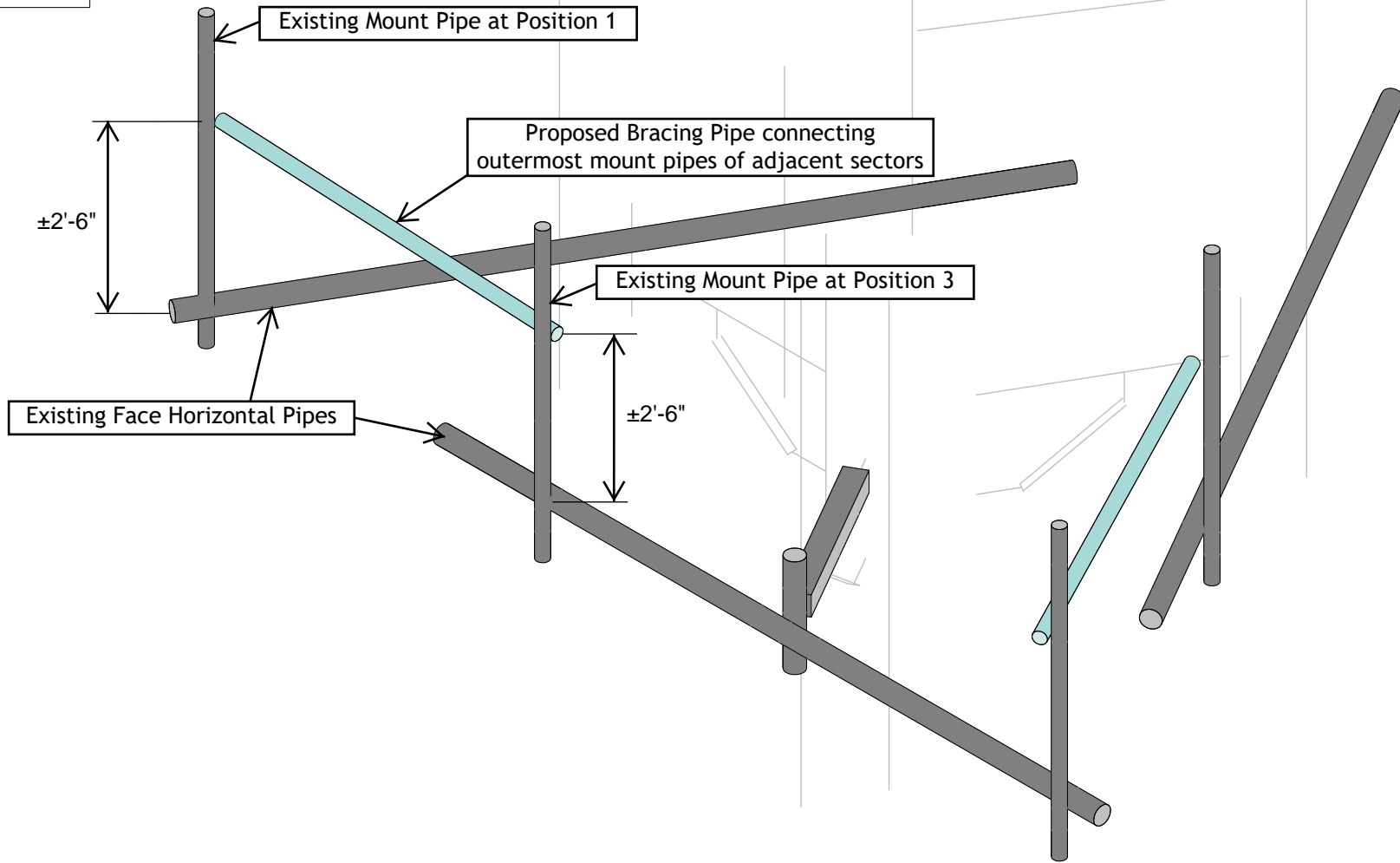
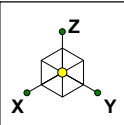

CLS
BP
41124-12927156-01-MA

41124-12927156-Old Lyme South CT
Bracing Pipe Installation Sketch - Isometric View

IN - 3
Apr 12, 2019 at 10:27 AM
41124-12927156-01-MA_Sketches.r3d

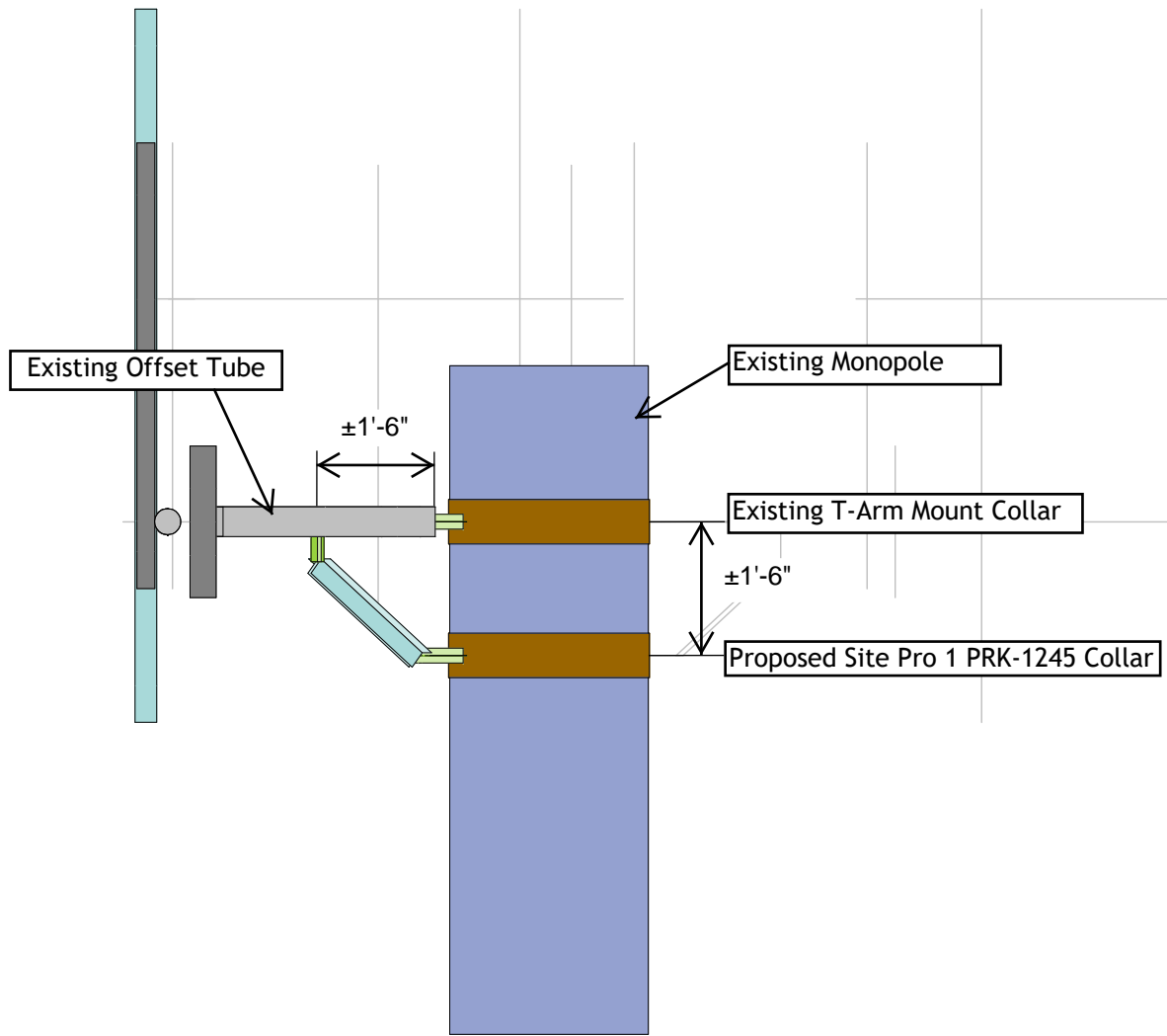

CLS
BP
41124-12927156-01-MA

41124-12927156-Old Lyme South CT
Site Pro 1 PRK-1245 Installation Sketch - Side Elevation

IN - 4
Apr 12, 2019 at 10:30 AM
41124-12927156-01-MA_Sketches.r3d

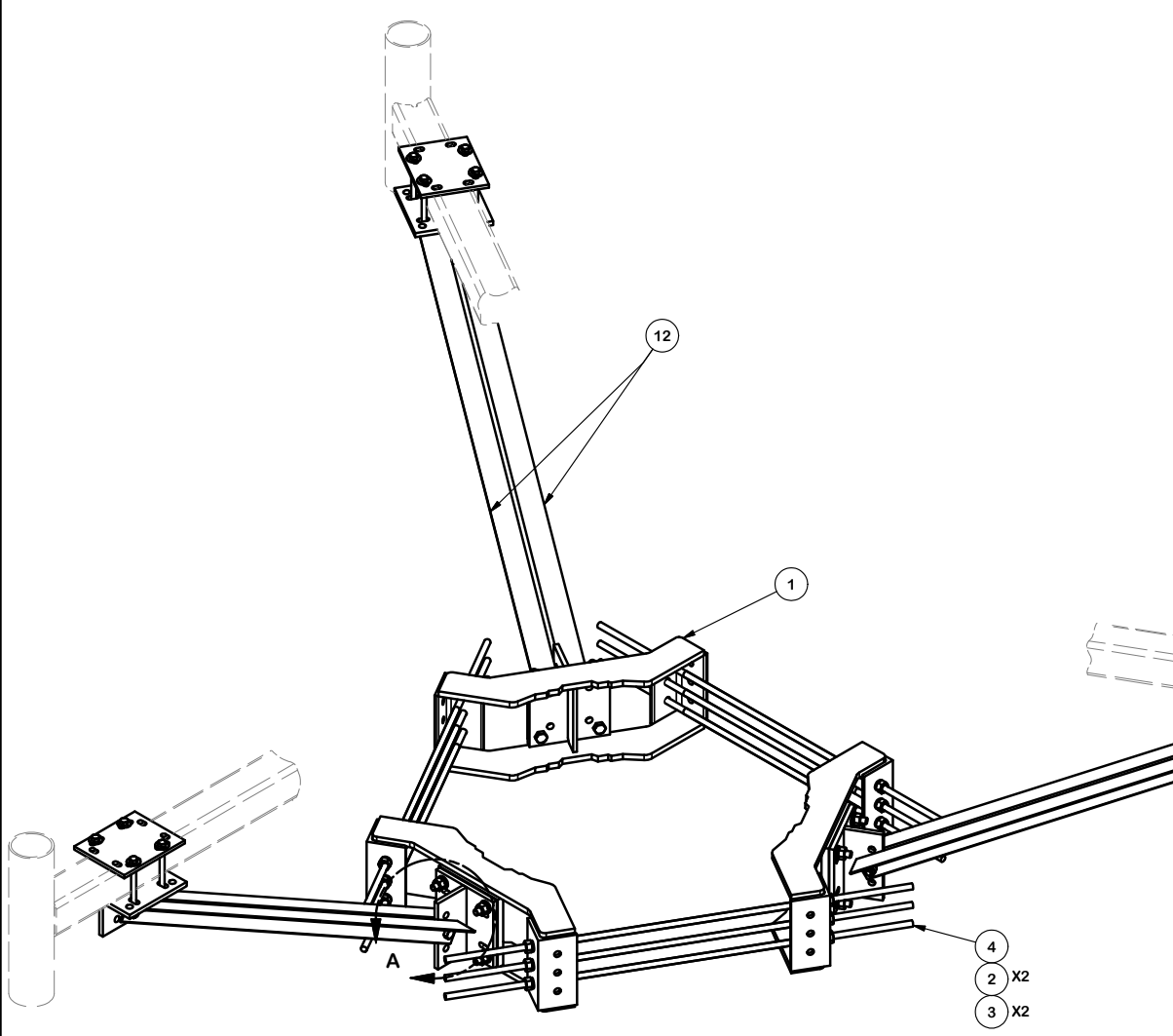

PARTS LIST						
ITEM	QTY	PART NO.	PART DESCRIPTION	LENGTH	UNIT WT.	NET WT.
1	3	X-LWRM	RING MOUNT WELDMENT		68.81	206.42
2	36	G58LW	5/8" HDG LOCKWASHER		0.03	0.94
3	30	A58NUT	5/8" HDG A325 HEX NUT		0.13	3.90
4	9	G58R-24	5/8" x 24" THREADED ROD (HDG.)		0.55	4.94
4	9	G58R-48	5/8" x 48" THREADED ROD (HDG.)		0.55	4.94
5	12	A58234	5/8" x 2-3/4" HDG A325 HEX BOLT	2 3/4 in	0.36	4.27
6	12	A58FW	5/8" HDG A325 FLATWASHER		0.03	0.41
7	24	G12FW	1/2" HDG USS FLATWASHER		0.03	0.82
8	12	G12LW	1/2" HDG LOCKWASHER		0.01	0.17
9	12	G12NUT	1/2" HDG HEAVY 2H HEX NUT		0.07	0.86
10	3	SCX4	CROSSOVER PLATE	8 1/2 in	6.02	18.06
11	6	G58NUT	5/8" HDG HEAVY 2H HEX NUT		0.13	0.78
12	6	X-253993	PLATFORM REINFORCEMENT KIT ANGLE	52 25/32 in	14.33	85.99
13	6	X-253992	T-BRACKET FOR REINFORCEMENT KIT		13.55	81.27
14	6	G5802	5/8" x 2" HDG HEX BOLT GR5		0.27	1.62
15	12	G12065	1/2" x 6-1/2" HDG HEX BOLT GR5 FULL THREAD	6 1/2 in	0.41	4.91
TOTAL WT. #						464.91

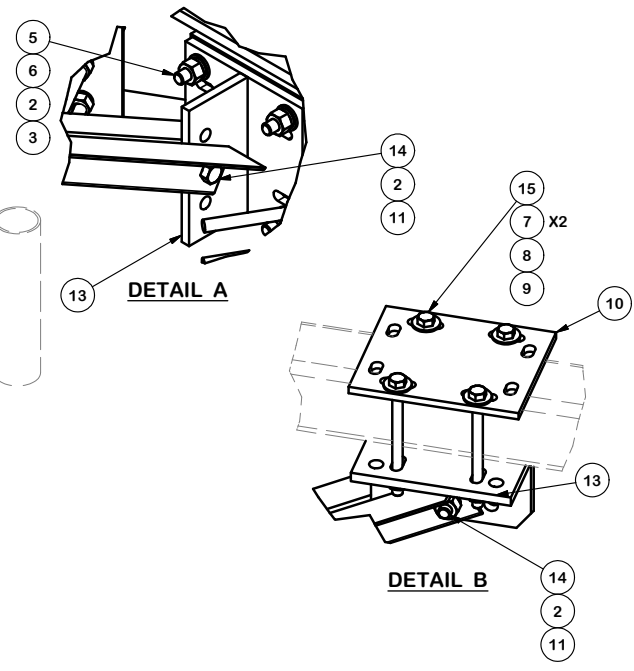

TOLERANCE NOTES
 TOLERANCES ON DIMENSIONS, UNLESS OTHERWISE NOTED ARE:
 SAWED, SHEARED AND GAS CUT EDGES ($\pm 0.030"$)
 DRILLED AND GAS CUT HOLES ($\pm 0.030"$) - NO CONING OF HOLES
 LASER CUT EDGES AND HOLES ($\pm 0.010"$) - NO CONING OF HOLES
 BENDS ARE $\pm 1/2$ DEGREE
 ALL OTHER MACHINING ($\pm 0.030"$)
 ALL OTHER ASSEMBLY ($\pm 0.060"$)

PROPRIETARY NOTE:
 THE DATA AND TECHNIQUES CONTAINED IN THIS DRAWING ARE PROPRIETARY INFORMATION OF VALMONT INDUSTRIES AND CONSIDERED A TRADE SECRET. ANY USE OR DISCLOSURE WITHOUT THE CONSENT OF VALMONT INDUSTRIES IS STRICTLY PROHIBITED.

DESCRIPTION PLATFORM REINFORCEMENT ON A 12" TO 45" POLE 4' 6" ANGLE		
CPD NO. 4488	DRAWN BY CEK 4/10/2014	ENG. APPROVAL
CLASS 81	SUB 01	DRAWING USAGE CUSTOMER
		CHECKED BY BMC 4/10/2014

 A valmont COMPANY	Locations: New York, NY Atlanta, GA Los Angeles, CA Plymouth, IN Salem, OR Dallas, TX
	Engineering Support Team: 1-888-753-7446
PART NO. PRK-1245	
DWG. NO. PRK-1245	

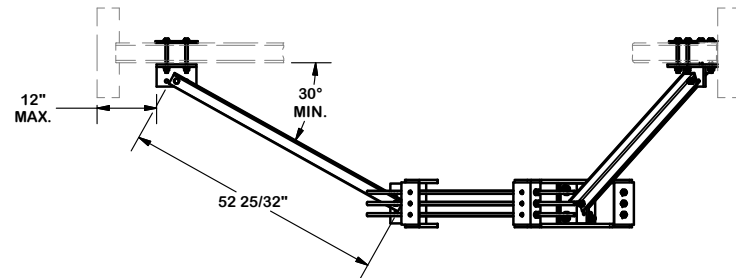
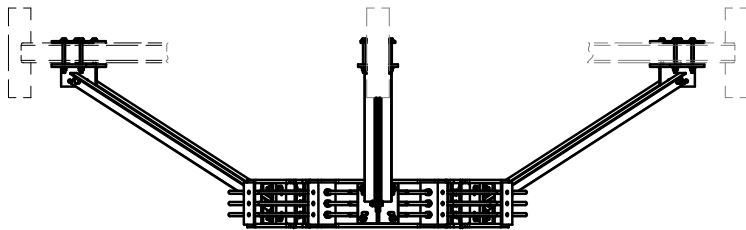
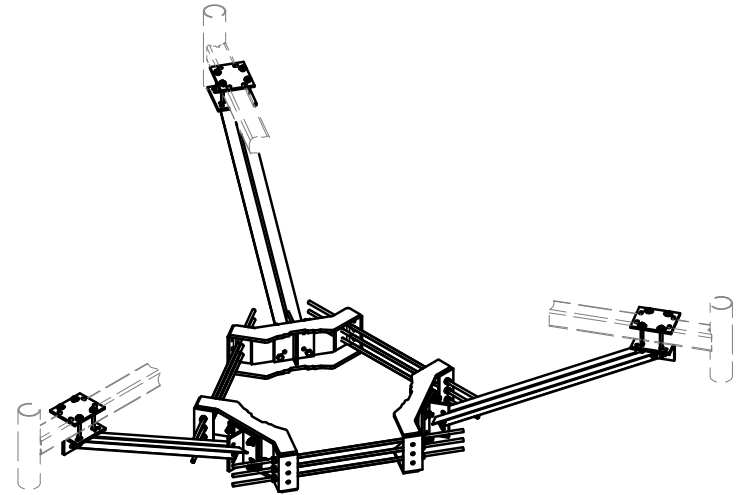
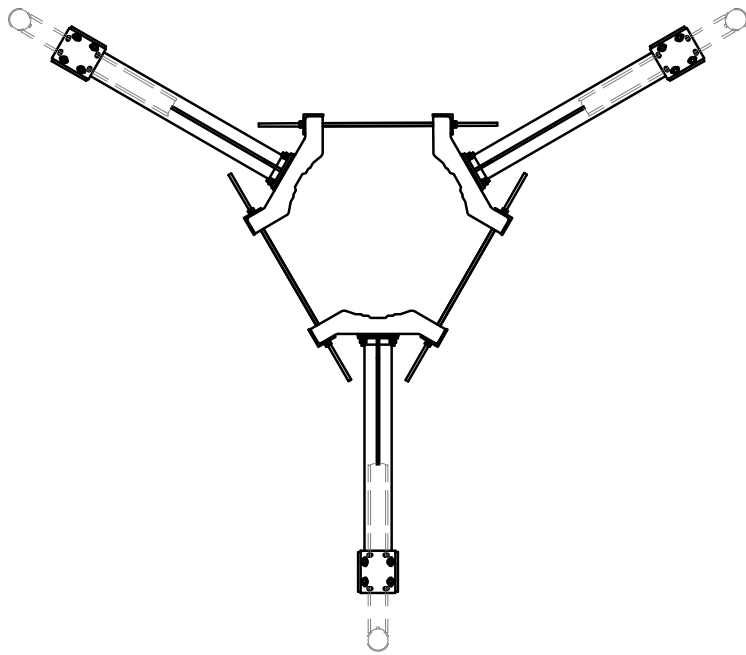

TOLERANCE NOTES

TOLERANCES ON DIMENSIONS, UNLESS OTHERWISE NOTED ARE:
 SAWED, SHEARED AND GAS CUT EDGES ($\pm 0.030"$)
 DRILLED AND GAS CUT HOLES ($\pm 0.030"$) - NO CONING OF HOLES
 LASER CUT EDGES AND HOLES ($\pm 0.010"$) - NO CONING OF HOLES
 BENDS ARE $\pm 1/2$ DEGREE
 ALL OTHER MACHINING ($\pm 0.030"$)
 ALL OTHER ASSEMBLY ($\pm 0.060"$)

PROPRIETARY NOTE:
 THE DATA AND TECHNIQUES CONTAINED IN THIS DRAWING ARE PROPRIETARY INFORMATION OF VALMONT INDUSTRIES AND CONSIDERED A TRADE SECRET. ANY USE OR DISCLOSURE WITHOUT THE CONSENT OF VALMONT INDUSTRIES IS STRICTLY PROHIBITED.

DESCRIPTION

PLATFORM REINFORCEMENT
 ON A 12" TO 45" POLE
 4' 6" ANGLE



Engineering Support Team:
 1-888-753-7446

Locations:
 New York, NY
 Atlanta, GA
 Los Angeles, CA
 Plymouth, IN
 Salem, OR
 Dallas, TX

CPD NO. 4488	DRAWN BY CEK 4/10/2014	ENG. APPROVAL
CLASS 81	SUB 01	DRAWING USAGE CUSTOMER
CHECKED BY BMC 4/10/2014		

PART NO. PRK-1245	PAGE 2 OF 2
DWG. NO. PRK-1245	

2-7/8" O.D. VERTICAL MOUNTING PIPES

ASSEMBLY "A"	PART NO. "B"	PART DESCRIPTION	LENGTH "C"	UNIT WT. "D"	NET WT. "E"	TOTAL WEIGHT
SP219-96H	P3096	2-7/8" DIA X 63" SCH 40 GALVANIZED PIPE	96"	49.24	49.24	62.45
SP219-120H	P30126	2-7/8" DIA X 63" SCH 40 GALVANIZED PIPE	126"	76.94	76.94	89.15

PARTS LIST

ITEM	QTY	PART NO.	PART DESCRIPTION	LENGTH	UNIT WT.	NET WT.
1	1	X-SP219	SMALL SUPPORT CROSS PLATE	8.250 in	8.61	8.61
3	2	X-UB1212	1/2" X 2-1/2" X 4-1/2" X 2" U-BOLT (HDG.)		0.26	0.51
3	2	X-UB1300	1/2" X 3" X 5" X 2" GALV U-BOLT		0.74	1.48
4	2	X-UB1306	1/2" X 3-5/8" X 6" X 3" GALV U-BOLT		0.83	1.66
5	8	G12NUT	1/2" HDG HEAVY 2H HEX NUT		0.07	0.57
6	8	G12LW	1/2" HDG LOCKWASHER		0.01	0.11
7	8	G12FW	1/2" HDG USS FLATWASHER		0.03	0.27
8	1	"B"	2-7/8" O.D. VERTICAL MOUNTING PIPES	"C"	"D"	"E"

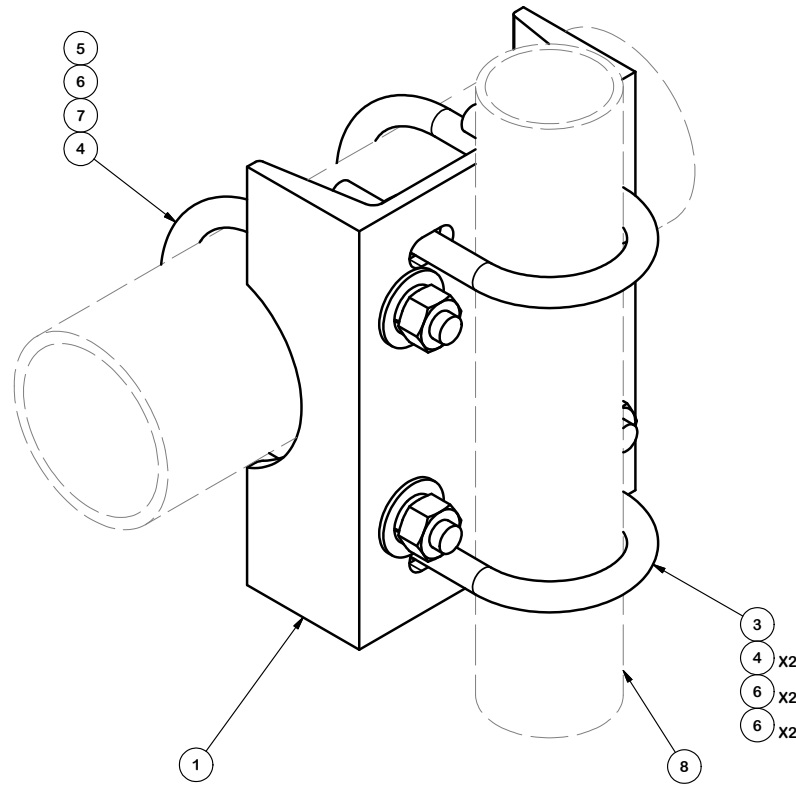

TOLERANCE NOTES

TOLERANCES ON DIMENSIONS, UNLESS OTHERWISE NOTED ARE:
 SAWED, SHEARED AND GAS CUT EDGES ($\pm 0.030"$)
 DRILLED AND GAS CUT HOLES ($\pm 0.030"$) - NO CONING OF HOLES
 LASER CUT EDGES AND HOLES ($\pm 0.010"$) - NO CONING OF HOLES
 BENDS ARE $\pm 1/2$ DEGREE
 ALL OTHER MACHINING ($\pm 0.030"$)
 ALL OTHER ASSEMBLY ($\pm 0.060"$)

PROPRIETARY NOTE:
 THE DATA AND TECHNIQUES CONTAINED IN THIS DRAWING ARE PROPRIETARY INFORMATION OF VALMONT INDUSTRIES AND CONSIDERED A TRADE SECRET. ANY USE OR DISCLOSURE WITHOUT THE CONSENT OF VALMONT INDUSTRIES IS STRICTLY PROHIBITED.

DESCRIPTION
 2-7/8" PIPE MOUNT KITS

CPD NO.	DRAWN BY	ENG. APPROVAL
CLASS	DRAWING USAGE	CHECKED BY
81	01	CUSTOMER
		BMC 2/2/2016

SITE PRO 1
 A valmont COMPANY

Locations:
 New York, NY
 Atlanta, GA
 Los Angeles, CA
 Plymouth, IN
 Salem, OR
 Dallas, TX

Engineering Support Team:
 1-888-753-7446

PART NO.	SP219-xxxH
DWG. NO.	SP219-xxxH

PARTS LIST						
ITEM	QTY	PART NO.	PART DESCRIPTION	LENGTH	UNIT WT.	NET WT.
1	1	SCX1	CROSSOVER PLATE 2-3/8" X 2-3/8"		3.71	3.71
2	4	X-UB1212	1/2" X 2-1/2" X 4-1/2" X 2" U-BOLT (HDG.)		0.63	2.50
3	8	G12FW	1/2" HDG USS FLATWASHER		0.03	0.27
4	8	G12LW	1/2" HDG LOCKWASHER		0.01	0.11
5	8	G12NUT	1/2" HDG HEAVY 2H HEX NUT		0.07	0.57
					TOTAL WT. #	7.16

2-3/8" O.D. ANTENNA PIPE
(ORDERED SEPARATELY)

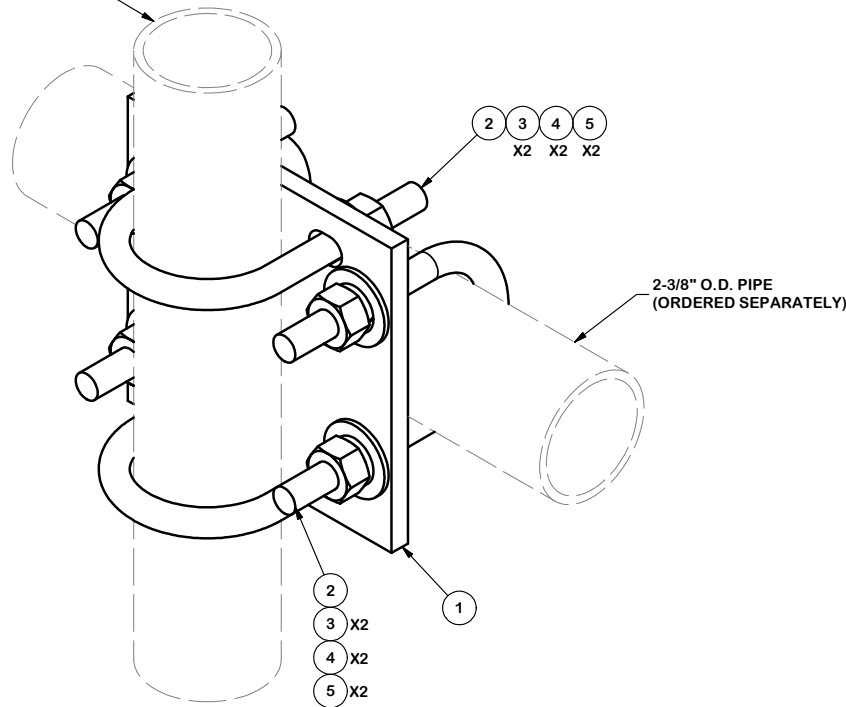

2-3/8" O.D. PIPE
(ORDERED SEPARATELY)

TOLERANCE NOTES

TOLERANCES ON DIMENSIONS, UNLESS OTHERWISE NOTED ARE:
 SAWED, SHEARED AND GAS CUT EDGES ($\pm 0.030"$)
 DRILLED AND GAS CUT HOLES ($\pm 0.030"$) - NO CONING OF HOLES
 LASER CUT EDGES AND HOLES ($\pm 0.010"$) - NO CONING OF HOLES
 BENDS ARE $\pm 1/2$ DEGREE
 ALL OTHER MACHINING ($\pm 0.030"$)
 ALL OTHER ASSEMBLY ($\pm 0.060"$)

PROPRIETARY NOTE:
 THE DATA AND TECHNIQUES CONTAINED IN THIS DRAWING ARE PROPRIETARY INFORMATION OF VALMONT INDUSTRIES AND CONSIDERED A TRADE SECRET. ANY USE OR DISCLOSURE WITHOUT THE CONSENT OF VALMONT INDUSTRIES IS STRICTLY PROHIBITED.

DESCRIPTION
CROSSOVER PLATE

SITE PRO 1
 Engineering Support Team:
 1-888-753-7446
 Locations:
 New York, NY
 Atlanta, GA
 Los Angeles, CA
 Plymouth, IN
 Salem, OR
 Dallas, TX

CPD NO.	DRAWN BY	ENG. APPROVAL
	CEK 6/30/2011	
CLASS	DRAWING USAGE	CHECKED BY
81	CUSTOMER	CEK 8/23/2012

PART NO.	SCX1-K
DWG. NO.	SCX1-K

REV	DESCRIPTION OF REVISIONS	CPD	BY	DATE
A	ADDED MISSING U-BOLT AND HRDWE		KC8	7/5/2012
REVISION HISTORY				

Wind & Ice Loading			
Nominal Mount Elevation (AGL), z_{mount}	169 ft	K_a	0.90
Nominal Rad Elevation (AGL), z_{rad}	171 ft	K_d	0.95
Elevation AMSL (ft)	-	K_e	-
TIA Standard	G	K_z	1.15
Basic Wind Speed, V_{ult} (bare)	135 mph	K_{zt}	1.00
Basic Wind Speed, V (ice)	50 mph	K_s	-
Design Ice Thickness, t_i	3/4 in	t_{iz}	1.77 in
Exposure Category	B	G_h	1.00
Risk Category	II	q_z (bare)	50.9 psf
Seismic Response Coeff., C_s	-	q_z (ice)	7.0 psf

Live Loading	
At Mount Pipes, L_M	500 lb
Joint Labels Considered	M1
	M2
	M3

Section Set Label	Shape Label	F_A (lb/ft)		Ice Wt. (lb/ft)
		Bare	Ice	
MOD Bracing Pipe	PIPE_2.0	10.88	3.71	8.94
MOD Mount Pipe	PIPE_2.5	13.17	4.03	10.01
MOD PRK	L2.5x2.5x3	19.08	2.42	10.42
Main Face Pipe	PIPE_3.0	16.03	4.42	11.36
Main Offset tube	HSS4X4X4	30.53	2.53	14.80
Mount Pipe	PIPE_2.0	10.88	3.71	8.94
Vertical pipe	PIPE_3.0	16.03	4.42	11.36

Appurtenances																														
Appurtenance Model	Status	Azimuth Offset ($^\circ, \cup$)	Rad Elev. Override (ft)	Swap Width & Depth	Area Factor		Qty. per Azimuth			Total Qty. Override	0° Joints		120° Joints		240° Joints		Height (in)	Width (in)	Depth (in)	Weight (Bare) (lb)	Shape	Weight of Ice (lb)	EPA _A (Bare) (ft²)		EPA _A (Ice) (ft²)		F _A (Bare) (lb)		F _A (Ice) (lb)	
					Front	Side	0°	120°	240°		1	2	1	2	1	2							N	T	N	T	N	T	N	T
Ericsson AIR 21, 1.3M, B4A B2P				<input type="checkbox"/>			1	1	1	3	A1	A2	A7	A8	A13	A14	55	12	7.9	83	Flat	168.09	5.92	4.22	7.93	6.12	272.24	193.88	50.01	38.58
APXVAARR24_43-U-NA20				<input type="checkbox"/>			1	1	1	3	A3	A4	A9	A10	A15	A16	0	0	0	153.3	Generic	398.17	14.67	5.32	17.36	7.69	674.11	244.46	109.41	48.47
Ericsson AIR 21, 1.3M, B2A B4P				<input type="checkbox"/>			1	1	1	3	A5	A6	A11	A12	A17	A18	55	12	7.9	83	Flat	168.09	5.92	4.22	7.93	6.12	272.24	193.88	50.01	38.58
KRY 112 144/1				<input type="checkbox"/>	0.25		1	1	1	3	T1		T2		T3		7	6	3	11	Flat	11.23	0.09	0.18	0.21	0.57	4.02	8.04	1.32	3.62
RADIO 4449 B12/B71				<input type="checkbox"/>	0.5		1	1	1	3	R1		R2		R3		15	13.2	10.4	75	Flat	60.84	0.83	1.30	1.29	2.15	37.91	59.74	8.15	13.57
DB201-A				<input type="checkbox"/>				1					D2				0	0	0	25	Generic	26.52	1.10	1.10	4.21	4.21	50.55	50.55	26.55	26.55
Dipole 12'				<input type="checkbox"/>			1				D1						144	4	4	50	Round	154.65	4.80	4.80	8.34	8.34	220.57	220.57	52.54	52.54
E-911 GPS				<input type="checkbox"/>						1							15	7	7	5	Round	33.67	0.51	0.51	0.95	0.95	23.45	23.45	5.98	5.98

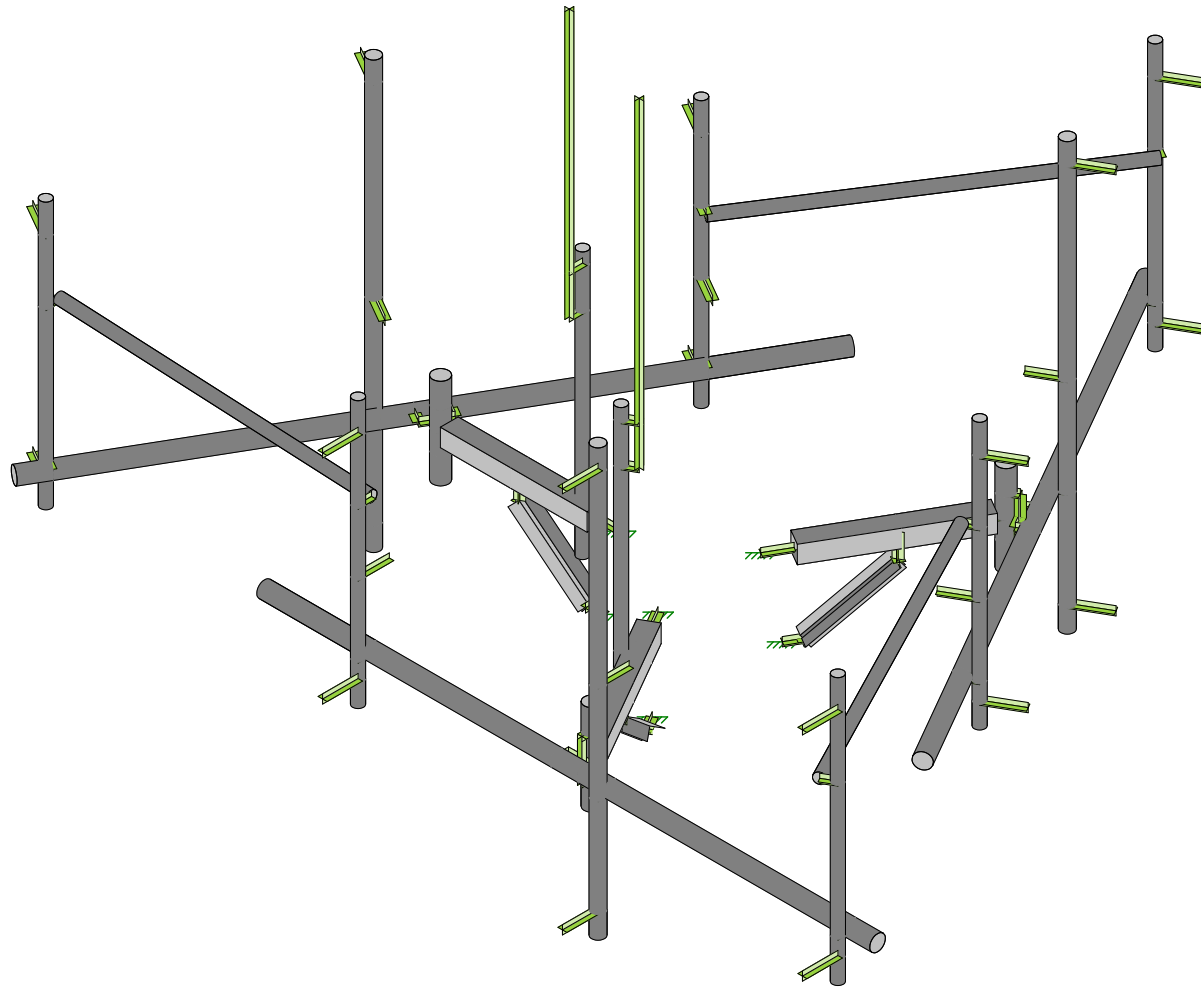
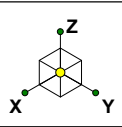

Envelope Only Solution

CLS
BP
41124-12927156-01-MA-R2

41124-12927156-Old Lyme South CT
Rendered

SK - 1
July 17, 2019 at 9:53 AM
41124-12927156-01-MA-R2.r3d

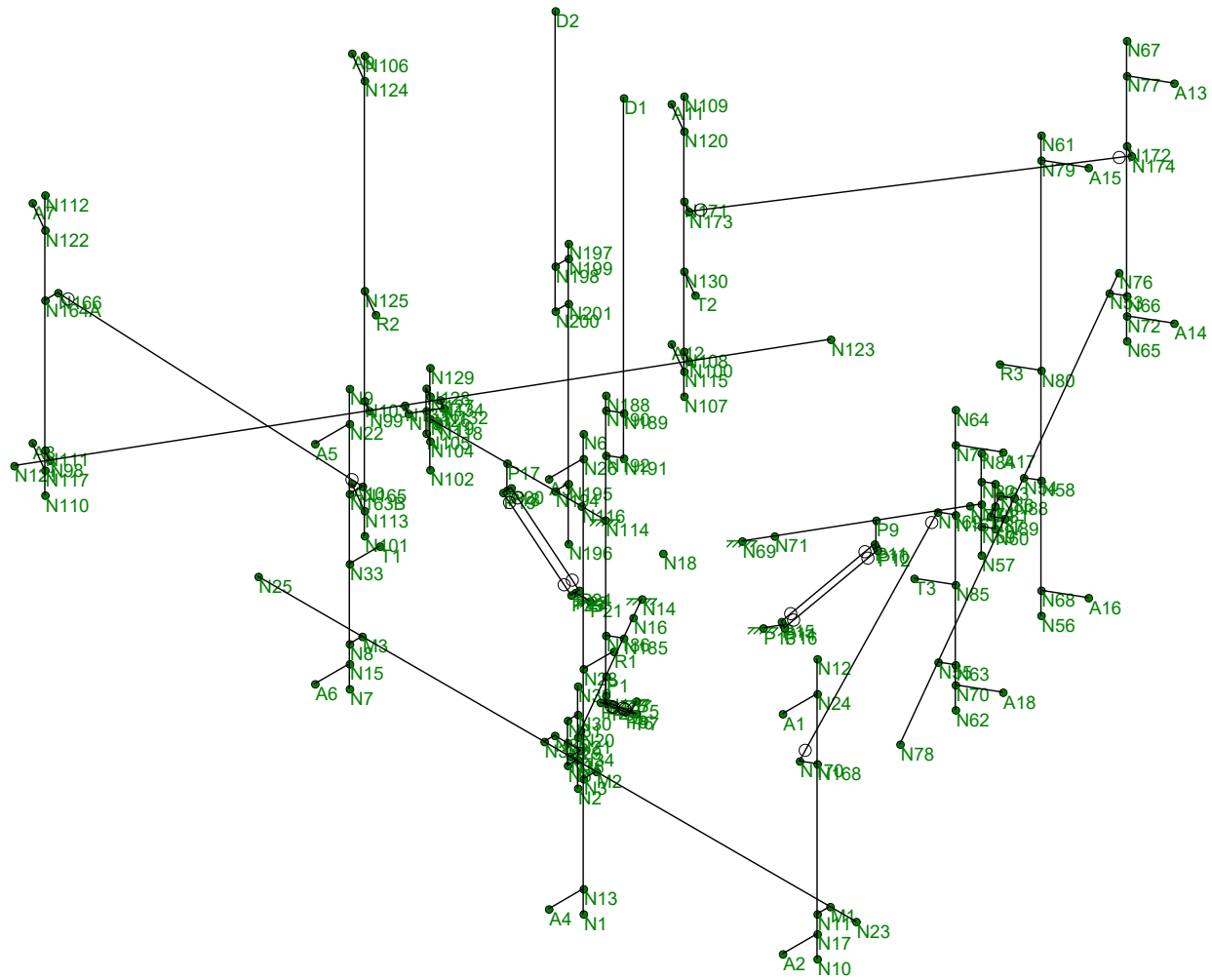
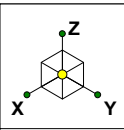

Envelope Only Solution

CLS
BP
41124-12927156-01-MA-R2

41124-12927156-Old Lyme South CT
Joint Labels

SK - 2
July 17, 2019 at 9:53 AM
41124-12927156-01-MA-R2.r3d

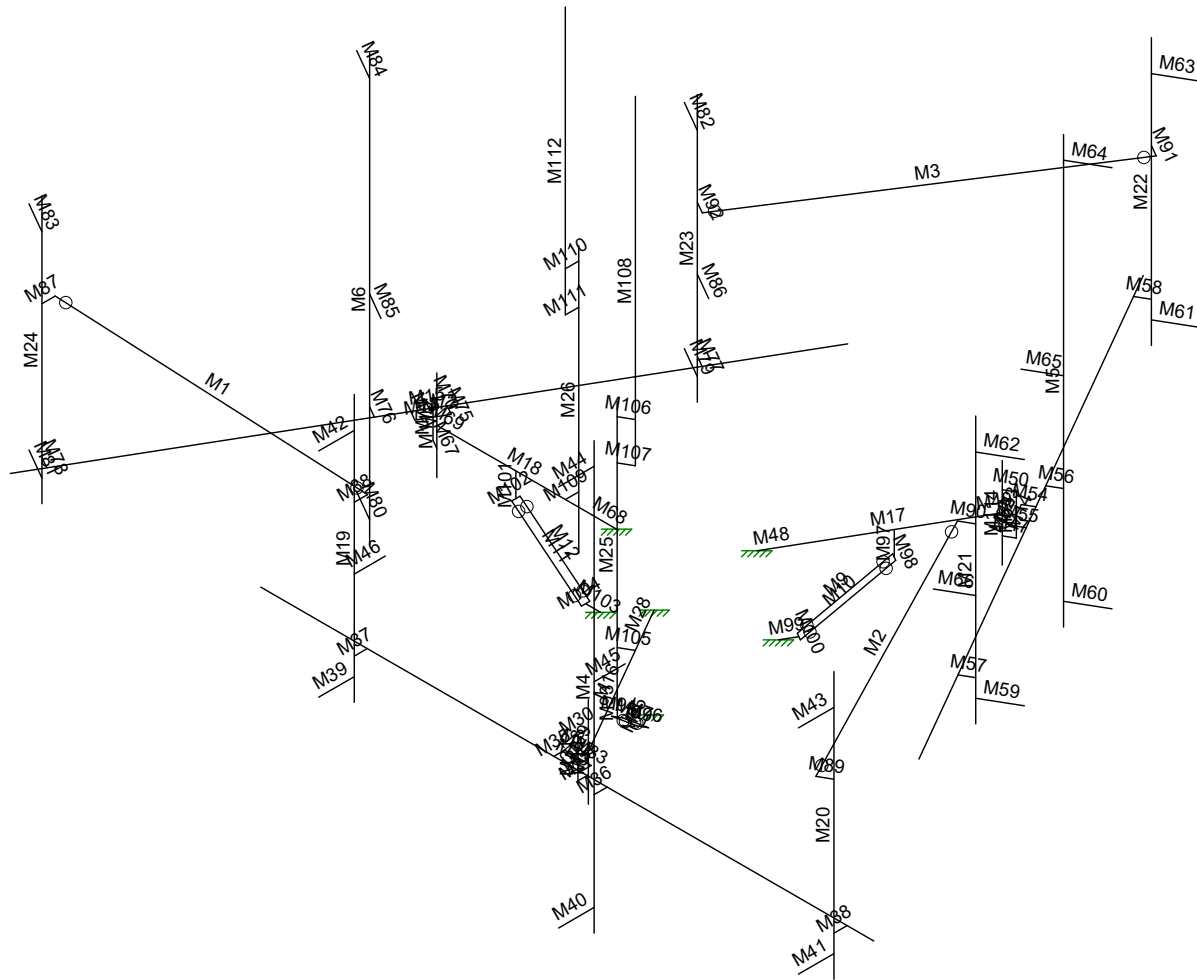
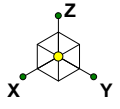

Envelope Only Solution

CLS
BP
41124-12927156-01-MA-R2

41124-12927156-Old Lyme South CT
Member Labels

SK - 3
July 17, 2019 at 9:53 AM
41124-12927156-01-MA-R2.r3d

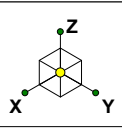

Section Sets	
Blue	Mount Pipe
Red	Main Offset tube
Magenta	Main Face Pipe
Grey	Vertical pipe
Cyan	MOD Mount Pipe
Green	MOD Bracing Pipe
Brown	MOD PRK
Yellow	RIGID

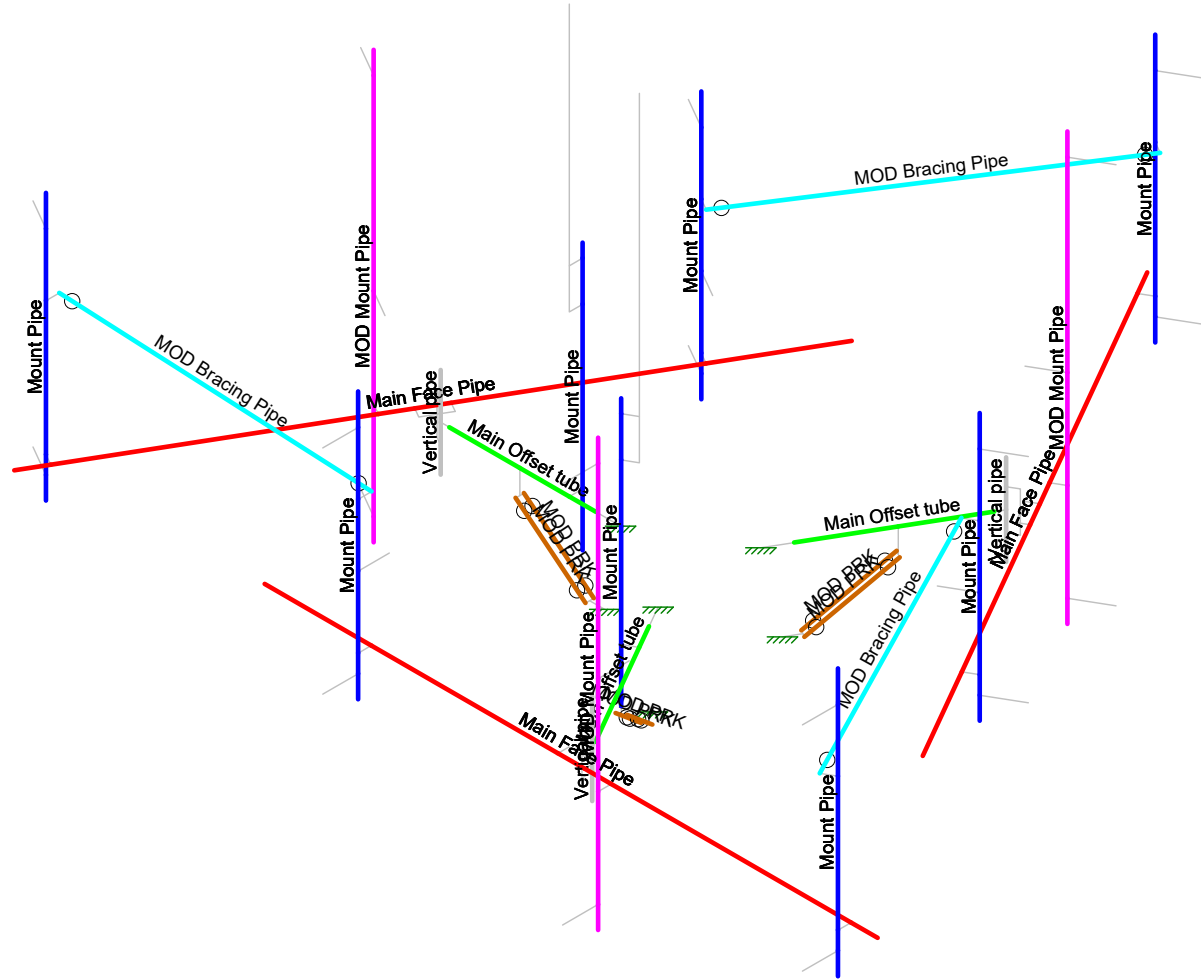

Envelope Only Solution

CLS
BP
41124-12927156-01-MA-R2

41124-12927156-Old Lyme South CT
Section Sets

SK - 4
July 17, 2019 at 9:53 AM
41124-12927156-01-MA-R2.r3d

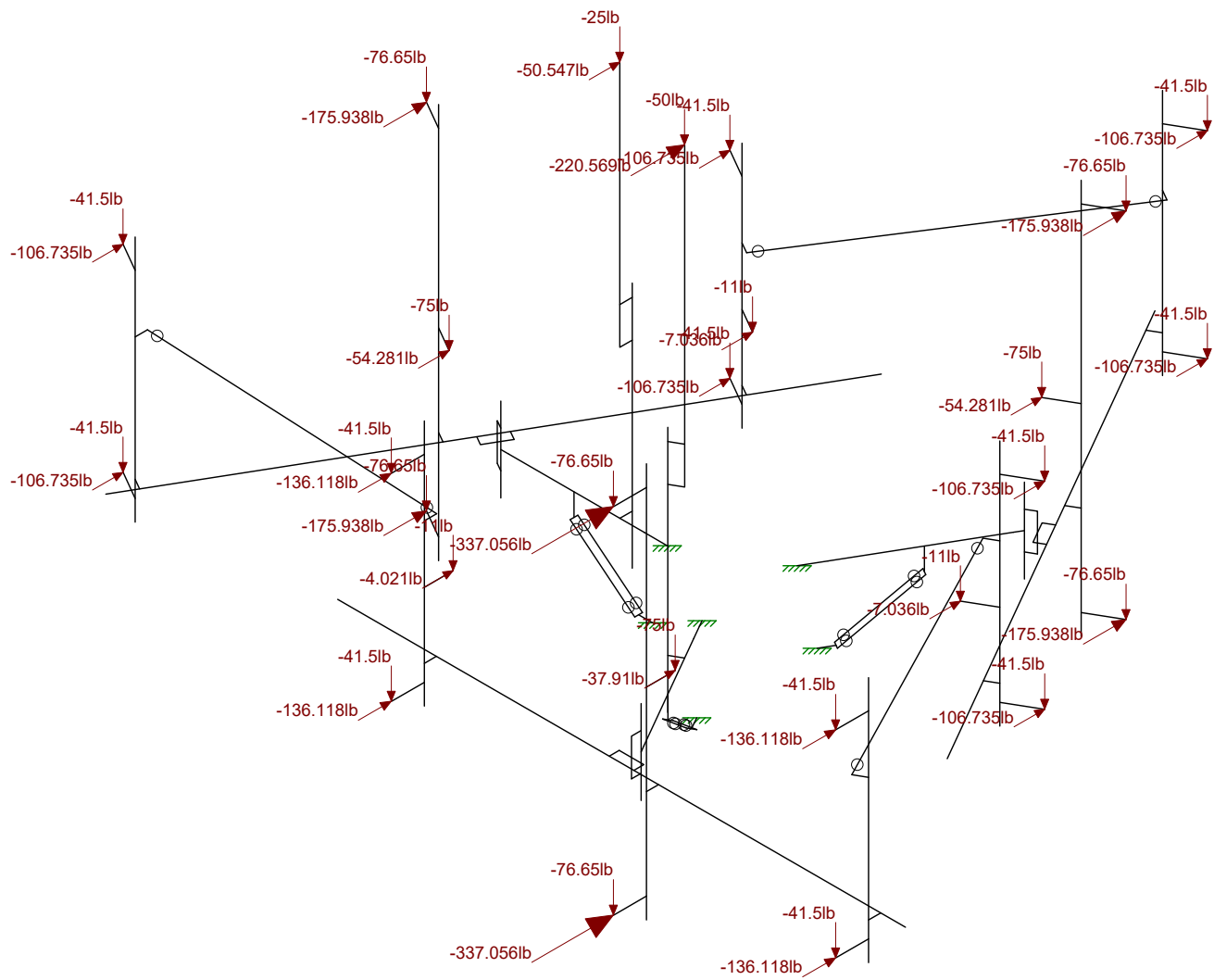
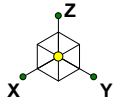

Loads: LC 1, DISPLAY (1.0D + 1.0W_0°)
Envelope Only Solution

CLS
BP
41124-12927156-01-MA-R2

41124-12927156-Old Lyme South CT
Joint Loads - Dead and Normal Wind

SK - 5
July 17, 2019 at 9:54 AM
41124-12927156-01-MA-R2.r3d

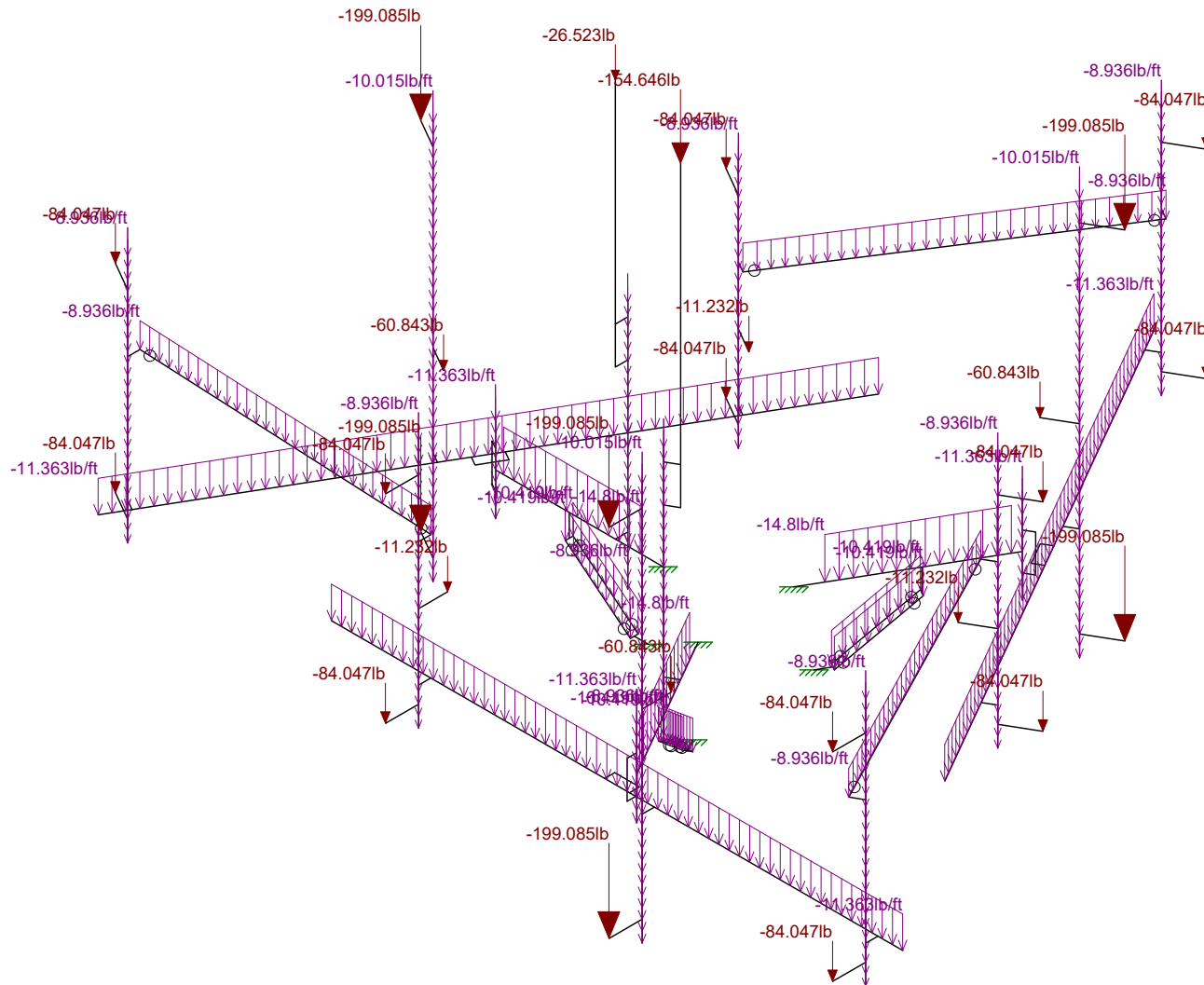
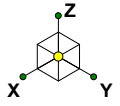

Loads: BLC 2, Ice Dead
Envelope Only Solution

CLS
BP
41124-12927156-01-MA-R2

41124-12927156-Old Lyme South CT
Ice Dead Loads

SK - 7
July 17, 2019 at 9:54 AM
41124-12927156-01-MA-R2.r3d

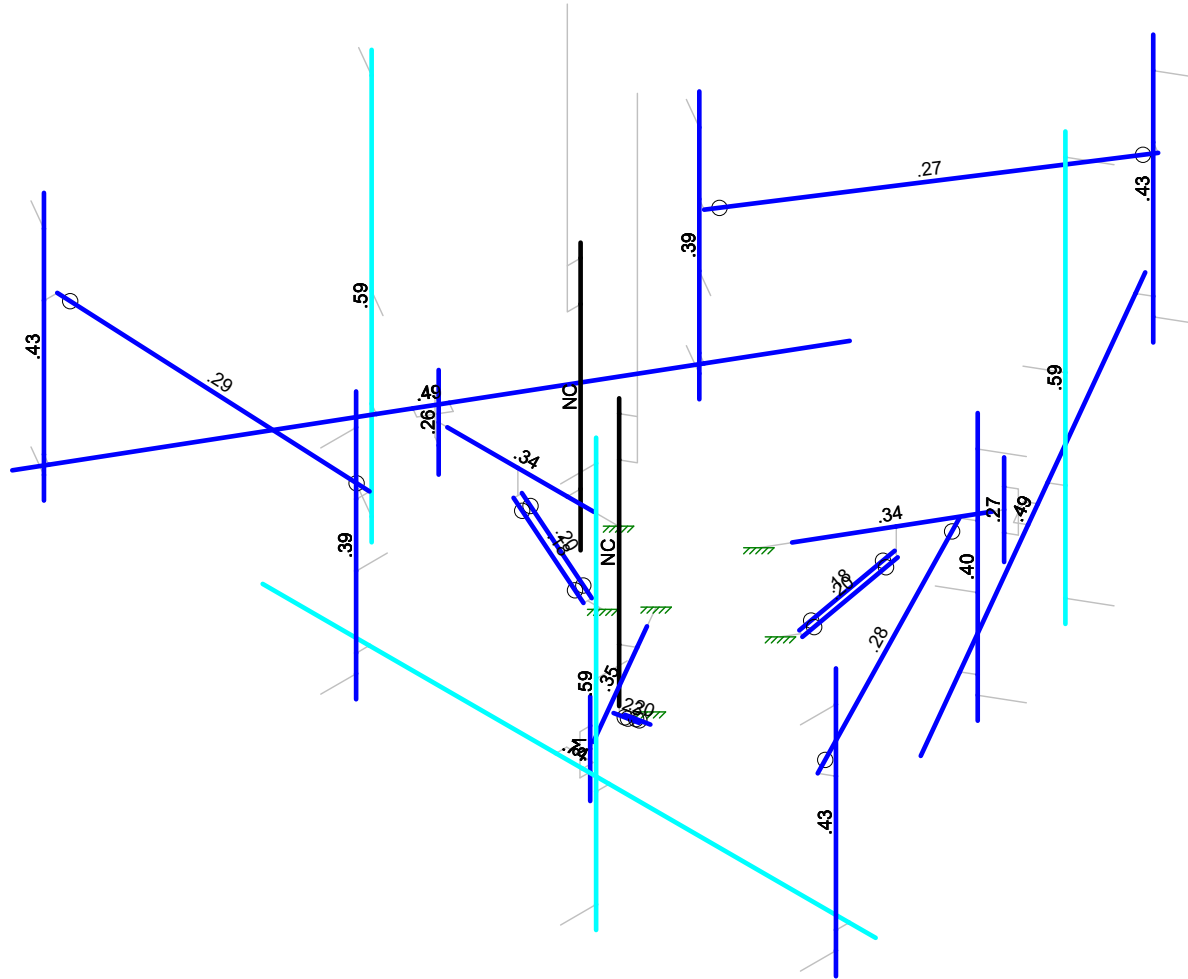
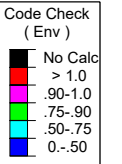
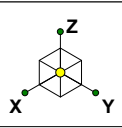

Member Code Checks Displayed (Enveloped)
Envelope Only Solution

CLS
BP
41124-12927156-01-MA-R2

41124-12927156-Old Lyme South CT
Envelope Member Unity Check Results - Bending

SK - 8
July 17, 2019 at 9:54 AM
41124-12927156-01-MA-R2.r3d

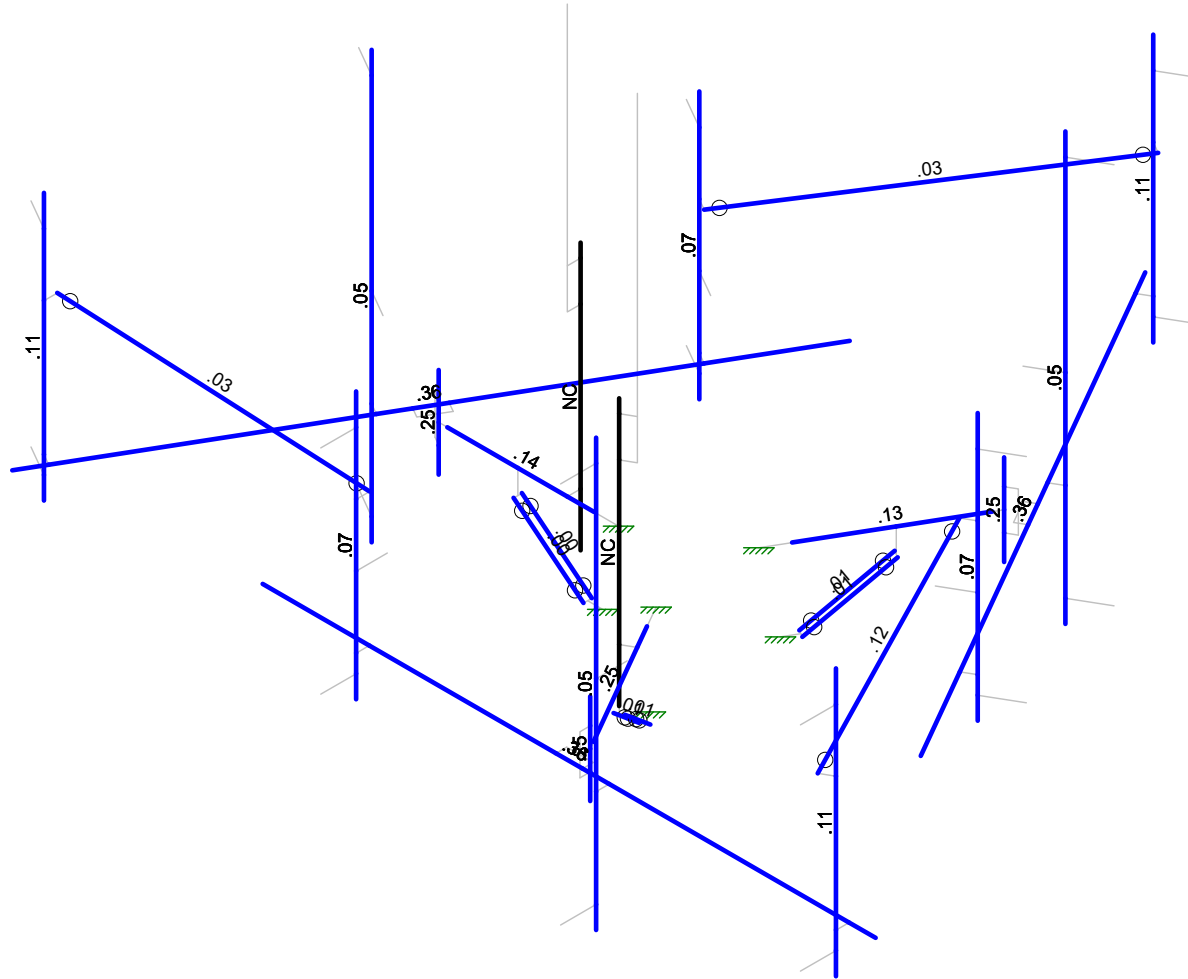
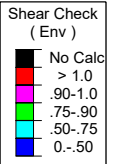
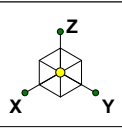

Member Shear Checks Displayed (Enveloped)
Envelope Only Solution

CLS	41124-12927156-Old Lyme South CT Envelope Member Check Results - Shear	SK - 9
BP		July 17, 2019 at 9:54 AM
41124-12927156-01-MA-R2		41124-12927156-01-MA-R2.r3d

Basic Load Cases

	BLC Description	Category	X Gravi...	Y Gravi...	Z Gravity	Joint	Point	Distributed	Area(Member)	Surfac...
1	Dead	DL			-1	26				
2	Ice Dead	RL				26		29		
4	Structure Wind 0°	None						29		
5	Structure Wind 30°	None						54		
6	Structure Wind 45°	None						58		
7	Structure Wind 60°	None						58		
8	Structure Wind 90°	None						27		
9	Structure Wind 120°	None						58		
10	Structure Wind 135°	None						58		
11	Structure Wind 150°	None						54		
12	Structure Wind w/ Ice 0°	None						29		
13	Structure Wind w/ Ice 30°	None						54		
14	Structure Wind w/ Ice 45°	None						58		
15	Structure Wind w/ Ice 60°	None						58		
16	Structure Wind w/ Ice 90°	None						27		
17	Structure Wind w/ Ice 120°	None						58		
18	Structure Wind w/ Ice 135°	None						58		
19	Structure Wind w/ Ice 150°	None						54		
20	Antenna Wind 0°	None				26				
21	Antenna Wind 30°	None				52				
22	Antenna Wind 45°	None				52				
23	Antenna Wind 60°	None				52				
24	Antenna Wind 90°	None				26				
25	Antenna Wind 120°	None				52				
26	Antenna Wind 135°	None				52				
27	Antenna Wind 150°	None				52				
28	Antenna Wind w/ Ice 0°	None				26				
29	Antenna Wind w/ Ice 30°	None				52				
30	Antenna Wind w/ Ice 45°	None				52				
31	Antenna Wind w/ Ice 60°	None				52				
32	Antenna Wind w/ Ice 90°	None				26				
33	Antenna Wind w/ Ice 120°	None				52				
34	Antenna Wind w/ Ice 135°	None				52				
35	Antenna Wind w/ Ice 150°	None				52				
39	Maintenance Live 500 (1)	OL1				1				
40	Maintenance Live 500 (2)	OL2				1				
41	Maintenance Live 500 (3)	OL3				1				

Load Combinations

	Description	S...P...S...	BLC	Factor	BLC	Factor	BLC	Factor	B...	Fa...	B...	Fa...	B...	Fa...	B...	Fa...	B...	Fa...	B...	Fa...
1	DISPLAY (1.0D + ...Y...	Y	DL	1	20	1														
2	1.4D	Y	DL	1.4																
3	1.2D + 1.0W 0°	Y...	DL	1.2	4	1	20	1												
4	1.2D + 1.0W 30°	Y...	DL	1.2	5	1	21	1												
5	1.2D + 1.0W 45°	Y...	DL	1.2	6	1	22	1												
6	1.2D + 1.0W 60°	Y...	DL	1.2	7	1	23	1												
7	1.2D + 1.0W 90°	Y...	DL	1.2	8	1	24	1												
8	1.2D + 1.0W 120°	Y...	DL	1.2	9	1	25	1												
9	1.2D + 1.0W 135°	Y...	DL	1.2	10	1	26	1												
10	1.2D + 1.0W 150°	Y...	DL	1.2	11	1	27	1												
11	1.2D + 1.0W 180°	Y...	DL	1.2	4	-1	20	-1												
12	1.2D + 1.0W 210°	Y...	DL	1.2	5	-1	21	-1												
13	1.2D + 1.0W 225°	Y...	DL	1.2	6	-1	22	-1												
14	1.2D + 1.0W 240°	Y...	DL	1.2	7	-1	23	-1												

Load Combinations (Continued)

	Description	S...	P...	S...	BLC	Factor	BLC	Factor	BLC	Factor	B...	Fa...	B...	Fa...	B...	Fa...	B...	Fa...	B...	Fa...
72	1.2D + 1.5Lm_3 +...Y...	Y		Y	DL	1.2	9	.052	25	.052	O...	1.5								
73	1.2D + 1.5Lm_3 +...Y...	Y		Y	DL	1.2	10	.052	26	.052	O...	1.5								
74	1.2D + 1.5Lm_3 +...Y...	Y		Y	DL	1.2	11	.052	27	.052	O...	1.5								
75	1.2D + 1.5Lm_3 +...Y...	Y		Y	DL	1.2	4	-.052	20	-.052	O...	1.5								
76	1.2D + 1.5Lm_3 +...Y...	Y		Y	DL	1.2	5	-.052	21	-.052	O...	1.5								
77	1.2D + 1.5Lm_3 +...Y...	Y		Y	DL	1.2	6	-.052	22	-.052	O...	1.5								
78	1.2D + 1.5Lm_3 +...Y...	Y		Y	DL	1.2	7	-.052	23	-.052	O...	1.5								
79	1.2D + 1.5Lm_3 +...Y...	Y		Y	DL	1.2	8	-.052	24	-.052	O...	1.5								
80	1.2D + 1.5Lm_3 +...Y...	Y		Y	DL	1.2	9	-.052	25	-.052	O...	1.5								
81	1.2D + 1.5Lm_3 +...Y...	Y		Y	DL	1.2	10	-.052	26	-.052	O...	1.5								
82	1.2D + 1.5Lm_3 +...Y...	Y		Y	DL	1.2	11	-.052	27	-.052	O...	1.5								

Hot Rolled Steel Properties

	Label	E [ksi]	G [ksi]	Nu	Therm (\1E...	Density[k/ft...	Yield[ksi]	Ry	Fu[ksi]	Rt
1	A992	29000	11154	.3	.65	.49	50	1.1	65	1.1
2	A36 Gr.36	29000	11154	.3	.65	.49	36	1.5	58	1.2
3	A572 Gr.50	29000	11154	.3	.65	.49	50	1.1	65	1.1
4	A500 Gr.B RND	29000	11154	.3	.65	.527	42	1.4	58	1.3
5	A500 Gr.B Rect	29000	11154	.3	.65	.527	46	1.4	58	1.3
6	A53 Gr.B	29000	11154	.3	.65	.49	35	1.6	60	1.2
7	A1085	29000	11154	.3	.65	.49	50	1.4	65	1.3
8	A500 GR.C RND	29000	11154	.3	.65	.49	46	1.5	58	1.3
9	A500 GR.C RECT	29000	11154	.3	.65	.49	50	1.5	58	1.3

Hot Rolled Steel Section Sets

	Label	Shape	Type	Design List	Material	Design R...	A [in2]	Iyy [in4]	Izz [in4]	J [in4]
1	Mount Pipe	PIPE 2.0	Beam	None	A53 Gr.B	Typical	1.02	.627	.627	1.25
2	Main Offset tube	HSS4X4X4	Beam	None	A500 Gr....	Typical	3.37	7.8	7.8	12.8
3	Main Face Pipe	PIPE 3.0	Beam	None	A53 Gr.B	Typical	2.07	2.85	2.85	5.69
4	Vertical pipe	PIPE 3.0	Beam	None	A53 Gr.B	Typical	2.07	2.85	2.85	5.69
5	MOD Mount Pipe	PIPE 2.5	Beam	None	A53 Gr.B	Typical	1.61	1.45	1.45	2.89
6	MOD Bracing Pipe	PIPE 2.0	Beam	None	A53 Gr.B	Typical	1.02	.627	.627	1.25
7	MOD PRK	L2.5x2.5x3	Beam	None	A36 Gr.36	Typical	.901	.535	.535	.011

Hot Rolled Steel Design Parameters

	Label	Shape	Length[in]	Lbyy[in]	Lbzz[in]	Lcomp top[in]	Lcomp bot[in]	L-torq...	Kyy	Kzz	Cb	Function
1	M1	MOD Bracin...	73.946			Lbyy						Lateral
2	M2	MOD Bracin...	73.946			Lbyy						Lateral
3	M3	MOD Bracin...	73.946			Lbyy						Lateral
4	M4	MOD Mount...	96			Lbyy						Lateral
5	M5	MOD Mount...	96			Lbyy						Lateral
6	M6	MOD Mount...	96			Lbyy						Lateral
7	M7	MOD PRK	20.16			Lbyy						Lateral
8	M8	MOD PRK	20.16			Lbyy						Lateral
9	M9	MOD PRK	20.16			Lbyy						Lateral
10	M10	MOD PRK	20.16			Lbyy						Lateral
11	M11	MOD PRK	20.16			Lbyy						Lateral
12	M12	MOD PRK	20.16			Lbyy						Lateral
13	M13	Main Face ...	138			Lbyy						Lateral
14	M14	Main Face ...	138			Lbyy						Lateral
15	M15	Main Face ...	138			Lbyy						Lateral
16	M16	Main Offset ...	33			Lbyy						Lateral

Hot Rolled Steel Design Parameters (Continued)

	Label	Shape	Length[in]	Lbyy[in]	Lbzz[in]	Lcomp top[in]	Lcomp bot[in]	L-torg...	Kyy	Kzz	Cb	Function
17	M17	Main Offset ...	33			Lbyy						Lateral
18	M18	Main Offset ...	33			Lbyy						Lateral
19	M19	Mount Pipe	60			Lbyy						Lateral
20	M20	Mount Pipe	60			Lbyy						Lateral
21	M21	Mount Pipe	60			Lbyy						Lateral
22	M22	Mount Pipe	60			Lbyy						Lateral
23	M23	Mount Pipe	60			Lbyy						Lateral
24	M24	Mount Pipe	60			Lbyy						Lateral
25	M25	Mount Pipe	60			Lbyy						Lateral
26	M26	Mount Pipe	60			Lbyy						Lateral
27	M113	Vertical pipe	20.4			Lbyy						Lateral
28	M114	Vertical pipe	20.4			Lbyy						Lateral
29	M115	Vertical pipe	20.4			Lbyy						Lateral

Envelope Joint Reactions

	Joint		X [lb]	LC	Y [lb]	LC	Z [lb]	LC	MX [lb-ft]	LC	MY [lb-ft]	LC	MZ [lb-ft]	LC
1	N14	max	2452.479	3	1809.302	17	1414.567	18	2301.247	5	2846.538	38	4605.818	13
2		min	-5705.672	11	-3650.803	9	-2799.589	10	-2843.366	13	-1014.389	14	-4642.48	5
3	N114	max	1392.227	18	5984.649	31	900.42	7	1857.037	31	1411.821	3	4357.47	18
4		min	-1348.283	10	-2114.584	7	-2415.574	31	-566.084	7	-1433.762	11	-4400.028	10
5	N69	max	5044.119	20	1300.08	14	717.18	13	653.346	11	765.167	14	4290.711	7
6		min	-1695.543	12	-3194.899	6	-2450.559	20	-1307.57	3	-1806.193	6	-4333.027	15
7	P5	max	5043.857	26	2913.192	26	4708.913	26	736.103	40	219.65	3	471.659	13
8		min	-819.044	18	-472.291	18	-763.995	18	-237.808	16	-1144.618	27	-484.22	5
9	P21	max	29.643	3	348.082	7	4610.817	31	79.789	7	322.157	18	407.431	18
10		min	-29.249	11	-5702.521	31	-283.694	7	-1296.792	31	-333.089	10	-421.962	10
11	P13	max	144.256	13	2796.421	20	4524.014	20	655.558	23	1117.173	20	396.176	7
12		min	-4845.361	20	-79.707	12	-136.833	13	-170.138	15	-68.895	12	-410.969	15
13	Totals:	max	4681.601	3	4681.554	15	6484.881	29						
14		min	-4681.61	11	-4681.596	7	2036.961	1						

Envelope AISC 14th(360-10): LRFD Steel Code Checks

	Member	Shape	Code Check	Loc[in]	LC	Shear Check	Loc[in]	Dir	LC	phi*Pn...	phi*Pn...	phi*Mn...	phi*Mn....	Eqn
1	M13	PIPE 3.0	.744	65.368	39	.356	65.368		11	32123...	65205	5748.75	5748.75...	H1-1b
2	M4	PIPE 2.5	.585	68.716	11	.053	46.484		5	30038...	50715	3596.25	3596.25...	H1-1b
3	M5	PIPE 2.5	.585	68.716	6	.053	68.716		15	30038...	50715	3596.25	3596.25...	H1-1b
4	M6	PIPE 2.5	.585	68.716	16	.053	68.716		10	30038...	50715	3596.25	3596.25...	H1-1b
5	M15	PIPE 3.0	.494	65.368	29	.357	65.368		16	32123...	65205	5748.75	5748.75...	H1-1b
6	M14	PIPE 3.0	.494	65.368	34	.357	65.368		6	32123...	65205	5748.75	5748.75...	H1-1b
7	M20	PIPE 2.0	.431	50.526	13	.105	50.526		14	23808...	32130	1871.6...	1871.6.....	H1-1b
8	M22	PIPE 2.0	.429	50.526	8	.105	50.526		8	23808...	32130	1871.6...	1871.6.....	H1-1b
9	M24	PIPE 2.0	.428	50.526	3	.105	50.526		3	23808...	32130	1871.6...	1871.6.....	H1-1b
10	M21	PIPE 2.0	.399	50.526	13	.072	50.526		14	23808...	32130	1871.6...	1871.6.....	H1-1b
11	M19	PIPE 2.0	.393	50.526	3	.072	50.526		3	23808...	32130	1871.6...	1871.6.....	H1-1b
12	M23	PIPE 2.0	.390	50.526	8	.073	50.526		9	23808...	32130	1871.6...	1871.6.....	H1-1b
13	M16	HSS4X4X4	.350	0	13	.254	0	z	6	13517...	139518	16180.5	16180.5...	H3-6
14	M17	HSS4X4X4	.344	17.368	19	.127	17.368	z	15	13517...	139518	16180.5	16180.5...	H1-1b
15	M18	HSS4X4X4	.344	17.368	30	.139	0	z	11	13517...	139518	16180.5	16180.5...	H1-1b
16	M113	PIPE 3.0	.308	10.307	41	.254	10.093		10	64204...	65205	5748.75	5748.75...	H1-1b
17	M1	PIPE 2.0	.289	73.946	9	.029	0		17	20379...	32130	1871.6...	1871.6.....	H1-1b
18	M2	PIPE 2.0	.278	73.946	4	.118	73.946		35	20379...	32130	1871.6...	1871.6.....	H1-1b
19	M3	PIPE 2.0	.275	73.946	15	.026	0		6	20379...	32130	1871.6...	1871.6.....	H1-1b
20	M114	PIPE 3.0	.267	10.093	5	.253	10.093		4	64204...	65205	5748.75	5748.75...	H1-1b
21	M115	PIPE 3.0	.264	10.093	15	.253	10.093		15	64204...	65205	5748.75	5748.75...	H1-1b

Envelope AISC 14th(360-10): LRFD Steel Code Checks (Continued)

Member	Shape	Code Check	Loc[in]	LC	Shear Check	Loc[in]	Dir	LC	phi*Pn...	phi*Pn...	phi*Mn...	phi*Mn.....	Eqn	
22	M8	L2.5x2.5x3	.225	9.974	12	.012	0	y	44	26234...	29192.4	872.574	1971.83...	H2-1
23	M12	L2.5x2.5x3	.204	9.974	18	.005	0	z	10	26234...	29192.4	872.574	1971.83...	H2-1
24	M7	L2.5x2.5x3	.202	10.398	40	.012	0	z	44	26234...	29192.4	872.574	1971.83...	H2-1
25	M10	L2.5x2.5x3	.199	9.974	7	.006	20.16	z	15	26234...	29192.4	872.574	1971.83...	H2-1
26	M11	L2.5x2.5x3	.184	10.186	11	.005	0	y	10	26234...	29192.4	872.574	1971.83...	H2-1
27	M9	L2.5x2.5x3	.180	10.186	16	.006	20.16	y	15	26234...	29192.4	872.574	1971.83...	H2-1

BOLTED CONNECTION ROTATIONAL SLIP RESISTANCE

v. 2017.11.20

DESIGN LOADS	
Factored Moment, M_u (lb-ft)	1636

BOLT PROPERTIES	
Bolt Type	U-Bolt
# of U-Bolts	2
Hole Type	Standard
Bolt Grade	A36
Bolt Diameter, d (in)	0.5
Leg Width, W_{leg} (in)	3.5
Bolt Torque Override, T (lb-ft)	50
Bolt Pretension Stress Override (ksi)	
Bolt Ultimate Strength, F_u (ksi)	58
Specified Torque, T (lb-ft)	50.00
Clamping Force per Bolt, P_u (lb)	6000.00
Bolt Pretension Stress (ksi)	30.56
Tensile Strength per Bolt, ϕP_n (lb)	6405.90
Slip Resistance per Bolt, ϕM_n (lb-ft)	593.25
Total Slip Resistance, ϕM_n (lb-ft)	2373.00
Connection Slip Usage, $M_u / \phi M_n$	0.69

FACTORS	
Nut Factor, K	0.20
$\phi_{(BOLT\ TENSION)}$	0.75
$\phi_{(SLIP-CRITICAL)}$	1.00
Mean Slip Coefficient, μ	0.30
Installed Pretension Ratio, D_u	1.13

Rule-of-thumb estimate

AISC 15th, J3.6

AISC 15th, J3.8

AISC 15th, J3.8

AISC 15th, J3.8

Using Torque Override

Exhibit F

Power Density/RF Emissions Report

**RADIO FREQUENCY EMISSIONS ANALYSIS REPORT
EVALUATION OF HUMAN EXPOSURE POTENTIAL
TO NON-IONIZING EMISSIONS**

T-Mobile Existing Facility

Site ID: CTNL802A

Amtrak Old Lyme Verizon
125 Mile Creek Road
Old Lyme, Connecticut 06371

May 30, 2019

EBI Project Number: 6219001997

Site Compliance Summary	
Compliance Status:	COMPLIANT
Site total MPE% of FCC general population allowable limit:	8.54%

May 30, 2019

T-Mobile

Attn: Jason Overbey, RF Manager
35 Griffin Road South
Bloomfield, Connecticut 06002

Emissions Analysis for Site: CTNL802A - Amtrak Old Lyme Verizon

EBI Consulting was directed to analyze the proposed T-Mobile facility located at **125 Mile Creek Road in Old Lyme, Connecticut** for the purpose of determining whether the emissions from the Proposed T-Mobile Antenna Installation located on this property are within specified federal limits.

All information used in this report was analyzed as a percentage of current Maximum Permissible Exposure (% MPE) as listed in the FCC OET Bulletin 65 Edition 97-01 and ANSI/IEEE Std C95.1. The FCC regulates Maximum Permissible Exposure in units of microwatts per square centimeter ($\mu\text{W}/\text{cm}^2$). The number of $\mu\text{W}/\text{cm}^2$ calculated at each sample point is called the power density. The exposure limit for power density varies depending upon the frequencies being utilized. Wireless Carriers and Paging Services use different frequency bands each with different exposure limits; therefore, it is necessary to report results and limits in terms of percent MPE rather than power density.

All results were compared to the FCC (Federal Communications Commission) radio frequency exposure rules, 47 CFR 1.1307(b)(1) – (b)(3), to determine compliance with the Maximum Permissible Exposure (MPE) limits for General Population/Uncontrolled environments as defined below.

General population/uncontrolled exposure limits apply to situations in which the general population may be exposed or in which persons who are exposed as a consequence of their employment may not be made fully aware of the potential for exposure or cannot exercise control over their exposure. Therefore, members of the general population would always be considered under this category when exposure is not employment related, for example, in the case of a telecommunications tower that exposes persons in a nearby residential area.

Public exposure to radio frequencies is regulated and enforced in units of microwatts per square centimeter ($\mu\text{W}/\text{cm}^2$). The general population exposure limits for the 600 MHz and 700 MHz frequency bands are approximately $400 \mu\text{W}/\text{cm}^2$ and $467 \mu\text{W}/\text{cm}^2$, respectively. The general population exposure limit for the 1900 MHz (PCS), 2100 MHz (AWS) and 11 GHz frequency bands is $1000 \mu\text{W}/\text{cm}^2$. Because each carrier will be using different frequency bands, and each frequency band has different exposure limits, it is necessary to report percent of MPE rather than power density.

Occupational/controlled exposure limits apply to situations in which persons are exposed as a consequence of their employment and in which those persons who are exposed have been made fully aware of the potential for exposure and can exercise control over their exposure. Occupational/controlled exposure limits also apply where exposure is of a transient nature as a result of incidental passage through a location where exposure levels may be above general population/uncontrolled limits (see below), as long as the exposed person has been made fully aware of the potential for exposure and can exercise control over his or her exposure by leaving the area or by some other appropriate means.

Additional details can be found in FCC OET 65.

CALCULATIONS

Calculations were done for the proposed T-Mobile Wireless antenna facility located at 125 Mile Creek Road in Old Lyme, Connecticut using the equipment information listed below. All calculations were performed per the specifications under FCC OET 65. Since T-Mobile is proposing highly focused directional panel antennas, which project most of the emitted energy out toward the horizon, all calculations were performed assuming a lobe representing the maximum gain of the antenna per the antenna manufacturer's supplied specifications, minus 10 dB for directional panel antennas and 20 dB for highly focused parabolic microwave dishes, was focused at the base of the tower. For this report, the sample point is the top of a 6-foot person standing at the base of the tower.

For all calculations, all equipment was calculated using the following assumptions:

- 1) 2 LTE channels (600 MHz Band) were considered for each sector of the proposed installation. These Channels have a transmit power of 30 Watts per Channel.
- 2) 2 LTE channels (700 MHz Band) were considered for each sector of the proposed installation. These Channels have a transmit power of 30 Watts per Channel.
- 3) 4 GSM channels (PCS Band - 1900 MHz) were considered for each sector of the proposed installation. These Channels have a transmit power of 30 Watts per Channel.
- 4) 2 UMTS channels (PCS Band - 1900 MHz) were considered for each sector of the proposed installation. These Channels have a transmit power of 30 Watts per Channel.
- 5) 2 UMTS channels (AWS Band - 2100 MHz) were considered for each sector of the proposed installation. These Channels have a transmit power of 30 Watts per Channel.

- 6) 2 LTE channels (AWS Band – 2100 MHz) were considered for each sector of the proposed installation. These Channels have a transmit power of 60 Watts per Channel.
- 7) All radios at the proposed installation were considered to be running at full power and were uncombined in their RF transmissions paths per carrier prescribed configuration. Per FCC OET Bulletin No. 65 - Edition 97-01 recommendations to achieve the maximum anticipated value at each sample point, all power levels emitting from the proposed antenna installation are increased by a factor of 2.56 to account for possible in-phase reflections from the surrounding environment. This is rarely the case, and if so, is never continuous.
- 8) For the following calculations, the sample point was the top of a 6-foot person standing at the base of the tower. The maximum gain of the antenna per the antenna manufacturer's supplied specifications, minus 10 dB for directional panel antennas and 20 dB for highly focused parabolic microwave dishes, was used in this direction. This value is a very conservative estimate as gain reductions for these particular antennas are typically much higher in this direction.
- 9) The antennas used in this modeling are the Ericsson AIR 21 for the 2100 MHz channel(s), the RFS APXVAARR24_43-U-NA20 for the 600 MHz / 700 MHz channel(s), the Ericsson AIR 21 for the 1900 MHz / 1900 MHz / 2100 MHz channel(s) in Sector A, the Ericsson AIR 21 for the 2100 MHz channel(s), the RFS APXVAARR24_43-U-NA20 for the 600 MHz / 700 MHz channel(s), the Ericsson AIR 21 for the 1900 MHz / 1900 MHz / 2100 MHz channel(s) in Sector B, the Ericsson AIR 21 for the 2100 MHz channel(s), the RFS APXVAARR24_43-U-NA20 for the 600 MHz / 700 MHz channel(s), the Ericsson AIR 21 for the 1900 MHz / 1900 MHz / 2100 MHz channel(s) in Sector C. This is based on feedback from the carrier with regard to anticipated antenna selection. All Antenna gain values and associated transmit power levels are shown in the Site Inventory and Power Data table below. The maximum gain of the antenna per the antenna manufacturer's supplied specifications, minus 10 dB for directional panel antennas and 20 dB for highly focused parabolic microwave dishes, was used for all calculations. This value is a very conservative estimate as gain reductions for these particular antennas are typically much higher in this direction.
- 10) The antenna mounting height centerline of the proposed antennas is 171 feet above ground level (AGL).
- 11) Emissions values for additional carriers were taken from the Connecticut Siting Council active database. Values in this database are provided by the individual carriers themselves.
- 12) All calculations were done with respect to uncontrolled / general population threshold limits.

T-Mobile Site Inventory and Power Data

Sector:	A	Sector:	B	Sector:	C
Antenna #:	1	Antenna #:	1	Antenna #:	1
Make / Model:	Ericsson AIR 21	Make / Model:	Ericsson AIR 21	Make / Model:	Ericsson AIR 21
Frequency Bands:	2100 MHz	Frequency Bands:	2100 MHz	Frequency Bands:	2100 MHz
Gain:	15.35 dBd	Gain:	15.35 dBd	Gain:	15.35 dBd
Height (AGL):	171 feet	Height (AGL):	171 feet	Height (AGL):	171 feet
Channel Count:	2	Channel Count:	2	Channel Count:	2
Total TX Power (W):	120 Watts	Total TX Power (W):	120 Watts	Total TX Power (W):	120 Watts
ERP (W):	4,113.21	ERP (W):	4,113.21	ERP (W):	4,113.21
Antenna A1 MPE %:	0.51%	Antenna B1 MPE %:	0.51%	Antenna C1 MPE %:	0.51%
Antenna #:	2	Antenna #:	2	Antenna #:	2
Make / Model:	RFS APXVAARR24_43-U-NA20	Make / Model:	RFS APXVAARR24_43-U-NA20	Make / Model:	RFS APXVAARR24_43-U-NA20
Frequency Bands:	600 MHz / 700 MHz	Frequency Bands:	600 MHz / 700 MHz	Frequency Bands:	600 MHz / 700 MHz
Gain:	12.95 dBd / 13.35 dBd	Gain:	12.95 dBd / 13.35 dBd	Gain:	12.95 dBd / 13.35 dBd
Height (AGL):	171 feet	Height (AGL):	171 feet	Height (AGL):	171 feet
Channel Count:	4	Channel Count:	4	Channel Count:	4
Total TX Power (W):	120 Watts	Total TX Power (W):	120 Watts	Total TX Power (W):	120 Watts
ERP (W):	2,481.08	ERP (W):	2,481.08	ERP (W):	2,481.08
Antenna A2 MPE %:	0.71%	Antenna B2 MPE %:	0.71%	Antenna C2 MPE %:	0.71%
Antenna #:	3	Antenna #:	3	Antenna #:	3
Make / Model:	Ericsson AIR 21	Make / Model:	Ericsson AIR 21	Make / Model:	Ericsson AIR 21
Frequency Bands:	1900 MHz / 1900 MHz / 2100 MHz	Frequency Bands:	1900 MHz / 1900 MHz / 2100 MHz	Frequency Bands:	1900 MHz / 1900 MHz / 2100 MHz
Gain:	15.35 dBd / 15.35 dBd / 15.35 dBd	Gain:	15.35 dBd / 15.35 dBd / 15.35 dBd	Gain:	15.35 dBd / 15.35 dBd / 15.35 dBd
Height (AGL):	171 feet	Height (AGL):	171 feet	Height (AGL):	171 feet
Channel Count:	8	Channel Count:	8	Channel Count:	8
Total TX Power (W):	240 Watts	Total TX Power (W):	240 Watts	Total TX Power (W):	240 Watts
ERP (W):	8,226.43	ERP (W):	8,226.43	ERP (W):	8,226.43
Antenna A3 MPE %:	1.01%	Antenna B3 MPE %:	1.01%	Antenna C3 MPE %:	1.01%

Site Composite MPE %	
Carrier	MPE %
T-Mobile (Max at Sector A):	2.22%
Sprint	2.77%
Verizon	2.8%
AT&T	0.75%
Site Total MPE % :	8.54%

T-Mobile MPE % Per Sector	
T-Mobile Sector A Total:	2.22%
T-Mobile Sector B Total:	2.22%
T-Mobile Sector C Total:	2.22%
Site Total MPE % :	
	8.54%

T-Mobile Maximum MPE Power Values (Sector A)							
T-Mobile Frequency Band / Technology (Sector A)	# Channels	Watts ERP (Per Channel)	Height (feet)	Total Power Density ($\mu\text{W}/\text{cm}^2$)	Frequency (MHz)	Allowable MPE ($\mu\text{W}/\text{cm}^2$)	Calculated % MPE
T-Mobile 2100 MHz LTE	2	2056.61	171.0	5.06	2100 MHz LTE	1000	0.51%
T-Mobile 600 MHz LTE	2	591.73	171.0	1.46	600 MHz LTE	400	0.36%
T-Mobile 700 MHz LTE	2	648.82	171.0	1.60	700 MHz LTE	467	0.34%
T-Mobile 1900 MHz GSM	4	1028.30	171.0	5.06	1900 MHz GSM	1000	0.51%
T-Mobile 1900 MHz UMTS	2	1028.30	171.0	2.53	1900 MHz UMTS	1000	0.25%
T-Mobile 2100 MHz UMTS	2	1028.30	171.0	2.53	2100 MHz UMTS	1000	0.25%
						Total:	2.22%

• NOTE: Totals may vary by approximately 0.01% due to summation of remainders in calculations.

Summary

All calculations performed for this analysis yielded results that were **within** the allowable limits for general population exposure to RF Emissions.

The anticipated maximum composite contributions from the T-Mobile facility as well as the site composite emissions value with regards to compliance with FCC's allowable limits for general population exposure to RF Emissions are shown here:

T-Mobile Sector	Power Density Value (%)
Sector A:	2.22%
Sector B:	2.22%
Sector C:	2.22%
T-Mobile Maximum MPE % (Sector A):	2.22%
Site Total:	8.54%
Site Compliance Status:	COMPLIANT

The anticipated composite MPE value for this site assuming all carriers present is **8.54%** of the allowable FCC established general population limit sampled at the ground level. This is based upon values listed in the Connecticut Siting Council database for existing carrier emissions.

FCC guidelines state that if a site is found to be out of compliance (over allowable thresholds), that carriers over a 5% contribution to the composite value will require measures to bring the site into compliance. For this facility, the composite values calculated were well within the allowable 100% threshold standard per the federal government.

Exhibit G

Mailing Receipts/Proof of Notice

UPS Internet Shipping: View/Print Label

1. **Ensure there are no other shipping or tracking labels attached to your package.** Select the Print button on the print dialog box that appears. Note: If your browser does not support this function select Print from the File menu to print the label.
2. **Fold the printed label at the solid line below.** Place the label in a UPS Shipping Pouch. If you do not have a pouch, affix the folded label using clear plastic shipping tape over the entire label.
3. **GETTING YOUR SHIPMENT TO UPS**
Customers with a Daily Pickup
 Your driver will pickup your shipment(s) as usual.

Customers without a Daily Pickup

Take your package to any location of The UPS Store®, UPS Access Point(TM) location, UPS Drop Box, UPS Customer Center, Staples® or Authorized Shipping Outlet near you. Items sent via UPS Return Services(SM) (including via Ground) are also accepted at Drop Boxes. To find the location nearest you, please visit the 'Find Locations' Quick link at ups.com.

Schedule a same day or future day Pickup to have a UPS driver pickup all of your Internet Shipping packages. Hand the package to any UPS driver in your area.

UPS Access Point™
 THE UPS STORE
 115 FRANKLIN TPKE
 MAHWAH ,NJ 07430

UPS Access Point™
 THE UPS STORE
 120 E MAIN ST
 RAMSEY ,NJ 07446

UPS Access Point™
 POSTNET NY137
 74 LAFAYETTE AVE
 SUFFERN ,NY 10901

FOLD HERE

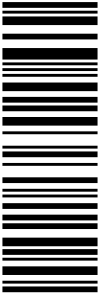
<p>1 LBS</p> <p>1 OF 1</p> <p>NEIL GUERRIERO 3473040176 TRANSCEND WIRELESS 10 INDUSTRIAL AVE MAHWAH NJ 07430</p> <p>SHIP TO: MACHNIK TODD & REBECCA L Q/C/S 126 MILE CREEK ROAD OLD LYME CT 06371-1718</p>	<p>CT 063 5-02</p>  	<p>UPS GROUND</p> <p>TRACKING #: 1Z V25 742 03 9134 3283</p> 	<p>BILLING: P/P</p> <p>Reference#1: CTTNL802A Reference#2: UPS-Prop Owner</p>  <p><small>UPS 21.5.22. WNTNVS0 12.04.04/2019</small></p>
--	---	---	---

UPS Internet Shipping: View/Print Label

1. **Ensure there are no other shipping or tracking labels attached to your package.** Select the Print button on the print dialog box that appears. Note: If your browser does not support this function select Print from the File menu to print the label.
2. **Fold the printed label at the solid line below.** Place the label in a UPS Shipping Pouch. If you do not have a pouch, affix the folded label using clear plastic shipping tape over the entire label.
3. **GETTING YOUR SHIPMENT TO UPS**
Customers with a Daily Pickup
Your driver will pickup your shipment(s) as usual.

Customers without a Daily Pickup

Take your package to any location of The UPS Store®, UPS Access Point(TM) location, UPS Drop Box, UPS Customer Center, Staples® or Authorized Shipping Outlet near you. Items sent via UPS Return Services(SM) (including via Ground) are also accepted at Drop Boxes. To find the location nearest you, please visit the 'Find Locations' Quick link at ups.com.

Schedule a same day or future day Pickup to have a UPS driver pickup all of your Internet Shipping packages. Hand the package to any UPS driver in your area.

UPS Access Point™
THE UPS STORE
115 FRANKLIN TPKE
MAHWAH ,NJ 07430

UPS Access Point™
THE UPS STORE
120 E MAIN ST
RAMSEY ,NJ 07446

UPS Access Point™
POSTNET NY137
74 LAFAYETTE AVE
SUFFERN ,NY 10901

FOLD HERE

<p>1 LBS</p> <p>1 OF 1</p> <p>NEIL GUERRIERO 3473040176 TRANSCEND WIRELESS 10 INDUSTRIAL AVE MAHWAH NJ 07430</p> <p>SHIP TO: KIM GROVES, LAND USE ADMINISTRATOR TOWN OF OLD LYME 52 LYME STREET OLD LYME CT 06371-2331</p>	 <p>CT 063 5-02</p> 	<p>UPS NEXT DAY AIR</p> <p>1</p> <p>TRACKING #: 1Z V25 742 01 9094 9376</p>		<p>BILLING: P/P</p> <p>Reference#1: CTNL802A Reference#2: planner</p>  <p>UPS 21.5.22. WNTNVS0 12.04.04/2019</p>
---	---	---	--	---

UPS Internet Shipping: View/Print Label

1. **Ensure there are no other shipping or tracking labels attached to your package.** Select the Print button on the print dialog box that appears. Note: If your browser does not support this function select Print from the File menu to print the label.

2. **Fold the printed label at the solid line below.** Place the label in a UPS Shipping Pouch. If you do not have a pouch, affix the folded label using clear plastic shipping tape over the entire label.

3. GETTING YOUR SHIPMENT TO UPS

Customers with a Daily Pickup

Your driver will pickup your shipment(s) as usual.

Customers without a Daily Pickup

Take your package to any location of The UPS Store®, UPS Access Point(TM) location, UPS Drop Box, UPS Customer Center, Staples® or Authorized Shipping Outlet near you. Items sent via UPS Return Services(SM) (including via Ground) are also accepted at Drop Boxes. To find the location nearest you, please visit the 'Find Locations' Quick link at ups.com.

Schedule a same day or future day Pickup to have a UPS driver pickup all of your Internet Shipping packages.



Hand the package to any UPS driver in your area.

UPS Access Point™
THE UPS STORE
115 FRANKLIN TPKE
MAHWAH ,NJ 07430

UPS Access Point™
THE UPS STORE
120 E MAIN ST
RAMSEY ,NJ 07446

UPS Access Point™
POSTNET NY137
74 LAFAYETTE AVE
SUFFERN ,NY 10901

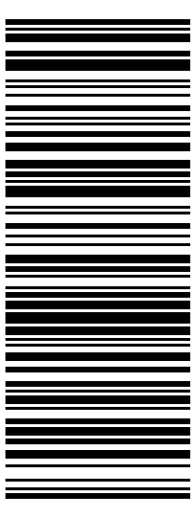
FOLD HERE

<p>NEIL GUERRIERO 3473040176 TRANSCEND WIRELESS 10 INDUSTRIAL AVE MAHWAH NJ 07430</p> <p>SHIP TO: BONNIE A. REEMSNYDER TOWN OF OLD LYME 52 LYME STREET OLD LYME CT 06371-2331</p>	<p style="text-align: right;">1 OF 1</p> <p style="text-align: center;">CT 063 5-02</p> 	<p style="text-align: center;">UPS GROUND</p> <p>TRACKING #: 1Z V25 742 03 9342 2907</p> 	<p style="text-align: center;">BILLING: P/P</p>  <p style="font-size: small; text-align: center;">UPS 21.5.22. WINTNVS0 12.0A 04/2019</p>
---	---	--	--

UPS Internet Shipping: View/Print Label

1. **Ensure there are no other shipping or tracking labels attached to your package.** Select the Print button on the print dialog box that appears. Note: If your browser does not support this function select Print from the File menu to print the label.

2. **Fold the printed label at the solid line below.** Place the label in a UPS Shipping Pouch. If you do not have a pouch, affix the folded label using clear plastic shipping tape over the entire label.

3. GETTING YOUR SHIPMENT TO UPS

Customers with a Daily Pickup

Your driver will pickup your shipment(s) as usual.

Customers without a Daily Pickup

Take your package to any location of The UPS Store®, UPS Access Point(TM) location, UPS Drop Box, UPS Customer Center, Staples® or Authorized Shipping Outlet near you. Items sent via UPS Return Services(SM) (including via Ground) are also accepted at Drop Boxes. To find the location nearest you, please visit the 'Find Locations' Quick link at ups.com.

Schedule a same day or future day Pickup to have a UPS driver pickup all of your Internet Shipping packages.



Hand the package to any UPS driver in your area.

UPS Access Point™
THE UPS STORE
115 FRANKLIN TPKE
MAHWAH ,NJ 07430

UPS Access Point™
THE UPS STORE
120 E MAIN ST
RAMSEY ,NJ 07446

UPS Access Point™
POSTNET NY137
74 LAFAYETTE AVE
SUFFERN ,NY 10901

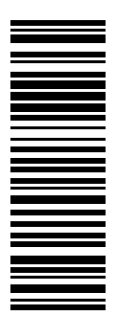
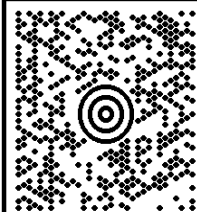
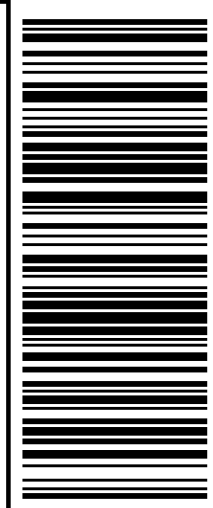
FOLD HERE

<p>NEIL GUERRIERO 3473040176 TRANSCEND WIRELESS 10 INDUSTRIAL AVE MAHWAH NJ 07430</p> <p>SHIP TO: CONTACTS MANAGEMENT AMERICAN TOWER CORPORATION 10 PRESIDENTIAL WAY WOBURN MA 01801-1053</p>	<p>1 LBS</p> <p>1 OF 1</p> <p>MA 018 9-04</p>  	<p>UPS GROUND</p> <p>TRACKING #: 1Z V25 742 03 9290 2882</p> 	<p>BILLING: P/P</p> <p>Reference#1: CTNL802A Reference#2: UPS-ATC</p>  <p>UPS 21.5.22. WNTNVS0 12.0A 04/2019</p>
---	--	--	---