



**NORTHEAST**  
SITE SOLUTIONS

*Turnkey Wireless Development*

Northeast Site Solutions  
Denise Sabo  
4 Angela's Way, Burlington, CT 06013  
860-209-4690  
denise@northeastsitesolutions.com

July 19, 2019

Members of the Siting Council  
Connecticut Siting Council  
Ten Franklin Square  
New Britain, CT 06051

RE: Exempt Modification Application  
72 Boggy Hole Road, Old Lyme CT 06371  
Latitude: 41. 32215  
Longitude: -72.30747  
T-Mobile Site #: CT11636A-L600

Dear Ms. Bachman:

T-Mobile is requesting to file an exempt modification for an existing 175-foot monopole tower located at 72 Boggy Hole Road, Old Lyme CT 06371. T-Mobile currently has nine (9) antennas at the 175-foot level of the existing 175-foot tower. The tower and property are owned by Wireless Solutions, LLC. T-Mobile now intends to replace three (3) antenna with three (3) new 600/700 MHz antenna. The new antenna would be installed at the 175-foot and level of the tower.

Planned Tower Modifications:

Remove: (3) 1-5/8" Coax  
(3) Twin TMA

Remove and Replace:

(3) LNX 6515 Antenna (**REMOVE**) – RFS-APXAARR24\_43U-NA20 Antenna 600/700 MHz (**REPLACE**)

Install New:

(3) Fiber line  
(3) RRU 4449 B71+B12  
Handrail Kit (SITEPRO01)

Existing to Remain:

(9) 1-5/8" coax  
(1) Fiber Line  
(3) AIR21 B2A/B4P– 1900 MHz  
(3) AIR21 B2P/B4A– 2100 MHz

**Ground:**

Upgrade Existing 6131 Cabinet (Internally)  
Upgrade existing Breaker

This facility was approved by the CT Siting Council Docket No.209 on June 25, 2002. This modification complies with this original approval. Please see attached.

Please accept this letter as notification pursuant to Regulations of Connecticut State Agencies § 16- SOJ-73, for construction that constitutes an exempt modification pursuant to R.C.S.A. § 16-50j-72(b)(2). In accordance with R.C.S.A. § 16-SOj-73, a copy of this letter is being sent to First Selectwoman Bonnie Reemsnyder, Elected Official and Keith Rosenfeld, Zoning Enforcement Officer for the Town of Old Lyme, as well as the property owner and the tower owner.

The planned modifications to the facility fall squarely within those activities explicitly provided for in R.C.S.A. § 16-50j-72(b)(2).

1. The proposed modifications will not result in an increase in the height of the existing structure.
2. The proposed modifications will not require the extension of the site boundary.
3. The proposed modifications will not increase noise levels at the facility by six decibels or more, or to levels that exceed state and local criteria.
4. The operation of the replacement antennas will not increase radio frequency emissions at the facility to a level at or above the Federal Communications Commission safety standard.
5. The proposed modifications will not cause a change or alteration in the physical or environmental characteristics of the site.
6. The existing structure and its foundation can support the proposed loading.

For the foregoing reasons, T-Mobile respectfully submits that the proposed modifications to the above referenced telecommunications facility constitute an exempt modification under R.C.S.A. § 16-50j-72(b)(2).

Sincerely,

Denise Sabo  
Mobile: 860-209-4690  
Fax: 413-521-0558  
Office: 4 Angela's Way, Burlington CT 06013  
Email: [denise@northeastsitesolutions.com](mailto:denise@northeastsitesolutions.com)

Attachments

cc:

First Selectwoman Bonnie Reemsnyder  
Old Lyme Memorial Town Hall  
52 Lyme Street  
Old Lyme, CT 06371

Old Lyme Memorial Town Hall  
52 Lyme Street  
Old Lyme, CT 06371  
Attn: Keith Rosenfeld  
Zoning Enforcement Officer

Wireless Solutions, LLC  
PO Box 284  
Old Lyme, CT 06371  
Attn: Ken Thomas

# Exhibit A

<b>DOCKET NO. 209</b> - Wireless Solutions, LLC Certificate of Environmental Compatibility and Public Need for the construction, maintenance, and operation of a wireless telecommunication facility at one of two locations at 72 Boggy Hole Road, or at 62-1 Boggy Hole Road, Old Lyme, Connecticut.	} } } }	Connecticut  Siting  Council  June 25, 2002
--	------------------	---

**Revised Decision and Order**

Pursuant to the foregoing Revised Findings of Fact and Opinion, the Connecticut Siting Council (Council) finds that the effects associated with the construction, operation, and maintenance of a telecommunications facility at the proposed Alternate #1 site in Old Lyme, Connecticut, including effects on the natural environment; ecological integrity and balance; public health and safety; scenic, historic, and recreational values; forests and parks; air and water purity; and fish and wildlife are not disproportionate either alone or cumulatively with other effects when compared to need, are not in conflict with the policies of the State concerning such effects, and therefore directs that a Certificate of Environmental Compatibility and Public Need (Certificate), be issued to Wireless Solutions, LLC for the construction, maintenance, and operation of a telecommunication facility at the proposed Alternate #1 site at 62-1 Boggy Hole Road, Old Lyme, Connecticut. We revoke the Decision and Order and Certificate issued to Wireless Solutions, LLC on December 11, 2001 for the construction, maintenance, and operation of a telecommunication facility at proposed alternate site at 72 Boggy Hole Road. The Council denies certification of the proposed prime and alternate sites at 72 Boggy Hole Road, Old Lyme.

The facility shall be constructed, operated, and maintained substantially as specified in the Council's record in this matter, and subject to the following conditions:

1. The tower shall be constructed as a monopole, no taller than necessary to provide the proposed telecommunications services, sufficient to accommodate the antennas for SNET Mobility, LLC, AT&T Wireless, Inc., Nextel Communications of the Mid-Atlantic, VoiceStream Wireless Corporation, and other telecommunications entities both public and private, but such tower shall not exceed a height of 175 feet above ground level (AGL), including antennas.
2. The Certificate Holder shall construct a single equipment building with suitable architectural treatment to accommodate the telecommunications equipment for the carriers who have executed a lease at the time of construction, and allow future carriers to add onto the equipment building in increments, with the same external design and finish.
3. The Certificate Holder shall prepare a Development and Management (D&M) Plan for this site in compliance with Sections 16-50j-75 through 16-50j-77 of the Regulations of Connecticut State Agencies. The D&M Plan shall be submitted to and approved by the Council prior to the commencement of facility construction and shall include: a final site plan(s) for development of the proposed Alternate #1 site, including the location and specifications for the tower foundation, antennas, equipment building, security fence, access road consistent with the Town of Old Lyme regulations, and utility line; construction plans for site grading, tree trimming, water drainage, and erosion and sedimentation controls consistent with the Connecticut Guidelines for Soil Erosion and Sediment Control, as amended; landscaping; a tower finish that may include painting; and provisions for the prevention and containment of spills and/or other discharge into surface water and groundwater bodies.

4. The Certificate Holder shall provide the Council with a determination from the Federal Aviation Administration regarding obstruction marking and lighting; and a determination from the Connecticut Department of Environmental Protection regarding Federal or State Endangered, Threatened or Special Concern Species at the Alternate #1 site, during the submission of the D&M Plan.
5. Upon the establishment of any new State or federal radio frequency standards applicable to frequencies of this facility, the facility granted herein shall be brought into compliance with such standards.
6. The Certificate Holder shall provide the Council with a recalculated report of electromagnetic radio frequency power density if and when circumstances in operation cause a change in power density above the levels originally calculated and provided in the application.
7. The Certificate Holder shall permit public or private entities to share space on the proposed tower for fair consideration, or shall provide any requesting entity with specific legal, technical, environmental, or economic reasons precluding such tower sharing.
8. If the facility does not initially provide, or permanently ceases to provide wireless services following completion of construction, this Decision and Order shall be void, and the Certificate Holder shall dismantle the tower and remove all associated equipment or reapply for any continued or new use to the Council before any such use is made.
9. Any antenna that becomes obsolete and ceases to function shall be removed within 60 days after such antennas become obsolete and cease to function.
10. Unless otherwise approved by the Council, this Decision and Order shall be void if all construction authorized herein is not completed within one year of the effective date of this Decision and Order or within one year after all appeals to this Decision and Order have been resolved.

Pursuant to General Statutes § 16-50p, we hereby direct that a copy of the Findings of Fact, Opinion, and Decision and Order be served on each person listed below, and notice of issuance shall be published in The Hartford Courant, The Day, and the Pictorial/Gazette.

By this Decision and Order, the Council disposes of the legal rights, duties, and privileges of each party named or admitted to the proceeding in accordance with Section 16-50j-17 of the Regulations of Connecticut State Agencies.

The parties and intervenors to this proceeding are:

**Certificate Holder**

Wireless Solutions, LLC

Peter J. Tyrell, Esq.  
Levy & Droney, P.C.  
74 Batterson Park Road  
Farmington, CT 06032

**Intervenor**

SNET Mobility, LLC

Charles R. Andres  
Tyler Cooper & Alcorn, LLP  
205 Church Street, P.O. Box 1936  
New Haven, CT 06509-1910

**Party**

Town of Old Lyme Zoning Commission

Eric Knapp, Esq.  
Branse & Willis, LLC  
41-C New London Turnpike  
Glen Lochen East  
Glastonbury, CT 06033-2038

**Intervenor**

Nextel Communications of the  
Mid-Atlantic, Inc. d/b/a Nextel  
Communications

Christopher B. Fisher, Esq.  
Cuddy & Feder & Worby  
90 Maple Avenue  
White Plains, NY 10601

**Intervenor**

VoiceStream Wireless Corporation

Stephen J. Humes  
Diane W. Whitney  
LeBoeuf, Lamb, Greene & MacRae, LLP  
Goodwin Square  
225 Asylum Street  
Hartford, CT 06103

**Intervenor**

Cellco Partnership d/b/a  
Verizon Wireless

Kenneth C. Baldwin, Esq.  
Robinson & Cole LLP  
280 Trumbull Street  
Hartford, CT 06103-3597

# Exhibit B



# 72 BOGGY HOLE RD

**Location** 72 BOGGY HOLE RD

**Mblu** 22 / / 75 / /

**Acct#** 00113900

**Owner** SANDERS MICHAEL

**Assessment** \$256,250

**Appraisal** \$414,600

**PID** 1294

**Building Count** 1

## Current Value

Appraisal			
Valuation Year	Improvements	Land	Total
2014	\$250,500	\$164,100	\$414,600

Assessment			
Valuation Year	Improvements	Land	Total
2014	\$175,400	\$80,850	\$256,250

## Owner of Record

**Owner** SANDERS MICHAEL  
**Co-Owner**  
**Address** 72 BOGGY HOLE RD  
OLD LYME, CT 06371

**Sale Price** \$26,000  
**Certificate**  
**Book & Page** 239/ 546  
**Sale Date** 07/01/1997

## Ownership History

Ownership History				
Owner	Sale Price	Certificate	Book & Page	Sale Date
SANDERS MICHAEL	\$26,000		239/ 546	07/01/1997

## Building Information

### Building 1 : Section 1

**Year Built:** 2000  
**Living Area:** 940  
**Replacement Cost:** \$198,150  
**Building Percent** 95  
**Good:**  
**Replacement Cost**  
**Less Depreciation:** \$188,200

Building Attributes	
Field	Description

Style	Cape Cod
Model	Residential
Grade:	Average +10
Stories:	2 3/4 Stories
Occupancy	1
Exterior Wall 1	Vinyl Siding
Exterior Wall 2	
Roof Structure:	Gable/Hip
Roof Cover	Asph/F Gls/Cmp
Interior Wall 1	Drywall/Sheet
Interior Wall 2	
Interior Flr 1	Hardwood
Interior Flr 2	Carpet
Heat Fuel	Oil
Heat Type:	Forced Air-Duc
AC Type:	None
Total Bedrooms:	2 Bedrooms
Total Bthrms:	1
Total Half Baths:	0
Total Xtra Fixtrs:	
Total Rooms:	4 Rooms
Bath Style:	Average
Kitchen Style:	Average

### Building Photo



(<http://images.vgsi.com/photos/OldLymeCTPhotos//\00\00\84\7/>)

### Building Layout

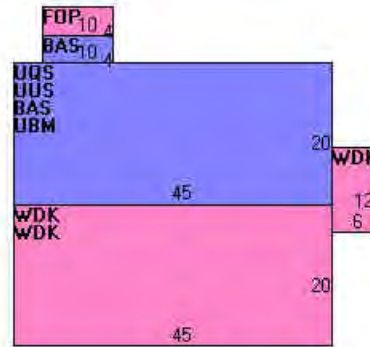

(<http://images.vgsi.com/photos/OldLymeCTPhotos//Sketches/12/>)

Building Sub-Areas (sq ft)			Legend
Code	Description	Gross Area	Living Area
BAS	First Floor	940	940
FOP	Porch, Open, Finished	40	0
UBM	Basement, Unfinished	900	0
UQS	Three Quater Story, unf	900	0
UUS	Upper Story, Unfinished	900	0
WDK	Deck, Wood	1,872	0
		5,552	940

### Extra Features

Extra Features	Legend
No Data for Extra Features	

### Land

**Land Use**

**Use Code** 1010  
**Description** Single Fam MDL-01  
**Zone** RU80  
**Neighborhood** 0050  
**Alt Land Appr Category** No

**Land Line Valuation**

**Size (Acres)** 29.50  
**Frontage** 0  
**Depth** 0  
**Assessed Value** \$80,850  
**Appraised Value** \$164,100

**Outbuildings**

<b>Outbuildings</b>						<b>Legend</b>
<b>Code</b>	<b>Description</b>	<b>Sub Code</b>	<b>Sub Description</b>	<b>Size</b>	<b>Value</b>	<b>Bldg #</b>
FGR5	W/LOFT GOOD			875 S.F.	\$18,400	1
SHD1	SHED FRAME			300 S.F.	\$2,100	1
PLT1	PLTRY HSE 1 ST			128 S.F.	\$400	1
	TOWER			1 UNIT	\$41,400	1

**Valuation History**

<b>Appraisal</b>			
<b>Valuation Year</b>	<b>Improvements</b>	<b>Land</b>	<b>Total</b>
2018	\$250,500	\$164,100	\$414,600
2017	\$250,500	\$164,100	\$414,600
2011	\$204,900	\$164,100	\$369,000

<b>Assessment</b>			
<b>Valuation Year</b>	<b>Improvements</b>	<b>Land</b>	<b>Total</b>
2018	\$175,400	\$80,850	\$256,250
2017	\$175,400	\$80,850	\$256,250
2011	\$143,400	\$78,720	\$222,120

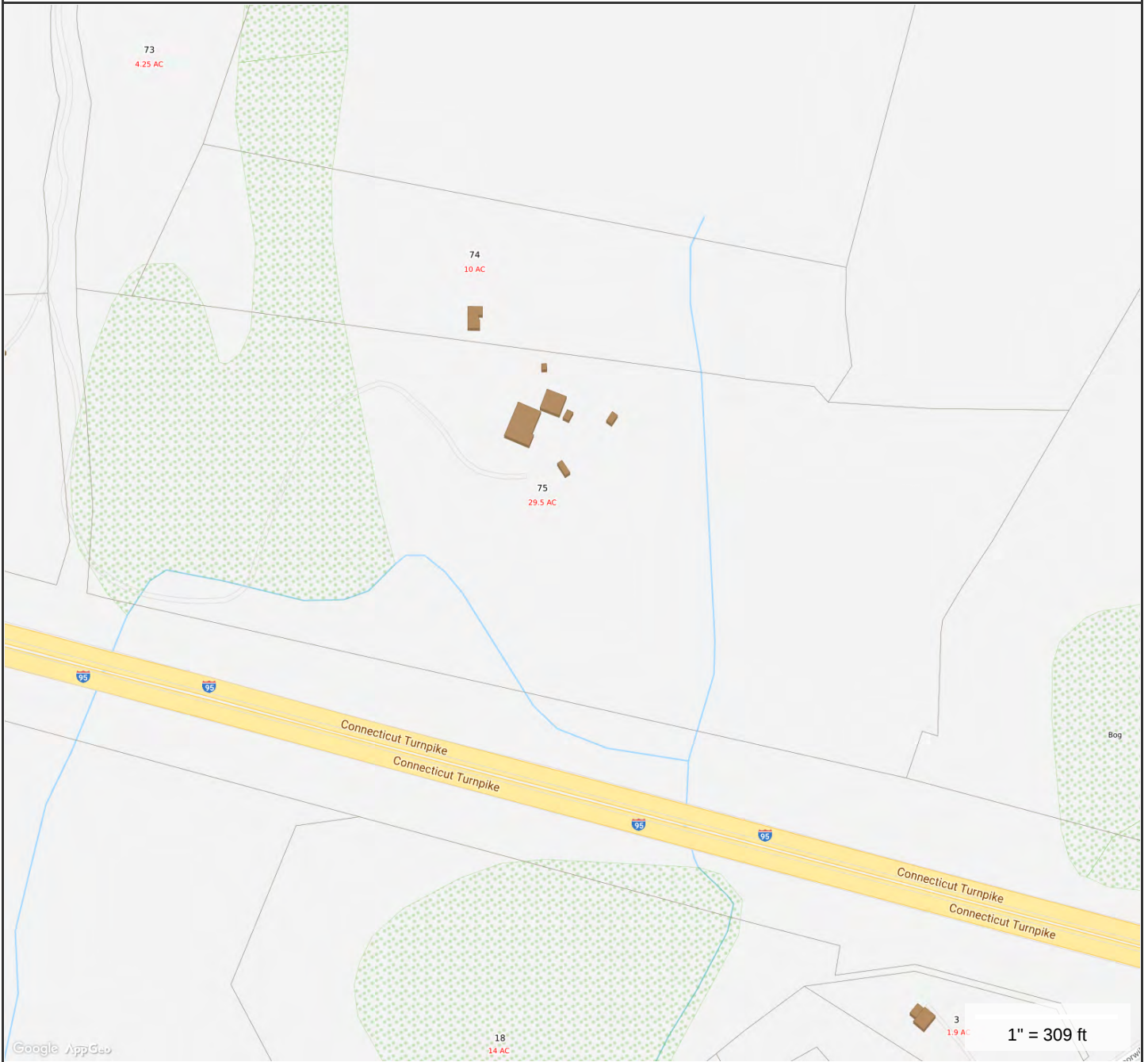

**MAP FOR REFERENCE ONLY  
NOT A LEGAL DOCUMENT**

Town of Old Lyme, CT makes no claims and no warranties, expressed or implied, concerning the validity or accuracy of the GIS data presented on this map.

Geometry updated 05/01/2018  
Data updated 11/19/2018

# Exhibit C



# ..T..Mobile..

NORTHEAST, LLC.

PROJECT: L600

SITE I.D. NUMBER:

CT11636A

SITE NAME:

WIRELESS SOLUTIONS OLD LYME

SITE ADDRESS:

72 BOGGY HOLE ROAD  
OLD LYME, CT 06371

**Tectonic**  
PRACTICAL SOLUTIONS. EXCEPTIONAL SERVICE.  
Tectonic Engineering & Surveying Consultants P.C.  
70 Pleasant Hill Road Phone: (845) 534-5959  
P.O. Box 37 (800) 529-6531  
Mountainville, NY 10953 www.tectonicengineering.com  
Project Contact Info  
1279 Route 300  
Newburgh, NY 12550 Phone: (845) 567-6656

..T..Mobile..  
NORTHEAST, LLC.  
35 GRIFFIN ROAD SOUTH  
BLOOMFIELD, CT 06002

**NSS** NORTHEAST  
SITE SOLUTIONS  
Turnkey Wireless Development

APPROVALS

LANDLORD \_\_\_\_\_  
RF \_\_\_\_\_  
CONSTRUCTION \_\_\_\_\_  
OPERATIONS \_\_\_\_\_  
SITE ACQ. \_\_\_\_\_

PROJECT NUMBER	DESIGNED BY
9927.CT11636A	VS

REV.	DATE	DESCRIPTION	DRAWN BY
1	07/19/19	ISSUED FOR CONSTRUCTION	BWY

ISSUED BY \_\_\_\_\_ DATE \_\_\_\_\_

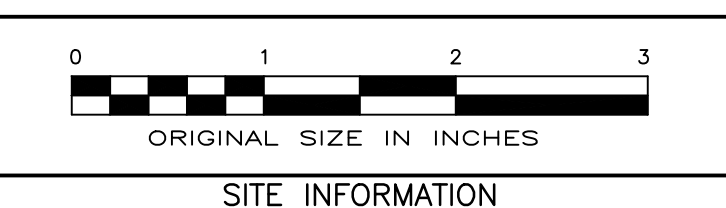

SITE INFORMATION

WIRELESS SOLUTION OLD LYME  
CT11636A  
72 BOGGY HOLE ROAD  
OLD LYME, CT 06371

SHEET TITLE

TITLE SHEET

SHEET NUMBER

T-1

PROJECT INDEX

SITE NUMBER: CT11636A	PROJECT CLIENT: NORTHEAST SITE SOLUTIONS, LLC SHELDON FREINCLE PHONE: (201) 776-8521
SITE NAME: WIRELESS SOLUTIONS OLD LYME	CONTACT: _____ PHONE: _____
SITE ADDRESS: 72 BOGGY HOLE ROAD OLD LYME, CT 06371	ENGINEER/ STRUCTURAL ENG: TECTONIC ENGINEERING CONSULTANTS, PC. EDWARD IAMICELI PHONE: (845) 567-6656x2811
PROPERTY OWNER: WIRELESS SOLUTIONS	CONTACT: _____ PHONE: _____
APPLICANT: T-MOBILE NORTHEAST LLC 35 GRIFFIN ROAD SOUTH BLOOMFIELD, CT 06002	
STRUCTURE TYPE: MONOPOLE	
LATTITUDE (NAD83): 41.32215" N	
LONGITUDE (NAD83): 72.30747" W	
GRADE ELEVATION: 60' (AMSL PER GOOGLE EARTH)	
ZONING: RU 80	
PARCEL ID: 22-75	

VICINITY MAP (NTS)



SHEET INDEX

SHEET NO	DESCRIPTION	REVISION	DATE
T-1	TITLE SHEET	0	07/19/19
A-1	SITE PLAN & T-MOBILE EQUIPMENT PLAN	0	07/19/19
A-2	ELEVATION	0	07/19/19
A-3	EXIST/NEW T-MOBILE ANTENNA PLANS & ANTENNA SCHEDULE	0	07/19/19
A-4	DETAILS & ANTENNA SCHEMATIC	0	07/19/19
A-5	NOTES	0	07/19/19
E-1	ELECTRICAL NOTES & ONE-LINE DIAGRAM	0	07/19/19
G-1	GROUNDING DETAILS & NOTES	0	07/19/19

CODE COMPLIANCE

- CODE INFORMATION
- STATE OF CONNECTICUT BUILDING CODE, LATEST EDITION
  - ANSI/TIA-222-G
  - NATIONAL ELECTRIC CODE, LATEST EDITION

RFDS DESIGN

DESIGN BASED ON RFDS DATED 05/07/2019, VERSION 3.1.  
RAN TEMPLATE: 67D02C OUTDOOR  
A&L TEMPLATE: 67D02C\_2xAIR+10P

STRUCTURAL NOTE

REFER TO THE STRUCTURAL ANALYSIS REPORT BY TECTONIC ENGINEERING & SURVEYING CONSULTANTS P.C. DATED JUNE 21, 2019.

COPIES OF THIS DOCUMENT WITHOUT A FACSIMILE OF THE SIGNATURE & AN ORIGINAL EMBOSSED SEAL OR ORIGINAL STAMP IN BLUE OR BLACK INK OF THE PROFESSIONAL ENGINEER OR LAND SURVEYOR SHALL NOT BE CONSIDERED VALID COPIES.

THIS DOCUMENT IS PREPARED SPECIFICALLY FOR THE CLIENT AND PROJECT DESIGNATED HEREON. MODIFICATION, ALTERATION, REVISION, DUPLICATION, OR USE WITHOUT THE CONSENT OF TECTONIC IS STRICTLY PROHIBITED. COPYRIGHT 2019 TECTONIC. ALL RIGHTS RESERVED.





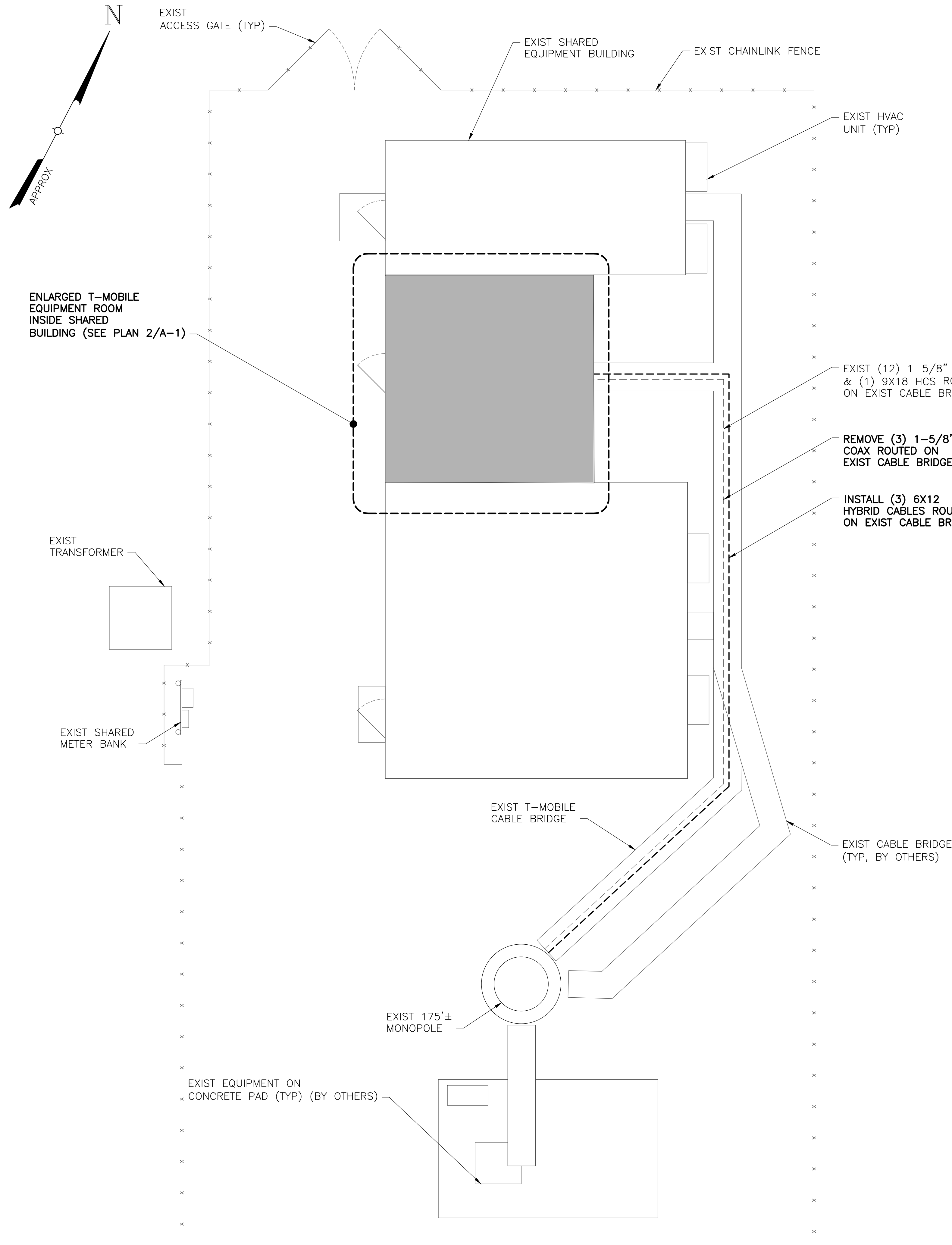

**1**  
A-1  
**SITE PLAN**  
SCALE: 1/4" = 1'-0"

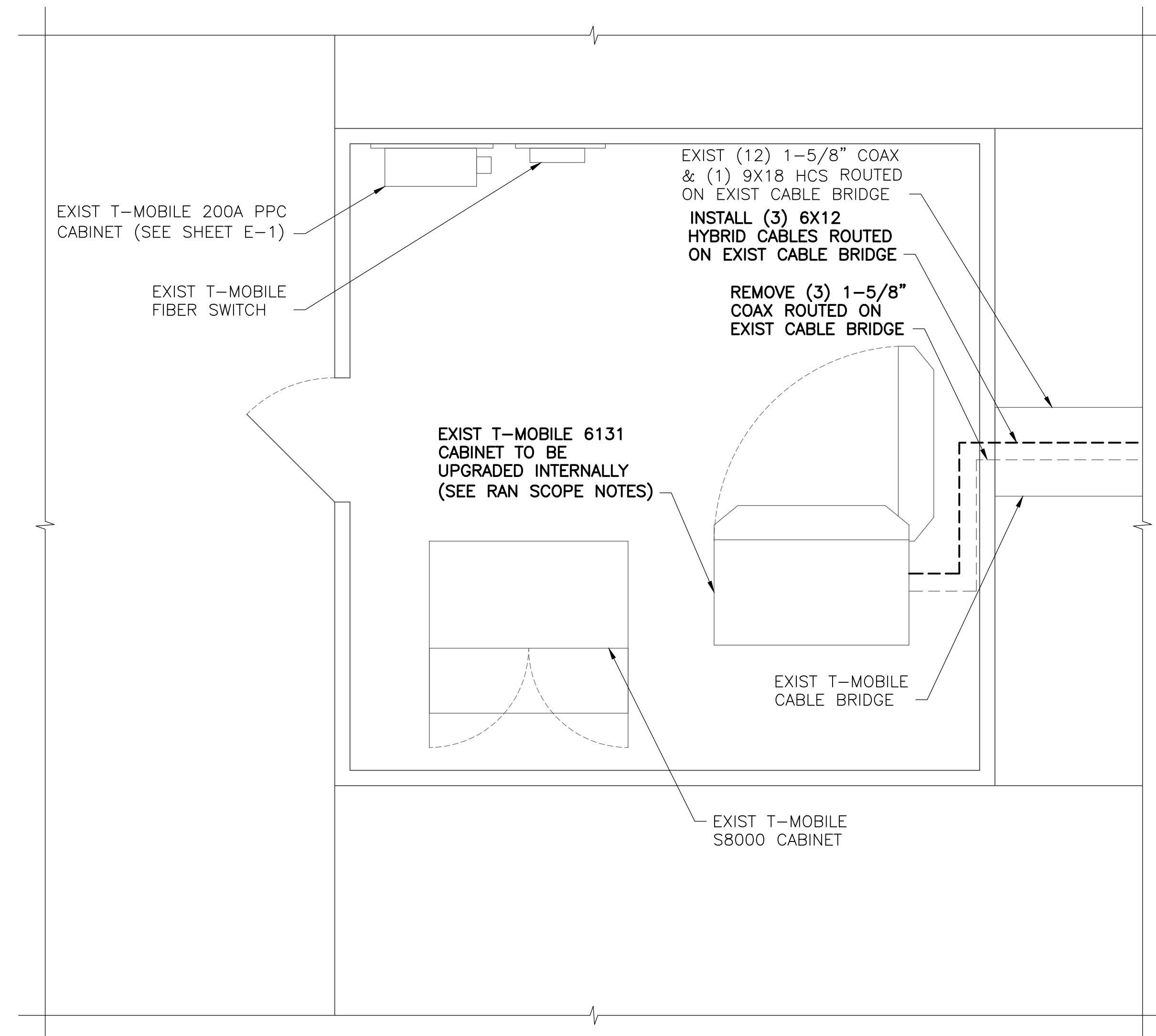

**2**  
A-1  
**T-MOBILE EQUIPMENT PLAN**  
SCALE: 1/2" = 1'-0"

- RAN SCOPE NOTES**
1. REPLACE (1) DUS41 WITH (1) BB6630 FOR LTE.
  2. INSTALL (1) BB630 FOR FUTURE 5G N600.
  3. REMOVE (1) XMU.
  4. ADD (3) 6X12 HCS
  5. EXIST (12) COAX LINES, (1) 9X18 HCS
  6. REMOVE (3) COAX LINES

**Tectonic**  
PRACTICAL SOLUTIONS. EXCEPTIONAL SERVICE.  
 Tectonic Engineering & Surveying Consultants P.C.  
 70 Pleasant Hill Road Phone: (845) 534-5959  
 P.O. Box 37 (800) 529-6531  
 Mountaintop, NY 10953 www.tectonicengineering.com  
Project Contact Info  
 1279 Route 300  
 Newburgh, NY 12550 Phone: (845) 567-6656

**T-Mobile**  
 NORTEAST, LLC.  
 35 GRIFFIN ROAD SOUTH  
 BLOOMFIELD, CT 06002

**NSS** NORTEAST  
 SITE SOLUTIONS  
 Turnkey Wireless Development

**APPROVALS**

LANDLORD \_\_\_\_\_  
 RF \_\_\_\_\_  
 CONSTRUCTION \_\_\_\_\_  
 OPERATIONS \_\_\_\_\_  
 SITE ACQ. \_\_\_\_\_

PROJECT NUMBER 9927.CT11636A DESIGNED BY VS

REV.	DATE	DESCRIPTION	DRAWN BY
1	07/19/19	ISSUED FOR CONSTRUCTION	BWY

ISSUED BY \_\_\_\_\_ DATE \_\_\_\_\_

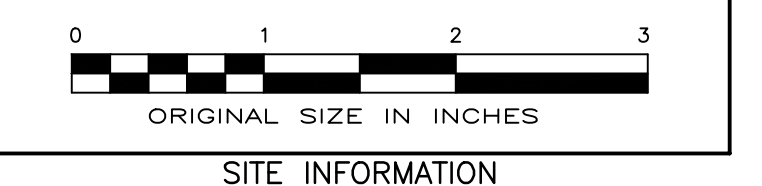

**SITE INFORMATION**

WIRELESS SOLUTION OLD LYME  
 CT11636A  
 72 BOGGY HOLE ROAD  
 OLD LYME, CT 06371

**SHEET TITLE**

SITE PLAN & T-MOBILE  
 EQUIPMENT PLAN

**SHEET NUMBER**

A-1

COPIES OF THIS DOCUMENT WITHOUT A FACSIMILE OF THE SIGNATURE & AN ORIGINAL EMBOSSED SEAL OR ORIGINAL STAMP IN BLUE OR BLACK INK OF THE PROFESSIONAL ENGINEER OR LAND SURVEYOR SHALL NOT BE CONSIDERED VALID COPIES.

THIS DOCUMENT IS PREPARED SPECIFICALLY FOR THE CLIENT AND PROJECT DESIGNATED HEREON. MODIFICATION, ALTERATION, REVISION, DUPLICATION, OR USE WITHOUT THE CONSENT OF TECTONIC IS STRICTLY PROHIBITED. COPYRIGHT 2019 TECTONIC. ALL RIGHTS RESERVED.

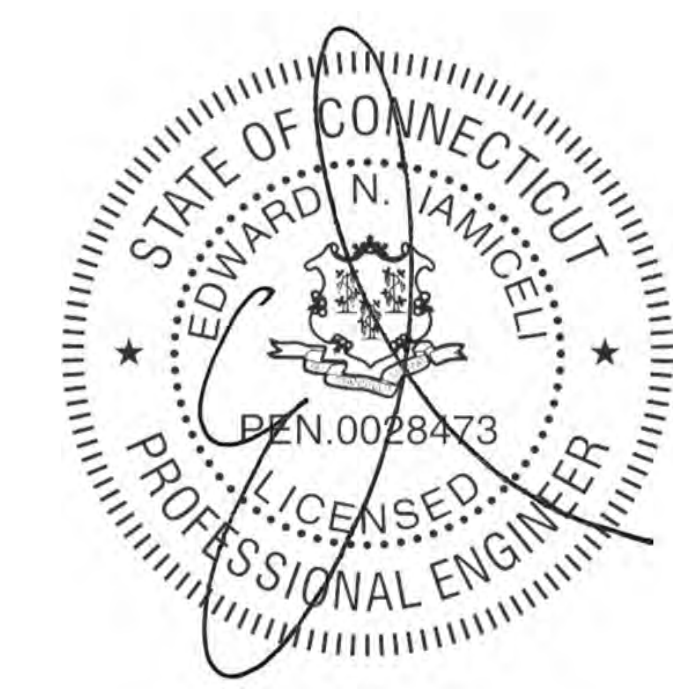

STRUCTURAL NOTE:  
REFER TO THE STRUCTURAL ANALYSIS REPORT  
BY TECTONIC ENGINEERING & SURVEYING  
CONSULTANTS P.C. DATED JUNE 21, 2019.

**Tectonic**  
PRACTICAL SOLUTIONS. EXCEPTIONAL SERVICE.  
Tectonic Engineering & Surveying Consultants P.C.  
70 Pleasant Hill Road Phone: (845) 534-5959  
P.O. Box 37 (800) 529-6531  
Mountainville, NY 10953 www.tectonicengineering.com  
Project Contact Info  
1279 Route 300  
Newburgh, NY 12550 Phone: (845) 567-6656

**Mobile**  
NORTHEAST, LLC.  
35 GRIFFIN ROAD SOUTH  
BLOOMFIELD, CT 06002

**NSS** NORTHEAST  
SITE SOLUTIONS  
Turnkey Wireless Development

APPROVALS

LANDLORD \_\_\_\_\_  
RF \_\_\_\_\_  
CONSTRUCTION \_\_\_\_\_  
OPERATIONS \_\_\_\_\_  
SITE ACQ. \_\_\_\_\_

PROJECT NUMBER 9927.CT11636A DESIGNED BY VS

REV.	DATE	DESCRIPTION	DRAWN BY
1	07/19/19	ISSUED FOR CONSTRUCTION	BWY

ISSUED BY \_\_\_\_\_ DATE \_\_\_\_\_



SITE INFORMATION  
WIRELESS SOLUTION OLD LYME  
CT11636A  
72 BOGGY HOLE ROAD  
OLD LYME, CT 06371

SHEET TITLE  
ELEVATION

SHEET NUMBER  
A-2

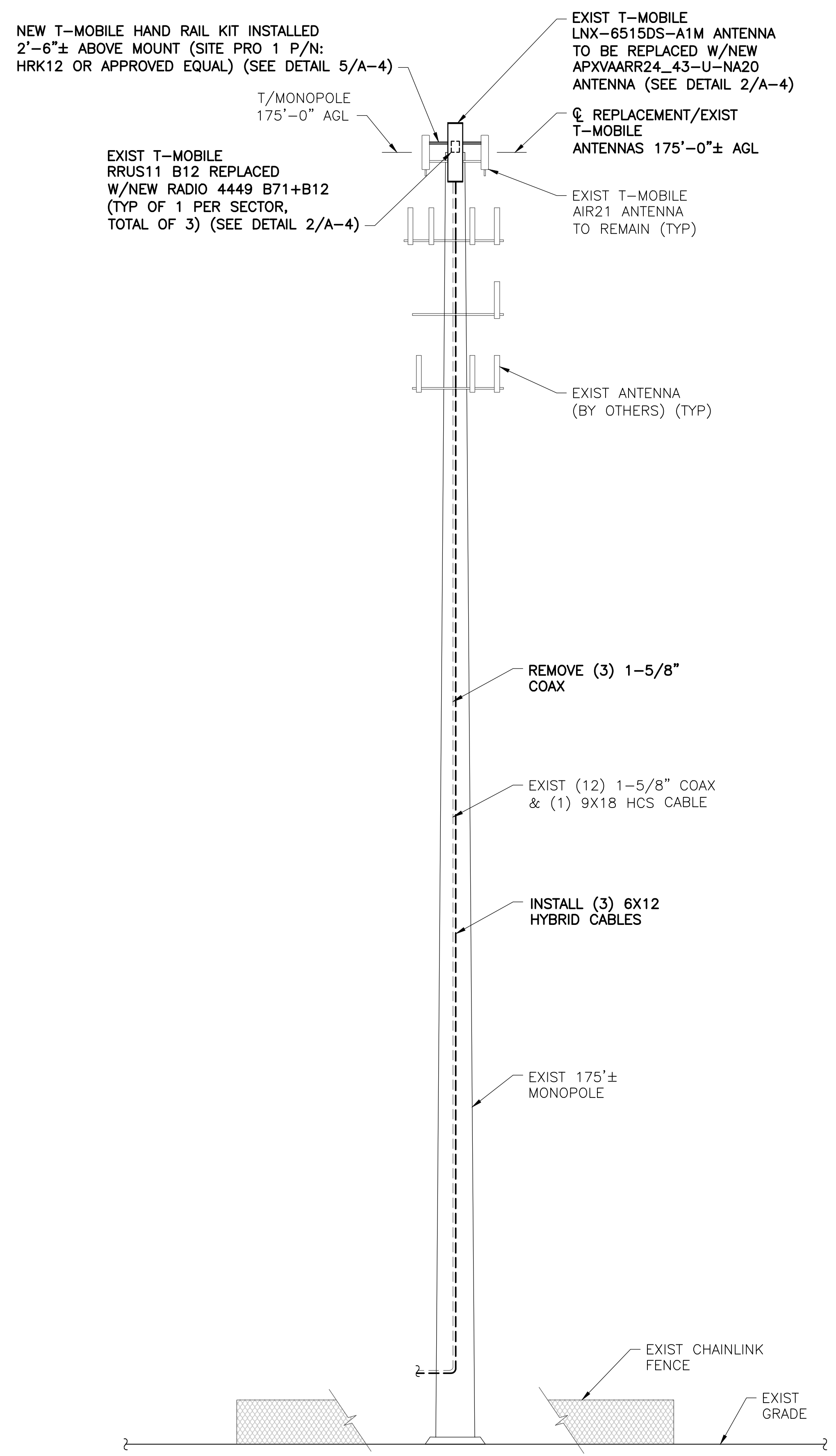

NOTE: NOT ALL SITE FEATURES SHOWN FOR CLARITY.

1  
A-2  
ELEVATION  
SCALE: 3/32" = 1'-0"

COPIES OF THIS DOCUMENT WITHOUT A  
FACSIMILE OF THE SIGNATURE & AN  
ORIGINAL EMBOSSED SEAL OR ORIGINAL  
STAMP IN BLUE OR BLACK INK OF THE  
PROFESSIONAL ENGINEER OR LAND SURVEYOR  
SHALL NOT BE CONSIDERED VALID COPIES.

THIS DOCUMENT IS PREPARED SPECIFICALLY  
FOR THE CLIENT AND PROJECT DESIGNATED  
HEREON. MODIFICATION, ALTERATION, REVISION,  
DUPLICATION, OR USE WITHOUT THE CONSENT  
OF TECTONIC IS STRICTLY PROHIBITED.  
COPYRIGHT 2019 TECTONIC. ALL RIGHTS  
RESERVED.





# ANTENNA AND COAXIAL CABLE SCHEDULE

SECTOR MARK	ANTENNA MODEL	AZIMUTH	ELEC. DOWNTILT	MECH. DOWNTILT	ANTENNA CENTERLINE	SECTOR	STATUS	TMA/RRU	CABLE	JUMPER TYPE	CABLE LENGTH
A-1 GSM/UMTS	ERICSSON AIR21 B2A/B4P	0°	2°	0°	175'-0"±	LEFT ALPHA	EXIST	0/0	EXIST (1) 9x18 HCS & (2) EXIST 1 5/8" COAX	FIBER	255'-0"
A-2 LTE	RFS APXVAARR24-43-U-NA20	0°	2°	0°	175'-0"±	CENTER ALPHA	REPLACED	0/1	NEW 6x12 HCS	FIBER	255'-0"
A-3 LTE	ERICSSON AIR21 B2P/B4A	0°	2°	0°	175'-0"±	RIGHT ALPHA	EXIST	0/0	EXIST SHARED 9x18 HCS	FIBER	255'-0"
B-1 GSM/UMTS	ERICSSON AIR21 B2A/B4P	120°	2°	0°	175'-0"±	LEFT BETA	EXIST	0/0	EXIST SHARED 9x18 HCS & (2) EXIST 1 5/8" COAX	FIBER	255'-0"
B-2 LTE	RFS APXVAARR24-43-U-NA20	120°	2°	0°	175'-0"±	CENTER BETA	REPLACED	0/1	NEW 6x12 HCS	FIBER	255'-0"
B-3 LTE	ERICSSON AIR21 B2P/B4A	120°	2°	0°	175'-0"±	RIGHT BETA	EXIST	0/0	EXIST SHARED 9x18 HCS	FIBER	255'-0"
C-1 GSM/UMTS	ERICSSON AIR21 B2A/B4P	240°	2°	0°	175'-0"±	LEFT GAMMA	EXIST	0/0	EXIST SHARED 9x18 HCS & (2) EXIST 1 5/8" COAX	FIBER	255'-0"
C-2 LTE	RFS APXVAARR24-43-U-NA20	240°	2°	0°	175'-0"±	CENTER GAMMA	REPLACED	0/1	NEW 6x12 HCS	FIBER	255'-0"
C-3 LTE	ERICSSON AIR21 B2P/B4A	240°	2°	0°	175'-0"±	RIGHT GAMMA	EXIST	0/0	EXIST SHARED 9x18 HCS	FIBER	255'-0"

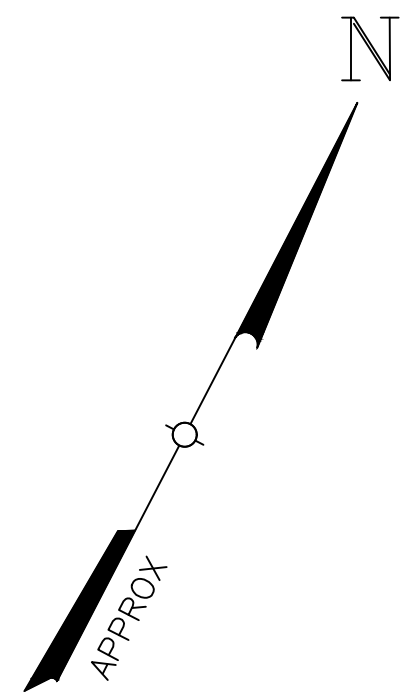

**STRUCTURAL NOTE:**  
REFER TO THE STRUCTURAL ANALYSIS REPORT  
BY TECTONIC ENGINEERING & SURVEYING  
CONSULTANTS P.C. DATED JUNE 21, 2019.

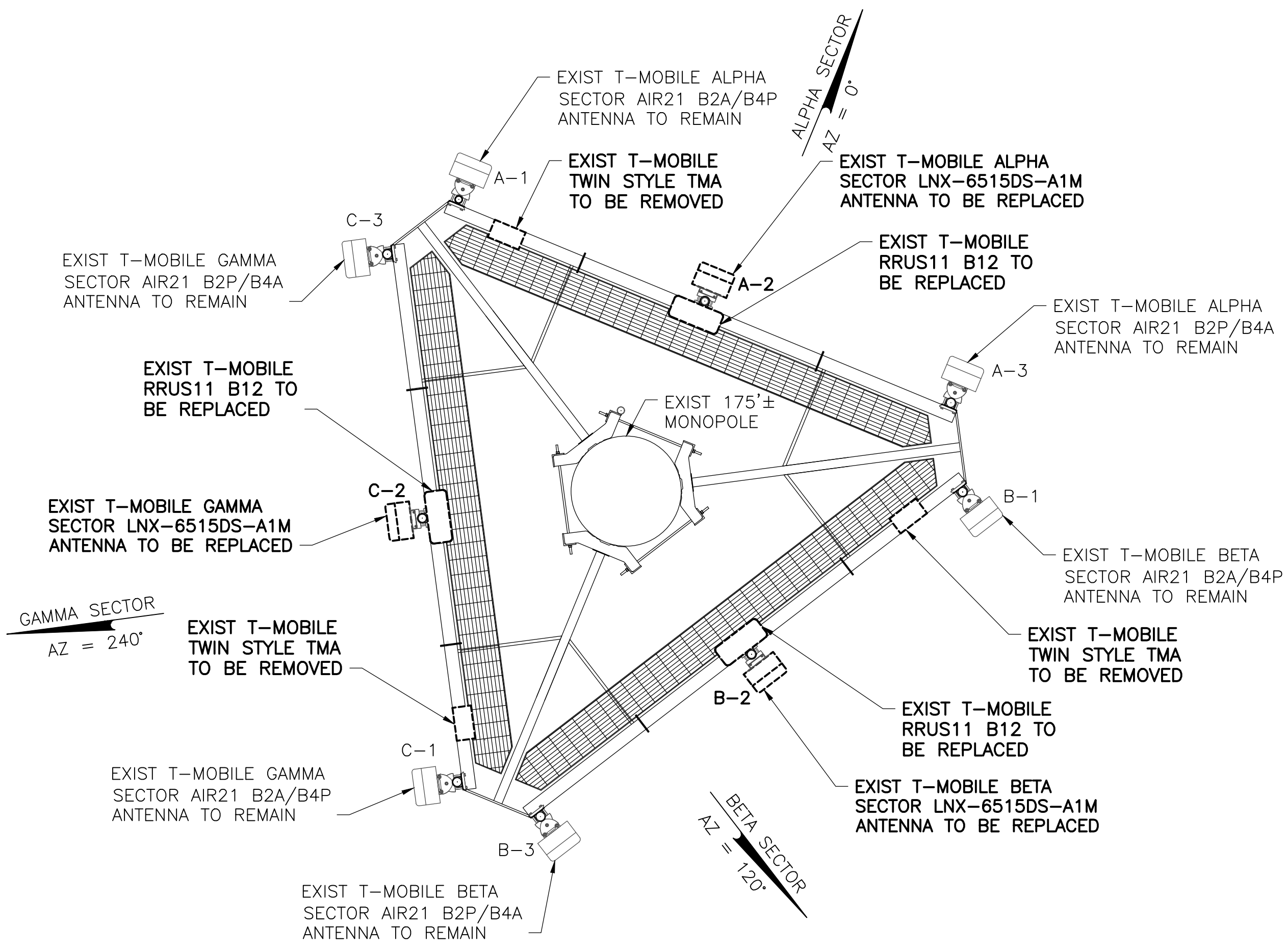

1  
A-3  
EXISTING T-MOBILE ANTENNA PLAN  
SCALE: 3/8" = 1'-0"

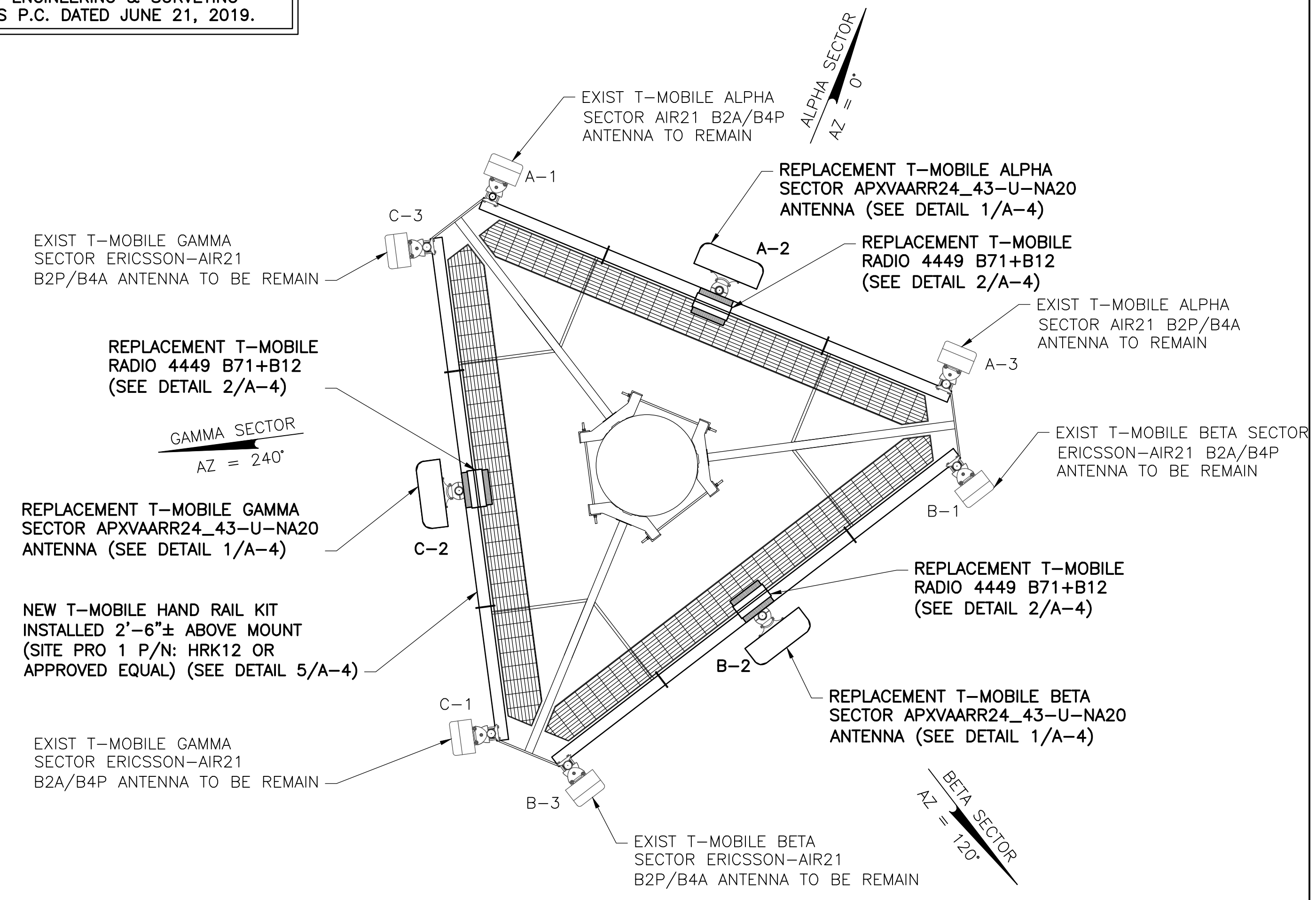

2  
A-3  
NEW T-MOBILE ANTENNA PLAN  
SCALE: 3/8" = 1'-0"

COPIES OF THIS DOCUMENT WITHOUT A FACSIMILE OF THE SIGNATURE & AN ORIGINAL EMBOSSED SEAL OR ORIGINAL STAMP IN BLUE OR BLACK INK OF THE PROFESSIONAL ENGINEER OR LAND SURVEYOR SHALL NOT BE CONSIDERED VALID COPIES.

THIS DOCUMENT IS PREPARED SPECIFICALLY FOR THE CLIENT AND PROJECT DESIGNATED HEREON. MODIFICATION, ALTERATION, REVISION, DUPLICATION, OR USE WITHOUT THE CONSENT OF TECTONIC IS STRICTLY PROHIBITED. COPYRIGHT 2019 TECTONIC. ALL RIGHTS RESERVED.

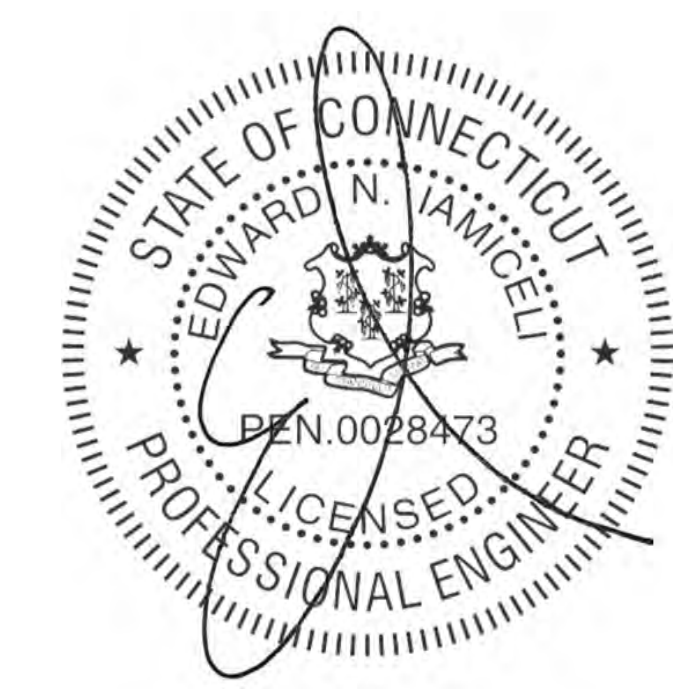

**Tectonic**  
PRACTICAL SOLUTIONS. EXCEPTIONAL SERVICE.  
Tectonic Engineering & Surveying Consultants P.C.  
70 Pleasant Hill Road Phone: (845) 534-5959  
P.O. Box 37 (800) 529-6531  
Mountainville, NY 10953 www.tectonicing.com  
Project Contact Info  
1279 Route 300  
Newburgh, NY 12550 Phone: (845) 567-6656

**T-Mobile**  
NORTHEAST, LLC.  
35 GRIFFIN ROAD SOUTH  
BLOOMFIELD, CT 06002

**NSS NORTHEAST**  
SITE SOLUTIONS  
Turnkey Wireless Development

APPROVALS

LANDLORD \_\_\_\_\_  
RF \_\_\_\_\_  
CONSTRUCTION \_\_\_\_\_  
OPERATIONS \_\_\_\_\_  
SITE ACQ. \_\_\_\_\_

PROJECT NUMBER 9927.CT11636A DESIGNED BY VS

REV.	DATE	DESCRIPTION	DRAWN BY
1	07/19/19	ISSUED FOR CONSTRUCTION	BWY

ISSUED BY \_\_\_\_\_ DATE \_\_\_\_\_

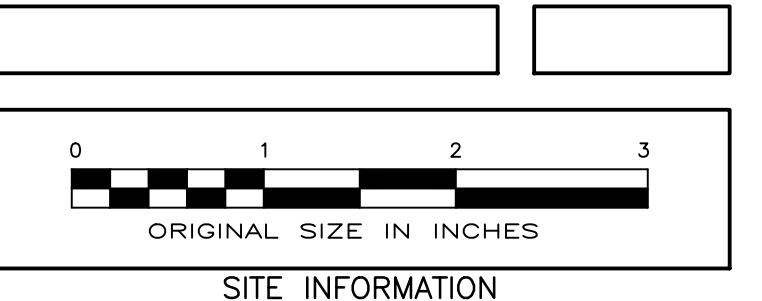

SITE INFORMATION  
WIRELESS SOLUTION OLD LYME  
CT11636A  
72 BOGGY HOLE ROAD  
OLD LYME, CT 06371

SHEET TITLE  
EXISTING/NEW  
T-MOBILE ANTENNA PLANS  
& ANTENNA SCHEDULE

SHEET NUMBER  
A-3



STRUCTURAL NOTE:  
REFER TO THE STRUCTURAL ANALYSIS REPORT  
BY TECTONIC ENGINEERING & SURVEYING  
CONSULTANTS P.C. DATED JUNE 21, 2019.

**Tectonic**  
PRACTICAL SOLUTIONS. EXCEPTIONAL SERVICE.  
Tectonic Engineering & Surveying Consultants P.C.  
70 Pleasant Hill Road Phone: (845) 534-5959  
P.O. Box 37 (800) 529-6531  
Mountainville, NY 10953 www.tectonicengineering.com  
Project Contact Info  
1279 Route 300  
Newburgh, NY 12550 Phone: (845) 567-6656

**Mobile**  
NORTHEAST, LLC.  
35 GRIFFIN ROAD SOUTH  
BLOOMFIELD, CT 06002

**NSS** NORTHEAST  
SITE SOLUTIONS  
Turnkey Wireless Development

APPROVALS

LANDLORD \_\_\_\_\_  
RF \_\_\_\_\_  
CONSTRUCTION \_\_\_\_\_  
OPERATIONS \_\_\_\_\_  
SITE ACQ. \_\_\_\_\_

PROJECT NUMBER 9927.CT11636A DESIGNED BY VS

REV.	DATE	DESCRIPTION	DRAWN BY
1	07/19/19	ISSUED FOR CONSTRUCTION	BWY

ISSUED BY \_\_\_\_\_ DATE \_\_\_\_\_

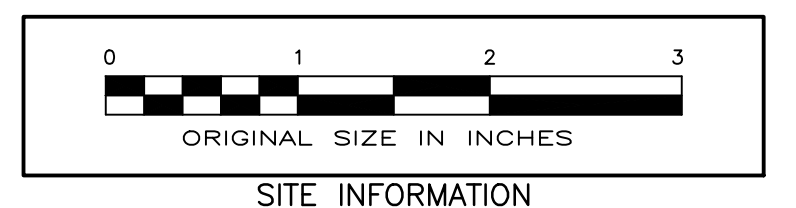

SITE INFORMATION  
WIRELESS SOLUTION OLD LYME  
CT11636A  
72 BOGGY HOLE ROAD  
OLD LYME, CT 06371

SHEET TITLE  
DETAILS & ANTENNA SCHEMATIC  
SHEET NUMBER

A-4

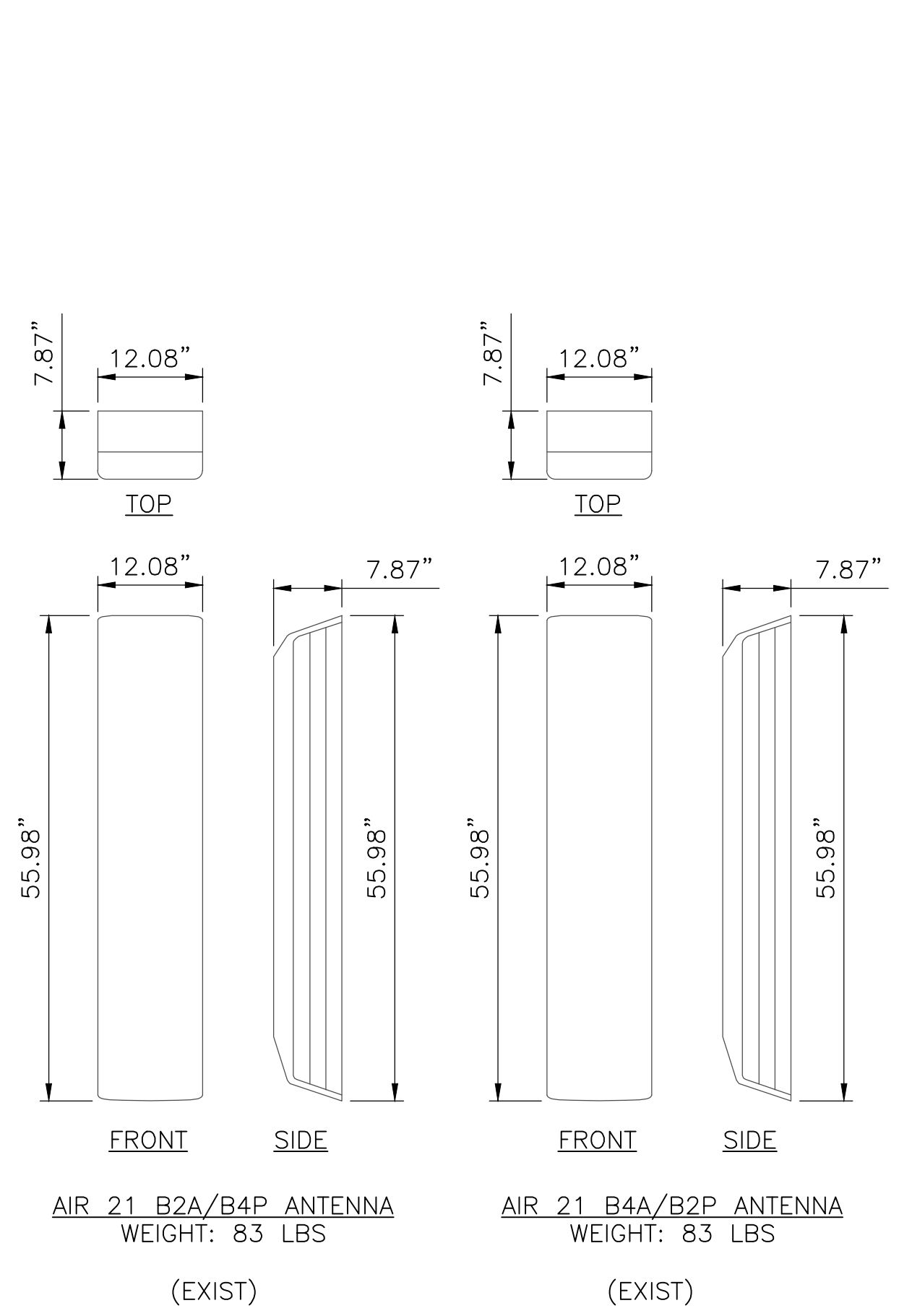

1 ANTENNA DETAIL  
A-4 SCALE: 3/4" = 1'-0"

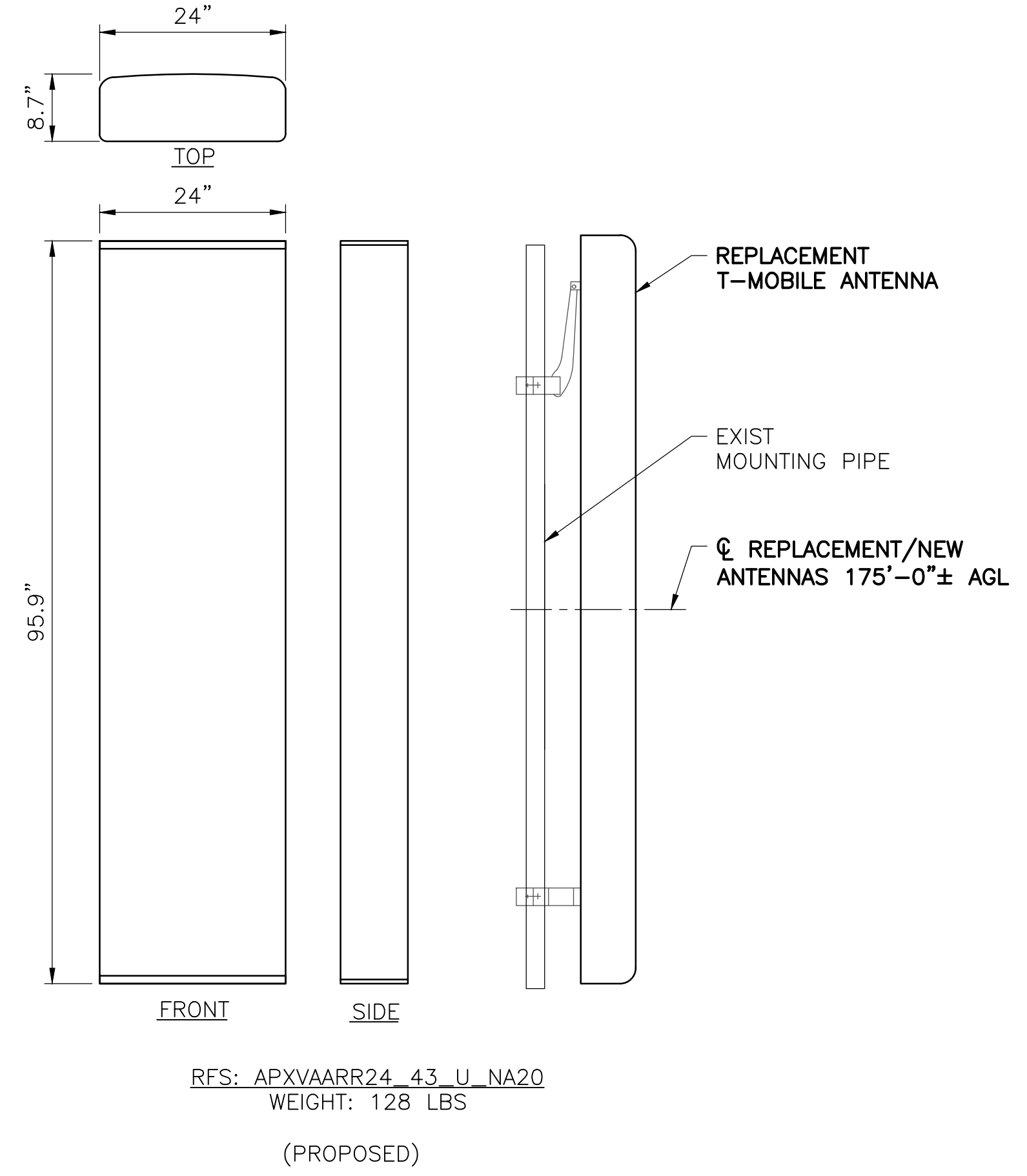

(PROPOSED)

2 RADIO MOUNTING DETAIL  
A-4 SCALE: 1" = 1'-0"

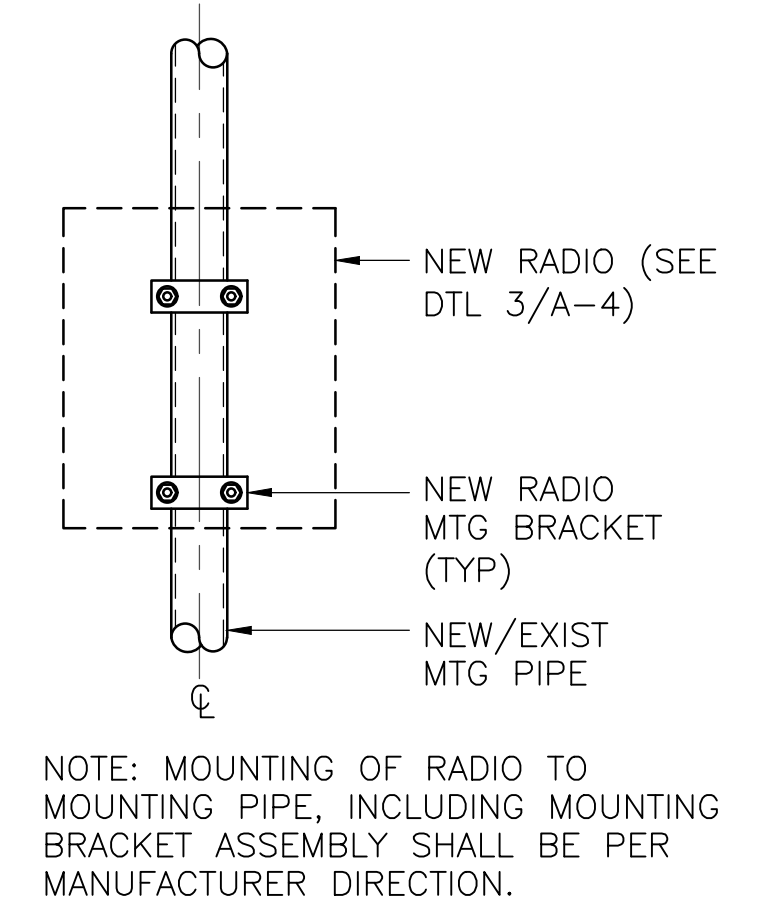

NOTE: MOUNTING OF RADIO TO MOUNTING PIPE, INCLUDING MOUNTING BRACKET ASSEMBLY SHALL BE PER MANUFACTURER DIRECTION.

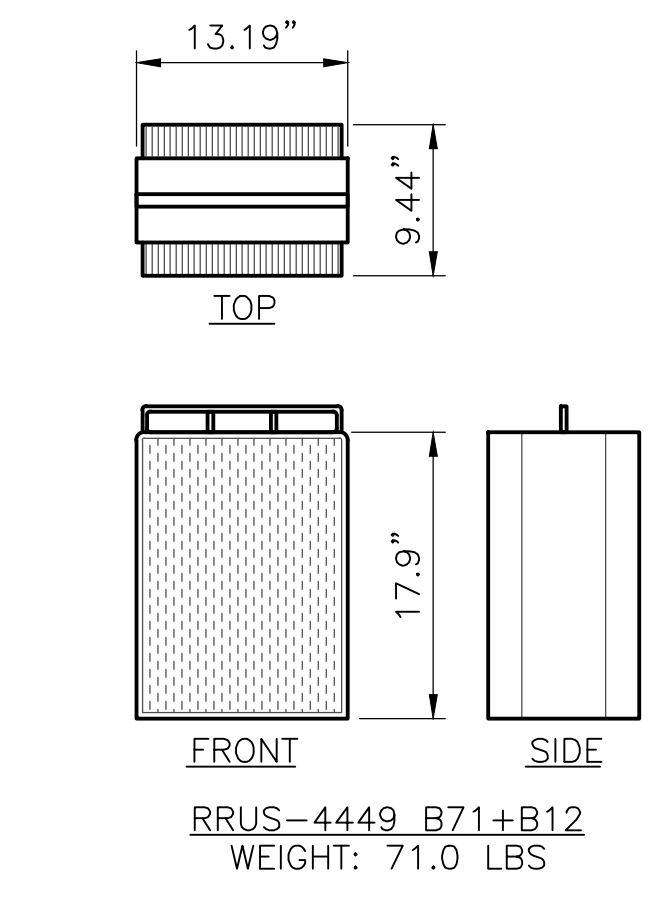

3 RADIO DETAIL  
A-4 SCALE: 1" = 1'-0"

AIR 21 B2A/B4P ANTENNA WEIGHT: 83 LBS (EXIST)  
AIR 21 B4A/B2P ANTENNA WEIGHT: 83 LBS (EXIST)

RFS: APXVAARR24\_43\_U\_NA20 WEIGHT: 128 LBS

RRUS-4449 B71+B12 WEIGHT: 71.0 LBS

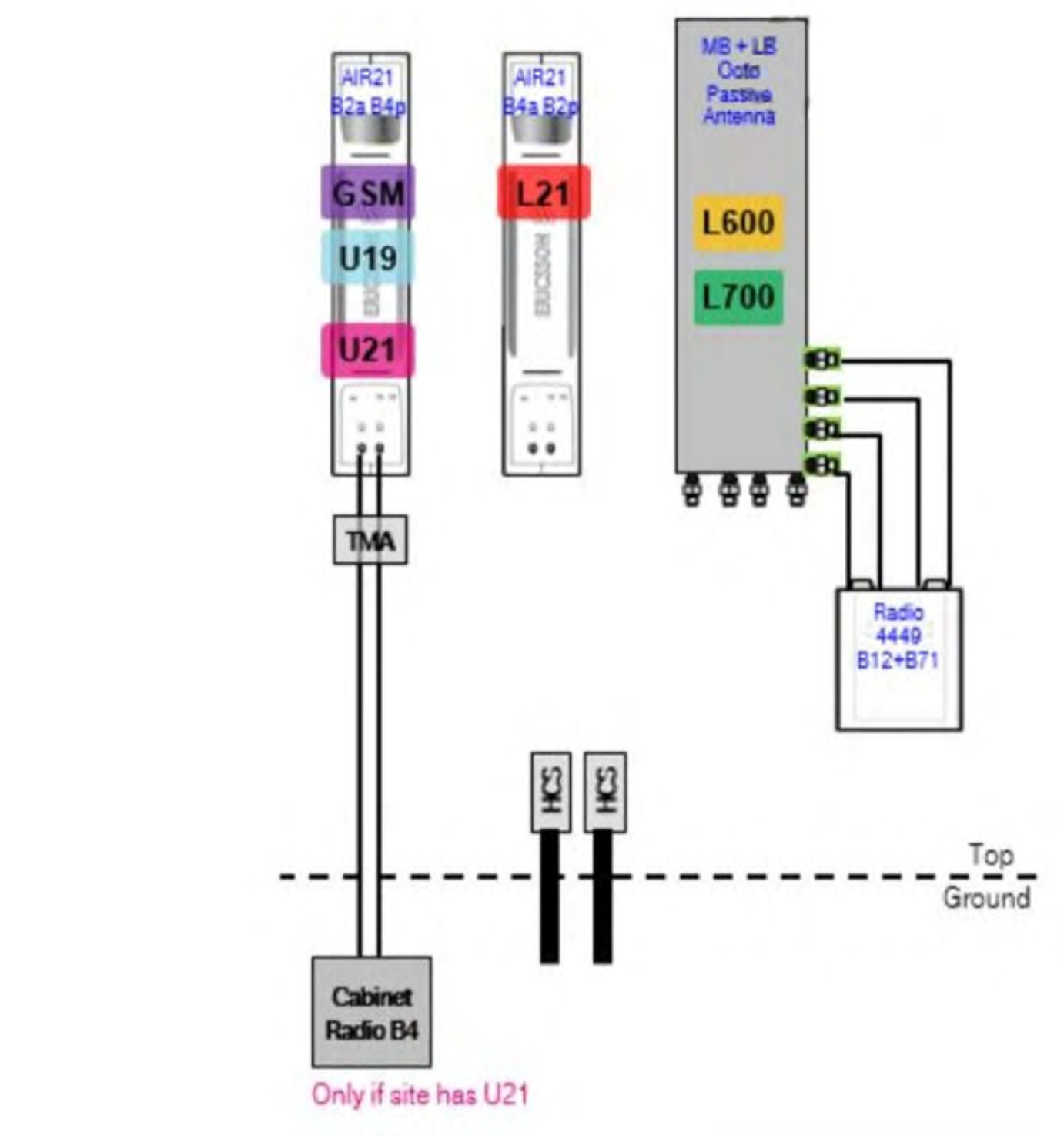

4 ANTENNA SCHEMATIC  
A-4 SCALE: NTS

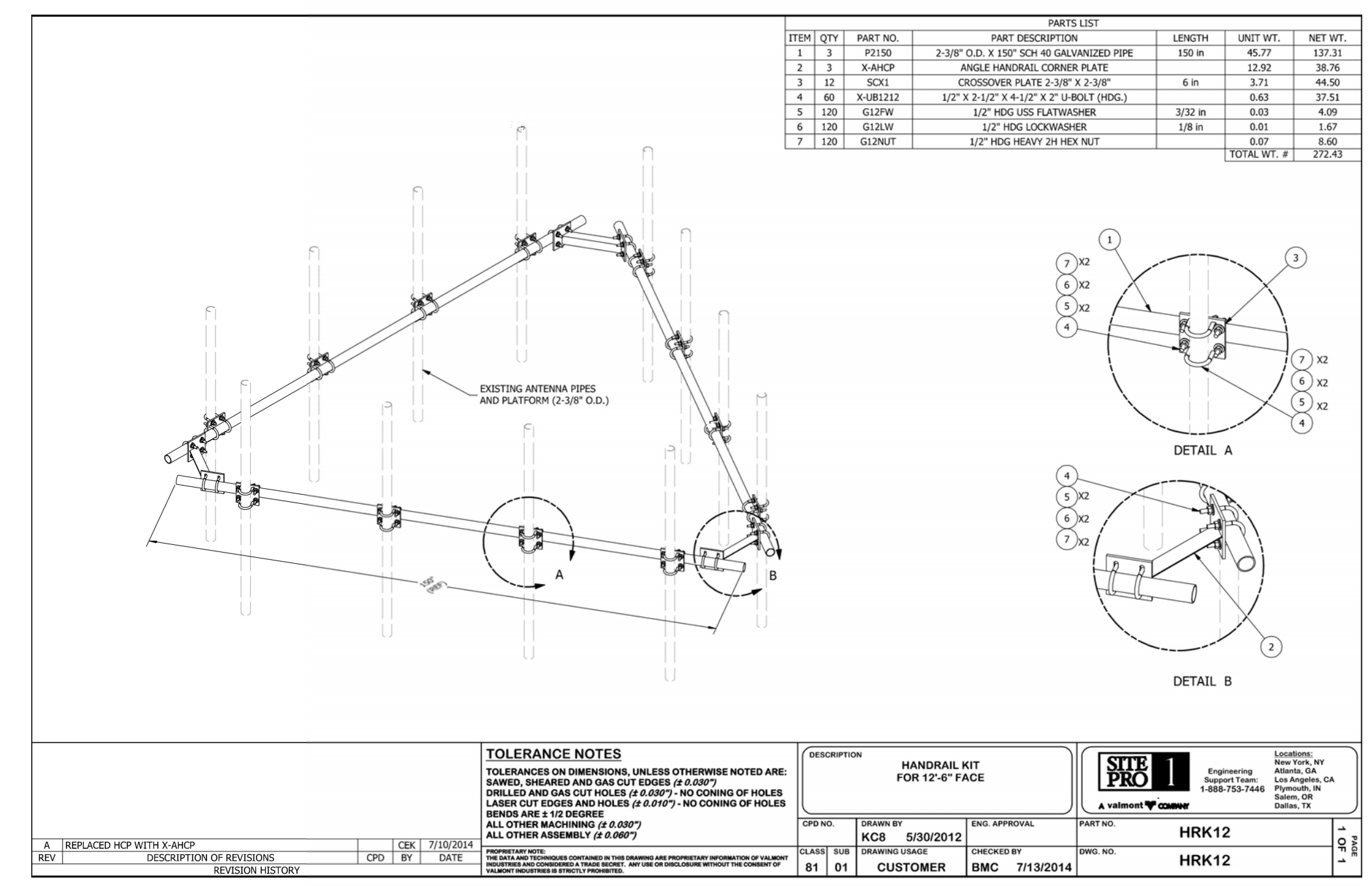

5 HAND RAIL KIT DETAIL  
A-4 SCALE: NTS

COPIES OF THIS DOCUMENT WITHOUT A FACSIMILE OF THE SIGNATURE & AN ORIGINAL EMBOSSED SEAL OR ORIGINAL STAMP IN BLUE OR BLACK INK OF THE PROFESSIONAL ENGINEER OR LAND SURVEYOR SHALL NOT BE CONSIDERED VALID COPIES.

THIS DOCUMENT IS PREPARED SPECIFICALLY FOR THE CLIENT AND PROJECT DESIGNATED HEREON. MODIFICATION, ALTERATION, REVISION, DUPLICATION, OR USE WITHOUT THE CONSENT OF TECTONIC IS STRICTLY PROHIBITED. COPYRIGHT 2019 TECTONIC. ALL RIGHTS RESERVED.





**GENERAL NOTES**

- ALL WORK SHALL CONFORM TO THE REQUIREMENTS OF THE STATE OF CONNECTICUT BUILDING CODE, LATEST VERSION AND ALL OTHER APPLICABLE CODES AND ORDINANCES.
- CONTRACTOR SHALL VISIT THE JOB SITE AND FAMILIARIZE HIMSELF WITH ALL CONDITIONS AFFECTING THE PROPOSED WORK AND MAKE PROVISIONS AS TO THE COST THEREOF. CONTRACTOR SHALL BE RESPONSIBLE FOR FAMILIARIZING HIMSELF WITH ALL CONTRACT DOCUMENTS, FIELD CONDITIONS AND DIMENSIONS AND CONFIRMING THAT THE WORK MAY BE ACCOMPLISHED AS SHOWN PRIOR TO PROCEEDING WITH CONSTRUCTION. ANY DISCREPANCIES SHALL BE BROUGHT TO THE ATTENTION OF THE ENGINEER PRIOR TO THE COMMENCEMENT OF WORK.
- PLANS ARE NOT TO BE SCALED. THESE PLANS ARE INTENDED TO BE A DIAGRAMMATIC OUTLINE ONLY, UNLESS OTHERWISE NOTED. THE WORK SHALL INCLUDE FURNISHING MATERIALS, EQUIPMENT, APPURTENANCES, AND LABOR NECESSARY TO EFFECT ALL INSTALLATIONS AS INDICATED ON THE DRAWINGS.
- DIMENSIONS SHOWN ARE TO FINISH SURFACES, UNLESS OTHERWISE NOTED. SPACING BETWEEN EQUIPMENT IS REQUIRED CLEARANCE. THEREFORE, IT IS CRITICAL TO FIELD VERIFY DIMENSIONS. SHOULD THERE BE ANY QUESTIONS REGARDING THE CONTRACT DOCUMENTS, EXISTING CONDITIONS AND/OR DESIGN INTENT, THE CONTRACTOR SHALL BE RESPONSIBLE FOR OBTAINING A CLARIFICATION FROM THE AUTHORIZED REPRESENTATIVE OR THE ENGINEER PRIOR TO PROCEEDING WITH THE WORK.
- DETAILS ARE INTENDED TO SHOW END RESULT OF DESIGN. MINOR MODIFICATIONS MAY BE REQUIRED TO SUIT JOB DIMENSIONS OR CONDITIONS, AND SUCH MODIFICATIONS SHALL BE INCLUDED AS PART OF THE WORK.
- CONTRACTOR SHALL RECEIVE CLARIFICATION IN WRITING, AND SHALL RECEIVE IN WRITING AUTHORIZATION TO PROCEED BEFORE STARTING WORK ON ANY ITEMS NOT CLEARLY DEFINED OR IDENTIFIED BY THE CONTRACT DOCUMENTS.
- ONCE THE CONTRACTOR HAS RECEIVED AND ACCEPTED THE "NOTICE TO PROCEED," CONTRACTOR WILL CONTACT THE CONSTRUCTION MANAGER OF RECORD A MINIMUM OF 48 HOURS PRIOR TO WORK START.
- CONTRACTOR SHALL NOTIFY THE CONSTRUCTION MANAGER OF ALL PRODUCTS OR ITEMS NOTED AS "EXISTING" WHICH ARE NOT FOUND TO BE IN THE FIELD.
- CONTRACTOR SHALL SUPERVISE AND DIRECT THE WORK USING THE BEST CONSTRUCTION SKILLS AND ATTENTION. CONTRACTOR SHALL BE SOLELY RESPONSIBLE FOR CONSTRUCTION MEANS, METHODS, TECHNIQUES, SEQUENCES, PROCEDURES, AND FOR COORDINATING ALL PORTIONS OF THE WORK UNDER CONTRACT, UNLESS OTHERWISE NOTED.
- ERECTION SHALL BE DONE IN A WORKMANLIKE MANNER BY COMPETENT EXPERIENCED WORKMEN IN ACCORDANCE WITH APPLICABLE CODES AND THE BEST ACCEPTED PRACTICE. ALL MEMBERS SHALL BE LAID PLUMB AND TRUE AS INDICATED ON THE DRAWINGS.
- CONTRACTOR SHALL BE RESPONSIBLE FOR THE SAFETY OF THE WORK AREA, ADJACENT AREAS, AND BUILDING OCCUPANTS THAT ARE LIKELY TO BE AFFECTED BY THE WORK UNDER THIS CONTRACT. WORK SHALL CONFORM TO ALL OSHA REQUIREMENTS.
- CONTRACTOR SHALL COORDINATE HIS WORK AND SCHEDULE HIS ACTIVITIES AND WORKING HOURS IN ACCORDANCE WITH THE REQUIREMENTS OF THE OWNER.
- CONTRACTOR SHALL BE RESPONSIBLE FOR COORDINATING HIS WORK WITH THE WORK OF OTHERS AS IT MAY RELATE TO RADIO EQUIPMENT, ANTENNAS AND ANY OTHER PORTIONS OF THE WORK.
- CONTRACTOR SHALL MAINTAIN LIABILITY INSURANCE TO PROTECT THE OWNER.
- INSTALL ALL EQUIPMENT AND MATERIALS IN ACCORDANCE WITH MANUFACTURER'S RECOMMENDATIONS UNLESS SPECIFICALLY INDICATED OR WHERE LOCAL CODES OR REGULATIONS TAKE PRECEDENCE.
- MAKE NECESSARY PROVISIONS TO PROTECT EXISTING SURFACES, EQUIPMENT, IMPROVEMENTS, AND PIPING. REPAIR ANY DAMAGE THAT OCCURS DURING CONSTRUCTION.
- REPAIR ALL EXISTING SURFACES DAMAGED DURING CONSTRUCTION SUCH THAT THEY MATCH AND BLEND WITH ADJACENT SURFACES.
- KEEP CONTRACT AREA CLEAN, HAZARD FREE, AND DISPOSE OF ALL DEBRIS AND RUBBISH. EQUIPMENT NOT SPECIFIED AS REMAINING ON THE PROPERTY OF THE OWNER SHALL BE REMOVED. LEAVE PREMISES IN CLEAN CONDITION AND FREE FROM PAINT SPOTS, DUST, OR SMUDGES OF ANY NATURE. CONTRACTOR SHALL BE RESPONSIBLE FOR MAINTAINING ALL ITEMS UNTIL COMPLETION OF CONSTRUCTION.
- CONTRACTOR SHALL VERIFY ALL DIMENSIONS AND CONDITIONS IN THE FIELD PRIOR TO FABRICATION AND ERECTION OF ANY MATERIAL. ANY UNUSUAL CONDITIONS SHALL BE REPORTED TO THE ATTENTION OF THE ENGINEER.
- PROVIDE 48 HOURS WRITTEN NOTICE TO THE ENGINEER PRIOR TO THE COMMENCEMENT OF WORK.
- ALL BROCHURES, OPERATING AND MAINTENANCE MANUALS, CATALOGS, SHOP DRAWINGS AND OTHER DOCUMENTATION SHALL BE TURNED OVER TO AT COMPLETION OF CONSTRUCTION.
- COMPLETE JOB SHALL BE GUARANTEED FOR A PERIOD OF ONE (1) YEAR AFTER DATE OF ACCEPTANCE BY. ANY WORK, MATERIALS OR EQUIPMENT FOUND TO BE DEFECTIVE DURING THAT PERIOD SHALL BE CORRECTED IMMEDIATELY UPON WRITTEN NOTIFICATION AT NO ADDITIONAL COST TO T-MOBILE.

**STRUCTURAL NOTES**

- CONTRACTOR SHALL VERIFY ALL DIMENSIONS AND CONDITIONS IN THE FIELD PRIOR TO FABRICATION AND ERECTION OF ANY MATERIAL. ANY UNUSUAL CONDITIONS SHALL BE REPORTED TO THE ATTENTION OF THE ENGINEER.
- DESIGN AND CONSTRUCTION OF STRUCTURAL STEEL SHALL CONFORM TO THE AMERICAN INSTITUTE OF STEEL CONSTRUCTION "SPECIFICATION FOR THE DESIGN, FABRICATION AND ERECTION OF STRUCTURAL STEEL FOR BUILDINGS", LATEST EDITION.
- STRUCTURAL STEEL BEAMS SHALL CONFORM TO ASTM A992 (Fy=50ksi). STRUCTURAL STEEL PLATES AND ANGLES SHALL CONFORM TO ASTM A36.
- ROUND AND SQUARE HOLLOW STRUCTURAL SECTIONS (HSS) CONFORM TO ASTM A500 "COLD-FORMED WELDED & SEAMLESS CARBON STEEL STRUCTURAL TUBING", GRADE C.
- STEEL PIPE SHALL CONFORM TO ASTM A500 "COLD-FORMED WELDED & SEAMLESS CARBON STEEL STRUCTURAL TUBING", GRADE B, OR ASTM A53 "PIPE, STEEL, BLACK AND HOT-DIPPED, ZINC-COATED WELDED AND SEAMLESS", TYPE E OR S, GRADE B.
- CONNECTIONS: WELD OR BOLT CONNECTIONS, AS INDICATED:
  - CONNECTIONS NOT DETAILED ON THE DRAWINGS SHALL CONFORM TO THE REQUIREMENTS OF THE CITED AISC SPECIFICATION.
  - STRUCTURAL BOLTS SHALL CONFORM TO THE LATEST ASTM A325 "HIGH STRENGTH BOLTS FOR STRUCTURAL JOINTS, INCLUDING SUITABLE NUTS AND PLAIN HARDENED WASHERS".
    - WHERE THE REACTION VALUES OF BEAMS, BRACING, STRUTS, ETC., ARE NOT SHOWN ON THE DRAWINGS THE CONNECTIONS SHALL BE DESIGNED TO SUPPORT THE END REACTION DERIVED FROM THE TABLES AND FORMULA OF UNIFORM LOAD CONSTANTS IN PART 2, NINTH EDITION, OF THE AISC MANUAL OF STEEL CONSTRUCTION FOR THE GIVEN MEMBER SIZE, SPAN AND YIELD STRENGTH.
  - MINIMUM 3/16" FILLET E70-XX WELD SHALL APPLY UNLESS NOTED.
  - MINIMUM 1/2" DIA. A325 BOLTS SHALL APPLY UNLESS NOTED.
  - MINIMUM SIZE OF CLIP ANGLES SHALL BE L3x3x3/8" UNLESS NOTED.
  - ALL GUSSET PLATES SHALL BE 3/8" THICK UNLESS NOTED.
  - ALL HOLES FOR BOLTS SHALL BE 1/16 INCH LARGER THAN THE BOLT DIAMETER WITH AN EDGE DISTANCE OF AT LEAST 1 1/2 TIMES THE BOLT DIAMETER AND A SPACING OF AT LEAST 3 TIMES THE BOLT DIAMETER. ALL BOLTS SHALL BE PROVIDED WITH PALNUTS OR LOCK NUTS.
- STRUCTURAL CONNECTION BOLTS SHALL BE HIGH STRENGTH BOLTS AND CONFORM TO ASTM A325 "HIGH STRENGTH BOLTS FOR STRUCTURAL JOINTS, INCLUDING SUITABLE NUTS AND PLAIN HARDENED WASHERS", LATEST EDITION. BOLTS SHALL BE 3/4 INCH DIA. UNLESS OTHERWISE NOTED.
- CONTRACTOR SHALL COMPLY WITH AWS CODE FOR PROCEDURES, APPEARANCE AND QUALITY OF WELDS AND FOR METHODS USED IN CORRECTING WELDING. ALL WELDERS AND WELDING PROCESSES SHALL BE QUALIFIED IN ACCORDANCE WITH AWS "STANDARD QUALIFICATION PROCEDURES".
- ALL STEEL MATERIALS SHALL BE GALVANIZED AFTER FABRICATION IN ACCORDANCE WITH ASTM A123 "ZINC (HOT-DIP GALVANIZED) COATINGS ON IRON AND STEEL PRODUCTS", UNLESS OTHERWISE NOTED.
- DAMAGED GALVANIZED SURFACES SHALL BE REPAIRED BY COLD GALVANIZING IN ACCORDANCE WITH ASTM A780.
- ALL BOLTS, ANCHORS AND MISCELLANEOUS HARDWARE SHALL BE GALVANIZED IN ACCORDANCE WITH ASTM A153 "ZINC-COATING (HOT-DIP) ON IRON AND STEEL HARDWARE", UNLESS OTHERWISE NOTED.
- ALL STEEL SUPPORTS SHALL BE INSTALLED WITH DOUBLE NUTS AND SHALL BE INSTALLED SNUG TIGHT.
- SLEEVE ANCHORS SHALL CONFORM TO FEDERAL SPECIFICATION FF-S-325, GROUP II, TYPE 3, CLASS 3, AS MANUFACTURED BY HILTI FASTENING SYSTEMS OR APPROVED EQUAL. INSTALLATION SHALL BE IN ACCORDANCE WITH THE MANUFACTURER'S RECOMMENDATIONS. MINIMUM EMBEDMENT SHALL BE THREE (3) INCHES.
- EXPANSION BOLTS SHALL CONFORM TO FEDERAL SPECIFICATION FF-S-325, GROUP II, TYPE 4, CLASS 1, HILTI KWIK BOLT II OR APPROVED EQUAL. INSTALLATION SHALL BE IN ACCORDANCE WITH THE MANUFACTURER'S RECOMMENDATIONS. MINIMUM EMBEDMENT SHALL BE FOUR (4) INCHES.
- EPOXY ANCHORING SYSTEM SHALL BE THE HILTI HY-270 FOR MASONRY CONSTRUCTION WITH HOLLOW BRICK OR BLOCK & THE HILTI HIT HY200 INJECTION ADHESIVE ANCHOR FOR GROUT FILLED CONCRETE MASONRY UNITS AND CONCRETE. EPOXY ANCHOR ASSEMBLY SHALL CONSIST OF 1/2"Ø STAINLESS STEEL ANCHOR ROD W/NUTS & WASHERS, AN INTERNALLY THREADED INSERT, A SCREEN TUBE FOR THE HY-270 ONLY & AN EPOXY ADHESIVE (6" MIN EMBEDMENT). THE INSTALLATION PROCEDURE SHALL BE AS FOLLOWS
  - DRILL THE HOLE USING MANUFACTURER RECOMMENDED DRILL BIT UP TO SPECIFIED DEPTH. HAMMERING IS NOT PERMITTED.
  - CLEAN THE HOLE USING NYLON BRUSH AND/OR COMPRESSED AIR. THE HOLE SHOULD BE CLEAR OF ANY LOOSE MATERIAL. IF WET, THE MASONRY SHOULD BE ALLOWED TO DRY FULLY BEFORE ANCHOR INSTALLATION.
  - INSERT SPECIFIED SCREEN TUBE INTO THE HOLE.
  - FILL THE SCREEN TUBE COMPLETELY WITH ADHESIVE, BEGINNING AT THE BOTTOM END.
  - INSERT ANCHOR ROD OR INTERNALLY THREADED INSERT INTO THE ADHESIVE-FILLED SCREEN TUBE, TWISTING SLIGHTLY.
  - LOAD FASTENER ONLY AFTER MANUFACTURER SPECIFIED CURE TIME HAS ELAPSED.
- GRATING SHALL BE GALVANIZED WELDED STEEL BAR GRATING TYPE W/BA WITH 1-1/4" BEARING BARS AT 1-3/16" OC. FASTEN TO SUPPORTING MEMBERS WITH SADDLE-TYPE CLIPS AT 2'-0" O.C. AND BAND ALL EXPOSED EDGES.
- SUBMIT DRAWINGS OF ALL STRUCTURAL AND MISCELLANEOUS STEEL TO THE ENGINEER FOR APPROVAL AND INCORPORATE ALL COMMENTS PRIOR TO FABRICATION.
- INCORRECTLY FABRICATED, DAMAGED OR OTHERWISE MISFITTING OR NONCONFORMING MATERIALS OR CONDITIONS SHALL BE REPORTED TO THE ENGINEER PRIOR TO REMEDIAL OR CORRECTIVE ACTION. ANY SUCH ACTION SHALL REQUIRE ENGINEER APPROVAL.
- ALL WORK SHALL BE INSPECTED BY THE ENGINEER DURING AND AT THE COMPLETION OF CONSTRUCTION.
- CONTRACTOR TO REMOVE MASTIC ON THE EXISTING WALL/PARAPET AT EVERY STEEL SUPPORT ATTACHMENT AND REPOINT MASONRY AS REQUIRED. A BED OF SILICONE SHALL BE APPLIED BEHIND AND ALL AROUND THE STEEL SUPPORT ATTACHMENT TO MAKE IT WEATHERPROOF.
- HAMMER DRILLS ARE NOT TO BE USED WHEN DRILLING HOLES FOR SLEEVE OR EXPANSION BOLTS INSTALLED IN MASONRY BLOCKS/BRICKS.
- ALL HOLES TO BE ADDED IN THE FIELD SHALL BE PUNCHED OR DRILLED. NO HOLE BURNING SHALL BE ALLOWED.
- NOTES ARE NOT PROJECT SPECIFIC.

**SITE NOTES**

- ALL SITE WORK SHALL BE AS INDICATED ON THE DRAWING.
- RUBBISH, STUMPS, DEBRIS, STICKS, STONES AND OTHER REFUSE SHALL BE REMOVED FROM THE SITE AND DISPOSED OF LEGALLY.
- THE SITE SHALL BE GRADED TO CAUSE SURFACE WATER TO FLOW AWAY FROM THE BTS EQUIPMENT AND TOWER AREAS.
- NO FILL OR EMBANKMENT MATERIAL SHALL BE PLACED ON FROZEN GROUND. FROZEN MATERIALS, SNOW OR ICE SHALL NOT BE PLACED IN ANY FILL OR EMBANKMENT.
- THE SUBGRADE SHALL BE COMPACTED AND BROUGHT TO A SMOOTH UNIFORM GRADE PRIOR TO FINISHED SURFACE APPLICATION.
- ALL EXISTING ACTIVE SEWER, WATER, GAS, ELECTRIC, AND OTHER UTILITIES WHERE ENCOUNTERED IN THE WORK, SHALL BE PROTECTED AT ALL TIMES, AND WHERE REQUIRED FOR THE PROPER EXECUTION OF THE WORK, SHALL BE RELOCATED AS DIRECTED BY ENGINEERS. EXTREME CAUTION SHOULD BE USED BY THE CONTRACTOR WHEN EXCAVATING OR PIER DRILLING AROUND OR NEAR UTILITIES.
- ALL EXISTING INACTIVE SEWER, WATER, GAS, ELECTRIC AND OTHER UTILITIES, WHICH INTERFERE WITH THE EXECUTION OF THE WORK, SHALL BE REMOVED AND/OR CAPPED, PLUGGED OR OTHERWISE DISCONTINUED AT POINTS WHICH WILL NOT INTERFERE WITH THE EXECUTION OF THE WORK, SUBJECT TO THE APPROVAL OF ENGINEER.
- THE AREAS OF THE OWNERS PROPERTY DISTURBED BY THE WORK SHALL BE GRADED TO A UNIFORM SLOPE, FERTILIZED, SEEDED, AND COVERED WITH MULCH.
- CONTRACTOR SHALL MINIMIZE DISTURBANCE TO EXISTING SITE DURING CONSTRUCTION. EROSION CONTROL MEASURES, IF REQUIRED DURING CONSTRUCTION, SHALL BE IN CONFORMANCE WITH THE LOCAL GUIDELINES FOR EROSION AND SEDIMENT CONTROL.
- CARE SHALL BE TAKEN TO RETAIN NATURAL GROWTH AND PREVENT DAMAGE TO TREES WITHIN AND OUTSIDE THE LIMITS OF CONSTRUCTION AND SPECIFIED WORK AREAS CAUSED BY EQUIPMENT AND MATERIALS. ANY DAMAGE TO THIS NATURAL GROWTH SHALL BE RESTORED AT THE EXPENSE OF THE CONTRACTOR.
- ALL AREAS DISTURBED BY THE CONTRACTOR WITHOUT AUTHORIZATION SHALL BE RESTORED BY THE CONTRACTOR.
- IN THE EVENT THE CONTRACTOR DAMAGES AN EXISTING UTILITY SERVICE CAUSING AN INTERRUPTION IN SAID SERVICE, HE SHALL IMMEDIATELY COMMENCE WORK TO RESTORE SERVICE AND MAY NOT CEASE HIS WORK OPERATION UNTIL SERVICE IS RESTORED.

COPIES OF THIS DOCUMENT WITHOUT A FACSIMILE OF THE SIGNATURE & AN ORIGINAL EMBOSSED SEAL OR ORIGINAL STAMP IN BLUE OR BLACK INK OF THE PROFESSIONAL ENGINEER OR LAND SURVEYOR SHALL NOT BE CONSIDERED VALID COPIES.

THIS DOCUMENT IS PREPARED SPECIFICALLY FOR THE CLIENT AND PROJECT DESIGNATED HEREON. MODIFICATION, ALTERATION, REVISION, DUPLICATION, OR USE WITHOUT THE CONSENT OF TECTONIC IS STRICTLY PROHIBITED. COPYRIGHT 2019 TECTONIC. ALL RIGHTS RESERVED.

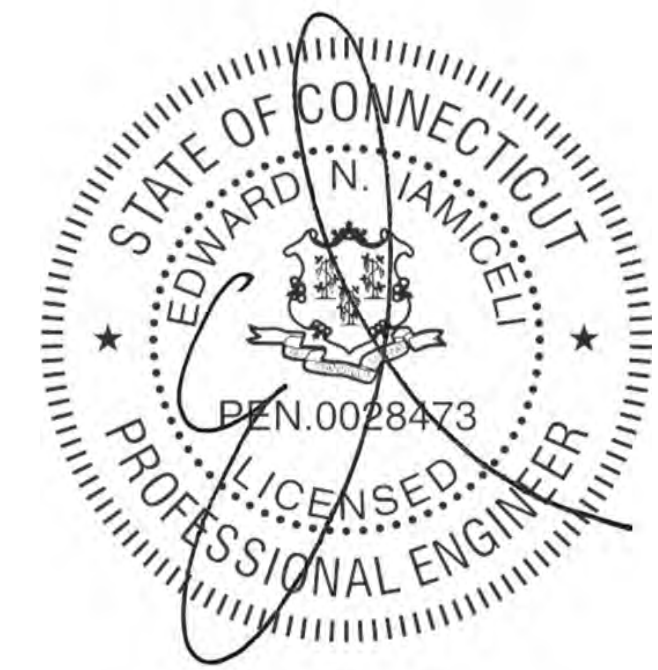

**Tectonic**  
 PRACTICAL SOLUTIONS. EXCEPTIONAL SERVICE.  
 Tectonic Engineering & Surveying Consultants P.C.  
 70 Pleasant Hill Road Phone: (845) 534-5959  
 P.O. Box 37 (800) 529-6531  
 Mountainville, NY 10953 www.tectonicengineering.com  
 Project Contact Info  
 1279 Route 300  
 Newburgh, NY 12550 Phone: (845) 567-6656

**Mobile**  
 NORTEAST, LLC.  
 35 GRIFFIN ROAD SOUTH  
 BLOOMFIELD, CT 06002

**NSS NORTEAST**  
 SITE SOLUTIONS  
 Turnkey Wireless Development

**APPROVALS**

LANDLORD \_\_\_\_\_  
 RF \_\_\_\_\_  
 CONSTRUCTION \_\_\_\_\_  
 OPERATIONS \_\_\_\_\_  
 SITE ACQ. \_\_\_\_\_

PROJECT NUMBER	DESIGNED BY
9927.CT11636A	VS

REV.	DATE	DESCRIPTION	DRAWN BY
△	07/19/19	ISSUED FOR CONSTRUCTION	BWY

ISSUED BY \_\_\_\_\_ DATE \_\_\_\_\_

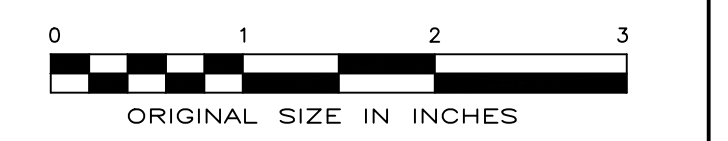

**SITE INFORMATION**

WIRELESS SOLUTION OLD LYME  
 CT11636A  
 72 BOGGY HOLE ROAD  
 OLD LYME, CT 06371

**SHEET TITLE**

NOTES

**SHEET NUMBER**

A-5



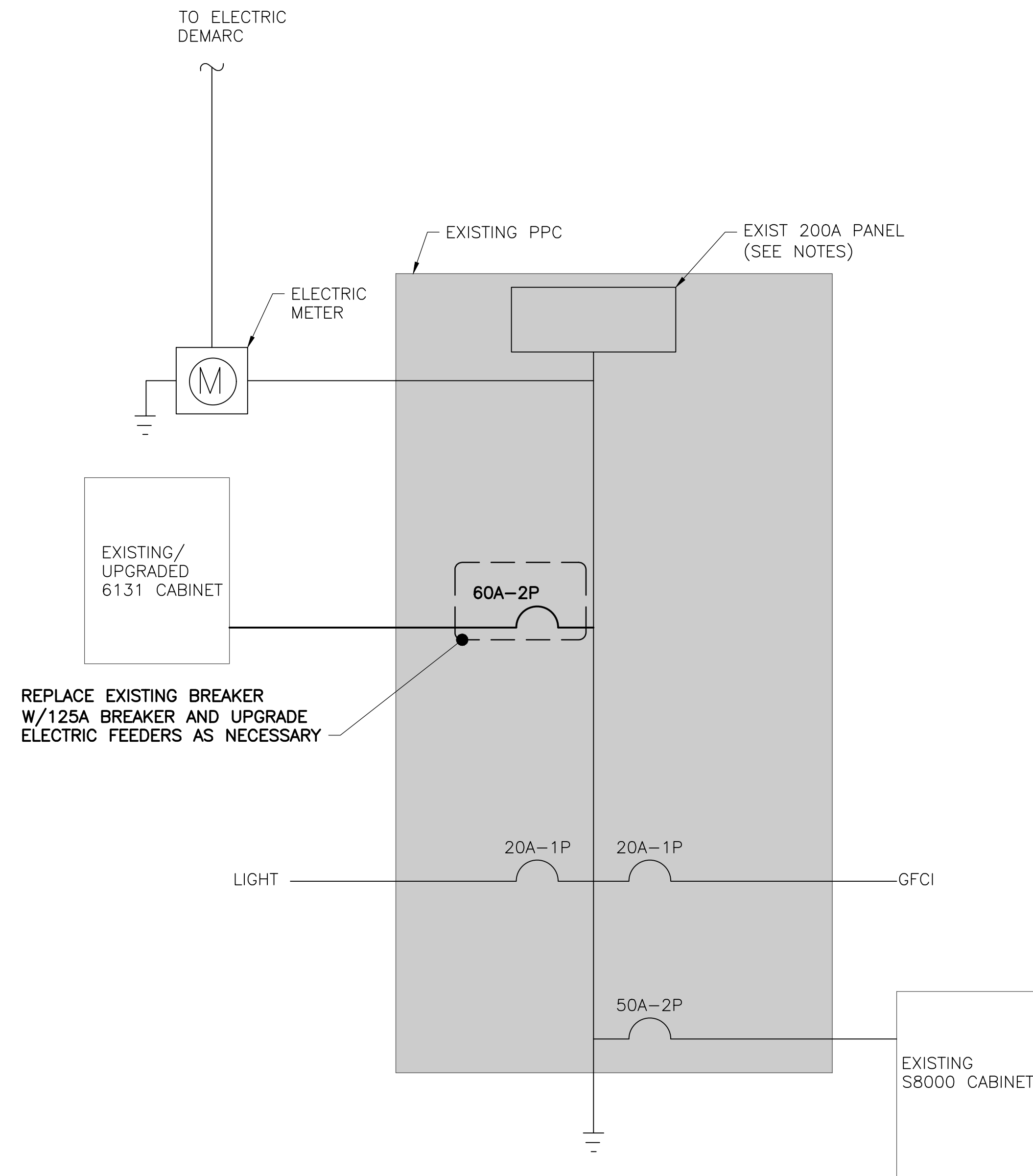

- NOTES:
1. THE ABOVE DIAGRAM IS GENERIC AND ANY ELECTRICAL WORK SHALL BE COMPLETED BY A LICENSED ELECTRICIAN IN ACCORDANCE WITH NEC STANDARDS.
  2. ELECTRICAL CONSULT SHALL BE PERFORMED PRIOR TO CONSTRUCTION TO CONFIRM THE POWER REQUIREMENTS AND FEASIBILITY.

1 ONE-LINE DIAGRAM  
E-1 SCALE: NTS

GENERAL ELECTRICAL NOTES

1. CONTRACTOR SHALL PERFORM ALL VERIFICATION OBSERVATION TESTS, AND EXAMINATION WORK PRIOR TO THE ORDERING OF THE ELECTRICAL EQUIPMENT AND THE ACTUAL CONSTRUCTION. CONTRACTOR SHALL ISSUE A WRITTEN NOTICE OF ALL FINDINGS TO THE ENGINEER LISTING ALL MALFUNCTIONS, FAULTY EQUIPMENT AND DISCREPANCIES.
2. CONTRACTOR SHALL PROVIDE ALL LABOR, MATERIALS, INSURANCE, EQUIPMENT, INSTALLATION, CONSTRUCTION TOOLS, TRANSPORTATION, ETC., FOR A COMPLETE AND PROPERLY OPERATIVE SYSTEM ENERGIZED THROUGHOUT AND AS INDICATED ON DRAWINGS, AS SPECIFIED HEREIN AND/OR AS OTHERWISE REQUIRED.
3. ALL MATERIALS AND EQUIPMENT SHALL BE NEW AND IN PERFECT CONDITION WHEN INSTALLED AND SHALL BE OF THE BEST GRADE AND OF THE SAME MANUFACTURER THROUGHOUT FOR EACH CLASS OR GROUP OF EQUIPMENT. MATERIALS SHALL BE LISTED AND APPROVED BY UNDERWRITER'S LABORATORIES (U.L.) AND SHALL BEAR THE INSPECTION LABEL "J" WHERE SUBJECT TO SUCH APPROVAL. MATERIALS SHALL MEET WITH APPROVAL OF ALL GOVERNING BODIES HAVING JURISDICTION. AND SHALL BE MANUFACTURED IN ACCORDANCE WITH APPLICABLE STANDARDS ESTABLISHED BY ANSI, NEMA AND NBFU.
4. CONTRACTOR TO COORDINATE WITH SITE OWNER FOR CONNECTION OF TEMPORARY AND PERMANENT POWER TO THE SITE. THE TEMPORARY POWER AND ALL HOOKUP COSTS TO BE PAID BY CONTRACTOR.
5. ALL CIRCUIT BREAKERS, FUSES AND ELECTRICAL EQUIPMENT SHALL HAVE AN INTERRUPTING RATING NOT LESS THAN THE MAXIMUM SHORT CIRCUIT CURRENT TO WHICH THEY MAY BE SUBJECTED, AND A MINIMUM OF 10,000 A.I.C.
6. ALL ELECTRICAL EQUIPMENT SHALL BE LABELED WITH PERMANENT ENGRAVED PLASTIC LABELS.
7. METER SOCKETS AMPERES, VOLTAGE AND NUMBER OF PHASES SHALL BE NOTED AND SHALL BE MANUFACTURED BY SQUARE "D" COMPANY, SANGAMO OR APPROVED EQUAL. METER SOCKET SHALL BE APPROVED BY UTILITY COMPANY PRIOR TO INSTALLATION.
8. WIRE AND CABLE CONDUCTORS SHALL BE COPPER #12 AWG MINIMUM WITH TYPE THHN INSULATION UNLESS SPECIFICALLY NOTED OTHERWISE.
9. ALL CONDUCTORS SHALL BE COPPER.
10. USE T-TAP CONNECTIONS ON ALL MULTI-CIRCUITS WITH COMMON NEUTRAL CONDUCTOR FOR LIGHTING FIXTURES.
11. EACH CONDUCTOR OF EVERY SYSTEM SHALL BE PERMANENTLY TAGGED IN EACH PANEL BOARD, PULLBOX, J-BOX, SWITCH BOX, ETC., IN COMPLIANCE WITH THE OCCUPATIONAL SAFETY AND HEALTH ACT (O.S.H.A.)
12. CONDUIT:
  - A. RIGID CONDUIT SHALL BE U.L. LABEL GALVANIZED ZINC COATED WITH ZINC INTERIOR AND SHALL BE USED WHEN INSTALLED IN OR UNDER CONCRETE SLABS, IN CONTACT WITH THE EARTH, UNDER PUBLIC ROADWAYS, IN MASONRY WALLS OR EXPOSED ON BUILDING EXTERIOR.
  - B. INTERMEDIATE METAL CONDUIT SHALL BE U.L. LABEL, FITTINGS SHALL BE THREADED ALUMINUM OR STEEL AND SHALL BE USED FOR ALL EXTERIOR RUNS. THREADLESS COUPLINGS AND CONNECTORS SHALL NOT BE USED.
  - C. ELECTRICAL METALLIC TUBING (EMT) SHALL HAVE U.L. LABEL, FITTINGS SHALL BE NO SET SCREW OR CRIMP TYPE FITTINGS SHALL BE USED. GLAND RING COMPRESSION TYPE. EMT SHALL BE USED ONLY FOR INTERIOR RUNS.
  - D. FLEXIBLE METALLIC CONDUIT SHALL HAVE U.L. LISTED LABEL AND MAY BE USED WHERE PERMITTED BY CODE. FITTINGS SHALL BE "JAKE" OR "SQUEEZE" TYPE, SEAL TIGHT FLEXIBLE CONDUIT. ALL CONDUIT IN EXCESS OF SIX FEET IN LENGTH SHALL HAVE FULL SIZE GROUND WIRE.
  - E. CONDUIT SHALL BE SIZED PER THE NEC AND AS SHOWN.
  - F. CONDUIT RUNS MAY BE SURFACE MOUNTED IN CEILINGS OR WALLS UNLESS INDICATED OTHERWISE. CONDUIT INDICATED SHALL RUN PARALLEL OR AT RIGHT ANGLES TO CEILING, FLOOR OR BEAMS. VERIFY EXACT ROUTING OF ALL EXPOSED CONDUIT WITH OWNER PRIOR TO INSTALLING.
  - G. ALL CONDUIT ONLY (C.O.) RUNS SHALL HAVE A PULL WIRE OR ROPE.
13. COVERPLATES SHALL BE BRUSHED STAINLESS STEEL FOR ALL SWITCHES, RECEPTACLES, TELEPHONE AND BLANKED OUTLETS, AND SHALL HAVE ENGRAVED LETTERING WHERE INDICATED WEATHERPROOF RECEPTACLES SHALL HAVE SIERRA #WPD-8 LIFT COVERPLATES.
14. REFER TO MANUFACTURERS MANUAL FOR RECOMMENDED FUSE AND WIRE SIZES.
15. ALL FINAL CONNECTIONS TO THE EQUIPMENT ARE TO BE OF FLEXIBLE WEATHERPROOF CONDUIT TO MEET APPLICABLE CODES.
16. THE ENTIRE ELECTRICAL INSTALLATION SHALL BE GROUNDED AS REQUIRED BY ALL APPLICABLE CODES.
17. GROUNDING CONDUCTORS SHALL BE SOLID TINNED COPPER AND ANNEALED #2, UNLESS OTHERWISE NOTED.
18. UPON COMPLETION OF WORK, CONDUCT CONTINUITY, SHORT CIRCUIT, AND FALL OF POTENTIAL GROUNDING TESTS FOR APPROVAL. SUBMIT TEST REPORTS TO THE CONSTRUCTION MANAGER. CLEAN PREMISES OF ALL DEBRIS RESULTING FROM WORK AND LEAVE WORK IN A COMPLETE AND UNDAMAGED CONDITION.
19. PROVIDE CONSTRUCTION MANAGER WITH ONE SET OF COMPLETE ELECTRICAL "AS INSTALLED" DRAWINGS AT THE COMPLETION OF THE JOB, SHOWING ACTUAL DIMENSIONS, ROUTINGS, AND CIRCUITS.
20. CONTRACTOR SHALL BE RESPONSIBLE FOR COORDINATING WITH GAINING APPROVALS AND PAYING ALL FEES ASSESSED BY UTILITY COMPANY FOR ELECTRICAL SERVICE.

COPIES OF THIS DOCUMENT WITHOUT A FACSIMILE OF THE SIGNATURE & AN ORIGINAL EMBOSSED SEAL OR ORIGINAL STAMP IN BLUE OR BLACK INK OF THE PROFESSIONAL ENGINEER OR LAND SURVEYOR SHALL NOT BE CONSIDERED VALID COPIES.

THIS DOCUMENT IS PREPARED SPECIFICALLY FOR THE CLIENT AND PROJECT DESIGNATED HEREON. MODIFICATION, ALTERATION, REVISION, DUPLICATION, OR USE WITHOUT THE CONSENT OF TECTONIC IS STRICTLY PROHIBITED. COPYRIGHT 2019 TECTONIC. ALL RIGHTS RESERVED.



**Tectonic**  
PRACTICAL SOLUTIONS. EXCEPTIONAL SERVICE.  
Tectonic Engineering & Surveying Consultants P.C.  
70 Pleasant Hill Road Phone: (845) 534-5959  
P.O. Box 37 (800) 529-6531  
Mountainville, NY 10953 www.tectonicing.com  
Project Contact Info  
1279 Route 300  
Newburgh, NY 12550 Phone: (845) 567-6656

**Mobile**  
NORTHEAST, LLC.  
35 GRIFFIN ROAD SOUTH  
BLOOMFIELD, CT 06002

**NSS NORTHEAST**  
SITE SOLUTIONS  
Turnkey Wireless Development

APPROVALS

LANDLORD \_\_\_\_\_

RF \_\_\_\_\_

CONSTRUCTION \_\_\_\_\_

OPERATIONS \_\_\_\_\_

SITE ACQ. \_\_\_\_\_

PROJECT NUMBER 9927.CT11636A DESIGNED BY VS

REV.	DATE	DESCRIPTION	DRAWN BY
1	07/19/19	ISSUED FOR CONSTRUCTION	BWY

ISSUED BY \_\_\_\_\_ DATE \_\_\_\_\_



SITE INFORMATION

WIRELESS SOLUTION OLD LYME  
CT11636A  
72 BOGGY HOLE ROAD  
OLD LYME, CT 06371

SHEET TITLE

ELECTRICAL NOTES  
& ONE-LINE DIAGRAM

SHEET NUMBER

E-1



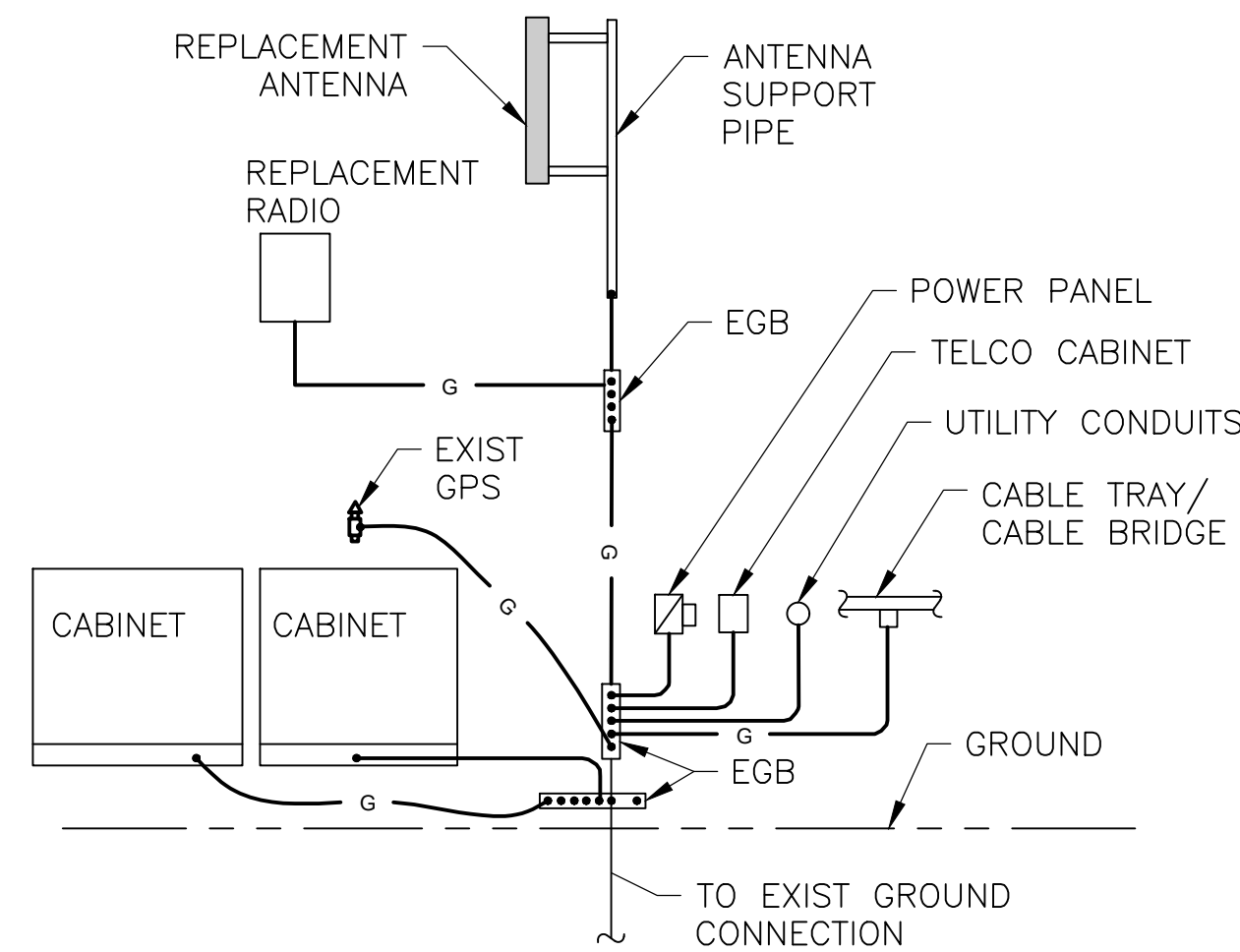

NOTE: CONTRACTOR SHALL CONFIRM ALL EQUIPMENT IS GROUNDED. IF NOT, CONTRACTOR SHALL GROUND EQUIPMENT AS SHOWN AND AS REQUIRED.

### 1 GROUNDING RISER DIAGRAM

SCALE: NTS

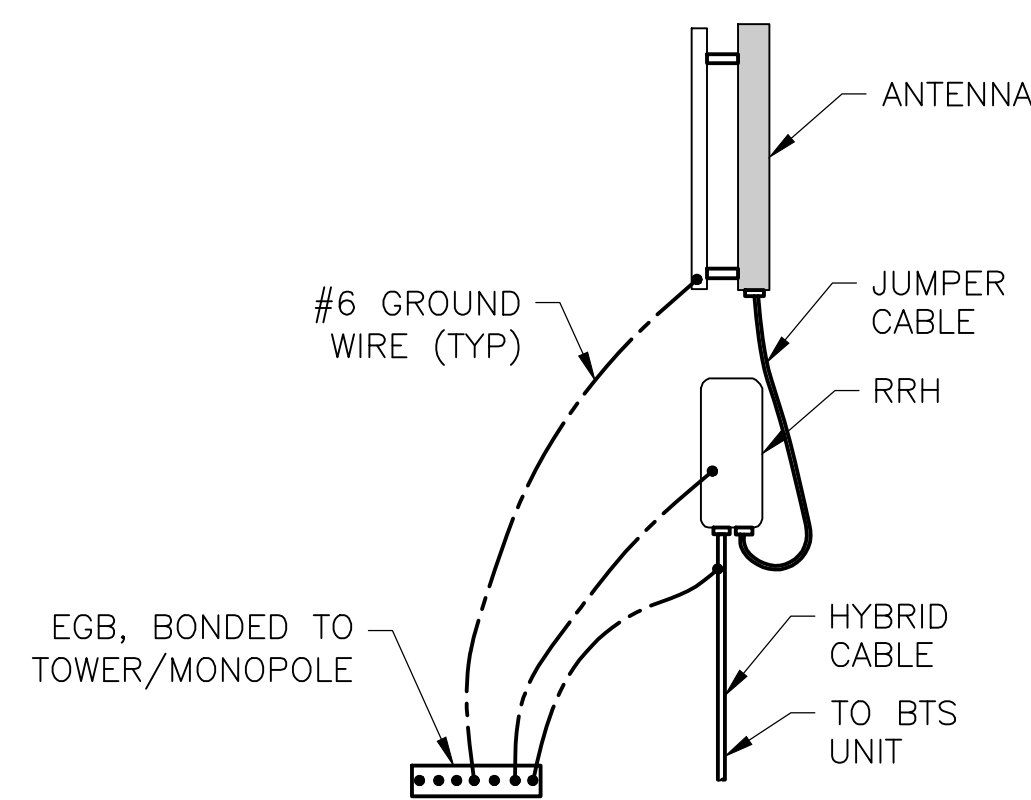

### 2 HYBRID CABLE CONNECTION DETAIL

SCALE: NTS

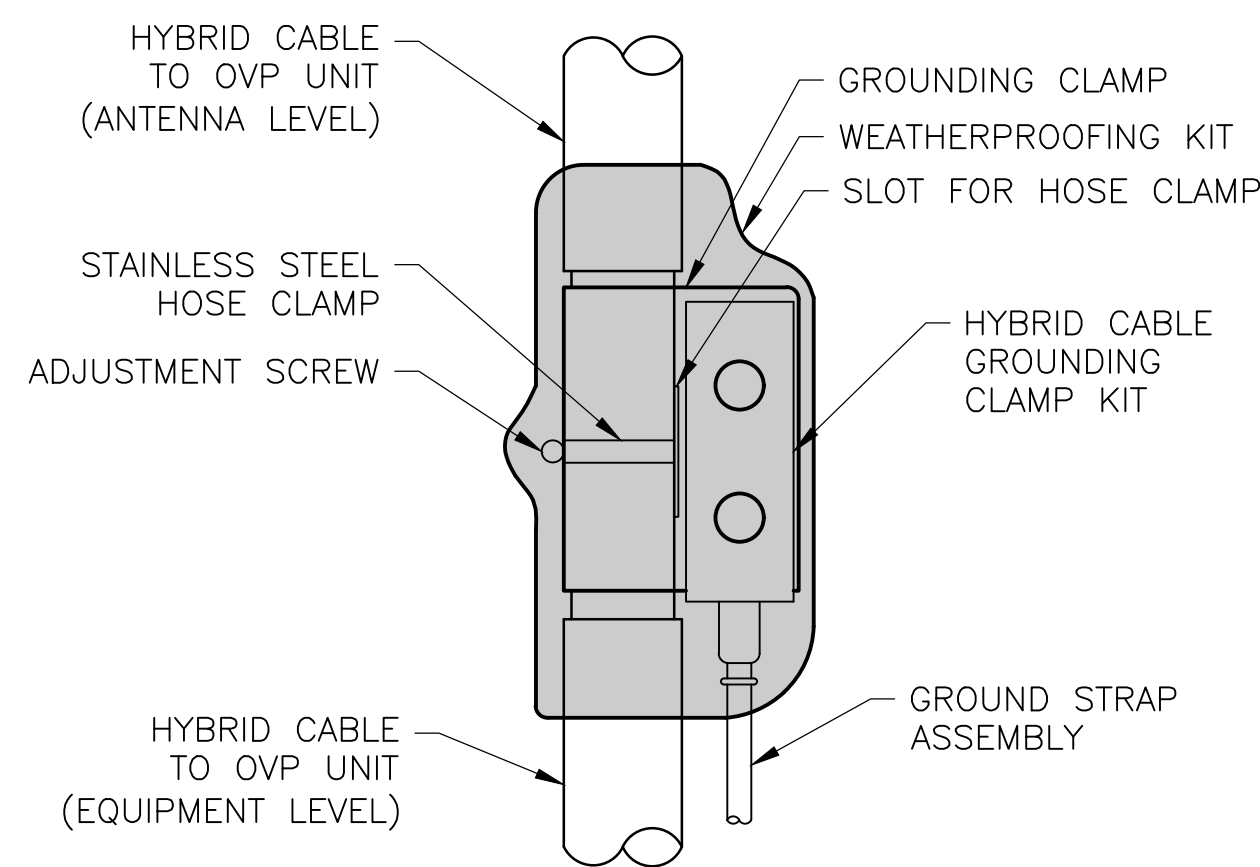

### 3 HYBRID CABLE GROUNDING DETAIL

SCALE: NTS

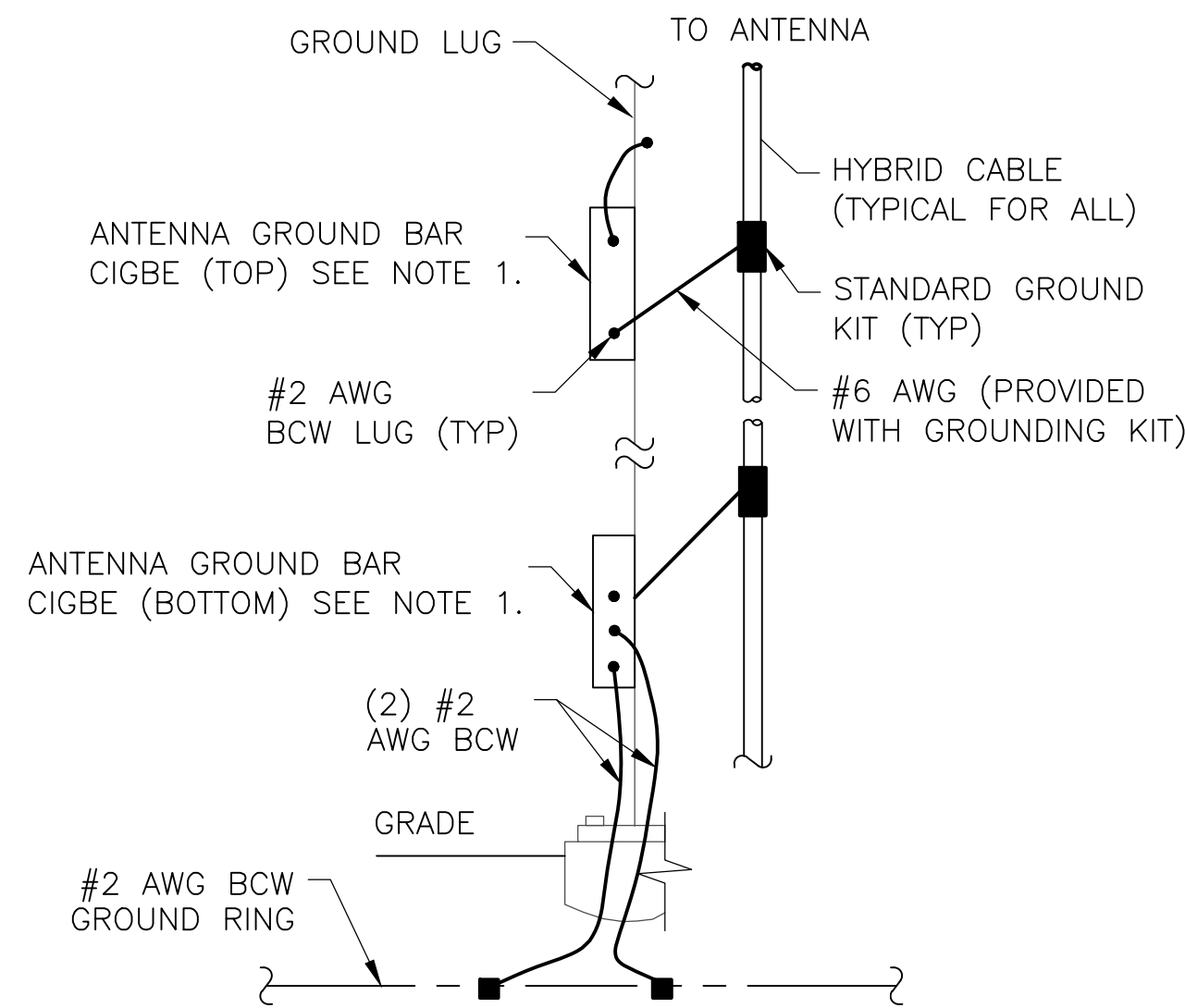

NOTES:

- NUMBER OF GROUND BARS MAY VARY DEPENDING ON THE TYPE OF TOWER, ANTENNA LOCATION AND CONNECTION ANTENNA LOCATION AND CONNECTION ORIENTATION. PROVIDE AS REQUIRED.
- A SEPARATE GROUND BAR TO BE USED FOR GPS UNIT IF REQUIRED.

### 4 ANTENNA CABLE GROUNDING

SCALE: NTS

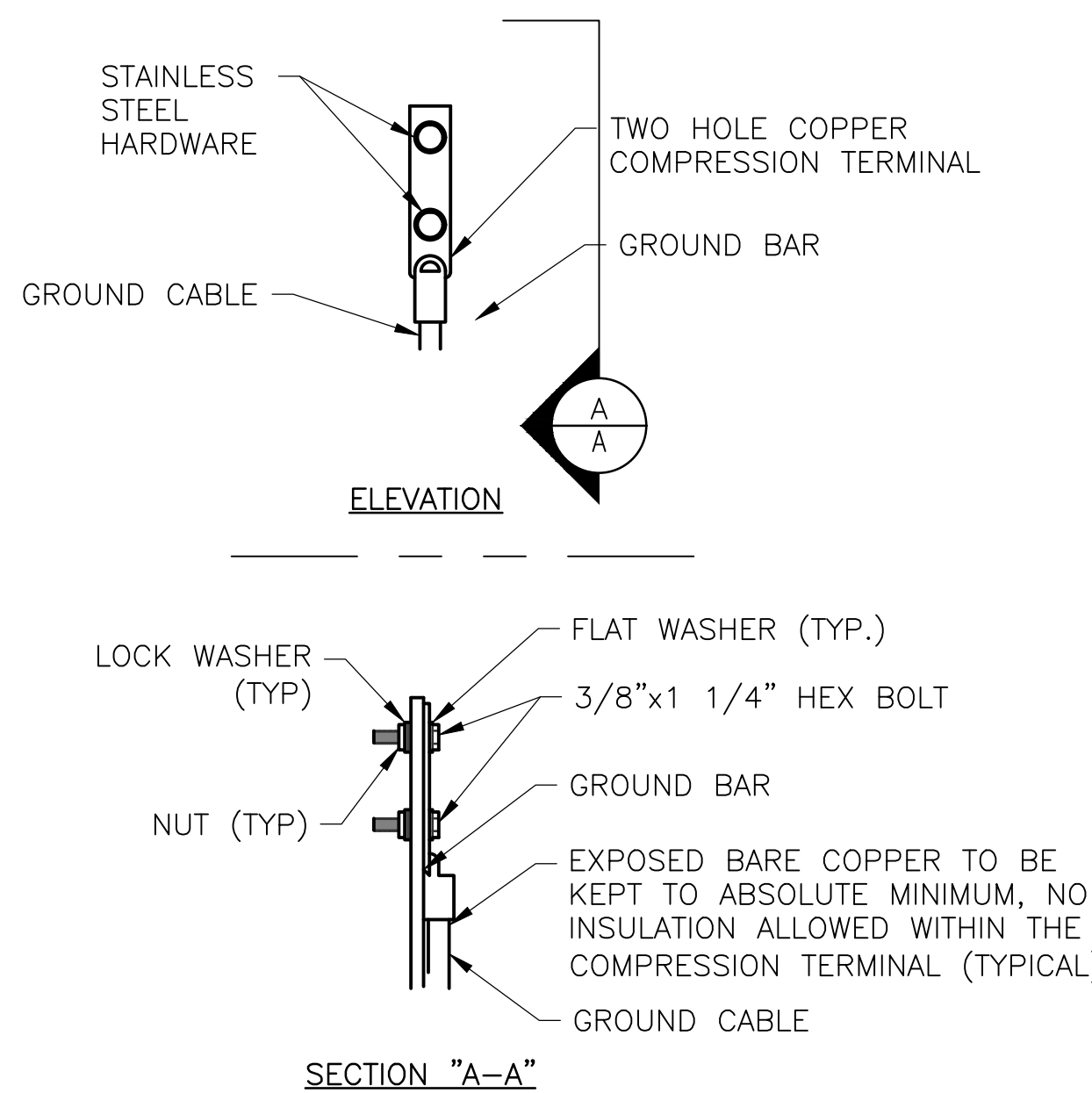

NOTES:

- "DOUBLING UP" OR "STACKING" OF CONNECTION IS NOT PERMITTED.
- OXIDE INHIBITING COMPOUND TO BE USED AT ALL LOCATIONS.
- CADWELD DOWNLEADS FROM UPPER EGB, LOWER EGB AND MGB.
- ALL GROUND LUGS MUST NE HEAT SHRUNK AT WIRE/LUG CONNECTION.

### 5 GROUND BAR CONNECTION DETAIL

SCALE: NTS

### GROUNDING NOTES

- THE ENTIRE ELECTRICAL INSTALLATION SHALL BE GROUNDED AS REQUIRED BY ALL APPLICABLE CODES.
- ALL GROUNDING WORK SHALL BE IN ACCORDANCE WITH T-MOBILE STANDARD PRACTICE.
- ALL BUS CONNECTORS SHALL BE TWO-HOLE, LONG-BARREL TYPE COMPRESSION LUGS, T&B OR EQUAL, UNLESS OTHERWISE NOTED ON DRAWINGS. ALL LUGS SHALL BE ATTACHED TO BUSES USING BOLTS, NUTS, AND LOCK WASHERS. NO WASHERS ARE ALLOWED BETWEEN THE ITEMS BEING GROUNDED.
- ALL CONNECTORS SHALL BE CRIMPED USING HYDRAULIC CRIMPING TOOLS, T&B #TBM 8 OR EQUIVALENT.
- ALL CONNECTIONS SHALL BE MADE TO BARE METAL. ALL PAINTED SURFACES SHALL BE FILED TO ENSURE PROPER CONTACT. NO WASHERS ARE ALLOWED BETWEEN THE ITEMS BEING GROUNDED. ALL CONNECTIONS ARE TO HAVE A NON-OXIDIZING AGENT APPLIED PRIOR TO INSTALLATION.
- ALL COPPER BUSES SHALL BE CLEANED, POLISHED, AND A NON-OXIDIZING AGENT APPLIED. NO FINGERPRINTS OR DISCOLORED COPPER WILL BE PERMITTED.
- ALL BENDS SHALL BE AS SHALLOW AS POSSIBLE, WITH NO TURN SHORTER THAN AN 8-INCH NOMINAL RADIUS.
- GROUNDING CONDUCTORS SHALL BE SOLID TINNED COPPER AND ANNEALED #2. ALL GROUNDING CONDUCTORS SHALL RUN THROUGH PVC SLEEVES WHEREVER CONDUCTORS RUN THROUGH WALLS, FLOORS, OR CEILINGS. IF CONDUCTORS MUST RUN THROUGH EMT, BOTH ENDS OF CONDUIT SHALL BE GROUNDED. SEAL BOTH ENDS OF CONDUIT WITH SILICONE CAULK.
- GROUNDING SYSTEM RESISTANCE SHALL NOT EXCEED 10 OHMS. IF THE RESISTANCE VALUE IS EXCEEDED, NOTIFY THE PROJECT MANAGER FOR FURTHER INSTRUCTION ON METHODS FOR REDUCING THE RESISTANCE VALUE.
- ALL ROOF TOP ANTENNA MOUNTS SHALL BE GROUNDED WITH A #2 GROUND WIRE CONNECTED TO THE NEAREST GROUND BUS. ALL CONNECTIONS ARE TO BE CAD-WELDED IF POSSIBLE.
- UPON COMPLETION OF WORK, CONDUCT CONTINUITY, SHORT CIRCUIT, AND FALL OF POTENTIAL GROUNDING TESTS FOR APPROVAL. SUBMIT TEST REPORTS TO THE PROJECT MANAGER.
- GROUNDING CONNECTION TO TRAVEL IN A DOWNWARD DIRECTION.
- ALL EXPOSED #2 WIRE MUST BE TINN NOT BTW.
- TECTONIC TAKES NO RESPONSIBILITY OR LIABILITY FOR THE GROUNDING SYSTEM AS SHOWN ON THIS SITE. THIS IS A STANDARD GROUNDING SYSTEM.

COPIES OF THIS DOCUMENT WITHOUT A FACSIMILE OF THE SIGNATURE & AN ORIGINAL EMBOSSED SEAL OR ORIGINAL STAMP IN BLUE OR BLACK INK OF THE PROFESSIONAL ENGINEER OR LAND SURVEYOR SHALL NOT BE CONSIDERED VALID COPIES.

THIS DOCUMENT IS PREPARED SPECIFICALLY FOR THE CLIENT AND PROJECT DESIGNATED HEREON. MODIFICATION, ALTERATION, REVISION, DUPLICATION, OR USE WITHOUT THE CONSENT OF TECTONIC IS STRICTLY PROHIBITED. COPYRIGHT 2019 TECTONIC. ALL RIGHTS RESERVED.



**Tectonic**  
 PRACTICAL SOLUTIONS. EXCEPTIONAL SERVICE.  
 Tectonic Engineering & Surveying Consultants P.C.  
 70 Pleasant Hill Road Phone: (845) 534-5959  
 P.O. Box 37 (800) 529-6531  
 Mountainville, NY 10953 www.tectonicengineering.com  
 Project Contact Info  
 1279 Route 300  
 Newburgh, NY 12550 Phone: (845) 567-6656

**Mobile**  
 NORTEAST, LLC.  
 35 GRIFFIN ROAD SOUTH  
 BLOOMFIELD, CT 06002

**NSS** NORTEAST  
 SITE SOLUTIONS  
 Turnkey Wireless Development

APPROVALS

LANDLORD \_\_\_\_\_

RF \_\_\_\_\_

CONSTRUCTION \_\_\_\_\_

OPERATIONS \_\_\_\_\_

SITE ACQ. \_\_\_\_\_

PROJECT NUMBER	DESIGNED BY
9927.CT11636A	VS

REV.	DATE	DESCRIPTION	DRAWN BY
1	07/19/19	ISSUED FOR CONSTRUCTION	BWY

ISSUED BY \_\_\_\_\_ DATE \_\_\_\_\_

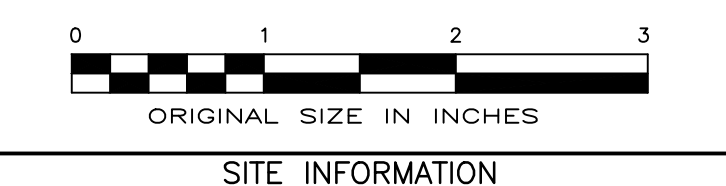

SITE INFORMATION

WIRELESS SOLUTION OLD LYME  
 CT11636A  
 72 BOGGY HOLE ROAD  
 OLD LYME, CT 06371

SHEET TITLE

GROUNDING DETAILS & NOTES

SHEET NUMBER

G-1

# Exhibit D

# STRUCTURAL ANALYSIS REPORT

## T-MOBILE "L600 SCOPE"

### SITE INFORMATION

STRUCTURAL ANALYSIS FOR L600 UPGRADE - MONOPOLE  
SITE NAME: WIRELESS SOLUTIONS OLD LYME  
SITE ADDRESS: 72 BOGGY HOLE ROAD, OLD LYME, CT 06371

PREPARED FOR:

NORTHEAST SITE SOLUTIONS

PREPARED BY:

TECTONIC ENGINEERING & SURVEYING CONSULTANTS P.C.



CONTACT:  
1279 ROUTE 300  
NEWBURGH, NY 12550  
1 (800) 829 – 6531

JUNE 21, 2019

TECTONIC WORK ORDER #: 9927.CT11636A

Passing Rate: 83%

APPROVED BY: \_\_\_\_\_

A handwritten signature in black ink, appearing to read "Ed N. Iamiceli", is written over a horizontal line.

EDWARD N. IAMICELI, P.E.

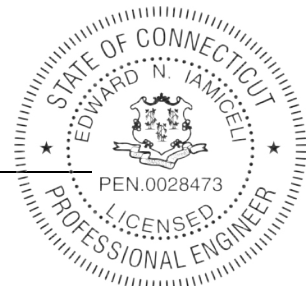

**ANALYSIS OF MONOPOLE & ANTENNA MOUNTS**  
**L600 UPGRADE**

**SITE NAME / ID**

WIRELESS SOLUTIONS OLD LYME

**SITE ADDRESS**

72 BOGGY HOLE ROAD  
OLD LYME, CT 06371

**PURPOSE**

ANALYSIS OF MONOPOLE AND LOW-PROFILE PLATFORM TO SUPPORT THE PROPOSED INSTALLATION.

**DESIGN CRITERIA**

1. EQUIPMENT MANUFACTURERS SPECIFICATIONS.
2. 2018 CONNECTICUT STATE BUILDING CODE (IBC 2015).
3. ASCE 7-10.
4. ANSI/TIA-222-G-2005.

**ASSUMPTIONS**

1. AS NOTED.

**REFERENCES**

1. FIELD NOTES AND FIELD PICTURES.
2. MANUAL OF STEEL CONSTRUCTION.
3. MAPPING REPPORT BY HIGHTOWER SOLUTIONS, DATED 6/7/19.

**PROCEDURE**

1. CALCULATE THE LOADS TO BE RESISTED.
2. CHECK MONOPOLE STRESSES TO RESIST LOADS.
3. CHECK MONOPOLE FOUNDATION TO RESIST LOADS.
4. CHECK LOW-PROFILE PLATFORM MEMBER STRESSES TO RESIST LOADS.
5. CHECK CONNECTIONS.

**RESULTS/CONCLUSIONS**

THE EXISTING MONOPOLE TOWER AND ITS FOUNDATION ARE ADEQUATE TO SUPPORT THE PROPOSED INSTALLATION.

THE EXISTING LOW-PROFILE PLATFORM AND ITS CONNECTIONS WILL HAVE ADEQUATE CAPACITY TO SUPPORT THE PROPOSED INSTALLATION. **IN ORDER FOR THE RESULTS OF THIS ANALYSIS TO BE VALID, A HANDRAIL KIT (SITEPRO1 #HRK12, OR APPROVED EQUAL) MUST BE INSTALLED PRIOR TO THE INSTALLATION OF THE PROPOSED EQUIPMENT.**

CONTRACTOR SHALL FIELD VERIFY EXISTING CONDITIONS AND RECOMMENDATIONS AS NOTED ON THE CONSTRUCTION DRAWINGS AND NOTIFY THE DESIGN ENGINEER OF ANY DISCREPANCIES PRIOR TO FABRICATION OF STEEL. ANY FURTHER CHANGES TO THE ANTENNA AND/OR EQUIPMENT CONFIGURATION SHOULD BE REVIEWED WITH RESPECT TO THEIR EFFECT ON STRUCTURAL LOADS PRIOR TO IMPLEMENTATION.

PREPARED BY: \_\_\_\_\_ G. EVANS \_\_\_\_\_

DATE: \_\_\_\_\_ 6/21/19 \_\_\_\_\_

CHECKED BY: \_\_\_\_\_ E. IAMICELI \_\_\_\_\_

DATE: \_\_\_\_\_ 6/21/19 \_\_\_\_\_



Project Information			
W.O. Number:	9927.CT11636A	Report Date:	6/21/19
Client:	T-Mobile / Northeast Site Solutions	Revision:	0
Site Name:	Wireless Solutions Old Lyme		
Owner:	Wireless Solutions LLC		
Address:	72 Boggy Hole Road	FCC Registration Number:	-
City, State, Zip:	Old Lyme, CT 06371	County:	New London

Structure Information			
Structure Type:	Monopole	Manufacturer:	Engineering Endeavors Inc.
Structure Height:	175 ft	Year Built:	2002
Original Drawings:	Structure: No	Foundation:	No
Previous Analysis:	Yes		
Documents provided:			
	<u>Item</u>	<u>By</u>	<u>No.</u>
Previous Structural Analysis		Centek Engineering	14001.037
RFDS		T-Mobile	CT11636A
Antenna/Coax Verification & Mount Mapping Report		Hightower Solutions	CT11636A
Construction Drawings		Tectonic Engineering	9927.CT11636A
			6/10/19

Inspection			
Type:	Limited visual inspection from ground. Tower Climb	Date:	5/15/19 6/6/2019
General Condition:			
	Tower: Good		
	Foundation: Good		
Observations:	An osprey nest was observed on T-Mobile's platform.		
Finish:	Galvanized	Condition:	Intact

Existing T-Mobile Installation						
Antennas:						
Height (ft.)	Carrier	Qty	Manuf.	Model	Mount	Comment
175	T-Mobile	3	Ericsson	Air-21 B2A/B4P	Low-Profile Platform	To Remain
		3	Ericsson	Air-21 B4A/B2P		
		3	Andrew	LNx-6515DS-A1M		To Be Removed
		3	-	Twin Style TMA		
		3	Ericsson	RRUS 11 B12		
Cables:						
Height (ft.)	Qty	Nom. Size	Location/Support			
175	9	1-5/8" Coax	Existing to remain along the interior of the pole			
175	3	1-5/8" Coax	Existing along the interior of the pole (To be removed)			
175	1	9x18 Hybriflex	Existing to remain along the interior of the pole			

Proposed T-Mobile Installation						
T-Mobile is proposing to replace three (3) of the existing nine (9) panel antennas with newer model antennas and associated appurtenances. The final T-Mobile configuration upon this installation will be as follows:						
Antennas:						
Height (ft.)	Carrier	Qty	Manuf.	Model	Mount	Location
175	T-Mobile	3	Ericsson	Air-21 B2A/B4P	Existing Low-Profile Platform w/ Handrail Kit (SitePro1 HRK12 or approved equal)	Face A, B, and C
		3	Ericsson	Air-21 B4A/B2P		
		3	RFS	APXVAARR24_43-U-NA20		
		3	Ericsson	RRU 4449 B71+B12		
Cables:						
Height (ft.)	Qty	Nom. Size	Location/Support			
175	9	1-5/8" Coax	Existing to remain along the interior of the pole			
175	1	9x18 Hybriflex	Existing to remain along the interior of the pole			
175	3	6x12 Hybriflex	Proposed to be routed along the interior of the pole			

W.O. Number:	9927.CT11636A	Report Date:	6/21/2019
Client:	T-Mobile / Northeast Site Solutions	Revision:	0
Site Name:	Wireless Solutions Old Lyme		

**Analysis Criteria**

Design Standard: ANSI/TIA/222-G-2005  
 Building Code: 2018 Connecticut State Building Code

	Capacity (no ice)	Capacity w/ ice	Service
Wind Speed:	105 mph*	50 mph	60 mph
Basic Ice Thickness:	0 inch	0.75 inch	0 inch

\*This analysis has been performed in accordance with the 2018 Connecticut State Building Code based upon an ultimate 3-second gust wind speed of 135 mph converted to a nominal 3-second gust wind speed of 105 mph per Section 1609.3 and Appendix N as required for use in the TIA-222-G Standard per Exception #5 of Section 1609.1.1. Exposure Category B with a maximum topographic factor, Kzt, of 1.0 and Risk Category II was/were used in this analysis.

Structure Class: 2 Seismic: No  
 Exposure Category: B  
 Topo Category: 1 Crest Height: 0 ft

- Assumptions:
1. The monopole and foundation were designed, manufactured, and constructed in accordance with the approved design drawings and applicable codes and standards in affect at the time.
  2. The slip jointed splices were assembled in accordance with the manufacturer's specs.
  3. The tower and foundation have been properly maintained in accordance with industry standards.
  4. The weight and wind area of certain appurtenances have been estimated.
  5. The tower geometry is based solely on the previous analysis report by Centek Engineering, referenced above.
  5. The foundation geometry and geotechnical values are based solely on the previous analysis report by Centek Engineering, referenced above.
  7. The rectangular HSS members of the low-profile platform have been assumed to be 1/4" thick.

**Analysis Results**

Tower Members:

Element	% Usage
Pole	35
Anchor Bolts	35
Base Plate	44
Base Foundation	40
Base Foundation Soil Interaction	41
Low-Profile Platform	83
Platform Connections	66

Service Load Deformations (Max):

Type	Actual	Allowable	% of Allowable
Tower Horizontal (in)	11.49	63.00	18%
Twist & Sway (deg):	0.61	4.00	15%

For detailed information, see the attached tnxTower output.

**Conclusions**

Based on our analysis, the existing tower and its foundation **have adequate capacity** to support the proposed T-Mobile installation as described herein in accordance with current code requirements.

The existing low-profile platform and its connections **will have adequate capacity** to support the proposed T-Mobile installation as described herein in accordance with current code requirements. **In order for the results of this analysis to be valid, a handrail kit (SitePro1 #HRK12, or approved equal) must be installed prior to the installation of the proposed equipment.**

This analysis is based on a limited visual inspection from the ground, an antenna/coax verification & mount mapping report, and the information provided by the client. Any further changes to the antenna configuration or other appurtenances should be reviewed with respect to their effect on structural loads prior to implementation. If the existing conditions are not as represented in this report, the design engineer should be immediately notified prior to construction.

Prepared by: Graham Evans, P.E.  
 Assistant Project Manager

Reviewed by: Ian Marinaccio  
 Project Engineer

Submitted By: Edward N. Lamiceli  
 Edward N. Lamiceli, P.E.  
 Senior Project Manager

Date: 6/21/19

<b>(APPENDIX N) MUNICIPALITY - SPECIFIC STRUCTURAL DESIGN PARAMETERS</b>												
<b>Municipality</b>	<b>Ground Snow Load (psf)</b>	<b>MCE Spectral Accelerations (%g)</b>		<b>Wind Design Parameters</b>								
		<b>S<sub>s</sub></b>	<b>S<sub>1</sub></b>	<b>Ultimate Design Wind Speeds, V<sub>ult</sub> (mph)</b>			<b>Nominal Design Wind Speeds, V<sub>asd</sub> (mph)</b>			<b>Wind-Borne Debris Regions<sup>1</sup></b>		<b>Hurricane-Prone Regions</b>
				<b>Risk Cat. I</b>	<b>Risk Cat. II</b>	<b>Risk Cat III-IV</b>	<b>Risk Cat. I</b>	<b>Risk Cat. II</b>	<b>Risk Cat. III-IV</b>	<b>Risk Cat. II &amp; III except Occup I-2</b>	<b>Risk Cat III Occup I-2 &amp; Risk Cat. IV</b>	
Montville	30	0.165	0.059	125	135	145	97	105	112		Type A	Yes
Morris	35	0.187	0.065	110	120	125	85	93	97			Yes
Naugatuck	30	0.190	0.064	110	125	135	85	97	105			Yes
New Britain	30	0.183	0.064	115	125	135	89	97	105			Yes
New Canaan	30	0.240	0.068	110	120	130	85	93	101			Yes
New Fairfield	35	0.212	0.067	105	115	125	81	89	97			
New Hartford	40	0.180	0.065	110	120	130	85	93	101			Yes
New Haven	30	0.186	0.062	115	125	135	89	97	105		Type C	Yes
Newington	30	0.182	0.064	115	125	135	89	97	105			Yes
<b>New London</b>	<b>30</b>	<b>0.161</b>	<b>0.058</b>	<b>125</b>	<b>135</b>	<b>145</b>	<b>97</b>	<b>105</b>	<b>112</b>	<b>Type B</b>	<b>Type A</b>	<b>Yes</b>
New Milford	35	0.198	0.066	105	115	125	81	89	97			
Newtown	30	0.208	0.066	110	120	130	85	93	101			Yes
Norfolk	40	0.175	0.065	105	115	125	81	89	97			
North Branford	30	0.179	0.061	120	130	140	93	101	108			Yes
North Canaan	40	0.173	0.065	105	115	120	81	89	93			
North Haven	30	0.184	0.062	115	125	135	89	97	105			Yes
North Stonington	30	0.163	0.059	125	135	145	97	105	112		Type A	Yes
Norwalk	30	0.232	0.067	110	120	130	85	93	101			Yes
Norwich	30	0.168	0.060	125	135	145	97	105	112		Type A	Yes
Old Lyme	30	0.164	0.059	125	135	145	97	105	112	Type B	Type A	Yes
Old Saybrook	30	0.164	0.059	125	135	145	97	105	112	Type B	Type A	Yes
Orange	30	0.192	0.063	115	125	135	89	97	105			Yes
Oxford	30	0.196	0.064	110	125	130	85	97	101			Yes
Plainfield	35	0.170	0.061	125	135	145	97	105	112		Type A	Yes
Plainville	35	0.184	0.064	115	125	135	89	97	105			Yes
Plymouth	35	0.186	0.064	110	120	130	85	93	101			Yes
Pomfret	40	0.172	0.063	120	130	140	93	101	108			Yes
Portland	30	0.180	0.063	115	130	135	89	101	105			Yes
Preston	30	0.167	0.060	125	135	145	97	105	112		Type A	Yes
Prospect	30	0.188	0.064	115	125	135	89	97	105			Yes
Putnam	40	0.172	0.063	120	130	140	93	101	108			Yes
Redding	30	0.220	0.067	110	120	130	85	93	101			Yes
Ridgefield	30	0.230	0.068	110	120	125	85	93	97			Yes
Rocky Hill	30	0.181	0.063	115	125	135	89	97	105			Yes
Roxbury	35	0.197	0.065	110	120	125	85	93	97			Yes
Salem	30	0.170	0.060	120	135	140	93	105	108		Type A	Yes
Salisbury	40	0.173	0.065	105	115	120	81	89	93			
Scotland	30	0.172	0.061	120	130	140	93	101	108			Yes
Seymour	30	0.194	0.064	115	125	135	89	97	105			Yes
Sharon	40	0.179	0.065	105	115	120	81	89	93			
Shelton	30	0.199	0.064	115	125	135	89	97	105			Yes
Sherman	35	0.202	0.066	105	115	120	81	89	93			

# TOWER ANALYSIS

**DESIGNED APPURTENANCE LOADING**

TYPE	ELEVATION	TYPE	ELEVATION
APXVAARR24_43_U_NA20 w/ Mount Pipe	172	RRH2x40-AWS	162
APXVAARR24_43_U_NA20 w/ Mount Pipe	172	RRH2x40-AWS	162
APXVAARR24_43_U_NA20 w/ Mount Pipe	172	EEL Low-Profile Platform	162
APXVAARR24_43_U_NA20 w/ Mount Pipe	172	(2) APXV18-206516S-C-A20_TIA w/ Mount Pipe	152
(2) AIR 21 B2A/B4P w/ Mount Pipe	172	(2) APXV18-206516S-C-A20_TIA w/ Mount Pipe	152
(2) AIR 21 B2A/B4P w/ Mount Pipe	172	(2) APXV18-206516S-C-A20_TIA w/ Mount Pipe	152
(2) AIR 21 B2A/B4P w/ Mount Pipe	172	(2) APXV18-206516S-C-A20_TIA w/ Mount Pipe	152
RADIO 4449 B12/B71	172	EEL Low-Profile Platform	150
RADIO 4449 B12/B71	172	RRUS 11 B12	145
RADIO 4449 B12/B71	172	RRUS 11 B12	145
8' x 2" STD Pipe	172	RRUS 11 B12	145
SitePro1 HRK12 Handrail Kit	172	Ericsson RRUS 16"x13"x5.5"	145
EEL Low-Profile Platform	172	Ericsson RRUS 16"x13"x5.5"	145
RHSDC-3315-PF-48	165	Ericsson RRUS 16"x13"x5.5"	145
2" STD Pipe (2.375 OD)x4'-0"	165	DC6-48-60-18-8F	145
Collar Mount	165	2" STD Pipe (2.375 OD)x4'-0"	145
BXA-70063-6CF-EDIN-0 w/ Mount Pipe	162	2" STD Pipe (2.375 OD)x4'-0"	145
BXA-70063-6CF-EDIN-0 w/ Mount Pipe	162	2" STD Pipe (2.375 OD)x4'-0"	145
BXA-70063-6CF-EDIN-0 w/ Mount Pipe	162	Collar Mount	145
BXA-70063-6CF-EDIN-0 w/ Mount Pipe	162	AM-X-CD-16-65-00T-RET_TIA w/ Mount Pipe	142
(2) HBXX-6517DS-VTM_TIA w/ Mount Pipe	162	AM-X-CD-16-65-00T-RET_TIA w/ Mount Pipe	142
(2) HBXX-6517DS-VTM_TIA w/ Mount Pipe	162	AM-X-CD-16-65-00T-RET_TIA w/ Mount Pipe	142
(2) HBXX-6517DS-VTM_TIA w/ Mount Pipe	162	AM-X-CD-16-65-00T-RET_TIA w/ Mount Pipe	142
(2) HBXX-6517DS-VTM_TIA w/ Mount Pipe	162	7770.00 w/Mount Pipe	142
(2) HBXX-6517DS-VTM_TIA w/ Mount Pipe	162	7770.00 w/Mount Pipe	142
(2) HBXX-6517DS-VTM_TIA w/ Mount Pipe	162	7770.00 w/Mount Pipe	142
LNX-6514DS-VTM w/ Mount Pipe	162	CCI 72"x14.5"x7.5" Antenna	142
LNX-6514DS-VTM w/ Mount Pipe	162	CCI 72"x14.5"x7.5" Antenna	142
LNX-6514DS-VTM w/ Mount Pipe	162	CCI 72"x14.5"x7.5" Antenna	142
RRH2X40-07-U	162	(2) DTMABP7819VG12A	142
RRH2X40-07-U	162	(2) DTMABP7819VG12A	142
RRH2X40-07-U	162	(2) DTMABP7819VG12A	142
RRH2X40-AWS	162	EEL Low-Profile Platform	142

**MATERIAL STRENGTH**

GRADE	Fy	Fu	GRADE	Fy	Fu
A572-65	65 ksi	80 ksi			

**TOWER DESIGN NOTES**

1. Tower is located in New London County, Connecticut.
2. Tower designed for Exposure B to the TIA-222-G Standard.
3. Tower designed for a 105 mph basic wind in accordance with the TIA-222-G Standard.
4. Tower is also designed for a 50 mph basic wind with 0.75 in ice. Ice is considered to increase in thickness with height.
5. Deflections are based upon a 60 mph wind.
6. Tower Structure Class II.
7. Topographic Category 1 with Crest Height of 0.000 ft
8. TOWER RATING: 34.6%

ALL REACTIONS ARE FACTORED

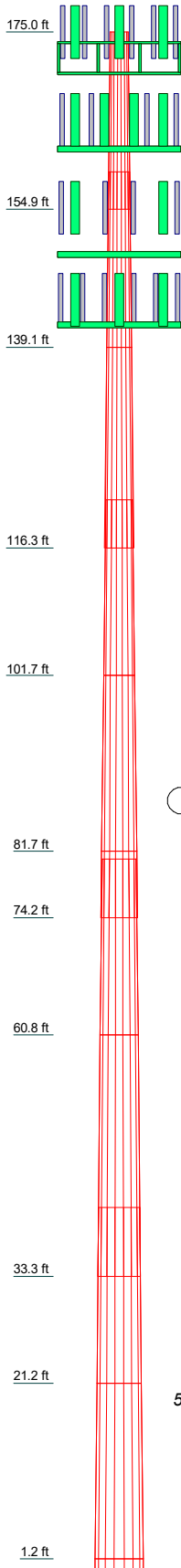
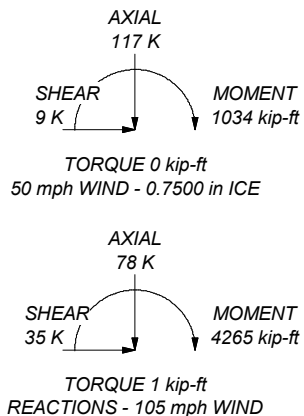

Section	Length (ft)	Number of Sides	Thickness (in)	Socket Length (ft)	Top Dia (in)	Bot Dia (in)	Grade	Weight (K)
1	20.130	18	0.1880	4.250	24.2100	29.4500	A572-65	1.1
2	20.000	18	0.3750	27.9677	33.1147	33.1147	A572-65	2.4
3	22.830	18	0.3750	5.420	33.1147	38.9900	A572-65	3.3
4	20.000	18	0.5000	36.8452	41.9881	41.9881	A572-65	4.2
5	20.000	18	0.5000	41.9881	47.1311	47.1311	A572-65	4.8
6	7.840	18	0.5000	6.670	47.1311	49.0700	A572-65	1.9
7	20.000	18	0.5630	46.3548	51.6159	51.6159	A572-65	5.9
8	27.500	18	0.5630	7.830	51.6159	58.8500	A572-65	9.1
9	20.000	18	0.6250	55.6643	60.6853	60.6853	A572-65	7.8
10	20.000	18	0.6250	60.6853	65.7063	65.7063	A572-65	8.4
11	1.170	18	0.4250	66.0000	66.0000	66.0000	A572-65	49.9

<p><b>Tectonic</b> 1279 Route 300 Newburgh, NY 12550 Phone: (845) 367-6658 FAX: (845) 367-8703</p>	<p>Job: <b>9927.CT11636A</b></p>		
	<p>Project: <b>175' Monopole</b></p>		
	Client: T-Mobile	Drawn by: John Julien	App'd:
	Code: TIA-222-G	Date: 07/01/19	Scale: NTS
	Path:		Dwg No. E-1

 <p><b>Tectonic</b> PRACTICAL SOLUTIONS. EXCEPTIONAL SERVICE.</p> <p><b>Tectonic</b> 1279 Route 300 Newburgh, NY 12550 Phone: (845) 367-6658 FAX: (845) 367-8703</p>	<b>Job</b>	9927.CT11636A	<b>Page</b>	1 of 30
	<b>Project</b>	175' Monopole	<b>Date</b>	10:23:22 07/01/19
	<b>Client</b>	T-Mobile	<b>Designed by</b>	John Julien

## Tower Input Data

The tower is a monopole.  
 This tower is designed using the TIA-222-G standard.  
 The following design criteria apply:

- Tower is located in New London County, Connecticut.
- Basic wind speed of 105 mph.
- Structure Class II.
- Exposure Category B.
- Topographic Category 1.
- Crest Height 0.000 ft.
- Nominal ice thickness of 0.7500 in.
- Ice thickness is considered to increase with height.
- Ice density of 56 pcf.
- A wind speed of 50 mph is used in combination with ice.
- Temperature drop of 50 °F.
- Deflections calculated using a wind speed of 60 mph.
- A non-linear (P-delta) analysis was used.
- Pressures are calculated at each section.
- Stress ratio used in pole design is 1.
- Local bending stresses due to climbing loads, feed line supports, and appurtenance mounts are not considered.

## Options

- |  |   |   |
|--|---|---|
| <ul style="list-style-type: none"> <li>Consider Moments - Legs</li> <li>Consider Moments - Horizontals</li> <li>Consider Moments - Diagonals</li> <li>Use Moment Magnification</li> <li>√ Use Code Stress Ratios</li> <li>√ Use Code Safety Factors - Guys</li> <li>Escalate Ice</li> <li>Always Use Max Kz</li> <li>Use Special Wind Profile</li> <li>Include Bolts In Member Capacity</li> <li>Leg Bolts Are At Top Of Section</li> <li>Secondary Horizontal Braces Leg</li> <li>Use Diamond Inner Bracing (4 Sided)</li> <li>SR Members Have Cut Ends</li> <li>SR Members Are Concentric</li> </ul> | <ul style="list-style-type: none"> <li>Distribute Leg Loads As Uniform</li> <li>Assume Legs Pinned</li> <li>√ Assume Rigid Index Plate</li> <li>√ Use Clear Spans For Wind Area</li> <li>Use Clear Spans For KL/r</li> <li>Retention Guys To Initial Tension</li> <li>√ Bypass Mast Stability Checks</li> <li>√ Use Azimuth Dish Coefficients</li> <li>√ Project Wind Area of Appurt.</li> <li>Autocalc Torque Arm Areas</li> <li>Add IBC .6D+W Combination</li> <li>√ Sort Capacity Reports By Component</li> <li>Triangulate Diamond Inner Bracing</li> <li>Treat Feed Line Bundles As Cylinder</li> <li>Ignore KL/ry For 60 Deg. Angle Legs</li> </ul> | <ul style="list-style-type: none"> <li>Use ASCE 10 X-Brace Ly Rules</li> <li>Calculate Redundant Bracing Forces</li> <li>Ignore Redundant Members in FEA</li> <li>SR Leg Bolts Resist Compression</li> <li>All Leg Panels Have Same Allowable</li> <li>Offset Girt At Foundation</li> <li>√ Consider Feed Line Torque</li> <li>Include Angle Block Shear Check</li> <li>Use TIA-222-G Bracing Resist. Exemption</li> <li>Use TIA-222-G Tension Splice Exemption</li> <li style="text-align: center;">Poles</li> <li>√ Include Shear-Torsion Interaction</li> <li>Always Use Sub-Critical Flow</li> <li>Use Top Mounted Sockets</li> <li>Pole Without Linear Attachments</li> <li>Pole With Shroud Or No Appurtenances</li> <li>Outside and Inside Corner Radii Are Known</li> </ul> |
|--|---|---|

## Tapered Pole Section Geometry

Section	Elevation	Section Length	Splice Length	Number of Sides	Top Diameter	Bottom Diameter	Wall Thickness	Bend Radius	Pole Grade
	ft	ft	in		in	in	in	in	
L1	175.000-154.87	20.130	51.00	18	24.2100	29.4500	0.1880	0.7520	A572-65



**Tectonic**  
 1279 Route 300  
 Newburgh, NY 12550  
 Phone: (845) 367-6658  
 FAX: (845) 367-8703

<b>Job</b>	9927.CT11636A	<b>Page</b>	2 of 30
<b>Project</b>	175' Monopole	<b>Date</b>	10:23:22 07/01/19
<b>Client</b>	T-Mobile	<b>Designed by</b>	John Julien

Section	Elevation ft	Section Length ft	Splice Length in	Number of Sides	Top Diameter in	Bottom Diameter in	Wall Thickness in	Bend Radius in	Pole Grade
L2	154.870-139.120	20.000	0.00	18	27.9677	33.1147	0.3750	1.5000	(65 ksi) A572-65
L3	139.120-116.290	22.830	65.04	18	33.1147	38.9900	0.3750	1.5000	(65 ksi) A572-65
L4	116.290-101.710	20.000	0.00	18	36.8452	41.9881	0.5000	2.0000	(65 ksi) A572-65
L5	101.710-81.710	20.000	0.00	18	41.9881	47.1311	0.5000	2.0000	(65 ksi) A572-65
L6	81.710-74.170	7.540	80.04	18	47.1311	49.0700	0.5000	2.0000	(65 ksi) A572-65
L7	74.170-60.840	20.000	0.00	18	46.3548	51.6159	0.5630	2.2520	(65 ksi) A572-65
L8	60.840-33.340	27.500	93.96	18	51.6159	58.8500	0.5630	2.2520	(65 ksi) A572-65
L9	33.340-21.170	20.000	0.00	18	55.6643	60.6853	0.6250	2.5000	(65 ksi) A572-65
L10	21.170-1.170	20.000	0.00	18	60.6853	65.7063	0.6250	2.5000	(65 ksi) A572-65
L11	1.170-0.000	1.170		18	65.7063	66.0000	0.6250	2.5000	(65 ksi) A572-65

### Tapered Pole Properties

Section	Tip Dia. in	Area in <sup>2</sup>	I in <sup>4</sup>	r in	C in	I/C in <sup>3</sup>	J in <sup>4</sup>	It/Q in <sup>2</sup>	w in	w/t
L1	24.5545	14.3342	1045.0323	8.5278	12.2987	84.9711	2091.4397	7.1685	3.9301	20.905
L2	29.8753	17.4610	1888.9229	10.3880	14.9606	126.2598	3780.3314	8.7322	4.8523	25.81
	29.4519	32.8422	3159.0596	9.7954	14.2076	222.3502	6322.2759	16.4242	4.2623	11.366
L3	33.5677	38.9684	5277.1511	11.6226	16.8223	313.7004	10561.2460	19.4879	5.1682	13.782
	33.5677	38.9684	5277.1511	11.6226	16.8223	313.7004	10561.2460	19.4879	5.1682	13.782
L4	39.5336	45.9615	8658.5219	13.7083	19.8069	437.1463	17328.4368	22.9851	6.2022	16.539
	38.7517	57.6798	9626.1850	12.9025	18.7173	514.2923	19265.0364	28.8454	5.6047	11.209
L5	42.5587	65.8417	14318.1197	14.7283	21.3300	671.2677	28655.0796	32.9271	6.5099	13.02
	42.5587	65.8417	14318.1197	14.7283	21.3300	671.2677	28655.0796	32.9271	6.5099	13.02
L6	47.7810	74.0036	20330.1876	16.5540	23.9426	849.1220	40687.1262	37.0088	7.4151	14.83
	47.7810	74.0036	20330.1876	16.5540	23.9426	849.1220	40687.1262	37.0088	7.4151	14.83
L7	49.7499	77.0806	22973.0516	17.2423	24.9276	921.5925	45976.3317	38.5476	7.7563	15.513
	48.7647	81.8282	21677.8637	16.2561	23.5482	920.5722	43384.2518	40.9219	7.1676	12.731
L8	52.3254	91.2297	30041.0593	18.1238	26.2209	1145.6913	60121.6474	45.6235	8.0935	14.376
	52.3254	91.2297	30041.0593	18.1238	26.2209	1145.6913	60121.6474	45.6235	8.0935	14.376
L9	59.6710	104.1567	44706.2123	20.6919	29.8958	1495.4011	89471.2502	52.0882	9.3667	16.637
	58.4226	109.1841	41787.1102	19.5389	28.2774	1477.7539	83629.2049	54.6024	8.6969	13.915
L10	61.5250	119.1446	54298.2997	21.3214	30.8281	1761.3239	108668.046	59.5836	9.5806	15.329
	61.5250	119.1446	54298.2997	21.3214	30.8281	1761.3239	108668.046	59.5836	9.5806	15.329
L11	66.6235	129.1050	69086.3849	23.1039	33.3788	2069.7693	138263.675	64.5648	10.4643	16.743
	66.6235	129.1050	69086.3849	23.1039	33.3788	2069.7693	138263.675	64.5648	10.4643	16.743
	66.9217	129.6877	70026.0284	23.2081	33.5280	2088.5835	140144.198	64.8562	10.5160	16.826

 <p><b>Tectonic</b> PRACTICAL SOLUTIONS. EXCEPTIONAL SERVICE.</p> <p><b>Tectonic</b> 1279 Route 300 Newburgh, NY 12550 Phone: (845) 367-6658 FAX: (845) 367-8703</p>	<b>Job</b>	9927.CT11636A	<b>Page</b>	3 of 30
	<b>Project</b>	175' Monopole	<b>Date</b>	10:23:22 07/01/19
	<b>Client</b>	T-Mobile	<b>Designed by</b>	John Julien

Tower Elevation	Gusset Area (per face)	Gusset Thickness	Gusset Grade	Adjust. Factor A <sub>f</sub>	Adjust. Factor A <sub>r</sub>	Weight Mult.	Double Angle Stitch Bolt Spacing Diagonals in	Double Angle Stitch Bolt Spacing Horizontals in	Double Angle Stitch Bolt Spacing Redundants in
ft	ft <sup>2</sup>	in							
L1 175.000-154.8				1	1	1			
70 L2 154.870-139.1				1	1	1			
20 L3 139.120-116.2				1	1	1			
90 L4 116.290-101.7				1	1	1			
10 L5 101.710-81.71				1	1	1			
0 L6 81.710-74.170				1	1	1			
L7 74.170-60.840				1	1	1			
L8 60.840-33.340				1	1	1			
L9 33.340-21.170				1	1	1			
L10 21.170-1.170				1	1	1			
L11 1.170-0.000				1	1	1			

### Feed Line/Linear Appurtenances - Entered As Round Or Flat

Description	Sector	Exclude From Torque Calculation	Component Type	Placement ft	Total Number	Number Per Row	Start/End Position	Width or Diameter in	Perimeter in	Weight plf
LCF158-50JA-A7(1 5/8)	B	No	Surface Ar (CaAa)	165.000 - 3.000	6	6	-0.500 -0.250	1.9800		0.72
*** Step Bolts	A	No	Surface Ar (CaAa)	175.000 - 8.000	1	1	0.000 0.000	0.3750		2.00
Safety Line 3/8	A	No	Surface Ar (CaAa)	175.000 - 8.000	1	1	0.000 0.000	0.3750		0.22
***										

### Feed Line/Linear Appurtenances - Entered As Area

Description	Face or Leg	Allow Shield	Exclude From Torque Calculation	Component Type	Placement ft	Total Number		C <sub>A</sub> A <sub>A</sub> ft <sup>2</sup> /ft	Weight plf
***T-Mobile*** LCF158-50JA-A7(1 5/8)	C	No	No	Inside Pole	175.000 - 6.000	9	No Ice 1/2" Ice	0.000 0.000	0.72 0.72



 <p><b>Tectonic</b> PRACTICAL SOLUTIONS. EXCEPTIONAL SERVICE.</p> <p><b>Tectonic</b> 1279 Route 300 Newburgh, NY 12550 Phone: (845) 367-6658 FAX: (845) 367-8703</p>	<b>Job</b> 9927.CT11636A	<b>Page</b> 4 of 30
	<b>Project</b> 175' Monopole	<b>Date</b> 10:23:22 07/01/19
	<b>Client</b> T-Mobile	<b>Designed by</b> John Julien

Description	Face or Leg	Allow Shield	Exclude From Torque Calculation	Component Type	Placement ft	Total Number		C <sub>AA</sub> ft <sup>2</sup> /ft	Weight plf
9x18 Hybriflex	C	No	No	Inside Pole	175.000 - 6.000	1	1" Ice	0.000	0.72
							No Ice	0.000	0.90
							1/2" Ice	0.000	0.90
6x12 Hybriflex	C	No	No	Inside Pole	175.000 - 6.000	3	1" Ice	0.000	0.90
							No Ice	0.000	0.55
							1/2" Ice	0.000	0.55
***Verizon***									
LCF158-50JA-A7(1 5/8)	C	No	No	Inside Pole	165.000 - 3.000	6	No Ice	0.000	0.72
							1/2" Ice	0.000	0.72
							1" Ice	0.000	0.72
1.5" Hybriflex	C	No	No	Inside Pole	165.000 - 3.000	1	No Ice	0.000	0.98
							1/2" Ice	0.000	0.98
							1" Ice	0.000	0.98
***Metro PCS***									
LCF158-50JA-A7(1 5/8)	C	No	No	Inside Pole	155.000 - 6.000	6	No Ice	0.000	0.72
							1/2" Ice	0.000	0.72
							1" Ice	0.000	0.72
0.4" Cable	C	No	No	Inside Pole	155.000 - 6.000	1	No Ice	0.000	0.17
							1/2" Ice	0.000	0.17
							1" Ice	0.000	0.17
***AT&T***									
LCF158-50JA-A7(1 5/8)	C	No	No	Inside Pole	145.000 - 6.000	12	No Ice	0.000	0.72
							1/2" Ice	0.000	0.72
							1" Ice	0.000	0.72
0.4" Cable	C	No	No	Inside Pole	145.000 - 6.000	1	No Ice	0.000	0.17
							1/2" Ice	0.000	0.17
							1" Ice	0.000	0.17
0.32" Cable	C	No	No	Inside Pole	145.000 - 6.000	1	No Ice	0.000	0.07
							1/2" Ice	0.000	0.07
							1" Ice	0.000	0.07
0.8" DC Cable	C	No	No	Inside Pole	145.000 - 6.000	2	No Ice	0.000	0.30
							1/2" Ice	0.000	0.30
							1" Ice	0.000	0.30
***									

### Feed Line/Linear Appurtenances Section Areas

Tower Section	Tower Elevation ft	Face	A <sub>R</sub> ft <sup>2</sup>	A <sub>F</sub> ft <sup>2</sup>	C <sub>AA</sub> In Face ft <sup>2</sup>	C <sub>AA</sub> Out Face ft <sup>2</sup>	Weight K
L1	175.000-154.870	A	0.000	0.000	1.510	0.000	0.04
		B	0.000	0.000	12.034	0.000	0.04
		C	0.000	0.000	0.000	0.000	0.24
L2	154.870-139.120	A	0.000	0.000	1.181	0.000	0.03
		B	0.000	0.000	18.711	0.000	0.07
		C	0.000	0.000	0.000	0.000	0.35
L3	139.120-116.290	A	0.000	0.000	1.712	0.000	0.05
		B	0.000	0.000	27.122	0.000	0.10
		C	0.000	0.000	0.000	0.000	0.65
L4	116.290-101.710	A	0.000	0.000	1.093	0.000	0.03
		B	0.000	0.000	17.321	0.000	0.06
		C	0.000	0.000	0.000	0.000	0.41
L5	101.710-81.710	A	0.000	0.000	1.500	0.000	0.04



**Tectonic**  
 1279 Route 300  
 Newburgh, NY 12550  
 Phone: (845) 367-6658  
 FAX: (845) 367-8703

<b>Job</b>	9927.CT11636A	<b>Page</b>	5 of 30
<b>Project</b>	175' Monopole	<b>Date</b>	10:23:22 07/01/19
<b>Client</b>	T-Mobile	<b>Designed by</b>	John Julien

Tower Section	Tower Elevation ft	Face	A <sub>R</sub> ft <sup>2</sup>	A <sub>F</sub> ft <sup>2</sup>	C <sub>AA</sub> In Face ft <sup>2</sup>	C <sub>AA</sub> Out Face ft <sup>2</sup>	Weight K
L6	81.710-74.170	B	0.000	0.000	23.760	0.000	0.09
		C	0.000	0.000	0.000	0.000	0.57
		A	0.000	0.000	0.566	0.000	0.02
L7	74.170-60.840	B	0.000	0.000	8.958	0.000	0.03
		C	0.000	0.000	0.000	0.000	0.21
		A	0.000	0.000	1.000	0.000	0.03
L8	60.840-33.340	B	0.000	0.000	15.836	0.000	0.06
		C	0.000	0.000	0.000	0.000	0.38
		A	0.000	0.000	2.063	0.000	0.06
L9	33.340-21.170	B	0.000	0.000	32.670	0.000	0.12
		C	0.000	0.000	0.000	0.000	0.78
		A	0.000	0.000	0.913	0.000	0.03
L10	21.170-1.170	B	0.000	0.000	14.458	0.000	0.05
		C	0.000	0.000	0.000	0.000	0.34
		A	0.000	0.000	0.988	0.000	0.03
L11	1.170-0.000	B	0.000	0.000	21.586	0.000	0.08
		C	0.000	0.000	0.000	0.000	0.45
		A	0.000	0.000	0.000	0.000	0.00
		B	0.000	0.000	0.000	0.000	0.00
		C	0.000	0.000	0.000	0.000	0.00
		A	0.000	0.000	0.000	0.000	0.00

**Feed Line/Linear Appurtenances Section Areas - With Ice**

Tower Section	Tower Elevation ft	Face or Leg	Ice Thickness in	A <sub>R</sub> ft <sup>2</sup>	A <sub>F</sub> ft <sup>2</sup>	C <sub>AA</sub> In Face ft <sup>2</sup>	C <sub>AA</sub> Out Face ft <sup>2</sup>	Weight K
L1	175.000-154.870	A	1.762	0.000	0.000	15.693	0.000	0.23
		B		0.000	0.000	19.504	0.000	0.28
		C		0.000	0.000	0.000	0.000	0.24
L2	154.870-139.120	A	1.741	0.000	0.000	12.279	0.000	0.18
		B		0.000	0.000	30.325	0.000	0.43
		C		0.000	0.000	0.000	0.000	0.35
L3	139.120-116.290	A	1.717	0.000	0.000	17.391	0.000	0.25
		B		0.000	0.000	43.702	0.000	0.61
		C		0.000	0.000	0.000	0.000	0.65
L4	116.290-101.710	A	1.690	0.000	0.000	11.107	0.000	0.16
		B		0.000	0.000	27.910	0.000	0.39
		C		0.000	0.000	0.000	0.000	0.41
L5	101.710-81.710	A	1.661	0.000	0.000	14.789	0.000	0.21
		B		0.000	0.000	38.005	0.000	0.52
		C		0.000	0.000	0.000	0.000	0.57
L6	81.710-74.170	A	1.635	0.000	0.000	5.495	0.000	0.08
		B		0.000	0.000	14.278	0.000	0.19
		C		0.000	0.000	0.000	0.000	0.21
L7	74.170-60.840	A	1.611	0.000	0.000	9.715	0.000	0.14
		B		0.000	0.000	25.242	0.000	0.34
		C		0.000	0.000	0.000	0.000	0.38
L8	60.840-33.340	A	1.553	0.000	0.000	19.149	0.000	0.26
		B		0.000	0.000	51.516	0.000	0.68
		C		0.000	0.000	0.000	0.000	0.78
L9	33.340-21.170	A	1.471	0.000	0.000	8.474	0.000	0.12
		B		0.000	0.000	22.798	0.000	0.30
		C		0.000	0.000	0.000	0.000	0.34
L10	21.170-1.170	A	1.344	0.000	0.000	8.070	0.000	0.10
		B		0.000	0.000	33.089	0.000	0.40
		C		0.000	0.000	0.000	0.000	0.45
L11	1.170-0.000	A	1.002	0.000	0.000	0.000	0.000	0.00
		B		0.000	0.000	0.000	0.000	0.00



**Tectonic**  
 1279 Route 300  
 Newburgh, NY 12550  
 Phone: (845) 367-6658  
 FAX: (845) 367-8703

<b>Job</b>	9927.CT11636A	<b>Page</b>	6 of 30
<b>Project</b>	175' Monopole	<b>Date</b>	10:23:22 07/01/19
<b>Client</b>	T-Mobile	<b>Designed by</b>	John Julien

Tower Section	Tower Elevation ft	Face or Leg C	Ice Thickness in	A <sub>R</sub> ft <sup>2</sup>	A <sub>F</sub> ft <sup>2</sup>	C <sub>AA</sub> In Face ft <sup>2</sup>	C <sub>AA</sub> Out Face ft <sup>2</sup>	Weight K
				0.000	0.000	0.000	0.000	0.00

### Feed Line Center of Pressure

Section	Elevation ft	CP <sub>X</sub> in	CP <sub>Z</sub> in	CP <sub>X</sub> Ice in	CP <sub>Z</sub> Ice in
L1	175.000-154.870	0.6735	-4.2871	-1.0464	-3.7522
L2	154.870-139.120	1.3678	-6.5874	-0.3454	-5.3482
L3	139.120-116.290	1.4383	-6.9398	-0.3529	-5.7267
L4	116.290-101.710	1.4881	-7.1889	-0.3772	-6.0073
L5	101.710-81.710	1.5353	-7.4251	-0.3610	-6.2587
L6	81.710-74.170	1.5687	-7.5921	-0.3567	-6.4411
L7	74.170-60.840	1.5843	-7.6702	-0.3638	-6.5319
L8	60.840-33.340	1.6270	-7.8835	-0.3178	-6.7402
L9	33.340-21.170	1.6548	-8.0226	-0.3289	-6.9036
L10	21.170-1.170	1.6807	-7.5289	0.3182	-6.2843
L11	1.170-0.000	0.0000	0.0000	0.0000	0.0000

Note: For pole sections, center of pressure calculations do not consider feed line shielding.

### Shielding Factor Ka

Tower Section	Feed Line Record No.	Description	Feed Line Segment Elev.	K <sub>a</sub> No Ice	K <sub>a</sub> Ice
L1	8	LCF158-50JA-A7( 1 5/8)	154.87 - 165.00	1.0000	1.0000
L1	19	Step Bolts	154.87 - 175.00	1.0000	1.0000
L1	20	Safety Line 3/8	154.87 - 175.00	1.0000	1.0000
L3	8	LCF158-50JA-A7( 1 5/8)	116.29 - 139.12	1.0000	1.0000
L3	19	Step Bolts	116.29 - 139.12	1.0000	1.0000
L3	20	Safety Line 3/8	116.29 - 139.12	1.0000	1.0000
L5	8	LCF158-50JA-A7( 1 5/8)	81.71 - 101.71	1.0000	1.0000
L5	19	Step Bolts	81.71 - 101.71	1.0000	1.0000
L5	20	Safety Line 3/8	81.71 - 101.71	1.0000	1.0000
L6	8	LCF158-50JA-A7( 1 5/8)	74.17 - 81.71	1.0000	1.0000
L6	19	Step Bolts	74.17 - 81.71	1.0000	1.0000
L6	20	Safety Line 3/8	74.17 - 81.71	1.0000	1.0000
L8	8	LCF158-50JA-A7( 1 5/8)	33.34 - 60.84	1.0000	1.0000
L8	19	Step Bolts	33.34 - 60.84	1.0000	1.0000
L8	20	Safety Line 3/8	33.34 - 60.84	1.0000	1.0000
L10	8	LCF158-50JA-A7( 1 5/8)	3.00 - 21.17	1.0000	1.0000
L10	19	Step Bolts	8.00 - 21.17	1.0000	1.0000
L10	20	Safety Line 3/8	8.00 - 21.17	1.0000	1.0000



**Tectonic**  
 1279 Route 300  
 Newburgh, NY 12550  
 Phone: (845) 367-6658  
 FAX: (845) 367-8703

<b>Job</b>	9927.CT11636A	<b>Page</b>	7 of 30
<b>Project</b>	175' Monopole	<b>Date</b>	10:23:22 07/01/19
<b>Client</b>	T-Mobile	<b>Designed by</b>	John Julien

### Discrete Tower Loads

Description	Face or Leg	Offset Type	Offsets:		Azimuth Adjustment	Placement	C <sub>AA</sub> Front	C <sub>AA</sub> Side	Weight	
			Horz Lateral	Vert						
			ft	ft	°	ft	ft <sup>2</sup>	ft <sup>2</sup>	K	
***T-Mobile***										
APXVAARR24_43_U_NA2 0 w/ Mount Pipe	A	From Face	3.500	0.000	0.0000	172.000	No Ice	20.245	10.789	0.18
			0.00				1/2" Ice	20.893	12.215	0.32
			3.00				1" Ice	21.548	13.493	0.46
APXVAARR24_43_U_NA2 0 w/ Mount Pipe	B	From Face	3.500	0.000	0.0000	172.000	No Ice	20.245	10.789	0.18
			0.00				1/2" Ice	20.893	12.215	0.32
			3.00				1" Ice	21.548	13.493	0.46
APXVAARR24_43_U_NA2 0 w/ Mount Pipe	C	From Face	3.500	0.000	0.0000	172.000	No Ice	20.245	10.789	0.18
			0.00				1/2" Ice	20.893	12.215	0.32
			3.00				1" Ice	21.548	13.493	0.46
(2) AIR 21 B2A/B4P w/ Mount Pipe	A	From Face	3.500	0.000	0.0000	172.000	No Ice	6.162	5.545	0.10
			0.00				1/2" Ice	6.600	6.303	0.16
			3.00				1" Ice	7.033	6.998	0.22
(2) AIR 21 B2A/B4P w/ Mount Pipe	B	From Face	3.500	0.000	0.0000	172.000	No Ice	6.162	5.545	0.10
			0.00				1/2" Ice	6.600	6.303	0.16
			3.00				1" Ice	7.033	6.998	0.22
(2) AIR 21 B2A/B4P w/ Mount Pipe	C	From Face	3.500	0.000	0.0000	172.000	No Ice	6.162	5.545	0.10
			0.00				1/2" Ice	6.600	6.303	0.16
			3.00				1" Ice	7.033	6.998	0.22
RADIO 4449 B12/B71	A	From Face	3.500	0.000	0.0000	172.000	No Ice	1.650	1.163	0.07
			0.00				1/2" Ice	1.810	1.301	0.09
			3.00				1" Ice	1.978	1.447	0.11
RADIO 4449 B12/B71	B	From Face	3.500	0.000	0.0000	172.000	No Ice	1.650	1.163	0.07
			0.00				1/2" Ice	1.810	1.301	0.09
			3.00				1" Ice	1.978	1.447	0.11
RADIO 4449 B12/B71	C	From Face	3.500	0.000	0.0000	172.000	No Ice	1.650	1.163	0.07
			0.00				1/2" Ice	1.810	1.301	0.09
			3.00				1" Ice	1.978	1.447	0.11
8' x 2" STD Pipe	C	From Face	3.500	0.000	0.0000	172.000	No Ice	1.900	1.900	0.03
			0.00				1/2" Ice	2.728	2.728	0.04
			3.00				1" Ice	3.401	3.401	0.06
SitePro1 HRK12 Handrail Kit	C	None			0.0000	172.000	No Ice	4.800	4.800	0.25
							1/2" Ice	6.700	6.700	0.29
							1" Ice	8.600	8.600	0.34
EEI Low-Profile Platform	C	None			0.0000	172.000	No Ice	16.500	16.500	1.55
							1/2" Ice	20.000	20.000	1.80
							1" Ice	23.500	23.500	2.05
***Verizon***										
RHSDC-3315-PF-48	C	From Face	0.500	0.000	0.0000	165.000	No Ice	3.364	2.192	0.03
			0.00				1/2" Ice	3.597	2.395	0.06
			0.00				1" Ice	3.838	2.606	0.09
2" STD Pipe (2.375 OD)x4'-0"	C	From Face	0.500	0.000	0.0000	165.000	No Ice	0.866	0.866	0.01
			0.00				1/2" Ice	1.111	1.111	0.02
			0.00				1" Ice	1.365	1.365	0.03
Collar Mount	C	None			0.0000	165.000	No Ice	0.000	0.000	0.10
							1/2" Ice	0.000	0.000	0.13
							1" Ice	0.000	0.000	0.16



**Tectonic**  
 1279 Route 300  
 Newburgh, NY 12550  
 Phone: (845) 367-6658  
 FAX: (845) 367-8703

<b>Job</b>	9927.CT11636A	<b>Page</b>	8 of 30
<b>Project</b>	175' Monopole	<b>Date</b>	10:23:22 07/01/19
<b>Client</b>	T-Mobile	<b>Designed by</b>	John Julien

Description	Face or Leg	Offset Type	Offsets:		Azimuth Adjustment	Placement	C <sub>AA</sub> Front	C <sub>AA</sub> Side	Weight
			Horz	Vert					
			ft	ft	°	ft	ft <sup>2</sup>	ft <sup>2</sup>	K
BXA-70063-6CF-EDIN-0 w/ Mount Pipe	A	From Face	3.500	0.000	0.0000	162.000	No Ice 7.806	5.801	0.06
			0.00				1/2" Ice 8.357	6.953	0.12
			3.00				1" Ice 8.872	7.819	0.19
BXA-70063-6CF-EDIN-0 w/ Mount Pipe	B	From Face	3.500	0.0000	0.0000	162.000	No Ice 7.806	5.801	0.06
			0.00				1/2" Ice 8.357	6.953	0.12
			3.00				1" Ice 8.872	7.819	0.19
BXA-70063-6CF-EDIN-0 w/ Mount Pipe	C	From Face	3.500	0.0000	0.0000	162.000	No Ice 7.806	5.801	0.06
			0.00				1/2" Ice 8.357	6.953	0.12
			3.00				1" Ice 8.872	7.819	0.19
(2) HBXX-6517DS-VTM_TIA w/ Mount Pipe	A	From Face	3.500	0.0000	0.0000	162.000	No Ice 8.779	6.974	0.08
			0.00				1/2" Ice 9.356	8.194	0.15
			3.00				1" Ice 9.904	9.158	0.22
(2) HBXX-6517DS-VTM_TIA w/ Mount Pipe	B	From Face	3.500	0.0000	0.0000	162.000	No Ice 8.779	6.974	0.08
			0.00				1/2" Ice 9.356	8.194	0.15
			3.00				1" Ice 9.904	9.158	0.22
(2) HBXX-6517DS-VTM_TIA w/ Mount Pipe	C	From Face	3.500	0.0000	0.0000	162.000	No Ice 8.779	6.974	0.08
			0.00				1/2" Ice 9.356	8.194	0.15
			3.00				1" Ice 9.904	9.158	0.22
LNx-6514DS-VTM w/ Mount Pipe	A	From Face	3.500	0.0000	0.0000	162.000	No Ice 8.411	7.082	0.06
			0.00				1/2" Ice 8.975	8.273	0.13
			3.00				1" Ice 9.505	9.185	0.21
LNx-6514DS-VTM w/ Mount Pipe	B	From Face	3.500	0.0000	0.0000	162.000	No Ice 8.411	7.082	0.06
			0.00				1/2" Ice 8.975	8.273	0.13
			3.00				1" Ice 9.505	9.185	0.21
LNx-6514DS-VTM w/ Mount Pipe	C	From Face	3.500	0.0000	0.0000	162.000	No Ice 8.411	7.082	0.06
			0.00				1/2" Ice 8.975	8.273	0.13
			3.00				1" Ice 9.505	9.185	0.21
RRH2X40-07-U	A	From Leg	3.500	0.0000	0.0000	162.000	No Ice 1.925	1.052	0.05
			0.00				1/2" Ice 2.098	1.187	0.07
			3.00				1" Ice 2.278	1.329	0.09
RRH2X40-07-U	B	From Leg	3.500	0.0000	0.0000	162.000	No Ice 1.925	1.052	0.05
			0.00				1/2" Ice 2.098	1.187	0.07
			3.00				1" Ice 2.278	1.329	0.09
RRH2X40-07-U	C	From Leg	3.500	0.0000	0.0000	162.000	No Ice 1.925	1.052	0.05
			0.00				1/2" Ice 2.098	1.187	0.07
			3.00				1" Ice 2.278	1.329	0.09
RRH2x40-AWS	A	From Face	3.500	0.0000	0.0000	162.000	No Ice 2.161	1.420	0.04
			0.00				1/2" Ice 2.360	1.590	0.06
			3.00				1" Ice 2.565	1.768	0.08
RRH2x40-AWS	B	From Face	3.500	0.0000	0.0000	162.000	No Ice 2.161	1.420	0.04
			0.00				1/2" Ice 2.360	1.590	0.06
			3.00				1" Ice 2.565	1.768	0.08
RRH2x40-AWS	C	From Face	3.500	0.0000	0.0000	162.000	No Ice 2.161	1.420	0.04
			0.00				1/2" Ice 2.360	1.590	0.06
			3.00				1" Ice 2.565	1.768	0.08
EEI Low-Profile Platform	C	None		0.0000	0.0000	162.000	No Ice 16.500	16.500	1.55
							1/2" Ice 20.000	20.000	1.80
							1" Ice 23.500	23.500	2.05
***Metro PCS***									
(2) APXV18-206516S-C-A20_TI A w/ Mount Pipe	A	From Face	3.500	0.0000	0.0000	152.000	No Ice 3.859	3.296	0.04
			0.00				1/2" Ice 4.274	4.004	0.07
			3.00				1" Ice 4.674	4.672	0.11
(2) APXV18-206516S-C-A20_TI A w/ Mount Pipe	B	From Face	3.500	0.0000	0.0000	152.000	No Ice 3.859	3.296	0.04
			0.00				1/2" Ice 4.274	4.004	0.07
			3.00				1" Ice 4.674	4.672	0.11
(2) APXV18-206516S-C-A20_TI A w/ Mount Pipe	C	From Face	3.500	0.0000	0.0000	152.000	No Ice 3.859	3.296	0.04
			0.00				1/2" Ice 4.274	4.004	0.07



**Tectonic**  
 1279 Route 300  
 Newburgh, NY 12550  
 Phone: (845) 367-6658  
 FAX: (845) 367-8703

<b>Job</b>	9927.CT11636A	<b>Page</b>	9 of 30
<b>Project</b>	175' Monopole	<b>Date</b>	10:23:22 07/01/19
<b>Client</b>	T-Mobile	<b>Designed by</b>	John Julien

Description	Face or Leg	Offset Type	Offsets:		Azimuth Adjustment	Placement	C <sub>AA</sub> Front	C <sub>AA</sub> Side	Weight
			Horz	Vert					
			ft	ft	°	ft	ft <sup>2</sup>	ft <sup>2</sup>	K
A w/ Mount Pipe			3.00						
EEI Low-Profile Platform	C	None			0.0000	150.000	1" Ice 4.674	4.672	0.11
							No Ice 16.500	16.500	1.55
							1/2" Ice 20.000	20.000	1.80
							1" Ice 23.500	23.500	2.05
***AT&T***									
RRUS 11 B12	A	From Face	0.500		0.0000	145.000	No Ice 2.833	1.182	0.05
			0.00				1/2" Ice 3.043	1.330	0.07
			1.00				1" Ice 3.259	1.485	0.10
RRUS 11 B12	B	From Face	0.500		0.0000	145.000	No Ice 2.833	1.182	0.05
			0.00				1/2" Ice 3.043	1.330	0.07
			1.00				1" Ice 3.259	1.485	0.10
RRUS 11 B12	C	From Face	0.500		0.0000	145.000	No Ice 2.833	1.182	0.05
			0.00				1/2" Ice 3.043	1.330	0.07
			1.00				1" Ice 3.259	1.485	0.10
Ericsson RRUS 16"x13"x5.5"	A	From Face	0.500		0.0000	145.000	No Ice 1.644	0.679	0.04
			0.00				1/2" Ice 1.804	0.791	0.06
			1.00				1" Ice 1.972	0.913	0.07
Ericsson RRUS 16"x13"x5.5"	B	From Face	0.500		0.0000	145.000	No Ice 1.644	0.679	0.04
			0.00				1/2" Ice 1.804	0.791	0.06
			1.00				1" Ice 1.972	0.913	0.07
Ericsson RRUS 16"x13"x5.5"	C	From Face	0.500		0.0000	145.000	No Ice 1.644	0.679	0.04
			0.00				1/2" Ice 1.804	0.791	0.06
			1.00				1" Ice 1.972	0.913	0.07
DC6-48-60-18-8F	C	From Leg	0.500		0.0000	145.000	No Ice 0.917	0.917	0.02
			0.00				1/2" Ice 1.458	1.458	0.04
			-1.00				1" Ice 1.643	1.643	0.06
2" STD Pipe (2.375 OD)x4'-0"	A	From Face	0.500		0.0000	145.000	No Ice 0.866	0.866	0.01
			0.00				1/2" Ice 1.111	1.111	0.02
			0.00				1" Ice 1.365	1.365	0.03
2" STD Pipe (2.375 OD)x4'-0"	B	From Face	0.500		0.0000	145.000	No Ice 0.866	0.866	0.01
			0.00				1/2" Ice 1.111	1.111	0.02
			0.00				1" Ice 1.365	1.365	0.03
2" STD Pipe (2.375 OD)x4'-0"	C	From Face	0.500		0.0000	145.000	No Ice 0.866	0.866	0.01
			0.00				1/2" Ice 1.111	1.111	0.02
			0.00				1" Ice 1.365	1.365	0.03
Collar Mount	C	None			0.0000	145.000	No Ice 0.000	0.000	0.10
							1/2" Ice 0.000	0.000	0.13
							1" Ice 0.000	0.000	0.16
AM-X-CD-16-65-00T-RET_ TIA w/ Mount Pipe	A	From Face	3.500		0.0000	142.000	No Ice 8.262	6.362	0.07
			0.00				1/2" Ice 8.822	7.538	0.14
			2.50				1" Ice 9.346	8.427	0.21
AM-X-CD-16-65-00T-RET_ TIA w/ Mount Pipe	B	From Face	3.500		0.0000	142.000	No Ice 8.262	6.362	0.07
			0.00				1/2" Ice 8.822	7.538	0.14
			2.50				1" Ice 9.346	8.427	0.21
AM-X-CD-16-65-00T-RET_ TIA w/ Mount Pipe	C	From Face	3.500		0.0000	142.000	No Ice 8.262	6.362	0.07
			0.00				1/2" Ice 8.822	7.538	0.14
			2.50				1" Ice 9.346	8.427	0.21
7770.00 w/Mount Pipe	A	From Face	3.500		0.0000	142.000	No Ice 5.845	4.353	0.05
			0.00				1/2" Ice 6.322	5.198	0.10
			2.50				1" Ice 6.775	5.919	0.15
7770.00 w/Mount Pipe	B	From Face	3.500		0.0000	142.000	No Ice 5.845	4.353	0.05
			0.00				1/2" Ice 6.322	5.198	0.10
			2.50				1" Ice 6.775	5.919	0.15
7770.00 w/Mount Pipe	C	From Face	3.500		0.0000	142.000	No Ice 5.845	4.353	0.05
			0.00				1/2" Ice 6.322	5.198	0.10
			2.50				1" Ice 6.775	5.919	0.15
CCI 72"x14.5"x7.5" Antenna	A	From Face	3.500		0.0000	142.000	No Ice 10.150	7.000	0.07



**Tectonic**  
 1279 Route 300  
 Newburgh, NY 12550  
 Phone: (845) 367-6658  
 FAX: (845) 367-8703

<b>Job</b>	9927.CT11636A	<b>Page</b>	10 of 30
<b>Project</b>	175' Monopole	<b>Date</b>	10:23:22 07/01/19
<b>Client</b>	T-Mobile	<b>Designed by</b>	John Julien

Description	Face or Leg	Offset Type	Offsets: Horz Lateral Vert	Azimuth Adjustment	Placement	C <sub>AA</sub> Front	C <sub>AA</sub> Side	Weight	
			ft ft ft	°	ft	ft <sup>2</sup>	ft <sup>2</sup>	K	
CCI 72"x14.5"x7.5" Antenna	B	From Face	0.00	0.0000	142.000	1/2" Ice	10.715	7.955	0.15
			2.50			1" Ice	11.289	8.787	0.23
			3.500			No Ice	10.150	7.000	0.07
			0.00			1/2" Ice	10.715	7.955	0.15
CCI 72"x14.5"x7.5" Antenna	C	From Face	2.50	0.0000	142.000	1" Ice	11.289	8.787	0.23
			3.500			No Ice	10.150	7.000	0.07
			0.00			1/2" Ice	10.715	7.955	0.15
			2.50			1" Ice	11.289	8.787	0.23
(2) DTMABP7819VG12A	A	From Face	3.500	0.0000	142.000	No Ice	0.976	0.339	0.02
			0.00			1/2" Ice	1.100	0.419	0.03
			2.50			1" Ice	1.232	0.510	0.04
			3.500			No Ice	0.976	0.339	0.02
(2) DTMABP7819VG12A	B	From Face	0.00	0.0000	142.000	1/2" Ice	1.100	0.419	0.03
			2.50			1" Ice	1.232	0.510	0.04
			3.500			No Ice	0.976	0.339	0.02
			0.00			1/2" Ice	1.100	0.419	0.03
(2) DTMABP7819VG12A	C	From Face	2.50	0.0000	142.000	1" Ice	1.232	0.510	0.04
			3.500			No Ice	0.976	0.339	0.02
			0.00			1/2" Ice	1.100	0.419	0.03
			2.50			1" Ice	1.232	0.510	0.04
EEI Low-Profile Platform	C	None	0.0000	0.0000	142.000	No Ice	16.500	16.500	1.55
						1/2" Ice	20.000	20.000	1.80
						1" Ice	23.500	23.500	2.05

\*\*\*

### Tower Pressures - No Ice

$$G_H = 1.100$$

Section Elevation	z	K <sub>Z</sub>	q <sub>z</sub>	A <sub>G</sub>	F a c e	A <sub>F</sub>	A <sub>R</sub>	A <sub>leg</sub>	Leg %	C <sub>AA</sub> In Face	C <sub>AA</sub> Out Face
ft	ft		psf	ft <sup>2</sup>	e	ft <sup>2</sup>	ft <sup>2</sup>	ft <sup>2</sup>		ft <sup>2</sup>	ft <sup>2</sup>
175.000-154.870	164.607	1.139	31	45.653	A	0.000	45.653	45.653	100.00	1.510	0.000
					B	0.000	45.653	100.00	12.034	0.000	
					C	0.000	45.653	100.00	0.000	0.000	
154.870-139.120	146.824	1.103	30	41.357	A	0.000	41.357	41.357	100.00	1.181	0.000
					B	0.000	41.357	100.00	18.711	0.000	
					C	0.000	41.357	100.00	0.000	0.000	
139.120-116.290	127.395	1.059	28	69.538	A	0.000	69.538	69.538	100.00	1.712	0.000
					B	0.000	69.538	100.00	27.122	0.000	
					C	0.000	69.538	100.00	0.000	0.000	
116.290-101.710	108.886	1.013	27	49.396	A	0.000	49.396	49.396	100.00	1.093	0.000
					B	0.000	49.396	100.00	17.321	0.000	
					C	0.000	49.396	100.00	0.000	0.000	
101.710-81.710	91.518	0.964	26	75.283	A	0.000	75.283	75.283	100.00	1.500	0.000
					B	0.000	75.283	100.00	23.760	0.000	
					C	0.000	75.283	100.00	0.000	0.000	
81.710-74.170	77.915	0.92	25	30.641	A	0.000	30.641	30.641	100.00	0.566	0.000
					B	0.000	30.641	100.00	8.958	0.000	
					C	0.000	30.641	100.00	0.000	0.000	
74.170-60.840	67.427	0.883	24	56.147	A	0.000	56.147	56.147	100.00	1.000	0.000
					B	0.000	56.147	100.00	15.836	0.000	



**Tectonic**  
 1279 Route 300  
 Newburgh, NY 12550  
 Phone: (845) 367-6658  
 FAX: (845) 367-8703

<b>Job</b>	9927.CT11636A	<b>Page</b>	11 of 30
<b>Project</b>	175' Monopole	<b>Date</b>	10:23:22 07/01/19
<b>Client</b>	T-Mobile	<b>Designed by</b>	John Julien

Section Elevation ft	z ft	K <sub>Z</sub>	q <sub>z</sub> psf	A <sub>G</sub> ft <sup>2</sup>	F a c e ft <sup>2</sup>	A <sub>F</sub> ft <sup>2</sup>	A <sub>R</sub> ft <sup>2</sup>	A <sub>leg</sub> ft <sup>2</sup>	Leg % ft <sup>2</sup>	C <sub>AA</sub> In Face ft <sup>2</sup>	C <sub>AA</sub> Out Face ft <sup>2</sup>
L8 60.840-33.340	46.790	0.795	21	128.329	C	0.000	56.147	128.329	100.00	0.000	0.000
					A	0.000	128.329		100.00	2.063	0.000
					B	0.000	128.329		100.00	32.670	0.000
L9 33.340-21.170	27.203	0.7	19	60.823	C	0.000	128.329	60.823	100.00	0.000	0.000
					A	0.000	60.823		100.00	0.913	0.000
					B	0.000	60.823		100.00	14.458	0.000
L10 21.170-1.170	11.038	0.7	19	106.790	C	0.000	60.823	106.790	100.00	0.000	0.000
					A	0.000	106.790		100.00	0.988	0.000
					B	0.000	106.790		100.00	21.586	0.000
L11 1.170-0.000	0.585	0.7	19	6.510	C	0.000	106.790	6.510	100.00	0.000	0.000
					A	0.000	6.510		100.00	0.000	0.000
					B	0.000	6.510		100.00	0.000	0.000
					C	0.000	6.510		100.00	0.000	0.000

### Tower Pressure - With Ice

$G_H = 1.100$

Section Elevation ft	z ft	K <sub>Z</sub>	q <sub>z</sub> psf	t <sub>z</sub> in	A <sub>G</sub> ft <sup>2</sup>	F a c e ft <sup>2</sup>	A <sub>F</sub> ft <sup>2</sup>	A <sub>R</sub> ft <sup>2</sup>	A <sub>leg</sub> ft <sup>2</sup>	Leg % ft <sup>2</sup>	C <sub>AA</sub> In Face ft <sup>2</sup>	C <sub>AA</sub> Out Face ft <sup>2</sup>
L1 175.000-154.870	164.607	1.139	7	1.7615	51.563	A	0.000	51.563	51.563	100.00	15.693	0.000
						B	0.000	51.563		100.00	19.504	0.000
						C	0.000	51.563		100.00	0.000	0.000
L2 154.870-139.120	146.824	1.103	7	1.7415	45.981	A	0.000	45.981	45.981	100.00	12.279	0.000
						B	0.000	45.981		100.00	30.325	0.000
						C	0.000	45.981		100.00	0.000	0.000
L3 139.120-116.290	127.395	1.059	6	1.7169	76.071	A	0.000	76.071	76.071	100.00	17.391	0.000
						B	0.000	76.071		100.00	43.702	0.000
						C	0.000	76.071		100.00	0.000	0.000
L4 116.290-101.710	108.886	1.013	6	1.6902	53.568	A	0.000	53.568	53.568	100.00	11.107	0.000
						B	0.000	53.568		100.00	27.910	0.000
						C	0.000	53.568		100.00	0.000	0.000
L5 101.710-81.710	91.518	0.964	6	1.6611	80.820	A	0.000	80.820	80.820	100.00	14.789	0.000
						B	0.000	80.820		100.00	38.005	0.000
						C	0.000	80.820		100.00	0.000	0.000
L6 81.710-74.170	77.915	0.92	6	1.6346	32.695	A	0.000	32.695	32.695	100.00	5.495	0.000
						B	0.000	32.695		100.00	14.278	0.000
						C	0.000	32.695		100.00	0.000	0.000
L7 74.170-60.840	67.427	0.883	5	1.6111	59.779	A	0.000	59.779	59.779	100.00	9.715	0.000
						B	0.000	59.779		100.00	25.242	0.000
						C	0.000	59.779		100.00	0.000	0.000
L8 60.840-33.340	46.790	0.795	5	1.5533	135.448	A	0.000	135.448	135.448	100.00	19.149	0.000
						B	0.000	135.448		100.00	51.516	0.000
						C	0.000	135.448		100.00	0.000	0.000
L9 33.340-21.170	27.203	0.7	4	1.4713	63.974	A	0.000	63.974	63.974	100.00	8.474	0.000
						B	0.000	63.974		100.00	22.798	0.000
						C	0.000	63.974		100.00	0.000	0.000
L10 21.170-1.170	11.038	0.7	4	1.3444	111.272	A	0.000	111.272	111.272	100.00	8.070	0.000
						B	0.000	111.272		100.00	33.089	0.000
						C	0.000	111.272		100.00	0.000	0.000
L11 1.170-0.000	0.585	0.7	4	1.0021	6.706	A	0.000	6.706	6.706	100.00	0.000	0.000
						B	0.000	6.706		100.00	0.000	0.000
						C	0.000	6.706		100.00	0.000	0.000





**Tectonic**  
 1279 Route 300  
 Newburgh, NY 12550  
 Phone: (845) 367-6658  
 FAX: (845) 367-8703

<b>Job</b>	9927.CT11636A	<b>Page</b>	12 of 30
<b>Project</b>	175' Monopole	<b>Date</b>	10:23:22 07/01/19
<b>Client</b>	T-Mobile	<b>Designed by</b>	John Julien

### Tower Pressure - Service

$G_H = 1.100$

Section Elevation ft	z ft	$K_Z$	$q_z$ psf	$A_G$ ft <sup>2</sup>	F a c e	$A_F$ ft <sup>2</sup>	$A_R$ ft <sup>2</sup>	$A_{leg}$ ft <sup>2</sup>	Leg %	$C_{AA}$ In Face ft <sup>2</sup>	$C_{AA}$ Out Face ft <sup>2</sup>
L1 175.000-154.8	164.607	1.139	9	45.653	A	0.000	45.653	45.653	100.00	1.510	0.000
70					B	0.000	45.653		100.00	12.034	0.000
L2 154.870-139.1	146.824	1.103	9	41.357	A	0.000	41.357	41.357	100.00	1.181	0.000
20					B	0.000	41.357		100.00	18.711	0.000
L3 139.120-116.2	127.395	1.059	8	69.538	A	0.000	69.538	69.538	100.00	1.712	0.000
90					B	0.000	69.538		100.00	27.122	0.000
L4 116.290-101.7	108.886	1.013	8	49.396	A	0.000	49.396	49.396	100.00	1.093	0.000
10					B	0.000	49.396		100.00	17.321	0.000
L5 101.710-81.71	91.518	0.964	8	75.283	A	0.000	75.283	75.283	100.00	1.500	0.000
0					B	0.000	75.283		100.00	23.760	0.000
L6 81.710-74.170	77.915	0.92	7	30.641	A	0.000	30.641	30.641	100.00	0.566	0.000
					B	0.000	30.641		100.00	8.958	0.000
L7 74.170-60.840	67.427	0.883	7	56.147	A	0.000	56.147	56.147	100.00	1.000	0.000
					B	0.000	56.147		100.00	15.836	0.000
L8 60.840-33.340	46.790	0.795	6	128.329	A	0.000	128.329	128.329	100.00	2.063	0.000
					B	0.000	128.329		100.00	32.670	0.000
L9 33.340-21.170	27.203	0.7	5	60.823	A	0.000	60.823	60.823	100.00	0.913	0.000
					B	0.000	60.823		100.00	14.458	0.000
L10 21.170-1.170	11.038	0.7	5	106.790	A	0.000	106.790	106.790	100.00	0.988	0.000
					B	0.000	106.790		100.00	21.586	0.000
L11 1.170-0.000	0.585	0.7	5	6.510	A	0.000	6.510	6.510	100.00	0.000	0.000
					B	0.000	6.510		100.00	0.000	0.000
					C	0.000	6.510		100.00	0.000	0.000

### Tower Forces - No Ice - Wind Normal To Face

Section Elevation ft	Add Weight K	Self Weight K	F a c e	e	$C_F$	$q_z$ psf	$D_F$	$D_R$	$A_E$ ft <sup>2</sup>	F K	w plf	Ctrl. Face
L1 175.000-154.8	0.32	1.09	A	1	0.65	31	1	1	45.653	1.00	49.54	C
70			B	1	0.65		1	1	45.653			
L2 154.870-139.1	0.46	2.44	A	1	0.65	30	1	1	41.357	0.87	55.52	C
20			B	1	0.65		1	1	41.357			
L3 139.120-116.2	0.80	3.30	A	1	0.65	28	1	1	69.538	1.41	61.84	C
90			B	1	0.65		1	1	69.538			
			C	1	0.65		1	1	69.538			



**Tectonic**  
 1279 Route 300  
 Newburgh, NY 12550  
 Phone: (845) 367-6658  
 FAX: (845) 367-8703

<b>Job</b>	9927.CT11636A	<b>Page</b>	13 of 30
<b>Project</b>	175' Monopole	<b>Date</b>	10:23:22 07/01/19
<b>Client</b>	T-Mobile	<b>Designed by</b>	John Julien

Section Elevation ft	Add Weight K	Self Weight K	F a c e	e	C <sub>F</sub>	q <sub>z</sub> psf	D <sub>F</sub>	D <sub>R</sub>	A <sub>E</sub> ft <sup>2</sup>	F K	w plf	Ctrl. Face
L4 116.290-101.7	0.51	4.20	A	1	0.65	27	1	1	49.396	0.96	65.77	C
10			B	1	0.65		1	1	49.396			
			C	1	0.65		1	1	49.396			
L5 101.710-81.71	0.70	4.76	A	1	0.65	26	1	1	75.283	1.39	69.53	C
0			B	1	0.65		1	1	75.283			
			C	1	0.65		1	1	75.283			
L6 81.710-74.170	0.26	1.94	A	1	0.65	25	1	1	30.641	0.54	71.69	C
			B	1	0.65		1	1	30.641			
			C	1	0.65		1	1	30.641			
L7 74.170-60.840	0.46	5.89	A	1	0.65	24	1	1	56.147	0.95	71.30	C
			B	1	0.65		1	1	56.147			
			C	1	0.65		1	1	56.147			
L8 60.840-33.340	0.96	9.14	A	1	0.65	21	1	1	128.329	1.96	71.16	C
			B	1	0.65		1	1	128.329			
			C	1	0.65		1	1	128.329			
L9 33.340-21.170	0.42	7.77	A	1	0.65	19	1	1	60.823	0.82	67.07	C
			B	1	0.65		1	1	60.823			
			C	1	0.65		1	1	60.823			
L10 21.170-1.170	0.55	8.45	A	1	0.65	19	1	1	106.790	1.43	71.66	C
			B	1	0.65		1	1	106.790			
			C	1	0.65		1	1	106.790			
L11 1.170-0.000	0.00	0.52	A	1	0.65	19	1	1	6.510	0.09	74.67	C
			B	1	0.65		1	1	6.510			
			C	1	0.65		1	1	6.510			
Sum Weight:	5.44	49.49						OTM	939.92 kip-ft	11.42		

### Tower Forces - No Ice - Wind 60 To Face

Section Elevation ft	Add Weight K	Self Weight K	F a c e	e	C <sub>F</sub>	q <sub>z</sub> psf	D <sub>F</sub>	D <sub>R</sub>	A <sub>E</sub> ft <sup>2</sup>	F K	w plf	Ctrl. Face
L1 175.000-154.8	0.32	1.09	A	1	0.65	31	1	1	45.653	1.00	49.54	C
70			B	1	0.65		1	1	45.653			
			C	1	0.65		1	1	45.653			
L2 154.870-139.1	0.46	2.44	A	1	0.65	30	1	1	41.357	0.87	55.52	C
20			B	1	0.65		1	1	41.357			
			C	1	0.65		1	1	41.357			
L3 139.120-116.2	0.80	3.30	A	1	0.65	28	1	1	69.538	1.41	61.84	C
90			B	1	0.65		1	1	69.538			
			C	1	0.65		1	1	69.538			
L4 116.290-101.7	0.51	4.20	A	1	0.65	27	1	1	49.396	0.96	65.77	C
10			B	1	0.65		1	1	49.396			
			C	1	0.65		1	1	49.396			
L5 101.710-81.71	0.70	4.76	A	1	0.65	26	1	1	75.283	1.39	69.53	C
0			B	1	0.65		1	1	75.283			
			C	1	0.65		1	1	75.283			
L6 81.710-74.170	0.26	1.94	A	1	0.65	25	1	1	30.641	0.54	71.69	C
			B	1	0.65		1	1	30.641			
			C	1	0.65		1	1	30.641			
L7 74.170-60.840	0.46	5.89	A	1	0.65	24	1	1	56.147	0.95	71.30	C
			B	1	0.65		1	1	56.147			
			C	1	0.65		1	1	56.147			



**Tectonic**  
 1279 Route 300  
 Newburgh, NY 12550  
 Phone: (845) 367-6658  
 FAX: (845) 367-8703

<b>Job</b>	9927.CT11636A	<b>Page</b>	14 of 30
<b>Project</b>	175' Monopole	<b>Date</b>	10:23:22 07/01/19
<b>Client</b>	T-Mobile	<b>Designed by</b>	John Julien

Section Elevation ft	Add Weight K	Self Weight K	F a c e	e	C <sub>F</sub>	q <sub>z</sub> psf	D <sub>F</sub>	D <sub>R</sub>	A <sub>E</sub> ft <sup>2</sup>	F K	w plf	Ctrl. Face
L8 60.840-33.340	0.96	9.14	A	1	0.65	21	1	1	128.329	1.96	71.16	C
			B	1	0.65		1	1	128.329			
			C	1	0.65		1	1	128.329			
L9 33.340-21.170	0.42	7.77	A	1	0.65	19	1	1	60.823	0.82	67.07	C
			B	1	0.65		1	1	60.823			
			C	1	0.65		1	1	60.823			
L10 21.170-1.170	0.55	8.45	A	1	0.65	19	1	1	106.790	1.43	71.66	C
			B	1	0.65		1	1	106.790			
			C	1	0.65		1	1	106.790			
L11 1.170-0.000	0.00	0.52	A	1	0.65	19	1	1	6.510	0.09	74.67	C
			B	1	0.65		1	1	6.510			
			C	1	0.65		1	1	6.510			
Sum Weight:	5.44	49.49						OTM	939.92 kip-ft	11.42		

### Tower Forces - No Ice - Wind 90 To Face

Section Elevation ft	Add Weight K	Self Weight K	F a c e	e	C <sub>F</sub>	q <sub>z</sub> psf	D <sub>F</sub>	D <sub>R</sub>	A <sub>E</sub> ft <sup>2</sup>	F K	w plf	Ctrl. Face
L1 175.000-154.8	0.32	1.09	A	1	0.65	31	1	1	45.653	1.00	49.54	C
			B	1	0.65		1	1	45.653			
			C	1	0.65		1	1	45.653			
L2 154.870-139.1	0.46	2.44	A	1	0.65	30	1	1	41.357	0.87	55.52	C
			B	1	0.65		1	1	41.357			
			C	1	0.65		1	1	41.357			
L3 139.120-116.2	0.80	3.30	A	1	0.65	28	1	1	69.538	1.41	61.84	C
			B	1	0.65		1	1	69.538			
			C	1	0.65		1	1	69.538			
L4 116.290-101.7	0.51	4.20	A	1	0.65	27	1	1	49.396	0.96	65.77	C
			B	1	0.65		1	1	49.396			
			C	1	0.65		1	1	49.396			
L5 101.710-81.7	0.70	4.76	A	1	0.65	26	1	1	75.283	1.39	69.53	C
			B	1	0.65		1	1	75.283			
			C	1	0.65		1	1	75.283			
L6 81.710-74.170	0.26	1.94	A	1	0.65	25	1	1	30.641	0.54	71.69	C
			B	1	0.65		1	1	30.641			
			C	1	0.65		1	1	30.641			
L7 74.170-60.840	0.46	5.89	A	1	0.65	24	1	1	56.147	0.95	71.30	C
			B	1	0.65		1	1	56.147			
			C	1	0.65		1	1	56.147			
L8 60.840-33.340	0.96	9.14	A	1	0.65	21	1	1	128.329	1.96	71.16	C
			B	1	0.65		1	1	128.329			
			C	1	0.65		1	1	128.329			
L9 33.340-21.170	0.42	7.77	A	1	0.65	19	1	1	60.823	0.82	67.07	C
			B	1	0.65		1	1	60.823			
			C	1	0.65		1	1	60.823			
L10 21.170-1.170	0.55	8.45	A	1	0.65	19	1	1	106.790	1.43	71.66	C
			B	1	0.65		1	1	106.790			
			C	1	0.65		1	1	106.790			
L11 1.170-0.000	0.00	0.52	A	1	0.65	19	1	1	6.510	0.09	74.67	C
			B	1	0.65		1	1	6.510			
			C	1	0.65		1	1	6.510			

 <p><b>Tectonic</b> PRACTICAL SOLUTIONS. EXCEPTIONAL SERVICE.</p> <p><b>Tectonic</b> 1279 Route 300 Newburgh, NY 12550 Phone: (845) 367-6658 FAX: (845) 367-8703</p>	<b>Job</b>	9927.CT11636A	<b>Page</b>	15 of 30
	<b>Project</b>	175' Monopole	<b>Date</b>	10:23:22 07/01/19
	<b>Client</b>	T-Mobile	<b>Designed by</b>	John Julien

Section Elevation	Add Weight	Self Weight	F a c e	e	C <sub>F</sub>	q <sub>z</sub>	D <sub>F</sub>	D <sub>R</sub>	A <sub>E</sub>	F	w	Ctrl. Face
ft	K	K				psf			ft <sup>2</sup>	K	plf	
Sum Weight:	5.44	49.49						OTM	939.92 kip-ft	11.42		

### Tower Forces - With Ice - Wind Normal To Face

Section Elevation	Add Weight	Self Weight	F a c e	e	C <sub>F</sub>	q <sub>z</sub>	D <sub>F</sub>	D <sub>R</sub>	A <sub>E</sub>	F	w	Ctrl. Face
ft	K	K				psf			ft <sup>2</sup>	K	plf	
L1 175.000-154.8	0.75	2.34	A	1	1.2	7	1	1	51.563	0.47	23.42	C
70			B	1	1.2		1	1	51.563			
			C	1	1.2		1	1	51.563			
L2 154.870-139.1	0.97	3.56	A	1	1.2	7	1	1	45.981	0.41	25.84	C
20			B	1	1.2		1	1	45.981			
			C	1	1.2		1	1	45.981			
L3 139.120-116.2	1.51	5.13	A	1	1.2	6	1	1	76.071	0.65	28.32	C
90			B	1	1.2		1	1	76.071			
			C	1	1.2		1	1	76.071			
L4 116.290-101.7	0.97	5.47	A	1	1.2	6	1	1	53.568	0.44	29.86	C
10			B	1	1.2		1	1	53.568			
			C	1	1.2		1	1	53.568			
L5 101.710-81.71	1.30	6.65	A	1	1.2	6	1	1	80.820	0.62	31.25	C
0			B	1	1.2		1	1	80.820			
			C	1	1.2		1	1	80.820			
L6 81.710-74.170	0.48	2.69	A	1	1.2	6	1	1	32.695	0.24	32.02	C
			B	1	1.2		1	1	32.695			
			C	1	1.2		1	1	32.695			
L7 74.170-60.840	0.86	7.25	A	1	1.2	5	1	1	59.779	0.42	31.78	C
			B	1	1.2		1	1	59.779			
			C	1	1.2		1	1	59.779			
L8 60.840-33.340	1.72	12.14	A	1	1.2	5	1	1	135.448	0.86	31.44	C
			B	1	1.2		1	1	135.448			
			C	1	1.2		1	1	135.448			
L9 33.340-21.170	0.76	9.11	A	1	1.2	4	1	1	63.974	0.36	29.53	C
			B	1	1.2		1	1	63.974			
			C	1	1.2		1	1	63.974			
L10 21.170-1.170	0.94	10.59	A	1	1.2	4	1	1	111.272	0.63	31.26	C
			B	1	1.2		1	1	111.272			
			C	1	1.2		1	1	111.272			
L11 1.170-0.000	0.00	0.61	A	1	1.2	4	1	1	6.706	0.04	32.20	C
			B	1	1.2		1	1	6.706			
			C	1	1.2		1	1	6.706			
Sum Weight:	10.25	65.55						OTM	428.87 kip-ft	5.14		

### Tower Forces - With Ice - Wind 60 To Face



**Tectonic**  
 1279 Route 300  
 Newburgh, NY 12550  
 Phone: (845) 367-6658  
 FAX: (845) 367-8703

<b>Job</b>	9927.CT11636A	<b>Page</b>	16 of 30
<b>Project</b>	175' Monopole	<b>Date</b>	10:23:22 07/01/19
<b>Client</b>	T-Mobile	<b>Designed by</b>	John Julien

Section Elevation ft	Add Weight K	Self Weight K	F a c e	e	C <sub>F</sub>	q <sub>z</sub> psf	D <sub>F</sub>	D <sub>R</sub>	A <sub>E</sub> ft <sup>2</sup>	F K	w plf	Ctrl. Face
L1 175.000-154.8	0.75	2.34	A	1	1.2	7	1	1	51.563	0.47	23.42	C
70			B	1	1.2		1	1	51.563			
L2 154.870-139.1	0.97	3.56	C	1	1.2		1	1	51.563			
20			A	1	1.2	7	1	1	45.981	0.41	25.84	C
L3 139.120-116.2	1.51	5.13	B	1	1.2		1	1	45.981			
90			C	1	1.2		1	1	45.981			
L4 116.290-101.7	0.97	5.47	A	1	1.2	6	1	1	76.071	0.65	28.32	C
10			B	1	1.2		1	1	76.071			
L5 101.710-81.71	1.30	6.65	C	1	1.2		1	1	76.071			
0			A	1	1.2	6	1	1	53.568	0.44	29.86	C
L6 81.710-74.170	0.48	2.69	B	1	1.2		1	1	53.568			
			C	1	1.2		1	1	53.568			
L7 74.170-60.840	0.86	7.25	A	1	1.2	5	1	1	80.820	0.62	31.25	C
			B	1	1.2		1	1	80.820			
			C	1	1.2		1	1	80.820			
L8 60.840-33.340	1.72	12.14	A	1	1.2	5	1	1	32.695	0.24	32.02	C
			B	1	1.2		1	1	32.695			
			C	1	1.2		1	1	32.695			
L9 33.340-21.170	0.76	9.11	A	1	1.2	4	1	1	59.779	0.42	31.78	C
			B	1	1.2		1	1	59.779			
			C	1	1.2		1	1	59.779			
L10 21.170-1.170	0.94	10.59	A	1	1.2	4	1	1	135.448	0.86	31.44	C
			B	1	1.2		1	1	135.448			
			C	1	1.2		1	1	135.448			
L11 1.170-0.000	0.00	0.61	A	1	1.2	4	1	1	63.974	0.36	29.53	C
			B	1	1.2		1	1	63.974			
			C	1	1.2		1	1	63.974			
Sum Weight:	10.25	65.55	A	1	1.2		1	1	111.272	0.63	31.26	C
			B	1	1.2		1	1	111.272			
			C	1	1.2		1	1	111.272			
			A	1	1.2	4	1	1	6.706	0.04	32.20	C
			B	1	1.2		1	1	6.706			
			C	1	1.2		1	1	6.706			
								OTM	428.87	5.14		
									kip-ft			

### Tower Forces - With Ice - Wind 90 To Face

Section Elevation ft	Add Weight K	Self Weight K	F a c e	e	C <sub>F</sub>	q <sub>z</sub> psf	D <sub>F</sub>	D <sub>R</sub>	A <sub>E</sub> ft <sup>2</sup>	F K	w plf	Ctrl. Face
L1 175.000-154.8	0.75	2.34	A	1	1.2	7	1	1	51.563	0.47	23.42	C
70			B	1	1.2		1	1	51.563			
L2 154.870-139.1	0.97	3.56	C	1	1.2		1	1	51.563			
20			A	1	1.2	7	1	1	45.981	0.41	25.84	C
L3 139.120-116.2	1.51	5.13	B	1	1.2		1	1	45.981			
90			C	1	1.2		1	1	45.981			
L4 116.290-101.7	0.97	5.47	A	1	1.2	6	1	1	76.071	0.65	28.32	C
10			B	1	1.2		1	1	76.071			
			C	1	1.2		1	1	76.071			
			A	1	1.2	6	1	1	53.568	0.44	29.86	C
			B	1	1.2		1	1	53.568			
			C	1	1.2		1	1	53.568			



**Tectonic**  
 1279 Route 300  
 Newburgh, NY 12550  
 Phone: (845) 367-6658  
 FAX: (845) 367-8703

<b>Job</b>	9927.CT11636A	<b>Page</b>	17 of 30
<b>Project</b>	175' Monopole	<b>Date</b>	10:23:22 07/01/19
<b>Client</b>	T-Mobile	<b>Designed by</b>	John Julien

Section Elevation ft	Add Weight K	Self Weight K	F a c e	e	C <sub>F</sub>	q <sub>z</sub> psf	D <sub>F</sub>	D <sub>R</sub>	A <sub>E</sub> ft <sup>2</sup>	F K	w plf	Ctrl. Face
L5 101.710-81.710	1.30	6.65	A B C	1 1 1	1.2 1.2 1.2	6	1 1 1	1 1 1	80.820 80.820 80.820	0.62	31.25	C
L6 81.710-74.170	0.48	2.69	A B C	1 1 1	1.2 1.2 1.2	6	1 1 1	1 1 1	32.695 32.695 32.695	0.24	32.02	C
L7 74.170-60.840	0.86	7.25	A B C	1 1 1	1.2 1.2 1.2	5	1 1 1	1 1 1	59.779 59.779 59.779	0.42	31.78	C
L8 60.840-33.340	1.72	12.14	A B C	1 1 1	1.2 1.2 1.2	5	1 1 1	1 1 1	135.448 135.448 135.448	0.86	31.44	C
L9 33.340-21.170	0.76	9.11	A B C	1 1 1	1.2 1.2 1.2	4	1 1 1	1 1 1	63.974 63.974 63.974	0.36	29.53	C
L10 21.170-1.170	0.94	10.59	A B C	1 1 1	1.2 1.2 1.2	4	1 1 1	1 1 1	111.272 111.272 111.272	0.63	31.26	C
L11 1.170-0.000	0.00	0.61	A B C	1 1 1	1.2 1.2 1.2	4	1 1 1	1 1 1	6.706 6.706 6.706	0.04	32.20	C
Sum Weight:	10.25	65.55						OTM	428.87 kip-ft	5.14		

### Tower Forces - Service - Wind Normal To Face

Section Elevation ft	Add Weight K	Self Weight K	F a c e	e	C <sub>F</sub>	q <sub>z</sub> psf	D <sub>F</sub>	D <sub>R</sub>	A <sub>E</sub> ft <sup>2</sup>	F K	w plf	Ctrl. Face
L1 175.000-154.870	0.32	1.09	A B C	1 1 1	0.65 0.65 0.65	9	1 1 1	1 1 1	45.653 45.653 45.653	0.29	14.47	C
L2 154.870-139.120	0.46	2.44	A B C	1 1 1	0.65 0.65 0.65	9	1 1 1	1 1 1	41.357 41.357 41.357	0.26	16.22	C
L3 139.120-116.290	0.80	3.30	A B C	1 1 1	0.65 0.65 0.65	8	1 1 1	1 1 1	69.538 69.538 69.538	0.41	18.07	C
L4 116.290-101.710	0.51	4.20	A B C	1 1 1	0.65 0.65 0.65	8	1 1 1	1 1 1	49.396 49.396 49.396	0.28	19.21	C
L5 101.710-81.710	0.70	4.76	A B C	1 1 1	0.65 0.65 0.65	8	1 1 1	1 1 1	75.283 75.283 75.283	0.41	20.31	C
L6 81.710-74.170	0.26	1.94	A B C	1 1 1	0.65 0.65 0.65	7	1 1 1	1 1 1	30.641 30.641 30.641	0.16	20.95	C
L7 74.170-60.840	0.46	5.89	A B C	1 1 1	0.65 0.65 0.65	7	1 1 1	1 1 1	56.147 56.147 56.147	0.28	20.83	C
L8 60.840-33.340	0.96	9.14	A B C	1 1 1	0.65 0.65 0.65	6	1 1 1	1 1 1	128.329 128.329 128.329	0.57	20.79	C



**Tectonic**  
 1279 Route 300  
 Newburgh, NY 12550  
 Phone: (845) 367-6658  
 FAX: (845) 367-8703

<b>Job</b>	9927.CT11636A	<b>Page</b>	18 of 30
<b>Project</b>	175' Monopole	<b>Date</b>	10:23:22 07/01/19
<b>Client</b>	T-Mobile	<b>Designed by</b>	John Julien

Section Elevation ft	Add Weight K	Self Weight K	F a c e	e	C <sub>F</sub>	q <sub>z</sub> psf	D <sub>F</sub>	D <sub>R</sub>	A <sub>E</sub> ft <sup>2</sup>	F K	w plf	Ctrl. Face
L9 33.340-21.170	0.42	7.77	A	1	0.65	5	1	1	60.823	0.24	19.60	C
			B	1	0.65		1	1	60.823			
			C	1	0.65		1	1	60.823			
L10 21.170-1.170	0.55	8.45	A	1	0.65	5	1	1	106.790	0.42	20.93	C
			B	1	0.65		1	1	106.790			
			C	1	0.65		1	1	106.790			
L11 1.170-0.000	0.00	0.52	A	1	0.65	5	1	1	6.510	0.03	21.82	C
			B	1	0.65		1	1	6.510			
			C	1	0.65		1	1	6.510			
Sum Weight:	5.44	49.49						OTM	274.60 kip-ft	3.34		

### Tower Forces - Service - Wind 60 To Face

Section Elevation ft	Add Weight K	Self Weight K	F a c e	e	C <sub>F</sub>	q <sub>z</sub> psf	D <sub>F</sub>	D <sub>R</sub>	A <sub>E</sub> ft <sup>2</sup>	F K	w plf	Ctrl. Face
L1 175.000-154.8	0.32	1.09	A	1	0.65	9	1	1	45.653	0.29	14.47	C
			B	1	0.65		1	1	45.653			
			C	1	0.65		1	1	45.653			
L2 154.870-139.1	0.46	2.44	A	1	0.65	9	1	1	41.357	0.26	16.22	C
			B	1	0.65		1	1	41.357			
			C	1	0.65		1	1	41.357			
L3 139.120-116.2	0.80	3.30	A	1	0.65	8	1	1	69.538	0.41	18.07	C
			B	1	0.65		1	1	69.538			
			C	1	0.65		1	1	69.538			
L4 116.290-101.7	0.51	4.20	A	1	0.65	8	1	1	49.396	0.28	19.21	C
			B	1	0.65		1	1	49.396			
			C	1	0.65		1	1	49.396			
L5 101.710-81.71	0.70	4.76	A	1	0.65	8	1	1	75.283	0.41	20.31	C
			B	1	0.65		1	1	75.283			
			C	1	0.65		1	1	75.283			
L6 81.710-74.170	0.26	1.94	A	1	0.65	7	1	1	30.641	0.16	20.95	C
			B	1	0.65		1	1	30.641			
			C	1	0.65		1	1	30.641			
L7 74.170-60.840	0.46	5.89	A	1	0.65	7	1	1	56.147	0.28	20.83	C
			B	1	0.65		1	1	56.147			
			C	1	0.65		1	1	56.147			
L8 60.840-33.340	0.96	9.14	A	1	0.65	6	1	1	128.329	0.57	20.79	C
			B	1	0.65		1	1	128.329			
			C	1	0.65		1	1	128.329			
L9 33.340-21.170	0.42	7.77	A	1	0.65	5	1	1	60.823	0.24	19.60	C
			B	1	0.65		1	1	60.823			
			C	1	0.65		1	1	60.823			
L10 21.170-1.170	0.55	8.45	A	1	0.65	5	1	1	106.790	0.42	20.93	C
			B	1	0.65		1	1	106.790			
			C	1	0.65		1	1	106.790			
L11 1.170-0.000	0.00	0.52	A	1	0.65	5	1	1	6.510	0.03	21.82	C
			B	1	0.65		1	1	6.510			
			C	1	0.65		1	1	6.510			
Sum Weight:	5.44	49.49						OTM	274.60 kip-ft	3.34		

 <p><b>Tectonic</b> PRACTICAL SOLUTIONS. EXCEPTIONAL SERVICE.</p> <p><b>Tectonic</b> 1279 Route 300 Newburgh, NY 12550 Phone: (845) 367-6658 FAX: (845) 367-8703</p>	<b>Job</b> 9927.CT11636A	<b>Page</b> 19 of 30
	<b>Project</b> 175' Monopole	<b>Date</b> 10:23:22 07/01/19
	<b>Client</b> T-Mobile	<b>Designed by</b> John Julien

### Tower Forces - Service - Wind 90 To Face

Section Elevation ft	Add Weight K	Self Weight K	F a c e	e	C <sub>F</sub>	q <sub>z</sub> psf	D <sub>F</sub>	D <sub>R</sub>	A <sub>E</sub> ft <sup>2</sup>	F K	w plf	Ctrl. Face
L1 175.000-154.8	0.32	1.09	A	1	0.65	9	1	1	45.653	0.29	14.47	C
70			B	1	0.65		1	1	45.653			
L2 154.870-139.1	0.46	2.44	C	1	0.65	9	1	1	45.653	0.26	16.22	C
20			A	1	0.65		1	1	41.357			
L3 139.120-116.2	0.80	3.30	B	1	0.65	8	1	1	41.357	0.41	18.07	C
90			C	1	0.65		1	1	69.538			
L4 116.290-101.7	0.51	4.20	A	1	0.65	8	1	1	69.538	0.28	19.21	C
10			B	1	0.65		1	1	49.396			
L5 101.710-81.71	0.70	4.76	C	1	0.65	8	1	1	49.396	0.41	20.31	C
0			A	1	0.65		1	1	75.283			
L6 81.710-74.170	0.26	1.94	B	1	0.65	7	1	1	75.283	0.16	20.95	C
			C	1	0.65		1	1	30.641			
L7 74.170-60.840	0.46	5.89	A	1	0.65	7	1	1	30.641	0.28	20.83	C
			B	1	0.65		1	1	56.147			
L8 60.840-33.340	0.96	9.14	C	1	0.65	6	1	1	56.147	0.57	20.79	C
			A	1	0.65		1	1	128.329			
L9 33.340-21.170	0.42	7.77	B	1	0.65	5	1	1	128.329	0.24	19.60	C
			C	1	0.65		1	1	60.823			
L10 21.170-1.170	0.55	8.45	A	1	0.65	5	1	1	60.823	0.42	20.93	C
			B	1	0.65		1	1	106.790			
L11 1.170-0.000	0.00	0.52	C	1	0.65	5	1	1	106.790	0.03	21.82	C
			A	1	0.65		1	1	6.510			
			B	1	0.65		1	1	6.510			
			C	1	0.65		1	1	6.510			
Sum Weight:	5.44	49.49						OTM	274.60 kip-ft	3.34		

### Force Totals

Load Case	Vertical Forces K	Sum of Forces X K	Sum of Forces Z K	Sum of Overturning Moments, M <sub>x</sub> kip-ft	Sum of Overturning Moments, M <sub>z</sub> kip-ft	Sum of Torques kip-ft
Leg Weight	49.49					
Bracing Weight	0.00					
Total Member Self-Weight	49.49					
Total Weight	65.36			-0.83	-0.59	
Wind 0 deg - No Ice		0.00	-21.66	-2589.98	-0.59	-0.04
Wind 30 deg - No Ice		10.81	-18.76	-2243.10	-1291.91	0.18





**Tectonic**  
 1279 Route 300  
 Newburgh, NY 12550  
 Phone: (845) 367-6658  
 FAX: (845) 367-8703

<b>Job</b>	9927.CT11636A	<b>Page</b>	20 of 30
<b>Project</b>	175' Monopole	<b>Date</b>	10:23:22 07/01/19
<b>Client</b>	T-Mobile	<b>Designed by</b>	John Julien

Load Case	Vertical Forces K	Sum of Forces X K	Sum of Forces Z K	Sum of Overturning Moments, M <sub>x</sub> kip-ft	Sum of Overturning Moments, M <sub>z</sub> kip-ft	Sum of Torques kip-ft
Wind 60 deg - No Ice		18.72	-10.83	-1295.40	-2237.22	0.35
Wind 90 deg - No Ice		21.62	0.00	-0.83	-2583.23	0.42
Wind 120 deg - No Ice		18.72	10.83	1293.74	-2237.22	0.39
Wind 150 deg - No Ice		10.81	18.76	2241.44	-1291.91	0.24
Wind 180 deg - No Ice		0.00	21.66	2588.32	-0.59	0.04
Wind 210 deg - No Ice		-10.81	18.76	2241.44	1290.74	-0.18
Wind 240 deg - No Ice		-18.72	10.83	1293.74	2236.05	-0.35
Wind 270 deg - No Ice		-21.62	0.00	-0.83	2582.06	-0.42
Wind 300 deg - No Ice		-18.72	-10.83	-1295.40	2236.05	-0.39
Wind 330 deg - No Ice		-10.81	-18.76	-2243.10	1290.74	-0.24
Member Ice	16.05					
Total Weight Ice	101.42			-4.79	-4.25	
Wind 0 deg - Ice		0.00	-8.53	-979.59	-4.25	-0.02
Wind 30 deg - Ice		4.26	-7.39	-849.00	-490.85	0.08
Wind 60 deg - Ice		7.38	-4.27	-492.19	-847.06	0.15
Wind 90 deg - Ice		8.53	0.00	-4.79	-977.44	0.19
Wind 120 deg - Ice		7.38	4.27	482.62	-847.06	0.17
Wind 150 deg - Ice		4.26	7.39	839.42	-490.85	0.11
Wind 180 deg - Ice		0.00	8.53	970.02	-4.25	0.02
Wind 210 deg - Ice		-4.26	7.39	839.42	482.35	-0.08
Wind 240 deg - Ice		-7.38	4.27	482.62	838.57	-0.15
Wind 270 deg - Ice		-8.53	0.00	-4.79	968.95	-0.19
Wind 300 deg - Ice		-7.38	-4.27	-492.19	838.57	-0.17
Wind 330 deg - Ice		-4.26	-7.39	-849.00	482.35	-0.11
Total Weight	65.36			-0.83	-0.59	
Wind 0 deg - Service		0.00	-6.33	-756.22	0.03	-0.01
Wind 30 deg - Service		3.16	-5.48	-654.88	-377.24	0.05
Wind 60 deg - Service		5.47	-3.16	-378.00	-653.42	0.10
Wind 90 deg - Service		6.32	0.00	0.22	-754.51	0.12
Wind 120 deg - Service		5.47	3.16	378.44	-653.42	0.11
Wind 150 deg - Service		3.16	5.48	655.32	-377.24	0.07
Wind 180 deg - Service		0.00	6.33	756.66	0.03	0.01
Wind 210 deg - Service		-3.16	5.48	655.32	377.30	-0.05
Wind 240 deg - Service		-5.47	3.16	378.44	653.49	-0.10
Wind 270 deg - Service		-6.32	0.00	0.22	754.57	-0.12
Wind 300 deg - Service		-5.47	-3.16	-378.00	653.49	-0.11
Wind 330 deg - Service		-3.16	-5.48	-654.88	377.30	-0.07

## Load Combinations

Comb. No.	Description
1	Dead Only
2	1.2 Dead+1.6 Wind 0 deg - No Ice
3	0.9 Dead+1.6 Wind 0 deg - No Ice
4	1.2 Dead+1.6 Wind 30 deg - No Ice
5	0.9 Dead+1.6 Wind 30 deg - No Ice
6	1.2 Dead+1.6 Wind 60 deg - No Ice
7	0.9 Dead+1.6 Wind 60 deg - No Ice
8	1.2 Dead+1.6 Wind 90 deg - No Ice
9	0.9 Dead+1.6 Wind 90 deg - No Ice
10	1.2 Dead+1.6 Wind 120 deg - No Ice
11	0.9 Dead+1.6 Wind 120 deg - No Ice
12	1.2 Dead+1.6 Wind 150 deg - No Ice
13	0.9 Dead+1.6 Wind 150 deg - No Ice
14	1.2 Dead+1.6 Wind 180 deg - No Ice



**Tectonic**  
 1279 Route 300  
 Newburgh, NY 12550  
 Phone: (845) 367-6658  
 FAX: (845) 367-8703

<b>Job</b>	9927.CT11636A	<b>Page</b>	21 of 30
<b>Project</b>	175' Monopole	<b>Date</b>	10:23:22 07/01/19
<b>Client</b>	T-Mobile	<b>Designed by</b>	John Julien

Comb. No.	Description
15	0.9 Dead+1.6 Wind 180 deg - No Ice
16	1.2 Dead+1.6 Wind 210 deg - No Ice
17	0.9 Dead+1.6 Wind 210 deg - No Ice
18	1.2 Dead+1.6 Wind 240 deg - No Ice
19	0.9 Dead+1.6 Wind 240 deg - No Ice
20	1.2 Dead+1.6 Wind 270 deg - No Ice
21	0.9 Dead+1.6 Wind 270 deg - No Ice
22	1.2 Dead+1.6 Wind 300 deg - No Ice
23	0.9 Dead+1.6 Wind 300 deg - No Ice
24	1.2 Dead+1.6 Wind 330 deg - No Ice
25	0.9 Dead+1.6 Wind 330 deg - No Ice
26	1.2 Dead+1.0 Ice+1.0 Temp
27	1.2 Dead+1.0 Wind 0 deg+1.0 Ice+1.0 Temp
28	1.2 Dead+1.0 Wind 30 deg+1.0 Ice+1.0 Temp
29	1.2 Dead+1.0 Wind 60 deg+1.0 Ice+1.0 Temp
30	1.2 Dead+1.0 Wind 90 deg+1.0 Ice+1.0 Temp
31	1.2 Dead+1.0 Wind 120 deg+1.0 Ice+1.0 Temp
32	1.2 Dead+1.0 Wind 150 deg+1.0 Ice+1.0 Temp
33	1.2 Dead+1.0 Wind 180 deg+1.0 Ice+1.0 Temp
34	1.2 Dead+1.0 Wind 210 deg+1.0 Ice+1.0 Temp
35	1.2 Dead+1.0 Wind 240 deg+1.0 Ice+1.0 Temp
36	1.2 Dead+1.0 Wind 270 deg+1.0 Ice+1.0 Temp
37	1.2 Dead+1.0 Wind 300 deg+1.0 Ice+1.0 Temp
38	1.2 Dead+1.0 Wind 330 deg+1.0 Ice+1.0 Temp
39	Dead+Wind 0 deg - Service
40	Dead+Wind 30 deg - Service
41	Dead+Wind 60 deg - Service
42	Dead+Wind 90 deg - Service
43	Dead+Wind 120 deg - Service
44	Dead+Wind 150 deg - Service
45	Dead+Wind 180 deg - Service
46	Dead+Wind 210 deg - Service
47	Dead+Wind 240 deg - Service
48	Dead+Wind 270 deg - Service
49	Dead+Wind 300 deg - Service
50	Dead+Wind 330 deg - Service

### Maximum Member Forces

Section No.	Elevation ft	Component Type	Condition	Gov. Load Comb.	Axial K	Major Axis Moment kip-ft	Minor Axis Moment kip-ft
L1	175 - 154.87	Pole	Max Tension	14	0.00	-0.00	0.00
			Max. Compression	26	-19.11	-0.06	-0.60
			Max. Mx	8	-7.82	-118.31	-0.16
			Max. My	14	-7.81	-0.00	-118.88
			Max. Vy	8	12.08	-118.31	-0.16
			Max. Vx	2	-12.14	-0.00	118.50
			Max. Torque	21			0.64
			Max Tension	1	0.00	0.00	0.00
L2	154.87 - 139.12	Pole	Max. Compression	26	-36.48	-0.25	-0.19
			Max. Mx	8	-16.68	-425.31	-0.09
			Max. My	14	-16.68	-0.02	-427.09
			Max. Vy	8	20.19	-425.31	-0.09
			Max. Vx	2	-20.26	-0.02	426.86
			Max. Torque	21			0.68
			Max Tension	1	0.00	0.00	0.00
			L3	139.12 - 116.29	Pole	Max Tension	1



**Tectonic**  
 1279 Route 300  
 Newburgh, NY 12550  
 Phone: (845) 367-6658  
 FAX: (845) 367-8703

<b>Job</b>	9927.CT11636A	<b>Page</b>	22 of 30
<b>Project</b>	175' Monopole	<b>Date</b>	10:23:22 07/01/19
<b>Client</b>	T-Mobile	<b>Designed by</b>	John Julien

Section No.	Elevation ft	Component Type	Condition	Gov. Load Comb.	Axial K	Major Axis Moment kip-ft	Minor Axis Moment kip-ft
L4	116.29 - 101.71	Pole	Max. Compression	26	-42.10	-0.65	0.34
			Max. Mx	8	-20.46	-791.50	0.01
			Max. My	14	-20.45	-0.08	-794.25
			Max. Vy	8	21.90	-791.50	0.01
			Max. Vx	2	-21.97	-0.08	794.24
			Max. Torque	21			0.68
			Max Tension	1	0.00	0.00	0.00
			Max. Compression	26	-51.79	-1.15	1.00
			Max. Mx	8	-27.42	-1251.81	0.14
			Max. My	2	-27.42	-0.17	1255.92
L5	101.71 - 81.71	Pole	Max. Vy	8	24.09	-1251.81	0.14
			Max. Vx	2	-24.16	-0.17	1255.92
			Max. Torque	21			0.68
			Max Tension	1	0.00	0.00	0.00
			Max. Compression	26	-60.83	-1.70	1.73
			Max. Mx	8	-34.11	-1754.90	0.29
			Max. My	2	-34.11	-0.26	1760.38
			Max. Vy	8	26.25	-1754.90	0.29
			Max. Vx	2	-26.32	-0.26	1760.38
			Max. Torque	21			0.68
L6	81.71 - 74.17	Pole	Max Tension	1	0.00	0.00	0.00
			Max. Compression	26	-61.25	-1.73	1.76
			Max. Mx	8	-34.42	-1777.78	0.30
			Max. My	2	-34.42	-0.26	1783.32
			Max. Vy	8	26.34	-1777.78	0.30
			Max. Vx	2	-26.41	-0.26	1783.32
			Max. Torque	21			0.68
			Max Tension	1	0.00	0.00	0.00
			Max. Compression	26	-74.52	-2.33	2.55
			Max. Mx	8	-44.51	-2327.85	0.46
L7	74.17 - 60.84	Pole	Max. My	2	-44.51	-0.36	2334.77
			Max. Vy	8	28.60	-2327.85	0.46
			Max. Vx	2	-28.66	-0.36	2334.77
			Max. Torque	21			0.68
			Max Tension	1	0.00	0.00	0.00
			Max. Compression	26	-85.72	-2.97	3.38
			Max. Mx	8	-53.22	-2909.48	0.65
			Max. My	2	-53.21	-0.47	2917.76
			Max. Vy	8	30.57	-2909.48	0.65
			Max. Vx	2	-30.64	-0.47	2917.76
L8	60.84 - 33.34	Pole	Max. Torque	21			0.67
			Max Tension	1	0.00	0.00	0.00
			Max. Compression	26	-102.76	-3.65	4.25
			Max. Mx	8	-66.80	-3542.56	0.85
			Max. My	2	-66.79	-0.58	3552.22
			Max. Vy	8	32.61	-3542.56	0.85
			Max. Vx	2	-32.68	-0.58	3552.22
			Max. Torque	21			0.67
			Max Tension	1	0.00	0.00	0.00
			Max. Compression	26	-116.09	-4.36	4.95
L9	33.34 - 21.17	Pole	Max. Mx	8	-77.80	-4213.39	1.02
			Max. My	2	-77.80	-0.72	4224.34
			Max. Vy	8	34.49	-4213.39	1.02
			Max. Vx	2	-34.55	-0.72	4224.34
			Max. Torque	21			0.67
			Max Tension	1	0.00	0.00	0.00
			Max. Compression	26	-116.81	-4.36	4.95
			Max. Mx	8	-78.43	-4253.79	1.02
			Max. My	2	-78.43	-0.72	4264.82
			Max. Vy	8	34.61	-4253.79	1.02



**Tectonic**  
 1279 Route 300  
 Newburgh, NY 12550  
 Phone: (845) 367-6658  
 FAX: (845) 367-8703

<b>Job</b>	9927.CT11636A	<b>Page</b>	23 of 30
<b>Project</b>	175' Monopole	<b>Date</b>	10:23:22 07/01/19
<b>Client</b>	T-Mobile	<b>Designed by</b>	John Julien

Section No.	Elevation ft	Component Type	Condition	Gov. Load Comb.	Axial K	Major Axis Moment kip-ft	Minor Axis Moment kip-ft
			Max. Vx	2	-34.67	-0.72	4264.82
			Max. Torque	21			0.67

### Maximum Reactions

Location	Condition	Gov. Load Comb.	Vertical K	Horizontal, X K	Horizontal, Z K
Pole	Max. Vert	26	116.81	0.00	0.00
	Max. H <sub>x</sub>	20	78.43	34.59	-0.00
	Max. H <sub>z</sub>	2	78.43	0.00	34.65
	Max. M <sub>x</sub>	2	4264.82	0.00	34.65
	Max. M <sub>z</sub>	8	4253.79	-34.59	-0.00
	Max. Torsion	21	0.67	34.59	0.00
	Min. Vert	19	58.83	29.96	-17.33
	Min. H <sub>x</sub>	8	78.43	-34.59	-0.00
	Min. H <sub>z</sub>	14	78.43	0.00	-34.65
	Min. M <sub>x</sub>	14	-4262.79	0.00	-34.65
	Min. M <sub>z</sub>	20	-4252.35	34.59	-0.00
	Min. Torsion	9	-0.67	-34.59	0.00

### Tower Mast Reaction Summary

Load Combination	Vertical K	Shear <sub>x</sub> K	Shear <sub>z</sub> K	Overturning Moment, M <sub>x</sub> kip-ft	Overturning Moment, M <sub>z</sub> kip-ft	Torque kip-ft
Dead Only	65.36	0.00	0.00	-0.83	-0.59	0.00
1.2 Dead+1.6 Wind 0 deg - No Ice	78.43	0.00	-34.65	-4264.82	-0.72	-0.06
0.9 Dead+1.6 Wind 0 deg - No Ice	58.83	0.00	-34.65	-4233.00	-0.54	-0.06
1.2 Dead+1.6 Wind 30 deg - No Ice	78.43	17.30	-30.01	-3693.59	-2127.25	0.29
0.9 Dead+1.6 Wind 30 deg - No Ice	58.83	17.30	-30.01	-3665.99	-2111.33	0.29
1.2 Dead+1.6 Wind 60 deg - No Ice	78.43	29.96	-17.33	-2132.93	-3683.99	0.55
0.9 Dead+1.6 Wind 60 deg - No Ice	58.83	29.96	-17.33	-2116.88	-3656.54	0.55
1.2 Dead+1.6 Wind 90 deg - No Ice	78.43	34.59	0.00	-1.02	-4253.79	0.67
0.9 Dead+1.6 Wind 90 deg - No Ice	58.83	34.59	0.00	-0.76	-4222.13	0.67
1.2 Dead+1.6 Wind 120 deg - No Ice	78.43	29.96	17.33	2130.89	-3683.99	0.61
0.9 Dead+1.6 Wind 120 deg - No Ice	58.83	29.96	17.33	2115.36	-3656.54	0.61
1.2 Dead+1.6 Wind 150 deg - No Ice	78.43	17.30	30.01	3691.55	-2127.26	0.39
0.9 Dead+1.6 Wind 150 deg - No Ice	58.83	17.30	30.01	3664.47	-2111.33	0.39
1.2 Dead+1.6 Wind 180 deg - No Ice	78.43	0.00	34.65	4262.79	-0.72	0.06



**Tectonic**  
 1279 Route 300  
 Newburgh, NY 12550  
 Phone: (845) 367-6658  
 FAX: (845) 367-8703

<b>Job</b>	9927.CT11636A	<b>Page</b>	24 of 30
<b>Project</b>	175' Monopole	<b>Date</b>	10:23:22 07/01/19
<b>Client</b>	T-Mobile	<b>Designed by</b>	John Julien

Load Combination	Vertical K	Shear <sub>x</sub> K	Shear <sub>z</sub> K	Overturning Moment, M <sub>x</sub> kip-ft	Overturning Moment, M <sub>z</sub> kip-ft	Torque kip-ft
0.9 Dead+1.6 Wind 180 deg - No Ice	58.83	0.00	34.65	4231.48	-0.54	0.06
1.2 Dead+1.6 Wind 210 deg - No Ice	78.43	-17.30	30.01	3691.55	2125.81	-0.29
0.9 Dead+1.6 Wind 210 deg - No Ice	58.83	-17.30	30.01	3664.47	2110.26	-0.29
1.2 Dead+1.6 Wind 240 deg - No Ice	78.43	-29.96	17.33	2130.89	3682.55	-0.55
0.9 Dead+1.6 Wind 240 deg - No Ice	58.83	-29.96	17.33	2115.36	3655.47	-0.56
1.2 Dead+1.6 Wind 270 deg - No Ice	78.43	-34.59	0.00	-1.02	4252.35	-0.67
0.9 Dead+1.6 Wind 270 deg - No Ice	58.83	-34.59	0.00	-0.76	4221.05	-0.67
1.2 Dead+1.6 Wind 300 deg - No Ice	78.43	-29.96	-17.33	-2132.93	3682.55	-0.61
0.9 Dead+1.6 Wind 300 deg - No Ice	58.83	-29.96	-17.33	-2116.88	3655.47	-0.61
1.2 Dead+1.6 Wind 330 deg - No Ice	78.43	-17.30	-30.01	-3693.59	2125.81	-0.39
0.9 Dead+1.6 Wind 330 deg - No Ice	58.83	-17.30	-30.01	-3665.99	2110.25	-0.39
1.2 Dead+1.0 Ice+1.0 Temp	116.81	0.00	0.00	-4.95	-4.36	0.00
1.2 Dead+1.0 Wind 0 deg+1.0 Ice+1.0 Temp	116.81	0.00	-8.53	-1033.00	-4.60	-0.02
1.2 Dead+1.0 Wind 30 deg+1.0 Ice+1.0 Temp	116.81	4.26	-7.39	-895.30	-517.65	0.08
1.2 Dead+1.0 Wind 60 deg+1.0 Ice+1.0 Temp	116.81	7.38	-4.27	-519.10	-893.22	0.15
1.2 Dead+1.0 Wind 90 deg+1.0 Ice+1.0 Temp	116.81	8.53	-0.00	-5.20	-1030.69	0.18
1.2 Dead+1.0 Wind 120 deg+1.0 Ice+1.0 Temp	116.81	7.38	4.27	508.71	-893.22	0.17
1.2 Dead+1.0 Wind 150 deg+1.0 Ice+1.0 Temp	116.81	4.26	7.39	884.91	-517.65	0.11
1.2 Dead+1.0 Wind 180 deg+1.0 Ice+1.0 Temp	116.81	0.00	8.53	1022.61	-4.60	0.02
1.2 Dead+1.0 Wind 210 deg+1.0 Ice+1.0 Temp	116.81	-4.26	7.39	884.91	508.45	-0.08
1.2 Dead+1.0 Wind 240 deg+1.0 Ice+1.0 Temp	116.81	-7.38	4.27	508.71	884.03	-0.15
1.2 Dead+1.0 Wind 270 deg+1.0 Ice+1.0 Temp	116.81	-8.53	-0.00	-5.20	1021.50	-0.18
1.2 Dead+1.0 Wind 300 deg+1.0 Ice+1.0 Temp	116.81	-7.38	-4.27	-519.10	884.03	-0.17
1.2 Dead+1.0 Wind 330 deg+1.0 Ice+1.0 Temp	116.81	-4.26	-7.39	-895.30	508.45	-0.11
Dead+Wind 0 deg - Service	65.36	0.00	-6.33	-775.89	-0.60	-0.01
Dead+Wind 30 deg - Service	65.36	3.16	-5.48	-672.05	-387.14	0.05
Dead+Wind 60 deg - Service	65.36	5.47	-3.16	-388.37	-670.11	0.10
Dead+Wind 90 deg - Service	65.36	6.32	0.00	-0.85	-773.69	0.12
Dead+Wind 120 deg - Service	65.36	5.47	3.16	386.68	-670.11	0.11
Dead+Wind 150 deg - Service	65.36	3.16	5.48	670.36	-387.14	0.07
Dead+Wind 180 deg - Service	65.36	0.00	6.33	774.20	-0.60	0.01
Dead+Wind 210 deg - Service	65.36	-3.16	5.48	670.36	385.95	-0.05
Dead+Wind 240 deg - Service	65.36	-5.47	3.16	386.68	668.92	-0.10
Dead+Wind 270 deg - Service	65.36	-6.32	0.00	-0.85	772.49	-0.12
Dead+Wind 300 deg - Service	65.36	-5.47	-3.16	-388.37	668.91	-0.11
Dead+Wind 330 deg - Service	65.36	-3.16	-5.48	-672.05	385.94	-0.07



**Tectonic**  
 1279 Route 300  
 Newburgh, NY 12550  
 Phone: (845) 367-6658  
 FAX: (845) 367-8703

<b>Job</b>	9927.CT11636A	<b>Page</b>	25 of 30
<b>Project</b>	175' Monopole	<b>Date</b>	10:23:22 07/01/19
<b>Client</b>	T-Mobile	<b>Designed by</b>	John Julien

## Solution Summary

Load Comb.	Sum of Applied Forces			Sum of Reactions			% Error
	PX K	PY K	PZ K	PX K	PY K	PZ K	
1	0.00	-65.36	0.00	0.00	65.36	0.00	0.000%
2	0.00	-78.43	-34.65	0.00	78.43	34.65	0.000%
3	0.00	-58.83	-34.65	0.00	58.83	34.65	0.000%
4	17.30	-78.43	-30.01	-17.30	78.43	30.01	0.000%
5	17.30	-58.83	-30.01	-17.30	58.83	30.01	0.000%
6	29.96	-78.43	-17.33	-29.96	78.43	17.33	0.000%
7	29.96	-58.83	-17.33	-29.96	58.83	17.33	0.000%
8	34.59	-78.43	0.00	-34.59	78.43	-0.00	0.000%
9	34.59	-58.83	0.00	-34.59	58.83	0.00	0.000%
10	29.96	-78.43	17.33	-29.96	78.43	-17.33	0.000%
11	29.96	-58.83	17.33	-29.96	58.83	-17.33	0.000%
12	17.30	-78.43	30.01	-17.30	78.43	-30.01	0.000%
13	17.30	-58.83	30.01	-17.30	58.83	-30.01	0.000%
14	0.00	-78.43	34.65	0.00	78.43	-34.65	0.000%
15	0.00	-58.83	34.65	0.00	58.83	-34.65	0.000%
16	-17.30	-78.43	30.01	17.30	78.43	-30.01	0.000%
17	-17.30	-58.83	30.01	17.30	58.83	-30.01	0.000%
18	-29.96	-78.43	17.33	29.96	78.43	-17.33	0.000%
19	-29.96	-58.83	17.33	29.96	58.83	-17.33	0.000%
20	-34.59	-78.43	0.00	34.59	78.43	-0.00	0.000%
21	-34.59	-58.83	0.00	34.59	58.83	0.00	0.000%
22	-29.96	-78.43	-17.33	29.96	78.43	17.33	0.000%
23	-29.96	-58.83	-17.33	29.96	58.83	17.33	0.000%
24	-17.30	-78.43	-30.01	17.30	78.43	30.01	0.000%
25	-17.30	-58.83	-30.01	17.30	58.83	30.01	0.000%
26	0.00	-116.81	0.00	0.00	116.81	0.00	0.000%
27	0.00	-116.81	-8.53	-0.00	116.81	8.53	0.000%
28	4.26	-116.81	-7.39	-4.26	116.81	7.39	0.000%
29	7.38	-116.81	-4.27	-7.38	116.81	4.27	0.000%
30	8.53	-116.81	0.00	-8.53	116.81	0.00	0.000%
31	7.38	-116.81	4.27	-7.38	116.81	-4.27	0.000%
32	4.26	-116.81	7.39	-4.26	116.81	-7.39	0.000%
33	0.00	-116.81	8.53	-0.00	116.81	-8.53	0.000%
34	-4.26	-116.81	7.39	4.26	116.81	-7.39	0.000%
35	-7.38	-116.81	4.27	7.38	116.81	-4.27	0.000%
36	-8.53	-116.81	0.00	8.53	116.81	0.00	0.000%
37	-7.38	-116.81	-4.27	7.38	116.81	4.27	0.000%
38	-4.26	-116.81	-7.39	4.26	116.81	7.39	0.000%
39	0.00	-65.36	-6.33	0.00	65.36	6.33	0.000%
40	3.16	-65.36	-5.48	-3.16	65.36	5.48	0.000%
41	5.47	-65.36	-3.16	-5.47	65.36	3.16	0.000%
42	6.32	-65.36	0.00	-6.32	65.36	0.00	0.000%
43	5.47	-65.36	3.16	-5.47	65.36	-3.16	0.000%
44	3.16	-65.36	5.48	-3.16	65.36	-5.48	0.000%
45	0.00	-65.36	6.33	0.00	65.36	-6.33	0.000%
46	-3.16	-65.36	5.48	3.16	65.36	-5.48	0.000%
47	-5.47	-65.36	3.16	5.47	65.36	-3.16	0.000%
48	-6.32	-65.36	0.00	6.32	65.36	0.00	0.000%
49	-5.47	-65.36	-3.16	5.47	65.36	3.16	0.000%
50	-3.16	-65.36	-5.48	3.16	65.36	5.48	0.000%

## Non-Linear Convergence Results



**Tectonic**  
 1279 Route 300  
 Newburgh, NY 12550  
 Phone: (845) 367-6658  
 FAX: (845) 367-8703

<b>Job</b>	9927.CT11636A	<b>Page</b>	26 of 30
<b>Project</b>	175' Monopole	<b>Date</b>	10:23:22 07/01/19
<b>Client</b>	T-Mobile	<b>Designed by</b>	John Julien

Load Combination	Converged?	Number of Cycles	Displacement Tolerance	Force Tolerance
1	Yes	4	0.0000001	0.0000001
2	Yes	4	0.0000001	0.00034206
3	Yes	4	0.0000001	0.00017421
4	Yes	5	0.0000001	0.00038266
5	Yes	5	0.0000001	0.00018553
6	Yes	5	0.0000001	0.00037535
7	Yes	5	0.0000001	0.00018182
8	Yes	4	0.0000001	0.00045706
9	Yes	4	0.0000001	0.00027106
10	Yes	5	0.0000001	0.00038468
11	Yes	5	0.0000001	0.00018666
12	Yes	5	0.0000001	0.00037686
13	Yes	5	0.0000001	0.00018258
14	Yes	4	0.0000001	0.00034196
15	Yes	4	0.0000001	0.00017417
16	Yes	5	0.0000001	0.00037738
17	Yes	5	0.0000001	0.00018290
18	Yes	5	0.0000001	0.00038399
19	Yes	5	0.0000001	0.00018634
20	Yes	4	0.0000001	0.00045694
21	Yes	4	0.0000001	0.00027101
22	Yes	5	0.0000001	0.00037471
23	Yes	5	0.0000001	0.00018152
24	Yes	5	0.0000001	0.00038323
25	Yes	5	0.0000001	0.00018587
26	Yes	4	0.0000001	0.00000001
27	Yes	5	0.0000001	0.00033013
28	Yes	5	0.0000001	0.00034920
29	Yes	5	0.0000001	0.00034874
30	Yes	5	0.0000001	0.00032953
31	Yes	5	0.0000001	0.00034702
32	Yes	5	0.0000001	0.00034640
33	Yes	5	0.0000001	0.00032733
34	Yes	5	0.0000001	0.00034441
35	Yes	5	0.0000001	0.00034426
36	Yes	5	0.0000001	0.00032665
37	Yes	5	0.0000001	0.00034600
38	Yes	5	0.0000001	0.00034722
39	Yes	4	0.0000001	0.00005308
40	Yes	4	0.0000001	0.00010837
41	Yes	4	0.0000001	0.00010453
42	Yes	4	0.0000001	0.00005391
43	Yes	4	0.0000001	0.00010977
44	Yes	4	0.0000001	0.00010502
45	Yes	4	0.0000001	0.00005300
46	Yes	4	0.0000001	0.00010515
47	Yes	4	0.0000001	0.00010923
48	Yes	4	0.0000001	0.00005384
49	Yes	4	0.0000001	0.00010415
50	Yes	4	0.0000001	0.00010863

### Maximum Tower Deflections - Service Wind

Section No.	Elevation ft	Horz. Deflection in	Gov. Load Comb.	Tilt °	Twist °
-------------	--------------	---------------------	-----------------	--------	---------



**Tectonic**  
 1279 Route 300  
 Newburgh, NY 12550  
 Phone: (845) 367-6658  
 FAX: (845) 367-8703

<b>Job</b>	9927.CT11636A	<b>Page</b>	27 of 30
<b>Project</b>	175' Monopole	<b>Date</b>	10:23:22 07/01/19
<b>Client</b>	T-Mobile	<b>Designed by</b>	John Julien

Section No.	Elevation ft	Horz. Deflection in	Gov. Load Comb.	Tilt °	Twist °
L1	175 - 154.87	11.490	39	0.6107	0.0008
L2	159.12 - 139.12	9.484	39	0.5861	0.0005
L3	139.12 - 116.29	7.132	39	0.5274	0.0003
L4	121.71 - 101.71	5.356	39	0.4434	0.0002
L5	101.71 - 81.71	3.645	39	0.3651	0.0001
L6	81.71 - 74.17	2.305	39	0.2748	0.0001
L7	80.84 - 60.84	2.255	39	0.2709	0.0001
L8	60.84 - 33.34	1.247	39	0.2018	0.0001
L9	41.17 - 21.17	0.575	39	0.1254	0.0000
L10	21.17 - 1.17	0.151	39	0.0691	0.0000
L11	1.17 - 0	0.000	39	0.0000	0.0000

### Critical Deflections and Radius of Curvature - Service Wind

Elevation ft	Appurtenance	Gov. Load Comb.	Deflection in	Tilt °	Twist °	Radius of Curvature ft
172.000	APXVAARR24_43_U_NA20 w/ Mount Pipe	39	11.107	0.6065	0.0008	80315
165.000	RHSDC-3315-PF-48	39	10.219	0.5962	0.0006	40157
162.000	BXA-70063-6CF-EDIN-0 w/ Mount Pipe	39	9.843	0.5913	0.0006	30926
152.000	(2) APXV18-206516S-C-A20_TIA w/ Mount Pipe	39	8.616	0.5704	0.0004	18824
150.000	EEL Low-Profile Platform	39	8.377	0.5651	0.0004	17563
145.000	RRUS 11 B12	39	7.793	0.5498	0.0004	15043
142.000	AM-X-CD-16-65-00T-RET_TIA w/ Mount Pipe	39	7.452	0.5390	0.0004	13879

### Maximum Tower Deflections - Design Wind

Section No.	Elevation ft	Horz. Deflection in	Gov. Load Comb.	Tilt °	Twist °
L1	175 - 154.87	63.228	2	3.3621	0.0045
L2	159.12 - 139.12	52.188	2	3.2273	0.0029
L3	139.12 - 116.29	39.241	2	2.9036	0.0018
L4	121.71 - 101.71	29.468	2	2.4409	0.0011
L5	101.71 - 81.71	20.051	2	2.0098	0.0008
L6	81.71 - 74.17	12.678	2	1.5121	0.0005
L7	80.84 - 60.84	12.404	2	1.4907	0.0005
L8	60.84 - 33.34	6.859	2	1.1105	0.0003
L9	41.17 - 21.17	3.161	2	0.6895	0.0002
L10	21.17 - 1.17	0.832	2	0.3802	0.0001
L11	1.17 - 0	0.002	2	0.0202	0.0000

### Critical Deflections and Radius of Curvature - Design Wind





**Tectonic**  
1279 Route 300  
Newburgh, NY 12550  
Phone: (845) 367-6658  
FAX: (845) 367-8703

<b>Job</b>	9927.CT11636A	<b>Page</b>	28 of 30
<b>Project</b>	175' Monopole	<b>Date</b>	10:23:22 07/01/19
<b>Client</b>	T-Mobile	<b>Designed by</b>	John Julien

Elevation	Appurtenance	Gov. Load Comb.	Deflection in	Tilt °	Twist °	Radius of Curvature ft
172.000	APXVAARR24_43_U_NA20 w/ Mount Pipe	2	61.123	3.3396	0.0042	14833
165.000	RHSDC-3315-PF-48	2	56.235	3.2833	0.0034	7416
162.000	BXA-70063-6CF-EDIN-0 w/ Mount Pipe	2	54.161	3.2562	0.0031	5710
152.000	(2) APXV18-206516S-C-A20_TIA w/ Mount Pipe	2	47.408	3.1407	0.0024	3456
150.000	EEL Low-Profile Platform	2	46.095	3.1115	0.0023	3220
145.000	RRUS 11 B12	2	42.880	3.0271	0.0021	2752
142.000	AM-X-CD-16-65-00T-RET_TIA w/ Mount Pipe	2	41.003	2.9677	0.0019	2536

### Compression Checks

### Pole Design Data

Section No.	Elevation ft	Size	L ft	L <sub>u</sub> ft	Kl/r	A in <sup>2</sup>	P <sub>u</sub> K	φP <sub>n</sub> K	Ratio $\frac{P_u}{\phi P_n}$
L1	175 - 154.87 (1)	TP29.45x24.21x0.188	20.130	0.000	0.0	16.8008	-7.81	1092.65	0.007
L2	154.87 - 139.12 (2)	TP33.1147x27.9677x0.375	20.000	0.000	0.0	38.9684	-16.68	2895.16	0.006
L3	139.12 - 116.29 (3)	TP38.99x33.1147x0.375	22.830	0.000	0.0	44.3013	-20.45	3291.37	0.006
L4	116.29 - 101.71 (4)	TP41.9881x36.8452x0.5	20.000	0.000	0.0	65.8417	-27.42	4891.71	0.006
L5	101.71 - 81.71 (5)	TP47.1311x41.9881x0.5	20.000	0.000	0.0	74.0036	-34.11	5498.09	0.006
L6	81.71 - 74.17 (6)	TP49.07x47.1311x0.5	7.540	0.000	0.0	74.3586	-34.42	5524.47	0.006
L7	74.17 - 60.84 (7)	TP51.6159x46.3548x0.563	20.000	0.000	0.0	91.2297	-44.51	6777.91	0.007
L8	60.84 - 33.34 (8)	TP58.85x51.6159x0.563	27.500	0.000	0.0	100.476	-53.21	7464.86	0.007
L9	33.34 - 21.17 (9)	TP60.6853x55.6643x0.625	20.000	0.000	0.0	119.145	-66.79	8851.85	0.008
L10	21.17 - 1.17 (10)	TP65.7063x60.6853x0.625	20.000	0.000	0.0	129.105	-77.80	9494.01	0.008
L11	1.17 - 0 (11)	TP66x65.7063x0.625	1.170	0.000	0.0	129.688	-78.43	9525.50	0.008

### Pole Bending Design Data

Section No.	Elevation ft	Size	M <sub>ux</sub> kip-ft	φM <sub>ux</sub> kip-ft	Ratio $\frac{M_{ux}}{\phi M_{ux}}$	M <sub>uy</sub> kip-ft	φM <sub>uy</sub> kip-ft	Ratio $\frac{M_{uy}}{\phi M_{uy}}$
L1	175 - 154.87 (1)	TP29.45x24.21x0.188	118.88	633.36	0.188	0.00	633.36	0.000
L2	154.87 -	TP33.1147x27.9677x0.375	427.09	1942.20	0.220	0.00	1942.20	0.000

 <p><b>Tectonic</b> PRACTICAL SOLUTIONS. EXCEPTIONAL SERVICE.</p> <p><b>Tectonic</b> 1279 Route 300 Newburgh, NY 12550 Phone: (845) 367-6658 FAX: (845) 367-8703</p>	<b>Job</b>	9927.CT11636A	<b>Page</b>	29 of 30
	<b>Project</b>	175' Monopole	<b>Date</b>	10:23:22 07/01/19
	<b>Client</b>	T-Mobile	<b>Designed by</b>	John Julien

Section No.	Elevation ft	Size	$M_{ux}$ kip-ft	$\phi M_{rx}$ kip-ft	Ratio $\frac{M_{ux}}{\phi M_{rx}}$	$M_{uy}$ kip-ft	$\phi M_{ry}$ kip-ft	Ratio $\frac{M_{uy}}{\phi M_{ry}}$
L3	139.12 (2)	TP38.99x33.1147x0.375	794.25	2513.58	0.316	0.00	2513.58	0.000
L4	139.12 - 116.29 (3)	TP41.9881x36.8452x0.5	1255.92	4155.98	0.302	0.00	4155.98	0.000
L5	116.29 - 101.71 (4)	TP47.1311x41.9881x0.5	1760.38	5257.13	0.335	0.00	5257.13	0.000
L6	101.71 - 81.71 (5)	TP49.07x47.1311x0.5	1783.32	5307.96	0.336	0.00	5307.96	0.000
L7	81.71 - 74.17 (6)	TP51.6159x46.3548x0.563	2334.77	7093.26	0.329	0.00	7093.26	0.000
L8	74.17 - 60.84 (7)	TP58.85x51.6159x0.563	2917.76	8612.58	0.339	0.00	8612.58	0.000
L9	60.84 - 33.34 (8)	TP60.6853x55.6643x0.625	3552.22	10904.83	0.326	0.00	10904.83	0.000
L10	33.34 - 21.17 (9)	TP65.7063x60.6853x0.625	4224.34	12683.75	0.333	0.00	12683.75	0.000
L11	21.17 - 1.17 (10)	TP66x65.7063x0.625	4264.82	12783.83	0.334	0.00	12783.83	0.000
	1.17 - 0 (11)							

### Pole Shear Design Data

Section No.	Elevation ft	Size	Actual $V_u$ K	$\phi V_n$ K	Ratio $\frac{V_u}{\phi V_n}$	Actual $T_u$ kip-ft	$\phi T_n$ kip-ft	Ratio $\frac{T_u}{\phi T_n}$
L1	175 - 154.87 (1)	TP29.45x24.21x0.188	12.14	543.25	0.022	0.00	1269.54	0.000
L2	154.87 - 139.12 (2)	TP33.1147x27.9677x0.375	20.26	1447.58	0.014	0.06	3895.85	0.000
L3	139.12 - 116.29 (3)	TP38.99x33.1147x0.375	21.97	1645.68	0.013	0.06	5040.95	0.000
L4	116.29 - 101.71 (4)	TP41.9881x36.8452x0.5	24.16	2445.85	0.010	0.06	8337.25	0.000
L5	101.71 - 81.71 (5)	TP47.1311x41.9881x0.5	26.32	2749.05	0.010	0.06	10544.08	0.000
L6	81.71 - 74.17 (6)	TP49.07x47.1311x0.5	26.41	2762.24	0.010	0.06	10646.00	0.000
L7	74.17 - 60.84 (7)	TP51.6159x46.3548x0.563	28.66	3388.95	0.008	0.06	14227.42	0.000
L8	60.84 - 33.34 (8)	TP58.85x51.6159x0.563	30.64	3732.43	0.008	0.06	17272.25	0.000
L9	33.34 - 21.17 (9)	TP60.6853x55.6643x0.625	32.68	4425.92	0.007	0.06	21870.50	0.000
L10	21.17 - 1.17 (10)	TP65.7063x60.6853x0.625	34.55	4747.00	0.007	0.06	25435.25	0.000
L11	1.17 - 0 (11)	TP66x65.7063x0.625	34.67	4762.75	0.007	0.06	25635.75	0.000

### Pole Interaction Design Data

Section No.	Elevation ft	Ratio $\frac{P_u}{\phi P_n}$	Ratio $\frac{M_{ux}}{\phi M_{rx}}$	Ratio $\frac{M_{uy}}{\phi M_{ry}}$	Ratio $\frac{V_u}{\phi V_n}$	Ratio $\frac{T_u}{\phi T_n}$	Comb. Stress Ratio	Allow. Stress Ratio	Criteria
-------------	-----------------	---------------------------------	---------------------------------------	---------------------------------------	---------------------------------	---------------------------------	--------------------------	---------------------------	----------



**Tectonic**  
1279 Route 300  
Newburgh, NY 12550  
Phone: (845) 367-6658  
FAX: (845) 367-8703

<b>Job</b>	9927.CT11636A	<b>Page</b>	30 of 30
<b>Project</b>	175' Monopole	<b>Date</b>	10:23:22 07/01/19
<b>Client</b>	T-Mobile	<b>Designed by</b>	John Julien

Section No.	Elevation ft	Ratio $P_u$	Ratio $M_{ux}$	Ratio $M_{uy}$	Ratio $V_u$	Ratio $T_u$	Comb. Stress Ratio	Allow. Stress Ratio	Criteria
L1	175 - 154.87 (1)	0.007	0.188	0.000	0.022	0.000	0.195	1.000	4.8.2 ✓
L2	154.87 - 139.12 (2)	0.006	0.220	0.000	0.014	0.000	0.226	1.000	4.8.2 ✓
L3	139.12 - 116.29 (3)	0.006	0.316	0.000	0.013	0.000	0.322	1.000	4.8.2 ✓
L4	116.29 - 101.71 (4)	0.006	0.302	0.000	0.010	0.000	0.308	1.000	4.8.2 ✓
L5	101.71 - 81.71 (5)	0.006	0.335	0.000	0.010	0.000	0.341	1.000	4.8.2 ✓
L6	81.71 - 74.17 (6)	0.006	0.336	0.000	0.010	0.000	0.342	1.000	4.8.2 ✓
L7	74.17 - 60.84 (7)	0.007	0.329	0.000	0.008	0.000	0.336	1.000	4.8.2 ✓
L8	60.84 - 33.34 (8)	0.007	0.339	0.000	0.008	0.000	0.346	1.000	4.8.2 ✓
L9	33.34 - 21.17 (9)	0.008	0.326	0.000	0.007	0.000	0.333	1.000	4.8.2 ✓
L10	21.17 - 1.17 (10)	0.008	0.333	0.000	0.007	0.000	0.341	1.000	4.8.2 ✓
L11	1.17 - 0 (11)	0.008	0.334	0.000	0.007	0.000	0.342	1.000	4.8.2 ✓

### Section Capacity Table

Section No.	Elevation ft	Component Type	Size	Critical Element	P K	$\phi P_{allow}$ K	% Capacity	Pass Fail	
L1	175 - 154.87	Pole	TP29.45x24.21x0.188	1	-7.81	1092.65	19.5	Pass	
L2	154.87 - 139.12	Pole	TP33.1147x27.9677x0.375	2	-16.68	2895.16	22.6	Pass	
L3	139.12 - 116.29	Pole	TP38.99x33.1147x0.375	3	-20.45	3291.37	32.2	Pass	
L4	116.29 - 101.71	Pole	TP41.9881x36.8452x0.5	4	-27.42	4891.71	30.8	Pass	
L5	101.71 - 81.71	Pole	TP47.1311x41.9881x0.5	5	-34.11	5498.09	34.1	Pass	
L6	81.71 - 74.17	Pole	TP49.07x47.1311x0.5	6	-34.42	5524.47	34.2	Pass	
L7	74.17 - 60.84	Pole	TP51.6159x46.3548x0.563	7	-44.51	6777.91	33.6	Pass	
L8	60.84 - 33.34	Pole	TP58.85x51.6159x0.563	8	-53.21	7464.86	34.6	Pass	
L9	33.34 - 21.17	Pole	TP60.6853x55.6643x0.625	9	-66.79	8851.85	33.3	Pass	
L10	21.17 - 1.17	Pole	TP65.7063x60.6853x0.625	10	-77.80	9494.01	34.1	Pass	
L11	1.17 - 0	Pole	TP66x65.7063x0.625	11	-78.43	9525.50	34.2	Pass	
							Summary		
							Pole (L8)	34.6	Pass
							<b>RATING =</b>	<b>34.6</b>	<b>Pass</b>

# Monopole Base Plate Connection

Site Info	
Site Name	WIRELESS SOLUTIONS OLD LYME
Order #	9927.CT11636A

Analysis Considerations	
TIA-222 Revision	G
Grout Considered:	No
$l_{ar}$ (in)	3
Eta Factor, $\eta$	0.5

Applied Loads	
Moment (kip-ft)	4264.82
Axial Force (kips)	78.43
Shear Force (kips)	34.67

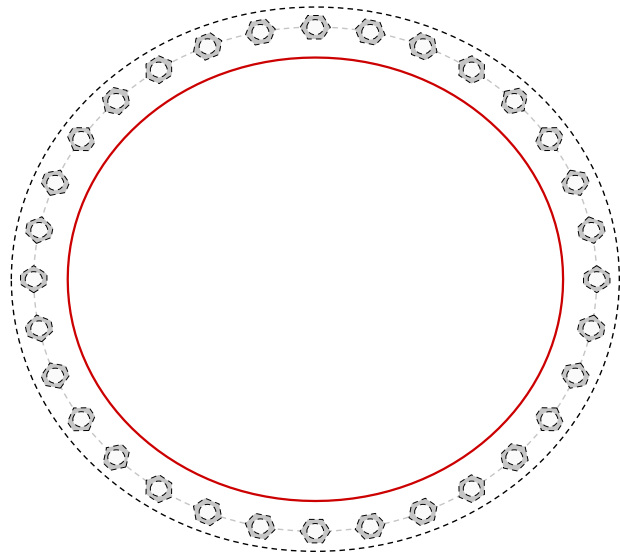

Connection Properties	Analysis Results
-----------------------	------------------

**Anchor Rod Data**  
 (32) 2-1/4"  $\phi$  bolts (A615-75 N; Fy=75 ksi, Fu=100 ksi) on 75" BC

**Base Plate Data**  
 81" OD x 2.5" Plate (A572-60; Fy=60 ksi, Fu=75 ksi)

**Stiffener Data**  
 N/A

**Pole Data**  
 66" x 0.625" 18-sided pole (A572-65; Fy=65 ksi, Fu=80 ksi)

**Anchor Rod Summary** *(units of kips, kip-in)*

Pu_c = 87.72	$\phi Pn_t = 260$	<b>Stress Rating</b>
Vu = 1.08	$\phi Vn = n/a$	<b>34.6%</b>
Mu = n/a	$\phi Mn = n/a$	<b>Pass</b>

**Base Plate Summary**

Max Stress (ksi):	23.58	(Flexural)
Allowable Stress (ksi):	54	
Stress Rating:	<b>43.7%</b>	<b>Pass</b>

# Pier and Pad Foundation

Site Name: 9927.CT636A  
 App. Number: WIRELESS SOLUTIONS OLD LYME

TIA-222 Revision: G  
 Tower Type: Monopole

Top & Bot. Pad Rein. Different?:   
 Block Foundation?:

Superstructure Analysis Reactions		
Compression, $P_{comp}$ :	78.43	kips
Base Shear, $V_{u\_comp}$ :	34.67	kips
Moment, $M_u$ :	4264.82	ft-kips
Tower Height, $H$ :	175	ft
BP Dist. Above Fdn, $bp_{dist}$ :	3	in

Foundation Analysis Checks				
	Capacity	Demand	Rating	Check
<i>Lateral (Sliding) (kips)</i>	269.95	34.67	12.8%	Pass
<i>Bearing Pressure (ksf)</i>	6.00	1.28	21.4%	Pass
<i>Overturing (kip*ft)</i>	10777.54	4464.17	41.4%	Pass
<i>Pier Flexure (Comp.) (kip*ft)</i>	10945.40	4351.50	39.8%	Pass
<i>Pier Compression (kip)</i>	40734.72	107.23	0.3%	Pass
<i>Pad Flexure (kip*ft)</i>	9130.25	1696.70	18.6%	Pass
<i>Pad Shear - 1-way (kips)</i>	1211.82	196.43	16.2%	Pass
<i>Pad Shear - 2-way (Comp) (ksi)</i>	0.190	0.036	19.1%	Pass

Pier Properties		
Pier Shape:	Square	
Pier Diameter, $dpier$ :	8	ft
Ext. Above Grade, $E$ :	1	ft
Pier Rebar Size, $Sc$ :	9	
Pier Rebar Quantity, $mc$ :	60	
Pier Tie/Spiral Size, $St$ :	4	
Pier Tie/Spiral Quantity, $mt$ :	3	
Pier Reinforcement Type:	Tie	
Pier Clear Cover, $cc_{pier}$ :	3	in

Soil Rating: 41.4%  
 Structural Rating: 39.8%

Pad Properties		
Depth, $D$ :	4.5	ft
Pad Width, $W$ :	34	ft
Pad Thickness, $T$ :	3	ft
Pad Rebar Size (Top), $Sp_{top}$ :	9	
Pad Top Rebar Quantity (Top), $mp_{top}$ :	36	
Pad Rebar Size (Bottom), $Sp$ :	9	
Pad Rebar Quantity (Bottom), $mp$ :	68	
Pad Clear Cover, $cc_{pad}$ :	3	in

Material Properties		
Rebar Grade, $F_y$ :	60	ksi
Concrete Compressive Strength, $F'_c$ :	4	ksi
Dry Concrete Density, $\delta_c$ :	150	pcf

Soil Properties		
Total Soil Unit Weight, $\gamma$ :	100	pcf
Ultimate Gross Bearing, $Q_{ult}$ :	8.000	ksf
Cohesion, $C_u$ :	0.000	ksf
Friction Angle, $\phi$ :	30	degrees
SPT Blow Count, $N_{blows}$ :		
Base Friction, $\mu$ :	0.45	
Neglected Depth, $N$ :	3.33	ft
Foundation Bearing on Rock?	No	
Groundwater Depth, $gw$ :	N/A	ft

<--Toggle between Gross and Net

## MOUNT ANALYSIS



Job No. 9927.CT11636A  
 Sheet No. 1 of 3  
 Calculated By GE Date : 06/21/19  
 Checked By IM Date : 06/21/19

**WIND AND ICE LOADS PER TIA-222-G**

W.O.	9927.CT11636A
Project Name	CT499/Greenwich Hyatt_RT
Location	72 Boggy Hole Road, Old Lyme, CT 06371
County	New London

Tower Type	MP	Monopole
Structure Class	2	Substantial hazard
Exposure Category	B	Suburban/wooded/obstructed
Topo Category	1	Flat or rolling terrain
Height of crest	0	ft

Basic Wind Speed (3-sec gust):		
Without ice	105	mph*
With ice	50	mph
Service	60	mph
Ice thickness	0.75	in

\*Nominal converted from 135mph ultimate risk cat. 2

Importance Factor	
Wind only	1.00
Wind with ice	1.00
Ice thickness	1.00
Supporting Data:	
$K_e$	0.90
$K_t$	N/A
$f$	N/A
$z_g$	1200
$\alpha$	7
$K_{z,min}$	0.7
$K_d$	0.95
$G_h$	1.00

Height	z (ft)	175
	$K_h$	N/A
	$K_{zt}$	1.00
	$K_z$	1.16
	$K_{iz}$	1.18
Wind Pressure, $q_z$ (psf)	No Ice	31.09
	With Ice	7.05
	Service	10.15
(tiz)	Ice Thk	1.77
Appurtenances ( $q_z G_h$ )	No Ice	31.09
	With Ice	7.05
	Service	10.15

### Appurtenance Information

Effective Projected Area for Appurtenance  $(EPA)_A = \text{Max}((EPA)_N, (EPA)_T)$

$$(EPA)_T = \sum(C_a A_a)_T$$

$$(EPA)_N = \sum(C_a A_a)_N$$

Reduction Factor = 0.9

#### Wind Only Load Combinations

Antenna Configuration	(E) or (P)	Qty per Sector	z (ft)	Length or Diameter (ft)	Width (in)	Depth (in)	Flat or Cylindrical?	Antenna $(Ca)_T$	Antenna $(Ca)_N$	Side Face $(A_a)_T$ (ft <sup>2</sup> )	Wind ward Side Face $(CaA_a)_T$ (ft <sup>2</sup> )	Face Normal $(A_a)_N$ (ft <sup>2</sup> )	Windward face Normal $(CaA_a)_N$ (ft <sup>2</sup> )	Normal Antenna Wind Load Each (lb)	Transverse Antenna Wind Load Each (lb)	Antenna Weight (lb)	Total Weight (lb)
AIR-21 B2A/B4P	E	1	175	4.67	12.00	8.00	Flat	1.40	1.30	3.11	3.92	4.67	5.44	169	122	83.0	83.0
AIR-21 B4A/B2P	E	1	175	4.67	12.00	8.00	Flat	1.40	1.30	3.11	3.92	4.67	5.44	169	122	83.0	83.0
APXVAARR24_43-U-NA20	P	1	175	7.99	24.00	8.70	Flat	1.53	1.27	5.79	8.00	15.98	18.22	566	249	153.3	153.3
RRU 4449 B71+B12	P	1	175	1.25	13.20	10.40	Flat	1.20	1.20	1.08	1.17	1.38	1.49	46	36	75.0	75.0
										$\sum(CaA_a)_T$	17.01	$\sum(CaA_a)_N$	30.59				394

#### Wind with Ice Load Combinations

Ice Thk= 1.77 in

Antenna Configuration	(E) or (P)	Qty per Sector	z (ft)	Length or Diameter (ft)	Width (in)	Depth (in)	Flat or Cylindrical?	Antenna $(Ca)_T$	Antenna $(Ca)_N$	Side Face $(A_a)_T$ (ft <sup>2</sup> )	Windward Side Face $(CaA_a)_T$ (ft <sup>2</sup> )	Face Normal $(A_a)_N$ (ft <sup>2</sup> )	Windward Face Normal $(CaA_a)_N$ (ft <sup>2</sup> )	Normal Antenna Wind Load Each (lb)	Transverse Antenna Wind Load Each (lb)	Ice Area for Weight (ft <sup>2</sup> )	Ice Weight Alone (lbs)
AIR-21 B2A/B4P	E	1	175	4.96	15.54	11.54	Cylindrical	0.73	0.73	4.77	3.13	6.43	4.22	30	22	15.6	128.7
AIR-21 B4A/B2P	E	1	175	4.96	15.54	11.54	Cylindrical	0.73	0.73	4.77	3.13	6.43	4.22	30	22	15.6	128.7
APXVAARR24_43-U-NA20	P	1	175	8.29	27.54	12.24	Cylindrical	0.72	0.72	8.46	5.52	19.02	12.41	87	39	43.6	360.2
RRU 4449 B71+B12	P	1	175	1.55	16.74	13.94	Cylindrical	0.7	0.7	1.80	1.13	2.16	1.36	10	8	4.9	40.7
										$\sum(CaA_a)_T$	12.92	$\sum(CaA_a)_N$	22.21				658

#### Wind Service Load Combinations

Antenna Configuration	(E) or (P)	Qty per Sector	z (ft)	Length or Diameter (ft)	Width (in)	Depth (in)	Flat or Cylindrical?	Antenna $(Ca)_T$	Antenna $(Ca)_N$	Side Face $(A_a)_T$ (ft <sup>2</sup> )	Windward Side Face $(CaA_a)_T$ (ft <sup>2</sup> )	Face Normal $(A_a)_N$ (ft <sup>2</sup> )	Windward Face Normal $(CaA_a)_N$ (ft <sup>2</sup> )	Normal Antenna Wind Load Each (lb)	Transverse Antenna Wind Load Each (lb)
AIR-21 B2A/B4P	E	1	175	4.67	12.00	8.00	Flat	1.40	1.30	3.11	3.92	4.67	5.44	55	40
AIR-21 B4A/B2P	E	1	175	4.67	12.00	8.00	Flat	1.40	1.30	3.11	3.92	4.67	5.44	55	40
APXVAARR24_43-U-NA20	P	1	175	7.99	24.00	8.70	Flat	1.53	1.27	5.79	8.00	15.98	18.22	185	81
RRU 4449 B71+B12	P	1	175	1.25	13.20	10.40	Flat	1.20	1.20	1.08	1.17	1.38	1.49	15	12





Job No. 9927.CT11636A  
 Sheet No. 3 of 3  
 Calculated By GE Date : 06/21/19  
 Checked By IM Date : 06/21/19

### Existing Low-Profile Platform

Mount Center Line= 175 ft

Member lengths and widths based on mapping report by Hightower Solutions, dated 6/7/19. T-Mobile's platform has been assumed to be the same as the AT&T platform below at 144'. Member thicknesses have been estimated.

Reduction Factor = 0.9

Mount Part	Quantity	Length (ft)	Projected Width (in)	Depth (in)	Flat or Cylindrical ?	Drag Factor	Projected Area (ft^2)	Wind Force (lbs/ft)	Ice Weight Area (ft^2)	Ice Weight (lbs/ft)	Projected Area with Ice (ft^2)	Wind Force Ice (lbs/ft)	Service Wind Force (lbs/ft)
Mount Pipe 2.0" STD	6	6.00	2.38	2.38	Cylindrical	1.2	8.55	6.6	22.37	5.1	21.31	3.8	2.2
Mount Pipe 2.0" STD	4	8.00	2.38	2.38	Cylindrical	1.2	7.60	6.6	19.89	5.1	18.94	3.8	2.2
Face Horizontal HSS4x4x1/4	3	12.50	4.00	4.00	Flat	2	25.00	18.7	50.00	11.0	47.15	8.0	6.1
Standoff HSS4x4x1/5	3	7.42	4.00	4.00	Flat	2	14.83	18.7	29.67	11.0	27.98	8.0	6.1
Handrail Horizontal 2.0" STD	3	12.50	2.38	2.38	Cylindrical	1.2	8.93	6.7	23.35	5.2	22.22	3.8	2.2
Handrail Corner Brace L2x2x3/16	3	1.00	2.00	2.00	Flat	2	1.00	9.3	2.00	5.5	2.77	5.9	3.0

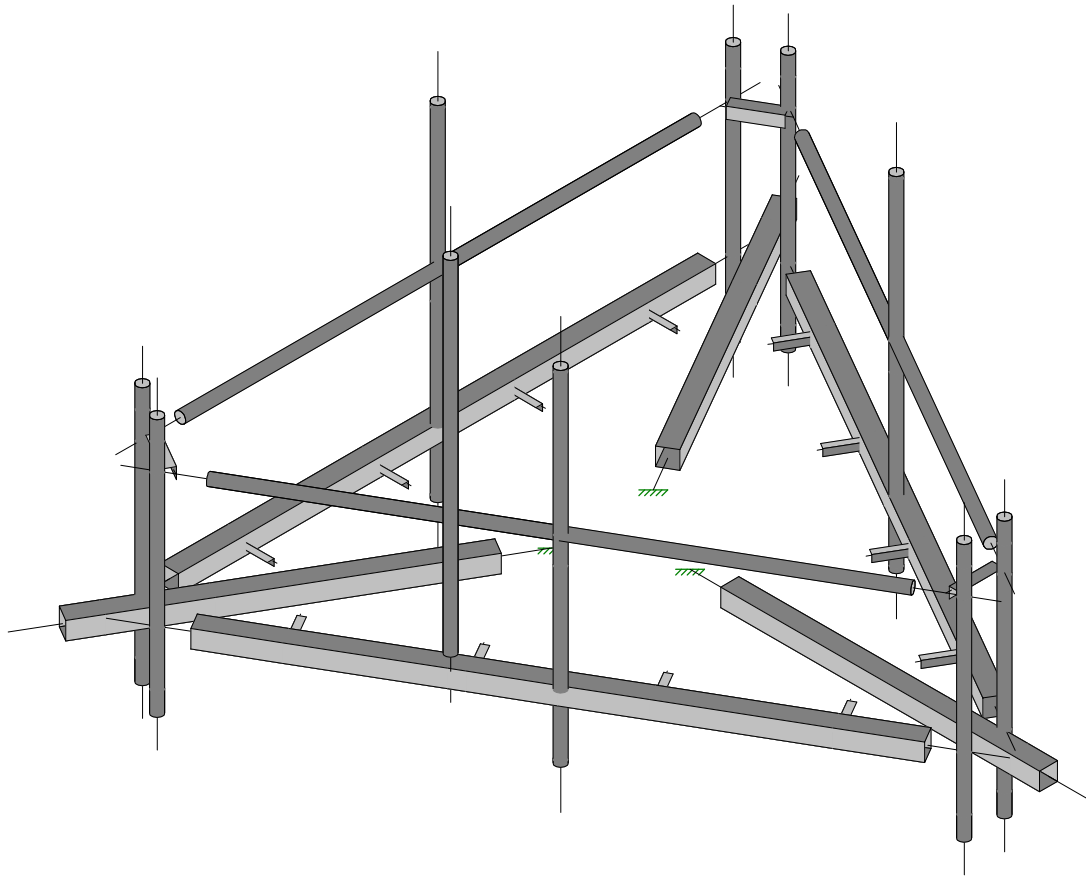
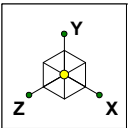

Envelope Only Solution

Tectonic	Platform Analysis Rendered Model	June 21, 2019 at 10:48 AM
GLE		9927.CT11636A - Mount Analysis....
9927.CT11636A		

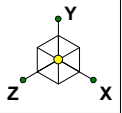

(P) SitePro1 Handrail Kit for 12'-6" face (Part #HRK12) or approved equal

(P) APXVRR24\_43-U-NA20 (TYP)

(P) RRU 4449 B71+B12 (TYP)

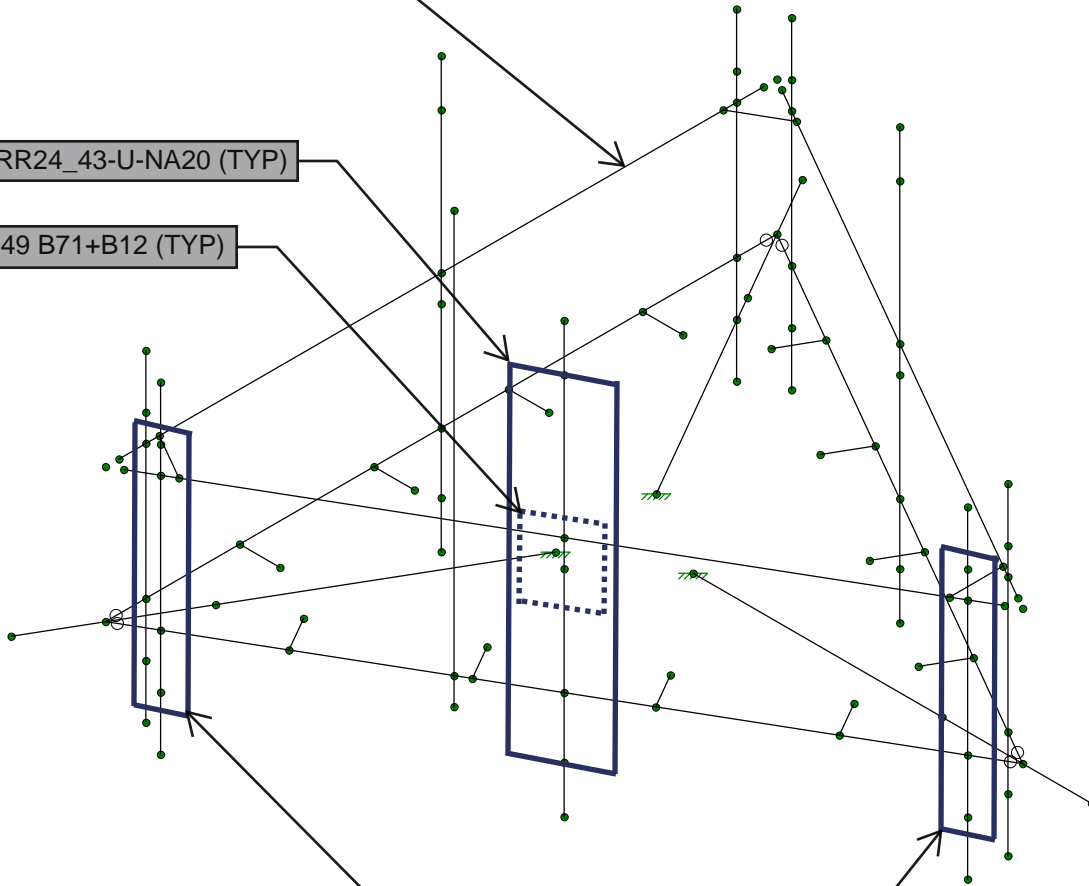

(E) Air-21 BPA/B4A (TYP)

(E) Air-21 B2A/B4P (TYP)

Envelope Only Solution

Tectonic

GLE

9927.CT11636A

Platform Analysis

Proposed Layout

June 21, 2019 at 10:48 AM

9927.CT11636A - Mount Analysis....

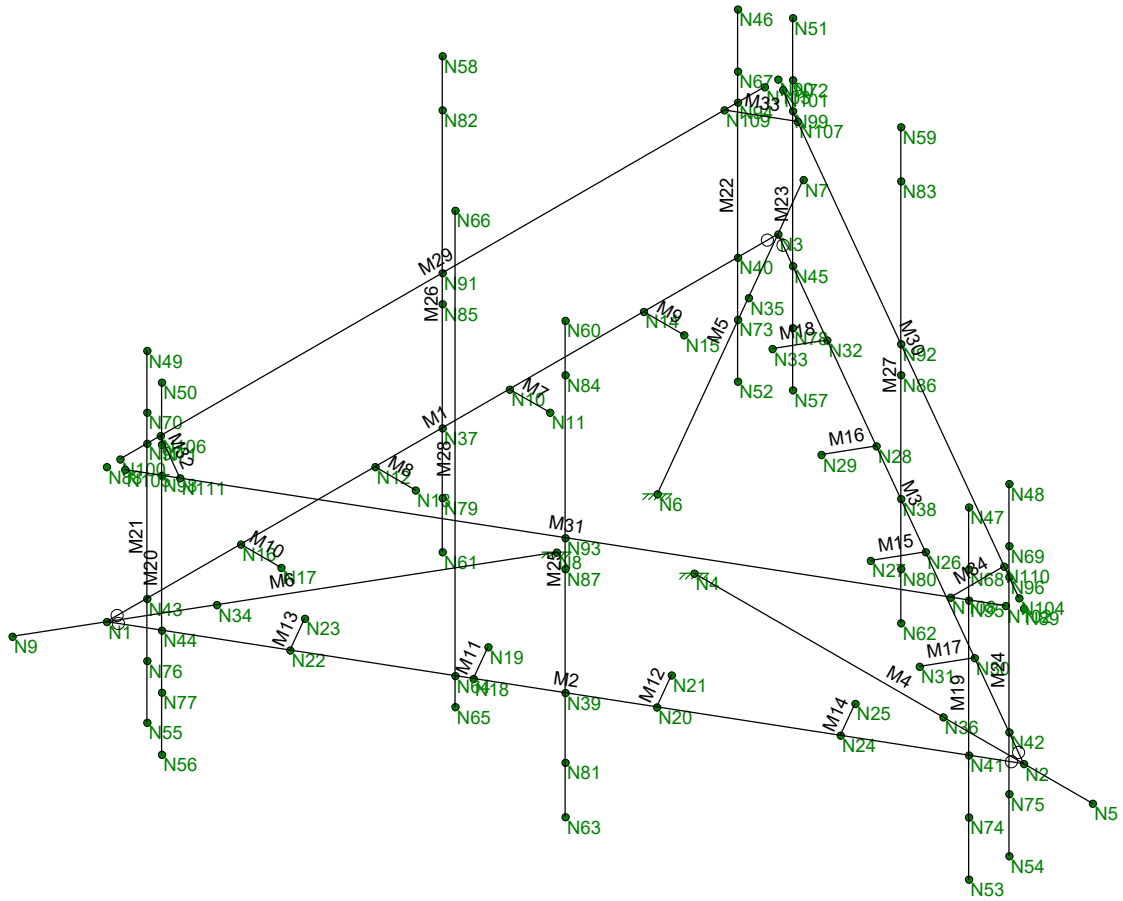
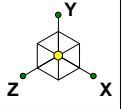

Envelope Only Solution

Tectonic

GLE

9927.CT11636A

Platform Analysis  
Nodes & Labels

June 21, 2019 at 10:51 AM

9927.CT11636A - Mount Analysis....

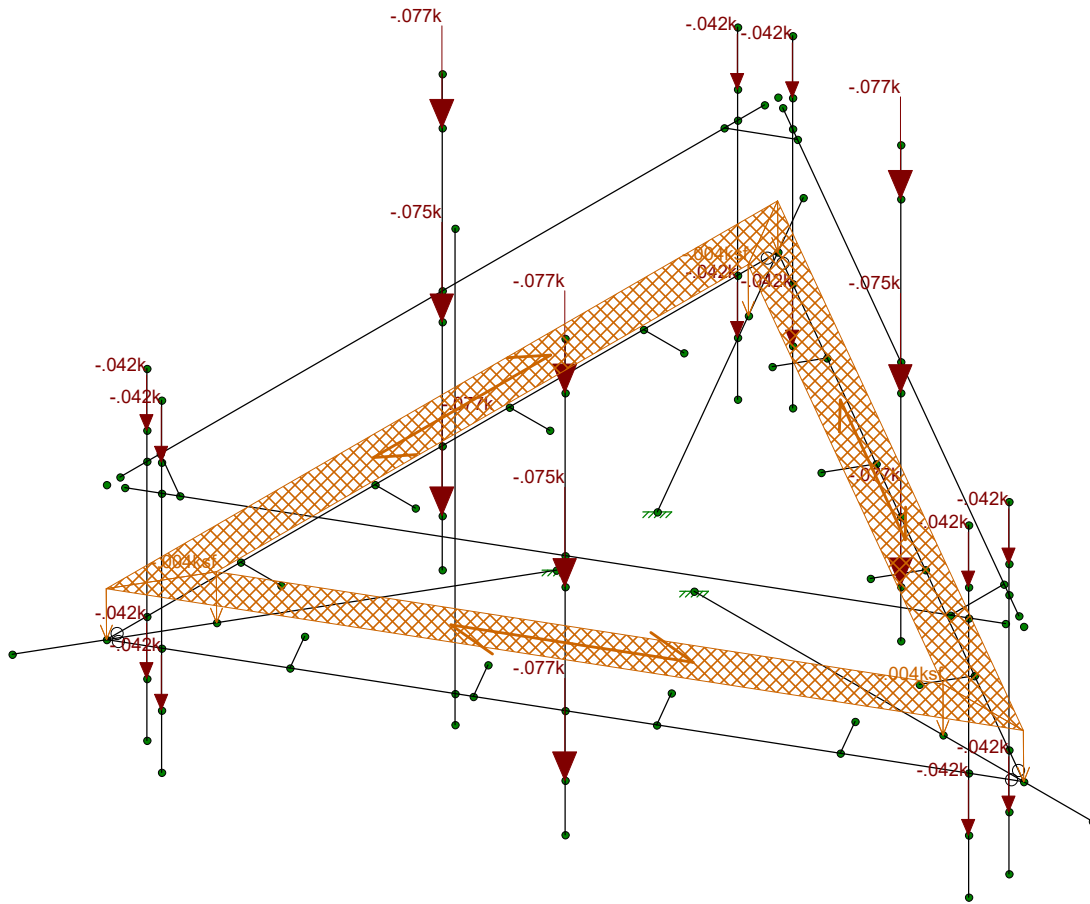
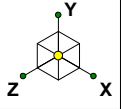

Loads: BLC 1, DL  
Envelope Only Solution

Tectonic
GLE
9927.CT11636A

Platform Analysis
Dead Loads

June 21, 2019 at 10:51 AM
9927.CT11636A - Mount Analysis....



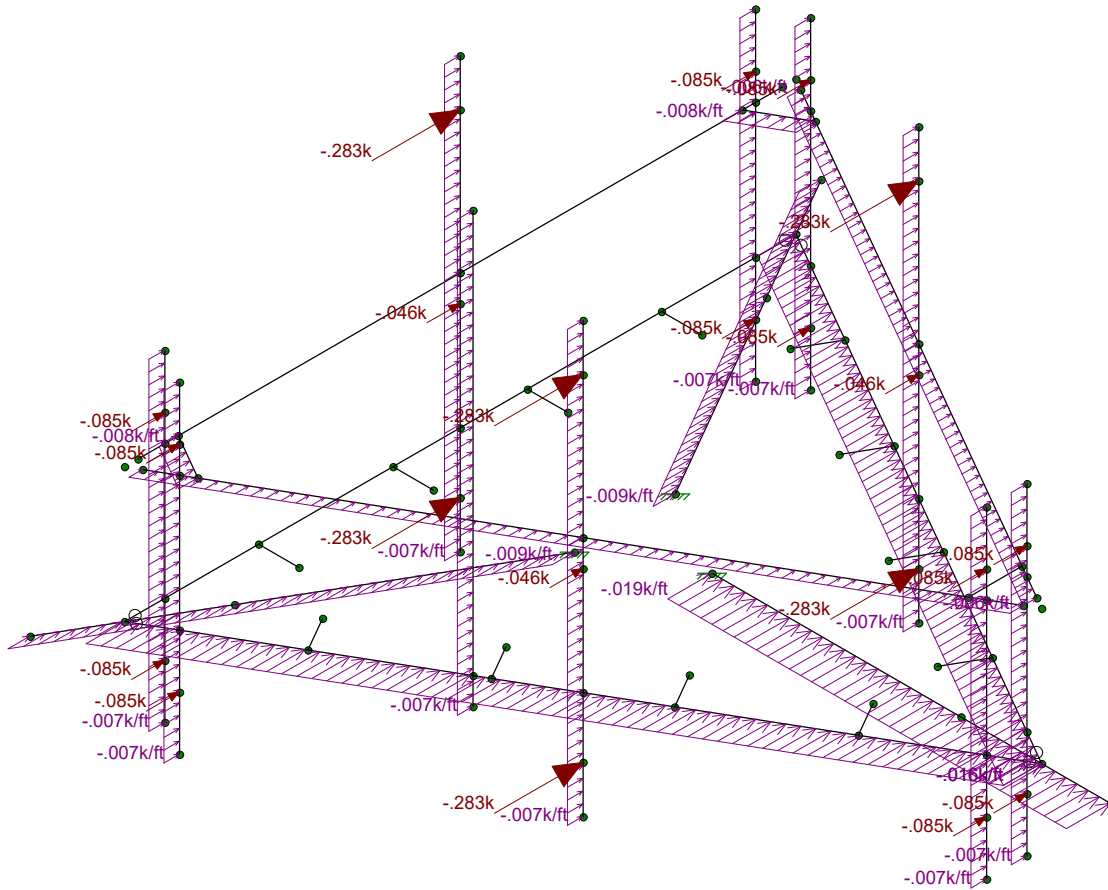
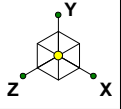

Loads: BLC 3, WLZ  
Envelope Only Solution

Tectonic		
GLE	Platform Analysis Wind Loads (Z)	June 21, 2019 at 10:52 AM
9927.CT11636A		9927.CT11636A - Mount Analysis....





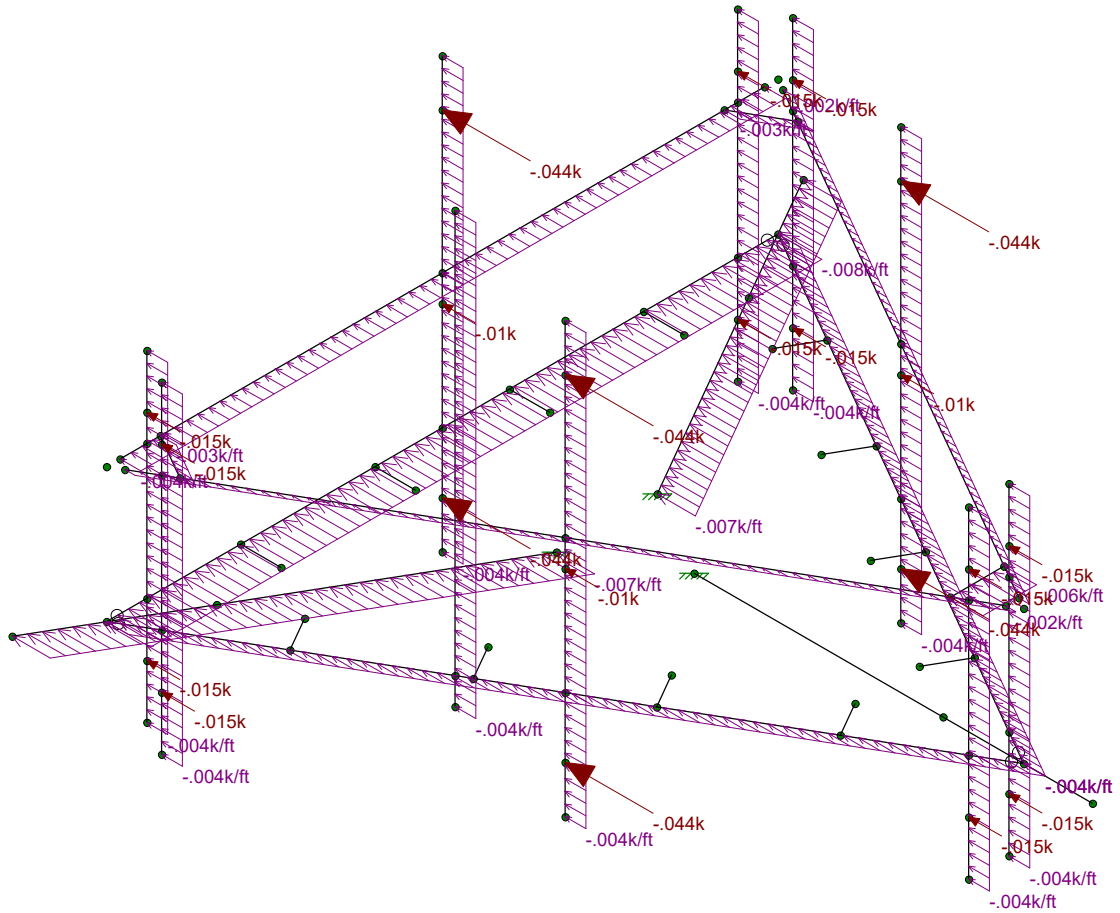
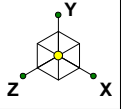

Loads: BLC 5, WLX (ICE)  
Envelope Only Solution

Tectonic		
GLE	Platform Analysis Ice Wind Loads (X)	June 21, 2019 at 10:53 AM
9927.CT11636A		9927.CT11636A - Mount Analysis....

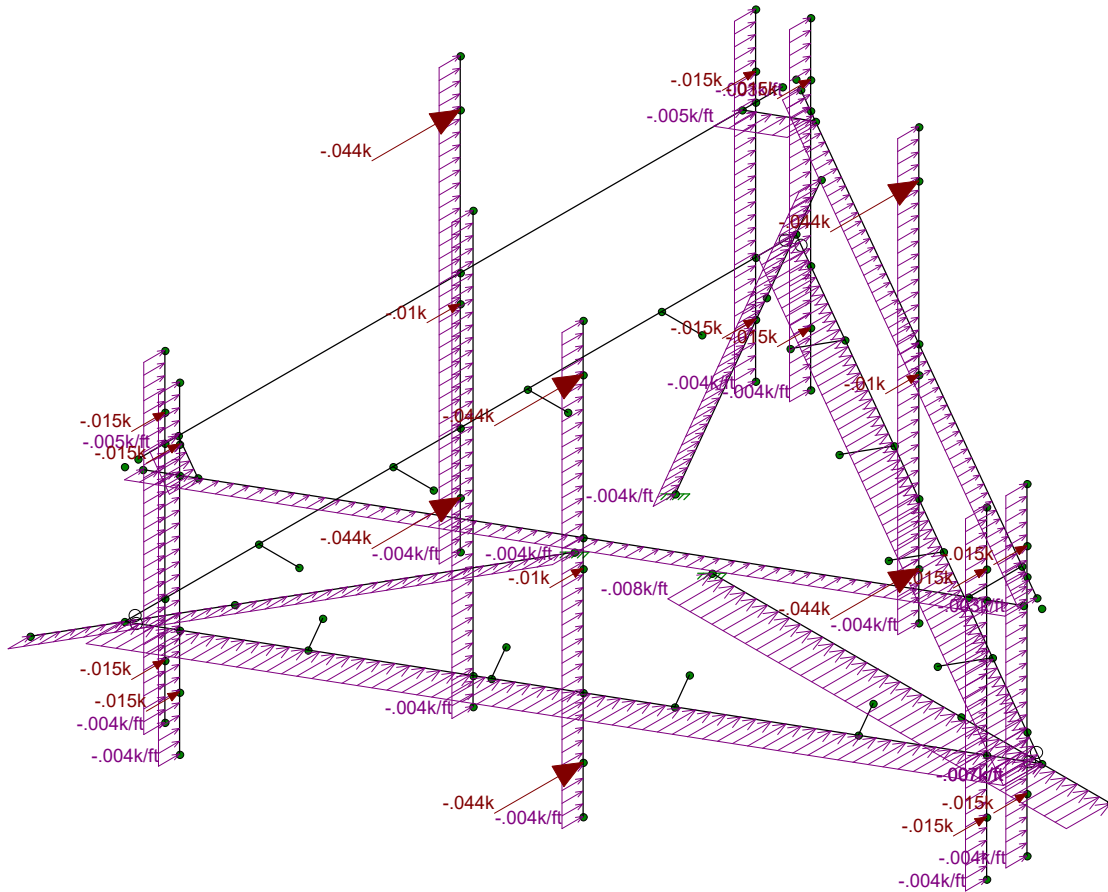
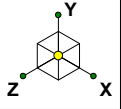

Loads: BLC 6, WLZ (ICE)  
Envelope Only Solution

Tectonic		
GLE	Platform Analysis Ice Wind Loads (Z)	June 21, 2019 at 10:53 AM
9927.CT11636A		9927.CT11636A - Mount Analysis....





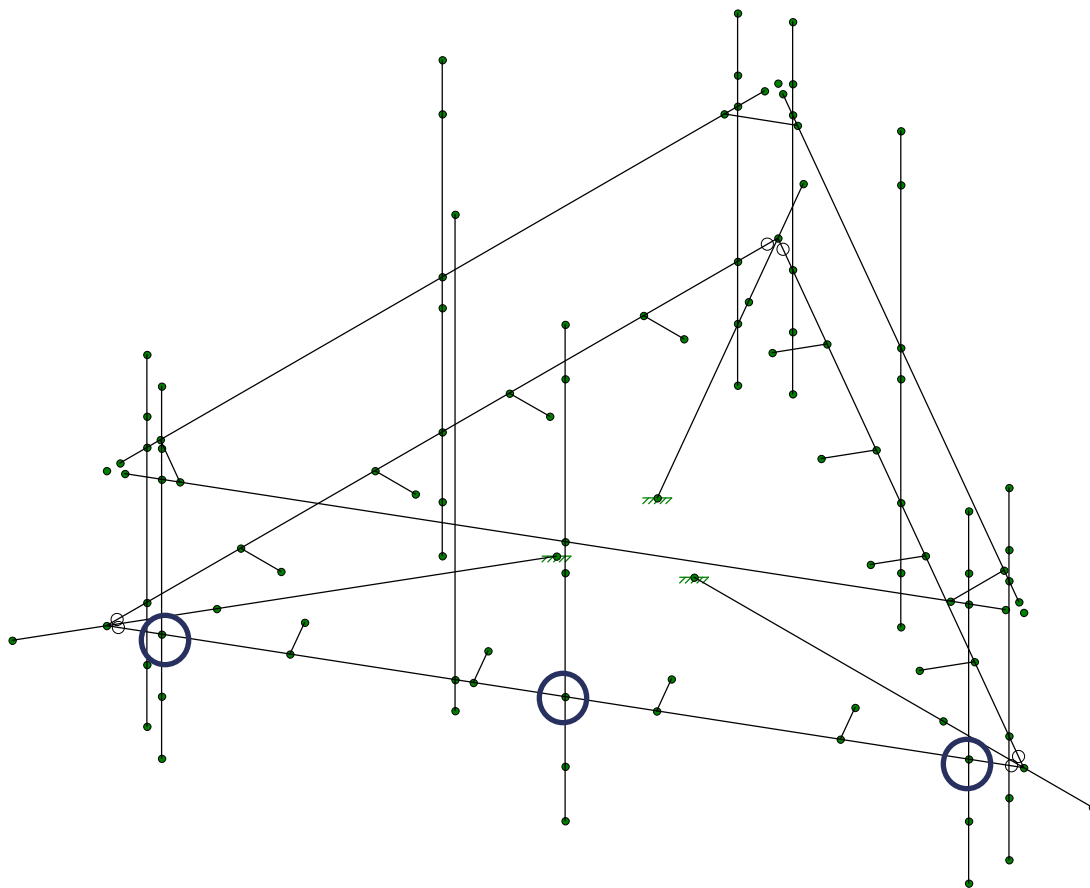
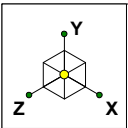

\* A 250 lb. man live load was applied individually at each location shown above

Envelope Only Solution

Tectonic	Platform Analysis Man Live Load	June 21, 2019 at 10:54 AM
GLE		9927.CT11636A - Mount Analysis....
9927.CT11636A		

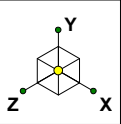

Code Check ( Env )	
Black	No Calc
Red	> 1.0
Pink	.90-1.0
Green	.75-.90
Cyan	.50-.75
Blue	0-.50

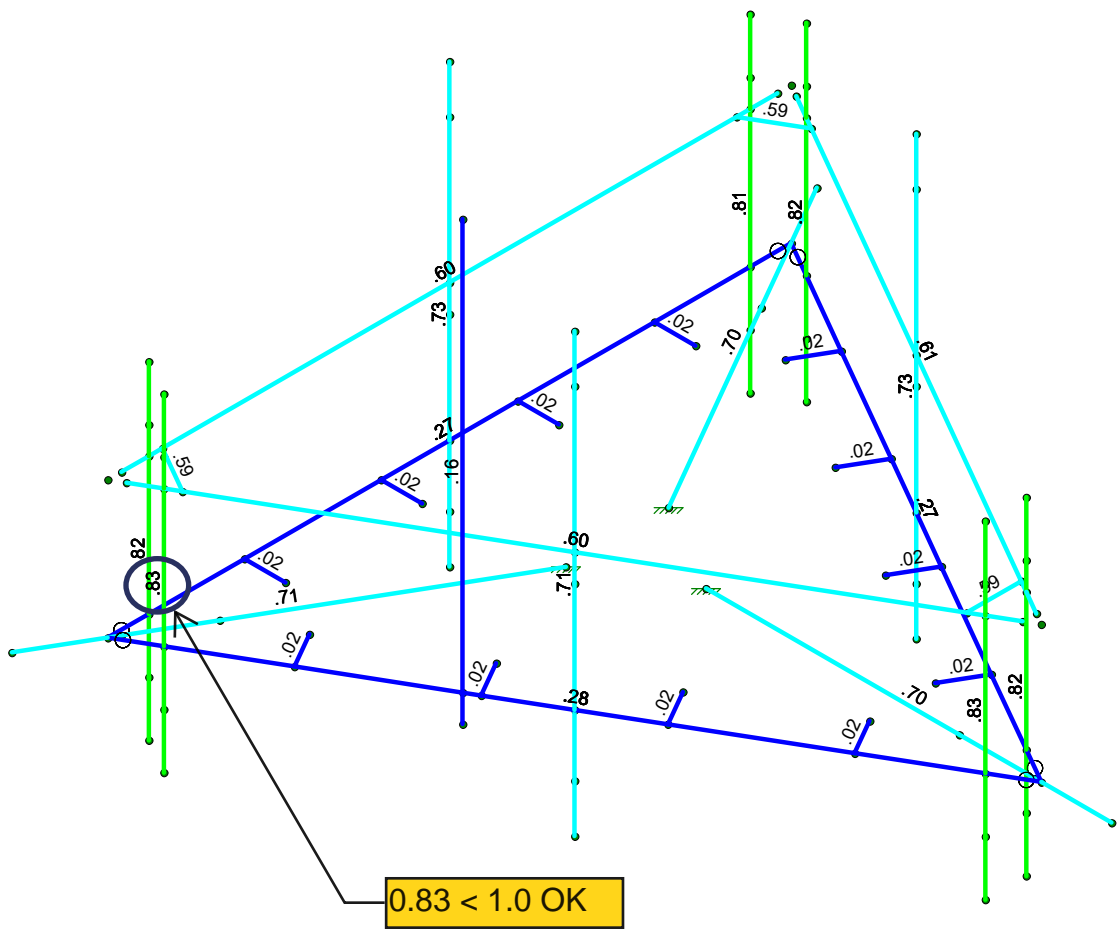

Member Code Checks Displayed (Enveloped)  
Envelope Only Solution

Tectonic	Platform Analysis Bending Stresses	June 21, 2019 at 11:01 AM
GLE		9927.CT11636A - Mount Analysis....
9927.CT11636A		



Company : Tectonic  
 Designer : GLE  
 Job Number : 9927.CT11636A  
 Model Name : Platform Analysis

June 21, 2019  
 11:02 AM  
 Checked By: \_\_\_\_\_

### Hot Rolled Steel Properties

	Label	E [ksi]	G [ksi]	Nu	Therm (1/E...)	Density[k/ft...]	Yield[ksi]	Ry	Fu[ksi]	Rt
1	A992	29000	11154	.3	.65	.49	50	1.1	65	1.1
2	A36 Gr.36	29000	11154	.3	.65	.49	36	1.5	58	1.2
3	A572 Gr.50	29000	11154	.3	.65	.49	50	1.1	65	1.1
4	A500 Gr.B RND	29000	11154	.3	.65	.527	42	1.4	58	1.3
5	A500 Gr.B Rect	29000	11154	.3	.65	.527	46	1.4	58	1.3
6	A53 Gr.B	29000	11154	.3	.65	.49	35	1.6	60	1.2
7	A1085	29000	11154	.3	.65	.49	50	1.4	65	1.3

### Hot Rolled Steel Design Parameters

	Label	Shape	Length[ft]	Lbyy[ft]	Lbzz[ft]	Lcomp top...	Lcomp bot...	L-torq...	Kyy	Kzz	Cb	Funcni...
1	M1	HSS4X4X4	12.5			Lbyy						Lateral
2	M2	HSS4X4X4	12.5			Lbyy						Lateral
3	M3	HSS4X4X4	12.5			Lbyy						Lateral
4	M4	HSS4X4X4	7.417	Segment	Segment	Lbyy						Lateral
5	M5	HSS4X4X4	7.417	Segment	Segment	Lbyy						Lateral
6	M6	HSS4X4X4	7.417	Segment	Segment	Lbyy						Lateral
7	M7	L1-1/2x1-1/2x3/16	.75			Lbyy						Lateral
8	M8	L1-1/2x1-1/2x3/16	.75			Lbyy						Lateral
9	M9	L1-1/2x1-1/2x3/16	.75			Lbyy						Lateral
10	M10	L1-1/2x1-1/2x3/16	.75			Lbyy						Lateral
11	M11	L1-1/2x1-1/2x3/16	.75			Lbyy						Lateral
12	M12	L1-1/2x1-1/2x3/16	.75			Lbyy						Lateral
13	M13	L1-1/2x1-1/2x3/16	.75			Lbyy						Lateral
14	M14	L1-1/2x1-1/2x3/16	.75			Lbyy						Lateral
15	M15	L1-1/2x1-1/2x3/16	.75			Lbyy						Lateral
16	M16	L1-1/2x1-1/2x3/16	.75			Lbyy						Lateral
17	M17	L1-1/2x1-1/2x3/16	.75			Lbyy						Lateral
18	M18	L1-1/2x1-1/2x3/16	.75			Lbyy						Lateral
19	M19	PIPE 2.0	6	Segment	Segment							Lateral
20	M20	PIPE 2.0	6	Segment	Segment							Lateral
21	M21	PIPE 2.0	6	Segment	Segment							Lateral
22	M22	PIPE 2.0	6	Segment	Segment							Lateral
23	M23	PIPE 2.0	6	Segment	Segment							Lateral
24	M24	PIPE 2.0	6	Segment	Segment							Lateral
25	M25	PIPE 2.0	8	Segment	Segment							Lateral
26	M26	PIPE 2.0	8	Segment	Segment							Lateral
27	M27	PIPE 2.0	8	Segment	Segment							Lateral
28	M28	PIPE 2.0	8	Segment	Segment							Lateral
29	M29	PIPE 2.0	12	Segment	Segment	Lbyy						Lateral
30	M30	PIPE 2.0	12	Segment	Segment	Lbyy						Lateral
31	M31	PIPE 2.0	12	Segment	Segment	Lbyy						Lateral
32	M32	L2.5x2.5x4	1			Lbyy						Lateral
33	M33	L2.5x2.5x4	1			Lbyy						Lateral
34	M34	L2.5x2.5x4	1			Lbyy						Lateral

### Basic Load Cases

	BLC Description	Category	X Grav...Y Grav...Z Grav...	Joint	Point	Distrib...	Area(Member)	Surfac...
1	DL	DL	-1.05	21			3	
2	WLX	WL+X		21		22		
3	WLZ	WL+Z		21		22		
4	DL (ICE)	SL		21		22		
5	WLX (ICE)	WL+X		21		22		
6	WLZ (ICE)	WL+Z		21		22		



Company : Tectonic  
 Designer : GLE  
 Job Number : 9927.CT11636A  
 Model Name : Platform Analysis

June 21, 2019  
 11:02 AM  
 Checked By: \_\_\_\_\_

**Basic Load Cases (Continued)**

	BLC Description	Category	X Grav...	Y Grav...	Z Grav...	Joint	Point	Distrib...	Area(Member)	Surfac...
7	WLX (MAINT)	WL+X				21		22		
8	WLZ (MAINT)	WL+Z				21		22		
9	Lm1	OL1				2				
10	Lm2	OL2				2				
11	Lm3	OL3				2				
12	BLC 1 Transient Area Loads	None						21		

**Load Combinations**

	Description	S...	PDelta	SRSS	B...	Fa...	B...	Fa...	B...	Fa...	B...	Fa...	B...	Fa...	B...	Fa...	B...	Fa...	B...	Fa...
1	1.4D	Yes	Y		1	1.4														
2	1.2D+1.6WLX	Yes	Y		1	1.2	2	1.6												
3	1.2D+1.6WLZ	Yes	Y		1	1.2	3	1.6												
4	1.2D+1.6(WLX+WLZ) - 0 Deg	Yes	Y		1	1.2	2	1.6												
5	1.2D+1.6(WLX+WLZ) - 30 D...	Yes	Y		1	1.2	2	1.3...	3	.8										
6	1.2D+1.6(WLX+WLZ) - 60 D...	Yes	Y		1	1.2	2	.8	3	1.3...										
7	1.2D+1.6(WLX+WLZ) - 90 D...	Yes	Y		1	1.2	2		3	1.6										
8	1.2D+1.6(WLX+WLZ) - 120 ...	Yes	Y		1	1.2	2	-.8	3	1.3...										
9	1.2D+1.6(WLX+WLZ) - 150 ...	Yes	Y		1	1.2	2	-1....	3	.8										
10	1.2D+1.6(WLX+WLZ) - 180 ...	Yes	Y		1	1.2	2	-1.6	3											
11	1.2D+1.6(WLX+WLZ) - 210 ...	Yes	Y		1	1.2	2	-1....	3	-.8										
12	1.2D+1.6(WLX+WLZ) - 240 ...	Yes	Y		1	1.2	2	-.8	3	-1....										
13	1.2D+1.6(WLX+WLZ) - 270 ...	Yes	Y		1	1.2	2		3	-1.6										
14	1.2D+1.6(WLX+WLZ) - 300 ...	Yes	Y		1	1.2	2	.8	3	-1....										
15	1.2D+1.6(WLX+WLZ) - 330 ...	Yes	Y		1	1.2	2	1.3...	3	-.8										
16	**Wind Load with Ice**																			
17	1.2D+1.0Di+1.0WLXi	Yes	Y		1	1.2	4	1	5	1										
18	1.2D+1.0Di+1.0WLZi	Yes	Y		1	1.2	4	1		6	1									
19	1.2D+1.0Di+1.0(WLXi+WLZi)...	Yes	Y		1	1.2	4	1	5	1	6									
20	1.2D+1.0Di+1.0(WLXi+WLZi)...	Yes	Y		1	1.2	4	1	5	.87	6	.5								
21	1.2D+1.0Di+1.0(WLXi+WLZi)...	Yes	Y		1	1.2	4	1	5	.5	6	.87								
22	1.2D+1.0Di+1.0(WLXi+WLZi)...	Yes	Y		1	1.2	4	1	5		6	1								
23	1.2D+1.0Di+1.0(WLXi+WLZi)...	Yes	Y		1	1.2	4	1	5	-.5	6	.87								
24	1.2D+1.0Di+1.0(WLXi+WLZi)...	Yes	Y		1	1.2	4	1	5	-.87	6	.5								
25	1.2D+1.0Di+1.0(WLXi+WLZi)...	Yes	Y		1	1.2	4	1	5	-1	6									
26	1.2D+1.0Di+1.0(WLXi+WLZi)...	Yes	Y		1	1.2	4	1	5	-.87	6	-.5								
27	1.2D+1.0Di+1.0(WLXi+WLZi)...	Yes	Y		1	1.2	4	1	5	-.5	6	-.87								
28	1.2D+1.0Di+1.0(WLXi+WLZi)...	Yes	Y		1	1.2	4	1	5		6	-1								
29	1.2D+1.0Di+1.0(WLXi+WLZi)...	Yes	Y		1	1.2	4	1	5	.5	6	-.87								
30	1.2D+1.0Di+1.0(WLXi+WLZi)...	Yes	Y		1	1.2	4	1	5	.87	6	-.5								
31	**Maintenance Load (With S...		Y																	
32	1.2D+1.5Lm1+1.0WLX (servi...	Yes	Y		1	1.2	9	1.5	7	1	8									
33	1.2D+1.5Lm1+1.0WLZ (servi...	Yes	Y		1	1.2	9	1.5	7		8	1								
34	1.2D+1.5Lm1+1.0(WLX+WL...	Yes	Y		1	1.2	9	1.5	7	1	8									
35	1.2D+1.5Lm1+1.0(WLX+WL...	Yes	Y		1	1.2	9	1.5	7	.87	8	.5								
36	1.2D+1.5Lm1+1.0(WLX+WL...	Yes	Y		1	1.2	9	1.5	7	.5	8	.87								
37	1.2D+1.5Lm1+1.0(WLX+WL...	Yes	Y		1	1.2	9	1.5	7		8	1								
38	1.2D+1.5Lm1+1.0(WLX+WL...	Yes	Y		1	1.2	9	1.5	7	-.5	8	.87								
39	1.2D+1.5Lm1+1.0(WLX+WL...	Yes	Y		1	1.2	9	1.5	7	-.87	8	.5								
40	1.2D+1.5Lm1+1.0(WLX+WL...	Yes	Y		1	1.2	9	1.5	7	-1	8									
41	1.2D+1.5Lm1+1.0(WLX+WL...	Yes	Y		1	1.2	9	1.5	7	-.87	8	-.5								
42	1.2D+1.5Lm1+1.0(WLX+WL...	Yes	Y		1	1.2	9	1.5	7	-.5	8	-.87								
43	1.2D+1.5Lm1+1.0(WLX+WL...	Yes	Y		1	1.2	9	1.5	7		8	-1								
44	1.2D+1.5Lm1+1.0(WLX+WL...	Yes	Y		1	1.2	9	1.5	7	.5	8	-.87								
45	1.2D+1.5Lm1+1.0(WLX+WL...	Yes	Y		1	1.2	9	1.5	7	.87	8	-.5								
46	**Maintenance Load (With S...		Y																	





**Load Combinations (Continued)**

Description	S...	PDelta	SRSS	B...	Fa...	B...	Fa...	B...	Fa...	B...	Fa...	B...	Fa...	B...	Fa...	B...	Fa...	B...	Fa...
47	1.2D+1.5Lm2+1.0WLX (servi...	Yes	Y		1	1.2	10	1.5	7	1	8								
48	1.2D+1.5Lm2+1.0WLZ (servi...	Yes	Y		1	1.2	10	1.5	7		8	1							
49	1.2D+1.5Lm2+1.0(WLX+WL...	Yes	Y		1	1.2	10	1.5	7	1	8								
50	1.2D+1.5Lm2+1.0(WLX+WL...	Yes	Y		1	1.2	10	1.5	7	.87	8	.5							
51	1.2D+1.5Lm2+1.0(WLX+WL...	Yes	Y		1	1.2	10	1.5	7	.5	8	.87							
52	1.2D+1.5Lm2+1.0(WLX+WL...	Yes	Y		1	1.2	10	1.5	7		8	1							
53	1.2D+1.5Lm2+1.0(WLX+WL...	Yes	Y		1	1.2	10	1.5	7	-5	8	.87							
54	1.2D+1.5Lm2+1.0(WLX+WL...	Yes	Y		1	1.2	10	1.5	7	-.87	8	.5							
55	1.2D+1.5Lm2+1.0(WLX+WL...	Yes	Y		1	1.2	10	1.5	7	-1	8								
56	1.2D+1.5Lm2+1.0(WLX+WL...	Yes	Y		1	1.2	10	1.5	7	-.87	8	-.5							
57	1.2D+1.5Lm2+1.0(WLX+WL...	Yes	Y		1	1.2	10	1.5	7	-5	8	-.87							
58	1.2D+1.5Lm2+1.0(WLX+WL...	Yes	Y		1	1.2	10	1.5	7		8	-1							
59	1.2D+1.5Lm2+1.0(WLX+WL...	Yes	Y		1	1.2	10	1.5	7	.5	8	-.87							
60	1.2D+1.5Lm2+1.0(WLX+WL...	Yes	Y		1	1.2	10	1.5	7	.87	8	-.5							
61	**Maintenance Load (With S...		Y																
62	1.2D+1.5Lm3+1.0WLX (servi...	Yes	Y		1	1.2	11	1.5	7	1	8								
63	1.2D+1.5Lm3+1.0WLZ (servi...	Yes	Y		1	1.2	11	1.5	7		8	1							
64	1.2D+1.5Lm3+1.0(WLX+WL...	Yes	Y		1	1.2	11	1.5	7	1	8								
65	1.2D+1.5Lm3+1.0(WLX+WL...	Yes	Y		1	1.2	11	1.5	7	.87	8	.5							
66	1.2D+1.5Lm3+1.0(WLX+WL...	Yes	Y		1	1.2	11	1.5	7	.5	8	.87							
67	1.2D+1.5Lm3+1.0(WLX+WL...	Yes	Y		1	1.2	11	1.5	7		8	1							
68	1.2D+1.5Lm3+1.0(WLX+WL...	Yes	Y		1	1.2	11	1.5	7	-5	8	.87							
69	1.2D+1.5Lm3+1.0(WLX+WL...	Yes	Y		1	1.2	11	1.5	7	-.87	8	.5							
70	1.2D+1.5Lm3+1.0(WLX+WL...	Yes	Y		1	1.2	11	1.5	7	-1	8								
71	1.2D+1.5Lm3+1.0(WLX+WL...	Yes	Y		1	1.2	11	1.5	7	-.87	8	-.5							
72	1.2D+1.5Lm3+1.0(WLX+WL...	Yes	Y		1	1.2	11	1.5	7	-.5	8	-.87							
73	1.2D+1.5Lm3+1.0(WLX+WL...	Yes	Y		1	1.2	11	1.5	7		8	-1							
74	1.2D+1.5Lm3+1.0(WLX+WL...	Yes	Y		1	1.2	11	1.5	7	.5	8	-.87							
75	1.2D+1.5Lm3+1.0(WLX+WL...	Yes	Y		1	1.2	11	1.5	7	.87	8	-.5							

**Envelope Joint Reactions**

Joint		X [k]	LC	Y [k]	LC	Z [k]	LC	MX [k-ft]	LC	MY [k-ft]	LC	MZ [k-ft]	LC	
1	N8	max	2.277	14	2.178	29	3.707	8	-855	8	.545	14	-.247	9
2		min	-2.255	8	.287	8	-3.73	14	-9.854	29	-.54	8	-5.71	30
3	N6	max	2.262	6	2.127	21	3.737	6	9.595	21	.477	13	-.225	11
4		min	-2.241	12	.278	12	-3.713	12	.827	12	-.479	3	-5.591	20
5	N4	max	4.302	4	2.162	25	.21	7	1.221	7	.753	13	11.279	25
6		min	-4.334	10	.274	2	-.211	13	-1.24	13	-.752	3	.907	2
7	Totals:	max	6.718	4	6.136	30	6.625	7						
8		min	-6.718	10	2.962	2	-6.625	13						

**Envelope AISC 14th(360-10): LRFD Steel Code Checks**

Member	Shape	Code Check	Loc[ft]	LC	Shear	Loc[ft]	Dir	LC	phi*Pnc	phi*Pnt [k]	phi*Mn y	phi*Mn z	Cb	Eqn
1	M1	HSS4X4X4	.275	6.25	4	.133	12.5	y	27	72.55	139.518	16.181	16.181	1...H1-1b
2	M2	HSS4X4X4	.278	6.25	12	.136	12.5	z	5	72.55	139.518	16.181	16.181	1...H1-1b
3	M3	HSS4X4X4	.268	6.25	8	.132	0	y	27	72.55	139.518	16.181	16.181	1...H1-1b
4	M4	HSS4X4X4	.703	0	24	.116	0	y	13	127.53	139.518	16.181	16.181	2...H1-1b
5	M5	HSS4X4X4	.695	0	21	.113	0	y	15	127.53	139.518	16.181	16.181	2...H1-1b
6	M6	HSS4X4X4	.715	0	29	.117	0	y	11	127.53	139.518	16.181	16.181	2...H1-1b
7	M7	L1-1/2x1-1/...	.016	0	1	.002	0	z	1	16.26	17.086	.293	.667	2...H2-1
8	M8	L1-1/2x1-1/...	.016	0	1	.002	0	z	1	16.26	17.086	.293	.667	2...H2-1
9	M9	L1-1/2x1-1/...	.016	0	1	.002	0	z	1	16.26	17.086	.293	.667	2...H2-1
10	M10	L1-1/2x1-1/...	.016	0	1	.002	0	z	1	16.26	17.086	.293	.667	2...H2-1
11	M11	L1-1/2x1-1/...	.016	0	1	.002	0	z	1	16.26	17.086	.293	.667	2...H2-1



**Envelope AISC 14th(360-10): LRFD Steel Code Checks (Continued)**

Member	Shape	Code Check	Loc(ft)	LC Shear	...Loc(ft)	Dir	LC	phi*Pnc	...phi*Pnt [k]	phi*Mn y	phi*Mn z	Cb	Eqn	
12	M12	L1-1/2x1-1/...	.016	0	1	.002	0	z	1	16.26	17.086	.293	.667	2... H2-1
13	M13	L1-1/2x1-1/...	.016	0	1	.002	0	z	1	16.26	17.086	.293	.667	2... H2-1
14	M14	L1-1/2x1-1/...	.016	0	1	.002	0	z	1	16.26	17.086	.293	.667	2... H2-1
15	M15	L1-1/2x1-1/...	.016	0	1	.002	0	z	1	16.26	17.086	.293	.667	2... H2-1
16	M16	L1-1/2x1-1/...	.016	0	1	.002	0	z	1	16.26	17.086	.293	.667	2... H2-1
17	M17	L1-1/2x1-1/...	.016	0	1	.002	0	z	1	16.26	17.086	.293	.667	2... H2-1
18	M18	L1-1/2x1-1/...	.016	0	1	.002	0	z	1	16.26	17.086	.293	.667	2... H2-1
19	M19	PIPE 2.0	.828	2	24	.171	2		8	31.747	32.13	1.872	1.872	2... H1-1b
20	M20	PIPE 2.0	.833	2	30	.176	2		4	31.747	32.13	1.872	1.872	2... H1-1b
21	M21	PIPE 2.0	.822	2	28	.178	2		12	31.747	32.13	1.872	1.872	2... H1-1b
22	M22	PIPE 2.0	.813	2	22	.171	2		8	31.747	32.13	1.872	1.872	2... H1-1b
23	M23	PIPE 2.0	.819	2	20	.177	2		4	31.747	32.13	1.872	1.872	2... H1-1b
24	M24	PIPE 2.0	.823	2	26	.176	2		12	31.747	32.13	1.872	1.872	2... H1-1b
25	M25	PIPE 2.0	.707	2	6	.109	4.5		9	31.646	32.13	1.872	1.872	1... H1-1b
26	M26	PIPE 2.0	.733	2	10	.112	4.5		13	31.646	32.13	1.872	1.872	1... H1-1b
27	M27	PIPE 2.0	.735	2	14	.112	4.5		11	31.646	32.13	1.872	1.872	1... H1-1b
28	M28	PIPE 2.0	.160	.5	12	.008	.5		12	32.034	32.13	1.872	1.872	2... H1-1b
29	M29	PIPE 2.0	.596	.75	13	.350	.75		4	32.106	32.13	1.872	1.872	1... H3-6
30	M30	PIPE 2.0	.610	.75	5	.351	11.25		8	23.088	32.13	1.872	1.872	1... H3-6
31	M31	PIPE 2.0	.604	11.25	15	.350	11.25		12	32.106	32.13	1.872	1.872	1... H3-6
32	M32	L2.5x2.5x4	.588	1	5	.133	0	z	5	37.318	38.556	1.114	2.537	2... H2-1
33	M33	L2.5x2.5x4	.586	1	15	.132	1	y	9	37.318	38.556	1.114	2.537	2... H2-1
34	M34	L2.5x2.5x4	.593	1	7	.134	0	y	7	37.318	38.556	1.114	2.537	2... H2-1

Maximum member stress is at 83% of its capacity; therefore, the existing mount members are adequate to support the proposed installation. In order for the results of this analysis to be valid, a handrail kit (SitePro1 #HRK12, or approved equal) must be installed prior to the installation of the proposed equipment.

Design connection per AISC Steel Manual, 14th edition [LRFD].

### Connection Details

Bolts	
Quantity =	4
Diameter =	0.625 in (assumed)
Vertical Spacing =	6 in (assumed)
Horizontal Spacing =	3.5 in (assumed)
Grade =	A325
$F_{nt}$ =	90 ksi
$F_{nv}$ =	54 ksi

### Loading Details

Node N4	
Shear, Z =	0.211 k
Shear, Y =	2.162 k
Tension, X =	4.334 k
Mz =	11.279 k-ft
My =	0.753 k-ft
Mx =	1.221 k-ft
	[Table J3.2]
	[Table J3.2]

### 1 - Tensile Capacity

$$\phi R_{nt} = F_{nt} A_b \quad \text{[Eqn. J3-1]}$$

$\phi$ =	0.75
$F_{nt}$ =	90 ksi
$A_b$ =	0.307 in <sup>2</sup>
$\phi R_{nt}$ =	20.72 k
$T_{max}$ =	13.65 k

**Rnt > Tmax**

66%

**OK**

### 2 - Shear Capacity

$$\phi R_{nv} = F_{nv} A_b \quad \text{[Eqn. J3-1]}$$

$\phi$ =	0.75
$F_{nv}$ =	54 ksi
$A_b$ =	0.307 in <sup>2</sup>
$\phi R_{nv}$ =	12.43 k
$V_{max}$ =	2.65 k

**Rnv > Vmax**

21%

**OK**

### 3 - Combined Tension and Shear Capacity

$$\phi R'_{nt} = F'_{nt} A_b \quad \text{[Eqn. J3-2]}$$

$$F'_{nt} = 1.3F_{nt} - \frac{F_{nt}}{\phi F_{nv}} f_{rv} \leq F_{nt} \quad \text{[Eqn. J3-3a]}$$

$\phi$ =	0.75
$F'_{nt}$ =	90 ksi
$A_b$ =	0.307 in <sup>2</sup>
$\phi R'_{nt}$ =	20.72 k
$T_{max}$ =	13.65 k

**R'nt > Tmax**

66%

**OK**

# Exhibit E



## RADIO FREQUENCY EMISSIONS ANALYSIS REPORT EVALUATION OF HUMAN EXPOSURE POTENTIAL TO NON-IONIZING EMISSIONS

T-Mobile Existing Facility

Site ID: CT11636A

WirelessSolutionsOldLyme  
72 Boggy Hole Road  
Old Lyme, Connecticut 06371

**May 22, 2019**

**EBI Project Number: 6219001737**

Site Compliance Summary	
Compliance Status:	<b>COMPLIANT</b>
Site total MPE% of FCC general population allowable limit:	<b>9.63%</b>

May 22, 2019

T-Mobile

Attn: Jason Overbey, RF Manager  
35 Griffin Road South  
Bloomfield, Connecticut 06002

Emissions Analysis for Site: CT11636A - WirelessSolutionsOldLyme

EBI Consulting was directed to analyze the proposed T-Mobile facility located at **72 Boggy Hole Road in Old Lyme, Connecticut** for the purpose of determining whether the emissions from the Proposed T-Mobile Antenna Installation located on this property are within specified federal limits.

All information used in this report was analyzed as a percentage of current Maximum Permissible Exposure (% MPE) as listed in the FCC OET Bulletin 65 Edition 97-01 and ANSI/IEEE Std C95.1. The FCC regulates Maximum Permissible Exposure in units of microwatts per square centimeter ( $\mu\text{W}/\text{cm}^2$ ). The number of  $\mu\text{W}/\text{cm}^2$  calculated at each sample point is called the power density. The exposure limit for power density varies depending upon the frequencies being utilized. Wireless Carriers and Paging Services use different frequency bands each with different exposure limits; therefore, it is necessary to report results and limits in terms of percent MPE rather than power density.

All results were compared to the FCC (Federal Communications Commission) radio frequency exposure rules, 47 CFR 1.1307(b)(1) – (b)(3), to determine compliance with the Maximum Permissible Exposure (MPE) limits for General Population/Uncontrolled environments as defined below.

General population/uncontrolled exposure limits apply to situations in which the general population may be exposed or in which persons who are exposed as a consequence of their employment may not be made fully aware of the potential for exposure or cannot exercise control over their exposure. Therefore, members of the general population would always be considered under this category when exposure is not employment related, for example, in the case of a telecommunications tower that exposes persons in a nearby residential area.

Public exposure to radio frequencies is regulated and enforced in units of microwatts per square centimeter ( $\mu\text{W}/\text{cm}^2$ ). The general population exposure limits for the 600 MHz and 700 MHz frequency bands are approximately  $400 \mu\text{W}/\text{cm}^2$  and  $467 \mu\text{W}/\text{cm}^2$ , respectively. The general population exposure limit for the 1900 MHz (PCS), 2100 MHz (AWS) and 11 GHz frequency bands is  $1000 \mu\text{W}/\text{cm}^2$ . Because each carrier will be using different frequency bands, and each frequency band has different exposure limits, it is necessary to report percent of MPE rather than power density.

Occupational/controlled exposure limits apply to situations in which persons are exposed as a consequence of their employment and in which those persons who are exposed have been made fully aware of the potential for exposure and can exercise control over their exposure. Occupational/controlled exposure limits also apply where exposure is of a transient nature as a result of incidental passage through a location where exposure levels may be above general population/uncontrolled limits (see below), as long as the exposed person has been made fully aware of the potential for exposure and can exercise control over his or her exposure by leaving the area or by some other appropriate means.

Additional details can be found in FCC OET 65.

## **CALCULATIONS**

Calculations were done for the proposed T-Mobile Wireless antenna facility located at 72 Boggy Hole Road in Old Lyme, Connecticut using the equipment information listed below. All calculations were performed per the specifications under FCC OET 65. Since T-Mobile is proposing highly focused directional panel antennas, which project most of the emitted energy out toward the horizon, all calculations were performed assuming a lobe representing the maximum gain of the antenna per the antenna manufacturer's supplied specifications, minus 10 dB for directional panel antennas and 20 dB for highly focused parabolic microwave dishes, was focused at the base of the tower. For this report, the sample point is the top of a 6-foot person standing at the base of the tower.

For all calculations, all equipment was calculated using the following assumptions:

- 1) 2 LTE channels (600 MHz Band) were considered for each sector of the proposed installation. These Channels have a transmit power of 30 Watts per Channel.
- 2) 2 LTE channels (700 MHz Band) were considered for each sector of the proposed installation. These Channels have a transmit power of 30 Watts per Channel.
- 3) 2 GSM/UMTS channels (PCS Band - 1900 MHz) were considered for each sector of the proposed installation. These Channels have a transmit power of 30 Watts per Channel.
- 4) 2 LTE channels (AWS Band – 2100 MHz) were considered for each sector of the proposed installation. These Channels have a transmit power of 60 Watts per Channel.
- 5) All radios at the proposed installation were considered to be running at full power and were uncombined in their RF transmissions paths per carrier prescribed configuration. Per FCC OET Bulletin No. 65 - Edition 97-01 recommendations to achieve the maximum anticipated value at each sample point, all power levels emitting from the proposed antenna installation

are increased by a factor of 2.56 to account for possible in-phase reflections from the surrounding environment. This is rarely the case, and if so, is never continuous.

- 6) For the following calculations, the sample point was the top of a 6-foot person standing at the base of the tower. The maximum gain of the antenna per the antenna manufacturer's supplied specifications, minus 10 dB for directional panel antennas and 20 dB for highly focused parabolic microwave dishes, was used in this direction. This value is a very conservative estimate as gain reductions for these particular antennas are typically much higher in this direction.
- 7) The antennas used in this modeling are the Ericsson AIR21 B2A\_B4P for the 1900 MHz channel(s), the RFS APXVAARR24\_43-U-NA20 for the 600 MHz / 700 MHz channel(s), the Ericsson AIR21 B2P\_B4A for the 2100 MHz channel(s) in Sector A, the Ericsson AIR21 B2A\_B4P for the 1900 MHz channel(s), the RFS APXVAARR24\_43-U-NA20 for the 600 MHz / 700 MHz channel(s), the Ericsson AIR21 B2P\_B4A for the 2100 MHz channel(s) in Sector B, the Ericsson AIR21 B2A\_B4P for the 1900 MHz channel(s), the RFS APXVAARR24\_43-U-NA20 for the 600 MHz / 700 MHz channel(s), the Ericsson AIR21 B2P\_B4A for the 2100 MHz channel(s) in Sector C. This is based on feedback from the carrier with regard to anticipated antenna selection. All Antenna gain values and associated transmit power levels are shown in the Site Inventory and Power Data table below. The maximum gain of the antenna per the antenna manufacturer's supplied specifications, minus 10 dB for directional panel antennas and 20 dB for highly focused parabolic microwave dishes, was used for all calculations. This value is a very conservative estimate as gain reductions for these particular antennas are typically much higher in this direction.
- 8) The antenna mounting height centerline of the proposed antennas is 175 feet above ground level (AGL).
- 9) Emissions values for additional carriers were taken from the Connecticut Siting Council active database. Values in this database are provided by the individual carriers themselves.
- 10) All calculations were done with respect to uncontrolled / general population threshold limits.



## T-Mobile Site Inventory and Power Data

Sector:	A	Sector:	B	Sector:	C
Antenna #:	I	Antenna #:	I	Antenna #:	I
Make / Model:	Ericsson AIR21 B2A_B4P	Make / Model:	Ericsson AIR21 B2A_B4P	Make / Model:	Ericsson AIR21 B2A_B4P
Frequency Bands:	1900 MHz	Frequency Bands:	1900 MHz	Frequency Bands:	1900 MHz
Gain:	15.35 dBd	Gain:	15.35 dBd	Gain:	15.35 dBd
Height (AGL):	175 feet	Height (AGL):	175 feet	Height (AGL):	175 feet
Channel Count:	2	Channel Count:	2	Channel Count:	2
Total TX Power (W):	60 Watts	Total TX Power (W):	60 Watts	Total TX Power (W):	60 Watts
ERP (W):	2,056.61	ERP (W):	2,056.61	ERP (W):	2,056.61
Antenna A1 MPE %:	<b>0.24%</b>	Antenna B1 MPE %:	<b>0.24%</b>	Antenna C1 MPE %:	<b>0.24%</b>
Antenna #:	2	Antenna #:	2	Antenna #:	2
Make / Model:	RFS APXVAARR24_43-U-NA20	Make / Model:	RFS APXVAARR24_43-U-NA20	Make / Model:	RFS APXVAARR24_43-U-NA20
Frequency Bands:	600 MHz / 700 MHz	Frequency Bands:	600 MHz / 700 MHz	Frequency Bands:	600 MHz / 700 MHz
Gain:	12.95 dBd / 13.35 dBd	Gain:	12.95 dBd / 13.35 dBd	Gain:	12.95 dBd / 13.35 dBd
Height (AGL):	175 feet	Height (AGL):	175 feet	Height (AGL):	175 feet
Channel Count:	4	Channel Count:	4	Channel Count:	4
Total TX Power (W):	120 Watts	Total TX Power (W):	120 Watts	Total TX Power (W):	120 Watts
ERP (W):	2,481.08	ERP (W):	2,481.08	ERP (W):	2,481.08
Antenna A2 MPE %:	<b>0.67%</b>	Antenna B2 MPE %:	<b>0.67%</b>	Antenna C2 MPE %:	<b>0.67%</b>
Antenna #:	3	Antenna #:	3	Antenna #:	3
Make / Model:	Ericsson AIR21 B2P_B4A	Make / Model:	Ericsson AIR21 B2P_B4A	Make / Model:	Ericsson AIR21 B2P_B4A
Frequency Bands:	2100 MHz	Frequency Bands:	2100 MHz	Frequency Bands:	2100 MHz
Gain:	15.35 dBd	Gain:	15.35 dBd	Gain:	15.35 dBd
Height (AGL):	175 feet	Height (AGL):	175 feet	Height (AGL):	175 feet
Channel Count:	2	Channel Count:	2	Channel Count:	2
Total TX Power (W):	120 Watts	Total TX Power (W):	120 Watts	Total TX Power (W):	120 Watts
ERP (W):	4,113.21	ERP (W):	4,113.21	ERP (W):	4,113.21
Antenna A3 MPE %:	<b>0.48%</b>	Antenna B3 MPE %:	<b>0.48%</b>	Antenna C3 MPE %:	<b>0.48%</b>

Site Composite MPE %	
Carrier	MPE %
T-Mobile (Max at Sector A):	1.40%
Nextel	0.36%
AT&T	5.76%
Verizon	2.11%
<b>Site Total MPE % :</b>	<b>9.63%</b>

T-Mobile Sector A Total:	1.40%
T-Mobile Sector B Total:	1.40%
T-Mobile Sector C Total:	1.40%
Site Total:	9.63%

### T-Mobile Maximum MPE Power Values (Sector A)

T-Mobile Frequency Band / Technology (Sector A)	# Channels	Watts ERP (Per Channel)	Height (feet)	Total Power Density ( $\mu\text{W}/\text{cm}^2$ )	Frequency (MHz)	Allowable MPE ( $\mu\text{W}/\text{cm}^2$ )	Calculated % MPE
T-Mobile 1900 MHz GSM/UMTS	2	1028.30	175.0	2.41	1900 MHz GSM/UMTS	1000	0.24%
T-Mobile 600 MHz LTE	2	591.73	175.0	1.39	600 MHz LTE	400	0.35%
T-Mobile 700 MHz LTE	2	648.82	175.0	1.52	700 MHz LTE	467	0.33%
T-Mobile 2100 MHz LTE AWS	2	2056.61	175.0	4.83	2100 MHz LTE AWS	1000	0.48%
						<b>Total:</b>	<b>1.40%</b>

• NOTE: Totals may vary by approximately 0.01% due to summation of remainders in calculations.

## Summary

All calculations performed for this analysis yielded results that were **within** the allowable limits for general population exposure to RF Emissions.

The anticipated maximum composite contributions from the T-Mobile facility as well as the site composite emissions value with regards to compliance with FCC's allowable limits for general population exposure to RF Emissions are shown here:

T-Mobile Sector	Power Density Value (%)
Sector A:	1.40%
Sector B:	1.40%
Sector C:	1.40%
T-Mobile Maximum MPE % (Sector A):	1.40%
Site Total:	9.63%
Site Compliance Status:	<b>COMPLIANT</b>

The anticipated composite MPE value for this site assuming all carriers present is **9.63%** of the allowable FCC established general population limit sampled at the ground level. This is based upon values listed in the Connecticut Siting Council database for existing carrier emissions.

FCC guidelines state that if a site is found to be out of compliance (over allowable thresholds), that carriers over a 5% contribution to the composite value will require measures to bring the site into compliance. For this facility, the composite values calculated were well within the allowable 100% threshold standard per the federal government.

# Exhibit F



**UNITED STATES  
POSTAL SERVICE®**

**Click-N-Ship®**

**P**

usps.com  
**US POSTAGE** \$7.35  
 Flat Rate Env  
 9405 5036 9930 0063 3306 86 0073 5000 0010 6371



07/19/2019 Mailed from 06002 062S0000000315

**PRIORITY MAIL 1-DAY™**

Expected Delivery Date: 07/20/19  
 Ref#: 636ZAP  
**0024**

Carrier -- Leave if No Response

**B004**

SHIP TO: KEN THOMAS  
 WIRELESS SOLUTIONS, LLC  
 PO BOX 284  
 OLD LYME CT 06371-0284

**USPS TRACKING #**

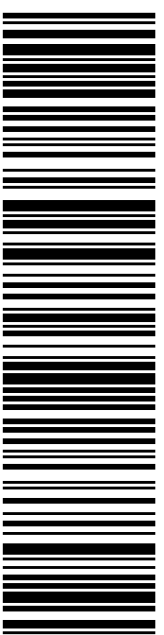

**9405 5036 9930 0063 3306 86**

Electronic Rate Approved #038555749

✂ ————— Cut on dotted line. —————

### Instructions

1. Each Click-N-Ship® label is unique. Labels are to be used as printed and used only once. DO NOT PHOTO COPY OR ALTER LABEL.
2. Place your label so it does not wrap around the edge of the package.
3. Adhere your label to the package. A self-adhesive label is recommended. If tape or glue is used, DO NOT TAPE OVER BARCODE. Be sure all edges are secure.
4. To mail your package with PC Postage®, you may schedule a Package Pickup online, hand to your letter carrier, take to a Post Office™, or drop in a USPS collection box.
5. Mail your package on the "Ship Date" you selected when creating this label.

### Click-N-Ship® Label Record

**USPS TRACKING # :**  
**9405 5036 9930 0063 3306 86**

Trans. #: 468589480	Priority Mail® Postage: <b>\$7.35</b>
Print Date: 07/19/2019	Total: <b>\$7.35</b>
Ship Date: 07/19/2019	
Expected Delivery Date: 07/20/2019	

**From:** DEBORAH CHASE      Ref#: 636ZAP  
 T-MOBILE/NSS  
 35 GRIFFIN RD S  
 BLOOMFIELD CT 06002-1351

**To:** KEN THOMAS  
 WIRELESS SOLUTIONS, LLC  
 PO BOX 284  
 OLD LYME CT 06371-0284

\* Retail Pricing Priority Mail rates apply. There is no fee for USPS Tracking® service on Priority Mail service with use of this electronic rate shipping label. Refunds for unused postage paid labels can be requested online 30 days from the print date.



Thank you for shipping with the United States Postal Service!  
 Check the status of your shipment on the USPS Tracking® page at usps.com



**UNITED STATES  
POSTAL SERVICE®**

**Click-N-Ship®**

**P**

usps.com  
**US POSTAGE**  
 Flat Rate Env  
 \$7.35

9405 5036 9930 0063 3307 09 0073 5000 0010 6371

07/19/2019

Mailed from 06002 062S0000000313

**PRIORITY MAIL 1-DAY™**

Expected Delivery Date: 07/20/19

Ref#: 636ZAP  
**0024**

Carrier -- Leave if No Response

**R005**

SHIP TO: BONNIE REEMSNYDER  
 FIRST SELECTWOMAN-TOWN OF OLD LYME  
 52 LYME ST  
 OLD LYME CT 06371-2331

**USPS TRACKING #**

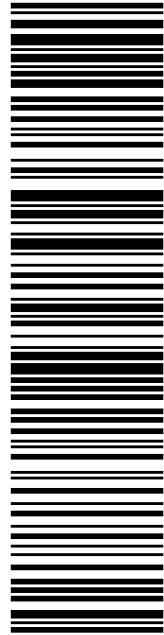

**9405 5036 9930 0063 3307 09**

Electronic Rate Approved #038555749



Cut on dotted line.

## Instructions

1. Each Click-N-Ship® label is unique. Labels are to be used as printed and used only once. DO NOT PHOTO COPY OR ALTER LABEL.
2. Place your label so it does not wrap around the edge of the package.
3. Adhere your label to the package. A self-adhesive label is recommended. If tape or glue is used, DO NOT TAPE OVER BARCODE. Be sure all edges are secure.
4. To mail your package with PC Postage®, you may schedule a Package Pickup online, hand to your letter carrier, take to a Post Office™, or drop in a USPS collection box.
5. Mail your package on the "Ship Date" you selected when creating this label.

## Click-N-Ship® Label Record

**USPS TRACKING # :**  
**9405 5036 9930 0063 3307 09**

Trans. #:	468589480	Priority Mail® Postage:	<b>\$7.35</b>
Print Date:	07/19/2019	Total	<b>\$7.35</b>
Ship Date:	07/19/2019		
Expected Delivery Date:	07/20/2019		

**From:** DEBORAH CHASE  
 T-MOBILE USA- NSS  
 35 GRIFFIN RD S  
 BLOOMFIELD CT 06002-1351

Ref#: 636ZAP

**To:** BONNIE REEMSNYDER  
 FIRST SELECTWOMAN-TOWN OF OLD LYME  
 52 LYME ST  
 OLD LYME CT 06371-2331

\* Retail Pricing Priority Mail rates apply. There is no fee for USPS Tracking® service on Priority Mail service with use of this electronic rate shipping label. Refunds for unused postage paid labels can be requested online 30 days from the print date.



Thank you for shipping with the United States Postal Service!  
 Check the status of your shipment on the USPS Tracking® page at usps.com



**UNITED STATES  
POSTAL SERVICE®**

**Click-N-Ship®**

**P**

usps.com  
**US POSTAGE**  
Flat Rate Env  
**\$7.35**

9405 5036 9930 0063 3307 23 0073 5000 0010 6371



07/19/2019

Mailed from 06002 062S0000000101

**PRIORITY MAIL 1-DAY™**

Expected Delivery Date: 07/20/19  
 Ref#: 363ZAP  
**0024**

DEBORAH CHASE  
 T-MOBILE USA- NSS  
 35 GRIFFIN RD S  
 BLOOMFIELD CT 06002-1351

SHIP TO: KEITH ROSENFELD  
 ZONING ENFORCEMENT OFFICER-  
 52 LYME ST  
 OLD LYME CT 06371-2331

**Carrier -- Leave if No Response**

**R005**

**USPS TRACKING #**

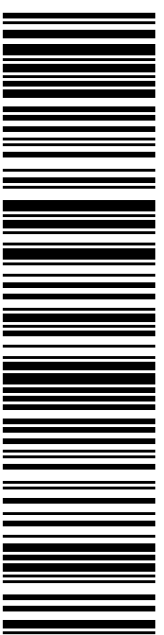

**9405 5036 9930 0063 3307 23**

Electronic Rate Approved #038555749



Cut on dotted line.

### Instructions

1. Each Click-N-Ship® label is unique. Labels are to be used as printed and used only once. DO NOT PHOTO COPY OR ALTER LABEL.
2. Place your label so it does not wrap around the edge of the package.
3. Adhere your label to the package. A self-adhesive label is recommended. If tape or glue is used, DO NOT TAPE OVER BARCODE. Be sure all edges are secure.
4. To mail your package with PC Postage®, you may schedule a Package Pickup online, hand to your letter carrier, take to a Post Office™, or drop in a USPS collection box.
5. Mail your package on the "Ship Date" you selected when creating this label.

### Click-N-Ship® Label Record

**USPS TRACKING # :**  
**9405 5036 9930 0063 3307 23**

Trans. #: 468589480	Priority Mail® Postage: <b>\$7.35</b>
Print Date: 07/19/2019	Total: <b>\$7.35</b>
Ship Date: 07/19/2019	
Expected Delivery Date: 07/20/2019	

**From:** DEBORAH CHASE  
 T-MOBILE USA- NSS  
 35 GRIFFIN RD S  
 BLOOMFIELD CT 06002-1351

Ref#: 363ZAP

**To:** KEITH ROSENFELD  
 ZONING ENFORCEMENT OFFICER-  
 52 LYME ST  
 OLD LYME CT 06371-2331

\* Retail Pricing Priority Mail rates apply. There is no fee for USPS Tracking® service on Priority Mail service with use of this electronic rate shipping label. Refunds for unused postage paid labels can be requested online 30 days from the print date.



Thank you for shipping with the United States Postal Service!  
 Check the status of your shipment on the USPS Tracking® page at usps.com