



STATE OF CONNECTICUT
CONNECTICUT SITING COUNCIL

Ten Franklin Square, New Britain, CT 06051
Phone: (860) 827-2935 Fax: (860) 827-2950
E-Mail: siting.council@ct.gov
Web Site: portal.ct.gov/csc

VIA ELECTRONIC MAIL

June 14, 2022

Victoria Masse
Northeast Site Solutions
420 Main Street #2
Sturbridge, MA 01566
victoria@northeastsitesolutions.com

RE: **EM-T-MOBILE-100-220422** – T-Mobile notice of intent to modify an existing telecommunications facility located at 36 Lower Road, North Canaan, Connecticut.

Dear Ms. Masse:

The Connecticut Siting Council (Council) is in receipt of your correspondence of June 9, 2022 submitted in response to the Council's May 13, 2022 notification of an incomplete request for exempt modification with regard to the above-referenced matter.

The submission renders the request for exempt modification complete and the Council will process the request in accordance with the Federal Communications Commission 60-day timeframe.

Thank you for your attention and cooperation.

Sincerely,

A handwritten signature in black ink, appearing to read 'Melanie Bachman'.

Melanie Bachman
Executive Director

c: Deborah Chase, Northeast Site Solutions (deborah@northeastsitesolutions.com)

MAB/FOC/laf

From: Deborah Chase <deborah@norheastsitesolutions.com>

Sent: Thursday, June 9, 2022 9:01 PM

To: CSC-DL Siting Council <Siting.Council@ct.gov>; Bachman, Melanie <Melanie.Bachman@ct.gov>; Fontaine, Lisa <Lisa.Fontaine@ct.gov>; Robidoux, Evan <Evan.Robidoux@ct.gov>

Cc: victoria@norheastsitesolutions.com; Matt Bandle <matt@norheastsitesolutions.com>; Derek Waite <dwaite@norheastsitesolutions.com>

Subject: Fwd: Council Incomplete Letter for EM-T-MOBILE-100-220422 (36 Lower Road, North Canaan)

EXTERNAL EMAIL: This email originated from outside of the organization. Do not click any links or open any attachments unless you trust the sender and know the content is safe.

Siting Council

Please see attached the updated Structural Analysis for the site referenced above that includes proposed and approved equipment by Verizon and other entities that are located at this facility.

Please also see the updated application containing the updated Structural Analysis.

Please let us know if this renders the application sufficient and complete.

Thank you very much

Deborah Chase

Senior Project Coordinator & Analyst

Mobile: 860-490-8839

🌱 Save a tree. Refuse. Reduce. Reuse. Recycle.



**STRUCTURAL ANALYSIS REPORT – REV.1
SELF SUPPORT TOWER**



Prepared For:
T-Mobile Northeast, LLC.
35 Griffin Rd. South
Bloomfield, CT 06002

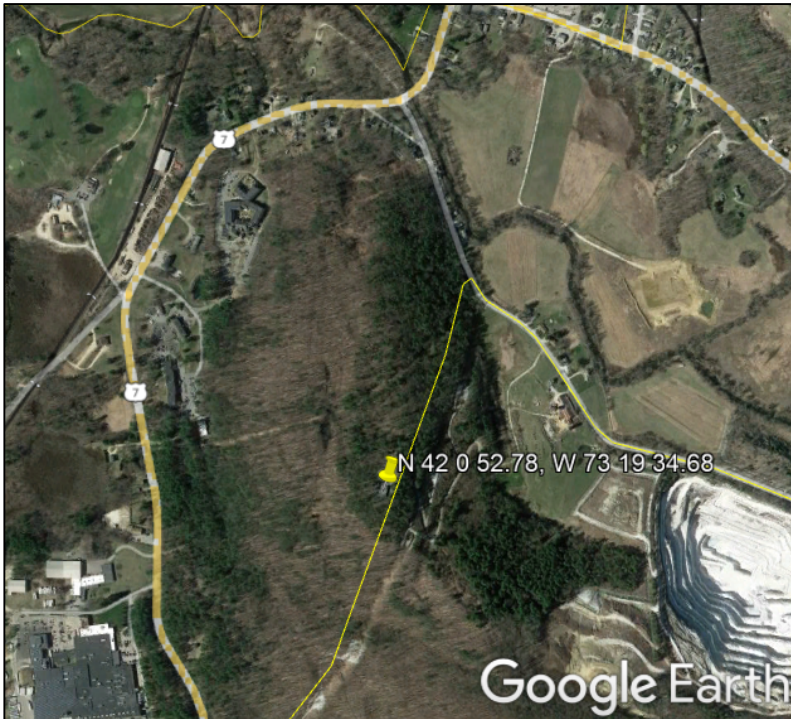

Structure Rating:

Tower:	Pass (91.1%)
Anchor Bolts:	Pass (37.5%)

Sincerely,
EFI Global, Inc.



Ahmet Colakoglu, PE
Connecticut Professional Engineer
License No: 27057

T-Mobile Site Name: North Canaan
T-Mobile Site ID: CTNH550A
38 Lower Road
North Canaan, CT 06024

CONTENTS

1.0 - SUBJECT AND REFERENCES

1.1 - STRUCTURE

2.0 - EXISTING AND PROPOSED APPURTENANCES

3.0 - CODES AND LOADING

4.0 - STANDARD CONDITIONS FOR ENGINEERING SERVICES ON EXISTING
STRUCTURES

5.0 - ANALYSIS AND ASSUMPTIONS

6.0 - RESULTS AND CONCLUSION

APPENDICES

A - SOFTWARE OUTPUT

1.0 SUBJECT AND REFERENCES

The purpose of this analysis is to evaluate the structural capacity of the 195 ft. tall self-support tower located at 38 Lower Road, North Canaan, CT 06024 for the additions and alterations proposed by T-Mobile.

The structural analysis is based on the following documentation provided to EFI Global, Inc. (EFI):

- RFDS prepared for T-Mobile, dated 01/04/2022.
- Construction Drawings prepared by Hudson Design Group, LLC, dated 08/20/2021.
- Structural Analysis Report prepared by Hudson Design Group, LLC, dated 08/16/2021.
- Structural Analysis Report prepared by Centek Engineering, dated 02/27/2018.

1.1 STRUCTURE

The subject structure is a three-sided, 195 ft. tall self-support tower formed by nine (9) 20 ft. sections, and one (1) 15 ft. section. Truss legs are X-braced with single and double angle diagonals. The tower is 26 ft. wide at the base, and has a constant taper down to 12 ft at 140 ft. Please refer to the software output in Appendix A for tower geometry, member sizes, and other details.

2.0 EXISTING AND PROPOSED APPURTENANCES

Existing Configuration T-Mobile Appurtenances:

Rad Center (ft.)	Antennas & Equipment	Coax	Mounts
125.0	(4) Air 32 B66A B2A (4) APXV18-206517S-C-A20 (4) APXVAA24_43-U-A20 (4) RRUS11 B12 (4) RRUS11 B2	(4) 6x12 Hybriflex	(1) Custom 4-sided sector frame

Proposed and Final Configuration of T-Mobile Appurtenances:

Rad Center (ft.)	Antennas & Equipment	Coax	Mounts
125.0	(4) AIR6449 B41 (4) VV-65A-R1 (4) APXVAALL24_43-U-NA20 (4) Radio 4480 B71+B85 (4) Radio 4460 B25+B66	(2) 6x24 Hybriflex (4) 6x12 Hybriflex	(1) Custom 4-sided sector frame

Appurtenances By Others:

RAD CENTER (FT)	ANTENNA & TMA	COAX	MOUNT
188.0	(1) 6' Dish	(6) 1-5/8"* (2) 1-1/4"* (2) 7/8"*	Leg Mount
184.0	(4) OTG9-840 (1) ANT150D3	-	(3) Box Arm
183.0	(1) ANT150F2	-	(1) 3' Side Arm
168.0	(6) LPA-80090-4CF (3) MT6407-77A (3) NHH-65B-R2B (3) B5/B13 RRH-BR04C (3) B2/B66A RRH-BR049 (1) Junction Box (1) 10' Dipole	(6) 1-5/8"* (1) 1-5/8"*	(3) Pirod 12' T-Frame
154.0	(3) APXV9ERR18-C-A20 (3) DT465B-2XR (6) RRH-800 (3) RRH-1900 (3) TD-RRH8x20-25	(3) 1-1/4" Hybrid Cable* (1) 1" (3) 1/2" (11) 3/8"	(3) Pirod 12' T-Frame
140.0	(3) 7770.00 (6) TPA65R-BU6DA (3) 4449 B5/B12 (3) B14 4478 (3) RRUS-32 (3) Diplexers (1) DC6 Surge Arrestor (2) Squid Surge Arrestors	(12) 1-5/8"* (3) Fiber Cable* (6) DC Cable*	(3) Pirod 12' T-Frame
118.0	-	-	(1) Box Arm
105.0	(1) ANT150D3	-	(1) Box Arm
101.0	(1) 6' Dish Ice Shield	-	-
98.0	(1) PD458-2	-	(2) Box Arm
97.0	(1) 6' Dish	-	-
78.0	(1) PD220 (1) PD1142 (1) BCD-80609 (1) 6' Yagi (1) DB222	-	(3) Box Arm
32.0	(1) GPS	-	(1) 2' Stand off

*: Coax located on interior tower.

3.0 CODES AND LOADING

This analysis has been performed in accordance with TIA-222-G, as referenced by the 2015 International Building Code, based upon an ultimate wind speed of 120 mph (Risk Category III) converted to a nominal 3-second gust wind speed of 93 mph per section 1609.3.1 as required for use in the TIA-222-G Standard per Exception #5 of Section 1609.1.1. The following loading criteria were used in the analysis:

- Basic wind speed 93 mph without ice (V)
- Basic wind speed 40 mph concurrent with design ice thickness of 1" (V_i and t_i)
- Exposure Category C, Structure Class III
- Topographic Category I

The following load combinations were used with wind blowing at 30° increments, measured from a line normal to the face of the tower:

- $1.2D + 1.6W_o$
- $0.9D + 1.6W_o$
- $1.2D + 1.0D_i + 1.0W_i$

D: Dead Load of structure and appurtenances, excluding guy assemblies

W_o : Wind Load, without ice

W_i : Concurrent wind load with factored ice thickness;

D_i : Weight of ice due to factored ice thickness

T_i : Load effects due to temperature

E_v : Vertical seismic load effect

E_h : Horizontal seismic load effect

4.0 STANDARD CONDITIONS FOR ENGINEERING SERVICES ON EXISTING STRUCTURES

The analysis is based on the information provided to EFI and is assumed to be current and correct. Unless otherwise noted, the structure and the foundation system are assumed to be in good condition, free of defects and can achieve theoretical strength.

It is assumed that the structure has been maintained and shall be maintained during its service. The superstructure and the foundation system are assumed to be designed with proper engineering practice and fabricated, constructed and erected in accordance with the design documents. EFI will accept no liability which may arise due to any existing deficiency in design, material, fabrication, erection, construction, etc. or lack of maintenance.

The analysis does not include a qualification of the mounts attached on the structure or their connections. The analysis is performed to verify the capacity of the main structural members, which is the current practice in the tower industry.

The analysis results presented in this report are only applicable for the previously mentioned existing and proposed additions and alterations. Any deviation of the proposed equipment and placement, etc., will require EFI to generate an additional structural analysis.

5.0 ANALYSIS AND ASSUMPTIONS

The tower was analyzed by utilizing tnxTower, a non-linear, three-dimensional, finite element-analysis software package, a product of Tower Numerics, Inc. Software output for this analysis is provided in Appendix A of this report.

6.0 **RESULTS AND CONCLUSION**

Based on an analysis per ANSI/TIA-222-G, the existing tower is found to have **adequate** structural capacity for the proposed changes by T-Mobile. For the aforementioned load combinations and as a maximum, the diagonal members between 0 and 20 ft. are stressed to **91.1%** of their structural capacity. The anchor rods are stressed to **37.5%** of their structural capacities, respectively.

Information regarding the tower base foundation was not available at the time of this analysis, thus a qualification of the foundation could not be completed.

Therefore, the proposed alterations and additions by T-Mobile **can** be implemented as intended, with the conditions outlined in this report.

Should you need any clarifications or have any questions about this report, please contact EFI at telecom@efiglobal.com.

APPENDIX A
SOFTWARE OUTPUT

Section	T1	T2	T3	T4	T5	T6	T7	T8	T9	T10	T11	T12	T13	12
Legs	Pirolod 105217	Pirolod 105216	Pirolod 105217	Pirolod 105217	Pirolod 105217	Pirolod 105218	Pirolod 105219	Pirolod 105219	Pirolod 105219	Pirolod 105220	Pirolod 105220	Pirolod 105220	Pirolod 105220	Pirolod 105244
Leg Grade														
Diagonals														
Diagonal Grade														
Top Girts														
Sec. Horizontals														
Face Width (ft)	26													
# Panels @ (ft)	1 @ 20													
Weight (lb) / 47699.1	7945.8													

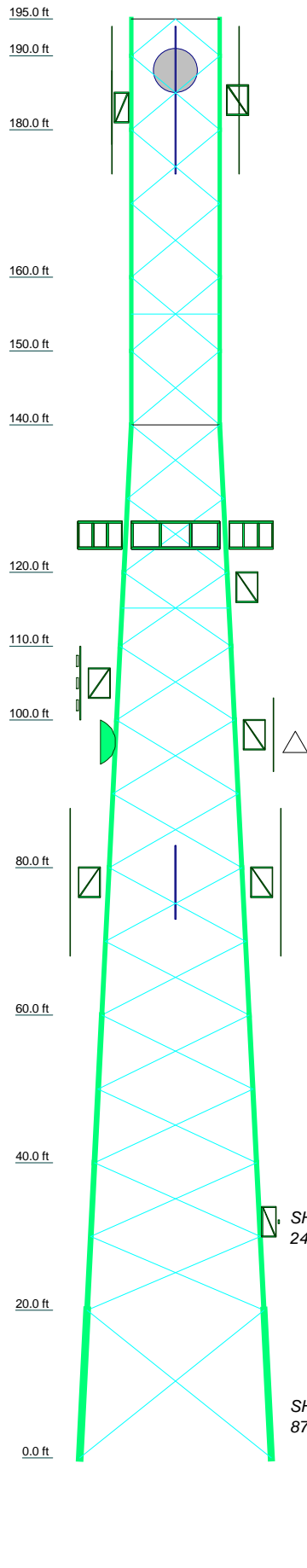

DESIGNED APPURTENANCE LOADING

TYPE	ELEVATION	TYPE	ELEVATION
6' Dish	188	RRUS 4449 B5/B12	140
Pipe Mount [PM 602-1]	187.5	RRUS 4478 B14	140
Pirolod 6-8' Box Arm	184	RRUS 4478 B14	140
Pirolod 6-8' Box Arm	184	RRUS 4478 B14	140
ANT150D3	184	RRUS 32	140
(2) OGT9-840	184	RRUS 32	140
(2) OGT9-840	184	RRUS 32	140
Pirolod 6-8' Box Arm	184	Diplexer	140
3' Side Mount Standoff	183	Diplexer	140
ANT150F2	183	Diplexer	140
Pirolod 12' T-Frame Sector Mount (1)	168	DC6 Surge Arrestor	140
Pirolod 12' T-Frame Sector Mount (1)	168	Squid Surge Arrestor	140
(2) LPA-80090/4CF w/ Mount Pipe	168	Squid Surge Arrestor	140
(2) LPA-80090/4CF w/ Mount Pipe	168	Pirolod 12' T-Frame Sector Mount (1)	140
(2) LPA-80090/4CF w/ Mount Pipe	168	8'-P3x0.216	125
(2) NHH-65B-R2B_TIA	168	8'-P3x0.216	125
(2) NHH-65B-R2B_TIA	168	8'-P3x0.216	125
(2) NHH-65B-R2B_TIA	168	8'-P3x0.216	125
MT6407-77A w/ Mount Pipe	168	AIR 6449 B41_TIA w/ Mount Pipe	125
MT6407-77A w/ Mount Pipe	168	AIR 6449 B41_TIA w/ Mount Pipe	125
MT6407-77A w/ Mount Pipe	168	AIR 6449 B41_TIA w/ Mount Pipe	125
B5/B13 RRH-BR04C	168	AIR 6449 B41_TIA w/ Mount Pipe	125
B5/B13 RRH-BR04C	168	VV-65A-R1_TIA w/ Mount Pipe	125
B5/B13 RRH-BR04C	168	VV-65A-R1_TIA w/ Mount Pipe	125
PCS/AWS DULA-BAND RRH B2/B66	168	VV-65A-R1_TIA w/ Mount Pipe	125
PCS/AWS DULA-BAND RRH B2/B66	168	VV-65A-R1_TIA w/ Mount Pipe	125
PCS/AWS DULA-BAND RRH B2/B66	168	APXVAALL24_43-U-NA20_TIA w/ Mount Pipe	125
Junction Box	168	APXVAALL24_43-U-NA20_TIA w/ Mount Pipe	125
10' Dipole	168	APXVAALL24_43-U-NA20_TIA w/ Mount Pipe	125
Pirolod 12' T-Frame Sector Mount (1)	168	APXVAALL24_43-U-NA20_TIA w/ Mount Pipe	125
Pirolod 12' T-Frame Sector Mount (1)	154	APXVAALL24_43-U-NA20_TIA w/ Mount Pipe	125
Pirolod 12' T-Frame Sector Mount (1)	154	APXVAALL24_43-U-NA20_TIA w/ Mount Pipe	125
APXV9ERR18-C-A20_TIA w/ Mount Pipe	154	APXVAALL24_43-U-NA20_TIA w/ Mount Pipe	125
APXV9ERR18-C-A20_TIA w/ Mount Pipe	154	RADIO 4460 B25 B66	125
APXV9ERR18-C-A20_TIA w/ Mount Pipe	154	RADIO 4460 B25 B66	125
APXV9ERR18-C-A20_TIA w/ Mount Pipe	154	RADIO 4460 B25 B66	125
APXV9ERR18-C-A20_TIA w/ Mount Pipe	154	RADIO 4460 B25 B66	125
DT465B-2XR_TIA w/ Mount Pipe	154	Radio 4480	125
DT465B-2XR_TIA w/ Mount Pipe	154	Radio 4480	125
DT465B-2XR_TIA w/ Mount Pipe	154	Radio 4480	125
(2) RRH 800	154	Radio 4480	125
(2) RRH 800	154	Custom 4-Sided Sector Mount	125
(2) RRH 800	154	Pirolod 6-8' Box Arm	118
1900MHz 4X40W RRH	154	ANT150D3	105
1900MHz 4X40W RRH	154	Pirolod 6-8' Box Arm	105
1900MHz 4X40W RRH	154	6' Dish Ice Shield	101
TD-RRH8x20-25	154	Pirolod 6-8' Box Arm	98
TD-RRH8x20-25	154	PD458-2	98
TD-RRH8x20-25	154	Pirolod 6-8' Box Arm	98
TD-RRH8x20-25	154	6' Dish	97
Pirolod 12' T-Frame Sector Mount (1)	140	Pirolod 6-8' Box Arm	78
Pirolod 12' T-Frame Sector Mount (1)	140	PD220	78
Pirolod 12' T-Frame Sector Mount (1)	140	PD1142	78
7770_TIA w/ Mount Pipe	140	BCD-80609	78
7770_TIA w/ Mount Pipe	140	6' Yagi	78
7770_TIA w/ Mount Pipe	140	DB222	78
(2) TPA65R-BU6D_TIA w/ Mount Pipe	140	Pirolod 6-8' Box Arm	78
(2) TPA65R-BU6D_TIA w/ Mount Pipe	140	Pirolod 6-8' Box Arm	78
(2) TPA65R-BU6D_TIA w/ Mount Pipe	140	2-ft Stand Off	32
RRUS 4449 B5/B12	140	GPS	32
RRUS 4449 B5/B12	140		

ALL AR MA TO REACTI

SYMBOL LIST

MARK	SIZE	MARK	SIZE
A	2L2 1/2x2 1/2x3/16x3/16	C	2L2 1/2x2 1/2x3/16x1/2
B	L2 1/2x2 1/2x3/16	D	L3 1/2x3 1/2x5/16

MATERIAL STRENGTH

GRADE	Fy	Fu	GRADE	Fy	Fu
A572-50	50 ksi	65 ksi	A36	36 ksi	58 ksi

TOWER DESIGN NOTES

1. Tower is located in Litchfield County, Connecticut.
2. Tower designed for Exposure C to the TIA-222-G Standard.
3. Tower designed for a 93 mph basic wind in accordance with the TIA-222-G Standard.
4. Tower is also designed for a 40 mph basic wind with 1.00 in ice. Ice is considered to increase in thickness with height.
5. Deflections are based upon a 60 mph wind.
- 6.

EFI Global, Inc.
 1117 Perimeter Center West, Suite E500
 Atlanta, GA 30338
 Phone: (470) 990-6593
 FAX:

Job: **CTNH550A**
 Project: **049.02894 - 2275002**
 Client: **ForeSite LLC.** Drawn by: **Ahmet Colakoglu** App'd:
 Code: **TIA-222-G** Date: **06/09/22** Scale: **NTS**
 Path: _____ Dwg No. **E-1**

Section	T1	T2	T3	T4	T5	T6	T7	T8	T9	T10	T11	T12	T13		12	
Legs	P1rod 105216	P1rod 105217	P1rod 105218	P1rod 105219	P1rod 105220	P1rod 105220	P1rod 105220	P1rod 105220	P1rod 105220	P1rod 105220	P1rod 105220	P1rod 105220	P1rod 105220	P1rod 105220	P1rod 105220	P1rod 105244
Leg Grade	A572-50															
Diagonals	A36															
Diagonal Grade	A36															
Top Girts	N.A.															
Sec. Horizontals	N.A.															
Face Width (ft)	N.A.															
# Panels @ (ft)	17 @ 10															
Weight (lb)	47699.1	7945.8	7251.3	6968.6	5470.7	4478.3	1960.2	2207.4	3748.4	1525.1	1754.0	2245.7	1146.2	956.4		

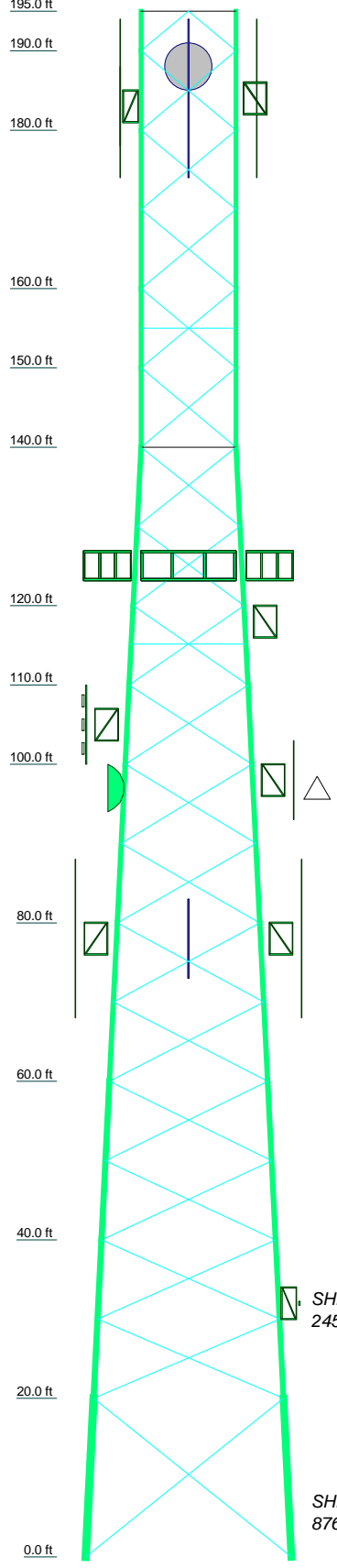

SYMBOL LIST

MARK	SIZE	MARK	SIZE
A	2L2 1/2x2 1/2x3/16x3/16	C	2L2 1/2x2 1/2x3/16x1/2
B	L2 1/2x2 1/2x3/16	D	L3 1/2x3 1/2x5/16

MATERIAL STRENGTH

GRADE	Fy	Fu	GRADE	Fy	Fu
A572-50	50 ksi	65 ksi	A36	36 ksi	58 ksi

TOWER DESIGN NOTES

1. Tower is located in Litchfield County, Connecticut.
2. Tower designed for Exposure C to the TIA-222-G Standard.
3. Tower designed for a 93 mph basic wind in accordance with the TIA-222-G Standard.
4. Tower is also designed for a 40 mph basic wind with 1.00 in ice. Ice is considered to increase in thickness with height.
5. Deflections are based upon a 60 mph wind.
6. Tower Structure Class III.
7. Topographic Category 1 with Crest Height of 0.00 ft
8. TOWER RATING: 91.1%

ALL REACTIONS ARE FACTORED

MAX. CORNER REACTIONS AT BASE:

DOWN: 442351 lb
SHEAR: 60392 lb

UPLIFT: -378419 lb
SHEAR: 52333 lb

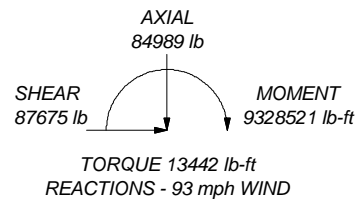
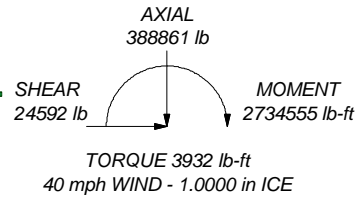

EFI Global, Inc.
 efi global 1117 Perimeter Center West, Suite E500
 Atlanta, GA 30338
 Phone: (470) 990-6593
 FAX:

Job: **CTNH550A**
 Project: **049.02894 - 2275002**
 Client: **ForeSite LLC.** Drawn by: **Ahmet Colakoglu** App'd:
 Code: **TIA-222-G** Date: **06/09/22** Scale: **NTS**
 Path: **Dwg No. E-1**

tnxTower EFI Global, Inc. 1117 Perimeter Center West, Suite E500 Atlanta, GA 30338 Phone: (470) 990-6593 FAX:	Job CTNH550A	Page 1 of 38
	Project 049.02894 - 2275002	Date 15:49:21 06/09/22
	Client ForeSite LLC.	Designed by Ahmet Colakoglu

Tower Input Data

The main tower is a 3x free standing tower with an overall height of 195.00 ft above the ground line.

The base of the tower is set at an elevation of 0.00 ft above the ground line.

The face width of the tower is 12.00 ft at the top and 26.00 ft at the base.

This tower is designed using the TIA-222-G standard.

The following design criteria apply:

Tower is located in Litchfield County, Connecticut.

Basic wind speed of 93 mph.

Structure Class III.

Exposure Category C.

Topographic Category 1.

Crest Height 0.00 ft.

Nominal ice thickness of 1.0000 in.

Ice thickness is considered to increase with height.

Ice density of 56 pcf.

A wind speed of 40 mph is used in combination with ice.

Temperature drop of 50 °F.

Deflections calculated using a wind speed of 60 mph.

A non-linear (P-delta) analysis was used.

Pressures are calculated at each section.

Stress ratio used in tower member design is 1.

Local bending stresses due to climbing loads, feed line supports, and appurtenance mounts are not considered.

Options

- | | | |
|--|---|--|
| <ul style="list-style-type: none"> Consider Moments - Legs Consider Moments - Horizontals Consider Moments - Diagonals Use Moment Magnification √ Use Code Stress Ratios √ Use Code Safety Factors - Guys Escalate Ice Always Use Max Kz Use Special Wind Profile √ Include Bolts In Member Capacity Leg Bolts Are At Top Of Section √ Secondary Horizontal Braces Leg Use Diamond Inner Bracing (4 Sided) SR Members Have Cut Ends SR Members Are Concentric | <ul style="list-style-type: none"> Distribute Leg Loads As Uniform Assume Legs Pinned √ Assume Rigid Index Plate √ Use Clear Spans For Wind Area √ Use Clear Spans For KL/r Retension Guys To Initial Tension √ Bypass Mast Stability Checks √ Use Azimuth Dish Coefficients √ Project Wind Area of Appurt. Autocalc Torque Arm Areas Add IBC .6D+W Combination √ Sort Capacity Reports By Component Triangulate Diamond Inner Bracing Treat Feed Line Bundles As Cylinder Ignore KL/ry For 60 Deg. Angle Legs | <ul style="list-style-type: none"> Use ASCE 10 X-Brace Ly Rules √ Calculate Redundant Bracing Forces Ignore Redundant Members in FEA √ SR Leg Bolts Resist Compression All Leg Panels Have Same Allowable Offset Girt At Foundation √ Consider Feed Line Torque √ Include Angle Block Shear Check Use TIA-222-G Bracing Resist. Exemption Use TIA-222-G Tension Splice Exemption <li style="background-color: #e0e0e0;">Poles Include Shear-Torsion Interaction Always Use Sub-Critical Flow Use Top Mounted Sockets Pole Without Linear Attachments Pole With Shroud Or No Appurtenances Outside and Inside Corner Radii Are Known |
|--|---|--|

tnxTower EFI Global, Inc. 1117 Perimeter Center West, Suite E500 Atlanta, GA 30338 Phone: (470) 990-6593 FAX:	Job CTNH550A	Page 2 of 38
	Project 049.02894 - 2275002	Date 15:49:21 06/09/22
	Client ForeSite LLC.	Designed by Ahmet Colakoglu

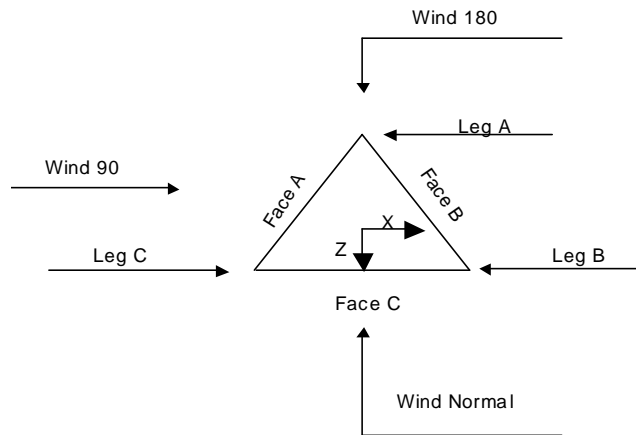

Triangular Tower

Tower Section Geometry

Tower Section	Tower Elevation	Assembly Database	Description	Section Width	Number of Sections	Section Length
	<i>ft</i>			<i>ft</i>		<i>ft</i>
T1	195.00-190.00			12.00	1	5.00
T2	190.00-180.00			12.00	1	10.00
T3	180.00-160.00			12.00	1	20.00
T4	160.00-150.00			12.00	1	10.00
T5	150.00-140.00			12.00	1	10.00
T6	140.00-120.00			12.00	1	20.00
T7	120.00-110.00			14.00	1	10.00
T8	110.00-100.00			15.00	1	10.00
T9	100.00-80.00			16.00	1	20.00
T10	80.00-60.00			18.00	1	20.00
T11	60.00-40.00			20.00	1	20.00
T12	40.00-20.00			22.00	1	20.00
T13	20.00-0.00			24.00	1	20.00

Tower Section Geometry (cont'd)

Tower Section	Tower Elevation	Diagonal Spacing	Bracing Type	Has K Brace End Panels	Has Horizontals	Top Girt Offset	Bottom Girt Offset
	<i>ft</i>	<i>ft</i>				<i>in</i>	<i>in</i>
T1	195.00-190.00	5.00	K Brace Down	No	Yes	0.0000	0.0000
T2	190.00-180.00	10.00	X Brace	No	No	0.0000	0.0000

tnxTower EFI Global, Inc. 1117 Perimeter Center West, Suite E500 Atlanta, GA 30338 Phone: (470) 990-6593 FAX:	Job	CTNH550A	Page	3 of 38
	Project	049.02894 - 2275002	Date	15:49:21 06/09/22
	Client	ForeSite LLC.	Designed by	Ahmet Colakoglu

Tower Section	Tower Elevation ft	Diagonal Spacing ft	Bracing Type	Has K Brace End Panels	Has Horizontals	Top Girt Offset in	Bottom Girt Offset in
T3	180.00-160.00	10.00	X Brace	No	No	0.0000	0.0000
T4	160.00-150.00	10.00	X Brace	No	Yes	0.0000	0.0000
T5	150.00-140.00	10.00	X Brace	No	No	0.0000	0.0000
T6	140.00-120.00	10.00	X Brace	No	Yes	0.0000	0.0000
T7	120.00-110.00	10.00	X Brace	No	Yes	0.0000	0.0000
T8	110.00-100.00	10.00	X Brace	No	No	0.0000	0.0000
T9	100.00-80.00	10.00	X Brace	No	No	0.0000	0.0000
T10	80.00-60.00	10.00	X Brace	No	No	0.0000	0.0000
T11	60.00-40.00	10.00	X Brace	No	No	0.0000	0.0000
T12	40.00-20.00	10.00	X Brace	No	No	0.0000	0.0000
T13	20.00-0.00	20.00	X Brace	No	No	0.0000	0.0000

Tower Section Geometry (cont'd)

Tower Elevation ft	Leg Type	Leg Size	Leg Grade	Diagonal Type	Diagonal Size	Diagonal Grade
T1 195.00-190.00	Truss Leg	Pirod 105244	A572-50 (50 ksi)	Double Equal Angle	2L2 1/2x2 1/2x3/16x3/16	A36 (36 ksi)
T2 190.00-180.00	Truss Leg	Pirod 105244	A572-50 (50 ksi)	Single Angle	L2 1/2x2 1/2x3/16	A36 (36 ksi)
T3 180.00-160.00	Truss Leg	Pirod 105216	A572-50 (50 ksi)	Single Angle	L3x3x3/16	A36 (36 ksi)
T4 160.00-150.00	Truss Leg	Pirod 105217	A572-50 (50 ksi)	Single Angle	L3x3x5/16	A36 (36 ksi)
T5 150.00-140.00	Truss Leg	Pirod 105217	A572-50 (50 ksi)	Single Angle	L3x3x5/16	A36 (36 ksi)
T6 140.00-120.00	Truss Leg	Pirod 105218	A572-50 (50 ksi)	Single Angle	L3x3x5/16	A36 (36 ksi)
T7 120.00-110.00	Truss Leg	Pirod 105218	A572-50 (50 ksi)	Single Angle	L3 1/2x3 1/2x5/16	A36 (36 ksi)
T8 110.00-100.00	Truss Leg	Pirod 105218	A572-50 (50 ksi)	Single Angle	L3 1/2x3 1/2x5/16	A36 (36 ksi)
T9 100.00-80.00	Truss Leg	Pirod 105219	A572-50 (50 ksi)	Single Angle	L4x4x1/4	A36 (36 ksi)
T10 80.00-60.00	Truss Leg	Pirod 105219	A572-50 (50 ksi)	Single Angle	L4x4x3/8	A36 (36 ksi)
T11 60.00-40.00	Truss Leg	Pirod 105220	A572-50 (50 ksi)	Single Angle	L5x5x3/8	A36 (36 ksi)
T12 40.00-20.00	Truss Leg	Pirod 105220	A572-50 (50 ksi)	Single Angle	L5x5x3/8	A36 (36 ksi)
T13 20.00-0.00	Truss Leg	Pirod 112738	A572-50 (50 ksi)	Double Equal Angle	2L3 1/2x3 1/2x5/16x3/8	A36 (36 ksi)

Tower Section Geometry (cont'd)

Tower Elevation ft	Top Girt Type	Top Girt Size	Top Girt Grade	Bottom Girt Type	Bottom Girt Size	Bottom Girt Grade
T6 140.00-120.00	Equal Angle	L3x3x5/16	A36 (36 ksi)	Pipe		A36 (36 ksi)

tnxTower EFI Global, Inc. 1117 Perimeter Center West, Suite E500 Atlanta, GA 30338 Phone: (470) 990-6593 FAX:	Job	CTNH550A	Page	4 of 38
	Project	049.02894 - 2275002	Date	15:49:21 06/09/22
	Client	ForeSite LLC.	Designed by	Ahmet Colakoglu

Tower Section Geometry (cont'd)

Tower Elevation	No. of Mid Girts	Mid Girt Type	Mid Girt Size	Mid Girt Grade	Horizontal Type	Horizontal Size	Horizontal Grade
ft							
T1 195.00-190.00	None	Flat Bar		A36 (36 ksi)	Double Equal Angle	2L2 1/2x2 1/2x3/16x1/2	A36 (36 ksi)

Tower Section Geometry (cont'd)

Tower Elevation	Secondary Horizontal Type	Secondary Horizontal Size	Secondary Horizontal Grade	Inner Bracing Type	Inner Bracing Size	Inner Bracing Grade
ft						
T4 160.00-150.00	Equal Angle	L3x3x5/16	A36 (36 ksi)	Single Angle		A36 (36 ksi)
T7 120.00-110.00	Equal Angle	L3 1/2x3 1/2x5/16	A36 (36 ksi)	Equal Angle		A36 (36 ksi)

Tower Section Geometry (cont'd)

Tower Elevation	Gusset Area (per face)	Gusset Thickness	Gusset Grade	Adjust. Factor A_f	Adjust. Factor A_r	Weight Mult.	Double Angle Stitch Bolt Spacing Diagonals	Double Angle Stitch Bolt Spacing Horizontals	Double Angle Stitch Bolt Spacing Redundants
ft	ft ²	in					in	in	in
T1	0.00	0.0000	A36	1	1	1.05	Mid-Pt	Mid-Pt	Mid-Pt
195.00-190.00			(36 ksi)						
T2	0.00	0.0000	A36	1	1	1.05	Mid-Pt	Mid-Pt	Mid-Pt
190.00-180.00			(36 ksi)						
T3	0.00	0.0000	A36	1	1	1.05	Mid-Pt	Mid-Pt	Mid-Pt
180.00-160.00			(36 ksi)						
T4	0.00	0.0000	A36	1	1	1.05	Mid-Pt	Mid-Pt	Mid-Pt
160.00-150.00			(36 ksi)						
T5	0.00	0.0000	A36	1	1	1.05	Mid-Pt	Mid-Pt	Mid-Pt
150.00-140.00			(36 ksi)						
T6	0.00	0.0000	A36	1	1	1.05	Mid-Pt	Mid-Pt	Mid-Pt
140.00-120.00			(36 ksi)						
T7	0.00	0.0000	A36	1	1	1.05	Mid-Pt	Mid-Pt	Mid-Pt
120.00-110.00			(36 ksi)						
T8	0.00	0.0000	A36	1	1	1.05	Mid-Pt	Mid-Pt	Mid-Pt
110.00-100.00			(36 ksi)						
T9	0.00	0.0000	A36	1	1	1.05	Mid-Pt	Mid-Pt	Mid-Pt
100.00-80.00			(36 ksi)						
T10	0.00	0.0000	A36	1	1	1.05	Mid-Pt	Mid-Pt	Mid-Pt
80.00-60.00			(36 ksi)						
T11	0.00	0.0000	A36	1	1	1.05	Mid-Pt	Mid-Pt	Mid-Pt
60.00-40.00			(36 ksi)						

tnxTower EFI Global, Inc. 1117 Perimeter Center West, Suite E500 Atlanta, GA 30338 Phone: (470) 990-6593 FAX:	Job CTNH550A	Page 5 of 38
	Project 049.02894 - 2275002	Date 15:49:21 06/09/22
	Client ForeSite LLC.	Designed by Ahmet Colakoglu

Tower Elevation	Gusset Area (per face)	Gusset Thickness	Gusset Grade	Adjust. Factor A_f	Adjust. Factor A_r	Weight Mult.	Double Angle Stitch Bolt Spacing Diagonals	Double Angle Stitch Bolt Spacing Horizontals	Double Angle Stitch Bolt Spacing Redundants
ft	ft ²	in					in	in	in
T12 40.00-20.00	0.00	0.0000	A36 (36 ksi)	1	1	1.05	Mid-Pt	Mid-Pt	Mid-Pt
T13 20.00-0.00	0.00	0.0000	A36 (36 ksi)	1	1	1.05	Mid-Pt	Mid-Pt	Mid-Pt

Tower Section Geometry (cont'd)

Tower Elevation	Calc K Single Angles	Calc K Solid Rounds	K Factors ¹								
			Legs	X Brace Diags	K Brace Diags	Single Diags	Girts	Horiz.	Sec. Horiz.	Inner Brace	
											X
ft			Y	Y	Y	Y	Y	Y	Y	Y	
T1 195.00-190.00	Yes	Yes	1	1	1	1	1	1	1	1	1
T2 190.00-180.00	Yes	Yes	1	1	1	1	1	1	1	1	1
T3 180.00-160.00	Yes	Yes	1	1	1	1	1	1	1	1	1
T4 160.00-150.00	Yes	Yes	1	1	1	1	1	1	1	1	1
T5 150.00-140.00	Yes	Yes	1	1	1	1	1	1	1	1	1
T6 140.00-120.00	Yes	Yes	1	1	1	1	1	1	1	1	1
T7 120.00-110.00	Yes	Yes	1	1	1	1	1	1	1	1	1
T8 110.00-100.00	Yes	Yes	1	1	1	1	1	1	1	1	1
T9 100.00-80.00	Yes	Yes	1	1	1	1	1	1	1	1	1
T10 80.00-60.00	Yes	Yes	1	1	1	1	1	1	1	1	1
T11 60.00-40.00	Yes	Yes	1	1	1	1	1	1	1	1	1
T12 40.00-20.00	Yes	Yes	1	1	1	1	1	1	1	1	1
T13 20.00-0.00	Yes	Yes	1	1	1	1	1	1	1	1	1

¹Note: K factors are applied to member segment lengths. K-braces without inner supporting members will have the K factor in the out-of-plane direction applied to the overall length.

Tower Section Geometry (cont'd)

Tower Elevation	Truss-Leg K Factors					
	Leg Panels	Truss-Legs Used As Leg Members		Leg Panels	Truss-Legs Used As Inner Members	
		X Brace Diagonals	Z Brace Diagonals		X Brace Diagonals	Z Brace Diagonals
ft						
T1 195.00-190.00	1	0.5	0.85	1	0.5	0.85

<p>tnxTower</p> <p>EFI Global, Inc. 1117 Perimeter Center West, Suite E500 Atlanta, GA 30338 Phone: (470) 990-6593 FAX:</p>	<p>Job</p> <p>CTNH550A</p>	<p>Page</p> <p>8 of 38</p>
	<p>Project</p> <p>049.02894 - 2275002</p>	<p>Date</p> <p>15:49:21 06/09/22</p>
	<p>Client</p> <p>ForeSite LLC.</p>	<p>Designed by</p> <p>Ahmet Colakoglu</p>

Tower Elevation ft	Leg Connection Type	Leg		Diagonal		Top Girt		Bottom Girt		Mid Girt		Long Horizontal		Short Horizontal	
		Bolt Size in	No.	Bolt Size in	No.	Bolt Size in	No.	Bolt Size in	No.	Bolt Size in	No.	Bolt Size in	No.	Bolt Size in	No.
T3 180.00-160.00	Flange	1.0000 A325N	6	1.0000 A325N	1	0.5000 A325N	0	0.5000 A325N	0	0.6250 A325N	0	0.0000 A325N	0	0.6250 A325N	0
T4 160.00-150.00	Flange	1.0000 A325N	6	1.0000 A325N	1	0.5000 A325N	0	0.0000 A325N	0	0.6250 A325N	0	0.0000 A325N	0	0.5000 A325N	2
T5 150.00-140.00	Flange	0.0000 A325N	0	1.0000 A325N	1	0.7500 A325N	0	0.5000 A325N	0	0.6250 A325N	0	0.0000 A325N	0	0.6250 A325N	0
T6 140.00-120.00	Flange	1.0000 A325N	6	1.0000 A325N	1	1.0000 A325N	1	0.0000 A325N	0	0.6250 A325N	0	0.0000 A325N	0	0.6250 A325N	0
T7 120.00-110.00	Flange	1.0000 A325N	6	1.0000 A325N	1	0.6250 A325N	0	0.0000 A325N	0	0.6250 A325N	0	0.0000 A325N	0	0.5000 A325N	1
T8 110.00-100.00	Flange	0.0000 A325N	0	1.0000 A325N	1	0.7500 A325N	0	0.0000 A325N	0	0.6250 A325N	0	0.0000 A325N	0	0.6250 A325N	0
T9 100.00-80.00	Flange	1.2500 A325N	6	1.2500 A325N	1	0.6250 A325N	0	0.0000 A325N	0	0.6250 A325N	0	0.0000 A325N	0	0.6250 A325N	0
T10 80.00-60.00	Flange	1.2500 A325N	6	1.2500 A325N	1	0.6250 A325N	0	0.0000 A325N	0	0.6250 A325N	0	0.0000 A325N	0	0.6250 A325N	0
T11 60.00-40.00	Flange	1.2500 A325N	6	1.2500 A325N	1	0.6250 A325N	0	0.5000 A325N	0	0.6250 A325N	0	0.0000 A325N	0	0.6250 A325N	0
T12 40.00-20.00	Flange	1.2500 A325N	6	1.2500 A325N	1	0.5000 A325N	0	0.5000 A325N	0	0.6250 A325N	0	0.0000 A325N	0	0.6250 A325N	0
T13 20.00-0.00	Flange	2.0000 A325N	6	1.0000 A325N	2	0.5000 A325N	0	0.5000 A325N	0	0.6250 A325N	0	0.0000 A325N	0	0.6250 A325N	0

Feed Line/Linear Appurtenances - Entered As Round Or Flat

Description	Face or Leg	Allow Shield	Exclude From Torque Calculation	Component Type	Placement ft	Total Number	Number Per Row	Clear Spacing in	Width or Diameter in	Perimeter in	Weight plf
**											
**											

Feed Line/Linear Appurtenances - Entered As Area

Description	Face or Leg	Allow Shield	Exclude From Torque Calculation	Component Type	Placement ft	Face Offset in	Lateral Offset (Frac FW)	#	C _{AA} ft ² /ft	Weight plf
**										
**										
Hybriflex 1-5/8"	C	No	Yes	CaAa (In Face)	125.00 - 0.00	-3.0000	0.47	6	No Ice 1/2" Ice 1" Ice	1.90 0.00 0.00
**										
1-1/4"	A	No	Yes	CaAa (In Face)	154.00 - 8.00	0.0000	0	3	No Ice 1/2" Ice 1" Ice	0.13 0.23 3.44
1"	A	No	Yes	CaAa (In Face)	154.00 - 8.00	0.0000	0	1	No Ice	0.10 0.30

tnxTower EFI Global, Inc. 1117 Perimeter Center West, Suite E500 Atlanta, GA 30338 Phone: (470) 990-6593 FAX:	Job CTNH550A	Page 9 of 38
	Project 049.02894 - 2275002	Date 15:49:21 06/09/22
	Client ForeSite LLC.	Designed by Ahmet Colakoglu

Description	Face or Leg	Allow Shield	Exclude From Torque Calculation	Component Type	Placement ft	Face Offset in	Lateral Offset (Frac FW)	#	CAAA ft ² /ft	Weight plf
				Face)					Ice	1.21
									1/2"	2.73
									Ice	
									1" Ice	
1/2"	A	No	Yes	CaAa (In Face)	154.00 - 8.00	0.0000	0	1	No	0.06
									Ice	0.15
									1/2"	0.84
									Ice	2.14
									1" Ice	
3/8"	A	No	Yes	CaAa (In Face)	154.00 - 8.00	0.0000	0	10	No	0.04
									Ice	0.08
									1/2"	0.65
									Ice	1.84
									1" Ice	
1/2"	A	No	Yes	CaAa (In Face)	154.00 - 8.00	0.0000	0	2	No	0.06
									Ice	0.15
									1/2"	0.84
									Ice	2.14
									1" Ice	
1/2"	A	No	Yes	CaAa (In Face)	154.00 - 8.00	0.0000	0	1	No	0.06
									Ice	0.15
									1/2"	0.84
									Ice	2.14
									1" Ice	
**										
1-5/8"	A	No	Yes	CaAa (In Face)	168.00 - 8.00	0.0000	0	6	No	0.20
									Ice	0.82
									1/2"	2.33
									Ice	4.46
									1" Ice	
1-5/8"	A	No	Yes	CaAa (In Face)	168.00 - 8.00	0.0000	0	1	No	0.20
									Ice	0.82
									1/2"	2.33
									Ice	4.46
									1" Ice	
**										
1-5/8"	B	No	Yes	CaAa (In Face)	188.00 - 8.00	0.0000	0	6	No	0.20
									Ice	0.82
									1/2"	2.33
									Ice	4.46
									1" Ice	
1-1/4"	B	No	Yes	CaAa (In Face)	188.00 - 8.00	0.0000	0	2	No	0.13
									Ice	0.63
									1/2"	1.73
									Ice	3.44
									1" Ice	
7/8"	B	No	Yes	CaAa (In Face)	188.00 - 8.00	0.0000	0	2	No	0.11
									Ice	0.33
									1/2"	1.30
									Ice	2.88
									1" Ice	
**										
1-5/8"	C	No	Yes	CaAa (In Face)	140.00 - 8.00	0.0000	0	12	No	0.20
									Ice	0.82
									1/2"	2.33
									Ice	4.46
									1" Ice	
DC Cable	C	No	Yes	CaAa (In Face)	140.00 - 8.00	0.0000	0	6	No	0.20
									Ice	0.82
									1/2"	2.33
									Ice	4.46

tnxTower EFI Global, Inc. 1117 Perimeter Center West, Suite E500 Atlanta, GA 30338 Phone: (470) 990-6593 FAX:	Job	CTNH550A	Page	10 of 38
	Project	049.02894 - 2275002	Date	15:49:21 06/09/22
	Client	ForeSite LLC.	Designed by	Ahmet Colakoglu

Description	Face or Leg	Allow Shield	Exclude From Torque Calculation	Component Type	Placement ft	Face Offset in	Lateral Offset (Frac FW)	#	C _{AA} ft ² /ft	Weight plf
Fiber	C	No	Yes	CaAa (In Face)	140.00 - 8.00	0.0000	0	3	Ice 1" Ice No 0.20 Ice 0.30 1/2" 0.40	0.82 2.33 4.46
Ice 1" Ice										
**										

Feed Line/Linear Appurtenances Section Areas

Tower Section	Tower Elevation ft	Face	A _R ft ²	A _F ft ²	C _{AA} In Face ft ²	C _{AA} Out Face ft ²	Weight lb
T1	195.00-190.00	A	0.000	0.000	0.000	0.000	0.00
		B	0.000	0.000	0.000	0.000	0.00
		C	0.000	0.000	0.000	0.000	0.00
T2	190.00-180.00	A	0.000	0.000	0.000	0.000	0.00
		B	0.000	0.000	13.326	0.000	54.72
		C	0.000	0.000	0.000	0.000	0.00
T3	180.00-160.00	A	0.000	0.000	11.088	0.000	45.92
		B	0.000	0.000	33.316	0.000	136.80
		C	0.000	0.000	0.000	0.000	0.00
T4	160.00-150.00	A	0.000	0.000	18.581	0.000	71.76
		B	0.000	0.000	16.658	0.000	68.40
		C	0.000	0.000	0.000	0.000	0.00
T5	150.00-140.00	A	0.000	0.000	25.663	0.000	93.30
		B	0.000	0.000	16.658	0.000	68.40
		C	0.000	0.000	0.000	0.000	0.00
T6	140.00-120.00	A	0.000	0.000	51.326	0.000	186.60
		B	0.000	0.000	33.316	0.000	136.80
		C	0.000	0.000	83.160	0.000	401.40
T7	120.00-110.00	A	0.000	0.000	25.663	0.000	93.30
		B	0.000	0.000	16.658	0.000	68.40
		C	0.000	0.000	41.580	0.000	286.20
T8	110.00-100.00	A	0.000	0.000	25.663	0.000	93.30
		B	0.000	0.000	16.658	0.000	68.40
		C	0.000	0.000	41.580	0.000	286.20
T9	100.00-80.00	A	0.000	0.000	51.326	0.000	186.60
		B	0.000	0.000	33.316	0.000	136.80
		C	0.000	0.000	83.160	0.000	572.40
T10	80.00-60.00	A	0.000	0.000	51.326	0.000	186.60
		B	0.000	0.000	33.316	0.000	136.80
		C	0.000	0.000	83.160	0.000	572.40
T11	60.00-40.00	A	0.000	0.000	51.326	0.000	186.60
		B	0.000	0.000	33.316	0.000	136.80
		C	0.000	0.000	83.160	0.000	572.40
T12	40.00-20.00	A	0.000	0.000	51.326	0.000	186.60
		B	0.000	0.000	33.316	0.000	136.80
		C	0.000	0.000	83.160	0.000	572.40
T13	20.00-0.00	A	0.000	0.000	30.796	0.000	111.96
		B	0.000	0.000	19.990	0.000	82.08
		C	0.000	0.000	49.896	0.000	434.64

tnxTower EFI Global, Inc. 1117 Perimeter Center West, Suite E500 Atlanta, GA 30338 Phone: (470) 990-6593 FAX:	Job CTNH550A	Page 11 of 38
	Project 049.02894 - 2275002	Date 15:49:21 06/09/22
	Client ForeSite LLC.	Designed by Ahmet Colakoglu

Feed Line/Linear Appurtenances Section Areas - With Ice

Tower Section	Tower Elevation ft	Face or Leg	Ice Thickness in	A _R ft ²	A _F ft ²	C _{AA} In Face ft ²	C _{AA} Out Face ft ²	Weight lb
T1	195.00-190.00	A	2.982	0.000	0.000	0.000	0.000	0.00
		B		0.000	0.000	0.000	0.000	0.00
		C		0.000	0.000	0.000	0.000	0.00
T2	190.00-180.00	A	2.970	0.000	0.000	0.000	0.000	0.00
		B		0.000	0.000	60.852	0.000	1498.32
		C		0.000	0.000	0.000	0.000	0.00
T3	180.00-160.00	A	2.945	0.000	0.000	44.076	0.000	1106.64
		B		0.000	0.000	151.129	0.000	3698.95
		C		0.000	0.000	0.000	0.000	0.00
T4	160.00-150.00	A	2.918	0.000	0.000	101.459	0.000	2384.00
		B		0.000	0.000	75.023	0.000	1824.11
		C		0.000	0.000	0.000	0.000	0.00
T5	150.00-140.00	A	2.899	0.000	0.000	170.605	0.000	3871.14
		B		0.000	0.000	74.635	0.000	1805.94
		C		0.000	0.000	0.000	0.000	0.00
T6	140.00-120.00	A	2.867	0.000	0.000	338.062	0.000	7607.15
		B		0.000	0.000	148.011	0.000	3552.92
		C		0.000	0.000	324.018	0.000	7980.53
T7	120.00-110.00	A	2.832	0.000	0.000	167.284	0.000	3728.59
		B		0.000	0.000	73.306	0.000	1743.73
		C		0.000	0.000	160.542	0.000	3918.73
T8	110.00-100.00	A	2.807	0.000	0.000	166.001	0.000	3673.54
		B		0.000	0.000	72.793	0.000	1719.71
		C		0.000	0.000	159.464	0.000	3866.22
T9	100.00-80.00	A	2.764	0.000	0.000	327.709	0.000	7162.79
		B		0.000	0.000	143.870	0.000	3359.00
		C		0.000	0.000	315.322	0.000	7556.63
T10	80.00-60.00	A	2.695	0.000	0.000	320.850	0.000	6868.37
		B		0.000	0.000	141.126	0.000	3230.52
		C		0.000	0.000	309.560	0.000	7275.75
T11	60.00-40.00	A	2.606	0.000	0.000	311.932	0.000	6485.59
		B		0.000	0.000	137.559	0.000	3063.48
		C		0.000	0.000	302.069	0.000	6910.59
T12	40.00-20.00	A	2.476	0.000	0.000	298.954	0.000	5928.53
		B		0.000	0.000	132.367	0.000	2820.38
		C		0.000	0.000	291.167	0.000	6379.16
T13	20.00-0.00	A	2.219	0.000	0.000	163.914	0.000	2893.61
		B		0.000	0.000	73.237	0.000	1402.68
		C		0.000	0.000	161.715	0.000	3194.52

Feed Line Center of Pressure

Section	Elevation ft	CP _x in	CP _z in	CP _x Ice in	CP _z Ice in
T1	195.00-190.00	0.0000	0.0000	0.0000	0.0000
T2	190.00-180.00	0.0000	0.0000	0.0000	0.0000
T3	180.00-160.00	0.0000	0.0000	0.0000	0.0000
T4	160.00-150.00	0.0000	0.0000	0.0000	0.0000
T5	150.00-140.00	0.0000	0.0000	0.0000	0.0000
T6	140.00-120.00	0.0000	0.0000	0.0000	0.0000
T7	120.00-110.00	0.0000	0.0000	0.0000	0.0000
T8	110.00-100.00	0.0000	0.0000	0.0000	0.0000
T9	100.00-80.00	0.0000	0.0000	0.0000	0.0000

tnxTower EFI Global, Inc. 1117 Perimeter Center West, Suite E500 Atlanta, GA 30338 Phone: (470) 990-6593 FAX:	Job	CTNH550A	Page	12 of 38
	Project	049.02894 - 2275002	Date	15:49:21 06/09/22
	Client	ForeSite LLC.	Designed by	Ahmet Colakoglu

Section	Elevation	CP _x	CP _z	CP _x	CP _z
	ft	in	in	Ice in	Ice in
T10	80.00-60.00	0.0000	0.0000	0.0000	0.0000
T11	60.00-40.00	0.0000	0.0000	0.0000	0.0000
T12	40.00-20.00	0.0000	0.0000	0.0000	0.0000
T13	20.00-0.00	0.0000	0.0000	0.0000	0.0000

Shielding Factor Ka

Tower Section	Feed Line Record No.	Description	Feed Line Segment Elev.	K _a No Ice	K _a Ice
T2	15	1-5/8"	180.00 - 188.00	0.6000	0.5371
T2	16	1-1/4"	180.00 - 188.00	0.6000	0.5371
T2	17	7/8"	180.00 - 188.00	0.6000	0.5371
T3	12	1-5/8"	160.00 - 168.00	0.6000	0.5219
T3	13	1-5/8"	160.00 - 168.00	0.6000	0.5219
T3	15	1-5/8"	160.00 - 180.00	0.6000	0.5219
T3	16	1-1/4"	160.00 - 180.00	0.6000	0.5219
T3	17	7/8"	160.00 - 180.00	0.6000	0.5219
T4	5	1-1/4"	150.00 - 154.00	0.6000	0.4619
T4	6	1"	150.00 - 154.00	0.6000	0.4619
T4	7	1/2"	150.00 - 154.00	0.6000	0.4619
T4	8	3/8"	150.00 - 154.00	0.6000	0.4619
T4	9	1/2"	150.00 - 154.00	0.6000	0.4619
T4	10	1/2"	150.00 - 154.00	0.6000	0.4619
T4	12	1-5/8"	150.00 - 160.00	0.6000	0.4619
T4	13	1-5/8"	150.00 - 160.00	0.6000	0.4619
T4	15	1-5/8"	150.00 - 160.00	0.6000	0.4619
T4	16	1-1/4"	150.00 - 160.00	0.6000	0.4619
T4	17	7/8"	150.00 - 160.00	0.6000	0.4619
T5	5	1-1/4"	140.00 - 150.00	0.6000	0.5227
T5	6	1"	140.00 - 150.00	0.6000	0.5227
T5	7	1/2"	140.00 - 150.00	0.6000	0.5227
T5	8	3/8"	140.00 - 150.00	0.6000	0.5227

tnxTower

EFI Global, Inc.
1117 Perimeter Center West, Suite E500
Atlanta, GA 30338
Phone: (470) 990-6593
FAX:

Job	CTNH550A	Page	13 of 38
Project	049.02894 - 2275002	Date	15:49:21 06/09/22
Client	ForeSite LLC.	Designed by	Ahmet Colakoglu

Tower Section	Feed Line Record No.	Description	Feed Line Segment Elev.	K_a No Ice	K_a Ice
T5	9	1/2"	140.00 - 150.00	0.6000	0.5227
T5	10	1/2"	140.00 - 150.00	0.6000	0.5227
T5	12	1-5/8"	140.00 - 150.00	0.6000	0.5227
T5	13	1-5/8"	140.00 - 150.00	0.6000	0.5227
T5	15	1-5/8"	140.00 - 150.00	0.6000	0.5227
T5	16	1-1/4"	140.00 - 150.00	0.6000	0.5227
T5	17	7/8"	140.00 - 150.00	0.6000	0.5227
T6	3	Hybriflex 1-5/8"	120.00 - 125.00	0.6000	0.5191
T6	5	1-1/4"	120.00 - 140.00	0.6000	0.5191
T6	6	1"	120.00 - 140.00	0.6000	0.5191
T6	7	1/2"	120.00 - 140.00	0.6000	0.5191
T6	8	3/8"	120.00 - 140.00	0.6000	0.5191
T6	9	1/2"	120.00 - 140.00	0.6000	0.5191
T6	10	1/2"	120.00 - 140.00	0.6000	0.5191
T6	12	1-5/8"	120.00 - 140.00	0.6000	0.5191
T6	13	1-5/8"	120.00 - 140.00	0.6000	0.5191
T6	15	1-5/8"	120.00 - 140.00	0.6000	0.5191
T6	16	1-1/4"	120.00 - 140.00	0.6000	0.5191
T6	17	7/8"	120.00 - 140.00	0.6000	0.5191
T6	19	1-5/8"	120.00 - 140.00	0.6000	0.5191
T6	20	DC Cable	120.00 - 140.00	0.6000	0.5191
T6	21	Fiber	120.00 - 140.00	0.6000	0.5191
T7	3	Hybriflex 1-5/8"	110.00 - 120.00	0.6000	0.5071
T7	5	1-1/4"	110.00 - 120.00	0.6000	0.5071
T7	6	1"	110.00 - 120.00	0.6000	0.5071
T7	7	1/2"	110.00 - 120.00	0.6000	0.5071
T7	8	3/8"	110.00 - 120.00	0.6000	0.5071
T7	9	1/2"	110.00 - 120.00	0.6000	0.5071
T7	10	1/2"	110.00 - 120.00	0.6000	0.5071
T7	12	1-5/8"	110.00 - 120.00	0.6000	0.5071
T7	13	1-5/8"	110.00 - 120.00	0.6000	0.5071

tnxTower

EFI Global, Inc.
 1117 Perimeter Center West, Suite E500
 Atlanta, GA 30338
 Phone: (470) 990-6593
 FAX:

Job	CTNH550A	Page	14 of 38
Project	049.02894 - 2275002	Date	15:49:21 06/09/22
Client	ForeSite LLC.	Designed by	Ahmet Colakoglu

Tower Section	Feed Line Record No.	Description	Feed Line Segment Elev.	K_a No Ice	K_a Ice
T7	15	1-5/8"	110.00 - 120.00	0.6000	0.5071
T7	16	1-1/4"	110.00 - 120.00	0.6000	0.5071
T7	17	7/8"	110.00 - 120.00	0.6000	0.5071
T7	19	1-5/8"	110.00 - 120.00	0.6000	0.5071
T7	20	DC Cable	110.00 - 120.00	0.6000	0.5071
T7	21	Fiber	110.00 - 120.00	0.6000	0.5071
T8	3	Hybriflex 1-5/8"	100.00 - 110.00	0.6000	0.5899
T8	5	1-1/4"	100.00 - 110.00	0.6000	0.5899
T8	6	1"	100.00 - 110.00	0.6000	0.5899
T8	7	1/2"	100.00 - 110.00	0.6000	0.5899
T8	8	3/8"	100.00 - 110.00	0.6000	0.5899
T8	9	1/2"	100.00 - 110.00	0.6000	0.5899
T8	10	1/2"	100.00 - 110.00	0.6000	0.5899
T8	12	1-5/8"	100.00 - 110.00	0.6000	0.5899
T8	13	1-5/8"	100.00 - 110.00	0.6000	0.5899
T8	15	1-5/8"	100.00 - 110.00	0.6000	0.5899
T8	16	1-1/4"	100.00 - 110.00	0.6000	0.5899
T8	17	7/8"	100.00 - 110.00	0.6000	0.5899
T8	19	1-5/8"	100.00 - 110.00	0.6000	0.5899
T8	20	DC Cable	100.00 - 110.00	0.6000	0.5899
T8	21	Fiber	100.00 - 110.00	0.6000	0.5899
T9	3	Hybriflex 1-5/8"	80.00 - 100.00	0.6000	0.6000
T9	5	1-1/4"	80.00 - 100.00	0.6000	0.6000
T9	6	1"	80.00 - 100.00	0.6000	0.6000
T9	7	1/2"	80.00 - 100.00	0.6000	0.6000
T9	8	3/8"	80.00 - 100.00	0.6000	0.6000
T9	9	1/2"	80.00 - 100.00	0.6000	0.6000
T9	10	1/2"	80.00 - 100.00	0.6000	0.6000
T9	12	1-5/8"	80.00 - 100.00	0.6000	0.6000
T9	13	1-5/8"	80.00 - 100.00	0.6000	0.6000
T9	15	1-5/8"	80.00 - 100.00	0.6000	0.6000
T9	16	1-1/4"	80.00 - 100.00	0.6000	0.6000
T9	17	7/8"	80.00 - 100.00	0.6000	0.6000
T9	19	1-5/8"	80.00 - 100.00	0.6000	0.6000
T9	20	DC Cable	80.00 - 100.00	0.6000	0.6000
T9	21	Fiber	80.00 - 100.00	0.6000	0.6000
T9	3	Hybriflex 1-5/8"	60.00 - 80.00	0.6000	0.6000
T10	5	1-1/4"	60.00 - 80.00	0.6000	0.6000
T10	6	1"	60.00 - 80.00	0.6000	0.6000
T10	7	1/2"	60.00 - 80.00	0.6000	0.6000
T10	8	3/8"	60.00 - 80.00	0.6000	0.6000

<i>Tower Section</i>	<i>Feed Line Record No.</i>	<i>Description</i>	<i>Feed Line Segment Elev.</i>	<i>K_a No Ice</i>	<i>K_a Ice</i>
T10	9	1/2"	60.00 - 80.00	0.6000	0.6000
T10	10	1/2"	60.00 - 80.00	0.6000	0.6000
T10	12	1-5/8"	60.00 - 80.00	0.6000	0.6000
T10	13	1-5/8"	60.00 - 80.00	0.6000	0.6000
T10	15	1-5/8"	60.00 - 80.00	0.6000	0.6000
T10	16	1-1/4"	60.00 - 80.00	0.6000	0.6000
T10	17	7/8"	60.00 - 80.00	0.6000	0.6000
T10	19	1-5/8"	60.00 - 80.00	0.6000	0.6000
T10	20	DC Cable	60.00 - 80.00	0.6000	0.6000
T10	21	Fiber	60.00 - 80.00	0.6000	0.6000
T11	3	Hybriflex 1-5/8"	40.00 - 60.00	0.6000	0.6000
T11	5	1-1/4"	40.00 - 60.00	0.6000	0.6000
T11	6	1"	40.00 - 60.00	0.6000	0.6000
T11	7	1/2"	40.00 - 60.00	0.6000	0.6000
T11	8	3/8"	40.00 - 60.00	0.6000	0.6000
T11	9	1/2"	40.00 - 60.00	0.6000	0.6000
T11	10	1/2"	40.00 - 60.00	0.6000	0.6000
T11	12	1-5/8"	40.00 - 60.00	0.6000	0.6000
T11	13	1-5/8"	40.00 - 60.00	0.6000	0.6000
T11	15	1-5/8"	40.00 - 60.00	0.6000	0.6000
T11	16	1-1/4"	40.00 - 60.00	0.6000	0.6000
T11	17	7/8"	40.00 - 60.00	0.6000	0.6000
T11	19	1-5/8"	40.00 - 60.00	0.6000	0.6000
T11	20	DC Cable	40.00 - 60.00	0.6000	0.6000
T11	21	Fiber	40.00 - 60.00	0.6000	0.6000
T12	3	Hybriflex 1-5/8"	20.00 - 40.00	0.6000	0.6000
T12	5	1-1/4"	20.00 - 40.00	0.6000	0.6000
T12	6	1"	20.00 - 40.00	0.6000	0.6000
T12	7	1/2"	20.00 - 40.00	0.6000	0.6000
T12	8	3/8"	20.00 - 40.00	0.6000	0.6000
T12	9	1/2"	20.00 - 40.00	0.6000	0.6000
T12	10	1/2"	20.00 - 40.00	0.6000	0.6000
T12	12	1-5/8"	20.00 - 40.00	0.6000	0.6000
T12	13	1-5/8"	20.00 - 40.00	0.6000	0.6000
T12	15	1-5/8"	20.00 - 40.00	0.6000	0.6000
T12	16	1-1/4"	20.00 - 40.00	0.6000	0.6000
T12	17	7/8"	20.00 - 40.00	0.6000	0.6000
T12	19	1-5/8"	20.00 - 40.00	0.6000	0.6000
T12	20	DC Cable	20.00 - 40.00	0.6000	0.6000
T12	21	Fiber	20.00 - 40.00	0.6000	0.6000
T13	3	Hybriflex 1-5/8"	0.00 - 20.00	0.6000	0.6000
T13	5	1-1/4"	8.00 - 20.00	0.6000	0.6000
T13	6	1"	8.00 - 20.00	0.6000	0.6000
T13	7	1/2"	8.00 - 20.00	0.6000	0.6000
T13	8	3/8"	8.00 - 20.00	0.6000	0.6000
T13	9	1/2"	8.00 - 20.00	0.6000	0.6000
T13	10	1/2"	8.00 - 20.00	0.6000	0.6000
T13	12	1-5/8"	8.00 - 20.00	0.6000	0.6000
T13	13	1-5/8"	8.00 - 20.00	0.6000	0.6000
T13	15	1-5/8"	8.00 - 20.00	0.6000	0.6000
T13	16	1-1/4"	8.00 - 20.00	0.6000	0.6000
T13	17	7/8"	8.00 - 20.00	0.6000	0.6000
T13	19	1-5/8"	8.00 - 20.00	0.6000	0.6000
T13	20	DC Cable	8.00 - 20.00	0.6000	0.6000
T13	21	Fiber	8.00 - 20.00	0.6000	0.6000

tnxTower EFI Global, Inc. 1117 Perimeter Center West, Suite E500 Atlanta, GA 30338 Phone: (470) 990-6593 FAX:	Job	CTNH550A	Page	16 of 38
	Project	049.02894 - 2275002	Date	15:49:21 06/09/22
	Client	ForeSite LLC.	Designed by	Ahmet Colakoglu

Discrete Tower Loads

<i>Description</i>	<i>Face or Leg</i>	<i>Offset Type</i>	<i>Offsets: Horz Lateral Vert</i> <i>ft ft ft</i>	<i>Azimuth Adjustment</i> <i>°</i>	<i>Placement</i> <i>ft</i>	<i>C_{AA} Front</i> <i>ft²</i>	<i>C_{AA} Side</i> <i>ft²</i>	<i>Weight</i> <i>lb</i>
Pipe Mount [PM 602-1]	B	From Leg	1.00 0.00 0.00	0.0000	187.50	No Ice 2.78 1/2" Ice 3.21 1" Ice 3.64	2.78 3.21 3.64	93.00 114.63 141.16

Pirod 6-8' Box Arm	A	From Leg	2.75 0.00 0.00	0.0000	184.00	No Ice 4.50 1/2" Ice 9.87 1" Ice 15.24	4.50 9.87 15.24	210.00 280.00 340.00
Pirod 6-8' Box Arm	B	From Leg	2.75 0.00 0.00	0.0000	184.00	No Ice 4.50 1/2" Ice 9.87 1" Ice 15.24	4.50 9.87 15.24	210.00 280.00 340.00
Pirod 6-8' Box Arm	B	From Leg	2.75 0.00 0.00	0.0000	184.00	No Ice 4.50 1/2" Ice 9.87 1" Ice 15.24	4.50 9.87 15.24	210.00 280.00 340.00
ANT150D3	C	From Leg	3.00 0.00 0.00	0.0000	184.00	No Ice 1.60 1/2" Ice 2.88 1" Ice 4.16	1.60 2.88 4.16	18.00 23.40 28.80
(2) OGT9-840	A	From Leg	3.00 0.00 0.00	0.0000	184.00	No Ice 2.27 1/2" Ice 3.44 1" Ice 4.61	2.27 3.44 4.61	18.50 36.09 60.98
(2) OGT9-840	B	From Leg	3.00 0.00 0.00	0.0000	184.00	No Ice 2.27 1/2" Ice 3.44 1" Ice 4.61	2.27 3.44 4.61	18.50 36.09 60.98

ANT150F2	C	From Leg	3.00 0.00 0.00	0.0000	183.00	No Ice 1.23 1/2" Ice 1.53 1" Ice 1.84	1.23 1.53 1.84	13.00 22.47 35.41
3' Side Mount Standoff	C	From Leg	1.50 0.00 0.00	0.0000	183.00	No Ice 2.00 1/2" Ice 3.69 1" Ice 4.74	2.00 3.69 4.74	40.00 50.00 60.00

Pirod 12' T-Frame Sector Mount (1)	A	From Leg	1.50 0.00 0.00	0.0000	168.00	No Ice 13.60 1/2" Ice 18.40 1" Ice 23.20	13.60 18.40 23.20	470.00 600.00 730.00
Pirod 12' T-Frame Sector Mount (1)	B	From Leg	1.50 0.00 0.00	0.0000	168.00	No Ice 13.60 1/2" Ice 18.40 1" Ice 23.20	13.60 18.40 23.20	470.00 600.00 730.00
Pirod 12' T-Frame Sector Mount (1)	C	From Leg	1.50 0.00 0.00	0.0000	168.00	No Ice 13.60 1/2" Ice 18.40 1" Ice 23.20	13.60 18.40 23.20	470.00 600.00 730.00
(2) LPA-80090/4CF w/ Mount Pipe	A	From Leg	4.00 0.00 0.00	0.0000	168.00	No Ice 2.86 1/2" Ice 3.22 1" Ice 3.59	5.21 5.82 6.44	29.01 68.63 113.93
(2) LPA-80090/4CF w/ Mount Pipe	B	From Leg	4.00 0.00 0.00	0.0000	168.00	No Ice 2.86 1/2" Ice 3.22 1" Ice 3.59	5.21 5.82 6.44	29.01 68.63 113.93
(2) LPA-80090/4CF w/ Mount Pipe	C	From Leg	4.00 0.00 0.00	0.0000	168.00	No Ice 2.86 1/2" Ice 3.22 1" Ice 3.59	5.21 5.82 6.44	29.01 68.63 113.93
(2) NHH-65B-R2B_TIA	A	From Leg	4.00 0.00 0.00	0.0000	168.00	No Ice 8.08 1/2" Ice 8.53 1" Ice 9.00	5.34 5.79 6.26	43.70 93.75 149.90
(2) NHH-65B-R2B_TIA	B	From Leg	4.00 0.00 0.00	0.0000	168.00	No Ice 8.08 1/2" Ice 8.53 1" Ice 9.00	5.34 5.79 6.26	43.70 93.75 149.90

tnxTower EFI Global, Inc. 1117 Perimeter Center West, Suite E500 Atlanta, GA 30338 Phone: (470) 990-6593 FAX:	Job	CTNH550A	Page	17 of 38
	Project	049.02894 - 2275002	Date	15:49:21 06/09/22
	Client	ForeSite LLC.	Designed by	Ahmet Colakoglu

Description	Face or Leg	Offset Type	Offsets:		Azimuth Adjustment	Placement	CAAA		Weight
			Horz	Lateral			Front	Side	
			ft	ft	°	ft	ft ²	ft ²	lb
(2) NHH-65B-R2B_TIA	C	From Leg	4.00	0.0000	168.00	No Ice	8.08	5.34	43.70
			0.00			1/2" Ice	8.53	5.79	93.75
			0.00			1" Ice	9.00	6.26	149.90
MT6407-77A w/ Mount Pipe	A	From Leg	4.00	0.0000	168.00	No Ice	4.91	2.68	95.88
			0.00			1/2" Ice	5.26	3.14	135.60
			0.00			1" Ice	5.61	3.62	180.44
MT6407-77A w/ Mount Pipe	B	From Leg	4.00	0.0000	168.00	No Ice	4.91	2.68	95.88
			0.00			1/2" Ice	5.26	3.14	135.60
			0.00			1" Ice	5.61	3.62	180.44
MT6407-77A w/ Mount Pipe	C	From Leg	4.00	0.0000	168.00	No Ice	4.91	2.68	95.88
			0.00			1/2" Ice	5.26	3.14	135.60
			0.00			1" Ice	5.61	3.62	180.44
B5/B13 RRH-BR04C	A	From Leg	4.00	0.0000	168.00	No Ice	1.88	1.01	70.30
			0.00			1/2" Ice	2.05	1.14	86.73
			0.00			1" Ice	2.22	1.28	105.83
B5/B13 RRH-BR04C	B	From Leg	4.00	0.0000	168.00	No Ice	1.88	1.01	70.30
			0.00			1/2" Ice	2.05	1.14	86.73
			0.00			1" Ice	2.22	1.28	105.83
B5/B13 RRH-BR04C	C	From Leg	4.00	0.0000	168.00	No Ice	1.88	1.01	70.30
			0.00			1/2" Ice	2.05	1.14	86.73
			0.00			1" Ice	2.22	1.28	105.83
PCS/AWS DULA-BAND RRH B2/B66	A	From Leg	4.00	0.0000	168.00	No Ice	1.88	1.25	84.40
			0.00			1/2" Ice	2.05	1.39	102.74
			0.00			1" Ice	2.22	1.54	123.87
PCS/AWS DULA-BAND RRH B2/B66	B	From Leg	4.00	0.0000	168.00	No Ice	1.88	1.25	84.40
			0.00			1/2" Ice	2.05	1.39	102.74
			0.00			1" Ice	2.22	1.54	123.87
PCS/AWS DULA-BAND RRH B2/B66	C	From Leg	4.00	0.0000	168.00	No Ice	1.88	1.25	84.40
			0.00			1/2" Ice	2.05	1.39	102.74
			0.00			1" Ice	2.22	1.54	123.87
Junction Box	C	From Leg	4.00	0.0000	168.00	No Ice	3.78	2.51	32.00
			0.00			1/2" Ice	4.03	2.72	63.40
			0.00			1" Ice	4.29	2.94	98.56
10' Dipole	C	From Leg	4.00	0.0000	168.00	No Ice	6.67	6.67	25.00
			0.00			1/2" Ice	7.82	7.82	60.81
			0.00			1" Ice	8.65	8.65	105.11

Pirod 12' T-Frame Sector Mount (1)	A	From Leg	1.50	0.0000	154.00	No Ice	13.60	13.60	470.00
			0.00			1/2" Ice	18.40	18.40	600.00
			0.00			1" Ice	23.20	23.20	730.00
Pirod 12' T-Frame Sector Mount (1)	B	From Leg	1.50	0.0000	154.00	No Ice	13.60	13.60	470.00
			0.00			1/2" Ice	18.40	18.40	600.00
			0.00			1" Ice	23.20	23.20	730.00
Pirod 12' T-Frame Sector Mount (1)	C	From Leg	1.50	0.0000	154.00	No Ice	13.60	13.60	470.00
			0.00			1/2" Ice	18.40	18.40	600.00
			0.00			1" Ice	23.20	23.20	730.00
APXV9ERR18-C-A20_TIA w/ Mount Pipe	A	From Leg	3.00	0.0000	154.00	No Ice	8.26	7.47	95.05
			0.00			1/2" Ice	8.82	8.66	165.53
			0.00			1" Ice	9.35	9.56	244.04
APXV9ERR18-C-A20_TIA w/ Mount Pipe	B	From Leg	3.00	0.0000	154.00	No Ice	8.26	7.47	95.05
			0.00			1/2" Ice	8.82	8.66	165.53
			0.00			1" Ice	9.35	9.56	244.04
APXV9ERR18-C-A20_TIA w/ Mount Pipe	C	From Leg	3.00	0.0000	154.00	No Ice	8.26	7.47	95.05
			0.00			1/2" Ice	8.82	8.66	165.53
			0.00			1" Ice	9.35	9.56	244.04
DT465B-2XR_TIA w/ Mount Pipe	A	From Leg	3.00	0.0000	154.00	No Ice	9.34	7.63	83.52
			0.00			1/2" Ice	9.91	8.82	160.00

tnxTower EFI Global, Inc. 1117 Perimeter Center West, Suite E500 Atlanta, GA 30338 Phone: (470) 990-6593 FAX:	Job	CTNH550A	Page	18 of 38
	Project	049.02894 - 2275002	Date	15:49:21 06/09/22
	Client	ForeSite LLC.	Designed by	Ahmet Colakoglu

Description	Face or Leg	Offset Type	Offsets:		Azimuth Adjustment	Placement	C _{AA} Front	C _{AA} Side	Weight	
			Horz	Vert						
			ft	ft	°	ft	ft ²	ft ²	lb	
DT465B-2XR_TIA w/ Mount Pipe	B	From Leg	0.00		0.0000	154.00	1" Ice	10.44	9.72	244.63
			3.00				No Ice	9.34	7.63	83.52
			0.00				1/2" Ice	9.91	8.82	160.00
DT465B-2XR_TIA w/ Mount Pipe	C	From Leg	0.00		0.0000	154.00	1" Ice	10.44	9.72	244.63
			3.00				No Ice	9.34	7.63	83.52
			0.00				1/2" Ice	9.91	8.82	160.00
(2) RRH 800	A	From Leg	0.00		0.0000	154.00	1" Ice	10.44	9.72	244.63
			3.00				No Ice	1.72	1.43	46.00
			0.00				1/2" Ice	1.90	1.60	62.55
(2) RRH 800	B	From Leg	0.00		0.0000	154.00	1" Ice	2.07	1.76	81.83
			3.00				No Ice	1.72	1.43	46.00
			0.00				1/2" Ice	1.90	1.60	62.55
(2) RRH 800	C	From Leg	0.00		0.0000	154.00	1" Ice	2.07	1.76	81.83
			3.00				No Ice	1.72	1.43	46.00
			0.00				1/2" Ice	1.90	1.60	62.55
1900MHz 4X40W RRH	A	From Leg	0.00		0.0000	154.00	1" Ice	2.07	1.76	81.83
			3.00				No Ice	2.32	2.24	59.50
			0.00				1/2" Ice	2.53	2.44	82.63
1900MHz 4X40W RRH	B	From Leg	0.00		0.0000	154.00	1" Ice	2.74	2.65	109.00
			3.00				No Ice	2.32	2.24	59.50
			0.00				1/2" Ice	2.53	2.44	82.63
1900MHz 4X40W RRH	C	From Leg	0.00		0.0000	154.00	1" Ice	2.74	2.65	109.00
			3.00				No Ice	2.32	2.24	59.50
			0.00				1/2" Ice	2.53	2.44	82.63
TD-RRH8x20-25	A	From Leg	0.00		0.0000	154.00	1" Ice	2.74	2.65	109.00
			3.00				No Ice	4.05	1.53	70.00
			0.00				1/2" Ice	4.30	1.71	97.15
TD-RRH8x20-25	B	From Leg	0.00		0.0000	154.00	1" Ice	4.56	1.90	127.83
			3.00				No Ice	4.05	1.53	70.00
			0.00				1/2" Ice	4.30	1.71	97.15
TD-RRH8x20-25	C	From Leg	0.00		0.0000	154.00	1" Ice	4.56	1.90	127.83
			3.00				No Ice	4.05	1.53	70.00
			0.00				1/2" Ice	4.30	1.71	97.15

Pirod 12' T-Frame Sector Mount (1)	A	From Leg	1.50		0.0000	140.00	No Ice	13.60	13.60	470.00
			0.00				1/2" Ice	18.40	18.40	600.00
			0.00				1" Ice	23.20	23.20	730.00
Pirod 12' T-Frame Sector Mount (1)	B	From Leg	1.50		0.0000	140.00	No Ice	13.60	13.60	470.00
			0.00				1/2" Ice	18.40	18.40	600.00
			0.00				1" Ice	23.20	23.20	730.00
Pirod 12' T-Frame Sector Mount (1)	C	From Leg	1.50		0.0000	140.00	No Ice	13.60	13.60	470.00
			0.00				1/2" Ice	18.40	18.40	600.00
			0.00				1" Ice	23.20	23.20	730.00
7770_TIA w/ Mount Pipe	A	From Leg	3.00		0.0000	140.00	No Ice	5.75	4.25	55.38
			0.00				1/2" Ice	6.18	5.01	102.81
			0.00				1" Ice	6.61	5.71	156.64
7770_TIA w/ Mount Pipe	B	From Leg	3.00		0.0000	140.00	No Ice	5.75	4.25	55.38
			0.00				1/2" Ice	6.18	5.01	102.81
			0.00				1" Ice	6.61	5.71	156.64
7770_TIA w/ Mount Pipe	C	From Leg	3.00		0.0000	140.00	No Ice	5.75	4.25	55.38
			0.00				1/2" Ice	6.18	5.01	102.81
			0.00				1" Ice	6.61	5.71	156.64
(2) TPA65R-BU6D_TIA w/ Mount Pipe	A	From Leg	3.00		0.0000	140.00	No Ice	13.11	7.32	97.81
			0.00				1/2" Ice	13.71	8.49	191.16
			0.00				1" Ice	14.28	9.37	293.06
(2) TPA65R-BU6D_TIA w/	B	From Leg	3.00		0.0000	140.00	No Ice	13.11	7.32	97.81

tnxTower EFI Global, Inc. 1117 Perimeter Center West, Suite E500 Atlanta, GA 30338 Phone: (470) 990-6593 FAX:	Job		CTNH550A					Page	
	Project		049.02894 - 2275002					Date	
	Client		ForeSite LLC.					Designed by	
							19 of 38		
							15:49:21 06/09/22		
							Ahmet Colakoglu		

Description	Face or Leg	Offset Type	Offsets:		Azimuth Adjustment	Placement	CAAA Front	CAAA Side	Weight	
			Horz	Vert						
			ft	ft	°	ft	ft ²	ft ²	lb	
Mount Pipe			0.00			1/2" Ice	13.71	8.49	191.16	
			0.00			1" Ice	14.28	9.37	293.06	
(2) TPA65R-BU6D_TIA w/ Mount Pipe	C	From Leg	3.00		0.0000	140.00	No Ice	13.11	7.32	97.81
			0.00				1/2" Ice	13.71	8.49	191.16
			0.00				1" Ice	14.28	9.37	293.06
RRUS 4449 B5/B12	A	From Leg	3.00		0.0000	140.00	No Ice	1.97	1.41	71.00
			0.00				1/2" Ice	2.14	1.56	89.51
			0.00				1" Ice	2.33	1.73	110.84
RRUS 4449 B5/B12	B	From Leg	3.00		0.0000	140.00	No Ice	1.97	1.41	71.00
			0.00				1/2" Ice	2.14	1.56	89.51
			0.00				1" Ice	2.33	1.73	110.84
RRUS 4449 B5/B12	C	From Leg	3.00		0.0000	140.00	No Ice	1.97	1.41	71.00
			0.00				1/2" Ice	2.14	1.56	89.51
			0.00				1" Ice	2.33	1.73	110.84
RRUS 4478 B14	A	From Leg	3.00		0.0000	140.00	No Ice	1.84	1.06	59.90
			0.00				1/2" Ice	2.01	1.20	75.78
			0.00				1" Ice	2.19	1.34	94.29
RRUS 4478 B14	B	From Leg	3.00		0.0000	140.00	No Ice	1.84	1.06	59.90
			0.00				1/2" Ice	2.01	1.20	75.78
			0.00				1" Ice	2.19	1.34	94.29
RRUS 4478 B14	C	From Leg	3.00		0.0000	140.00	No Ice	1.84	1.06	59.90
			0.00				1/2" Ice	2.01	1.20	75.78
			0.00				1" Ice	2.19	1.34	94.29
RRUS 32	A	From Leg	3.00		0.0000	140.00	No Ice	2.86	1.78	55.12
			0.00				1/2" Ice	3.08	1.97	77.39
			0.00				1" Ice	3.32	2.17	102.93
RRUS 32	B	From Leg	3.00		0.0000	140.00	No Ice	2.86	1.78	55.12
			0.00				1/2" Ice	3.08	1.97	77.39
			0.00				1" Ice	3.32	2.17	102.93
RRUS 32	C	From Leg	3.00		0.0000	140.00	No Ice	2.86	1.78	55.12
			0.00				1/2" Ice	3.08	1.97	77.39
			0.00				1" Ice	3.32	2.17	102.93
Diplexer	A	From Leg	3.00		0.0000	140.00	No Ice	0.24	0.10	6.00
			0.00				1/2" Ice	0.31	0.14	8.47
			0.00				1" Ice	0.38	0.20	12.04
Diplexer	B	From Leg	3.00		0.0000	140.00	No Ice	0.24	0.10	6.00
			0.00				1/2" Ice	0.31	0.14	8.47
			0.00				1" Ice	0.38	0.20	12.04
Diplexer	C	From Leg	3.00		0.0000	140.00	No Ice	0.24	0.10	6.00
			0.00				1/2" Ice	0.31	0.14	8.47
			0.00				1" Ice	0.38	0.20	12.04
DC6 Surge Arrestor	A	From Leg	3.00		0.0000	140.00	No Ice	3.05	1.24	44.00
			0.00				1/2" Ice	3.26	1.40	65.28
			0.00				1" Ice	3.49	1.72	89.65
Squid Surge Arrestor	B	From Leg	3.00		0.0000	140.00	No Ice	0.81	0.81	33.00
			0.00				1/2" Ice	1.30	1.30	48.38
			0.00				1" Ice	1.48	1.48	66.11
Squid Surge Arrestor	C	From Leg	3.00		0.0000	140.00	No Ice	0.81	0.81	33.00
			0.00				1/2" Ice	1.30	1.30	48.38
			0.00				1" Ice	1.48	1.48	66.11
**										
**										

Custom 4-Sided Sector Mount	C	None			0.0000	125.00	No Ice	36.00	36.00	3000.00
							1/2" Ice	42.00	42.00	3300.00
							1" Ice	48.00	48.00	3600.00
8'-P3x0.216	A	From Leg	4.00		0.0000	125.00	No Ice	2.67	2.67	72.96

<p>tnxTower</p> <p>EFI Global, Inc. 1117 Perimeter Center West, Suite E500 Atlanta, GA 30338 Phone: (470) 990-6593 FAX:</p>	Job		CTNH550A					Page	
	Project		049.02894 - 2275002					Date	
	Client		ForeSite LLC.					Designed by	
							20 of 38		
							15:49:21 06/09/22		
							Ahmet Colakoglu		

Description	Face or Leg	Offset Type	Offsets:		Azimuth Adjustment	Placement	CAAA Front	CAAA Side	Weight
			Horz	Vert					
			ft	ft	°	ft	ft ²	ft ²	lb
			0.00			1/2" Ice	3.41	3.41	93.02
			0.00			1" Ice	3.89	3.89	118.48
8'-P3x0.216	B	From Leg	4.00	0.0000	125.00	No Ice	2.67	2.67	72.96
			0.00			1/2" Ice	3.41	3.41	93.02
			0.00			1" Ice	3.89	3.89	118.48
8'-P3x0.216	C	From Leg	4.00	0.0000	125.00	No Ice	2.67	2.67	72.96
			0.00			1/2" Ice	3.41	3.41	93.02
			0.00			1" Ice	3.89	3.89	118.48
8'-P3x0.216	C	From Face	4.00	0.0000	125.00	No Ice	2.67	2.67	72.96
			0.00			1/2" Ice	3.41	3.41	93.02
			0.00			1" Ice	3.89	3.89	118.48
AIR 6449 B41_TIA w/ Mount Pipe	A	From Leg	4.00	0.0000	125.00	No Ice	5.87	3.27	128.35
			0.00			1/2" Ice	6.23	3.73	177.29
			0.00			1" Ice	6.61	4.20	231.68
AIR 6449 B41_TIA w/ Mount Pipe	B	From Leg	4.00	0.0000	125.00	No Ice	5.87	3.27	128.35
			0.00			1/2" Ice	6.23	3.73	177.29
			0.00			1" Ice	6.61	4.20	231.68
AIR 6449 B41_TIA w/ Mount Pipe	C	From Leg	4.00	0.0000	125.00	No Ice	5.87	3.27	128.35
			0.00			1/2" Ice	6.23	3.73	177.29
			0.00			1" Ice	6.61	4.20	231.68
AIR 6449 B41_TIA w/ Mount Pipe	C	From Face	4.00	0.0000	125.00	No Ice	5.87	3.27	128.35
			0.00			1/2" Ice	6.23	3.73	177.29
			0.00			1" Ice	6.61	4.20	231.68
VV-65A-R1_TIA w/ Mount Pipe	A	From Leg	4.00	0.0000	125.00	No Ice	6.12	4.05	53.59
			0.00			1/2" Ice	6.56	4.80	101.88
			0.00			1" Ice	6.99	5.49	156.58
VV-65A-R1_TIA w/ Mount Pipe	B	From Leg	4.00	0.0000	125.00	No Ice	6.12	4.05	53.59
			0.00			1/2" Ice	6.56	4.80	101.88
			0.00			1" Ice	6.99	5.49	156.58
VV-65A-R1_TIA w/ Mount Pipe	C	From Leg	4.00	0.0000	125.00	No Ice	6.12	4.05	53.59
			0.00			1/2" Ice	6.56	4.80	101.88
			0.00			1" Ice	6.99	5.49	156.58
VV-65A-R1_TIA w/ Mount Pipe	C	From Face	4.00	0.0000	125.00	No Ice	6.12	4.05	53.59
			0.00			1/2" Ice	6.56	4.80	101.88
			0.00			1" Ice	6.99	5.49	156.58
APXVAALL24_43-U-NA20_TIA w/ Mount Pipe	A	From Leg	4.00	0.0000	125.00	No Ice	20.48	10.87	182.72
			0.00			1/2" Ice	21.23	12.39	318.21
			0.00			1" Ice	21.99	13.94	464.50
APXVAALL24_43-U-NA20_TIA w/ Mount Pipe	B	From Leg	4.00	0.0000	125.00	No Ice	20.48	10.87	182.72
			0.00			1/2" Ice	21.23	12.39	318.21
			0.00			1" Ice	21.99	13.94	464.50
APXVAALL24_43-U-NA20_TIA w/ Mount Pipe	C	From Leg	4.00	0.0000	125.00	No Ice	20.48	10.87	182.72
			0.00			1/2" Ice	21.23	12.39	318.21
			0.00			1" Ice	21.99	13.94	464.50
APXVAALL24_43-U-NA20_TIA w/ Mount Pipe	C	From Face	4.00	0.0000	125.00	No Ice	20.48	10.87	182.72
			0.00			1/2" Ice	21.23	12.39	318.21
			0.00			1" Ice	21.99	13.94	464.50
RADIO 4460 B25 B66	A	From Leg	4.00	0.0000	125.00	No Ice	2.14	1.69	109.00
			0.00			1/2" Ice	2.32	1.85	131.16
			0.00			1" Ice	2.51	2.02	156.36
RADIO 4460 B25 B66	B	From Leg	4.00	0.0000	125.00	No Ice	2.14	1.69	109.00
			0.00			1/2" Ice	2.32	1.85	131.16
			0.00			1" Ice	2.51	2.02	156.36
RADIO 4460 B25 B66	C	From Leg	4.00	0.0000	125.00	No Ice	2.14	1.69	109.00
			0.00			1/2" Ice	2.32	1.85	131.16
			0.00			1" Ice	2.51	2.02	156.36
RADIO 4460 B25 B66	C	From Face	4.00	0.0000	125.00	No Ice	2.14	1.69	109.00

tnxTower EFI Global, Inc. 1117 Perimeter Center West, Suite E500 Atlanta, GA 30338 Phone: (470) 990-6593 FAX:	Job	CTNH550A	Page	21 of 38
	Project	049.02894 - 2275002	Date	15:49:21 06/09/22
	Client	ForeSite LLC.	Designed by	Ahmet Colakoglu

Description	Face or Leg	Offset Type	Offsets:		Azimuth Adjustment	Placement	CAAA Front	CAAA Side	Weight
			Horz	Lateral					
			0.00						
			0.00			1/2" Ice	2.32	1.85	131.16
			0.00			1" Ice	2.51	2.02	156.36
Radio 4480	C	From Leg	4.00	0.0000	125.00	No Ice	2.80	1.38	93.00
			0.00			1/2" Ice	3.01	1.54	114.40
			0.00			1" Ice	3.23	1.71	138.90
Radio 4480	C	From Leg	4.00	0.0000	125.00	No Ice	2.80	1.38	93.00
			0.00			1/2" Ice	3.01	1.54	114.40
			0.00			1" Ice	3.23	1.71	138.90
Radio 4480	C	From Leg	4.00	0.0000	125.00	No Ice	2.80	1.38	93.00
			0.00			1/2" Ice	3.01	1.54	114.40
			0.00			1" Ice	3.23	1.71	138.90
Radio 4480	C	From Leg	4.00	0.0000	125.00	No Ice	2.80	1.38	93.00
			0.00			1/2" Ice	3.01	1.54	114.40
			0.00			1" Ice	3.23	1.71	138.90
***			0.00			1" Ice	3.23	1.71	138.90
Pirod 6-8' Box Arm	B	From Leg	3.00	0.0000	118.00	No Ice	4.50	4.50	210.00
			0.00			1/2" Ice	9.87	9.87	280.00
			0.00			1" Ice	15.24	15.24	340.00
***			0.00			1" Ice	15.24	15.24	340.00
Pirod 6-8' Box Arm	C	From Leg	3.00	0.0000	105.00	No Ice	4.50	4.50	210.00
			0.00			1/2" Ice	9.87	9.87	280.00
			0.00			1" Ice	15.24	15.24	340.00
ANT150D3	C	From Leg	6.00	0.0000	105.00	No Ice	1.60	1.60	18.00
			0.00			1/2" Ice	2.88	2.88	23.40
			0.00			1" Ice	4.16	4.16	28.80
***			0.00			1" Ice	4.16	4.16	28.80
6' Dish Ice Shield	C	From Leg	3.00	0.0000	101.00	No Ice	5.00	5.00	210.00
			0.00			1/2" Ice	7.00	7.00	280.00
			0.00			1" Ice	9.00	9.00	340.00
***			0.00			1" Ice	9.00	9.00	340.00
Pirod 6-8' Box Arm	A	From Leg	3.00	0.0000	98.00	No Ice	4.50	4.50	210.00
			0.00			1/2" Ice	9.87	9.87	280.00
			0.00			1" Ice	15.24	15.24	340.00
Pirod 6-8' Box Arm	B	From Leg	3.00	0.0000	98.00	No Ice	4.50	4.50	210.00
			0.00			1/2" Ice	9.87	9.87	280.00
			0.00			1" Ice	15.24	15.24	340.00
PD458-2	B	From Leg	6.00	0.0000	98.00	No Ice	3.40	3.40	22.00
			0.00			1/2" Ice	4.79	4.79	47.24
			0.00			1" Ice	6.20	6.20	81.19
***			0.00			1" Ice	6.20	6.20	81.19
Pirod 6-8' Box Arm	A	From Leg	3.00	0.0000	78.00	No Ice	4.50	4.50	210.00
			0.00			1/2" Ice	9.87	9.87	280.00
			0.00			1" Ice	15.24	15.24	340.00
Pirod 6-8' Box Arm	B	From Leg	3.00	0.0000	78.00	No Ice	4.50	4.50	210.00
			0.00			1/2" Ice	9.87	9.87	280.00
			0.00			1" Ice	15.24	15.24	340.00
Pirod 6-8' Box Arm	C	From Leg	3.00	0.0000	78.00	No Ice	4.50	4.50	210.00
			0.00			1/2" Ice	9.87	9.87	280.00
			0.00			1" Ice	15.24	15.24	340.00
PD220	A	From Leg	6.00	0.0000	78.00	No Ice	3.08	3.08	210.00
			0.00			1/2" Ice	5.30	5.30	280.00
			0.00			1" Ice	7.54	7.54	340.00
PD1142	A	From Leg	6.00	0.0000	78.00	No Ice	1.32	1.32	10.00
			0.00			1/2" Ice	3.21	3.21	23.85
			0.00			1" Ice	5.12	5.12	49.42
BCD-80609	B	From Leg	6.00	0.0000	78.00	No Ice	2.95	2.95	26.50
			0.00			1/2" Ice	4.11	4.11	48.29

tnxTower EFI Global, Inc. 1117 Perimeter Center West, Suite E500 Atlanta, GA 30338 Phone: (470) 990-6593 FAX:	Job	CTNH550A	Page	22 of 38
	Project	049.02894 - 2275002	Date	15:49:21 06/09/22
	Client	ForeSite LLC.	Designed by	Ahmet Colakoglu

Description	Face or Leg	Offset Type	Offsets:		Azimuth Adjustment	Placement	CAAA Front	CAAA Side	Weight	
			Horz Lateral	Vert						
			ft	ft	°	ft	ft ²	ft ²	lb	
6' Yagi	B	From Leg	0.00	0.00	0.0000	78.00	1" Ice	5.29	5.29	77.42
			6.00	0.00			No Ice	5.00	5.00	40.00
			0.00	0.00			1/2" Ice	6.50	6.50	60.00
			0.00	0.00			1" Ice	8.00	8.00	80.00
DB222	C	From Leg	6.00	0.00	0.0000	78.00	No Ice	1.60	1.60	20.00
			0.00	0.00			1/2" Ice	2.88	2.88	20.00
			0.00	0.00			1" Ice	4.16	4.16	30.00
			0.00	0.00						

2-ft Stand Off	B	From Leg	1.50	0.00	0.0000	32.00	No Ice	1.07	1.07	20.00
			0.00	0.00			1/2" Ice	1.62	1.62	30.00
			0.00	0.00			1" Ice	2.17	2.17	40.00
			0.00	0.00						
GPS	B	From Leg	3.00	0.00	0.0000	32.00	No Ice	0.33	0.33	6.08
			0.00	0.00			1/2" Ice	0.48	0.48	11.71
			0.00	0.00			1" Ice	0.65	0.65	18.88
			0.00	0.00						
**										
*										
*										
*										
*										
*										

Dishes

Description	Face or Leg	Dish Type	Offset Type	Offsets:		Azimuth Adjustment	3 dB Beam Width	Elevation	Outside Diameter	Aperture Area	Weight	
				Horz Lateral	Vert							
			ft	ft	°	°	ft	ft	ft ²	lb		
6' Dish	A	Paraboloid w/o Radome	From Leg	0.00	0.00	0.0000		188.00	6.00	No Ice	28.30	80.00
				0.00	0.00					1/2" Ice	29.05	100.00
				0.00	0.00					1" Ice	29.80	120.00
				0.00	0.00							
6' Dish	C	Paraboloid w/o Radome	From Leg	0.00	0.00	0.0000		97.00	6.00	No Ice	28.30	80.00
				0.00	0.00					1/2" Ice	29.05	100.00
				0.00	0.00					1" Ice	29.80	120.00
				0.00	0.00							

Truss-Leg Properties

Section Designation	Area	Area Ice	Self Weight	Ice Weight	Equiv. Diameter	Equiv. Diameter Ice	Leg Area
	in ²	in ²	lb	lb	in	in	in ²
Pirod 105244	1026.8606	3703.4895	562.76	1382.29	7.1310	25.7187	3.6816
Pirod 105244	1026.8606	3698.2947	562.76	1379.08	7.1310	25.6826	3.6816
Pirod 105216	1998.0891	7564.7141	505.25	2806.59	6.9378	26.2664	3.6816
Pirod 105217	2130.7479	7612.7738	619.35	2790.60	7.3984	26.4332	5.3014
Pirod 105217	2130.7479	7595.6265	619.35	2758.94	7.3984	26.3737	5.3014
Pirod 105218	2263.4687	7639.7955	754.52	2736.34	7.8593	26.5271	7.2158
Pirod 105218	2263.4687	7608.9086	754.52	2680.16	7.8593	26.4198	7.2158

<p>tnxTower</p> <p>EFI Global, Inc. 1117 Perimeter Center West, Suite E500 Atlanta, GA 30338 Phone: (470) 990-6593 FAX:</p>	<p>Job</p> <p>CTNH550A</p>	<p>Page</p> <p>23 of 38</p>
	<p>Project</p> <p>049.02894 - 2275002</p>	<p>Date</p> <p>15:49:21 06/09/22</p>
	<p>Client</p> <p>ForeSite LLC.</p>	<p>Designed by</p> <p>Ahmet Colakoglu</p>

Section Designation	Area	Area Ice	Self Weight	Ice Weight	Equiv. Diameter	Equiv. Diameter Ice	Leg Area
	in ²	in ²	lb	lb	in	in	in ²
Pirod 105218	2263.4687	7586.2338	754.52	2639.26	7.8593	26.3411	7.2158
Pirod 105219	2441.8688	7620.2794	944.27	2637.47	8.4787	26.4593	9.4248
Pirod 105219	2441.8688	7559.6426	944.27	2529.79	8.4787	26.2488	9.4248
Pirod 105220	2578.8005	7552.8085	1121.16	2420.30	8.9542	26.2250	11.9282
Pirod 105220	2578.8005	7438.0816	1121.16	2227.16	8.9542	25.8267	11.9282
Pirod 112738	3466.5160	9318.2669	1689.34	2586.97	12.0365	32.3551	14.7262

Load Combinations

Comb. No.	Description
1	Dead Only
2	1.2 Dead+1.6 Wind 0 deg - No Ice
3	0.9 Dead+1.6 Wind 0 deg - No Ice
4	1.2 Dead+1.6 Wind 30 deg - No Ice
5	0.9 Dead+1.6 Wind 30 deg - No Ice
6	1.2 Dead+1.6 Wind 60 deg - No Ice
7	0.9 Dead+1.6 Wind 60 deg - No Ice
8	1.2 Dead+1.6 Wind 90 deg - No Ice
9	0.9 Dead+1.6 Wind 90 deg - No Ice
10	1.2 Dead+1.6 Wind 120 deg - No Ice
11	0.9 Dead+1.6 Wind 120 deg - No Ice
12	1.2 Dead+1.6 Wind 150 deg - No Ice
13	0.9 Dead+1.6 Wind 150 deg - No Ice
14	1.2 Dead+1.6 Wind 180 deg - No Ice
15	0.9 Dead+1.6 Wind 180 deg - No Ice
16	1.2 Dead+1.6 Wind 210 deg - No Ice
17	0.9 Dead+1.6 Wind 210 deg - No Ice
18	1.2 Dead+1.6 Wind 240 deg - No Ice
19	0.9 Dead+1.6 Wind 240 deg - No Ice
20	1.2 Dead+1.6 Wind 270 deg - No Ice
21	0.9 Dead+1.6 Wind 270 deg - No Ice
22	1.2 Dead+1.6 Wind 300 deg - No Ice
23	0.9 Dead+1.6 Wind 300 deg - No Ice
24	1.2 Dead+1.6 Wind 330 deg - No Ice
25	0.9 Dead+1.6 Wind 330 deg - No Ice
26	1.2 Dead+1.0 Ice+1.0 Temp
27	1.2 Dead+1.0 Wind 0 deg+1.0 Ice+1.0 Temp
28	1.2 Dead+1.0 Wind 30 deg+1.0 Ice+1.0 Temp
29	1.2 Dead+1.0 Wind 60 deg+1.0 Ice+1.0 Temp
30	1.2 Dead+1.0 Wind 90 deg+1.0 Ice+1.0 Temp
31	1.2 Dead+1.0 Wind 120 deg+1.0 Ice+1.0 Temp
32	1.2 Dead+1.0 Wind 150 deg+1.0 Ice+1.0 Temp
33	1.2 Dead+1.0 Wind 180 deg+1.0 Ice+1.0 Temp
34	1.2 Dead+1.0 Wind 210 deg+1.0 Ice+1.0 Temp
35	1.2 Dead+1.0 Wind 240 deg+1.0 Ice+1.0 Temp
36	1.2 Dead+1.0 Wind 270 deg+1.0 Ice+1.0 Temp
37	1.2 Dead+1.0 Wind 300 deg+1.0 Ice+1.0 Temp
38	1.2 Dead+1.0 Wind 330 deg+1.0 Ice+1.0 Temp
39	Dead+Wind 0 deg - Service
40	Dead+Wind 30 deg - Service
41	Dead+Wind 60 deg - Service
42	Dead+Wind 90 deg - Service
43	Dead+Wind 120 deg - Service
44	Dead+Wind 150 deg - Service
45	Dead+Wind 180 deg - Service
46	Dead+Wind 210 deg - Service

tnxTower EFI Global, Inc. 1117 Perimeter Center West, Suite E500 Atlanta, GA 30338 Phone: (470) 990-6593 FAX:	Job	CTNH550A	Page	24 of 38
	Project	049.02894 - 2275002	Date	15:49:21 06/09/22
	Client	ForeSite LLC.	Designed by	Ahmet Colakoglu

Comb. No.	Description
47	Dead+Wind 240 deg - Service
48	Dead+Wind 270 deg - Service
49	Dead+Wind 300 deg - Service
50	Dead+Wind 330 deg - Service

Maximum Member Forces

Section No.	Elevation ft	Component Type	Condition	Gov. Load Comb.	Axial lb	Major Axis Moment lb-ft	Minor Axis Moment lb-ft
T1	195 - 190	Leg	Max Tension	1	0.00	0.00	0.00
			Max. Compression	33	-691.63	-966.96	77.56
			Max. Mx	14	-204.33	-1194.80	108.64
			Max. My	24	-202.85	-182.76	-290.33
			Max. Vy	14	317.22	-1194.80	108.64
			Max. Vx	24	137.07	0.01	-0.00
		Diagonal	Max Tension	11	2.72	0.00	0.00
			Max. Compression	33	-575.74	0.00	0.00
			Max. Mx	32	-386.52	220.21	0.00
			Max. My	35	-373.45	0.00	0.36
			Max. Vy	32	-112.78	0.00	0.00
			Max. Vx	35	0.18	0.00	0.00
		Top Girt	Max Tension	18	194.41	0.00	0.00
			Max. Compression	13	-146.69	-33.08	2.39
			Max. Mx	33	70.04	-166.80	4.37
			Max. My	31	95.73	-162.66	-4.93
			Max. Vy	33	143.72	-166.80	4.37
			Max. Vx	31	1.07	0.00	0.00
T2	190 - 180	Leg	Max Tension	15	1024.49	-1153.74	108.26
			Max. Compression	31	-6255.18	941.41	58.30
			Max. Mx	14	910.34	-1194.80	108.64
			Max. My	16	-1819.68	267.76	-1608.65
			Max. Vy	14	-921.24	-1194.80	108.64
			Max. Vx	16	759.19	87.86	-73.67
		Diagonal	Max Tension	14	1862.97	0.00	0.00
			Max. Compression	10	-1766.48	0.00	0.00
			Max. Mx	27	405.17	164.09	2.25
			Max. My	33	52.11	162.65	3.05
			Max. Vy	32	-103.60	163.77	0.33
			Max. Vx	33	0.51	0.00	0.00
T3	180 - 160	Leg	Max Tension	15	13991.83	-1036.82	-49.33
			Max. Compression	31	-20492.56	600.95	-10.84
			Max. Mx	18	-17379.36	-1737.75	-104.13
			Max. My	24	-2541.33	53.73	-1922.73
			Max. Vy	6	-1330.66	-1079.87	-11.67
			Max. Vx	24	1382.92	-159.12	781.98
		Diagonal	Max Tension	24	5221.22	0.00	0.00
			Max. Compression	10	-5452.61	0.00	0.00
			Max. Mx	31	1033.28	192.96	1.65
			Max. My	24	-1119.39	24.84	-4.26
			Max. Vy	31	-116.52	192.96	1.65
			Max. Vx	33	0.66	0.00	0.00
T4	160 - 150	Leg	Max Tension	15	26448.56	-1501.54	-39.16
			Max. Compression	10	-33583.05	-611.44	370.54
			Max. Mx	27	-27652.41	2862.61	-6.89
			Max. My	12	-7464.52	-584.47	-2968.92
			Max. Vy	10	1794.26	2454.33	-24.63
		Diagonal	Max. Vx	12	1047.08	-584.47	-2968.92
			Max Tension	25	7986.26	37.70	-5.39

<p>tnxTower</p> <p>EFI Global, Inc. 1117 Perimeter Center West, Suite E500 Atlanta, GA 30338 Phone: (470) 990-6593 FAX:</p>	<p>Job</p> <p>CTNH550A</p>	<p>Page</p> <p>25 of 38</p>
	<p>Project</p> <p>049.02894 - 2275002</p>	<p>Date</p> <p>15:49:21 06/09/22</p>
	<p>Client</p> <p>ForeSite LLC.</p>	<p>Designed by</p> <p>Ahmet Colakoglu</p>

Section No.	Elevation ft	Component Type	Condition	Gov. Load Comb.	Axial lb	Major Axis Moment lb-ft	Minor Axis Moment lb-ft				
T5	150 - 140	Secondary Horizontal	Max. Compression	24	-8177.65	0.00	0.00				
			Max. Mx	30	1989.22	202.46	1.57				
			Max. My	24	-8139.07	31.84	-8.77				
			Max. Vy	32	-125.63	202.40	-1.43				
			Max. Vx	24	-1.12	0.00	0.00				
			Max Tension	18	1273.81	17.13	-4.59				
		T6	140 - 120	Leg	Max. Compression	15	-916.01	37.81	5.59		
					Max. Mx	29	471.21	140.29	0.16		
					Max. My	37	891.86	134.09	-7.24		
					Max. Vy	29	122.87	140.29	0.16		
					Max. Vx	33	1.44	0.00	0.00		
					Max Tension	15	44225.19	-306.59	18.76		
				T7	120 - 110	Diagonal	Max. Compression	10	-53194.02	2683.46	-37.44
							Max. Mx	27	-41930.87	2884.32	-23.13
Max. My	12						-8484.40	-584.44	-2968.91		
Max. Vy	27						-603.97	2884.32	-23.13		
Max. Vx	12						-470.99	-584.44	-2968.91		
Max Tension	13						9608.21	0.00	0.00		
T6	140 - 120					Leg	Max. Compression	24	-9941.04	0.00	0.00
							Max. Mx	27	1294.11	227.04	-1.40
		Max. My	18				-9617.60	31.24	7.42		
		Max. Vy	27				-128.05	227.04	-1.40		
		Max. Vx	18				-1.00	0.00	0.00		
		Max Tension	15				86388.79	-3024.34	-47.22		
		T7	120 - 110			Diagonal	Max. Compression	18	-103918.35	2365.45	-69.68
							Max. Mx	14	84538.29	-3124.47	-43.89
				Max. My	12		-11743.77	-318.79	-4411.87		
				Max. Vy	6		-1190.33	-3032.47	-22.37		
				Max. Vx	12		-1262.85	-318.78	-4411.87		
				Max Tension	4		11679.06	0.00	0.00		
				T6	140 - 120	Top Girt	Max. Compression	4	-11807.97	0.00	0.00
							Max. Mx	27	2831.51	248.51	32.06
Max. My	35						205.14	232.84	36.37		
Max. Vy	37						142.20	245.64	34.84		
Max. Vx	35						8.41	0.00	0.00		
Max Tension	29						754.63	0.00	0.00		
T7	120 - 110					Leg	Max. Compression	3	-499.55	0.00	0.00
							Max. Mx	26	615.35	-585.46	0.00
		Max. My	34				536.95	0.00	16.90		
		Max. Vy	26				195.15	0.00	0.00		
		Max. Vx	34				-5.63	0.00	0.00		
		Max Tension	15				109205.69	-2749.72	-59.08		
		T7	120 - 110			Leg	Max. Compression	18	-129533.07	-258.33	-288.65
							Max. Mx	18	-129332.07	7647.33	-43.96
				Max. My	12		-17608.96	-509.73	-3931.04		
				Max. Vy	18		1610.80	7647.32	-43.92		
				Max. Vx	16		783.57	-95.40	3577.23		
				Max Tension	21		13290.38	91.36	2.68		
				T7	120 - 110	Diagonal	Max. Compression	20	-13960.37	0.00	0.00
							Max. Mx	35	2002.75	305.27	31.30
Max. My	33						-4429.91	265.00	35.06		
Max. Vy	33						166.12	285.97	29.58		
Max. Vx	33						8.60	0.00	0.00		
Max Tension	16						1936.60	38.91	-4.82		
T7	120 - 110					Secondary Horizontal	Max. Compression	17	-1532.25	59.77	26.93
							Max. Mx	33	652.18	229.82	49.78
		Max. My	35				687.09	225.84	51.32		
		Max. Vy	33				-161.63	229.82	49.78		
		Max. Vx	35				-11.12	0.00	0.00		

tnxTower EFI Global, Inc. 1117 Perimeter Center West, Suite E500 Atlanta, GA 30338 Phone: (470) 990-6593 FAX:	Job	CTNH550A	Page	26 of 38
	Project	049.02894 - 2275002	Date	15:49:21 06/09/22
	Client	ForeSite LLC.	Designed by	Ahmet Colakoglu

Section No.	Elevation ft	Component Type	Condition	Gov. Load Comb.	Axial lb	Major Axis Moment lb-ft	Minor Axis Moment lb-ft			
T8	110 - 100	Leg	Max Tension	15	134754.00	-648.02	-74.27			
			Max. Compression	18	-158573.79	3744.21	-215.33			
			Max. Mx	10	-157474.49	3746.43	75.04			
			Max. My	12	-18953.26	-509.72	-3931.04			
			Max. Vy	2	-657.80	3741.87	140.34			
			Max. Vx	12	-381.70	-509.72	-3931.04			
		Diagonal	Max Tension	8	13515.64	0.00	0.00			
			Max. Compression	20	-13596.79	0.00	0.00			
			Max. Mx	35	3294.50	350.03	-41.44			
			Max. My	35	207.71	319.11	48.07			
			Max. Vy	33	176.94	329.33	45.71			
			Max. Vx	35	10.06	0.00	0.00			
			T9	100 - 80	Leg	Max Tension	15	183972.68	-2904.02	-71.87
						Max. Compression	18	-213401.20	5383.76	-156.31
Max. Mx	18	-213401.20				5383.76	-156.31			
Max. My	16	-22222.84				163.19	4536.63			
Max. Vy	6	-739.94				-3444.02	10.38			
Max. Vx	4	-689.56				279.73	-2691.43			
Diagonal	Max Tension	8			14880.18	0.00	0.00			
	Max. Compression	8			-15156.45	0.00	0.00			
	Max. Mx	35			3356.91	428.58	54.00			
	Max. My	35			104.72	395.75	59.43			
	Max. Vy	33			205.79	418.06	56.69			
	Max. Vx	35			11.35	0.00	0.00			
	T10	80 - 60			Leg	Max Tension	15	232217.56	-3009.20	24.74
						Max. Compression	18	-269003.41	4831.93	-159.44
Max. Mx			18	-240505.33		5383.74	-156.31			
Max. My			16	-23183.21		163.20	4536.63			
Max. Vy			14	-674.75		-5192.81	-16.22			
Max. Vx			16	528.01		163.20	4536.63			
Diagonal			Max Tension	8	16169.77	0.00	0.00			
			Max. Compression	8	-16399.29	0.00	0.00			
			Max. Mx	35	4261.42	579.93	-67.94			
			Max. My	35	244.64	526.61	73.98			
			Max. Vy	33	247.89	551.06	72.16			
			Max. Vx	35	13.13	0.00	0.00			
			T11	60 - 40	Leg	Max Tension	15	279321.27	-3813.90	-11.12
						Max. Compression	18	-324165.73	2293.74	-337.84
Max. Mx	14	252093.58				-4876.78	-35.09			
Max. My	16	-29134.26				-886.75	7756.57			
Max. Vy	2	387.98				4551.19	29.55			
Max. Vx	16	-633.53				-886.75	7756.57			
Diagonal	Max Tension	8			17156.88	0.00	0.00			
	Max. Compression	8			-17174.68	0.00	0.00			
	Max. Mx	35			4627.33	806.90	92.18			
	Max. My	34			-2055.20	709.44	99.35			
	Max. Vy	33			316.54	751.68	95.59			
	Max. Vx	34			16.36	0.00	0.00			
	T12	40 - 20			Leg	Max Tension	15	326394.92	-5071.75	28.86
						Max. Compression	18	-380286.78	5436.69	-755.17
Max. Mx			14	320388.82		-8302.61	-106.91			
Max. My			16	-33207.12		-1559.11	20912.63			
Max. Vy			2	-703.42		7755.52	-95.68			
Max. Vx			16	-2801.71		-1559.11	20912.63			
Diagonal			Max Tension	10	18673.89	0.00	0.00			
			Max. Compression	20	-18784.85	0.00	0.00			
			Max. Mx	34	5073.42	889.42	93.06			
			Max. My	33	-4515.02	810.32	125.32			
			Max. Vy	34	333.15	874.67	-106.43			
			Max. Vx	33	18.01	0.00	0.00			
			T13	20 - 0	Leg	Max Tension	15	352005.04	-7889.08	-98.15

tnxTower EFI Global, Inc. 1117 Perimeter Center West, Suite E500 Atlanta, GA 30338 Phone: (470) 990-6593 FAX:	Job	CTNH550A	Page	27 of 38
	Project	049.02894 - 2275002	Date	15:49:21 06/09/22
	Client	ForeSite LLC.	Designed by	Ahmet Colakoglu

Section No.	Elevation ft	Component Type	Condition	Gov. Load Comb.	Axial lb	Major Axis Moment lb-ft	Minor Axis Moment lb-ft
			Max. Compression	18	-409064.40	0.00	-0.02
			Max. Mx	14	346561.40	-8302.62	-106.91
			Max. My	16	-32645.30	-1559.08	20912.63
			Max. Vy	6	-787.93	-8223.54	95.04
			Max. Vx	16	1364.54	-1559.08	20912.63
		Diagonal	Max Tension	7	23681.31	0.00	0.00
			Max. Compression	10	-27519.43	0.00	0.00
			Max. Mx	34	6057.81	-1148.13	-169.13
			Max. My	36	286.43	-1127.57	-186.71
			Max. Vy	34	-354.46	-1148.13	-169.13
			Max. Vx	36	-21.88	0.00	0.00

Maximum Reactions

Location	Condition	Gov. Load Comb.	Vertical lb	Horizontal, X lb	Horizontal, Z lb
Leg C	Max. Vert	18	442351.35	52526.76	-29800.59
	Max. H _x	18	442351.35	52526.76	-29800.59
	Max. H _z	7	-370314.97	-45018.13	25769.05
	Min. Vert	7	-370314.97	-45018.13	25769.05
	Min. H _x	7	-370314.97	-45018.13	25769.05
	Min. H _z	18	442351.35	52526.76	-29800.59
Leg B	Max. Vert	10	439937.56	-52386.88	-29703.10
	Max. H _x	23	-366157.15	44414.91	25396.32
	Max. H _z	23	-366157.15	44414.91	25396.32
	Min. Vert	23	-366157.15	44414.91	25396.32
	Min. H _x	10	439937.56	-52386.88	-29703.10
	Min. H _z	10	439937.56	-52386.88	-29703.10
Leg A	Max. Vert	2	441380.20	-14.39	60472.52
	Max. H _x	19	-198294.35	866.36	-27355.95
	Max. H _z	2	441380.20	-14.39	60472.52
	Min. Vert	15	-378418.75	21.27	-52332.55
	Min. H _x	9	24749.45	-978.13	3061.26
	Min. H _z	15	-378418.75	21.27	-52332.55

Tower Mast Reaction Summary

Load Combination	Vertical lb	Shear _x lb	Shear _z lb	Overturning Moment, M _x lb-ft	Overturning Moment, M _z lb-ft	Torque lb-ft
Dead Only	70824.26	-0.00	0.00	20345.21	14518.90	-0.10
1.2 Dead+1.6 Wind 0 deg - No Ice	84989.10	1463.40	-87662.37	-9300517.91	-128365.46	1839.68
0.9 Dead+1.6 Wind 0 deg - No Ice	63741.83	1463.40	-87662.58	-9297968.06	-132632.88	1856.01
1.2 Dead+1.6 Wind 30 deg - No Ice	84989.10	42760.84	-72754.57	-7746653.68	-4532885.88	6107.19
0.9 Dead+1.6 Wind 30 deg - No Ice	63741.83	42760.93	-72754.73	-7745491.25	-4532998.81	6103.24
1.2 Dead+1.6 Wind 60 deg - No Ice	84989.10	71677.09	-41874.50	-4455877.55	-7609675.89	8034.11
0.9 Dead+1.6 Wind 60 deg - No Ice	63741.83	71677.23	-41874.59	-4457812.64	-7606898.92	8013.31

<p style="text-align: center;">tnxTower</p> <p style="text-align: center;">EFI Global, Inc. 1117 Perimeter Center West, Suite E500 Atlanta, GA 30338 Phone: (470) 990-6593 FAX:</p>	Job	CTNH550A	Page	28 of 38
	Project	049.02894 - 2275002	Date	15:49:21 06/09/22
	Client	ForeSite LLC.	Designed by	Ahmet Colakoglu

Load Combination	Vertical lb	Shear _x lb	Shear _z lb	Overturning Moment, M _x lb-ft	Overturning Moment, M _z lb-ft	Torque lb-ft
Ice						
1.2 Dead+1.6 Wind 90 deg - No Ice	84989.10	83371.24	-951.53	-72785.71	-8819711.97	8341.82
0.9 Dead+1.6 Wind 90 deg - No Ice	63741.83	83371.42	-951.52	-78857.18	-8815818.15	8309.38
1.2 Dead+1.6 Wind 120 deg - No Ice	84989.10	75392.54	43913.73	4815836.47	-7921379.92	9644.63
0.9 Dead+1.6 Wind 120 deg - No Ice	63741.83	75392.71	43913.84	4805109.51	-7918410.93	9606.24
1.2 Dead+1.6 Wind 150 deg - No Ice	84989.10	40831.36	73132.44	7915245.69	-4292553.75	7961.67
0.9 Dead+1.6 Wind 150 deg - No Ice	63741.83	40831.46	73132.61	7901602.91	-4292904.70	7933.16
1.2 Dead+1.6 Wind 180 deg - No Ice	84989.10	-270.05	83380.95	9013815.59	47215.73	1713.06
0.9 Dead+1.6 Wind 180 deg - No Ice	63741.83	-270.05	83381.12	8999144.08	42813.23	1698.37
1.2 Dead+1.6 Wind 210 deg - No Ice	84989.10	-41323.23	73668.74	7970878.18	4381358.47	-5606.72
0.9 Dead+1.6 Wind 210 deg - No Ice	63741.83	-41323.33	73668.91	7957190.89	4372909.50	-5603.74
1.2 Dead+1.6 Wind 240 deg - No Ice	84989.10	-74821.86	45274.04	4954177.48	7904267.04	-11481.43
0.9 Dead+1.6 Wind 240 deg - No Ice	63741.83	-74822.03	45274.15	4943344.31	7892577.76	-11460.39
1.2 Dead+1.6 Wind 270 deg - No Ice	84989.10	-82883.46	131.47	39518.86	8807201.31	-13442.43
0.9 Dead+1.6 Wind 270 deg - No Ice	63741.83	-82883.65	131.48	33357.83	8794588.55	-13409.98
1.2 Dead+1.6 Wind 300 deg - No Ice	84989.10	-70829.41	-41073.27	-4371924.08	7558690.78	-9744.33
0.9 Dead+1.6 Wind 300 deg - No Ice	63741.83	-70829.56	-41073.36	-4373926.86	7547227.13	-9709.31
1.2 Dead+1.6 Wind 330 deg - No Ice	84989.10	-41360.53	-72179.52	-7687250.82	4425590.55	-3358.88
0.9 Dead+1.6 Wind 330 deg - No Ice	63741.83	-41360.62	-72179.69	-7686135.49	4417061.29	-3330.10
1.2 Dead+1.0 Ice+1.0 Temp	388861.17	0.67	-0.64	83324.50	99617.77	3.98
1.2 Dead+1.0 Wind 0 deg+1.0 Ice+1.0 Temp	388861.17	165.20	-24591.14	-2521876.69	83765.15	3124.76
1.2 Dead+1.0 Wind 30 deg+1.0 Ice+1.0 Temp	388861.17	12252.08	-21051.63	-2149100.24	-1197393.71	3870.55
1.2 Dead+1.0 Wind 60 deg+1.0 Ice+1.0 Temp	388861.17	20988.48	-12160.98	-1206742.78	-2122610.58	3542.91
1.2 Dead+1.0 Wind 90 deg+1.0 Ice+1.0 Temp	388861.17	24260.79	-107.67	73139.64	-2465395.34	2326.44
1.2 Dead+1.0 Wind 120 deg+1.0 Ice+1.0 Temp	388861.17	21258.30	12305.34	1401953.94	-2143204.08	810.37
1.2 Dead+1.0 Wind 150 deg+1.0 Ice+1.0 Temp	388861.17	12033.57	21094.17	2330620.61	-1170208.99	-970.58
1.2 Dead+1.0 Wind 180 deg+1.0 Ice+1.0 Temp	388861.17	-31.04	24280.00	2668842.07	103948.08	-2723.88
1.2 Dead+1.0 Wind 210 deg+1.0 Ice+1.0 Temp	388861.17	-12090.04	21155.14	2337034.59	1377400.99	-3815.23
1.2 Dead+1.0 Wind 240 deg+1.0 Ice+1.0 Temp	388861.17	-21194.83	12459.45	1417846.93	2338269.22	-3932.12
1.2 Dead+1.0 Wind 270 deg+1.0 Ice+1.0 Temp	388861.17	-24205.94	15.45	85803.50	2661225.25	-2876.79
1.2 Dead+1.0 Wind 300 deg+1.0 Ice+1.0 Temp	388861.17	-20892.49	-12069.72	-1197026.82	2313667.36	-817.24
1.2 Dead+1.0 Wind 330	388861.17	-12093.46	-20986.30	-2142247.99	1381947.81	1491.81

<p>tnxTower</p> <p>EFI Global, Inc. 1117 Perimeter Center West, Suite E500 Atlanta, GA 30338 Phone: (470) 990-6593 FAX:</p>	Job	CTNH550A	Page	29 of 38
	Project	049.02894 - 2275002	Date	15:49:21 06/09/22
	Client	ForeSite LLC.	Designed by	Ahmet Colakoglu

Load Combination	Vertical lb	Shear _x lb	Shear _z lb	Overturning Moment, M _x lb-ft	Overturning Moment, M _z lb-ft	Torque lb-ft
deg+1.0 Ice+1.0 Temp						
Dead+Wind 0 deg - Service	70824.26	331.04	-19833.99	-2088197.72	-18421.04	419.88
Dead+Wind 30 deg - Service	70824.26	9674.88	-16461.17	-1736837.84	-1014394.53	1387.02
Dead+Wind 60 deg - Service	70824.26	16217.43	-9474.37	-992713.80	-1710142.66	1820.58
Dead+Wind 90 deg - Service	70824.26	18863.28	-215.26	-1587.12	-1983766.99	1886.56
Dead+Wind 120 deg - Service	70824.26	17057.91	9935.67	1103824.89	-1780632.64	2181.83
Dead+Wind 150 deg - Service	70824.26	9238.39	16546.65	1804691.90	-960069.47	1802.91
Dead+Wind 180 deg - Service	70824.26	-61.09	18865.47	2053113.86	21276.10	385.55
Dead+Wind 210 deg - Service	70824.26	-9349.66	16667.97	1817271.39	1001350.62	-1273.79
Dead+Wind 240 deg - Service	70824.26	-16928.81	10243.39	1135103.48	1797967.68	-2601.03
Dead+Wind 270 deg - Service	70824.26	-18752.94	29.73	23801.66	2002142.70	-3041.25
Dead+Wind 300 deg - Service	70824.26	-16025.67	-9293.12	-973733.01	1719818.96	-2205.51
Dead+Wind 330 deg - Service	70824.26	-9358.11	-16331.08	-1723406.21	1011340.63	-760.94

Solution Summary

Load Comb.	Sum of Applied Forces			Sum of Reactions			% Error
	PX lb	PY lb	PZ lb	PX lb	PY lb	PZ lb	
1	-0.00	-70824.26	0.00	0.00	70824.26	-0.00	0.000%
2	1463.41	-84989.11	-87663.12	-1463.40	84989.10	87662.37	0.001%
3	1463.41	-63741.83	-87663.12	-1463.40	63741.83	87662.58	0.001%
4	42761.25	-84989.11	-72755.20	-42760.84	84989.10	72754.57	0.001%
5	42761.25	-63741.83	-72755.20	-42760.93	63741.83	72754.73	0.001%
6	71677.72	-84989.11	-41874.88	-71677.09	84989.10	41874.50	0.001%
7	71677.72	-63741.83	-41874.88	-71677.23	63741.83	41874.59	0.001%
8	83371.98	-84989.11	-951.57	-83371.24	84989.10	951.53	0.001%
9	83371.98	-63741.83	-951.57	-83371.42	63741.83	951.52	0.001%
10	75393.16	-84989.11	43914.14	-75392.54	84989.10	-43913.73	0.001%
11	75393.16	-63741.83	43914.14	-75392.71	63741.83	-43913.84	0.001%
12	40831.69	-84989.11	73133.14	-40831.36	84989.10	-73132.44	0.001%
13	40831.69	-63741.83	73133.14	-40831.46	63741.83	-73132.61	0.001%
14	-270.05	-84989.11	83381.71	270.05	84989.10	-83380.95	0.001%
15	-270.05	-63741.83	83381.71	270.05	63741.83	-83381.12	0.001%
16	-41323.56	-84989.11	73669.44	41323.23	84989.10	-73668.74	0.001%
17	-41323.56	-63741.83	73669.44	41323.33	63741.83	-73668.91	0.001%
18	-74822.49	-84989.11	45274.46	74821.86	84989.10	-45274.04	0.001%
19	-74822.49	-63741.83	45274.46	74822.03	63741.83	-45274.15	0.001%
20	-82884.20	-84989.11	131.43	82883.46	84989.10	-131.47	0.001%
21	-82884.20	-63741.83	131.43	82883.65	63741.83	-131.48	0.001%
22	-70830.05	-84989.11	-41073.64	70829.41	84989.10	41073.27	0.001%
23	-70830.05	-63741.83	-41073.64	70829.56	63741.83	41073.36	0.001%
24	-41360.94	-84989.11	-72180.15	41360.53	84989.10	72179.52	0.001%
25	-41360.94	-63741.83	-72180.15	41360.62	63741.83	72179.69	0.001%
26	-0.00	-388861.17	0.00	-0.67	388861.17	0.64	0.000%
27	165.19	-388861.17	-24591.34	-165.20	388861.17	24591.14	0.000%
28	12252.17	-388861.17	-21051.80	-12252.08	388861.17	21051.63	0.000%
29	20988.65	-388861.17	-12161.08	-20988.48	388861.17	12160.98	0.000%
30	24260.98	-388861.17	-107.67	-24260.79	388861.17	107.67	0.000%
31	21258.47	-388861.17	12305.45	-21258.30	388861.17	-12305.34	0.000%
32	12033.66	-388861.17	21094.35	-12033.57	388861.17	-21094.17	0.000%
33	-31.05	-388861.17	24280.21	31.04	388861.17	-24280.00	0.000%
34	-12090.15	-388861.17	21155.33	12090.04	388861.17	-21155.14	0.000%
35	-21195.01	-388861.17	12459.56	21194.83	388861.17	-12459.45	0.000%
36	-24206.15	-388861.17	15.45	24205.94	388861.17	-15.45	0.000%
37	-20892.67	-388861.17	-12069.82	20892.49	388861.17	12069.72	0.000%
38	-12093.57	-388861.17	-20986.46	12093.46	388861.17	20986.30	0.000%
39	331.04	-70824.26	-19834.14	-331.04	70824.26	19833.99	0.000%

tnxTower EFI Global, Inc. 1117 Perimeter Center West, Suite E500 Atlanta, GA 30338 Phone: (470) 990-6593 FAX:	Job	CTNH550A	Page	30 of 38
	Project	049.02894 - 2275002	Date	15:49:21 06/09/22
	Client	ForeSite LLC.	Designed by	Ahmet Colakoglu

Load Comb.	Sum of Applied Forces			Sum of Reactions			% Error
	PX lb	PY lb	PZ lb	PX lb	PY lb	PZ lb	
40	9674.95	-70824.26	-16461.29	-9674.88	70824.26	16461.17	0.000%
41	16217.55	-70824.26	-9474.44	-16217.43	70824.26	9474.37	0.000%
42	18863.43	-70824.26	-215.26	-18863.28	70824.26	215.26	0.000%
43	17058.03	-70824.26	9935.75	-17057.91	70824.26	-9935.67	0.000%
44	9238.46	-70824.26	16546.79	-9238.39	70824.26	-16546.65	0.000%
45	-61.09	-70824.26	18865.63	61.09	70824.26	-18865.47	0.000%
46	-9349.73	-70824.26	16668.11	9349.66	70824.26	-16667.97	0.000%
47	-16928.94	-70824.26	10243.47	16928.81	70824.26	-10243.39	0.000%
48	-18753.08	-70824.26	29.73	18752.94	70824.26	-29.73	0.000%
49	-16025.80	-70824.26	-9293.19	16025.67	70824.26	9293.12	0.000%
50	-9358.18	-70824.26	-16331.21	9358.11	70824.26	16331.08	0.000%

Non-Linear Convergence Results

Load Combination	Converged?	Number of Cycles	Displacement Tolerance	Force Tolerance
1	Yes	6	0.0000001	0.0000001
2	Yes	8	0.0000001	0.00006899
3	Yes	8	0.0000001	0.00005006
4	Yes	8	0.0000001	0.00007501
5	Yes	8	0.0000001	0.00005600
6	Yes	8	0.0000001	0.00008014
7	Yes	8	0.0000001	0.00006096
8	Yes	8	0.0000001	0.00007491
9	Yes	8	0.0000001	0.00005594
10	Yes	8	0.0000001	0.00006910
11	Yes	8	0.0000001	0.00005015
12	Yes	8	0.0000001	0.00007572
13	Yes	8	0.0000001	0.00005664
14	Yes	8	0.0000001	0.00008060
15	Yes	8	0.0000001	0.00006133
16	Yes	8	0.0000001	0.00007561
17	Yes	8	0.0000001	0.00005655
18	Yes	8	0.0000001	0.00006909
19	Yes	8	0.0000001	0.00005016
20	Yes	8	0.0000001	0.00007473
21	Yes	8	0.0000001	0.00005578
22	Yes	8	0.0000001	0.00008011
23	Yes	8	0.0000001	0.00006094
24	Yes	8	0.0000001	0.00007496
25	Yes	8	0.0000001	0.00005595
26	Yes	6	0.0000001	0.00008049
27	Yes	9	0.0000001	0.00004107
28	Yes	9	0.0000001	0.00004059
29	Yes	9	0.0000001	0.00004064
30	Yes	9	0.0000001	0.00004060
31	Yes	9	0.0000001	0.00004162
32	Yes	9	0.0000001	0.00004260
33	Yes	9	0.0000001	0.00004363
34	Yes	9	0.0000001	0.00004370
35	Yes	9	0.0000001	0.00004353
36	Yes	9	0.0000001	0.00004294
37	Yes	9	0.0000001	0.00004257
38	Yes	9	0.0000001	0.00004169
39	Yes	8	0.0000001	0.00005709
40	Yes	8	0.0000001	0.00005805

tnxTower EFI Global, Inc. 1117 Perimeter Center West, Suite E500 Atlanta, GA 30338 Phone: (470) 990-6593 FAX:	Job	CTNH550A	Page	31 of 38
	Project	049.02894 - 2275002	Date	15:49:21 06/09/22
	Client	ForeSite LLC.	Designed by	Ahmet Colakoglu

41	Yes	8	0.0000001	0.00005900
42	Yes	8	0.0000001	0.00005786
43	Yes	8	0.0000001	0.00005724
44	Yes	8	0.0000001	0.00005855
45	Yes	8	0.0000001	0.00005962
46	Yes	8	0.0000001	0.00005852
47	Yes	8	0.0000001	0.00005724
48	Yes	8	0.0000001	0.00005779
49	Yes	8	0.0000001	0.00005893
50	Yes	8	0.0000001	0.00005800

Maximum Tower Deflections - Service Wind

Section No.	Elevation ft	Horz. Deflection in	Gov. Load Comb.	Tilt °	Twist °
T1	195 - 190	3.531	47	0.1337	0.0039
T2	190 - 180	3.392	47	0.1337	0.0039
T3	180 - 160	3.110	47	0.1334	0.0037
T4	160 - 150	2.544	47	0.1297	0.0034
T5	150 - 140	2.267	47	0.1264	0.0033
T6	140 - 120	1.999	47	0.1208	0.0033
T7	120 - 110	1.494	47	0.1082	0.0033
T8	110 - 100	1.262	47	0.0998	0.0030
T9	100 - 80	1.050	47	0.0899	0.0027
T10	80 - 60	0.677	47	0.0727	0.0017
T11	60 - 40	0.389	47	0.0525	0.0010
T12	40 - 20	0.183	47	0.0349	0.0006
T13	20 - 0	0.048	47	0.0158	0.0002

Critical Deflections and Radius of Curvature - Service Wind

Elevation ft	Appurtenance	Gov. Load Comb.	Deflection in	Tilt °	Twist °	Radius of Curvature ft
188.00	6' Dish	47	3.336	0.1337	0.0039	158749
187.50	Pipe Mount [PM 602-1]	47	3.322	0.1337	0.0039	165152
184.00	Pirod 6-8' Box Arm	47	3.224	0.1336	0.0037	295762
183.00	ANT150F2	47	3.195	0.1336	0.0037	371878
168.00	Pirod 12' T-Frame Sector Mount (1)	47	2.770	0.1315	0.0035	363698
154.00	Pirod 12' T-Frame Sector Mount (1)	47	2.377	0.1280	0.0033	146341
140.00	Pirod 12' T-Frame Sector Mount (1)	47	1.999	0.1208	0.0033	116027
125.00	Custom 4-Sided Sector Mount	47	1.615	0.1117	0.0034	89601
118.00	Pirod 6-8' Box Arm	47	1.446	0.1067	0.0033	74643
105.00	Pirod 6-8' Box Arm	47	1.154	0.0948	0.0029	66770
101.00	6' Dish Ice Shield	47	1.071	0.0909	0.0027	78940
98.00	Pirod 6-8' Box Arm	47	1.010	0.0881	0.0026	80209
97.00	6' Dish	47	0.990	0.0872	0.0026	78683
78.00	Pirod 6-8' Box Arm	47	0.644	0.0708	0.0016	52060
32.00	2-ft Stand Off	47	0.119	0.0272	0.0005	59745

Maximum Tower Deflections - Design Wind

tnxTower EFI Global, Inc. 1117 Perimeter Center West, Suite E500 Atlanta, GA 30338 Phone: (470) 990-6593 FAX:	Job	CTNH550A	Page	32 of 38
	Project	049.02894 - 2275002	Date	15:49:21 06/09/22
	Client	ForeSite LLC.	Designed by	Ahmet Colakoglu

Section No.	Elevation ft	Horz. Deflection in	Gov. Load Comb.	Tilt °	Twist °
T1	195 - 190	15.514	18	0.5872	0.0172
T2	190 - 180	14.902	18	0.5872	0.0174
T3	180 - 160	13.657	18	0.5863	0.0164
T4	160 - 150	11.165	18	0.5705	0.0150
T5	150 - 140	9.946	18	0.5553	0.0145
T6	140 - 120	8.767	18	0.5297	0.0144
T7	120 - 110	6.553	18	0.4740	0.0147
T8	110 - 100	5.540	18	0.4368	0.0133
T9	100 - 80	4.611	18	0.3939	0.0120
T10	80 - 60	2.972	18	0.3186	0.0074
T11	60 - 40	1.708	18	0.2301	0.0046
T12	40 - 20	0.803	18	0.1528	0.0027
T13	20 - 0	0.211	2	0.0693	0.0011

Critical Deflections and Radius of Curvature - Design Wind

Elevation ft	Appurtenance	Gov. Load Comb.	Deflection in	Tilt °	Twist °	Radius of Curvature ft
188.00	6' Dish	18	14.655	0.5872	0.0172	35969
187.50	Pipe Mount [PM 602-1]	18	14.593	0.5872	0.0171	37429
184.00	Pirod 6-8' Box Arm	18	14.157	0.5870	0.0165	70093
183.00	ANT150F2	18	14.032	0.5869	0.0165	92261
168.00	Pirod 12' T-Frame Sector Mount (1)	18	12.156	0.5789	0.0156	86956
154.00	Pirod 12' T-Frame Sector Mount (1)	18	10.430	0.5625	0.0147	33934
140.00	Pirod 12' T-Frame Sector Mount (1)	18	8.767	0.5297	0.0144	26730
125.00	Custom 4-Sided Sector Mount	18	7.086	0.4893	0.0150	20490
118.00	Pirod 6-8' Box Arm	18	6.344	0.4673	0.0145	17055
105.00	Pirod 6-8' Box Arm	18	5.066	0.4153	0.0127	15399
101.00	6' Dish Ice Shield	18	4.701	0.3981	0.0121	18232
98.00	Pirod 6-8' Box Arm	18	4.434	0.3859	0.0116	18482
97.00	6' Dish	18	4.346	0.3820	0.0114	18124
78.00	Pirod 6-8' Box Arm	18	2.828	0.3103	0.0070	11872
32.00	2-ft Stand Off	18	0.522	0.1194	0.0020	13632

Bolt Design Data

Section No.	Elevation ft	Component Type	Bolt Grade	Bolt Size in	Number Of Bolts	Maximum Load per Bolt lb	Allowable Load per Bolt lb	Ratio Load Allowable	Allowable Ratio	Criteria
T1	195	Leg	A325N	1.0000	6	38.42	53014.40	0.001	1	Bolt Tension
		Diagonal	A325N	1.0000	1	575.74	41760.00	0.014	1	Member Bearing
T2	190	Leg	A325N	1.0000	6	347.51	53014.40	0.007	1	Bolt Tension
		Diagonal	A325N	1.0000	1	1862.97	9144.14	0.204	1	Member Block Shear
T3	180	Leg	A325N	1.0000	6	2331.97	53014.40	0.044	1	Bolt Tension
		Diagonal	A325N	1.0000	1	5221.22	10163.70	0.514	1	Member Block Shear
T4	160	Leg	A325N	1.0000	6	4379.69	53014.40	0.083	1	Bolt Tension
		Diagonal	A325N	1.0000	1	7986.26	16939.50	0.471	1	Member Block

tnxTower EFI Global, Inc. 1117 Perimeter Center West, Suite E500 Atlanta, GA 30338 Phone: (470) 990-6593 FAX:	Job	CTNH550A	Page	33 of 38
	Project	049.02894 - 2275002	Date	15:49:21 06/09/22
	Client	ForeSite LLC.	Designed by	Ahmet Colakoglu

Section No.	Elevation ft	Component Type	Bolt Grade	Bolt Size in	Number Of Bolts	Maximum Load per Bolt lb	Allowable Load per Bolt lb	Ratio Load Allowable	Allowable Ratio	Criteria
		Secondary Horizontal	A325N	0.5000	2	636.91	7952.16	0.080	1	Shear Bolt Shear
T5	150	Diagonal	A325N	1.0000	1	9608.21	16939.50	0.567	1	Member Block Shear
T6	140	Leg Diagonal	A325N	1.0000	6	14398.10	53014.40	0.272	1	Bolt Tension
			A325N	1.0000	1	11679.10	16939.50	0.689	1	Member Block Shear
		Top Girt	A325N	1.0000	1	1802.17	16939.50	0.106	1	Member Block Shear
T7	120	Leg Diagonal	A325N	1.0000	6	18159.30	53014.40	0.343	1	Bolt Tension
			A325N	1.0000	1	13290.40	20337.90	0.653	1	Member Block Shear
		Secondary Horizontal	A325N	0.5000	1	2246.38	7952.16	0.282	1	Bolt Shear
T8	110	Diagonal	A325N	1.0000	1	13515.60	20337.90	0.665	1	Member Block Shear
T9	100	Leg Diagonal	A325N	1.2500	6	30662.10	82835.00	0.370	1	Bolt Tension
			A325N	1.2500	1	14880.20	16429.70	0.906	1	Member Block Shear
T10	80	Leg Diagonal	A325N	1.2500	6	38702.90	82835.00	0.467	1	Bolt Tension
			A325N	1.2500	1	16169.80	24644.50	0.656	1	Member Block Shear
T11	60	Leg Diagonal	A325N	1.2500	6	46553.50	82835.00	0.562	1	Bolt Tension
			A325N	1.2500	1	17156.90	31972.50	0.537	1	Member Bearing
T12	40	Leg Diagonal	A325N	1.2500	6	54399.20	82835.00	0.657	1	Bolt Tension
			A325N	1.2500	1	18673.90	31972.50	0.584	1	Member Bearing
T13	20	Leg Diagonal	A325N	2.0000	6	58667.50	212058.00	0.277	1	Bolt Tension
			A325N	1.0000	2	11840.70	35525.40	0.333	1	Member Block Shear

Compression Checks

Leg Design Data (Compression)

Section No.	Elevation ft	Size	L ft	L _u ft	Kl/r	A in ²	P _u lb	φP _n lb	Ratio $\frac{P_u}{\phi P_n}$
T1	195 - 190	Pirod 105244	5.00	5.00	45.4 K=1.00	3.6816	-691.63	142493.00	0.005 ¹
T2	190 - 180	Pirod 105244	10.00	10.00	45.4 K=1.00	3.6816	-6255.18	142493.00	0.044 ¹
T3	180 - 160	Pirod 105216	20.00	10.00	45.4 K=1.00	3.6816	-20492.60	142493.00	0.144 ¹
T4	160 - 150	Pirod 105217	10.00	5.00	37.8 K=1.00	5.3014	-33583.00	214859.00	0.156 ¹
T5	150 - 140	Pirod 105217	10.00	10.00	37.8 K=1.00	5.3014	-53194.00	214859.00	0.248 ¹
T6	140 - 120	Pirod 105218	20.03	10.02	32.4 K=1.00	7.2158	-103918.00	300681.00	0.346 ¹
T7	120 - 110	Pirod 105218	10.02	5.18	32.4 K=1.00	7.2158	-129533.00	300681.00	0.431 ¹

tnxTower EFI Global, Inc. 1117 Perimeter Center West, Suite E500 Atlanta, GA 30338 Phone: (470) 990-6593 FAX:	Job	CTNH550A	Page	34 of 38
	Project	049.02894 - 2275002	Date	15:49:21 06/09/22
	Client	ForeSite LLC.	Designed by	Ahmet Colakoglu

Section No.	Elevation ft	Size	L ft	L _u ft	Kl/r	A in ²	P _u lb	φP _n lb	Ratio $\frac{P_u}{\phi P_n}$
T8	110 - 100	Pirod 105218	10.02	10.02	32.4 K=1.00	7.2158	-158574.00	300681.00	0.527 ¹
T9	100 - 80	Pirod 105219	20.03	10.02	28.4 K=1.00	9.4248	-213401.00	399868.00	0.534 ¹
T10	80 - 60	Pirod 105219	20.03	10.02	28.4 K=1.00	9.4248	-269003.00	399868.00	0.673 ¹
T11	60 - 40	Pirod 105220	20.03	10.02	25.2 K=1.00	11.9282	-324166.00	512375.00	0.633 ¹
T12	40 - 20	Pirod 105220	20.03	10.02	25.2 K=1.00	11.9282	-380287.00	512375.00	0.742 ¹
T13	20 - 0	Pirod 112738	20.03	20.03	32.6 K=1.00	14.7262	-409064.00	613145.00	0.667 ¹

¹ P_u / φP_n controls

Truss-Leg Diagonal Data

Section No.	Elevation ft	Diagonal Size	L _d ft	Kl/r	φP _n lb	A in ²	V _u lb	φV _n lb	Stress Ratio
T1	195 - 190	0.5	1.48	121.0	165670.00	0.1963	317.96	3388.58	0.094
T2	190 - 180	0.5	1.48	121.0	165670.00	0.1963	937.64	3388.58	0.277
T3	180 - 160	0.5	1.48	121.0	165670.00	0.1963	1384.91	3292.47	0.421
T4	160 - 150	0.5	1.47	120.0	238565.00	0.1963	1796.01	3335.33	0.539
T5	150 - 140	0.5	1.47	120.0	238565.00	0.1963	604.10	3335.33	0.181
T6	140 - 120	0.5	1.46	119.0	324713.00	0.1963	1308.05	3377.71	0.387
T7	120 - 110	0.5	1.46	119.0	324713.00	0.1963	1611.49	3377.71	0.477
T8	110 - 100	0.5	1.46	119.0	324713.00	0.1963	667.52	3377.71	0.198
T9	100 - 80	0.625	1.45	94.4	424115.00	0.3068	741.48	6957.62	0.107
T10	80 - 60	0.625	1.45	94.4	424115.00	0.3068	679.19	6957.62	0.098
T11	60 - 40	0.625	1.43	93.6	536771.00	0.3068	652.94	7011.35	0.093
T12	40 - 20	0.625	1.43	93.6	536771.00	0.3068	2822.97	7011.35	0.403
T13	20 - 0	0.75	1.73	93.9	662680.00	0.4418	1371.12	14363.90	0.096

Diagonal Design Data (Compression)

Section No.	Elevation ft	Size	L ft	L _u ft	Kl/r	A in ²	P _u lb	φP _n lb	Ratio $\frac{P_u}{\phi P_n}$
T1	195 - 190	2L2 1/2x2 1/2x3/16x3/16	7.81	6.83	111.0 K=1.00	1.8047	-575.74	30571.50	0.019 ¹
T2	190 - 180	2L 'a' > 39.0654 in - 10 L2 1/2x2 1/2x3/16	15.62	6.99	169.5 K=1.00	0.9020	-1766.48	7090.89	0.249 ¹
T3	180 - 160	L3x3x3/16	15.62	6.99	140.8 K=1.00	1.0900	-5452.61	12422.30	0.439 ¹
T4	160 - 150	L3x3x5/16	15.62	6.99	142.5 K=1.00	1.7800	-8177.65	19812.30	0.413 ¹
T5	150 - 140	L3x3x5/16	15.62	6.99	142.5 K=1.00	1.7800	-9941.04	19812.30	0.502 ¹
T6	140 - 120	L3x3x5/16	16.80	7.92	161.4 K=1.00	1.7800	-11808.00	15430.20	0.765 ¹
T7	120 - 110	L3 1/2x3 1/2x5/16	17.62	8.34	145.0	2.0900	-13960.40	22455.00	0.622 ¹

tnxTower EFI Global, Inc. 1117 Perimeter Center West, Suite E500 Atlanta, GA 30338 Phone: (470) 990-6593 FAX:	Job	CTNH550A	Page	35 of 38
	Project	049.02894 - 2275002	Date	15:49:21 06/09/22
	Client	ForeSite LLC.	Designed by	Ahmet Colakoglu

Section No.	Elevation ft	Size	L ft	L _u ft	Kl/r	A in ²	P _u lb	φP _n lb	Ratio $\frac{P_u}{\phi P_n}$
T8	110 - 100	L3 1/2x3 1/2x5/16	18.45	8.76	K=1.00 152.3	2.0900	-13596.80	20343.20	0.668 ¹
T9	100 - 80	L4x4x1/4	20.16	9.59	K=1.00 144.8	1.9400	-15156.50	20902.60	0.725 ¹
T10	80 - 60	L4x4x3/8	21.92	10.48	K=1.00 159.6	2.8600	-16399.30	25370.10	0.646 ¹
T11	60 - 40	L5x5x3/8	23.71	11.38	K=1.00 138.0	3.6100	-17086.40	42837.90	0.399 ¹
T12	40 - 20	L5x5x3/8	24.62	11.84	K=1.00 143.6	3.6100	-18784.90	39567.80	0.475 ¹
T13	20 - 0	2L3 1/2x3 1/2x5/16x3/8	32.02	15.40	K=1.00 176.8	4.1800	-27519.40	30200.60	0.911 ¹
					K=1.00				
					2L 'a' > 82.2703 in - 161				

¹ P_u / φP_n controls

Secondary Horizontal Design Data (Compression)

Section No.	Elevation ft	Size	L ft	L _u ft	Kl/r	A in ²	P _u lb	φP _n lb	Ratio $\frac{P_u}{\phi P_n}$
T4	160 - 150	L3x3x5/16	12.00	10.67	138.8	1.7800	-916.01	20864.20	0.044 ¹
T7	120 - 110	L3 1/2x3 1/2x5/16	14.48	13.27	K=1.00 147.5	2.0900	-2246.38	21704.00	0.104 ¹
					K=1.00				

¹ P_u / φP_n controls

Top Girt Design Data (Compression)

Section No.	Elevation ft	Size	L ft	L _u ft	Kl/r	A in ²	P _u lb	φP _n lb	Ratio $\frac{P_u}{\phi P_n}$
T1	195 - 190	2L2 1/2x2 1/2x3/16x1/2	12.00	8.25	104.8	1.8047	-146.69	32783.60	0.004 ¹
					K=1.00				
T6	140 - 120	2L 'a' > 31.4764 in - 4 L3x3x5/16	12.00	10.67	217.3	1.7800	-1802.17	8514.72	0.212 ¹
					K=1.00				
					KL/R > 200 (C) - 63				

¹ P_u / φP_n controls

Tension Checks

tnxTower EFI Global, Inc. 1117 Perimeter Center West, Suite E500 Atlanta, GA 30338 Phone: (470) 990-6593 FAX:	Job CTNH550A	Page 36 of 38
	Project 049.02894 - 2275002	Date 15:49:21 06/09/22
	Client ForeSite LLC.	Designed by Ahmet Colakoglu

Leg Design Data (Tension)

Section No.	Elevation ft	Size	L ft	L _u ft	Kl/r	A in ²	P _u lb	φP _n lb	Ratio $\frac{P_u}{\phi P_n}$
T2	190 - 180	Pirod 105244	10.00	10.00	45.4	3.6816	1024.49	165670.00	0.006 ¹
T3	180 - 160	Pirod 105216	20.00	10.00	45.4	3.6816	13991.80	165670.00	0.084 ¹
T4	160 - 150	Pirod 105217	10.00	5.00	37.8	5.3014	26448.60	238565.00	0.111 ¹
T5	150 - 140	Pirod 105217	10.00	10.00	37.8	5.3014	44225.20	238565.00	0.185 ¹
T6	140 - 120	Pirod 105218	20.03	10.02	32.4	7.2158	86388.80	324713.00	0.266 ¹
T7	120 - 110	Pirod 105218	10.02	4.84	32.4	7.2158	109206.00	324713.00	0.336 ¹
T8	110 - 100	Pirod 105218	10.02	10.02	32.4	7.2158	134754.00	324713.00	0.415 ¹
T9	100 - 80	Pirod 105219	20.03	10.02	28.4	9.4248	183973.00	424115.00	0.434 ¹
T10	80 - 60	Pirod 105219	20.03	10.02	28.4	9.4248	232218.00	424115.00	0.548 ¹
T11	60 - 40	Pirod 105220	20.03	10.02	25.2	11.9282	279321.00	536771.00	0.520 ¹
T12	40 - 20	Pirod 105220	20.03	10.02	25.2	11.9282	326395.00	536771.00	0.608 ¹
T13	20 - 0	Pirod 112738	20.03	20.03	32.6	14.7262	352005.00	662680.00	0.531 ¹

¹ P_u / φP_n controls

Truss-Leg Diagonal Data

Section No.	Elevation ft	Diagonal Size	L _d ft	Kl/r	φP _n lb	A in ²	V _n lb	φV _n lb	Stress Ratio
T1	195 - 190	0.5	1.48	121.0	165670.00	0.1963	317.96	3388.58	0.094
T2	190 - 180	0.5	1.48	121.0	165670.00	0.1963	937.64	3388.58	0.277
T3	180 - 160	0.5	1.48	121.0	165670.00	0.1963	1384.91	3292.47	0.421
T4	160 - 150	0.5	1.47	120.0	238565.00	0.1963	1796.01	3335.33	0.539
T5	150 - 140	0.5	1.47	120.0	238565.00	0.1963	604.10	3335.33	0.181
T6	140 - 120	0.5	1.46	119.0	324713.00	0.1963	1308.05	3377.71	0.387
T7	120 - 110	0.5	1.46	119.0	324713.00	0.1963	1611.49	3377.71	0.477
T8	110 - 100	0.5	1.46	119.0	324713.00	0.1963	667.52	3377.71	0.198
T9	100 - 80	0.625	1.45	94.4	424115.00	0.3068	741.48	6957.62	0.107
T10	80 - 60	0.625	1.45	94.4	424115.00	0.3068	679.19	6957.62	0.098
T11	60 - 40	0.625	1.43	93.6	536771.00	0.3068	652.94	7011.35	0.093
T12	40 - 20	0.625	1.43	93.6	536771.00	0.3068	2822.97	7011.35	0.403
T13	20 - 0	0.75	1.73	93.9	662680.00	0.4418	1371.12	14363.90	0.096

Diagonal Design Data (Tension)

Section No.	Elevation ft	Size	L ft	L _u ft	Kl/r	A in ²	P _u lb	φP _n lb	Ratio $\frac{P_u}{\phi P_n}$
T1	195 - 190	2L2 1/2x2 1/2x3/16x3/16 2L 'a' > 39.0654 in - 7	7.81	6.83	110.4	1.0371	2.72	45114.30	0.000 ¹
T2	190 - 180	L2 1/2x2 1/2x3/16	15.62	6.99	110.4	0.5183	1862.97	22545.90	0.083 ¹
T3	180 - 160	L3x3x3/16	15.62	6.99	91.5	0.6593	5221.22	28679.40	0.182 ¹
T4	160 - 150	L3x3x5/16	15.62	6.99	93.2	1.0713	7986.26	46602.80	0.171 ¹
T5	150 - 140	L3x3x5/16	15.62	6.99	93.2	1.0713	9608.21	46602.80	0.206 ¹
T6	140 - 120	L3x3x5/16	16.80	7.92	105.3	1.0713	11679.10	46602.80	0.251 ¹
T7	120 - 110	L3 1/2x3 1/2x5/16	17.62	8.34	94.5	1.3038	13290.40	56716.50	0.234 ¹
T8	110 - 100	L3 1/2x3 1/2x5/16	18.45	8.76	99.2	1.3038	13515.60	56716.50	0.238 ¹
T9	100 - 80	L4x4x1/4	20.16	9.59	94.0	1.1972	14880.20	52077.70	0.286 ¹
T10	80 - 60	L4x4x3/8	21.92	10.48	104.2	1.7583	16169.80	76485.20	0.211 ¹

tnxTower EFI Global, Inc. 1117 Perimeter Center West, Suite E500 Atlanta, GA 30338 Phone: (470) 990-6593 FAX:	Job CTNH550A	Page 37 of 38
	Project 049.02894 - 2275002	Date 15:49:21 06/09/22
	Client ForeSite LLC.	Designed by Ahmet Colakoglu

Section No.	Elevation ft	Size	L ft	L _u ft	Kl/r	A in ²	P _u lb	φP _n lb	Ratio $\frac{P_u}{\phi P_n}$
T11	60 - 40	L5x5x3/8	23.71	11.38	89.1	2.3208	17156.90	100954.00	0.170 ¹
T12	40 - 20	L5x5x3/8	25.54	12.30	96.1	2.3208	18673.90	100954.00	0.185 ¹
T13	20 - 0	2L3 1/2x3 1/2x5/16x3/8 2L 'a' > 82.2703 in - 160	32.02	15.40	174.3	2.6077	23681.30	113433.00	0.209 ¹

¹ P_u / φP_n controls

Secondary Horizontal Design Data (Tension)

Section No.	Elevation ft	Size	L ft	L _u ft	Kl/r	A in ²	P _u lb	φP _n lb	Ratio $\frac{P_u}{\phi P_n}$
T4	160 - 150	L3x3x5/16	12.00	10.67	143.2	1.1885	1273.81	51700.40	0.025 ¹
T7	120 - 110	L3 1/2x3 1/2x5/16	14.48	13.27	149.8	1.4210	2246.38	61814.20	0.036 ¹

¹ P_u / φP_n controls

Top Girt Design Data (Tension)

Section No.	Elevation ft	Size	L ft	L _u ft	Kl/r	A in ²	P _u lb	φP _n lb	Ratio $\frac{P_u}{\phi P_n}$
T1	195 - 190	2L2 1/2x2 1/2x3/16x1/2 2L 'a' > 31.4764 in - 5	12.00	8.25	84.8	1.8047	194.41	58471.90	0.003 ¹
T6	140 - 120	L3x3x5/16	12.00	10.67	143.2	1.0713	1802.17	46602.80	0.039 ¹

¹ P_u / φP_n controls

Section Capacity Table

Section No.	Elevation ft	Component Type	Size	Critical Element	P lb	φP _{allow} lb	% Capacity	Pass Fail
T1	195 - 190	Leg	Pirod 105244	3	-691.63	142493.00	9.4	Pass
T2	190 - 180	Leg	Pirod 105244	15	-5210.92	142493.00	27.7	Pass
T3	180 - 160	Leg	Pirod 105216	22	-17379.40	142493.00	42.1	Pass
T4	160 - 150	Leg	Pirod 105217	38	-33583.00	214859.00	53.9	Pass
T5	150 - 140	Leg	Pirod 105217	50	-53194.00	214859.00	24.8	Pass
T6	140 - 120	Leg	Pirod 105218	58	-103918.00	300681.00	38.7	Pass
T7	120 - 110	Leg	Pirod 105218	76	-129533.00	300681.00	47.7	Pass
T8	110 - 100	Leg	Pirod 105218	88	-158574.00	300681.00	52.7	Pass
T9	100 - 80	Leg	Pirod 105219	97	-213401.00	399868.00	53.4	Pass
T10	80 - 60	Leg	Pirod 105219	112	-269003.00	399868.00	67.3	Pass
T11	60 - 40	Leg	Pirod 105220	127	-324166.00	512375.00	63.3	Pass
T12	40 - 20	Leg	Pirod 105220	142	-380287.00	512375.00	74.2	Pass
T13	20 - 0	Leg	Pirod 112738	157	-409064.00	613145.00	66.7	Pass
T1	195 - 190	Diagonal	2L2 1/2x2 1/2x3/16x3/16	10	-575.74	30571.50	1.9	Pass
T2	190 - 180	Diagonal	L2 1/2x2 1/2x3/16	18	-1766.48	7090.89	24.9	Pass

<p>tnxTower</p> <p>EFI Global, Inc. 1117 Perimeter Center West, Suite E500 Atlanta, GA 30338 Phone: (470) 990-6593 FAX:</p>	Job	CTNH550A	Page	38 of 38
	Project	049.02894 - 2275002	Date	15:49:21 06/09/22
	Client	ForeSite LLC.	Designed by	Ahmet Colakoglu

Section No.	Elevation ft	Component Type	Size	Critical Element	P lb	ϕP_{allow} lb	% Capacity	Pass Fail	
T3	180 - 160	Diagonal	L3x3x3/16	27	-5452.61	12422.30	43.9	Pass	
T4	160 - 150	Diagonal	L3x3x5/16	43	-8177.65	19812.30	51.4 (b)	Pass	
T5	150 - 140	Diagonal	L3x3x5/16	55	-9941.04	19812.30	47.1 (b)	Pass	
T6	140 - 120	Diagonal	L3x3x5/16	68	-11808.00	15430.20	50.2	Pass	
T7	120 - 110	Diagonal	L3 1/2x3 1/2x5/16	79	-13960.40	22455.00	56.7 (b)	Pass	
T8	110 - 100	Diagonal	L3 1/2x3 1/2x5/16	91	-13596.80	20343.20	62.2	Pass	
T9	100 - 80	Diagonal	L4x4x1/4	101	-15156.50	20902.60	65.3 (b)	Pass	
T10	80 - 60	Diagonal	L4x4x3/8	116	-16399.30	25370.10	66.8	Pass	
T11	60 - 40	Diagonal	L5x5x3/8	131	-17086.40	42837.90	72.5	Pass	
T12	40 - 20	Diagonal	L5x5x3/8	151	-18784.90	39567.80	90.6 (b)	Pass	
T13	20 - 0	Diagonal	2L3 1/2x3 1/2x5/16x3/8	161	-27519.40	30200.60	58.4 (b)	Pass	
T4	160 - 150	Secondary Horizontal	L3x3x5/16	47	-916.01	20864.20	91.1	Pass	
T7	120 - 110	Secondary Horizontal	L3 1/2x3 1/2x5/16	87	-2246.38	21704.00	4.4	Pass	
T1	195 - 190	Top Girt	2L2 1/2x2 1/2x3/16x1/2	6	-121.45	32783.60	8.0 (b)	Pass	
T6	140 - 120	Top Girt	L3x3x5/16	63	-1802.17	8514.72	10.4	Pass	
							Summary		
							Leg (T12)	74.2	Pass
							Diagonal (T13)	91.1	Pass
							Secondary Horizontal (T7)	28.2	Pass
							Top Girt (T6)	21.2	Pass
							Bolt Checks	90.6	Pass
							RATING =	91.1	Pass

Self Support Anchor Rod Capacity

Site Info	
Site Name	CTNH550A

Analysis Considerations	
TIA-222 Revision	G
Grout Considered:	No
l_{ar} (in)	3
Eta Factor, η	0.5

Applied Loads		
	Comp.	Uplift
Axial Force (kips)	442.35	378.42
Shear Force (kips)	60.39	52.33

Considered Eccentricity	
Leg Mod Eccentricity (in)	0.000
Anchor Rod N.A Shift (in)	0.000
Total Eccentricity (in)	0.000

*Anchor Rod Eccentricity Applied

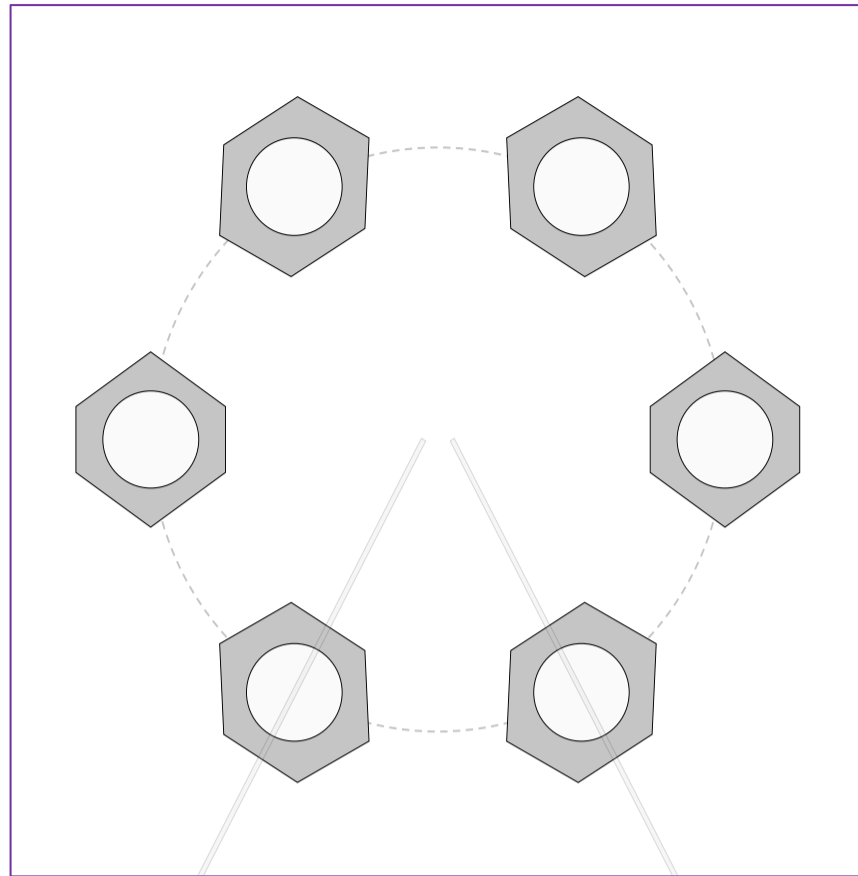

Connection Properties

Anchor Rod Data

(6) 2" ϕ bolts (A687 N; $F_y=105$ ksi, $F_u=125$ ksi)
 l_{ar} (in): 3

Analysis Results

Anchor Rod Summary

(units of kips, kip-in)

$P_{u_c} = 73.73$	$\phi P_{n_t} = 250$	Stress Rating
$V_u = 10.07$	$\phi V_n = n/a$	37.5%
$M_u = n/a$	$\phi M_n = n/a$	Pass

ASCE 7 Hazards Report

Address:
No Address at This
Location

Standard: ASCE/SEI 7-10
Risk Category: III
Soil Class: D - Stiff Soil

Elevation: 961.21 ft (NAVD 88)
Latitude: 42.014722
Longitude: -73.32639

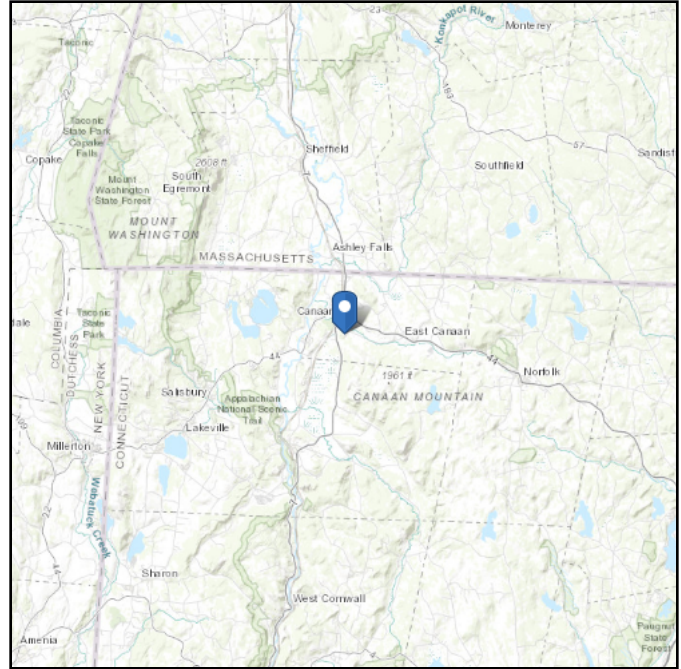
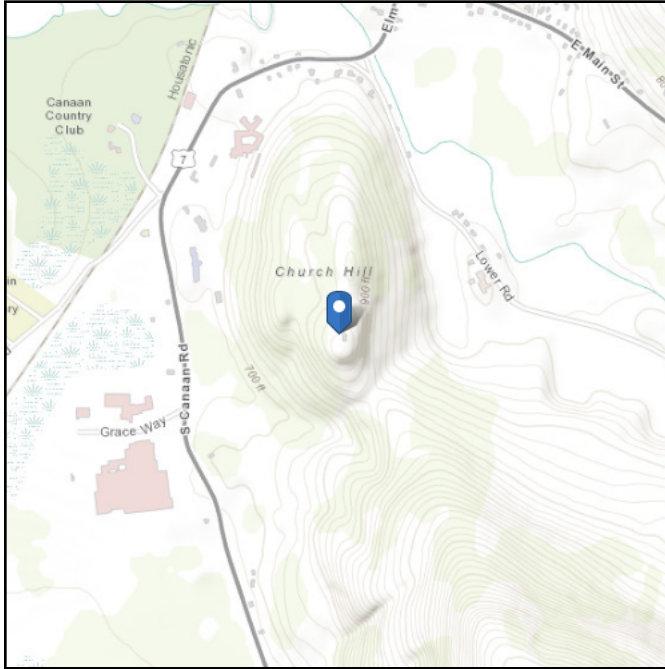

Site Soil Class: D - Stiff Soil

Results:

S_S :	0.173	S_{DS} :	0.185
S_1 :	0.065	S_{D1} :	0.104
F_a :	1.6	T_L :	6
F_v :	2.4	PGA :	0.084
S_{MS} :	0.277	PGA _M :	0.135
S_{M1} :	0.156	F _{PGA} :	1.6
		I_e :	1.25

Seismic Design Category B

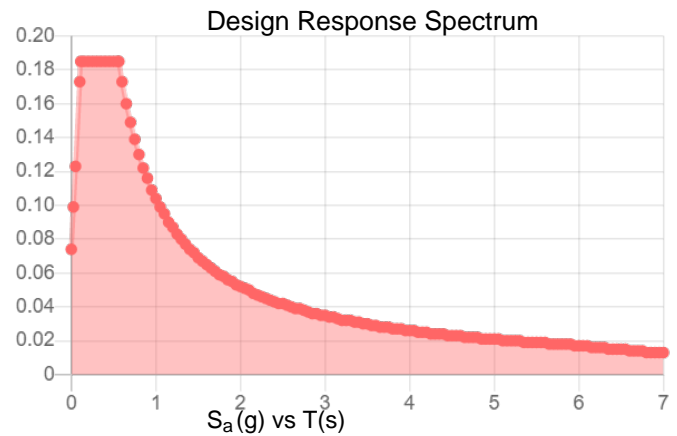
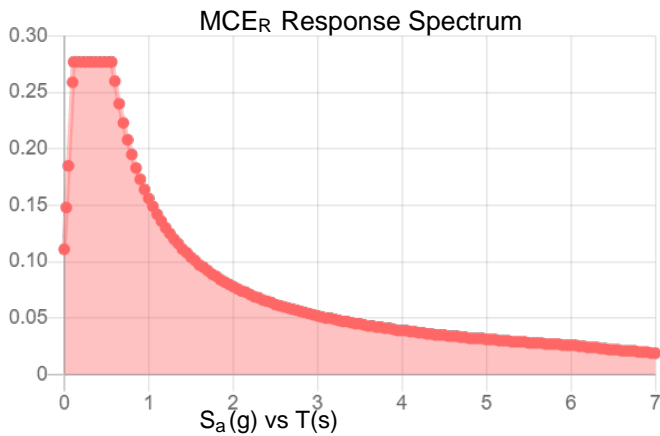

Data Accessed: Fri Feb 04 2022

Date Source:

USGS Seismic Design Maps based on ASCE/SEI 7-10, incorporating Supplement 1 and errata of March 31, 2013, and ASCE/SEI 7-10 Table 1.5-2. Additional data for site-specific ground motion procedures in accordance with ASCE/SEI 7-10 Ch. 21 are available from USGS.

Ice

Results:

Ice Thickness: 1.00 in.
Concurrent Temperature: 5 F
Gust Speed 40 mph

Data Source: Standard ASCE/SEI 7-10, Figs. 10-2 through 10-8

Date Accessed: Fri Feb 04 2022

Ice thicknesses on structures in exposed locations at elevations higher than the surrounding terrain and in valleys and gorges may exceed the mapped values.

Values provided are equivalent radial ice thicknesses due to freezing rain with concurrent 3-second gust speeds, for a 50-year mean recurrence interval, and temperatures concurrent with ice thicknesses due to freezing rain. Thicknesses for ice accretions caused by other sources shall be obtained from local meteorological studies. Ice thicknesses in exposed locations at elevations higher than the surrounding terrain and in valleys and gorges may exceed the mapped values.

The ASCE 7 Hazard Tool is provided for your convenience, for informational purposes only, and is provided “as is” and without warranties of any kind. The location data included herein has been obtained from information developed, produced, and maintained by third party providers; or has been extrapolated from maps incorporated in the ASCE 7 standard. While ASCE has made every effort to use data obtained from reliable sources or methodologies, ASCE does not make any representations or warranties as to the accuracy, completeness, reliability, currency, or quality of any data provided herein. Any third-party links provided by this Tool should not be construed as an endorsement, affiliation, relationship, or sponsorship of such third-party content by or from ASCE.

ASCE does not intend, nor should anyone interpret, the results provided by this Tool to replace the sound judgment of a competent professional, having knowledge and experience in the appropriate field(s) of practice, nor to substitute for the standard of care required of such professionals in interpreting and applying the contents of this Tool or the ASCE 7 standard.

In using this Tool, you expressly assume all risks associated with your use. Under no circumstances shall ASCE or its officers, directors, employees, members, affiliates, or agents be liable to you or any other person for any direct, indirect, special, incidental, or consequential damages arising from or related to your use of, or reliance on, the Tool or any information obtained therein. To the fullest extent permitted by law, you agree to release and hold harmless ASCE from any and all liability of any nature arising out of or resulting from any use of data provided by the ASCE 7 Hazard Tool.



NSS **NORTHEAST**
SITE SOLUTIONS
Turnkey Wireless Development

Northeast Site Solutions
Victoria Masse
420 Main Street #2, Sturbridge, MA 01566
860-306-2326
victoria@northeastsitesolutions.com

April 21, 2022

Members of the Siting Council
Connecticut Siting Council
Ten Franklin Square
New Britain, CT 06051

RE: Notice of Exempt Modification
38 Lower Road, North Canaan, CT 06024
Latitude: 42.01472200
Longitude: -73.32639000
T-Mobile Site#: CTNH550A_Anchor & L600

Dear Ms. Bachman:

T-Mobile currently maintains twelve (12) antenna at the 125-foot level of the existing 195-foot self-support tower located at 38 Lower Road, North Canaan, CT 06024. The 195-foot self-support tower and property are owned by Litchfield County Dispatch. T-Mobile now intends to install eight (8) new 600/700/1900/2500 MHz antenna. The new antennas would be installed at the 125-foot level level of the tower. This modification includes B2, B5 hardware that is both 4G (LTE), and 5G capable.

T-Mobile Planned Modifications:

Remove: None

Remove and Replace:

- (4) Air 32 B66A B2A Antenna (Remove) – (4) AIR6449 B41 2500 MHz Antenna (Replace)
- (4) APXV18-206517S Antenna (Remove) – (4) Commscope VV-65A-R1 1900/2100 MHz Antenna (Replace)
- (4) RRUS11 B12 (Remove) – (4) Radio 4480 B71+B85 (Replace)
- (4) RRUS11 B2 (Remove) – (4) Radio 4460 B25+B66 (Replace)

Install New:

- (2) Hybrid Lines

Existing to Remain:

- (4) APXVAA24_43-U-A20 600/700 MHz Antenna
- (4) Hybrid Line



NSS **NORTHEAST**
SITE SOLUTIONS
Turnkey Wireless Development

This facility was approved by the Town of North Canaan –on April 24, 1998. Please see attached.

Please accept this letter as notification pursuant to Regulations of Connecticut State Agencies §16-50j-73, for construction that constitutes an exempt modification pursuant to R.C.S.A. § 16-50j-72(b)(2). In accordance with R.C.S.A. § 16-SOj-73, a copy of this letter is being sent to First Selectman Charles Perotti, Elected Official, and George Martin, Zoning Enforcement Officer, as well as the tower and property owner.

1. The proposed modifications will not result in an increase in the height of the existing structure.
2. The proposed modifications will not require the extension of the site boundary.
3. The proposed modifications will not increase noise levels at the facility by six decibels or more, or to levels that exceed state and local criteria.
4. The operation of the replacement antennas will not increase radio frequency emissions at the facility to a level at or above the Federal Communications Commission safety standard.
5. The proposed modifications will not cause a change or alteration in the physical or environmental characteristics of the site.
6. The existing structure and its foundation can support the proposed loading.

For the foregoing reasons, T-Mobile respectfully submits that the proposed modifications to the above referenced telecommunications facility constitute an exempt modification under R.C.S.A. § 16-50j-72(b)(2).

Sincerely,

Victoria Masse

Victoria Masse
Mobile: 860-306-2326
Fax: 413-521-0558
Office: 420 Main Street, Unit 2, Sturbridge MA 01566
Email: victoria@northeastitesolutions.com

Attachments:



NSS

NORTHEAST
SITE SOLUTIONS

Turnkey Wireless Development

cc: Charles Perotti, First Selectman of North Canaan
100 Pease Street #3
North Canaan, CT 06018

George Martin, Zoning Enforcement Officer
100 Pease Street #3
North Canaan, CT 06018

Litchfield County Dispatch Inc, as property and tower owner
452 Bantam Road
Litchfield, CT 06759

Exhibit A

Original Facility Approval



STATE OF CONNECTICUT

CONNECTICUT SITING COUNCIL

Ten Franklin Square, New Britain, CT 06051

Phone: (860) 827-2935 Fax: (860) 827-2950

E-Mail: siting.council@ct.gov

www.ct.gov/csc

May 11, 2018

Kyle Richers
Transcend Wireless
10 Industrial Avenue, Suite 3
Mahwah, NJ 07430

RE: **TS-T-MOBILE-100-180410** – T-Mobile Northeast LLC request for an order to approve tower sharing at an existing telecommunications facility located at 36 Lower Road, North Canaan, Connecticut.

Dear Mr. Richers:

At a public meeting held on May 10, 2018, the Connecticut Siting Council (Council) ruled that the shared use of this existing tower site is technically, legally, environmentally, and economically feasible and meets public safety concerns, and therefore, in compliance with General Statutes § 16-50aa, the Council has ordered the shared use of this facility to avoid the unnecessary proliferation of tower structures with the following conditions:

1. Any deviation from the proposed installation as specified in the original tower share request and supporting materials with the Council shall render this decision invalid;
2. Any material changes to the proposed installation as specified in the original tower share request and supporting materials filed with the Council shall require an explicit request for modification to the Council pursuant to Connecticut General Statutes § 16-50aa, including all relevant information regarding the proposed change with cumulative worst-case modeling of radio frequency exposure at the closest point of uncontrolled access to the tower base, consistent with Federal Communications Commission, Office of Engineering and Technology, Bulletin 65;
3. Not less than 45 days after completion of the proposed installation, the Council shall be notified in writing that the installation has been completed;
4. Any nonfunctioning antenna and associated antenna mounting equipment on this facility owned and operated by T-Mobile Northeast LLC shall be removed within 60 days of the date the antenna ceased to function;
5. The validity of this action shall expire one year from the date of this letter; and
6. The applicant may file a request for an extension of time beyond the one year deadline provided that such request is submitted to the Council not less than 60 days prior to the expiration.

This decision is under the exclusive jurisdiction of the Council and applies only to this request for tower sharing dated March 29, 2018. This facility has been carefully modeled to ensure that radio frequency emissions are conservatively below State and federal standards applicable to the frequencies now used on this tower. Any deviation from the approved tower sharing request is enforceable under the provisions of Connecticut General Statutes § 16-50u.

The proposed shared use is to be implemented as specified in your letter dated March 29, 2018, including the placement of all necessary equipment and shelters within the tower compound.

Please be advised that the validity of this action shall expire one year from the date of this letter.

Thank you for your attention and cooperation.

Sincerely,

Robert Stein
Chairman

RS/MAB/FOC/lm

- c: The Honorable Charles P. Perotti, First Selectman, Town of North Canaan
Ruth Mulcahy, Zoning Enforcement Officer, Town of North Canaan
Steve Allyn, Planning and Zoning Chairman, Town of North Canaan
Litchfield County Dispatch, property owner



Permit # 5830

Building Inspector

W Bonaf

Date 4-24-98

BUILDING PERMIT

ISSUED TO

Litchfield County Dispatch

TO

AT LOCATION

38 Lous Rd

TOWN OF NORTH CANAAN, CONN.

THIS PERMIT EXPIRES ONE YEAR FROM DATE OF ISSUE

POST THIS CARD AT BUILDING SIGHT IN A DRY AREA AVAILABLE TO THE BUILDING OFFICIAL

Where applicable, separate permits are required for electrical, plumbing and mechanical installations.

Work shall not proceed until the Inspector has approved the various stages of construction.

	Date Inspected	Date Inspected
Preliminary & or Excavation	_____	Plumbing Rough-In _____
Footings & Foundations	_____	HVAC Rough-In _____
Waterproofing/Foundation Coating	_____	Electric Rough-In _____
Footing Drains	_____	Fireplace & Masonry Chimneys _____
Electrical Service	_____	Insulation Inspection _____
Framing Inspection	_____	Sheetrock or Plaster _____
Roofing Inspection	_____	Fuel Tanks and Lines _____

This Structure is Not to be Used in Whole or Part Until a Certificate of Occupancy is Issued

APPLICATION FOR BUILDING PERMIT

(APPLICATION MUST BE TYPED OR PRINTED)

TOWN OF North Canaan PERMIT NO. 5830

LOCATION OF JOB	FEE SCHEDULE	TYPE OF JOB
<u>38 LOWER Road</u> NO. STREET <u>N. CANAAN Ct 06018</u> TOWN STATE ZIP	FEE ESTIMATED VALUE \$12 FOR 1ST \$1000 (MINIMUM FEE). \$ 5 FOR EACH ADDITIONAL \$1000 OR PART THEREOF. BUILDING OFFICIAL MAY DEMAND AFFIDAVIT OF ACTUAL VALUE.	<input checked="" type="checkbox"/> ORIGINAL CONST. <input type="checkbox"/> REPAIR <input type="checkbox"/> ALTERATION <input type="checkbox"/> DEMOLITION <input type="checkbox"/> ADDITION <input type="checkbox"/> CHANGE OF USE
OWNER	VALUE-FEES	REQUIREMENTS
<u>Litchfield County Dispatch Inc</u> NAME <u>452 Bantam Rd</u> NO. STREET <u>Litchfield Ct 06759</u> TOWN STATE ZIP	VALUE FEE ESTIMATED <u>\$750,000.00</u> <u>\$3,750.00</u> ACTUAL _____ DIFFERENCE _____ ADDITIONAL FEE _____	<input type="checkbox"/> BLUEPRINTS <input type="checkbox"/> TOWN ZONING <input type="checkbox"/> SANITATION APPLIC. <input type="checkbox"/> PLOT PLAN <input type="checkbox"/> OTHER _____
APPLICANT	DEPARTMENT DECISION	TYPE OF BUILDING
<u>Litchfield County Dispatch Inc</u> NAME <u>452 Bantam Rd</u> NO. STREET <u>Litchfield Ct 06759</u> TOWN STATE ZIP	APPLICATION IS HEREBY <input checked="" type="checkbox"/> APPROVED <input type="checkbox"/> DISAPPROVED <u>4-24-98</u> <u>W Bond</u> DATE INSPECTOR	<input type="checkbox"/> RESIDENTIAL <input type="checkbox"/> COMMERCIAL <input checked="" type="checkbox"/> <u>Emergency 911 Radio Tower and Transmitter Building -</u> OTHER



BUILDER-CONTRACTOR INFORMATION	
NAME _____	CONTRACTOR LICENSE - REGISTRATION NUMBER _____
NO. _____ STREET _____	EXPIRATION DATE _____ CONTRACTOR TELEPHONE _____
TOWN _____ STATE _____ ZIP _____	CONTRACTOR SIGNATURE _____

MECHANICAL CONTRACTORS ARE REQUIRED TO OBTAIN PERMITS BEFORE STARTING ANY WORK. PERMITS EXPIRE ONE (1) YEAR FROM DATE OF ISSUE.

DISTANCE FROM EACH SIDE LOT LINE	1. DESCRIPTION OF STRUCTURE
NORTH _____ EAST _____	<u>Communication tower and 1 story Bldg</u> TYPE <u>3A</u> NO. OF STORIES <u>1/57</u>
SOUTH _____ WEST _____	2. PROPOSED USE <u>911 Communication</u> USE GROUP <u>M</u>
	3. TWO (2) COPIES OF PLANS AND SPECIFICATIONS ATTACHED <input type="checkbox"/> YES <input type="checkbox"/> NO
	4. PLOT PLAN ATTACHED <input type="checkbox"/> YES <input type="checkbox"/> NO

REMARKS:
 1. Seismic Requirement (see Spec Page 135) design will follow.
 2. Plot Plan will follow.

This is to certify that I am the owner or authorized agent for the owner. All work covered by this application has been authorized by the owner of this property and will be done according to the Connecticut Basic Building Code. As the applicant I understand that a Certificate of Use and Occupancy document is required before occupancy.

4-24-98 Alan J. Ford "Manager"
 DATE APPLICANT SIGNATURE

Exhibit B

Property Card

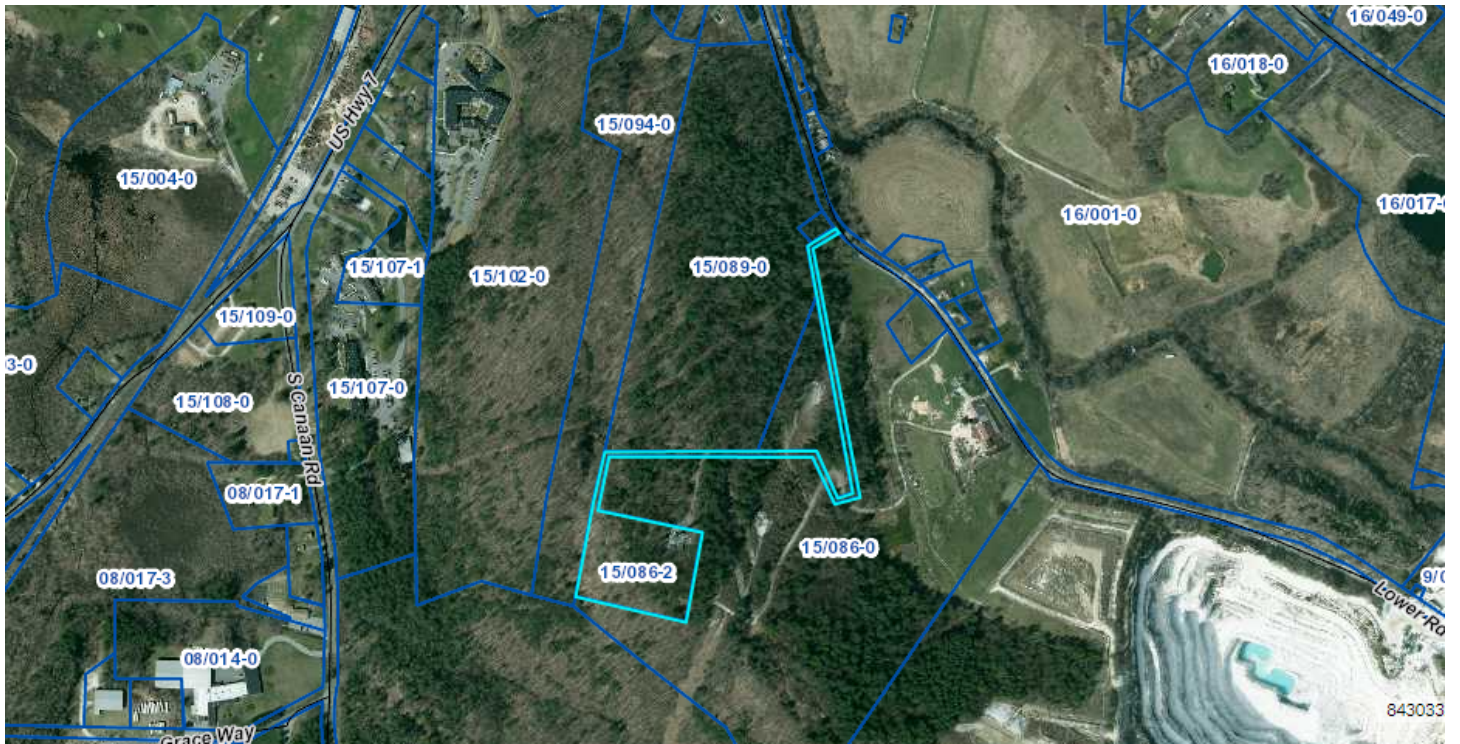

Summary

ParcelId 15/086-2
Location Address 36 LOWER RD
Map-Block-Lot 15/086-2
Use Class/Description Storage Building
Assessing Neighborhood 7 Commercial
Survey
Acreage 6.37



Owner

Current Owner
LITCHFIELD COUNTY
DISPATCH INC
452 BANTAM RD
LITCHFIELD, CT 06759

Land

Use	Class	Land Type	Zoning	Area	Value
Storage Building	C	Commercial Excess	1	5.68	\$19,310
Storage Building	C	Primary Site	1	0.69	\$86,250

Commercial Building

Building # 1
Style
Actual Year Built 1999
Effective Year Built 2007
Living Area 1804
Stories 1
Grade
Exterior Wall
Interior Wall
Roof Cover
Roof Structure
Floor Type Concrete

Heat Type
 Fuel Type
 AC
 Bdrms/Ful Bth/Hlf Bth/Ttl Rm 0/0/0/0
 Basement Finished Area 0
 Basement Garages 0

Out Buildings\Extra Features

Description	Sub Description	Area	Year Built	Value
Sup Tower	Tower	1	1998	\$824,514

Sales History

Sale Date	Sale Price	Owner
12/29/1997	\$75,000	

Permit Information

Permit ID	Issue Date	Type	Amount	Inspection Date	% Complete	Date Complete	Comments
21-52	03-17-2021	Miscellaneous	\$25,000	1/1/1900 12:00:00 AM	100	04-27-2021	INSTALLED 2 NEW CELL PH ANTENNAS ON EXISTING TELECOMM TOWER
9157	11-12-2019	Electrical	\$45,000	1/1/1900 12:00:00 AM	100	10-01-2020	MODIFY EXISTING AT&T ANTENNA FACILITY
E8778	07-25-2018	Electrical	\$7,000	1/1/1900 12:00:00 AM	100	01-01-1900	ROOM FITOUT FOR T-MOBILE PP ~ DLP
8771	07-19-2018	Plumbing	\$2,000	1/1/1900 12:00:00 AM	100	01-01-1900	RUN NEW LINE TO GENERATOR - MECHANICAL PERMIT
B8755	06-28-2018	Generator	\$15,000	1/1/1900 12:00:00 AM	100	01-01-1900	NEW GENERATOR FOR BACKUP ~ DLP
B8750	06-18-2018		\$85,000	1/1/1900 12:00:00 AM	100	01-01-1900	NEW ANTENNA - PP - DLP
8364	10-17-2016	Electrical	\$5,000	10/1/2017 12:00:00 AM	100	01-01-1900	REPLACE 3 ANTENNAS AND REMOTE UNITS ON TOWER
7619	12-30-2013	Comm Renovations	\$9,500	1/1/1900 12:00:00 AM	100	01-01-1900	replace (3) antennas on cell tower

Exhibit C

Construction Drawings

MODIFICATION OF EXISTING WIRELESS FACILITY BY



T-MOBILE NORTHEAST LLC

PROJECT TITLE: ANCHOR

SITE NUMBER: CTNH550A

SITE NAME: NORTH CANAAN

SITE ADDRESS: 38 LOWER ROAD

NORTH CANAAN, CT 06024

RF CONFIGURATION: 4Sec-67E5998E_1xAIR+1OP+1QP

APPLICANT:

T-MOBILE NORTHEAST LLC
 35 GRIFFIN ROAD SOUTH
 BLOOMFIELD, CT 06002
 860-692-7100

PROJECT MANAGER

NORTHEAST SITE SOLUTIONS
Turning Wireless Development
 420 MAIN STREET, BLDG 4
 STURBRIDGE, MA 01566
 203-275-6669

CONSULTANT:

FORESITE LLC
 Architects . Engineers . Surveyors
 462 WALNUT STREET, SUITE 1
 NEWTON, MA 02460
 617-212-3123

THIS DOCUMENT IS THE DESIGN PROPERTY AND COPYRIGHT OF FORESITE, LLC. AND FOR THE EXCLUSIVE USE BY THE TITLE CLIENT. DUPLICATION OR USE WITHOUT THE EXPRESS WRITTEN CONSENT OF THE CREATOR IS STRICTLY PROHIBITED. DRAWING SCALES ARE INTENDED FOR 11"x17" SIZE PRINTED MEDIA ONLY. ALL OTHER PRINTED SIZES ARE DEEMED "NOT TO SCALE".

REV	DESCRIPTION	DATE
A	PRELIMINARY	02/01/22
B	CORRECTED ANTENNA MODEL	04/06/22
0	FINAL ISSUED	04/21/22

SITE NUMBER: CTNH550A
SITE NAME: NORTH CANAAN
SITE ADDRESS: 38 LOWER ROAD
NORTH CANAAN, CT 06024

SHEET TITLE:
T-1: TITLE SHEET

PROJECT NOTES:

- THIS IS AN UNMANNED TELECOMMUNICATION FACILITY AND NOT FOR HUMAN HABITATION: HANDICAPPED ACCESS IS NOT REQUIRED. POTABLE WATER OR SANITARY SERVICE IS NOT REQUIRED. NO OUTDOOR STORAGE OR ANY SOLID WASTE RECEPTACLES REQUIRED.
- DEVELOPMENT AND USE OF THE SITE WILL CONFORM TO ALL APPLICABLE CODES, ORDINANCES AND SPECIFICATIONS.

CODE COMPLIANCE:

ALL WORK SHALL COMPLY WITH THE CURRENT NATIONAL AND CONNECTICUT STATE BUILDING AND LIFE SAFETY CODES, SUPPLEMENTS AND AMENDMENTS INCLUDING BUT NOT LIMITED TO THE LATEST EDITION OF:

- CONNECTICUT STATE BUILDING CODE (CSBC).
- ANSI/TIA-222-G STRUCTURAL STANDARD FOR ANTENNA SUPPORTING STRUCTURES AND ANTENNAS.
- NATIONAL ELECTRICAL CODE (NEC) FOR POWER AND GROUNDING REQUIREMENTS.
- OCCUPATIONAL SAFETY AND HEALTH ACT (OSHA).
- NFPA - NATIONAL FIRE PROTECTION ASSOCIATION.

Advance Notice:
 Minimum of 2 working days in advance, no more than 30 days in advance

CONTRACTOR'S NOTES:

CONTRACTOR SHALL VERIFY ALL PLANS, EXISTING DIMENSIONS, AND CONDITIONS ON THE JOB SITE. CONTRACTOR SHALL IMMEDIATELY NOTIFY THE ARCHITECT/ENGINEER IN WRITING OF ANY DISCREPANCIES BEFORE PROCEEDING WITH THE WORK. FAILURE TO NOTIFY THE ARCHITECT/ENGINEER PLACES THE RESPONSIBILITY ON THE CONTRACTOR TO CORRECT THE DISCREPANCIES AT THE CONTRACTOR'S EXPENSE.

REFER TO STRUCTURAL REPORTS / DRAWINGS:
 TOWER ANALYSIS REPORT - , DATED 02/04/2022 BY EFI GLOBAL INC.

APPROVALS:

FSA CM	DATE
RF ENGINEER	DATE
FOP	DATE
T-MOBILE ENGINEERING AND DEVELOPMENT	DATE
	DATE
	DATE

SITE IMAGE:



SITE VICINITY :



PROJECT SUMMARY:

THE PROPOSED PROJECT SCOPE WILL INCLUDE THE FOLLOWING EQUIPMENT MODIFICATIONS:

CABINETS: INSTALL (1) ENCLOSURE 6160 AC V1 AND (1) B160 CABINETS.

ANTENNAS: REPLACE (8) OF (12) EXISTING ANTENNAS.

RADIOS: REPLACE (8) OF (8) EXISTING RRUS.

CABLES: REMOVE ALL EXISTING COAX, ADD (2) 6X24 HYBRID TRUNK FOR TOTAL OF (4) 6X12 AND (2) 6X24 HYBRID CABLES).

PROJECT INFORMATION:

ADDRESS: 38 LOWER ROAD
 NORTH CANAAN, CT 06024

COORDINATES: 42°00' 52.78" N, 73°19' 34.68" W
GROUND ELEV: 962.8' ± (AMSL)

PROJECT TEAM:

APPLICANT: T-MOBILE NORTHEAST, LLC.
 35 GRIFFIN ROAD SOUTH
 BLOOMFIELD, CT 06002
 860-692-7100

PROJECT MANAGER: NORTHEAST SITE SOLUTIONS
 420 MAIN STREET, BLDG 4
 STURBRIDGE, MA 01566
 CONTACT: SHELDON FREINCLE
 SHELDON@NORTHEASTSITESOLUTIONS.COM
 201-776-8521

CONSULTANTS: FORESITE LLC
 462 WALNUT ST
 NEWTON, MA 02460
 CONTACT: SAEED MOSSAVAT
 SMOSSAVAT@FORESITELLC.COM
 617-212-3123

SHEET INDEX:

- T-1: TITLE SHEET
- N-1: GENERAL NOTES
- A-1: PLANS
- A-2: ELEVATION AND ANTENNA PLAN
- A-3: ANTENNA AND EQUIPMENT SPECIFICATIONS
- A-4: ANTENNA MOUNTING DETAILS
- E-1: ELECTRICAL AND GROUNDING DETAILS

Copyright © 2020 Foresite LLC. All rights reserved. The details, templates, drawing formats or any portion of this document generated by Foresite LLC may not be duplicated, traced or used otherwise for any profit-driven enterprise.

Copyright © 2020 Foresite LLC all rights reserved. The details, templates, drawing formats or any portion of this document generated by Foresite LLC may not be duplicated, traced or used otherwise for any profit-driven enterprise.

GENERAL NOTES:

1. THE CONTRACTOR SHALL GIVE ALL NOTICES AND COMPLY WITH ALL LAWS, ORDINANCES, RULES, REGULATIONS AND LAWFUL ORDERS OF ANY PUBLIC AUTHORITY, MUNICIPAL AND UTILITY COMPANY SPECIFICATIONS, AND LOCAL AND STATE JURISDICTIONAL CODES BEARING ON THE PERFORMANCE OF THE WORK. THE WORK PERFORMED ON THE PROJECT AND THE MATERIALS INSTALLED SHALL BE IN STRICT ACCORDANCE WITH ALL APPLICABLE CODES, REGULATIONS, AND ORDINANCES.
2. THE ARCHITECT/ENGINEER HAS MADE EVERY EFFORT TO SET FORTH IN THE CONSTRUCTION AND CONTRACT DOCUMENTS THE COMPLETE SCOPE OF WORK. THE CONTRACTOR BIDDING THE JOB IS NEVERTHELESS CAUTIONED THAT MINOR OMISSIONS OR ERRORS IN THE DRAWINGS AND OR SPECIFICATIONS SHALL NOT EXCUSE SAID CONTRACTOR FROM COMPLETING THE PROJECT AND IMPROVEMENTS IN ACCORDANCE WITH THE INTENT OF THESE DOCUMENTS.
3. THE CONTRACTOR OR BIDDER SHALL BEAR THE RESPONSIBILITY OF NOTIFYING (IN WRITING) THE CLIENT'S REPRESENTATIVE OF ANY CONFLICTS, ERRORS, OR OMISSIONS PRIOR TO THE SUBMISSION OF CONTRACTOR'S PROPOSAL OR PERFORMANCE OF WORK.
5. THE CONTRACTOR SHALL VISIT THE JOB SITE PRIOR TO THE SUBMISSION OF BIDS OR PERFORMING WORK TO FAMILIARIZE HIMSELF WITH THE FIELD CONDITIONS AND TO VERIFY THAT THE PROJECT CAN BE CONSTRUCTED IN ACCORDANCE WITH THE CONSTRUCTION DOCUMENTS.
6. THE CONTRACTOR SHALL INSTALL ALL EQUIPMENT AND MATERIALS ACCORDING TO THE MANUFACTURER'S / VENDOR'S SPECIFICATIONS UNLESS NOTED OTHERWISE OR WHERE LOCAL CODES OR ORDINANCES TAKE PRECEDENCE.
7. THE CONTRACTOR SHALL MAKE NECESSARY PROVISIONS TO PROTECT EXISTING IMPROVEMENTS DURING CONSTRUCTION.
8. THE CONTRACTOR SHALL COMPLY WITH ALL PERTINENT SECTIONS OF THE BASIC STATE BUILDING CODE, LATEST EDITION, AND ALL OSHA REQUIREMENTS AS THEY APPLY TO THIS PROJEC
9. THE CONTRACTOR SHALL NOTIFY THE CLIENT'S REPRESENTATIVE IN WRITING WHERE A CONFLICT OCCURS ON ANY OF THE CONTRACT DOCUMENTS. THE CONTRACTOR IS NOT TO ORDER MATERIAL OR CONSTRUCT ANY PORTION OF THE WORK THAT IS IN CONFLICT UNTIL CONFLICT IS RESOLVED BY THE CLIENT'S REPRESENTATIVE.
10. THE WORK SHALL CONFORM TO THE CODES AND STANDARDS OF THE FOLLOWING AGENCIES AS FURTHER CITED HEREIN:
 - A. ASTM: AMERICAN SOCIETY FOR TESTING AND MATERIALS, AS PUBLISHED IN "COMPILATION OF ASTM STANDARDS BUILDING CODES" OR LATEST EDITION.
 - B. AWS: AMERICAN WELDING SOCIETY INC. AS PUBLISHED IN "STANDARD D1.1-08, STRUCTURAL WELDING CODE" OR LATEST EDITION.
 - C. AISC: AMERICAN INSTITUTE FOR STEEL CONSTRUCTION AS PUBLISHED IN "CODE FOR STANDARD PRACTICE FOR STEEL BUILDINGS AND BRIDGES"; "SPECIFICATIONS FOR THE DESIGN, FABRICATION AND ERECTION OF STRUCTURAL STEEL FOR BUILDINGS" (LATEST EDITION).
11. BOLTING:
 - A. BOLTS SHALL BE CONFORMING TO ASTM A325 HIGH STRENGTH, HOT DIP GALVANIZED WITH ASTM A153 HEAVY HEX TYPE NUTS.
 - B. BOLTS SHALL BE 3/4"Ø MINIMUM (UNLESS OTHERWISE NOTED)
 - C. ALL CONNECTIONS SHALL BE 2 BOLTS MINIMUM.
12. FABRICATION:
 - A. FABRICATION OF STEEL SHALL CONFORM TO THE AISC AND AWS STANDARDS AND CODES (LATEST EDITION).
 - B. ALL STRUCTURAL STEEL SHALL BE HOT-DIP GALVANIZED AFTER FABRICATION IN ACCORDANCE WITH ASTM A123 (LATEST EDITION), UNLESS OTHERWISE NOTED.
13. ERECTION OF STEEL:
 - A. PROVIDE ALL ERECTION EQUIPMENT, BRACING, PLANKING, FIELD BOLTS, NUTS, WASHERS, DRIFT PINS, AND SIMILAR MATERIALS WHICH DO NOT FORM A PART OF THE COMPLETED CONSTRUCTION BUT ARE NECESSARY FOR ITS PROPER ERECTION.
 - B. ERECT AND ANCHOR ALL STRUCTURAL STEEL IN ACCORDANCE WITH AISC REFERENCE STANDARDS. ALL WORK SHALL BE ACCURATELY SET TO ESTABLISHED LINES AND ELEVATIONS AND RIGIDLY FASTENED IN PLACE WITH SUITABLE ATTACHMENTS TO THE CONSTRUCTION OF THE BUILDING.
 - C. TEMPORARY BRACING, GUYING AND SUPPORT SHALL BE PROVIDED TO KEEP THE STRUCTURE SAFE AND ALIGNED AT ALL TIMES DURING CONSTRUCTION, AND TO PREVENT DANGER TO PERSONS AND PROPERTY. CHECK ALL TEMPORARY LOADS AND STAY WITHIN SAFE CAPACITY OF ALL BUILDING COMPONENTS.
14. ANTENNA INSTALLATION:
 - A. INSTALL ANTENNAS AS INDICATED ON DRAWINGS AND CLIENT'S REPRESENTATIVE SPECIFICATIONS.
 - B. INSTALL GALVANIZED STEEL ANTENNA MOUNTS AS INDICATED ON DRAWINGS.

- C. INSTALL COAXIAL / FIBER CABLES AND TERMINATIONS BETWEEN ANTENNAS AND EQUIPMENT PER MANUFACTURER'S RECOMMENDATIONS. WEATHERPROOF ALL CONNECTORS BETWEEN THE ANTENNA AND EQUIPMENT PER MANUFACTURER'S REQUIREMENTS.
15. ANTENNA AND COAXIAL / FIBER CABLE GROUNDING:
 - A. ALL EXTERIOR #6 GREEN GROUND WIRE "DAISY CHAIN" CONNECTIONS ARE TO BE WEATHER SEALED WITH ANDREWS CONNECTOR/SPLICE WEATHERPROOFING KIT TYPE #221213 OR EQUAL.
 - B. ALL COAXIAL / FIBER CABLE GROUNDING KITS ARE TO BE INSTALLED ON STRAIGHT RUNS OF COAXIAL / FIBER CABLE (NOT WITHIN BENDS).
16. RELATED WORK, FURNISH THE FOLLOWING WORK AS SPECIFIED UNDER CONSTRUCTION DOCUMENTS, BUT COORDINATE WITH OTHER TRADES PRIOR TO BID:
 - A. FLASHING OF OPENING INTO OUTSIDE WALLS
 - B. SEALING AND CAULKING ALL OPENINGS
 - C. PAINTING
 - D. CUTTING AND PATCHING
17. REQUIREMENTS OF REGULATORY AGENCIES:
 - A. FURNISH U.L. LISTED EQUIPMENT WHERE SUCH LABEL IS AVAILABLE. INSTALL IN CONFORMANCE WITH U.L. STANDARDS WHERE APPLICABLE.
 - B. INSTALL ANTENNA, ANTENNA CABLES, GROUNDING SYSTEM IN ACCORDANCE WITH DRAWINGS AND SPECIFICATION IN EFFECT AT PROJECT LOCATION AND RECOMMENDATIONS OF STATE AND LOCAL BUILDING CODES, AND SPECIAL CODES HAVING JURISDICTION OVER SPECIFIC PORTIONS OF WORK. THIS WORK INCLUDES BUT IS NOT LIMITED TO THE FOLLOWING:
 - C. TIA-EIA - 222 (LATEST EDITION). STRUCTURAL STANDARDS FOR STEEL ANTENNA TOWERS AND ANTENNA SUPPORTING STRUCTURES.
 - D. FAA - FEDERAL AVIATION ADMINISTRATION ADVISORY CIRCULAR AC 70/7460-IH, OBSTRUCTION MARKING AND LIGHTING.
 - E. FCC - FEDERAL COMMUNICATIONS COMMISSION RULES AND REGULATIONS FORM 715, OBSTRUCTION MARKING AND LIGHTING SPECIFICATION FOR ANTENNA STRUCTURES AND FORM 715A, HIGH INTENSITY OBSTRUCTION LIGHTING SPECIFICATIONS FOR ANTENNA STRUCTURES.
 - F. AISC - AMERICAN INSTITUTE OF STEEL CONSTRUCTION SPECIFICATION FOR STRUCTURAL JOINTS USING ASTM A325 BOLTS (LATEST EDITION).
 - G. NEC - NATIONAL ELECTRICAL CODE - ON TOWER LIGHTING KITS.
 - H. UL - UNDERWRITER'S LABORATORIES APPROVED ELECTRICAL PRODUCTS.
 - I. IN ALL CASES, PART 77 OF THE FAA RULES AND PARTS 17 AND 22 OF THE FCC RULES ARE APPLICABLE AND IN THE EVENT OF CONFLICT, SUPERSEDE ANY OTHER STANDARDS OR SPECIFICATIONS.
 - J. 2018 LIFE SAFETY CODE NFPA - 101.

APPLICANT:

T-MOBILE NORTHEAST LLC
 35 GRIFFIN ROAD SOUTH
 BLOOMFIELD, CT 06002
 860-692-7100

PROJECT MANAGER

 420 MAIN STREET, BLDG 4
 STURBRIDGE, MA 01566
 203-275-6669

CONSULTANT:

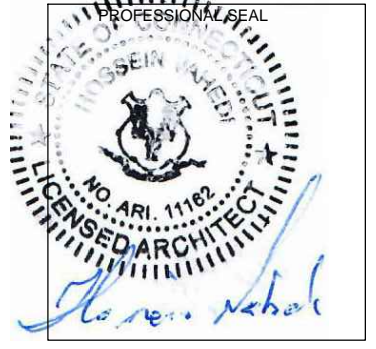
 Architects . Engineers . Surveyors
 462 WALNUT STREET, SUITE 1
 NEWTON, MA 02460
 617-212-3123



THIS DOCUMENT IS THE DESIGN PROPERTY AND COPYRIGHT OF FORESITE, LLC. AND FOR THE EXCLUSIVE USE BY THE TITLE CLIENT. DUPLICATION OR USE WITHOUT THE EXPRESS WRITTEN CONSENT OF THE CREATOR IS STRICTLY PROHIBITED. DRAWING SCALES ARE INTENDED FOR 11"x17" SIZE PRINTED MEDIA ONLY. ALL OTHER PRINTED SIZES ARE DEEMED "NOT TO SCALE".

REV	DESCRIPTION	DATE
A	PRELIMINARY	02/01/22
B	CORRECTED ANTENNA MODEL	04/06/22
0	FINAL ISSUED	04/21/22

SITE NUMBER: CTNH550A
 SITE NAME: NORTH CANAAN
 SITE ADDRESS: 38 LOWER ROAD
 NORTH CANAAN, CT 06024

SHEET TITLE:
 N-1: GENERAL NOTES

Copyright © 2020 Foresite LLC all rights reserved. The details, templates, drawing formats or any portion of this document generated by Foresite LLC may not be duplicated, traced or used otherwise for any profit-driven enterprise.

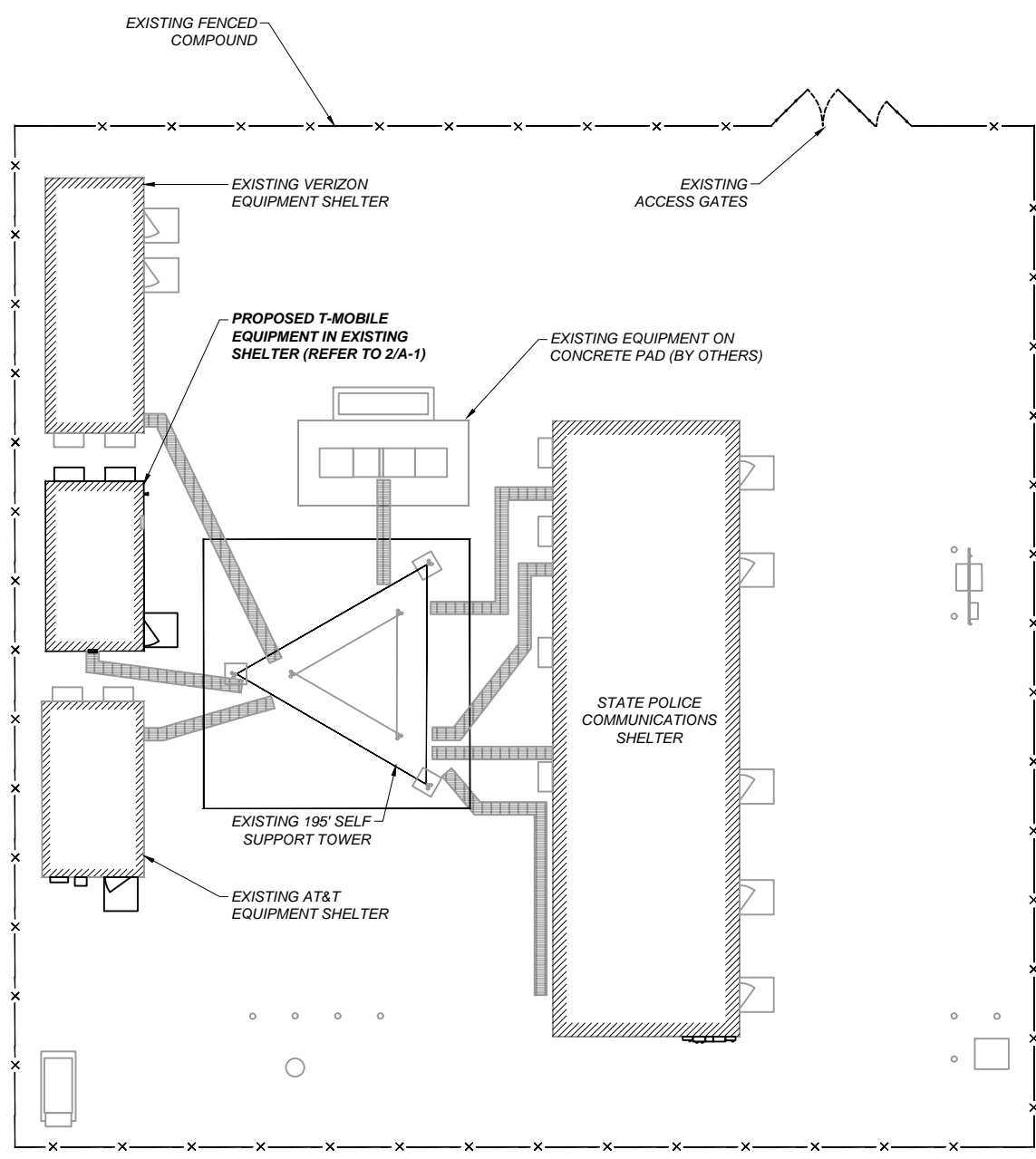

SITE PLAN
SCALE: 1"=20'

1
A-1

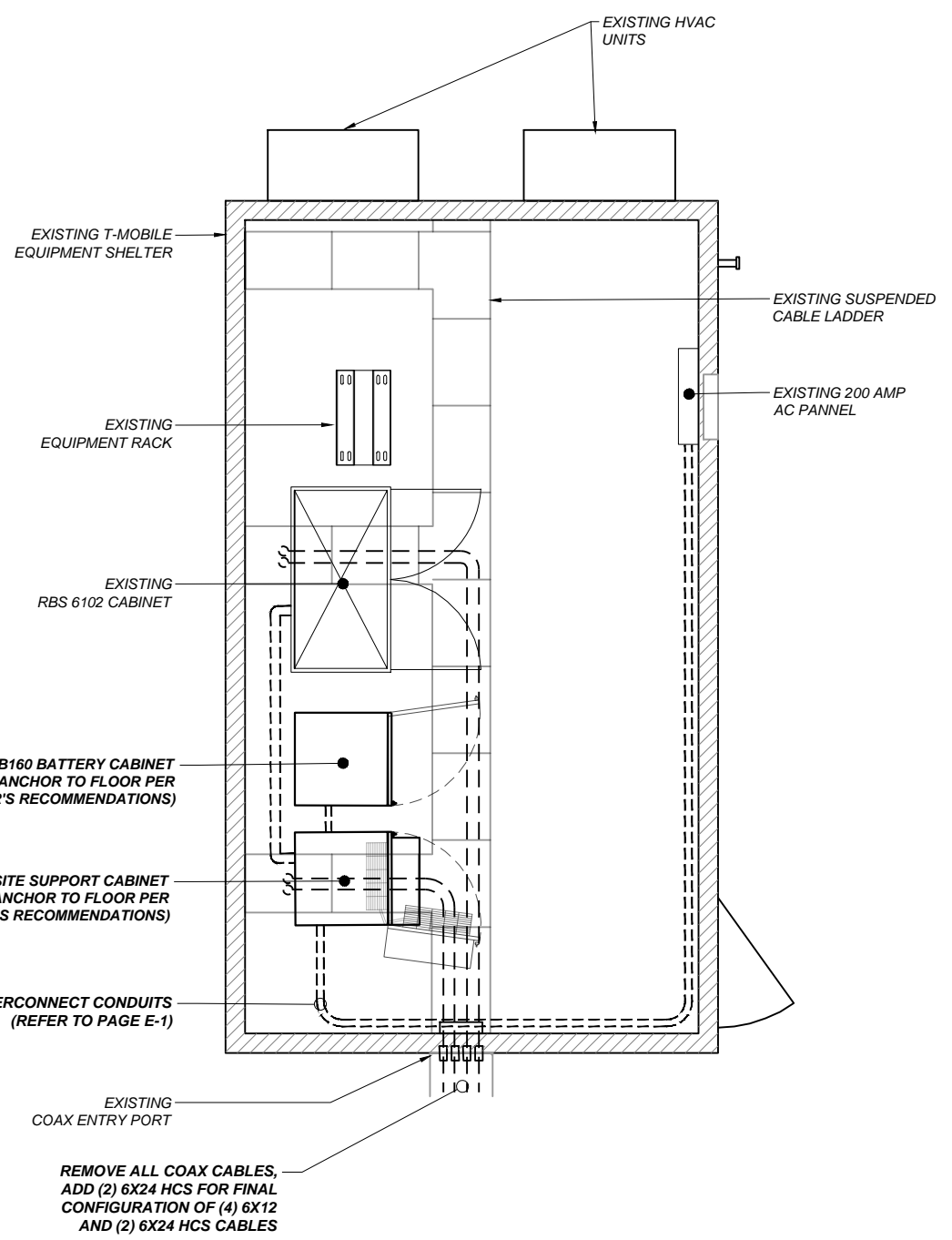

EQUIPMENT PLAN
SCALE: 1/4"=1'-0"

2
A-1

APPLICANT:
T-Mobile
T-MOBILE NORTHEAST LLC
35 GRIFFIN ROAD SOUTH
BLOOMFIELD, CT 06002
860-692-7100

PROJECT MANAGER
NORTHEAST SITE SOLUTIONS
Turnkey Wireless Development
420 MAIN STREET, BLDG 4
STURBRIDGE, MA 01566
203-275-6669

CONSULTANT:
FORESITE LLC
Architects - Engineers - Surveyors
462 WALNUT STREET, SUITE 1
NEWTON, MA 02460
617-212-3123

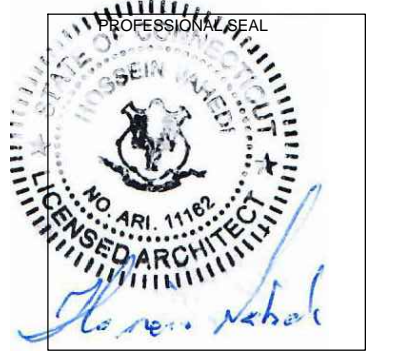

THIS DOCUMENT IS THE DESIGN PROPERTY AND COPYRIGHT OF FORESITE, LLC. AND FOR THE EXCLUSIVE USE BY THE TITLE CLIENT. DUPLICATION OR USE WITHOUT THE EXPRESS WRITTEN CONSENT OF THE CREATOR IS STRICTLY PROHIBITED. DRAWING SCALES ARE INTENDED FOR 11"x17" SIZE PRINTED MEDIA ONLY. ALL OTHER PRINTED SIZES ARE DEEMED "NOT TO SCALE".

REV	DESCRIPTION	DATE
A	PRELIMINARY	02/01/22
B	CORRECTED ANTENNA MODEL	04/06/22
0	FINAL ISSUED	04/21/22

SITE NUMBER: CTNH550A
SITE NAME: NORTH CANAAN
SITE ADDRESS: 38 LOWER ROAD
NORTH CANAAN, CT 06024

SHEET TITLE:
A-1: SITE PLAN

Copyright © 2020 Foresite LLC all rights reserved. The details, templates, drawing formats or any portion of this document generated by Foresite LLC may not be duplicated, traced or used otherwise for any profit-driven enterprise.

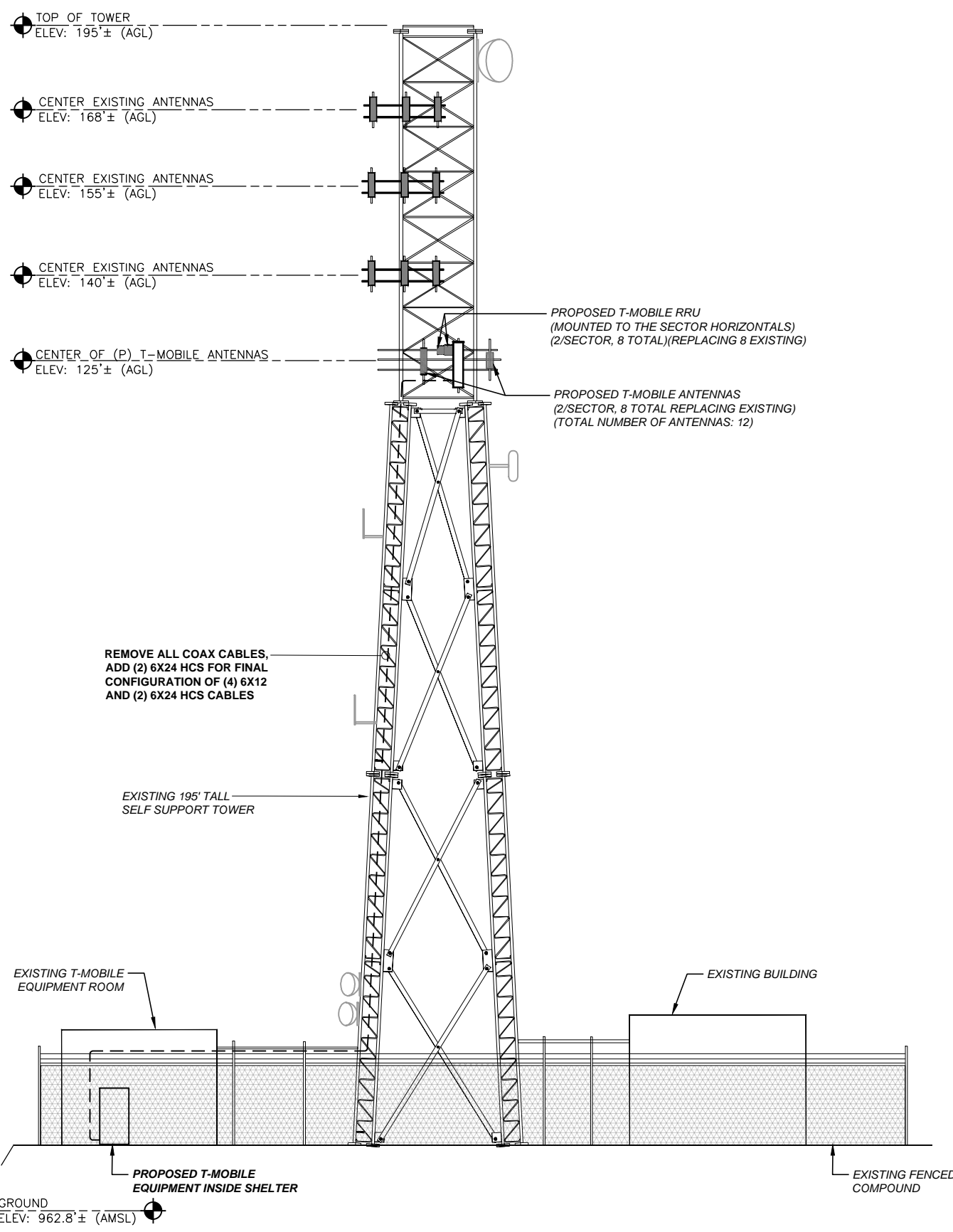

ELEVATION
SCALE: 3/16"=1'-0" 1
A-2



NOTE: ANTENNA MODELS
TYPICAL ALL SECTORS

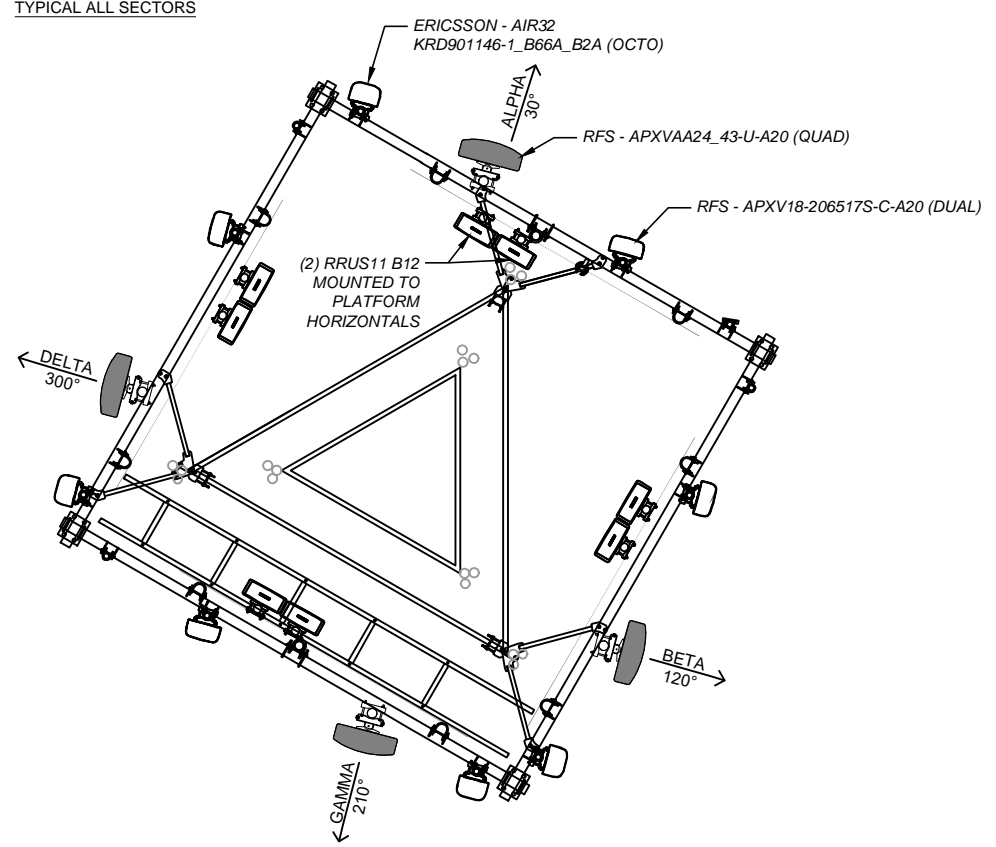

EXISTING ANTENNA LAYOUT
N.T.S. 2
A-2

NOTE: ANTENNA MODELS
TYPICAL ALL SECTORS

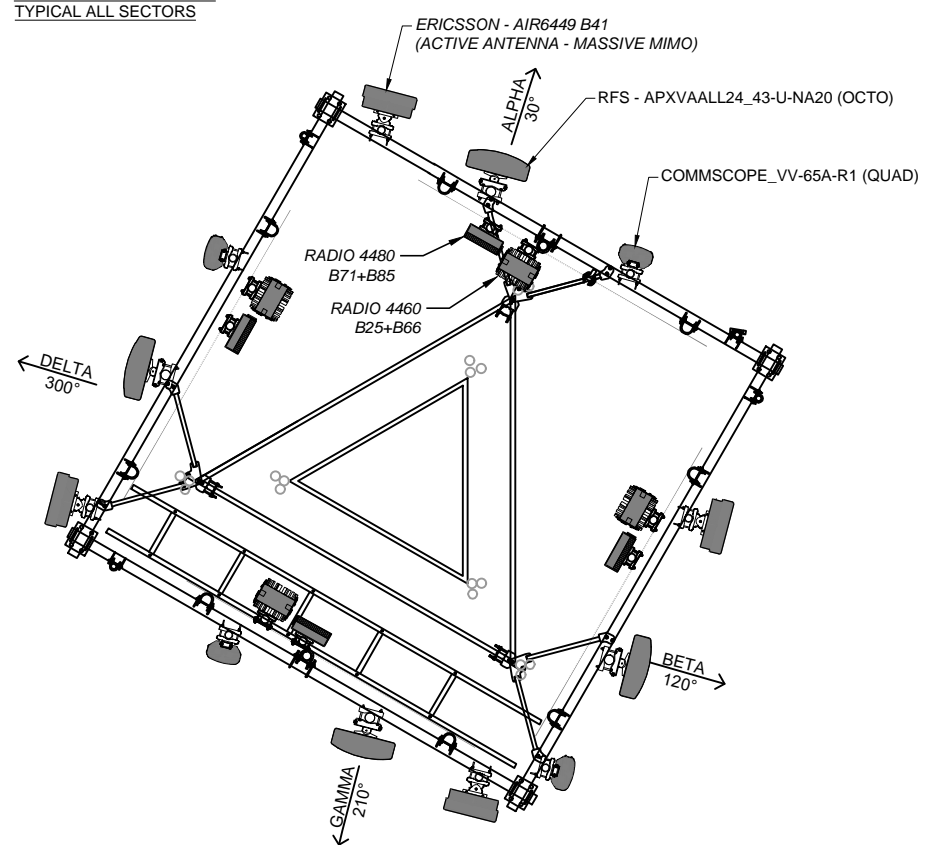

FINAL ANTENNA LAYOUT
N.T.S. 3
A-2

APPLICANT:
T-Mobile
T-MOBILE NORTHEAST LLC
 35 GRIFFIN ROAD SOUTH
 BLOOMFIELD, CT 06002
 860-692-7100

PROJECT MANAGER

 420 MAIN STREET, BLDG 4
 STURBRIDGE, MA 01566
 203-275-6669

CONSULTANT:
FORESITE LLC
 Architects . Engineers . Surveyors
 462 WALNUT STREET, SUITE 1
 NEWTON, MA 02460
 617-212-3123



THIS DOCUMENT IS THE DESIGN PROPERTY AND
 COPYRIGHT OF FORESITE, LLC. AND FOR THE
 EXCLUSIVE USE BY THE TITLE CLIENT.
 DUPLICATION OR USE WITHOUT THE EXPRESS
 WRITTEN CONSENT OF THE CREATOR IS STRICTLY
 PROHIBITED. DRAWING SCALES ARE INTENDED FOR
 11"x17" SIZE PRINTED MEDIA ONLY. ALL OTHER
 PRINTED SIZES ARE DEEMED "NOT TO SCALE".

REV	DESCRIPTION	DATE
A	PRELIMINARY	02/01/22
B	CORRECTED ANTENNA MODEL	04/06/22
0	FINAL ISSUED	04/21/22

SITE NUMBER: CTNH550A
SITE NAME: NORTH CANAAN
 SITE ADDRESS: 38 LOWER ROAD
 NORTH CANAAN, CT 06024

SHEET TITLE:
**A-3: ELEVATION AND ANTENNA
 LAYOUT PLAN**

Copyright © 2020 Foresite LLC all rights reserved. The details, templates, drawing formats or any portion of this document generated by Foresite LLC may not be duplicated, traced or used otherwise for any profit-driven enterprise.

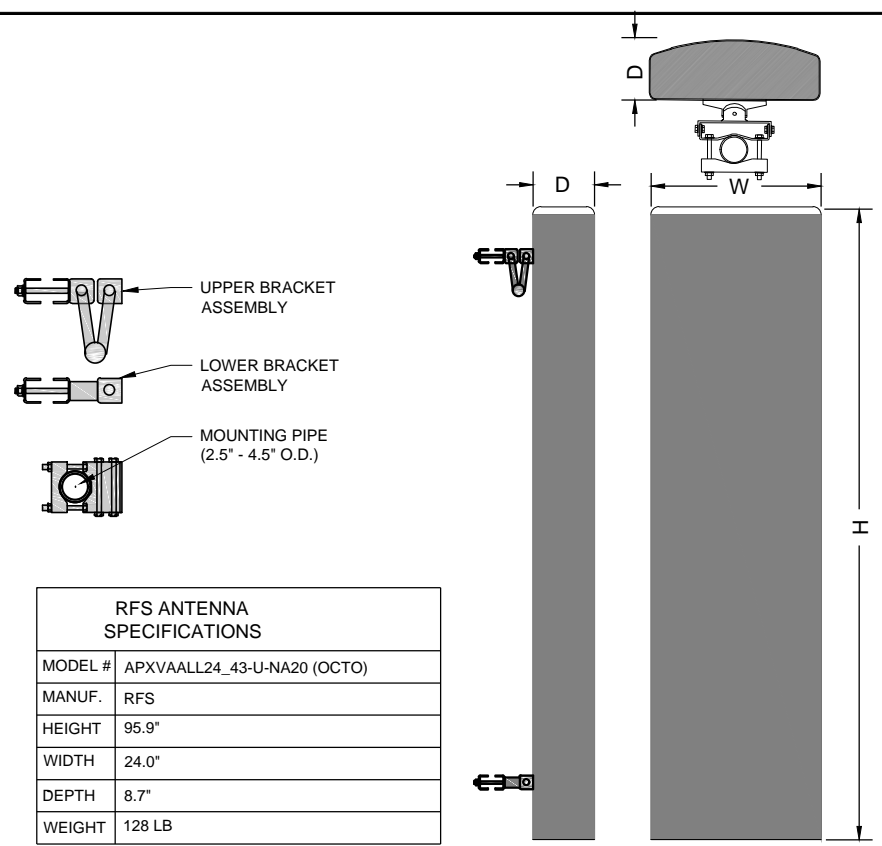

RFS ANTENNA SPECIFICATIONS	
MODEL #	APXVAALL24_43-U-NA20 (OCTO)
MANUF.	RFS
HEIGHT	95.9"
WIDTH	24.0"
DEPTH	8.7"
WEIGHT	128 LB

RFS ANTENNA
N.T.S

1
A-4

ERICSSON ANTENNA SPECIFICATIONS	
MODEL #	VV-65A-R1
MANUF.	COMMSCOPE
LENGTH	54.7"
WIDTH	12.1"
DEPTH	4.6"
WEIGHT	41.9 LB

COMMSCOPE ANTENNA
N.T.S

1
A-3

ERICSSON ANTENNA SPECIFICATIONS	
MODEL #	AIR6449 B41
MANUF.	ERICSSON
HEIGHT	33.1"
WIDTH	20.5"
DEPTH	8.3"
WEIGHT	103 LB

ERICSSON ANTENNA
N.T.S

2
A-3

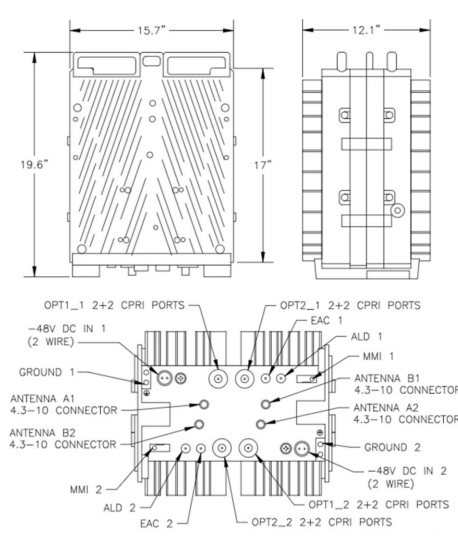

RRU SPECIFICATIONS	
MODEL #	4460 B2/25
MANUF.	ERICSSON
LENGTH	19.6"
WIDTH	15.7"
DEPTH	12.1"
WEIGHT	109 LB

REMOTE RADIO UNIT
N.T.S

3
A-3

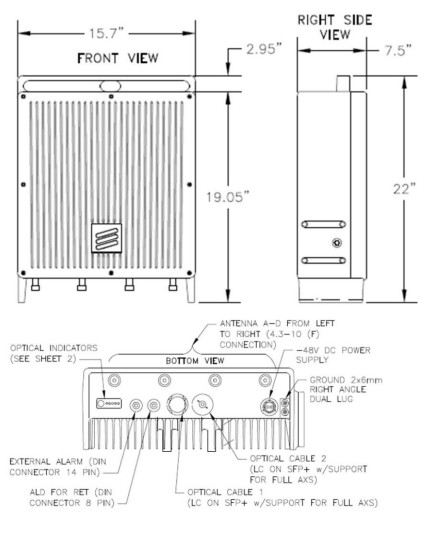

RRU SPECIFICATIONS	
MODEL #	4480 B71
MANUF.	ERICSSON
LENGTH	22.0"
WIDTH	15.7"
DEPTH	7.5"
WEIGHT	93.0 LB

REMOTE RADIO UNIT
N.T.S

4
A-3

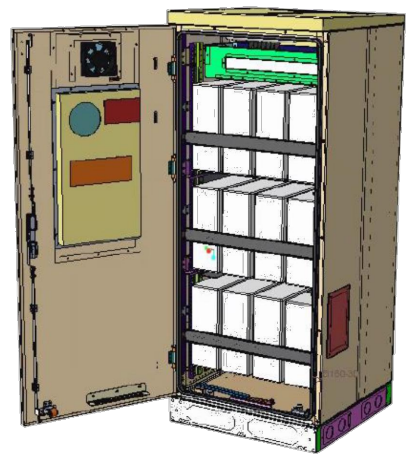

BATTERY CABINET SPECIFICATIONS	
MODEL #	B160
MANUF.	ERICSSON
HEIGHT	63"
WIDTH	26"
DEPTH	26"
WEIGHT	1883 lbs

BATTERY CABINET
N.T.S.

5
A-3

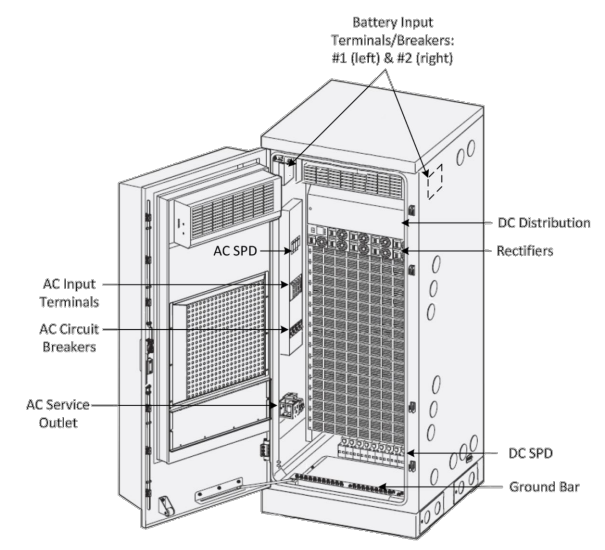

SITE SUPPORT CABINET SPECIFICATIONS	
MODEL #	6160
MANUF.	ERICSSON
HEIGHT	63"
WIDTH	25.6"
DEPTH	33.5"
WEIGHT	605 lbs

SITE SUPPORT CABINET
N.T.S.

6
A-3

APPLICANT:
T-Mobile
T-MOBILE NORTHEAST LLC
35 GRIFFIN ROAD SOUTH
BLOOMFIELD, CT 06002
860-692-7100

PROJECT MANAGER
NORTHEAST SITE SOLUTIONS
Turnkey Wireless Development
420 MAIN STREET, BLDG 4
STURBRIDGE, MA 01566
203-275-6669

CONSULTANT:
FORESITE LLC
Architects . Engineers . Surveyors
462 WALNUT STREET, SUITE 1
NEWTON, MA 02460
617-212-3123



THIS DOCUMENT IS THE DESIGN PROPERTY AND COPYRIGHT OF FORESITE, LLC. AND FOR THE EXCLUSIVE USE BY THE TITLE CLIENT. DUPLICATION OR USE WITHOUT THE EXPRESS WRITTEN CONSENT OF THE CREATOR IS STRICTLY PROHIBITED. DRAWING SCALES ARE INTENDED FOR 11"x17" SIZE PRINTED MEDIA ONLY. ALL OTHER PRINTED SIZES ARE DEEMED "NOT TO SCALE".

REV	DESCRIPTION	DATE
A	PRELIMINARY	02/01/22
B	CORRECTED ANTENNA MODEL	04/06/22
0	FINAL ISSUED	04/21/22

SITE NUMBER: CTNH550A
SITE NAME: NORTH CANAAN
SITE ADDRESS: 38 LOWER ROAD
NORTH CANAAN, CT 06024

SHEET TITLE:
A-3: ANTENNA AND EQUIPMENT SPECS

Copyright © 2020 Foresite LLC all rights reserved. The details, templates, drawing formats or any portion of this document generated by Foresite LLC may not be duplicated, traced or used otherwise for any profit-driven enterprise.

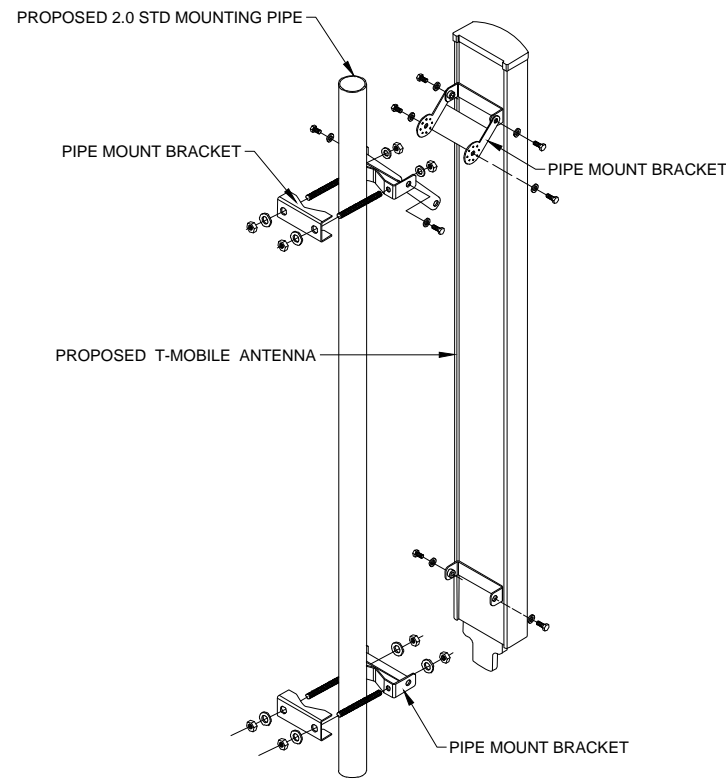

ANTENNA MOUNT DETAIL 1
N.T.S A-4

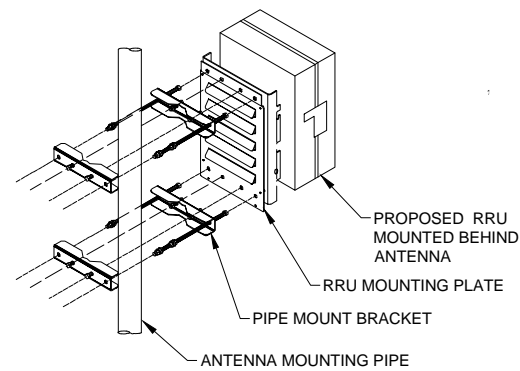

RRU MOUNT DETAIL 2
N.T.S A-4

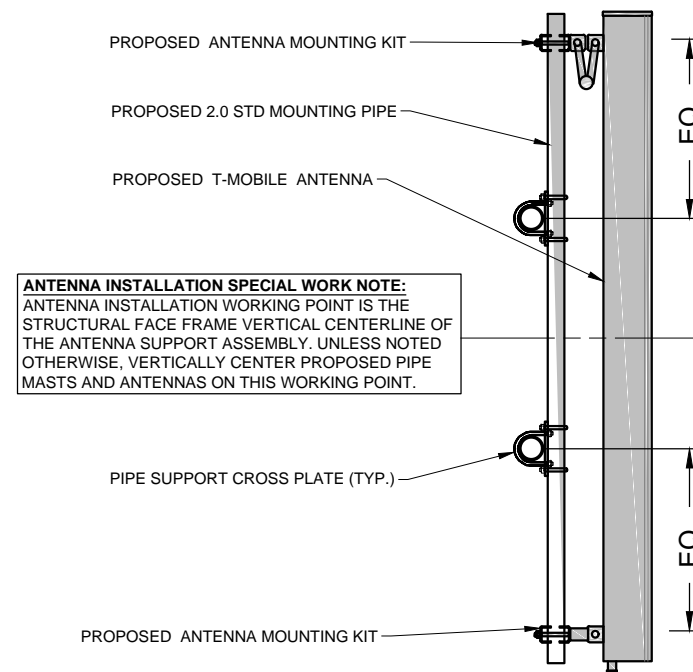

ANTENNA ELEVATION 3
N.T.S A-4

APPLICANT:
T-Mobile
T-MOBILE NORTHEAST LLC
35 GRIFFIN ROAD SOUTH
BLOOMFIELD, CT 06002
860-692-7100

PROJECT MANAGER

NORTHEAST SITE SOLUTIONS
Turnkey Wireless Development
420 MAIN STREET, BLDG 4
STURBRIDGE, MA 01566
203-275-6669

CONSULTANT:
FORESITE LLC
Architects · Engineers · Surveyors
462 WALNUT STREET, SUITE 1
NEWTON, MA 02460
617-212-3123



THIS DOCUMENT IS THE DESIGN PROPERTY AND COPYRIGHT OF FORESITE, LLC. AND FOR THE EXCLUSIVE USE BY THE TITLE CLIENT. DUPLICATION OR USE WITHOUT THE EXPRESS WRITTEN CONSENT OF THE CREATOR IS STRICTLY PROHIBITED. DRAWING SCALES ARE INTENDED FOR 11"x17" SIZE PRINTED MEDIA ONLY. ALL OTHER PRINTED SIZES ARE DEEMED "NOT TO SCALE".

REV	DESCRIPTION	DATE
A	PRELIMINARY	02/01/22
B	CORRECTED ANTENNA MODEL	04/06/22
0	FINAL ISSUED	04/21/22

SITE NUMBER: CTNH550A
SITE NAME: NORTH CANAAN
SITE ADDRESS: 38 LOWER ROAD
NORTH CANAAN, CT 06024

SHEET TITLE:
A-4: ANTENNA MOUNTING DETAILS

Copyright © 2020 Foresite LLC all rights reserved. The details, templates, drawing formats or any portion of this document generated by Foresite LLC may not be duplicated, traced or used otherwise for any profit-driven enterprise.

ELECTRICAL & GROUNDING NOTES

1. ALL ELECTRICAL WORK SHALL CONFORM TO THE REQUIREMENTS OF THE NATIONAL ELECTRICAL CODE (NEC) AS WELL AS APPLICABLE STATE AND LOCAL CODES.
2. ALL ELECTRICAL ITEMS SHALL BE U.L. APPROVED OR LISTED AND PRODUCED PER SPECIFICATION REQUIREMENTS.
3. THE ELECTRICAL WORK INCLUDES ALL LABOR AND MATERIAL DESCRIBED BY DRAWINGS AND SPECIFICATION INCLUDING INCIDENTAL WORK TO PROVIDE COMPLETE OPERATING AND APPROVED ELECTRICAL SYSTEM.
4. GENERAL CONTRACTOR SHALL PAY FEES FOR PERMITS, AND RESPONSIBLE FOR OBTAINING SAID PERMITS AND COORDINATION OF INSPECTIONS.
5. ELECTRICAL AND TELCO WIRING OUTSIDE A BUILDING AND EXPOSED TO WEATHER SHALL BE IN WATER TIGHT GALVANIZED RIGID STEEL CONDUITS OR SCHEDULE 80 PVC (AS PERMITTED BY CODE) ND WHERE REQUIRED IN LIQUID TIGHT FLEXIBLE METAL OR NONMETALLIC CONDUITS.
6. RIGID STEEL CONDUITS SHALL BE GROUNDED AT BOTH ENDS.
7. ELECTRICAL WIRING SHALL BE COPPER WITH TYPE XHHW, THWN, OR THIN INSULATION.
8. RUN ELECTRICAL CONDUIT OR CABLING BETWEEN ELECTRICAL ROOM AND PROPOSED CELL SITE ARE PEDESTAL AS INDICATED ON THIS DRAWING. PROVIDE FULL LENGTH PULL ROPE. COORDINATE INSTALLATION WITH UTILITY COMPANY.
9. RUN TELCO CONDUIT OR CABLE BETWEEN TELEPHONE UTILITY DEMARCATION POINT AND PROPOSED CELL SITE TELCOM CABINET AND RBS CABINET AS INDICATED ON DRAWING A -1. PROVIDE FULL LENGTH PULL ROPE INSTALLED TELCO CONDUIT. PROVIDE GREENLEE CONDUIT MEASURING TAPE AT EACH END.
10. ALL EQUIPMENT LOCATED OUTSIDE SHALL HAVE NAME 3R ENCLOSURE.
11. GROUNDING SHALL COMPLY WITH NEC ART. 250.
12. GROUNDING COAX CABLE SHIELDS MINIMUM AT BOTH ENDS USING MANUFACTURES COAX CABLE GROUNDING KITS SUPPLIED BY PROJECT OWNER.
13. USE #6 COPPER STRANDED WIRE WITH GREEN COLOR INSTALLATION FOR ABOVE GRADE GROUNDING (UNLESS OTHERWISE SPECIFIED) AND #2 SOLID TINNED BARE COPPER WIRE FOR BELOW GRADE GROUNDING AS INDICATED ON THE GROUND.
14. ALL GROUND CONNECTION TO BE BURNDY HYGROUND COMPRESSION TYPE CONNECTORS OR CADWELD EXOTHERMIC WELD. DO NOT ALLOW BARE COPPER WIRE TO BE IN CONTACT WITH GALVANIZED STEEL.
15. ROUTE GROUNDING CONDUCTORS ALONG THE SHORTEST AND STRAIGHTEST PATH POSSIBLE, EXCEPT AS OTHERWISE INDICATED. GROUNDING LEADS SHOULD NEVER BE BENT AS RIGHT ANGLE. ALWAYS MAKE AT LEAST 12" RADIUS BENDS. #6 WIRE CAN BE BENT AT 6" RADIUS WHEN NECESSARY BOND ANY METER OBJECTS WITHIN 7 FEET OF PROPOSED EQUIPMENT OR CABINET TO MASTER GROUND BAR.
16. CONNECTIONS TO MGB SHALL BE ARRANGED IN THREE MAIN GROUPS: SURGE PROCEDURES (COAXIAL CABLE GROUND KITS, TELCO AND POWER PANEL GROUND); (GROUNDING ELECTRODE RING OR BUILDING STEEL); NON-SURGING OBJECTS (EGB GROUND IN RBS UNIT).
17. CONNECTIONS TO GROUND BARS SHALL BE MADE WITH TWO HOLE COMPRESSION TYPE COPPER LUGS. APPLY OXIDE INHIBITING COMPOUND TO ALL LOCATIONS.
18. APPLY OXIDE INHIBITING COMPOUND TO ALL COMPRESSION TYPE GROUND CONNECTION.
19. BOND ANTENNA MOUNTING BRACKETS, COAXIAL CABLE GROUND KITS, AND ALNA TO EGB PLACED NEAR THE ANTENNA LOCATION.
20. BOND ANTENNA EGB'S AND MGB TO WATER MAIN.
21. TEST COMPLETED GROUND SYSTEM AND RECORD RESULTS FOR PROJECT CLOSE-OUT DOCUMENTATION.
22. BOND ANY METAL OBJECTS WITHIN 7 FEET OF PROPOSED EQUIPMENT OR CABINET TO MASTER GROUND BAR.
23. VERIFY PROPOSED SERVICE UPGRADE WITH LOCAL UTILITY COMPANY PRIOR TO CONSTRUCTION.

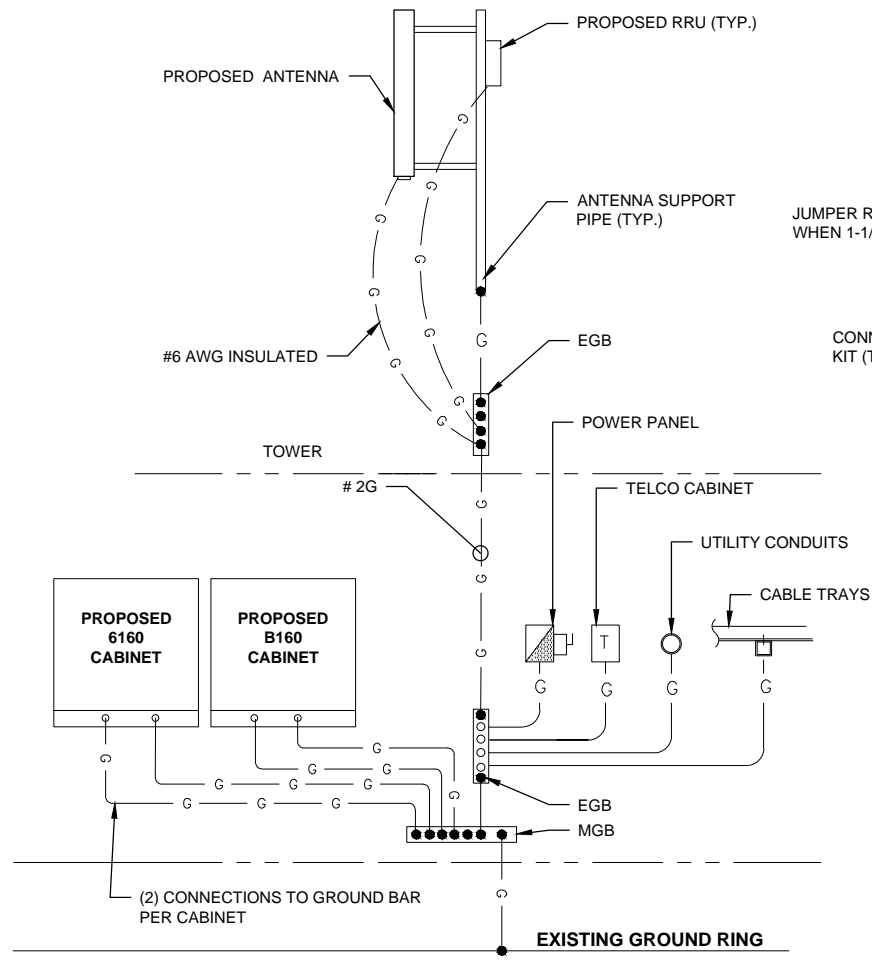

GROUNDING RISER DIAGRAM
N.T.S.

1
E-1

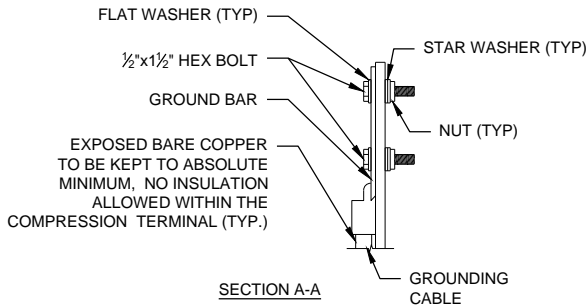
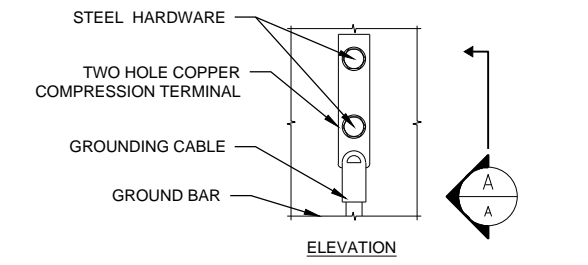

- NOTES:
1. "DOUBLING UP" OR "STACKING" OF CONNECTION IS NOT PERMITTED.
2. OXIDE INHIBITING COMPOUND TO BE USED AT ALL LOCATIONS.

TYPICAL GROUND BAR CONNECTIONS DETAIL
N.T.S.

3
E-1

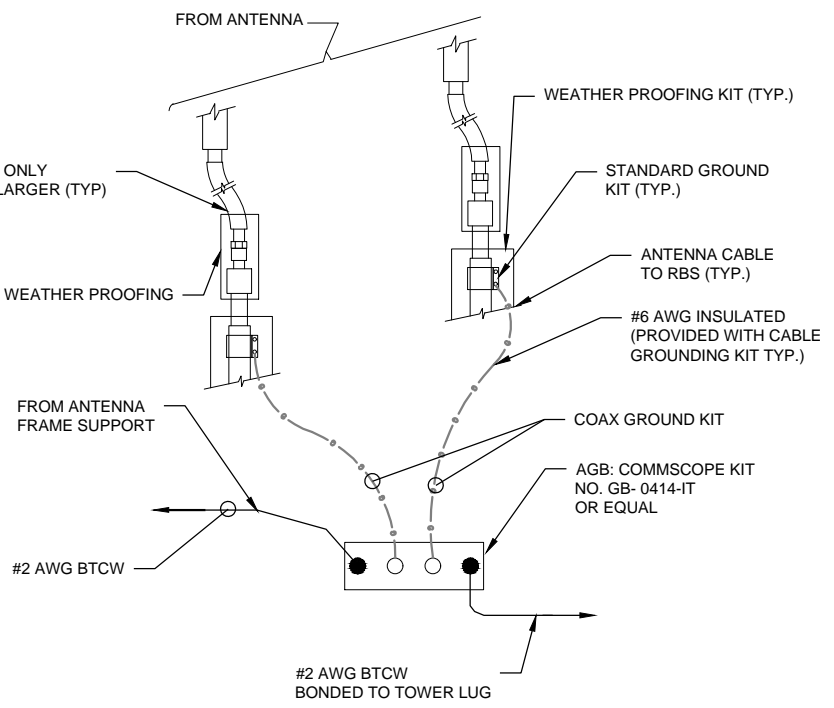

NOTES:
INSTALL CABLE GROUND KIT ABOVE HORIZONTAL BEND AND ALWAYS DIRECT GROUND WIRE DOWN TO AGB/EGB

TOWER TOP CABLE GROUNDING DETAIL
N.T.S.

2
E-1

SPECIAL CONTRACTOR'S NOTES:

CONTRACTOR TO VERIFY THE POWER FEED & PHASE OF METER BANK AND THAT THE EXISTING AND PROPOSED CONDUITS AND WIRE SIZES ARE ADEQUATE FOR THE PROPOSED LOADING IN ACCORDANCE WITH NEC AND INCLUDE ELECTRICAL UPGRADES IN THE SCOPE OF WORK AS REQUIRED.

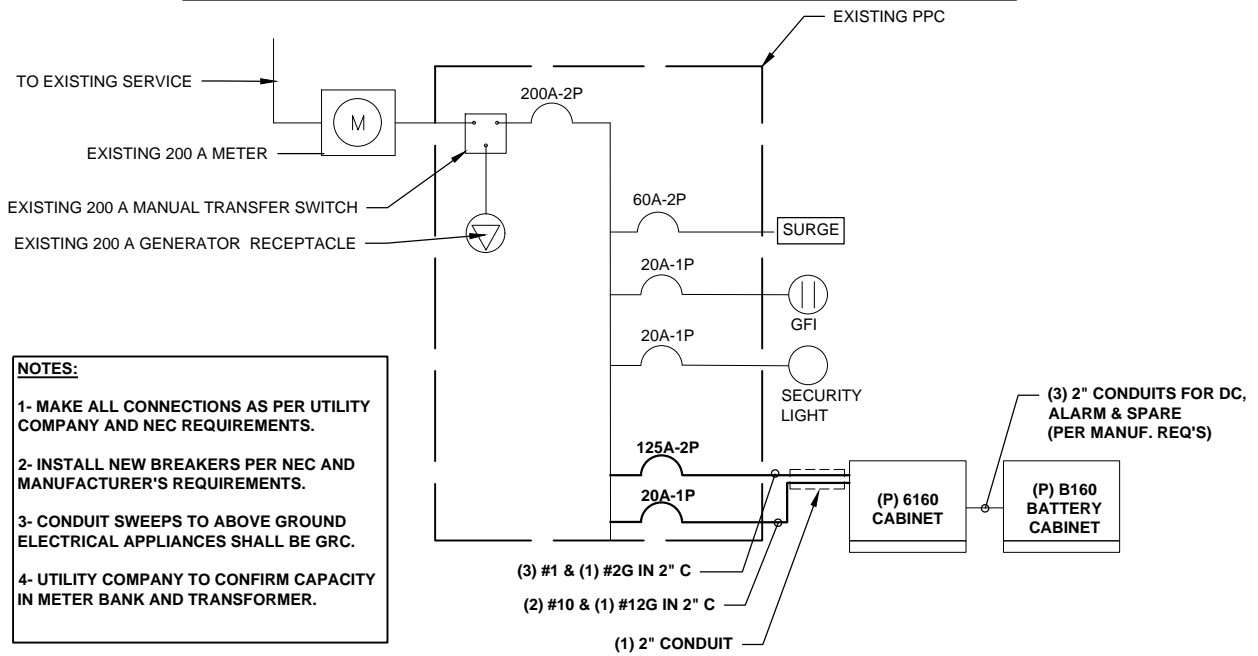

- NOTES:
1- MAKE ALL CONNECTIONS AS PER UTILITY COMPANY AND NEC REQUIREMENTS.
2- INSTALL NEW BREAKERS PER NEC AND MANUFACTURER'S REQUIREMENTS.
3- CONDUIT SWEEPS TO ABOVE GROUND ELECTRICAL APPLIANCES SHALL BE GRC.
4- UTILITY COMPANY TO CONFIRM CAPACITY IN METER BANK AND TRANSFORMER.

TYPICAL ONE LINE DIAGRAM
N.T.S.

4
E-1

APPLICANT:
T-Mobile
T-MOBILE NORTHEAST LLC
35 GRIFFIN ROAD SOUTH
BLOOMFIELD, CT 06002
860-692-7100

PROJECT MANAGER
NORTHEAST SITE SOLUTIONS
Trendy Wireless Development
420 MAIN STREET, BLDG 4
STURBRIDGE, MA 01566
203-275-6669

CONSULTANT:
FORESITE LLC
Architects - Engineers - Surveyors
462 WALNUT STREET, SUITE 1
NEWTON, MA 02460
617-212-3123
PROFESSIONAL SEAL
NO. ARI. 11162
LICENSED ARCHITECT
Thomas A. Nehal

THIS DOCUMENT IS THE DESIGN PROPERTY AND COPYRIGHT OF FORESITE, LLC. AND FOR THE EXCLUSIVE USE BY THE TITLE CLIENT. DUPLICATION OR USE WITHOUT THE EXPRESS WRITTEN CONSENT OF THE CREATOR IS STRICTLY PROHIBITED. DRAWING SCALES ARE INTENDED FOR 11"x17" SIZE PRINTED MEDIA ONLY. ALL OTHER PRINTED SIZES ARE DEEMED "NOT TO SCALE".

REV	DESCRIPTION	DATE
A	PRELIMINARY	02/01/22
B	CORRECTED ANTENNA MODEL	04/06/22
0	FINAL ISSUED	04/21/22

SITE NUMBER: CTNH550A
SITE NAME: NORTH CANAAN
SITE ADDRESS: 38 LOWER ROAD
NORTH CANAAN, CT 06024

SHEET TITLE:
E-1: ELECTRICAL & GROUNDING DETAIL

Exhibit D

Structural Analysis Report

**STRUCTURAL ANALYSIS REPORT – REV.1
SELF SUPPORT TOWER**



Prepared For:
T-Mobile Northeast, LLC.
35 Griffin Rd. South
Bloomfield, CT 06002

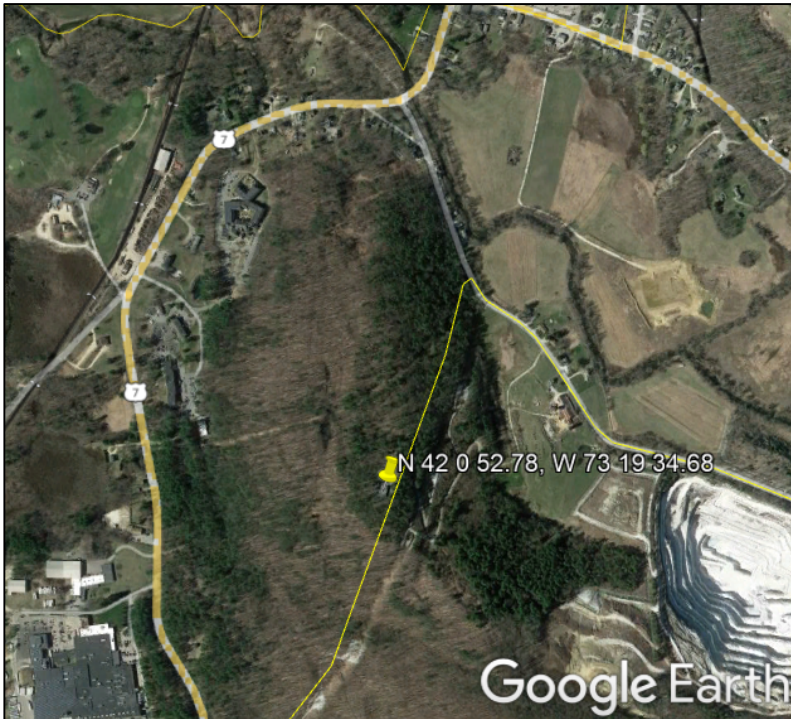

Structure Rating:

Tower:	Pass (91.1%)
Anchor Bolts:	Pass (37.5%)

Sincerely,
EFI Global, Inc.



Ahmet Colakoglu, PE
Connecticut Professional Engineer
License No: 27057

T-Mobile Site Name: North Canaan
T-Mobile Site ID: CTNH550A
38 Lower Road
North Canaan, CT 06024

CONTENTS

1.0 - SUBJECT AND REFERENCES

1.1 - STRUCTURE

2.0 - EXISTING AND PROPOSED APPURTENANCES

3.0 - CODES AND LOADING

4.0 - STANDARD CONDITIONS FOR ENGINEERING SERVICES ON EXISTING
STRUCTURES

5.0 - ANALYSIS AND ASSUMPTIONS

6.0 - RESULTS AND CONCLUSION

APPENDICES

A - SOFTWARE OUTPUT

1.0 SUBJECT AND REFERENCES

The purpose of this analysis is to evaluate the structural capacity of the 195 ft. tall self-support tower located at 38 Lower Road, North Canaan, CT 06024 for the additions and alterations proposed by T-Mobile.

The structural analysis is based on the following documentation provided to EFI Global, Inc. (EFI):

- RFDS prepared for T-Mobile, dated 01/04/2022.
- Construction Drawings prepared by Hudson Design Group, LLC, dated 08/20/2021.
- Structural Analysis Report prepared by Hudson Design Group, LLC, dated 08/16/2021.
- Structural Analysis Report prepared by Centek Engineering, dated 02/27/2018.

1.1 STRUCTURE

The subject structure is a three-sided, 195 ft. tall self-support tower formed by nine (9) 20 ft. sections, and one (1) 15 ft. section. Truss legs are X-braced with single and double angle diagonals. The tower is 26 ft. wide at the base, and has a constant taper down to 12 ft at 140 ft. Please refer to the software output in Appendix A for tower geometry, member sizes, and other details.

2.0 EXISTING AND PROPOSED APPURTENANCES

Existing Configuration T-Mobile Appurtenances:

Rad Center (ft.)	Antennas & Equipment	Coax	Mounts
125.0	(4) Air 32 B66A B2A (4) APXV18-206517S-C-A20 (4) APXVAA24_43-U-A20 (4) RRUS11 B12 (4) RRUS11 B2	(4) 6x12 Hybriflex	(1) Custom 4-sided sector frame

Proposed and Final Configuration of T-Mobile Appurtenances:

Rad Center (ft.)	Antennas & Equipment	Coax	Mounts
125.0	(4) AIR6449 B41 (4) VV-65A-R1 (4) APXVAALL24_43-U-NA20 (4) Radio 4480 B71+B85 (4) Radio 4460 B25+B66	(2) 6x24 Hybriflex (4) 6x12 Hybriflex	(1) Custom 4-sided sector frame

Appurtenances By Others:

RAD CENTER (FT)	ANTENNA & TMA	COAX	MOUNT
188.0	(1) 6' Dish	(6) 1-5/8"* (2) 1-1/4"* (2) 7/8"*	Leg Mount
184.0	(4) OTG9-840 (1) ANT150D3	-	(3) Box Arm
183.0	(1) ANT150F2	-	(1) 3' Side Arm
168.0	(6) LPA-80090-4CF (3) MT6407-77A (3) NHH-65B-R2B (3) B5/B13 RRH-BR04C (3) B2/B66A RRH-BR049 (1) Junction Box (1) 10' Dipole	(6) 1-5/8"* (1) 1-5/8"*	(3) Pirod 12' T-Frame
154.0	(3) APXV9ERR18-C-A20 (3) DT465B-2XR (6) RRH-800 (3) RRH-1900 (3) TD-RRH8x20-25	(3) 1-1/4" Hybrid Cable* (1) 1" (3) 1/2" (11) 3/8"	(3) Pirod 12' T-Frame
140.0	(3) 7770.00 (6) TPA65R-BU6DA (3) 4449 B5/B12 (3) B14 4478 (3) RRUS-32 (3) Diplexers (1) DC6 Surge Arrestor (2) Squid Surge Arrestors	(12) 1-5/8"* (3) Fiber Cable* (6) DC Cable*	(3) Pirod 12' T-Frame
118.0	-	-	(1) Box Arm
105.0	(1) ANT150D3	-	(1) Box Arm
101.0	(1) 6' Dish Ice Shield	-	-
98.0	(1) PD458-2	-	(2) Box Arm
97.0	(1) 6' Dish	-	-
78.0	(1) PD220 (1) PD1142 (1) BCD-80609 (1) 6' Yagi (1) DB222	-	(3) Box Arm
32.0	(1) GPS	-	(1) 2' Stand off

*: Coax located on interior tower.

3.0 CODES AND LOADING

This analysis has been performed in accordance with TIA-222-G, as referenced by the 2015 International Building Code, based upon an ultimate wind speed of 120 mph (Risk Category III) converted to a nominal 3-second gust wind speed of 93 mph per section 1609.3.1 as required for use in the TIA-222-G Standard per Exception #5 of Section 1609.1.1. The following loading criteria were used in the analysis:

- Basic wind speed 93 mph without ice (V)
- Basic wind speed 40 mph concurrent with design ice thickness of 1" (V_i and t_i)
- Exposure Category C, Structure Class III
- Topographic Category I

The following load combinations were used with wind blowing at 30° increments, measured from a line normal to the face of the tower:

- $1.2D + 1.6W_o$
- $0.9D + 1.6W_o$
- $1.2D + 1.0D_i + 1.0W_i$

D: Dead Load of structure and appurtenances, excluding guy assemblies

W_o : Wind Load, without ice

W_i : Concurrent wind load with factored ice thickness;

D_i : Weight of ice due to factored ice thickness

T_i : Load effects due to temperature

E_v : Vertical seismic load effect

E_h : Horizontal seismic load effect

4.0 STANDARD CONDITIONS FOR ENGINEERING SERVICES ON EXISTING STRUCTURES

The analysis is based on the information provided to EFI and is assumed to be current and correct. Unless otherwise noted, the structure and the foundation system are assumed to be in good condition, free of defects and can achieve theoretical strength.

It is assumed that the structure has been maintained and shall be maintained during its service. The superstructure and the foundation system are assumed to be designed with proper engineering practice and fabricated, constructed and erected in accordance with the design documents. EFI will accept no liability which may arise due to any existing deficiency in design, material, fabrication, erection, construction, etc. or lack of maintenance.

The analysis does not include a qualification of the mounts attached on the structure or their connections. The analysis is performed to verify the capacity of the main structural members, which is the current practice in the tower industry.

The analysis results presented in this report are only applicable for the previously mentioned existing and proposed additions and alterations. Any deviation of the proposed equipment and placement, etc., will require EFI to generate an additional structural analysis.

5.0 ANALYSIS AND ASSUMPTIONS

The tower was analyzed by utilizing tnxTower, a non-linear, three-dimensional, finite element-analysis software package, a product of Tower Numerics, Inc. Software output for this analysis is provided in Appendix A of this report.

6.0 RESULTS AND CONCLUSION

Based on an analysis per ANSI/TIA-222-G, the existing tower is found to have **adequate** structural capacity for the proposed changes by T-Mobile. For the aforementioned load combinations and as a maximum, the diagonal members between 0 and 20 ft. are stressed to **91.1%** of their structural capacity. The anchor rods are stressed to **37.5%** of their structural capacities, respectively.

Information regarding the tower base foundation was not available at the time of this analysis, thus a qualification of the foundation could not be completed.

Therefore, the proposed alterations and additions by T-Mobile **can** be implemented as intended, with the conditions outlined in this report.

Should you need any clarifications or have any questions about this report, please contact EFI at telecom@efiglobal.com.

APPENDIX A
SOFTWARE OUTPUT

Section	T1	T2	T3	T4	T5	T6	T7	T8	T9	T10	T11	T12	T13	T14	T15	T16	T17	T18	T19	T20	T21	T22	T23	T24	T25	T26	T27	T28	T29	T30									
Legs	Pirot 112738	Pirot 105220	Pirot 105219	Pirot 105218	Pirot 105217	Pirot 105216	Pirot 105244																																
Leg Grade																																							
Diagonals	2L3 1/2x3 1/2x5/16x3/8	L5x5x3/8	L4x4x3/8	L4x4x1/4	L3 1/2x3 1/2x5/16	L3x3x3/16																																	
Diagonal Grade																																							
Top Girts																																							
Sec. Horizontals																																							
Face Width (ft)	26	22	22	22	22	22	22	22	22	22	22	22	22	22	22	22	22	22	22	22	22	22	22	22	22	22	22	22	22	22	22	22	22	22	22	22	22	22	
# Panels @ (ft)	1 @ 20																																						
Weight (lb)	47699.1	7945.8	7251.3	6968.6	54707.7	44783.3	1960.2	2207.4	3748.4	1525.1	1754.0	2245.7	1146.2	856.4																									

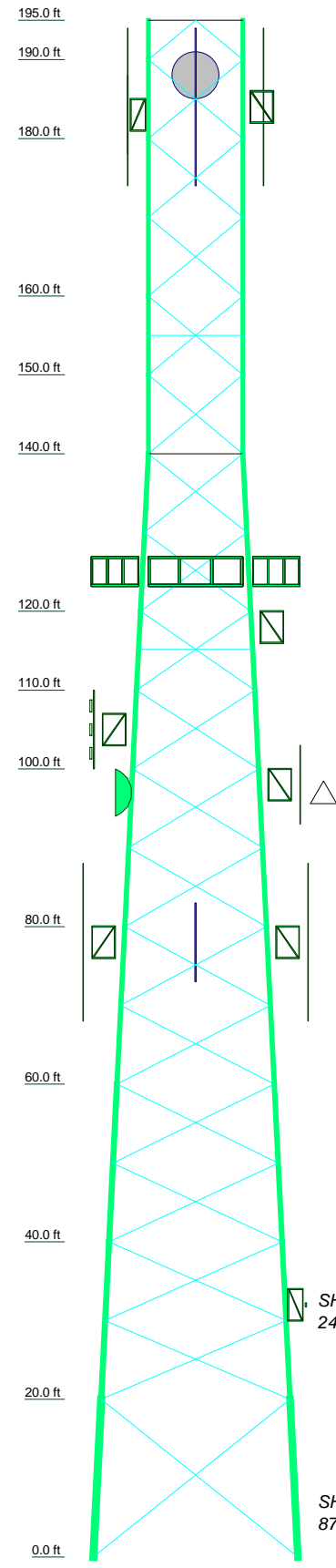

DESIGNED APPURTENANCE LOADING

TYPE	ELEVATION	TYPE	ELEVATION
6' Dish	188	RRUS 4449 B5/B12	140
Pipe Mount [PM 602-1]	187.5	RRUS 4478 B14	140
Pirot 6-8' Box Arm	184	RRUS 4478 B14	140
Pirot 6-8' Box Arm	184	RRUS 4478 B14	140
ANT150D3	184	RRUS 32	140
(2) OGT9-840	184	RRUS 32	140
(2) OGT9-840	184	RRUS 32	140
Pirot 6-8' Box Arm	184	Diplexer	140
3' Side Mount Standoff	183	Diplexer	140
ANT150F2	183	Diplexer	140
Pirot 12' T-Frame Sector Mount (1)	168	DC6 Surge Arrestor	140
Pirot 12' T-Frame Sector Mount (1)	168	Squid Surge Arrestor	140
(2) LPA-80090/4CF w/ Mount Pipe	168	Squid Surge Arrestor	140
(2) LPA-80090/4CF w/ Mount Pipe	168	Pirot 12' T-Frame Sector Mount (1)	140
(2) LPA-80090/4CF w/ Mount Pipe	168	8'-P3x0.216	125
(2) NHH-65B-R2B_TIA	168	8'-P3x0.216	125
(2) NHH-65B-R2B_TIA	168	8'-P3x0.216	125
(2) NHH-65B-R2B_TIA	168	8'-P3x0.216	125
MT6407-77A w/ Mount Pipe	168	AIR 6449 B41_TIA w/ Mount Pipe	125
MT6407-77A w/ Mount Pipe	168	AIR 6449 B41_TIA w/ Mount Pipe	125
MT6407-77A w/ Mount Pipe	168	AIR 6449 B41_TIA w/ Mount Pipe	125
B5/B13 RRH-BR04C	168	AIR 6449 B41_TIA w/ Mount Pipe	125
B5/B13 RRH-BR04C	168	VV-65A-R1_TIA w/ Mount Pipe	125
B5/B13 RRH-BR04C	168	VV-65A-R1_TIA w/ Mount Pipe	125
PCS/AWS DULA-BAND RRH B2/B66	168	VV-65A-R1_TIA w/ Mount Pipe	125
PCS/AWS DULA-BAND RRH B2/B66	168	VV-65A-R1_TIA w/ Mount Pipe	125
PCS/AWS DULA-BAND RRH B2/B66	168	VV-65A-R1_TIA w/ Mount Pipe	125
Junction Box	168	APXVAALL24_43-U-NA20_TIA w/ Mount Pipe	125
10' Dipole	168	APXVAALL24_43-U-NA20_TIA w/ Mount Pipe	125
Pirot 12' T-Frame Sector Mount (1)	168	APXVAALL24_43-U-NA20_TIA w/ Mount Pipe	125
Pirot 12' T-Frame Sector Mount (1)	154	APXVAALL24_43-U-NA20_TIA w/ Mount Pipe	125
Pirot 12' T-Frame Sector Mount (1)	154	APXVAALL24_43-U-NA20_TIA w/ Mount Pipe	125
APXV9ERR18-C-A20_TIA w/ Mount Pipe	154	RADIO 4460 B25 B66	125
RADIO 4460 B25 B66	125	RADIO 4460 B25 B66	125
RADIO 4460 B25 B66	125	RADIO 4460 B25 B66	125
RADIO 4460 B25 B66	125	RADIO 4460 B25 B66	125
Radio 4480	125	Radio 4480	125
Radio 4480	125	Radio 4480	125
Radio 4480	125	Radio 4480	125
Radio 4480	125	Radio 4480	125
Custom 4-Sided Sector Mount	125	Pirot 6-8' Box Arm	118
Pirot 6-8' Box Arm	118	ANT150D3	105
ANT150D3	105	Pirot 6-8' Box Arm	105
Pirot 6-8' Box Arm	105	6' Dish Ice Shield	101
6' Dish Ice Shield	101	Pirot 6-8' Box Arm	98
Pirot 6-8' Box Arm	98	PD458-2	98
PD458-2	98	Pirot 6-8' Box Arm	98
Pirot 6-8' Box Arm	98	6' Dish	97
6' Dish	97	Pirot 6-8' Box Arm	78
Pirot 6-8' Box Arm	78	PD220	78
PD220	78	PD1142	78
PD1142	78	BCD-80609	78
BCD-80609	78	6' Yagi	78
6' Yagi	78	DB222	78
DB222	78	Pirot 6-8' Box Arm	78
Pirot 6-8' Box Arm	78	Pirot 6-8' Box Arm	78
Pirot 6-8' Box Arm	78	2-ft Stand Off	32
2-ft Stand Off	32	GPS	32
GPS	32		

ALL
AR
MA

SHEAR
24592 lb

TO
40 mph

SHEAR
87675 lb

TO
REACTI

SYMBOL LIST

MARK	SIZE	MARK	SIZE
A	2L2 1/2x2 1/2x3/16x3/16	C	2L2 1/2x2 1/2x3/16x1/2
B	L2 1/2x2 1/2x3/16	D	L3 1/2x3 1/2x5/16

MATERIAL STRENGTH

GRADE	Fy	Fu	GRADE	Fy	Fu
A572-50	50 ksi	65 ksi	A36	36 ksi	58 ksi

TOWER DESIGN NOTES

- Tower is located in Litchfield County, Connecticut.
- Tower designed for Exposure C to the TIA-222-G Standard.
- Tower designed for a 93 mph basic wind in accordance with the TIA-222-G Standard.
- Tower is also designed for a 40 mph basic wind with 1.00 in ice. Ice is considered to increase in thickness with height.
- Deflections are based upon a 60 mph wind.

EFI Global, Inc.
 1117 Perimeter Center West, Suite E500
 Atlanta, GA 30338
 Phone: (470) 990-6593
 FAX:

Job: **CTNH550A**
 Project: **049.02894 - 2275002**
 Client: **ForeSite LLC.** Drawn by: **Ahmet Colakoglu** App'd:
 Code: **TIA-222-G** Date: **06/09/22** Scale: **NTS**
 Path: **Dwg No. E-1**

Section	T1	T2	T3	T4	T5	T6	T7	T8	T9	T10	T11	T12	T13		12	
Legs	P105217	P105216	P105218	P105217	P105216	P105218	P105217	P105216	P105219	P105220	P105238	P105238	P105238	P105238		1 @ 5
Leg Grade									A572-50							1 @ 5
Diagonals									L4x4x1/4	L4x4x3/8	L5x5x3/8	L5x5x3/8	L5x5x3/8	L5x5x3/8		1 @ 5
Diagonal Grade									A36							1 @ 5
Top Girts																1 @ 5
Sec. Horizontals																1 @ 5
Face Width (ft)	14	15	14	15	16	18	20	22	24	26	28	30	32	34	36	1 @ 5
# Panels @ (ft)	17 @ 10	18 @ 10	19 @ 10	20 @ 10	21 @ 10	22 @ 10	23 @ 10	24 @ 10	25 @ 10	26 @ 10	27 @ 10	28 @ 10	29 @ 10	30 @ 10	31 @ 10	1 @ 5
Weight (lb) 47699.1	1146.2	2245.7	3748.4	5251	6754.1	8256.8	9759.5	11262.2	12764.9	14267.6	15770.3	17273.0	18775.7	20278.4	21781.1	1 @ 5

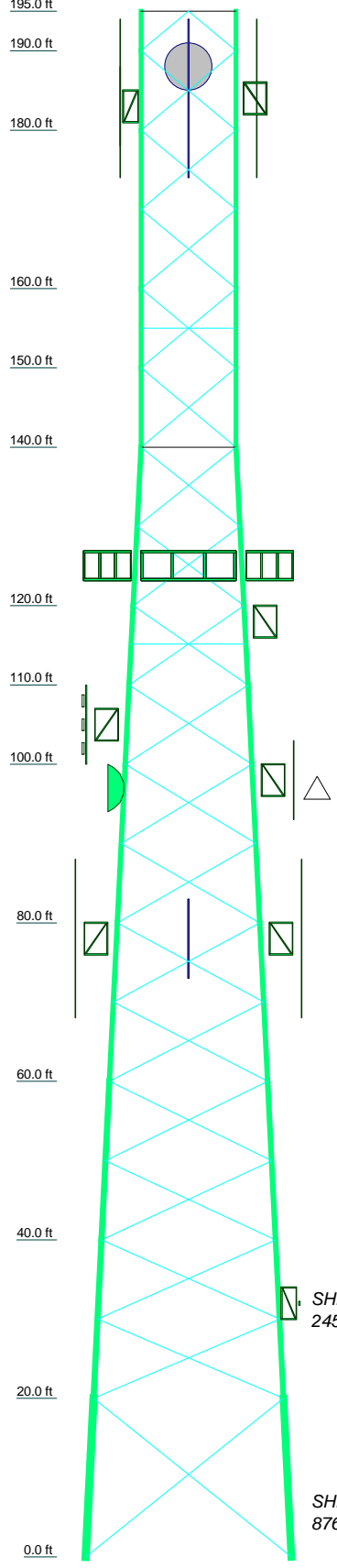

SYMBOL LIST

MARK	SIZE	MARK	SIZE
A	2L2 1/2x2 1/2x3/16x3/16	C	2L2 1/2x2 1/2x3/16x1/2
B	L2 1/2x2 1/2x3/16	D	L3 1/2x3 1/2x5/16

MATERIAL STRENGTH

GRADE	Fy	Fu	GRADE	Fy	Fu
A572-50	50 ksi	65 ksi	A36	36 ksi	58 ksi

TOWER DESIGN NOTES

1. Tower is located in Litchfield County, Connecticut.
2. Tower designed for Exposure C to the TIA-222-G Standard.
3. Tower designed for a 93 mph basic wind in accordance with the TIA-222-G Standard.
4. Tower is also designed for a 40 mph basic wind with 1.00 in ice. Ice is considered to increase in thickness with height.
5. Deflections are based upon a 60 mph wind.
6. Tower Structure Class III.
7. Topographic Category 1 with Crest Height of 0.00 ft
8. TOWER RATING: 91.1%

ALL REACTIONS ARE FACTORED

MAX. CORNER REACTIONS AT BASE:

DOWN: 442351 lb
SHEAR: 60392 lb

UPLIFT: -378419 lb
SHEAR: 52333 lb

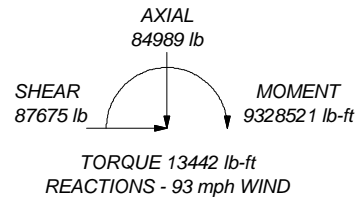
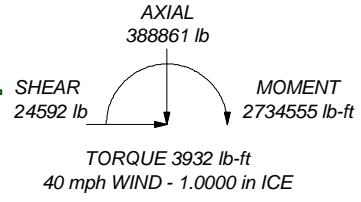

EFI Global, Inc.
 efi global 1117 Perimeter Center West, Suite E500
 Atlanta, GA 30338
 Phone: (470) 990-6593
 FAX:

Job: **CTNH550A**
 Project: **049.02894 - 2275002**
 Client: ForeSite LLC. Drawn by: Ahmet Colakoglu App'd:
 Code: TIA-222-G Date: 06/09/22 Scale: NTS
 Path: Dwg No. E-1

tnxTower EFI Global, Inc. 1117 Perimeter Center West, Suite E500 Atlanta, GA 30338 Phone: (470) 990-6593 FAX:	Job CTNH550A	Page 1 of 38
	Project 049.02894 - 2275002	Date 15:49:21 06/09/22
	Client ForeSite LLC.	Designed by Ahmet Colakoglu

Tower Input Data

The main tower is a 3x free standing tower with an overall height of 195.00 ft above the ground line.

The base of the tower is set at an elevation of 0.00 ft above the ground line.

The face width of the tower is 12.00 ft at the top and 26.00 ft at the base.

This tower is designed using the TIA-222-G standard.

The following design criteria apply:

Tower is located in Litchfield County, Connecticut.

Basic wind speed of 93 mph.

Structure Class III.

Exposure Category C.

Topographic Category 1.

Crest Height 0.00 ft.

Nominal ice thickness of 1.0000 in.

Ice thickness is considered to increase with height.

Ice density of 56 pcf.

A wind speed of 40 mph is used in combination with ice.

Temperature drop of 50 °F.

Deflections calculated using a wind speed of 60 mph.

A non-linear (P-delta) analysis was used.

Pressures are calculated at each section.

Stress ratio used in tower member design is 1.

Local bending stresses due to climbing loads, feed line supports, and appurtenance mounts are not considered.

Options

<ul style="list-style-type: none"> Consider Moments - Legs Consider Moments - Horizontals Consider Moments - Diagonals Use Moment Magnification √ Use Code Stress Ratios √ Use Code Safety Factors - Guys Escalate Ice Always Use Max Kz Use Special Wind Profile √ Include Bolts In Member Capacity Leg Bolts Are At Top Of Section √ Secondary Horizontal Braces Leg Use Diamond Inner Bracing (4 Sided) SR Members Have Cut Ends SR Members Are Concentric 	<ul style="list-style-type: none"> Distribute Leg Loads As Uniform Assume Legs Pinned √ Assume Rigid Index Plate √ Use Clear Spans For Wind Area √ Use Clear Spans For KL/r Retension Guys To Initial Tension √ Bypass Mast Stability Checks √ Use Azimuth Dish Coefficients √ Project Wind Area of Appurt. Autocalc Torque Arm Areas Add IBC .6D+W Combination √ Sort Capacity Reports By Component Triangulate Diamond Inner Bracing Treat Feed Line Bundles As Cylinder Ignore KL/ry For 60 Deg. Angle Legs 	<ul style="list-style-type: none"> Use ASCE 10 X-Brace Ly Rules √ Calculate Redundant Bracing Forces Ignore Redundant Members in FEA √ SR Leg Bolts Resist Compression All Leg Panels Have Same Allowable Offset Girt At Foundation √ Consider Feed Line Torque √ Include Angle Block Shear Check Use TIA-222-G Bracing Resist. Exemption Use TIA-222-G Tension Splice Exemption <li style="text-align: center;">Poles Include Shear-Torsion Interaction Always Use Sub-Critical Flow Use Top Mounted Sockets Pole Without Linear Attachments Pole With Shroud Or No Appurtenances Outside and Inside Corner Radii Are Known
--	---	---

tnxTower EFI Global, Inc. 1117 Perimeter Center West, Suite E500 Atlanta, GA 30338 Phone: (470) 990-6593 FAX:	Job CTNH550A	Page 2 of 38
	Project 049.02894 - 2275002	Date 15:49:21 06/09/22
	Client ForeSite LLC.	Designed by Ahmet Colakoglu

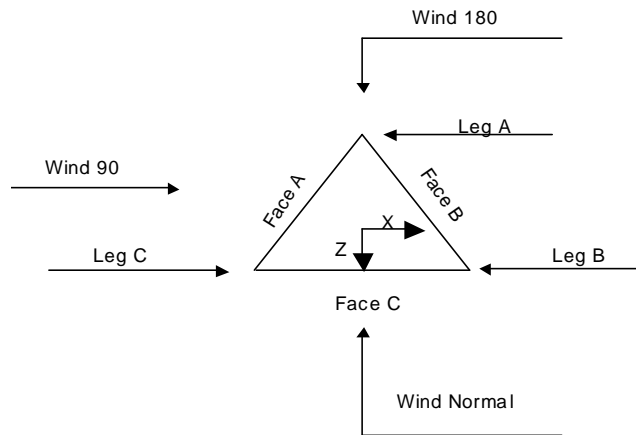

Triangular Tower

Tower Section Geometry

Tower Section	Tower Elevation	Assembly Database	Description	Section Width	Number of Sections	Section Length
	<i>ft</i>			<i>ft</i>		<i>ft</i>
T1	195.00-190.00			12.00	1	5.00
T2	190.00-180.00			12.00	1	10.00
T3	180.00-160.00			12.00	1	20.00
T4	160.00-150.00			12.00	1	10.00
T5	150.00-140.00			12.00	1	10.00
T6	140.00-120.00			12.00	1	20.00
T7	120.00-110.00			14.00	1	10.00
T8	110.00-100.00			15.00	1	10.00
T9	100.00-80.00			16.00	1	20.00
T10	80.00-60.00			18.00	1	20.00
T11	60.00-40.00			20.00	1	20.00
T12	40.00-20.00			22.00	1	20.00
T13	20.00-0.00			24.00	1	20.00

Tower Section Geometry (cont'd)

Tower Section	Tower Elevation	Diagonal Spacing	Bracing Type	Has K Brace End Panels	Has Horizontals	Top Girt Offset	Bottom Girt Offset
	<i>ft</i>	<i>ft</i>				<i>in</i>	<i>in</i>
T1	195.00-190.00	5.00	K Brace Down	No	Yes	0.0000	0.0000
T2	190.00-180.00	10.00	X Brace	No	No	0.0000	0.0000

tnxTower EFI Global, Inc. 1117 Perimeter Center West, Suite E500 Atlanta, GA 30338 Phone: (470) 990-6593 FAX:	Job	CTNH550A	Page	3 of 38
	Project	049.02894 - 2275002	Date	15:49:21 06/09/22
	Client	ForeSite LLC.	Designed by	Ahmet Colakoglu

Tower Section	Tower Elevation ft	Diagonal Spacing ft	Bracing Type	Has K Brace End Panels	Has Horizontals	Top Girt Offset in	Bottom Girt Offset in
T3	180.00-160.00	10.00	X Brace	No	No	0.0000	0.0000
T4	160.00-150.00	10.00	X Brace	No	Yes	0.0000	0.0000
T5	150.00-140.00	10.00	X Brace	No	No	0.0000	0.0000
T6	140.00-120.00	10.00	X Brace	No	Yes	0.0000	0.0000
T7	120.00-110.00	10.00	X Brace	No	Yes	0.0000	0.0000
T8	110.00-100.00	10.00	X Brace	No	No	0.0000	0.0000
T9	100.00-80.00	10.00	X Brace	No	No	0.0000	0.0000
T10	80.00-60.00	10.00	X Brace	No	No	0.0000	0.0000
T11	60.00-40.00	10.00	X Brace	No	No	0.0000	0.0000
T12	40.00-20.00	10.00	X Brace	No	No	0.0000	0.0000
T13	20.00-0.00	20.00	X Brace	No	No	0.0000	0.0000

Tower Section Geometry (cont'd)

Tower Elevation ft	Leg Type	Leg Size	Leg Grade	Diagonal Type	Diagonal Size	Diagonal Grade
T1 195.00-190.00	Truss Leg	Pirod 105244	A572-50 (50 ksi)	Double Equal Angle	2L2 1/2x2 1/2x3/16x3/16	A36 (36 ksi)
T2 190.00-180.00	Truss Leg	Pirod 105244	A572-50 (50 ksi)	Single Angle	L2 1/2x2 1/2x3/16	A36 (36 ksi)
T3 180.00-160.00	Truss Leg	Pirod 105216	A572-50 (50 ksi)	Single Angle	L3x3x3/16	A36 (36 ksi)
T4 160.00-150.00	Truss Leg	Pirod 105217	A572-50 (50 ksi)	Single Angle	L3x3x5/16	A36 (36 ksi)
T5 150.00-140.00	Truss Leg	Pirod 105217	A572-50 (50 ksi)	Single Angle	L3x3x5/16	A36 (36 ksi)
T6 140.00-120.00	Truss Leg	Pirod 105218	A572-50 (50 ksi)	Single Angle	L3x3x5/16	A36 (36 ksi)
T7 120.00-110.00	Truss Leg	Pirod 105218	A572-50 (50 ksi)	Single Angle	L3 1/2x3 1/2x5/16	A36 (36 ksi)
T8 110.00-100.00	Truss Leg	Pirod 105218	A572-50 (50 ksi)	Single Angle	L3 1/2x3 1/2x5/16	A36 (36 ksi)
T9 100.00-80.00	Truss Leg	Pirod 105219	A572-50 (50 ksi)	Single Angle	L4x4x1/4	A36 (36 ksi)
T10 80.00-60.00	Truss Leg	Pirod 105219	A572-50 (50 ksi)	Single Angle	L4x4x3/8	A36 (36 ksi)
T11 60.00-40.00	Truss Leg	Pirod 105220	A572-50 (50 ksi)	Single Angle	L5x5x3/8	A36 (36 ksi)
T12 40.00-20.00	Truss Leg	Pirod 105220	A572-50 (50 ksi)	Single Angle	L5x5x3/8	A36 (36 ksi)
T13 20.00-0.00	Truss Leg	Pirod 112738	A572-50 (50 ksi)	Double Equal Angle	2L3 1/2x3 1/2x5/16x3/8	A36 (36 ksi)

Tower Section Geometry (cont'd)

Tower Elevation ft	Top Girt Type	Top Girt Size	Top Girt Grade	Bottom Girt Type	Bottom Girt Size	Bottom Girt Grade
T6 140.00-120.00	Equal Angle	L3x3x5/16	A36 (36 ksi)	Pipe		A36 (36 ksi)

tnxTower EFI Global, Inc. 1117 Perimeter Center West, Suite E500 Atlanta, GA 30338 Phone: (470) 990-6593 FAX:	Job	CTNH550A	Page	4 of 38
	Project	049.02894 - 2275002	Date	15:49:21 06/09/22
	Client	ForeSite LLC.	Designed by	Ahmet Colakoglu

Tower Section Geometry (cont'd)

Tower Elevation	No. of Mid Girts	Mid Girt Type	Mid Girt Size	Mid Girt Grade	Horizontal Type	Horizontal Size	Horizontal Grade
ft							
T1 195.00-190.00	None	Flat Bar		A36 (36 ksi)	Double Equal Angle	2L2 1/2x2 1/2x3/16x1/2	A36 (36 ksi)

Tower Section Geometry (cont'd)

Tower Elevation	Secondary Horizontal Type	Secondary Horizontal Size	Secondary Horizontal Grade	Inner Bracing Type	Inner Bracing Size	Inner Bracing Grade
ft						
T4 160.00-150.00	Equal Angle	L3x3x5/16	A36 (36 ksi)	Single Angle		A36 (36 ksi)
T7 120.00-110.00	Equal Angle	L3 1/2x3 1/2x5/16	A36 (36 ksi)	Equal Angle		A36 (36 ksi)

Tower Section Geometry (cont'd)

Tower Elevation	Gusset Area (per face)	Gusset Thickness	Gusset Grade	Adjust. Factor A_f	Adjust. Factor A_r	Weight Mult.	Double Angle Stitch Bolt Spacing Diagonals	Double Angle Stitch Bolt Spacing Horizontals	Double Angle Stitch Bolt Spacing Redundants
ft	ft ²	in					in	in	in
T1	0.00	0.0000	A36	1	1	1.05	Mid-Pt	Mid-Pt	Mid-Pt
195.00-190.00			(36 ksi)						
T2	0.00	0.0000	A36	1	1	1.05	Mid-Pt	Mid-Pt	Mid-Pt
190.00-180.00			(36 ksi)						
T3	0.00	0.0000	A36	1	1	1.05	Mid-Pt	Mid-Pt	Mid-Pt
180.00-160.00			(36 ksi)						
T4	0.00	0.0000	A36	1	1	1.05	Mid-Pt	Mid-Pt	Mid-Pt
160.00-150.00			(36 ksi)						
T5	0.00	0.0000	A36	1	1	1.05	Mid-Pt	Mid-Pt	Mid-Pt
150.00-140.00			(36 ksi)						
T6	0.00	0.0000	A36	1	1	1.05	Mid-Pt	Mid-Pt	Mid-Pt
140.00-120.00			(36 ksi)						
T7	0.00	0.0000	A36	1	1	1.05	Mid-Pt	Mid-Pt	Mid-Pt
120.00-110.00			(36 ksi)						
T8	0.00	0.0000	A36	1	1	1.05	Mid-Pt	Mid-Pt	Mid-Pt
110.00-100.00			(36 ksi)						
T9	0.00	0.0000	A36	1	1	1.05	Mid-Pt	Mid-Pt	Mid-Pt
100.00-80.00			(36 ksi)						
T10	0.00	0.0000	A36	1	1	1.05	Mid-Pt	Mid-Pt	Mid-Pt
80.00-60.00			(36 ksi)						
T11	0.00	0.0000	A36	1	1	1.05	Mid-Pt	Mid-Pt	Mid-Pt
60.00-40.00			(36 ksi)						

tnxTower EFI Global, Inc. 1117 Perimeter Center West, Suite E500 Atlanta, GA 30338 Phone: (470) 990-6593 FAX:	Job CTNH550A	Page 5 of 38
	Project 049.02894 - 2275002	Date 15:49:21 06/09/22
	Client ForeSite LLC.	Designed by Ahmet Colakoglu

Tower Elevation	Gusset Area (per face)	Gusset Thickness	Gusset Grade	Adjust. Factor A_f	Adjust. Factor A_r	Weight Mult.	Double Angle Stitch Bolt Spacing Diagonals	Double Angle Stitch Bolt Spacing Horizontals	Double Angle Stitch Bolt Spacing Redundants
ft	ft ²	in					in	in	in
T12 40.00-20.00	0.00	0.0000	A36 (36 ksi)	1	1	1.05	Mid-Pt	Mid-Pt	Mid-Pt
T13 20.00-0.00	0.00	0.0000	A36 (36 ksi)	1	1	1.05	Mid-Pt	Mid-Pt	Mid-Pt

Tower Section Geometry (cont'd)

Tower Elevation	Calc K Single Angles	Calc K Solid Rounds	K Factors ¹								
			Legs	X Brace Diags	K Brace Diags	Single Diags	Girts	Horiz.	Sec. Horiz.	Inner Brace	
											X
ft			Y	Y	Y	Y	Y	Y	Y	Y	
T1 195.00-190.00	Yes	Yes	1	1	1	1	1	1	1	1	1
T2 190.00-180.00	Yes	Yes	1	1	1	1	1	1	1	1	1
T3 180.00-160.00	Yes	Yes	1	1	1	1	1	1	1	1	1
T4 160.00-150.00	Yes	Yes	1	1	1	1	1	1	1	1	1
T5 150.00-140.00	Yes	Yes	1	1	1	1	1	1	1	1	1
T6 140.00-120.00	Yes	Yes	1	1	1	1	1	1	1	1	1
T7 120.00-110.00	Yes	Yes	1	1	1	1	1	1	1	1	1
T8 110.00-100.00	Yes	Yes	1	1	1	1	1	1	1	1	1
T9 100.00-80.00	Yes	Yes	1	1	1	1	1	1	1	1	1
T10 80.00-60.00	Yes	Yes	1	1	1	1	1	1	1	1	1
T11 60.00-40.00	Yes	Yes	1	1	1	1	1	1	1	1	1
T12 40.00-20.00	Yes	Yes	1	1	1	1	1	1	1	1	1
T13 20.00-0.00	Yes	Yes	1	1	1	1	1	1	1	1	1

¹Note: K factors are applied to member segment lengths. K-braces without inner supporting members will have the K factor in the out-of-plane direction applied to the overall length.

Tower Section Geometry (cont'd)

Tower Elevation	Truss-Leg K Factors					
	Leg Panels	Truss-Legs Used As Leg Members		Leg Panels	Truss-Legs Used As Inner Members	
		X Brace Diagonals	Z Brace Diagonals		X Brace Diagonals	Z Brace Diagonals
ft						
T1 195.00-190.00	1	0.5	0.85	1	0.5	0.85

tnxTower EFI Global, Inc. 1117 Perimeter Center West, Suite E500 Atlanta, GA 30338 Phone: (470) 990-6593 FAX:	Job	CTNH550A	Page	8 of 38
	Project	049.02894 - 2275002	Date	15:49:21 06/09/22
	Client	ForeSite LLC.	Designed by	Ahmet Colakoglu

Tower Elevation ft	Leg Connection Type	Leg		Diagonal		Top Girt		Bottom Girt		Mid Girt		Long Horizontal		Short Horizontal	
		Bolt Size in	No.	Bolt Size in	No.	Bolt Size in	No.	Bolt Size in	No.	Bolt Size in	No.	Bolt Size in	No.	Bolt Size in	No.
T3 180.00-160.00	Flange	1.0000 A325N	6	1.0000 A325N	1	0.5000 A325N	0	0.5000 A325N	0	0.6250 A325N	0	0.0000 A325N	0	0.6250 A325N	0
T4 160.00-150.00	Flange	1.0000 A325N	6	1.0000 A325N	1	0.5000 A325N	0	0.0000 A325N	0	0.6250 A325N	0	0.0000 A325N	0	0.5000 A325N	2
T5 150.00-140.00	Flange	0.0000 A325N	0	1.0000 A325N	1	0.7500 A325N	0	0.5000 A325N	0	0.6250 A325N	0	0.0000 A325N	0	0.6250 A325N	0
T6 140.00-120.00	Flange	1.0000 A325N	6	1.0000 A325N	1	1.0000 A325N	1	0.0000 A325N	0	0.6250 A325N	0	0.0000 A325N	0	0.6250 A325N	0
T7 120.00-110.00	Flange	1.0000 A325N	6	1.0000 A325N	1	0.6250 A325N	0	0.0000 A325N	0	0.6250 A325N	0	0.0000 A325N	0	0.5000 A325N	1
T8 110.00-100.00	Flange	0.0000 A325N	0	1.0000 A325N	1	0.7500 A325N	0	0.0000 A325N	0	0.6250 A325N	0	0.0000 A325N	0	0.6250 A325N	0
T9 100.00-80.00	Flange	1.2500 A325N	6	1.2500 A325N	1	0.6250 A325N	0	0.0000 A325N	0	0.6250 A325N	0	0.0000 A325N	0	0.6250 A325N	0
T10 80.00-60.00	Flange	1.2500 A325N	6	1.2500 A325N	1	0.6250 A325N	0	0.0000 A325N	0	0.6250 A325N	0	0.0000 A325N	0	0.6250 A325N	0
T11 60.00-40.00	Flange	1.2500 A325N	6	1.2500 A325N	1	0.6250 A325N	0	0.5000 A325N	0	0.6250 A325N	0	0.0000 A325N	0	0.6250 A325N	0
T12 40.00-20.00	Flange	1.2500 A325N	6	1.2500 A325N	1	0.5000 A325N	0	0.5000 A325N	0	0.6250 A325N	0	0.0000 A325N	0	0.6250 A325N	0
T13 20.00-0.00	Flange	2.0000 A325N	6	1.0000 A325N	2	0.5000 A325N	0	0.5000 A325N	0	0.6250 A325N	0	0.0000 A325N	0	0.6250 A325N	0

Feed Line/Linear Appurtenances - Entered As Round Or Flat

Description	Face or Leg	Allow Shield	Exclude From Torque Calculation	Component Type	Placement ft	Total Number	Number Per Row	Clear Spacing in	Width or Diameter in	Perimeter in	Weight plf
**											
**											

Feed Line/Linear Appurtenances - Entered As Area

Description	Face or Leg	Allow Shield	Exclude From Torque Calculation	Component Type	Placement ft	Face Offset in	Lateral Offset (Frac FW)	#	C _{AA} ft ² /ft	Weight plf
**										
**										
Hybriflex 1-5/8"	C	No	Yes	CaAa (In Face)	125.00 - 0.00	-3.0000	0.47	6	No Ice 1/2" Ice 1" Ice	1.90 0.00 0.00
**										
1-1/4"	A	No	Yes	CaAa (In Face)	154.00 - 8.00	0.0000	0	3	No Ice 1/2" Ice 1" Ice	0.63 1.73 3.44
1"	A	No	Yes	CaAa (In Face)	154.00 - 8.00	0.0000	0	1	No Ice	0.30

tnxTower EFI Global, Inc. 1117 Perimeter Center West, Suite E500 Atlanta, GA 30338 Phone: (470) 990-6593 FAX:	Job	CTNH550A	Page	9 of 38
	Project	049.02894 - 2275002	Date	15:49:21 06/09/22
	Client	ForeSite LLC.	Designed by	Ahmet Colakoglu

Description	Face or Leg	Allow Shield	Exclude From Torque Calculation	Component Type	Placement ft	Face Offset in	Lateral Offset (Frac FW)	#	C _A A _A ft ² /ft	Weight plf
				Face)					Ice	1.21
									1/2"	2.73
									Ice	
									1" Ice	
1/2"	A	No	Yes	CaAa (In Face)	154.00 - 8.00	0.0000	0	1	No	0.06
									Ice	0.15
									1/2"	0.84
									Ice	2.14
									1" Ice	
3/8"	A	No	Yes	CaAa (In Face)	154.00 - 8.00	0.0000	0	10	No	0.04
									Ice	0.08
									1/2"	0.65
									Ice	1.84
									1" Ice	
1/2"	A	No	Yes	CaAa (In Face)	154.00 - 8.00	0.0000	0	2	No	0.06
									Ice	0.15
									1/2"	0.84
									Ice	2.14
									1" Ice	
1/2"	A	No	Yes	CaAa (In Face)	154.00 - 8.00	0.0000	0	1	No	0.06
									Ice	0.15
									1/2"	0.84
									Ice	2.14
									1" Ice	
**										
1-5/8"	A	No	Yes	CaAa (In Face)	168.00 - 8.00	0.0000	0	6	No	0.20
									Ice	0.82
									1/2"	2.33
									Ice	4.46
									1" Ice	
1-5/8"	A	No	Yes	CaAa (In Face)	168.00 - 8.00	0.0000	0	1	No	0.20
									Ice	0.82
									1/2"	2.33
									Ice	4.46
									1" Ice	
**										
1-5/8"	B	No	Yes	CaAa (In Face)	188.00 - 8.00	0.0000	0	6	No	0.20
									Ice	0.82
									1/2"	2.33
									Ice	4.46
									1" Ice	
1-1/4"	B	No	Yes	CaAa (In Face)	188.00 - 8.00	0.0000	0	2	No	0.13
									Ice	0.63
									1/2"	1.73
									Ice	3.44
									1" Ice	
7/8"	B	No	Yes	CaAa (In Face)	188.00 - 8.00	0.0000	0	2	No	0.11
									Ice	0.33
									1/2"	1.30
									Ice	2.88
									1" Ice	
**										
1-5/8"	C	No	Yes	CaAa (In Face)	140.00 - 8.00	0.0000	0	12	No	0.20
									Ice	0.82
									1/2"	2.33
									Ice	4.46
									1" Ice	
DC Cable	C	No	Yes	CaAa (In Face)	140.00 - 8.00	0.0000	0	6	No	0.20
									Ice	0.82
									1/2"	2.33
									Ice	4.46

tnxTower EFI Global, Inc. 1117 Perimeter Center West, Suite E500 Atlanta, GA 30338 Phone: (470) 990-6593 FAX:	Job	CTNH550A	Page	10 of 38
	Project	049.02894 - 2275002	Date	15:49:21 06/09/22
	Client	ForeSite LLC.	Designed by	Ahmet Colakoglu

Description	Face or Leg	Allow Shield	Exclude From Torque Calculation	Component Type	Placement ft	Face Offset in	Lateral Offset (Frac FW)	#	C _{AA} ft ² /ft	Weight plf
Fiber	C	No	Yes	CaAa (In Face)	140.00 - 8.00	0.0000	0	3	Ice 1" Ice No 0.20 Ice 0.30 1/2" 0.40 Ice 1" Ice	0.82 2.33 4.46
**										

Feed Line/Linear Appurtenances Section Areas

Tower Section	Tower Elevation ft	Face	A _R ft ²	A _F ft ²	C _{AA} In Face ft ²	C _{AA} Out Face ft ²	Weight lb
T1	195.00-190.00	A	0.000	0.000	0.000	0.000	0.00
		B	0.000	0.000	0.000	0.000	0.00
		C	0.000	0.000	0.000	0.000	0.00
T2	190.00-180.00	A	0.000	0.000	0.000	0.000	0.00
		B	0.000	0.000	13.326	0.000	54.72
		C	0.000	0.000	0.000	0.000	0.00
T3	180.00-160.00	A	0.000	0.000	11.088	0.000	45.92
		B	0.000	0.000	33.316	0.000	136.80
		C	0.000	0.000	0.000	0.000	0.00
T4	160.00-150.00	A	0.000	0.000	18.581	0.000	71.76
		B	0.000	0.000	16.658	0.000	68.40
		C	0.000	0.000	0.000	0.000	0.00
T5	150.00-140.00	A	0.000	0.000	25.663	0.000	93.30
		B	0.000	0.000	16.658	0.000	68.40
		C	0.000	0.000	0.000	0.000	0.00
T6	140.00-120.00	A	0.000	0.000	51.326	0.000	186.60
		B	0.000	0.000	33.316	0.000	136.80
		C	0.000	0.000	83.160	0.000	401.40
T7	120.00-110.00	A	0.000	0.000	25.663	0.000	93.30
		B	0.000	0.000	16.658	0.000	68.40
		C	0.000	0.000	41.580	0.000	286.20
T8	110.00-100.00	A	0.000	0.000	25.663	0.000	93.30
		B	0.000	0.000	16.658	0.000	68.40
		C	0.000	0.000	41.580	0.000	286.20
T9	100.00-80.00	A	0.000	0.000	51.326	0.000	186.60
		B	0.000	0.000	33.316	0.000	136.80
		C	0.000	0.000	83.160	0.000	572.40
T10	80.00-60.00	A	0.000	0.000	51.326	0.000	186.60
		B	0.000	0.000	33.316	0.000	136.80
		C	0.000	0.000	83.160	0.000	572.40
T11	60.00-40.00	A	0.000	0.000	51.326	0.000	186.60
		B	0.000	0.000	33.316	0.000	136.80
		C	0.000	0.000	83.160	0.000	572.40
T12	40.00-20.00	A	0.000	0.000	51.326	0.000	186.60
		B	0.000	0.000	33.316	0.000	136.80
		C	0.000	0.000	83.160	0.000	572.40
T13	20.00-0.00	A	0.000	0.000	30.796	0.000	111.96
		B	0.000	0.000	19.990	0.000	82.08
		C	0.000	0.000	49.896	0.000	434.64

tnxTower EFI Global, Inc. 1117 Perimeter Center West, Suite E500 Atlanta, GA 30338 Phone: (470) 990-6593 FAX:	Job CTNH550A	Page 11 of 38
	Project 049.02894 - 2275002	Date 15:49:21 06/09/22
	Client ForeSite LLC.	Designed by Ahmet Colakoglu

Feed Line/Linear Appurtenances Section Areas - With Ice

Tower Section	Tower Elevation ft	Face or Leg	Ice Thickness in	A _R ft ²	A _F ft ²	C _{AA} In Face ft ²	C _{AA} Out Face ft ²	Weight lb
T1	195.00-190.00	A	2.982	0.000	0.000	0.000	0.000	0.00
		B		0.000	0.000	0.000	0.000	0.00
		C		0.000	0.000	0.000	0.000	0.00
T2	190.00-180.00	A	2.970	0.000	0.000	0.000	0.000	0.00
		B		0.000	0.000	60.852	0.000	1498.32
		C		0.000	0.000	0.000	0.000	0.00
T3	180.00-160.00	A	2.945	0.000	0.000	44.076	0.000	1106.64
		B		0.000	0.000	151.129	0.000	3698.95
		C		0.000	0.000	0.000	0.000	0.00
T4	160.00-150.00	A	2.918	0.000	0.000	101.459	0.000	2384.00
		B		0.000	0.000	75.023	0.000	1824.11
		C		0.000	0.000	0.000	0.000	0.00
T5	150.00-140.00	A	2.899	0.000	0.000	170.605	0.000	3871.14
		B		0.000	0.000	74.635	0.000	1805.94
		C		0.000	0.000	0.000	0.000	0.00
T6	140.00-120.00	A	2.867	0.000	0.000	338.062	0.000	7607.15
		B		0.000	0.000	148.011	0.000	3552.92
		C		0.000	0.000	324.018	0.000	7980.53
T7	120.00-110.00	A	2.832	0.000	0.000	167.284	0.000	3728.59
		B		0.000	0.000	73.306	0.000	1743.73
		C		0.000	0.000	160.542	0.000	3918.73
T8	110.00-100.00	A	2.807	0.000	0.000	166.001	0.000	3673.54
		B		0.000	0.000	72.793	0.000	1719.71
		C		0.000	0.000	159.464	0.000	3866.22
T9	100.00-80.00	A	2.764	0.000	0.000	327.709	0.000	7162.79
		B		0.000	0.000	143.870	0.000	3359.00
		C		0.000	0.000	315.322	0.000	7556.63
T10	80.00-60.00	A	2.695	0.000	0.000	320.850	0.000	6868.37
		B		0.000	0.000	141.126	0.000	3230.52
		C		0.000	0.000	309.560	0.000	7275.75
T11	60.00-40.00	A	2.606	0.000	0.000	311.932	0.000	6485.59
		B		0.000	0.000	137.559	0.000	3063.48
		C		0.000	0.000	302.069	0.000	6910.59
T12	40.00-20.00	A	2.476	0.000	0.000	298.954	0.000	5928.53
		B		0.000	0.000	132.367	0.000	2820.38
		C		0.000	0.000	291.167	0.000	6379.16
T13	20.00-0.00	A	2.219	0.000	0.000	163.914	0.000	2893.61
		B		0.000	0.000	73.237	0.000	1402.68
		C		0.000	0.000	161.715	0.000	3194.52

Feed Line Center of Pressure

Section	Elevation ft	CP _x in	CP _z in	CP _x Ice in	CP _z Ice in
T1	195.00-190.00	0.0000	0.0000	0.0000	0.0000
T2	190.00-180.00	0.0000	0.0000	0.0000	0.0000
T3	180.00-160.00	0.0000	0.0000	0.0000	0.0000
T4	160.00-150.00	0.0000	0.0000	0.0000	0.0000
T5	150.00-140.00	0.0000	0.0000	0.0000	0.0000
T6	140.00-120.00	0.0000	0.0000	0.0000	0.0000
T7	120.00-110.00	0.0000	0.0000	0.0000	0.0000
T8	110.00-100.00	0.0000	0.0000	0.0000	0.0000
T9	100.00-80.00	0.0000	0.0000	0.0000	0.0000

tnxTower EFI Global, Inc. 1117 Perimeter Center West, Suite E500 Atlanta, GA 30338 Phone: (470) 990-6593 FAX:	Job CTNH550A	Page 12 of 38
	Project 049.02894 - 2275002	Date 15:49:21 06/09/22
	Client ForeSite LLC.	Designed by Ahmet Colakoglu

Section	Elevation	CP _x	CP _z	CP _x Ice	CP _z Ice
	ft	in	in	in	in
T10	80.00-60.00	0.0000	0.0000	0.0000	0.0000
T11	60.00-40.00	0.0000	0.0000	0.0000	0.0000
T12	40.00-20.00	0.0000	0.0000	0.0000	0.0000
T13	20.00-0.00	0.0000	0.0000	0.0000	0.0000

Shielding Factor Ka

Tower Section	Feed Line Record No.	Description	Feed Line Segment Elev.	K _a No Ice	K _a Ice
T2	15	1-5/8"	180.00 - 188.00	0.6000	0.5371
T2	16	1-1/4"	180.00 - 188.00	0.6000	0.5371
T2	17	7/8"	180.00 - 188.00	0.6000	0.5371
T3	12	1-5/8"	160.00 - 168.00	0.6000	0.5219
T3	13	1-5/8"	160.00 - 168.00	0.6000	0.5219
T3	15	1-5/8"	160.00 - 180.00	0.6000	0.5219
T3	16	1-1/4"	160.00 - 180.00	0.6000	0.5219
T3	17	7/8"	160.00 - 180.00	0.6000	0.5219
T4	5	1-1/4"	150.00 - 154.00	0.6000	0.4619
T4	6	1"	150.00 - 154.00	0.6000	0.4619
T4	7	1/2"	150.00 - 154.00	0.6000	0.4619
T4	8	3/8"	150.00 - 154.00	0.6000	0.4619
T4	9	1/2"	150.00 - 154.00	0.6000	0.4619
T4	10	1/2"	150.00 - 154.00	0.6000	0.4619
T4	12	1-5/8"	150.00 - 160.00	0.6000	0.4619
T4	13	1-5/8"	150.00 - 160.00	0.6000	0.4619
T4	15	1-5/8"	150.00 - 160.00	0.6000	0.4619
T4	16	1-1/4"	150.00 - 160.00	0.6000	0.4619
T4	17	7/8"	150.00 - 160.00	0.6000	0.4619
T5	5	1-1/4"	140.00 - 150.00	0.6000	0.5227
T5	6	1"	140.00 - 150.00	0.6000	0.5227
T5	7	1/2"	140.00 - 150.00	0.6000	0.5227
T5	8	3/8"	140.00 - 150.00	0.6000	0.5227

tnxTower

EFI Global, Inc.
 1117 Perimeter Center West, Suite E500
 Atlanta, GA 30338
 Phone: (470) 990-6593
 FAX:

Job	CTNH550A	Page	13 of 38
Project	049.02894 - 2275002	Date	15:49:21 06/09/22
Client	ForeSite LLC.	Designed by	Ahmet Colakoglu

Tower Section	Feed Line Record No.	Description	Feed Line Segment Elev.	K_a No Ice	K_a Ice
T5	9	1/2"	140.00 - 150.00	0.6000	0.5227
T5	10	1/2"	140.00 - 150.00	0.6000	0.5227
T5	12	1-5/8"	140.00 - 150.00	0.6000	0.5227
T5	13	1-5/8"	140.00 - 150.00	0.6000	0.5227
T5	15	1-5/8"	140.00 - 150.00	0.6000	0.5227
T5	16	1-1/4"	140.00 - 150.00	0.6000	0.5227
T5	17	7/8"	140.00 - 150.00	0.6000	0.5227
T6	3	Hybriflex 1-5/8"	120.00 - 125.00	0.6000	0.5191
T6	5	1-1/4"	120.00 - 140.00	0.6000	0.5191
T6	6	1"	120.00 - 140.00	0.6000	0.5191
T6	7	1/2"	120.00 - 140.00	0.6000	0.5191
T6	8	3/8"	120.00 - 140.00	0.6000	0.5191
T6	9	1/2"	120.00 - 140.00	0.6000	0.5191
T6	10	1/2"	120.00 - 140.00	0.6000	0.5191
T6	12	1-5/8"	120.00 - 140.00	0.6000	0.5191
T6	13	1-5/8"	120.00 - 140.00	0.6000	0.5191
T6	15	1-5/8"	120.00 - 140.00	0.6000	0.5191
T6	16	1-1/4"	120.00 - 140.00	0.6000	0.5191
T6	17	7/8"	120.00 - 140.00	0.6000	0.5191
T6	19	1-5/8"	120.00 - 140.00	0.6000	0.5191
T6	20	DC Cable	120.00 - 140.00	0.6000	0.5191
T6	21	Fiber	120.00 - 140.00	0.6000	0.5191
T7	3	Hybriflex 1-5/8"	110.00 - 120.00	0.6000	0.5071
T7	5	1-1/4"	110.00 - 120.00	0.6000	0.5071
T7	6	1"	110.00 - 120.00	0.6000	0.5071
T7	7	1/2"	110.00 - 120.00	0.6000	0.5071
T7	8	3/8"	110.00 - 120.00	0.6000	0.5071
T7	9	1/2"	110.00 - 120.00	0.6000	0.5071
T7	10	1/2"	110.00 - 120.00	0.6000	0.5071
T7	12	1-5/8"	110.00 - 120.00	0.6000	0.5071
T7	13	1-5/8"	110.00 - 120.00	0.6000	0.5071

tnxTower

EFI Global, Inc.
1117 Perimeter Center West, Suite E500
Atlanta, GA 30338
Phone: (470) 990-6593
FAX:

Job	CTNH550A	Page	14 of 38
Project	049.02894 - 2275002	Date	15:49:21 06/09/22
Client	ForeSite LLC.	Designed by	Ahmet Colakoglu

Tower Section	Feed Line Record No.	Description	Feed Line Segment Elev.	K_a No Ice	K_a Ice
T7	15	1-5/8"	110.00 - 120.00	0.6000	0.5071
T7	16	1-1/4"	110.00 - 120.00	0.6000	0.5071
T7	17	7/8"	110.00 - 120.00	0.6000	0.5071
T7	19	1-5/8"	110.00 - 120.00	0.6000	0.5071
T7	20	DC Cable	110.00 - 120.00	0.6000	0.5071
T7	21	Fiber	110.00 - 120.00	0.6000	0.5071
T8	3	Hybriflex 1-5/8"	100.00 - 110.00	0.6000	0.5899
T8	5	1-1/4"	100.00 - 110.00	0.6000	0.5899
T8	6	1"	100.00 - 110.00	0.6000	0.5899
T8	7	1/2"	100.00 - 110.00	0.6000	0.5899
T8	8	3/8"	100.00 - 110.00	0.6000	0.5899
T8	9	1/2"	100.00 - 110.00	0.6000	0.5899
T8	10	1/2"	100.00 - 110.00	0.6000	0.5899
T8	12	1-5/8"	100.00 - 110.00	0.6000	0.5899
T8	13	1-5/8"	100.00 - 110.00	0.6000	0.5899
T8	15	1-5/8"	100.00 - 110.00	0.6000	0.5899
T8	16	1-1/4"	100.00 - 110.00	0.6000	0.5899
T8	17	7/8"	100.00 - 110.00	0.6000	0.5899
T8	19	1-5/8"	100.00 - 110.00	0.6000	0.5899
T8	20	DC Cable	100.00 - 110.00	0.6000	0.5899
T8	21	Fiber	100.00 - 110.00	0.6000	0.5899
T9	3	Hybriflex 1-5/8"	80.00 - 100.00	0.6000	0.6000
T9	5	1-1/4"	80.00 - 100.00	0.6000	0.6000
T9	6	1"	80.00 - 100.00	0.6000	0.6000
T9	7	1/2"	80.00 - 100.00	0.6000	0.6000
T9	8	3/8"	80.00 - 100.00	0.6000	0.6000
T9	9	1/2"	80.00 - 100.00	0.6000	0.6000
T9	10	1/2"	80.00 - 100.00	0.6000	0.6000
T9	12	1-5/8"	80.00 - 100.00	0.6000	0.6000
T9	13	1-5/8"	80.00 - 100.00	0.6000	0.6000
T9	15	1-5/8"	80.00 - 100.00	0.6000	0.6000
T9	16	1-1/4"	80.00 - 100.00	0.6000	0.6000
T9	17	7/8"	80.00 - 100.00	0.6000	0.6000
T9	19	1-5/8"	80.00 - 100.00	0.6000	0.6000
T9	20	DC Cable	80.00 - 100.00	0.6000	0.6000
T9	21	Fiber	80.00 - 100.00	0.6000	0.6000
T9	3	Hybriflex 1-5/8"	60.00 - 80.00	0.6000	0.6000
T10	5	1-1/4"	60.00 - 80.00	0.6000	0.6000
T10	6	1"	60.00 - 80.00	0.6000	0.6000
T10	7	1/2"	60.00 - 80.00	0.6000	0.6000
T10	8	3/8"	60.00 - 80.00	0.6000	0.6000

Job	CTNH550A	Page	15 of 38
Project	049.02894 - 2275002	Date	15:49:21 06/09/22
Client	ForeSite LLC.	Designed by	Ahmet Colakoglu

Tower Section	Feed Line Record No.	Description	Feed Line Segment Elev.	K_a No Ice	K_a Ice
T10	9	1/2"	60.00 - 80.00	0.6000	0.6000
T10	10	1/2"	60.00 - 80.00	0.6000	0.6000
T10	12	1-5/8"	60.00 - 80.00	0.6000	0.6000
T10	13	1-5/8"	60.00 - 80.00	0.6000	0.6000
T10	15	1-5/8"	60.00 - 80.00	0.6000	0.6000
T10	16	1-1/4"	60.00 - 80.00	0.6000	0.6000
T10	17	7/8"	60.00 - 80.00	0.6000	0.6000
T10	19	1-5/8"	60.00 - 80.00	0.6000	0.6000
T10	20	DC Cable	60.00 - 80.00	0.6000	0.6000
T10	21	Fiber	60.00 - 80.00	0.6000	0.6000
T11	3	Hybriflex 1-5/8"	40.00 - 60.00	0.6000	0.6000
T11	5	1-1/4"	40.00 - 60.00	0.6000	0.6000
T11	6	1"	40.00 - 60.00	0.6000	0.6000
T11	7	1/2"	40.00 - 60.00	0.6000	0.6000
T11	8	3/8"	40.00 - 60.00	0.6000	0.6000
T11	9	1/2"	40.00 - 60.00	0.6000	0.6000
T11	10	1/2"	40.00 - 60.00	0.6000	0.6000
T11	12	1-5/8"	40.00 - 60.00	0.6000	0.6000
T11	13	1-5/8"	40.00 - 60.00	0.6000	0.6000
T11	15	1-5/8"	40.00 - 60.00	0.6000	0.6000
T11	16	1-1/4"	40.00 - 60.00	0.6000	0.6000
T11	17	7/8"	40.00 - 60.00	0.6000	0.6000
T11	19	1-5/8"	40.00 - 60.00	0.6000	0.6000
T11	20	DC Cable	40.00 - 60.00	0.6000	0.6000
T11	21	Fiber	40.00 - 60.00	0.6000	0.6000
T12	3	Hybriflex 1-5/8"	20.00 - 40.00	0.6000	0.6000
T12	5	1-1/4"	20.00 - 40.00	0.6000	0.6000
T12	6	1"	20.00 - 40.00	0.6000	0.6000
T12	7	1/2"	20.00 - 40.00	0.6000	0.6000
T12	8	3/8"	20.00 - 40.00	0.6000	0.6000
T12	9	1/2"	20.00 - 40.00	0.6000	0.6000
T12	10	1/2"	20.00 - 40.00	0.6000	0.6000
T12	12	1-5/8"	20.00 - 40.00	0.6000	0.6000
T12	13	1-5/8"	20.00 - 40.00	0.6000	0.6000
T12	15	1-5/8"	20.00 - 40.00	0.6000	0.6000
T12	16	1-1/4"	20.00 - 40.00	0.6000	0.6000
T12	17	7/8"	20.00 - 40.00	0.6000	0.6000
T12	19	1-5/8"	20.00 - 40.00	0.6000	0.6000
T12	20	DC Cable	20.00 - 40.00	0.6000	0.6000
T12	21	Fiber	20.00 - 40.00	0.6000	0.6000
T13	3	Hybriflex 1-5/8"	0.00 - 20.00	0.6000	0.6000
T13	5	1-1/4"	8.00 - 20.00	0.6000	0.6000
T13	6	1"	8.00 - 20.00	0.6000	0.6000
T13	7	1/2"	8.00 - 20.00	0.6000	0.6000
T13	8	3/8"	8.00 - 20.00	0.6000	0.6000
T13	9	1/2"	8.00 - 20.00	0.6000	0.6000
T13	10	1/2"	8.00 - 20.00	0.6000	0.6000
T13	12	1-5/8"	8.00 - 20.00	0.6000	0.6000
T13	13	1-5/8"	8.00 - 20.00	0.6000	0.6000
T13	15	1-5/8"	8.00 - 20.00	0.6000	0.6000
T13	16	1-1/4"	8.00 - 20.00	0.6000	0.6000
T13	17	7/8"	8.00 - 20.00	0.6000	0.6000
T13	19	1-5/8"	8.00 - 20.00	0.6000	0.6000
T13	20	DC Cable	8.00 - 20.00	0.6000	0.6000
T13	21	Fiber	8.00 - 20.00	0.6000	0.6000

tnxTower EFI Global, Inc. 1117 Perimeter Center West, Suite E500 Atlanta, GA 30338 Phone: (470) 990-6593 FAX:	Job	CTNH550A	Page	16 of 38
	Project	049.02894 - 2275002	Date	15:49:21 06/09/22
	Client	ForeSite LLC.	Designed by	Ahmet Colakoglu

Discrete Tower Loads

Description	Face or Leg	Offset Type	Offsets: Horz Lateral Vert ft ft ft	Azimuth Adjustment °	Placement ft	C _{AA} Front ft ²	C _{AA} Side ft ²	Weight lb
Pipe Mount [PM 602-1]	B	From Leg	1.00 0.00 0.00	0.0000	187.50	No Ice 2.78 1/2" Ice 3.21 1" Ice 3.64	2.78 3.21 3.64	93.00 114.63 141.16

Pirod 6-8' Box Arm	A	From Leg	2.75 0.00 0.00	0.0000	184.00	No Ice 4.50 1/2" Ice 9.87 1" Ice 15.24	4.50 9.87 15.24	210.00 280.00 340.00
Pirod 6-8' Box Arm	B	From Leg	2.75 0.00 0.00	0.0000	184.00	No Ice 4.50 1/2" Ice 9.87 1" Ice 15.24	4.50 9.87 15.24	210.00 280.00 340.00
Pirod 6-8' Box Arm	B	From Leg	2.75 0.00 0.00	0.0000	184.00	No Ice 4.50 1/2" Ice 9.87 1" Ice 15.24	4.50 9.87 15.24	210.00 280.00 340.00
ANT150D3	C	From Leg	3.00 0.00 0.00	0.0000	184.00	No Ice 1.60 1/2" Ice 2.88 1" Ice 4.16	1.60 2.88 4.16	18.00 23.40 28.80
(2) OGT9-840	A	From Leg	3.00 0.00 0.00	0.0000	184.00	No Ice 2.27 1/2" Ice 3.44 1" Ice 4.61	2.27 3.44 4.61	18.50 36.09 60.98
(2) OGT9-840	B	From Leg	3.00 0.00 0.00	0.0000	184.00	No Ice 2.27 1/2" Ice 3.44 1" Ice 4.61	2.27 3.44 4.61	18.50 36.09 60.98

ANT150F2	C	From Leg	3.00 0.00 0.00	0.0000	183.00	No Ice 1.23 1/2" Ice 1.53 1" Ice 1.84	1.23 1.53 1.84	13.00 22.47 35.41
3' Side Mount Standoff	C	From Leg	1.50 0.00 0.00	0.0000	183.00	No Ice 2.00 1/2" Ice 3.69 1" Ice 4.74	2.00 3.69 4.74	40.00 50.00 60.00

Pirod 12' T-Frame Sector Mount (1)	A	From Leg	1.50 0.00 0.00	0.0000	168.00	No Ice 13.60 1/2" Ice 18.40 1" Ice 23.20	13.60 18.40 23.20	470.00 600.00 730.00
Pirod 12' T-Frame Sector Mount (1)	B	From Leg	1.50 0.00 0.00	0.0000	168.00	No Ice 13.60 1/2" Ice 18.40 1" Ice 23.20	13.60 18.40 23.20	470.00 600.00 730.00
Pirod 12' T-Frame Sector Mount (1)	C	From Leg	1.50 0.00 0.00	0.0000	168.00	No Ice 13.60 1/2" Ice 18.40 1" Ice 23.20	13.60 18.40 23.20	470.00 600.00 730.00
(2) LPA-80090/4CF w/ Mount Pipe	A	From Leg	4.00 0.00 0.00	0.0000	168.00	No Ice 2.86 1/2" Ice 3.22 1" Ice 3.59	5.21 5.82 6.44	29.01 68.63 113.93
(2) LPA-80090/4CF w/ Mount Pipe	B	From Leg	4.00 0.00 0.00	0.0000	168.00	No Ice 2.86 1/2" Ice 3.22 1" Ice 3.59	5.21 5.82 6.44	29.01 68.63 113.93
(2) LPA-80090/4CF w/ Mount Pipe	C	From Leg	4.00 0.00 0.00	0.0000	168.00	No Ice 2.86 1/2" Ice 3.22 1" Ice 3.59	5.21 5.82 6.44	29.01 68.63 113.93
(2) NHH-65B-R2B_TIA	A	From Leg	4.00 0.00 0.00	0.0000	168.00	No Ice 8.08 1/2" Ice 8.53 1" Ice 9.00	5.34 5.79 6.26	43.70 93.75 149.90
(2) NHH-65B-R2B_TIA	B	From Leg	4.00 0.00 0.00	0.0000	168.00	No Ice 8.08 1/2" Ice 8.53 1" Ice 9.00	5.34 5.79 6.26	43.70 93.75 149.90

tnxTower EFI Global, Inc. 1117 Perimeter Center West, Suite E500 Atlanta, GA 30338 Phone: (470) 990-6593 FAX:	Job	CTNH550A	Page	17 of 38
	Project	049.02894 - 2275002	Date	15:49:21 06/09/22
	Client	ForeSite LLC.	Designed by	Ahmet Colakoglu

Description	Face or Leg	Offset Type	Offsets:		Azimuth Adjustment	Placement	CAAA		Weight
			Horz	Lateral			Front	Side	
			ft	ft	°	ft	ft ²	ft ²	lb
(2) NHH-65B-R2B_TIA	C	From Leg	4.00	0.0000	168.00	No Ice	8.08	5.34	43.70
			0.00			1/2" Ice	8.53	5.79	93.75
			0.00			1" Ice	9.00	6.26	149.90
MT6407-77A w/ Mount Pipe	A	From Leg	4.00	0.0000	168.00	No Ice	4.91	2.68	95.88
			0.00			1/2" Ice	5.26	3.14	135.60
			0.00			1" Ice	5.61	3.62	180.44
MT6407-77A w/ Mount Pipe	B	From Leg	4.00	0.0000	168.00	No Ice	4.91	2.68	95.88
			0.00			1/2" Ice	5.26	3.14	135.60
			0.00			1" Ice	5.61	3.62	180.44
MT6407-77A w/ Mount Pipe	C	From Leg	4.00	0.0000	168.00	No Ice	4.91	2.68	95.88
			0.00			1/2" Ice	5.26	3.14	135.60
			0.00			1" Ice	5.61	3.62	180.44
B5/B13 RRH-BR04C	A	From Leg	4.00	0.0000	168.00	No Ice	1.88	1.01	70.30
			0.00			1/2" Ice	2.05	1.14	86.73
			0.00			1" Ice	2.22	1.28	105.83
B5/B13 RRH-BR04C	B	From Leg	4.00	0.0000	168.00	No Ice	1.88	1.01	70.30
			0.00			1/2" Ice	2.05	1.14	86.73
			0.00			1" Ice	2.22	1.28	105.83
B5/B13 RRH-BR04C	C	From Leg	4.00	0.0000	168.00	No Ice	1.88	1.01	70.30
			0.00			1/2" Ice	2.05	1.14	86.73
			0.00			1" Ice	2.22	1.28	105.83
PCS/AWS DULA-BAND RRH B2/B66	A	From Leg	4.00	0.0000	168.00	No Ice	1.88	1.25	84.40
			0.00			1/2" Ice	2.05	1.39	102.74
			0.00			1" Ice	2.22	1.54	123.87
PCS/AWS DULA-BAND RRH B2/B66	B	From Leg	4.00	0.0000	168.00	No Ice	1.88	1.25	84.40
			0.00			1/2" Ice	2.05	1.39	102.74
			0.00			1" Ice	2.22	1.54	123.87
PCS/AWS DULA-BAND RRH B2/B66	C	From Leg	4.00	0.0000	168.00	No Ice	1.88	1.25	84.40
			0.00			1/2" Ice	2.05	1.39	102.74
			0.00			1" Ice	2.22	1.54	123.87
Junction Box	C	From Leg	4.00	0.0000	168.00	No Ice	3.78	2.51	32.00
			0.00			1/2" Ice	4.03	2.72	63.40
			0.00			1" Ice	4.29	2.94	98.56
10' Dipole	C	From Leg	4.00	0.0000	168.00	No Ice	6.67	6.67	25.00
			0.00			1/2" Ice	7.82	7.82	60.81
			0.00			1" Ice	8.65	8.65	105.11

Pirod 12' T-Frame Sector Mount (1)	A	From Leg	1.50	0.0000	154.00	No Ice	13.60	13.60	470.00
			0.00			1/2" Ice	18.40	18.40	600.00
			0.00			1" Ice	23.20	23.20	730.00
Pirod 12' T-Frame Sector Mount (1)	B	From Leg	1.50	0.0000	154.00	No Ice	13.60	13.60	470.00
			0.00			1/2" Ice	18.40	18.40	600.00
			0.00			1" Ice	23.20	23.20	730.00
Pirod 12' T-Frame Sector Mount (1)	C	From Leg	1.50	0.0000	154.00	No Ice	13.60	13.60	470.00
			0.00			1/2" Ice	18.40	18.40	600.00
			0.00			1" Ice	23.20	23.20	730.00
APXV9ERR18-C-A20_TIA w/ Mount Pipe	A	From Leg	3.00	0.0000	154.00	No Ice	8.26	7.47	95.05
			0.00			1/2" Ice	8.82	8.66	165.53
			0.00			1" Ice	9.35	9.56	244.04
APXV9ERR18-C-A20_TIA w/ Mount Pipe	B	From Leg	3.00	0.0000	154.00	No Ice	8.26	7.47	95.05
			0.00			1/2" Ice	8.82	8.66	165.53
			0.00			1" Ice	9.35	9.56	244.04
APXV9ERR18-C-A20_TIA w/ Mount Pipe	C	From Leg	3.00	0.0000	154.00	No Ice	8.26	7.47	95.05
			0.00			1/2" Ice	8.82	8.66	165.53
			0.00			1" Ice	9.35	9.56	244.04
DT465B-2XR_TIA w/ Mount Pipe	A	From Leg	3.00	0.0000	154.00	No Ice	9.34	7.63	83.52
			0.00			1/2" Ice	9.91	8.82	160.00

tnxTower EFI Global, Inc. 1117 Perimeter Center West, Suite E500 Atlanta, GA 30338 Phone: (470) 990-6593 FAX:	Job	CTNH550A	Page	18 of 38
	Project	049.02894 - 2275002	Date	15:49:21 06/09/22
	Client	ForeSite LLC.	Designed by	Ahmet Colakoglu

Description	Face or Leg	Offset Type	Offsets:		Azimuth Adjustment	Placement	C _{AA} Front	C _{AA} Side	Weight	
			Horz	Vert						
			ft	ft	°	ft	ft ²	ft ²	lb	
DT465B-2XR_TIA w/ Mount Pipe	B	From Leg	0.00		0.0000	154.00	1" Ice	10.44	9.72	244.63
			3.00				No Ice	9.34	7.63	83.52
			0.00				1/2" Ice	9.91	8.82	160.00
DT465B-2XR_TIA w/ Mount Pipe	C	From Leg	0.00		0.0000	154.00	1" Ice	10.44	9.72	244.63
			3.00				No Ice	9.34	7.63	83.52
			0.00				1/2" Ice	9.91	8.82	160.00
(2) RRH 800	A	From Leg	0.00		0.0000	154.00	1" Ice	10.44	9.72	244.63
			3.00				No Ice	1.72	1.43	46.00
			0.00				1/2" Ice	1.90	1.60	62.55
(2) RRH 800	B	From Leg	0.00		0.0000	154.00	1" Ice	2.07	1.76	81.83
			3.00				No Ice	1.72	1.43	46.00
			0.00				1/2" Ice	1.90	1.60	62.55
(2) RRH 800	C	From Leg	0.00		0.0000	154.00	1" Ice	2.07	1.76	81.83
			3.00				No Ice	1.72	1.43	46.00
			0.00				1/2" Ice	1.90	1.60	62.55
1900MHz 4X40W RRH	A	From Leg	0.00		0.0000	154.00	1" Ice	2.07	1.76	81.83
			3.00				No Ice	2.32	2.24	59.50
			0.00				1/2" Ice	2.53	2.44	82.63
1900MHz 4X40W RRH	B	From Leg	0.00		0.0000	154.00	1" Ice	2.74	2.65	109.00
			3.00				No Ice	2.32	2.24	59.50
			0.00				1/2" Ice	2.53	2.44	82.63
1900MHz 4X40W RRH	C	From Leg	0.00		0.0000	154.00	1" Ice	2.74	2.65	109.00
			3.00				No Ice	2.32	2.24	59.50
			0.00				1/2" Ice	2.53	2.44	82.63
TD-RRH8x20-25	A	From Leg	0.00		0.0000	154.00	1" Ice	2.74	2.65	109.00
			3.00				No Ice	4.05	1.53	70.00
			0.00				1/2" Ice	4.30	1.71	97.15
TD-RRH8x20-25	B	From Leg	0.00		0.0000	154.00	1" Ice	4.56	1.90	127.83
			3.00				No Ice	4.05	1.53	70.00
			0.00				1/2" Ice	4.30	1.71	97.15
TD-RRH8x20-25	C	From Leg	0.00		0.0000	154.00	1" Ice	4.56	1.90	127.83
			3.00				No Ice	4.05	1.53	70.00
			0.00				1/2" Ice	4.30	1.71	97.15

Pirod 12' T-Frame Sector Mount (1)	A	From Leg	1.50		0.0000	140.00	No Ice	13.60	13.60	470.00
			0.00				1/2" Ice	18.40	18.40	600.00
			0.00				1" Ice	23.20	23.20	730.00
Pirod 12' T-Frame Sector Mount (1)	B	From Leg	1.50		0.0000	140.00	No Ice	13.60	13.60	470.00
			0.00				1/2" Ice	18.40	18.40	600.00
			0.00				1" Ice	23.20	23.20	730.00
Pirod 12' T-Frame Sector Mount (1)	C	From Leg	1.50		0.0000	140.00	No Ice	13.60	13.60	470.00
			0.00				1/2" Ice	18.40	18.40	600.00
			0.00				1" Ice	23.20	23.20	730.00
7770_TIA w/ Mount Pipe	A	From Leg	3.00		0.0000	140.00	No Ice	5.75	4.25	55.38
			0.00				1/2" Ice	6.18	5.01	102.81
			0.00				1" Ice	6.61	5.71	156.64
7770_TIA w/ Mount Pipe	B	From Leg	3.00		0.0000	140.00	No Ice	5.75	4.25	55.38
			0.00				1/2" Ice	6.18	5.01	102.81
			0.00				1" Ice	6.61	5.71	156.64
7770_TIA w/ Mount Pipe	C	From Leg	3.00		0.0000	140.00	No Ice	5.75	4.25	55.38
			0.00				1/2" Ice	6.18	5.01	102.81
			0.00				1" Ice	6.61	5.71	156.64
(2) TPA65R-BU6D_TIA w/ Mount Pipe	A	From Leg	3.00		0.0000	140.00	No Ice	13.11	7.32	97.81
			0.00				1/2" Ice	13.71	8.49	191.16
			0.00				1" Ice	14.28	9.37	293.06
(2) TPA65R-BU6D_TIA w/	B	From Leg	3.00		0.0000	140.00	No Ice	13.11	7.32	97.81

tnxTower EFI Global, Inc. 1117 Perimeter Center West, Suite E500 Atlanta, GA 30338 Phone: (470) 990-6593 FAX:	Job		CTNH550A					Page	
	Project		049.02894 - 2275002					Date	
	Client		ForeSite LLC.					Designed by	
							19 of 38		
							15:49:21 06/09/22		
							Ahmet Colakoglu		

Description	Face or Leg	Offset Type	Offsets:		Azimuth Adjustment	Placement	CAAA Front	CAAA Side	Weight	
			Horz	Vert						
			ft	ft	°	ft	ft ²	ft ²	lb	
Mount Pipe			0.00			1/2" Ice	13.71	8.49	191.16	
			0.00			1" Ice	14.28	9.37	293.06	
(2) TPA65R-BU6D_TIA w/ Mount Pipe	C	From Leg	3.00		0.0000	140.00	No Ice	13.11	7.32	97.81
			0.00				1/2" Ice	13.71	8.49	191.16
			0.00				1" Ice	14.28	9.37	293.06
RRUS 4449 B5/B12	A	From Leg	3.00		0.0000	140.00	No Ice	1.97	1.41	71.00
			0.00				1/2" Ice	2.14	1.56	89.51
			0.00				1" Ice	2.33	1.73	110.84
RRUS 4449 B5/B12	B	From Leg	3.00		0.0000	140.00	No Ice	1.97	1.41	71.00
			0.00				1/2" Ice	2.14	1.56	89.51
			0.00				1" Ice	2.33	1.73	110.84
RRUS 4449 B5/B12	C	From Leg	3.00		0.0000	140.00	No Ice	1.97	1.41	71.00
			0.00				1/2" Ice	2.14	1.56	89.51
			0.00				1" Ice	2.33	1.73	110.84
RRUS 4478 B14	A	From Leg	3.00		0.0000	140.00	No Ice	1.84	1.06	59.90
			0.00				1/2" Ice	2.01	1.20	75.78
			0.00				1" Ice	2.19	1.34	94.29
RRUS 4478 B14	B	From Leg	3.00		0.0000	140.00	No Ice	1.84	1.06	59.90
			0.00				1/2" Ice	2.01	1.20	75.78
			0.00				1" Ice	2.19	1.34	94.29
RRUS 4478 B14	C	From Leg	3.00		0.0000	140.00	No Ice	1.84	1.06	59.90
			0.00				1/2" Ice	2.01	1.20	75.78
			0.00				1" Ice	2.19	1.34	94.29
RRUS 32	A	From Leg	3.00		0.0000	140.00	No Ice	2.86	1.78	55.12
			0.00				1/2" Ice	3.08	1.97	77.39
			0.00				1" Ice	3.32	2.17	102.93
RRUS 32	B	From Leg	3.00		0.0000	140.00	No Ice	2.86	1.78	55.12
			0.00				1/2" Ice	3.08	1.97	77.39
			0.00				1" Ice	3.32	2.17	102.93
RRUS 32	C	From Leg	3.00		0.0000	140.00	No Ice	2.86	1.78	55.12
			0.00				1/2" Ice	3.08	1.97	77.39
			0.00				1" Ice	3.32	2.17	102.93
Diplexer	A	From Leg	3.00		0.0000	140.00	No Ice	0.24	0.10	6.00
			0.00				1/2" Ice	0.31	0.14	8.47
			0.00				1" Ice	0.38	0.20	12.04
Diplexer	B	From Leg	3.00		0.0000	140.00	No Ice	0.24	0.10	6.00
			0.00				1/2" Ice	0.31	0.14	8.47
			0.00				1" Ice	0.38	0.20	12.04
Diplexer	C	From Leg	3.00		0.0000	140.00	No Ice	0.24	0.10	6.00
			0.00				1/2" Ice	0.31	0.14	8.47
			0.00				1" Ice	0.38	0.20	12.04
DC6 Surge Arrestor	A	From Leg	3.00		0.0000	140.00	No Ice	3.05	1.24	44.00
			0.00				1/2" Ice	3.26	1.40	65.28
			0.00				1" Ice	3.49	1.72	89.65
Squid Surge Arrestor	B	From Leg	3.00		0.0000	140.00	No Ice	0.81	0.81	33.00
			0.00				1/2" Ice	1.30	1.30	48.38
			0.00				1" Ice	1.48	1.48	66.11
Squid Surge Arrestor	C	From Leg	3.00		0.0000	140.00	No Ice	0.81	0.81	33.00
			0.00				1/2" Ice	1.30	1.30	48.38
			0.00				1" Ice	1.48	1.48	66.11
**										
**										

Custom 4-Sided Sector Mount	C	None			0.0000	125.00	No Ice	36.00	36.00	3000.00
							1/2" Ice	42.00	42.00	3300.00
							1" Ice	48.00	48.00	3600.00
8'-P3x0.216	A	From Leg	4.00		0.0000	125.00	No Ice	2.67	2.67	72.96

tnxTower EFI Global, Inc. 1117 Perimeter Center West, Suite E500 Atlanta, GA 30338 Phone: (470) 990-6593 FAX:	Job	CTNH550A	Page	20 of 38
	Project	049.02894 - 2275002	Date	15:49:21 06/09/22
	Client	ForeSite LLC.	Designed by	Ahmet Colakoglu

Description	Face or Leg	Offset Type	Offsets:		Azimuth Adjustment	Placement	C _{AA} Front	C _{AA} Side	Weight
			Horz	Vert					
			Lateral		°	ft	ft ²	ft ²	lb
			0.00			1/2" Ice	3.41	3.41	93.02
			0.00			1" Ice	3.89	3.89	118.48
8'-P3x0.216	B	From Leg	4.00		0.0000	No Ice	2.67	2.67	72.96
			0.00			1/2" Ice	3.41	3.41	93.02
			0.00			1" Ice	3.89	3.89	118.48
8'-P3x0.216	C	From Leg	4.00		0.0000	No Ice	2.67	2.67	72.96
			0.00			1/2" Ice	3.41	3.41	93.02
			0.00			1" Ice	3.89	3.89	118.48
8'-P3x0.216	C	From Face	4.00		0.0000	No Ice	2.67	2.67	72.96
			0.00			1/2" Ice	3.41	3.41	93.02
			0.00			1" Ice	3.89	3.89	118.48
AIR 6449 B41_TIA w/ Mount Pipe	A	From Leg	4.00		0.0000	No Ice	5.87	3.27	128.35
			0.00			1/2" Ice	6.23	3.73	177.29
			0.00			1" Ice	6.61	4.20	231.68
AIR 6449 B41_TIA w/ Mount Pipe	B	From Leg	4.00		0.0000	No Ice	5.87	3.27	128.35
			0.00			1/2" Ice	6.23	3.73	177.29
			0.00			1" Ice	6.61	4.20	231.68
AIR 6449 B41_TIA w/ Mount Pipe	C	From Leg	4.00		0.0000	No Ice	5.87	3.27	128.35
			0.00			1/2" Ice	6.23	3.73	177.29
			0.00			1" Ice	6.61	4.20	231.68
AIR 6449 B41_TIA w/ Mount Pipe	C	From Face	4.00		0.0000	No Ice	5.87	3.27	128.35
			0.00			1/2" Ice	6.23	3.73	177.29
			0.00			1" Ice	6.61	4.20	231.68
VV-65A-R1_TIA w/ Mount Pipe	A	From Leg	4.00		0.0000	No Ice	6.12	4.05	53.59
			0.00			1/2" Ice	6.56	4.80	101.88
			0.00			1" Ice	6.99	5.49	156.58
VV-65A-R1_TIA w/ Mount Pipe	B	From Leg	4.00		0.0000	No Ice	6.12	4.05	53.59
			0.00			1/2" Ice	6.56	4.80	101.88
			0.00			1" Ice	6.99	5.49	156.58
VV-65A-R1_TIA w/ Mount Pipe	C	From Leg	4.00		0.0000	No Ice	6.12	4.05	53.59
			0.00			1/2" Ice	6.56	4.80	101.88
			0.00			1" Ice	6.99	5.49	156.58
VV-65A-R1_TIA w/ Mount Pipe	C	From Face	4.00		0.0000	No Ice	6.12	4.05	53.59
			0.00			1/2" Ice	6.56	4.80	101.88
			0.00			1" Ice	6.99	5.49	156.58
APXVAALL24_43-U-NA20_TIA w/ Mount Pipe	A	From Leg	4.00		0.0000	No Ice	20.48	10.87	182.72
			0.00			1/2" Ice	21.23	12.39	318.21
			0.00			1" Ice	21.99	13.94	464.50
APXVAALL24_43-U-NA20_TIA w/ Mount Pipe	B	From Leg	4.00		0.0000	No Ice	20.48	10.87	182.72
			0.00			1/2" Ice	21.23	12.39	318.21
			0.00			1" Ice	21.99	13.94	464.50
APXVAALL24_43-U-NA20_TIA w/ Mount Pipe	C	From Leg	4.00		0.0000	No Ice	20.48	10.87	182.72
			0.00			1/2" Ice	21.23	12.39	318.21
			0.00			1" Ice	21.99	13.94	464.50
APXVAALL24_43-U-NA20_TIA w/ Mount Pipe	C	From Face	4.00		0.0000	No Ice	20.48	10.87	182.72
			0.00			1/2" Ice	21.23	12.39	318.21
			0.00			1" Ice	21.99	13.94	464.50
RADIO 4460 B25 B66	A	From Leg	4.00		0.0000	No Ice	2.14	1.69	109.00
			0.00			1/2" Ice	2.32	1.85	131.16
			0.00			1" Ice	2.51	2.02	156.36
RADIO 4460 B25 B66	B	From Leg	4.00		0.0000	No Ice	2.14	1.69	109.00
			0.00			1/2" Ice	2.32	1.85	131.16
			0.00			1" Ice	2.51	2.02	156.36
RADIO 4460 B25 B66	C	From Leg	4.00		0.0000	No Ice	2.14	1.69	109.00
			0.00			1/2" Ice	2.32	1.85	131.16
			0.00			1" Ice	2.51	2.02	156.36
RADIO 4460 B25 B66	C	From Face	4.00		0.0000	No Ice	2.14	1.69	109.00

tnxTower EFI Global, Inc. 1117 Perimeter Center West, Suite E500 Atlanta, GA 30338 Phone: (470) 990-6593 FAX:	Job	CTNH550A	Page	21 of 38
	Project	049.02894 - 2275002	Date	15:49:21 06/09/22
	Client	ForeSite LLC.	Designed by	Ahmet Colakoglu

Description	Face or Leg	Offset Type	Offsets:		Azimuth Adjustment	Placement	CAAA Front	CAAA Side	Weight
			Horz	Lateral Vert					
			ft	ft	°	ft	ft ²	ft ²	lb
			0.00			1/2" Ice	2.32	1.85	131.16
			0.00			1" Ice	2.51	2.02	156.36
Radio 4480	C	From Leg	4.00		0.0000	No Ice	2.80	1.38	93.00
			0.00			1/2" Ice	3.01	1.54	114.40
			0.00			1" Ice	3.23	1.71	138.90
Radio 4480	C	From Leg	4.00		0.0000	No Ice	2.80	1.38	93.00
			0.00			1/2" Ice	3.01	1.54	114.40
			0.00			1" Ice	3.23	1.71	138.90
Radio 4480	C	From Leg	4.00		0.0000	No Ice	2.80	1.38	93.00
			0.00			1/2" Ice	3.01	1.54	114.40
			0.00			1" Ice	3.23	1.71	138.90
Radio 4480	C	From Leg	4.00		0.0000	No Ice	2.80	1.38	93.00
			0.00			1/2" Ice	3.01	1.54	114.40
			0.00			1" Ice	3.23	1.71	138.90
***			0.00			1" Ice	3.23	1.71	138.90
Pirod 6-8' Box Arm	B	From Leg	3.00		0.0000	No Ice	4.50	4.50	210.00
			0.00			1/2" Ice	9.87	9.87	280.00
			0.00			1" Ice	15.24	15.24	340.00
***			0.00			1" Ice	15.24	15.24	340.00
Pirod 6-8' Box Arm	C	From Leg	3.00		0.0000	No Ice	4.50	4.50	210.00
			0.00			1/2" Ice	9.87	9.87	280.00
			0.00			1" Ice	15.24	15.24	340.00
ANT150D3	C	From Leg	6.00		0.0000	No Ice	1.60	1.60	18.00
			0.00			1/2" Ice	2.88	2.88	23.40
			0.00			1" Ice	4.16	4.16	28.80
***			0.00			1" Ice	4.16	4.16	28.80
6' Dish Ice Shield	C	From Leg	3.00		0.0000	No Ice	5.00	5.00	210.00
			0.00			1/2" Ice	7.00	7.00	280.00
			0.00			1" Ice	9.00	9.00	340.00
***			0.00			1" Ice	9.00	9.00	340.00
Pirod 6-8' Box Arm	A	From Leg	3.00		0.0000	No Ice	4.50	4.50	210.00
			0.00			1/2" Ice	9.87	9.87	280.00
			0.00			1" Ice	15.24	15.24	340.00
Pirod 6-8' Box Arm	B	From Leg	3.00		0.0000	No Ice	4.50	4.50	210.00
			0.00			1/2" Ice	9.87	9.87	280.00
			0.00			1" Ice	15.24	15.24	340.00
PD458-2	B	From Leg	6.00		0.0000	No Ice	3.40	3.40	22.00
			0.00			1/2" Ice	4.79	4.79	47.24
			0.00			1" Ice	6.20	6.20	81.19
***			0.00			1" Ice	6.20	6.20	81.19
Pirod 6-8' Box Arm	A	From Leg	3.00		0.0000	No Ice	4.50	4.50	210.00
			0.00			1/2" Ice	9.87	9.87	280.00
			0.00			1" Ice	15.24	15.24	340.00
Pirod 6-8' Box Arm	B	From Leg	3.00		0.0000	No Ice	4.50	4.50	210.00
			0.00			1/2" Ice	9.87	9.87	280.00
			0.00			1" Ice	15.24	15.24	340.00
Pirod 6-8' Box Arm	C	From Leg	3.00		0.0000	No Ice	4.50	4.50	210.00
			0.00			1/2" Ice	9.87	9.87	280.00
			0.00			1" Ice	15.24	15.24	340.00
PD220	A	From Leg	6.00		0.0000	No Ice	3.08	3.08	210.00
			0.00			1/2" Ice	5.30	5.30	280.00
			0.00			1" Ice	7.54	7.54	340.00
PD1142	A	From Leg	6.00		0.0000	No Ice	1.32	1.32	10.00
			0.00			1/2" Ice	3.21	3.21	23.85
			0.00			1" Ice	5.12	5.12	49.42
BCD-80609	B	From Leg	6.00		0.0000	No Ice	2.95	2.95	26.50
			0.00			1/2" Ice	4.11	4.11	48.29

tnxTower EFI Global, Inc. 1117 Perimeter Center West, Suite E500 Atlanta, GA 30338 Phone: (470) 990-6593 FAX:	Job CTNH550A	Page 22 of 38
	Project 049.02894 - 2275002	Date 15:49:21 06/09/22
	Client ForeSite LLC.	Designed by Ahmet Colakoglu

Description	Face or Leg	Offset Type	Offsets:		Azimuth Adjustment	Placement	CAAA Front	CAAA Side	Weight	
			Horz Lateral	Vert						
			ft	ft	°	ft	ft ²	ft ²	lb	
6' Yagi	B	From Leg	0.00		0.0000	78.00	1" Ice	5.29	5.29	77.42
			6.00				No Ice	5.00	5.00	40.00
			0.00				1/2" Ice	6.50	6.50	60.00
			0.00				1" Ice	8.00	8.00	80.00
DB222	C	From Leg	6.00		0.0000	78.00	No Ice	1.60	1.60	20.00
			0.00				1/2" Ice	2.88	2.88	20.00
			0.00				1" Ice	4.16	4.16	30.00
			0.00							

2-ft Stand Off	B	From Leg	1.50		0.0000	32.00	No Ice	1.07	1.07	20.00
			0.00				1/2" Ice	1.62	1.62	30.00
			0.00				1" Ice	2.17	2.17	40.00
			0.00							
GPS	B	From Leg	3.00		0.0000	32.00	No Ice	0.33	0.33	6.08
			0.00				1/2" Ice	0.48	0.48	11.71
			0.00				1" Ice	0.65	0.65	18.88
			0.00							
**										
*										
*										
*										
*										
*										

Dishes

Description	Face or Leg	Dish Type	Offset Type	Offsets:		Azimuth Adjustment	3 dB Beam Width	Elevation	Outside Diameter	Aperture Area	Weight	
				Horz Lateral	Vert							
			ft	ft	°	°	ft	ft	ft ²	lb		
6' Dish	A	Paraboloid w/o Radome	From Leg	0.00		0.0000		188.00	6.00	No Ice	28.30	80.00
				0.00						1/2" Ice	29.05	100.00
				0.00						1" Ice	29.80	120.00
				0.00								
6' Dish	C	Paraboloid w/o Radome	From Leg	0.00		0.0000		97.00	6.00	No Ice	28.30	80.00
				0.00						1/2" Ice	29.05	100.00
				0.00						1" Ice	29.80	120.00
				0.00								

Truss-Leg Properties

Section Designation	Area	Area Ice	Self Weight	Ice Weight	Equiv. Diameter	Equiv. Diameter Ice	Leg Area
	in ²	in ²	lb	lb	in	in	in ²
Pirod 105244	1026.8606	3703.4895	562.76	1382.29	7.1310	25.7187	3.6816
Pirod 105244	1026.8606	3698.2947	562.76	1379.08	7.1310	25.6826	3.6816
Pirod 105216	1998.0891	7564.7141	505.25	2806.59	6.9378	26.2664	3.6816
Pirod 105217	2130.7479	7612.7738	619.35	2790.60	7.3984	26.4332	5.3014
Pirod 105217	2130.7479	7595.6265	619.35	2758.94	7.3984	26.3737	5.3014
Pirod 105218	2263.4687	7639.7955	754.52	2736.34	7.8593	26.5271	7.2158
Pirod 105218	2263.4687	7608.9086	754.52	2680.16	7.8593	26.4198	7.2158

<p>tnxTower</p> <p>EFI Global, Inc. 1117 Perimeter Center West, Suite E500 Atlanta, GA 30338 Phone: (470) 990-6593 FAX:</p>	<p>Job</p> <p>CTNH550A</p>	<p>Page</p> <p>23 of 38</p>
	<p>Project</p> <p>049.02894 - 2275002</p>	<p>Date</p> <p>15:49:21 06/09/22</p>
	<p>Client</p> <p>ForeSite LLC.</p>	<p>Designed by</p> <p>Ahmet Colakoglu</p>

Section Designation	Area <i>in</i> ²	Area Ice <i>in</i> ²	Self Weight <i>lb</i>	Ice Weight <i>lb</i>	Equiv. Diameter <i>in</i>	Equiv. Diameter Ice <i>in</i>	Leg Area <i>in</i> ²
Pirod 105218	2263.4687	7586.2338	754.52	2639.26	7.8593	26.3411	7.2158
Pirod 105219	2441.8688	7620.2794	944.27	2637.47	8.4787	26.4593	9.4248
Pirod 105219	2441.8688	7559.6426	944.27	2529.79	8.4787	26.2488	9.4248
Pirod 105220	2578.8005	7552.8085	1121.16	2420.30	8.9542	26.2250	11.9282
Pirod 105220	2578.8005	7438.0816	1121.16	2227.16	8.9542	25.8267	11.9282
Pirod 112738	3466.5160	9318.2669	1689.34	2586.97	12.0365	32.3551	14.7262

Load Combinations

Comb. No.	Description
1	Dead Only
2	1.2 Dead+1.6 Wind 0 deg - No Ice
3	0.9 Dead+1.6 Wind 0 deg - No Ice
4	1.2 Dead+1.6 Wind 30 deg - No Ice
5	0.9 Dead+1.6 Wind 30 deg - No Ice
6	1.2 Dead+1.6 Wind 60 deg - No Ice
7	0.9 Dead+1.6 Wind 60 deg - No Ice
8	1.2 Dead+1.6 Wind 90 deg - No Ice
9	0.9 Dead+1.6 Wind 90 deg - No Ice
10	1.2 Dead+1.6 Wind 120 deg - No Ice
11	0.9 Dead+1.6 Wind 120 deg - No Ice
12	1.2 Dead+1.6 Wind 150 deg - No Ice
13	0.9 Dead+1.6 Wind 150 deg - No Ice
14	1.2 Dead+1.6 Wind 180 deg - No Ice
15	0.9 Dead+1.6 Wind 180 deg - No Ice
16	1.2 Dead+1.6 Wind 210 deg - No Ice
17	0.9 Dead+1.6 Wind 210 deg - No Ice
18	1.2 Dead+1.6 Wind 240 deg - No Ice
19	0.9 Dead+1.6 Wind 240 deg - No Ice
20	1.2 Dead+1.6 Wind 270 deg - No Ice
21	0.9 Dead+1.6 Wind 270 deg - No Ice
22	1.2 Dead+1.6 Wind 300 deg - No Ice
23	0.9 Dead+1.6 Wind 300 deg - No Ice
24	1.2 Dead+1.6 Wind 330 deg - No Ice
25	0.9 Dead+1.6 Wind 330 deg - No Ice
26	1.2 Dead+1.0 Ice+1.0 Temp
27	1.2 Dead+1.0 Wind 0 deg+1.0 Ice+1.0 Temp
28	1.2 Dead+1.0 Wind 30 deg+1.0 Ice+1.0 Temp
29	1.2 Dead+1.0 Wind 60 deg+1.0 Ice+1.0 Temp
30	1.2 Dead+1.0 Wind 90 deg+1.0 Ice+1.0 Temp
31	1.2 Dead+1.0 Wind 120 deg+1.0 Ice+1.0 Temp
32	1.2 Dead+1.0 Wind 150 deg+1.0 Ice+1.0 Temp
33	1.2 Dead+1.0 Wind 180 deg+1.0 Ice+1.0 Temp
34	1.2 Dead+1.0 Wind 210 deg+1.0 Ice+1.0 Temp
35	1.2 Dead+1.0 Wind 240 deg+1.0 Ice+1.0 Temp
36	1.2 Dead+1.0 Wind 270 deg+1.0 Ice+1.0 Temp
37	1.2 Dead+1.0 Wind 300 deg+1.0 Ice+1.0 Temp
38	1.2 Dead+1.0 Wind 330 deg+1.0 Ice+1.0 Temp
39	Dead+Wind 0 deg - Service
40	Dead+Wind 30 deg - Service
41	Dead+Wind 60 deg - Service
42	Dead+Wind 90 deg - Service
43	Dead+Wind 120 deg - Service
44	Dead+Wind 150 deg - Service
45	Dead+Wind 180 deg - Service
46	Dead+Wind 210 deg - Service

tnxTower EFI Global, Inc. 1117 Perimeter Center West, Suite E500 Atlanta, GA 30338 Phone: (470) 990-6593 FAX:	Job	CTNH550A	Page	24 of 38
	Project	049.02894 - 2275002	Date	15:49:21 06/09/22
	Client	ForeSite LLC.	Designed by	Ahmet Colakoglu

Comb. No.	Description
47	Dead+Wind 240 deg - Service
48	Dead+Wind 270 deg - Service
49	Dead+Wind 300 deg - Service
50	Dead+Wind 330 deg - Service

Maximum Member Forces

Section No.	Elevation ft	Component Type	Condition	Gov. Load Comb.	Axial lb	Major Axis Moment lb-ft	Minor Axis Moment lb-ft
T1	195 - 190	Leg	Max Tension	1	0.00	0.00	0.00
			Max. Compression	33	-691.63	-966.96	77.56
			Max. Mx	14	-204.33	-1194.80	108.64
			Max. My	24	-202.85	-182.76	-290.33
			Max. Vy	14	317.22	-1194.80	108.64
			Max. Vx	24	137.07	0.01	-0.00
		Diagonal	Max Tension	11	2.72	0.00	0.00
			Max. Compression	33	-575.74	0.00	0.00
			Max. Mx	32	-386.52	220.21	0.00
			Max. My	35	-373.45	0.00	0.36
			Max. Vy	32	-112.78	0.00	0.00
			Max. Vx	35	0.18	0.00	0.00
		Top Girt	Max Tension	18	194.41	0.00	0.00
			Max. Compression	13	-146.69	-33.08	2.39
			Max. Mx	33	70.04	-166.80	4.37
			Max. My	31	95.73	-162.66	-4.93
			Max. Vy	33	143.72	-166.80	4.37
			Max. Vx	31	1.07	0.00	0.00
T2	190 - 180	Leg	Max Tension	15	1024.49	-1153.74	108.26
			Max. Compression	31	-6255.18	941.41	58.30
			Max. Mx	14	910.34	-1194.80	108.64
			Max. My	16	-1819.68	267.76	-1608.65
			Max. Vy	14	-921.24	-1194.80	108.64
			Max. Vx	16	759.19	87.86	-73.67
		Diagonal	Max Tension	14	1862.97	0.00	0.00
			Max. Compression	10	-1766.48	0.00	0.00
			Max. Mx	27	405.17	164.09	2.25
			Max. My	33	52.11	162.65	3.05
			Max. Vy	32	-103.60	163.77	0.33
			Max. Vx	33	0.51	0.00	0.00
T3	180 - 160	Leg	Max Tension	15	13991.83	-1036.82	-49.33
			Max. Compression	31	-20492.56	600.95	-10.84
			Max. Mx	18	-17379.36	-1737.75	-104.13
			Max. My	24	-2541.33	53.73	-1922.73
			Max. Vy	6	-1330.66	-1079.87	-11.67
			Max. Vx	24	1382.92	-159.12	781.98
		Diagonal	Max Tension	24	5221.22	0.00	0.00
			Max. Compression	10	-5452.61	0.00	0.00
			Max. Mx	31	1033.28	192.96	1.65
			Max. My	24	-1119.39	24.84	-4.26
			Max. Vy	31	-116.52	192.96	1.65
			Max. Vx	33	0.66	0.00	0.00
T4	160 - 150	Leg	Max Tension	15	26448.56	-1501.54	-39.16
			Max. Compression	10	-33583.05	-611.44	370.54
			Max. Mx	27	-27652.41	2862.61	-6.89
			Max. My	12	-7464.52	-584.47	-2968.92
			Max. Vy	10	1794.26	2454.33	-24.63
			Max. Vx	12	1047.08	-584.47	-2968.92
		Diagonal	Max Tension	25	7986.26	37.70	-5.39

<p>tnxTower</p> <p>EFI Global, Inc. 1117 Perimeter Center West, Suite E500 Atlanta, GA 30338 Phone: (470) 990-6593 FAX:</p>	Job	CTNH550A	Page	25 of 38
	Project	049.02894 - 2275002	Date	15:49:21 06/09/22
	Client	ForeSite LLC.	Designed by	Ahmet Colakoglu

Section No.	Elevation ft	Component Type	Condition	Gov. Load Comb.	Axial lb	Major Axis Moment lb-ft	Minor Axis Moment lb-ft				
T5	150 - 140	Secondary Horizontal	Max. Compression	24	-8177.65	0.00	0.00				
			Max. Mx	30	1989.22	202.46	1.57				
			Max. My	24	-8139.07	31.84	-8.77				
			Max. Vy	32	-125.63	202.40	-1.43				
			Max. Vx	24	-1.12	0.00	0.00				
			Max Tension	18	1273.81	17.13	-4.59				
		T6	140 - 120	Leg	Max. Compression	15	-916.01	37.81	5.59		
					Max. Mx	29	471.21	140.29	0.16		
					Max. My	37	891.86	134.09	-7.24		
					Max. Vy	29	122.87	140.29	0.16		
					Max. Vx	33	1.44	0.00	0.00		
					Max Tension	15	44225.19	-306.59	18.76		
				T7	120 - 110	Diagonal	Max. Compression	10	-53194.02	2683.46	-37.44
							Max. Mx	27	-41930.87	2884.32	-23.13
Max. My	12						-8484.40	-584.44	-2968.91		
Max. Vy	27						-603.97	2884.32	-23.13		
Max. Vx	12						-470.99	-584.44	-2968.91		
Max Tension	13						9608.21	0.00	0.00		
T6	140 - 120					Leg	Max. Compression	24	-9941.04	0.00	0.00
							Max. Mx	27	1294.11	227.04	-1.40
		Max. My	18				-9617.60	31.24	7.42		
		Max. Vy	27				-128.05	227.04	-1.40		
		Max. Vx	18				-1.00	0.00	0.00		
		Max Tension	15				86388.79	-3024.34	-47.22		
		T7	120 - 110			Diagonal	Max. Compression	18	-103918.35	2365.45	-69.68
							Max. Mx	14	84538.29	-3124.47	-43.89
				Max. My	12		-11743.77	-318.79	-4411.87		
				Max. Vy	6		-1190.33	-3032.47	-22.37		
				Max. Vx	12		-1262.85	-318.78	-4411.87		
				Max Tension	4		11679.06	0.00	0.00		
				T6	140 - 120	Top Girt	Max. Compression	4	-11807.97	0.00	0.00
							Max. Mx	27	2831.51	248.51	32.06
Max. My	35						205.14	232.84	36.37		
Max. Vy	37						142.20	245.64	34.84		
Max. Vx	35						8.41	0.00	0.00		
Max Tension	29						754.63	0.00	0.00		
T7	120 - 110					Leg	Max. Compression	3	-499.55	0.00	0.00
							Max. Mx	26	615.35	-585.46	0.00
		Max. My	34				536.95	0.00	16.90		
		Max. Vy	26				195.15	0.00	0.00		
		Max. Vx	34				-5.63	0.00	0.00		
		Max Tension	15				109205.69	-2749.72	-59.08		
		T7	120 - 110			Leg	Max. Compression	18	-129533.07	-258.33	-288.65
							Max. Mx	18	-129332.07	7647.33	-43.96
				Max. My	12		-17608.96	-509.73	-3931.04		
				Max. Vy	18		1610.80	7647.32	-43.92		
				Max. Vx	16		783.57	-95.40	3577.23		
				Max Tension	21		13290.38	91.36	2.68		
				T7	120 - 110	Diagonal	Max. Compression	20	-13960.37	0.00	0.00
							Max. Mx	35	2002.75	305.27	31.30
Max. My	33						-4429.91	265.00	35.06		
Max. Vy	33						166.12	285.97	29.58		
Max. Vx	33						8.60	0.00	0.00		
Max Tension	16						1936.60	38.91	-4.82		
T7	120 - 110					Secondary Horizontal	Max. Compression	17	-1532.25	59.77	26.93
							Max. Mx	33	652.18	229.82	49.78
		Max. My	35				687.09	225.84	51.32		
		Max. Vy	33				-161.63	229.82	49.78		
		Max. Vx	35				-11.12	0.00	0.00		

tnxTower EFI Global, Inc. 1117 Perimeter Center West, Suite E500 Atlanta, GA 30338 Phone: (470) 990-6593 FAX:	Job	CTNH550A	Page	26 of 38
	Project	049.02894 - 2275002	Date	15:49:21 06/09/22
	Client	ForeSite LLC.	Designed by	Ahmet Colakoglu

Section No.	Elevation ft	Component Type	Condition	Gov. Load Comb.	Axial lb	Major Axis Moment lb-ft	Minor Axis Moment lb-ft			
T8	110 - 100	Leg	Max Tension	15	134754.00	-648.02	-74.27			
			Max. Compression	18	-158573.79	3744.21	-215.33			
			Max. Mx	10	-157474.49	3746.43	75.04			
			Max. My	12	-18953.26	-509.72	-3931.04			
			Max. Vy	2	-657.80	3741.87	140.34			
			Max. Vx	12	-381.70	-509.72	-3931.04			
		Diagonal	Max Tension	8	13515.64	0.00	0.00			
			Max. Compression	20	-13596.79	0.00	0.00			
			Max. Mx	35	3294.50	350.03	-41.44			
			Max. My	35	207.71	319.11	48.07			
			Max. Vy	33	176.94	329.33	45.71			
			Max. Vx	35	10.06	0.00	0.00			
			T9	100 - 80	Leg	Max Tension	15	183972.68	-2904.02	-71.87
						Max. Compression	18	-213401.20	5383.76	-156.31
Max. Mx	18	-213401.20				5383.76	-156.31			
Max. My	16	-22222.84				163.19	4536.63			
Max. Vy	6	-739.94				-3444.02	10.38			
Max. Vx	4	-689.56				279.73	-2691.43			
Diagonal	Max Tension	8			14880.18	0.00	0.00			
	Max. Compression	8			-15156.45	0.00	0.00			
	Max. Mx	35			3356.91	428.58	54.00			
	Max. My	35			104.72	395.75	59.43			
	Max. Vy	33			205.79	418.06	56.69			
	Max. Vx	35			11.35	0.00	0.00			
	T10	80 - 60			Leg	Max Tension	15	232217.56	-3009.20	24.74
						Max. Compression	18	-269003.41	4831.93	-159.44
Max. Mx			18	-240505.33		5383.74	-156.31			
Max. My			16	-23183.21		163.20	4536.63			
Max. Vy			14	-674.75		-5192.81	-16.22			
Max. Vx			16	528.01		163.20	4536.63			
Diagonal			Max Tension	8	16169.77	0.00	0.00			
			Max. Compression	8	-16399.29	0.00	0.00			
			Max. Mx	35	4261.42	579.93	-67.94			
			Max. My	35	244.64	526.61	73.98			
			Max. Vy	33	247.89	551.06	72.16			
			Max. Vx	35	13.13	0.00	0.00			
			T11	60 - 40	Leg	Max Tension	15	279321.27	-3813.90	-11.12
						Max. Compression	18	-324165.73	2293.74	-337.84
Max. Mx	14	252093.58				-4876.78	-35.09			
Max. My	16	-29134.26				-886.75	7756.57			
Max. Vy	2	387.98				4551.19	29.55			
Max. Vx	16	-633.53				-886.75	7756.57			
Diagonal	Max Tension	8			17156.88	0.00	0.00			
	Max. Compression	8			-17174.68	0.00	0.00			
	Max. Mx	35			4627.33	806.90	92.18			
	Max. My	34			-2055.20	709.44	99.35			
	Max. Vy	33			316.54	751.68	95.59			
	Max. Vx	34			16.36	0.00	0.00			
	T12	40 - 20			Leg	Max Tension	15	326394.92	-5071.75	28.86
						Max. Compression	18	-380286.78	5436.69	-755.17
Max. Mx			14	320388.82		-8302.61	-106.91			
Max. My			16	-33207.12		-1559.11	20912.63			
Max. Vy			2	-703.42		7755.52	-95.68			
Max. Vx			16	-2801.71		-1559.11	20912.63			
Diagonal			Max Tension	10	18673.89	0.00	0.00			
			Max. Compression	20	-18784.85	0.00	0.00			
			Max. Mx	34	5073.42	889.42	93.06			
			Max. My	33	-4515.02	810.32	125.32			
			Max. Vy	34	333.15	874.67	-106.43			
			Max. Vx	33	18.01	0.00	0.00			
			T13	20 - 0	Leg	Max Tension	15	352005.04	-7889.08	-98.15

tnxTower EFI Global, Inc. 1117 Perimeter Center West, Suite E500 Atlanta, GA 30338 Phone: (470) 990-6593 FAX:	Job	CTNH550A	Page	27 of 38
	Project	049.02894 - 2275002	Date	15:49:21 06/09/22
	Client	ForeSite LLC.	Designed by	Ahmet Colakoglu

Section No.	Elevation ft	Component Type	Condition	Gov. Load Comb.	Axial lb	Major Axis Moment lb-ft	Minor Axis Moment lb-ft
			Max. Compression	18	-409064.40	0.00	-0.02
			Max. Mx	14	346561.40	-8302.62	-106.91
			Max. My	16	-32645.30	-1559.08	20912.63
			Max. Vy	6	-787.93	-8223.54	95.04
			Max. Vx	16	1364.54	-1559.08	20912.63
		Diagonal	Max Tension	7	23681.31	0.00	0.00
			Max. Compression	10	-27519.43	0.00	0.00
			Max. Mx	34	6057.81	-1148.13	-169.13
			Max. My	36	286.43	-1127.57	-186.71
			Max. Vy	34	-354.46	-1148.13	-169.13
			Max. Vx	36	-21.88	0.00	0.00

Maximum Reactions

Location	Condition	Gov. Load Comb.	Vertical lb	Horizontal, X lb	Horizontal, Z lb
Leg C	Max. Vert	18	442351.35	52526.76	-29800.59
	Max. H _x	18	442351.35	52526.76	-29800.59
	Max. H _z	7	-370314.97	-45018.13	25769.05
	Min. Vert	7	-370314.97	-45018.13	25769.05
	Min. H _x	7	-370314.97	-45018.13	25769.05
	Min. H _z	18	442351.35	52526.76	-29800.59
Leg B	Max. Vert	10	439937.56	-52386.88	-29703.10
	Max. H _x	23	-366157.15	44414.91	25396.32
	Max. H _z	23	-366157.15	44414.91	25396.32
	Min. Vert	23	-366157.15	44414.91	25396.32
	Min. H _x	10	439937.56	-52386.88	-29703.10
	Min. H _z	10	439937.56	-52386.88	-29703.10
Leg A	Max. Vert	2	441380.20	-14.39	60472.52
	Max. H _x	19	-198294.35	866.36	-27355.95
	Max. H _z	2	441380.20	-14.39	60472.52
	Min. Vert	15	-378418.75	21.27	-52332.55
	Min. H _x	9	24749.45	-978.13	3061.26
	Min. H _z	15	-378418.75	21.27	-52332.55

Tower Mast Reaction Summary

Load Combination	Vertical lb	Shear _x lb	Shear _z lb	Overturning Moment, M _x lb-ft	Overturning Moment, M _z lb-ft	Torque lb-ft
Dead Only	70824.26	-0.00	0.00	20345.21	14518.90	-0.10
1.2 Dead+1.6 Wind 0 deg - No Ice	84989.10	1463.40	-87662.37	-9300517.91	-128365.46	1839.68
0.9 Dead+1.6 Wind 0 deg - No Ice	63741.83	1463.40	-87662.58	-9297968.06	-132632.88	1856.01
1.2 Dead+1.6 Wind 30 deg - No Ice	84989.10	42760.84	-72754.57	-7746653.68	-4532885.88	6107.19
0.9 Dead+1.6 Wind 30 deg - No Ice	63741.83	42760.93	-72754.73	-7745491.25	-4532998.81	6103.24
1.2 Dead+1.6 Wind 60 deg - No Ice	84989.10	71677.09	-41874.50	-4455877.55	-7609675.89	8034.11
0.9 Dead+1.6 Wind 60 deg - No Ice	63741.83	71677.23	-41874.59	-4457812.64	-7606898.92	8013.31

<p style="text-align: center;">tnxTower</p> <p style="text-align: center;">EFI Global, Inc. 1117 Perimeter Center West, Suite E500 Atlanta, GA 30338 Phone: (470) 990-6593 FAX:</p>	Job	CTNH550A	Page	28 of 38
	Project	049.02894 - 2275002	Date	15:49:21 06/09/22
	Client	ForeSite LLC.	Designed by	Ahmet Colakoglu

Load Combination	Vertical lb	Shear _x lb	Shear _z lb	Overturning Moment, M _x lb-ft	Overturning Moment, M _z lb-ft	Torque lb-ft
Ice						
1.2 Dead+1.6 Wind 90 deg - No Ice	84989.10	83371.24	-951.53	-72785.71	-8819711.97	8341.82
0.9 Dead+1.6 Wind 90 deg - No Ice	63741.83	83371.42	-951.52	-78857.18	-8815818.15	8309.38
1.2 Dead+1.6 Wind 120 deg - No Ice	84989.10	75392.54	43913.73	4815836.47	-7921379.92	9644.63
0.9 Dead+1.6 Wind 120 deg - No Ice	63741.83	75392.71	43913.84	4805109.51	-7918410.93	9606.24
1.2 Dead+1.6 Wind 150 deg - No Ice	84989.10	40831.36	73132.44	7915245.69	-4292553.75	7961.67
0.9 Dead+1.6 Wind 150 deg - No Ice	63741.83	40831.46	73132.61	7901602.91	-4292904.70	7933.16
1.2 Dead+1.6 Wind 180 deg - No Ice	84989.10	-270.05	83380.95	9013815.59	47215.73	1713.06
0.9 Dead+1.6 Wind 180 deg - No Ice	63741.83	-270.05	83381.12	8999144.08	42813.23	1698.37
1.2 Dead+1.6 Wind 210 deg - No Ice	84989.10	-41323.23	73668.74	7970878.18	4381358.47	-5606.72
0.9 Dead+1.6 Wind 210 deg - No Ice	63741.83	-41323.33	73668.91	7957190.89	4372909.50	-5603.74
1.2 Dead+1.6 Wind 240 deg - No Ice	84989.10	-74821.86	45274.04	4954177.48	7904267.04	-11481.43
0.9 Dead+1.6 Wind 240 deg - No Ice	63741.83	-74822.03	45274.15	4943344.31	7892577.76	-11460.39
1.2 Dead+1.6 Wind 270 deg - No Ice	84989.10	-82883.46	131.47	39518.86	8807201.31	-13442.43
0.9 Dead+1.6 Wind 270 deg - No Ice	63741.83	-82883.65	131.48	33357.83	8794588.55	-13409.98
1.2 Dead+1.6 Wind 300 deg - No Ice	84989.10	-70829.41	-41073.27	-4371924.08	7558690.78	-9744.33
0.9 Dead+1.6 Wind 300 deg - No Ice	63741.83	-70829.56	-41073.36	-4373926.86	7547227.13	-9709.31
1.2 Dead+1.6 Wind 330 deg - No Ice	84989.10	-41360.53	-72179.52	-7687250.82	4425590.55	-3358.88
0.9 Dead+1.6 Wind 330 deg - No Ice	63741.83	-41360.62	-72179.69	-7686135.49	4417061.29	-3330.10
1.2 Dead+1.0 Ice+1.0 Temp	388861.17	0.67	-0.64	83324.50	99617.77	3.98
1.2 Dead+1.0 Wind 0 deg+1.0 Ice+1.0 Temp	388861.17	165.20	-24591.14	-2521876.69	83765.15	3124.76
1.2 Dead+1.0 Wind 30 deg+1.0 Ice+1.0 Temp	388861.17	12252.08	-21051.63	-2149100.24	-1197393.71	3870.55
1.2 Dead+1.0 Wind 60 deg+1.0 Ice+1.0 Temp	388861.17	20988.48	-12160.98	-1206742.78	-2122610.58	3542.91
1.2 Dead+1.0 Wind 90 deg+1.0 Ice+1.0 Temp	388861.17	24260.79	-107.67	73139.64	-2465395.34	2326.44
1.2 Dead+1.0 Wind 120 deg+1.0 Ice+1.0 Temp	388861.17	21258.30	12305.34	1401953.94	-2143204.08	810.37
1.2 Dead+1.0 Wind 150 deg+1.0 Ice+1.0 Temp	388861.17	12033.57	21094.17	2330620.61	-1170208.99	-970.58
1.2 Dead+1.0 Wind 180 deg+1.0 Ice+1.0 Temp	388861.17	-31.04	24280.00	2668842.07	103948.08	-2723.88
1.2 Dead+1.0 Wind 210 deg+1.0 Ice+1.0 Temp	388861.17	-12090.04	21155.14	2337034.59	1377400.99	-3815.23
1.2 Dead+1.0 Wind 240 deg+1.0 Ice+1.0 Temp	388861.17	-21194.83	12459.45	1417846.93	2338269.22	-3932.12
1.2 Dead+1.0 Wind 270 deg+1.0 Ice+1.0 Temp	388861.17	-24205.94	15.45	85803.50	2661225.25	-2876.79
1.2 Dead+1.0 Wind 300 deg+1.0 Ice+1.0 Temp	388861.17	-20892.49	-12069.72	-1197026.82	2313667.36	-817.24
1.2 Dead+1.0 Wind 330	388861.17	-12093.46	-20986.30	-2142247.99	1381947.81	1491.81

<p>tnxTower</p> <p>EFI Global, Inc. 1117 Perimeter Center West, Suite E500 Atlanta, GA 30338 Phone: (470) 990-6593 FAX:</p>	Job	CTNH550A	Page	29 of 38
	Project	049.02894 - 2275002	Date	15:49:21 06/09/22
	Client	ForeSite LLC.	Designed by	Ahmet Colakoglu

Load Combination	Vertical lb	Shear _x lb	Shear _z lb	Overturning Moment, M _x lb-ft	Overturning Moment, M _z lb-ft	Torque lb-ft
deg+1.0 Ice+1.0 Temp						
Dead+Wind 0 deg - Service	70824.26	331.04	-19833.99	-2088197.72	-18421.04	419.88
Dead+Wind 30 deg - Service	70824.26	9674.88	-16461.17	-1736837.84	-1014394.53	1387.02
Dead+Wind 60 deg - Service	70824.26	16217.43	-9474.37	-992713.80	-1710142.66	1820.58
Dead+Wind 90 deg - Service	70824.26	18863.28	-215.26	-1587.12	-1983766.99	1886.56
Dead+Wind 120 deg - Service	70824.26	17057.91	9935.67	1103824.89	-1780632.64	2181.83
Dead+Wind 150 deg - Service	70824.26	9238.39	16546.65	1804691.90	-960069.47	1802.91
Dead+Wind 180 deg - Service	70824.26	-61.09	18865.47	2053113.86	21276.10	385.55
Dead+Wind 210 deg - Service	70824.26	-9349.66	16667.97	1817271.39	1001350.62	-1273.79
Dead+Wind 240 deg - Service	70824.26	-16928.81	10243.39	1135103.48	1797967.68	-2601.03
Dead+Wind 270 deg - Service	70824.26	-18752.94	29.73	23801.66	2002142.70	-3041.25
Dead+Wind 300 deg - Service	70824.26	-16025.67	-9293.12	-973733.01	1719818.96	-2205.51
Dead+Wind 330 deg - Service	70824.26	-9358.11	-16331.08	-1723406.21	1011340.63	-760.94

Solution Summary

Load Comb.	Sum of Applied Forces			Sum of Reactions			% Error
	PX lb	PY lb	PZ lb	PX lb	PY lb	PZ lb	
1	-0.00	-70824.26	0.00	0.00	70824.26	-0.00	0.000%
2	1463.41	-84989.11	-87663.12	-1463.40	84989.10	87662.37	0.001%
3	1463.41	-63741.83	-87663.12	-1463.40	63741.83	87662.58	0.001%
4	42761.25	-84989.11	-72755.20	-42760.84	84989.10	72754.57	0.001%
5	42761.25	-63741.83	-72755.20	-42760.93	63741.83	72754.73	0.001%
6	71677.72	-84989.11	-41874.88	-71677.09	84989.10	41874.50	0.001%
7	71677.72	-63741.83	-41874.88	-71677.23	63741.83	41874.59	0.001%
8	83371.98	-84989.11	-951.57	-83371.24	84989.10	951.53	0.001%
9	83371.98	-63741.83	-951.57	-83371.42	63741.83	951.52	0.001%
10	75393.16	-84989.11	43914.14	-75392.54	84989.10	-43913.73	0.001%
11	75393.16	-63741.83	43914.14	-75392.71	63741.83	-43913.84	0.001%
12	40831.69	-84989.11	73133.14	-40831.36	84989.10	-73132.44	0.001%
13	40831.69	-63741.83	73133.14	-40831.46	63741.83	-73132.61	0.001%
14	-270.05	-84989.11	83381.71	270.05	84989.10	-83380.95	0.001%
15	-270.05	-63741.83	83381.71	270.05	63741.83	-83381.12	0.001%
16	-41323.56	-84989.11	73669.44	41323.23	84989.10	-73668.74	0.001%
17	-41323.56	-63741.83	73669.44	41323.33	63741.83	-73668.91	0.001%
18	-74822.49	-84989.11	45274.46	74821.86	84989.10	-45274.04	0.001%
19	-74822.49	-63741.83	45274.46	74822.03	63741.83	-45274.15	0.001%
20	-82884.20	-84989.11	131.43	82883.46	84989.10	-131.47	0.001%
21	-82884.20	-63741.83	131.43	82883.65	63741.83	-131.48	0.001%
22	-70830.05	-84989.11	-41073.64	70829.41	84989.10	41073.27	0.001%
23	-70830.05	-63741.83	-41073.64	70829.56	63741.83	41073.36	0.001%
24	-41360.94	-84989.11	-72180.15	41360.53	84989.10	72179.52	0.001%
25	-41360.94	-63741.83	-72180.15	41360.62	63741.83	72179.69	0.001%
26	-0.00	-388861.17	0.00	-0.67	388861.17	0.64	0.000%
27	165.19	-388861.17	-24591.34	-165.20	388861.17	24591.14	0.000%
28	12252.17	-388861.17	-21051.80	-12252.08	388861.17	21051.63	0.000%
29	20988.65	-388861.17	-12161.08	-20988.48	388861.17	12160.98	0.000%
30	24260.98	-388861.17	-107.67	-24260.79	388861.17	107.67	0.000%
31	21258.47	-388861.17	12305.45	-21258.30	388861.17	-12305.34	0.000%
32	12033.66	-388861.17	21094.35	-12033.57	388861.17	-21094.17	0.000%
33	-31.05	-388861.17	24280.21	31.04	388861.17	-24280.00	0.000%
34	-12090.15	-388861.17	21155.33	12090.04	388861.17	-21155.14	0.000%
35	-21195.01	-388861.17	12459.56	21194.83	388861.17	-12459.45	0.000%
36	-24206.15	-388861.17	15.45	24205.94	388861.17	-15.45	0.000%
37	-20892.67	-388861.17	-12069.82	20892.49	388861.17	12069.72	0.000%
38	-12093.57	-388861.17	-20986.46	12093.46	388861.17	20986.30	0.000%
39	331.04	-70824.26	-19834.14	-331.04	70824.26	19833.99	0.000%

tnxTower EFI Global, Inc. 1117 Perimeter Center West, Suite E500 Atlanta, GA 30338 Phone: (470) 990-6593 FAX:	Job	CTNH550A	Page	30 of 38
	Project	049.02894 - 2275002	Date	15:49:21 06/09/22
	Client	ForeSite LLC.	Designed by	Ahmet Colakoglu

Load Comb.	Sum of Applied Forces			Sum of Reactions			% Error
	PX lb	PY lb	PZ lb	PX lb	PY lb	PZ lb	
40	9674.95	-70824.26	-16461.29	-9674.88	70824.26	16461.17	0.000%
41	16217.55	-70824.26	-9474.44	-16217.43	70824.26	9474.37	0.000%
42	18863.43	-70824.26	-215.26	-18863.28	70824.26	215.26	0.000%
43	17058.03	-70824.26	9935.75	-17057.91	70824.26	-9935.67	0.000%
44	9238.46	-70824.26	16546.79	-9238.39	70824.26	-16546.65	0.000%
45	-61.09	-70824.26	18865.63	61.09	70824.26	-18865.47	0.000%
46	-9349.73	-70824.26	16668.11	9349.66	70824.26	-16667.97	0.000%
47	-16928.94	-70824.26	10243.47	16928.81	70824.26	-10243.39	0.000%
48	-18753.08	-70824.26	29.73	18752.94	70824.26	-29.73	0.000%
49	-16025.80	-70824.26	-9293.19	16025.67	70824.26	9293.12	0.000%
50	-9358.18	-70824.26	-16331.21	9358.11	70824.26	16331.08	0.000%

Non-Linear Convergence Results

Load Combination	Converged?	Number of Cycles	Displacement Tolerance	Force Tolerance
1	Yes	6	0.0000001	0.0000001
2	Yes	8	0.0000001	0.00006899
3	Yes	8	0.0000001	0.00005006
4	Yes	8	0.0000001	0.00007501
5	Yes	8	0.0000001	0.00005600
6	Yes	8	0.0000001	0.00008014
7	Yes	8	0.0000001	0.00006096
8	Yes	8	0.0000001	0.00007491
9	Yes	8	0.0000001	0.00005594
10	Yes	8	0.0000001	0.00006910
11	Yes	8	0.0000001	0.00005015
12	Yes	8	0.0000001	0.00007572
13	Yes	8	0.0000001	0.00005664
14	Yes	8	0.0000001	0.00008060
15	Yes	8	0.0000001	0.00006133
16	Yes	8	0.0000001	0.00007561
17	Yes	8	0.0000001	0.00005655
18	Yes	8	0.0000001	0.00006909
19	Yes	8	0.0000001	0.00005016
20	Yes	8	0.0000001	0.00007473
21	Yes	8	0.0000001	0.00005578
22	Yes	8	0.0000001	0.00008011
23	Yes	8	0.0000001	0.00006094
24	Yes	8	0.0000001	0.00007496
25	Yes	8	0.0000001	0.00005595
26	Yes	6	0.0000001	0.00008049
27	Yes	9	0.0000001	0.00004107
28	Yes	9	0.0000001	0.00004059
29	Yes	9	0.0000001	0.00004064
30	Yes	9	0.0000001	0.00004060
31	Yes	9	0.0000001	0.00004162
32	Yes	9	0.0000001	0.00004260
33	Yes	9	0.0000001	0.00004363
34	Yes	9	0.0000001	0.00004370
35	Yes	9	0.0000001	0.00004353
36	Yes	9	0.0000001	0.00004294
37	Yes	9	0.0000001	0.00004257
38	Yes	9	0.0000001	0.00004169
39	Yes	8	0.0000001	0.00005709
40	Yes	8	0.0000001	0.00005805

tnxTower EFI Global, Inc. 1117 Perimeter Center West, Suite E500 Atlanta, GA 30338 Phone: (470) 990-6593 FAX:	Job	CTNH550A	Page	31 of 38
	Project	049.02894 - 2275002	Date	15:49:21 06/09/22
	Client	ForeSite LLC.	Designed by	Ahmet Colakoglu

41	Yes	8	0.0000001	0.00005900
42	Yes	8	0.0000001	0.00005786
43	Yes	8	0.0000001	0.00005724
44	Yes	8	0.0000001	0.00005855
45	Yes	8	0.0000001	0.00005962
46	Yes	8	0.0000001	0.00005852
47	Yes	8	0.0000001	0.00005724
48	Yes	8	0.0000001	0.00005779
49	Yes	8	0.0000001	0.00005893
50	Yes	8	0.0000001	0.00005800

Maximum Tower Deflections - Service Wind

Section No.	Elevation ft	Horz. Deflection in	Gov. Load Comb.	Tilt °	Twist °
T1	195 - 190	3.531	47	0.1337	0.0039
T2	190 - 180	3.392	47	0.1337	0.0039
T3	180 - 160	3.110	47	0.1334	0.0037
T4	160 - 150	2.544	47	0.1297	0.0034
T5	150 - 140	2.267	47	0.1264	0.0033
T6	140 - 120	1.999	47	0.1208	0.0033
T7	120 - 110	1.494	47	0.1082	0.0033
T8	110 - 100	1.262	47	0.0998	0.0030
T9	100 - 80	1.050	47	0.0899	0.0027
T10	80 - 60	0.677	47	0.0727	0.0017
T11	60 - 40	0.389	47	0.0525	0.0010
T12	40 - 20	0.183	47	0.0349	0.0006
T13	20 - 0	0.048	47	0.0158	0.0002

Critical Deflections and Radius of Curvature - Service Wind

Elevation ft	Appurtenance	Gov. Load Comb.	Deflection in	Tilt °	Twist °	Radius of Curvature ft
188.00	6' Dish	47	3.336	0.1337	0.0039	158749
187.50	Pipe Mount [PM 602-1]	47	3.322	0.1337	0.0039	165152
184.00	Pirod 6-8' Box Arm	47	3.224	0.1336	0.0037	295762
183.00	ANT150F2	47	3.195	0.1336	0.0037	371878
168.00	Pirod 12' T-Frame Sector Mount (1)	47	2.770	0.1315	0.0035	363698
154.00	Pirod 12' T-Frame Sector Mount (1)	47	2.377	0.1280	0.0033	146341
140.00	Pirod 12' T-Frame Sector Mount (1)	47	1.999	0.1208	0.0033	116027
125.00	Custom 4-Sided Sector Mount	47	1.615	0.1117	0.0034	89601
118.00	Pirod 6-8' Box Arm	47	1.446	0.1067	0.0033	74643
105.00	Pirod 6-8' Box Arm	47	1.154	0.0948	0.0029	66770
101.00	6' Dish Ice Shield	47	1.071	0.0909	0.0027	78940
98.00	Pirod 6-8' Box Arm	47	1.010	0.0881	0.0026	80209
97.00	6' Dish	47	0.990	0.0872	0.0026	78683
78.00	Pirod 6-8' Box Arm	47	0.644	0.0708	0.0016	52060
32.00	2-ft Stand Off	47	0.119	0.0272	0.0005	59745

Maximum Tower Deflections - Design Wind

tnxTower EFI Global, Inc. 1117 Perimeter Center West, Suite E500 Atlanta, GA 30338 Phone: (470) 990-6593 FAX:	Job	CTNH550A	Page	32 of 38
	Project	049.02894 - 2275002	Date	15:49:21 06/09/22
	Client	ForeSite LLC.	Designed by	Ahmet Colakoglu

Section No.	Elevation ft	Horz. Deflection in	Gov. Load Comb.	Tilt °	Twist °
T1	195 - 190	15.514	18	0.5872	0.0172
T2	190 - 180	14.902	18	0.5872	0.0174
T3	180 - 160	13.657	18	0.5863	0.0164
T4	160 - 150	11.165	18	0.5705	0.0150
T5	150 - 140	9.946	18	0.5553	0.0145
T6	140 - 120	8.767	18	0.5297	0.0144
T7	120 - 110	6.553	18	0.4740	0.0147
T8	110 - 100	5.540	18	0.4368	0.0133
T9	100 - 80	4.611	18	0.3939	0.0120
T10	80 - 60	2.972	18	0.3186	0.0074
T11	60 - 40	1.708	18	0.2301	0.0046
T12	40 - 20	0.803	18	0.1528	0.0027
T13	20 - 0	0.211	2	0.0693	0.0011

Critical Deflections and Radius of Curvature - Design Wind

Elevation ft	Appurtenance	Gov. Load Comb.	Deflection in	Tilt °	Twist °	Radius of Curvature ft
188.00	6' Dish	18	14.655	0.5872	0.0172	35969
187.50	Pipe Mount [PM 602-1]	18	14.593	0.5872	0.0171	37429
184.00	Pirod 6-8' Box Arm	18	14.157	0.5870	0.0165	70093
183.00	ANT150F2	18	14.032	0.5869	0.0165	92261
168.00	Pirod 12' T-Frame Sector Mount (1)	18	12.156	0.5789	0.0156	86956
154.00	Pirod 12' T-Frame Sector Mount (1)	18	10.430	0.5625	0.0147	33934
140.00	Pirod 12' T-Frame Sector Mount (1)	18	8.767	0.5297	0.0144	26730
125.00	Custom 4-Sided Sector Mount	18	7.086	0.4893	0.0150	20490
118.00	Pirod 6-8' Box Arm	18	6.344	0.4673	0.0145	17055
105.00	Pirod 6-8' Box Arm	18	5.066	0.4153	0.0127	15399
101.00	6' Dish Ice Shield	18	4.701	0.3981	0.0121	18232
98.00	Pirod 6-8' Box Arm	18	4.434	0.3859	0.0116	18482
97.00	6' Dish	18	4.346	0.3820	0.0114	18124
78.00	Pirod 6-8' Box Arm	18	2.828	0.3103	0.0070	11872
32.00	2-ft Stand Off	18	0.522	0.1194	0.0020	13632

Bolt Design Data

Section No.	Elevation ft	Component Type	Bolt Grade	Bolt Size in	Number Of Bolts	Maximum Load per Bolt lb	Allowable Load per Bolt lb	Ratio Load Allowable	Allowable Ratio	Criteria
T1	195	Leg	A325N	1.0000	6	38.42	53014.40	0.001	1	Bolt Tension
		Diagonal	A325N	1.0000	1	575.74	41760.00	0.014	1	Member Bearing
T2	190	Leg	A325N	1.0000	6	347.51	53014.40	0.007	1	Bolt Tension
		Diagonal	A325N	1.0000	1	1862.97	9144.14	0.204	1	Member Block Shear
T3	180	Leg	A325N	1.0000	6	2331.97	53014.40	0.044	1	Bolt Tension
		Diagonal	A325N	1.0000	1	5221.22	10163.70	0.514	1	Member Block Shear
T4	160	Leg	A325N	1.0000	6	4379.69	53014.40	0.083	1	Bolt Tension
		Diagonal	A325N	1.0000	1	7986.26	16939.50	0.471	1	Member Block

tnxTower EFI Global, Inc. 1117 Perimeter Center West, Suite E500 Atlanta, GA 30338 Phone: (470) 990-6593 FAX:	Job	CTNH550A	Page	33 of 38
	Project	049.02894 - 2275002	Date	15:49:21 06/09/22
	Client	ForeSite LLC.	Designed by	Ahmet Colakoglu

Section No.	Elevation ft	Component Type	Bolt Grade	Bolt Size in	Number Of Bolts	Maximum Load per Bolt lb	Allowable Load per Bolt lb	Ratio Load Allowable	Allowable Ratio	Criteria
		Secondary Horizontal	A325N	0.5000	2	636.91	7952.16	0.080	1	Shear Bolt Shear
T5	150	Diagonal	A325N	1.0000	1	9608.21	16939.50	0.567	1	Member Block Shear
T6	140	Leg Diagonal	A325N	1.0000	6	14398.10	53014.40	0.272	1	Bolt Tension
		Diagonal	A325N	1.0000	1	11679.10	16939.50	0.689	1	Member Block Shear
		Top Girt	A325N	1.0000	1	1802.17	16939.50	0.106	1	Member Block Shear
T7	120	Leg Diagonal	A325N	1.0000	6	18159.30	53014.40	0.343	1	Bolt Tension
		Diagonal	A325N	1.0000	1	13290.40	20337.90	0.653	1	Member Block Shear
		Secondary Horizontal	A325N	0.5000	1	2246.38	7952.16	0.282	1	Bolt Shear
T8	110	Diagonal	A325N	1.0000	1	13515.60	20337.90	0.665	1	Member Block Shear
T9	100	Leg Diagonal	A325N	1.2500	6	30662.10	82835.00	0.370	1	Bolt Tension
		Diagonal	A325N	1.2500	1	14880.20	16429.70	0.906	1	Member Block Shear
T10	80	Leg Diagonal	A325N	1.2500	6	38702.90	82835.00	0.467	1	Bolt Tension
		Diagonal	A325N	1.2500	1	16169.80	24644.50	0.656	1	Member Block Shear
T11	60	Leg Diagonal	A325N	1.2500	6	46553.50	82835.00	0.562	1	Bolt Tension
		Diagonal	A325N	1.2500	1	17156.90	31972.50	0.537	1	Member Bearing
T12	40	Leg Diagonal	A325N	1.2500	6	54399.20	82835.00	0.657	1	Bolt Tension
		Diagonal	A325N	1.2500	1	18673.90	31972.50	0.584	1	Member Bearing
T13	20	Leg Diagonal	A325N	2.0000	6	58667.50	212058.00	0.277	1	Bolt Tension
		Diagonal	A325N	1.0000	2	11840.70	35525.40	0.333	1	Member Block Shear

Compression Checks

Leg Design Data (Compression)

Section No.	Elevation ft	Size	L ft	L _u ft	Kl/r	A in ²	P _u lb	φP _n lb	Ratio $\frac{P_u}{\phi P_n}$
T1	195 - 190	Pirod 105244	5.00	5.00	45.4 K=1.00	3.6816	-691.63	142493.00	0.005 ¹
T2	190 - 180	Pirod 105244	10.00	10.00	45.4 K=1.00	3.6816	-6255.18	142493.00	0.044 ¹
T3	180 - 160	Pirod 105216	20.00	10.00	45.4 K=1.00	3.6816	-20492.60	142493.00	0.144 ¹
T4	160 - 150	Pirod 105217	10.00	5.00	37.8 K=1.00	5.3014	-33583.00	214859.00	0.156 ¹
T5	150 - 140	Pirod 105217	10.00	10.00	37.8 K=1.00	5.3014	-53194.00	214859.00	0.248 ¹
T6	140 - 120	Pirod 105218	20.03	10.02	32.4 K=1.00	7.2158	-103918.00	300681.00	0.346 ¹
T7	120 - 110	Pirod 105218	10.02	5.18	32.4 K=1.00	7.2158	-129533.00	300681.00	0.431 ¹

tnxTower EFI Global, Inc. 1117 Perimeter Center West, Suite E500 Atlanta, GA 30338 Phone: (470) 990-6593 FAX:	Job	CTNH550A	Page	34 of 38
	Project	049.02894 - 2275002	Date	15:49:21 06/09/22
	Client	ForeSite LLC.	Designed by	Ahmet Colakoglu

Section No.	Elevation ft	Size	L ft	L _u ft	Kl/r	A in ²	P _u lb	φP _n lb	Ratio $\frac{P_u}{\phi P_n}$
T8	110 - 100	Pirod 105218	10.02	10.02	32.4 K=1.00	7.2158	-158574.00	300681.00	0.527 ¹
T9	100 - 80	Pirod 105219	20.03	10.02	28.4 K=1.00	9.4248	-213401.00	399868.00	0.534 ¹
T10	80 - 60	Pirod 105219	20.03	10.02	28.4 K=1.00	9.4248	-269003.00	399868.00	0.673 ¹
T11	60 - 40	Pirod 105220	20.03	10.02	25.2 K=1.00	11.9282	-324166.00	512375.00	0.633 ¹
T12	40 - 20	Pirod 105220	20.03	10.02	25.2 K=1.00	11.9282	-380287.00	512375.00	0.742 ¹
T13	20 - 0	Pirod 112738	20.03	20.03	32.6 K=1.00	14.7262	-409064.00	613145.00	0.667 ¹

¹ P_u / φP_n controls

Truss-Leg Diagonal Data

Section No.	Elevation ft	Diagonal Size	L _d ft	Kl/r	φP _n lb	A in ²	V _u lb	φV _n lb	Stress Ratio
T1	195 - 190	0.5	1.48	121.0	165670.00	0.1963	317.96	3388.58	0.094
T2	190 - 180	0.5	1.48	121.0	165670.00	0.1963	937.64	3388.58	0.277
T3	180 - 160	0.5	1.48	121.0	165670.00	0.1963	1384.91	3292.47	0.421
T4	160 - 150	0.5	1.47	120.0	238565.00	0.1963	1796.01	3335.33	0.539
T5	150 - 140	0.5	1.47	120.0	238565.00	0.1963	604.10	3335.33	0.181
T6	140 - 120	0.5	1.46	119.0	324713.00	0.1963	1308.05	3377.71	0.387
T7	120 - 110	0.5	1.46	119.0	324713.00	0.1963	1611.49	3377.71	0.477
T8	110 - 100	0.5	1.46	119.0	324713.00	0.1963	667.52	3377.71	0.198
T9	100 - 80	0.625	1.45	94.4	424115.00	0.3068	741.48	6957.62	0.107
T10	80 - 60	0.625	1.45	94.4	424115.00	0.3068	679.19	6957.62	0.098
T11	60 - 40	0.625	1.43	93.6	536771.00	0.3068	652.94	7011.35	0.093
T12	40 - 20	0.625	1.43	93.6	536771.00	0.3068	2822.97	7011.35	0.403
T13	20 - 0	0.75	1.73	93.9	662680.00	0.4418	1371.12	14363.90	0.096

Diagonal Design Data (Compression)

Section No.	Elevation ft	Size	L ft	L _u ft	Kl/r	A in ²	P _u lb	φP _n lb	Ratio $\frac{P_u}{\phi P_n}$
T1	195 - 190	2L2 1/2x2 1/2x3/16x3/16	7.81	6.83	111.0 K=1.00	1.8047	-575.74	30571.50	0.019 ¹
T2	190 - 180	2L 'a' > 39.0654 in - 10 L2 1/2x2 1/2x3/16	15.62	6.99	169.5 K=1.00	0.9020	-1766.48	7090.89	0.249 ¹
T3	180 - 160	L3x3x3/16	15.62	6.99	140.8 K=1.00	1.0900	-5452.61	12422.30	0.439 ¹
T4	160 - 150	L3x3x5/16	15.62	6.99	142.5 K=1.00	1.7800	-8177.65	19812.30	0.413 ¹
T5	150 - 140	L3x3x5/16	15.62	6.99	142.5 K=1.00	1.7800	-9941.04	19812.30	0.502 ¹
T6	140 - 120	L3x3x5/16	16.80	7.92	161.4 K=1.00	1.7800	-11808.00	15430.20	0.765 ¹
T7	120 - 110	L3 1/2x3 1/2x5/16	17.62	8.34	145.0	2.0900	-13960.40	22455.00	0.622 ¹

tnxTower EFI Global, Inc. 1117 Perimeter Center West, Suite E500 Atlanta, GA 30338 Phone: (470) 990-6593 FAX:	Job	CTNH550A	Page	35 of 38
	Project	049.02894 - 2275002	Date	15:49:21 06/09/22
	Client	ForeSite LLC.	Designed by	Ahmet Colakoglu

Section No.	Elevation ft	Size	L ft	L _u ft	Kl/r	A in ²	P _u lb	φP _n lb	Ratio $\frac{P_u}{\phi P_n}$
T8	110 - 100	L3 1/2x3 1/2x5/16	18.45	8.76	K=1.00 152.3	2.0900	-13596.80	20343.20	0.668 ¹
T9	100 - 80	L4x4x1/4	20.16	9.59	K=1.00 144.8	1.9400	-15156.50	20902.60	0.725 ¹
T10	80 - 60	L4x4x3/8	21.92	10.48	K=1.00 159.6	2.8600	-16399.30	25370.10	0.646 ¹
T11	60 - 40	L5x5x3/8	23.71	11.38	K=1.00 138.0	3.6100	-17086.40	42837.90	0.399 ¹
T12	40 - 20	L5x5x3/8	24.62	11.84	K=1.00 143.6	3.6100	-18784.90	39567.80	0.475 ¹
T13	20 - 0	2L3 1/2x3 1/2x5/16x3/8	32.02	15.40	K=1.00 176.8	4.1800	-27519.40	30200.60	0.911 ¹
					K=1.00				
					2L 'a' > 82.2703 in - 161				

¹ P_u / φP_n controls

Secondary Horizontal Design Data (Compression)

Section No.	Elevation ft	Size	L ft	L _u ft	Kl/r	A in ²	P _u lb	φP _n lb	Ratio $\frac{P_u}{\phi P_n}$
T4	160 - 150	L3x3x5/16	12.00	10.67	138.8	1.7800	-916.01	20864.20	0.044 ¹
T7	120 - 110	L3 1/2x3 1/2x5/16	14.48	13.27	K=1.00 147.5 K=1.00	2.0900	-2246.38	21704.00	0.104 ¹

¹ P_u / φP_n controls

Top Girt Design Data (Compression)

Section No.	Elevation ft	Size	L ft	L _u ft	Kl/r	A in ²	P _u lb	φP _n lb	Ratio $\frac{P_u}{\phi P_n}$
T1	195 - 190	2L2 1/2x2 1/2x3/16x1/2	12.00	8.25	104.8 K=1.00	1.8047	-146.69	32783.60	0.004 ¹
T6	140 - 120	2L 'a' > 31.4764 in - 4 L3x3x5/16	12.00	10.67	217.3 K=1.00	1.7800	-1802.17	8514.72	0.212 ¹
					KL/R > 200 (C) - 63				

¹ P_u / φP_n controls

Tension Checks

tnxTower EFI Global, Inc. 1117 Perimeter Center West, Suite E500 Atlanta, GA 30338 Phone: (470) 990-6593 FAX:	Job CTNH550A	Page 36 of 38
	Project 049.02894 - 2275002	Date 15:49:21 06/09/22
	Client ForeSite LLC.	Designed by Ahmet Colakoglu

Leg Design Data (Tension)

Section No.	Elevation ft	Size	L ft	L _u ft	Kl/r	A in ²	P _u lb	φP _n lb	Ratio $\frac{P_u}{\phi P_n}$
T2	190 - 180	Pirod 105244	10.00	10.00	45.4	3.6816	1024.49	165670.00	0.006 ¹
T3	180 - 160	Pirod 105216	20.00	10.00	45.4	3.6816	13991.80	165670.00	0.084 ¹
T4	160 - 150	Pirod 105217	10.00	5.00	37.8	5.3014	26448.60	238565.00	0.111 ¹
T5	150 - 140	Pirod 105217	10.00	10.00	37.8	5.3014	44225.20	238565.00	0.185 ¹
T6	140 - 120	Pirod 105218	20.03	10.02	32.4	7.2158	86388.80	324713.00	0.266 ¹
T7	120 - 110	Pirod 105218	10.02	4.84	32.4	7.2158	109206.00	324713.00	0.336 ¹
T8	110 - 100	Pirod 105218	10.02	10.02	32.4	7.2158	134754.00	324713.00	0.415 ¹
T9	100 - 80	Pirod 105219	20.03	10.02	28.4	9.4248	183973.00	424115.00	0.434 ¹
T10	80 - 60	Pirod 105219	20.03	10.02	28.4	9.4248	232218.00	424115.00	0.548 ¹
T11	60 - 40	Pirod 105220	20.03	10.02	25.2	11.9282	279321.00	536771.00	0.520 ¹
T12	40 - 20	Pirod 105220	20.03	10.02	25.2	11.9282	326395.00	536771.00	0.608 ¹
T13	20 - 0	Pirod 112738	20.03	20.03	32.6	14.7262	352005.00	662680.00	0.531 ¹

¹ P_u / φP_n controls

Truss-Leg Diagonal Data

Section No.	Elevation ft	Diagonal Size	L _d ft	Kl/r	φP _n lb	A in ²	V _n lb	φV _n lb	Stress Ratio
T1	195 - 190	0.5	1.48	121.0	165670.00	0.1963	317.96	3388.58	0.094
T2	190 - 180	0.5	1.48	121.0	165670.00	0.1963	937.64	3388.58	0.277
T3	180 - 160	0.5	1.48	121.0	165670.00	0.1963	1384.91	3292.47	0.421
T4	160 - 150	0.5	1.47	120.0	238565.00	0.1963	1796.01	3335.33	0.539
T5	150 - 140	0.5	1.47	120.0	238565.00	0.1963	604.10	3335.33	0.181
T6	140 - 120	0.5	1.46	119.0	324713.00	0.1963	1308.05	3377.71	0.387
T7	120 - 110	0.5	1.46	119.0	324713.00	0.1963	1611.49	3377.71	0.477
T8	110 - 100	0.5	1.46	119.0	324713.00	0.1963	667.52	3377.71	0.198
T9	100 - 80	0.625	1.45	94.4	424115.00	0.3068	741.48	6957.62	0.107
T10	80 - 60	0.625	1.45	94.4	424115.00	0.3068	679.19	6957.62	0.098
T11	60 - 40	0.625	1.43	93.6	536771.00	0.3068	652.94	7011.35	0.093
T12	40 - 20	0.625	1.43	93.6	536771.00	0.3068	2822.97	7011.35	0.403
T13	20 - 0	0.75	1.73	93.9	662680.00	0.4418	1371.12	14363.90	0.096

Diagonal Design Data (Tension)

Section No.	Elevation ft	Size	L ft	L _u ft	Kl/r	A in ²	P _u lb	φP _n lb	Ratio $\frac{P_u}{\phi P_n}$
T1	195 - 190	2L2 1/2x2 1/2x3/16x3/16 2L 'a' > 39.0654 in - 7	7.81	6.83	110.4	1.0371	2.72	45114.30	0.000 ¹
T2	190 - 180	L2 1/2x2 1/2x3/16	15.62	6.99	110.4	0.5183	1862.97	22545.90	0.083 ¹
T3	180 - 160	L3x3x3/16	15.62	6.99	91.5	0.6593	5221.22	28679.40	0.182 ¹
T4	160 - 150	L3x3x5/16	15.62	6.99	93.2	1.0713	7986.26	46602.80	0.171 ¹
T5	150 - 140	L3x3x5/16	15.62	6.99	93.2	1.0713	9608.21	46602.80	0.206 ¹
T6	140 - 120	L3x3x5/16	16.80	7.92	105.3	1.0713	11679.10	46602.80	0.251 ¹
T7	120 - 110	L3 1/2x3 1/2x5/16	17.62	8.34	94.5	1.3038	13290.40	56716.50	0.234 ¹
T8	110 - 100	L3 1/2x3 1/2x5/16	18.45	8.76	99.2	1.3038	13515.60	56716.50	0.238 ¹
T9	100 - 80	L4x4x1/4	20.16	9.59	94.0	1.1972	14880.20	52077.70	0.286 ¹
T10	80 - 60	L4x4x3/8	21.92	10.48	104.2	1.7583	16169.80	76485.20	0.211 ¹

tnxTower EFI Global, Inc. 1117 Perimeter Center West, Suite E500 Atlanta, GA 30338 Phone: (470) 990-6593 FAX:	Job CTNH550A	Page 37 of 38
	Project 049.02894 - 2275002	Date 15:49:21 06/09/22
	Client ForeSite LLC.	Designed by Ahmet Colakoglu

Section No.	Elevation ft	Size	L ft	L _u ft	Kl/r	A in ²	P _u lb	φP _n lb	Ratio $\frac{P_u}{\phi P_n}$
T11	60 - 40	L5x5x3/8	23.71	11.38	89.1	2.3208	17156.90	100954.00	0.170 ¹
T12	40 - 20	L5x5x3/8	25.54	12.30	96.1	2.3208	18673.90	100954.00	0.185 ¹
T13	20 - 0	2L3 1/2x3 1/2x5/16x3/8 2L 'a' > 82.2703 in - 160	32.02	15.40	174.3	2.6077	23681.30	113433.00	0.209 ¹

¹ P_u / φP_n controls

Secondary Horizontal Design Data (Tension)

Section No.	Elevation ft	Size	L ft	L _u ft	Kl/r	A in ²	P _u lb	φP _n lb	Ratio $\frac{P_u}{\phi P_n}$
T4	160 - 150	L3x3x5/16	12.00	10.67	143.2	1.1885	1273.81	51700.40	0.025 ¹
T7	120 - 110	L3 1/2x3 1/2x5/16	14.48	13.27	149.8	1.4210	2246.38	61814.20	0.036 ¹

¹ P_u / φP_n controls

Top Girt Design Data (Tension)

Section No.	Elevation ft	Size	L ft	L _u ft	Kl/r	A in ²	P _u lb	φP _n lb	Ratio $\frac{P_u}{\phi P_n}$
T1	195 - 190	2L2 1/2x2 1/2x3/16x1/2 2L 'a' > 31.4764 in - 5	12.00	8.25	84.8	1.8047	194.41	58471.90	0.003 ¹
T6	140 - 120	L3x3x5/16	12.00	10.67	143.2	1.0713	1802.17	46602.80	0.039 ¹

¹ P_u / φP_n controls

Section Capacity Table

Section No.	Elevation ft	Component Type	Size	Critical Element	P lb	φP _{allow} lb	% Capacity	Pass Fail
T1	195 - 190	Leg	Pirod 105244	3	-691.63	142493.00	9.4	Pass
T2	190 - 180	Leg	Pirod 105244	15	-5210.92	142493.00	27.7	Pass
T3	180 - 160	Leg	Pirod 105216	22	-17379.40	142493.00	42.1	Pass
T4	160 - 150	Leg	Pirod 105217	38	-33583.00	214859.00	53.9	Pass
T5	150 - 140	Leg	Pirod 105217	50	-53194.00	214859.00	24.8	Pass
T6	140 - 120	Leg	Pirod 105218	58	-103918.00	300681.00	38.7	Pass
T7	120 - 110	Leg	Pirod 105218	76	-129533.00	300681.00	47.7	Pass
T8	110 - 100	Leg	Pirod 105218	88	-158574.00	300681.00	52.7	Pass
T9	100 - 80	Leg	Pirod 105219	97	-213401.00	399868.00	53.4	Pass
T10	80 - 60	Leg	Pirod 105219	112	-269003.00	399868.00	67.3	Pass
T11	60 - 40	Leg	Pirod 105220	127	-324166.00	512375.00	63.3	Pass
T12	40 - 20	Leg	Pirod 105220	142	-380287.00	512375.00	74.2	Pass
T13	20 - 0	Leg	Pirod 112738	157	-409064.00	613145.00	66.7	Pass
T1	195 - 190	Diagonal	2L2 1/2x2 1/2x3/16x3/16	10	-575.74	30571.50	1.9	Pass
T2	190 - 180	Diagonal	L2 1/2x2 1/2x3/16	18	-1766.48	7090.89	24.9	Pass

<p>tnxTower</p> <p>EFI Global, Inc. 1117 Perimeter Center West, Suite E500 Atlanta, GA 30338 Phone: (470) 990-6593 FAX:</p>	Job	CTNH550A	Page	38 of 38
	Project	049.02894 - 2275002	Date	15:49:21 06/09/22
	Client	ForeSite LLC.	Designed by	Ahmet Colakoglu

Section No.	Elevation ft	Component Type	Size	Critical Element	P lb	ϕP_{allow} lb	% Capacity	Pass Fail	
T3	180 - 160	Diagonal	L3x3x3/16	27	-5452.61	12422.30	43.9	Pass	
T4	160 - 150	Diagonal	L3x3x5/16	43	-8177.65	19812.30	51.4 (b)	Pass	
T5	150 - 140	Diagonal	L3x3x5/16	55	-9941.04	19812.30	47.1 (b)	Pass	
T6	140 - 120	Diagonal	L3x3x5/16	68	-11808.00	15430.20	50.2	Pass	
T7	120 - 110	Diagonal	L3 1/2x3 1/2x5/16	79	-13960.40	22455.00	56.7 (b)	Pass	
T8	110 - 100	Diagonal	L3 1/2x3 1/2x5/16	91	-13596.80	20343.20	62.2	Pass	
T9	100 - 80	Diagonal	L4x4x1/4	101	-15156.50	20902.60	65.3 (b)	Pass	
T10	80 - 60	Diagonal	L4x4x3/8	116	-16399.30	25370.10	66.8	Pass	
T11	60 - 40	Diagonal	L5x5x3/8	131	-17086.40	42837.90	72.5	Pass	
T12	40 - 20	Diagonal	L5x5x3/8	151	-18784.90	39567.80	90.6 (b)	Pass	
T13	20 - 0	Diagonal	2L3 1/2x3 1/2x5/16x3/8	161	-27519.40	30200.60	58.4 (b)	Pass	
T4	160 - 150	Secondary Horizontal	L3x3x5/16	47	-916.01	20864.20	91.1	Pass	
T7	120 - 110	Secondary Horizontal	L3 1/2x3 1/2x5/16	87	-2246.38	21704.00	4.4	Pass	
T1	195 - 190	Top Girt	2L2 1/2x2 1/2x3/16x1/2	6	-121.45	32783.60	8.0 (b)	Pass	
T6	140 - 120	Top Girt	L3x3x5/16	63	-1802.17	8514.72	10.4	Pass	
							28.2 (b)		
							Summary		
							Leg (T12)	74.2	Pass
							Diagonal (T13)	91.1	Pass
							Secondary Horizontal (T7)	28.2	Pass
							Top Girt (T6)	21.2	Pass
							Bolt Checks	90.6	Pass
							RATING =	91.1	Pass

Self Support Anchor Rod Capacity

Site Info	
Site Name	CTNH550A

Analysis Considerations	
TIA-222 Revision	G
Grout Considered:	No
l_{ar} (in)	3
Eta Factor, η	0.5

Applied Loads		
	Comp.	Uplift
Axial Force (kips)	442.35	378.42
Shear Force (kips)	60.39	52.33

Considered Eccentricity	
Leg Mod Eccentricity (in)	0.000
Anchor Rod N.A Shift (in)	0.000
Total Eccentricity (in)	0.000

*Anchor Rod Eccentricity Applied

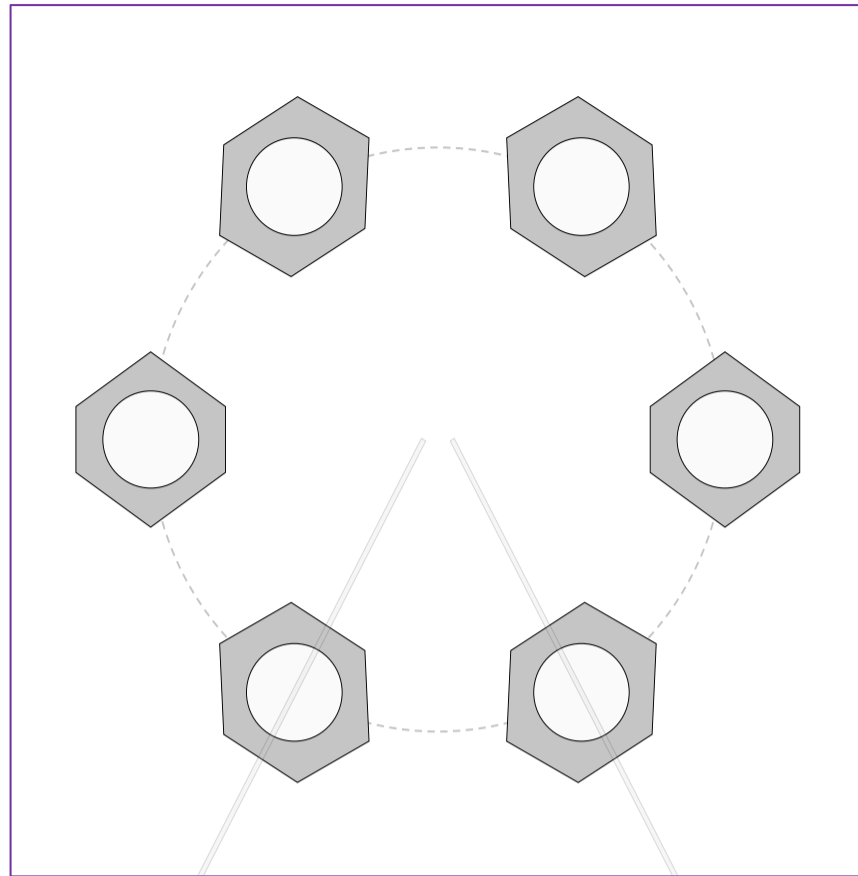

Connection Properties

Anchor Rod Data

(6) 2" ϕ bolts (A687 N; $F_y=105$ ksi, $F_u=125$ ksi)
 l_{ar} (in): 3

Analysis Results

Anchor Rod Summary

(units of kips, kip-in)

$Pu_c = 73.73$	$\phi Pn_t = 250$	Stress Rating
$Vu = 10.07$	$\phi Vn = n/a$	37.5%
$Mu = n/a$	$\phi Mn = n/a$	Pass

ASCE 7 Hazards Report

Address:
No Address at This
Location

Standard: ASCE/SEI 7-10
Risk Category: III
Soil Class: D - Stiff Soil

Elevation: 961.21 ft (NAVD 88)
Latitude: 42.014722
Longitude: -73.32639

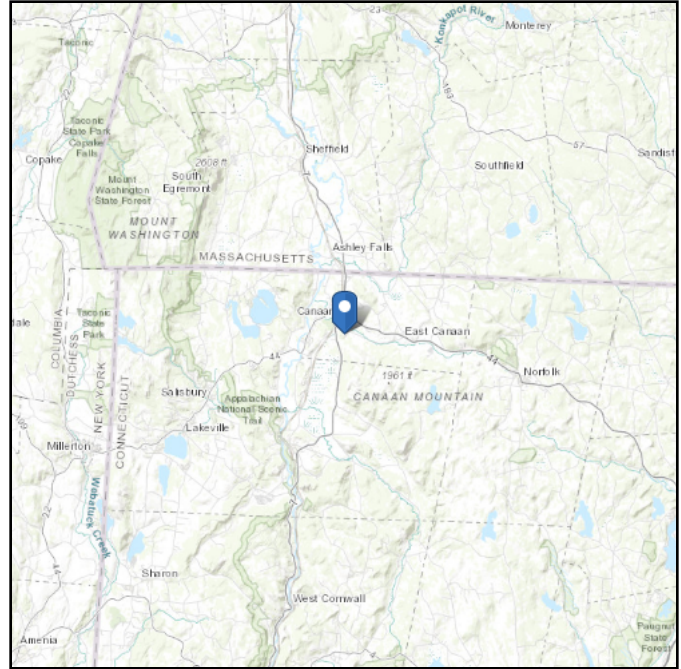
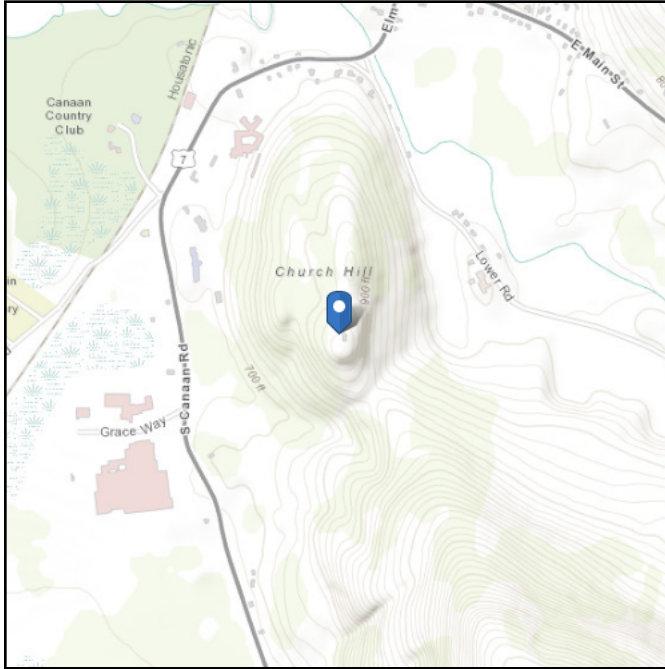

Site Soil Class: D - Stiff Soil

Results:

S_S :	0.173	S_{DS} :	0.185
S_1 :	0.065	S_{D1} :	0.104
F_a :	1.6	T_L :	6
F_v :	2.4	PGA :	0.084
S_{MS} :	0.277	PGA _M :	0.135
S_{M1} :	0.156	F _{PGA} :	1.6
		I_e :	1.25

Seismic Design Category B

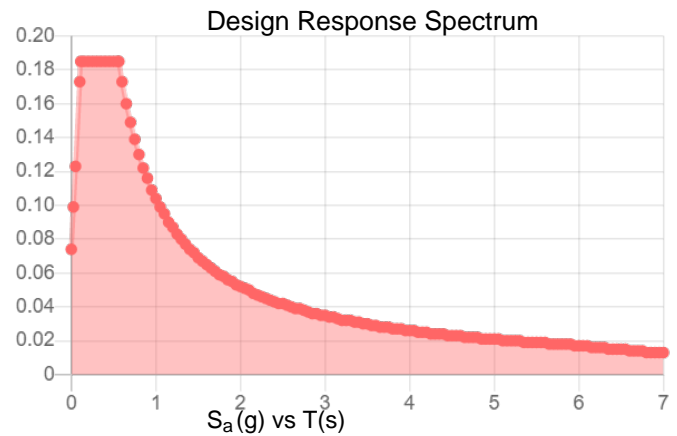
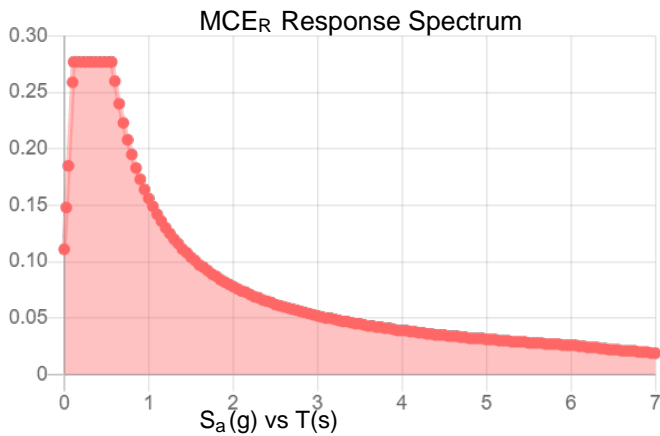

Data Accessed: Fri Feb 04 2022

Date Source:

USGS Seismic Design Maps based on ASCE/SEI 7-10, incorporating Supplement 1 and errata of March 31, 2013, and ASCE/SEI 7-10 Table 1.5-2. Additional data for site-specific ground motion procedures in accordance with ASCE/SEI 7-10 Ch. 21 are available from USGS.

Ice

Results:

Ice Thickness: 1.00 in.
Concurrent Temperature: 5 F
Gust Speed 40 mph

Data Source: Standard ASCE/SEI 7-10, Figs. 10-2 through 10-8

Date Accessed: Fri Feb 04 2022

Ice thicknesses on structures in exposed locations at elevations higher than the surrounding terrain and in valleys and gorges may exceed the mapped values.

Values provided are equivalent radial ice thicknesses due to freezing rain with concurrent 3-second gust speeds, for a 50-year mean recurrence interval, and temperatures concurrent with ice thicknesses due to freezing rain. Thicknesses for ice accretions caused by other sources shall be obtained from local meteorological studies. Ice thicknesses in exposed locations at elevations higher than the surrounding terrain and in valleys and gorges may exceed the mapped values.

The ASCE 7 Hazard Tool is provided for your convenience, for informational purposes only, and is provided “as is” and without warranties of any kind. The location data included herein has been obtained from information developed, produced, and maintained by third party providers; or has been extrapolated from maps incorporated in the ASCE 7 standard. While ASCE has made every effort to use data obtained from reliable sources or methodologies, ASCE does not make any representations or warranties as to the accuracy, completeness, reliability, currency, or quality of any data provided herein. Any third-party links provided by this Tool should not be construed as an endorsement, affiliation, relationship, or sponsorship of such third-party content by or from ASCE.

ASCE does not intend, nor should anyone interpret, the results provided by this Tool to replace the sound judgment of a competent professional, having knowledge and experience in the appropriate field(s) of practice, nor to substitute for the standard of care required of such professionals in interpreting and applying the contents of this Tool or the ASCE 7 standard.

In using this Tool, you expressly assume all risks associated with your use. Under no circumstances shall ASCE or its officers, directors, employees, members, affiliates, or agents be liable to you or any other person for any direct, indirect, special, incidental, or consequential damages arising from or related to your use of, or reliance on, the Tool or any information obtained therein. To the fullest extent permitted by law, you agree to release and hold harmless ASCE from any and all liability of any nature arising out of or resulting from any use of data provided by the ASCE 7 Hazard Tool.

Exhibit E

Mount Analysis

Date: 2/4/2022

To: T-Mobile Northeast, LLC
35 Griffin Road South
Bloomfield, CT 06002

Subject: Mount Structural Analysis Report

T-Mobile Designation: **Site ID:** CTNH550A
Site Name: CTNH550A

EFI Designation: **Project Number:** 049.02894 - 2275002

Site Data: **38 Lower Road, North Canaan, CT 06024**
Latitude 42.014722° , Longitude -73.326390°

EFI Global, Inc. is pleased to submit this “**Mount Structural Analysis Report**” to determine the structural capacity of the antenna mount utilized by T-Mobile at the above referenced site.

The purpose of the analysis is to determine acceptability of the mount stress level for the changes proposed by T-Mobile. Under the following load case we have determined the mount to have:

Existing + Proposed Equipment **Adequate Capacity (99.6%)**
Note: See Analysis Criteria for loading configuration

The analysis has been performed in accordance with TIA-222-G Standard and the 2018 Connecticut State Building Code (2015 IBC).

We at *EFI Global, Inc.* appreciate the opportunity of providing our continuing professional services to you. If you have any questions or need further assistance on this or any other projects, please give us a call.

Sincerely,
EFI Global, Inc.
License No: PEC0001245

2/4/2022



Ahmet Colakoglu, PE
Connecticut Professional Engineer
License No: 27057

1) ANALYSIS CRITERIA

The analysis was performed for the existing and proposed appurtenances as specified in the loading information referenced below, and per the following loading criteria of Table 1.

Table 1 – Loading and Analysis Criteria

Rad Center	125'
Structure Type	Self-Support Tower
Exposure Category	C
Basic Wind Speed	115 mph* $\sqrt{0.6}$ = 89.1 mph (ASD)
Ice Loading	1.00" with 40 mph Wind
Risk Category	II
Topographic Factor	Kzt = 1.0

Table 1.1 – Existing Appurtenance Configuration

Qty	Model
4	Ericsson AIR32 KRD901146-1_B66A_B2A – Antennas
4	RFS APXVAA24_43-U-NA20 – Antennas
4	RFS APXV18-206517S-C-A20 – Antennas
4	Ericsson RRUS-11 B2 – RRUs
4	Ericsson RRUS-11 B12 – RRUs

Table 1.2 – Proposed and Final Appurtenance Configuration

Qty	Model
4	Ericsson AIR6449 B41 – Antennas
4	RFS APXVAALL24_43-U-NA20 – Antennas
4	Commscope VV-65A-R1 – Antennas
4	Ericsson Radio 4480 B71+B85 – RRUs*
4	Ericsson Radio 4460 B25+B66 – RRUs*

***To be mounted behind antennas.**

Table 1.3 – Assumed Material Properties

Member Type	ASTM Material Designation	Fy (ksi)	Fu (ksi)
Pipes	A53 Gr. B	35	60
Angles/Channels	A36	36	58
Rectangular HSS	A500 Gr. B - 46	46	58
Round HSS	A500 Gr. B - 42	42	58
Others (UNO)	A572 Gr. 50	50	65

2) ANALYSIS PROCEDURE

The analysis is based on the following information:

Table 2 – Documents

Document	Provided By	Date
RFDS	T-Mobile	01/24/2022
Construction Drawings	Centek Engineering, Inc.	06/04/2018
Structural Analysis Report	Centek Engineering, Inc.	02/27/2018

2.1) Analysis Method

Risa-3D, a commercially available analysis software package, was used to create a three-dimensional model of the mount and calculate member stresses for various loading cases. Selected output from the analysis is included in the Appendix.

2.2) Analysis Conditions and Assumptions

- 1) The mount was built and installed in accordance with the manufacturer's specifications.
- 2) The mount has been maintained and will be maintained in accordance with the manufacturer's specifications. All structural members and connections of the mount are in good condition and can achieve theoretical strength.
- 3) The configuration of antennas is as specified in "1) Analysis Criteria".
- 4) The analysis was performed for the subject mount only. It does not include an evaluation of the other mounts or the tank, which should be analyzed by others.
- 5) The evaluation does not include any antenna rigging loads. The equipment should not be rigged using the subject antenna mount as the support.
- 6) The analysis includes a minimum 250 lbf maintenance point load at the worst-case location on the mount, as well as a minimum 250 lbf maintenance point load at each antenna location in conjunction with a 30 mph wind load.
- 7) Any steel grating represented in this model is for loading purposes only and it is not considered to provide any structural restraint or support.
- 8) Member sizes per the construction drawings and assumed based on our experience with similar structures. Please refer to calculation output in the appendix of this report for sizes and lengths assumed.
- 9) All member connections are assumed to have been designed to meet or exceed the load carrying capacity of the connected member unless otherwise specified in this report.

EFI Global, Inc (EFI), must be notified immediately if any of these assumptions are discovered to be incorrect. The results of this analysis may be affected if any of the assumptions are not valid or have been made in error.

3) ANALYSIS RESULTS AND CONCLUSION

The analysis results are shown on the table below.

Table 3.1 – Mount Component Stresses vs. Capacity

Component	% Capacity	Pass / Fail
Horizontal Face Pipe	70.6	Pass
Vertical Face Pipe	41.7	Pass
Support Rail Pipe	64.4	Pass
Vertical Tower Connection Pipe	37.0	Pass
Antenna Mount Pipe	99.6	Pass
Tie-Back	<20.0	Pass

Platform Mount: The existing platform mount has **adequate** capacity for the proposed changes by T-Mobile. For the code specified load combinations and as a maximum, the mount members are stressed to **99.6%** of their structural capacity.

APPENDIX
INPUT LOADS
ANALYSIS OUTPUT

CLIENT: Foresite LLC/T-Mobile
 PROJECT: CTNH550A
 SUBJECT: Antenna Loads - G Code with Sections 16 Revisions

Tower Height	195.00	ft	Type of Mount	Platform
Basic Wind Speed, V	89.1	mph (=Ultimate Speed* $\sqrt{0.6}$)		
Basic Wind Speed with Ice, V_i	40	mph		
Maintenance Load Factor, L_{FM}	0.1134	Load Factor for Maint. Load Cases (Basic Wind Speed=30 mph)		
Design Ice Thickness, t_i	1	inches		

Table 2-3 Importance Factors

Structure Classification	Wind Load Without Ice	Wind Load With Ice	Ice Thicknesses	Earthquake
II	1	1	1	1

Table 2-4 Exposure Category Coefficients

Exposure Category	Z_g	α	K_{zmin}	K_e	m
C	900	9.5	0.85	1	0.6

Table 2-5 Topographic Categories

K_{zt} 1.000

Table 2-2 Wind Directionality Factor, K_d

Structure Type	K_d	
Lattice Tower	0.95	DOES NOT CHANGE

Gust Effect Factor G_h

Structure Type	G_h	
Lattice Tower	1.00	DOES NOT CHANGE

Shielding Factor, K_a

Structure Type	K_a	
Lattice Tower	0.90	DOES NOT CHANGE

CLIENT: **Foresite LLC/T-Mobile**
 PROJECT: **CTNH550A**
 SUBJECT: **Antenna Loads - G Code with Sections 16 Revisions**

Rad Center **125.00** ft

Antenna AND Mount Without Ice

Mounting Pole	Height (ft)	Model Number	#	Weight (lbs)	H (in)	*W (in)	D (in)	Ka	**A _N (ft ²)	***A _T (ft ²)	Aspect (FRONT)	Aspect (SIDE)	Ca (FRONT)	Ca (SIDE)	K _z	q _z (psf)	Pounds					
																	Wind Load (Front)	Wind Load (Side)	Dead Load	Total Wind Load (Front)	Total Wind Load (Side)	Total Dead Load
Pos. 1	125.00	Ericsson AIR6449 B41	1	114.6	33.1	20.5	8.5	0.90	4.71	1.96	1.61	3.88	1.20	1.26	1.326	25.6	130.3	57.1	114.63	130	57	115
		Empty		0.0	-	-	-	0.90	-	-	-	-	-	-	-	-	0.0	0.0	0			
		Empty		0.0	-	-	-	0.90	-	-	-	-	-	-	-	-	0.0	0.0	0			
		Empty		0.0	-	-	-	0.90	-	-	-	-	-	-	-	-	0.0	0.0	0			
		Empty		0.0	-	-	-	0.90	-	-	-	-	-	-	-	-	0.0	0.0	0			
Pos. 2	125.00	RFS APXVAALL24_43-U-NA20	1	149.9	95.9	24.0	8.5	0.90	15.98	5.66	4.00	11.28	1.27	1.54	1.326	25.6	466.6	201.3	149.9	467	233	234
	125.00	Ericsson Radio 4480 B71+B85	1	84.0	21.8	N/A	7.5	0.90	-	1.14	-	2.91	-	1.22	1.326	25.6	0.0	31.9	84			
		Empty		0.0	-	-	-	0.90	-	-	-	-	-	-	-	-	0.0	0.0	0			
		Empty		0.0	-	-	-	0.90	-	-	-	-	-	-	-	-	0.0	0.0	0			
		Empty		0.0	-	-	-	0.90	-	-	-	-	-	-	-	-	0.0	0.0	0			
Pos. 3	125.00	Commscope VV-65A-R1	1	23.8	54.7	12.1	4.6	0.90	4.59	1.77	4.53	11.78	1.29	1.56	1.326	25.6	136.6	63.5	23.81	137	109	133
	125.00	Ericsson Radio 4460 B25+B66	1	109.0	19.6	N/A	12.1	0.90	-	1.65	-	1.62	-	1.20	1.326	25.6	0.0	45.6	109			
		Empty		0.0	-	-	-	0.90	-	-	-	-	-	-	-	-	0.0	0.0	0			
		Empty		0.0	-	-	-	0.90	-	-	-	-	-	-	-	-	0.0	0.0	0			
		Empty		0.0	-	-	-	0.90	-	-	-	-	-	-	-	-	0.0	0.0	0			
Pos. 4 Beta Only	125.00	RFS SC2-W100AB	1	22.0	26.4	26.4	16.3	0.90	4.84	2.99	1.00	1.62	1.20	1.20	1.326	25.6	133.9	82.7	22	134	83	22
		Empty		0.0	-	-	-	0.90	-	-	-	-	-	-	-	-	0.0	0.0	0			
		Empty		0.0	-	-	-	0.90	-	-	-	-	-	-	-	-	0.0	0.0	0			
		Empty		0.0	-	-	-	0.90	-	-	-	-	-	-	-	-	0.0	0.0	0			
		Empty		0.0	-	-	-	0.90	-	-	-	-	-	-	-	-	0.0	0.0	0			

* Enter N/A in the W column for front shielded apertances.

** A_N is the product of H and W

*** A_T is the product of H and D

DL 371

Mount	Height (ft)	Member	*L (in)	**W (in)	D (in)	*** Ca	K _z	q _z (psf)	Wind Load (PLF)
	125.00	4.0 STD Pipe	12.00	4.50	0.00	1.20	1.326	23.0	10.4
	125.00	3.0 STD Pipe	12.00	3.50	0.00	1.20	1.326	23.0	8.1
	125.00	2.0 STD Pipe	12.00	2.38	0.00	1.20	1.326	23.0	5.5
	125.00	2.5 X-Strong Pipe	0.00	2.88	0.00	-	-	-	-
	125.00	(L3x3x4)	0.00	3.00	3.00	-	-	-	-
	125.00	(L2.5x2.5x4)	0.00	2.50	2.50	-	-	-	-
	125.00	(L2x2x3)	0.00	2.00	2.00	-	-	-	-
	125.00	PL0.375X6	0.00	6.00	0.38	-	-	-	-
	125.00	Plate Horizontal (PL2.125x3/16)	0.00	2.13	0.19	-	-	-	-
	125.00	HSS 4x4x4	0.00	4.00	4.00	-	-	-	-
	125.00	PL0.5X6	0.00	6.00	0.50	-	-	-	-
	125.00	Double Angle (LL2.5x2.5x3x6)	0.00	2.50	2.50	-	-	-	-
	125.00	Double Angle (LL3x3x4x3)	0.00	3.00	6.00	-	-	-	-
	125.00	Channel (Weak Axis Bending)	0.00	0.00	0.00	-	-	-	-
	125.00	Invert U 5.375x3.625x.375	0.00	3.63	5.38	-	-	-	-

* The dimension L is the longest dimension of the member

** The dimension W is the height or width of the member that resists wind load

*** Ca will equal 1.2 for round members and 2.0 for flat members

CLIENT: Foresite LLC/T-Mobile
 PROJECT: CTNH550A
 SUBJECT: Antenna Loads - G Code with Sections 16 Revisions

ti (in) 2.284913 Kiz 1.1424563 reduction 0.20154

Antenna AND Mount With Ice

Mounting Pole	Height (ft)	Model Number	#	H (in)	W (in)	D (in)	Ka	*A _N (ft ²)	*A _T (ft ²)	*Volume Ice (ft ³)	*Weight Ice (lbs)	**Ca (FRONT)	**Ca (SIDE)	Kz	q _z (psf)	Pounds							
																Ice Wind Load (Front)	Ice Wind Load (Side)	Combined Wind Load (Front)	Combined Wind Load (Side)	Ice Dead Load	**Total Wind Load (Front)	**Total Wind Load (Side)	Total Ice Load
Pos. 1	125.00	Ericsson AIR6449 B41	1	33.1	20.5	8.5	0.90	1.85	1.47	3.81	213.43	0.70	0.70	1.326	5.2	6.0	4.8	32.3	16.3	213	32	16	213
		Empty		-	-	-	0.90	-	-	-	0.00	-	-	-	-	0.0	0.0	0.0	0.0	0			
		Empty		-	-	-	0.90	-	-	-	0.00	-	-	-	-	0.0	0.0	0.0	0.0	0			
		Empty		-	-	-	0.90	-	-	-	0.00	-	-	-	-	0.0	0.0	0.0	0.0	0			
		Empty		-	-	-	0.90	-	-	-	0.00	-	-	-	-	0.0	0.0	0.0	0.0	0			
Pos. 2	125.00	RFS APXVAALL24_43-U-NA20	1	95.9	24.0	8.5	0.90	3.95	3.46	10.39	581.78	0.70	0.70	1.326	5.2	12.8	11.2	106.9	51.8	582	107	62	708
	125.00	Ericsson Radio 4480 B71+B85	1	21.8	15.7	7.5	0.90	-	1.07	2.25	125.89	0.70	0.70	1.326	5.2	0.0	3.5	0.0	9.9	126			
		Empty		-	-	-	0.90	-	-	-	0.00	-	-	-	-	0.0	0.0	0.0	0.0	0			
		Empty		-	-	-	0.90	-	-	-	0.00	-	-	-	-	0.0	0.0	0.0	0.0	0			
		Empty		-	-	-	0.90	-	-	-	0.00	-	-	-	-	0.0	0.0	0.0	0.0	0			
Pos. 3	125.00	Commscope VV-65A-R1	1	54.7	12.1	4.6	0.90	2.27	2.03	3.49	195.38	0.70	0.70	1.326	5.2	7.4	6.6	34.9	19.4	195	35	32	339
	125.00	Ericsson Radio 4460 B25+B66	1	19.6	15.7	12.1	0.90	-	1.15	2.57	144.00	0.70	0.70	1.326	5.2	0.0	3.7	0.0	12.9	144			
		Empty		-	-	-	0.90	-	-	-	0.00	-	-	-	-	0.0	0.0	0.0	0.0	0			
		Empty		-	-	-	0.90	-	-	-	0.00	-	-	-	-	0.0	0.0	0.0	0.0	0			
		Empty		-	-	-	0.90	-	-	-	0.00	-	-	-	-	0.0	0.0	0.0	0.0	0			
Pos. 4 Beta Only	125.00	RFS SC2-W100AB	1	26.4	26.4	16.3	0.90	1.82	1.50	5.01	280.53	0.70	0.70	1.326	5.2	5.9	4.9	32.9	21.5	281	33	22	281
		Empty		-	-	-	0.90	-	-	-	0.00	-	-	-	-	0.0	0.0	0.0	0.0	0			
		Empty		-	-	-	0.90	-	-	-	0.00	-	-	-	-	0.0	0.0	0.0	0.0	0			
		Empty		-	-	-	0.90	-	-	-	0.00	-	-	-	-	0.0	0.0	0.0	0.0	0			
		Empty		-	-	-	0.90	-	-	-	0.00	-	-	-	-	0.0	0.0	0.0	0.0	0			
																					17	11	141

* A_N, A_T, Volume Ice and Weight Ice are calculated per unit
 ** Ca will equal 1.2 for all ice load calculations

Mount	Height (ft)	Member	*L (in)	**W (in)	D (in)	***A _N (ft ²)	Volume Ice (ft ³)	Weight Ice (lbs)	****Ca (FRONT)	Kz	q _z (psf)	PLF		
												Ice Wind Load (Front)	Combined Wind Load (Front)	Ice Dead Load
	125.00	4.0 STD Pipe	12.00	4.50	0.00	0.67	0.34	18.94	1.20	1.326	4.6	3.7	5.8	18.9
	125.00	3.0 STD Pipe	12.00	3.50	0.00	0.64	0.29	16.15	1.20	1.326	4.6	3.6	5.2	16.1
	125.00	2.0 STD Pipe	12.00	2.38	0.00	0.60	0.23	13.01	1.20	1.326	4.6	3.4	4.5	13.0
	125.00	2.5 X-Strong Pipe	0.00	2.88	0.00	-	-	-	-	-	-	-	-	-
	125.00	(L3x3x4)	0.00	3.00	3.00	-	-	-	-	-	-	-	-	-
	125.00	(L2.5x2.5x4)	0.00	2.50	2.50	-	-	-	-	-	-	-	-	-
	125.00	(L2x2x3)	0.00	2.00	2.00	-	-	-	-	-	-	-	-	-
	125.00	PL0.375X6	0.00	6.00	0.38	-	-	-	-	-	-	-	-	-
	125.00	Plate Horizontal (PL2.125x3/16)	0.00	2.13	0.19	-	-	-	-	-	-	-	-	-
	125.00	HSS 4x4x4	0.00	4.00	4.00	-	-	-	-	-	-	-	-	-
	125.00	PL0.5X6	0.00	6.00	0.50	-	-	-	-	-	-	-	-	-
	125.00	Double Angle (LL2.5x2.5x3x6)	0.00	2.50	2.50	-	-	-	-	-	-	-	-	-
	125.00	Double Angle (LL3x3x4x3)	0.00	3.00	6.00	-	-	-	-	-	-	-	-	-
	125.00	Channel (Weak Axis Bending)	0.00	0.00	0.00	-	-	-	-	-	-	-	-	-
	125.00	Invert U 5.375x3.625x.375	0.00	3.63	5.38	-	-	-	-	-	-	-	-	-

* The dimension L is the longest dimension of the member
 ** The dimension W is the height or width of the member that resists wind load
 *** A_N is the area of ice built up on the LW plane
 **** Ca will equal 1.2 for all ice load calculations

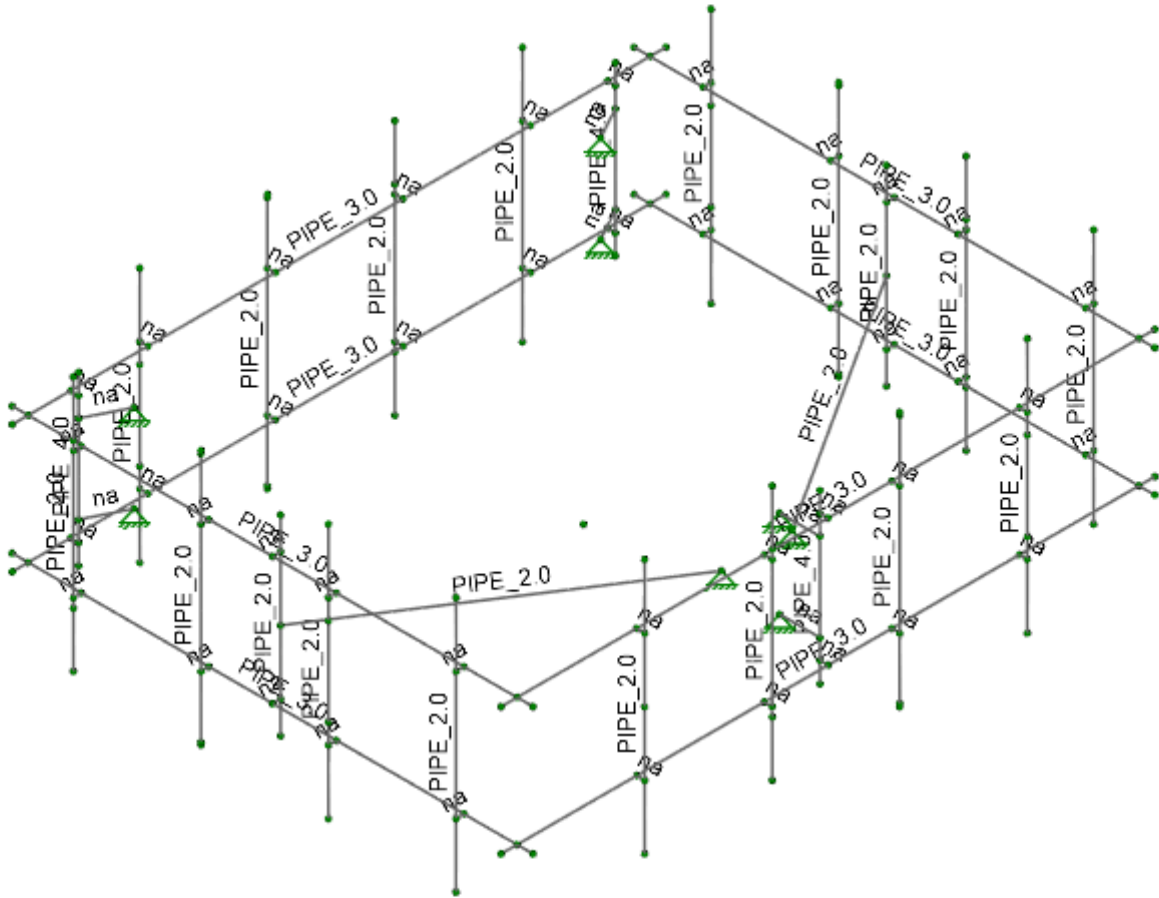

Envelope Only Solution

Foresite/EFI
KS
049.02894 - 2275002

CTNH550A

SK-1
Feb 04, 2022
CTNH550A.r3d

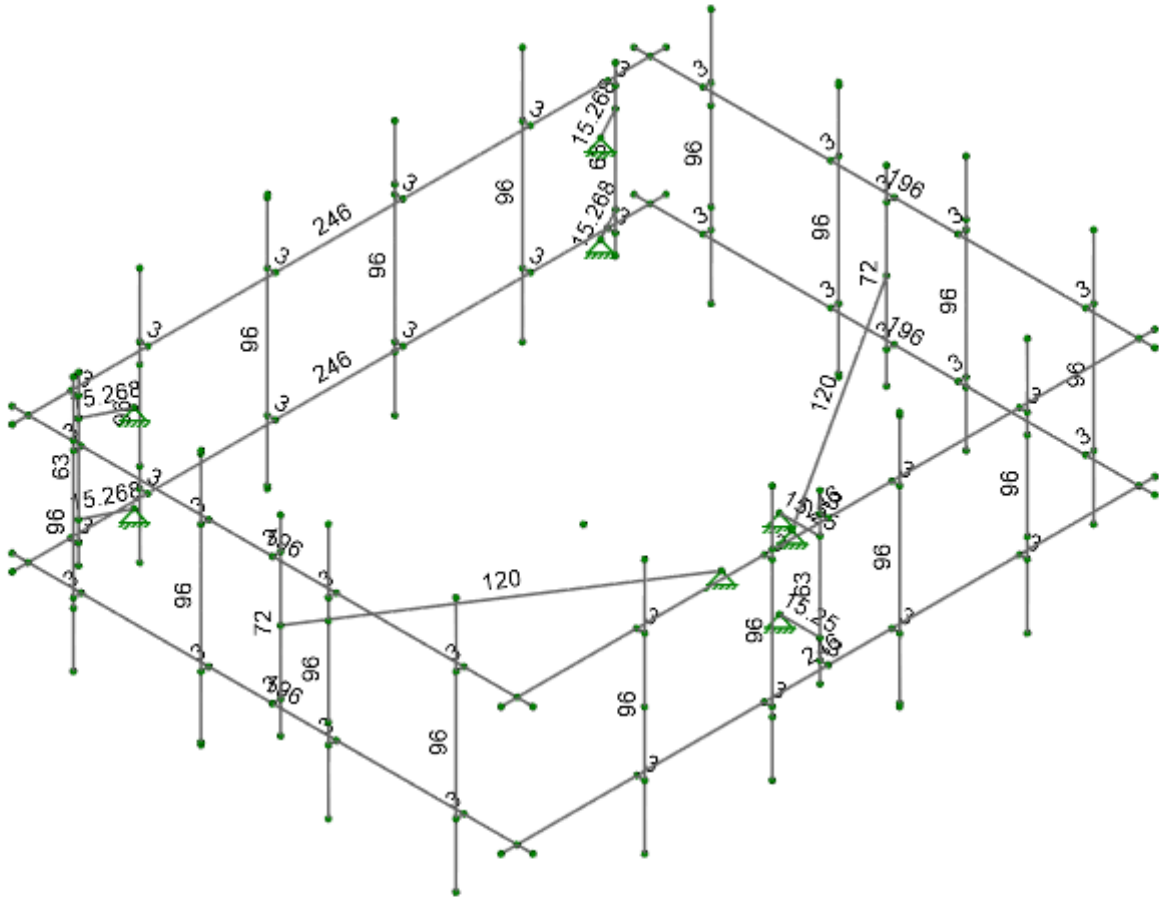

Member Length (in) Displayed
Envelope Only Solution

Foresite/EFI	CTNH550A	SK-2
KS		Feb 04, 2022
049.02894 - 2275002		CTNH550A.r3d

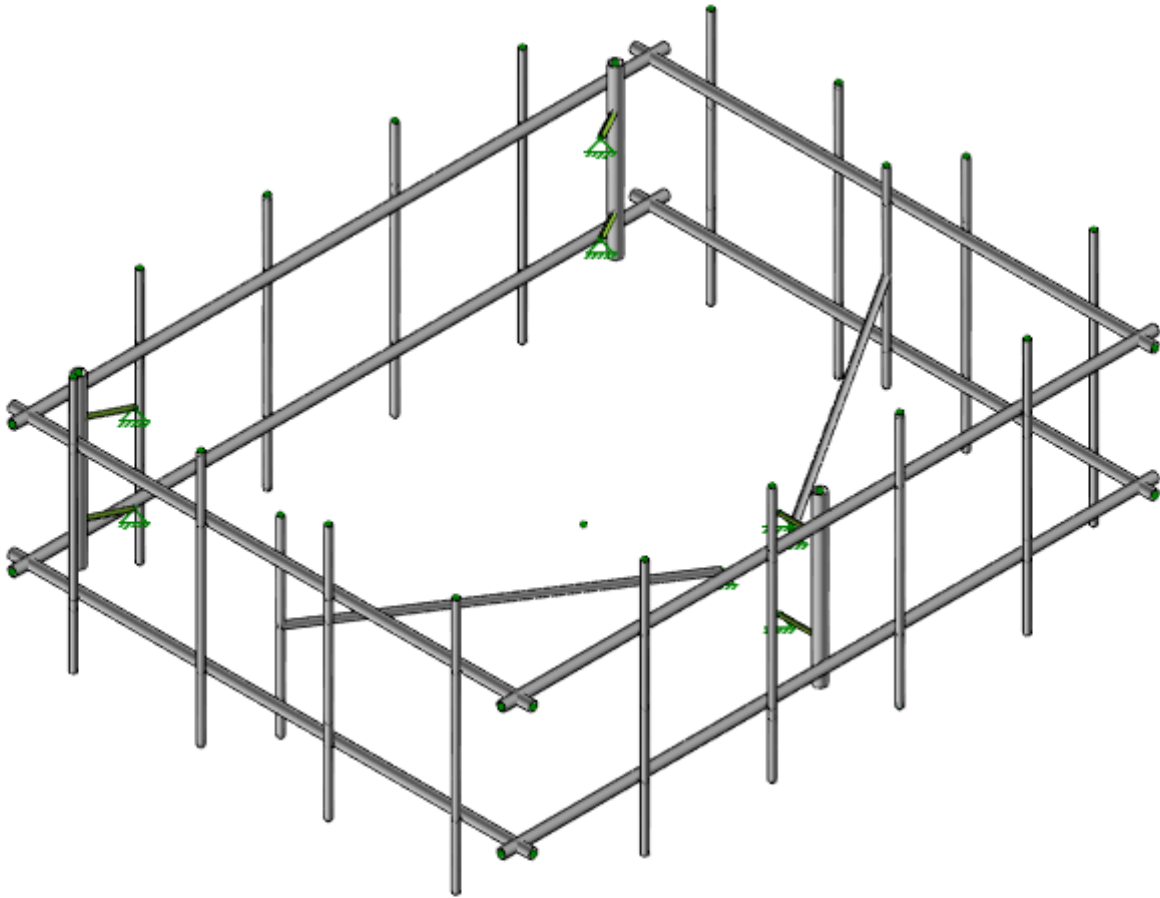

Envelope Only Solution

Foresite/EFI

KS

049.02894 - 2275002

CTNH550A

SK-3

Feb 04, 2022

CTNH550A.r3d

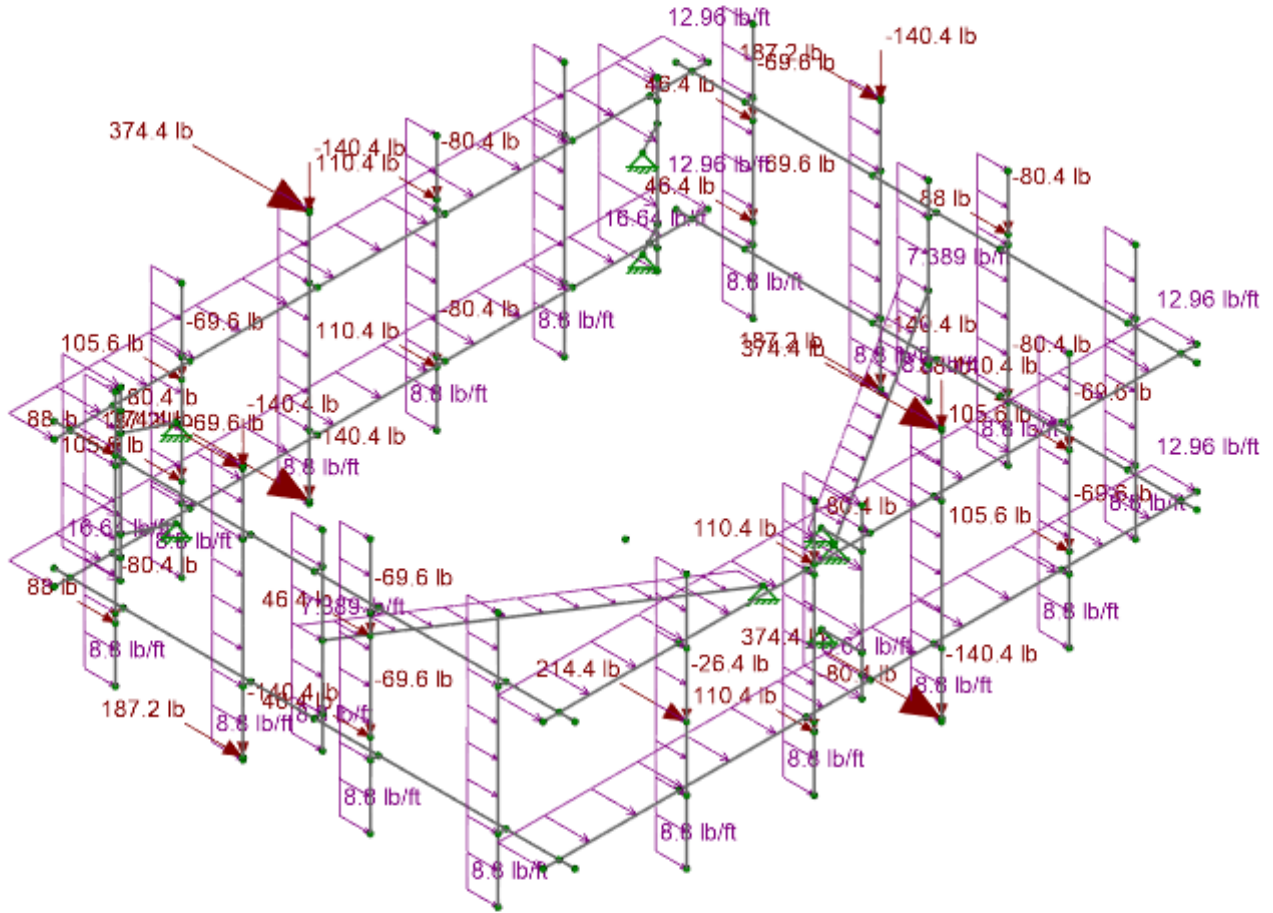
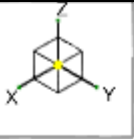

Loads: LC 1, DL + WL (NO ICE) 0 Degree
Envelope Only Solution

Foresite/EFI	CTNH550A	SK-4
KS		Feb 04, 2022
049.02894 - 2275002		CTNH550A.r3d

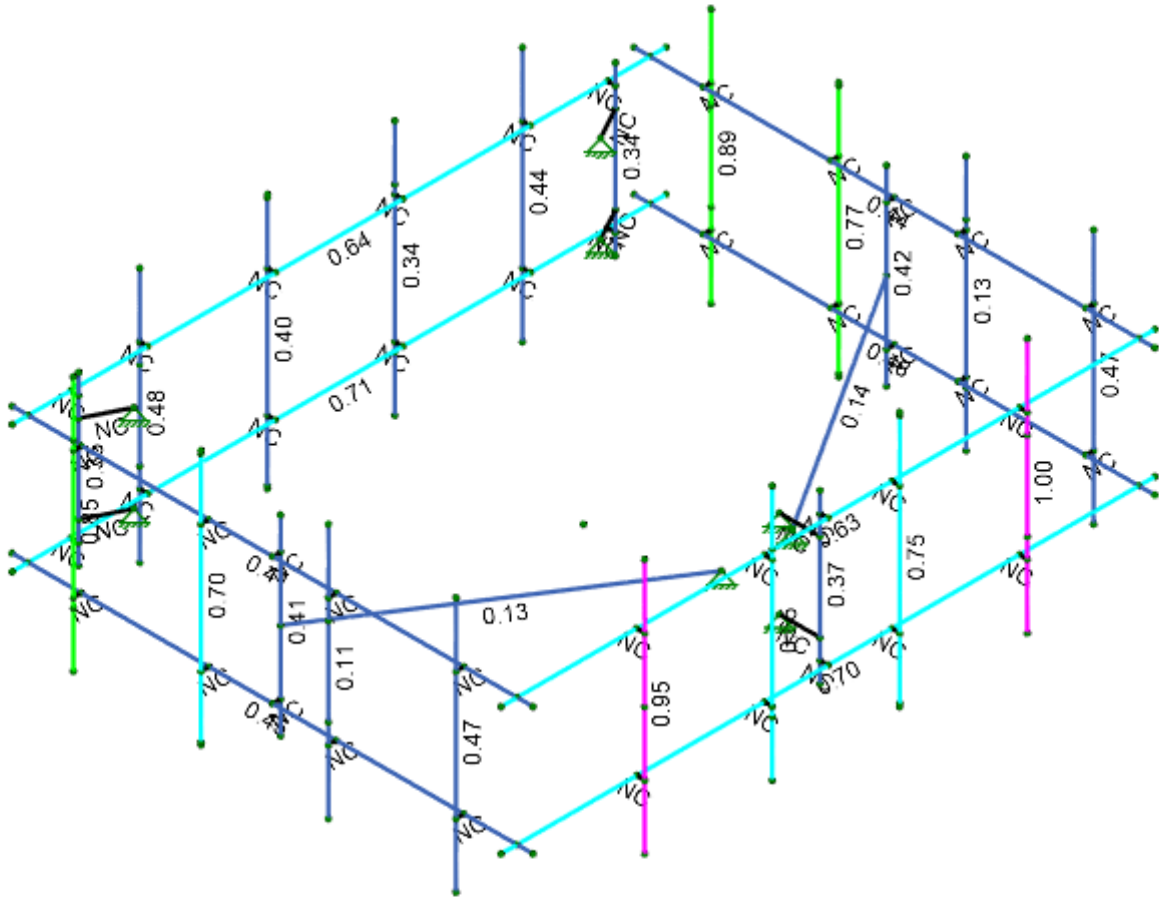
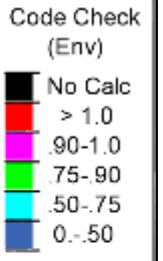
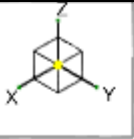

Member Code Checks Displayed (Enveloped)
Envelope Only Solution

Foresite/EFI	CTNH550A	SK-5
KS		Feb 04, 2022
049.02894 - 2275002		CTNH550A.r3d

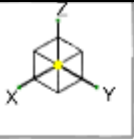

Shear Check (Env)

- No Calc
- > 1.0
- .90-1.0
- 75-90
- .50-.75
- 0-.50

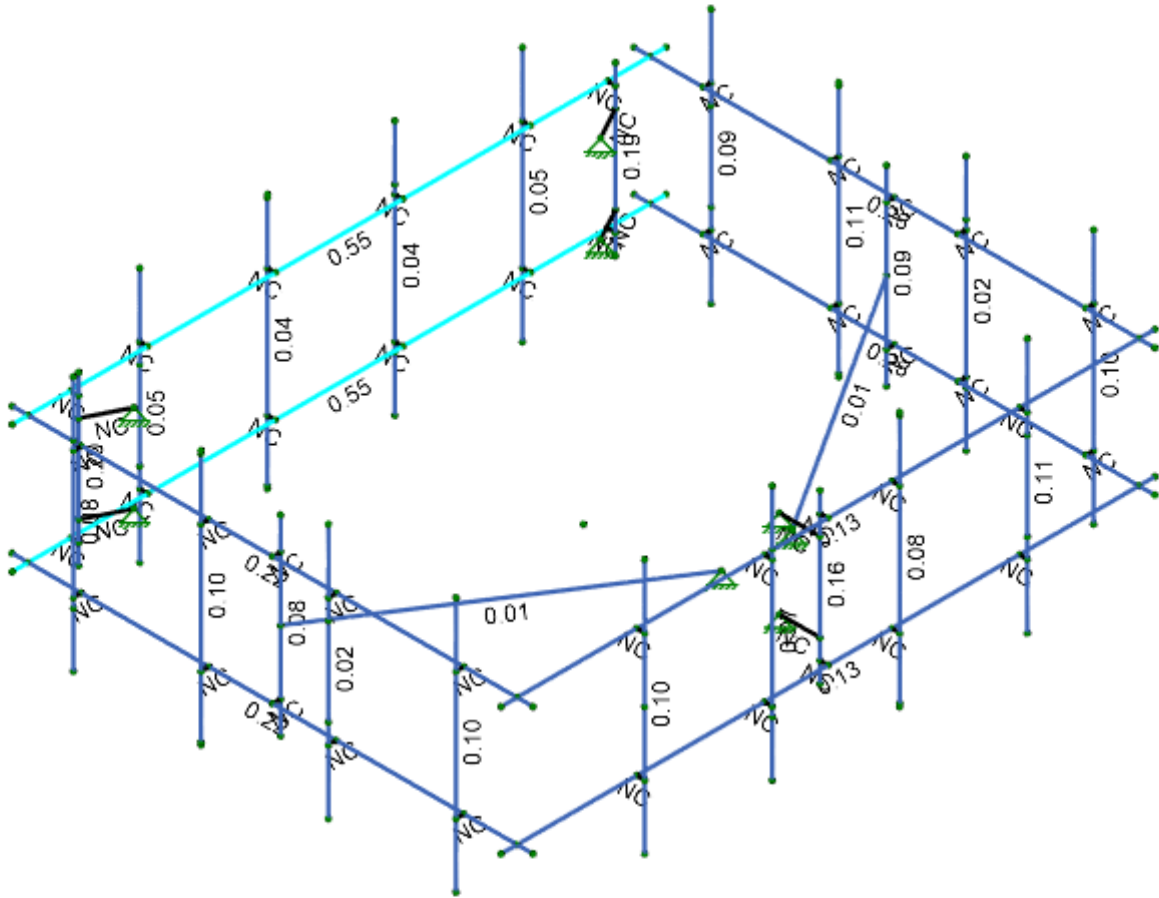

Member Shear Checks Displayed (Enveloped)
Envelope Only Solution

Foresite/EFI
KS
049.02894 - 2275002

CTNH550A

SK-6
Feb 04, 2022
CTNH550A.r3d

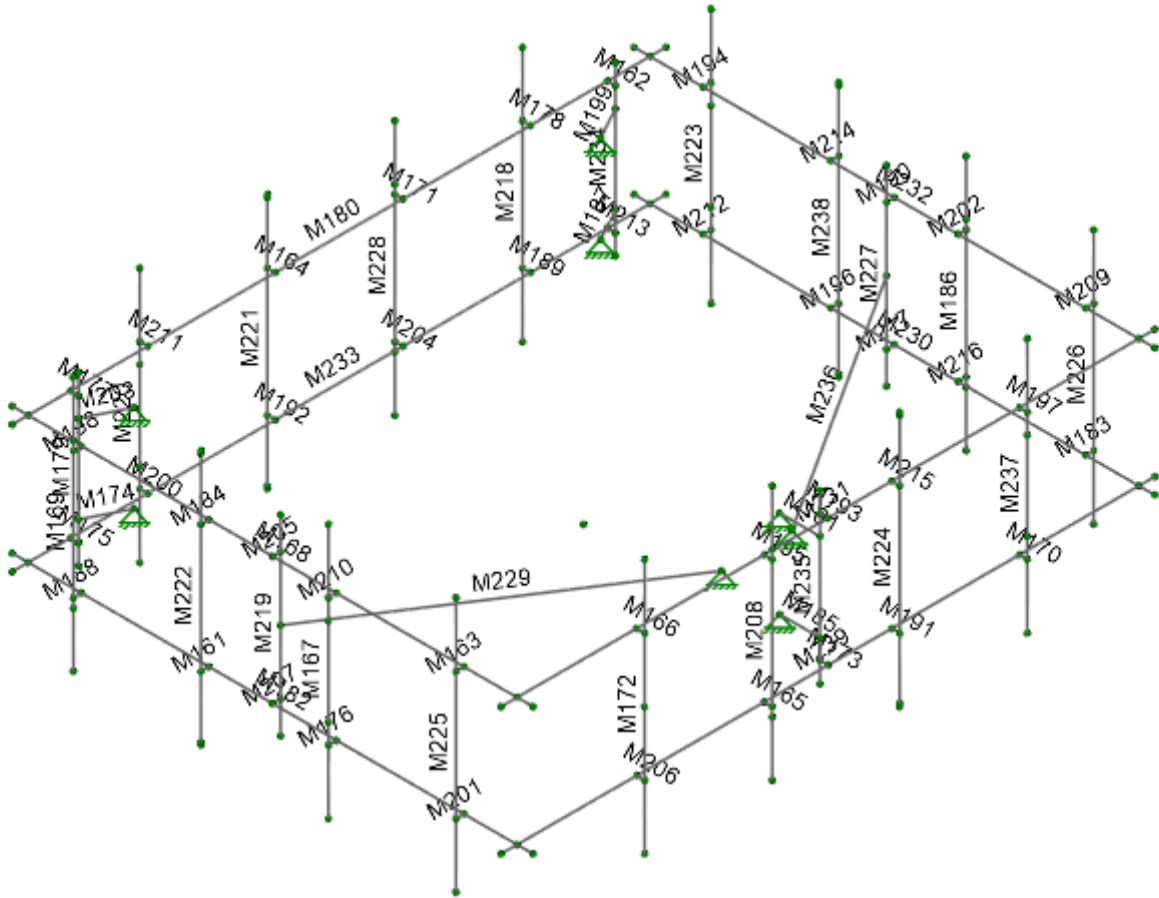
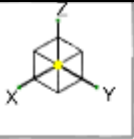

Envelope Only Solution

Foresite/EFI
KS
049.02894 - 2275002

CTNH550A

SK-7
Feb 04, 2022
CTNH550A.r3d

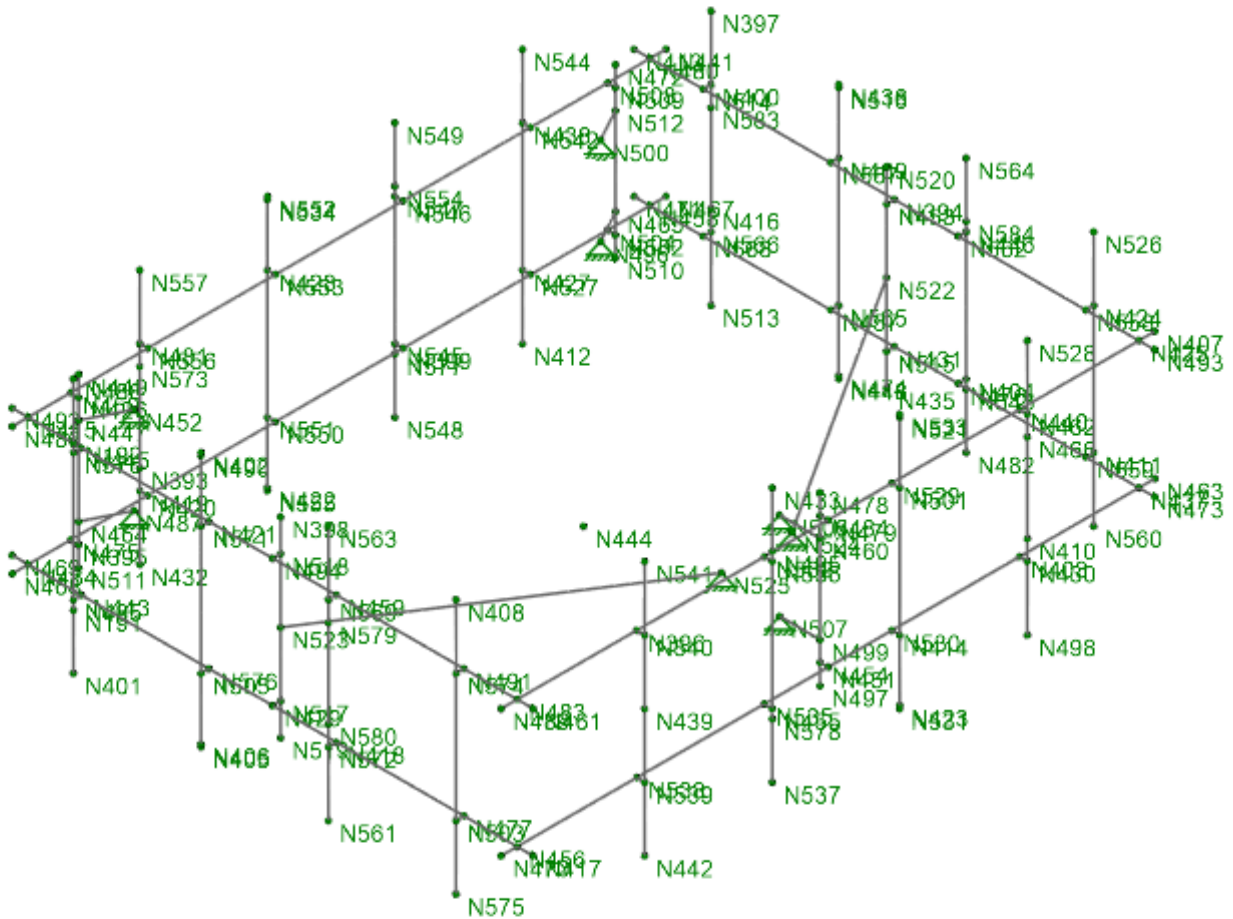

Envelope Only Solution

Foresite/EFI

CTNH550A

SK-8

KS

Feb 04, 2022

049.02894 - 2275002

CTNH550A.r3d

Model Settings

Solution

Members

Number of Reported Sections	5
Number of Internal Sections	100
Member Area Load Mesh Size (in ²)	144
Consider Shear Deformation	Yes
Consider Torsional Warping	Yes

Wall Panels

Approximate Mesh Size (in)	12
Transfer Forces Between Intersecting Wood Walls	Yes
Increase Wood Wall Nailing Capacity for Wind Loads	Yes
Include P-Delta for Walls	Yes
Optimize Masonry and Wood Walls	No
Maximum Number of Iterations	3

Processor Core Utilization

Single	No
Multiple (Optimum)	Yes
Maximum	No

Axis

Vertical Global Axis

Global Axis corresponding to vertical direction	Z
Convert Existing Data	Yes

Default Member Orientation

Default Global Plane for z-axis	XY
---------------------------------	----

Plate Axis

Plate Local Axis Orientation	Nodal
------------------------------	-------

Codes

Hot Rolled Steel	AISC 14th (360-10): LRFD
Stiffness Adjustment	Yes (Iterative)
Notional Annex	None
Connections	AISC 13th (360-05): LRFD
Cold Formed Steel	AISI NAS-01: ASD
Stiffness Adjustment	Yes (Iterative)
Wood	AF&PA NDS-05/08: ASD
Temperature	< 100F
Concrete	ACI 318-05
Masonry	ACI 530-05: ASD
Aluminum	AA ADM1-05: ASD
Structure Type	Building
Stiffness Adjustment	Yes (Iterative)
Stainless	AISC 14th (360-10): ASD
Stiffness Adjustment	Yes (Iterative)

Concrete

Column Design

Analysis Methodology	PCA Load Contour Method
Parme Beta Factor	0.65

Compression Stress Block	Rectangular Stress Block
Analyze using Cracked Sections	Yes
Leave room for horizontal rebar splices (2*d bar spacing)	No
List forces which were ignored for design in the Detail Report	Yes

Rebar

Column Min Steel	1
Column Max Steel	8
Rebar Material Spec	ASTM A615
Warn if beam-column framing arrangement is not understood	No

Model Settings (Continued)

Shear Reinforcement

Number of Shear Regions	4
Region 2 & 3 Spacing Increase Increment (in)	4

Seismic

RISA-3D Seismic Load Options

Code	UBC 1997
Occupancy Cat	4
Seismic Zone	3
Base Elevation (ft)	
Include the weight of the structure in base shear calcs	No

Site Parameters

C_a	0.36
C_v	0.54

Structure Characteristics

T Z (sec)	
T X (sec)	
$C_r X$	0.035
R Z	8.5
R X	8.5
$\Omega_0 Z$	1
$\Omega_0 X$	1
ρZ	1
ρX	1

Project Grid Lines

No Data to Print...

Hot Rolled Steel Properties

	Label	E [ksi]	G [ksi]	Nu	Therm. Coeff. [1e ⁶ F ⁻¹]	Density [k/ft ³]	Yield [ksi]	Ry	Fu [ksi]	Rt
1	A36 Gr.36	29000	11154	0.3	0.65	0.49	36	1.5	58	1.2
2	A572 Gr.50	29000	11154	0.3	0.65	0.49	50	1.1	65	1.2
3	A992	29000	11154	0.3	0.65	0.49	50	1.1	65	1.2
4	A500 Gr.42	29000	11154	0.3	0.65	0.49	42	1.3	58	1.1
5	A500 Gr.46	29000	11154	0.3	0.65	0.49	46	1.2	58	1.1
6	A53 Gr.B	29000	11154	0.3	0.65	0.49	35	1.5	60	1.2
7	Q235	29000	11154	0.3	0.65	0.49	34	1.5	58	1.2
8	A500 Gr.B RND	29000	11154	0.3	0.65	0.527	42	1.4	58	1.3
9	A500 Gr.B Rect	29000	11154	0.3	0.65	0.527	46	1.4	58	1.3
10	A1085	29000	11154	0.3	0.65	0.49	50	1.4	65	1.3

Member Primary Data

	Label	I Node	J Node	Section/Shape	Type	Design List	Material	Design Rule
1	M236	N522	N524	PIPE 2.0	Beam	Pipe	A53 Gr.B	Typical
2	M223	N513	N397	PIPE 2.0	Beam	Pipe	A53 Gr.B	Typical
3	M237	N498	N528	PIPE 2.0	Beam	Pipe	A53 Gr.B	Typical
4	M238	N448	N436	PIPE 2.0	Beam	Pipe	A53 Gr.B	Typical
5	M208	N537	N433	PIPE 2.0	Beam	Pipe	A53 Gr.B	Typical
6	M218	N412	N544	PIPE 2.0	Beam	Pipe	A53 Gr.B	Typical
7	M167	N561	N563	PIPE 2.0	Beam	Pipe	A53 Gr.B	Typical
8	M169	N401	N488	PIPE 2.0	Beam	Pipe	A53 Gr.B	Typical
9	M220	N432	N557	PIPE 2.0	Beam	Pipe	A53 Gr.B	Typical
10	M172	N442	N541	PIPE 2.0	Beam	Pipe	A53 Gr.B	Typical
11	M224	N531	N533	PIPE 2.0	Beam	Pipe	A53 Gr.B	Typical
12	M228	N548	N549	PIPE 2.0	Beam	Pipe	A53 Gr.B	Typical
13	M226	N560	N526	PIPE 2.0	Beam	Pipe	A53 Gr.B	Typical
14	M225	N575	N408	PIPE 2.0	Beam	Pipe	A53 Gr.B	Typical
15	M222	N405	N402	PIPE 2.0	Beam	Pipe	A53 Gr.B	Typical
16	M186	N482	N564	PIPE 2.0	Beam	Pipe	A53 Gr.B	Typical
17	M229	N523	N525	PIPE 2.0	Beam	Pipe	A53 Gr.B	Typical
18	M219	N519	N398	PIPE 2.0	Beam	Pipe	A53 Gr.B	Typical
19	M227	N435	N520	PIPE 2.0	Beam	Pipe	A53 Gr.B	Typical
20	M221	N555	N552	PIPE 2.0	Beam	Pipe	A53 Gr.B	Typical
21	M232	N493	N413	PIPE 3.0	Beam	Pipe	A53 Gr.B	Typical
22	M233	N467	N468	PIPE 3.0	Beam	Pipe	A53 Gr.B	Typical
23	M231	N407	N489	PIPE 3.0	Beam	Pipe	A53 Gr.B	Typical
24	M168	N461	N492	PIPE 3.0	Beam	Pipe	A53 Gr.B	Typical
25	M180	N441	N486	PIPE 3.0	Beam	Pipe	A53 Gr.B	Typical
26	M182	N417	N469	PIPE 3.0	Beam	Pipe	A53 Gr.B	Typical
27	M230	N473	N471	PIPE 3.0	Beam	Pipe	A53 Gr.B	Typical
28	M239	N463	N470	PIPE 3.0	Beam	Pipe	A53 Gr.B	Typical
29	M179	N511	N449	PIPE 4.0	Beam	Pipe	A53 Gr.B	Typical
30	M235	N497	N478	PIPE 4.0	Beam	Pipe	A53 Gr.B	Typical
31	M234	N510	N472	PIPE 4.0	Beam	Pipe	A53 Gr.B	Typical
32	M202	N562	N446	RIGID	None	None	RIGID	Typical
33	M187	N465	N496	RIGID	None	None	RIGID	Typical
34	M184	N421	N571	RIGID	None	None	RIGID	Typical
35	M162	N508	N509	RIGID	None	None	RIGID	Typical
36	M171	N546	N547	RIGID	None	None	RIGID	Typical
37	M201	N477	N503	RIGID	None	None	RIGID	Typical
38	M163	N491	N574	RIGID	None	None	RIGID	Typical
39	M164	N553	N428	RIGID	None	None	RIGID	Typical
40	M204	N399	N545	RIGID	None	None	RIGID	Typical
41	M199	N512	N500	RIGID	None	None	RIGID	Typical
42	M185	N499	N507	RIGID	None	None	RIGID	Typical
43	M197	N440	N462	RIGID	None	None	RIGID	Typical
44	M196	N457	N565	RIGID	None	None	RIGID	Typical
45	M195	N532	N536	RIGID	None	None	RIGID	Typical
46	M193	N479	N484	RIGID	None	None	RIGID	Typical
47	M192	N550	N551	RIGID	None	None	RIGID	Typical



Member Primary Data (Continued)

Label	I Node	J Node	Section/Shape	Type	Design List	Material	Design Rule
48	M191	N530	N414	RIGID	None	None	Typical
49	M190	N394	N453	RIGID	None	None	Typical
50	M189	N527	N427	RIGID	None	None	Typical
51	M188	N443	N485	RIGID	None	None	Typical
52	M165	N535	N455	RIGID	None	None	Typical
53	M198	N445	N570	RIGID	None	None	Typical
54	M166	N396	N540	RIGID	None	None	Typical
55	M216	N476	N404	RIGID	None	None	Typical
56	M173	N451	N454	RIGID	None	None	Typical
57	M207	N429	N517	RIGID	None	None	Typical
58	M209	N558	N424	RIGID	None	None	Typical
59	M210	N459	N569	RIGID	None	None	Typical
60	M211	N556	N481	RIGID	None	None	Typical
61	M214	N567	N409	RIGID	None	None	Typical
62	M213	N504	N502	RIGID	None	None	Typical
63	M206	N538	N539	RIGID	None	None	Typical
64	M215	N529	N501	RIGID	None	None	Typical
65	M194	N514	N400	RIGID	None	None	Typical
66	M217	N431	N515	RIGID	None	None	Typical
67	M212	N568	N566	RIGID	None	None	Typical
68	M205	N494	N518	RIGID	None	None	Typical
69	M200	N420	N419	RIGID	None	None	Typical
70	M203	N447	N452	RIGID	None	None	Typical
71	M181	N460	N506	RIGID	None	None	Typical
72	M178	N542	N438	RIGID	None	None	Typical
73	M177	N450	N426	RIGID	None	None	Typical
74	M176	N418	N572	RIGID	None	None	Typical
75	M175	N475	N395	RIGID	None	None	Typical
76	M174	N464	N487	RIGID	None	None	Typical
77	M183	N559	N411	RIGID	None	None	Typical
78	M170	N403	N430	RIGID	None	None	Typical
79	M161	N576	N505	RIGID	None	None	Typical

Member Advanced Data

	Label	Physical	Deflection Ratio Options	Seismic DR
1	M236	Yes		None
2	M223	Yes	Default	None
3	M237	Yes	Default	None
4	M238	Yes	Default	None
5	M208	Yes	Default	None
6	M218	Yes	Default	None
7	M167	Yes	Default	None
8	M169	Yes	Default	None
9	M220	Yes	Default	None
10	M172	Yes	Default	None
11	M224	Yes	Default	None
12	M228	Yes	Default	None
13	M226	Yes	Default	None
14	M225	Yes	Default	None
15	M222	Yes	Default	None
16	M186	Yes	Default	None
17	M229	Yes		None
18	M219	Yes		None
19	M227	Yes		None
20	M221	Yes	Default	None
21	M232	Yes	Default	None
22	M233	Yes	Default	None
23	M231	Yes	Default	None
24	M168	Yes	Default	None
25	M180	Yes	Default	None
26	M182	Yes	Default	None
27	M230	Yes	Default	None
28	M239	Yes	Default	None
29	M179	Yes	Default	None

Member Advanced Data (Continued)

	Label	Physical	Deflection Ratio Options	Seismic DR
30	M235	Yes	Default	None
31	M234	Yes	Default	None
32	M202	Yes	** NA **	None
33	M187	Yes	** NA **	None
34	M184	Yes	** NA **	None
35	M162	Yes	** NA **	None
36	M171	Yes	** NA **	None
37	M201	Yes	** NA **	None
38	M163	Yes	** NA **	None
39	M164	Yes	** NA **	None
40	M204	Yes	** NA **	None
41	M199	Yes	** NA **	None
42	M185	Yes	** NA **	None
43	M197	Yes	** NA **	None
44	M196	Yes	** NA **	None
45	M195	Yes	** NA **	None
46	M193	Yes	** NA **	None
47	M192	Yes	** NA **	None
48	M191	Yes	** NA **	None
49	M190	Yes	** NA **	None
50	M189	Yes	** NA **	None
51	M188	Yes	** NA **	None
52	M165	Yes	** NA **	None
53	M198	Yes	** NA **	None
54	M166	Yes	** NA **	None
55	M216	Yes	** NA **	None
56	M173	Yes	** NA **	None
57	M207	Yes	** NA **	None
58	M209	Yes	** NA **	None
59	M210	Yes	** NA **	None
60	M211	Yes	** NA **	None
61	M214	Yes	** NA **	None
62	M213	Yes	** NA **	None
63	M206	Yes	** NA **	None
64	M215	Yes	** NA **	None
65	M194	Yes	** NA **	None
66	M217	Yes	** NA **	None
67	M212	Yes	** NA **	None
68	M205	Yes	** NA **	None
69	M200	Yes	** NA **	None
70	M203	Yes	** NA **	None
71	M181	Yes	** NA **	None
72	M178	Yes	** NA **	None
73	M177	Yes	** NA **	None
74	M176	Yes	** NA **	None
75	M175	Yes	** NA **	None
76	M174	Yes	** NA **	None
77	M183	Yes	** NA **	None
78	M170	Yes	** NA **	None
79	M161	Yes	** NA **	None

Hot Rolled Steel Design Parameters

	Label	Shape	Length [in]	Lcomp top [in]	Function
1	M236	PIPE 2.0	120	Lbyy	Lateral
2	M223	PIPE 2.0	96	Lbyy	Lateral
3	M237	PIPE 2.0	96	Lbyy	Lateral
4	M238	PIPE 2.0	96	Lbyy	Lateral
5	M208	PIPE 2.0	96	Lbyy	Lateral
6	M218	PIPE 2.0	96	Lbyy	Lateral
7	M167	PIPE 2.0	96	Lbyy	Lateral
8	M169	PIPE 2.0	96	Lbyy	Lateral
9	M220	PIPE 2.0	96	Lbyy	Lateral
10	M172	PIPE 2.0	96	Lbyy	Lateral
11	M224	PIPE 2.0	96	Lbyy	Lateral

Hot Rolled Steel Design Parameters (Continued)

	Label	Shape	Length [in]	Lcomp top [in]	Function
12	M228	PIPE 2.0	96	Lbyy	Lateral
13	M226	PIPE 2.0	96	Lbyy	Lateral
14	M225	PIPE 2.0	96	Lbyy	Lateral
15	M222	PIPE 2.0	96	Lbyy	Lateral
16	M186	PIPE 2.0	96	Lbyy	Lateral
17	M229	PIPE 2.0	120	Lbyy	Lateral
18	M219	PIPE 2.0	72	Lbyy	Lateral
19	M227	PIPE 2.0	72	Lbyy	Lateral
20	M221	PIPE 2.0	96	Lbyy	Lateral
21	M232	PIPE 3.0	196	Lbyy	Lateral
22	M233	PIPE 3.0	246	Lbyy	Lateral
23	M231	PIPE 3.0	246	Lbyy	Lateral
24	M168	PIPE 3.0	196	Lbyy	Lateral
25	M180	PIPE 3.0	246	Lbyy	Lateral
26	M182	PIPE 3.0	196	Lbyy	Lateral
27	M230	PIPE 3.0	196	Lbyy	Lateral
28	M239	PIPE 3.0	246	Lbyy	Lateral
29	M179	PIPE 4.0	63	Lbyy	Lateral
30	M235	PIPE 4.0	63	Lbyy	Lateral
31	M234	PIPE 4.0	63	Lbyy	Lateral

Node Coordinates

	Label	X [in]	Y [in]	Z [in]	Detach From Diaphragm
1	N393	72	-95	7.45	
2	N394	-117	0	48	
3	N395	101	-89	0	
4	N396	72	92	48	
5	N397	-120	-72	72	
6	N398	114	0	60	
7	N399	-24	-92	0	
8	N400	-120	-72	48	
9	N401	120	-72	-24	
10	N402	120	-24	72	
11	N403	-72	92	0	
12	N404	-120	24	0	
13	N405	120	-24	-24	
14	N406	120	-24	-23	
15	N407	-123	92	48	
16	N408	120	72	72	
17	N409	-120	-24	48	
18	N410	-72	95	7.45	
19	N411	-120	72	0	
20	N412	-72	-95	-24	
21	N413	-117	-98	48	
22	N414	-24	95	0	
23	N415	117	-92	48	
24	N416	-120	-72	7.45	
25	N417	117	98	0	
26	N418	117	24	0	
27	N419	72	-95	0	
28	N420	72	-92	0	
29	N421	117	-24	48	
30	N422	24	-95	-23	
31	N423	-24	95	-23	
32	N424	-120	72	48	
33	N425	-117	92	48	
34	N426	101	-89	48	
35	N427	-72	-95	0	
36	N428	24	-95	48	
37	N429	117	0	0	
38	N430	-72	95	0	
39	N431	-117	0	0	
40	N432	72	-95	-24	
41	N433	24	95	72	



Node Coordinates (Continued)

	Label	X [in]	Y [in]	Z [in]	Detach From Diaphragm
42	N434	117	-92	0	
43	N435	-114	0	-12	
44	N436	-120	-24	72	
45	N437	-117	92	0	
46	N438	-72	-95	48	
47	N439	72	95	24	
48	N440	-72	92	48	
49	N441	-123	-92	48	
50	N442	72	95	-24	
51	N443	117	-72	0	
52	N444	0	0	0	
53	N445	117	-72	48	
54	N446	-120	24	48	
55	N447	101	-89	40.5	
56	N448	-120	-24	-24	
57	N449	101	-89	55.5	
58	N450	101	-92	48	
59	N451	0	92	0	
60	N452	87.793113	-81.375	41.25	
61	N453	-114	0	48	
62	N454	0	89	0	
63	N455	24	95	0	
64	N456	117	92	0	
65	N457	-117	-24	0	
66	N458	-117	-92	0	
67	N459	117	24	48	
68	N460	0	89	40.5	
69	N461	117	98	48	
70	N462	-72	95	48	
71	N463	-123	92	0	
72	N464	101	-89	7.5	
73	N465	-101	-89	7.5	
74	N466	-72	95	40.55	
75	N467	-123	-92	0	
76	N468	123	-92	0	
77	N469	117	-98	0	
78	N470	123	92	0	
79	N471	-117	-98	0	
80	N472	-101	-89	55.5	
81	N473	-117	98	0	
82	N474	-120	-24	-23	
83	N475	101	-92	0	
84	N476	-117	24	0	
85	N477	117	72	0	
86	N478	0	89	55.5	
87	N479	0	92	48	
88	N480	-117	-92	48	
89	N481	72	-95	48	
90	N482	-120	24	-24	
91	N483	117	92	48	
92	N484	0	89	48	
93	N485	120	-72	0	
94	N486	123	-92	48	
95	N487	87.793113	-81.375	8.25	
96	N488	120	-72	72	
97	N489	123	92	48	
98	N490	120	-24	71	
99	N491	117	72	48	
100	N492	117	-98	48	
101	N493	-117	98	48	
102	N494	117	0	48	
103	N495	24	95	51.35	
104	N496	-87.793113	-81.375	8.25	
105	N497	0	89	-7.5	
106	N498	-72	95	-24	



Node Coordinates (Continued)

	Label	X [in]	Y [in]	Z [in]	Detach From Diaphragm
107	N499	0	89	7.5	
108	N500	-87.793113	-81.375	41.25	
109	N501	-24	95	48	
110	N502	-101	-89	0	
111	N503	120	72	0	
112	N504	-101	-92	0	
113	N505	120	-24	0	
114	N506	0	73.75	40.5	
115	N507	0	73.75	7.5	
116	N508	-101	-92	48	
117	N509	-101	-89	48	
118	N510	-101	-89	-7.5	
119	N511	101	-89	-7.5	
120	N512	-101	-89	40.5	
121	N513	-120	-72	-24	
122	N514	-117	-72	48	
123	N515	-114	0	0	
124	N516	-120	-24	71	
125	N517	114	0	0	
126	N518	114	0	48	
127	N519	114	0	-12	
128	N520	-114	0	60	
129	N521	-24	95	71	
130	N522	-114	0	24	
131	N523	114	0	24	
132	N524	-13.245654	65.180992	24	
133	N525	13.245654	65.180992	24	
134	N526	-120	72	72	
135	N527	-72	-92	0	
136	N528	-72	95	72	
137	N529	-24	92	48	
138	N530	-24	92	0	
139	N531	-24	95	-24	
140	N532	24	92	48	
141	N533	-24	95	72	
142	N534	24	-95	71	
143	N535	24	92	0	
144	N536	24	95	48	
145	N537	24	95	-24	
146	N538	72	92	0	
147	N539	72	95	0	
148	N540	72	95	48	
149	N541	72	95	72	
150	N542	-72	-92	48	
151	N543	-120	24	-3.35	
152	N544	-72	-95	72	
153	N545	-24	-95	0	
154	N546	-24	-92	48	
155	N547	-24	-95	48	
156	N548	-24	-95	-24	
157	N549	-24	-95	72	
158	N550	24	-92	0	
159	N551	24	-95	0	
160	N552	24	-95	72	
161	N553	24	-92	48	
162	N554	-24	-95	51.35	
163	N555	24	-95	-24	
164	N556	72	-92	48	
165	N557	72	-95	72	
166	N558	-117	72	48	
167	N559	-117	72	0	
168	N560	-120	72	-24	
169	N561	120	24	-24	
170	N562	-117	24	48	
171	N563	120	24	72	

Node Coordinates (Continued)

	Label	X [in]	Y [in]	Z [in]	Detach From Diaphragm
172	N564	-120	24	72	
173	N565	-120	-24	0	
174	N566	-120	-72	0	
175	N567	-117	-24	48	
176	N568	-117	-72	0	
177	N569	120	24	48	
178	N570	120	-72	48	
179	N571	120	-24	48	
180	N572	120	24	0	
181	N573	72	-95	40.55	
182	N574	120	72	48	
183	N575	120	72	-24	
184	N576	117	-24	0	
185	N577	-24	-95	-3.35	
186	N578	24	95	-3.35	
187	N579	120	24	40.55	
188	N580	120	24	7.45	
189	N583	-120	-72	40.55	
190	N584	-120	24	51.35	
191	N191	120	-72	-3.35	
192	N192	120	-72	51.35	

Node Boundary Conditions

	Y [k/in]	X [k/in]	Z [k/in]	Node Label
1	Reaction	Reaction	Reaction	N452
2	Reaction	Reaction	Reaction	N487
3	Reaction	Reaction	Reaction	N496
4	Reaction	Reaction	Reaction	N500
5	Reaction	Reaction	Reaction	N506
6	Reaction	Reaction	Reaction	N507
7	Reaction	Reaction	Reaction	N524
8	Reaction	Reaction	Reaction	N525

Basic Load Cases

	BLC Description	Category	Z Gravity	Nodal	Distributed
1	DEAD LOAD	None	-1	25	
2	DEAD LOAD ICE	None		25	31
3	WIND LOAD (NO ICE) FRONT	None		25	31
4	WIND LOAD (NO ICE) SIDE	None		25	31
5	WIND LOAD (ICE) FRONT	None		25	31
6	WIND LOAD (ICE) SIDE	None		25	31
7	LIVE LOAD1	None		1	
8	LIVE LOAD2	None		1	
9	LIVE LOAD3	None		1	
10	MAINTENANCE LOAD1	None		1	
11	MAINTENANCE LOAD2	None		1	
12	MAINTENANCE LOAD3	None		1	
13	MAINTENANCE LOAD4	None		1	

Node Loads and Enforced Displacements (BLC 1 : DEAD LOAD)

	Node Label	L, D, M	Direction	Magnitude [(lb, k-ft), (in, rad), (lb*s ² /in, lb*s ² *in)]
1	N439	L	Z	-22
2	N393	L	Z	-58
3	N579	L	Z	-58
4	N583	L	Z	-58
5	N410	L	Z	-58
6	N416	L	Z	-58
7	N573	L	Z	-58
8	N466	L	Z	-58
9	N580	L	Z	-58
10	N578	L	Z	-67

Node Loads and Enforced Displacements (BLC 1 : DEAD LOAD) (Continued)

	Node Label	L, D, M	Direction	Magnitude [(lb, k-ft), (in, rad), (lb*s ² /in, lb*s ² *in)]
11	N191	L	Z	-67
12	N192	L	Z	-67
13	N577	L	Z	-67
14	N554	L	Z	-67
15	N543	L	Z	-67
16	N584	L	Z	-67
17	N495	L	Z	-67
18	N406	L	Z	-117
19	N516	L	Z	-117
20	N423	L	Z	-117
21	N474	L	Z	-117
22	N534	L	Z	-117
23	N490	L	Z	-117
24	N422	L	Z	-117
25	N521	L	Z	-117

Node Loads and Enforced Displacements (BLC 2 : DEAD LOAD ICE)

	Node Label	L, D, M	Direction	Magnitude [(lb, k-ft), (in, rad), (lb*s ² /in, lb*s ² *in)]
1	N466	L	Z	-107
2	N410	L	Z	-107
3	N393	L	Z	-107
4	N573	L	Z	-107
5	N583	L	Z	-107
6	N416	L	Z	-107
7	N579	L	Z	-107
8	N580	L	Z	-107
9	N521	L	Z	-354
10	N423	L	Z	-354
11	N422	L	Z	-354
12	N534	L	Z	-354
13	N516	L	Z	-354
14	N474	L	Z	-354
15	N490	L	Z	-354
16	N406	L	Z	-354
17	N495	L	Z	-170
18	N578	L	Z	-170
19	N554	L	Z	-170
20	N577	L	Z	-170
21	N584	L	Z	-170
22	N543	L	Z	-170
23	N191	L	Z	-170
24	N192	L	Z	-170
25	N439	L	Z	-281

Node Loads and Enforced Displacements (BLC 3 : WIND LOAD (NO ICE) FRONT)

	Node Label	L, D, M	Direction	Magnitude [(lb, k-ft), (in, rad), (lb*s ² /in, lb*s ² *in)]
1	N466	L	Y	66
2	N410	L	Y	66
3	N393	L	Y	66
4	N573	L	Y	66
5	N583	L	Y	29
6	N416	L	Y	29
7	N579	L	Y	29
8	N580	L	Y	29
9	N521	L	Y	234
10	N423	L	Y	234
11	N422	L	Y	234
12	N534	L	Y	234
13	N516	L	Y	117
14	N474	L	Y	117
15	N490	L	Y	117
16	N406	L	Y	117
17	N495	L	Y	69

Node Loads and Enforced Displacements (BLC 3 : WIND LOAD (NO ICE) FRONT) (Continued)

	Node Label	L, D, M	Direction	Magnitude [(lb, k-ft), (in, rad), (lb*s ² /in, lb*s ² *in)]
18	N578	L	Y	69
19	N554	L	Y	69
20	N577	L	Y	69
21	N584	L	Y	55
22	N543	L	Y	55
23	N191	L	Y	55
24	N192	L	Y	55
25	N439	L	Y	134

Node Loads and Enforced Displacements (BLC 4 : WIND LOAD (NO ICE) SIDE)

	Node Label	L, D, M	Direction	Magnitude [(lb, k-ft), (in, rad), (lb*s ² /in, lb*s ² *in)]
1	N466	L	X	29
2	N410	L	X	29
3	N393	L	X	29
4	N573	L	X	29
5	N583	L	X	66
6	N416	L	X	66
7	N579	L	X	66
8	N580	L	X	66
9	N521	L	X	117
10	N423	L	X	117
11	N422	L	X	117
12	N534	L	X	117
13	N516	L	X	234
14	N474	L	X	234
15	N490	L	X	234
16	N406	L	X	234
17	N495	L	X	55
18	N578	L	X	55
19	N554	L	X	55
20	N577	L	X	55
21	N584	L	X	69
22	N543	L	X	69
23	N191	L	X	69
24	N192	L	X	69
25	N439	L	X	83

Node Loads and Enforced Displacements (BLC 5 : WIND LOAD (ICE) FRONT)

	Node Label	L, D, M	Direction	Magnitude [(lb, k-ft), (in, rad), (lb*s ² /in, lb*s ² *in)]
1	N466	L	Y	17
2	N410	L	Y	17
3	N393	L	Y	17
4	N573	L	Y	17
5	N583	L	Y	9
6	N416	L	Y	9
7	N579	L	Y	9
8	N580	L	Y	9
9	N521	L	Y	54
10	N423	L	Y	54
11	N422	L	Y	54
12	N534	L	Y	54
13	N516	L	Y	31
14	N474	L	Y	31
15	N490	L	Y	31
16	N406	L	Y	31
17	N495	L	Y	18
18	N578	L	Y	18
19	N554	L	Y	18
20	N577	L	Y	18
21	N584	L	Y	17
22	N543	L	Y	17
23	N191	L	Y	17
24	N192	L	Y	17

Node Loads and Enforced Displacements (BLC 5 : WIND LOAD (ICE FRONT) (Continued))

	Node Label	L, D, M	Direction	Magnitude [(lb, k-ft), (in, rad), (lb*s ² /in, lb*s ² *in)]
25	N439	L	Y	33

Node Loads and Enforced Displacements (BLC 6 : WIND LOAD (ICE SIDE))

	Node Label	L, D, M	Direction	Magnitude [(lb, k-ft), (in, rad), (lb*s ² /in, lb*s ² *in)]
1	N466	L	X	9
2	N410	L	X	9
3	N393	L	X	9
4	N573	L	X	9
5	N583	L	X	17
6	N416	L	X	17
7	N579	L	X	17
8	N580	L	X	17
9	N521	L	X	31
10	N423	L	X	31
11	N422	L	X	31
12	N534	L	X	31
13	N516	L	X	54
14	N474	L	X	54
15	N490	L	X	54
16	N406	L	X	54
17	N495	L	X	17
18	N578	L	X	17
19	N554	L	X	17
20	N577	L	X	17
21	N584	L	X	18
22	N543	L	X	18
23	N191	L	X	18
24	N192	L	X	18
25	N439	L	X	22

Node Loads and Enforced Displacements (BLC 7 : LIVE LOAD1)

	Node Label	L, D, M	Direction	Magnitude [(lb, k-ft), (in, rad), (lb*s ² /in, lb*s ² *in)]
1	N470	L	Z	-250

Node Loads and Enforced Displacements (BLC 8 : LIVE LOAD2)

	Node Label	L, D, M	Direction	Magnitude [(lb, k-ft), (in, rad), (lb*s ² /in, lb*s ² *in)]
1	N473	L	Z	-250

Node Loads and Enforced Displacements (BLC 9 : LIVE LOAD3)

	Node Label	L, D, M	Direction	Magnitude [(lb, k-ft), (in, rad), (lb*s ² /in, lb*s ² *in)]
1	N467	L	Z	-250

Node Loads and Enforced Displacements (BLC 10 : MAINTENANCE LOAD1)

	Node Label	L, D, M	Direction	Magnitude [(lb, k-ft), (in, rad), (lb*s ² /in, lb*s ² *in)]
1	N442	L	Z	-500

Node Loads and Enforced Displacements (BLC 11 : MAINTENANCE LOAD2)

	Node Label	L, D, M	Direction	Magnitude [(lb, k-ft), (in, rad), (lb*s ² /in, lb*s ² *in)]
1	N537	L	Z	-500

Node Loads and Enforced Displacements (BLC 12 : MAINTENANCE LOAD3)

	Node Label	L, D, M	Direction	Magnitude [(lb, k-ft), (in, rad), (lb*s ² /in, lb*s ² *in)]
1	N531	L	Z	-500



Node Loads and Enforced Displacements (BLC 13 : MAINTENANCE LOAD4)

Node Label	L, D, M	Direction	Magnitude [(lb, k-ft), (in, rad), (lb*s ² /in, lb*s ² *in)]	
1	N498	L	Z	-500

Member Point Loads

No Data to Print...			
---------------------	--	--	--

Member Distributed Loads (BLC 2 : DEAD LOAD ICE)

Member Label	Direction	Start Magnitude [lb/ft, F, psf, k-ft/in]	End Magnitude [lb/ft, F, psf, k-ft/in]	Start Location [(in, %)]	End Location [(in, %)]
1	M236	Z	-13	0	%100
2	M223	Z	-13	0	%100
3	M237	Z	-13	0	%100
4	M238	Z	-13	0	%100
5	M208	Z	-13	0	%100
6	M218	Z	-13	0	%100
7	M167	Z	-13	0	%100
8	M169	Z	-13	0	%100
9	M220	Z	-13	0	%100
10	M172	Z	-13	0	%100
11	M224	Z	-13	0	%100
12	M228	Z	-13	0	%100
13	M226	Z	-13	0	%100
14	M225	Z	-13	0	%100
15	M222	Z	-13	0	%100
16	M186	Z	-13	0	%100
17	M229	Z	-13	0	%100
18	M219	Z	-13	0	%100
19	M227	Z	-13	0	%100
20	M221	Z	-13	0	%100
21	M232	Z	-16.1	0	%100
22	M233	Z	-16.1	0	%100
23	M231	Z	-16.1	0	%100
24	M168	Z	-16.1	0	%100
25	M180	Z	-16.1	0	%100
26	M182	Z	-16.1	0	%100
27	M230	Z	-16.1	0	%100
28	M239	Z	-16.1	0	%100
29	M179	Z	-18.9	0	%100
30	M235	Z	-18.9	0	%100
31	M234	Z	-18.9	0	%100

Member Distributed Loads (BLC 3 : WIND LOAD (NO ICE) FRONT)

Member Label	Direction	Start Magnitude [lb/ft, F, psf, k-ft/in]	End Magnitude [lb/ft, F, psf, k-ft/in]	Start Location [(in, %)]	End Location [(in, %)]
1	M236	PY	5.5	0	%100
2	M223	PY	5.5	0	%100
3	M237	PY	5.5	0	%100
4	M238	PY	5.5	0	%100
5	M208	PY	5.5	0	%100
6	M218	PY	5.5	0	%100
7	M167	PY	5.5	0	%100
8	M169	PY	5.5	0	%100
9	M220	PY	5.5	0	%100
10	M172	PY	5.5	0	%100
11	M224	PY	5.5	0	%100
12	M228	PY	5.5	0	%100
13	M226	PY	5.5	0	%100
14	M225	PY	5.5	0	%100
15	M222	PY	5.5	0	%100
16	M186	PY	5.5	0	%100
17	M229	PY	5.5	0	%100
18	M219	PY	5.5	0	%100
19	M227	PY	5.5	0	%100
20	M221	PY	5.5	0	%100



Company : Foresite/EFI
 Designer : KS
 Job Number : 049.02894 - 2275002
 Model Name : CTNH550A

2/4/2022
 9:48:42 AM
 Checked By : _____

Member Distributed Loads (BLC 3 : WIND LOAD (NO ICE) FRONT) (Continued)

Member Label	Direction	Start Magnitude [lb/ft, F, psf, k-ft/in]	End Magnitude [lb/ft, F, psf, k-ft/in]	Start Location [(in, %)]	End Location [(in, %)]
21	M232	PY	8.1	8.1	0 %100
22	M233	PY	8.1	8.1	0 %100
23	M231	PY	8.1	8.1	0 %100
24	M168	PY	8.1	8.1	0 %100
25	M180	PY	8.1	8.1	0 %100
26	M182	PY	8.1	8.1	0 %100
27	M230	PY	8.1	8.1	0 %100
28	M239	PY	8.1	8.1	0 %100
29	M179	PY	10.4	10.4	0 %100
30	M235	PY	10.4	10.4	0 %100
31	M234	PY	10.4	10.4	0 %100

Member Distributed Loads (BLC 4 : WIND LOAD (NO ICE) SIDE)

Member Label	Direction	Start Magnitude [lb/ft, F, psf, k-ft/in]	End Magnitude [lb/ft, F, psf, k-ft/in]	Start Location [(in, %)]	End Location [(in, %)]
1	M236	PX	5.5	5.5	0 %100
2	M223	PX	5.5	5.5	0 %100
3	M237	PX	5.5	5.5	0 %100
4	M238	PX	5.5	5.5	0 %100
5	M208	PX	5.5	5.5	0 %100
6	M218	PX	5.5	5.5	0 %100
7	M167	PX	5.5	5.5	0 %100
8	M169	PX	5.5	5.5	0 %100
9	M220	PX	5.5	5.5	0 %100
10	M172	PX	5.5	5.5	0 %100
11	M224	PX	5.5	5.5	0 %100
12	M228	PX	5.5	5.5	0 %100
13	M226	PX	5.5	5.5	0 %100
14	M225	PX	5.5	5.5	0 %100
15	M222	PX	5.5	5.5	0 %100
16	M186	PX	5.5	5.5	0 %100
17	M229	PX	5.5	5.5	0 %100
18	M219	PX	5.5	5.5	0 %100
19	M227	PX	5.5	5.5	0 %100
20	M221	PX	5.5	5.5	0 %100
21	M232	PX	8.1	8.1	0 %100
22	M233	PX	8.1	8.1	0 %100
23	M231	PX	8.1	8.1	0 %100
24	M168	PX	8.1	8.1	0 %100
25	M180	PX	8.1	8.1	0 %100
26	M182	PX	8.1	8.1	0 %100
27	M230	PX	8.1	8.1	0 %100
28	M239	PX	8.1	8.1	0 %100
29	M179	PX	10.4	10.4	0 %100
30	M235	PX	10.4	10.4	0 %100
31	M234	PX	10.4	10.4	0 %100

Member Distributed Loads (BLC 5 : WIND LOAD (ICE) FRONT)

Member Label	Direction	Start Magnitude [lb/ft, F, psf, k-ft/in]	End Magnitude [lb/ft, F, psf, k-ft/in]	Start Location [(in, %)]	End Location [(in, %)]
1	M236	PY	4.5	4.5	0 %100
2	M223	PY	4.5	4.5	0 %100
3	M237	PY	4.5	4.5	0 %100
4	M238	PY	4.5	4.5	0 %100
5	M208	PY	4.5	4.5	0 %100
6	M218	PY	4.5	4.5	0 %100
7	M167	PY	4.5	4.5	0 %100
8	M169	PY	4.5	4.5	0 %100
9	M220	PY	4.5	4.5	0 %100
10	M172	PY	4.5	4.5	0 %100
11	M224	PY	4.5	4.5	0 %100
12	M228	PY	4.5	4.5	0 %100
13	M226	PY	4.5	4.5	0 %100
14	M225	PY	4.5	4.5	0 %100
15	M222	PY	4.5	4.5	0 %100



Member Distributed Loads (BLC 5 : WIND LOAD (ICE) FRONT) (Continued)

Member Label	Direction	Start Magnitude [lb/ft, F, psf, k-ft/in]	End Magnitude [lb/ft, F, psf, k-ft/in]	Start Location [(in, %)]	End Location [(in, %)]
16	M186	PY	4.5	4.5	0 %100
17	M229	PY	4.5	4.5	0 %100
18	M219	PY	4.5	4.5	0 %100
19	M227	PY	4.5	4.5	0 %100
20	M221	PY	4.5	4.5	0 %100
21	M232	PY	5.2	5.2	0 %100
22	M233	PY	5.2	5.2	0 %100
23	M231	PY	5.2	5.2	0 %100
24	M168	PY	5.2	5.2	0 %100
25	M180	PY	5.2	5.2	0 %100
26	M182	PY	5.2	5.2	0 %100
27	M230	PY	5.2	5.2	0 %100
28	M239	PY	5.2	5.2	0 %100
29	M179	PY	5.8	5.8	0 %100
30	M235	PY	5.8	5.8	0 %100
31	M234	PY	5.8	5.8	0 %100

Member Distributed Loads (BLC 6 : WIND LOAD (ICE) SIDE)

Member Label	Direction	Start Magnitude [lb/ft, F, psf, k-ft/in]	End Magnitude [lb/ft, F, psf, k-ft/in]	Start Location [(in, %)]	End Location [(in, %)]
1	M236	PX	4.5	4.5	0 %100
2	M223	PX	4.5	4.5	0 %100
3	M237	PX	4.5	4.5	0 %100
4	M238	PX	4.5	4.5	0 %100
5	M208	PX	4.5	4.5	0 %100
6	M218	PX	4.5	4.5	0 %100
7	M167	PX	4.5	4.5	0 %100
8	M169	PX	4.5	4.5	0 %100
9	M220	PX	4.5	4.5	0 %100
10	M172	PX	4.5	4.5	0 %100
11	M224	PX	4.5	4.5	0 %100
12	M228	PX	4.5	4.5	0 %100
13	M226	PX	4.5	4.5	0 %100
14	M225	PX	4.5	4.5	0 %100
15	M222	PX	4.5	4.5	0 %100
16	M186	PX	4.5	4.5	0 %100
17	M229	PX	4.5	4.5	0 %100
18	M219	PX	4.5	4.5	0 %100
19	M227	PX	4.5	4.5	0 %100
20	M221	PX	4.5	4.5	0 %100
21	M232	PX	5.2	5.2	0 %100
22	M233	PX	5.2	5.2	0 %100
23	M231	PX	5.2	5.2	0 %100
24	M168	PX	5.2	5.2	0 %100
25	M180	PX	5.2	5.2	0 %100
26	M182	PX	5.2	5.2	0 %100
27	M230	PX	5.2	5.2	0 %100
28	M239	PX	5.2	5.2	0 %100
29	M179	PX	5.8	5.8	0 %100
30	M235	PX	5.8	5.8	0 %100
31	M234	PX	5.8	5.8	0 %100

Member Area Loads

No Data to Print...

Load Combinations

	Description	Solve	P-Delta	BLC	Factor	BLC	Factor	BLC	Factor	BLC	Factor
1	DL + WL (NO ICE) 0 Degree	Yes	Y	1	1.2			3	1.6		
2	DL + WL (NO ICE) 30 Degree	Yes	Y	1	1.2			3	1.386	4	0.8
3	DL + WL (NO ICE) 60 Degree	Yes	Y	1	1.2			3	0.8	4	1.386
4	DL + WL (NO ICE) 90 Degree	Yes	Y	1	1.2					4	1.6
5	DL + WL (NO ICE) 120 Degree	Yes	Y	1	1.2			3	-0.8	4	1.386
6	DL + WL (NO ICE) 150 Degree	Yes	Y	1	1.2			3	-1.386	4	0.8

Load Combinations (Continued)

	Description	Solve	P-Delta	BLC	Factor	BLC	Factor	BLC	Factor	BLC	Factor
7	DL + WL (NO ICE) 180 Degree	Yes	Y	1	1.2			3	-1.6		
8	DL + WL (NO ICE) 210 Degree	Yes	Y	1	1.2			3	-1.386	4	-0.8
9	DL + WL (NO ICE) 240 Degree	Yes	Y	1	1.2			3	-0.8	4	-1.386
10	DL + WL (NO ICE) 270 Degree	Yes	Y	1	1.2					4	-1.6
11	DL + WL (NO ICE) 300 Degree	Yes	Y	1	1.2			3	0.8	4	-1.386
12	DL + WL (NO ICE) 330 Degree	Yes	Y	1	1.2			3	1.386	4	-0.8
13	DL + DL ICE + WL (ICE) 0 Degree	Yes	Y	1	1.2	2	1	5	1		
14	DL + DL ICE + WL (ICE) 30 Degree	Yes	Y	1	1.2	2	1	5	0.866	6	0.5
15	DL + DL ICE + WL (ICE) 60 Degree	Yes	Y	1	1.2	2	1	5	0.5	6	0.866
16	DL + DL ICE + WL (ICE) 90 Degree	Yes	Y	1	1.2	2	1			6	1
17	DL + DL ICE + WL (ICE) 120 Degree	Yes	Y	1	1.2	2	1	5	-0.5	6	0.866
18	DL + DL ICE + WL (ICE) 150 Degree	Yes	Y	1	1.2	2	1	5	-0.866	6	0.5
19	DL + DL ICE + WL (ICE) 180 Degree	Yes	Y	1	1.2	2	1	5	-1		
20	DL + DL ICE + WL (ICE) 210 Degree	Yes	Y	1	1.2	2	1	5	-0.866	6	-0.5
21	DL + DL ICE + WL (ICE) 240 Degree	Yes	Y	1	1.2	2	1	5	-0.5	6	-0.866
22	DL + DL ICE + WL (ICE) 270 Degree	Yes	Y	1	1.2	2	1			6	-1
23	DL + DL ICE + WL (ICE) 300 Degree	Yes	Y	1	1.2	2	1	5	0.5	6	-0.866
24	DL + DL ICE + WL (ICE) 330 Degree	Yes	Y	1	1.2	2	1	5	0.866	6	-0.5
25	DEAD LOAD + LIVE LOAD1	Yes	Y	1	1.2					7	1.5
26	DEAD LOAD + LIVE LOAD2	Yes	Y	1	1.2					8	1.5
27	DEAD LOAD + LIVE LOAD3	Yes	Y	1	1.2					9	1.5
28	DL + MAIN L1+30MPH WL FRONT	Yes	Y	1	1.2	10	1.5	3	0.113		
29	DL + MAIN L2+30MPH WL FRONT	Yes	Y	1	1.2	11	1.5	3	0.113		
30	DL + MAIN L3+30MPH WL FRONT	Yes	Y	1	1.2	12	1.5	3	0.113		
31	DL + MAIN L4+30MPH WL FRONT	Yes	Y	1	1.2	13	1.5	3	0.113		
32	DL + MAIN L1+30MPH WL SIDE	Yes	Y	1	1.2	10	1.5	4	0.113		
33	DL + MAIN L2+30MPH WL SIDE	Yes	Y	1	1.2	11	1.5	4	0.113		
34	DL + MAIN L3+30MPH WL SIDE	Yes	Y	1	1.2	12	1.5	4	0.113		
35	DL + MAIN L4+30MPH WL SIDE	Yes	Y	1	1.2	13	1.5	4	0.113		
36	DL + MAIN L1+30MPH WL FRONT (REVERSED)	Yes	Y	1	1.2	10	1.5	3	-0.113		
37	DL + MAIN L2+30MPH WL FRONT (REVERSED)	Yes	Y	1	1.2	11	1.5	3	-0.113		
38	DL + MAIN L3+30MPH WL FRONT (REVERSED)	Yes	Y	1	1.2	12	1.5	3	-0.113		
39	DL + MAIN L4+30MPH WL FRONT (REVERSED)	Yes	Y	1	1.2	13	1.5	3	-0.113		
40	DL + MAIN L1+30MPH WL SIDE (REVERSED)	Yes	Y	1	1.2	10	1.5	4	-0.113		
41	DL + MAIN L2+30MPH WL SIDE (REVERSED)	Yes	Y	1	1.2	11	1.5	4	-0.113		
42	DL + MAIN L3+30MPH WL SIDE (REVERSED)	Yes	Y	1	1.2	12	1.5	4	-0.113		
43	DL + MAIN L4+30MPH WL SIDE (REVERSED)	Yes	Y	1	1.2	13	1.5	4	-0.113		

Envelope Node Reactions

Node Label	X [lb]	LC	Y [lb]	LC	Z [lb]	LC	MX [k-ft]	LC	MY [k-ft]	LC	MZ [k-ft]	LC		
1	N452	max	3791.151	24	580.367	7	2332.216	13	0	43	0	43	0	43
2		min	297.619	5	-2500.086	13	-14.124	6	0	1	0	1	0	1
3	N487	max	-201.905	11	2534.734	19	2760.137	19	0	43	0	43	0	43
4		min	-3838.696	18	-680.204	1	108.08	12	0	1	0	1	0	1
5	N496	max	3814.414	20	2944.451	19	2537.666	19	0	43	0	43	0	43
6		min	191.892	3	-345.468	12	158.376	2	0	1	0	1	0	1
7	N500	max	-284.927	9	252.723	6	2081.878	13	0	43	0	43	0	43
8		min	-3768.054	14	-2909.019	13	24.565	8	0	1	0	1	0	1
9	N506	max	1247.055	43	-69.902	7	2829.057	19	0	43	0	43	0	43
10		min	-780.603	32	-3188.4	13	185.999	1	0	1	0	1	0	1
11	N507	max	783.672	40	3190.198	19	2823.777	13	0	43	0	43	0	43
12		min	-1250.105	35	65.698	1	190.295	7	0	1	0	1	0	1
13	N524	max	1052.132	10	662.362	10	91.711	22	0	43	0	43	0	43
14		min	-1051.999	4	-665.217	4	18.938	4	0	1	0	1	0	1
15	N525	max	1047.643	10	659.614	4	89.168	16	0	43	0	43	0	43
16		min	-1047.776	4	-662.465	10	18.556	10	0	1	0	1	0	1
17	Totals:	max	6216.501	10	6566.211	7	14526.062	24						
18		min	-6216.446	4	-6566.193	1	4450.371	8						

Envelope Node Displacements

Node Label	X [in]	LC	Y [in]	LC	Z [in]	LC	X Rotation [rad]	LC	Y Rotation [rad]	LC	Z Rotation [rad]	LC		
1	N393	max	0.036	5	0.114	1	-0.027	36	8.031e-4	1	-1.158e-4	28	6.398e-3	7
2		min	-0.05	11	-0.119	7	-0.111	16	-1.037e-3	7	-1.335e-3	21	-6.293e-3	1
3	N394	max	0.119	4	0.094	11	-0.318	32	-1.681e-3	40	1.656e-3	4	1.476e-3	22
4		min	-0.174	10	-0.048	5	-1.256	17	-7.647e-3	17	-4.513e-3	22	-1.88e-4	3
5	N395	max	0.026	4	0.038	4	0.003	19	2.256e-4	2	3.494e-5	10	2.525e-3	5
6		min	-0.025	10	-0.047	10	0	1	-2.105e-3	20	-6.413e-4	16	-2.845e-3	11
7	N396	max	0.066	4	0.045	12	-0.095	35	3.6e-4	12	1.114e-2	22	1.61e-3	4
8		min	-0.08	10	-0.042	6	-0.688	22	-1.248e-3	36	2.075e-3	35	-1.771e-3	10
9	N397	max	0.062	4	0.413	23	-0.065	40	-3.539e-3	40	6.04e-4	4	1.578e-3	10
10		min	-0.088	10	0.068	5	-0.266	16	-1.38e-2	15	-2.103e-3	22	-1.582e-3	4
11	N398	max	0.208	4	0.143	16	-0.252	35	-9.738e-4	35	3.712e-3	4	2.743e-4	10
12		min	-0.151	10	-0.034	10	-1.102	21	-6.101e-3	22	-1.964e-3	10	-1.177e-3	16
13	N399	max	0.036	4	0.362	1	-0.105	1	2.258e-3	1	3.841e-3	18	4.328e-3	1
14		min	-0.031	10	-0.373	7	-0.374	19	-2.475e-3	7	1.025e-3	12	-4.451e-3	7
15	N400	max	0.048	4	0.089	11	-0.065	40	-3.539e-3	40	4.878e-4	4	1.578e-3	10
16		min	-0.045	10	-0.044	5	-0.266	16	-1.379e-2	16	-2.043e-3	22	-1.582e-3	4
17	N401	max	0.077	4	-0.046	4	-0.052	35	-2.947e-3	43	1.971e-3	10	1.605e-3	10
18		min	-0.091	10	-0.364	21	-0.238	22	-1.251e-2	18	-1.12e-3	4	-1.537e-3	4
19	N402	max	0.361	4	0.321	15	-0.213	35	8.055e-4	7	1.121e-2	4	6.92e-4	10
20		min	-0.304	10	-0.019	9	-0.916	21	-1.11e-2	13	-9.745e-3	10	-1.398e-3	16
21	N403	max	0.083	4	0.083	2	-0.183	40	6.207e-4	1	-3.07e-3	28	1.948e-3	3
22		min	-0.066	10	-0.092	8	-0.852	16	-1.547e-3	26	-1.304e-2	18	-1.718e-3	9
23	N404	max	0.196	4	0.051	11	-0.349	40	-5.899e-4	32	1.863e-4	10	5.671e-4	8
24		min	-0.127	10	-0.096	5	-1.415	17	-4.009e-3	22	-5.432e-3	16	-7.236e-4	2
25	N405	max	0.305	4	0.024	3	-0.213	35	8.597e-4	1	1.122e-2	10	1.409e-3	22
26		min	-0.364	10	-0.32	21	-0.917	21	-1.09e-2	19	-9.75e-3	4	-7.003e-4	4
27	N406	max	0.295	4	0.025	3	-0.213	35	8.596e-4	1	1.122e-2	10	1.409e-3	22
28		min	-0.353	10	-0.309	21	-0.917	21	-1.09e-2	19	-9.75e-3	4	-7.003e-4	4
29	N407	max	0.065	4	0.108	10	-0.345	36	6.288e-4	18	-2.597e-3	32	1.853e-3	3
30		min	-0.081	10	-0.055	4	-1.522	17	-2.061e-3	31	-1.141e-2	22	-3.22e-3	9
31	N408	max	0.215	16	0.09	32	-0.228	35	1.058e-3	43	6.286e-3	16	2.431e-3	4
32		min	-0.083	10	-0.075	10	-1.253	21	-1.82e-3	32	7.105e-4	43	-1.276e-3	10
33	N409	max	0.116	4	0.089	11	-0.262	40	-2.937e-3	32	2.467e-3	4	1.686e-3	22
34		min	-0.15	10	-0.047	5	-1.025	17	-1.211e-2	22	-4.531e-3	10	-5.883e-4	4
35	N410	max	0.059	4	0.081	2	-0.184	40	2.323e-4	1	1.482e-5	32	1.909e-3	3
36		min	-0.081	10	-0.087	8	-0.854	17	-9.424e-4	39	-3.473e-3	20	-1.749e-3	9
37	N411	max	0.141	4	0.053	11	-0.344	40	4.823e-4	40	-1.35e-3	40	2.494e-3	4
38		min	-0.096	10	-0.103	5	-1.487	17	-2.894e-3	26	-7.777e-3	16	-1.318e-3	10
39	N412	max	0.006	3	0.109	1	-0.016	35	7.255e-4	1	5.078e-3	21	5.097e-3	1
40		min	-0.122	21	-0.139	7	-0.082	22	-1.583e-3	19	1.315e-3	2	-5.037e-3	7
41	N413	max	0.027	5	0.092	11	0.043	15	-2.393e-3	40	-2.365e-4	4	2.878e-4	6
42		min	-0.044	11	-0.048	5	0.005	27	-9.44e-3	15	-2.291e-3	22	-2.376e-3	24
43	N414	max	0.087	3	0.069	3	-0.031	40	1.76e-3	1	-1.77e-3	40	2.278e-3	8
44		min	-0.072	9	-0.073	9	-0.195	16	-2.644e-3	7	-9.848e-3	15	-2.416e-3	2
45	N415	max	0.032	4	0.08	4	0.002	43	-1.932e-3	35	1.895e-3	16	1.924e-3	15
46		min	-0.032	10	-0.055	10	-0.011	17	-8.497e-3	23	-4.973e-5	10	-1.119e-4	9
47	N416	max	0.038	4	0.07	11	-0.065	40	-1.085e-3	32	5.114e-4	10	1.568e-3	10
48		min	-0.045	10	-0.073	5	-0.266	16	-5.35e-3	23	-7.173e-4	4	-1.59e-3	4
49	N417	max	0.074	3	0.057	4	-0.197	35	1.222e-3	16	9.868e-3	22	1.806e-3	5
50		min	-0.053	9	-0.082	10	-1.206	22	-2.092e-3	25	1.888e-3	35	-3.014e-3	11
51	N418	max	0.137	4	0.057	4	-0.265	31	8.599e-5	43	4.233e-3	22	2.347e-4	40
52		min	-0.181	10	-0.082	10	-1.217	21	-2.999e-3	32	-3.852e-4	4	-2.434e-4	35
53	N419	max	0.043	5	0.122	1	-0.027	36	1.372e-3	1	-1.41e-3	2	6.411e-3	7
54		min	-0.042	11	-0.129	7	-0.111	16	-1.772e-3	7	-5.904e-3	20	-6.305e-3	1
55	N420	max	0.034	4	0.122	1	-0.028	28	1.372e-3	1	-1.41e-3	2	6.411e-3	7
56		min	-0.033	10	-0.129	7	-0.114	19	-1.772e-3	7	-5.904e-3	20	-6.305e-3	1
57	N421	max	0.144	4	0.08	4	-0.212	35	-2.215e-3	43	4.259e-3	4	6.92e-4	10
58		min	-0.121	10	-0.055	10	-0.91	22	-1.045e-2	16	-2.802e-3	10	-1.398e-3	16
59	N422	max	0.119	4	0.608	1	-0.118	25	1.116e-2	1	3.053e-3	10	3.333e-3	7
60		min	-0.075	10	-0.621	7	-0.407	19	-1.121e-2	7	-4.85e-3	4	-3.216e-3	1
61	N423	max	0.276	16	0.194	2	-0.031	40	8.667e-3	1	6.665e-4	10	2.278e-3	8
62		min	-0.059	10	-0.218	8	-0.196	16	-9.548e-3	7	-1.037e-2	16	-2.416e-3	2
63	N424	max	0.094	4	0.1	11	-0.344	40	4.814e-4	32	-1.358e-3	32	1.319e-3	4
64		min	-0.139	10	-0.051	5	-1.487	17	-2.401e-3	43	-7.704e-3	22	-2.464e-3	10
65	N425	max	0.065	4	0.094	11	-0.329	40	6.288e-4	18	-2.597e-3	32	1.853e-3	3

Envelope Node Displacements (Continued)

Node Label		X [in]	LC	Y [in]	LC	Z [in]	LC	X Rotation [rad]	LC	Y Rotation [rad]	LC	Z Rotation [rad]	LC	
66		min	-0.081	10	-0.048	5	-1.454	17	-2.061e-3	31	-1.141e-2	22	-3.22e-3	9
67	N426	max	0.024	4	0.045	4	0.003	19	1.059e-4	7	1.44e-5	32	2.821e-3	5
68		min	-0.024	10	-0.036	10	0	12	-2.028e-3	13	-6.039e-4	22	-2.467e-3	11
69	N427	max	0.04	4	0.093	1	-0.016	35	6.094e-4	1	5.061e-3	19	5.097e-3	1
70		min	-0.032	10	-0.102	7	-0.082	22	-1.524e-3	19	1.325e-3	1	-5.037e-3	7
71	N428	max	0.033	5	0.4	1	-0.118	25	4.044e-3	7	-4.458e-4	4	3.231e-3	7
72		min	-0.036	11	-0.403	7	-0.406	19	-4.084e-3	1	-3.116e-3	22	-3.218e-3	1
73	N429	max	0.128	4	0.057	4	-0.252	35	-9.782e-4	39	3.782e-3	10	1.184e-3	22
74		min	-0.166	10	-0.082	10	-1.112	21	-6.046e-3	15	-2.e-3	4	-2.889e-4	4
75	N430	max	0.077	4	0.083	2	-0.184	40	6.207e-4	1	-3.07e-3	28	1.948e-3	3
76		min	-0.061	10	-0.092	8	-0.854	17	-1.547e-3	26	-1.304e-2	18	-1.718e-3	9
77	N431	max	0.177	4	0.05	11	-0.317	40	-1.687e-3	32	1.708e-3	10	2.03e-4	9
78		min	-0.12	10	-0.096	5	-1.259	17	-7.586e-3	22	-4.526e-3	16	-1.487e-3	16
79	N432	max	0.151	17	0.157	1	-0.027	36	1.488e-3	1	-1.452e-3	1	6.411e-3	7
80		min	-0.002	11	-0.173	7	-0.111	16	-1.888e-3	7	-5.901e-3	18	-6.305e-3	1
81	N433	max	0.187	16	0.069	10	-0.003	35	-1.309e-4	7	7.427e-3	18	1.318e-3	11
82		min	-0.038	10	-0.038	4	-0.139	22	-1.516e-3	13	5.497e-4	43	-1.43e-3	5
83	N434	max	0.033	4	0.057	4	0.004	5	-1.929e-3	31	1.868e-3	22	1.327e-4	3
84		min	-0.033	10	-0.081	10	-0.011	24	-8.556e-3	19	-1.077e-4	4	-1.917e-3	21
85	N435	max	0.229	4	0.02	11	-0.316	40	-1.687e-3	32	1.722e-3	10	2.03e-4	9
86		min	-0.141	10	-0.187	17	-1.245	17	-7.588e-3	21	-4.533e-3	16	-1.487e-3	16
87	N436	max	0.291	4	0.382	23	-0.262	40	5.821e-5	7	9.41e-3	4	1.686e-3	22
88		min	-0.374	10	-0.007	6	-1.025	17	-1.277e-2	13	-1.148e-2	10	-5.883e-4	4
89	N437	max	0.083	4	0.05	11	-0.328	40	6.082e-4	23	-2.588e-3	40	3.25e-3	3
90		min	-0.066	10	-0.096	5	-1.456	17	-3.187e-3	26	-1.151e-2	16	-1.863e-3	9
91	N438	max	0.031	3	0.097	1	-0.016	35	4.847e-4	7	5.026e-3	23	4.875e-3	1
92		min	-0.038	9	-0.092	7	-0.081	22	-1.413e-3	13	1.341e-3	6	-5.112e-3	7
93	N439	max	0.076	4	0.056	12	-0.095	35	-6.472e-5	27	-1.461e-3	41	1.708e-3	4
94		min	-0.076	10	-0.056	6	-0.69	22	-3.956e-4	18	-6.137e-3	17	-1.707e-3	10
95	N440	max	0.065	4	0.091	2	-0.183	40	6.123e-4	7	-3.072e-3	40	1.696e-3	3
96		min	-0.081	10	-0.083	8	-0.852	17	-1.538e-3	31	-1.304e-2	16	-1.919e-3	9
97	N441	max	0.028	4	0.102	23	-0.002	32	-2.393e-3	40	-2.369e-4	4	2.88e-4	6
98		min	-0.036	10	-0.049	5	-0.028	21	-9.441e-3	15	-2.292e-3	22	-2.376e-3	24
99	N442	max	0.003	4	0.036	11	-0.095	35	2.541e-4	6	1.118e-2	22	1.805e-3	4
100		min	-0.277	22	-0.046	32	-0.689	22	-1.211e-3	28	2.078e-3	35	-1.643e-3	10
101	N443	max	0.05	4	0.057	4	-0.051	43	-2.948e-3	43	1.813e-3	10	1.605e-3	10
102		min	-0.045	10	-0.082	10	-0.233	20	-1.247e-2	17	-9.612e-4	4	-1.537e-3	4
103	N444	max	0	43	0	43	0	43	0	43	0	43	0	43
104		min	0	1	0	1	0	1	0	1	0	1	0	1
105	N445	max	0.044	4	0.08	4	-0.051	35	-2.936e-3	35	1.761e-3	4	1.551e-3	10
106		min	-0.05	10	-0.055	10	-0.234	22	-1.249e-2	22	-9.124e-4	10	-1.594e-3	4
107	N446	max	0.126	4	0.094	11	-0.349	40	-5.859e-4	40	1.121e-4	4	7.305e-4	8
108		min	-0.193	10	-0.049	5	-1.415	17	-4.048e-3	16	-5.39e-3	22	-5.536e-4	2
109	N447	max	0.024	4	0.041	4	0.003	19	2.257e-4	8	3.262e-4	2	3.124e-3	4
110		min	-0.022	10	-0.038	10	0	12	-9.258e-4	14	-2.24e-4	39	-2.874e-3	10
111	N448	max	0.377	4	0.011	12	-0.262	40	1.203e-4	1	9.42e-3	10	5.974e-4	10
112		min	-0.292	10	-0.382	17	-1.026	17	-1.254e-2	18	-1.149e-2	4	-1.702e-3	16
113	N449	max	0.024	4	0.05	4	0.003	19	1.065e-4	7	1.444e-5	32	2.821e-3	5
114		min	-0.027	10	-0.034	10	0	12	-2.028e-3	13	-6.042e-4	22	-2.467e-3	11
115	N450	max	0.032	4	0.045	4	0.009	14	1.059e-4	7	1.44e-5	32	2.821e-3	5
116		min	-0.032	10	-0.036	10	0.001	8	-2.028e-3	13	-6.039e-4	22	-2.467e-3	11
117	N451	max	0.082	4	-0.003	1	-0.009	1	-2.826e-4	1	1.367e-3	40	3.288e-3	9
118		min	-0.067	10	-0.015	19	-0.034	19	-2.104e-3	19	-2.273e-3	35	-3.665e-3	3
119	N452	max	0	5	0	13	0	6	2.257e-4	8	3.262e-4	2	3.124e-3	4
120		min	0	24	0	7	0	13	-9.258e-4	14	-2.24e-4	39	-2.874e-3	10
121	N453	max	0.119	4	0.096	11	-0.316	40	-1.681e-3	40	1.656e-3	4	1.476e-3	22
122		min	-0.174	10	-0.048	5	-1.246	17	-7.647e-3	17	-4.513e-3	22	-1.88e-4	3
123	N454	max	0.071	4	-0.003	1	-0.008	2	-2.826e-4	1	1.367e-3	40	3.288e-3	9
124		min	-0.057	10	-0.015	19	-0.028	20	-2.104e-3	19	-2.273e-3	35	-3.665e-3	3
125	N455	max	0.085	4	0.048	10	-0.003	35	-2.855e-4	1	7.426e-3	22	1.442e-3	11
126		min	-0.071	10	-0.06	4	-0.139	22	-1.456e-3	18	5.51e-4	39	-1.327e-3	5
127	N456	max	0.081	4	0.057	4	-0.204	35	1.223e-3	16	9.868e-3	22	1.806e-3	5
128		min	-0.068	10	-0.082	10	-1.212	22	-2.092e-3	25	1.888e-3	35	-3.015e-3	11
129	N457	max	0.153	4	0.05	11	-0.26	32	-2.883e-3	11	2.515e-3	10	5.974e-4	10
130		min	-0.117	10	-0.096	5	-1.014	18	-1.216e-2	17	-4.592e-3	4	-1.702e-3	16

Envelope Node Displacements (Continued)

Node Label	X [in]	LC	Y [in]	LC	Z [in]	LC	X Rotation [rad]	LC	Y Rotation [rad]	LC	Z Rotation [rad]	LC		
131	N458	max	0.037	4	0.05	11	0.001	9	-2.397e-3	28	-1.759e-4	10	2.366e-3	18
132		min	-0.029	10	-0.095	5	-0.022	27	-9.518e-3	19	-2.254e-3	16	-3.034e-4	12
133	N459	max	0.179	4	0.08	4	-0.264	35	9.006e-5	35	4.188e-3	16	2.433e-4	43
134		min	-0.136	10	-0.055	10	-1.219	21	-3.003e-3	40	-3.129e-4	10	-2.371e-4	32
135	N460	max	0.057	4	0	13	-0.008	8	-5.3e-4	8	1.041e-3	32	4.244e-3	10
136		min	-0.065	10	0	7	-0.027	15	-1.796e-3	15	-1.716e-3	43	-3.739e-3	4
137	N461	max	0.052	3	0.08	4	-0.198	31	1.233e-3	22	9.781e-3	17	2.992e-3	5
138		min	-0.073	9	-0.055	10	-1.203	21	-1.55e-3	32	1.896e-3	43	-1.792e-3	11
139	N462	max	0.06	4	0.091	2	-0.184	40	6.123e-4	7	-3.072e-3	40	1.696e-3	3
140		min	-0.076	10	-0.083	8	-0.854	17	-1.538e-3	31	-1.304e-2	16	-1.919e-3	9
141	N463	max	0.083	4	0.056	10	-0.344	40	6.082e-4	23	-2.589e-3	40	3.25e-3	3
142		min	-0.066	10	-0.111	4	-1.525	17	-3.187e-3	26	-1.151e-2	16	-1.863e-3	9
143	N464	max	0.022	4	0.039	4	0.003	19	3.555e-4	2	3.403e-4	8	2.936e-3	4
144		min	-0.024	10	-0.042	10	0	1	-9.891e-4	20	-2.377e-4	31	-3.152e-3	10
145	N465	max	0.026	4	0.035	10	0.004	19	-1.803e-5	12	9.003e-5	28	3.414e-3	4
146		min	-0.02	10	-0.046	4	-0.002	27	-1.602e-3	18	-6.111e-4	17	-2.663e-3	10
147	N466	max	0.08	4	0.086	2	-0.184	40	2.143e-4	7	2.201e-5	40	1.735e-3	3
148		min	-0.059	10	-0.081	8	-0.854	17	-9.492e-4	31	-3.504e-3	16	-1.888e-3	9
149	N467	max	0.037	4	0.051	11	-0.001	9	-2.397e-3	28	-1.762e-4	10	2.366e-3	18
150		min	-0.029	10	-0.104	17	-0.034	27	-9.518e-3	19	-2.255e-3	16	-3.039e-4	12
151	N468	max	0.033	4	0.058	4	0.004	5	-1.929e-3	31	1.869e-3	22	1.33e-4	3
152		min	-0.033	10	-0.087	10	-0.022	23	-8.556e-3	19	-1.073e-4	4	-1.917e-3	21
153	N469	max	0.034	4	0.057	4	0.044	18	-1.929e-3	31	1.868e-3	22	1.332e-4	3
154		min	-0.039	10	-0.081	10	0.003	11	-8.555e-3	19	-1.077e-4	4	-1.917e-3	21
155	N470	max	0.081	4	0.067	4	-0.215	35	1.223e-3	16	9.87e-3	22	1.806e-3	5
156		min	-0.068	10	-0.1	10	-1.271	22	-2.092e-3	25	1.889e-3	35	-3.014e-3	11
157	N471	max	0.045	5	0.05	11	0.046	20	-2.397e-3	28	-1.759e-4	10	2.366e-3	18
158		min	-0.029	11	-0.095	5	-0.007	27	-9.517e-3	19	-2.254e-3	16	-3.037e-4	12
159	N472	max	0.022	4	0.061	23	0.004	19	-3.396e-4	6	3.104e-4	32	2.116e-3	4
160		min	-0.028	10	-0.028	5	-0.002	27	-2.694e-3	13	-2.154e-4	27	-2.983e-3	10
161	N473	max	0.064	4	0.05	11	-0.325	40	6.071e-4	23	-2.588e-3	40	3.25e-3	3
162		min	-0.056	10	-0.096	5	-1.454	17	-3.289e-3	26	-1.151e-2	16	-1.862e-3	9
163	N474	max	0.366	4	0.011	12	-0.262	40	1.203e-4	1	9.42e-3	10	5.974e-4	10
164		min	-0.282	10	-0.369	17	-1.026	17	-1.254e-2	18	-1.149e-2	4	-1.702e-3	16
165	N475	max	0.033	4	0.038	4	0.009	19	2.256e-4	2	3.494e-5	10	2.525e-3	5
166		min	-0.033	10	-0.047	10	-0.001	1	-2.105e-3	20	-6.413e-4	16	-2.845e-3	11
167	N476	max	0.196	4	0.05	11	-0.347	28	-5.899e-4	32	1.863e-4	10	5.671e-4	8
168		min	-0.127	10	-0.096	5	-1.398	17	-4.009e-3	22	-5.432e-3	16	-7.236e-4	2
169	N477	max	0.111	4	0.057	4	-0.226	35	1.06e-3	35	6.297e-3	22	1.279e-3	4
170		min	-0.124	10	-0.082	10	-1.234	21	-2.141e-3	25	7.111e-4	35	-2.455e-3	10
171	N478	max	0.053	4	0.031	13	-0.008	9	-2.855e-4	7	1.362e-3	32	3.631e-3	9
172		min	-0.073	10	0.005	7	-0.028	16	-2.108e-3	13	-2.269e-3	39	-3.235e-3	3
173	N479	max	0.065	4	0.015	13	-0.009	7	-2.862e-4	7	1.362e-3	32	3.631e-3	9
174		min	-0.08	10	0.003	7	-0.034	13	-2.107e-3	13	-2.269e-3	39	-3.235e-3	3
175	N480	max	0.028	4	0.092	11	0	32	-2.393e-3	40	-2.365e-4	4	2.875e-4	6
176		min	-0.036	10	-0.048	5	-0.015	21	-9.441e-3	15	-2.291e-3	22	-2.376e-3	24
177	N481	max	0.041	5	0.123	1	-0.027	40	1.23e-3	7	-1.432e-3	8	6.327e-3	7
178		min	-0.042	11	-0.121	7	-0.111	16	-1.624e-3	1	-5.87e-3	15	-6.227e-3	1
179	N482	max	0.282	4	0.011	11	-0.349	40	-5.899e-4	32	3.45e-4	10	5.671e-4	8
180		min	-0.134	10	-0.184	17	-1.415	17	-4.041e-3	20	-5.496e-3	16	-7.236e-4	2
181	N483	max	0.066	4	0.08	4	-0.204	35	1.234e-3	22	9.781e-3	17	2.993e-3	5
182		min	-0.08	10	-0.055	10	-1.21	21	-1.55e-3	32	1.896e-3	43	-1.793e-3	11
183	N484	max	0.055	4	0.015	13	-0.008	9	-2.862e-4	7	1.362e-3	32	3.631e-3	9
184		min	-0.069	10	0.003	7	-0.028	16	-2.107e-3	13	-2.269e-3	39	-3.235e-3	3
185	N485	max	0.05	4	0.052	4	-0.052	35	-2.948e-3	43	1.813e-3	10	1.605e-3	10
186		min	-0.045	10	-0.077	10	-0.238	22	-1.247e-2	17	-9.612e-4	4	-1.537e-3	4
187	N486	max	0.032	4	0.085	4	0.002	10	-1.932e-3	35	1.896e-3	16	1.924e-3	15
188		min	-0.032	10	-0.055	10	-0.022	17	-8.497e-3	23	-4.935e-5	10	-1.122e-4	9
189	N487	max	0	18	0	1	0	12	3.555e-4	2	3.403e-4	8	2.936e-3	4
190		min	0	11	0	19	0	19	-9.891e-4	20	-2.377e-4	31	-3.152e-3	10
191	N488	max	0.089	4	0.36	16	-0.052	35	-2.936e-3	35	1.92e-3	4	1.551e-3	10
192		min	-0.075	10	0.05	10	-0.238	22	-1.251e-2	23	-1.071e-3	10	-1.594e-3	4
193	N489	max	0.066	4	0.098	4	-0.216	31	1.234e-3	22	9.782e-3	17	2.992e-3	5
194		min	-0.08	10	-0.065	10	-1.269	21	-1.55e-3	32	1.897e-3	43	-1.793e-3	11
195	N490	max	0.35	4	0.31	15	-0.213	35	8.055e-4	7	1.121e-2	4	6.92e-4	10

Envelope Node Displacements (Continued)

Node Label		X [in]	LC	Y [in]	LC	Z [in]	LC	X Rotation [rad]	LC	Y Rotation [rad]	LC	Z Rotation [rad]	LC	
196		min	-0.294	10	-0.02	9	-0.916	21	-1.11e-2	13	-9.745e-3	10	-1.398e-3	16
197	N491	max	0.122	4	0.08	4	-0.226	35	1.058e-3	43	6.225e-3	16	2.431e-3	4
198		min	-0.109	10	-0.055	10	-1.235	21	-1.82e-3	32	7.186e-4	43	-1.276e-3	10
199	N492	max	0.038	4	0.08	4	0.042	23	-1.932e-3	35	1.895e-3	16	1.924e-3	15
200		min	-0.032	10	-0.055	10	0.004	5	-8.496e-3	23	-4.973e-5	10	-1.124e-4	9
201	N493	max	0.055	4	0.094	11	-0.326	36	6.277e-4	18	-2.597e-3	32	1.852e-3	3
202		min	-0.063	10	-0.048	5	-1.45	16	-2.062e-3	31	-1.141e-2	22	-3.22e-3	9
203	N494	max	0.164	4	0.081	4	-0.253	43	-9.738e-4	35	3.697e-3	4	2.743e-4	10
204		min	-0.127	10	-0.055	10	-1.109	21	-6.103e-3	21	-1.95e-3	10	-1.177e-3	16
205	N495	max	0.076	4	0.061	10	-0.003	35	-2.049e-4	7	7.425e-3	20	1.318e-3	11
206		min	-0.077	10	-0.046	4	-0.139	22	-1.478e-3	13	5.501e-4	31	-1.43e-3	5
207	N496	max	0	3	0	12	0	2	-1.803e-5	12	9.003e-5	28	3.414e-3	4
208		min	0	20	0	19	0	19	-1.602e-3	18	-6.111e-4	17	-2.663e-3	10
209	N497	max	0.075	4	-0.005	1	-0.008	2	-2.82e-4	1	1.367e-3	40	3.288e-3	9
210		min	-0.055	10	-0.031	19	-0.028	20	-2.104e-3	19	-2.273e-3	35	-3.665e-3	3
211	N498	max	0.352	16	0.097	2	-0.184	40	7.368e-4	1	-3.07e-3	28	1.948e-3	3
212		min	0.037	10	-0.117	8	-0.854	17	-1.547e-3	26	-1.308e-2	17	-1.718e-3	9
213	N499	max	0.066	4	0	1	-0.008	2	-5.273e-4	2	1.045e-3	40	3.795e-3	10
214		min	-0.058	10	0	19	-0.027	19	-1.797e-3	19	-1.72e-3	35	-4.305e-3	4
215	N500	max	0	14	0	13	0	8	-1.204e-4	6	8.512e-5	36	2.599e-3	4
216		min	0	9	0	6	0	13	-1.507e-3	24	-5.879e-4	24	-3.385e-3	10
217	N501	max	0.07	3	0.072	3	-0.031	40	1.764e-3	7	-1.776e-3	28	2.411e-3	8
218		min	-0.086	9	-0.068	9	-0.195	16	-2.645e-3	1	-9.831e-3	19	-2.262e-3	2
219	N502	max	0.028	4	0.033	11	0.004	19	-2.35e-4	12	3.204e-4	40	3.006e-3	4
220		min	-0.022	10	-0.054	5	-0.002	27	-2.8e-3	18	-3.753e-4	27	-2.172e-3	10
221	N503	max	0.111	4	0.061	4	-0.228	35	1.06e-3	35	6.297e-3	22	1.279e-3	4
222		min	-0.124	10	-0.089	10	-1.253	21	-2.141e-3	25	7.111e-4	35	-2.455e-3	10
223	N504	max	0.037	4	0.033	11	0.012	19	-2.35e-4	12	3.204e-4	40	3.006e-3	4
224		min	-0.029	10	-0.054	5	0	27	-2.8e-3	18	-3.753e-4	27	-2.172e-3	10
225	N505	max	0.122	4	0.055	4	-0.213	35	-2.156e-3	3	4.319e-3	10	1.409e-3	22
226		min	-0.146	10	-0.078	10	-0.916	21	-1.05e-2	21	-2.846e-3	4	-7.003e-4	4
227	N506	max	0	32	0	13	0	1	-5.3e-4	8	1.041e-3	32	4.244e-3	10
228		min	0	43	0	7	0	19	-1.796e-3	15	-1.716e-3	43	-3.739e-3	4
229	N507	max	0	35	0	1	0	7	-5.273e-4	2	1.045e-3	40	3.795e-3	10
230		min	0	40	0	19	0	13	-1.797e-3	19	-1.72e-3	35	-4.305e-3	4
231	N508	max	0.028	4	0.051	11	0.012	24	-3.402e-4	6	3.104e-4	32	2.116e-3	4
232		min	-0.036	10	-0.031	5	0	27	-2.694e-3	13	-2.154e-4	27	-2.983e-3	10
233	N509	max	0.021	4	0.051	11	0.004	19	-3.402e-4	6	3.104e-4	32	2.116e-3	4
234		min	-0.027	10	-0.031	5	-0.002	27	-2.694e-3	13	-2.154e-4	27	-2.983e-3	10
235	N510	max	0.03	4	0.03	11	0.004	19	-2.344e-4	12	3.204e-4	40	3.006e-3	4
236		min	-0.024	10	-0.065	17	-0.002	27	-2.8e-3	18	-3.753e-4	27	-2.172e-3	10
237	N511	max	0.029	4	0.036	4	0.003	19	2.262e-4	2	3.556e-5	10	2.525e-3	5
238		min	-0.025	10	-0.052	10	0	1	-2.105e-3	20	-6.415e-4	16	-2.845e-3	11
239	N512	max	0.02	4	0.044	10	0.004	19	-1.204e-4	6	8.512e-5	36	2.599e-3	4
240		min	-0.026	10	-0.035	4	-0.002	27	-1.507e-3	24	-5.879e-4	24	-3.385e-3	10
241	N513	max	0.091	4	-0.063	11	-0.065	40	-3.551e-3	32	6.558e-4	10	1.566e-3	10
242		min	-0.063	10	-0.419	17	-0.266	16	-1.381e-2	20	-2.066e-3	16	-1.591e-3	4
243	N514	max	0.048	4	0.093	11	-0.064	40	-3.539e-3	40	4.878e-4	4	1.578e-3	10
244		min	-0.045	10	-0.048	5	-0.261	16	-1.379e-2	16	-2.043e-3	22	-1.582e-3	4
245	N515	max	0.177	4	0.05	11	-0.316	40	-1.687e-3	32	1.708e-3	10	2.03e-4	9
246		min	-0.12	10	-0.098	5	-1.245	17	-7.586e-3	22	-4.526e-3	16	-1.487e-3	16
247	N516	max	0.281	4	0.369	23	-0.262	40	5.82e-5	7	9.41e-3	4	1.686e-3	22
248		min	-0.363	10	-0.007	6	-1.025	17	-1.277e-2	13	-1.148e-2	10	-5.883e-4	4
249	N517	max	0.128	4	0.058	4	-0.252	35	-9.782e-4	39	3.782e-3	10	1.184e-3	22
250		min	-0.166	10	-0.085	10	-1.101	21	-6.046e-3	15	-2.e-3	4	-2.889e-4	4
251	N518	max	0.164	4	0.083	4	-0.252	35	-9.738e-4	35	3.697e-3	4	2.743e-4	10
252		min	-0.127	10	-0.056	10	-1.102	21	-6.103e-3	21	-1.95e-3	10	-1.177e-3	16
253	N519	max	0.152	4	0.037	4	-0.252	35	-9.792e-4	39	3.797e-3	10	1.184e-3	22
254		min	-0.212	10	-0.145	22	-1.101	21	-6.044e-3	17	-2.015e-3	4	-2.889e-4	4
255	N520	max	0.139	4	0.184	23	-0.316	40	-1.681e-3	40	1.67e-3	4	1.476e-3	22
256		min	-0.225	10	-0.017	5	-1.246	17	-7.645e-3	16	-4.521e-3	22	-1.88e-4	3
257	N521	max	0.055	4	0.218	2	-0.031	40	8.705e-3	7	5.506e-4	4	2.411e-3	8
258		min	-0.276	22	-0.194	8	-0.196	16	-9.588e-3	1	-1.05e-2	22	-2.262e-3	2
259	N522	max	0.072	4	0.099	10	-0.316	40	2.041e-4	40	-4.612e-4	40	5.808e-4	11
260		min	-0.071	10	-0.099	4	-1.246	17	-9.36e-4	35	-3.415e-3	17	-5.792e-4	5

Envelope Node Displacements (Continued)

Node Label		X [in]	LC	Y [in]	LC	Z [in]	LC	X Rotation [rad]	LC	Y Rotation [rad]	LC	Z Rotation [rad]	LC	
261	N523	max	0.071	4	0.099	4	-0.252	35	5.019e-4	35	2.47e-3	22	7.999e-4	8
262		min	-0.071	10	-0.099	10	-1.102	21	-6.38e-4	40	4.568e-5	35	-7.997e-4	2
263	N524	max	0	4	0	4	0	4	7.552e-3	19	-3.872e-3	40	2.878e-3	5
264		min	0	10	0	10	0	22	2.052e-3	27	-1.645e-2	17	-2.87e-3	11
265	N525	max	0	4	0	10	0	10	7.541e-3	18	1.461e-2	21	2.793e-3	3
266		min	0	10	0	4	0	16	2.107e-3	25	3.022e-3	35	-2.794e-3	9
267	N526	max	0.055	4	0.114	43	-0.344	40	4.815e-4	32	-1.349e-3	32	1.319e-3	4
268		min	-0.284	22	-0.056	5	-1.487	17	-2.401e-3	43	-7.766e-3	22	-2.464e-3	10
269	N527	max	0.037	4	0.093	1	-0.018	31	6.094e-4	1	5.061e-3	19	5.097e-3	1
270		min	-0.029	10	-0.102	7	-0.086	20	-1.524e-3	19	1.325e-3	1	-5.037e-3	7
271	N528	max	-0.041	4	0.117	2	-0.184	40	7.285e-4	7	-3.072e-3	36	1.696e-3	3
272		min	-0.348	22	-0.096	8	-0.854	17	-1.546e-3	31	-1.299e-2	14	-1.919e-3	9
273	N529	max	0.065	4	0.072	3	-0.028	28	1.764e-3	7	-1.776e-3	28	2.411e-3	8
274		min	-0.08	10	-0.068	9	-0.191	18	-2.645e-3	1	-9.831e-3	19	-2.262e-3	2
275	N530	max	0.082	4	0.069	3	-0.028	36	1.76e-3	1	-1.77e-3	40	2.278e-3	8
276		min	-0.067	10	-0.073	9	-0.191	15	-2.644e-3	7	-9.848e-3	15	-2.416e-3	2
277	N531	max	0.286	16	0.202	2	-0.031	40	8.667e-3	1	6.665e-4	10	2.278e-3	8
278		min	-0.06	10	-0.227	8	-0.196	16	-9.548e-3	7	-1.037e-2	16	-2.416e-3	2
279	N532	max	0.066	4	0.06	10	-0.001	35	-2.896e-4	7	7.447e-3	21	1.318e-3	11
280		min	-0.08	10	-0.048	4	-0.134	22	-1.449e-3	13	5.501e-4	31	-1.43e-3	5
281	N533	max	0.056	4	0.227	2	-0.031	40	8.705e-3	7	5.506e-4	4	2.411e-3	8
282		min	-0.286	22	-0.202	8	-0.196	16	-9.588e-3	1	-1.05e-2	22	-2.262e-3	2
283	N534	max	0.074	4	0.602	1	-0.118	25	1.099e-2	7	3.079e-3	4	3.231e-3	7
284		min	-0.119	10	-0.604	7	-0.407	19	-1.103e-2	1	-4.887e-3	10	-3.218e-3	1
285	N535	max	0.082	4	0.048	10	-0.001	35	-2.855e-4	1	7.426e-3	22	1.442e-3	11
286		min	-0.067	10	-0.06	4	-0.134	22	-1.456e-3	18	5.51e-4	39	-1.327e-3	5
287	N536	max	0.069	4	0.06	10	-0.003	35	-2.896e-4	7	7.447e-3	21	1.318e-3	11
288		min	-0.083	10	-0.048	4	-0.139	22	-1.449e-3	13	5.501e-4	31	-1.43e-3	5
289	N537	max	0.042	4	0.039	10	-0.003	35	-1.268e-4	1	7.489e-3	22	1.442e-3	11
290		min	-0.19	22	-0.07	4	-0.139	22	-1.521e-3	19	5.416e-4	35	-1.327e-3	5
291	N538	max	0.081	4	0.043	12	-0.095	35	3.548e-4	6	1.113e-2	21	1.805e-3	4
292		min	-0.068	10	-0.045	6	-0.688	21	-1.238e-3	28	2.083e-3	31	-1.643e-3	10
293	N539	max	0.076	4	0.043	12	-0.095	35	3.548e-4	6	1.113e-2	21	1.805e-3	4
294		min	-0.063	10	-0.045	6	-0.689	22	-1.238e-3	28	2.083e-3	31	-1.643e-3	10
295	N540	max	0.061	4	0.045	12	-0.095	35	3.6e-4	12	1.114e-2	22	1.61e-3	4
296		min	-0.074	9	-0.042	6	-0.689	22	-1.248e-3	36	2.075e-3	35	-1.771e-3	10
297	N541	max	0.274	16	0.046	40	-0.095	35	2.594e-4	12	1.11e-2	19	1.61e-3	4
298		min	0.002	9	-0.036	5	-0.689	22	-1.24e-3	36	2.083e-3	35	-1.771e-3	10
299	N542	max	0.028	4	0.097	1	-0.018	39	4.847e-4	7	5.026e-3	23	4.875e-3	1
300		min	-0.035	10	-0.092	7	-0.086	24	-1.413e-3	13	1.341e-3	6	-5.112e-3	7
301	N543	max	0.208	4	0.045	11	-0.349	40	-5.899e-4	32	2.71e-4	10	5.671e-4	8
302		min	-0.128	10	-0.104	17	-1.415	17	-4.021e-3	21	-5.459e-3	16	-7.236e-4	2
303	N544	max	0.121	15	0.131	1	-0.016	35	6.009e-4	7	5.047e-3	15	4.875e-3	1
304		min	-0.005	9	-0.106	7	-0.082	22	-1.472e-3	13	1.349e-3	8	-5.112e-3	7
305	N545	max	0.034	4	0.362	1	-0.108	35	2.258e-3	1	3.841e-3	18	4.328e-3	1
306		min	-0.029	10	-0.373	7	-0.372	19	-2.475e-3	7	1.025e-3	12	-4.451e-3	7
307	N546	max	0.03	4	0.36	1	-0.106	7	2.047e-3	7	3.821e-3	23	4.321e-3	1
308		min	-0.035	10	-0.362	7	-0.372	23	-2.248e-3	1	1.049e-3	6	-4.333e-3	7
309	N547	max	0.028	4	0.36	1	-0.108	35	2.047e-3	7	3.821e-3	23	4.321e-3	1
310		min	-0.033	10	-0.362	7	-0.372	19	-2.248e-3	1	1.049e-3	6	-4.333e-3	7
311	N548	max	0.009	3	0.419	1	-0.108	35	2.416e-3	1	3.876e-3	21	4.328e-3	1
312		min	-0.096	21	-0.436	7	-0.372	19	-2.634e-3	7	1.012e-3	2	-4.451e-3	7
313	N549	max	0.096	16	0.417	1	-0.108	35	2.206e-3	7	3.883e-3	16	4.321e-3	1
314		min	-0.008	9	-0.414	7	-0.372	19	-2.407e-3	1	1.021e-3	9	-4.333e-3	7
315	N550	max	0.035	4	0.403	1	-0.109	1	4.255e-3	1	-4.619e-4	10	3.333e-3	7
316		min	-0.032	10	-0.415	7	-0.409	19	-4.307e-3	7	-3.102e-3	16	-3.216e-3	1
317	N551	max	0.037	5	0.403	1	-0.118	25	4.255e-3	1	-4.619e-4	10	3.333e-3	7
318		min	-0.033	11	-0.415	7	-0.406	19	-4.307e-3	7	-3.102e-3	16	-3.216e-3	1
319	N552	max	0.077	4	0.613	1	-0.118	25	1.099e-2	7	3.079e-3	4	3.231e-3	7
320		min	-0.124	10	-0.615	7	-0.407	19	-1.103e-2	1	-4.887e-3	10	-3.218e-3	1
321	N553	max	0.031	4	0.4	1	-0.111	7	4.044e-3	7	-4.458e-4	4	3.231e-3	7
322		min	-0.034	10	-0.403	7	-0.406	13	-4.084e-3	1	-3.116e-3	22	-3.218e-3	1
323	N554	max	0.032	4	0.368	1	-0.108	35	2.132e-3	7	3.844e-3	16	4.321e-3	1
324		min	-0.029	10	-0.369	7	-0.372	19	-2.333e-3	1	1.061e-3	8	-4.333e-3	7
325	N555	max	0.124	4	0.619	1	-0.118	25	1.116e-2	1	3.053e-3	10	3.333e-3	7

Envelope Node Displacements (Continued)

Node Label		X [in]	LC	Y [in]	LC	Z [in]	LC	X Rotation [rad]	LC	Y Rotation [rad]	LC	Z Rotation [rad]	LC	
326		min	-0.078	10	-0.632	7	-0.407	19	-1.121e-2	7	-4.85e-3	4	-3.216e-3	1
327	N556	max	0.032	4	0.123	1	-0.028	36	1.23e-3	7	-1.432e-3	8	6.327e-3	7
328		min	-0.032	10	-0.121	7	-0.114	14	-1.624e-3	1	-5.87e-3	15	-6.227e-3	1
329	N557	max	0	5	0.165	1	-0.027	40	1.346e-3	7	-1.486e-3	7	6.327e-3	7
330		min	-0.15	23	-0.153	7	-0.111	16	-1.74e-3	1	-5.863e-3	24	-6.227e-3	1
331	N558	max	0.094	4	0.094	11	-0.34	40	4.814e-4	32	-1.358e-3	32	1.319e-3	4
332		min	-0.139	10	-0.048	5	-1.464	17	-2.401e-3	43	-7.704e-3	22	-2.464e-3	10
333	N559	max	0.141	4	0.05	11	-0.34	40	4.823e-4	40	-1.35e-3	40	2.494e-3	4
334		min	-0.096	10	-0.096	5	-1.464	17	-2.894e-3	26	-7.777e-3	16	-1.318e-3	10
335	N560	max	0.287	16	0.058	11	-0.344	40	4.822e-4	40	-1.341e-3	40	2.494e-3	4
336		min	-0.059	10	-0.12	26	-1.487	17	-2.894e-3	26	-7.834e-3	16	-1.318e-3	10
337	N561	max	0.149	4	0.03	4	-0.265	35	8.598e-5	43	4.291e-3	22	2.347e-4	40
338		min	-0.247	10	-0.131	21	-1.23	21	-2.998e-3	32	-5.013e-4	4	-2.434e-4	35
339	N562	max	0.126	4	0.094	11	-0.346	40	-5.859e-4	40	1.121e-4	4	7.305e-4	8
340		min	-0.193	10	-0.048	5	-1.4	17	-4.048e-3	16	-5.39e-3	22	-5.536e-4	2
341	N563	max	0.243	4	0.129	16	-0.265	35	9.007e-5	35	4.249e-3	16	2.433e-4	43
342		min	-0.146	10	-0.027	10	-1.23	21	-3.003e-3	40	-4.291e-4	10	-2.371e-4	32
343	N564	max	0.131	4	0.181	23	-0.349	40	-5.859e-4	40	2.709e-4	4	7.305e-4	8
344		min	-0.277	10	-0.007	5	-1.415	17	-4.07e-3	15	-5.459e-3	22	-5.536e-4	2
345	N565	max	0.153	4	0.048	11	-0.262	40	-2.883e-3	11	2.515e-3	10	5.974e-4	10
346		min	-0.117	10	-0.092	5	-1.025	17	-1.216e-2	17	-4.592e-3	4	-1.702e-3	16
347	N566	max	0.047	4	0.046	11	-0.065	40	-3.552e-3	32	5.397e-4	10	1.566e-3	10
348		min	-0.048	10	-0.091	5	-0.266	16	-1.377e-2	21	-2.007e-3	16	-1.591e-3	4
349	N567	max	0.116	4	0.093	11	-0.259	40	-2.937e-3	32	2.467e-3	4	1.686e-3	22
350		min	-0.15	10	-0.048	5	-1.017	17	-1.211e-2	22	-4.531e-3	10	-5.883e-4	4
351	N568	max	0.047	4	0.05	11	-0.064	32	-3.552e-3	32	5.397e-4	10	1.566e-3	10
352		min	-0.048	10	-0.095	5	-0.26	17	-1.377e-2	21	-2.007e-3	16	-1.591e-3	4
353	N569	max	0.179	4	0.08	4	-0.265	35	9.006e-5	35	4.188e-3	16	2.433e-4	43
354		min	-0.136	10	-0.054	10	-1.23	21	-3.003e-3	40	-3.129e-4	10	-2.371e-4	32
355	N570	max	0.044	4	0.075	4	-0.052	35	-2.936e-3	35	1.761e-3	4	1.551e-3	10
356		min	-0.05	10	-0.05	10	-0.238	22	-1.249e-2	22	-9.124e-4	10	-1.594e-3	4
357	N571	max	0.144	4	0.076	4	-0.213	35	-2.215e-3	43	4.259e-3	4	6.92e-4	10
358		min	-0.121	10	-0.053	10	-0.916	21	-1.045e-2	16	-2.802e-3	10	-1.398e-3	16
359	N572	max	0.137	4	0.056	4	-0.265	35	8.599e-5	43	4.233e-3	22	2.347e-4	40
360		min	-0.181	10	-0.082	10	-1.23	21	-2.999e-3	32	-3.852e-4	4	-2.434e-4	35
361	N573	max	0.05	5	0.114	1	-0.027	40	6.714e-4	7	-9.791e-5	9	6.34e-3	7
362		min	-0.035	11	-0.114	7	-0.111	16	-9.005e-4	1	-1.336e-3	15	-6.239e-3	1
363	N574	max	0.122	4	0.088	4	-0.228	35	1.058e-3	43	6.225e-3	16	2.431e-3	4
364		min	-0.109	10	-0.059	10	-1.253	21	-1.82e-3	32	7.186e-4	43	-1.276e-3	10
365	N575	max	0.087	4	0.078	4	-0.228	35	1.06e-3	35	6.354e-3	22	1.279e-3	4
366		min	-0.218	22	-0.093	25	-1.253	21	-2.141e-3	25	7.028e-4	35	-2.455e-3	10
367	N576	max	0.122	4	0.057	4	-0.212	43	-2.156e-3	3	4.319e-3	10	1.409e-3	22
368		min	-0.146	10	-0.082	10	-0.907	20	-1.05e-2	21	-2.846e-3	4	-7.003e-4	4
369	N577	max	0.03	4	0.37	1	-0.108	35	2.342e-3	1	3.846e-3	20	4.328e-3	1
370		min	-0.033	10	-0.382	7	-0.372	19	-2.56e-3	7	1.041e-3	1	-4.451e-3	7
371	N578	max	0.079	4	0.047	10	-0.003	35	-2.008e-4	1	7.453e-3	22	1.442e-3	11
372		min	-0.078	10	-0.062	4	-0.139	22	-1.484e-3	19	5.468e-4	35	-1.327e-3	5
373	N579	max	0.163	4	0.078	4	-0.265	35	3.152e-5	35	3.446e-3	16	2.024e-4	10
374		min	-0.136	10	-0.062	10	-1.23	21	-2.275e-3	21	1.814e-5	43	-1.906e-4	16
375	N580	max	0.137	4	0.064	4	-0.265	35	2.642e-5	43	3.497e-3	22	1.927e-4	22
376		min	-0.165	10	-0.08	10	-1.23	21	-2.235e-3	15	1.186e-5	35	-2.164e-4	4
377	N583	max	0.044	4	0.071	11	-0.065	40	-1.074e-3	40	4.698e-4	4	1.577e-3	10
378		min	-0.037	10	-0.069	5	-0.266	16	-5.372e-3	17	-6.761e-4	10	-1.583e-3	4
379	N584	max	0.126	4	0.101	23	-0.349	40	-5.859e-4	40	1.969e-4	4	7.305e-4	8
380		min	-0.204	10	-0.043	5	-1.415	17	-4.051e-3	15	-5.42e-3	22	-5.536e-4	2
381	N191	max	0.054	4	0.039	4	-0.052	35	-2.948e-3	43	1.897e-3	10	1.605e-3	10
382		min	-0.051	10	-0.109	22	-0.238	22	-1.248e-2	18	-1.046e-3	4	-1.537e-3	4
383	N192	max	0.05	4	0.107	16	-0.052	35	-2.936e-3	35	1.846e-3	4	1.551e-3	10
384		min	-0.053	10	-0.036	10	-0.238	22	-1.25e-2	22	-9.972e-4	10	-1.594e-3	4

Envelope AISC 14TH (360-10): LRFD Member Steel Code Checks

Member	Shape	Code Check	Loc[in]	LC	Shear	Check	Loc[in]	LC	phi*Pnc [lb]	phi*Pnt [lb]	phi*Mn y-y [k-ft]	phi*Mn z-z [k-ft]	Cb	Eqn
1	M180 PIPE 3.0	0.644	20.5	14	0.553	20.5	15	10639.335	65205	5.749	5.749	2.415	H3-6	
2	M233 PIPE 3.0	0.706	222.938	19	0.552	20.5	20	10639.335	65205	5.749	5.749	2.403	H1-1a	



Company : Foresite/EFI
 Designer : KS
 Job Number : 049.02894 - 2275002
 Model Name : CTNH550A

2/4/2022
 9:48:42 AM
 Checked By : _____

Envelope AISC 14TH (360-10): LRFD Member Steel Code Checks (Continued)

Member	Shape	Code Check	Loc[in]	LC	Shear	Check	Loc[in]	LC	phi*Pnc [lb]	phi*Pnt [lb]	phi*Mn y-y [k-ft]	phi*Mn z-z [k-ft]	Cb	Eqn
3	M232	PIPE 3.0	0.437	189.875	22	0.226	6.125	16	16759.944	65205	5.749	5.749	2.118	H1-1b
4	M230	PIPE 3.0	0.479	189.875	17	0.226	6.125	21	16759.944	65205	5.749	5.749	2.129	H1-1b
5	M168	PIPE 3.0	0.412	189.875	16	0.217	6.125	22	16759.944	65205	5.749	5.749	2.133	H1-1b
6	M182	PIPE 3.0	0.45	189.875	21	0.216	6.125	17	16759.944	65205	5.749	5.749	2.144	H1-1b
7	M179	PIPE 4.0	0.35	14.438	19	0.2	14.438	8	85371.279	93240	10.631	10.631	2.675	H1-1b
8	M234	PIPE 4.0	0.342	14.438	19	0.194	14.438	23	85371.279	93240	10.631	10.631	2.364	H1-1b
9	M235	PIPE 4.0	0.37	15.094	16	0.157	15.094	35	85371.279	93240	10.631	10.631	1.513	H1-1b
10	M231	PIPE 3.0	0.628	123	17	0.127	123	7	10639.335	65205	5.749	5.749	1.711	H1-1b
11	M239	PIPE 3.0	0.703	123	23	0.127	123	1	10639.335	65205	5.749	5.749	1.711	H1-1b
12	M238	PIPE 2.0	0.767	72	23	0.113	24	18	14916.096	32130	1.872	1.872	1.476	H1-1b
13	M237	PIPE 2.0	0.996	24	17	0.105	24	16	14916.096	32130	1.872	1.872	1.983	H1-1b
14	M226	PIPE 2.0	0.474	24	15	0.101	24	15	14916.096	32130	1.872	1.872	1.464	H1-1b
15	M225	PIPE 2.0	0.466	24	22	0.099	24	23	14916.096	32130	1.872	1.872	1.473	H1-1b
16	M222	PIPE 2.0	0.701	72	15	0.098	24	20	14916.096	32130	1.872	1.872	1.476	H1-1b
17	M172	PIPE 2.0	0.946	24	22	0.096	72	16	14916.096	32130	1.872	1.872	1.532	H1-1b
18	M227	PIPE 2.0	0.417	36	4	0.089	36	3	20866.733	32130	1.872	1.872	1.826	H1-1b
19	M223	PIPE 2.0	0.893	24	19	0.087	72	13	14916.096	32130	1.872	1.872	1.477	H1-1b
20	M169	PIPE 2.0	0.854	72	23	0.083	24	20	14916.096	32130	1.872	1.872	1.474	H1-1b
21	M219	PIPE 2.0	0.409	36	10	0.079	36	11	20866.733	32130	1.872	1.872	1.749	H1-1b
22	M224	PIPE 2.0	0.751	72	22	0.079	24	16	14916.096	32130	1.872	1.872	1.473	H1-1b
23	M208	PIPE 2.0	0.651	72	17	0.068	24	22	14916.096	32130	1.872	1.872	1.514	H1-1b
24	M218	PIPE 2.0	0.444	24	20	0.05	72	15	14916.096	32130	1.872	1.872	1.552	H1-1b
25	M220	PIPE 2.0	0.483	24	18	0.05	72	23	14916.096	32130	1.872	1.872	1.732	H1-1b
26	M221	PIPE 2.0	0.405	72	7	0.042	72	7	14916.096	32130	1.872	1.872	1.303	H1-1b
27	M228	PIPE 2.0	0.337	72	16	0.035	72	17	14916.096	32130	1.872	1.872	1.152	H1-1b
28	M186	PIPE 2.0	0.131	72	31	0.022	72	31	14916.096	32130	1.872	1.872	1.474	H1-1b
29	M167	PIPE 2.0	0.111	24	36	0.017	72	28	14916.096	32130	1.872	1.872	1.481	H1-1b
30	M236	PIPE 2.0	0.139	58.75	16	0.009	120	18	9836.597	32130	1.872	1.872	1.128	H1-1b
31	M229	PIPE 2.0	0.133	60	22	0.009	120	20	9836.597	32130	1.872	1.872	1.134	H1-1b

Exhibit F

Power Density/RF Emissions Report



Radio Frequency Emissions Analysis Report



Site ID: CTNH550A

38 Lower Road
North Canaan, CT 06024

April 21, 2022

Fox Hill Telecom Project Number: 220859

Site Compliance Summary	
Compliance Status:	COMPLIANT
Site total MPE% of FCC general population allowable limit:	26.87 %



April 21, 2022

T-MOBILE
Attn: RF Manager
35 Griffin Road South
Bloomfield, CT 06009

Emissions Analysis for Site: **CTNH550A**

Fox Hill Telecom, Inc (“Fox Hill”) was directed to analyze the proposed upgrades to the T-MOBILE facility located at **38 Lower Road, North Canaan, CT**, for the purpose of determining whether the emissions from the Proposed T-MOBILE Antenna Installation located on this property are within specified federal limits.

All information used in this report was analyzed as a percentage of current Maximum Permissible Exposure (% MPE) as listed in the FCC OET Bulletin 65 Edition 97-01 and ANSI/IEEE Std C95.1. The FCC regulates Maximum Permissible Exposure in units of microwatts per square centimeter ($\mu\text{W}/\text{cm}^2$). The number of $\mu\text{W}/\text{cm}^2$ calculated at each sample point is called the power density. The exposure limit for power density varies depending upon the frequencies being utilized. Wireless Carriers and Paging Services use different frequency bands each with different exposure limits, therefore it is necessary to report results and limits in terms of percent MPE rather than power density.

All results were compared to the FCC (Federal Communications Commission) radio frequency exposure rules, 47 CFR 1.1307(b)(1) – (b)(3), to determine compliance with the Maximum Permissible Exposure (MPE) limits for General Population/Uncontrolled environments as defined below.

General population/uncontrolled exposure limits apply to situations in which the general population may be exposed or in which persons who are exposed as a consequence of their employment may not be made fully aware of the potential for exposure or cannot exercise control over their exposure. Therefore, members of the general population would always be considered under this category when exposure is not employment related, for example, in the case of a telecommunications tower that exposes persons in a nearby residential area.

General population exposure to radio frequencies is regulated and enforced in units of microwatts per square centimeter ($\mu\text{W}/\text{cm}^2$). The general population exposure limits for the 600 MHz & 700 MHz bands are approximately $400 \mu\text{W}/\text{cm}^2$ and $467 \mu\text{W}/\text{cm}^2$ respectively. The general population exposure limit for the 1900 MHz (PCS), 2100 MHz (AWS) and 2500 MHz (BRS) bands is $1000 \mu\text{W}/\text{cm}^2$. Because each carrier will be using different frequency bands, and each frequency band has different exposure limits, it is necessary to report percent of MPE rather than power density.



Occupational/controlled exposure limits apply to situations in which persons are exposed as a consequence of their employment and in which those persons who are exposed have been made fully aware of the potential for exposure and can exercise control over their exposure. Occupational/controlled exposure limits also apply where exposure is of a transient nature as a result of incidental passage through a location where exposure levels may be above general population/uncontrolled limits (see below), as long as the exposed person has been made fully aware of the potential for exposure and can exercise control over his or her exposure by leaving the area or by some other appropriate means.

Additional details can be found in FCC OET 65.



CALCULATIONS

Calculations were performed for the proposed upgrades to the T-MOBILE antenna facility located at **38 Lower Road, North Canaan, CT**, using the equipment information listed below. All calculations were performed per the specifications under FCC OET 65. Since T-MOBILE is proposing highly focused directional panel antennas, which project most of the emitted energy out toward the horizon, all calculations were performed assuming a lobe representing the maximum gain of the antenna per the antenna manufactures supplied specifications, minus 10 dB for directional panel antennas, was focused at the base of the tower. For this report the sample point is the top of a 6-foot person standing at the base of the tower.

Per FCC OET Bulletin No. 65 - Edition 97-01 recommendations to achieve the maximum anticipated value at each sample point, all power levels emitting from the proposed antenna installation are increased by a factor of 2.56 to account for possible in-phase reflections from the surrounding environment. All power values expressed and analyzed are maximum power levels expected to be used on all radios.

All emissions values for additional carriers were taken from the Connecticut Siting Council (CSC) active MPE database. Values in this database are provided by the individual carriers themselves

For each sector the following channel counts, frequency bands and power levels were utilized as shown in *Table 1*:

Technology	Frequency Band	Channel Count	Transmit Power per Channel (W)
LTE / 5G NR	600 MHz	2	40
LTE	700 MHz	2	20
LTE	1900 MHz (PCS)	4	40
UMTS	1900 MHz (PCS)	1	40
LTE	2100 MHz (AWS)	4	40
LTE / 5G NR	2500 MHz (BRS)	8	20

Table 1: Channel Data Table



The following antennas listed in *Table 2* were used in the modeling for transmission in the 600 MHz, 700 MHz, 1900 MHz (PCS), 2100 MHz (AWS) and 2500 MHz (BRS) frequency bands. This is based on feedback from the carrier with regards to anticipated antenna selection. Maximum gain values for all antennas are listed in the Inventory and Power Data table below. The maximum gain of the antenna per the antenna manufactures supplied specifications, minus 10 dB for directional panel antennas, was used for all calculations. This value is a very conservative estimate as gain reductions for these particular antennas are typically much higher in this direction.

Sector	Antenna Number	Antenna Make / Model	Antenna Centerline (ft)
A	1	RFS APXVAALL24 43-U-NA20	125
A	2	Commscope VV-65A-R1	125
A	3	Ericsson AIR6449 B41	125
B	1	RFS APXVAALL24 43-U-NA20	125
B	2	Commscope VV-65A-R1	125
B	3	Ericsson AIR6449 B41	125
C	1	RFS APXVAALL24 43-U-NA20	125
C	2	Commscope VV-65A-R1	125
C	3	Ericsson AIR6449 B41	125
D	1	RFS APXVAALL24 43-U-NA20	125
D	2	Commscope VV-65A-R1	125
D	3	Ericsson AIR6449 B41	125

Table 2: Antenna Data

All calculations were done with respect to uncontrolled / general population threshold limits.



RESULTS

Per the calculations completed for the proposed T-MOBILE configurations *Table 3* shows resulting emissions power levels and percentages of the FCC’s allowable general population limit.

Antenna ID	Antenna Make / Model	Frequency Bands	Antenna Gain (dBd)	Channel Count	Total TX Power (W)	ERP (W)	MPE %
Antenna A1	RFS APXVAALL24 43-U-NA20	600 MHz / 700 MHz	13.65 / 13.85	4	120	2,824.56	1.71
Antenna A2	Commscope VV-65A-R1	1900 MHz (PCS) / 2100 MHz (AWS)	15.55 / 16.05	9	360	13,621.91	3.46
Antenna A3	Ericsson AIR6449 B41	2500 MHz (BRS)	21.5	8	160	22,600.60	5.74
Sector A Composite MPE%							10.91
Antenna B1	RFS APXVAALL24 43-U-NA20	600 MHz / 700 MHz	13.65 / 13.85	4	120	2,824.56	1.71
Antenna B2	Commscope VV-65A-R1	1900 MHz (PCS) / 2100 MHz (AWS)	15.55 / 16.05	9	360	13,621.91	3.46
Antenna B3	Ericsson AIR6449 B41	2500 MHz (BRS)	21.5	8	160	22,600.60	5.74
Sector B Composite MPE%							10.91
Antenna C1	RFS APXVAALL24 43-U-NA20	600 MHz / 700 MHz	13.65 / 13.85	4	120	2,824.56	1.71
Antenna C2	Commscope VV-65A-R1	1900 MHz (PCS) / 2100 MHz (AWS)	15.55 / 16.05	9	360	13,621.91	3.46
Antenna C3	Ericsson AIR6449 B41	2500 MHz (BRS)	21.5	8	160	22,600.60	5.74
Sector C Composite MPE%							10.91
Antenna D1	RFS APXVAALL24 43-U-NA20	600 MHz / 700 MHz	13.65 / 13.85	4	120	2,824.56	1.71
Antenna D2	Commscope VV-65A-R1	1900 MHz (PCS) / 2100 MHz (AWS)	15.55 / 16.05	9	360	13,621.91	3.46
Antenna D3	Ericsson AIR6449 B41	2500 MHz (BRS)	21.5	8	160	22,600.60	5.74
Sector D Composite MPE%							10.91

Table 3: T-MOBILE Emissions Levels



The Following table (*table 4*) shows all additional carriers on site and their MPE% as recorded in the CSC active MPE database for this facility along with the newly calculated maximum T-MOBILE MPE contributions per this report. FCC OET 65 specifies that for carriers utilizing directional antennas that the highest recorded sector value be used for composite site MPE values due to their greatly reduced emissions contributions in the directions of the adjacent sectors. For this site, all four sectors have the same configuration yielding the same results on all four sectors. *Table 5* below shows a summary for each T-MOBILE Sector as well as the composite MPE value for the site.

Site Composite MPE%	
Carrier	MPE%
T-MOBILE – Max Per Sector Value	10.91 %
CT State Police	3.24 %
LCD	1.65 %
Eversource	2.63 %
Arch	0.45 %
Town of No. Canaan	0.49 %
Sprint	1.92 %
AT&T	4.72 %
Verizon Wireless	0.86 %
Site Total MPE %:	26.87 %

Table 4: All Carrier MPE Contributions

T-MOBILE Sector A Total:	10.91 %
T-MOBILE Sector B Total:	10.91 %
T-MOBILE Sector C Total:	10.91 %
T-MOBILE Sector D Total:	10.91 %
Site Total:	
	26.87 %

Table 5: Site MPE Summary



FCC OET 65 specifies that for carriers utilizing directional antennas that the highest recorded sector value be used for composite site MPE values due to their greatly reduced emissions contributions in the directions of the adjacent sectors. *Table 6* below details a breakdown by frequency band and technology for the MPE power values for the maximum calculated T-MOBILE sector(s). For this site, all four sectors have the same configuration yielding the same results on all four sectors.

T-MOBILE _ Frequency Band / Technology Max Power Values (Per Sector)	# Channels	Watts ERP (Per Channel)	Height (feet)	Total Power Density ($\mu\text{W}/\text{cm}^2$)	Frequency (MHz)	Allowable MPE ($\mu\text{W}/\text{cm}^2$)	Calculated % MPE
T-Mobile 600 MHz LTE / 5G NR	2	926.96	125	4.71	600 MHz	400	1.18%
T-Mobile 700 MHz LTE	2	485.32	125	2.46	700 MHz	467	0.53%
T-Mobile 1900 MHz (PCS) LTE	4	1,435.69	125	14.58	1900 MHz (PCS)	1000	1.46%
T-Mobile 1900 MHz (PCS) UMTS	1	1,435.69	125	3.64	1900 MHz (PCS)	1000	0.36%
T-Mobile 2100 MHz (AWS) LTE	4	1,610.87	125	16.36	2100 MHz (AWS)	1000	1.64%
T-Mobile 2500 MHz (BRS) LTE / 5G NR	8	2,825.08	125	57.38	2500 MHz (BRS)	1000	5.74%
						Total:	10.91%

Table 6: T-MOBILE Maximum Sector MPE Power Values



Summary

All calculations performed for this analysis yielded results that were **within** the allowable limits for general population exposure to RF Emissions.

The anticipated maximum composite contributions from the T-MOBILE facility as well as the site composite emissions value with regards to compliance with FCC's allowable limits for general population exposure to RF Emissions are shown here:

T-MOBILE Sector	Power Density Value (%)
Sector A:	10.91 %
Sector B:	10.91 %
Sector C:	10.91 %
Sector D:	10.91 %
T-MOBILE Maximum Total (per sector):	10.91 %
Site Total:	26.87 %
Site Compliance Status:	COMPLIANT

The anticipated composite MPE value for this site assuming all carriers present is **26.87 %** of the allowable FCC established general population limit sampled at the ground level. This is based upon values listed in the Connecticut Siting Council database for existing carrier emissions.

FCC guidelines state that if a site is found to be out of compliance (over allowable thresholds), that carriers over a 5% contribution to the composite value will require measures to bring the site into compliance. For this facility, the composite values calculated were well within the allowable 100% threshold standard per the federal government.

Scott Heffernan
Principal RF Engineer
Fox Hill Telecom, Inc
Holden, MA 01520
(978)660-3998

Exhibit G

Recipient Mailings



**UNITED STATES
POSTAL SERVICE®**

Click-N-Ship®

P

USPS.com 9405 5036 9930 0229 0901 88 0089 5000 0010 6018
US POSTAGE
 Flat Rate Env
 04/21/2022

U.S. POSTAGE PAID
click-n-ship®

Mailed from 01566

PRIORITY MAIL 2-DAY™

Expected Delivery Date: 04/25/22
 Ref#: CTNH550A
0006

DEBORAH CHASE
 NORTHEAST SITE SOLUTIONS
 420 MAIN ST
 STE 1
 STURBRIDGE MA 01566-1359

R011

SHIP TO: CHARLES PEROTTI
 FIRST SELECTMAN-NORTH CANAAN
 100 PEASE ST
 UNIT 3
 CANAAN CT 06018-2067

USPS TRACKING #

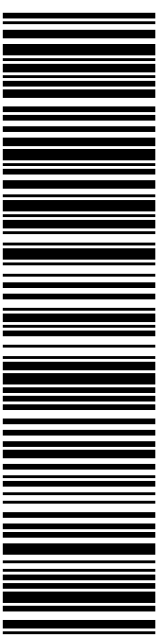

9405 5036 9930 0229 0901 88

Electronic Rate Approved #038555749



Cut on dotted line.

Instructions

1. Each Click-N-Ship® label is unique. Labels are to be used as printed and used only once. DO NOT PHOTO COPY OR ALTER LABEL.
2. Place your label so it does not wrap around the edge of the package.
3. Adhere your label to the package. A self-adhesive label is recommended. If tape or glue is used, DO NOT TAPE OVER BARCODE. Be sure all edges are secure.
4. To mail your package with PC Postage®, you may schedule a Package Pickup online, hand to your letter carrier, take to a Post Office™, or drop in a USPS collection box.
5. Mail your package on the "Ship Date" you selected when creating this label.

Click-N-Ship® Label Record

USPS TRACKING # :
9405 5036 9930 0229 0901 88

Trans. #: 561825203	Priority Mail® Postage: \$8.95
Print Date: 04/21/2022	Total: \$8.95
Ship Date: 04/21/2022	
Expected Delivery Date: 04/25/2022	

From: DEBORAH CHASE Ref#: CTNH550A
 NORTHEAST SITE SOLUTIONS
 420 MAIN ST
 STE 1
 STURBRIDGE MA 01566-1359

To: CHARLES PEROTTI
 FIRST SELECTMAN-NORTH CANAAN
 100 PEASE ST
 UNIT 3
 CANAAN CT 06018-2067

* Retail Pricing Priority Mail rates apply. There is no fee for USPS Tracking® service on Priority Mail service with use of this electronic rate shipping label. Refunds for unused postage paid labels can be requested online 30 days from the print date.



Thank you for shipping with the United States Postal Service!
 Check the status of your shipment on the USPS Tracking® page at usps.com

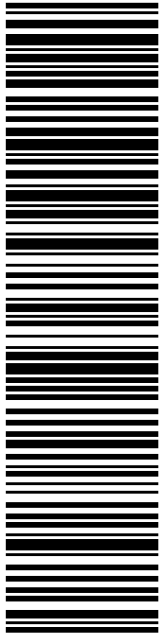

USPS TRACKING #

9405 5036 9930 0229 0901 95

Electronic Rate Approved #038555749

SHIP TO: GEORGE MARTIN
 ZONING ENFORCEMENT OFFICER-NORTH CANAAN
 100 PEASE ST
 UNIT 3
 CANAAN CT 06018-2067

P

USPS.com 9405 5036 9930 0229 0901 95 0089 5000 0010 6018
US POSTAGE
 Flat Rate Env
 04/21/2022 Mailed from 01566

U.S. POSTAGE PAID
 Click-N-Ship®

PRIORITY MAIL 2-DAY™

DEBORAH CHASE
 NORTHEAST SITE SOLUTIONS
 420 MAIN ST
 STE 1
 STURBRIDGE MA 01566-1359

Expected Delivery Date: 04/25/22
 Ref#: CTNH550A
0006

R011

UNITED STATES POSTAL SERVICE®

Click-N-Ship®



Cut on dotted line.

Instructions

1. Each Click-N-Ship® label is unique. Labels are to be used as printed and used only once. DO NOT PHOTO COPY OR ALTER LABEL.
2. Place your label so it does not wrap around the edge of the package.
3. Adhere your label to the package. A self-adhesive label is recommended. If tape or glue is used, DO NOT TAPE OVER BARCODE. Be sure all edges are secure.
4. To mail your package with PC Postage®, you may schedule a Package Pickup online, hand to your letter carrier, take to a Post Office™, or drop in a USPS collection box.
5. Mail your package on the "Ship Date" you selected when creating this label.

Click-N-Ship® Label Record

USPS TRACKING # :
9405 5036 9930 0229 0901 95

Trans. #: 561825203	Priority Mail® Postage: \$8.95
Print Date: 04/21/2022	Total: \$8.95
Ship Date: 04/21/2022	
Expected Delivery Date: 04/25/2022	

From: DEBORAH CHASE Ref#: CTNH550A
 NORTHEAST SITE SOLUTIONS
 420 MAIN ST
 STE 1
 STURBRIDGE MA 01566-1359

To: GEORGE MARTIN
 ZONING ENFORCEMENT OFFICER-NORTH CANAAN
 100 PEASE ST
 UNIT 3
 CANAAN CT 06018-2067

* Retail Pricing Priority Mail rates apply. There is no fee for USPS Tracking® service on Priority Mail service with use of this electronic rate shipping label. Refunds for unused postage paid labels can be requested online 30 days from the print date.



Thank you for shipping with the United States Postal Service!
 Check the status of your shipment on the USPS Tracking® page at usps.com



**UNITED STATES
POSTAL SERVICE®**

Click-N-Ship®

P

USPS.com 9405 5036 9930 0229 0902 01 0089 5000 0010 6759
US POSTAGE
 Flat Rate Env
U.S. POSTAGE PAID
click-n-ship®

04/21/2022 Mailed from 01566

PRIORITY MAIL 2-DAY™

Expected Delivery Date: 04/25/22
 Ref#: CTNH550A
0006

R004

SHIP TO:
 LITCHFIELD COUNTY DISPATCH INC.
 452 BANTAM RD
 LITCHFIELD CT 06759-3201

USPS TRACKING #

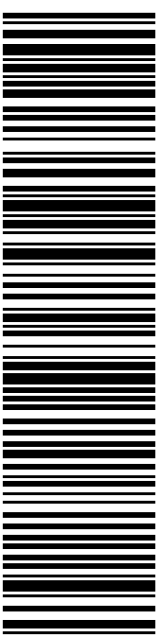

9405 5036 9930 0229 0902 01

Electronic Rate Approved #038555749



Cut on dotted line.

Instructions

1. Each Click-N-Ship® label is unique. Labels are to be used as printed and used only once. DO NOT PHOTO COPY OR ALTER LABEL.
2. Place your label so it does not wrap around the edge of the package.
3. Adhere your label to the package. A self-adhesive label is recommended. If tape or glue is used, DO NOT TAPE OVER BARCODE. Be sure all edges are secure.
4. To mail your package with PC Postage®, you may schedule a Package Pickup online, hand to your letter carrier, take to a Post Office™, or drop in a USPS collection box.
5. Mail your package on the "Ship Date" you selected when creating this label.

Click-N-Ship® Label Record

USPS TRACKING # :
9405 5036 9930 0229 0902 01

Trans. #: 561825203	Priority Mail® Postage: \$8.95
Print Date: 04/21/2022	Total: \$8.95
Ship Date: 04/21/2022	
Expected Delivery Date: 04/25/2022	

From: DEBORAH CHASE Ref#: CTNH550A
 NORTHEAST SITE SOLUTIONS
 420 MAIN ST
 STE 1
 STURBRIDGE MA 01566-1359

To: LITCHFIELD COUNTY DISPATCH INC.
 452 BANTAM RD
 LITCHFIELD CT 06759-3201

* Retail Pricing Priority Mail rates apply. There is no fee for USPS Tracking® service on Priority Mail service with use of this electronic rate shipping label. Refunds for unused postage paid labels can be requested online 30 days from the print date.



Thank you for shipping with the United States Postal Service!
 Check the status of your shipment on the USPS Tracking® page at usps.com

CTINH ESSOA Anchor
L 600



FARMINGTON
210 MAIN ST
FARMINGTON, CT 06032-9998
(800)275-8777

04/22/2022 08:53 AM

Product	Qty	Unit Price	Price
Prepaid Mail Canaan, CT 06018 Weight: 0 lb 6.20 oz Acceptance Date: Fri 04/22/2022 Tracking #: 9405 5036 9930 0229 0901 88	1		\$0.00
Prepaid Mail Litchfield, CT 06759 Weight: 0 lb 6.20 oz Acceptance Date: Fri 04/22/2022 Tracking #: 9405 5036 9930 0229 0902 01	1		\$0.00
Prepaid Mail Canaan, CT 06018 Weight: 0 lb 6.20 oz Acceptance Date: Fri 04/22/2022 Tracking #: 9405 5036 9930 0229 0901 95	1		\$0.00

Grand Total: \$0.00

Every household in the U.S. is now
eligible to receive a second set
of 4 free test kits.
Go to www.covidtests.gov

Preview your Mail
Track your Packages
Sign up for FREE @
<https://informeddelivery.usps.com>

All sales final on stamps and postage.
Refunds for guaranteed services only.
Thank you for your business.

Tell us about your experience.
Go to: <https://postalexperience.com/Pos>
or scan this code with your mobile device,

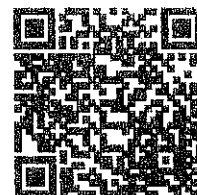

or call 1-800-410-7420.