



INDUSTRIAL AVE,
STATE 3
MORRIS HAWAH NJ 07430
PHONE: 201.684.0055
FAX: 201.684.0066

May 8, 2023

Members of the Siting Council
Connecticut Siting Council
10 Franklin Square
New Britain, CT 06051

RE: Notice of Exempt Modification
453 Loon Meadow Road, Norfolk, CT 06058
Latitude: 42.009075
Longitude: -73.1808881
T-Mobile Site#: CT11349A - Anchor / Hardening

Dear Ms. Bachman:

T-Mobile currently maintains six (6) antennas at the 120-foot level of the existing 160-foot guyed tower at 453 Loon Meadow Road, Norfolk, CT. The 160-foot guyed tower and property is owned and operated by SRR Towers. T-Mobile now intends to remove and replace six (6) antennas at the 120-foot level of the existing tower. The antennas support 5G services. T-Mobile also intends to add a 48 KW diesel powered backup generator. T-Mobile will be remodeling their existing ground equipment. They will remove their existing equipment room and install an 8' x 20' concrete pad for their cabinets and generator.

Planned Modifications:

Tower:

Install New:

- (3) AIR 6419 B41 Antennas
- (3) APXVAALL24 Antennas
- (3) Radio 4480 B71 B85
- (3) Radio 4460 B25 B66
- (2) 6x24 Hybrid Cables

To Be Removed:

- Existing Coax Cables
- Existing TMAs
- Existing Diplexers
- (3) LNX-6515DS-A1M Antennas
- (3) RR90-17-XXDP Antennas

Ground:

Remove:

Existing T-Mobile Equipment Shelter and Existing Ground Equipment
Existing T-Mobile Ice Bridge

Install New:

(1) 200A PPC Cabinet
(1) 6160 Power Enclosure and (1) B160 Battery Cabinet
(1) 48 KW Diesel Powered Backup Generator
(1) Cable Ice-Bridge

This facility was approved by the Connecticut Siting Council in Petition No. 106 on July, 17, 1984. The proposed modifications comply with existing conditions.

Please accept this letter as notification pursuant to Regulations of Connecticut State Agencies § 16- SOj-73, for construction that constitutes an exempt modification pursuant to R.C.S.A. § 16-50j-72(b)(2). In accordance with R.C.S.A. § 16-SOj-73, a copy of this letter is being sent to First Selectman Matthew Riiska, Elected Official, and Michael Halloran, Zoning Enforcement Officer, as well as the tower and property owner.

The planned modifications to the facility fall squarely within those activities explicitly provided for in R.C.S.A. § 16-50j-72(b)(2).

1. The proposed modifications will not result in an increase in the height of the existing structure.
2. The proposed modifications will not require the extension of the site boundary.
3. The proposed modifications will not increase noise levels at the facility by six decibels or more, or to levels that exceed state and local criteria.
4. The operation of the replacement antennas will not increase radio frequency emissions at the facility to a level at or above the Federal Communications Commission safety standard.
5. The proposed modifications will not cause a change or alteration in the physical or environmental characteristics of the site.
6. The existing structure and its foundation can support the proposed loading.

For the foregoing reasons, T-Mobile respectfully submits that the proposed modifications to the above referenced telecommunications facility constitute an exempt modification under R.C.S.A. § 16-50j-72(b)(2).

Sincerely,

Eric Breun

Transcend Wireless

Cell: 201-658-7728

Email: ebreun@transcendwireless.com

Attachments

cc: Matthew Riiska - First Selectman of Norfolk

Michael Halloran - ZEO

SRR Towers LLC - Tower Owner

ERIC BREUN
2016587728
1 INTERNATIONAL BLVD.
MAHWAH NJ 07495

1 LBS
DWT: 10.2,1

1 OF 1

SHIP TO:
ZEO

MICHAEL HALLORAN
19 MAPLE AVENUE
NORFOLK HISTORIC DISTRICT CT 06058



CT 067 9-02



UPS GROUND

TRACKING #: 1Z V25 742 03 9509 9979

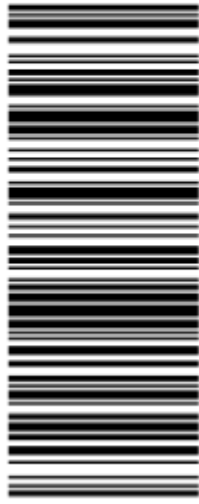

BILLING: P/P

Reference #1: CT11349A

XOL 23.01.33

NV/15 17.04.04/2023*



TM

ERIC BREUN
2016587728
1 INTERNATIONAL BLVD.
MAHWAH NJ 07495

1 LBS
DWT: 12.10,1

1 OF 1

SHIP TO:

MATHEW RIISKA
FIRST SELECTMAN
19 MAPLE AVENUE
NORFOLK HISTORIC DISTRICT CT 06058



CT 067 9-02



UPS GROUND

TRACKING #: 1Z V25 742 03 9514 9969



BILLING: P/P

Reference #1: CT11349A

XOL 23.01.33

NV/15 17.04.04/2023*

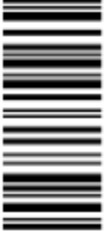
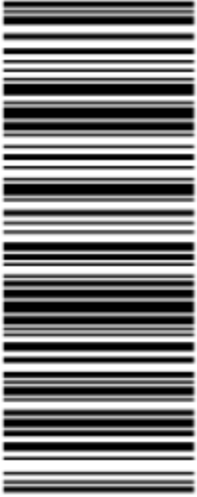

TM

<p>ERIC BREUN 2016587728 1 INTERNATIONAL BLVD. MAHWAH NJ 07495</p> <p>SHIP TO: SRR TOWERS LLC 57 EAST WASHINGTON STREET CHAGRIN FALLS OH 44022</p> <p>1 LBS 1 OF 1 DWT: 12,10,1</p>	<p>OH 440 9-70</p>  	<p>UPS GROUND TRACKING #: 1Z V25 742 03 9506 9984</p>		<p>BILLING: P/P</p> <p>Reference #1: CT11349A</p> <p>XOL 23.04.33 NV-15 17.0A 0-0/2023*  TM</p>
--	---	--	--	--

Hello, your package has been delivered.

Delivery Date: Tuesday, 05/02/2023
 Delivery Time: 11:06 AM
 Signed by: PRENTICE

TRANSCEND WIRELESS

Tracking Number: [1ZV257420395069984](#)

Ship To: SRR TOWERS LLC
 57 EAST WASHINGTON STREET
 CHAGRIN FALLS, OH 44022
 US

Number of Packages: 1

UPS Service: UPS Ground

Package Weight: 1.0 LBS

Reference Number: [CT11349A](#)

Hello, your package has been delivered.

Delivery Date: Monday, 05/01/2023

Delivery Time: 10:25 AM

Signed by: YARD

TRANSCEND WIRELESS

Tracking Number: [1ZV257420395099979](#)

Ship To: MICHAEL HALLORAN
19 MAPLE AVENUE
NORFOLK HISTORIC DISTRICT, CT 06058
US

Number of Packages: 1

UPS Service: UPS Ground

Package Weight: 1.0 LBS

Reference Number: [CT11349A](#)

Hello, your package has been delivered.

Delivery Date: Monday, 05/01/2023

Delivery Time: 10:25 AM

Signed by: YARD

TRANSCEND WIRELESS

Tracking Number: [1ZV257420395149969](#)

Ship To: FIRST SELECTMAN
19 MAPLE AVENUE
NORFOLK HISTORIC DISTRICT, CT 06058
US

Number of Packages: 1

UPS Service: UPS Ground

Package Weight: 1.0 LBS

Reference Number: [CT11349A](#)

Parcel ID	574	Alternate ID	*01017	Owner Address	SRR TOWERS LLC
Sec/Twp/Rng	6-14-7-	Class	C		57 E WASHINGTON STREET
Property Address	453 LOON MEADOW DR	Acreage	4.98		CHAGRIN FALLS OH 44022
	NORFOLK				

Summary

Account Number *01017
 Parcel ID 574
 Property Address 453 LOON MEADOW DR
 Use Class/Description 5-2 VAC COMM
 Map/Block/Block Cut 6-14/7//
 Zoning RU
 Acres 4.98

[View Map](#)

Owner

SRR TOWERS LLC
 57 E WASHINGTON STREET
 CHAGRIN FALLS, OH 44022

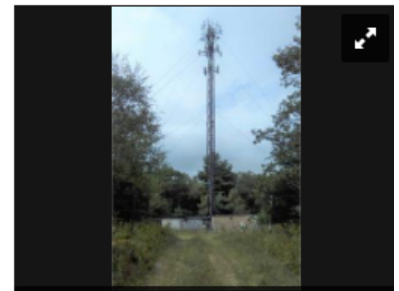

Valuation

Columns ▼

Assessed Year	2022	2021
Appraised Building Value	\$0.00	\$0.00
Appraised XF/OB Value	\$1,048,780.00	\$1,048,780.00
Appraised Land Value	\$102,860.00	\$102,860.00
Appraised Total Value	\$1,151,640.00	\$1,151,640.00
Assessed Building Value	\$0.00	\$0.00
Assessed XF/OB Value	\$734,150.00	\$734,150.00
Assessed Land Value	\$72,000.00	\$72,000.00
Assessed Total Value	\$806,150.00	\$806,150.00

Land

Building Number	1	Land Units	1 AC
Land Use	5-2 - VAC COMM	Value	75,000

Building Number	1	Land Units	3.98 AC
Land Use	5-2 - VAC COMM	Value	27,860

Building Information

Building #	1
Style	Outbuildings
Occupancy	0
Actual Year Built	0
Effective Year Built	0
Living Area	0
Stories	
Grade	
Condition	
Exterior Wall	
Interior Wall	

Notes	CELL TOWER 2013 REVALUED CELL TOWER/BLDGS 21GL GENERATOR 95 AC TO NORFOLK LAND TRUST V 83/401
-------	--

Fireplaces	
Roof Cover	
Roof Structure	
Floor Type	
Heat Type	
Fuel Type	
AC	
Bdrms/Full Bth/Hlf Bth/Ttl Rm	
Basement Finished Area	
Basement Sq. Ft.	

Code	Description	Living Area	Gross Area	Effective Area
------	-------------	-------------	------------	----------------

Out Buildings\Extra Features

Description	1 STORY FRAME	Year Built	0
Sub Description		Value	\$20,400
Area	408 S.F.		

Description	1 STORY FRAME	Year Built	0
Sub Description		Value	\$6,400
Area	256 S.F.		

Description	8' FENCE	Year Built	0
Sub Description		Value	\$1,980
Area	360 L.F.		

Description	CELL TOWER C	Year Built	0
Sub Description		Value	\$1,000,000
Area	1 UNITS		

Description	GENERATOR	Year Built	2021
Sub Description		Value	\$20,000
Area	1 UNITS		

Sales History

Columns ▾

Sales Date	Instrument Type	Grantor	Grantee	Book/Page
5/18/2020	Unqualified Sale - Nonspecific	NEW CINGULAR WIRELESS PCS LLC	SRR TOWERS LLC	125-001
6/22/2015	Unqualified Sale - Nonspecific	AT&T CAPITAL SERVICES INC	NEW CINGULAR WIRELESS PCS LLC ATTN PROPERTY TAX DEPT	0118-1088
10/28/2014	No Consideration Sale	SOUTHERN NEW ENGLAND TELEPHONE	AT&T CAPITAL SERVICES INC	0118-0311
8/2/1957			SOUTHERN NEW ENGLAND TELEPHONE	0042-0294

Permit Information

Permit ID	Issue Date	Type	Description	Amount	Inspection Date	% Complete	Date Complete	Comments
19-025E	04-01-2019	EL	Electric	\$7,000		100		GENERATOR
828E	03-27-2015	EL	Electric	\$15,000		100		UPG 3 ANTENNAS
388-E	03-02-2013	EL	Electric	\$12,000		100		6 NEW ANTENNAS
7470-E	01-18-2001	EL	Electric	\$54,000		100		ADD ANTENNAS TO TOWER
7457	12-18-2000	EL	Electric	\$10,000		100		INSTALL CONDUITS

Photos





STATE OF CONNECTICUT

CONNECTICUT SITING COUNCIL

1 CENTRAL PARK PLAZA • NEW BRITAIN, CONN. 06051

PHONE: 827-2604

Petition No. 106
Field Review of July 17, 1984
Norfolk, Connecticut

Owen Clark, Colin Tait, and Robert Erling of the Connecticut Siting Council met Richard Kischell of the Southern New England Telephone Company (SNET) for a field review of Petition No. 106 on July 17, 1984. SNET is petitioning the Council for a declaratory ruling that no certificate of environmental compatibility and public need is necessary for the replacement of the company's existing 160' guyed microwave tower in Norfolk, Connecticut.

SNET proposes to replace its existing tower with another tower the same height, but stronger, and thus more resistant to the high winds which cause signal fading. The new tower would be 8 feet away from the existing tower which would be dismantled and removed from the site. Two microwave dishes on the existing tower would be transferred to the new tower, and placed at the same height as at present. The project would take two weeks to complete, during which time SNET would utilize its existing land line cable system to provide service.

Power densities at the base of the proposed tower would remain the same as those at the existing tower, $.00025 \text{ uW/cm}^2$.

The proposed tower would continue the service which links telephone traffic between towers in Canaan and Harwinton.

Robert K. Erling
Siting Analyst

RKE/kp

T-Mobile

SITE NAME: NORFOLK SNET_1

SITE ID: CT11349A
 453 LOON MEADOW DR
 NORFOLK, CT 06058

T-MOBILE A/L TEMPLATE (PROVIDED BY RFDS)

67E5998E_1xAIR+1OP

T-MOBILE RAN TEMPLATE (PROVIDED BY RFDS)

67E5D998E ODE+6160

GENERAL NOTES

- ALL WORK SHALL BE IN ACCORDANCE WITH THE 2021 INTERNATIONAL BUILDING CODE AS MODIFIED BY THE 2022 CONNECTICUT SUPPLEMENT, INCLUDING THE TIA/EIA-222 REVISION "H" "STRUCTURAL STANDARDS FOR STEEL ANTENNA TOWERS AND SUPPORTING STRUCTURES." 2022 CONNECTICUT FIRE SAFETY CODE, NATIONAL ELECTRICAL CODE AND LOCAL CODES.
- SHOULD ANY FIELD CONDITIONS PRECLUDE COMPLIANCE WITH THE DRAWINGS, THE CONTRACTOR SHALL IMMEDIATELY NOTIFY THE ENGINEER AND SHALL NOT PROCEED WITH ANY AFFECTED WORK.
- CONTRACTOR SHALL REVIEW ALL DRAWINGS AND SPECIFICATIONS IN THE CONTRACT DOCUMENT SET. CONTRACTOR SHALL COORDINATE ALL WORK SHOWN IN THE SET OF DRAWINGS. THE CONTRACTOR SHALL PROVIDE A COMPLETE SET OF DRAWINGS TO ALL SUBCONTRACTORS AND ALL RELATED PARTIES. THE SUBCONTRACTORS SHALL EXAMINE ALL THE DRAWINGS AND SPECIFICATIONS FOR THE INFORMATION THAT AFFECTS THEIR WORK.
- BEFORE BEGINNING THE WORK, THE CONTRACTOR IS RESPONSIBLE FOR MAKING SUCH INVESTIGATIONS CONCERNING PHYSICAL CONDITIONS (SURFACE AND SUBSURFACE) AT OR CONTIGUOUS TO THE SITE, WHICH MAY AFFECT PERFORMANCE AND COST OF THE WORK.
- ALL DIMENSIONS, ELEVATIONS, AND OTHER REFERENCES TO EXISTING STRUCTURES, SURFACE, AND SUBSURFACE CONDITIONS ARE APPROXIMATE. NO GUARANTEE IS MADE FOR THE ACCURACY OR COMPLETENESS OF THE INFORMATION SHOWN. THE CONTRACTOR SHALL VERIFY AND COORDINATE ALL DIMENSIONS, ELEVATIONS AND ANGLES WITH EXISTING CONDITIONS AND WITH ARCHITECTURAL AND SITE DRAWINGS BEFORE PROCEEDING WITH ANY WORK.
- AS THE WORK PROGRESSES, THE CONTRACTOR SHALL NOTIFY THE OWNER OF ANY CONDITIONS WHICH ARE IN CONFLICT OR OTHERWISE NOT CONSISTENT WITH THE CONSTRUCTION DOCUMENTS, AND SHALL NOT PROCEED WITH SUCH WORK UNTIL THE CONFLICT IS SATISFACTORILY RESOLVED.
- CONTRACTOR SHALL PROVIDE A COMPLETE BUILD-OUT WITH ALL FINISHES, STRUCTURAL, MECHANICAL, AND ELECTRICAL COMPONENTS AND PROVIDE ALL ITEMS AS SHOWN OR INDICATED ON THE DRAWINGS OR IN THE WRITTEN SPECIFICATIONS.
- CONTRACTOR SHALL FURNISH ALL MATERIAL, LABOR AND EQUIPMENT TO COMPLETE THE WORK AND FURNISH A COMPLETED JOB ALL IN ACCORDANCE WITH LOCAL AND STATE GOVERNING AUTHORITIES AND OTHER AUTHORITIES HAVING LAWFUL JURISDICTION OVER THE WORK.
- CONTRACTOR SHALL SECURE AND PAY FOR ALL PERMITS AND ALL INSPECTIONS REQUIRED AND SHALL ALSO PAY FEES REQUIRED FOR THE GENERAL CONSTRUCTION, PLUMBING, ELECTRICAL, AND HVAC. PERMITS SHALL BE PAID FOR BY THE RESPECTIVE SUBCONTRACTORS.
- CONTRACTOR SHALL MAINTAIN A CURRENT SET OF DRAWINGS AND SPECIFICATIONS ON SITE AT ALL TIMES AND INSURE DISTRIBUTION OF NEW DRAWINGS TO SUBCONTRACTORS AND OTHER RELEVANT PARTIES AS SOON AS THEY ARE MADE AVAILABLE. ALL OLD DRAWINGS SHALL BE MARKED VOID AND REMOVED FROM THE CONTRACT AREA. THE CONTRACTOR SHALL FURNISH AN "AS-BUILT" SET OF DRAWINGS TO OWNER UPON COMPLETION OF PROJECT.
- LOCATION OF EQUIPMENT AND WORK SUPPLIED BY OTHERS THAT IS DIAGRAMMATICALLY INDICATED ON THE DRAWINGS, SHALL BE DETERMINED BY THE CONTRACTOR. THE CONTRACTOR SHALL DETERMINE LOCATIONS AND DIMENSIONS SUBJECT TO STRUCTURAL CONDITIONS AND WORK OF THE SUBCONTRACTORS.
- THE CONTRACTOR IS SOLELY RESPONSIBLE TO DETERMINE CONSTRUCTION PROCEDURE AND SEQUENCE AND TO ENSURE THE SAFETY OF THE EXISTING STRUCTURES AND ITS COMPONENT PARTS DURING CONSTRUCTION. THIS INCLUDES THE ADDITION OF WHATEVER SHORING, BRACING, UNDERPINNING, ETC. THAT MAY BE NECESSARY.
- ALL EQUIPMENT AND PRODUCTS PURCHASED ARE TO BE REVIEWED BY CONTRACTOR AND ALL APPLICABLE SUB-CONTRACTORS FOR ANY CONDITION PER THE MANUFACTURER'S RECOMMENDATIONS. CONTRACTOR TO SUPPLY THESE ITEMS AT NO COST TO OWNER OR CONSTRUCTION MANAGER.
- DRAWINGS INDICATE THE MINIMUM STANDARDS, BUT IF ANY WORK SHOULD BE INDICATED TO BE SUBSTANDARD TO ANY ORDINANCES, LAWS, CODES, RULES, OR REGULATIONS BEARING ON THE WORK, THE CONTRACTOR SHALL INCLUDE IN HIS WORK AND SHALL EXECUTE THE WORK CORRECTLY IN ACCORDANCE WITH SUCH ORDINANCES, LAWS, CODES, RULES OR REGULATIONS WITH NO INCREASE IN COSTS.
- ALL UTILITY WORK SHALL BE IN ACCORDANCE WITH LOCAL UTILITY COMPANY REQUIREMENTS AND SPECIFICATIONS.
- ALL EQUIPMENT AND PRODUCTS PURCHASED ARE TO BE REVIEWED BY CONTRACTOR AND ALL APPLICABLE SUBCONTRACTORS FOR ANY CONDITION PER MANUFACTURER'S RECOMMENDATIONS. CONTRACTOR TO SUPPLY THESE ITEMS AT NO COST TO OWNER OR CONSTRUCTION MANAGER.
- ANY AND ALL ERRORS, DISCREPANCIES, AND 'MISSED' ITEMS ARE TO BE BROUGHT TO THE ATTENTION OF THE T-MOBILE CONSTRUCTION MANAGER DURING THE BIDDING PROCESS BY THE CONTRACTOR. ALL THESE ITEMS ARE TO BE INCLUDED IN THE BID. NO 'EXTRA' WILL BE ALLOWED FOR MISSED ITEMS.
- CONTRACTOR SHALL BE RESPONSIBLE FOR ALL ON-SITE SAFETY FROM THE TIME THE JOB IS AWARDED UNTIL ALL WORK IS COMPLETE AND ACCEPTED BY THE OWNER.
- CONTRACTOR TO REVIEW ALL SHOP DRAWINGS AND SUBMIT COPY TO ENGINEER FOR APPROVAL. DRAWINGS MUST BEAR THE CHECKER'S INITIALS BEFORE SUBMITTING TO THE CONSTRUCTION MANAGER FOR REVIEW.
- THE CONTRACTOR SHALL FIELD VERIFY ALL DIMENSIONS, ELEVATIONS, ANGLES AND EXISTING CONDITIONS AT THE SITE, PRIOR TO FABRICATION AND/OR INSTALLATION OF ANY WORK IN THE CONTRACT AREA.
- COORDINATION, LAYOUT, FURNISHING AND INSTALLATION OF CONDUITS AND ALL APPURTENANCES REQUIRED FOR PROPER INSTALLATION OF ELECTRICAL AND TELECOMMUNICATION SERVICE SHALL BE THE SOLE RESPONSIBILITY OF THE CONTRACTOR AND CONFIRMED WITH THE PROJECT MANAGER AND OWNER PRIOR TO THE COMMENCEMENT OF ANY WORK
- ALL DAMAGE CAUSED TO ANY EXISTING STRUCTURE SHALL BE THE SOLE RESPONSIBILITY OF THE CONTRACTOR. THE CONTRACTOR WILL BE HELD LIABLE FOR ALL REPAIRS REQUIRED FOR EXISTING STRUCTURES IF DAMAGED DURING CONSTRUCTION ACTIVITIES.
- THE CONTRACTOR SHALL CONTACT 'CALL BEFORE YOU DIG' AT LEAST 48 HOURS PRIOR TO ANY EXCAVATIONS AT 1-800-922-4455. ALL UTILITIES SHALL BE IDENTIFIED AND CLEARLY MARKED. CONTRACTOR SHALL MAINTAIN AND PROTECT MARKED UTILITIES THROUGHOUT PROJECT COMPLETION.
- CONTRACTOR SHALL COMPLY WITH THE OWNER'S ENVIRONMENTAL ENGINEER ON ALL METHODS AND PROVISIONS FOR ALL EXCAVATION ACTIVITIES INCLUDING SOIL DISPOSAL. ALL BACKFILL MATERIALS TO BE PROVIDED BY THE CONTRACTOR.
- THE COUNTY/CITY/TOWN MAY MAKE PERIODIC FIELD INSPECTIONS TO ENSURE COMPLIANCE WITH THE DESIGN PLANS, SPECIFICATIONS, AND CONTRACT DOCUMENTS.
- THE COUNTY/CITY/TOWN MUST BE NOTIFIED (2) WORKING DAYS PRIOR TO CONCEALMENT/BURIAL OF ANY SYSTEM OR MATERIAL THAT WILL PREVENT THE DIRECT INSPECTION OF MATERIALS, METHODS OR WORKMANSHIP. EXAMPLES OF THESE PROCESSES ARE BACKFILLING A GROUND RING OR TOWER FOUNDATION, POURING TOWER FOUNDATIONS, BURYING GROUND RODS, PLATES OR GRIDS, ETC. THE CONTRACTOR MAY PROCEED WITH THE SCHEDULED PROCESS (2) WORKING DAYS AFTER PROVIDING NOTICE UNLESS NOTIFIED OTHERWISE BY THE COUNTY/CITY/TOWN.
- PRIOR TO THE SUBMISSION OF BIDS, THE CONTRACTOR SHALL VISIT THE SITE TO FAMILIARIZE WITH THE EXISTING CONDITIONS AND TO CONFIRM THAT THE WORK CAN BE ACCOMPLISHED AS SHOWN ON THE CONSTRUCTION DRAWINGS. ANY DISCREPANCY FOUND SHALL BE BROUGHT TO THE ATTENTION OF ENGINEER ON RECORD, PRIOR TO THE COMMENCEMENT OF ANY WORK.

SITE LOCATION MAP

N.T.S.



VICINITY MAP

N.T.S.

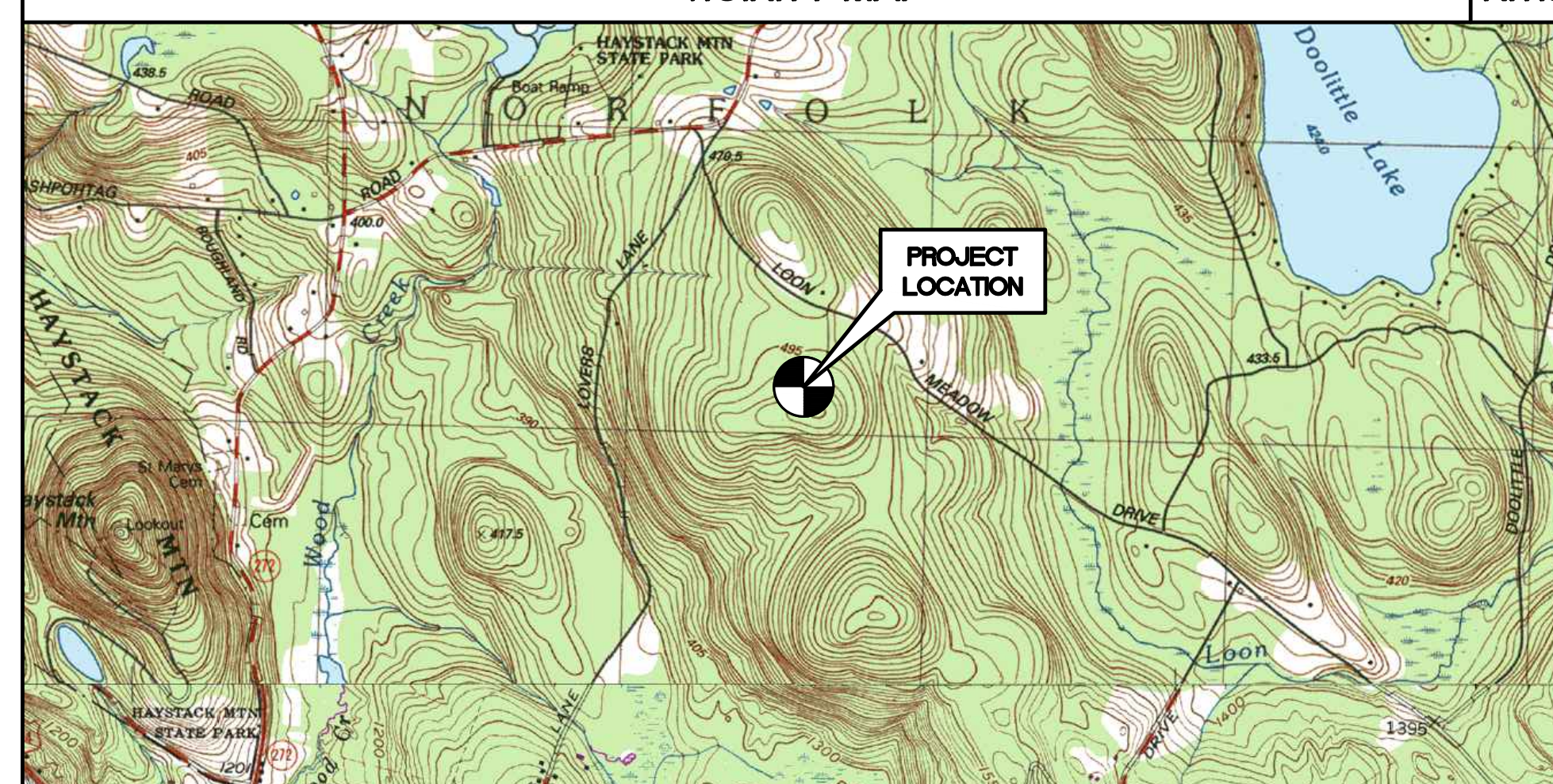

SITE COORDINATES AND GROUND ELEVATION REFERENCED FROM FAA 1A SURVEY, COMPLETED BY CENTEK ENGINEERING, DATED 05/17/22.

SITE COORDINATES: LATITUDE: 42° 00' 32.68" N
 LONGITUDE: 73° 10' 51.20" W
 GROUND ELEVATION: ±1658.50' AMSL



PROJECT SUMMARY

THE PROPOSED SCOPE OF WORK CONSISTS OF A MODIFICATION TO THE EXISTING UNMANNED TELECOMMUNICATIONS FACILITY INCLUDING THE FOLLOWING:

- REPAIR CONCRETE SLAB PER SPECIFIED REQUIREMENTS PRIOR TO ANY INSTALLATION ATOP THE AFOREMENTIONED PAD. REFER TO SHEET S-1 AND S-2 FOR ADDITIONAL DETAILS.
- REMOVE EXISTING COAX CABLES
- REMOVE EXISTING EMS: RR90-17-XXDP ANTENNAS, TYP. (1) PER SECTOR; TOTAL OF (3)
- REMOVE EXISTING TMA
- REMOVE EXISTING DIPLEXER
- REMOVE EXISTING ANDREW: LNX-6515DS-A1M ANTENNAS, TYP. (1) PER SECTOR; TOTAL OF (3)
- REMOVE EXISTING ANTENNA MOUNTS
- REMOVE EXISTING T-MOBILE EQUIPMENT LOCATED INSIDE THE EXISTING SHELTER.
- REMOVE EXISTING T-MOBILE ICE-BRIDGE
- INSTALL (2) 6x24 HYBRID CABLES
- INSTALL ERICSSON: AIR6419 B41 ANTENNA, TYP. (1) PER SECTOR; TOTAL OF (3)
- INSTALL RFS: APXVALL24_43-U-NA20 ANTENNA, TYP. (1) PER SECTOR; TOTAL OF (3)
- INSTALL ERICSSON: RADIO 4460 B25+B66, TYP. (1) PER SECTOR; TOTAL OF (3)
- INSTALL ERICSSON: RADIO 4480 B71+B85, TYP. (1) PER SECTOR; TOTAL OF (3)
- INSTALL T-MOBILE 6160 POWER ENCLOSURE ATOP EXISTING CONCRETE PAD
- INSTALL T-MOBILE B160 BATTERY CABINET ATOP EXISTING CONCRETE PAD
- INSTALL NEW 200A PPC CABINET ON EXISTING FRAME.
- INSTALL SITE PRO: VFA12-HD ANTENNA FRAMES, TYP. (1) PER SECTOR; TOTAL OF (3)
- INSTALL NEW CABLE ICE-BRIDGE

PROJECT INFORMATION

SITE NAME: NORFOLK SNET_1
 SITE ID: CT11349A
 SITE ADDRESS: 453 LOON MEADOW DR
 NORFOLK, CT 06058
 APPLICANT: T-MOBILE NORTHEAST, LLC
 35 GRIFFIN ROAD SOUTH
 BLOOMFIELD, CT. 06002
 CONTACT PERSON: DAN REID (PROJECT MANAGER)
 TRANSCEND WIRELESS, LLC
 (203) 592-8291
 ENGINEER OF RECORD: CENTEK ENGINEERING, INC.
 63-2 NORTH BRANFORD ROAD
 BRANFORD, CT. 06405
 CARLO F. CENTORE, PE
 (203) 488-0580 EXT. 122
 SITE COORDINATES: LATITUDE: 42°-00'-32.68" N
 LONGITUDE: 73°-10'-51.20" W
 GROUND ELEVATION: 1658.50± AMSL
 SITE COORDINATES AND GROUND ELEVATION REFERENCED FROM FAA 1A SURVEY, COMPLETED BY CENTEK ENGINEERING, DATED 05/17/22.

SHEET INDEX

SHEET NO.	DESCRIPTION	REV.
T-1	TITLE SHEET	2
N-1	NOTES AND SPECIFICATIONS, ANT. SCHEDULE	2
C-1	COMPOUND PLAN, EQUIPMENT PLANS AND ELEVATION	2
C-2	ANTENNA PLANS AND ELEVATIONS	2
C-3	TYPICAL EQUIPMENT DETAILS	2
C-4	TYPICAL EQUIPMENT DETAILS	2
S-1	CONCRETE RESTORATION NOTES	2
S-2	CONCRETE RESTORATION PLAN AND DETAILS	2
E-1	ELECTRICAL RISER DIAGRAM AND CONDUIT ROUTING	2
E-2	TYPICAL ELECTRICAL DETAILS	2
E-3	ELECTRICAL SPECIFICATIONS	2

CONSTRUCTION DRAWINGS — REVISED PER EQUIPMENT RELOCATION
 CONSTRUCTION DRAWINGS — UPDATED PER NEW BUILDING CODES
 CONSTRUCTION DRAWINGS — ISSUED FOR CONSTRUCTION

TUR TUR ASC
 TUR RTS RTS
 TUR RTS RTS

03/31/23
 01/27/23
 09/27/22

2
 1
 0

REV. DATE DRAWN BY CHECKED BY DESCRIPTION

PROFESSIONAL ENGINEER SEAL

 CENTEK engineering
 Continued on Subsheet
 (203) 488-0580
 (203) 488-8387 Fax
 63-2 North Branford Road
 Branford, CT 06405
 www.CentekEng.com

T-MOBILE NORTHEAST LLC
 SITE NAME: NORFOLK SNET_1
 SITE ID: CT11349A
 453 LOON MEADOW DR
 NORFOLK, CT 06058

DATE: 03/16/22
 SCALE: AS NOTED
 JOB NO. 22022.16

TITLE SHEET

T-1
 SHEET NO. 1 OF 11

NOTES AND SPECIFICATIONS:

DESIGN BASIS:

GOVERNING CODE: 2021 INTERNATIONAL BUILDING (IBC) AS MODIFIED BY THE 2022 CONNECTICUT STATE BUILDING CODE.

- DESIGN CRITERIA:
 - RISK CATEGORY II (BASED ON IBC TABLE 1604.5)
 - NOMINAL DESIGN SPEED: 89 MPH (V_sd) (EXPOSURE B/ IMPORTANCE FACTOR 1.0 BASED ON ASCE 7-16).

SITE NOTES

- THE CONTRACTOR SHALL CALL UTILITIES PRIOR TO THE START OF CONSTRUCTION.
- ACTIVE EXISTING UTILITIES, WHERE ENCOUNTERED IN THE WORK, SHALL BE PROTECTED AT ALL TIMES. THE ENGINEER SHALL BE NOTIFIED IMMEDIATELY, PRIOR TO PROCEEDING, SHOULD ANY UNCOVERED EXISTING UTILITY PRECLUDE COMPLETION OF THE WORK IN ACCORDANCE WITH THE CONTRACT DOCUMENTS.
- THE AREAS OF THE COMPOUND DISTURBED BY THE WORK SHALL BE RETURNED TO THEIR ORIGINAL CONDITION.
- CONTRACTOR SHALL MINIMIZE DISTURBANCE TO EXISTING SITE DURING CONSTRUCTION. EROSION CONTROL MEASURES, SHALL BE IN CONFORMANCE WITH THE LOCAL GUIDELINES FOR EROSION AND SEDIMENT CONTROL.
- IF ANY FIELD CONDITIONS EXIST WHICH PRECLUDE COMPLIANCE WITH THE DRAWINGS, THE CONTRACTOR SHALL IMMEDIATELY NOTIFY THE ENGINEER AND SHALL PROCEED WITH AFFECTED WORK AFTER CONFLICT IS SATISFACTORILY RESOLVED.

GENERAL NOTES

- ALL WORK SHALL BE IN ACCORDANCE WITH THE 2021 INTERNATIONAL BUILDING CODE AS MODIFIED BY THE 2022 CONNECTICUT SUPPLEMENT, INCLUDING THE TIA/EIA-222 REVISION "H" "STRUCTURAL STANDARDS FOR STEEL ANTENNA TOWERS AND SUPPORTING STRUCTURES," 2022 CONNECTICUT FIRE SAFETY CODE, NATIONAL ELECTRICAL CODE AND LOCAL CODES.
- SHOULD ANY FIELD CONDITIONS PRECLUDE COMPLIANCE WITH THE DRAWINGS, THE CONTRACTOR SHALL IMMEDIATELY NOTIFY THE ENGINEER AND SHALL NOT PROCEED WITH ANY AFFECTED WORK.
- CONTRACTOR SHALL REVIEW ALL DRAWINGS AND SPECIFICATIONS IN THE CONTRACT DOCUMENT SET. CONTRACTOR SHALL COORDINATE ALL WORK SHOWN IN THE SET OF DRAWINGS. THE CONTRACTOR SHALL PROVIDE A COMPLETE SET OF DRAWINGS TO ALL SUBCONTRACTORS AND ALL RELATED PARTIES. THE SUBCONTRACTORS SHALL EXAMINE ALL THE DRAWINGS AND SPECIFICATIONS FOR THE INFORMATION THAT AFFECTS THEIR WORK.
- BEFORE BEGINNING THE WORK, THE CONTRACTOR IS RESPONSIBLE FOR MAKING SUCH INVESTIGATIONS CONCERNING PHYSICAL CONDITIONS (SURFACE AND SUBSURFACE) AT OR CONTIGUOUS TO THE SITE, WHICH MAY AFFECT PERFORMANCE AND COST OF THE WORK.
- ALL DIMENSIONS, ELEVATIONS, AND OTHER REFERENCES TO EXISTING STRUCTURES, SURFACE, AND SUBSURFACE CONDITIONS ARE APPROXIMATE. NO GUARANTEE IS MADE FOR THE ACCURACY OR COMPLETENESS OF THE INFORMATION SHOWN. THE CONTRACTOR SHALL VERIFY AND COORDINATE ALL DIMENSIONS, ELEVATIONS AND ANGLES WITH EXISTING CONDITIONS AND WITH ARCHITECTURAL AND SITE DRAWINGS BEFORE PROCEEDING WITH ANY WORK.
- AS THE WORK PROGRESSES, THE CONTRACTOR SHALL NOTIFY THE OWNER OF ANY CONDITIONS WHICH ARE IN CONFLICT OR OTHERWISE NOT CONSISTENT WITH THE CONSTRUCTION DOCUMENTS, AND SHALL NOT PROCEED WITH SUCH WORK UNTIL THE CONFLICT IS SATISFACTORILY RESOLVED.
- CONTRACTOR SHALL PROVIDE A COMPLETE BUILD-OUT WITH ALL FINISHES, STRUCTURAL, MECHANICAL, AND ELECTRICAL COMPONENTS AND PROVIDE ALL ITEMS AS SHOWN OR INDICATED ON THE DRAWINGS OR IN THE WRITTEN SPECIFICATIONS.
- CONTRACTOR SHALL FURNISH ALL MATERIAL, LABOR AND EQUIPMENT TO COMPLETE THE WORK AND FURNISH A COMPLETED JOB ALL IN ACCORDANCE WITH LOCAL AND STATE GOVERNING AUTHORITIES AND OTHER AUTHORITIES HAVING LAWFUL JURISDICTION OVER THE WORK.
- CONTRACTOR SHALL SECURE AND PAY FOR ALL PERMITS AND ALL INSPECTIONS REQUIRED AND SHALL ALSO PAY FEES REQUIRED FOR THE GENERAL CONSTRUCTION, PLUMBING, ELECTRICAL, AND HVAC. PERMITS SHALL BE PAID FOR BY THE RESPECTIVE SUBCONTRACTORS.
- CONTRACTOR SHALL MAINTAIN A CURRENT SET OF DRAWINGS AND SPECIFICATIONS ON SITE AT ALL TIMES AND INSURE DISTRIBUTION OF NEW DRAWINGS TO SUBCONTRACTORS AND OTHER RELEVANT PARTIES AS SOON AS THEY ARE MADE AVAILABLE. ALL OLD DRAWINGS SHALL BE MARKED VOID AND REMOVED FROM THE CONTRACT AREA. THE CONTRACTOR SHALL FURNISH AN 'AS-BUILT' SET OF DRAWINGS TO OWNER UPON COMPLETION OF PROJECT.
- LOCATION OF EQUIPMENT AND WORK SUPPLIED BY OTHERS THAT IS DIAGRAMMATICALLY INDICATED ON THE DRAWINGS, SHALL BE DETERMINED BY THE CONTRACTOR. THE CONTRACTOR SHALL DETERMINE LOCATIONS AND DIMENSIONS SUBJECT TO STRUCTURAL CONDITIONS AND WORK OF THE SUBCONTRACTORS.
- THE CONTRACTOR IS SOLELY RESPONSIBLE TO DETERMINE CONSTRUCTION PROCEDURE AND SEQUENCE AND TO ENSURE THE SAFETY OF THE EXISTING STRUCTURES AND ITS COMPONENT PARTS DURING CONSTRUCTION. THIS INCLUDES THE ADDITION OF WHATEVER SHORING, BRACING, UNDERPINNING, ETC. THAT MAY BE NECESSARY.
- ALL EQUIPMENT AND PRODUCTS PURCHASED ARE TO BE REVIEWED BY CONTRACTOR AND ALL APPLICABLE SUB-CONTRACTORS FOR ANY CONDITION PER THE MANUFACTURER'S RECOMMENDATIONS. CONTRACTOR TO SUPPLY THESE ITEMS AT NO COST TO OWNER OR CONSTRUCTION MANAGER.

- DRAWINGS INDICATE THE MINIMUM STANDARDS, BUT IF ANY WORK SHOULD BE INDICATED TO BE SUBSTANDARD TO ANY ORDINANCES, LAWS, CODES, RULES, OR REGULATIONS BEARING ON THE WORK, THE CONTRACTOR SHALL INCLUDE IN HIS WORK AND SHALL EXECUTE THE WORK CORRECTLY IN ACCORDANCE WITH SUCH ORDINANCES, LAWS, CODES, RULES OR REGULATIONS WITH NO INCREASE IN COSTS.
- ALL UTILITY WORK SHALL BE IN ACCORDANCE WITH LOCAL UTILITY COMPANY REQUIREMENTS AND SPECIFICATIONS.
- ALL EQUIPMENT AND PRODUCTS PURCHASED ARE TO BE REVIEWED BY CONTRACTOR AND ALL APPLICABLE SUBCONTRACTORS FOR ANY CONDITION PER MANUFACTURER'S RECOMMENDATIONS. CONTRACTOR TO SUPPLY THESE ITEMS AT NO COST TO OWNER OR CONSTRUCTION MANAGER.
- ANY AND ALL ERRORS, DISCREPANCIES, AND 'MISSED' ITEMS ARE TO BE BROUGHT TO THE ATTENTION OF THE T-MOBILE CONSTRUCTION MANAGER DURING THE BIDDING PROCESS BY THE CONTRACTOR. ALL THESE ITEMS ARE TO BE INCLUDED IN THE BID. NO 'EXTRA' WILL BE ALLOWED FOR MISSED ITEMS.
- CONTRACTOR SHALL BE RESPONSIBLE FOR ALL ON-SITE SAFETY FROM THE TIME THE JOB IS AWARDED UNTIL ALL WORK IS COMPLETE AND ACCEPTED BY THE OWNER.
- CONTRACTOR TO REVIEW ALL SHOP DRAWINGS AND SUBMIT COPY TO ENGINEER FOR APPROVAL. DRAWINGS MUST BEAR THE CHECKER'S INITIALS BEFORE SUBMITTING TO THE CONSTRUCTION MANAGER FOR REVIEW.
- THE CONTRACTOR SHALL FIELD VERIFY ALL DIMENSIONS, ELEVATIONS, ANGLES AND EXISTING CONDITIONS AT THE SITE, PRIOR TO FABRICATION AND/OR INSTALLATION OF ANY WORK IN THE CONTRACT AREA.
- COORDINATION, LAYOUT, FURNISHING AND INSTALLATION OF CONDUITS AND ALL APPURTENANCES REQUIRED FOR PROPER INSTALLATION OF ELECTRICAL AND TELECOMMUNICATION SERVICE SHALL BE THE SOLE RESPONSIBILITY OF THE CONTRACTOR AND CONFIRMED WITH THE PROJECT MANAGER AND OWNER PRIOR TO THE COMMENCEMENT OF ANY WORK
- ALL DAMAGE CAUSED TO ANY EXISTING STRUCTURE SHALL BE THE SOLE RESPONSIBILITY OF THE CONTRACTOR. THE CONTRACTOR WILL BE HELD LIABLE FOR ALL REPAIRS REQUIRED FOR EXISTING STRUCTURES IF DAMAGED DURING CONSTRUCTION ACTIVITIES.
- THE CONTRACTOR SHALL CONTACT 'CALL BEFORE YOU DIG' AT LEAST 48 HOURS PRIOR TO ANY EXCAVATIONS AT 1-800-922-4455. ALL UTILITIES SHALL BE IDENTIFIED AND CLEARLY MARKED. CONTRACTOR SHALL MAINTAIN AND PROTECT MARKED UTILITIES THROUGHOUT PROJECT COMPLETION.
- CONTRACTOR SHALL COMPLY WITH THE OWNER'S ENVIRONMENTAL ENGINEER ON ALL METHODS AND PROVISIONS FOR ALL EXCAVATION ACTIVITIES INCLUDING SOIL DISPOSAL. ALL BACKFILL MATERIALS TO BE PROVIDED BY THE CONTRACTOR.
- THE COUNTY/CITY/TOWN MAY MAKE PERIODIC FIELD INSPECTIONS TO ENSURE COMPLIANCE WITH THE DESIGN PLANS, SPECIFICATIONS, AND CONTRACT DOCUMENTS.
- THE COUNTY/CITY/TOWN MUST BE NOTIFIED (2) WORKING DAYS PRIOR TO CONCEALMENT/BURIAL OF ANY SYSTEM OR MATERIAL THAT WILL PREVENT THE DIRECT INSPECTION OF MATERIALS, METHODS OR WORKMANSHIP. EXAMPLES OF THESE PROCESSES ARE BACKFILLING A GROUND RING OR TOWER FOUNDATION, POURING TOWER FOUNDATIONS, BURYING GROUND RODS, PLATES OR GRIDS, ETC. THE CONTRACTOR MAY PROCEED WITH THE SCHEDULED PROCESS (2) WORKING DAYS AFTER PROVIDING NOTICE UNLESS NOTIFIED OTHERWISE BY THE COUNTY/CITY/TOWN.
- PRIOR TO THE SUBMISSION OF BIDS, THE CONTRACTOR SHALL VISIT THE SITE TO FAMILIARIZE WITH THE EXISTING CONDITIONS AND TO CONFIRM THAT THE WORK CAN BE ACCOMPLISHED AS SHOWN ON THE CONSTRUCTION DRAWINGS. ANY DISCREPANCY FOUND SHALL BE BROUGHT TO THE ATTENTION OF ENGINEER ON RECORD, PRIOR TO THE COMMENCEMENT OF ANY WORK.

STRUCTURAL STEEL

- ALL STRUCTURAL STEEL IS DESIGNED BY ALLOWABLE STRESS DESIGN (ASD)
 - A. STRUCTURAL STEEL (W SHAPES)---ASTM A992 (FY = 50 KSI)
 - B. STRUCTURAL STEEL (OTHER SHAPES)---ASTM A36 (FY = 36 KSI)
 - C. STRUCTURAL HSS (RECTANGULAR SHAPES)---ASTM A500 GRADE B, (FY = 46 KSI)
 - D. STRUCTURAL HSS (ROUND SHAPES)---ASTM A500 GRADE B, (FY = 42 KSI)
 - E. PIPE---ASTM A53 (FY = 35 KSI)
 - F. CONNECTION BOLTS---ASTM A325-N
 - G. U-BOLTS---ASTM A36
 - H. ANCHOR RODS---ASTM F 1554
 - I. WELDING ELECTRODE---ASTM E 70XX
- CONTRACTOR TO REVIEW ALL SHOP DRAWINGS AND SUBMIT COPY TO ENGINEER FOR APPROVAL. DRAWINGS MUST BEAR THE CHECKER'S INITIALS BEFORE SUBMITTING TO THE ENGINEER FOR REVIEW. SHOP DRAWINGS SHALL INCLUDE THE FOLLOWING: SECTION PROFILES, SIZES, CONNECTION ATTACHMENTS, REINFORCING, ANCHORAGE, SIZE AND TYPE OF FASTENERS AND ACCESSORIES. INCLUDE ERECTION DRAWINGS, ELEVATIONS AND DETAILS.
- STRUCTURAL STEEL SHALL BE DETAILED, FABRICATED AND ERECTED IN ACCORDANCE WITH THE LATEST PROVISIONS OF AISC MANUAL OF STEEL CONSTRUCTION.
- PROVIDE ALL PLATES, CLIP ANGLES, CLOSURE PIECES, STRAP ANCHORS, MISCELLANEOUS PIECES AND HOLES REQUIRED TO COMPLETE THE STRUCTURE.
- FIT AND SHOP ASSEMBLE FABRICATIONS IN THE LARGEST PRACTICAL SECTIONS FOR DELIVERY TO SITE.
- INSTALL FABRICATIONS PLUMB AND LEVEL, ACCURATELY FITTED, AND FREE FROM DISTORTIONS OR DEFECTS.
- AFTER ERECTION OF STRUCTURES, TOUCHUP ALL WELDS, ABRASIONS AND NON-GALVANIZED SURFACES WITH A 95% ORGANIC ZINC RICH PAINT IN ACCORDANCE WITH ASTM 780.
- ALL STEEL MATERIAL (EXPOSED TO WEATHER) SHALL BE GALVANIZED AFTER FABRICATION IN ACCORDANCE WITH ASTM A123 "ZINC (HOT DIPPED GALVANIZED) COATINGS" ON IRONS AND STEEL PRODUCTS.
- ALL BOLTS, ANCHORS AND MISCELLANEOUS HARDWARE SHALL BE GALVANIZED IN ACCORDANCE WITH ASTM A153 "ZINC COATING (HOT-DIP) ON IRON AND STEEL HARDWARE".
- THE ENGINEER SHALL BE NOTIFIED OF ANY INCORRECTLY FABRICATED, DAMAGED OR OTHERWISE MISFITTING OR NON CONFORMING MATERIALS OR CONDITIONS TO REMEDIAL OR CORRECTIVE ACTION. ANY SUCH ACTION SHALL REQUIRE ENGINEER REVIEW.
- CONNECTION ANGLES SHALL HAVE A MINIMUM THICKNESS OF 1/4 INCHES.
- STRUCTURAL CONNECTION BOLTS SHALL CONFORM TO ASTM A325. ALL BOLTS SHALL BE 3/4" DIAMETER MINIMUM AND SHALL HAVE A MINIMUM OF TWO BOLTS, UNLESS OTHERWISE ON THE DRAWINGS.
- LOCK WASHER ARE NOT PERMITTED FOR A325 STEEL ASSEMBLIES.
- SHOP CONNECTIONS SHALL BE WELDED OR HIGH STRENGTH BOLTED.
- MILL BEARING ENDS OF COLUMNS, STIFFENERS, AND OTHER BEARING SURFACES TO TRANSFER LOAD OVER ENTIRE CROSS SECTION.
- FABRICATE BEAMS WITH MILL CAMBER UP.
- LEVEL AND PLUMB INDIVIDUAL MEMBERS OF THE STRUCTURE TO AN ACCURACY OF 1:500, BUT NOT TO EXCEED 1/4" IN THE FULL HEIGHT OF THE COLUMN.
- COMMENCEMENT OF STRUCTURAL STEEL WORK WITHOUT NOTIFYING THE ENGINEER OF ANY DISCREPANCIES WILL BE CONSIDERED ACCEPTANCE OF PRECEDING WORK.
- INSPECTION AND TESTING OF ALL WELDING AND HIGH STRENGTH BOLTING SHALL BE PERFORMED BY AN INDEPENDENT TESTING LABORATORY.
- FOUR COPIES OF ALL INSPECTION TEST REPORTS SHALL BE SUBMITTED TO THE ENGINEER WITHIN TEN (10) WORKING DAYS OF THE DATE OF INSPECTION.

ANTENNA/APPURTENANCE SCHEDULE

SECTOR	EXISTING/PROPOSED	ANTENNA	SIZE (INCHES) (L x W x D)	ANTENNA Ø HEIGHT	AZIMUTH	(E/P) RRU (QTY)	(E/P) TMA (QTY)	(QTY) PROPOSED HYBRID/COAX
A1	PROPOSED	ERICSSON (AIR6419 B41)	33 x 16 x 9	120'	60°			(2) 6x24 HYBRID CABLE
A2	PROPOSED	RFS (APXVAALL24_43-U_NA20)	95.9 x 24 x 8.7	120'	60°	(P) RADIO 4480 B71+B85 (1), (P) RADIO 4460 B25+B66 (1)		
B1	PROPOSED	ERICSSON (AIR6419 B41)	33 x 16 x 9	120'	160°			
B2	PROPOSED	RFS (APXVAALL24_43-U_NA20)	95.9 x 24 x 8.7	120'	160°	(P) RADIO 4480 B71+B85 (1), (P) RADIO 4460 B25+B66 (1)		
C1	PROPOSED	ERICSSON (AIR6419 B41)	33 x 16 x 9	120'	280°			
C2	PROPOSED	RFS (APXVAALL24_43-U_NA20)	95.9 x 24 x 8.7	120'	280°	(P) RADIO 4480 B71+B85 (1), (P) RADIO 4460 B25+B66 (1)		

NOTE:
ALL HYBRID/COAX LENGTHS TO BE MEASURED
AND VERIFIED IN FIELD BEFORE ORDERING

CONSTRUCTION DRAWINGS -- REVISED PER EQUIPMENT RELOCATION

CONSTRUCTION DRAWINGS -- UPDATED PER NEW BUILDING CODES

CONSTRUCTION DRAWINGS -- ISSUED FOR CONSTRUCTION

T-MOBILE NORTHEAST LLC

SITE NAME: NORFOLK SNET_1
 SITE ID: CT11349A
 453 LOON MEADOW DR
 NORFOLK, CT 06058

DATE: 03/16/22

SCALE: AS NOTED

JOB NO. 22022.16

NOTES AND SPECIFICATIONS ANT. SCHEDULE

N-1

SHEET NO. 2 OF 11

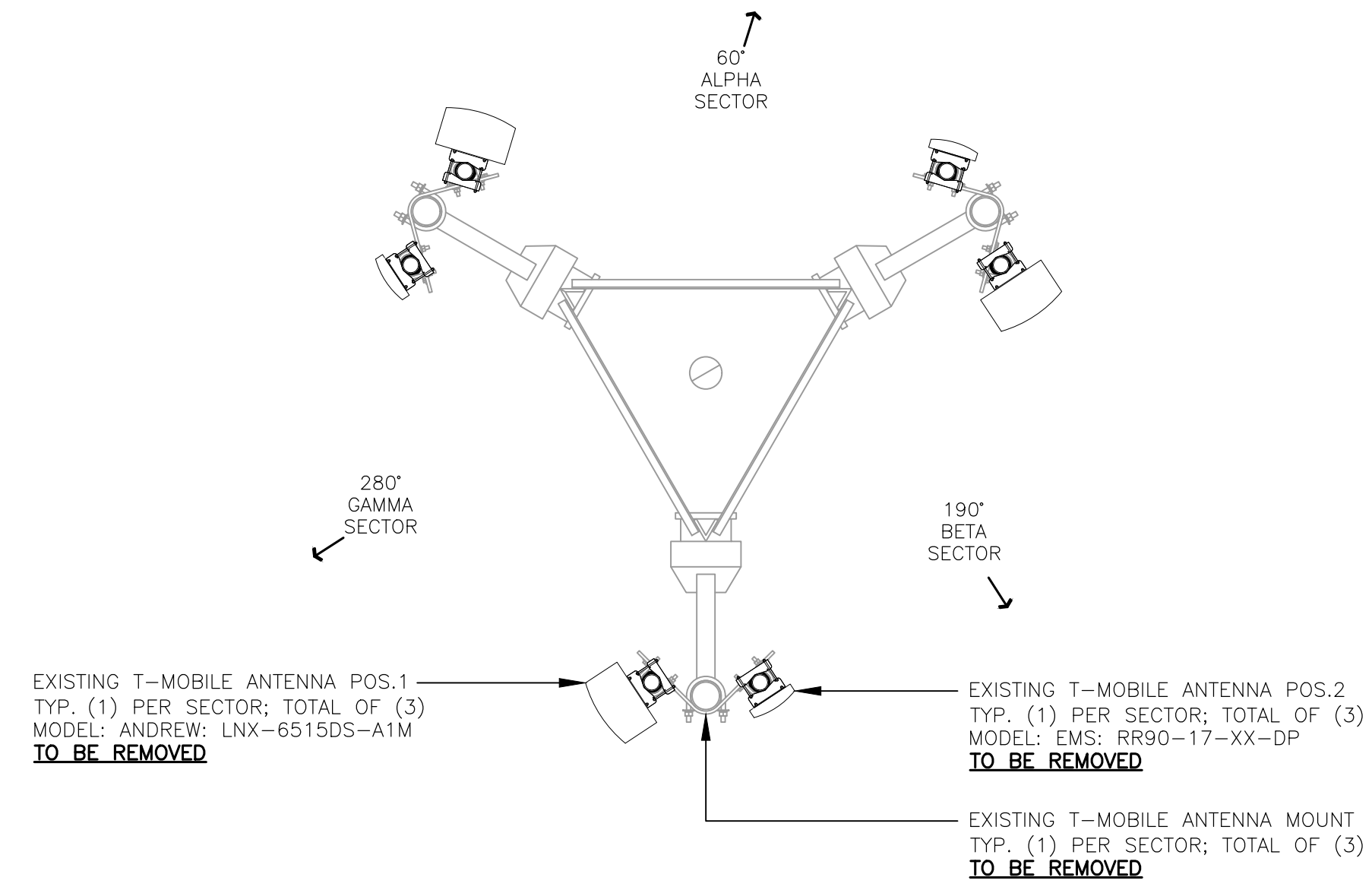

1 ANTENNA PLAN - EXISTING
 C-2 SCALE: 3/8" = 1' TRUE NORTH

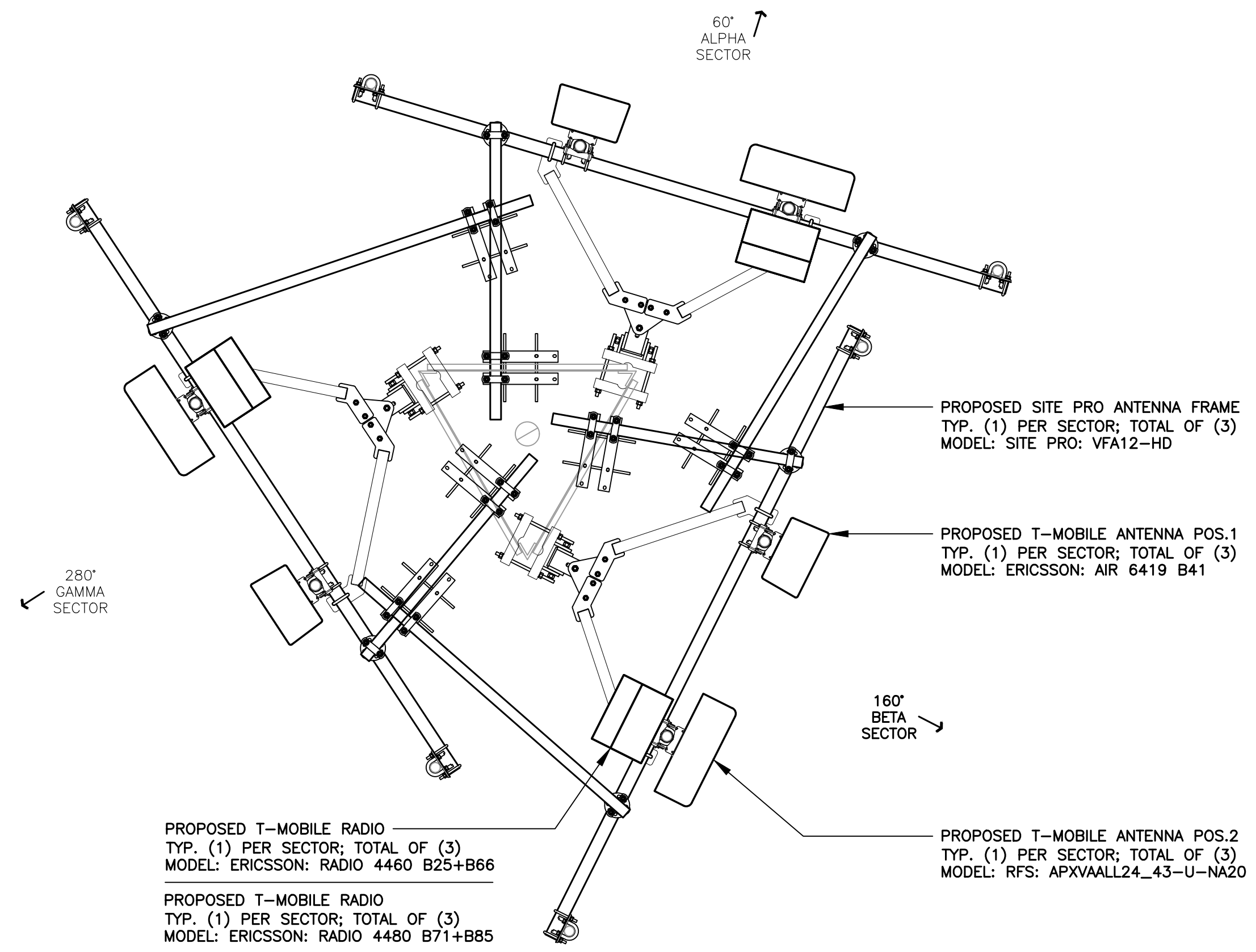

2 ANTENNA PLAN - PROPOSED
 C-2 SCALE: 3/8" = 1' TRUE NORTH

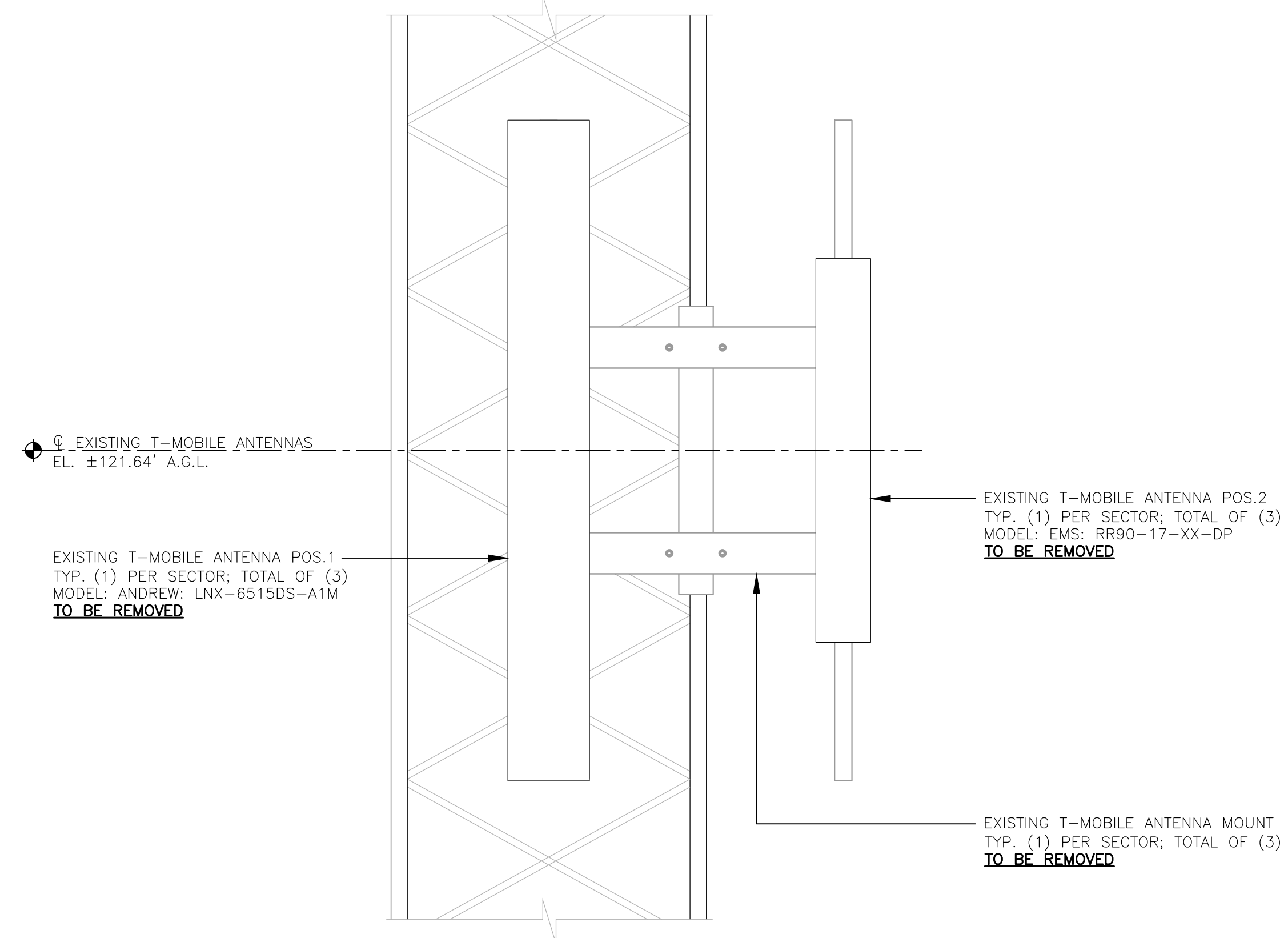

1A ANTENNA ELEVATION - EXISTING
 C-2 SCALE: 3/8" = 1'

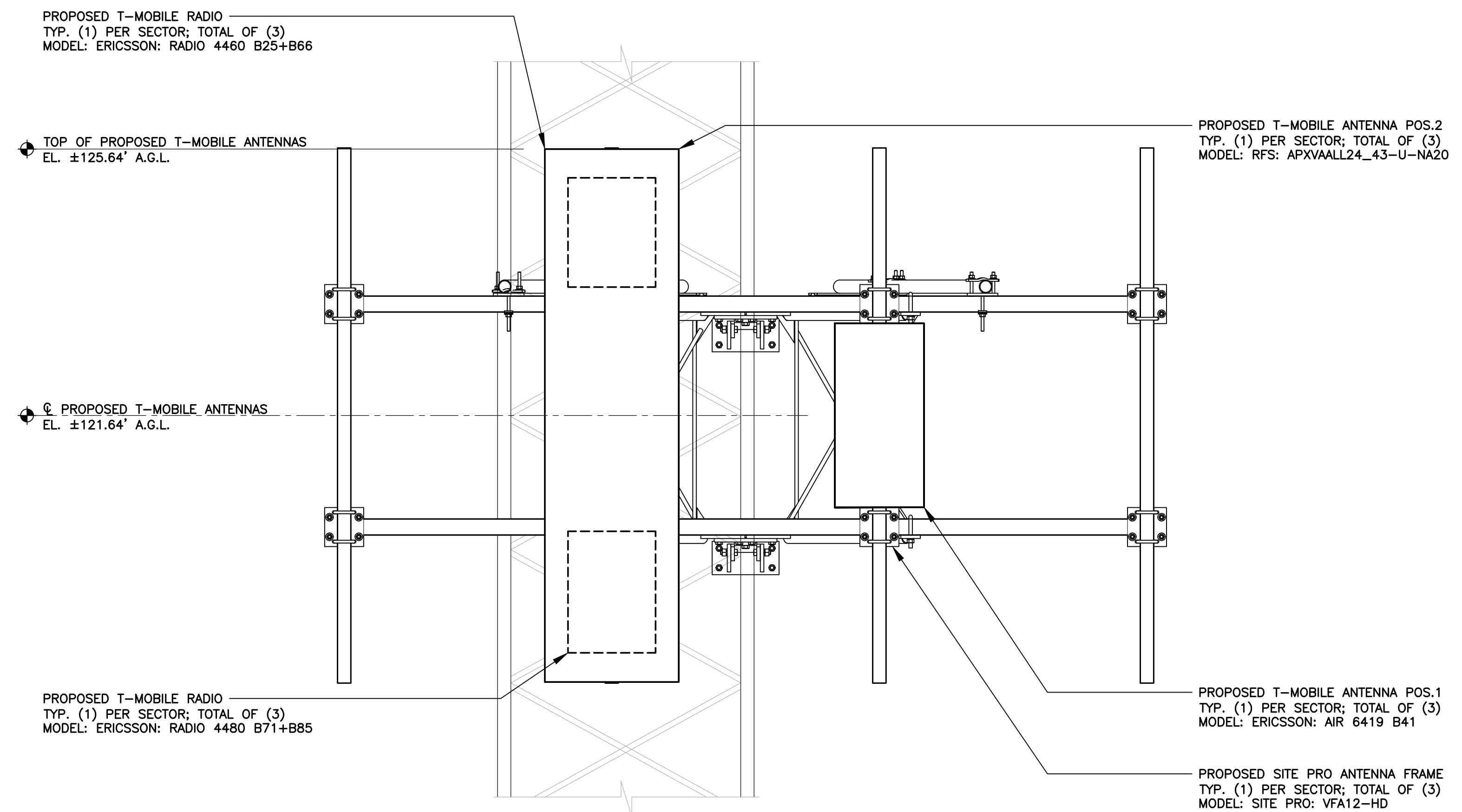

2A ANTENNA ELEVATION - PROPOSED
 C-2 SCALE: 3/8" = 1'

CONSTRUCTION DRAWINGS - REVISED PER EQUIPMENT RELOCATION	TJR	ASC	03/31/23	ASC	03/31/23
CONSTRUCTION DRAWINGS - UPDATED PER NEW BUILDING CODES	TJR	RTS	01/27/23	RTS	01/27/23
CONSTRUCTION DRAWINGS - ISSUED FOR CONSTRUCTION	TJR	RTS	09/27/22	RTS	09/27/22
	REV.	DATE	DRAWN BY	CHECKED BY	DESCRIPTION

PROFESSIONAL ENGINEER SEAL
 STATE OF CONNECTICUT
 ENGINEERING
 CEREK engineering
 Centered on Solutions™
 [203] 488-0580
 [203] 488-8387 Fax
 632 North Branford Road
 Branford, CT 06405
 www.CerkeEng.com

T-Mobile
 T-Mobile
 T-Mobile

T-MOBILE NORTHEAST LLC
 SITE NAME: NORFOLK SNET_1
 SITE ID: CT11349A
 453 LOON MEADOW DR
 NORFOLK, CT 06058

DATE: 03/16/22
 SCALE: AS NOTED
 JOB NO. 22022.16

ANTENNA PLANS AND ELEVATIONS

C-2

SHEET NO. 4 OF 11

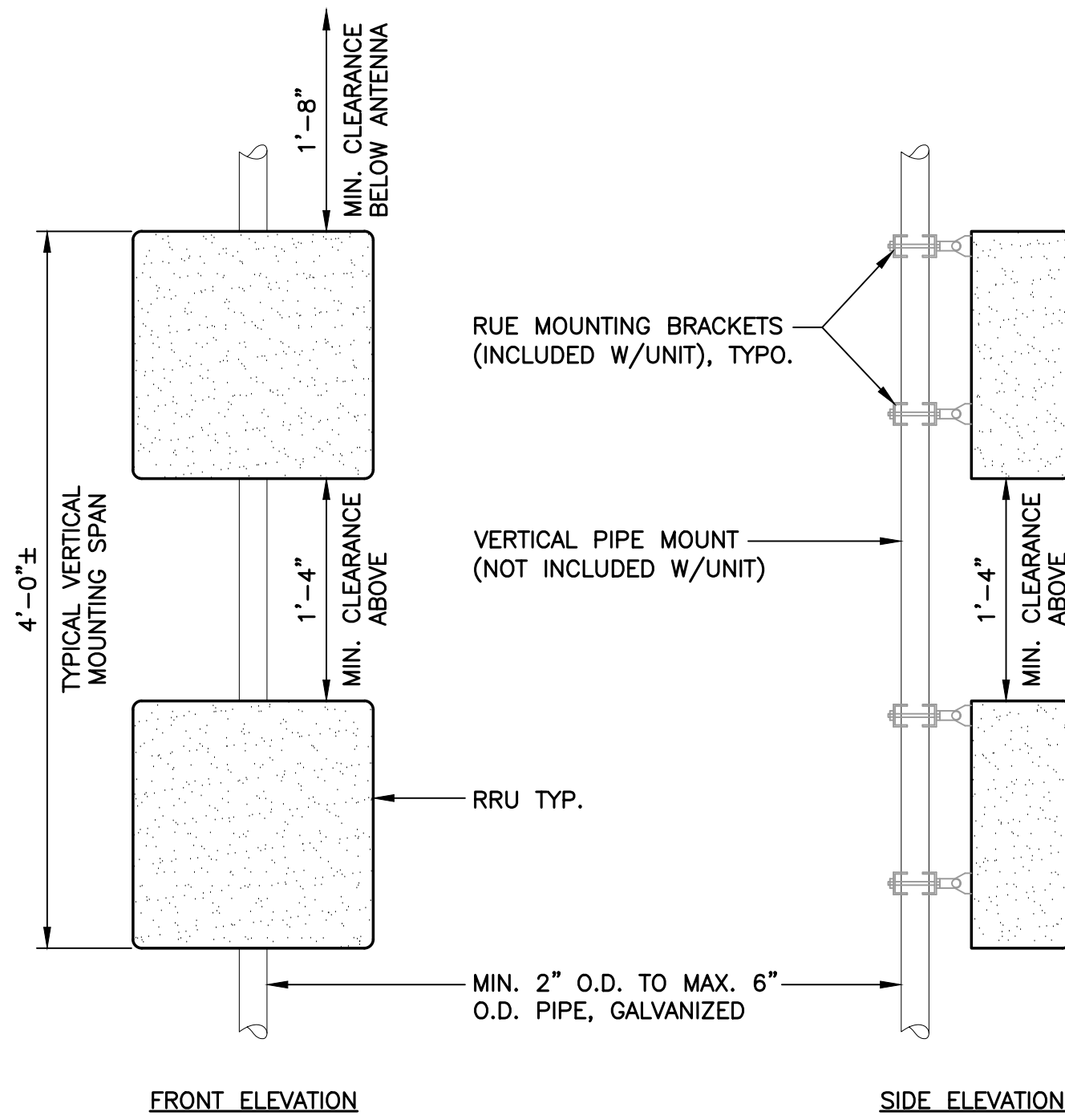

NOTES: (PIPE MOUNTING)

1. T-MOBILE SHALL SUPPLY RRU, AND RRU POLE-MOUNTING BRACKET. CONTRACTOR SHALL SUPPLY POLE/PIPE AND INSTALL ALL MOUNTING HARDWARE INCLUDING ERICSSON RRU POLE-MOUNTING BRACKET.
2. NO PAINTING OF THE RRU OR SOLAR SHIELD IS ALLOWED.

1 TYPICAL RRU MOUNTING DETAILS
C-3 SCALE: NOT TO SCALE

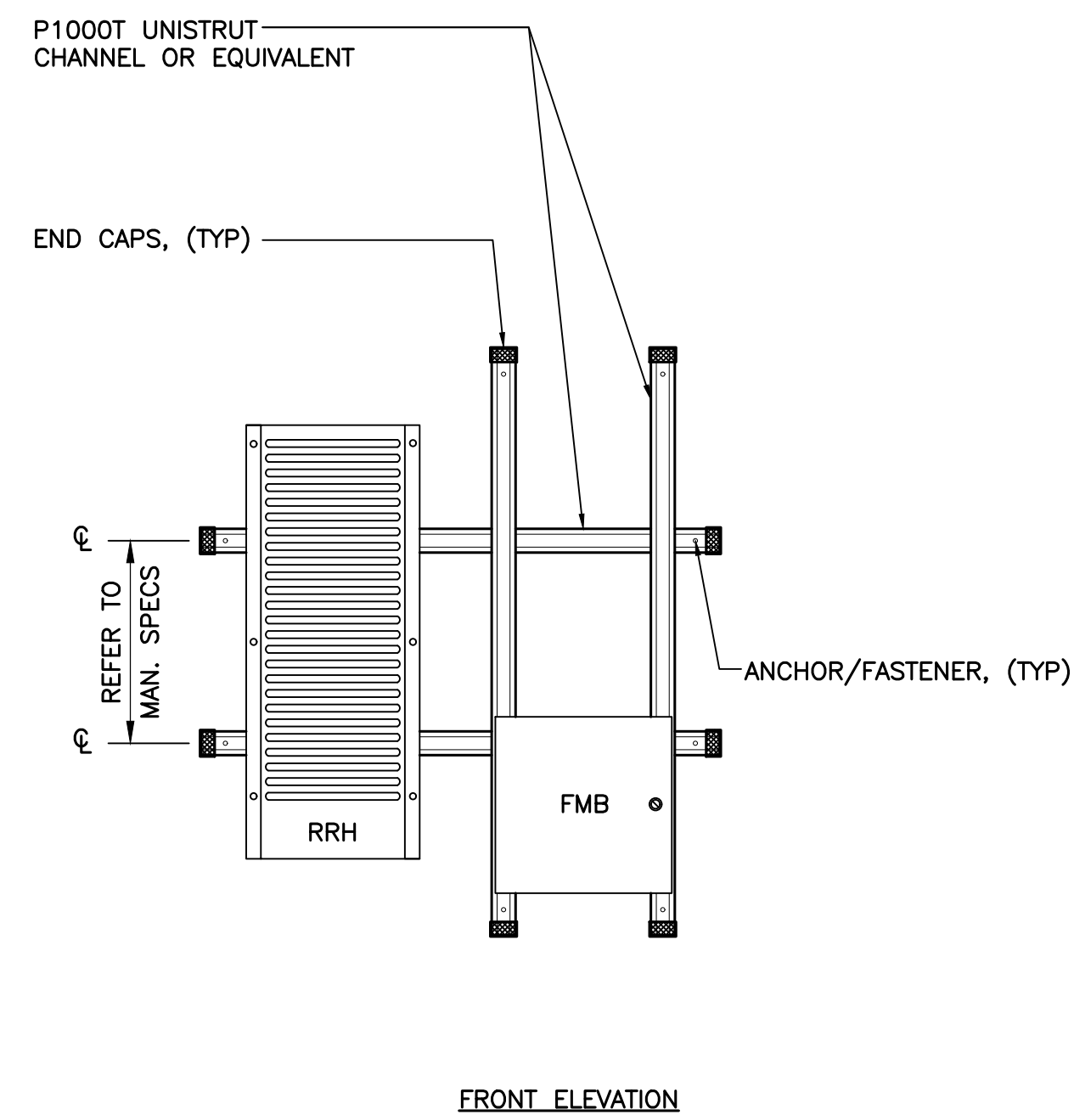

NOTES: (UNISTRUT MOUNTING)

1. INSTALL A MINIMUM OF (2) ANCHORS PER UNISTRUT ($\pm 16^\circ/c$ MIN).
2. MOUNT RRU TO UNISTRUT WITH 3/8\"/>



ALPHA/BETA/GAMMA ANTENNA		
EQUIPMENT	DIMENSIONS	WEIGHT
MAKE: ERICSSON MODEL: AIR6419 B41	33\"/>	
MAKE: RFS MODEL: APXVAALL24_43-U-NA20	95.9\"/>	

NOTES:
1. CONTRACTOR TO COORDINATE FINAL EQUIPMENT MODEL SELECTION WITH T-MOBILE CONSTRUCTION MANAGER PRIOR TO ORDERING.

2 PROPOSED ANTENNA DETAIL
C-3 SCALE: NOT TO SCALE



RRU (REMOTE RADIO UNIT)			
EQUIPMENT	DIMENSIONS	WEIGHT	CLEARANCES
MAKE: ERICSSON MODEL: RADIO 4460 B25+B66	19.6\"/>		
MAKE: ERICSSON MODEL: RADIO 4480 B71+B85	21.8\"/>		

NOTES:
1. CONTRACTOR TO COORDINATE FINAL EQUIPMENT MODEL SELECTION WITH T-MOBILE CONSTRUCTION MANAGER PRIOR TO ORDERING.

3 PROPOSED RRU DETAIL
C-3 SCALE: NOT TO SCALE

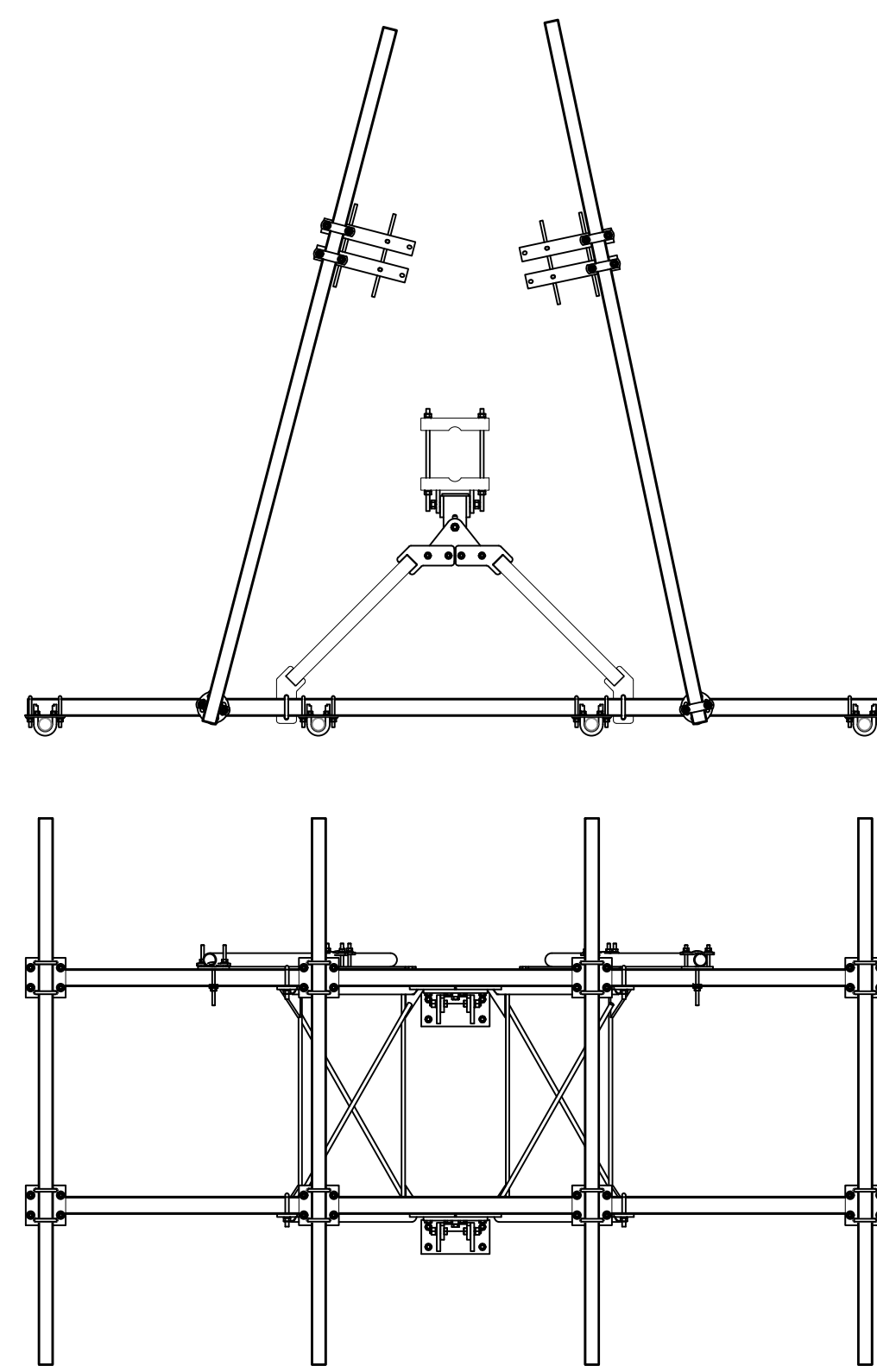

SITE PRO: VFA12-HD

4 PROPOSED ANTENNA MOUNT DETAIL
C-3 SCALE: NOT TO SCALE

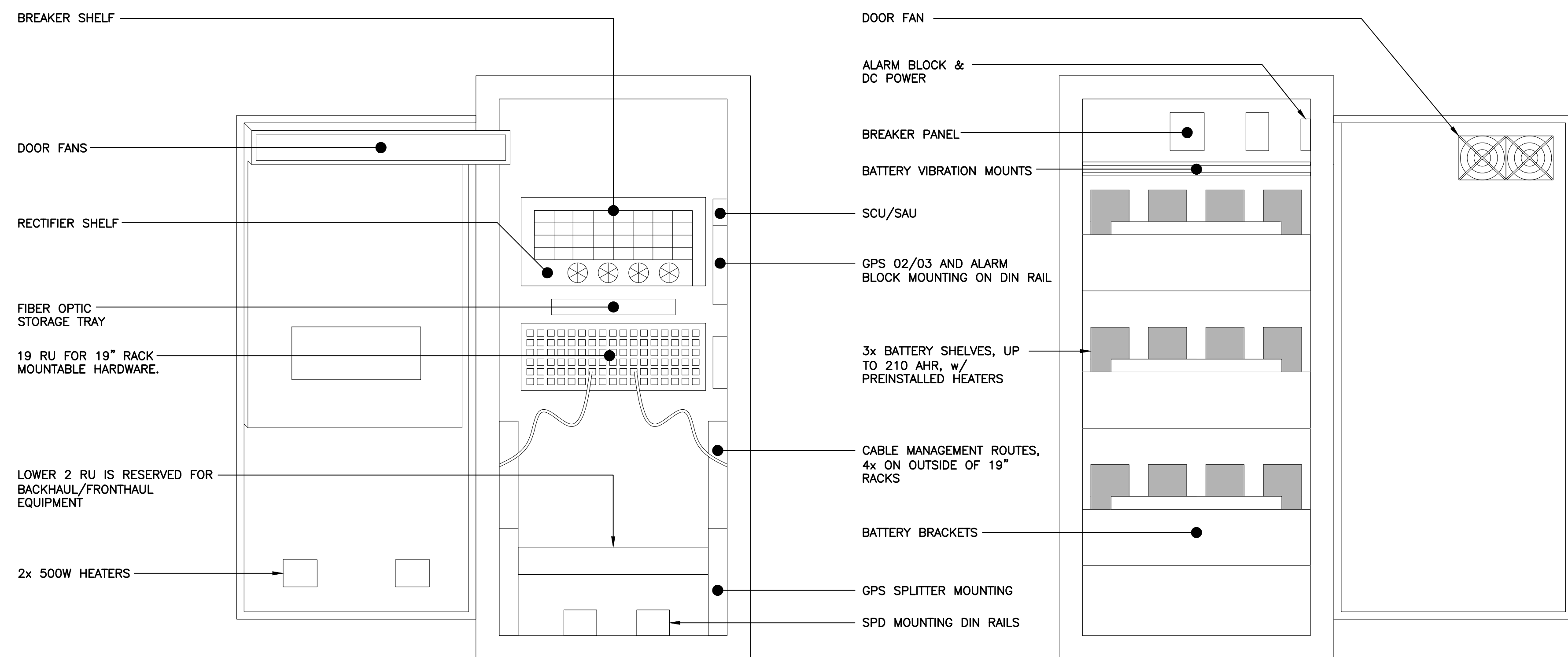

EQUIPMENT CABINET		
EQUIPMENT	DIMENSIONS	WEIGHT
MAKE: ERICSSON MODEL: ENCLOSURE 6160 CABINET	62.0\"/>	

5 ENCLOSURE 6160 CABINET DETAIL
C-3 SCALE: NOT TO SCALE

EQUIPMENT CABINET		
EQUIPMENT	DIMENSIONS	WEIGHT
MAKE: ERICSSON MODEL: BATTERY B160 CABINET	62.0\"/>	

6 BATTERY B160 CABINET DETAIL
C-3 SCALE: NOT TO SCALE

CONSTRUCTION DRAWINGS — REVISED PER EQUIPMENT RELOCATION
CONSTRUCTION DRAWINGS — UPDATED PER NEW BUILDING CODES
CONSTRUCTION DRAWINGS — ISSUED FOR CONSTRUCTION

TUR ASC 03/31/23
TUR RTS 01/27/23
TUR RTS 09/27/22

DATE DRAWN BY CHECKED BY DESCRIPTION

PROFESSIONAL ENGINEER SEAL

T-Mobile
T-Mobile Northeast LLC
SITE NAME: NORFOLK SNET_1
SITE ID: CT11349A
453 LOON MEADOW DR
NORFOLK, CT 06058

CERK engineering
Centered on Solutions™
[203] 488-0580
[203] 488-8387 Fax
632 North Branford Road
Branford, CT 06405
www.CentrelEng.com

DATE: 03/16/22
SCALE: AS NOTED
JOB NO. 22022.16

TYPICAL EQUIPMENT DETAILS

C-3
SHEET NO. 5 OF 11



1 TYPICAL SEPARATION



2 MINOR SPALLING



3 BROKEN FOUNDATION CORNER

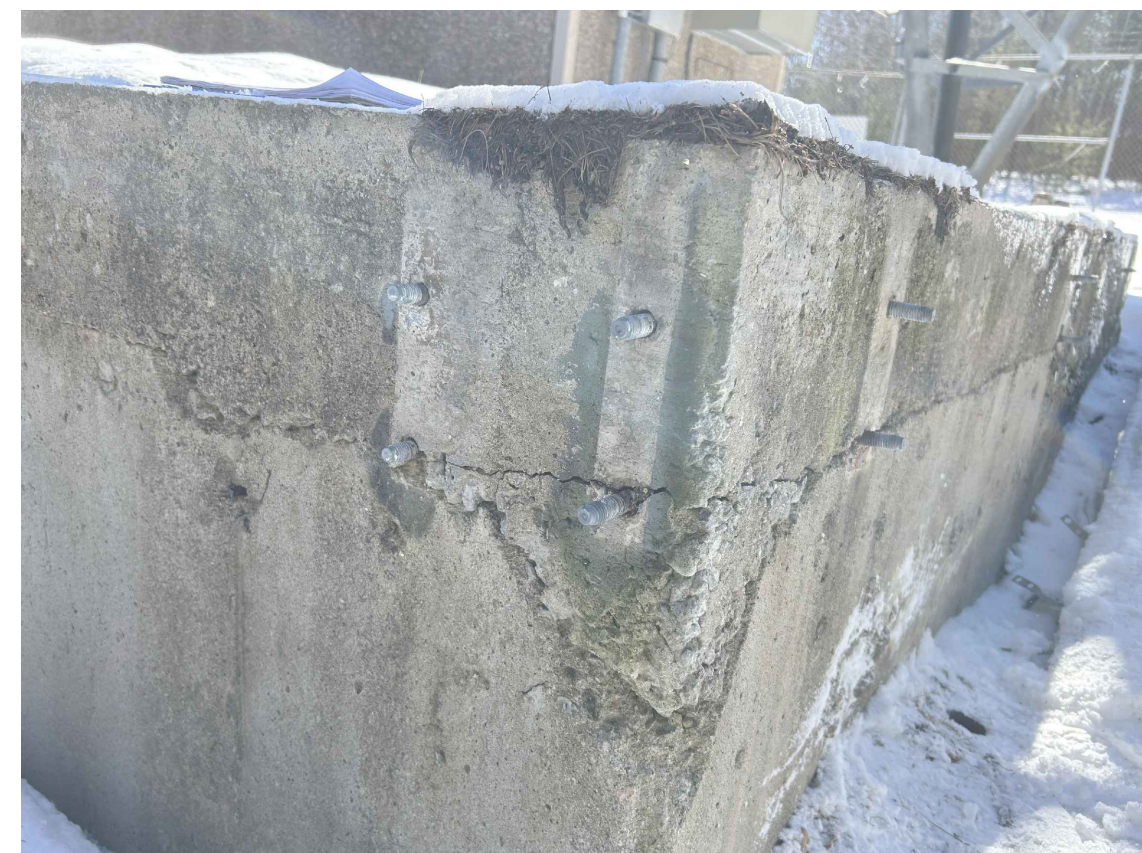

4 ABONDANED ANCHOR ROD

RESTORATION SCHEDULE		
TAG	TYPE	DESCRIPTION
1	TYPICAL SEPARATION	TYPICAL FOUNDATION WALL AND TOP SLAB SEPARATION CRACK. (CONTINUOUS AROUND SLAB)
2	MINOR SPALLING	CONCRETE SPALLING WITH DEPTH OF APPROX 1" OR AREA LESS THAN 2 SQFT.
3	BROKEN FOUNDATION CORNER	CRACKED OR BROKEN CONCRETE AT CORNER OF EXISTING FOUNDATION WALL
4	ABANDONED ANCHOR ROD	ABANDONED ANCHOR ROD/SLEEVE TO BE GROUND FLUSH

RESTORATION NOTES	
TYPICAL SEPERATION	
1. PREPARE SEPARATION CRACKS PER MASTEREMACO NP 1 SPECIFICATIONS. 2. APPLY MASTEREMACO MASTERSEAL NP 1 PER MANUFACTURER RECOMMENDATIONS.	
SPALLED CONCRETE AREAS:	
1. "SOUND OUT" ALL CONCRETE AND REMOVE ALL UNSOUND CONCRETE TO DETERMINE PATCHING BOUNDARIES. SQUARE OFF ALL REPAIR AREAS AND SAW CUT (1/4" MINIMUM DEPTH). 2. CLEAN ALL EXPOSED REBAR TO A WHITE METAL FINISH AND APPLY MASTEREMACO P 124 PER MANUFACTURER'S RECOMMENDATIONS ALLOWING PRIMER TO DRY TO TOUCH. 3. PATCH AREAS WITH MASTEREMACO N 425 PER MANUFACTURER'S RECOMMENDATIONS. 4. FOR ALL FORM AND POUR APPLICATIONS, APPLY MASTEREMACO REPAIR MORTAR PER MANUFACTURER'S RECOMMENDATIONS.	
BROKEN CORNER REPLACEMENT	
1. SOUND OUT AND REMOVE DAMAGED AND UNSOUND CONCRETE. SQUARE OFF ALL REPAIR AREAS. 2. CLEAN ALL EXPOSED BARS TO A WHITE METAL FINISH AND APPLY MASTEREMACO P 124 PER MANUFACTURER'S RECOMMENDATIONS. LET THE PRIMER DRY TO THE TOUCH. 3. PATCH AREAS WITH MASTEREMACO N 425 PER MANUFACTURER'S RECOMMENDATIONS.	
ABANDONED ANCHOR RODS	
1. CUT ALL EXISTING ANCHOR RODS/SLEEVES FLUSH WITH CONCRETE TO PREVENT INTERFERENCE WITH FUTURE CANOPY INSTALLATION. 2. APPLY COLD GALVANIZED TOUCH UP TO ALL EXPOSED METAL STUDS AFTER CUTTING/GRINDING FOR CORROSION PROTECTION.	

RESTORATION PLAN NOTES	
1. EXTENTS OF ALL DIMENSIONS FOR EXISTING CRACKING/SPALLING LOCATIONS ARE APPROXIMATE AND ARE TO BE VERIFIED IN FIELD BY CONTRACTOR PRIOR TO RESTORATION.	
2. PHOTOS ARE PROVIDED AS EXAMPLES OF EACH TYPE OF RESTORATION REQUIRED. RESTORATION IS NOT LIMITED TO THE LOCATIONS SHOWN IN THE PHOTOS.	

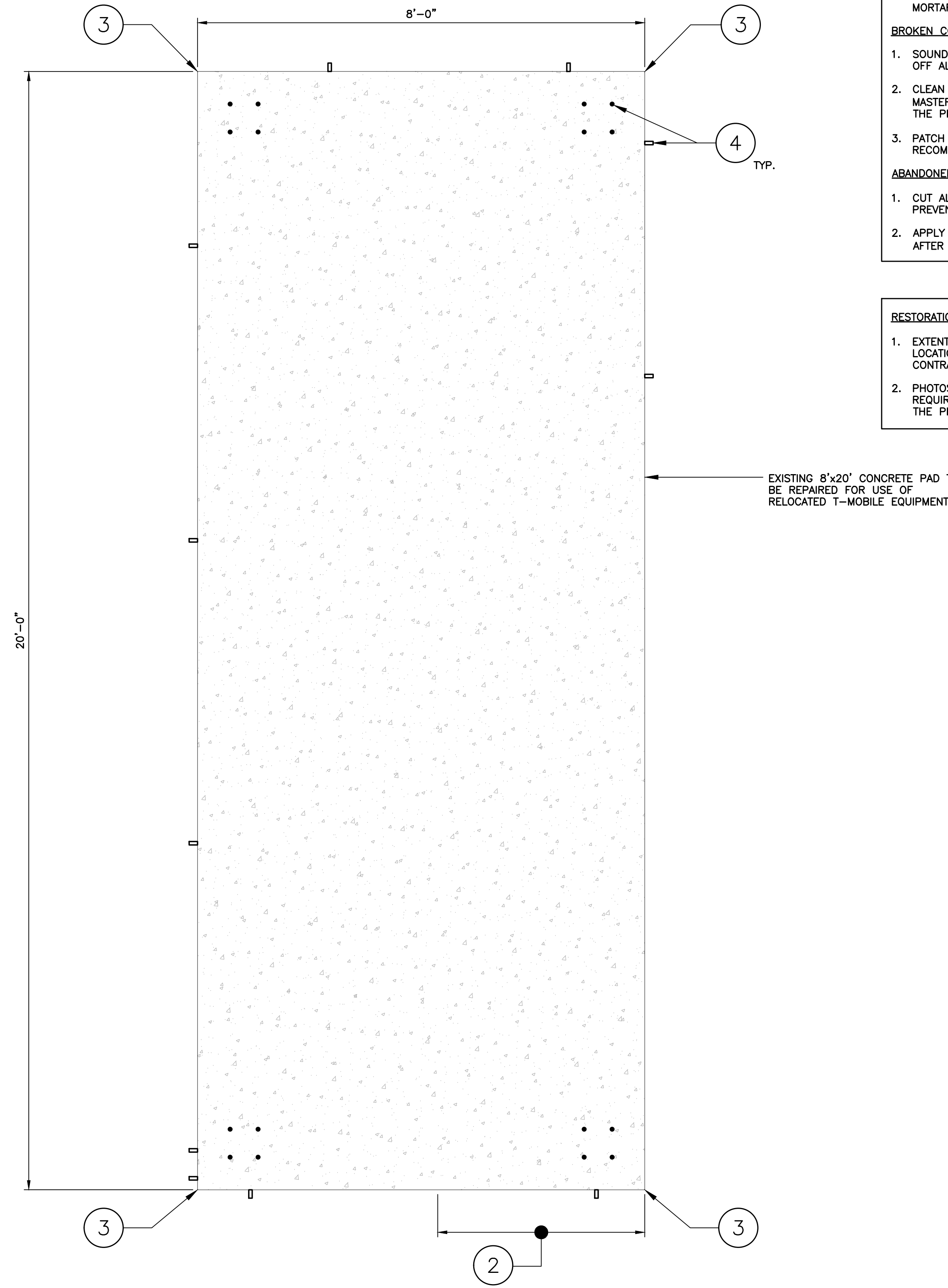

1 CONCRETE RESTORATION PLAN
 S-2 SCALE: 3/4" = 1' APPROX. NORTH

CONSTRUCTION DRAWINGS — REVISED PER EQUIPMENT RELOCATION	TJR	ASC	03/16/22	DATE	BY	DESCRIPTION
CONSTRUCTION DRAWINGS — UPDATED PER NEW BUILDING CODES	TJR	RTS	01/27/23	DATE	BY	DESCRIPTION
CONSTRUCTION DRAWINGS — ISSUED FOR CONSTRUCTION	TJR	RTS	09/27/22	DATE	BY	DESCRIPTION
REV.	0					
REV.	1					
REV.	2					

PROFESSIONAL ENGINEER SEAL

T-Mobile
 T-Mobile
 T-Mobile

CEREK engineering
 Centered on Solutions™
 (203) 488-0580
 (203) 488-8387 Fax
 632 North Branford Road
 Branford, CT 06405
 www.CentrelEng.com

T-MOBILE NORTHEAST LLC
 SITE NAME: NORFOLK SNET_1
 SITE ID: CT11349A
 453 LOON MEADOW DR
 NORFOLK, CT 06058

DATE: 03/16/22
 SCALE: AS NOTED
 JOB NO. 22022.16

CONCRETE RESTORATION PLAN AND DETAILS

S-2

SHEET NO. 8 OF 11

T-Mobile

SITE NAME: NORFOLK SNET_1

SITE ID: CT11349A

453 LOON MEADOW RD
NORFOLK, CT 06058

GENERAL NOTES

- ALL WORK SHALL BE IN ACCORDANCE WITH THE 2012 INTERNATIONAL BUILDING CODE AS MODIFIED BY THE 2022 CONNECTICUT SUPPLEMENT, INCLUDING THE IA/EIA-222 REVISION "H" "STRUCTURAL STANDARDS FOR STEEL ANTENNA TOWERS AND SUPPORTING STRUCTURES." 2022 CONNECTICUT FIRE SAFETY CODE, NATIONAL ELECTRICAL CODE AND LOCAL CODES.
- SHOULD ANY FIELD CONDITIONS PRECLUDE COMPLIANCE WITH THE DRAWINGS, THE CONTRACTOR SHALL IMMEDIATELY NOTIFY THE ENGINEER AND SHALL NOT PROCEED WITH ANY AFFECTED WORK.
- CONTRACTOR SHALL REVIEW ALL DRAWINGS AND SPECIFICATIONS IN THE CONTRACT DOCUMENT SET. CONTRACTOR SHALL COORDINATE ALL WORK SHOWN IN THE SET OF DRAWINGS. THE CONTRACTOR SHALL PROVIDE A COMPLETE SET OF DRAWINGS TO ALL SUBCONTRACTORS AND ALL RELATED PARTIES. THE SUBCONTRACTORS SHALL EXAMINE ALL THE DRAWINGS AND SPECIFICATIONS FOR THE INFORMATION THAT AFFECTS THEIR WORK.
- BEFORE BEGINNING THE WORK, THE CONTRACTOR IS RESPONSIBLE FOR MAKING SUCH INVESTIGATIONS CONCERNING PHYSICAL CONDITIONS (SURFACE AND SUBSURFACE) AT OR CONTIGUOUS TO THE SITE, WHICH MAY AFFECT PERFORMANCE AND COST OF THE WORK.
- ALL DIMENSIONS, ELEVATIONS, AND OTHER REFERENCES TO EXISTING STRUCTURES, SURFACE, AND SUBSURFACE CONDITIONS ARE APPROXIMATE. NO GUARANTEE IS MADE FOR THE ACCURACY OR COMPLETENESS OF THE INFORMATION SHOWN. THE CONTRACTOR SHALL VERIFY AND COORDINATE ALL DIMENSIONS, ELEVATIONS AND ANGLES WITH EXISTING CONDITIONS AND WITH ARCHITECTURAL AND SITE DRAWINGS BEFORE PROCEEDING WITH ANY WORK.
- AS THE WORK PROGRESSES, THE CONTRACTOR SHALL NOTIFY THE OWNER OF ANY CONDITIONS WHICH ARE IN CONFLICT OR OTHERWISE NOT CONSISTENT WITH THE CONSTRUCTION DOCUMENTS, AND SHALL NOT PROCEED WITH SUCH WORK UNTIL THE CONFLICT IS SATISFACTORILY RESOLVED.
- CONTRACTOR SHALL PROVIDE A COMPLETE BUILD-OUT WITH ALL FINISHES, STRUCTURAL, MECHANICAL, AND ELECTRICAL COMPONENTS AND PROVIDE ALL ITEMS AS SHOWN OR INDICATED ON THE DRAWINGS OR IN THE WRITTEN SPECIFICATIONS.
- CONTRACTOR SHALL FURNISH ALL MATERIAL, LABOR AND EQUIPMENT TO COMPLETE THE WORK AND FURNISH A COMPLETED JOB ALL IN ACCORDANCE WITH LOCAL AND STATE GOVERNING AUTHORITIES AND OTHER AUTHORITIES HAVING LAWFUL JURISDICTION OVER THE WORK.
- CONTRACTOR SHALL SECURE AND PAY FOR ALL PERMITS AND ALL INSPECTIONS REQUIRED AND SHALL ALSO PAY FEES REQUIRED FOR THE GENERAL CONSTRUCTION, PLUMBING, ELECTRICAL, AND HVAC. PERMITS SHALL BE PAID FOR BY THE RESPECTIVE SUBCONTRACTORS.
- CONTRACTOR SHALL MAINTAIN A CURRENT SET OF DRAWINGS AND SPECIFICATIONS ON SITE AT ALL TIMES AND INSURE DISTRIBUTION OF NEW DRAWINGS TO SUBCONTRACTORS AND OTHER RELEVANT PARTIES AS SOON AS THEY ARE MADE AVAILABLE. ALL OLD DRAWINGS SHALL BE MARKED VOID AND REMOVED FROM THE CONTRACT AREA. THE CONTRACTOR SHALL FURNISH AN "AS-BUILT" SET OF DRAWINGS TO OWNER UPON COMPLETION OF PROJECT.
- LOCATION OF EQUIPMENT AND WORK SUPPLIED BY OTHERS THAT IS DIAGRAMMATICALLY INDICATED ON THE DRAWINGS, SHALL BE DETERMINED BY THE CONTRACTOR. THE CONTRACTOR SHALL DETERMINE LOCATIONS AND DIMENSIONS SUBJECT TO STRUCTURAL CONDITIONS AND WORK OF THE SUBCONTRACTORS.
- THE CONTRACTOR IS SOLELY RESPONSIBLE TO DETERMINE CONSTRUCTION PROCEDURE AND SEQUENCE AND TO ENSURE THE SAFETY OF THE EXISTING STRUCTURES AND ITS COMPONENT PARTS DURING CONSTRUCTION. THIS INCLUDES THE ADDITION OF WHATEVER SHORING, BRACING, UNDERPINNING, ETC. THAT MAY BE NECESSARY.
- ALL EQUIPMENT AND PRODUCTS PURCHASED ARE TO BE REVIEWED BY CONTRACTOR AND ALL APPLICABLE SUB-CONTRACTORS FOR ANY CONDITION PER THE MANUFACTURER'S RECOMMENDATIONS. CONTRACTOR TO SUPPLY THESE ITEMS AT NO COST TO OWNER OR CONSTRUCTION MANAGER.
- DRAWINGS INDICATE THE MINIMUM STANDARDS, BUT IF ANY WORK SHOULD BE INDICATED TO BE SUBSTANDARD TO ANY ORDINANCES, LAWS, CODES, RULES, OR REGULATIONS BEARING ON THE WORK, THE CONTRACTOR SHALL INCLUDE IN HIS WORK AND SHALL EXECUTE THE WORK CORRECTLY IN ACCORDANCE WITH SUCH ORDINANCES, LAWS, CODES, RULES OR REGULATIONS WITH NO INCREASE IN COSTS.
- ALL UTILITY WORK SHALL BE IN ACCORDANCE WITH LOCAL UTILITY COMPANY REQUIREMENTS AND SPECIFICATIONS.
- ALL EQUIPMENT AND PRODUCTS PURCHASED ARE TO BE REVIEWED BY CONTRACTOR AND ALL APPLICABLE SUBCONTRACTORS FOR ANY CONDITION PER MANUFACTURER'S RECOMMENDATIONS. CONTRACTOR TO SUPPLY THESE ITEMS AT NO COST TO OWNER OR CONSTRUCTION MANAGER.
- ANY AND ALL ERRORS, DISCREPANCIES, AND 'MISSED' ITEMS ARE TO BE BROUGHT TO THE ATTENTION OF THE T-MOBILE CONSTRUCTION MANAGER DURING THE BIDDING PROCESS BY THE CONTRACTOR. ALL THESE ITEMS ARE TO BE INCLUDED IN THE BID. NO 'EXTRA' WILL BE ALLOWED FOR MISSED ITEMS.
- CONTRACTOR SHALL BE RESPONSIBLE FOR ALL ON-SITE SAFETY FROM THE TIME THE JOB IS AWARDED UNTIL ALL WORK IS COMPLETE AND ACCEPTED BY THE OWNER.
- CONTRACTOR TO REVIEW ALL SHOP DRAWINGS AND SUBMIT COPY TO ENGINEER FOR APPROVAL. DRAWINGS MUST BEAR THE CHECKER'S INITIALS BEFORE SUBMITTING TO THE CONSTRUCTION MANAGER FOR REVIEW.
- THE CONTRACTOR SHALL FIELD VERIFY ALL DIMENSIONS, ELEVATIONS, ANGLES AND EXISTING CONDITIONS AT THE SITE. PRIOR TO FABRICATION AND/OR INSTALLATION OF ANY WORK IN THE CONTRACT AREA.
- COORDINATION, LAYOUT, FURNISHING AND INSTALLATION OF CONDUITS AND ALL APPURTENANCES REQUIRED FOR PROPER INSTALLATION OF ELECTRICAL AND TELECOMMUNICATION SERVICE SHALL BE THE SOLE RESPONSIBILITY OF THE CONTRACTOR AND CONFIRMED WITH THE PROJECT MANAGER AND OWNER PRIOR TO THE COMMENCEMENT OF ANY WORK
- ALL DAMAGE CAUSED TO ANY EXISTING STRUCTURE SHALL BE THE SOLE RESPONSIBILITY OF THE CONTRACTOR. THE CONTRACTOR WILL BE HELD LIABLE FOR ALL REPAIRS REQUIRED FOR EXISTING STRUCTURES IF DAMAGED DURING CONSTRUCTION ACTIVITIES.
- THE CONTRACTOR SHALL CONTACT 'CALL BEFORE YOU DIG' AT LEAST 48 HOURS PRIOR TO ANY EXCAVATIONS AT 1-800-922-4455. ALL UTILITIES SHALL BE IDENTIFIED AND CLEARLY MARKED. CONTRACTOR SHALL MAINTAIN AND PROTECT MARKED UTILITIES THROUGHOUT PROJECT COMPLETION.
- CONTRACTOR SHALL COMPLY WITH THE OWNER'S ENVIRONMENTAL ENGINEER ON ALL METHODS AND PROVISIONS FOR ALL EXCAVATION ACTIVITIES INCLUDING SOIL DISPOSAL. ALL BACKFILL MATERIALS TO BE PROVIDED BY THE CONTRACTOR.
- THE COUNTY/CITY/TOWN MAY MAKE PERIODIC FIELD INSPECTIONS TO ENSURE COMPLIANCE WITH THE DESIGN PLANS, SPECIFICATIONS, AND CONTRACT DOCUMENTS.
- THE COUNTY/CITY/TOWN MUST BE NOTIFIED (2) WORKING DAYS PRIOR TO CONCEALMENT/BURIAL OF ANY SYSTEM OR MATERIAL THAT WILL PREVENT THE DIRECT INSPECTION OF MATERIALS. METHODS OR WORKMANSHIP. EXAMPLES OF THESE PROCESSES ARE BACKFILLING A GROUND RING OR TOWER FOUNDATION, POURING TOWER FOUNDATIONS, BURYING GROUND RODS, PLATES OR GRIDS, ETC. THE CONTRACTOR MAY PROCEED WITH THE SCHEDULED PROCESS (2) WORKING DAYS AFTER PROVIDING NOTICE UNLESS NOTIFIED OTHERWISE BY THE COUNTY/CITY/TOWN.
- PRIOR TO THE SUBMISSION OF BIDS, THE CONTRACTOR SHALL VISIT THE SITE TO FAMILIARIZE WITH THE EXISTING CONDITIONS AND TO CONFIRM THAT THE WORK CAN BE ACCOMPLISHED AS SHOWN ON THE CONSTRUCTION DRAWINGS. ANY DISCREPANCY FOUND SHALL BE BROUGHT TO THE ATTENTION OF ENGINEER ON RECORD, PRIOR TO THE COMMENCEMENT OF ANY WORK.

SITE LOCATION MAP

N.T.S.



VICINITY MAP

N.T.S.

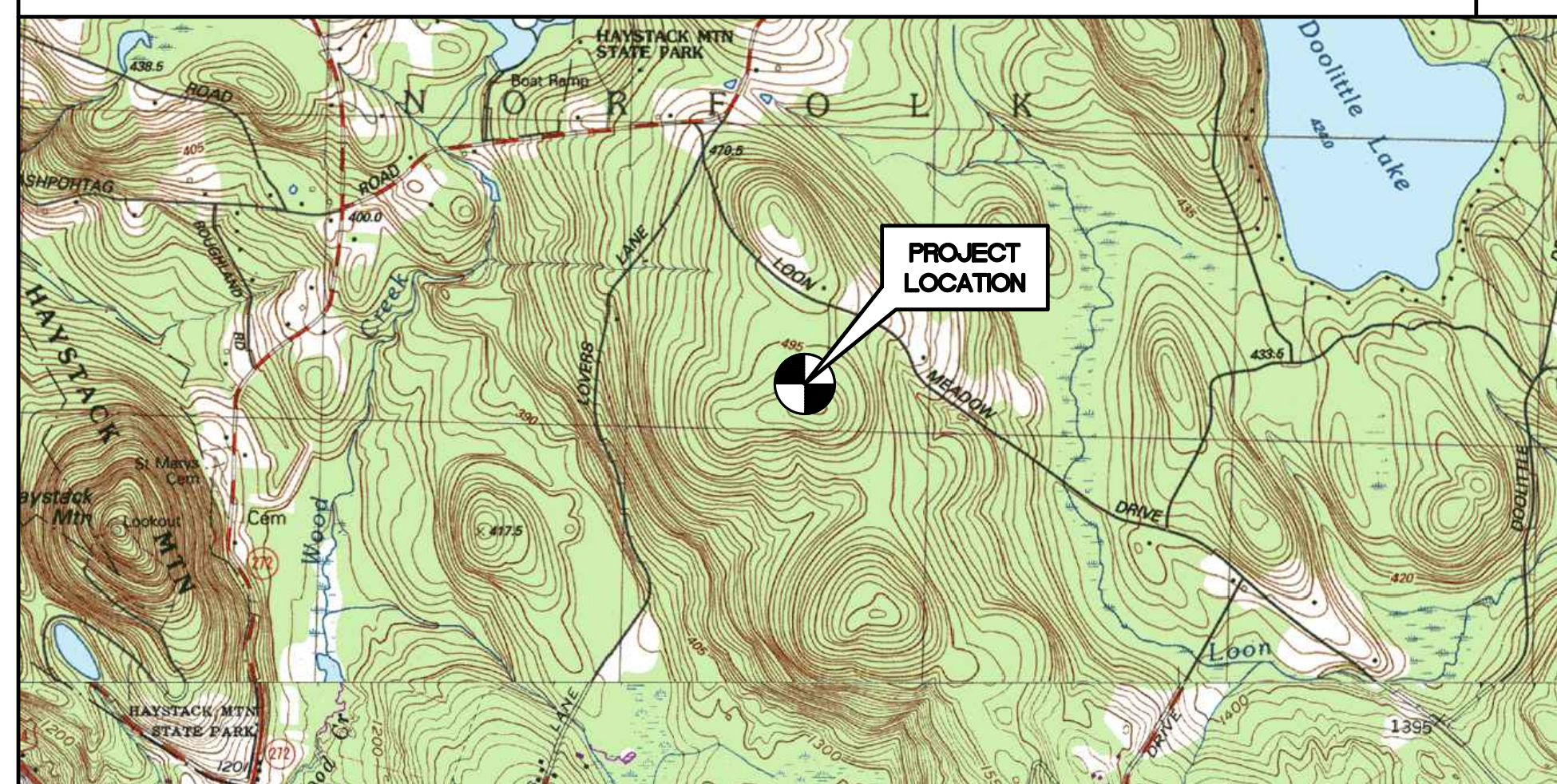

COORDINATES AND GROUND ELEVATION ARE REFERENCED FROM GOOGLE EARTH.

SITE COORDINATES: LATITUDE: 42° 00' 32" N
LONGITUDE: 73° 10' 51" W
GROUND ELEVATION: ±1656' AMSL



PROJECT SUMMARY

THE PROPOSED SCOPE OF WORK CONSISTS OF A MODIFICATION TO THE EXISTING UNMANNED TELECOMMUNICATIONS FACILITY INCLUDING THE FOLLOWING:

- INSTALL (1) NEW 48 KW DIESEL FUELED BACK-UP AC GENERATOR ON AN EXISTING 8' x 20' CONCRETE PAD.
- INSTALL NEW ICE-CANOPY WITH ASSOCIATED HANDRAILS.
- INSTALL (1) 200A AUTOMATIC TRANSFER SWITCH.

PROJECT INFORMATION

SITE NAME:	NORFOLK SNET_1
SITE ID:	CT11349A
SITE ADDRESS:	453 LOON MEADOW RD NORFOLK, CT 06058
APPLICANT:	T-MOBILE NORTHEAST, LLC 35 GRIFFIN ROAD SOUTH BLOOMFIELD, CT. 06002
CONTACT PERSON:	DAN REID (PROJECT MANAGER) TRANSCEND WIRELESS, LLC (203) 592-8291
ENGINEER OF RECORD:	CEN TEK ENGINEERING, INC. 63-2 NORTH BRANFORD ROAD BRANFORD, CT. 06405 CARLO F. CENTORE, PE (203) 488-0580 EXT. 122
SITE COORDINATES:	LATITUDE: 42°-00'-32" N LONGITUDE: 73°-10'-51" W GROUND ELEVATION: 1656'± AMSL SITE COORDINATES AND GROUND ELEVATION REFERENCED FROM GOOGLE EARTH.

SHEET INDEX

SHEET NO.	DESCRIPTION	REV.
T-1	TITLE SHEET	3
N-1	GENERAL NOTES AND SPECIFICATIONS	3
C-1	COMPOUND AND EQUIPMENT PLANS	3
C-2	TYPICAL EQUIPMENT DETAILS	3
C-3	ICE-CANOPY PLANS AND DETAILS	3
E-1	ELECTRICAL RISER, GROUNDING AND CONDUIT ROUTING	3
E-2	ELECTRICAL SPECIFICATIONS	3

PROFESSIONAL ENGINEER SEAL

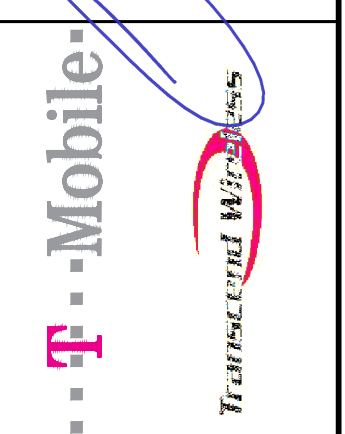

CEN TEK engineering
Centered on solutions

(203) 488-0580
(203) 488-0587 fax
632 North Branford Road
Branford, CT 06405
www.CenTekEng.com

T-MOBILE NORTHEAST LLC

SITE NAME: NORFOLK SNET_1
SITE ID: CT11349A
453 LOON MEADOW RD
NORFOLK, CT 06058

DATE: 02/02/22
SCALE: AS NOTED
JOB NO. 22015.06

TITLE SHEET

T-1

Sheet No. 1 of 7

REV.	DATE	DESCRIPTION
3	03/31/23	ASC CONSTRUCTION DRAWINGS - REVISED PER GEN. RELOCATION
2	08/16/22	URS CONSTRUCTION DRAWINGS - REVISED PER ELECTRICAL UPGRADE
1	07/29/22	URS CONSTRUCTION DRAWINGS - REVISED PER ELECTRICAL UPGRADE
0	07/19/22	JLD CONSTRUCTION DRAWINGS - ISSUED FOR CONSTRUCTION

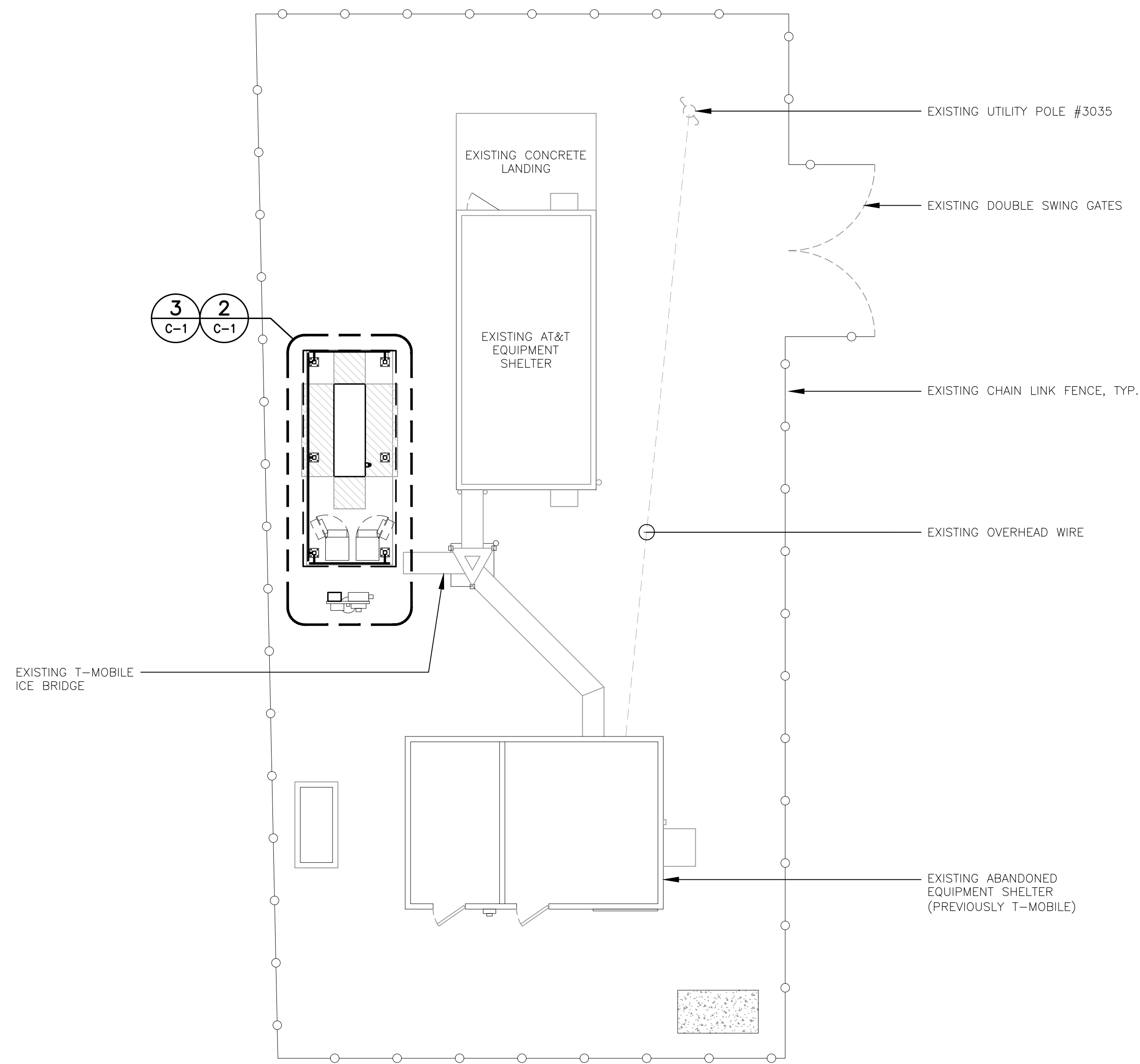

1
C-1

COMPOUND PLAN - PROPOSED

SCALE: 1/8" = 1'

TRUE NORTH

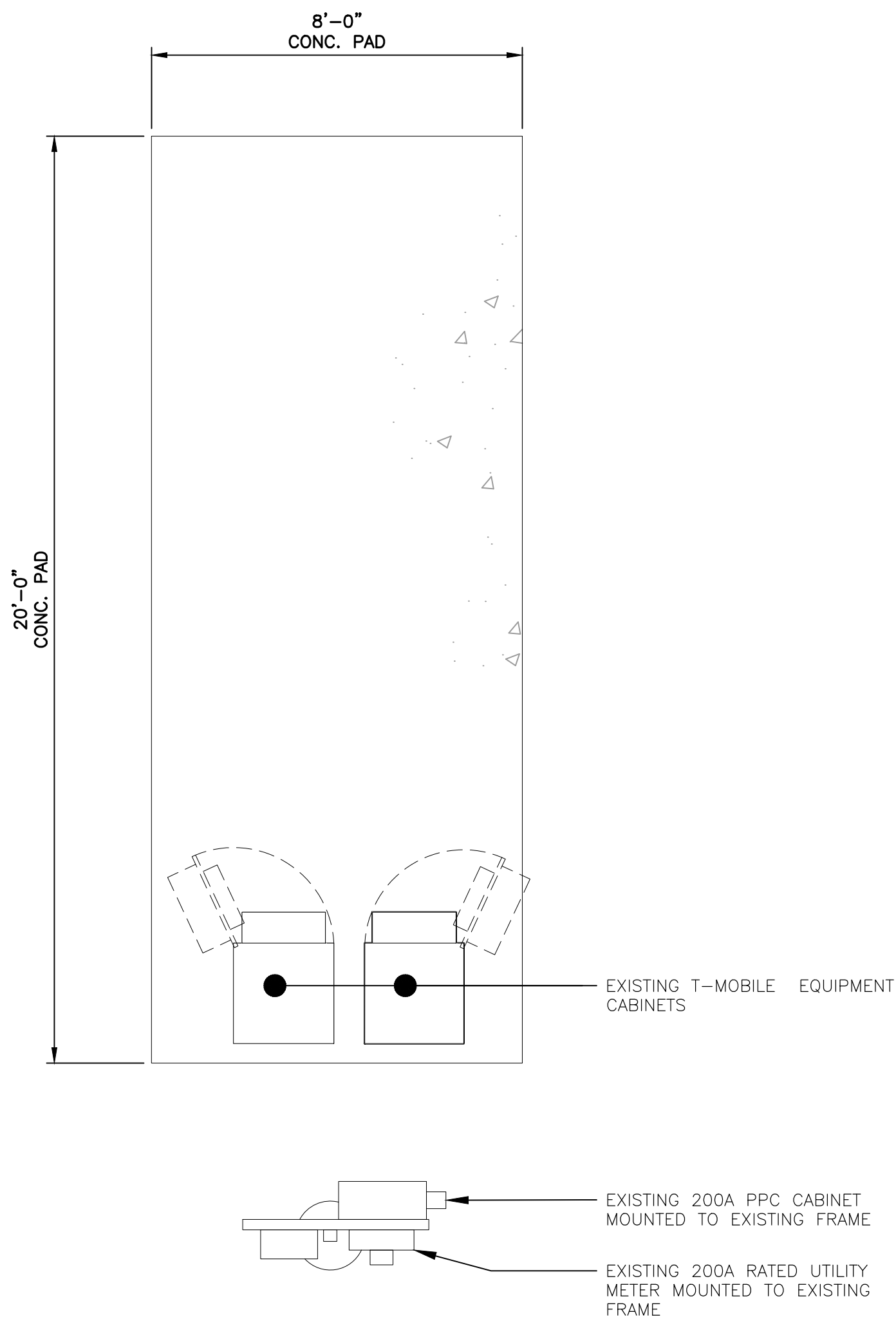

2
C-1

EQUIPMENT PLAN - EXISTING

SCALE: 3/8" = 1'

TRUE NORTH

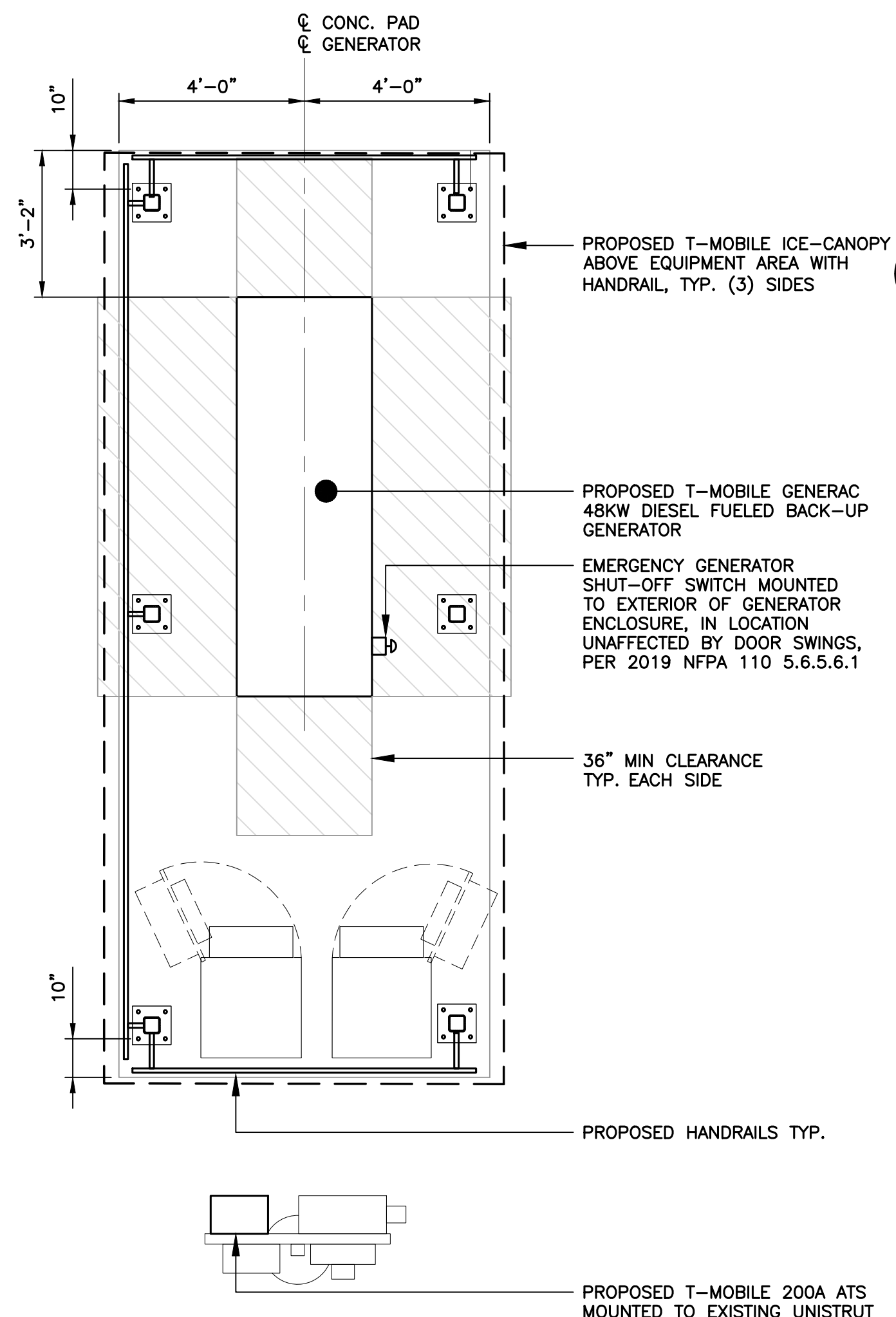

3
C-1

EQUIPMENT PLAN - PROPOSED

SCALE: 3/8" = 1'

TRUE NORTH

PROFESSIONAL ENGINEER SEAL

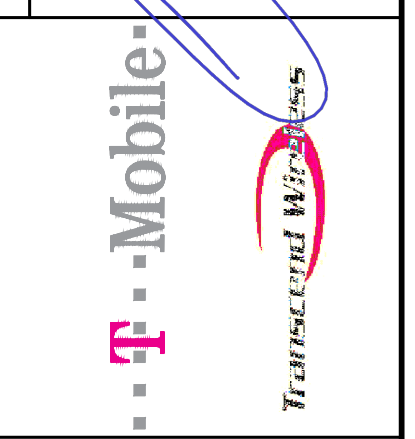
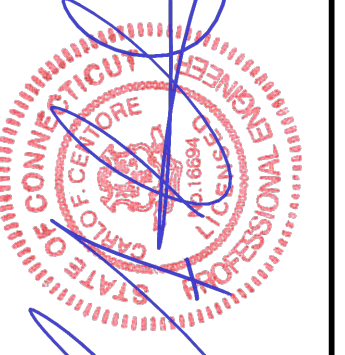

CENTEK engineering
Centered on solutions

(203) 488-0580
(203) 488-5587 fax
652 North Branford Road
Branford, CT 06405
www.CentekEng.com

T-MOBILE NORTHEAST LLC

SITE NAME: NORFOLK SNET_L

SITE ID: CT11349A

453 LOON MEADOW RD

NORFOLK, CT 06058

DATE: 02/02/22

SCALE: AS NOTED

JOB NO. 22015.06

COMPOUND AND EQUIPMENT PLANS

C-1

Sheet No. 3 of 7

REV.	DATE	DRAWN BY	CHK'D BY	DESCRIPTION
3	02/21/22	ASC	TJR	CONSTRUCTION DRAWINGS - REVISED PER GEN. RELOCATION
2	02/16/22	RIS	TJR	CONSTRUCTION DRAWINGS - REVISED PER ELECTRICAL UPGRADE
1	02/15/22	RIS	TJR	CONSTRUCTION DRAWINGS - REVISED PER ELECTRICAL UPGRADE
0	02/15/22	JLD	TJR	CONSTRUCTION DRAWINGS - ISSUED FOR CONSTRUCTION

Structural Analysis Report

Antenna Mount Analysis

T-Mobile Site #: CT11349A

*453 Loon Meadow Road
Norfolk, CT*

Centek Project No. 22022.16

~~Date: April 21, 2022~~

Rev 1: January 24, 2023

Max Stress Ratio = 54%

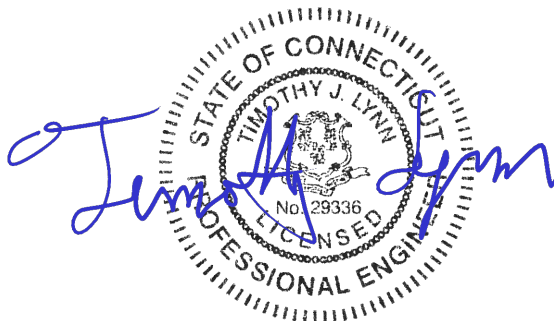

Prepared for:
T-Mobile USA
35 Griffin Road
Bloomfield, CT 06002

Table of Contents

SECTION 1 – REPORT

- ANTENNA AND APPURTENANCE SUMMARY
- STRUCTURE LOADING
- CONCLUSION

SECTION 2 – CALCULATIONS

- WIND LOAD ON APPURTENANCES
- RISA3D OUTPUT REPORT
- MOUNT CONNECTION

January 24, 2023

Mr. Dan Reid
Transcend Wireless
10 Industrial Ave
Mahwah, NJ 07430

Re: *Structural Letter ~ Antenna Mount*
T-Mobile – Site Ref: CT11349A
453 Loon Meadow Road
Norfolk, CT

Centek Project No. 22022.16

Dear Mr. Reid,

Centek Engineering, Inc. has reviewed the T-Mobile antenna installation at the above referenced site. The purpose of the review is to determine the structural adequacy of the **proposed mount, consisting of three (3) V-frame sector mounts (SitePro P/N: VFA12-HD)** to support the proposed equipment configuration. The review considered the effects of wind load, dead load and ice load in accordance with the 2021 International Building Code as modified by the 2022 Connecticut State Building Code (CTBC) including ASCE 7-16 and ANSI/TIA-222-H *Structural Standard for Antenna Supporting Structures, Antennas and Small Wind Turbine Support Structures*.

The loads considered in this analysis consist of the following:

- **T-Mobile:**
V-Frames: Three (3) Ericsson AIR6419 panel antennas, three (3) RFS APXVAALL24_43-U-NA20 panel antennas, three (3) Ericsson 4480 B71+B85 remote radio heads and three (3) Ericsson 4460 B25+B66 remote radio heads mounted on three (3) V-Frames with a RAD center elevation of 120-ft +/- AGL.

The antenna mount was analyzed per the requirements of the 2021 International Building Code as modified by the 2022 Connecticut State Building Code considering a Ultimate design wind speed of 115 mph for Norfolk as required in Appendix P of the 2022 Connecticut State Building Code.

Based on our review of the installation, it is our opinion that the **subject antenna mount has sufficient capacity** to support the aforementioned antenna configuration.

If there are any questions regarding this matter, please feel free to call.

Respectfully Submitted by:

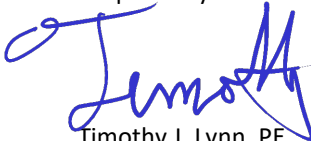

Timothy J. Lynn, PE
Structural Engineer

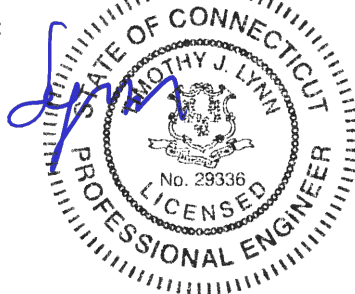

CEN TEK Engineering, Inc.
Structural Analysis – Mount Analysis
T-Mobile Site Ref. ~ CT11349A
Norfolk, CT
Rev 1 ~ January 24, 2023

Section 2 - Calculations

**Development of Design Heights, Exposure Coefficients,
 and Velocity Pressures Per TIA-222-H**

Wind Speeds

Basic Wind Speed	V := 115	mph	(User Input - CSBC 2022 Appendix P)
Basic Wind Speed with Ice	V _i := 50	mph	(User Input - TIA-222-H Annex B)
Basic Wind Speed (Mount)	V _m := 30	mph	(User Input - TIA-222-H Section 16.3)

Input

Structure Type =	Structure_Type := Flexible	(User Input)
Structure Category =	SC := II	(User Input)
Exposure Category =	Exp := B	(User Input)
Structure Height =	h := 160	ft (User Input)
Height to Center of Antennas =	z _{ant} := 120	ft (User Input)
Radial Ice Thickness =	t _i := 1.0	in (User Input per Annex B of TIA-222-H)
Radial Ice Density =	Id := 56.00	pcf (User Input)
Topographic Factor =	K _{zt} := 1	(User Input)
Shielding Factor for Appurtenances =	K _a := 1.0	(User Input)
Rooftop Wind Speed-up Factor =	K _s := 1.0	(User Input)
Ground Elevation Factor =	K _e = 0.996	(User Input)
Gust Response Factor =	G _H = 1.35	(User Input)

Output

Wind Direction Probability Factor = K_d := 0.95 (Per Table 2-2 of TIA-222-H)

Importance Factors = I_{ice} := $\begin{cases} 0 & \text{if } SC = 1 \\ 1.00 & \text{if } SC = 2 \\ 1.15 & \text{if } SC = 3 \\ 1.25 & \text{if } SC = 4 \end{cases} = 1$ (Per Table 2-3 of TIA-222-H)

I_{Seismic} := $\begin{cases} 0 & \text{if } SC = 1 \\ 1.00 & \text{if } SC = 2 \\ 1.25 & \text{if } SC = 3 \\ 1.50 & \text{if } SC = 4 \end{cases} = 1$

$$K_{iz} := \left(\frac{z_{ant}}{33} \right)^{0.1} = 1.138$$

$$t_{iz} := t_i \cdot I_{ice} \cdot K_{iz} \cdot K_{zt}^{0.35} = 1.138$$

Velocity Pressure Coefficient Antennas =

$$K_{z_{ant}} := 2.01 \left(\frac{z_{ant}}{z_g} \right)^{\frac{2}{\alpha}} = 1.041$$

Velocity Pressure w/o Ice Antennas =

$$q_{z_{ant}} := 0.00256 \cdot K_{zt} \cdot K_s \cdot K_e \cdot K_d \cdot K_{z_{ant}} V^2 = 33.337$$

Velocity Pressure with Ice Antennas =

$$q_{z_{ice,ant}} := 0.00256 \cdot K_{zt} \cdot K_s \cdot K_e \cdot K_d \cdot K_{z_{ant}} V_i^2 = 6.302$$

Velocity Pressure with Ice Antennas =

$$q_{z_m} := 0.00256 \cdot K_{zt} \cdot K_s \cdot K_e \cdot K_d \cdot K_{z_{ant}} V_m^2 = 2.269$$

Development of Wind & Ice Load on Appurtenances

Appurtenance Data:

Appurtenance Model =	RFSAPXVAALL24_43	
Appurtenance Shape =	Flat	(User Input)
Appurtenance Height =	$L_{app} := 95.9$	in (User Input)
Appurtenance Width =	$W_{app} := 24$	in (User Input)
Appurtenance Thickness =	$T_{app} := 8.5$	in (User Input)
Appurtenance Weight =	$WT_{app} := 150$	lbs (User Input)
Number of Appurtenances =	$N_{app} := 1$	(User Input)
Appurtenance Aspect Ratio =	$Ar_{app} := \frac{L_{app}}{W_{app}} = 4.0$	
Appurtenance Force Coefficient =	$Ca_{app} = 1.27$	

Wind Load (without ice)

Surface Area for One Appurtenance (Front) =	$SA_{appF} := \frac{L_{app} \cdot W_{app}}{144} = 16$	sf
Total Appurtenance Wind Force =	$F_{app} := qz_{ant} \cdot G_H \cdot Ca_{app} \cdot K_a \cdot SA_{appF} = 911$	lbs
Surface Area for One Appurtenance (Side) =	$SA_{appS} := \frac{L_{app} \cdot T_{app}}{144} = 5.7$	sf
Total Appurtenance Wind Force =	$F_{app} := qz_{ant} \cdot G_H \cdot Ca_{app} \cdot K_a \cdot SA_{appS} = 323$	lbs

Wind Load (with ice)

Surface Area for One Appurtenance w/ Ice (Front) =	$SA_{ICEappF} := \frac{(L_{app} + 2 \cdot t_{iz}) \cdot (W_{app} + 2 \cdot t_{iz})}{144} = 17.9$	sf
Total Appurtenance Wind Force w/ Ice =	$F_{iapp} := qz_{ice,ant} \cdot G_H \cdot Ca_{app} \cdot K_a \cdot SA_{ICEappF} = 193$	lbs
Surface Area for One Appurtenance w/ Ice (Side) =	$SA_{ICEappS} := \frac{(L_{app} + 2 \cdot t_{iz}) \cdot (T_{app} + 2 \cdot t_{iz})}{144} = 7.3$	sf
Total Appurtenance Wind Force w/ Ice =	$F_{iapp} := qz_{ice,ant} \cdot G_H \cdot Ca_{app} \cdot K_a \cdot SA_{ICEappS} = 79$	lbs

Wind Load (Mount)

Surface Area for One Appurtenance (Front) =	$SA_{appF} := \frac{L_{app} \cdot W_{app}}{144} = 16$	sf
Total Appurtenance Wind Force =	$F_{app} := qz_m \cdot G_H \cdot Ca_{app} \cdot K_a \cdot SA_{appF} = 62$	lbs
Surface Area for One Appurtenance (Side) =	$SA_{appS} := \frac{L_{app} \cdot T_{app}}{144} = 5.7$	sf
Total Appurtenance Wind Force =	$F_{app} := qz_m \cdot G_H \cdot Ca_{app} \cdot K_a \cdot SA_{appS} = 22$	lbs

Gravity Loads (ice only)

Volume of Each Appurtenance =	$V_{app} := L_{app} \cdot W_{app} \cdot T_{app} = 2 \times 10^4$	cu in
Volume of Ice on Each Appurtenance =	$V_{ice} := (L_{app} + 2 \cdot t_{iz}) \cdot (W_{app} + 2 \cdot t_{iz}) \cdot (T_{app} + 2 \cdot t_{iz}) - V_{app} = 8233$	cu in
Weight of Ice on Each Appurtenance =	$W_{ICEapp} := \frac{V_{ice}}{1728} \cdot Id = 267$	lbs
Weight of Ice on All Appurtenances =	$W_{ICEapp} \cdot N_{app} = 267$	lbs

Development of Wind & Ice Load on Appurtenances

Appurtenance Data:

Appurtenance Model =	Ericsson AIR6419	
Appurtenance Shape =	Flat	(User Input)
Appurtenance Height =	$L_{app} := 36.3$	in (User Input)
Appurtenance Width =	$W_{app} := 20.9$	in (User Input)
Appurtenance Thickness =	$T_{app} := 9.0$	in (User Input)
Appurtenance Weight =	$WT_{app} := 83$	lbs (User Input)
Number of Appurtenances =	$N_{app} := 1$	(User Input)
Appurtenance Aspect Ratio =	$Ar_{app} := \frac{L_{app}}{W_{app}} = 1.7$	
Appurtenance Force Coefficient =	$Ca_{app} = 1.2$	

Wind Load (without ice)

Surface Area for One Appurtenance (Front) =	$SA_{appF} := \frac{L_{app} \cdot W_{app}}{144} = 5.3$	sf
Total Appurtenance Wind Force =	$F_{app} := qz_{ant} \cdot G_H \cdot Ca_{app} \cdot K_a \cdot SA_{appF} = 285$	lbs
Surface Area for One Appurtenance (Side) =	$SA_{appS} := \frac{L_{app} \cdot T_{app}}{144} = 2.3$	sf
Total Appurtenance Wind Force =	$F_{app} := qz_{ant} \cdot G_H \cdot Ca_{app} \cdot K_a \cdot SA_{appS} = 123$	lbs

Wind Load (with ice)

Surface Area for One Appurtenance w/ Ice (Front) =	$SA_{ICEappF} := \frac{(L_{app} + 2 \cdot t_{iz}) \cdot (W_{app} + 2 \cdot t_{iz})}{144} = 6.2$	sf
Total Appurtenance Wind Force w/ Ice =	$F_{iapp} := qz_{ice. ant} \cdot G_H \cdot Ca_{app} \cdot K_a \cdot SA_{ICEappF} = 63$	lbs
Surface Area for One Appurtenance w/ Ice (Side) =	$SA_{ICEappS} := \frac{(L_{app} + 2 \cdot t_{iz}) \cdot (T_{app} + 2 \cdot t_{iz})}{144} = 3$	sf
Total Appurtenance Wind Force w/ Ice =	$F_{iapp} := qz_{ice. ant} \cdot G_H \cdot Ca_{app} \cdot K_a \cdot SA_{ICEappS} = 31$	lbs

Wind Load (Mount)

Surface Area for One Appurtenance (Front) =	$SA_{appF} := \frac{L_{app} \cdot W_{app}}{144} = 5.3$	sf
Total Appurtenance Wind Force =	$F_{app} := qz_m \cdot G_H \cdot Ca_{app} \cdot K_a \cdot SA_{appF} = 19$	lbs
Surface Area for One Appurtenance (Side) =	$SA_{appS} := \frac{L_{app} \cdot T_{app}}{144} = 2.3$	sf
Total Appurtenance Wind Force =	$F_{app} := qz_m \cdot G_H \cdot Ca_{app} \cdot K_a \cdot SA_{appS} = 8$	lbs

Gravity Loads (ice only)

Volume of Each Appurtenance =	$V_{app} := L_{app} \cdot W_{app} \cdot T_{app} = 6828$	cu in
Volume of Ice on Each Appurtenance =	$V_{ice} := (L_{app} + 2 \cdot t_{iz}) \cdot (W_{app} + 2 \cdot t_{iz}) \cdot (T_{app} + 2 \cdot t_{iz}) - V_{app} = 3253$	cu in
Weight of Ice on Each Appurtenance =	$W_{ICEapp} := \frac{V_{ice}}{1728} \cdot Id = 105$	lbs
Weight of Ice on All Appurtenances =	$W_{ICEapp} \cdot N_{app} = 105$	lbs

Development of Wind & Ice Load on Appurtenances

Appurtenance Data:

Appurtenance Model =	Ericsson 4460 RRU
Appurtenance Shape =	Flat (User Input)
Appurtenance Height =	$L_{app} := 19.6$ in (User Input)
Appurtenance Width =	$W_{app} := 15.7$ in (User Input)
Appurtenance Thickness =	$T_{app} := 12.1$ in (User Input)
Appurtenance Weight =	$WT_{app} := 109$ lbs (User Input)
Number of Appurtenances =	$N_{app} := 1$ (User Input)
Appurtenance Aspect Ratio =	$Ar_{app} := \frac{L_{app}}{W_{app}} = 1.2$
Appurtenance Force Coefficient =	$Ca_{app} = 1.2$

Wind Load (without ice)

Surface Area for One Appurtenance (Front) =	$SA_{appF} := \frac{L_{app} \cdot W_{app}}{144} = 2.1$	sf
Total Appurtenance Wind Force =	$F_{app} := qz_{ant} \cdot G_H \cdot Ca_{app} \cdot K_a \cdot SA_{appF} = 115$	lbs
Surface Area for One Appurtenance (Side) =	$SA_{appS} := \frac{L_{app} \cdot T_{app}}{144} = 1.6$	sf
Total Appurtenance Wind Force =	$F_{app} := qz_{ant} \cdot G_H \cdot Ca_{app} \cdot K_a \cdot SA_{appS} = 89$	lbs

Wind Load (with ice)

Surface Area for One Appurtenance w/ Ice (Front) =	$SA_{ICEappF} := \frac{(L_{app} + 2 \cdot t_{iz}) \cdot (W_{app} + 2 \cdot t_{iz})}{144} = 2.7$	sf
Total Appurtenance Wind Force w/ Ice =	$F_{app} := qz_{ice.ant} \cdot G_H \cdot Ca_{app} \cdot K_a \cdot SA_{ICEappF} = 28$	lbs
Surface Area for One Appurtenance w/ Ice (Side) =	$SA_{ICEappS} := \frac{(L_{app} + 2 \cdot t_{iz}) \cdot (T_{app} + 2 \cdot t_{iz})}{144} = 2.2$	sf
Total Appurtenance Wind Force w/ Ice =	$F_{app} := qz_{ice.ant} \cdot G_H \cdot Ca_{app} \cdot K_a \cdot SA_{ICEappS} = 22$	lbs

Wind Load (Mount)

Surface Area for One Appurtenance (Front) =	$SA_{appF} := \frac{L_{app} \cdot W_{app}}{144} = 2.1$	sf
Total Appurtenance Wind Force =	$F_{app} := qz_m \cdot G_H \cdot Ca_{app} \cdot K_a \cdot SA_{appF} = 8$	lbs
Surface Area for One Appurtenance (Side) =	$SA_{appS} := \frac{L_{app} \cdot T_{app}}{144} = 1.6$	sf
Total Appurtenance Wind Force =	$F_{app} := qz_m \cdot G_H \cdot Ca_{app} \cdot K_a \cdot SA_{appS} = 6$	lbs

Gravity Loads (ice only)

Volume of Each Appurtenance =	$V_{app} := L_{app} \cdot W_{app} \cdot T_{app} = 3723$	cu in
Volume of Ice on Each Appurtenance =	$V_{ice} := (L_{app} + 2 \cdot t_{iz}) \cdot (W_{app} + 2 \cdot t_{iz}) \cdot (T_{app} + 2 \cdot t_{iz}) - V_{app} = 1929$	cu in
Weight of Ice on Each Appurtenance =	$W_{ICEapp} := \frac{V_{ice}}{1728} \cdot Id = 63$	lbs
Weight of Ice on All Appurtenances =	$W_{ICEapp} \cdot N_{app} = 63$	lbs

Development of Wind & Ice Load on Appurtenances

Appurtenance Data:

Appurtenance Model =	Ericsson 4480 RRU
Appurtenance Shape =	Flat (User Input)
Appurtenance Height =	$L_{app} := 21.8$ in (User Input)
Appurtenance Width =	$W_{app} := 15.7$ in (User Input)
Appurtenance Thickness =	$T_{app} := 7.5$ in (User Input)
Appurtenance Weight =	$WT_{app} := 84$ lbs (User Input)
Number of Appurtenances =	$N_{app} := 1$ (User Input)
Appurtenance Aspect Ratio =	$Ar_{app} := \frac{L_{app}}{W_{app}} = 1.4$
Appurtenance Force Coefficient =	$Ca_{app} = 1.2$

Wind Load (without ice)

Surface Area for One Appurtenance (Front) =	$SA_{appF} := \frac{L_{app} \cdot W_{app}}{144} = 2.4$	sf
Total Appurtenance Wind Force =	$F_{app} := qz_{ant} \cdot G_H \cdot Ca_{app} \cdot K_a \cdot SA_{appF} = 128$	lbs
Surface Area for One Appurtenance (Side) =	$SA_{appS} := \frac{L_{app} \cdot T_{app}}{144} = 1.1$	sf
Total Appurtenance Wind Force =	$F_{app} := qz_{ant} \cdot G_H \cdot Ca_{app} \cdot K_a \cdot SA_{appS} = 61$	lbs

Wind Load (with ice)

Surface Area for One Appurtenance w/ Ice (Front) =	$SA_{ICEappF} := \frac{(L_{app} + 2 \cdot t_{iz}) \cdot (W_{app} + 2 \cdot t_{iz})}{144} = 3$	sf
Total Appurtenance Wind Force w/ Ice =	$F_{app} := qz_{ice,ant} \cdot G_H \cdot Ca_{app} \cdot K_a \cdot SA_{ICEappF} = 31$	lbs
Surface Area for One Appurtenance w/ Ice (Side) =	$SA_{ICEappS} := \frac{(L_{app} + 2 \cdot t_{iz}) \cdot (T_{app} + 2 \cdot t_{iz})}{144} = 1.6$	sf
Total Appurtenance Wind Force w/ Ice =	$F_{app} := qz_{ice,ant} \cdot G_H \cdot Ca_{app} \cdot K_a \cdot SA_{ICEappS} = 17$	lbs

Wind Load (Mount)

Surface Area for One Appurtenance (Front) =	$SA_{appF} := \frac{L_{app} \cdot W_{app}}{144} = 2.4$	sf
Total Appurtenance Wind Force =	$F_{app} := qz_m \cdot G_H \cdot Ca_{app} \cdot K_a \cdot SA_{appF} = 9$	lbs
Surface Area for One Appurtenance (Side) =	$SA_{appS} := \frac{L_{app} \cdot T_{app}}{144} = 1.1$	sf
Total Appurtenance Wind Force =	$F_{app} := qz_m \cdot G_H \cdot Ca_{app} \cdot K_a \cdot SA_{appS} = 4$	lbs

Gravity Loads (ice only)

Volume of Each Appurtenance =	$V_{app} := L_{app} \cdot W_{app} \cdot T_{app} = 2567$	cu in
Volume of Ice on Each Appurtenance =	$V_{ice} := (L_{app} + 2 \cdot t_{iz})(W_{app} + 2 \cdot t_{iz})(T_{app} + 2 \cdot t_{iz}) - V_{app} = 1664$	cu in
Weight of Ice on Each Appurtenance =	$W_{ICEapp} := \frac{V_{ice}}{1728} \cdot \rho_d = 54$	lbs
Weight of Ice on All Appurtenances =	$W_{ICEapp} \cdot N_{app} = 54$	lbs

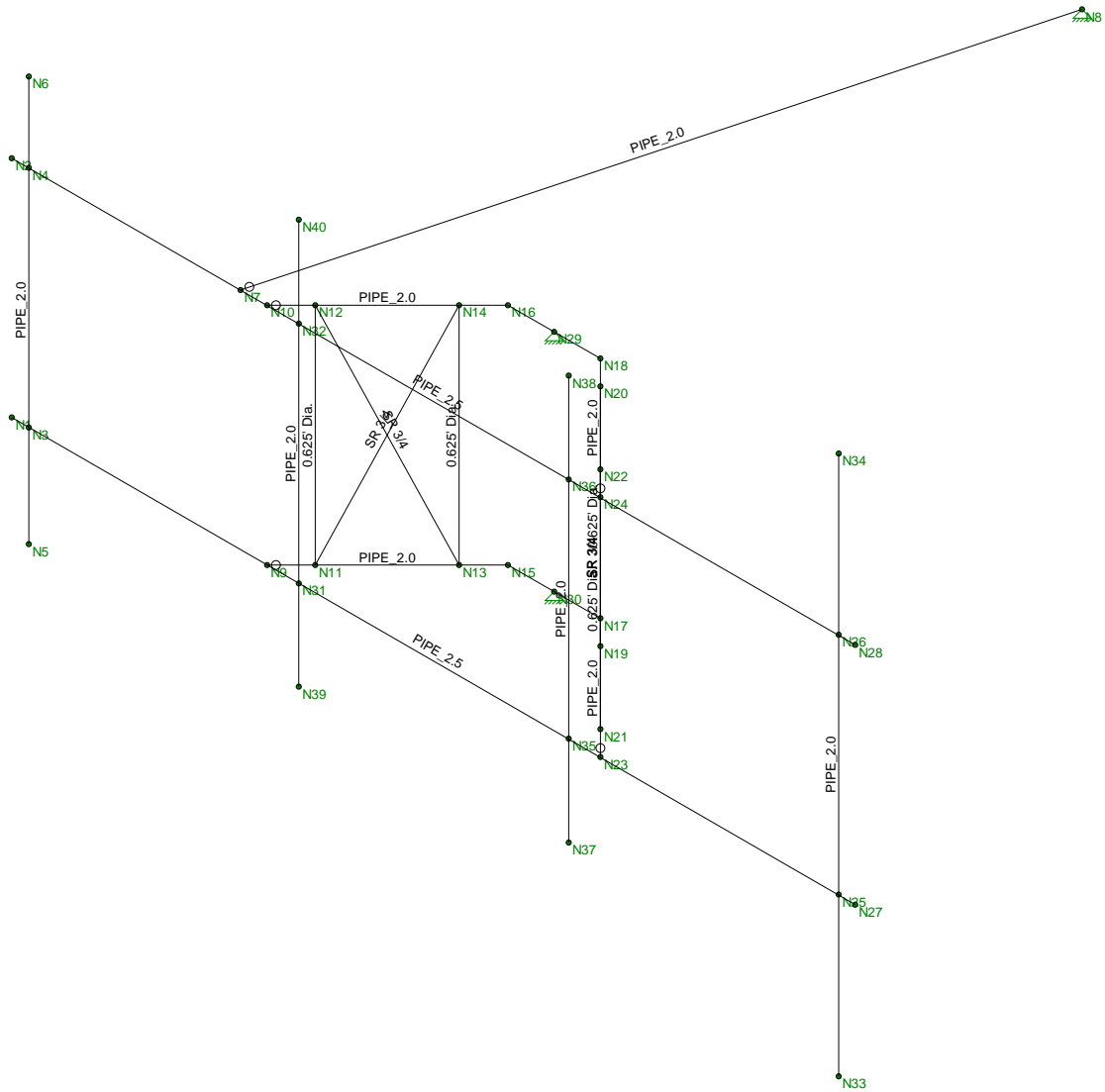

Envelope Only Solution

Centek Engineering

TJL

22022.16

CT11349A

Member Framing

Jan 24, 2023 at 5:07 PM

Mount.R3D

(Global) Model Settings

Display Sections for Member Calcs	5
Max Internal Sections for Member Calcs	97
Include Shear Deformation?	Yes
Increase Nailing Capacity for Wind?	Yes
Include Warping?	Yes
Trans Load Btwn Intersecting Wood Wall?	Yes
Area Load Mesh (in^2)	144
Merge Tolerance (in)	.12
P-Delta Analysis Tolerance	0.50%
Include P-Delta for Walls?	Yes
Automatically Iterate Stiffness for Walls?	Yes
Max Iterations for Wall Stiffness	3
Gravity Acceleration (ft/sec^2)	32.2
Wall Mesh Size (in)	12
Eigensolution Convergence Tol. (1.E-)	4
Vertical Axis	Y
Global Member Orientation Plane	XZ
Static Solver	Sparse Accelerated
Dynamic Solver	Accelerated Solver

Hot Rolled Steel Code	AISC 15th(360-16): LRFD
Adjust Stiffness?	Yes(Iterative)
RISAConnection Code	AISC 15th(360-16): LRFD
Cold Formed Steel Code	AISI S100-10: ASD
Wood Code	AWC NDS-12: ASD
Wood Temperature	< 100F
Concrete Code	ACI 318-11
Masonry Code	ACI 530-11: ASD
Aluminum Code	AA ADM1-10: ASD - Building
Stainless Steel Code	AISC 14th(360-10): ASD
Adjust Stiffness?	Yes(Iterative)

Number of Shear Regions	4
Region Spacing Increment (in)	4
Biaxial Column Method	Exact Integration
Parme Beta Factor (PCA)	.65
Concrete Stress Block	Rectangular
Use Cracked Sections?	Yes
Use Cracked Sections Slab?	No
Bad Framing Warnings?	No
Unused Force Warnings?	Yes
Min 1 Bar Diam. Spacing?	No
Concrete Rebar Set	REBAR_SET_ASTMA615
Min % Steel for Column	1
Max % Steel for Column	8

(Global) Model Settings, Continued

Seismic Code	ASCE 7-10
Seismic Base Elevation (ft)	Not Entered
Add Base Weight?	Yes
Ct X	.02
Ct Z	.02
T X (sec)	Not Entered
T Z (sec)	Not Entered
R X	3
R Z	3
Ct Exp. X	.75
Ct Exp. Z	.75
SD1	1
SDS	1
S1	1
TL (sec)	5
Risk Cat	I or II
Drift Cat	Other
Om Z	1
Om X	1
Cd Z	1
Cd X	1
Rho Z	1
Rho X	1
Footing Overturning Safety Factor	1
Optimize for OTM/Sliding	No
Check Concrete Bearing	No
Footing Concrete Weight (k/ft^3)	150.001
Footing Concrete f'c (ksi)	4
Footing Concrete Ec (ksi)	3644
Lambda	1
Footing Steel fy (ksi)	60
Minimum Steel	0.0018
Maximum Steel	0.0075
Footing Top Bar	#3
Footing Top Bar Cover (in)	2
Footing Bottom Bar	#3
Footing Bottom Bar Cover (in)	3.5
Pedestal Bar	#3
Pedestal Bar Cover (in)	1.5
Pedestal Ties	#3

Hot Rolled Steel Properties

	Label	E [ksi]	G [ksi]	Nu	Therm (\... Density[k/ft^3]	Yield[ksi]	Ry	Fu[ksi]	Rt
1	A36 Gr.36	29000	11154	.3	.65 .49	36	1.5	58	1.2
2	A572 Gr.50	29000	11154	.3	.65 .49	50	1.1	58	1.2
3	A992	29000	11154	.3	.65 .49	50	1.1	58	1.2
4	A500 Gr.42	29000	11154	.3	.65 .49	42	1.3	58	1.1
5	A500 Gr.46	29000	11154	.3	.65 .49	46	1.2	58	1.1
6	A53 Grade B	29000	11154	.3	.65 .49	35	1.5	58	1.2

Hot Rolled Steel Section Sets

	Label	Shape	Type	Design List	Material	Design Rul...	A [in ²]	I _{yy} [in ⁴]	I _{zz} [in ⁴]	J [in ⁴]
1	Antenna Mast_2.0 STD ...	PIPE_2.0	Column	Pipe	A53 Grade B	Typical	1.02	.627	.627	1.25
2	Horizontal_2.5 STD Pipe	PIPE_2.5	Beam	Pipe	A53 Grade B	Typical	1.61	1.45	1.45	2.89
3	Outrigger_2.0 STD Pipe	PIPE_2.0	Beam	Pipe	A53 Grade B	Typical	1.02	.627	.627	1.25
4	Stabilizer_2.0 STD Pipe	PIPE_2.0	Beam	Pipe	A53 Grade B	Typical	1.02	.627	.627	1.25
5	0.625" Dia. Bar	0.625" Dia.	Column	BAR	A36 Gr.36	Typical	.307	.007	.007	.015
6	0.75"Dia. Bar	SR 3/4	Column	BAR	A36 Gr.36	Typical	.442	.016	.016	.031

Hot Rolled Steel Design Parameters

	Label	Shape	Length[ft]	L _{byy} [ft]	L _{bzz} [ft]	L _{comp top} [...]	L _{comp bot} [...]	L-torq...	K _{yy}	K _{zz}	C _b	Funci...
1	M1	Horizontal_2.5 STD...	12.5	Segment				L _{byy}				Lateral
2	M2	Horizontal_2.5 STD...	12.5	Segment				L _{byy}				Lateral
3	M3	Stabilizer_2.0 STD ...	10.18					L _{byy}				Lateral
4	M4	Outrigger_2.0 STD ...	2.521	Segment	Segment			L _{byy}				Lateral
5	M5	Outrigger_2.0 STD ...	2.521	Segment	Segment			L _{byy}				Lateral
6	M6	Outrigger_2.0 STD ...	2.521	Segment	Segment			L _{byy}				Lateral
7	M7	Outrigger_2.0 STD ...	2.521	Segment	Segment			L _{byy}				Lateral
8	M8	0.625" Dia. Bar	3.333									Lateral
9	M9	0.625" Dia. Bar	3.333									Lateral
10	M10	0.75"Dia. Bar	3.659	1.83	1.83			L _{byy}				Lateral
11	M11	0.625" Dia. Bar	3.333									Lateral
12	M12	0.75"Dia. Bar	3.659	1.83	1.83			L _{byy}				Lateral
13	M13	0.625" Dia. Bar	3.333									Lateral
14	M14	0.75"Dia. Bar	3.659	1.83	1.83			L _{byy}				Lateral
15	M15	0.75"Dia. Bar	3.659	1.83	1.83			L _{byy}				Lateral
16	M16	Antenna Mast_2.0 ...	6					L _{byy}				Lateral
17	M17	Antenna Mast_2.0 ...	8					L _{byy}				Lateral
18	M18	Antenna Mast_2.0 ...	6					L _{byy}				Lateral
19	M21	Antenna Mast_2.0 ...	6					L _{byy}				Lateral

Member Primary Data

	Label	I Joint	J Joint	K Joint	Rotate(...)	Section/Shape	Type	Design List	Material	Design ...
1	M1	N2	N28			Horizontal_2.5 STD Pipe	Beam	Pipe	A53 Grade B	Typical
2	M2	N1	N27			Horizontal_2.5 STD Pipe	Beam	Pipe	A53 Grade B	Typical
3	M3	N7	N8			Stabilizer_2.0 STD Pipe	Beam	Pipe	A53 Grade B	Typical
4	M4	N10	N16			Outrigger_2.0 STD Pipe	Beam	Pipe	A53 Grade B	Typical
5	M5	N9	N15			Outrigger_2.0 STD Pipe	Beam	Pipe	A53 Grade B	Typical
6	M6	N24	N18			Outrigger_2.0 STD Pipe	Beam	Pipe	A53 Grade B	Typical
7	M7	N23	N17			Outrigger_2.0 STD Pipe	Beam	Pipe	A53 Grade B	Typical
8	M8	N12	N11			0.625" Dia. Bar	Column	BAR	A36 Gr.36	Typical
9	M9	N14	N13			0.625" Dia. Bar	Column	BAR	A36 Gr.36	Typical
10	M10	N12	N13			0.75"Dia. Bar	Column	BAR	A36 Gr.36	Typical
11	M11	N22	N21			0.625" Dia. Bar	Column	BAR	A36 Gr.36	Typical
12	M12	N14	N11			0.75"Dia. Bar	Column	BAR	A36 Gr.36	Typical
13	M13	N20	N19			0.625" Dia. Bar	Column	BAR	A36 Gr.36	Typical
14	M14	N22	N19			0.75"Dia. Bar	Column	BAR	A36 Gr.36	Typical
15	M15	N20	N21			0.75"Dia. Bar	Column	BAR	A36 Gr.36	Typical
16	M16	N6	N5			Antenna Mast_2.0 STD Pi...	Column	Pipe	A53 Grade B	Typical
17	M17	N34	N33			Antenna Mast_2.0 STD Pi...	Column	Pipe	A53 Grade B	Typical



Company : Centek Engineering
 Designer : T.J.L.
 Job Number : 22022.16
 Model Name : CT11349A

Jan 24, 2023
 5:06 PM
 Checked By: _____

Member Primary Data (Continued)

	Label	I Joint	J Joint	K Joint	Rotate(...)	Section/Shape	Type	Design List	Material	Design ...
18	M18	N37	N38			Antenna Mast_2.0 STD Pi...	Column	Pipe	A53 Grade B	Typical
19	M19	N15	N17			RIGID	None	None	RIGID	Typical
20	M20	N16	N18			RIGID	None	None	RIGID	Typical
21	M21	N39	N40			Antenna Mast_2.0 STD Pi...	Column	Pipe	A53 Grade B	Typical

Joint Coordinates and Temperatures

	Label	X [ft]	Y [ft]	Z [ft]	Temp [F]	Detach From Diap...
1	N1	0	0.	-0.	0	
2	N2	0	3.333334	-0.	0	
3	N3	.25	0.	-0.	0	
4	N4	.25	3.333334	-0.	0	
5	N5	.25	-1.5	0	0	
6	N6	.25	4.5	0	0	
7	N7	3.390625	3.333334	-0.	0	
8	N8	6.025403	3.333334	-9.833125	0	
9	N9	3.78125	0.	-0.	0	
10	N10	3.78125	3.333334	-0.	0	
11	N11	4.138628	0.	-0.357378	0	
12	N12	4.138628	3.333334	-0.357378	0	
13	N13	5.206335	0.	-1.425085	0	
14	N14	5.206335	3.333334	-1.425085	0	
15	N15	5.563713	0.	-1.782463	0	
16	N16	5.563713	3.333334	-1.782463	0	
17	N17	6.936287	0.	-1.782463	0	
18	N18	6.936287	3.333334	-1.782463	0	
19	N19	7.293665	0.	-1.425085	0	
20	N20	7.293665	3.333334	-1.425085	0	
21	N21	8.361372	0.	-0.357378	0	
22	N22	8.361372	3.333334	-0.357378	0	
23	N23	8.71875	0.	-0.	0	
24	N24	8.71875	3.333334	-0.	0	
25	N25	12.25	0.	-0.	0	
26	N26	12.25	3.333334	-0.	0	
27	N27	12.5	0.	-0.	0	
28	N28	12.5	3.333334	-0.	0	
29	N29	6.25	3.333334	-1.782463	0	
30	N30	6.25	0.	-1.782463	0	
31	N31	4.25	0.	-0.	0	
32	N32	4.25	3.333334	-0.	0	
33	N33	12.25	-2.333333	0	0	
34	N34	12.25	5.666667	0	0	
35	N35	8.25	0.	-0.	0	
36	N36	8.25	3.333334	-0.	0	
37	N37	8.25	-1.333333	-0.	0	
38	N38	8.25	4.666667	-0.	0	
39	N39	4.25	-1.333333	-0.	0	
40	N40	4.25	4.666667	-0.	0	

Joint Boundary Conditions

	Joint Label	X [k/in]	Y [k/in]	Z [k/in]	X Rot.[k-ft/rad]	Y Rot.[k-ft/rad]	Z Rot.[k-ft/rad]
1	N8	Reaction	Reaction	Reaction			
2	N15						
3	N16						
4	N13						
5	N14						
6	N17						
7	N18						
8	N19						
9	N20						
10	N29	Reaction	Reaction	Reaction			
11	N30	Reaction	Reaction	Reaction			

Member Point Loads (BLC 2 : Dead Load)

	Member Label	Direction	Magnitude[k,k-ft]	Location[ft,%]
1	M17	Y	-.075	.5
2	M17	Y	-.075	7.5
3	M16	Y	-.042	2
4	M16	Y	-.042	5
5	M17	Y	-.109	2
6	M17	Y	-.084	6

Member Point Loads (BLC 3 : Ice Load)

	Member Label	Direction	Magnitude[k,k-ft]	Location[ft,%]
1	M17	Y	-.134	.5
2	M17	Y	-.134	7.5
3	M16	Y	-.053	2
4	M16	Y	-.053	5
5	M17	Y	-.063	2
6	M17	Y	-.054	6

Member Point Loads (BLC 4 : Lm Maintenance Load (500lb))

	Member Label	Direction	Magnitude[k,k-ft]	Location[ft,%]
1	M17	Y	-.5	%50

Member Point Loads (BLC 5 : Lv Maintenance Load (250lb))

	Member Label	Direction	Magnitude[k,k-ft]	Location[ft,%]
1	M1	Y	-.25	%50

Member Point Loads (BLC 6 : Wind with Ice X)

	Member Label	Direction	Magnitude[k,k-ft]	Location[ft,%]
1	M17	X	.04	.5
2	M17	X	.04	7.5
3	M16	X	.016	2
4	M16	X	.016	5
5	M17	X	.022	2
6	M17	X	.017	6

Member Point Loads (BLC 7 : Wind X)

	Member Label	Direction	Magnitude[k,k-ft]	Location[ft,%]
1	M17	X	.162	.5
2	M17	X	.162	7.5
3	M16	X	.062	2
4	M16	X	.062	5
5	M17	X	.089	2
6	M17	X	.061	6

Member Point Loads (BLC 8 : Wm Wind X)

	Member Label	Direction	Magnitude[k,k-ft]	Location[ft,%]
1	M17	X	.011	.5
2	M17	X	.011	7.5
3	M16	X	.004	2
4	M16	X	.004	5
5	M17	X	.006	2
6	M17	X	.004	6

Member Point Loads (BLC 9 : Wind with Ice Z)

	Member Label	Direction	Magnitude[k,k-ft]	Location[ft,%]
1	M17	Z	.097	.5
2	M17	Z	.097	7.5
3	M16	Z	.032	2
4	M16	Z	.032	5

Member Point Loads (BLC 10 : Wind Z)

	Member Label	Direction	Magnitude[k,k-ft]	Location[ft,%]
1	M17	Z	.456	.5
2	M17	Z	.456	7.5
3	M16	Z	.143	2
4	M16	Z	.143	5

Member Point Loads (BLC 11 : Wm Wind Z)

	Member Label	Direction	Magnitude[k,k-ft]	Location[ft,%]
1	M17	Z	.031	.5
2	M17	Z	.031	7.5
3	M16	Z	.01	2
4	M16	Z	.01	5

Member Distributed Loads (BLC 6 : Wind with Ice X)

	Member Label	Direction	Start Magnitude[k/ft,F,ksf]	End Magnitude[k/ft,F,k...	Start Location[ft..	End Location[ft,...
1	M3	X	.002	.002	0	0
2	M4	X	.002	.002	0	0
3	M5	X	.002	.002	0	0
4	M6	X	.002	.002	0	0
5	M7	X	.002	.002	0	0
6	M8	X	.002	.002	0	0
7	M9	X	.002	.002	0	0
8	M10	X	.002	.002	0	0
9	M11	X	.002	.002	0	0



Member Distributed Loads (BLC 6 : Wind with Ice X) (Continued)

	Member Label	Direction	Start Magnitude[k/ft,F,ksf]	End Magnitude[k/ft,F,k...	Start Location[ft..	End Location[ft,...
10	M12	X	.002	.002	0	0
11	M13	X	.002	.002	0	0
12	M14	X	.002	.002	0	0
13	M15	X	.002	.002	0	0
14	M16	X	.002	.002	0	0
15	M17	X	.002	.002	0	0
16	M18	X	.002	.002	0	0
17	M21	X	.002	.002	0	0

Member Distributed Loads (BLC 7 : Wind X)

	Member Label	Direction	Start Magnitude[k/ft,F,ksf]	End Magnitude[k/ft,F,k...	Start Location[ft..	End Location[ft,...
1	M3	X	.008	.008	0	0
2	M4	X	.008	.008	0	0
3	M5	X	.008	.008	0	0
4	M6	X	.008	.008	0	0
5	M7	X	.008	.008	0	0
6	M8	X	.008	.008	0	0
7	M9	X	.008	.008	0	0
8	M10	X	.008	.008	0	0
9	M11	X	.008	.008	0	0
10	M12	X	.008	.008	0	0
11	M13	X	.008	.008	0	0
12	M14	X	.008	.008	0	0
13	M15	X	.008	.008	0	0
14	M16	X	.008	.008	0	0
15	M17	X	.008	.008	0	0
16	M18	X	.008	.008	0	0
17	M21	X	.008	.008	0	0

Member Distributed Loads (BLC 8 : Wm Wind X)

	Member Label	Direction	Start Magnitude[k/ft,F,ksf]	End Magnitude[k/ft,F,k...	Start Location[ft..	End Location[ft,...
1	M3	X	.002	.002	0	0
2	M4	X	.002	.002	0	0
3	M5	X	.002	.002	0	0
4	M6	X	.002	.002	0	0
5	M7	X	.002	.002	0	0
6	M8	X	.002	.002	0	0
7	M9	X	.002	.002	0	0
8	M10	X	.002	.002	0	0
9	M11	X	.002	.002	0	0
10	M12	X	.002	.002	0	0
11	M13	X	.002	.002	0	0
12	M14	X	.002	.002	0	0
13	M15	X	.002	.002	0	0
14	M16	X	.002	.002	0	0
15	M17	X	.002	.002	0	0
16	M18	X	.002	.002	0	0
17	M21	X	.002	.002	0	0

Member Distributed Loads (BLC 9 : Wind with Ice Z)

	Member Label	Direction	Start Magnitude[k/ft,F,ksf]	End Magnitude[k/ft,F,k...	Start Location[ft..	End Location[ft,...
--	--------------	-----------	-----------------------------	---------------------------	---------------------	---------------------

Member Distributed Loads (BLC 9 : Wind with Ice Z) (Continued)

	Member Label	Direction	Start Magnitude[k/ft,F,ksf]	End Magnitude[k/ft,F,k...	Start Location[ft..	End Location[ft,...
1	M1	Z	.002	.002	0	0
2	M2	Z	.002	.002	0	0
3	M4	Z	.002	.002	0	0
4	M5	Z	.002	.002	0	0
5	M6	Z	.002	.002	0	0
6	M7	Z	.002	.002	0	0
7	M8	Z	.002	.002	0	0
8	M9	Z	.002	.002	0	0
9	M10	Z	.002	.002	0	0
10	M11	Z	.002	.002	0	0
11	M12	Z	.002	.002	0	0
12	M13	Z	.002	.002	0	0
13	M14	Z	.002	.002	0	0
14	M15	Z	.002	.002	0	0
15	M18	Z	.002	.002	0	0
16	M21	Z	.002	.002	0	0

Member Distributed Loads (BLC 10 : Wind Z)

	Member Label	Direction	Start Magnitude[k/ft,F,ksf]	End Magnitude[k/ft,F,k...	Start Location[ft..	End Location[ft,...
1	M1	Z	.008	.008	0	0
2	M2	Z	.008	.008	0	0
3	M4	Z	.008	.008	0	0
4	M5	Z	.008	.008	0	0
5	M6	Z	.008	.008	0	0
6	M7	Z	.008	.008	0	0
7	M8	Z	.008	.008	0	0
8	M9	Z	.008	.008	0	0
9	M10	Z	.008	.008	0	0
10	M11	Z	.008	.008	0	0
11	M12	Z	.008	.008	0	0
12	M13	Z	.008	.008	0	0
13	M14	Z	.008	.008	0	0
14	M15	Z	.008	.008	0	0
15	M18	Z	.008	.008	0	0
16	M21	Z	.008	.008	0	0

Member Distributed Loads (BLC 11 : Wm Wind Z)

	Member Label	Direction	Start Magnitude[k/ft,F,ksf]	End Magnitude[k/ft,F,k...	Start Location[ft..	End Location[ft,...
1	M1	Z	.002	.002	0	0
2	M2	Z	.002	.002	0	0
3	M4	Z	.002	.002	0	0
4	M5	Z	.002	.002	0	0
5	M6	Z	.002	.002	0	0
6	M7	Z	.002	.002	0	0
7	M8	Z	.002	.002	0	0
8	M9	Z	.002	.002	0	0
9	M10	Z	.002	.002	0	0
10	M11	Z	.002	.002	0	0
11	M12	Z	.002	.002	0	0
12	M13	Z	.002	.002	0	0
13	M14	Z	.002	.002	0	0



Member Distributed Loads (BLC 11 : Wm Wind Z) (Continued)

Member Label	Direction	Start Magnitude[k/ft,F,ksf]	End Magnitude[k/ft,F,k...	Start Location[ft..End Location[ft,...
14	M15	Z	.002	.002 0 0
15	M18	Z	.002	.002 0 0
16	M21	Z	.002	.002 0 0

Basic Load Cases

	BLC Description	Category	X Gra...Y Gra...Z Gra...	Joint	Point	Distrib..Area(... Surfa...
1	Self Weight	None				
2	Dead Load	None			6	
3	Ice Load	None			6	
4	Lm Maintenance Load (500lb)	None			1	
5	Lv Maintenance Load (250lb)	None			1	
6	Wind with Ice X	None			6	17
7	Wind X	None			6	17
8	Wm Wind X	None			6	17
9	Wind with Ice Z	None			4	16
10	Wind Z	None			4	16
11	Wm Wind Z	None			4	16

Load Combinations

Description	So..P... S...	BLCFac..BLCFac..BLCFac..BLCFac..BLCFac..BLCFac..BLCFac..BLCFac..BLCFac..BLCFac...
1	1.4D	Yes Y 1 1.4 2 1.4
2	1.2D + 1.5Lv	Yes Y 1 1.2 2 1.2 5 1.5
3	1.2D + 1.0W (X-directi...	Yes Y 1 1.2 2 1.2 7 1
4	1.2D + 1.0Di + 1.0Wi (...)	Yes Y 1 1.2 2 1.2 3 1 6 1
5	1.2D + 1.5Lm+ 1.0Wm ...	Yes Y 1 1.2 2 1.2 4 1.5 8 1
6	1.2D + 1.0W (Z-directi...	Yes Y 1 1.2 2 1.2 10 1
7	1.2D + 1.0Di + 1.0Wi (...)	Yes Y 1 1.2 2 1.2 3 1 9 1
8	1.2D + 1.5Lm+ 1.0Wm ...	Yes Y 1 1.2 2 1.2 4 1.5 11 1

Envelope Joint Reactions

Joint	X [k]	LC	Y [k]	LC	Z [k]	LC	MX [k-ft]	LC	MY [k-ft]	LC	MZ [k-ft]	LC
1	N8	max	.159	3	0	6	1.571	6	0	8	0	8
2		min	-.422	6	0	3	-.747	3	0	1	0	1
3	N29	max	-.137	6	.645	8	.474	3	0	8	0	8
4		min	-2.029	5	.157	6	-2.691	6	0	1	0	1
5	N30	max	1.909	8	.625	5	.676	5	0	8	0	8
6		min	-.007	3	.281	3	-.678	6	0	1	0	1
7	Totals:	max	0	8	1.262	5	0	2				
8		min	-1.192	3	.512	3	-1.798	6				

Envelope Joint Displacements

Joint	X [in]	LC	Y [in]	LC	Z [in]	LC	X Rotation [rad]	LC	Y Rotation [rad]	LC	Z Rotation [rad]	LC		
1	N1	max	.028	3	.169	8	.272	6	2.821e-03	6	1.204e-02	6	4.803e-04	3
2		min	-.141	6	0	3	-.121	5	-9.932e-04	3	-1.085e-03	5	-2.107e-03	8
3	N2	max	.032	5	.169	8	.425	6	3.457e-03	6	1.142e-02	6	5.252e-04	3
4		min	-.051	6	0	3	-.023	5	-1.049e-03	3	-9.599e-04	5	-2.112e-03	8

Envelope Joint Displacements (Continued)

	Joint		X [in]	LC	Y [in]	LC	Z [in]	LC	X Rotation [rad]	LC	Y Rotation [rad]	LC	Z Rotation [rad]	LC
5	N3	max	.028	3	.162	8	.236	6	2.821e-03	6	1.204e-02	6	4.803e-04	3
6		min	-.141	6	.002	3	-.118	5	-9.932e-04	3	-1.085e-03	5	-2.107e-03	8
7	N4	max	.032	5	.162	8	.391	6	3.457e-03	6	1.142e-02	6	5.252e-04	3
8		min	-.051	6	.002	3	-.02	5	-1.049e-03	3	-9.599e-04	5	-2.112e-03	8
9	N5	max	.039	3	.162	8	.188	6	2.643e-03	6	1.204e-02	6	6.014e-04	3
10		min	-.167	6	.002	3	-.158	5	-9.929e-04	3	-1.085e-03	5	-2.106e-03	8
11	N6	max	.059	5	.162	8	.439	6	3.457e-03	6	1.142e-02	6	5.042e-04	3
12		min	-.03	6	.002	3	-.02	3	-1.049e-03	3	-9.599e-04	5	-2.112e-03	8
13	N7	max	.032	5	.095	8	.011	3	2.805e-03	6	1.012e-02	6	2.136e-04	3
14		min	-.051	6	.023	3	-.022	6	-4.43e-04	3	-8.405e-04	3	-1.814e-03	8
15	N8	max	0	8	0	8	0	8	1.34e-04	6	3.603e-03	3	2.613e-04	3
16		min	0	1	0	1	0	1	-2.995e-04	4	-4.479e-04	6	-2.382e-03	8
17	N9	max	.028	3	.086	8	.04	3	1.791e-03	8	5.442e-03	6	5.915e-05	3
18		min	-.141	6	.019	2	-.185	6	-2.583e-04	3	-1.763e-03	5	-1.934e-03	8
19	N10	max	.032	5	.086	8	.016	3	2.724e-03	6	9.266e-03	6	2.603e-05	3
20		min	-.051	6	.021	2	-.069	6	-3.676e-04	3	-7.518e-04	3	-1.925e-03	8
21	N11	max	.023	3	.088	8	.035	3	2.428e-03	8	1.161e-03	3	-1.477e-04	3
22		min	-.11	6	.023	2	-.155	6	-7.048e-05	3	-7.054e-03	6	-1.92e-03	8
23	N12	max	.018	5	.088	8	.006	3	2.43e-03	8	3.06e-03	5	-3.407e-05	3
24		min	-.041	6	.023	2	-.06	6	-1.653e-04	3	-2.206e-03	6	-1.929e-03	8
25	N13	max	.006	3	.08	8	.019	3	1.407e-03	8	1.445e-03	3	-1.028e-03	3
26		min	-.025	6	.016	3	-.07	6	1.069e-04	3	-6.026e-03	6	-5.043e-03	8
27	N14	max	-.002	3	.08	8	-.007	2	1.388e-03	8	1.926e-04	3	-9.445e-04	3
28		min	-.011	6	.016	3	-.032	6	5.536e-05	3	-2.397e-03	6	-5.035e-03	8
29	N15	max	0	8	.057	8	.013	3	5.109e-04	2	1.529e-03	3	-1.378e-03	3
30		min	0	1	.011	3	-.045	6	2.564e-07	6	-5.515e-03	6	-6.968e-03	8
31	N16	max	0	8	.057	8	-.006	2	5.566e-04	2	-7.006e-04	2	-1.385e-03	3
32		min	0	1	.011	3	-.022	6	1.341e-04	3	-2.633e-03	6	-6.965e-03	8
33	N17	max	0	8	-.011	3	.045	6	5.109e-04	2	1.529e-03	3	-1.378e-03	3
34		min	0	1	-.057	8	-.013	3	2.563e-07	6	-5.515e-03	6	-6.968e-03	8
35	N18	max	0	8	-.011	3	.022	6	5.566e-04	2	-7.006e-04	2	-1.385e-03	3
36		min	0	1	-.057	8	.006	2	1.341e-04	3	-2.633e-03	6	-6.965e-03	8
37	N19	max	.006	3	-.017	3	.071	6	-8.367e-05	2	1.439e-03	3	-1.27e-03	3
38		min	-.025	6	-.084	8	-.019	3	-1.301e-03	8	-6.182e-03	6	-5.538e-03	8
39	N20	max	-.002	2	-.018	3	.033	6	-1.509e-06	3	2.428e-04	3	-1.13e-03	3
40		min	-.011	6	-.084	8	.008	2	-1.285e-03	8	-2.602e-03	6	-5.514e-03	8
41	N21	max	.023	3	-.026	3	.157	6	-3.189e-04	3	1.171e-03	3	-1.598e-03	2
42		min	-.112	6	-.098	8	-.036	3	-3.498e-03	6	-7.055e-03	6	-4.871e-03	8
43	N22	max	.019	5	-.026	3	.066	6	-2.361e-04	3	3.067e-03	5	-8.812e-04	6
44		min	-.042	6	-.098	8	-.008	3	-3.157e-03	8	-2.389e-03	6	-4.742e-03	8
45	N23	max	.028	3	-.034	3	.188	6	4.963e-04	3	1.623e-03	3	-2.244e-03	2
46		min	-.142	6	-.109	5	-.041	3	-4.921e-03	6	-2.005e-02	6	-7.516e-03	8
47	N24	max	.033	5	-.03	3	.076	6	1.486e-03	6	1.312e-03	3	-1.902e-03	3
48		min	-.052	6	-.109	8	-.018	3	-8.943e-04	8	-1.787e-02	6	-7.539e-03	8
49	N25	max	.028	3	-.164	3	1.36	6	6.381e-04	3	1.467e-03	3	-8.799e-04	3
50		min	-.142	6	-.555	8	-.105	3	-1.135e-02	6	-3.138e-02	6	-8.227e-03	8
51	N26	max	.033	5	-.164	3	1.222	6	5.397e-03	6	1.448e-03	3	-2.701e-03	2
52		min	-.052	6	-.555	8	-.077	3	-1.867e-03	5	-3.15e-02	6	-8.228e-03	8
53	N27	max	.028	3	-.167	3	1.454	6	6.381e-04	3	1.467e-03	3	-8.799e-04	3
54		min	-.142	6	-.579	8	-.109	3	-1.135e-02	6	-3.138e-02	6	-8.227e-03	8
55	N28	max	.033	5	-.174	3	1.317	6	5.397e-03	6	1.448e-03	3	-2.701e-03	2
56		min	-.052	6	-.579	8	-.082	3	-1.867e-03	5	-3.15e-02	6	-8.228e-03	8



Envelope Joint Displacements (Continued)

	Joint		X [in]	LC	Y [in]	LC	Z [in]	LC	X Rotation [rad]	LC	Y Rotation [rad]	LC	Z Rotation [rad]	LC
57	N29	max	0	8	0	8	0	8	5.566e-04	2	-7.006e-04	2	-1.385e-03	3
58		min	0	1	0	1	0	1	1.341e-04	3	-2.633e-03	6	-6.965e-03	8
59	N30	max	0	8	0	8	0	8	5.109e-04	2	1.529e-03	3	-1.378e-03	3
60		min	0	1	0	1	0	1	2.564e-07	6	-5.515e-03	6	-6.968e-03	8
61	N31	max	.028	3	.076	5	.036	3	1.556e-03	8	3.621e-03	6	-8.815e-05	3
62		min	-.141	6	.016	2	-.211	6	-2.399e-04	3	-1.901e-03	5	-2.03e-03	8
63	N32	max	.032	5	.076	5	.019	3	2.642e-03	6	7.484e-03	6	-1.687e-04	3
64		min	-.051	6	.016	2	-.116	6	-3.297e-04	3	-3.694e-04	3	-2.024e-03	8
65	N33	max	.064	3	-.164	3	1.836	6	6.365e-04	3	1.467e-03	3	2.013e-03	3
66		min	-.314	8	-.555	8	-.123	3	-1.89e-02	6	-3.138e-02	6	-8.206e-03	8
67	N34	max	.267	5	-.164	3	1.532	6	1.302e-02	6	1.448e-03	3	-2.709e-03	2
68		min	.057	6	-.555	8	-.06	3	-1.872e-03	5	-3.15e-02	6	-8.418e-03	5
69	N35	max	.028	3	-.02	6	.084	6	4.444e-04	3	1.645e-03	3	-1.639e-03	2
70		min	-.142	6	-.072	5	-.031	3	-4.279e-03	6	-1.703e-02	6	-5.541e-03	8
71	N36	max	.033	5	-.02	6	-.002	2	1.032e-03	6	1.267e-03	3	-1.196e-03	2
72		min	-.052	6	-.072	5	-.014	6	-9.013e-04	8	-1.437e-02	6	-5.556e-03	8
73	N37	max	0	3	-.02	6	.153	6	4.444e-04	3	1.645e-03	3	-1.639e-03	2
74		min	-.177	6	-.072	5	-.038	3	-4.311e-03	6	-1.703e-02	6	-5.541e-03	8
75	N38	max	.12	5	-.02	6	.003	6	1.063e-03	6	1.267e-03	3	-1.196e-03	2
76		min	-.014	6	-.072	5	-.024	5	-8.935e-04	8	-1.437e-02	6	-5.556e-03	8
77	N39	max	.027	3	.076	5	.04	3	1.548e-03	8	3.621e-03	6	-5.686e-05	3
78		min	-.155	6	.016	2	-.225	6	-2.399e-04	3	-1.901e-03	5	-2.03e-03	8
79	N40	max	.063	5	.076	5	.034	5	2.674e-03	6	7.484e-03	6	-2.e-04	3
80		min	-.038	6	.016	2	-.074	6	-3.297e-04	3	-3.694e-04	3	-2.024e-03	8

Envelope AISC 15th(360-16): LRFD Steel Code Checks

Memb...	Shape	Code Check	L...	LC	Sh...L...	Dir	...phi*P...	phi*Pn...	phi*Mn y-y [k-ft]	phi*...Cb	Eqn
1	M1 PIPE 2.5	.533	8...	6	.1223...	6	14.559	50.715	3.596	3.5962...	H1..
2	M2 PIPE 2.5	.451	8...	6	.1618...	6	14.559	50.715	3.596	3.5962...	H1..
3	M3 PIPE 2.0	.171	0	6	.0041...	3	9.492	32.13	1.872	1.872 1	H1..
4	M4 PIPE 2.0	.342	2...	5	.0982...	5	32.032	32.13	1.872	1.8721...	H1..
5	M5 PIPE 2.0	.336	2...	8	.094.5...	8	32.032	32.13	1.872	1.8721...	H1..
6	M6 PIPE 2.0	.404	2...	8	.122.4...	5	32.032	32.13	1.872	1.8721...	H1..
7	M7 PIPE 2.0	.402	2...	8	.128.4...	8	32.032	32.13	1.872	1.8721...	H1..
8	M8 0.625' Dia.	.099	3...	6	.037 0	8	1.058	9.94	.104	.1042...	H1..
9	M9 0.625' Dia.	.130	0	5	.019 0	6	1.058	9.94	.104	.1042...	H1..
10	M10 SR 3/4	.103	0	5	.026 0	8	6.954	14.314	.179	.179 1	H1..
11	M11 0.625' Dia.	.107	3...	6	.0373...	8	1.058	9.94	.104	.1041...	H1..
12	M12 SR 3/4	.120	0	5	.026 0	8	6.954	14.314	.179	.1792...	H1..
13	M13 0.625' Dia.	.139	0	5	.019 0	6	1.058	9.94	.104	.1042...	H1..
14	M14 SR 3/4	.322	0	5	.022 0	6	6.954	14.314	.179	.1791...	H1..
15	M15 SR 3/4	.180	3...	8	.0223...	8	6.954	14.314	.179	.1792...	H1..
16	M16 PIPE 2.0	.120	4.5	6	.0264.5	6	20.867	32.13	1.872	1.8721...	H1..
17	M17 PIPE 2.0	.538	2...	5	.0652...	5	14.916	32.13	1.872	1.8724...	H1..
18	M18 PIPE 2.0	.285	4...	5	.0724...	8	20.867	32.13	1.872	1.8721...	H1..
19	M21 PIPE 2.0	.156	1...	6	.0851...	6	20.867	32.13	1.872	1.8721...	H1..



Code Check (Env)	
Black	No Calc
Red	> 1.0
Magenta	.90-1.0
Green	.75-.90
Cyan	.50-.75
Blue	0-.50

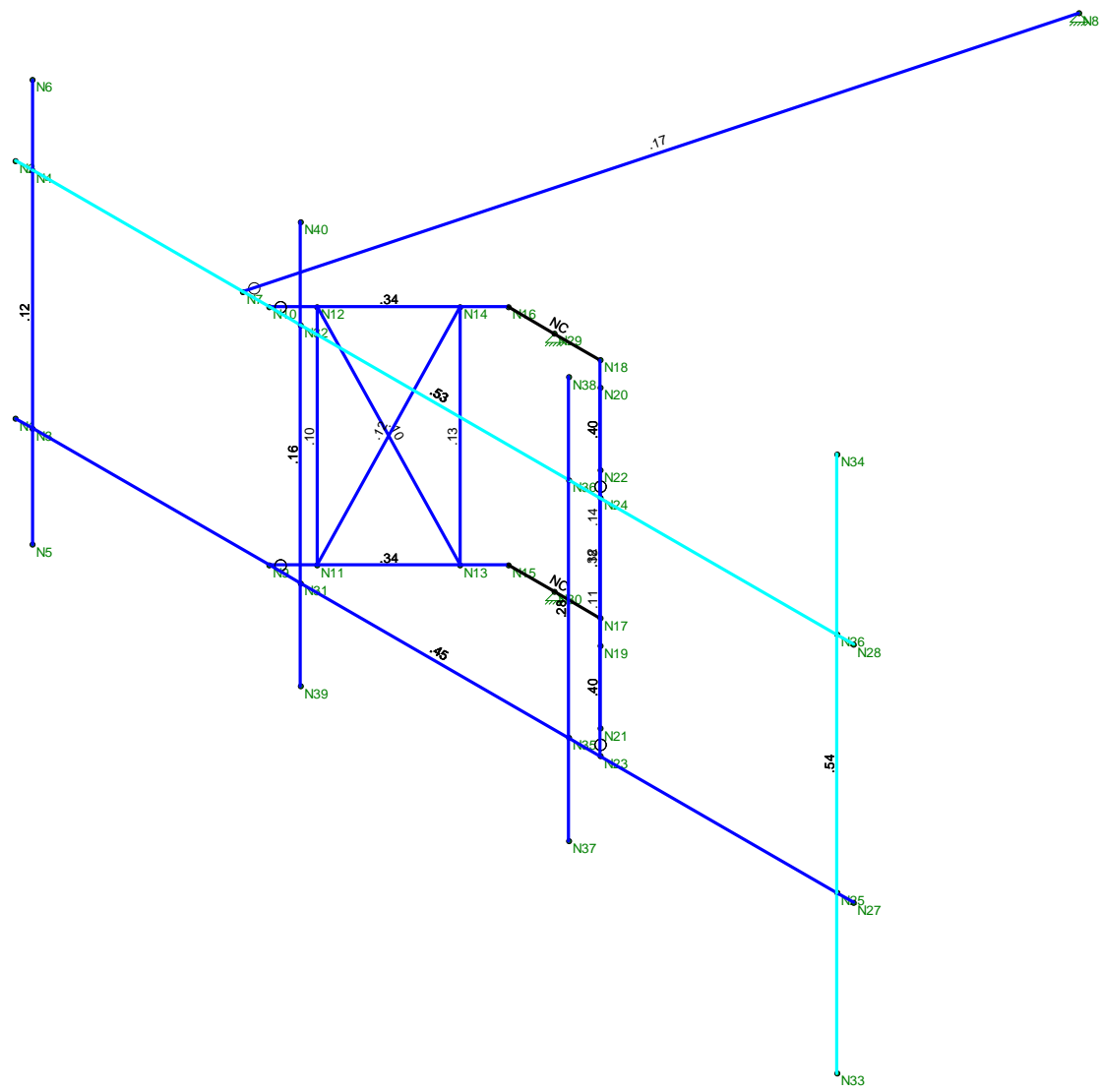

Member Code Checks Displayed (Enveloped)
Envelope Only Solution

Centek Engineering	CT11349A Unity Check	Jan 24, 2023 at 5:06 PM
TJL		Mount.R3D
22022.16		

Subject:

Connection to Host Building

Location:

Norfolk, CT

Rev. 1: 2/24/23

Prepared by: T.J.L. Checked by: C.F.C.
 Job No. 22022.16

Antenna Mount Connection:

Anchor Data:

A307 Thru-Bolt =

Number of Anchor Bolts = N := 4 (User Input)

Diameter of Bolts = D := 0.625in (User Input)

Design Tension = T_{design} := 10.4-kips (User Input)

Design Shear = V_{design} := 6.23-kips (User Input)

Design Reactions:

Shear X = F_x := 2.1-kips (User Input)

Shear Y = F_y := 0.7-kips (User Input)

Shear Z = F_z := 2.7-kips (User Input)

Anchor Check:

Max Tension Force = $T_{Max} := \frac{F_z}{N} = 675\text{lb}$

Max Shear Force = $V_{Max} := \frac{F_y + F_x}{N} = 700\text{lb}$

Condition 1 = $\text{Condition 1} := \text{if} \left(\frac{T_{Max}}{T_{design}} + \frac{V_{Max}}{V_{design}} \leq 1.0, \text{"OK"}, \text{"NG"} \right) = \text{"OK"}$

% of Capacity = $\max \left[\frac{T_{Max}}{T_{design}}, \frac{V_{Max}}{V_{design}}, \left(\frac{\frac{T_{Max}}{T_{design}} + \frac{V_{Max}}{V_{design}}}{1.0} \right) \right] = 17.7\%$



BST MANAGEMENT
LLC

BST Management, LLC
352 Park Street, Suite 106
North Reading, MA 01864



GPD Engineering and Architecture
Professional Corporation

Dan Palkovic
520 South Main Street, Suite 2531
Akron, OH 44311
(216) 927-8663
dpalkovic@gpdgroup.com

GPD# 2022703.43
January 18, 2023

COMPREHENSIVE STRUCTURAL ANALYSIS REPORT

SITE DESIGNATION: **BST Site #:** **CT-1188**
 T-Mobile Site #: **CT11349A**
 T-Mobile Site Name: **Norfolk SNET 1**

ANALYSIS CRITERIA: **Codes:** **TIA-222-H & 2022 Connecticut State Building Code**
 114 mph (ultimate 3-second gust) w/ 0" ice
 40 mph (3-second gust) w/ 1" ice

SITE DATA: **402 Loon Meadow Drive, Norfolk, CT 6058, Litchfield County**
 Latitude 42° 00' 32.00" N, Longitude 73° 10' 50.99" W
 160' Guyed Tower

To whom it may concern,

GPD is pleased to submit this Comprehensive Structural Analysis Report to determine the structural integrity of the aforementioned tower. The purpose of the analysis is to determine the suitability of the tower with the existing and proposed loading configuration detailed in the analysis report.

Analysis Results

Tower Stress Level with Proposed Equipment: 62.3% Sufficient Capacity
Foundation Ratio with Proposed Equipment: 72.2% Sufficient Capacity

We at GPD appreciate the opportunity of providing our continuing professional services to you and BST Management, LLC. If you have any questions or need further assistance on this or any other projects please do not hesitate to call.

Respectfully submitted,

Christopher J. Scheks, P.E.
Connecticut #: 0030026

1/18/2023

SUMMARY & RESULTS

The purpose of this analysis was to verify whether the existing structure is capable of carrying the proposed loading configuration as specified by T-Mobile and commissioned by BST Management, LLC.

This analysis utilizes an ultimate 3-second gust wind speed of 114 mph as required by the 2022 Connecticut State Building Code. Applicable Standard references and design criteria are listed in Appendices A & B.

The proposed feedlines shall be installed as shown in Appendices A & B for the analysis results to be valid.

TOWER SUMMARY AND RESULTS

Member	Capacity	Results
Legs	35.5%	Pass
Bracing	62.3%	Pass
Bolt Checks	62.3%	Pass
Guy Wires	49.8%	Pass
Torque Arm	13.7%	Pass
Guy Anchors	28.3%	Pass
Base Foundation	72.2%	Pass

RECOMMENDATIONS

The tower and its foundation(s) have sufficient capacity to carry the proposed loading configuration. No modifications are required at this time.

ANALYSIS METHOD

tnxTower (Version 8.1.1.0), a commercially available software program, was used to create a three-dimensional model of the tower and calculate primary member stresses for various load cases. Selected output from the analysis is included the report appendices. The following table details the information provided to complete this structural analysis. This analysis is solely based on this information.

DOCUMENTS PROVIDED

Document	Remarks	Source
Collocation Application	Application site #: CT-1188, dated 3/18/2022	BST Management, LLC
Tower Design	Not Provided	N/A
Foundation Design	WEI Project #: 2010-1212, dated 9/15/2010	BST
Geotechnical Report	WEI Project #: 2010-1212, dated 9/15/2010	BST
Previous Tower Analysis	GPD Job #:2022702.97, dated 6/7/2022	GPD
Tower Mapping	GPD & MTSI Northeast, dated 7/21/2010	GPD
Boring Log Review	GPD Job #: 2018704.07, dated 5/15/2018	GPD

ASSUMPTIONS

This structural analysis is based on the theoretical capacity of the members and is not a condition assessment of the tower. This analysis is from information supplied, and therefore, its results are based on and are as accurate as that supplied data. GPD has made no independent determination, nor is it required to, of its accuracy. The following assumptions were made for this structural analysis.

1. The tower member sizes and shapes are considered accurate as supplied. The material grade is as per data supplied and/or as assumed and as stated in the materials section.
2. The appurtenance configuration is as supplied, determined from available photos, and/or as modeled in the analysis. It is assumed to be complete and accurate. All antennas, mounts, coax and waveguides are assumed to be properly installed and supported as per manufacturer requirements.
3. All mounts, if applicable, are considered adequate to support the loading. No actual analysis of the mount(s) is performed. This analysis is limited to analyzing the tower only.
4. The soil parameters are as per data supplied or as assumed and stated in the calculations.
5. Foundations are properly designed and constructed to resist the original design loads indicated in the documents provided.
6. The tower and structures have been properly maintained in accordance with TIA Standards and/or with manufacturer's specifications.
7. All welds and connections are assumed to develop at least the member capacity unless determined otherwise and explicitly stated in this report.
8. All prior structural modifications, if applicable, are assumed to be as per data supplied/available and to have been properly installed.
9. Loading interpreted from photos is accurate to $\pm 5'$ AGL, antenna size accurate to ± 3.3 sf, and coax equal to the number of existing antennas without reserve.
10. All existing and proposed loading has been taken from the available site photos as well as documents supplied to GPD at the time of generating this report. All such documents are listed in the Documents Provided Table and are assumed to be accurate. GPD is not responsible for loading scenarios outside those conveyed in the supplied documentation.

If any of these assumptions are not valid or have been made in error, this analysis may be affected, and GPD should be allowed to review any new information to determine its effect on the structural integrity of the tower.

DISCLAIMER OF WARRANTIES

GPD has not performed a site visit to the tower to verify the member sizes or antenna/coax loading. If the existing conditions are not as represented on the tower elevation contained in this report, we should be contacted immediately to evaluate the significance of the discrepancy. This is not a condition assessment of the tower or foundation. This report does not replace a full tower inspection. The tower and foundations are assumed to have been properly fabricated, erected, maintained, in good condition, twist free, and plumb.

The engineering services rendered by GPD in connection with this Rigorous Structural Analysis are limited to a computer analysis of the tower structure and theoretical capacity of its main structural members. No allowance was made for any damaged, bent, missing, loose, or rusted members (above and below ground). No allowance was made for loose bolts or cracked welds.

This analysis is limited to the designated maximum wind and seismic conditions per the governing tower standards and code. Wind forces resulting in tower vibrations near the structure's resonant frequencies were not considered in this analysis and are outside the scope of this analysis. Lateral loading from any dynamic response was not evaluated under a time-domain based fatigue analysis.

GPD does not analyze the fabrication of the structure (including welding). It is not possible to have all the very detailed information needed to perform a thorough analysis of every structural sub-component and connection of an existing tower. GPD provides a limited scope of service in that we cannot verify the adequacy of every weld, plate connection detail, etc. The purpose of this report is to assess the capability of adding appurtenances usually accompanied by transmission lines to the structure.

It is the owner's responsibility to determine the amount of ice accumulation in excess of the code specified amount, if any, that should be considered in the structural analysis.

The attached sketches are a schematic representation of the analyzed tower. If any material is fabricated from these sketches, the contractor shall be responsible for field verifying the existing conditions, proper fit, and clearance in the field. Any mentions of structural modifications are reasonable estimates and should not be used as a precise construction document. Precise modification drawings are obtainable from GPD, but are beyond the scope of this report.

Miscellaneous items such as antenna mounts, etc., have not been designed or detailed as a part of our work. We recommend that material of adequate size and strength be purchased from a reputable tower manufacturer.

Towers are designed to carry gravity, wind, and ice loads. All members, legs, diagonals, struts, and redundant members provide structural stability to the tower with little redundancy. Absence or removal of a member can trigger catastrophic failure unless a substitute is provided before any removal. Legs carry axial loads and derive their strength from shorter unbraced lengths by the presence of redundant members and their connection to the diagonals with bolts or welds. If the bolts or welds are removed without providing any substitute to the frame, the leg is subjected to a higher unbraced length that immediately reduces its load carrying capacity. If a diagonal is also removed in addition to the connection, the unbraced length of the leg is greatly increased, jeopardizing its load carrying capacity. Failure of one leg can result in a tower collapse because there is no redundancy. Redundant members and diagonals are critical to the stability of the tower.

GPD makes no warranties, expressed and/or implied, in connection with this report and disclaims any liability arising from material, fabrication, and erection of this tower. GPD will not be responsible whatsoever for, or on account of, consequential or incidental damages sustained by any person, firm, or organization as a result of any data or conclusions contained in this report. The maximum liability of GPD pursuant to this report will be limited to the total fee received for preparation of this report.

APPENDIX A

Tower Analysis Summary Form

APPENDIX B

Tower Analysis Output File

Section		T1	T2	T3	T4	T5	T6	T7	T8	T9
Legs						V5x5/16				
Leg Grade						A572-50				
Diagonals										
Diagonal Grade						A36				
Top Girts						N.A.				
Horizontalis						L2x2x3/16				
Top Guy Pull-Offs						L 2 x 2 x 3/16				
Bot Guy Pull-Offs						N.A.				
Face Width (ft)						27 @ 5				
# Panels @ (ft)										2 @ 3
Weight (K)										8.5
										0.3
										1.7
										1.0
										0.7
										1.0
										1.0
										1.0
										1.0
										1.0
										1.0
										1.0
										1.0
										1.0

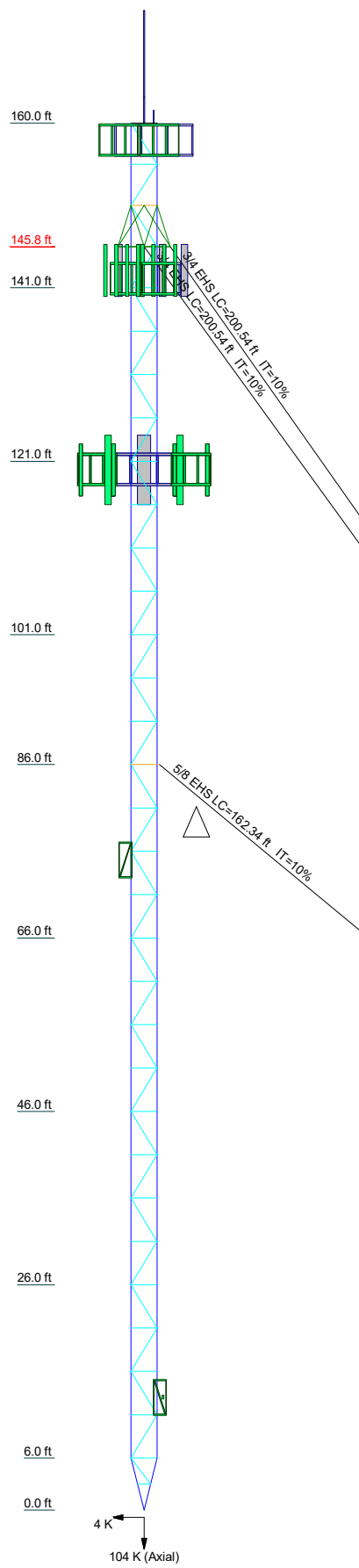

DESIGNED APPURTENANCE LOADING

TYPE	ELEVATION	TYPE	ELEVATION
10' Dipole	160	(4) 7020.00 RET	142
Pipe Mount 3'x2.375"	160	(4) 7020.00 RET	142
3' Omni	160	RRUS-11	142
Rohn 12' Boom Gate	158	RRUS-11	142
Rohn 12' Boom Gate	158	RRUS-11	142
Rohn 12' Boom Gate	158	B14 4478	142
APXVSPP18-C-A20 w/ Mount Pipe	158	B14 4478	142
APXVSPP18-C-A20 w/ Mount Pipe	158	B14 4478	142
APXVSPP18-C-A20 w/ Mount Pipe	158	RRUS 32 B2	142
800MHz 2x50w	154	RRUS 32 B2	142
800MHz 2x50w	154	RRUS 32 B2	142
800MHz 2x50w	154	ABT-DFDM-ADBH	142
1900MHz 2x40w	154	ABT-DFDM-ADBH	142
1900MHz 2x40w	154	4' Sidearm - Flat (GPD)	137
1900MHz 2x40w	154	4' Sidearm - Flat (GPD)	137
800MHz 2x50w Notch Filter	154	SITE PRO 1 VFA12-HD (3)	120
800MHz 2x50w Notch Filter	154	AIR6419 w/ Mount Pipe	120
800MHz 2x50w Notch Filter	154	AIR6419 w/ Mount Pipe	120
4' Yagi	148	AIR6419 w/ Mount Pipe	120
Pipe Mount 4'x2.375"	148	APXVAALL24_43-U-NA20 w/ Mount Pipe	120
8' Frame	142	APXVAALL24_43-U-NA20 w/ Mount Pipe	120
8' Frame	142	APXVAALL24_43-U-NA20 w/ Mount Pipe	120
8' Frame	142	APXVAALL24_43-U-NA20 w/ Mount Pipe	120
AM-X-CD-16-65-00T w/ Mount Pipe	142	Radio 4480 B71+B85	120
AM-X-CD-16-65-00T w/ Mount Pipe	142	Radio 4480 B71+B85	120
AM-X-CD-16-65-00T w/ Mount Pipe	142	Radio 4480 B71+B85	120
(2) 7770.00 w/Mount Pipe	142	Radio 4460 B25+B66	120
(2) 7770.00 w/Mount Pipe	142	Radio 4460 B25+B66	120
(2) 7770.00 w/Mount Pipe	142	Radio 4460 B25+B66	120
80010965 w/ Mount Pipe	142	GPS-TMG-HR-26NCM	75
80010965 w/ Mount Pipe	142	2' Sidearm - Round (GPD)	75
(2) TT19-08BP111-001	142	GPS	13
(2) TT19-08BP111-001	142	1' Sidearm - Flat (GPD)	13
(4) 7020.00 RET	142		

SYMBOL LIST

MARK	SIZE	MARK	SIZE
A	L2 1/2x2 1/2x3/16		

MATERIAL STRENGTH

GRADE	F _y	F _u	GRADE	F _y	F _u
A572-50	50 ksi	65 ksi	A36	36 ksi	58 ksi

TOWER DESIGN NOTES

1. Tower is located in Litchfield County, Connecticut.
2. Tower designed for Exposure B to the TIA-222-H Standard.
3. Tower designed for a 114 mph basic wind in accordance with the TIA-222-H Standard.
4. Tower is also designed for a 40 mph basic wind with 1.00 in ice. Ice is considered to increase in thickness with height.
5. Deflections are based upon a 60 mph wind.
6. Tower Risk Category II.
7. Topographic Category 1 with Crest Height of 0.00 ft
8. TOWER RATING: 62.3%

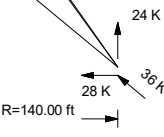

ALL REACTIONS ARE FACTORED

GPD
520 South Main Street Suite 2531
Akron, Ohio 44311
Phone: (330) 572-2222
FAX: (330) 572-3722

Job: (CT-1188) NORFOLK
Project: 2022703.43
Client: BST Management, LLC Drawn by: TDeak App'd:
Code: TIA-222-H Date: 06/16/22 Scale: NTS
Path: T:\A\gpr\GNET\2022\11_2022\203.43\BST_5415_Structural\02_Struss\Rev 003_Modeling\2022703.43.rvt Dwg No. E-1

Feed Line Distribution Chart 6' - 160'

— Round
 — Flat
 — App In Face
 — App Out Face
 — Truss Leg

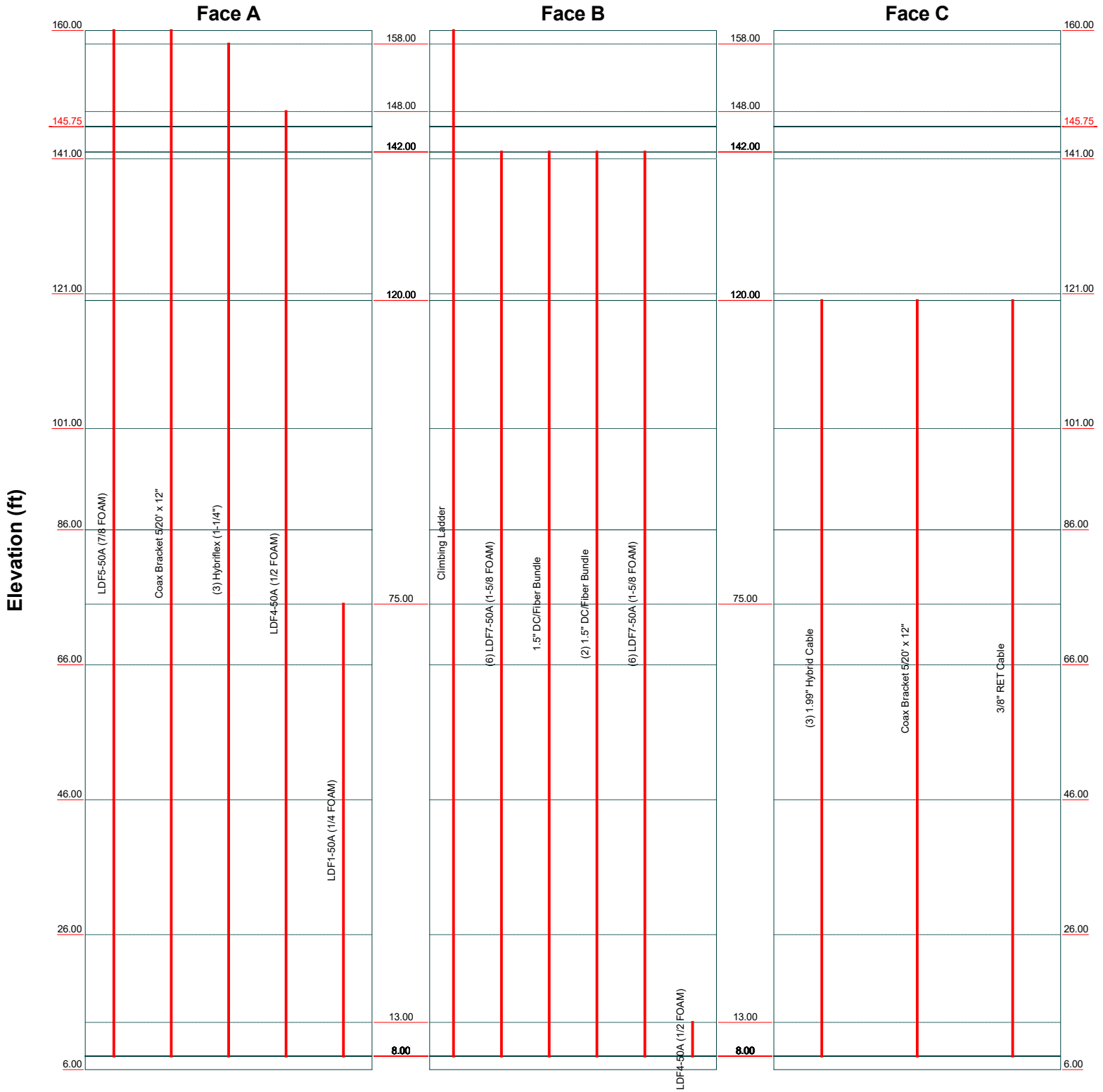



GPD
 520 South Main Street Suite 2531
 Akron, Ohio 44311
 Phone: (330) 572-2222
 FAX: (330) 572-3722

Job: (CT-1188) NORFOLK			
Project: 2022703.43			
Client: BST Management, LLC	Drawn by: TDeak	App'd:	
Code: TIA-222-H	Date: 06/16/22	Scale: NTS	
Path:		Dwg No. E-7	

Feed Line Plan

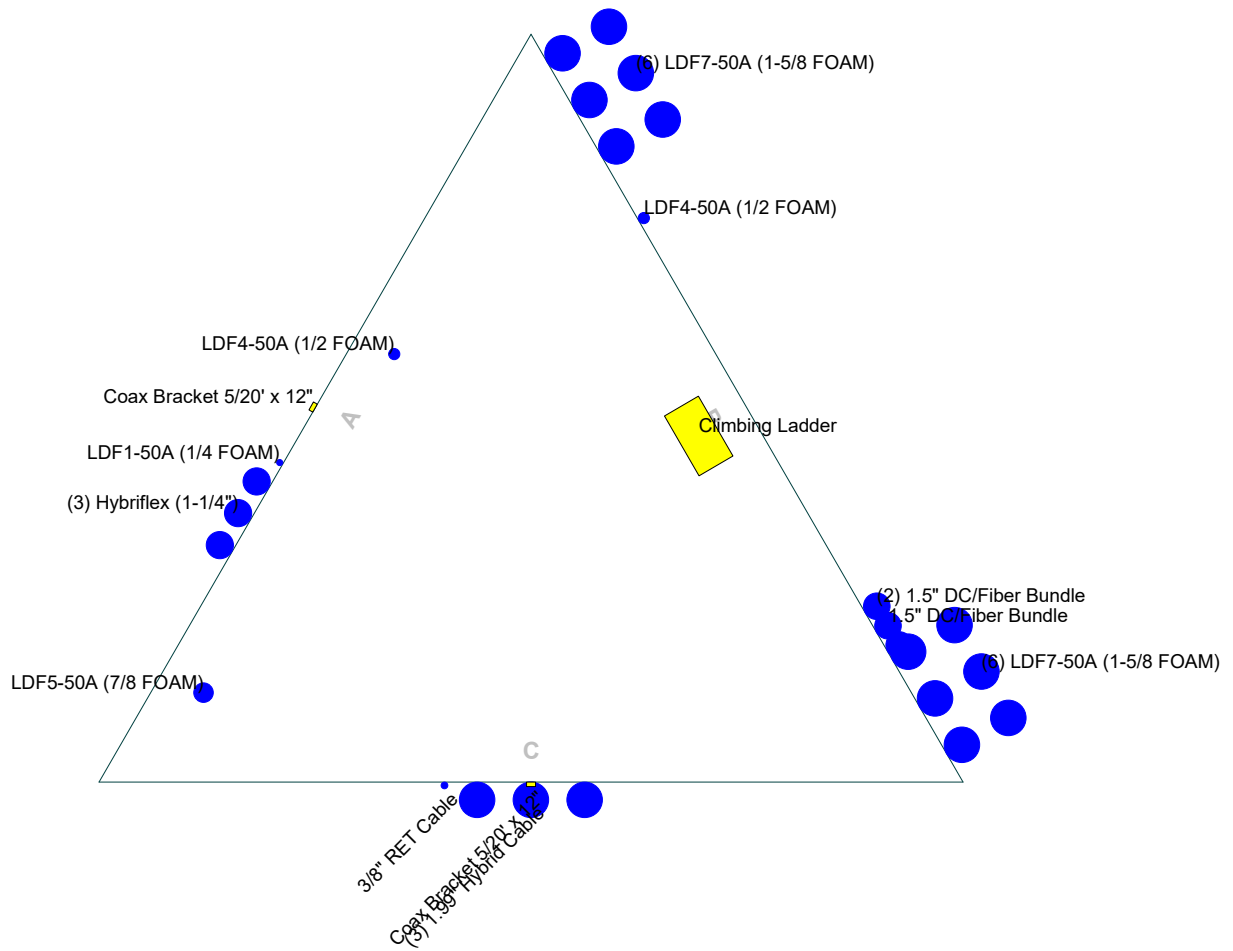
— Round
 — Flat
 — App In Face
 — App Out Face



 <p>GPD 520 South Main Street Suite 2531 Akron, Ohio 44311 Phone: (330) 572-2222 FAX: (330) 572-3722</p>	Job: (CT-1188) NORFOLK		
	Project: 2022703.43		
	Client: BST Management, LLC	Drawn by: TDeak	App'd:
	Code: TIA-222-H	Date: 06/16/22	Scale: NTS
	Path:		Dwg No. E-7

T:\A\Year\NET\2022\11-2022\703.43\EST-5A16_Structural\00_Structure\00_Rev-003_Model\2022703.43.rvt

tnxTower GPD 520 South Main Street Suite 2531 Akron, Ohio 44311 Phone: (330) 572-2222 FAX: (330) 572-3722	Job (CT-1188) NORFOLK	Page 1 of 29
	Project 2022703.43	Date 11:55:52 06/16/22
	Client BST Management, LLC	Designed by TDeak

Tower Input Data

The main tower is a 3x guyed tower with an overall height of 160.00 ft above the ground line.

The base of the tower is set at an elevation of 0.00 ft above the ground line.

The face width of the tower is 4.00 ft at the top and tapered at the base.

This tower is designed using the TIA-222-H standard.

The following design criteria apply:

Tower is located in Litchfield County, Connecticut.

Tower base elevation above sea level: 0.00 ft.

Basic wind speed of 114 mph.

Risk Category II.

Exposure Category B.

Simplified Topographic Factor Procedure for wind speed-up calculations is used.

Topographic Category: 1.

Crest Height: 0.00 ft.

Nominal ice thickness of 1.0000 in.

Ice thickness is considered to increase with height.

Ice density of 56 pcf.

A wind speed of 40 mph is used in combination with ice.

Temperature drop of 50 °F.

Deflections calculated using a wind speed of 60 mph.

Pressures are calculated at each section.

Stress ratio used in tower member design is 1.

Safety factor used in guy design is 1.

Local bending stresses due to climbing loads, feed line supports, and appurtenance mounts are not considered.

Options

Consider Moments - Legs Consider Moments - Horizontals Consider Moments - Diagonals Use Moment Magnification √ Use Code Stress Ratios √ Use Code Safety Factors - Guys Escalate Ice Always Use Max Kz Use Special Wind Profile √ Include Bolts In Member Capacity Leg Bolts Are At Top Of Section √ Secondary Horizontal Braces Leg Use Diamond Inner Bracing (4 Sided) √ SR Members Have Cut Ends SR Members Are Concentric	Distribute Leg Loads As Uniform Assume Legs Pinned √ Assume Rigid Index Plate √ Use Clear Spans For Wind Area Use Clear Spans For KL/r √ Retension Guys To Initial Tension √ Bypass Mast Stability Checks √ Use Azimuth Dish Coefficients √ Project Wind Area of Appurt. √ Autocalc Torque Arm Areas Add IBC .6D+W Combination √ Sort Capacity Reports By Component Triangulate Diamond Inner Bracing Treat Feed Line Bundles As Cylinder Ignore KL/ry For 60 Deg. Angle Legs	Use ASCE 10 X-Brace Ly Rules √ Calculate Redundant Bracing Forces Ignore Redundant Members in FEA √ SR Leg Bolts Resist Compression All Leg Panels Have Same Allowable Offset Girt At Foundation √ Consider Feed Line Torque √ Include Angle Block Shear Check Use TIA-222-H Bracing Resist. Exemption Use TIA-222-H Tension Splice Exemption Poles Include Shear-Torsion Interaction Always Use Sub-Critical Flow Use Top Mounted Sockets Pole Without Linear Attachments Pole With Shroud Or No Appurtenances Outside and Inside Corner Radii Are Known
--	---	---

tnxTower GPD 520 South Main Street Suite 2531 Akron, Ohio 44311 Phone: (330) 572-2222 FAX: (330) 572-3722	Job (CT-1188) NORFOLK	Page 2 of 29
	Project 2022703.43	Date 11:55:52 06/16/22
	Client BST Managment, LLC	Designed by TDeak

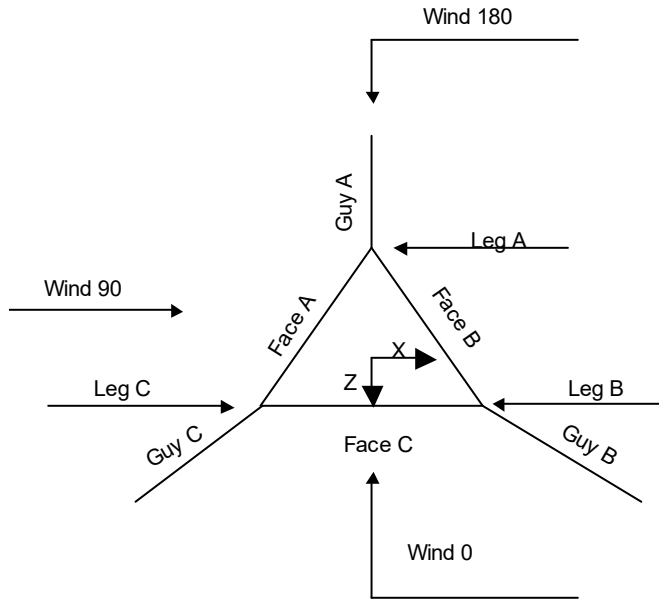

Corner & Starmount Guyed Tower

tnxTower GPD 520 South Main Street Suite 2531 Akron, Ohio 44311 Phone: (330) 572-2222 FAX: (330) 572-3722	Job (CT-1188) NORFOLK	Page 3 of 29
	Project 2022703.43	Date 11:55:52 06/16/22
	Client BST Managment, LLC	Designed by TDeak

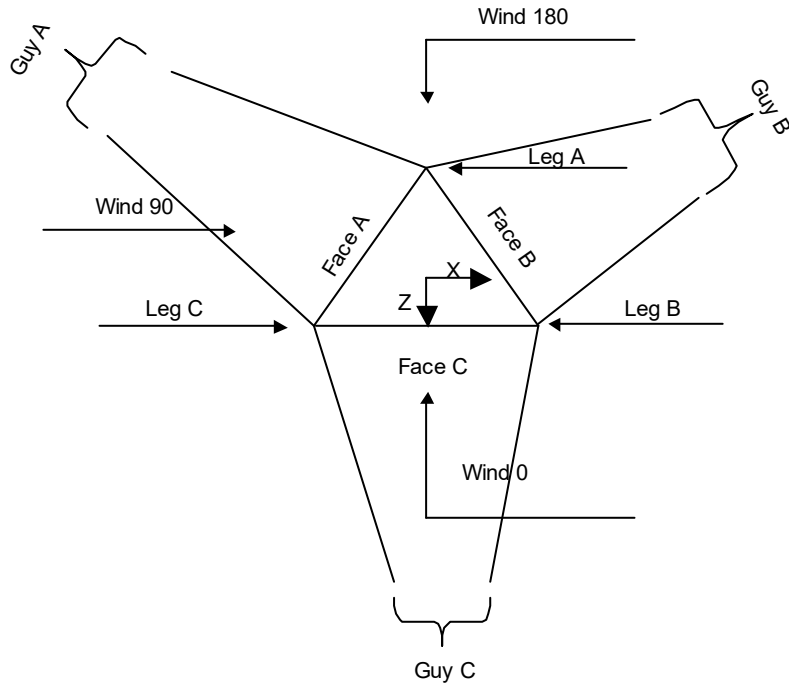

Face Guyed

Tower Section Geometry

<i>Tower Section</i>	<i>Tower Elevation</i>	<i>Assembly Database</i>	<i>Description</i>	<i>Section Width</i>	<i>Number of Sections</i>	<i>Section Length</i>
	<i>ft</i>			<i>ft</i>		<i>ft</i>
T1	160.00-141.00			4.00	1	19.00
T2	141.00-121.00			4.00	1	20.00
T3	121.00-101.00			4.00	1	20.00
T4	101.00-86.00			4.00	1	15.00
T5	86.00-66.00			4.00	1	20.00
T6	66.00-46.00			4.00	1	20.00
T7	46.00-26.00			4.00	1	20.00
T8	26.00-6.00			4.00	1	20.00
T9	6.00-0.00			4.00	1	6.00

Tower Section Geometry (cont'd)

tnxTower GPD 520 South Main Street Suite 2531 Akron, Ohio 44311 Phone: (330) 572-2222 FAX: (330) 572-3722	Job	Page	
		(CT-1188) NORFOLK	4 of 29
	Project	2022703.43	Date
		11:55:52 06/16/22	
Client	BST Management, LLC	Designed by	
		TDeak	

Tower Section	Tower Elevation	Diagonal Spacing	Bracing Type	Has K Brace End Panels	Has Horizontals	Top Girt Offset	Bottom Girt Offset
	ft	ft				in	in
T1	160.00-141.00	4.75	K Brace Left	No	Yes	0.0000	0.0000
T2	141.00-121.00	5.00	K Brace Left	No	Yes	0.0000	0.0000
T3	121.00-101.00	5.00	K Brace Left	No	Yes	0.0000	0.0000
T4	101.00-86.00	5.00	K Brace Left	No	Yes	0.0000	0.0000
T5	86.00-66.00	5.00	K Brace Left	No	Yes	0.0000	0.0000
T6	66.00-46.00	5.00	K Brace Left	No	Yes	0.0000	0.0000
T7	46.00-26.00	5.00	K Brace Left	No	Yes	0.0000	0.0000
T8	26.00-6.00	5.00	K Brace Left	No	Yes	0.0000	0.0000
T9	6.00-0.00	3.00	Diag Down	No	Yes	0.0000	0.0000

Tower Section Geometry (cont'd)

Tower Elevation	Leg Type	Leg Size	Leg Grade	Diagonal Type	Diagonal Size	Diagonal Grade
ft						
T1 160.00-141.00	60 Angle	V5x5x5/16	A572-50 (50 ksi)	Double Equal Angle	2L2 1/2x2 1/2x3/16	A36 (36 ksi)
T2 141.00-121.00	60 Angle	V5x5x5/16	A572-50 (50 ksi)	Equal Angle	L2 1/2x2 1/2x3/16	A36 (36 ksi)
T3 121.00-101.00	60 Angle	V5x5x5/16	A572-50 (50 ksi)	Equal Angle	L2 1/2x2 1/2x3/16	A36 (36 ksi)
T4 101.00-86.00	60 Angle	V5x5x5/16	A572-50 (50 ksi)	Equal Angle	L2 1/2x2 1/2x3/16	A36 (36 ksi)
T5 86.00-66.00	60 Angle	V5x5x5/16	A572-50 (50 ksi)	Equal Angle	L2 1/2x2 1/2x3/16	A36 (36 ksi)
T6 66.00-46.00	60 Angle	V5x5x5/16	A572-50 (50 ksi)	Equal Angle	L2 1/2x2 1/2x3/16	A36 (36 ksi)
T7 46.00-26.00	60 Angle	V5x5x5/16	A572-50 (50 ksi)	Equal Angle	L2 1/2x2 1/2x3/16	A36 (36 ksi)
T8 26.00-6.00	60 Angle	V5x5x5/16	A572-50 (50 ksi)	Equal Angle	L2 1/2x2 1/2x3/16	A36 (36 ksi)
T9 6.00-0.00	60 Angle	V5x5x5/16	A572-50 (50 ksi)	Equal Angle	L2 1/2x2 1/2x3/16	A36 (36 ksi)

Tower Section Geometry (cont'd)

Tower Elevation	No. of Mid Girts	Mid Girt Type	Mid Girt Size	Mid Girt Grade	Horizontal Type	Horizontal Size	Horizontal Grade
ft							
T1 160.00-141.00	None	Flat Bar		A36 (36 ksi)	Equal Angle	L2 1/2x2 1/2x3/16	A36 (36 ksi)
T2 141.00-121.00	None	Flat Bar		A36 (36 ksi)	Equal Angle	L2x2x3/16	A36 (36 ksi)
T3 121.00-101.00	None	Flat Bar		A36 (36 ksi)	Equal Angle	L2x2x3/16	A36 (36 ksi)
T4 101.00-86.00	None	Flat Bar		A36 (36 ksi)	Equal Angle	L2x2x3/16	A36 (36 ksi)
T5 86.00-66.00	None	Flat Bar		A36 (36 ksi)	Equal Angle	L2x2x3/16	A36 (36 ksi)
T6 66.00-46.00	None	Flat Bar		A36 (36 ksi)	Equal Angle	L2x2x3/16	A36 (36 ksi)

tnxTower GPD 520 South Main Street Suite 2531 Akron, Ohio 44311 Phone: (330) 572-2222 FAX: (330) 572-3722	Job	(CT-1188) NORFOLK	Page	7 of 29
	Project	2022703.43	Date	11:55:52 06/16/22
	Client	BST Managment, LLC	Designed by	TDeak

Tower Elevation ft	Redundant Horizontal		Redundant Diagonal		Redundant Sub-Diagonal		Redundant Sub-Horizontal		Redundant Vertical		Redundant Hip		Redundant Hip Diagonal	
	Net Width Deduct in	U	Net Width Deduct in	U	Net Width Deduct in	U	Net Width Deduct in	U	Net Width Deduct in	U	Net Width Deduct in	U	Net Width Deduct in	U
T8 26.00-6.00	0.0000	0.75	0.0000	0.75	0.0000	0.75	0.0000	0.75	0.0000	0.75	0.0000	0.75	0.0000	0.75
T9 6.00-0.00	0.0000	0.75	0.0000	0.75	0.0000	0.75	0.0000	0.75	0.0000	0.75	0.0000	0.75	0.0000	0.75

Tower Section Geometry (cont'd)

Tower Elevation ft	Leg Connection Type	Leg Bolt Size in	Leg No.	Diagonal		Top Girt		Bottom Girt		Mid Girt		Long Horizontal		Short Horizontal	
				Bolt Size in	No.	Bolt Size in	No.	Bolt Size in	No.	Bolt Size in	No.	Bolt Size in	No.	Bolt Size in	No.
T1 160.00-141.00	Sleeve DS	0.6250	12	0.6250	2	0.6250	0	0.6250	0	0.6250	0	0.6250	2	0.6250	0
T2 141.00-121.00	Sleeve DS	0.6250	12	0.6250	1	0.6250	0	0.6250	0	0.6250	0	0.6250	1	0.6250	0
T3 121.00-101.00	Sleeve DS	0.6250	12	0.6250	1	0.6250	0	0.6250	0	0.6250	0	0.6250	1	0.6250	0
T4 101.00-86.00	Sleeve DS	0.6250	12	0.6250	1	0.6250	0	0.6250	0	0.6250	0	0.6250	1	0.6250	0
T5 86.00-66.00	Sleeve DS	0.6250	12	0.6250	1	0.6250	0	0.6250	0	0.6250	0	0.6250	1	0.6250	0
T6 66.00-46.00	Sleeve DS	0.6250	12	0.6250	1	0.6250	0	0.6250	0	0.6250	0	0.6250	1	0.6250	0
T7 46.00-26.00	Sleeve DS	0.6250	12	0.6250	1	0.6250	0	0.6250	0	0.6250	0	0.6250	1	0.6250	0
T8 26.00-6.00	Flange	0.7500	3	0.6250	1	0.6250	0	0.6250	0	0.6250	0	0.6250	1	0.6250	0
T9 6.00-0.00	Flange	0.7500	0	0.6250	0	0.6250	0	0.6250	0	0.6250	0	0.6250	0	0.6250	0

Guy Data

Guy Elevation ft	Guy Grade	Guy Size	Initial Tension K	%	Guy Modulus ksi	Guy Weight plf	L _u ft	Anchor Radius ft	Anchor Azimuth Adj. °	Anchor Elevation ft	End Fitting Efficiency %
145.75	EHS	A 3/4	5.83	10%	24000	1.155	226.46	162.00	0.0000	-15.00	100%
		B 3/4	5.83	10%	24000	1.155	190.62	131.00	0.0000	5.00	100%
		C 3/4	5.83	10%	24000	1.155	200.40	140.00	0.0000	0.00	100%
86	EHS	A 5/8	4.24	10%	23000	0.813	188.81	162.00	0.0000	-15.00	100%
		B 5/8	4.24	10%	23000	0.813	151.94	131.00	0.0000	5.00	100%
		C 5/8	4.24	10%	23000	0.813	162.22	140.00	0.0000	0.00	100%

Guy Data(cont'd)

tnxTower GPD 520 South Main Street Suite 2531 Akron, Ohio 44311 Phone: (330) 572-2222 FAX: (330) 572-3722	Job	(CT-1188) NORFOLK	Page	8 of 29
	Project	2022703.43	Date	11:55:52 06/16/22
	Client	BST Management, LLC	Designed by	TDeak

Guy Elevation ft	Mount Type	Torque-Arm Spread ft	Torque-Arm Leg Angle °	Torque-Arm Style	Torque-Arm Grade	Torque-Arm Type	Torque-Arm Size
145.75	Torque Arm	8.00	30.0000	Dog Ear	A36 (36 ksi)	Double Angle	2L2 1/2x2x1/4 2L3x2 1/2x1/4
86	Corner						

Guy Data (cont'd)

Guy Elevation ft	Diagonal Grade	Diagonal Type	Upper Diagonal Size	Lower Diagonal Size	Is Strap.	Pull-Off Grade	Pull-Off Type	Pull-Off Size
145.75	A572-50 (50 ksi)	Solid Round			No	A36 (36 ksi)	Equal Angle	L2 1/2x2 1/2x3/16
86.00	A572-50 (50 ksi)	Solid Round			No	A36 (36 ksi)	Equal Angle	L 2 x 2 x 3/16

Guy Data (cont'd)

Guy Elevation ft	Cable Weight A K	Cable Weight B K	Cable Weight C K	Cable Weight D K	Tower Intercept A ft	Tower Intercept B ft	Tower Intercept C ft	Tower Intercept D ft
145.75	0.26	0.22	0.23		5.00	3.55	3.92	
86	0.15	0.12	0.13		3.9 sec/pulse	3.3 sec/pulse	3.4 sec/pulse	
					3.39	2.20	2.50	
					3.2 sec/pulse	2.6 sec/pulse	2.7 sec/pulse	

Guy Data (cont'd)

Guy Elevation ft	Calc K Single Angles	Calc K Solid Rounds	Torque Arm		Pull Off		Diagonal	
			K _x	K _y	K _x	K _y	K _x	K _y
145.75	No	No	1	1	1	1	1	1
86	No	No			1	1	1	1

Guy Data (cont'd)

Guy Elevation ft	Torque-Arm				Pull Off				Diagonal			
	Bolt Size in	Number	Net Width Deduct in	U	Bolt Size in	Number	Net Width Deduct in	U	Bolt Size in	Number	Net Width Deduct in	U
145.75	0.0000 A325N	0	0.0000	1	0.6250 A325N	0	0.0000	0.75	0.6250 A325N	0	0.0000	0.75

tnxTower GPD 520 South Main Street Suite 2531 Akron, Ohio 44311 Phone: (330) 572-2222 FAX: (330) 572-3722	Job	(CT-1188) NORFOLK	Page	9 of 29
	Project	2022703.43	Date	11:55:52 06/16/22
	Client	BST Management, LLC	Designed by	TDeak

Guy Elevation ft	Torque-Arm				Pull Off				Diagonal			
	Bolt Size in	Number	Net Width Deduct in	U	Bolt Size in	Number	Net Width Deduct in	U	Bolt Size in	Number	Net Width Deduct in	U
86	0.6250 A325N	0	0.0000	0.75	0.6250 A325N	0	0.0000	0.75	0.6250 A325N	0	0.0000	0.75

Guy Pressures

Guy Elevation ft	Guy Location	z ft	q _z psf	q _z Ice psf	Ice Thickness in
145.75	A	65.38	25	3	1.0708
	B	75.38	26	3	1.0861
	C	72.88	26	3	1.0824
86	A	35.50	21	3	1.0073
	B	45.50	22	3	1.0326
	C	43.00	22	3	1.0268

Feed Line/Linear Appurtenances - Entered As Round Or Flat

Description	Face or Leg	Allow Shield	Exclude From Torque Calculation	Component Type	Placement ft	Face Offset in	Lateral Offset (Frac FW)	#	# Per Row	Clear Spacing in	Width or Diameter in	Perimeter in	Weight plf
Climbing Ladder	B	No	No	Af (CaAa)	160.00 - 8.00	-2.0000	0	1	1	1.0000	3.8400		7.90
LDF5-50A (7/8 FOAM)	A	No	No	Ar (CaAa)	160.00 - 8.00	-2.0000	-0.35	1	1	1.0000	1.0900		0.33
Coax Bracket 5/20' x 12"	A	No	No	Af (CaAa)	160.00 - 8.00	0.0000	0	1	1	0.5000	0.5000		0.43
Hybriflex (1-1/4")	A	No	No	Ar (CaAa)	158.00 - 8.00	0.0000	-0.15	3	3	0.5000	1.5400		1.30
LDF4-50A (1/2 FOAM)	A	No	No	Ar (CaAa)	148.00 - 8.00	-2.0000	0.1	1	1	0.0000	0.6300		0.15
LDF7-50A (1-5/8 FOAM)	B	No	No	Ar (CaAa)	142.00 - 8.00	0.0000	0.4	6	3	1.0000	1.9800		0.82
1.5" DC/Fiber Bundle	B	No	No	Ar (CaAa)	142.00 - 8.00	0.0000	0.3	1	1	1.0000	1.5000		0.80
1.5" DC/Fiber Bundle	B	No	No	Ar (CaAa)	142.00 - 8.00	0.0000	0.3	2	2	1.0000	1.5000		0.80
LDF7-50A (1-5/8 FOAM)	B	No	No	Ar (CaAa)	142.00 - 8.00	0.0000	-0.4	6	3	1.0000	1.9800		0.82
1.99" Hybrid Cable	C	No	No	Ar (CaAa)	120.00 - 8.00	0.0000	0	3	3	1.0000	1.9900		0.32
Coax Bracket 5/20' x 12"	C	No	No	Af (CaAa)	120.00 - 8.00	0.0000	0	1	1	0.5000	0.5000		0.43
3/8" RET Cable	C	No	No	Ar (CaAa)	120.00 - 8.00	0.0000	0.1	1	1	0.3750	0.3750		0.10
LDF1-50A (1/4 FOAM)	A	No	No	Ar (CaAa)	75.00 - 8.00	0.0000	-0.075	1	1	0.3500	0.3500		0.06
LDF4-50A (1/2 FOAM)	B	No	No	Ar (CaAa)	13.00 - 8.00	0.0000	-0.25	1	1	0.6300	0.6300		0.15

tnxTower GPD 520 South Main Street Suite 2531 Akron, Ohio 44311 Phone: (330) 572-2222 FAX: (330) 572-3722	Job (CT-1188) NORFOLK	Page 10 of 29
	Project 2022703.43	Date 11:55:52 06/16/22
	Client BST Managment, LLC	Designed by TDeak

Feed Line/Linear Appurtenances Section Areas

Tower Section	Tower Elevation ft	Face	A_R ft ²	A_F ft ²	C_{AA} In Face ft ²	C_{AA} Out Face ft ²	Weight K
T1	160.00-141.00	A	0.000	0.000	11.949	0.000	0.08
		B	0.000	0.000	14.986	0.000	0.16
		C	0.000	0.000	0.000	0.000	0.00
T2	141.00-121.00	A	0.000	0.000	14.347	0.000	0.10
		B	0.000	0.000	69.320	0.000	0.40
		C	0.000	0.000	0.000	0.000	0.00
T3	121.00-101.00	A	0.000	0.000	14.347	0.000	0.10
		B	0.000	0.000	69.320	0.000	0.40
		C	0.000	0.000	13.639	0.000	0.03
T4	101.00-86.00	A	0.000	0.000	10.760	0.000	0.07
		B	0.000	0.000	51.990	0.000	0.30
		C	0.000	0.000	10.768	0.000	0.02
T5	86.00-66.00	A	0.000	0.000	14.662	0.000	0.10
		B	0.000	0.000	69.320	0.000	0.40
		C	0.000	0.000	14.357	0.000	0.03
T6	66.00-46.00	A	0.000	0.000	15.047	0.000	0.10
		B	0.000	0.000	69.320	0.000	0.40
		C	0.000	0.000	14.357	0.000	0.03
T7	46.00-26.00	A	0.000	0.000	15.047	0.000	0.10
		B	0.000	0.000	69.320	0.000	0.40
		C	0.000	0.000	14.357	0.000	0.03
T8	26.00-6.00	A	0.000	0.000	13.542	0.000	0.09
		B	0.000	0.000	62.703	0.000	0.36
		C	0.000	0.000	12.921	0.000	0.03
T9	6.00-0.00	A	0.000	0.000	0.000	0.000	0.00
		B	0.000	0.000	0.000	0.000	0.00
		C	0.000	0.000	0.000	0.000	0.00

Feed Line/Linear Appurtenances Section Areas - With Ice

Tower Section	Tower Elevation ft	Face or Leg	Ice Thickness in	A_R ft ²	A_F ft ²	C_{AA} In Face ft ²	C_{AA} Out Face ft ²	Weight K
T1	160.00-141.00	A	1.164	0.000	0.000	33.353	0.000	0.36
		B		0.000	0.000	21.038	0.000	0.36
		C		0.000	0.000	0.000	0.000	0.00
T2	141.00-121.00	A	1.148	0.000	0.000	40.871	0.000	0.43
		B		0.000	0.000	106.093	0.000	1.56
		C		0.000	0.000	0.000	0.000	0.00
T3	121.00-101.00	A	1.129	0.000	0.000	40.518	0.000	0.42
		B		0.000	0.000	105.550	0.000	1.55
		C		0.000	0.000	37.179	0.000	0.34
T4	101.00-86.00	A	1.110	0.000	0.000	30.120	0.000	0.31
		B		0.000	0.000	78.748	0.000	1.15
		C		0.000	0.000	29.143	0.000	0.26
T5	86.00-66.00	A	1.087	0.000	0.000	42.006	0.000	0.42
		B		0.000	0.000	104.342	0.000	1.51
		C		0.000	0.000	38.526	0.000	0.34
T6	66.00-46.00	A	1.054	0.000	0.000	44.042	0.000	0.43
		B		0.000	0.000	103.400	0.000	1.48
		C		0.000	0.000	38.051	0.000	0.33
T7	46.00-26.00	A	1.009	0.000	0.000	43.010	0.000	0.41
		B		0.000	0.000	102.089	0.000	1.45
		C		0.000	0.000	37.390	0.000	0.32

tnxTower GPD 520 South Main Street Suite 2531 Akron, Ohio 44311 Phone: (330) 572-2222 FAX: (330) 572-3722	Job	(CT-1188) NORFOLK	Page	11 of 29
	Project	2022703.43	Date	11:55:52 06/16/22
	Client	BST Managment, LLC	Designed by	TDeak

Tower Section	Tower Elevation ft	Face or Leg	Ice Thickness in	A_R ft ²	A_F ft ²	C_{AA} In Face ft ²	C_{AA} Out Face ft ²	Weight K
T8	26.00-6.00	A	0.930	0.000	0.000	37.108	0.000	0.34
		B		0.000	0.000	91.088	0.000	1.25
		C		0.000	0.000	32.627	0.000	0.26
T9	6.00-0.00	A	0.787	0.000	0.000	0.000	0.000	0.00
		B		0.000	0.000	0.000	0.000	0.00
		C		0.000	0.000	0.000	0.000	0.00

Feed Line Center of Pressure

Section	Elevation ft	CP_x in	CP_z in	CP_x Ice in	CP_z Ice in
T1	160.00-141.00	-0.4527	-0.5364	-1.3289	-0.5921
T2	141.00-121.00	3.2278	-1.9895	3.0813	-1.6290
T3	121.00-101.00	2.9405	-1.3311	2.5491	-0.2147
T4	101.00-86.00	2.9267	-1.2978	2.5319	-0.1583
T5	86.00-66.00	2.8938	-1.3032	2.3878	-0.2078
T6	66.00-46.00	2.8538	-1.3097	2.2217	-0.2692
T7	46.00-26.00	2.8538	-1.3097	2.2422	-0.2977
T8	26.00-6.00	2.6870	-1.2725	2.1776	-0.4321
T9	6.00-0.00	0.0000	0.0000	0.0000	0.0000

Shielding Factor Ka

Tower Section	Feed Line Record No.	Description	Feed Line Segment Elev.	K_a No Ice	K_a Ice
T1	1	Climbing Ladder	141.00 - 160.00	0.6000	0.5703
T1	2	LDF5-50A (7/8 FOAM)	141.00 - 160.00	0.6000	0.5703
T1	3	Coax Bracket 5/20' x 12"	141.00 - 160.00	0.6000	0.5703
T1	4	Hybriflex (1-1/4")	141.00 - 158.00	0.6000	0.5703
T1	5	LDF4-50A (1/2 FOAM)	141.00 - 148.00	0.0000	0.0000
T1	6	LDF7-50A (1-5/8 FOAM)	141.00 - 142.00	0.6000	0.5703
T1	7	1.5" DC/Fiber Bundle	141.00 - 142.00	0.6000	0.5703
T1	8	1.5" DC/Fiber Bundle	141.00 - 142.00	0.6000	0.5703
T1	9	LDF7-50A (1-5/8 FOAM)	141.00 - 142.00	0.6000	0.5703
T2	1	Climbing Ladder	121.00 - 141.00	0.6000	0.5841
T2	2	LDF5-50A (7/8 FOAM)	121.00 - 141.00	0.6000	0.5841
T2	3	Coax Bracket 5/20' x 12"	121.00 - 141.00	0.6000	0.5841
T2	4	Hybriflex (1-1/4")	121.00 -	0.6000	0.5841

tnxTower GPD 520 South Main Street Suite 2531 Akron, Ohio 44311 Phone: (330) 572-2222 FAX: (330) 572-3722	Job (CT-1188) NORFOLK	Page 12 of 29
	Project 2022703.43	Date 11:55:52 06/16/22
	Client BST Managment, LLC	Designed by TDeak

Tower Section	Feed Line Record No.	Description	Feed Line Segment Elev.	K _a No Ice	K _a Ice
			141.00		
T2	5	LDF4-50A (1/2 FOAM)	121.00 - 141.00	0.0000	0.0000
T2	6	LDF7-50A (1-5/8 FOAM)	121.00 - 141.00	0.6000	0.5841
T2	7	1.5" DC/Fiber Bundle	121.00 - 141.00	0.6000	0.5841
T2	8	1.5" DC/Fiber Bundle	121.00 - 141.00	0.6000	0.5841
T2	9	LDF7-50A (1-5/8 FOAM)	121.00 - 141.00	0.6000	0.5841
T3	1	Climbing Ladder	101.00 - 121.00	0.6000	0.5864
T3	2	LDF5-50A (7/8 FOAM)	101.00 - 121.00	0.6000	0.5864
T3	3	Coax Bracket 5/20' x 12"	101.00 - 121.00	0.6000	0.5864
T3	4	Hybriflex (1-1/4")	101.00 - 121.00	0.6000	0.5864
T3	5	LDF4-50A (1/2 FOAM)	101.00 - 121.00	0.0000	0.0000
T3	6	LDF7-50A (1-5/8 FOAM)	101.00 - 121.00	0.6000	0.5864
T3	7	1.5" DC/Fiber Bundle	101.00 - 121.00	0.6000	0.5864
T3	8	1.5" DC/Fiber Bundle	101.00 - 121.00	0.6000	0.5864
T3	9	LDF7-50A (1-5/8 FOAM)	101.00 - 121.00	0.6000	0.5864
T3	10	1.99" Hybrid Cable	101.00 - 120.00	0.6000	0.5864
T3	11	Coax Bracket 5/20' x 12"	101.00 - 120.00	0.6000	0.5864
T3	12	3/8" RET Cable	101.00 - 120.00	0.6000	0.5864
T4	1	Climbing Ladder	86.00 - 101.00	0.6000	0.5888
T4	2	LDF5-50A (7/8 FOAM)	86.00 - 101.00	0.6000	0.5888
T4	3	Coax Bracket 5/20' x 12"	86.00 - 101.00	0.6000	0.5888
T4	4	Hybriflex (1-1/4")	86.00 - 101.00	0.6000	0.5888
T4	5	LDF4-50A (1/2 FOAM)	86.00 - 101.00	0.0000	0.0000
T4	6	LDF7-50A (1-5/8 FOAM)	86.00 - 101.00	0.6000	0.5888
T4	7	1.5" DC/Fiber Bundle	86.00 - 101.00	0.6000	0.5888
T4	8	1.5" DC/Fiber Bundle	86.00 - 101.00	0.6000	0.5888
T4	9	LDF7-50A (1-5/8 FOAM)	86.00 - 101.00	0.6000	0.5888
T4	10	1.99" Hybrid Cable	86.00 - 101.00	0.6000	0.5888
T4	11	Coax Bracket 5/20' x 12"	86.00 - 101.00	0.6000	0.5888
T4	12	3/8" RET Cable	86.00 - 101.00	0.6000	0.5888
T5	1	Climbing Ladder	66.00 - 86.00	0.6000	0.5916
T5	2	LDF5-50A (7/8 FOAM)	66.00 - 86.00	0.6000	0.5916
T5	3	Coax Bracket 5/20' x 12"	66.00 - 86.00	0.6000	0.5916
T5	4	Hybriflex (1-1/4")	66.00 - 86.00	0.6000	0.5916
T5	5	LDF4-50A (1/2 FOAM)	66.00 - 86.00	0.0000	0.0000
T5	6	LDF7-50A (1-5/8 FOAM)	66.00 - 86.00	0.6000	0.5916
T5	7	1.5" DC/Fiber Bundle	66.00 - 86.00	0.6000	0.5916
T5	8	1.5" DC/Fiber Bundle	66.00 - 86.00	0.6000	0.5916
T5	9	LDF7-50A (1-5/8 FOAM)	66.00 - 86.00	0.6000	0.5916
T5	10	1.99" Hybrid Cable	66.00 - 86.00	0.6000	0.5916
T5	11	Coax Bracket 5/20' x 12"	66.00 - 86.00	0.6000	0.5916
T5	12	3/8" RET Cable	66.00 - 86.00	0.6000	0.5916
T5	13	LDF1-50A (1/4 FOAM)	66.00 - 75.00	0.6000	0.5916
T6	1	Climbing Ladder	46.00 - 66.00	0.6000	0.5957
T6	2	LDF5-50A (7/8 FOAM)	46.00 - 66.00	0.6000	0.5957

tnxTower GPD 520 South Main Street Suite 2531 Akron, Ohio 44311 Phone: (330) 572-2222 FAX: (330) 572-3722	Job (CT-1188) NORFOLK	Page 13 of 29
	Project 2022703.43	Date 11:55:52 06/16/22
	Client BST Managment, LLC	Designed by TDeak

Tower Section	Feed Line Record No.	Description	Feed Line Segment Elev.	K_a No Ice	K_a Ice
T6	3	Coax Bracket 5/20' x 12"	46.00 - 66.00	0.6000	0.5957
T6	4	Hybriflex (1-1/4")	46.00 - 66.00	0.6000	0.5957
T6	5	LDF4-50A (1/2 FOAM)	46.00 - 66.00	0.0000	0.0000
T6	6	LDF7-50A (1-5/8 FOAM)	46.00 - 66.00	0.6000	0.5957
T6	7	1.5" DC/Fiber Bundle	46.00 - 66.00	0.6000	0.5957
T6	8	1.5" DC/Fiber Bundle	46.00 - 66.00	0.6000	0.5957
T6	9	LDF7-50A (1-5/8 FOAM)	46.00 - 66.00	0.6000	0.5957
T6	10	1.99" Hybrid Cable	46.00 - 66.00	0.6000	0.5957
T6	11	Coax Bracket 5/20' x 12"	46.00 - 66.00	0.6000	0.5957
T6	12	3/8" RET Cable	46.00 - 66.00	0.6000	0.5957
T6	13	LDF1-50A (1/4 FOAM)	46.00 - 66.00	0.6000	0.5957
T7	1	Climbing Ladder	26.00 - 46.00	0.6000	0.6000
T7	2	LDF5-50A (7/8 FOAM)	26.00 - 46.00	0.6000	0.6000
T7	3	Coax Bracket 5/20' x 12"	26.00 - 46.00	0.6000	0.6000
T7	4	Hybriflex (1-1/4")	26.00 - 46.00	0.6000	0.6000
T7	5	LDF4-50A (1/2 FOAM)	26.00 - 46.00	0.0000	0.0000
T7	6	LDF7-50A (1-5/8 FOAM)	26.00 - 46.00	0.6000	0.6000
T7	7	1.5" DC/Fiber Bundle	26.00 - 46.00	0.6000	0.6000
T7	8	1.5" DC/Fiber Bundle	26.00 - 46.00	0.6000	0.6000
T7	9	LDF7-50A (1-5/8 FOAM)	26.00 - 46.00	0.6000	0.6000
T7	10	1.99" Hybrid Cable	26.00 - 46.00	0.6000	0.6000
T7	11	Coax Bracket 5/20' x 12"	26.00 - 46.00	0.6000	0.6000
T7	12	3/8" RET Cable	26.00 - 46.00	0.6000	0.6000
T7	13	LDF1-50A (1/4 FOAM)	26.00 - 46.00	0.6000	0.6000
T8	1	Climbing Ladder	8.00 - 26.00	0.6000	0.6000
T8	2	LDF5-50A (7/8 FOAM)	8.00 - 26.00	0.6000	0.6000
T8	3	Coax Bracket 5/20' x 12"	8.00 - 26.00	0.6000	0.6000
T8	4	Hybriflex (1-1/4")	8.00 - 26.00	0.6000	0.6000
T8	5	LDF4-50A (1/2 FOAM)	8.00 - 26.00	0.0000	0.0000
T8	6	LDF7-50A (1-5/8 FOAM)	8.00 - 26.00	0.6000	0.6000
T8	7	1.5" DC/Fiber Bundle	8.00 - 26.00	0.6000	0.6000
T8	8	1.5" DC/Fiber Bundle	8.00 - 26.00	0.6000	0.6000
T8	9	LDF7-50A (1-5/8 FOAM)	8.00 - 26.00	0.6000	0.6000
T8	10	1.99" Hybrid Cable	8.00 - 26.00	0.6000	0.6000
T8	11	Coax Bracket 5/20' x 12"	8.00 - 26.00	0.6000	0.6000
T8	12	3/8" RET Cable	8.00 - 26.00	0.6000	0.6000
T8	13	LDF1-50A (1/4 FOAM)	8.00 - 26.00	0.6000	0.6000
T8	14	LDF4-50A (1/2 FOAM)	8.00 - 13.00	0.6000	0.6000

Discrete Tower Loads

Description	Face or Leg	Offset Type	Offsets: Horz Lateral	Azimuth Adjustment	Placement	C_{AA} Front	C_{AA} Side	Weight
			ft ft ft	°	ft	ft ²	ft ²	K
10' Dipole	A	From Leg	0.50 0.00 8.00	0.0000	160.00	No Ice 1/2" Ice 1" Ice	2.00 3.02 4.07	0.02 0.04 0.06
Pipe Mount 3'x2.375"	A	From Leg	0.25 0.00 1.50	0.0000	160.00	No Ice 1/2" Ice 1" Ice	0.58 0.77 0.97	0.01 0.02 0.02
3' Omni	B	From Face	0.50	0.0000	160.00	No Ice	0.52	0.02

tnxTower GPD 520 South Main Street Suite 2531 Akron, Ohio 44311 Phone: (330) 572-2222 FAX: (330) 572-3722	Job	(CT-1188) NORFOLK	Page	14 of 29
	Project	2022703.43	Date	11:55:52 06/16/22
	Client	BST Managment, LLC	Designed by	TDeak

Description	Face or Leg	Offset Type	Offsets:		Azimuth Adjustment	Placement	C _{AA} Front	C _{AA} Side	Weight	
			Horz Lateral	Vert						°
			0.00				1/2" Ice	0.71	0.71	0.02
			0.00				1" Ice	0.90	0.90	0.03
Rohn 12' Boom Gate	A	From Leg	1.29	50.0000	158.00		No Ice	15.35	14.00	0.56
			1.53				1/2" Ice	21.29	20.81	0.74
			0.00				1" Ice	27.23	27.62	0.92
Rohn 12' Boom Gate	B	From Leg	1.29	50.0000	158.00		No Ice	15.35	14.00	0.56
			1.53				1/2" Ice	21.29	20.81	0.74
			0.00				1" Ice	27.23	27.62	0.92
Rohn 12' Boom Gate	C	From Leg	1.29	50.0000	158.00		No Ice	15.35	14.00	0.56
			1.53				1/2" Ice	21.29	20.81	0.74
			0.00				1" Ice	27.23	27.62	0.92
APXVSPP18-C-A20 w/ Mount Pipe	A	From Leg	2.57	70.0000	158.00		No Ice	8.02	6.71	0.08
			3.05				1/2" Ice	8.48	7.66	0.14
			0.00				1" Ice	8.94	8.49	0.22
APXVSPP18-C-A20 w/ Mount Pipe	B	From Leg	2.57	70.0000	158.00		No Ice	8.02	6.71	0.08
			3.05				1/2" Ice	8.48	7.66	0.14
			0.00				1" Ice	8.94	8.49	0.22
APXVSPP18-C-A20 w/ Mount Pipe	C	From Leg	2.57	30.0000	158.00		No Ice	8.02	6.71	0.08
			3.05				1/2" Ice	8.48	7.66	0.14
			0.00				1" Ice	8.94	8.49	0.22
800MHz 2x50w	A	From Leg	0.50	0.0000	154.00		No Ice	2.49	2.07	0.05
			0.00				1/2" Ice	2.71	2.27	0.07
			0.00				1" Ice	2.93	2.48	0.10
800MHz 2x50w	B	From Leg	0.50	0.0000	154.00		No Ice	2.49	2.07	0.05
			0.00				1/2" Ice	2.71	2.27	0.07
			0.00				1" Ice	2.93	2.48	0.10
800MHz 2x50w	C	From Leg	0.50	0.0000	154.00		No Ice	2.49	2.07	0.05
			0.00				1/2" Ice	2.71	2.27	0.07
			0.00				1" Ice	2.93	2.48	0.10
1900MHz 2x40w	A	From Leg	0.50	0.0000	154.00		No Ice	2.49	3.06	0.09
			0.00				1/2" Ice	2.71	3.30	0.12
			0.00				1" Ice	2.93	3.54	0.15
1900MHz 2x40w	B	From Leg	0.50	0.0000	154.00		No Ice	2.49	3.06	0.09
			0.00				1/2" Ice	2.71	3.30	0.12
			0.00				1" Ice	2.93	3.54	0.15
1900MHz 2x40w	C	From Leg	0.50	0.0000	154.00		No Ice	2.49	3.06	0.09
			0.00				1/2" Ice	2.71	3.30	0.12
			0.00				1" Ice	2.93	3.54	0.15
800MHz 2x50w Notch Filter	A	From Leg	0.50	0.0000	154.00		No Ice	0.85	0.37	0.01
			0.00				1/2" Ice	0.97	0.46	0.02
			0.00				1" Ice	1.11	0.56	0.03
800MHz 2x50w Notch Filter	B	From Leg	0.50	0.0000	154.00		No Ice	0.85	0.37	0.01
			0.00				1/2" Ice	0.97	0.46	0.02
			0.00				1" Ice	1.11	0.56	0.03
800MHz 2x50w Notch Filter	C	From Leg	0.50	0.0000	154.00		No Ice	0.85	0.37	0.01
			0.00				1/2" Ice	0.97	0.46	0.02
			0.00				1" Ice	1.11	0.56	0.03
4' Yagi	B	From Face	6.50	0.0000	148.00		No Ice	0.79	0.79	0.01
			0.00				1/2" Ice	1.03	1.03	0.01
			0.00				1" Ice	1.28	1.28	0.02
Pipe Mount 4'x2.375"	B	From Face	6.00	0.0000	148.00		No Ice	0.87	0.87	0.02
			0.00				1/2" Ice	1.11	1.11	0.03
			0.00				1" Ice	1.36	1.36	0.04

8' Frame	A	From Leg	0.48	50.0000	142.00		No Ice	14.48	3.61	0.31
			0.57				1/2" Ice	18.67	4.62	0.45
			0.00				1" Ice	22.86	5.62	0.60

tnxTower GPD 520 South Main Street Suite 2531 Akron, Ohio 44311 Phone: (330) 572-2222 FAX: (330) 572-3722	Job		(CT-1188) NORFOLK		Page		15 of 29	
	Project		2022703.43		Date		11:55:52 06/16/22	
	Client		BST Managment, LLC		Designed by		TDeak	

Description	Face or Leg	Offset Type	Offsets:		Azimuth Adjustment	Placement	C _{AA}		Weight
			Horz	Vert			Front	Side	
			ft	ft	°	ft	ft ²	ft ²	K
8' Frame	B	From Leg	0.48	50.0000	142.00	No Ice	14.48	3.61	0.31
			0.57			1/2" Ice	18.67	4.62	0.45
			0.00			1" Ice	22.86	5.62	0.60
8' Frame	C	From Leg	0.48	50.0000	142.00	No Ice	14.48	3.61	0.31
			0.57			1/2" Ice	18.67	4.62	0.45
			0.00			1" Ice	22.86	5.62	0.60
AM-X-CD-16-65-00T w/ Mount Pipe	A	From Leg	0.96	43.0000	142.00	No Ice	8.55	6.65	0.09
			1.15			1/2" Ice	9.18	7.68	0.16
			1.00			1" Ice	9.79	8.56	0.23
AM-X-CD-16-65-00T w/ Mount Pipe	B	From Leg	0.96	43.0000	142.00	No Ice	8.55	6.65	0.09
			1.15			1/2" Ice	9.18	7.68	0.16
			1.00			1" Ice	9.79	8.56	0.23
AM-X-CD-16-65-00T w/ Mount Pipe	C	From Leg	0.96	43.0000	142.00	No Ice	8.55	6.65	0.09
			1.15			1/2" Ice	9.18	7.68	0.16
			1.00			1" Ice	9.79	8.56	0.23
(2) 7770.00 w/Mount Pipe	A	From Leg	0.96	43.0000	142.00	No Ice	5.51	4.10	0.06
			1.15			1/2" Ice	5.87	4.73	0.11
			1.00			1" Ice	6.23	5.37	0.16
(2) 7770.00 w/Mount Pipe	B	From Leg	0.96	43.0000	142.00	No Ice	5.51	4.10	0.06
			1.15			1/2" Ice	5.87	4.73	0.11
			1.00			1" Ice	6.23	5.37	0.16
(2) 7770.00 w/Mount Pipe	C	From Leg	0.96	44.0000	142.00	No Ice	5.51	4.10	0.06
			1.15			1/2" Ice	5.87	4.73	0.11
			1.00			1" Ice	6.23	5.37	0.16
80010965 w/ Mount Pipe	A	From Leg	0.96	43.0000	142.00	No Ice	14.05	7.63	0.13
			1.15			1/2" Ice	14.69	8.90	0.22
			1.00			1" Ice	15.30	9.96	0.33
80010965 w/ Mount Pipe	B	From Leg	0.96	43.0000	142.00	No Ice	14.05	7.63	0.13
			1.15			1/2" Ice	14.69	8.90	0.22
			1.00			1" Ice	15.30	9.96	0.33
80010965 w/ Mount Pipe	C	From Leg	0.96	43.0000	142.00	No Ice	14.05	7.63	0.13
			1.15			1/2" Ice	14.69	8.90	0.22
			1.00			1" Ice	15.30	9.96	0.33
(2) TT19-08BP111-001	A	From Leg	0.96	50.0000	142.00	No Ice	0.55	0.45	0.02
			1.15			1/2" Ice	0.65	0.53	0.02
			1.00			1" Ice	0.75	0.63	0.03
(2) TT19-08BP111-001	B	From Leg	0.96	50.0000	142.00	No Ice	0.55	0.45	0.02
			1.15			1/2" Ice	0.65	0.53	0.02
			1.00			1" Ice	0.75	0.63	0.03
(2) TT19-08BP111-001	C	From Leg	0.96	50.0000	142.00	No Ice	0.55	0.45	0.02
			1.15			1/2" Ice	0.65	0.53	0.02
			1.00			1" Ice	0.75	0.63	0.03
(4) 7020.00 RET	A	From Leg	0.96	50.0000	142.00	No Ice	0.10	0.17	0.00
			1.15			1/2" Ice	0.15	0.24	0.01
			1.00			1" Ice	0.20	0.31	0.01
(4) 7020.00 RET	B	From Leg	0.96	50.0000	142.00	No Ice	0.10	0.17	0.00
			1.15			1/2" Ice	0.15	0.24	0.01
			1.00			1" Ice	0.20	0.31	0.01
(4) 7020.00 RET	C	From Leg	0.96	50.0000	142.00	No Ice	0.10	0.17	0.00
			1.15			1/2" Ice	0.15	0.24	0.01
			1.00			1" Ice	0.20	0.31	0.01
RRUS-11	A	From Leg	0.96	50.0000	142.00	No Ice	2.78	1.19	0.05
			1.15			1/2" Ice	2.99	1.33	0.07
			1.00			1" Ice	3.21	1.49	0.09
RRUS-11	B	From Leg	0.96	50.0000	142.00	No Ice	2.78	1.19	0.05
			1.15			1/2" Ice	2.99	1.33	0.07
			1.00			1" Ice	3.21	1.49	0.09

tnxTower GPD 520 South Main Street Suite 2531 Akron, Ohio 44311 Phone: (330) 572-2222 FAX: (330) 572-3722	Job	(CT-1188) NORFOLK	Page	16 of 29
	Project	2022703.43	Date	11:55:52 06/16/22
	Client	BST Managment, LLC	Designed by	TDeak

Description	Face or Leg	Offset Type	Offsets:		Azimuth Adjustment	Placement	C _{AA} Front	C _{AA} Side	Weight
			Horz	Vert					
			Lateral		°	ft	ft ²	ft ²	K
RRUS-11	C	From Leg	0.96	50.0000	142.00	No Ice	2.78	1.19	0.05
			1.15			1/2" Ice	2.99	1.33	0.07
			1.00			1" Ice	3.21	1.49	0.09
B14 4478	A	From Leg	0.96	50.0000	142.00	No Ice	1.84	1.06	0.06
			1.15			1/2" Ice	2.01	1.20	0.08
			1.00			1" Ice	2.19	1.34	0.09
B14 4478	B	From Leg	0.96	50.0000	142.00	No Ice	1.84	1.06	0.06
			1.15			1/2" Ice	2.01	1.20	0.08
			1.00			1" Ice	2.19	1.34	0.09
B14 4478	C	From Leg	0.96	50.0000	142.00	No Ice	1.84	1.06	0.06
			1.15			1/2" Ice	2.01	1.20	0.08
			1.00			1" Ice	2.19	1.34	0.09
RRUS 32 B2	A	From Leg	0.96	50.0000	142.00	No Ice	2.73	1.67	0.05
			1.15			1/2" Ice	2.95	1.86	0.07
			1.00			1" Ice	3.18	2.05	0.10
RRUS 32 B2	B	From Leg	0.96	50.0000	142.00	No Ice	2.73	1.67	0.05
			1.15			1/2" Ice	2.95	1.86	0.07
			1.00			1" Ice	3.18	2.05	0.10
RRUS 32 B2	C	From Leg	0.96	50.0000	142.00	No Ice	2.73	1.67	0.05
			1.15			1/2" Ice	2.95	1.86	0.07
			1.00			1" Ice	3.18	2.05	0.10
ABT-DFDM-ADBH	A	From Leg	0.96	50.0000	142.00	No Ice	0.02	0.04	0.00
			1.15			1/2" Ice	0.04	0.08	0.00
			1.00			1" Ice	0.07	0.11	0.00
ABT-DFDM-ADBH	B	From Leg	0.96	50.0000	142.00	No Ice	0.02	0.04	0.00
			1.15			1/2" Ice	0.04	0.08	0.00
			1.00			1" Ice	0.07	0.11	0.00

4' Sidearm - Flat (GPD)	B	From Leg	2.00	0.0000	137.00	No Ice	0.80	3.20	0.06
			0.00			1/2" Ice	1.05	4.00	0.07
			0.00			1" Ice	1.30	4.80	0.09
4' Sidearm - Flat (GPD)	C	From Leg	2.00	0.0000	137.00	No Ice	0.80	3.20	0.06
			0.00			1/2" Ice	1.05	4.00	0.07
			0.00			1" Ice	1.30	4.80	0.09

SITE PRO 1 VFA12-HD (3)	A	None		0.0000	120.00	No Ice	25.20	25.20	1.97
						1/2" Ice	38.36	38.36	2.41
						1" Ice	51.52	51.52	2.85
AIR6419 w/ Mount Pipe	A	From Leg	4.00	60.0000	120.00	No Ice	5.29	3.96	0.11
			0.00			1/2" Ice	6.13	4.98	0.16
			0.00			1" Ice	6.73	5.67	0.22
AIR6419 w/ Mount Pipe	B	From Leg	4.00	70.0000	120.00	No Ice	5.29	3.96	0.11
			0.00			1/2" Ice	6.13	4.98	0.16
			0.00			1" Ice	6.73	5.67	0.22
AIR6419 w/ Mount Pipe	C	From Leg	4.00	40.0000	120.00	No Ice	5.29	3.96	0.11
			0.00			1/2" Ice	6.13	4.98	0.16
			0.00			1" Ice	6.73	5.67	0.22
APXVAALL24_43-U-NA20 w/ Mount Pipe	A	From Leg	4.00	60.0000	120.00	No Ice	20.24	10.63	0.18
			0.00			1/2" Ice	20.89	12.06	0.31
			0.00			1" Ice	21.55	13.34	0.46
APXVAALL24_43-U-NA20 w/ Mount Pipe	B	From Leg	4.00	70.0000	120.00	No Ice	20.24	10.63	0.18
			0.00			1/2" Ice	20.89	12.06	0.31
			0.00			1" Ice	21.55	13.34	0.46
APXVAALL24_43-U-NA20 w/ Mount Pipe	C	From Leg	4.00	40.0000	120.00	No Ice	20.24	10.63	0.18
			0.00			1/2" Ice	20.89	12.06	0.31
			0.00			1" Ice	21.55	13.34	0.46
Radio 4480 B71+B85	A	From Leg	4.00	0.0000	120.00	No Ice	2.85	1.38	0.08

tnxTower GPD 520 South Main Street Suite 2531 Akron, Ohio 44311 Phone: (330) 572-2222 FAX: (330) 572-3722	Job	(CT-1188) NORFOLK	Page	17 of 29
	Project	2022703.43	Date	11:55:52 06/16/22
	Client	BST Managment, LLC	Designed by	TDeak

Description	Face or Leg	Offset Type	Offsets:		Azimuth Adjustment	Placement	C _{AA} Front	C _{AA} Side	Weight
			Horz Lateral	Vert					
			ft	ft	°	ft	ft ²	ft ²	K
			0.00			1/2" Ice	3.06	1.54	0.11
			0.00			1" Ice	3.28	1.71	0.13
Radio 4480 B71+B85	B	From Leg	4.00	0.0000	120.00	No Ice	2.85	1.38	0.08
			0.00			1/2" Ice	3.06	1.54	0.11
			0.00			1" Ice	3.28	1.71	0.13
Radio 4480 B71+B85	C	From Leg	4.00	0.0000	120.00	No Ice	2.85	1.38	0.08
			0.00			1/2" Ice	3.06	1.54	0.11
			0.00			1" Ice	3.28	1.71	0.13
Radio 4460 B25+B66	A	From Leg	4.00	0.0000	120.00	No Ice	2.14	1.69	0.11
			0.00			1/2" Ice	2.32	1.85	0.13
			0.00			1" Ice	2.51	2.02	0.16
Radio 4460 B25+B66	B	From Leg	4.00	0.0000	120.00	No Ice	2.14	1.69	0.11
			0.00			1/2" Ice	2.32	1.85	0.13
			0.00			1" Ice	2.51	2.02	0.16
Radio 4460 B25+B66	C	From Leg	4.00	0.0000	120.00	No Ice	2.14	1.69	0.11
			0.00			1/2" Ice	2.32	1.85	0.13
			0.00			1" Ice	2.51	2.02	0.16

GPS-TMG-HR-26NCM	C	From Leg	2.00	0.0000	75.00	No Ice	0.80	0.93	0.03
			0.00			1/2" Ice	1.05	1.17	0.03
			0.00			1" Ice	1.30	1.41	0.04
2' Sidearm - Round (GPD)	C	From Leg	1.00	0.0000	75.00	No Ice	0.80	0.93	0.03
			0.00			1/2" Ice	1.05	1.17	0.03
			0.00			1" Ice	1.30	1.41	0.04
GPS	B	From Leg	1.00	0.0000	13.00	No Ice	0.13	0.13	0.00
			0.00			1/2" Ice	0.21	0.21	0.00
			0.00			1" Ice	0.28	0.28	0.01
1' Sidearm - Flat (GPD)	B	From Leg	0.50	0.0000	13.00	No Ice	0.80	0.80	0.02
			0.00			1/2" Ice	1.05	1.00	0.02
			0.00			1" Ice	1.30	1.20	0.03

Load Combinations

Comb. No.	Description
1	Dead Only
2	1.2 Dead+1.0 Wind 0 deg - No Ice+1.0 Guy
3	1.2D+1.0W (pattern 1) 0 deg - No Ice+1.0 Guy
4	1.2D+1.0W (pattern 2) 0 deg - No Ice+1.0 Guy
5	1.2D+1.0W (pattern 3) 0 deg - No Ice+1.0 Guy
6	1.2 Dead+1.0 Wind 30 deg - No Ice+1.0 Guy
7	1.2D+1.0W (pattern 1) 30 deg - No Ice+1.0 Guy
8	1.2D+1.0W (pattern 2) 30 deg - No Ice+1.0 Guy
9	1.2D+1.0W (pattern 3) 30 deg - No Ice+1.0 Guy
10	1.2 Dead+1.0 Wind 60 deg - No Ice+1.0 Guy
11	1.2D+1.0W (pattern 1) 60 deg - No Ice+1.0 Guy
12	1.2D+1.0W (pattern 2) 60 deg - No Ice+1.0 Guy
13	1.2D+1.0W (pattern 3) 60 deg - No Ice+1.0 Guy
14	1.2 Dead+1.0 Wind 90 deg - No Ice+1.0 Guy
15	1.2D+1.0W (pattern 1) 90 deg - No Ice+1.0 Guy

tnxTower GPD 520 South Main Street Suite 2531 Akron, Ohio 44311 Phone: (330) 572-2222 FAX: (330) 572-3722	Job	(CT-1188) NORFOLK	Page	18 of 29
	Project	2022703.43	Date	11:55:52 06/16/22
	Client	BST Managment, LLC	Designed by	TDeak

<i>Comb. No.</i>	<i>Description</i>
16	1.2D+1.0W (pattern 2) 90 deg - No Ice+1.0 Guy
17	1.2D+1.0W (pattern 3) 90 deg - No Ice+1.0 Guy
18	1.2 Dead+1.0 Wind 120 deg - No Ice+1.0 Guy
19	1.2D+1.0W (pattern 1) 120 deg - No Ice+1.0 Guy
20	1.2D+1.0W (pattern 2) 120 deg - No Ice+1.0 Guy
21	1.2D+1.0W (pattern 3) 120 deg - No Ice+1.0 Guy
22	1.2 Dead+1.0 Wind 150 deg - No Ice+1.0 Guy
23	1.2D+1.0W (pattern 1) 150 deg - No Ice+1.0 Guy
24	1.2D+1.0W (pattern 2) 150 deg - No Ice+1.0 Guy
25	1.2D+1.0W (pattern 3) 150 deg - No Ice+1.0 Guy
26	1.2 Dead+1.0 Wind 180 deg - No Ice+1.0 Guy
27	1.2D+1.0W (pattern 1) 180 deg - No Ice+1.0 Guy
28	1.2D+1.0W (pattern 2) 180 deg - No Ice+1.0 Guy
29	1.2D+1.0W (pattern 3) 180 deg - No Ice+1.0 Guy
30	1.2 Dead+1.0 Wind 210 deg - No Ice+1.0 Guy
31	1.2D+1.0W (pattern 1) 210 deg - No Ice+1.0 Guy
32	1.2D+1.0W (pattern 2) 210 deg - No Ice+1.0 Guy
33	1.2D+1.0W (pattern 3) 210 deg - No Ice+1.0 Guy
34	1.2 Dead+1.0 Wind 240 deg - No Ice+1.0 Guy
35	1.2D+1.0W (pattern 1) 240 deg - No Ice+1.0 Guy
36	1.2D+1.0W (pattern 2) 240 deg - No Ice+1.0 Guy
37	1.2D+1.0W (pattern 3) 240 deg - No Ice+1.0 Guy
38	1.2 Dead+1.0 Wind 270 deg - No Ice+1.0 Guy
39	1.2D+1.0W (pattern 1) 270 deg - No Ice+1.0 Guy
40	1.2D+1.0W (pattern 2) 270 deg - No Ice+1.0 Guy
41	1.2D+1.0W (pattern 3) 270 deg - No Ice+1.0 Guy
42	1.2 Dead+1.0 Wind 300 deg - No Ice+1.0 Guy
43	1.2D+1.0W (pattern 1) 300 deg - No Ice+1.0 Guy
44	1.2D+1.0W (pattern 2) 300 deg - No Ice+1.0 Guy
45	1.2D+1.0W (pattern 3) 300 deg - No Ice+1.0 Guy
46	1.2 Dead+1.0 Wind 330 deg - No Ice+1.0 Guy
47	1.2D+1.0W (pattern 1) 330 deg - No Ice+1.0 Guy
48	1.2D+1.0W (pattern 2) 330 deg - No Ice+1.0 Guy
49	1.2D+1.0W (pattern 3) 330 deg - No Ice+1.0 Guy
50	1.2 Dead+1.0 Ice+1.0 Temp+Guy
51	1.2 Dead+1.0 Wind 0 deg+1.0 Ice+1.0 Temp+1.0 Guy
52	1.2 Dead+1.0 Wind 30 deg+1.0 Ice+1.0 Temp+1.0 Guy
53	1.2 Dead+1.0 Wind 60 deg+1.0 Ice+1.0 Temp+1.0 Guy
54	1.2 Dead+1.0 Wind 90 deg+1.0 Ice+1.0 Temp+1.0 Guy
55	1.2 Dead+1.0 Wind 120 deg+1.0 Ice+1.0 Temp+1.0 Guy
56	1.2 Dead+1.0 Wind 150 deg+1.0 Ice+1.0 Temp+1.0 Guy
57	1.2 Dead+1.0 Wind 180 deg+1.0 Ice+1.0 Temp+1.0 Guy
58	1.2 Dead+1.0 Wind 210 deg+1.0 Ice+1.0 Temp+1.0 Guy
59	1.2 Dead+1.0 Wind 240 deg+1.0 Ice+1.0 Temp+1.0 Guy
60	1.2 Dead+1.0 Wind 270 deg+1.0 Ice+1.0 Temp+1.0 Guy
61	1.2 Dead+1.0 Wind 300 deg+1.0 Ice+1.0 Temp+1.0 Guy
62	1.2 Dead+1.0 Wind 330 deg+1.0 Ice+1.0 Temp+1.0 Guy
63	Dead+Wind 0 deg - Service+Guy
64	Dead+Wind 30 deg - Service+Guy
65	Dead+Wind 60 deg - Service+Guy
66	Dead+Wind 90 deg - Service+Guy
67	Dead+Wind 120 deg - Service+Guy
68	Dead+Wind 150 deg - Service+Guy
69	Dead+Wind 180 deg - Service+Guy
70	Dead+Wind 210 deg - Service+Guy
71	Dead+Wind 240 deg - Service+Guy
72	Dead+Wind 270 deg - Service+Guy
73	Dead+Wind 300 deg - Service+Guy
74	Dead+Wind 330 deg - Service+Guy

tnxTower GPD 520 South Main Street Suite 2531 Akron, Ohio 44311 Phone: (330) 572-2222 FAX: (330) 572-3722	Job	(CT-1188) NORFOLK	Page	19 of 29
	Project	2022703.43	Date	11:55:52 06/16/22
	Client	BST Managment, LLC	Designed by	TDeak

Maximum Tower Deflections - Service Wind

Section No.	Elevation ft	Horz. Deflection in	Gov. Load Comb.	Tilt °	Twist °
T1	160 - 141	0.612	63	0.0590	0.0368
T2	141 - 121	0.823	63	0.0606	0.0643
T3	121 - 101	1.015	63	0.0366	0.1047
T4	101 - 86	1.062	63	0.0089	0.1421
T5	86 - 66	1.036	63	0.0068	0.1890
T6	66 - 46	1.036	71	0.0175	0.2165
T7	46 - 26	0.909	71	0.0524	0.2304
T8	26 - 6	0.603	71	0.0910	0.2387
T9	6 - 0	0.149	71	0.1146	0.2368

Critical Deflections and Radius of Curvature - Service Wind

Elevation ft	Appurtenance	Gov. Load Comb.	Deflection in	Tilt °	Twist °	Radius of Curvature ft
160.00	10' Dipole	63	0.612	0.0590	0.0368	Inf
158.00	Rohn 12' Boom Gate	63	0.634	0.0597	0.0393	Inf
154.00	800MHz 2x50w	63	0.679	0.0611	0.0444	871982
148.00	4' Yagi	63	0.745	0.0622	0.0527	435991
145.75	Guy	63	0.770	0.0621	0.0562	367181
142.00	8' Frame	63	0.812	0.0611	0.0625	395859
137.00	4' Sidearm - Flat (GPD)	63	0.867	0.0578	0.0721	137167
120.00	SITE PRO 1 VFA12-HD (3)	63	1.021	0.0350	0.1064	24801
86.00	Guy	63	1.036	0.0068	0.1890	48339
75.00	GPS-TMG-HR-26NCM	71	1.039	0.0096	0.2086	97166
13.00	GPS	71	0.319	0.1071	0.2379	60296

Maximum Tower Deflections - Design Wind

Section No.	Elevation ft	Horz. Deflection in	Gov. Load Comb.	Tilt °	Twist °
T1	160 - 141	2.546	7	0.4371	0.1685
T2	141 - 121	3.444	34	0.4344	0.2152
T3	121 - 101	4.862	34	0.3114	0.3622
T4	101 - 86	5.572	34	0.1397	0.4766
T5	86 - 66	5.698	34	0.0806	0.5712
T6	66 - 46	5.625	34	0.1146	0.6507
T7	46 - 26	4.808	37	0.3013	0.6986
T8	26 - 6	3.124	37	0.4845	0.7262
T9	6 - 0	0.763	37	0.5904	0.7298

Critical Deflections and Radius of Curvature - Design Wind

tnxTower GPD 520 South Main Street Suite 2531 Akron, Ohio 44311 Phone: (330) 572-2222 FAX: (330) 572-3722	Job	(CT-1188) NORFOLK	Page	20 of 29
	Project	2022703.43	Date	11:55:52 06/16/22
	Client	BST Management, LLC	Designed by	TDeak

Elevation	Appurtenance	Gov. Load Comb.	Deflection in	Tilt °	Twist °	Radius of Curvature ft
160.00	10' Dipole	7	2.546	0.4371	0.1685	78730
158.00	Rohn 12' Boom Gate	7	2.604	0.4395	0.1706	78730
154.00	800MHz 2x50w	7	2.721	0.4436	0.1756	65608
148.00	4' Yagi	6	2.975	0.4452	0.1878	32804
145.75	Guy	6	3.084	0.4436	0.1947	27625
142.00	8' Frame	34	3.366	0.4370	0.2101	23356
137.00	4' Sidearm - Flat (GPD)	34	3.754	0.4196	0.2395	22855
120.00	SITE PRO 1 VFA12-HD (3)	34	4.917	0.3029	0.3690	5180
86.00	Guy	34	5.698	0.0806	0.5712	14433
75.00	GPS-TMG-HR-26NCM	34	5.717	0.0869	0.6216	8470
13.00	GPS	37	1.636	0.5567	0.7295	13764

Bolt Design Data

Section No.	Elevation ft	Component Type	Bolt Grade	Bolt Size in	Number Of Bolts	Maximum Load per Bolt K	Allowable Load per Bolt K	Ratio Load Allowable	Allowable Ratio	Criteria
T1	160	Leg	A325N	0.6250	12	3.05	22.75	0.134 ✓	1	Bearing
		Diagonal	A325N	0.6250	2	3.49	14.38	0.243 ✓	1	Member Block Shear
		Horizontal	A325N	0.6250	2	0.29	7.19	0.040 ✓	1	Member Block Shear
T2	141	Leg	A325N	0.6250	12	5.67	22.75	0.249 ✓	1	Bearing
		Diagonal	A325N	0.6250	1	4.88	7.83	0.623 ✓	1	Member Bearing
		Horizontal	A325N	0.6250	1	1.34	6.83	0.196 ✓	1	Member Block Shear
T3	121	Leg	A325N	0.6250	12	5.38	22.75	0.237 ✓	1	Bearing
		Diagonal	A325N	0.6250	1	3.41	7.83	0.435 ✓	1	Member Bearing
		Horizontal	A325N	0.6250	1	1.32	6.83	0.193 ✓	1	Member Block Shear
T4	101	Leg	A325N	0.6250	12	4.25	22.75	0.187 ✓	1	Bearing
		Diagonal	A325N	0.6250	1	4.49	7.83	0.574 ✓	1	Member Bearing
		Horizontal	A325N	0.6250	1	2.66	6.83	0.389 ✓	1	Member Block Shear
T5	86	Leg	A325N	0.6250	12	6.27	22.75	0.275 ✓	1	Bearing
		Diagonal	A325N	0.6250	1	3.71	7.83	0.474 ✓	1	Member Bearing
		Horizontal	A325N	0.6250	1	0.80	6.83	0.117 ✓	1	Member Block Shear
T6	66	Leg	A325N	0.6250	12	7.35	22.75	0.323 ✓	1	Bearing
		Diagonal	A325N	0.6250	1	3.07	13.05	0.235 ✓	1	Member Bearing
		Horizontal	A325N	0.6250	1	0.85	6.83	0.125 ✓	1	Member Block Shear
T7	46	Leg	A325N	0.6250	12	6.79	22.75	0.298 ✓	1	Bearing
		Diagonal	A325N	0.6250	1	2.91	13.05	0.223 ✓	1	Member Bearing
		Horizontal	A325N	0.6250	1	0.89	6.83	0.130 ✓	1	Member Block Shear
T8	26	Leg	A325N	0.7500	3	3.95	30.10	0.131 ✓	1	Bolt Tension
		Diagonal	A325N	0.6250	1	3.60	7.83	0.459 ✓	1	Member Bearing

tnxTower GPD 520 South Main Street Suite 2531 Akron, Ohio 44311 Phone: (330) 572-2222 FAX: (330) 572-3722	Job	(CT-1188) NORFOLK	Page	21 of 29
	Project	2022703.43	Date	11:55:52 06/16/22
	Client	BST Managment, LLC	Designed by	TDeak

Section No.	Elevation ft	Component Type	Bolt Grade	Bolt Size in	Number Of Bolts	Maximum Load per Bolt K	Allowable Load per Bolt K	Ratio Load Allowable	Allowable Ratio	Criteria
		Horizontal	A325N	0.6250	1	0.89	6.83	0.131 ✓	1	Member Block Shear

Guy Design Data

Section No.	Elevation ft	Size	Initial Tension K	Breaking Load K	Actual T_u K	Allowable ϕT_n K	Required S.F.	Actual S.F.
T1	145.75 (A) (235)	3/4 EHS	5.83	58.30	11.78	34.98	1.000	2.969 ✓
	145.75 (A) (236)	3/4 EHS	5.83	58.30	11.30	34.98	1.000	3.096 ✓
	145.75 (B) (229)	3/4 EHS	5.83	58.30	12.00	34.98	1.000	2.916 ✓
	145.75 (B) (230)	3/4 EHS	5.83	58.30	12.44	34.98	1.000	2.811 ✓
	145.75 (C) (223)	3/4 EHS	5.83	58.30	12.15	34.98	1.000	2.879 ✓
	145.75 (C) (224)	3/4 EHS	5.83	58.30	12.26	34.98	1.000	2.854 ✓
T5	86.00 (A) (243)	5/8 EHS	4.24	42.40	11.84	25.44	1.000	2.149 ✓
	86.00 (B) (242)	5/8 EHS	4.24	42.40	12.38	25.44	1.000	2.054 ✓
	86.00 (C) (241)	5/8 EHS	4.24	42.40	12.67	25.44	1.000	2.008 ✓

Compression Checks

Leg Design Data (Compression)

Section No.	Elevation ft	Size	L ft	L_u ft	Kl/r	A in^2	P_u K	ϕP_n K	Ratio $\frac{P_u}{\phi P_n}$
T1	160 - 141	V5x5x5/16	19.00	4.75	47.7 K=1.00	3.0273	-18.28	125.41	0.146 ¹ ✓
T2	141 - 121	V5x5x5/16	20.00	5.00	50.2 K=1.00	3.0273	-33.99	124.06	0.274 ¹ ✓
T3	121 - 101	V5x5x5/16	20.00	5.00	50.2 K=1.00	3.0273	-37.18	124.06	0.300 ¹ ✓
T4	101 - 86	V5x5x5/16	15.00	5.00	50.2 K=1.00	3.0273	-29.32	124.06	0.236 ¹ ✓
T5	86 - 66	V5x5x5/16	20.00	5.00	50.2 K=1.00	3.0273	-37.60	124.06	0.303 ¹ ✓
T6	66 - 46	V5x5x5/16	20.00	5.00	50.2 K=1.00	3.0273	-44.08	124.06	0.355 ¹ ✓

tnxTower GPD 520 South Main Street Suite 2531 Akron, Ohio 44311 Phone: (330) 572-2222 FAX: (330) 572-3722	Job (CT-1188) NORFOLK	Page 22 of 29
	Project 2022703.43	Date 11:55:52 06/16/22
	Client BST Managment, LLC	Designed by TDeak

Section No.	Elevation ft	Size	L ft	L _u ft	Kl/r	A in ²	P _u K	φP _n K	Ratio $\frac{P_u}{\phi P_n}$
T7	46 - 26	V5x5x5/16	20.00	5.00	50.2 K=1.00	3.0273	-43.62	124.06	0.352 ¹ ✓
T8	26 - 6	V5x5x5/16	20.00	5.00	50.2 K=1.00	3.0273	-38.47	124.06	0.310 ¹ ✓
T9	6 - 0	V5x5x5/16	6.43	3.21	32.3 K=1.00	3.0273	-38.29	132.18	0.290 ¹ ✓

¹ P_u / φP_n controls

Diagonal Design Data (Compression)

Section No.	Elevation ft	Size	L ft	L _u ft	Kl/r	A in ²	P _u K	φP _n K	Ratio $\frac{P_u}{\phi P_n}$
T1	160 - 141	2L2 1/2x2 1/2x3/16	6.21	5.81	89.7 K=1.00	1.8000	-8.00	48.41	0.165 ¹ ✓
T2	141 - 121	L2 1/2x2 1/2x3/16	6.40	6.16	149.4 K=1.00	0.9020	-5.25	11.56	0.454 ¹ ✓
T3	121 - 101	L2 1/2x2 1/2x3/16	6.40	6.16	149.4 K=1.00	0.9020	-4.04	11.56	0.349 ¹ ✓
T4	101 - 86	L2 1/2x2 1/2x3/16	6.40	6.16	149.4 K=1.00	0.9020	-5.75	11.56	0.497 ¹ ✓
T5	86 - 66	L2 1/2x2 1/2x3/16	6.40	6.16	149.4 K=1.00	0.9020	-4.77	11.56	0.412 ¹ ✓
T6	66 - 46	L2 1/2x2 1/2x3/16	6.40	6.16	149.4 K=1.00	0.9020	-3.07	11.56	0.265 ¹ ✓
T7	46 - 26	L2 1/2x2 1/2x3/16	6.40	6.16	149.4 K=1.00	0.9020	-2.91	11.56	0.251 ¹ ✓
T8	26 - 6	L2 1/2x2 1/2x3/16	6.40	6.16	149.4 K=1.00	0.9020	-4.25	11.56	0.368 ¹ ✓
T9	6 - 0	L2 1/2x2 1/2x3/16	4.28	4.28	111.9 K=1.08	0.9020	-0.75	19.69	0.038 ¹ ✓

¹ P_u / φP_n controls

Horizontal Design Data (Compression)

Section No.	Elevation ft	Size	L ft	L _u ft	Kl/r	A in ²	P _u K	φP _n K	Ratio $\frac{P_u}{\phi P_n}$
T1	160 - 141	L2 1/2x2 1/2x3/16	4.00	3.60	103.7 K=1.19	0.9020	-0.56	21.49	0.026 ¹ ✓
T2	141 - 121	L2x2x3/16	4.00	3.76	117.3 K=1.02	0.7148	-0.79	14.60	0.054 ¹ ✓
T3	121 - 101	L2x2x3/16	4.00	3.76	117.3 K=1.02	0.7148	-0.64	14.60	0.044 ¹ ✓
T4	101 - 86	L2x2x3/16	4.00	3.76	117.3	0.7148	-2.27	14.60	0.155 ¹ ✓

tnxTower GPD 520 South Main Street Suite 2531 Akron, Ohio 44311 Phone: (330) 572-2222 FAX: (330) 572-3722	Job (CT-1188) NORFOLK	Page 23 of 29
	Project 2022703.43	Date 11:55:52 06/16/22
	Client BST Managment, LLC	Designed by TDeak

Section No.	Elevation ft	Size	L ft	L _u ft	Kl/r	A in ²	P _u K	φP _n K	Ratio $\frac{P_u}{\phi P_n}$
T5	86 - 66	L2x2x3/16	4.00	3.76	K=1.02 117.3	0.7148	-0.65	14.60	0.045 ¹ ✓
T6	66 - 46	L2x2x3/16	4.00	3.76	K=1.02 117.3	0.7148	-0.76	14.60	0.052 ¹ ✓
T7	46 - 26	L2x2x3/16	4.00	3.76	K=1.02 117.3	0.7148	-0.76	14.60	0.052 ¹ ✓
T8	26 - 6	L2x2x3/16	4.00	3.76	K=1.02 117.3	0.7148	-0.67	14.60	0.046 ¹ ✓
T9	6 - 0	L2 1/2x2 1/2x3/16	4.00	4.00	K=1.02 108.5	0.9020	-0.70	20.46	0.034 ¹ ✓

¹ P_u / φP_n controls

Top Girt Design Data (Compression)

Section No.	Elevation ft	Size	L ft	L _u ft	Kl/r	A in ²	P _u K	φP _n K	Ratio $\frac{P_u}{\phi P_n}$
T1	160 - 141	L2 1/2x2 1/2x3/16	4.00	4.00	K=1.12 108.5	0.9020	-0.40	20.46	0.019 ¹ ✓

¹ P_u / φP_n controls

Top Guy Pull-Off Design Data (Compression)

Section No.	Elevation ft	Size	L ft	L _u ft	Kl/r	A in ²	P _u K	φP _n K	Ratio $\frac{P_u}{\phi P_n}$
T1	160 - 141	L2 1/2x2 1/2x3/16	4.00	4.00	K=1.00 97.0	0.9020	-2.15	22.87	0.094 ¹ ✓

¹ P_u / φP_n controls

Bottom Guy Pull-Off Design Data (Compression)

Section No.	Elevation ft	Size	L ft	L _u ft	Kl/r	A in ²	P _u K	φP _n K	Ratio $\frac{P_u}{\phi P_n}$
T1	160 - 141	L2 1/2x2 1/2x3/16	4.00	4.00	K=1.00 97.0	0.9020	-3.53	22.87	0.154 ¹ ✓

tnxTower GPD 520 South Main Street Suite 2531 Akron, Ohio 44311 Phone: (330) 572-2222 FAX: (330) 572-3722	Job (CT-1188) NORFOLK	Page 24 of 29
	Project 2022703.43	Date 11:55:52 06/16/22
	Client BST Managment, LLC	Designed by TDeak

¹ $P_u / \phi P_n$ controls

Torque-Arm Bottom Design Data

Section No.	Elevation ft	Size	L ft	L _u ft	Kl/r	A in ²	P _u K	φP _n K	Ratio $\frac{P_u}{\phi P_n}$
T1	160 - 141 (227)	2L3x2 1/2x1/4	4.00	4.00	50.8 K=1.00	2.6300	-7.01	85.42	0.082 ¹
T1	160 - 141 (228)	2L3x2 1/2x1/4	4.00	4.00	50.8 K=1.00	2.6300	-6.55	85.42	0.077 ¹
T1	160 - 141 (233)	2L3x2 1/2x1/4	4.00	4.00	50.8 K=1.00	2.6300	-6.89	85.42	0.081 ¹
T1	160 - 141 (234)	2L3x2 1/2x1/4	4.00	4.00	50.8 K=1.00	2.6300	-7.49	85.42	0.088 ¹
T1	160 - 141 (239)	2L3x2 1/2x1/4	4.00	4.00	50.8 K=1.00	2.6300	-7.66	85.42	0.090 ¹
T1	160 - 141 (240)	2L3x2 1/2x1/4	4.00	4.00	50.8 K=1.00	2.6300	-6.61	85.42	0.077 ¹

¹ $P_u / \phi P_n$ controls

Tension Checks

Leg Design Data (Tension)

Section No.	Elevation ft	Size	L ft	L _u ft	Kl/r	A in ²	P _u K	φP _n K	Ratio $\frac{P_u}{\phi P_n}$
T1	160 - 141	V5x5x5/16	19.00	4.75	44.1	2.5586	2.21	124.73	0.018 ¹
T2	141 - 121	V5x5x5/16	20.00	5.00	46.4	2.5586	17.33	124.73	0.139 ¹
T3	121 - 101	V5x5x5/16	20.00	5.00	46.4	2.5586	20.25	124.73	0.162 ¹
T4	101 - 86	V5x5x5/16	15.00	5.00	46.4	2.5586	10.21	124.73	0.082 ¹
T5	86 - 66	V5x5x5/16	20.00	5.00	46.4	2.5586	13.03	124.73	0.104 ¹
T6	66 - 46	V5x5x5/16	20.00	5.00	46.4	2.5586	18.25	124.73	0.146 ¹
T7	46 - 26	V5x5x5/16	20.00	5.00	46.4	2.5586	17.29	124.73	0.139 ¹
T8	26 - 6	V5x5x5/16	20.00	5.00	46.4	3.0273	6.29	136.23	0.046 ¹

¹ $P_u / \phi P_n$ controls

tnxTower GPD 520 South Main Street Suite 2531 Akron, Ohio 44311 Phone: (330) 572-2222 FAX: (330) 572-3722	Job (CT-1188) NORFOLK	Page 25 of 29
	Project 2022703.43	Date 11:55:52 06/16/22
	Client BST Managment, LLC	Designed by TDeak

Diagonal Design Data (Tension)

Section No.	Elevation <i>ft</i>	Size	<i>L</i> <i>ft</i>	<i>L_u</i> <i>ft</i>	<i>Kl/r</i>	<i>A</i> <i>in²</i>	<i>P_u</i> <i>K</i>	ϕP_n <i>K</i>	Ratio $\frac{P_u}{\phi P_n}$
T1	160 - 141	2L2 1/2x2 1/2x3/16	6.21	5.81	95.8	1.1391	6.98	49.55	0.141 ¹
T2	141 - 121	L2 1/2x2 1/2x3/16	6.40	6.16	98.8	0.5710	4.88	24.84	0.197 ¹
T3	121 - 101	L2 1/2x2 1/2x3/16	6.40	6.16	98.8	0.5710	3.41	24.84	0.137 ¹
T4	101 - 86	L2 1/2x2 1/2x3/16	6.40	6.16	98.8	0.5710	4.49	24.84	0.181 ¹
T5	86 - 66	L2 1/2x2 1/2x3/16	6.40	6.16	98.8	0.5710	3.71	24.84	0.150 ¹
T6	66 - 46	L2 1/2x2 1/2x3/16	6.40	6.16	98.8	0.5710	1.57	24.84	0.063 ¹
T7	46 - 26	L2 1/2x2 1/2x3/16	6.40	6.16	98.8	0.5710	1.61	24.84	0.065 ¹
T8	26 - 6	L2 1/2x2 1/2x3/16	6.40	6.16	98.8	0.5710	3.60	24.84	0.145 ¹

¹ $P_u / \phi P_n$ controls

Horizontal Design Data (Tension)

Section No.	Elevation <i>ft</i>	Size	<i>L</i> <i>ft</i>	<i>L_u</i> <i>ft</i>	<i>Kl/r</i>	<i>A</i> <i>in²</i>	<i>P_u</i> <i>K</i>	ϕP_n <i>K</i>	Ratio $\frac{P_u}{\phi P_n}$
T1	160 - 141	L2 1/2x2 1/2x3/16	4.00	3.60	61.7	0.5710	0.58	24.84	0.023 ¹
T2	141 - 121	L2x2x3/16	4.00	3.76	77.8	0.4307	1.34	18.73	0.071 ¹
T3	121 - 101	L2x2x3/16	4.00	3.76	77.8	0.4307	1.32	18.73	0.070 ¹
T4	101 - 86	L2x2x3/16	4.00	3.76	77.8	0.4307	2.66	18.73	0.142 ¹
T5	86 - 66	L2x2x3/16	4.00	3.76	77.8	0.4307	0.80	18.73	0.043 ¹
T6	66 - 46	L2x2x3/16	4.00	3.76	77.8	0.4307	0.85	18.73	0.046 ¹
T7	46 - 26	L2x2x3/16	4.00	3.76	77.8	0.4307	0.89	18.73	0.047 ¹
T8	26 - 6	L2x2x3/16	4.00	3.76	77.8	0.4307	0.89	18.73	0.048 ¹
T9	6 - 0	L2 1/2x2 1/2x3/16	4.00	4.00	61.7	0.9020	8.13	29.22	0.278 ¹

¹ $P_u / \phi P_n$ controls

tnxTower GPD 520 South Main Street Suite 2531 Akron, Ohio 44311 Phone: (330) 572-2222 FAX: (330) 572-3722	Job (CT-1188) NORFOLK	Page 26 of 29
	Project 2022703.43	Date 11:55:52 06/16/22
	Client BST Managment, LLC	Designed by TDeak

Top Girt Design Data (Tension)

Section No.	Elevation ft	Size	L ft	L _u ft	Kl/r	A in ²	P _u K	φP _n K	Ratio $\frac{P_u}{\phi P_n}$
T1	160 - 141	L2 1/2x2 1/2x3/16	4.00	4.00	61.7	0.9020	0.40	29.22	0.014 ¹ ✓

¹ P_u / φP_n controls

Top Guy Pull-Off Design Data (Tension)

Section No.	Elevation ft	Size	L ft	L _u ft	Kl/r	A in ²	P _u K	φP _n K	Ratio $\frac{P_u}{\phi P_n}$
T1	160 - 141	L2 1/2x2 1/2x3/16	4.00	4.00	61.7	0.9020	3.64	29.22	0.124 ¹ ✓
T5	86 - 66	L 2 x 2 x 3/16	4.00	4.00	77.8	0.7150	6.33	23.17	0.273 ¹ ✓

¹ P_u / φP_n controls

Bottom Guy Pull-Off Design Data (Tension)

Section No.	Elevation ft	Size	L ft	L _u ft	Kl/r	A in ²	P _u K	φP _n K	Ratio $\frac{P_u}{\phi P_n}$
T1	160 - 141	L2 1/2x2 1/2x3/16	4.00	4.00	61.7	0.9020	5.15	29.22	0.176 ¹ ✓

¹ P_u / φP_n controls

Torque-Arm Top Design Data

Section No.	Elevation ft	Size	L ft	L _u ft	Kl/r	A in ²	P _u K	φP _n K	Ratio $\frac{P_u}{\phi P_n}$
T1	160 - 141 (225)	2L2 1/2x2x1/4	6.21	6.21	95.0	2.1300	7.89	69.01	0.114 ¹ ✓
T1	160 - 141 (226)	2L2 1/2x2x1/4	6.21	6.21	95.0	2.1300	9.21	69.01	0.133 ¹ ✓
T1	160 - 141 (231)	2L2 1/2x2x1/4	6.21	6.21	95.0	2.1300	9.38	69.01	0.136 ¹ ✓
T1	160 - 141 (232)	2L2 1/2x2x1/4	6.21	6.21	95.0	2.1300	8.50	69.01	0.123 ¹ ✓

tnxTower GPD 520 South Main Street Suite 2531 Akron, Ohio 44311 Phone: (330) 572-2222 FAX: (330) 572-3722	Job (CT-1188) NORFOLK	Page 27 of 29
	Project 2022703.43	Date 11:55:52 06/16/22
	Client BST Managment, LLC	Designed by TDeak

Section No.	Elevation ft	Size	L ft	L _u ft	Kl/r	A in ²	P _u K	φP _n K	Ratio $\frac{P_u}{\phi P_n}$
T1	160 - 141 (237)	2L2 1/2x2x1/4	6.21	6.21	95.0	2.1300	9.38	69.01	0.136 ¹ ✓
T1	160 - 141 (238)	2L2 1/2x2x1/4	6.21	6.21	95.0	2.1300	8.27	69.01	0.120 ¹ ✓

¹ P_u / φP_n controls

Torque-Arm Bottom Design Data

Section No.	Elevation ft	Size	L ft	L _u ft	Kl/r	A in ²	P _u K	φP _n K	Ratio $\frac{P_u}{\phi P_n}$
T1	160 - 141 (227)	2L3x2 1/2x1/4	4.00	4.00	50.8	2.6300	3.27	85.21	0.038 ¹ ✓
T1	160 - 141 (228)	2L3x2 1/2x1/4	4.00	4.00	50.8	2.6300	4.36	85.21	0.051 ¹ ✓
T1	160 - 141 (233)	2L3x2 1/2x1/4	4.00	4.00	50.8	2.6300	4.08	85.21	0.048 ¹ ✓
T1	160 - 141 (234)	2L3x2 1/2x1/4	4.00	4.00	50.8	2.6300	3.62	85.21	0.042 ¹ ✓
T1	160 - 141 (239)	2L3x2 1/2x1/4	4.00	4.00	50.8	2.6300	3.69	85.21	0.043 ¹ ✓
T1	160 - 141 (240)	2L3x2 1/2x1/4	4.00	4.00	50.8	2.6300	4.24	85.21	0.050 ¹ ✓

¹ P_u / φP_n controls

Section Capacity Table

Section No.	Elevation ft	Component Type	Size	Critical Element	P K	φP _{allow} K	% Capacity	Pass Fail
T1	160 - 141	Leg	V5x5x5/16	2	-18.28	125.41	14.6	Pass
T2	141 - 121	Leg	V5x5x5/16	30	-33.99	124.06	27.4	Pass
T3	121 - 101	Leg	V5x5x5/16	55	-37.18	124.06	30.0	Pass
T4	101 - 86	Leg	V5x5x5/16	84	-29.32	124.06	23.6	Pass
T5	86 - 66	Leg	V5x5x5/16	105	-37.60	124.06	30.3	Pass
T6	66 - 46	Leg	V5x5x5/16	132	-44.08	124.06	35.5	Pass
T7	46 - 26	Leg	V5x5x5/16	157	-43.62	124.06	35.2	Pass
T8	26 - 6	Leg	V5x5x5/16	184	-38.47	124.06	31.0	Pass
T9	6 - 0	Leg	V5x5x5/16	212	-38.29	132.18	29.0	Pass
T1	160 - 141	Diagonal	2L2 1/2x2 1/2x3/16	8	-8.00	48.41	16.5	Pass
T2	141 - 121	Diagonal	L2 1/2x2 1/2x3/16	47	-5.25	11.56	24.3 (b)	Pass
T3	121 - 101	Diagonal	L2 1/2x2 1/2x3/16	63	-4.04	11.56	45.4	Pass
T4	101 - 86	Diagonal	L2 1/2x2 1/2x3/16	90	-5.75	11.56	62.3 (b)	Pass
							34.9	Pass
							43.5 (b)	Pass
							49.7	Pass

tnxTower GPD 520 South Main Street Suite 2531 Akron, Ohio 44311 Phone: (330) 572-2222 FAX: (330) 572-3722	Job (CT-1188) NORFOLK	Page 28 of 29
	Project 2022703.43	Date 11:55:52 06/16/22
	Client BST Managment, LLC	Designed by TDeak

Section No.	Elevation ft	Component Type	Size	Critical Element	P K	ϕP_{allow} K	% Capacity	Pass Fail
T5	86 - 66	Diagonal	L2 1/2x2 1/2x3/16	128	-4.77	11.56	57.4 (b) 41.2	Pass
T6	66 - 46	Diagonal	L2 1/2x2 1/2x3/16	155	-3.07	11.56	47.4 (b) 26.5	Pass
T7	46 - 26	Diagonal	L2 1/2x2 1/2x3/16	165	-2.91	11.56	25.1	Pass
T8	26 - 6	Diagonal	L2 1/2x2 1/2x3/16	198	-4.25	11.56	36.8	Pass
T9	6 - 0	Diagonal	L2 1/2x2 1/2x3/16	222	-0.75	19.69	45.9 (b) 3.8	Pass
T1	160 - 141	Horizontal	L2 1/2x2 1/2x3/16	24	-0.56	21.49	2.6	Pass
T2	141 - 121	Horizontal	L2x2x3/16	31	1.34	18.73	4.0 (b) 7.1	Pass
T3	121 - 101	Horizontal	L2x2x3/16	58	1.32	18.73	19.6 (b) 7.0	Pass
T4	101 - 86	Horizontal	L2x2x3/16	87	-2.27	14.60	19.3 (b) 15.5	Pass
T5	86 - 66	Horizontal	L2x2x3/16	119	-0.65	14.60	38.9 (b) 4.5	Pass
T6	66 - 46	Horizontal	L2x2x3/16	134	-0.76	14.60	11.7 (b) 5.2	Pass
T7	46 - 26	Horizontal	L2x2x3/16	168	-0.76	14.60	12.5 (b) 5.2	Pass
T8	26 - 6	Horizontal	L2x2x3/16	187	0.89	18.73	13.0 (b) 4.8	Pass
T9	6 - 0	Horizontal	L2 1/2x2 1/2x3/16	214	8.13	29.22	13.1 (b) 27.8	Pass
T1	160 - 141	Top Girt	L2 1/2x2 1/2x3/16	5	-0.40	20.46	1.9	Pass
T1	160 - 141	Guy A@145.75	3/4	235	11.78	34.98	33.7	Pass
T5	86 - 66	Guy A@86	5/8	243	11.84	25.44	46.5	Pass
T1	160 - 141	Guy B@145.75	3/4	230	12.44	34.98	35.6	Pass
T5	86 - 66	Guy B@86	5/8	242	12.38	25.44	48.7	Pass
T1	160 - 141	Guy C@145.75	3/4	224	12.26	34.98	35.0	Pass
T5	86 - 66	Guy C@86	5/8	241	12.67	25.44	49.8	Pass
T1	160 - 141	Top Guy	L2 1/2x2 1/2x3/16	17	3.64	29.22	12.4	Pass
T5	86 - 66	Pull-Off@145.75						
		Top Guy	L 2 x 2 x 3/16	108	6.33	23.17	27.3	Pass
		Pull-Off@86						
T1	160 - 141	Bottom Guy	L2 1/2x2 1/2x3/16	11	5.15	29.22	17.6	Pass
		Pull-Off@145.75						
T1	160 - 141	Torque Arm	2L2 1/2x2x1/4	231	9.38	69.01	13.6	Pass
		Top@145.75						
T1	160 - 141	Torque Arm	2L3x2 1/2x1/4	239	-7.66	85.42	9.0	Pass
		Bottom@145.75						

Summary	ELC:	Proposed
Leg (T6)	35.5	Pass
Diagonal (T2)	62.3	Pass
Horizontal (T4)	38.9	Pass
Top Girt (T1)	1.9	Pass
Guy A (T5)	46.5	Pass
Guy B (T5)	48.7	Pass
Guy C (T5)	49.8	Pass
Top Guy Pull-Off (T5)	27.3	Pass
Bottom Guy Pull-Off (T1)	17.6	Pass

tnxTower GPD 520 South Main Street Suite 2531 Akron, Ohio 44311 Phone: (330) 572-2222 FAX: (330) 572-3722	Job	(CT-1188) NORFOLK	Page	29 of 29
	Project	2022703.43	Date	11:55:52 06/16/22
	Client	BST Managment, LLC	Designed by	TDeak

Section No.	Elevation ft	Component Type	Size	Critical Element	P K	θP_{allow} K	% Capacity	Pass Fail
						Torque Arm	13.6	Pass
						Top (T1)		
						Torque Arm	9.0	Pass
						Bottom (T1)		
						Bolt Checks	62.3	Pass
						Rating =	62.3	Pass

APPENDIX C

Additional Calculations



Mat Foundation Analysis
NORFOLK (CT-1188)
2022703.43

General Info	
Foundation Criteria	GPD
TIA Code	TIA-222-H
Apply TIA-222-H Section 15.5?	No
Soil Code	AASHTO 2012
Concrete Code	ACI 318-11
Seismic Design Category	B
Tower Height	160 ft
Bearing On	Rock
Foundation Type	Guyed Pad
Pier Type	None
Reinforcing Known	Yes
Max Bearing Capacity	105%
Max Overturning Capacity	105%

Tower Reactions	
Moment, M	0 k-ft
Axial, P	104 k
Shear, V	4 k

Pad & Pier Geometry	
Pier N/A	0 ft
Pad Length, L [y]	4 ft
Pad Width, W [x]	4 ft
Pad Thickness, t	3.5 ft
Depth, D	3.5 ft
Height Above Grade, HG	0.5 ft
Tower Centroid, X	2 ft
Tower Centroid, Y	2 ft
Tower Eccentricity	0.0000 ft

Pad & Pier Reinforcing	
Rebar Fy	60 ksi
Concrete F'c	3 ksi
Pier Reinforcing Clear Cover	
Shear Rebar Type	Tie
Shear Rebar Size	# 4
Pad Reinforcing Clear Cover	3 in
Reinforced Top & Bottom?	No
Pad Reinforcing Size	# 6
Pad Quantity Per Layer	5
Pier Rebar Size	
Pier Quantity of Rebar	

Soil Properties	
Soil Type	Cohesive
Soil Unit Weight	135 pcf
Cohesion, Cu (ksf)	2.5
Base Friction Coeff. Provided in Geo?	Yes
Base Friction Coefficient, μ	0.4
Bearing Type	Net
Ultimate Bearing	21 ksf
Water Table Depth	99 ft
Neglected Depth	3.33 ft

Bearing Summary					
Case	Demand/Limits	Capacity/Availability	Check	Eccentricity	Load Case
Qxmax	8.70 ksf	12.88 ksf	OK, <= 105%	L/29.3	1.2D+1.0W
Qymax	8.70 ksf	12.88 ksf	OK, <= 105%	W/29.3	1.2D+1.0W
Qmax @ 45°	9.30 ksf	12.88 ksf	OK, <= 105%	W/41.7	1.2D+1.0W
Controlling Capacity		72.2%	Pass		

Overturning Summary					
Case	Demand/Limits	Capacity/Availability	Check	Load Case	
Ovtx	15.8 k-ft	231.0 k-ft	9.1% OK	0.9D+1.0W	
Ovty	15.8 k-ft	231.0 k-ft	9.1% OK	0.9D+1.0W	
Ovtxy	11.1 k-ft	231.0 k-ft	6.4% OK	0.9D+1.0W	
Controlling Capacity		9.1%	Pass		

Sliding Summary					
Case	Demand/Limits	Capacity/Availability	Check	Load Case	
Slidingx	4.0 k	28.8 k	13.9% OK	0.9D+1.0W	
Slidingy	4.0 k	28.8 k	13.9% OK	0.9D+1.0W	
Controlling Capacity		13.9%	Pass		

Reinforcement Summary					
Component	Demand/Limits	Capacity/Availability	Check	Load Case	
Pad Flexural Bending	59.9 k-ft	429.0 k-ft	14.0% OK	1.2D+1.0W	
One-Way Shear in Pad	0.0 k	173.0 k	0.0% OK	1.2D+1.0W	
Two-Way Shear in Pad	41.2 k	1265.2 k	3.3% OK	0.9D+1.0W	
As Min Pad Met?	0.55 sq. in.	0.14 sq. in.	Yes		
Controlling Capacity		14.0%	Pass		

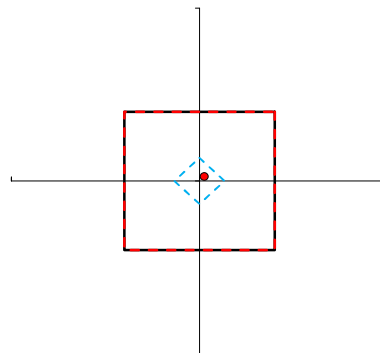
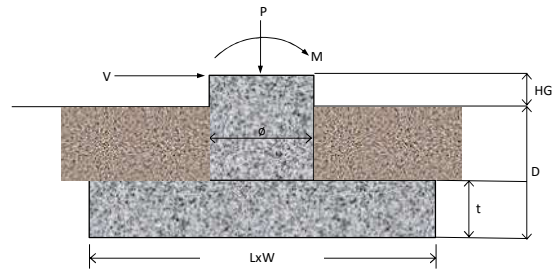



**Guyed Tower Anchor Foundation
NORFOLK (CT-1188)
2022703.43**

Guy Anchor Location	
Azimuth/Leg	A/B/C
Radius (ft)	131'
Tower Height (ft)	160'

Tower Reactions	
Vertical	24 k
Horizontal	28 k

Anchor Block Geometry	
Width	5 ft
Height	5 ft
Length	12.5 ft
Depth	4.5 ft

General Info	
Foundation Criteria	GPD
TIA Code	TIA-222-H
Soil	105%
Reinforcement/Steel	105%
Apply TIA-222-H Section 15.5?	No

Soil Capacity Calculations	
W_s	0.00 k
W_c	46.88 k
Uplift Resistance	84.96 k
Horizontal Resistance	110.83 k
Uplift Capacity=	28.3% OK
Horizontal Capacity=	25.3% OK

Anchor Block Reinforcement	
Is Reinforcement Known?	assume min
f_c'	4 ksi
F_y	60 ksi

Capacity Summary		
Soil Capacity=	28.3%	OK
Reinforcing Capacity=	4.4%	OK
Controlling Capacity=	28.3%	OK

Minimum steel has been assumed

Soil Properties									
Layer	C_u , psf	ϕ , degrees	γ_{soil} , pcf	$\gamma_{concrete}$, pcf	Thickness, ft	$P_{p,top}$, psf	$P_{p,bot}$, psf	f_u , psf	
1	0	0	120	150	2.5	0	0	0	
2	2500	0	135	150	2.5	5000	5000	1500	
3									
4									
5									
6									
Ignored Depth	2.5 ft				Consider soil for uplift	User Input Angle (°)			
Water Table	99 ft				Cohesive	Angle for Uplift (°)	0		

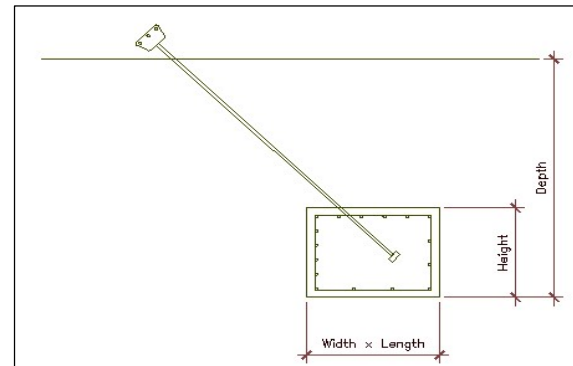

Block Moment and Shear Calculations			
<i>Moment Check</i>			
M_{ux} =	37.50 k-ft	M_{uy} =	43.75 k-ft
ϕM_{rx} =	2736.73 k-ft	ϕM_{ry} =	2748.96 k-ft
Capacity	1.4% OK	Capacity	1.6% OK
<i>Shear Check</i>			
V_{ux} =	12.00 k	V_{uy} =	14.00 k
ϕV_{rx} =	318.76 k	ϕV_{ry} =	319.47 k
Capacity	3.8% OK	Capacity	4.4% OK

Guy Anchor Shaft Calculations	
Shape of Anchor Shaft	Unknown

RAN Template: 67E5D998E ODE+6160	A&L Template: 67E5998E_1xAIR+1OP
--	--

Section 1 - Site Information

Site ID: CT11349A	Site Name: Norfolk SNET_1	Latitude: 42.00907300
Status: Final	Site Class: Self Support Tower	Longitude: -73.18093400
Version: 3	Site Type: Structure Non Building	Address: 453 Loon Meadow Road
Project Type: Anchor	Plan Year: 2022	City, State: Norfolk, CT
Approved: 3/7/2022 8:24:09 AM	Market: CONNECTICUT CT	Region: NORTHEAST
Approved By: Pratik.Patil30@T-Mobile.com	Vendor: Ericsson	
Last Modified: 3/7/2022 8:24:09 AM	Landlord: SNET LL	
Last Modified By: Pratik.Patil30@T-Mobile.com		

RAN Template: 67E5D998E ODE+6160		AL Template: 67E5998E_1xAIR+1OP		
Sector Count: 3	Antenna Count: 6	Coax Line Count: 0	TMA Count: 0	RRU Count: 6

Section 2 - Existing Template Images

----- This section is intentionally blank. -----

Section 3 - Proposed Template Images

67E5A998E.JPG

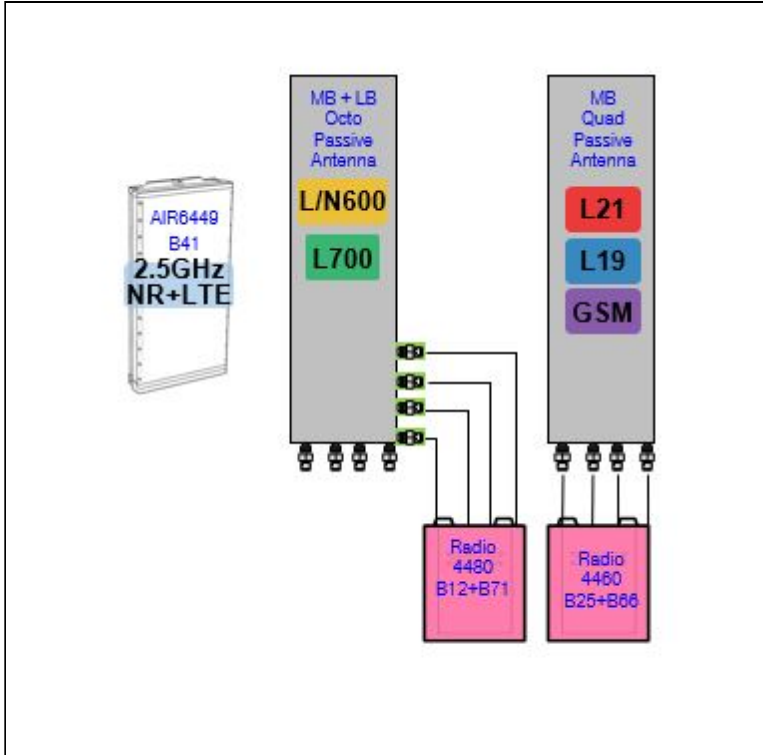

Notes:

Section 4 - Siteplan Images

----- This section is intentionally blank. -----

RAN Template: 67E5D998E ODE+6160	A&L Template: 67E5998E_1xAIR+1OP
--	--

Section 5 - RAN Equipment

Existing RAN Equipment

Template: 704G

Enclosure	1								
Enclosure Type	RBS 6201								
Baseband	<table border="0"> <tr> <td>DUG20</td> <td>BB 5216</td> </tr> <tr> <td>G1900</td> <td>L1900</td> </tr> <tr> <td></td> <td>L700</td> </tr> </table>			DUG20	BB 5216	G1900	L1900		L700
DUG20	BB 5216								
G1900	L1900								
	L700								
Radio	RUS01 B2 (x 3) L1900	RUS01 B2 (x 3) G1900	RUS01 B12 (x 6) L700						

Proposed RAN Equipment

Template: 67E5D998E ODE+6160

Enclosure	1	2	3	4															
Enclosure Type	RBS 6201	Ancillary Equipment (Ericsson)	Enclosure 6160 AC V1	B160															
Baseband	<table border="0"> <tr> <td>DUG20</td> <td>RP 6651</td> <td>RP 6651</td> </tr> <tr> <td>G1900</td> <td>L700</td> <td>L2100</td> </tr> <tr> <td></td> <td>L600</td> <td>L1900</td> </tr> <tr> <td></td> <td>N600</td> <td></td> </tr> </table>	DUG20	RP 6651	RP 6651	G1900	L700	L2100		L600	L1900		N600			<table border="0"> <tr> <td>RP 6651</td> </tr> <tr> <td>L2500</td> </tr> <tr> <td>N2500</td> </tr> </table>	RP 6651	L2500	N2500	
DUG20	RP 6651	RP 6651																	
G1900	L700	L2100																	
	L600	L1900																	
	N600																		
RP 6651																			
L2500																			
N2500																			
Hybrid Cable System	PSU 4813 vR4A (Kit)	Ericsson Hybrid Trunk 6/24 4AWG 50m (x 3)	PSU 4813 vR4A (Kit)																
Multiplexer	XMU																		
Transport System			CSR IXRe V2 (Gen2)																

RAN Scope of Work:

Remove and return all cabinet radios from existing base station cabinet.

Remove (1) BB 5216 from 6201.

Add (1) RP 6651 for L1900, L2100 to existing cabinet 6201.

Add (1) RP 6651 for L600, L700 and N600 to existing cabinet 6201.

Add (1) XMU to existing cabinet 6201 for climate control.

Add (1) Enclosure 6160.

Add (1) iXRe Router to new Enclosure 6160.

Add (1) RP 6651 for L2500/N2500 to new Enclosure 6160.

Add (1) PSU4813 Voltage Booster to new Enclosure 6160.

Add (1) PSU4813 Voltage Booster to 6201.

Add (1) Battery Cabinet B160.

Existing :

Remove all Coax,

Add (2) 6X24 HCS terminating at the Enclosure 6160. And (1) 6x24 terminating at 6201. Connect DC for the AIR6419 B41 to the PSU4813 Voltage Booster.

RAN Template: 67E5D998E ODE+6160	A&L Template: 67E5998E_1xAIR+1OP
--	--

Section 6 - A&L Equipment

Existing Template: 704G
 Proposed Template: 67E5998E_1xAIR+1OP

Sector 1 (Existing) view from behind

Coverage Type	A - Outdoor Macro		
Antenna	1	2	3
Antenna Model	Empty Antenna Mount (Empty mount)	EMS - RR90-17-XXDP (Dual)	Andrew - LNX-6515DS-A1M (Dual)
Azimuth		60	60
M. Tilt		0	0
Height		120	120
Ports		P1	P2
Active Tech.		L1900 G1900	L700
Dark Tech.			
Restricted Tech.			
Decomm. Tech.			
E. Tilt		2	2
Cables		1-5/8" Coax - 210 ft.	1-5/8" Coax - 210 ft.
TMA's		Generic Twin Style 1A - PCS (AtAntenna)	
Diplexers / Combiners			
Radio			
Sector Equipment			

Unconnected Equipment:

Scope of Work:

RAN Template: 67E5D998E ODE+6160	A&L Template: 67E5998E_1xAIR+1OP
--	--

CT11349A_Anchor_3

Print Name: Preliminary (RFDS_For_Scoping)
PORs: Anchor_Phase 3
 L600_L600 Coverage

Sector 1 (Proposed) view from behind						
Coverage Type	A - Outdoor Macro					
Antenna	1			2		
Antenna Model	AIR 6419 B41 (Active Antenna - Massive MIMO)			RFS - APXVAALL24_43-U-NA20 (Octo)		
Azimuth	60			60		
M. Tilt	0			0		
Height	120			120		
Ports	P1	P2		P3	P4	P5
Active Tech.	L2500 N2500	L2500 N2500	L700 L600 N600	L700 L600 N600	L2100 L1900 G1900	L2100 L1900 G1900
Dark Tech.						
Restricted Tech.						
Decomm. Tech.						
E. Tilt	2	2	2	2	2	2
Cables	Fiber Jumper (x2)	Fiber Jumper (x2)	Coax Jumper (x2) Fiber Jumper	Coax Jumper (x2) Fiber Jumper	Coax Jumper (x2) Fiber Jumper	Coax Jumper (x2) Fiber Jumper
TMAs						
Diplexers / Combiners						
Radio			Radio 4480 B71+B85 (At Antenna)	SHARED Radio 4480 B71+B85 (At Antenna)	Radio 4460 B25+B66 (At Antenna)	SHARED Radio 4460 B25+B66 (At Antenna)
Sector Equipment						

Unconnected Equipment:

Scope of Work:

**new azimuths at 60/160/280

There will be two antennae per sector.

Remove all TMAs.

Remove all diplexers.

Remove all Coaxial Lines.

Install (1) AIR6419 B41 for L2500 and N2500 in Position 1.

Replace antenna in Position 2 with (1) MB LB Octo.

Add (1) Radio 4480 B71+B85 for L600, L700 and N600 at antenna to Position 2.

Add (1) Radio 4460 B25+B66 for L2100, L1900 (Both carriers), and GSM to Position 2 at antenna.

Ensure RET control is enabled for all technology layers according to the Design Documents

*A dashed border indicates shared equipment. Any connected equipment is denoted with the SHARED keyword.

RAN Template: 67E5D998E ODE+6160	A&L Template: 67E5998E_1xAIR+1OP
--	--

Sector 2 (Existing) view from behind			
Coverage Type	A - Outdoor Macro		
Antenna	1	2	3
Antenna Model	Empty Antenna Mount (Empty mount)	EMS - RR90-17-XXDP (Dual)	Andrew - LNX-6515DS-A1M (Dual)
Azimuth		190	190
M. Tilt		0	0
Height		120	120
Ports		P1	P2
Active Tech.		L1900 G1900	L700
Dark Tech.			
Restricted Tech.			
Decomm. Tech.			
E. Tilt		2	2
Cables		1-5/8" Coax - 210 ft.	1-5/8" Coax - 210 ft.
TMA's		Generic Twin Style 1A - PCS (AtAntenna)	
Diplexers / Combiners			
Radio			
Sector Equipment			
Unconnected Equipment:			
Scope of Work:			

RAN Template: 67E5D998E ODE+6160	A&L Template: 67E5998E_1xAIR+1OP
--	--

CT11349A_Anchor_3

Print Name: Preliminary (RFDS_For_Scoping)
PORs: Anchor_Phase 3
 L600_L600 Coverage

Sector 2 (Proposed) view from behind						
Coverage Type	A - Outdoor Macro					
Antenna	1			2		
Antenna Model	AIR 6419 B41 (Active Antenna - Massive MIMO)			RFS - APXVAALL24_43-U-NA20 (Octo)		
Azimuth	160			160		
M. Tilt	0			0		
Height	120			120		
Ports	P1	P2		P3	P4	P5
Active Tech.	L2500 N2500	L2500 N2500	L700 L600 N600	L700 L600 N600	L2100 L1900 G1900	L2100 L1900 G1900
Dark Tech.						
Restricted Tech.						
Decomm. Tech.						
E. Tilt	2	2	2	2	2	2
Cables	Fiber Jumper (x2)	Fiber Jumper (x2)	Coax Jumper (x2) Fiber Jumper	Coax Jumper (x2) Fiber Jumper	Coax Jumper (x2) Fiber Jumper	Coax Jumper (x2) Fiber Jumper
TMAs						
Diplexers / Combiners						
Radio			Radio 4480 B71+B85 (At Antenna)	SHARED Radio 4480 B71+B85 (At Antenna)	Radio 4460 B25+B66 (At Antenna)	SHARED Radio 4460 B25+B66 (At Antenna)
Sector Equipment						

Unconnected Equipment:

Scope of Work:

**new azimuths at 60/160/280

There will be two antennae per sector.

Remove all TMAs.

Remove all diplexers.

Remove all Coaxial Lines.

Install (1) AIR6419 B41 for L2500 and N2500 in Position 1.

Replace antenna in Position 2 with (1) MB LB Octo.

Add (1) Radio 4480 B71+B85 for L600, L700 and N600 at antenna to Position 2.

Add (1) Radio 4460 B25+B66 for L2100, L1900 (Both carriers), and GSM to Position 2 at antenna.

Ensure RET control is enabled for all technology layers according to the Design Documents

*A dashed border indicates shared equipment. Any connected equipment is denoted with the SHARED keyword.

RAN Template: 67E5D998E ODE+6160	A&L Template: 67E5998E_1xAIR+1OP
--	--

Sector 3 (Existing) view from behind			
Coverage Type	A - Outdoor Macro		
Antenna	1	2	3
Antenna Model	Empty Antenna Mount (Empty mount)	EMS - RR90-17-XXDP (Dual)	Andrew - LNX-6515DS-A1M (Dual)
Azimuth		280	280
M. Tilt		0	0
Height		120	120
Ports		P1	P2
Active Tech.		L1900 G1900	L700
Dark Tech.			
Restricted Tech.			
Decomm. Tech.			
E. Tilt		2	2
Cables		1-5/8" Coax - 210 ft.	1-5/8" Coax - 210 ft.
TMA's		Generic Twin Style 1A - PCS (AtAntenna)	
Diplexers / Combiners			
Radio			
Sector Equipment			
Unconnected Equipment:			
Scope of Work:			

RAN Template: 67E5D998E ODE+6160	A&L Template: 67E5998E_1xAIR+1OP
--	--

Sector 3 (Proposed) view from behind						
Coverage Type	A - Outdoor Macro					
Antenna	1			2		
Antenna Model	AIR 6419 B41 (Active Antenna - Massive MIMO)			RFS - APXVAALL24_43-U-NA20 (Octo)		
Azimuth	280			280		
M. Tilt	0			0		
Height	120			120		
Ports	P1	P2		P3	P4	P5
Active Tech.	L2500 N2500	L2500 N2500	L700 L600 N600	L700 L600 N600	L2100 L1900 G1900	L2100 L1900 G1900
Dark Tech.						
Restricted Tech.						
Decomm. Tech.						
E. Tilt	2	2	2	2	2	2
Cables	Fiber Jumper (x2)	Fiber Jumper (x2)	Coax Jumper (x2) Fiber Jumper	Coax Jumper (x2) Fiber Jumper	Coax Jumper (x2) Fiber Jumper	Coax Jumper (x2) Fiber Jumper
TMA's						
Diplexers / Combiners						
Radio			Radio 4480 B71+B85 (At Antenna)	SHARED Radio 4480 B71+B85 (At Antenna)	Radio 4460 B25+B66 (At Antenna)	SHARED Radio 4460 B25+B66 (At Antenna)
Sector Equipment						

Unconnected Equipment:

Scope of Work:

**new azimuths at 60/160/280

There will be two antennae per sector.

Remove all TMA's.

Remove all diplexers.

Remove all Coaxial Lines.

Install (1) AIR6419 B41 for L2500 and N2500 in Position 1.

Replace antenna in Position 2 with (1) MB LB Octo.

Add (1) Radio 4480 B71+B85 for L600, L700 and N600 at antenna to Position 2.

Add (1) Radio 4460 B25+B66 for L2100, L1900 (Both carriers), and GSM to Position 2 at antenna.

Ensure RET control is enabled for all technology layers according to the Design Documents

*A dashed border indicates shared equipment. Any connected equipment is denoted with the SHARED keyword.

RAN Template: 67E5D998E ODE+6160	A&L Template: 67E5998E_1xAIR+1OP
--	--

Section 7 - Power Systems Equipment

Existing Power Systems Equipment
----- This section is intentionally blank. -----

Proposed Power Systems Equipment	
Enclosure	1
Enclosure Type	Enclosure 6160 AC V1

RADIO FREQUENCY EMISSIONS ANALYSIS REPORT
EVALUATION OF HUMAN EXPOSURE POTENTIAL
TO NON-IONIZING EMISSIONS

T-Mobile Existing Facility

Site ID: CT11349A

Norfolk SNET_I
453 Loon Meadow Road
Norfolk, Connecticut 06058

January 26, 2023

EBI Project Number: 6222005902

Site Compliance Summary	
Compliance Status:	COMPLIANT
Site total MPE% of FCC general population allowable limit:	1.17%

January 26, 2023

T-Mobile

Attn: Jason Overbey, RF Manager
35 Griffin Road South
Bloomfield, Connecticut 06002

Emissions Analysis for Site: CT11349A - Norfolk SNET_I

EBI Consulting was directed to analyze the proposed T-Mobile facility located at **453 Loon Meadow Road in Norfolk, Connecticut** for the purpose of determining whether the emissions from the Proposed T-Mobile Antenna Installation located on this property are within specified federal limits.

All information used in this report was analyzed as a percentage of current Maximum Permissible Exposure (% MPE) as listed in the FCC OET Bulletin 65 Edition 97-01 and ANSI/IEEE Std C95.1. The FCC regulates Maximum Permissible Exposure in units of microwatts per square centimeter ($\mu\text{W}/\text{cm}^2$). The number of $\mu\text{W}/\text{cm}^2$ calculated at each sample point is called the power density. The exposure limit for power density varies depending upon the frequencies being utilized. Wireless Carriers and Paging Services use different frequency bands each with different exposure limits; therefore, it is necessary to report results and limits in terms of percent MPE rather than power density.

All results were compared to the FCC (Federal Communications Commission) radio frequency exposure rules, 47 CFR 1.1307(b)(1) – (b)(3), to determine compliance with the Maximum Permissible Exposure (MPE) limits for General Population/Uncontrolled environments as defined below.

General population/uncontrolled exposure limits apply to situations in which the general population may be exposed or in which persons who are exposed as a consequence of their employment may not be made fully aware of the potential for exposure or cannot exercise control over their exposure. Therefore, members of the general population would always be considered under this category when exposure is not employment related, for example, in the case of a telecommunications tower that exposes persons in a nearby residential area.

Public exposure to radio frequencies is regulated and enforced in units of microwatts per square centimeter ($\mu\text{W}/\text{cm}^2$). The general population exposure limits for the 600 MHz and 700 MHz frequency bands are approximately $400 \mu\text{W}/\text{cm}^2$ and $467 \mu\text{W}/\text{cm}^2$, respectively. The general population exposure limit for the 1900 MHz (PCS), 2100 MHz (AWS) and 11 GHz frequency bands is $1000 \mu\text{W}/\text{cm}^2$. Because each carrier will be using different frequency bands, and each frequency band has different exposure limits, it is necessary to report percent of MPE rather than power density.

Occupational/controlled exposure limits apply to situations in which persons are exposed as a consequence of their employment and in which those persons who are exposed have been made fully aware of the potential for exposure and can exercise control over their exposure. Occupational/controlled exposure limits also apply where exposure is of a transient nature as a result of incidental passage through a location where exposure levels may be above general population/uncontrolled limits (see below), as long as the exposed person has been made fully aware of the potential for exposure and can exercise control over his or her exposure by leaving the area or by some other appropriate means.

Additional details can be found in FCC OET 65.

CALCULATIONS

Calculations were done for the proposed T-Mobile Wireless antenna facility located at 453 Loon Meadow Road in Norfolk, Connecticut using the equipment information listed below. Modeling of the antennas and associated equipment was completed using RoofMaster™ software, which is a widely-used predictive modeling program that has been developed to predict RF power density values for rooftop and tower telecommunications sites produced by vertical collinear antennas that are typically used in the cellular, PCS, paging and other communications services. Using the computational methods set forth in Federal Communications (FCC) Office of Engineering & Technology (OET) Bulletin 65, “Evaluating Compliance with FCC Guidelines for Human Exposure to Radiofrequency Electromagnetic Fields” (OET-65), RoofMaster™ calculates predicted power density in a scalable grid based on the contributions of all RF sources characterized in the study scenario. At each grid location, the cumulative power density is expressed as a percentage of the FCC limits. Manufacturer antenna pattern data is utilized in these calculations. RoofMaster™ models consist of the Far Field model as specified in OET-65 and an implementation of the OET-65 Cylindrical Model (Sula9). The models utilize several operational specifications for different types of antennas to produce a plot of spatially-averaged power densities that can be expressed as a percentage of the applicable exposure limit.

Since T-Mobile is proposing highly focused directional panel antennas, which project most of the emitted energy out toward the horizon, all calculations were performed assuming a lobe representing the maximum gain of the antenna per the antenna manufacturer’s supplied specifications, minus 10 dB for directional panel antennas and 20 dB for highly focused parabolic microwave dishes, was focused at the base of the tower. For this report, the sample point is the top of a 6-foot person standing at the base of the tower. For power density calculations, the broadcast footprint of the AIR6449 or similar SON antenna has been considered. Due to the beamforming nature of these antennas, the actual beam locations vary depending on demand and are narrow in nature. Using the broadcast footprint accounts for the potential location of beams at any given time.

For all calculations, telecommunications equipment was modeled using the following assumptions:

- 1) 1 LTE channel (600 MHz Band) was considered for each sector of the proposed installation. These Channels have a transmit power of 40 Watts per Channel.
- 2) 1 NR channel (600 MHz Band) was considered for each sector of the proposed installation. This Channel has a transmit power of 80 Watts.
- 3) 1 LTE channel (700 MHz Band) was considered for each sector of the proposed installation. These Channels have a transmit power of 40 Watts per Channel.
- 4) 1 GSM channel (PCS Band - 1900 MHz) was considered for each sector of the proposed installation. These Channels have a transmit power of 10 Watts per Channel.
- 5) 1 LTE channel (PCS Band - 1900 MHz) was considered for each sector of the proposed installation. These Channels have a transmit power of 160 Watts per Channel.
- 6) 1 LTE channel (AWS Band – 2100 MHz) was considered for each sector of the proposed installation. These Channels have a transmit power of 160 Watts per Channel.
- 7) 1 LTE Traffic channel (LTE 1C and 2C BRS Band - 2500 MHz) was considered for each sector of the proposed installation. This Channel has a transmit power of 45 Watts.
- 8) 1 LTE Broadcast channel (LTE 1C and 2C BRS Band - 2500 MHz) was considered for each sector of the proposed installation. This Channel has a transmit power of 15 Watts.
- 9) 1 NR Traffic channel (BRS Band - 2500 MHz) was considered for each sector of the proposed installation. This Channel has a transmit power of 90 Watts.
- 10) 1 NR Broadcast channel (BRS Band - 2500 MHz) was considered for each sector of the proposed installation. This Channel has a transmit power of 30 Watts.
- 11) All radios at the proposed installation were considered to be running at full power and were uncombined in their RF transmissions paths per carrier prescribed configuration. Per FCC OET Bulletin No. 65 - Edition 97-01 recommendations to achieve the maximum anticipated value at each sample point, all power levels emitting from the proposed antenna installation are increased by a factor of 2.56 to account for possible in-phase reflections from the surrounding environment. This is rarely the case, and if so, is never continuous.
- 12) For the following calculations, the sample point was the top of a 6-foot person standing at the base of the tower. The maximum gain of the antenna per the antenna manufacturer's supplied specifications, minus 10 dB for directional panel antennas and 20 dB for highly focused

parabolic microwave dishes, was used in this direction. This value is a very conservative estimate as gain reductions for these particular antennas are typically much higher in this direction.

- 13) The antennas used in this modeling are the ERICSSON SON_AIR6419 B4I LTE TB 02.09.21 2500 TMO for the 2500 MHz / 2500 MHz / 2500 MHz / 2500 MHz channel(s), the RFS APXVAALL24_43-U-NA20 02DT 600 for the 600 MHz / 600 MHz / 700 MHz / 1900 MHz / 1900 MHz / 2100 MHz channel(s) in Sector A, the ERICSSON SON_AIR6419 B4I LTE TB 02.09.21 2500 TMO for the 2500 MHz / 2500 MHz / 2500 MHz / 2500 MHz channel(s), the RFS APXVAALL24_43-U-NA20 02DT 600 for the 600 MHz / 600 MHz / 700 MHz / 1900 MHz / 1900 MHz / 2100 MHz channel(s) in Sector B, the ERICSSON SON_AIR6419 B4I LTE TB 02.09.21 2500 TMO for the 2500 MHz / 2500 MHz / 2500 MHz / 2500 MHz channel(s), the RFS APXVAALL24_43-U-NA20 02DT 600 for the 600 MHz / 600 MHz / 700 MHz / 1900 MHz / 1900 MHz / 2100 MHz channel(s) in Sector C. This is based on feedback from the carrier with regard to anticipated antenna selection. All Antenna gain values and associated transmit power levels are shown in the Site Inventory and Power Data table below. The maximum gain of the antenna per the antenna manufacturer's supplied specifications, minus 10 dB for directional panel antennas and 20 dB for highly focused parabolic microwave dishes, was used for all calculations. This value is a very conservative estimate as gain reductions for these particular antennas are typically much higher in this direction.
- 14) The antenna mounting height centerline of the proposed antennas is 120 feet above ground level (AGL).
- 15) Emissions values for additional carriers were calculated in Far Field utilizing the antenna models provided in the structural analysis.
- 16) All calculations were done with respect to uncontrolled / general population threshold limits.

T-Mobile Site Inventory and Power Data

Sector:	A	Sector:	B	Sector:	C
Antenna #:	I	Antenna #:	I	Antenna #:	I
Make / Model:	ERICSSON SON_AIR6419 B41 LTE TB 02.09.21 2500 TMO	Make / Model:	ERICSSON SON_AIR6419 B41 LTE TB 02.09.21 2500 TMO	Make / Model:	ERICSSON SON_AIR6419 B41 LTE TB 02.09.21 2500 TMO
Frequency Bands:	2500 MHz / 2500 MHz / 2500 MHz / 2500 MHz	Frequency Bands:	2500 MHz / 2500 MHz / 2500 MHz / 2500 MHz	Frequency Bands:	2500 MHz / 2500 MHz / 2500 MHz / 2500 MHz
Gain:	22.05 dBd / 22.05 dBd / 15.55 dBd / 15.55 dBd	Gain:	22.05 dBd / 22.05 dBd / 15.55 dBd / 15.55 dBd	Gain:	22.05 dBd / 22.05 dBd / 15.55 dBd / 15.55 dBd
Height (AGL):	120 feet	Height (AGL):	120 feet	Height (AGL):	120 feet
Channel Count:	4	Channel Count:	4	Channel Count:	4
Total TX Power (W):	180.00 Watts	Total TX Power (W):	180.00 Watts	Total TX Power (W):	180.00 Watts
ERP (W):	23,258.96	ERP (W):	23,258.96	ERP (W):	23,258.96
Antenna AI MPE %:	6.43%	Antenna BI MPE %:	6.43%	Antenna CI MPE %:	6.43%
Antenna #:	2	Antenna #:	2	Antenna #:	2
Make / Model:	RFS APXVAALL24_43-U- NA20 02DT 600	Make / Model:	RFS APXVAALL24_43-U- NA20 02DT 600	Make / Model:	RFS APXVAALL24_43-U- NA20 02DT 600
Frequency Bands:	600 MHz / 600 MHz / 700 MHz / 1900 MHz / 1900 MHz / 2100 MHz	Frequency Bands:	600 MHz / 600 MHz / 700 MHz / 1900 MHz / 1900 MHz / 2100 MHz	Frequency Bands:	600 MHz / 600 MHz / 700 MHz / 1900 MHz / 1900 MHz / 2100 MHz
Gain:	12.95 dBd / 12.95 dBd / 13.65 dBd / 15.45 dBd / 15.45 dBd / 16.45 dBd	Gain:	12.95 dBd / 12.95 dBd / 13.65 dBd / 15.45 dBd / 15.45 dBd / 16.45 dBd	Gain:	12.95 dBd / 12.95 dBd / 13.65 dBd / 15.45 dBd / 15.45 dBd / 16.45 dBd
Height (AGL):	120 feet	Height (AGL):	120 feet	Height (AGL):	120 feet
Channel Count:	6	Channel Count:	6	Channel Count:	6
Total TX Power (W):	490.00 Watts	Total TX Power (W):	490.00 Watts	Total TX Power (W):	490.00 Watts
ERP (W):	14,173.46	ERP (W):	14,173.46	ERP (W):	14,173.46
Antenna A2 MPE %:	5.04%	Antenna B2 MPE %:	5.04%	Antenna C2 MPE %:	5.04%

Site Composite MPE %	
Carrier	MPE %
T-Mobile (Combined Sectors):	1.06%
AT&T	0.03%
PageNet	0.08%
Sprint	0.003%
Site Total MPE % :	1.17%

T-Mobile MPE % Per Sector	
T-Mobile Sector A Total:	1.03%
T-Mobile Sector B Total:	1.06%
T-Mobile Sector C Total:	1.03%
T-Mobile Total MPE % :	1.06%

T-Mobile Maximum MPE Power Values (Sector B)							
T-Mobile Frequency Band / Technology (Sector B)	# Channels	Watts ERP (Per Channel)	Height (feet)	Total Power Density ($\mu\text{W}/\text{cm}^2$)	Frequency (MHz)	Allowable MPE ($\mu\text{W}/\text{cm}^2$)	Calculated % MPE
T-Mobile 2500 MHz LTE	1	7214.604258	120	19.95810727	2500 MHz LTE	1000.0	2.00%
T-Mobile 2500 MHz NR	1	14429.20852	120	39.91621455	2500 MHz NR	1000.0	3.99%
T-Mobile 2500 MHz LTE	1	538.382902	120	1.489354555	2500 MHz LTE	1000.0	0.15%
T-Mobile 2500 MHz NR	1	1076.765804	120	2.978709109	2500 MHz NR	1000.0	0.30%
T-Mobile 600 MHz LTE	1	689.5408364	120	1.90751003	600 MHz LTE	400.0	0.48%
T-Mobile 600 MHz NR	1	1379.081673	120	3.815020059	600 MHz NR	400.0	0.95%
T-Mobile 700 MHz LTE	1	810.1398427	120	2.24112887	700 MHz LTE	467.0	0.48%
T-Mobile 1900 MHz GSM	1	304.0885026	120	0.841214672	1900 MHz GSM	1000.0	0.08%
T-Mobile 1900 MHz LTE	1	4865.416041	120	13.45943475	1900 MHz LTE	1000.0	1.35%
T-Mobile 2100 MHz LTE	1	6125.195893	120	16.94442444	2100 MHz LTE	1000.0	1.69%
						T-Mobile Total:	1.06%

- NOTE: Total T-Mobile MPE values reflect all T-Mobile antennas as reported by RoofMaster™ combined modeling.
- NOTE: Totals may vary by approximately 0.01% due to summation of remainders in calculations.

Summary

All calculations performed for this analysis yielded results that were **within** the allowable limits for general population exposure to RF Emissions.

The anticipated maximum composite contributions from the T-Mobile facility as well as the site composite emissions value with regards to compliance with FCC's allowable limits for general population exposure to RF Emissions are shown here:

T-Mobile Sector	Power Density Value (%)
Sector A:	1.03%
Sector B:	1.06%
Sector C:	1.03%
T-Mobile Maximum MPE % (Sector B):	1.06%
T-Mobile Combined Sectors MPE %:	1.06%
Site Total:	1.17%
Site Compliance Status:	COMPLIANT

The anticipated composite MPE value for this site assuming all carriers present is **1.17%** of the allowable FCC established general population limit sampled at the ground level. This is based upon values listed in the Connecticut Siting Council database for existing carrier emissions or documents available on the Connecticut Siting Council website.

FCC guidelines state that if a site is found to be out of compliance (over allowable thresholds), that carriers over a 5% contribution to the composite value will require measures to bring the site into compliance. For this facility, the composite values calculated were well within the allowable 100% threshold standard per the federal government.