



1280 Route 46 West, Suite 9, Parsippany NJ, 07054

Melanie Bachman  
Executive Director  
CT Siting Council  
10 Franklin Square  
New Britain, CT 06051

Re: Notice of Exempt Modification Application  
453 Loon Meadow Rd, Norwalk, CT 06058

Latitude: N42.00908  
Longitude: W73.1811

Dear Ms. Bachman:

Sprint currently maintains 3 existing panel antennas and 6 remote radio units at the 158'3" centerline level of the existing guyed tower. Sprint proposes to add 3 panel antennas and 3 remote radio unit at the 158'3" centerline on the tower. Sprint further proposes to add 3 hybrid cable and 33 Antenna to RRH jumper cables. Sprint is performing a new high-performance upgrade for cellular mobile communications. It is designed to increase the capacity and speed of mobile telephone networks.

Please accept this letter as notification to the Council, pursuant to R.C.S.A. Section 16-50j-73, for construction which constitutes an exempt modification pursuant to R.C.S.A. Section 16-50j-72(b)(2). In compliance with R.C.S.A. Section 16-50j-73, a copy of this letter is being sent to 1<sup>st</sup> Selectman Matthew T. Riiska for the town of Norfolk as well as Michael Halloran, Zoning Officer for the Town of Norfolk and AT&T, owner of the tower.

Attached is a summary of the planned modifications, including power density calculations reflecting the change in Sprint's operations at the site. Also included is documentation of the structural sufficiency of the tower with proposed modifications to accommodate the revised antenna configuration as well as the latest CSC decision, tax sheet and tax map.

### **Existing Facility**

CSC Summary Statement – CT33XC116 – 453 Loon  
Meadow Rd, Norfolk CT 06058

The Communications Tower facility is located at 453 Loon Meadow Rd, Norfolk CT and is owned by AT&T, the Site coordinates are: N42.00908 W73.18117.

The existing facility consists of a 160' Guyed Tower. Sprint currently operates wireless communications equipment on a platform on a concrete slab at the facility and has 3 antennas and 6 RRU's mounted on at centerline of 158'3" feet.

## **Statutory Considerations**

The planned modifications to the facility fall within the activities explicitly provided for in R.C.S.A. 16-50j-72(b)(2)

1. The height of the overall structure will be unaffected.
2. The proposed changes will not require an extension of the property boundaries.
3. The proposed additions will not increase the noise level at the existing facility by six decibels or more, or to levels that exceed state and/or local criteria
4. The changes will not increase the calculated “worst case” power density for the combined operations at the site to a level at or above the Federal Communications Commission safety standard.
5. The proposed modifications will not cause a change or alteration in the physical or environmental characteristics of the site.
6. The existing structure and its foundation can support the proposed loading.

For the foregoing reasons, Sprint respectfully submits that the proposed changes at the referenced site constitute exempt modifications under R.C.S.A Section §16-50j-72(b)(2).

Respectfully submitted,



Ryan G Bailey

Charles Cherundolo Consulting

856-625-1596

[ryan@mackenzierealtyconsulting.com](mailto:ryan@mackenzierealtyconsulting.com)

Additional Recipients:

1<sup>st</sup> Selectman Matthew T Riiska for the Town of Norfolk– Via FedEx

Michael Halloran, Zoning Officer for the Town of Norfolk - Via FedEx

AT&T, owner of the tower – Via FedEx

# Sprint<sup>®</sup>



## "DO MACRO UPGRADE"

**CT33XC116**  
**453 LOON MEADOW ROAD**  
**NORFOLK, CT 06058**  
**LITCHFIELD COUNTY**

**COM-EX**  
 Consultants  
 115 Route 46  
 Suite E39  
 Mountain Lakes, NJ 07046  
 PHONE: 862.209.4300  
 FAX: 862.209.4301

**Sprint**  
 8100 SPRINT PARKWAY  
 OVERLAND PARK, KS 66251



SCHEDULE OF REVISIONS		
REV NO.	DATE	DESCRIPTION OF CHANGES
7		
6		
5		
4		
3		
2		
1	11/12/17	ISSUED FOR CONSTRUCTION
0	08/23/17	INITIAL SUBMISSION

**DRAWN BY:** JW  
**CHECKED BY:** NDB  
**SCALE:** AS NOTED  
**JOB NO:** 17109-CHE

Documents prepared by Com-Ex Consultants, including this document, are to be used only for the specific project and specific use for which they were intended. Any extension of use to any other projects, by owner or by any other party, without the expressed written consent of Com-Ex Consultants, is done unlawfully and at the users own risk. If used in a way other than that specifically intended, user will hold Com-Ex Consultants, harmless from all claims and losses.

INFORMATION ON THIS SET OF DRAWINGS IS NOT FOR OFFICIAL USE UNLESS ACCOMPANIED BY THE ISSUING SEAL & SIGNATURE OF A PROFESSIONAL ENGINEER  
  
**NICHOLAS D. BARILE**  
 PROFESSIONAL ENGINEER No. 28643

**CT33XC116**  
**453 LOON MEADOW ROAD**  
**NORFOLK, CT 06058**  
**LITCHFIELD COUNTY**

**DRAWING TITLE:**  
 TITLE SHEET

**DRAWING SHEET: 1 OF 6**  
**T-1**

SHEET INDEX	
SHEET NO.	SHEET DESCRIPTION
T-1	TITLE SHEET
C-1	SITE LAYOUT & GENERAL NOTES
C-2	EXISTING & FINAL ANTENNA PLANS
C-3	ELEVATION, B.O.M. & FINAL EQUIPMENT PLAN
C-4	CONSTRUCTION DETAILS & SCHEMATIC
E-1	ELECTRICAL & GROUNDING DETAILS, NOTES & COAX COLOR CODE

SITE LOCATION INFORMATION	
SITE ID NUMBER:	CT33XC116
SITE NAME:	FISHS EDDY / SNET CORP
SITE ADDRESS:	453 LOON MEADOW ROAD NORFOLK, CT 06058
PARCEL ID:	6-14-7
PROPERTY OWNER:	NEW CINGULAR WIRELESS PCS 5565 GLENRIDGE CONNECTOR SUITE 1520 ATLANTA, GA 30342
APPLICANT:	SPRINT
COUNTY:	LITCHFIELD COUNTY

SITE CHARACTERISTICS	
LATITUDE:	42.00908055
LONGITUDE:	-73.18117222
STRUCTURE TYPE:	GUYED TOWER
LOCATION OF PROPOSED EQUIPMENT:	EXISTING EQUIPMENT PAD
STRUCTURE HEIGHT:	±160'-0" AGL
ANTENNA (RAD CENTER):	±158'-3" AGL (ALPHA) ±158'-3" AGL (BETA) ±158'-3" AGL (GAMMA)



**KEY MAP**  
 SCALE = N.T.S.

SIGNATURE BLOCK:	
SPRINT REPRESENTATIVE:	DATE
SPRINT RF ENGINEER:	DATE
PROPERTY OWNER:	DATE

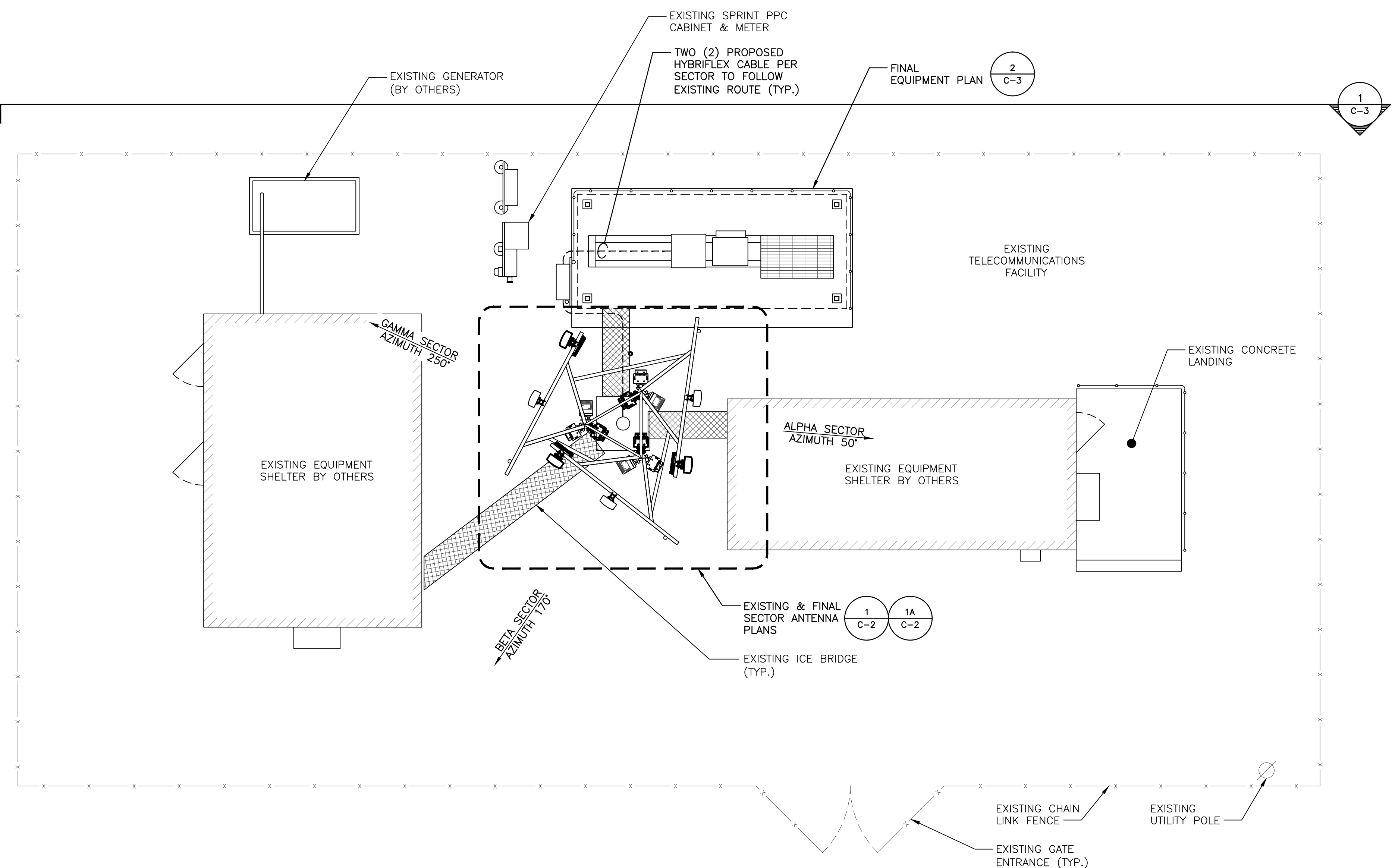
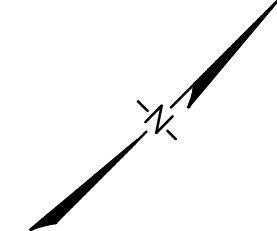

1 C-1 SITE LAYOUT  
SCALE: 3/16"=1'  
( 24"x36" SHEET SIZE )

**GENERAL NOTES:**

1. SUBJECT PROPERTY IS KNOWN AS TAX PARCEL ID 6-14-7 AS SHOWN THE OFFICIAL TAX MAP OF THE TOWN OF NORFOLK, CT.
2. THE APPLICANT PROPOSES TO INSTALL ONE (1) NEW ANTENNA PER SECTOR (3 TOTAL) ON EXISTING MOUNTING FRAME AND TWO (2) RRRs PER SECTOR (6 TOTAL) ON PROPOSED MOUNTING HARDWARE.
3. CONTRACTOR SHALL NOT COMMENCE ANY WORK UNTIL HE OBTAINS, AT HIS OWN EXPENSE, ALL INSURANCE REQUIRED BY SPRINT, THE PROPERTY OWNER AND/OR PROPERTY MANAGEMENT COMPANY.
4. THIS SET OF PLANS HAS BEEN PREPARED FOR THE PURPOSES OF MUNICIPAL AND AGENCY REVIEW AND APPROVAL. THIS SET OF PLANS SHALL NOT BE UTILIZED AS CONSTRUCTION DOCUMENTS UNTIL ALL CONDITIONS OF APPROVAL HAVE BEEN SATISFIED AND EACH OF THE DRAWINGS HAVE BEEN REVISED TO INDICATED "ISSUED FOR CONSTRUCTION".
5. SITE INFORMATION SHOWN TAKEN FROM PLANS PREPARED BY ALCATEL-LUCENT FOR SPRINT'S INSTALLATION ON THIS FACILITY. DRAWINGS ENTITLED "SPRINT, SITE ID: CT33XC116, SITE NAME: FISHS EDDY / SNET CORP DATED 07/24/14. ADDITIONAL SITE INFORMATION WAS SUPPLEMENTED WITH A LIMITED SITE VISIT BY COM-EX CONSULTANTS ON 08/15/17.
6. THE CONTRACTOR SHALL COMPLY WITH ALL APPLICABLE CODES, ORDINANCES, LAWS AND REGULATIONS OF ALL MUNICIPALITIES, UTILITIES OR OTHER PUBLIC AUTHORITIES.
7. THE CONTRACTOR SHALL BE RESPONSIBLE FOR OBTAINING ALL PERMITS AND INSPECTIONS THAT MAY BE REQUIRED BY ANY FEDERAL, STATE, COUNTY OR MUNICIPAL AUTHORITIES.
8. THE CONTRACTOR SHALL NOTIFY THE CONSTRUCTION MANAGER, IN WRITING, OF ANY CONFLICTS, ERRORS OR OMISSIONS PRIOR TO THE SUBMISSION OF BIDS OR PERFORMANCE OF WORK. MINOR OMISSIONS OR ERRORS IN THE BID DOCUMENTS SHALL NOT EXCUSE SAID CONTRACTOR FROM COMPLETING THIS PROJECT IN ACCORDANCE WITH THE OVERALL INTENT OF THESE DRAWINGS.
9. THE CONTRACTOR SHALL BE RESPONSIBLE FOR PROTECTING ALL EXISTING SITE IMPROVEMENTS PRIOR TO COMMENCING CONSTRUCTION. THE CONTRACTOR SHALL REPAIR ANY DAMAGE CAUSED AS A RESULT OF CONSTRUCTION OF THIS FACILITY.
10. THE SCOPE OF WORK FOR THIS PROJECT SHALL INCLUDE PROVIDING ALL MATERIALS, EQUIPMENT AND LABOR REQUIRED TO COMPLETE THIS PROJECT. ALL EQUIPMENT SHALL BE INSTALLED IN ACCORDANCE WITH THE MANUFACTURER'S RECOMMENDATIONS.
11. THE CONTRACTOR SHALL VISIT THE PROJECT SITE PRIOR TO SUBMITTING A BID TO VERIFY THAT THE PROJECT CAN BE CONSTRUCTED IN ACCORDANCE WITH THE CONTRACT DOCUMENTS.
12. CONTRACTOR SHALL VERIFY ANTENNA ELEVATION AND AZIMUTH WITH RF ENGINEERING PRIOR TO INSTALLATION.
13. ALL STRUCTURAL ELEMENTS SHALL BE HOT DIPPED GALVANIZED STEEL.
14. THE CONSTRUCTION CONTRACTOR IS SOLELY RESPONSIBLE FOR DETERMINING ALL CONSTRUCTION MEANS AND METHODS. THE CONSTRUCTION CONTRACTOR IS ALSO RESPONSIBLE FOR ALL JOB SITE SAFETY.
15. CONTRACTOR SHALL FIELD VERIFY ALL DIMENSIONS, ELEVATIONS, ANGLES AND EXISTING CONDITIONS AT THE SITE PRIOR TO FABRICATION AND/OR INSTALLATION OF ANY WORK IN THE CONTRACT AREA AND SUBMIT TO THE ENGINEER ANY DISCREPANCIES FROM THE DRAWINGS.
16. THE CONTRACTOR IS TO REVIEW ALL DRAWINGS AND SPECIFICATIONS IN THE CONTRACT DOCUMENT SET. THE CONTRACTOR SHALL COORDINATE ALL WORK SHOWN IN THE SET OF DRAWINGS. THE CONTRACTOR SHALL PROVIDE A COMPLETE SET OF DRAWINGS TO ALL SUBCONTRACTORS AND RELATED PARTIES. THE SUBCONTRACTOR SHALL EXAMINE ALL THE DRAWINGS AND SPECIFICATIONS FOR THE INFORMATION THAT EFFECTS THEIR WORK.
17. THE CONTRACTOR SHALL MAINTAIN A CURRENT SET OF DRAWINGS AND SPECIFICATIONS ON THE SITE AT ALL TIMES AND INSURE THE DISTRIBUTION OF NEW DRAWINGS TO SUBCONTRACTORS AND OTHER RELEVANT PARTIES AS SOON AS THEY ARE MADE AVAILABLE. OLD DRAWINGS SHALL BE MARKED VOID AND REMOVED FROM THE CONTRACT AREA CONTRACTOR FURNISH 3 SETS OF REDLINE "AS-BUILT" DRAWINGS TO SPRINT UPON COMPLETION OF THE WORK.
18. DETAILS ARE INTENDED TO SHOW END RESULT OF DESIGN. MINOR MODIFICATIONS MAY BE REQUIRED TO SUIT JOB DIMENSIONS OR CONDITIONS, AND SUCH MODIFICATIONS SHALL INCLUDED AS PART OF THE WORK.
19. ALL MATERIAL PROVIDED BY IS TO BE REVIEWED BY THE CONTRACTOR AND ALL APPLICABLE SUB-CONTRACTOR PRIOR TO INSTALLATION. ANY DEFICIENCIES TO PROVIDE MATERIALS SHALL BE BROUGHT TO THE CONSTRUCTION MANAGERS ATTENTION IMMEDIATELY.
20. THE MATERIALS INSTALLED SHALL MEET REQUIREMENTS OF CONTRACTORS DOCUMENTS. NO SUBSTITUTIONS ARE ALLOWED.
21. THE CONTRACTOR SHALL COORDINATE ALL CIVIL, STRUCTURAL AND ELECTRICAL DRAWINGS FOR THE LOCATIONS OF ALL OPENINGS, RECESSES, BUILT-IN WORK, ETC..
22. THE CONTRACTOR SHALL RECEIVE CLARIFICATION IN WRITING AND SHALL RECEIVE IN WRITING AUTHORIZATION TO PROCEED BEFORE STARTING WORK ON ANY ITEMS NOT CLEARLY DEFINED OR IDENTIFIED BY THE CONTACT DOCUMENTS.
23. THE CONTRACTOR SHALL NOTIFY THE CONSTRUCTION MANAGER OF ALL PRODUCTS OR ITEMS NOTED AS "EXISTING" WHICH ARE NOT FOUND TO BE IN THE FIELD.
24. ERECTION SHALL BE DONE IN A WORKMANLIKE MANNER BY COMPETENT EXPERIENCED WORKMEN IN ACCORDANCE WITH APPLICABLE CODES AND THE BEST-ACCEPTED PRACTICE. ALL MEMBERS SHALL BE LAND PLUMB AND TRUE AS INDICATED ON THE DRAWINGS.
25. THE CONTRACTOR SHALL COORDINATE HIS WORK AND SCHEDULE HIS ACTIVITIES AND WORKING HOURS IN ACCORDANCE WITH THE REQUIREMENTS OF THE PROPERTY OWNER AND/OR PROPERTY MANAGEMENT COMPANY.
26. THE CONTRACTOR SHALL BE RESPONSIBLE FOR COORDINATING HIS WORK WITH THE WORK OF OTHERS AS IT MAY RELATE TO RADIO EQUIPMENT, ANTENNAS AND ANY OTHER PORTIONS OF THE WORK.
27. THE CONTRACTOR SHALL INSTALL ALL EQUIPMENT AND MATERIALS IN ACCORDANCE WITH THE MANUFACTURE'S RECOMMENDATIONS UNLESS SPECIFICALLY INDICATED OR WHERE LOCAL CODES OR REGULATIONS MAY TAKE PRECEDENCE.
28. THE CONTRACTOR SHALL REPAIR ALL EXISTING SURFACES DAMAGED DURING CONSTRUCTION SUCH THAT THEY MATCH AND BLEND WITH ADJACENT SURFACES.
29. THE CONTRACTOR SHALL KEEP CONTRACT AREA CLEAN, HAZARD FREE AND DISPOSE OF ALL DEBRIS AND RUBBISH. LEAVE PREMISES IN CLEAN CONDITION AND FREE FROM PAINT SPOTS. THE CONTRACTOR SHALL BE RESPONSIBLE FOR MAINTAINING ALL ITEMS UNTIL COMPLETION OF CONSTRUCTION.
30. BEFORE FINAL ACCEPTANCE OF THE WORK, THE CONTRACTOR SHALL REMOVE ALL EQUIPMENT, TEMPORARY WORKS, UNUSED AND USELESS MATERIALS, RUBBISH AND TEMPORARY STRUCTURES.
31. DESIGN REQUIREMENTS PER INTERNATIONAL BUILDING CODE 2015 AND THE EIA/TIA-222-G STRUCTURAL STANDARDS FOR STEEL ANTENNA TOWERS AND ANTENNA SUPPORTING STRUCTURES.

**COM-EX**  
Consultants  
115 Route 46  
Suite E39  
Mountain Lakes, NJ 07046  
PHONE: 862.209.4300  
FAX: 862.209.4301

**Sprint**  
6100 SPRINT PARKWAY  
OVERLAND PARK, KS 66251

**Cherundolo Consulting**

**SCHEDULE OF REVISIONS**

REV. NO.	DATE	DESCRIPTION OF CHANGES
7		
6		
5		
4		
3		
2		
1	11/12/17	ISSUED FOR CONSTRUCTION
0	08/23/17	INITIAL SUBMISSION

**DRAWN BY:** JW  
**CHECKED BY:** NDB  
**SCALE:** AS NOTED  
**JOB NO.:** 17109-CHE

Documents prepared by Com-Ex Consultants, including this document, are to be used only for the specific project and specific use for which they were intended. Any extension of use to any other projects, by owner or by any other party, without the expressed written consent of Com-Ex Consultants, is done unlawfully and at the users own risk. If used in a way other than that specifically intended, user will hold Com-Ex Consultants, harmless from all claims and losses.

INFORMATION ON THIS SET OF DRAWINGS IS NOT FOR OFFICIAL USE UNLESS ACCOMPANIED BY THE ENGINEER'S SEAL & SIGNATURE OF A PROFESSIONAL ENGINEER

*Nicholas D. Barile*  
**NICHOLAS D. BARILE**  
PROFESSIONAL ENGINEER, REG. NO. 28643

**CT33XC116**  
**453 LOON MEADOW ROAD**  
**NORFOLK, CT 06058**  
**LITCHFIELD COUNTY**

**DRAWING TITLE:**

**SITE LAYOUT & GENERAL NOTES**

**DRAWING SHEET: 2 OF 6**

**C-1**

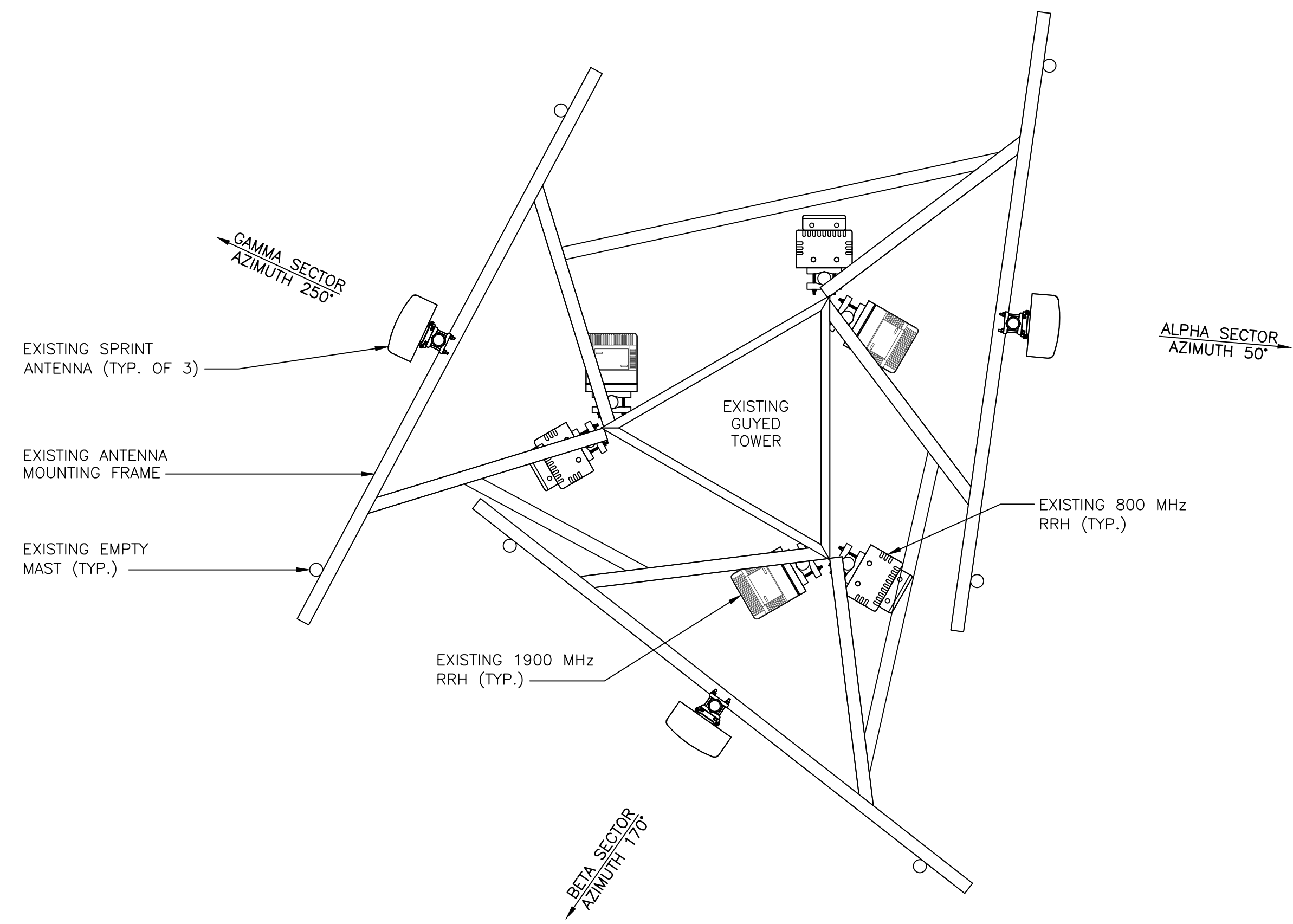
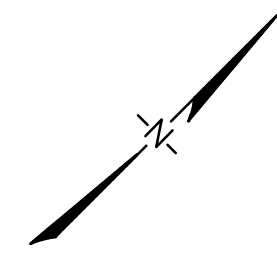

1 EXISTING ANTENNA PLAN (ALL SECTORS)  
C-2 SCALE: 1/2"=1'

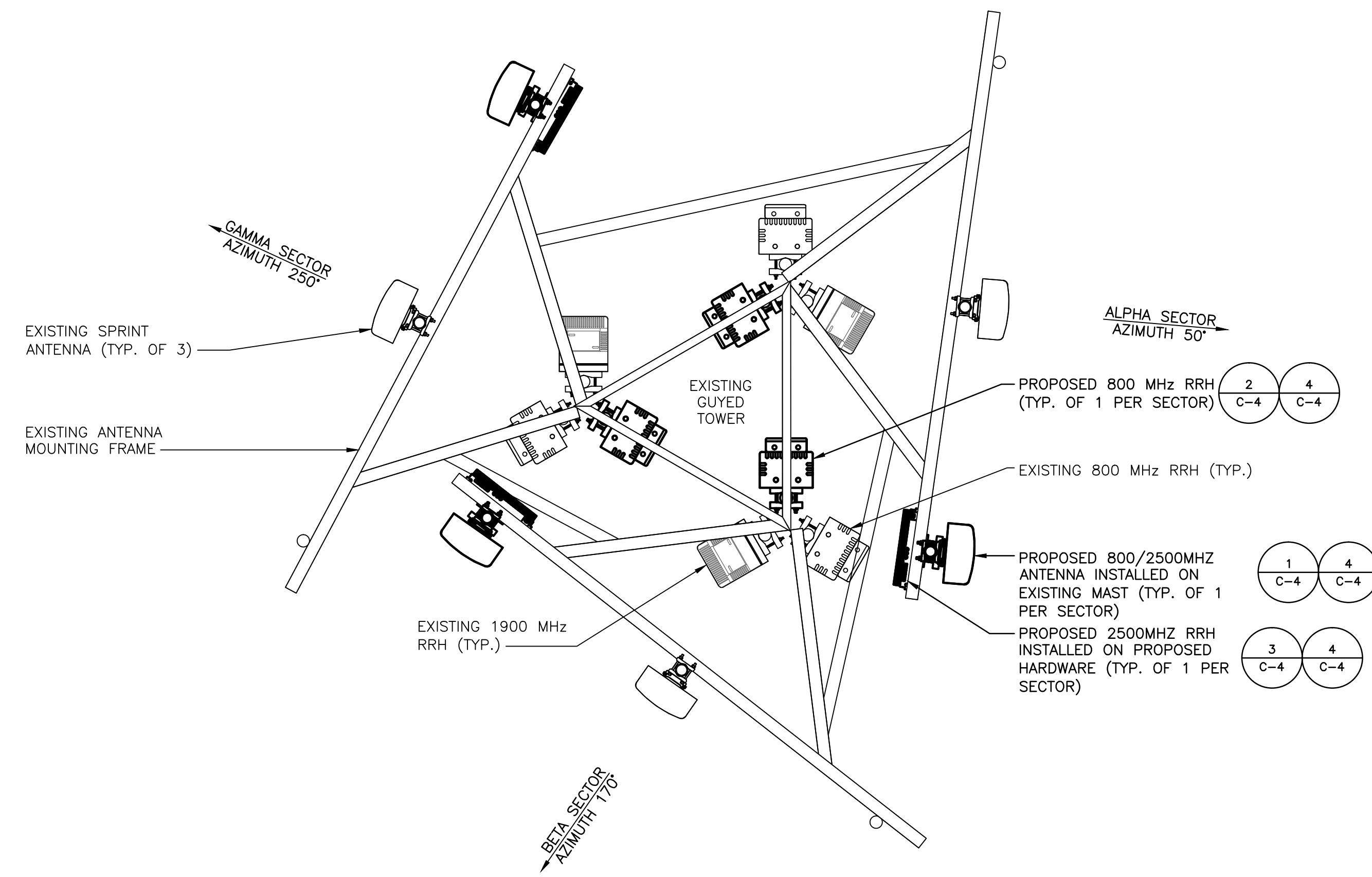
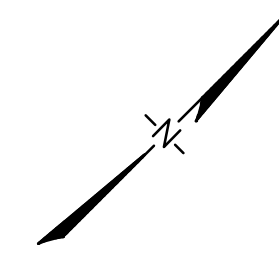

1A FINAL ANTENNA PLAN (ALL SECTORS)  
C-2 SCALE: 3/8"=1'

ALL LOADING ASSOCIATED WITH PROPOSED EQUIPMENT CABINETS, ANTENNAS, AND CABLE ROUTING SHALL BE VERIFIED BY A PASSING STRUCTURAL ANALYSIS PERFORMED BY A LICENSED ENGINEER PRIOR TO INSTALLATION

UNUSED SPRINT COAX CABLES TO BE REMOVED

**COM-EX**  
Consultants

115 Route 46  
Suite E39  
Mountain Lakes, NJ 07046  
PHONE: 862.209.4300  
FAX: 862.209.4301



6100 SPRINT PARKWAY  
OVERLAND PARK, KS 66251



**SCHEDULE OF REVISIONS**

REV NO.	DATE	DESCRIPTION OF CHANGES
7		
6		
5		
4		
3		
2		
1	11/12/17	ISSUED FOR CONSTRUCTION
0	08/23/17	INITIAL SUBMISSION

**DRAWN BY:** JW  
**CHECKED BY:** NDB  
**SCALE:** AS NOTED  
**JOB NO:** 17109-CHE

Documents prepared by Com-Ex Consultants, including this document, are to be used only for the specific project and specific use for which they were intended. Any extension of use to any other projects, by owner or by any other party, without the expressed written consent of Com-Ex Consultants, is done unlawfully and at the users own risk. If used in a way other than that specifically intended, user will hold Com-Ex Consultants, harmless from all claims and losses.

INFORMATION ON THIS SET OF DRAWINGS IS NOT FOR OFFICIAL USE UNLESS ACCOMPANIED BY THE ENGINEER'S SEAL & SIGNATURE OF A PROFESSIONAL ENGINEER

*Nicholas D. Barile*  
**NICHOLAS D. BARILE**  
PROFESSIONAL ENGINEER No. 28643

**CT33XC116**  
**453 LOON MEADOW ROAD**  
**NORFOLK, CT 06058**  
**LITCHFIELD COUNTY**

**DRAWING TITLE:**

**EXISTING & FINAL ANTENNA PLANS**

**DRAWING SHEET: 3 OF 6**

**C-2**

BILL OF MATERIALS				
DESCRIPTION	QUANTITY EACH	DIMENSIONS (HxWxD)	WEIGHT (LBS) EACH	MANUFACTURER: PART/ MODEL#
800/2500 MHz PANEL ANTENNA - SECTOR 1	1	72"x14"x8"	58 LBS W/OUT MOUNTING HARDWARE	COMMSCOPE: DT465B-2XR
800 MHz RRH, 2x50W, -48V	1	16"x13"x10"	69.1 LBS W/OUT MOUNTING HARDWARE	ALU: RRH-2x50-800
800MHz RRH NOTCH FILTER	1	8.9"x8.9"x4.5"	9.45 LBS W/OUT MOUNTING HARDWARE	TBD
2500 MHz RRH, 8x20-25	1	26"x18.6"x6.7"	76.2 LBS W/OUT MOUNTING HARDWARE	ALU: TD-RRH8x20-25
800/2500 MHz PANEL ANTENNA - SECTOR 2	1	72"x14"x8"	58 LBS W/OUT MOUNTING HARDWARE	COMMSCOPE: DT465B-2XR
800 MHz RRH, 2x50W, -48V	1	16"x13"x10"	69.1 LBS W/OUT MOUNTING HARDWARE	ALU: RRH-2x50-800
800MHz RRH NOTCH FILTER	1	8.9"x8.9"x4.5"	9.45 LBS W/OUT MOUNTING HARDWARE	TBD
2500 MHz RRH, 8x20-25	1	26"x18.6"x6.7"	76.2 LBS W/OUT MOUNTING HARDWARE	ALU: TD-RRH8x20-25
800/2500 MHz PANEL ANTENNA - SECTOR 3	1	72"x14"x8"	58 LBS W/OUT MOUNTING HARDWARE	COMMSCOPE: DT465B-2XR
800 MHz RRH, 2x50W, -48V	1	16"x13"x10"	69.1 LBS W/OUT MOUNTING HARDWARE	ALU: RRH-2x50-800
800MHz RRH NOTCH FILTER	1	8.9"x8.9"x4.5"	9.45 LBS W/OUT MOUNTING HARDWARE	TBD
2500 MHz RRH, 8x20-25	1	26"x18.6"x6.7"	76.2 LBS W/OUT MOUNTING HARDWARE	ALU: TD-RRH8x20-25
DESCRIPTION	QUANTITY EACH	DIMENSIONS (LENGTH)	WEIGHT (LBS/FOOT)	MANUFACTURER: SIZE/PART/MODEL#
SECTOR 1 HYBRIFLEX RUN (BTS TO RRH)	1	±190'	1.3 LBS	RFS: 1-1/4" / HB114-1-08U4-M5J
SECTOR 1 COAX CABLE JUMPERS	11	10'	N/A	LDF4-50 (OR EQUIVALENT)
SECTOR 1 R.E.T. CABLES	4	(3) 10' / (1) 2'	N/A	TBD
SECTOR 2 COAX CABLE JUMPERS	11	10'	N/A	LDF4-50 (OR EQUIVALENT)
SECTOR 2 R.E.T. CABLES	4	(3) 10' / (1) 2'	N/A	TBD
SECTOR 3 COAX CABLE JUMPERS	11	10'	N/A	LDF4-50 (OR EQUIVALENT)
SECTOR 3 R.E.T. CABLES	4	(3) 10' / (1) 2'	N/A	TBD

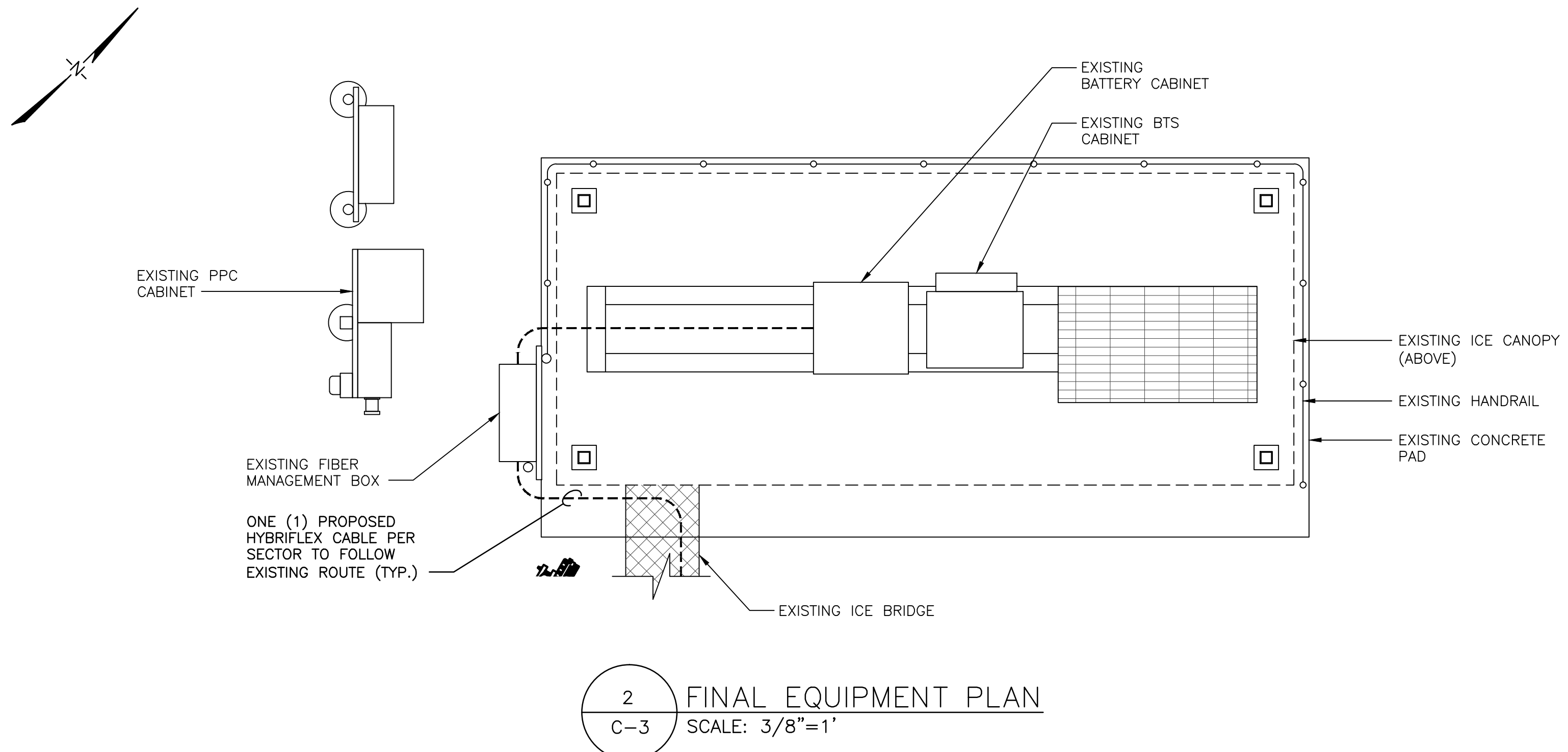
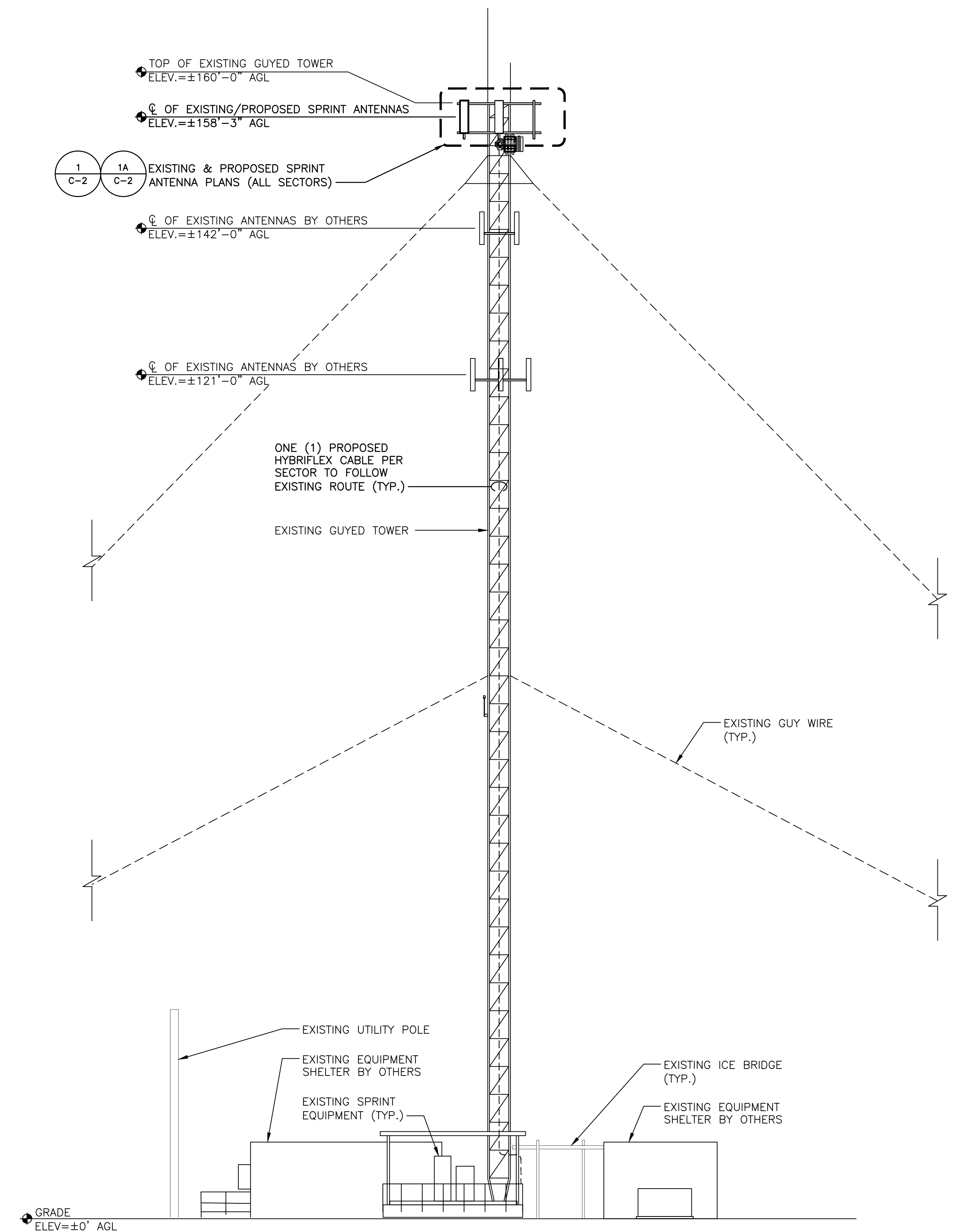

1 ELEVATION  
C-3 SCALE: 3/32"=1'  
(24"x36" SHEET SIZE)

ALL LOADING ASSOCIATED WITH PROPOSED EQUIPMENT CABINETS, ANTENNAS, AND CABLE ROUTING SHALL BE VERIFIED BY A PASSING STRUCTURAL ANALYSIS PERFORMED BY A LICENSED ENGINEER PRIOR TO INSTALLATION

2 FINAL EQUIPMENT PLAN  
C-3 SCALE: 3/8"=1'

**COM-EX**  
Consultants  
115 Route 46  
Suite E39  
Mountain Lakes, NJ 07046  
PHONE: 862.209.4300  
FAX: 862.209.4301

**Sprint**  
6100 SPRINT PARKWAY  
OVERLAND PARK, KS 66251

**Cherundolo Consulting**

SCHEDULE OF REVISIONS		
REV NO.	DATE	DESCRIPTION OF CHANGES
7		
6		
5		
4		
3		
2		
1	11/12/17	ISSUED FOR CONSTRUCTION
0	08/23/17	INITIAL SUBMISSION

DRAWN BY: JW  
CHECKED BY: NDB  
SCALE: AS NOTED  
JOB NO: 17109-CHE

Documents prepared by Com-Ex Consultants, including this document, are to be used only for the specific project and specific use for which they were intended. Any extension of use to any other projects, by owner or by any other party, without the expressed written consent of Com-Ex Consultants, is done unlawfully and at the users own risk. If used in a way other than that specifically intended, user will hold Com-Ex Consultants, harmless from all claims and losses.

INFORMATION ON THIS SET OF DRAWINGS IS NOT FOR OFFICIAL USE UNLESS ACCOMPANIED BY THE ISSUING SEAL & SIGNATURE OF A PROFESSIONAL ENGINEER  
**NICHOLAS D. BARILE**  
PROFESSIONAL ENGINEER, REG. NO. 28643

**CT33XC116**  
453 LOON MEADOW ROAD  
NORFOLK, CT 06058  
LITCHFIELD COUNTY

DRAWING TITLE:  
**ELEVATION, B.O.M., & FINAL EQUIPMENT PLAN**

DRAWING SHEET: 4 OF 6  
**C-3**

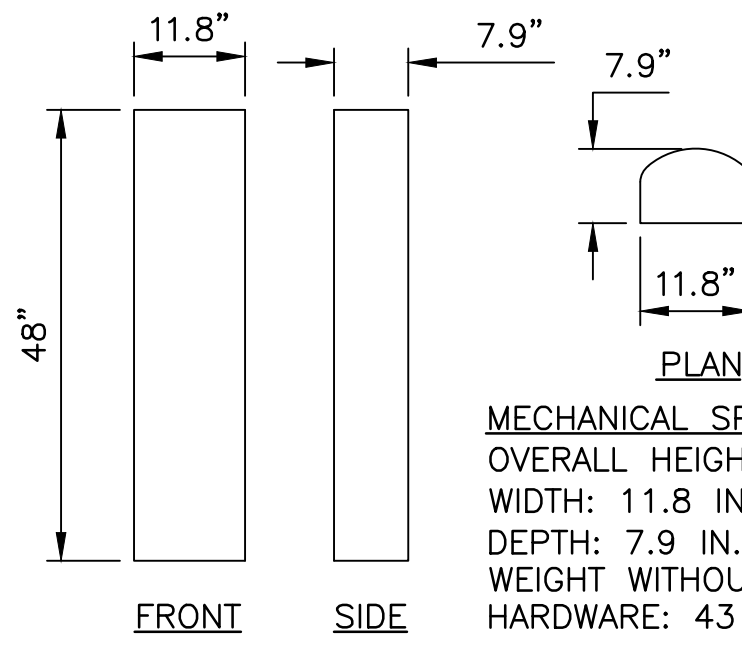

**MECHANICAL SPECIFICATIONS**  
 OVERALL HEIGHT: 48 IN. (1219.2mm)  
 WIDTH: 11.8 IN. (299.7mm)  
 DEPTH: 7.9 IN. (200.7mm)  
 WEIGHT WITHOUT MOUNTING HARDWARE: 43 LBS.

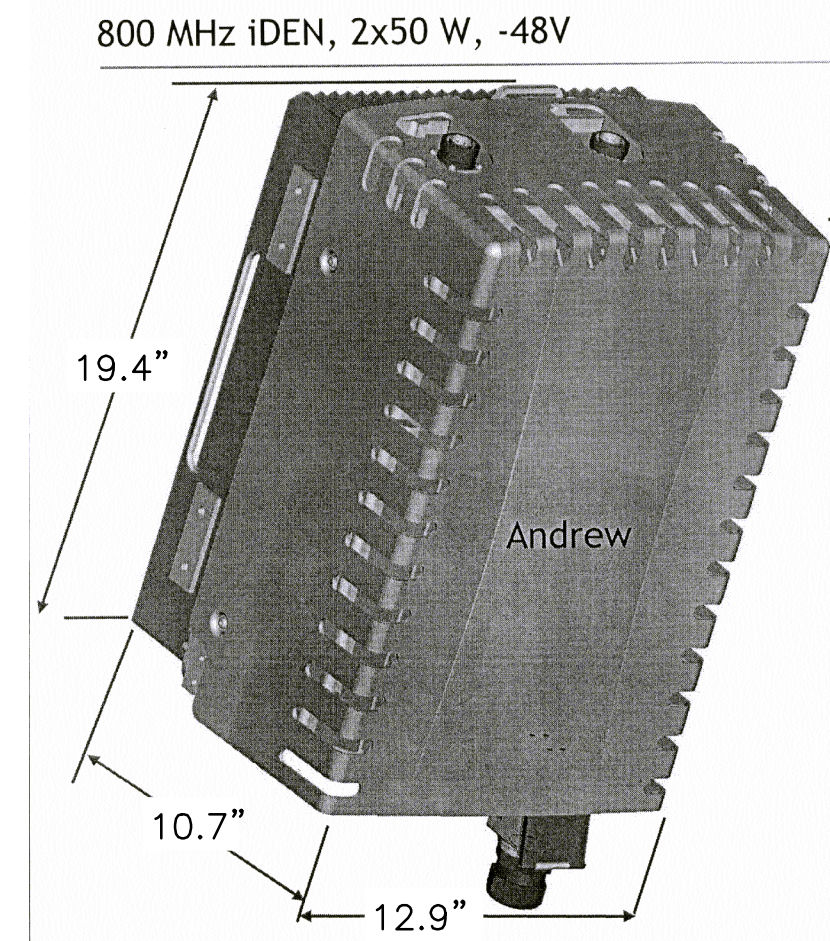

2 800MHz RRH DETAIL  
 SCALE: N.T.S.

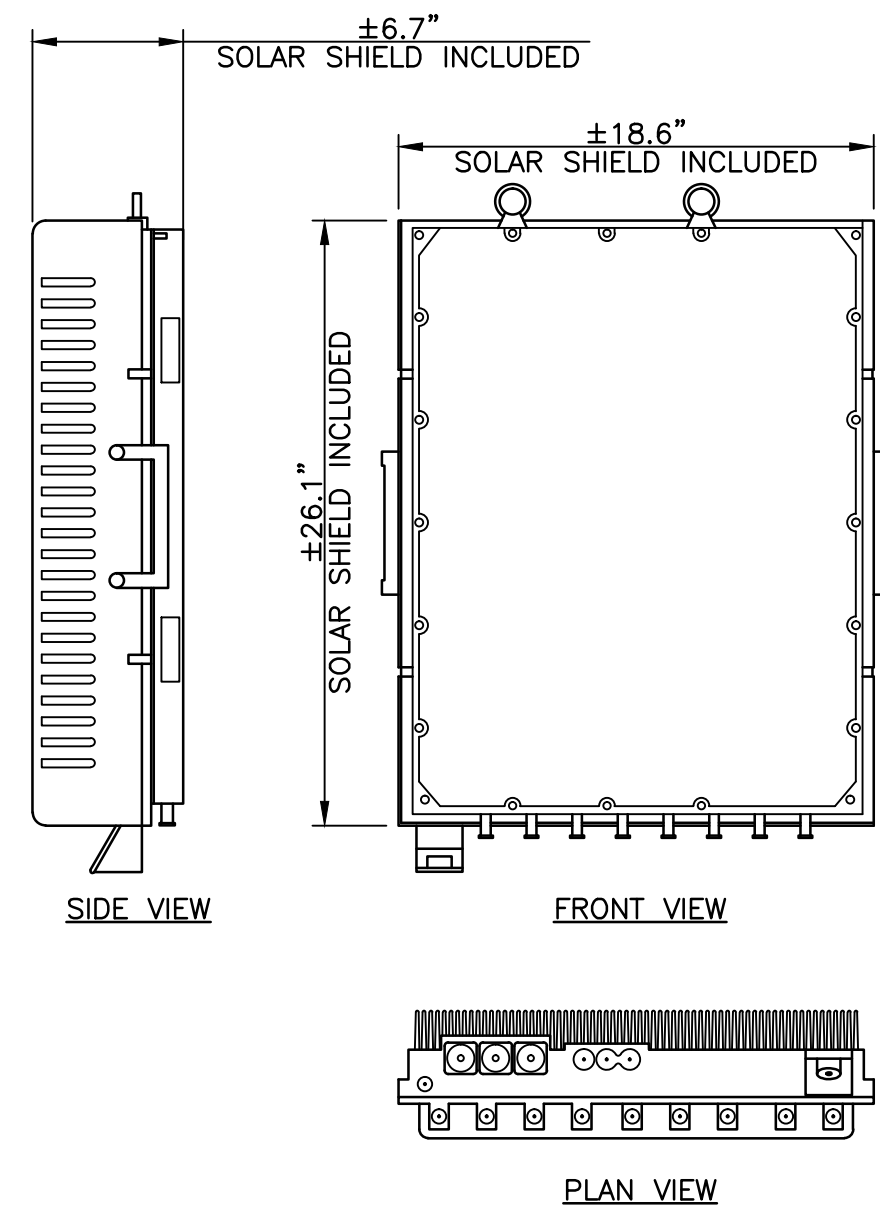

3 2500MHz RRH DETAIL  
 SCALE: N.T.S.

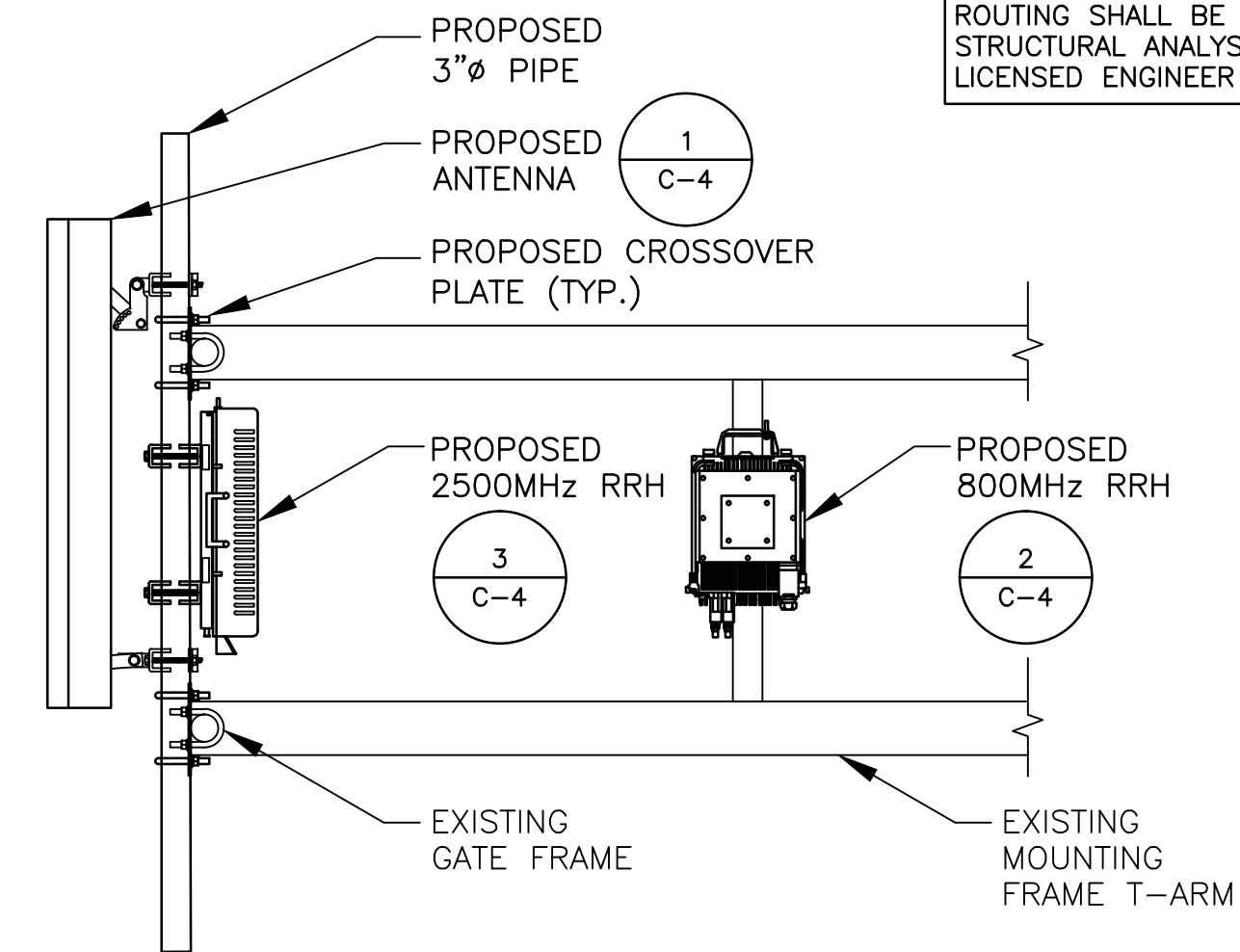

4 TYPICAL ANTENNA AND RRH INSTALLATION DETAIL  
 SCALE: N.T.S.

ALL LOADING ASSOCIATED WITH PROPOSED EQUIPMENT CABINETS, ANTENNAS, AND CABLE ROUTING SHALL BE VERIFIED BY A PASSING STRUCTURAL ANALYSIS PERFORMED BY A LICENSED ENGINEER PRIOR TO INSTALLATION

1 800/2500MHz ANTENNA COMMSCOPE: DT465B-2XR  
 SCALE: 1/2"=1"

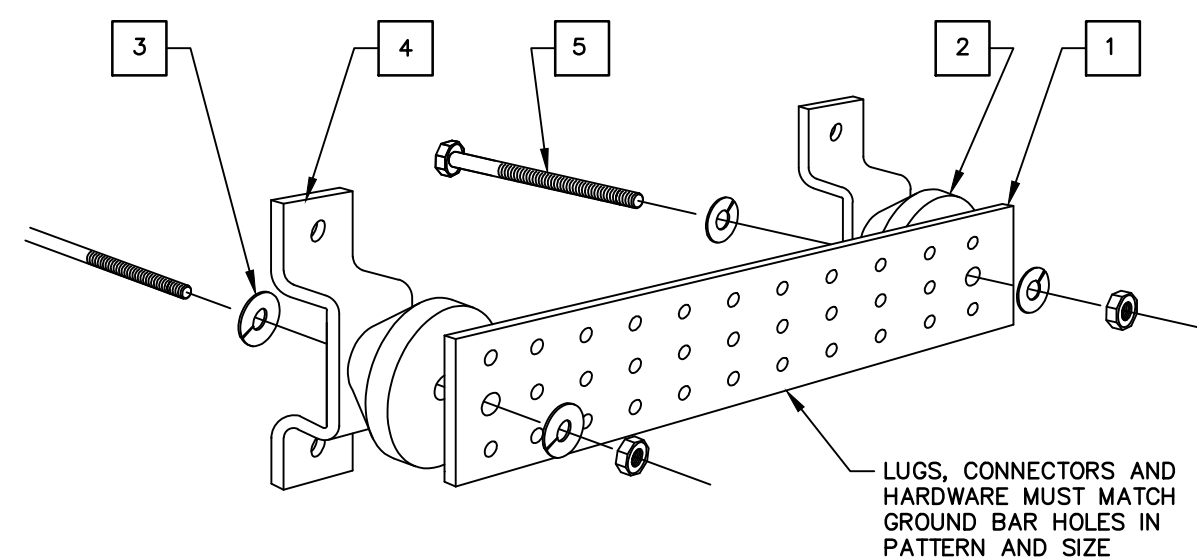

**LEGEND**

1. COPPER GROUND BAR, 7/16" X 4" X 20", NEWTON INSTRUMENT CO. CAT. NO. B-6142. HOLE CENTERS TO MATCH NEMA DOUBLE LUG CONFIGURATION.
2. INSULATORS, NEWTON INSTRUMENT CO. CAT. NO. 3081-4.
3. 5/8" LOCKWASHERS, NEWTON INSTRUMENT CO. CAT. NO. 3015-8.
4. WALL MOUNTING BRACKET, NEWTON INSTRUMENT CO. CAT. NO. A-6056.
5. 5/8-11 X 1" H.C.S.BOLTS, NEWTON INSTRUMENT CO. CAT. NO. 3012-1

GROUND BAR SCHEDULE				
TYPE	QTY.	MANUFACTURER	CAT. NO.	REMARKS
MGB	2	HARGER	GB14420TMGB	OR EQUAL
CGB	3	HARGER	GB14412TMGB	OR EQUAL

5 TYPICAL GROUND BAR DETAIL  
 SCALE: NTS

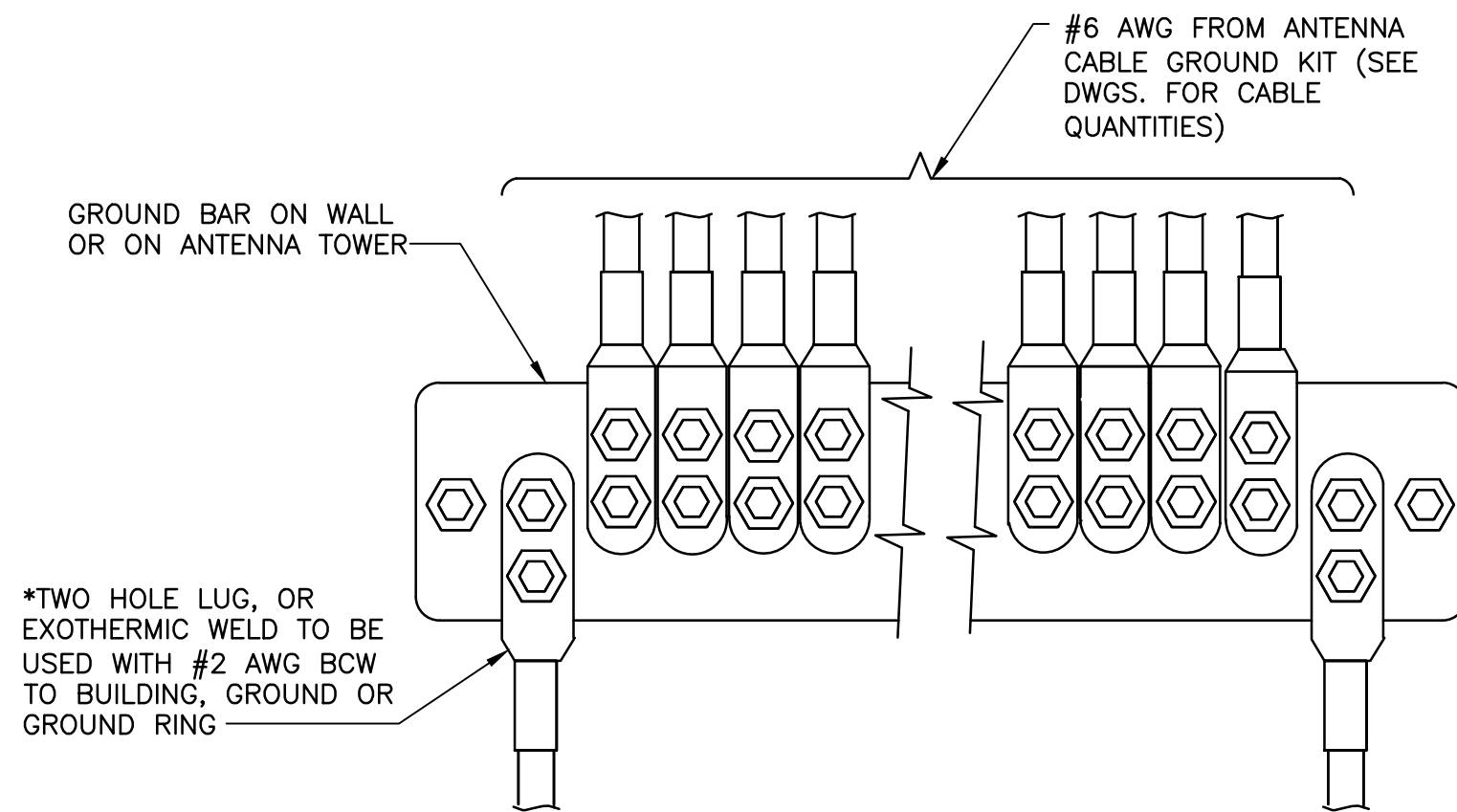

- \* - GROUND BARS AT THE BOTTOM OF TOWERS/MONOPOLES SHALL ONLY USE EXOTHERMIC WELDS.
- ATTACH "DO NOT DISCONNECT" LABELS TO GROUND BARS. CAN USE BRASS TAG "DO NOT DISCONNECT" AT EACH HYBRIFLEX GROUND POINT OR BACK-A-LITE PLATE LABEL ON GROUND BAR.
- CONNECT SEQUENCE- BOLT/WASHER/NO-OX/GROUND BAR/NO-OX/WASHER/LOCK-WASHER/NUT. THIS IS REPEATED FOR EACH LUG CONNECTION POINT.

6 TYPICAL GROUND BAR CONNECTION PLAN  
 SCALE: NTS

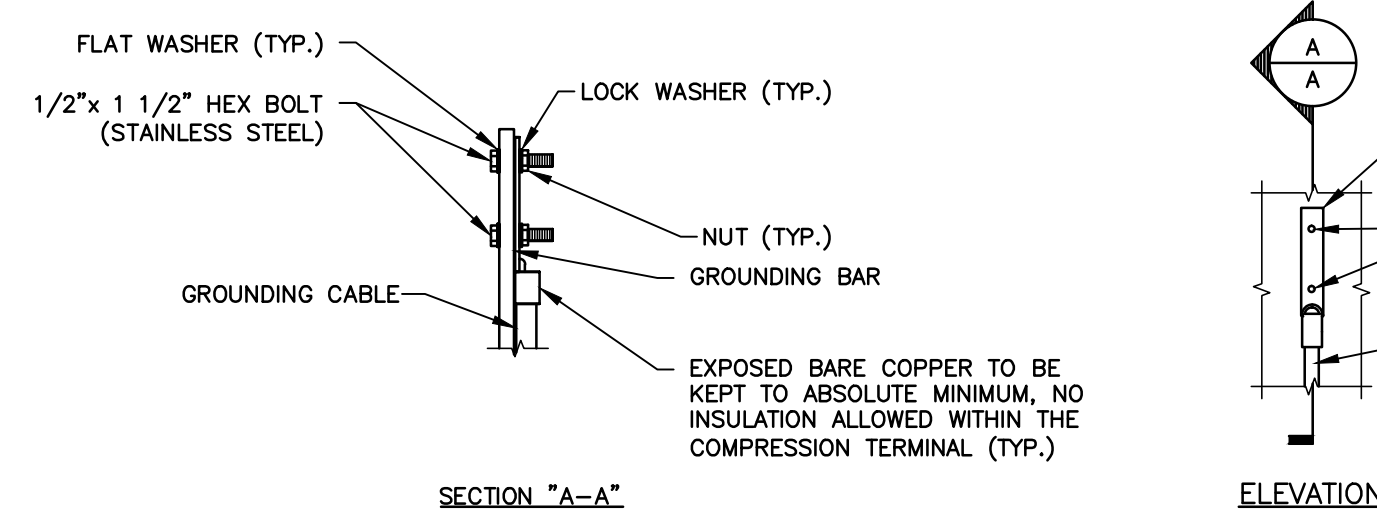

- NOTE:**
1. "DOUBLING UP" OR "STACKING" OF CONNECTIONS IS NOT PERMITTED.
  2. OXIDE INHIBITING COMPOUND TO BE USED AT ALL LOCATIONS.

7 TYPICAL GROUND BAR CONNECTION DETAIL  
 SCALE: NTS

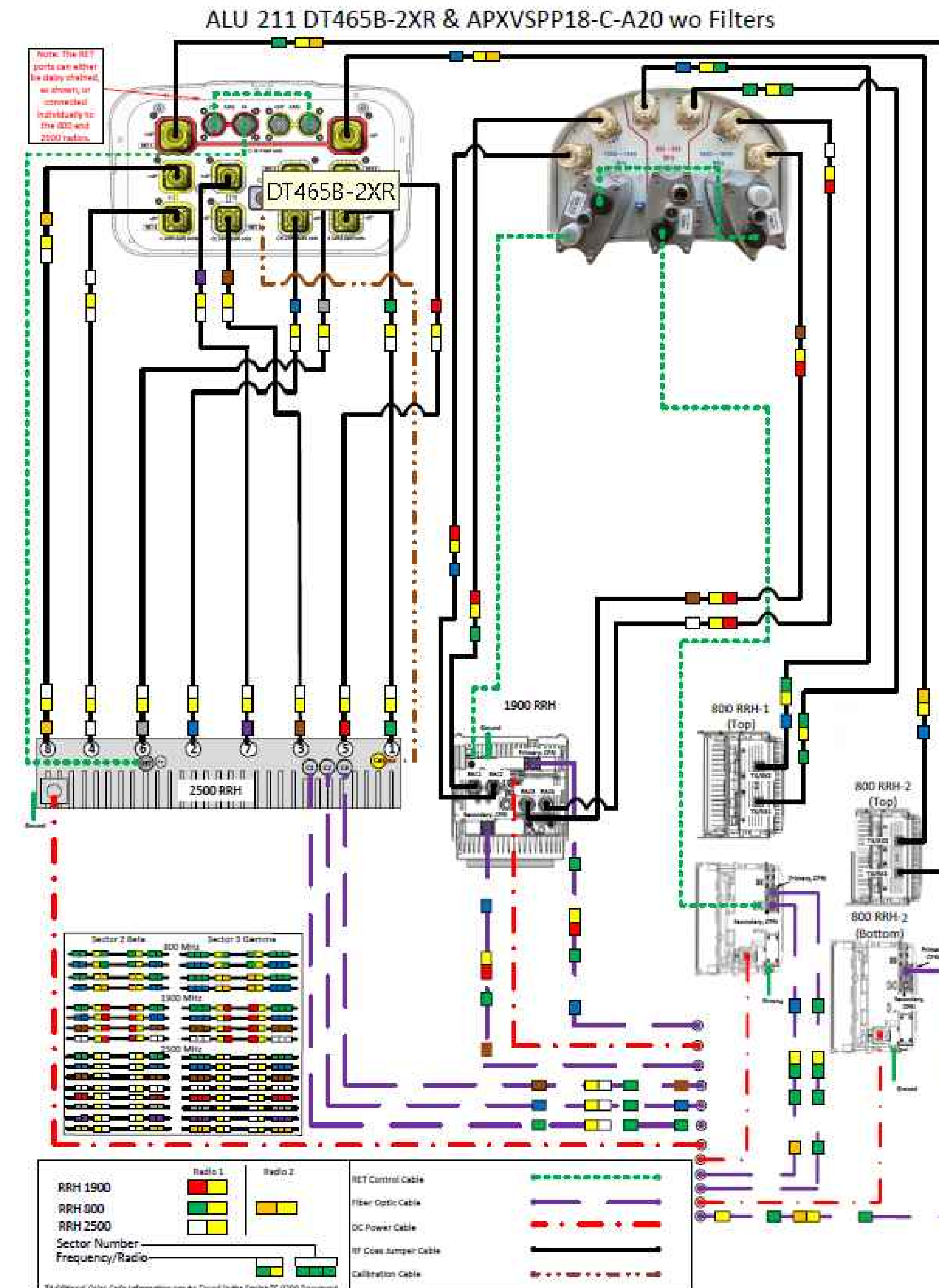

SCHEDULE OF REVISIONS		
REV NO.	DATE	DESCRIPTION OF CHANGES
7		
6		
5		
4		
3		
2		
1	11/12/17	ISSUED FOR CONSTRUCTION
0	08/23/17	INITIAL SUBMISSION

**DRAWN BY:** JW  
**CHECKED BY:** NDB  
**SCALE:** AS NOTED  
**JOB NO:** 17109-CHE

Documents prepared by Com-Ex Consultants, including this document, are to be used only for the specific project and specific use for which they were intended. Any extension of use to any other projects, by owner or by any other party, without the expressed written consent of Com-Ex Consultants, is done unlawfully and at the users own risk. If used in a way other than that specifically intended, user will hold Com-Ex Consultants, harmless from all claims and losses.

INFORMATION ON THIS SET OF DRAWINGS IS NOT FOR OFFICIAL USE UNLESS ACCOMPANIED BY THE ISSUING SEAL & SIGNATURE OF A PROFESSIONAL ENGINEER  
**NICHOLAS P. BARILE**  
 PROFESSIONAL ENGINEER, No. 28643

**CT33XC116**  
**453 LOON MEADOW ROAD**  
**NORFOLK, CT 06058**  
**LITCHFIELD COUNTY**

**DRAWING TITLE:**  
**CONSTRUCTION DETAILS & SCHEMATIC**

**DRAWING SHEET: 5 OF 6**

**C-4**

**SCHEDULE OF REVISIONS**

REV NO.	DATE	DESCRIPTION OF CHANGES
7		
6		
5		
4		
3		
2		
1	11/12/17	ISSUED FOR CONSTRUCTION
0	08/23/17	INITIAL SUBMISSION

**DRAWN BY:** JW  
**CHECKED BY:** NDB  
**SCALE:** AS NOTED  
**JOB NO:** 17109-CHE

Documents prepared by Com-Ex Consultants, including this document, are to be used only for the specific project and specific use for which they were intended. Any extension of use to any other projects, by owner or by any other party, without the expressed written consent of Com-Ex Consultants, is done unlawfully and at the users own risk. If used in a way other than that specifically intended, user will hold Com-Ex Consultants, harmless from all claims and losses.

INFORMATION ON THIS SET OF DRAWINGS IS NOT FOR OFFICIAL USE UNLESS ACCOMPANIED BY THE OFFICIAL SEAL & SIGNATURE OF A PROFESSIONAL ENGINEER  
**NICHOLAS D. BARILE**  
PROFESSIONAL ELECTRICAL ENGINEER No. 28643

**CT33XC116**  
**453 LOON MEADOW ROAD**  
**NORFOLK, CT 06058**  
**LITCHFIELD COUNTY**

**DRAWING TITLE:**  
**ELECTRICAL**  
**GROUNDING**  
**DETAILS, NOTES, &**  
**COAX COLOR CODE**

**DRAWING SHEET: 6 OF 6**

**E-1**

**ELECTRICAL AND GROUNDING NOTES**

- ALL ELECTRICAL WORK SHALL CONFORM TO THE REQUIREMENTS OF THE NATIONAL ELECTRICAL CODE (NEC) AS WELL AS APPLICABLE STATE AND LOCAL CODES.
- ALL ELECTRICAL ITEMS SHALL BE U.L. APPROVED OR LISTED AND PROCURED PER SPECIFICATION REQUIREMENTS.
- ELECTRICAL AND TELCO WIRING OUTSIDE A BUILDING AND EXPOSED TO WEATHER SHALL BE IN WATER TIGHT GALVANIZED RIGID STEEL CONDUITS OR SCHEDULE 80 PVC (AS PERMITTED BY CODE) AND WHERE REQUIRED IN LIQUID TIGHT FLEXIBLE METAL OR NONMETALLIC CONDUITS.
- BURIED CONDUIT SHALL BE SCHEDULE 40 PVC.
- ELECTRICAL WIRING SHALL BE COPPER WITH TYPE XHHW, THWN, OR THHN INSULATION.
- RUN TELCO CONDUIT OR CABLE BETWEEN TELEPHONE UTILITY DEMARCATION POINT AND PROJECT OWNER CELL SITE TELCO CABINET AND BTS CABINET AS INDICATED ON THIS DRAWING PROVIDE FULL LENGTH PULL ROPE IN INSTALLED TELCO CONDUIT. PROVIDE GREENLEE CONDUIT MEASURING TAPE AT EACH END.
- WHERE CONDUIT BETWEEN BTS AND PROJECT OWNER CELL SITE PPC AND BETWEEN BTS AND PROJECT OWNER CELL SITE TELCO SERVICE CABINET ARE UNDERGROUND USE PVC, SCHEDULE 40 CONDUIT. ABOVE THE GROUND PORTION OF THESE CONDUITS SHALL BE PVC CONDUIT.
- ALL EQUIPMENT LOCATED OUTSIDE SHALL HAVE NEMA 3R ENCLOSURE.
- GROUNDING SHALL COMPLY WITH NEC ART. 250.
- GROUND HYBRIFLEX CABLE SHIELDS AT 3 LOCATIONS USING MANUFACTURER'S HYBRIFLEX CABLE GROUNDING KITS SUPPLIED BY PROJECT OWNER.
- USE #6 COPPER STRANDED WIRE WITH GREEN COLOR INSULATION FOR ABOVE GRADE GROUNDING (UNLESS OTHERWISE SPECIFIED) AND #2 SOLID TINNED BARE COPPER WIRE FOR BELOW GRADE GROUNDING AS INDICATED ON THE DRAWING.
- ALL GROUND CONNECTIONS TO BE BURNDY HYGROUND COMPRESSION TYPE CONNECTORS OR CADWELD EXOTHERMIC WELD. DO NOT ALLOW BARE COPPER WIRE TO BE IN CONTACT WITH GALVANIZED STEEL.
- ROUTE GROUNDING CONDUCTORS ALONG THE SHORTEST AND STRAIGHTEST PATH POSSIBLE, EXCEPT AS OTHERWISE INDICATED. GROUNDING LEADS SHOULD NEVER BE BENT AT RIGHT ANGLE. ALWAYS MAKE AT LEAST 12" RADIUS BENDS. #6 WIRE CAN BE BENT AT 6" RADIUS WHEN NECESSARY. BOND ANY METAL OBJECTS WITHIN 6 FEET OF PROJECT OWNER EQUIPMENT OR CABINET TO MASTER GROUND BAR OR GROUNDING RING.
- CONNECTIONS TO GROUND BARS SHALL BE MADE WITH TWO HOLE COMPRESSION TYPE COPPER LUGS. APPLY OXIDE INHIBITING COMPOUND TO ALL LOCATIONS.
- APPLY OXIDE INHIBITING COMPOUND TO ALL COMPRESSION TYPE GROUND CONNECTIONS.
- BOND ANTENNA MOUNTING BRACKETS, HYBRIFLEX CABLE GROUND KITS, AND RRHs TO EGB PLACED NEAR THE ANTENNA LOCATION.
- BOND ANTENNA EGB'S AND MGB TO GROUND RING.
- CONTRACTOR SHALL TEST COMPLETED GROUND SYSTEM AND RECORD RESULT FOR PROJECT CLOSE-OUT DOCUMENTATION. 5 OHMS MINIMUM RESISTANCE REQUIRED.
- CONTRACTOR SHALL CONDUCT ANTENNA, HYBRIFLEX CABLES, AND RRH RETURN-LOSS AND DISTANCE-TO-FAULT MEASUREMENTS (SWEEP TESTS) AND RECORD RESULTS FOR PROJECT CLOSE OUT.
- CONTRACTOR (CERTIFIED ELECTRICIAN) SHALL CHECK CAPACITY OF EXISTING SERVICE & PANEL ON SITE TO DETERMINE IF CAPACITY EXISTS TO ACCOMMODATE THE ADDED LOAD OF THIS PROJECT. ADVISE ENGINEER OF ANY DISCREPANCY.

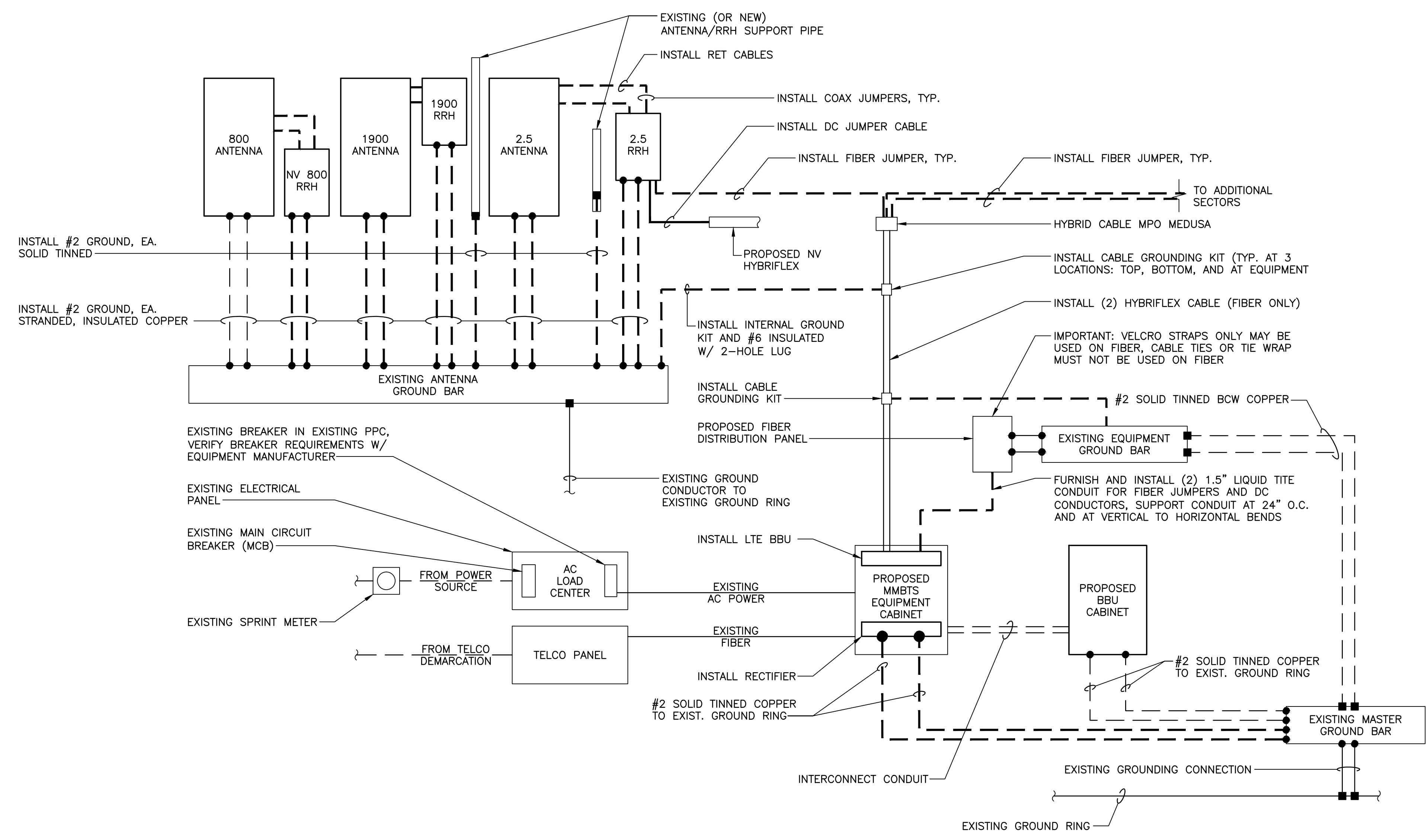

**1**  
**E-1** TYPICAL POWER & GROUNDING ONE-LINE DIAGRAM  
SCALE: N.T.S.

**COAXIAL CABLE COLOR CODE**

SECTOR	CABLE	FIRST RING	SECOND RING	THIRD RING
1ALPHA	1	GREEN	NO TAPE	NO TAPE
	2	BLUE	NO TAPE	NO TAPE
	3	BROWN	NO TAPE	NO TAPE
	4	WHITE	NO TAPE	NO TAPE
	5	RED	NO TAPE	NO TAPE
	6	SLATE	NO TAPE	NO TAPE
	7	PURPE	NO TAPE	NO TAPE
	8	ORANGE	NO TAPE	NO TAPE
2BETA	1	GREEN	GREEN	NO TAPE
	2	BLUE	BLUE	NO TAPE
	3	BROWN	BROWN	NO TAPE
	4	WHITE	WHITE	NO TAPE
	5	RED	RED	NO TAPE
	6	SLATE	SLATE	NO TAPE
	7	PURPLE	PURPLE	NO TAPE
	8	ORANGE	ORANGE	NO TAPE
3GAMMA	1	GREEN	GREEN	GREEN
	2	BLUE	BLUE	BLUE
	3	BROWN	BROWN	BROWN
	4	WHITE	WHITE	WHITE
	5	RED	RED	RED
	6	SLATE	SLATE	SLATE
	7	PURPLE	PURPLE	PURPLE
	8	ORANGE	ORANGE	ORANGE

CONTRACTOR TO REPLACE ALL EXISTING GROUND BARS AND GROUND WIRES THROUGHOUT SITE INCLUDING COAX CABLE GROUNDING AND SECTOR GROUND BARS LOCATED AT ANTENNAS. CONTRACTOR IS TO ALSO REPLACE GROUND WIRE FROM GROUND BAR AT EQUIPMENT TO BUILDING WATER MAIN THROUGH EXISTING CONDUIT.

**NOTES:**  
1. CONTRACTOR (ELECTRICIAN) TO VERIFY IN FIELD THAT THE CABLING SERVING THE EXISTING BTS CABINET FROM THE EXISTING POWER PANEL IS RATED EQUAL TO OR GREATER THAN (2) #1 AWG AND (2) #8 AWG SPECIFIED FOR THE PROPOSED BTS 9927/9928 CABINET. UPGRADE THE CABLING AND CONDUIT IF NEEDED.  
2. ALU SUPPLIED SEALTITE BETWEEN BTS AND DISTRIBUTION BOX MUST BE SUPPORTED EVERY 24" MAX.

**SPECIAL GROUNDING NOTE:**  
FOR NEW OR REPAIRED GROUNDING EQUIPMENT, REFER TO SPRINT GROUNDING STANDARDS AND THE FOLLOWING (SUPPLEMENTS).  
• ANTI-THEFT UPDATE TO SPRINT GROUNDING 08.24.12  
• SPRINT ENGINEERING LETTER EL-0504 DATED 04.20.12

**SPRINT CONSTRUCTION STANDARDS:**  
GENERAL CONTRACTOR SHALL ADHERE TO THE FOLLOWING SPRINT CONSTRUCTION STANDARDS (AS AMENDED FROM TIME TO TIME AND AVAILABLE ON THE ALU FST DATABASE):  
1. CONSTRUCTION STANDARDS: INTEGRATED CONSTRUCTION STANDARDS FOR WIRELESS SITES VERSION 4.0, INCLUDING EXHIBITS A-M.  
2. CONSTRUCTION SPECIFICATIONS: CONSTRUCTION STANDARDS EXHIBIT A - STANDARD CONSTRUCTION SPECIFICATIONS FOR WIRELESS SITES (VERSION 4.0).  
3. GROUNDING STANDARDS: EXTERIOR GROUNDING SYSTEM DESIGN.  
4. GROUNDING STANDARDS (SUPPLEMENT): ANTI-THEFT UPDATE TO SPRINT GROUNDING 082412 AND SPRINT ENGINEERING LETTER EL-0504 DATED 04.20.12.  
5. WEATHER PROOFING STANDARDS: EXCERPT FROM CONSTRUCTION STANDARDS EXHIBIT A, SECTION 3.6 WEATHERPROOFING CONNECTORS AND GROUND KITS.  
6. COLOR CODING: SPRINT NEXTEL ANT AND LINE COLOR CODING (DRAFT) V3 09-08-11.





## SUMMARY & RESULTS

The purpose of this analysis was to verify whether the existing structure is capable of carrying the proposed loading configuration as specified by Sprint to AT&T Towers. This report was commissioned by Ms. Reggie Barrau of AT&T Towers.

This analysis has been performed in accordance with the 2016 Connecticut State Building Code based upon an ultimate 3-second gust wind speed of 115 mph converted to a nominal 3-second gust wind speed of 89 mph per Section 1609.3 and Appendix N as required for use in the TIA-222-G Standard per Exception #5 of Section 1609.1.1. Exposure Category B with a maximum topographic factor, Kzt, of 1.000 and Risk Category II were used in this analysis.

Modifications by GPD Project #: 2018723.01.71285.02, dated 6/28/2018, have been considered in this analysis.

### TOWER SUMMARY AND RESULTS

Member	Capacity	Results
Legs	44.9%	Pass
Diagonals	54.9%	Pass
Horizontals	36.4%	Pass
Guy Wires	51.4%	Pass
Guy Pull-Offs	29.0%	Pass
Torque Arms	15.5%	Pass
Bolt Checks	54.9%	Pass
Guy Anchor Foundation	28.1%	Pass
Tower Base Foundation	61.9%	Pass

## ANALYSIS METHOD

tnxTower (Version 7.0.7.0), a commercially available software program, was used to create a three-dimensional model of the tower and calculate primary member stresses for various dead, live, wind, and ice load cases. Selected output from the analysis is included in Appendix B. The following table details the information provided to complete this structural analysis. This analysis is solely based on this information and is being completed without the benefit of a recent detailed site visit.

### DOCUMENTS PROVIDED

Document	Remarks	Source
Site Lease Application	Sprint Colocation Application, dated 5/2/2018	AT&T
Tower Design	Not Provided	N/A
Foundation Design	Not Provided	N/A
Geotechnical Report	WEI Project # 2010-1212, dated 9/15/2010	AT&T
Previous Structural Analysis	GPD Job #: 2018702.82, dated 4/3/2018	AT&T
Modification Drawings	GPD Project #: 2018723.01.71285.02, dated 6/28/2018	GPD
Tower Mapping	GPD & MTSI Northeast, dated 7/21/2010	AT&T
Foundation Mapping	WEI Project # 2010-1212, dated 9/15/2010	AT&T

## ASSUMPTIONS

This structural analysis is based on the theoretical capacity of the members and is not a condition assessment of the tower. This analysis is from information supplied, and therefore, its results are based on and are as accurate as that supplied data. GPD has made no independent determination, nor is it required to, of its accuracy. The following assumptions were made for this structural analysis.

1. The tower member sizes and shapes are considered accurate as supplied. The material grade is as per data supplied and/or as assumed and as stated in the materials section.
2. The antenna configuration is as supplied and/or as modeled in the analysis. It is assumed to be complete and accurate. All antennas, mounts, coax and waveguides are assumed to be properly installed and supported as per manufacturer requirements.
3. Some assumptions are made regarding antennas and mount sizes and their projected areas based on best interpretation of data supplied and of best knowledge of antenna type and industry practice.
4. All mounts, if applicable, are considered adequate to support the loading. No actual analysis of the mount(s) is performed. This analysis is limited to analyzing the tower only.
5. The soil parameters are as per data supplied or as assumed and stated in the calculations.
6. Foundations are properly designed and constructed to resist the original design loads indicated in the documents provided.
7. The tower and structures have been properly maintained in accordance with TIA Standards and/or with manufacturer's specifications.
8. All welds and connections are assumed to develop at least the member capacity unless determined otherwise and explicitly stated in this report.
9. All prior structural modifications are assumed to be as per data supplied/available and to have been properly installed.
10. Loading interpreted from photos is accurate to  $\pm 5'$  AGL, antenna size accurate to  $\pm 3.3$  sf, and coax equal to the number of existing antennas without reserve.
11. The existing loading was obtained from the previous structural analysis by GPD (Job #: 2018702.82, dated 4/3/2018), the provided Site Lease Application and site photos and is assumed to be accurate.
12. The azimuth orientation of Leg A was assumed to be at 340 degrees based on the tower mapping performed by GPD & MTSI Northeast (dated 7/21/2010).
13. Foundation steel was not able to be determined. Therefore it was assumed that the foundation steel in place is equal to the minimum required steel per code specifications.

If any of these assumptions are not valid or have been made in error, this analysis may be affected, and GPD should be allowed to review any new information to determine its effect on the structural integrity of the tower.

## DISCLAIMER OF WARRANTIES

GPD has not performed a recent site visit to the tower to verify the member sizes or antenna/coax loading. If the existing conditions are not as represented on the tower elevation contained in this report, we should be contacted immediately to evaluate the significance of the discrepancy. This is not a condition assessment of the tower or foundation. This report does not replace a full tower inspection. The tower and foundations are assumed to have been properly fabricated, erected, maintained, in good condition, twist free, and plumb.

The engineering services rendered by GPD in connection with this Rigorous Structural Analysis are limited to a computer analysis of the tower structure and theoretical capacity of its main structural members. No allowance was made for any damaged, bent, missing, loose, or rusted members (above and below ground). No allowance was made for loose bolts or cracked welds.

This analysis is limited to the designated maximum wind and seismic conditions per the governing tower standards and code. Wind forces resulting in tower vibrations near the structure's resonant frequencies were not considered in this analysis and are outside the scope of this analysis. Lateral loading from any dynamic response was not evaluated under a time-domain based fatigue analysis.

GPD does not analyze the fabrication of the structure (including welding). It is not possible to have all the very detailed information needed to perform a thorough analysis of every structural sub-component and connection of an existing tower. GPD provides a limited scope of service in that we cannot verify the adequacy of every weld, plate connection detail, etc. The purpose of this report is to assess the capability of adding appurtenances usually accompanied by transmission lines to the structure.

It is the owner's responsibility to determine the amount of ice accumulation in excess of the code specified amount, if any, that should be considered in the structural analysis.

The attached sketches are a schematic representation of the analyzed tower. If any material is fabricated from these sketches, the contractor shall be responsible for field verifying the existing conditions, proper fit, and clearance in the field. Any mentions of structural modifications are reasonable estimates and should not be used as a precise construction document. Precise modification drawings are obtainable from GPD, but are beyond the scope of this report.

Miscellaneous items such as antenna mounts, etc., have not been designed or detailed as a part of our work. We recommend that material of adequate size and strength be purchased from a reputable tower manufacturer.

Towers are designed to carry gravity, wind, and ice loads. All members, legs, diagonals, struts, and redundant members provide structural stability to the tower with little redundancy. Absence or removal of a member can trigger catastrophic failure unless a substitute is provided before any removal. Legs carry axial loads and derive their strength from shorter unbraced lengths by the presence of redundant members and their connection to the diagonals with bolts or welds. If the bolts or welds are removed without providing any substitute to the frame, the leg is subjected to a higher unbraced length that immediately reduces its load carrying capacity. If a diagonal is also removed in addition to the connection, the unbraced length of the leg is greatly increased, jeopardizing its load carrying capacity. Failure of one leg can result in a tower collapse because there is no redundancy. Redundant members and diagonals are critical to the stability of the tower.

GPD makes no warranties, expressed and/or implied, in connection with this report and disclaims any liability arising from material, fabrication, and erection of this tower. GPD will not be responsible whatsoever for, or on account of, consequential or incidental damages sustained by any person, firm, or organization as a result of any data or conclusions contained in this report. The maximum liability of GPD pursuant to this report will be limited to the total fee received for preparation of this report.

## **APPENDIX A**

### Tower Analysis Summary Form

## Tower Analysis Summary Form

### General Info

Site Name	NORFOLK-LOON MEADOW RD
Site Number	71285
FA Number	10035022
Date of Analysis	6/28/2018
Company Performing Analysis	GPD

The information contained in this summary report is not to be used independently from the PE stamped tower analysis.

Tower Info	Description	Date
Tower Type (G, SST, MP)	G	
Tower Height (top of steel AGL)	160'	
Tower Manufacturer	n/a	
Tower Model	n/a	
Tower Design	n/a	
Foundation Design	n/a	
Geotech Report	WEI Project #: 2010-1212	9/15/2010
Tower Mapping	GPD & MTSI Northeast	7/21/2010
Previous Structural Analysis	GPD Job #: 2018702.82	4/3/2018
Foundation Mapping	WEI Project #: 2010-1212	9/15/2010

Design Parameters	
Design Code Used	TIA-222-G, 2012 IBC & 2016 CTBC
Location of Tower (County, State)	Litchfield, Connecticut
Basic Wind Speed (mph)	89-mph (3-second gust)
Ice Thickness (in)	0.75
Structure Classification (I, II, III)	II
Exposure Category (B, C, D)	B
Topographic Category (1 to 5)	1

Analysis Results (% Maximum Usage)	
<b>Existing/Reserved + Future + Proposed Condition (Modified)</b>	
Tower (%)	54.9%
Guy Wires (%)	51.4%
Foundation (%)	61.9%
Foundation Adequate?	Yes

Analysis Results (% Maximum Usage)	
<b>Existing/Reserved (Unmodified)</b>	
Tower (%)	51.1%
Guy Wires (%)	49.7%
Foundation (%)	118.3%
Foundation Adequate?	No

Analysis Results (% Maximum Usage)	
<b>Existing/Reserved + Proposed Condition (Unmodified)</b>	
Tower (%)	54.3%
Guy Wires (%)	51.1%
Foundation (%)	122.6%
Foundation Adequate?	No

### Steel Yield Strength (ksi)

Legs	50
Braces	36
Member Bolts	A325
Guy Wires	EHS

Note: Steel grades assumed based on past experience with similar towers.

Modification drawings by GPD Project #: 2018723.01.71285.02, dated 6/28/2018, have been considered in this analysis.

### Existing / Reserved Loading

Antenna Owner	Mount Height (ft)	Antenna CL (ft)	Antenna					Mount			Transmission Line			
			Quantity	Type	Manufacturer	Model	Azimuth	Quantity	Manufacturer	Type	Quantity	Model	Size	Attachment Leg/Face
AT&T Mobility	160	168	1	Dipole	Unknown	10' Dipole		1	Unknown	Pipe Mount	1	Unknown	7/8"	Face A
AT&T Mobility	160	160	1	Omni	Unknown	3' Omni				Flush Mount				
Sprint	158	158	3	Panel	RFS	APXVSP18-C-A20	50/170/250	3	Unknown	12' Boom Gate	3	Hybriflex	1-1/4"	Face A
Sprint	154	154	3	RRU	Alcatel Lucent	RRH2X50-800				Flush Mounted	1	RET Cable	3/8"	Face A
Sprint	154	154	3	RRU	Alcatel Lucent	RRH1900-4X40				Flush Mounted				
AT&T Mobility	148	148	1	Yagi	Unknown	4' Yagi		1	Unknown	Pipe Mount	1	Unknown	1/2"	Face A
AT&T Mobility	142	143	3	Panel	KMW	AM-X-CD-16-65-00T-RET	23/143/264	3	Unknown	8' Frame	12	Unknown	1-5/8"	Face B
AT&T Mobility	142	143	6	Panel	Powerwave	7770	23/143/264			on the same mounts	2	DC/Fiber Bundle	1-1/2"	Face B
AT&T Mobility	142	143	3	Panel	Kathrein	800-10965	23/143/264			on the same mounts				
AT&T Mobility	142	143	6	TMA	Powerwave	TT19-08BP111-001				on the same mounts				
AT&T Mobility	142	143	12	RET	Powerwave	7020				on the same mounts				
AT&T Mobility	142	143	3	RRU	Ericsson	RRUS 11				on the same mounts				
AT&T Mobility	142	143	3	RRU	Ericsson	B14 4478				on the same mounts				
AT&T Mobility	142	143	3	RRU	Ericsson	RRUS-32 B2				on the same mounts				
AT&T Mobility	142	143	2	Surge	Andrew	ABT-DFDM-ADBH				on the same mounts				
Unknown	137							2	Unknown	4' Sidearm				
T-Mobile	120	120	3	Panel	EMS	RR90-17-02DP	60/190/280	3	Unknown	4' Standoff	6	Unknown	1-1/4"	Face A
T-Mobile	120	120	3	Panel	Commscope	LNX-6515DS-VTM	60/190/280			on the same mounts	6	Unknown	1-5/8"	Face B
T-Mobile	120	120	6	TMA	RFS	1412D-1A20				on the same mounts	1	RET Cable	3/8"	Face B
AT&T Mobility	113	113	1	GPS	Unknown	GPS		1	Unknown	1' Sidearm	1	Unknown	1/2"	Face B

### Proposed Loading

Antenna Owner	Mount Height (ft)	Antenna CL (ft)	Antenna					Mount			Transmission Line			
			Quantity	Type	Manufacturer	Model	Azimuth	Quantity	Manufacturer	Type	Quantity	Model	Size	Attachment Leg/Face
Sprint	158	158	3	Panel	Commscope	DT465B-2XR				on the existing mounts				
Sprint	158	158	3	RRU	Alcatel Lucent	TD-RRH8X20-25	50/170/250			on the existing mounts	1	Unknown	1/2"	Face A
Sprint	154	154	3	RRU	Alcatel Lucent	RRH-2x50-800				Flush Mounted				

Note: The proposed loading shall be in addition to the existing equipment at the same elevation.

Note: The proposed coax shall be installed in a single row with the existing Sprint feedlines on Face A in order for the analysis to be valid. See Appendix C for the proposed coax layout.

### Future Loading

Antenna Owner	Mount Height (ft)	Antenna CL (ft)	Antenna					Mount			Transmission Line			
			Quantity	Type	Manufacturer	Model	Azimuth	Quantity	Manufacturer	Type	Quantity	Model	Size	Attachment Leg/Face
AT&T Mobility	142	143	3	Panel	Kathrein	800-10965	23/143/264			on the existing mounts	6	Unknown	1-5/8"	Face B

Note: The future loading shall be in addition to the existing equipment at the same elevation.

Note: The future coax shall be stacked on top of the existing AT&T coax on Face B to form two different (3) on (3) on (3) configurations. See Appendix C for the proposed coax layout.

## **APPENDIX B**

tnxTower Output File

<b>tnxTower</b>  <b>GPD</b> 520 South Main Street Suite 2531 Akron, Ohio 44311 Phone: (555) 555-1234 FAX: (555) 555-1235	<b>Job</b>	71285 NORFOLK-LOON MEADOW RD	<b>Page</b>	1 of 8
	<b>Project</b>	2018723.01.71285.02	<b>Date</b>	16:23:29 06/18/18
	<b>Client</b>	AT&T	<b>Designed by</b>	mmoeller

## Tower Input Data

The main tower is a 3x guyed tower with an overall height of 160.00 ft above the ground line.

The base of the tower is set at an elevation of 0.00 ft above the ground line.

The face width of the tower is 4.00 ft at the top and tapered at the base.

This tower is designed using the TIA-222-G standard.

The following design criteria apply:

Tower is located in Litchfield County, Connecticut.

Basic wind speed of 89 mph.

Structure Class II.

Exposure Category B.

Topographic Category 1.

Crest Height 0.00 ft.

Nominal ice thickness of 0.7500 in.

Ice thickness is considered to increase with height.

Ice density of 56 pcf.

A wind speed of 40 mph is used in combination with ice.

Temperature drop of 50 °F.

Deflections calculated using a wind speed of 60 mph.

Pressures are calculated at each section.

Safety factor used in guy design is 1.

Stress ratio used in tower member design is 1.

Local bending stresses due to climbing loads, feed line supports, and appurtenance mounts are not considered.

## Feed Line/Linear Appurtenances - Entered As Round Or Flat

Description	Face or Leg	Allow Shield	Component Type	Placement ft	Face Offset in	Lateral Offset (Frac FW)	#	# Per Row	Clear Spacing in	Width or Diameter in	Perimeter in	Weight plf
Climbing Ladder	B	No	Af (CaAa)	160.00 - 8.00	-2.0000	0	1	1	3.8400	3.8400		7.90
LDF5-50A (7/8 FOAM)	A	No	Ar (CaAa)	160.00 - 8.00	-2.0000	-0.35	1	1	1.0000	1.0900		0.33
Coax Bracket 5/20' x 12"	A	No	Af (CaAa)	160.00 - 8.00	0.0000	0	1	1	0.5000	0.5000		0.43
Hybriflex (1-1/4")	A	No	Ar (CaAa)	158.00 - 8.00	0.0000	-0.15	3	3	0.5000	1.5400		1.30
LDF4-50A (1/2 FOAM)	A	No	Ar (CaAa)	158.00 - 8.00	0.0000	-0.08	1	1	0.6300	0.6300		0.15
3/8" RET Cable	A	No	Ar (CaAa)	158.00 - 8.00	0.0000	-0.07	1	1	0.3750	0.3750		0.10
LDF4-50A (1/2 FOAM)	A	No	Ar (CaAa)	148.00 - 8.00	-2.0000	0.1	1	1	0.0000	0.6300		0.15
LDF7-50A (1-5/8 FOAM)	B	No	Ar (CaAa)	142.00 - 8.00	0.0000	0.4	9	3	1.0000	1.9800		0.82
1.5" DC/Fiber Bundle	B	No	Ar (CaAa)	142.00 - 8.00	0.0000	0.3	2	2	1.5000	1.5000		0.80
LDF7-50A (1-5/8 FOAM)	B	No	Ar (CaAa)	142.00 - 8.00	0.0000	-0.4	9	3	1.0000	1.9800		0.82
LDF6-50A (1-1/4 FOAM)	A	No	Ar (CaAa)	120.00 - 8.00	-1.5000	0	6	6	1.0000	1.5500		0.66
LDF7-50A (1-5/8 FOAM)	C	No	Ar (CaAa)	120.00 - 8.00	0.0000	0	6	3	1.0000	1.9800		0.82
Coax Bracket	C	No	Af (CaAa)	120.00 - 8.00	0.0000	0	1	1	0.5000	0.5000		0.43



<b>tnxTower</b>  <b>GPD</b> 520 South Main Street Suite 2531 Akron, Ohio 44311 Phone: (555) 555-1234 FAX: (555) 555-1235	<b>Job</b>	71285 NORFOLK-LOON MEADOW RD	<b>Page</b>	2 of 8
	<b>Project</b>	2018723.01.71285.02	<b>Date</b>	16:23:29 06/18/18
	<b>Client</b>	AT&T	<b>Designed by</b>	mmoeller

Description	Face or Leg	Allow Shield	Component Type	Placement ft	Face Offset in	Lateral Offset (Frac FW)	#	# Per Row	Clear Spacing in	Width or Diameter in	Perimeter in	Weight plf
5/20' x 12" 3/8" RET Cable	C	No	Ar (CaAa)	120.00 - 8.00	0.0000	0.1	1	1	0.3750	0.3750		0.10
LDF4-50A (1/2 FOAM)	B	No	Ar (CaAa)	13.00 - 8.00	0.0000	-0.25	1	1	0.6300	0.6300		0.15

### Discrete Tower Loads

Description	Face or Leg	Offset Type	Offsets:		Azimuth Adjustment °	Placement ft	CAAA Front ft <sup>2</sup>	CAAA Side ft <sup>2</sup>	Weight K
			Horz Lateral ft	Vert ft					
10' Dipole	A	From Leg	0.50	0.0000	160.00	No Ice	2.00	2.00	0.02
			0.00			1/2" Ice	3.02	3.02	0.04
			8.00			1" Ice	4.07	4.07	0.06
Pipe Mount 3'x2.375"	A	From Leg	0.25	0.0000	160.00	No Ice	0.58	0.58	0.01
			0.00			1/2" Ice	0.77	0.77	0.02
			1.50			1" Ice	0.97	0.97	0.02
3' Omni	B	From Face	0.50	0.0000	160.00	No Ice	0.52	0.52	0.02
			0.00			1/2" Ice	0.71	0.71	0.02
			0.00			1" Ice	0.90	0.90	0.03
Rohn 12' Boom Gate	A	From Leg	1.29	50.0000	158.00	No Ice	15.35	14.00	0.56
			1.53			1/2" Ice	21.29	20.81	0.74
			0.00			1" Ice	27.23	27.62	0.92
Rohn 12' Boom Gate	B	From Leg	1.29	50.0000	158.00	No Ice	15.35	14.00	0.56
			1.53			1/2" Ice	21.29	20.81	0.74
			0.00			1" Ice	27.23	27.62	0.92
Rohn 12' Boom Gate	C	From Leg	1.29	50.0000	158.00	No Ice	15.35	14.00	0.56
			1.53			1/2" Ice	21.29	20.81	0.74
			0.00			1" Ice	27.23	27.62	0.92
APXVSPP18-C-A20 w/ Mount Pipe	A	From Leg	2.57	70.0000	158.00	No Ice	8.02	6.71	0.08
			3.05			1/2" Ice	8.48	7.66	0.14
			0.00			1" Ice	8.94	8.49	0.22
APXVSPP18-C-A20 w/ Mount Pipe	B	From Leg	2.57	70.0000	158.00	No Ice	8.02	6.71	0.08
			3.05			1/2" Ice	8.48	7.66	0.14
			0.00			1" Ice	8.94	8.49	0.22
APXVSPP18-C-A20 w/ Mount Pipe	C	From Leg	2.57	30.0000	158.00	No Ice	8.02	6.71	0.08
			3.05			1/2" Ice	8.48	7.66	0.14
			0.00			1" Ice	8.94	8.49	0.22
DT465B-2XR w/ Mount Pipe	A	From Leg	2.57	70.0000	158.00	No Ice	9.10	7.40	0.08
			3.05			1/2" Ice	9.57	8.36	0.15
			0.00			1" Ice	10.04	9.19	0.24
DT465B-2XR w/ Mount Pipe	B	From Leg	2.57	70.0000	158.00	No Ice	9.10	7.40	0.08
			3.05			1/2" Ice	9.57	8.36	0.15
			0.00			1" Ice	10.04	9.19	0.24
DT465B-2XR w/ Mount Pipe	C	From Leg	2.57	30.0000	158.00	No Ice	9.10	7.40	0.08
			3.05			1/2" Ice	9.57	8.36	0.15
			0.00			1" Ice	10.04	9.19	0.24
TD-RRH8x20-25	A	From Leg	2.57	70.0000	158.00	No Ice	3.70	1.29	0.07
			3.05			1/2" Ice	3.95	1.46	0.09
			0.00			1" Ice	4.20	1.64	0.12
TD-RRH8x20-25	B	From Leg	2.57	70.0000	158.00	No Ice	3.70	1.29	0.07
			3.05			1/2" Ice	3.95	1.46	0.09
			0.00			1" Ice	4.20	1.64	0.12
TD-RRH8x20-25	C	From Leg	2.57	30.0000	158.00	No Ice	3.70	1.29	0.07

<b>tnxTower</b>  <b>GPD</b> 520 South Main Street Suite 2531 Akron, Ohio 44311 Phone: (555) 555-1234 FAX: (555) 555-1235	<b>Job</b>	71285 NORFOLK-LOON MEADOW RD	<b>Page</b>	3 of 8
	<b>Project</b>	2018723.01.71285.02	<b>Date</b>	16:23:29 06/18/18
	<b>Client</b>	AT&T	<b>Designed by</b>	mmoeller

Description	Face or Leg	Offset Type	Offsets:		Azimuth Adjustment	Placement	C <sub>AA</sub> Front	C <sub>AA</sub> Side	Weight
			Horz	Lateral					
			3.05						
			0.00			1/2" Ice	3.95	1.46	0.09
			0.00			1" Ice	4.20	1.64	0.12
(2) RRH2X50-800	A	From Leg	0.50	0.0000	154.00	No Ice	1.70	1.28	0.05
			0.00			1/2" Ice	1.86	1.43	0.07
			0.00			1" Ice	2.03	1.58	0.09
(2) RRH2X50-800	B	From Leg	0.50	0.0000	154.00	No Ice	1.70	1.28	0.05
			0.00			1/2" Ice	1.86	1.43	0.07
			0.00			1" Ice	2.03	1.58	0.09
(2) RRH2X50-800	C	From Leg	0.50	0.0000	154.00	No Ice	1.70	1.28	0.05
			0.00			1/2" Ice	1.86	1.43	0.07
			0.00			1" Ice	2.03	1.58	0.09
RRH1900-4X40	A	From Leg	0.50	0.0000	154.00	No Ice	2.32	2.24	0.06
			0.00			1/2" Ice	2.53	2.44	0.08
			0.00			1" Ice	2.74	2.65	0.11
RRH1900-4X40	B	From Leg	0.50	0.0000	154.00	No Ice	2.32	2.24	0.06
			0.00			1/2" Ice	2.53	2.44	0.08
			0.00			1" Ice	2.74	2.65	0.11
RRH1900-4X40	C	From Leg	0.50	0.0000	154.00	No Ice	2.32	2.24	0.06
			0.00			1/2" Ice	2.53	2.44	0.08
			0.00			1" Ice	2.74	2.65	0.11
4' Yagi	B	From Face	6.50	0.0000	148.00	No Ice	0.79	0.79	0.01
			0.00			1/2" Ice	1.03	1.03	0.01
			0.00			1" Ice	1.28	1.28	0.02
Pipe Mount 4'x2.375"	B	From Face	6.00	0.0000	148.00	No Ice	0.87	0.87	0.02
			0.00			1/2" Ice	1.11	1.11	0.03
			0.00			1" Ice	1.36	1.36	0.04
8' Frame	A	From Leg	0.48	50.0000	142.00	No Ice	14.48	3.61	0.31
			0.57			1/2" Ice	18.67	4.62	0.45
			0.00			1" Ice	22.86	5.62	0.60
8' Frame	B	From Leg	0.48	50.0000	142.00	No Ice	14.48	3.61	0.31
			0.57			1/2" Ice	18.67	4.62	0.45
			0.00			1" Ice	22.86	5.62	0.60
8' Frame	C	From Leg	0.48	50.0000	142.00	No Ice	14.48	3.61	0.31
			0.57			1/2" Ice	18.67	4.62	0.45
			0.00			1" Ice	22.86	5.62	0.60
AM-X-CD-16-65-00T w/ Mount Pipe	A	From Leg	0.96	43.0000	142.00	No Ice	8.55	6.65	0.09
			1.15			1/2" Ice	9.18	7.68	0.16
			1.00			1" Ice	9.79	8.56	0.23
AM-X-CD-16-65-00T w/ Mount Pipe	B	From Leg	0.96	43.0000	142.00	No Ice	8.55	6.65	0.09
			1.15			1/2" Ice	9.18	7.68	0.16
			1.00			1" Ice	9.79	8.56	0.23
AM-X-CD-16-65-00T w/ Mount Pipe	C	From Leg	0.96	43.0000	142.00	No Ice	8.55	6.65	0.09
			1.15			1/2" Ice	9.18	7.68	0.16
			1.00			1" Ice	9.79	8.56	0.23
(2) 7770.00 w/Mount Pipe	A	From Leg	0.96	43.0000	142.00	No Ice	5.51	4.10	0.06
			1.15			1/2" Ice	5.87	4.73	0.11
			1.00			1" Ice	6.23	5.37	0.16
(2) 7770.00 w/Mount Pipe	B	From Leg	0.96	43.0000	142.00	No Ice	5.51	4.10	0.06
			1.15			1/2" Ice	5.87	4.73	0.11
			1.00			1" Ice	6.23	5.37	0.16
(2) 7770.00 w/Mount Pipe	C	From Leg	0.96	44.0000	142.00	No Ice	5.51	4.10	0.06
			1.15			1/2" Ice	5.87	4.73	0.11
			1.00			1" Ice	6.23	5.37	0.16
(2) 80010965 w/ Mount Pipe	A	From Leg	0.96	43.0000	142.00	No Ice	14.05	7.63	0.13
			1.15			1/2" Ice	14.69	8.90	0.22
			1.00			1" Ice	15.30	9.96	0.33
(2) 80010965 w/ Mount Pipe	B	From Leg	0.96	43.0000	142.00	No Ice	14.05	7.63	0.13

<b>tnxTower</b>  <b>GPD</b> 520 South Main Street Suite 2531 Akron, Ohio 44311 Phone: (555) 555-1234 FAX: (555) 555-1235	<b>Job</b>	71285 NORFOLK-LOON MEADOW RD	<b>Page</b>	4 of 8
	<b>Project</b>	2018723.01.71285.02	<b>Date</b>	16:23:29 06/18/18
	<b>Client</b>	AT&T	<b>Designed by</b>	mmoeller

Description	Face or Leg	Offset Type	Offsets:		Azimuth Adjustment °	Placement ft	C <sub>AA</sub> Front ft <sup>2</sup>	C <sub>AA</sub> Side ft <sup>2</sup>	Weight K	
			Horz ft	Lateral ft						
			1.15				1/2" Ice	14.69	8.90	0.22
			1.00				1" Ice	15.30	9.96	0.33
(2) 80010965 w/ Mount Pipe	C	From Leg	0.96	43.0000	142.00		No Ice	14.05	7.63	0.13
			1.15				1/2" Ice	14.69	8.90	0.22
			1.00				1" Ice	15.30	9.96	0.33
(2) TT19-08BP111-001	A	From Leg	0.96	50.0000	142.00		No Ice	0.55	0.45	0.02
			1.15				1/2" Ice	0.65	0.53	0.02
			1.00				1" Ice	0.75	0.63	0.03
(2) TT19-08BP111-001	B	From Leg	0.96	50.0000	142.00		No Ice	0.55	0.45	0.02
			1.15				1/2" Ice	0.65	0.53	0.02
			1.00				1" Ice	0.75	0.63	0.03
(2) TT19-08BP111-001	C	From Leg	0.96	50.0000	142.00		No Ice	0.55	0.45	0.02
			1.15				1/2" Ice	0.65	0.53	0.02
			1.00				1" Ice	0.75	0.63	0.03
(4) 7020.00 RET	A	From Leg	0.96	50.0000	142.00		No Ice	0.10	0.17	0.00
			1.15				1/2" Ice	0.15	0.24	0.01
			1.00				1" Ice	0.20	0.31	0.01
(4) 7020.00 RET	B	From Leg	0.96	50.0000	142.00		No Ice	0.10	0.17	0.00
			1.15				1/2" Ice	0.15	0.24	0.01
			1.00				1" Ice	0.20	0.31	0.01
(4) 7020.00 RET	C	From Leg	0.96	50.0000	142.00		No Ice	0.10	0.17	0.00
			1.15				1/2" Ice	0.15	0.24	0.01
			1.00				1" Ice	0.20	0.31	0.01
RRUS 11	A	From Leg	0.96	50.0000	142.00		No Ice	2.78	1.19	0.05
			1.15				1/2" Ice	2.99	1.33	0.07
			1.00				1" Ice	3.21	1.49	0.10
RRUS 11	B	From Leg	0.96	50.0000	142.00		No Ice	2.78	1.19	0.05
			1.15				1/2" Ice	2.99	1.33	0.07
			1.00				1" Ice	3.21	1.49	0.10
RRUS 11	C	From Leg	0.96	50.0000	142.00		No Ice	2.78	1.19	0.05
			1.15				1/2" Ice	2.99	1.33	0.07
			1.00				1" Ice	3.21	1.49	0.10
B14 4478	A	From Leg	0.96	50.0000	142.00		No Ice	1.84	1.06	0.06
			1.15				1/2" Ice	2.01	1.20	0.08
			1.00				1" Ice	2.19	1.34	0.09
B14 4478	B	From Leg	0.96	50.0000	142.00		No Ice	1.84	1.06	0.06
			1.15				1/2" Ice	2.01	1.20	0.08
			1.00				1" Ice	2.19	1.34	0.09
B14 4478	C	From Leg	0.96	50.0000	142.00		No Ice	1.84	1.06	0.06
			1.15				1/2" Ice	2.01	1.20	0.08
			1.00				1" Ice	2.19	1.34	0.09
RRUS 32 B2	A	From Leg	0.96	50.0000	142.00		No Ice	2.73	1.67	0.05
			1.15				1/2" Ice	2.95	1.86	0.07
			1.00				1" Ice	3.18	2.05	0.10
RRUS 32 B2	B	From Leg	0.96	50.0000	142.00		No Ice	2.73	1.67	0.05
			1.15				1/2" Ice	2.95	1.86	0.07
			1.00				1" Ice	3.18	2.05	0.10
RRUS 32 B2	C	From Leg	0.96	50.0000	142.00		No Ice	2.73	1.67	0.05
			1.15				1/2" Ice	2.95	1.86	0.07
			1.00				1" Ice	3.18	2.05	0.10
ABT-DFDM-ADBH	A	From Leg	0.96	50.0000	142.00		No Ice	0.02	0.04	0.00
			1.15				1/2" Ice	0.04	0.08	0.00
			1.00				1" Ice	0.07	0.11	0.00
ABT-DFDM-ADBH	B	From Leg	0.96	50.0000	142.00		No Ice	0.02	0.04	0.00
			1.15				1/2" Ice	0.04	0.08	0.00
			1.00				1" Ice	0.07	0.11	0.00
4' Sidearm - Flat (GPD)	B	From Leg	2.00	0.0000	137.00		No Ice	0.80	3.20	0.06

<b>tnxTower</b>  <b>GPD</b> 520 South Main Street Suite 2531 Akron, Ohio 44311 Phone: (555) 555-1234 FAX: (555) 555-1235	<b>Job</b>	71285 NORFOLK-LOON MEADOW RD	<b>Page</b>	5 of 8
	<b>Project</b>	2018723.01.71285.02	<b>Date</b>	16:23:29 06/18/18
	<b>Client</b>	AT&T	<b>Designed by</b>	mmoeller

Description	Face or Leg	Offset Type	Offsets:		Azimuth Adjustment	Placement	C <sub>AA</sub> Front	C <sub>AA</sub> Side	Weight
			Horz	Lateral					
			ft	ft	°	ft	ft <sup>2</sup>	ft <sup>2</sup>	K
			0.00			1/2" Ice	1.05	4.00	0.07
			0.00			1" Ice	1.30	4.80	0.09
4' Sidearm - Flat (GPD)	C	From Leg	2.00	0.0000	137.00	No Ice	0.80	3.20	0.06
			0.00			1/2" Ice	1.05	4.00	0.07
			0.00			1" Ice	1.30	4.80	0.09
RR90-17-02DP w/ Mount Pipe	A	From Leg	4.00	60.0000	120.00	No Ice	4.59	3.32	0.03
			0.00			1/2" Ice	5.02	4.09	0.07
			0.00			1" Ice	5.44	4.78	0.12
RR90-17-02DP w/ Mount Pipe	A	From Leg	4.00	-60.0000	120.00	No Ice	4.59	3.32	0.03
			0.00			1/2" Ice	5.02	4.09	0.07
			0.00			1" Ice	5.44	4.78	0.12
RR90-17-02DP w/ Mount Pipe	B	From Leg	4.00	60.0000	120.00	No Ice	4.59	3.32	0.03
			0.00			1/2" Ice	5.02	4.09	0.07
			0.00			1" Ice	5.44	4.78	0.12
LNx-6515DS-VTM w/ Mount Pipe	B	From Leg	4.00	-60.0000	120.00	No Ice	11.64	9.79	0.08
			0.00			1/2" Ice	12.34	11.30	0.17
			0.00			1" Ice	13.04	12.80	0.27
LNx-6515DS-VTM w/ Mount Pipe	C	From Leg	4.00	60.0000	120.00	No Ice	11.64	9.79	0.08
			0.00			1/2" Ice	12.34	11.30	0.17
			0.00			1" Ice	13.04	12.80	0.27
LNx-6515DS-VTM w/ Mount Pipe	C	From Leg	4.00	-60.0000	120.00	No Ice	11.64	9.79	0.08
			0.00			1/2" Ice	12.34	11.30	0.17
			0.00			1" Ice	13.04	12.80	0.27
(2) 1412D-1A20	A	From Leg	4.00	0.0000	120.00	No Ice	0.00	0.47	0.01
			0.00			1/2" Ice	0.00	0.57	0.02
			0.00			1" Ice	0.00	0.69	0.03
(2) 1412D-1A20	B	From Leg	4.00	0.0000	120.00	No Ice	0.00	0.47	0.01
			0.00			1/2" Ice	0.00	0.57	0.02
			0.00			1" Ice	0.00	0.69	0.03
(2) 1412D-1A20	C	From Leg	4.00	0.0000	120.00	No Ice	0.00	0.47	0.01
			0.00			1/2" Ice	0.00	0.57	0.02
			0.00			1" Ice	0.00	0.69	0.03
4' Standoff - Flat (GPD)	A	From Leg	2.00	0.0000	120.00	No Ice	1.96	6.13	0.07
			0.00			1/2" Ice	3.08	8.58	0.11
			0.00			1" Ice	4.20	11.03	0.14
4' Standoff - Flat (GPD)	B	From Leg	2.00	0.0000	120.00	No Ice	1.96	6.13	0.07
			0.00			1/2" Ice	3.08	8.58	0.11
			0.00			1" Ice	4.20	11.03	0.14
4' Standoff - Flat (GPD)	C	From Leg	2.00	0.0000	120.00	No Ice	1.96	6.13	0.07
			0.00			1/2" Ice	3.08	8.58	0.11
			0.00			1" Ice	4.20	11.03	0.14
GPS	B	From Leg	1.00	0.0000	13.00	No Ice	0.14	0.14	0.00
			0.00			1/2" Ice	0.21	0.21	0.00
			0.00			1" Ice	0.28	0.28	0.01
1' Sidearm - Flat (GPD)	B	From Leg	0.50	0.0000	13.00	No Ice	0.80	0.80	0.02
			0.00			1/2" Ice	1.05	1.00	0.02
			0.00			1" Ice	1.30	1.20	0.03

<b>tnxTower</b>  <b>GPD</b> 520 South Main Street Suite 2531 Akron, Ohio 44311 Phone: (555) 555-1234 FAX: (555) 555-1235	<b>Job</b> 71285 NORFOLK-LOON MEADOW RD	<b>Page</b> 6 of 8
	<b>Project</b> 2018723.01.71285.02	<b>Date</b> 16:23:29 06/18/18
	<b>Client</b> AT&T	<b>Designed by</b> mmoeller

### Critical Deflections and Radius of Curvature - Service Wind

Elevation	Appurtenance	Gov. Load	Deflection	Tilt	Twist	Radius of Curvature
ft		Comb.	in	°	°	ft
160.00	10' Dipole	63	0.724	0.0549	0.0113	605045
158.00	Rohn 12' Boom Gate	63	0.746	0.0558	0.0138	605045
154.00	(2) RRH2X50-800	63	0.791	0.0575	0.0188	504200
148.00	4' Yagi	63	0.860	0.0591	0.0249	252102
145.75	Guy	63	0.886	0.0593	0.0266	212306
142.00	8' Frame	63	0.929	0.0589	0.0300	199783
137.00	4' Sidearm - Flat (GPD)	63	0.987	0.0568	0.0335	190779
120.00	RR90-17-02DP w/ Mount Pipe	63	1.156	0.0381	0.0394	28458
86.00	Guy	63	1.211	0.0100	0.0831	45218
13.00	GPS	63	0.368	0.1242	0.1033	53437

### Bolt Design Data

Section No.	Elevation	Component Type	Bolt Grade	Bolt Size	Number Of Bolts	Maximum Load per Bolt	Allowable Load	Ratio	Allowable Ratio	Criteria
	ft			in		K	K	Allowable		
T1	160	Leg	A325N	0.6250	12	3.73	22.75	0.164	✓	1 Bearing
		Diagonal	A325N	0.6250	2	3.43	14.38	0.239	✓	1 Member Block Shear
		Horizontal	A325N	0.6250	2	0.39	7.19	0.054	✓	1 Member Block Shear
T2	141	Leg	A325N	0.6250	12	5.23	22.75	0.230	✓	1 Bearing
		Diagonal	A325N	0.6250	1	3.68	7.83	0.470	✓	1 Member Bearing
		Horizontal	A325N	0.6250	1	1.54	6.83	0.225	✓	1 Member Block Shear
T3	121	Leg	A325N	0.6250	12	5.24	22.75	0.230	✓	1 Bearing
		Diagonal	A325N	0.6250	1	2.12	7.83	0.271	✓	1 Member Bearing
		Horizontal	A325N	0.6250	1	1.07	6.83	0.157	✓	1 Member Block Shear
T4	101	Leg	A325N	0.6250	12	5.21	22.75	0.229	✓	1 Bearing
		Diagonal	A325N	0.6250	1	3.66	7.83	0.468	✓	1 Member Bearing
		Horizontal	A325N	0.6250	1	2.03	6.83	0.297	✓	1 Member Block Shear
T5	86	Leg	A325N	0.6250	12	6.94	22.75	0.305	✓	1 Bearing
		Diagonal	A325N	0.6250	1	4.30	7.83	0.549	✓	1 Member Bearing
		Horizontal	A325N	0.6250	1	1.00	6.83	0.147	✓	1 Member Block Shear
T6	66	Leg	A325N	0.6250	12	7.73	22.75	0.340	✓	1 Bearing
		Diagonal	A325N	0.6250	1	2.96	12.43	0.238	✓	1 Bolt Shear
		Horizontal	A325N	0.6250	1	1.09	6.83	0.159	✓	1 Member Block Shear
T7	46	Leg	A325N	0.6250	12	7.86	22.75	0.345	✓	1 Bearing
		Diagonal	A325N	0.6250	1	3.04	12.43	0.244	✓	1 Bolt Shear
		Horizontal	A325N	0.6250	1	1.14	6.83	0.167	✓	1 Member Block Shear
T8	26	Leg	A325N	0.7500	3	5.16	29.82	0.173	✓	1 Bolt Tension

<b>tnxTower</b>  <b>GPD</b> 520 South Main Street Suite 2531 Akron, Ohio 44311 Phone: (555) 555-1234 FAX: (555) 555-1235	<b>Job</b>	71285 NORFOLK-LOON MEADOW RD	<b>Page</b>	7 of 8
	<b>Project</b>	2018723.01.71285.02	<b>Date</b>	16:23:29 06/18/18
	<b>Client</b>	AT&T	<b>Designed by</b>	mmoeller

Section No.	Elevation ft	Component Type	Bolt Grade	Bolt Size in	Number Of Bolts	Maximum Load per Bolt K	Allowable Load K	Ratio Load Allowable	Allowable Ratio	Criteria
		Diagonal	A325N	0.6250	1	3.95	7.83	0.504	✓	1 Member Bearing
		Horizontal	A325N	0.6250	1	1.15	6.83	0.168	✓	1 Member Block Shear

### Section Capacity Table

Section No.	Elevation ft	Component Type	Size	Critical Element	P K	$\phi P_{allow}$ K	% Capacity	Pass Fail
T1	160 - 141	Leg	V5x5x5/16	2	-22.40	106.64	21.0	Pass
T2	141 - 121	Leg	V5x5x5/16	30	-31.40	104.91	29.9	Pass
T3	121 - 101	Leg	V5x5x5/16	57	-32.61	104.91	31.1	Pass
T4	101 - 86	Leg	V5x5x5/16	84	-31.58	104.91	30.1	Pass
T5	86 - 66	Leg	V5x5x5/16	105	-41.64	104.91	39.7	Pass
T6	66 - 46	Leg	V5x5x5/16	132	-46.37	104.91	44.2	Pass
T7	46 - 26	Leg	V5x5x5/16	159	-47.13	104.91	44.9	Pass
T8	26 - 6	Leg	V5x5x5/16	186	-46.89	104.91	44.7	Pass
T9	6 - 0	Leg	V5x5x5/16	212	-50.08	115.78	43.3	Pass
T1	160 - 141	Diagonal	2L2 1/2x2 1/2x3/16	7	-7.80	41.74	18.7	Pass
							23.9 (b)	
T2	141 - 121	Diagonal	L2 1/2x2 1/2x3/16	52	-4.61	11.48	40.2	Pass
							47.0 (b)	
T3	121 - 101	Diagonal	L2 1/2x2 1/2x3/16	61	-2.92	11.48	25.4	Pass
							27.1 (b)	
T4	101 - 86	Diagonal	L2 1/2x2 1/2x3/16	88	-4.78	11.48	41.6	Pass
							46.8 (b)	
T5	86 - 66	Diagonal	L2 1/2x2 1/2x3/16	128	-5.23	11.48	45.6	Pass
							54.9 (b)	
T6	66 - 46	Diagonal	L2 1/2x2 1/2x3/16	155	-2.96	11.48	25.8	Pass
T7	46 - 26	Diagonal	L2 1/2x2 1/2x3/16	165	-3.04	11.48	26.4	Pass
T8	26 - 6	Diagonal	L2 1/2x2 1/2x3/16	198	-4.55	11.48	39.7	Pass
							50.4 (b)	
T9	6 - 0	Diagonal	L2 1/2x2 1/2x3/16	222	-0.96	16.39	5.9	Pass
T1	160 - 141	Horizontal	L2 1/2x2 1/2x3/16	24	-0.74	17.51	4.2	Pass
							5.4 (b)	
T2	141 - 121	Horizontal	L2x2x3/16	31	1.54	18.73	8.2	Pass
							22.5 (b)	
T3	121 - 101	Horizontal	L2x2x3/16	60	1.07	18.73	5.7	Pass
							15.7 (b)	
T4	101 - 86	Horizontal	L2x2x3/16	85	-1.52	12.12	12.6	Pass
							29.7 (b)	
T5	86 - 66	Horizontal	L2x2x3/16	114	-0.72	12.12	6.0	Pass
							14.7 (b)	
T6	66 - 46	Horizontal	L2x2x3/16	135	-0.80	12.12	6.6	Pass
							15.9 (b)	
T7	46 - 26	Horizontal	L2x2x3/16	162	-0.82	12.12	6.7	Pass
							16.7 (b)	
T8	26 - 6	Horizontal	L2x2x3/16	189	-0.82	12.12	6.7	Pass
							16.8 (b)	
T9	6 - 0	Horizontal	L2 1/2x2 1/2x3/16	214	10.63	29.22	36.4	Pass
T1	160 - 141	Top Girt	L2 1/2x2 1/2x3/16	5	-0.55	16.64	3.3	Pass
T1	160 - 141	Guy A@145.75	3/4	235	11.51	34.98	32.9	Pass
T5	86 - 66	Guy A@86	5/8	243	12.32	25.44	48.4	Pass
T1	160 - 141	Guy B@145.75	3/4	230	12.12	34.98	34.6	Pass
T5	86 - 66	Guy B@86	5/8	242	13.07	25.44	51.4	Pass
T1	160 - 141	Guy C@145.75	3/4	224	11.93	34.98	34.1	Pass

<b>tnxTower</b>  <b>GPD</b> 520 South Main Street Suite 2531 Akron, Ohio 44311 Phone: (555) 555-1234 FAX: (555) 555-1235	<b>Job</b>	71285 NORFOLK-LOON MEADOW RD	<b>Page</b>	8 of 8
	<b>Project</b>	2018723.01.71285.02	<b>Date</b>	16:23:29 06/18/18
	<b>Client</b>	AT&T	<b>Designed by</b>	mmoeller

Section No.	Elevation ft	Component Type	Size	Critical Element	P K	$\phi P_{allow}$ K	% Capacity	Pass Fail
T5	86 - 66	Guy C@86	5/8	241	12.84	25.44	50.5	Pass
T1	160 - 141	Top Guy Pull-Off@145.75	L2 1/2x2 1/2x3/16	17	3.86	29.22	13.2	Pass
T5	86 - 66	Top Guy Pull-Off@86	L 2 x 2 x 3/16	106	6.71	23.17	29.0	Pass
T1	160 - 141	Bottom Guy Pull-Off@145.75	L2 1/2x2 1/2x3/16	11	-3.45	19.64	17.6	Pass
T1	160 - 141	Torque Arm Top@145.75	2L2 1/2x2x1/4	231	10.73	69.01	15.5	Pass
T1	160 - 141	Torque Arm Bottom@145.75	2L3x2 1/2x1/4	239	-7.88	75.42	10.4	Pass
						Summary	ELC:	Future
						Leg (T7)	44.9	Pass
						Diagonal (T5)	54.9	Pass
						Horizontal (T9)	36.4	Pass
						Top Girt (T1)	3.3	Pass
						Guy A (T5)	48.4	Pass
						Guy B (T5)	51.4	Pass
						Guy C (T5)	50.5	Pass
						Top Guy Pull-Off (T5)	29.0	Pass
						Bottom Guy Pull-Off (T1)	17.6	Pass
						Torque Arm Top (T1)	15.5	Pass
						Torque Arm Bottom (T1)	10.4	Pass
						Bolt Checks Rating =	54.9	Pass

## APPENDIX C

### Tower Elevation Drawing



Section	T1	T2	T3	T4	T5	T6	T7	T8	T9
Legs	V5x5x5/16								
Leg Grade	A572-50								
Diagonals	L2 1/2x2 1/2x3/16								
Diagonal Grade	A36								
Top Girts	N.A.								
Horizontals	L2x2x3/16								
Top Guy Pull-Offs	N.A.								
Bot Guy Pull-Offs	L 2 x 2 x 3/16								
Face Width (ft)	N.A.								
# Panels @ (ft)	27 @ 5								
Weight (K)	8.5								
	4 @ 4.75								
	1.7								

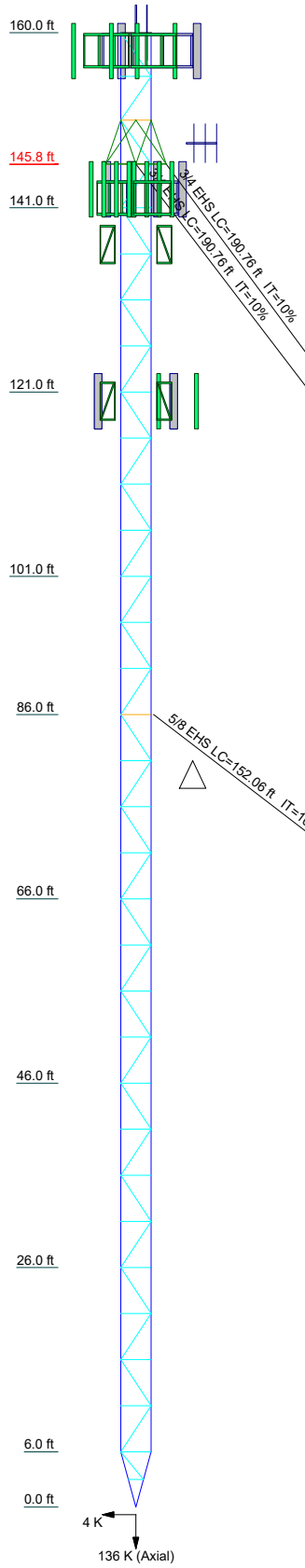

**SYMBOL LIST**

MARK	SIZE	MARK	SIZE
A	L2 1/2x2 1/2x3/16		

**MATERIAL STRENGTH**

GRADE	Fy	Fu	GRADE	Fy	Fu
A572-50	50 ksi	65 ksi	A36	36 ksi	58 ksi

**TOWER DESIGN NOTES**

1. Tower is located in Litchfield County, Connecticut.
2. Tower designed for Exposure B to the TIA-222-G Standard.
3. Tower designed for a 89 mph basic wind in accordance with the TIA-222-G Standard.
4. Tower is also designed for a 40 mph basic wind with 0.75 in ice. Ice is considered to increase in thickness with height.
5. Deflections are based upon a 60 mph wind.
6. Tower Structure Class II.
7. Topographic Category 1 with Crest Height of 0.00 ft
8. TOWER RATING: 54.9%

ALL REACTIONS ARE FACTORED

 <b>GPD</b> 520 South Main Street Suite 2531 Akron, Ohio 44311 Phone: (555) 555-1234 FAX: (555) 555-1235	<b>Job: 71285 NORFOLK-LOON MEADOW RD</b>		
	<b>Project: 2018723.01.71285.02</b>		
	Client: AT&T	Drawn by: mmoeller	App'd:
	Code: TIA-222-G	Date: 06/18/18	Scale: NTS
	Path: T:\ATandT\71285\02_2018723_01_71285_02_AT&T_Models\Rev_0\lms\71285.dwg	Dwg No. E-1	

## **APPENDIX D**

### Foundation Analysis



**Mat Foundation Analysis**  
**71285 NORFOLK-LOON MEADOW RD**  
**2018723.01.71285.02**

General Info	
Foundation Criteria	GPD
TIA Code	TIA-222-G
Soil Code	AASHTO 2012
Concrete Code	ACI 318-11
Seismic Design Category	B
Tower Height	160 ft
Bearing On	Rock
Foundation Type	Guyed Pad
Pier Type	None
Reinforcing Known	Yes
Max Bearing Capacity	105%
Max Overturning Capacity	105%

Tower Reactions	
Moment, M	0 k-ft
Axial, P	136 k
Shear, V	4 k

Pad & Pier Geometry	
Pier N/A	0 ft
Pad Length, L [y]	8 ft
Pad Width, W [x]	4 ft
Pad Thickness, t	3.5 ft
Depth, D	3.5 ft
Height Above Grade, HG	0.5 ft
Tower Centroid, X	2 ft
Tower Centroid, Y	4 ft
Tower Eccentricity	0.0000 ft

Pad & Pier Reinforcing	
Rebar Fy	60 ksi
Concrete F'c	3 ksi
Pier Reinforcing Clear Cover	
Shear Rebar Type	Tie
Shear Rebar Size	# 4
Pad Reinforcing Clear Cover	3 in
Reinforced Top & Bottom?	No
Direction of Reinforcing	L                  W
Pad Reinforcing Size	# 10              # 10
Pad Quantity Per Layer	6                  6
Pier Rebar Size	
Pier Quantity of Rebar	

Soil Properties	
Soil Type	Cohesive
Soil Unit Weight	135 pcf
Cohesion, Cu (ksf)	2.5
Base Friction Coeff. Provided in Geo?	Yes
Base Friction Coefficient, $\mu$	0.4
Bearing Type	Net
Ultimate Bearing	15 ksf
Water Table Depth	99 ft
Frost Depth	3.33 ft

Bearing Summary					
Case	Demand/Limits	Capacity/Availability	Check	Eccentricity	Load Case
Qxmax	5.34 ksf	9.28 ksf	OK, <= 105%	L/80.7	1.2D+1.6W
Qymax	5.70 ksf	9.28 ksf	OK, <= 105%	W/40.6	1.2D+1.6W
Qmax @ 45°	5.75 ksf	9.28 ksf	OK, <= 105%	W/57.5	1.2D+1.6W
<b>Controlling Capacity</b>		<b>61.9%</b>	<b>Pass</b>		

Overturning Summary					
Case	Demand/Limits	Capacity/Availability	Check	Load Case	
Ovtx	15.8 k-ft	636.2 k-ft	3.3% OK	0.9D+1.6W	
Ovty	15.7 k-ft	318.1 k-ft	6.6% OK	0.9D+1.6W	
Ovtxy	11.1 k-ft	318.1 k-ft	4.6% OK	0.9D+1.6W	
<b>Controlling Capacity</b>		<b>6.6%</b>	<b>Pass</b>		

Sliding Summary					
Case	Demand/Limits	Capacity/Availability	Check	Load Case	
Slidingx	4.0 k	38.6 k	10.4% OK	0.9D+1.6W	
Slidingy	4.0 k	41.4 k	9.7% OK	0.9D+1.6W	
<b>Controlling Capacity</b>		<b>10.4%</b>	<b>Pass</b>		

Reinforcement Summary					
Component	Demand/Limits	Capacity/Availability	Check	Load Case	
Pad Flexural Bending	36.0 k-ft	353.4 k-ft	10.2% OK	1.2D+1.6W	
One-Way Shear in Pad	7.5 k	169.9 k	4.4% OK	1.2D+1.6W	
Two-Way Shear in Pad	97.2 k	1220.7 k	8.0% OK	0.9D+1.6W	
As Min Pad Met?	0.95 sq. in.	0.05 sq. in.	Yes		
<b>Controlling Capacity</b>		<b>10.2%</b>	<b>Pass</b>		

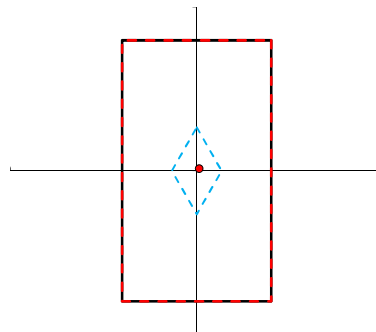
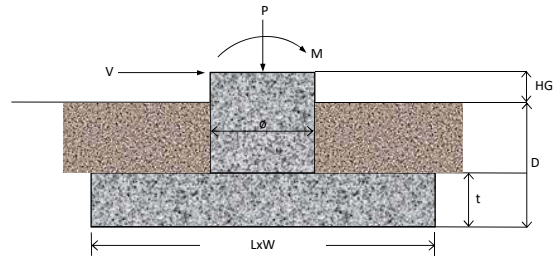



**Guyed Tower Anchor Foundation**  
**71285 NORFOLK-LOON MEADOW RD**  
**2018723.01.71285.02**

Guy Anchor Location	
Azimuth/Leg	A/B/C
Radius	131'
Tower Height (ft)	160'

Tower Reactions	
Vertical	24 k
Horizontal	27 k

Anchor Block Geometry	
Width	5 ft
Height	5 ft
Length	12.5 ft
Depth	4.5 ft

General Info	
Foundation Criteria	GPD
TIA Code	TIA-222-G

Soil Capacity Calculations	
$W_s$	0.00 k
$W_c$	46.88 k
Uplift Resistance	85.26 k
Horizontal Resistance	110.57 k
Uplift Capacity=	28.1% <b>OK</b>
Horizontal Capacity=	24.4% <b>OK</b>

Anchor Block Reinforcement	
Is Reinforcement Known?	assume min
$f_c'$	4 ksi
$F_y$	60 ksi

Capacity Summary		
Soil Capacity=	28.1%	<b>OK</b>
Reinforcing Capacity=	4.2%	<b>OK</b>
Controlling Capacity=	28.1%	<b>OK</b>

Minimum steel has been assumed

Soil Properties									
Layer	$C_u$ , psf	$\phi$ , degrees	$\gamma_{soil}$ , pcf	$\gamma_{concrete}$ , pcf	d, ft	$P_{p,top}$ , psf	$P_{p,bot}$ , psf	$f_s$ , psf	
1	0	0	120	150	2.5	0	0	0	
2	2500	0	135	150	2.5	5000	5000	1500	
3									
4									
5									
6									
Ignored Depth	2.5 ft				Consider soil for uplift		User Input Angle (°)		
Water Table	99 ft				Cohesive		Angle for Uplift (°)	0	

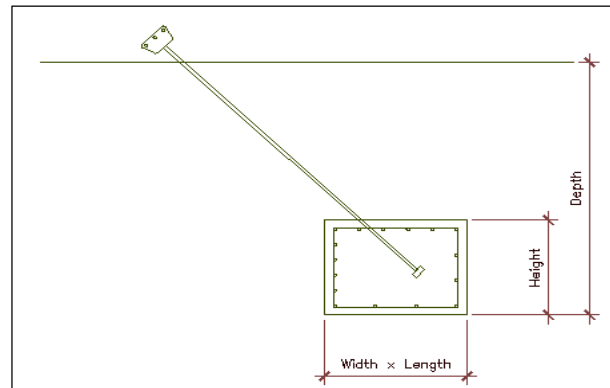

Block Moment and Shear Calculations			
<i>Moment Check</i>			
$M_{ux}$ =	37.50 k-ft	$M_{uy}$ =	42.19 k-ft
$\phi M_{nx}$ =	2736.73 k-ft	$\phi M_{ny}$ =	2736.73 k-ft
Capacity	1.4% <b>OK</b>	Capacity	1.5% <b>OK</b>
<i>Shear Check</i>			
$V_{ux}$ =	12.00 k	$V_{uy}$ =	13.50 k
$\phi V_{nx}$ =	318.76 k	$\phi V_{ny}$ =	318.76 k
Capacity	3.8% <b>OK</b>	Capacity	4.2% <b>OK</b>

Guy Anchor Shaft Calculations	
Shape of Anchor Shaft	Unknown

## APPENDIX E

### Modification Drawings

# NORFOLK-LOON MEADOW RD.

## USID #:71285

## CLIENT #: CT33XC116



### SITE MAP:



QUALIFIED ENGINEERING SERVICES ARE AVAILABLE FROM GPD TO ASSIST CONTRACTORS IN CLASS IV RIGGING PLAN REVIEWS. FOR REQUESTING QUALIFIED ENGINEERING SERVICES PLEASE CONTACT GPD AT GPDMODS@GPDGROUP.COM.

### CLIENT CONTACT:

REGGIE BARRAU  
5600 GLENRIDGE DRIVE  
ATLANTA, GA 30342  
678-917-0899

### ENGINEER OF RECORD:

GPD ENGINEERING AND ARCHITECTURE  
PROFESSIONAL CORPORATION  
520 SOUTH MAIN STREET, SUITE 2531  
AKRON, OH 44311  
FOR QUESTIONS PLEASE EMAIL:  
[GPDMODS@GPDGROUP.COM](mailto:GPDMODS@GPDGROUP.COM)

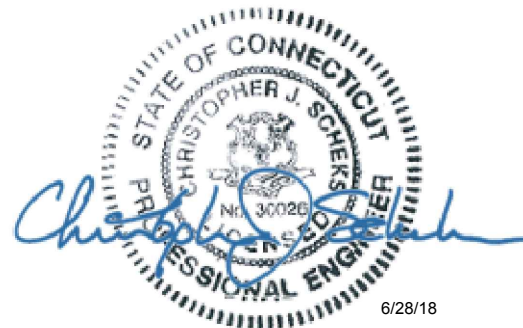

### TOWER INFORMATION:

TOWER MAPPING : GPD/DATED #: 7/21/10  
TOWER HEIGHT/TYPE: 160'-0" GUYED TOWER  
TOWER LOCATION:  
LAT.: 42° 0' 32.004"  
LONG.: -73° 10' 51"  
STREET ADDRESS: 402 LOON MEADOW DR.  
CITY, STATE ZIP: NORFOLK, CT 06058  
COUNTY: LITCHFIELD COUNTY  
REFERENCED ANALYSIS: GPD/PROJ #:2018723.01.71285.01  
ANALYSIS DATE: 05/09/2018

### CODE COMPLIANCE:

GOVERNING CODES: TIA-222-G, 2012 IBC, AND 2016 CTBC  
WIND SPEEDS: 115 MPH 3-SECOND GUST (ULTIMATE)  
89 MPH 3 SECOND GUST (NOMINAL)  
40 MPH 3 SECOND GUST (W/ ICE)  
ICE THICKNESS: 3/4"  
STRUCTURE CLASS: II  
EXPOSURE CATEGORY: B  
TOPO CATEGORY: 1

### SHEET INDEX:

T-01: TITLE SHEET  
N-01: PROJECT NOTES  
S-01: TOWER ELEVATION AND MODIFICATION SCHEDULE  
S-02: GUY ANCHOR PLAN AND GUY WIRE SCHEDULE  
F-01: FOUNDATION DETAILS AND SITE PLAN  
MI-01: MODIFICATION INSPECTION CHECKLIST



520 South Main Street  
Akron, Ohio 44311  
330.572.2100 Fax 330.572.2102



NORFOLK-LOON MEADOW RD.  
USID #71285

DESIGN DRAWINGS  
PREPARED FOR:



CLIENT #: CT33XC116

REV.	DATE	DESCRIPTION
0	6/28/18	INITIAL RELEASE

NORFOLK-LOON MEADOW RD.  
402 LOON MEADOW DR.  
NORFOLK, CT 06058

TITLE SHEET

ISSUED FOR:	
PERMIT	6/28/2018
BID	-
CONSTRUCTION	-
RECORD	-

ENGINEER	DESIGNER
MM	JW
PROJECT MANAGER	APPROVED BY
CB	CJS

JOB NO.  
2018723.01.71285.02

T-01

## GENERAL NOTES

- THESE MODIFICATIONS HAVE BEEN DESIGNED IN ACCORDANCE WITH THE GOVERNING PROVISIONS OF TIA/EIA-222, AWS, ANSI TIA-322, AND AISC. MATERIALS, FABRICATION, INSTALLATION, AND ALL OTHER SERVICES PROVIDED BY THE CONTRACTOR SHALL CONFORM TO THE ABOVE MENTIONED CODES AND THE CONTRACT SPECIFICATIONS.
- THIS DESIGN ASSUMES THE TOWER AND FOUNDATIONS HAVE BEEN WELL MAINTAINED. IN GOOD CONDITION AND ARE WITHOUT DEFECT. BENT MEMBERS, CORRODED MEMBERS, LOOSE BOLTS, CRACKED WELDS AND OTHER MEMBER DEFECTS HAVE NOT BEEN CONSIDERED. THE TOWER IS ASSUMED TO BE PLUMB AND THE SITE IS ASSUMED TO BE LEVEL. THIS DESIGN IS BEING PROVIDED WITHOUT THE BENEFIT OF A CONDITION ASSESSMENT BY GPD GROUP. CONTRACTOR SHALL COMMISSION A COMPLETE CONDITION ASSESSMENT PRIOR TO ORDERING ANY REINFORCING MATERIALS AND SUPPLY CONDITION ASSESSMENT TO ENGINEER FOR REVIEW. SEE CONTRACTOR NOTES.
- THE CONTRACTOR SHALL VISIT THE SITE PRIOR TO BIDDING. ANY PROBLEMS WITH ACCESS, INTERFERENCE, ETC. SHALL BE RESOLVED PRIOR TO MOBILIZATION. CONTRACTOR SHALL FIELD VERIFY ALL DIMENSIONS AND NOTE ANY EXISTING CONDITIONS THAT ARE NOT REPRESENTED ON THESE DRAWINGS OR THAT INTERFERE WITH THE CONTINUOUS INSTALLATION OF THE MODIFICATIONS. CONTRACTOR SHALL NOTE ALL ATTACHMENT POINTS, ANTENNAS, MOUNTS, COAX, LIGHTING, CLIMBING SUPPORTS, STEP BOLTS, PORT HOLES, AND ANY OTHER TOWER APPURTENANCES IN THE REGION OF THE MODIFICATIONS. GPD GROUP SHALL BE CONTACTED IMMEDIATELY TO EVALUATE THE SIGNIFICANCE OF ANY DEVIATION PRIOR TO ORDERING MATERIAL.
- ALL MATERIAL SPECIFIED FOR THIS PROJECT MUST BE NEW AND FREE OF ANY DEFECTS. ANY MATERIAL SUBSTITUTIONS, INCLUDING BUT NOT LIMITED TO ALTERED SIZES AND/OR STRENGTHS, MUST BE APPROVED BY THE OWNER AND ENGINEER IN WRITING. CONTRACTOR SHALL PROVIDE DOCUMENTATION TO ENGINEER FOR DETERMINING IF SUBSTITUTE IS SUITABLE FOR USE AND MEETS THE ORIGINAL DESIGN CRITERIA. DIFFERENCES FROM THE ORIGINAL DESIGN, INCLUDING MAINTENANCE, REPAIR AND REPLACEMENT, SHALL BE NOTED. ESTIMATES OF COSTS/CREDITS ASSOCIATED WITH THE SUBSTITUTION (INCLUDING RE-DESIGN COSTS AND COSTS TO SUB-CONTRACTORS) SHALL BE PROVIDED TO THE ENGINEER.
- CONTRACTOR IS RESPONSIBLE FOR ENGAGING A MODIFICATION INSPECTOR AT THE TIME OF AWARD TO COORDINATE AN INSPECTION SCHEDULE AND ENSURE PROPER DOCUMENTATION IS RETAINED THROUGHOUT THE PROJECT. FOUNDATION WORK REQUIRES INSPECTION PRIOR TO THE CONCRETE POUR AND MAY INVOLVE A SEPARATE INSPECTION VISIT. REFER TO SHEET M1-01 FOR MODIFICATION INSPECTION CHECKLIST. REFERENCE THE GPD CONTACT INFORMATION ON THE TITLE SHEET TO OBTAIN PRICING TO COMPLETE FINAL AND/OR FOUNDATION INSPECTION SERVICES, IF NOT ALREADY COORDINATED WITH THE TOWER OWNER / PROGRAM MANAGER / CARRIER. INSTALLATION OF PROPOSED LOADING PRIOR TO COMPLETION OF POST MODIFICATION INSPECTION IS PROHIBITED WITHOUT PRIOR APPROVAL FROM TOWER OWNER AND ENGINEER OF RECORD. INSTALLATION OF THE PROPOSED LOADING IS BY OTHERS AND IS BEYOND THE SCOPE OF THESE DRAWINGS.
- ALL CONTRACTORS AND LOWER TIER CONTRACTORS MUST ACKNOWLEDGE IN WRITING TO TOWER OWNER AND GPD GROUP THAT THEY HAVE OBTAINED, UNDERSTAND, AND WILL FOLLOW TOWER OWNER STANDARDS OF PRACTICE, CONSTRUCTION GUIDELINES, AT SITE AND TOWER SAFETY PROCEDURES, ALL PRODUCT LIMITATIONS AND INSTALLATION PROCEDURES USED ON SITE, AND PROPOSED MODIFICATIONS DESCRIBED. RECEIPT OF ACKNOWLEDGMENT MUST OCCUR PRIOR TO BEGINNING CONSTRUCTION OR CLIMBING. IT IS THE RESPONSIBILITY OF THE GENERAL CONTRACTOR TO PROVIDE THIS DOCUMENTATION FOR TOWER OWNER AND GPD GROUP ON COMPANY LETTERHEAD AND THE RESPONSIBILITY OF THE GENERAL CONTRACTOR TO OBTAIN THIS DOCUMENTATION FROM LOWER TIER SUBCONTRACTORS (ON SUBCONTRACTOR LETTERHEAD) AND DELIVER IT TO TOWER OWNER AND GPD GROUP.
- IT IS ASSUMED THAT ANY STRUCTURAL MODIFICATION WORK SPECIFIED ON THESE PLANS WILL BE ACCOMPLISHED BY KNOWLEDGEABLE WORKMEN WITH TOWER CONSTRUCTION EXPERIENCE. THIS INCLUDES PROVIDING THE NECESSARY CERTIFICATIONS TO THE TOWER OWNER AND ENGINEER.
- THESE DRAWINGS DO NOT INDICATE THE METHOD OF CONSTRUCTION. THE CONTRACTOR SHALL SUPERVISE AND DIRECT THE WORK AND SHALL BE SOLELY RESPONSIBLE FOR ALL CONSTRUCTION METHODS, MEANS, TECHNIQUES, SEQUENCES, AND PROCEDURES.
- CONSTRUCTION WORK PRESENTS UNIQUE THREATS TO HEALTH AND SAFETY. THE CONTRACTOR IS RESPONSIBLE TO EDUCATE THEIR WORK FORCE OF THESE DANGERS AND LIMIT THEIR EXPOSURE TO HAZARDS. THIS EDUCATION SHALL INCLUDE BUT NOT BE LIMITED TO APPLICABLE TRAINING COURSES AND CERTIFICATIONS, PROPER PERSONAL PROTECTIVE EQUIPMENT USAGE, DAILY TAILGATE MEETINGS AND ANY OTHER PREVENTATIVE MEASURES WHICH MAY BE REASONABLY EXPECTED. THE CONTRACTOR AND ALL SUB-CONTRACTORS SHALL BE RESPONSIBLE FOR THE SAFETY OF THE WORK AREA, ADJACENT AREAS AND ANY PROPERTY OCCUPANTS WHO MAY BE AFFECTED BY THE WORK UNDER CONTRACT. THE CONTRACTOR SHALL REVIEW ALL LANDOWNER, PRIME CONTRACTOR, CARRIER, OSHA, AND LOCAL SAFETY GUIDELINES AND AT ALL TIMES SHALL CONFORM TO THE MOST RESTRICTIVE OF THESE STANDARDS TO ENSURE A SAFE WORKPLACE.
- TOWER WORK PRESENTS ADDITIONAL THREATS TO HEALTH AND SAFETY. ALL TOWER WORKERS WORKING ON A TOWER MUST BE ADEQUATELY TRAINED AND MONITORED TO ENSURE THAT SAFE WORK PRACTICES ARE LEARNED AND FOLLOWED. AS REQUIRED BY OSHA, WHEN WORKING ON EXISTING COMMUNICATION TOWERS, EMPLOYEES MUST BE PROVIDED WITH APPROPRIATE FALL PROTECTION, TRAINED TO USE THIS FALL PROTECTION PROPERLY AND THE USE OF FALL PROTECTION MUST BE CONSISTENTLY SUPERVISED AND ENFORCED BY THE CONTRACTOR.
- ALL SAFETY EQUIPMENT SHALL BE INSPECTED ACCORDING TO ALL OSHA AND INDUSTRY SCHEDULED INTERVALS AND ALL INSPECTIONS SHALL BE DOCUMENTED PER APPLICABLE CODES AND STANDARDS.
- CONTRACTOR IS RESPONSIBLE FOR TEMPORARILY REMOVING ALL COAX, T-BRACKETS, ANTENNA MOUNTS, AND ANY OTHER TOWER APPURTENANCE THAT MAY INTERFERE WITH THE TOWER MODIFICATIONS. ALL TOWER APPURTENANCES MUST BE REPLACED AND/OR RESTORED TO ITS ORIGINAL LOCATION. SOME ATTACHMENTS MAY REQUIRE CUSTOM MODIFICATIONS TO PROPERLY FIT THE MODIFIED REGION OF THE STRUCTURE. THESE CUSTOMIZATIONS ARE DESIGNED BY OTHERS AND MUST BE APPROVED BY THE ENGINEER PRIOR TO REMOVING SUCH ATTACHMENTS. ANY CARRIER DOWNTIME MUST BE COORDINATED WITH THE TOWER OWNER IN WRITING.

## GENERAL NOTES CONTINUED

- CONTRACTOR SHALL ONLY WORK WITHIN THE LIMITS OF THE TOWER OWNER'S PROPERTY OR LEASE AREA AND APPROVED EASEMENTS. IT IS THE RESPONSIBILITY OF THE CONTRACTOR TO VERIFY WORK IS WITHIN THESE BOUNDARIES. CONTRACTOR SHALL EMPLOY A SURVEYOR AS REQUIRED. ANY WORK OUTSIDE THESE BOUNDARIES SHALL BE APPROVED IN WRITING BY THE LAND OWNER PRIOR TO MOBILIZATION. CONSTRUCTION STAKING AND BOUNDARY MARKING IS THE RESPONSIBILITY OF THE CONTRACTOR.
- TOWERS ARE DESIGNED TO CARRY GRAVITY, WIND, AND ICE LOADS. ALL MEMBERS, LEGS, DIAGONALS, STRUTS, AND REDUNDANT MEMBERS PROVIDE STRUCTURAL STABILITY TO THE TOWER WITH LITTLE REDUNDANCY. ABSENCE OR REMOVAL OF A MEMBER CAN TRIGGER CATASTROPHIC FAILURE UNLESS A SUBSTITUTE IS PROVIDED BEFORE ANY REMOVAL. LEGS CARRY AXIAL LOADS AND DERIVE THEIR STRENGTH FROM SHORTER UN-BRACED LENGTHS BY THE PRESENCE OF REDUNDANT MEMBERS AND THEIR CONNECTION TO THE DIAGONALS WITH BOLTS OR WELDS. IF THE BOLTS OR WELDS ARE REMOVED WITHOUT PROVIDING ANY SUBSTITUTE TO THE FRAME, THE LEG IS SUBJECTED TO A HIGHER UN-BRACED LENGTH THAT IMMEDIATELY REDUCES ITS LOAD CARRYING CAPACITY. IF A DIAGONAL IS ALSO REMOVED IN ADDITION TO THE CONNECTION, THE UN-BRACED LENGTH OF THE LEG IS GREATLY INCREASED JEOPARDIZING ITS LOAD CARRYING CAPACITY. FAILURE OF ONE LEG CAN RESULT IN A TOWER COLLAPSE BECAUSE THERE IS NO REDUNDANCY. REDUNDANT MEMBERS AND DIAGONALS ARE CRITICAL TO THE STABILITY OF THE TOWER.
- WORK SHALL ONLY BE PERFORMED DURING CALM DRY DAYS (WINDS LESS THAN 10-MPH). CONTRACTOR IS RESPONSIBLE FOR ALL TEMPORARY LOCAL TOWER SHORING, TEMPORARY GLOBAL TOWER SHORING, AND ALL SHORING OF SURROUNDING BUILDINGS, PADS, AND OTHER OUTDOOR SITE OBSTRUCTIONS. ALL SHORING, TEMPORARY BRACING, AND TEMPORARY SUPPORTS ARE THE RESPONSIBILITY OF THE CONTRACTOR.
- MODIFICATIONS SHOWN SHALL BE INSTALLED ON ALL THREE (3) TOWER LEGS/FACES.
- ABSOLUTELY NO WELDING, TORCH CUTTING, OR OPEN FLAME OF ANY TYPE IS PERMITTED ON THIS STRUCTURE AND ON THIS CONSTRUCTION SITE UNLESS DIRECTLY SPECIFIED WITHIN THESE DRAWINGS.
- FAA/FCC FILING AND LIGHTING MAY BE REQUIRED. ALL GOVERNMENTAL REGULATORY DETERMINATIONS AND FILINGS BY OTHERS, NOT GPD.
- VERIFY IF THIS STRUCTURE IS AN FM TOWER AND TAKE NECESSARY ACTIONS TO PROVIDE SAFE WORKING CONDITIONS INCLUDING BUT NOT LIMITED TO, HAVING FM SIGNAL TURNED OFF. CONTRACTOR SHALL HAVE PROPER RADMAN FOR NOTIFICATION OF EXCESSIVE RF EXPOSURE FOR ALL INDIVIDUALS WORKING ON SITE IF FM ANTENNAS ARE PRESENT.
- ALL MANUFACTURERS HARDWARE AND ASSEMBLY INSTRUCTIONS SHALL BE FOLLOWED EXACTLY. DEVIATION FROM THE INSTRUCTIONS IS UNACCEPTABLE AND REQUIRES WRITTEN APPROVAL FROM ENGINEER.
- DO NOT SCALE DRAWINGS.
- THE CLIMBING FACILITIES, SAFETY CLIMB AND ALL ASSOCIATED HARDWARE SHALL NOT BE IMPEDED OR MODIFIED WITHOUT THE WRITTEN CONSENT OF GPD GROUP.
- ANY WORK PERFORMED WITHOUT A PREFABRICATION MAPPING IS DONE AT THE RISK OF THE GC AND/OR FABRICATOR.
- IMPROPER FIT-UP OF NEW BOLTED HARDWARE DUE TO OVERSIZED, DOUBLE-PUNCHED, OR SLOTTED HOLES FOUND ON THE EXISTING STRUCTURE SHALL BE REPORTED TO GPD AND THE TOWER OWNER IMMEDIATELY. INSTALLATION OF SUCH HARDWARE WILL NOT BE ACCEPTABLE AND ALL COSTS ASSOCIATED WITH REMEDYING THE INSTALLATION WILL BE THE RESPONSIBILITY OF THE GC.

## GUY WIRE NOTES

- THE GENERAL CONTRACTOR SHALL TENSION THE GUY WIRE TO WITHIN A RANGE FROM THE TARGET TENSION LISTED WITHIN THE GUY WIRE SCHEDULE TO + OR - 10% OF THE TARGET TENSION LISTED FOR GUY WIRES  $\leq 1"$  AND WITHIN + OR - 5% FOR GUY WIRES  $> 1"$  IN DIAMETER. THE GENERAL CONTRACTOR SHOULD TENSION TO THE UPPER 75TH PERCENTILE OF THE LIMITS.

## FOUNDATION NOTES

- CONTRACTOR IS RESPONSIBLE FOR ENGAGING A MODIFICATION INSPECTOR AT THE TIME OF AWARD TO COORDINATE AN INSPECTION SCHEDULE AND ENSURE PROPER DOCUMENTATION IS RETAINED THROUGHOUT THE PROJECT. FOUNDATION WORK REQUIRES INSPECTION PRIOR TO THE CONCRETE POUR. CONTRACTOR SHALL NOTIFY THE PREVIOUSLY ENGAGED MODIFICATION INSPECTOR A MINIMUM OF 5 BUSINESS DAYS, PREFERABLY 10, PRIOR TO FOUNDATION CONSTRUCTION IN ORDER TO COORDINATE INSPECTION. REFER TO SHEET M1-01 FOR MODIFICATION INSPECTION CHECKLIST. REFERENCE THE GPD CONTACT INFORMATION ON THE TITLE SHEET TO OBTAIN PRICING TO COMPLETE FINAL AND/OR FOUNDATION INSPECTION SERVICES, IF NOT ALREADY COORDINATED WITH THE TOWER OWNER / PROGRAM MANAGER / CARRIER.
- EXISTING FOUNDATION INFORMATION BASED UPON A FOUNDATION MAPPING BY WEI (PROJECT #: 2010-1212, DATED SEPTEMBER 15, 2010). CONTRACTOR SHALL OBTAIN AND BECOME FAMILIAR WITH THE REFERENCED FOUNDATION DOCUMENT. IF EXISTING FOUNDATION CONDITIONS DIFFER FROM THE REFERENCED DOCUMENT, CONTACT ENGINEER AND TOWER OWNER IMMEDIATELY.
- CONCRETE WORK SHALL BE IN ACCORDANCE WITH LOCAL CODES, SAFETY REGULATIONS AND UNLESS OTHERWISE NOTED, THE LATEST REVISION OF ACI 318, "BUILDING CODE REQUIREMENTS FOR REINFORCED CONCRETE". PROCEDURES FOR THE PROTECTION OF EXCAVATIONS, EXISTING CONSTRUCTION AND UTILITIES SHALL BE ESTABLISHED PRIOR TO FOUNDATION INSTALLATION.
- MAXIMUM SIZE OF AGGREGATE SHALL NOT EXCEED SIZE SUITABLE FOR INSTALLATION METHOD UTILIZED OR 1/3 CLEAR DISTANCE BEHIND OR BETWEEN REINFORCING. MAXIMUM SIZE MAY BE INCREASED TO 2/3 CLEAR DISTANCE PROVIDED WORKABILITY AND METHODS OF CONSOLIDATION SUCH AS VIBRATING WILL PREVENT HONEYCOMBS OR VOIDS.
- CONCRETE SHALL DEVELOP A MINIMUM COMPRESSIVE STRENGTH OF 4500 PSI IN 28 DAYS.
- ALL FOUNDATIONS SHALL REST ON AND AGAINST FIRM UNDISTURBED SOIL FREE FROM WATER, ORGANIC MATTER, AND FORM WORK. CONTRACTOR SHALL COMPACT SUBGRADE AS REQUIRED.
- REINFORCEMENT SHALL BE DEFORMED AND CONFORM TO THE REQUIREMENTS OF ASTM A615 GRADE 60 UNLESS OTHERWISE NOTED. SPLICES IN REINFORCEMENT SHALL NOT BE ALLOWED UNLESS OTHERWISE INDICATED. WELDING IS PROHIBITED ON REINFORCING STEEL AND EMBEDMENTS.
- MINIMUM CONCRETE COVER FOR REINFORCEMENT SHALL BE 3 INCHES UNLESS OTHERWISE NOTED. APPROVED SPACERS SHALL BE USED TO ENSURE A 3 INCH MINIMUM COVER OF REINFORCEMENT. ALL REINFORCING SHALL BE EQUALLY SPACED UNLESS NOTED OTHERWISE.
- SOIL INFORMATION IS BASED ON A GEOTECHNICAL REPORT BY WEI (PROJECT #: 2010-1212, DATED SEPTEMBER 15, 2010). CONTRACTOR SHALL OBTAIN AND IMPLEMENT ALL RECOMMENDATIONS CONTAINED IN THE REFERENCED GEOTECHNICAL REPORT. IF SOIL CONDITIONS ENCOUNTERED ARE DIFFERENT FROM REFERENCED GEOTECHNICAL REPORT, NOTIFY ENGINEER IMMEDIATELY.
  - ULTIMATE BEARING = 15 KSF AT 3'-6" BELOW GRADE
  - UNIT WEIGHT OF SOIL = 135 PCF
  - GROUNDWATER = NOT ENCOUNTERED
- BACKFILL SHALL BE CLEAN, FREE OF DEBRIS, AND ORGANIC FREE. CONTRACTOR SHALL UTILIZE CLEAN FILL AS REQUIRED. (MIN. UNIT WEIGHT = 120 PCF). ALL BACKFILL SHALL BE CONTROLLED-COMPACTED, PLACED IN A MAXIMUM OF 8" LIFTS, MOISTURE CONDITIONED TO WITHIN THREE PERCENT OF OPTIMUM MOISTURE, AND COMPACTED TO 95% OF STANDARD PROCTOR MAXIMUM DRY DENSITY PER ASTM D698.
- CARE SHALL BE TAKEN DURING INSTALLATION OF DOWELS SO THAT EXISTING REINFORCING STEEL AND ANCHOR BOLTS ARE NOT DAMAGED. CONTRACTOR SHALL USE X-RAY OR OTHER ENGINEER APPROVED NON-DESTRUCTIVE MEANS TO LOCATE EXISTING REINFORCING STEEL AND ANCHOR BOLTS. CONTACT ENGINEER IMMEDIATELY IF EXISTING STEEL IS ENCOUNTERED.
- CONTRACTOR SHALL OBTAIN AND BECOME FAMILIAR WITH REFERENCED EPOXY INSTALLATION PROCEDURES AND RECOMMENDATIONS. PRIOR TO INSTALLATION OF NEW CONCRETE, CLEAN FACE OF EXISTING FOUNDATION SUCH THAT IT IS FREE FROM ALL DIRT, DEBRIS, AND FOREIGN MATTER.
- CONTRACTOR SHALL SECURE SITE BACK TO EXISTING CONDITION UNDER SUPERVISION OF OWNER. ALL FENCE, STONE, GEOTEXTILE, GROUNDING, AND SURROUNDING GRADE SHALL BE REPLACED AND REPAIRED AS REQUIRED TO ACHIEVE OWNER APPROVAL. POSITIVE DRAINAGE AWAY FROM TOWER SITE SHALL BE MAINTAINED.
- ALL GROUNDING SHALL ACHIEVE 50 OR LESS RESISTANCE UPON COMPLETION. ALL GROUNDING ENCOUNTERED SHALL BE RELOCATED 3'-0" BEYOND FOUNDATION. ALL GROUNDING SHALL BE CONTINUOUS AND COORDINATED WITH OWNER, GROUNDING DESIGN AND ENGINEERING IS BEYOND THE SCOPE OF THESE DESIGN DRAWINGS AND IS THE RESPONSIBILITY OF THE CONTRACTOR TO COMMISSION.
- CONTRACTOR TO VERIFY LOCATION OF ALL EXISTING PUBLIC AND PRIVATE UTILITIES PRIOR TO EXCAVATION. IF NECESSARY UTILITIES SHALL BE RELOCATED PRIOR TO FOUNDATION MODIFICATION. CONSENT FROM THE TOWER OWNER AND EOR MUST BE OBTAINED TO ENCASE UTILITIES IN CONCRETE.
- EQUIPMENT PAD, SHELTER, AND ICE BRIDGE SUPPORT IS THE RESPONSIBILITY OF THE CONTRACTOR TO COMMISSION. CONTRACTOR SHALL TAKE GREAT CARE AND ALL NECESSARY PROVISIONS WHEN SHORING IS REQUIRED.
- ALL FOUNDATION UPGRADES REQUIRE A PRETEST ON THE EXISTING GROUNDING SYSTEM. IF THE RESULTS OF THE TESTING IS ABOVE 50 A CALL TO THE TOWER OWNER IS REQUIRED BEFORE FURTHER CONSTRUCTION CAN BE DONE.
- A POST OHMS TEST OF THE GROUNDING SHALL BE CONDUCTED. THE RESULTS OF THE TESTING SHALL BE AT OR BELOW THE PRE-CONSTRUCTION TEST RESULTS.
- THE ADHESIVE ANCHOR SYSTEM USED FOR POST-INSTALLED DOWELS TO CONCRETE SHALL CONFORM TO THE MOST RECENTLY PUBLISHED ACI 308.4, ACCEPTANCE CRITERIA FOR QUALIFICATION OF POST-INSTALLED ADHESIVE ANCHORS IN CONCRETE AND COMMENTARY. THE ANCHOR SYSTEM SHALL BE ONE OF THE FOLLOWING:
  - HILTI HIT-HY200 (ICC #: ESR-3187) EPOXY
  - AN ENGINEER APPROVED EQUAL MEETING ACI 308.4 AND THE MINIMUM BOND STRESS VALUES BELOW. BULK MIXED ADHESIVES ARE NOT PERMITTED.
- DOWEL DESIGN IS IN ACCORDANCE WITH ACI 318. FOR DOWELS, THE FOLLOWING MINIMUM VALUES FOR BOND STRESS WERE ASSUMED FOR THE DESIGN:
  - UNCRACKED CONCRETE BOND STRESS (BASED ON HAMMER DRILLING):  
 $T_{UNCR} = 1560 \text{ PSI}$

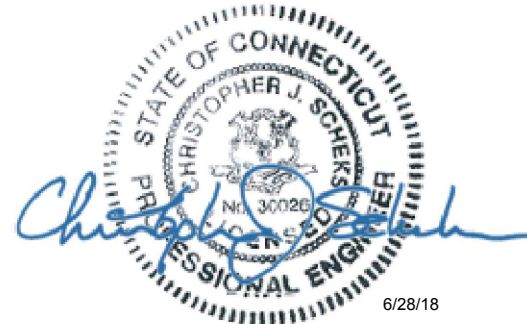

6/28/18



520 South Main Street  
Akron, Ohio 44311  
330.572.2100 Fax 330.572.2102



NORFOLK-LOON MEADOW RD.  
USID #71285

DESIGN DRAWINGS  
PREPARED FOR:



CLIENT #: CT33XC116

REV.	DATE	DESCRIPTION	INITIAL RELEASE
0	6/28/18		

NORFOLK-LOON MEADOW RD.  
402 LOON MEADOW DR.  
NORFOLK, CT 06058

PROJECT NOTES

ISSUED FOR:	
PERMIT	6/28/2018
BID	-
CONSTRUCTION	-
RECORD	-

ENGINEER	DESIGNER
MM	JW
PROJECT MANAGER	APPROVED BY
CB	CJS

JOB NO.  
2018723.01.71285.02

N-01

MODIFICATION SCHEDULE					
MEMBER TYPE	ELEVATION	EXISTING MEMBER	NEW MEMBER	REFERENCE DETAIL	NOTES
PLUMB AND TENSION	-	-	-	SHEET S-02	THE TOWER SHALL BE PLUMB AND ALL EXISTING WIRES TENSIONED IN ACCORDANCE WITH THESE PLANS
FOUNDATION	GRADE	CONCRETE PAD	ADDITIONAL CONCRETE	F-01	INSTALL ADDITIONAL CONCRETE TO THE EXISTING TOWER BASE FOUNDATION PAD



NORFOLK-LOON MEADOW RD.  
USID #71285

DESIGN DRAWINGS  
PREPARED FOR:



CLIENT #: CT33XC116

REV.	DATE	DESCRIPTION
0	6/28/18	INITIAL RELEASE

NORFOLK-LOON MEADOW RD.  
402 LOON MEADOW DR.  
NORFOLK, CT 06058

**TOWER ELEVATION &  
MODIFICATION SCHEDULE**

ISSUED FOR:	
PERMIT	6/28/2018
BID	-
CONSTRUCTION	-
RECORD	-

ENGINEER	DESIGNER
MM	JW
PROJECT MANAGER	APPROVED BY
CB	CJS

JOB NO.  
2018723.01.71285.02

**S-01**

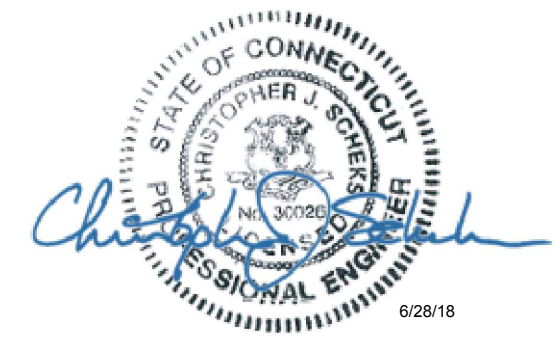
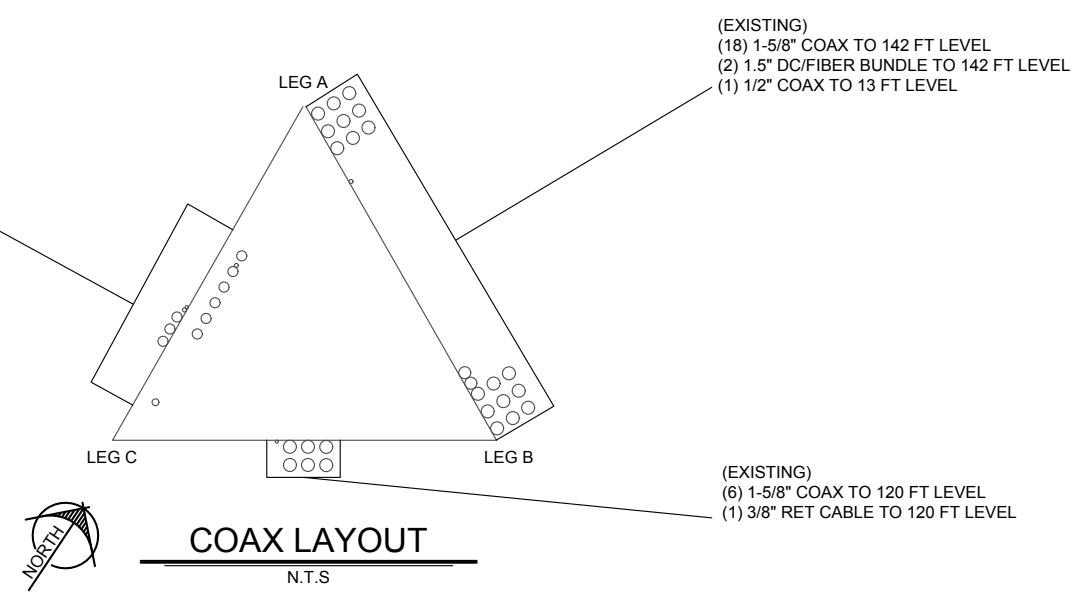
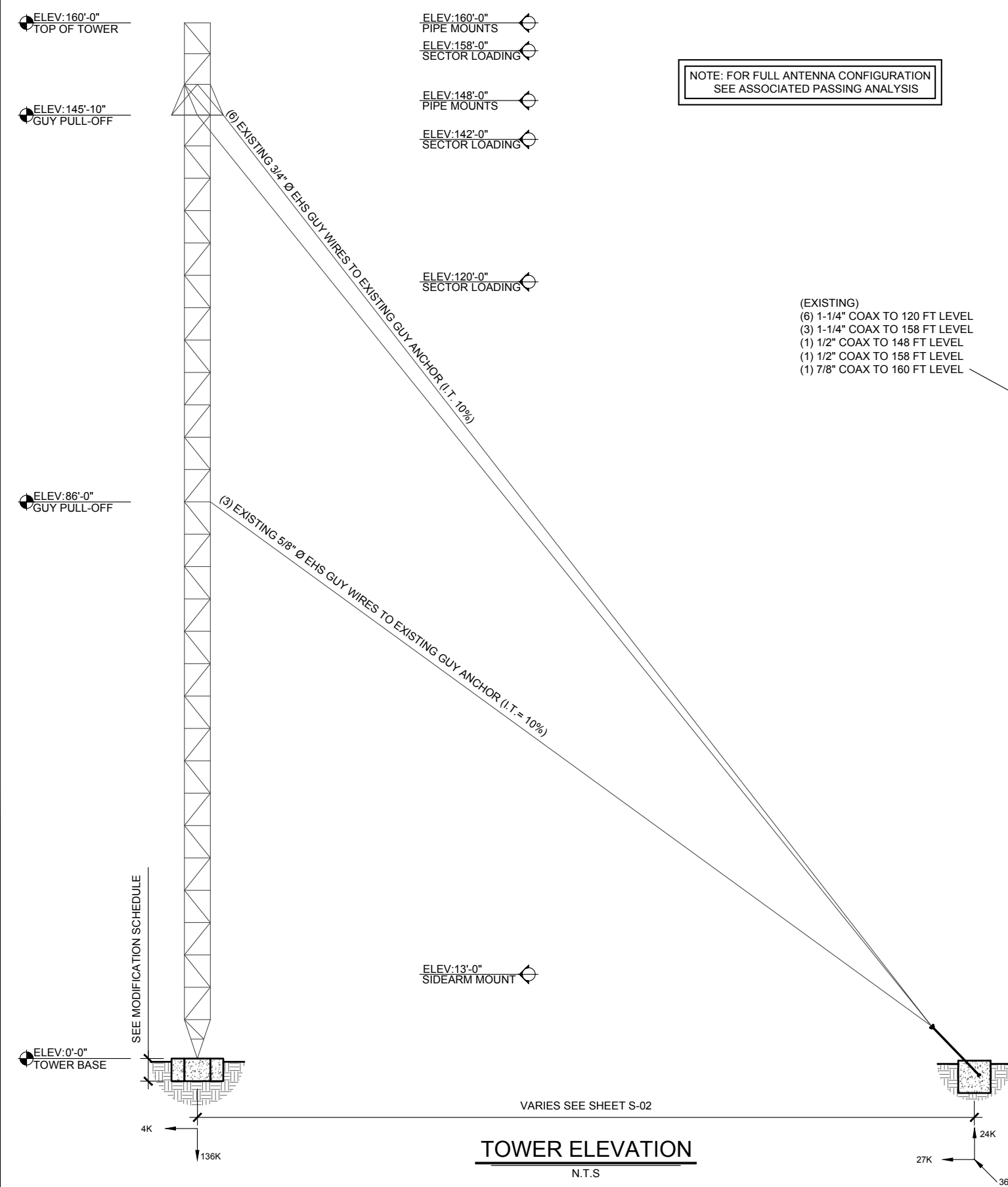



GUY ELEVATION (FT.)	GUY WIRE SIZE (IN.)	GUY ANCHOR RADIUS (FT.)	ANCHOR	ANCHOR ELEVATION TO TOWER BASE (FT.)	ULTIMATE BREAKING STRENGTH (LBS)	% INITIAL TENSION	TARGET TENSION (LBS)									
							20°F	30°F	40°F	50°F	60°F	70°F	80°F	90°F	100°F	110°F
145.8	3/4	162.0	A	-15	58,300	10%	6945.3	6666.5	6387.7	6108.8	5830.0	5551.2	5272.3	4993.5	4714.7	4435.9
	3/4	131.0	B	5	58,300	10%	6732.4	6506.8	6281.2	6055.6	5830.0	5604.4	5378.8	5153.2	4927.6	4702.0
	3/4	140.0	C	0	58,300	10%	6802.8	6559.6	6316.4	6073.2	5830.0	5586.8	5343.6	5100.4	4857.2	4614.0
86.0	5/8	162.0	A	-15	42,400	10%	5310.4	5042.8	4775.2	4507.6	4240.0	3972.4	3704.8	3437.2	3169.6	2902.0
	5/8	131.0	B	5	42,400	10%	5232.6	4984.5	4736.3	4488.2	4240.0	3991.8	3743.7	3495.5	3247.4	2999.2
	5/8	140.0	C	0	42,400	10%	5260.3	5005.2	4750.1	4495.1	4240.0	3984.9	3729.9	3474.8	3219.7	2964.6

**NOTES:**  
 1. IF GUY ANCHOR ELEVATIONS VARY BY MORE THAN 10'-0"± FROM SHOWN ON GUY ANCHOR PLAN CONTACT ENGINEER IMMEDIATELY. SEE GUY WIRE NOTES ON SHEET N-01 FOR TENSION REQUIREMENTS.

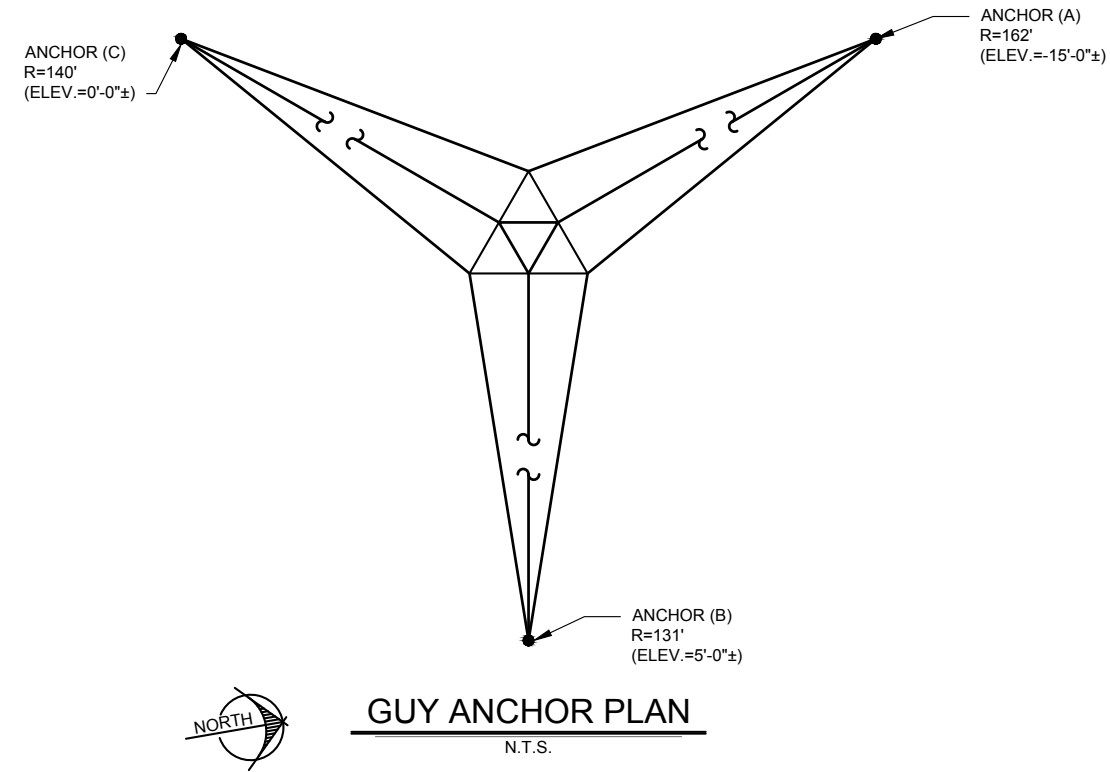

**CFD Engineering and Architecture**  
 Professional Corporation  
 520 South Main Street  
 Akron, Ohio 44311  
 330.572.2100 Fax 330.572.2102

**at&t**  
 NORFOLK-LOON MEADOW RD.  
 USID #71285  
 DESIGN DRAWINGS  
 PREPARED FOR:  
**Sprint**  
 CLIENT #: CT33XC116

REV.	DATE	DESCRIPTION
0	6/28/18	INITIAL RELEASE

**EHS HARDWARE TABLE**

GUY WIRE SIZE	TURNBUCKLE		SHACKLE		THIMBLE	DEADEND SLEEVE	PREFORM
	SIZE	MIN. BREAKING STRENGTH (KIPS)	SIZE	MIN. BREAKING STRENGTH (KIPS)	SIZE	SIZE	SIZE
5/16" EHS	3/4x18	26.0	1/2	20.00	1/2 EXTRA HVY	5/16	5/16
3/8" EHS	3/4x18	26.0	1/2	20.00	1/2 EXTRA HVY	3/8	3/8
7/16" EHS	3/4x18	26.0	5/8	32.50	1/2 EXTRA HVY	7/16	7/16
1/2" EHS	7/8x18	36.0	5/8	32.50	5/8 EXTRA HVY	1/2	1/2
9/16" EHS	1x18	50.0	3/4	47.50	5/8 EXTRA HVY	9/16	9/16
5/8" EHS	1x18	50.0	3/4	47.50	3/4 EXTRA HVY	5/8	5/8
11/16" EHS	1-1/4x18	76.0	7/8	65.00	7/8 EXTRA HVY	3/4	3/4
3/4" EHS	1-1/4x18	76.0	7/8	65.00	7/8 EXTRA HVY	3/4	3/4
7/8" EHS	1-1/2x18	107.0	1	85.00	1-1/8 EXTRA HVY	7/8	7/8
1" EHS	1-1/2x18	107.0	1-1/4	120.00	1-1/8 EXTRA HVY	1	1

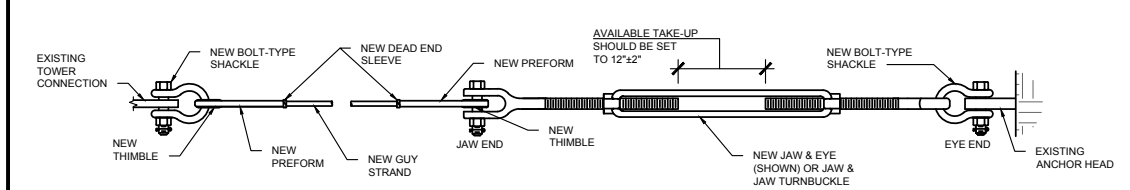

USE 0.041"Ø STAINLESS STEEL LOCK WIRE OR APPROVED EQUIVALENT TO LOOP THROUGH HOLE IN COLLAR OF PIN AND AROUND ADJACENT LEG OF SHACKLE BODY. WIRE ENDS MUST BE SECURELY TWISTED TOGETHER.

ALL EXISTING SCREW TYPE SHACKLES AT THE FAN PLATE SHALL HAVE MOUSING INSTALLED AS PART OF THE MODIFICATION

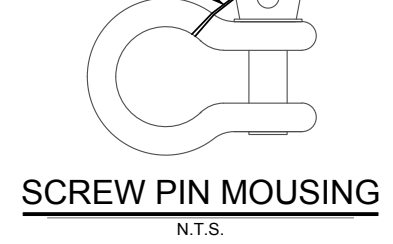

Christopher J. Schekels  
 PROFESSIONAL ENGINEER  
 6/28/18

**NORFOLK-LOON MEADOW RD.**  
**402 LOON MEADOW DR.**  
**NORFOLK, CT 06058**  
**TOWER ELEVATION & MODIFICATION SCHEDULE**

ISSUED FOR:	
PERMIT	6/28/2018
BID	-
CONSTRUCTION	-
RECORD	-
ENGINEER	DESIGNER
MM	JW
PROJECT MANAGER	APPROVED BY
CB	CJS
JOB NO. 2018723.01.71285.02	
<b>S-02</b>	

REV.	DATE	DESCRIPTION
0	6/28/18	INITIAL RELEASE

NORFOLK-LOON MEADOW RD.  
402 LOON MEADOW DR.  
NORFOLK, CT 06058

**FOUNDATION DETAILS & SITE PLAN**

ISSUED FOR:	
PERMIT	6/28/2018
BID	-
CONSTRUCTION	-
RECORD	-

ENGINEER	DESIGNER
MM	JW
PROJECT MANAGER	APPROVED BY
CB	CJS

JOB NO.  
2018723.01.71285.02

**F-01**

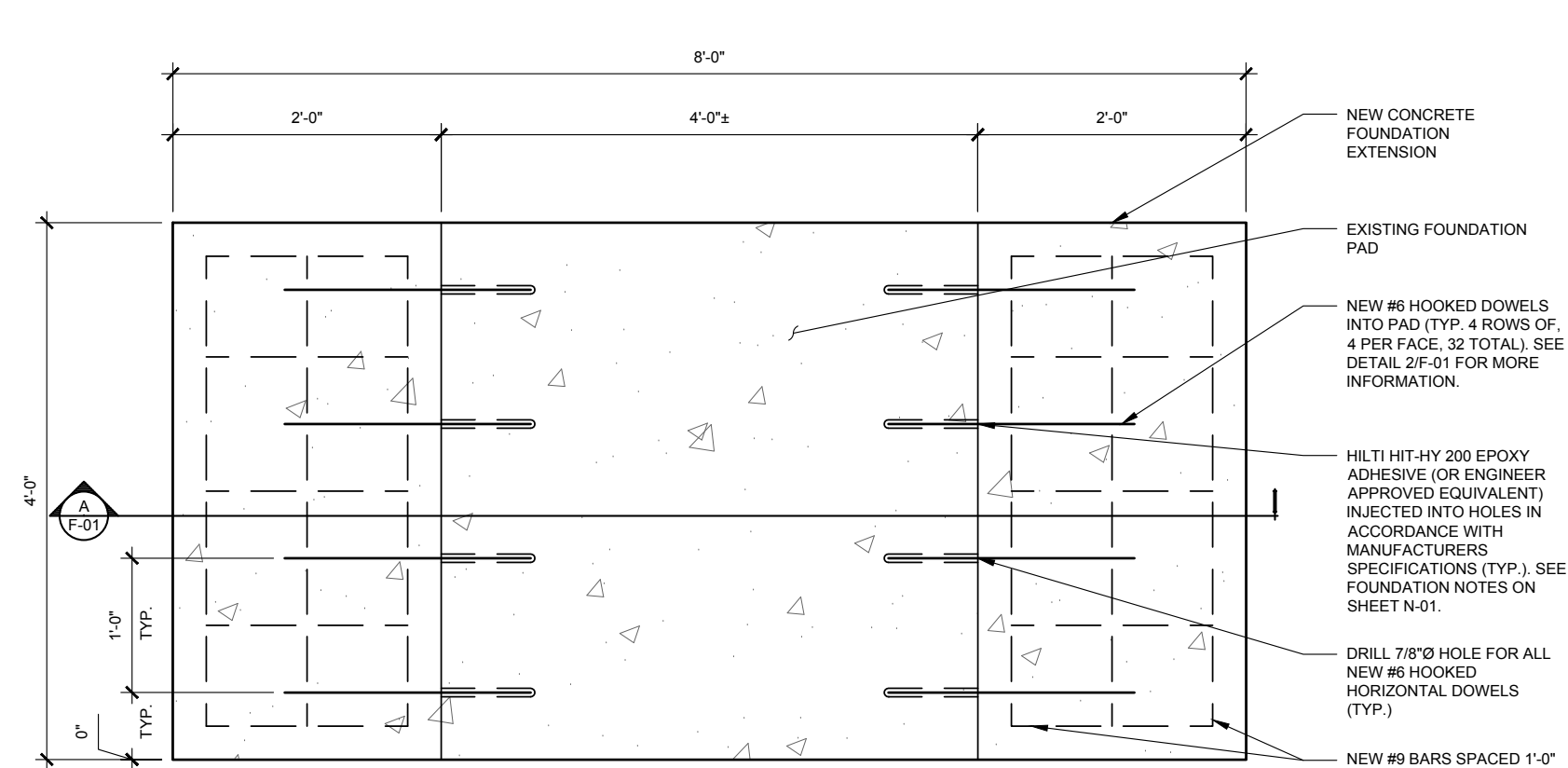

**1 FOUNDATION DETAIL**  
F-01 SCALE: 3/4"=1'-0"

**NOTE:**  
1. EXISTING FOUNDATION IS BEING EXCAVATED. CONTRACTOR IS RESPONSIBLE FOR SUPPORTING THE TOWER AND EQUIPMENT DURING ALL PHASES OF CONSTRUCTION. SEE FOUNDATION NOTES ON SHEET N-01.

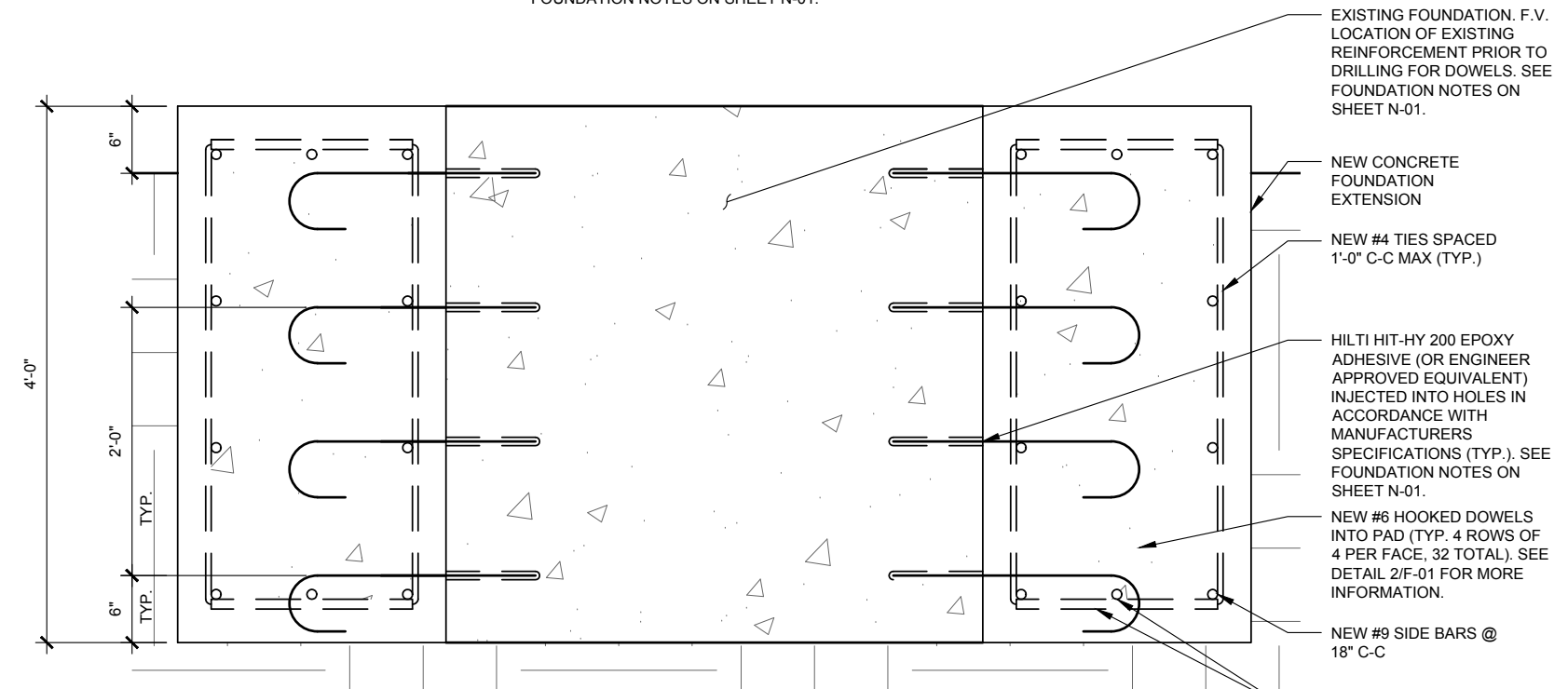

**A SECTION**  
F-01 SCALE: 3/4"=1'-0"

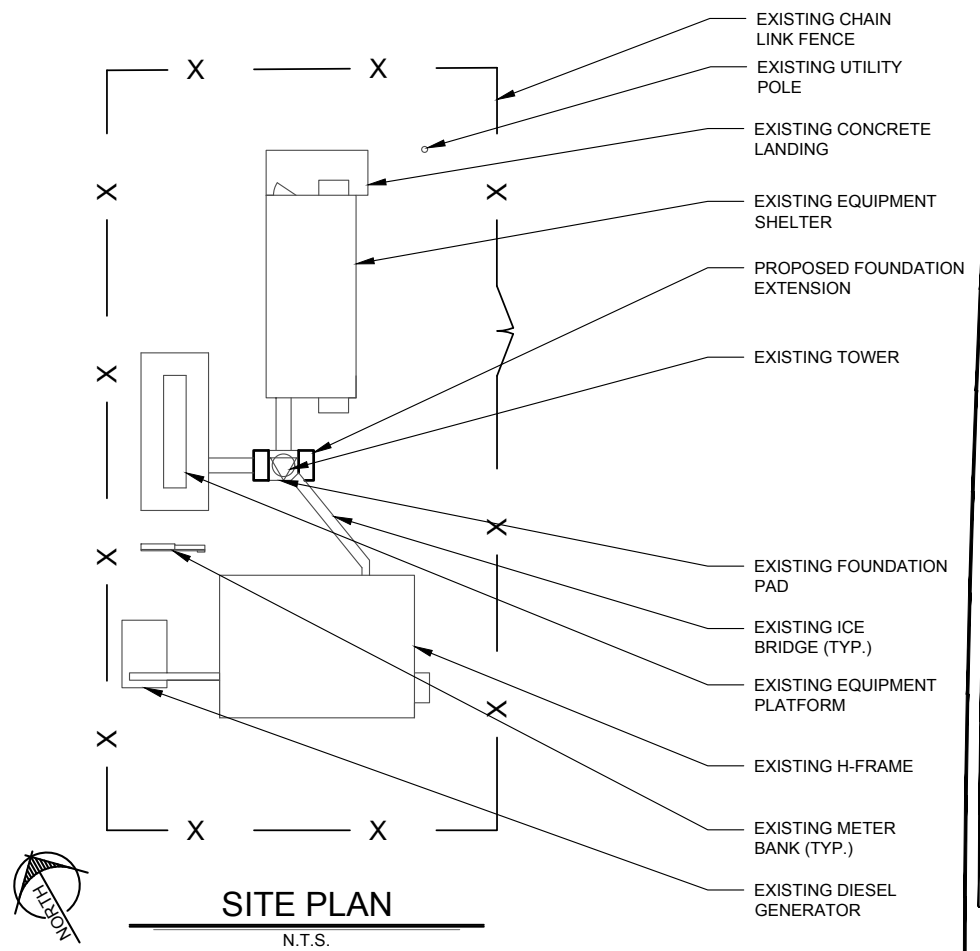

**SITE PLAN**  
N.T.S.

**NOTES:**  
1. ALL SITE LAYOUT & FOUNDATION ORIENTATION INFORMATION IS CONSIDERED APPROXIMATE. CONTRACTOR SHALL VERIFY ALL SITE DIMENSIONS, ORIENTATIONS, AND UTILITY LOCATIONS PRIOR TO MOBILIZING (SEE NOTES ON SHEET N-01).  
2. CONTRACTOR TO VERIFY LOCATION OF ALL EXISTING PUBLIC AND PRIVATE UTILITIES PRIOR TO EXCAVATION. IF NECESSARY, UTILITIES SHALL BE RELOCATED PRIOR TO FOUNDATION MODIFICATION. UTILITIES SHALL NOT BE ENCASED IN CONCRETE.

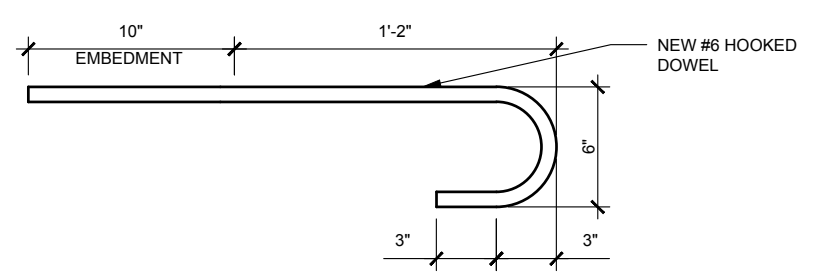

**2 HOOKED DOWEL**  
F-01 SCALE: 1-1/2"=1'-0"



TO OBTAIN LOCATION OF PARTICIPANTS UNDERGROUND FACILITIES BEFORE YOU DIG IN CONNECTICUT, CONTACT CALL BEFORE YOU DIG TOLL FREE: 1-800-922-4455 OR www.cbyd.com

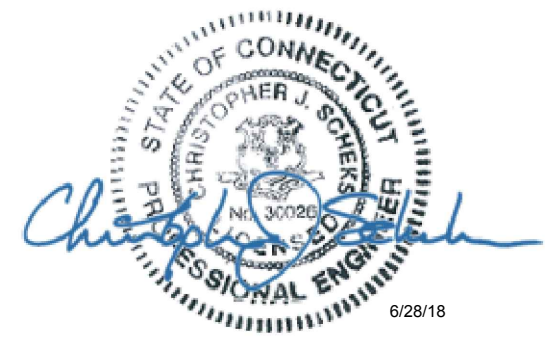

6/28/18

CONNECTICUT STATUTE REQUIRES MIN OF 2 WORKING DAYS NOTICE BEFORE YOU EXCAVATE

NOTE: X DENOTES A DOCUMENT NEEDED FOR THE MODIFICATION INSPECTION REPORT  
 - DENOTES A DOCUMENT THAT IS NOT REQUIRED FOR THE MODIFICATION INSPECTION REPORT

CONSTRUCTION PROCESS			REPORT ITEM	STAMPED REPORT REQUIRED
BEFORE	DURING	AFTER		
X	-	-	• SHOP DRAWINGS	
X	-	-	• MATERIAL TEST REPORT (ALL MODIFICATION MATERIALS)	
X	-	-	• PACKING SLIPS	
			• PHOTOS:	
X	-	-	• PRE-CONSTRUCTION PHOTOS (COMPOUND, ACCESS DRIVE, ROAD ENTRANCE, TOWER)	
-	X	-	• DURING CONSTRUCTION	
-	-	X	• POST CONSTRUCTION	
-	-	-	• BASE PLATE GROUT VERIFICATION	
-	-	X	• ON SITE COLD GALVANIZING VERIFICATION	
-	-	X	• GC AS-BUILT DRAWINGS	
-	-	X	• LIEN RELEASE (GPD SERVICES ONLY)	

CONSTRUCTION PROCESS			REPORT ITEM	STAMPED REPORT REQUIRED
BEFORE	DURING	AFTER		
X	-	-	• PRE-TENSION, PLUMB, & TWIST RESULTS	
-	-	X	• POST TENSION REPORT	
-	-	X	• POST PLUMB AND TWIST REPORT	
-	X	-	• PHOTOS OF TENSION GAUGE FOR ALL GUY CABLES	
X	-	-	• PACKING SLIP FROM MANUFACTURER WITH ALL GUY WIRE HARDWARE	

CONSTRUCTION PROCESS			REPORT ITEM	STAMPED REPORT REQUIRED
BEFORE	DURING	AFTER		
X	-	-	• PRE-POUR REBAR INSPECTION	ENGINEER
X	X	-	• EPOXY VERIFICATION - ONSITE PHOTO OF EPOXY LABEL	
X	-	-	• EPOXY PACKING SLIP	
X	X	-	• CONCRETE MIX DESIGN, LOAD TICKETS, AND SLUMP TESTS	
-	X	-	• PRE-POUR CONCRETE SURFACE ROUGHENING VERIFICATION	
-	X	X	• CONCRETE COMP. STRENGTH TEST RESULTS	ENGINEER
-	-	-	• EARTHWORK: LIFT AND DENSITY (REPORT REQUIRED)	ENGINEER

## MODIFICATION INSPECTION NOTES:

### GENERAL NOTES

1. THE MODIFICATION INSPECTION IS A VISUAL INSPECTION OF TOWER MODIFICATIONS AND A REVIEW OF CONSTRUCTION INSPECTIONS AND OTHER REPORTS TO ENSURE THE INSTALLATION WAS CONSTRUCTED IN ACCORDANCE WITH THE CONTRACT DOCUMENTS, NAMELY THE MODIFICATION DRAWINGS, AS DESIGNED BY THE ENGINEER OF RECORD.
2. THE MODIFICATION INSPECTION IS TO CONFIRM INSTALLATION CONFIGURATION AND WORKMANSHIP ONLY AND IS NOT A REVIEW OF THE MODIFICATION DESIGN ITSELF, NOR DOES THE MODIFICATION INSPECTOR TAKE OWNERSHIP OF THE MODIFICATION DESIGN. OWNERSHIP OF THE STRUCTURAL MODIFICATION DESIGN EFFECTIVENESS AND INTENT RESIDES WITH THE ENGINEER OF RECORD AT ALL TIMES.
3. TO ENSURE THAT THE REQUIREMENTS OF THE MODIFICATION INSPECTION ARE MET, IT IS VITAL THAT THE GENERAL CONTRACTOR (GC) AND THE MODIFICATION INSPECTOR BEGIN COMMUNICATING AND COORDINATING AS SOON AS A PO OR PAYMENT IS RECEIVED. IT IS EXPECTED THAT EACH PARTY WILL BE PROACTIVE IN REACHING OUT TO THE OTHER PARTY. CONTACT LISTED ON THE TITLE SHEET SHALL BE CONTACTED IF SPECIFIC INSPECTOR CONTACT INFORMATION IS NOT KNOWN.

### MODIFICATION INSPECTOR

1. THE MODIFICATION INSPECTOR IS REQUIRED TO CONTACT THE GC AS SOON AS RECEIVING A PO OR PAYMENT FOR THE MODIFICATION INSPECTION TO:
  - REVIEW THE REQUIREMENTS OF THE MODIFICATION INSPECTION CHECKLIST
  - WORK WITH THE GC TO DEVELOP A SCHEDULE TO CONDUCT ON-SITE INSPECTIONS, INCLUDING FOUNDATION INSPECTIONS
  - DISCUSS ANY SITE SPECIFIC INSPECTIONS OR CONCERNS
2. THE MODIFICATION INSPECTOR IS RESPONSIBLE FOR COLLECTING ALL GENERAL CONTRACTOR (GC) INSPECTION AND TEST REPORTS, REVIEWING THE DOCUMENTS FOR ADHERENCE TO THE CONTRACT DOCUMENTS, CONDUCTING THE IN-FIELD INSPECTIONS, AND SUBMITTING THE MODIFICATION INSPECTION REPORT.

### GENERAL CONTRACTOR

1. THE GC IS REQUIRED TO CONTACT THE MODIFICATION INSPECTOR AS SOON AS RECEIVING A PO OR PAYMENT FOR THE MODIFICATION INSTALLATION OR TURNKEY PROJECT TO:
  - REVIEW THE REQUIREMENTS OF THE MODIFICATION INSPECTION CHECKLIST
  - WORK WITH THE MI INSPECTOR TO DEVELOP A SCHEDULE TO CONDUCT ON-SITE MODIFICATION INSPECTIONS, INCLUDING FOUNDATION INSPECTIONS
  - BETTER UNDERSTAND ALL INSPECTION AND TESTING REQUIREMENTS
2. THE GC SHALL PERFORM AND RECORD THE TEST AND INSPECTION RESULTS IN ACCORDANCE WITH THE REQUIREMENTS OF THE MODIFICATION INSPECTION CHECKLIST.

### RECOMMENDATIONS

THE FOLLOWING RECOMMENDATIONS AND SUGGESTIONS ARE OFFERED TO ENHANCE THE EFFICIENCY AND EFFECTIVENESS OF DELIVERING A MODIFICATION INSPECTION REPORT:

- IT IS SUGGESTED THAT THE GC PROVIDE A MINIMUM OF 5 BUSINESS DAYS NOTICE, PREFERABLY 10, TO THE MODIFICATION INSPECTOR AS TO WHEN THE SITE WILL BE READY FOR THE MODIFICATION INSPECTION TO BE CONDUCTED.
- THE GC AND MODIFICATION INSPECTOR COORDINATE CLOSELY THROUGHOUT THE ENTIRE PROJECT.
- WHEN POSSIBLE, IT IS PREFERRED TO HAVE THE GC AND MODIFICATION INSPECTOR ON-SITE SIMULTANEOUSLY FOR ANY GUY WIRE TENSIONING OR RE-TENSIONING OPERATIONS.
- IT MAY BE BENEFICIAL TO INSTALL ALL TOWER MODIFICATIONS PRIOR TO CONDUCTING THE FOUNDATION INSPECTIONS TO ALLOW FOUNDATION AND MODIFICATION INSPECTION(S) TO COMMENCE WITH ONE SITE VISIT.
- WHEN POSSIBLE, IT IS PREFERRED TO HAVE THE GC AND MODIFICATION INSPECTOR ON-SITE DURING THE MODIFICATION INSPECTION TO HAVE ANY DEFICIENCIES CORRECTED DURING THE INITIAL MODIFICATION INSPECTION. THEREFORE, THE GC MAY CHOOSE TO COORDINATE THE MODIFICATION INSPECTION CAREFULLY TO ENSURE ALL CONSTRUCTION FACILITIES ARE AT THEIR DISPOSAL WHEN THE MI INSPECTOR IS ON SITE.

### CANCELLATION OR DELAYS

1. IF THE GC AND MODIFICATION INSPECTOR AGREE TO A DATE ON WHICH THE MODIFICATION INSPECTION WILL BE CONDUCTED, AND EITHER PARTY CANCELS OR DELAYS, THE TOWER OWNER SHALL NOT BE RESPONSIBLE FOR ANY COSTS, FEES, LOSS OF DEPOSITS AND/OR OTHER PENALTIES RELATED TO THE CANCELLATION OR DELAY INCURRED BY EITHER PARTY FOR ANY TIME (E.G. TRAVEL AND LODGING, COSTS OF KEEPING EQUIPMENT ON-SITE, ETC.). EXCEPTIONS MAY BE MADE IN THE EVENT THAT THE DELAY/CANCELLATION IS CAUSED BY WEATHER OR OTHER CONDITIONS THAT MAY COMPROMISE THE SAFETY OF THE PARTIES INVOLVED.

### FAILING INSPECTION CORRECTIONS

1. IF THE MODIFICATION INSTALLATION WOULD FAIL THE MODIFICATION INSPECTION ("FAILED MODIFICATION INSPECTION"), THE GC SHALL WORK WITH MODIFICATION INSPECTOR TO COORDINATE A REMEDIATION PLAN IN ONE OF TWO WAYS:

- CORRECT FAILING ISSUES TO COMPLY WITH THE SPECIFICATIONS CONTAINED IN THE ORIGINAL CONTRACT DOCUMENTS AND COORDINATE A SUPPLEMENT MODIFICATION INSPECTION.
- OR, WITH TOWER OWNER'S APPROVAL, THE GC MAY WORK WITH THE ENGINEER OF RECORD TO RE-ANALYZE THE MODIFICATION/REINFORCEMENT USING THE AS-BUILT CONDITION.

### VERIFICATION INSPECTIONS

1. TOWER OWNER RESERVES THE RIGHT TO CONDUCT A VERIFICATION INSPECTION TO VERIFY THE ACCURACY AND COMPLETENESS OF PREVIOUSLY COMPLETED MODIFICATION INSPECTION(S) ON TOWER MODIFICATION PROJECTS.
2. VERIFICATION INSPECTION MAY BE CONDUCTED BY AN INDEPENDENT FIRM AFTER A MODIFICATION PROJECT IS COMPLETED, AS MARKED BY THE DATE OF AN ACCEPTED "PASSING MODIFICATION INSPECTION" OR "PASS AS NOTED MODIFICATION INSPECTION" REPORT FOR THE ORIGINAL PROJECT.

### REQUIRED PHOTOS

1. BETWEEN THE GC AND THE MI INSPECTOR THE FOLLOWING PHOTOGRAPHS ARE TO BE TAKEN AND INCLUDED IN THE MODIFICATION INSPECTION REPORT:
  - PRE-CONSTRUCTION GENERAL SITE CONDITION
  - PHOTOGRAPHS DURING THE REINFORCEMENT MODIFICATION CONSTRUCTION/ERECTION AND INSPECTION:
    - RAW MATERIALS
    - PHOTOS OF ALL CRITICAL DETAILS
    - FOUNDATION MODIFICATIONS
    - WELD PREPARATION
    - BOLT INSTALLATION AND TORQUE
    - FINAL INSTALLED CONDITION
    - SURFACE COATING REPAIR
  - POST CONSTRUCTION PHOTOGRAPHS:
    - FINAL INFIELD CONDITION
    - ANY OTHER PHOTOS DEEMED RELEVANT TO SHOW COMPLETE DETAILS OF MODIFICATIONS.
2. PHOTOS OF ELEVATED MODIFICATIONS TAKEN FROM THE GROUND SHALL BE CONSIDERED INADEQUATE.



520 South Main Street  
 Akron, Ohio 44311  
 330.572.2100 Fax 330.572.2102



NORFOLK-LOON MEADOW RD.  
 USID # 71285

DESIGN DRAWINGS  
 PREPARED FOR:



CLIENT #: CT33XC116

REV.	DATE	DESCRIPTION
0	6/28/18	INITIAL RELEASE

NORFOLK-LOON MEADOW RD.  
 402 LOON MEADOW DR.  
 NORFOLK, CT 06058

### MODIFICATION INSPECTION CHECKLIST

ISSUED FOR:	
PERMIT	6/28/2018
BID	-
CONSTRUCTION	-
RECORD	-

ENGINEER	DESIGNER
MM	JW
PROJECT MANAGER	APPROVED BY
CB	CJS

JOB NO.  
 2018723.01.71285.02

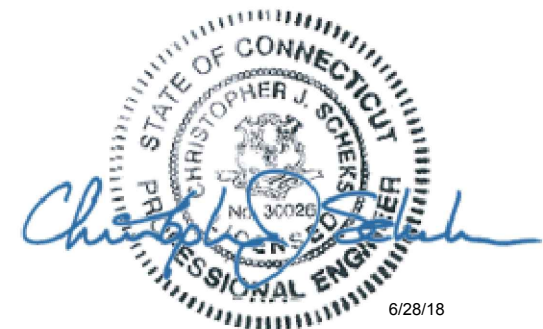

6/28/18

MI-01



## RADIO FREQUENCY EMISSIONS ANALYSIS REPORT EVALUATION OF HUMAN EXPOSURE POTENTIAL TO NON-IONIZING EMISSIONS

SPRINT Existing Facility

Site ID: CT33XC116

Fishs Eddy / SNet Corp  
453 Loon Meadow Road  
Norfolk, CT 06058

**July 12, 2018**

**EBI Project Number: 6218004977**

Site Compliance Summary	
Compliance Status:	<b>COMPLIANT</b>
Site total MPE% of FCC general population allowable limit:	<b>6.90 %</b>



July 12, 2018

SPRINT

Attn: RF Engineering Manager  
1 International Boulevard, Suite 800  
Mahwah, NJ 07495

## Emissions Analysis for Site: **CT33XC116 – Fishs Eddy / SNet Corp**

EBI Consulting was directed to analyze the proposed SPRINT facility located at **453 Loon Meadow Road, Norfolk, CT**, for the purpose of determining whether the emissions from the Proposed SPRINT Antenna Installation located on this property are within specified federal limits.

All information used in this report was analyzed as a percentage of current Maximum Permissible Exposure (% MPE) as listed in the FCC OET Bulletin 65 Edition 97-01 and ANSI/IEEE Std C95.1. The FCC regulates Maximum Permissible Exposure in units of microwatts per square centimeter ( $\mu\text{W}/\text{cm}^2$ ). The number of  $\mu\text{W}/\text{cm}^2$  calculated at each sample point is called the power density. The exposure limit for power density varies depending upon the frequencies being utilized. Wireless Carriers and Paging Services use different frequency bands each with different exposure limits, therefore it is necessary to report results and limits in terms of percent MPE rather than power density.

All results were compared to the FCC (Federal Communications Commission) radio frequency exposure rules, 47 CFR 1.1307(b)(1) – (b)(3), to determine compliance with the Maximum Permissible Exposure (MPE) limits for General Population/Uncontrolled environments as defined below.

General population/uncontrolled exposure limits apply to situations in which the general population may be exposed or in which persons who are exposed as a consequence of their employment may not be made fully aware of the potential for exposure or cannot exercise control over their exposure. Therefore, members of the general population would always be considered under this category when exposure is not employment related, for example, in the case of a telecommunications tower that exposes persons in a nearby residential area.

General population exposure to radio frequencies is regulated and enforced in units of microwatts per square centimeter ( $\mu\text{W}/\text{cm}^2$ ). The general population exposure limits for the 850 MHz Band is approximately  $567 \mu\text{W}/\text{cm}^2$ . The general population exposure limit for the 1900 MHz (PCS) and 2500 MHz (BRS) bands is  $1000 \mu\text{W}/\text{cm}^2$ . Because each carrier will be using different frequency bands, and each frequency band has different exposure limits, it is necessary to report percent of MPE rather than power density.



Occupational/controlled exposure limits apply to situations in which persons are exposed as a consequence of their employment and in which those persons who are exposed have been made fully aware of the potential for exposure and can exercise control over their exposure. Occupational/controlled exposure limits also apply where exposure is of a transient nature as a result of incidental passage through a location where exposure levels may be above general population/uncontrolled limits (see below), as long as the exposed person has been made fully aware of the potential for exposure and can exercise control over his or her exposure by leaving the area or by some other appropriate means.

Additional details can be found in FCC OET 65.

## CALCULATIONS

Calculations were done for the proposed SPRINT Wireless antenna facility located at **453 Loon Meadow Road, Norfolk, CT**, using the equipment information listed below. All calculations were performed per the specifications under FCC OET 65. Since SPRINT is proposing highly focused directional panel antennas, which project most of the emitted energy out toward the horizon, all calculations were performed assuming a lobe representing the maximum gain of the antenna per the antenna manufactures supplied specifications, minus 10 dB, was focused at the base of the tower. For this report the sample point is the top of a 6-foot person standing at the base of the tower.

For all calculations, all equipment was calculated using the following assumptions:

- 1) 1 CDMA channels (850 MHz) were considered for each sector of the proposed installation. These Channels have a transmit power of 20 Watts per Channel.
- 2) 2 LTE channels (850 MHz) were considered for each sector of the proposed installation. These Channels have a transmit power of 50 Watts per Channel.
- 3) 5 CDMA channels (1900 MHz (PCS)) were considered for each sector of the proposed installation. These Channels have a transmit power of 16 Watts per Channel.
- 4) 2 LTE channels (1900 MHz (PCS)) were considered for each sector of the proposed installation. These Channels have a transmit power of 40 Watts per Channel.
- 5) 8 LTE channels (2500 MHz (BRS)) were considered for each sector of the proposed installation. These Channels have a transmit power of 20 Watts per Channel.



- 6) All radios at the proposed installation were considered to be running at full power and were uncombined in their RF transmissions paths per carrier prescribed configuration. Per FCC OET Bulletin No. 65 - Edition 97-01 recommendations to achieve the maximum anticipated value at each sample point, all power levels emitting from the proposed antenna installation are increased by a factor of 2.56 to account for possible in-phase reflections from the surrounding environment. This is rarely the case, and if so, is never continuous.
- 7) For the following calculations, the sample point was the top of a 6-foot person standing at the base of the tower. The maximum gain of the antenna per the antenna manufactures supplied specifications minus 10 dB was used in this direction. This value is a very conservative estimate as gain reductions for these particular antennas are typically much higher in this direction.
- 8) The antennas used in this modeling are the **Commscope DT465B-2XR** and the **RFS APXVSPP18-C-A20** for transmission in the 850 MHz, 1900 MHz (PCS) and 2500 MHz (BRS) frequency bands. This is based on feedback from the carrier with regards to anticipated antenna selection. Maximum gain values for all antennas are listed in the Inventory and Power Data table below. The maximum gain of the antenna per the antenna manufactures supplied specifications, minus 10 dB, was used for all calculations. This value is a very conservative estimate as gain reductions for these particular antennas are typically much higher in this direction.
- 9) The antenna mounting height centerlines of the proposed antennas are **158 feet** above ground level (AGL) for **Sector A**, **158 feet** above ground level (AGL) for **Sector B** and **158 feet** above ground level (AGL) for Sector C.
- 10) Emissions values for additional carriers were taken from the Connecticut Siting Council active database. Values in this database are provided by the individual carriers themselves.

All calculations were done with respect to uncontrolled / general population threshold limits.



## SPRINT Site Inventory and Power Data by Antenna

Sector:	A	Sector:	B	Sector:	C
Antenna #:	<b>1</b>	Antenna #:	<b>1</b>	Antenna #:	<b>1</b>
Make / Model:	RFS APXVSPP18-C-A20	Make / Model:	RFS APXVSPP18-C-A20	Make / Model:	RFS APXVSPP18-C-A20
Gain:	13.4 / 15.9 dBd	Gain:	13.4 / 15.9 dBd	Gain:	13.4 / 15.9 dBd
Height (AGL):	<b>158 feet</b>	Height (AGL):	<b>158 feet</b>	Height (AGL):	<b>158 feet</b>
Frequency Bands	850 MHz / 1900 MHz (PCS)	Frequency Bands	850 MHz / 1900 MHz (PCS)	Frequency Bands	850 MHz / 1900 MHz (PCS)
Channel Count	8	Channel Count	8	Channel Count	8
Total TX Power(W):	180 Watts	Total TX Power(W):	180 Watts	Total TX Power(W):	180 Watts
ERP (W):	6,662.27	ERP (W):	6,662.27	ERP (W):	6,662.27
Antenna A1 MPE%	<b>1.09 %</b>	Antenna B1 MPE%	<b>1.09 %</b>	Antenna C1 MPE%	<b>1.09 %</b>
Antenna #:	<b>2</b>	Antenna #:	<b>2</b>	Antenna #:	<b>2</b>
Make / Model:	Commscope DT465B-2XR	Make / Model:	Commscope DT465B-2XR	Make / Model:	Commscope DT465B-2XR
Gain:	15.05 dBd	Gain:	15.05 dBd	Gain:	15.05 dBd
Height (AGL):	<b>158 feet</b>	Height (AGL):	<b>158 feet</b>	Height (AGL):	<b>158 feet</b>
Frequency Bands	2500 MHz (BRS) / 850 MHz	Frequency Bands	2500 MHz (BRS) / 850 MHz	Frequency Bands	2500 MHz (BRS) / 850 MHz
Channel Count	10	Channel Count	10	Channel Count	10
Total TX Power(W):	260 Watts	Total TX Power(W):	260 Watts	Total TX Power(W):	260 Watts
ERP (W):	7,280.95	ERP (W):	7,280.95	ERP (W):	7,280.95
Antenna A2 MPE%	<b>1.39 %</b>	Antenna B2 MPE%	<b>1.39 %</b>	Antenna C2 MPE%	<b>1.39 %</b>

Site Composite MPE%	
Carrier	MPE%
SPRINT – Max per sector	<b>2.48 %</b>
AT&T	1.74 %
T-Mobile	2.34 %
PageNet	0.34 %
<b>Site Total MPE %:</b>	<b>6.90 %</b>

SPRINT Sector A Total:	2.48 %
SPRINT Sector B Total:	2.48 %
SPRINT Sector C Total:	2.48 %
<b>Site Total:</b>	<b>6.90 %</b>

SPRINT _ Frequency Band / Technology (All Sectors)	# Channels	Watts ERP (Per Channel)	Height (feet)	Total Power Density ( $\mu\text{W}/\text{cm}^2$ )	Frequency (MHz)	Allowable MPE ( $\mu\text{W}/\text{cm}^2$ )	Calculated % MPE
Sprint 850 MHz CDMA	1	437.55	158	0.68	850 MHz	567	0.13%
Sprint 1900 MHz (PCS) CDMA	5	622.47	158	4.84	1900 MHz (PCS)	1000	0.48%
Sprint 1900 MHz (PCS) LTE	2	1,556.18	158	4.84	1900 MHz (PCS)	1000	0.48%
Sprint 2500 MHz (BRS) LTE	8	639.78	158	7.96	2500 MHz (BRS)	1000	0.80%
Sprint 850 MHz LTE	2	1,081.36	158	3.37	850 MHz	567	0.59%
						<b>Total:</b>	<b>2.48%</b>





## Summary

All calculations performed for this analysis yielded results that were **within** the allowable limits for general population exposure to RF Emissions.

The anticipated maximum composite contributions from the SPRINT facility as well as the site composite emissions value with regards to compliance with FCC's allowable limits for general population exposure to RF Emissions are shown here:

SPRINT Sector	Power Density Value (%)
Sector A:	2.48 %
Sector B:	2.48 %
Sector C:	2.48 %
SPRINT Maximum Total (per sector):	2.48 %
Site Total:	6.90 %
Site Compliance Status:	<b>COMPLIANT</b>

The anticipated composite MPE value for this site assuming all carriers present is **6.90 %** of the allowable FCC established general population limit sampled at the ground level. This is based upon values listed in the Connecticut Siting Council database for existing carrier emissions.

FCC guidelines state that if a site is found to be out of compliance (over allowable thresholds), that carriers over a 5% contribution to the composite value will require measures to bring the site into compliance. For this facility, the composite values calculated were well within the allowable 100% threshold standard per the federal government.

# Town of Norfolk

## "Icebox" of Connecticut

[Recent Sales in Neighborhood](#)   
 [Previous Parcel](#)   
 [Next Parcel](#)   
 [Field Definitions](#)   
 [Return to Main Search](#)   
 [Norfolk Home](#)

### Owner and Parcel Information

<b>Owner Name</b>	NEW CINGULAR WIRELESS PCS LLC ATTN PROPERTY TAX DEPT	<b>Today's Date</b>	July 30, 2018
<b>Mailing Address</b>	1010 PINE; 9E-L-01 ST LOUIS, MO 63101	<b>Parcel ID</b>	574 (Account #: 6-14/007-0)
<b>Location Address</b>	453 LOON MEADOW DR	<b>Fire District</b>	
<b>Map/Lot</b>	6-14/7	<b>Census Tract</b>	3081
<b>Use Class / Description</b>	5-2 VAC COMM	<b>Acreage</b>	4.98
<b>Assessing Neighborhood</b>	0001A	<b>Utilities</b>	

### Current Appraised Value Information

Building Value	XF Value	OB Value	Land Value	Special Land Value	Total Appraised Value	Net Appraised Value	Current Assessment
\$ 0	\$ 0	\$ 1,028,780	\$ 127,860		\$ 1,156,640	\$ 1,156,640	\$ 809,650

### Assessment History

Year	Building	OB/ Misc	Land	Total Assessment
Current	0	\$ 720,150	\$ 89,500	\$ 809,650
2017	0	\$ 720,150	\$ 89,500	\$ 809,650
2016	0	\$ 720,150	\$ 89,500	\$ 809,650

### Land Information

Use	Class	Zoning	Area	Value
VAC COMM	C	RU	1 AC	\$ 100,000
VAC COMM	C		3.98 AC	\$ 27,860

### Building Information

No Building Information available for this parcel.

### Out Buildings / Extra Features

Description	Sub Description	Area	Year Built	Value
1 STORY FRAME		408 S.F.		\$ 20,400
1 STORY FRAME		256 S.F.		\$ 6,400
8' FENCE		360 L.F.		\$ 1,980
CELL TOWER C		1 UNITS		\$ 1,000,000

### Sale Information

Sale Date	Sale Price	Deed Book / Page	Sale Qualification	Reason	Vacant or Improved	Owner
06/22/2015		118/1088	Unqualified	Unqualified Sale - Nonspecific	Vacant	NEW CINGULAR WIRELESS PCS LLC ATTN PROPERTY TAX DEPT
10/28/2014		118/ 311	Unqualified	No Consideration Sale	Improved	AT&T CAPITAL SERVICES INC
08/02/1957		42/ 29	Unqualified			SOUTHERN NEW ENGLAND TELEPHONE

### Permit Information

Permit ID	Issue Date	Type	Description	Amount	Inspection Date	% Complete	Date Complete	Comments
828E	03/27/2015	EL	Electric	\$ 15,000		0		UPG 3 ANTENNAS
388-E	03/02/2013	EL	Electric	\$ 12,000		0		6 NEW ANTENNAS
7470-E	01/18/2001	EL	Electric	\$ 54,000		0		ADD ANTENNAS TO TOWER
7457	12/18/2000	EL	Electric	\$ 10,000		0		INSTALL CONDUITS

[Recent Sales in Neighborhood](#)   
 [Previous Parcel](#)   
 [Next Parcel](#)   
 [Field Definitions](#)   
 [Return to Main Search Page](#)   
 [Norfolk Home](#)

The Town of Norfolk Assessor's Office makes every effort to produce the most accurate information possible. No warranties, expressed or implied, are provided for the data herein, its use or interpretation. Website Updated: July 29, 2018



STATE OF CONNECTICUT  
CONNECTICUT SITING COUNCIL

CT33XC116

Ten Franklin Square, New Britain, CT 06051

Phone: (860) 827-2935 Fax: (860) 827-2950

E-Mail: [siting.council@ct.gov](mailto:siting.council@ct.gov)

[www.ct.gov/csc](http://www.ct.gov/csc)

December 14, 2012

Jennifer Palumbo  
Sprint  
48 Spruce Street  
Oakland, NJ 07436

RE: **EM-SPRINT-098-121129** – Sprint Spectrum L.P. notice of intent to modify an existing telecommunications facility located at 453 Loon Meadow Road, Norfolk, Connecticut.

Dear Ms. Palumbo:

The Connecticut Siting Council (Council) hereby acknowledges your notice to modify this existing telecommunications facility, pursuant to Section 16-50j-73 of the Regulations of Connecticut State Agencies with the following conditions:

- The proposed coax shall be installed in accordance with the recommendations made in the Structural Analysis Report prepared by GPD Group dated November 15, 2012 and stamped by David Granger; and
- Not more than 45 days following completion of the antenna installation, Sprint shall provide documentation certifying that its installation complied with the engineer's recommendation.
- Any deviation from the proposed modification as specified in this notice and supporting materials with Council shall render this acknowledgement invalid;
- Any material changes to this modification as proposed shall require the filing of a new notice with the Council;
- Not more than 45 days after completion of construction, the Council shall be notified in writing that construction has been completed;
- The validity of this action shall expire one year from the date of this letter; and
- The applicant may file a request for an extension of time beyond the one year deadline provided that such request is submitted to the Council not less than 60 days prior to the expiration;

The proposed modifications including the placement of all necessary equipment and shelters within the tower compound are to be implemented as specified here and in your notice dated November 26, 2012. The modifications are in compliance with the exception criteria in Section 16-50j-72 (b) of the Regulations of Connecticut State Agencies as changes to an existing facility site that would not increase tower height, extend the boundaries of the tower site, increase noise levels at the tower site boundary by six decibels, and increase the total radio frequencies electromagnetic radiation power density measured at the tower site boundary to or above the standard adopted by the State Department of Environmental Protection pursuant to General Statutes § 22a-162. This facility has also been carefully modeled to ensure that radio frequency emissions are conservatively below State and federal standards applicable to the frequencies now used on this tower.



This decision is under the exclusive jurisdiction of the Council. Please be advised that the validity of this action shall expire one year from the date of this letter. Any additional change to this facility will require explicit notice to this agency pursuant to Regulations of Connecticut State Agencies Section 16-50j-73. Such notice shall include all relevant information regarding the proposed change with cumulative worst-case modeling of radio frequency exposure at the closest point of uncontrolled access to the tower base, consistent with Federal Communications Commission, Office of Engineering and Technology, Bulletin 65. Thank you for your attention and cooperation.

Very truly yours,



Linda Roberts  
Executive Director

LR/CDM/cm

- c: The Honorable Susan M. Dyer, First Selectman, Town of Norfolk
- Joanne M. Munch, Chm, Zoning Bd. Of Appeals, Chm., Town of Norfolk

ORIGIN ID:CBZA (973) 477-8032  
STEVE SOFMAN  
CHARLES CHERUNDOLLO CONSULTING  
1280 ROUTE 46 WEST  
SUITE 9  
PARLIPPANY, NJ 07054  
UNITED STATES US

SHIP DATE: 30 JUL 18  
ACTWGT: 1.00 LB  
CAD: 111040781/NET4040  
BILL SENDER

TO MICHAEL HALLORAN  
TOWN OF NORFOLK  
19 MAPLE AVE  
NORFOLK CT 06058

(866) 542-6804 REF: CT3XCT16 CSC-FLING  
INV. DEPT.  
PO.

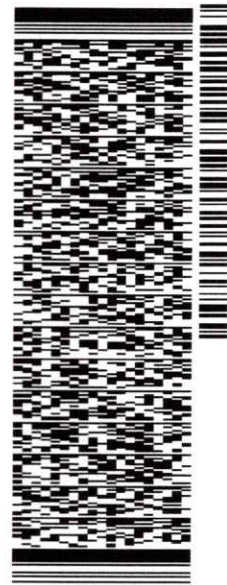

TRK# 0201 7728 5490 2707

THU - 02 AUG 4:30P  
EXPRESS SAVER

K7 HFDA 06058  
CT-US BDL



552J11/3309/DCA5

**After printing this label:**

1. Use the 'Print' button on this page to print your label to your laser or inkjet printer.
2. Fold the printed page along the horizontal line.
3. Place label in shipping pouch and affix it to your shipment so that the barcode portion of the label can be read and scanned.

**Warning:** Use only the printed original label for shipping. Using a photocopy of this label for shipping purposes is fraudulent and could result in additional billing charges, along with the cancellation of your FedEx account number.

Use of this system constitutes your agreement to the service conditions in the current FedEx Service Guide, available on fedex.com. FedEx will not be responsible for any claim in excess of \$100 per package, whether the result of loss, damage, delay, non-delivery, misdelivery, or misinformation, unless you declare a higher value, pay an additional charge, document your actual loss and file a timely claim. Limitations found in the current FedEx Service Guide apply. Your right to recover from FedEx for any loss, including intrinsic value of the package, loss of sales, income interest, profit, attorney's fees, costs, and other forms of damage whether direct, incidental, consequential, or special is limited to the greater of \$100 or the authorized declared value. Recovery cannot exceed actual documented loss. Maximum for items of extraordinary value is \$1,000, e.g. jewelry, precious metals, negotiable instruments and other items listed in our ServiceGuide. Written claims must be filed within strict time limits, see current FedEx Service Guide.

ORIGIN ID: CBZA (973) 477-8032  
STEVE SOFMAN  
CHARLES CHERUNDI LO CONSULTING  
1280 ROUTE 46 WEST  
SUITE 9  
PARISPPANY, NJ 07054  
UNITED STATES US

SHIP DATE: 30 JUL 18  
ACTWGT: 1.00 LB  
CAD: 111040781/MET4040  
BILL SENDER

TO **MATTHEW T RIISKA**  
**BOARD OF SELECTMEN**  
**PO BOX 592**

**NORFOLK CT 06058**  
(860) 542-5829 REF: CT33XC116 CSC: FLING  
INV. DEPT.  
PO.

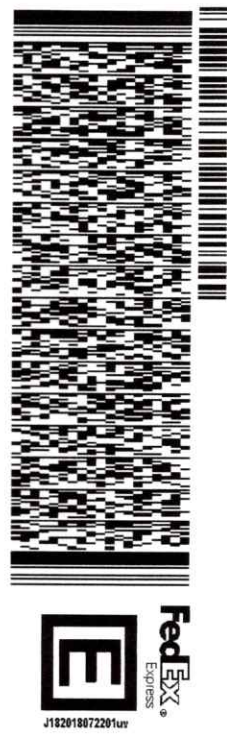

TRK# 7728 5486 1828 THU - 02 AUG 4:30P  
0201 EXPRESS SAVER

**K7 HFDA** 06058  
CT-US BDL

**After printing this label:**

1. Use the 'Print' button on this page to print your label to your laser or inkjet printer.
2. Fold the printed page along the horizontal line.
3. Place label in shipping pouch and affix it to your shipment so that the barcode portion of the label can be read and scanned.

**Warning:** Use only the printed original label for shipping. Using a photocopy of this label for shipping purposes is fraudulent and could result in additional billing charges, along with the cancellation of your FedEx account number.

Use of this system constitutes your agreement to the service conditions in the current FedEx Service Guide, available on fedex.com. FedEx will not be responsible for any claim in excess of \$100 per package, whether the result of loss, damage, delay, non-delivery, misdelivery, or misinformation, unless you declare a higher value, pay an additional charge, document your actual loss and file a timely claim. Limitations found in the current FedEx Service Guide apply. Your right to recover from FedEx for any loss, including intrinsic value of the package, loss of sales, income interest, profit, attorney's fees, costs, and other forms of damage whether direct, incidental, consequential, or special is limited to the greater of \$100 or the authorized declared value. Recovery cannot exceed actual documented loss. Maximum for items of extraordinary value is \$1,000, e.g. jewelry, precious metals, negotiable instruments and other items listed in our ServiceGuide. Written claims must be filed within strict time limits, see current FedEx Service Guide.

ORIGIN ID: KKA (856) 625-1596  
RYAN BAILEY  
CHARLES CHERUNDOLLO CONSULTING  
3 PROSPECT PL  
B MADISON, NJ 07940  
UNITED STATES US

SHIP DATE: 30 JUL 18  
ACT WGT: 1.00 LB  
CAD: 11104078/IN/ET/4040

BILL SENDER

TO DEBORAH KRENC

AT&T TOWERS

5600 GLENRIDGE DR

CUBE @6E92F

ATLANTA GA 30342

(678) 917-1026 REF: CT33XC116 CSC FILING  
INV/ DEPT  
PO

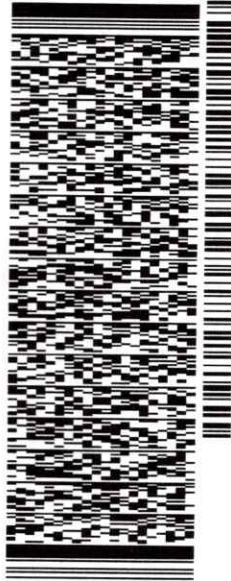

TRK# 7728 5489 0802  
0201

THU - 02 AUG 4:30P  
EXPRESS SAVER

SH TMAA

30342  
GA-US ATL

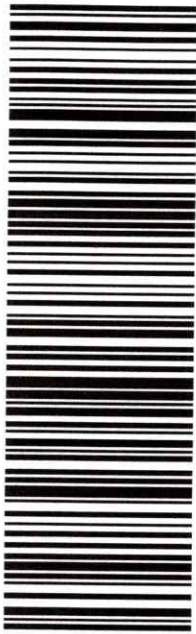

**After printing this label:**

1. Use the 'Print' button on this page to print your label to your laser or inkjet printer.
2. Fold the printed page along the horizontal line.
3. Place label in shipping pouch and affix it to your shipment so that the barcode portion of the label can be read and scanned.

**Warning:** Use only the printed original label for shipping. Using a photocopy of this label for shipping purposes is fraudulent and could result in additional billing charges, along with the cancellation of your FedEx account number.

Use of this system constitutes your agreement to the service conditions in the current FedEx Service Guide, available on [fedex.com](http://fedex.com). FedEx will not be responsible for any claim in excess of \$100 per package, whether the result of loss, damage, delay, non-delivery, misdelivery, or misinformation, unless you declare a higher value, pay an additional charge, document your actual loss and file a timely claim. Limitations found in the current FedEx Service Guide apply. Your right to recover from FedEx for any loss, including intrinsic value of the package, loss of sales, income interest, profit, attorney's fees, costs, and other forms of damage whether direct, incidental, consequential, or special is limited to the greater of \$100 or the authorized declared value. Recovery cannot exceed actual documented loss. Maximum for items of extraordinary value is \$1,000, e.g. jewelry, precious metals, negotiable instruments and other items listed in our Service Guide. Written claims must be filed within strict time limits, see current FedEx Service Guide.