



Crown Castle
3 Corporate Park Drive, Suite 101
Clifton Park, NY 12065

October 4, 2017

Melanie A. Bachman
Acting Executive Director
Connecticut Siting Council
10 Franklin Square
New Britain, CT 06051

RE: Notice of Exempt Modification for Sprint 2.5 Rework Crown Site BU: 826222
Sprint Site ID: CT54XC716
201 South Main Street, Newtown, CT 06470
Latitude: 41° 22' 41.32"/ Longitude: -73° 16' 26.94"

Dear Ms. Bachman:

Sprint currently maintains three (3) antennas at the 137-foot level of the existing 150-foot monopole tower at 201 South Main Street in Newtown, CT. The tower is owned by Crown Castle. The property is owned by BlueLinx Corp. Sprint intends to install three (3) antennas, three (3) RRHs and one (1) hybrid cable.

The Town of Newtown could not confirm the original date and conditions of zoning.

Please accept this letter as notification pursuant to Regulations of Connecticut State Agencies § 16-50j-73, for construction that constitutes an exempt modification pursuant to R.C.S.A. § 16-50j-72(b)(2). In accordance with R.S.C.A. § 16-50j-73, a copy of this letter is being sent to Ms. E. Patricia Llodra, First Selectman, Town of Newtown, Planning and Zoning, and the property owner.

The proposed modifications will not result in an increase in the height of the existing tower.

1. The proposed modifications will not require the extension of the site boundary.
2. The proposed modification will not increase noise levels at the facility by six decibels or more, or to levels that exceed state and local criteria.
3. The operation of the replacement antennas will not increase radio frequency emissions at the facility to a level at or above the Federal Communication Commission safety standard.
4. The proposed modifications will not cause a change or alteration in the physical or environmental characteristics of the site.

Melanie A. Bachman

October 4, 2017

Page 2

5. The existing structure and its foundation can support the proposed loading.

For the foregoing reasons, Sprint respectfully submits that the proposed modifications to the above-reference telecommunications facility constitutes an exempt modification under R.C.S.A. § 16-50j-72(b)(2). Please send approval/rejection letter to Attn: Jeffrey Barbadora.

Sincerely,

Jeffrey Barbadora
Real Estate Specialist
12 Gill Street, Suite 5800, Woburn, MA 01801
781-729-0053
Jeff.Barbadora@crowncastle.com

Attachments:

Tab 1: Exhibit-1: Compound plan and elevation depicting the planned changes

Tab 2: Exhibit-2: Structural Modification Report

Tab 3: Exhibit-3: General Power Density Table Report (RF Emissions Analysis Report)

cc: Ms. E. Patricia Llodra, First-Selectman
Newtown Municipal Center
3 Primrose Street
Newtown, CT 06470

Planning and Zoning
Newtown Municipal Center
3 Primrose Street
Newtown, CT 06470

BlueLinx Corp
4300 Wildwood Parkway
Atlanta, GA 30339



Property Information

Owner	BLUELIX CORP
Co-Owner	
Address	201 SOUTH MAIN STREET
Mailing Address	4300 WILDWOOD PARKWAY ATLANTA GA 30339
Land Use	3920 UNDEV LAND
Land Class	C
Vision ID	15198
School Zone	
Town Clerk Map	

Fire District	
Census Tract	
Neighborhood	
Zoning Code	M-1
Acreage	0
Utilities	Well,Septic
Lot Setting/Desc	
Voting District	
Borough	
Historic	

Photo

No Photo Available

Sketch

Construction Details

Year Built	
Stories	
Building Style	
Building Use	
Building Condition	
Floors	
Total Rooms	

Bedrooms	0
Full Bathrooms	
Half Bathrooms	
Bath Style	
Kitchen Style	
Roof Style	
Roof Cover	

Exterior Walls	
Interior Walls	
Heating Type	
Heating Fuel	
AC Type	
Gross Bldg Area	
Total Living Area	0

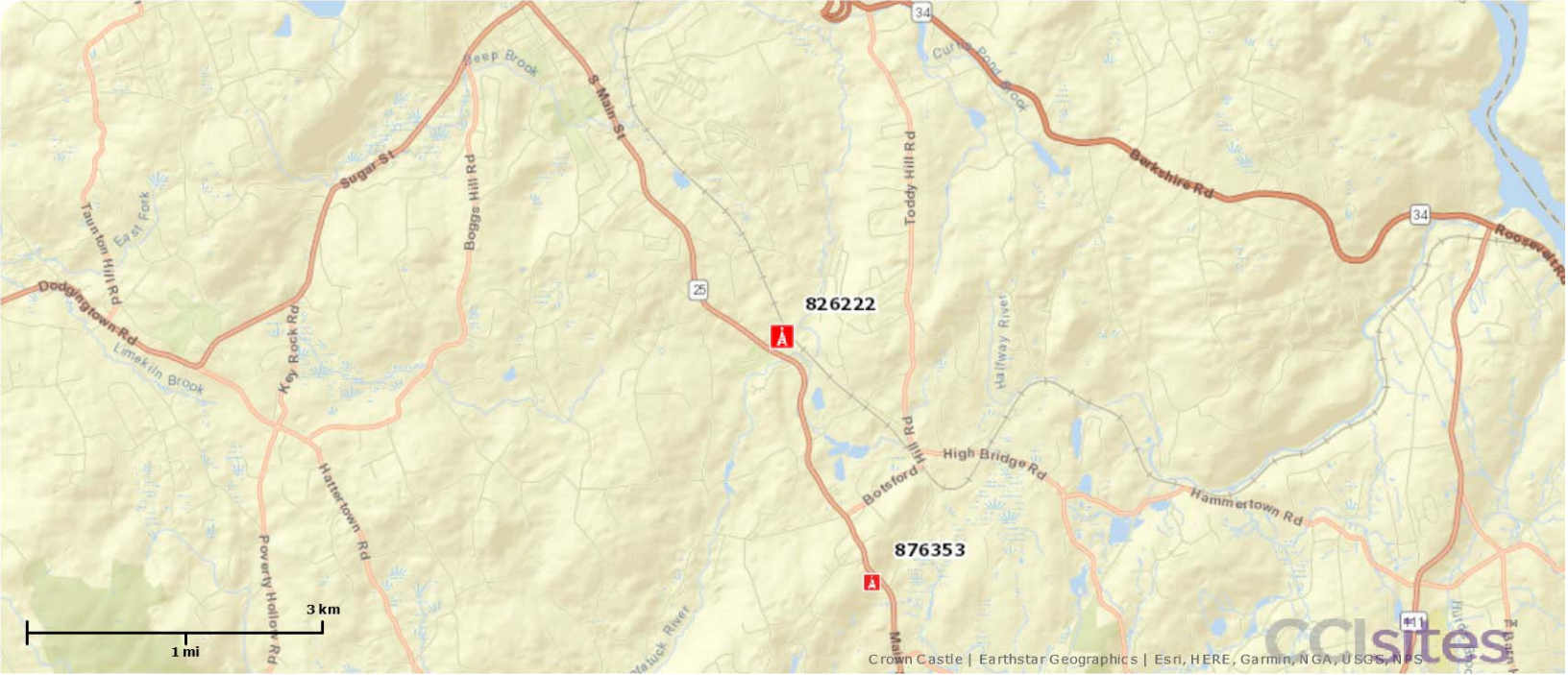



2.5 EQUIPMENT DEPLOYMENT

SITE NUMBER:
CT54XC716

SITE NAME:
NEWTOWN GEORGIA PACIFIC/VIS

SITE ADDRESS:
201 SOUTH MAIN STREET
NEWTOWN, CT 06470

APPROVED
By Craig Koppang at 8:41 am, Sep 11, 2017

APPROVED
By Susan Vale at 3:12 pm, Jan 09, 2015

CROWN ID#: 826222
CROWN SITE NAME: NEWTOWN/RT-25

2.5 EQUIPMENT DEPLOYMENT
6580 SPRINT PARKWAY
OVERLAND PARK, KANSAS 66251



TECTONIC ENGINEERING & SURVEYING CONSULTANTS P.C.

1279 Route 300
Newburgh, NY 12550
Phone: (845) 567-6656
Fax: (845) 567-8703
www.tectonicengineering.com

SHEET INFORMATION

SITE NUMBER:	CT54XC716	LANDLORD:	CROWN CASTLE USA 2000 CORPORATE DRIVE CANONSBURG, PA
SITE ADDRESS:	201 SOUTH MAIN STREET NEWTOWN, CT 06470	LOCAL POWER COMPANY:	CONNECTICUT LIGHT AND POWER CONTACT CUSTOMER SERVICE (800) 286-2000
SITE NAME:	NEWTOWN GEORGIA PACIFIC/VIS	APPLICANT:	SPRINT 6580 SPRINT PARKWAY OVERLAND PARK, KANSAS 66251
COUNTY:	FAIRFIELD	ENGINEER:	JAMES QUICKSELL (845) 567-6656 EXT. 2835 JQuicksell@tectonicengineering.com
COORDINATES: (NAD 83)	41° 22' 41.32" N 73° 16' 28.94" W	SPRINT CM:	PETER CULBERT (603) 203-6446 Peter.Culbert@sprint.com
GROUND ELEV:	377'± AMSL	CROWN CM:	JASON D'AMICO (860) 209-0104 jason.d'amico@crowncastle.com
STRUCTURE TYPE:	MONOPOLE		
STRUCTURE HEIGHT:	150'-0"± AGL		
STRUCTURE RAD CENTER:	138'-0"± AGL		
ZONING CLASSIFICATION:	M-1		
MAP-BLOCK-LOT:	36/12/10/C/		

VICINITY MAP (NOT TO SCALE)

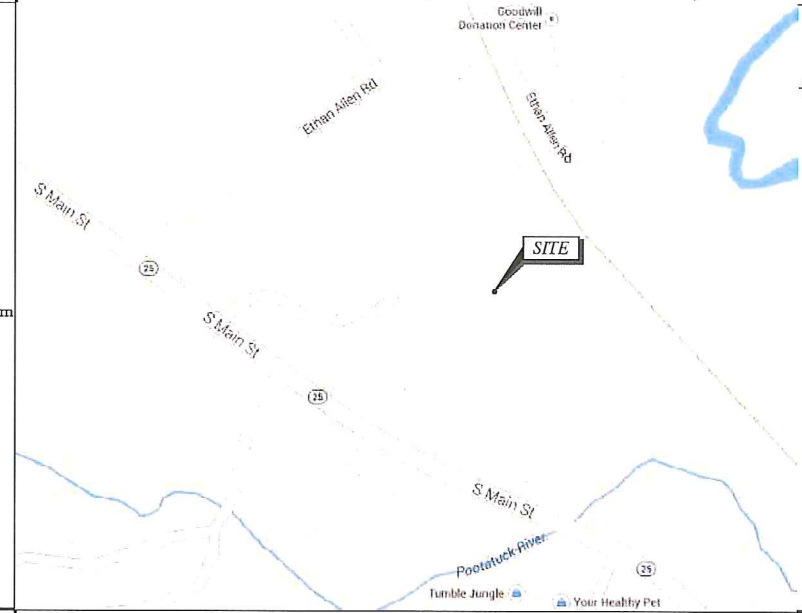

SHEET INDEX

SHT. NO.	SHEET DESCRIPTION
T-1	TITLE SHEET
SP-1	GENERAL NOTES
SP-2	GENERAL NOTES
A-1	SITE PLAN
A-2	ELEVATION
A-3	ENLARGED EQUIPMENT LAYOUT PLANS
A-4	ANTENNA LAYOUT PLANS
A-5	RAN WIRING DIAGRAM
A-6	CABLE DETAILS
S-1	EQUIPMENT DETAILS
S-2	EQUIPMENT SCHEMATIC DETAILS
E-1	ELECTRICAL & GROUNDING PLANS
E-2	GROUNDING DETAILS & NOTES

THIS DOCUMENT IS THE CREATION, DESIGN, PROPERTY AND COPYRIGHTED WORK OF SPRINT COMMUNICATIONS, INC. ANY DUPLICATION OR USE WITHOUT EXPRESS WRITTEN CONSENT IS STRICTLY PROHIBITED. DUPLICATION AND USE BY GOVERNMENT AGENCIES FOR THE PURPOSES OF CONDUCTING THEIR LAWFULLY AUTHORIZED REGULATORY AND ADMINISTRATIVE FUNCTIONS IS SPECIFICALLY ALLOWED.

SUBMITTALS

PROJECT NO: 7225.CT54XC716

NO	DATE	DESCRIPTION	BY
0	07/14/14	FOR COMMENT	MP
1	11/21/14	FOR CONSTRUCTION	MP
2	01/08/15	PER REVISED SA	MP

DATE	REVIEWED BY
1/8/15	JMG

GENERAL NOTES

- THIS IS AN UNMANNED TELECOMMUNICATION FACILITY AND NOT FOR HUMAN HABITATION. HANDICAP ACCESS REQUIREMENTS ARE NOT REQUIRED. FACILITY HAS NO PLUMBING OR REFRIGERANTS. THIS FACILITY SHALL MEET OR EXCEED ALL FAA AND FCC REGULATOR REQUIREMENTS.
- CONTRACTOR SHALL VERIFY ALL PLANS AND EXISTING DIMENSIONS AND CONDITIONS ON THE JOB SITE AND SHALL IMMEDIATELY NOTIFY THE PROJECT OWNER'S REPRESENTATIVE IN WRITING OF DISCREPANCIES BEFORE PROCEEDING WITH THE WORK OR BE RESPONSIBLE FOR SAME.
- DEVELOPMENT AND USE OF THIS SITE WILL CONFORM TO ALL APPLICABLE CODES AND ORDINANCES.
 - 2005 STATE OF CONNECTICUT BUILDING CODE.
 - ANSI/TIA/EIA-222-F-1996.
 - NATIONAL ELECTRICAL CODE, LATEST EDITION.

AERIAL VIEW (NOT TO SCALE)



APPROVALS

THE FOLLOWING PARTIES HEREBY APPROVE AND ACCEPT THESE DOCUMENTS AND AUTHORIZE THE CONTRACTOR TO PROCEED WITH THE CONSTRUCTION DESCRIBED HEREIN. ALL DOCUMENTS ARE SUBJECT TO REVIEW BY THE LOCAL BUILDING DEPARTMENT AND MAY IMPOSE CHANGES OR MODIFICATIONS.

CONSTRUCTION: _____ DATE: _____

LEASING/SITE ACQUISITION: _____ DATE: _____

LANDLORD/PROPERTY OWNER: _____ DATE: _____

R.F. ENGINEER: _____ DATE: _____



PROJECT DESCRIPTION

- (1) NEW 2.5 EQUIPMENT RACK INSIDE EXIST MMBTS CABINET.
- (3) NEW RFS APXVTM14-C-120 ANTENNAS.
- (3) NEW TD-RRH8x20-25 RRH.
- (1) NEW 1-1/4" HYBRID CABLE.
- (3) NEW RFS APXVSP18C-A20 ANTENNAS.



SITE NUMBER:
CT54XC716

SITE NAME:
NEWTOWN GEORGIA
PACIFIC/VIS

SITE ADDRESS:
201 SOUTH MAIN STREET
NEWTOWN, CT 06470

SHEET TITLE:
TITLE SHEET

SHEET NO:
T-1

DIVISION 01000—GENERAL NOTES

- THE CONTRACTOR SHALL GIVE ALL NOTICES AND COMPLY WITH ALL LAWS, ORDINANCES, RULES, REGULATIONS AND LAWFUL ORDERS OF ANY PUBLIC AUTHORITY, MUNICIPAL AND UTILITY COMPANY SPECIFICATIONS, AND LOCAL AND STATE JURISDICTIONAL CODES BEARING ON THE PERFORMANCE OF THE WORK. THE WORK PERFORMED ON THE PROJECT AND THE MATERIALS INSTALLED SHALL BE IN STRICT ACCORDANCE WITH ALL APPLICABLE CODES, REGULATIONS, AND ORDINANCES.
- THE ARCHITECT/ENGINEER HAVE MADE EVERY EFFORT TO SET FORTH IN THE CONSTRUCTION AND CONTRACT DOCUMENTS THE COMPLETE SCOPE OF WORK. THE CONTRACTOR BIDDING THE JOB IS NEVERTHELESS CAUTIONED THAT MINOR OMISSIONS OR ERRORS IN THE DRAWINGS AND OR SPECIFICATIONS SHALL NOT EXCUSE SAID CONTRACTOR FROM COMPLETING THE PROJECT AND IMPROVEMENTS IN ACCORDANCE WITH THE INTENT OF THESE DOCUMENTS.
- THE CONTRACTOR OR BIDDER SHALL BEAR THE RESPONSIBILITY OF NOTIFYING (IN WRITING) THE PROJECT OWNER'S REPRESENTATIVE OF ANY CONFLICTS, ERRORS, OR OMISSIONS PRIOR TO THE SUBMISSION OF CONTRACTOR'S PROPOSAL OR PERFORMANCE OF WORK.
- THE SCOPE OF WORK SHALL INCLUDE FURNISHING ALL MATERIALS, EQUIPMENT, LABOR AND ALL OTHER MATERIALS AND LABOR DEEMED NECESSARY TO COMPLETE THE WORK/PROJECT AS DESCRIBED HEREIN.
- THE CONTRACTOR SHALL VISIT THE JOB SITE PRIOR TO THE SUBMISSION OF BIDS OR PERFORMING WORK TO FAMILIARIZE HIMSELF WITH THE FIELD CONDITIONS AND TO VERIFY THAT THE PROJECT CAN BE CONSTRUCTED IN ACCORDANCE WITH THE CONTRACT DOCUMENTS.
- ONCE THE CONTRACTOR HAS RECEIVED AND ACCEPTED THE NOTICE TO PROCEED, CONTRACTOR WILL CONTACT THE CROWN CASTLE CONSTRUCTION MANAGER OF RECORD (NOTED ON THE FIRST PAGE ON THIS CONSTRUCTION DRAWING) A MINIMUM OF 48 HOURS PRIOR TO WORK START. UPON ARRIVAL TO THE JOB SITE, CONTRACTOR CREW IS REQUIRED CALL 1-800-788-7011 TO NOTIFY THE CROWN CASTLE NOC WORK HAS BEGUN.
- THE CONTRACTOR SHALL INSTALL ALL EQUIPMENT AND MATERIALS ACCORDING TO THE MANUFACTURER'S/VENDOR'S SPECIFICATIONS UNLESS NOTED OTHERWISE OR WHERE LOCAL CODES OR ORDINANCES TAKE PRECEDENCE.
- THE CONTRACTOR SHALL PROVIDE A FULL SET OF CONSTRUCTION DOCUMENTS AT THE SITE UPDATED WITH THE LATEST REVISIONS AND ADDENDUMS OR CLARIFICATIONS AVAILABLE FOR THE USE BY ALL PERSONNEL INVOLVED WITH THE PROJECT.
- THE CONTRACTOR SHALL SUPERVISE AND DIRECT THE PROJECT DESCRIBED HEREIN. THE CONTRACTOR SHALL BE SOLELY RESPONSIBLE FOR ALL CONSTRUCTION MEANS, METHODS, TECHNIQUES, SEQUENCES AND PROCEDURES AND FOR COORDINATING ALL PORTIONS OF THE WORK UNDER THE CONTRACT.
- THE CONTRACTOR SHALL BE RESPONSIBLE FOR OBTAINING ALL PERMITS AND INSPECTIONS WHICH MAY BE REQUIRED FOR THE WORK BY THE ARCHITECT/ENGINEER, THE STATE, COUNTY OR LOCAL GOVERNMENT AUTHORITY.
- THE CONTRACTOR SHALL MAKE NECESSARY PROVISIONS TO PROTECT EXISTING IMPROVEMENTS, EASEMENTS, PAVING, CURBING, ETC. DURING CONSTRUCTION. UPON COMPLETION OF WORK, THE CONTRACTOR SHALL REPAIR ANY DAMAGE THAT MAY HAVE OCCURRED DUE TO CONSTRUCTION ON OR ABOUT THE PROPERTY.
- THE CONTRACTOR SHALL KEEP THE GENERAL WORK AREA CLEAN AND HAZARD FREE DURING CONSTRUCTION AND DISPOSE OF ALL DIRT, DEBRIS, RUBBISH AND REMOVE EQUIPMENT NOT SPECIFIED AS REMAINING ON THE PROPERTY. PREMISES SHALL BE LEFT IN CLEAN CONDITION AND FREE FROM PAINT SPOTS, DUST, OR SMUDGES OF ANY NATURE.
- THE CONTRACTOR SHALL COMPLY WITH ALL PERTINENT SECTIONS OF THE BASIC STATE BUILDING CODE, LATEST EDITION, AND ALL OSHA REQUIREMENTS AS THEY APPLY TO THIS PROJECT. ALL EXISTING ACTIVE SEWER, WATER, GAS, ELECTRIC, AND OTHER UTILITIES WHERE ENCOUNTERED IN THE WORK SHALL BE PROTECTED AT ALL TIMES, AND WHERE REQUIRED FOR THE PROPER EXECUTION OF THE WORK SHALL BE RELOCATED AS DIRECTED BY THE ARCHITECT/ENGINEER. EXTREME CAUTION SHOULD BE USED BY THE CONTRACTOR WHEN EXCAVATING OR PIER DRILLING AROUND OR NEAR UTILITIES. THE CONTRACTOR SHALL PROVIDE SAFETY TRAINING FOR THE WORKING CREW. THIS WILL INCLUDE BUT NOT LIMITED TO A) FALL PROTECTION, B) CONFINED SPACE, C) ELECTRICAL SAFETY, D) TRENCHING AND EXCAVATION OF ALL EXISTING INACTIVE SEWER, WATER, GAS, ELECTRIC AND OTHER UTILITIES WHICH INTERFERE WITH THE EXECUTION OF THE WORK SHALL BE REMOVED AND OR CAPPED, PLUGGED OR OTHERWISE DISCONTINUED AT THE POINTS WHICH WILL NOT INTERFERE WITH THE EXECUTION OF THE WORK SUBJECT TO THE APPROVAL OF THE ARCHITECT/ENGINEER.
- THE CONTRACTOR SHALL NOTIFY THE PROJECT OWNER'S REPRESENTATIVE IN WRITING WHERE A CONFLICT OCCURS ON ANY OF THE CONTRACT DOCUMENTS. THE CONTRACTOR IS NOT TO ORDER MATERIAL OR CONSTRUCT ANY PORTION OF THE WORK THAT IS IN CONFLICT UNTIL CONFLICT IS RESOLVED BY THE LESSEE/LICENSEE REPRESENTATIVE.
- THE CONTRACTOR SHALL VERIFY ALL DIMENSIONS, ELEVATIONS, PROPERTY LINES, ETC. ON THE JOB.
- THE CONTRACTOR SHALL NOTIFY THE THE RF ENGINEER FOR ANTENNA AZIMUTH VERIFICATION (DURING ANTENNA INSTALLATION) PRIOR TO CONDUCTING SWEEP TESTS.
- THE CONTRACTOR SHALL SUBMIT AT THE END OF THE PROJECT A COMPLETE SET OF AS-BUILT DRAWINGS TO THE CLIENT REPRESENTATIVE.

- REFER TO: CONSTRUCTION STANDARDS—SPRINT DOCUMENT EXHIBIT A—STANDARD CONSTRUCTION SPECIFICATIONS FOR WIRELESS SITES REV. 4.0— 02.15.2011.DOCM.
- REFER TO: WEATHER PROOFING SPECS: EXCERPT EXH A—WIHRPRF—STD CONSTR SPECS...157201110421855492.DOCM.
- REFER TO: COLOR CODING—SPRINT NEXTEL ANT AND LINE COLOR CODING (DRAFT) V3 09-08-11.PDF
- REFER TO LATEST DOCUMENTATION REVISION.

DIVISION 03000—CONCRETE

- 1.03 APPLICABLE STANDARDS (USE LATEST EDITIONS)
- ACI-301 — SPECIFICATIONS FOR STRUCTURAL CONCRETE FOR BUILDINGS.
 - ACI-347 GUIDE TO FORM WORK FOR CONCRETE.
 - ASTM C33— CONCRETE AGGREGATE
 - ASTM C94 — READY MIXED CONCRETE e. ASTM C150 — PORTLAND CEMENT.
 - ASTM C260 — AIR—ENTRAINING ADMIXTURES FOR CONCRETE
 - ASTM C309— LIQUID MEMBRANE FORMING COMPOUNDS FOR CURING CONCRETE.
 - ASTM C494 — CHEMICAL ADMIXTURES FOR CONCRETE
 - ASTM A615— DEFORMED AND PLAIN BILLET—STEEL BARS FOR CONCRETE REINFORCEMENT
 - ASTM A185— STEEL WELDED WIRE FABRIC (PLAIN) FOR CONCRETE REINFORCEMENT
- 1.04 QUALITY ASSURANCE
- CONCRETE MATERIALS AND OPERATIONS SHALL BE TESTED AND INSPECTED BY THE ARCHITECT/ENGINEER AS DIRECTED BY THE CLIENT'S REPRESENTATIVE.
- 3.04 SURFACE FINISHES
- SURFACES AGAINST WHICH BACKFILL OR CONCRETE SHALL BE PLACED REQUIRE NO TREATMENT EXCEPT REPAIR OF DEFECTIVE AREAS.
 - SURFACES THAT WILL BE PERMANENTLY EXPOSED SHALL PRESENT A UNIFORM FINISH PROVIDED BY THE REMOVAL OF FINIS AND THE FILLING HOLES AND OTHER IRREGULARITIES WITH DRY PACK GROUT, OR BY SACKING WITH UTILITY OR ORDINARY GROUT.
 - SURFACES THAT WOULD NORMALLY BE LEVEL AND WHICH WILL BE PERMANENTLY EXPOSED TO THE WEATHER SHALL BE SLOPED FOR DRAINAGE. UNLESS ENGINEER'S DESIGN DRAWING SPECIFIES A HORIZONTAL SURFACE OR SURFACES SUCH AS STAIR TREADS, WALLS, CURBS, AND PARAPETS SHALL BE SLOPED APPROXIMATELY 1/4" PER FOOT.
 - SURFACES THAT WILL BE COVERED BY BACKFILL OR CONCRETE SHALL BE SMOOTH SCREENED.
 - EXPOSED SLAB SURFACES SHALL BE CONSOLIDATED, SCREENED, FLOATED, AND STEEL TROWELED. HAND OR POWER—DRIVEN EQUIPMENT MAY BE USED FOR FLOATING. FLOATING SHALL BE STARTED AS SOON AS THE SCREENED SURFACE HAS ATTAINED A STIFFNESS TO PERMIT FINISHING OPERATIONS. OPERATIONS. ALL EDGES MUST HAVE A 3/4" CHAMFER.
- 1.04 QUALITY ASSURANCE CONCRETE MATERIALS AND OPERATIONS SHALL BE TESTED AND INSPECTED BY THE ENGINEER.
- 3.05 PATCHING
- THE CONTRACTOR SHALL NOTIFY THE ENGINEER IMMEDIATELY UPON REMOVAL OF THE FORMS TO OBSERVE CONCRETE SURFACE CONDITIONS. IMPERFECTIONS SHALL BE PATCHED ACCORDING TO THE ENGINEER'S DIRECTION.
- 3.06 DEFECTIVE CONCRETE
- THE CONTRACTOR SHALL NOTIFY OR REPLACE CONCRETE NOT CONFORMING TO REQUIRED LEVELS AND LINES, DETAILS, AND ELEVATIONS AS SPECIFIED IN ACI 301.
- 3.07 PROTECTION
- IMMEDIATELY AFTER PLACEMENT. THE CONTRACTOR SHALL PROTECT THE CONCRETE FROM PREMATURE DRYING, EXCESSIVELY HOT OR COLD TEMPERATURES, AND MECHANICAL INJURY. FINISHED WORK SHALL BE PROTECTED.
 - CONCRETE SHALL BE MAINTAINED WITH MINIMAL MOISTURE LOSS AT RELATIVELY CONSTANT TEMPERATURE FOR PERIOD NECESSARY FOR HYDRATION OF CEMENT AND HARDENING OF CONCRETE.
 - ALL CONCRETE SHALL BE WATER CURED PER ACCEPTABLE PRACTICES SPECIFIED BY ACI CODE (LATEST EDITION)

DIVISION 05000 — METALS

- PART 1 — GENERAL
- 1.01 WORK INCLUDED
- THE WORK CONSISTS OF THE FABRICATION AND INSTALLATION OF ALL MATERIALS TO BE FURNISHED. AND WITHOUT LIMITING THE GENERALITY THEREOF, INCLUDING ALL EQUIPMENT, LABOR AND SERVICES REQUIRED FOR ALL STRUCTURAL STEEL WORK AND ALL ITEMS INCIDENTAL AS SPECIFIED AND AS SHOWN ON THE DRAWINGS:
 - STEEL FRAMING INCLUDING BEAMS, ANGLES, CHANNELS AND PLATES.
 - WELDING AND BOLTING OF ATTACHMENTS.
- 1.02 REFERENCE STANDARDS
- THE WORK SHALL CONFORM TO THE CODES AND STANDARDS OF THE FOLLOWING AGENCIES AS FURTHER CITED HEREIN:
 - ASTM: AMERICAN SOCIETY FOR TESTING AND MATERIALS AS PUBLISHED IN "COMPILATION OF ASTM STANDARDS IN BUILDING CODES" OR LATEST EDITION.
 - AWS: AMERICAN WELDING SOCIETY CODE OR LATEST EDITION.
 - AISC: AMERICAN INSTITUTE OF STEEL CONSTRUCTION, "SPECIFICATION FOR THE DESIGN, FABRICATION AND ERECTION OF STRUCTURAL STEEL FOR BUILDINGS" (LATEST EDITION).
- PART 2 — PRODUCTS
- 2.01 MATERIALS
- STRUCTURAL STEEL: SHALL COMPLY WITH THE REQUIREMENTS OF ASTM A36 AND A992 FOR STRUCTURAL STEEL.
- ALL PROPOSED STRUCTURAL STEEL SHALL BE FABRICATED AND ERECTED IN ACCORDANCE WITH AISC CODE AND ASTM SPECIFICATIONS (LATEST EDITION) ALL NEW STEEL SHALL CONFORM TO THE FOLLOWING.
- STRUCTURAL WIDE FLANGE: ASTM A992 Fy=50KSI.
 - MISCELLANEOUS STEEL (PLATES), CHANNELS, ANGLES, ETC): ASTM A36 (Fy=36KSI).
 - STRUCTURAL TUBING: ASTM A500 Gr. B (Fy=46KSI).
 - STEEL PIPE: ASTM A53 Gr B (Fy=35KSI).
- 2.02 WELDING
- ALL WELDING SHALL BE DONE BY CERTIFIED WELDERS. CERTIFICATION DOCUMENTS SHALL BE MADE AVAILABLE FOR ENGINEER'S AND/OR OWNER'S REVIEW IF REQUESTED.
 - WELDING ELECTRODES FOR MANUAL SHIELDED METAL ARC WELDING SHALL CONFORM TO ASTM 1-233, E70 SERIES. BARE ELECTRODES AND GRANULAR FLUX USED IN THE SUBMERGED ARC PROCESS SHALL CONFORM TO AISC SPECIFICATIONS.
 - FIELD WELDING SHALL BE DONE AS PER AWS D1.1 REQUIREMENTS VISUAL INSPECTION IS ACCEPTABLE.
 - STUD WELDING SHALL BE ACCOMPLISHED BY CAPACITOR DISCHARGE (CD) WELDING TECHNIQUE USING CAPACITOR DISCHARGE STUD WELDER.
 - PROVIDE STUD FASTENERS OF MATERIALS AND SIZES SHOWN ON DRAWINGS OR AS RECOMMENDED BY THE MANUFACTURER FOR STRUCTURAL LOADINGS REQUIRED.
 - FOLLOW MANUFACTURERS SPECIFICATIONS AND INSTRUCTIONS TO PROPERLY SELECT AND INSTALL STUD WELDS.
- 2.03 BOLTING
- BOLTS SHALL BE CONFORMING TO ASTM A35 HIGH STRENGTH HOT DIP GALVANIZED WITH ASTM A153 HEAVY HEX TYPE NUTS.
 - BOLTS SHALL BE 3/4" (MINIMUM) CONFORMING TO ASTM A325, HOT DIP GALVANIZED, ASTM A153 NUTS SHALL BE HEAVY HEX TYPE.
 - ALL CONNECTIONS SHALL BE 2 BOLTS MINIMUM.
 - EXCEPT WHERE SHOWN, ALL BEAM TO BEAM AND BEAM TO COLUMN CONNECTIONS TO BE DOUBLE ANGLED CONNECTIONS WITH HIGH STRENGTH BOLTS (THREADS EXCLUDED FROM SHEAR PLANE) AND HARDENED WASHERS.
 - STANDARD, OVERSIZED OR HORIZONTAL SHORT SLOTTED HOLES.
 - SNUG—TIGHT STRENGTH BEARING BOLTS MAY BE USED IN STANDARD HOLES CONFORMING TO ACIS, USING THE TURN OF THE NUT METHOD.
 - FULLY—TENSIONED HIGH STRENGTH (SLIP CRITICAL) SHALL BE USED IN OVERSIZED SLOT HOLES (RESPECTIVE OF SLOT ORIENTATION).
 - ALL BRACED CONNECTION, MOMENT CONNECTION AND CONNECTIONS NOTED AS "SLIP CRITICAL" SHALL BE BE SLIP CRITICAL JOINTS WITH CLASS A SURFACE CONDITIONS, UNLESS OTHERWISE NOTED.
 - EPOXY ANCHOR ASSEMBLIES SHALL BE AS MANUFACTURED BY HILTI OR ENGINEER APPROVED EQUAL, AS FOLLOWS:
- | BASE MATERIAL | ANCHOR SYSTEM |
|-------------------------------|------------------|
| CONCRETE | HILTI HIT—HY 200 |
| HOLLOW & GROUTED CMU OR BRICK | HILTI HIT—HY 70 |
- 2.04 FABRICATION
- FABRICATION OF STEEL SHALL CONFORM TO THE AISC AND AWS

- 2.05 FINISH
- STRUCTURAL STEEL EXPOSED TO WEATHER SHALL BE HOT—DIP GALVANIZED AFTER FABRICATION IN ACCORDANCE WITH ASTM A123. (LATEST EDITION) UNLESS OTHERWISE NOTED.
- 2.06 PROTECTION
- UPON COMPLETION OF ERECTION, INSPECT ALL GALVANIZED STEEL AND PAINT ANY FIELD CUTS, WELDS OR GALVANIZED BREAKS WITH (2) COATS OF ZINC—RICH COLD GALVANIZING PAINT.
- PART 3 — ERECTION
- PROVIDE ALL ERECTION, EQUIPMENT, BRACING, PLANKING, FIELD BOLTS, NUTS, WASHERS, DRIFT PINS, AND SIMILAR MATERIALS WHICH DO NOT FORM A PART OF THE COMPLETED CONSTRUCTION, BUT ARE NECESSARY FOR ITS PROPER ERECTION.
 - ERECT AND ANCHOR ALL STRUCTURAL STEEL IN ACCORDANCE WITH AISC REFERENCE STANDARDS. ALL WORK SHALL BE ACCURATELY SET TO ESTABLISHED SUITABLE ATTACHMENTS TO THE CONSTRUCTION OF THE BUILDING
 - TEMPORARY BRACING, GUYING, AND SUPPORT SHALL BE PROVIDED TO KEEP THE STRUCTURE SET AND ALIGNED AT ALL TIMES DURING CONSTRUCTION, AND TO PREVENT DANGER TO PERSONS AND PROPERTY. CHECK ALL TEMPORARY LOADS AND STAY WITHIN SAFE CAPACITY OF ALL BUILDING COMPONENTS.



TECTONIC Engineering & Surveying Consultants P.C.

1279 Route 300
Newburgh, NY 12550
Phone: (845) 567-6656
Fax: (845) 567-8703
www.tectonicengineering.com

THIS DOCUMENT IS THE CREATION, DESIGN, PROPERTY AND COPYRIGHTED WORK OF SPRINT COMMUNICATIONS, INC. ANY DUPLICATION OR USE WITHOUT EXPRESS WRITTEN CONSENT IS STRICTLY PROHIBITED. DUPLICATION AND USE BY GOVERNMENT AGENCIES FOR THE PURPOSES OF CONDUCTING THEIR LAWFULLY AUTHORIZED REGULATORY AND ADMINISTRATIVE FUNCTIONS IS SPECIFICALLY ALLOWED.

SUBMITTALS			
PROJECT NO: 7225.CT54XC716			
NO	DATE	DESCRIPTION	BY
0	07/14/14	FOR COMMENT	MP
1	11/21/14	FOR CONSTRUCTION	MP
2	01/08/15	PER REVISED SA	MP

DATE	REVIEWED BY
1/8/15	JMQ

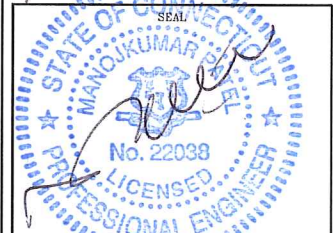

SITE NUMBER:
CT54XC716

SITE NAME:
NEWTOWN GEORGIA
PACIFIC/VS

SITE ADDRESS:
201 SOUTH MAIN STREET
NEWTOWN, CT 06470

SHEET TITLE:
GENERAL NOTES

SHEET NO:
SP-1

DIVISION 13000--SPECIAL CONSTRUCTION ANTENNA INSTALLATION

PART 1 - GENERAL

1.01 WORK INCLUDED

A. ANTENNAS AND HYBRIFLEX CABLES ARE FURNISHED BY CLIENT'S REPRESENTATIVE UNDER SEPARATE CONTRACT. THE CONTRACTOR SHALL ASSIST ANTENNA INSTALLATION CONTRACTOR IN TERMS OF COORDINATION AND SITE ACCESS. ERECTION SUBCONTRACTOR SHALL BE RESPONSIBLE FOR THE PROPERTY.

B. INSTALL ANTENNAS AS INDICATED ON DRAWINGS AND CLIENT'S REPRESENTATIVE SPECIFICATIONS.

C. INSTALL GALVANIZED STEEL ANTENNA MOUNTS AS INDICATED ON DRAWINGS.

D. INSTALL FURNISHED GALVANIZED STEEL OR ALUMINUM WAVEGUIDE AND PROVIDE PRINTOUT OF THAT RESULT

F. INSTALL HYBRIFLEX CABLES AND TERMINATIONS BETWEEN ANTENNAS AND EQUIPMENT PER MANUFACTURER'S RECOMMENDATIONS. WEATHERPROOF ALL CONNECTORS BETWEEN THE ANTENNA AND EQUIPMENT PER MANUFACTURER'S REQUIREMENTS.

G. ANTENNA AND HYBRIFLEX CABLE GROUNDING:

1. ALL EXTERIOR #6 GREEN GROUND WIRE DAISY CHAIN CONNECTIONS ARE TO BE WEATHER SEALED WITH ANDREWS CONNECTOR/SPLICE WEATHERPROOFING KIT TYPE 3221213 OR EQUIVALENT.
2. ALL HYBRIFLEX CABLE GROUNDING KITS ARE TO BE INSTALLED ON STRAIGHT RUNS OF HYBRIFLEX CABLE (NOT WITHIN BENDS). 1.02 RELATED WORK FURNISH THE FOLLOWING WORK AS SPECIFIED UNDER CONSTRUCTION DOCUMENTS, BUT COORDINATE WITH QOTHER TRADES PRIOR TO BID:
 1. FLASHING OF OPENING INTO OUTSIDE WALLS.
 2. SEALING AND CAULKING ALL OPENINGS.
 3. PAINTING.
 4. CUTTING AND PATCHING.

1.03 REQUIREMENTS OF REGULATOR AGENCIES

- A. FURNISH U.L. LISTED EQUIPMENT WHERE SUCH LABEL IS AVAILABLE. INSTALL IN CONFORMANCE WITH U.L. STANDARDS WHERE APPLICABLE.
- B. INSTALL ANTENNA, ANTENNA CABLES, GROUNDING SYSTEM IN ACCORDANCE WITH DRAWINGS AND SPECIFICATIONS IN EFFECT AT PROJECT LOCATION AND RECOMMENDATIONS OF STATE AND LOCAL BUILDING CODES HAVING JURISDICTION OVER SPECIFIC PORTIONS OF WORK. THIS WORK INCLUDES, BUT IS NOT LIMITED TO THE FOLLOWING:
 1. EIA - ELECTRONIC INDUSTRIES ASSOCIATION RS-22. STRUCTURAL STANDARDS FOR STEEL ANTENNA TOWERS AND ANTENNA SUPPORTING STRUCTURES.
 2. FAA - FEDERAL AVIATION ADMINISTRATION ADVISORY CIRCULAR AC 70/7480-IH, CONSTRUCTION MARKING AND LIGHTING.
 3. FCC - FEDERAL COMMUNICATION COMMISSION RULES AND REGULATIONS FORM 715, OBSTRUCTION MARKING AND LIGHTING SPECIFICATION FOR ANTENNA STRUCTURES
 4. AISC - AMERICAN INSTITUTE OF STEEL CONSTRUCTION FOR STRUCTURAL JOINTS USING ASTM 1325 OR A490 BOLTS.
 5. NEC - NATIONAL ELECTRIC CODE - ON TOWER LIGHTING KITS.
 6. UL - UNDERWRITER'S LABORATORIES APPROVED ELECTRICAL PRODUCTS.
 7. IN ALL CASES, PART 77 OF THE FAA RULES AND PARTS 17 AND 22 OF THE FCC RULES ARE APPLICABLE AND IN THE EVENT OF CONFLICT, SUPERSEDE ANY OTHER STANDARDS OR SPECIFICATIONS.
- B. LIFE SAFETY CODE NFPA, LATEST EDITION.

DIVISION 13000--EARTHWORK

PART 1 GENERAL

1.01 WORK INCLUDED: REFER TO SURVEY AND SITE PLAN FOR WORK INCLUDED.

1.02 RELATED WORK

- A. CONSTRUCTION OF EQUIPMENT FOUNDATIONS
- B. INSTALLATION OF ANTENNA SYSTEM

PART 2 PRODUCTS

2.01 MATERIALS

- A. ROAD AND SITE MATERIALS; FILL MATERIAL SHALL BE ACCEPTABLE, SELECT FILL SHALL BE IN ACCORDANCE WITH LOCAL DEPARTMENT OF HIGHWAY AND PUBLIC TRANSPORTATION STANDARD SPECIFICATIONS.
- B. SOIL STERILIZER SHALL BE EPA REGISTERED OF LIQUID COMPOSITION AND OF PRE-EMERGENCE DESIGN.
- C. SOIL STABILIZER FABRIC SHALL BE MIRAFI OR EQUAL - 600X AT ACCESS ROAD AND COMPOUND.
- D. GRAVEL FILL; WELL GRADED, HARD, DURABLE, NATURAL SAND AND GRAVEL, FREE FROM ICE AND SNOW, ROOTS, SOD RUBBISH, AND OTHER DELETERIOUS OR ORGANIC MATTER.

MATERIAL SHALL CONFORM TO THE FOLLOWING GRADATION REQUIREMENTS.

GRAVEL FILL TO BE PLACED IN LIFTS OF 9" MAXIMUM THICKNESS AND 90 % DENSITY. COMPACTED TO 95

E. NO FILL OR EMBANKMENT MATERIALS SHALL BE PLACED ON FROZEN GROUND. FROZEN MATERIALS SNOW OR ICE SHALL NOT BE PLACED IN ANY FILL OF EMBANKMENT

2.02 EQUIPMENT

- A. COMPACTION SHALL BE ACCOMPLISHED BY MECHANICAL MEANS. LARGER AREAS SHALL BE COMPACTED BY SHEEPS FOOT, VIBRATORY OR RUBBER TIED ROLLERS WEIGHING AT LEAST FIVE TONS. SMALLER AREAS SHALL BE COMPACTED BY POWER-DRIVER, HAND HELD TAMPERS.
- B. PRIOR TO OTHER EXCAVATION AND CONSTRUCTION EFFORTS GRUB ORGANIC MATERIAL TO A MINIMUM OF 6" BELOW ORIGINAL GROUND LEVEL.
- C. UNLESS OTHERWISE INSTRUCTED BY CLIENT'S REPRESENTATIVE. REMOVE TREES, BRUSH AND DEBRIS FROM THE PROPERTY TO AN AUTHORIZED DISPOSAL LOCATION.
- D. PRIOR TO PLACEMENT OF FILL OR BASE MATERIALS, ROLL THE SOIL.
- E. WHERE UNSTABLE SOIL CONDITIONS ARE ENCOUNTERED, LINE THE GRUBBED AREAS WITH STABILIZER MAT PRIOR TO PLACEMENT OF FILL OR BASE MATERIAL.

3.03 INSTALLATION

- A. THE SITE AND TURNAROUND AREAS SHALL BE AT THE SUB-BASE COURSE ELEVATION PRIOR TO FORMING FOUNDATIONS. GRADE OR FILL THE SITE AND ACCESS ROAD AS REQUIRED TO PRODUCE EVEN DISTRIBUTION OF SPOILS RESULTING FROM FOUNDATION EXCAVATIONS. THE RESULTING GRADE SHALL CORRESPOND WITH SAID SUB-BASE COURSE. ELEVATIONS ARE TO BE CALCULATED FROM FINISHED GRADES OR SLOPES INDICATED.
- B. THE ACCESS ROAD SHALL BE BROUGHT TO BASE COURSE ELEVATION PRIOR TO FOUNDATION CONSTRUCTION.
- C. DO NOT CREATE DEPRESSIONS WHERE WATER MAY POND.
- D. THE CONTRACT INCLUDES ALL NECESSARY GRADING, BANKING, DITCHING AND COMPLETE SURFACE COURSE FOR ACCESS ROAD. ALL ROADS OR ROUTES UTILIZED FOR ACCESS TO PUBLIC THOROUGHFARE IS INCLUDED IN SCOPE OF WORK UNLESS OTHERWISE INDICATED.
- E. WHEN IMPROVING AN EXISTING ACCESS ROAD, GRADE THE EXISTING ROAD TO REMOVE ANY ORGANIC MATTER AND SMOOTH THE SURFACE BEFORE PLACING FILL OR STONE.
- F. PLACE FILL OR STONE IN 3" MAXIMUM LIFTS AND COMPACT BEFORE PLACING NEXT LIFT.
- G. THE FINISH GRADE, INCLUDING TOP SURFACE COURSE, SHALL EXTEND A MINIMUM OF 12" BEYOND THE SITE FENCE AND SHALL COVER THE AREA AS INDICATED.
- H. RIPRAP SHALL BE APPLIED TO THE SIDE SLOPES OF ALL FENCED AREAS, PARKING AREAS AND TO ALL OTHER SLOPES GREATER THAN 2:1.
- I. RIPRAP SHALL BE APPLIED TO THE SIDES OF DITCHES OR DRAINAGE SWALES AS INDICATED ON PLANS.
- J. RIPRAP ENTIRE DITCH FOR 6'-0" IN ALL DIRECTIONS AT CULVERT OPENINGS.

K. SEED, FERTILIZER AND STRAW COVER SHALL BE APPLIED TO ALL OTHER DISTURBED AREAS AND DITCHES, DRAINAGE, SWALES, NOT OTHERWISE RIP-RAPPED.

L. UNDER NO CIRCUMSTANCES SHALL DITCHES, SWALES OR CULVERTS BE PLACED SO THEY DIRECT WATER TOWARDS, OR PERMIT STANDING WATER IMMEDIATELY ADJACENT TO SITE. IF OWNER DESIGNS OR IF DESIGN ELEVATIONS CONFLICT WITH THIS GUIDANCE ADVISE THE OWNER IMMEDIATELY.

M. IF A DITCH LIES WITH SLOPE GREATER THAN TEN PERCENT, MOUND DIVERSIONARY HEADWALL IN THE DITCH AT CULVERT ENTRANCES. RIP-RAP THE UPSTREAM SIDE OF THE HEADWALL AS WELL AS THE DITCH FOR 6'-0" ABOVE THE CULVERT.

N. IF A DITCH LIES WITH SLOPES GREATER THAN TEN PERCENT, MOUND DIVERSIONARY HEADWALLS IN THE DITCH FOR 6'-0" ABOVE THE CULVERT ENTRANCE.

O. SEED AND FERTILIZER SHALL BE APPLIED TO SURFACE CONDITIONS WHICH WILL ENCOURAGE ROOTING. RAKE AREAS TO BE SEEDED TO EVEN THE SURFACE AND TO LOOSEN THE SOIL.

P. SOW SEED IN TWO DIRECTIONS IN TWICE THE QUANTITY RECOMMENDED BY THE SEED PRODUCER.

Q. IT IS THE CONTRACTOR'S RESPONSIBILITY TO ENSURE GROWTH OF SEEDED AND LANDSCAPED AREAS BY WATERING UP TO THE POINT OF RELEASE FROM THE CONTRACT. CONTINUE TO REWORK BARE AREAS UNTIL COMPLETE COVERAGE IS OBTAINED.

3.04 FIELD QUALITY CONTROL

A. COMPACTION SHALL BE D-1557 FOR SITE WORK AND 95 % MAXIMUM DENSITY UNDER SLAB AREAS. AREAS OF SETTLEMENT WILL BE EXCAVATED AND REFILLED AT CONTRACTOR'S EXPENSE. REQUIRED. USE OF EROSION CONTROL MESH OR MULCH NET SHALL BE AN ACCEPTABLE ALTERNATIVE.

B. THE COMPACTION TEST RESULTS SHALL BE AVAILABLE PRIOR TO THE CONCRETE POUR.

3.05 PROTECTION

A. PROTECT SEEDED AREAS FORM EROSION BY SPREADING STRAW TO A UNIFORM LOOSE DEPTH OF 1"-2". STAKE AND TIE DOWN AS REQUIRED. USE OF EROSION CONTROL MESH OR MULCH NET SHALL BE AN ACCEPTABLE ALTERNATIVE.

B. ALL TREES PLACED IN CONJUNCTION WITH A LANDSCAPE CONTRACT SHALL BE WRAPPED, TIED WITH HOSE PROTECTED WIRE AND SECURED TO STAKES EXTENDING 2'-0" INTO THE GROUND ON FOUR SIDES OF THE TREE.

C. ALL EXPOSED AREAS SHALL BE PROTECTED AGAINST WASHOUTS AND SOIL EROSION. STRAW BALES SHALL BE PLACED AT THE INLET APPROACH TO ALL NEW OR EXISTING CULVERTS. REFER TO DETAILS ON DRAWINGS

SYMBOLS	ABBREVIATIONS
--- o --- o ---	GROUND WIRE
--- E --- E ---	ELECTRIC
--- T --- T ---	TELEPHONE
--- O --- O --- O --- O ---	OVERHEAD WIRE
---	PROPERTY LINE
- x - x - x -	CHAIN LINK FENCE
A-1	ANTENNA MARK
(E)	EXISTING
(P)	PROPOSED DETAIL
DET # SHT #	REFERENCE
⊕	SURFACE ELEVATION

2.5 EQUIPMENT DEPLOYMENT
6580 SPRINT PARKWAY
OVERLAND PARK, KANSAS 66251

TECTONIC Engineering & Surveying Consultants P.C.
1279 Route 300
Newburgh, NY 12550
Phone: (845) 567-6656
Fax: (845) 567-8703
www.tectonicengineering.com

THIS DOCUMENT IS THE CREATION, DESIGN, PROPERTY AND COPYRIGHTED WORK OF SPRINT COMMUNICATIONS, INC. ANY DUPLICATION OR USE WITHOUT EXPRESS WRITTEN CONSENT IS STRICTLY PROHIBITED. DUPLICATION AND USE BY GOVERNMENT AGENCIES FOR THE PURPOSES OF CONDUCTING THEIR LAWFULLY AUTHORIZED REGULATORY AND ADMINISTRATIVE FUNCTIONS IS SPECIFICALLY ALLOWED.

SUBMITTALS			
PROJECT NO: 7225.CT54XC716			
NO	DATE	DESCRIPTION	BY
0	07/14/14	FOR COMMENT	MP
1	11/21/14	FOR CONSTRUCTION	MP
2	01/08/15	PER REVISED SA	MP

DATE	REVIEWED BY
1/8/15	JMA



SITE NUMBER:
CT54XC716
SITE NAME:
NEWTOWN GEORGIA
PACIFIC/VS
SITE ADDRESS:
201 SOUTH MAIN STREET
NEWTOWN, CT 06470

SHEET TITLE:
GENERAL NOTES

SHEET NO:
SP-2



NORTH NOTE:
 NORTH SHOWN HAS BEEN ESTABLISHED USING THE USGS QUADRANGLE 7.5 MINUTE MAPS AND IS APPROXIMATE. VERIFY TRUE NORTH PRIOR TO INSTALLATION OF ANTENNAS.

1
A-2

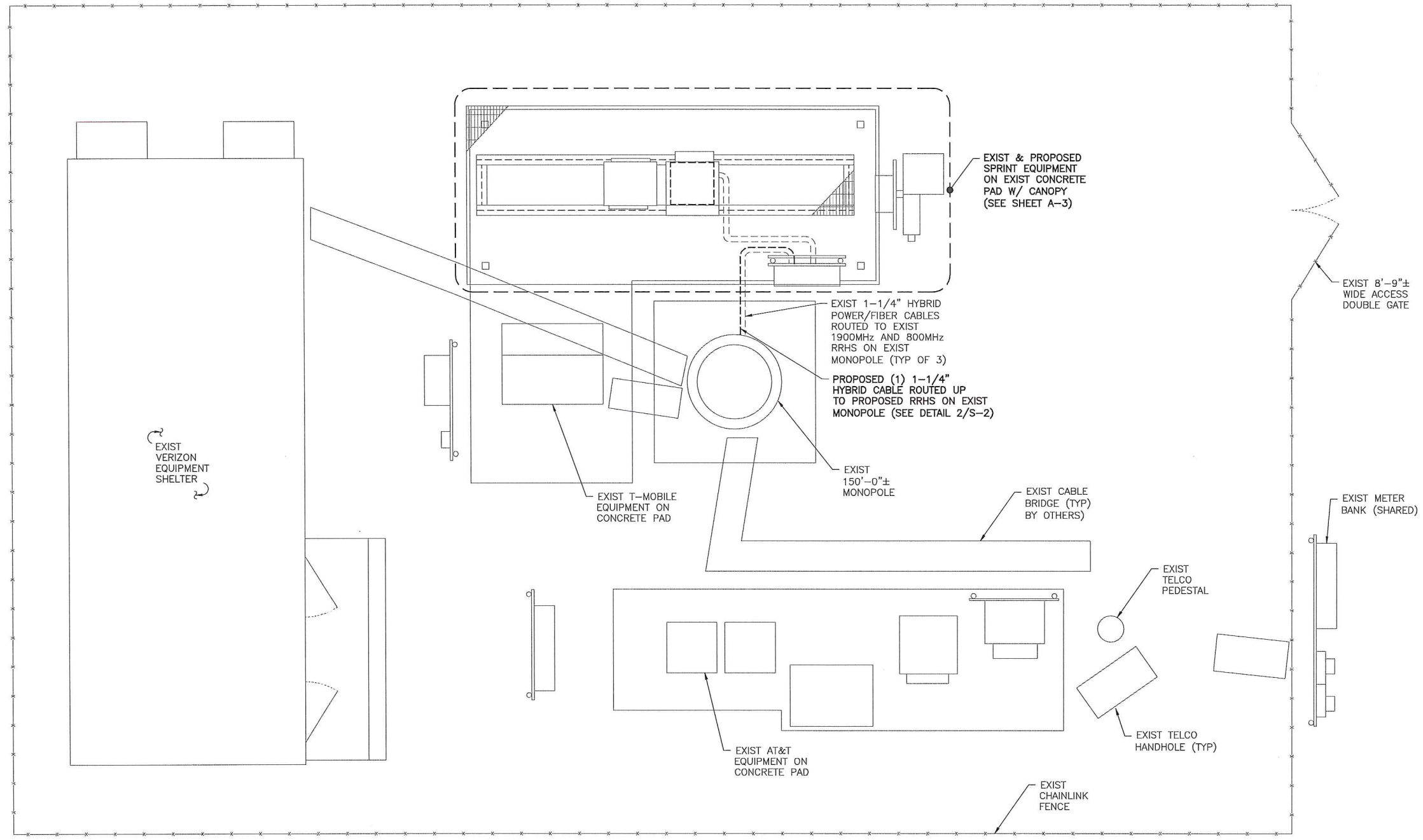

1
A-1 **SITE PLAN**
 SCALE: 3/8" = 1'-0"

Sprint
 2.5 EQUIPMENT DEPLOYMENT
 6580 SPRINT PARKWAY
 OVERLAND PARK, KANSAS 66251

CROWN CASTLE

TECTONIC
 • PLANNING
 • ENGINEERING
 • SURVEYING
 • CONSTRUCTION MANAGEMENT
TECTONIC Engineering & Surveying Consultants P.C.
 1279 Route 300
 Newburgh, NY 12550
 Phone: (845) 567-6656
 Fax: (845) 567-8703
 www.tectonicengineering.com

THIS DOCUMENT IS THE CREATION, DESIGN, PROPERTY AND COPYRIGHTED WORK OF SPRINT COMMUNICATIONS, INC. ANY DUPLICATION OR USE WITHOUT EXPRESS WRITTEN CONSENT IS STRICTLY PROHIBITED. DUPLICATION AND USE BY GOVERNMENT AGENCIES FOR THE PURPOSES OF CONDUCTING THEIR LAWFULLY AUTHORIZED REGULATORY AND ADMINISTRATIVE FUNCTIONS IS SPECIFICALLY ALLOWED.

SUBMITTALS

PROJECT NO: 7225.CT54XC716

NO.	DATE	DESCRIPTION	BY
0	07/14/14	FOR COMMENT	MP
1	11/21/14	FOR CONSTRUCTION	MP
2	01/08/15	PER REVISED SA	MP

DATE	REVIEWED BY
1/8/15	JMG



SITE NUMBER:
 CT54XC716
 SITE NAME:
 NEWTOWN GEORGIA
 PACIFIC/VIS
 SITE ADDRESS:
 201 SOUTH MAIN STREET
 NEWTOWN, CT 06470

SHEET TITLE:
 SITE PLAN

SHEET NO:
 A-1

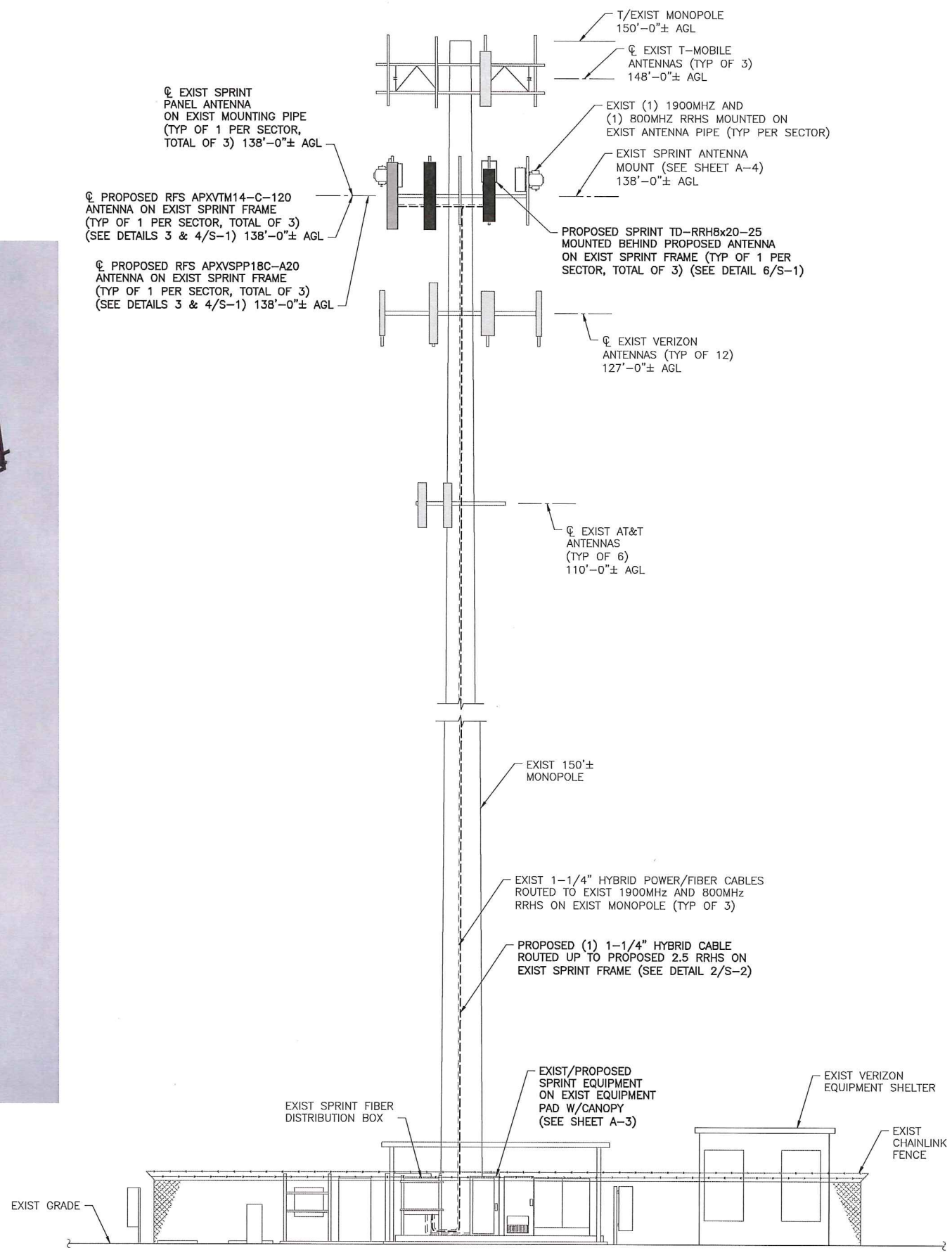

THE EXISTING MONOPOLE SHALL BE ANALYZED BY A PROFESSIONAL ENGINEER LICENSED IN THE STATE OF CONNECTICUT (TO BE COORDINATED BY OTHERS).

THE EXISTING MOUNT HAS BEEN ANALYZED BY TECTONIC ENGINEERING AND FOUND TO BE ADEQUATE TO SUPPORT THE PROPOSED SPRINT UPGRADE AS DETAILED IN THE STRUCTURAL ANALYSIS EVALUATION LETTER DATED 01/08/15, REV 1.

Sprint
 2.5 EQUIPMENT DEPLOYMENT
 6580 SPRINT PARKWAY
 OVERLAND PARK, KANSAS 66251



TECTONIC
 • PLANNING
 • ENGINEERING
 • SURVEYING
 • CONSTRUCTION MANAGEMENT

TECTONIC Engineering & Surveying Consultants P.C.
 1279 Route 300
 Newburgh, NY 12550
 Phone: (845) 567-6656
 Fax: (845) 567-8703
 www.tectonicengineering.com

THIS DOCUMENT IS THE CREATION, DESIGN, PROPERTY AND COPYRIGHTED WORK OF SPRINT COMMUNICATIONS, INC. ANY DUPLICATION OR USE WITHOUT EXPRESS WRITTEN CONSENT IS STRICTLY PROHIBITED. DUPLICATION AND USE BY GOVERNMENT AGENCIES FOR THE PURPOSES OF CONDUCTING THEIR LAWFULLY AUTHORIZED REGULATORY AND ADMINISTRATIVE FUNCTIONS IS SPECIFICALLY ALLOWED.

SUBMITTALS			
PROJECT NO: 7225.CT54XC716			
NO.	DATE	DESCRIPTION	BY
0	07/14/14	FOR COMMENT	MP
1	11/21/14	FOR CONSTRUCTION	MP
2	01/08/15	PER REVISED SA	MP

DATE: 1/8/15 REVIEWED BY: JMQ

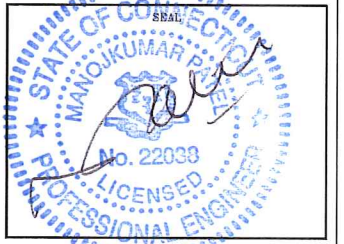

SITE NUMBER: CT54XC716
 SITE NAME: NEWTOWN GEORGIA PACIFIC/VS
 SITE ADDRESS: 201 SOUTH MAIN STREET NEWTOWN, CT 06470

SHEET TITLE: ELEVATION

SHEET NO: A-2

1 ELEVATION
 A-2 SCALE: 3/16" = 1'-0"

Sprint
 2.5 EQUIPMENT DEPLOYMENT
 6580 SPRINT PARKWAY
 OVERLAND PARK, KANSAS 66251

CROWN CASTLE

TECTONIC
 * PLANNING
 * ENGINEERING
 * SURVEYING
 * CONSTRUCTION MANAGEMENT

TECTONIC Engineering & Surveying Consultants P.C.
 1279 Route 300
 Newburgh, NY 12550
 Phone: (845) 567-6656
 Fax: (845) 567-8703
 www.tectonicengineering.com

THIS DOCUMENT IS THE CREATION, DESIGN, PROPERTY AND COPYRIGHTED WORK OF SPRINT COMMUNICATIONS, INC. ANY DUPLICATION OR USE WITHOUT EXPRESS WRITTEN CONSENT IS STRICTLY PROHIBITED. DUPLICATION AND USE BY GOVERNMENT AGENCIES FOR THE PURPOSES OF CONDUCTING THEIR LAWFULLY AUTHORIZED REGULATORY AND ADMINISTRATIVE FUNCTIONS IS SPECIFICALLY ALLOWED.

SUBMITTALS

PROJECT NO: 7225.CT54XC716

NO	DATE	DESCRIPTION	BY
0	07/14/14	FOR COMMENT	MP
1	11/21/14	FOR CONSTRUCTION	MP
2	01/08/15	PER REVISED SA	MP

DATE	REVIEWED BY
1/8/15	JMG

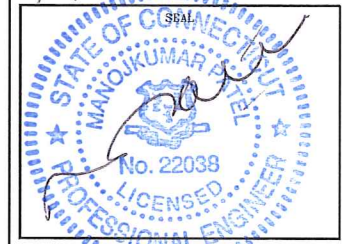

SITE NUMBER:
 CT54XC716

SITE NAME:
 NEWTOWN GEORGIA
 PACIFIC/VS

SITE ADDRESS:
 201 SOUTH MAIN STREET
 NEWTOWN, CT 06470

SHEET TITLE:
 ENLARGED EQUIPMENT
 LAYOUT PLANS

SHEET NO:
 A-3

NORTH NOTE:
 NORTH SHOWN HAS BEEN ESTABLISHED USING THE USGS QUADRANGLE 7.5 MINUTE MAPS AND IS APPROXIMATE. VERIFY TRUE NORTH PRIOR TO INSTALLATION OF ANTENNAS.

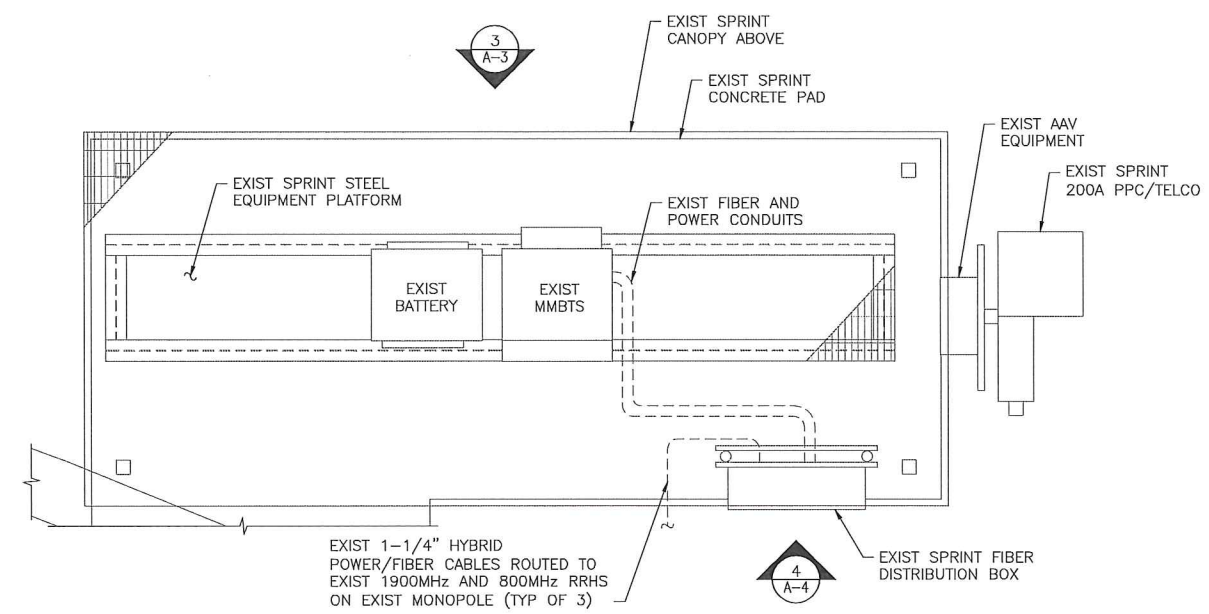

1 ENLARGED EQUIPMENT LAYOUT PLAN (EXIST)
 SCALE: 1/2" = 1'-0"

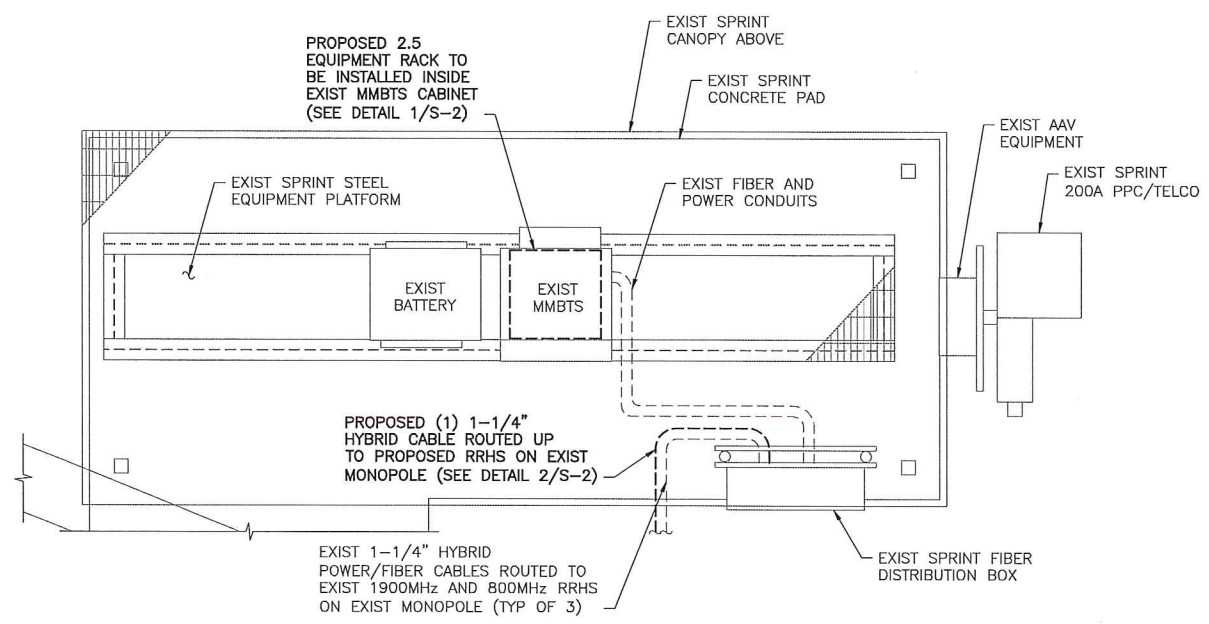

2 ENLARGED EQUIPMENT LAYOUT PLAN (FINAL)
 SCALE: 1/2" = 1'-0"

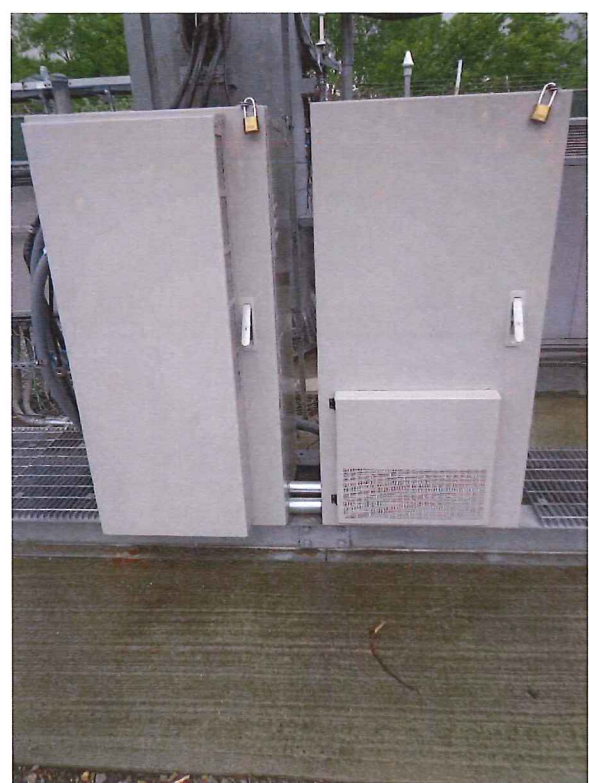

3 EXIST EQUIPMENT PAD
 SCALE: NTS



4 EXIST FIBER DISTRIBUTION BOX
 SCALE: NTS

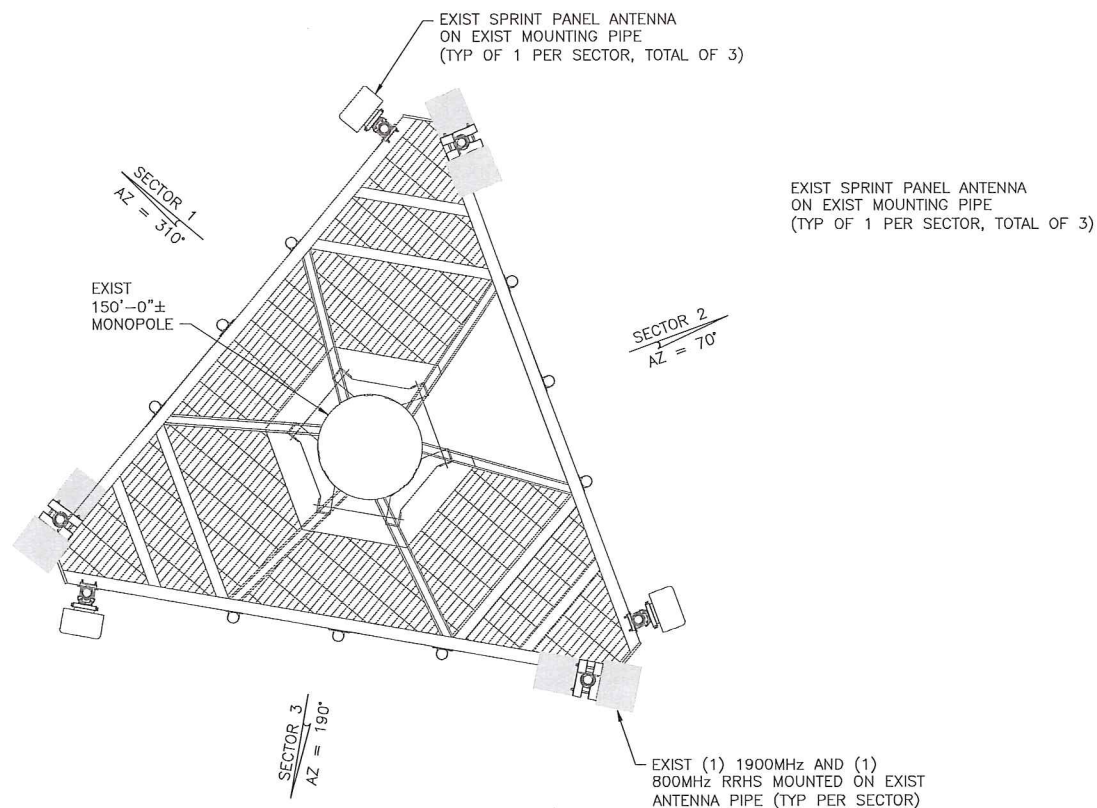

1
A-4
ANTENNA LAYOUT PLAN (EXIST)
SCALE: 1/2" = 1'-0"

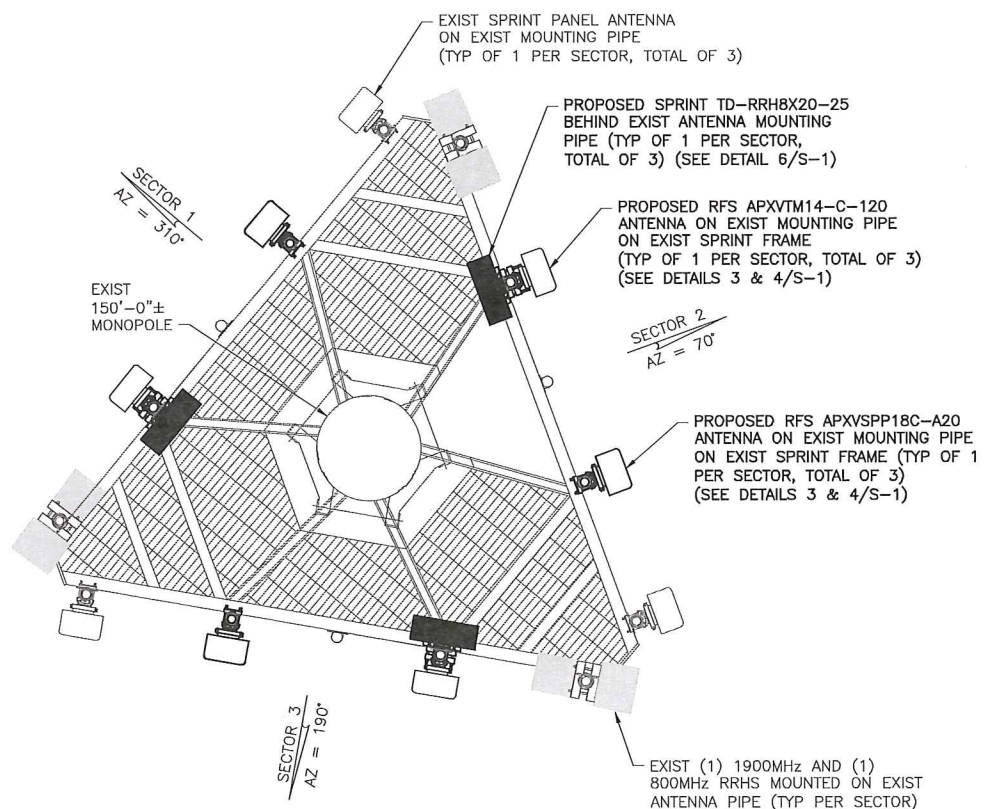

2
A-4
ANTENNA LAYOUT PLAN (FINAL)
SCALE: 1/2" = 1'-0"

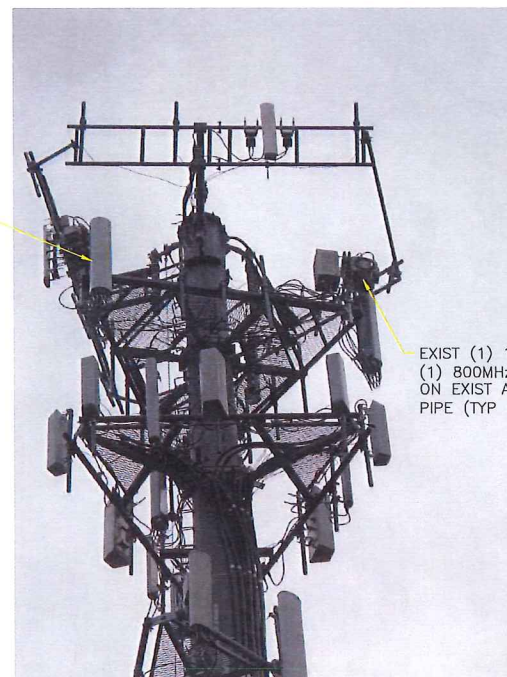

EXIST SPRINT PANEL ANTENNA ON EXIST MOUNTING PIPE (TYP OF 1 PER SECTOR, TOTAL OF 3)

EXIST (1) 1900MHz AND (1) 800MHz RRH MOUNTED ON EXIST ANTENNA MOUNTING PIPE (TYP PER SECTOR)

THE EXISTING MONOPOLE SHALL BE ANALYZED BY A PROFESSIONAL ENGINEER LICENSED IN THE STATE OF CONNECTICUT (TO BE COORDINATED BY OTHERS).

THE EXISTING MOUNT HAS BEEN ANALYZED BY TECTONIC ENGINEERING AND FOUND TO BE ADEQUATE TO SUPPORT THE PROPOSED SPRINT UPGRADE AS DETAILED IN THE STRUCTURAL ANALYSIS EVALUATION LETTER DATED 01/08/15, REV 1.

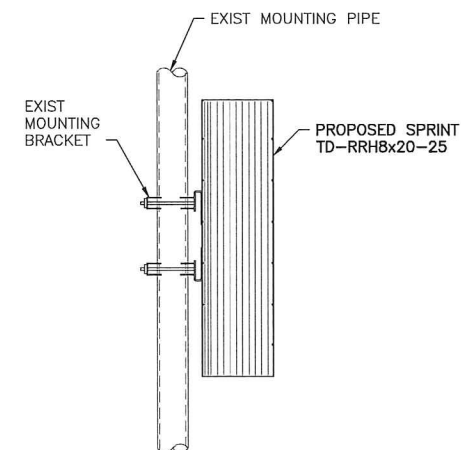

3
A-4
RRH MOUNTING DETAIL
SCALE: 1 1/2" = 1'-0"

ANTENNA DATA

Status	Exist (Proposed)	Proposed
Antenna Manufacturer	RFS-CEL WAVE	RFS-CEL WAVE
Antenna Model Number	APXVSP18C-A20	APXVTM14-C-120
Number of Antennas	3 (3)	3
Antenna RAD Center	138'	138'
Antenna Azimuth	310/70/190	310/70/190
Antenna RRH Model Number	1900MHz/800MHz RRHS	2.5GHz RRH-V3
Number of RRH	6	3



TECTONIC Engineering & Surveying Consultants P.C.
1279 Route 300
Newburgh, NY 12550
Phone: (845) 567-6656
Fax: (845) 567-8703
www.tectonicengineering.com

THIS DOCUMENT IS THE CREATION, DESIGN, PROPERTY AND COPYRIGHTED WORK OF SPRINT COMMUNICATIONS, INC. ANY DUPLICATION OR USE WITHOUT EXPRESS WRITTEN CONSENT IS STRICTLY PROHIBITED. DUPLICATION AND USE BY GOVERNMENT AGENCIES FOR THE PURPOSES OF CONDUCTING THEIR LAWFULLY AUTHORIZED REGULATORY AND ADMINISTRATIVE FUNCTIONS IS SPECIFICALLY ALLOWED.

SUBMITTALS

PROJECT NO: 7225.CT54XC716

NO	DATE	DESCRIPTION	BY
0	07/14/14	FOR COMMENT	MP
1	11/21/14	FOR CONSTRUCTION	MP
2	01/08/15	PER REVISED SA	MP

DATE	REVIEWED BY
1/8/15	SMA



SITE NUMBER: CT54XC716
SITE NAME: NEWTOWN GEORGIA PACIFIC/V3
SITE ADDRESS: 201 SOUTH MAIN STREET NEWTOWN, CT 06470

SHEET TITLE: ANTENNA LAYOUT PLANS

SHEET NO: A-4

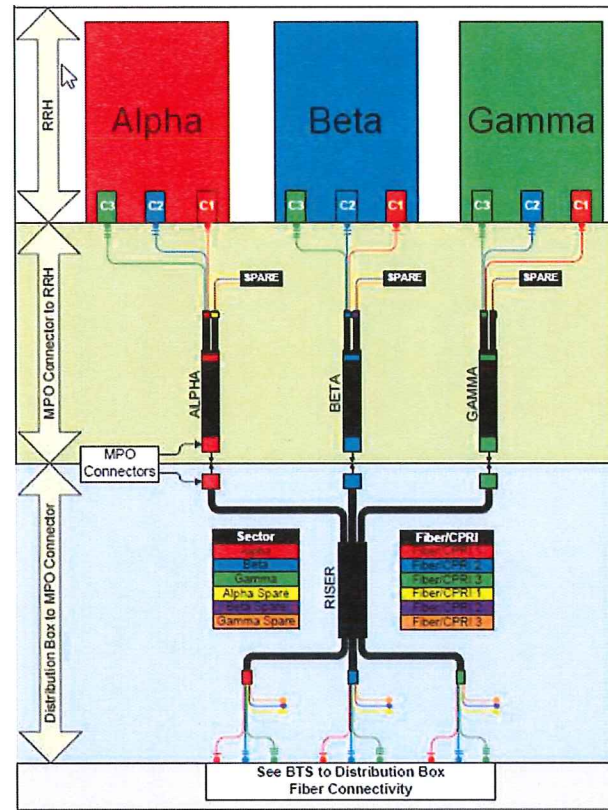

1 2.5 CABLE COLOR CODING
A-5 SCALE: N.T.S.

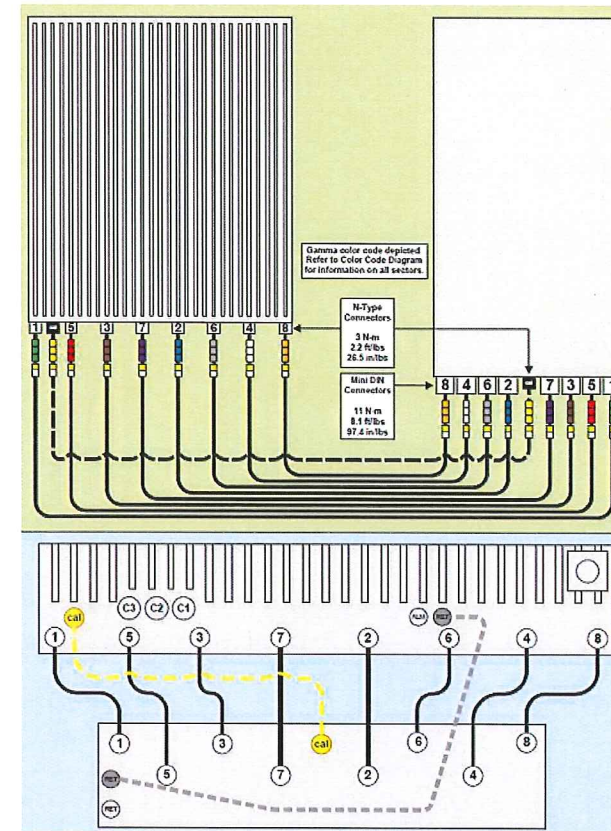

2 RRH CONNECTIVITY
A-5 SCALE: N.T.S.

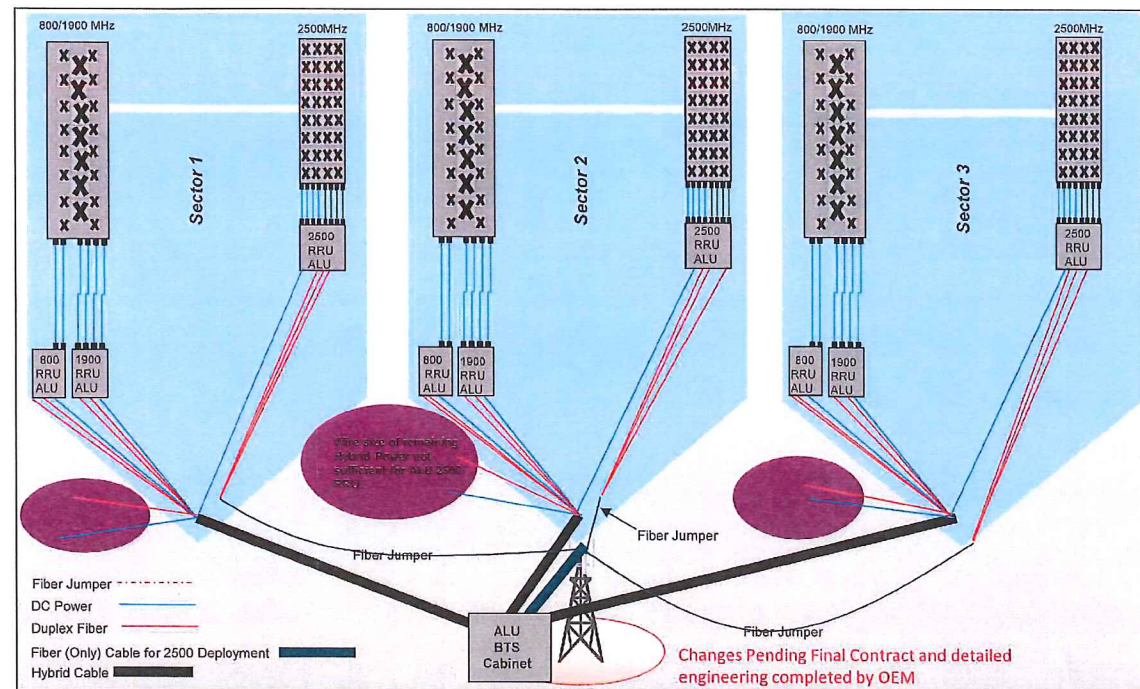

3 RAN WIRING
A-5 SCALE: N.T.S.

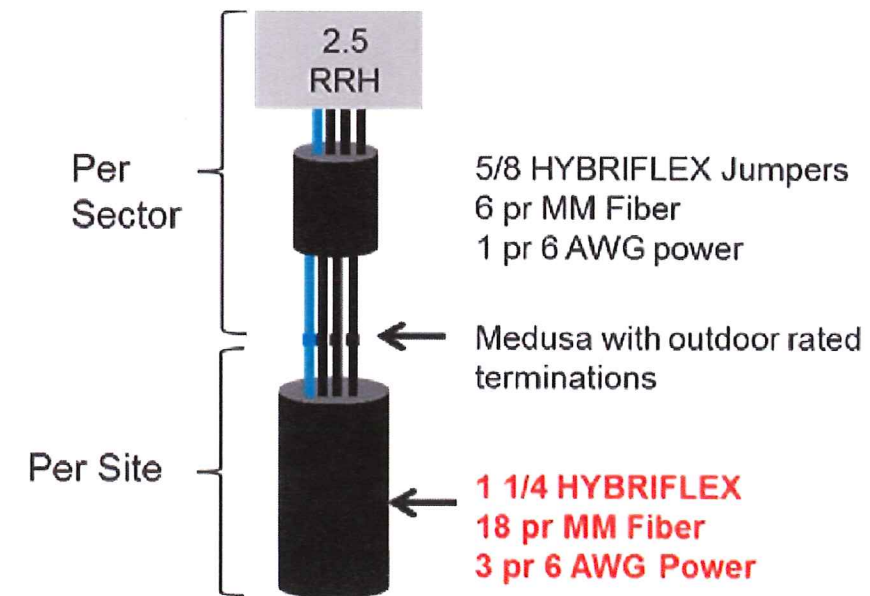

4 CABLE SCENARIO
A-5 SCALE: N.T.S.

Sprint

2.5 EQUIPMENT DEPLOYMENT
6580 SPRINT PARKWAY
OVERLAND PARK, KANSAS 66251

CROWN CASTLE

TECTONIC

PLANNING
ENGINEERING
SURVEYING
CONSTRUCTION MANAGEMENT

TECTONIC Engineering & Surveying Consultants P.C.

1279 Route 300
Newburgh, NY 12550
Phone: (845) 567-6656
Fax: (845) 567-8703
www.tectonicengineering.com

THIS DOCUMENT IS THE CREATION, DESIGN, PROPERTY AND COPYRIGHTED WORK OF SPRINT COMMUNICATIONS, INC. ANY DUPLICATION OR USE WITHOUT EXPRESS WRITTEN CONSENT IS STRICTLY PROHIBITED. DUPLICATION AND USE BY GOVERNMENT AGENCIES FOR THE PURPOSES OF CONDUCTING THEIR LAWFULLY AUTHORIZED REGULATORY AND ADMINISTRATIVE FUNCTIONS IS SPECIFICALLY ALLOWED.

SUBMITTALS

PROJECT NO: 7225.CT54XC716

NO	DATE	DESCRIPTION	BY
0	07/14/14	FOR COMMENT	MP
1	11/21/14	FOR CONSTRUCTION	MP
2	01/08/15	PER REVISED SA	MP

DATE	REVIEWED BY
1/8/15	JMO

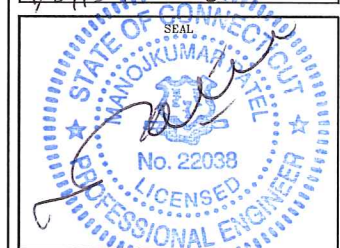

SITE NUMBER:
CT54XC716

SITE NAME:
NEWTOWN GEORGIA
PACIFIC/VIS

SITE ADDRESS:
201 SOUTH MAIN STREET
NEWTOWN, CT 06470

SHEET TITLE:
RAN WIRING DIAGRAM

SHEET NO:
A-5

THIS DOCUMENT IS THE CREATION, DESIGN, PROPERTY AND COPYRIGHTED WORK OF SPRINT COMMUNICATIONS, INC. ANY DUPLICATION OR USE WITHOUT EXPRESS WRITTEN CONSENT IS STRICTLY PROHIBITED. DUPLICATION AND USE BY GOVERNMENT AGENCIES FOR THE PURPOSES OF CONDUCTING THEIR LAWFULLY AUTHORIZED REGULATORY AND ADMINISTRATIVE FUNCTIONS IS SPECIFICALLY ALLOWED.

SUBMITTALS			
NO.	DATE	DESCRIPTION	BY
0	07/14/14	FOR COMMENT	MP
1	11/21/14	FOR CONSTRUCTION	MP
2	01/08/15	PER REVISED SA	MP

DATE	REVIEWED BY
1/8/15	J.MQ

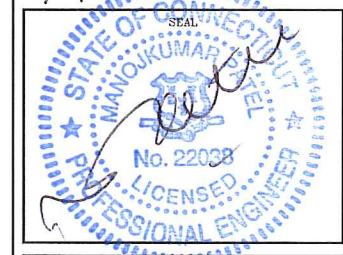

SITE NUMBER:
CT54XC716
 SITE NAME:
NEWTOWN GEORGIA
PACIFIC/VS
 SITE ADDRESS:
201 SOUTH MAIN STREET
NEWTOWN, CT 06470

SHEET TITLE:
CABLE DETAILS

SHEET NO:
A-6

IMPORTANT!! LINE UP WHITE MARKINGS ON JUMPER AND RISER IP-MPO CONNECTOR. PUSH THE WHITE MARK ON THE JUMPER CONNECTOR FLUSH AGAINST THE RED SEAL ON THE RISER CONNECTION



IMPORTANT!! ROTATE THE BAYONET HOUSING CLOCKWISE UNTIL A CLICK SOUND IS HEARD TO ENSURE A GOOD CONNECTION

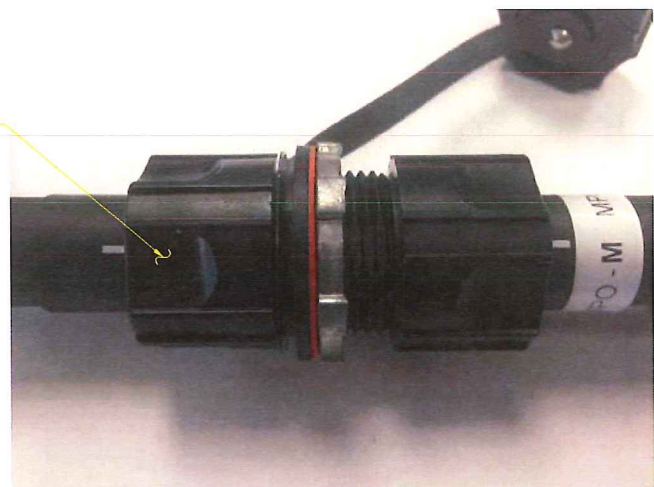

1 HYBRIFLEX RISER/JUMPER CONNECTION DETAILS
 SCALE: N.T.S.

TRUNK-LINE TO JUMPER CONNECTION (MPO) TO BE INSTALLED PER MANUFACTURER REQUIREMENTS. SEE DETAIL.

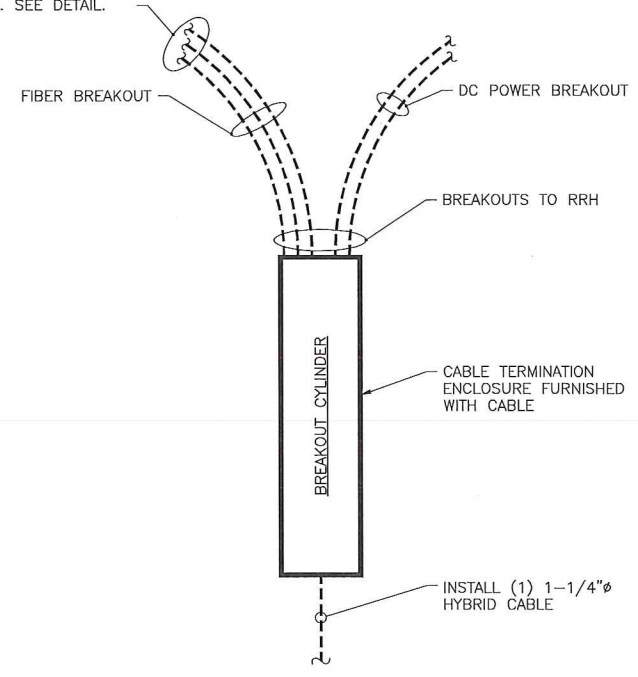

2.5 HYBRID CABLE W/FIBER & DC FEEDERS

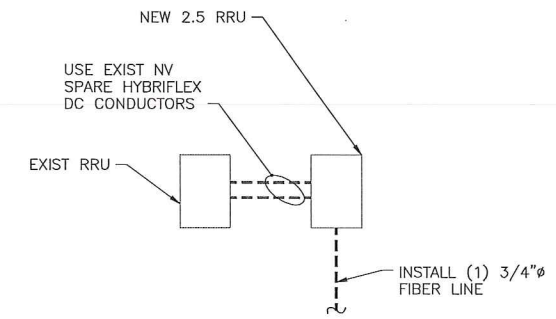

FIBER ONLY TRUNK LINES

2 TRUNK LINE DETAILS (TYPICAL)
 SCALE: N.T.S.

SPECIAL NOTES: CABLE MARKINGS AT RAD CENTER AND ALL WALL/BLDG. PENETRATIONS

- ALL COLOR CODE TAPE SHALL BE 3M-35 AND SHALL BE INSTALLED USING A MINIMUM OF (3) WRAPS OF TAPE.
- ALL COLOR BANDS INSTALLED AT THE TOWER TOP SHALL BE A MINIMUM OF 3" WIDE AND SHALL HAVE A MINIMUM OF 3/4" OF SPACING BETWEEN EACH COLOR.
- ALL COLOR BANDS INSTALLED AT OR NEAR THE GROUND MAY BE ONLY 3/4" WIDE. EACH TOP-JUMPER SHALL BE COLOR CODED WITH (1) SET OF 3" WIDE BANDS.
- EACH MAIN COAX SHALL BE COLOR CODED WITH (1) SET OF 3" BANDS NEAR THE TOP-JUMPER CONNECTION AND WITH 3/4" COLOR BANDS JUST PRIOR TO ENTERING THE BTS OR TRANSMITTER BUILDING.
- ALL BOTTOM JUMPERS SHALL BE COLOR CODED WITH (1) SET OF 3/4" BANDS ON EACH END OF THE BOTTOM JUMPER.
- ALL COLOR CODES SHALL BE INSTALLED SO AS TO ALIGN NEATLY WITH ONE ANOTHER FROM SIDE-TO-SIDE.
- EACH COLOR BAND SHALL HAVE A MINIMUM OF (3) WRAPS AND SHALL BE NEATLY TRIMMED AND SMOOTHED OUT AS TO AVOID UNRAVELING.
- X-POLE ANTENNAS SHOULD USE "XX-1" FOR THE "+45" PORT, "XX-2" FOR THE "-45" PORT.
- COLOR BAND #4 REFERS TO THE FREQUENCY BAND: ORANGE=850, VIOLET=1900. USED ON JUMPERS ONLY.
- RF FEEDLINE SHALL BE IDENTIFIED WITH A METAL TAG (STAINLESS OR BRASS) AND STAMPED WITH THE SECTOR, ANTENNA POSITION, AND CABLE NUMBER.
- ANTENNAS MUST BE IDENTIFIED, USING THE SECTOR LETTER AND ANTENNA NUMBER, WITH A BLACK MARKER PRIOR TO INSTALLATION.

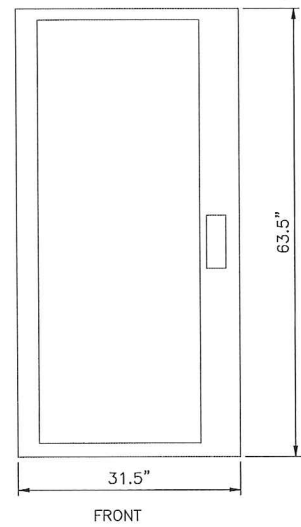

9927 MMBTS MODULAR CELL
 SPECIFICATIONS:
 HEIGHT: 63.5"
 WIDTH: 31.5"
 DEPTH: 38.0"

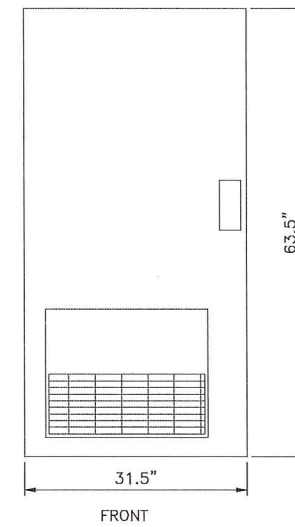

BATTERY
 SPECIFICATIONS:
 HEIGHT: 63.5"
 WIDTH: 31.5"
 DEPTH: 28.0"

1 (EXIST) MMBTS CABINET
 S-1 SCALE: 1" = 1'-0"

2 (EXIST) BATTERY CABINET
 S-1 SCALE: 1" = 1'-0"

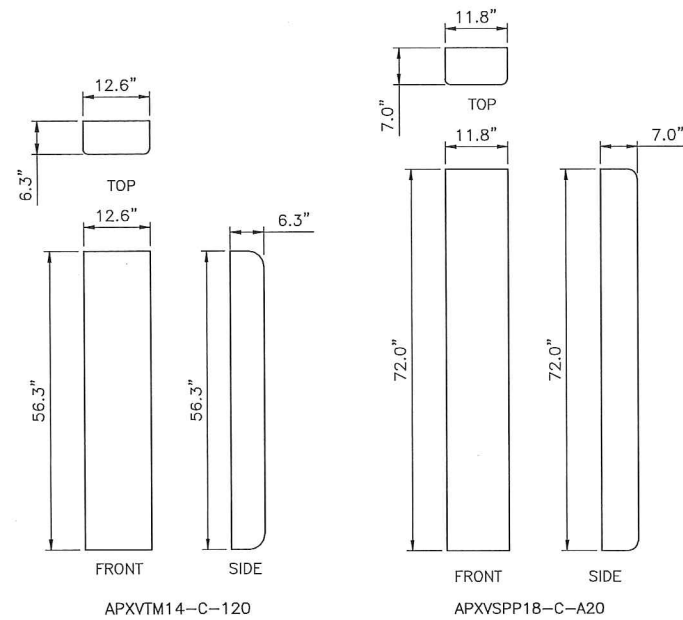

3 ANTENNA DETAILS
 S-1 SCALE: 3/4" = 1'-0"

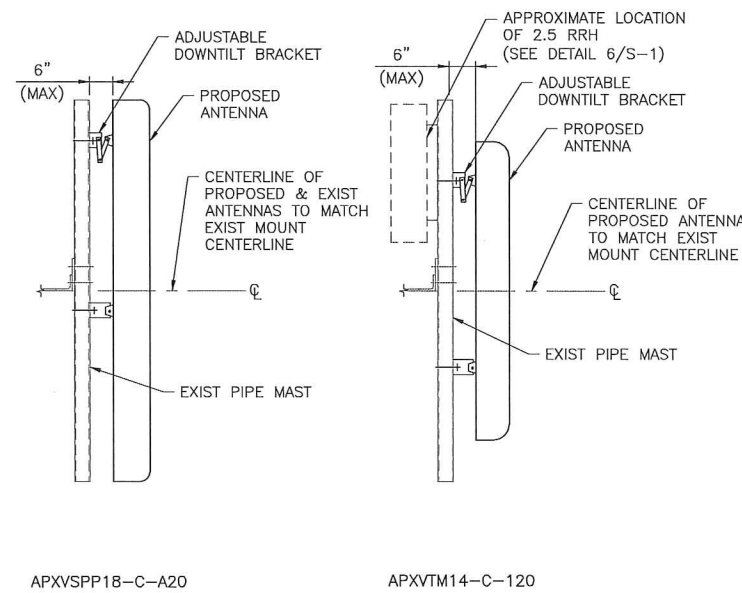

4 ANTENNA MOUNTING DETAILS
 S-1 SCALE: 3/4" = 1'-0"

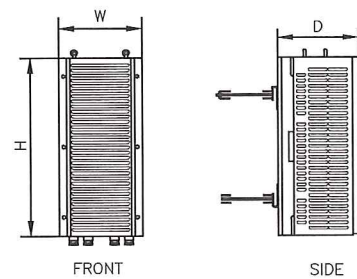

TYPE: 1900 MHz 4x45W
 MODEL #: RRH 1900 4X45 65MHz
 HEIGHT: 25.0"
 WIDTH: 11.1"
 DEPTH: 11.4"
 WEIGHT: ±60 LBS.

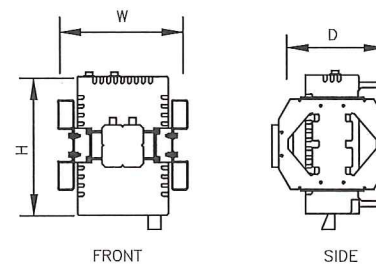

TYPE: 800 MHz 2x50W
 MODEL #: FD-RRH-2x50-800
 HEIGHT: 19.7"
 WIDTH: 13"
 DEPTH: 10.8"
 WEIGHT: ±53 LBS

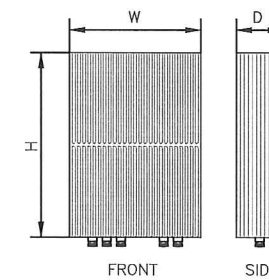

TYPE: 2.5 RRH
 MODEL #: TD-RRH8x20-25
 HEIGHT: 26.1"
 WIDTH: 18.6"
 DEPTH: 6.7"
 WEIGHT: ±70 LBS

5 (EXIST) RRH DETAILS
 S-1 SCALE: 1 1/2" = 1'-0"

6 (PROPOSED) RRH DETAIL
 S-1 SCALE: 1" = 1'-0"

Sprint
 2.5 EQUIPMENT DEPLOYMENT
 6580 SPRINT PARKWAY
 OVERLAND PARK, KANSAS 66251

CROWN CASTLE

TECTONIC
 • PLANNING
 • ENGINEERING
 • SURVEYING
 • CONSTRUCTION
 • MANAGEMENT
 TECTONIC Engineering & Surveying
 Consultants P.C.
 1279 Route 300
 Newburgh, NY 12550
 Phone: (845) 567-6656
 Fax: (845) 567-8703
 www.tectonicengineering.com

THIS DOCUMENT IS THE CREATION, DESIGN, PROPERTY AND COPYRIGHTED WORK OF SPRINT COMMUNICATIONS, INC. ANY DUPLICATION OR USE WITHOUT EXPRESS WRITTEN CONSENT IS STRICTLY PROHIBITED. DUPLICATION AND USE BY GOVERNMENT AGENCIES FOR THE PURPOSES OF CONDUCTING THEIR LAWFULLY AUTHORIZED REGULATORY AND ADMINISTRATIVE FUNCTIONS IS SPECIFICALLY ALLOWED.

SUBMITTALS

PROJECT NO: 7225.CT54XC716

NO	DATE	DESCRIPTION	BY
0	07/14/14	FOR COMMENT	MP
1	11/21/14	FOR CONSTRUCTION	MP
2	01/08/15	PER REVISED SA	MP

DATE	REVIEWED BY
1/8/15	JMA



SITE NUMBER:
 CT54XC716
 SITE NAME:
 NEWTOWN GEORGIA
 PACIFIC/VS
 SITE ADDRESS:
 201 SOUTH MAIN STREET
 NEWTOWN, CT 06470

SHEET TITLE:
 EQUIPMENT DETAILS

SHEET NO:
 S-1

NOTE:
LOCATIONS SHOWN FOR
INSTALLATION OF NEW
EQUIPMENT IN EXISTING
CABINET ARE APPROXIMATE.
ACTUAL SPACE AVAILABLE
TO BE VERIFIED IN FIELD
ON A SITE BY SITE BASIS.

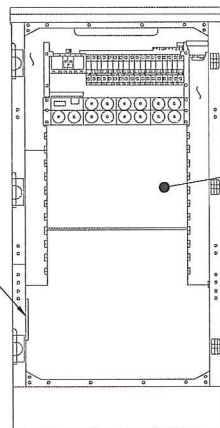

EXIST GROUND
BAR TO BE UTILIZED

INSTALL NEW 2.5
EQUIPMENT IN EXIST MMBTS
CABINET INCLUDING BUT
NOT LIMITED TO BASE BAND
UNIT, CELL SITE ROUTER
AND SURGE ARRESTORS.
GROUND EQUIPMENT TO
EXIST INTERIOR CABINET
GROUND BAR

FRONT ELEVATION
(CABINET INTERIOR)

1
S-2 MMBTS INTERIOR DETAIL
SCALE: N.T.S.

- LEGEND:
1. P1000T-HG UNISTRUT, 12" LONG.
 2. 6" PIPE HANGER.
 3. EXISTING SUPPORT PIPE.
 4. NEW STANDOFF BRACKET, ANDREW PART# 30848-4.
 5. NEW ROUND MEMBER ADAPTER SIZED FOR EXISTING PIPE SUPPORT.
 6. BREAKOUT UNIT.
 7. CABLE.

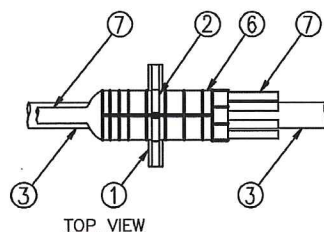
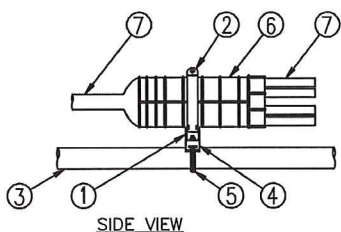

3
S-2 MEDUSA HEAD DETAIL
SCALE: NTS

RFS HYBRIFLEX RISER CABLES SCHEDULE

Fiber Only (Existing DC Power)	Hybrid cable MN: HB058-M12-050F 12x multi-mode fiber pairs, Top: Outdoor protected connectors, Bottom: LC Connectors, 5/8 cable, 50ft	50 ft
	MN: HB058-M12-075F	75 ft
	MN: HB058-M12-100F	100 ft
	MN: HB058-M12-125F	125 ft
	MN: HB058-M12-150F	150 ft
	MN: HB058-M12-175F	175 ft
	MN: HB058-M12-200F	200 ft

8 AWG Power	Hybrid cable MN: HB114-08U3M12-050F 3x 8 AWG power pairs, 12x multi-mode fiber pairs, Outdoor rated connectors & LC Connectors, 1 1/4 cable, 50ft	50 ft
	MN: HB114-08U3M12-075F	75 ft
	MN: HB114-08U3M12-100F	100 ft
	MN: HB114-08U3M12-125F	125 ft
	MN: HB114-08U3M12-150F	150 ft
	MN: HB114-08U3M12-175F	175 ft
	MN: HB114-08U3M12-200F	200 ft

6 AWG Power	Hybrid cable MN: HB114-13U3M12-225F 3x 6 AWG power pairs, 12x multi-mode fiber pairs, Outdoor rated connectors & LC Connectors, 1 1/4 cable, 225ft	225 ft
	MN: HB114-13U3M12-250F	250 ft
	MN: HB114-13U3M12-275F	275 ft
	MN: HB114-13U3M12-300F	300 ft

4 AWG Power	Hybrid cable MN: HB114-21U3M12-225F 3x 4 AWG power pairs, 12x multi-mode fiber pairs, Outdoor rated connectors & LC Connectors, 1 1/4 cable, 225ft	325 ft
	MN: HB114-21U3M12-350F	350 ft
	MN: HB114-21U3M12-375F	375 ft

RFS HYBRIFLEX JUMPER CABLE SCHEDULE

Fiber Only	Hybrid Jumper cable MN: HBF012-M3-5F1 5 ft, 3x multi-mode fiber pairs, Outdoor & LC connectors, 1/2 cable	5 ft
	MN: HBF012-M3-10F1	10 ft
	MN: HBF012-M3-15F1	15 ft
	MN: HBF012-M3-20F1	20 ft
	MN: HBF012-M3-25F1	25 ft
	MN: HBF012-M3-30F1	30 ft

8 AWG Power	Hybrid Jumper cable MN: HBF058-08U1M3-5F1 5 ft, 1x 8 AWG power pair, 3x multi-mode fiber pairs, Outdoor & LC Connectors, 5/8 cable	5 ft
	MN: HBF058-08U1M3-10F1	10 ft
	MN: HBF058-08U1M3-15F1	15 ft
	MN: HBF058-08U1M3-20F1	20 ft
	MN: HBF058-08U1M3-25F1	25 ft
	MN: HBF058-08U1M3-30F1	30 ft

6 AWG Power	Hybrid Jumper cable MN: HBF058-13U1M3-5F1 5 ft, 1x 6 AWG power pair, 3x multi-mode fiber pairs, Outdoor & LC Connectors, 5/8 cable	5 ft
	MN: HBF058-13U1M3-10F1	10 ft
	MN: HBF058-13U1M3-15F1	15 ft
	MN: HBF058-13U1M3-20F1	20 ft
	MN: HBF058-13U1M3-25F1	25 ft

4 AWG Power	Hybrid Jumper cable MN: HBF078-21U1M3-5F1 5 ft, 1x 4 AWG power pair, 3x multi-mode fiber pairs, Outdoor & LC Connectors, 7/8 cable	5 ft
	MN: HBF078-21U1M3-10F1	10 ft
	MN: HBF078-21U1M3-15F1	15 ft
	MN: HBF078-21U1M3-20F1	20 ft
	MN: HBF078-21U1M3-25F1	25 ft

HYBRID CABLE DC CONDUCTOR SIZE GUIDELINE

MANUF:	RFS	DC CONDUCTOR	CABLE DIAMETER
CABLE	LENGTH	USE NV HYBRIFLEX	
FIBER ONLY	VARIES	8 AWG	7/8"
HYBRIFLEX	<200'	8 AWG	1-1/4"
HYBRIFLEX	225-300'	6 AWG	1-1/4"
HYBRIFLEX	325-375'	4 AWG	1-1/4"

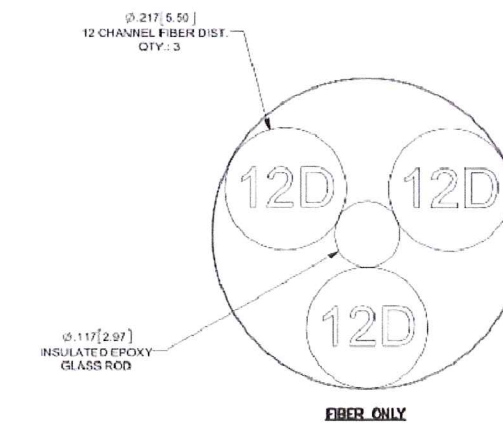
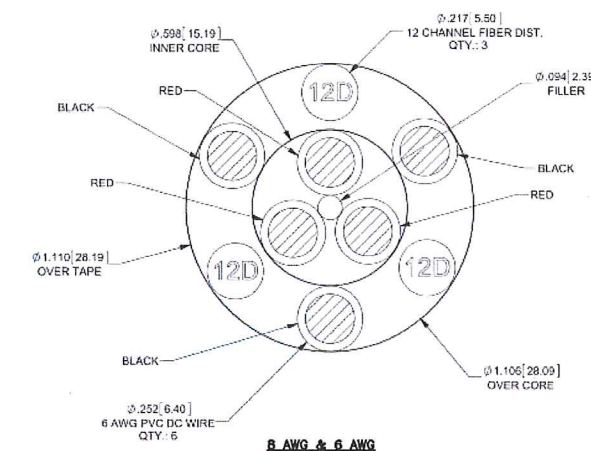
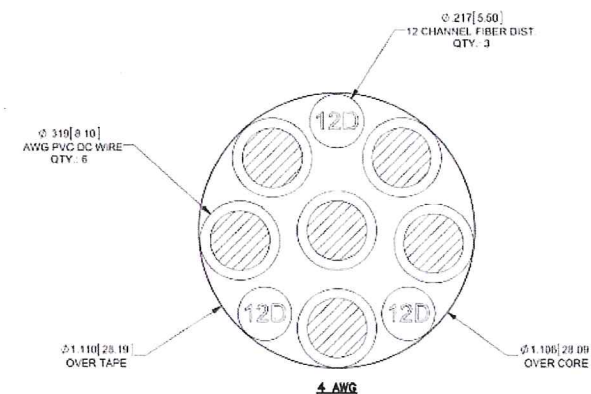

2
S-2 2.5 HYBRID CABLE X-SECTION AND DATA
SCALE: NTS

Sprint
2.5 EQUIPMENT DEPLOYMENT
6580 SPRINT PARKWAY
OVERLAND PARK, KANSAS 66251

CROWN CASTLE

TECTONIC • PLANNING
• ENGINEERING
• SURVEYING
• CONSTRUCTION
MANAGEMENT
TECTONIC Engineering & Surveying
Consultants P.C.
1279 Route 300
Newburgh, NY 12550
Phone: (845) 567-6656
Fax: (845) 567-8703
www.tectonicengineering.com

THIS DOCUMENT IS THE CREATION,
DESIGN, PROPERTY AND COPYRIGHTED
WORK OF SPRINT COMMUNICATIONS, INC.
ANY DUPLICATION OR USE WITHOUT
EXPRESS WRITTEN CONSENT IS STRICTLY
PROHIBITED. DUPLICATION AND USE BY
GOVERNMENT AGENCIES FOR THE
PURPOSES OF CONDUCTING THEIR
LAWFULLY AUTHORIZED REGULATORY AND
ADMINISTRATIVE FUNCTIONS IS
SPECIFICALLY ALLOWED.

SUBMITTALS

PROJECT NO: 7225.CT54XC716

NO	DATE	DESCRIPTION	BY
0	07/14/14	FOR COMMENT	MP
1	11/21/14	FOR CONSTRUCTION	MP
2	01/08/15	PER REVISED SA	MP

DATE	REVIEWED BY
1/8/15	JMG

STATE OF CONNECTICUT
MANOJ KUMAR PATEL
No. 22038
LICENSED PROFESSIONAL ENGINEER

SITE NUMBER:
CT54XC716
SITE NAME:
NEWTOWN GEORGIA
PACIFIC/VS
SITE ADDRESS:
201 SOUTH MAIN STREET
NEWTOWN, CT 06470

SHEET TITLE:
EQUIPMENT
SCHEMATIC DETAILS

SHEET NO:
S-2

THIS DOCUMENT IS THE CREATION, DESIGN, PROPERTY AND COPYRIGHTED WORK OF SPRINT COMMUNICATIONS, INC. ANY DUPLICATION OR USE WITHOUT EXPRESS WRITTEN CONSENT IS STRICTLY PROHIBITED. DUPLICATION AND USE BY GOVERNMENT AGENCIES FOR THE PURPOSES OF CONDUCTING THEIR LAWFULLY AUTHORIZED REGULATORY AND ADMINISTRATIVE FUNCTIONS IS SPECIFICALLY ALLOWED.

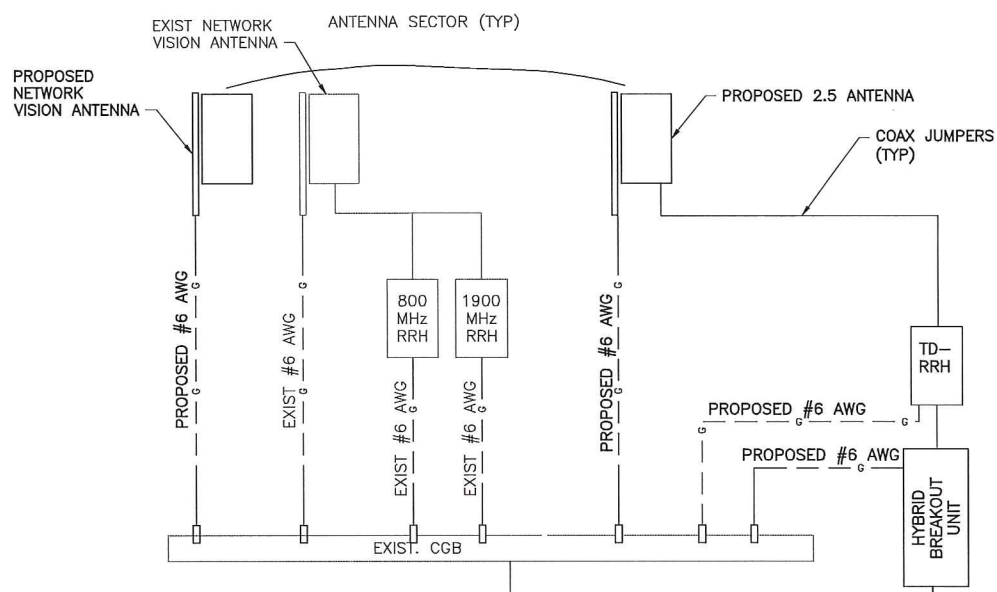

NOTE:
 ALL CONDUCTORS SHALL BE #6 AWG SOLID TINNED UNLESS OTHERWISE NOTED.

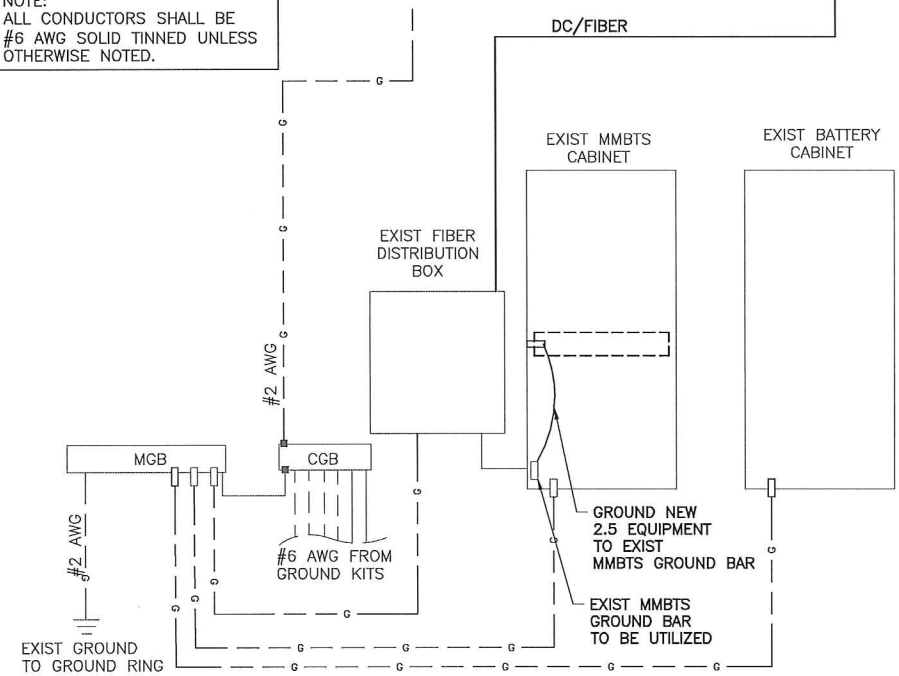

LEGEND
 ■ CADWELD CONNECTION
 □ MECHANICAL CONNECTION
 ● COMPRESSION CONNECTION

1 TYPICAL GROUNDING ONE LINE DIAGRAM
 E-1 SCALE: NTS

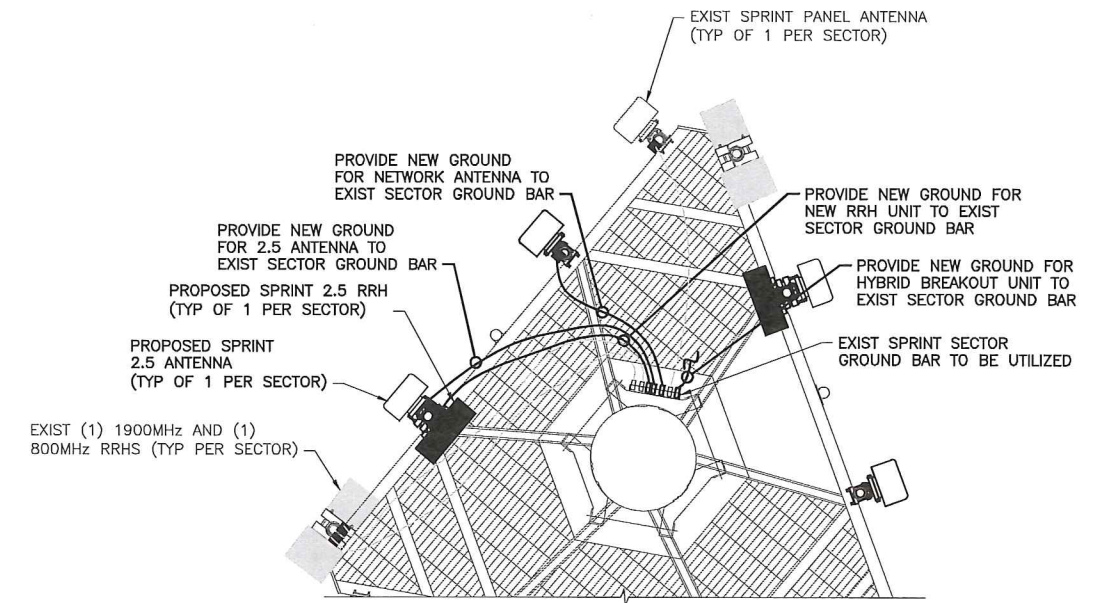

2 TYPICAL ANTENNA GROUNDING PLAN
 E-1 SCALE: NTS

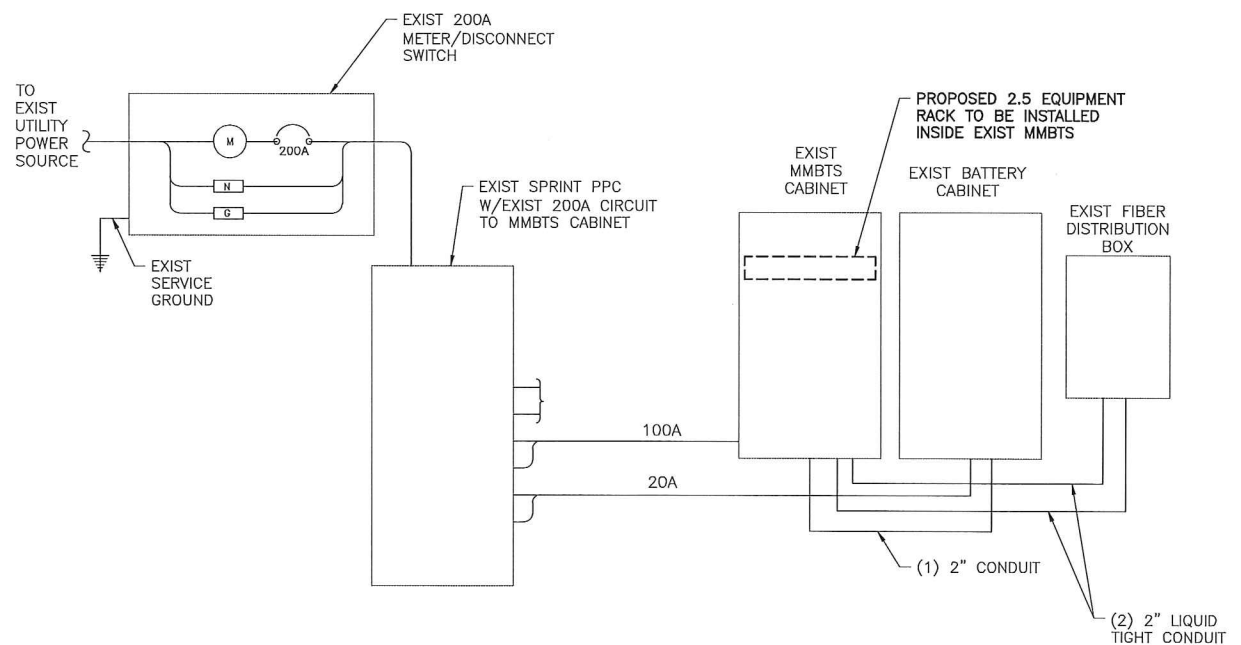

3 TYPICAL ELECTRICAL & TELCO PLAN
 E-1 SCALE: NTS

SUBMITTALS

PROJECT NO: 7225.CT54XC716

NO	DATE	DESCRIPTION	BY
0	07/14/14	FOR COMMENT	MP
1	11/21/14	FOR CONSTRUCTION	MP
2	01/08/15	PER REVISED SA	MP

DATE	REVIEWED BY
1/8/15	JMG

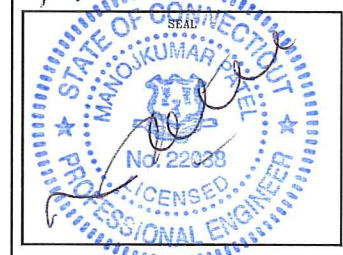

SITE NUMBER:
 CT54XC716
 SITE NAME:
 NEWTOWN GEORGIA
 PACIFIC/VIS
 SITE ADDRESS:
 201 SOUTH MAIN STREET
 NEWTOWN, CT 06470

SHEET TITLE:
 ELECTRICAL & GROUNDING
 PLANS

SHEET NO:
 E-1

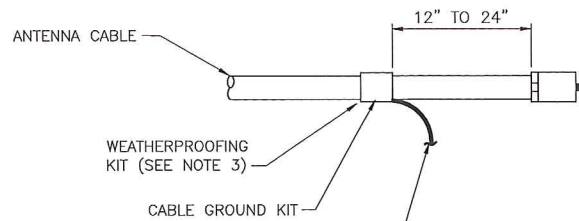

6 AWG STRANDED Cu WIRE WITH GREEN, 600V, THWN INSULATION OR BLACK, MARKED AS REQUIRED BY THE NEC (GROUNDED TO GROUND BAR) (SEE NOTES 1 & 2)

CONNECTION OF CABLE GROUND KIT TO ANTENNA CABLE

NOTES:

DO NOT INSTALL CABLE GROUND KIT AT A BEND AND ALWAYS DIRECT GROUND WIRE DOWN TO GROUND BAR.

GROUNTING KIT SHALL BE TYPE AND PART NUMBER AS SUPPLIED OR RECOMMENDED BY CABLE MANUFACTURER.

WEATHER PROOFING SHALL BE (TYPE AND PART NUMBER) AS SUPPLIED OR RECOMMENDED BY CABLE MANUFACTURER AND APPROVED BY CONTRACTOR.

1 CABLE GROUNDING KIT DETAIL

SCALE: N.T.S.

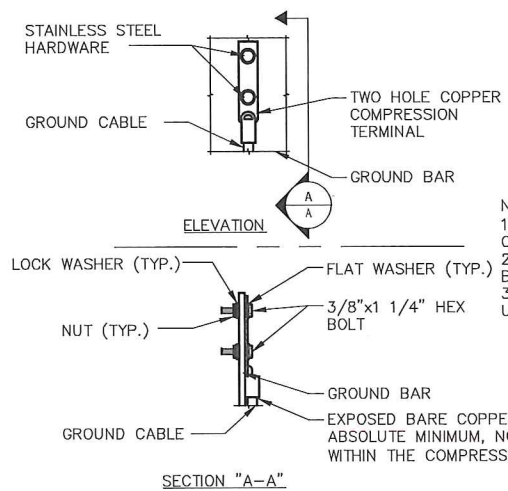

NOTE:
1. "DOUBLING UP" OR "STACKING" OF CONNECTION IS NOT PERMITTED.
2. OXIDE INHIBITING COMPOUND TO BE USED AT ALL LOCATIONS.
3. CADWELD DOWNLEADS FROM UPPER EGB, LOWER EGB AND MGB.

SECTION "A-A"

2 GROUNDING BAR CONN. DETAIL

SCALE: NTS

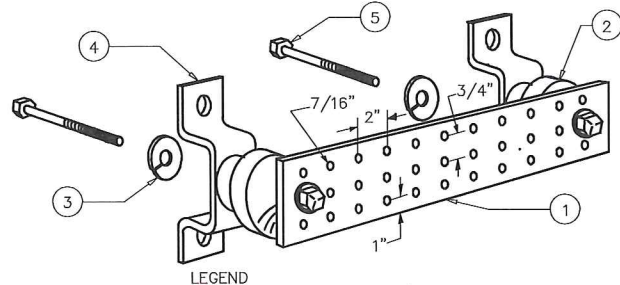

LEGEND

- 1- COPPER TINNED GROUND BAR, 1/4" X 4" X 20", OR OTHER LENGTH AS REQUIRED, HOLE CENTERS TO MATCH NEMA DOUBLE LUG CONFIGURATION
- 2- INSULATORS, NEWTON INSTRUMENT CAT. NO. 3061-4 OR EQUAL
- 3- 5/8" LOCKWASHERS OR EQUAL
- 4- WALL MOUNTING BRACKET, NEWTON INSTRUMENT CO. CAT NO. A-6056 OR EQUAL
- 5- 5/8-11 X 1" H.H.C.S.BOLTS

NOTE:
ALL BOLTS, NUTS, WASHERS AND LOCK WASHERS SHALL BE 18-8 STAINLESS STEEL.

3 GROUNDING BAR DETAIL

SCALE: NTS

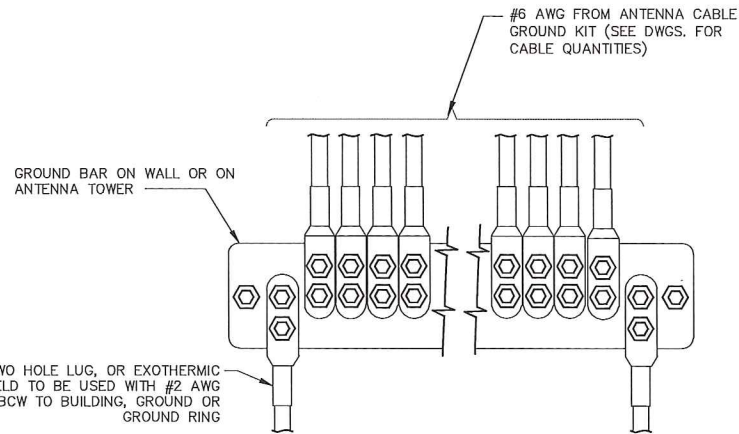

*TWO HOLE LUG, OR EXOTHERMIC WELD TO BE USED WITH #2 AWG BCW TO BUILDING, GROUND OR GROUND RING

* - GROUND BARS AT THE BOTTOM OF TOWERS/MONOPOLES SHALL ONLY USE EXOTHERMIC WELDS.

- ATTACH "DO NOT DISCONNECT" LABELS TO GROUND BARS. CAN USE BRASS TAG "DO NOT DISCONNECT" AT EACH HYBRID GROUND POINT OR BACK-A-LITE PLATE LABEL ON GROUND BAR.

- CONNECT SEQUENCE- BOLT/WASHER/NO-OX/GROUND BAR/NO-OX/WASHER/LOCK-WASHER/NUT. THIS IS REPEATED FOR EACH LUG CONNECTION POINT.

4 ANTENNA GROUND BAR DETAIL

SCALE: NTS

GROUNDING NOTES:

1. GROUNDING SHALL BE IN ACCORDANCE WITH NEC ARTICLE 250-GROUNDING AND BONDING.
2. ALL GROUND WIRES SHALL BE #2 AWG UNLESS NOTED OTHERWISE.
3. ALL GROUNDING WIRES SHALL PROVIDE A STRAIGHT, DOWNWARD PATH TO GROUND WITH GRADUAL BENDS AS REQUIRED. GROUND WIRES SHALL NOT BE LOOPED OR SHARPLY BENT.
4. EACH EQUIPMENT CABINET SHALL BE CONNECTED TO THE MASTER ISOLATION GROUND BAR (MGB) WITH #2 AWG INSULATED STRANDED COPPER WIRE. EQUIPMENT CABINETS WALL HAVE (2) CONNECTIONS.
5. PROVIDE DEDICATED #2 AWG COPPER GROUND WIRE FROM EACH ANTENNA MOUNTING PIPE TO ASSOCIATED CIGBE.
6. THE CONTRACTOR SHALL VERIFY THAT THE EXISTING GROUND BARS HAVE ENOUGH SPACE/HOLES FOR ADDITIONAL TWO HOLE LUGS.
7. ALL CONDUITS SHALL BE RIGID GALVANIZED STEEL AND SHALL BE PROVIDED WITH GROUNDING BUSHINGS.
8. PROVIDE GROUND CONNECTIONS FOR ALL METALLIC STRUCTURES, ENCLOSURES, RACEWAYS AND OTHER CONDUCTIVE ITEMS ASSOCIATED WITH THE INSTALLATION OF CARRIER'S EQUIPMENT.
9. WHEN CABLE LENGTH IS OVER 20' THE MANUFACTURERS GROUND KIT MUST BE INSTALLED PER THE MANUFACTURERS SPECIFICATIONS.
10. REFER TO "ANTI-THEFT UPDATE TO SPRINT GROUNDING 082412.PDF" FOR GUIDELINE TO SUSPECTED OR ACTUAL THEFT OF GROUNDING.
11. HOME RUN GROUNDS ARE NOT APPROVED BY CROWN CASTLE CONSTRUCTION STANDARDS AND THAT ANTENNA BUSS BARS SHOULD BE INSTALLED DIRECTLY TO TOWER STEEL WITHOUT INSULATORS OR DOWN CONDUCTORS.

PROTECTIVE GROUNDING SYSTEM GENERAL NOTES:

1. AT ALL TERMINATIONS AT EQUIPMENT ENCLOSURES, PANEL, AND FRAMES OF EQUIPMENT AND WHERE EXPOSED FOR GROUNDING. CONDUCTOR TERMINATION SHALL BE PERFORMED UTILIZING TWO HOLE BOLTED TONGUE COMPRESSION TYPE LUGS WITH STAINLESS STEEL SELF-TAPPING SCREWS.
2. ALL CLAMPS AND SUPPORTS USED TO SUPPORT THE GROUNDING SYSTEM CONDUCTORS AND PVC CONDUITS SHALL BE PVC TYPE (NON CONDUCTIVE). DO NOT USE METAL BRACKETS OR SUPPORTS WHICH WOULD FORM A COMPLETE RING AROUND ANY GROUNDING CONDUCTOR.
3. ALL GROUNDING CONNECTIONS SHALL BE COATED WITH A COPPER SHIELD ANTI-CORROSIVE AGENT SUCH AS T&B KOPR SHIELD. VERIFY PRODUCT WITH PROJECT MANAGER.
4. ALL BOLTS, WASHERS, AND NUTS USED ON GROUNDING CONNECTIONS SHALL BE STAINLESS STEEL.
5. INSTALL GROUND BUSHING ON ALL METALLIC CONDUITS AND BOND TO THE EQUIPMENT GROUND BUS IN THE PANEL BOARD.
6. GROUND ANTENNA BASES, FRAMES, CABLE RACKS, AND OTHER METALLIC COMPONENTS WITH #2 INSULATED TINNED STRANDED COPPER GROUNDING CONDUCTORS AND CONNECT TO INSULATED SURFACE MOUNTED GROUND BARS. CONNECTION DETAILS SHALL FOLLOW MANUFACTURER'S SPECIFICATIONS FOR GROUNDING.
7. GROUND HYBRID CABLE SHIELD AT BOTH ENDS USING MANUFACTURER'S GUIDELINES.

ELECTRICAL AND GROUNDING NOTES

1. ALL ELECTRICAL WORK SHALL CONFORM TO THE REQUIREMENTS OF THE NATIONAL ELECTRICAL CODE (NEC) AS WELL AS APPLICABLE STATE AND LOCAL CODES.
2. ALL ELECTRICAL ITEMS SHALL BE U.L. APPROVED OR LISTED AND PROCURED PER SPECIFICATION REQUIREMENTS.
3. ELECTRICAL AND TELCO WIRING OUTSIDE A BUILDING AND EXPOSED TO WEATHER SHALL BE IN WATER TIGHT GALVANIZED RIGID STEEL CONDUITS OR SCHEDULE 80 PVC (AS PERMITTED BY CODE) AND WHERE REQUIRED IN LIQUID TIGHT FLEXIBLE METAL OR NONMETALLIC CONDUITS.
4. BURIED CONDUIT SHALL BE SCHEDULE 40 PVC.
5. ELECTRICAL WIRING SHALL BE COPPER WITH TYPE XHHW, THWN, OR THHN INSULATION.
6. RUN TELCO CONDUIT OR CABLE BETWEEN TELEPHONE UTILITY DEMARCATION POINT AND PROJECT OWNER CELL SITE TELCO CABINET AND BTS CABINET AS INDICATED ON THIS DRAWING PROVIDE FULL LENGTH PULL ROPE IN INSTALLED TELCO CONDUIT. PROVIDE GREENLEE CONDUIT MEASURING TAPE AT EACH END.
7. WHERE CONDUIT BETWEEN BTS AND PROJECT OWNER CELL SITE PPC AND BETWEEN BTS AND PROJECT OWNER CELL SITE TELCO SERVICE CABINET ARE UNDERGROUND USE PVC, SCHEDULE 40 CONDUIT. ABOVE THE GROUND PORTION OF THESE CONDUITS SHALL BE PVC CONDUIT.
8. ALL EQUIPMENT LOCATED OUTSIDE SHALL HAVE NEMA 3R ENCLOSURE.
9. GROUNDING SHALL COMPLY WITH NEC ART. 250.
10. GROUND HYBRID CABLE SHIELDS AT 3 LOCATIONS USING MANUFACTURER'S HYBRID CABLE GROUNDING KITS SUPPLIED BY PROJECT OWNER.
11. USE #2 COPPER STRANDED WIRE WITH GREEN COLOR INSULATION FOR ABOVE GRADE GROUNDING (UNLESS OTHERWISE SPECIFIED) AND #2 SOLID TINNED BARE COPPER WIRE FOR BELOW GRADE GROUNDING AS INDICATED ON THE DRAWING.
12. ALL GROUND CONNECTIONS TO BE BURNDY HYGROUND COMPRESSION TYPE CONNECTORS OR CADWELD EXOTHERMIC WELD. DO NOT ALLOW BARE COPPER WIRE TO BE IN CONTACT WITH GALVANIZED STEEL.
13. ROUTE GROUNDING CONDUCTORS ALONG THE SHORTEST AND STRAIGHTEST PATH POSSIBLE, EXCEPT AS OTHERWISE INDICATED. GROUNDING LEADS SHOULD NEVER BE BENT AT RIGHT ANGLE. ALWAYS MAKE AT LEAST 12" RADIUS BENDS. #2 WIRE CAN BE BENT AT 6" RADIUS WHEN NECESSARY. BOND ANY METAL OBJECTS WITHIN 6 FEET OF PROJECT OWNER EQUIPMENT OR CABINET TO MASTER GROUND BAR OR GROUNDING RING.
14. CONNECTIONS TO GROUND BARS SHALL BE MADE WITH TWO HOLE COMPRESSION TYPE COPPER LUGS. APPLY OXIDE INHIBITING COMPOUND TO ALL LOCATIONS.
15. APPLY OXIDE INHIBITING COMPOUND TO ALL COMPRESSION TYPE GROUND CONNECTIONS.
16. BOND ANTENNA MOUNTING BRACKETS, HYBRID CABLE GROUND KITS, AND RRHs TO EGB PLACED NEAR THE ANTENNA LOCATION.
17. BOND ANTENNA EGB'S AND MGB TO GROUND RING.
18. CONTRACTOR SHALL TEST COMPLETED GROUND SYSTEM AND RECORD RESULT FOR PROJECT CLOSE-OUT DOCUMENTATION. 5 OHMS MINIMUM RESISTANCE REQUIRED.
19. CONTRACTOR SHALL CONDUCT ANTENNA, HYBRID CABLES, GPS COAX AND RRH RETURN-LOSS AND DISTANCE- TO-FAULT MEASUREMENTS (SWEEP TESTS) AND RECORD RESULTS FOR PROJECT CLOSE OUT.
20. CONTRACTOR SHALL CHECK CAPACITY OF EXISTING SERVICE & PANEL ON SITE TO DETERMINE IF CAPACITY EXISTS TO ACCOMMODATE THE ADDED LOAD OF THIS PROJECT. ADVISE ENGINEER OF ANY DISCREPANCY.
21. LOCATION OF ALL OUTLET, BOXES, ETC, AND THE TYPE OF CONNECTION (PLUG OR DIRECT) SHALL BE CONFIRMED WITH THE OWNER'S REPRESENTATIVE PRIOR TO ROUGH-IN.
22. ELECTRICAL CHARACTERISTICS OF ALL EQUIPMENT (NEW AND EXISTING) SHALL BE FIELD VERIFIED WITH THE OWNERS REPRESENTATIVE AND EQUIPMENT SUPPLIER PRIOR TO ROUGH-IN OF CONDUIT AND WIRE. ALL EQUIPMENT SHALL BE PROPERLY CONNECTED ACCORDING TO THE NAMEPLATE DATA FURNISHED ON THE EQUIPMENT.

Sprint
2.5 EQUIPMENT DEPLOYMENT
6580 SPRINT PARKWAY
OVERLAND PARK, KANSAS 66251

CROWN CASTLE

TECTONIC
PLANNING
ENGINEERING
SURVEYING
CONSTRUCTION MANAGEMENT
TECTONIC Engineering & Surveying Consultants P.C.
1279 Route 300
Newburgh, NY 12550
Phone: (845) 567-6656
Fax: (845) 567-8703
www.tectonicengineering.com

THIS DOCUMENT IS THE CREATION, DESIGN, PROPERTY AND COPYRIGHTED WORK OF SPRINT COMMUNICATIONS, INC. ANY DUPLICATION OR USE WITHOUT EXPRESS WRITTEN CONSENT IS STRICTLY PROHIBITED. DUPLICATION AND USE BY GOVERNMENT AGENCIES FOR THE PURPOSES OF CONDUCTING THEIR LAWFULLY AUTHORIZED REGULATORY AND ADMINISTRATIVE FUNCTIONS IS SPECIFICALLY ALLOWED.

SUBMITTALS

PROJECT NO: 7225.CT54XC716

NO	DATE	DESCRIPTION	BY
0	07/14/14	FOR COMMENT	MP
1	11/21/14	FOR CONSTRUCTION	MP
2	01/08/15	PER REVISED SA	MP

DATE	REVIEWED BY
1/8/15	SMG

MANOJ KUMAR
STATE OF CONNECTICUT
PROFESSIONAL ENGINEER
No. 22038

SITE NUMBER:
CT54XC716
SITE NAME:
NEWTOWN GEORGIA
PACIFIC/VS
SITE ADDRESS:
201 SOUTH MAIN STREET
NEWTOWN, CT 06470

SHEET TITLE:
GROUNDING DETAILS & NOTES

SHEET NO:
E-2



Date: August 31, 2017

Paul J. Ford and Company
250 East Broad St., Suite 600
Columbus, OH 43215
614-221-6679
mtimas@pjfweb.com

Jay Patton
Crown Castle
3530 Toringdon Way Suite 300
Charlotte, NC 28277
(980)-209-8250

Subject: Structural Analysis Report

Carrier Designation: Sprint PCS Co-Locate
Carrier Site Number: CT54XC716
Carrier Site Name: CT54XC716

Crown Castle Designation: Crown Castle BU Number: 826222
Crown Castle Site Name: Newtown/RT-25
Crown Castle JDE Job Number: 450832
Crown Castle Work Order Number: 1452347
Crown Castle Application Number: 399485 Rev. 2

Engineering Firm Designation: Paul J. Ford and Company Project Number: 37517-3089.001.7805

Site Data: 201 South Main Street, Newtown, Fairfield County, CT
Latitude 41° 22' 41.32", Longitude -73° 16' 26.94"
150 Foot - Monopole Tower

Dear Jay Patton,

Paul J. Ford and Company is pleased to submit this "Structural Analysis Report" to determine the structural integrity of the above mentioned tower. This analysis has been performed in accordance with the Crown Castle Structural 'Statement of Work' and the terms of Crown Castle Purchase Order Number 1076346, in accordance with application 399485, revision 2.

The purpose of the analysis is to determine acceptability of the tower stress level. Based on our analysis we have determined the tower stress level for the structure and foundation, under the following load case, to be:

LC7: Existing + Reserved + Proposed Equipment **Sufficient Capacity**
Note: See Table I and Table II for the proposed and existing/reserved loading, respectively.

This analysis has been performed in accordance with the 2016 Connecticut State Building Code based upon an ultimate 3-second gust wind speed of 120 mph converted to a nominal 3-second gust wind speed of 93 mph per Section 1609.3 and Appendix N as required for use in the ANSI/TIA-222-G-2005 Standard, "Structural Standard for Antenna Supporting Structures and Antennas", with ANSI/TIA-222-G-1-2007 and ANSI/TIA-222-G-2-2009 Addenda per Exception #5 of Section 1609.1.1. Risk Category II, Exposure Category C and Topographic Category 1 with a maximum Topographic Factor, Kzt, of 1.0 were used in this analysis.

We at Paul J. Ford and Company appreciate the opportunity of providing our continuing professional services to you and Crown Castle. If you have any questions or need further assistance on this or any other projects please give us a call.

Respectfully submitted by:

Michael Timas, E.I. 303
Structural Designer

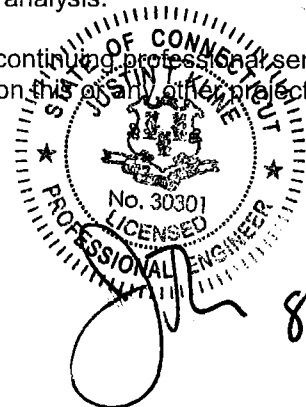

8-31-17

Date: **August 31, 2017**

Jay Patton
Crown Castle
3530 Toringdon Way Suite 300
Charlotte, NC 28277
(980)-209-8250

Paul J. Ford and Company
250 East Broad St., Suite 600
Columbus, OH 43215
614-221-6679
mtimas@pjfweb.com

Subject: Structural Analysis Report

Carrier Designation: **Sprint PCS Co-Locate**
Carrier Site Number: CT54XC716
Carrier Site Name: CT54XC716

Crown Castle Designation: **Crown Castle BU Number:** 826222
Crown Castle Site Name: Newtown/RT-25
Crown Castle JDE Job Number: 450832
Crown Castle Work Order Number: 1452347
Crown Castle Application Number: 399485 Rev. 2

Engineering Firm Designation: **Paul J. Ford and Company Project Number:** 37517-3089.001.7805

Site Data: **201 South Main Street, Newtown, Fairfield County, CT**
Latitude 41° 22' 41.32", Longitude -73° 16' 26.94"
150 Foot - Monopole Tower

Dear Jay Patton,

Paul J. Ford and Company is pleased to submit this "**Structural Analysis Report**" to determine the structural integrity of the above mentioned tower. This analysis has been performed in accordance with the Crown Castle Structural 'Statement of Work' and the terms of Crown Castle Purchase Order Number 1076346, in accordance with application 399485, revision 2.

The purpose of the analysis is to determine acceptability of the tower stress level. Based on our analysis we have determined the tower stress level for the structure and foundation, under the following load case, to be:

LC7: Existing + Reserved + Proposed Equipment

Sufficient Capacity

Note: See Table I and Table II for the proposed and existing/reserved loading, respectively.

This analysis has been performed in accordance with the 2016 Connecticut State Building Code based upon an ultimate 3-second gust wind speed of 120 mph converted to a nominal 3-second gust wind speed of 93 mph per Section 1609.3 and Appendix N as required for use in the ANSI/TIA-222-G-2005 Standard, "Structural Standard for Antenna Supporting Structures and Antennas", with ANSI/TIA-222-G-1-2007 and ANSI/TIA-222-G-2-2009 Addenda per Exception #5 of Section 1609.1.1. Risk Category II, Exposure Category C and Topographic Category 1 with a maximum Topographic Factor, Kzt, of 1.0 were used in this analysis.

We at *Paul J. Ford and Company* appreciate the opportunity of providing our continuing professional services to you and Crown Castle. If you have any questions or need further assistance on this or any other projects please give us a call.

Respectfully submitted by:

Michael Timas, E.I.
Structural Designer

TABLE OF CONTENTS

1) INTRODUCTION

2) ANALYSIS CRITERIA

Table 1 - Proposed Antenna and Cable Information

Table 2 - Existing and Reserved Antenna and Cable Information

Table 3 - Design Antenna and Cable Information

3) ANALYSIS PROCEDURE

Table 4 - Documents Provided

3.1) Analysis Method

3.2) Assumptions

4) ANALYSIS RESULTS

Table 5 - Section Capacity (Summary)

Table 6 – Tower Components vs. Capacity

4.1) Recommendations

5) APPENDIX A

tnxTower Output

6) APPENDIX B

Base Level Drawing

7) APPENDIX C

Additional Calculations

1) INTRODUCTION

This tower is a 150-ft Monopole tower designed by PIROD MANUFACTURES INC. in October of 2000. The tower was originally designed for a wind speed of 85 mph per TIA/EIA-222-F.

2) ANALYSIS CRITERIA

This analysis has been performed in accordance with the 2016 Connecticut State Building Code based upon an ultimate 3-second gust wind speed of 120 mph converted to a nominal 3-second gust wind speed of 93 mph per Section 1609.3 and Appendix N as required for use in the ANSI/TIA-222-G-2005 Standard, "Structural Standard for Antenna Supporting Structures and Antennas", with ANSI/TIA-222-G-1-2007 and ANSI/TIA-222-G-2-2009 Addenda per Exception #5 of Section 1609.1.1. Risk Category II, Exposure Category C and Topographic Category 1 with a maximum Topographic Factor, Kzt, of 1.0 were used in this analysis.

Table 1 - Proposed Antenna and Cable Information

Mounting Level (ft)	Center Line Elevation (ft)	Number of Antennas	Antenna Manufacturer	Antenna Model	Number of Feed Lines	Feed Line Size (in)	Note
138.0	137.0	3	alcatel lucent	TD-RRH8x20-25	1	1-1/4	-
		3	rfs celwave	APXVSP18-C-A20 w/ Mount Pipe			
		3	rfs celwave	APXVTM14-C-120 w/ Mount Pipe			

Table 2 - Existing and Reserved Antenna and Cable Information

Mounting Level (ft)	Center Line Elevation (ft)	Number of Antennas	Antenna Manufacturer	Antenna Model	Number of Feed Lines	Feed Line Size (in)	Note
148.0	148.0	3	commscope	LNx-6515DS-VTM w/ Mount Pipe	11 1	1-5/8 1-1/4	1
		3	ericsson	ERICSSON AIR 21 B2A B4P w/ Mount Pipe			
		3	ericsson	ERICSSON AIR 21 B4A B2P w/ Mount Pipe			
		3	ericsson	KRY 112 144/1			
		3	ericsson	RRUS 11 B12			
		1	tower mounts	Sector Mount [SM 410-3]			
138.0	138.0	1	tower mounts	Platform Mount [LP 601-1]	3	1-1/4	1
	137.0	3	alcatel lucent	1900MHz RRH			
		3	alcatel lucent	800MHZ RRH			
		3	rfs celwave	APXVSP18-C-A20 w/ Mount Pipe			
127.0	127.0	3	alcatel lucent	RRH2X60-PCS	1	1-5/8	2
		3	alcatel lucent	RRH2x60-700			
		3	alcatel lucent	RRH4X45-AWS4 B66			
		9	commscope	SBNHH-1D65B w/ Mount Pipe			
		1	rfs celwave	DB-B1-6C-8AB-0Z	7	1-5/8	1
		1	rfs celwave	DB-T1-6Z-8AB-0Z			
		6	rfs celwave	APL866513-42T0 w/ Mount Pipe			
		6	rfs celwave	FD9R6004/2C-3L			
		1	tower mounts	Platform Mount [LP 304-1]			
110.0	110.0	6	ericsson	RRUS-11	2 1 1 6	7/8 3/8 3/4 1-1/4	1
		3	powerwave technologies	7770.00 w/ Mount Pipe			
		6	powerwave technologies	LGP21401			
		3	powerwave technologies	P65-16-XLH-RR w/ Mount Pipe			
		1	raycap	DC6-48-60-18-8F			
		1	tower mounts	Platform Mount [LP 304-1]			

Notes:
 1) Existing Equipment
 2) Reserved Equipment

Table 3 - Design Antenna and Cable Information

Mounting Level (ft)	Center Line Elevation (ft)	Number of Antennas	Antenna Manufacturer	Antenna Model	Number of Feed Lines	Feed Line Size (in)
-	-	-	-	-	-	-

3) ANALYSIS PROCEDURE

Table 4 - Documents Provided

Document	Remarks	Reference	Source
4-GEOTECHNICAL REPORTS	Dr. Clarence Welti Geotechnica Engineering, 10/16/2000	3536527	CCISITES
4-TOWER MANUFACTURER DRAWINGS	Pirod, A-117711-F-1001206, 10/17/2000	3536528	CCISITES
4-POST MODIFICATION INSPECTION	SGS, 130625, 6/30/2014	5156735	CCISITES
4-POST MODIFICATION INSPECTION	SGS, 156630, 3/16/2016	6139913	CCISITES

3.1) Analysis Method

tnxTower (version 7.0.5.1), a commercially available analysis software package, was used to create a three-dimensional model of the tower and calculate member stresses for various loading cases. Selected output from the analysis is included in Appendix A.

3.2) Assumptions

- 1) Tower and structures were built in accordance with the manufacturer's specifications.
- 2) The tower and structures have been maintained in accordance with the manufacturer's specification.
- 3) The configuration of antennas, transmission cables, mounts and other appurtenances are as specified in Tables 1 and 2 and the referenced drawings.
- 4) Monopole was modified in conformance with referenced modification drawings.

This analysis may be affected if any assumptions are not valid or have been made in error. Paul J. Ford and Company should be notified to determine the effect on the structural integrity of the tower.

4) ANALYSIS RESULTS

Table 5 - Section Capacity (Summary)

Section No.	Elevation (ft)	Component Type	Size	Critical Element	P (K)	SF*P_allow (K)	% Capacity	Pass / Fail
L1	150 - 133	Pole	TP26x21.83x0.25	1	-5.81	1475.55	9.5	Pass
L2	133 - 98.42	Pole	TP34.0625x24.7837x0.3125	2	-16.04	2387.51	42.1	Pass
L3	98.42 - 64.75	Pole	TP41.75x32.4898x0.375	3	-23.73	3492.62	52.5	Pass
L4	64.75 - 31.92	Pole	TP49.0625x39.8468x0.375	4	-32.98	3911.23	64.3	Pass
L5	31.92 - 0	Pole	TP56.125x46.9609x0.375	5	-45.56	4329.08	73.9	Pass
							Summary	
						Pole (L5)	73.9	Pass
						Rating =	73.9	Pass

Table 6 - Tower Component Stresses vs. Capacity – LC7

Notes	Component	Elevation (ft)	% Capacity	Pass / Fail
1	Anchor Rods	0	68.1	Pass
1	Base Plate	0	55.5	Pass
1	Base Foundation Structural Steel	0	70.7	Pass
1	Base Foundation Soil Interaction	0	14.7	Pass

Structure Rating (max from all components) =	73.9%
---	--------------

Notes:

- 1) See additional documentation in "Appendix C – Additional Calculations" for calculations supporting the % capacity consumed.

4.1) Recommendations

The monopole and its foundation have sufficient capacity to carry the proposed loading configuration. No modifications are required at this time.

APPENDIX A
TNXTOWER OUTPUT

Tower Input Data

There is a pole section.

This tower is designed using the TIA-222-G standard.

The following design criteria apply:

- 3) Tower is located in Fairfield County, Connecticut.
- 4) Basic wind speed of 93 mph.
- 5) Structure Class II.
- 6) Exposure Category C.
- 7) Topographic Category 1.
- 8) Crest Height 0.0000 ft.
- 9) Nominal ice thickness of 0.7500 in.
- 10) Ice thickness is considered to increase with height.
- 11) Ice density of 56.00 pcf.
- 12) A wind speed of 50 mph is used in combination with ice.
- 13) Deflections calculated using a wind speed of 60 mph.
- 14) A non-linear (P-delta) analysis was used.
- 15) Pressures are calculated at each section.
- 16) Stress ratio used in pole design is 1.
- 17) Local bending stresses due to climbing loads, feed line supports, and appurtenance mounts are not considered.

Options

- | | | |
|--|--|---|
| Consider Moments - Legs
Consider Moments - Horizontals
Consider Moments - Diagonals
Use Moment Magnification
✓ Use Code Stress Ratios
✓ Use Code Safety Factors - Guys
Escalate Ice
Always Use Max Kz
Use Special Wind Profile

Include Bolts In Member Capacity

Leg Bolts Are At Top Of Section
Secondary Horizontal Braces Leg
Use Diamond Inner Bracing (4 Sided)
SR Members Have Cut Ends
SR Members Are Concentric | Distribute Leg Loads As Uniform
Assume Legs Pinned
✓ Assume Rigid Index Plate
✓ Use Clear Spans For Wind Area
Use Clear Spans For KL/r
Retension Guys To Initial Tension
✓ Bypass Mast Stability Checks
✓ Use Azimuth Dish Coefficients
✓ Project Wind Area of Appurt.

Autocalc Torque Arm Areas

Add IBC .6D+W Combination
Sort Capacity Reports By Component
Triangulate Diamond Inner Bracing
Treat Feed Line Bundles As Cylinder | Use ASCE 10 X-Brace Ly Rules
Calculate Redundant Bracing Forces
Ignore Redundant Members in FEA
SR Leg Bolts Resist Compression
All Leg Panels Have Same Allowable
Offset Girt At Foundation
✓ Consider Feed Line Torque
Include Angle Block Shear Check
Use TIA-222-G Bracing Resist.
Exemption
Use TIA-222-G Tension Splice
Exemption

<div style="text-align: center; background-color: #e0e0e0; padding: 2px;">Poles</div> ✓ Include Shear-Torsion Interaction
Always Use Sub-Critical Flow
Use Top Mounted Sockets |
|--|--|---|

Tapered Pole Section Geometry

Section	Elevation ft	Section Length ft	Splice Length ft	Number of Sides	Top Diameter in	Bottom Diameter in	Wall Thickness in	Bend Radius in	Pole Grade
L1	150.0000-133.0000	17.0000	2.92	18	21.8300	26.0000	0.2500	1.0000	A572-65 (65 ksi)
L2	133.0000-98.4200	37.5000	3.83	18	24.7837	34.0625	0.3125	1.2500	A572-65 (65 ksi)
L3	98.4200-64.7500	37.5000	4.67	18	32.4898	41.7500	0.3750	1.5000	A572-65 (65 ksi)
L4	64.7500-31.9200	37.5000	5.50	18	39.8468	49.0625	0.3750	1.5000	A572-65 (65 ksi)
L5	31.9200-0.0000	37.4200		18	46.9609	56.1250	0.3750	1.5000	A572-65 (65 ksi)

Tapered Pole Properties

Section	Tip Dia. in	Area in ²	I in ⁴	r in	C in	I/C in ³	J in ⁴	It/Q in ²	w in	w/t
L1	22.1668	17.1237	1007.4853	7.6609	11.0896	90.8492	2016.2962	8.5635	3.4021	13.608
	26.4011	20.4326	1711.6544	9.1412	13.2080	129.5922	3425.5610	10.2183	4.1360	16.544
L2	25.8997	24.2724	1836.3793	8.6873	12.5901	145.8585	3675.1749	12.1385	3.8119	12.198
	34.5880	33.4758	4817.4335	11.9812	17.3038	278.4040	9641.2058	16.7411	5.4450	17.424
L3	33.9514	38.2247	4980.7243	11.4008	16.5048	301.7737	9968.0023	19.1160	5.0582	13.489
	42.3941	49.2466	10650.982	14.6881	21.2090	502.1916	21315.979	24.6280	6.6880	17.835
L4	41.6269	46.9813	9247.7576	14.0125	20.2422	456.8559	18507.683	23.4951	6.3530	16.941
	49.8194	57.9503	17355.137	17.2841	24.9238	696.3293	34733.111	28.9807	7.9750	21.267
L5	49.0530	55.4488	15203.308	16.5380	23.8561	637.2918	30426.621	27.7297	7.6051	20.28
	56.9908	66.3564	26056.150	19.7913	28.5115	913.8821	52146.586	33.1845	9.2180	24.581

Tower Elevation ft	Gusset Area (per face) ft ²	Gusset Thickness in	Gusset Grade	Adjust. Factor A _r	Adjust. Factor A _r	Weight Mult.	Double Angle Stitch Bolt Spacing Diagonals in	Double Angle Stitch Bolt Spacing Horizontal in	Double Angle Stitch Bolt Spacing Redundants in
L1 150.0000-133.0000				1	1	1			
L2 133.0000-98.4200				1	1	1			
L3 98.4200-64.7500				1	1	1			
L4 64.7500-31.9200				1	1	1			
L5 31.9200-0.0000				1	1	1			

Feed Line/Linear Appurtenances - Entered As Area

Description	Face or Leg	Allow Shield	Component Type	Placement ft	Total Number	C _{AA}		Weight
						ft ² /ft	plf	
LDF7-50A(1-5/8)	C	No	Inside Pole	148.0000 - 0.0000	11	No Ice	0.0000	0.82
						1/2" Ice	0.0000	0.82
						1" Ice	0.0000	0.82
MLE Hybrid 3Power/6Fiber RL 2(1-1/4) *****	C	No	Inside Pole	148.0000 - 0.0000	1	No Ice	0.0000	0.68
						1/2" Ice	0.0000	0.68
						1" Ice	0.0000	0.68
HB114-1-0813U4-M5J(1-1/4)	C	No	Inside Pole	138.0000 - 0.0000	3	No Ice	0.0000	1.20
						1/2" Ice	0.0000	1.20
						1" Ice	0.0000	1.20
HB114-21U3M12-XXXF(1-1/4) *****	C	No	Inside Pole	138.0000 - 0.0000	1	No Ice	0.0000	1.22
						1/2" Ice	0.0000	1.22
						1" Ice	0.0000	1.22
HB158-1-08U8-S8J18(1-5/8)	C	No	CaAa (Out Of Face)	127.0000 - 0.0000	1	No Ice	0.0000	1.30
						1/2" Ice	0.0000	2.81
						1" Ice	0.0000	4.94
HB158-1-08U8-S8J18(1-5/8)	C	No	CaAa (Out Of Face)	127.0000 - 0.0000	1	No Ice	0.0000	1.30
						1/2" Ice	0.0000	2.81
						1" Ice	0.0000	4.94
LDF7-50A(1-5/8)	C	No	CaAa (Out Of Face)	127.0000 - 0.0000	4	No Ice	0.0000	0.82
						1/2" Ice	0.0000	2.33
						1" Ice	0.0000	4.46
LDF7-50A(1-5/8) *****	C	No	CaAa (Out Of Face)	127.0000 - 0.0000	2	No Ice	0.1980	0.82
						1/2" Ice	0.2980	2.33
						1" Ice	0.3980	4.46
2" (Nominal) Conduit	C	No	Inside Pole	110.0000 - 0.0000	1	No Ice	0.0000	0.72
						1/2" Ice	0.0000	0.72
						1" Ice	0.0000	0.72
LDF2-50A(3/8)	C	No	Inside Pole	110.0000 - 0.0000	1	No Ice	0.0000	0.08
						1/2" Ice	0.0000	0.08
						1" Ice	0.0000	0.08
LDF5-50A(7/8)	C	No	Inside Pole	110.0000 - 0.0000	2	No Ice	0.0000	0.33
						1/2" Ice	0.0000	0.33
						1" Ice	0.0000	0.33
LDF6-50A(1-1/4)	C	No	Inside Pole	110.0000 - 0.0000	6	No Ice	0.0000	0.60
						1/2" Ice	0.0000	0.60
						1" Ice	0.0000	0.60
ASU9328TYP01(3/4) *****	C	No	Inside Pole	110.0000 - 0.0000	1	No Ice	0.0000	0.28
						1/2" Ice	0.0000	0.28
						1" Ice	0.0000	0.28

Feed Line/Linear Appurtenances Section Areas

Tower Section	Tower Elevation ft	Face	A _R	A _F	C _{AA} In Face	C _{AA} Out Face	Weight K
			ft ²	ft ²	ft ²	ft ²	
L1	150.0000-133.0000	A	0.000	0.000	0.000	0.000	0.00
		B	0.000	0.000	0.000	0.000	0.00
		C	0.000	0.000	0.000	0.000	0.17
L2	133.0000-98.4200	A	0.000	0.000	0.000	0.000	0.00
		B	0.000	0.000	0.000	0.000	0.00
		C	0.000	0.000	0.000	11.318	0.78
L3	98.4200-64.7500	A	0.000	0.000	0.000	0.000	0.00
		B	0.000	0.000	0.000	0.000	0.00
		C	0.000	0.000	0.000	13.333	0.92
L4	64.7500-31.9200	A	0.000	0.000	0.000	0.000	0.00
		B	0.000	0.000	0.000	0.000	0.00
		C	0.000	0.000	0.000	13.001	0.90
L5	31.9200-0.0000	A	0.000	0.000	0.000	0.000	0.00
		B	0.000	0.000	0.000	0.000	0.00
		C	0.000	0.000	0.000	12.640	0.87

Feed Line/Linear Appurtenances Section Areas - With Ice

Tower Section	Tower Elevation ft	Face or Leg	Ice Thickness in	A_R ft ²	A_F ft ²	$C_A A_A$ In Face ft ²	$C_A A_A$ Out Face ft ²	Weight K
L1	150.0000-133.0000	A	1.735	0.000	0.000	0.000	0.000	0.00
		B		0.000	0.000	0.000	0.000	0.00
		C		0.000	0.000	0.000	0.000	0.17
L2	133.0000-98.4200	A	1.699	0.000	0.000	0.000	0.000	0.00
		B		0.000	0.000	0.000	0.000	0.00
		C		0.000	0.000	0.000	31.149	2.63
L3	98.4200-64.7500	A	1.641	0.000	0.000	0.000	0.000	0.00
		B		0.000	0.000	0.000	0.000	0.00
		C		0.000	0.000	0.000	36.222	3.05
L4	64.7500-31.9200	A	1.558	0.000	0.000	0.000	0.000	0.00
		B		0.000	0.000	0.000	0.000	0.00
		C		0.000	0.000	0.000	34.553	2.88
L5	31.9200-0.0000	A	1.395	0.000	0.000	0.000	0.000	0.00
		B		0.000	0.000	0.000	0.000	0.00
		C		0.000	0.000	0.000	32.529	2.67

Feed Line Center of Pressure

Section	Elevation ft	CP_x in	CP_z in	CP_x Ice in	CP_z Ice in
L1	150.0000-133.0000	0.0000	0.0000	0.0000	0.0000
L2	133.0000-98.4200	-0.3798	0.2193	-0.8023	0.4632
L3	98.4200-64.7500	-0.4505	0.2601	-0.9643	0.5567
L4	64.7500-31.9200	-0.4589	0.2650	-0.9988	0.5767
L5	31.9200-0.0000	-0.4649	0.2684	-1.0111	0.5838

Shielding Factor K_a

Tower Section	Feed Line Record No.	Description	Feed Line Segment Elev.	K_a No Ice	K_a Ice

Discrete Tower Loads

Description	Face or Leg	Offset Type	Offsets: Horz Lateral Vert ft ft ft	Azimuth Adjustmen t °	Placement ft		C _{AA} Front ft ²	C _{AA} Side ft ²	Weight K
ERICSSON AIR 21 B2A B4P w/ Mount Pipe	A	From Face	4.0000	0.00	148.0000	No Ice	6.3292	5.6424	0.11
			0.00			1/2"	6.7751	6.4259	0.17
			0.00			Ice	7.2137	7.1313	0.23
ERICSSON AIR 21 B2A B4P w/ Mount Pipe	B	From Face	4.0000	0.00	148.0000	1" Ice	6.3292	5.6424	0.11
			0.00			No Ice	6.7751	6.4259	0.17
			0.00			1/2"	7.2137	7.1313	0.23
ERICSSON AIR 21 B2A B4P w/ Mount Pipe	C	From Face	4.0000	0.00	148.0000	Ice	6.3292	5.6424	0.11
			0.00			1/2"	6.7751	6.4259	0.17
			0.00			Ice	7.2137	7.1313	0.23
LNX-6515DS-VTM w/ Mount Pipe	A	From Face	4.0000	0.00	148.0000	1" Ice	11.6828	9.8418	0.08
			0.00			No Ice	12.4043	11.3657	0.17
			0.00			1/2"	13.1351	12.9138	0.27
LNX-6515DS-VTM w/ Mount Pipe	B	From Face	4.0000	0.00	148.0000	Ice	11.6828	9.8418	0.08
			0.00			No Ice	12.4043	11.3657	0.17
			0.00			1/2"	13.1351	12.9138	0.27
LNX-6515DS-VTM w/ Mount Pipe	C	From Face	4.0000	0.00	148.0000	1" Ice	11.6828	9.8418	0.08
			0.00			No Ice	12.4043	11.3657	0.17
			0.00			1/2"	13.1351	12.9138	0.27
ERICSSON AIR 21 B4A B2P w/ Mount Pipe	A	From Face	4.0000	0.00	148.0000	Ice	6.3186	5.6334	0.11
			0.00			1/2"	6.7646	6.4160	0.17
			0.00			Ice	7.2032	7.1208	0.23
ERICSSON AIR 21 B4A B2P w/ Mount Pipe	B	From Face	4.0000	0.00	148.0000	1" Ice	6.3186	5.6334	0.11
			0.00			No Ice	6.7646	6.4160	0.17
			0.00			1/2"	7.2032	7.1208	0.23
ERICSSON AIR 21 B4A B2P w/ Mount Pipe	C	From Face	4.0000	0.00	148.0000	Ice	6.3186	5.6334	0.11
			0.00			1/2"	6.7646	6.4160	0.17
			0.00			Ice	7.2032	7.1208	0.23
KRY 112 144/1	A	From Face	4.0000	0.00	148.0000	1" Ice	0.3500	0.1750	0.01
			0.00			No Ice	0.4259	0.2343	0.01
			0.00			1/2"	0.5093	0.3009	0.02
KRY 112 144/1	B	From Face	4.0000	0.00	148.0000	Ice	0.3500	0.1750	0.01
			0.00			No Ice	0.4259	0.2343	0.01
			0.00			1/2"	0.5093	0.3009	0.02
KRY 112 144/1	C	From Face	4.0000	0.00	148.0000	1" Ice	0.3500	0.1750	0.01
			0.00			No Ice	0.4259	0.2343	0.01
			0.00			1/2"	0.5093	0.3009	0.02
RRUS 11 B12	A	From Face	4.0000	0.00	148.0000	Ice	2.8333	1.1821	0.05
			0.00			No Ice	3.0426	1.3299	0.07
			0.00			1/2"	3.2593	1.4848	0.10
RRUS 11 B12	B	From Face	4.0000	0.00	148.0000	1" Ice	2.8333	1.1821	0.05
			0.00			No Ice	3.0426	1.3299	0.07
			0.00			1/2"	3.2593	1.4848	0.10
RRUS 11 B12	C	From Face	4.0000	0.00	148.0000	Ice	2.8333	1.1821	0.05
			0.00			No Ice	3.0426	1.3299	0.07
			0.00			1/2"	3.2593	1.4848	0.10
Sector Mount [SM 410-3]	C	None		0.00	148.0000	1" Ice	23.9600	23.9600	1.10
						No Ice	34.0600	34.0600	1.60

Description	Face or Leg	Offset Type	Offsets: Horz Lateral Vert ft ft ft	Azimuth Adjustment °	Placement ft		C _{AA} Front ft ²	C _{AA} Side ft ²	Weight K
						Ice 1" Ice	44.1600	44.1600	2.10
*** APXVTM14-C-120 w/ Mount Pipe	A	From Leg	4.0000 0.00 -1.00	0.00	138.0000	No Ice 1/2" Ice 1" Ice	6.5799 7.0306 7.4733	4.9591 5.7544 6.4723	0.08 0.13 0.19
APXVTM14-C-120 w/ Mount Pipe	B	From Leg	4.0000 0.00 -1.00	0.00	138.0000	No Ice 1/2" Ice 1" Ice	6.5799 7.0306 7.4733	4.9591 5.7544 6.4723	0.08 0.13 0.19
APXVTM14-C-120 w/ Mount Pipe	C	From Leg	4.0000 0.00 -1.00	0.00	138.0000	No Ice 1/2" Ice 1" Ice	6.5799 7.0306 7.4733	4.9591 5.7544 6.4723	0.08 0.13 0.19
APXVSP18-C-A20 w/ Mount Pipe	B	From Leg	4.0000 0.00 -1.00	0.00	138.0000	No Ice 1/2" Ice 1" Ice	8.2619 8.8215 9.3462	6.9458 8.1266 9.0212	0.08 0.15 0.23
(2) APXVSP18-C-A20 w/ Mount Pipe	C	From Leg	4.0000 0.00 -1.00	0.00	138.0000	No Ice 1/2" Ice 1" Ice	8.2619 8.8215 9.3462	6.9458 8.1266 9.0212	0.08 0.15 0.23
TD-RRH8x20-25	A	From Leg	4.0000 0.00 -1.00	0.00	138.0000	No Ice 1/2" Ice 1" Ice	4.0455 4.2975 4.5570	1.5345 1.7142 1.9008	0.07 0.10 0.13
TD-RRH8x20-25	B	From Leg	4.0000 0.00 -1.00	0.00	138.0000	No Ice 1/2" Ice 1" Ice	4.0455 4.2975 4.5570	1.5345 1.7142 1.9008	0.07 0.10 0.13
TD-RRH8x20-25	C	From Leg	4.0000 0.00 -1.00	0.00	138.0000	No Ice 1/2" Ice 1" Ice	4.0455 4.2975 4.5570	1.5345 1.7142 1.9008	0.07 0.10 0.13
(2) APXVSP18-C-A20 w/ Mount Pipe	A	From Leg	4.0000 0.00 -1.00	0.00	138.0000	No Ice 1/2" Ice 1" Ice	8.2619 8.8215 9.3462	6.9458 8.1266 9.0212	0.08 0.15 0.23
APXVSP18-C-A20 w/ Mount Pipe	B	From Leg	4.0000 0.00 -1.00	0.00	138.0000	No Ice 1/2" Ice 1" Ice	8.2619 8.8215 9.3462	6.9458 8.1266 9.0212	0.08 0.15 0.23
1900MHz RRH	A	From Leg	4.0000 0.00 -1.00	0.00	138.0000	No Ice 1/2" Ice 1" Ice	2.4917 2.6954 2.9065	3.2583 3.4843 3.7176	0.04 0.08 0.11
1900MHz RRH	B	From Leg	4.0000 0.00 -1.00	0.00	138.0000	No Ice 1/2" Ice 1" Ice	2.4917 2.6954 2.9065	3.2583 3.4843 3.7176	0.04 0.08 0.11
1900MHz RRH	C	From Leg	4.0000 0.00 -1.00	0.00	138.0000	No Ice 1/2" Ice 1" Ice	2.4917 2.6954 2.9065	3.2583 3.4843 3.7176	0.04 0.08 0.11
800MHZ RRH	A	From Leg	4.0000 0.00 -1.00	0.00	138.0000	No Ice 1/2" Ice 1" Ice	2.1342 2.3195 2.5123	1.7730 1.9461 2.1267	0.05 0.07 0.10
800MHZ RRH	B	From Leg	4.0000 0.00 -1.00	0.00	138.0000	No Ice 1/2" Ice 1" Ice	2.1342 2.3195 2.5123	1.7730 1.9461 2.1267	0.05 0.07 0.10
800MHZ RRH	C	From Leg	4.0000 0.00	0.00	138.0000	No Ice 1/2"	2.1342 2.3195	1.7730 1.9461	0.05 0.07

Description	Face or Leg	Offset Type	Offsets: Horz Lateral Vert ft ft ft	Azimuth Adjustment °	Placement ft	C _{AA} Front ft ²	C _{AA} Side ft ²	Weight K	
			-1.00						
Platform Mount [LP 601-1]	C	None		0.00	138.0000	Ice 1" Ice No Ice 1/2" Ice 1" Ice	2.5123 28.4700 33.5900 38.7100	2.1267 28.4700 33.5900 38.7100	0.10 1.12 1.51 1.91
2.375" OD x 6' Mount Pipe	A	From Face	4.0000 0.00 0.00	0.00	138.0000	No Ice 1/2" Ice 1" Ice	1.4250 1.9250 2.2939	1.4250 1.9250 2.2939	0.03 0.04 0.05
2.375" OD x 6' Mount Pipe	B	From Face	4.0000 0.00 0.00	0.00	138.0000	No Ice 1/2" Ice 1" Ice	1.4250 1.9250 2.2939	1.4250 1.9250 2.2939	0.03 0.04 0.05
2.375" OD x 6' Mount Pipe	C	From Face	4.0000 0.00 0.00	0.00	138.0000	No Ice 1/2" Ice 1" Ice	1.4250 1.9250 2.2939	1.4250 1.9250 2.2939	0.03 0.04 0.05

(3) SBNHH-1D65B w/ Mount Pipe	A	From Leg	4.0000 0.00 0.00	0.00	127.0000	No Ice 1/2" Ice 1" Ice	8.3995 8.9639 9.4943	7.0730 8.2637 9.1753	0.07 0.14 0.21
(3) SBNHH-1D65B w/ Mount Pipe	B	From Leg	4.0000 0.00 0.00	0.00	127.0000	No Ice 1/2" Ice 1" Ice	8.3995 8.9639 9.4943	7.0730 8.2637 9.1753	0.07 0.14 0.21
(3) SBNHH-1D65B w/ Mount Pipe	C	From Leg	4.0000 0.00 0.00	0.00	127.0000	No Ice 1/2" Ice 1" Ice	8.3995 8.9639 9.4943	7.0730 8.2637 9.1753	0.07 0.14 0.21
RRH2x60-700	A	From Leg	4.0000 0.00 0.00	0.00	127.0000	No Ice 1/2" Ice 1" Ice	3.5002 3.7609 4.0285	1.8157 2.0519 2.2894	0.06 0.08 0.11
RRH2x60-700	B	From Leg	4.0000 0.00 0.00	0.00	127.0000	No Ice 1/2" Ice 1" Ice	3.5002 3.7609 4.0285	1.8157 2.0519 2.2894	0.06 0.08 0.11
RRH2x60-700	C	From Leg	4.0000 0.00 0.00	0.00	127.0000	No Ice 1/2" Ice 1" Ice	3.5002 3.7609 4.0285	1.8157 2.0519 2.2894	0.06 0.08 0.11
RRH2X60-PCS	A	From Leg	4.0000 0.00 0.00	0.00	127.0000	No Ice 1/2" Ice 1" Ice	2.2000 2.3926 2.5926	1.7233 1.9015 2.0870	0.06 0.08 0.10
RRH2X60-PCS	B	From Leg	4.0000 0.00 0.00	0.00	127.0000	No Ice 1/2" Ice 1" Ice	2.2000 2.3926 2.5926	1.7233 1.9015 2.0870	0.06 0.08 0.10
RRH2X60-PCS	C	From Leg	4.0000 0.00 0.00	0.00	127.0000	No Ice 1/2" Ice 1" Ice	2.2000 2.3926 2.5926	1.7233 1.9015 2.0870	0.06 0.08 0.10
RRH4X45-AWS4 B66	A	From Leg	4.0000 0.00 0.00	0.00	127.0000	No Ice 1/2" Ice 1" Ice	2.6600 2.8781 3.1037	1.5861 1.7690 1.9588	0.06 0.08 0.11
RRH4X45-AWS4 B66	B	From Leg	4.0000 0.00 0.00	0.00	127.0000	No Ice 1/2" Ice 1" Ice	2.6600 2.8781 3.1037	1.5861 1.7690 1.9588	0.06 0.08 0.11
RRH4X45-AWS4 B66	C	From Leg	4.0000 0.00	0.00	127.0000	No Ice 1/2"	2.6600 2.8781	1.5861 1.7690	0.06 0.08

Description	Face or Leg	Offset Type	Offsets: Horz Lateral Vert ft ft ft	Azimuth Adjustment t °	Placement ft	C _{AA} Front ft ²	C _{AA} Side ft ²	Weight K
			0.00			Ice 1" Ice No Ice	3.1037 1.9588	0.11
DB-B1-6C-8AB-0Z	C	From Leg	4.0000 0.00 0.00	0.00	127.0000	1/2" Ice 1" Ice No Ice	4.8000 5.0704 5.3481 2.0000	2.1926 2.3926 0.04
DB-T1-6Z-8AB-0Z	C	From Leg	4.0000 0.00 0.00	0.00	127.0000	1/2" Ice 1" Ice No Ice	4.8000 5.0704 5.3481 2.0000	2.1926 2.3926 0.04
(2) APL866513-42T0 w/ Mount Pipe	A	From Leg	4.0000 0.00 0.00	0.00	127.0000	1/2" Ice 1" Ice No Ice	4.2879 4.6611 5.0420 4.8023	5.4160 6.0401 0.03
(2) APL866513-42T0 w/ Mount Pipe	B	From Leg	4.0000 0.00 0.00	0.00	127.0000	1/2" Ice 1" Ice No Ice	4.2879 4.6611 5.0420 4.8023	5.4160 6.0401 0.03
(2) APL866513-42T0 w/ Mount Pipe	C	From Leg	4.0000 0.00 0.00	0.00	127.0000	1/2" Ice 1" Ice No Ice	4.2879 4.6611 5.0420 4.8023	5.4160 6.0401 0.03
(2) FD9R6004/2C-3L	A	From Leg	4.0000 0.00 0.00	0.00	127.0000	1/2" Ice 1" Ice No Ice	0.3142 0.3862 0.4656 0.0762	0.1189 0.1685 0.01
(2) FD9R6004/2C-3L	B	From Leg	4.0000 0.00 0.00	0.00	127.0000	1/2" Ice 1" Ice No Ice	0.3142 0.3862 0.4656 0.0762	0.1189 0.1685 0.01
(2) FD9R6004/2C-3L	C	From Leg	4.0000 0.00 0.00	0.00	127.0000	1/2" Ice 1" Ice No Ice	0.3142 0.3862 0.4656 0.0762	0.1189 0.1685 0.01
Platform Mount [LP 304-1]	C	None		0.00	127.0000	1" Ice No Ice 1/2" Ice 1" Ice	17.4600 22.4400 27.4200 17.4600	1.35 1.62 1.90

7770.00 w/ Mount Pipe	A	From Face	4.0000 0.00 0.00	0.00	110.0000	No Ice 1/2" Ice 1" Ice	5.7460 6.1791 6.6067 4.2543	5.0137 5.7109 0.06
7770.00 w/ Mount Pipe	B	From Face	4.0000 0.00 0.00	0.00	110.0000	No Ice 1/2" Ice 1" Ice	5.7460 6.1791 6.6067 4.2543	5.0137 5.7109 0.06
7770.00 w/ Mount Pipe	C	From Face	4.0000 0.00 0.00	0.00	110.0000	No Ice 1/2" Ice 1" Ice	5.7460 6.1791 6.6067 4.2543	5.0137 5.7109 0.06
P65-16-XLH-RR w/ Mount Pipe	A	From Face	4.0000 0.00 0.00	0.00	110.0000	No Ice 1/2" Ice 1" Ice	8.3708 8.9314 9.4571 6.3625	7.5378 8.4270 0.08
P65-16-XLH-RR w/ Mount Pipe	B	From Face	4.0000 0.00 0.00	0.00	110.0000	No Ice 1/2" Ice 1" Ice	8.3708 8.9314 9.4571 6.3625	7.5378 8.4270 0.08
P65-16-XLH-RR w/ Mount Pipe	C	From Face	4.0000 0.00 0.00	0.00	110.0000	No Ice 1/2" Ice 1" Ice	8.3708 8.9314 9.4571 6.3625	7.5378 8.4270 0.08
(2) LGP21401	A	From Face	4.0000 0.00	0.00	110.0000	No Ice 1/2"	1.1040 1.2388	0.3471 0.4422

Description	Face or Leg	Offset Type	Offsets: Horz Lateral Vert ft ft ft	Azimuth Adjustment t °	Placement ft	C _{AA} Front ft ²	C _{AA} Side ft ²	Weight K
			0.00			Ice 1" Ice 1.3810	0.5444	0.03
(2) LGP21401	B	From Face	4.0000 0.00 0.00	0.00	110.0000	No Ice 1/2" 1.2388 Ice 1.3810	0.3471 0.4422 0.5444	0.01 0.02 0.03
(2) LGP21401	C	From Face	4.0000 0.00 0.00	0.00	110.0000	No Ice 1/2" 1.2388 Ice 1.3810	0.3471 0.4422 0.5444	0.01 0.02 0.03
DC6-48-60-18-8F	A	From Face	4.0000 0.00 0.00	0.00	110.0000	No Ice 1/2" 1.4583 Ice 1.6431	0.9167 1.4583 1.6431	0.02 0.04 0.06
(2) RRUS-11	A	From Face	4.0000 0.00 0.00	0.00	110.0000	No Ice 1/2" 2.9984 Ice 3.2134	1.1923 1.3395 1.4957	0.05 0.07 0.09
(2) RRUS-11	B	From Face	4.0000 0.00 0.00	0.00	110.0000	No Ice 1/2" 2.9984 Ice 3.2134	1.1923 1.3395 1.4957	0.05 0.07 0.09
(2) RRUS-11	C	From Face	4.0000 0.00 0.00	0.00	110.0000	No Ice 1/2" 2.9984 Ice 3.2134	1.1923 1.3395 1.4957	0.05 0.07 0.09
Platform Mount [LP 304-1]	C	None		0.00	110.0000	No Ice 1/2" 22.4400 Ice 27.4200 1" Ice	17.4600 22.4400 27.4200	1.35 1.62 1.90
**								

Tower Pressures - No Ice

$G_H = 1.100$

Section Elevation ft	z ft	K_z	q_z psf	A_G ft ²	F a c e	A_F ft ²	A_R ft ²	A_{leg} ft ²	Leg %	C_{AA} In Face ft ²	C_{AA} Out Face ft ²
L1 150.0000-133.0000	141.2530	1.361	28.629	34.402	A	0.000	34.402	34.402	100.00	0.000	0.000
					B	0.000	34.402	100.00	0.000	0.000	
					C	0.000	34.402	100.00	0.000	0.000	
L2 133.0000-98.4200	115.0176	1.303	27.398	87.153	A	0.000	87.153	87.153	100.00	0.000	0.000
					B	0.000	87.153	100.00	0.000	0.000	
					C	0.000	87.153	100.00	0.000	11.318	
L3 98.4200-64.7500	81.1475	1.211	25.441	107.106	A	0.000	107.106	107.106	100.00	0.000	0.000
					B	0.000	107.106	100.00	0.000	0.000	
					C	0.000	107.106	100.00	0.000	13.333	
L4 64.7500-31.9200	48.1412	1.085	22.739	125.091	A	0.000	125.091	125.091	100.00	0.000	0.000
					B	0.000	125.091	100.00	0.000	0.000	
					C	0.000	125.091	100.00	0.000	13.001	
L5 31.9200-0.0000	15.9453	0.86	18.748	141.038	A	0.000	141.038	141.038	100.00	0.000	0.000
					B	0.000	141.038	100.00	0.000	0.000	
					C	0.000	141.038	100.00	0.000	12.640	

Tower Pressure - With Ice

$G_H = 1.100$

Section Elevation ft	z ft	K_z	q_z psf	t_z in	A_G ft ²	F a c e	A_F ft ²	A_R ft ²	A_{leg} ft ²	Leg %	C_{AA} In Face ft ²	C_{AA} Out Face ft ²
L1 150.0000-133.0000	141.2530	1.361	8.275	1.7348	39.317	A	0.000	39.317	39.317	100.00	0.000	0.000
						B	0.000	39.317	100.00	0.000	0.000	
						C	0.000	39.317	100.00	0.000	0.000	
L2 133.0000-98.4200	115.0176	1.303	7.919	1.6995	97.151	A	0.000	97.151	97.151	100.00	0.000	0.000
						B	0.000	97.151	100.00	0.000	0.000	
						C	0.000	97.151	100.00	0.000	31.149	
L3 98.4200-64.7500	81.1475	1.211	7.354	1.6412	116.643	A	0.000	116.643	116.643	100.00	0.000	0.000
						B	0.000	116.643	100.00	0.000	0.000	
						C	0.000	116.643	100.00	0.000	36.222	
L4 64.7500-31.9200	48.1412	1.085	6.573	1.5577	134.071	A	0.000	134.071	134.071	100.00	0.000	0.000
						B	0.000	134.071	100.00	0.000	0.000	
						C	0.000	134.071	100.00	0.000	34.553	
L5 31.9200-0.0000	15.9453	0.86	5.419	1.3948	149.325	A	0.000	149.325	149.325	100.00	0.000	0.000
						B	0.000	149.325	100.00	0.000	0.000	
						C	0.000	149.325	100.00	0.000	32.529	

Tower Pressure - Service

$G_H = 1.100$

Section Elevation ft	z ft	K_z	q_z psf	A_G ft ²	F a c e	A_F ft ²	A_R ft ²	A_{leg} ft ²	Leg %	C_{AA} In Face ft ²	C_{AA} Out Face ft ²
L1 150.0000-133.0000	141.2530	1.361	10.662	34.402	A	0.000	34.402	34.402	100.00	0.000	0.000
					B	0.000	34.402	100.00	0.000	0.000	
					C	0.000	34.402	100.00	0.000	0.000	
L2 133.0000-98.4200	115.0176	1.303	10.203	87.153	A	0.000	87.153	87.153	100.00	0.000	0.000
					B	0.000	87.153	100.00	0.000	0.000	
					C	0.000	87.153	100.00	0.000	11.318	
L3 98.4200-64.7500	81.1475	1.211	9.475	107.106	A	0.000	107.106	107.106	100.00	0.000	0.000
					B	0.000	107.106	100.00	0.000	0.000	
					C	0.000	107.106	100.00	0.000	13.333	
L4 64.7500-31.9200	48.1412	1.085	8.468	125.091	A	0.000	125.091	125.091	100.00	0.000	0.000
					B	0.000	125.091	100.00	0.000	0.000	
					C	0.000	125.091	100.00	0.000	13.001	
L5 31.9200-0.0000	15.9453	0.86	6.982	141.038	A	0.000	141.038	141.038	100.00	0.000	0.000
					B	0.000	141.038	100.00	0.000	0.000	
					C	0.000	141.038	100.00	0.000	12.640	

Load Combinations

Comb. No.	Description
1	Dead Only
2	1.2 Dead+1.6 Wind 0 deg - No Ice
3	0.9 Dead+1.6 Wind 0 deg - No Ice
4	1.2 Dead+1.6 Wind 30 deg - No Ice
5	0.9 Dead+1.6 Wind 30 deg - No Ice
6	1.2 Dead+1.6 Wind 60 deg - No Ice
7	0.9 Dead+1.6 Wind 60 deg - No Ice
8	1.2 Dead+1.6 Wind 90 deg - No Ice
9	0.9 Dead+1.6 Wind 90 deg - No Ice
10	1.2 Dead+1.6 Wind 120 deg - No Ice
11	0.9 Dead+1.6 Wind 120 deg - No Ice
12	1.2 Dead+1.6 Wind 150 deg - No Ice
13	0.9 Dead+1.6 Wind 150 deg - No Ice
14	1.2 Dead+1.6 Wind 180 deg - No Ice
15	0.9 Dead+1.6 Wind 180 deg - No Ice
16	1.2 Dead+1.6 Wind 210 deg - No Ice
17	0.9 Dead+1.6 Wind 210 deg - No Ice
18	1.2 Dead+1.6 Wind 240 deg - No Ice
19	0.9 Dead+1.6 Wind 240 deg - No Ice
20	1.2 Dead+1.6 Wind 270 deg - No Ice
21	0.9 Dead+1.6 Wind 270 deg - No Ice
22	1.2 Dead+1.6 Wind 300 deg - No Ice
23	0.9 Dead+1.6 Wind 300 deg - No Ice
24	1.2 Dead+1.6 Wind 330 deg - No Ice
25	0.9 Dead+1.6 Wind 330 deg - No Ice
26	1.2 Dead+1.0 Ice
27	1.2 Dead+1.0 Wind 0 deg+1.0 Ice
28	1.2 Dead+1.0 Wind 30 deg+1.0 Ice
29	1.2 Dead+1.0 Wind 60 deg+1.0 Ice
30	1.2 Dead+1.0 Wind 90 deg+1.0 Ice
31	1.2 Dead+1.0 Wind 120 deg+1.0 Ice
32	1.2 Dead+1.0 Wind 150 deg+1.0 Ice
33	1.2 Dead+1.0 Wind 180 deg+1.0 Ice
34	1.2 Dead+1.0 Wind 210 deg+1.0 Ice
35	1.2 Dead+1.0 Wind 240 deg+1.0 Ice
36	1.2 Dead+1.0 Wind 270 deg+1.0 Ice
37	1.2 Dead+1.0 Wind 300 deg+1.0 Ice
38	1.2 Dead+1.0 Wind 330 deg+1.0 Ice
39	Dead+Wind 0 deg - Service
40	Dead+Wind 30 deg - Service
41	Dead+Wind 60 deg - Service
42	Dead+Wind 90 deg - Service
43	Dead+Wind 120 deg - Service
44	Dead+Wind 150 deg - Service
45	Dead+Wind 180 deg - Service
46	Dead+Wind 210 deg - Service
47	Dead+Wind 240 deg - Service
48	Dead+Wind 270 deg - Service
49	Dead+Wind 300 deg - Service
50	Dead+Wind 330 deg - Service

Maximum Member Forces

Section No.	Elevation ft	Component Type	Condition	Gov. Load Comb.	Axial K	Major Axis Moment kip-ft	Minor Axis Moment kip-ft
L1	150 - 133	Pole	Max Tension	9	0.00	0.00	0.00
			Max. Compression	26	-16.91	0.06	-0.03
			Max. Mx	20	-5.82	68.85	-0.02
			Max. My	14	-5.82	0.03	-68.84
			Max. Vy	20	-10.82	68.85	-0.02
			Max. Vx	14	10.82	0.03	-68.84
L2	133 - 98.42	Pole	Max. Torque	14			-0.00
			Max Tension	1	0.00	0.00	0.00
			Max. Compression	26	-40.65	4.73	-2.20
			Max. Mx	20	-16.05	664.07	-2.83
			Max. My	14	-16.07	3.29	-660.73
			Max. Vy	20	-23.38	664.07	-2.83
L3	98.42 - 64.75	Pole	Max. Vx	14	23.27	3.29	-660.73
			Max. Torque	25			1.49
			Max Tension	1	0.00	0.00	0.00
			Max. Compression	26	-52.89	8.30	-4.23
			Max. Mx	20	-23.74	1490.99	-6.37
			Max. My	14	-23.75	7.02	-1483.69
L4	64.75 - 31.92	Pole	Max. Vy	20	-26.97	1490.99	-6.37
			Max. Vx	14	26.85	7.02	-1483.69
			Max. Torque	25			2.36
			Max Tension	1	0.00	0.00	0.00
			Max. Compression	26	-66.80	12.18	-6.46
			Max. Mx	20	-32.98	2409.44	-9.83
L5	31.92 - 0	Pole	Max. My	14	-32.99	10.69	-2398.27
			Max. Vy	20	-30.32	2409.44	-9.83
			Max. Vx	14	30.20	10.69	-2398.27
			Max. Torque	25			3.30
			Max Tension	1	0.00	0.00	0.00
			Max. Compression	26	-84.69	16.80	-9.13
			Max. Mx	20	-45.56	3608.51	-13.83
			Max. My	14	-45.56	14.95	-3592.85
			Max. Vy	20	-33.57	3608.51	-13.83
			Max. Vx	14	33.46	14.95	-3592.85
			Max. Torque	25			4.37

Maximum Reactions

Location	Condition	Gov. Load Comb.	Vertical K	Horizontal, X K	Horizontal, Z K
Pole	Max. Vert	26	84.69	-0.00	0.00
	Max. H _x	21	34.18	33.54	-0.10
	Max. H _z	3	34.18	-0.10	33.43
	Max. M _x	2	3590.41	-0.10	33.43
	Max. M _z	8	3603.81	-33.54	0.10
	Max. Torsion	25	4.37	16.69	28.91
	Min. Vert	9	34.18	-33.54	0.10
	Min. H _x	8	45.58	-33.54	0.10
	Min. H _z	15	34.18	0.10	-33.43
	Min. M _x	14	-3592.85	0.10	-33.43
	Min. M _z	20	-3608.51	33.54	-0.10
	Min. Torsion	13	-4.37	-16.69	-28.91

Tower Mast Reaction Summary

Load Combination	Vertical K	Shear _x K	Shear _z K	Overturning Moment, M _x kip-ft	Overturning Moment, M _z kip-ft	Torque kip-ft
Dead Only	37.98	-0.00	0.00	0.98	1.88	0.00
1.2 Dead+1.6 Wind 0 deg - No Ice	45.58	0.10	-33.43	-3590.41	-10.28	-3.86
0.9 Dead+1.6 Wind 0 deg - No Ice	34.18	0.10	-33.43	-3556.43	-10.75	-3.86
1.2 Dead+1.6 Wind 30 deg - No Ice	45.58	16.86	-29.00	-3115.63	-1811.74	-2.32
0.9 Dead+1.6 Wind 30 deg - No Ice	34.18	16.86	-29.00	-3086.13	-1794.99	-2.32
1.2 Dead+1.6 Wind 60 deg - No Ice	45.58	29.10	-16.80	-1805.57	-3127.11	-0.16
0.9 Dead+1.6 Wind 60 deg - No Ice	34.18	29.10	-16.80	-1788.60	-3097.77	-0.16
1.2 Dead+1.6 Wind 90 deg - No Ice	45.58	33.54	-0.10	-11.40	-3603.81	2.05
0.9 Dead+1.6 Wind 90 deg - No Ice	34.18	33.54	-0.10	-11.58	-3569.79	2.05
1.2 Dead+1.6 Wind 120 deg - No Ice	45.58	29.00	16.63	1786.18	-3114.55	3.70
0.9 Dead+1.6 Wind 120 deg - No Ice	34.18	29.00	16.63	1768.80	-3085.34	3.71
1.2 Dead+1.6 Wind 150 deg - No Ice	45.58	16.69	28.91	3105.51	-1789.93	4.37
0.9 Dead+1.6 Wind 150 deg - No Ice	34.18	16.69	28.91	3075.50	-1773.39	4.37
1.2 Dead+1.6 Wind 180 deg - No Ice	45.58	-0.10	33.43	3592.85	14.95	3.86
0.9 Dead+1.6 Wind 180 deg - No Ice	34.18	-0.10	33.43	3558.24	14.22	3.87
1.2 Dead+1.6 Wind 210 deg - No Ice	45.58	-16.86	29.00	3118.08	1816.42	2.32
0.9 Dead+1.6 Wind 210 deg - No Ice	34.18	-16.86	29.00	3087.95	1798.46	2.32
1.2 Dead+1.6 Wind 240 deg - No Ice	45.58	-29.10	16.80	1808.01	3131.80	0.16
0.9 Dead+1.6 Wind 240 deg - No Ice	34.18	-29.10	16.80	1790.41	3101.25	0.16
1.2 Dead+1.6 Wind 270 deg - No Ice	45.58	-33.54	0.10	13.83	3608.51	-2.05
0.9 Dead+1.6 Wind 270 deg - No Ice	34.18	-33.54	0.10	13.39	3573.46	-2.05
1.2 Dead+1.6 Wind 300 deg - No Ice	45.58	-29.00	-16.63	-1783.76	3119.23	-3.70
0.9 Dead+1.6 Wind 300 deg - No Ice	34.18	-29.00	-16.63	-1767.00	3088.81	-3.71
1.2 Dead+1.6 Wind 330 deg - No Ice	45.58	-16.69	-28.91	-3103.08	1794.60	-4.37
0.9 Dead+1.6 Wind 330 deg - No Ice	34.18	-16.69	-28.91	-3073.70	1776.85	-4.37
1.2 Dead+1.0 Ice	84.69	0.00	-0.00	9.13	16.80	-0.00
1.2 Dead+1.0 Wind 0 deg+1.0 Ice	84.69	0.02	-11.57	-1267.49	13.64	-1.72
1.2 Dead+1.0 Wind 30 deg+1.0 Ice	84.69	5.82	-10.03	-1098.23	-626.23	-1.04
1.2 Dead+1.0 Wind 60 deg+1.0 Ice	84.69	10.05	-5.80	-632.07	-1093.77	-0.07
1.2 Dead+1.0 Wind 90 deg+1.0 Ice	84.69	11.59	-0.02	5.91	-1263.55	0.91
1.2 Dead+1.0 Wind 120 deg+1.0 Ice	84.69	10.03	5.76	644.77	-1090.49	1.65
1.2 Dead+1.0 Wind 150 deg+1.0 Ice	84.69	5.78	10.01	1113.33	-620.54	1.95
1.2 Dead+1.0 Wind 180 deg+1.0 Ice	84.69	-0.02	11.57	1285.88	20.21	1.72
1.2 Dead+1.0 Wind 210 deg+1.0 Ice	84.69	-5.82	10.03	1116.62	660.09	1.04

Load Combination	Vertical K	Shear _x K	Shear _z K	Overturning Moment, M _x kip-ft	Overturning Moment, M _z kip-ft	Torque kip-ft
1.2 Dead+1.0 Wind 240 deg+1.0 Ice	84.69	-10.05	5.80	650.46	1127.63	0.07
1.2 Dead+1.0 Wind 270 deg+1.0 Ice	84.69	-11.59	0.02	12.48	1297.40	-0.91
1.2 Dead+1.0 Wind 300 deg+1.0 Ice	84.69	-10.03	-5.76	-626.38	1124.35	-1.65
1.2 Dead+1.0 Wind 330 deg+1.0 Ice	84.69	-5.78	-10.01	-1094.94	654.41	-1.95
Dead+Wind 0 deg - Service	37.98	0.02	-7.78	-830.56	-0.97	-0.20
Dead+Wind 30 deg - Service	37.98	3.92	-6.75	-720.61	-418.05	-0.13
Dead+Wind 60 deg - Service	37.98	6.77	-3.91	-417.30	-722.59	-0.04
Dead+Wind 90 deg - Service	37.98	7.81	-0.02	-1.91	-833.00	0.07
Dead+Wind 120 deg - Service	37.98	6.75	3.87	414.27	-719.67	0.16
Dead+Wind 150 deg - Service	37.98	3.88	6.73	719.72	-412.99	0.21
Dead+Wind 180 deg - Service	37.98	-0.02	7.78	832.59	4.87	0.20
Dead+Wind 210 deg - Service	37.98	-3.92	6.75	722.64	421.95	0.13
Dead+Wind 240 deg - Service	37.98	-6.77	3.91	419.33	726.49	0.04
Dead+Wind 270 deg - Service	37.98	-7.81	0.02	3.93	836.90	-0.07
Dead+Wind 300 deg - Service	37.98	-6.75	-3.87	-412.24	723.57	-0.16
Dead+Wind 330 deg - Service	37.98	-3.88	-6.73	-717.69	416.89	-0.21

Solution Summary

Load Comb.	Sum of Applied Forces			Sum of Reactions			% Error
	PX K	PY K	PZ K	PX K	PY K	PZ K	
1	0.00	-37.98	0.00	0.00	37.98	0.00	0.000%
2	0.10	-45.58	-33.43	-0.10	45.58	33.43	0.002%
3	0.10	-34.18	-33.43	-0.10	34.18	33.43	0.002%
4	16.86	-45.58	-29.00	-16.86	45.58	29.00	0.000%
5	16.86	-34.18	-29.00	-16.86	34.18	29.00	0.000%
6	29.10	-45.58	-16.80	-29.10	45.58	16.80	0.000%
7	29.10	-34.18	-16.80	-29.10	34.18	16.80	0.000%
8	33.54	-45.58	-0.10	-33.54	45.58	0.10	0.002%
9	33.54	-34.18	-0.10	-33.54	34.18	0.10	0.005%
10	29.00	-45.58	16.63	-29.00	45.58	-16.63	0.000%
11	29.00	-34.18	16.63	-29.00	34.18	-16.63	0.000%
12	16.69	-45.58	28.91	-16.69	45.58	-28.91	0.000%
13	16.69	-34.18	28.91	-16.69	34.18	-28.91	0.000%
14	-0.10	-45.58	33.43	0.10	45.58	-33.43	0.002%
15	-0.10	-34.18	33.43	0.10	34.18	-33.43	0.002%
16	-16.86	-45.58	29.00	16.86	45.58	-29.00	0.000%
17	-16.86	-34.18	29.00	16.86	34.18	-29.00	0.000%
18	-29.10	-45.58	16.80	29.10	45.58	-16.80	0.000%
19	-29.10	-34.18	16.80	29.10	34.18	-16.80	0.000%
20	-33.54	-45.58	0.10	33.54	45.58	-0.10	0.002%
21	-33.54	-34.18	0.10	33.54	34.18	-0.10	0.002%
22	-29.00	-45.58	-16.63	29.00	45.58	16.63	0.000%
23	-29.00	-34.18	-16.63	29.00	34.18	16.63	0.000%
24	-16.69	-45.58	-28.91	16.69	45.58	28.91	0.000%
25	-16.69	-34.18	-28.91	16.69	34.18	28.91	0.000%
26	0.00	-84.69	0.00	-0.00	84.69	0.00	0.000%
27	0.02	-84.69	-11.57	-0.02	84.69	11.57	0.002%
28	5.82	-84.69	-10.03	-5.82	84.69	10.03	0.001%
29	10.05	-84.69	-5.80	-10.05	84.69	5.80	0.001%
30	11.60	-84.69	-0.02	-11.59	84.69	0.02	0.002%
31	10.03	-84.69	5.76	-10.03	84.69	-5.76	0.001%
32	5.78	-84.69	10.01	-5.78	84.69	-10.01	0.001%
33	-0.02	-84.69	11.57	0.02	84.69	-11.57	0.002%
34	-5.82	-84.69	10.03	5.82	84.69	-10.03	0.001%
35	-10.05	-84.69	5.80	10.05	84.69	-5.80	0.001%
36	-11.60	-84.69	0.02	11.59	84.69	-0.02	0.002%
37	-10.03	-84.69	-5.76	10.03	84.69	5.76	0.001%
38	-5.78	-84.69	-10.01	5.78	84.69	10.01	0.001%
39	0.02	-37.98	-7.78	-0.02	37.98	7.78	0.002%
40	3.92	-37.98	-6.75	-3.92	37.98	6.75	0.002%
41	6.77	-37.98	-3.91	-6.77	37.98	3.91	0.002%
42	7.81	-37.98	-0.02	-7.81	37.98	0.02	0.002%
43	6.75	-37.98	3.87	-6.75	37.98	-3.87	0.002%
44	3.88	-37.98	6.73	-3.88	37.98	-6.73	0.002%
45	-0.02	-37.98	7.78	0.02	37.98	-7.78	0.002%
46	-3.92	-37.98	6.75	3.92	37.98	-6.75	0.002%
47	-6.77	-37.98	3.91	6.77	37.98	-3.91	0.002%
48	-7.81	-37.98	0.02	7.81	37.98	-0.02	0.002%
49	-6.75	-37.98	-3.87	6.75	37.98	3.87	0.002%
50	-3.88	-37.98	-6.73	3.88	37.98	6.73	0.002%

Non-Linear Convergence Results

Load Combination	Converged?	Number of Cycles	Displacement Tolerance	Force Tolerance
1	Yes	4	0.00000001	0.00000001
2	Yes	8	0.00003023	0.00011177
3	Yes	8	0.00000001	0.00008796
4	Yes	11	0.00000001	0.00010345
5	Yes	11	0.00000001	0.00007347
6	Yes	11	0.00000001	0.00010567
7	Yes	11	0.00000001	0.00007508
8	Yes	8	0.00003021	0.00005705
9	Yes	7	0.00005370	0.00012570
10	Yes	11	0.00000001	0.00010689
11	Yes	11	0.00000001	0.00007608
12	Yes	11	0.00000001	0.00010011
13	Yes	11	0.00000001	0.00007110
14	Yes	8	0.00003022	0.00014515
15	Yes	8	0.00000001	0.00011311
16	Yes	11	0.00000001	0.00010793
17	Yes	11	0.00000001	0.00007667
18	Yes	11	0.00000001	0.00010580
19	Yes	11	0.00000001	0.00007507
20	Yes	8	0.00003020	0.00008741
21	Yes	8	0.00000001	0.00006871
22	Yes	11	0.00000001	0.00010087
23	Yes	11	0.00000001	0.00007160
24	Yes	11	0.00000001	0.00010757
25	Yes	11	0.00000001	0.00007658
26	Yes	5	0.00000001	0.00000413
27	Yes	8	0.00013438	0.00004962
28	Yes	9	0.00000001	0.00007887
29	Yes	9	0.00000001	0.00008459
30	Yes	8	0.00013437	0.00002888
31	Yes	9	0.00000001	0.00009454
32	Yes	9	0.00000001	0.00007669
33	Yes	8	0.00013438	0.00005300
34	Yes	9	0.00000001	0.00009884
35	Yes	9	0.00000001	0.00009263
36	Yes	8	0.00013438	0.00003202
37	Yes	9	0.00000001	0.00008074
38	Yes	9	0.00000001	0.00009910
39	Yes	7	0.00000001	0.00002997
40	Yes	7	0.00000001	0.00007507
41	Yes	7	0.00000001	0.00007929
42	Yes	7	0.00000001	0.00002890
43	Yes	7	0.00000001	0.00008178
44	Yes	7	0.00000001	0.00007195
45	Yes	7	0.00000001	0.00003052
46	Yes	7	0.00000001	0.00008340
47	Yes	7	0.00000001	0.00007935
48	Yes	7	0.00000001	0.00002927
49	Yes	7	0.00000001	0.00007362
50	Yes	7	0.00000001	0.00008329

Maximum Tower Deflections - Service Wind

Section No.	Elevation ft	Horz. Deflection in	Gov. Load Comb.	Tilt °	Twist °
L1	150 - 133	21.41	47	1.19	0.00
L2	135.92 - 98.42	17.92	47	1.17	0.00
L3	102.25 - 64.75	10.29	47	0.95	0.00
L4	69.42 - 31.92	4.75	47	0.64	0.00
L5	37.42 - 0	1.39	47	0.34	0.00

Critical Deflections and Radius of Curvature - Service Wind

Elevation ft	Appurtenance	Gov. Load Comb.	Deflection in	Tilt °	Twist °	Radius of Curvature ft
148.0000	ERICSSON AIR 21 B2A B4P w/ Mount Pipe	47	20.91	1.19	0.00	55824
138.0000	APXVTM14-C-120 w/ Mount Pipe	47	18.43	1.17	0.00	23275
127.0000	(3) SBNHH-1D65B w/ Mount Pipe	47	15.77	1.13	0.00	12352
110.0000	7770.00 w/ Mount Pipe	47	11.91	1.01	0.00	7188

Maximum Tower Deflections - Design Wind

Section No.	Elevation ft	Horz. Deflection in	Gov. Load Comb.	Tilt °	Twist °
L1	150 - 133	92.22	18	5.12	0.01
L2	135.92 - 98.42	77.23	18	5.04	0.01
L3	102.25 - 64.75	44.38	18	4.09	0.01
L4	69.42 - 31.92	20.47	18	2.78	0.00
L5	37.42 - 0	6.00	18	1.46	0.00

Critical Deflections and Radius of Curvature - Design Wind

Elevation ft	Appurtenance	Gov. Load Comb.	Deflection in	Tilt °	Twist °	Radius of Curvature ft
148.0000	ERICSSON AIR 21 B2A B4P w/ Mount Pipe	18	90.08	5.11	0.01	13139
138.0000	APXVTM14-C-120 w/ Mount Pipe	18	79.42	5.06	0.01	5478
127.0000	(3) SBNHH-1D65B w/ Mount Pipe	18	67.97	4.89	0.01	2909
110.0000	7770.00 w/ Mount Pipe	18	51.33	4.38	0.01	1690

Compression Checks

Pole Design Data

Section No.	Elevation ft	Size	L ft	L_u ft	Kl/r	A in^2	P_u K	ϕP_n K	Ratio $\frac{P_u}{\phi P_n}$
L1	150 - 133 (1)	TP26x21.83x0.25	17.000 0	0.0000	0.0	19.864 3	-5.81	1475.55	0.004
L2	133 - 98.42 (2)	TP34.0625x24.7837x0.31 25	37.500 0	0.0000	0.0	32.535 8	-16.04	2387.51	0.007
L3	98.42 - 64.75 (3)	TP41.75x32.4898x0.375	37.500 0	0.0000	0.0	47.874 0	-23.73	3492.62	0.007
L4	64.75 - 31.92 (4)	TP49.0625x39.8468x0.37 5	37.500 0	0.0000	0.0	56.341 5	-32.98	3911.23	0.008
L5	31.92 - 0 (5)	TP56.125x46.9609x0.375	37.420 0	0.0000	0.0	66.356 4	-45.56	4329.08	0.011

Pole Bending Design Data

Section No.	Elevation ft	Size	M_{ux} kip-ft	ϕM_{nx} kip-ft	Ratio $\frac{M_{ux}}{\phi M_{nx}}$	M_{uy} kip-ft	ϕM_{ny} kip-ft	Ratio $\frac{M_{uy}}{\phi M_{ny}}$
L1	150 - 133 (1)	TP26x21.83x0.25	68.87	757.98	0.091	0.00	757.98	0.000
L2	133 - 98.42 (2)	TP34.0625x24.7837x0.31 25	665.60	1607.78	0.414	0.00	1607.78	0.000
L3	98.42 - 64.75 (3)	TP41.75x32.4898x0.375	1494.51	2884.53	0.518	0.00	2884.53	0.000
L4	64.75 - 31.92 (4)	TP49.0625x39.8468x0.37 5	2414.91	3806.88	0.634	0.00	3806.88	0.000
L5	31.92 - 0 (5)	TP56.125x46.9609x0.375	3616.22	4968.46	0.728	0.00	4968.46	0.000

Pole Shear Design Data

Section No.	Elevation ft	Size	Actual V_u K	ϕV_n K	Ratio $\frac{V_u}{\phi V_n}$	Actual T_u kip-ft	ϕT_n kip-ft	Ratio $\frac{T_u}{\phi T_n}$
L1	150 - 133 (1)	TP26x21.83x0.25	10.83	737.77	0.015	0.00	1517.81	0.000
L2	133 - 98.42 (2)	TP34.0625x24.7837x0.31 25	23.44	1193.76	0.020	0.16	3219.48	0.000
L3	98.42 - 64.75 (3)	TP41.75x32.4898x0.375	27.03	1746.31	0.015	0.16	5776.11	0.000
L4	64.75 - 31.92 (4)	TP49.0625x39.8468x0.37 5	30.38	1955.62	0.016	0.16	7623.07	0.000
L5	31.92 - 0 (5)	TP56.125x46.9609x0.375	33.63	2164.54	0.016	0.16	9949.08	0.000

Pole Interaction Design Data

Section No.	Elevation ft	Ratio P_u	Ratio M_{ux}	Ratio M_{uy}	Ratio V_u	Ratio T_u	Comb. Stress Ratio	Allow. Stress Ratio	Criteria
		ϕP_n	ϕM_{nx}	ϕM_{ny}	ϕV_n	ϕT_n			
L1	150 - 133 (1)	0.004	0.091	0.000	0.015	0.000	0.095	1.000	4.8.2
L2	133 - 98.42 (2)	0.007	0.414	0.000	0.020	0.000	0.421	1.000	4.8.2
L3	98.42 - 64.75 (3)	0.007	0.518	0.000	0.015	0.000	0.525	1.000	4.8.2
L4	64.75 - 31.92 (4)	0.008	0.634	0.000	0.016	0.000	0.643	1.000	4.8.2
L5	31.92 - 0 (5)	0.011	0.728	0.000	0.016	0.000	0.739	1.000	4.8.2

Section Capacity Table

Section No.	Elevation ft	Component Type	Size	Critical Element	P K	ϕP_{allow} K	% Capacity	Pass Fail	
L1	150 - 133	Pole	TP26x21.83x0.25	1	-5.81	1475.55	9.5	Pass	
L2	133 - 98.42	Pole	TP34.0625x24.7837x0.3125	2	-16.04	2387.51	42.1	Pass	
L3	98.42 - 64.75	Pole	TP41.75x32.4898x0.375	3	-23.73	3492.62	52.5	Pass	
L4	64.75 - 31.92	Pole	TP49.0625x39.8468x0.375	4	-32.98	3911.23	64.3	Pass	
L5	31.92 - 0	Pole	TP56.125x46.9609x0.375	5	-45.56	4329.08	73.9	Pass	
							Summary		
							Pole (L5)	73.9	Pass
							RATING =	73.9	Pass

APPENDIX B BASE LEVEL DRAWING

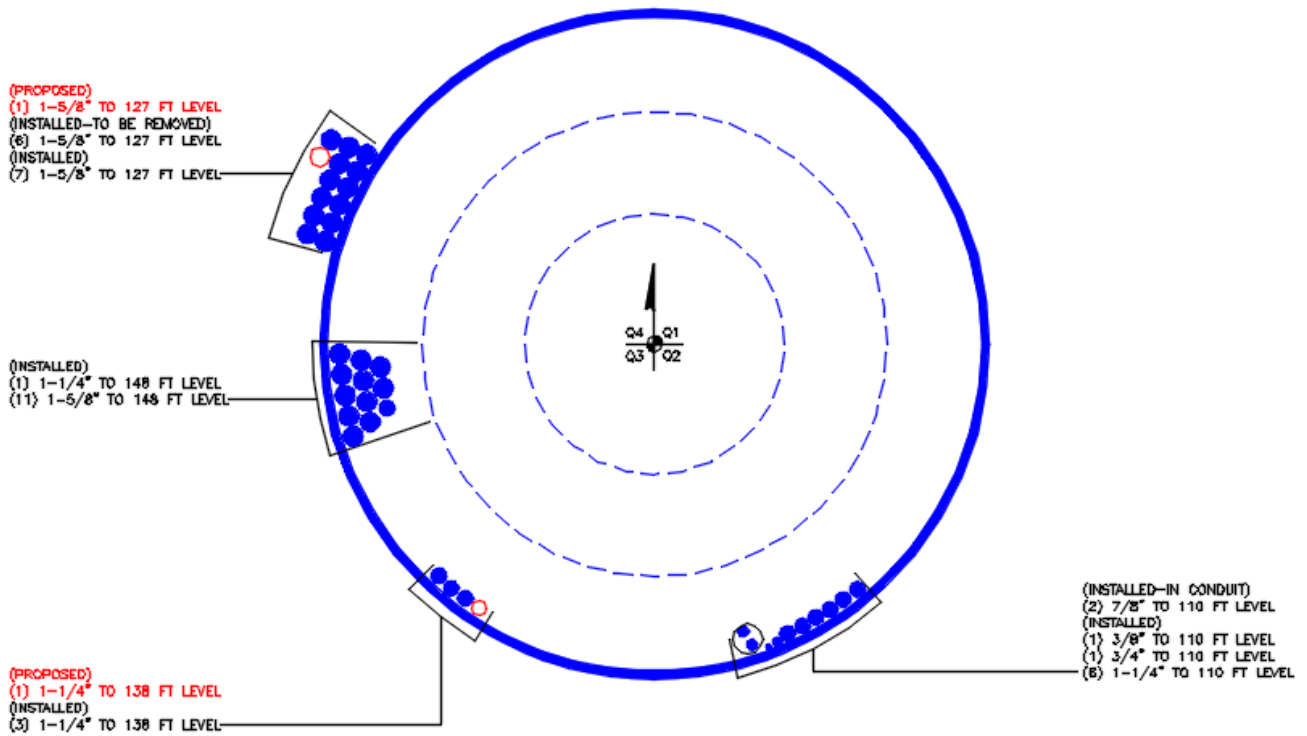

APPENDIX C
ADDITIONAL CALCULATIONS

DESIGNED APPURTENANCE LOADING

TYPE	ELEVATION	TYPE	ELEVATION
ERICSSON AIR 21 B2A B4P w/ Mount Pipe	148	2.375" OD x 6' Mount Pipe	138
ERICSSON AIR 21 B2A B4P w/ Mount Pipe	148	2.375" OD x 6' Mount Pipe	138
ERICSSON AIR 21 B2A B4P w/ Mount Pipe	148	(3) SBNHH-1D65B w/ Mount Pipe	127
ERICSSON AIR 21 B2A B4P w/ Mount Pipe	148	(3) SBNHH-1D65B w/ Mount Pipe	127
LNx-6515DS-VTM w/ Mount Pipe	148	(3) SBNHH-1D65B w/ Mount Pipe	127
LNx-6515DS-VTM w/ Mount Pipe	148	RRH2x60-700	127
LNx-6515DS-VTM w/ Mount Pipe	148	RRH2x60-700	127
ERICSSON AIR 21 B4A B2P w/ Mount Pipe	148	RRH2x60-700	127
ERICSSON AIR 21 B4A B2P w/ Mount Pipe	148	RRH2x60-PCS	127
ERICSSON AIR 21 B4A B2P w/ Mount Pipe	148	RRH2X60-PCS	127
ERICSSON AIR 21 B4A B2P w/ Mount Pipe	148	RRH2X60-PCS	127
ERICSSON AIR 21 B4A B2P w/ Mount Pipe	148	RRH4X45-AWS4 B66	127
KRY 112 144/1	148	RRH4X45-AWS4 B66	127
KRY 112 144/1	148	DB-B1-6C-8AB-OZ	127
KRY 112 144/1	148	DB-T1-6Z-8AB-OZ	127
RRUS 11 B12	148	(2) APL866513-42T0 w/ Mount Pipe	127
RRUS 11 B12	148	(2) APL866513-42T0 w/ Mount Pipe	127
RRUS 11 B12	148	(2) APL866513-42T0 w/ Mount Pipe	127
Sector Mount [SM 410-3]	148	(2) FD9R6004/2C-3L	127
APXVTM14-C-120 w/ Mount Pipe	138	(2) FD9R6004/2C-3L	127
APXVTM14-C-120 w/ Mount Pipe	138	(2) FD9R6004/2C-3L	127
APXVTM14-C-120 w/ Mount Pipe	138	Platform Mount [LP 304-1]	127
APXVSPP18-C-A20 w/ Mount Pipe	138	7770.00 w/ Mount Pipe	110
(2) APXVSPP18-C-A20 w/ Mount Pipe	138	7770.00 w/ Mount Pipe	110
TD-RRH8x20-25	138	7770.00 w/ Mount Pipe	110
TD-RRH8x20-25	138	P65-16-XLH-RR w/ Mount Pipe	110
TD-RRH8x20-25	138	P65-16-XLH-RR w/ Mount Pipe	110
(2) APXVSPP18-C-A20 w/ Mount Pipe	138	P65-16-XLH-RR w/ Mount Pipe	110
APXVSPP18-C-A20 w/ Mount Pipe	138	(2) LGP21401	110
1900MHz RRH	138	(2) LGP21401	110
1900MHz RRH	138	(2) LGP21401	110
1900MHz RRH	138	DC6-48-60-18-8F	110
800MHz RRH	138	(2) RRUS-11	110
800MHz RRH	138	(2) RRUS-11	110
800MHz RRH	138	(2) RRUS-11	110
Platform Mount [LP 601-1]	138	Platform Mount [LP 304-1]	110

MATERIAL STRENGTH

GRADE	F _y	F _u	GRADE	F _y	F _u
A572-65	65 ksi	80 ksi			

TOWER DESIGN NOTES

1. Tower is located in Fairfield County, Connecticut.
2. Tower designed for Exposure C to the TIA-222-G Standard.
3. Tower designed for a 93 mph basic wind in accordance with the TIA-222-G Standard.
4. Tower is also designed for a 50 mph basic wind with 0.75 in ice. Ice is considered to increase in thickness with height.
5. Deflections are based upon a 60 mph wind.
6. Tower Structure Class II.
7. Topographic Category 1 with Crest Height of 0.0000 ft
8. TOWER RATING: 73.9%

ALL REACTIONS
ARE FACTORED

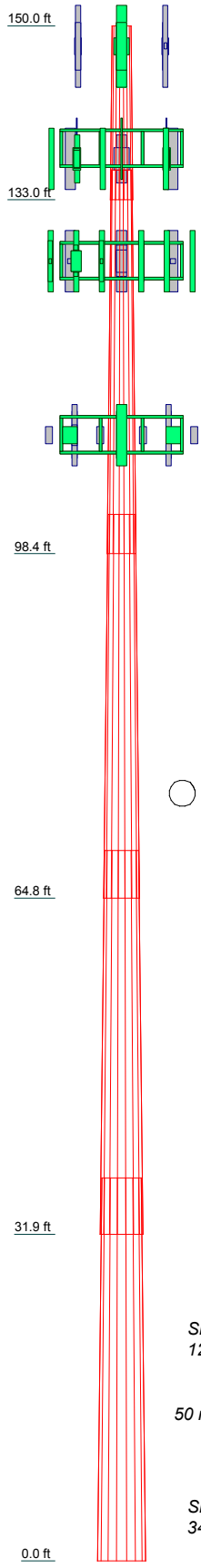
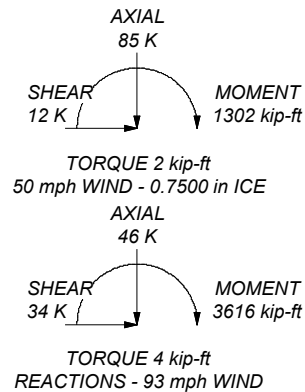

Section	Length (ft)	Number of Sides	Thickness (in)	Socket Length (ft)	Top Dia (in)	Bot Dia (in)	Grade	Weight (K)
1	17.0000	18	0.2500	2.9200	21.8300	28.0000	A572-65	1.1
2	37.5000	18	0.3125	3.8300	24.7837	34.0625	A572-65	3.7
3	37.5000	18	0.3750	4.6700	32.4898	41.7500	A572-65	5.6
4	37.5000	18	0.3750	5.5000	39.8468	49.0625	A572-65	6.7
5	37.4200	18	0.3750	46.9609	56.1250		A572-65	7.8
								24.8

Paul J. Ford and Company
 250 East Broad St., Suite 600
 Columbus, OH 43215
 Phone: 614-221-6679
 FAX:

Job: 150' Monopole / Newtown		
Project: PJF 37517-3089.001.7805 / BU 826222		
Client: Crown Castle	Drawn by: mtimas	App'd:
Code: TIA-222-G	Date: 09/01/17	Scale: NTS
Path:		Dwg No. E-1

©11/2016/03/25 Conn. Castle2017/03/17-3089 826222 Newtown, RI 25/37517-3089.001.7805, SA 1452347/rev/37517-3089.001.7805.dwg

v4.4 - Effective 7-12-13

Asymmetric Anchor Rod Analysis

Moment = 3616 k-ft
 Axial = 46.0 kips
 Shear = 34.0 kips
 Anchor Qty = 45

TIA Ref. = G
 ASIF = N/A
 Max Ratio = 100.0%

Location = Base Plate
 η = 0.50 for BP, Rev. G Sect. 4.9.9
 Threads = N/A for FP, Rev. G

**** For Post Installed Anchors: Check anchors for embedment, epoxy/grout bond, and capacity based on proof load. ****

Item	Nominal Anchor Dia, in	Spec	Fy, ksi	Fu, ksi	Location, degrees	Anchor Circle, in	Area Override, in ²	Area, in ²	Max Net Compression, kips	Max Net Tension, kips	Load for Capacity Calc, kips	Capacity Override, kips	Capacity, kips	Capacity Ratio
1	1.250	Other	105	125	4.6	61.00	0.00	1.23	64.46	62.33	66.03	0.00	96.90	68.1%
2	1.250	Other	105	125	13.8	61.00	0.00	1.23	64.46	62.33	66.03	0.00	96.90	68.1%
3	1.250	Other	105	125	23.1	61.00	0.00	1.23	64.46	62.33	66.03	0.00	96.90	68.1%
4	1.250	Other	105	125	32.3	61.00	0.00	1.23	64.46	62.33	66.03	0.00	96.90	68.1%
5	1.250	Other	105	125	41.5	61.00	0.00	1.23	64.46	62.33	66.03	0.00	96.90	68.1%
6	1.250	Other	105	125	50.8	61.00	0.00	1.23	64.46	62.33	66.03	0.00	96.90	68.1%
7	1.250	Other	105	125	60.0	61.00	0.00	1.23	64.46	62.33	66.03	0.00	96.90	68.1%
8	1.250	Other	105	125	69.2	61.00	0.00	1.23	64.46	62.33	66.03	0.00	96.90	68.1%
9	1.250	Other	105	125	78.5	61.00	0.00	1.23	64.46	62.33	66.03	0.00	96.90	68.1%
10	1.250	Other	105	125	87.7	61.00	0.00	1.23	64.46	62.33	66.03	0.00	96.90	68.1%
11	1.250	Other	105	125	96.9	61.00	0.00	1.23	64.46	62.33	66.03	0.00	96.90	68.1%
12	1.250	Other	105	125	106.2	61.00	0.00	1.23	64.46	62.33	66.03	0.00	96.90	68.1%
13	1.250	Other	105	125	115.4	61.00	0.00	1.23	64.46	62.33	66.03	0.00	96.90	68.1%
14	1.250	Other	105	125	124.6	61.00	0.00	1.23	64.46	62.33	66.03	0.00	96.90	68.1%
15	1.250	Other	105	125	133.8	61.00	0.00	1.23	64.46	62.33	66.03	0.00	96.90	68.1%
16	1.250	Other	105	125	143.1	61.00	0.00	1.23	64.46	62.33	66.03	0.00	96.90	68.1%
17	1.250	Other	105	125	152.3	61.00	0.00	1.23	64.46	62.33	66.03	0.00	96.90	68.1%
18	1.250	Other	105	125	161.5	61.00	0.00	1.23	64.46	62.33	66.03	0.00	96.90	68.1%
19	1.250	Other	105	125	170.8	61.00	0.00	1.23	64.46	62.33	66.03	0.00	96.90	68.1%
20	1.250	Other	105	125	180.0	61.00	0.00	1.23	64.46	62.33	66.03	0.00	96.90	68.1%
21	1.250	Other	105	125	189.2	61.00	0.00	1.23	64.46	62.33	66.03	0.00	96.90	68.1%
22	1.250	Other	105	125	198.5	61.00	0.00	1.23	64.46	62.33	66.03	0.00	96.90	68.1%
23	1.250	Other	105	125	207.7	61.00	0.00	1.23	64.46	62.33	66.03	0.00	96.90	68.1%
24	1.250	Other	105	125	216.9	61.00	0.00	1.23	64.46	62.33	66.03	0.00	96.90	68.1%
25	1.250	Other	105	125	226.2	61.00	0.00	1.23	64.46	62.33	66.03	0.00	96.90	68.1%
26	1.250	Other	105	125	235.4	61.00	0.00	1.23	64.46	62.33	66.03	0.00	96.90	68.1%
27	1.250	Other	105	125	244.6	61.00	0.00	1.23	64.46	62.33	66.03	0.00	96.90	68.1%
28	1.250	Other	105	125	253.8	61.00	0.00	1.23	64.46	62.33	66.03	0.00	96.90	68.1%
29	1.250	Other	105	125	263.1	61.00	0.00	1.23	64.46	62.33	66.03	0.00	96.90	68.1%
30	1.250	Other	105	125	272.3	61.00	0.00	1.23	64.46	62.33	66.03	0.00	96.90	68.1%
31	1.250	Other	105	125	281.5	61.00	0.00	1.23	64.46	62.33	66.03	0.00	96.90	68.1%
32	1.250	Other	105	125	290.8	61.00	0.00	1.23	64.46	62.33	66.03	0.00	96.90	68.1%
33	1.250	Other	105	125	300.0	61.00	0.00	1.23	64.46	62.33	66.03	0.00	96.90	68.1%
34	1.250	Other	105	125	309.2	61.00	0.00	1.23	64.46	62.33	66.03	0.00	96.90	68.1%
35	1.250	Other	105	125	318.5	61.00	0.00	1.23	64.46	62.33	66.03	0.00	96.90	68.1%
36	1.250	Other	105	125	327.7	61.00	0.00	1.23	64.46	62.33	66.03	0.00	96.90	68.1%
37	1.250	Other	105	125	336.9	61.00	0.00	1.23	64.46	62.33	66.03	0.00	96.90	68.1%
38	1.250	Other	105	125	346.2	61.00	0.00	1.23	64.46	62.33	66.03	0.00	96.90	68.1%
39	1.250	Other	105	125	355.4	61.00	0.00	1.23	64.46	62.33	66.03	0.00	96.90	68.1%
40	1.000	Dywidag (150 ksi)	127.7	150	28.0	71.13	0.00	0.89	54.07	52.54	55.20	0.00	102.00	54.1%
41	1.000	Dywidag (150 ksi)	127.7	150	83.0	71.13	0.00	0.89	54.07	52.54	55.20	0.00	102.00	54.1%
42	1.000	Dywidag (150 ksi)	127.7	150	148.0	71.13	0.00	0.89	54.07	52.54	55.20	0.00	102.00	54.1%
43	1.000	Dywidag (150 ksi)	127.7	150	203.0	71.13	0.00	0.89	54.07	52.54	55.20	0.00	102.00	54.1%
44	1.000	Dywidag (150 ksi)	127.7	150	268.0	71.13	0.00	0.89	54.07	52.54	55.20	0.00	102.00	54.1%
45	1.000	Dywidag (150 ksi)	127.7	150	323.0	71.13	0.00	0.89	54.07	52.54	55.20	0.00	102.00	54.1%

Stiffened or Unstiffened, UngROUTED, Circular Base Plate - Any Rod Material

TIA Rev G

Assumption: Clear space between bottom of leveling nut and top of concrete not exceeding (1)*(Rod Diameter)

Site Data

BU#: 826222
Site Name: Newtown/RT-25
App #:
Pole Manufacturer: <i>Other</i>

Anchor Rod Data

Qty:	39	
Diam:	1.25	in
Rod Material:	Other	
Strength (Fu):	125	ksi
Yield (Fy):	105	ksi
Bolt Circle:	61	in

Plate Data

Diam:	65	in
Thick:	1.5	in
Grade:	50	ksi
Single-Rod B-eff:	4.57	in

Stiffener Data (Welding at both sides)

Config:	1	*
Weld Type:	Fillet	
Groove Depth:		<-- Disregard
Groove Angle:		<-- Disregard
Fillet H. Weld:	0.5	in
Fillet V. Weld:	0.5	in
Width:	4	in
Height:	12	in
Thick:	0.75	in
Notch:	0.5	in
Grade:	50	ksi
Weld str.:	70	ksi

Pole Data

Diam:	56.125	in
Thick:	0.375	in
Grade:	65	ksi
# of Sides:	18	"0" IF Round
Fu	80	ksi
Reinf. Fillet Weld	0	"0" if None

Reactions

Mu:	3142.2244	ft-kips
Axial, Pu:	41.4	kips
Shear, Vu:	30.6	kips
Eta Factor, η	0.5	TIA G (Fig. 4-4)

If No stiffeners, Criteria: **AISC LRFD** <-Only Applicable to Unstiffened Cases

Anchor Rod Results

Max Rod (Cu+ Vu/η): 66.0 Kips

See asymmetric spreadsheet
for anchor calculations

Stiffened
AISC LRFD
φ*Tn

Base Plate Results

Base Plate Stress: 5.4 ksi
Allowable Plate Stress: 27.0 ksi
Base Plate Stress Ratio: 19.9% **Pass**

Shear Check Only

Stiffened
AISC LRFD
φ*Fy
Y.L. Length: N/A, Roark

Stiffener Results

Horizontal Weld : 55.5% **Pass**
Vertical Weld: 18.5% **Pass**
Plate Flex+Shear, fb/Fb+(fv/Fv)^2: 9.0% **Pass**
Plate Tension+Shear, ft/Ft+(fv/Fv)^2: 38.0% **Pass**
Plate Comp. (AISC Bracket): 39.1% **Pass**

Pole Results

Pole Punching Shear Check: 7.4% **Pass**

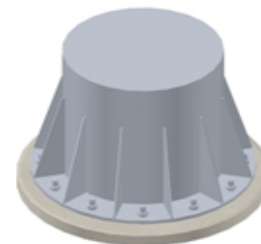
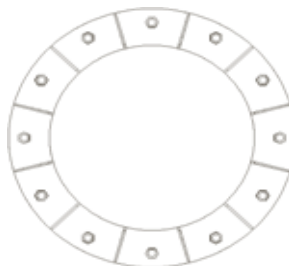

* 0 = none, 1 = every bolt, 2 = every 2 bolts, 3 = 2 per bolt

** Note: for complete joint penetration groove welds the groove depth must be exactly 1/2 the stiffener thickness for calculation purposes

(W) RISA-3D Plate Forces:		(L) RISA-3D Plate Forces:	
Comp (1.2)	Tension (0.9)	Comp (1.2)	Tension (0.9)
-18.544	-7.456		
-18.463	-7.53		
-19.212	-6.847		
-20.43	-5.731		
-21.983	-4.294		
-23.845	-2.551		
-26.051	-0.467		
-28.71	2.037		
-32.011	5.085		
-36.37	8.912		
-41.542	13.425		
-46.742	18.26		
-51.889	23.385		
-57.598	29.092		
-63.936	35.381		
-70.288	41.884		
-76.245	48.278		
-81.459	54.194		
-85.635	59.208		
-88.534	62.882		
-89.997	64.849		
-89.944	64.898		
-88.372	63.03		
-85.345	59.45		
-81.008	54.527		
-75.568	48.697		
-69.27	42.385		
-62.363	35.961		
-55.163	29.753		
-48.106	24.131		
-42.984	19.097		
-37.747	14.355		
-32.477	9.936		
-29.392	6.208		
-26.882	3.263		
-24.707	0.862		
-22.773	-1.122		
-21.07	-2.773		
-19.611	-4.129		
-18.449	-5.178		
-17.73	-5.82		
-17.81	-5.753		
-1966.255	883.774	0	0 k-ft
-983.1275	441.887	0	0 k-ft

Anchor Spring Constant		Soil Weight	
Ag =	1.94 in ²	Height Above Grade =	0.5 ft
E =	29000 ksi	Soil Unit Weight =	115 pcf
Lu =	5 ft	Apply Soil Weight =	Center Point
k = An*E / Lu = 937.67 k/in		Volume =	1568.00 ft ³
Soil Spring Constant		Weight =	180.32 kips
Subgrade Modulus =	lb/in ³	Weight per Sq. Ft =	460 psf
k =	270 k/ft ³		

Foundation Weight		Pad/Mat Analysis	
Number Sides =	4	Thickness	2 ft
Pier Width/Diameter =	7 ft	Width	21 ft
Pier Height =	4.5 ft	f'c	3 ksi
Pad Thickness =	2 ft	Top Bar Quantity	27
Pad Width =	21 ft	Top Bar Size #	8
Pad Length =	21 ft	Top Clear Spacing	3 in
Concrete Density =	150 pcf	Bot Bar Quantity	27
Volume =	220.5 ft ³	Bot Bar Size #	8
Weight =	33.075 kips	Bot Clear Spacing	3 in
Applied Reactions for RISA 3D		As,min	10.8864 0 in ²
TNX Moment =	3616 k-ft	As, compression	21.33 0 in ²
TNX Axial =	46 kips	d,compression	19.5 -4.5 in
TNX Shear =	34 kips	a	23.9 #DIV/0! in
Total Unfactored Axial =	251.73 kips	c	3.8 #DIV/0! in
Side Bending Moment =	3837 k-ft	c/d	0.194 #DIV/0!
Corner Bending Moment (Mx) =	2713.2 k-ft	Ø	0.900 #DIV/0!
Corner Bending Moment (Mz) =	2713.2 k-ft	ØMn,compression	1776 #DIV/0! k-ft
Tension from Anchors (Tension side only)		Mu	441.9 0.0 k-ft
Load (kips) Distance to Center (ft)		Ratio =	24.9% #DIV/0!
1		As, Tension	21.33 0 in ²
2		d,tension	19.5 -4.5 in
3		a	23.9 #DIV/0! in
4		c	3.8 #DIV/0! in
5		c/d	0.194 #DIV/0!
6		Ø	0.900 #DIV/0!
Pole/Pier Diameter = inches		ØMn,tension	1776 #DIV/0! k-ft
Bending Moment = Σ P*(D-d) = 0 k-in		Mu	983.1 0.0 k-ft
Bending Moment (Tension) = 0.0 k-ft		Ratio =	55.4% #DIV/0!
Anchor Capacity		Bearing Check	
Max Tension from RISA =	117.626 kips	Max Bearing Load =	0.825 kip
Anchor Type =	Micropile	Plate Width =	0.5 ft
Ultimate Capacity =	208 kips	Plate Length =	0.5 ft
An =	in ²	Ult. Bearing Capacity =	30 ksf
Capacity (Kips) = 0.8*Ult =	166.4	Bearing Pressure =	3.3 ksf
Ratio = 117.626 / 166.4 =	70.7%	Ratio =	14.7%

(per linear ft of plate)
(Divide by 2 for a 0.5 ft plate)

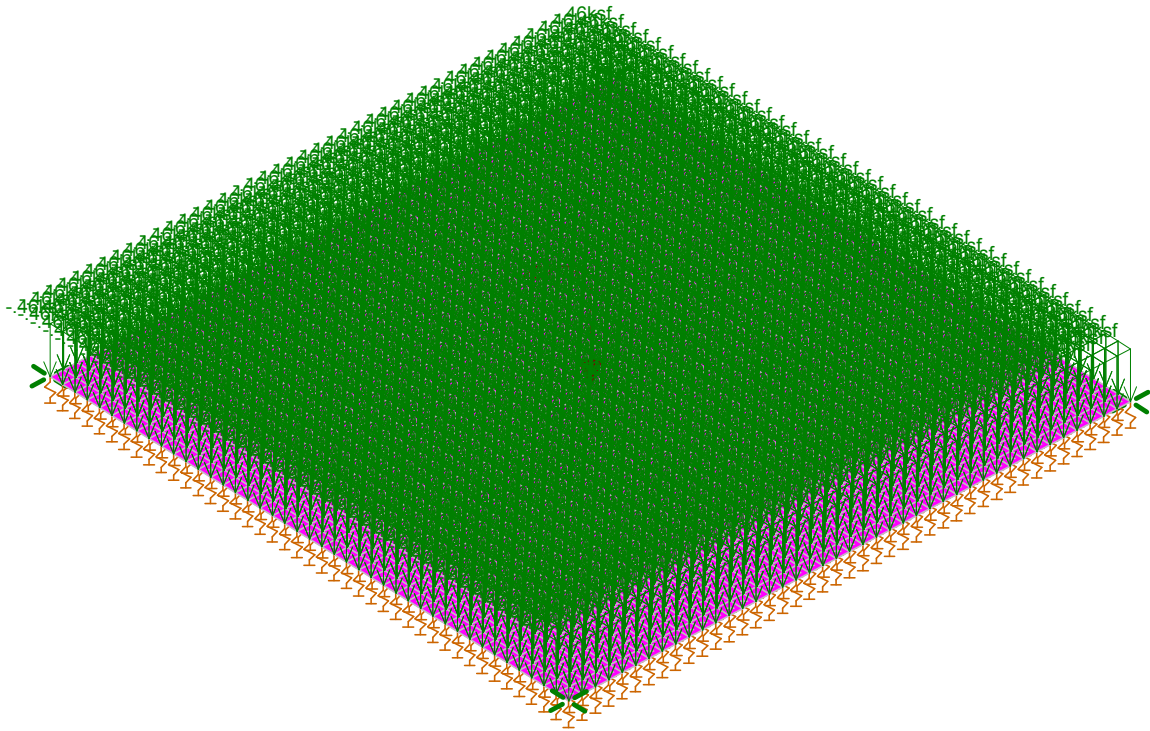
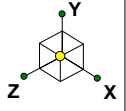

Loads: BLC 1, Dead

Paul J. Ford and Company
KAT
37517-3089.001.7805

BU 826222 / Newtown-RT-25

SK - 1

Sept 1, 2017 at 3:52 PM

37517-3089.001.7805_Composite ...

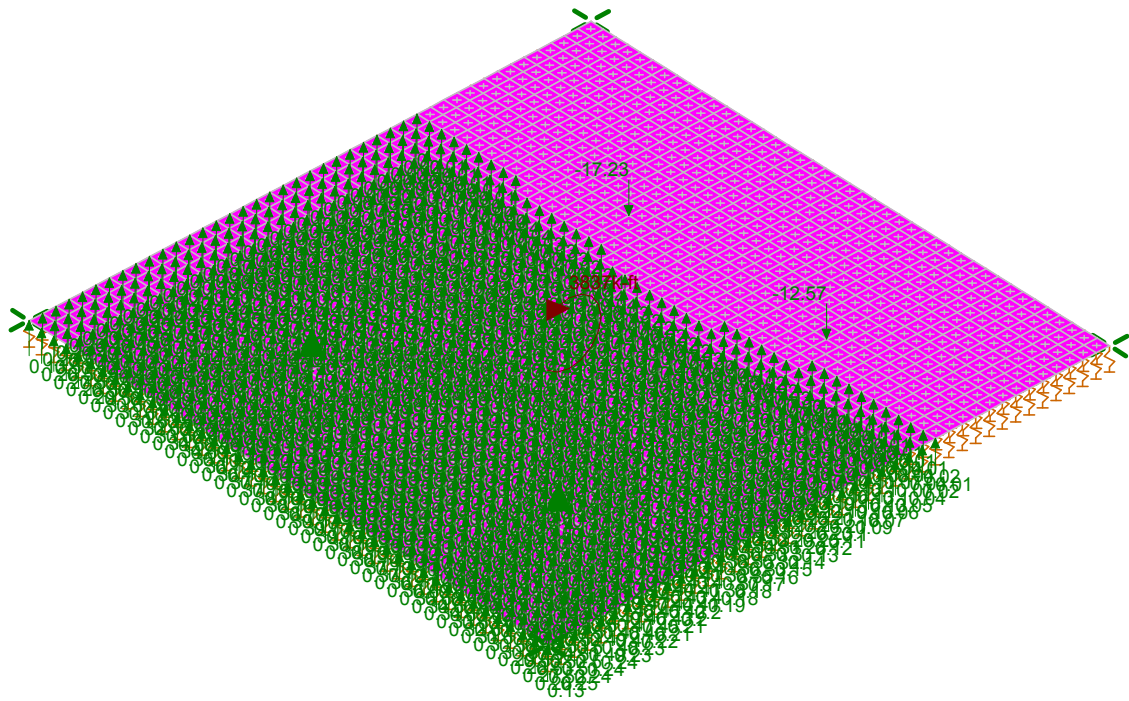
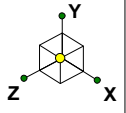

Loads: BLC 2, Wind 0
Y-direction Reaction Units are k and k-ft

Paul J. Ford and Company

KAT

37517-3089.001.7805

BU 826222 / Newtown-RT-25

SK - 2

Sept 1, 2017 at 3:53 PM

37517-3089.001.7805_Composite ...

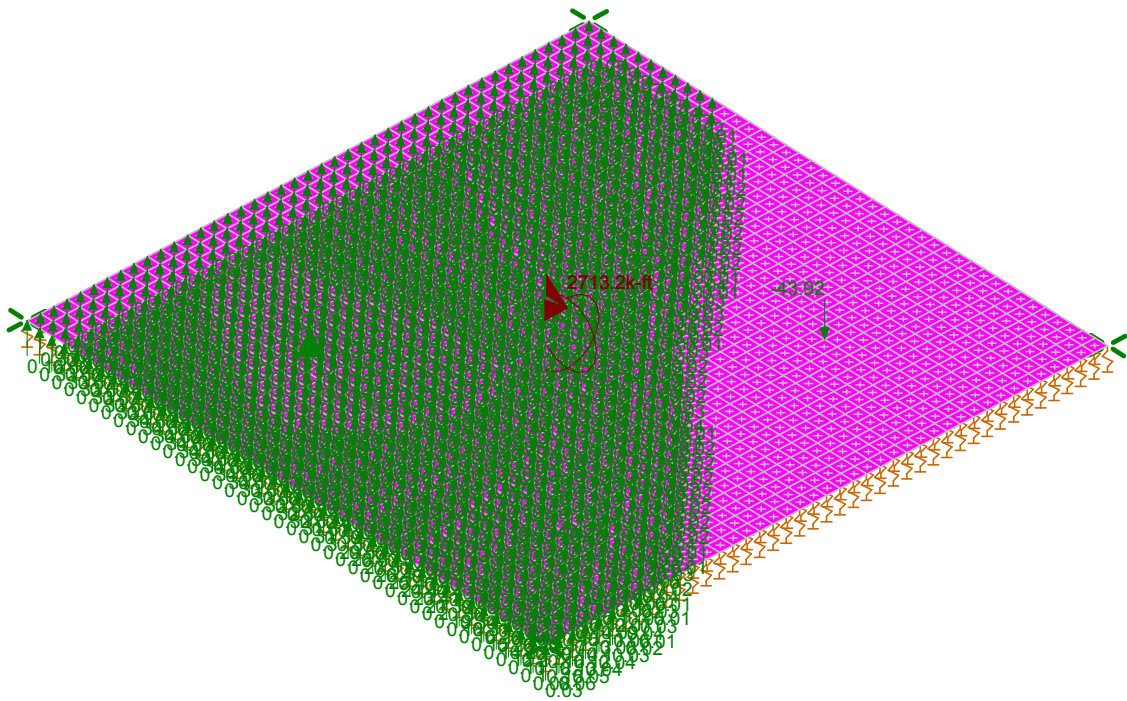
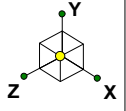

Loads: BLC 3, Wind 45
 Y-direction Reaction Units are k and k-ft

Paul J. Ford and Company	BU 826222 / Newtown-RT-25	SK - 3
KAT		Sept 1, 2017 at 3:53 PM
37517-3089.001.7805		37517-3089.001.7805_Composite ...

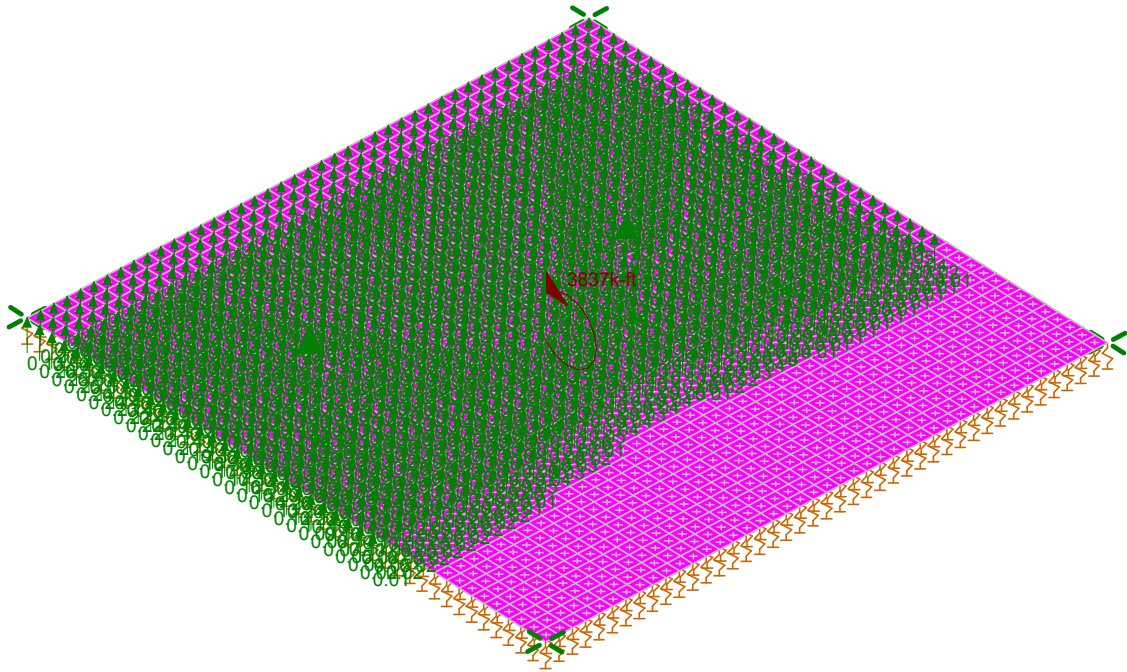
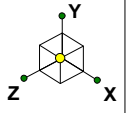

Loads: BLC 4, Wind 90
Y-direction Reaction Units are k and k-ft

Paul J. Ford and Company

KAT

37517-3089.001.7805

BU 826222 / Newtown-RT-25

SK - 4

Sept 1, 2017 at 3:53 PM

37517-3089.001.7805_Composite ...

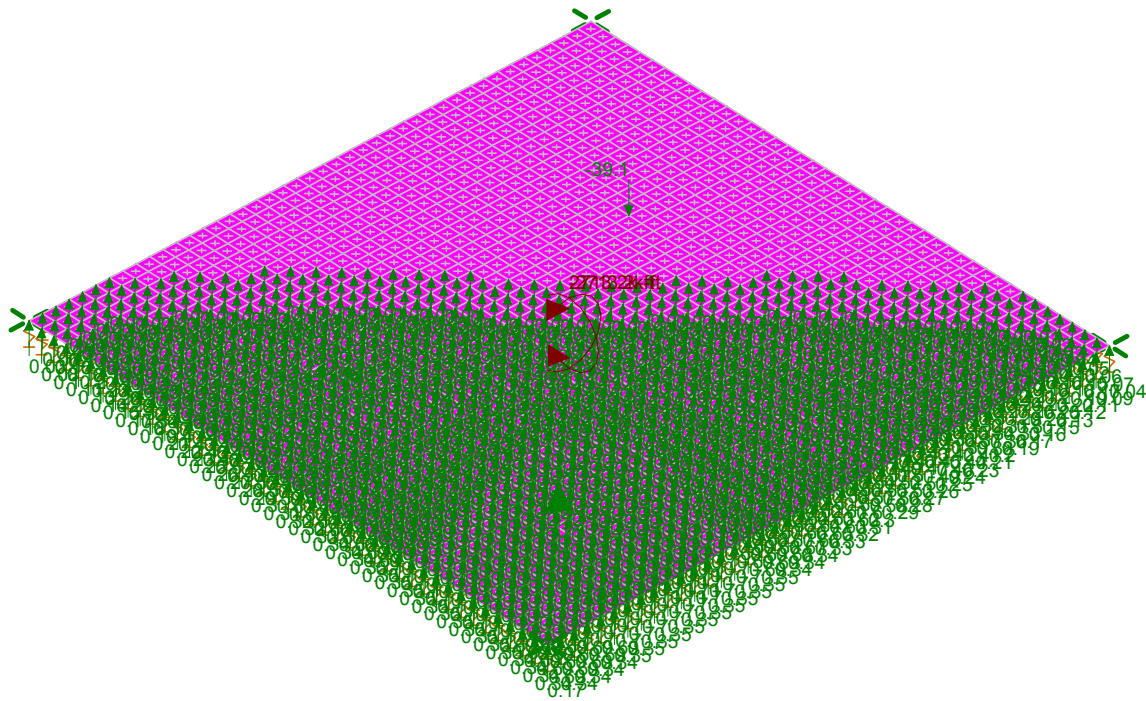
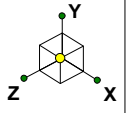

Loads: BLC 5, Wind 135
 Y-direction Reaction Units are k and k-ft

Paul J. Ford and Company	BU 826222 / Newtown-RT-25	SK - 5
KAT		Sept 1, 2017 at 3:54 PM
37517-3089.001.7805		37517-3089.001.7805_Composite ...



(Global) Model Settings

Display Sections for Member Calcs	5
Max Internal Sections for Member Calcs	97
Include Shear Deformation?	Yes
Increase Nailing Capacity for Wind?	Yes
Include Warping?	Yes
Trans Load Btwn Intersecting Wood Wall?	Yes
Area Load Mesh (in^2)	144
Merge Tolerance (in)	.12
P-Delta Analysis Tolerance	0.50%
Include P-Delta for Walls?	Yes
Automatically Iterate Stiffness for Walls?	Yes
Max Iterations for Wall Stiffness	3
Gravity Acceleration (ft/sec^2)	32.2
Wall Mesh Size (in)	12
Eigensolution Convergence Tol. (1.E-)	4
Vertical Axis	Y
Global Member Orientation Plane	XZ
Static Solver	Sparse Accelerated
Dynamic Solver	Accelerated Solver

Hot Rolled Steel Code	None
RISAConnection Code	None
Cold Formed Steel Code	None
Wood Code	None
Wood Temperature	< 100F
Concrete Code	ACI 318-11
Masonry Code	None
Aluminum Code	None - Building

Number of Shear Regions	4
Region Spacing Increment (in)	4
Biaxial Column Method	Exact Integration
Parme Beta Factor (PCA)	.65
Concrete Stress Block	Rectangular
Use Cracked Sections?	Yes
Use Cracked Sections Slab?	Yes
Bad Framing Warnings?	No
Unused Force Warnings?	Yes
Min 1 Bar Diam. Spacing?	No
Concrete Rebar Set	REBAR_SET_ASTMA615
Min % Steel for Column	1
Max % Steel for Column	8



(Global) Model Settings, Continued

Seismic Code	ASCE 7-10
Seismic Base Elevation (ft)	Not Entered
Add Base Weight?	Yes
Ct X	.02
Ct Z	.02
T X (sec)	Not Entered
T Z (sec)	Not Entered
R X	3
R Z	3
Ct Exp. X	.75
Ct Exp. Z	.75
SD1	1
SDS	1
S1	1
TL (sec)	5
Risk Cat	I or II
Drift Cat	Other
Om Z	1
Om X	1
Cd Z	1
Cd X	1
Rho Z	1
Rho X	1

Basic Load Cases

	BLC Description	Category	X Grav...	Y Grav...	Z Grav...	Joint	Point	Distrib...	Area(M...	Surfac...
1	Dead	None		-1		1				1764
2	Wind 0	None				1				
3	Wind 45	None				2				
4	Wind 90	None				1				
5	Wind 135	None				2				

Load Combinations

	Description	Solve P...	SRSS	BLC	Fa...B...	Fa...B...	Fa...B...	Fa...B...	Fa...B...	Fa...B...	Fa...B...	Fa...B...	Fa...B...	Fa...B...	Fa...
1	1.2 Dead + Wind 0	Yes	Y		1	1.2	2	1							
2	0.9 Dead + Wind 0	Yes	Y		1	.9	2	1							
3	1.2 Dead + Wind 45	Yes	Y		1	1.2	3	1							
4	0.9 Dead + Wind 45	Yes	Y		1	.9	3	1							
5	1.2 Dead + Wind 90	Yes	Y		1	1.2	4	1							
6	0.9 Dead + Wind 90	Yes	Y		1	.9	4	1							
7	1.2 Dead + Wind 135	Yes	Y		1	1.2	5	1							
8	0.9 Dead + Wind 135	Yes	Y		1	.9	5	1							
9	1.2 Dead + Wind 180	Yes	Y		1	1.2	2	-1							
10	0.9 Dead + Wind 180	Yes	Y		1	.9	2	-1							
11	1.2 Dead + Wind 225	Yes	Y		1	1.2	3	-1							
12	0.9 Dead + Wind 225	Yes	Y		1	.9	3	-1							
13	1.2 Dead + Wind 270	Yes	Y		1	1.2	4	-1							
14	0.9 Dead + Wind 270	Yes	Y		1	.9	4	-1							
15	1.2 Dead + Wind 315	Yes	Y		1	1.2	5	-1							
16	0.9 Dead + Wind 315	Yes	Y		1	.9	5	-1							



Joint Loads and Enforced Displacements (BLC 1 : Dead)

	Joint Label	L,D,M	Direction	Magnitude[(k,k-ft), (in,rad), (k*s^2/ft, k*s^2*ft)]
1	CENTER	L	Y	-251.73

Joint Loads and Enforced Displacements (BLC 2 : Wind 0)

	Joint Label	L,D,M	Direction	Magnitude[(k,k-ft), (in,rad), (k*s^2/ft, k*s^2*ft)]
1	CENTER	L	Mx	3837

Joint Loads and Enforced Displacements (BLC 3 : Wind 45)

	Joint Label	L,D,M	Direction	Magnitude[(k,k-ft), (in,rad), (k*s^2/ft, k*s^2*ft)]
1	CENTER	L	Mx	2713.2
2	CENTER	L	Mz	2713.2

Joint Loads and Enforced Displacements (BLC 4 : Wind 90)

	Joint Label	L,D,M	Direction	Magnitude[(k,k-ft), (in,rad), (k*s^2/ft, k*s^2*ft)]
1	CENTER	L	Mz	3837

Joint Loads and Enforced Displacements (BLC 5 : Wind 135)

	Joint Label	L,D,M	Direction	Magnitude[(k,k-ft), (in,rad), (k*s^2/ft, k*s^2*ft)]
1	CENTER	L	Mx	2713.2
2	CENTER	L	Mz	-2713.2

Concrete Properties

	Label	E [ksi]	G [ksi]	Nu	Therm (1E...Density[k/ft...	f'c[ksi]	Lambda	Flex Steel[...Shear Stee...		
1	Conc3000NW	3156	1372	.15	.6	.145	3	60	60	
2	Conc3500NW	3409	1482	.15	.6	.145	3.5	60	60	
3	Conc4000NW	3644	1584	.15	.6	.145	4	60	60	
4	Conc3000LW	2085	907	.15	.6	.11	3	.75	60	60
5	Conc3500LW	2252	979	.15	.6	.11	3.5	.75	60	60
6	Conc4000LW	2408	1047	.15	.6	.11	4	.75	60	60



RADIO FREQUENCY EMISSIONS ANALYSIS REPORT EVALUATION OF HUMAN EXPOSURE POTENTIAL TO NON-IONIZING EMISSIONS

SPRINT Existing Facility

Site ID: CT54XC716

Newtown Georgia Pacific/VS
201 South Main Street
Newtown, CT 06470

September 22, 2017

EBI Project Number: 6217004143

Site Compliance Summary	
Compliance Status:	COMPLIANT
Site total MPE% of FCC general population allowable limit:	8.32 %



September 22, 2017

SPRINT

Attn: RF Engineering Manager
1 International Boulevard, Suite 800
Mahwah, NJ 07495

Emissions Analysis for Site: **CT54XC716 – Newtown Georgia Pacific/VS**

EBI Consulting was directed to analyze the proposed SPRINT facility located at **201 South Main Street, Newtown, CT**, for the purpose of determining whether the emissions from the Proposed SPRINT Antenna Installation located on this property are within specified federal limits.

All information used in this report was analyzed as a percentage of current Maximum Permissible Exposure (% MPE) as listed in the FCC OET Bulletin 65 Edition 97-01 and ANSI/IEEE Std C95.1. The FCC regulates Maximum Permissible Exposure in units of microwatts per square centimeter ($\mu\text{W}/\text{cm}^2$). The number of $\mu\text{W}/\text{cm}^2$ calculated at each sample point is called the power density. The exposure limit for power density varies depending upon the frequencies being utilized. Wireless Carriers and Paging Services use different frequency bands each with different exposure limits, therefore it is necessary to report results and limits in terms of percent MPE rather than power density.

All results were compared to the FCC (Federal Communications Commission) radio frequency exposure rules, 47 CFR 1.1307(b)(1) – (b)(3), to determine compliance with the Maximum Permissible Exposure (MPE) limits for General Population/Uncontrolled environments as defined below.

General population/uncontrolled exposure limits apply to situations in which the general population may be exposed or in which persons who are exposed as a consequence of their employment may not be made fully aware of the potential for exposure or cannot exercise control over their exposure. Therefore, members of the general population would always be considered under this category when exposure is not employment related, for example, in the case of a telecommunications tower that exposes persons in a nearby residential area.

Population exposure to radio frequencies is regulated and enforced in units of microwatts per square centimeter ($\mu\text{W}/\text{cm}^2$). The general population exposure limits for the 850 MHz Band is approximately $567 \mu\text{W}/\text{cm}^2$. The general population exposure limit for the 1900 MHz (PCS) and 2500 MHz (BRS) bands is $1000 \mu\text{W}/\text{cm}^2$. Because each carrier will be using different frequency bands, and each frequency band has different exposure limits, it is necessary to report percent of MPE rather than power density.



Occupational/controlled exposure limits apply to situations in which persons are exposed as a consequence of their employment and in which those persons who are exposed have been made fully aware of the potential for exposure and can exercise control over their exposure. Occupational/controlled exposure limits also apply where exposure is of a transient nature as a result of incidental passage through a location where exposure levels may be above general population/uncontrolled limits (see below), as long as the exposed person has been made fully aware of the potential for exposure and can exercise control over his or her exposure by leaving the area or by some other appropriate means.

Additional details can be found in FCC OET 65.

CALCULATIONS

Calculations were done for the proposed SPRINT Wireless antenna facility located at **201 South Main Street, Newtown, CT**, using the equipment information listed below. All calculations were performed per the specifications under FCC OET 65. Since SPRINT is proposing highly focused directional panel antennas, which project most of the emitted energy out toward the horizon, all calculations were performed assuming a lobe representing the maximum gain of the antenna per the antenna manufactures supplied specifications, minus 10 dB, was focused at the base of the tower. For this report the sample point is the top of a 6-foot person standing at the base of the tower.

For all calculations, all equipment was calculated using the following assumptions:

- 1) 1 CDMA channels (850 MHz) were considered for each sector of the proposed installation. These Channels have a transmit power of 20 Watts per Channel.
- 2) 2 LTE channels (850 MHz) were considered for each sector of the proposed installation. These Channels have a transmit power of 20 Watts per Channel.
- 3) 5 CDMA channels (1900 MHz (PCS)) were considered for each sector of the proposed installation. These Channels have a transmit power of 16 Watts per Channel.
- 4) 2 LTE channels (1900 MHz (PCS)) were considered for each sector of the proposed installation. These Channels have a transmit power of 40 Watts per Channel.
- 5) 8 LTE channels (2500 MHz (BRS)) were considered for each sector of the proposed installation. These Channels have a transmit power of 20 Watts per Channel.



- 6) All radios at the proposed installation were considered to be running at full power and were uncombined in their RF transmissions paths per carrier prescribed configuration. Per FCC OET Bulletin No. 65 - Edition 97-01 recommendations to achieve the maximum anticipated value at each sample point, all power levels emitting from the proposed antenna installation are increased by a factor of 2.56 to account for possible in-phase reflections from the surrounding environment. This is rarely the case, and if so, is never continuous.
- 7) For the following calculations, the sample point was the top of a 6-foot person standing at the base of the tower. The maximum gain of the antenna per the antenna manufactures supplied specifications minus 10 dB was used in this direction. This value is a very conservative estimate as gain reductions for these particular antennas are typically much higher in this direction.
- 8) The antennas used in this modeling are the **RFS APXVSP18-C-A20** and the **RFS APXVTM14-C-120** for transmission in the 850 MHz, 1900 MHz (PCS) and 2500 MHz (BRS) frequency bands. This is based on feedback from the carrier with regards to anticipated antenna selection. Maximum gain values for all antennas are listed in the Inventory and Power Data table below. The maximum gain of the antenna per the antenna manufactures supplied specifications, minus 10 dB, was used for all calculations. This value is a very conservative estimate as gain reductions for these particular antennas are typically much higher in this direction.
- 9) The antenna mounting height centerlines of the proposed antennas are **137 feet** above ground level (AGL) for **Sector A**, **137 feet** above ground level (AGL) for **Sector B** and **137 feet** above ground level (AGL) for Sector C.
- 10) Emissions values for additional carriers were taken from the Connecticut Siting Council active database. Values in this database are provided by the individual carriers themselves.

All calculations were done with respect to uncontrolled / general population threshold limits.



SPRINT Site Inventory and Power Data by Antenna

Sector:	A	Sector:	B	Sector:	C
Antenna #:	1	Antenna #:	1	Antenna #:	1
Make / Model:	RFS APXVSPPI8-C-A20	Make / Model:	RFS APXVSPPI8-C-A20	Make / Model:	RFS APXVSPPI8-C-A20
Gain:	13.4 / 15.9 dBd	Gain:	13.4 / 15.9 dBd	Gain:	13.4 / 15.9 dBd
Height (AGL):	137 feet	Height (AGL):	137 feet	Height (AGL):	137 feet
Frequency Bands	850 MHz / 1900 MHz (PCS)	Frequency Bands	850 MHz / 1900 MHz (PCS)	Frequency Bands	850 MHz / 1900 MHz (PCS)
Channel Count	10	Channel Count	10	Channel Count	10
Total TX Power(W):	220 Watts	Total TX Power(W):	220 Watts	Total TX Power(W):	220 Watts
ERP (W):	7,537.38	ERP (W):	7,537.38	ERP (W):	7,537.38
Antenna A1 MPE%	1.79 %	Antenna B1 MPE%	1.79 %	Antenna C1 MPE%	1.79 %
Antenna #:	2	Antenna #:	2	Antenna #:	2
Make / Model:	RFS APXVTM14-C-120	Make / Model:	RFS APXVTM14-C-120	Make / Model:	RFS APXVTM14-C-120
Gain:	15.9 dBd	Gain:	15.9 dBd	Gain:	15.9 dBd
Height (AGL):	137 feet	Height (AGL):	137 feet	Height (AGL):	137 feet
Frequency Bands	2500 MHz (BRS)	Frequency Bands	2500 MHz (BRS)	Frequency Bands	2500 MHz (BRS)
Channel Count	8	Channel Count	8	Channel Count	8
Total TX Power(W):	160 Watts	Total TX Power(W):	160 Watts	Total TX Power(W):	160 Watts
ERP (W):	6,224.72	ERP (W):	6,224.72	ERP (W):	6,224.72
Antenna A2 MPE%	1.30 %	Antenna B2 MPE%	1.30 %	Antenna C2 MPE%	1.30 %

Site Composite MPE%	
Carrier	MPE%
SPRINT – Max per sector	3.09 %
AT&T	1.64 %
T-Mobile	0.85 %
Verizon Wireless	2.74 %
Site Total MPE %:	8.32 %

SPRINT Sector A Total:	3.09 %
SPRINT Sector B Total:	3.09 %
SPRINT Sector C Total:	3.09 %
Site Total:	8.32 %

SPRINT _ Max Values per Frequency Band / Technology Per Sector	# Channels	Watts ERP (Per Channel)	Height (feet)	Total Power Density ($\mu\text{W}/\text{cm}^2$)	Frequency (MHz)	Allowable MPE ($\mu\text{W}/\text{cm}^2$)	Calculated % MPE
Sprint 850 MHz CDMA	1	437.55	137	0.92	850 MHz	567	0.16%
Sprint 850 MHz LTE	2	437.55	137	1.83	850 MHz	567	0.32%
Sprint 1900 MHz (PCS) CDMA	5	622.47	137	6.52	1900 MHz (PCS)	1000	0.65%
Sprint 1900 MHz (PCS) LTE	2	1,556.18	137	6.52	1900 MHz (PCS)	1000	0.65%
Sprint 2500 MHz (BRS) LTE	8	778.09	137	13.04	2500 MHz (BRS)	1000	1.30%
						Total:*	3.09%

NOTE: Totals may vary by 0.01% due to summing of remainders



Summary

All calculations performed for this analysis yielded results that were **within** the allowable limits for general population exposure to RF Emissions.

The anticipated maximum composite contributions from the SPRINT facility as well as the site composite emissions value with regards to compliance with FCC's allowable limits for general population exposure to RF Emissions are shown here:

SPRINT Sector	Power Density Value (%)
Sector A:	3.09 %
Sector B:	3.09 %
Sector C:	3.09 %
SPRINT Maximum Total (per sector):	3.09 %
Site Total:	8.32 %
Site Compliance Status:	COMPLIANT

The anticipated composite MPE value for this site assuming all carriers present is **8.32 %** of the allowable FCC established general population limit sampled at the ground level. This is based upon values listed in the Connecticut Siting Council database for existing carrier emissions.

FCC guidelines state that if a site is found to be out of compliance (over allowable thresholds), that carriers over a 5% contribution to the composite value will require measures to bring the site into compliance. For this facility, the composite values calculated were well within the allowable 100% threshold standard per the federal government.