



Crown Castle
3 Corporate Park Drive, Suite 101
Clifton Park, NY 12065

August 10, 2017

Melanie A. Bachman
Acting Executive Director
Connecticut Siting Council
10 Franklin Square
New Britain, CT 06051

RE: Notice of Exempt Modification for Sprint 2.5 Rework Crown Site BU: 806354
Sprint Site ID: CT03XC368
21 Berkshire Road, Newtown, CT 06482
Latitude: 41° 24' 45.53"/ Longitude: -73° 16' 12.34"

Dear Ms. Bachman:

Sprint currently maintains three (3) antennas at the 165-foot level of the existing 185-foot monopole tower at 21 Berkshire Road in Newtown, CT. The tower is owned by Crown Castle. The property is owned by the Carmine Renzulli. Sprint intends to install three (3) antennas, three (3) RRHs and one (1) hybrid cable.

This facility was approved by the by the Connecticut Siting Council in Docket No. 89 on March 3, 1988. This approval included the conditions that:

1. The monopole tower at the Newtown site shall be no taller than necessary to provide the proposed service, and in no event shall exceed a total height of 193 feet, including antennas and associated equipment.
2. The facility shall be constructed in accordance with all applicable federal, state, and municipal laws and regulations.
3. Unless necessary to comply with condition number 2, above, no lights shall be installed on this tower.

This modification complies with the aforementioned condition(s).

Please accept this letter as notification pursuant to Regulations of Connecticut State Agencies § 16-50j-73, for construction that constitutes an exempt modification pursuant to R.C.S.A. § 16-50j-72(b)(2). In accordance with R.S.C.A. § 16-50j-73, a copy of this letter is being sent to Ms. E. Patricia Llodra, First Selectman, Town of Newtown, as well as the Town Planner, and property owner.

The proposed modifications will not result in an increase in the height of the existing tower.

The Foundation for a Wireless World.

CrownCastle.com

Melanie A. Bachman

August 10, 2017

Page 2

1. The proposed modifications will not require the extension of the site boundary.
2. The proposed modification will not increase noise levels at the facility by six decibels or more, or to levels that exceed state and local criteria.
3. The operation of the replacement antennas will not increase radio frequency emissions at the facility to a level at or above the Federal Communication Commission safety standard.
4. The proposed modifications will not cause a change or alteration in the physical or environmental characteristics of the site.
5. The existing structure and its foundation can support the proposed loading.

For the foregoing reasons, AT&T respectfully submits that the proposed modifications to the above-reference telecommunications facility constitutes an exempt modification under R.C.S.A. § 16-50j-72(b)(2). Please send approval/rejection letter to Attn: Jeffrey Barbadora.

Sincerely,

Jeffrey Barbadora
Real Estate Specialist
12 Gill Street, Suite 5800, Woburn, MA 01801
781-729-0053
Jeff.Barbadora@crowncastle.com

Attachments:

Tab 1: Exhibit-1: Compound plan and elevation depicting the planned changes

Tab 2: Exhibit-2: Structural Modification Report

Tab 3: Exhibit-3: General Power Density Table Report (RF Emissions Analysis Report)

cc: Ms. E. Patricia Llodra
Newtown Municipal Center
3 Primrose Street
Newtown, CT 06470

Carmine Renzulli
505 Westport Ave, Lot 31
Norwalk, CT 06851

Planning and Zoning
Newtown Municipal Center
3 Primrose Street
Newtown, CT 06470

DOCKET NO. 89 - An application of Metro : CONNECTICUT SITING
Mobile CTS of Fairfield County, Inc., : COUNCIL
for a Certificate of Environmental
Compatibility and Public Need for
cellular telephone antennas and : March 3, 1988
associated equipment in the
Town of Newtown, Connecticut

D E C I S I O N A N D O R D E R

Pursuant to the forgoing opinion, the Connecticut Siting Council hereby directs that a Certificate of Environmental Compatibility and Public Need, as provided by Section 16-50k of the General Statutes of Connecticut (CGS) be issued to Metro Mobile CTS of Fairfield County, Inc., for the construction, operation, and maintenance of a cellular telephone tower site and associated equipment at the "LM/A-Newtown" alternative site off of Route 34 in the Town of Newtown, Connecticut.

The "LM-Newtown" site off of Commerce Road is hereby denied.

The facility shall be constructed, operated, and maintained as specified in the Council's record in this matter, and subject to the following conditions:

1. The monopole tower at the Newtown site shall be no taller than necessary to provide the proposed service, and in no event shall exceed a total height of 193 feet, including antennas and associated equipment.

2. The facility shall be constructed in accordance with all applicable federal, state, and municipal laws and regulations.

3. Unless necessary to comply with condition number 2, above, no lights shall be installed on this tower.

4. The Certificate Holder shall prepare a development and management (D&M) plan for the Newtown site in compliance with sections 16-50j-75 through 16-50j-77 of the Regulations of State Agencies. The D&M plan shall provide for permanent evergreen screening around the outside perimeter of the eight-foot chain link fence which will surround the site.

5. The Certificate Holder or its successor shall notify the Council if and when directional antennas or any equipment other than that listed in this application is added to this facility.

6. The Certificate Holder or its successor shall permit public or private entities to share space on the tower for due consideration, or shall provide the requesting entity with specific legal, technical, environmental, or economic reasons precluding such tower sharing.

7. If this facility does not provide, or permanently ceases to provide, cellular service following completion of construction, this Decision and Order shall be void, and the tower and all associated equipment in this application shall be dismantled and removed or reapplication for any new use shall be made to the Council before any such new use is made.

8. The Certificate Holder shall comply with any future radio frequency (RF) standards promulgated by State or federal regulatory agencies. Upon the establishment of any new governmental RF standards, the facility granted in the Decision and Order shall be brought into compliance with such standards.

9. Unless otherwise approved by the Council, this Decision and Order shall be void if all construction authorized herein is not completed within three years of the the issuance of this Decision and Order.

Pursuant to CGS Section 16-50p, we hereby direct that a copy of this Decision and Order be served on each person listed below. A notice of the issuance shall be published in the Danbury News-Times and Newtown Bee.

By this Decision and Order the Council disposes of the legal rights, duties, and privileges of each party named or admitted to the proceeding in accordance with Section 16-50j-17 of the Regulations of State Agencies.

The parties or intervenors to this proceeding are:

Metro Mobile CTS of (applicant)
Fairfield County, Inc.
50 Rockland Road
South Norwalk, CT 06854
ATTN: Peter Kelley
Vice President

Howard L. Slater, Esq. (its representative)
Jennifer Young Gaudet, Esq.
Byrne, Slater, Sandler, Shulman
& Rouse, P.C.
330 Main Street
P.O. Box 3216
Hartford, CT 06103

Fleishman and Walsh, P.C. (party)
1725 N Street, N.W.
Washington, D.C. 20036
ATTN: Richard Rubin, Esq.

Theodore G. Whippie (party)
Chairman
Planning & Zoning Comm.
Edmond Town Hall
45 Main Street
Newtown, CT 06470

CERTIFICATION

The undersigned members of the Connecticut Siting Council hereby certify that they have heard this case in Docket 89 or read the record thereof, and that we voted as follows:

Dated at New Britain, Connecticut the 3rd day of March, 1988.

<u>Council Members</u>	<u>Vote Cast</u>
<u><i>Gloria Dibble Pond</i></u> Gloria Dibble Pond Chairperson	Yes
<u><i>Roland G. Miller</i></u> Commissioner Peter Boucher Designee: Roland Miller	Yes
<u><i>Brian J. Emerick</i></u> Commissioner Leslie Carothers Designee: Brian Emerick	Yes
<u>Owen L. Clark</u>	Absent
<u><i>Fred J. Doggy</i></u> Fred J. Doggy	Yes
<u><i>Mortimer A. Gelston</i></u> Mortimer A. Gelston	Yes
<u><i>James G. Horsfall</i></u> James G. Horsfall	Yes
<u><i>William H. Smith</i></u> William H. Smith	Yes
<u>Colin C. Tait</u>	Absent

CERTIFICATION

The undersigned members of the Connecticut Siting Council hereby certify that they have heard this case in Docket 89 or read the record thereof, and that we voted as follows:

Dated at New Britain, Connecticut the 3rd day of March, 1988.

<u>Council Members</u>	<u>Vote Cast</u>
<u>Gloria Dibble Pond</u> Gloria Dibble Pond Chairperson	Yes
<u>Roland G. Miller</u> Commissioner Peter Boucher Designee: Roland Miller	Yes
<u>Brian Emerick</u> Commissioner Leslie Carothers Designee: Brian Emerick	Yes
<u>Owen L. Clark</u>	Absent
<u>Fred J. Dodcy</u>	Yes
<u>Mortimer A. Gelston</u>	Yes
<u>James G. Horsfall</u>	Yes
<u>William H. Smith</u>	Yes
<u>Colin C. Tait</u>	Absent



Property Information

Owner	RENZULLI CARMINE V
Co-Owner	
Address	21 BERKSHIRE ROAD
Mailing Address	505 WESTPORT AVE LT 31 NORWALK CT 06851
Land Use	1060 Vacant W/ OB
Land Class	R
Vision ID	15220
School Zone	
Town Clerk Map	

Fire District	
Census Tract	
Neighborhood	
Zoning Code	B-3
Acreage	0.25
Utilities	Well,Septic
Lot Setting/Desc	
Voting District	
Borough	
Historic	

Photo

No Photo Available

Sketch

Construction Details

Year Built	
Stories	
Building Style	
Building Use	
Building Condition	
Floors	
Total Rooms	

Bedrooms	0
Full Bathrooms	
Half Bathrooms	
Bath Style	
Kitchen Style	
Roof Style	
Roof Cover	

Exterior Walls	
Interior Walls	
Heating Type	
Heating Fuel	
AC Type	
Gross Bldg Area	
Total Living Area	0



Valuation Summary (Assessed value = 70% of Appraised Value)

Item	Appraised	Assessed
Buildings	0	0
Outbuildings	96000	67200
Improvements	96000	67200
Extras	0	0
Land	360000	252000
Total	456000	319200

Outbuilding and Extra Items

Type	Description
Cell Tower	1 Units

Sub Areas

Subarea Type	Gross Area (sq ft)	Living Area (sq ft)
Total Area		

Sales History

Owner of Record	Book/ Page	Sale Date	Sale Price
RENZULLI CARMINE V	0306/0377	12/25/2009	

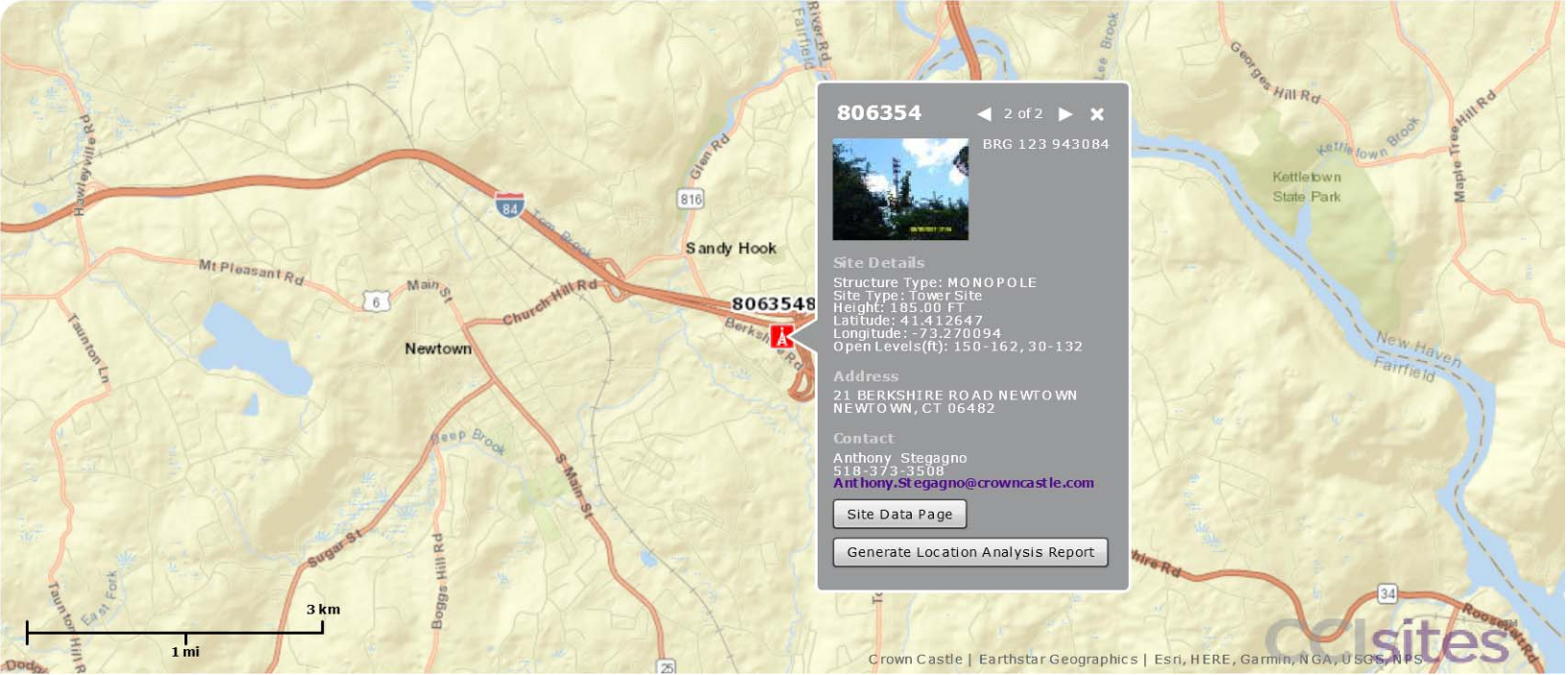

806354

◀ 2 of 2 ▶ ✕

BRG 123 943084



Site Details

Structure Type: MONOPOLE
Site Type: Tower Site
Height: 135.00 FT
Latitude: 41.412647
Longitude: -73.270094
Open Levels(ft): 150 - 162, 30 - 132

Address

21 BERKSHIRE ROAD NEW TOWN
NEW TOWN, CT 06482

Contact

Anthony Stegagno
518-373-3508
Anthony.Stegagno@crowncastle.com

Site Data Page

Generate Location Analysis Report



Sprint

2.5 EQUIPMENT DEPLOYMENT

SITE NUMBER:
CT03XC368

SITE NAME:
NEWTOWN

SITE ADDRESS:
21 BERKSHIRE RD
NEWTOWN, CT 06482

CROWN ID#: 806354

CROWN SITE NAME: BRG 123 943089

APPROVED

By Jason D'Amico at 1:13 pm, Jun 29, 2017

APPROVED

By Susan Vale at 9:53 am, Nov 04, 2014

Sprint

2.5 EQUIPMENT DEPLOYMENT
6580 SPRINT PARKWAY
OVERLAND PARK, KANSAS 66251

CROWN CASTLE

TECTONIC

TECTONIC Engineering & Surveying
Consultants P.C.
1279 Route 300
Newburgh, NY 12550
Phone: (845) 567-6656
Fax: (845) 567-8703
www.tectonicengineering.com

THIS DOCUMENT IS THE CREATION, DESIGN, PROPERTY AND COPYRIGHTED WORK OF SPRINT COMMUNICATIONS, INC. ANY DUPLICATION OR USE WITHOUT EXPRESS WRITTEN CONSENT IS STRICTLY PROHIBITED. DUPLICATION AND USE BY GOVERNMENT AGENCIES FOR THE PURPOSES OF CONDUCTING THEIR LAWFULLY AUTHORIZED REGULATORY AND ADMINISTRATIVE FUNCTIONS IS SPECIFICALLY ALLOWED.

SHEET INFORMATION

SITE NUMBER:	CT03XC368	LANDLORD:	CROWN CASTLE USA 2000 CORPORATE DRIVE CANONSBURG, PA
SITE NAME:	NEWTOWN	LOCAL POWER COMPANY:	CONNECTICUT LIGHT AND POWER CONTACT CUSTOMER SERVICE (800) 286-2000
SITE ADDRESS:	21 BERKSHIRE RD NEWTOWN, CT 06482	APPLICANT:	SPRINT 6580 SPRINT PARKWAY OVERLAND PARK, KANSAS 66251
COUNTY:	FAIRFIELD	ENGINEER:	JAMES QUICKSELL (845) 567-6656 EXT. 2835 JQuicksell@tectonicengineering.com
COORDINATES: (NAD 83)	41° 24' 45.53" N 73° 16' 12.34" W	SPRINT CM:	GARY WOOD (860) 940-9168 gary.wood@sprint.com
GROUND ELEV:	415'± AMSL	CROWN CM:	JASON D'AMICO (860) 209-0104 jason.d'amico@crowncastle.com
STRUCTURE TYPE:	MONOPOLE	AAV:	AT&T
STRUCTURE HEIGHT:	185'-0"± AGL		
STRUCTURE RAD CENTER:	165'-0"± AGL		
ZONING CLASSIFICATION:	B-3		
MAP-BLOCK-LOT:	38-10-3		

VICINITY MAP (NOT TO SCALE)

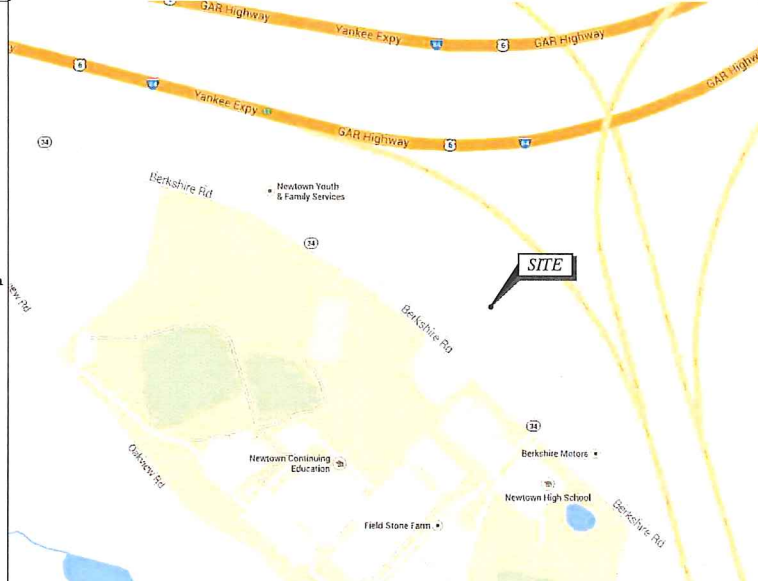

SHEET INDEX

SHT. NO.	SHEET DESCRIPTION
T-1	TITLE SHEET
SP-1	GENERAL NOTES
SP-2	GENERAL NOTES
A-1	SITE PLAN
A-2	ELEVATION
A-3	ENLARGED EQUIPMENT LAYOUT PLANS
A-4	ANTENNA LAYOUT PLANS
A-5	RAN WIRING DIAGRAM
A-6	CABLE DETAILS
S-1	EQUIPMENT DETAILS
S-2	EQUIPMENT SCHEMATIC DETAILS
E-1	ELECTRICAL & GROUNDING PLANS
E-2	GROUNDING DETAILS & NOTES

SUBMITTALS

PROJECT NO: 7225.CT03XC368

NO	DATE	DESCRIPTION	BY
0	06/14/14	FOR COMMENT	JT
1	10/31/14	FOR CONSTRUCTION	DC

DATE	REVIEWED BY
10/31/14	JMG

GENERAL NOTES

- THIS IS AN UNMANNED TELECOMMUNICATION FACILITY AND NOT FOR HUMAN HABITATION. HANDICAP ACCESS REQUIREMENTS ARE NOT REQUIRED. FACILITY HAS NO PLUMBING OR REFRIGERANTS. THIS FACILITY SHALL MEET OR EXCEED ALL FAA AND FCC REGULATOR REQUIREMENTS.
- CONTRACTOR SHALL VERIFY ALL PLANS AND EXISTING DIMENSIONS AND CONDITIONS ON THE JOB SITE AND SHALL IMMEDIATELY NOTIFY THE PROJECT OWNER'S REPRESENTATIVE IN WRITING OF DISCREPANCIES BEFORE PROCEEDING WITH THE WORK OR BE RESPONSIBLE FOR SAME.
- DEVELOPMENT AND USE OF THIS SITE WILL CONFORM TO ALL APPLICABLE CODES AND ORDINANCES.
 - 2005 STATE OF CONNECTICUT BUILDING CODE.
 - ANSI/TIA/EIA-222-F-1996.
 - NATIONAL ELECTRICAL CODE, LATEST EDITION.

AERIAL VIEW (NOT TO SCALE)

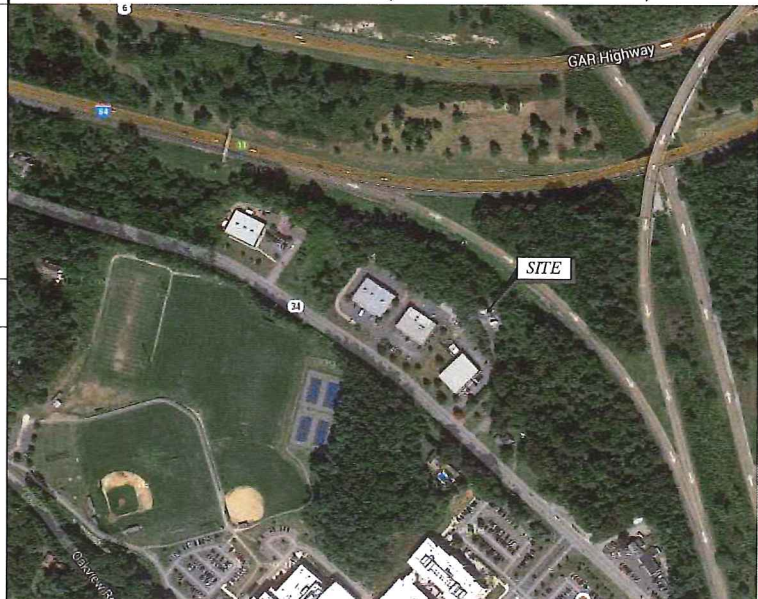

APPROVALS

THE FOLLOWING PARTIES HEREBY APPROVE AND ACCEPT THESE DOCUMENTS AND AUTHORIZE THE CONTRACTOR TO PROCEED WITH THE CONSTRUCTION DESCRIBED HEREIN. ALL DOCUMENTS ARE SUBJECT TO REVIEW BY THE LOCAL BUILDING DEPARTMENT AND MAY IMPOSE CHANGES OR MODIFICATIONS.

CONSTRUCTION: _____ DATE: _____

LEASING/
SITE ACQUISITION: _____ DATE: _____

LANDLORD/
PROPERTY OWNER: _____ DATE: _____

R.F. ENGINEER: _____ DATE: _____

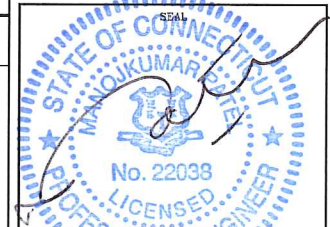

PROJECT DESCRIPTION

- (1) NEW 2.5 EQUIPMENT RACK INSIDE EXIST MMBTS CABINET.
- (3) NEW RFS APXVTM14-C-120 ANTENNAS.
- (3) NEW TD-RRH6x20-25 RRH.
- (1) NEW 5/8" FIBER CABLE.
- (3) NEW HANDRAIL KIT SITE PRO P/N HRK12.



SITE NUMBER:
CT03XC368

SITE NAME:
NEWTOWN

SITE ADDRESS:
21 BERKSHIRE RD
NEWTOWN, CT 06482

SHEET TITLE:
TITLE SHEET

SHEET NO:
T-1

DIVISION 01000--GENERAL NOTES

1. THE CONTRACTOR SHALL GIVE ALL NOTICES AND COMPLY WITH ALL LAWS, ORDINANCES, RULES, REGULATIONS AND LAWFUL ORDERS OF ANY PUBLIC AUTHORITY, MUNICIPAL AND UTILITY COMPANY SPECIFICATIONS, AND LOCAL AND STATE JURISDICTIONAL CODES BEARING ON THE PERFORMANCE OF THE WORK. THE WORK PERFORMED ON THE PROJECT AND THE MATERIALS INSTALLED SHALL BE IN STRICT ACCORDANCE WITH ALL APPLICABLE CODES, REGULATIONS, AND ORDINANCES.
2. THE ARCHITECT/ENGINEER HAVE MADE EVERY EFFORT TO SET FORTH IN THE CONSTRUCTION AND CONTRACT DOCUMENTS THE COMPLETE SCOPE OF WORK. THE CONTRACTOR BIDDING THE JOB IS NEVERTHELESS CAUTIONED THAT MINOR OMISSIONS OR ERRORS IN THE DRAWINGS AND OR SPECIFICATIONS SHALL NOT EXCUSE SAID CONTRACTOR FROM COMPLETING THE PROJECT AND IMPROVEMENTS IN ACCORDANCE WITH THE INTENT OF THESE DOCUMENTS.
3. THE CONTRACTOR OR BIDDER SHALL BEAR THE RESPONSIBILITY OF NOTIFYING (IN WRITING) THE PROJECT OWNER'S REPRESENTATIVE OF ANY CONFLICTS, ERRORS, OR OMISSIONS PRIOR TO THE SUBMISSION OF CONTRACTOR'S PROPOSAL OR PERFORMANCE OF WORK.
4. THE SCOPE OF WORK SHALL INCLUDE FURNISHING ALL MATERIALS, EQUIPMENT, LABOR AND ALL OTHER MATERIALS AND LABOR DEEMED NECESSARY TO COMPLETE THE WORK/PROJECT AS DESCRIBED HEREIN.
5. THE CONTRACTOR SHALL VISIT THE JOB SITE PRIOR TO THE SUBMISSION OF BIDS OR PERFORMING WORK TO FAMILIARIZE HIMSELF WITH THE FIELD CONDITIONS AND TO VERIFY THAT THE PROJECT CAN BE CONSTRUCTED IN ACCORDANCE WITH THE CONTRACT DOCUMENTS.
6. ONCE THE CONTRACTOR HAS RECEIVED AND ACCEPTED THE NOTICE TO PROCEED, CONTRACTOR WILL CONTACT THE CROWN CASTLE CONSTRUCTION MANAGER OF RECORD (NOTED ON THE FIRST PAGE ON THIS CONSTRUCTION DRAWING) A MINIMUM OF 48 HOURS PRIOR TO WORK START. UPON ARRIVAL TO THE JOB SITE, CONTRACTOR CREW IS REQUIRED CALL 1-800-788-7011 TO NOTIFY THE CROWN CASTLE NOC WORK HAS BEGUN.
7. THE CONTRACTOR SHALL INSTALL ALL EQUIPMENT AND MATERIALS ACCORDING TO THE MANUFACTURER'S/VENDOR'S SPECIFICATIONS UNLESS NOTED OTHERWISE OR WHERE LOCAL CODES OR ORDINANCES TAKE PRECEDENCE.
8. THE CONTRACTOR SHALL PROVIDE A FULL SET OF CONSTRUCTION DOCUMENTS AT THE SITE UPDATED WITH THE LATEST REVISIONS AND ADDENDUMS OR CLARIFICATIONS AVAILABLE FOR THE USE BY ALL PERSONNEL INVOLVED WITH THE PROJECT.
9. THE CONTRACTOR SHALL SUPERVISE AND DIRECT THE PROJECT DESCRIBED HEREIN. THE CONTRACTOR SHALL BE SOLELY RESPONSIBLE FOR ALL CONSTRUCTION MEANS, METHODS, TECHNIQUES, SEQUENCES AND PROCEDURES AND FOR COORDINATING ALL PORTIONS OF THE WORK UNDER THE CONTRACT.
10. THE CONTRACTOR SHALL BE RESPONSIBLE FOR OBTAINING ALL PERMITS AND INSPECTIONS WHICH MAY BE REQUIRED FOR THE WORK BY THE ARCHITECT/ENGINEER, THE STATE, COUNTY OR LOCAL GOVERNMENT AUTHORITY.
11. THE CONTRACTOR SHALL MAKE NECESSARY PROVISIONS TO PROTECT EXISTING IMPROVEMENTS, EASEMENTS, PAVING, CURBING, ETC. DURING CONSTRUCTION. UPON COMPLETION OF WORK, THE CONTRACTOR SHALL REPAIR ANY DAMAGE THAT MAY HAVE OCCURRED DUE TO CONSTRUCTION ON OR ABOUT THE PROPERTY.
12. THE CONTRACTOR SHALL KEEP THE GENERAL WORK AREA CLEAN AND HAZARD FREE DURING CONSTRUCTION AND DISPOSE OF ALL DIRT, DEBRIS, RUBBISH AND REMOVE EQUIPMENT NOT SPECIFIED AS REMAINING ON THE PROPERTY. PREMISES SHALL BE LEFT IN CLEAN CONDITION AND FREE FROM PAINT SPOTS, DUST, OR SMUDGES OF ANY NATURE.
13. THE CONTRACTOR SHALL COMPLY WITH ALL PERTINENT SECTIONS OF THE BASIC STATE BUILDING CODE, LATEST EDITION, AND ALL OSHA REQUIREMENTS AS THEY APPLY TO THIS PROJECT. ALL EXISTING ACTIVE SEWER, WATER, GAS, ELECTRIC, AND OTHER UTILITIES WHERE ENCOUNTERED IN THE WORK SHALL BE PROTECTED AT ALL TIMES, AND WHERE REQUIRED FOR THE PROPER EXECUTION OF THE WORK SHALL BE RELOCATED AS DIRECTED BY THE ARCHITECT/ENGINEER. EXTREME CAUTION SHOULD BE USED BY THE CONTRACTOR WHEN EXCAVATING OR PIER DRILLING AROUND OR NEAR UTILITIES. THE CONTRACTOR SHALL PROVIDE SAFETY TRAINING FOR THE WORKING CREW. THIS WILL INCLUDE BUT NOT LIMITED TO A) FALL PROTECTION, B) CONFINED SPACE, C) ELECTRICAL SAFETY, D) TRENCHING AND EXCAVATION OF ALL EXISTING INACTIVE SEWER, WATER, GAS, ELECTRIC AND OTHER UTILITIES WHICH INTERFERE WITH THE EXECUTION OF THE WORK SHALL BE REMOVED AND OR CAPPED, PLUGGED OR OTHERWISE DISCONTINUED AT THE POINTS WHICH WILL NOT INTERFERE WITH THE EXECUTION OF THE WORK SUBJECT TO THE APPROVAL OF THE ARCHITECT/ENGINEER.
14. THE CONTRACTOR SHALL NOTIFY THE PROJECT OWNER'S REPRESENTATIVE IN WRITING WHERE A CONFLICT OCCURS ON ANY OF THE CONTRACT DOCUMENTS. THE CONTRACTOR IS NOT TO ORDER MATERIAL OR CONSTRUCT ANY PORTION OF THE WORK THAT IS IN CONFLICT UNTIL CONFLICT IS RESOLVED BY THE LESSEE/LICENSEE REPRESENTATIVE.
15. THE CONTRACTOR SHALL VERIFY ALL DIMENSIONS, ELEVATIONS, PROPERTY LINES, ETC. ON THE JOB.
16. THE CONTRACTOR SHALL NOTIFY THE THE RF ENGINEER FOR ANTENNA AZIMUTH VERIFICATION (DURING ANTENNA INSTALLATION) PRIOR TO CONDUCTING SWEEP TESTS.
17. THE CONTRACTOR SHALL SUBMIT AT THE END OF THE PROJECT A COMPLETE SET OF AS-BUILT DRAWINGS TO THE CLIENT REPRESENTATIVE.

18. REFER TO: CONSTRUCTION STANDARDS--SPRINT DOCUMENT EXHIBIT A--STANDARD CONSTRUCTION SPECIFICATIONS FOR WIRELESS SITES REV. 4.0-- 02.15.2011.DOCM.
19. REFER TO: WEATHER PROOFING SPECS: EXCERPT EXH A--WHRPRF--STD CONSTR SPECS...157201110421855492.DOCM.
20. REFER TO: COLOR CODING--SPRINT NEXTEL ANT AND LINE COLOR CODING (DRAFT) V3 09-08-11.PDF
21. REFER TO LATEST DOCUMENTATION REVISION.

DIVISION 03000--CONCRETE

- 1.03 APPLICABLE STANDARDS (USE LATEST EDITIONS)
 - A. ACI-301 - SPECIFICATIONS FOR STRUCTURAL CONCRETE FOR BUILDINGS.
 - B. ACI-347 GUIDE TO FORM WORK FOR CONCRETE.
 - C. ASTM C33- CONCRETE AGGREGATE
 - D. ASTM C94 - READY MIXED CONCRETE e. ASTM C150 - PORTLAND CEMENT.
 - E. ASTM C260 - AIR-ENTRAINING ADMIXTURES FOR CONCRETE
 - F. ASTM C309- LIQUID MEMBRANE FORMING COMPOUNDS FOR CURING CONCRETE.
 - H. ASTM C494 - CHEMICAL ADMIXTURES FOR CONCRETE
 - I. ASTM A615- DEFORMED AND PLAIN BILLET-STEEL BARS FOR CONCRETE REINFORCEMENT
 - J. ASTM A185- STEEL WELDED WIRE FABRIC (PLAIN) FOR CONCRETE REINFORCEMENT
- 1.04 QUALITY ASSURANCE
CONCRETE MATERIALS AND OPERATIONS SHALL BE TESTED AND INSPECTED BY THE ARCHITECT/ENGINEER AS DIRECTED BY THE CLIENT'S REPRESENTATIVE.
- 3.04 SURFACE FINISHES
 - A. SURFACES AGAINST WHICH BACKFILL OR CONCRETE SHALL BE PLACED REQUIRE NO TREATMENT EXCEPT REPAIR OF DEFECTIVE AREAS.
 - B. SURFACES THAT WILL BE PERMANENTLY EXPOSED SHALL PRESENT A UNIFORM FINISH PROVIDED BY THE REMOVAL OF FINIS AND THE FILLING HOLES AND OTHER IRREGULARITIES WITH DRY PACK GROUT, OR BY SACKING WITH UTILITY OR ORDINARY GROUT.
 - C. SURFACES THAT WOULD NORMALLY BE LEVEL AND WHICH WILL BE PERMANENTLY EXPOSED TO THE WEATHER SHALL BE SLOPED FOR DRAINAGE. UNLESS ENGINEER'S DESIGN DRAWING SPECIFIES A HORIZONTAL SURFACE OR SURFACES SUCH AS STAIR TREADS, WALLS, CURBS, AND PARAPETS SHALL BE SLOPED APPROXIMATELY 1/4" PER FOOT.
 - D. SURFACES THAT WILL BE COVERED BY BACKFILL OR CONCRETE SHALL BE SMOOTH SCREENED.
 - E. EXPOSED SLAB SURFACES SHALL BE CONSOLIDATED, SCREENED, FLOATED, AND STEEL TROWELED. HAND OR POWER-DRIVEN EQUIPMENT MAY BE USED FOR FLOATING. FLOATING SHALL BE STARTED AS SOON AS THE SCREENED SURFACE HAS ATTAINED A STIFFNESS TO PERMIT FINISHING OPERATIONS. OPERATIONS. ALL EDGES MUST HAVE A 3/4" CHAMFER.
- 1.04 QUALITY ASSURANCE CONCRETE MATERIALS AND OPERATIONS SHALL BE TESTED AND INSPECTED BY THE ENGINEER.

- 3.05 PATCHING
THE CONTRACTOR SHALL NOTIFY THE ENGINEER IMMEDIATELY UPON REMOVAL OF THE FORMS TO OBSERVE CONCRETE SURFACE CONDITIONS. IMPERFECTIONS SHALL BE PATCHED ACCORDING TO THE ENGINEER'S DIRECTION.

- 3.06 DEFECTIVE CONCRETE
THE CONTRACTOR SHALL NOTIFY OR REPLACE CONCRETE NOT CONFORMING TO REQUIRED LEVELS AND LINES, DETAILS, AND ELEVATIONS AS SPECIFIED IN ACI 301.

- 3.07 PROTECTION
 - A. IMMEDIATELY AFTER PLACEMENT. THE CONTRACTOR SHALL PROTECT THE CONCRETE FROM PREMATURE DRYING, EXCESSIVELY HOT OR COLD TEMPERATURES, AND MECHANICAL INJURY. FINISHED WORK SHALL BE PROTECTED.
 - B. CONCRETE SHALL BE MAINTAINED WITH MINIMAL MOISTURE LOSS AT RELATIVELY CONSTANT TEMPERATURE FOR PERIOD NECESSARY FOR HYDRATION OF CEMENT AND HARDENING OF CONCRETE.
 - C. ALL CONCRETE SHALL BE WATER CURED PER ACCEPTABLE PRACTICES SPECIFIED BY ACI CODE (LATEST EDITION)

DIVISION 05000 -- METALS

- PART 1 -- GENERAL
- 1.01 WORK INCLUDED
 - A. THE WORK CONSISTS OF THE FABRICATION AND INSTALLATION OF ALL MATERIALS TO BE FURNISHED. AND WITHOUT LIMITING THE GENERALITY THEREOF, INCLUDING ALL EQUIPMENT, LABOR AND SERVICES REQUIRED FOR ALL STRUCTURAL STEEL WORK AND ALL ITEMS INCIDENTAL AS SPECIFIED AND AS SHOWN ON THE DRAWINGS:
1. STEEL FRAMING INCLUDING BEAMS, ANGLES, CHANNELS AND PLATES. WELDING AND BOLTING OF ATTACHMENTS.
- 2.02 REFERENCE STANDARDS
 - A. THE WORK SHALL CONFORM TO THE CODES AND STANDARDS OF THE FOLLOWING AGENCIES AS FURTHER CITED HEREIN:
 1. ASTM: AMERICAN SOCIETY FOR TESTING AND MATERIALS AS PUBLISHED IN "COMPILATION OF ASTM STANDARDS IN BUILDING CODES" OR LATEST EDITION.
 2. AWS: AMERICAN WELDING SOCIETY CODE OR LATEST EDITION.
 3. AISC: AMERICAN INSTITUTE OF STEEL CONSTRUCTION, "SPECIFICATION FOR THE DESIGN, FABRICATION AND ERECTION OF STRUCTURAL STEEL FOR BUILDINGS" (LATEST EDITION).
- PART 2 -- PRODUCTS
- 2.01 MATERIALS
 - A. STRUCTURAL STEEL: SHALL COMPLY WITH THE REQUIREMENTS OF ASTM A36 AND A992 FOR STRUCTURAL STEEL.
- ALL PROPOSED STRUCTURAL STEEL SHALL BE FABRICATED AND ERECTED IN ACCORDANCE WITH AISC CODE AND ASTM SPECIFICATIONS (LATEST EDITION) ALL NEW STEEL SHALL CONFORM TO THE FOLLOWING.
 1. STRUCTURAL WIDE FLANGE: ASTM A992 Fy=50KSI.
 2. MISCELLANEOUS STEEL (PLATES), CHANNELS, ANGLES, ETC): ASTM A36 (Fy=36KSI).
 3. STRUCTURAL TUBING: ASTM A500 Gr. B (Fy=46KSI).
 4. STEEL PIPE: ASTM A53 Gr B (Fy=35KSI).
- 2.02 WELDING
 - A. ALL WELDING SHALL BE DONE BY CERTIFIED WELDERS. CERTIFICATION DOCUMENTS SHALL BE MADE AVAILABLE FOR ENGINEER'S AND/OR OWNER'S REVIEW IF REQUESTED.
 - B. WELDING ELECTRODES FOR MANUAL SHIELDED METAL ARC WELDING SHALL CONFORM TO ASTM 1-233, E70 SERIES. BARE ELECTRODES AND GRANULAR FLUX USED IN THE SUBMERGED ARC PROCESS SHALL CONFORM TO AISC SPECIFICATIONS.
 - C. FIELD WELDING SHALL BE DONE AS PER AWS D1.1 REQUIREMENTS VISUAL INSPECTION IS ACCEPTABLE.
 - D. STUD WELDING SHALL BE ACCOMPLISHED BY CAPACITOR DISCHARGE (CD) WELDING TECHNIQUE USING CAPACITOR DISCHARGE STUD WELDER.
 - E. PROVIDE STUD FASTENERS OF MATERIALS AND SIZES SHOWN ON DRAWINGS OR AS RECOMMENDED BY THE MANUFACTURER FOR STRUCTURAL LOADINGS REQUIRED.
 - F. FOLLOW MANUFACTURERS SPECIFICATIONS AND INSTRUCTIONS TO PROPERLY SELECT AND INSTALL STUD WELDS.
- 2.03 BOLTING
 - A. BOLTS SHALL BE CONFORMING TO ASTM A35 HIGH STRENGTH HOT DIP GALVANIZED WITH ASTM A153 HEAVY HEX TYPE NUTS.
 - B. BOLTS SHALL BE 3/4" (MINIMUM) CONFORMING TO ASTM A325, HOT DIP GALVANIZED, ASTM A153 NUTS SHALL BE HEAVY HEX TYPE.
 - C. ALL CONNECTIONS SHALL BE 2 BOLTS MINIMUM.
 - D. EXCEPT WHERE SHOWN, ALL BEAM TO BEAM AND BEAM TO COLUMN CONNECTIONS TO BE DOUBLE ANGLED CONNECTIONS WITH HIGH STRENGTH BOLTS (THREADS EXCLUDED FROM SHEAR PLANE) AND HARDENED WASHERS.
 - E. STANDARD, OVERSIZED OR HORIZONTAL SHORT SLOTTED HOLES.
 - F. SNUG--TIGHT STRENGTH BEARING BOLTS MAY BE USED IN STANDARD HOLES CONFORMING TO ACIS, USING THE TURN OF THE NUT METHOD.
 - H. FULLY--TENSIONED HIGH STRENGTH (SLIP CRITICAL) SHALL BE USED IN OVERSIZED SLOT HOLES (RESPECTIVE OF SLOT ORIENTATION).
 - I. ALL BRACED CONNECTION, MOMENT CONNECTION AND CONNECTIONS NOTED AS "SLIP CRITICAL" SHALL BE BE SLIP CRITICAL JOINTS WITH CLASS A SURFACE CONDITIONS, UNLESS OTHERWISE NOTED.
 - J. EPOXY ANCHOR ASSEMBLIES SHALL BE AS MANUFACTURED BY HILTI OR ENGINEER APPROVED EQUAL, AS FOLLOWS:

<u>BASE MATERIAL</u>	<u>ANCHOR SYSTEM</u>
CONCRETE	HILTI HIT--HY 200
HOLLOW & GROUTED CMU OR BRICK	HILTI HIT--HY 70
- 2.04 FABRICATION
 - A. FABRICATION OF STEEL SHALL CONFORM TO THE AISC AND AWS

- 2.05 FINISH
 - A. STRUCTURAL STEEL EXPOSED TO WEATHER SHALL BE HOT--DIP GALVANIZED AFTER FABRICATION IN ACCORDANCE WITH ASTM A123. (LATEST EDITION) UNLESS OTHERWISE NOTED.
- 2.06 PROTECTION
 - A. UPON COMPLETION OF ERECTION, INSPECT ALL GALVANIZED STEEL AND PAINT ANY FIELD CUTS, WELDS OR GALVANIZED BREAKS WITH (2) COATS OF ZINC-RICH COLD GALVANIZING PAINT.
- PART 3 -- ERECTION
 - A. PROVIDE ALL ERECTION, EQUIPMENT, BRACING, PLANKING, FIELD BOLTS, NUTS, WASHERS, DRIFT PINS, AND SIMILAR MATERIALS WHICH DO NOT FORM A PART OF THE COMPLETED CONSTRUCTION, BUT ARE NECESSARY FOR ITS PROPER ERECTION.
 - B. ERECT AND ANCHOR ALL STRUCTURAL STEEL IN ACCORDANCE WITH AISC REFERENCE STANDARDS. ALL WORK SHALL BE ACCURATELY SET TO ESTABLISHED SUITABLE ATTACHMENTS TO THE CONSTRUCTION OF THE BUILDING
 - C. TEMPORARY BRACING, GUYING, AND SUPPORT SHALL BE PROVIDED TO KEEP THE STRUCTURE SET AND ALIGNED AT ALL TIMES DURING CONSTRUCTION, AND TO PREVENT DANGER TO PERSONS AND PROPERTY. CHECK ALL TEMPORARY LOADS AND STAY WITHIN SAFE CAPACITY OF ALL BUILDING COMPONENTS.



TECTONIC • PLANNING
• ENGINEERING
• SURVEYING
• CONSTRUCTION MANAGEMENT

TECTONIC Engineering & Surveying Consultants P.C.

1279 Route 300
Newburgh, NY 12550
Phone: (845) 567-6656
Fax: (845) 567-8703
www.tectonicengineering.com

THIS DOCUMENT IS THE CREATION, DESIGN, PROPERTY AND COPYRIGHTED WORK OF SPRINT COMMUNICATIONS, INC. ANY DUPLICATION OR USE WITHOUT EXPRESS WRITTEN CONSENT IS STRICTLY PROHIBITED. DUPLICATION AND USE BY GOVERNMENT AGENCIES FOR THE PURPOSES OF CONDUCTING THEIR LAWFULLY AUTHORIZED REGULATORY AND ADMINISTRATIVE FUNCTIONS IS SPECIFICALLY ALLOWED.

SUBMITTALS			
PROJECT NO: 7225.CT03XC368			
NO	DATE	DESCRIPTION	BY
0	06/16/14	FOR COMMENT	JT
1	10/31/14	FOR CONSTRUCTION	DC

DATE: 10/31/14 REVIEWED BY: JMC



SITE NUMBER:
CT03XC368

SITE NAME:
NEWTOWN

SITE ADDRESS:
21 BERKSHIRE RD
NEWTOWN, CT 06482

SHEET TITLE:
GENERAL NOTES

SHEET NO:
SP-1

DIVISION 13000—SPECIAL CONSTRUCTION ANTENNA INSTALLATION

PART 1 — GENERAL

1.01 WORK INCLUDED

A. ANTENNAS AND HYBRIFLEX CABLES ARE FURNISHED BY CLIENT'S REPRESENTATIVE UNDER SEPARATE CONTRACT. THE CONTRACTOR SHALL ASSIST ANTENNA INSTALLATION CONTRACTOR IN TERMS OF COORDINATION AND SITE ACCESS. ERECTION SUBCONTRACTOR SHALL BE RESPONSIBLE FOR THE PROPERTY.

B. INSTALL ANTENNAS AS INDICATED ON DRAWINGS AND CLIENT'S REPRESENTATIVE SPECIFICATIONS.

C. INSTALL GALVANIZED STEEL ANTENNA MOUNTS AS INDICATED ON DRAWINGS.

D. INSTALL FURNISHED GALVANIZED STEEL OR ALUMINUM WAVEGUIDE AND PROVIDE PRINTOUT OF THAT RESULT

F. INSTALL HYBRIFLEX CABLES AND TERMINATIONS BETWEEN ANTENNAS AND EQUIPMENT PER MANUFACTURER'S RECOMMENDATIONS. WEATHERPROOF ALL CONNECTORS BETWEEN THE ANTENNA AND EQUIPMENT PER MANUFACTURER'S REQUIREMENTS.

G. ANTENNA AND HYBRIFLEX CABLE GROUNDING:

1. ALL EXTERIOR #6 GREEN GROUND WIRE DAISY CHAIN CONNECTIONS ARE TO BE WEATHER SEALED WITH ANDREWS CONNECTOR/SPLICE WEATHERPROOFING KIT TYPE 3221213 OR EQUIVALENT.

2. ALL HYBRIFLEX CABLE GROUNDING KITS ARE TO BE INSTALLED ON STRAIGHT RUNS OF HYBRIFLEX CABLE (NOT WITHIN BENDS). 1.02 RELATED WORK FURNISH THE FOLLOWING WORK AS SPECIFIED UNDER CONSTRUCTION DOCUMENTS, BUT COORDINATE WITH OTHER TRADES PRIOR TO BID:

1. FLASHING OF OPENING INTO OUTSIDE WALLS.
2. SEALING AND CAULKING ALL OPENINGS.
3. PAINTING.
4. CUTTING AND PATCHING.

1.03 REQUIREMENTS OF REGULATOR AGENCIES

A. FURNISH U.L. LISTED EQUIPMENT WHERE SUCH LABEL IS AVAILABLE. INSTALL IN CONFORMANCE WITH U.L. STANDARDS WHERE APPLICABLE.

B. INSTALL ANTENNA, ANTENNA CABLES, GROUNDING SYSTEM IN ACCORDANCE WITH DRAWINGS AND SPECIFICATIONS IN EFFECT AT PROJECT LOCATION AND RECOMMENDATIONS OF STATE AND LOCAL BUILDING CODES HAVING JURISDICTION OVER SPECIFIC PORTIONS OF WORK. THIS WORK INCLUDES, BUT IS NOT LIMITED TO THE FOLLOWING:

1. EIA — ELECTRONIC INDUSTRIES ASSOCIATION RS-22. STRUCTURAL STANDARDS FOR STEEL ANTENNA TOWERS AND ANTENNA SUPPORTING STRUCTURES.

2. FAA — FEDERAL AVIATION ADMINISTRATION ADVISORY CIRCULAR AC 70/7480-1H, CONSTRUCTION MARKING AND LIGHTING.

3. FCC — FEDERAL COMMUNICATION COMMISSION RULES AND REGULATIONS FORM 715, OBSTRUCTION MARKING AND LIGHTING SPECIFICATION FOR ANTENNA STRUCTURES

4. AISC — AMERICAN INSTITUTE OF STEEL CONSTRUCTION FOR STRUCTURAL JOINTS USING ASTM 1325 OR A490 BOLTS.

5. NEC — NATIONAL ELECTRIC CODE — ON TOWER LIGHTING KITS.

6. UL — UNDERWRITER'S LABORATORIES APPROVED ELECTRICAL PRODUCTS.

7. IN ALL CASES, PART 77 OF THE FAA RULES AND PARTS 17 AND 22 OF THE FCC RULES ARE APPLICABLE AND IN THE EVENT OF CONFLICT, SUPERSEDE ANY OTHER STANDARDS OR SPECIFICATIONS.

B. LIFE SAFETY CODE NFPA, LATEST EDITION.

DIVISION 13000—EARTHWORK

PART 1 GENERAL

1.01 WORK INCLUDED: REFER TO SURVEY AND SITE PLAN FOR WORK INCLUDED.

1.02 RELATED WORK

A. CONSTRUCTION OF EQUIPMENT FOUNDATIONS
B. INSTALLATION OF ANTENNA SYSTEM

PART 2 PRODUCTS

2.01 MATERIALS

A. ROAD AND SITE MATERIALS; FILL MATERIAL SHALL BE ACCEPTABLE. SELECT FILL SHALL BE IN ACCORDANCE WITH LOCAL DEPARTMENT OF HIGHWAY AND PUBLIC TRANSPORTATION STANDARD SPECIFICATIONS.

B. SOIL STERILIZER SHALL BE EPA REGISTERED OF LIQUID COMPOSITION AND OF PRE-EMERGENCE DESIGN.

C. SOIL STABILIZER FABRIC SHALL BE MIRAFI OR EQUAL — 600X AT ACCESS ROAD AND COMPOUND.

D. GRAVEL FILL; WELL GRADED, HARD, DURABLE, NATURAL SAND AND GRAVEL, FREE FROM ICE AND SNOW, ROOTS, SOD RUBBISH, AND OTHER DELETERIOUS OR ORGANIC MATTER.

MATERIAL SHALL CONFORM TO THE FOLLOWING GRADATION REQUIREMENTS.

GRAVEL FILL TO BE PLACED IN LIFTS OF 9" MAXIMUM THICKNESS AND 90 % DENSITY. COMPACTED TO 95

E. NO FILL OR EMBANKMENT MATERIALS SHALL BE PLACED ON FROZEN GROUND. FROZEN MATERIALS SNOW OR ICE SHALL NOT BE PLACED IN ANY FILL OF EMBANKMENT

2.02 EQUIPMENT

A. COMPACTION SHALL BE ACCOMPLISHED BY MECHANICAL MEANS. LARGER AREAS SHALL BE COMPACTED BY SHEEP'S FOOT, VIBRATORY OR RUBBER TIED ROLLERS WEIGHING AT LEAST FIVE TONS. SMALLER AREAS SHALL BE COMPACTED BY POWER-DRIVER, HAND HELD TAMPERS.

B. PRIOR TO OTHER EXCAVATION AND CONSTRUCTION EFFORTS GRUB ORGANIC MATERIAL TO A MINIMUM OF 6" BELOW ORIGINAL GROUND LEVEL.

C. UNLESS OTHERWISE INSTRUCTED BY CLIENT'S REPRESENTATIVE, REMOVE TREES, BRUSH AND DEBRIS FROM THE PROPERTY TO AN AUTHORIZED DISPOSAL LOCATION.

D. PRIOR TO PLACEMENT OF FILL OR BASE MATERIALS, ROLL THE SOIL.

E. WHERE UNSTABLE SOIL CONDITIONS ARE ENCOUNTERED, LINE THE GRUBBED AREAS WITH STABILIZER MAT PRIOR TO PLACEMENT OF FILL OR BASE MATERIAL.

3.03 INSTALLATION

A. THE SITE AND TURNAROUND AREAS SHALL BE AT THE SUB-BASE COURSE ELEVATION PRIOR TO FORMING FOUNDATIONS. GRADE OR FILL THE SITE AND ACCESS ROAD AS REQUIRED TO PRODUCE EVEN DISTRIBUTION OF SPOILS RESULTING FROM FOUNDATION EXCAVATIONS. THE RESULTING GRADE SHALL CORRESPOND WITH SAID SUB-BASE COURSE, ELEVATIONS ARE TO BE CALCULATED FROM FINISHED GRADES OR SLOPES INDICATED.

B. THE ACCESS ROAD SHALL BE BROUGHT TO BASE COURSE ELEVATION PRIOR TO FOUNDATION CONSTRUCTION.

C. DO NOT CREATE DEPRESSIONS WHERE WATER MAY POND.

D. THE CONTRACT INCLUDES ALL NECESSARY GRADING, BANKING, DITCHING AND COMPLETE SURFACE COURSE FOR ACCESS ROAD. ALL ROADS OR ROUTES UTILIZED FOR ACCESS TO PUBLIC THROUGHFARE IS INCLUDED IN SCOPE OF WORK UNLESS OTHERWISE INDICATED.

E. WHEN IMPROVING AN EXISTING ACCESS ROAD, GRADE THE EXISTING ROAD TO REMOVE ANY ORGANIC MATTER AND SMOOTH THE SURFACE BEFORE PLACING FILL OR STONE.

F. PLACE FILL OR STONE IN 3" MAXIMUM LIFTS AND COMPACT BEFORE PLACING NEXT LIFT.

G. THE FINISH GRADE, INCLUDING TOP SURFACE COURSE, SHALL EXTEND A MINIMUM OF 12" BEYOND THE SITE FENCE AND SHALL COVER THE AREA AS INDICATED.

H. RIPRAP SHALL BE APPLIED TO THE SIDE SLOPES OF ALL FENCED AREAS, PARKING AREAS AND TO ALL OTHER SLOPES GREATER THAN 2:1.

I. RIPRAP SHALL BE APPLIED TO THE SIDES OF DITCHES OR DRAINAGE SWALES AS INDICATED ON PLANS.

J. RIPRAP ENTIRE DITCH FOR 6'-0" IN ALL DIRECTIONS AT CULVERT OPENINGS.

K. SEED, FERTILIZER AND STRAW COVER SHALL BE APPLIED TO ALL OTHER DISTURBED AREAS AND DITCHES, DRAINAGE, SWALES, NOT OTHERWISE RIP-RAPPED.

L. UNDER NO CIRCUMSTANCES SHALL DITCHES, SWALES OR CULVERTS BE PLACED SO THEY DIRECT WATER TOWARDS, OR PERMIT STANDING WATER IMMEDIATELY ADJACENT TO SITE. IF OWNER DESIGNS OR IF DESIGN ELEVATIONS CONFLICT WITH THIS GUIDANCE ADVISE THE OWNER IMMEDIATELY.

M. IF A DITCH LIES WITH SLOPE GREATER THAN TEN PERCENT, MOUND DIVERSIONARY HEADWALL IN THE DITCH AT CULVERT ENTRANCES. RIP-RAP THE UPSTREAM SIDE OF THE HEADWALL AS WELL AS THE DITCH FOR 6'-0" ABOVE THE CULVERT.

N. IF A DITCH LIES WITH SLOPES GREATER THAN TEN PERCENT, MOUND DIVERSIONARY HEADWALLS IN THE DITCH FOR 6'-0" ABOVE THE CULVERT ENTRANCE.

O. SEED AND FERTILIZER SHALL BE APPLIED TO SURFACE CONDITIONS WHICH WILL ENCOURAGE ROOTING. RAKE AREAS TO BE SEEDED TO EVEN THE SURFACE AND TO LOOSEN THE SOIL.

P. SOW SEED IN TWO DIRECTIONS IN TWICE THE QUANTITY RECOMMENDED BY THE SEED PRODUCER.

Q. IT IS THE CONTRACTOR'S RESPONSIBILITY TO ENSURE GROWTH OF SEEDED AND LANDSCAPED AREAS BY WATERING UP TO THE POINT OF RELEASE FROM THE CONTRACT. CONTINUE TO REWORK BARE AREAS UNTIL COMPLETE COVERAGE IS OBTAINED.

3.04 FIELD QUALITY CONTROL

A. COMPACTION SHALL BE D-1557 FOR SITE WORK AND 95 % MAXIMUM DENSITY UNDER SLAB AREAS. AREAS OF SETTLEMENT WILL BE EXCAVATED AND REFILLED AT CONTRACTOR'S EXPENSE. REQUIRED. USE OF EROSION CONTROL MESH OR MULCH NET SHALL BE AN ACCEPTABLE ALTERNATIVE.

B. THE COMPACTION TEST RESULTS SHALL BE AVAILABLE PRIOR TO THE CONCRETE POUR.

3.05 PROTECTION

A. PROTECT SEEDED AREAS FORM EROSION BY SPREADING STRAW TO A UNIFORM LOOSE DEPTH OF 1"-2". STAKE AND TIE DOWN AS REQUIRED. USE OF EROSION CONTROL MESH OR MULCH NET SHALL BE AN ACCEPTABLE ALTERNATIVE.

B. ALL TREES PLACED IN CONJUNCTION WITH A LANDSCAPE CONTRACT SHALL BE WRAPPED, TIED WITH HOSE PROTECTED WIRE AND SECURED TO STAKES EXTENDING 2'-0" INTO THE GROUND ON FOUR SIDES OF THE TREE.

C. ALL EXPOSED AREAS SHALL BE PROTECTED AGAINST WASHOUTS AND SOIL EROSION. STRAW BALES SHALL BE PLACED AT THE INLET APPROACH TO ALL NEW OR EXISTING CULVERTS. REFER TO DETAILS ON DRAWINGS

SYMBOLS	ABBREVIATIONS
— — — — G — — — — G —	GROUND WIRE
— — — — E — — — — E —	ELECTRIC
— — — — T — — — — T —	TELEPHONE
— — — — O — — — — O —	OVERHEAD WIRE
— — — — — — — — — —	PROPERTY LINE
— X — — — X — — — — X —	CHAIN LINK FENCE
A-1	ANTENNA MARK
(E)	EXISTING
(P)	PROPOSED DETAIL
	REFERENCE
	SURFACE ELEVATION

2.5 EQUIPMENT DEPLOYMENT
6580 SPRINT PARKWAY
OVERLAND PARK, KANSAS 66251

TECTONIC Engineering & Surveying Consultants P.C.
1279 Route 300
Newburgh, NY 12550
Phone: (845) 567-6656
Fax: (845) 567-8703
www.tectonicengineering.com

THIS DOCUMENT IS THE CREATION, DESIGN, PROPERTY AND COPYRIGHTED WORK OF SPRINT COMMUNICATIONS, INC. ANY DUPLICATION OR USE WITHOUT EXPRESS WRITTEN CONSENT IS STRICTLY PROHIBITED. DUPLICATION AND USE BY GOVERNMENT AGENCIES FOR THE PURPOSES OF CONDUCTING THEIR LAWFULLY AUTHORIZED REGULATORY AND ADMINISTRATIVE FUNCTIONS IS SPECIFICALLY ALLOWED.

SUBMITTALS			
PROJECT NO: 7225.CT03XC368			
NO	DATE	DESCRIPTION	BY
0	06/14/14	FOR COMMENT	JT
1	10/31/14	FOR CONSTRUCTION	DC

DATE: 10/31/14
REVIEWED BY: JMC

SITE NUMBER:
CT03XC368
SITE NAME:
NEWTOWN
SITE ADDRESS:
21 BERKSHIRE RD
NEWTOWN, CT 06482

SHEET TITLE:
GENERAL NOTES

SHEET NO:
SP-2

NORTH NOTE:

NORTH SHOWN HAS BEEN ESTABLISHED USING THE USGS QUADRANGLE 7.5 MINUTE MAPS AND IS APPROXIMATE. VERIFY TRUE NORTH PRIOR TO INSTALLATION OF ANTENNAS.

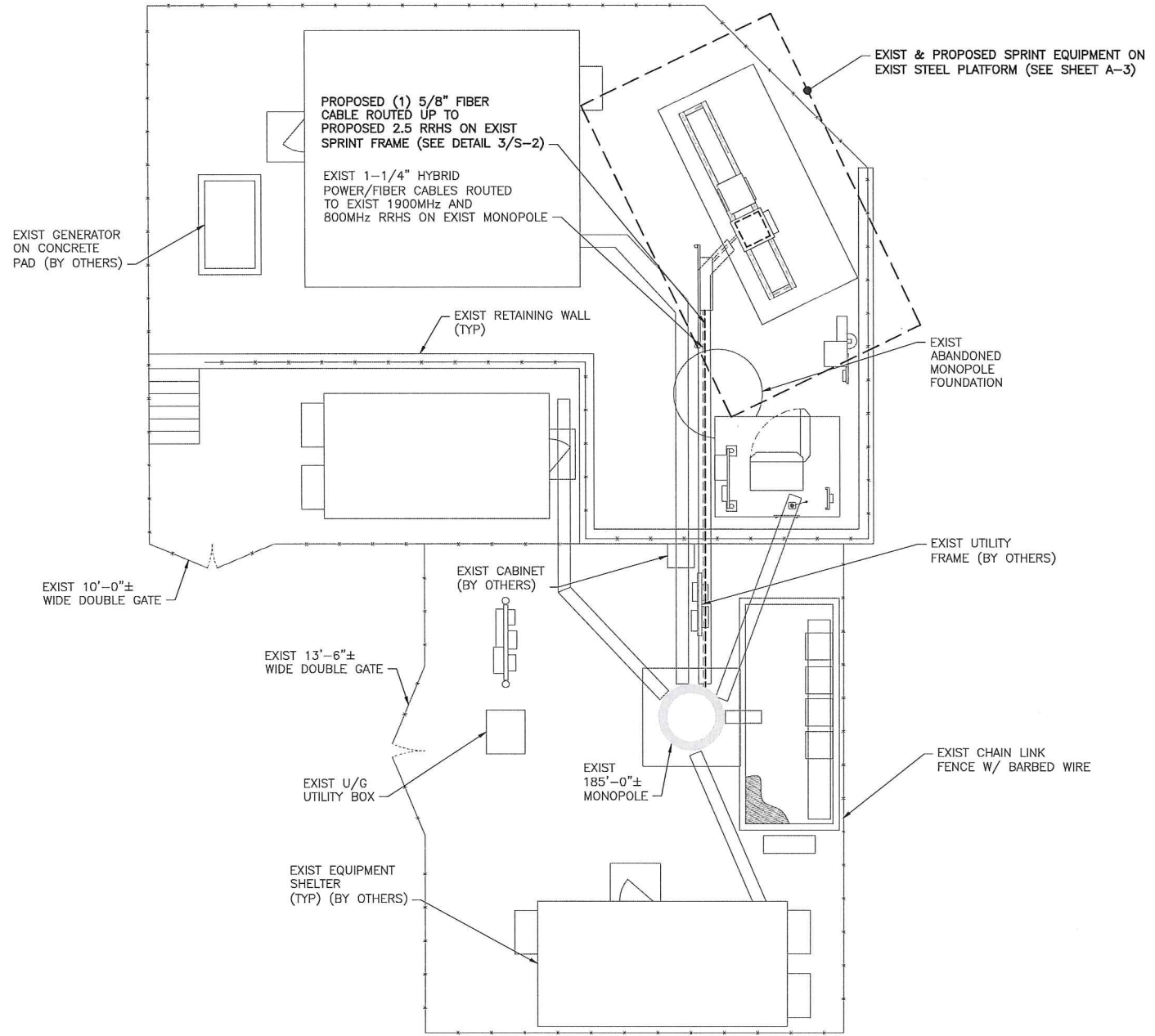

1 SITE PLAN
A-1 SCALE: 1/4" = 1'-0"

Sprint
2.5 EQUIPMENT DEPLOYMENT
6580 SPRINT PARKWAY
OVERLAND PARK, KANSAS 66251

CROWN CASTLE

TECTONIC • PLANNING
• ENGINEERING
• SURVEYING
• CONSTRUCTION MANAGEMENT
TECTONIC Engineering & Surveying Consultants P.C.
1279 Route 300
Newburgh, NY 12550
Phone: (845) 567-6656
Fax: (845) 567-8703
www.tectonicengineering.com

THIS DOCUMENT IS THE CREATION, DESIGN, PROPERTY AND COPYRIGHTED WORK OF SPRINT COMMUNICATIONS, INC. ANY DUPLICATION OR USE WITHOUT EXPRESS WRITTEN CONSENT IS STRICTLY PROHIBITED. DUPLICATION AND USE BY GOVERNMENT AGENCIES FOR THE PURPOSES OF CONDUCTING THEIR LAWFULLY AUTHORIZED REGULATORY AND ADMINISTRATIVE FUNCTIONS IS SPECIFICALLY ALLOWED.

SUBMITTALS

PROJECT NO: 7225.CT03XC368

NO	DATE	DESCRIPTION	BY
0	06/14/14	FOR COMMENT	JT
1	10/31/14	FOR CONSTRUCTION	DC

DATE: 10/31/14 REVIEWED BY: Jma



SITE NUMBER:
CT03XC368
SITE NAME:
NEWTOWN
SITE ADDRESS:
21 BERKSHIRE RD
NEWTOWN, CT 06482

SHEET TITLE:
SITE PLAN

SHEET NO:
A-1

THE EXISTING MONOPOLE SHALL BE ANALYZED BY A PROFESSIONAL ENGINEER LICENSED IN THE STATE OF CONNECTICUT (TO BE COORDINATED BY OTHERS).

THE EXISTING MOUNT HAS BEEN ANALYZED BY TECTONIC ENGINEERING AND FOUND TO BE ADEQUATE TO SUPPORT THE PROPOSED SPRINT UPGRADE ONCE THE PROPOSED MODIFICATIONS HAVE BEEN COMPLETED AS DETAILED IN THE STRUCTURAL ANALYSIS EVALUATION LETTER DATED 10/31/14.

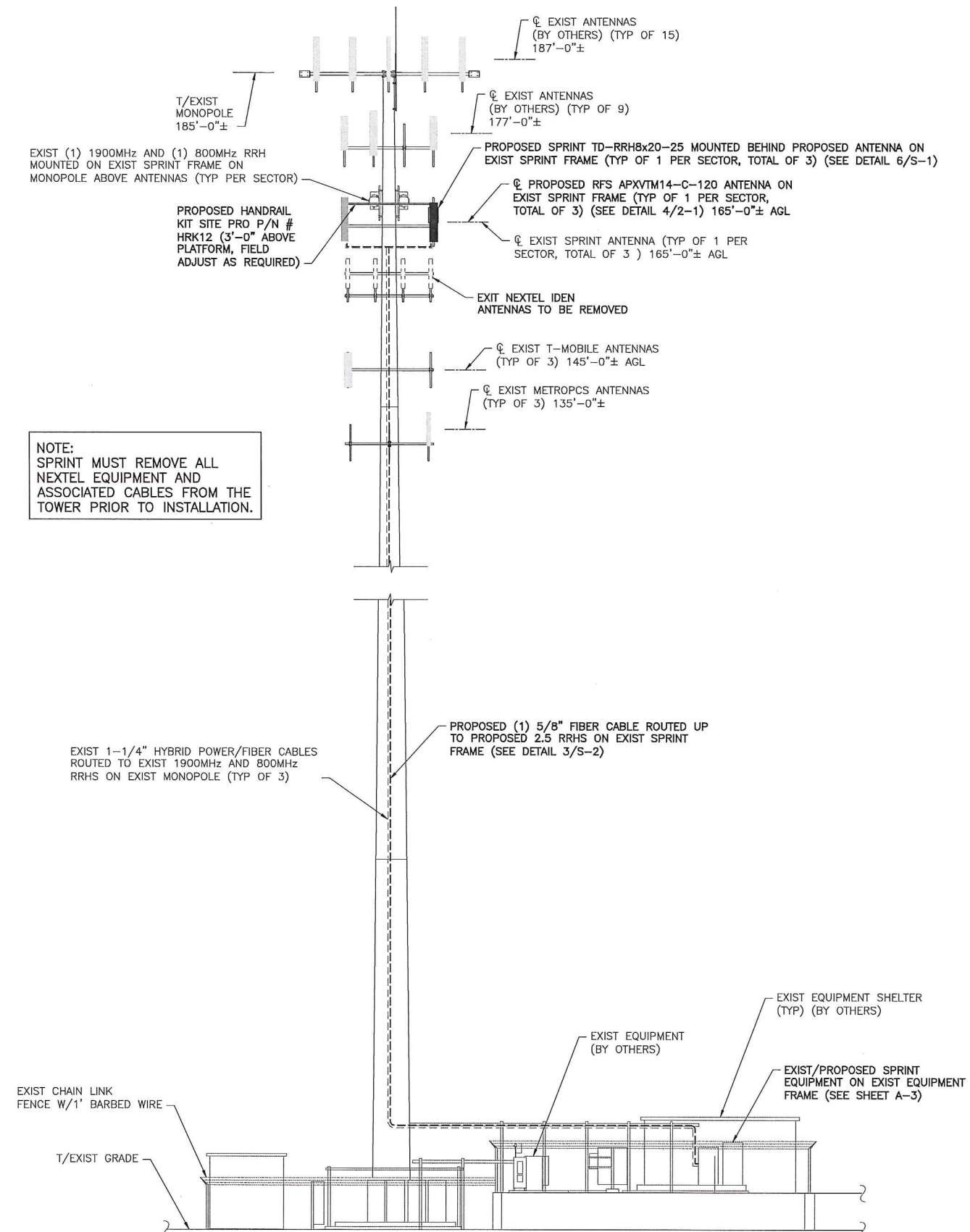

NOTE:
SPRINT MUST REMOVE ALL NEXTEL EQUIPMENT AND ASSOCIATED CABLES FROM THE TOWER PRIOR TO INSTALLATION.

1 ELEVATION
A-2 SCALE: 3/16" = 1'-0"

Sprint
2.5 EQUIPMENT DEPLOYMENT
6580 SPRINT PARKWAY
OVERLAND PARK, KANSAS 66251

CROWN CASTLE

TECTONIC ENGINEERING & SURVEYING CONSULTANTS P.C.
1279 Route 300
Newburgh, NY 12550
Phone: (845) 567-6656
Fax: (845) 567-8703
www.tectonicengineering.com

THIS DOCUMENT IS THE CREATION, DESIGN, PROPERTY AND COPYRIGHTED WORK OF SPRINT COMMUNICATIONS, INC. ANY DUPLICATION OR USE WITHOUT EXPRESS WRITTEN CONSENT IS STRICTLY PROHIBITED. DUPLICATION AND USE BY GOVERNMENT AGENCIES FOR THE PURPOSES OF CONDUCTING THEIR LAWFULLY AUTHORIZED REGULATORY AND ADMINISTRATIVE FUNCTIONS IS SPECIFICALLY ALLOWED.

SUBMITTALS

PROJECT NO: 7225.CT03XC368

NO	DATE	DESCRIPTION	BY
0	06/14/14	FOR COMMENT	JT
1	10/31/14	FOR CONSTRUCTION	DC

DATE: 10/31/14
REVIEWED BY: J.M.G.

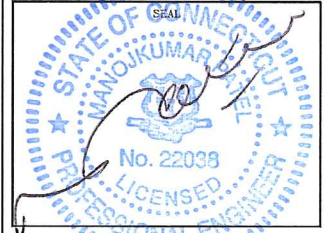

SITE NUMBER: CT03XC368
SITE NAME: NEWTOWN
SITE ADDRESS: 21 BERKSHIRE RD
NEWTOWN, CT 06482

SHEET TITLE: ELEVATION

SHEET NO: A-2

Sprint
 2.5 EQUIPMENT DEPLOYMENT
 6580 SPRINT PARKWAY
 OVERLAND PARK, KANSAS 66251

CROWN CASTLE

TECTONIC • PLANNING
 • ENGINEERING
 • SURVEYING
 • CONSTRUCTION MANAGEMENT
TECTONIC Engineering & Surveying
 Consultants P.C.
 1279 Route 300
 Newburgh, NY 12550
 Phone: (845) 567-6656
 Fax: (845) 567-8703
 www.tectonicengineering.com

THIS DOCUMENT IS THE CREATION, DESIGN, PROPERTY AND COPYRIGHTED WORK OF SPRINT COMMUNICATIONS, INC. ANY DUPLICATION OR USE WITHOUT EXPRESS WRITTEN CONSENT IS STRICTLY PROHIBITED. DUPLICATION AND USE BY GOVERNMENT AGENCIES FOR THE PURPOSES OF CONDUCTING THEIR LAWFULLY AUTHORIZED REGULATORY AND ADMINISTRATIVE FUNCTIONS IS SPECIFICALLY ALLOWED.

SUBMITTALS			
NO	DATE	DESCRIPTION	BY
0	06/14/14	FOR COMMENT	JT
1	10/31/14	FOR CONSTRUCTION	DC

DATE	REVIEWED BY
10/31/14	JMG



SITE NUMBER:
 CT03XC368
 SITE NAME:
 NEWTOWN
 SITE ADDRESS:
 21 BERKSHIRE RD
 NEWTOWN, CT 06482

SHEET TITLE:
 ENLARGED EQUIPMENT
 LAYOUT PLANS

SHEET NO:
 A-3

NORTH NOTE:
 NORTH SHOWN HAS BEEN ESTABLISHED USING THE USGS QUADRANGLE 7.5 MINUTE MAPS AND IS APPROXIMATE. VERIFY TRUE NORTH PRIOR TO INSTALLATION OF ANTENNAS.

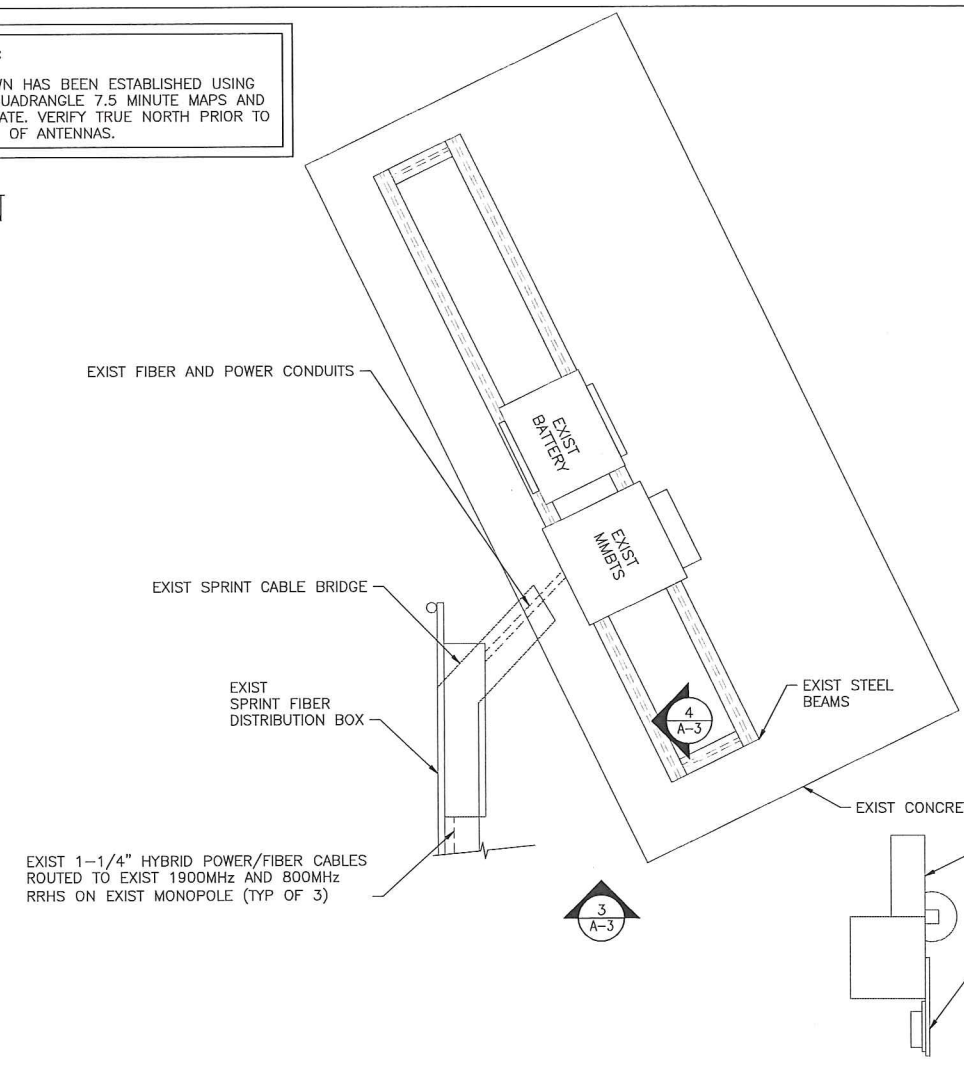

1 ENLARGED EQUIP. LAYOUT PLAN (EXIST)
 A-3 SCALE: 3/4" = 1'-0"



3 EXIST EQUIPMENT PAD
 A-3 SCALE: NTS

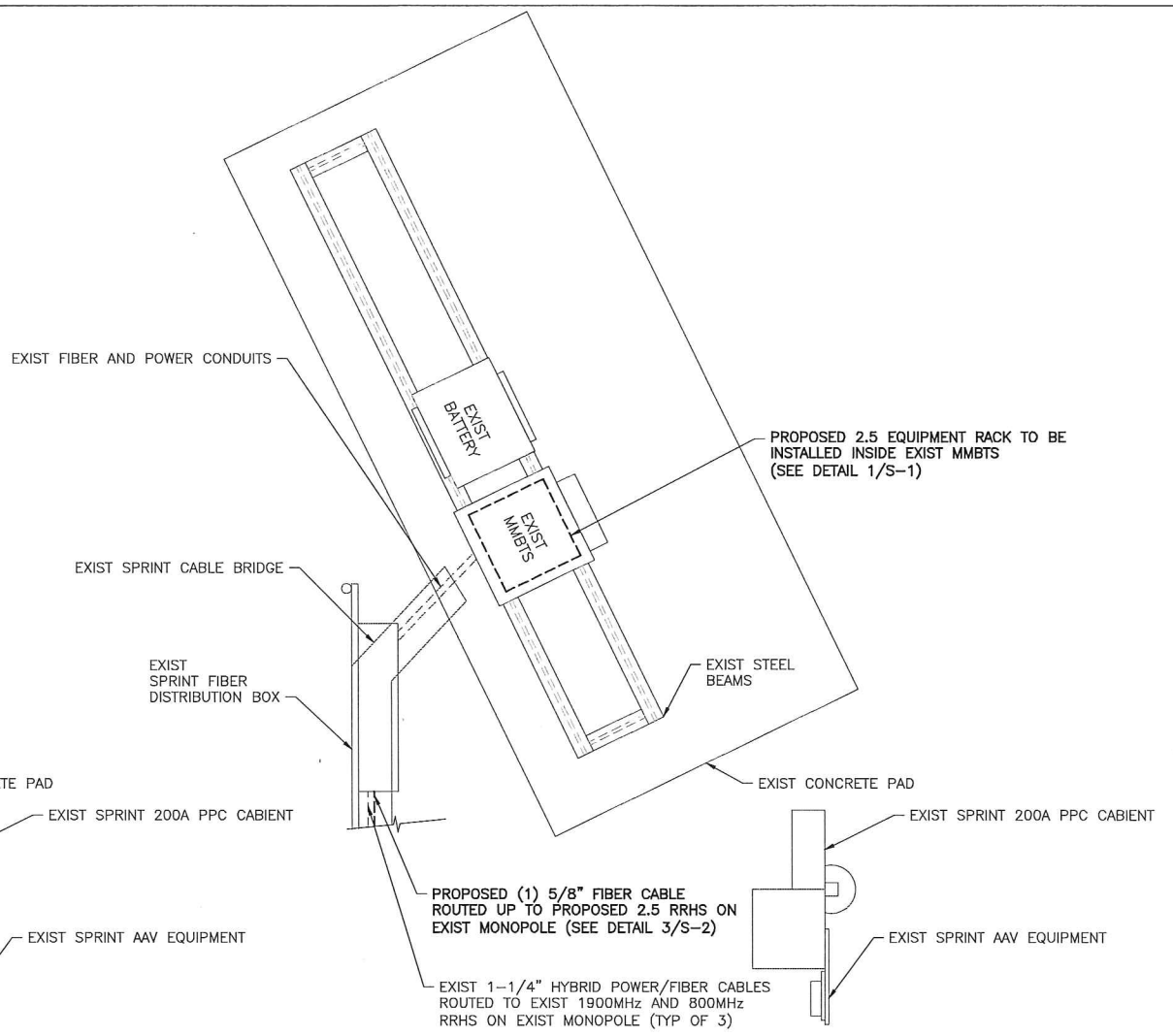

2 ENLARGED EQUIP. LAYOUT PLAN (FINAL)
 A-3 SCALE: 3/4" = 1'-0"

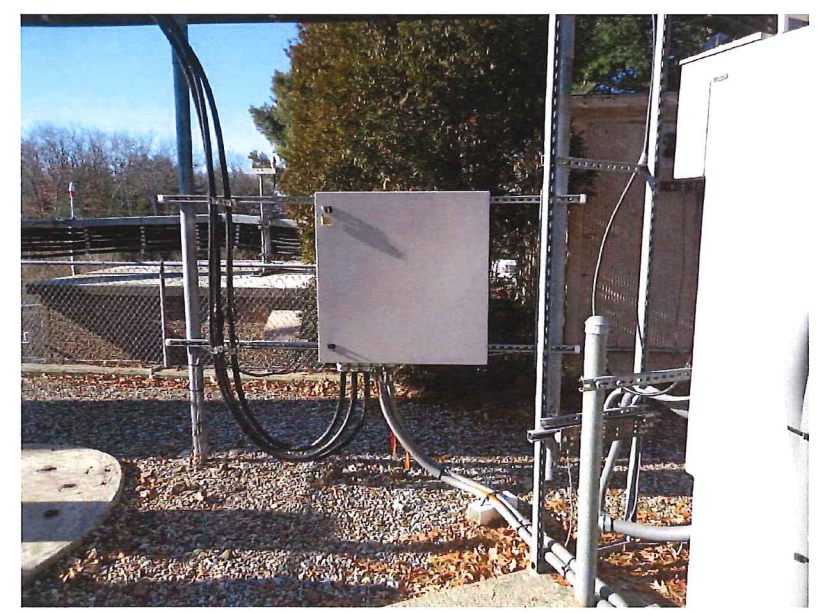

4 EXIST FIBER DISTRIBUTION BOX
 A-3 SCALE: NTS

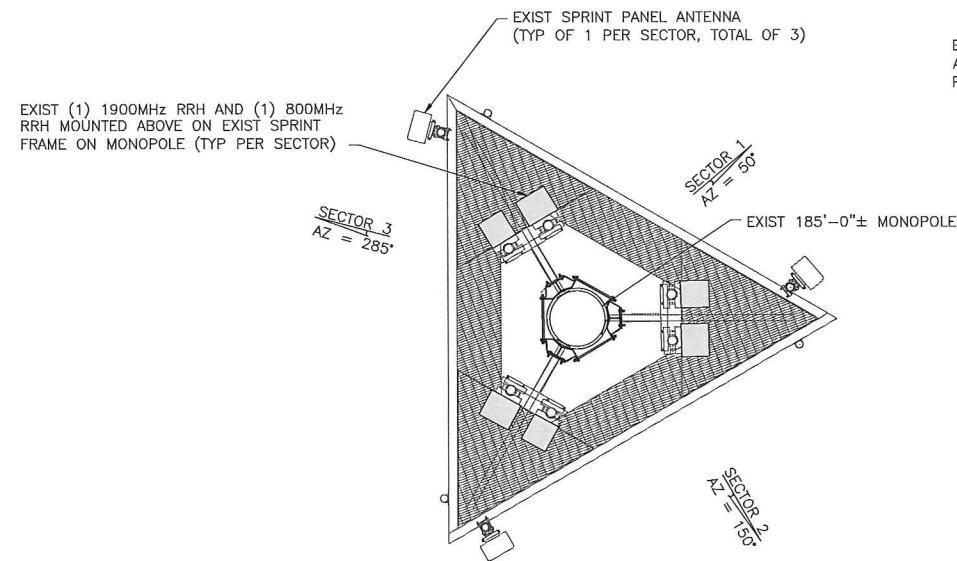

1 ANTENNA LAYOUT PLAN (EXIST)
A-4 SCALE: 3/8" = 1'-0"



THE EXISTING MONOPOLE SHALL BE ANALYZED BY A PROFESSIONAL ENGINEER LICENSED IN THE STATE OF CONNECTICUT (TO BE COORDINATED BY OTHERS).

THE EXISTING MOUNT HAS BEEN ANALYZED BY TECTONIC ENGINEERING AND FOUND TO BE ADEQUATE TO SUPPORT THE PROPOSED SPRINT UPGRADE ONCE THE PROPOSED MODIFICATIONS HAVE BEEN COMPLETED AS DETAILED IN THE STRUCTURAL ANALYSIS EVALUATION LETTER DATED 10/31/14.

Sprint
2.5 EQUIPMENT DEPLOYMENT
6580 SPRINT PARKWAY
OVERLAND PARK, KANSAS 66251

CROWN CASTLE

TECTONIC • PLANNING • ENGINEERING • SURVEYING • CONSTRUCTION MANAGEMENT
TECTONIC Engineering & Surveying Consultants P.C.
1279 Route 300
Newburgh, NY 12550
Phone: (845) 567-6656
Fax: (845) 567-8703
www.tectonicengineering.com

THIS DOCUMENT IS THE CREATION, DESIGN, PROPERTY AND COPYRIGHTED WORK OF SPRINT COMMUNICATIONS, INC. ANY DUPLICATION OR USE WITHOUT EXPRESS WRITTEN CONSENT IS STRICTLY PROHIBITED. DUPLICATION AND USE BY GOVERNMENT AGENCIES FOR THE PURPOSES OF CONDUCTING THEIR LAWFULLY AUTHORIZED REGULATORY AND ADMINISTRATIVE FUNCTIONS IS SPECIFICALLY ALLOWED.

SUBMITTALS

PROJECT NO: 7225.CT03XC368

NO	DATE	DESCRIPTION	BY
0	06/14/14	FOR COMMENT	JT
1	10/31/14	FOR CONSTRUCTION	DC

DATE	REVIEWED BY
10/31/14	JMG

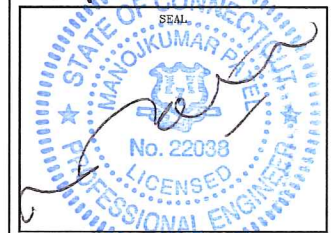

SITE NUMBER:
CT03XC368
SITE NAME:
NEWTOWN
SITE ADDRESS:
21 BERKSHIRE RD
NEWTOWN, CT 06482

SHEET TITLE:
ANTENNA LAYOUT PLANS

SHEET NO:
A-4

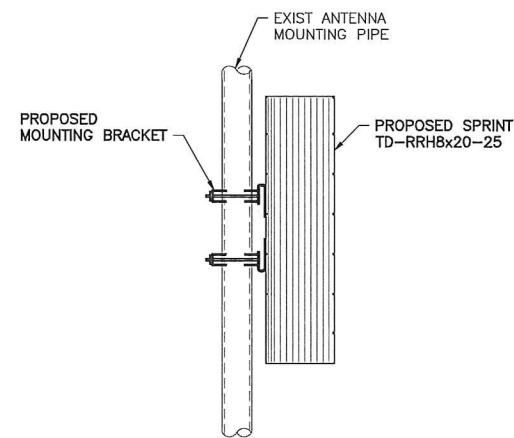

3 RRH MOUNTING DETAIL
A-4 SCALE: 1 1/2" = 1'-0"

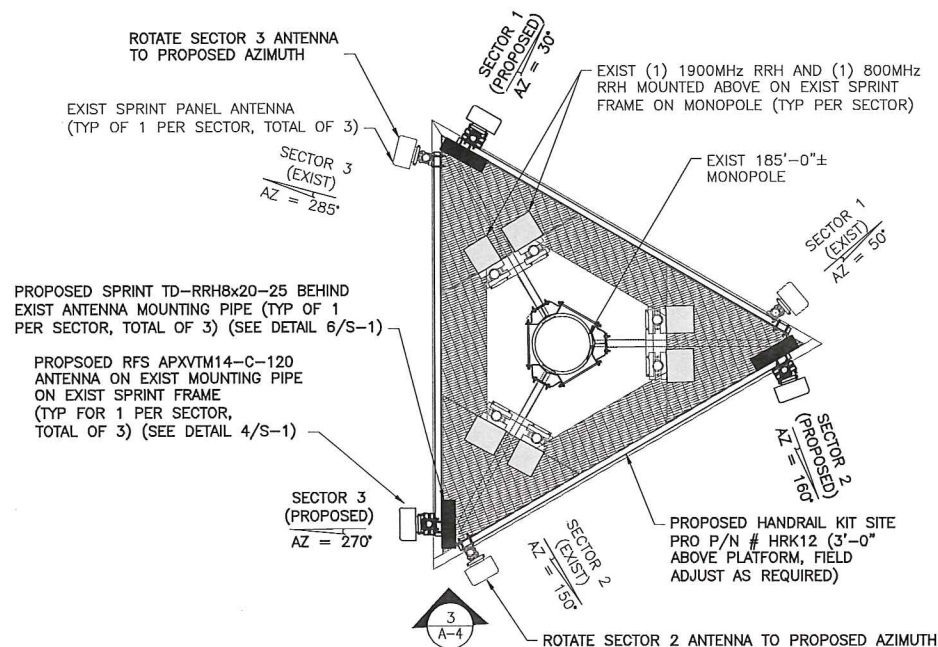

2 ANTENNA LAYOUT PLAN (FINAL)
A-4 SCALE: 3/8" = 1'-0"

ANTENNA DATA

Status	Exist	Proposed
Antenna Manufacturer	RFS-CEL WAVE	RFS-CEL WAVE
Antenna Model Number	APXVSP18C-A20	APXVTM14-C-120
Number of Antennas	3	3
Antenna RAD Center	165'	165'
Antenna Azimuth	50/150/285	30/160/270
Antenna RRH Model Number	1900MHz/800MHz RRHS	TD-RRHx20-25
Number of RRH	3	3

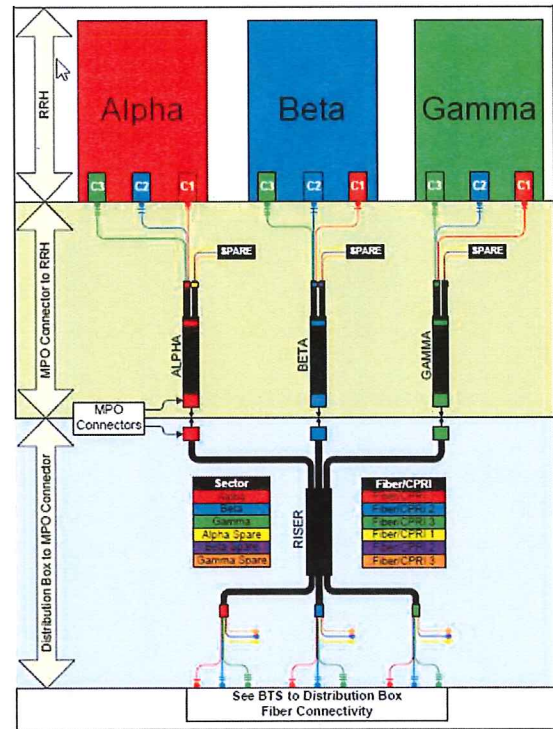

1 2.5 CABLE COLOR CODING
A-5 SCALE: N.T.S.

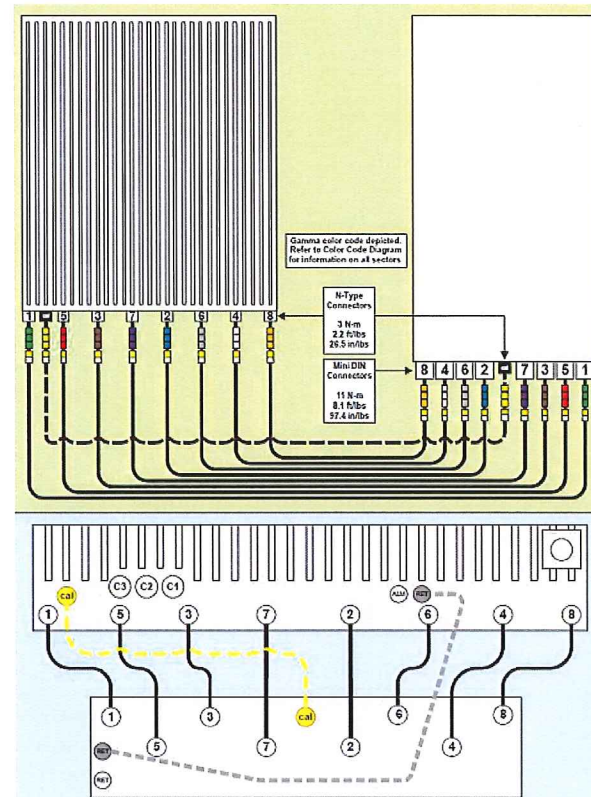

2 RRH CONNECTIVITY
A-5 SCALE: N.T.S.

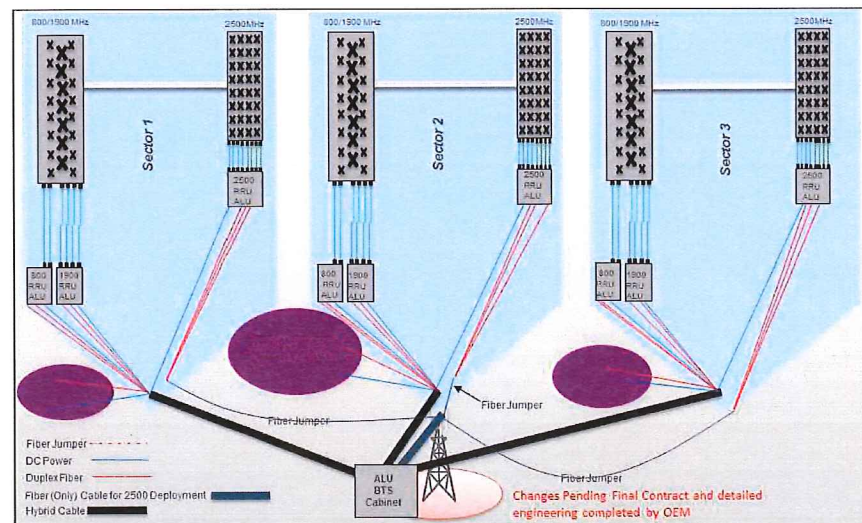

3 RAN WIRING
A-5 SCALE: N.T.S.

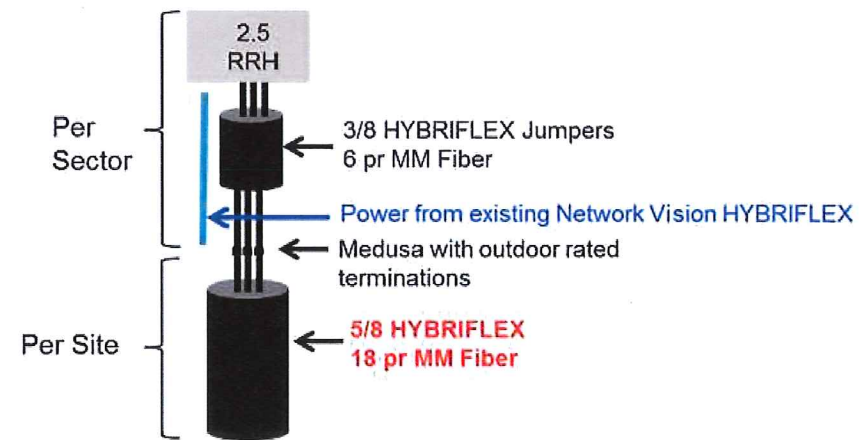

4 CABLE SCENARIO
A-5 SCALE: N.T.S.

Sprint

2.5 EQUIPMENT DEPLOYMENT
6580 SPRINT PARKWAY
OVERLAND PARK, KANSAS 66251

CROWN CASTLE

TECTONIC • PLANNING
• ENGINEERING
• SURVEYING
• CONSTRUCTION
MANAGEMENT

TECTONIC Engineering & Surveying
Consultants P.C.

1279 Route 300
Newburgh, NY 12550
Phone: (845) 567-6656
Fax: (845) 567-8703
www.tectonicengineering.com

THIS DOCUMENT IS THE CREATION, DESIGN, PROPERTY AND COPYRIGHTED WORK OF SPRINT COMMUNICATIONS, INC. ANY DUPLICATION OR USE WITHOUT EXPRESS WRITTEN CONSENT IS STRICTLY PROHIBITED. DUPLICATION AND USE BY GOVERNMENT AGENCIES FOR THE PURPOSES OF CONDUCTING THEIR LAWFULLY AUTHORIZED REGULATORY AND ADMINISTRATIVE FUNCTIONS IS SPECIFICALLY ALLOWED.

SUBMITTALS

PROJECT NO: 7225.CT03XC368

NO	DATE	DESCRIPTION	BY
0	06/14/14	FOR COMMENT	JT
1	10/31/14	FOR CONSTRUCTION	DC

DATE	REVIEWED BY
10/31/14	JMA

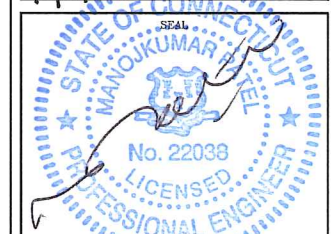

SITE NUMBER:
CT03XC368
SITE NAME:
NEWTOWN
SITE ADDRESS:
21 BERKSHIRE RD
NEWTOWN, CT 06482

SHEET TITLE:
RAN WIRING DIAGRAM

SHEET NO:
A-5

IMPORTANT!! LINE UP WHITE MARKINGS ON JUMPER AND RISER IP-MPO CONNECTOR. PUSH THE WHITE MARK ON THE JUMPER CONNECTOR FLUSH AGAINST THE RED SEAL ON THE RISER CONNECTION



IMPORTANT!! ROTATE THE BAYONET HOUSING CLOCKWISE UNTIL A CLICK SOUND IS HEARD TO EXSURE A GOOD CONNECTION

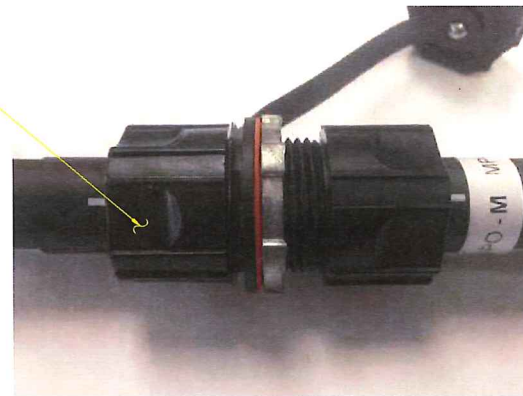

1 HYBRIFLEX RISER/JUMPER CONNECTION DETAILS
A-6 SCALE: N.T.S.

TRUNK-LINE TO JUMPER CONNECTION (MPO) TO BE INSTALLED PER MANUFACTURER REQUIREMENTS. SEE DETAIL.

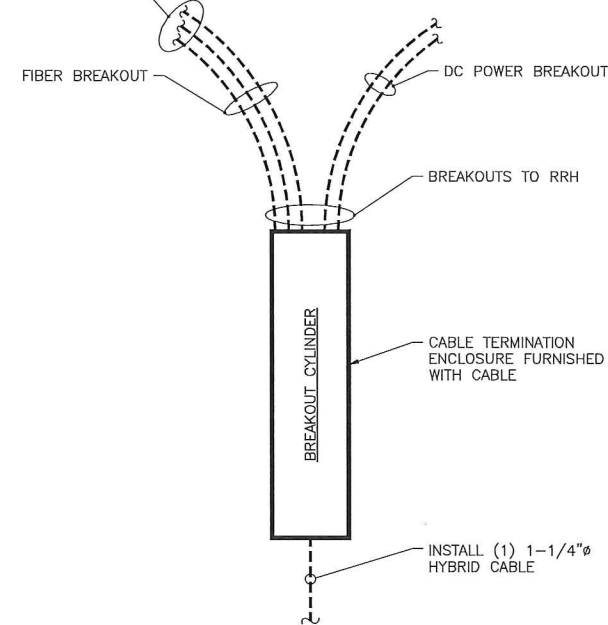

2.5 HYBRID CABLE W/FIBER & DC FEEDERS

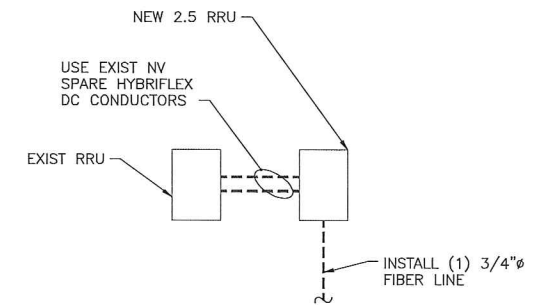

FIBER ONLY TRUNK LINES

2 TRUNK LINE DETAILS (TYPICAL)
A-6 SCALE: N.T.S.

SPECIAL NOTES: CABLE MARKINGS AT RAD CENTER AND ALL WALL/BLDG. PENETRATIONS

- ALL COLOR CODE TAPE SHALL BE 3M-35 AND SHALL BE INSTALLED USING A MINIMUM OF (3) WRAPS OF TAPE.
- ALL COLOR BANDS INSTALLED AT THE TOWER TOP SHALL BE A MINIMUM OF 3" WIDE AND SHALL HAVE A MINIMUM OF 3/4" OF SPACING BETWEEN EACH COLOR.
- ALL COLOR BANDS INSTALLED AT OR NEAR THE GROUND MAY BE ONLY 3/4" WIDE. EACH TOP-JUMPER SHALL BE COLOR CODED WITH (1) SET OF 3" WIDE BANDS.
- EACH MAIN COAX SHALL BE COLOR CODED WITH (1) SET OF 3" BANDS NEAR THE TOP-JUMPER CONNECTION AND WITH 3/4" COLOR BANDS JUST PRIOR TO ENTERING THE BTS OR TRANSMITTER BUILDING.
- ALL BOTTOM JUMPERS SHALL BE COLOR CODED WITH (1) SET OF 3/4" BANDS ON EACH END OF THE BOTTOM JUMPER.
- ALL COLOR CODES SHALL BE INSTALLED SO AS TO ALIGN NEATLY WITH ONE ANOTHER FROM SIDE-TO-SIDE.
- EACH COLOR BAND SHALL HAVE A MINIMUM OF (3) WRAPS AND SHALL BE NEATLY TRIMMED AND SMOOTHED OUT AS TO AVOID UNRAVELING.
- X-POLE ANTENNAS SHOULD USE "XX-1" FOR THE "+45" PORT, "XX-2" FOR THE "-45" PORT.
- COLOR BAND #4 REFERS TO THE FREQUENCY BAND: ORANGE=850, VIOLET=1900. USED ON JUMPERS ONLY.
- RF FEEDLINE SHALL BE IDENTIFIED WITH A METAL TAG (STAINLESS OR BRASS) AND STAMPED WITH THE SECTOR, ANTENNA POSITION, AND CABLE NUMBER.
- ANTENNAS MUST BE IDENTIFIED, USING THE SECTOR LETTER AND ANTENNA NUMBER, WITH A BLACK MARKER PRIOR TO INSTALLATION.

Sprint
2.5 EQUIPMENT DEPLOYMENT
6580 SPRINT PARKWAY
OVERLAND PARK, KANSAS 66251

CROWN CASTLE

TECTONIC • PLANNING
• ENGINEERING
• SURVEYING
• CONSTRUCTION
MANAGEMENT
TECTONIC Engineering & Surveying
Consultants P.C.
1279 Route 300
Newburgh, NY 12550
Phone: (845) 567-6656
Fax: (845) 567-8703
www.tectonicengineering.com

THIS DOCUMENT IS THE CREATION, DESIGN, PROPERTY AND COPYRIGHTED WORK OF SPRINT COMMUNICATIONS, INC. ANY DUPLICATION OR USE WITHOUT EXPRESS WRITTEN CONSENT IS STRICTLY PROHIBITED. DUPLICATION AND USE BY GOVERNMENT AGENCIES FOR THE PURPOSES OF CONDUCTING THEIR LAWFULLY AUTHORIZED REGULATORY AND ADMINISTRATIVE FUNCTIONS IS SPECIFICALLY ALLOWED.

SUBMITTALS			
NO	DATE	DESCRIPTION	BY
0	06/14/14	FOR COMMENT	JT
1	10/31/14	FOR CONSTRUCTION	DC

DATE: 10/31/14
REVIEWED BY: JMG

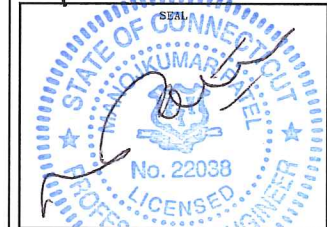

SITE NUMBER:
CT03XC368
SITE NAME:
NEWTOWN
SITE ADDRESS:
21 BERKSHIRE RD
NEWTOWN, CT 06482

SHEET TITLE:
CABLE DETAILS

SHEET NO:
A-6

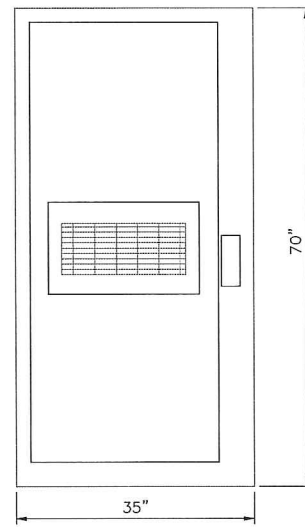

CABINET FRONT
9928 MMBTS MODULAR CELL
SPECIFICATIONS:
HEIGHT: 70"
WIDTH: 35"
DEPTH: 37.8"
WEIGHT: 1090 LBS.

1 (EXIST) MMBTS CABINET
S-1 SCALE: 1" = 1'-0"

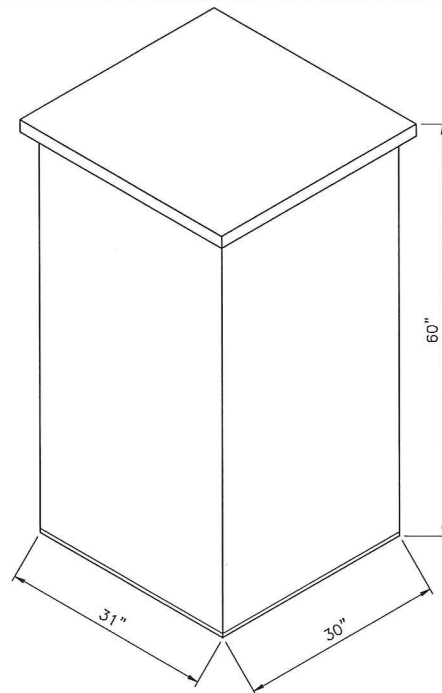

ANDREW 60ECv2
SPECIFICATIONS:
HEIGHT: 60"
WIDTH: 31"
DEPTH: 30"
WEIGHT: 2430 LBS.

2 (EXIST) BATTERY CABINET
S-1 SCALE: 1" = 1'-0"

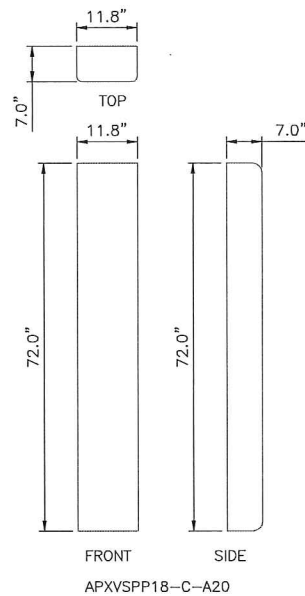

APXVSP18-C-A20

3 (EXIST) ANTENNA DETAILS
S-1 SCALE: 3/4" = 1'-0"

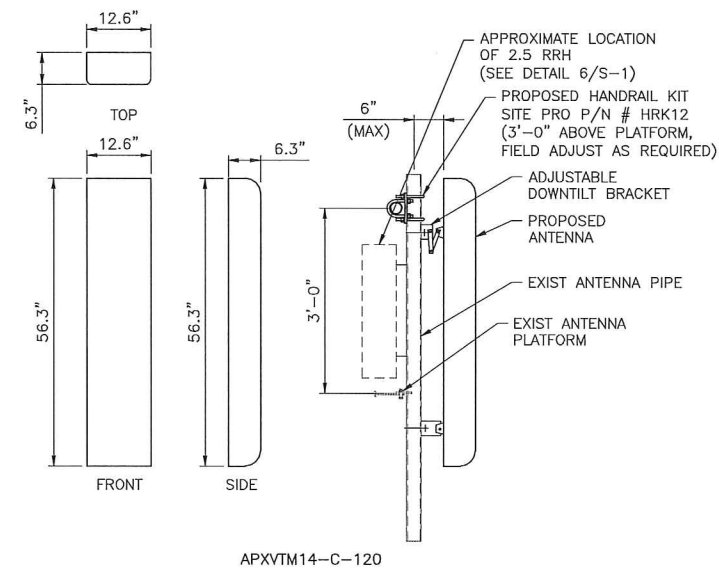

APXVTM14-C-120

4 (PROPOSED) ANTENNA DETAIL
S-1 SCALE: 3/4" = 1'-0"

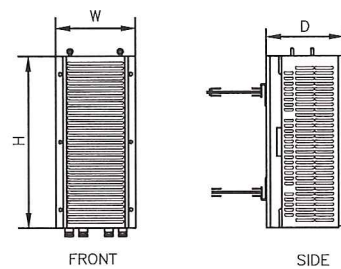

TYPE: 1900 MHz 4x45W
MODEL #: RRH 1900 4X45 65MHz
HEIGHT: 25.0"
WIDTH: 11.1"
DEPTH: 11.4"
WEIGHT: ±60 LBS.

5 (EXIST) RRH DETAILS
S-1 SCALE: 1 1/2" = 1'-0"

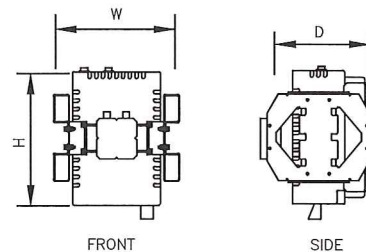

TYPE: 800 MHz 2x50W
MODEL #: FD-RRH-2x50-800
HEIGHT: 19.7"
WIDTH: 13"
DEPTH: 10.8"
WEIGHT: ±53 LBS

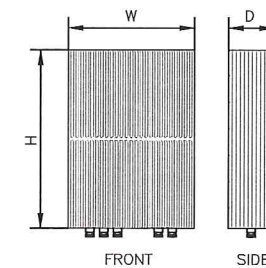

TYPE: 2.5 RRH
MODEL #: TD-RRH8x20-25
HEIGHT: 26.1"
WIDTH: 18.6"
DEPTH: 6.7"
WEIGHT: ±70 LBS

6 (PROPOSED) RRH DETAIL
S-1 SCALE: N.T.S.

Sprint
2.5 EQUIPMENT DEPLOYMENT
6580 SPRINT PARKWAY
OVERLAND PARK, KANSAS 66251

CROWN CASTLE

TECTONIC ENGINEERING & SURVEYING CONSULTANTS P.C.
TECTONIC Engineering & Surveying Consultants P.C.
1279 Route 300
Newburgh, NY 12550
Phone: (845) 567-6656
Fax: (845) 567-8703
www.tectonicengineering.com

THIS DOCUMENT IS THE CREATION, DESIGN, PROPERTY AND COPYRIGHTED WORK OF SPRINT COMMUNICATIONS, INC. ANY DUPLICATION OR USE WITHOUT EXPRESS WRITTEN CONSENT IS STRICTLY PROHIBITED. DUPLICATION AND USE BY GOVERNMENT AGENCIES FOR THE PURPOSES OF CONDUCTING THEIR LAWFULLY AUTHORIZED REGULATORY AND ADMINISTRATIVE FUNCTIONS IS SPECIFICALLY ALLOWED.

SUBMITTALS

PROJECT NO: 7225.CT03XC368

NO	DATE	DESCRIPTION	BY
0	06/14/14	FOR COMMENT	JT
1	10/31/14	FOR CONSTRUCTION	DC

DATE	REVIEWED BY
10/31/14	JMG

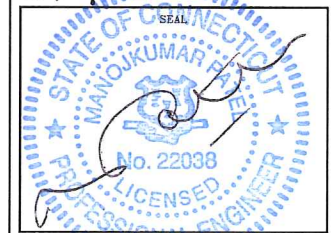

SITE NUMBER:
CT03XC368
SITE NAME:
NEWTOWN
SITE ADDRESS:
21 BERKSHIRE RD
NEWTOWN, CT 06482

SHEET TITLE:
EQUIPMENT DETAILS

SHEET NO:
S-1

NOTE:
LOCATIONS SHOWN FOR
INSTALLATION OF NEW
EQUIPMENT IN EXISTING
CABINET ARE APPROXIMATE.
ACTUAL SPACE AVAILABLE
TO BE VERIFIED IN FIELD
ON A SITE BY SITE BASIS.

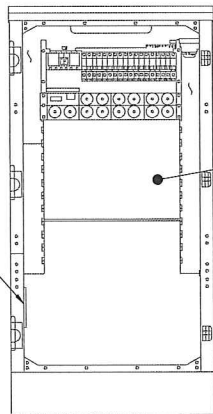

EXIST GROUND
BAR TO BE UTILIZED

INSTALL NEW 2.5
EQUIPMENT IN EXIST MMBTS
CABINET INCLUDING BUT
NOT LIMITED TO BASE BAND
UNIT, CELL SITE ROUTER
AND SURGE ARRESTORS.
GROUND EQUIPMENT TO
EXIST INTERIOR CABINET
GROUND BAR

FRONT ELEVATION
(CABINET INTERIOR)

1 MMBTS INTERIOR DETAIL
SCALE: N.T.S.

- LEGEND:
1. P1000T-HG UNISTRUT,
12" LONG.
2. 6" PIPE HANGER.
3. EXISTING SUPPORT PIPE.
4. NEW STANDOFF BRACKET,
ANDREW PART# 30848-4.
5. NEW ROUND MEMBER
ADAPTER SIZED FOR
EXISTING PIPE SUPPORT.
6. BREAKOUT UNIT.
7. CABLE.

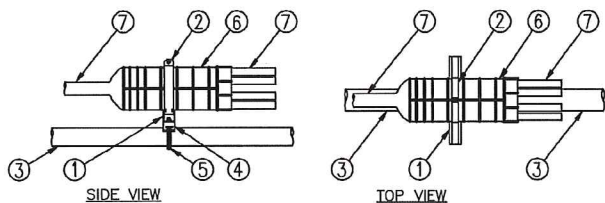

2 MEDUSA HEAD DETAIL
SCALE: N.T.S.

RFS HYBRIFLEX RISER CABLES SCHEDULE

Power	Hybrid cable	Length	
Fiber Only (Existing DC Power)	MN: HB058-M12-050F 12x multi-mode fiber pairs, Top: Outdoor protected connectors, Bottom: LC Connectors, 5/8 cable, 50ft	50 ft	
	MN: HB058-M12-075F	75 ft	
	MN: HB058-M12-100F	100 ft	
	MN: HB058-M12-125F	125 ft	
	MN: HB058-M12-150F	150 ft	
	MN: HB058-M12-175F	175 ft	
8 AWG Power	MN: HB114-08U3M12-050F 3x 8 AWG power pairs, 12x multi-mode fiber pairs, Outdoor rated connectors & LC Connectors, 1 1/4 cable, 50ft	50 ft	
	MN: HB114-08U3M12-075F	75 ft	
	MN: HB114-08U3M12-100F	100 ft	
	MN: HB114-08U3M12-125F	125 ft	
	MN: HB114-08U3M12-150F	150 ft	
	MN: HB114-08U3M12-175F	175 ft	
6 AWG Power	MN: HB114-13U3M12-225F 3x 6 AWG power pairs, 12x multi-mode fiber pairs, Outdoor rated connectors & LC Connectors, 1 1/4 cable, 225ft	225 ft	
	MN: HB114-13U3M12-250F	250 ft	
	MN: HB114-13U3M12-275F	275 ft	
	MN: HB114-13U3M12-300F	300 ft	
	4 AWG Power	MN: HB114-21U3M12-225F 3x 4 AWG power pairs, 12x multi-mode fiber pairs, Outdoor rated connectors & LC Connectors, 1 1/4 cable, 225ft	225 ft
		MN: HB114-21U3M12-250F	250 ft
MN: HB114-21U3M12-275F		275 ft	
MN: HB114-21U3M12-300F		300 ft	

RFS HYBRIFLEX JUMPER CABLE SCHEDULE

Power	Hybrid Jumper cable	Length
Fiber Only	MN: HBF012-M3-5F1 5 ft, 3x multi-mode fiber pairs, Outdoor & LC connectors, 1/2 cable	5 ft
	MN: HBF012-M3-10F1	10 ft
	MN: HBF012-M3-15F1	15 ft
	MN: HBF012-M3-20F1	20 ft
	MN: HBF012-M3-25F1	25 ft
	MN: HBF012-M3-30F1	30 ft
8 AWG Power	MN: HBF058-08U1M3-5F1 5 ft, 1x 8 AWG power pair, 3x multi-mode fiber pairs, Outdoor & LC Connectors, 5/8 cable	5 ft
	MN: HBF058-08U1M3-10F1	10 ft
	MN: HBF058-08U1M3-15F1	15 ft
	MN: HBF058-08U1M3-20F1	20 ft
	MN: HBF058-08U1M3-25F1	25 ft
	MN: HBF058-08U1M3-30F1	30 ft
6 AWG Power	MN: HBF058-13U1M3-5F1 5 ft, 1x 6 AWG power pair, 3x multi-mode fiber pairs, Outdoor & LC Connectors, 5/8 cable	5 ft
	MN: HBF058-13U1M3-10F1	10 ft
	MN: HBF058-13U1M3-15F1	15 ft
	MN: HBF058-13U1M3-20F1	20 ft
	MN: HBF058-13U1M3-25F1	25 ft
	MN: HBF058-13U1M3-30F1	30 ft
4 AWG Power	MN: HBF078-21U1M3-5F1 5 ft, 1x 4 AWG power pair, 3x multi-mode fiber pairs, Outdoor & LC Connectors, 7/8 cable	5 ft
	MN: HBF078-21U1M3-10F1	10 ft
	MN: HBF078-21U1M3-15F1	15 ft
	MN: HBF078-21U1M3-20F1	20 ft
	MN: HBF078-21U1M3-25F1	25 ft
	MN: HBF078-21U1M3-30F1	30 ft

HYBRID CABLE DC CONDUCTOR SIZE GUIDELINE

MANUF:	RFS	DC CONDUCTOR	CABLE DIAMETER
FIBER ONLY	VARIES	USE NV HYBRIFLEX	7/8"
HYBRIFLEX	<200'	8 AWG	1-1/4"
HYBRIFLEX	225-300'	6 AWG	1-1/4"
HYBRIFLEX	325-375'	4 AWG	1-1/4"

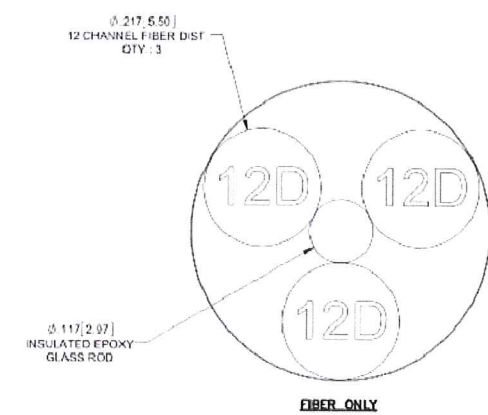
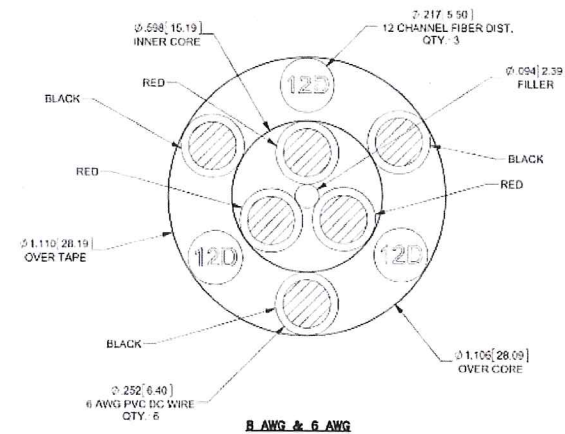
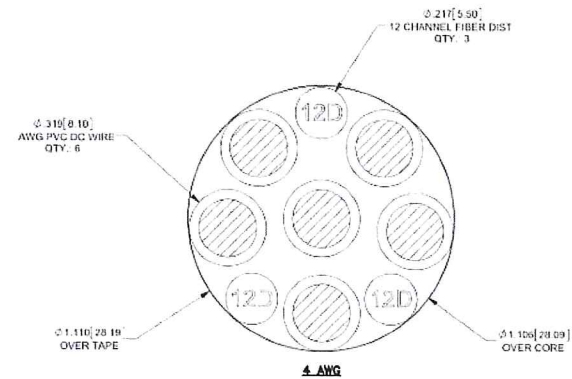

3 2.5 HYBRID CABLE X-SECTION AND DATA
SCALE: N.T.S.

Sprint
2.5 EQUIPMENT DEPLOYMENT
6580 SPRINT PARKWAY
OVERLAND PARK, KANSAS 66251

CROWN CASTLE

TECTONIC ENGINEERING & SURVEYING CONSULTANTS P.C.
1279 Route 300
Newburgh, NY 12550
Phone: (845) 567-6656
Fax: (845) 567-8703
www.tectonicengineering.com

THIS DOCUMENT IS THE CREATION, DESIGN, PROPERTY AND COPYRIGHTED WORK OF SPRINT COMMUNICATIONS, INC. ANY DUPLICATION OR USE WITHOUT EXPRESS WRITTEN CONSENT IS STRICTLY PROHIBITED. DUPLICATION AND USE BY GOVERNMENT AGENCIES FOR THE PURPOSES OF CONDUCTING THEIR LAWFULLY AUTHORIZED REGULATORY AND ADMINISTRATIVE FUNCTIONS IS SPECIFICALLY ALLOWED.

SUBMITTALS

PROJECT NO: 7225.CT03XC368

NO	DATE	DESCRIPTION	BY
0	06/16/14	FOR COMMENT	JT
1	10/31/14	FOR CONSTRUCTION	DC

DATE: 10/31/14
REVIEWED BY: JMA

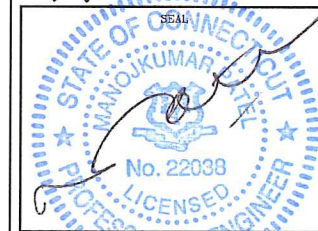

SITE NUMBER:
CT03XC368
SITE NAME:
NEWTOWN
SITE ADDRESS:
21 BERKSHIRE RD
NEWTOWN, CT 06482

SHEET TITLE:
EQUIPMENT
SCHEMATIC DETAILS

SHEET NO:
S-2

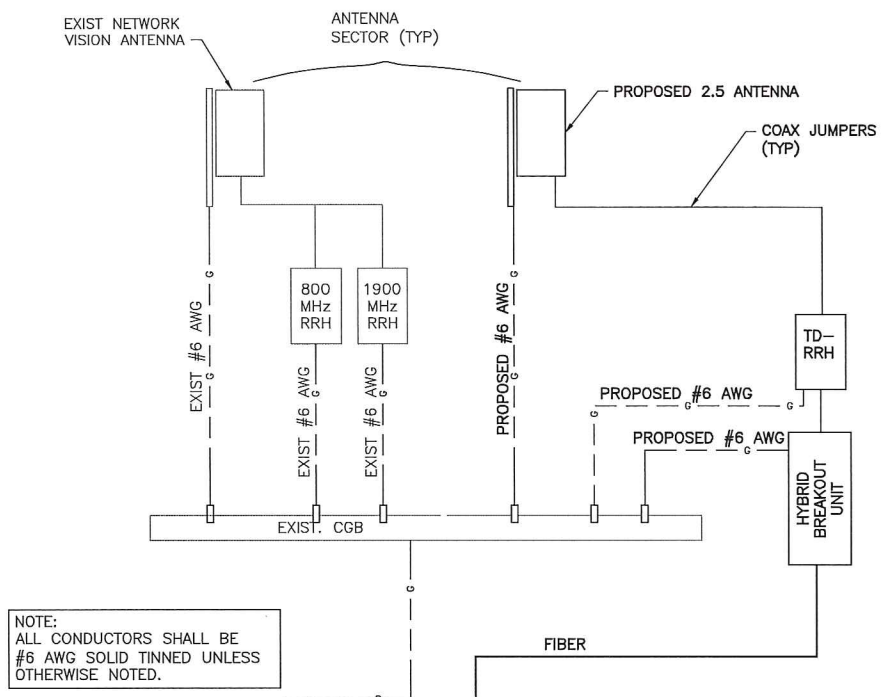

1
E-1
SCALE: NTS

TYPICAL GROUNDING ONE LINE DIAGRAM

- LEGEND**
- CADWELD CONNECTION
 - MECHANICAL CONNECTION
 - COMPRESSION CONNECTION

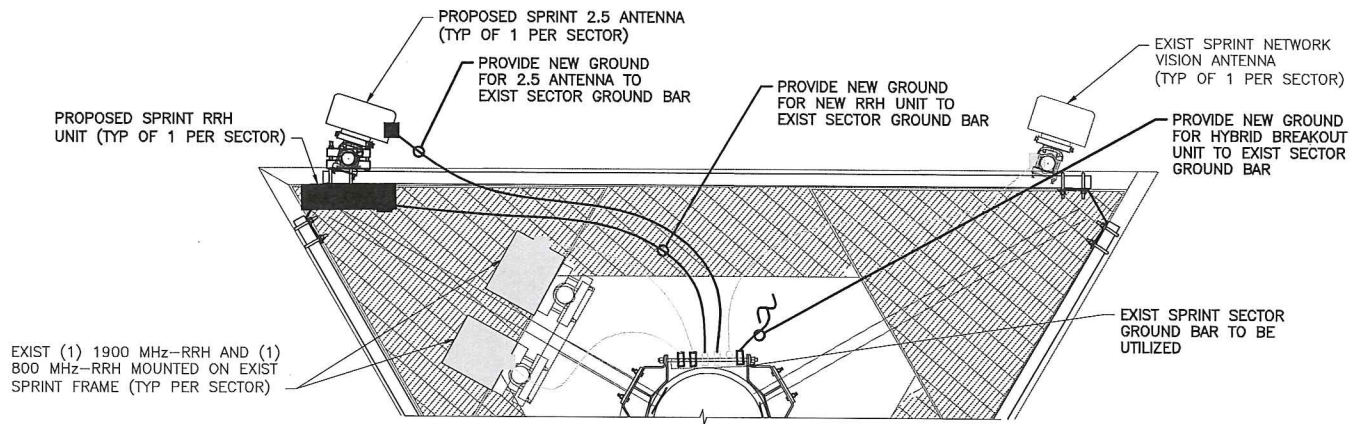

2
E-1
SCALE: NTS

TYPICAL ANTENNA GROUNDING PLAN

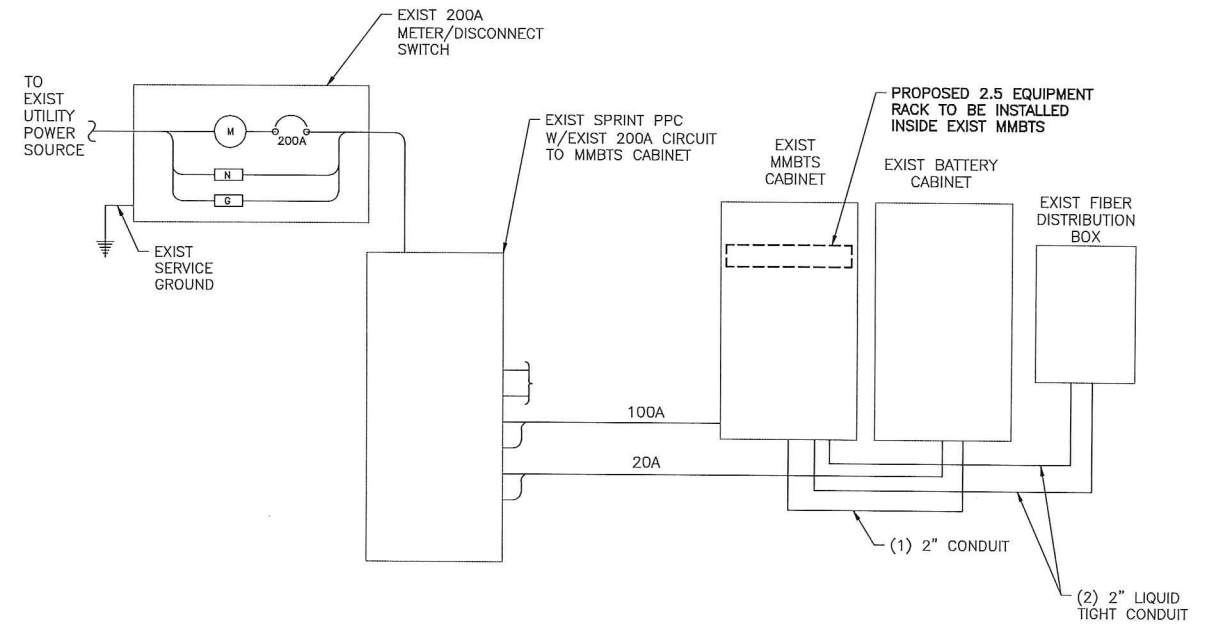

3
E-1
SCALE: NTS

TYPICAL ELECTRICAL & TELCO PLAN

Sprint

2.5 EQUIPMENT DEPLOYMENT
6580 SPRINT PARKWAY
OVERLAND PARK, KANSAS 66251

CROWN CASTLE

TECTONIC

• PLANNING
• ENGINEERING
• SURVEYING
• CONSTRUCTION MANAGEMENT

TECTONIC Engineering & Surveying Consultants P.C.

1279 Route 300
Newburgh, NY 12550
Phone: (845) 567-6656
Fax: (845) 567-8703
www.tectonicengineering.com

THIS DOCUMENT IS THE CREATION, DESIGN, PROPERTY AND COPYRIGHTED WORK OF SPRINT COMMUNICATIONS, INC. ANY DUPLICATION OR USE WITHOUT EXPRESS WRITTEN CONSENT IS STRICTLY PROHIBITED. DUPLICATION AND USE BY GOVERNMENT AGENCIES FOR THE PURPOSES OF CONDUCTING THEIR LAWFULLY AUTHORIZED REGULATORY AND ADMINISTRATIVE FUNCTIONS IS SPECIFICALLY ALLOWED.

SUBMITTALS

PROJECT NO: 7225.CT03XC368

NO	DATE	DESCRIPTION	BY
0	06/14/14	FOR COMMENT	JT
1	10/31/14	FOR CONSTRUCTION	DC

DATE: 10/31/14
REVIEWED BY: JMG

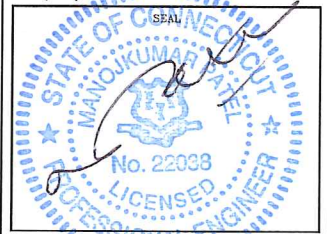

SITE NUMBER:
CT03XC368

SITE NAME:
NEWTOWN

SITE ADDRESS:
21 BERKSHIRE RD
NEWTOWN, CT 06482

SHEET TITLE:
ELECTRICAL & GROUNDING PLANS

SHEET NO:
E-1

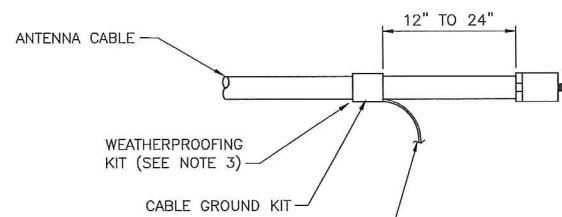

6 AWG STRANDED Cu WIRE WITH GREEN, 600V, THWN INSULATION OR BLACK, MARKED AS REQUIRED BY THE NEC (GROUNDED TO GROUND BAR) (SEE NOTES 1 & 2)

CONNECTION OF CABLE GROUND KIT TO ANTENNA CABLE

NOTES:

DO NOT INSTALL CABLE GROUND KIT AT A BEND AND ALWAYS DIRECT GROUND WIRE DOWN TO GROUND BAR.

GROUNING KIT SHALL BE TYPE AND PART NUMBER AS SUPPLIED OR RECOMMENDED BY CABLE MANUFACTURER.

WEATHER PROOFING SHALL BE (TYPE AND PART NUMBER) AS SUPPLIED OR RECOMMENDED BY CABLE MANUFACTURER AND APPROVED BY CONTRACTOR.

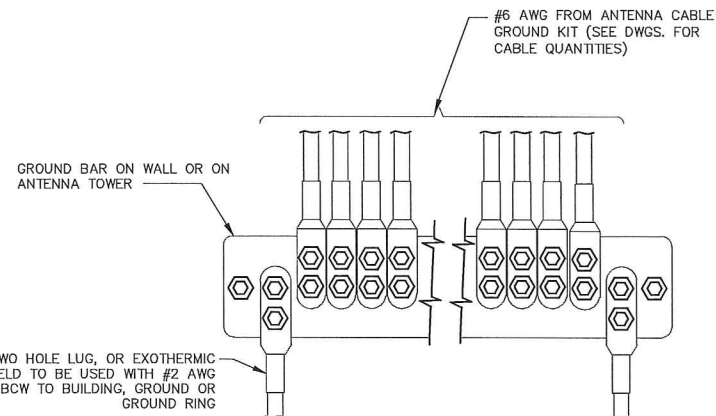

*TWO HOLE LUG, OR EXOTHERMIC WELD TO BE USED WITH #2 AWG BCW TO BUILDING, GROUND OR GROUND RING

* - GROUND BARS AT THE BOTTOM OF TOWERS/MONOPOLES SHALL ONLY USE EXOTHERMIC WELDS.

- ATTACH "DO NOT DISCONNECT" LABELS TO GROUND BARS. CAN USE BRASS TAG "DO NOT DISCONNECT" AT EACH HYBRID GROUND POINT OR BACK-A-LITE PLATE LABEL ON GROUND BAR.

- CONNECT SEQUENCE- BOLT/WASHER/NO-OX/GROUND BAR/NO-OX/WASHER/LOCK-WASHER/NUT. THIS IS REPEATED FOR EACH LUG CONNECTION POINT.

4 ANTENNA GROUND BAR DETAIL

SCALE: NTS

GROUNDING NOTES:

- GROUNDING SHALL BE IN ACCORDANCE WITH NEC ARTICLE 250-GROUNDING AND BONDING.
- ALL GROUND WIRES SHALL BE #2 AWG UNLESS NOTED OTHERWISE.
- ALL GROUNDING WIRES SHALL PROVIDE A STRAIGHT, DOWNWARD PATH TO GROUND WITH GRADUAL BENDS AS REQUIRED. GROUND WIRES SHALL NOT BE LOOPED OR SHARPLY BENT.
- EACH EQUIPMENT CABINET SHALL BE CONNECTED TO THE MASTER ISOLATION GROUND BAR (MGB) WITH #2 AWG INSULATED STRANDED COPPER WIRE. EQUIPMENT CABINETS WALL HAVE (2) CONNECTIONS.
- PROVIDE DEDICATED #2 AWG COPPER GROUND WIRE FROM EACH ANTENNA MOUNTING PIPE TO ASSOCIATED CIGBE.
- THE CONTRACTOR SHALL VERIFY THAT THE EXISTING GROUND BARS HAVE ENOUGH SPACE/HOLES FOR ADDITIONAL TWO HOLE LUGS.
- ALL CONDUITS SHALL BE RIGID GALVANIZED STEEL AND SHALL BE PROVIDED WITH GROUNDING BUSHINGS.
- PROVIDE GROUND CONNECTIONS FOR ALL METALLIC STRUCTURES, ENCLOSURES, RACEWAYS AND OTHER CONDUCTIVE ITEMS ASSOCIATED WITH THE INSTALLATION OF CARRIER'S EQUIPMENT.
- WHEN CABLE LENGTH IS OVER 20' THE MANUFACTURERS GROUND KIT MUST BE INSTALLED PER THE MANUFACTURERS SPECIFICATIONS.
- REFER TO "ANTI-THEFT UPDATE TO SPRINT GROUNDING 082412.PDF" FOR GUIDELINE TO SUSPECTED OR ACTUAL THEFT OF GROUNDING.
- HOME RUN GROUNDS ARE NOT APPROVED BY CROWN CASTLE CONSTRUCTION STANDARDS AND THAT ANTENNA BUSS BARS SHOULD BE INSTALLED DIRECTLY TO TOWER STEEL WITHOUT INSULATORS OR DOWN CONDUCTORS.

PROTECTIVE GROUNDING SYSTEM GENERAL NOTES:

- AT ALL TERMINATIONS AT EQUIPMENT ENCLOSURES, PANEL, AND FRAMES OF EQUIPMENT AND WHERE EXPOSED FOR GROUNDING. CONDUCTOR TERMINATION SHALL BE PERFORMED UTILIZING TWO HOLE BOLTED TONGUE COMPRESSION TYPE LUGS WITH STAINLESS STEEL SELF-TAPPING SCREWS.
- ALL CLAMPS AND SUPPORTS USED TO SUPPORT THE GROUNDING SYSTEM CONDUCTORS AND PVC CONDUITS SHALL BE PVC TYPE (NON CONDUCTIVE). DO NOT USE METAL BRACKETS OR SUPPORTS WHICH WOULD FORM A COMPLETE RING AROUND ANY GROUNDING CONDUCTOR.
- ALL GROUNDING CONNECTIONS SHALL BE COATED WITH A COPPER SHIELD ANTI-CORROSIVE AGENT SUCH AS T&B KOPR SHIELD. VERIFY PRODUCT WITH PROJECT MANAGER.
- ALL BOLTS, WASHERS, AND NUTS USED ON GROUNDING CONNECTIONS SHALL BE STAINLESS STEEL.
- INSTALL GROUND BUSHING ON ALL METALLIC CONDUITS AND BOND TO THE EQUIPMENT GROUND BUS IN THE PANEL BOARD.
- GROUND ANTENNA BASES, FRAMES, CABLE RACKS, AND OTHER METALLIC COMPONENTS WITH #2 INSULATED TINNED STRANDED COPPER GROUNDING CONDUCTORS AND CONNECT TO INSULATED SURFACE MOUNTED GROUND BARS. CONNECTION DETAILS SHALL FOLLOW MANUFACTURER'S SPECIFICATIONS FOR GROUNDING.
- GROUND HYBRID CABLE SHIELD AT BOTH ENDS USING MANUFACTURER'S GUIDELINES.

ELECTRICAL AND GROUNDING NOTES

- ALL ELECTRICAL WORK SHALL CONFORM TO THE REQUIREMENTS OF THE NATIONAL ELECTRICAL CODE (NEC) AS WELL AS APPLICABLE STATE AND LOCAL CODES.
- ALL ELECTRICAL ITEMS SHALL BE U.L. APPROVED OR LISTED AND PROCURED PER SPECIFICATION REQUIREMENTS.
- ELECTRICAL AND TELCO WIRING OUTSIDE A BUILDING AND EXPOSED TO WEATHER SHALL BE IN WATER TIGHT GALVANIZED RIGID STEEL CONDUITS OR SCHEDULE 80 PVC (AS PERMITTED BY CODE) AND WHERE REQUIRED IN LIQUID TIGHT FLEXIBLE METAL OR NONMETALLIC CONDUITS.
- BURIED CONDUIT SHALL BE SCHEDULE 40 PVC.
- ELECTRICAL WIRING SHALL BE COPPER WITH TYPE XHHW, THWN, OR THHN INSULATION.
- RUN TELCO CONDUIT OR CABLE BETWEEN TELEPHONE UTILITY DEMARCATION POINT AND PROJECT OWNER CELL SITE TELCO CABINET AND BTS CABINET AS INDICATED ON THIS DRAWING PROVIDE FULL LENGTH PULL ROPE IN INSTALLED TELCO CONDUIT. PROVIDE GREENLEE CONDUIT MEASURING TAPE AT EACH END.
- WHERE CONDUIT BETWEEN BTS AND PROJECT OWNER CELL SITE PPC AND BETWEEN BTS AND PROJECT OWNER CELL SITE TELCO SERVICE CABINET ARE UNDERGROUND USE PVC, SCHEDULE 40 CONDUIT. ABOVE THE GROUND PORTION OF THESE CONDUITS SHALL BE PVC CONDUIT.
- ALL EQUIPMENT LOCATED OUTSIDE SHALL HAVE NEMA 3R ENCLOSURE.
- GROUNDING SHALL COMPLY WITH NEC ART. 250.
- GROUND HYBRID CABLE SHIELDS AT 3 LOCATIONS USING MANUFACTURER'S HYBRID CABLE GROUNDING KITS SUPPLIED BY PROJECT OWNER.
- USE #2 COPPER STRANDED WIRE WITH GREEN COLOR INSULATION FOR ABOVE GRADE GROUNDING (UNLESS OTHERWISE SPECIFIED) AND #2 SOLID TINNED BARE COPPER WIRE FOR BELOW GRADE GROUNDING AS INDICATED ON THE DRAWING.
- ALL GROUND CONNECTIONS TO BE BURNDY HYGROUND COMPRESSION TYPE CONNECTORS OR CADWELD EXOTHERMIC WELD. DO NOT ALLOW BARE COPPER WIRE TO BE IN CONTACT WITH GALVANIZED STEEL.
- ROUTE GROUNDING CONDUCTORS ALONG THE SHORTEST AND STRAIGHTEST PATH POSSIBLE, EXCEPT AS OTHERWISE INDICATED. GROUNDING LEADS SHOULD NEVER BE BENT AT RIGHT ANGLE. ALWAYS MAKE AT LEAST 12" RADIUS BENDS. #2 WIRE CAN BE BENT AT 6" RADIUS WHEN NECESSARY. BOND ANY METAL OBJECTS WITHIN 6 FEET OF PROJECT OWNER EQUIPMENT OR CABINET TO MASTER GROUND BAR OR GROUNDING RING.
- CONNECTIONS TO GROUND BARS SHALL BE MADE WITH TWO HOLE COMPRESSION TYPE COPPER LUGS. APPLY OXIDE INHIBITING COMPOUND TO ALL LOCATIONS.
- APPLY OXIDE INHIBITING COMPOUND TO ALL COMPRESSION TYPE GROUND CONNECTIONS.
- BOND ANTENNA MOUNTING BRACKETS, HYBRID CABLE GROUND KITS, AND RRRs TO EGB PLACED NEAR THE ANTENNA LOCATION.
- BOND ANTENNA EGB'S AND MGB TO GROUND RING.
- CONTRACTOR SHALL TEST COMPLETED GROUND SYSTEM AND RECORD RESULT FOR PROJECT CLOSE-OUT DOCUMENTATION. 5 OHMS MINIMUM RESISTANCE REQUIRED.
- CONTRACTOR SHALL CONDUCT ANTENNA, HYBRID CABLES, GPS COAX AND RRR RETURN-LOSS AND DISTANCE- TO-FAULT MEASUREMENTS (SWEEP TESTS) AND RECORD RESULTS FOR PROJECT CLOSE OUT.
- CONTRACTOR SHALL CHECK CAPACITY OF EXISTING SERVICE & PANEL ON SITE TO DETERMINE IF CAPACITY EXISTS TO ACCOMMODATE THE ADDED LOAD OF THIS PROJECT. ADVISE ENGINEER OF ANY DISCREPANCY.
- LOCATION OF ALL OUTLET, BOXES, ETC, AND THE TYPE OF CONNECTION (PLUG OR DIRECT) SHALL BE CONFIRMED WITH THE OWNER'S REPRESENTATIVE PRIOR TO ROUGH-IN.
- ELECTRICAL CHARACTERISTICS OF ALL EQUIPMENT (NEW AND EXISTING) SHALL BE FIELD VERIFIED WITH THE OWNERS REPRESENTATIVE AND EQUIPMENT SUPPLIER PRIOR TO ROUGH-IN OF CONDUIT AND WIRE. ALL EQUIPMENT SHALL BE PROPERLY CONNECTED ACCORDING TO THE NAMEPLATE DATA FURNISHED ON THE EQUIPMENT.

1 CABLE GROUNDING KIT DETAIL

SCALE: N.T.S.

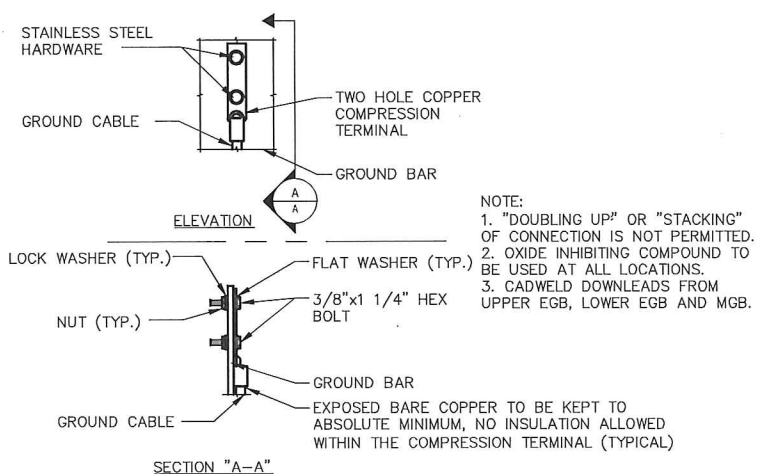

NOTE:
1. "DOUBLING UP" OR "STACKING" OF CONNECTION IS NOT PERMITTED.
2. OXIDE INHIBITING COMPOUND TO BE USED AT ALL LOCATIONS.
3. CADWELD DOWNLEADS FROM UPPER EGB, LOWER EGB AND MGB.

SECTION "A-A"

2 GROUNDING BAR CONN. DETAIL

SCALE: NTS

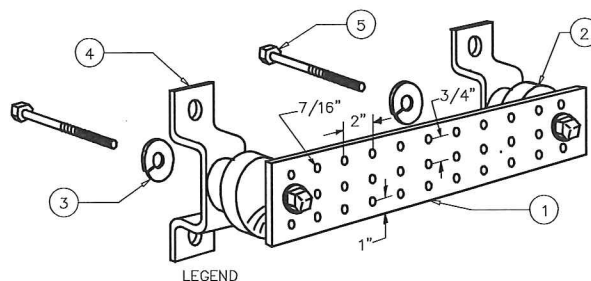

LEGEND

- COPPER TINNED GROUND BAR, 1/4" X 4" X 20", OR OTHER LENGTH AS REQUIRED, HOLE CENTERS TO MATCH NEMA DOUBLE LUG CONFIGURATION
- INSULATORS, NEWTON INSTRUMENT CAT. NO. 3061-4 OR EQUAL
- 5/8" LOCKWASHERS OR EQUAL
- WALL MOUNTING BRACKET, NEWTON INSTRUMENT CO. CAT NO. A-6056 OR EQUAL
- 5/8-11 X 1" H.H.C.S.BOLTS

NOTE:
ALL BOLTS, NUTS, WASHERS AND LOCK WASHERS SHALL BE 18-8 STAINLESS STEEL.

3 GROUNDING BAR DETAIL

SCALE: NTS

Sprint
2.5 EQUIPMENT DEPLOYMENT
6580 SPRINT PARKWAY
OVERLAND PARK, KANSAS 66251

CROWN CASTLE

TECTONIC • PLANNING
• ENGINEERING
• SURVEYING
• CONSTRUCTION
MANAGEMENT
TECTONIC Engineering & Surveying
Consultants P.C.
1279 Route 300
Newburgh, NY 12550
Phone: (845) 567-6656
Fax: (845) 567-8703
www.tectonicengineering.com

THIS DOCUMENT IS THE CREATION, DESIGN, PROPERTY AND COPYRIGHTED WORK OF SPRINT COMMUNICATIONS, INC. ANY DUPLICATION OR USE WITHOUT EXPRESS WRITTEN CONSENT IS STRICTLY PROHIBITED. DUPLICATION AND USE BY GOVERNMENT AGENCIES FOR THE PURPOSES OF CONDUCTING THEIR LAWFULLY AUTHORIZED REGULATORY AND ADMINISTRATIVE FUNCTIONS IS SPECIFICALLY ALLOWED.

SUBMITTALS

PROJECT NO: 7225.CT03XC368			
NO	DATE	DESCRIPTION	BY
0	06/14/14	FOR COMMENT	JT
1	10/31/14	FOR CONSTRUCTION	DC

DATE	REVIEWED BY
10/31/14	S.M.O.

SEAL
STATE OF CONNECTICUT
MANOJKUMAR
No. 22038
LICENSED PROFESSIONAL ENGINEER

SITE NUMBER:
CT03XC368
SITE NAME:
NEWTOWN
SITE ADDRESS:
21 BERKSHIRE RD
NEWTOWN, CT 06482

SHEET TITLE:
GROUNDING DETAILS & NOTES

SHEET NO:
E-2

Date: **June 15, 2017**

Rebecca Klein
Crown Castle
3530 Toringdon Way Suite 300
Charlotte, NC 28277

JACOBS
Jacobs Engineering Group, Inc.
5449 Bells Ferry Road
Acworth, GA 30102
(770) 701-2500

Subject: **Structural Analysis Report**

Carrier Designation: **Sprint PCS Co-Locate**
Carrier Site Number: CT03XC368

Crown Castle Designation:
Crown Castle BU Number: 806354
Crown Castle Site Name: BRG 123 943084
Crown Castle JDE Job Number: 442045
Crown Castle Work Order Number: 1417811
Crown Castle Application Number: 393537 Rev. 0

Engineering Firm Designation: **Jacobs Engineering Group, Inc. Project Number:** 1417811

Site Data: **21 BERKSHIRE ROAD NEWTOWN, NEWTOWN, Fairfield County, CT**
Latitude 41° 24' 45.53"; Longitude -73° 16' 12.34"
185 Foot - Monopole Tower

Dear Rebecca Klein,

Jacobs Engineering Group, Inc. is pleased to submit this "Structural Analysis Report" to determine the structural integrity of the above mentioned tower. This analysis has been performed in accordance with the Crown Castle Structural 'Statement of Work' and the terms of Crown Castle Purchase Order Number 1046831, in accordance with application 393537, revision 0.

The purpose of the analysis is to determine acceptability of the tower stress level. Based on our analysis we have determined the tower stress level for the structure and foundation, under the following load case, to be:

LC5: Existing + Proposed Equipment

Sufficient Capacity

Note: See Table I and Table II for the proposed and existing loading, respectively.

This analysis has been performed in accordance with the 2016 Connecticut State Building Code based upon an ultimate 3-second gust wind speed of 120 mph converted to a nominal 3-second gust wind speed of 93 mph per Section 1609.3 and Appendix N as required for use in the TIA-222-G Standard per Exception #5 of Section 1609.1.1. Exposure Category C with a maximum topographic factor, Kzt, of 1.000 and Risk Category II were used in this analysis.

All modifications and equipment proposed in this report shall be installed in accordance with the attached drawings for the determined available structural capacity to be effective.

We at Jacobs Engineering Group, Inc. appreciate the opportunity of providing our continuing professional services to you and Crown Castle. If you have any questions or need further assistance on this or any other projects please give us a call.

Structural analysis prepared by:



Narendra Malviya
Structural Engineer



Reviewed by:

Matthew E. Watkins, P.E.
Engineering Project Manager

TABLE OF CONTENTS

1) INTRODUCTION

2) ANALYSIS CRITERIA

- Table 1 - Proposed Antenna and Cable Information
- Table 2 - Existing Antenna and Cable Information
- Table 3 - Design Antenna and Cable Information

3) ANALYSIS PROCEDURE

- Table 4 - Documents Provided
- 3.1) Analysis Method
- 3.2) Assumptions

4) ANALYSIS RESULTS

- Table 5 - Section Capacity (Summary)
- Table 6 – Tower Components vs. Capacity
- 4.1) Recommendations

5) APPENDIX A

- tnxTower Output

6) APPENDIX B

- Base Level Drawing

7) APPENDIX C

- Additional Calculations

1) INTRODUCTION

This tower is a 185 ft Monopole tower designed by ENGINEERED ENDEAVORS, INC. in August of 1999. The tower was originally designed for a wind speed of 90 mph per TIA/EIA-222-F. The tower has been modified per reinforcement drawings prepared by Vertical Structures, Inc., in February of 2009. Reinforcement consists of the addition of base transition stiffeners.

2) ANALYSIS CRITERIA

The structural analysis was performed for this tower in accordance with the requirements of TIA-222-G Structural Standards for Antenna Supporting Structures and Antennas using a 3-second gust wind speed of 93 mph with no ice, 50 mph with 0.75 inch ice thickness and 60 mph under service loads, exposure category C with topographic category 1.

Table 1 - Proposed Antenna and Cable Information

Mounting Level (ft)	Center Line Elevation (ft)	Number of Antennas	Antenna Manufacturer	Antenna Model	Number of Feed Lines	Feed Line Size (in)	Note
165.0	165.0	3	alcatel lucent	TD-RRH8x20-25	1	1-1/4	-
		3	rfs celwave	APXVTM14-ALU-I20 w/ Mount Pipe			
		1	tower mounts (crown)	Miscellaneous [NA 507-1]			

Table 2 - Existing Antenna and Cable Information

Mounting Level (ft)	Center Line Elevation (ft)	Number of Antennas	Antenna Manufacturer	Antenna Model	Number of Feed Lines	Feed Line Size (in)	Note
185.0	187.0	3	alcatel lucent	RRH2X60-PCS	14	1-5/8	1
		3	alcatel lucent	RRH2x60-700			
		3	alcatel lucent	RRH4X45-AWS4 B66			
		6	commscope	SBNHH-1D85C w/ Mount Pipe			
		6	decibel	DB846F65ZAXY w/ Mount Pipe			
	2	rfs celwave	DB-T1-6Z-8AB-0Z				
	185.0	1	tower mounts (crown)	Platform Mount [LP 712-1]			
182.0	188.0	1	decibel	ASP-601	1	1/2	1
	182.0	1	tower mounts (crown)	Side Arm Mount [SO 104-3]			
	182.0	1	tower mounts (crown)	Side Arm Mount [SO 202-3]			

Mounting Level (ft)	Center Line Elevation (ft)	Number of Antennas	Antenna Manufacturer	Antenna Model	Number of Feed Lines	Feed Line Size (in)	Note
175.0	177.0	3	cci antennas	OPA-65R-LCUU-H6 w/ Mount Pipe	12 2 1	1-5/8 5/8 3/8	1
		3	ericsson	RRUS-11			
		3	ericsson	RRUS12/RRUS A2			
		12	powerwave technologies	7020.00			
		6	powerwave technologies	7770.00 w/ Mount Pipe			
		6	powerwave technologies	LGP2140X			
	175.0	3	cci antennas	DTMABP7819VG12A			
		1	raycap	DC6-48-60-18-8F			
1		tower mounts (crown)	Platform Mount [LP 712-1]				
167.0	167.0	3	alcatel lucent	TME-1900MHz RRH (65MHz)	-	-	1
		3	alcatel lucent	TME-800MHZ RRH			
		1	tower mounts (crown)	Side Arm Mount [SO 104-3]			
165.0	165.0	3	alcatel lucent	800 EXTERNAL NOTCH FILTER	3	1-1/4	1
		9	rfs celwave	ACU-A20-N			
		3	rfs celwave	APXVSP18-C-A20 w/ Mount Pipe			
		1	tower mounts (crown)	Platform Mount [LP 712-1]			
155.0	155.0	1	tower mounts (crown)	Side Arm Mount [SO 102-1]	-	-	2
145.0	148.0	6	ericsson	ERICSSON AIR 21 B2A B4P w/ Mount Pipe	7	1-5/8	1
		3	ericsson	KRY 112 144/1			
		3	ericsson	RRUS 11 B12			
	145.0	3	commscope	LNx-6515DS-A1M w/ Mount Pipe			
		1	tower mounts (crown)	Platform Mount [LP 712-1]			
135.0	137.0	3	kathrein	800 10504 w/ Mount Pipe	6	1-5/8	1
		3	kathrein	860 10025			
	135.0	1	tower mounts (crown)	T-Arm Mount [TA 602-3]			

Notes:

- 1) Existing Equipment
- 2) Empty Mount; Considered In This Analysis

Table 3 - Design Antenna and Cable Information

Mounting Level (ft)	Center Line Elevation (ft)	Number of Antennas	Antenna Manufacturer	Antenna Model	Number of Feed Lines	Feed Line Size (in)
185.0	185.0	12	swedcom	ALP 9212	-	-
175.0	175.0	12	swedcom	ALP 11011	-	-
165.0	165.0	9	decibel	DB 980	-	-
155.0	155.0	12	swedcom	ALP 9011	-	-
145.0	145.0	6	ems wireless	RR65-18	-	-
		1	scala	OGB9-900	-	-
110.0	110.0	1	generic	GPS	-	-
50.0	50.0	1	generic	GPS	-	-

3) ANALYSIS PROCEDURE

Table 4 - Documents Provided

Document	Remarks	Reference	Source
4-GEOTECHNICAL REPORTS	Dr. Clarence Welti, P.E., P.C.	2297011	CCISITES
4-TOWER FOUNDATION DRAWINGS/DESIGN/SPECS	Engineered Endeavors, Inc.	822037	CCISITES
4-TOWER MANUFACTURER DRAWINGS	Engineered Endeavors, Inc.	822035	CCISITES
4-TOWER REINFORCEMENT DESIGN/DRAWINGS/DATA	Vertical Structures, Inc.	2381114	CCISITES
4-POST MODIFICATION INSPECTION	Vertical Structures, Inc.	2447231	CCISITES

3.1) Analysis Method

tnxTower (version 7.0.7.0), a commercially available analysis software package, was used to create a three-dimensional model of the tower and calculate member stresses for various loading cases. Selected output from the analysis is included in Appendix A.

3.2) Assumptions

- 1) Tower and structures were built in accordance with the manufacturer's specifications.
- 2) The tower and structures have been maintained in accordance with the manufacturer's specification.
- 3) The configuration of antennas, transmission cables, mounts and other appurtenances are as specified in Tables 1 and 2 and the referenced drawings.

This analysis may be affected if any assumptions are not valid or have been made in error. Jacobs Engineering Group, Inc. should be notified to determine the effect on the structural integrity of the tower.

4) ANALYSIS RESULTS

Table 5 - Section Capacity (Summary)

Section No.	Elevation (ft)	Component Type	Size	Critical Element	P (K)	SF*P_allow (K)	% Capacity	Pass / Fail
L1	185 - 149.622	Pole	TP36.0404x29x0.25	1	-12.8	1850.0	39.2	Pass
L2	149.622 - 114.221	Pole	TP42.4605x34.5443x0.3125	2	-24.1	2785.9	65.0	Pass
L3	114.221 - 76.8021	Pole	TP49.157x40.6978x0.375	3	-35.7	3919.2	73.6	Pass
L4	76.8021 - 38.3802	Pole	TP55.9285x47.1064x0.4375	4	-51.0	5246.2	73.8	Pass
L5	38.3802 - 0	Pole	TP62.5x53.5869x0.5	5	-74.0	6871.4	72.0	Pass
							Summary	
						Pole (L4)	73.8	Pass
						Rating =	73.8	Pass

Table 6 - Tower Component Stresses vs. Capacity – LC5

Notes	Component	Elevation (ft)	% Capacity	Pass / Fail
1	Anchor Rods	0	68.1	Pass
1	Base Plate	0	79.6	Pass
1	Base Foundation (Structural)	0	64.7	Pass
1	Base Foundation (Soil Interaction)	0	74.3	Pass

Structure Rating (max from all components) =	79.6%
---	--------------

Notes:

- 1) See additional documentation in "Appendix C – Additional Calculations" for calculations supporting the % capacity consumed.

4.1) Recommendations

The tower and its foundation have sufficient capacity to carry the proposed load configuration. No modifications are required at this time.

APPENDIX A
TNXTOWER OUTPUT

DESIGNED APPURTENANCE LOADING

TYPE	ELEVATION	TYPE	ELEVATION
Lightning Rod 2"x10'	185	TME-800MHZ RRH	167
(2) DB846F65ZAXY w/ Mount Pipe	185	Side Arm Mount [SO 104-3]	167
(2) DB846F65ZAXY w/ Mount Pipe	185	APXVSP18-C-A20 w/ Mount Pipe	165
(2) DB846F65ZAXY w/ Mount Pipe	185	APXVSP18-C-A20 w/ Mount Pipe	165
(2) SBNHH-1D85C w/ Mount Pipe	185	APXVSP18-C-A20 w/ Mount Pipe	165
(2) SBNHH-1D85C w/ Mount Pipe	185	APXVTM14-ALU-I20 w/ Mount Pipe	165
(2) SBNHH-1D85C w/ Mount Pipe	185	APXVTM14-ALU-I20 w/ Mount Pipe	165
RRH2x60-700	185	APXVTM14-ALU-I20 w/ Mount Pipe	165
RRH2x60-700	185	(3) ACU-A20-N	165
RRH2x60-700	185	(3) ACU-A20-N	165
RRH2X60-PCS	185	(3) ACU-A20-N	165
RRH2X60-PCS	185	800 EXTERNAL NOTCH FILTER	165
RRH2X60-PCS	185	800 EXTERNAL NOTCH FILTER	165
RRH4X45-AWS4 B66	185	800 EXTERNAL NOTCH FILTER	165
RRH4X45-AWS4 B66	185	TD-RRH8x20-25	165
RRH4X45-AWS4 B66	185	TD-RRH8x20-25	165
DB-T1-6Z-8AB-0Z	185	TD-RRH8x20-25	165
DB-T1-6Z-8AB-0Z	185	Climbing Ladder - 5'	165
6' x 2" Mount Pipe	185	6' x 2" Mount Pipe	165
6' x 2" Mount Pipe	185	6' x 2" Mount Pipe	165
6' x 2" Mount Pipe	185	6' x 2" Mount Pipe	165
6' x 2" Mount Pipe	185	6' x 2" Mount Pipe	165
Climbing Ladder - 5'	185	Miscellaneous [NA 507-1]	165
Platform Mount [LP 712-1]	185	Platform Mount [LP 712-1]	165
Side Arm Mount [SO 202-3]	185	Side Arm Mount [SO 102-1]	155
ASP-601	182	(2) ERICSSON AIR 21 B2A B4P w/ Mount Pipe	145
Side Arm Mount [SO 104-3]	182	(2) ERICSSON AIR 21 B2A B4P w/ Mount Pipe	145
(2) 7770.00 w/ Mount Pipe	175	(2) ERICSSON AIR 21 B2A B4P w/ Mount Pipe	145
(2) 7770.00 w/ Mount Pipe	175	(2) ERICSSON AIR 21 B2A B4P w/ Mount Pipe	145
(2) 7770.00 w/ Mount Pipe	175	(2) ERICSSON AIR 21 B2A B4P w/ Mount Pipe	145
OPA-65R-LCUU-H6 w/ Mount Pipe	175	KRY 112 144/1	145
OPA-65R-LCUU-H6 w/ Mount Pipe	175	KRY 112 144/1	145
OPA-65R-LCUU-H6 w/ Mount Pipe	175	KRY 112 144/1	145
(2) LGP2140X	175	LNX-6515DS-A1M w/ Mount Pipe	145
(2) LGP2140X	175	LNX-6515DS-A1M w/ Mount Pipe	145
(2) LGP2140X	175	LNX-6515DS-A1M w/ Mount Pipe	145
RRUS-11	175	RRUS 11 B12	145
RRUS-11	175	RRUS 11 B12	145
RRUS-11	175	RRUS 11 B12	145
DTMABP7819VG12A	175	Platform Mount [LP 712-1]	145
DTMABP7819VG12A	175	800 10504 w/ Mount Pipe	135
DTMABP7819VG12A	175	800 10504 w/ Mount Pipe	135
(4) 7020.00	175	800 10504 w/ Mount Pipe	135
(4) 7020.00	175	860 10025	135
(4) 7020.00	175	860 10025	135
RRUS12/RRUS A2	175	860 10025	135
RRUS12/RRUS A2	175	(2) 6' x 2" Mount Pipe	135
RRUS12/RRUS A2	175	(2) 6' x 2" Mount Pipe	135
DC6-48-60-18-8F	175	(2) 6' x 2" Mount Pipe	135
6' x 2" Mount Pipe	175	T-Arm Mount [TA 602-3]	135
6' x 2" Mount Pipe	175	GPS	108
Platform Mount [LP 712-1]	175	Side Arm Mount [SO 901-1]	108
TME-1900MHz RRH (65MHz)	167	GPS	107
TME-1900MHz RRH (65MHz)	167	Side Arm Mount [SO 901-1]	107
TME-1900MHz RRH (65MHz)	167	GPS	51
TME-800MHz RRH	167	Side Arm Mount [SO 901-1]	51
TME-800MHz RRH	167		

Section	1	2	3	4	5
Length (ft)	35.38	40.41	43.23	45.07	45.87
Number of Sides	18	18	18	18	18
Thickness (in)	0.2500	0.3125	0.3750	0.4375	0.5000
Socket Length (ft)	5.01	5.81	6.65	7.49	7.49
Top Dia (in)	29.0000	34.5443	40.6978	47.1064	53.5869
Bot Dia (in)	36.0404	42.4605	49.1570	55.9285	62.5000
Grade			A572-65		
Weight (K)	3.1	5.2	7.8	10.9	14.3

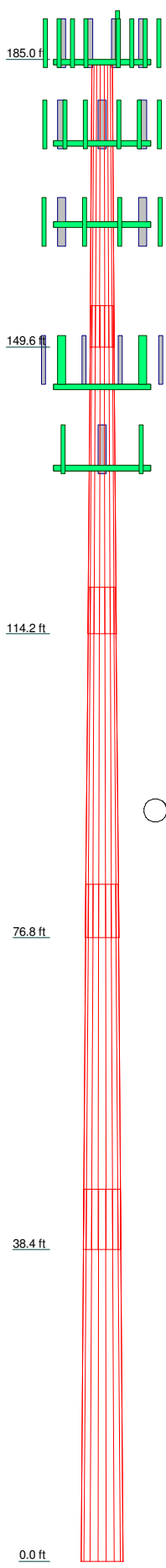

JACOBS Jacobs Engineering Group, Inc. 5449 Bells Ferry Road Acworth, GA 30102 Phone: (770) 701-2500 FAX: (770) 701-2501

Job: 185' MP, BRG 123 943084
 Project: BU806354_WO1417811
 Client: CROWN CASTLE Drawn by: Narendra Malviya App'd:
 Code: TIA-222-G Date: 06/15/17 Scale: NTS
 Path: C:\Users\malviya\Desktop\Projects\Under review\806354 BRG 123 943084\WO 1417811\Analysis\Modelling\BU 806354_WO 1417811.dwg Dwg No. E-1

Section	1	2	3	4	5
Length (ft)	35.38	40.41	43.23	45.07	45.87
Number of Sides	18	18	18	18	18
Thickness (in)	0.2500	0.3125	0.3750	0.4375	0.5000
Socket Length (ft)	5.01	5.81	6.65	7.49	8.33
Top Dia (in)	29.0000	34.5443	40.6978	47.1064	53.5869
Bot Dia (in)	36.0404	42.4605	49.1570	55.9285	62.5000
Grade			A572-65		
Weight (K)	3.1	5.2	7.8	10.9	14.3

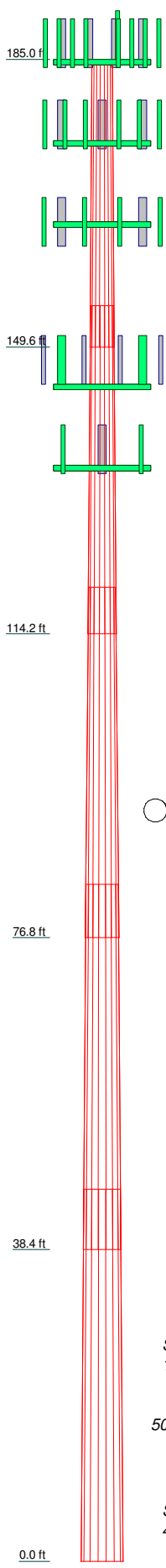

MATERIAL STRENGTH

GRADE	Fy	Fu	GRADE	Fy	Fu
A572-65	65 ksi	80 ksi			

TOWER DESIGN NOTES

1. Tower is located in Fairfield County, Connecticut.
2. Tower designed for Exposure C to the TIA-222-G Standard.
3. Tower designed for a 93 mph basic wind in accordance with the TIA-222-G Standard.
4. Tower is also designed for a 50 mph basic wind with 0.75 in ice. Ice is considered to increase in thickness with height.
5. Deflections are based upon a 60 mph wind.
6. Tower Structure Class II.
7. Topographic Category 1 with Crest Height of 0.00 ft
8. TOWER RATING: 73.8%

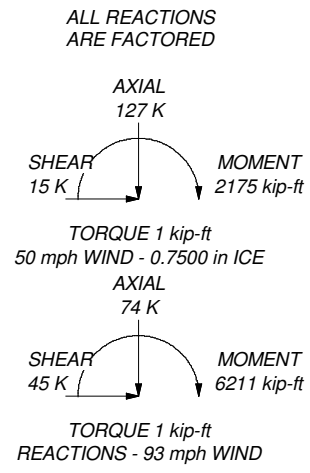

 Jacobs Engineering Group, Inc.	Jacobs Engineering Group, Inc.		Job: 185' MP, BRG 123 943084
	5449 Bells Ferry Road Acworth, GA 30102 Phone: (770) 701-2500 FAX: (770) 701-2501		Project: BU806354_WO1417811
	Client: CROWN CASTLE	Drawn by: Narendra Malviya	App'd:
	Code: TIA-222-G	Date: 06/15/17	Scale: NTS
	Path:	Dwg No. E-1	

C:\Users\malviya\Desktop\Projects\Under review\806354 BRG 123 943084\WO 1417811\Analysis\Modelling\BU 806354_WO 1417811.dwg

Tower Input Data

There is a pole section.

This tower is designed using the TIA-222-G standard.

The following design criteria apply:

- 3) Tower is located in Fairfield County, Connecticut.
- 4) Basic wind speed of 93 mph.
- 5) Structure Class II.
- 6) Exposure Category C.
- 7) Topographic Category 1.
- 8) Crest Height 0.00 ft.
- 9) Nominal ice thickness of 0.7500 in.
- 10) Ice thickness is considered to increase with height.
- 11) Ice density of 56 pcf.
- 12) A wind speed of 50 mph is used in combination with ice.
- 13) Temperature drop of 50 °F.
- 14) Deflections calculated using a wind speed of 60 mph.
- 15) A non-linear (P-delta) analysis was used.
- 16) Pressures are calculated at each section.
- 17) Stress ratio used in pole design is 1.
- 18) Local bending stresses due to climbing loads, feed line supports, and appurtenance mounts are not considered.

Options

Consider Moments - Legs Consider Moments - Horizontals Consider Moments - Diagonals Use Moment Magnification ✓ Use Code Stress Ratios ✓ Use Code Safety Factors - Guys Escalate Ice Always Use Max Kz Use Special Wind Profile Include Bolts In Member Capacity Leg Bolts Are At Top Of Section Secondary Horizontal Braces Leg Use Diamond Inner Bracing (4 Sided) SR Members Have Cut Ends SR Members Are Concentric	Distribute Leg Loads As Uniform Assume Legs Pinned ✓ Assume Rigid Index Plate ✓ Use Clear Spans For Wind Area Use Clear Spans For KL/r Retension Guys To Initial Tension ✓ Bypass Mast Stability Checks ✓ Use Azimuth Dish Coefficients ✓ Project Wind Area of Appurt. Autocalc Torque Arm Areas Add IBC .6D+W Combination Sort Capacity Reports By Component Triangulate Diamond Inner Bracing Treat Feed Line Bundles As Cylinder	Use ASCE 10 X-Brace Ly Rules Calculate Redundant Bracing Forces Ignore Redundant Members in FEA SR Leg Bolts Resist Compression All Leg Panels Have Same Allowable Offset Girt At Foundation ✓ Consider Feed Line Torque Include Angle Block Shear Check Use TIA-222-G Bracing Resist. Exemption Use TIA-222-G Tension Splice Exemption <div style="text-align: center; background-color: #e0e0e0; padding: 2px;">Poles</div> ✓ Include Shear-Torsion Interaction Always Use Sub-Critical Flow Use Top Mounted Sockets
--	--	---

Tapered Pole Section Geometry

Section	Elevation <small>ft</small>	Section Length <small>ft</small>	Splice Length <small>ft</small>	Number of Sides	Top Diameter <small>in</small>	Bottom Diameter <small>in</small>	Wall Thickness <small>in</small>	Bend Radius <small>in</small>	Pole Grade
L1	185.00-149.62	35.38	5.01	18	29.0000	36.0404	0.2500	1.0000	A572-65 (65 ksi)
L2	149.62-114.22	40.41	5.81	18	34.5443	42.4605	0.3125	1.2500	A572-65 (65 ksi)
L3	114.22-76.80	43.23	6.65	18	40.6978	49.1570	0.3750	1.5000	A572-65 (65 ksi)
L4	76.80-38.38	45.07	7.49	18	47.1064	55.9285	0.4375	1.7500	A572-65 (65 ksi)
L5	38.38-0.00	45.87		18	53.5869	62.5000	0.5000	2.0000	A572-65 (65 ksi)

Tapered Pole Properties

Section	Tip Dia. in	Area in ²	I in ⁴	r in	C in	I/C in ³	J in ⁴	It/Q in ²	w in	w/t
L1	29.4474	22.8131	2382.3081	10.2063	14.7320	161.7098	4767.7509	11.4087	4.6640	18.656
	36.5964	28.3997	4596.0425	12.7056	18.3085	251.0329	9198.1326	14.2025	5.9031	23.612
L2	36.0729	33.9537	5026.7193	12.1523	17.5485	286.4469	10060.052	16.9801	5.5298	17.695
	43.1155	41.8055	9382.6455	14.9625	21.5699	434.9872	18777.637	20.9067	6.9230	22.154
L3	42.4796	47.9942	9858.8582	14.3146	20.6745	476.8616	19730.688	24.0016	6.5028	17.341
	49.9153	58.0628	17456.390	17.3176	24.9718	699.0454	34935.750	29.0369	7.9916	21.311
L4	49.1541	64.8057	17832.256	16.5675	23.9301	745.1819	35687.976	32.4090	7.5207	17.19
	56.7913	77.0562	29977.132	19.6993	28.4117	1055.0990	59993.709	38.5354	9.0734	20.739
L5	55.8918	84.2489	29996.898	18.8458	27.2221	1101.9301	60033.267	42.1325	8.5513	17.103
	63.4642	98.3940	47784.764	22.0100	31.7500	1505.0319	95632.404	49.2063	10.1200	20.24

Tower Elevation	Gusset Area (per face)	Gusset Thickness	Gusset Grade	Adjust. Factor A _r	Adjust. Factor A _r	Weight Mult.	Double Angle Stitch Bolt Spacing Diagonals	Double Angle Stitch Bolt Spacing Horizontals	Double Angle Stitch Bolt Spacing Redundants
ft	ft ²	in					in	in	in
L1 185.00-149.62				1	1	1			
L2 149.62-114.22				1	1	1			
L3 114.22-76.80				1	1	1			
L4 76.80-38.38				1	1	1			
L5 38.38-0.00				1	1	1			

Feed Line/Linear Appurtenances - Entered As Round Or Flat

Description	Section	Component Type	Placement	Total Number	Number Per Row	Start/End Position	Width or Diameter	Perimeter	Weight
	r		ft				in	in	plf
HB158-1-08U8-S8J18(1-5/8")	A	Surface Ar (CaAa)	185.00 - 0.00	2	2	0.320 0.360	1.9800		1.30
CR 50 1873PE(1-5/8")	A	Surface Ar (CaAa)	175.00 - 0.00	12	12	-0.200 0.200	1.9800		0.83
*** *** ***B*** ***									
HB114-1-08U4-M5J(1-1/4)	B	Surface Ar (CaAa)	165.00 - 0.00	1	1	-0.350 -0.350	1.5400		1.08
MLE Hybrid 9Power/18Fiber RL 2(1 5/8)	B	Surface Ar (CaAa)	145.00 - 0.00	1	1	-0.100 -0.100	1.6250		1.07
C *** ***									

Feed Line/Linear Appurtenances - Entered As Area

Description	Face or Leg	Allow Shield	Component Type	Placement ft	Total Number	C _A A _A		Weight
						ft ² /ft	plf	
A								
LDF4P-50A(1/2")	A	No	Inside Pole	182.00 - 0.00	1	No Ice	0.00	0.15
						1/2" Ice	0.00	0.15
						1" Ice	0.00	0.15
HJ7-50A(1-5/8")	A	No	Inside Pole	185.00 - 0.00	12	No Ice	0.00	1.04
						1/2" Ice	0.00	1.04
						1" Ice	0.00	1.04
2" Rigid Conduit	A	No	Inside Pole	175.00 - 0.00	1	No Ice	0.00	2.80
						1/2" Ice	0.00	2.80
						1" Ice	0.00	2.80
FB-L98B-002-75000(3/8")	A	No	Inside Pole	175.00 - 0.00	1	No Ice	0.00	0.06
						1/2" Ice	0.00	0.06
						1" Ice	0.00	0.06
WR-VG82ST-BRDA(5/8")	A	No	Inside Pole	175.00 - 0.00	2	No Ice	0.00	0.31
						1/2" Ice	0.00	0.31
						1" Ice	0.00	0.31

B								
HB114-1-08U4-M5J(1-1/4)	B	No	Inside Pole	165.00 - 0.00	3	No Ice	0.00	1.08
						1/2" Ice	0.00	1.08
						1" Ice	0.00	1.08
LDF7-50A(1-5/8")	B	No	Inside Pole	145.00 - 0.00	6	No Ice	0.00	0.82
						1/2" Ice	0.00	0.82
						1" Ice	0.00	0.82
CR 50 1873(1-5/8")	B	No	Inside Pole	135.00 - 0.00	6	No Ice	0.00	0.83
						1/2" Ice	0.00	0.83
						1" Ice	0.00	0.83
C								

GPS								
LDF4P-50A(1/2")	B	No	Inside Pole	40.00 - 0.00	1	No Ice	0.00	0.15
						1/2" Ice	0.00	0.15
						1" Ice	0.00	0.15
LDF4P-50A(1/2")	C	No	Inside Pole	100.00 - 0.00	2	No Ice	0.00	0.15
						1/2" Ice	0.00	0.15
						1" Ice	0.00	0.15

Safety Line 3/8	C	No	CaAa (Out Of Face)	185.00 - 0.00	1	No Ice	0.04	0.22
						1/2" Ice	0.14	0.75
						1" Ice	0.24	1.28

Feed Line/Linear Appurtenances Section Areas

Tower Section	Tower Elevation ft	Face	A _R ft ²	A _F ft ²	C _A A _A In Face ft ²	C _A A _A Out Face ft ²	Weight K
L1	185.00-149.62	A	0.000	0.000	74.307	0.000	0.9
		B	0.000	0.000	2.368	0.000	0.1
		C	0.000	0.000	0.000	1.327	0.0
L2	149.62-114.22	A	0.000	0.000	98.132	0.000	1.0
		B	0.000	0.000	10.453	0.000	0.4
		C	0.000	0.000	0.000	1.328	0.0
L3	114.22-76.80	A	0.000	0.000	103.726	0.000	1.1
		B	0.000	0.000	11.843	0.000	0.6
		C	0.000	0.000	0.000	1.403	0.0
L4	76.80-38.38	A	0.000	0.000	106.505	0.000	1.1
		B	0.000	0.000	12.161	0.000	0.6
		C	0.000	0.000	0.000	1.441	0.0
L5	38.38-0.00	A	0.000	0.000	106.390	0.000	1.1
		B	0.000	0.000	12.147	0.000	0.6
		C	0.000	0.000	0.000	1.439	0.0

Feed Line/Linear Appurtenances Section Areas - With Ice

Tower Section	Tower Elevation ft	Face or Leg	Ice Thickness in	A_R ft ²	A_F ft ²	C_{AA} In Face ft ²	C_{AA} Out Face ft ²	Weight K
L1	185.00-149.62	A	1.764	0.000	0.000	119.674	0.000	2.3
		B		0.000	0.000	7.793	0.000	0.2
		C		0.000	0.000	0.000	13.806	0.1
L2	149.62-114.22	A	1.722	0.000	0.000	153.885	0.000	2.9
		B		0.000	0.000	33.799	0.000	0.9
		C		0.000	0.000	0.000	13.816	0.1
L3	114.22-76.80	A	1.668	0.000	0.000	161.884	0.000	3.0
		B		0.000	0.000	37.624	0.000	1.1
		C		0.000	0.000	0.000	14.294	0.1
L4	76.80-38.38	A	1.586	0.000	0.000	165.169	0.000	3.0
		B		0.000	0.000	37.790	0.000	1.1
		C		0.000	0.000	0.000	14.256	0.1
L5	38.38-0.00	A	1.423	0.000	0.000	163.415	0.000	2.9
		B		0.000	0.000	36.489	0.000	1.1
		C		0.000	0.000	0.000	13.610	0.1

Feed Line Center of Pressure

Section	Elevation ft	CP_x in	CP_z in	CP_x Ice in	CP_z Ice in
L1	185.00-149.62	-1.4424	-1.1307	-1.4348	-1.1422
L2	149.62-114.22	-1.6526	-1.4265	-1.4866	-1.5279
L3	114.22-76.80	-1.7457	-1.5288	-1.6097	-1.6934
L4	76.80-38.38	-1.8420	-1.6132	-1.7549	-1.8353
L5	38.38-0.00	-1.9240	-1.6852	-1.8889	-1.9583

Shielding Factor Ka

Tower Section	Feed Line Record No.	Description	Feed Line Segment Elev.	K_a No Ice	K_a Ice
L1	4	HB158-1-08U8-S8J18(1-5/8")	149.62 - 185.00	1.0000	1.0000
L1	6	CR 50 1873PE(1-5/8")	149.62 - 175.00	1.0000	1.0000
L1	14	HB114-1-08U4-M5J(1-1/4)	149.62 - 165.00	1.0000	1.0000
L1	17	MLE Hybrid 9Power/18Fiber RL 2(1-5/8)	149.62 - 145.00	1.0000	1.0000
L2	4	HB158-1-08U8-S8J18(1-5/8")	114.22 - 149.62	1.0000	1.0000
L2	6	CR 50 1873PE(1-5/8")	114.22 - 149.62	1.0000	1.0000
L2	14	HB114-1-08U4-M5J(1-1/4)	114.22 - 149.62	1.0000	1.0000
L2	17	MLE Hybrid 9Power/18Fiber RL 2(1-5/8)	114.22 - 145.00	1.0000	1.0000
L3	4	HB158-1-08U8-S8J18(1-5/8")	76.80 - 114.22	1.0000	1.0000
L3	6	CR 50 1873PE(1-5/8")	76.80 - 114.22	1.0000	1.0000
L3	14	HB114-1-08U4-M5J(1-1/4)	76.80 - 114.22	1.0000	1.0000

Tower Section	Feed Line Record No.	Description	Feed Line Segment Elev.	K _a No Ice	K _a Ice
L3	17	MLE Hybrid 9Power/18Fiber RL 2(1 5/8)	76.80 - 114.22	1.0000	1.0000
L4	4	HB158-1-08U8-S8J18(1- 5/8")	38.38 - 76.80	1.0000	1.0000
L4	6	CR 50 1873PE(1-5/8")	38.38 - 76.80	1.0000	1.0000
L4	14	HB114-1-08U4-M5J(1-1/4)	38.38 - 76.80	1.0000	1.0000
L4	17	MLE Hybrid 9Power/18Fiber RL 2(1 5/8)	38.38 - 76.80	1.0000	1.0000

Discrete Tower Loads

Description	Face or Leg	Offset Type	Offsets: Horz Lateral Vert ft ft ft	Azimuth Adjustmen t °	Placement ft		C _{AA} Front ft ²	C _{AA} Side ft ²	Weight K
Lightning Rod 2"x10'	B	From Leg	0.00 0.00 5.00	0.0000	185.00	No Ice	2.00	2.00	0.1
						1/2"	3.02	3.02	0.1
						Ice	4.07	4.07	0.1
						1" Ice			
185' Verizon Wireless									
185' Verizon Wireless									
(2) DB846F65ZAXY w/ Mount Pipe	A	From Leg	4.00 0.00 2.00	0.0000	185.00	No Ice	7.15	7.70	0.0
						1/2"	7.66	8.78	0.1
						Ice	8.14	9.64	0.2
						1" Ice			
(2) DB846F65ZAXY w/ Mount Pipe	B	From Leg	4.00 0.00 2.00	0.0000	185.00	No Ice	7.15	7.70	0.0
						1/2"	7.66	8.78	0.1
						Ice	8.14	9.64	0.2
						1" Ice			
(2) DB846F65ZAXY w/ Mount Pipe	C	From Leg	4.00 0.00 2.00	0.0000	185.00	No Ice	7.15	7.70	0.0
						1/2"	7.66	8.78	0.1
						Ice	8.14	9.64	0.2
						1" Ice			
(2) SBNHH-1D85C w/ Mount Pipe	A	From Leg	4.00 0.00 2.00	0.0000	185.00	No Ice	11.63	9.79	0.1
						1/2"	12.35	11.31	0.2
						Ice	13.07	12.85	0.3
						1" Ice			
(2) SBNHH-1D85C w/ Mount Pipe	B	From Leg	4.00 0.00 2.00	0.0000	185.00	No Ice	11.63	9.79	0.1
						1/2"	12.35	11.31	0.2
						Ice	13.07	12.85	0.3
						1" Ice			
(2) SBNHH-1D85C w/ Mount Pipe	C	From Leg	4.00 0.00 2.00	0.0000	185.00	No Ice	11.63	9.79	0.1
						1/2"	12.35	11.31	0.2
						Ice	13.07	12.85	0.3
						1" Ice			
RRH2x60-700	A	From Leg	4.00 0.00 2.00	0.0000	185.00	No Ice	3.50	1.82	0.1
						1/2"	3.76	2.05	0.1
						Ice	4.03	2.29	0.1
						1" Ice			
RRH2x60-700	B	From Leg	4.00 0.00 2.00	0.0000	185.00	No Ice	3.50	1.82	0.1
						1/2"	3.76	2.05	0.1
						Ice	4.03	2.29	0.1
						1" Ice			
RRH2x60-700	C	From Leg	4.00 0.00	0.0000	185.00	No Ice	3.50	1.82	0.1
						1/2"	3.76	2.05	0.1

Description	Face or Leg	Offset Type	Offsets: Horz Lateral Vert ft ft ft	Azimuth Adjustment t °	Placement ft	C _{AA} Front ft ²	C _{AA} Side ft ²	Weight K	
			2.00			Ice 4.03	2.29	0.1	
RRH2X60-PCS	A	From Leg	4.00	0.0000	185.00	1" Ice	2.20	1.72	0.1
			0.00			No Ice			
			2.00			1/2"			
			2.00			Ice	2.59	2.09	0.1
						1" Ice			
						No Ice			
RRH2X60-PCS	B	From Leg	4.00	0.0000	185.00	1" Ice	2.20	1.72	0.1
			0.00			No Ice			
			2.00			1/2"			
			2.00			Ice	2.59	2.09	0.1
						1" Ice			
						No Ice			
RRH2X60-PCS	C	From Leg	4.00	0.0000	185.00	1" Ice	2.20	1.72	0.1
			0.00			No Ice			
			2.00			1/2"			
			2.00			Ice	2.59	2.09	0.1
						1" Ice			
						No Ice			
RRH4X45-AWS4 B66	A	From Leg	4.00	0.0000	185.00	1" Ice	2.66	1.59	0.1
			0.00			No Ice			
			2.00			1/2"			
			2.00			Ice	3.10	1.96	0.1
						1" Ice			
						No Ice			
RRH4X45-AWS4 B66	B	From Leg	4.00	0.0000	185.00	1" Ice	2.66	1.59	0.1
			0.00			No Ice			
			2.00			1/2"			
			2.00			Ice	3.10	1.96	0.1
						1" Ice			
						No Ice			
RRH4X45-AWS4 B66	C	From Leg	4.00	0.0000	185.00	1" Ice	2.66	1.59	0.1
			0.00			No Ice			
			2.00			1/2"			
			2.00			Ice	3.10	1.96	0.1
						1" Ice			
						No Ice			
DB-T1-6Z-8AB-0Z	A	From Leg	4.00	0.0000	185.00	1" Ice	4.80	2.00	0.0
			0.00			No Ice			
			2.00			1/2"			
			2.00			Ice	5.35	2.39	0.1
						1" Ice			
						No Ice			
DB-T1-6Z-8AB-0Z	C	From Leg	4.00	0.0000	185.00	1" Ice	4.80	2.00	0.0
			0.00			No Ice			
			2.00			1/2"			
			2.00			Ice	5.35	2.39	0.1
						1" Ice			
						No Ice			
6' x 2" Mount Pipe	A	From Leg	4.00	0.0000	185.00	1" Ice	1.43	1.43	0.0
			0.00			No Ice			
			0.00			1/2"			
			0.00			Ice	2.29	2.29	0.0
						1" Ice			
						No Ice			
6' x 2" Mount Pipe	B	From Leg	4.00	0.0000	185.00	1" Ice	1.43	1.43	0.0
			0.00			No Ice			
			0.00			1/2"			
			0.00			Ice	2.29	2.29	0.0
						1" Ice			
						No Ice			
6' x 2" Mount Pipe	C	From Leg	4.00	0.0000	185.00	1" Ice	1.43	1.43	0.0
			0.00			No Ice			
			0.00			1/2"			
			0.00			Ice	2.29	2.29	0.0
						1" Ice			
						No Ice			
Climbing Ladder - 5'	B	From Leg	3.00	0.0000	185.00	1" Ice	2.05	2.05	0.1
			0.00			No Ice			
			0.00			1/2"			
			0.00			Ice	2.78	2.78	0.1
						1" Ice			
						No Ice			
Platform Mount [LP 712-1]	C	None		0.0000	185.00	1" Ice	24.53	24.53	1.3
						No Ice			
						1/2"			
						Ice	35.35	35.35	2.0
						1" Ice			
						No Ice			
Side Arm Mount [SO 202-3]	C	None		0.0000	185.00	1" Ice	6.18	6.18	0.3
						No Ice			
						1/2"			
						Ice	10.94	10.94	0.5
						1" Ice			
						No Ice			
182' NEWTOWN ASP-601	B	From Leg	1.00	0.0000	182.00	1" Ice	2.34	2.34	0.0
			0.00			No Ice			
			6.00			1/2"			
						Ice	6.08	6.08	0.0
						1" Ice			
						No Ice			
Side Arm Mount [SO 104-3]	C	None		0.0000	182.00	1" Ice	3.30	3.30	0.3
						No Ice			
						1/2"	4.13	4.13	0.3

Description	Face or Leg	Offset Type	Offsets: Horz Lateral Vert ft ft ft	Azimuth Adjustment t °	Placement ft		C _{AA} Front ft ²	C _{AA} Side ft ²	Weight K
						Ice	4.96	4.96	0.3
						1" Ice			
175' AT&T Mobility									
(2) 7770.00 w/ Mount Pipe	A	From Leg	4.00 0.00 2.00	0.0000	175.00	No Ice	5.75	4.25	0.1
						1/2"	6.18	5.01	0.1
						Ice	6.61	5.71	0.2
						1" Ice			
(2) 7770.00 w/ Mount Pipe	B	From Leg	4.00 0.00 2.00	0.0000	175.00	No Ice	5.75	4.25	0.1
						1/2"	6.18	5.01	0.1
						Ice	6.61	5.71	0.2
						1" Ice			
(2) 7770.00 w/ Mount Pipe	C	From Leg	4.00 0.00 2.00	0.0000	175.00	No Ice	5.75	4.25	0.1
						1/2"	6.18	5.01	0.1
						Ice	6.61	5.71	0.2
						1" Ice			
OPA-65R-LCUU-H6 w/ Mount Pipe	A	From Leg	4.00 0.00 2.00	0.0000	175.00	No Ice	9.90	7.18	0.1
						1/2"	10.47	8.36	0.2
						Ice	11.01	9.26	0.3
						1" Ice			
OPA-65R-LCUU-H6 w/ Mount Pipe	B	From Leg	4.00 0.00 2.00	0.0000	175.00	No Ice	9.90	7.18	0.1
						1/2"	10.47	8.36	0.2
						Ice	11.01	9.26	0.3
						1" Ice			
OPA-65R-LCUU-H6 w/ Mount Pipe	C	From Leg	4.00 0.00 2.00	0.0000	175.00	No Ice	9.90	7.18	0.1
						1/2"	10.47	8.36	0.2
						Ice	11.01	9.26	0.3
						1" Ice			
(2) LGP2140X	A	From Leg	4.00 0.00 2.00	0.0000	175.00	No Ice	1.08	0.36	0.0
						1/2"	1.21	0.45	0.0
						Ice	1.35	0.56	0.0
						1" Ice			
(2) LGP2140X	B	From Leg	4.00 0.00 2.00	0.0000	175.00	No Ice	1.08	0.36	0.0
						1/2"	1.21	0.45	0.0
						Ice	1.35	0.56	0.0
						1" Ice			
(2) LGP2140X	C	From Leg	4.00 0.00 2.00	0.0000	175.00	No Ice	1.08	0.36	0.0
						1/2"	1.21	0.45	0.0
						Ice	1.35	0.56	0.0
						1" Ice			
RRUS-11	A	From Leg	4.00 0.00 2.00	0.0000	175.00	No Ice	2.52	1.07	0.1
						1/2"	2.72	1.21	0.1
						Ice	2.92	1.36	0.1
						1" Ice			
RRUS-11	B	From Leg	4.00 0.00 2.00	0.0000	175.00	No Ice	2.52	1.07	0.1
						1/2"	2.72	1.21	0.1
						Ice	2.92	1.36	0.1
						1" Ice			
RRUS-11	C	From Leg	4.00 0.00 2.00	0.0000	175.00	No Ice	2.52	1.07	0.1
						1/2"	2.72	1.21	0.1
						Ice	2.92	1.36	0.1
						1" Ice			
DTMABP7819VG12A	A	From Leg	4.00 0.00 0.00	0.0000	175.00	No Ice	0.98	0.34	0.0
						1/2"	1.10	0.42	0.0
						Ice	1.23	0.51	0.0
						1" Ice			
DTMABP7819VG12A	B	From Leg	4.00 0.00 0.00	0.0000	175.00	No Ice	0.98	0.34	0.0
						1/2"	1.10	0.42	0.0
						Ice	1.23	0.51	0.0
						1" Ice			
DTMABP7819VG12A	C	From Leg	4.00 0.00 0.00	0.0000	175.00	No Ice	0.98	0.34	0.0
						1/2"	1.10	0.42	0.0
						Ice	1.23	0.51	0.0
						1" Ice			
(4) 7020.00	A	From Leg	4.00 0.00	0.0000	175.00	No Ice	0.10	0.17	0.0
						1/2"	0.15	0.24	0.0

Description	Face or Leg	Offset Type	Offsets:			Azimuth Adjustment	Placement	C _{AA} _{Front}	C _{AA} _{Side}	Weight
			Horz	Lateral	Vert					
			ft	ft	ft	°	ft	ft ²	ft ²	K
			2.00				Ice	0.20	0.31	0.0
(4) 7020.00	B	From Leg	4.00	0.0000	175.00		1" Ice	0.10	0.17	0.0
			0.00				No Ice	0.15	0.24	0.0
			2.00				1/2"	0.20	0.31	0.0
							Ice			
(4) 7020.00	C	From Leg	4.00	0.0000	175.00		1" Ice	0.10	0.17	0.0
			0.00				No Ice	0.15	0.24	0.0
			2.00				1/2"	0.20	0.31	0.0
							Ice			
RRUS12/RRUS A2	A	From Leg	4.00	0.0000	175.00		1" Ice	3.14	1.84	0.1
			0.00				No Ice	3.36	2.01	0.1
			2.00				1/2"	3.59	2.20	0.1
							Ice			
RRUS12/RRUS A2	B	From Leg	4.00	0.0000	175.00		1" Ice	3.14	1.84	0.1
			0.00				No Ice	3.36	2.01	0.1
			2.00				1/2"	3.59	2.20	0.1
							Ice			
RRUS12/RRUS A2	C	From Leg	4.00	0.0000	175.00		1" Ice	3.14	1.84	0.1
			0.00				No Ice	3.36	2.01	0.1
			2.00				1/2"	3.59	2.20	0.1
							Ice			
DC6-48-60-18-8F	C	From Leg	4.00	0.0000	175.00		1" Ice	0.92	0.92	0.0
			0.00				No Ice	1.46	1.46	0.1
			0.00				1/2"	1.64	1.64	0.1
							Ice			
6' x 2" Mount Pipe	A	From Leg	4.00	0.0000	175.00		1" Ice	1.43	1.43	0.0
			0.00				No Ice	1.92	1.92	0.0
			0.00				1/2"	2.29	2.29	0.0
							Ice			
6' x 2" Mount Pipe	B	From Leg	4.00	0.0000	175.00		1" Ice	1.43	1.43	0.0
			0.00				No Ice	1.92	1.92	0.0
			0.00				1/2"	2.29	2.29	0.0
							Ice			
6' x 2" Mount Pipe	C	From Leg	4.00	0.0000	175.00		1" Ice	1.43	1.43	0.0
			0.00				No Ice	1.92	1.92	0.0
			0.00				1/2"	2.29	2.29	0.0
							Ice			
Platform Mount [LP 712-1]	C	None		0.0000	175.00		1" Ice	24.53	24.53	1.3
							No Ice	29.94	29.94	1.6
							1/2"	35.35	35.35	2.0
							Ice			
****167' SPRINT PCS****							1" Ice			
TME-1900MHz RRH (65MHz)	A	From Leg	4.00	0.0000	167.00		No Ice	2.31	2.38	0.1
			0.00				1/2"	2.52	2.58	0.1
			0.00				Ice	2.73	2.79	0.1
							1" Ice			
TME-1900MHz RRH (65MHz)	B	From Leg	4.00	0.0000	167.00		No Ice	2.31	2.38	0.1
			0.00				1/2"	2.52	2.58	0.1
			0.00				Ice	2.73	2.79	0.1
							1" Ice			
TME-1900MHz RRH (65MHz)	C	From Leg	4.00	0.0000	167.00		No Ice	2.31	2.38	0.1
			0.00				1/2"	2.52	2.58	0.1
			0.00				Ice	2.73	2.79	0.1
							1" Ice			
TME-800MHZ RRH	A	From Leg	4.00	0.0000	167.00		No Ice	2.13	1.77	0.1
			0.00				1/2"	2.32	1.95	0.1
			0.00				Ice	2.51	2.13	0.1
							1" Ice			
TME-800MHZ RRH	B	From Leg	4.00	0.0000	167.00		No Ice	2.13	1.77	0.1
			0.00				1/2"	2.32	1.95	0.1
			0.00				Ice	2.51	2.13	0.1
							1" Ice			
TME-800MHZ RRH	C	From Leg	4.00	0.0000	167.00		No Ice	2.13	1.77	0.1
			0.00				1/2"	2.32	1.95	0.1

Description	Face or Leg	Offset Type	Offsets: Horz Lateral Vert ft ft ft	Azimuth Adjustment °	Placement ft	C _{AA} Front ft ²	C _{AA} Side ft ²	Weight K
			0.00			Ice 2.51	2.13	0.1
Side Arm Mount [SO 104-3]	C	None		0.0000	167.00	1" Ice No Ice 3.30	3.30	0.3
						1/2" Ice 4.13 4.96	4.13 4.96	0.3
						1" Ice		0.3
165' Sprint PCS APXVSP18-C-A20 w/ Mount Pipe	A	From Leg	4.00 0.00 0.00	0.0000	165.00	No Ice 1/2" Ice 8.26 8.82 9.35	6.95 8.13 9.02	0.1 0.2 0.2
APXVSP18-C-A20 w/ Mount Pipe	B	From Leg	4.00 0.00 0.00	0.0000	165.00	No Ice 1/2" Ice 8.26 8.82 9.35	6.95 8.13 9.02	0.1 0.2 0.2
APXVSP18-C-A20 w/ Mount Pipe	C	From Leg	4.00 0.00 0.00	0.0000	165.00	No Ice 1/2" Ice 8.26 8.82 9.35	6.95 8.13 9.02	0.1 0.2 0.2
APXVTM14-ALU-I20 w/ Mount Pipe	A	From Leg	4.00 0.00 0.00	0.0000	165.00	No Ice 1/2" Ice 6.58 7.03 7.47	4.96 5.75 6.47	0.1 0.1 0.2
APXVTM14-ALU-I20 w/ Mount Pipe	B	From Leg	4.00 0.00 0.00	0.0000	165.00	No Ice 1/2" Ice 6.58 7.03 7.47	4.96 5.75 6.47	0.1 0.1 0.2
APXVTM14-ALU-I20 w/ Mount Pipe	C	From Leg	4.00 0.00 0.00	0.0000	165.00	No Ice 1/2" Ice 6.58 7.03 7.47	4.96 5.75 6.47	0.1 0.1 0.2
(3) ACU-A20-N	A	From Leg	4.00 0.00 0.00	0.0000	165.00	No Ice 1/2" Ice 0.07 0.10 0.15	0.12 0.16 0.21	0.0 0.0 0.0
(3) ACU-A20-N	B	From Leg	4.00 0.00 0.00	0.0000	165.00	No Ice 1/2" Ice 0.07 0.10 0.15	0.12 0.16 0.21	0.0 0.0 0.0
(3) ACU-A20-N	C	From Leg	4.00 0.00 0.00	0.0000	165.00	No Ice 1/2" Ice 0.07 0.10 0.15	0.12 0.16 0.21	0.0 0.0 0.0
800 EXTERNAL NOTCH FILTER	A	From Leg	4.00 0.00 0.00	0.0000	165.00	No Ice 1/2" Ice 0.66 0.76 0.87	0.32 0.40 0.48	0.0 0.0 0.0
800 EXTERNAL NOTCH FILTER	B	From Leg	4.00 0.00 0.00	0.0000	165.00	No Ice 1/2" Ice 0.66 0.76 0.87	0.32 0.40 0.48	0.0 0.0 0.0
800 EXTERNAL NOTCH FILTER	C	From Leg	4.00 0.00 0.00	0.0000	165.00	No Ice 1/2" Ice 0.66 0.76 0.87	0.32 0.40 0.48	0.0 0.0 0.0
TD-RRH8x20-25	A	From Leg	4.00 0.00 0.00	0.0000	165.00	No Ice 1/2" Ice 4.05 4.30 4.56	1.53 1.71 1.90	0.1 0.1 0.1
TD-RRH8x20-25	B	From Leg	4.00 0.00 0.00	0.0000	165.00	No Ice 1/2" Ice 4.05 4.30 4.56	1.53 1.71 1.90	0.1 0.1 0.1
TD-RRH8x20-25	C	From Leg	4.00 0.00	0.0000	165.00	No Ice 1/2" 4.05 4.30	1.53 1.71	0.1 0.1

Description	Face or Leg	Offset Type	Offsets: Horz Lateral Vert ft ft ft	Azimuth Adjustment t °	Placement ft	C _{AA} Front ft ²	C _{AA} Side ft ²	Weight K				
			0.00			Ice 4.56	1.90	0.1				
Climbing Ladder - 5'	A	From Leg	3.00	0.0000	165.00	1" Ice	2.05	2.05	0.1			
			0.00			No Ice				2.41	2.41	0.1
			0.00			1/2"				2.41	2.41	0.1
			0.00			Ice				2.78	2.78	0.1
6' x 2" Mount Pipe	A	From Leg	4.00	0.0000	165.00	1" Ice	1.43	1.43	0.0			
			0.00			No Ice				1.92	1.92	0.0
			0.00			1/2"				1.92	1.92	0.0
			0.00			Ice				2.29	2.29	0.0
6' x 2" Mount Pipe	B	From Leg	4.00	0.0000	165.00	1" Ice	1.43	1.43	0.0			
			0.00			No Ice				1.92	1.92	0.0
			0.00			1/2"				1.92	1.92	0.0
			0.00			Ice				2.29	2.29	0.0
6' x 2" Mount Pipe	C	From Leg	4.00	0.0000	165.00	1" Ice	1.43	1.43	0.0			
			0.00			No Ice				1.92	1.92	0.0
			0.00			1/2"				1.92	1.92	0.0
			0.00			Ice				2.29	2.29	0.0
Miscellaneous [NA 507-1]	C	None		0.0000	165.00	1" Ice	4.80	4.80	0.2			
						No Ice				6.70	6.70	0.3
						1/2"				6.70	6.70	0.3
						Ice				8.60	8.60	0.3
Platform Mount [LP 712-1]	C	None		0.0000	165.00	1" Ice	24.53	24.53	1.3			
						No Ice				29.94	29.94	1.6
						1/2"				29.94	29.94	1.6
						Ice				35.35	35.35	2.0
155 Sprint PCS Side Arm Mount [SO 102-1]	A	None		0.0000	155.00	1" Ice	1.50	1.50	0.0			
						No Ice				1.74	1.75	0.0
						1/2"				1.74	1.75	0.0
						Ice				1.98	2.00	0.0
145' T-Mobile (2) ERICSSON AIR 21 B2A B4P w/ Mount Pipe	A	From Face	4.00	0.0000	145.00	1" Ice	6.33	5.64	0.1			
			0.00			No Ice				6.78	6.43	0.2
			3.00			1/2"				6.78	6.43	0.2
			3.00			Ice				7.21	7.13	0.2
(2) ERICSSON AIR 21 B2A B4P w/ Mount Pipe	B	From Face	4.00	0.0000	145.00	1" Ice	6.33	5.64	0.1			
			0.00			No Ice				6.78	6.43	0.2
			3.00			1/2"				6.78	6.43	0.2
			3.00			Ice				7.21	7.13	0.2
(2) ERICSSON AIR 21 B2A B4P w/ Mount Pipe	C	From Face	4.00	0.0000	145.00	1" Ice	6.33	5.64	0.1			
			0.00			No Ice				6.78	6.43	0.2
			3.00			1/2"				6.78	6.43	0.2
			3.00			Ice				7.21	7.13	0.2
KRY 112 144/1	A	From Face	4.00	0.0000	145.00	1" Ice	0.35	0.16	0.0			
			0.00			No Ice				0.43	0.22	0.0
			3.00			1/2"				0.43	0.22	0.0
			3.00			Ice				0.51	0.28	0.0
KRY 112 144/1	B	From Face	4.00	0.0000	145.00	1" Ice	0.35	0.16	0.0			
			0.00			No Ice				0.43	0.22	0.0
			3.00			1/2"				0.43	0.22	0.0
			3.00			Ice				0.51	0.28	0.0
KRY 112 144/1	C	From Face	4.00	0.0000	145.00	1" Ice	0.35	0.16	0.0			
			0.00			No Ice				0.43	0.22	0.0
			3.00			1/2"				0.43	0.22	0.0
			3.00			Ice				0.51	0.28	0.0
LNX-6515DS-A1M w/ Mount Pipe	A	From Face	4.00	0.0000	145.00	1" Ice	11.45	9.36	0.1			
			0.00			No Ice				12.06	10.68	0.2
			0.00			1/2"				12.06	10.68	0.2
			0.00			Ice				12.69	11.71	0.3
LNX-6515DS-A1M w/ Mount Pipe	B	From Face	4.00	0.0000	145.00	1" Ice	11.45	9.36	0.1			
			0.00			No Ice				12.06	10.68	0.2
			0.00			1/2"				12.06	10.68	0.2
			0.00			Ice				12.69	11.71	0.3
LNX-6515DS-A1M w/	C	From Face	4.00	0.0000	145.00	No Ice	11.45	9.36	0.1			

Description	Face or Leg	Offset Type	Offsets:		Azimuth Adjustment	Placement	C _{AA} _{Front}	C _{AA} _{Side}	Weight				
			Horz	Lateral						ft	ft	ft ²	ft ²
Mount Pipe			0.00			1/2"	12.06	10.68	0.2				
			0.00			Ice	12.69	11.71	0.3				
RRUS 11 B12	A	From Face	4.00		0.0000	145.00	1" Ice	2.83	1.18	0.1			
			0.00				No Ice						
			1/2"				3.04				1.33	0.1	
			3.00				Ice				3.26	1.48	0.1
RRUS 11 B12	B	From Face	4.00		0.0000	145.00	1" Ice	2.83	1.18	0.1			
			0.00				No Ice						
			1/2"				3.04				1.33	0.1	
			3.00				Ice				3.26	1.48	0.1
RRUS 11 B12	C	From Face	4.00		0.0000	145.00	1" Ice	2.83	1.18	0.1			
			0.00				No Ice						
			1/2"				3.04				1.33	0.1	
			3.00				Ice				3.26	1.48	0.1
Platform Mount [LP 712-1]	C	None			0.0000	145.00	1" Ice	24.53	24.53	1.3			
							No Ice						
							1/2"				29.94	29.94	1.6
							Ice				35.35	35.35	2.0
135' METRO PCS 800 10504 w/ Mount Pipe	A	From Leg	4.00		0.0000	135.00	No Ice	3.48	3.19	0.0			
			0.00				1/2"				3.86	3.82	0.1
			2.00				Ice				4.24	4.47	0.1
							1" Ice						
800 10504 w/ Mount Pipe	B	From Leg	4.00		0.0000	135.00	No Ice	3.48	3.19	0.0			
			0.00				1/2"				3.86	3.82	0.1
			2.00				Ice				4.24	4.47	0.1
							1" Ice						
800 10504 w/ Mount Pipe	C	From Leg	4.00		0.0000	135.00	No Ice	3.48	3.19	0.0			
			0.00				1/2"				3.86	3.82	0.1
			2.00				Ice				4.24	4.47	0.1
							1" Ice						
860 10025	A	From Leg	4.00		0.0000	135.00	No Ice	0.14	0.12	0.0			
			0.00				1/2"				0.20	0.17	0.0
			2.00				Ice				0.26	0.23	0.0
							1" Ice						
860 10025	B	From Leg	4.00		0.0000	135.00	No Ice	0.14	0.12	0.0			
			0.00				1/2"				0.20	0.17	0.0
			2.00				Ice				0.26	0.23	0.0
							1" Ice						
860 10025	C	From Leg	4.00		0.0000	135.00	No Ice	0.14	0.12	0.0			
			0.00				1/2"				0.20	0.17	0.0
			2.00				Ice				0.26	0.23	0.0
							1" Ice						
(2) 6' x 2" Mount Pipe	A	From Leg	4.00		0.0000	135.00	No Ice	1.43	1.43	0.0			
			0.00				1/2"				1.92	1.92	0.0
			0.00				Ice				2.29	2.29	0.0
							1" Ice						
(2) 6' x 2" Mount Pipe	B	From Leg	4.00		0.0000	135.00	No Ice	1.43	1.43	0.0			
			0.00				1/2"				1.92	1.92	0.0
			0.00				Ice				2.29	2.29	0.0
							1" Ice						
(2) 6' x 2" Mount Pipe	C	From Leg	4.00		0.0000	135.00	No Ice	1.43	1.43	0.0			
			0.00				1/2"				1.92	1.92	0.0
			0.00				Ice				2.29	2.29	0.0
							1" Ice						
T-Arm Mount [TA 602-3]	C	None			0.0000	135.00	No Ice	11.59	11.59	0.8			
							1/2"				15.44	15.44	1.0
							Ice				19.29	19.29	1.2
							1" Ice						
GPS GPS	C	From Leg	2.00		0.0000	108.00	No Ice	0.08	0.08	0.0			
			0.00				1/2"				0.14	0.14	0.0
			0.00				Ice				0.22	0.22	0.0
							1" Ice						

Description	Face or Leg	Offset Type	Offsets:		Azimuth Adjustment	Placement	C _A A _A Front	C _A A _A Side	Weight
			Horz	Lateral					
			ft	ft	°	ft	ft ²	ft ²	K
GPS	C	From Leg	2.00	0.0000	107.00	No Ice	0.08	0.08	0.0
			0.00			1/2"	0.14	0.14	0.0
			0.00			Ice	0.22	0.22	0.0
GPS	C	From Leg	2.00	0.0000	51.00	No Ice	0.08	0.08	0.0
			0.00			1/2"	0.14	0.14	0.0
			0.00			Ice	0.22	0.22	0.0
Side Arm Mount [SO 901-1]	C	From Leg	1.00	0.0000	108.00	No Ice	0.50	0.88	0.1
			0.00			1/2"	0.68	1.13	0.1
			0.00			Ice	0.86	1.38	0.1
Side Arm Mount [SO 901-1]	C	From Leg	1.00	0.0000	107.00	No Ice	0.50	0.88	0.1
			0.00			1/2"	0.68	1.13	0.1
			0.00			Ice	0.86	1.38	0.1
Side Arm Mount [SO 901-1]	C	From Leg	1.00	0.0000	51.00	No Ice	0.50	0.88	0.1
			0.00			1/2"	0.68	1.13	0.1
			0.00			Ice	0.86	1.38	0.1

Compression Checks

Pole Design Data

Section No.	Elevation	Size	L	L _u	KI/r	A	P _u	φP _n	Ratio
	ft		ft	ft		in ²	K	K	$\frac{P_u}{\phi P_n}$
L1	185 - 149.622 (1)	TP36.0404x29x0.25	35.38	0.00	0.0	27.609 3	-12.8	1850.0	0.007
L2	149.622 - 114.221 (2)	TP42.4605x34.5443x0.31 25	40.41	0.00	0.0	40.677 1	-24.1	2785.9	0.009
L3	114.221 - 76.8021 (3)	TP49.157x40.6978x0.375	43.23	0.00	0.0	56.514 8	-35.7	3919.2	0.009
L4	76.8021 - 38.3802 (4)	TP55.9285x47.1064x0.43 75	45.07	0.00	0.0	75.019 6	-51.0	5246.2	0.010
L5	38.3802 - 0 (5)	TP62.5x53.5869x0.5	45.87	0.00	0.0	98.394 0	-74.0	6871.4	0.011

Pole Bending Design Data

Section No.	Elevation	Size	M _{ux}	φM _{nx}	Ratio	M _{uy}	φM _{ny}	Ratio
	ft		kip-ft	kip-ft	$\frac{M_{ux}}{\phi M_{nx}}$	kip-ft	kip-ft	$\frac{M_{uy}}{\phi M_{ny}}$
L1	185 - 149.622 (1)	TP36.0404x29x0.25	509.1	1324.6	0.384	0.0	1324.6	0.000
L2	149.622 - 114.221 (2)	TP42.4605x34.5443x0.31 25	1505.2	2349.9	0.641	0.0	2349.9	0.000
L3	114.221 - 76.8021 (3)	TP49.157x40.6978x0.375	2778.7	3826.4	0.726	0.0	3826.4	0.000
L4	76.8021 - 38.3802 (4)	TP55.9285x47.1064x0.43 75	4242.7	5826.8	0.728	0.0	5826.8	0.000

Section No.	Elevation ft	Size	M_{ux} kip-ft	ϕM_{nx} kip-ft	Ratio $\frac{M_{ux}}{\phi M_{nx}}$	M_{uy} kip-ft	ϕM_{ny} kip-ft	Ratio $\frac{M_{uy}}{\phi M_{ny}}$
L5	38.3802 - 0 (5)	TP62.5x53.5869x0.5	6211.0	8758.7	0.709	0.0	8758.7	0.000

Pole Shear Design Data

Section No.	Elevation ft	Size	Actual V_u K	ϕV_n K	Ratio $\frac{V_u}{\phi V_n}$	Actual T_u kip-ft	ϕT_n kip-ft	Ratio $\frac{T_u}{\phi T_n}$
L1	185 - 149.622 (1)	TP36.0404x29x0.25	22.7	925.0	0.025	0.0	2652.4	0.000
L2	149.622 - 114.221 (2)	TP42.4605x34.5443x0.31 25	32.6	1392.9	0.023	0.1	4705.6	0.000
L3	114.221 - 76.8021 (3)	TP49.157x40.6978x0.375	36.8	1959.6	0.019	0.0	7662.2	0.000
L4	76.8021 - 38.3802 (4)	TP55.9285x47.1064x0.43 75	40.9	2623.1	0.016	0.0	11667.7	0.000
L5	38.3802 - 0 (5)	TP62.5x53.5869x0.5	44.6	3435.7	0.013	0.4	17538.8	0.000

Pole Interaction Design Data

Section No.	Elevation ft	Ratio P_u ϕP_n	Ratio M_{ux} ϕM_{nx}	Ratio M_{uy} ϕM_{ny}	Ratio V_u ϕV_n	Ratio T_u ϕT_n	Comb. Stress Ratio	Allow. Stress Ratio	Criteria
L1	185 - 149.622 (1)	0.007	0.384	0.000	0.025	0.000	0.392	1.000	4.8.2 ✓
L2	149.622 - 114.221 (2)	0.009	0.641	0.000	0.023	0.000	0.650	1.000	4.8.2 ✓
L3	114.221 - 76.8021 (3)	0.009	0.726	0.000	0.019	0.000	0.736	1.000	4.8.2 ✓
L4	76.8021 - 38.3802 (4)	0.010	0.728	0.000	0.016	0.000	0.738	1.000	4.8.2 ✓
L5	38.3802 - 0 (5)	0.011	0.709	0.000	0.013	0.000	0.720	1.000	4.8.2 ✓

Section Capacity Table

Section No.	Elevation ft	Component Type	Size	Critical Element	P K	ϕP_{allow} K	% Capacity	Pass Fail
L1	185 - 149.622	Pole	TP36.0404x29x0.25	1	-12.8	1850.0	39.2	Pass
L2	149.622 - 114.221	Pole	TP42.4605x34.5443x0.3125	2	-24.1	2785.9	65.0	Pass
L3	114.221 - 76.8021	Pole	TP49.157x40.6978x0.375	3	-35.7	3919.2	73.6	Pass
L4	76.8021 - 38.3802	Pole	TP55.9285x47.1064x0.4375	4	-51.0	5246.2	73.8	Pass
L5	38.3802 - 0	Pole	TP62.5x53.5869x0.5	5	-74.0	6871.4	72.0	Pass
Summary								
Pole (L4)							73.8	Pass
RATING =							73.8	Pass

APPENDIX B
BASE LEVEL DRAWING

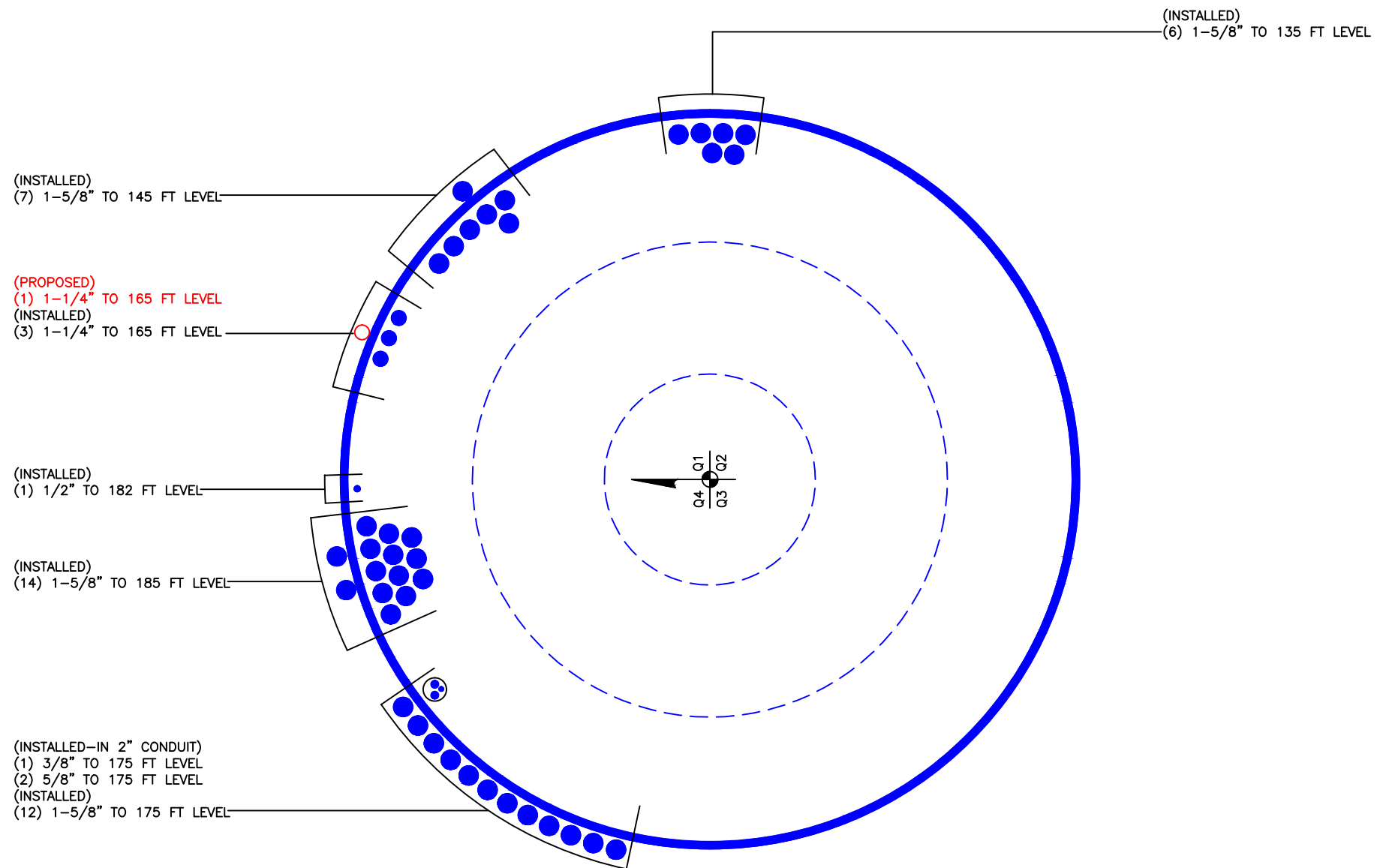

CROWN REGION ADDRESS
USA

ZMK	SLW	ARR	JRP	WJT	SLW	SF	PB	KB
8/4/2015	14/7/2015	7/8/2015	20/8/2015	21/03/16	29/04/16	28/01/17	29/03/17	12/06/17
UPDATED PER WORK ORDER 1040576	UPDATED PER WORK ORDER 1082978	UPDATED PER WORK ORDER 1102143,1089147	UPDATED PER WORK ORDER 1108561	UPDATED PER WORK ORDER 1197826	UPDATED PER WORK ORDER 1216464	UPDATED PER WORK ORDER 1353993	UPDATED PER WORK ORDER 1362540	UPDATED PER WORK ORDER 1417788

DRAWN BY: CDR
CHECKED BY:
DRAWING DATE: 18/07/05

SITE NUMBER:

SITE NAME:

BRG 123 943084

BUSINESS UNIT NUMBER:

806354

SITE ADDRESS:

ROUTE 34 - WASHINGTON AVENUE
NEWTOWN, CT 06482
FAIRFIELD COUNTY
USA

SHEET TITLE:

BASE LEVEL

SHEET NUMBER:

BUSINESS UNIT: 806354 TOWER ID: C_BASELEVEL

Xref R:\Standards - URE\CAD Standards v5.0\Templates\Typical Blocks For Templates\TITLE-BLOCK STD-VER 5.1.dwg

APPENDIX C
ADDITIONAL CALCULATIONS

Stiffened or Unstiffened, Ungrouted, Circular Base Plate - Any Rod Material

TIA Rev G

Assumption: Clear space between bottom of leveling nut and top of concrete **not** exceeding (1)*(Rod Diameter)

Site Data	
BU#:	806354
Site Name:	BRG 123 943084
App #:	393537 Rev#0
Pole Manufacturer:	Other

Reactions		
Mu:	6211	ft-kips
Axial, Pu:	74	kips
Shear, Vu:	45	kips
Eta Factor, η	0.5	TIA G (Fig. 4-4)

Anchor Rod Data		
Qty:	24	
Diam:	2.25	in
Rod Material:	A615-J	
Strength (Fu):	100	ksi
Yield (Fy):	75	ksi
Bolt Circle:	73	in

If No stiffeners, Criteria: **AISC LRFD** <-Only Applicable to Unstiffened Cases

Anchor Rod Results

Max Rod ($C_u + V_u/\eta$): 177.0 Kips
 Allowable Axial, $\Phi * F_u * A_{net}$: 260.0 Kips
 Anchor Rod Stress Ratio: 68.1% **Pass**

Stiffened
AISC LRFD
$\phi * T_n$

Plate Data		
Diam:	79	in
Thick:	2.5	in
Grade:	60	ksi
Single-Rod B-eff:	8.27	in

Base Plate Results

Base Plate Stress: 20.9 ksi
 Allowable Plate Stress: 54.0 ksi
 Base Plate Stress Ratio: 38.7% **Pass**

Flexural Check

Stiffened
AISC LRFD
$\phi * F_y$
Y.L. Length:
N/A, Roark

Stiffener Data (Welding at both sides)		
Config:	1	*
Weld Type:	Fillet	
Groove Depth:		<-- Disregard
Groove Angle:		<-- Disregard
Fillet H. Weld:	0.5	in
Fillet V. Weld:	0.375	in
Width:	7	in
Height:	15	in
Thick:	0.75	in
Notch:	0.5	in
Grade:	50	ksi
Weld str.:	70	ksi

Stiffener Results

Horizontal Weld : 79.6% **Pass**
 Vertical Weld: 55.1% **Pass**
 Plate Flex+Shear, $f_b/F_b + (f_v/F_v)^2$: 29.5% **Pass**
 Plate Tension+Shear, $f_t/F_t + (f_v/F_v)^2$: 58.7% **Pass**
 Plate Comp. (AISC Bracket): 74.4% **Pass**

Pole Results

Pole Punching Shear Check: 15.4% **Pass**

Pole Data		
Diam:	62.5	in
Thick:	0.5	in
Grade:	65	ksi
# of Sides:	18	"0" IF Round
Fu	80	ksi
Reinf. Fillet Weld	0	"0" if None

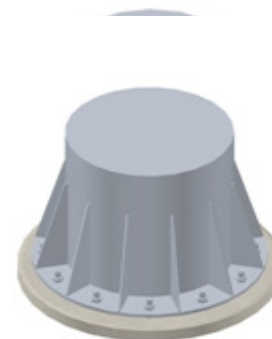
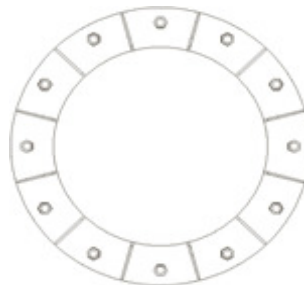

* 0 = none, 1 = every bolt, 2 = every 2 bolts, 3 = 2 per bolt

** Note: for complete joint penetration groove welds the groove depth must be exactly 1/2 the stiffener thickness for calculation purposes

(Bearing and Stability Checks) Tool for TIA Rev F or G - Application (MP, SST with unitbase)

Site Data

BU#: 806354
Site Name: BRG 123 943084
App #: 393537 Rev#0

Monopole Base Reaction Forces		
TIA Revision:	G	<--Pull Down
Factored DL Axial, PDU:	74	kips
Factored WL Axial, PWu:	0	kips
Factored WL Shear, Vu:	45	kips
Factored WL Moment, Mu:	6211	ft-kips

Loads Already Factored		
For P (DL)	1.2	<----Disregard
For P,V, and M (WL)	1.35	<----Disregard

Load Factor	Shaft Factored Loads		
1.00	1.2D+1.6W, Pu:	74	kips
0.90	0.9D+1.6W, Pu:	55.5	kips
1.00	Vu:	45	kips
	Mu:	6211	ft-kips

Pad & Pier Data		
Base PL Dist. Above Pier:	4.5	in
Pier Dist. Above Grade:	12	in
Pad Bearing Depth, D:	6	ft
Pad Thickness, T:	3	ft
Pad Width=Length, L:	28	ft
Pier Cross Section Shape:	Square	<--Pull Down
Enter Pier Side Width:	8	ft
Concrete Density:	150.0	pcf
Pier Cross Section Area:	64.00	ft^2
Pier Height:	4.00	ft
Soil (above pad) Height:	3.00	ft

1.2D+1.6W Load Combination, Bearing Results:

(No Soil Wedges) [Reaction+Conc+Soil]	854.48	P1="1.2D+1.6W" (Kips)
Factored "1.6W" Overturning Moment (MW-Msoil), M1	6482.88	ft-kips

Orthogonal Direction:

ecc1 = M1/P1 = 7.59 ft
 Orthogonal qu= 2.38 ksf
 qu/φ*qn Ratio= **26.44% Pass**

Diagonal Direction:

ecc2 = (0.707M1)/P1 = 5.36 ft
 Diagonal qu= 2.86 ksf
 qu/φ*qn Ratio= **31.83% Pass**

<-- Press Upon Completing All Input

Soil Parameters		
Unit Weight, γ:	120.0	pcf
Ultimate Bearing Capacity, qn:	12.00	ksf
Strength Reduct. factor, φ:	0.75	
Angle of Friction, Φ:	34.0	degrees
Undrained Shear Strength, Cu:	0.00	ksf
Allowable Bearing: φ*qn:	9.00	ksf
Passive Pres. Coeff., Kp	3.54	

Overturning Stability Check

0.9D+1.6W Load Combination, Bearing Results:

(w/ Soil Wedges) [Reaction+Conc+Soil]	663.33	P2="0.9D+1.6W" (Kips)
Factored "1.6W" Overturning Moment (MW-Msoil) - 0.9(M of Wedge + M of Cohesion), M2	6278.85	ft-kips

Orthogonal ecc3 = M2/P2 = 9.47 ft
 Ortho Non Bearing Length,NBL= **18.93 ft**
 Orthogonal qu= 2.61 ksf
 Diagonal qu= 3.11 ksf

Forces/Moments due to Wind and Lateral Soil		
Minimum of (φ*Ultimate Pad Passive Force, Vu):	45.0	kips
Pad Force Location Above D:	1.33	ft
φ(Passive Pressure Moment):	60.00	ft-kips
Factored O.T. M(WL), "1.6W":	6542.9	ft-kips
Factored OT (MW-Msoil), M1	6482.88	ft-kips

Resistance due to Foundation Gravity		
Soil Wedge Projection grade, a:	2.02	ft
Sum of Soil Wedges Wt:	24.97	kips
Soil Wedges ecc, K1:	9.08	ft
Ftg+Soil above Pad wt:	650.4	kips
Unfactored (Total ftg-soil Wt):	675.37	kips
1.2D. No Soil Wedges.	854.48	kips
0.9D. With Soil Wedges	663.33	kips

Max Reaction Moment (ft-kips) so that qu=φ*qn = 100% Capacity Rating

Actual M:	6211.00		
M Orthogonal:	8359.34	74.30%	Pass
M Diagonal:	8359.34	74.30%	Pass

Resistance due to Cohesion (Vertical)		
φ*(1/2*Cu)(Total Vert. Planes)	0.00	kips
Cohesion Force Eccentricity, K2	0.00	ft

Project Name: BRG 123 943084
 Project Number: BU#806354
 Job Number: WO#1417811
 Date: 6/15/2017



Created On: 6/3/2014
 Checked By: DW
 Revised On: 3/4/2015
 Revision No.: 1.6

Monopole Pad & Pier Foundation

Foundation Parameters

Load	
Code	G
Axial	74 kips
Shear	45 kips
Moment	6211 k-ft
Soil Unit Weight	120 pcf
Friction Angle	34
Cohesion	0 psf

Material	
Concrete Strength (F'c)	4000 psi
Concrete Density	150 pcf
Rebar Tensile (Fy)	60 ksi
Clear Cover	3 in

Pad	
Thickness	3 ft
Bearing Depth	6 ft
Width	28 ft
Rebar Size	9
Rebar Quantity	45

Pier	
Pier type	Square
Width	8 ft
Height above Grade	1 ft
Rebar Size	9
Rebar Quantity	48
Tie Size	4
Tie C/C Spacing	10.5 in

Structural Checks

Pad Beam Shear Capacity	998.0 kips
Pad Beam Shear	409.4 kips
Pad Beam Shear Check	41.0% Pass

Pad Bending Moment Capacity	6100.6 k-ft
Pad Bending Moment	2611.5 k-ft
Pad Bending Moment Check	42.8% Pass

Punching Shear Capacity	3025.0 kips
Punching Shear	465.4 kips
Punching Shear Check	15.4% Pass

Pad-Pier Bearing Capacity	40734.7 kips
Pad-Pier Bearing	854.5 kips
Pad-Pier Bearing Check	2.1% Pass

Pier Beam Shear Capacity	942.4 kips
Pier Beam Shear	45.0 kips
Pier Beam Shear Check	4.8% Pass

Pier Bending Moment Capacity	9871.3 k-ft
Pier Bending Moment	6382.2 k-ft
Pier Bending Moment Check	64.7% Pass



RADIO FREQUENCY EMISSIONS ANALYSIS REPORT EVALUATION OF HUMAN EXPOSURE POTENTIAL TO NON-IONIZING EMISSIONS

SPRINT Existing Facility

Site ID: CT03XC368

Newtown
21 Berkshire Road
Newtown, CT 06482

July 24, 2017

EBI Project Number: 6217003220

Site Compliance Summary	
Compliance Status:	COMPLIANT
Site total MPE% of FCC general population allowable limit:	8.35 %



July 24, 2017

SPRINT

Attn: RF Engineering Manager
1 International Boulevard, Suite 800
Mahwah, NJ 07495

Emissions Analysis for Site: **CT03XC368 – Newtown**

EBI Consulting was directed to analyze the proposed SPRINT facility located at **21 Berkshire Road, Newtown, CT**, for the purpose of determining whether the emissions from the Proposed SPRINT Antenna Installation located on this property are within specified federal limits.

All information used in this report was analyzed as a percentage of current Maximum Permissible Exposure (% MPE) as listed in the FCC OET Bulletin 65 Edition 97-01 and ANSI/IEEE Std C95.1. The FCC regulates Maximum Permissible Exposure in units of microwatts per square centimeter ($\mu\text{W}/\text{cm}^2$). The number of $\mu\text{W}/\text{cm}^2$ calculated at each sample point is called the power density. The exposure limit for power density varies depending upon the frequencies being utilized. Wireless Carriers and Paging Services use different frequency bands each with different exposure limits, therefore it is necessary to report results and limits in terms of percent MPE rather than power density.

All results were compared to the FCC (Federal Communications Commission) radio frequency exposure rules, 47 CFR 1.1307(b)(1) – (b)(3), to determine compliance with the Maximum Permissible Exposure (MPE) limits for General Population/Uncontrolled environments as defined below.

General population/uncontrolled exposure limits apply to situations in which the general population may be exposed or in which persons who are exposed as a consequence of their employment may not be made fully aware of the potential for exposure or cannot exercise control over their exposure. Therefore, members of the general population would always be considered under this category when exposure is not employment related, for example, in the case of a telecommunications tower that exposes persons in a nearby residential area.

Population exposure to radio frequencies is regulated and enforced in units of microwatts per square centimeter ($\mu\text{W}/\text{cm}^2$). The general population exposure limits for the 850 MHz Band is approximately $567 \mu\text{W}/\text{cm}^2$. The general population exposure limit for the 1900 MHz (PCS) and 2500 MHz (BRS) bands is $1000 \mu\text{W}/\text{cm}^2$. Because each carrier will be using different frequency bands, and each frequency band has different exposure limits, it is necessary to report percent of MPE rather than power density.



Occupational/controlled exposure limits apply to situations in which persons are exposed as a consequence of their employment and in which those persons who are exposed have been made fully aware of the potential for exposure and can exercise control over their exposure. Occupational/controlled exposure limits also apply where exposure is of a transient nature as a result of incidental passage through a location where exposure levels may be above general population/uncontrolled limits (see below), as long as the exposed person has been made fully aware of the potential for exposure and can exercise control over his or her exposure by leaving the area or by some other appropriate means.

Additional details can be found in FCC OET 65.

CALCULATIONS

Calculations were done for the proposed SPRINT Wireless antenna facility located at **21 Berkshire Road, Newtown, CT**, using the equipment information listed below. All calculations were performed per the specifications under FCC OET 65. Since SPRINT is proposing highly focused directional panel antennas, which project most of the emitted energy out toward the horizon, all calculations were performed assuming a lobe representing the maximum gain of the antenna per the antenna manufactures supplied specifications, minus 10 dB, was focused at the base of the tower. For this report the sample point is the top of a 6-foot person standing at the base of the tower.

For all calculations, all equipment was calculated using the following assumptions:

- 1) 1 CDMA channels (850 MHz) were considered for each sector of the proposed installation. These Channels have a transmit power of 20 Watts per Channel.
- 2) 2 LTE channels (850 MHz) were considered for each sector of the proposed installation. These Channels have a transmit power of 20 Watts per Channel.
- 3) 5 CDMA channels (1900 MHz (PCS)) were considered for each sector of the proposed installation. These Channels have a transmit power of 16 Watts per Channel.
- 4) 2 LTE channels (1900 MHz (PCS)) were considered for each sector of the proposed installation. These Channels have a transmit power of 40 Watts per Channel.
- 5) 8 LTE channels (2500 MHz (BRS)) were considered for each sector of the proposed installation. These Channels have a transmit power of 20 Watts per Channel.



- 6) All radios at the proposed installation were considered to be running at full power and were uncombined in their RF transmissions paths per carrier prescribed configuration. Per FCC OET Bulletin No. 65 - Edition 97-01 recommendations to achieve the maximum anticipated value at each sample point, all power levels emitting from the proposed antenna installation are increased by a factor of 2.56 to account for possible in-phase reflections from the surrounding environment. This is rarely the case, and if so, is never continuous.
- 7) For the following calculations, the sample point was the top of a 6-foot person standing at the base of the tower. The maximum gain of the antenna per the antenna manufactures supplied specifications minus 10 dB was used in this direction. This value is a very conservative estimate as gain reductions for these particular antennas are typically much higher in this direction.
- 8) The antennas used in this modeling are the **RFS APXVSP18-C-A20** and **RFS APXVTM14-C-I20** for transmission in the 850 MHz, 1900 MHz (PCS) and 2500 MHz (BRS) frequency bands. This is based on feedback from the carrier with regards to anticipated antenna selection. Maximum gain values for all antennas are listed in the Inventory and Power Data table below. The maximum gain of the antenna per the antenna manufactures supplied specifications, minus 10 dB, was used for all calculations. This value is a very conservative estimate as gain reductions for these particular antennas are typically much higher in this direction.
- 9) The antenna mounting height centerlines of the proposed antennas are **165 feet** above ground level (AGL) for **Sector A**, **165 feet** above ground level (AGL) for **Sector B** and **165 feet** above ground level (AGL) for Sector C.
- 10) Emissions values for additional carriers were taken from the Connecticut Siting Council active database. Values in this database are provided by the individual carriers themselves.

All calculations were done with respect to uncontrolled / general population threshold limits.



SPRINT Site Inventory and Power Data by Antenna

Sector:	A	Sector:	B	Sector:	C
Antenna #:	1	Antenna #:	1	Antenna #:	1
Make / Model:	RFS APXVSP18-C-A20	Make / Model:	RFS APXVSP18-C-A20	Make / Model:	RFS APXVSP18-C-A20
Gain:	13.4 / 15.9 dBd	Gain:	13.4 / 15.9 dBd	Gain:	13.4 / 15.9 dBd
Height (AGL):	165 feet	Height (AGL):	165 feet	Height (AGL):	165 feet
Frequency Bands	850 MHz / 1900 MHz (PCS)	Frequency Bands	850 MHz / 1900 MHz (PCS)	Frequency Bands	850 MHz / 1900 MHz (PCS)
Channel Count	10	Channel Count	10	Channel Count	10
Total TX Power(W):	220 Watts	Total TX Power(W):	220 Watts	Total TX Power(W):	220 Watts
ERP (W):	7,537.38	ERP (W):	7,537.38	ERP (W):	7,537.38
Antenna A1 MPE%	1.21 %	Antenna B1 MPE%	1.21 %	Antenna C1 MPE%	1.21 %
Antenna #:	2	Antenna #:	2	Antenna #:	2
Make / Model:	RFS APXVTM14-C-I20	Make / Model:	RFS APXVTM14-C-I20	Make / Model:	RFS APXVTM14-C-I20
Gain:	15.9 dBd	Gain:	15.9 dBd	Gain:	15.9 dBd
Height (AGL):	165 feet	Height (AGL):	165 feet	Height (AGL):	165 feet
Frequency Bands	2500 MHz (BRS)	Frequency Bands	2500 MHz (BRS)	Frequency Bands	2500 MHz (BRS)
Channel Count	8	Channel Count	8	Channel Count	8
Total TX Power(W):	160 Watts	Total TX Power(W):	160 Watts	Total TX Power(W):	160 Watts
ERP (W):	6,224.72	ERP (W):	6,224.72	ERP (W):	6,224.72
Antenna A2 MPE%	0.89 %	Antenna B2 MPE%	0.89 %	Antenna C2 MPE%	0.89 %

Site Composite MPE %	
Carrier	MPE%
SPRINT – Max per sector	2.10 %
AT&T	2.06 %
Verizon Wireless	1.65 %
Nextel	0.26 %
T-Mobile	2.28 %
Site Total MPE %:	8.35 %

SPRINT Sector A Total:	2.10 %
SPRINT Sector B Total:	2.10 %
SPRINT Sector C Total:	2.10 %
Site Total:	8.35 %

SPRINT _ Max Values per Frequency Band / Technology per sector	# Channels	Watts ERP (Per Channel)	Height (feet)	Total Power Density ($\mu\text{W}/\text{cm}^2$)	Frequency (MHz)	Allowable MPE ($\mu\text{W}/\text{cm}^2$)	Calculated % MPE
Sprint 850 MHz CDMA	1	437.55	165	0.62	850 MHz	567	0.11%
Sprint 850 MHz LTE	2	437.55	165	1.24	850 MHz	567	0.22%
Sprint 1900 MHz (PCS) CDMA	5	622.47	165	4.43	1900 MHz (PCS)	1000	0.44%
Sprint 1900 MHz (PCS) LTE	2	1,556.18	165	4.43	1900 MHz (PCS)	1000	0.44%
Sprint 2500 MHz (BRS) LTE	8	778.09	165	8.85	2500 MHz (BRS)	1000	0.89%
						Total:	2.10%



Summary

All calculations performed for this analysis yielded results that were **within** the allowable limits for general population exposure to RF Emissions.

The anticipated maximum composite contributions from the SPRINT facility as well as the site composite emissions value with regards to compliance with FCC's allowable limits for general population exposure to RF Emissions are shown here:

SPRINT Sector	Power Density Value (%)
Sector A:	2.10 %
Sector B:	2.10 %
Sector C:	2.10 %
SPRINT Maximum Total (per sector):	2.10 %
Site Total:	8.35 %
Site Compliance Status:	COMPLIANT

The anticipated composite MPE value for this site assuming all carriers present is **8.35 %** of the allowable FCC established general population limit sampled at the ground level. This is based upon values listed in the Connecticut Siting Council database for existing carrier emissions.

FCC guidelines state that if a site is found to be out of compliance (over allowable thresholds), that carriers over a 5% contribution to the composite value will require measures to bring the site into compliance. For this facility, the composite values calculated were well within the allowable 100% threshold standard per the federal government.