

NB+C, LLC

1777 Sentry Parkway, VEVA 17, Suite 210,  
Blue Bell, PA 19422

Mobile 845-401-5291

Agent for American Tower Corporation

Dori Gilbert – Project Manager

dgilbert@nbcllc.com

August 12, 2019

Melanie A. Bachman  
Acting Executive Director  
Connecticut Siting Council  
10 Franklin Square  
New Britain, CT 06051

**Notice of Exempt Modification**

**Facility Address: 6 Fairfield Drive a/k/a 25 Meridian Ridge Drive**

**Facility Coordinates (N) 41.425528**

**(W) -73.374047**

Dear Ms. Bachman:

American Tower Corporation, Inc (ATC) currently maintains an Existing Cellular Tower Facility (150' Monopole) at 6 Fairfield Dr., Newtown, Book and Page 713/565 in the Town of Newtown, CT. The property is owned by HW 1945 LLC, American Tower Corporation, Inc (ATC) now intends to install a 50kw Generator within the leased, fenced ground space area of the facility. The purpose of the generator installation is to allow for a shared back up emergency power option for its current (and future) wireless carrier tenants.

This tower facility was approved by the Connecticut Siting Council via Docket #75 on May 13, 1987. Because this proposed generator is within the existing, approved compound space, and the applicant is NOT requesting expansion of ground space beyond the approved conditions, this modification request complies with the conditions of the original Tower Approval.

Please accept this letter, as notification pursuant to Regulations of Connecticut State Agencies @16-50j-73, for construction that constitutes an exempt modification pursuant to R.C.S.A. @16-50j-72(b)(2). IN accordance with R.C.S.A. @16-50j-73, a copy of this letter is being sent to Daniel Rosenthal- First Selectman, Elected Official of the Town of Newtown, George Benson -Director of Planning for the Town of Newtown, as well as the property owner, and the tower owner American Tower Corporation.

## ATTACHMENT A

The planned modifications to the facility fall squarely within those activities explicitly provided for in R.C.S.A @ 16-50j-72(b)(2).

1. The proposed modifications will not result in an increase in the height of the existing structure.
2. The proposed modifications will not require the extension of the site boundary
3. The proposed modifications will not increase noise levels at the facility by six decibels or more, or to levels that exceed state and local criteria.
4. The operation of the generator back up power facility will not increase radio frequency emissions at the facility to the level at or above the Federal Communications Commission safety standard.
5. The proposed modifications will not cause a change or alteration in the physical or environmental characteristics of the site.
6. The existing structure and its foundation can support the proposed loading if the tower will be re-enforced to support them. <<< NOTE – This condition is N/A. The proposed Generator is based on the ground, and not associated or loaded onto the tower or foundation.

For the foregoing reasons, American Tower Corporation (ATC) respectfully submits that the proposed modifications to the above referenced telecommunications facility constitute an exempt modification under R.C.S.A. @16-50j-72(b)(2).

Sincerely,

*Dori Gilbert*

Attachments

Cc:

Daniel C. Rosenthal- First Selectman, Chief Elected Official

George Benson - Director of Planning

American Tower Corporation (ATC) –tower owner

Constantine Macriostas c/o Phototronics Inc –property owner



**AMERICAN TOWER<sup>®</sup>**  
CORPORATION

LETTER OF AUTHORIZATION

SITE NO: 302518

SITE NAME: Newtown CT 3

ADDRESS: 6 Fairfield Dr, Brookfield CT

I, Margaret Robinson, Senior Counsel, US Tower Division on behalf of American Tower\*, , owner of the tower facility located at the address identified above (the "Tower Facility"), do hereby authorize Network Building + Consulting, LLC, its successors and assigns, to act as American Tower's non-exclusive agent for the purpose of filing and securing any zoning, land-use, building permit and/or electrical permit application(s) and approvals of the applicable jurisdiction for and to conduct the construction of the installation of antennas and related telecommunications equipment on the Tower Facility located at the above address. This installation shall not affect adjoining lands and will occur only within the area leased by American Tower.

American Tower understands that the application may be denied, modified or approved with conditions. The above authorization is limited to the acceptance by American Tower of conditions related to American Tower's installation. Any such conditions of approval or modifications will not be effective unless approved in writing by American Tower.

The above authorization does not permit Network Building + Consulting, LLC to modify or alter any existing permit(s) and/or zoning or land-use conditions or impose any additional conditions unrelated to American Tower's installation of telecommunications equipment without the prior written approval of American Tower.

Signature: \_\_\_\_\_

Margaret Robinson, Senior Counsel  
US Tower Division

**NOTARY BLOCK**

COMMONWEALTH OF MASSACHUSETTS  
County of Middlesex

This instrument was acknowledged before me by Margaret Robinson, Senior Counsel of American Tower (Tower Facility owner and/or operator), personally known to me (or proved to me on the basis of satisfactory evidence) to be the person whose name is subscribed to the within instrument and acknowledged to me that he/she executed the same.

WITNESS my hand and official seal, this 1<sup>st</sup> day of July, 2019.

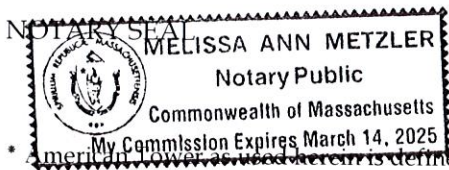

Notary Public \_\_\_\_\_  
My Commission Expires: March 14, 2025

\* American Tower as used herein is defined as American Tower Corporation and any of its affiliates or subsidiaries.



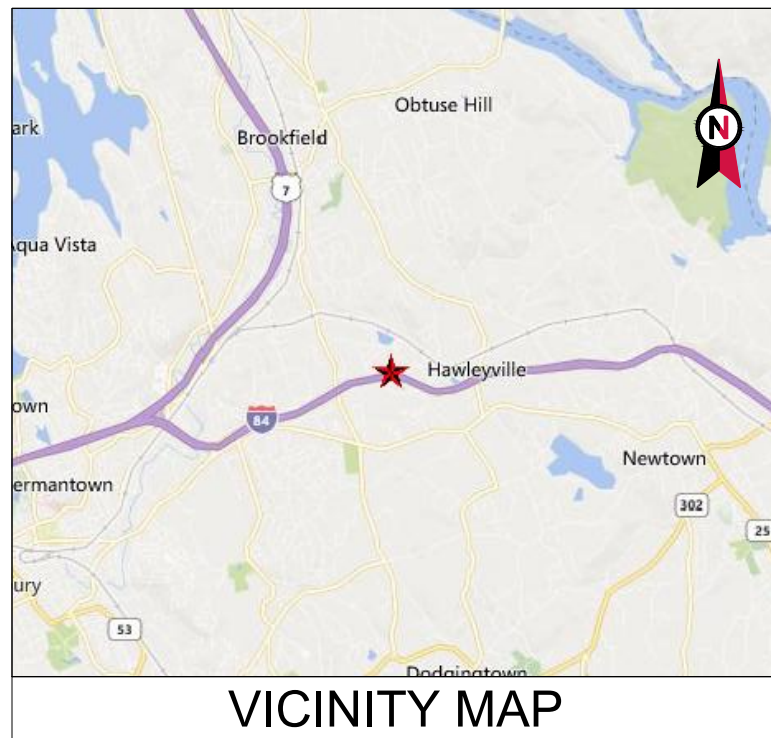

VICINITY MAP



**AMERICAN TOWER®**

ATC SITE NAME: NEWTOWN CT 3  
 SITE NUMBER: 302518  
 SITE ADDRESS: 6 FAIRFIELD DR  
 NEWTOWN, CT 06470

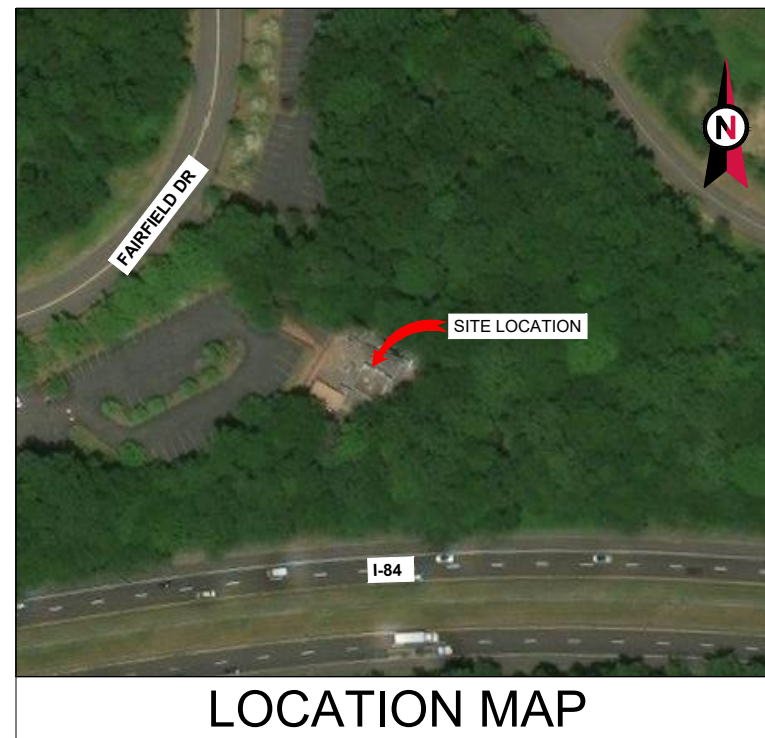

LOCATION MAP

SHARED GENERATOR PROGRAM  
 ANCHOR TENANT

**AMERICAN TOWER®**  
 A.T. ENGINEERING SERVICE, PLLC  
 3500 REGENCY PARKWAY  
 SUITE 100  
 CARY, NC 27518  
 PHONE: (919) 468-0112  
 COA: PEC.0001553

THESE DRAWINGS AND/OR THE ACCOMPANYING SPECIFICATION AS INSTRUMENTS OR SERVICE ARE THE EXCLUSIVE PROPERTY OF AMERICAN TOWER. THEIR USE AND PUBLICATION SHALL BE RESTRICTED TO THE ORIGINAL SITE FOR WHICH THEY ARE PREPARED. ANY USE OR DISCLOSURE OTHER THAN THAT WHICH RELATES TO AMERICAN TOWER OR THE SPECIFIED CARRIER IS STRICTLY PROHIBITED. TITLE TO THESE DOCUMENTS SHALL REMAIN THE PROPERTY OF AMERICAN TOWER WHETHER OR NOT THE PROJECT IS EXECUTED. NEITHER THE ARCHITECT NOR THE ENGINEER WILL BE PROVIDING ON-SITE CONSTRUCTION REVIEW OF THIS PROJECT. CONTRACTOR(S) MUST VERIFY ALL DIMENSIONS AND ADVISE AMERICAN TOWER OF ANY DISCREPANCIES. ANY PRIOR ISSUANCE OF THIS DRAWING IS SUPERSEDED BY THE LATEST VERSION ON FILE WITH AMERICAN TOWER.

REV.	DESCRIPTION	BY	DATE
0	FOR CONSTRUCTION	LM	06/28/19

ATC SITE NUMBER:  
**302518**  
 ATC SITE NAME:  
**NEWTOWN CT 3**  
 SITE ADDRESS:  
 6 FAIRFIELD DR  
 NEWTOWN, CT 06470

SEAL:



DRAWN BY:	LM
APPROVED BY:	PPB
DATE DRAWN:	06/28/19
ATC JOB NO:	12969446

TITLE SHEET  
 SHEET NUMBER: **G-001**  
 REVISION: **0**

**COMPLIANCE CODE**

ALL WORK SHALL BE PERFORMED AND MATERIALS INSTALLED IN ACCORDANCE WITH THE CURRENT EDITIONS OF THE FOLLOWING CODES AS ADOPTED BY THE LOCAL GOVERNMENT AUTHORITIES. NOTHING IN THESE PLANS IS TO BE CONSTRUED TO PERMIT WORK NOT CONFORMING TO THESE CODES.

- INTERNATIONAL BUILDING CODE (IBC)
- NATIONAL ELECTRIC CODE (NEC)
- LOCAL BUILDING CODE
- CITY/COUNTY ORDINANCES

**PROJECT SUMMARY**

SITE ADDRESS:  
 6 FAIRFIELD DR  
 NEWTOWN, CT 06470  
 COUNTY: FAIRFIELD

GEOGRAPHIC COORDINATES:  
 LATITUDE: 41.42552778  
 LONGITUDE: -73.37404722  
 GROUND ELEVATION: 426' AMSL

**PROJECT TEAM**

ATC REGIONAL NETWORK DEVELOPMENT PROJECT MANAGER:  
 GREG CSAPO  
 (919) 749-6927

ATC NETWORK OPERATIONS CENTER:  
 (877) 518-6937

TOWER OWNER:  
 AMERICAN TOWER  
 10 PRESIDENTIAL WAY  
 WOBURN, MA 01801

PROPERTY OWNER:  
 CONSTANTINE MACRIOSTAS C/O PHOTRONICS INC.  
 5509 PENNOCK POINT ROAD  
 JUPITER, FL 33058

ENGINEERED BY:  
 ATC TOWER SERVICES  
 3500 REGENCY PARKWAY SUITE 100  
 CARY, NC 27518

**PROJECT DESCRIPTION**

THE PROPOSED PROJECT INSTALLS AN OPTIONAL STANDBY GENERATOR SYSTEM, AUTOMATIC TRANSFER SWITCH, GENERATOR AUXILIARY POWER DISTRIBUTION, AND REMOTE MONITORING COMMUNICATIONS CIRCUITRY FOR A COMMUNICATION TOWER TENANT.

**PROJECT NOTES**

- THE FACILITY IS UNMANNED.
- A TECHNICIAN WILL VISIT THE SITE APPROXIMATELY ONCE A MONTH FOR ROUTINE INSPECTION AND MAINTENANCE.
- THE PROJECT WILL NOT RESULT IN ANY SIGNIFICANT LAND DISTURBANCE OR EFFECT OF STORM WATER DRAINAGE.
- NO SANITARY SEWER, POTABLE WATER OR TRASH DISPOSAL IS REQUIRED.
- HANDICAP ACCESS IS NOT REQUIRED.

**PROJECT LOCATION DIRECTIONS**

I-84 W TO EXIT 9. TURN RIGHT OFF EXIT THEN LEFT ON OLD HAWLEYVILLE RD. AT FORK STAY TO THE RIGHT ONTO SECOR RD. AFTER BRIDGE TURN RIGHT ON FAIRFIELD DR. TOWER IS AHEAD ON RIGHT.

SHEET NO:	DESCRIPTION:	REV:	DATE:	BY:	SHEET INDEX					
G-001	TITLE SHEET	0	06/28/19	LM						
G-002	GENERAL NOTES	0	06/28/19	LM						
C-101	SITE PLAN	0	06/28/19	LM						
C-501	CONCRETE PAD DETAILS	0	06/28/19	LM						
E-601	ELECTRICAL ONE-LINE AND WIRING DETAILS	0	06/28/19	LM						
R-601	SUPPLEMENTAL									

Copyright © 2019 ATC IP LLC. All Rights Reserved.

**GENERAL CONSTRUCTION NOTES:**

1. ALL WORK SHALL CONFORM TO ALL CURRENT APPLICABLE FEDERAL, STATE, AND LOCAL CODES, INCLUDING ANSIEA/TIA-222, AND COMPLY WITH ATC MASTER SPECIFICATIONS.
2. CONTRACTOR SHALL CONTACT LOCAL 811 FOR IDENTIFICATION OF UNDERGROUND UTILITIES PRIOR TO START OF CONSTRUCTION.
3. CONTRACTOR SHALL BE RESPONSIBLE FOR COORDINATING ALL REQUIRED INSPECTIONS.
4. ALL DIMENSIONS TO, OF, AND ON EXISTING BUILDINGS, DRAINAGE STRUCTURES, AND SITE IMPROVEMENTS SHALL BE VERIFIED IN FIELD BY CONTRACTOR WITH ALL DISCREPANCIES REPORTED TO THE ENGINEER.
5. DO NOT CHANGE SIZE OR SPACING OF STRUCTURAL ELEMENTS.
6. DETAILS SHOWN ARE TYPICAL; SIMILAR DETAILS APPLY TO SIMILAR CONDITIONS UNLESS OTHERWISE NOTED.
7. THESE DRAWINGS DO NOT INCLUDE NECESSARY COMPONENTS FOR CONSTRUCTION SAFETY WHICH SHALL BE THE SOLE RESPONSIBILITY OF THE CONTRACTOR.
8. CONTRACTOR SHALL BRACE STRUCTURES UNTIL ALL STRUCTURAL ELEMENTS NEEDED FOR STABILITY ARE INSTALLED. THESE ELEMENTS ARE AS FOLLOWS: LATERAL BRACING, ANCHOR BOLTS, ETC.
9. CONTRACTOR SHALL DETERMINE EXACT LOCATION OF EXISTING UTILITIES, GROUNDS DRAINS, DRAIN PIPES, VENTS, ETC. BEFORE COMMENCING WORK.
10. INCORRECTLY FABRICATED, DAMAGED, OR OTHERWISE MISFITTING OR NONCONFORMING MATERIALS OR CONDITIONS SHALL BE REPORTED TO THE ATC CM PRIOR TO REMEDIAL OR CORRECTIVE ACTION. ANY SUCH REMEDIAL ACTION SHALL REQUIRE WRITTEN APPROVAL BY THE ATC CM PRIOR TO PROCEEDING.
11. EACH CONTRACTOR SHALL COOPERATE WITH THE ATC CM, AND COORDINATE HIS WORK WITH THE WORK OF OTHERS.
12. CONTRACTOR SHALL REPAIR ANY DAMAGE CAUSED BY CONSTRUCTION OF THIS PROJECT TO MATCH EXISTING PRE-CONSTRUCTION CONDITIONS TO THE SATISFACTION OF THE ATC CONSTRUCTION MANAGER.
13. ALL CABLE/CONDUIT ENTRY/EXIT PORTS SHALL BE WEATHERPROOFED DURING INSTALLATION USING A SILICONE SEALANT.
14. WHERE EXISTING CONDITIONS DO NOT MATCH THOSE SHOWN IN THIS PLAN SET, CONTRACTOR SHALL NOTIFY THE ATC CONSTRUCTION MANAGER IMMEDIATELY.
15. CONTRACTOR SHALL ENSURE ALL SUBCONTRACTORS ARE PROVIDED WITH A COMPLETE AND CURRENT SET OF DRAWINGS AND SPECIFICATIONS FOR THIS PROJECT.
16. CONTRACTOR SHALL REMOVE ALL RUBBISH AND DEBRIS FROM THE SITE AT THE END OF EACH DAY.
17. CONTRACTOR SHALL COORDINATE WORK SCHEDULE WITH LANDLORD AND TAKE PRECAUTIONS TO MINIMIZE IMPACT AND DISRUPTION OF OTHER OCCUPANTS OF THE FACILITY.
18. CONTRACTOR SHALL FURNISH ATC WITH A PDF MARKED UP AS-BUILT SET OF DRAWINGS UPON COMPLETION OF WORK.
19. PRIOR TO SUBMISSION OF BID, CONTRACTOR SHALL COORDINATE WITH ATC CM TO DETERMINE WHAT, IF ANY, ITEMS WILL BE PROVIDED. ALL ITEMS NOT PROVIDED SHALL BE PROVIDED AND INSTALLED BY THE CONTRACTOR. CONTRACTOR WILL INSTALL ALL ITEMS PROVIDED.
20. PRIOR TO SUBMISSION OF BID, CONTRACTOR SHALL COORDINATE WITH ATC CONSTRUCTION MANAGER TO DETERMINE IF ANY PERMITS WILL BE OBTAINED BY ATC. ALL REQUIRED PERMITS NOT OBTAINED BY ATC MUST BE OBTAINED, AND PAID FOR, BY THE CONTRACTOR.
21. CONTRACTOR SHALL INSTALL ALL SITE SIGNAGE IN ACCORDANCE WITH ATC SPECIFICATIONS AND REQUIREMENTS.
22. CONTRACTOR SHALL SUBMIT ALL SHOP DRAWINGS TO ATC FOR REVIEW AND APPROVAL PRIOR TO FABRICATION.
23. ALL EQUIPMENT SHALL BE INSTALLED ACCORDING TO MANUFACTURER'S SPECIFICATIONS AND LOCATED ACCORDING TO ATC SPECIFICATIONS, AND AS SHOWN IN THESE PLANS.
24. THE CONTRACTOR SHALL SUPERVISE AND DIRECT THE PROJECT DESCRIBED HEREIN. THE CONTRACTOR SHALL BE SOLELY RESPONSIBLE FOR ALL THE CONSTRUCTION MEANS, METHODS, TECHNIQUES, SEQUENCES AND PROCEDURES AND FOR COORDINATING ALL PORTIONS OF THE WORK UNDER THE CONTRACT.
25. CONTRACTOR SHALL NOTIFY ATC CM A MINIMUM OF 48 HOURS IN ADVANCE OF POURING CONCRETE OR BACKFILLING ANY UNDERGROUND UTILITIES, FOUNDATIONS OR SEALING ANY WALL, FLOOR OR ROOF PENETRATIONS FOR ENGINEERING REVIEW AND APPROVAL.
26. CONTRACTOR SHALL BE RESPONSIBLE FOR SITE SAFETY INCLUDING COMPLIANCE WITH ALL APPLICABLE OSHA STANDARDS AND RECOMMENDATIONS AND SHALL PROVIDE ALL NECESSARY SAFETY DEVICES INCLUDING PPE AND PPM AND CONSTRUCTION DEVICES SUCH AS WELDING AND FIRE PREVENTION, TEMPORARY SHORING, SCAFFOLDING, TRENCH BOXES/SLOPING, BARRIERS, ETC.
27. THE CONTRACTOR SHALL PROTECT AT HIS OWN EXPENSE, ALL EXISTING FACILITIES AND SUCH OF HIS NEW WORK LIABLE TO INJURY DURING THE CONSTRUCTION PERIOD. ANY DAMAGE CAUSED BY NEGLIGENCE ON THE PART OF THIS CONTRACTOR OR HIS REPRESENTATIVES, OR BY THE ELEMENTS DUE TO NEGLIGENCE ON THE PART OF THIS CONTRACTOR OR HIS

REPRESENTATIVES, EITHER TO THE EXISTING WORK, OR TO HIS WORK OR THE WORK OF ANY OTHER CONTRACTOR, SHALL BE REPAIRED AT HIS EXPENSE TO THE OWNER'S SATISFACTION.

28. ALL WORK SHALL BE INSTALLED IN A FIRST CLASS, NEAT AND WORKMANLIKE MANNER BY MECHANICS SKILLED IN THE TRADE INVOLVED. THE QUALITY OF WORKMANSHIP SHALL BE SUBJECT TO THE APPROVAL OF THE ATC CM. ANY WORK FOUND BY THE ATC CM TO BE OF INFERIOR QUALITY AND/OR WORKMANSHIP SHALL BE REPLACED AND/OR REWORKED AT CONTRACTOR EXPENSE UNTIL APPROVAL IS OBTAINED.
29. IN ORDER TO ESTABLISH STANDARDS OF QUALITY AND PERFORMANCE, ALL TYPES OF MATERIALS LISTED HEREINAFTER BY MANUFACTURER'S NAMES AND/OR MANUFACTURER'S CATALOG NUMBER SHALL BE PROVIDED BY THESE MANUFACTURERS AS SPECIFIED.

**CONCRETE AND REINFORCING STEEL NOTES:**

1. DESIGN AND CONSTRUCTION OF ALL CONCRETE ELEMENTS SHALL CONFORM TO THE LATEST EDITIONS OF ALL APPLICABLE CODES INCLUDING: ACI 301 "SPECIFICATIONS FOR STRUCTURAL CONCRETE FOR BUILDINGS", ACI 117 "SPECIFICATIONS FOR TOLERANCES FOR CONCRETE CONSTRUCTION AND MATERIALS", AND ACI 318 "BUILDING CODE REQUIREMENTS FOR REINFORCED CONCRETE."
2. MIX DESIGN SHALL BE APPROVED BY ATC CM PRIOR TO PLACING CONCRETE.
3. CONCRETE SHALL BE NORMAL WEIGHT, 6 % AIR ENTRAINED (+/- 1.5%) WITH A SLUMP RANGE OF 3-5" AND HAVE A MINIMUM 28-DAY COMPRESSIVE STRENGTH OF 4000 PSI UNLESS OTHERWISE NOTED.
4. THE FOLLOWING MATERIALS SHALL BE USED:
  - PORTLAND CEMENT: ASTM C150, TYPE 2
  - REINFORCEMENT: ASTM A185, PLAIN STEEL WELDED WIRE FABRIC
  - REINFORCEMENT BARS: ASTM A615, GRADE 60, DEFORMED
  - NORMAL WEIGHT AGGREGATE: ASTM C33
  - WATER: ASTM C 94/C 94M
  - ADMIXTURES:
    - WATER-REDUCING AGENT: ASTM C 494/C 494M, TYPE A
    - AIR-ENTERING AGENT: ASTM C 260/C 260M
    - SUPERPLASTICIZER: ASTM C494, TYPE F OR TYPE G
    - RETARDING: ASTM C 494/C 494M, TYPE B
5. MINIMUM CONCRETE COVER FOR REINFORCING STEEL SHALL BE NO LESS THAN 3".
6. A 3/4" CHAMFER SHALL BE PROVIDED AT ALL EXPOSED EDGES OF CONCRETE IN ACCORDANCE WITH ACI 301 SECTION 4.2.4, UNLESS NOTED OTHERWISE.
7. INSTALLATION OF CONCRETE EXPANSION/WEDGE ANCHOR SHALL BE PER MANUFACTURER'S WRITTEN RECOMMENDED PROCEDURE. THE ANCHOR BOLT, DOWEL, OR ROD SHALL CONFORM TO MANUFACTURER'S RECOMMENDATION FOR EMBEDMENT DEPTH OR AS SHOWN ON THE DRAWINGS. NO REBAR SHALL BE CUT WITHOUT PRIOR ATC CM APPROVAL WHEN DRILLING HOLES IN CONCRETE.
8. ADMIXTURES SHALL CONFORM TO THE APPROPRIATE ASTM STANDARD AS REFERENCED IN "METHOD 1" OF ACI 301.
9. DO NOT WELD OR TACK WELD REINFORCING STEEL.
10. ALL DOWELS, ANCHOR BOLTS, EMBEDDED STEEL, ELECTRICAL CONDUITS, PIPE SLEEVES, GROUNDS AND ALL OTHER EMBEDDED ITEMS AND FORMED DETAILS SHALL BE IN PLACE BEFORE START OF CONCRETE PLACEMENT.
11. REINFORCEMENT SHALL BE COLD BENT WHENEVER BENDING IS REQUIRED.
12. DO NOT PLACE CONCRETE IN WATER, ICE, OR ON FROZEN GROUND.
13. DO NOT ALLOW REINFORCEMENT, CONCRETE OR SUBBASE TO FREEZE DURING CONCRETE CURING AND SETTING PERIOD, OR FOR A MINIMUM OF 3 DAYS AFTER PLACEMENT.
14. FOR COLD-WEATHER(ACI 306) AND HOT-WEATHER(ACI 301M) CONCRETE PLACEMENT, CONFORM TO APPLICABLE ACI CODES AND RECOMMENDATIONS. IN EITHER CASE, MATERIALS CONTAINING CHLORIDE, CALCIUM, SALTS, ETC. SHALL NOT BE USED. PROTECT FRESH CONCRETE FROM WEATHER FOR 7 DAYS, MINIMUM.
15. ALL CONCRETE SHALL HAVE A "SMOOTH FORM FINISH."
16. UNLESS OTHERWISE NOTED:
  - A. ALL REINFORCING STEEL SHALL BE DEFORMED BARS CONFORMING TO ASTM A615/A 615M/A-996, GRADE 60.
  - B. WELDED WIRE FABRIC SHALL CONFORM TO ASTM A185.
17. SPLICING OF REINFORCEMENT IS PERMITTED ONLY AT LOCATIONS SHOWN IN THE CONTRACT DRAWINGS OR AS ACCEPTED BY THE ENGINEER. UNLESS OTHERWISE SHOWN OR NOTED REINFORCING STEEL SHALL BE SPLICED TO DEVELOP ITS FULL TENSILE CAPACITY (CLASS A) IN ACCORDANCE WITH ACI 318.
18. REINFORCING BAR DEVELOPMENT LENGTHS, AS COMPUTED IN ACCORDANCE WITH ACI 318, FORM THE BASIS FOR BAR EMBEDMENT LENGTHS AND BAR SPLICED LENGTHS SHOWN IN THE

DRAWINGS. APPLY APPROPRIATE MODIFICATION FACTORS FOR TOP STEEL, BAR SPACING, COVER AND THE LIKE.

19. DETAILING OF REINFORCING STEEL SHALL CONFORM TO "ACI MANUAL OF STANDARD PRACTICE FOR DETAILING REINFORCED CONCRETE STRUCTURES" (ACI 315).
20. ALL SLAB CONSTRUCTION SHALL BE CAST MONOLITHICALLY WITHOUT HORIZONTAL CONSTRUCTION JOINTS, UNLESS SHOWN IN THE CONTRACT DRAWINGS.
21. LOCATION OF ALL CONSTRUCTION JOINTS ARE SUBJECT TO THE REQUIREMENTS OF THE CONTRACT DOCUMENTS, CONFORMANCE WITH ACI 318, AND ACCEPTANCE OF THE ENGINEER. DRAWINGS SHOWING LOCATION OF DETAILS OF THE PROPOSED CONSTRUCTION JOINTS SHALL BE SUBMITTED WITH REINFORCING STEEL PLACEMENT DRAWINGS.
22. SPLICES OF WWF, AT ALL SPLICED EDGES, SHALL BE SUCH THAT THE OVERLAP MEASURED BETWEEN OUTERMOST CROSS WIRES OF EACH FABRIC SHEET IS NOT LESS THAN THE SPACING OF THE CROSS WIRE PLUS 2 INCHES, NOR LESS THAN 6".
23. BAR SUPPORTS SHALL BE ALL-GALVANIZED METAL WITH PLASTIC TIPS.
24. ALL REINFORCEMENT SHALL BE SECURELY TIED IN PLACE TO PREVENT DISPLACEMENT BY CONSTRUCTION TRAFFIC OR CONCRETE. TIE WIRE SHALL BE OF SUFFICIENT STRENGTH FOR INTENDED PURPOSE, BUT NOT LESS THAN NO. 18 GAUGE.
25. SLAB ON GROUND:
  - A. COMPACT SUBGRADE AND ENSURE THERE IS PLACE 6" GRAVEL BENEATH SLAB.
  - B. PROVIDE VAPOR BARRIER BENEATH SLAB ON GROUND.

**STRUCTURAL STEEL NOTES:**

1. STRUCTURAL STEEL SHALL CONFORM TO THE LATEST EDITION OF THE AISC "SPECIFICATION FOR THE DESIGN, FABRICATION AND ERECTION OF STRUCTURAL STEEL FOR BUILDINGS."
2. STRUCTURAL STEEL ROLLED SHAPES, PLATES AND BARS SHALL CONFORM TO THE FOLLOWING ASTM DESIGNATIONS:
  - A. ASTM A-572, GRADE 50 - ALL W SHAPES, UNLESS NOTED OR A992 OTHERWISE
  - B. ASTM A-36 - ALL OTHER ROLLED SHAPES, PLATES AND BARS UNLESS NOTED OTHERWISE.
  - C. ASTM A-500, GRADE B - HSS SECTION (SQUARE, RECTANGULAR, AND ROUND)
  - D. ASTM A-325, TYPE SC OR N - ALL BOLTS FOR CONNECTING STRUCTURAL MEMBERS
  - E. ASTM F-1554 07 - ALL ANCHOR BOLTS, UNLESS NOTED OTHERWISE
3. ALL EXPOSED STRUCTURAL STEEL MEMBERS SHALL BE HOT-DIPPED GALVANIZED AFTER FABRICATION PER ASTM A123. EXPOSED STEEL HARDWARE AND ANCHOR BOLTS SHALL BE GALVANIZED PER ASTM A153 OR B695.
4. ALL FIELD CUT SURFACES, FIELD DRILLED HOLES AND GROUND SURFACES WHERE EXISTING PAINT OR GALVANIZATION REMOVAL WAS REQUIRED SHALL BE REPAIRED WITH (2) BRUSHED COATS OF ZRC GALVILITE COLD GALVANIZING COMPOUND PER ASTM A780 AND MANUFACTURER'S RECOMMENDATIONS.
5. DO NOT DRILL HOLES THROUGH STRUCTURAL STEEL MEMBERS EXCEPT AS SHOWN AND DETAILED ON STRUCTURAL DRAWINGS.
6. CONNECTIONS:
  - A. ALL WELDING TO BE PERFORMED BY AWS CERTIFIED WELDERS AND CONDUCTED IN ACCORDANCE WITH THE LATEST EDITION OF THE AWS WELDING CODE D1.1.
  - B. ALL WELDS SHALL BE INSPECTED VISUALLY. 25% OF WELDS SHALL BE INSPECTED WITH DYE PENETRANT OR MAGNETIC PARTICLE TO MEET THE ACCEPTANCE CRITERIA OF AWS D1.1. REPAIR ALL WELDS AS NECESSARY.
  - C. INSPECTION SHALL BE PERFORMED BY AN AWS CERTIFIED WELD INSPECTOR.
  - D. IT IS THE CONTRACTORS RESPONSIBILITY TO PROVIDE BURNING/WELDING PERMITS AS REQUIRED BY LOCAL GOVERNING AUTHORITY AND IF REQUIRED SHALL HAVE FIRE DEPARTMENT DETAIL FOR ANY WELDING ACTIVITY.
  - E. ALL ELECTRODES TO BE LOW HYDROGEN, MATCHING FILLER METAL, PER AWS D1.1, UNLESS NOTED OTHERWISE.
  - F. MINIMUM WELD SIZE TO BE 0.1875 INCH FILLET WELDS, UNLESS NOTED OTHERWISE.
  - G. PRIOR TO FIELD WELDING GALVANIZING MATERIAL, CONTRACTOR SHALL GRIND OFF GALVANIZING 1/2" BEYOND ALL FIELD WELD SURFACES. AFTER WELD AND WELD INSPECTION IS COMPLETE, REPAIR ALL GROUND AND WELDED SURFACES WITH ZRC GALVILITE COLD GALVANIZING COMPOUND PER ASTM A780 AND MANUFACTURERS RECOMMENDATIONS.

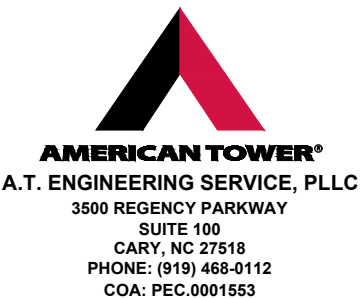

THESE DRAWINGS AND/OR THE ACCOMPANYING SPECIFICATION AS INSTRUMENTS OR SERVICE ARE THE EXCLUSIVE PROPERTY OF AMERICAN TOWER. THEIR USE AND PUBLICATION SHALL BE RESTRICTED TO THE ORIGINAL SITE FOR WHICH THEY ARE PREPARED. ANY USE OR DISCLOSURE OTHER THAN THAT WHICH RELATES TO AMERICAN TOWER OR THE SPECIFIED CARRIER IS STRICTLY PROHIBITED. TITLE TO THESE DOCUMENTS SHALL REMAIN THE PROPERTY OF AMERICAN TOWER WHETHER OR NOT THE PROJECT IS EXECUTED. NEITHER THE ARCHITECT NOR THE ENGINEER WILL BE PROVIDING ON-SITE CONSTRUCTION REVIEW OF THIS PROJECT. CONTRACTOR(S) MUST VERIFY ALL DIMENSIONS AND ADVISE AMERICAN TOWER OF ANY DISCREPANCIES. ANY PRIOR ISSUANCE OF THIS DRAWING IS SUPERSEDED BY THE LATEST VERSION ON FILE WITH AMERICAN TOWER.

REV.	DESCRIPTION	BY	DATE
0	FOR CONSTRUCTION	LM	06/28/19

ATC SITE NUMBER:

**302518**

ATC SITE NAME:

**NEWTOWN CT 3**

SITE ADDRESS:

6 FAIRFIELD DR  
NEWTOWN, CT 06470

SEAL:



DRAWN BY:	LM
APPROVED BY:	PPB
DATE DRAWN:	06/28/19
ATC JOB NO:	12969446

**GENERAL NOTES**

SHEET NUMBER:

**G-002**

REVISION:

**0**

Copyright © 2019 ATC IP, LLC. All Rights Reserved.



**SITE PLAN NOTES:**

1. THIS SITE PLAN REPRESENTS THE BEST PRESENT KNOWLEDGE AVAILABLE TO THE ENGINEER AT THE TIME OF THIS DESIGN. THE CONTRACTOR SHALL VISIT THE SITE PRIOR TO CONSTRUCTION AND VERIFY ALL EXISTING CONDITIONS RELATED TO THE SCOPE OF WORK FOR THIS PROJECT.
2. ICE BRIDGE, CABLE LADDER, COAX PORT, AND COAX CABLE ARE SHOWN FOR REFERENCE ONLY. CONTRACTOR SHALL CONFIRM THE EXACT LOCATION OF ALL PROPOSED AND EXISTING EQUIPMENT AND STRUCTURES DEPICTED ON THIS PLAN. BEFORE UTILIZING EXISTING CABLE SUPPORTS, COAX PORTS, INSTALLING NEW PORTS OR ANY OTHER EQUIPMENT, CONTRACTOR SHALL VERIFY ALL ASPECTS OF THE COMPONENTS MEET THE ATC SPECIFICATIONS.
3. IT IS THE RESPONSIBILITY OF THE CONTRACTOR TO COORDINATE WITH THE ATC CONSTRUCTION MANAGER AND LOCAL UTILITY COMPANY FOR THE INSTALLATION OF CONDUITS, CONDUCTORS, BREAKERS, DISCONNECTS, OR ANY OTHER EQUIPMENT REQUIRED FOR ELECTRICAL SERVICE. ALL ELECTRICAL WORK SHALL BE PERFORMED IN ACCORDANCE WITH LATEST EDITION OF THE STATE AND NATIONAL CODES, ORDINANCES AND REGULATIONS APPLICABLE TO THIS PROJECT.
4. CONTRACTOR SHALL INSURE THAT ALL WORKING SPACE REQUIREMENTS ARE MET PER APPLICABLE CODES AND MANUFACTURER SPECIFICATIONS.
5. ABOVE GROUND CONDUITS NEED TO BE SUPPORTED/FASTENED PER NEC 344, NEC 352, AND PER ATC MASTER SPECIFICATIONS.
6. THE FOLLOWING SIGNS SHALL BE INSTALLED AT TENANT SERVICE MAIN DISCONNECT PER NEC 702.7.
  - 6.1. "CAUTION: TWO SOURCES OF SUPPLY STANDBY GENERATOR LOCATED OUTDOORS"
  - 6.2. "WARNING: SHOCK HAZARD EXISTS IF GROUNDING ELECTRODE CONDUCTOR OR BONDING JUMPER CONNECTION IN THIS EQUIPMENT IS REMOVED WHILE ALTERNATE SOURCE IS ENERGIZED"

**RODENT CONTROL AROUND GENERATOR ENVELOPE:**

1. INSTALL ALL PROVIDED SEALS, PLUGS, COVERS, ETC. IN GENERATOR AND FUEL TANK ENVELOPE. SEAL ALL REMAINING OPENINGS (EXCEPT NORMAL VENTING) WITH RODENT FOAM SEALANT. NO OPENING SHALL BE LARGER THAN 1/4 INCH ANY DIMENSION.
2. SEAL ALL CONDUITS INCLUDING CONDUITS ENTERING GENERATOR EQUIPMENT, BOXES, ATTACHMENTS, ETC. WITH RODENT FOAM SEALANT.
3. SEAL ALL CONDUIT ACCESS OPENINGS THROUGH CONCRETE PAD WITH CONCRETE.
4. SLOPE GRAVEL BASE AT CONCRETE PAD PERIMETER FROM ABOVE PAD BASE TO EXISTING GRADE LEVEL TYPICAL ALL PERIMETER SIDES.

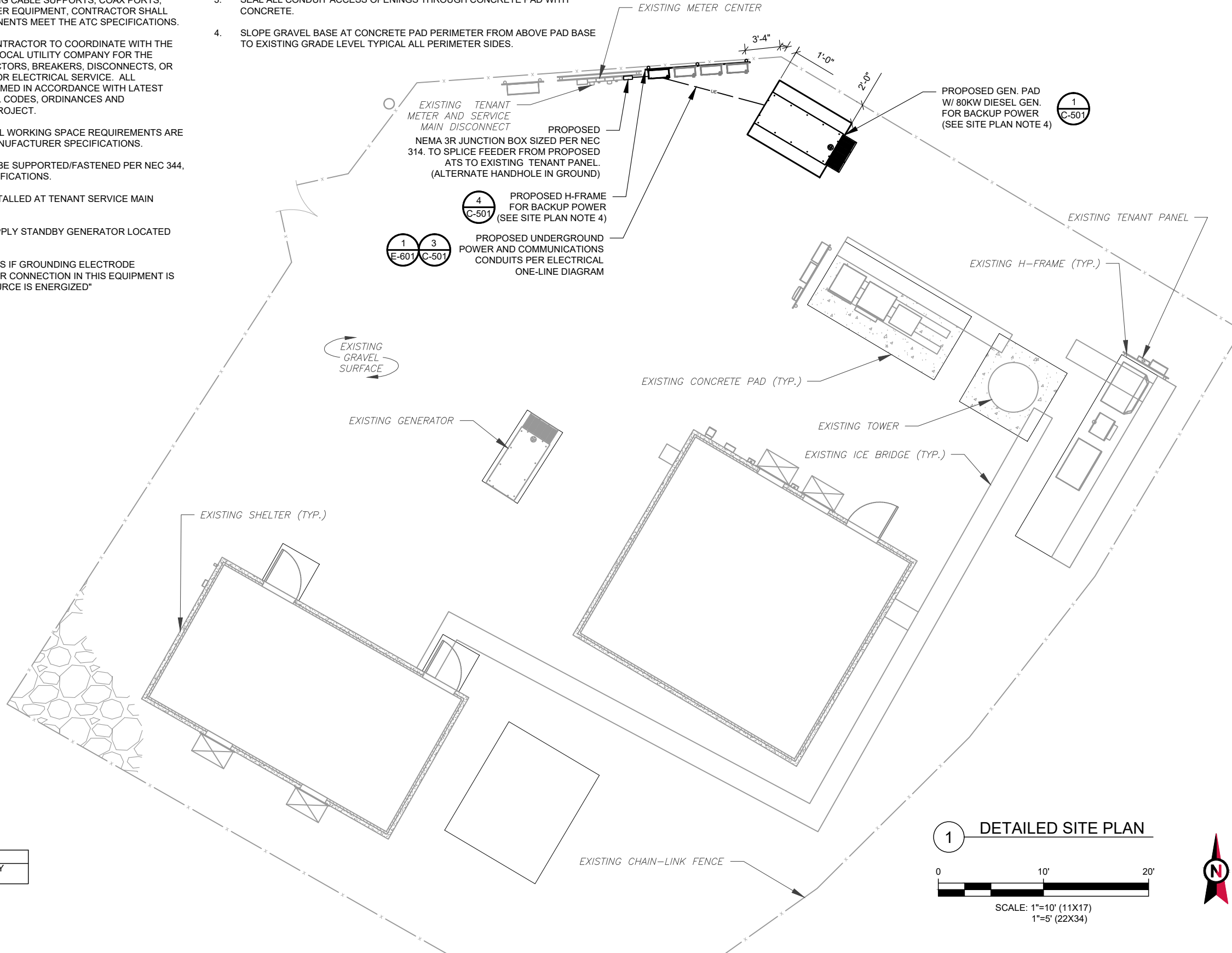

APPROXIMATE DISTANCES	
LINEAR DISTANCE FROM STANDBY GENERATOR TO POWER SOURCE	
11'	

1 DETAILED SITE PLAN

SCALE: 1"=10' (11X17)  
1"=5' (22X34)



**AMERICAN TOWER®**  
**A.T. ENGINEERING SERVICE, PLLC**  
 3500 REGENCY PARKWAY  
 SUITE 100  
 CARY, NC 27518  
 PHONE: (919) 468-0112  
 COA: PEC.0001553

THESE DRAWINGS AND/OR THE ACCOMPANYING SPECIFICATION AS INSTRUMENTS OR SERVICE ARE THE EXCLUSIVE PROPERTY OF AMERICAN TOWER. THEIR USE AND PUBLICATION SHALL BE RESTRICTED TO THE ORIGINAL SITE FOR WHICH THEY ARE PREPARED. ANY USE OR DISCLOSURE OTHER THAN THAT WHICH RELATES TO AMERICAN TOWER OR THE SPECIFIED CARRIER IS STRICTLY PROHIBITED. TITLE TO THESE DOCUMENTS SHALL REMAIN THE PROPERTY OF AMERICAN TOWER WHETHER OR NOT THE PROJECT IS EXECUTED. NEITHER THE ARCHITECT NOR THE ENGINEER WILL BE PROVIDING ON-SITE CONSTRUCTION REVIEW OF THIS PROJECT. CONTRACTOR(S) MUST VERIFY ALL DIMENSIONS AND ADVISE AMERICAN TOWER OF ANY DISCREPANCIES. ANY PRIOR ISSUANCE OF THIS DRAWING IS SUPERSEDED BY THE LATEST VERSION ON FILE WITH AMERICAN TOWER.

REV.	DESCRIPTION	BY	DATE
0	FOR CONSTRUCTION	LM	06/28/19

ATC SITE NUMBER:  
**302518**

ATC SITE NAME:  
**NEWTOWN CT 3**

SITE ADDRESS:  
 6 FAIRFIELD DR  
 NEWTOWN, CT 06470

SEAL:



DRAWN BY:	LM
APPROVED BY:	PPB
DATE DRAWN:	06/28/19
ATC JOB NO:	12969446

**SITE PLAN**

SHEET NUMBER:	REVISION:
<b>C-101</b>	<b>0</b>

Copyright © 2019 ATC IP, LLC. All Rights Reserved.

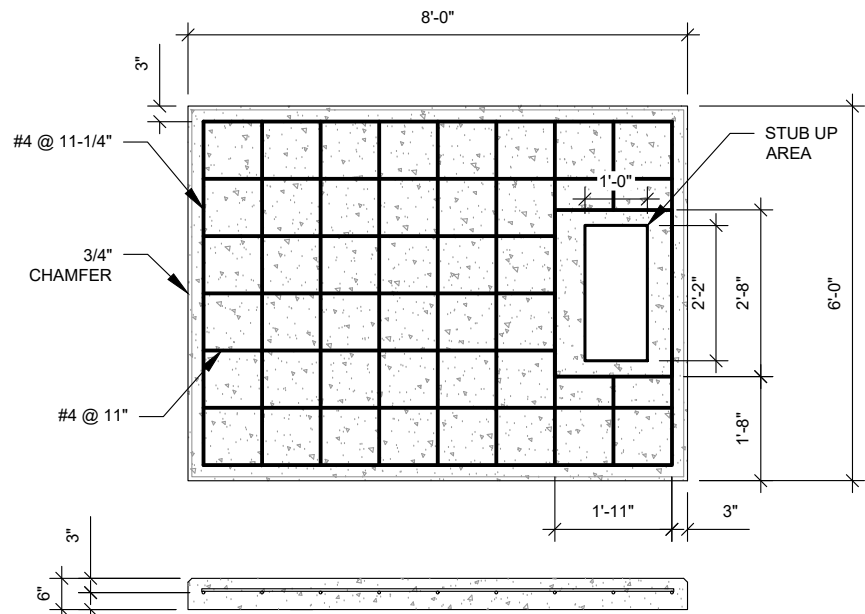

**PAD NOTES:**

1. PADS SHALL BE PRE-CAST MATCHING THIS DESIGN WHERE ALLOWED BY LOCAL JURISDICTION.
2. PADS SHALL HAVE A MIN 28 DAY COMPRESSIVE STRENGTH OF 4000 PSI MIN.
3. REFER TO CONCRETE & REINFORCED STEEL NOTES ON SHEET G-002 & ATC SPEC 033000 FOR CAST-IN-PLACE PADS.
4. STUB UP AREA SHALL BE FILLED WITH QUIKRETE, OR APPROVED EQUAL, PRIOR TO FINAL SET OF GENERATOR ON PAD.
5. AFTER FINAL SET OF GENERATOR ON PAD, GROUT ALL EXTERIOR OPENINGS AT PAD INTERFACE SO THAT FINISHED MAXIMUM OPENING SHALL BE 1/4 INCH.
6. GROUT SHALL BE PER ATC MASTER SPECIFICATION DIVISION 03, CONCRETE.

**1 REINFORCED PAD LAYOUT**

SCALE: N.T.S.

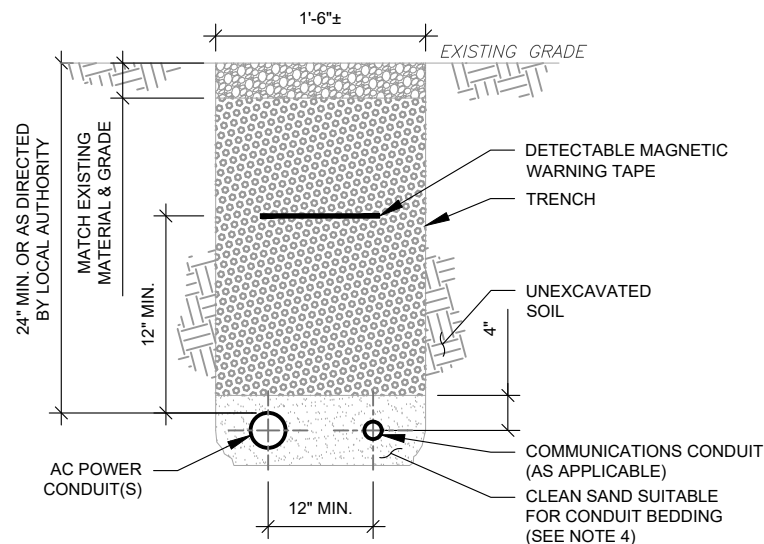

**PAD NOTES:**

1. SUBGRADE AND FILL SHALL CONSIST OF CLEAN SOIL. DELETERIOUS MATERIAL AND ORGANICS SHALL BE REMOVED.
2. MECHANICALLY COMPACT FOOTPRINT OF PAD PLUS 2' PERIMETER USING A MECHANICAL PLATE TAMPER, MIN 3 PASSES. SEE ATC MASTER SPEC 312000 ACCESS ROAD AND EARTH WORK.
3. USE GALVANIZED HILTI EXPANSION ANCHORS OR, APPROVED EQUAL, FOR EQUIPMENT ANCHORAGE.
4. FOR SIZE AND LOCATION OF ANCHORS AND OTHER REQUIREMENT, SEE EQUIPMENT VENDOR DRAWINGS.

**2 GRAVEL PREPARATION**

SCALE: N.T.S.

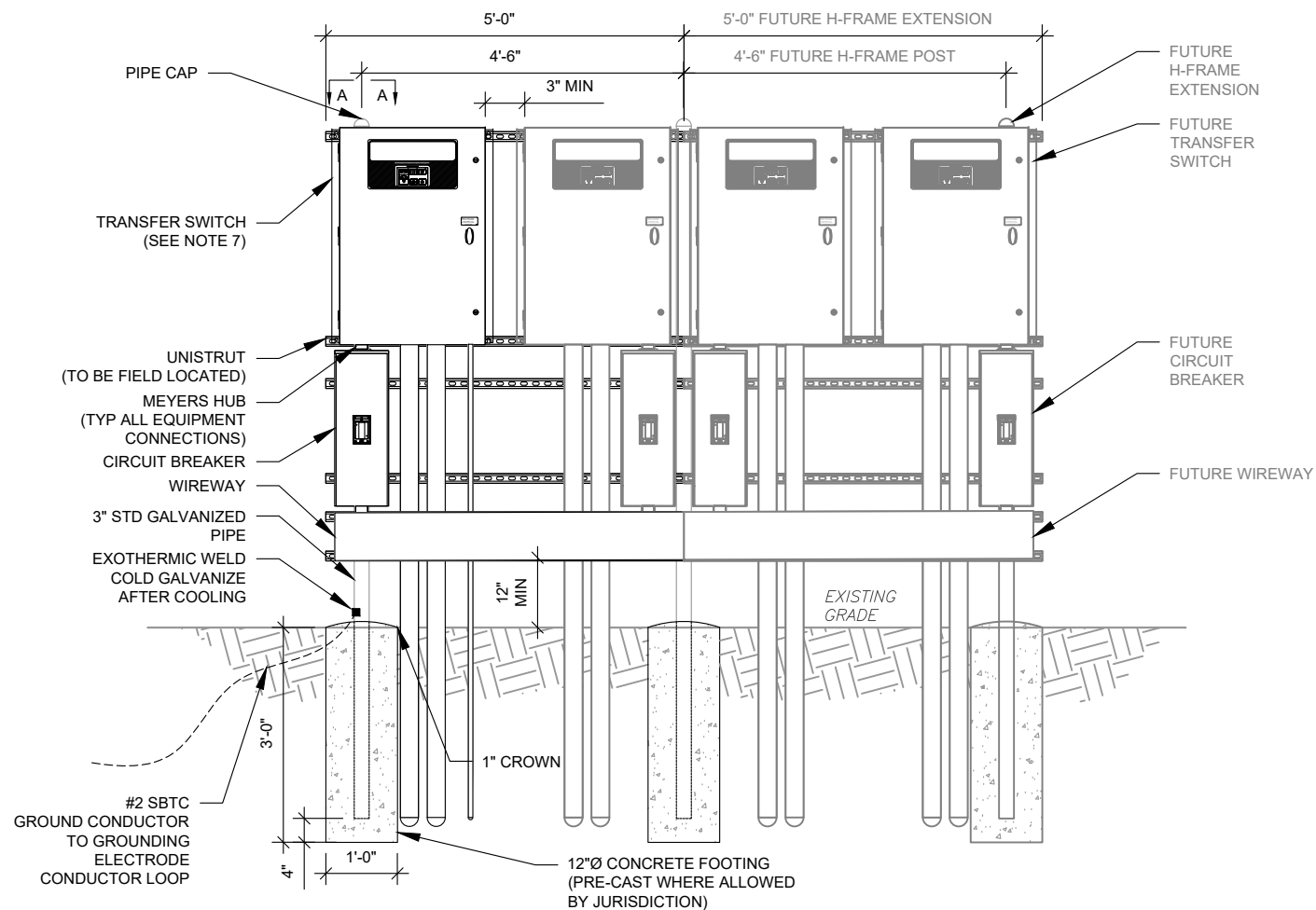

**TRENCH NOTES:**

1. IF FREE OF ORGANIC OR OTHER DELETERIOUS MATERIAL, EXCAVATED MATERIAL MAY BE USED FOR BACKFILL. IF NOT, PROVIDE CLEAN, COMPACTIBLE MATERIAL.
2. COMPACT IN 8" LIFTS USING A MECHANICAL PLATE TAMPER, MIN 3 PASSES. REMOVE ANY LARGE ROCKS PRIOR TO BACKFILLING. CONTRACTOR TO VERIFY LOCATION OF EXISTING U/G UTILITIES PRIOR TO DIGGING. SEE ATC MASTER SPEC 312000 SECTION 3.15.
3. IF CURRENT AS-BUILT DRAWINGS ARE NOT AVAILABLE CONTRACTOR SHALL HAND DIG U/G TRENCHING.
4. CONFIRM SPACING AND DEPTH WITH NEC OR LOCAL CODE REQUIREMENTS

**3 CONDUIT TRENCH DETAILS**

SCALE: N.T.S.

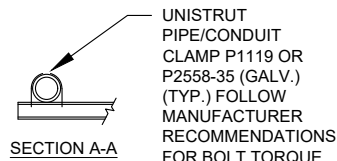

**H-FRAME NOTES:**

1. IF IT IS NECESSARY TO EXTEND THE H-FRAME, AN ADDITIONAL POST SHALL BE REQUIRED.
2. PROPOSED UNISTRUTS TO BE FIELD CUT AND SHALL NOT EXTEND MORE THAN 6 INCHES BEYOND THE LAST POST.
3. SPRAY ENDS OF UNISTRUT WITH COLD GALVANIZING SPRAY PAINT, ALLOW TO DRY, THEN COVER WITH RUBBER PROTECTIVE CAPS FOR SAFETY.
4. UNISTRUT TO BE CUT FLUSH WITH NO SHARP OR JAGGED EDGES.
5. ALL PROPOSED HARDWARE TO BE MOUNTED AND GROUNDED PER MANUFACTURERS SPECS
6. ALL ITEMS ARE PROPOSED UNLESS OTHERWISE NOTED.
7. LAYOUT H-FRAME & PROPOSED EQUIPMENT EXACTLY AS SHOWN TO ALLOW FOR FUTURE EQUIPMENT. ANY DEVIATIONS MUST BE APPROVED BY ATC CM, IN WRITING, NO EXCEPTIONS.
8. FOOTINGS SHALL BE ONE OF THE FOLLOWING: USS POLECRETE STABILIZER SYSTEM, PRECAST CONCRETE (WHERE ALLOWED BY JURISDICTION) OR CAST IN PLACE. FOR PRECAST FOOTINGS, CONTRACTORS SHALL THOROUGHLY COMPACT THE PERIMETER (2' MIN) OF FOOTING WITH MECHANICAL PLATE TAMPER.

**4 H-FRAME**

SCALE: N.T.S.

THESE DRAWINGS AND/OR THE ACCOMPANYING SPECIFICATION AS INSTRUMENTS OR SERVICE ARE THE EXCLUSIVE PROPERTY OF AMERICAN TOWER. THEIR USE AND PUBLICATION SHALL BE RESTRICTED TO THE ORIGINAL SITE FOR WHICH THEY ARE PREPARED. ANY USE OR DISCLOSURE OTHER THAN THAT WHICH RELATES TO AMERICAN TOWER OR THE SPECIFIED CARRIER IS STRICTLY PROHIBITED. TITLE TO THESE DOCUMENTS SHALL REMAIN THE PROPERTY OF AMERICAN TOWER WHETHER OR NOT THE PROJECT IS EXECUTED. NEITHER THE ARCHITECT NOR THE ENGINEER WILL BE PROVIDING ON-SITE CONSTRUCTION REVIEW OF THIS PROJECT. CONTRACTOR(S) MUST VERIFY ALL DIMENSIONS AND ADVISE AMERICAN TOWER OF ANY DISCREPANCIES. ANY PRIOR ISSUANCE OF THIS DRAWING IS SUPERSEDED BY THE LATEST VERSION ON FILE WITH AMERICAN TOWER.

REV.	DESCRIPTION	BY	DATE
0	FOR CONSTRUCTION	LM	06/28/19

ATC SITE NUMBER:

**302518**

ATC SITE NAME:

**NEWTOWN CT 3**

SITE ADDRESS:

6 FAIRFIELD DR  
 NEWTOWN, CT 06470

SEAL:



DRAWN BY:	LM
APPROVED BY:	PPB
DATE DRAWN:	06/28/19
ATC JOB NO:	12969446

**CONCRETE PAD DETAILS**

SHEET NUMBER:	REVISION:
<b>C-501</b>	<b>0</b>

Copyright © 2019 ATC IP, LLC. All Rights Reserved.

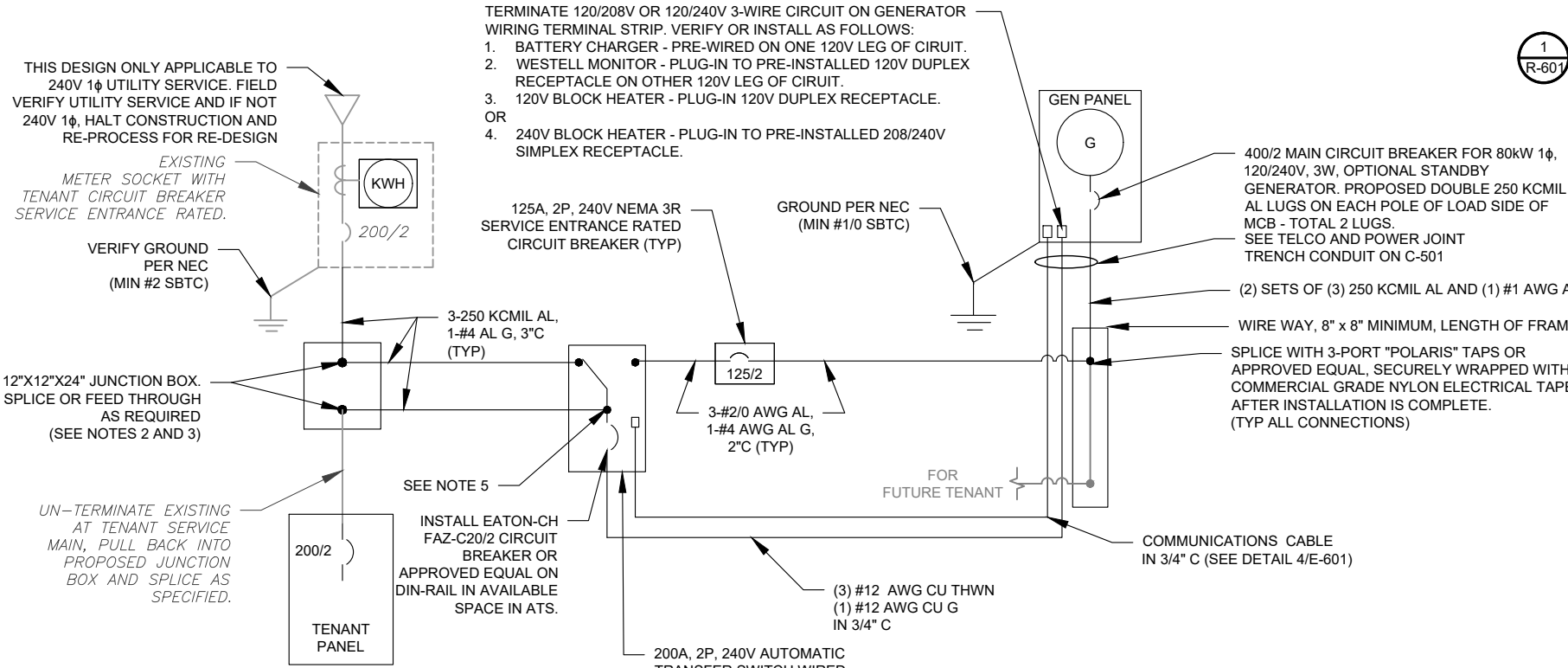

- ONE-LINE NOTES:
- CONNECT CT'S PER HTS OWNERS MANUAL-SECTION 3.11.2 INSTRUMENT PACKAGE
  - SPLICE WITH "POLARIS" TAPS OR APPROVED EQUAL, SECURELY WRAPPED WITH COMMERCIAL GRADE NYLON ELECTRICAL TAPE AFTER INSTALLATION IS COMPLETE.
  - UTILIZE EXISTING ENCLOSURES FOR SPLICING (PER NEC 312.8) OR INSTALL NEW JUNCTION BOX AS APPLICABLE PER SITE CONDITIONS AND CODES. SIZE JUNCTION BOX AS PER NEC 314.28
  - IF TAPPING AT TENANT EQUIPMENT, NO TAPS MAY BE MADE WITHIN THEIR EXISTING EQUIPMENT, INCLUDING PPC.
  - TAP GENERATOR PANEL CIRCUIT TO GENERAC LUGS #G0A9949 ON T-TERMINALS (LOAD SIDE) WITH AUXILIARY TAP SCREW GENERAC #GO26902 #8-32X1/4". TERMINATE #12 AWG CONDUCTOR ON EACH LUG WITH INSULATED RING TERMINAL PROPERLY SIZED.

**1 ELECTRICAL ONE-LINE DIAGRAM**  
SCALE: NOT TO SCALE

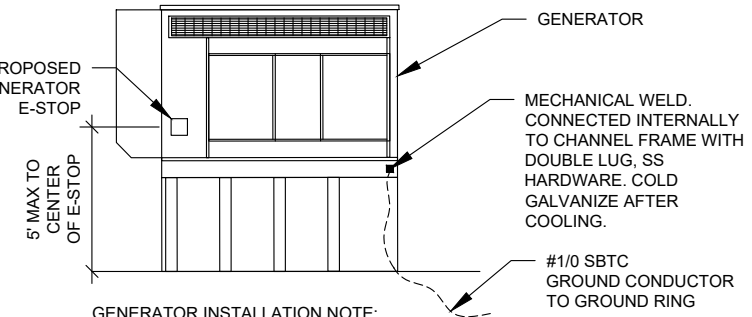

INSTALL GENERATOR AND TRANSFER SWITCH WITH ALL SUPPLIED ACCESSORIES PER MANUFACTURER'S INSTALLATION INSTRUCTIONS AND SPECIFICATIONS. THIS INCLUDES, BUT IS NOT LIMITED TO, ACCESSORIES FOR THE EXHAUST SYSTEM, FUEL SYSTEM, ENCLOSURE INTEGRITY (CAPS, PLUGS, COVERS, ETC.), ELECTRICAL CONNECTIONS, AND GROUNDING CONNECTIONS. INSTALL REMOTE E-STOP SWITCH ON EXTERIOR OF GENERATOR ENCLOSURE, ON SAME SIDE OF GENERATOR AS AS H100 CONTROL PANEL.

**2 GENERATOR GROUNDING AND E-STOP**  
SCALE: NOT TO SCALE

DEMAND LOAD CALCULATION	
GENERATOR LOADS	2.5 KW
TENANT PANEL DEMAND LOADS	25.0 KW
TOTAL DEMAND LOADS (KW)	27.5 KW
TOTAL DEMAND CURRENT (A)	114.5 A
AT 120/240V, 1PH, 3W	

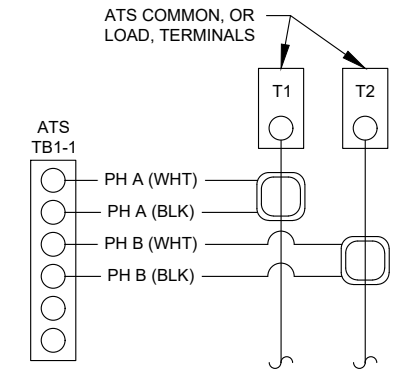

**3 CT WIRING DIAGRAM**  
SCALE: NOT TO SCALE

- NOTES:
- INSTALL NETWORK OPERATING CENTER (NOC) MONITORING COMMUNICATION SYSTEM (RMC-700) IN GENERATOR. THE RMC-700 IS FURNISHED BY ATC. COMPLETE WITH MOUNTING MAGNETS TO MOUNT OPPOSITE THE H-100 GENERATOR CONTROLLER PANEL INSIDE THE GENERATOR ENCLOSURE.
  - INSTALL EXTERNAL ANTENNA KIT (FURNISHED BY ATC). ANTENNA MOUNTS TO GENERATOR ENCLOSURE TOP NEAR TOP VENT. FEED CABLE THROUGH TOP VENT TO RMC-700. PRESS FIT CABLE INTO GENERATOR INSULATION FOLDS AND CREVICES WITHOUT DAMAGE TO CABLE, INSULATION, OR ENCLOSURE. FEED CABLE THROUGH RMC-700 ENTRY PORT #3 AND CONNECT TO ANTENNA PORT TX/RX. HAND TIGHTEN ONLY. LEAVE POWER AND DATA CABLES IN RMC-700 UNCONNECTED FOR COMMISSIONING TEAM
  - SEE ATC MOP 2017.01.04 RMC-700 GEN ONLY-METHOD OF PROCEDURE BY ATC (VER 1.11)

**5 PROPOSED MONITORING**  
SCALE: NOT TO SCALE

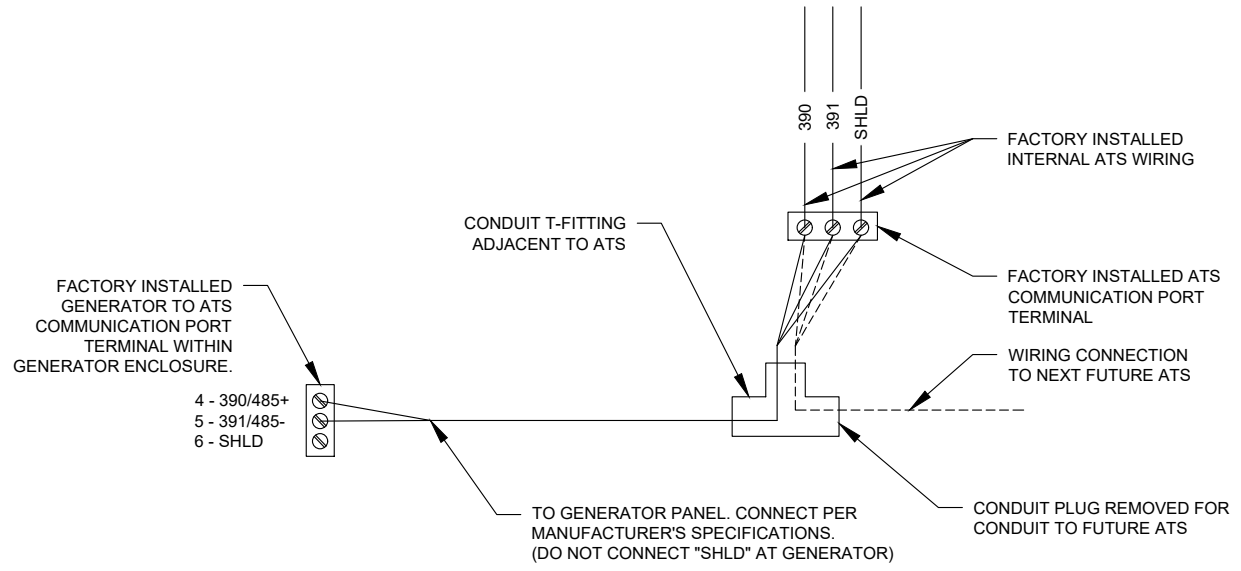

**4 COMMUNICATIONS CABLE DETAIL**  
SCALE: NOT TO SCALE



THESE DRAWINGS AND/OR THE ACCOMPANYING SPECIFICATION AS INSTRUMENTS OR SERVICE ARE THE EXCLUSIVE PROPERTY OF AMERICAN TOWER. THEIR USE AND PUBLICATION SHALL BE RESTRICTED TO THE ORIGINAL SITE FOR WHICH THEY ARE PREPARED. ANY USE OR DISCLOSURE OTHER THAN THAT WHICH RELATES TO AMERICAN TOWER OR THE SPECIFIED CARRIER IS STRICTLY PROHIBITED. TITLE TO THESE DOCUMENTS SHALL REMAIN THE PROPERTY OF AMERICAN TOWER WHETHER OR NOT THE PROJECT IS EXECUTED. NEITHER THE ARCHITECT NOR THE ENGINEER WILL BE PROVIDING ON-SITE CONSTRUCTION REVIEW OF THIS PROJECT. CONTRACTOR(S) MUST VERIFY ALL DIMENSIONS AND ADVISE AMERICAN TOWER OF ANY DISCREPANCIES. ANY PRIOR ISSUANCE OF THIS DRAWING IS SUPERSEDED BY THE LATEST VERSION ON FILE WITH AMERICAN TOWER.

REV.	DESCRIPTION	BY	DATE
0	FOR CONSTRUCTION	LM	06/28/19

ATC SITE NUMBER:  
**302518**

ATC SITE NAME:  
**NEWTOWN CT 3**

SITE ADDRESS:  
6 FAIRFIELD DR  
NEWTOWN, CT 06470

SEAL:



DRAWN BY:	LM
APPROVED BY:	PPB
DATE DRAWN:	06/28/19
ATC JOB NO:	12969446

**ELECTRICAL ONE-LINE AND WIRING DETAILS**

SHEET NUMBER:  
**E-601**

REVISION:  
**0**

Copyright © 2019 ATC IP, LLC. All Rights Reserved.



## REMOTE EMERGENCY STOP SWITCH SURFACE MOUNT, H-PANEL

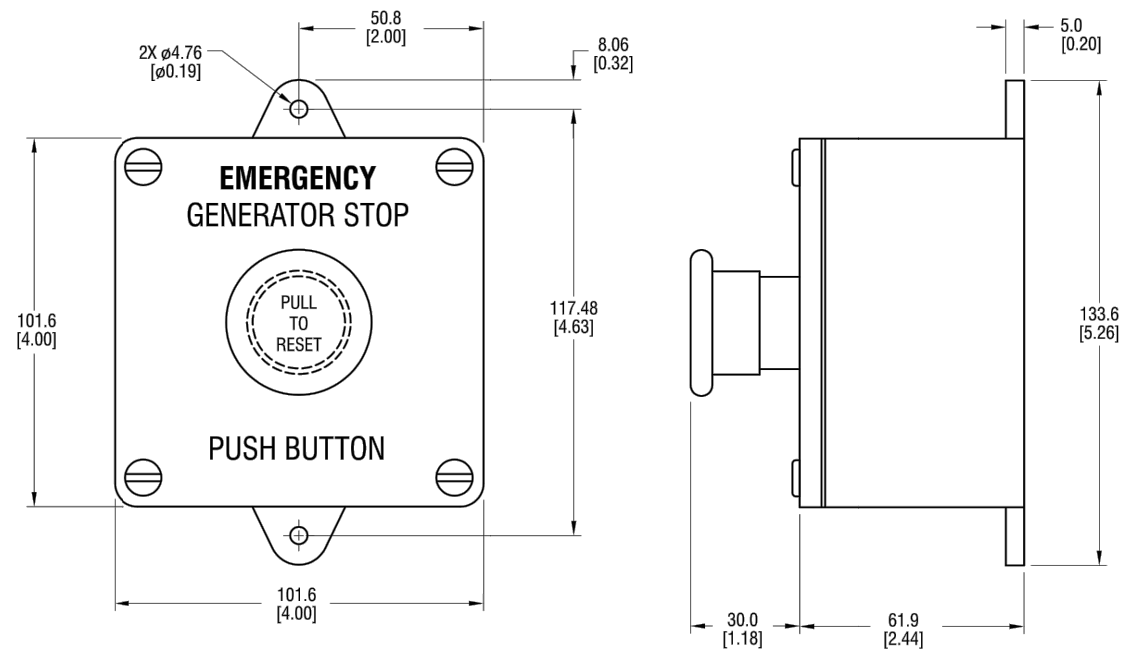

- MANUFACTURER: PILLA ELECTRICAL PRODUCTS, INC.
- MODEL SG120
- GENERAC PART NUMBER 061129E
- SURFACE MOUNT, NEMA 4X
- NONMETALLIC BACKBOX

DIMENSIONS: mm[INCHES]

GENSET CONTROLS

1 OF 2

## REMOTE EMERGENCY STOP SWITCH SURFACE MOUNT, H-PANEL

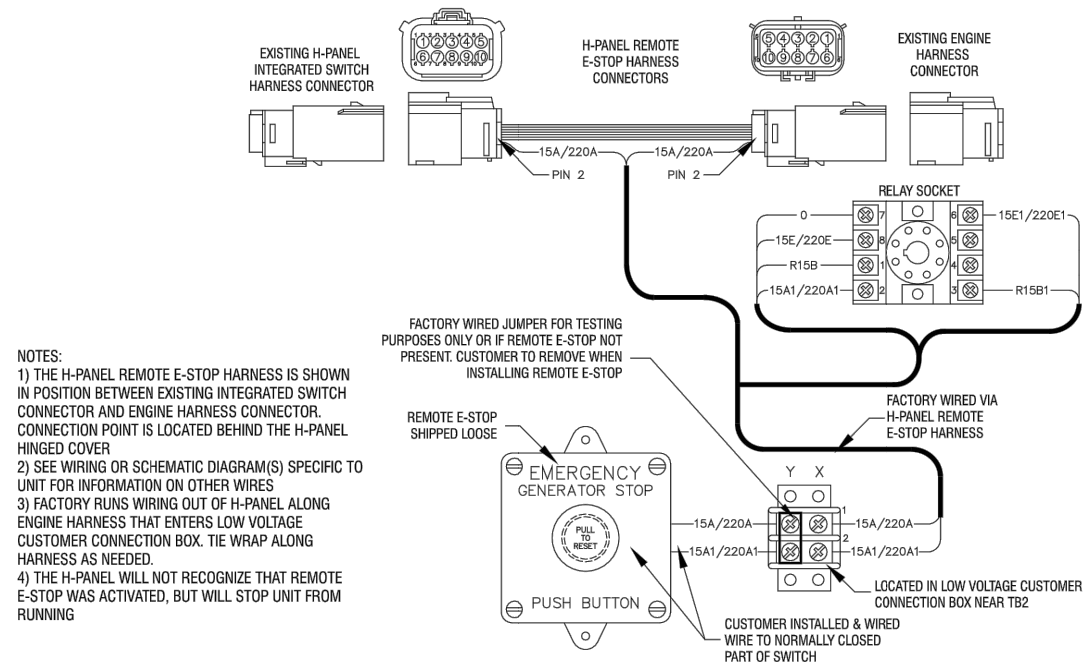

- NOTES:
- 1) THE H-PANEL REMOTE E-STOP HARNESS IS SHOWN IN POSITION BETWEEN EXISTING INTEGRATED SWITCH CONNECTOR AND ENGINE HARNESS CONNECTOR. CONNECTION POINT IS LOCATED BEHIND THE H-PANEL HINGED COVER
  - 2) SEE WIRING OR SCHEMATIC DIAGRAM(S) SPECIFIC TO UNIT FOR INFORMATION ON OTHER WIRES
  - 3) FACTORY RUNS WIRING OUT OF H-PANEL ALONG ENGINE HARNESS THAT ENTERS LOW VOLTAGE CUSTOMER CONNECTION BOX. TIE WRAP ALONG HARNESS AS NEEDED.
  - 4) THE H-PANEL WILL NOT RECOGNIZE THAT REMOTE E-STOP WAS ACTIVATED, BUT WILL STOP UNIT FROM RUNNING

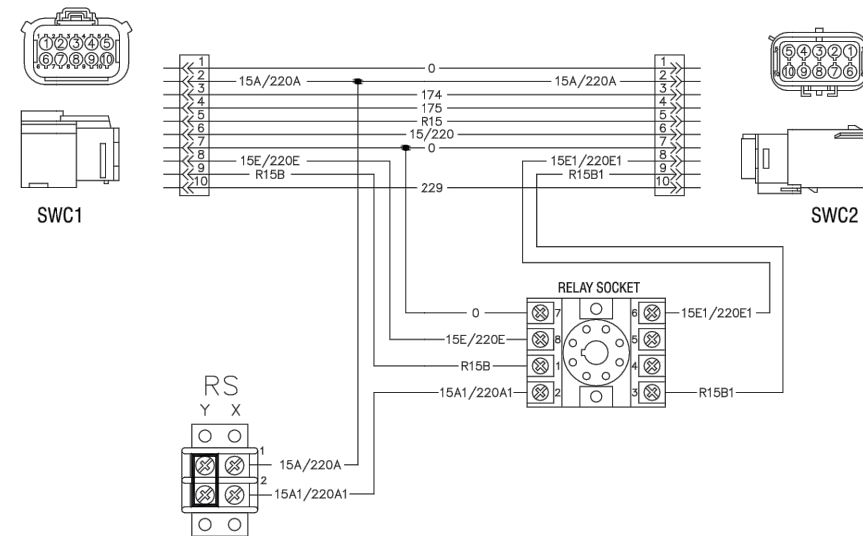

GENSET CONTROLS

2 OF 2

Generac Power Systems, Inc. | P.O. Box 8 | Waukesha, WI 53187  
P: (262) 544-4811 © 2015 Generac Power Systems, Inc. All rights reserved. All specifications are subject to change without notice.

Part No. 0L6260  
Rev A 10/15/15

# SD050 | 3.4L | 50 kW INDUSTRIAL DIESEL GENERATOR SET

EPA Certified Stationary Emergency

## Standby Power Rating

50 kW, 63 kVA, 60 Hz

## Prime Power Rating\*

45 kW, 56 kVA, 60 Hz



Image used for illustration purposes only



\*Assembled in the USA using domestic and foreign parts

\*EPA Certified Prime ratings are not available in the US or its Territories

## Codes and Standards

Generac products are designed to the following standards:



UL2200, UL508, UL489, UL142



CSA 22.2



BS5514 and DIN 6271



SAE J1349



NFPA 37, 70, 99, 110



NEC700, 701, 702, 708



ISO 3046, 7637, 8528, 9001



NEMA ICS10, MG1, 250, ICS6, AB1



ANSI C62.41



IBC 2009, CBC 2010, IBC 2012,  
ASCE 7-05, ASCE 7-10, ICC-ES AC-156 (2012)

## Powering Ahead

For over 50 years, Generac has provided innovative design and superior manufacturing.

Generac ensures superior quality by designing and manufacturing most of its generator components, including alternators, enclosures and base tanks, control systems and communications software.

Generac gensets utilize a wide variety of options, configurations and arrangements, allowing us to meet the standby power needs of practically every application.

Generac searched globally to ensure the most reliable engines power our generators. We choose only engines that have already been proven in heavy-duty industrial applications under adverse conditions.

Generac is committed to ensuring our customers' service support continues after their generator purchase.

# SD050 | 3.4L | 50 kW INDUSTRIAL DIESEL GENERATOR SET

EPA Certified Stationary Emergency

## STANDARD FEATURES

### ENGINE SYSTEM

- Oil Drain Extension
- Air Cleaner
- Fan Guard
- Stainless Steel Flexible Exhaust Connection
- Factory Filled Oil and Coolant
- Radiator Duct Adapter (Open Set Only)
- Critical Exhaust Silencer (Enclosed Only)

### Fuel System

- Fuel Lockoff Solenoid
- Primary Fuel Filter

### Cooling System

- Closed Coolant Recovery System
- UV/Ozone Resistant Hoses
- Factory-Installed Radiator
- Radiator Drain Extension
- 50/50 Ethylene Glycol Antifreeze
- 120 VAC Coolant Heater

### Electrical System

- Battery Charging Alternator
- Battery Cables
- Battery Tray
- Rubber-Booted Engine Electrical Connections
- Solenoid Activated Starter Motor

### ALTERNATOR SYSTEM

- GENprotect™
- 12 Leads (3-Phase, Non 600V)
- Class H Insulation Material
- Vented Rotor
- 2/3 Pitch
- Skewed Stator
- Auxiliary Voltage Regulator Power Winding
- Brushless Excitation
- Sealed Bearing
- Automated Manufacturing (Winding, Insertion, Lacing, Varnishing)
- Rotor Dynamically Spin Balanced
- Amortisseur Winding
- Full Load Capacity Alternator
- Protective Thermal Switch

### GENERATOR SET

- Internal Genset Vibration Isolation
- Separation of Circuits - High/Low Voltage
- Separation of Circuits - Multiple Breakers
- Wrapped Exhaust Piping
- Standard Factory Testing
- 2 Year Limited Warranty (Standby Rated Units)
- 1 Year Limited Warranty (Prime Rated Units)
- Silencer Mounted in the Discharge Hood (Enclosed Only)
- Silencer of Heat Shield

### ENCLOSURE (If Selected)

- Rust-Proof Fasteners with Nylon Washers to Protect Finish
- High Performance Sound-Absorbing Material (Sound Attenuation Enclosures)
- Gasketed Doors
- Stamped Air-Intake Louvers
- Upward Facing Discharge Hoods (Radiator and Exhaust)
- Stainless Steel Lift Off Door Hinges
- Stainless Steel Lockable Handles
- RhinoCoat™ - Textured Polyester Powder Coat Paint

### TANKS (If Selected)

- UL 142
- Double Wall Construction
- Vents
- Sloped Top
- Sloped Bottom
- Factory Pressure Tested - 2 psi (14 kPa)
- Rupture Basin Alarm
- Fuel Level
- Check Valve In Supply and Return Lines
- RhinoCoat™ - Textured Polyester Powder Coat Paint
- Stainless Steel Hardware

## CONTROL SYSTEM



### Digital H Control Panel- Dual 4x20 Display

#### Program Functions

- Programmable Crank Limiter
- 7-Day Programmable Exerciser
- Special Applications Programmable Logic Controller
- RS-232/485 Communications
- 3-Phase Sensing Digital Voltage Regulator
- 2-Wire Start Capability
- Date/Time Fault History (Event Log)
- Isochronous Governor Control
- Waterproof/Sealed Connectors

- Audible Alarms and Shutdowns
- Not in Auto (Flashing Light)
- Auto/Off/Manual Switch
- E-Stop (Red Mushroom-Type)
- NFPA110 Level I and II (Programmable)
- Customizable Alarms, Warnings, and Events
- Modbus® Protocol
- Predictive Maintenance Algorithm
- Sealed Boards
- Password Parameter Adjustment Protection
- Single Point Ground
- 16 Channel Remote Trending
- 0.2 msec High Speed Remote Trending
- Alarm Information Automatically Annunciated on the Display

#### Full System Status Display

- Power Output (kW)
- Power Factor
- kW Hours, Total, and Last Run
- Real/Reactive/Apparent Power
- All Phase AC Voltage
- All Phase Currents

- Oil Pressure
- Coolant Temperature
- Coolant Level
- Engine Speed
- Battery Voltage
- Frequency

#### Alarms and Warnings

- Oil Pressure
- Coolant Temperature
- Coolant Level
- Engine Overspeed
- Battery Voltage
- Alarms and Warnings Time and Date Stamped
- Snap Shots of Key Operation Parameters During Alarms and Warnings
- Alarms and Warnings Spelled Out (No Alarm Codes)



# SD050 | 3.4L | 50 kW INDUSTRIAL DIESEL GENERATOR SET

EPA Certified Stationary Emergency

## CONFIGURABLE OPTIONS

### ENGINE SYSTEM

- Oil Make-Up System
- Oil Heater
- Industrial Exhaust Silencer (Open Set)

### FUEL SYSTEM

- Flexible Fuel Lines
- Primary Fuel Filter

### ELECTRICAL SYSTEM

- 10A UL Battery Charger
- 2.5A UL Battery Charger
- Battery Warmer

### ALTERNATOR SYSTEM

- Alternator Upsizing
- Anti-Condensation Heater
- Tropical Coating
- Permanent Magnet Excitation

### GENERATOR SET

- GenLink® Communications Software (English Only)
- 8 Position Load Center

### CIRCUIT BREAKER OPTIONS

- Main Line Circuit Breaker
- 2nd Main Line Circuit Breaker
- Shunt Trip and Auxiliary Contact
- Electronic Trip Breakers

### ENCLOSURE

- Weather Protected Enclosure
- Level 1 Sound Attenuation
- Level 2 Sound Attenuation
- Level 2 Sound Attenuation with Motorized Dampers
- Steel Enclosure
- Aluminum Enclosure
- Up to 200 MPH Wind Load Rating (Contact Factory for Availability)
- AC/DC Enclosure Lighting Kit
- Door Alarm Switch

### WARRANTY (Standby Gensets Only)

- 2 Year Extended Limited Warranty
- 5 Year Limited Warranty
- 5 Year Extended Limited Warranty
- 7 Year Extended Limited Warranty
- 10 Year Extended Limited Warranty

### CONTROL SYSTEM

- NFPA 110 Compliant 21-Light Remote Annunciator
- Remote Relay Assembly (8 or 16)
- Oil Temperature Sender with Alarm
- Remote E-Stop (Break Glass-Type, Surface Mount)
- Remote E-Stop (Red Mushroom-Type, Surface Mount)
- Remote E-Stop (Red Mushroom-Type, Flush Mount)
- Remote Communication - Modem
- 10A Run Relay
- Ground Fault Indication and Protection Functions

### TANKS (Size On Last Page)

- Electric Fuel Level
- Mechanical Fuel Level
- 8 in (203.2 mm) Fill Extension
- 13 in (330.2 mm) Fill Extension
- 19 in (482.6 mm) Fill Extension

## ENGINEERED OPTIONS

### ENGINE SYSTEM

- Coolant Heater Ball Valves
- Fluid Containment Pan
- Block Heaters

### CONTROL SYSTEM

- Spare Inputs (x4) / Outputs (x4)
- Battery Disconnect Switch

### ALTERNATOR SYSTEM

- 3rd Breaker System

### GENERATOR SET

- Special Testing
- IBC Seismic Certification

### ENCLOSURE

- Door Switch for Intrusion Alarm
- Enclosure Ambient Heaters

### TANKS

- Overfill Protection Valve
- UL2085 Tank
- ULC S-601 Tank
- Stainless Steel Tanks
- Special Fuel Tanks (MIDEQ and FL DEP/DERM, etc.)
- Vent Extensions

# SD050 | 3.4L | 50 kW INDUSTRIAL DIESEL GENERATOR SET

EPA Certified Stationary Emergency

## APPLICATION AND ENGINEERING DATA

### ENGINE SPECIFICATIONS

#### General

Make	Generac
EPA Emissions Compliance	Stationary Emergency
EPA Emissions Reference	See Emission Data Sheet
Cylinder #	4
Type	In-Line
Displacement - in <sup>3</sup> (L)	207.48 (3.4)
Bore - in (mm)	3.86 (98)
Stroke - in (mm)	4.45 (113)
Compression Ratio	18.5:1
Intake Air Method	Turbocharged/Aftercooled
Cylinder Head	Cast Iron OHV
Piston Type	Aluminum
Crankshaft Type	Forged Steel

#### Engine Governing

Governor	Electronic Isochronous
Frequency Regulation (Steady State)	±0.25%

#### Lubrication System

Oil Pump Type	Gear
Oil Filter Type	Full Flow Cartridge
Crankcase Capacity - qt (L)	7.4 (7)

#### Cooling System

Cooling System Type	Closed Recovery
Water Pump Type	Pre-Lubed, Self Sealing
Fan Type	Pusher
Fan Speed - rpm	2,250
Fan Diameter - in (mm)	560 (22)

#### Fuel System

Fuel Type	Ultra Low Sulfur Diesel Fuel #2
Fuel Specifications	ASTM
Fuel Filtering (microns)	10
Fuel Inject Pump	Bosch (VE)
Fuel Pump Type	Engine Driven Gear
Injector Type	Pintel - 2,100 psi (14,479 kPa)
Fuel Supply Line - in (mm)	0.312 (7.92) NPT
Fuel Return Line - in (mm)	0.312 (7.92) NPT

#### Engine Electrical System

System Voltage	12 VDC
Battery Charger Alternator	Standard
Battery Size	See Battery Index 0161970SBY
Battery Voltage	12 VDC
Ground Polarity	Negative

### ALTERNATOR SPECIFICATIONS

Standard Model	Generac 390 mm
Poles	4
Field Type	Revolving
Insulation Class - Rotor	H
Insulation Class - Stator	H
Total Harmonic Distortion	<5% (3-Phase)
Telephone Interference Factor (TIF)	< 50

Standard Excitation	Synchronous Brushless
Bearings	Single Sealed Cartridge
Coupling	Direct via Flexible Disc
Load Capacity - Standby	100%
Prototype Short Circuit Test	Yes
Voltage Regulator Type	Digital
Number of Sensed Phases	All
Regulation Accuracy (Steady State)	±0.25%

# SD050 | 3.4L | 50 kW

## INDUSTRIAL DIESEL GENERATOR SET

EPA Certified Stationary Emergency

### OPERATING DATA

#### POWER RATINGS

		Standby
Single-Phase 120/240 VAC @1.0pf	50 kW	Amps: 208
Three-Phase 120/208 VAC @0.8pf	50 kW	Amps: 173
Three-Phase 120/240 VAC @0.8pf	50 kW	Amps: 150
Three-Phase 277/480 VAC @0.8pf	50 kW	Amps: 75
Three-Phase 346/600 VAC @0.8pf	50 kW	Amps: 60

#### STARTING CAPABILITIES (sKVA)

##### sKVA vs. Voltage Dip

		277/480 VAC						208/240 VAC							
Alternator	kW	10%	15%	20%	25%	30%	35%	Alternator	kW	10%	15%	20%	25%	30%	35%
Standard	50	34	52	69	86	103	120	Standard	50	26	39	52	65	77	90
Upsize 1	60	42	63	83	104	125	146	Upsize 1	60	32	47	62	78	94	110

#### FUEL CONSUMPTION RATES\*

Fuel Pump Lift - ft (m)		Diesel - gph (lph)	
		Percent Load	Standby
3 (1)		25%	1.3 (4.9)
		50%	2.3 (8.7)
Total Fuel Pump Flow (Combustion + Return) - gph (lph)		75%	3.3 (12.5)
3.57 (13.51)		100%	4.3 (16.4)

\* Fuel supply installation must accommodate fuel consumption rates at 100% load.

#### COOLING

		Standby
Coolant Flow	gpm (lpm)	12.2 (46)
Coolant System Capacity	gal (L)	2.5 (9.5)
Heat Rejection to Coolant	BTU/hr (kW)	135,900 (39.8)
Inlet Air	cfm (m <sup>3</sup> /hr)	7,500 (212)
Maximum Operating Ambient Temperature	°F (°C)	122 (50)
Maximum Ambient Temperature (Before Derate)	See Bulletin No. 0199280SSD	
Maximum Radiator Backpressure	in H <sub>2</sub> O (kPa)	0.5 (0.12)

#### COMBUSTION AIR REQUIREMENTS

	Standby
Flow at Rated Power cfm (m <sup>3</sup> /min)	166 (4.7)

#### ENGINE

		Standby
Rated Engine Speed	rpm	1,800
Horsepower at Rated kW**	hp	86
Piston Speed	ft/min (m/min)	1,335 (406.9)
BMEP	psi (kPa)	169 (1,165)

#### EXHAUST

		Standby
Exhaust Flow (Rated Output)	cfm (m <sup>3</sup> /min)	448 (12.7)
Max. Allowable Backpressure	inHg (kPa)	1.5 (5.1)
Exhaust Temp (Rated Output)	°F (°C)	1,044 (562)

\*\* Refer to "Emissions Data Sheet" for maximum bHP for EPA and SCAQMD permitting purposes.

Deration – Operational characteristics consider maximum ambient conditions. Derate factors may apply under atypical site conditions.

Please contact a Generac Power Systems Industrial Dealer for additional details. All performance ratings in accordance with ISO3046, BS5514, ISO8528, and DIN6271 standards.

Standby - See Bulletin 0187500SSB

Prime - See Bulletin 0187510SSB



# SD050 | 3.4L | 50 kW INDUSTRIAL DIESEL GENERATOR SET

EPA Certified Stationary Emergency

## DIMENSIONS AND WEIGHTS\*

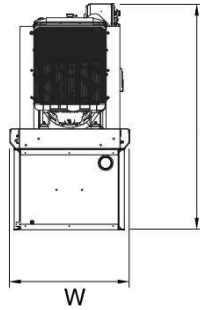
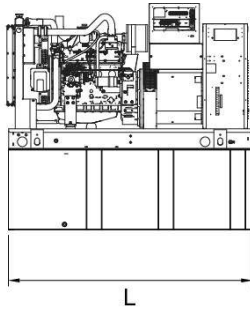

### OPEN SET (Includes Exhaust Flex)

Run Time - Hours	Usable Capacity - gal (L)	L x W x H - in (mm)	Weight - lbs (kg)
No Tank	-	76.7 (1,948) x 37.4 (950) x 45.2 (1,147)	1,776 (806)
12	54 (204.4)	76.7 (1,948) x 37.4 (950) x 58.2 (1,477)	2,256 (1,024)
30	132 (499.7)	76.7 (1,948) x 37.4 (950) x 70.2 (1,782)	2,486 (1,128)
49	211 (798.7)	76.7 (1,948) x 37.4 (950) x 82.2 (2,087)	2,695 (1,223)
69	300 (1,135.6)	92.9 (2,360) x 37.4 (950) x 85.7 (2,176)	2,758 (1,251)

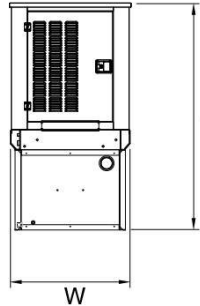
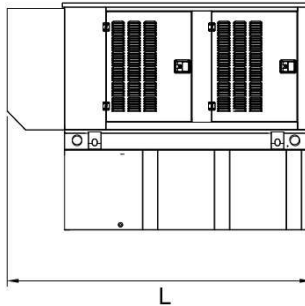

### STANDARD ENCLOSURE

Run Time - Hours	Usable Capacity - gal (L)	L x W x H - in (mm)	Weight - lbs (kg) Enclosure Only	
			Steel	Aluminum
No Tank	-	94.8 (2,409) x 38.0 (965) x 49.5 (1,258)		
12	54 (204.4)	94.8 (2,409) x 38.0 (965) x 62.5 (1,588)	334 (152)	115 (52)
30	132 (499.7)	94.8 (2,409) x 38.0 (965) x 74.5 (1,893)		
49	211 (798.7)	94.8 (2,409) x 38.0 (965) x 86.5 (2,198)		
69	300 (1,135.6)	94.8 (2,409) x 38.0 (965) x 90.0 (2,287)		

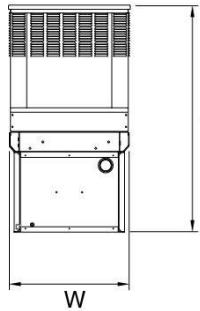
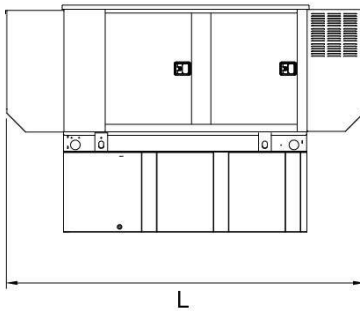

### LEVEL 1 ACOUSTIC ENCLOSURE

Run Time - Hours	Usable Capacity - gal (L)	L x W x H - in (mm)	Weight - lbs (kg) Enclosure Only	
			Steel	Aluminum
No Tank	-	112.5 (2,857) x 38.0 (965) x 49.5 (1,258)		
12	54 (204.4)	112.5 (2,857) x 38.0 (965) x 62.5 (1,588)	435 (198)	150 (68)
30	132 (499.7)	112.5 (2,857) x 38.0 (965) x 74.5 (1,893)		
49	211 (798.7)	112.5 (2,857) x 38.0 (965) x 86.5 (2,198)		
69	300 (1,135.6)	112.5 (2,857) x 38.0 (965) x 90.0 (2,287)		

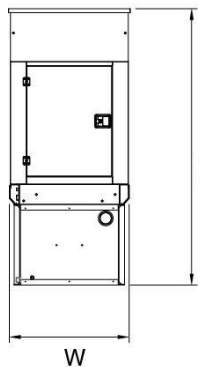
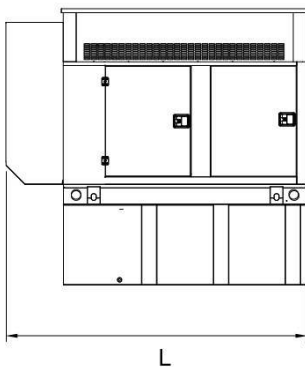

### LEVEL 2 ACOUSTIC ENCLOSURE

Run Time - Hours	Usable Capacity - gal (L)	L x W x H - in (mm)	Weight - lbs (kg) Enclosure Only	
			Steel	Aluminum
No Tank	-	94.8 (2,409) x 38.0 (965) x 61.9 (1,572)		
12	54 (204.4)	94.8 (2,409) x 38.0 (965) x 74.9 (1,902)	520 (236)	179 (81)
30	132 (499.7)	94.8 (2,409) x 38.0 (965) x 86.9 (2,207)		
49	211 (798.7)	94.8 (2,409) x 38.0 (965) x 98.9 (2,512)		
69	300 (1,135.6)	94.8 (2,409) x 38.0 (965) x 102.4 (2,601)		

\* All measurements are approximate and for estimation purposes only. Specification characteristics may change without notice. Please contact a Generac Power Systems Industrial Dealer for detailed installation drawings.

# Property Detail Report

For Property Located At :

6 FAIRFIELD DR, BROOKFIELD, CT 06804



RealQuest

## Owner Information

Owner Name: **PHOTRONICS INC**  
 Mailing Address: **15 SECOR RD, BROOKFIELD CT 06804-3937 R010**  
 Vesting Codes: **//**

## Location Information

Legal Description:  
 County: **FAIRFIELD, CT** APN: **BROO-000017G-000000-000034**  
 Census Tract / Block: **2053.00 / 1** Alternate APN: **58071**  
 Township-Range-Sect:  
 Legal Book/Page: Subdivision:  
 Legal Lot: Map Reference: **/**  
 Legal Block: Tract #:  
 Market Area: School District:  
 Neighbor Code: School District Name: **BROOKFIELD**  
 Munic/Township:

## Owner Transfer Information

Recording/Sale Date: **/** Deed Type:  
 Sale Price: 1st Mtg Document #:  
 Document #:

## Last Market Sale Information

Recording/Sale Date: **07/26/2002 /** 1st Mtg Amount/Type: **/**  
 Sale Price: **\$2,200,000** 1st Mtg Int. Rate/Type: **/**  
 Sale Type: **FULL** 1st Mtg Document #: **/**  
 Document #: **417-853** 2nd Mtg Amount/Type: **/**  
 Deed Type: **WARRANTY DEED** 2nd Mtg Int. Rate/Type: **/**  
 Transfer Document #: Price Per SqFt: **\$103.68**  
 New Construction: Multi/Split Sale:  
 Title Company:  
 Lender:  
 Seller Name: **MACRICOSTAS GEO & STEPHEN**

## Prior Sale Information

Prior Rec/Sale Date: **/ 08/10/1984** Prior Lender:  
 Prior Sale Price: Prior 1st Mtg Amt/Type: **/**  
 Prior Doc Number: **160-639** Prior 1st Mtg Rate/Type: **/**  
 Prior Deed Type: **DEED (REG)**

## Property Characteristics

Year Built / Eff: **1985 /** Total Rooms/Offices  
 Gross Area: **21,219** Total Restrooms:  
 Building Area: **21,219** Roof Type: **FLAT**  
 Tot Adj Area: Roof Material: **TAR & GRAVEL**  
 Above Grade: Construction: **STEEL/HEAVY**  
 # of Stories: **2** Foundation:  
 Other Improvements: **Building Permit** Exterior wall:  
 Basement Area:

Garage Area:  
 Garage Capacity:  
 Parking Spaces:  
 Heat Type: **FORCED AIR**  
 Air Cond: **YES**  
 Pool:  
 Quality:  
 Condition: **EXCELLENT**

## Site Information

Zoning: **IR80SE** Acres: **1.90** County Use:  
 Lot Area: **82,764** Lot Width/Depth: **x** State Use: **INDUSTRIAL BUILDING (405)**  
 Land Use: **INDUSTRIAL (NEC)** Commercial Units: **1** Water Type:  
 Site Influence: Sewer Type: Building Class:

## Tax Information

Total Value: **\$1,394,290** Assessed Year: **2019** Property Tax: **\$40,630.00**  
 Land Value: **\$174,750** Improved %: **87%** Tax Area: **118**  
 Improvement Value: **\$1,219,540** Tax Year: **2019** Tax Exemption:  
 Total Taxable Value:

# Street Map Plus Report

For Property Located At



**6 FAIRFIELD DR, BROOKFIELD, CT 06804**

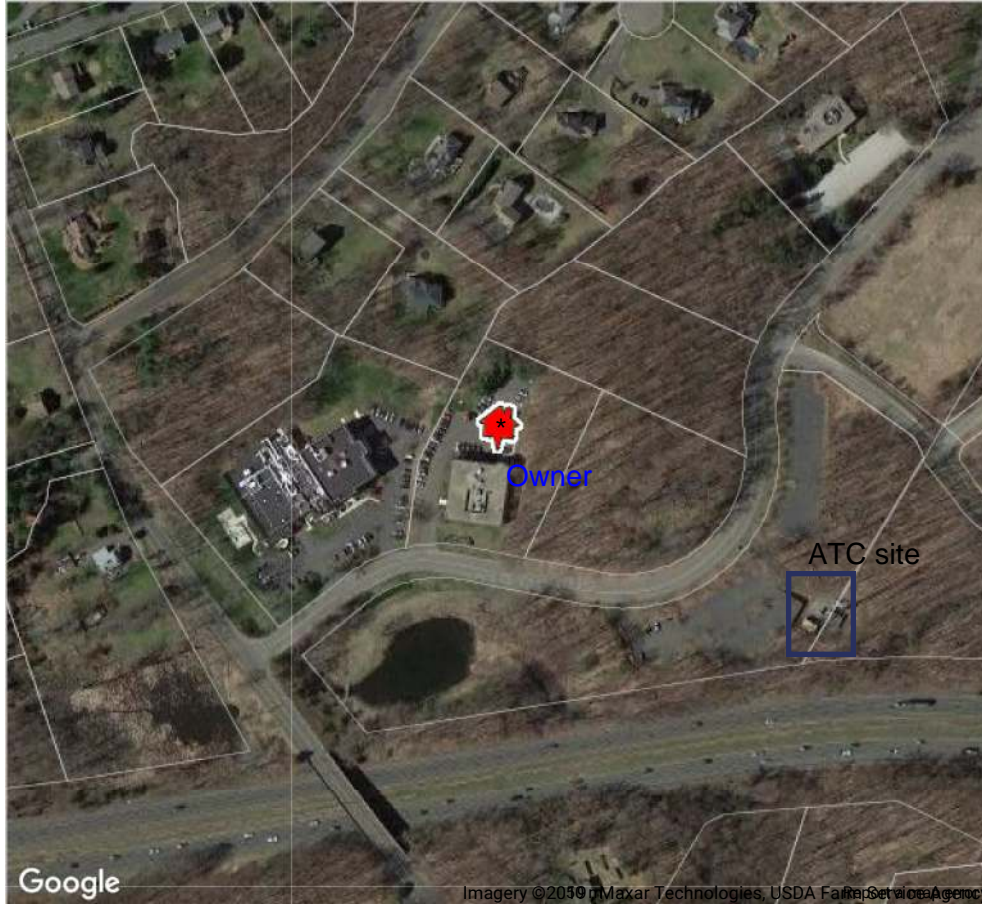



## Teresa Wodack

**From:** TrackingUpdates@fedex.com  
**Sent:** Monday, August 19, 2019 1:48 PM  
**To:** Teresa Wodack  
**Subject:** FedEx Shipment 776007147477 Delivered

# Your package has been delivered

Tracking # 776007147477

Ship date:  
Fri, 8/16/2019

**Teresa Wodack**  
NB+C  
BLUE BELL, PA 19422  
US

Delivery date:  
Mon, 8/19/2019 1:44  
pm

**Daniel Rosenthal**  
First Selectman  
3 Primrose Street  
Chief Elected Official  
NEWTOWN, CT 06470  
US



## Shipment Facts

Our records indicate that the following package has been delivered.

<b>Tracking number:</b>	<a href="#">776007147477</a>
<b>Status:</b>	Delivered: 08/19/2019 1:44 PM Signed for By: M.LESLIE
<b>Reference:</b>	100510-302518
<b>Signed for by:</b>	M.LESLIE
<b>Delivery location:</b>	NEWTOWN, CT
<b>Delivered to:</b>	Receptionist/Front Desk
<b>Service type:</b>	FedEx 2Day®
<b>Packaging type:</b>	FedEx® Pak
<b>Number of pieces:</b>	1
<b>Weight:</b>	1.00 lb.
<b>Special handling/Services:</b>	Deliver Weekday
<b>Standard transit:</b>	8/20/2019 by 4:30 pm

✉ Please do not respond to this message. This email was sent from an unattended mailbox. This report was generated at approximately 12:48 PM CDT on 08/19/2019.



## Teresa Wodack

**From:** TrackingUpdates@fedex.com  
**Sent:** Monday, August 19, 2019 1:50 PM  
**To:** Teresa Wodack  
**Subject:** FedEx Shipment 776007199121 Delivered

# Your package has been delivered

Tracking # 776007199121

Ship date:  
Fri, 8/16/2019

**Teresa Wodack**  
NB+C  
BLUE BELL, PA 19422  
US

Delivery date:  
Mon, 8/19/2019 1:46  
pm

**George Benson**  
Director of Planning  
3 Primrose Street  
Newtown Municipal Center  
NEWTOWN, CT 06470  
US



## Shipment Facts

Our records indicate that the following package has been delivered.

<b>Tracking number:</b>	<a href="#">776007199121</a>
<b>Status:</b>	Delivered: 08/19/2019 1:46 PM Signed for By: D.FRIED
<b>Reference:</b>	100510-302518
<b>Signed for by:</b>	D.FRIED
<b>Delivery location:</b>	NEWTOWN, CT
<b>Delivered to:</b>	Receptionist/Front Desk
<b>Service type:</b>	FedEx 2Day®
<b>Packaging type:</b>	FedEx® Pak
<b>Number of pieces:</b>	1
<b>Weight:</b>	1.00 lb.
<b>Special handling/Services:</b>	Deliver Weekday
<b>Standard transit:</b>	8/20/2019 by 4:30 pm

✉ Please do not respond to this message. This email was sent from an unattended mailbox. This report was generated at approximately 12:49 PM CDT on 08/19/2019.



# Teresa Wodack

**From:** TrackingUpdates@fedex.com  
**Sent:** Monday, August 19, 2019 2:17 PM  
**To:** Teresa Wodack  
**Subject:** FedEx Shipment 776007276260 Delivered

## Your package has been delivered

Tracking # 776007276260

Ship date:  
Fri, 8/16/2019

**Teresa Wodack**  
NB+C  
BLUE BELL, PA 19422  
US

Delivery date:  
Mon, 8/19/2019 2:15  
pm

**Property Owner**  
Constantine Macriostas c/o  
Photroni  
5509 Pennock Point Rd  
JUPITER, FL 33458  
US



### Shipment Facts

Our records indicate that the following package has been delivered.

**Tracking number:** [776007276260](#)

**Status:** Delivered: 08/19/2019 2:15 PM  
Signed for By: Signature not required

**Reference:** 100510-302518

**Signed for by:** Signature not required

**Delivery location:** JUPITER, FL

**Delivered to:** Residence

**Service type:** FedEx 2Day®

**Packaging type:** FedEx® Pak

**Number of pieces:** 1

**Weight:** 1.00 lb.

**Special handling/Services:** Deliver Weekday  
Residential Delivery

**Standard transit:** 8/20/2019 by 8:00 pm