

October 16, 2023

Melanie A. Bachman, Esq.
Executive Director/Staff Attorney
Connecticut Siting Council
10 Franklin Square
New Britain, CT 06051

Re: **Notice of Exempt Modification – Facility Modification
951 Bank Street, New London, Connecticut**

Dear Attorney Bachman:

Cellco Partnership d/b/a Verizon Wireless (“Cellco”) currently maintains a wireless telecommunications facility at the above-referenced address (the “Property”). Cellco’s facility consists of antennas and remote radio heads attached to a roof-top tower. Equipment associated with the facility is located on the roof of the building. Cellco’s roof-top tower was approved by the Siting Council (“Council”) in January of 2020 (Petition No. 1390). A copy of the Council’s Petition No. 1390 approval letter and staff report are included in [Attachment 1](#).

Cellco’s proposed modification involves the installation of two (2) interference mitigation filters (“Filters”) on its existing antenna mounting assembly. The Filter specification sheet is included in [Attachment 2](#).

Please accept this letter as notification pursuant to R.C.S.A. § 16-50j-73, for construction that constitutes an exempt modification pursuant to R.C.S.A. § 16-50j-72(b)(2). In accordance with R.C.S.A. § 16-50j-73, a copy of this letter is being sent to New London’s Chief Elected Official and Land Use Officer. A copy of this letter is also being sent to the owner of the Property.

The planned modifications to the facility fall squarely within those activities explicitly provided for in R.C.S.A. § 16-50j-72(b)(2).

1. The proposed modification will not result in an increase in the height of the existing tower. The Filters will be installed on Cellco’s existing antenna mounting assembly.

28022079-v1

Melanie A. Bachman, Esq.
October 16, 2023
Page 2

2. The proposed modifications will not involve any change to ground-mounted equipment and therefore, will not require the extension of the site boundary.
3. The proposed modifications will not increase noise levels at the facility by six decibels or more, or to levels that exceed state and local criteria.
4. The installation of Cellco's new Filters will not result in a change to radio frequency (RF) emissions from the facility. Therefore, no new RF emissions information is included in this filing.
5. The proposed modifications will not cause a change or alteration in the physical or environmental characteristics of the site.
6. According to the attached Structural Analysis Report ("SA") and Antenna Mount Analysis Report ("MA"), the existing roof-top tower, enclosure, host building, antenna mounting assembly can support Cellco's proposed modifications. A copy of the SA and MA are included in Attachment 3.

A copy of the parcel map and Property owner information is included in Attachment 4. A Certificate of Mailing verifying that this filing was sent to municipal officials and the property owner is included in Attachment 5.

For the foregoing reasons, Cellco respectfully submits that the proposed modifications to the above-referenced telecommunications facility constitutes an exempt modification under R.C.S.A. § 16-50j-72(b)(2).

Sincerely,



Kenneth C. Baldwin

Enclosures

Copy to:

Michael E. Passero, Mayor
Michelle Johnson Scovish, Planning, Zoning and Wetlands Official
RL New London LLC, Property Owner
Alex Tyurin, Verizon Wireless

ATTACHMENT 1



STATE OF CONNECTICUT

CONNECTICUT SITING COUNCIL

Ten Franklin Square, New Britain, CT 06051

Phone: (860) 827-2935 Fax: (860) 827-2950

E-Mail: siting.council@ct.gov

www.ct.gov/csc

CERTIFIED MAIL RETURN RECEIPT REQUESTED

January 17, 2020

Kenneth C. Baldwin, Esq.
Robinson & Cole LLP
280 Trumbull Street
Hartford, CT 06103-3597

RE: **PETITION NO. 1390** – Cellco Partnership d/b/a Verizon Wireless petition for a declaratory ruling, pursuant to Connecticut General Statutes §4-176 and §16-50k, for the proposed installation of a wireless telecommunications facility and associated equipment on the roof of an existing commercial building located at 951 Bank Street, New London, Connecticut.

Dear Attorney Baldwin:

At a public meeting held on January 16, 2020, the Connecticut Siting Council (Council) considered and ruled that the above-referenced proposal would not have a substantial adverse environmental effect, and pursuant to Connecticut General Statutes § 16-50k, would not require a Certificate of Environmental Compatibility and Public Need with the following conditions:

1. Approval of any minor project changes be delegated to Council staff;
2. Submit the Federal Aviation Administration Notice of Determination letter, and any resulting modifications to the proposed facility to the Council prior to construction;
3. Perform structural reinforcements specified by a structural analysis performed by BL Companies, dated December 11, 2017, as noted on Petition Site Plan Sheet C-2 prior to installation of the tower and rooftop steel mounting frame;
4. Within 45 days following completion of the specified structural reinforcements, Cellco shall provide documentation certified by a Professional Engineer that its installation complied with the recommendations of the BL Companies structural analysis, dated December 11, 2017;
5. Resolution of any potential interference issues with other existing wireless communications systems in the vicinity of the site resulting from the operation of Cellco's equipment;
6. Unless otherwise approved by the Council, if the facility authorized herein is not fully constructed within three years from the date of the mailing of the Council's decision, this decision shall be void, and the facility owner/operator shall dismantle the facility and remove all associated equipment or reapply for any continued or new use to the Council before any such use is made. The time between the filing and resolution of any appeals of the Council's decision shall not be counted in calculating this deadline. Authority to monitor and modify this schedule, as necessary, is delegated to the Executive Director. The facility owner/operator shall provide written notice to the Executive Director of any schedule changes as soon as is practicable;



CONNECTICUT SITING COUNCIL
Affirmative Action / Equal Opportunity Employer

7. Any request for extension of the time period to fully construct the facility shall be filed with the Council not later than 60 days prior to the expiration date of this decision and shall be served on all parties and intervenors, if applicable, and the City of New London;
8. Within 45 days after completion of construction, the Council shall be notified in writing that construction has been completed;
9. Any nonfunctioning antenna and associated antenna mounting equipment on this facility owned and operated by the Petitioner shall be removed within 60 days of the date the antenna ceased to function;
10. The facility owner/operator shall remit timely payments associated with annual assessments and invoices submitted by the Council for expenses attributable to the facility under Conn. Gen. Stat. §16-50v;
11. If the facility ceases to provide wireless services for a period of one year the Petitioner shall dismantle the tower and remove all associated equipment or reapply for any continued or new use to the Council within 90 days from the one year period of cessation of service. The Petitioner may submit a written request to the Council for an extension of the 90 day period not later than 60 days prior to the expiration of the 90 day period; and
12. This Declaratory Ruling may be transferred or partially transferred, provided both the facility owner/operator/transferor and the transferee are current with payments to the Council for their respective annual assessments and invoices under Conn. Gen. Stat. §16-50v. The Council shall be notified of such sale and/or transfer and of any change in contact information for the individual or representative responsible for management and operations of the facility within 30 days of the sale and/or transfer. Both the facility owner/operator/transferor and the transferee shall provide the Council with a written agreement as to the entity responsible for any quarterly assessment charges under Conn. Gen. Stat. §16-50v(b)(2) that may be associated with this facility.

Additionally, the Council recommends that the weekly maintenance testing of the back-up generator be performed during regular business hours, Monday-Friday, 9 a.m. to 5 p.m.

This decision is under the exclusive jurisdiction of the Council and is not applicable to any other modification or construction. All work is to be implemented as specified in the petition dated December 3, 2019 and additional information dated January 7, 2020.

Enclosed for your information is a copy of the staff report on this project.

Sincerely,



Melanie A. Bachman
Executive Director

MAB/RDM/emr

Enclosure: Staff Report dated January 16, 2020

c: The Honorable Michael E. Passero, Mayor, City of New London
Felix J. Reyes, Director of the Office of Development & Planning, City of New London



STATE OF CONNECTICUT

CONNECTICUT SITING COUNCIL

Ten Franklin Square, New Britain, CT 06051

Phone: (860) 827-2935 Fax: (860) 827-2950

E-Mail: siting.council@ct.gov

Web Site: www.ct.gov/csc

Petition No. 1390

Cellco Partnership d/b/a Verizon Wireless 951 Bank Street, New London Rooftop Wireless Telecommunications Facility

Staff Report

January 16, 2020

On December 3, 2019, the Connecticut Siting Council (Council) received a petition from Cellco Partnership d/b/a Verizon Wireless (Cellco) for a declaratory ruling, pursuant to Connecticut General Statutes §4-176 and §16-50k, for the proposed installation of a rooftop wireless telecommunications facility and a Centralized Radio Access Network (C-RAN) at 951 Bank Street in New London, Connecticut.

On December 3, 2019, the Petitioner notified the City of New London (City), the underlying property owner and abutting property owners. The Council received comments from an abutter located at 49 Westwood Avenue (Slick LLC) who expressed various concerns regarding public health, property values and wireless interference. For interference concerns, Slick LLC stated there are ongoing issues with his existing wireless communications equipment from the operation of an existing Cellco installation at a tower facility abutting his property at 59 Westwood Avenue, and the potential for continued wireless interference issues from operation of the proposed facility. Slick LLC also believes that the operation of a generator at the existing tower is currently causing wireless interference issues. Cellco is unaware of any existing issues from operation of its existing installation for the last 30 years. Additionally, Cellco complies with all Federal Communication Commission guidelines that are designed to prevent interference. Cellco contends the generator will not cause interference issues and operation of Cellco's wireless equipment will be in frequency ranges that would not interfere with Slick LLC's operating frequencies (35 MHz range). If interference does occur from operation of its equipment, Cellco would take measures to address the issue.

On December 3, 2019, the Council sent correspondence to the City stating that the Council has received the Petition and invited the City to contact the Council with any questions or comments by January 2, 2020. The Council has not received any comments to date.

On December 20, 2019, the Council issued interrogatories to Cellco. On January 8, 2020, Cellco submitted responses to the Council's interrogatories.

The 951 Bank Street property is 3.71 acres in size and is zoned General Commercial (C-1). It is surrounded by commercial and light industrial uses on Bank Street and Westwood Avenue. The property hosts Mike's Famous Harley Davidson dealership. An 80-foot tall light duty lattice tower, formerly used for radio dispatch for Coca-Cola, the former occupant of the property, is located on the east end of the roof, adjacent to Bank Street. This tower, no longer in use, is not structurally capable of supporting Cellco's proposed installation.

Cellco proposes to install an approximately 50-foot tall monopole tower attached to a steel frame mounted on the western portion of the roof. This section of the building roof extends to a height of 23 feet above ground level (agl). The tower would reach a height of approximately 72.5 feet agl. The building would require structural reinforcement prior to installation of the proposed tower and steel-mounting frame. Four roof-mounted HVAC units would be relocated to the steel frame.

Cellco would install 9 panel antennas at a centerline height of approximately 69.5 feet agl, 6 remote radio heads, 3 diplexers, and a overvoltage protection box on pipe mounts with a centerline height of 62 feet agl.

The proposed rooftop tower would replace an existing Cellco facility located on an 80-foot tower, owned by Atlantic Broadband, at 59 Westwood Avenue in New London that provides 700 MHz and 2100 MHz service. The proposed facility would deploy these frequencies as well as 850 MHz and 1900 MHz service, enhancing wireless service to the surrounding area. Cellco does not intend to deploy 5G service (3.500 MHz) at the site at this time.

The proposed rooftop facility is approximately 290 feet southeast of the existing tower. The existing tower is not structurally capable of supporting additional antennas and equipment upgrades. Cellco does not know if the Atlantic Broadband tower will remain in place after it relocates to the proposed rooftop tower.

Radio and C-RAN equipment would be located within a 244 square-foot equipment room in an existing concrete storage building at the west end of the building. A C-RAN connects several individual telecommunications facilities to a local centralized hub, thereby decreasing the amount of hardware required at the individual facilities. This allows for more flexibility in the selection of future cell site locations and a reduction in operational cost.

Cellco's equipment room would be accessed from a paved parking area at the west end (rear) of the building. Two roof-mounted fan units would be installed on the concrete storage building. Existing electrical and telecom service would connect to the proposed equipment along and within the building roof.

Emergency power would be supplied from a new 100-kilowatt natural gas-fueled generator to be located adjacent to the concrete storage building. The natural gas-fueled generator would be pipeline supplied, and thus, its run time would not be limited by on-site fuel supply. Gas service would extend from existing building service at the east end of the building, routed up the exterior wall to, and across, the roof to a rear exterior wall adjacent to the proposed generator location.

Commercial Mobile Radio Service (CMRS) providers are licensed by and are under the jurisdiction and authority of the Federal Communications Commission (FCC). At present, no standards for backup power for CMRS providers have been promulgated by the FCC. Every year since 2006, AT&T, Sprint, T-Mobile, and Cellco have certified their compliance with the CTIA Business Continuity/Disaster Recovery Program and the Communications Security, Reliability and Interoperability Council standards and best practices to ensure network reliability during power outages.

The proposed project would occur within and on the existing building and no ground disturbance is necessary except for installation of the emergency generator on a paved area.

The proposed tower requires notice to the Federal Aviation Administration because it exceeds notice criteria by 6 feet. Cellco will submit the results of the FAA's determination once it is received. Cellco does not anticipate the tower would require aviation hazard marking and/or lighting because the existing tower at 59 Westwoods Avenue and the existing tower on the building are slightly taller and do not have FAA marking and/or lighting. If FAA marking and/or lighting is required for the proposed installation, Cellco would examine the feasibility of lowering the tower below the FAA threshold.

In general, the proposed tower would be visible year-round to the immediate adjacent area, predominately from Bank Street north and south of the site and from Braemer Place north of the site, out to a distance of

0.2-mile. Year-round views from residential areas include, but are not limited to, the Bank Street-Beckwith Street intersection (0.13 mile south), Bank Street-Faye Street intersection (+75 feet north), and Lee Avenue (0.18 mile northeast). Exterior conduits would be painted to match adjacent building materials, where appropriate.

No public schools or commercial child day care centers are within 250 feet of the site. The nearest school or daycare is approximately 1,700 feet to the east-southeast at 25 Squire Street.

The highest calculated worst-case (ground level) power density level for Cellco's proposed antennas would be 24.2 percent of the applicable public exposure limit established by the Federal Communications Commission with a -10 dB off-beam adjustment.

The facility would have a cumulative worst-case power density of 24.2 percent of the applicable limit established by the Federal Communications Commission using a -10 dB off-beam adjustment.

A Professional Engineer duly licensed in the State of Connecticut has certified that the proposed tower, steel platform and the existing building are structurally adequate to support the proposed loading with certain recommendations.

Cellco contends that this proposed project would not have a substantial adverse environmental impact.

If approved, staff recommends the following conditions:

1. Approval of any minor project changes be delegated to Council staff;
2. Submit the FAA Notice of Determination letter, and any resulting modifications to the proposed facility to the Council prior to construction;
3. Perform structural reinforcements specified by a structural analysis performed by BL Companies, dated December 11, 2017, as noted on Petition Site Plan Sheet C-2 prior to installation of the tower and rooftop steel mounting frame; and
4. Within 45 days following completion of the specified structural reinforcements, Cellco shall provide documentation certified by a Professional Engineer that its installation complied with the recommendations of the BL Companies structural analysis, dated December 11, 2017.

Site Location

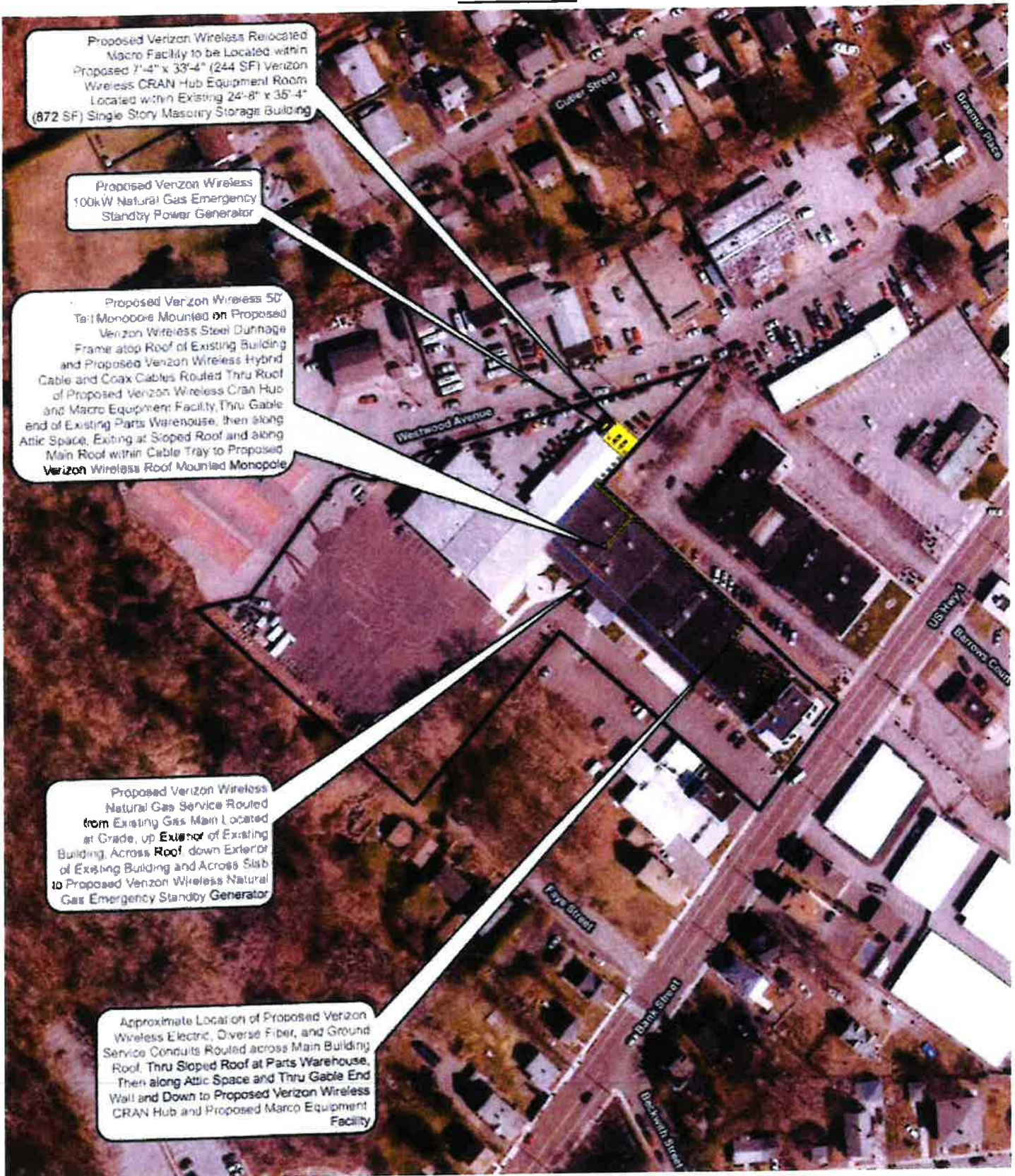

Site Plan

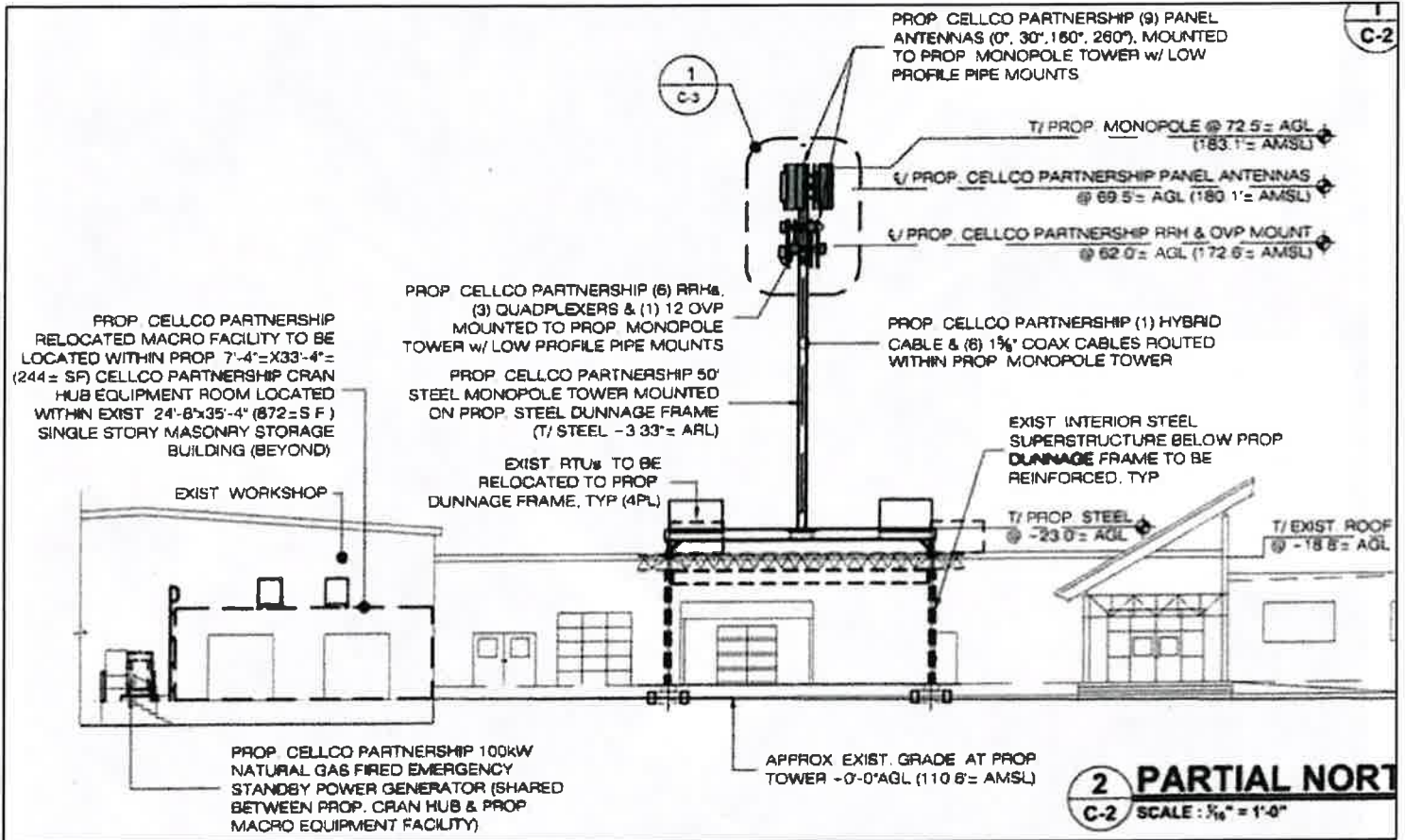

ATTACHMENT 2

BSF0020F3V1-1

TWIN BANDSTOP 900MHZ INTERFERENCE MITIGATION FILTER

The BSF0020 is ideal for co-located 700, 850 and 900 networks. Utilising a 2.6MHz guardband the BSF0020 provides rejection of the 900 UL band while passing 700/850 UL and DL bands. Capable of being used in an outdoor environment the BSF0020 contains two identical bandstop filters, suitable for 2x2 MIMO configuration, offering excellent insertion loss, group delay and rejection.

FEATURES

- Passes full 700 and 850 bands
- Low insertion loss
- Rejection of 900MHz uplink
- DC/AISG pass
- Twin unit
- Dual twin mounting available



TECHNICAL SPECIFICATIONS

BAND NAME	700 PATH / 850 UPLINK PATH	850 DOWNLINK PATH
Passband	698 - 849MHz	869 - 891.5MHz
Insertion loss	0.1dB typical / 0.3dB maximum	0.5dB typical, 1.45dB maximum
Return loss	24dB typical, 18dB minimum	
Maximum input power (Per Port)	100W average	200W average and 66W per 5MHz
Rejection	53dB minimum @ 894.1 - 896.5MHz	
ELECTRICAL		
Impedance	50Ohms	
Intermodulation products	-160dBc maximum in UL Band (assuming 20MHz Signal), with 2 x 43dBm carriers -153dBc maximum with 2 x 43dBm	
DC / AISG		
Passband	0 - 13MHz	
Insertion loss	0.3dB maximum	
Return loss	15dB minimum	
Input voltage range	± 33V	
DC current rating	2A continuous, 4A peak	
Compliance	3GPP TS 25.461	
ENVIRONMENTAL		
For further details of environmental compliance, please contact Kaelus.		
Temperature range	-20°C to +60°C -4°F to +140°F	
Ingress protection	IP67	
Altitude	2600m 8530ft	
Lightning protection	RF port: ±5kA maximum (8/20us), IEC 61000-4-5 – Unit must be terminated with some lightning protection circuits.	
MTBF	>1,000,000 hours	
Compliance	ETS! EN 300 019 class 4.1H, RoHS, NEBS GR-487-CORE	
MECHANICAL		
Dimensions H x D x W	269 x 277 x 80mm 10.60 x 10.90 x 3.15in (Excluding brackets and connectors)	
Weight	8.0 kg 17.6 lbs (no bracket)	
Finish	Powder coated, light grey (RAL7035)	
Connectors	RF: 4.3-10 (F) x 4	
Mounting	Optional pole/wall bracket supplied with two metal clamps 45-178mm diameter poles or custom bracket. See ordering information.	

ORDERING INFORMATION

PART NUMBER	CONFIGURATION	OPTIONAL FEATURES	CONNECTORS
BSF0020F3V1	TWIN, 2 in / 2 out	DC/AISG PASS NO BRACKET	4.3-10 (F)
BSF0020F3V1-1	TWIN, 2 in / 2 out	DC/AISG PASS	4.3-10 (F)
BSF0020F3V1-2	QUAD, 4 in / 4 out	DC/AISG PASS	4.3-10 (F)

ELECTRICAL BLOCK DIAGRAM

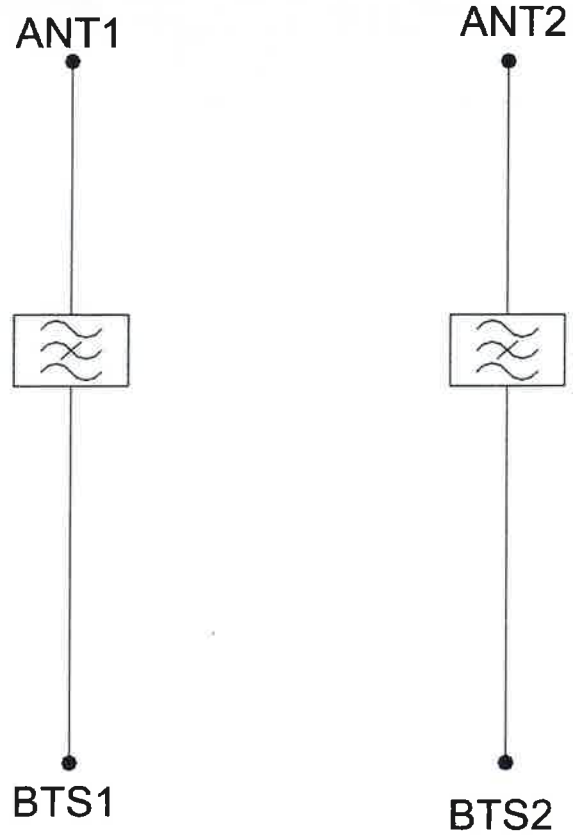

MECHANICAL BLOCK DIAGRAM

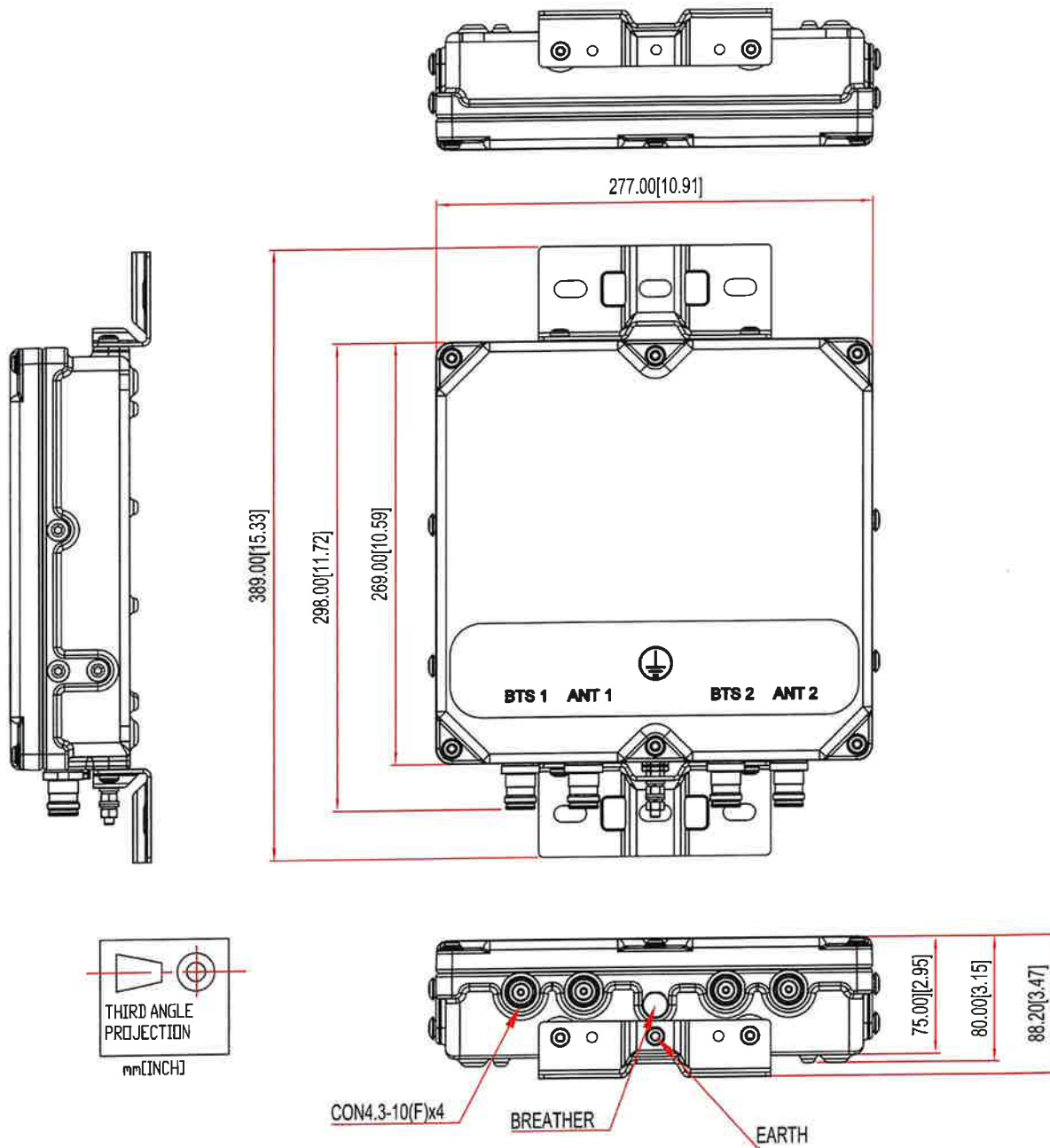

ATTACHMENT 3



**STRUCTURAL ANALYSIS REPORT
FOR PROPOSED ANTENNA AND APPURTENANCE
MODIFICATION ON A 49.5'± ROOFTOP MONOPOLE TOWER
NEW LONDON, CONNECTICUT**

Prepared for
Verizon Wireless



**Verizon Site Ref.
469376; New London CT**

Site Address: 951 Bank Street, New London, Connecticut 06320
FUZE ID: 17123887
PSLC: 469376
MDG Location I.D: 5000247672
Project Type: Filter Add

APT Filing No. CT141_14070

~~Rev 0 September 21, 2023~~
Rev 1 September 25, 2023



STRUCTURAL ANALYSIS REPORT
49.5'± ROOFTOP MONOPOLE TOWER
NEW LONDON, CONNECTICUT
prepared for
Verizon Wireless

EXECUTIVE SUMMARY:

All-Points Technology Corporation, P.C. (APT) performed a structural analysis of an existing 49.5'± tapered steel rooftop-mounted monopole tower structure to support a proposed Verizon equipment modification.

The proposed Verizon antenna and appurtenance modification consists of the installation of two (2) new Kaelus mitigation filters. Reference can be made to the equipment table on the following page.

The results of this analysis indicate that the existing monopole tower structure meets the requirements of the 2021 International Building Code (IBC), as amended by the 2022 Connecticut State Building Code, and that ANSI/TIA-222-H standard with Verizon's proposed equipment modification.

The tower steel component usage is summarized in the table below:

Elevation/Component	Usage (%)
0-49.5'	55%
Base Plate	60%
Anchor Bolts	29%

INTRODUCTION:

A structural analysis of this communications tower was performed by APT for Verizon Wireless. The tower is located at 951 Bank Street in New London, Connecticut.

The following information was utilized in the preparation of this analysis:

- Construction Drawings prepared by APT (APT Project No. CT141_14070), marked Rev 1, dated 09/25/23.
- Permit drawings prepared by Valmont, File ID #478921-P2, dated 2/21/22.
- Communication Structure Calculations by Valmont, File ID 478921 dated 2/21/22.
- Structural Analysis and Design Calculations prepared by BL Companies, dated 07/31/20.

The tower is a 49.5'±, 18-sided tapered steel monopole tower structure manufactured by Valmont. The structure is mounted on a rooftop steel dunnage frame.

The analysis was conducted using the following antenna inventory (proposed equipment shown in **bold text**):

Carrier	Antenna and Appurtenance Make/Model	Elevation (AGL) ¹	Status ²	Mount Type	Coax/Feed-Line ³
Verizon	(6) Commscope JAHH-65B-R3B panel antennas ⁴	69.5'±	ETR	Six (6) SitePro1 T-Arm (P/N UDS-NP) & six (6) P2.5 STD x 6.5'L antenna mounting pipes.	(1) 12x24 hybrid line
	(3) Samsung B2/B66a (RF4439d-25A) ORAN RRHs, (3) Commscope CBC1923Q-43 Quad Diplexers	65.5'± 64'±	ETR	(1) SitePro1 UWS6-NP Ring Mount & six (6) 2.0 STD x 7.0'L mounting pipes	
	(3) Samsung B5/B13 (RF4440d-13A) ORAN RRHs, (2) Kaelus KA-6030 Filters	62'±	ETR P		

Notes:

- Elevations refer to AGL. (Tower Base Elevation = 23' ± A.G.L.)
- ETR = Existing to Remain; ERL = Existing to be Relocated; P = Proposed.
- All feed lines run inside the pole.
- Mounted side-by-side on Commscope BSAMNT-SBS-2-2 bracket.

STRUCTURAL ANALYSIS:

Methodology:

This structural analysis has been prepared in accordance with the ANSITIA-222-H standard entitled "Structural Standard for Antenna Supporting Structures, Antennas and Small Wind Turbine Support Structures"; American Institute of Steel Construction (AISC) Manual of Steel Construction, and the 2021 International Building Code (IBC), as amended by the 2022 Connecticut State Building Code utilizing the following criteria:

- o Load Case 1: 130 mph (3-second gust), 0" ice
- o Load Case 2: 50 mph (3-second gust) w/ 1.0" ice thickness required
- o Load Case 3: 60 mph (3-second gust) (Service Load)
- o Structure Class: II
- o Exposure Category: C
- o Topographic Category: 1

Analysis Results:

The analysis was conducted in accordance with the criteria outlined above with the aforementioned loading. The following table summarizes the results of the analysis:

Elevation/Component	Usage (%)
0-49.5'	55%
Base Plate	60%
Anchor Bolts	29%

Dunnage Frame and Host Building:

Evaluation of the existing supporting dunnage frame and host building was performed by comparing reactions calculated with the existing and proposed loading against the original design reactions indicated within the aforementioned original Valmont tower design documents and structural design report prepared by BL Companies. Factored base reactions imposed by the existing and proposed loading are less than the published design reactions, indicating that the host structure is adequately sized.

The calculated base reactions with the existing and proposed equipment loading are indicated within the table below:

Load Effect	Original Design (TIA-222-G)	Calculated Reactions	Result
Base Axial	5,584 lbs ⁽⁵⁾	5,517 lbs	PASS
Base Shear	6,831 lbs	4,932 lbs	PASS
Overturning Moment	3,183 in-kips	2,256 in-kips	PASS

Notes:

- 5. Original design axial force per BL Companies structural design report, dated 07/31/20.

CONCLUSIONS:

In conclusion, our analysis indicates the 49.5'± monopole tower structure located at 951 Bank Street in New London, Connecticut meets the requirements of the 2021 International Building Code (IBC), as amended by the 2022 Connecticut State Building Code, and the ANSI/TIA-222-H standard with Verizon's proposed equipment modification.

Sincerely,
All-Points Technology Corp. P.C.



Michael S. Trodden, P.E.
Senior Structural Engineer



Prepared by:
All-Points Technology Corp. P.C.



Domenic Aversa, PE
Senior Structural Engineer

LIMITATIONS:

This report is based on the following:

1. Tower/structure is properly installed and maintained.
2. All members and components are in a non-deteriorated condition.
3. All required members are in place.
4. All bolts are in place and are properly tightened.
5. Tower/structure is in plumb condition.
6. All tower members were properly designed, detailed, fabricated, and installed and have been properly maintained since erection.
7. Material yield stress values as follows:
 - Monopole: 65 ksi
 - Base plate: 50 ksi
 - Anchor bolts: 105 ksi

All-Points Technology Corporation, P.C. (APT) is not responsible for any modifications completed prior to or hereafter which APT is not or was not directly involved. Modifications include but are not limited to:

1. Replacing or reinforcing bracing members.
2. Reinforcing members in any manner.
3. Adding or relocating antennas.
4. Installing antenna mounts or waveguide cables.
5. Extending tower.

APT hereby states that this document represents the entire report and that it assumes no liability for any factual changes that may occur after the date of this report. All representations, recommendations, and conclusions are based upon the information contained and set forth herein. If you are aware of any information which conflicts with that which is contained herein, or you are aware of any defects arising from original design, material, fabrication, or erection deficiencies, you should disregard this report and immediately contact APT. APT disclaims all liability for any representation, recommendation, or conclusion not expressly stated herein.

Appendix A

Design Criteria

Municipality	Basic Design Wind Speeds, V (mph)				Allowable Stress Design Wind Speeds, V_{asd} (mph)				Ground Snow Load P_g (psf)	MCE Ground Accelerations		Wind-Borne Debris Region ¹		Hurricane- Prone Region
	Risk Cat. I	Risk Cat. II	Risk Cat. III	Risk Cat. IV	Risk Cat. I	Risk Cat. II	Risk Cat. III	Risk Cat. IV		S_S (g)	S_I (g)	Risk Cat. III Occup. I-2	Risk Cat. IV	
Hampton	115	125	130	135	89	97	101	105	35	0.184	0.054		Yes	
Hartford	110	120	130	135	85	93	101	105	30	0.189	0.055		Yes	
Hartland	110	115	125	130	85	89	97	101	35	0.167	0.054			
Harwinton	110	120	125	130	85	93	97	101	35	0.177	0.054		Yes	
Hebron	115	125	130	135	89	97	101	105	30	0.200	0.055		Yes	
Kent	105	115	125	130	81	89	97	101	40	0.184	0.054			
Killingly	115	125	135	140	89	97	105	108	35	0.186	0.055		Yes	
Killingworth	115	125	135	140	89	97	105	108	30	0.210	0.055		Yes	
Lebanon	115	125	135	135	89	97	105	105	30	0.196	0.055		Yes	
Ledyard	120	130	140	140	93	101	108	108	30	0.190	0.053		Yes	
Lisbon	115	125	135	140	89	97	105	108	30	0.190	0.054		Yes	
Litchfield	110	115	125	130	85	89	97	101	35	0.178	0.054			
Lyme	115	125	135	140	89	97	105	108	30	0.207	0.054		Yes	
Madison	115	125	135	140	89	97	105	108	30	0.206	0.054	Type B	Yes	
Manchester	110	120	130	135	85	93	101	105	30	0.190	0.055		Yes	
Mansfield	110	120	130	135	85	93	101	105	35	0.186	0.055		Yes	
Marlborough	110	125	130	135	85	97	101	105	30	0.205	0.056		Yes	
Meriden	110	120	130	135	85	93	101	105	30	0.203	0.055		Yes	
Middlebury	110	120	130	130	85	93	101	101	35	0.194	0.054		Yes	
Middlefield	110	120	130	135	85	93	101	105	30	0.209	0.055		Yes	
Middletown	110	120	130	135	85	93	101	105	30	0.209	0.056		Yes	
Milford	110	120	130	135	85	93	101	105	30	0.202	0.053	Type B	Yes	
Monroe	110	120	130	135	85	93	101	105	30	0.208	0.055		Yes	
Montville	120	125	135	140	93	97	105	108	30	0.198	0.054		Yes	
Morris	110	115	125	130	85	89	97	101	35	0.182	0.054			
Naugatuck	110	120	130	135	85	93	101	105	30	0.197	0.054		Yes	
New Britain	110	120	130	135	85	93	101	105	30	0.195	0.055		Yes	
New Canaan	110	120	130	135	85	93	101	105	30	0.252	0.058		Yes	
New Fairfield	110	115	125	130	85	89	97	101	30	0.219	0.056			
New Hartford	110	115	125	130	85	89	97	101	35	0.172	0.054			
New Haven	110	125	130	135	85	97	101	105	30	0.201	0.054	Type B	Yes	
New London	120	130	140	140	93	101	108	108	30	0.191	0.053	Type B Type A	Yes Yes	

ASCE 7 Hazards Report

Address:
No Address at This Location

Standard: ASCE/SEI 7-16
Risk Category: II
Soil Class: undefined

Latitude: 41.346252
Longitude: -72.112351
Elevation: 112.18192742512339 ft
(NAVD 88)

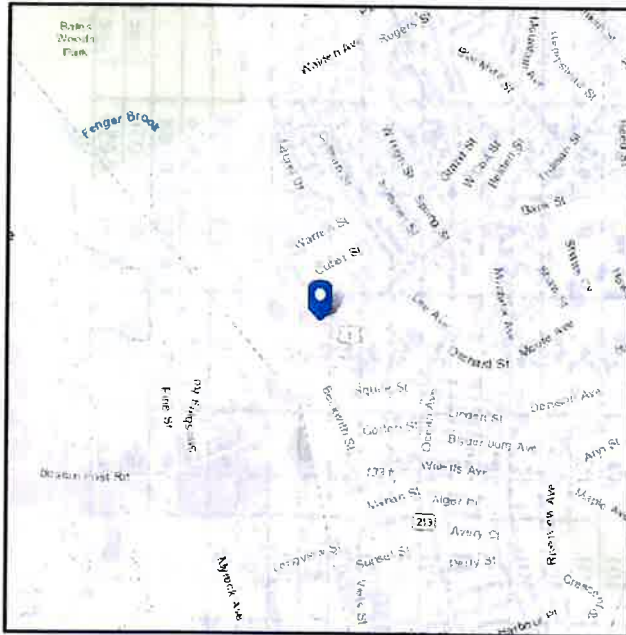

Wind

Results:

Wind Speed	127 Vmph
10-year MRI	76 Vmph
25-year MRI	86 Vmph
50-year MRI	98 Vmph
100-year MRI	104 Vmph

Data Source: ASCE/SEI 7-16, Fig. 26.5-1B and Figs. CC.2-1–CC.2-4, and Section 26.5.2
Date Accessed: Mon Jul 31 2023

Value provided is 3-second gust wind speeds at 33 ft above ground for Exposure C Category, based on linear interpolation between contours. Wind speeds are interpolated in accordance with the 7-16 Standard. Wind speeds correspond to approximately a 7% probability of exceedance in 50 years (annual exceedance probability = 0.00143, MRI = 700 years).

Site is in a hurricane-prone region as defined in ASCE/SEI 7-16 Section 26.2. Glazed openings need not be protected against wind-borne debris.

Results:

Ice Thickness: 1.00 in.

Concurrent Temperature: 15 F

Gust Speed 50 mph

Data Source: Standard ASCE/SEI 7-16, Figs. 10-2 through 10-8

Date Accessed: Mon Jun 26 2023

Ice thicknesses on structures in exposed locations at elevations higher than the surrounding terrain and in valleys and gorges may exceed the mapped values.

Values provided are equivalent radial ice thicknesses due to freezing rain with concurrent 3-second gust speeds, for a 500-year mean recurrence interval, and temperatures concurrent with ice thicknesses due to freezing rain. Thicknesses for ice accretions caused by other sources shall be obtained from local meteorological studies. Ice thicknesses in exposed locations at elevations higher than the surrounding terrain and in valleys and gorges may exceed the mapped values.

The ASCE 7 Hazard Tool is provided for your convenience, for informational purposes only, and is provided "as is" and without warranties of any kind. The location data included herein has been obtained from information developed, produced, and maintained by third party providers; or has been extrapolated from maps incorporated in the ASCE 7 standard. While ASCE has made every effort to use data obtained from reliable sources or methodologies, ASCE does not make any representations or warranties as to the accuracy, completeness, reliability, currency, or quality of any data provided herein. Any third-party links provided by this Tool should not be construed as an endorsement, affiliation, relationship, or sponsorship of such third-party content by or from ASCE.

ASCE does not intend, nor should anyone interpret, the results provided by this Tool to replace the sound judgment of a competent professional, having knowledge and experience in the appropriate field(s) of practice, nor to substitute for the standard of care required of such professionals in interpreting and applying the contents of this Tool or the ASCE 7 standard.

In using this Tool, you expressly assume all risks associated with your use. Under no circumstances shall ASCE or its officers, directors, employees, members, affiliates, or agents be liable to you or any other person for any direct, indirect, special, incidental, or consequential damages arising from or related to your use of, or reliance on, the Tool or any information obtained therein. To the fullest extent permitted by law, you agree to release and hold harmless ASCE from any and all liability of any nature arising out of or resulting from any use of data provided by the ASCE 7 Hazard Tool.

Appendix B

Tower Schematic

72.5 ft

Section	1
Length (ft)	49.50
Number of Sides	18
Thickness (in)	0.1880
Top Dia (in)	12.5000
Bot Dia (in)	20.0000
Grade	A572-65
Weight (lb)	1614.4

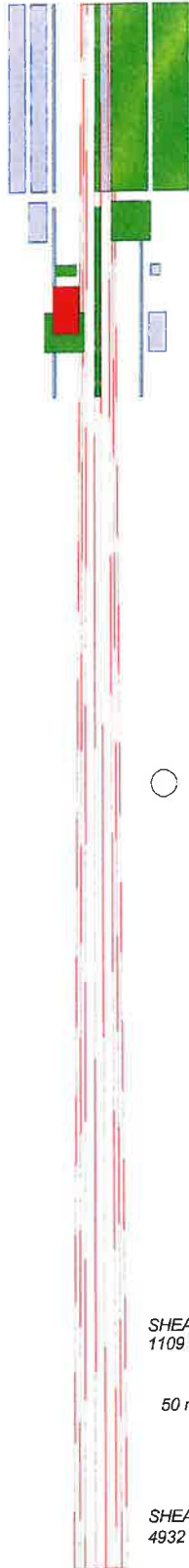

DESIGNED APPURTENANCE LOADING

TYPE	ELEVATION	TYPE	ELEVATION
SitePRO1 UDS-NP (Verizon)	71.38	Commscope CBC1923Q-43 Quad Diplexer (Verizon)	64
JAHH-65-R3B (Verizon)	69.5	Commscope CBC1923Q-43 Quad Diplexer (Verizon)	64
JAHH-65-R3B (Verizon)	69.5	(2) P2.0 x 7.0' Pipe Mount (Verizon)	63
JAHH-65-R3B (Verizon)	69.5	(2) P2.0 x 7.0' Pipe Mount (Verizon)	63
JAHH-65-R3B (Verizon)	69.5	(2) P2.0 x 7.0' Pipe Mount (Verizon)	63
(2) P2.5 Std x 6.5' Pipe Mount (Verizon)	69.5	(2) KA-6030 (Verizon)	62
(2) P2.5 Std x 6.5' Pipe Mount (Verizon)	69.5	Samsung B5/B13 700/850 RRH (Verizon)	62
(2) P2.5 Std x 6.5' Pipe Mount (Verizon)	69.5	Samsung B5/B13 700/850 RRH (Verizon)	62
JAHH-65-R3B (Verizon)	69.5	Samsung B5/B13 700/850 RRH (Verizon)	62
SitePRO1 UDS-NP (Verizon)	67.63	Raycap RDC-6627-PF-48 OVP (Verizon)	62
Samsung B2/B66 PCS/AWS RRH (Verizon)	65.5	Samsung B5/B13 700/850 RRH (Verizon)	62
Samsung B2/B66 PCS/AWS RRH (Verizon)	65.5	UWS6-NP - No Pipes (Verizon)	61.42
Samsung B2/B66 PCS/AWS RRH (Verizon)	65.5		
UWS6-NP - No Pipes (Verizon)	65.21		
Commscope CBC1923Q-43 Quad Diplexer (Verizon)	64		

MATERIAL STRENGTH

GRADE	Fy	Fu	GRADE	Fy	Fu
A572-65	65 ksi	80 ksi			

TOWER DESIGN NOTES

1. Tower designed for Exposure C to the TIA-222-H Standard.
2. Tower designed for a 130 mph basic wind in accordance with the TIA-222-H Standard.
3. Tower is also designed for a 50 mph basic wind with 1.00 in ice. Ice is considered to increase in thickness with height.
4. Deflections are based upon a 60 mph wind.
5. Tower Risk Category II.
6. Topographic Category 1 with Crest Height of 0.00 ft
7. TOWER RATING: 60.2%

ALL REACTIONS ARE FACTORED

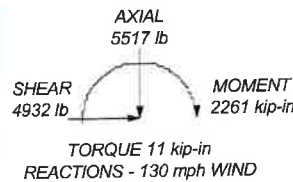
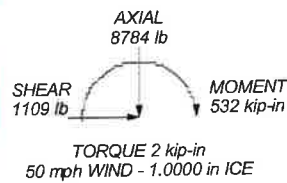

All-Points Technology Corporation, P.C.
 567 Vauxhall Street Ext., Suite 311
 Waterford, CT 06385
 Phone: (860) 663-1697
 FAX:

Job: 49.5' Rooftop-Mounted Monopole		
Project: CT141 14070 New London		
Client: Verizon Wireless	Drawn by: JRM	App'd:
Code: TIA-222-H	Date: 09/25/23	Scale: NTS
Path:		Dwg No. E-1

Appendix C

Calculations

tnxTower All-Points Technology Corporation, P.C. 567 Vauxhall Street Ext., Suite 311 Waterford, CT 06385 Phone: (860) 663-1697 FAX:	Job 49.5' Rooftop-Mounted Monopole	Page 1 of 4
	Project CT141_14070 New London	Date 19:42:39 09/21/23
	Client Verizon Wireless	Designed by JRM

Tower Input Data

The tower is a monopole.

This tower is designed using the TIA-222-H standard.

The following design criteria apply:

Tower base elevation above sea level: 135.20 ft.

Basic wind speed of 130 mph.

Risk Category II.

Exposure Category C.

Simplified Topographic Factor Procedure for wind speed-up calculations is used.

Topographic Category: 1.

Crest Height: 0.00 ft.

Nominal ice thickness of 1.0000 in.

Ice thickness is considered to increase with height.

Ice density of 56 pcf.

A wind speed of 50 mph is used in combination with ice.

Temperature drop of 50 °F.

Deflections calculated using a wind speed of 60 mph.

A non-linear (P-delta) analysis was used.

Pressures are calculated at each section.

Stress ratio used in pole design is 1.

Local bending stresses due to climbing loads, feed line supports, and appurtenance mounts are not considered.

Monopole Base Plate Data

Base Plate Data	
Base plate is square	
Base plate is grouted	
Anchor bolt grade	F1554-105
Anchor bolt size	1.2500 in
Number of bolts	10
Embedment length	12.0000 in
f_c	4 ksi
Grout space	0.0000 in
Base plate grade	A572-50
Base plate thickness	1.5000 in
Bolt circle diameter	25.2500 in
Outer diameter	29.0300 in
Inner diameter	13.6300 in
Base plate type	Plain Plate

Feed Line/Linear Appurtenances - Entered As Round Or Flat

Description	Sector	Exclude From Torque Calculation	Component Type	Placement ft	Total Number	Number Per Row	Start/End Position	Width or Diameter in	Perimeter in	Weight plf
Safety Line 3/8	C	No	Surface Ar (CaAa)	72.50 - 23.00	1	1	0.000 0.000	0.3750		0.22

tnxTower All-Points Technology Corporation, P.C. 567 Vauxhall Street Ext., Suite 311 Waterford, CT 06385 Phone: (860) 663-1697 FAX:	Job 49.5' Rooftop-Mounted Monopole	Page 2 of 4
	Project CT141_14070 New London	Date 19:42:39 09/21/23
	Client Verizon Wireless	Designed by JRM

Feed Line/Linear Appurtenances - Entered As Area

Description	Face or Leg	Allow Shield	Exclude From Torque Calculation	Component Type	Placement ft	Total Number		C _A A _A ft ² /ft	Weight plf
HB158-U12S24-xxx -LI (Verizon)	C	No	No	Inside Pole	51.50 - 23.00	2	No Ice	0.00	3.20
							1/2" Ice	0.00	3.20
							1" Ice	0.00	3.20

Discrete Tower Loads

Description	Face or Leg	Offset Type	Offsets: Horz Lateral Vert ft ft ft	Azimuth Adjustment °	Placement ft		C _A A _A Front ft ²	C _A A _A Side ft ²	Weight K
JAHH-65-R3B (Verizon)	A	From Face	1.00	0.0000	69.50	No Ice	9.11	5.98	0.06
			-2.33			1/2" Ice	9.58	6.44	0.12
			0.00			1" Ice	10.05	6.91	0.19
JAHH-65-R3B (Verizon)	B	From Face	1.00	0.0000	69.50	No Ice	9.11	5.98	0.06
			-2.33			1/2" Ice	9.58	6.44	0.12
			0.00			1" Ice	10.05	6.91	0.19
JAHH-65-R3B (Verizon)	C	From Face	1.00	0.0000	69.50	No Ice	9.11	5.98	0.06
			-2.33			1/2" Ice	9.58	6.44	0.12
			0.00			1" Ice	10.05	6.91	0.19
JAHH-65-R3B (Verizon)	A	From Face	1.00	0.0000	69.50	No Ice	9.11	5.98	0.06
			-1.00			1/2" Ice	9.58	6.44	0.12
			0.00			1" Ice	10.05	6.91	0.19
JAHH-65-R3B (Verizon)	B	From Face	1.00	0.0000	69.50	No Ice	9.11	5.98	0.06
			-1.00			1/2" Ice	9.58	6.44	0.12
			0.00			1" Ice	10.05	6.91	0.19
JAHH-65-R3B (Verizon)	C	From Face	1.00	0.0000	69.50	No Ice	9.11	5.98	0.06
			-1.00			1/2" Ice	9.58	6.44	0.12
			0.00			1" Ice	10.05	6.91	0.19
(2) P2.5 Std x 6.5' Pipe Mount (Verizon)	A	From Face	1.00	0.0000	69.50	No Ice	1.87	1.87	0.04
			0.00			1/2" Ice	2.33	2.33	0.05
			0.00			1" Ice	2.73	2.73	0.07
(2) P2.5 Std x 6.5' Pipe Mount (Verizon)	B	From Face	1.00	0.0000	69.50	No Ice	1.87	1.87	0.04
			0.00			1/2" Ice	2.33	2.33	0.05
			0.00			1" Ice	2.73	2.73	0.07
(2) P2.5 Std x 6.5' Pipe Mount (Verizon)	C	From Face	1.00	0.0000	69.50	No Ice	1.87	1.87	0.04
			0.00			1/2" Ice	2.33	2.33	0.05
			0.00			1" Ice	2.73	2.73	0.07
SitePRO1 UDS-NP (Verizon)	C	From Face	1.00	0.0000	71.38	No Ice	4.24	4.18	0.40
			0.00			1/2" Ice	5.14	5.04	0.46
			0.00			1" Ice	6.11	5.98	0.53
SitePRO1 UDS-NP (Verizon)	C	From Face	1.00	0.0000	67.63	No Ice	4.24	4.18	0.40
			0.00			1/2" Ice	5.14	5.04	0.46
			0.00			1" Ice	6.11	5.98	0.53
Samsung B5/B13 700/850 RRH (Verizon)	A	From Face	1.00	0.0000	62.00	No Ice	1.88	1.01	0.08
			1.00			1/2" Ice	2.05	1.14	0.10
			0.00			1" Ice	2.22	1.28	0.12
Samsung B5/B13 700/850 RRH (Verizon)	B	From Face	1.00	0.0000	62.00	No Ice	1.88	1.01	0.08
			1.00			1/2" Ice	2.05	1.14	0.10
			0.00			1" Ice	2.22	1.28	0.12
Samsung B5/B13 700/850	C	From Face	1.00	0.0000	62.00	No Ice	1.88	1.01	0.08

tnxTower All-Points Technology Corporation, P.C. 567 Vauxhall Street Ext., Suite 311 Waterford, CT 06385 Phone: (860) 663-1697 FAX:	Job 49.5' Rooftop-Mounted Monopole	Page 3 of 4
	Project CT141_14070 New London	Date 19:42:39 09/21/23
	Client Verizon Wireless	Designed by JRM

Description	Face or Leg	Offset Type	Offsets:		Azimuth Adjustment	Placement	C _{AA} Front	C _{AA} Side	Weight
			Horz	Lateral					
			Vert						
			ft	ft	°	ft	ft ²	ft ²	K
RRH			1.00			1/2" Ice	2.05	1.14	0.10
(Verizon)			0.00			1" Ice	2.22	1.28	0.12
Samsung B2/B66 PCS/AWS	A	From Face	1.00	0.0000	65.50	No Ice	1.88	1.25	0.10
RRH			-1.00			1/2" Ice	2.05	1.39	0.12
(Verizon)			0.00			1" Ice	2.22	1.54	0.14
Samsung B2/B66 PCS/AWS	B	From Face	1.00	0.0000	65.50	No Ice	1.88	1.25	0.10
RRH			-1.00			1/2" Ice	2.05	1.39	0.12
(Verizon)			0.00			1" Ice	2.22	1.54	0.14
Samsung B2/B66 PCS/AWS	C	From Face	1.00	0.0000	65.50	No Ice	1.88	1.25	0.10
RRH			-1.00			1/2" Ice	2.05	1.39	0.12
(Verizon)			0.00			1" Ice	2.22	1.54	0.14
Commscope CBC1923Q-43	A	From Face	1.00	0.0000	64.00	No Ice	0.32	0.13	0.01
Quad Diplexer			1.00			1/2" Ice	0.39	0.17	0.01
(Verizon)			0.00			1" Ice	0.48	0.23	0.01
Commscope CBC1923Q-43	B	From Face	1.00	0.0000	64.00	No Ice	0.32	0.13	0.01
Quad Diplexer			1.00			1/2" Ice	0.39	0.17	0.01
(Verizon)			0.00			1" Ice	0.48	0.23	0.01
Commscope CBC1923Q-43	C	From Face	1.00	0.0000	64.00	No Ice	0.32	0.13	0.01
Quad Diplexer			1.00			1/2" Ice	0.39	0.17	0.01
(Verizon)			0.00			1" Ice	0.48	0.23	0.01
Raycap RDC-6627-PF-48	C	From Face	1.00	0.0000	62.00	No Ice	4.06	3.10	0.03
OVP			1.00			1/2" Ice	4.32	3.34	0.07
(Verizon)			0.00			1" Ice	4.58	3.58	0.11
(2) KA-6030	A	From Face	1.00	0.0000	62.00	No Ice	0.96	0.29	0.02
(Verizon)			-1.00			1/2" Ice	1.09	0.37	0.02
			0.00			1" Ice	1.22	0.45	0.03
(2) P2.5 Std x 6.5' Pipe	A	From Face	1.00	0.0000	63.00	No Ice	1.87	1.87	0.04
Mount			0.00			1/2" Ice	2.33	2.33	0.05
(Verizon)			0.00			1" Ice	2.73	2.73	0.07
(2) P2.5 Std x 6.5' Pipe	B	From Face	1.00	0.0000	63.00	No Ice	1.87	1.87	0.04
Mount			0.00			1/2" Ice	2.33	2.33	0.05
(Verizon)			0.00			1" Ice	2.73	2.73	0.07
(2) P2.5 Std x 6.5' Pipe	C	From Face	1.00	0.0000	63.00	No Ice	1.87	1.87	0.04
Mount			0.00			1/2" Ice	2.33	2.33	0.05
(Verizon)			0.00			1" Ice	2.73	2.73	0.07
UWS6-NP - No Pipes	C	From Face	1.00	0.0000	65.21	No Ice	3.09	3.09	0.29
(Verizon)			0.00			1/2" Ice	4.25	4.25	0.33
			0.00			1" Ice	5.51	5.51	0.40
UWS6-NP - No Pipes	C	From Face	1.00	0.0000	61.42	No Ice	3.09	3.09	0.29
(Verizon)			0.00			1/2" Ice	4.25	4.25	0.33
			0.00			1" Ice	5.51	5.51	0.40

Base Plate Design Data

Plate Thickness	Number of Anchor Bolts	Anchor Bolt Size	Actual Allowable Ratio Bolt Tension K	Actual Allowable Ratio Concrete Stress ksi	Actual Allowable Ratio Plate Stress ksi	Actual Allowable Ratio Stiffener Stress ksi	Controlling Condition	Critical Ratio
in		in						
1.5000	10	1.2500	26.71	1.508	27.325		Plate	0.61
			90.85	4.080	45.000			✓
			0.29	0.37	0.61			

tnxTower All-Points Technology Corporation, P.C. 567 Vauxhall Street Ext., Suite 311 Waterford, CT 06385 Phone: (860) 663-1697 FAX:	Job 49.5' Rooftop-Mounted Monopole	Page 4 of 4
	Project CT141_14070 New London	Date 19:42:39 09/21/23
	Client Verizon Wireless	Designed by JRM

Section Capacity Table

Section No.	Elevation ft	Component Type	Size	Critical Element	P K	$\emptyset P_{allow}$ K	% Capacity	Pass Fail	
L1	72.5 - 23	Pole	TP20x12.5x0.188	1	-5.58	691.59	55.5	Pass	
							Summary		
							Pole (L1)	55.5	Pass
							Base Plate	60.7	Pass
							RATING =	60.7	Pass

Program Version 8.1.1.0 - 6/3/2021 File:Z:/Shared/CT office/APT Files/VZ NE - 141 All Sites (fka CT)/New London Relo CT/New London (Filter Add) - CT141_14070/Engineering/Resources/Structure/Tower SA/Rev 0/tnxtower/New London CT.eri



**MOUNT ANALYSIS REPORT
49.5'± ROOFTOP MOUNTED MONOPOLE TOWER
NEW LONDON, CONNECTICUT**

Prepared for
Verizon Wireless



**Verizon Site Ref:
469376; New London CT**

Site Address: 951 Bank Street, New London, CT 06320
FUZE ID: 17123887
BZ PSCL: 469376
VZ Location ID: 5000247672
Project Type: Filter Add

APT Filing No. CT141_14070

Rev 0: September 25, 2023



MOUNT ANALYSIS REPORT
49.5'± ROOFTOP MOUNTED MONOPOLE TOWER
NEW LONDON, CONNECTICUT
prepared for
Verizon Wireless

EXECUTIVE SUMMARY:

All-Points Technology Corporation, P.C. (APT) performed a structural analysis of an existing antenna mount assembly to support a proposed Verizon equipment installation. This evaluation was limited to the proposed mount assembly and its connection to the existing host tower structure.

The proposed Verizon installation consists of two (2) new Kaelus mitigation filters installed on an existing ring mount. The proposed Verizon equipment shall be fed by the existing cables routed within the host tower. Additional reference can be made to the table on the following page.

The results of this analysis indicate that the existing antenna mount assembly meets the requirements of the 2021 International Building Code (IBC), as amended by the 2022 Connecticut State Building Code, and the ANSI/TIA-222-H standard with Verizon's proposed equipment installation.

The mount assembly component usage is summarized in the table below:

Mount Assembly Component	Usage (%)
Members (Tube Standoff Arm)	19%
Connection (Plate)	15%

INTRODUCTION:

A structural analysis of the existing antenna mount assembly was performed by APT for the purpose of supporting the proposed Verizon Wireless equipment installation. The subject host structure is a rooftop-mounted monopole tower designed by Valmont located at 951 Bank Street in New London, Connecticut.

The following information was utilized in the preparation of this analysis:

- Construction Drawings prepared by APT (APT Project No. CT141_14070), marked Rev 1, dated September 25, 2023.
- Assembly Drawings for the Monopole Antenna Mount (P/N: UWS6-NP) prepared by SitePro1., dated January 5, 2012.

The analysis was conducted using the following antenna inventory (proposed equipment shown in **bold** text):

Carrier	Antenna and Appurtenance Make/Model	Elevation	Status	Mount Type
Verizon	(6) Commscope JAHH-65B-R3B panel antennas ²	69.5' ±	ETR	Six (6) SitePro1 T-Arm (P/N UDS-NP) & six (6) P2.5 STD x 6.5'L antenna mounting pipes.
	(3) Samsung B2/B66a (RF4439d-25A) ORAN RRHs, (3) Commscope CBC1923Q-43 Quad Diplexer	64' ±	ETR	(1) SitePro1 UWS6-NP Ring Mount & six (6) 2.0 STD x 7.0'L mounting pipes
	(3) Samsung B5/B13 (RF4440d-13A) ORAN RRHs, (2) Kaelus KA-6030 Filters	61' ±	ETR P	

Notes:

1. ETR = Existing to Remain; ERL = Existing to be Relocated; **P** = Proposed; F = Future; R= Reserved.
2. Mounted side-by-side on Commscope BSAMNT-SBS-2-2 bracket

STRUCTURAL ANALYSIS:

Antenna Frame Analysis Criteria:

The structural analysis has been prepared in accordance with the ANSI/TIA-222-H standard entitled "Structural Standard for Antenna Supporting Structures, Antennas and Small Wind Turbine Support Structures"; American Institute of Steel Construction (AISC) Manual of Steel Construction, and the 2021 International Building Code (IBC), as amended by the 2022 Connecticut State Building Code utilizing the following criteria:

- Load Case 1: 130 mph (3-second gust) wind speed
- Load Case 2: 50mph (3-second gust) wind speed w/ 1.00" ice thickness
- Risk Category: II
- Exposure Category: C
- Topographic Category 1

ANALYSIS RESULTS:

The analysis of the antenna mount assembly was conducted in accordance with the criteria outlined herein with the aforementioned proposed equipment loading. The following table summarizes the results of the analysis:

Mount Assembly Component	Usage (%)
Members (Tube Standoff Arm)	19%
Connection (Plate)	15%

CONCLUSIONS AND RECOMMENDATIONS:

In conclusion, we find that the existing mount assembly located at 951 Bank Street in New London, Connecticut meets the requirements of the 2021 International Building Code (IBC), as amended by the 2022 Connecticut State Building Code, and the ANSI/TIA-222-H standard under the proposed equipment loading.

Sincerely,
All-Points Technology Corp. P.C.

Michael S. Trodden, P.E.
Senior Structural Engineer



Prepared by:
All-Points Technology Corp. P.C.

Domenic Aversa, PE
Senior Structural Engineer

LIMITATIONS:

This report is based on the following:

1. Tower/structure is properly installed and maintained.
2. With the exception of the anchor bolts, all members are in a non-deteriorated condition.
3. All required members are in place.
4. All bolts are in place and are properly tightened.
5. Tower/structure is in plumb condition.
6. All tower members were properly designed, detailed, fabricated, and installed and have been properly maintained since erection.
7. Mount Assembly material yield stress values as follows:
 - Tubes: ASTM A500 Gr. B (46 KSI)
 - Pipes: ASTM A53 Gr. B (35 KSI)
 - End Connection Plates: ASTM A572 Gr. 50 (50 KSI)
 - Misc. Steel: ASTM A36 (36 KSI)

All-Points Technology Corporation, P.C. (APT) is not responsible for any modifications completed prior to or hereafter which APT is not or was not directly involved. Modifications include but are not limited to:

1. Replacing or reinforcing bracing members.
2. Reinforcing members in any manner.
3. Installing antenna mounts.
4. Extending tower/structure.

APT hereby states that this document represents the entire report and that it assumes no liability for any factual changes that may occur after the date of this report. All representations, recommendations, and conclusions are based upon the information contained and set forth herein. If you are aware of any information which is contrary to that which is contained herein, or you are aware of any defects arising from the original design, material, fabrication, and erection deficiencies, you should disregard this report and immediately contact APT. APT disclaims all liability for any representation, recommendation, or conclusion not expressly stated herein.

Appendix A

Design Criteria

Municipality	Basic Design Wind Speeds, V (mph)				Allowable Stress Design Wind Speeds, V_{wind} (mph)				Ground Snow Load P_g (psf)	MCE Ground Accelerations		Wind-Borne Debris Region ¹		Hurricane- Prone Region
	Risk Cat. I	Risk Cat. II	Risk Cat. III	Risk Cat. IV	Risk Cat. I	Risk Cat. II	Risk Cat. III	Risk Cat. IV		S_S (g)	S_I (g)	Risk Cat. III Occup. I-2	Risk Cat. IV	
Hampton	115	125	130	135	89	97	101	105	35	0.184	0.054		Yes	
Hartford	110	120	130	135	85	93	101	105	30	0.189	0.055		Yes	
Hartland	110	115	125	130	85	89	97	101	35	0.167	0.054			
Harwinton	110	120	125	130	85	93	97	101	35	0.177	0.054		Yes	
Hebron	115	125	130	135	89	97	101	105	30	0.200	0.055		Yes	
Kent	105	115	125	130	81	89	97	101	40	0.184	0.054			
Killingly	115	125	135	140	89	97	105	108	35	0.186	0.055		Yes	
Killingworth	115	125	135	140	89	97	105	108	30	0.210	0.055		Yes	
Lebanon	115	125	135	135	89	97	105	105	30	0.196	0.055		Yes	
Ledyard	120	130	140	140	93	101	108	108	30	0.190	0.053		Yes	
Lisbon	115	125	135	140	89	97	105	108	30	0.190	0.054		Yes	
Litchfield	110	115	125	130	85	89	97	101	35	0.178	0.054			
Lyme	115	125	135	140	89	97	105	108	30	0.207	0.054		Yes	
Madison	115	125	135	140	89	97	105	108	30	0.206	0.054	Type B	Yes	
Manchester	110	120	130	135	85	93	101	105	30	0.190	0.055		Yes	
Mansfield	110	120	130	135	85	93	101	105	35	0.186	0.055		Yes	
Marlborough	110	125	130	135	85	97	101	105	30	0.205	0.056		Yes	
Meriden	110	120	130	135	85	93	101	105	30	0.203	0.055		Yes	
Middlebury	110	120	130	130	85	93	101	101	35	0.194	0.054		Yes	
Middlefield	110	120	130	135	85	93	101	105	30	0.209	0.055		Yes	
Middletown	110	120	130	135	85	93	101	105	30	0.209	0.056		Yes	
Milford	110	120	130	135	85	93	101	105	30	0.202	0.053	Type B	Yes	
Monroe	110	120	130	135	85	93	101	105	30	0.208	0.055		Yes	
Montville	120	125	135	140	93	97	105	108	30	0.198	0.054		Yes	
Morris	110	115	125	130	85	89	97	101	35	0.182	0.054			
Naugatuck	110	120	130	135	85	93	101	105	30	0.197	0.054		Yes	
New Britain	110	120	130	135	85	93	101	105	30	0.195	0.055		Yes	
New Canaan	110	120	130	135	85	93	101	105	30	0.252	0.058		Yes	
New Fairfield	110	115	125	130	85	89	97	101	30	0.219	0.056			
New Hartford	110	115	125	130	85	89	97	101	35	0.172	0.054			
New Haven	110	125	130	135	85	97	101	105	30	0.201	0.054	Type B	Yes	
New London	120	130	140	140	93	101	108	108	30	0.191	0.053	Type B Type A	Yes Yes	



ASCE 7 Hazards Report

Address:
No Address at This Location

Standard: ASCE/SEI 7-16
Risk Category: II
Soil Class: undefined

Latitude: 41.346252
Longitude: -72.112351
Elevation: 112.18192742512339 ft (NAVD 88)

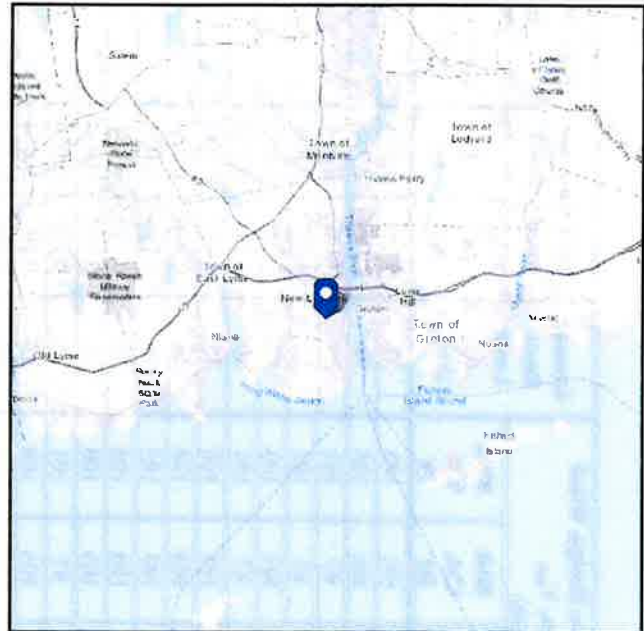
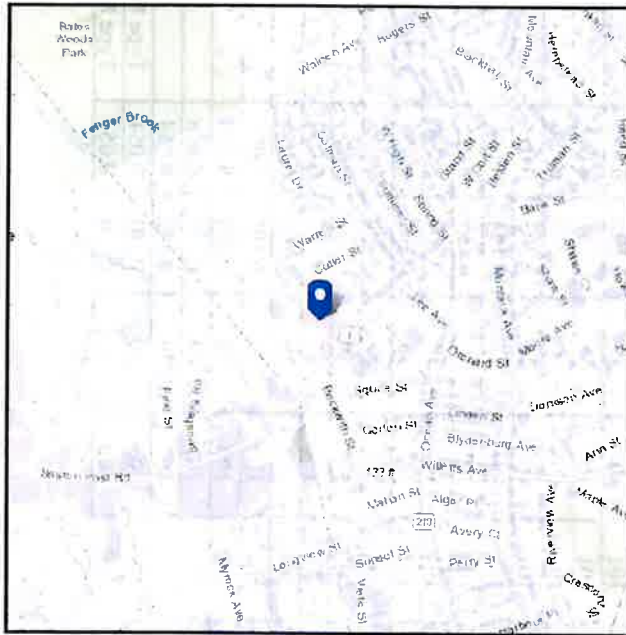

Wind

Results:

Wind Speed	127 Vmph
10-year MRI	76 Vmph
25-year MRI	86 Vmph
50-year MRI	98 Vmph
100-year MRI	104 Vmph

Data Source: ASCE/SEI 7-16, Fig. 26.5-1B and Figs. CC.2-1–CC.2-4, and Section 26.5.2

Date Accessed: Mon Jul 31 2023

Value provided is 3-second gust wind speeds at 33 ft above ground for Exposure C Category, based on linear interpolation between contours. Wind speeds are interpolated in accordance with the 7-16 Standard. Wind speeds correspond to approximately a 7% probability of exceedance in 50 years (annual exceedance probability = 0.00143, MRI = 700 years).

Site is in a hurricane-prone region as defined in ASCE/SEI 7-16 Section 26.2. Glazed openings need not be protected against wind-borne debris.



Ice

Results:

Ice Thickness: 1.00 in.
Concurrent Temperature: 15 F
Gust Speed 50 mph

Data Source: Standard ASCE/SEI 7-16, Figs. 10-2 through 10-8

Date Accessed: Mon Jul 31 2023

Ice thicknesses on structures in exposed locations at elevations higher than the surrounding terrain and in valleys and gorges may exceed the mapped values.

Values provided are equivalent radial ice thicknesses due to freezing rain with concurrent 3-second gust speeds, for a 500-year mean recurrence interval, and temperatures concurrent with ice thicknesses due to freezing rain. Thicknesses for ice accretions caused by other sources shall be obtained from local meteorological studies. Ice thicknesses in exposed locations at elevations higher than the surrounding terrain and in valleys and gorges may exceed the mapped values.

The ASCE 7 Hazard Tool is provided for your convenience, for informational purposes only, and is provided "as is" and without warranties of any kind. The location data included herein has been obtained from information developed, produced, and maintained by third party providers; or has been extrapolated from maps incorporated in the ASCE 7 standard. While ASCE has made every effort to use data obtained from reliable sources or methodologies, ASCE does not make any representations or warranties as to the accuracy, completeness, reliability, currency, or quality of any data provided herein. Any third-party links provided by this Tool should not be construed as an endorsement, affiliation, relationship, or sponsorship of such third-party content by or from ASCE.

ASCE does not intend, nor should anyone interpret, the results provided by this Tool to replace the sound judgment of a competent professional, having knowledge and experience in the appropriate field(s) of practice, nor to substitute for the standard of care required of such professionals in interpreting and applying the contents of this Tool or the ASCE 7 standard.

In using this Tool, you expressly assume all risks associated with your use. Under no circumstances shall ASCE or its officers, directors, employees, members, affiliates, or agents be liable to you or any other person for any direct, indirect, special, incidental, or consequential damages arising from or related to your use of, or reliance on, the Tool or any information obtained therein. To the fullest extent permitted by law, you agree to release and hold harmless ASCE from any and all liability of any nature arising out of or resulting from any use of data provided by the ASCE 7 Hazard Tool.

Appendix B

Mount Analysis



Project ID: CT141_14070
 Site Name: New London
 Date: 9/20/2023

(Based on ANSI/TIA-222-H)

<u>Site Name:</u>	New London
<u>Site Address:</u>	951 Bank Street New London, CT 06320
<u>Site County:</u>	Suffolk

Design Criteria

Risk Category =	II	Sect. 2.2 & Table 2-1
Exposure Category =	C	Section 2.6.5
Ultimate Design Wind Speed, V =	130 mph	Fig. B-2 & ASCE 7-16 Fig. 26.5-1B
Design Wind Speed with Ice, V _i =	50 mph	Fig. B-9
Design Ice Thickness, t _i =	1.00 in	Fig. B-9
Importance Factor, I =	1.00	Table 2-3
Basic Wind Speed, V _m =	30 mph	Section 16.3
Maintenance Load, L _m =	500.0 lbs	Section 16.3
Assembly Maintenance Load, L _v =	250.0 lbs	Section 16.3
Platform Maintenance Load, L _v =	30.0 psf	Section 12.4 (See note)

Note: Per Section 12.4, minimum factored load on platforms, including dead loads, shall be 37 psf over the working surface but not less than a normal factored load of 750 lbs. Consider 7 psf for grating dead load (unfactored) and 30 psf working load (unfactored) for conservative approach.

Wind Pressure Analysis:

$$q_z = 0.00256K_zK_{zt}K_sK_eK_dV^2$$

Section 2.6.11.6

K_z :

See Next Sheet

z_g = 900 Table 2-4

α = 9.5 Table 2-4

K_{zmin} = 0.85 Table 2-4

K_{zt} :

K_{zt} = 1.00 Section 2.6.6

K_s :

K_s = 1.00 Section 2.6.7

K_e :

K_e = 1.00 Section 2.6.8

K_d :

K_d = 0.95 Section 16.6

q_z' = 41.10 psf

q_{zi}' = 6.08 psf

q_{zm}' = 2.19 psf

$$F = q_z G_h (EPA)_A = q_z G_h K_a [(EPA)_N \cos^2(\theta) + (EPA)_T \sin^2(\theta)]$$

Section 2.6.11.2

G_h = 1.00 Section 16.6

K_a = 0.90 Section 16.6



Project ID: CT141_14070
 Site Name: New London
 Date: 9/20/2023

(Based on ANSI/TIA-222-H)

Rooftop Wind Speed-Up Factor (Section 2.6.7)

Building Information:

Building Height, $H = 23.0$ ft., +/- (Roof Height)
 Bulkhead/Parapet Height, $H_{ppt} = 0.00$ ft., +/- (max.)
 Largest Windward Face of Structure, $W_s = 275.0$ ft., +/-
 $H_s = 23.0$ ft
 $W_s/H_s = 0.08$

Rooftop Wind Speed-Up Factor Criteria:

Does the site meet the following conditions?:

Condition 1: The building is greater than 50ft [15m] in height and is isolated and unobstructed for a continuous 90 degree quadrant by other buildings of comparable height for a distance from the windward wall equal to 2,600ft [792m] or twenty times the building height, whichever is less.

NO

Condition 2: The building protrudes 50ft [15m] above the average height of immediately adjacent buildings in a continuous 90 degree quadrant.

NO

Rooftop Wind Speed-Up Factor Determination:

Antenna Centerline = 41.0 ft, +/-
 Height above roof, $z_r = 18.0$ ft
 $x_b = 50$ ft
 $H_1 = 10.0$ ft
 $H_2 = 23.0$ ft

$K_s = 1.00$

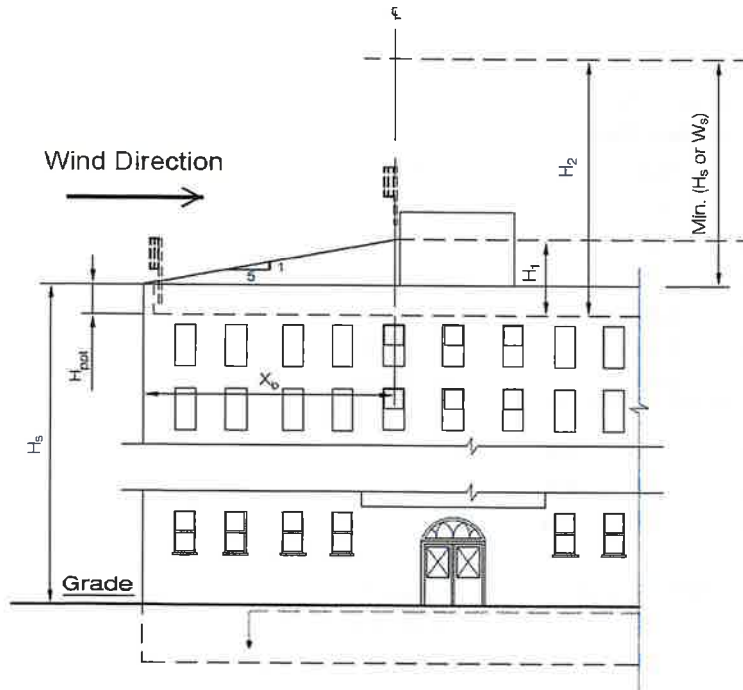



Design Criteria: (From Previous Sheet)
 Street 41.10 psf
 $q_b = 6.08$ psf
 $q_{sw} = 2.19$ psf
 $t_i = 1.00$ in

$G_s = 1.00$ Section 16.6
 $K_s = 0.90$ Section 16.6
 $Z_g = 900$ Table 2.4
 $d = 9.5$ Table 2.4
 $K_{dir} = 0.85$ Table 2.4
 $I = 1.00$ Table 2.3
 $K_{st} = 1.00$ Section 2.6.6

Description	Elev. z, ft	K_s	q_b , psf	Dimensions			Flat Panel Front Coefficient				Flat Panel Side Coefficient				Front Wind		Side Wind		
				Height, in	Width, in	Depth, in	Wght., lbs	Area, ft ²	Aspect Ratio	Ca	C_pA_s	Area, ft ²	Aspect Ratio	Ca	C_pA_s	Force, lbs	Weight, lbs	Force, lbs	Weight, lbs
B2/866A RRH-BR049	64.0	1.152	47.35	35.1	16.1	5.5	74.7	3.92	2.180	1.20	4.71	1.341	6.382	1.37	1.840	201.0	74.7	201.0	74.7
B13/85 RRH-BR04C	61.0	1.141	46.88	15.0	15.0	10.0	70.3	1.56	1.000	1.20	1.88	1.042	1.500	1.20	1.250	80.0	53.0	80.0	53.0
CBC/87-D5-43 Twin Triplexers	64.0	1.152	47.35	6.9	8.3	4.8	14.1	0.40	0.838	1.20	0.48	0.229	1.454	1.20	0.275	21.0	12.0	21.0	12.0
KA-6030	61.0	1.141	56.49	6.4	6.9	9.7	20.7	0.31	0.921	1.20	0.37	0.428	0.661	1.20	0.513	19.0	27.0	19.0	20.7

Description	z, ft	K_s	q_b , psf	Dimensions with Ice			Flat Panel Front Coefficient				Flat Panel Side Coefficient				Front Wind		Side Wind		
				Ice Thick., t_w , in	Height, in	Depth, in	Ice Wght., lbs	Area, ft ²	Aspect Ratio	Ca	C_pA_s	Area, ft ²	Aspect Ratio	Ca	C_pA_s	Force, lbs	Weight, lbs	Force, lbs	Weight, lbs
B2/866A RRH-BR049	64.0	1.152	7.005	1.07	37.24	17.01	73.2	4.72	2.19	0.70	3.301	1.975	2.19	0.70	1.382	21.0	9.0	21.0	347.9
B13/85 RRH-BR04C	61.0	1.141	6.934	1.06	17.13	18.03	35.4	2.04	0.95	0.70	1.426	1.442	0.95	0.70	1.010	9.0	7.0	9.0	105.7
CBC/87-D5-43 Twin Triplexers	64.0	1.152	7.005	1.07	9.07	9.54	40.5	0.66	0.95	0.70	0.459	0.434	0.95	0.70	0.304	3.0	2.0	3.0	24.6
KA-6030	61.0	1.141	6.934	1.06	8.51	11.88	11.9	0.54	0.72	0.70	0.375	0.696	0.72	0.70	0.487	3.0	4.0	3.0	32.6

Description	Elev. z, ft	K_s	q_b , psf	Dimensions			Flat Panel Front Coefficient				Flat Panel Side Coefficient				Front Wind		Side Wind		
				Height, in	Width, in	Depth, in	Wght., lbs	Area, ft ²	Aspect Ratio	Ca	C_pA_s	Area, ft ²	Aspect Ratio	Ca	C_pA_s	Force, lbs	Weight, lbs	Force, lbs	Weight, lbs
B2/866A RRH-BR049	64.0	1.152	2.52	35.1	16.1	5.5	74.7	3.92	2.180	1.20	4.71	1.341	6.382	1.37	1.840	11.0	5.0	11.0	74.7
B13/85 RRH-BR04C	61.0	1.141	2.50	15.0	15.0	10.0	70.3	1.56	1.000	1.20	1.88	1.042	1.500	1.20	1.250	5.0	3.0	5.0	70.3
CBC/87-D5-43 Twin Triplexers	64.0	1.152	2.52	6.9	8.3	4.8	14.1	0.40	0.838	1.20	0.48	0.229	1.454	1.20	0.275	2.0	1.0	2.0	14.109
KA-6030	61.0	1.141	2.50	6.4	6.9	9.7	20.7	0.31	0.921	1.20	0.37	0.428	0.661	1.20	0.513	1.0	2.0	1.0	20.72



Design Criteria: (From Previous Sheet)

Street **41.10 psf**
 q_{s1} = **6.08 psf**
 q_{s2} = **2.19 psf**
 q_1 = **1.00 in**

G_s = **1.00** Section 16.6
 K_s = **0.90** Section 16.6
 z_p = **900** Table 2-4
 α = **9.5** Table 2-4
 K_{min} = **0.85** Table 2-4

I = **1.00** Table 2-3
 K_{st} = **1.00** Section 2.6.6

Description	Elev. z, ft	K_s	q_{s1} , psf	Ice Thick., t_w , in	q_{s2} , psf	q_{s3} , psf	Dimensions			Loading, No Ice			With Ice			Maintenance			
							Width or Dib, in	Depth, in	Thickness, in	Flat or Round	Ca	Wind, lbs/ft	Width or Dia, in	Weight, lbs/ft	Dc, in	Ca	Wind, lbs/ft	Ca	Wind, lbs/ft
2' STD	62.0	1.144	47.04	1.07	5.96	2.50	2.380	0.154	3.66	ROUND	1.20	10.08	4.51	3.366	5.77	1.20	2.82	1.20	0.54
6" Plate	62.0	1.144	47.04	1.07	6.96	2.50	6.000	0.500	10.20	FLAT	2.00	42.33	8.13	6.021	9.22	2.00	8.49	2.00	2.25
HSS4x4	62.0	1.144	47.04	1.07	6.96	2.50	4.000	0.250	12.20	HSS	1.25	17.64	6.13	5.657	8.75	1.25	4.00	1.25	0.94

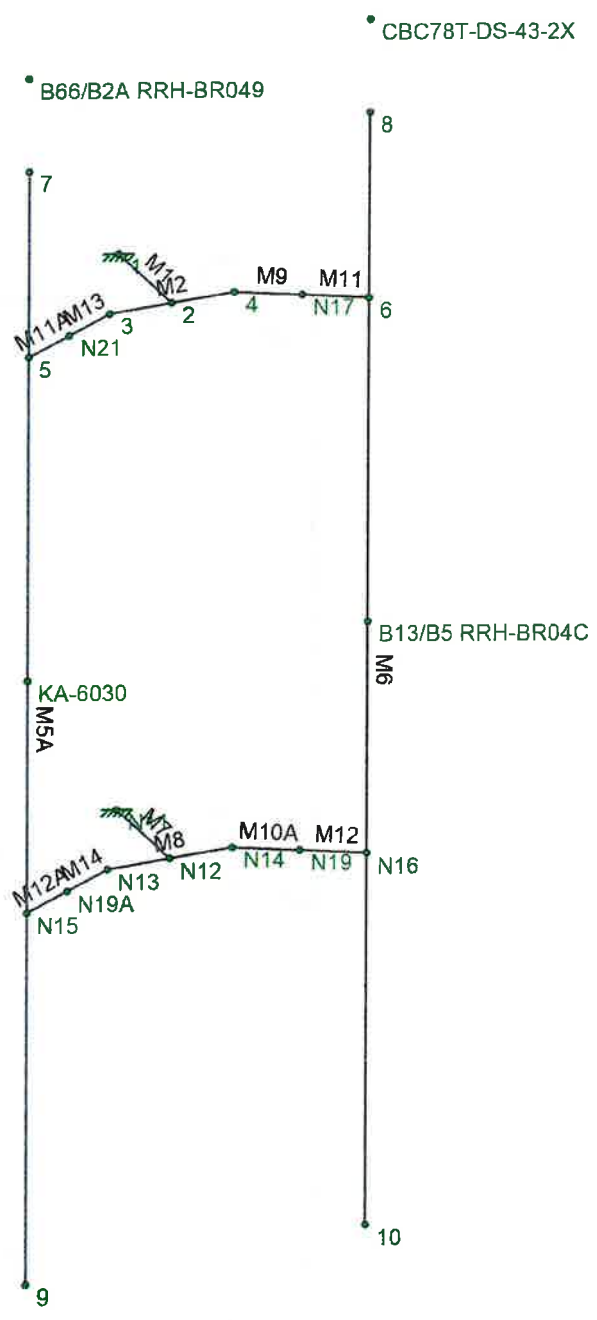
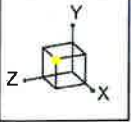

APT
 DJA
 New London

TYP Mount

SK-1
 Sep 20, 2023 at 05:57 PM
 CT141_14070 - New London...

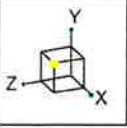

Code Check (Env)	
Black	No Calc
Red	> 1.0
Magenta	.90-1.0
Green	.75-.90
Cyan	.50-.75
Blue	0.-.50

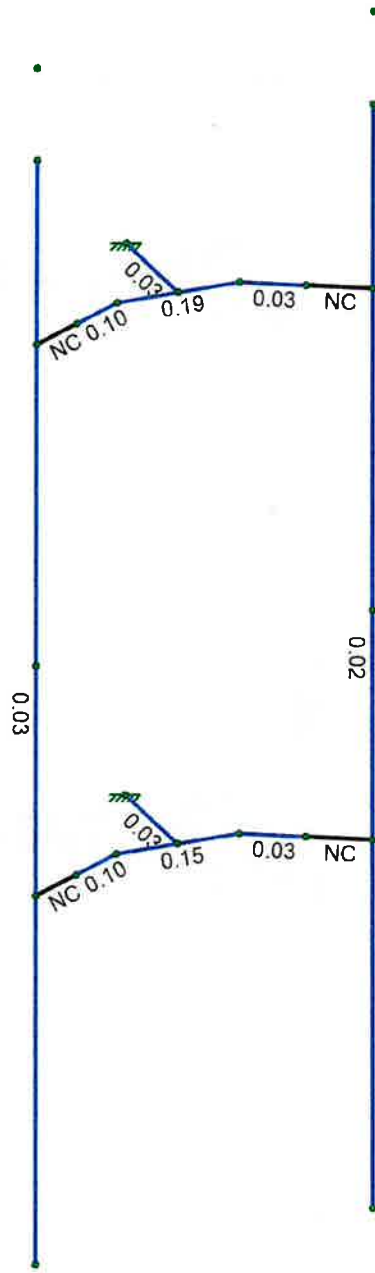

Member Code Checks Displayed (Enveloped)



APT
DJA
New London

TYP Mount

SK-2
Sep 20, 2023 at 05:57 PM
CT141_14070 - New London...



Company : APT
 Designer : DJA
 Job Number : New London
 Model Name : TYP Mount

9/20/2023
 5:58:29 PM
 Checked By :

Hot Rolled Steel Properties

	Label	E [ksi]	G [ksi]	Nu	Therm. Coeff. [1e ⁵ F ⁻¹]	Density [k/ft ³]	Yield [ksi]	Ry	Fu [ksi]	Rt
1	A992	29000	11154	0.3	0.65	0.49	50	1.1	65	1.1
2	A36 Gr.36	29000	11154	0.3	0.65	0.49	36	1.5	58	1.2
3	A572 Gr.50	29000	11154	0.3	0.65	0.49	50	1.1	65	1.1
4	A500 Gr.B RND	29000	11154	0.3	0.65	0.527	42	1.4	58	1.3
5	A500 Gr.B Rect	29000	11154	0.3	0.65	0.527	34	1.4	58	1.3
6	A53 Gr.B	29000	11154	0.3	0.65	0.49	35	1.6	60	1.2
7	A1085	29000	11154	0.3	0.65	0.49	50	1.4	65	1.3
8	Q235	29000	11154	0.3	0.65	0.527	34	1.5	58	1.2

Hot Rolled Steel Section Sets

	Label	Shape	Type	Design List	Material	Design Rule	Area [in ²]	Iyy [in ⁴]	Izz [in ⁴]	J [in ⁴]
1	2.5" STD	PIPE 2.5	Column	Pipe	A53 Gr.B	Typical	1.61	1.45	1.45	2.89
2	HSS4x4	HSS4X4X4	Beam	Tube	Q235	Typical	3.37	7.8	7.8	12.8
3	1/2" Plate	1/2X6	Beam	None	A36 Gr.36	Typical	3	9	0.063	0.237

Member Primary Data

	Label	I Node	J Node	Rotate(deg)	Section/Shape	Type	Design List	Material	Design Rule
1	M1	1	2		HSS4x4	Beam	Tube	Q235	Typical
2	M2	3	4	90	1/2" Plate	Beam	None	A36 Gr.36	Typical
3	M5A	7	9		2.5" STD	Column	Pipe	A53 Gr.B	Typical
4	M6	8	10		2.5" STD	Column	Pipe	A53 Gr.B	Typical
5	M7	N11	N12		HSS4x4	Beam	Tube	Q235	Typical
6	M8	N13	N14	90	1/2" Plate	Beam	None	A36 Gr.36	Typical
7	M9	4	N17	90	1/2" Plate	Beam	None	A36 Gr.36	Typical
8	M10A	N14	N19	90	1/2" Plate	Beam	None	A36 Gr.36	Typical
9	M11	N17	6		RIGID	None	None	RIGID	Typical
10	M12	N19	N16		RIGID	None	None	RIGID	Typical
11	M11A	N21	5		RIGID	None	None	RIGID	Typical
12	M12A	N19A	N15		RIGID	None	None	RIGID	Typical
13	M13	3	N21	90	1/2" Plate	Beam	None	A36 Gr.36	Typical
14	M14	N13	N19A	90	1/2" Plate	Beam	None	A36 Gr.36	Typical

Hot Rolled Steel Design Parameters

	Label	Shape	Length [in]	Lcomp top [in]	Channel Conn.	a [in]	Function
1	M1	HSS4x4	8	Lbyy	N/A	N/A	Lateral
2	M2	1/2" Plate	8.001	Lbyy	N/A	N/A	Lateral
3	M5A	2.5" STD	72		N/A	N/A	Lateral
4	M6	2.5" STD	72		N/A	N/A	Lateral
5	M7	HSS4x4	8	Lbyy	N/A	N/A	Lateral
6	M8	1/2" Plate	8.001	Lbyy	N/A	N/A	Lateral
7	M9	1/2" Plate	4	Lbyy	N/A	N/A	Lateral
8	M10A	1/2" Plate	4	Lbyy	N/A	N/A	Lateral
9	M13	1/2" Plate	4	Lbyy	N/A	N/A	Lateral
10	M14	1/2" Plate	4	Lbyy	N/A	N/A	Lateral

Basic Load Cases

	BLC Description	Category	Y Gravity	Point	Distributed
1	DL	DL	-1.05	4	
2	WLX	WLX		4	8



Company : APT
 Designer : DJA
 Job Number : New London
 Model Name : TYP Mount

9/20/2023
 5:58:29 PM
 Checked By :

Basic Load Cases (Continued)

	BLC Description	Category	Y Gravity	Point	Distributed
3	WLZ	WLZ		4	10
5	DLi	OL1		4	10
6	WLXi	WL+X		4	8
7	WLZi	WL+Z		4	10

Load Combinations

	Description	Solve	P-Delta	BLC	Factor	BLC	Factor	BLC	Factor	BLC	Factor
1	1.4DL	Yes	Y	DL	1.4						
2											
3	1.2DL + WLX	Yes	Y	DL	1.2	WLX	1				
4	1.2DL + 0.75WLX + 0.25WLZ	Yes	Y	DL	1.2	WLX	0.75	WLZ	0.25		
5	1.2DL + 0.25WLX + 0.75WLZ	Yes	Y	DL	1.2	WLX	0.25	WLZ	0.75		
6	1.2DL + WLZ	Yes	Y	DL	1.2	WLZ	1				
7	1.2DL + 0.25WL-X + 0.75WLZ	Yes	Y	DL	1.2	WLX	-0.25	WLZ	0.75		
8	1.2DL + 0.75WL-X + 0.25WLZ	Yes	Y	DL	1.2	WLX	-0.75	WLZ	0.25		
9	1.2DL + WL-X	Yes	Y	DL	1.2	WLX	-1				
10	1.2DL + 0.75WL-X + 0.25WL-Z	Yes	Y	DL	1.2	WLX	-0.75	WLZ	-0.25		
11	1.2DL + 0.25WL-X + 0.75WL-Z	Yes	Y	DL	1.2	WLX	-0.25	WLZ	-0.75		
12	1.2DL + WL-Z	Yes	Y	DL	1.2	WLZ	-1				
13	1.2DL + 0.25WLX + 0.75WL-Z	Yes	Y	DL	1.2	WLX	0.25	WLZ	-0.75		
14	1.2DL + 0.75WLX + 0.25WL-Z	Yes	Y	DL	1.2	WLX	0.75	WLZ	-0.25		
15											
16	1.2DL + DLi + WLXi	Yes	Y	DL	1.2	OL1	1	WL+X	1		
17	1.2DL + DLi + 0.75WLXi + 0.25WLZi	Yes	Y	DL	1.2	OL1	1	WL+X	0.75	WL+Z	0.25
18	1.2DL + DLi + 0.25WLXi + 0.75WLZi	Yes	Y	DL	1.2	OL1	1	WL+X	0.25	WL+Z	0.75
19	1.2DL + DLi + WLZi	Yes	Y	DL	1.2	OL1	1	WL+Z	1		
20	1.2DL + DLi + 0.25WL-Xi + 0.75WLZi	Yes	Y	DL	1.2	OL1	1	WL+X	-0.25	WL+Z	0.75
21	1.2DL + DLi + 0.75WL-Xi + 0.25WLZi	Yes	Y	DL	1.2	OL1	1	WL+X	-0.75	WL+Z	0.25
22	1.2DL + DLi + WL-Xi	Yes	Y	DL	1.2	OL1	1	WL+X	-1		
23	1.2DL + DLi + 0.75WL-Xi + 0.25WL-Zi	Yes	Y	DL	1.2	OL1	1	WL+X	-0.75	WL+Z	-0.25
24	1.2DL + DLi + 0.25WL-Xi + 0.75WL-Zi	Yes	Y	DL	1.2	OL1	1	WL+X	-0.25	WL+Z	-0.75
25	1.2DL + DLi + WL-Zi	Yes	Y	DL	1.2	OL1	1	WL+Z	-1		
26	1.2DL + DLi + 0.25WLXi + 0.75WL-Zi	Yes	Y	DL	1.2	OL1	1	WL+X	0.25	WL+Z	-0.75
27	1.2DL + DLi + 0.75WLXi + 0.25WL-Zi	Yes	Y	DL	1.2	OL1	1	WL+X	0.75	WL+Z	-0.25
28											

Envelope Node Reactions

Node Label	X [lb]	LC	Y [lb]	LC	Z [lb]	LC	MX [lb-ft]	LC	MY [lb-ft]	LC	MZ [lb-ft]	LC		
1	1	max	295.595	3	388.014	16	162.2	6	1.634	9	155.532	12	279.733	16
2		min	-348.471	9	162.277	9	-165.954	12	-57.344	19	-153.86	6	119.405	9
3	N11	max	251.694	3	392.512	22	181.501	6	0.714	12	165.266	12	280.008	25
4		min	-198.818	9	162.574	3	-177.746	12	-55.921	19	-167.276	6	114.023	3
5	Totals:	max	547.289	3	769.611	19	343.701	6						
6		min	-547.289	9	353.617	9	-343.701	12						

Node Reactions

LC	Node Label	X [lb]	Y [lb]	Z [lb]	MX [lb-ft]	MY [lb-ft]	MZ [lb-ft]
1	1	-30.838	206.102	-2.189	-4.889	1.079	145.989
2	1	30.838	206.451	2.189	-2.579	-1.079	146.267
3	1	Totals:	0	412.553	0		
4	1	COG (in):	X: 11.192	Y: -0.93	Z: 0.408		
5	3	1	295.595	191.043	0.688	-10.044	132.466

Node Reactions (Continued)

	LC	Node Label	X [lb]	Y [lb]	Z [lb]	MX [lb-ft]	MY [lb-ft]	MZ [lb-ft]
6	3	N11	251.694	162.574	-0.689	-4.057	87.701	114.023
7	3	Totals:	547.289	353.617	0			
8	3	COG (in):	X: 11.192	Y: -0.93	Z: 0.408			
9	4	1	215.104	187.772	41.064	-9.452	60.906	129.647
10	4	N11	195.362	165.844	44.861	-4.323	23.983	116.683
11	4	Totals:	410.466	353.617	85.925			
12	4	COG (in):	X: 11.192	Y: -0.93	Z: 0.408			
13	5	1	54.122	181.232	121.82	-8.273	-82.257	127.243
14	5	N11	82.7	172.385	135.955	-4.86	-103.505	122
15	5	Totals:	136.822	353.617	257.775			
16	5	COG (in):	X: 11.192	Y: -0.93	Z: 0.408			
17	6	1	-26.369	177.961	162.2	-7.687	-153.86	126.041
18	6	N11	26.369	175.655	181.501	-5.131	-167.276	124.658
19	6	Totals:	0	353.617	343.701			
20	6	COG (in):	X: 11.192	Y: -0.93	Z: 0.408			
21	7	1	-106.893	174.04	120.543	-5.354	-147.992	124.384
22	7	N11	-29.929	179.576	137.232	-3.944	-147.801	127.671
23	7	Totals:	-136.822	353.617	257.776			
24	7	COG (in):	X: 11.192	Y: -0.93	Z: 0.408			
25	8	1	-267.944	166.198	37.235	-0.694	-136.007	121.066
26	8	N11	-142.522	187.419	48.691	-1.574	-108.619	133.694
27	8	Totals:	-410.466	353.617	85.925			
28	8	COG (in):	X: 11.192	Y: -0.93	Z: 0.408			
29	9	1	-348.471	162.277	-4.418	1.634	-129.89	119.405
30	9	N11	-198.818	191.34	4.418	-0.391	-88.911	136.703
31	9	Totals:	-547.289	353.617	0			
32	9	COG (in):	X: 11.192	Y: -0.93	Z: 0.408			
33	10	1	-267.976	165.547	-44.804	1.055	-58.513	120.612
34	10	N11	-142.49	188.07	-41.121	-0.112	-25.341	134.05
35	10	Totals:	-410.466	353.617	-85.925			
36	10	COG (in):	X: 11.192	Y: -0.93	Z: 0.408			
37	11	1	-106.988	172.087	-125.572	-0.108	84.198	123.023
38	11	N11	-29.834	181.53	-132.203	0.441	101.748	128.741
39	11	Totals:	-136.822	353.617	-257.775			
40	11	COG (in):	X: 11.192	Y: -0.93	Z: 0.408			
41	12	1	-26.495	175.357	-165.954	-0.692	155.532	124.227
42	12	N11	26.495	178.26	-177.746	0.714	165.266	126.085
43	12	Totals:	0	353.617	-343.701			
44	12	COG (in):	X: 11.192	Y: -0.93	Z: 0.408			
45	13	1	54.029	179.278	-124.296	-3.028	149.641	125.884
46	13	N11	82.793	174.339	-133.48	-0.476	145.759	123.072
47	13	Totals:	136.822	353.617	-257.776			
48	13	COG (in):	X: 11.192	Y: -0.93	Z: 0.408			
49	14	1	215.074	187.121	-40.974	-7.704	138.108	129.195
50	14	N11	195.393	166.495	-44.951	-2.862	106.976	117.041
51	14	Totals:	410.466	353.617	-85.925			
52	14	COG (in):	X: 11.192	Y: -0.93	Z: 0.408			
53	16	1	-31.893	388.014	-29.77	-56.165	6.784	279.733
54	16	N11	122.858	381.598	29.77	-45.136	-17.703	276.827
55	16	Totals:	90.965	769.611	0			
56	16	COG (in):	X: 11.396	Y: -8.403	Z: 2.972			
57	17	1	-38.82	387.703	-24.997	-56.46	3.697	279.011
58	17	N11	107.044	381.908	41.706	-47.832	-27.345	276.411
59	17	Totals:	68.224	769.611	16.708			
60	17	COG (in):	X: 11.396	Y: -8.403	Z: 2.972			



Company : APT
 Designer : DJA
 Job Number : New London
 Model Name : TYP Mount

9/20/2023
 5:58:29 PM
 Checked By :

Node Reactions (Continued)

	LC	Node Label	X [lb]	Y [lb]	Z [lb]	MX [lb-ft]	MY [lb-ft]	MZ [lb-ft]
61	18	1	-52.673	387.082	-15.451	-57.049	-2.481	277.565
62	18	N11	75.415	382.529	65.576	-53.225	-46.636	275.579
63	18	Totals:	22.741	769.611	50.125			
64	18	COG (in):	X: 11.396	Y: -8.403	Z: 2.972			
65	19	1	-59.6	386.771	-10.678	-57.344	-5.573	276.843
66	19	N11	59.6	382.84	77.511	-55.921	-56.283	275.163
67	19	Totals:	0	769.611	66.833			
68	19	COG (in):	X: 11.396	Y: -8.403	Z: 2.972			
69	20	1	-66.593	384.353	-15.431	-54.545	1.46	274.709
70	20	N11	43.851	385.258	65.556	-55.787	-45.125	275.959
71	20	Totals:	-22.741	769.611	50.125			
72	20	COG (in):	X: 11.396	Y: -8.403	Z: 2.972			
73	21	1	-80.578	379.517	-24.936	-48.946	15.528	270.442
74	21	N11	12.354	390.094	41.645	-55.518	-22.803	277.55
75	21	Totals:	-68.224	769.611	16.708			
76	21	COG (in):	X: 11.396	Y: -8.403	Z: 2.972			
77	22	1	-87.57	377.099	-29.689	-46.147	22.564	268.308
78	22	N11	-3.395	392.512	29.689	-55.384	-11.641	278.345
79	22	Totals:	-90.965	769.611	0			
80	22	COG (in):	X: 11.396	Y: -8.403	Z: 2.972			
81	23	1	-80.644	377.41	-34.462	-45.852	25.657	269.031
82	23	N11	12.42	392.202	17.754	-52.687	-1.991	278.761
83	23	Totals:	-68.224	769.611	-16.708			
84	23	COG (in):	X: 11.396	Y: -8.403	Z: 2.972			
85	24	1	-66.791	378.031	-44.009	-45.263	31.838	270.476
86	24	N11	44.05	391.58	-6.117	-47.295	17.302	279.592
87	24	Totals:	-22.741	769.611	-50.125			
88	24	COG (in):	X: 11.396	Y: -8.403	Z: 2.972			
89	25	1	-59.865	378.342	-48.782	-44.968	34.927	271.198
90	25	N11	59.864	391.27	-18.052	-44.599	26.946	280.008
91	25	Totals:	0	769.611	-66.833			
92	25	COG (in):	X: 11.396	Y: -8.403	Z: 2.972			
93	26	1	-52.872	380.76	-44.029	-47.767	27.89	273.332
94	26	N11	75.613	388.852	-6.096	-44.733	15.782	279.213
95	26	Totals:	22.741	769.611	-50.125			
96	26	COG (in):	X: 11.396	Y: -8.403	Z: 2.972			
97	27	1	-38.886	385.596	-34.523	-53.366	13.818	277.599
98	27	N11	107.11	384.016	17.815	-45.001	-6.542	277.622
99	27	Totals:	68.224	769.611	-16.708			
100	27	COG (in):	X: 11.396	Y: -8.403	Z: 2.972			

Envelope AISC 14TH (360-10): LRFD Member Steel Code Checks

Member	Shape	Code Check	Loc[in]	LC	Shear Check	Loc[in]	Dir	LC	phi*Pnc [lb]	phi*Pnt [lb]	phi*Mn y-y [lb-ft]	phi*Mn z-z [lb-ft]	Cb	Eqn
1	M1	HSS4X4X4	0.026	0	25	0.019	0	y	19102980.324	103122	11959.5	11959.5	1.581	H1-1b
2	M2	1/2X6	0.189	4.001	9	0.022	0	y	1682788.604	97200	12150	1012.5	1.19	H1-1b
3	M5A	PIPE 2.5	0.032	48	16	0.024	12	9	37773.818	50715	3596.25	3596.25	1	H1-1b
4	M6	PIPE 2.5	0.016	48	16	0.006	48	3	37773.818	50715	3596.25	3596.25	1	H1-1b
5	M7	HSS4X4X4	0.028	0	19	0.019	0	y	22102980.324	103122	11959.5	11959.5	1.579	H1-1b
6	M8	1/2X6	0.149	4.001	3	0.026	4.001	y	1682788.604	97200	12150	1012.5	1.183	H1-1b
7	M9	1/2X6	0.032	0	3	0.014	0	y	2293378.457	97200	12150	1012.5	2.135	H1-1b
8	M10A	1/2X6	0.033	0	9	0.014	0	y	2593378.457	97200	12150	1012.5	2.167	H1-1b
9	M13	1/2X6	0.105	0	3	0.021	0	y	393378.457	97200	12150	1012.5	2.154	H1-1b
10	M14	1/2X6	0.099	0	9	0.019	0	y	2293378.457	97200	12150	1012.5	2.195	H1-1b



Project ID: CT141_14070
 Site Name: New London
 Date: 9/20/2023

PROPOSED CONNECTION CHECK

>> Max Reactions per RISA Output: N11, LC6

<i>(Axial)</i>	F _x =	26.4 lbs		M _x =	5.1 lbs-ft
	F _y =	175.7 lbs		M _y =	167.3 lbs-ft
	F _z =	181.5 lbs		M _z =	124.7 lbs-ft

>> Proposed Connection:

Member Size =	L, in	4	x	W, in	4	
Plate =	L, in	8	x	W, in	8	t, in
						0.25
Bolt Spac. =		6 in		F _y =	36	ksi
Bolt Dia =		0.625 in		Grade =	A325	
# of Bolts =		4				

>> Check Proposed Bolts: 5/8" DIA A325 Bolts

T _{all} =	20700 lbs		V _{all} =	12400 lbs
T _{M_y} =	167.3 lbs		V _{F_y/F_z} =	63.14531 lbs
T _{M_z} =	124.658 lbs		V _{M_x} =	5.131 lbs
T _{F_a} =	6.59 lbs			
F _t =	298.5 lbs		F _v =	68.27631 lbs

>> Bolt Interaction:

$$0.014422 + 0.006 = 0.020 < 1.0, \text{ OK}$$

>> Check Existing Plate:

Z _x =	0.125 in ³			
Flange Arm =	1.00 in			<i>(Face of Member to Centerline of Bolt)</i>
f _{act.} =	4.78 ksi		f _{all} =	32.40 ksi

>> Plate Interaction:

$$0.147 < 1.0, \text{ OK}$$

Appendix C

References

NOTE:
FOR POLE SIZES
28" TO 42" DIAMETER
ORDER SEPARATELY
PART # "LP-42"

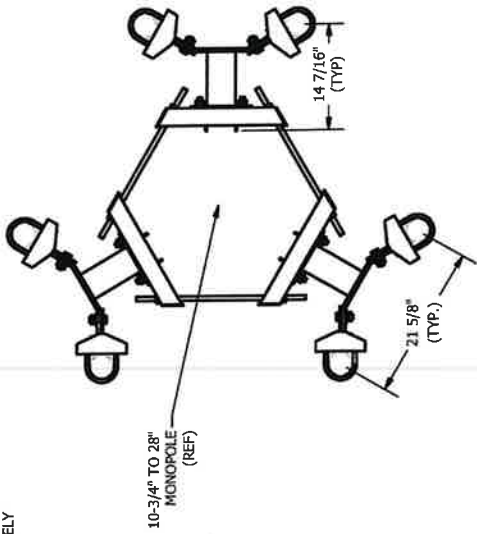

2-3/8" TO 3-1/2"
O.D. PIPE
(ORDER SEPARATELY)

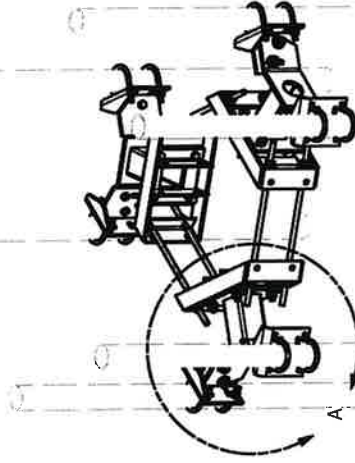
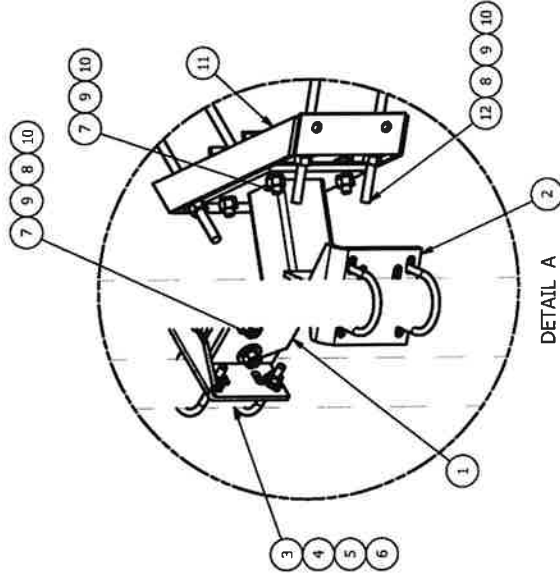
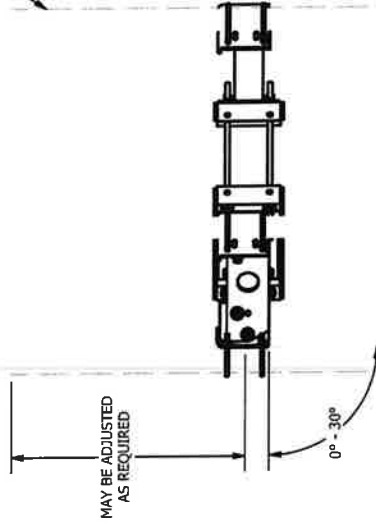

PARTS LIST

ITEM	QTY	PART NO.	PART DESCRIPTION	LENGTH	UNIT WT.	NET WT.
1	3	X-210717	STANDOFF BRACKET WELDMENT		28.98	85.74
2	6	X-ATB	PIPE ATTACHMENT BRACKET		10.68	64.10
3	12	X-JB1358	1/2" X 3-5/8" X 5-1/2" X 3" U-BOLT (HDG.)		0.77	9.27
3	12	X-JB1300	1/2" X 3" X 5" X 2" U-BOLT (HDG.)		0.70	8.40
3	12	X-JB1212	1/2" X 2-1/2" X 4-1/2" X 2" U-BOLT (HDG.)		0.63	7.56
4	24	G12FW	1/2" HDG USS FLATWASHER	3/32 in	0.03	0.82
5	24	G12LW	1/2" HDG LOCKWASHER	1/8 in	0.01	0.33
6	24	G12NUT	1/2" HDG HEAVY 2H HEX NUT		0.07	1.72
7	24	G2902	5/8" x 2" HDG HEX BOLT GR5		0.27	6.47
8	24	G58FW	5/8" HDG USS FLATWASHER	1/8 in	0.07	1.69
9	36	G58LW	5/8" HDG LOCKWASHER		0.03	0.94
10	36	G58NUT	5/8" HDG HEAVY 2H HEX NUT		0.13	4.68
11	3	X-UJLM	MINI RING MOUNT WELDMENT		21.67	65.00
12	6	G58R-24	5/8" x 24" THREADED ROD (HDG.)	24 in	0.40	2.39
12	6	G58R-14	5/8" x 14" THREADED ROD (HDG.)		0.40	2.39
					TOTAL WT. #	276.40

TOLERANCE NOTE
TOLERANCES ON DIMENSIONS, UNLESS OTHERWISE NOTED ARE:
SAWED, SHEARED AND GAS CUT EDGES (± 0.030")
DRILLED AND GAS CUT HOLES (± 0.030") - NO CONING OF HOLES
LASER CUT EDGES AND HOLES (± 0.010") - NO CONING OF HOLES
BENDS ARE ± 1/2 DEGREE - ALL OTHER MACHINING (± 0.030")
ALL OTHER ASSEMBLY (± 0.060")

PROPRIETARY NOTE
THE DATA AND TECHNIQUES CONTAINED IN THIS DRAWING ARE PROPRIETARY INFORMATION OF VALMONT INDUSTRIES AND CONSIDERED A TRADE SECRET. ANY USE OR REPRODUCTION WITHOUT THE CONSENT OF VALMONT INDUSTRIES IS STRICTLY PROHIBITED.

DESCRIPTION
ANTENNA MOUNT - MONOPOLE
(14-1/2" STANDOFF)

DRAWN BY
CEK 1/4/2012

CPD NO.
1/4/2012

CHECKED BY
BMC

DRAWING USAGE
CUSTOMER

DATE
1/6/2012

SITE PRO
A VALMONT COMPANY

Engineering
Support Team
1-888-765-7446

Locations:
New York, NY
Atlanta, GA
Los Angeles, CA
Houston, TX
Salt Lake City, UT
Dallas, TX

PART NO.
UWS6-NP

DWG. NO.
UWS6-NP

PAGE
1 OF 1

REV	DESCRIPTION OF REVISIONS	DATE
A	REPLACED X-210746 WITH X-ATB	1/5/2012

REVISION HISTORY

ATTACHMENT 4

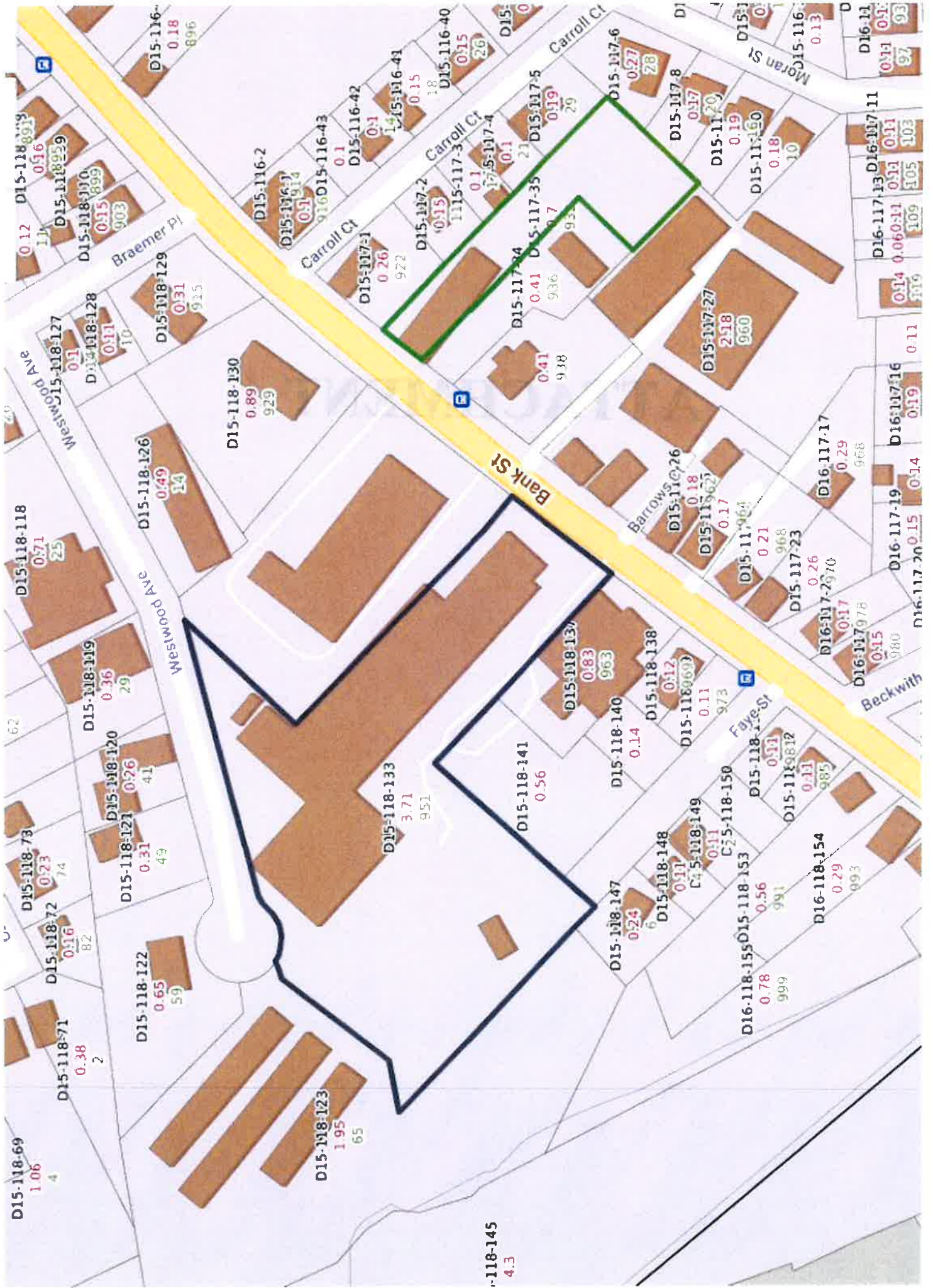

D15-118-69
1.06
4

D15-118-71
0.38
2

D15-118-72
0.16
82

D15-118-73
0.23
74

D15-118-118
0.71
25

D15-118-119
0.36
29

D15-118-120
0.26
41

D15-118-121
0.31
49

D15-118-122
0.65
59

D15-118-123
1.95
65

D15-118-127
0.1
10

D15-118-128
0.11
10

D15-118-126
0.49
14

D15-118-130
0.89
929

D15-118-133
3.71
951

D15-118-137
0.83
963

D15-118-140
0.14

D15-118-147
0.24
6

D15-118-148
0.11
6

D15-118-149
0.11
6

D15-118-153
0.56
991

D15-118-154
0.29
993

D15-118-155
0.78
999

D15-118-150
0.11
973

D15-118-151
0.21
968

D15-118-152
0.17
970

D15-118-153
0.18
968

D15-118-154
0.17
968

D15-118-155
0.17
968

D15-118-156
0.18
968

D15-117-1
0.26
922

D15-117-2
0.15
18

D15-117-3
0.15
26

D15-117-4
0.1
21

D15-117-5
0.19
29

D15-117-6
0.27
28

D15-117-7
0.17
29

D15-117-8
0.17
29

D15-117-9
0.41
936

D15-117-10
0.41
936

D15-117-11
0.41
936

D15-117-12
0.19
10

D15-117-13
0.19
10

D15-117-14
0.18
10

D15-117-15
0.18
10

D15-117-16
0.14
995

D15-117-17
0.17
980

D15-117-18
0.17
980

D15-117-19
0.15
980

D15-117-20
0.14
980

D16-117-21
0.19
10

D16-117-22
0.19
10

D16-117-23
0.26
968

D16-117-24
0.17
970

D16-117-25
0.17
970

D16-117-26
0.18
968

D16-117-27
0.18
968

D16-117-28
0.18
968

D16-117-29
0.18
968

D16-117-30
0.18
968

D16-117-31
0.14
995

D16-117-32
0.14
995

D16-117-33
0.14
995

D16-117-34
0.14
995

D16-117-35
0.14
995

D16-117-36
0.14
995

D16-117-37
0.14
995

D16-117-38
0.14
995

D16-117-39
0.14
995

D16-117-40
0.14
995

D16-117-41
0.14
995

D16-117-42
0.14
995

D16-117-43
0.14
995

D16-117-44
0.14
995

D16-117-45
0.14
995

D16-117-46
0.14
995

D16-117-47
0.14
995

D16-117-48
0.14
995

D16-117-49
0.14
995

D16-117-50
0.14
995

D16-117-51
0.14
995

D16-117-52
0.14
995

D16-117-53
0.14
995

D16-117-54
0.14
995

D16-117-55
0.14
995

D16-117-56
0.14
995

D16-117-57
0.14
995

D16-117-58
0.14
995

D16-117-59
0.14
995

D16-117-60
0.14
995

D16-117-61
0.14
995

D16-117-62
0.14
995

D16-117-63
0.14
995

D16-117-64
0.14
995

D16-117-65
0.14
995

D16-117-66
0.14
995

D16-117-67
0.14
995

D16-117-68
0.14
995

D16-117-69
0.14
995

D16-117-70
0.14
995

951 BANK ST

Location 951 BANK ST

City, State, Zip ,

Mblu D15/ 118/ 133/ /

Acct# 4017

Owner RL NEW LONDON LLC

Assessment \$969,640

Appraisal \$1,385,200

PID 4017

Building Count 2

Current Value

Appraisal			
Valuation Year	Improvements	Land	Total
2018	\$781,100	\$604,100	\$1,385,200
Assessment			
Valuation Year	Improvements	Land	Total
2018	\$546,770	\$422,870	\$969,640

Owner of Record

Owner RL NEW LONDON LLC

Sale Price \$550,000

Co-Owner

Certificate

Address 211 N MARKET STREET
WILMINGTON, DE 19801

Book & Page 2035/0111

Sale Date 08/19/2013

Instrument 07

Ownership History

Ownership History					
Owner	Sale Price	Certificate	Book & Page	Instrument	Sale Date
RL NEW LONDON LLC	\$550,000		2035/0111	07	08/19/2013
COCA-COLA BOTTLING COMPANY OF	\$0		2017/0258	25	05/15/2013
COCA-COLA BOTTLING CO OF N	\$0		0318/0269		01/01/1900

Building Information

Building 1 : Section 1

Year Built: 1938

Living Area: 31,827

Replacement Cost: \$2,331,203

Building Percent Good: 17

ATTACHMENT 5

Certificate of Mailing — Firm



Name and Address of Sender

Kenneth C. Baldwin, Esq.
 Robinson & Cole LLP
 280 Trumbull Street
 Hartford, CT 06103

TOTAL NO.
of Pieces Listed by Sender

3

TOTAL NO.
of Pieces Received at Post Office™

3

Postmaster, per (name of receiving employee)

[Signature]

Affix Stamp Here
 Postmark with Date of Receipt.



neopostSM
 10/16/2023
US POSTAGE \$003.19
 ZIP 06103
 041L12203937

USPS® Tracking Number
 Firm-specific Identifier

Address
 (Name, Street, City, State, and ZIP Code™)

	Postage	Fee	Special Handling	Parcel Airlift
1.	Michael E. Passero, Mayor City of New London 181 State Street New London, CT 06320			
2.	Michelle Johnson Scovish, Planning, Zoning and Wetlands Official City of New London 181 State Street New London, CT 06320			
3.	RL New London LLC 211 N Market Street Wilmington, DE 19801			
4.				
5.				
6.				