

JULIE D. KOHLER

PLEASE REPLY TO: Bridgeport
WRITER'S DIRECT DIAL: (203) 337-4157
E-Mail Address: jkohler@cohenandwolf.com

October 17, 2014

Attorney Melanie Bachman
Acting Executive Director
Connecticut Siting Council
Ten Franklin Square
New Britain, CT 06051

**Re: Notice of Exempt Modification
Connecticut State Police Facility /T-Mobile co-location
Site ID CT11086B
240 Baldwin Drive, New Haven CT**

Dear Attorney Bachman:

This office represents T-Mobile Northeast LLC ("T-Mobile") and has been retained to file exempt modification filings with the Connecticut Siting Council on its behalf.

In this case, the Department of Emergency Services and Public Protection – Division of State Police owns the existing lattice telecommunications tower and related facility at 240 Baldwin Drive, New Haven CT (aka 142 Baldwin Drive, West Rock State Park), Connecticut (Latitude: 41.34544, Longitude: -72.97071). T-Mobile intends to add three (3) antennas with and related equipment at this existing telecommunications facility in New Haven ("New Haven Facility"). Please accept this letter as notification, pursuant to R.C.S.A. § 16-50j-73, of construction which constitutes an exempt modification pursuant to R.C.S.A. § 16-50j-72(b)(2). In accordance with R.C.S.A. § 16-50j-73, a copy of this letter is being sent to Mayor Toni Harp, and the property owner, Department of Emergency Services and Public Protection – Division of State Police.

The existing New Haven Facility consists of a 120 self-supporting lattice structure.¹ T-Mobile plans to add three (3) antennas and three (3) RRUs (remote radio units) on proposed pipe mounts at a centerline of 95 feet. (See the plans revised to August 12, 2014 attached hereto as Exhibit A). The existing New Haven Facility is structurally capable of supporting T-

¹ The online Connecticut Siting Council database does not include a docket or petition number for the approval of this structure, and therefore does not include limitations on the configuration of the antennas. There have been several notices of intent to modify the facility, the most recent being EM-SPRINT-062-130912, EM-CING-093-121031 and EM-T-MOBILE-093-140407.

October 17, 2014
Site ID CT11086B
Page 2

Mobile's proposed modifications, as indicated in the structural analysis dated September 22, 2014 and attached hereto as Exhibit B.²

The planned modifications to the New Haven Facility fall squarely within those activities explicitly provided for in R.C.S.A. § 16-50j-72(b)(2).

1 . The proposed antennas and RRUs will not increase the height of the tower. T-Mobile's additional antennas will be installed at a centerline of 95 feet, merely supplementing antennas located at the same 95 foot elevation. The enclosed tower drawing confirms that the proposed modification will not increase the height of the tower.

2 . The proposed modifications will not require an extension of the site boundaries or lease area, as depicted on Sheet A-1 of Exhibit A. T-Mobile's equipment will be located entirely within the existing concrete pad and therefore within the existing compound area.

3 . The proposed modification to the New Haven Facility will not increase the noise levels at the existing facility by six decibels or more.

4 . The operation of the proposed antennas will not increase the total radio frequency (RF) power density, measured at the base of the tower, to a level at or above the applicable standard. According to a Radio Frequency Emissions Analysis Report prepared by EBI Consulting dated October 8, 2014, T-Mobile's operations would add 15.24% of the FCC Standard. Therefore, the calculated "worst case" power density for the planned combined operation at the site including all of the proposed antennas would be 59.00% of the FCC Standard as calculated for a mixed frequency site as evidenced by the engineering exhibit attached hereto as Exhibit C.

² The structural analysis provides that certain modifications must be made to the tower before the tower will be structurally capable of supporting both Sprint and T-Mobile's equipment. Those modifications will be completed prior to T-Mobile's installation.

October 17, 2014
Site ID CT11086B
Page 3

For the foregoing reasons, T-Mobile respectfully submits that the proposed antennas and equipment at the New Haven Facility constitutes an exempt modification under R.C.S.A. § 16-50j-72(b)(2). Upon acknowledgement by the Council of this proposed exempt modification, T-Mobile shall commence construction approximately sixty days from the date of the Council's notice of acknowledgement.

Sincerely,

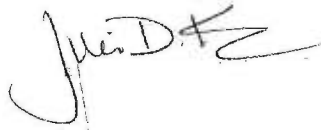
A handwritten signature in black ink, appearing to read "Julie D. Kohler". The signature is fluid and cursive, with a large initial "J" and a stylized "K" at the end.

Julie D. Kohler, Esq.

cc: City of New Haven, Mayor Toni Harp
Department of Emergency Services and Public Protection – Division of State Police
Elizabeth Jamieson, Transcend Wireless

EXHIBIT A

SITE NAME: NEW HAVEN/WC X59

240 BALDWIN DRIVE (WEST ROCK STATE PARK)

NEW HAVEN, CT 06515

NEW HAVEN COUNTY

SITE NUMBER: CT11086B

L700 - 702CU CONFIGURATION

T-MOBILE NORTHEAST LLC

35 GRIFFIN ROAD SOUTH
BLOOMFIELD, CT 06002
OFFICE: (860) 648-1116

Transcend Wireless

TRANSCEND WIRELESS
1400 OSGOOD STREET
MANSFIELD, NJ 07430
TEL: (201) 684-0255
FAX: (201) 684-0256



1400 OSGOOD STREET
BUILDING 20 NORTH, SUITE 800
N. ANDOVER, MA 01845
TEL: (978) 527-5553
FAX: (978) 336-5886



APPROVALS

CONSTRUCTION	DATE
RF ENGINEERING	DATE
ZONING/SITE ACQ.	DATE
OPERATIONS	DATE
TOWER OWNER	DATE
PROJECT NO:	CT11086B
DRAWN BY:	KMS
CHECKED BY:	DR

PROJECT INFORMATION

SCOPE OF WORK: UNMANNED TELECOMMUNICATIONS FACILITY T-MOBILE EQUIPMENT MODERNIZATION

ZONING JURISDICTION: BASED ON INFORMATION PROVIDED BY T-MOBILE, THIS TELECOMMUNICATIONS EQUIPMENT DEPLOYMENT IS AN ELIGIBLE FACILITY UNDER THE TAX RELIEF ACT OF 2012, 47 USC 1455(A), AND IS SUBJECT TO AN EXPEDITED ELIGIBLE FACILITIES REQUEST/REVIEW AND ZONING PRE-EMPTION FOR LOCAL DISCRETIONARY PERMITS (VARIANCE, SPECIAL PERMIT, SITE PLAN REVIEW).

SITE ADDRESS: 240 BALDWIN DRIVE
NEW HAVEN, CT 06515

LATITUDE: 41° 20' 43.5" N
LONGITUDE: -72° 58' 14.5" W

JURISDICTION: NATIONAL, STATE & LOCAL CODES OR ORDINANCES

CURRENT USE: TELECOMMUNICATIONS FACILITY

PROPOSED USE: TELECOMMUNICATIONS FACILITY



GENERAL NOTES

1. THIS DOCUMENT IS THE CREATION, DESIGN, PROPERTY AND COPYRIGHTED WORK OF T-MOBILE. ANY DUPLICATION OR USE WITHOUT EXPRESS WRITTEN CONSENT IS STRICTLY PROHIBITED. DUPLICATION AND USE BY GOVERNMENT AGENCIES FOR THE PURPOSES OF CONDUCTING THEIR LAWFULLY AUTHORIZED REGULATORY AND ADMINISTRATIVE FUNCTIONS IS SPECIFICALLY ALLOWED.
2. THE FACILITY IS AN UNMANNED PRIVATE AND SECURED EQUIPMENT INSTALLATION. IT IS ONLY ACCESSED BY TRAINED TECHNICIANS FOR PERIODIC ROUTINE MAINTENANCE AND THEREFORE DOES NOT REQUIRE ANY WATER OR SANITARY SEWER SERVICE. THE FACILITY IS NOT GOVERNED BY REGULATIONS REQUIRING PUBLIC ACCESS PER ADA REQUIREMENTS.
3. CONTRACTOR SHALL VERIFY ALL PLANS AND EXISTING DIMENSIONS AND CONDITIONS ON THE JOB SITE AND SHALL IMMEDIATELY NOTIFY THE T-MOBILE NORTHEAST, LLC REPRESENTATIVE IN WRITING OF DISCREPANCIES BEFORE PROCEEDING WITH THE WORK OR BE RESPONSIBLE FOR SAME.

SPECIAL STRUCTURAL NOTES

1. STRUCTURAL DESIGNS AND DETAILS FOR ANTENNA MOUNTS COMPLETED BY HUDSON DESIGN ON BEHALF OF T-MOBILE ARE INCLUSIVE OF THE ENTIRE ANTENNA SUPPORT STRUCTURE (GLOBAL STRUCTURAL STABILITY ANALYSIS BY OTHERS), EXISTING TOWER PLATFORM, EXISTING ANTENNA MOUNTS AND ALL OTHER ASPECTS OF THE STRUCTURE THAT WILL SUPPORT THE T-MOBILE MODERNIZATION EQUIPMENT DEPLOYMENT AS DEPICTED HEREIN.
2. HUDSON DESIGN ASSUMES THAT THE TOWER IS PROPERLY CONSTRUCTED AND MAINTAINED. ALL STRUCTURAL MEMBERS AND THEIR CONNECTION ARE ASSUMED TO BE IN GOOD CONDITION AND ARE FREE FROM DEFECTS WITH NO DETERIORATION TO ITS MEMBER CAPACITIES

T-MOBILE TECHNICIAN SITE SAFETY NOTES

LOCATION	SPECIAL RESTRICTIONS
SECTOR A:	ACCESS NOT PERMITTED
SECTOR B:	ACCESS NOT PERMITTED
SECTOR C:	ACCESS NOT PERMITTED
GPS/LMU:	UNRESTRICTED
RADIO CABINETS:	UNRESTRICTED
PRC DISCONNECT:	UNRESTRICTED
MAIN CIRCUIT D/C:	UNRESTRICTED
NIU/T DEMARC:	UNRESTRICTED
OTHER/SPECIAL:	NONE



CALL BEFORE YOU DIG
CALL TOLL FREE 800-922-4455
OR CALL 811
UNDERGROUND SERVICE ALERT

DRAWING INDEX

TITLE SHEET	REV
T-1	1
GN-1 GENERAL NOTES	1
A-1 COMPOUND & ELEVATION PLAN	1
A-2 ANTENNA PLAN & DETAILS	1
G-1 GROUNDING DETAILS	1

SITE NUMBER: CT11086B
SITE NAME: NEW HAVEN/WC X59
(WEST ROCK STATE PARK)

240 BALDWIN DRIVE
NEW HAVEN, CT 06515
NEW HAVEN COUNTY

SHEET TITLE
TITLE SHEET
SHEET NUMBER

NOTE:
 GENERAL CONTRACTOR TO REFER TO THE STRUCTURAL ANALYSIS AND TOWER REINFORCEMENT AND EQUIPMENT INSTALLATION RECOMMENDATIONS BY: URS CORPORATION, DATED: SEPTEMBER 22, 2014 PRIOR TO COMMENCING CONSTRUCTION

PROPOSED ANTENNA SCHEDULE			
SECTOR	MAKE	MODEL#	SIZE (INCHES)
ALPHA:	COMMSCOPE	LNX-6515DS-VTM	96.3X11.9X7.1
BETA:	COMMSCOPE	LNX-6515DS-VTM	96.3X11.9X7.1
GAMMA:	COMMSCOPE	LNX-6515DS-VTM	96.3X11.9X7.1

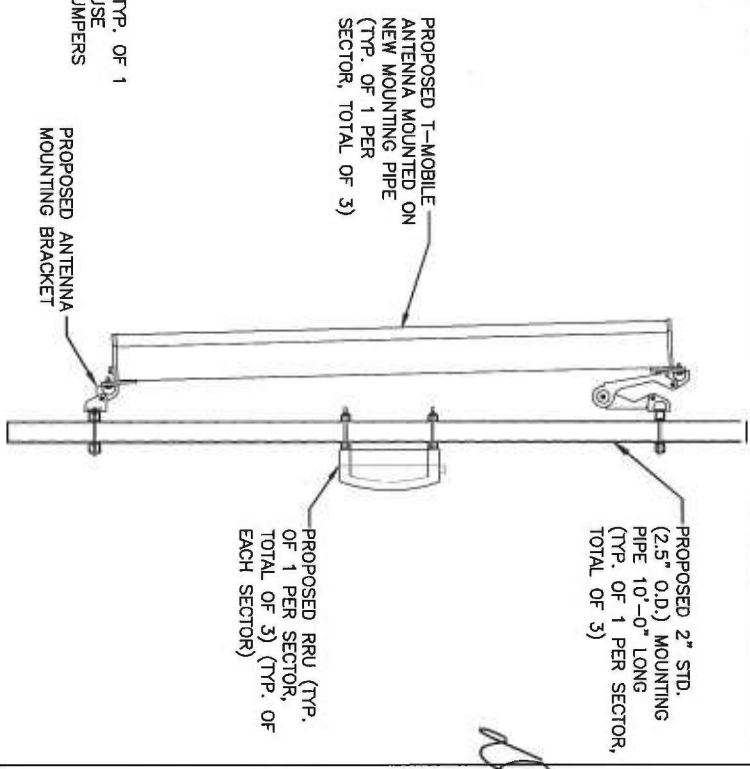

3 ANTENNA MOUNT (TYP.)
 SCALE: N.I.S.

3 A-3

PROPOSED T-MOBILE ANTENNAS ON PROPOSED PIPE (TYP. OF 1 PER SECTOR, TOTAL OF 3)

EXISTING GSM/UMTS ANTENNA TO REMAIN (TYP. OF 2 PER SECTOR, TOTAL OF 6)

PROPOSED T-MOBILE RRU (TYP. OF 1 PER SECTOR, TOTAL OF 3)(USE SPARE FIBER AND POWER JUMPERS FOR LTE 700)

EXISTING LITE ANTENNA TO REMAIN (TYP. OF 2 PER SECTOR, TOTAL OF 6)

2 PROPOSED ANTENNA PLAN
 SCALE: N.I.S.

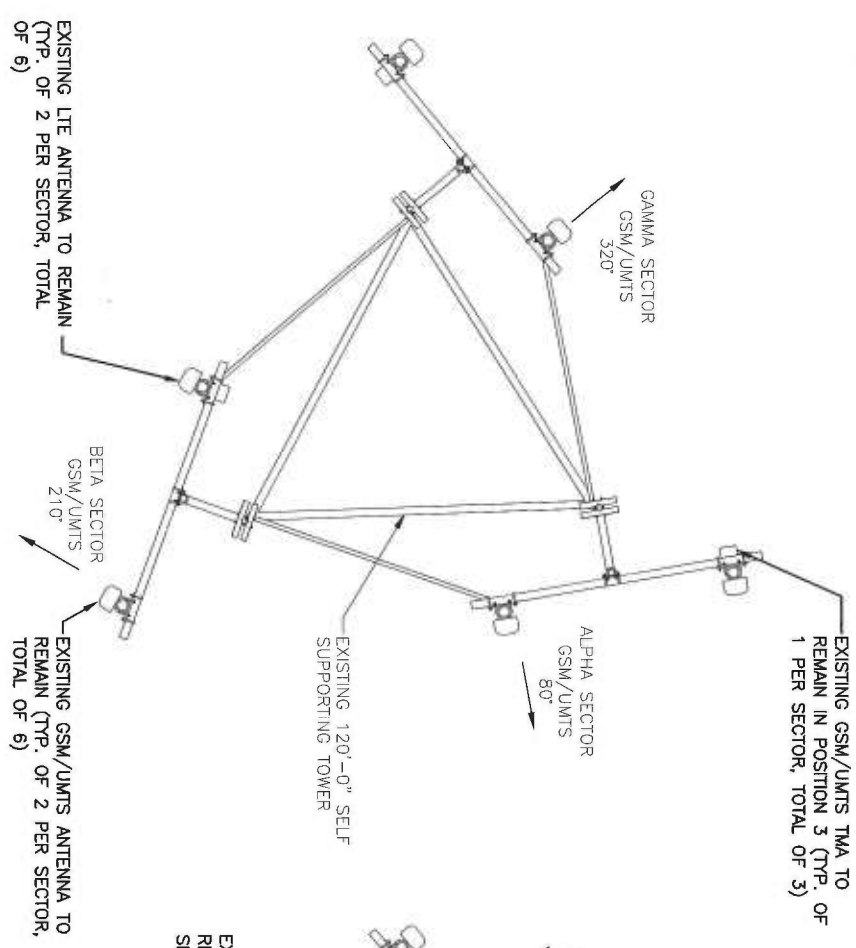
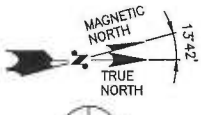

1 EXISTING ANTENNA PLAN
 SCALE: N.I.S.

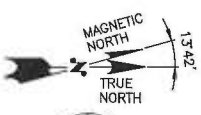

NOTE:
 REFER TO THE FINAL RF DATA SHEET FOR FINAL ANTENNA SETTINGS.

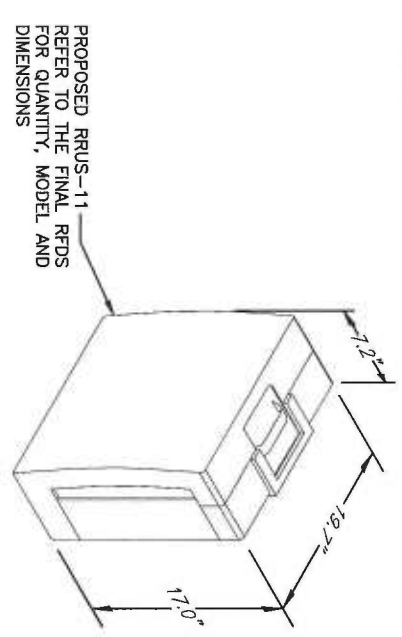

RRU DETAIL
 SCALE: N.I.S.

NOTE:
 MOUNT PER MANUFACTURER'S SPECIFICATIONS.

T-MOBILE NORTHEAST LLC
 35 GRIFFIN ROAD SOUTH
 BLOOMFIELD, CT 06002
 OFFICE: (860) 648-1116

Transcend Wireless
 TRANSCEND WIRELESS
 10 INDUSTRIAL AVE
 MAHWAH, NJ 07430
 TEL: (201) 684-0355
 FAX: (201) 684-0046

Hudson Design Group
 1620 OSBORN STREET
 BUILDING 20 NORTH SUITE 800
 N. ANDOVER, MA 01854
 TEL: (978) 552-5533
 FAX: (978) 552-5585

APPROVALS
 CONSTRUCTION DATE
 RF ENGINEERING DATE
 ZONING/SITE ACQ. DATE
 OPERATIONS DATE
 TOWER OWNER DATE
 PROJECT NO: CT110868B
 DRAWN BY: KMS
 CHECKED BY: DR

SITE NUMBER: CT110868B	
SITE NAME: NEW HAVEN/WC X59 (WEST ROCK STATE PARK)	
240 BALDWIN DRIVE NEW HAVEN, CT 06515 NEW HAVEN COUNTY	
SHEET TITLE ANTENNA PLAN & DETAILS	
SHEET NUMBER A-2	

EXHIBIT B

DETAILED STRUCTURAL ANALYSIS AND REINFORCEMENT OF AN EXISTING 120' SELF-SUPPORT LATTICE TOWER FOR NEW ANTENNA ARRANGEMENT

Site I.D. : (T-Mobile) CT11086B
(Sprint) CT03XC003
Site Name: New Haven - State Police Tower #27
Address: 142 Baldwin Drive, New Haven, CT
(aka 1065 Wintergreen Avenue, Hamden, CT)

prepared for



Transcend Wireless
10 Industrial Avenue, Suite 3
Mahwah, NJ 07430



HPC Wireless Services
22 Shelter Rock Lane, Bldg. C
Danbury, CT 06810

prepared by



URS CORPORATION
500 ENTERPRISE DRIVE, SUITE 3B
ROCKY HILL, CT 06067
TEL. 860-529-8882

36931329.00000
TWM-002

September 22, 2014

TABLE OF CONTENTS

1. EXECUTIVE SUMMARY
2. INTRODUCTION
3. ANALYSIS METHODOLOGY AND LOADING CONDITIONS
4. FINDINGS AND EVALUATION
5. CONCLUSIONS AND RECOMMENDATIONS
6. DRAWINGS AND DATA
 - TOWER REINFORCEMENT DRAWING SK-1
 - TNX TOWER INPUT / OUTPUT SUMMARY
 - TNX TOWER FEEDLINE DISTRIBUTION CHART
 - TNX TOWER FEEDLINE PLAN
 - TNX TOWER DEFLECTION, TILT, AND TWIST
 - TNX TOWER DETAILED OUTPUT
 - ANCHOR BOLT ANALYSIS
 - FOUNDATION ANALYSIS

1. **EXECUTIVE SUMMARY**

This report summarizes the structural analysis of the existing 120' self-supporting lattice tower structure located at 142 Baldwin Drive, New Haven; (aka 1065 Wintergreen Avenue, Hamden), Connecticut. The analysis was conducted in accordance with the 2005 Connecticut State Building Code, the TIA/EIA-222-F standard, and the Connecticut State Police Requirements for a wind velocity of 90 mph (fastest mile) and 90 mph (fastest mile) concurrent with 0.5" ice. Rotation (Twist) and deflection (sway) were determined in accordance with Connecticut State Police Requirements for a wind velocity of 90 mph (fastest mile) concurrent with 0.5" ice. The antenna loading considered in the analysis consists of all existing and proposed antennas, transmission lines, and ancillary items as outlined in the Introduction of this report.

The proposed T-Mobile and Sprint antenna modifications are listed below:

Proposed Antenna and Mount	Carrier	Antenna Center Elevation
Install: (3) Commscope LNX-6515DS-VTM Panel Antennas (3) Ericsson RRUS_11 RRH Units (3) Antenna Pipe Mounts	T-Mobile (Proposed)	@ 95'
(3) RFS APXVTM14-C-I20 Panel Antennas (3) TD-RRH8x20-25 RRH Units (27) Antenna Jumper Cables (3) Commscope ATCB-B01-006 AISG Ret Control Cables (1) ALU Hybriflex Cable	Sprint (Proposed)	@ 72'

The results of an initial analysis indicated the tower structure did not have sufficient capacity to support the proposed loadings without modification. The required modifications are shown in SK-1. **Once the modifications are performed, the tower, anchor bolts, and foundation are considered structurally adequate with the wind loading classification specified above and all the existing and proposed antenna loading. No installation of new antennas or equipment shall occur until the modifications have been completed.**

The tower deflection (sway) is 0.3478 degrees, and the tower rotation (twist) is 0.1216 degrees with a wind velocity of 90 mph concurrent with 0.5" ice. **The tower deflection and rotation are within the Connecticut State Police specification of 0.75 degrees for combined deflection (sway) and rotation (twist).**

1. EXECUTIVE SUMMARY - continued

This analysis is based on:

- 1) The tower structure's theoretical capacity, not including any assessment of the condition of the tower.
- 2) Tower geometry and structural member sizes utilized in the preparation of this report were obtained from manufacturer's original design documents prepared by Stainless, Inc. report number 358810, noted as revision B, dated March 3, 1995.
- 3) Previous structural analysis performed by URS Corporation, project number HPC-069 / 36928677, signed and sealed March 19, 2014.
- 4) Antenna inventory provided by Connecticut State Police via e-mail on February 8, 2014.
- 5) Previous structural analysis performed by URS Corporation, on behalf of Sprint, project number 36928689, signed and sealed March, 28, 2014.
- 6) T-Mobile RFDS dated July 18, 2014.
- 7) Antenna and mount configuration as specified within Section 2 and 6 of this report.
- 8) Coax cable orientation as specified in section 6 of this report.

This report is only valid as per the assumptions and data utilized in this report for antenna inventory, mounts and associated cables. The user of this report shall field verify the assumption of the antenna and mount configuration as well as the physical condition of the tower. Notify the engineer in writing immediately if any of the information in this report is found to be other than specified.

If you should have any questions, please call.

Sincerely,

URS Corporation

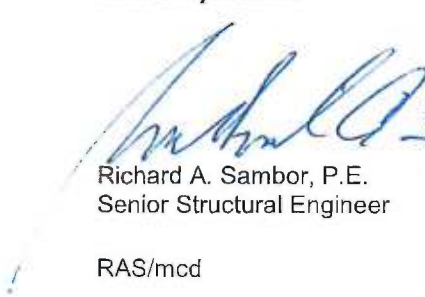
Richard A. Sambor, P.E.
Senior Structural Engineer

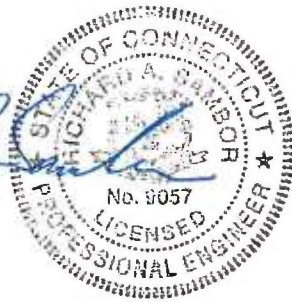

RAS/mcd

2. INTRODUCTION

The subject tower is located at 142 Baldwin Drive, New Haven; (aka 1065 Wintergreen Avenue, Hamden), Connecticut. The structure is an existing 120' self supporting steel tapered lattice tower, designed and manufactured by Stainless, Inc.

The inventory is summarized in the table below:

Antenna Type	Carrier	Mount	Antenna Centerline Elevation	Cable
(1) 4' Lightning Rod	Tower (existing)	18' Pipe Mast on Top of Tower	138'	---
(1) RFS Celwave PD1142 -2B Omni	DOT - 1 (existing)	(3) Side Arms	120'	(1) 7/8"
(1) RFS Celwave PD458 Omni	CTT - 2 (existing)		120'	(1) 7/8"
(2) Katherein OGT9-806 Omni	CSP 8 & 9 (existing)		120'	(2) 1-5/8"
(1) 6' Dipole	CSP - 52 (existing)		120'	(1) 1-1/4"
(3) 6' Microwave Dishes	CSP - 69,70 & 71 (future)		120'	---
(3) SC479-HF1DF (1) TTA Unit	CSP 65 - 68 (existing)		120'	(3) 1-5/8" (1) 1/2"
(1) 6' Microwave Dish	CSP - 6 (existing)		(3) Dish Mounts	116'
(1) 6' Microwave Dish	CSP - 4 (existing)	115'		(1) WE65
(1) 6' Microwave Dish	CSP - 7 (existing)	111'		(1) WE65
(1) Filter/Diplexer	CSP - 62 (existing)	(2) Side Arms	110'	(1) 1/2"
(1) Kathrein AP13-850/065 panel antennas	CSP - 41 (existing)		110'	(1) 1-5/8"
(1) SC479-HF1LDF	CSP - 54 (existing)		110'	(1) 1-5/8"
(3) SC479-HF1LDF (1) TTA Unit	CSP - 59 - 62 (existing)		110'	(3) 1-5/8" (1) 1/2"
(1) AP13-850/065/ADT	CSP - 42 (existing)	Leg Mounted	105'	(1) 1-5/8"
(1) Filter/Diplexer	DEHMS - 43 (existing)	Leg Mounted	105'	---
(2) Katherein OGT9-806 Omni	CSP 10 & 11 (existing)	(2) Pipe Mounts	103'	(2) 1-5/8"
(1) RFS Celwave PD458 Omni	CTT - 3 (existing)	Leg Mounted	100'	(1) 7/8"
(3) Commscope LNX-6515DS-VTM Panel Antennas (3) Ericsson RRUS_11 RRH Units (3) Antenna Pipe Mounts	T-Mobile (Proposed)	See Mount Below	95'	See Below Cables

<i>Antenna Type</i>	<i>Carrier</i>	<i>Mount</i>	<i>Antenna Centerline Elevation</i>	<i>Cable</i>
(3) Ericsson AIR21 B2A B4P Panel Antennas (3) Ericsson AIR21 B4A B2P Panel Antennas (3) (AWS) TMA Units	T-Mobile (existing)	(3) T-Arm Mounts	95'	(6) 1 5/8" (1) 1 1/4" F.O. Cable (2) Fiber Optic Cables
(1) 20' 4-Bay Dipole	USS – 24 (existing)	Side Arm	90'	(1) 7/8"
(1) RFS Celwave PD1142 -2B Omni	DEHMS – 26 (existing)	Side Arm	85'	(1) 7/8"
(1) 3' Yagi antenna	CSP – 14 (existing)	Leg Mounted	85'	(1) 7/8"
(4) SBNH-1D6565C (2A & 2B) (2) AM-X-CD-16-65-00T (2C) (6) TMAs (12) Diplexers	AT&T (existing)	Frame Mount	80'	(8) 1-1/4" (4) 1-1/4"
(1) 20' 4-Bay Dipole	USS – 12 (existing)	Leg Mounted	78'	(1) 7/8"
(3) RFS APXVTM14-C-1 20 Panel Antennas (3) TD-RRH8x20-25 RRH Units (27) Antenna Jumper Cables	Sprint (Proposed)	See Mount Below	72'	(3) Commscope ATCB-B01-006 AISG Ret Control Cables (1) ALU Hybriflex 1-1/4" Coax
(3) RFS APXVSPP18-C-A20 (6) ALU RRH 4X45 65MHz (3) ALU RRH 800 MHz 2x50W (3) 800 MHz NOTCH FILTER (3) 1900 RRH COMBINER	Sprint (existing)	Pipe Mounts on existing Frame	72'	(3) HYBRIFLEX 1 -1/4" Coax
(1) 2' Microwave Panel	NHVN – 57 (existing)	Leg Mounted	70'	(1) CAT5
(1) DB212	DEHMS – 47 (existing)	(2) Stand-offs	60'	(1) 7/8"
(1) DB803M-Y	CSP – 53 (existing)		60'	(1) 1/2"
(1) GPS	AT&T – 25 (existing)		60'	(1) 7/8"
(1) GPS	Sprint – 18 (existing)		60'	(1) 1/2"
(1) BA6312 Omni	NHVN – 45 (existing)		60'	(1) 7/8"
(1) 4' Whip	NHVN – 46 (existing)		60'	(1) 7/8"
(1) 20' Dipole	USS – 13 (existing)	2' Side Arm	56'	(1) 7/8"
(1) Decibel DB-264	CSP – 5 (existing)	Leg Mounted	55'	(1) 7/8"
(1) 1' Microwave Panel	NHVN – 58 (existing)	Leg Mounted	50'	(1) CAT5

<i>Antenna Type</i>	<i>Carrier</i>	<i>Mount</i>	<i>Antenna Centerline Elevation</i>	<i>Cable</i>
(1) 4' Dish	NHVN – 44 (existing)	3' Side Arm	40'	(2) 1/2"
(1) 3' Microwave Panel	FBI – 51 (existing)	Leg Mount	40'	(1) 1/2"
(1) 1' Whip	FBI – 50 (existing)	Leg Mount	35'	(1) 1/2"
(1) 3' Whip	CSP – 48 (existing)	Leg Mount	30'	(1) 1/2"

Notes: Refer to coax feed-line plan within Section 6 of this report for coax locations.

This structural analysis of the communications tower was performed by URS Corporation (URS) for T-Mobile and Sprint. The purpose of this analysis was to investigate the structural integrity of the reinforced tower with its existing, future and proposed antenna loads. This analysis was conducted to evaluate twist (rotation), sway (deflection), and stress on the tower and the effect of forces.

3. ANALYSIS METHODOLOGY AND LOADING CONDITIONS

The structural analysis was done in accordance with the 2005 Connecticut State Building Code, TIA/EIA-222-F - Structural Standard for Steel Antenna Towers and Antenna Supporting Structures, and the American Institute of Steel Construction (AISC) Manual of Steel Construction - Allowable Stress Design (ASD).

The analysis was conducted using TNX Tower 6.1.3.1. Two load conditions were evaluated as shown below which were compared to allowable stresses according to AISC and TIA/EIA.

Load Condition 1 = 90 mph (fastest mile) Wind Load + Tower Dead Load

Load Condition 2 = 90 mph (fastest mile) Wind Load (with ice) + Ice Load + Tower Dead Load

The TIA/EIA standard permits a one-third increase in allowable stresses for towers and monopoles less than 700 feet tall. For the purposes of this analysis, in computing the load capacity the allowable stresses of the tower members were increased by one-third.

4. FINDINGS AND EVALUATION

The combined axial and bending stresses on the tower structure were evaluated to compare with the allowable stress in accordance with AISC. The results of an initial analysis indicated that the tower required modification. The required modifications are shown in SK-1 located in Section 6 of this report. This analysis indicated that once these modifications are performed, the tower, anchor bolts and foundation are considered structurally adequate with the wind load classification specified above and the proposed antenna loading. The table below summarizes the critical members for each tower component.

The tower deflection (sway) is 0.3368 degrees, and the tower rotation (twist) is 0.1225 degrees. These figures are within the Connecticut State Police specification of 0.75 degrees for deflection (sway) and rotation (twist).

Tower Base Reactions:

Base Reactions	Proposed Tower Reactions
Axial Load (kips)	53
Shear per Leg (kips)	32
Total Shear (kips)	58
Uplift per Leg (kips)	216
Comp.per Leg (kips)	257
O.T. Moment (ft-kips)	4363

For detailed proposed tower reactions, see drawing no. E-1 in section 6 of this report.

Tower Component Stress vs. Capacity Summary:

Component/ (Section No.)	Existing Component Size	Controlling Component/Elevation	Stress (% capacity)	Pass/Fail
Tower Leg (T8)	P5x0.4	Compression/25'-50'	89.3 %	Pass
Diagonal (T5)	2L 2 1/2x2x3/16	Compression/83'-92'	96.4 %	Pass
Horizontal (T7)	L3x3x1/4	Compression/50'-75'	89.0 %	Pass
Top Girt (T8)	L3x3x1/4	Compression/25'-50'	99.5 %	Pass
Inner Bracing (T8)	L2-1/2x2x3/16	Compression/25'-50'	7.7 %	Pass
Bolt Checks	(1) 3/4" A325X Diagonal Bolt	Member Bearing/50'	81.1 %	Pass
Anchor Bolts	1 1/2" dia. A36	Tension & Shear	94 %	Pass
Foundation	Rock Anchors	Tension	76 %	Pass

Tower Deflection (Sway) and Rotation (Twist) at the top of the tower (degrees):

Description	Current	Allowable
Tower Sway (degrees)	0.3478	N/A
Tower Twist (degrees)	0.1216	
Total (degrees)	0.4694	0.750

5. CONCLUSIONS AND RECOMMENDATIONS

The results of an initial analysis indicated the tower structure did not have sufficient capacity to support the proposed loadings without modification. The required modifications are shown in SK-1. **Once the modifications are performed, the tower, anchor bolts, and foundation are considered structurally adequate with the wind loading classification specified above and all the existing and proposed antenna loading. No installation of new antennas or equipment shall occur until the modifications have been completed.**

The tower deflection (sway) is 0.3478 degrees, and the tower rotation (twist) is 0.1216 degrees with a wind velocity of 90 mph concurrent with 0.5" ice. **The tower deflection and rotation are within the Connecticut State Police specification of 0.75 degrees for combined deflection (sway) and rotation (twist).**

Limitations/Assumptions:

This report is based on the following:

1. Tower inventory as listed in this report.
2. Tower is properly installed and maintained.
3. All members are as specified in the original design documents and are in good condition.
4. All required members are in place.
5. All bolts are in place and are properly tightened.
6. Tower is in plumb condition.
7. All member protective coatings are in good condition.
8. All tower members were properly designed, detailed, fabricated, and installed and have been properly maintained since erection.
9. Foundations were properly constructed to support original design loads as specified in the original design documents.

URS is not responsible for any modifications completed prior to or hereafter in which URS is not or was not directly involved. Modifications include but are not limited to:

- A. Adding antennas
- B. Removing/replacing antennas
- C. Adding coaxial cables

URS hereby states that this document represents the entire report and that it assumes no liability for any factual changes that may occur after the date of this report. All representations, recommendations, and conclusions are based upon information contained and set forth herein. If you are aware of any information which conflicts with that which is contained herein, or you are aware of any defects arising from original design, material, fabrication, or erection deficiencies, you should disregard this report and immediately contact URS. URS disclaims all liability for any representation, recommendation, or conclusion not expressly stated herein.

Ongoing and Periodic Inspection and Maintenance:

After the Contractor has successfully completed the installation and the work has been accepted, the owner will be responsible for the ongoing and periodic inspection and maintenance of the tower.

The owner shall refer to TIA/EIA-222-F for recommendations for maintenance and inspection. The frequency of the inspection and maintenance intervals is to be determined by the owner based upon actual site and environmental conditions. It is recommended that a complete and thorough inspection of the entire tower structural system be performed at least yearly and more frequently as conditions warrant. According to TIA/EIA-222-F section 14.1, Note 1: It is recommended that the structure be inspected after severe wind and/or ice storms or other extreme loading condition.

6. DRAWINGS AND DATA

TOWER REINFORCEMENT DRAWING SK-1

GENERAL CONSTRUCTION NOTES

- ALL WORK SHALL COMPLY WITH THE CONNECTICUT STATE BUILDING AND LIFE SAFETY CODES, SUPPLEMENTS AND AMENDMENTS.
- CONTRACTOR IS TO REVIEW ALL DRAWINGS AND SPECIFICATIONS IN THE CONTRACT DOCUMENT SET. CONTRACTOR SHALL COORDINATE ALL WORK SHOWN IN THE SET OF DRAWINGS. THE CONTRACTOR SHALL PROVIDE A COMPLETE SET OF DRAWINGS TO ALL SUB-CONTRACTORS AND ALL RELATED PARTIES. THE SUB-CONTRACTORS SHALL EXAMINE ALL THE DRAWINGS AND SPECIFICATIONS FOR THE INFORMATION THAT AFFECTS THEIR WORK.
- CONTRACTOR SHALL PROVIDE A COMPLETE BUILD-OUT WITH ALL FINISHES, STRUCTURAL, AND ELECTRICAL COMPONENTS AND PROVIDE ALL ITEMS AS SHOWN OR INDICATED ON DRAWINGS OR WRITTEN IN SPECIFICATIONS.
- CONTRACTOR SHALL FURNISH ALL MATERIAL, LABOR AND EQUIPMENT TO COMPLETE THE WORK AND FURNISH A COMPLETED JOB ALL IN ACCORDANCE WITH LOCAL AND STATE GOVERNING AUTHORITIES AND OTHER AUTHORITIES HAVING LAWFUL JURISDICTION OVER THE WORK.
- CONTRACTOR SHALL SECURE AND PAY FOR ALL PERMITS AND ALL INSPECTIONS REQUIRED AND SHALL ALSO PAY FEES REQUIRED FOR THE GENERAL CONSTRUCTION, AND ELECTRICAL SUB-CONTRACTORS SHALL PAY FOR THEIR PERMITS.
- CONTRACTOR SHALL MAINTAIN A CURRENT SET OF DRAWINGS AND SPECIFICATIONS ON SITE AT ALL TIMES AND ENSURE THE DISTRIBUTION OF NEW DRAWINGS TO SUB-CONTRACTORS AND OTHER RELEVANT PARTIES AS SOON AS THEY ARE MADE AVAILABLE. ALL OLD DRAWINGS SHALL BE MARKED VOID AND REMOVED FROM THE CONTRACT AREA. CONTRACTOR SHALL FURNISH "AS-BUILT" SET OF DRAWINGS TO OWNER UPON COMPLETION OF PROJECT.
- INSTALLATION OF THIS WIRELESS COMMUNICATIONS EQUIPMENT SITE REQUIRES WORK IN THE IMMEDIATE VICINITY OF EXISTING TELECOMMUNICATION SYSTEMS. THE CONTRACTOR SHALL PROVIDE AND COORDINATE THE METHODS OF PROTECTION WITH THE VARIOUS TELECOMMUNICATION CARRIERS.
- ALL EQUIPMENT AND PRODUCTS PURCHASED ARE TO BE REVIEWED BY CONTRACTOR AND ALL APPLICABLE SUB-CONTRACTORS FOR ANY CONDITION PER MFR'S RECOMMENDATIONS. CONTRACTOR TO SUPPLY THESE ITEMS AT NO COST TO OWNER OR ARCHITECT.
- CONTRACTOR SHALL BE RESPONSIBLE FOR ALL ON-SITE SAFETY FROM THE TIME THE JOB IS AWARDED UNTIL ALL WORK IS COMPLETE AND ACCEPTED BY THE OWNER.
- CONTRACTOR TO REVIEW ALL SHOP DRAWINGS AND SUBMIT COPY TO ARCHITECT FOR REVIEW. DRAWINGS MUST BEAR THE CHECKER'S INITIALS BEFORE SUBMITTAL TO THE ARCHITECT FOR REVIEW.
- THE CONTRACTOR SHALL FIELD VERIFY ALL DIMENSIONS, ELEVATIONS, ANGLES, AND EXISTING CONDITIONS AT THE SITE, PRIOR TO FABRICATION AND/OR INSTALLATION OF ANY WORK IN THE CONTRACT AREA. SUBMIT TO THE ARCHITECT ANY DISCREPANCIES FROM THE DRAWINGS.
- THE CONTRACTOR IS SOLELY RESPONSIBLE TO DETERMINE CONSTRUCTION PROCEDURE AND SEQUENCE, AND TO ENSURE THE SAFETY OF THE EXISTING TOWER AND ITS COMPONENT PARTS DURING CONSTRUCTION. THIS INCLUDES THE ADDITION OF WHATEVER SHORING, BRACING, UNDERPINNING, ETC. THAT MAY BE NECESSARY.
- CONTRACTOR TO CONTACT "CALL BEFORE YOU DIG" AT 1-800-922-4455 TO VERIFY AND IDENTIFY THE EXACT LOCATIONS OF ALL UNDERGROUND UTILITIES AND OBSTRUCTIONS IDENTIFIED PRIOR TO COMMENCING WORK IN THE CONTRACT AREA.
- CONTRACTOR SHALL COMPLY WITH OWNER ENVIRONMENTAL ENGINEER ON ALL METHODS AND PROVISIONS FOR ALL EXCAVATION ACTIVITIES INCLUDING SOIL DISPOSAL. ALL BACKFILL MATERIALS TO BE PROVIDED BY THE CONTRACTOR.
- EXISTING DIMENSIONS OF STRUCTURE SHOWN ON THESE DOCUMENTS ARE NOT GUARANTEED. CONTRACTOR SHALL TAKE FIELD DIMENSIONS AS NECESSARY TO ASSURE PROPER FIT OF ALL FINISHED WORK AND SHALL ASSUME FULL RESPONSIBILITY FOR THEIR ACCURACY. WHEN SHOP DRAWINGS BASED ON FILED MEASUREMENTS ARE SUBMITTED FOR REVIEW, DIMENSIONS ARE PROVIDED FOR THE ENGINEER'S REVERENCE ONLY.
- CONTRACTOR TO VERIFY REQUIRED CLEARANCES INCLUDING BUT NOT LIMITED TO EXISTING BUILDINGS, EQUIPMENT PADS AND SHELTERS PRIOR TO COMMENCING WORK.
- THE OMISSION OF ANY MATERIAL THAT WAS SHOWN ON THE CONTRACT DRAWINGS SHALL NOT RELIEVE THE CONTRACTOR OF PROVIDING THE SAME.
- STRUCTURE IS DESIGNED TO BE LEVEL AND PLUMB, SELF-SUPPORTING AND STABLE AFTER WORK IS COMPLETED.
- THE CONTRACTOR IS RESPONSIBLE FOR THE STABILITY OF THE STRUCTURE DURING CONSTRUCTION. THE CONTRACTOR SHALL BE AWARE OF WEATHER AND WIND CONDITIONS AND NOT PERFORM TOWER MEMBER REPLACEMENT IN A WIND.

STRUCTURAL NOTES

STRUCTURAL STEEL MATERIAL:

STRUCTURAL PLATES ASTM A36
 STEEL BEAMS, CHANNELS & ANGLES ASTM A36
 CONNECTION BOLTS ASTM A325N

MODIFICATIONS SHOWN ARE FOR EACH FACE OR LEG UNLESS NOTED OTHERWISE

UNLESS OTHERWISE NOTED, ALL STEEL WILL BE GALVANIZED IN ACCORDANCE WITH ASTM 123 AFTER FABRICATION. TOUCH UP ALL DAMAGED GALVANIZED STEEL WITH APPROVED COLD ZINC, "GALVANOX", "DRY GALV", "ZINC-IT", OR APPROVED EQUIVALENT, IN ACCORDANCE WITH MANUFACTURERS GUIDELINES. TOUCH-UP DAMAGED NON GALVANIZED STEEL WITH SAME PAINT APPLIED IN SHOP OR FIELD.

EXISTING DIMENSIONS OF STRUCTURE SHOWN ON THESE DOCUMENTS ARE NOT GUARANTEED. CONTRACTOR SHALL TAKE FIELD DIMENSIONS AS NECESSARY TO ASSURE PROPER FIT OF ALL FINISHED WORK AND SHALL ASSUME FULL RESPONSIBILITY FOR THEIR ACCURACY. WHEN SHOP DRAWINGS BASED ON FIELD MEASUREMENT ARE SUBMITTED FOR REVIEW, DIMENSIONS ARE PROVIDED FOR THE ENGINEER'S REFERENCE ONLY.

ALL WELDING SHALL BE DONE BY A CERTIFIED WELDER IN ACCORDANCE WITH AWS STANDARDS, USING E70XX ELECTRODES UNLESS OTHERWISE NOTED. WHERE WELD SIZES ARE NOT SHOWN, PROVIDE THE MINIMUM SIZES PER "PREQUALIFIED WELDED JOINTS" TABLES IN ALSO "MANUAL OF STEEL CONSTRUCTION", NINTH EDITION.

IF WELDING GALVANIZED MATERIALS, USE PRECAUTIONS & PROCEDURES PER AWS D1.1.

MILL BEARING ENDS OF COLUMNS, STIFFENERS, AND OTHER BEARING SURFACES TO TRANSFER LOAD OVER ENTIRE CROSS SECTION.

CONNECTIONS / FIELD ASSEMBLY:

COMMENCEMENT OF STRUCTURAL STEEL WORK WITHOUT NOTIFYING THE ENGINEER OF ANY DISCREPANCIES WILL BE CONSIDERED ACCEPTANCE OF PRECEDING WORK.

BOLT REQUIREMENTS:

BOLTED CONNECTIONS REMOVED DURING CONSTRUCTION SHALL BE REPLACED IN KIND AND BOLTS SHALL CONFORM TO THE REQUIREMENTS OF ASTM A325.

BOLTED CONNECTIONS SHALL BE TIGHTENED TO SNUG TIGHT AS DEFINED BY THE AISC, SPECIFICALLY THE SPECIFICATION FOR STRUCTURAL JOINTS USING ASTM A325 OR A490 BOLTS.

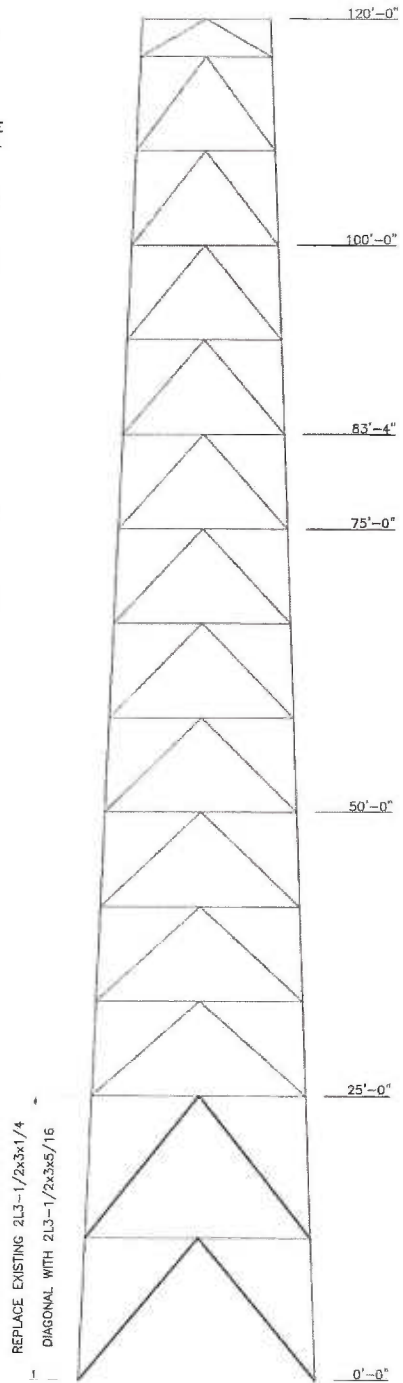

1 TOWER ELEVATION
 SK-1 SCALE: N.T.S.

SITE # NO: 36937329
 Designed by: MCD
 Drawn by: PD
 Checked by: ICA
 Approved by: RAS

URS CORPORATION AES
 500 ENTERPRISE DRIVE
 ROCKY HILL, CONNECTICUT
 860-529-8882

Sprint

SITE ADDRESS:
 120' State Police Tower
 Tower #27
 142 BALDWIN DRIVE
 NEW HAVEN, CONNECTICUT

REV.	DATE:	DESCRIPTION
Scale:	Date: 09/17/14	
Job No. TWM-002	File No.	

Draw. No.
SK-1
 Dwg. 1 of 1

EXHIBIT C

**RADIO FREQUENCY EMISSIONS ANALYSIS REPORT
EVALUATION OF HUMAN EXPOSURE POTENTIAL
TO NON-IONIZING EMISSIONS**

T-Mobile Existing Facility

Site ID: CT11086B

**New Haven / XC X59 (West Rock State Park)
240 Baldwin Drive
New Haven, CT 06515**

October 8, 2014

EBI Project Number: 62142010

Site Compliance Summary	
Compliance Status:	COMPLIANT
Site total MPE% of FCC general public allowable limit:	59.00 %

October 8, 2014

T-Mobile USA
Attn: Jason Overbey, RF Manager
35 Griffin Road South
Bloomfield, CT 06002

Emissions Analysis for Site: **CT11086B – New Haven / XC X59 (West Rock State Park)**

EBI Consulting was directed to analyze the proposed T-Mobile facility located at **240 Baldwin Drive, New Haven, CT**, for the purpose of determining whether the emissions from the Proposed T-Mobile Antenna Installation located on this property are within specified federal limits.

All information used in this report was analyzed as a percentage of current Maximum Permissible Exposure (% MPE) as listed in the FCC OET Bulletin 65 Edition 97-01 and ANSI/IEEE Std C95.1. The FCC regulates Maximum Permissible Exposure in units of microwatts per square centimeter ($\mu\text{W}/\text{cm}^2$). The number of $\mu\text{W}/\text{cm}^2$ calculated at each sample point is called the power density. The exposure limit for power density varies depending upon the frequencies being utilized. Wireless Carriers and Paging Services use different frequency bands each with different exposure limits, therefore it is necessary to report results and limits in terms of percent MPE rather than power density.

All results were compared to the FCC (Federal Communications Commission) radio frequency exposure rules, 47 CFR 1.1307(b)(1) – (b)(3), to determine compliance with the Maximum Permissible Exposure (MPE) limits for General Population/Uncontrolled environments as defined below.

General population/uncontrolled exposure limits apply to situations in which the general public may be exposed or in which persons who are exposed as a consequence of their employment may not be made fully aware of the potential for exposure or cannot exercise control over their exposure. Therefore, members of the general public would always be considered under this category when exposure is not employment related, for example, in the case of a telecommunications tower that exposes persons in a nearby residential area.

Public exposure to radio frequencies is regulated and enforced in units of microwatts per square centimeter ($\mu\text{W}/\text{cm}^2$). The general population exposure limit for the 700 MHz Band is $467 \mu\text{W}/\text{cm}^2$, and the general population exposure limit for the PCS and AWS bands is $1000 \mu\text{W}/\text{cm}^2$. Because each carrier will be using different frequency bands, and each frequency band has different exposure limits, it is necessary to report percent of MPE rather than power density.

Occupational/controlled exposure limits apply to situations in which persons are exposed as a consequence of their employment and in which those persons who are exposed have been made fully aware of the potential for exposure and can exercise control over their exposure. Occupational/controlled exposure limits also apply where exposure is of a transient nature as a result of incidental passage through a location where exposure levels may be above general population/uncontrolled limits (see below), as long as the exposed person has been made fully aware of the potential for exposure and can exercise control over his or her exposure by leaving the area or by some other appropriate means.

Additional details can be found in FCC OET 65.

CALCULATIONS

Calculations were done for the proposed T-Mobile Wireless antenna facility located at **240 Baldwin Drive, New Haven, CT**, using the equipment information listed below. All calculations were performed per the specifications under FCC OET 65. Since T-Mobile is proposing highly focused directional panel antennas, which project most of the emitted energy out toward the horizon, all calculations were performed assuming a lobe representing the maximum gain of the antenna per the antenna manufactures supplied specifications, minus 10 dB, was focused at the base of the tower. For this report the sample point is the top of a 6 foot person standing at the base of the tower.

For all calculations, all equipment was calculated using the following assumptions:

- 1) 2 GSM channels (PCS Band - 1900 MHz) were considered for each sector of the proposed installation. These Channels have a transmit power of 30 Watts per Channel
- 2) 2 UMTS channels (AWS Band – 2100 MHz) were considered for each sector of the proposed installation. These Channels have a transmit power of 30 Watts per Channel.
- 3) 2 LTE channels (AWS Band – 2100 MHz) were considered for each sector of the proposed installation. These Channels have a transmit power of 60 Watts per Channel.
- 4) 1 LTE channel (700 MHz Band) was considered for each sector of the proposed installation. This channel has a transmit power of 30 Watts.
- 5) All radios at the proposed installation were considered to be running at full power and were uncombined in their RF transmissions paths per carrier prescribed configuration. Per FCC OET Bulletin No. 65 - Edition 97-01 recommendations to achieve the maximum anticipated value at each sample point, all power levels emitting from the proposed antenna installation are increased by a factor of 2.56 to account for possible in-phase reflections from the surrounding environment. This is rarely the case, and if so, is never continuous.

- 6) For the following calculations the sample point was the top of a six foot person standing at the base of the tower. The maximum gain of the antenna per the antenna manufactures supplied specifications minus 10 dB was used in this direction. This value is a very conservative estimate as gain reductions for these particular antennas are typically much higher in this direction.
- 7) The antennas used in this modeling are the **Ericsson AIR21 B4A/B2P** for 1900 MHz (PCS) and 2100 MHz (AWS) channels and the **Commscope LNX-6515DS-VTM** for 700 MHz channels. This is based on feedback from the carrier with regards to anticipated antenna selection. The **Ericsson AIR21 B4A/B2P** has a maximum gain of **15.9 dBd** at its main lobe. The **Commscope LNX-6515DS-VTM** has a maximum gain of **14.6 dBd** at its main lobe. The maximum gain of the antenna per the antenna manufactures supplied specifications, minus 10 dB, was used for all calculations. This value is a very conservative estimate as gain reductions for these particular antennas are typically much higher in this direction.
- 8) The antenna mounting height centerline of the proposed antennas is **95 feet** above ground level (AGL).
- 9) Emissions values for additional carriers were taken from the Connecticut Siting Council active database. Values in this database are provided by the individual carriers themselves.

All calculations were done with respect to uncontrolled / general public threshold limits.

T-Mobile Site Inventory and Power Data

Sector:	A	Sector:	B	Sector:	C
Antenna #:	1	Antenna #:	1	Antenna #:	1
Make / Model:	Ericsson AIR21 B4A/B2P	Make / Model:	Ericsson AIR21 B4A/B2P	Make / Model:	Ericsson AIR21 B4A/B2P
Gain:	15.9 dBd	Gain:	15.9 dBd	Gain:	15.9 dBd
Height (AGL):	95	Height (AGL):	95	Height (AGL):	95
Frequency Bands	1900 MHz(PCS) / 2100 MHz (AWS)	Frequency Bands	1900 MHz(PCS) / 2100 MHz (AWS)	Frequency Bands	1900 MHz(PCS) / 2100 MHz (AWS)
Channel Count	2	Channel Count	2	# PCS Channels:	2
Total TX Power:	120	Total TX Power:	120	# AWS Channels:	120
ERP (W):	1,906.06	ERP (W):	1,906.06	ERP (W):	1,906.06
Antenna A1 MPE%	2.12	Antenna B1 MPE%	2.12	Antenna C1 MPE%	2.12
Antenna #:	2	Antenna #:	2	Antenna #:	2
Make / Model:	Ericsson AIR21 B4A/B2P	Make / Model:	Ericsson AIR21 B4A/B2P	Make / Model:	Ericsson AIR21 B4A/B2P
Gain:	15.9 dBd	Gain:	15.9 dBd	Gain:	15.9 dBd
Height (AGL):	95	Height (AGL):	95	Height (AGL):	95
Frequency Bands	1900 MHz(PCS) / 2100 MHz (AWS)	Frequency Bands	1900 MHz(PCS) / 2100 MHz (AWS)	Frequency Bands	1900 MHz(PCS) / 2100 MHz (AWS)
Channel Count	4	Channel Count	4	Channel Count	4
Total TX Power:	120	Total TX Power:	120	Total TX Power:	120
ERP (W):	1,906.06	ERP (W):	1,906.06	ERP (W):	1,906.06
Antenna A2 MPE%	2.12	Antenna B2 MPE%	2.12	Antenna C2 MPE%	2.12
Antenna #:	3	Antenna #:	3	Antenna #:	3
Make / Model:	Commscope LNX-6515DS-VTM	Make / Model:	Commscope LNX-6515DS-VTM	Make / Model:	Commscope LNX-6515DS-VTM
Gain:	14.6 dBd	Gain:	14.6 dBd	Gain:	14.6 dBd
Height (AGL):	95	Height (AGL):	95	Height (AGL):	95
Frequency Bands	700 Mhz	Frequency Bands	700 Mhz	Frequency Bands	700 Mhz
Channel Count	1	Channel Count	1	Channel Count	1
Total TX Power:	30	Total TX Power:	30	Total TX Power:	30
ERP (W):	445.37	ERP (W):	445.37	ERP (W):	445.37
Antenna A3 MPE%	0.84	Antenna B3 MPE%	0.84	Antenna C3 MPE%	0.84

Site Composite MPE %	
Carrier	MPE%
T-Mobile	15.24
AT&T	8.00 %
CTT	1.73 %
CSP	3.17 %
Sprint	14.71 %
DOT	1.40 %
FBI	8.50 %
IRS	3.35 %
OEM	2.90 %
Site Total MPE %:	59.00 %

T-Mobile Sector 1 Total:	5.08 %
T-Mobile Sector 2 Total:	5.08 %
T-Mobile Sector 3 Total:	5.08 %
Site Total:	59.00 %

Summary

All calculations performed for this analysis yielded results that were **within** the allowable limits for general public exposure to RF Emissions.

The anticipated maximum composite contributions from the T-Mobile facility as well as the site composite emissions value with regards to compliance with FCC's allowable limits for general public exposure to RF Emissions are shown here:

T-Mobile Sector	Power Density Value (%)
Sector 1:	5.08 %
Sector 2:	5.08 %
Sector 3 :	5.08 %
T-Mobile Total:	15.24 %
Site Total:	59.00 %
Site Compliance Status:	COMPLIANT

The anticipated composite MPE value for this site assuming all carriers present is **59.00%** of the allowable FCC established general public limit sampled at the ground level. This is based upon values listed in the Connecticut Siting Council database for existing carrier emissions.

FCC guidelines state that if a site is found to be out of compliance (over allowable thresholds), that carriers over a 5% contribution to the composite value will require measures to bring the site into compliance. For this facility, the composite values calculated were well within the allowable 100% threshold standard per the federal government.



Scott Heffernan
RF Engineering Director

EBI Consulting

21 B Street
Burlington, MA 01803`