

Centerline Communications  
Mark Appleby  
750 West Center Street, Floor 3  
West Bridgewater, MA 02379  
860-209-4694  
[mappleby@clinellc.com](mailto:mappleby@clinellc.com)

October 20, 2021

Members of the Siting Council  
Connecticut Siting Council  
Ten Franklin Square  
New Britain, CT 06051

Notice of Exempt Modification  
208 Valley Rd, New Canaan, CT 06840  
Latitude: 41.1467309  
Longitude: -73.4691852  
T-Mobile Site#: CT11098B\_ Hardening

Dear Ms. Bachman:

T-Mobile currently maintains nine (9) antennas at the 117-foot level of the existing 120-foot monopole tower at 208 Valley Rd, New Canaan, CT 06840. The 120-foot tower is owned by Tarpon Towers and property is owned by Silver Hill Hospital Inc. T-Mobile now intends to add a 25Kw Generator to its existing concrete pad within the existing compound. No modifications to the tower, antennas or equipment are proposed.

**Planned Modifications**

**Ground:**

Install new:

(1) Generac RD025 25Kw AC Diesel Generator-240 gallon double walled self- containing tank with fuel sensor  
Requires (2) 12- minute run cycles bi-weekly

This facility was approved by the CT Siting Council under Docket No.401, on February 2, 2012.. There were no conditions that could feasibility be violated by this modification.

Please accept this letter as notification, pursuant to Regulations of Connecticut State Agencies§ 16- 50j-73, for construction that constitutes an exempt modification pursuant to R.C.S.A. §16-50j-72(b)(2). In accordance with R.C.SA. §16-50j-73, a copy of this letter is being sent to Kevin Moynihan, First Selectman Town of New Canaan and Lynn Brooks, Town Planner for the New Canaan, as well as the property owner and the tower owner.

The planned modifications to the facility fall squarely within those activities explicitly provided for in R.C.S;A. § 16-50j-72(b)(2). Specifically:

1. The proposed modifications will not result in an increase in the height of the existing structure.
2. The proposed modifications will not require an extension of the site boundary.
3. The proposed modification will not increase noise levels at the facility by six decibels or more, or to levels that exceed state and local criteria.
4. The operation of the modified facility will not increase radio frequency emissions at the facility to a level at or above the Federal Communications Commission safety standard.
5. The proposed modifications will not cause a change or alteration in the physical or environmental characteristics of the site.

For the foregoing reasons, T-Mobile respectfully submits that the proposed modifications to the above referenced telecommunications facility constitute an exempt modification under R.C.S.A. § 16-50j-72(b)(2).

Sincerely,

**Mark Appleby**

Mobile: 860-209-4694

Fax: 508-819-3017

Office: 90 Hamilton Ave, Southington, CT, CT 06489

Email: [mappleby@clinellc.com](mailto:mappleby@clinellc.com)

Attachments

cc: Kevin Moynihan, First Selectman Town of New Canaan  
Lynn Brooks, Town Planner for the Town of New Canaan  
Tarpon Towers -Tower Owner  
Silver Hill Hospital Inc- Property Owner

# Exhibit A

Original Facility Approval

**DOCKET NO. 401** - T-Mobile Northeast LLC application for a Certificate of Environmental Compatibility and Public Need for the construction, maintenance and operation of a telecommunications facility located at 208 Valley Road, New Canaan, Connecticut.

Connecticut

Siting

Council

February 2, 2012

### Decision and Order

Pursuant to the foregoing Findings of Fact and Opinion, the Connecticut Siting Council (Council) finds that the effects associated with the construction, maintenance, and operation of a telecommunications facility, including effects on the natural environment; ecological integrity and balance; public health and safety; scenic, historic, and recreational values; forests and parks; air and water purity; and fish and wildlife are not disproportionate, either alone or cumulatively with other effects, when compared to need, are not in conflict with the policies of the State concerning such effects, and are not sufficient reason to deny the application, and therefore directs that a Certificate of Environmental Compatibility and Public Need, as provided by General Statutes § 16-50k, be issued to T-Mobile Northeast LLC (T-Mobile), hereinafter referred to as the Certificate Holder, for a telecommunications facility at 208 Valley Road, New Canaan, Connecticut.

Unless otherwise approved by the Council, the facility shall be constructed, operated, and maintained substantially as specified in the Council's record in this matter, and subject to the following conditions:

1. The tower shall be constructed as a monopole with concealed antennas, no taller than necessary to provide the proposed telecommunications services, sufficient to accommodate the antennas of T-Mobile, Verizon Wireless and other entities, both public and private, but such tower shall not exceed a height of 120 feet above ground level. The height at the top of the Certificate Holder's antennas shall not exceed 120 feet above ground level.
2. The Certificate Holder shall prepare a Development and Management (D&M) Plan for this site in compliance with Sections 16-50j-75 through 16-50j-77 of the Regulations of Connecticut State Agencies. The D&M Plan shall be served on the Town of New Canaan for comment, and all parties and intervenors as listed in the service list, and submitted to and approved by the Council prior to the commencement of facility construction and shall include:
  - a) a final site plan(s) of site development to include specifications for the tower, tower foundation, antennas, equipment compound, radio equipment, access road, utility line, and landscaping; and
  - b) construction plans for site clearing, grading, landscaping, water drainage, and erosion and sedimentation controls consistent with the 2002 Connecticut Guidelines for Soil Erosion and Sediment Control, as amended.
3. Prior to the commencement of operation, the Certificate Holder shall provide the Council worst-case modeling of the electromagnetic radio frequency power density of all proposed entities' antennas at the closest point of uncontrolled access to the tower base, consistent with Federal Communications Commission, Office of Engineering and Technology, Bulletin No. 65, August 1997. The Certificate Holder shall ensure a recalculated report of the electromagnetic radio frequency power density be submitted to the Council if and when circumstances in operation cause a change in power density above the levels calculated and provided pursuant to this Decision and Order.

4. Upon the establishment of any new state or federal radio frequency standards applicable to frequencies of this facility, the facility granted herein shall be brought into compliance with such standards.
5. The Certificate Holder shall permit public or private entities to share space on the proposed tower for fair consideration, or shall provide any requesting entity with specific legal, technical, environmental, or economic reasons precluding such tower sharing.
6. The Certificate Holder shall provide reasonable space on the tower for no compensation for any Town of New Canaan public safety services (police, fire and medical services), provided such use can be accommodated and is compatible with the structural integrity of the tower.
7. Unless otherwise approved by the Council, if the facility authorized herein is not fully constructed with at least one fully operational wireless telecommunications carrier providing wireless service within eighteen months from the date of the mailing of the Council's Findings of Fact, Opinion, and Decision and Order (collectively called "Final Decision"), this Decision and Order shall be void, and the Certificate Holder shall dismantle the tower and remove all associated equipment or reapply for any continued or new use to the Council before any such use is made. The time between the filing and resolution of any appeals of the Council's Final Decision shall not be counted in calculating this deadline. Authority to monitor and modify this schedule, as necessary, is delegated to the Executive Director. The Certificate Holder shall provide written notice to the Executive Director of any schedule changes as soon as is practicable.
8. Any request for extension of the time period referred to in Condition 7 shall be filed with the Council not later than 60 days prior to the expiration date of this Certificate and shall be served on all parties and intervenors, as listed in the service list, and the Town of New Canaan. Any proposed modifications to this Decision and Order shall likewise be so served.
9. If the facility ceases to provide wireless services for a period of one year, this Decision and Order shall be void, and the Certificate Holder shall dismantle the tower and remove all associated equipment or reapply for any continued or new use to the Council before any such use is made.
10. Any nonfunctioning antenna, and associated antenna mounting equipment, on this facility shall be removed within 60 days of the date the antenna ceased to function.
11. In accordance with Section 16-50j-77 of the Regulations of Connecticut State Agencies, the Certificate Holder shall provide the Council with written notice two weeks prior to the commencement of site construction activities. In addition, the Certificate Holder shall provide the Council with written notice of the completion of site construction, and the commencement of site operation.
12. The Certificate Holder shall remit timely payments associated with annual assessments and invoices submitted by the Council for expenses attributable to the facility under Conn. Gen. Stat. §16-50v.
13. This Certificate may be transferred in accordance with Conn. Gen. Stat. §16-50k(b), provided both the Certificate Holder\transferor and the transferee are current with payments to the Council for their respective annual assessments and invoices under Conn. Gen. Stat. §16-50v. In addition, both the Certificate Holder\transferor and the transferee shall provide the Council a written agreement as to the entity responsible for any quarterly assessment charges under Conn. Gen. Stat. §16-50v(b)(2) that may be associated with this facility.

14. The Certificate Holder shall maintain the facility and associated equipment, including but not limited to, the tower, tower foundation, antennas, equipment compound, radio equipment, access road, utility line and landscaping in a reasonable physical and operational condition that is consistent with this Decision and Order and a Development and Management Plan to be approved by the Council.
15. If the Certificate Holder is a wholly-owned subsidiary of a corporation or other entity and is sold/transferred to another corporation or other entity, the Council shall be notified of such sale and/or transfer and of any change in contact information for the individual or representative responsible for management and operations of the Certificate Holder within 30 days of the sale and/or transfer.

Pursuant to General Statutes § 16-50p, the Council hereby directs that a copy of the Findings of Fact, Opinion, and Decision and Order be served on each person listed below, and notice of issuance shall be published in The Stamford Advocate and The Hour.

By this Decision and Order, the Council disposes of the legal rights, duties, and privileges of each party named or admitted to the proceeding in accordance with Section 16-50j-17 of the Regulations of Connecticut State Agencies.

The parties and intervenors to this proceeding are:

**Applicant**

T-Mobile Northeast, LLC

**Its Representative**

Julie D. Kohler, Esq.  
Jesse A. Langer, Esq.  
Cohen and Wolf, P.C.  
1115 Broad Street  
Bridgeport, CT 06604

**Intervenor**

Cellco Partnership d/b/a Verizon Wireless

**Its Representative**

Kenneth C. Baldwin, Esq.  
Robinson & Cole LLP  
280 Trumbull Street  
Hartford, CT 06103-3597

# Exhibit B

Property Card

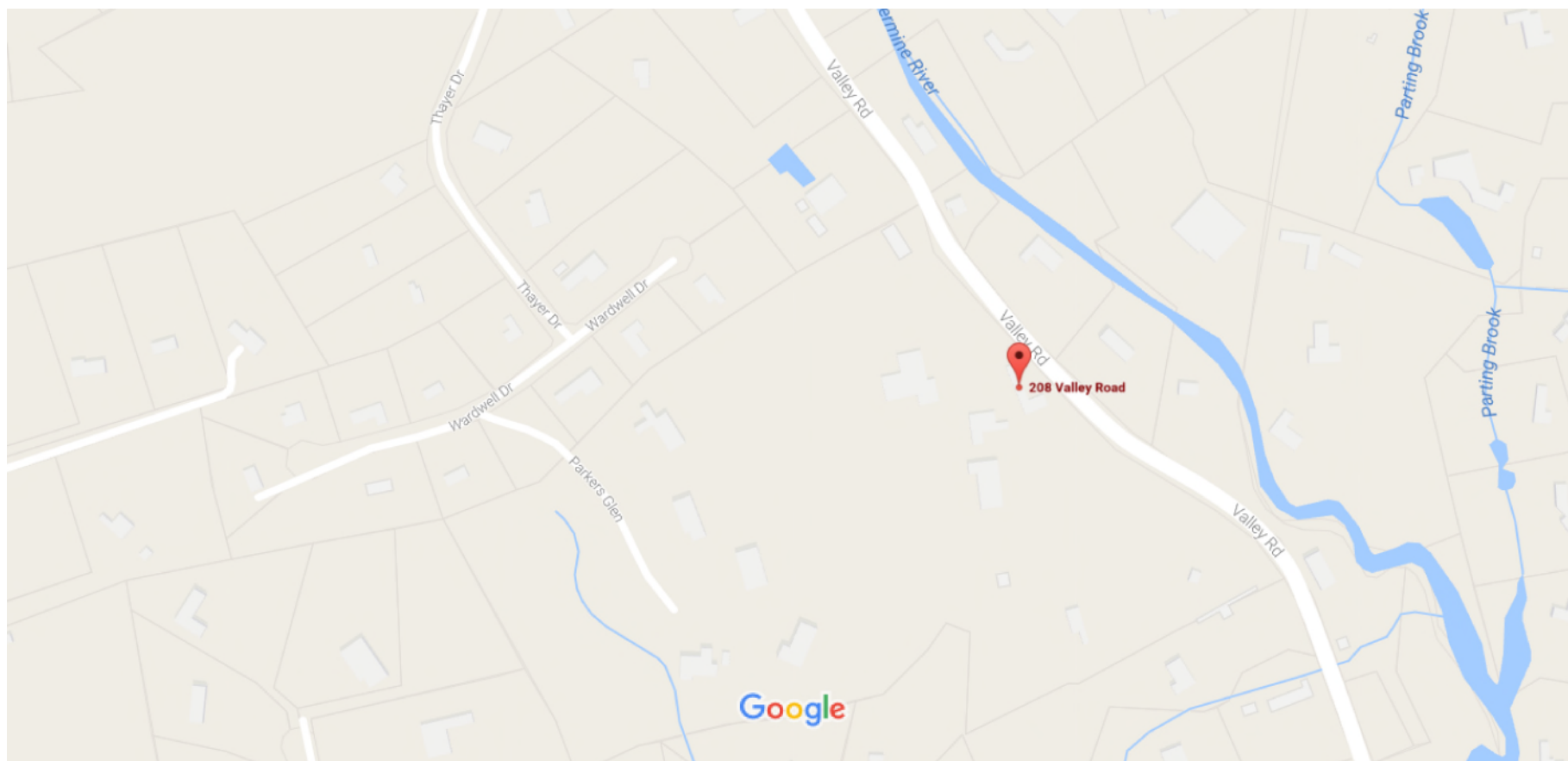





[New Search](#)   
 [Back to Results](#)   
 [View Property](#)   
 [Print](#)   
 [View Map](#)

Location	Owner	Account	MBLU
208 VALLEY RD	SILVER HILL HOSPITAL INC	30126	0044/ 0108/ 0120/

**Parcel Value**

Item	Appraised Value	Assessed Value
Buildings	9,890,300	6,923,210
Extra Building Features	0	0
Outbuildings	67,700	47,390
Land	5,092,000	3,564,400
<b>Total</b>	<b>15,050,000</b>	<b>10,535,000</b>

**Owner of Record**

SILVER HILL HOSPITAL INC 208 VALLEY RD NEW CANAAN, CT 06840
---

**Owner History**

Name	Book/Page	Sale Date	Sale Price
SILVER HILL HOSPITAL INC	702/ 281	11/09/2004	0
SILVER HILL FOUNDATION INC	67/ 13	05/18/1940	136,567

**Assessment History**

Year	Total Assessment
2015	10,535,000
2014	10,535,000
2013	10,535,000
2012	9,209,060
2011	9,209,060
2010	9,209,060
2009	9,209,100
2008	10,969,100
2007	4,710,900
2006	4,710,900
2005	4,710,900
2004	4,710,900
2003	4,710,900
2002	6,112,960

**Building Permits**

Permit ID	Issue Date	Amount	Description
16-00064	01/28/2016	10,000	"REPAIR WATER DAMAGE AT MAIN HOUSE."
15-01238	12/09/2015	80,000	MARTIN CENTER - REPLACE EXISTING ENTRANCE STAIRS AND ROOF.
15-01184	11/30/2015	75,000	RENOVATE 18 EXISTING RESTROOMS (WITH NEW FINISHES AND NEW TOILETS AND SHOWER CONTROLS FOR PATIENT SAFETY.) NO INCREASE IN FIXTURE COUNT.
15-00466	06/01/2015	300,000	MAIN HOUSE - INTERIOR RENOVATIONS TO THE 2ND FLOOR
15-00280	04/07/2015	90,000	'ENLARGE MED ROOM AND SWAP LOUNGE & TREATMENT ROOMS TO FACILITATE PATIENT CARE, ADD AC UNITS TO MED, TREATMENT AND & NURSE STATION.'
14-1307	12/16/2014	72,000	CONSTRUCT A 12 X 24 SHELTER- FOR PROPANE GENERATOR, 6 ANTENNAS, UG PROPANE TANKS

14-0244	03/24/2014	400,000	"MARTIN CENTER BUILDING OFFICE: - RENOVATE EXISTING OFFICE SPACE INCLUDING ADA ACCESS TO UPPER LEVEL, INCLUDES ADDING HVAC & EXTERIOR WINDOWS [**REVISION- \$25,000: CREATE NEW RESTROOM TO REPLACE ONE MOVED TO CREAT DATA CLOSET. NEW RESTROOM TO BE ADA COMPL
14-0297	03/19/2014	175,000	WIRELESS CELL TOWER ONLY.
14-0296	03/19/2014	30,000	INSTALLATION OF EQUIPMENT ON 12x20 CONCRETE PAD, CONCRETE PAD & 3 PANEL ANTENNAS AT 86'
14-0169	02/26/2014	1,600,000	"RESIDENTIAL BUILDING" -- RENOVATION TOTHE EXISTING 7800 SQ FT RESIDENTIAL BUILDING - INCLUDING ADA UPGRADES, NEW WINDOWS SIDING, ROOF, MECHANICALS AND FINISHES FOR THE K HOUSE
14-0168	02/12/2014	20,000	REMOVE POLE MOUNTED FLOOD LIGHTS & REPLACE WITH CAMPUS STD LOW LIGHT POST LIGHTS.
12-0452	09/21/2012	1,500,000	COM ADDS & ALTS
12-0359	04/02/2012	30,000	COM ADDS & ALTS
11-0059	03/15/2011	1,234,000	COM ADDS & ALTS
11-0037	01/19/2011	65,000	ASBESTOS ABATEMENT, EXPLORATION DEMO
10-0086	03/24/2010	735,000	COM ADDS & ALTS
09-0649	01/29/2010	0	SIDEWALKS & ACCESSIBLE ROUTE
09-0109	04/14/2009	100,000	COM ADDS & ALTS
08-0846	11/18/2008	25,000	INT ALTS AND DECK
07-1210	02/28/2008	250,000	CHANGE OF USE INT. ALTS & RAMP R-4
07-0675	08/20/2007	6,199,000	COM ADDITIONS AND ALTERATIONS
07-0402	05/11/2007	50,000	COM ADDS & ALTS
07-0309	04/25/2007	25,000	COM ADDS & ALTS
01-0773A	11/06/2001	0	COM CO
01-0773	09/17/2001	20,000	NEW OUTSIDE STAIRS
01-0096	03/12/2001	73,000	PATIENT ROOM REMO
20343	01/03/2001	42,000	
1914-0120	09/23/1998	150,000	SILVERHILL FOUNDATION, INC.
1796-0120	07/29/1996	1,000	SILVERHILL FOUNDATION, INC.

**Land Line Valuation**

Size	Zone	Dev Map #	Appraised Value	Assessed Value
21.57 AC	2 AC	7319, 7350	5,092,000	3,564,400

**Building Details - Click Buildings Below**

Building 1	Building 2	Building 3	Building 4	Building 5	Building 6	Building 7	Building 8
------------	------------	------------	------------	------------	------------	------------	------------

**Building 1**



0044-0108-0120-00000

**Building Sketch**

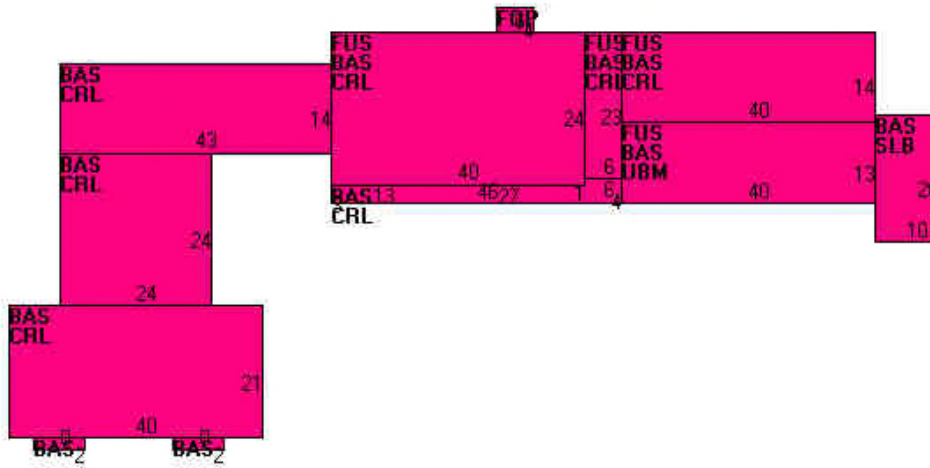

**Subarea Summary**

<b>Code</b>	<b>Description</b>	<b>Gross Area</b>	<b>Living Area</b>
BAS	First Floor	4,572	4,572
CRL	Crawl Space	3,820	0
FOP	Open Porch	24	0
FUS	Upper Story, Finished	2,178	2,178
SLB	Slab	200	0
UBM	Basement, Unfinished	520	0
		<b>Total Living Area:</b>	<b>6,750</b>

# Exhibit C

Construction Drawings

## PROJECT INFORMATION

TOWER OWNER: PHOENIX PARTNERSHIP LLC  
110 WASHINGTON AVENUE  
NORTH HAVEN, CT 06473

SITE NUMBER: CT11098B

SITE NAME: SILVER HILL

SITE ADDRESS: 208 VALLEY ROAD  
NEW CANAAN, CT 06840

LATITUDE: N 41°09'53.03" (41.1647309°) (NAD83)

LONGITUDE: W 73°28'09.06" (-73.4691852°) (NAD83)

STRUCTURE HEIGHT: 120'-0"± AGL

ANTENNA CENTER: N/A± AGL

ZONING JURISDICTION: TOWN OF NEW CANAAN

COUNTY: FAIRFIELD

DESCRIPTION OF WORK: HARDENING



**T - Mobile**  
NORTHEAST LLC

SITE NAME: SILVER HILL  
208 VALLEY ROAD  
NEW CANAAN, CT 06840

SITE ID: CT11098B  
MODIFICATION: HARDENING

**T - Mobile**  
NORTHEAST LLC

T-MOBILE NORTHEAST, LLC.  
35 GRIFFIN RD S  
BLOOMFIELD, CT 06002  
PHONE: (860) 629-1700



750 W CENTER ST, SUITE 301  
WEST BRIDGEWATER, MA 02379  
PHONE: 781.713.4725

### REVISIONS

REV	DATE	DESCRIPTION	BY
0	10/07/21	ISSUED FOR CONSTRUCTION	SS
A	10/05/21	ISSUED FOR REVIEW	RL

DESIGNED BY: RL  
APPROVED BY: WRD

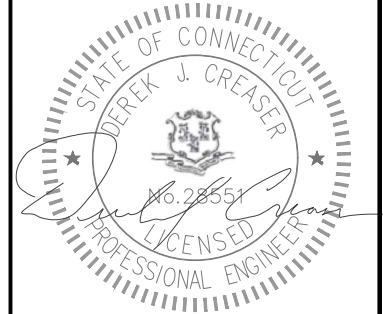

DATE: 10/07/2021

IT IS A VIOLATION OF LAW FOR ANY PERSON UNLESS THEY ARE ACTING UNDER THE DIRECTION OF A LICENSED PROFESSIONAL ENGINEER TO ALTER THIS DOCUMENT. UNLESS EXPLICITLY AGREED TO BY THE ENGINEER IN WRITING, THE ENGINEER DISCLAIMS ALL LIABILITY ASSOCIATED WITH THE REUSE, ALTERATION OR MODIFICATION OF THE CONTENTS HEREIN.

## PROJECT DIRECTORY

ENGINEERING FIRM:  
CENTERLINE COMMUNICATIONS  
750 WEST CENTER ST, SUITE 301  
WEST BRIDGEWATER, MA 02379  
DEREK CREASER (617) 306-3034

CARRIER:  
T-MOBILE NORTHEAST, LLC.  
35 GRIFFIN RD S  
BLOOMFIELD, CT 06002  
PHONE: (860) 692-1700



Know what's below.  
Call before you dig.

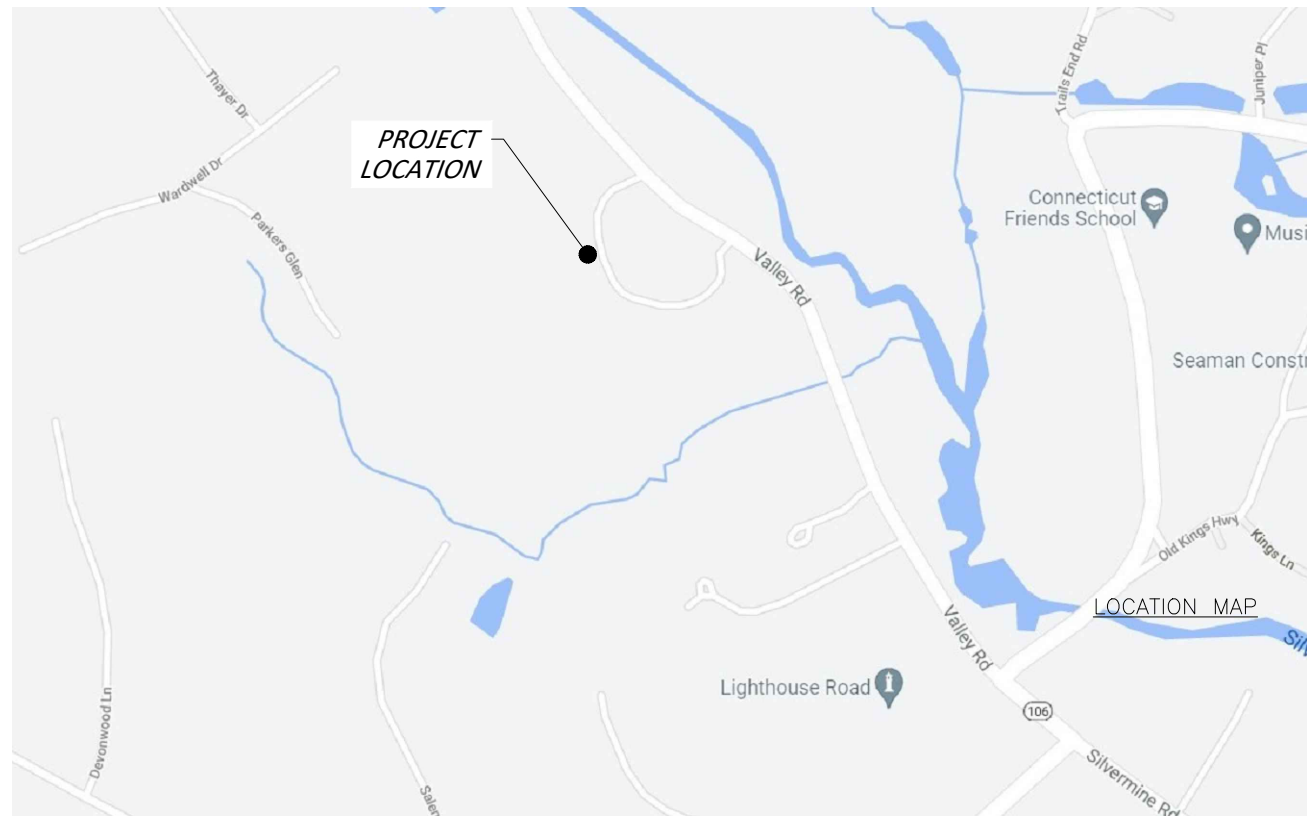

VICINITY MAP  
NOT TO SCALE

## GENERAL NOTES

1. THIS DOCUMENT IS THE CREATION, DESIGN, PROPERTY AND COPYRIGHTED WORK OF T-MOBILE. ANY DUPLICATION OR USE WITHOUT EXPRESS WRITTEN CONSENT IS STRICTLY PROHIBITED. DUPLICATION AND USE BY GOVERNMENT AGENCIES FOR THE PURPOSE OF CONDUCTING THEIR LAWFULLY AUTHORIZED REGULATORY AND ADMINISTRATIVE FUNCTIONS IS SPECIFICALLY ALLOWED.
2. THE FACILITY IS AN UNMANNED PRIVATE AND SECURED EQUIPMENT INSTALLATION. IT IS ONLY ACCESSED BY TRAINED TECHNICIANS FOR PERIODIC ROUTINE MAINTENANCE AND THEREFORE DOES NOT REQUIRE ANY WATER OR SANITARY SEWER SERVICE. THE FACILITY IS NOT GOVERNED BY REGULATIONS REQUIRING PUBLIC ACCESS PER ADA REQUIREMENTS.
3. CONTRACTOR SHALL VERIFY ALL PLANS AND EXISTING DIMENSIONS AND CONDITIONS ON THE JOB SITE AND SHALL IMMEDIATELY NOTIFY THE T-MOBILE REPRESENTATIVE IN WRITING OF DISCREPANCIES BEFORE PROCEEDING WITH THE WORK OR BE RESPONSIBLE FOR SAME.

## DRAWING INDEX

NO.	DESCRIPTION
T-1	TITLE SHEET
GN-1	GENERAL NOTES
A-1	COMPOUND & EQUIPMENT PLAN
A-2	GENERATOR DETAIL
A-3	ATS SPEC SHEET
E-1	ELECTRICAL PLAN & DETAILS
G-1	GROUNDING PLAN

SITE NAME:  
SILVER HILL

SITE ID:  
CT11098B

SITE ADDRESS:  
208 VALLEY ROAD  
NEW CANAAN, CT 06840  
FAIRFIELD COUNTY

SHEET TITLE:  
TITLE SHEET

DRAWING:  
T-1

# GENERAL NOTES

- FOR THE PURPOSE OF CONSTRUCTION DRAWING, THE FOLLOWING DEFINITIONS SHALL APPLY:  
CONTRACTOR - CENTERLINE COMMUNICATIONS  
SUBCONTRACTOR - GENERAL CONTRACTOR (CONSTRUCTION)  
OWNER - T-MOBILE
- PRIOR TO THE SUBMISSION OF BIDS, THE BIDDING SUBCONTRACTOR SHALL VISIT THE CELL SITE TO FAMILIARIZE WITH THE EXISTING CONDITIONS AND TO CONFIRM THAT THE WORK CAN BE ACCOMPLISHED AS SHOWN ON THE CONSTRUCTION DRAWINGS. ANY DISCREPANCY FOUND SHALL BE BROUGHT TO THE ATTENTION OF CONTRACTOR.
- ALL MATERIALS FURNISHED AND INSTALLED SHALL BE IN STRICT ACCORDANCE WITH ALL APPLICABLE CODES, REGULATIONS, AND ORDINANCES. SUBCONTRACTOR SHALL ISSUE ALL APPROPRIATE NOTICES AND COMPLY WITH ALL LAWS, ORDINANCES, RULES, REGULATIONS, AND LAWFUL ORDERS OF ANY PUBLIC AUTHORITY REGARDING THE PERFORMANCE OF THE WORK. ALL WORK CARRIED OUT SHALL COMPLY WITH ALL APPLICABLE MUNICIPAL AND UTILITY COMPANY SPECIFICATIONS AND LOCAL JURISDICTIONAL CODES, ORDINANCES AND APPLICABLE REGULATIONS.
- DRAWINGS PROVIDED HERE ARE NOT TO BE SCALED AND ARE INTENDED TO SHOW OUTLINE ONLY.
- UNLESS NOTED OTHERWISE, THE WORK SHALL INCLUDE FURNISHING MATERIALS, EQUIPMENT, APPURTENANCES, AND LABOR NECESSARY TO COMPLETE ALL INSTALLATIONS AS INDICATED ON THE DRAWINGS.
- "KITTING LIST" SUPPLIED WITH THE BID PACKAGE IDENTIFIES ITEMS THAT WILL BE SUPPLIED BY CONTRACTOR. ITEMS NOT INCLUDED IN THE BILL OF MATERIALS AND KITTING LIST SHALL BE SUPPLIED BY THE SUBCONTRACTOR.
- THE SUBCONTRACTOR SHALL INSTALL ALL EQUIPMENT AND MATERIALS IN ACCORDANCE WITH MANUFACTURER'S RECOMMENDATIONS UNLESS SPECIFICALLY STATED OTHERWISE.
- IF THE SPECIFIED EQUIPMENT CANNOT BE INSTALLED AS SHOWN ON THESE DRAWINGS, THE SUBCONTRACTOR SHALL PROPOSE AN ALTERNATIVE INSTALLATION SPACE FOR APPROVAL BY THE CONTRACTOR.
- SUBCONTRACTOR SHALL DETERMINE ACTUAL ROUTING OF CONDUIT, POWER AND T1 CABLES, GROUNDING CABLES AS SHOWN ON THE POWER, GROUNDING AND TELCO PLAN DRAWING. SUBCONTRACTOR SHALL UTILIZE EXISTING TRAYS AND/OR SHALL ADD NEW TRAYS AS NECESSARY. SUBCONTRACTOR SHALL CONFIRM THE ACTUAL ROUTING WITH THE CONTRACTOR.
- THE SUBCONTRACTOR SHALL PROTECT EXISTING IMPROVEMENTS, PAVEMENTS, CURBS, LANDSCAPING AND STRUCTURES. ANY DAMAGED PART SHALL BE REPAIRED AT SUBCONTRACTOR'S EXPENSE TO THE SATISFACTION OF OWNER.
- SUBCONTRACTOR SHALL LEGALLY AND PROPERLY DISPOSE OF ALL SCRAP MATERIALS SUCH AS COAXIAL CABLES AND OTHER ITEMS REMOVED FROM THE EXISTING FACILITY. ANTENNAS REMOVED SHALL BE RETURNED TO THE OWNER'S DESIGNATED LOCATION.
- SUBCONTRACTOR SHALL LEAVE PREMISES IN CLEAN CONDITION.
- ALL CONCRETE REPAIR WORK SHALL BE DONE IN ACCORDANCE WITH AMERICAN CONCRETE INSTITUTE (ACI) 301.
- ANY NEW CONCRETE NEEDED FOR THE CONSTRUCTION SHALL BE AIR-ENTRAINED AND SHALL HAVE 4000 PSI STRENGTH AT 28 DAYS. ALL CONCRETE WORK SHALL BE DONE IN ACCORDANCE WITH ACI 318 CODE REQUIREMENTS.

- ALL STRUCTURAL STEEL WORK SHALL BE DETAILED, FABRICATED AND ERECTED IN ACCORDANCE WITH AISC SPECIFICATIONS. ALL STRUCTURAL STEEL SHALL BE ASTM A36 (Fy = 36 ksi) UNLESS OTHERWISE NOTED. PIPES SHALL BE ASTM A53 TYPE E (Fy = 36 ksi). ALL STEEL EXPOSED TO WEATHER SHALL BE HOT DIPPED GALVANIZED. TOUCHUP ALL SCRATCHES AND OTHER MARKS IN THE FIELD AFTER STEEL IS ERECTED USING A COMPATIBLE ZINC RICH PAINT.
- CONSTRUCTION SHALL COMPLY WITH SPECIFICATIONS AND "GENERAL CONSTRUCTION SERVICES FOR CONSTRUCTION OF T-MOBILE MOBILITY SITES."
- SUBCONTRACTOR SHALL VERIFY ALL EXISTING DIMENSIONS AND CONDITIONS PRIOR TO COMMENCING ANY WORK. ALL DIMENSIONS OF EXISTING CONSTRUCTION SHOWN ON THE DRAWINGS MUST BE VERIFIED. SUBCONTRACTOR SHALL NOTIFY THE CONTRACTOR OF ANY DISCREPANCIES PRIOR TO ORDERING MATERIAL OR PROCEEDING WITH CONSTRUCTION.
- THE EXISTING CELL SITE IS IN FULL COMMERCIAL OPERATION. ANY CONSTRUCTION WORK BY SUBCONTRACTOR SHALL NOT DISRUPT THE EXISTING NORMAL OPERATION. ANY WORK ON EXISTING EQUIPMENT MUST BE COORDINATED WITH CONTRACTOR. ALSO, WORK SHOULD BE SCHEDULED FOR AN APPROPRIATE MAINTENANCE WINDOW USUALLY IN LOW TRAFFIC PERIODS AFTER MIDNIGHT.
- SINCE THE CELL SITE IS ACTIVE, ALL SAFETY PRECAUTIONS MUST BE TAKEN WHEN WORKING AROUND HIGH LEVELS OF ELECTROMAGNETIC RADIATION. EQUIPMENT SHOULD BE SHUTDOWN PRIOR TO PERFORMING ANY WORK THAT COULD EXPOSE THE WORKERS TO DANGER. PERSONAL RF EXPOSURE MONITORS ARE ADVISED TO BE WORN TO ALERT OF ANY DANGEROUS EXPOSURE LEVELS.
- APPLICABLE BUILDING CODES:  
SUBCONTRACTOR'S WORK SHALL COMPLY WITH ALL APPLICABLE NATIONAL, STATE, AND LOCAL CODES AS ADOPTED BY THE LOCAL AUTHORITY HAVING JURISDICTION (AHJ) FOR THE LOCATION. THE EDITION OF THE AHJ ADOPTED CODES AND STANDARDS IN EFFECT ON THE DATE OF CONTRACT AWARD SHALL GOVERN THE DESIGN.  
  
BUILDING CODE: IBC 2015 & CONNECTICUT STATE BUILDING CODE 2018  
ELECTRICAL CODE: 2017 NATIONAL ELECTRICAL CODE  
LIGHTNING CODE: NFPA 70-2017
- SUBCONTRACTOR'S WORK SHALL COMPLY WITH THE LATEST EDITION OF THE FOLLOWING STANDARDS:  
  
AMERICAN CONCRETE INSTITUTE (ACI) 318; BUILDING CODE REQUIREMENTS FOR STRUCTURAL CONCRETE;  
  
AMERICAN INSTITUTE OF STEEL CONSTRUCTION (AISC)  
  
MANUAL OF STEEL CONSTRUCTION, ASD, FOURTEENTH EDITION;  
  
TELECOMMUNICATIONS INDUSTRY ASSOCIATION (TIA) 222-G, STRUCTURAL STANDARDS FOR STEEL  
  
ANTENNA TOWER AND ANTENNA SUPPORTING STRUCTURES; REFER TO ELECTRICAL DRAWINGS FOR SPECIFIC ELECTRICAL STANDARDS.

FOR ANY CONFLICTS BETWEEN SECTIONS OF LISTED CODES AND STANDARDS REGARDING MATERIAL, METHODS OF CONSTRUCTION, OR OTHER REQUIREMENTS, THE MOST RESTRICTIVE REQUIREMENT SHALL GOVERN. WHERE THERE IS CONFLICT BETWEEN A GENERAL REQUIREMENT AND A SPECIFIC REQUIREMENT, THE SPECIFIC REQUIREMENT SHALL GOVERN.

# RF NOTES

- ACTUAL LENGTHS SHALL BE DETERMINED PER SITE CONDITION BY SUBCONTRACTOR
- THE DESIGN IS BASED ON RF DATA SHEETS, SIGNED AND APPROVED.
- RADIO SIGNAL CABLE AND RACEWAY SHALL COMPLY WITH THE REQUIREMENTS OF THE NATIONAL ELECTRICAL CODE (NEC, NFPA 70), CHAPTER 8.
- ALL SPECIFIED MATERIAL FOR EACH LOCATION (E.G. OUT DOORS-OCCUPIED, INDOORS-UNOCCUPIED, PLENUMS, RISER SHAFTS, ETC.) SHALL BE APPROVED, LISTED, OR LABELED AS REQUIRED BY THE NEC.
- RADIO SIGNAL CABLE SHALL BE SUPPORTED AT MINIMUM OF EVERY THREE (3) FEET EXCEPT INSIDE MONOPOLES OR MONOPOLES WHERE CABLE AND CONNECTOR MANUFACTURERS SUPPORT RECOMMENDATIONS SHALL BE FOLLOWED. MANUFACTURER RECOMMENDATION CABLES SUPPORT ACCESSORIES SHALL BE USED.
- THE OUTDOOR CABLE SUPPORT SYSTEM SHALL BE PROVIDED WITH AN ICE SHIELD TO SUPPORT AND PROTECT ANTENNA CABLE RUNS.
- DRIP LOOPS SHALL BE REQUIRED ON ALL OUTSIDE CABLES. CABLES SHALL BE SLOPED AWAY FROM BUILDING OR OUTDOOR BTS CABINETS TO PREVENT WATER FROM ENTERING THROUGH THE COAXIAL CABLE PORT.
- ALL FEEDER LINE AND JUMPER CONNECTORS SHALL BE 7/16 DIN CABLE CONNECTORS THAT MEET IP68 STANDARDS.
- 7/16 DIN CONNECTORS REQUIRE NO ADDITIONAL WEATHER PROOFING IN INDOOR APPLICATIONS IF INSTALLED AND TORQUED PROPERLY. IN OUTDOOR APPLICATIONS WEATHER PROOFING IS REQUIRED AND THE FOLLOWING PROCEDURE SHOULD BE FOLLOWED.
- USING WEATHERPROOFING KIT APPROVED BY CABLE MANUFACTURER AND CONTRACTOR START TAPE APPROXIMATELY 5 INCHES FROM THE CONNECTOR, AND WRAP 2 INCHES TOWARD THE CONNECTOR, THEN REVERSE THE TAPE SO THAT THE STICKY SIDE IS UP. TAPE OVER THE CONNECTOR OR SURGE ARRESTOR UNTIL THREE (3) TO FOUR (4) INCHES BEYOND THE CONNECTOR AND REVERSE AGAIN WITH THE STICKY SIDE DOWN FOR ANOTHER INCH OR TWO. PASS THE BUTYL RUBBER AND FINISH WITH A FINAL LAYER OF TAPE.
- ANTENNAS SHALL BE PAINTED WHEN REQUIRED, BY THE LANDLORD OR AUTHORITY OF HAVING JURISDICTION IN ACCORDANCE WITH ANTENNA MANUFACTURERS' SURFACES PREPARATION AND PAINTING REQUIREMENTS.
- CABLE SHIELDS AND TOWER CONDUITS SHALL BE GROUNDED AT THE TOP OF THE TOWER WITHIN 10 FEET OF THEIR CONNECTORS, AND AT THE BOTTOM OF THE TOWER ABOUT 6 INCHES BEFORE THEY TURN TOWARD THE FACILITY. THEY SHALL BE GROUNDED AT THE MIDPOINT OF THE TOWERS THAT ARE BETWEEN 60 FEET AND 200 FEET HIGH, AND AT INTERVALS OF 60 FEET OR LESS ON TOWERS THAT ARE HIGHER THAN 200 FEET.

## ANTENNA CABLE AND SCHEDULING NOTES

- SUBCONTRACTOR SHALL VERIFY THE ACTUAL LENGTH IN THE FIELD BEFORE INSTALLATION.
- TAG AND COLOR CODE ALL MAIN CABLES AT LOCATIONS PER T-MOBILE ANTENNA CABLE MARKING STANDARD:
  - TOP OF TOWER END OF MAIN COAX
  - BOTTOM OF TOWER END OF MAIN COAX
  - DIRECTLY BEFORE AND AFTER RF EQUIPMENT
  - END OF JUMPERS AT BTS EQUIPMENT
- ANTENNAS SHALL BE PROCURED AND INSTALLED WITH DOWN TILT MOUNTING BRACKETS SUPPLIED BY ANTENNA MANUFACTURER.
- PRIOR APPROVAL IS REQUIRED BEFORE PERFORMING ANY WORK ON EXISTING CELL SITE EQUIPMENT.

# T - Mobile NORTHEAST LLC

T-MOBILE NORTHEAST, LLC.  
35 GRIFFIN RD S  
BLOOMFIELD, CT 06002  
PHONE: (860) 629-1700



750 W CENTER ST, SUITE 301  
WEST BRIDGEWATER, MA 02379  
PHONE: 781.713.4725

## REVISIONS

REV	DATE	DESCRIPTION	BY
0	10/07/21	ISSUED FOR CONSTRUCTION	SS
A	10/05/21	ISSUED FOR REVIEW	RL

DESIGNED BY: RL	APPROVED BY: WRD
--------------------	---------------------

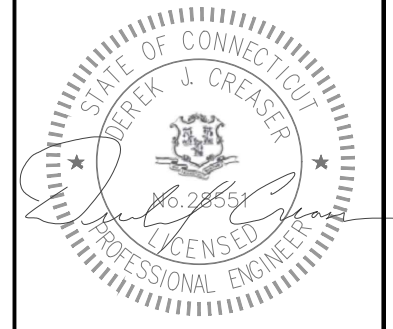

**DATE: 10/07/2021**

IT IS A VIOLATION OF LAW FOR ANY PERSON UNLESS THEY ARE ACTING UNDER THE DIRECTION OF A LICENSED PROFESSIONAL ENGINEER TO ALTER THIS DOCUMENT. UNLESS EXPLICITLY AGREED TO BY THE ENGINEER IN WRITING, THE ENGINEER DISCLAIMS ALL LIABILITY ASSOCIATED WITH THE REUSE, ALTERATION OR MODIFICATION OF THE CONTENTS HEREIN.

# ABBREVIATIONS

AGL	ABOVE GRADE LEVEL	G.C.	GENERAL CONTRACTOR	RF	RADIO FREQUENCY
AWG	AMERICAN WIRE GAUGE	MGB	MASTER GROUND BUS		
BCW	BARE COPPER WIRE	MIN	MINIMUM	TBD	TO BE DETERMINED
BTS	BASE TRANSCEIVER STATION	PROPOSED	NEW	TBR	TO BE REMOVED
EXISTING	EXISTING	N.T.S.	NOT TO SCALE	TBRR	TO BE REMOVED AND REPLACED
EG	EQUIPMENT GROUND	REF	REFERENCE	TYP	TYPICAL
EGR	EQUIPMENT GROUND RING	REQ	REQUIRED		

<b>SITE NAME:</b>	SILVER HILL
<b>SITE ID:</b>	CT11098B
<b>SITE ADDRESS:</b>	208 VALLEY ROAD NEW CANAAN, CT 06840 FAIRFIELD COUNTY

<b>SHEET TITLE:</b>	<b>GENERAL NOTES</b>
<b>DRAWING:</b>	<b>GN-1</b>

# T-Mobile NORTHEAST LLC

T-MOBILE NORTHEAST, LLC.  
35 GRIFFIN RD S  
BLOOMFIELD, CT 06002  
PHONE: (860) 629-1700



750 W CENTER ST, SUITE 301  
WEST BRIDGEWATER, MA 02379  
PHONE: 781.713.4725

## REVISIONS

REV	DATE	DESCRIPTION	BY
0	10/07/21	ISSUED FOR CONSTRUCTION	SS
A	10/05/21	ISSUED FOR REVIEW	RL

DESIGNED BY: RL	APPROVED BY: WRD
--------------------	---------------------

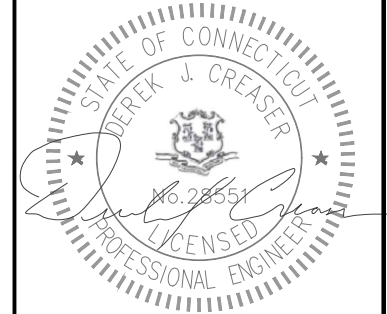

DATE: 10/07/2021

IT IS A VIOLATION OF LAW FOR ANY PERSON UNLESS THEY ARE ACTING UNDER THE DIRECTION OF A LICENSED PROFESSIONAL ENGINEER TO ALTER THIS DOCUMENT, UNLESS EXPLICITLY AGREED TO BY THE ENGINEER IN WRITING. THE ENGINEER DISCLAIMS ALL LIABILITY ASSOCIATED WITH THE REUSE, ALTERATION OR MODIFICATION OF THE CONTENTS HEREIN.

SITE NAME: <b>SILVER HILL</b>
SITE ID: <b>CT11098B</b>
SITE ADDRESS: <b>208 VALLEY ROAD NEW CANAAN, CT 06840 FAIRFIELD COUNTY</b>

SHEET TITLE: <b>COMPOUND &amp; EQUIPMENT PLAN</b>
DRAWING: <b>A-1</b>

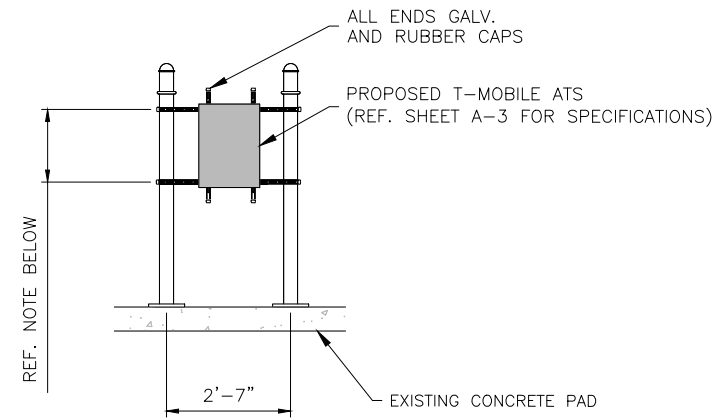

NOTE:  
HORIZONTAL & VERTICAL UNISTRUT TO BE  
SPACED SO EQUIPMENT MOUNTING HOLES ALIGN.

3  
A-1  
**H-FRAME DETAIL**

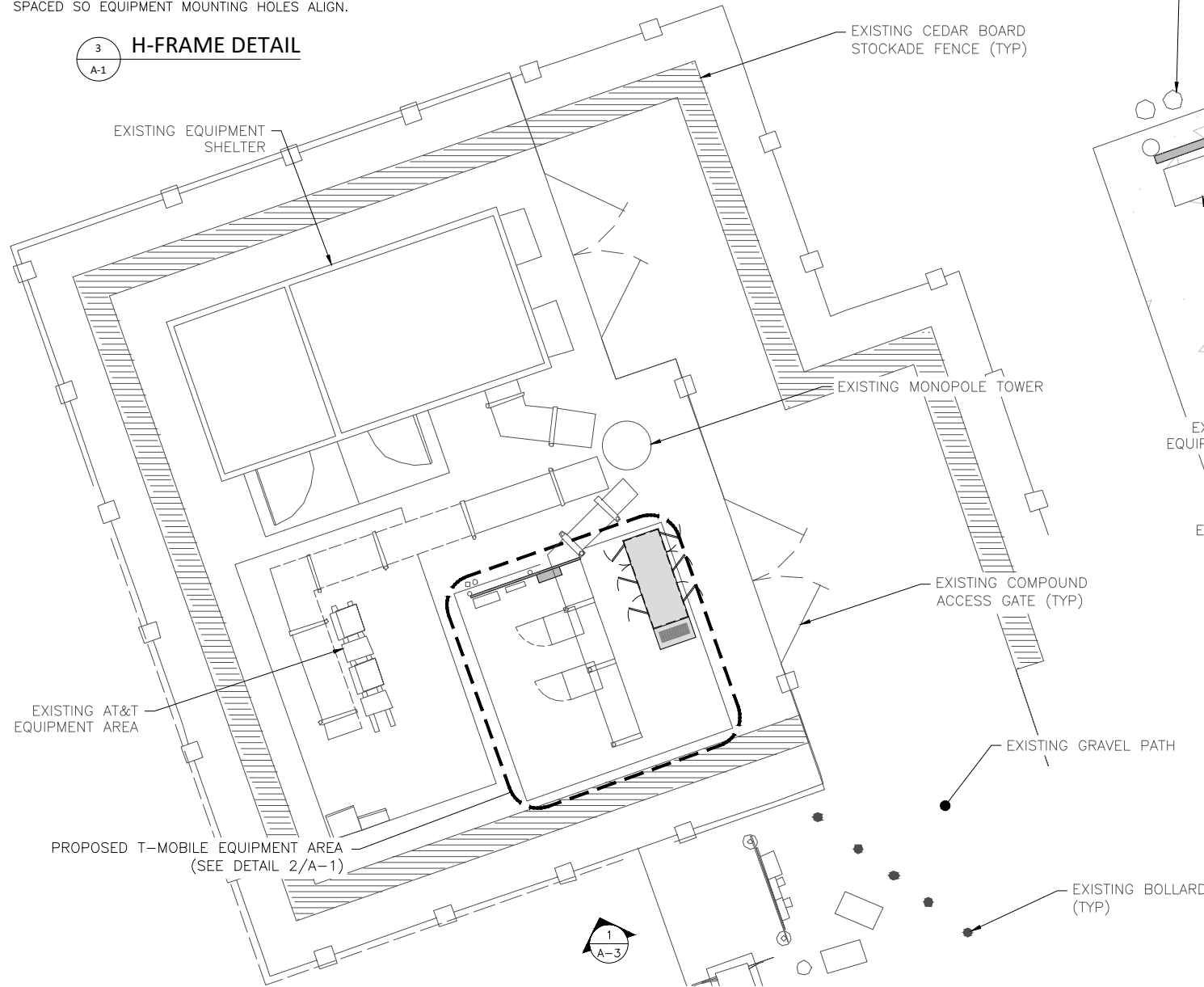

1  
A-1  
**COMPOUND PLAN**

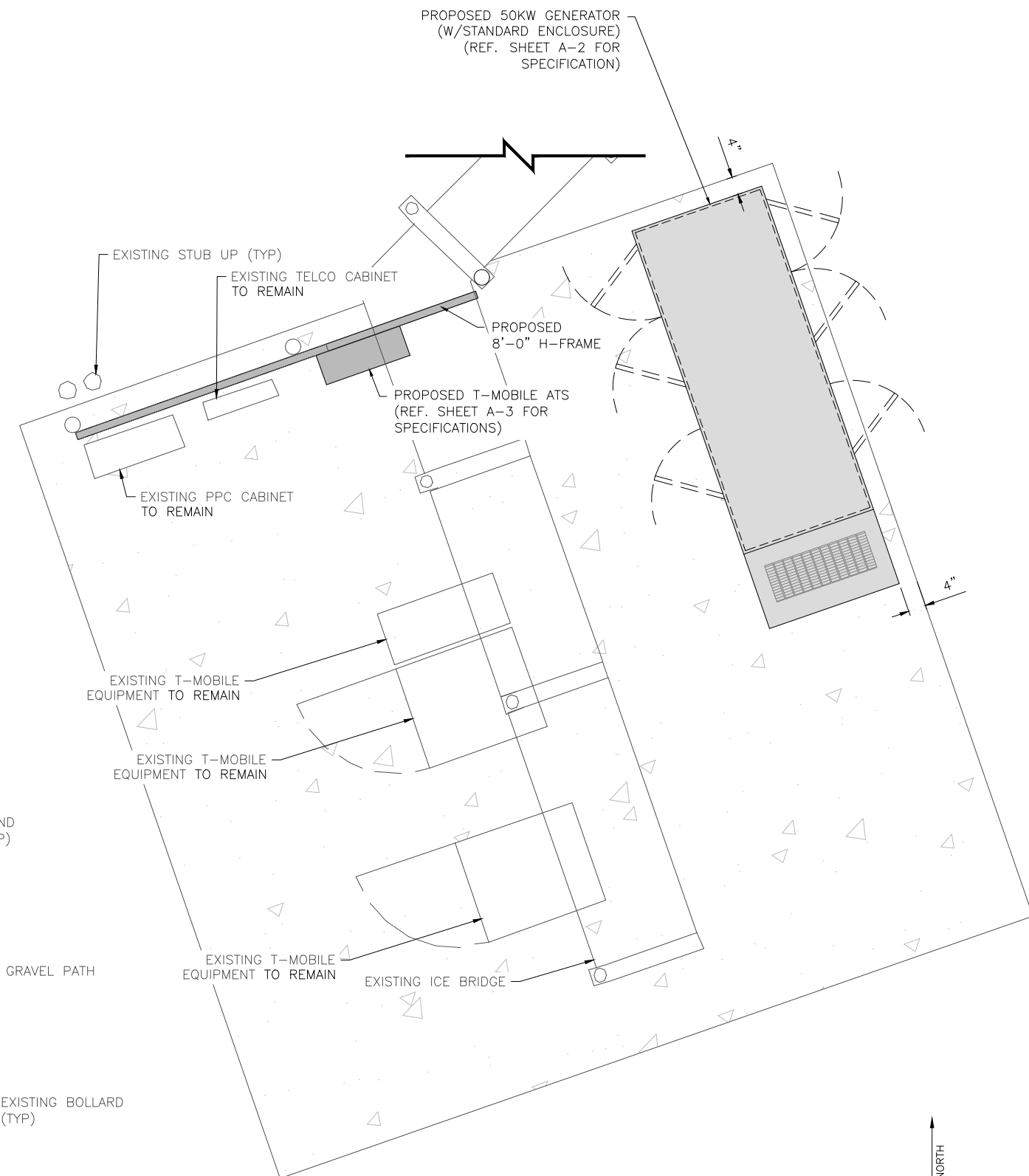
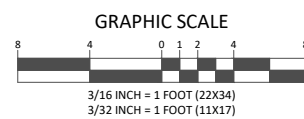

2  
A-1  
**PROPOSED EQUIPMENT PLAN**

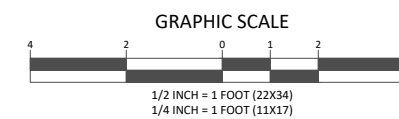

# Protector™ Series

# GENERAC®

## Diesel Generator Set

Protector™ Series  
Protector™ Series

1 of 12 2 of 12

### INCLUDES:

- Two Line LCD Multilingual Digital Evolution™ Controller (English/Spanish/French/Portuguese) with external viewing window for easy indication of generator status and breaker position.
- Isochronous Electronic Governor
- Sound Attenuated Aluminum Enclosure
- Smart Battery Charger
- UV/Ozone Resistant Hoses
- ±1% Voltage Regulation
- Integrated Base Tank Provides Up to 40 Hours of Run Time
- 5 Year Limited Warranty\*
- UL 2200 / UL142 / ULC S601 Listed
- Meets code requirements for External Vent and Fill

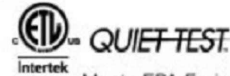

Meets EPA Emission Regulations  
CA/MA Emissions Compliant

\* 5 year warranty applicable to U.S. and Territories/Canada. International warranty is 3 year limited.

**Standby Power Rating**  
 Model RD015 - 15 kW 60 Hz  
 Model RD020 - 20 kW 60 Hz  
 Model RD030 - 30 kW 60 Hz  
 Model RD048 - 48 kW 60 Hz (single phase only)  
 Model RD050 - 50 kW 60 Hz (three phase only)

### FEATURES

- **INNOVATIVE DESIGN & PROTOTYPE TESTING** are key components of GENERAC'S success in "IMPROVING POWER BY DESIGN." But it doesn't stop there. Total commitment to component testing, reliability testing, environmental testing, destruction and life testing, plus testing to applicable CSA, NEMA, EGSA, and other standards, allows you to choose GENERAC POWER SYSTEMS with the confidence that these systems will provide superior performance.
- **SOLID-STATE, FREQUENCY COMPENSATED VOLTAGE REGULATION.** This state-of-the-art power maximizing regulation system is standard on all Generac models. It provides optimized FAST RESPONSE to changing load conditions and MAXIMUM MOTOR STARTING CAPABILITY by electronically torque-matching the surge loads to the engine. Digital voltage regulation at ±1%.
- **SINGLE SOURCE SERVICE RESPONSE** from Generac's extensive dealer network provides parts and service know-how for the entire unit, from the engine to the smallest electronic component.
- **GENERAC TRANSFER SWITCHES.** Long life and reliability are synonymous with GENERAC POWER SYSTEMS. One reason for this confidence is that the GENERAC product line includes its own transfer systems and controls for total system compatibility.
- **TEST CRITERIA:**
  - ✓ PROTOTYPE TESTED
  - ✓ SYSTEM TORSIONAL TESTED
  - ✓ NEMA MG1-22 EVALUATION
  - ✓ MOTOR STARTING ABILITY



15 • 20 • 30 • 48 • 50 kW

**GENERAC®**  
application & engineering data

### GENERATOR SPECIFICATIONS

Type	Synchronous
Rotor Insulation Class	H (15 & 20 kW) or F (30, 48 & 50 kW)
Stator Insulation Class	H
Telephone Interference Factor (TIF)	<50
Alternator Output Leads 1-Phase	3 wire
Alternator Output Leads 3-Phase	6 wire
Bearings	Single Sealed Cartridge
Coupling	Direct, Flexible Disc
Excitation System	Direct

### VOLTAGE REGULATION

Type	Electronic
Sensing	Single Phase
Regulation	± 1%
Features	Adjustable Voltage & Gain

### GOVERNOR SPECIFICATIONS

Type	Electronic Isochronous
Steady State Regulation	± 0.25%

### ELECTRICAL SYSTEM

Battery Charge Alternator	50 Amp (15 & 20 kW) or 70 Amp (30, 48 & 50 kW)
Smart Battery Charger	2 Amp
Recommended Battery (battery not included)	Group 27F, 700 CCA
System Voltage	12 Volts

### GENERATOR FEATURES

Revolving field heavy duty generator  
 Directly connected to the engine  
 Operating temperature rise 120°C above a 40°C ambient  
 Class H insulation is NEMA rated  
 Class F insulation is NEMA rated  
 All models fully prototype tested

### ENCLOSURE FEATURES

Aluminum weather protective enclosure	Ensures protection against mother nature. Electrostatically applied textured epoxy paint for added durability.
Enclosed critical grade muffler	Quiet, critical grade muffler is mounted inside the unit to prevent injuries and maximize sound dampening.
Small, compact, attractive	Makes for an easy, eye appealing installation.
SAE	Sound attenuated enclosure ensures quiet operation.

(All ratings in accordance with BS5514, ISO3046, ISO8528, SAE J1349 and DIN6271)

**T-Mobile**  
NORTHEAST LLC

T-MOBILE NORTHEAST, LLC.  
35 GRIFFIN RD S  
BLOOMFIELD, CT 06002  
PHONE: (860) 629-1700



750 W CENTER ST, SUITE 301  
WEST BRIDGEWATER, MA 02379  
PHONE: 781.713.4725

### REVISIONS

REV	DATE	DESCRIPTION	BY
0	10/07/21	ISSUED FOR CONSTRUCTION	SS
A	10/05/21	ISSUED FOR REVIEW	RL

DESIGNED BY: RL	APPROVED BY: WRD
--------------------	---------------------

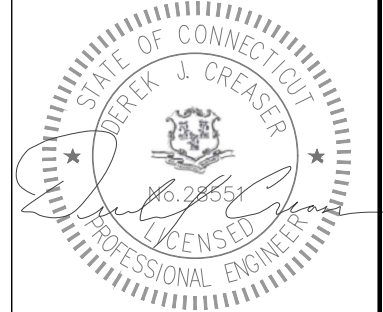

DATE: 10/07/2021

IT IS A VIOLATION OF LAW FOR ANY PERSON UNLESS THEY ARE ACTING UNDER THE DIRECTION OF A LICENSED PROFESSIONAL ENGINEER TO ALTER THIS DOCUMENT. UNLESS EXPLICITLY AGREED TO BY THE ENGINEER IN WRITING, THE ENGINEER DISCLAIMS ALL LIABILITY ASSOCIATED WITH THE REUSE, ALTERATION OR MODIFICATION OF THE CONTENTS HEREIN.

SITE NAME:	SILVER HILL
SITE ID:	CT11098B
SITE ADDRESS:	208 VALLEY ROAD NEW CANAAN, CT 06840 FAIRFIELD COUNTY

SHEET TITLE:	GENERATOR DETAIL
--------------	------------------

DRAWING:	A-2
----------	-----



## Automatic Transfer Switches

# GENERAC®

## Service and non-Service rated Automatic Smart Transfer Switches

### 100 - 400 Amps, Single Phase

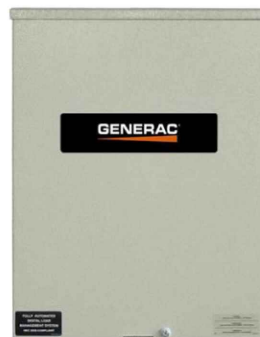

\*CUL only applies to non-service rated switches

Automatic Transfer Switches

Automatic Transfer Switches

1 of 2 2 of 2

# GENERAC®

## Automatic Smart Transfer Switches

### 100-400 Amps, Single Phase

#### Functions

All timing and sensing functions originate in the generator controller

Utility voltage drop-out.....	<65%
Timer to generator start .....	10 second factory set, adjustable between 2-1500 seconds by a qualified dealer*
Engine warm up delay .....	5 seconds
Standby voltage sensor .....	65% for 5 seconds
Utility voltage pickup.....	>80%
Re-transfer time delay .....	15 seconds
Engine cool-down timer .....	60 seconds
Exerciser .....	.5 or 12 minutes adjustable weekly/Bi-weekly/Monthly**

The transfer switch can be operated manually without power applied.

\*When used in conjunction with units utilizing Evolution™ controls \*\*Adjustable via the controller

#### Specifications

Model	RXSC100A3	RXSC200A3
Amps	100	200
Voltage	120/240, 1Ø	120/240, 1Ø
Load Transition Type (Automatic)	Open Transition	Open Transition
Enclosure Type	NEMA/UL3R	NEMA/UL3R
UL Rating	UL/CUL	UL/CUL
Withstand Rating (Amps)	10,000	10,000
Lug Range	1/0 - #14	250 MCM - #6

#### Dimensions

Model	RXSC100A3	RXSC200A3
Height (in./mm)	H1	17.24/437.9
	H2	20/508
Width (in./mm)	W1	12.5/317.5
	W2	14.6/370.8
Depth (in./mm)	7.09/180.1	7.09/180.1
Weight (lbs./kilos)	20/9.07	20/9.07

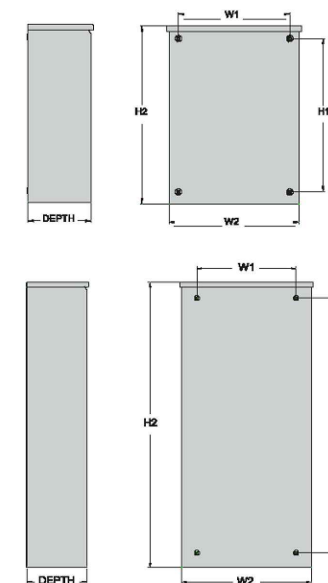

#### Description

Generac Automatic Transfer Switches are designed for use with single phase generators that utilize an Evolution™ or Nexus™ Controller. The 100, 200, and 400 amp open transition switches are available in single phase in both service equipment rated and non-service equipment rated configurations. The 150 and 300 amp open transition switches are only available in a service rated equipment configuration.

#### Standard Features

Service rated (RXSW) Generac Automatic Transfer Switches are housed in an aluminum NEMA/UL Type 3R enclosure\*, with electrostatically applied and baked powder paint. The Heavy Duty Generac Contactor is a UL recognized device, designed for years of service. The controller at the generator handles all the timing, sensing, exercising functions, and transfer commands. All switches are covered by a 5 year limited warranty.

\*Non-service rated (RXSC) switches are housed in a steel enclosure.

#### DPM Technology

Through the use of digital power technology (DPM), these switches have the capability to manage up to 4 individual HVAC (24 VAC controlled) loads with no additional hardware. When used in tandem with Smart Management Modules, up to 8 more loads can be managed as well, providing the most installation efficient power management options available.



Generac Power Systems, Inc. • 545 W29290 HWY. 59, Waukesha, WI 53189 • generac.com  
©2017 Generac Power Systems, Inc. All rights reserved. All specifications are subject to change without notice. Bulletin 10000013459-A 04/24/17

# T-Mobile

## NORTHEAST LLC

T-MOBILE NORTHEAST, LLC.  
35 GRIFFIN RD S  
BLOOMFIELD, CT 06002  
PHONE: (860) 629-1700



750 W CENTER ST, SUITE 301  
WEST BRIDGEWATER, MA 02379  
PHONE: 781.713.4725

#### REVISIONS

REV	DATE	DESCRIPTION	BY
0	10/07/21	ISSUED FOR CONSTRUCTION	SS
A	10/05/21	ISSUED FOR REVIEW	RL

DESIGNED BY: RL APPROVED BY: WRD

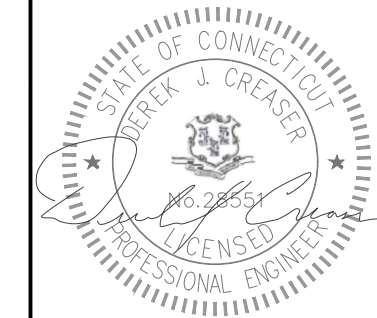

DATE: 10/07/2021

IT IS A VIOLATION OF LAW FOR ANY PERSON UNLESS THEY ARE ACTING UNDER THE DIRECTION OF A LICENSED PROFESSIONAL ENGINEER TO ALTER THIS DOCUMENT. UNLESS EXPLICITLY AGREED TO BY THE ENGINEER IN WRITING, THE ENGINEER DISCLAIMS ALL LIABILITY ASSOCIATED WITH THE REUSE, ALTERATION OR MODIFICATION OF THE CONTENTS HEREIN.

SITE NAME: SILVER HILL  
SITE ID: CT11098B  
SITE ADDRESS: 208 VALLEY ROAD  
NEW CANAAN, CT 06840  
FAIRFIELD COUNTY

SHEET TITLE: ATS SPEC SHEET

DRAWING: A-3

# ELECTRICAL NOTES

- SUBMITTAL OF BID INDICATES THAT THE CONTRACTOR IS COGNIZANT OF ALL JOB SITE CONDITIONS AND WORK TO BE PERFORMED UNDER THIS CONTRACT.
- CONTRACTOR SHALL PERFORM ALL VERIFICATIONS, OBSERVATION TESTS, AND EXAMINATION WORK PRIOR TO ORDERING OF ANY EQUIPMENT AND THE ACTUAL CONSTRUCTION. CONTRACTOR SHALL ISSUE A WRITTEN NOTICE OF ALL FINDINGS TO THE PROJECT MANAGER LISTING ALL MALFUNCTIONS, FAULTY EQUIPMENT AND DISCREPANCIES.
- THESE PLANS ARE DIAGRAMMATIC ONLY, FOLLOW AS CLOSELY AS POSSIBLE.
- CONTRACTOR SHALL COORDINATE ALL WORK BETWEEN TRADES AND ALL OTHER SCHEDULING AND PROVISIONARY CIRCUMSTANCES SURROUNDING THE PROJECT.
- CONTRACTOR SHALL PROVIDE ALL LABOR, MATERIALS, INSURANCE, EQUIPMENT, INSTALLATION CONSTRUCTION TOOLS, TRANSPORTATION, ETC., FOR COMPLETE AND FUNCTIONALLY OPERATING SYSTEMS ENERGIZED AND READY FOR USE THROUGHOUT AS INDICATED ON DRAWINGS, AS SPECIFIED HEREIN AND/OR AS OTHERWISE REQUIRED.
- ALL MATERIALS AND EQUIPMENT SHALL BE NEW AND IN PERFECT CONDITION WHEN INSTALLED AND SHALL BE OF THE BEST GRADE AND OF THE SAME MANUFACTURER THROUGHOUT FOR EACH CLASS OR GROUP OF EQUIPMENT. ELECTRICAL MATERIALS SHALL BE LISTED AND APPROVED BY UNDERWRITER'S LABORATORIES AND SHALL BEAR THE INSPECTION LABEL "J" WHERE SUBJECT TO

- SUCH APPROVAL. MATERIALS SHALL MEET WITH APPROVAL OF ALL GOVERNING BODIES HAVING JURISDICTION OVER THE CONSTRUCTION. MATERIALS SHALL BE MANUFACTURED IN ACCORDANCE WITH ALL CURRENT APPLICABLE STANDARDS ESTABLISHED BY ANSI, NEMA AND NBFU. ALL MATERIALS AND EQUIPMENT SHALL BE APPROVED FOR THEIR INTENDED USE AND LOCATION.
- ALL WORK SHALL COMPLY WITH ALL APPLICABLE GOVERNING STATE, COUNTY AND CITY CODES AND OSHA, NFPA, NEC & ASHRAE REQUIREMENTS.
  - ENTIRE JOB SHALL BE GUARANTEED FOR A PERIOD OF ONE (1) YEAR AFTER THE DATE OF JOB ACCEPTANCE. ALL WORK, MATERIAL AND EQUIPMENT FOUND TO BE FAULTY DURING THAT PERIOD SHALL BE CORRECTED AT ONCE, UPON WRITTEN NOTIFICATION, AT THE EXPENSE OF THE CONTRACTOR.
  - PROPERLY SEAL ALL PENETRATIONS. PROVIDE UL LISTED FIRE-STOPS WHERE PENETRATIONS ARE MADE THROUGH FIRE-RATED ASSEMBLIES. WATER-TIGHT USING SILICONE SEALANT.
  - DELIVER ALL BROCHURES, OPERATING MANUALS, CATALOGS AND SHOP DRAWINGS TO THE PROJECT MANAGER AT JOB COMPLETION. PROVIDE MAINTENANCE MANUALS FOR MECHANICAL EQUIPMENT. AFFIX MAINTENANCE LABELS TO MECHANICAL EQUIPMENT.
  - ALL CONDUCTORS SHALL BE COPPER. MINIMUM CONDUCTOR SIZE SHALL BE #12 AWG., UNLESS OTHERWISE NOTED. CONDUCTORS SHALL BE TYPE THHW, RATED IN ACCORDANCE WITH NEC 110-14(C).
  - ALL CIRCUIT BREAKERS, FUSES AND ELECTRICAL EQUIPMENT SHALL HAVE AN INTERRUPTING RATING NOT LESS THE MAXIMUM INTERRUPTING CURRENT TO WHICH THEY MAY BE SUBJECTED.

- THE ENTIRE ELECTRICAL INSTALLATION SHALL BE GROUNDED IN ACCORDANCE WITH THE NATIONAL ELECTRICAL CODE; ARTICLES 250 & 810 AND THE UTILITY COMPANY STANDARDS.
- CONDUIT:
  - RIGID CONDUIT SHALL BE U.L. LABEL GALVANIZED ZINC COATED WITH ZINC INTERIOR AND SHALL BE USED WHEN INSTALLED IN OR UNDER CONCRETE SLABS, IN CONTACT WITH THE EARTH, UNDER PUBLIC ROADWAYS, IN MASONRY WALLS OR EXPOSED ON BUILDING EXTERIOR. RIGID CONDUIT IN CONTACT WITH EARTH SHALL BE 1/2 LAPPED WRAPPED WITH HUNTS WRAP PROCESS NO. 3.
  - ELECTRICAL METALLIC TUBING SHALL HAVE U.L. LABEL, FITTINGS SHALL BE GLAND RING COMPRESSION TYPE. EMT SHALL BE USED ONLY FOR INTERIOR RUNS.
  - LIQUID-TIGHT FLEXIBLE METAL CONDUIT SHALL BE U.L. LISTED AND SHALL BE USED AT FINAL CONNECTIONS TO MECHANICAL EQUIPMENT & RECTIFIERS AND WHERE PERMITTED BY CODE. ALL CONDUIT IN EXCESS OF SIX FEET IN LENGTH SHALL CONTAIN A FULL-SIZE GROUND CONDUCTOR.
  - CONDUIT RUNS SHALL BE SURFACE MOUNTED ON CEILINGS OR WALLS UNLESS NOTED OTHERWISE. ALL CONDUIT SHALL RUN PARALLEL OR PERPENDICULAR TO WALLS, FLOOR, CEILING, OR BEAMS. VERIFY EXACT ROUTING OF ALL EXPOSED CONDUIT WITH THE PROJECT MANAGER PRIOR TO INSTALLING.

- PVC CONDUIT MAY BE PROVIDED ONLY WHERE SHOWN, OR IN UNDERGROUND INSTALLATIONS. PROVIDE UV-RESISTANT CONDUIT WHERE EXPOSED TO THE ATMOSPHERE. PROVIDE GROUND CONDUCTOR IN ALL PVC RUNS; EXCEPT WHERE PERMITTED BY CODE TO OMIT.
- ALL ELECTRICAL EQUIPMENT SHALL BE LABELED WITH PERMANENT ENGRAVED PLASTIC LABELS. BACKGROUND SHALL BE BLACK WITH WHITE LETTERS; EXCEPT AS REQUIRED BY CODE TO FOLLOW A DIFFERENT SCHEME.
- UPON COMPLETION OF WORK, CONDUCT CONTINUITY, SHORT CIRCUIT, AND FALL OF POTENTIAL GROUNDING TESTS FOR APPROVAL. SUBMIT TEST REPORTS TO PROJECT MANAGER. GROUNDING SYSTEM RESISTANCE SHALL NOT EXCEED 5 OHMS. IF THE RESISTANCE VALUE IS EXCEEDED, NOTIFY THE PROJECT MANAGER FOR FURTHER INSTRUCTION ON METHODS FOR REDUCING THE RESISTANCE VALUE.
- CLEAN PREMISES OF ALL DEBRIS RESULTING FROM WORK AND LEAVE WORK IN A COMPLETE AND UNDAMAGED CONDITION. LEGALLY DISPOSE OF ALL REMOVED, UNUSED AND EXCESS MATERIAL GENERATED BY THE WORK OF THIS CONTRACT. DELIVER ITEMS INDICATED ON THE DRAWINGS TO THE OWNER IN GOOD CONDITION. OBTAIN SIGNED RECEIPT UPON DELIVERY.
- COORDINATE WITH UTILITY COMPANY FOR CONNECTION OF TEMPORARY AND PERMANENT POWER TO THE SITE. THE TEMPORARY POWER AND ALL HOOKUP COSTS SHALL BE PAID BY THE CONTRACTOR.
- VERIFY ALL EXISTING CIRCUITRY PRIOR TO REMOVAL AND NEW WORK. MAINTAIN POWER TO ALL OTHER AREAS & CIRCUITS NOT SCHEDULED FOR REMOVAL.
- RED LINED AS-BUILT PLANS SHALL BE PROVIDED TO THE CONSTRUCTION MANAGER.

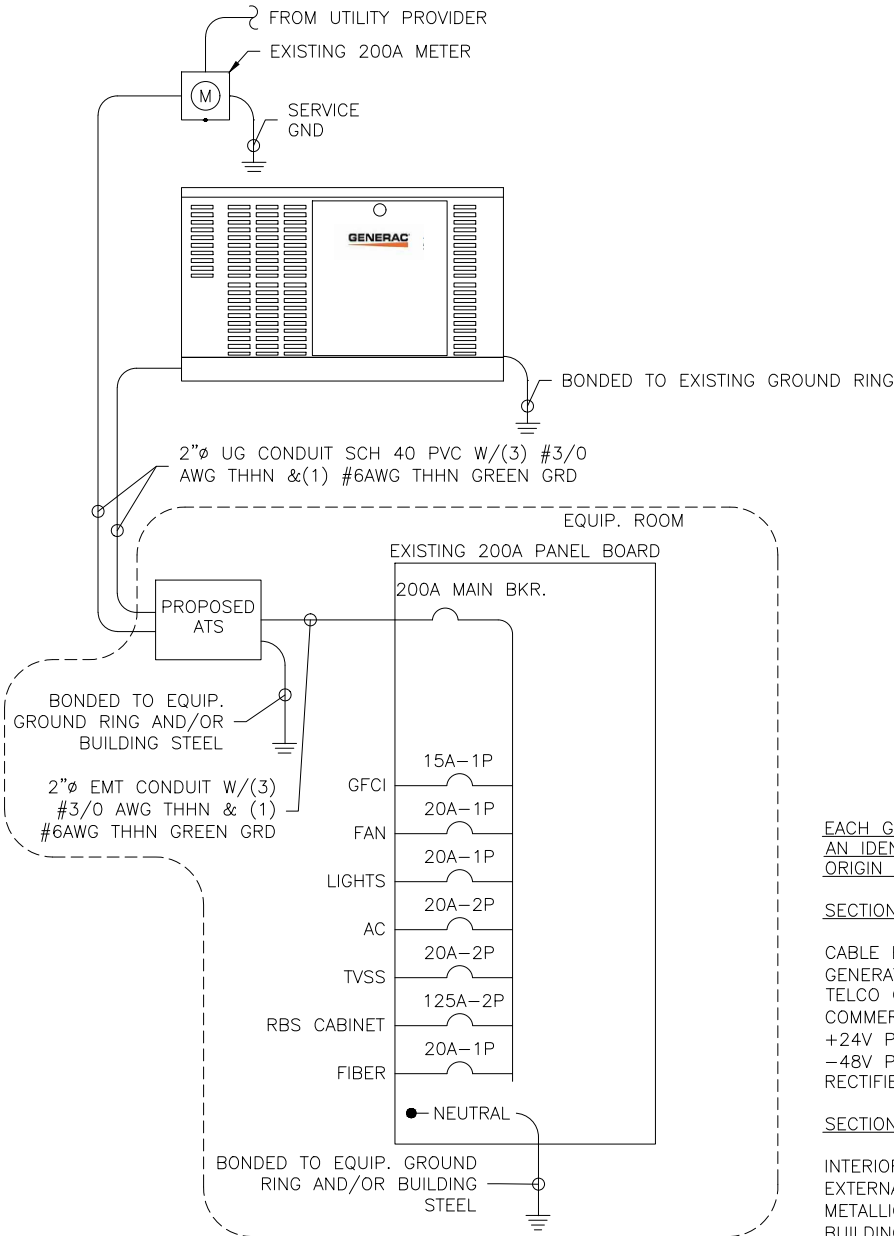

1 ONE LINE DIAGRAM  
E-1

EACH GROUND CONDUCTOR TERMINATING ON ANY GROUND BAR SHALL HAVE AN IDENTIFICATION TAG ATTACHED AT EACH END THAT WILL IDENTIFY ITS ORIGIN AND DESTINATION.

SECTION "P" - SURGE PRODUCERS

- CABLE ENTRY PORTS (HATCH PLATES) (#2)
- GENERATOR FRAMEWORK (IF AVAILABLE) (#2)
- TELCO GROUND BAR
- COMMERCIAL POWER COMMON NEUTRAL/GROUND BOND (#2)
- +24V POWER SUPPLY RETURN BAR (#2)
- 48V POWER SUPPLY RETURN BAR (#2)
- RECTIFIER FRAMES.

SECTION "A" - SURGE ABSORBERS

- INTERIOR GROUND RING (#2)
- EXTERNAL EARTH GROUND FIELD (BURIED GROUND RING) (#2)
- METALLIC COLD WATER PIPE (IF AVAILABLE) (#2)
- BUILDING STEEL (IF AVAILABLE) (#2)

2 GROUND WIRE SCHEDULE  
E-1

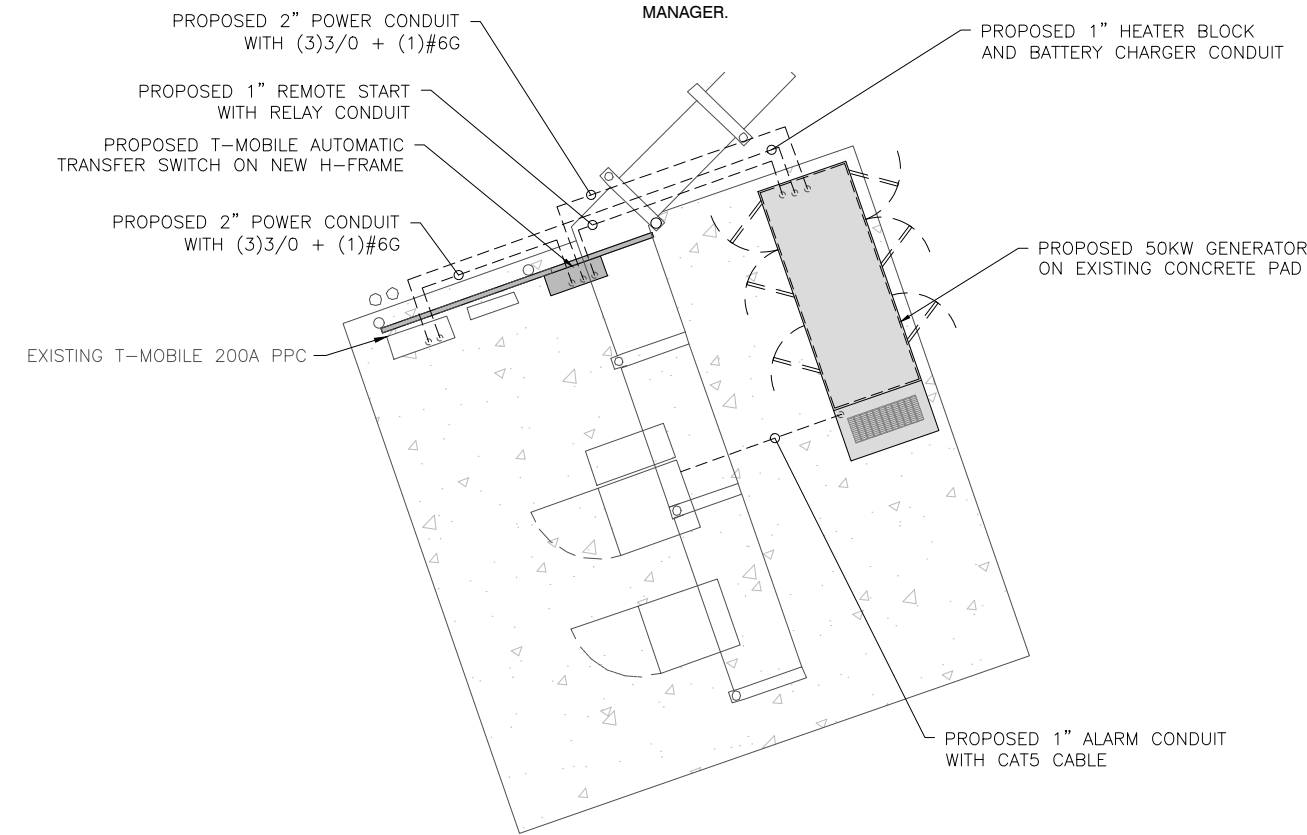

5 ELECTRICAL PLAN  
E-1

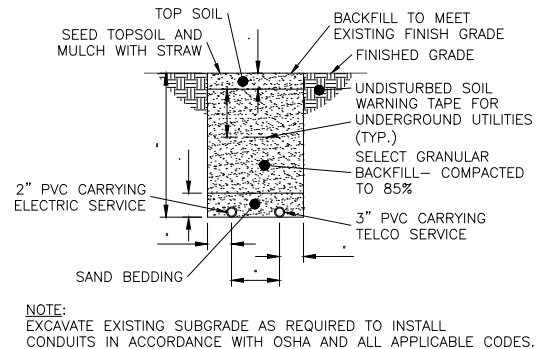

3 TYPICAL TRENCH DETAIL  
E-1

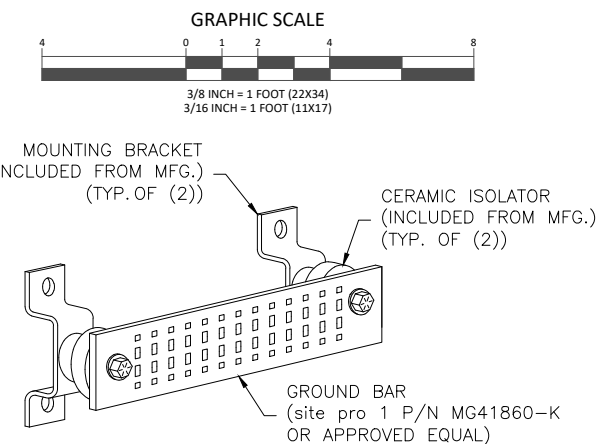

4 GROUND BAR DETAIL  
E-1

**T-Mobile**  
NORTHEAST LLC

T-MOBILE NORTHEAST, LLC.  
35 GRIFFIN RD S  
BLOOMFIELD, CT 06002  
PHONE: (860) 629-1700

**CENTERLINE**  
COMMUNICATIONS

750 W CENTER ST, SUITE 301  
WEST BRIDGEWATER, MA 02379  
PHONE: 781.713.4725

REVISIONS			
REV	DATE	DESCRIPTION	BY
0	10/07/21	ISSUED FOR CONSTRUCTION	SS
A	10/05/21	ISSUED FOR REVIEW	RL

DESIGNED BY: RL	APPROVED BY: WRD
--------------------	---------------------

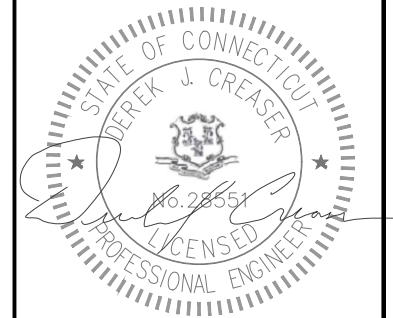

DATE: 10/07/2021

IT IS A VIOLATION OF LAW FOR ANY PERSON UNLESS THEY ARE ACTING UNDER THE DIRECTION OF A LICENSED PROFESSIONAL ENGINEER TO ALTER THIS DOCUMENT. UNLESS EXPLICITLY AGREED TO BY THE ENGINEER IN WRITING, THE ENGINEER DISCLAIMS ALL LIABILITY ASSOCIATED WITH THE REUSE, ALTERATION OR MODIFICATION OF THE CONTENTS HEREIN.

SITE NAME: SILVER HILL

SITE ID: CT11098B

SITE ADDRESS: 208 VALLEY ROAD  
NEW CANAAN, CT 06840  
FAIRFIELD COUNTY

SHEET TITLE: ELECTRICAL PLAN & DETAILS

DRAWING: E-1

# GROUNDING NOTES:

- GROUNDING SHALL COMPLY WITH ARTICLE 250 OF THE NATIONAL ELECTRICAL CODE.
- ALL GROUNDING DEVICES SHALL BE U.L. APPROVED OR LISTED FOR THEIR INTENDED USE.
- ALL WIRES SHALL BE AWG THHN/THWN COPPER UNLESS NOTED OTHERWISE.
- GROUNDING CONNECTIONS TO GROUND RODS, GROUND RING WIRE, TOWER BASE AND FENCE POSTS SHALL BE EXOTHERMIC ("CADWELDS") UNLESS NOTED OTHERWISE. CLEAN SURFACES TO SHINY METAL. WHERE GROUND WIRES ARE CADWELDED TO GALVANIZED SURFACES, SPRAY CADWELD WITH GALVANIZING PAINT.
- GROUNDING CONNECTIONS TO GROUND BARS ARE TO BE TWO-HOLE BRASS MECHANICAL CONNECTORS WITH STAINLESS STEEL HARDWARE (INCLUDING SCREW SET) CLEAN GROUND BAR TO SHINY METAL. AFTER MECHANICAL CONNECTION, TREAT WITH PROTECTIVE ANTIOXIDANT COATING.
- GROUND COAXIAL CABLE SHIELDS AT BOTH ENDS WITH MANUFACTURER'S GROUNDING KITS.
- ROUTE GROUNDING CONDUCTORS THE SHORTEST AND STRAIGHTEST PATH POSSIBLE. BEND GROUNDING LEADS WITH A MINIMUM 12" RADIUS.
- INSTALL #2 AWG GREEN-INSULATED STRANDED WIRE FOR ABOVE GRADE GROUNDING AND #2 TINNED SOLID COPPER WIRE FOR BELOW GRADE GROUNDING UNLESS OTHERWISE NOTED.

- REFER TO GROUNDING PLAN FOR GROUND BAR LOCATIONS. GROUNDING CONNECTIONS SHALL BE EXOTHERMIC TYPE ("CADWELDS") TO ANTENNA MOUNTS AND GROUND RING. REMAINING GROUNDING CONNECTIONS SHALL BE COMPRESSION FITTINGS. CONNECTIONS TO GROUND BARS SHALL BE MADE WITH TWO-HOLE LUGS.
- THE GROUND ELECTRODE SYSTEM SHALL CONSIST OF DRIVEN GROUND RODS POSITION ACCORDING TO GROUNDING PLAN. THE GROUND RODS SHALL BE 5/8"x10'-0" COPPER CLAD STEEL INTERCONNECTED WITH #2 TINNED SOLID COPPER WIRE BURIED 36" BELOW GRADE. BURY GROUND RODS A MAXIMUM OF 15' APART, AND A MINIMUM OF 8' APART.
- IF ROCK IS ENCOUNTERED GROUND RODS SHALL BE PLACED AT AN OBLIQUE ANGLE NOT TO EXCEED 45°.
- EXOTHERMIC WELDS SHALL BE MADE IN ACCORDANCE WITH ERICO PRODUCTS BULLETIN A-AT.
- CONSTRUCTION OF GROUND RING AND CONNECTIONS TO EXISTING GROUND RING SYSTEM SHALL BE DOCUMENTED WITH PHOTOGRAPHS PRIOR TO BACKFILLING SITE. PROVIDE PHOTOS TO THE CONSTRUCTION MANAGER.
- ALL GROUND LEADS EXCEPT THOSE TO THE EQUIPMENT ARE TO BE #2 TINNED SOLID COPPER WIRE. ALL EXTERIOR GROUND BARS TINNED COPPER.
- PRIOR TO INSTALLING LUGS ON GROUND WIRES, APPLY THOMAS & BETTS KOPR-SHIELD (TM OF JET LUBE INC.). PRIOR TO BOLTING GROUND WIRE LUGS TO GROUND BARS, APPLY KOPR-SHIELD OR EQUAL.
- ENGAGE AN INDEPENDENT ELECTRICAL TESTING FIRM TO TEST AND VERIFY THAT IMPEDANCE DOES NOT EXCEED FIVE OHMS TO GROUND BY MEANS OF "FALL OF POTENTIAL TEST". TEST SHALL BE WITNESSED BY A T-MOBILE REPRESENTATIVE, AND RECORDED ON THE "GROUND RESISTANCE TEST" FORM.

- WHERE BARE COPPER GROUND WIRES ARE ROUTED FROM ANY CONNECTION ABOVE GRADE TO GROUND RING, INSTALL WIRE IN 3/4" PVC SLEEVE, FROM 1' BELOW GRADE AND SEAL TOP WITH SILICONE MATERIAL.
- PREPARE ALL BONDING SURFACES FOR GROUNDING CONNECTIONS BY REMOVING ALL PAINT AND CORROSION DOWN TO SHINY METAL. FOLLOWING CONNECTION, APPLY APPROPRIATE ANTI-OXIDIZATION PAINT.
- ANY SITE WHERE THE EQUIPMENT (BTS, CABLE BRIDGE, PPC, GENERATOR, ETC.) IS LOCATED WITHIN 6 FEET OF METAL FENCING, THE GROUND RING SHALL BE BONDED TO THE NEAREST FENCE POST USING (3) RUNS OF #2 BARE TINNED COPPER WIRE.

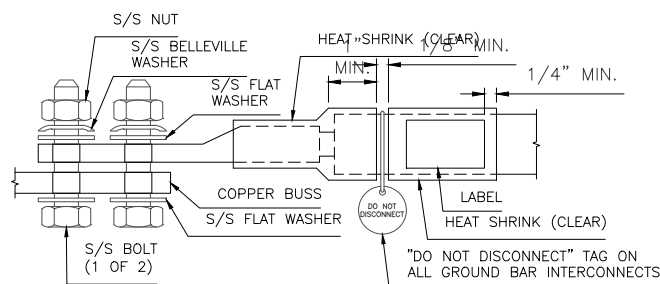
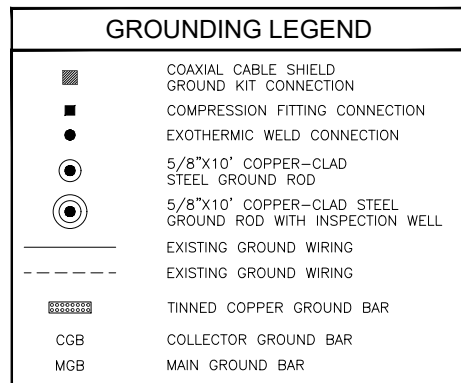

- NOTES:
- ALL HARDWARE 18-8 STAINLESS STEEL INCLUDING BELLEVILLES. COAT ALL SURFACES WITH ANTI-OXIDATION COMPOUND BEFORE MATING.
  - FOR GROUND BOND TO STEEL ONLY: INSERT A DRAGON TOOTH WASHER BETWEEN LUG AND STEEL, COAT ALL SURFACES WITH ANTI-OXIDATION COMPOUND.
  - COAT ALL BARRELS WITH ANTI-OXIDATION COMPOUND BEFORE CRIMPING.

## 1 GENERAL LUG DETAIL

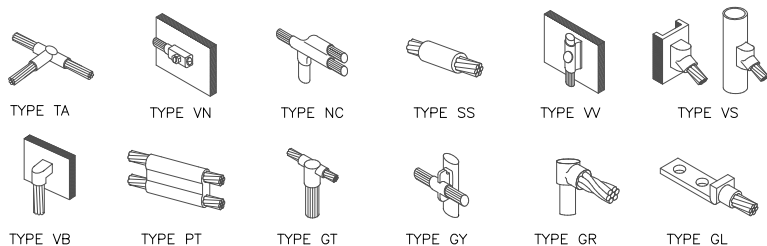

## 2 GROUNDING CONNECTION DETAILS

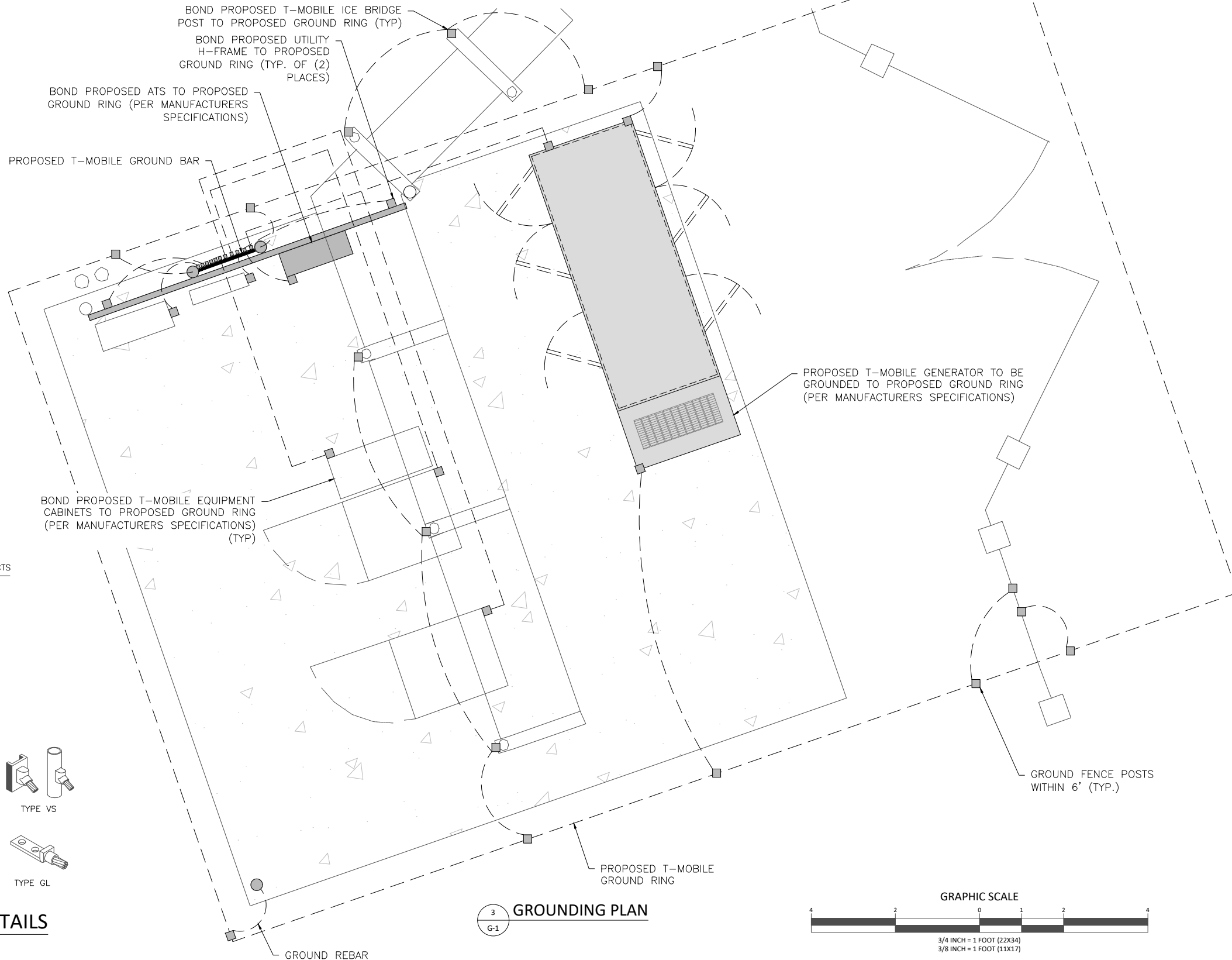

## 3 GROUNDING PLAN

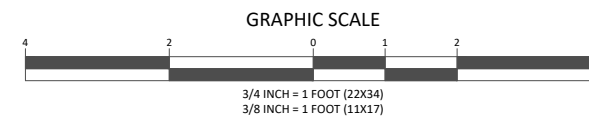

# T-Mobile

## NORTHEAST LLC

T-MOBILE NORTHEAST, LLC.  
35 GRIFFIN RD S  
BLOOMFIELD, CT 06002  
PHONE: (860) 629-1700



750 W CENTER ST, SUITE 301  
WEST BRIDGEWATER, MA 02379  
PHONE: 781.713.4725

REVISIONS			
REV	DATE	DESCRIPTION	BY
0	10/07/21	ISSUED FOR CONSTRUCTION	SS
A	10/05/21	ISSUED FOR REVIEW	RL

DESIGNED BY: RL	APPROVED BY: WRD
--------------------	---------------------

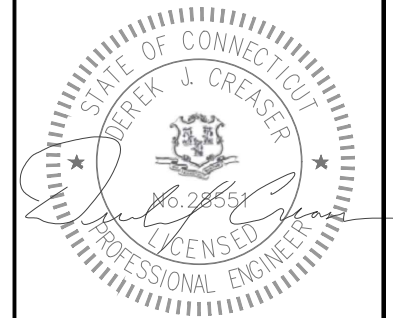

DATE: 10/07/2021

IT IS A VIOLATION OF LAW FOR ANY PERSON UNLESS THEY ARE ACTING UNDER THE DIRECTION OF A LICENSED PROFESSIONAL ENGINEER TO ALTER THIS DOCUMENT. UNLESS EXPLICITLY AGREED TO BY THE ENGINEER IN WRITING, THE ENGINEER DISCLAIMS ALL LIABILITY ASSOCIATED WITH THE REUSE, ALTERATION OR MODIFICATION OF THE CONTENTS HEREIN.

SITE NAME: <b>SILVER HILL</b>
SITE ID: <b>CT11098B</b>
SITE ADDRESS: <b>208 VALLEY ROAD NEW CANAAN, CT 06840 FAIRFIELD COUNTY</b>

SHEET TITLE: <b>GROUNDING PLAN</b>
DRAWING: <b>G-1</b>

# Generac RD025 Design Document

Diesel, AC, 25kW External Fill Tank Model#7192-0 SKU#33651

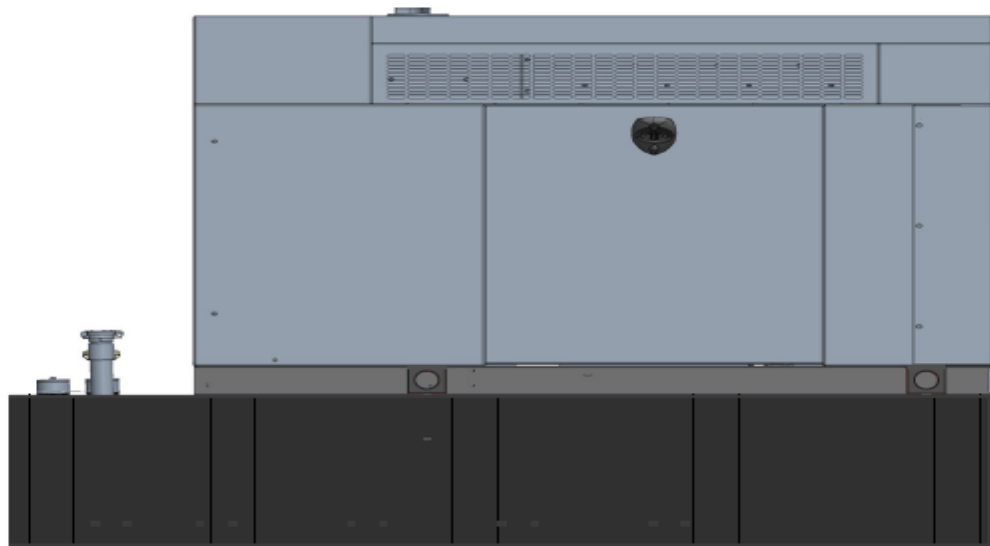

The following are responsible for this project document:

Kevin Smith

SR. Engineer (770) 256-3594

Project Design Spec Revision	1.0	Last Date:08/23/2018	5/14/2018
Final doc URL (~Dnnnnn):			
Location	Use the InfoRouter Search (Advanced) putting the Document ID (nnnnn without the D) to find the location of the master document.		
Template URL:	<a href="http://docs.eng.t-mobile.com/InfoRouter/docs/~D423750">http://docs.eng.t-mobile.com/InfoRouter/docs/~D423750</a>	Slightly updated 1/2011	

## Table of Contents

<b>1</b>	<b>Introduction / Project Summary .....</b>	<b>3</b>
1.1	Purpose of Project	3
1.2	Feature Description	3
1.3	Dimensions	3
<b>2</b>	<b>Fuel Tanks.....</b>	<b>4</b>
<b>3</b>	<b>RXSC200A3 ATS/ Controller .....</b>	<b>4</b>
3.1	Hardware	4
<b>4</b>	<b>Architecture/Alarms.....</b>	<b>7</b>
4.1	Interfaces and Alarming	7
<b>5</b>	<b>Regulatory Requirements .....</b>	<b>9</b>
<b>6</b>	<b>Configuration/Diagrams .....</b>	<b>9</b>
<b>7</b>	<b>Maintenance.....</b>	<b>14</b>

# 1 Introduction / Project Summary

## 1.1 Purpose of Project

T-Mobile’s nationwide cell site hardening plan is providing a refuellable backup power system capable of powering a site for a minimum of 48 hours before refueling is required. The purpose of this project is to give T-Mobile customers reliable service during power outages and provide a sufficient layer of coverage. This design document is for Generac’s RD025 model#7192-0, which is a Diesel AC generator with a capacity of 25kW.

## 1.2 Feature Description

The Generac RD025 is a 25kW AC, diesel generator is one of the generators selected as part of the T-Mobile RFP in support of the nationwide cell site hardening plan. The RD025 has a Level 2 acoustic enclosure, 3 phase sensing, and +/-0.25% digital voltage regulation. It is equipped with RS232, RS485 and canbus remote ports and Evolution control panel. It is also equipped with a automatic transfer switch, the RXSC200A3 (Automatic Transfer Switch) Controls the process of transferring commercial AC power and generator power. The RXSC200A3 is a 200Amp, switch that is programmed to perform engine test runs and also has adjustable engine run time capabilities. For RXSC200A3 Owners Manual and full feature descriptions [LINK](#)

## 1.3 Dimensions

The dimensions of a level 2 Acoustic Enclosure L x W x H in inches 103.4 x 35 x 91.7. T-Mobile requires a 36-inch radius around the generator that will cover the 18” door swing on the generator.

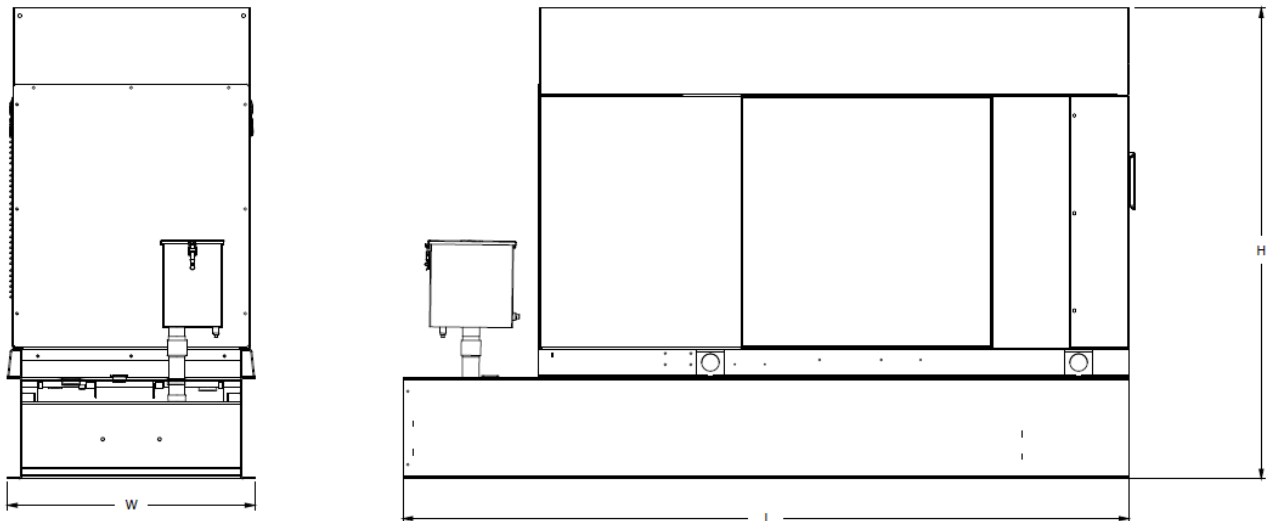

Weights and Dimensions

Unit Weight - lbs	Unit Weight with Skid - lbs	Dimensions (L x W x H) - in
2,123	2,161	103.4 x 35.0 x 73.8

## 2 Fuel Tanks

The RD025 has a 102.7" 240 Gallon Double-Wall UL142 Base tank to provide 98 hours of backup power at full load deployed on site. Below is the Install drawing for the 240-gallon tank for the RD025kW.

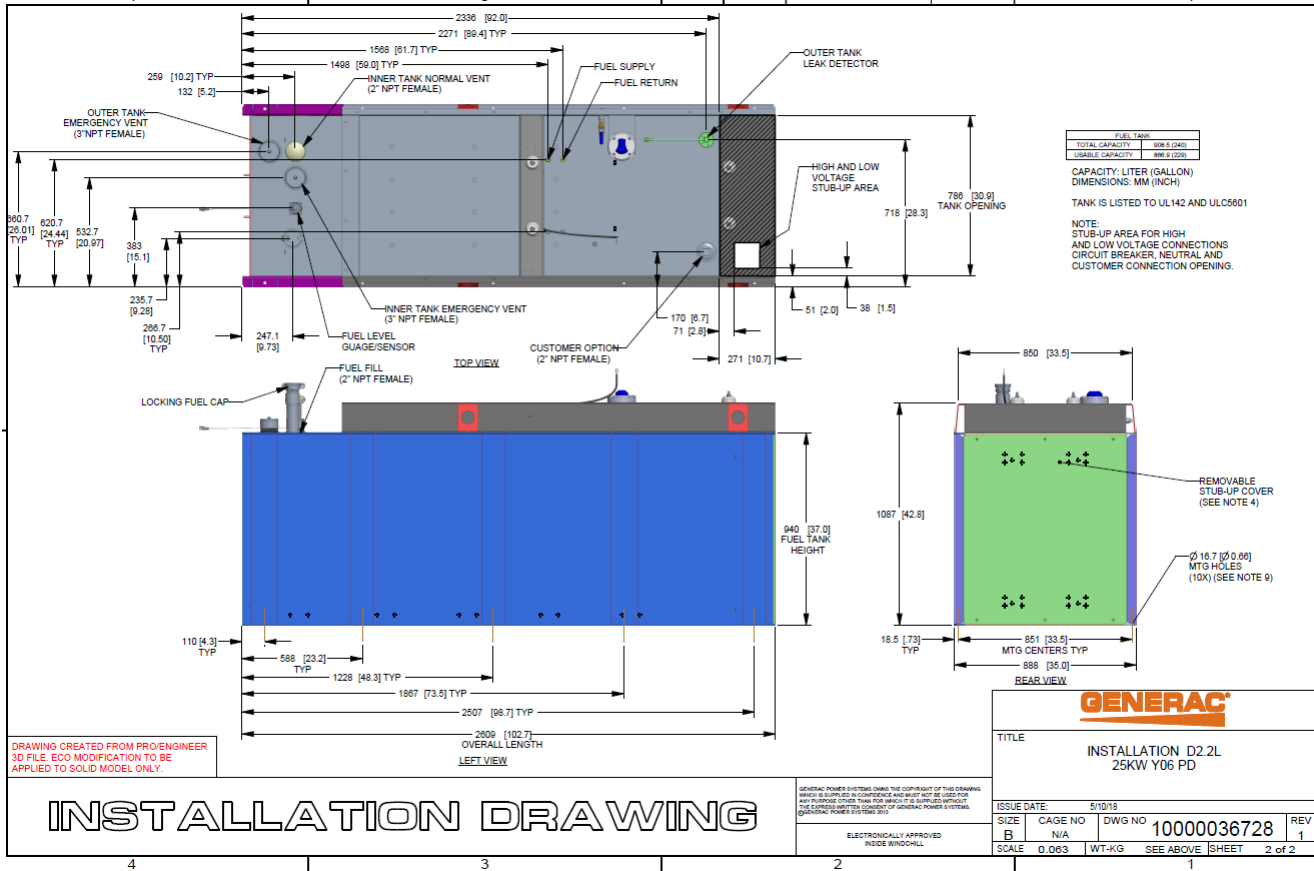

## 3 RXSC200A3 ATS/ Controller

### 3.1 Hardware

The RD025 will come with a RXSC200A3 and an Evollution controller. The sites considered for the RD025 should not have a DC power consumption above 20kW

RXSC200A3 [Link](#)

RXSC200A3 install drawing [Link](#)

Evolution controller spec sheet [Link](#)

RD025 installation drawings and supporting documentation [Link](#)

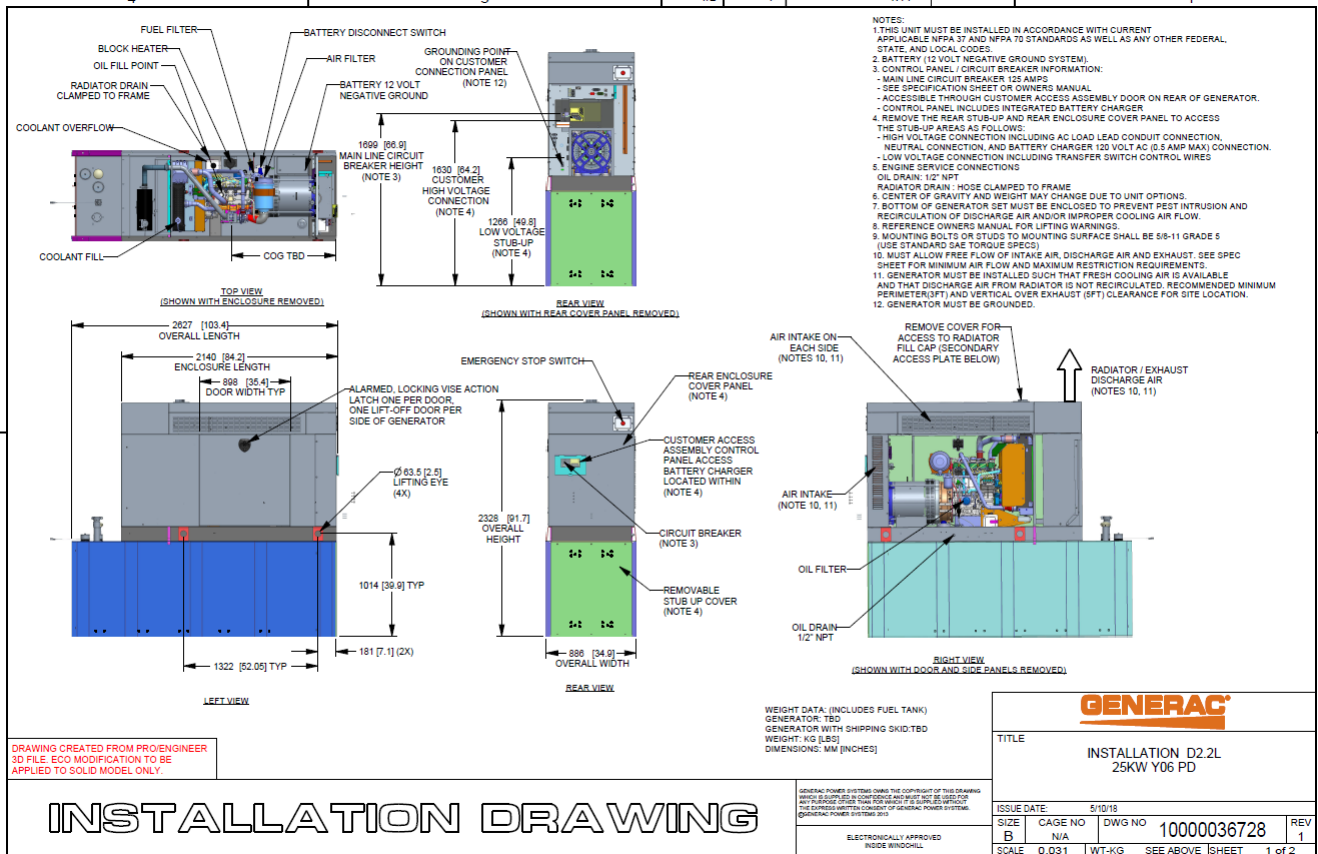

### 3.2 RXSC200A3 Automatic Transfer Switch

The RXSC200A3 (Automatic Transfer Switch) is equipped with the following functions. Utility voltage drop-out <65%. Timer to Generator start: 10 second factory set, adjustable between 2-1500 seconds. Engine Warm up delay: 5 seconds. Standby Voltage Sensor: 65% for 5 seconds. Utility Voltage Pickup >80%. Re-Transfer Time Delay: 15 seconds. Engine Cool-Down Timer: 60 seconds. Exerciser: 5 or 12 minute adjustable weekly/by-weekly/monthly. The transfer switch can also be operated manually without power applied



**RXSC200A3 Dimensions**

Model		RXSC200A3
Height (in./mm)	H1	17.24/437.9
	H2	20/508
Width (in./mm)	W1	12.5/317.5
	W2	14.6/370.8
Depth (in./mm)		7.09/180.1
Weight (lbs./kilos)		20/9.07

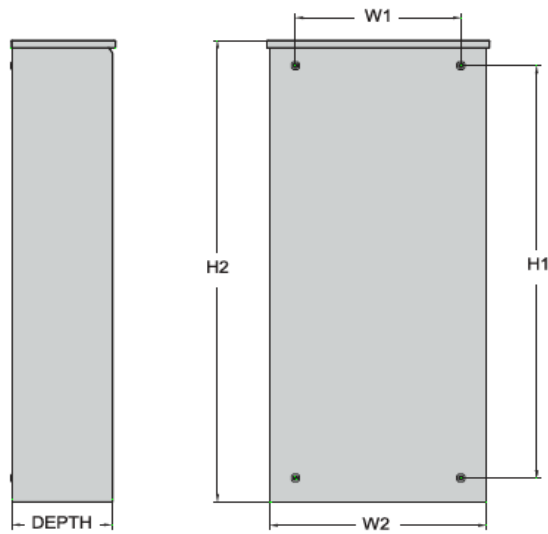

## 4 Architecture/Alarms

### 4.1 Interfaces and Alarming

The generator will be monitored by external alarms, conduit and cat five cables have to be installed from the Evolution Controllers Low Voltage Box located in the Generac generator to the appropriate cell site equipment. Nokia FSEB or FSEE and in Ericsson the SAU.

At a Nokia site, this connection is at the FSEB or an FSEE module. For the wiring diagram and instructions for the FSEB click the [Link](#) (The FSEE is the Nokia module that will be replacing the FSEB. For details on the FSEE contact: HQNokiaCellsiteDesigns@T-Mobile.com)

Ericsson sites will connect to the SAU module via OVP Expansion Kit for 8 External Alarms. Product number: UTOVP-ALM8EXP. For the wiring diagram and instructions for this click the [link](#)

The RXSC200A3 has auxiliary contacts that will facilitate the *ATS in Emergency position* alarm and will be a Normally Closed contact. Below is the wiring schematic for this contact and it can be found in the RXSC200A3 owners manual.

#### Auxiliary Contact

See [Figure 3-4](#). If desired, there is one normally-closed Auxiliary Contact (A) on the transfer switch to operate customer accessories, remote advisory lights, or remote annunciator devices. A suitable power source must be connected to the common terminal. If needed, an extra auxiliary contact can be added.

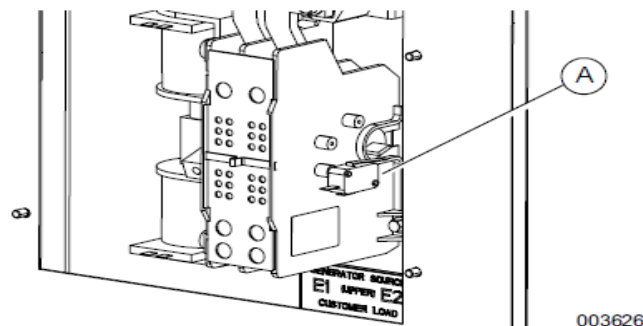

**Figure 3-4. Auxiliary Contact**

The auxiliary contact is normally closed when the transfer switch is in utility mode. The contacts will open when the transfer switch is in the standby power mode.

**NOTE:** Auxiliary Contact is rated 10 amps at 125 or 250 volts AC, and 0.6 amps at 125 volts DC.

#### **CAUTION**

Equipment damage. Exceeding rated voltage and current will damage the auxiliary contacts. Verify that voltage and current are within specification before energizing this equipment.

(000134a)

T-Mobile has four relays available from the Generac controller that are user-defined. T-Mobile can have four-alarm categories and a limitless number of subcategories. T-Mobile will utilize Normally Closed (NC) dry contacts for alarms in Low Voltage Connection box in the spare outputs section. Ericsson cabinets need to be equipped with the alarm expansion kit (UTOVP-ALM8EXP) to handle external alarms.

Customer Connections Inside the RD025

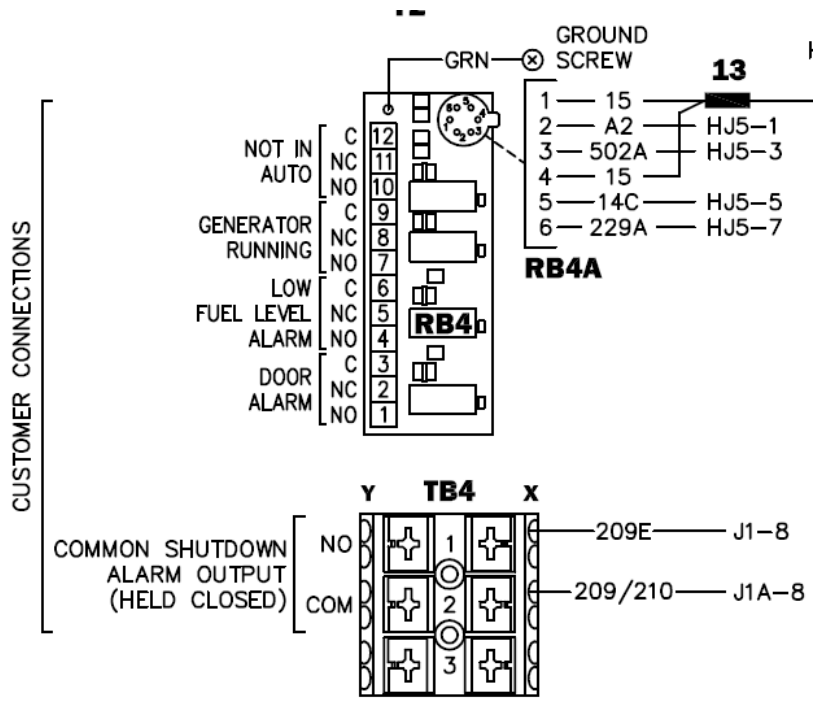

Ericsson UTOVP- ALM8EXP



UTOVP-ALM8EXP	OVP Expansion Kit for 8 External Alarms	Qty
<b>Product no</b>	<b>Denomination</b>	
UTOVP-ALM8EXP	OVP Expansion Kit for 8 External Alarms	1
NFD30234/08	OVERVOLTAGE ARRESTER/OVP-ALM 8	1
RPM777143/01200	CABLE WITH CONNECTOR/SIGNAL CABLE	2

Evolution Controller Customer Connections	Nokia FSEB Alarm Connections 13-24	T-Mobile Standard Alarms
NC#8-Gen Running	NC 4110 grd 4111 pin 13	Generator Running
NC#11-Not In Auto	NC 4110 grd 4111 pin 14	Generator Alarm Critical
NC#2-Door Alarm	NC 4110 grd 4111 pin 15	Generator Alarm NSI
NC#5-Low Fuel	NC 4110 grd 4111 pin 16	Low Fuel
RXSC200A3-Auxiliary Contacts	NC 4110 grd 4111 pin 17	ATS in Emergency Position

Evolution Controller Customer Connections	Ericsson Alarm 8expConnections	T-Mobile Standard Alarms
NC#8- Gen. Running	NC - A5	Generator Running
NC#11-Not In Auto	NC - A6	Generator Alarm Critical
NC#2-Door Alarm	NC - A7	Generator Alarm NSI
NC#5-Low Fuel	NC - A8	Low Fuel
RXSC200A3-Auxiliary Contacts	NC - A9	ATS in Emergency Position

## 5 Regulatory Requirements

Level 2 Acoustic Enclosure provides a noise level of 67.5dBA. It is EPA certified and meets NFPA 99 and 110 requirements(NFPA National Fire Protection Association). The RD025 generator engines is a tier 4 engine and meets the EPA final standards.

## 6 Configuration/Diagrams

The physical configuration of the Generator and the RXSC200A3 is, ATS before the PPC to ensure overcurrent protection when commercial power is restored. The RD025 and the RXSC200A3 has to be wired to Commercial AC power.

Commercial Power Connection Points  
On The RXSC200A3

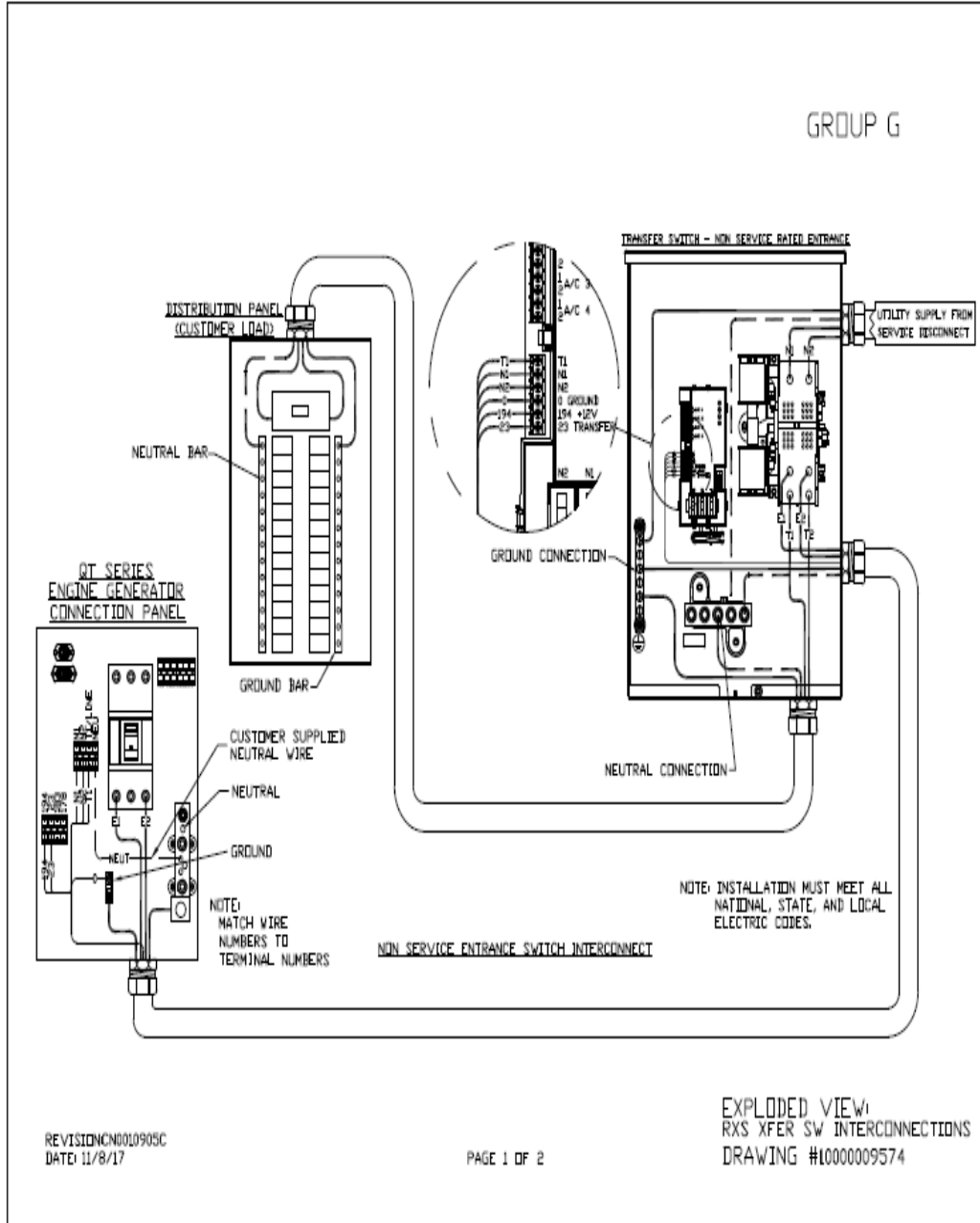

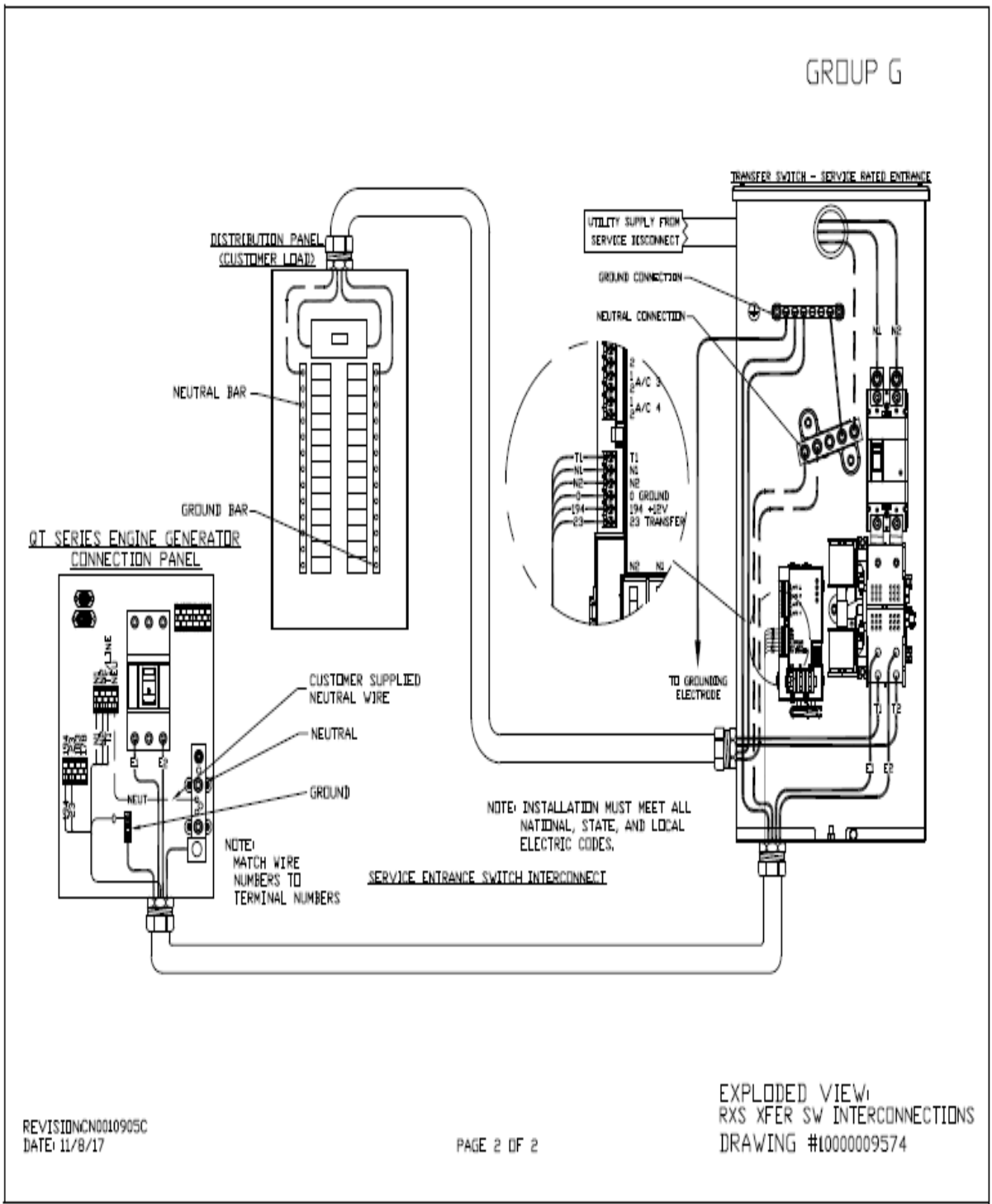

### Compound Diagram:

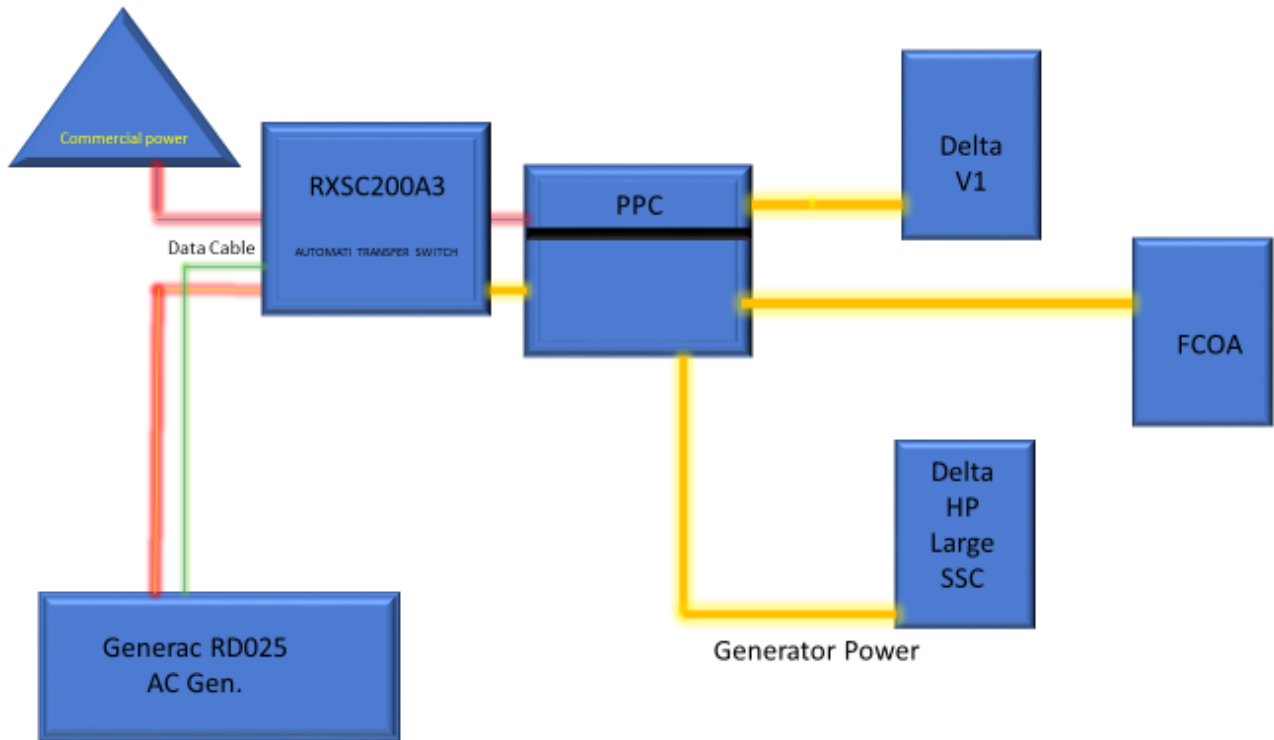



## 7 Maintenance

---

T-Mobile is recommending preventive maintenance to be performed every 250 hours of run-time or every 12 months, whichever comes first.

T-Mobile requires this minimum service checklist for the generator engine:

- Check engine mounts and support. Tighten fasteners.
- Check all the engine hoses and clamps for proper fit, and any signs of cracking and fatigue from wear.
- Inspect all belts for signs of cracking and fatigue from wear and adjust for proper tension.
- Inspect the exhaust system for leaks, burns and wet stacking. Drain exhaust line and tighten any clamps and flange bolts.
- Inspect silencer and plumbing for leaks, cracks or any other signs of wear.
- Inspect the system for fuel, oil and coolant leaks and signs of corrosion.
- Replace water separator.
- Replace water filter/ conditioner.
- Check Anti-Freeze (Spector-Analysis).
- Check coolant level and add, if needed.
- Inspect radiator mounting for signs or wear and cracking.
- Inspect/ clean air filter and change per manufacturer specifications.
- Inspect air intakes and outlets and tighten clamps and brackets, if applicable.
- Replace fuel filter.
- Inspect the carburetor fuel injection system, fuel injection pump and choke, if equipped. Adjust to manufacturers specifications.
- Change engine oil, oil filter and record the date on the filter casing.
- Check engine heater operation, if equipped.
- Check and adjust the battery charger operations, and charge rate within the manufacturer's recommended operating specifications.

- Inspect the battery housing, hardware connections, and cables for corrosion and wear.
- Check the battery electrolyte levels and specific gravity levels.
- Load test generator battery.
- Check, adjust and record generator output voltage, as necessary.
- Check and record the alternator charge rate.
- During inspection run the generator for 30 minutes under load. During this time, and after the engine is at full operational speed and has reached engine operating temperature; determine and record the condition of all inspection points: oil pressure, water/ coolant temperature, Fuel pressure, generator gauge, indicator operations, generator battery.
- Check the engine timing and adjust to manufacturers specifications, if necessary.
- Inspect, adjust and record governor and frequency, if necessary.
- Verify that the low fuel alarm is operational and configured correctly to trigger when the fuel tank reaches 50% of fuel tank capacity.

Check fuel level and refuel the generator during the preventive/ corrective maintenance visit.

**UPS CampusShip: View/Print Label**

- 1. **Ensure there are no other shipping or tracking labels attached to your package.** Select the Print button on the print dialog box that appears. Note: If your browser does not support this function select Print from the File menu to print the label.
- 2. **Fold the printed label at the solid line below.** Place the label in a UPS Shipping Pouch. If you do not have a pouch, affix the folded label using clear plastic shipping tape over the entire label.

**3. GETTING YOUR SHIPMENT TO UPS**

**Customers with a Daily Pickup**

Your driver will pickup your shipment(s) as usual.

**Customers without a Daily Pickup**

Take your package to any location of The UPS Store®, UPS Access Point(TM) location, UPS Drop Box, UPS Customer Center, Staples® or Authorized Shipping Outlet near you. Items sent via UPS Return Services(SM) (including via Ground) are also accepted at Drop Boxes. To find the location nearest you, please visit the Resources area of CampusShip and select UPS Locations.





Schedule a same day or future day Pickup to have a UPS driver pickup all your CampusShip packages. Hand the package to any UPS driver in your area.

UPS Access Point™  
 CVS STORE # 1060  
 326 MAIN ST  
 SOUTHLINGTON ,CT 06489

UPS Access Point™  
 MICHAELS STORE # 1279  
 98 EXECUTIVE BLVD  
 SOUTHLINGTON ,CT 06489

UPS Access Point™  
 ADVANCE AUTO PARTS STORE 8525  
 151 QUEEN ST  
 SOUTHLINGTON ,CT 06489

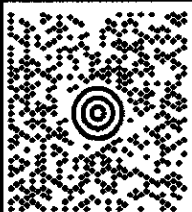
FOLD HERE

<p style="text-align: right;"><b>1 OF 1</b></p> <p><b>1 LBS</b>      DWT: 13,10,1</p> <p>MARK APPLEBY        8602094694        CENTERLINE COMMUNICATIONS        90 HAMILTON AVENUE        SOUTHLINGTON CT 06489-3883</p> <p><b>SHIP TO:</b>        MELANIE A. BACHMAN        8608272935        CONNECTICUT SITING COUNCIL        EXECUTIVE DIRECTOR        TEN FRANKLIN SQUARE        NEW BRITAIN CT 06051-2655</p>	<p style="font-size: 2em; font-weight: bold;">CT 067 9-06</p> 	<p style="font-size: 1.5em; font-weight: bold;">UPS GROUND</p> <p>TRACKING #: 1Z 9Y4 503 43 0834 7587</p> 
		<p style="text-align: right;"><b>BILLING: P/P</b></p>
		
<small>CS 22.0.18. WNTN150-43.0A 10/2021*</small>		



# Shipment Receipt

Transaction Date: 21 Oct 2021

Tracking Number:

1Z9Y45034308347587

## ① Address Information

**Ship To:**

Connecticut Siting Council  
Melanie A. Bachman  
Ten Franklin Square  
Executive Director  
NEW BRITAIN CT 060512655  
Telephone:8608272935

**Ship From:**

Centerline Communications  
Mark Appleby  
90 Hamilton Avenue  
SOUTHINGTON CT 064893883  
Telephone:8602094694  
email:mappleby@clinellc.com  
Residential

**Return Address:**

Centerline Communications  
Mark Appleby  
90 Hamilton Avenue  
SOUTHINGTON CT 064893883  
Telephone:8602094694 email:mappleby@clinellc.com  
Residential

## ② Package Information

	Weight	Dimensions / Packaging	Declared Value	Reference Numbers
1.	0.5 lbs (1.0 lbs billable)	13 x 10 x 1in. Other Packaging		

## ③ UPS Shipping Service and Shipping Options

**Service:**

UPS Ground Service

**Guaranteed By:**

End of Day Friday, Oct 22, 2021

**Shipping Fees Subtotal:**

9.59 USD

**Additional Shipping Options****Transportation**

8.76 USD

**Delivery Confirmation:****Fuel Surcharge**

0.83 USD

Package1: Delivery Confirmation

2.00 USD

**Total Shipping Charges**

11.59 USD

## ④ Payment Information

**Bill Shipping Charges to:**

Shipper's Account 9Y4503

<b>Shipping Charges:</b>	11.59 USD
<b>Subtotal Shipping Charges:</b>	11.59 USD
<b>Total Charged:</b>	11.59 USD

Note: This document is not an invoice. Your final invoice may vary from the displayed reference rates.

\* For delivery and guarantee information, see the UPS Service Guide ({}). To speak to a customer service representative, call 1-800-PICK-UPS for domestic services and 1-800-782-7892 for international services.

### This website uses cookies

We do this to better understand how visitors use our site and to offer you a more personal experience. Please see our [Privacy Notice \(https://www.ups.com/us/en/help-center/legal-terms-conditions/privacy-notice.page\)](https://www.ups.com/us/en/help-center/legal-terms-conditions/privacy-notice.page) for more information. You can manage your preferences by selecting [Cookie Settings](#).



**UPS CampusShip: View/Print Label**

- 1. Ensure there are no other shipping or tracking labels attached to your package.** Select the Print button on the print dialog box that appears. Note: If your browser does not support this function select Print from the File menu to print the label.
- 2. Fold the printed label at the solid line below.** Place the label in a UPS Shipping Pouch. If you do not have a pouch, affix the folded label using clear plastic shipping tape over the entire label.
- 3. GETTING YOUR SHIPMENT TO UPS**  
**Customers with a Daily Pickup**  
 Your driver will pickup your shipment(s) as usual.

**Customers without a Daily Pickup**

Take your package to any location of The UPS Store®, UPS Access Point(TM) location, UPS Drop Box, UPS Customer Center, Staples® or Authorized Shipping Outlet near you. Items sent via UPS Return Services(SM) (including via Ground) are also accepted at Drop Boxes. To find the location nearest you, please visit the Resources area of CampusShip and select UPS Locations.



Schedule a same day or future day Pickup to have a UPS driver pickup all your CampusShip packages. Hand the package to any UPS driver in your area.

UPS Access Point™  
CVS STORE # 1060  
326 MAIN ST  
SOUTHINGTON ,CT 06489

UPS Access Point™  
MICHAELS STORE # 1279  
99 EXECUTIVE BLVD  
SOUTHINGTON ,CT 06489

UPS Access Point™  
ADVANCE AUTO PARTS STORE 8525  
151 QUEEN ST  
SOUTHINGTON ,CT 06489

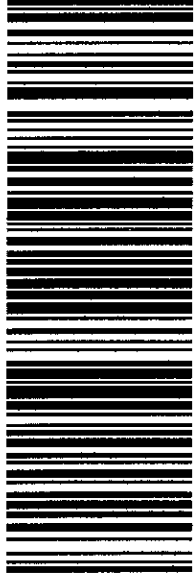
FOLD HERE

<p><b>1 LBS</b> <b>1 OF 1</b></p> <p>DWT: 13,10,1</p> <p>MARK APPLEBY 8602094694 CENTERLINE COMMUNICATIONS 90 HAMILTON AVENUE SOUTHINGTON CT 06489-3883</p> <p><b>SHIP TO:</b> KEVIN MOYNIHAN &amp; LYNN BROOKS TOWN OF NEW CANAAN CT LOWER LEVEL 77 MAIN STREET <b>NEW CANAAN CT 06840-4710</b></p>	<p><b>CT 069 9-04</b></p> 	<p><b>UPS GROUND</b></p> <p>TRACKING #: 1Z 9Y4 503 P2 1786 6598</p> 	 <p><b>BILLING: P/P</b> <b>ATTENTION UPS DRIVER: SHIPPER RELEASE</b></p> <p><small>CS 22.D.1B. WNTNV50-43.0A.10/2021*</small></p>
--	---	---	--



# Shipment Receipt

**Transaction Date:** 21 Oct 2021

**Tracking Number:**

1Z9Y4503P217866598

## ① Address Information

<b>Ship To:</b>	<b>Ship From:</b>	<b>Return Address:</b>
Town of New Canaan CT Kevin Moynihan & Lynn Brooks 77 Main Street Lower Level NEW CANAAN CT 068404710	Centerline Communications Mark Appleby 90 Hamilton Avenue SOUTHINGTON CT 064893883 Telephone:8602094694 email:mappleby@clinellc.com Residential	Centerline Communications Mark Appleby 90 Hamilton Avenue SOUTHINGTON CT 064893883 Telephone:8602094694 email:mappleby@clinellc.com Residential

## ② Package Information

	Weight	Dimensions / Packaging	Declared Value	Reference Numbers
1.	0.5 lbs (1.0 lbs billable)	13 x 10 x 1 in. Other Packaging		

## ③ UPS Shipping Service and Shipping Options

<b>Service:</b>	UPS Ground Service		
<b>Guaranteed By:</b>	End of Day Friday, Oct 22, 2021		
<b>Shipping Fees Subtotal:</b>	12.99 USD	<b>Additional Shipping Options</b>	
<b>Transportation</b>	8.76 USD	<b>Deliver Without Signature</b>	
<b>Fuel Surcharge</b>	1.13 USD	Package1: Deliver Without Signature	0.00 USD
<b>Delivery Area Surcharge</b>	3.10 USD	<b>Quantum View Notify E-mail Notifications:</b>	No Charge
Package 1		1 mappleby@clinellc.com: Delivery	

## ④ Payment Information

**Bill Shipping Charges to:** Shipper's Account 9Y4503

<b>Shipping Charges:</b>	12.99 USD
<b>Subtotal Shipping Charges:</b>	12.99 USD
<b>Total Charged:</b>	12.99 USD

Note: This document is not an invoice. Your final invoice may vary from the displayed reference rates.

\* For delivery and guarantee information, see the UPS Service Guide ({}). To speak to a customer service representative, call 1-800-PICK-UPS for domestic services and 1-800-782-7892 for international services.

**UPS CampusShip: View/Print Label**

- 1. **Ensure there are no other shipping or tracking labels attached to your package.** Select the Print button on the print dialog box that appears. Note: If your browser does not support this function select Print from the File menu to print the label.
- 2. **Fold the printed label at the solid line below.** Place the label in a UPS Shipping Pouch. If you do not have a pouch, affix the folded label using clear plastic shipping tape over the entire label.

**3. GETTING YOUR SHIPMENT TO UPS**

**Customers with a Daily Pickup**

Your driver will pickup your shipment(s) as usual.

**Customers without a Daily Pickup**

Take your package to any location of The UPS Store®, UPS Access Point(TM) location, UPS Drop Box, UPS Customer Center, Staples® or Authorized Shipping Outlet near you. Items sent via UPS Return Services(SM) (including via Ground) are also accepted at Drop Boxes. To find the location nearest you, please visit the Resources area of CampusShip and select UPS Locations.

Schedule a same day or future day Pickup to have a UPS driver pickup all your CampusShip packages.



Hand the package to any UPS driver in your area.

UPS Access Point™  
 CVS STORE # 1060  
 326 MAIN ST  
 SOUTHLINGTON ,CT 06489

UPS Access Point™  
 MICHAELS STORE # 1279  
 99 EXECUTIVE BLVD  
 SOUTHLINGTON ,CT 06489

UPS Access Point™  
 ADVANCE AUTO PARTS STORE 8525  
 151 QUEEN ST  
 SOUTHLINGTON ,CT 06489

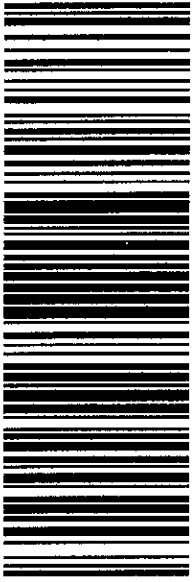
FOLD HERE

<p><b>1 LBS</b> <b>1 OF 1</b></p> <p>DWT: 13,10,1</p> <p>MARK APPLEBY        8602094694        CENTERLINE COMMUNICATIONS        90 HAMILTON AVENUE        SOUTHLINGTON CT 06489-3883</p> <p><b>SHIP TO:</b>        TODD BOWMAN, SITE ADMIN &amp; ACQ        (914) 757-5010 108        TARPON TOWERS II, LLC        SUITE 103        8916 77TH TERRACE EAST  <b>LAKWOOD RANCH FL 34202-6415</b></p>	<p><b>FL 335 0-02</b></p> 	<p><b>UPS GROUND</b></p> <p>TRACKING #: 1Z 9Y4 503 P2 1118 7609</p> 	<p><b>BILLING: P/P</b>  <b>ATTENTION UPS DRIVER: SHIPPER RELEASE</b></p>  <p>CS 22.0.1B. WNTNVS04B.0A 10/2021*</p>
--	---	---	---



# Shipment Receipt

Transaction Date: 21 Oct 2021

Tracking Number:

1Z9Y4503P211187609

## ① Address Information

**Ship To:**

Tarpon Towers II, LLC  
 Todd Bowman, Site Admin &  
 Acq  
 8916 77th Terrace East  
 Suite 103  
 LAKEWOOD  
 RANCH FL 342026415  
 Telephone:(914) 757-5010  
 x108  
 email:tbowman@tarpontowers.  
 com

**Ship From:**

Centerline Communications  
 Mark Appleby  
 90 Hamilton Avenue  
 SOUTHLINGTON CT 064893883  
 Telephone:8602094694  
 email:mappleby@clinellc.com  
 Residential

**Return Address:**

Centerline Communications  
 Mark Appleby  
 90 Hamilton Avenue  
 SOUTHLINGTON CT 064893883  
 Telephone:8602094694 email:mappleby@clinellc.com  
 Residential

## ② Package Information

	Weight	Dimensions / Packaging	Declared Value	Reference Numbers
1.	0.5 lbs (1.0 lbs billable)	13 x 10 x 1in. Other Packaging		

## ③ UPS Shipping Service and Shipping Options

**Service:**

UPS Ground Service

**Guaranteed By:**

End of Day Tuesday, Oct 26, 2021

**Shipping Fees Subtotal:**

11.73 USD

**Additional Shipping Options****Transportation**

10.71 USD

**Deliver Without Signature****Fuel Surcharge**

1.02 USD

Package1: Deliver Without Signature

0.00 USD

## ④ Payment Information

**Bill Shipping Charges to:**

Shipper's Account 9Y4503

<b>Shipping Charges:</b>	11.73 USD
<b>Subtotal Shipping Charges:</b>	11.73 USD
<b>Total Charged:</b>	11.73 USD

Note: This document is not an invoice. Your final invoice may vary from the displayed reference rates.

\* For delivery and guarantee information, see the UPS Service Guide ({}). To speak to a customer service representative, call 1-800-PICK-UPS for domestic services and 1-800-782-7892 for international services.



**UPS CampusShip: View/Print Label**

- 1. Ensure there are no other shipping or tracking labels attached to your package.** Select the Print button on the print dialog box that appears. Note: If your browser does not support this function select Print from the File menu to print the label.
- 2. Fold the printed label at the solid line below.** Place the label in a UPS Shipping Pouch. If you do not have a pouch, affix the folded label using clear plastic shipping tape over the entire label.
- 3. GETTING YOUR SHIPMENT TO UPS**  
**Customers with a Daily Pickup**  
 Your driver will pickup your shipment(s) as usual.

**Customers without a Daily Pickup**



Take your package to any location of The UPS Store®, UPS Access Point(TM) location, UPS Drop Box, UPS Customer Center, Staples® or Authorized Shipping Outlet near you. Items sent via UPS Return Services(SM) (including via Ground) are also accepted at Drop Boxes. To find the location nearest you, please visit the Resources area of CampusShip and select UPS Locations.  
 Schedule a same day or future day Pickup to have a UPS driver pickup all your CampusShip packages.  
 Hand the package to any UPS driver in your area.

UPS Access Point™  
 CVS STORE # 1060  
 328 MAIN ST  
 SOUTHLINGTON ,CT 06489

UPS Access Point™  
 MICHAELS STORE # 1279  
 99 EXECUTIVE BLVD  
 SOUTHLINGTON ,CT 06489

UPS Access Point™  
 ADVANCE AUTO PARTS STORE 8525  
 151 QUEEN ST  
 SOUTHLINGTON ,CT 06489

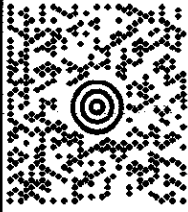
FOLD HERE

<p><b>1 LBS</b> DWT: 13.10.1</p> <p><b>1 OF 1</b></p> <p>MARK APPELBY        8602094694        CENTERLINE COMMUNICATIONS        90 HAMILTON AVENUE        SOUTHLINGTON ,CT 06489-3883</p> <p><b>SHIP TO:</b>        DR ANDREW GERBER        866 452-4455        SILVER VALLEY HOSPITAL        208 VALLEY RD  <b>NEW CANAAN CT 06840-3812</b></p>	<p><b>CT 069 9-04</b></p>  	<p><b>UPS GROUND</b></p> <p>TRACKING #: 1Z 9Y4 503 P2 0871 0610</p> 	<p><b>BILLING: P/P</b>  <b>ATTENTION UPS DRIVER: SHIPPER RELEASE</b></p>  <p>CS 22.0.1.B. WNTN150-43-DA.10/2021*</p>
--	---	---	---



# Shipment Receipt

**Transaction Date:** 21 Oct 2021

**Tracking Number:**

1Z9Y4503P208710610

## ① Address Information

**Ship To:**

Silver Valley Hospital  
Dr Andrew Gerber  
208 Valley Rd  
NEW CANAAN CT 068403812  
Telephone:866 452-4455

**Ship From:**

Centerline Communications  
Mark Appleby  
90 Hamilton Avenue  
SOUTHINGTON CT 064893883  
Telephone:8602094694  
email:mappleby@clinellc.com  
Residential

**Return Address:**

Centerline Communications  
Mark Appleby  
90 Hamilton Avenue  
SOUTHINGTON CT 064893883  
Telephone:8602094694 email:mappleby@clinellc.com  
Residential

## ② Package Information

	Weight	Dimensions / Packaging	Declared Value	Reference Numbers
1.	0.5 lbs (1.0 lbs billable)	13 x 10 x 1in. Other Packaging		

## ③ UPS Shipping Service and Shipping Options

**Service:** UPS Ground Service

**Guaranteed By:** End of Day Friday, Oct 22, 2021

**Shipping Fees Subtotal:** 12.99 USD **Additional Shipping Options**

**Transportation:** 8.76 USD **Deliver Without Signature**

**Fuel Surcharge:** 1.13 USD **Package1: Deliver Without Signature** 0.00 USD

**Delivery Area Surcharge:** 3.10 USD **Quantum View Notify E-mail Notifications:** No Charge

Package 1 1 mappleby@clinellc.com: Delivery

## ④ Payment Information

**Bill Shipping Charges to:** Shipper's Account 9Y4503

<b>Shipping Charges:</b>	12.99 USD
<b>Subtotal Shipping Charges:</b>	12.99 USD
<b>Total Charged:</b>	12.99 USD

Note: This document is not an invoice. Your final invoice may vary from the displayed reference rates.

\* For delivery and guarantee information, see the UPS Service Guide ({}). To speak to a customer service representative, call 1-800-PICK-UPS for domestic services and 1-800-782-7892 for international services.