



Northeast Site Solutions
Denise Sabo
420 Main Street, Sturbridge, MA 01655
860-209-4690
denise@northeastitesolutions.com

August 20, 2018

Members of the Siting Council
Connecticut Siting Council
Ten Franklin Square
New Britain, CT 06051

RE: Exempt Modification Application
35 Wildwood Street, New Britain CT 06051
Latitude: 41.668239
Longitude: -72.754955
T-Mobile Site#: CT11634C-L600-L700 4x2

Dear Ms. Bachman:

T-Mobile is requesting to file an exempt modification for an existing 110-foot monopole located at 35 Wildwood Street, New Britain CT 06051. T-Mobile currently has nine (9) antennas at the 110-foot level of the existing 110-foot tower. The property is owned by the City of New Britain and the monopole is owned by AT&T. T-Mobile now intends to replace three (3) antenna with three new 600/700 MHZ antenna. The new antenna would be installed at the 110-foot and level of the tower.

Planned Tower Modifications:

Remove:
NONE

Remove and Replace:

(3) LNX6515 Antenna – 700 Mhz (remove) – RFS-APXAARR24_43U-NA20 Antenna 600/700 Mhz (**replace**)
(3) RRUS11 B12 (remove) – 4449 B71+B12 RRU (**replace**)

Install New:

(1)Fiber line

Existing to Remain:

(12) 1-5/8” coax
(2) Fiber Lines
(3) RRU
(3) AIR32 Antenna – 1900/2100 Mhz
(3) AIR21 Antenna – 1900/2100 Mhz
(3)Twin TMA

This facility was approved by the City of New Britain PZC at a public hearing on August 11, 2004. The City approved the replacement of the existing 60-foot light pole with a new 110-foot pole– See attached letter from Cingular notifying Council.

Please accept this letter as notification pursuant to Regulations of Connecticut State Agencies § 16- SOj-73, for construction that constitutes an exempt modification pursuant to R.C.S.A. § 16-50j-72(b)(2). In accordance with R.C.S.A. § 16-SOj-73, a copy of this letter is being sent Mayor Erin Stewart, Elected Official and David Zajac, Zoning Enforcement for the City of New Britain, as well as the property owner and the tower owner.

The planned modifications to the facility fall squarely within those activities explicitly provided for in R.C.S.A. § 16-50j-72(b)(2).

1. The proposed modifications will not result in an increase in the height of the existing structure.
2. The proposed modifications will not require the extension of the site boundary.
3. The proposed modifications will not increase noise levels at the facility by six decibels or more, or to levels that exceed state and local criteria.
4. The operation of the replacement antennas will not increase radio frequency emissions at the facility to a level at or above the Federal Communications Commission safety standard.
5. The proposed modifications will not cause a change or alteration in the physical or environmental characteristics of the site.
6. The existing structure and its foundation can support the proposed loading.

For the foregoing reasons, T-Mobile respectfully submits that the proposed modifications to the above referenced telecommunications facility constitute an exempt modification under R.C.S.A. § 16-50j-72(b)(2).

Sincerely,

Denise Sabo
Mobile: 860-209-4690
Fax: 413-521-0558
Office: 420 Main Street, Sturbridge, MA 01655
Email: denise@northeastsitesolutions.com

Attachments

cc: Erin Stewart- Mayor - as elected official
Davis Zajac, Zoning Enforcement Officer
AT&T - as tower owner
City of New Britain – as property owner

Exhibit A

Petition No. 703
New Cingular Wireless PCS, LLC
New Britain, Connecticut
Staff Report
March 3, 2005

New Cingular Wireless LLC (Cingular) is petitioning the Council for a declaratory ruling that no Certificate of Environmental Compatibility and Public Need (Certificate) is required for a proposed light pole facility in the City of New Britain on the basis that the light pole is not within the Council's jurisdiction.

Cingular intends to replace a 60-foot light pole with a 110-foot light pole at a ball field in Chesley Park, a municipal park on Wildwood Avenue in New Britain. The existing light pole is one of 14 in the park.

The proposed light pole would contain stadium lights at the 60-foot level and Cingular's antennas at the 110-foot level. A fenced compound containing an equipment shelter and ball field scoreboard would be located at the base of the light pole.

The City of New Britain approved the project during a public hearing on August 11, 2004. The City of New Britain would own the proposed light pole.

Cingular asserts the proposed light pole is not within the Council's jurisdiction since the light pole is an existing use and does not constitute a telecommunications tower. Furthermore, if the Council rules that the light pole is a telecommunications tower, Cingular asserts it would be a municipal tower since it would be owned by the city, located on city owned property, and would be available to the city for future communication use.

Exhibit B

City of New Britain, Connecticut - Assessment Parcel Map

MBL: A8B 1

Address: 35 WILDWOOD ST

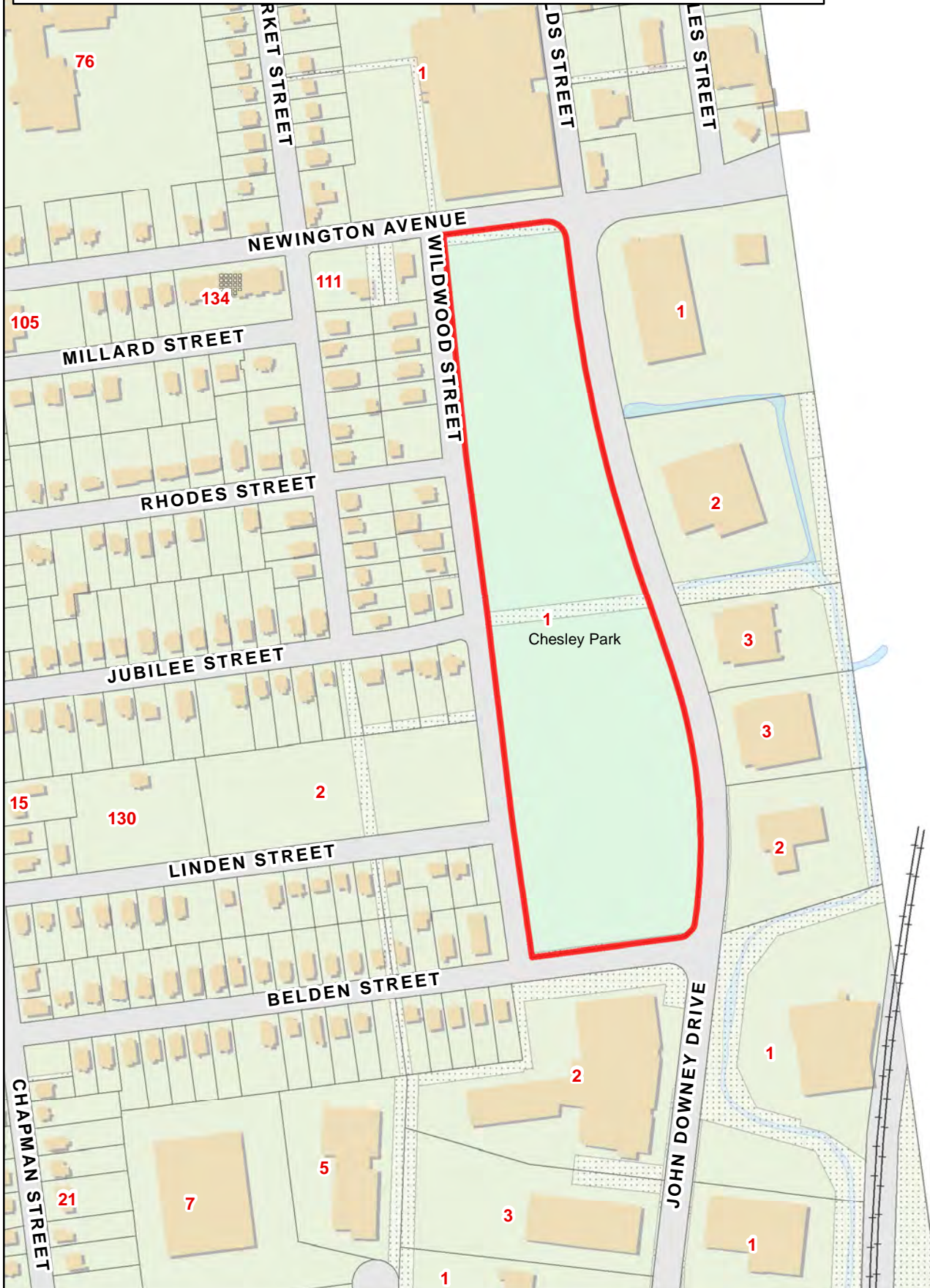

Approximate Scale:

1 inch = 300 feet

Disclaimer:

This map is for informational purposes only.
All information is subject to verification by any user.
The City of New Britain and its mapping contractors
assume no legal responsibility for the information contained herein.

Map Produced January 2015

35 WILDWOOD ST

Location 35 WILDWOOD ST

Mblu A8B/ 1/ / /

Acct# 91200035

Owner NEW BRITAIN CITY OF - PARK

Assessment \$1,632,330

Appraisal \$2,331,900

PID 1830

Building Count 1

Current Value

Appraisal			
Valuation Year	Improvements	Land	Total
2012	\$1,646,900	\$685,000	\$2,331,900

Assessment			
Valuation Year	Improvements	Land	Total
2012	\$1,152,830	\$479,500	\$1,632,330

Owner of Record

Owner NEW BRITAIN CITY OF - PARK
 Co-Owner CHESLEY PARK
 Address 27 WEST MAIN ST
 NEW BRITAIN, CT 06051

Sale Price \$0
 Certificate
 Book & Page
 Sale Date 01/01/1900

Ownership History

Ownership History				
Owner	Sale Price	Certificate	Book & Page	Sale Date
NEW BRITAIN CITY OF - PARK	\$0			01/01/1900

Building Information

Building 1 : Section 1

Year Built:
 Living Area: 0
 Replacement Cost: \$0
 Building Percent
 Good:
 Replacement Cost
 Less Depreciation: \$0

Building Attributes	
Field	Description

Style	Outbuildings
Model	
Grade	
Stories	
Occupancy	
Exterior Wall 1	
Exterior Wall 2	
Roof Structure	
Roof Cover	
Interior Wall 1	
Interior Wall 2	
Interior Flr 1	
Interior Flr 2	
Central Heat Sys	
AC Type	
Total Bedrooms	
Total Full Baths	
Total Half Baths	
Total Xtra Fixtrs	
Total Rooms	
Bath Style	
Kitchen Style	
Whirlpool Tub	
Fireplaces	
Rec Room Finish	
Rec Room Qual	
Bsmt Garages	
Bldg Nbhd	

Building Photo



(http://images.vgsi.com/photos/NewBritainCTPhotos//\00\02\1'

Building Layout



Building Sub-Areas (sq ft)	<u>Legend</u>
No Data for Building Sub-Areas	

Extra Features

Extra Features	<u>Legend</u>
No Data for Extra Features	

Land

Land Use

Use Code	903A
Description	Mun Park MDL-00
Zone	T
Neighborhood	107

Land Line Valuation

Size (Acres)	11.85
Depth	
Assessed Value	\$479,500
Appraised Value	\$685,000

Exhibit C

Copyright © 2018 Foresite LLC. All rights reserved. The details, templates, drawing formats or any portion of this document generated by Foresite LLC may not be duplicated, traced or used otherwise for any profit-driven enterprise.

ANTENNA UPGRADES BY



T-MOBILE NORTHEAST LLC

PROJECT: L700 4X2

SITE NUMBER: CT11634C

SITE NAME: CT634/Cing/ChesleyPark_ET

SITE ADDRESS: 35 WILDWOOD STREET

NEW BRITAIN, CT 06051

(RF CONFIGURATION 67D92DB)

APPLICANT:
T-Mobile
T-MOBILE NORTHEAST LLC
 35 GRIFFIN ROAD SOUTH
 BLOOMFIELD, CT 06002
 860-692-7100

PROJECT MANAGER

NSS NORTHEAST
 SITE SOLUTIONS
Turnkey Wireless Development
 420 MAIN STREET, BLDG 4
 STURBRIDGE, MA 01566
 203-275-6669

CONSULTANT:

FORESITE LLC
 Architects . Engineers . Surveyors

462 WALNUT STREET
 NEWTON, MA 02460
 617-212-3123

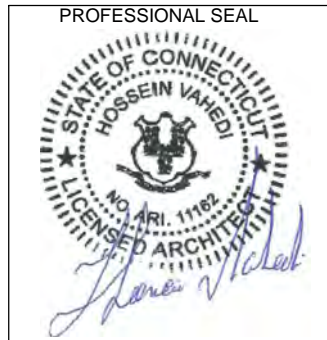

THIS DOCUMENT IS THE DESIGN PROPERTY AND COPYRIGHT OF FORESITE, LLC. AND FOR THE EXCLUSIVE USE BY THE TITLE CLIENT. DUPLICATION OR USE WITHOUT THE EXPRESS WRITTEN CONSENT OF THE CREATOR IS STRICTLY PROHIBITED. DRAWING SCALES ARE INTENDED FOR 11"x17" SIZE PRINTED MEDIA ONLY. ALL OTHER PRINTED SIZES ARE DEEMED "NOT TO SCALE".

REV	DESCRIPTION	DATE
A	PRELIMINARY	08/03/18
0	SIGNED AND SEALED	08/08/18

SITE NUMBER: CT11634C
 SITE NAME: CT634/CING/CHESLEYPARK_ET
 SITE ADDRESS: 35 WILDWOOD STREET
 NEW BRITAIN, CT 06051

SHEET TITLE:
 T-1: TITLE SHEET

SITE IMAGE:



VICINITY MAP:



PROJECT SCOPE:

UPGRADE OF EXISTING WIRELESS FACILITY AS FOLLOWS:
 REPLACE (3) EXISTING ANTENNAS,
 REPLACE (3) REMOTE RADIO UNITS,
 ADD (1) HYBRID CABLE.

PROJECT NOTES:

1. THIS IS AN UNMANNED TELECOMMUNICATION FACILITY AND NOT FOR HUMAN HABITATION. HANDICAPPED ACCESS IS NOT REQUIRED. POTABLE WATER OR SANITARY SERVICE IS NOT REQUIRED. NO OUTDOOR STORAGE OR ANY SOLID WASTE RECEPTACLES REQUIRED.
2. CONTRACTOR SHALL VERIFY ALL PLANS, EXISTING DIMENSIONS, AND CONDITIONS ON THE JOB SITE. CONTRACTOR SHALL IMMEDIATELY NOTIFY THE ARCHITECT/ENGINEER IN WRITING OF ANY DISCREPANCIES BEFORE PROCEEDING WITH THE WORK. FAILURE TO NOTIFY THE ARCHITECT/ENGINEER PLACES THE RESPONSIBILITY ON THE CONTRACTOR TO CORRECT THE DISCREPANCIES AT THE CONTRACTOR'S EXPENSE.
3. DEVELOPMENT AND USE OF THE SITE WILL CONFORM TO ALL APPLICABLE CODES, ORDINANCES AND SPECIFICATIONS.
4. REFER TO STRUCTURAL ANALYSIS REPORT BY OTHERS TITLED "RIGOROUS STRUCTURAL ANALYSIS REPORT" SITE ID: CT11634C, DATED JUNE 21, 2018, PREPARED BY GPD ENGINEERING AND ARCHITECTURE PROFESSIONAL CORPORATION.

APPLICABLE STATE ADOPTION CODES:

2016 CONNECTICUT STATE BUILDING CODE (CSBC).
 ANSI/TIA-222-G-2005 STRUCTURAL STANDARD FOR ANTENNA SUPPORTING STRUCTURES AND ANTENNAS.
 2014 NATIONAL ELECTRICAL CODE (NFPA 70) FOR POWER AND GROUNDING REQUIREMENTS.

APPROVALS:

FSA CM	DATE
RF ENGINEER	DATE
FOPS	DATE
T-MOBILE ENGINEERING AND DEVELOPMENT	DATE
	DATE
	DATE

PROJECT INFORMATION:

ADDRESS: 35 WILDWOOD STREET
 NEW BRITAIN, CT 06051
 STRUCTURE TYPE: MONOPOLE
 COORDINATES: 41.668239 N -72.754955 W

PROJECT TEAM:

APPLICANT: T-MOBILE NORTHEAST, LLC.
 35 GRIFFIN ROAD SOUTH
 BLOOMFIELD, CT 06002
 860-692-7100
 LANDLORD: CINGULAR WIRELESS
 PROJECT MANAGER: NORTHEAST SITE SOLUTIONS
 420 MAIN STREET, BLDG 4
 STURBRIDGE, MA 01566
 SHELDON FREINCLE
 SHELDON@NORTHEASTSITE
 SOLUTIONS.COM
 201-776-8521
 CONSULTANTS: FORESITE LLC
 462 WALNUT ST
 NEWTON, MA 02460
 SAEED MOSSAVAT
 SMOSSAVAT@FORESITELLC.COM
 617-212-3123

SHEET INDEX:

- T-1: TITLE SHEET
- N-1: GENERAL NOTES
- A-1: PLAN
- A-2: ELEVATION
- A-3: ANTENNA PLAN
- A-4: ANTENNA DETAILS
- E-1: GROUNDING DETAILS

Copyright © 2018 Foresite LLC all rights reserved. The details, templates, drawing formats or any portion of this document generated by Foresite LLC may not be duplicated, traced or used otherwise for any profit-driven enterprise.

GENERAL NOTES:

1. THE CONTRACTOR SHALL GIVE ALL NOTICES AND COMPLY WITH ALL LAWS, ORDINANCES, RULES, REGULATIONS AND LAWFUL ORDERS OF ANY PUBLIC AUTHORITY, MUNICIPAL AND UTILITY COMPANY SPECIFICATIONS, AND LOCAL AND STATE JURISDICTIONAL CODES BEARING ON THE PERFORMANCE OF THE WORK. THE WORK PERFORMED ON THE PROJECT AND THE MATERIALS INSTALLED SHALL BE IN STRICT ACCORDANCE WITH ALL APPLICABLE CODES, REGULATIONS, AND ORDINANCES.
2. THE ARCHITECT/ENGINEER HAS MADE EVERY EFFORT TO SET FORTH IN THE CONSTRUCTION AND CONTRACT DOCUMENTS THE COMPLETE SCOPE OF WORK. THE CONTRACTOR BIDDING THE JOB IS NEVERTHELESS CAUTIONED THAT MINOR OMISSIONS OR ERRORS IN THE DRAWINGS AND OR SPECIFICATIONS SHALL NOT EXCUSE SAID CONTRACTOR FROM COMPLETING THE PROJECT AND IMPROVEMENTS IN ACCORDANCE WITH THE INTENT OF THESE DOCUMENTS.
3. THE CONTRACTOR OR BIDDER SHALL BEAR THE RESPONSIBILITY OF NOTIFYING (IN WRITING) THE CLIENT'S REPRESENTATIVE OF ANY CONFLICTS, ERRORS, OR OMISSIONS PRIOR TO THE SUBMISSION OF CONTRACTOR'S PROPOSAL OR PERFORMANCE OF WORK.
5. THE CONTRACTOR SHALL VISIT THE JOB SITE PRIOR TO THE SUBMISSION OF BIDS OR PERFORMING WORK TO FAMILIARIZE HIMSELF WITH THE FIELD CONDITIONS AND TO VERIFY THAT THE PROJECT CAN BE CONSTRUCTED IN ACCORDANCE WITH THE CONSTRUCTION DOCUMENTS.
6. THE CONTRACTOR SHALL INSTALL ALL EQUIPMENT AND MATERIALS ACCORDING TO THE MANUFACTURER'S / VENDOR'S SPECIFICATIONS UNLESS NOTED OTHERWISE OR WHERE LOCAL CODES OR ORDINANCES TAKE PRECEDENCE.
7. THE CONTRACTOR SHALL MAKE NECESSARY PROVISIONS TO PROTECT EXISTING IMPROVEMENTS DURING CONSTRUCTION.
8. THE CONTRACTOR SHALL COMPLY WITH ALL PERTINENT SECTIONS OF THE BASIC STATE BUILDING CODE, LATEST EDITION, AND ALL OSHA REQUIREMENTS AS THEY APPLY TO THIS PROJEC
9. THE CONTRACTOR SHALL NOTIFY THE CLIENT'S REPRESENTATIVE IN WRITING WHERE A CONFLICT OCCURS ON ANY OF THE CONTRACT DOCUMENTS. THE CONTRACTOR IS NOT TO ORDER MATERIAL OR CONSTRUCT ANY PORTION OF THE WORK THAT IS IN CONFLICT UNTIL CONFLICT IS RESOLVED BY THE CLIENT'S REPRESENTATIVE.
10. THE WORK SHALL CONFORM TO THE CODES AND STANDARDS OF THE FOLLOWING AGENCIES AS FURTHER CITED HEREIN:
 - A. ASTM: AMERICAN SOCIETY FOR TESTING AND MATERIALS, AS PUBLISHED IN "COMPILATION OF ASTM STANDARDS BUILDING CODES" OR LATEST EDITION.
 - B. AWS: AMERICAN WELDING SOCIETY INC. AS PUBLISHED IN "STANDARD D1.1-08, STRUCTURAL WELDING CODE" OR LATEST EDITION.
 - C. AISC: AMERICAN INSTITUTE FOR STEEL CONSTRUCTION AS PUBLISHED IN "CODE FOR STANDARD PRACTICE FOR STEEL BUILDINGS AND BRIDGES"; "SPECIFICATIONS FOR THE DESIGN, FABRICATION AND ERECTION OF STRUCTURAL STEEL FOR BUILDINGS" (LATEST EDITION).
11. BOLTING:
 - A. BOLTS SHALL BE CONFORMING TO ASTM A325 HIGH STRENGTH, HOT DIP GALVANIZED WITH ASTM A153 HEAVY HEX TYPE NUTS.
 - B. BOLTS SHALL BE 3/4"Ø MINIMUM (UNLESS OTHERWISE NOTED)
 - C. ALL CONNECTIONS SHALL BE 2 BOLTS MINIMUM.
12. FABRICATION:
 - A. FABRICATION OF STEEL SHALL CONFORM TO THE AISC AND AWS STANDARDS AND CODES (LATEST EDITION).
 - B. ALL STRUCTURAL STEEL SHALL BE HOT-DIP GALVANIZED AFTER FABRICATION IN ACCORDANCE WITH ASTM A123 (LATEST EDITION), UNLESS OTHERWISE NOTED.
13. ERECTION OF STEEL:
 - A. PROVIDE ALL ERECTION EQUIPMENT, BRACING, PLANKING, FIELD BOLTS, NUTS, WASHERS, DRIFT PINS, AND SIMILAR MATERIALS WHICH DO NOT FORM A PART OF THE COMPLETED CONSTRUCTION BUT ARE NECESSARY FOR ITS PROPER ERECTION.
 - B. ERECT AND ANCHOR ALL STRUCTURAL STEEL IN ACCORDANCE WITH AISC REFERENCE STANDARDS. ALL WORK SHALL BE ACCURATELY SET TO ESTABLISHED LINES AND ELEVATIONS AND RIGIDLY FASTENED IN PLACE WITH SUITABLE ATTACHMENTS TO THE CONSTRUCTION OF THE BUILDING.
 - C. TEMPORARY BRACING, GUYING AND SUPPORT SHALL BE PROVIDED TO KEEP THE STRUCTURE SAFE AND ALIGNED AT ALL TIMES DURING CONSTRUCTION, AND TO PREVENT DANGER TO PERSONS AND PROPERTY. CHECK ALL TEMPORARY LOADS AND STAY WITHIN SAFE CAPACITY OF ALL BUILDING COMPONENTS.

14. ANTENNA INSTALLATION:
 - A. INSTALL ANTENNAS AS INDICATED ON DRAWINGS AND CLIENT'S REPRESENTATIVE SPECIFICATIONS.
 - B. INSTALL GALVANIZED STEEL ANTENNA MOUNTS AS INDICATED ON DRAWINGS.
 - C. INSTALL COAXIAL / FIBER CABLES AND TERMINATIONS BETWEEN ANTENNAS AND EQUIPMENT PER MANUFACTURER'S RECOMMENDATIONS. WEATHERPROOF ALL CONNECTORS BETWEEN THE ANTENNA AND EQUIPMENT PER MANUFACTURER'S REQUIREMENTS.
15. ANTENNA AND COAXIAL / FIBER CABLE GROUNDING:
 - A. ALL EXTERIOR #6 GREEN GROUND WIRE "DAISY CHAIN" CONNECTIONS ARE TO BE WEATHER SEALED WITH ANDREWS CONNECTOR/SPLICE WEATHERPROOFING KIT TYPE #221213 OR EQUAL.
 - B. ALL COAXIAL / FIBER CABLE GROUNDING KITS ARE TO BE INSTALLED ON STRAIGHT RUNS OF COAXIAL / FIBER CABLE (NOT WITHIN BENDS).
16. RELATED WORK, FURNISH THE FOLLOWING WORK AS SPECIFIED UNDER CONSTRUCTION DOCUMENTS, BUT COORDINATE WITH OTHER TRADES PRIOR TO BID:
 - A. FLASHING OF OPENING INTO OUTSIDE WALLS
 - B. SEALING AND CAULKING ALL OPENINGS
 - C. PAINTING
 - D. CUTTING AND PATCHING
17. REQUIREMENTS OF REGULATORY AGENCIES:
 - A. FURNISH U.L. LISTED EQUIPMENT WHERE SUCH LABEL IS AVAILABLE. INSTALL IN CONFORMANCE WITH U.L. STANDARDS WHERE APPLICABLE.
 - B. INSTALL ANTENNA, ANTENNA CABLES, GROUNDING SYSTEM IN ACCORDANCE WITH DRAWINGS AND SPECIFICATION IN EFFECT AT PROJECT LOCATION AND RECOMMENDATIONS OF STATE AND LOCAL BUILDING CODES, AND SPECIAL CODES HAVING JURISDICTION OVER SPECIFIC PORTIONS OF WORK. THIS WORK INCLUDES BUT IS NOT LIMITED TO THE FOLLOWING:
 - C. TIA-EIA - 222 (LATEST EDITION). STRUCTURAL STANDARDS FOR STEEL ANTENNA TOWERS AND ANTENNA SUPPORTING STRUCTURES.
 - D. FAA - FEDERAL AVIATION ADMINISTRATION ADVISORY CIRCULAR AC 70/7460-IH, OBSTRUCTION MARKING AND LIGHTING.
 - E. FCC - FEDERAL COMMUNICATIONS COMMISSION RULES AND REGULATIONS FORM 715, OBSTRUCTION MARKING AND LIGHTING SPECIFICATION FOR ANTENNA STRUCTURES AND FORM 715A, HIGH INTENSITY OBSTRUCTION LIGHTING SPECIFICATIONS FOR ANTENNA STRUCTURES.
 - F. AISC - AMERICAN INSTITUTE OF STEEL CONSTRUCTION SPECIFICATION FOR STRUCTURAL JOINTS USING ASTM A325 BOLTS (LATEST EDITION).
 - G. NEC - NATIONAL ELECTRICAL CODE - ON TOWER LIGHTING KITS.
 - H. UL - UNDERWRITER'S LABORATORIES APPROVED ELECTRICAL PRODUCTS.
 - I. IN ALL CASES, PART 77 OF THE FAA RULES AND PARTS 17 AND 22 OF THE FCC RULES ARE APPLICABLE AND IN THE EVENT OF CONFLICT, SUPERSEDE ANY OTHER STANDARDS OR SPECIFICATIONS.
 - J. 2009 LIFE SAFETY CODE NFPA - 101.

APPLICANT:

T-MOBILE NORTHEAST LLC
 35 GRIFFIN ROAD SOUTH
 BLOOMFIELD, CT 06002
 860-692-7100

 **PROJECT MANAGER**
NSS NORTHEAST
Site Solutions
Turkey Wireless Development
 420 MAIN STREET, BLDG 4
 STURBRIDGE, MA 01566
 203-275-6669

CONSULTANT:

Architects . Engineers . Surveyors
 462 WALNUT STREET
 NEWTON, MA 02460
 617-212-3123

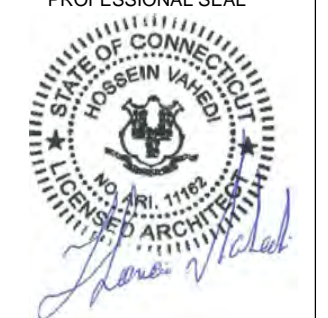
PROFESSIONAL SEAL



THIS DOCUMENT IS THE DESIGN PROPERTY AND COPYRIGHT OF FORESITE, LLC. AND FOR THE EXCLUSIVE USE BY THE TITLE CLIENT. DUPLICATION OR USE WITHOUT THE EXPRESS WRITTEN CONSENT OF THE CREATOR IS STRICTLY PROHIBITED. DRAWING SCALES ARE INTENDED FOR 11"x17" SIZE PRINTED MEDIA ONLY. ALL OTHER PRINTED SIZES ARE DEEMED "NOT TO SCALE".

REV	DESCRIPTION	DATE
A	PRELIMINARY	08/03/18
0	SIGNED AND SEALED	08/08/18

SITE NUMBER: CT11634C
 SITE NAME: CT634/CING/CHESLEYPARK_ET
 SITE ADDRESS: 35 WILDWOOD STREET
 NEW BRITAIN, CT 06051

SHEET TITLE:
N-1: NOTES AND DISCLAIMERS

Copyright © 2018 Foresite LLC all rights reserved. The details, templates, drawing formats or any portion of this document generated by Foresite LLC may not be duplicated, traced or used otherwise for any profit-driven enterprise.

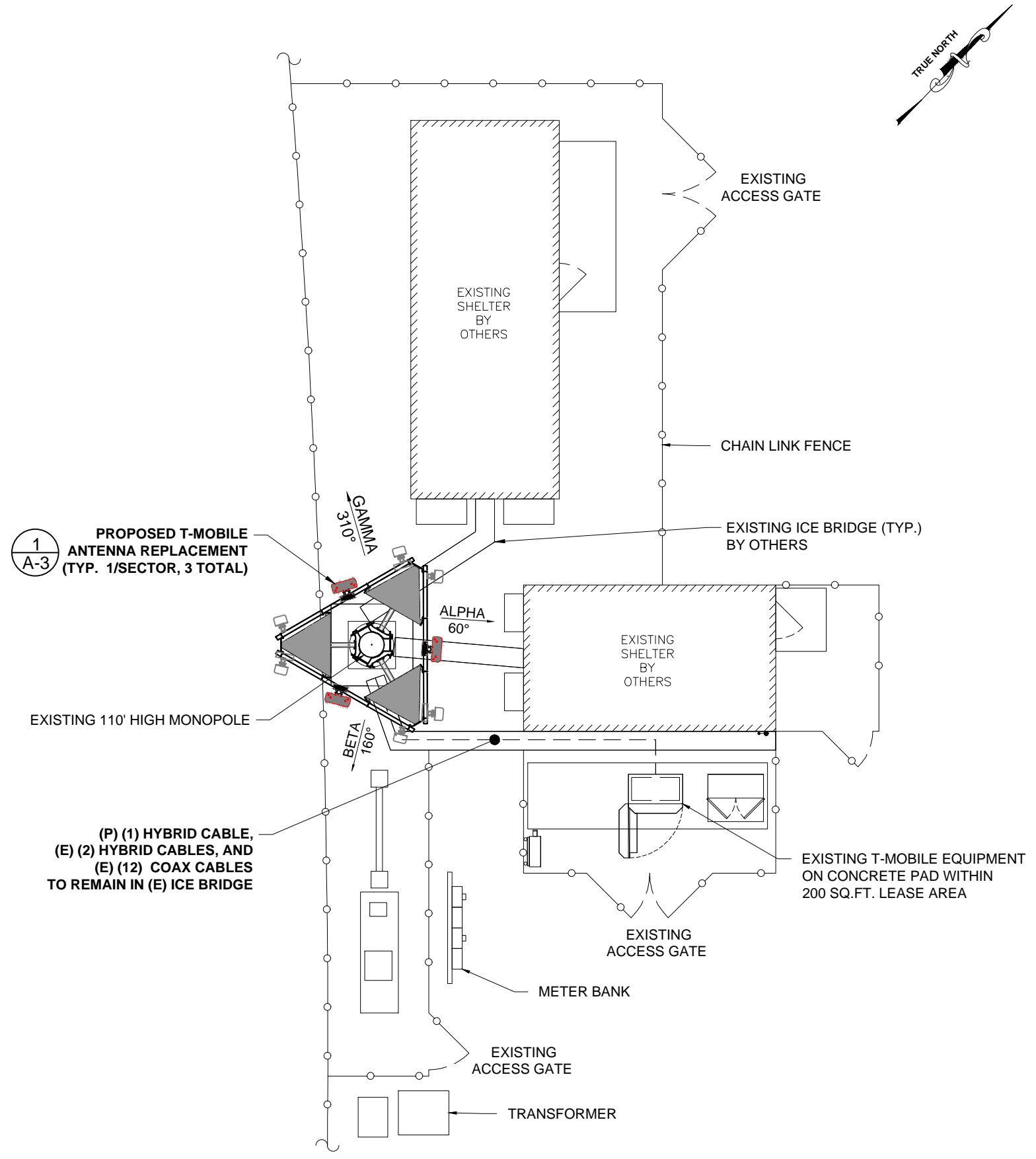

1
A-3
PROPOSED T-MOBILE ANTENNA REPLACEMENT (TYP. 1/SECTOR, 3 TOTAL)

EXISTING 110' HIGH MONOPOLE

(P) (1) HYBRID CABLE, (E) (2) HYBRID CABLES, AND (E) (12) COAX CABLES TO REMAIN IN (E) ICE BRIDGE

SITE PLAN
SCALE: 1" = 10'-0"
1
A-1

APPLICANT:
T-Mobile
T-MOBILE NORTHEAST LLC
35 GRIFFIN ROAD SOUTH
BLOOMFIELD, CT 06002
860-692-7100

PROJECT MANAGER
NSS NORTHEAST
SITE SOLUTIONS
Turnkey Wireless Development
420 MAIN STREET, BLDG 4
STURBRIDGE, MA 01566
203-275-6669

CONSULTANT:
FORESITE LLC
Architects . Engineers . Surveyors
462 WALNUT STREET
NEWTON, MA 02460
617-212-3123

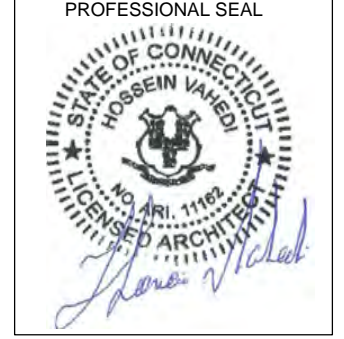

THIS DOCUMENT IS THE DESIGN PROPERTY AND COPYRIGHT OF FORESITE, LLC. AND FOR THE EXCLUSIVE USE BY THE TITLE CLIENT. DUPLICATION OR USE WITHOUT THE EXPRESS WRITTEN CONSENT OF THE CREATOR IS STRICTLY PROHIBITED. DRAWING SCALES ARE INTENDED FOR 11"x17" SIZE PRINTED MEDIA ONLY. ALL OTHER PRINTED SIZES ARE DEEMED "NOT TO SCALE".

REV	DESCRIPTION	DATE
A	PRELIMINARY	08/03/18
0	SIGNED AND SEALED	08/08/18

SITE NUMBER: CT11634C
SITE NAME: CT634/CING/CHESLEY PARK_ET
SITE ADDRESS: 35 WILDWOOD STREET
NEW BRITAIN, CT 06051

SHEET TITLE:
A-1: PLAN

Copyright © 2018 Foresite LLC all rights reserved. The details, templates, drawing formats or any portion of this document generated by Foresite LLC may not be duplicated, traced or used otherwise for any profit-driven enterprise.

- TOP OF HIGHEST APPURTENANCE
ELEV: 114'-0"± (AGL)
- TOP OF EXISTING MONOPOLE
ELEV: 110'-0"± (AGL)
- TOP OF T-MOBILE ANTENNAS
ELEV: 100'-0"± (AGL)

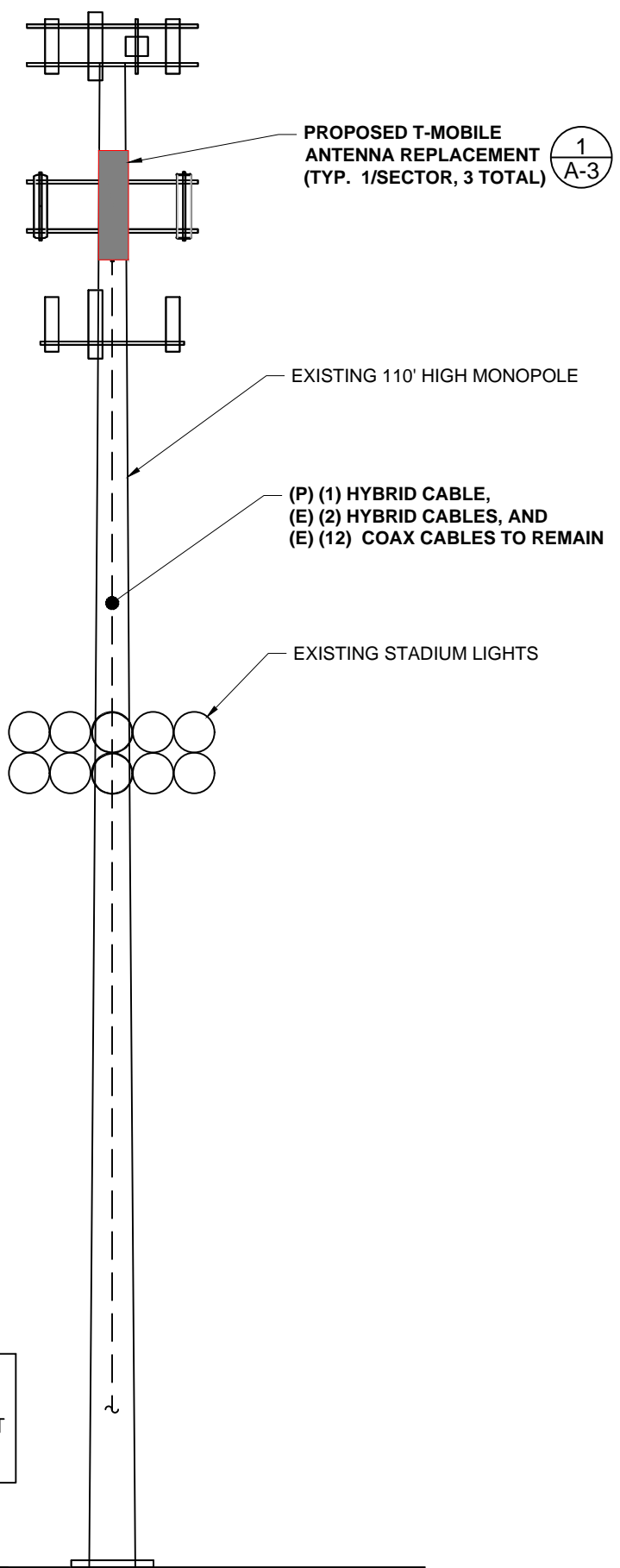

STRUCTURAL NOTE:
REFER TO STRUCTURAL ANALYSIS REPORT BY OTHERS TITLED "RIGOROUS STRUCTURAL ANALYSIS REPORT" SITE ID: CT11634C, DATED JUNE 21, 2018, PREPARED BY GPD ENGINEERING AND ARCHITECTURE PROFESSIONAL CORPORATION.

NOTE:
*GROUND EQUIPMENT NOT SHOWN FOR CLARITY

● GROUND

ELEVATION
SCALE: NTS

APPLICANT:
T-Mobile
T-MOBILE NORTHEAST LLC
35 GRIFFIN ROAD SOUTH
BLOOMFIELD, CT 06002
860-692-7100

PROJECT MANAGER
NSS NORTHEAST
SITE SOLUTIONS
Turnkey Wireless Development
420 MAIN STREET, BLDG 4
STURBRIDGE, MA 01566
203-275-6669

CONSULTANT:
FORESITE LLC
Architects . Engineers . Surveyors
462 WALNUT STREET
NEWTON, MA 02460
617-212-3123

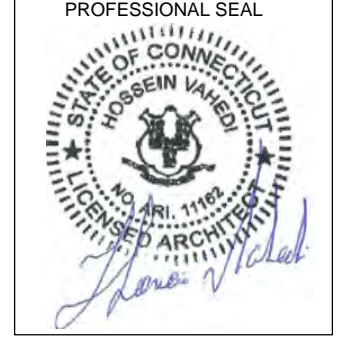

THIS DOCUMENT IS THE DESIGN PROPERTY AND COPYRIGHT OF FORESITE, LLC. AND FOR THE EXCLUSIVE USE BY THE TITLE CLIENT. DUPLICATION OR USE WITHOUT THE EXPRESS WRITTEN CONSENT OF THE CREATOR IS STRICTLY PROHIBITED. DRAWING SCALES ARE INTENDED FOR 11"x17" SIZE PRINTED MEDIA ONLY. ALL OTHER PRINTED SIZES ARE DEEMED "NOT TO SCALE".

REV	DESCRIPTION	DATE
A	PRELIMINARY	08/03/18
0	SIGNED AND SEALED	08/08/18

SITE NUMBER: CT11634C
SITE NAME: CT634/CING/CHESLEYPARK_ET
SITE ADDRESS: 35 WILDWOOD STREET
NEW BRITAIN, CT 06051

SHEET TITLE:
A-2: ELEVATION

Copyright © 2018 Foresite LLC. All rights reserved. The details, templates, drawing formats or any portion of this document generated by Foresite LLC may not be duplicated, traced or used otherwise for any profit-driven enterprise.

EXISTING ANTENNA PLAN

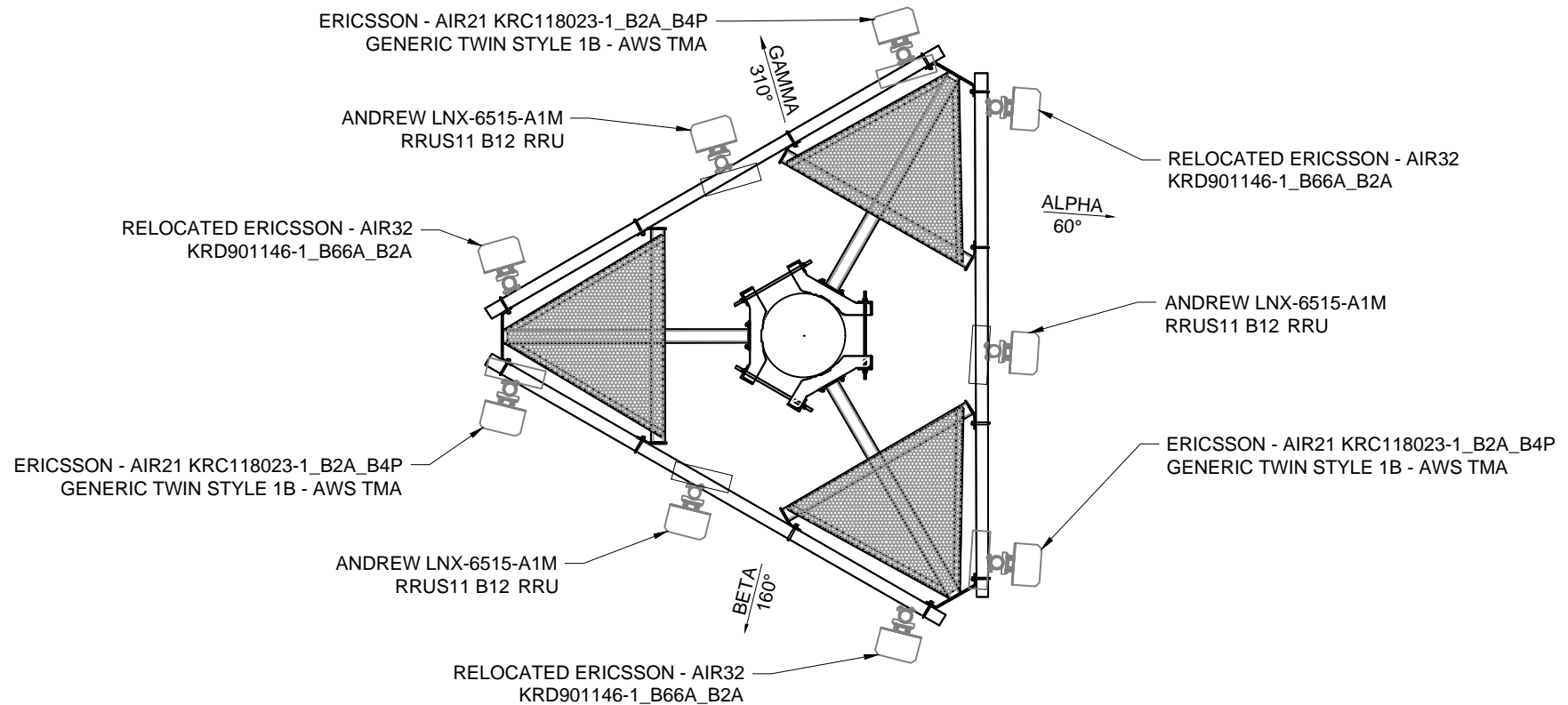

FINAL ANTENNA PLAN

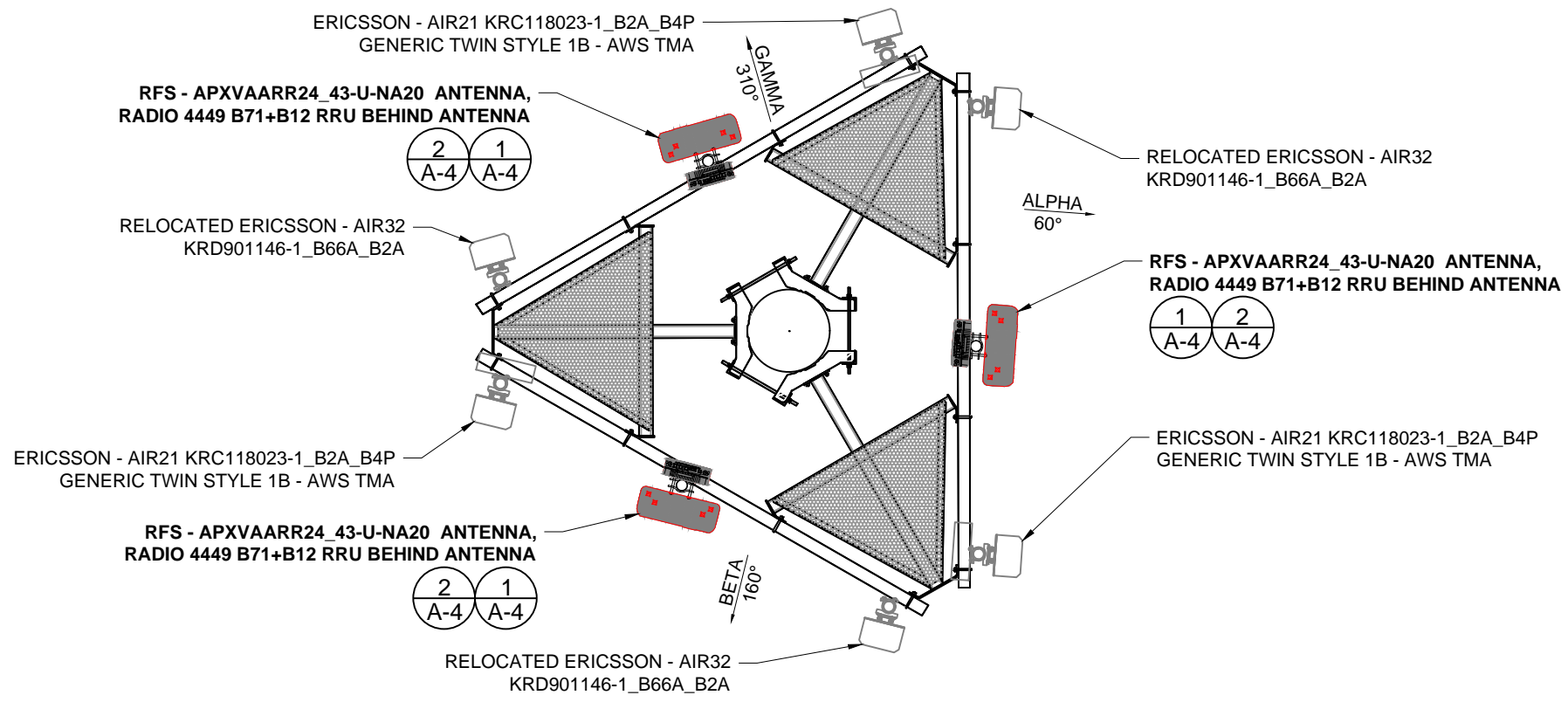

ANTENNA PLAN
SCALE: NTS

1
A-3

APPLICANT:
T-Mobile
T-MOBILE NORTHEAST LLC
35 GRIFFIN ROAD SOUTH
BLOOMFIELD, CT 06002
860-692-7100

PROJECT MANAGER
NSS NORTHEAST
SITE SOLUTIONS
Turnkey Wireless Development
420 MAIN STREET, BLDG 4
STURBRIDGE, MA 01566
203-275-6669

CONSULTANT:
FORESITE LLC
Architects . Engineers . Surveyors
462 WALNUT STREET
NEWTON, MA 02460
617-212-3123



THIS DOCUMENT IS THE DESIGN PROPERTY AND COPYRIGHT OF FORESITE, LLC. AND FOR THE EXCLUSIVE USE BY THE TITLE CLIENT. DUPLICATION OR USE WITHOUT THE EXPRESS WRITTEN CONSENT OF THE CREATOR IS STRICTLY PROHIBITED. DRAWING SCALES ARE INTENDED FOR 11"x17" SIZE PRINTED MEDIA ONLY. ALL OTHER PRINTED SIZES ARE DEEMED "NOT TO SCALE".

REV	DESCRIPTION	DATE
A	PRELIMINARY	08/03/18
0	SIGNED AND SEALED	08/08/18

SITE NUMBER: CT11634C
SITE NAME: CT634/CING/CHESLEYPARK_ET
SITE ADDRESS: 35 WILDWOOD STREET
NEW BRITAIN, CT 06051

SHEET TITLE:
A-3: ANTENNA PLAN

Copyright © 2018 Foresite LLC all rights reserved. The details, templates, drawing formats or any portion of this document generated by Foresite LLC may not be duplicated, traced or used otherwise for any profit-driven enterprise.

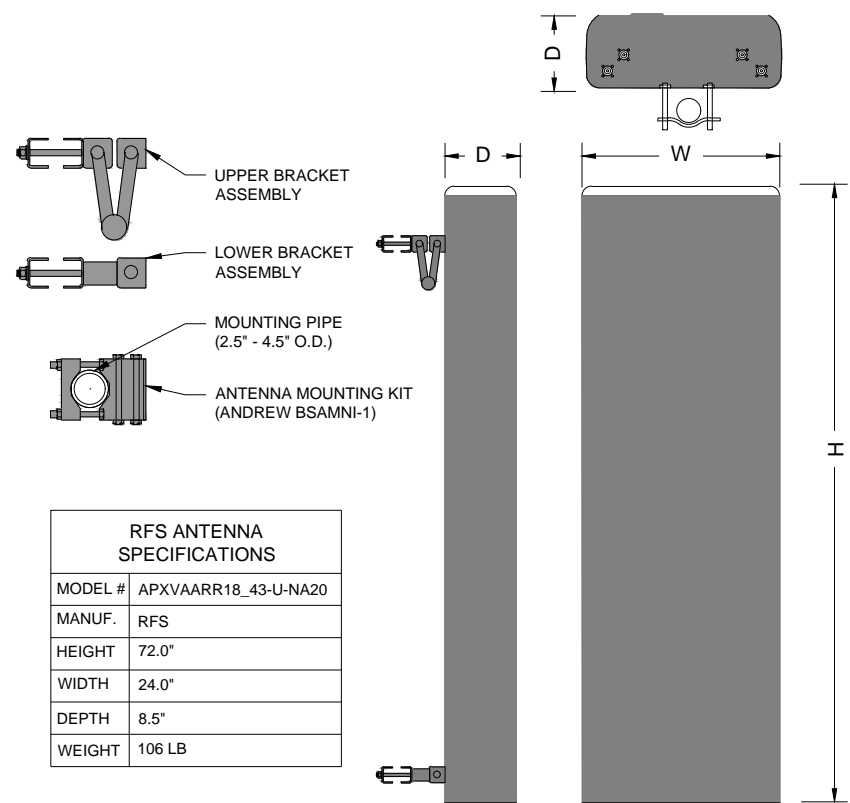

RFS ANTENNA SPECIFICATIONS	
MODEL #	APXVAARR18_43-U-NA20
MANUF.	RFS
HEIGHT	72.0"
WIDTH	24.0"
DEPTH	8.5"
WEIGHT	106 LB

RFS ANTENNA
N.T.S

1
A-4

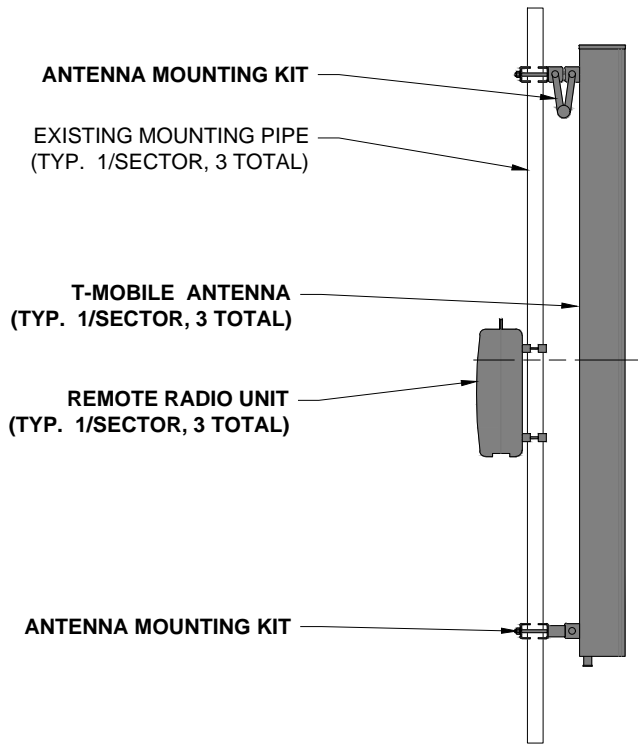

STRUCTURAL NOTES:
PRIOR TO COMMENCING CONSTRUCTION, GC SHALL REFER TO ROOFTOP STRUCTURAL ANALYSIS REPORT TO DETERMINE IF THERE IS ANY SUPPLEMENTAL OF SPECIAL INSTALLATION REQUIRED FOR ROOFTOP EQUIPMENT AND FOR CABLE BUNDLING, SHIELDING, MOUNTING, OR RELOCATION ARRANGEMENTS.

ANTENNA INSTALLATION SPECIAL WORK NOTE:
ANTENNA INSTALLATION WORKING POINT IS THE STRUCTURAL FACE FRAME VERTICAL CENTERLINE OF THE EXISTING ANTENNA SUPPORT ASSEMBLY. UNLESS NOTED OTHERWISE, VERTICALLY CENTERED PROPOSED PIPE MASTS AND ANTENNAS ON THIS WORKING POINT.

ANTENNA MOUNTING DETAIL
N.T.S

3
A-4

REMOTE RADIO UNIT SPECIFICATIONS	
MODEL #	RADIO 4449 B71+B12
MANUF.	ERICSSON
HEIGHT	14.9"
WIDTH	13.2"
DEPTH	10.4"
WEIGHT	74 LB

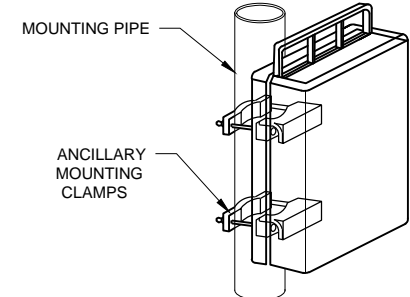
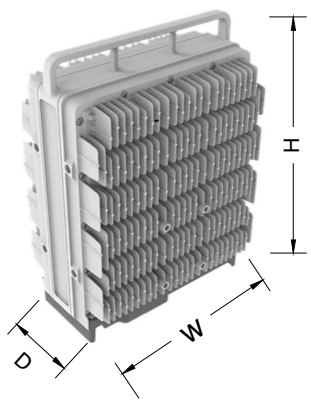

REMOTE RADIO UNIT
N.T.S

2
A-4

APPLICANT:
T-Mobile
T-MOBILE NORTHEAST LLC
35 GRIFFIN ROAD SOUTH
BLOOMFIELD, CT 06002
860-692-7100

PROJECT MANAGER
NSS NORTHEAST
SITE SOLUTIONS
Turnkey Wireless Development
420 MAIN STREET, BLDG 4
STURBRIDGE, MA 01566
203-275-6669

CONSULTANT:
FORESITE LLC
Architects . Engineers . Surveyors
462 WALNUT STREET
NEWTON, MA 02460
617-212-3123

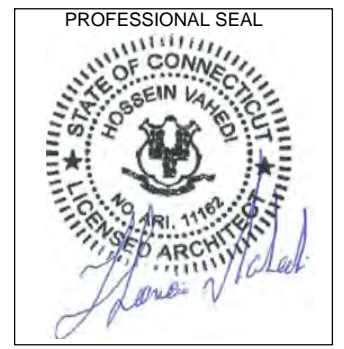

THIS DOCUMENT IS THE DESIGN PROPERTY AND COPYRIGHT OF FORESITE, LLC. AND FOR THE EXCLUSIVE USE BY THE TITLE CLIENT. DUPLICATION OR USE WITHOUT THE EXPRESS WRITTEN CONSENT OF THE CREATOR IS STRICTLY PROHIBITED. DRAWING SCALES ARE INTENDED FOR 11"x17" SIZE PRINTED MEDIA ONLY. ALL OTHER PRINTED SIZES ARE DEEMED "NOT TO SCALE".

REV	DESCRIPTION	DATE
A	PRELIMINARY	08/03/18
0	SIGNED AND SEALED	08/08/18

SITE NUMBER: CT11634C
SITE NAME: CT634/CING/CHESLEYPARK_ET
SITE ADDRESS: 35 WILDWOOD STREET
NEW BRITAIN, CT 06051

SHEET TITLE:
A-4: ANTENNA DETAILS

Copyright © 2018 Foresite LLC all rights reserved. The details, templates, drawing formats or any portion of this document generated by Foresite LLC may not be duplicated, traced or used otherwise for any profit-driven enterprise.

ELECTRICAL & GROUNDING NOTES

1. ALL ELECTRICAL WORK SHALL CONFORM TO THE REQUIREMENTS OF THE NATIONAL ELECTRICAL CODE (NEC) AS WELL AS APPLICABLE STATE AND LOCAL CODES.
2. ALL ELECTRICAL ITEMS SHALL BE U.L. APPROVED OR LISTED AND PRODUCED PER SPECIFICATION REQUIREMENTS.
3. THE ELECTRICAL WORK INCLUDES ALL LABOR AND MATERIAL DESCRIBED BY DRAWINGS AND SPECIFICATION INCLUDING INCIDENTAL WORK TO PROVIDE COMPLETE OPERATING AND APPROVED ELECTRICAL SYSTEM.
4. GENERAL CONTRACTOR SHALL PAY FEES FOR PERMITS, AND RESPONSIBLE FOR OBTAINING SAID PERMITS AND COORDINATION OF INSPECTIONS.
5. ELECTRICAL AND TELCO WIRING OUTSIDE A BUILDING AND EXPOSED TO WEATHER SHALL BE IN WATER TIGHT GALVANIZED RIGID STEEL CONDUITS OR SCHEDULE 80 PVC (AS PERMITTED BY CODE) AND WHERE REQUIRED IN LIQUID TIGHT FLEXIBLE METAL OR NONMETALLIC CONDUITS.
6. RIGID STEEL CONDUITS SHALL BE GROUNDED AT BOTH ENDS.
7. ELECTRICAL WIRING SHALL BE COPPER WITH TYPE XHHW, THWN, OR THIN INSULATION.
8. RUN ELECTRICAL CONDUIT OR CABLING BETWEEN ELECTRICAL ROOM AND PROPOSED CELL SITE ARE PEDESTAL AS INDICATED ON THIS DRAWING. PROVIDE FULL LENGTH PULL ROPE. COORDINATE INSTALLATION WITH UTILITY COMPANY.
9. RUN TELCO CONDUIT OR CABLE BETWEEN TELEPHONE UTILITY DEMARCATION POINT AND PROPOSED CELL SITE TELECOM CABINET AND RBS CABINET AS INDICATED ON DRAWING A -1. PROVIDE FULL LENGTH PULL ROPE INSTALLED TELCO CONDUIT. PROVIDE GREENLEE CONDUIT MEASURING TAPE AT EACH END.
10. ALL EQUIPMENT LOCATED OUTSIDE SHALL HAVE NAME 3R ENCLOSURE.
11. GROUNDING SHALL COMPLY WITH NEC ART. 250.
12. GROUNDING COAX CABLE SHIELDS MINIMUM AT BOTH ENDS USING MANUFACTURES COAX CABLE GROUNDING KITS SUPPLIED BY PROJECT OWNER.
13. USE #6 COPPER STRANDED WIRE WITH GREEN COLOR INSTALLATION FOR ABOVE GRADE GROUNDING (UNLESS OTHERWISE SPECIFIED) AND #2 SOLID TINNED BARE COPPER WIRE FOR BELOW GRADE GROUNDING AS INDICATED ON THE GROUND.
14. ALL GROUND CONNECTION TO BE BURNDY HYGROUND COMPRESSION TYPE CONNECTORS OR CADWELD EXOTHERMIC WELD. DO NOT ALLOW BARE COPPER WIRE TO BE IN CONTACT WITH GALVANIZED STEEL.
15. ROUTE GROUNDING CONDUCTORS ALONG THE SHORTEST AND STRAIGHTEST PATH POSSIBLE, EXCEPT AS OTHERWISE INDICATED. GROUNDING LEADS SHOULD NEVER BE BENT AS RIGHT ANGLE. ALWAYS MAKE AT LEAST 12" RADIUS BENDS. #6 WIRE CAN BE BENT AT 6" RADIUS WHEN NECESSARY BOND ANY METER OBJECTS WITHIN 7 FEET OF PROPOSED EQUIPMENT OR CABINET TO MASTER GROUND BAR.
16. CONNECTIONS TO MGB SHALL BE ARRANGED IN THREE MAIN GROUPS: SURGE PROCEDURES (COAXIAL CABLE GROUND KITS, TELCO AND POWER PANEL GROUND); (GROUNDING ELECTRODE RING OR BUILDING STEEL); NON-SURGING OBJECTS (EGB GROUND IN RBS UNIT).
17. CONNECTIONS TO GROUND BARS SHALL BE MADE WITH TWO HOLE COMPRESSION TYPE COPPER LUGS. APPLY OXIDE INHIBITING COMPOUND TO ALL LOCATIONS.
18. APPLY OXIDE INHIBITING COMPOUND TO ALL COMPRESSION TYPE GROUND CONNECTION.
19. BOND ANTENNA MOUNTING BRACKETS, COAXIAL CABLE GROUND KITS, AND ALNA TO EGB PLACED NEAR THE ANTENNA LOCATION.
20. BOND ANTENNA EGB'S AND MGB TO WATER MAIN.
21. TEST COMPLETED GROUND SYSTEM AND RECORD RESULTS FOR PROJECT CLOSE-OUT DOCUMENTATION.
22. BOND ANY METAL OBJECTS WITHIN 7 FEET OF PROPOSED EQUIPMENT OR CABINET TO MASTER GROUND BAR.
23. VERIFY PROPOSED SERVICE UPGRADE WITH LOCAL UTILITY COMPANY PRIOR TO CONSTRUCTION.

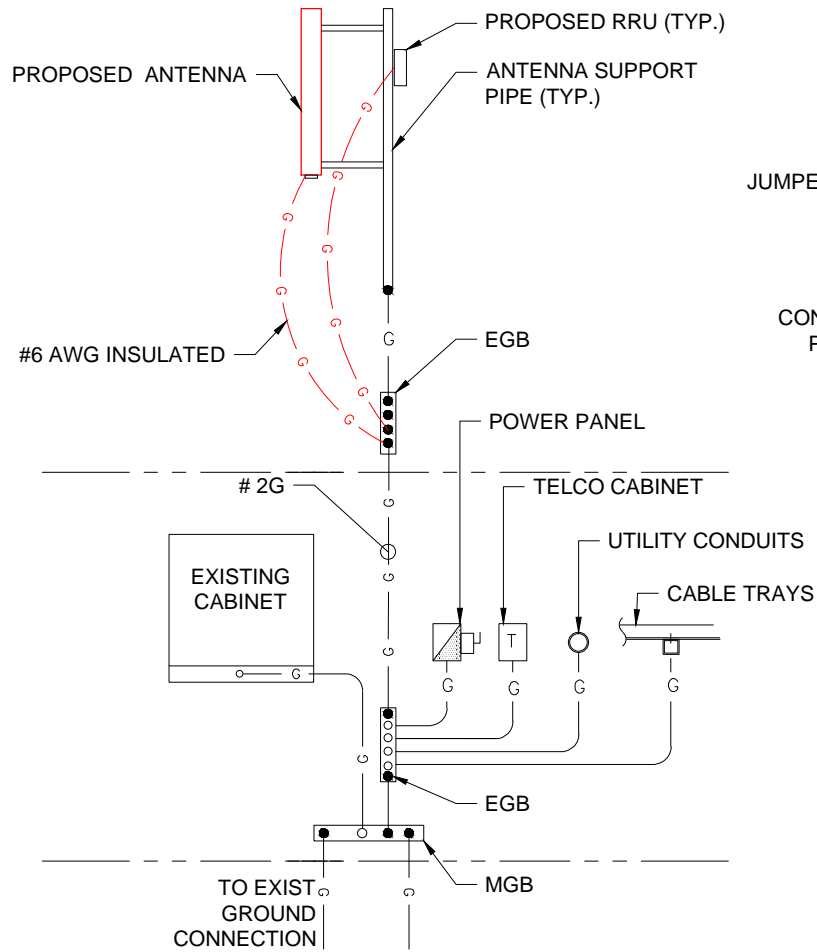

GROUNDING RISER DIAGRAM 1
SCALE: N.T.S. E-1

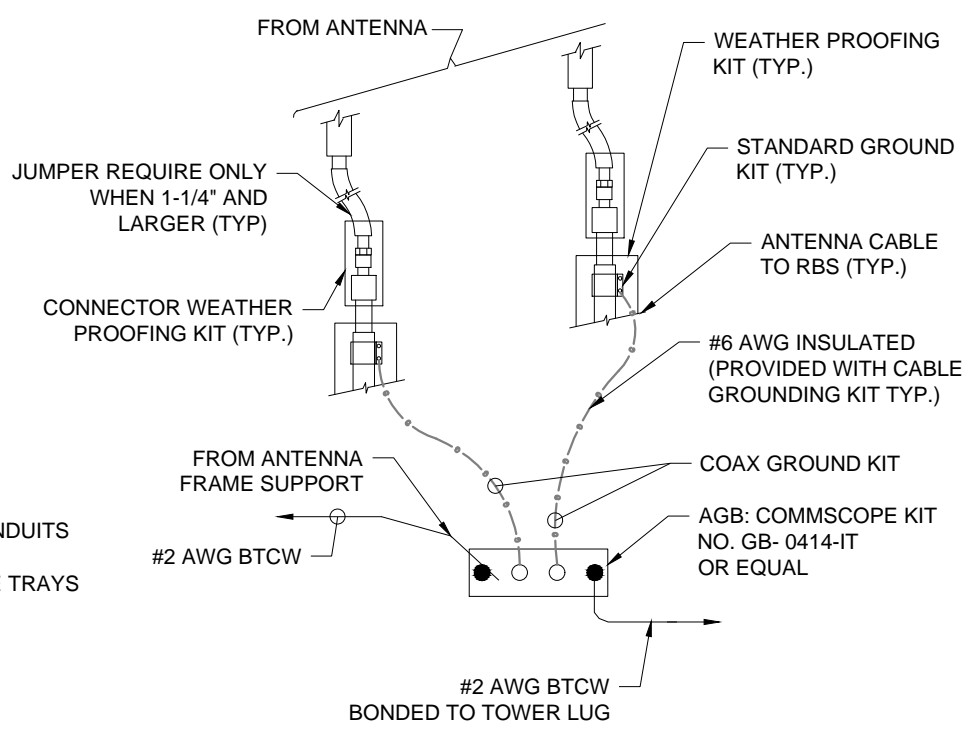

NOTES:
INSTALL CABLE GROUND KIT ABOVE HORIZONTAL BEND AND ALWAYS DIRECT GROUND WIRE DOWN TO AGB/EGB

TOWER TOP CABLE GROUNDING DETAIL 2
SCALE: N.T.S. E-1

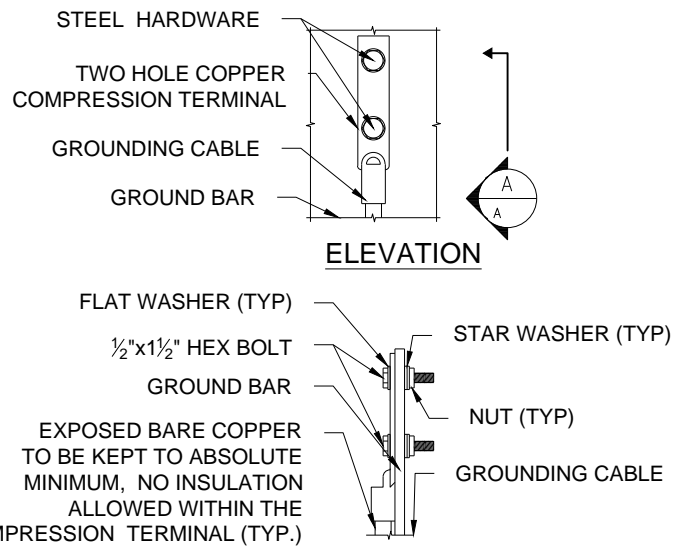

NOTES:
1. "DOUBLING UP" OR "STACKING" OF CONNECTION IS NOT PERMITTED.
2. OXIDE INHIBITING COMPOUND TO BE USED AT ALL LOCATIONS.

TYPICAL GROUND BAR CONNECTIONS DETAIL 3
SCALE: N.T.S. E-1

APPLICANT:
T-Mobile
T-MOBILE NORTHEAST LLC
35 GRIFFIN ROAD SOUTH
BLOOMFIELD, CT 06002
860-692-7100

PROJECT MANAGER
NSS NORTHEAST
SITE SOLUTIONS
Turnkey Wireless Development
420 MAIN STREET, BLDG 4
STURBRIDGE, MA 01566
203-275-6669

CONSULTANT:
FORESITE LLC
Architects . Engineers . Surveyors
462 WALNUT STREET
NEWTON, MA 02460
617-212-3123

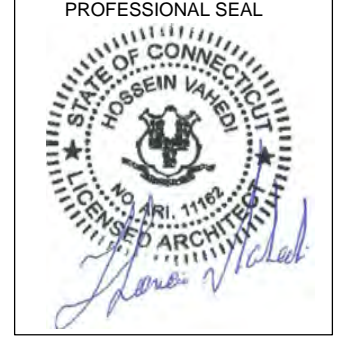

THIS DOCUMENT IS THE DESIGN PROPERTY AND COPYRIGHT OF FORESITE, LLC. AND FOR THE EXCLUSIVE USE BY THE TITLE CLIENT. DUPLICATION OR USE WITHOUT THE EXPRESS WRITTEN CONSENT OF THE CREATOR IS STRICTLY PROHIBITED. DRAWING SCALES ARE INTENDED FOR 11"x17" SIZE PRINTED MEDIA ONLY. ALL OTHER PRINTED SIZES ARE DEEMED "NOT TO SCALE".

REV	DESCRIPTION	DATE
A	PRELIMINARY	08/03/18
0	SIGNED AND SEALED	08/08/18

SITE NUMBER: CT11634C
SITE NAME: CT634/CING/CHESLEY PARK_ET
SITE ADDRESS: 35 WILDWOOD STREET
NEW BRITAIN, CT 06051

SHEET TITLE:
E-1: GROUNDING AND ELECTRICAL DETAILS

Exhibit D



AT&T Towers
 5600 Glenridge Drive
 Atlanta, GA 30342
 (678) 917-1026



GPD Engineering and Architecture
 Professional Corporation
 Brian Daugherty
 520 South Main St, Suite 2531
 Akron OH, 44311
 (216) 927-8687
 bdaugherty@gpdgroup.com

GPD# 2018723.01.88241.02
 June 21, 2018

RIGOROUS STRUCTURAL ANALYSIS REPORT

AT&T DESIGNATION: **Site USID:** **88241**
 Site FA: **10050945**
 Site Name: **NEW BRITAIN WILDWOOD STREET**
 T-Mobile #: **CT11634C**
 AT&T Project: **TMO Amend#5 Modification 5-29-18**

ANALYSIS CRITERIA: **Codes:** **TIA-222-G, 2012 IBC & 2016 CSBC**
 125-mph (Ultimate 3-second gust) with 0" ice
 97-mph (Nominal 3-second gust) with 0" ice
 40-mph (Nominal 3-second gust) with 1" ice

SITE DATA: **Wildwood Street, New Britain, CT 06051, Hartford County**
 Latitude 41° 40' 5.47" N, Longitude 72° 45' 18.72" W
 Market: New England
 110' Monopole

Ms. Deborah Krenc,

GPD is pleased to submit this Rigorous Structural Analysis Report to determine the structural integrity of the aforementioned tower. The purpose of the analysis is to determine the suitability of the tower with the existing and proposed loading configuration detailed in the analysis report.

Analysis Results

Tower Stress Level with Proposed Equipment:	92.9%	Pass
Foundation Ratio with Proposed Equipment:	59.8%	Pass

We at GPD appreciate the opportunity of providing our continuing professional services to you and AT&T Towers. If you have any questions or need further assistance on this or any other projects please do not hesitate to call.

Respectfully submitted,

Christopher J Scheks, P.E.
 Connecticut #: 0030026

6/21/2018

SUMMARY & RESULTS

The purpose of this analysis was to verify whether the existing structure is capable of carrying the proposed loading configuration as specified by T-Mobile to AT&T Towers. This report was commissioned by Ms. Deborah Krenc of AT&T Towers.

This analysis has been performed in accordance with the 2016 Connecticut State Building Code based upon an ultimate 3-second gust wind speed of 125 mph converted to a nominal 3-second gust wind speed of 97 mph per Section 1609.3 and Appendix N as required for use in the TIA-222-G Standard per Exception #5 of Section 1609.1.1. Exposure Category C and Risk Category II were used in this analysis.

The proposed coax shall be installed internal to the monopole in order for the analysis to be valid.

TOWER SUMMARY AND RESULTS

Member	Capacity	Results
Monopole	92.9%	Pass
Anchor Rods	70.5%	Pass
Base Plate	79.5%	Pass
Foundation	59.8%	Pass

ANALYSIS METHOD

tnxTower (Version 7.0.7.0), a commercially available software program, was used to create a three-dimensional model of the tower and calculate primary member stresses for various dead, live, wind, and ice load cases. Selected output from the analysis is included in Appendix B. The following table details the information provided to complete this structural analysis. This analysis is based solely on this information and is being completed without the benefit of a detailed site visit.

DOCUMENTS PROVIDED

Document	Remarks	Source
Site Lease Application	T-Mobile Colocation Application, dated 5/16/2018	AT&T
Tower Design	PJF Job #: 29205-0027, dated 4/29/2005	AT&T
Foundation Design	Not Provided	n/a
Geotechnical Report	Not Provided	n/a
Previous Structural Analysis	GPD Job #: 2017723.13.88241.01 Rev. 1, dated 3/22/2017	AT&T

ASSUMPTIONS

This rigorous structural analysis is based on the theoretical capacity of the members and is not a condition assessment of the tower. This analysis is from information supplied, and therefore, its results are based on and are as accurate as that supplied data. GPD has made no independent determination, nor is it required to, of its accuracy. The following assumptions were made for this structural analysis.

1. The tower member sizes and shapes are considered accurate as supplied. The material grade is as per data supplied and/or as assumed and as stated in the materials section.
2. The antenna configuration is as supplied and/or as modeled in the analysis. It is assumed to be complete and accurate. All antennas, mounts, coax and waveguides are assumed to be properly installed and supported as per manufacturer requirements.
3. Some assumptions are made regarding antennas and mount sizes and their projected areas based on best interpretation of data supplied and of best knowledge of antenna type and industry practice.
4. All mounts, if applicable, are considered adequate to support the loading. No actual analysis of the mount(s) is performed. This analysis is limited to analyzing the tower only.
5. The soil parameters are as per data supplied or as assumed and stated in the calculations.
6. Foundations are properly designed and constructed to resist the original design loads indicated in the documents provided.
7. The tower and structures have been properly maintained in accordance with TIA Standards and/or with manufacturer's specifications.
8. All welds and connections are assumed to develop at least the member capacity unless determined otherwise and explicitly stated in this report.
9. All prior structural modifications are assumed to be as per data supplied/available and to have been properly installed.
10. Loading interpreted from photos is accurate to $\pm 5'$ AGL, antenna size accurate to ± 3.3 sf, and coax equal to the number of existing antennas without reserve.
11. All existing loading was obtained from the previous structural analysis by GPD (Job #: 2017723.13.88241.01 Rev. 1, dated 3/22/2017), the provided colocation application and site photos and is assumed to be accurate.
12. The proposed coax shall be installed internal to the monopole in order for the analysis to be valid.
13. The future loading has been based on the generic future AT&T loading scenario.

If any of these assumptions are not valid or have been made in error, this analysis may be affected, and GPD should be allowed to review any new information to determine its effect on the structural integrity of the tower.

DISCLAIMER OF WARRANTIES

GPD has not performed a site visit to the tower to verify the member sizes or antenna/coax loading. If the existing conditions are not as represented on the tower elevation contained in this report, we should be contacted immediately to evaluate the significance of the discrepancy. This is not a condition assessment of the tower or foundation. This report does not replace a full tower inspection. The tower and foundations are assumed to have been properly fabricated, erected, maintained, in good condition, twist free, and plumb.

The engineering services rendered by GPD in connection with this Rigorous Structural Analysis are limited to a computer analysis of the tower structure and theoretical capacity of its main structural members. No allowance was made for any damaged, bent, missing, loose, or rusted members (above and below ground). No allowance was made for loose bolts or cracked welds.

This analysis is limited to the designated maximum wind and seismic conditions per the governing tower standards and code. Wind forces resulting in tower vibrations near the structure's resonant frequencies were not considered in this analysis and are outside the scope of this analysis. Lateral loading from any dynamic response was not evaluated under a time-domain based fatigue analysis.

GPD does not analyze the fabrication of the structure (including welding). It is not possible to have all the very detailed information needed to perform a thorough analysis of every structural sub-component and connection of an existing tower. GPD provides a limited scope of service in that we cannot verify the adequacy of every weld, plate connection detail, etc. The purpose of this report is to assess the capability of adding appurtenances usually accompanied by transmission lines to the structure.

It is the owner's responsibility to determine the amount of ice accumulation in excess of the code specified amount, if any, that should be considered in the structural analysis.

The attached sketches are a schematic representation of the analyzed tower. If any material is fabricated from these sketches, the contractor shall be responsible for field verifying the existing conditions, proper fit, and clearance in the field. Any mentions of structural modifications are reasonable estimates and should not be used as a precise construction document. Precise modification drawings are obtainable from GPD, but are beyond the scope of this report.

Miscellaneous items such as antenna mounts, etc., have not been designed or detailed as a part of our work. We recommend that material of adequate size and strength be purchased from a reputable tower manufacturer.

Towers are designed to carry gravity, wind, and ice loads. All members, legs, diagonals, struts, and redundant members provide structural stability to the tower with little redundancy. Absence or removal of a member can trigger catastrophic failure unless a substitute is provided before any removal. Legs carry axial loads and derive their strength from shorter unbraced lengths by the presence of redundant members and their connection to the diagonals with bolts or welds. If the bolts or welds are removed without providing any substitute to the frame, the leg is subjected to a higher unbraced length that immediately reduces its load carrying capacity. If a diagonal is also removed in addition to the connection, the unbraced length of the leg is greatly increased, jeopardizing its load carrying capacity. Failure of one leg can result in a tower collapse because there is no redundancy. Redundant members and diagonals are critical to the stability of the tower.

GPD makes no warranties, expressed and/or implied, in connection with this report and disclaims any liability arising from material, fabrication, and erection of this tower. GPD will not be responsible whatsoever for, or on account of, consequential or incidental damages sustained by any person, firm, or organization as a result of any data or conclusions contained in this report. The maximum liability of GPD pursuant to this report will be limited to the total fee received for preparation of this report.

APPENDIX A

Tower Analysis Summary Form

Tower Analysis Summary Form

General Info

Site Name	NEW BRITAIN WILDWOOD STREET
Site Number	88241
FA Number	10050945
Date of Analysis	6/21/2018
Company Performing Analysis	GPD

The information contained in this summary report is not to be used independently from the PE stamped tower analysis.

Tower Info	Description	Date
Tower Type (G, SST, MP)	MP	
Tower Height (top of steel AGL)	110'	
Tower Manufacturer	Penn Summit	2005
Tower Model	n/a	
Tower Design	PJF Job # 29205-0027	4/29/2005
Foundation Design	n/a	
Geotech Report	n/a	
Tower Mapping	n/a	
Previous Structural Analysis	GPD Job #: 2017723.13.88241.01 Rev. 1	3/22/2017
Foundation Mapping	n/a	

Design Parameters

Design Code Used	TIA-222-G & 2012 IBC
Location of Tower (County, State)	Hartford, CT
Nominal Wind Speed (mph)	97 (3-second gust)
Ice Thickness (in)	1
Risk Category (I, II, III)	II
Exposure Category (B, C, D)	C
Topographic Category (1 to 5)	1

Analysis Results (% Maximum Usage)

Existing/Reserved + Future + Proposed Condition	
Tower (%)	92.9%
Tower Base (%)	79.5%
Foundation (%)	59.8%
Foundation Adequate?	Yes

Steel Yield Strength (ksi)

Pole	65
Base Plate	50
Anchor Rods	75

Existing / Reserved Loading

Antenna								Mount			Transmission Line			
Antenna Owner	Mount Height (ft)	Antenna CL (ft)	Quantity	Type	Manufacturer	Model	Azimuth	Quantity	Manufacturer	Type	Quantity	Model	Size	Attachment Int/Ext
AT&T Mobility	110	113	6	Panel	Powerwave	7770.00	30/150/270	1	Unknown	LP Platform	12	Unknown	1-5/8"	Internal
AT&T Mobility	110	113	3	Panel	KMW	AM-X-CD-16-65-00T-RET	30/150/270			on the same mount	2	DC Power	3/4"	Internal
AT&T Mobility	110	113	6	TMA	Powerwave	LGP 21401				on the same mount	1	Fiber Cable	1/2"	Internal
AT&T Mobility	110	113	6	Diplexer	Powerwave	LGP 13519				on the same mount				
AT&T Mobility	110	113	3	RRU	Ericsson	RRUS 11				on the same mount				
AT&T Mobility	110	113	3	RRU	Ericsson	RRUS 12				on the same mount				
AT&T Mobility	110	113	1	Surge	Raycap	DC6-48-60-18-8F				on the same mount				
T-Mobile	100	100	3	Panel	Ericsson	AIR 21 B2A B4P	60/160/310	1	Unknown	Platform w/ Rails	12	Unknown	1-5/8"	Internal
T-Mobile	100	100	3	Panel	Commscope	LNX-6515DS-A1M	60/160/310			on the same mount	2	Hybrid Cable	1-1/4"	Internal
T-Mobile	100	100	3	Panel	Ericsson	AIR 32 B66AaB2a				on the same mount				
T-Mobile	100	100	3	RRU	Ericsson	RRUS11-B12				on the same mount				
T-Mobile	100	100	3	TMA	RFS	1412D-1S20				on the same mount				
Verizon	90	90	3	Panel	Antel	BXA-80063/4CF	0/120/240	3	Unknown	T-Arms	12	Unknown	1-5/8"	Internal
Verizon	90	90	3	Panel	Antel	BXA-171063-8BF	0/120/240			on the same mounts	6	Unknown	1-5/8"	External
Verizon	90	90	3	Panel	Antel	BXA-70063-6CF_2	0/120/240			on the same mounts				
Township	60	60	10	Lights	Unknown	Stadium Lights		1	Unknown	Stadium Light Rack				

Note: (3) LNX-6515DS-A1M panel antennas, (3) RRUS11-B12 RRUs, (3) 1412D-1S20 TMAs and (1) 1-5/8" coax at 100' shall be removed prior to the installation of the proposed loading. All remaining equipment shall be reused.

Proposed Loading

Antenna								Mount			Transmission Line			
Antenna Owner	Mount Height (ft)	Antenna CL (ft)	Quantity	Type	Manufacturer	Model	Azimuth	Quantity	Manufacturer	Type	Quantity	Model	Size	Attachment Int/Ext
T-Mobile	100	100	3	Panel	RFS	APXVARR24 43 U-NA20	60/160/310			on the existing mounts	1	Hybrid Cable	1-1/4"	Internal
T-Mobile	100	100	3	RRU	Ericsson	4449-B12+71				on the existing mounts				

Note: The proposed loading is in addition to the remaining loading at the same elevation.

The future coax shall be installed internal to the monopole in order for the analysis to be valid.

Future Loading

Antenna								Mount			Transmission Line			
Antenna Owner	Mount Height (ft)	Antenna CL (ft)	Quantity	Type	Manufacturer	Model	Azimuth	Quantity	Manufacturer	Type	Quantity	Model	Size	Attachment Int/Ext
AT&T Mobility	110	113	3	Panel	KMW	AM-X-CD-16-65-00T-RET	30/150/270			on the existing mounts	6	Unknown	1-5/8"	Internal

Note: The future loading shall be installed in addition to the existing/reserved at the same elevation.

Note: The future coax shall be installed internal to the monopole in order for the analysis to be valid.

APPENDIX B

tnxTower Output File

tnxTower GPD 520 South Main Street Suite 2531 Akron, Ohio 44311 Phone: (330) 572-2100 FAX: (330) 572-2101	Job 88241 NEW BRITAIN WILDWOOD STREET	Page 1 of 5
	Project 2018723.01.88241.02	Date 08:19:02 06/20/18
	Client AT&T Towers	Designed by mrisley

Tower Input Data

There is a pole section.

This tower is designed using the TIA-222-G standard.

The following design criteria apply:

Tower is located in Hartford County, Connecticut.

ASCE 7-10 Wind Data is used (wind speeds converted to nominal values).

Basic wind speed of 97 mph.

Structure Class II.

Exposure Category C.

Topographic Category 1.

Crest Height 0.00 ft.

Nominal ice thickness of 1.0000 in.

Ice thickness is considered to increase with height.

Ice density of 56 pcf.

A wind speed of 40 mph is used in combination with ice.

Temperature drop of 50 °F.

Deflections calculated using a wind speed of 60 mph.

A non-linear (P-delta) analysis was used.

Pressures are calculated at each section.

Stress ratio used in pole design is 1.

Local bending stresses due to climbing loads, feed line supports, and appurtenance mounts are not considered.

Feed Line/Linear Appurtenances - Entered As Round Or Flat

Description	Sector	Component Type	Placement ft	Total Number	Number Per Row	Start/End Position	Width or	Perimeter	Weight
							Diameter in	in	plf
Climbing Pegs	B	Surface Ar (CaAa)	110.00 - 8.00	1	1	0.000 0.000	0.1500		0.31
LDF7-50A (1-5/8 FOAM)	C	Surface Ar (CaAa)	90.00 - 8.00	6	6	0.000 0.000	1.9800		0.82

Feed Line/Linear Appurtenances - Entered As Area

Description	Face or Leg	Allow Shield	Component Type	Placement ft	Total Number	C _{AA}	Weight
							plf
Safety Line (3/8")	B	No	CaAa (Out Of Face)	110.00 - 8.00	1	No Ice	0.04
							0.22
							0.14
							0.24
LDF7-50A (1-5/8 FOAM)	B	No	Inside Pole	110.00 - 8.00	18	No Ice	0.00
							0.82
							0.00
							0.00
3/4" DC Power Line	B	No	Inside Pole	110.00 - 8.00	2	No Ice	0.00
							0.33
							0.00
							0.00
1/2" Fiber Cable	B	No	Inside Pole	110.00 - 8.00	1	No Ice	0.00
							0.15
							0.00
							0.00
LDF7-50A (1-5/8 FOAM)	A	No	Inside Pole	100.00 - 8.00	11	No Ice	0.00
							0.82
							0.00
							0.00
1-1/4" Hybrid Cable	A	No	Inside Pole	100.00 - 8.00	3	No Ice	0.00
							1.00
							0.00
							0.00

tnxTower GPD 520 South Main Street Suite 2531 Akron, Ohio 44311 Phone: (330) 572-2100 FAX: (330) 572-2101	Job	88241 NEW BRITAIN WILDWOOD STREET	Page	2 of 5
	Project	2018723.01.88241.02	Date	08:19:02 06/20/18
	Client	AT&T Towers	Designed by	mrisley

Description	Face or Leg	Allow Shield	Component Type	Placement ft	Total Number		C _{AA} ft ² /ft	Weight plf
LDF7-50A (1-5/8 FOAM)	C	No	Inside Pole	90.00 - 8.00	12	1" Ice	0.00	1.00
						No Ice	0.00	0.82
						1/2" Ice	0.00	0.82
						1" Ice	0.00	0.82

Discrete Tower Loads

Description	Face or Leg	Offset Type	Offsets:		Azimuth Adjustment °	Placement ft	C _{AA}		Weight K	
			Horz Lateral ft	Vert ft			Front ft ²	Side ft ²		
Platform Mount [LP 1201-1]	C	None			0.0000	110.00	No Ice 1/2" Ice 1" Ice	23.10 26.80 30.50	23.10 26.80 30.50	2.10 2.50 2.90
(2) 7770.00 w/Mount Pipe	A	From Centroid-Le	4.00	0.00	30.0000	110.00	No Ice 1/2" Ice 1" Ice	5.51 5.87 6.23	4.10 4.73 5.37	0.06 0.11 0.16
(2) 7770.00 w/Mount Pipe	B	From Centroid-Le	4.00	0.00	30.0000	110.00	No Ice 1/2" Ice 1" Ice	5.51 5.87 6.23	4.10 4.73 5.37	0.06 0.11 0.16
(2) 7770.00 w/Mount Pipe	C	From Centroid-Le	4.00	0.00	30.0000	110.00	No Ice 1/2" Ice 1" Ice	5.51 5.87 6.23	4.10 4.73 5.37	0.06 0.11 0.16
(2) AM-X-CD-16-65-00T-RET w/ Mount Pipe	A	From Centroid-Le	4.00	0.00	30.0000	110.00	No Ice 1/2" Ice 1" Ice	8.31 8.85 9.37	6.65 7.68 8.56	0.09 0.16 0.23
(2) AM-X-CD-16-65-00T-RET w/ Mount Pipe	B	From Centroid-Le	4.00	0.00	30.0000	110.00	No Ice 1/2" Ice 1" Ice	8.31 8.85 9.37	6.65 7.68 8.56	0.09 0.16 0.23
(2) AM-X-CD-16-65-00T-RET w/ Mount Pipe	C	From Centroid-Le	4.00	0.00	30.0000	110.00	No Ice 1/2" Ice 1" Ice	8.31 8.85 9.37	6.65 7.68 8.56	0.09 0.16 0.23
(2) LGP21401	A	From Centroid-Le	4.00	0.00	30.0000	110.00	No Ice 1/2" Ice 1" Ice	1.10 1.24 1.38	0.21 0.27 0.35	0.01 0.02 0.03
(2) LGP21401	B	From Centroid-Le	4.00	0.00	30.0000	110.00	No Ice 1/2" Ice 1" Ice	1.10 1.24 1.38	0.21 0.27 0.35	0.01 0.02 0.03
(2) LGP21401	C	From Centroid-Le	4.00	0.00	30.0000	110.00	No Ice 1/2" Ice 1" Ice	1.10 1.24 1.38	0.21 0.27 0.35	0.01 0.02 0.03
(2) LGP13519	A	From Centroid-Le	4.00	0.00	30.0000	110.00	No Ice 1/2" Ice 1" Ice	0.29 0.36 0.44	0.18 0.24 0.31	0.01 0.01 0.01
(2) LGP13519	B	From Centroid-Le	4.00	0.00	30.0000	110.00	No Ice 1/2" Ice 1" Ice	0.29 0.36 0.44	0.18 0.24 0.31	0.01 0.01 0.01
(2) LGP13519	C	From Centroid-Le	4.00	0.00	30.0000	110.00	No Ice 1/2" Ice 1" Ice	0.29 0.36 0.44	0.18 0.24 0.31	0.01 0.01 0.01
RRUS 11	A	From Centroid-Le	4.00	0.00	30.0000	110.00	No Ice 1/2" Ice 1" Ice	2.78 2.99 3.21	1.19 1.33 1.49	0.05 0.07 0.10
RRUS 11	B	From Centroid-Le	4.00	0.00	30.0000	110.00	No Ice 1/2" Ice 1" Ice	2.78 2.99 3.21	1.19 1.33 1.49	0.05 0.07 0.10

tnxTower GPD 520 South Main Street Suite 2531 Akron, Ohio 44311 Phone: (330) 572-2100 FAX: (330) 572-2101	Job	88241 NEW BRITAIN WILDWOOD STREET	Page	3 of 5
	Project	2018723.01.88241.02	Date	08:19:02 06/20/18
	Client	AT&T Towers	Designed by	mrisley

Description	Face or Leg	Offset Type	Offsets:		Azimuth Adjustment	Placement	C _{AA}		Weight	
			Horz Lateral	Vert			Front	Side		
			ft	ft	°	ft	ft ²	ft ²	K	
RRUS 11	C	From	4.00		30.0000	110.00	No Ice	2.78	1.19	0.05
		Centroid-Le	0.00				1/2" Ice	2.99	1.33	0.07
		g	3.00				1" Ice	3.21	1.49	0.10
RRUS 12	A	From	4.00		30.0000	110.00	No Ice	3.15	1.29	0.06
		Centroid-Le	0.00				1/2" Ice	3.36	1.44	0.08
		g	3.00				1" Ice	3.59	1.60	0.11
RRUS 12	B	From	4.00		30.0000	110.00	No Ice	3.15	1.29	0.06
		Centroid-Le	0.00				1/2" Ice	3.36	1.44	0.08
		g	3.00				1" Ice	3.59	1.60	0.11
RRUS 12	C	From	4.00		30.0000	110.00	No Ice	3.15	1.29	0.06
		Centroid-Le	0.00				1/2" Ice	3.36	1.44	0.08
		g	3.00				1" Ice	3.59	1.60	0.11
DC6-48-60-18-8F Surge Suppression Unit	C	From	4.00		30.0000	110.00	No Ice	0.92	0.92	0.02
		Centroid-Le	0.00				1/2" Ice	1.46	1.46	0.04
		g	3.00				1" Ice	1.64	1.64	0.06
Platform Mount [LP 302-1]	C	None			0.0000	100.00	No Ice	33.03	33.03	1.71
							1/2" Ice	44.60	44.60	2.19
							1" Ice	56.17	56.17	2.68
AIR 21 B2A/B4P w/ Mount Pipe	A	From	4.00		30.0000	100.00	No Ice	6.16	5.55	0.10
		Centroid-Le	0.00				1/2" Ice	6.60	6.30	0.16
		g	0.00				1" Ice	7.03	7.00	0.22
AIR 21 B2A/B4P w/ Mount Pipe	B	From	4.00		30.0000	100.00	No Ice	6.16	5.55	0.10
		Centroid-Le	0.00				1/2" Ice	6.60	6.30	0.16
		g	0.00				1" Ice	7.03	7.00	0.22
AIR 21 B2A/B4P w/ Mount Pipe	C	From	4.00		30.0000	100.00	No Ice	6.16	5.55	0.10
		Centroid-Le	0.00				1/2" Ice	6.60	6.30	0.16
		g	0.00				1" Ice	7.03	7.00	0.22
AIR32 B66Aa/B2A w/ 60" Mount Pipe	A	From	4.00		30.0000	100.00	No Ice	6.58	5.90	0.15
		Centroid-Le	0.00				1/2" Ice	6.97	6.56	0.21
		g	0.00				1" Ice	7.37	7.24	0.28
AIR32 B66Aa/B2A w/ 60" Mount Pipe	B	From	4.00		30.0000	100.00	No Ice	6.58	5.90	0.15
		Centroid-Le	0.00				1/2" Ice	6.97	6.56	0.21
		g	0.00				1" Ice	7.37	7.24	0.28
AIR32 B66Aa/B2A w/ 60" Mount Pipe	C	From	4.00		30.0000	100.00	No Ice	6.58	5.90	0.15
		Centroid-Le	0.00				1/2" Ice	6.97	6.56	0.21
		g	0.00				1" Ice	7.37	7.24	0.28
APXVARR24_43 U-NA20 w/ Mount Pipe	A	From	4.00		30.0000	100.00	No Ice	17.15	10.64	0.12
		Centroid-Le	0.00				1/2" Ice	17.77	12.07	0.24
		g	0.00				1" Ice	18.40	13.35	0.37
APXVARR24_43 U-NA20 w/ Mount Pipe	B	From	4.00		30.0000	100.00	No Ice	17.15	10.64	0.12
		Centroid-Le	0.00				1/2" Ice	17.77	12.07	0.24
		g	0.00				1" Ice	18.40	13.35	0.37
APXVARR24_43 U-NA20 w/ Mount Pipe	C	From	4.00		30.0000	100.00	No Ice	17.15	10.64	0.12
		Centroid-Le	0.00				1/2" Ice	17.77	12.07	0.24
		g	0.00				1" Ice	18.40	13.35	0.37
RRRUS 4449-B12+71	A	From	4.00		30.0000	100.00	No Ice	1.65	1.16	0.07
		Centroid-Le	0.00				1/2" Ice	1.81	1.30	0.09
		g	0.00				1" Ice	1.98	1.45	0.10
RRRUS 4449-B12+71	B	From	4.00		30.0000	100.00	No Ice	1.65	1.16	0.07
		Centroid-Le	0.00				1/2" Ice	1.81	1.30	0.09
		g	0.00				1" Ice	1.98	1.45	0.10
RRRUS 4449-B12+71	C	From	4.00		30.0000	100.00	No Ice	1.65	1.16	0.07
		Centroid-Le	0.00				1/2" Ice	1.81	1.30	0.09
		g	0.00				1" Ice	1.98	1.45	0.10
10' T-Arm - Round (GPD)	A	From Leg	1.50		0.0000	90.00	No Ice	3.90	2.33	0.25
			0.00				1/2" Ice	4.30	2.96	0.30
			0.00				1" Ice	4.70	3.60	0.35

tnxTower GPD 520 South Main Street Suite 2531 Akron, Ohio 44311 Phone: (330) 572-2100 FAX: (330) 572-2101	Job	88241 NEW BRITAIN WILDWOOD STREET	Page	4 of 5
	Project	2018723.01.88241.02	Date	08:19:02 06/20/18
	Client	AT&T Towers	Designed by	mrisley

Description	Face or Leg	Offset Type	Offsets:		Azimuth Adjustment	Placement	C _{AA}		Weight
			Horz Lateral	Vert			Front	Side	
			ft	ft	°	ft	ft ²	ft ²	K
10' T-Arm - Round (GPD)	B	From Leg	1.50	0.0000	90.00	No Ice	3.90	2.33	0.25
			0.00			1/2" Ice	4.30	2.96	0.30
			0.00			1" Ice	4.70	3.60	0.35
10' T-Arm - Round (GPD)	C	From Leg	1.50	0.0000	90.00	No Ice	3.90	2.33	0.25
			0.00			1/2" Ice	4.30	2.96	0.30
			0.00			1" Ice	4.70	3.60	0.35
BXA-80063-4CF w/ mount pipe	A	From Leg	3.00	0.0000	90.00	No Ice	3.58	3.66	0.03
			0.00			1/2" Ice	3.88	4.21	0.06
			0.00			1" Ice	4.20	4.77	0.10
BXA-80063-4CF w/ mount pipe	B	From Leg	3.00	0.0000	90.00	No Ice	3.58	3.66	0.03
			0.00			1/2" Ice	3.88	4.21	0.06
			0.00			1" Ice	4.20	4.77	0.10
BXA-80063-4CF w/ mount pipe	C	From Leg	5.00	0.0000	90.00	No Ice	3.58	3.66	0.03
			0.00			1/2" Ice	3.88	4.21	0.06
			0.00			1" Ice	4.20	4.77	0.10
BXA-171063-8BF w/ Mount Pipe	A	From Leg	3.00	0.0000	90.00	No Ice	3.18	3.35	0.03
			0.00			1/2" Ice	3.56	3.97	0.06
			0.00			1" Ice	3.93	4.60	0.10
BXA-171063-8BF w/ Mount Pipe	B	From Leg	3.00	0.0000	90.00	No Ice	3.18	3.35	0.03
			0.00			1/2" Ice	3.56	3.97	0.06
			0.00			1" Ice	3.93	4.60	0.10
BXA-171063-8BF w/ Mount Pipe	C	From Leg	3.00	0.0000	90.00	No Ice	3.18	3.35	0.03
			0.00			1/2" Ice	3.56	3.97	0.06
			0.00			1" Ice	3.93	4.60	0.10
BXA-70063-6CF-2 w/ Mount Pipe	A	From Leg	3.00	0.0000	90.00	No Ice	7.81	5.80	0.04
			0.00			1/2" Ice	8.36	6.95	0.10
			0.00			1" Ice	8.87	7.82	0.17
BXA-70063-6CF-2 w/ Mount Pipe	B	From Leg	3.00	0.0000	90.00	No Ice	7.81	5.80	0.04
			0.00			1/2" Ice	8.36	6.95	0.10
			0.00			1" Ice	8.87	7.82	0.17
BXA-70063-6CF-2 w/ Mount Pipe	C	From Leg	3.00	0.0000	90.00	No Ice	7.81	5.80	0.04
			0.00			1/2" Ice	8.36	6.95	0.10
			0.00			1" Ice	8.87	7.82	0.17
10' T-Arm - Round (GPD)	C	From Face	1.50	0.0000	60.00	No Ice	3.90	2.33	0.25
			0.00			1/2" Ice	4.30	2.96	0.30
			1.50			1" Ice	4.70	3.60	0.35
10' T-Arm - Round (GPD)	C	From Face	1.50	0.0000	60.00	No Ice	3.90	2.33	0.25
			0.00			1/2" Ice	4.30	2.96	0.30
			-1.50			1" Ice	4.70	3.60	0.35

Dishes

Description	Face or Leg	Dish Type	Offset Type	Offsets:		Azimuth Adjustment	3 dB Beam Width	Elevation	Outside Diameter	Aperture Area	Weight
				Horz Lateral	Vert						
				ft	ft	°	°	ft	ft	ft ²	K
Stadium Light (2')	C	Paraboloid w/o Radome	From Face	3.00	0.0000	60.00		2.00	No Ice	3.14	0.08
				-6.00					1/2" Ice	3.41	0.02
				1.50					1" Ice	3.68	0.00
Stadium Light (2')	C	Paraboloid w/o Radome	From Face	3.00	0.0000	60.00		2.00	No Ice	3.14	0.08
				-3.00					1/2" Ice	3.41	0.02
				1.50					1" Ice	3.68	0.00
Stadium Light (2')	C	Paraboloid w/o Radome	From Face	3.00	0.0000	60.00		2.00	No Ice	3.14	0.08
				0.00					1/2" Ice	3.41	0.02

tnxTower GPD 520 South Main Street Suite 2531 Akron, Ohio 44311 Phone: (330) 572-2100 FAX: (330) 572-2101	Job	88241 NEW BRITAIN WILDWOOD STREET	Page	5 of 5
	Project	2018723.01.88241.02	Date	08:19:02 06/20/18
	Client	AT&T Towers	Designed by	mrисley

Description	Face or Leg	Dish Type	Offset Type	Offsets: Horz Lateral	Azimuth Adjustment	3 dB Beam Width	Elevation	Outside Diameter	Aperture Area	Weight	
				ft	°	°	ft	ft	ft ²	K	
Stadium Light (2')	C	Paraboloid w/o Radome	From Face	1.50 3.00 3.00	0.0000		60.00	2.00	1" Ice No Ice 1/2" Ice	3.68 3.14 3.41	0.00 0.08 0.02
Stadium Light (2')	C	Paraboloid w/o Radome	From Face	1.50 3.00 6.00	0.0000		60.00	2.00	1" Ice No Ice 1/2" Ice	3.68 3.14 3.41	0.00 0.08 0.02
Stadium Light (2')	C	Paraboloid w/o Radome	From Face	1.50 3.00 -6.00	0.0000		60.00	2.00	1" Ice No Ice 1/2" Ice	3.68 3.14 3.41	0.00 0.08 0.02
Stadium Light (2')	C	Paraboloid w/o Radome	From Face	1.50 3.00 -1.50	0.0000		60.00	2.00	1" Ice No Ice 1/2" Ice	3.68 3.14 3.41	0.00 0.08 0.02
Stadium Light (2')	C	Paraboloid w/o Radome	From Face	1.50 3.00 0.00	0.0000		60.00	2.00	1" Ice No Ice 1/2" Ice	3.68 3.14 3.41	0.00 0.08 0.02
Stadium Light (2')	C	Paraboloid w/o Radome	From Face	1.50 3.00 -1.50	0.0000		60.00	2.00	1" Ice No Ice 1/2" Ice	3.68 3.14 3.41	0.00 0.08 0.02
Stadium Light (2')	C	Paraboloid w/o Radome	From Face	1.50 3.00 -1.50	0.0000		60.00	2.00	1" Ice No Ice 1/2" Ice	3.68 3.14 3.41	0.00 0.08 0.02
Stadium Light (2')	C	Paraboloid w/o Radome	From Face	1.50 3.00 6.00	0.0000		60.00	2.00	1" Ice No Ice 1/2" Ice	3.68 3.14 3.41	0.00 0.08 0.02
Stadium Light (2')	C	Paraboloid w/o Radome	From Face	1.50 3.00 -1.50	0.0000		60.00	2.00	1" Ice No Ice 1/2" Ice	3.68 3.14 3.41	0.00 0.08 0.02

Critical Deflections and Radius of Curvature - Service Wind

Elevation	Appurtenance	Gov. Load Comb.	Deflection	Tilt	Twist	Radius of Curvature
ft			in	°	°	ft
110.00	Platform Mount [LP 1201-1]	45	19.483	1.4843	0.0051	22620
100.00	Platform Mount [LP 302-1]	45	16.416	1.4356	0.0049	11310
90.00	10' T-Arm - Round (GPD)	45	13.452	1.3617	0.0047	5947
61.50	Stadium Light (2')	45	6.306	0.9676	0.0036	3157
60.00	10' T-Arm - Round (GPD)	45	6.003	0.9427	0.0035	3080
58.50	Stadium Light (2')	45	5.708	0.9177	0.0034	3007

Section Capacity Table

Section No.	Elevation ft	Component Type	Size	Critical Element	P K	ϕP_{allow} K	% Capacity	Pass Fail
L1	110 - 88.75	Pole	TP24.825x21x0.1875	1	-7.82	988.23	39.0	Pass
L2	88.75 - 47	Pole	TP31.9875x23.865x0.25	2	-16.63	1718.42	82.9	Pass
L3	47 - 0	Pole	TP39.93x30.7655x0.3125	3	-27.74	2723.90	92.9	Pass
Summary							ELC:	Existing + Proposed + Future
Pole (L3)							92.9	Pass
Rating =							92.9	Pass

APPENDIX C

Tower Elevation Drawing

DESIGNED APPURTENANCE LOADING

TYPE	ELEVATION	TYPE	ELEVATION
Platform Mount [LP 1201-1]	110	APXVARR24_43 U-NA20 w/ Mount Pipe	100
(2) 7770.00 w/Mount Pipe	110		
(2) 7770.00 w/Mount Pipe	110	APXVARR24_43 U-NA20 w/ Mount Pipe	100
(2) 7770.00 w/Mount Pipe	110		
(2) AM-X-CD-16-65-00T-RET w/ Mount Pipe	110	RRRUS 4449-B12+71	100
		RRRUS 4449-B12+71	100
		RRRUS 4449-B12+71	100
(2) AM-X-CD-16-65-00T-RET w/ Mount Pipe	110	10' T-Arm - Round (GPD)	90
(2) AM-X-CD-16-65-00T-RET w/ Mount Pipe	110	10' T-Arm - Round (GPD)	90
(2) LGP21401	110	10' T-Arm - Round (GPD)	90
(2) LGP21401	110	BXA-80063-4CF w/ mount pipe	90
(2) LGP21401	110	BXA-80063-4CF w/ mount pipe	90
(2) LGP13519	110	BXA-80063-4CF w/ mount pipe	90
(2) LGP13519	110	BXA-171063-8BF w/ Mount Pipe	90
(2) LGP13519	110	BXA-171063-8BF w/ Mount Pipe	90
RRUS 11	110	BXA-171063-8BF w/ Mount Pipe	90
RRUS 11	110	BXA-70063-6CF-2 w/ Mount Pipe	90
RRUS 12	110	BXA-70063-6CF-2 w/ Mount Pipe	90
RRUS 12	110	10' T-Arm - Round (GPD)	60
RRUS 12	110	10' T-Arm - Round (GPD)	60
RRUS 12	110	Stadium Light (2')	60
DC6-48-60-18-8F Surge Suppression Unit	110	Stadium Light (2')	60
Platform Mount [LP 302-1]	100	Stadium Light (2')	60
AIR 21 B2A/B4P w/ Mount Pipe	100	Stadium Light (2')	60
AIR 21 B2A/B4P w/ Mount Pipe	100	Stadium Light (2')	60
AIR 21 B2A/B4P w/ Mount Pipe	100	Stadium Light (2')	60
AIR 21 B2A/B4P w/ Mount Pipe	100	Stadium Light (2')	60
AIR32 B66Aa/B2A w/ 60" Mount Pipe	100	Stadium Light (2')	60
AIR32 B66Aa/B2A w/ 60" Mount Pipe	100	Stadium Light (2')	60
AIR32 B66Aa/B2A w/ 60" Mount Pipe	100	Stadium Light (2')	60
AIR32 B66Aa/B2A w/ 60" Mount Pipe	100	Stadium Light (2')	60
APXVARR24_43 U-NA20 w/ Mount Pipe	100	Stadium Light (2')	60

MATERIAL STRENGTH

GRADE	Fy	Fu	GRADE	Fy	Fu
A572-65	65 ksi	80 ksi			

TOWER DESIGN NOTES

1. Tower is located in Hartford County, Connecticut.
2. Tower designed for Exposure C to the TIA-222-G Standard.
3. Tower designed for a 97 mph basic wind in accordance with the TIA-222-G Standard.
4. Tower is also designed for a 40 mph basic wind with 1.00 in ice. Ice is considered to increase in thickness with height.
5. Deflections are based upon a 60 mph wind.
6. Tower Structure Class II.
7. Topographic Category 1 with Crest Height of 0.00 ft
8. TOWER RATING: 92.9%

ALL REACTIONS ARE FACTORED

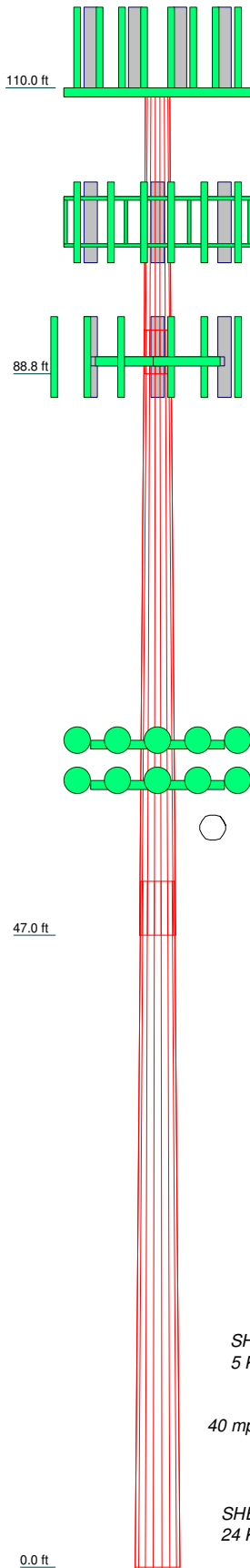
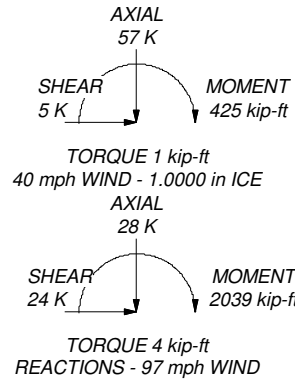

Section	Length (ft)	Number of Sides	Thickness (in)	Socket Length (ft)	Top Dia (in)	Bot Dia (in)	Grade	Weight (K)
1	110.0	18	0.1875	3.25	21.0000	24.8250	A572-65	1.0
2	45.00	18	0.2500	4.00	23.8650	31.9875	A572-65	3.4
3	51.00	18	0.3125	30.7655	39.9300		A572-65	6.0

GPD
520 South Main Street Suite 2531
Akron, Ohio 44311
Phone: (330) 572-2100
FAX: (330) 572-2101

Job: **88241 NEW BRITAIN WILDWOOD STREET**
Project: **2018723.01.88241.02**

Client: AT&T Towers	Drawn by: mrisley	App'd:
Code: TIA-222-G	Date: 06/20/18	Scale: NTS
Path: T:\ATandT\88241\05_2018723_01_88241_02\AT&T_SA\mri88241.mxd		Dwg No. E-1

Feed Line Distribution Chart

0' - 110'

— Round
 — Flat
 — App In Face
 — App Out Face
 — Truss Leg

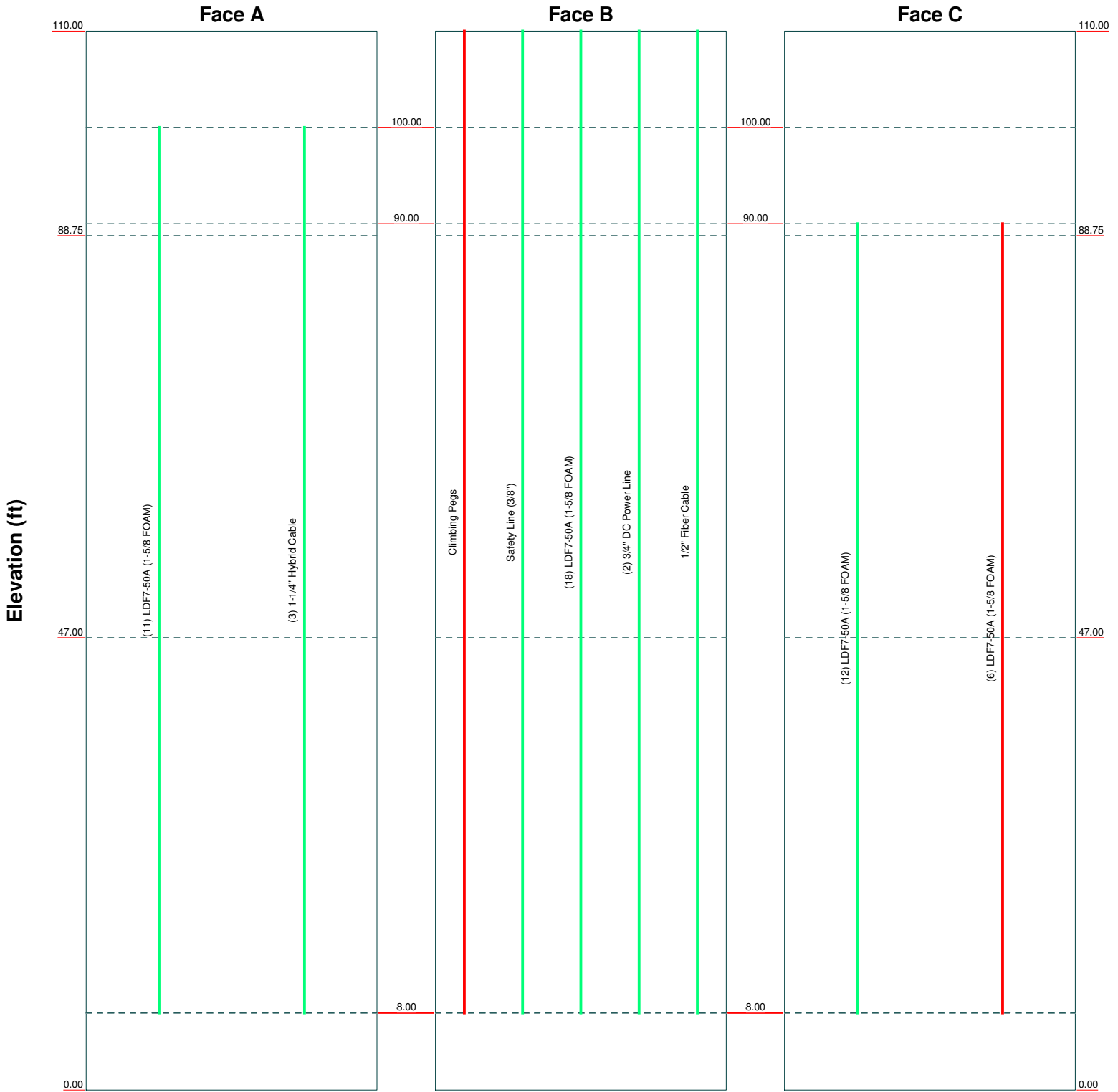

<p>GPD 520 South Main Street Suite 2531 Akron, Ohio 44311 Phone: (330) 572-2100 FAX: (330) 572-2101</p>	Job: 88241 NEW BRITAIN WILDWOOD STREET		
	Project: 2018723.01.88241.02		
	Client: AT&T Towers	Drawn by: mrisley	App'd:
	Code: TIA-222-G	Date: 06/20/18	Scale: NTS
Path: T:\ATend\88241\05_2018723_01_88241_02_AT&T_SA\mri\88241.tmx.dwg		Dwg No. E-7	

Feed Line Plan

— Round
 — Flat
 — App In Face
 — App Out Face

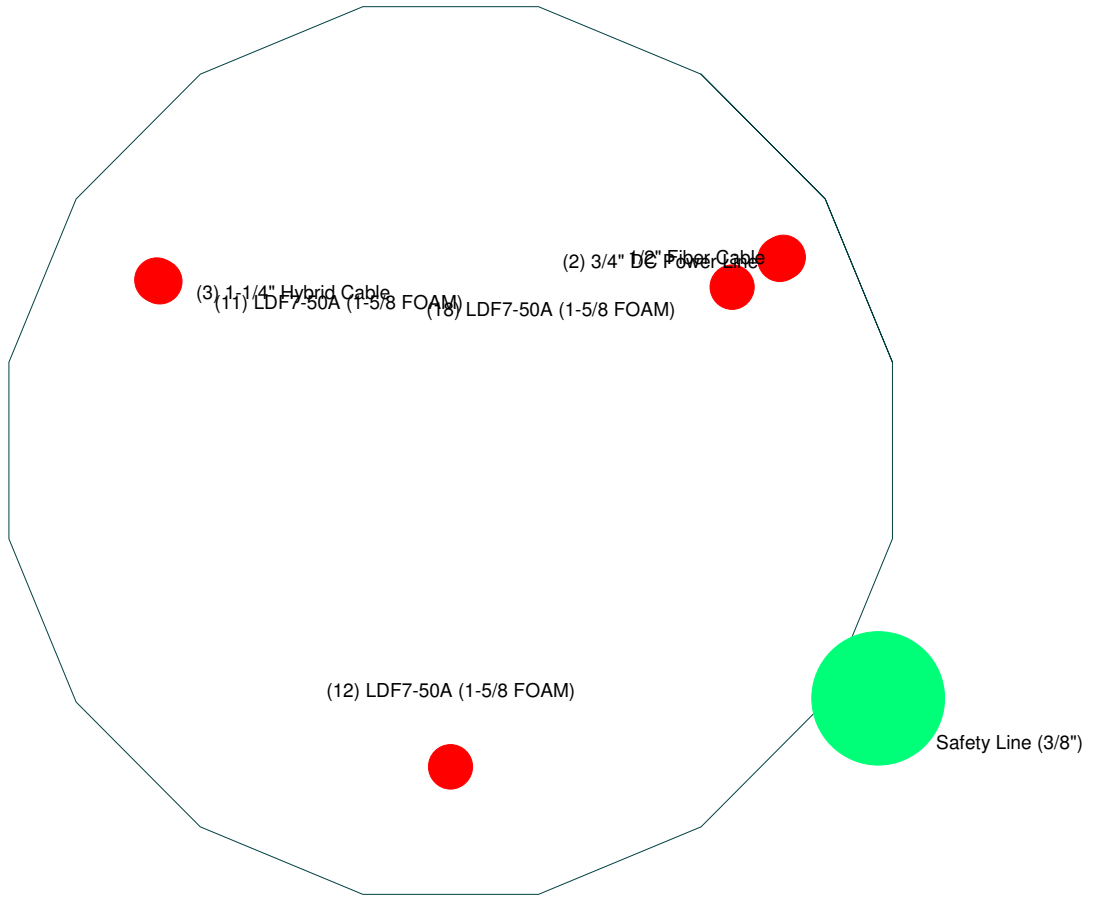

 GPD 520 South Main Street Suite 2531 Akron, Ohio 44311 Phone: (330) 572-2100 FAX: (330) 572-2101	Job: 88241 NEW BRITAIN WILDWOOD STREET		
	Project: 2018723.01.88241.02		
	Client: AT&T Towers	Drawn by: mrisley	App'd:
	Code: TIA-222-G	Date: 06/20/18	Scale: NTS
Path: T:\ATandT\88241\05 2018723 01 88241 02 AT&T SA\mri\88241.txd		Dwg No. E-7	

APPENDIX D

Anchor Rod and Base Plate Analysis



Anchor Rod and Base Plate Stresses, TIA-222-G-1
88241 New Britain Wildwood Street
2018723.01.88241.02

Overtuning Moment =	2038.52	k*ft
Axial Force =	27.78	k
Shear Force =	23.68	k

Acceptable Stress Ratio =	105.0%
---------------------------	--------

Anchor Rods		
Pole Diameter =	39.93	in
Number of Rods =	12	
ϕ =	0.8	
Rod Ultimate Strength (F_u) =	100	ksi
Base Plate Detail Type* =	d	
Rod Circle =	46	in
Rod Diameter =	2.25	in
Net Tensile Area =	3.25	in ²
Max Tension on Rod =	174.74	kips
Max Compression on Rod =	179.37	kips
P_u =	179.37	kips
V_u =	1.97	kips
η =	0.50	
$P_u + V_u / \eta$ =	183.31	kips
ϕR_{nt} =	260.00	kips
Anchor Rod Capacity =	70.5%	OK

Base Plate		
Plate Strength (F_y) =	50	ksi
ϕ =	0.9	
Plate Thickness =	2.5	in
Plate Width =	45	in
Est. Dist. b/w ea. Rod =	6	in
w_{calc} =	36.90	in
w_{max} =	23.71	in
w =	23.71	in
Z =	37.05	in ³
M_u =	1325.24	k-in
ϕM_n =	1667.08	k-in
Base Plate Capacity =	79.5%	OK

(Section 4.9.9, TIA-222-G-1)

***This analysis assumes the clear distance from the top of the concrete to the bottom of the leveling nut is less than the diameter of the anchor rod. Notify GPD Group immediately if existing field conditions do not meet this assumption.**

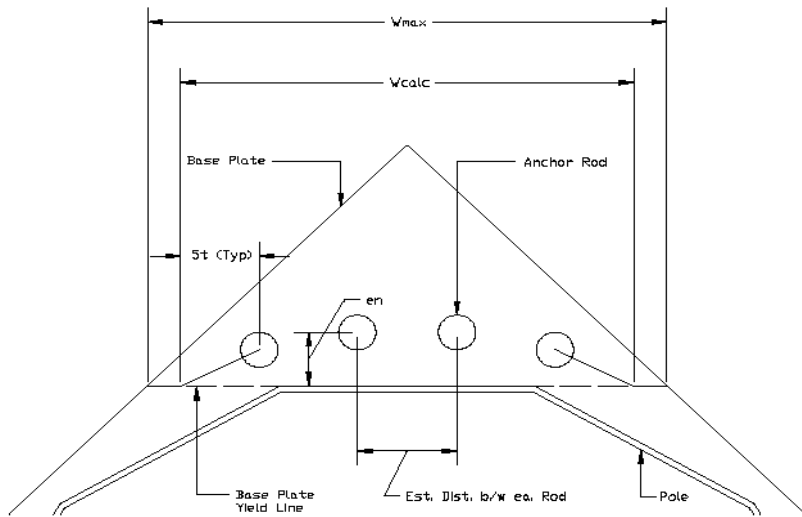

APPENDIX E

Foundation Analysis



Mat Foundation Analysis
88241 NEW BRITAIN WILDWOOD STREET
2018723.01.88241.02

General Info	
Foundation Criteria	GPD
TIA Code	TIA-222-G
Soil Code	AASHTO 2012
Concrete Code	ACI 318-11
Seismic Design Category	B
Tower Height	110 ft
Bearing On	Soil
Foundation Type	Monopole Pad
Pier Type	Square
Reinforcing Known	Yes
Max Bearing Capacity	105%
Max Overturning Capacity	105%

Tower Reactions	
Moment, M	2038.52 k-ft
Axial, P	27.78 k
Shear, V	23.68 k

Pad & Pier Geometry	
Pier Width, ϕ	6 ft
Pad Length, L [y]	21.5 ft
Pad Width, W [x]	21.5 ft
Pad Thickness, t	3 ft
Depth, D	6 ft
Height Above Grade, HG	0.5 ft
Tower Centroid, X	10.75 ft
Tower Centroid, Y	10.75 ft
Tower Eccentricity	0.0000 ft

Pad & Pier Reinforcing	
Rebar Fy	60 ksi
Concrete F'c	3 ksi
Pier Reinforcing Clear Cover	3 in
Shear Rebar Type	Tie
Shear Rebar Size	# 4
Pad Reinforcing Clear Cover	3 in
Reinforced Top & Bottom?	Yes
Pad Reinforcing Size	# 8
Pad Quantity Per Layer	22
Pier Rebar Size	# 8
Pier Quantity of Rebar	36

Soil Properties	
Soil Type	Cohesive
Soil Unit Weight	100 pcf
Cohesion, Cu (ksf)	0
Base Friction Coeff. Provided in Geo?	Yes
Base Friction Coefficient, μ	0.3
Bearing Type	Gross
Ultimate Bearing	6 ksf
Water Table Depth	99 ft
Frost Depth	3.333 ft

GPD Mat Foundation Analysis - V3.2

Bearing Summary					
Case	Demand/Limits	Capacity/Availability	Check	Eccentricity	Load Case
Qxmax	2.37 ksf	4.50 ksf	OK, <= 105%	L/4.5	1.2D+1.6W
Qymax	2.37 ksf	4.50 ksf	OK, <= 105%	W/4.5	1.2D+1.6W
Qmax @ 45°	2.21 ksf	4.50 ksf	OK, <= 105%	W/4.7	0.9D+1.6W
Controlling Capacity		52.7%	Pass		

Overturning Summary					
Case	Demand/Limits	Capacity/Availability	Check	Load Case	
Ovtx	2185.4 k-ft	4875.4 k-ft	59.8% OK	0.9D+1.6W	
Ovty	2185.4 k-ft	4875.4 k-ft	59.8% OK	0.9D+1.6W	
Ovtxy	1546.2 k-ft	3656.5 k-ft	42.3% OK	0.9D+1.6W	
Controlling Capacity		59.8%	Pass		

Sliding Summary					
Case	Demand/Limits	Capacity/Availability	Check	Load Case	
Slidingx	23.7 k	83.7 k	28.3% OK	0.9D+1.6W	
Slidingy	23.7 k	83.7 k	28.3% OK	0.9D+1.6W	
Controlling Capacity		28.3%	Pass		

Reinforcement Summary					
Component	Demand/Limits	Capacity/Availability	Check	Load Case	
Pad Flexural Bending	38.4 k-ft	111.7 k-ft	34.4% OK	0.9D+1.6W	
One-Way Shear in Pad	141.3 k	667.7 k	21.2% OK	0.9D+1.6W	
Two-Way Shear in Pad	344.5 k	2142.9 k	16.1% OK	0.9D+1.6W	
Compression on Pier	50.5 k	17185.0 k	0.3% OK	1.2D+1.6W	
Moment on Pier	2121.4 k-ft	3783.6 k-ft	56.1% OK	1.2D+1.6W	
As Min Pad Met?	1.62 sq. in.	0.30 sq. in.	Yes		
As Min Pier Met?	28.44 sq. in.	25.92 sq. in.	Yes		
Controlling Capacity		56.1%	Pass		

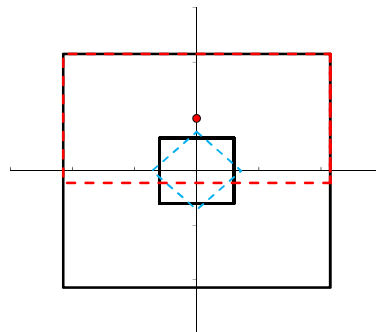
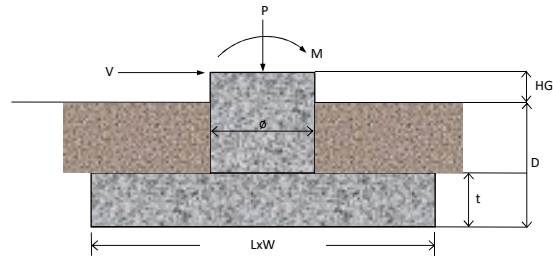

Exhibit E

August 7, 2018

To: T-Mobile Northeast, LLC
35 Griffin Road South
Bloomfield, CT 06002

Subject: Mount Assessment – CT11634C (Destek Job #: 1875061)

Per your request, Destek Engineering, LLC (Destek) has performed a structural assessment of the antenna mounting system which supports the T-Mobile Equipment at the referenced site. We have evaluated the subject mount for the additions and alterations specified in the RFDS, which is referenced in Table 1. This assessment is based on the documents and information listed in Table 1 and is in accordance with the mount loading and evaluation criteria stated in Table 2.

Based on our experience with similar mount structures and with respect to the changes in applied loads, Destek opines that the mount **WILL BE ADEQUATE.**

This assessment is only valid for the loading scenario described herein. Variations between this document and actual field conditions will void this assessment. It is assumed that all structural members and connections of the subject mount are in good condition and the mount has been properly designed, constructed and assembled. Discrepancies between this document and field conditions should be immediately brought to our attention. It is assumed that the tower and other components of the site have been analyzed and qualified by others.

We at *Destek Engineering, LLC* appreciate the opportunity of providing our continuing professional services to you. If you have any questions or need further assistance on this or any other project, please do not hesitate to contact us.

Sincerely,
Destek Engineering, LLC
License No: PEC00001429



Ahmet Colakoglu, PE
Connecticut Professional Engineer
License No: 27057

References and Loading

Table 1: Documents and Information Provided

DOCUMENT	PREPARED BY	DATE
Rigorous Structural Analysis Report	GPD Group	06/21/2018
Site Photos	ForeSite LLC	02/08/2017

Table 2: Mount Loading and Evaluation Criteria

LOCATION	New Britain, Hartford County, CT
BUILDING CODE AND TOWER STANDARD	2016 Connecticut State Building Code and TIA-222-G
RAD CENTER	100 ft
STRUCTURE TYPE	Monopole
EXPOSURE CATEGORY	C
WIND LOADING	125 mph ultimate basic wind (97 mph nominal wind speed)
ICE LOADING	1.00 inch ice with 50 mph basic wind. Ice is considered to increase in thickness with height
CLASS	II
TOPOGRAPHIC CATEGORY	1

Table 2.1 –Existing Appurtenance Configuration

QTY	MODEL
3	AIR21 B2A B4P – Antennas
3	LNx-6515DS-A1M – Antennas
3	AIR32 B66A B2A – Antennas
3	RRUS11 B12 – RRUs
3	Generic Twin Style 1B - AWS – TMAs

Table 2.2 – Proposed and Final Appurtenance Configuration

QTY	MODEL
3	AIR21 B2A B4P – Antennas
3	APXVAARR24-43-U-NA20 – Antennas
3	AIR32 B66A B2A – Antennas
3	Generic Twin Style 1B - AWS – TMAs
3	Radio 4449 B71 + B12 – RRUs*

***To be mounted behind antenna**

Mount Photos

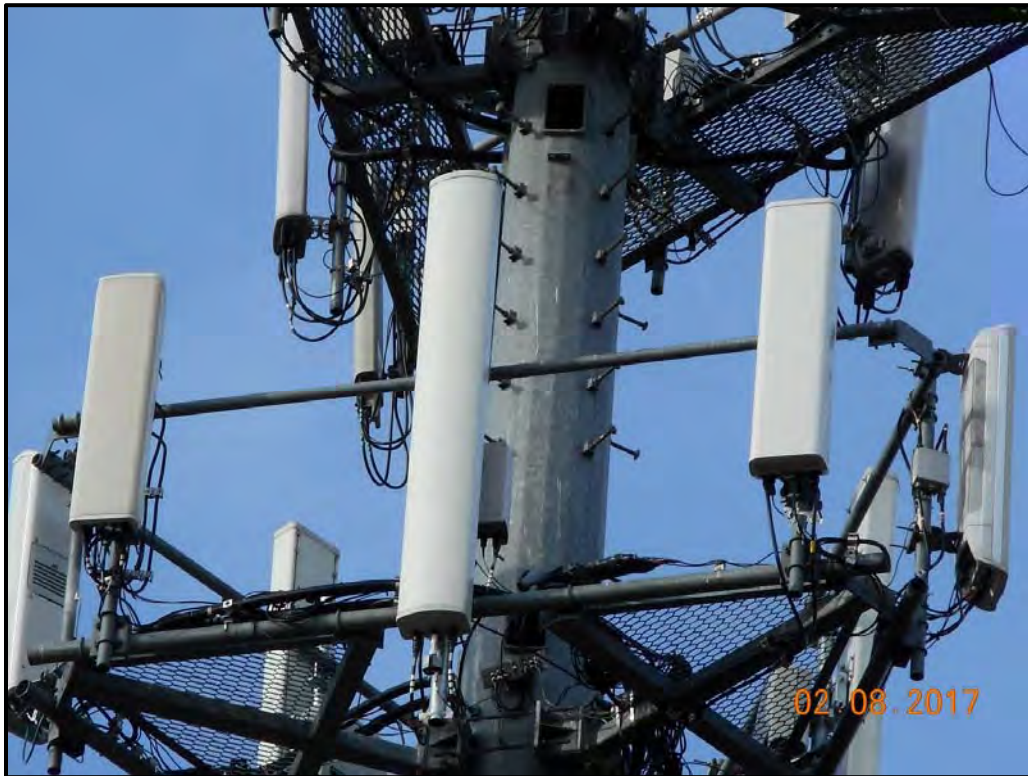

Exhibit F



RADIO FREQUENCY EMISSIONS ANALYSIS REPORT EVALUATION OF HUMAN EXPOSURE POTENTIAL TO NON-IONIZING EMISSIONS

T-Mobile Existing Facility

Site ID: CT11634C

CT634/Cing/ChesleyPark_ET
35 Wildwood Street
New Britain, CT 06051

August 6, 2018

EBI Project Number: 6218005437

Site Compliance Summary	
Compliance Status:	COMPLIANT
Site total MPE% of FCC general population allowable limit:	15.50 %



August 6, 2018

T-Mobile USA
Attn: Jason Overbey, RF Manager
35 Griffin Road South
Bloomfield, CT 06002

Emissions Analysis for Site: **CT11634C – CT634/Cing/ChesleyPark_ET**

EBI Consulting was directed to analyze the proposed T-Mobile facility located at **35 Wildwood Street, New Britain, CT**, for the purpose of determining whether the emissions from the Proposed T-Mobile Antenna Installation located on this property are within specified federal limits.

All information used in this report was analyzed as a percentage of current Maximum Permissible Exposure (% MPE) as listed in the FCC OET Bulletin 65 Edition 97-01 and ANSI/IEEE Std C95.1. The FCC regulates Maximum Permissible Exposure in units of microwatts per square centimeter ($\mu\text{W}/\text{cm}^2$). The number of $\mu\text{W}/\text{cm}^2$ calculated at each sample point is called the power density. The exposure limit for power density varies depending upon the frequencies being utilized. Wireless Carriers and Paging Services use different frequency bands each with different exposure limits, therefore it is necessary to report results and limits in terms of percent MPE rather than power density.

All results were compared to the FCC (Federal Communications Commission) radio frequency exposure rules, 47 CFR 1.1307(b)(1) – (b)(3), to determine compliance with the Maximum Permissible Exposure (MPE) limits for General Population/Uncontrolled environments as defined below.

General population/uncontrolled exposure limits apply to situations in which the general population may be exposed or in which persons who are exposed as a consequence of their employment may not be made fully aware of the potential for exposure or cannot exercise control over their exposure. Therefore, members of the general population would always be considered under this category when exposure is not employment related, for example, in the case of a telecommunications tower that exposes persons in a nearby residential area.

Public exposure to radio frequencies is regulated and enforced in units of microwatts per square centimeter ($\mu\text{W}/\text{cm}^2$). The general population exposure limits for the 600 MHz and 700 MHz frequency bands are approximately $400 \mu\text{W}/\text{cm}^2$ and $467 \mu\text{W}/\text{cm}^2$ respectively. The general population exposure limit for the 1900 MHz (PCS) and 2100 MHz (AWS) frequency bands is $1000 \mu\text{W}/\text{cm}^2$. Because each carrier will be using different frequency bands, and each frequency band has different exposure limits, it is necessary to report percent of MPE rather than power density.



Occupational/controlled exposure limits apply to situations in which persons are exposed as a consequence of their employment and in which those persons who are exposed have been made fully aware of the potential for exposure and can exercise control over their exposure. Occupational/controlled exposure limits also apply where exposure is of a transient nature as a result of incidental passage through a location where exposure levels may be above general population/uncontrolled limits (see below), as long as the exposed person has been made fully aware of the potential for exposure and can exercise control over his or her exposure by leaving the area or by some other appropriate means.

Additional details can be found in FCC OET 65.

CALCULATIONS

Calculations were done for the proposed T-Mobile Wireless antenna facility located at **35 Wildwood Street, New Britain, CT**, using the equipment information listed below. All calculations were performed per the specifications under FCC OET 65. Since T-Mobile is proposing highly focused directional panel antennas, which project most of the emitted energy out toward the horizon, all calculations were performed assuming a lobe representing the maximum gain of the antenna per the antenna manufactures supplied specifications, minus 10 dB for directional panel antennas, was focused at the base of the tower. For this report the sample point is the top of a 6-foot person standing at the base of the tower.

For all calculations, all equipment was calculated using the following assumptions:

- 1) 1 GSM channels (PCS Band - 1900 MHz) was considered for each sector of the proposed installation. This Channel has a transmit power of 15 Watts per Channel.
- 2) 1 UMTS channels (AWS Band – 2100 MHz) was considered for each sector of the proposed installation. This Channel has a transmit power of 40 Watts per Channel.
- 3) 2 LTE channels (PCS Band - 1900 MHz) were considered for each sector of the proposed installation. These Channels have a transmit power of 40 Watts per Channel.
- 4) 4 LTE channels (AWS Band – 2100 MHz) were considered for each sector of the proposed installation. These Channels have a transmit power of 40 Watts per Channel.
- 5) 2 LTE channels (600 MHz Band) were considered for each sector of the proposed installation. These Channels have a transmit power of 40 Watts per Channel.
- 6) 2 LTE channels (700 MHz Band) were considered for each sector of the proposed installation. These Channels have a transmit power of 20 Watts per Channel.



- 7) All radios at the proposed installation were considered to be running at full power and were uncombined in their RF transmissions paths per carrier prescribed configuration. Per FCC OET Bulletin No. 65 - Edition 97-01 recommendations to achieve the maximum anticipated value at each sample point, all power levels emitting from the proposed antenna installation are increased by a factor of 2.56 to account for possible in-phase reflections from the surrounding environment. This is rarely the case, and if so, is never continuous.
- 8) For the following calculations the sample point was the top of a 6-foot person standing at the base of the tower. The maximum gain of the antenna per the antenna manufactures supplied specifications, minus 10 dB for directional panel antennas, was used in this direction. This value is a very conservative estimate as gain reductions for these particular antennas are typically much higher in this direction.
- 9) The antennas used in this modeling are the **Ericsson AIR32 B66Aa/B2A & Ericsson AIR21 B2A/B4P** for 1900 MHz (PCS) and 2100 MHz (AWS) channels and the **RFS APXVAARR24_43-U-NA20** for 600 MHz and 700 MHz channels. This is based on feedback from the carrier with regard to anticipated antenna selection. All Antenna gain values and associated transmit power levels are shown in the Site Inventory and Power Data table below. The maximum gain of the antenna per the antenna manufactures supplied specifications, minus 10 dB for directional panel antennas, was used for all calculations. This value is a very conservative estimate as gain reductions for these particular antennas are typically much higher in this direction.
- 10) The antenna mounting height centerline of the proposed antennas is **100 feet** above ground level (AGL).
- 11) Emissions values for additional carriers were taken from the Connecticut Siting Council active database. Values in this database are provided by the individual carriers themselves.
- 12) All calculations were done with respect to uncontrolled / general population threshold limits.



T-Mobile Site Inventory and Power Data

Sector:	A	Sector:	B	Sector:	C
Antenna #:	1	Antenna #:	1	Antenna #:	1
Make / Model:	Ericsson AIR32 B66Aa/B2A	Make / Model:	Ericsson AIR32 B66Aa/B2A	Make / Model:	Ericsson AIR32 B66Aa/B2A
Gain:	15.9 dBd	Gain:	15.9 dBd	Gain:	15.9 dBd
Height (AGL):	100 feet	Height (AGL):	100 feet	Height (AGL):	100 feet
Frequency Bands	1900 MHz (PCS) / 2100 MHz (AWS)	Frequency Bands	1900 MHz (PCS) / 2100 MHz (AWS)	Frequency Bands	1900 MHz (PCS) / 2100 MHz (AWS)
Channel Count	6	Channel Count	6	Channel Count	6
Total TX Power(W):	240	Total TX Power(W):	240	Total TX Power(W):	240
ERP (W):	9,337.08	ERP (W):	9,337.08	ERP (W):	9,337.08
Antenna A1 MPE%	3.80	Antenna B1 MPE%	3.80	Antenna C1 MPE%	3.80
Antenna #:	2	Antenna #:	2	Antenna #:	2
Make / Model:	Ericsson AIR21 B2A/B4P	Make / Model:	Ericsson AIR21 B2A/B4P	Make / Model:	Ericsson AIR21 B2A/B4P
Gain:	15.9 dBd	Gain:	15.9 dBd	Gain:	15.9 dBd
Height (AGL):	100 feet	Height (AGL):	100 feet	Height (AGL):	100 feet
Frequency Bands	1900 MHz (PCS) / 2100 MHz (AWS)	Frequency Bands	1900 MHz (PCS) / 2100 MHz (AWS)	Frequency Bands	1900 MHz (PCS) / 2100 MHz (AWS)
Channel Count	2	Channel Count	2	Channel Count	2
Total TX Power(W):	55	Total TX Power(W):	55	Total TX Power(W):	55
ERP (W):	2,139.75	ERP (W):	2,139.75	ERP (W):	2,139.75
Antenna A2 MPE%	0.87	Antenna B2 MPE%	0.87	Antenna C2 MPE%	0.87
Antenna #:	3	Antenna #:	3	Antenna #:	3
Make / Model:	RFS APXVAARR24_43-U- NA20	Make / Model:	RFS APXVAARR24_43-U- NA20	Make / Model:	RFS APXVAARR24_43-U- NA20
Gain:	dBd	Gain:	dBd	Gain:	dBd
Height (AGL):	100 feet	Height (AGL):	100 feet	Height (AGL):	100 feet
Frequency Bands	600 MHz / 700 MHz	Frequency Bands	600 MHz / 700 MHz	Frequency Bands	600 MHz / 700 MHz
Channel Count	4	Channel Count	4	Channel Count	4
Total TX Power(W):	120	Total TX Power(W):	120	Total TX Power(W):	120
ERP (W):	2,443.03	ERP (W):	2,443.03	ERP (W):	2,443.03
Antenna A3 MPE%	2.36	Antenna B3 MPE%	2.36	Antenna C3 MPE%	2.36

Site Composite MPE%	
Carrier	MPE%
T-Mobile (Per Sector Max)	7.03 %
AT&T	2.77 %
Clearwire	0.69 %
Verizon Wireless	5.01 %
Site Total MPE %:	15.50 %

T-Mobile Sector A Total:	7.03 %
T-Mobile Sector B Total:	7.03 %
T-Mobile Sector C Total:	7.03 %
Site Total:	
	15.50 %



T-Mobile Maximum MPE Power Values (Per Sector)

T-Mobile_Frequency Band / Technology (Per Sector)	# Channels	Watts ERP (Per Channel)	Height (feet)	Total Power Density ($\mu\text{W}/\text{cm}^2$)	Frequency (MHz)	Allowable MPE ($\mu\text{W}/\text{cm}^2$)	Calculated % MPE
T-Mobile PCS - 1900 MHz LTE	2	1,556.18	100	12.66	PCS - 1900 MHz	1000.00	1.27%
T-Mobile AWS - 2100 MHz LTE	4	1,556.18	100	25.33	AWS - 2100 MHz	1000.00	2.53%
T-Mobile PCS - 1900 MHz GSM	1	583.57	100	2.37	PCS - 1900 MHz	1000.00	0.24%
T-Mobile AWS - 2100 MHz UMTS	1	1,556.18	100	6.33	AWS - 2100 MHz	1000.00	0.63%
T-Mobile 600 MHz LTE	2	788.97	100	6.42	600 MHz	400.00	1.61%
T-Mobile 700 MHz LTE	2	432.54	100	3.52	700 MHz	467.00	0.75%
						Total:	7.03%



Summary

All calculations performed for this analysis yielded results that were **within** the allowable limits for general population exposure to RF Emissions.

The anticipated maximum composite contributions from the T-Mobile facility as well as the site composite emissions value with regards to compliance with FCC's allowable limits for general population exposure to RF Emissions are shown here:

T-Mobile Sector	Power Density Value (%)
Sector A:	7.03 %
Sector B:	7.03 %
Sector C:	7.03 %
T-Mobile Maximum MPE % (Per Sector):	7.03 %
Site Total:	15.50 %
Site Compliance Status:	COMPLIANT

The anticipated composite MPE value for this site assuming all carriers present is **15.50%** of the allowable FCC established general population limit sampled at the ground level. This is based upon values listed in the Connecticut Siting Council database for existing carrier emissions.

FCC guidelines state that if a site is found to be out of compliance (over allowable thresholds), that carriers over a 5% contribution to the composite value will require measures to bring the site into compliance. For this facility, the composite values calculated were well within the allowable 100% threshold standard per the federal government.

Exhibit G



**UNITED STATES
POSTAL SERVICE®**

Click-N-Ship®

P

usps.com
US POSTAGE
 Flat Rate Env
 \$6.70

9405 5036 9930 0282 4573 55 0067 0000 0010 6051



08/21/2018

Mailed from 06002 062S00000001309

PRIORITY MAIL 1-DAY™

DEBORAH CHASE
 T-MOBILE USA- NSS
 35 GRIFFIN RD S
 BLOOMFIELD CT 06002-1351

Expected Delivery Date: 08/22/18
 Re#: 634-L74X2
0024

Carrier -- Leave if No Response

C020

SHIP TO: ERIN STEWART
 MAYOR- CITY OF NEW BRITAIN
 27 W MAIN ST
 NEW BRITAIN CT 06051-2283

USPS TRACKING #



9405 5036 9930 0282 4573 55

Electronic Rate Approved #038555749



Cut on dotted line.

Instructions

1. Each Click-N-Ship® label is unique. Labels are to be used as printed and used only once. DO NOT PHOTO COPY OR ALTER LABEL.
2. Place your label so it does not wrap around the edge of the package.
3. Adhere your label to the package. A self-adhesive label is recommended. If tape or glue is used, DO NOT TAPE OVER BARCODE. Be sure all edges are secure.
4. To mail your package with PC Postage®, you may schedule a Package Pickup online, hand to your letter carrier, take to a Post Office™, or drop in a USPS collection box.
5. Mail your package on the "Ship Date" you selected when creating this label.

Click-N-Ship® Label Record

USPS TRACKING # :
9405 5036 9930 0282 4573 55

Trans. #: 442236690	Priority Mail® Postage: \$6.70
Print Date: 08/21/2018	Total: \$6.70
Ship Date: 08/21/2018	
Expected Delivery Date: 08/22/2018	

From: DEBORAH CHASE
 T-MOBILE USA- NSS
 35 GRIFFIN RD S
 BLOOMFIELD CT 06002-1351

Re#: 634-L74X2

To: ERIN STEWART
 MAYOR- CITY OF NEW BRITAIN
 27 W MAIN ST
 NEW BRITAIN CT 06051-2283

* Retail Pricing Priority Mail rates apply. There is no fee for USPS Tracking® service on Priority Mail service with use of this electronic rate shipping label. Refunds for unused postage paid labels can be requested online 30 days from the print date.



Thank you for shipping with the United States Postal Service!
 Check the status of your shipment on the USPS Tracking® page at usps.com



**UNITED STATES
POSTAL SERVICE®**

Click-N-Ship®

P

usps.com
US POSTAGE
 Flat Rate Env
 \$6.70
 9405 5036 9930 0282 4573 62 0067 0000 0010 6051



08/21/2018 Mailed from 06002 062S00000001308

PRIORITY MAIL 1-DAY™

DEBORAH CHASE
 T-MOBILE USA- NSS
 35 GRIFFIN RD S
 BLOOMFIELD CT 06002-1351

Expected Delivery Date: 08/22/18
 Ref#: 634-L74x2
0024

Carrier -- Leave if No Response

C020

SHIP TO: DAVIS ZAJAC
 ZONING ENFORCEMENT OFFICER-NEW BRITAIN
 27 W MAIN ST
 NEW BRITAIN CT 06051-2283

USPS TRACKING #

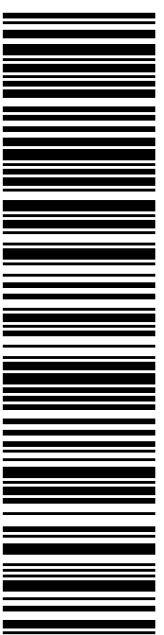

9405 5036 9930 0282 4573 62

Electronic Rate Approved #038555749



Cut on dotted line.

Instructions

1. Each Click-N-Ship® label is unique. Labels are to be used as printed and used only once. DO NOT PHOTO COPY OR ALTER LABEL.
2. Place your label so it does not wrap around the edge of the package.
3. Adhere your label to the package. A self-adhesive label is recommended. If tape or glue is used, DO NOT TAPE OVER BARCODE. Be sure all edges are secure.
4. To mail your package with PC Postage®, you may schedule a Package Pickup online, hand to your letter carrier, take to a Post Office™, or drop in a USPS collection box.
5. Mail your package on the "Ship Date" you selected when creating this label.

Click-N-Ship® Label Record

USPS TRACKING # :
9405 5036 9930 0282 4573 62

Trans. #: 442236690	Priority Mail® Postage: \$6.70
Print Date: 08/21/2018	Total: \$6.70
Ship Date: 08/21/2018	
Expected Delivery Date: 08/22/2018	

From: DEBORAH CHASE
 T-MOBILE USA- NSS
 35 GRIFFIN RD S
 BLOOMFIELD CT 06002-1351

Ref#: 634-L74x2

To: DAVIS ZAJAC
 ZONING ENFORCEMENT OFFICER-NEW BRITAIN
 27 W MAIN ST
 NEW BRITAIN CT 06051-2283

* Retail Pricing Priority Mail rates apply. There is no fee for USPS Tracking® service on Priority Mail service with use of this electronic rate shipping label. Refunds for unused postage paid labels can be requested online 30 days from the print date.



Thank you for shipping with the United States Postal Service!
 Check the status of your shipment on the USPS Tracking® page at usps.com



**UNITED STATES
POSTAL SERVICE®**

Click-N-Ship®

P

usps.com 9405 5036 9930 0282 4573 79 0067 0000 0010 6051
US POSTAGE \$6.70
 Flat Rate Enviv



08/21/2018 Mailed from 01566 062S00000001311

PRIORITY MAIL 2-DAY™

Expected Delivery Date: 08/23/18

DEBORAH CHASE
 NORTHEAST SITE SOLUTIONS, LLC
 420 MAIN ST STE 2
 STURBRIDGE MA 01566-1359

0006

Carrier -- Leave if No Response

C020

SHIP TO:
 CITY NEW BRITAIN
 27 W MAIN ST
 NEW BRITAIN CT 06051-2283

USPS TRACKING #



9405 5036 9930 0282 4573 79

Electronic Rate Approved #038555749



Cut on dotted line.

Instructions

1. Each Click-N-Ship® label is unique. Labels are to be used as printed and used only once. DO NOT PHOTO COPY OR ALTER LABEL.
2. Place your label so it does not wrap around the edge of the package.
3. Adhere your label to the package. A self-adhesive label is recommended. If tape or glue is used, DO NOT TAPE OVER BARCODE. Be sure all edges are secure.
4. To mail your package with PC Postage®, you may schedule a Package Pickup online, hand to your letter carrier, take to a Post Office™, or drop in a USPS collection box.
5. Mail your package on the "Ship Date" you selected when creating this label.

Click-N-Ship® Label Record

USPS TRACKING # :
9405 5036 9930 0282 4573 79

Trans. #: 442236690	Priority Mail® Postage: \$6.70
Print Date: 08/21/2018	Total: \$6.70
Ship Date: 08/21/2018	
Expected Delivery Date: 08/23/2018	

From: DEBORAH CHASE
 NORTHEAST SITE SOLUTIONS, LLC
 420 MAIN ST STE 2
 STURBRIDGE MA 01566-1359

To: CITY NEW BRITAIN
 27 W MAIN ST
 NEW BRITAIN CT 06051-2283

* Retail Pricing Priority Mail rates apply. There is no fee for USPS Tracking® service on Priority Mail service with use of this electronic rate shipping label. Refunds for unused postage paid labels can be requested online 30 days from the print date.



Thank you for shipping with the United States Postal Service!
 Check the status of your shipment on the USPS Tracking® page at usps.com



**UNITED STATES
POSTAL SERVICE®**

Click-N-Ship®

P

usps.com
US POSTAGE
Flat Rate Env



08/21/2018

Mailed from 01566 062S0000001309

PRIORITY MAIL 1-DAY™

Expected Delivery Date: 08/22/18
 Re#: 634-L74X2
0005

Carrier -- Leave if No Response

C009

SHIP TO: NICHOLAS J CARKIN
 AT&T TOWERS AND AT&T NEUTRAL HOST DAS
 550 COCHITUATE RD
 STE 2
 FRAMINGHAM MA 01701-4600

USPS TRACKING #

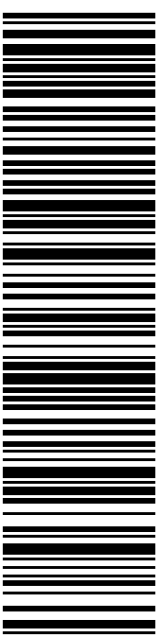

9405 5036 9930 0282 4573 86

Electronic Rate Approved #038555749



Cut on dotted line.

Instructions

1. Each Click-N-Ship® label is unique. Labels are to be used as printed and used only once. DO NOT PHOTO COPY OR ALTER LABEL.
2. Place your label so it does not wrap around the edge of the package.
3. Adhere your label to the package. A self-adhesive label is recommended. If tape or glue is used, DO NOT TAPE OVER BARCODE. Be sure all edges are secure.
4. To mail your package with PC Postage®, you may schedule a Package Pickup online, hand to your letter carrier, take to a Post Office™, or drop in a USPS collection box.
5. Mail your package on the "Ship Date" you selected when creating this label.

Click-N-Ship® Label Record

USPS TRACKING # :
9405 5036 9930 0282 4573 86

Trans. #: 442236690	Priority Mail® Postage: \$6.70
Print Date: 08/21/2018	Total: \$6.70
Ship Date: 08/21/2018	
Expected Delivery Date: 08/22/2018	

From: DEBORAH CHASE Re#: 634-L74X2
 NORTHEAST SITE SOLUTIONS, LLC
 420 MAIN ST STE 2
 STURBRIDGE MA 01566-1359

To: NICHOLAS J CARKIN
 AT&T TOWERS AND AT&T NEUTRAL HOST DAS
 550 COCHITUATE RD
 STE 2
 FRAMINGHAM MA 01701-4600

* Retail Pricing Priority Mail rates apply. There is no fee for USPS Tracking® service on Priority Mail service with use of this electronic rate shipping label. Refunds for unused postage paid labels can be requested online 30 days from the print date.



Thank you for shipping with the United States Postal Service!
 Check the status of your shipment on the USPS Tracking® page at usps.com