



Northeast Site Solutions
Victoria Masse
420 Main St Unit 1 Box 2
Sturbridge, MA 01566
victoria@northeastitesolutions.com

September 19, 2023

Members of the Siting Council
Connecticut Siting Council
Ten Franklin Square
New Britain, CT 06051

RE: Tower Share Application
0 Clark Hill Road, Naugatuck, CT 06770
Latitude: 41.5179691 N
Longitude: 73.0184418 W
Site#: BOHVN00186A

Dear Ms. Bachman:

This letter and attachments are submitted on behalf of Dish Wireless LLC. Dish Wireless LLC plans to install antennas and related equipment to the guyed tower site located at 0 Clark Hill Road, Naugatuck, Connecticut.

Dish Wireless LLC proposes to install three (3) 600/1900/2100 5G MHz antenna and six (6) RRUs, at the 170-foot level of the existing 277-foot guyed tower, three (1) Fiber cable will also be installed. Dish Wireless LLC equipment cabinets will be placed within 5"x7" lease area. Included are plans by Centek, dated September 20, 2023, Exhibit C. Also included is a structural analysis prepared by Centek, dated September 14, 2023 confirming that the existing guyed tower is structurally capable of supporting the proposed equipment. Attached as Exhibit D. This facility was approved by the Borough of Naugatuck, on June 18, 1991. Please see attached Exhibit A.

Please accept this letter as notification pursuant to Regulations of Connecticut State Agencies 16-50aa, of Dish Wireless LLC intent to share a telecommunications facility pursuant to R.C.S.A. 16-50j-88. In accordance with R.C.S.A., a copy of this letter is being sent to N. Warren "Pete" Hess III, Mayor for the Borough of Naugatuck, Lori Rotella, Town Planner, as well as the property owner and tower owner.

The planned modifications of the facility fall squarely within those activities explicitly provided for in R.C.S.A. 16-50j-89.

1. The proposed modifications will not result in an increase in the height of the existing structure. The top of the guyed tower is 277-feet; Dish Wireless LLC proposed antennas will be located at a center line height of 170-feet.
2. The proposed modification will not result in the increase of the site boundary as depicted on the attached site plan.
3. The proposed modification will not increase the noise levels at the facility by six decibels or more, or to levels that exceed local and state criteria. The incremental effect of the proposed changes will be negligible.

420 Main Street, Unit 1 Box 2, Sturbridge, MA 01566



4. The operation of the proposed antennas will not increase radio frequency emissions at the facility to a level at or above the Federal Communications Commission safety standard. As indicated in the attached power density calculations, the combined site operations will result in a total density of 6.27% as evidenced by Exhibit F.

Connecticut General Statutes 16-50-aa indicates that the Council must approve the shared use of a telecommunications facility provided it finds the shared use is technically, legally, environmentally, and economically feasible and meets public safety concerns. As demonstrated in this letter, Dish Wireless LLC respectfully indicates that the shared use of this facility satisfies these criteria.

A. **Technical Feasibility.** The existing guyed tower has been deemed structurally capable of supporting Dish Wireless LLC proposed loading. The structural analysis is included in Exhibit D.

B. **Legal Feasibility.** As referenced above, C.G.S. 16-50aa has been authorized to issue orders approving the shared use of an existing guyed tower such as this guyed tower in Naugatuck. Under the authority granted to the Council, an order of the Council approving the requested shared use would permit Dish Wireless LLC to obtain a building permit for the proposed installation. Further, a letter of Authorization is included as Exhibit G, authorizing Dish Wireless LLC to file this application for shared use.

C. **Environmental Feasibility.** The proposed shared use of this facility would have a minimal environmental impact. The installation of Dish Wireless LLC equipment at the 170-foot level of the existing 277-foot guyed tower would have an insignificant visual impact on the area around the guyed tower. Dish Wireless LLC ground equipment would be installed within the existing facility compound. Dish Wireless LLC shared use would therefore not cause any significant alteration in the physical or environmental characteristics of the existing site. Additionally, as evidenced by Exhibit F, the proposed antennas would not increase radio frequency emissions to a level at or above the Federal Communications Commission safety standard.

D. **Economic Feasibility.** Dish Wireless LLC will be entering into an agreement with the owner of this facility to mutually agreeable terms. As previously mentioned, the Letter of Authorization has been provided by the owner to assist Dish Wireless LLC with this tower share application.

E. **Public Safety Concerns.** As discussed above, the water tank is structurally capable of supporting Dish Wireless LLC proposed loading. Dish Wireless LLC is not aware of any public safety concerns relative to the proposed sharing of the existing water tank. Dish Wireless LLC intentions of providing new and improved wireless service through the shared use of this facility is expected to enhance the safety and welfare of local residents and individuals traveling through Naugatuck.

Sincerely,

Victoria Masse
Mobile: 860-306-2326
Fax: 413-521-0558
Office: 420 Main Street, Unit 1 Box 2, Sturbridge, MA 01566
Email: victoria@northeastsitesolutions.com



Attachments

Cc:

N. Warren "Pete" Hess III, Mayor
Borough of Naugatuck
229 Church Street, 4th Floor
Naugatuck, CT 06770

Lori Rotella, Town Planner
Borough of Naugatuck
229 Church Street, 4th Floor
Naugatuck, CT 06770

Tegna Broadcast Holdings LLC, Property and Tower Owner
8350 Broad Street
Tyson, VA 22102

Exhibit A

Original Facility Approval



BOROUGH OF NAUGATUCK

INLAND WETLANDS COMMISSION
PLANNING COMMISSION
ZONING BOARD OF APPEALS
ZONING COMMISSION

LAND USE OFFICE
213 CHURCH STREET
NAUGATUCK, CT 06770
203/729-4571

I HEREBY CERTIFY THAT Channel 20, Inc. owner of record
(owners address) 414 Meadow Street, Waterbury CT 06702, filed an
application pursuant to Section 32 of the Zoning Regulations of
the Borough of Naugatuck for a SPECIAL PERMIT for property at
described in the attached Schedule A, which was APPROVED
AT THE MEETING OF THE ZONING COMMISSION HELD ON:

Wednesday, July 17, 1991
DAY DATE

FOR THE PURPOSE OF: Erecting and operating a transmission and communication
tower with an overall height of 281 feet, with supporting anchors and
guy wires.

SIGNED: Robert Wagner (cfm)
Zoning Commission Chairman

Michael Moenile
Zoning Enforcement Officer

This action shall be filed with the Town Clerk on the Land Records of the Town as required by Section 8-3c(b) of the State Statutes.

SCHEDULE A

All that certain piece or parcel of land situated on the southerly side of East Side Boulevard in the City of Waterbury and in the Borough of Naugatuck, County of New Haven and State of Connecticut, bounded and described as follows:

Beginning at a point in the southerly line of East Side Boulevard in the City of Waterbury, Connecticut at the north-easterly corner of a parcel designated as a 50' R.O.W. on a map entitled "Subdivision of Peach Orchard Estates, Section Four, Waterbury, Conn., August, 1972, Scale: 1"=50'", recorded in Map Drawer IV, Page 386 of Waterbury Land Records, said 50' R.O.W. being located easterly of Lot #107 as shown on said Map, thence running easterly in the southerly line of East Side Boulevard and in a line curving to the left having a radius of 110.26 feet, a distance of 50.00 feet to land now or formerly of L & M Builders, Incorporated, thence running in line of land now or formerly of L & M Builder, Incorporated S 2°43'42W and crossing the Waterbury-Naugatuck Town Line from Waterbury 15.17feet into Naugatuck S 1° 19' 46" E, 125.00 feet, thence continuing in line of land now or formerly of L & M Builders, Incorporated S 87° 32' 18" E, 100.22 feet to The Naugatuck-Prospect Town Line and land now or formerly of George and Jennie Nardozza, thence running in line of land now or formerly of George and Jennie Nardozza, land now or formerly of Mary F. Raynor, land now or formerly of Grace M. Perun, land now or formerly of Thomas Bros., Inc., and land now or formerly of Philip J. Langdo S 1° 19' 46" E, 821.13 feet to land now or formerly of Estate of Stanley J. Lucas, the last described line being the Naugatuck-Prospect Town Line, thence running in line of land now or formerly of Estate of Stanley J. Lucas N 73° 32' 16" W, 181.07 feet, N 70° 15' 58" W, 117.30 feet, and N 69° 28' 34" W, 130.68 feet, N 57° 19' 46" W, 94.73 feet, N 71° 30' 34" W, 73.64 feet, and N 80° 52' 16" W, 45.91 feet to a point, thence running in line of remaining land of Francis M. McWeeney, Jr., N 1° 19' 46" W, 200.00 feet, N 88° 40' 14" E, 266.87 feet, N 1° 19' 46" W, 516.79 feet to Lot #107 as shown on a map entitled "Subdivision of Peach Orchard Estates Section Four", thence running in line of said lot #107 and a 50' wide Right of Way S 87° 32' 18" E, 165.00 feet, the last described line being the Naugatuck-Waterbury Town Line, thence running in the easterly line of a 50' wide Right of Way N 30° 36' 32" E, 31.53 feet to East Side Boulevard and the point of beginning. Bounded:

- Northerly - by Lot #107 "Peach Orchard Estates Section Four", a 50' wide Right of Way, East Side Boulevard, and land now or formerly of L & M Builders, Incorporated;
- Easterly - by land now or formerly of George & Jennie Nardozza, land now or formerly of Mary F. Raynor, land now or formerly of Grace M. Perun, land now or formerly of Thomas Bros. Inc., and land now or formerly of Philip J. Langdo;
- Southerly - by land now or formerly of Estate of Stanley J. Lucas;
- Westerly - by land now or formerly of Francis M. McWeeney, Jr.

Being a portion of the premises conveyed to Francis M. McWeeney, Jr., by L & M Builders, Incorporated a/k/a L & M Builders, Inc. by Quit-Claim Deed dated and recorded December 11, 1973 in Volume 1122, Page 152 of the Waterbury Land Records and in Volume 180, Page 27 of the Naugatuck Land Records.

SCHEDULE A
(continued)

Together with a right of way over area designated at 50' R.O.W. on map of "Subdivision of Peach Orchard Estates Section Four, Waterbury, Conn., August, 1972, Scale: 1"=50'", recorded in Drawer IV, Page 386, Waterbury Land Records, said right of way being located easterly of Lot #107 as shown on said Map and running southerly from East Side Boulevard to the Waterbury-Naugatuck Town Line as described in Volume 1121, Pages 011 and 012 of Waterbury Land Records.

Together with an easement and right of way through, over, under and across (a) the remaining land owned by Francis M. McWeeney, Jr. located northerly of the Waterbury town line and lying between said town line and the southerly line of East Side Boulevard, as shown on a map entitled "Map of Land of Thomas Bros., Inc. Prospect, Conn. The A. J. Patton Co., Surveyor, Waterbury, Conn. June 15, 1979 Scale: 1" = 40' Additions Oct. 21, 1980" (the "Map"), and (b) the remaining land of Francis M. McWeeney, Jr. located in the Town of Naugatuck, bounded northerly by the Waterbury town line, westerly and southerly by the Premises and easterly by land N/F of Grace M. Franco, as shown on said Map, to use said lands for all purposes customarily made of a public highway, including, without limiting the generality of the foregoing, the right to pass and repass on foot or in vehicles, to enter upon, travel and transport materials over and upon said lands and, if necessary or convenient, in connection therewith, the right to grade, excavate, fill or otherwise improve said lands, said easement and right of way to terminate upon the completion of the construction of a television tower and station upon the Premises.

Together with a permanent easement and right of way sufficient in width to satisfy town road specifications for the zone district in which the remaining land of Francis M. McWeeney, Jr. (as defined herein and hereinafter referred to as the "Remaining Property") is located, said easement to begin at a point in the westerly boundary of the Premises and running therefrom generally westerly through, over, under and across the Remaining Property to any future public highway constructed on or which adjoins or benefits the Remaining Property, to use said land for all purposes customarily made of a public highway, including without limiting the generality of the foregoing, the right to lay, install and maintain sewer, water and storm water lines therein, the right to pass and repass on foot or in vehicles, and, if necessary or convenient, in connection therewith, the right to grade, excavate, fill or otherwise improve said right of way. Said easement and right of way shall be located in such area as Francis M. McWeeney, Jr. or his successor shall determine; provided, however, that said easement and right shall be subject to the approval of the Naugatuck Economic Development Commission.

Exhibit C



BOROUGH OF NAUGATUCK

ZONING PERMIT

PERMIT NO. _____

DATE June 18 19 91

PERMISSION TO: (BUILD) ~~(MAKE ALTERATIONS)~~ ~~(BUILD ON ADDITION)~~

A ~~FAVOR OWNERS OR OTHER~~ transmission tower 281 feet high

DESCRIPTION OF PREMISES: ZONING PDD-8/ICC VALUE \$70,000

Northeast corner of Naugatuck, at rear of William C. Rado Sr. Drive
and Industrial Park, bordering Town of Prospect and City of Waterbury;

Tax Map 354 C, Block 20E138, Lot A.

FEE 35⁰⁰

- ZONING
- PLANNING
- WETLAND--FLOOD PLAIN
- ZONING BOARD OF APPEALS
- HEALTH-LIQUID WASTE
- SEPTIC TANK

APPLICANT: I hereby certify that the information contained herein is accurate.

Robert H. Hall

Signature of Applicant

Robert H. Hall, Attorney for Channel 20, Inc.

Name of Applicant (Print)

43 Main St., P.O. Box 395, Newtown, CT 06470

Address

426-8177

Telephone No.

ZONING ENFORCEMENT OFFICER _____

Granted, DATE _____

THIS APPROVAL IS SUBJECT TO COMPLIANCE (PRIOR TO OCCUPANCY) WITH THE PROVISIONS OF THE ZONING REGULATIONS AND THE SUBDIVISION REGULATIONS OF THE BOROUGH OF NAUGATUCK (WHERE APPLICABLE) AND AS AUTHORIZED UNDER SECTION 8 OF THE CONNECTICUT GENERAL STATUTES, AS AMENDED. THIS PERMIT IS BASED UPON THE PLOT PLAN SUBMITTED. FALSIFICATION BY MISREPRESENTATION OR OMISSION SHALL CONSTITUTE A VIOLATION OF THE BOROUGH ZONING REGULATIONS.

Exhibit B

Property Card



Borough of Naugatuck, CT

Property Listing Report

Map Block Lot **76-2**

Building # **1**

Unique Identifier

011-3060

Property Information

Property Location	0 CLARK HILL RD
Mailing Address	8350 BROAD STREET TYSON VA 22102
Land Use	Radio/TV Trans
Zoning Code	R15
Neighborhood	08

Owner	TEGNA BROADCAST HOLDINGS LLC
Co-Owner	
Book / Page	1035/0001
Land Class	Public Utility
Census Tract	345100
Acreage	7.9

Valuation Summary

(Assessed value = 70% of Appraised Value)

Item	Appraised	Assessed
Buildings	278100	194670
Outbuildings	421500	295050
Land	233100	163170
Total	932700	652890

Utility Information

Electric	No
Gas	No
Sewer	No
Public Water	No
Well	No

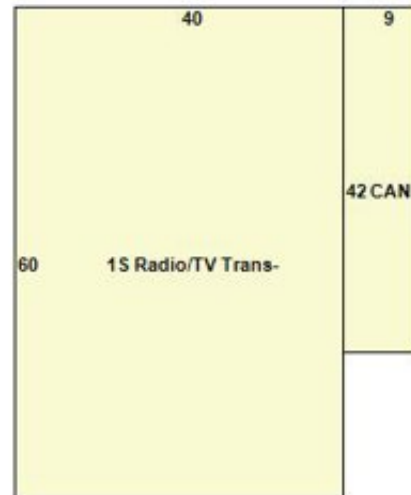

Primary Construction Details

Year Built	1980
Building Desc.	Commercial
Building Style	
Stories	1
Exterior Walls	Pre-Finish Metal
Exterior Walls 2	Aluminum Siding
Interior Walls	Drywall
Interior Walls 2	
Interior Floors 1	Concrete
Interior Floors 2	

Heating Fuel	Electric
Heating Type	Electric Baseboard
AC Type	Central
Bedrooms	0
Full Bathrooms	1
Half Bathrooms	0
Extra Fixtures	0
Total Rooms	0
Bath Style	NA
Kitchen Style	
Occupancy	0

Building Use	Radio/TV Station
Building Condition	Good
Frame Type	B-
Fireplaces	0
Bsmt Gar	0
Fin Bsmt Area	0
Fin Bsmt Quality	
Building Grade	0
Roof Style	Gable
Roof Cover	Metal

Report Created On

9/20/2023

Borough of Naugatuck, CT

Property Listing Report

Map Block Lot **76-2**

Building # **1**

Unique Identifier

011-3060

Detached Outbuildings

Type	Description	Area (sq ft)	Condition	Year Built
Shed	Cell Shed	140	Fair	2000
Shed	Cell Shed	360	Average	2005
Fence	8 Ft Chain	500	Average	2005
Shed	Cell Shed	264	Fair	2000
Tower	Tower	280	Fair	1980
Tower	Tower	980	Fair	1980
Shed	Cell Shed	170	Average	2004

Attached Extra Features

Type	Description	Area (sq ft)	Condition	Year Built
Canopy	Canopy	378	Fair	1980

Sales History

Owner of Record	Book/ Page	Sale Date	Sale Price
TEGNA BROADCAST HOLDINGS LLC	1035_0001	9/30/2019	611632
TRIBUNE BROADCASTING COMPANY LLC	1034_0883	9/30/2019	0
CT-WTIC LLC	1034_0896	9/30/2019	10
CHANNEL 20 INC C/O WTIC TV	0328_0466	3/3/1989	1800000

Borough of Naugatuck, Connecticut - Assessment Parcel Map

Parcel Account Number: 011-3060

Address: 0 CLARK HILL RD

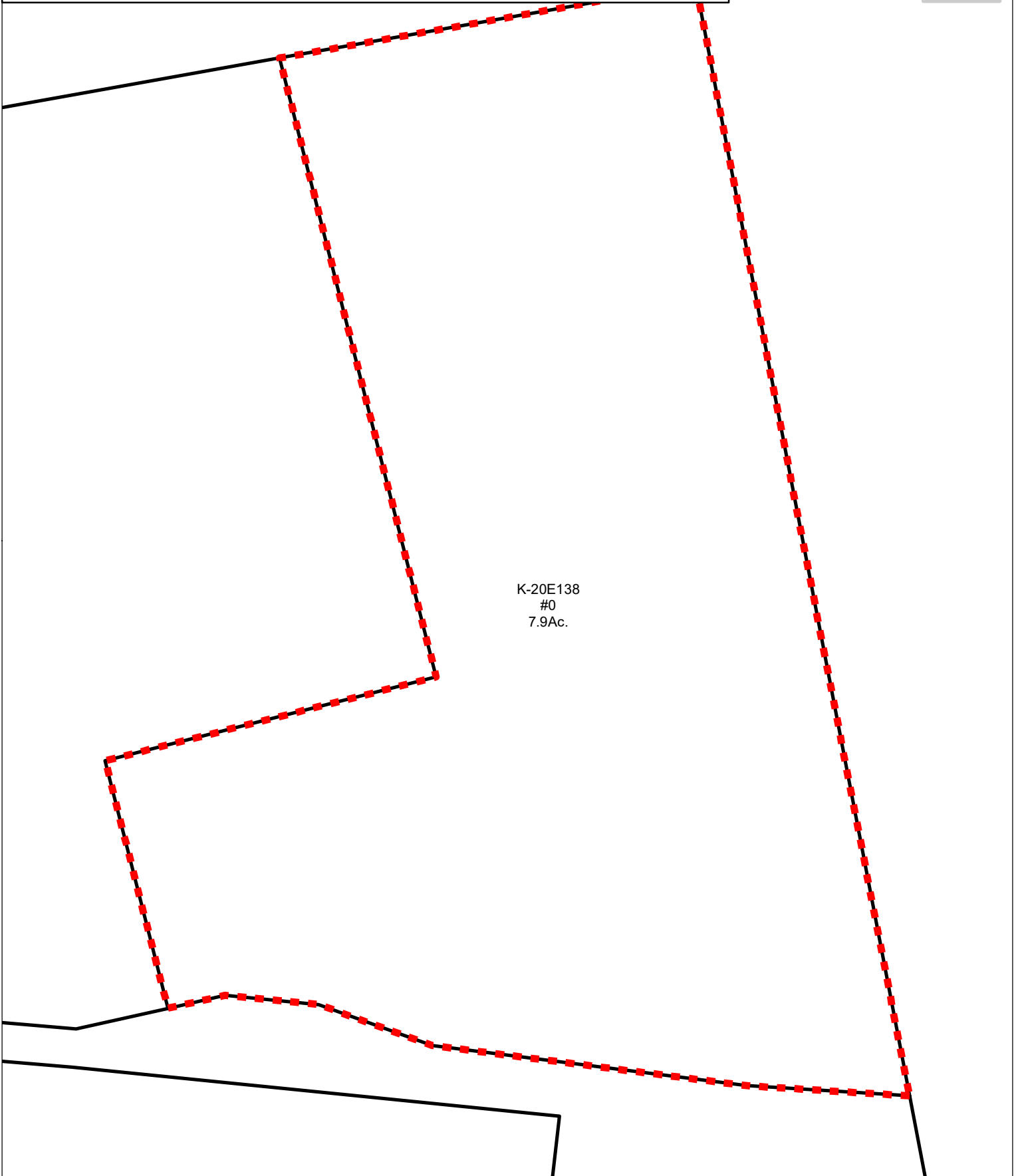

K-20E138
#0
7.9Ac.

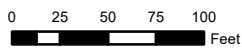

Disclaimer: This map is for informational purposes only.
All information is subject to verification by any user.
The Borough of Naugatuck and its mapping contractors
assume no legal responsibility for the information contained herein.

Map Produced March 2019

Exhibit C

Construction Drawings



DISH Wireless L.L.C. SITE ID:
BOHVN00186A

DISH Wireless L.L.C. SITE ADDRESS:
**0 CLARK HILL ROAD
NAUGATUCK, CT 06770**

CODE COMPLIANCE

ALL WORK SHALL BE PERFORMED AND MATERIALS INSTALLED IN ACCORDANCE WITH THE CURRENT EDITIONS OF THE FOLLOWING CODES AS ADOPTED BY THE LOCAL GOVERNING AUTHORITIES. NOTHING IN THESE PLANS IS TO BE CONSTRUED TO PERMIT WORK NOT CONFORMING TO THESE CODES:

CODE TYPE	CODE
BUILDING	2022 CT STATE BUILDING CODE/2021 IBC W/ CT AMENDMENTS
ELECTRICAL	2022 CT STATE BUILDING CODE/2020 NEC W/ CT AMENDMENTS

SHEET INDEX

SHEET NO.	SHEET TITLE
T-1	TITLE SHEET
C-1	OVERALL SITE PLAN
C-2	ELEVATION, ANT. LAYOUT AND SCHEDULE
C-3	EQUIPMENT PLATFORM AND H-FRAME DETAILS
C-4	TYPICAL EQUIPMENT DETAILS
C-5	TYPICAL EQUIPMENT DETAILS
E-1	ELECTRICAL AND FIBER ROUTING PLAN WITH NOTES
E-2	TELCO CABINET DETAILS
E-3	ELECTRICAL RISER, PANEL SCHEDULE, AND SCHEMATIC
G-1	COMPOUND/ANTENNA GROUNDING PLAN AND NOTES
G-2	TYPICAL GROUNDING DETAILS
G-3	TYPICAL GROUNDING DETAILS
G-4	ELECTRICAL SPECIFICATIONS
GN-1	SPECIFICATIONS AND NOTES
RF-1	RF CABLE COLOR CODE

SCOPE OF WORK

THIS IS NOT AN ALL INCLUSIVE LIST. CONTRACTOR SHALL UTILIZE SPECIFIED EQUIPMENT PART OR ENGINEER APPROVED EQUIVALENT. CONTRACTOR SHALL VERIFY ALL NEEDED EQUIPMENT TO PROVIDE A FUNCTIONAL SITE. THE PROJECT GENERALLY CONSISTS OF THE FOLLOWING:

- TOWER SCOPE OF WORK:**
- INSTALL (3) PROPOSED PANEL ANTENNAS (1 PER SECTOR)
 - INSTALL (3) PROPOSED SABRE ANTENNA MOUNTS (1 PER SECTOR)
 - INSTALL PROPOSED JUMPERS
 - INSTALL (6) PROPOSED RRU's (2 PER SECTOR)
 - INSTALL (1) PROPOSED OVER VOLTAGE PROTECTION DEVICE (OVP)
 - INSTALL (1) PROPOSED HYBRID CABLE

- GROUND SCOPE OF WORK:**
- INSTALL (1) PROPOSED STEEL EQUIPMENT PLATFORM
 - INSTALL (1) PROPOSED ICE BRIDGE
 - INSTALL (1) PROPOSED PPC CABINET
 - INSTALL (1) PROPOSED EQUIPMENT CABINET
 - INSTALL (1) PROPOSED POWER CONDUIT
 - INSTALL (1) PROPOSED TELCO CONDUIT
 - INSTALL (1) PROPOSED TELCO-FIBER BOX
 - INSTALL (1) PROPOSED GPS UNIT
 - INSTALL (1) PROPOSED SAFETY SWITCH (IF REQUIRED)
 - INSTALL (1) PROPOSED FIBER NID (IF REQUIRED)
 - INSTALL (1) PROPOSED 200A RATED UTILITY METER

SITE PHOTO

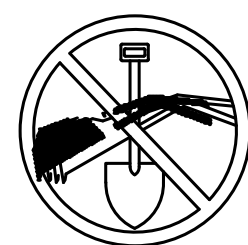

UNDERGROUND SERVICE ALERT
UTILITY NOTIFICATION CENTER OF (CT)
1-800-922-4455



CALL 2 WORKING DAYS UTILITY NOTIFICATION PRIOR TO CONSTRUCTION

GENERAL NOTES

THE FACILITY IS UNMANNED AND NOT FOR HUMAN HABITATION. A TECHNICIAN WILL VISIT THE SITE AS REQUIRED FOR ROUTINE MAINTENANCE. THE PROJECT WILL NOT RESULT IN ANY SIGNIFICANT DISTURBANCE OR EFFECT ON DRAINAGE. NO SANITARY SEWER SERVICE, POTABLE WATER, OR TRASH DISPOSAL IS REQUIRED AND NO COMMERCIAL SIGNAGE IS PROPOSED.

11"x17" PLOT WILL BE HALF SCALE UNLESS OTHERWISE NOTED

CONTRACTOR SHALL VERIFY ALL PLANS, EXISTING DIMENSIONS, AND CONDITIONS ON THE JOB SITE, AND SHALL IMMEDIATELY NOTIFY THE ENGINEER IN WRITING OF ANY DISCREPANCIES BEFORE PROCEEDING WITH THE WORK.

SITE INFORMATION

PROPERTY OWNER: TEGNA BROADCAST HOLDINGS
ADDRESS: 0 CLARK HILL ROAD
NAUGATUCK, CT 06770

SITE TYPE: GUYED TOWER
COUNTY: NEW HAVEN
LATITUDE (NAD 83): 41.5179691
LONGITUDE (NAD 83): 73.0184418

ZONING JURISDICTION: CSC
ZONING CODE: R15
PARCEL NUMBER: AA19 20E138 A

OCCUPANCY GROUP: N/A
CONSTRUCTION TYPE: N/A
POWER COMPANY: TBD
TELEPHONE COMPANY: TBD

PROJECT DIRECTORY

APPLICANT: DISH Wireless L.L.C.
5701 SOUTH SANTA FE DRIVE
LITTLETON, CO 80120

SITE DESIGNER: CENTEK ENGINEERING, INC.
63-2 NORTH BRANFORD ROAD
BRANFORD, CT. 06405
(203) 488-0580

SITE ACQUISITION: DAVID GOODFELLOW
(860) 305-3841

CONSTRUCTION MANAGER: CHAD WILCOX
(860) 573-2758

RF ENGINEER: DIPESH PARIKH
(312) 929-9086

DIRECTIONS

DIRECTIONS FROM AIRPORT (BDL) TO WIRELESS SITE

1. HEAD NORTHWEST. GO FOR 0.2 MI.
2. CONTINUE STRAIGHT AHEAD. GO FOR 0.3 MI.
3. KEEP RIGHT TOWARD CT-20/1-91. GO FOR 0.1 MI.
4. CONTINUE ON BRADLEY FIELD CONN. GO FOR 0.5 MI.
5. CONTINUE ON CT-20 (BRADLEY FIELD CONN). GO FOR 3.2 MI.
6. TAKE THE EXIT TOWARD HARTFORD ONTO I-91 S (RICHARD P HORAN MEMORIAL HWY). GO FOR 1.3 MI.
7. KEEP RIGHT ONTO I-91 (RICHARD P HORAN MEMORIAL HWY). GO FOR 8.1 MI.
8. TAKE EXIT 32A-32B TOWARD WATERBURY ONTO I-84 W. GO FOR 28.5 MI.
9. TAKE EXIT 23 TOWARD CT-69/HAMILTON AVE. GO FOR 0.3 MI.
10. TURN LEFT ONTO HAMILTON AVE (CT-69)/ GO FOR 0.6 MI
11. TURN RIGHT ONOT HAMILTON AVE. GO FOR 0.4 MI.
12. TURN ONTO 0 CLARK HILL RD, NAUGATUCK, CT 06706

VICINITY MAP



5701 SOUTH SANTA FE DRIVE
LITTLETON, CO 80120



CEN TEK engineering
Centered on Solutions™

(203) 488-0580
(203) 488-5587 Fax
63-2 North Branford Road
Branford, CT 06405

www.CentekEng.com

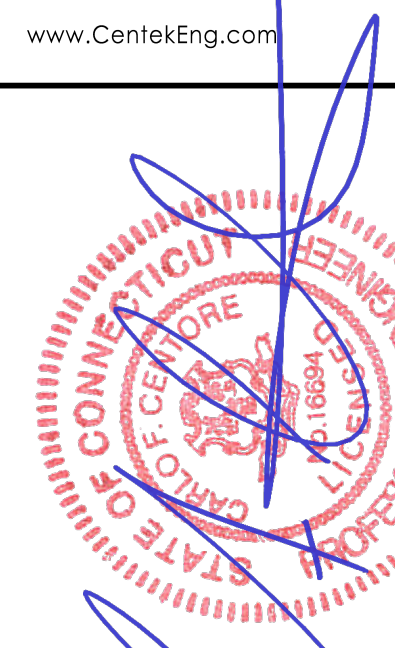

IT IS A VIOLATION OF LAW FOR ANY PERSON, UNLESS THEY ARE ACTING UNDER THE DIRECTION OF A LICENSED PROFESSIONAL ENGINEER, TO ALTER THIS DOCUMENT

DRAWN BY: RTS	CHECKED BY: TJR	APPROVED BY:
---------------	-----------------	--------------

RFDS REV #: 1 - 12/14/2022

CONSTRUCTION DOCUMENTS

SUBMITTALS

REV	DATE	DESCRIPTION
A	03/29/23	ISSUED FOR CLIENT REVIEW
B	04/13/23	REVISED PER CLIENT COMMENTS
0	07/24/23	ISSUED FOR CONSTRUCTION
1	07/27/23	REVISED PER CLIENT COMMENTS
2	08/08/23	REVISED PER CLIENT COMMENTS

CEN TEK PROJECT NUMBER
23009.03

DISH Wireless L.L.C.
PROJECT INFORMATION
BOHVN00186A
0 CLARK HILL ROAD
NAUGATUCK CT, 06770

SHEET TITLE
TITLE SHEET

SHEET NUMBER
T-1



AERIAL VIEW PLAN

NO SCALE 2

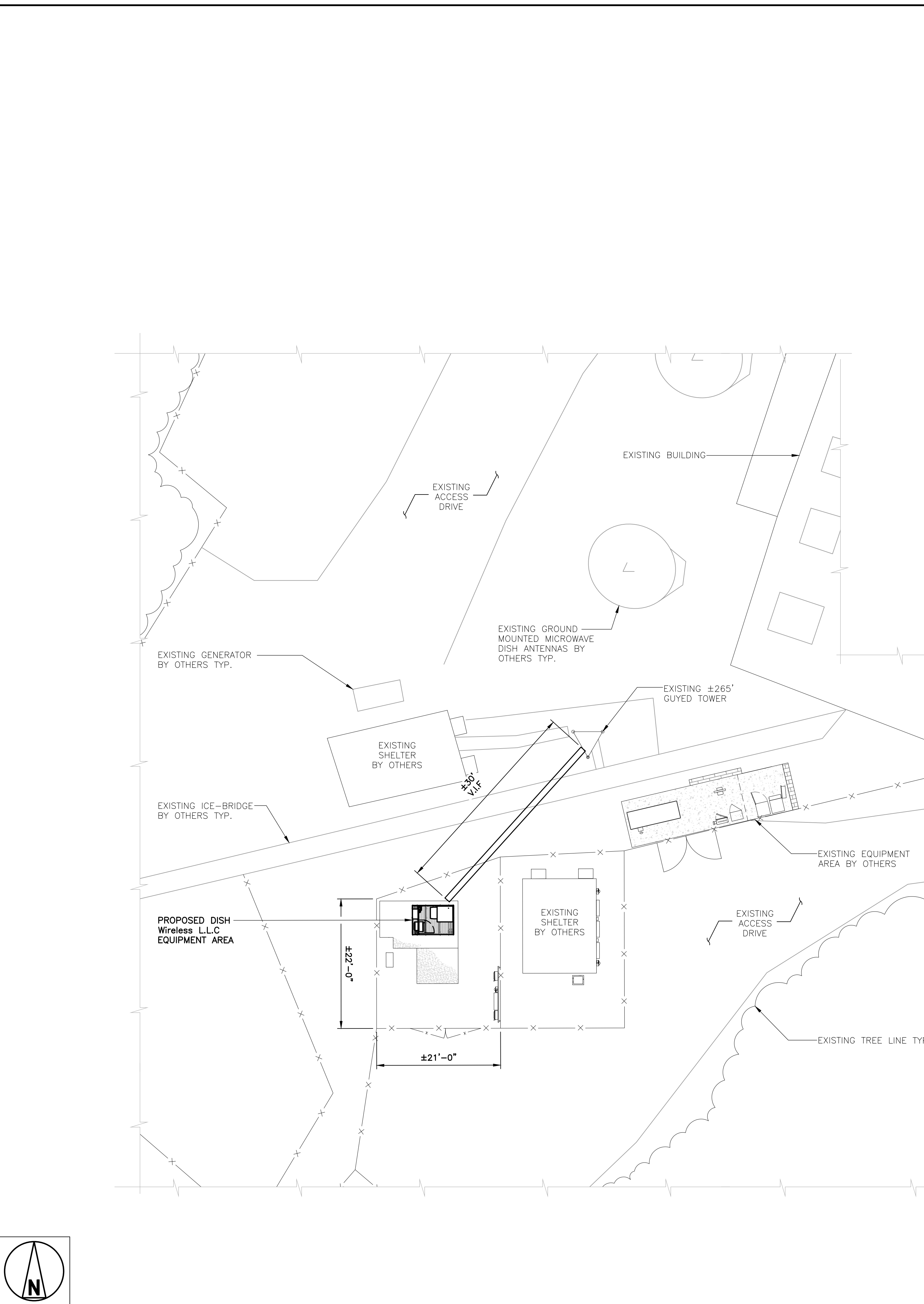
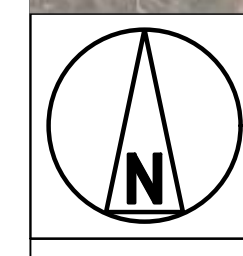

OVERALL SITE PLAN

6' 4' 2' 0 5' 10'
1/16"=1'-0" 1

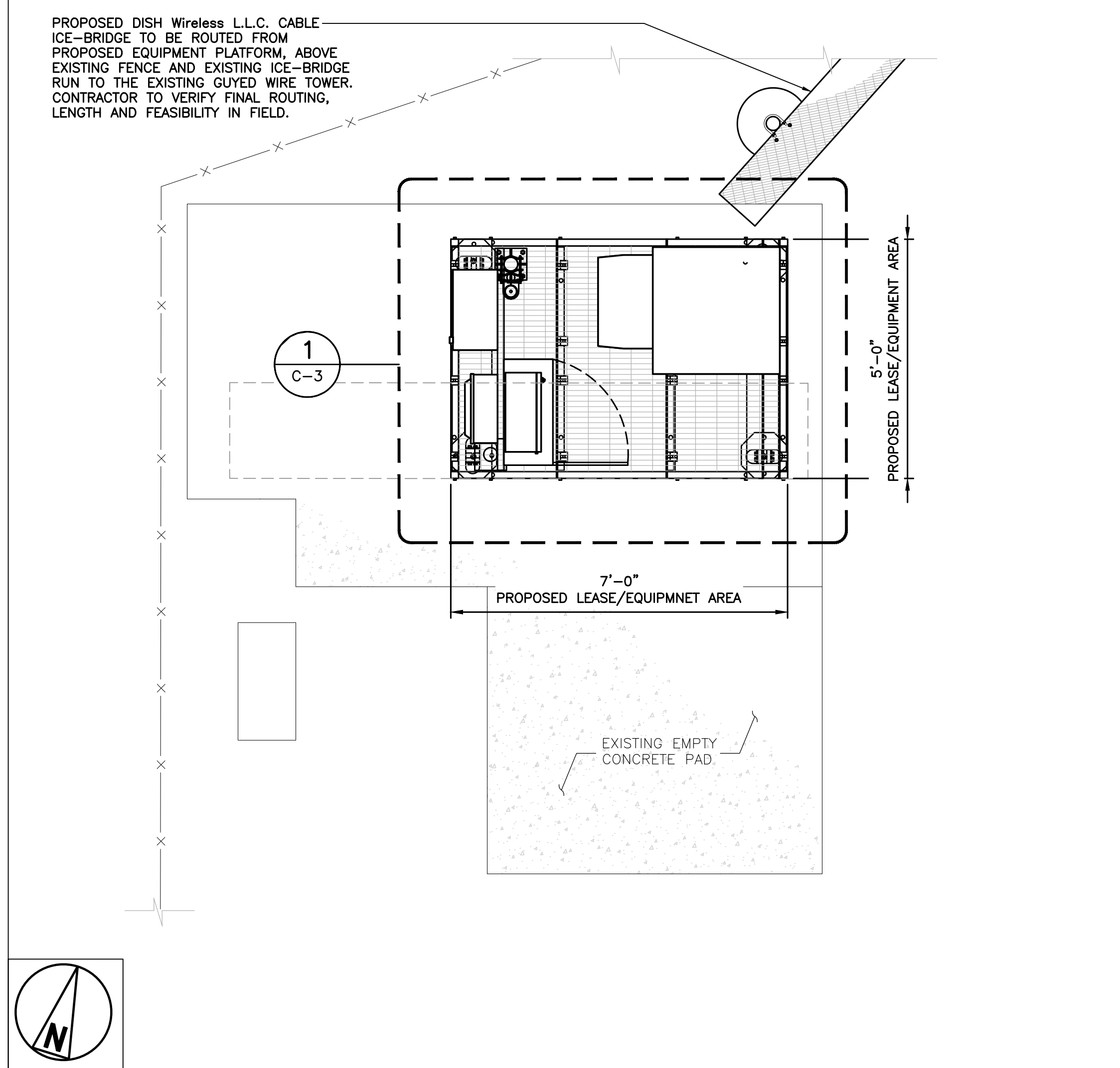
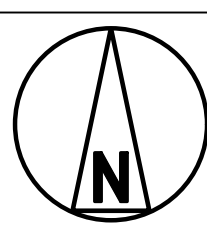

ENLARGED SITE PLAN

12' 6" 0 1' 2' 3' 4' 5'
1/2"=1'-0" 3

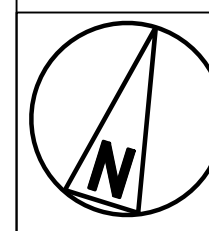

5701 SOUTH SANTA FE DRIVE
LITTLETON, CO 80120



CEN TEK engineering
Centered on Solutions™

(203) 488-0580
(203) 488-8587 Fax
63-2 North Branford Road
Branford, CT 06405

www.CentekEng.com

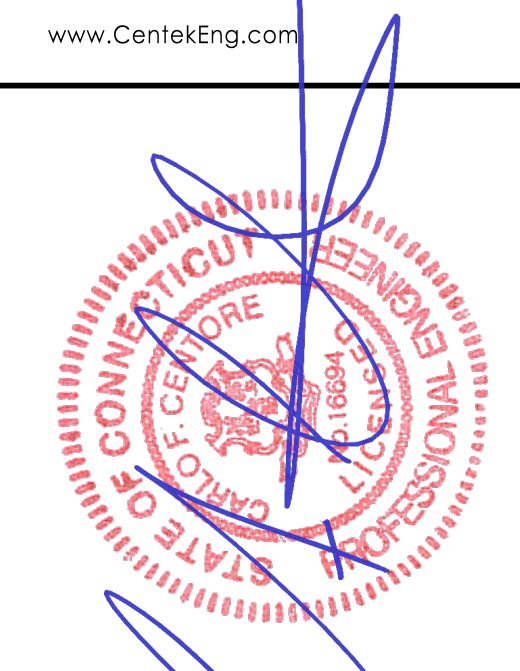

IT IS A VIOLATION OF LAW FOR ANY PERSON, UNLESS THEY ARE ACTING UNDER THE DIRECTION OF A LICENSED PROFESSIONAL ENGINEER, TO ALTER THIS DOCUMENT

DRAWN BY:	CHECKED BY:	APPROVED BY:
RTS	TJR	

RFDS REV #: 1 - 12/14/2022

CONSTRUCTION DOCUMENTS

SUBMITTALS		
REV	DATE	DESCRIPTION
A	03/29/23	ISSUED FOR CLIENT REVIEW
B	04/13/23	REVISED PER CLIENT COMMENTS
0	07/24/23	ISSUED FOR CONSTRUCTION
1	07/27/23	REVISED PER CLIENT COMMENTS
2	08/08/23	REVISED PER CLIENT COMMENTS

CEN TEK PROJECT NUMBER
23009.03

DISH Wireless L.L.C.
PROJECT INFORMATION

BOHVN00186A
0 CLARK HILL ROAD
NAUGATUCK CT, 06770

SHEET TITLE
OVERALL SITE PLAN

SHEET NUMBER
C-1

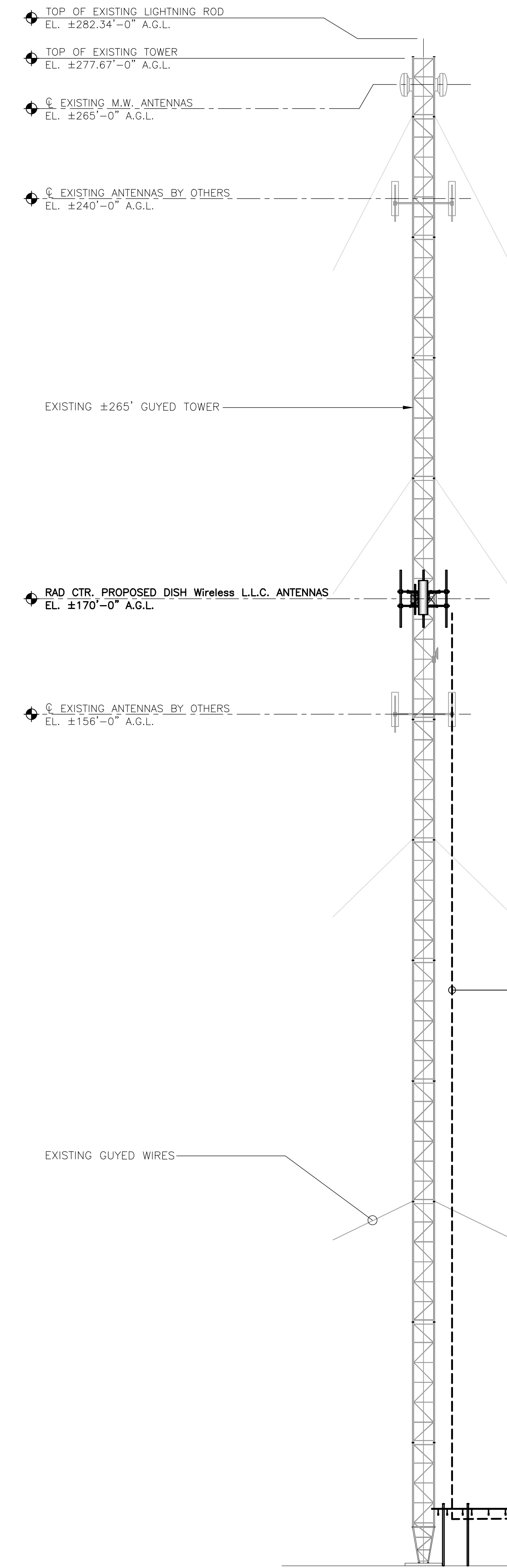

TOWER ELEVATION

STRUCTURAL COMPLIANCE

ANTENNA MOUNTS
 A STRUCTURAL ANALYSIS OF THE ANTENNA MOUNTS WAS PERFORMED FOR THE PROPOSED EQUIPMENT INSTALLATION AND THEY WERE FOUND TO BE STRUCTURALLY SUFFICIENT TO ACCOMMODATE THE PROPOSED LOADING.
 REFER TO THE ANTENNA MOUNT ANALYSIS REPORT PREPARED BY "INFINIGY" (JOB # 1197-F001-B) DATED 03/14/23 FOR ADDITIONAL INFORMATION AND REQUIREMENTS.

TOWER AND TOWER FOUNDATION
 A STRUCTURAL ANALYSIS OF THE TOWER AND TOWER FOUNDATION WAS PERFORMED FOR THE PROPOSED EQUIPMENT INSTALLATION AND THEY WERE FOUND TO BE STRUCTURALLY SUFFICIENT TO ACCOMMODATE THE PROPOSED LOADING.
 REFER TO THE STRUCTURAL ANALYSIS REPORT PREPARED BY CENTEK ENGINEERING (PROJECT # 23009.03) DATED 07/17/23 FOR ADDITIONAL INFORMATION AND REQUIREMENTS.

NOTE: NO EQUIPMENT SHALL BE INSTALLED ON THE HOSTING STRUCTURE WITHOUT A PASSING STRUCTURAL ANALYSIS REPORT AND CONTRACTOR PRIOR CONFIRMATION THAT ANY AND ALL REQUISITE MODIFICATIONS HAVE BEEN COMPLETED.
 PRIOR TOWER REINFORCEMENT MODIFICATIONS OUTLINED IN THE PREVIOUS STRUCTURAL ANALYSIS REPORT PREPARED BY "FULLERTON ENGINEERING P.C", JOB NO. 2021.0215.0004, DATED JULY 15, 2022 ARE TO BE COMPLETED PRIOR TO ANY PROPOSED TOWER WORK SHOWN HEREIN.

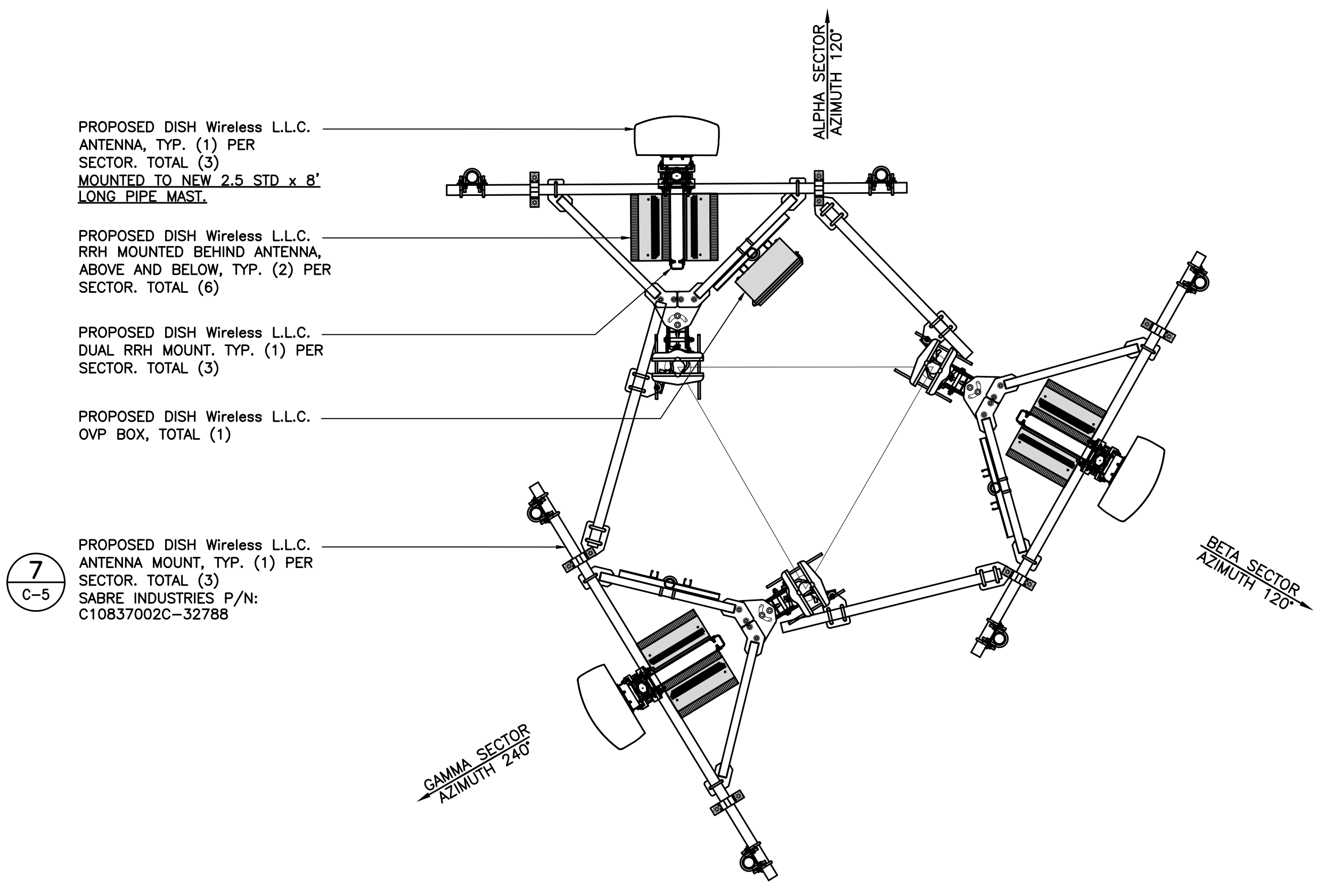

ALPHA/BETA/GAMMA SECTOR TYP.

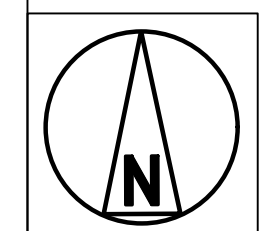

ANTENNA CONFIGURATION PLAN

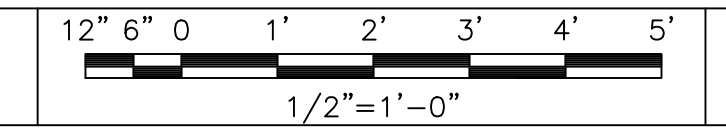

1

SECTOR	POSITION	ANTENNA						TRANSMISSION CABLE	
		EXISTING OR PROPOSED	MANUFACTURER - MODEL NUMBER	TECHNOLOGY	SIZE (HxW)	AZIMUTH	RAD CENTER	FEED LINE TYPE AND LENGTH	
ALPHA	A1	PROPOSED	JMA - MX08FR0665-21	n70, n71, n66	72.0" x 20.0"	0°	170'-0"	CU12PSM6P4XXX_4AWG	200FT
BETA	B1	PROPOSED	JMA - MX08FR0665-21	n70, n71, n66	72.0" x 20.0"	120°	170'-0"		200FT
GAMMA	C1	PROPOSED	JMA - MX08FR0665-21	n70, n71, n66	72.0" x 20.0"	240°	170'-0"		200FT

SECTOR	POSITION	RRH	
		MANUFACTURER - MODEL NUMBER	TECHNOLOGY
ALPHA	A1	FUJITSU - TA08025-B605	n71
	A1	FUJITSU - TA08025-B604	n70 n66
BETA	B1	FUJITSU - TA08025-B605	n71
	B1	FUJITSU - TA08025-B604	n70 n66
GAMMA	C1	FUJITSU - TA08025-B605	n71
	C1	FUJITSU - TA08025-B604	n70 n66

NOTES

- CONTRACTOR TO REFER TO FINAL CONSTRUCTION RFDS FOR ALL RF DETAILS.
- ANTENNA AND RRH MODELS MAY CHANGE DUE TO EQUIPMENT AVAILABILITY. ALL EQUIPMENT CHANGES MUST BE APPROVED AND REMAIN IN COMPLIANCE WITH THE PROPOSED DESIGN AND STRUCTURAL ANALYSES.

NOTE: ALL HYBRID/COAX LENGTHS TO BE MEASURED AND VERIFIED IN FIELD BEFORE ORDERING

ANTENNA SCHEDULE

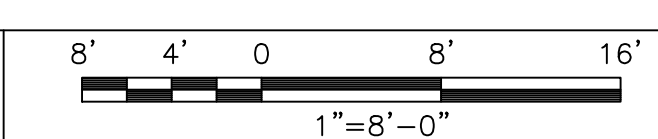

1



5701 SOUTH SANTA FE DRIVE
LITTLETON, CO 80120



CENTEK engineering
Centered on Solutions™

(203) 488-0580
(203) 488-8587 Fax
63-2 North Branford Road
Branford, CT 06405

www.CentekEng.com

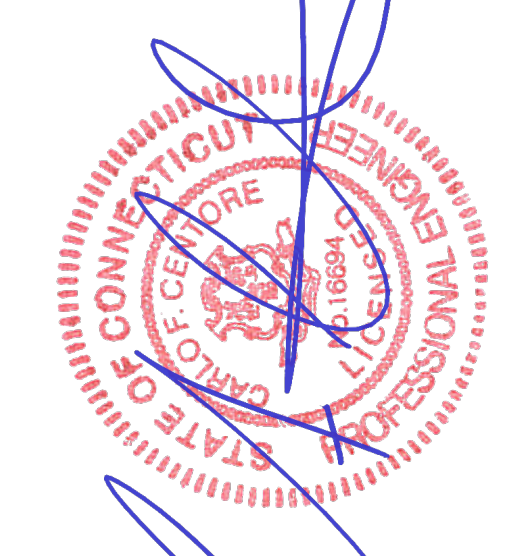

IT IS A VIOLATION OF LAW FOR ANY PERSON, UNLESS THEY ARE ACTING UNDER THE DIRECTION OF A LICENSED PROFESSIONAL ENGINEER, TO ALTER THIS DOCUMENT

DRAWN BY:	CHECKED BY:	APPROVED BY:
RTS	TJR	

RFDS REV #: 1 - 12/14/2022

CONSTRUCTION DOCUMENTS

SUBMITTALS

REV	DATE	DESCRIPTION
A	03/29/23	ISSUED FOR CLIENT REVIEW
B	04/13/23	REVISED PER CLIENT COMMENTS
0	07/24/23	ISSUED FOR CONSTRUCTION
1	07/27/23	REVISED PER CLIENT COMMENTS
2	08/08/23	REVISED PER CLIENT COMMENTS

CENTEK PROJECT NUMBER
23009.03

DISH Wireless L.L.C.
PROJECT INFORMATION

BOHVN00186A
0 CLARK HILL ROAD
NAUGATUCK CT, 06770

SHEET TITLE
ELEVATION, ANT. LAYOUT
AND SCHEDULE

SHEET NUMBER

C-2

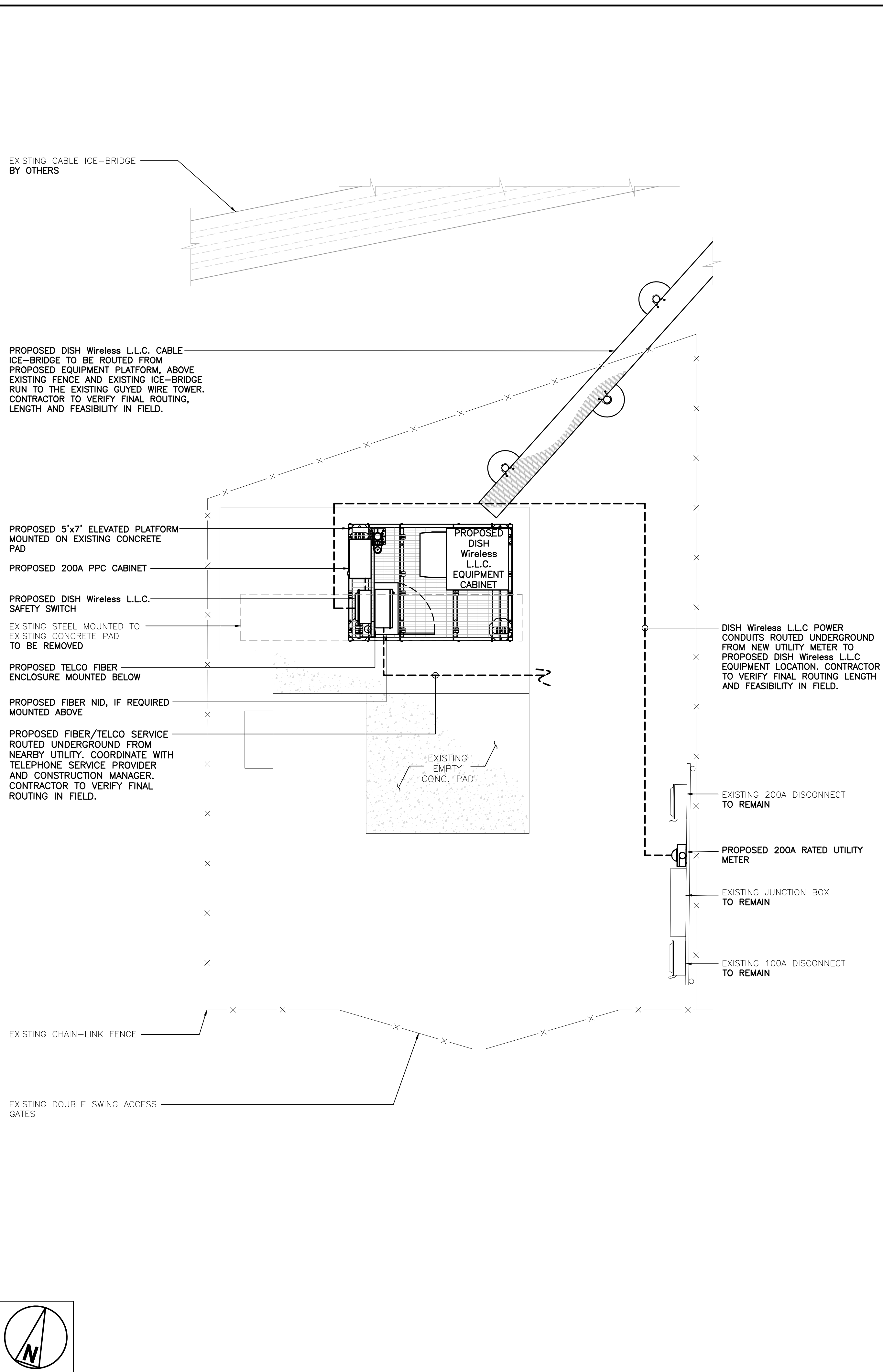

PROPOSED EQUIPMENT PLAN

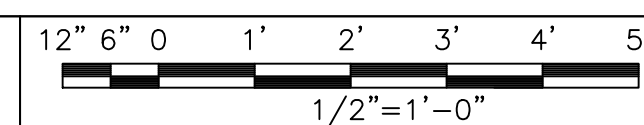

1

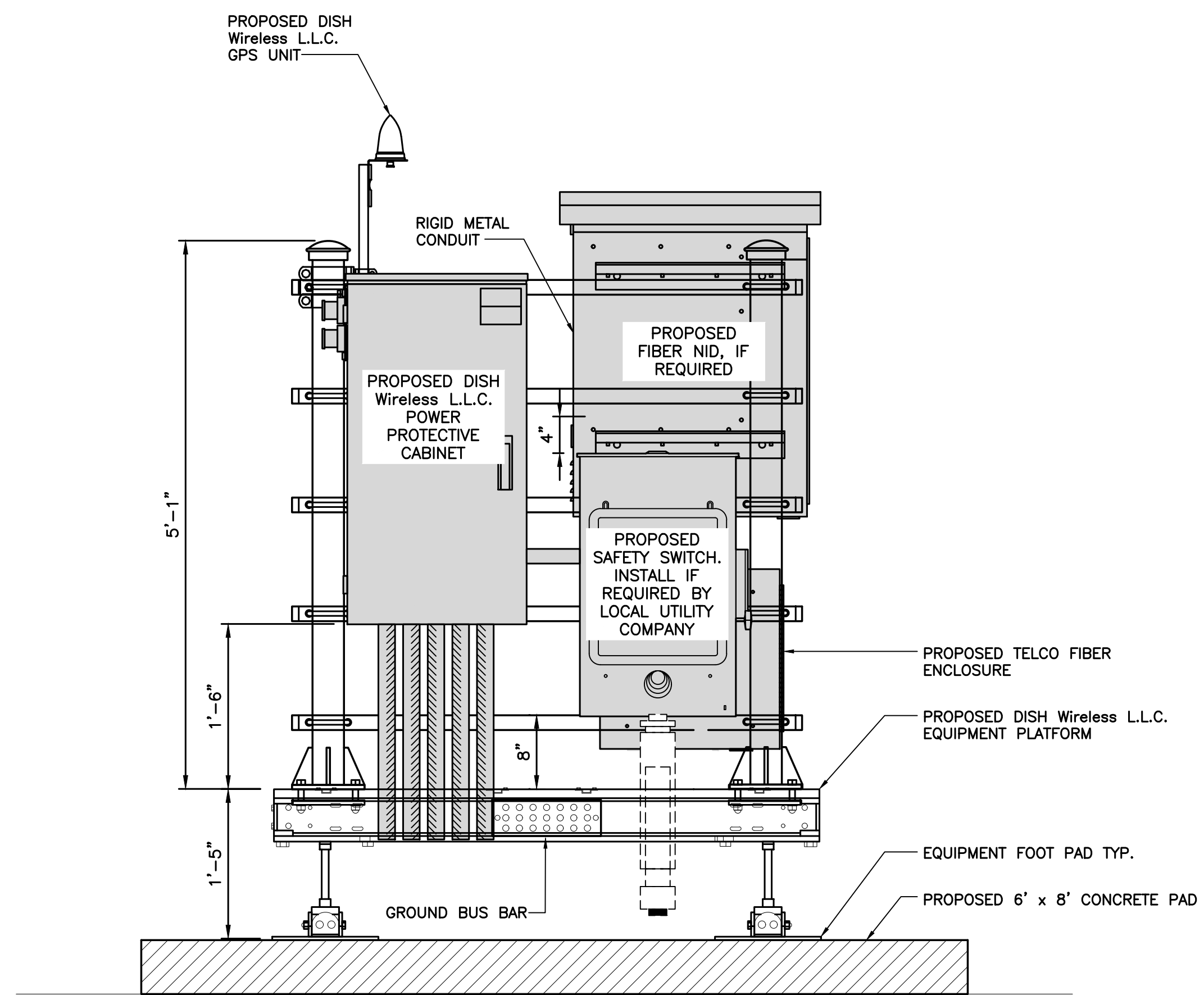

EQUIPMENT ELEVATION

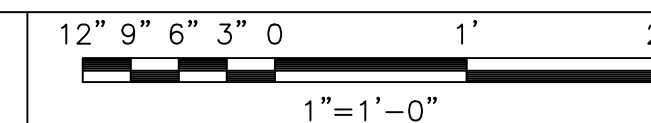

2

COMMSCOPE MTC4045LP 5X7 PLATFORM	
DIMENSIONS (HxWxL)	16"x84"x60"
WEIGHT/ VOLUME	423 LBS

NOTE:
GC TO PROVIDE EXTENDED THREAD FOR PLATFORM IF REQUIRED HEIGHT EXCEEDS 17"

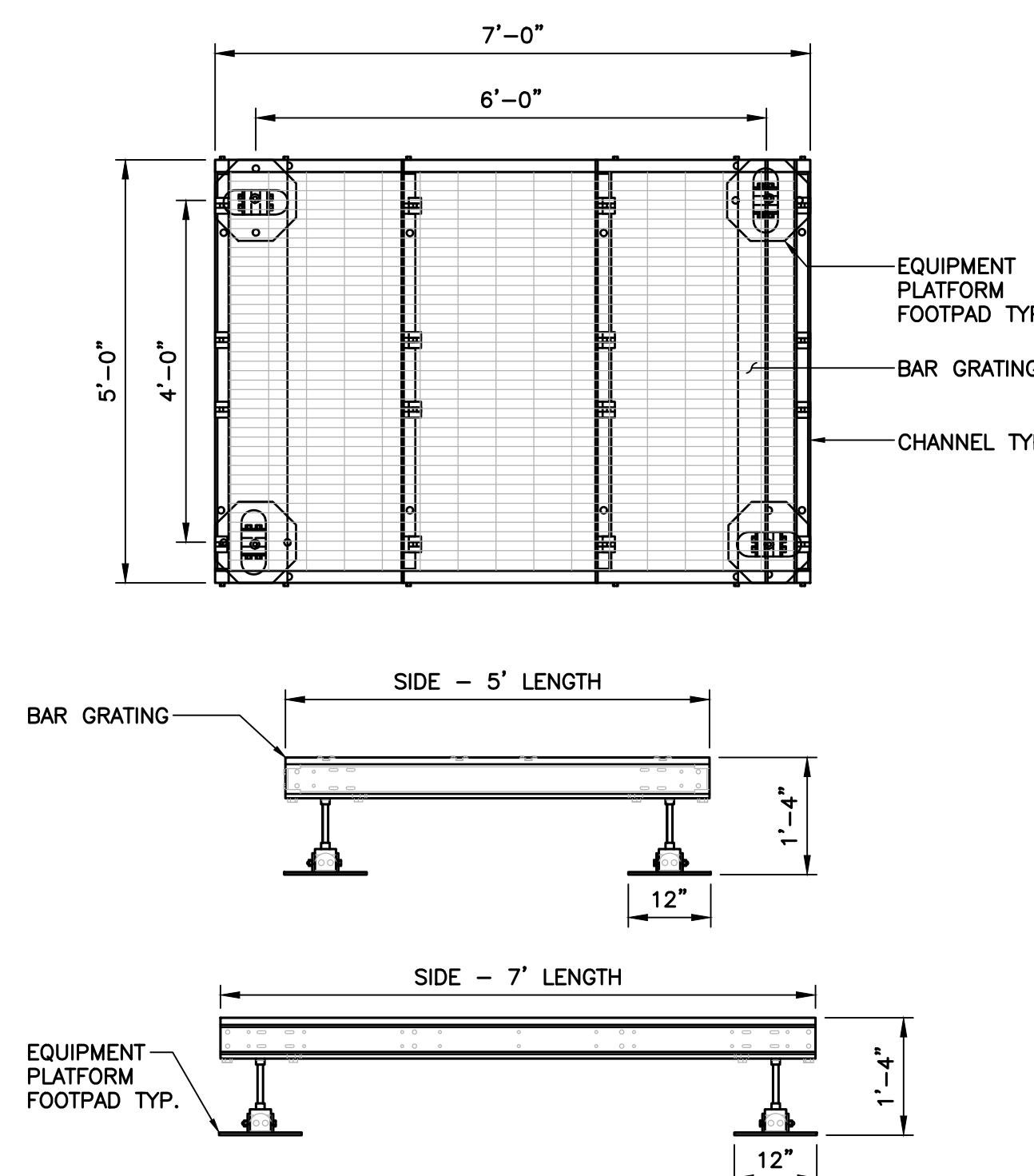

PLATFORM DETAIL

NO SCALE

3

COMMSCOPE MTC4045HFLD H-FRAME	
UNISTRUT/SUPPORT RAILS QTY	5
WEIGHT	59.74 LBS

NOTE:
OR DISH Wireless L.L.C. APPROVED EQUIVALENT

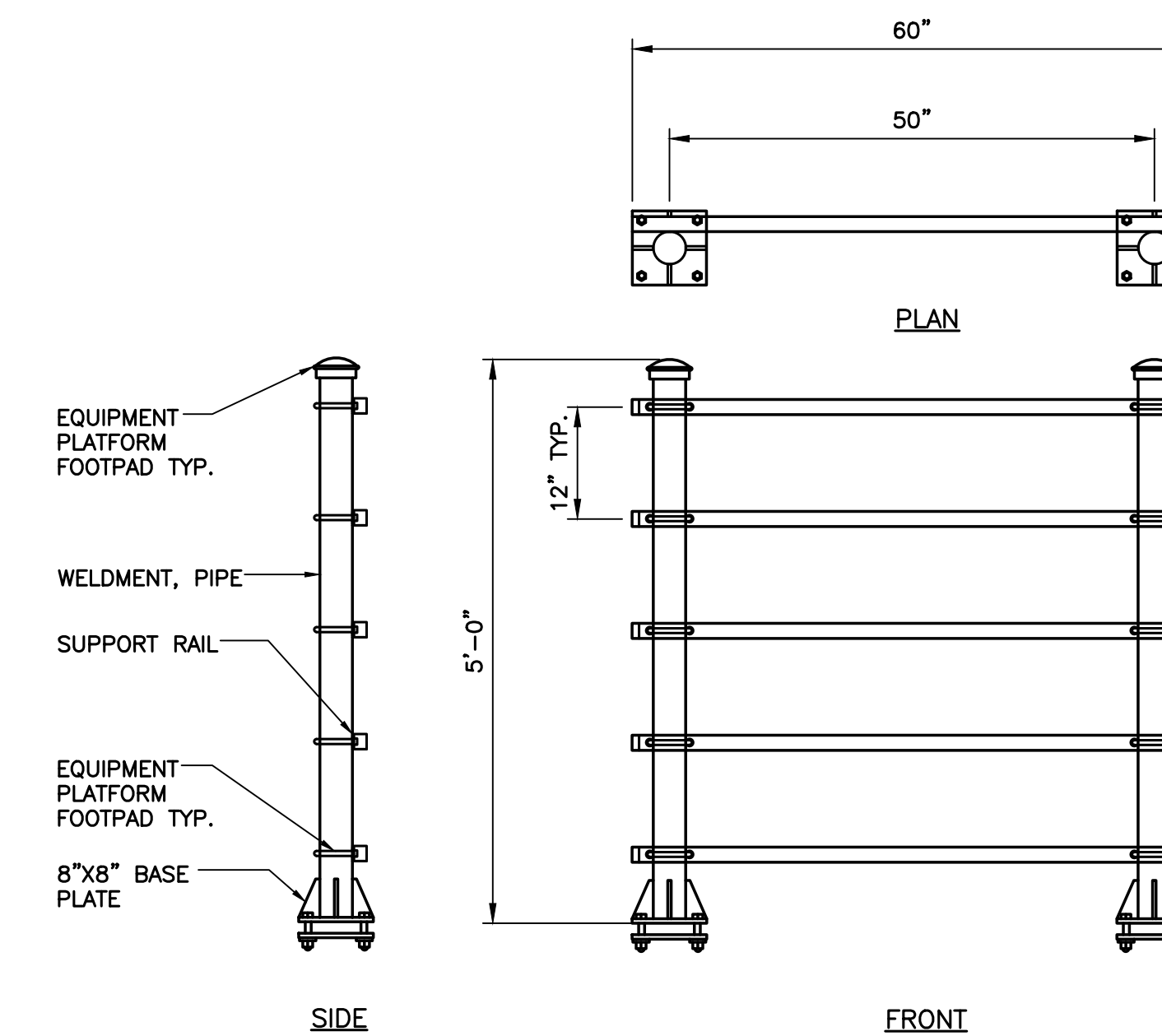

H-FRAME DETAIL

NO SCALE

4

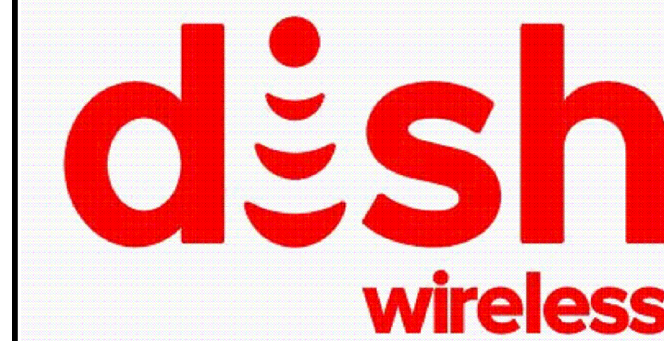

5701 SOUTH SANTA FE DRIVE
LITTLETON, CO 80120



CEN TEK engineering
Centered on Solutions™

(203) 488-0580
(203) 488-8587 Fax
63-2 North Branford Road
Branford, CT 06405

www.CentekEng.com

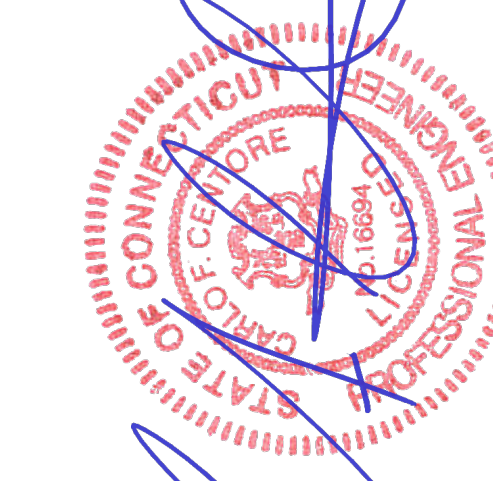

IT IS A VIOLATION OF LAW FOR ANY PERSON, UNLESS THEY ARE ACTING UNDER THE DIRECTION OF A LICENSED PROFESSIONAL ENGINEER, TO ALTER THIS DOCUMENT

DRAWN BY:	CHECKED BY:	APPROVED BY:
RTS	TJR	

RFDS REV #: 1 - 12/14/2022

CONSTRUCTION DOCUMENTS

SUBMITTALS		
REV	DATE	DESCRIPTION
A	03/29/23	ISSUED FOR CLIENT REVIEW
B	04/13/23	REVISED PER CLIENT COMMENTS
0	07/24/23	ISSUED FOR CONSTRUCTION
1	07/27/23	REVISED PER CLIENT COMMENTS
2	08/08/23	REVISED PER CLIENT COMMENTS

CEN TEK PROJECT NUMBER
23009.03

DISH Wireless L.L.C.
PROJECT INFORMATION
BOHVN00186A
0 CLARK HILL ROAD
NAUGATUCK CT, 06770

SHEET TITLE
EQUIPMENT PLATFORM
AND H-FRAME DETAILS

SHEET NUMBER

C-3

SQUARE D SAFETY SWITCHES D224NRB	
ENCLOSURE DIM (HxWxD)	29.25"x19.00"x8.50"
ENCLOSURE TYPE	NEMA 3R RAINPROOF
UL LISTED	FILE E-2875

TOP

SIDE

FRONT

RAYCAP PPC RDIAC-2465-P-240-MTS	
ENCLOSURE DIMENSIONS (HxWxD):	39"x22.855"x12.593
WEIGHT:	80 lbs
OPERATING AC VOLTAGE	240/120 1 PHASE 3W+G

TOP

BACK

SIDE

FRONT

SIDE

CHARLES INDUSTRY HEX CUBE-PM639155N4	
DIMENSIONS (HxWxD):	74"x32"x32"
POWER PLANT:	-48VDC ABB/600W
TOTAL WEIGHT (EMPTY)	408 LBS

PLAN

SIDE

BACK

SIDE

FRONT

SAFETY SWITCH DETAIL NO SCALE 1

POWER PROTECTIVE CABINET DETAIL NO SCALE 2

CABINET DETAIL NO SCALE 3

SITEPROT: CABLE LADDER	
DIMENSIONS (LxW) (PER CABLE LADDER SECTION)	237.5" x 29.5"
WEIGHT/ VOLUME	81.5 LBS
CABLE RUN (QTY)	9
MODEL	WCL9

ROSENBERGER GPSGLONASS-36-N-S	
DIMENSION (DIA x H)	69mm x 98.5mm
WEIGHT (WITH ACCESSORIES)	515.74g
CONNECTOR	N-FEMALE
FREQUENCY RANGE	1559 MHz ~ 1610.5MHz

TOP

SIDE

BACK

MINIMUM OF 75% OR 270° IN ANY DIRECTION

GPS

GPS UNIT

OBSTRUCTIONS MUST BE BELOW 10°

CABLE LADDER DETAIL NO SCALE 4

GPS DETAIL NO SCALE 5

GPS MINIMUM SKY VIEW REQUIREMENTS NO SCALE 6

CHARLES CFT-PF2020DSH1 FIBER TELCO ENCLOSURE	
ENCLOSURE DIMS (HxWxD)	20"x20"x9"
ENCLOSURE WEIGHT	20 lbs
MOUNTING	WALL
COMPLIANCE	TYPE 4

FRONT

SIDE

BACK

FRONT

1.75"φ

27" MIN BEND RADIUS

CU12PSM6P4XXX (4 AWG CONDUCTORS)

1.60"φ

24" MIN BEND RADIUS

CU12PSM9P6XXX (6 AWG CONDUCTORS)

1.41"φ

22" MIN BEND RADIUS

CU12PSM9P8XXX (8 AWG CONDUCTORS)

ZAYO 5RU CABINET LEFT SWING DOOR ('LIT' SITES)	
DIMENSIONS (HxWxD)	36.115"x29"x12.9"
WEIGHT	85 LBS
POWER INPUT	20A, -48VDC

FRONT

SIDE

BACK

FIBER TELCO ENCLOSURE DETAIL NO SCALE 7

CABLES UNLIMITED HYBRID CABLE MINIMUM BEND RADIUS NO SCALE 8

FIBER NID ENCLOSURE DETAIL NO SCALE 9

5701 SOUTH SANTA FE DRIVE
LITTLETON, CO 80120

NSS
NORTHEAST
SITE SOLUTIONS
Turnkey Wireless Development

CEN^{TEK}engineering
Centered on Solutions™

(203) 488-0580
(203) 488-8587 Fax
63-2 North Branford Road
Branford, CT 06405

www.CentekEng.com

IT IS A VIOLATION OF LAW FOR ANY PERSON, UNLESS THEY ARE ACTING UNDER THE DIRECTION OF A LICENSED PROFESSIONAL ENGINEER, TO ALTER THIS DOCUMENT

DRAWN BY:	CHECKED BY:	APPROVED BY:
RTS	TJR	

RFDS REV #: 1 - 12/14/2022

CONSTRUCTION DOCUMENTS

SUBMITTALS		
REV	DATE	DESCRIPTION
A	03/29/23	ISSUED FOR CLIENT REVIEW
B	04/13/23	REVISED PER CLIENT COMMENTS
0	07/24/23	ISSUED FOR CONSTRUCTION
1	07/27/23	REVISED PER CLIENT COMMENTS
2	08/08/23	REVISED PER CLIENT COMMENTS

CEN^{TEK} PROJECT NUMBER
23009.03

DISH Wireless L.L.C.
PROJECT INFORMATION

BOHVN00186A
0 CLARK HILL ROAD
NAUGATUCK CT, 06770

SHEET TITLE
TYPICAL EQUIPMENT
DETAILS

SHEET NUMBER
C-4

FUJITSU DUAL BAND TA08025-B604	
DIMENSIONS (HxWxD)	14.9"x15.7"x7.8"
WEIGHT	63.9 lbs
CONNECTOR TYPE	4.3-10 RF CONNECTOR
POWER SUPPLY	DC -58~-36V

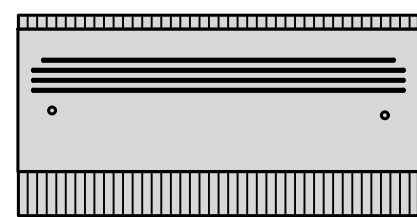

PLAN

NOTE:
ALL VISIBLE RRH'S SHALL BE WRAPPED IN CONCEALFAB MMW VINYL FILM WRAP (PART #900864-99 OR APPROVED EQUAL)

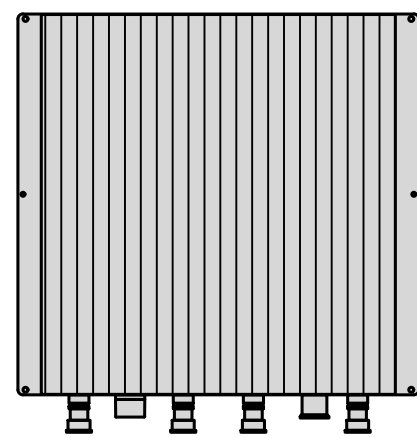

BACK

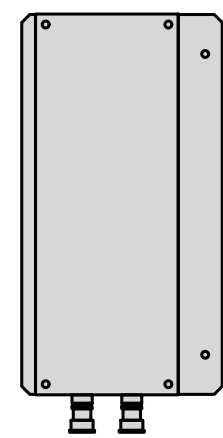

SIDE

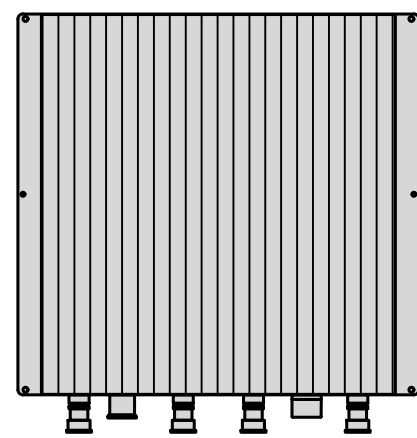

FRONT

RRH DETAIL

NO SCALE 1

FUJITSU TRIPLE BAND TA08025-B605	
DIMENSIONS (HxWxD)	14.9"x15.7"x9"
WEIGHT	74.95 lbs
CONNECTOR TYPE	4.3-10 RF CONNECTOR
POWER SUPPLY	DC -58~-36V

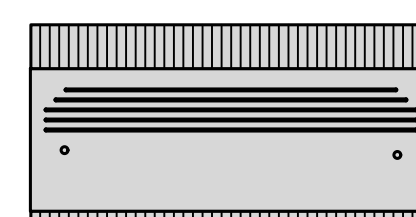

PLAN

NOTE:
ALL VISIBLE RRH'S SHALL BE WRAPPED IN CONCEALFAB MMW VINYL FILM WRAP (PART #900864-99 OR APPROVED EQUAL)

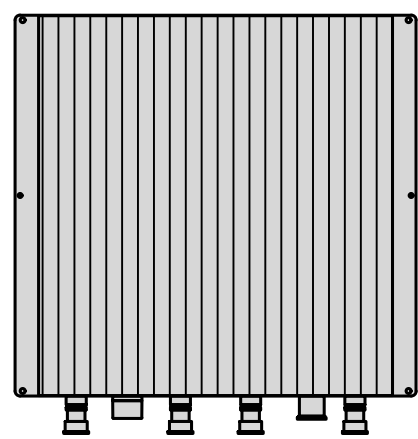

BACK

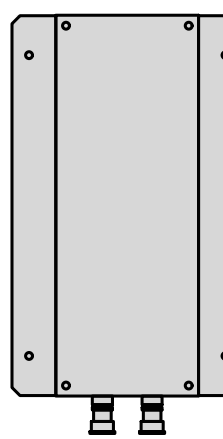

SIDE

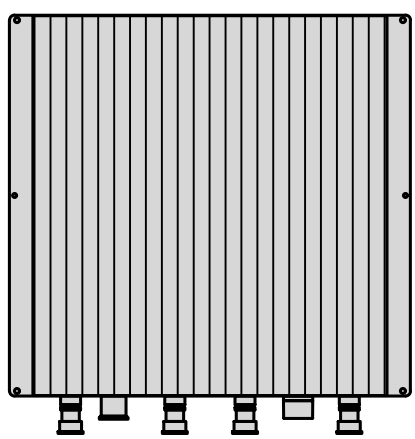

FRONT

RRH DETAIL

NO SCALE 2

SABRE DOUBLE Z-BRACKET C10123155	
DIMENSIONS (HxWxD) (1 BRACKET)	5"x20"x1-13/16"
WEIGHT (FULL ASSEMBLY)	35.79 lbs
PACKAGE QUANTITY	4

#	DESCRIPTION
1	PLATE, CHANNEL BRACKET
2	RRH Z BRACKET, 3/16"
3	THREADED ROD ASSEMBLY 1/2"x12"

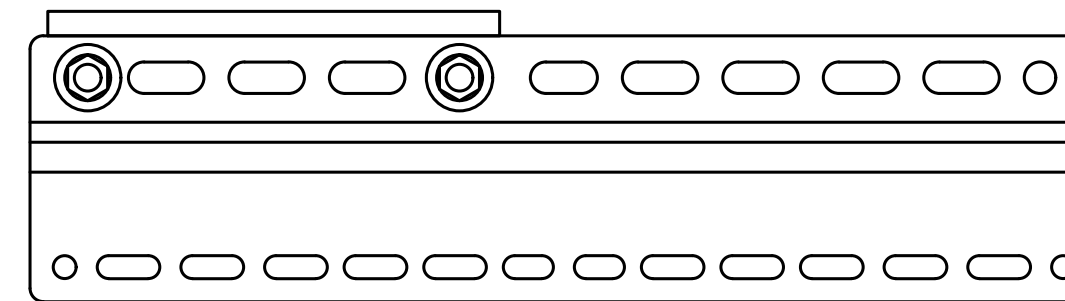

NOTE:
OR DISH Wireless L.L.C. APPROVED EQUIVALENT

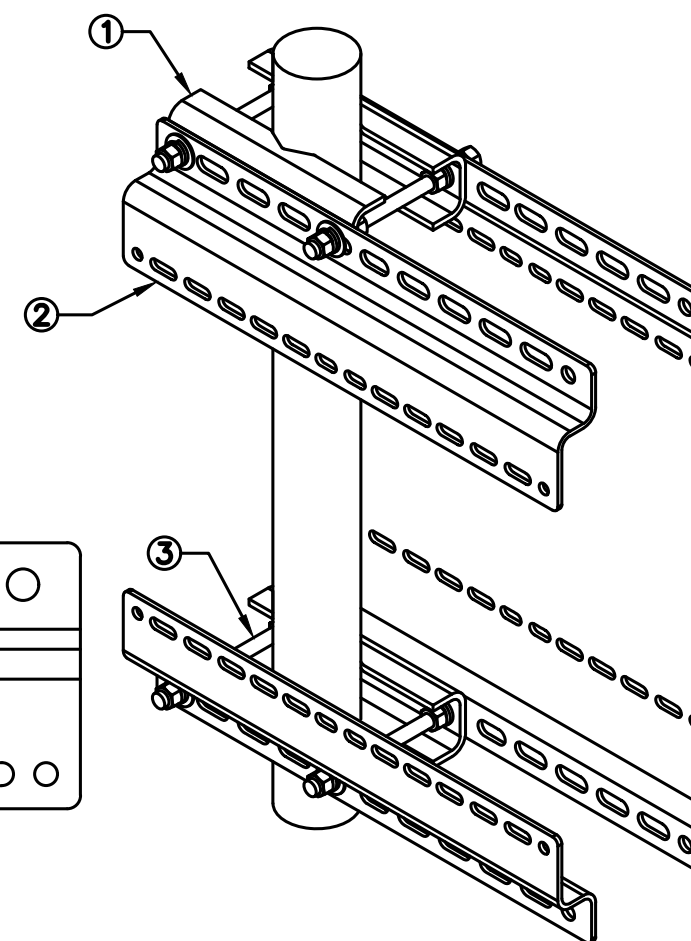

RRH MOUNT DETAIL

NO SCALE 3

RAYCAP RDIC-3045-PF-48 SURGE PROTECTION DEVICE (OVP)	
DIMENSIONS (HxWxD)	18.97"x16.21"x9.64"
WEIGHT	21 lbs

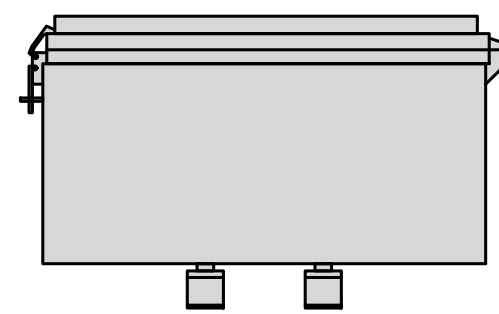

PLAN

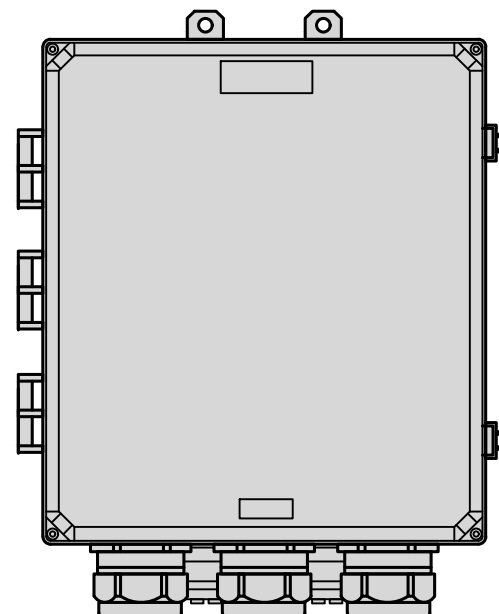
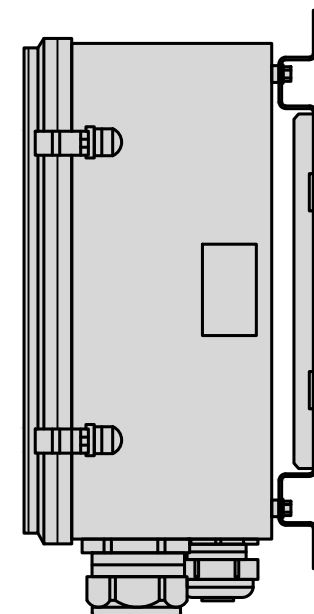
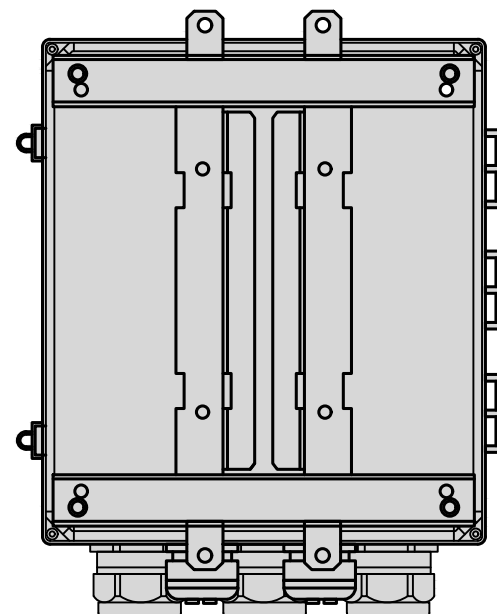

SURGE PROTECTION DEVICE DETAIL (OVP)

NO SCALE 4

JMA MX08FRO665-21	
DIMENSIONS (HxWxD)	72"x20.0"x8.0"
RF PORTS, CONNECTOR TYPE	8 x 4.3-10 FEMALE
WEIGHT	64.5 lbs
WEIGHT WITH BRACKETS	82.5 lbs

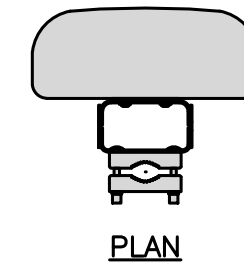

PLAN

NOTE:
ALL VISIBLE ANTENNAS SHALL BE WRAPPED IN CONCEALFAB MMW VINYL FILM WRAP (PART #900864-99 OR APPROVED EQUAL)

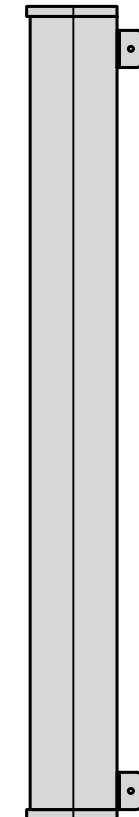

SIDE

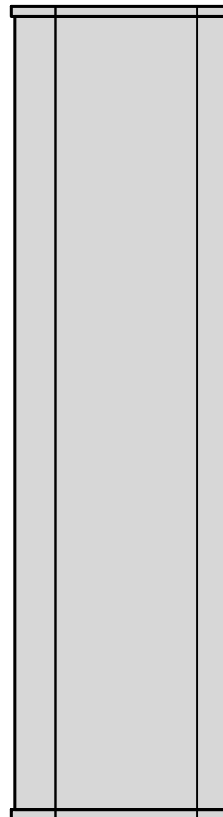

FRONT

ANTENNA DETAIL

NO SCALE 5

JMA ANTENNA MOUNT BRACKET #91900318	
TOTAL WEIGHT (WITH BRACKETS)	18 lbs (8.18 Kg)
POLE DIAMETER RANGE	2.5" TO 4.5"

NOTE:
KIT #91900318: TOP AND BOTTOM BRACKETS FOR 4-, 6-, AND 8-FOOT ANTENNAS
ANTENNA BRACKET NOT PART OF KIT

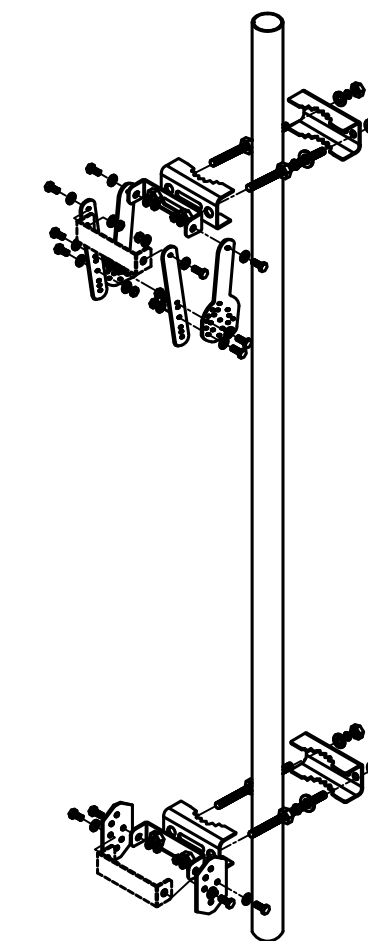

NOTE:
OR DISH Wireless L.L.C. APPROVED EQUIVALENT

ANTENNA BRACKET DETAIL

NO SCALE 6

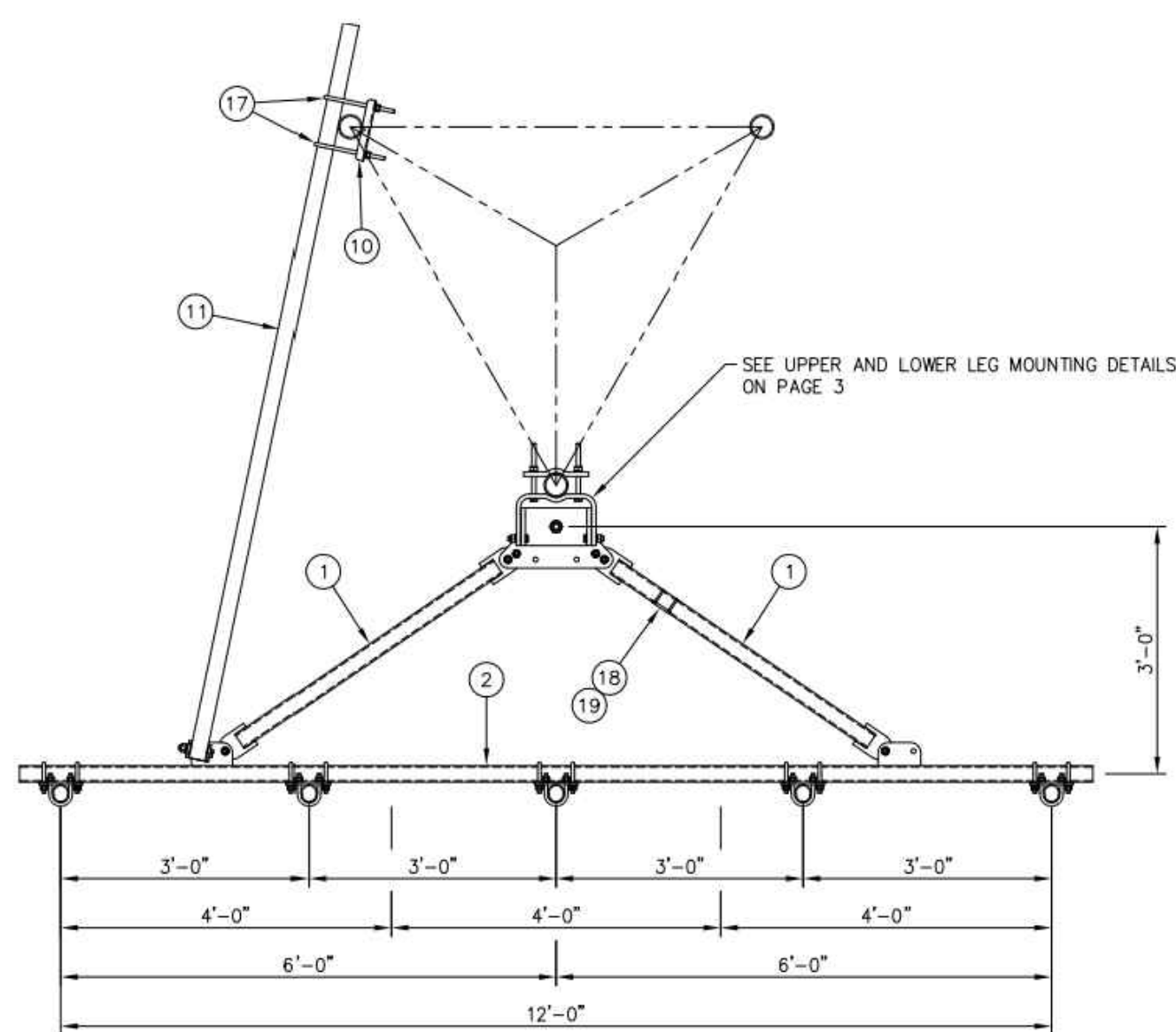

SABRE INDUSTRIES P/N: C10837002C-32788

ANTENNA FRAME DETAIL

NO SCALE 7

COMMSCOPE: WB-K110-B WAVEGUIDE BRIDGE KIT		INCLUDED PRODUCTS:
DIMENSIONS (HxL)	160"x10"	WB-T12-3 TRAPEZE KIT, 3 RUNGS
WEIGHT/VOLUME	325 lbs	WB-LB12-3 SUPPORT BRACKET
CABLE RUN (QTY)	12	MF-130 DIRECT BURIAL PIPE COLUMN, 13'-4"

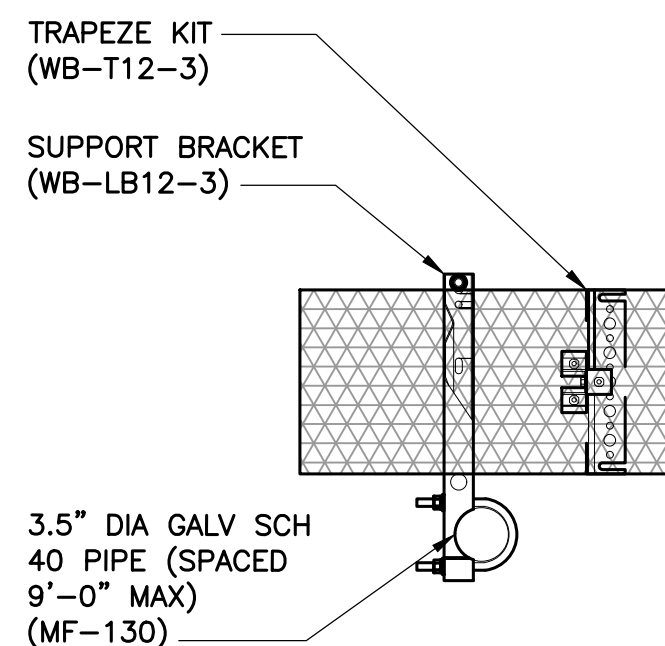

3.5" DIA GALV SCH 40 PIPE (SPACED 9'-0" MAX) (MF-130)

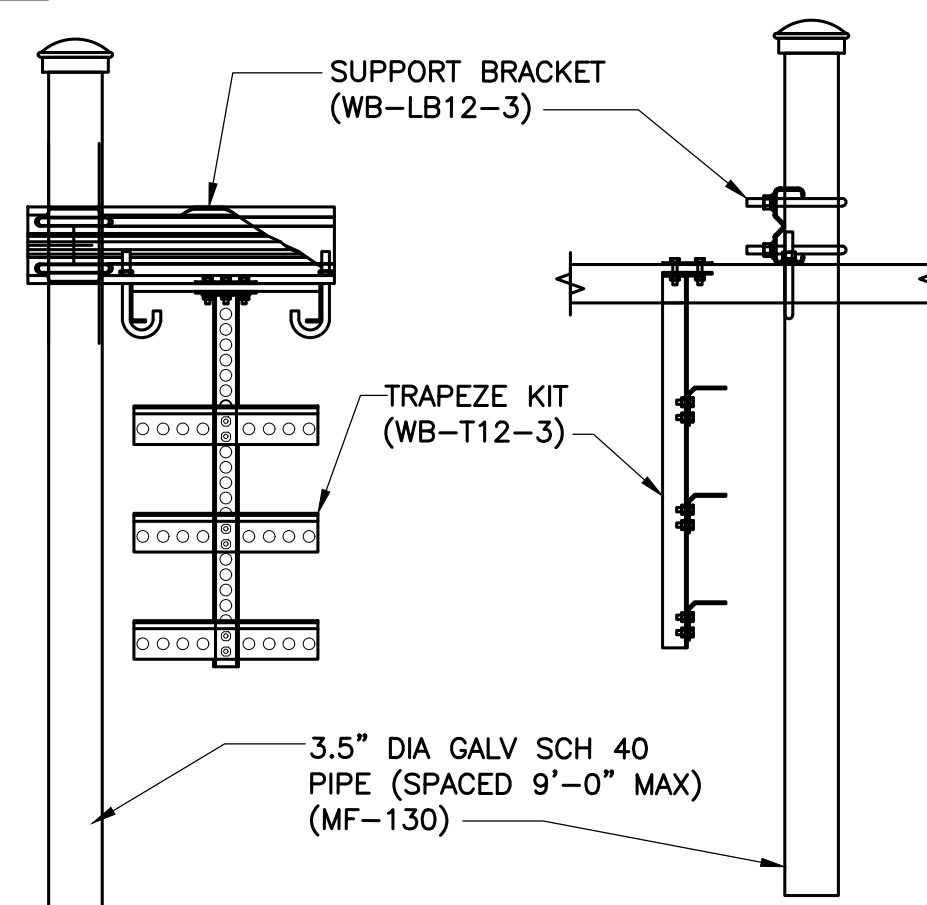

3.5" DIA GALV SCH 40 PIPE (SPACED 9'-0" MAX) (MF-130)

ICE-BRIDGE DETAIL

NO SCALE 8

NOT USED

NO SCALE 9



5701 SOUTH SANTA FE DRIVE
LITTLETON, CO 80120



CEN TEK engineering
Centered on Solutions™

(203) 488-0580
(203) 488-8587 Fax
63-2 North Branford Road
Branford, CT 06405

www.CentekEng.com

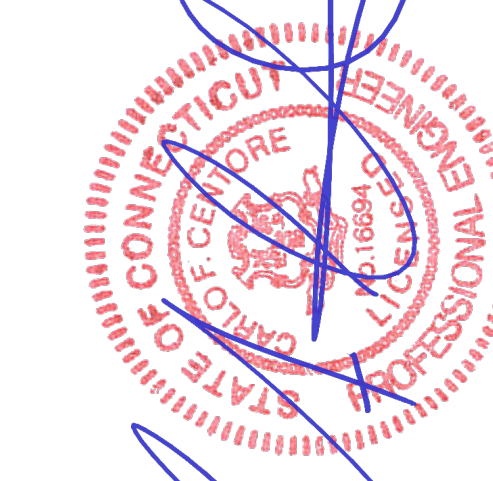

IT IS A VIOLATION OF LAW FOR ANY PERSON, UNLESS THEY ARE ACTING UNDER THE DIRECTION OF A LICENSED PROFESSIONAL ENGINEER, TO ALTER THIS DOCUMENT

DRAWN BY:	CHECKED BY:	APPROVED BY:
RTS	TJR	

RFDS REV #: 1 - 12/14/2022

CONSTRUCTION DOCUMENTS

SUBMITTALS		
REV	DATE	DESCRIPTION
A	03/29/23	ISSUED FOR CLIENT REVIEW
B	04/13/23	REVISED PER CLIENT COMMENTS
0	07/24/23	ISSUED FOR CONSTRUCTION
1	07/27/23	REVISED PER CLIENT COMMENTS
2	08/08/23	REVISED PER CLIENT COMMENTS

CEN TEK PROJECT NUMBER
23009.03

DISH Wireless L.L.C.
PROJECT INFORMATION

BOHVN00186A
0 CLARK HILL ROAD
NAUGATUCK CT, 06770

SHEET TITLE
TYPICAL EQUIPMENT
DETAILS

SHEET NUMBER

C-5

NOTES

1. CONTRACTOR SHALL FIELD VERIFY ALL PROPOSED UNDERGROUND UTILITY CONDUIT ROUTES.
2. ANTENNAS AND MOUNTS NOT SHOWN FOR CLARITY.
3. THE GROUND LEASE PROVIDES BROAD/BLANKET UTILITY RIGHTS. "PWR" AND "FBR" PATH DEPICTED ON C-2 AND E-1 ARE BASED ON BEST AVAILABLE INFORMATION INCLUDING BUT NOT LIMITED TO FIELD VERIFICATION, PRIOR PROJECT DOCUMENTATION AND OTHER REAL PROPERTY RIGHTS DOCUMENTS. WHEN INSTALLING THE UTILITIES PLEASE LOCATE AND FOLLOW EXISTING PATH. IF EXISTING PATH IS NOT AN OPTION, PLEASE NOTIFY TOWER OWNER AS FURTHER COORDINATION MAY BE NEEDED.

NOTE

CONTRACTOR IS RESPONSIBLE TO VERIFY FINAL CONDUIT ROUTING, LENGTH OF RUN, AND FEASIBILITY.

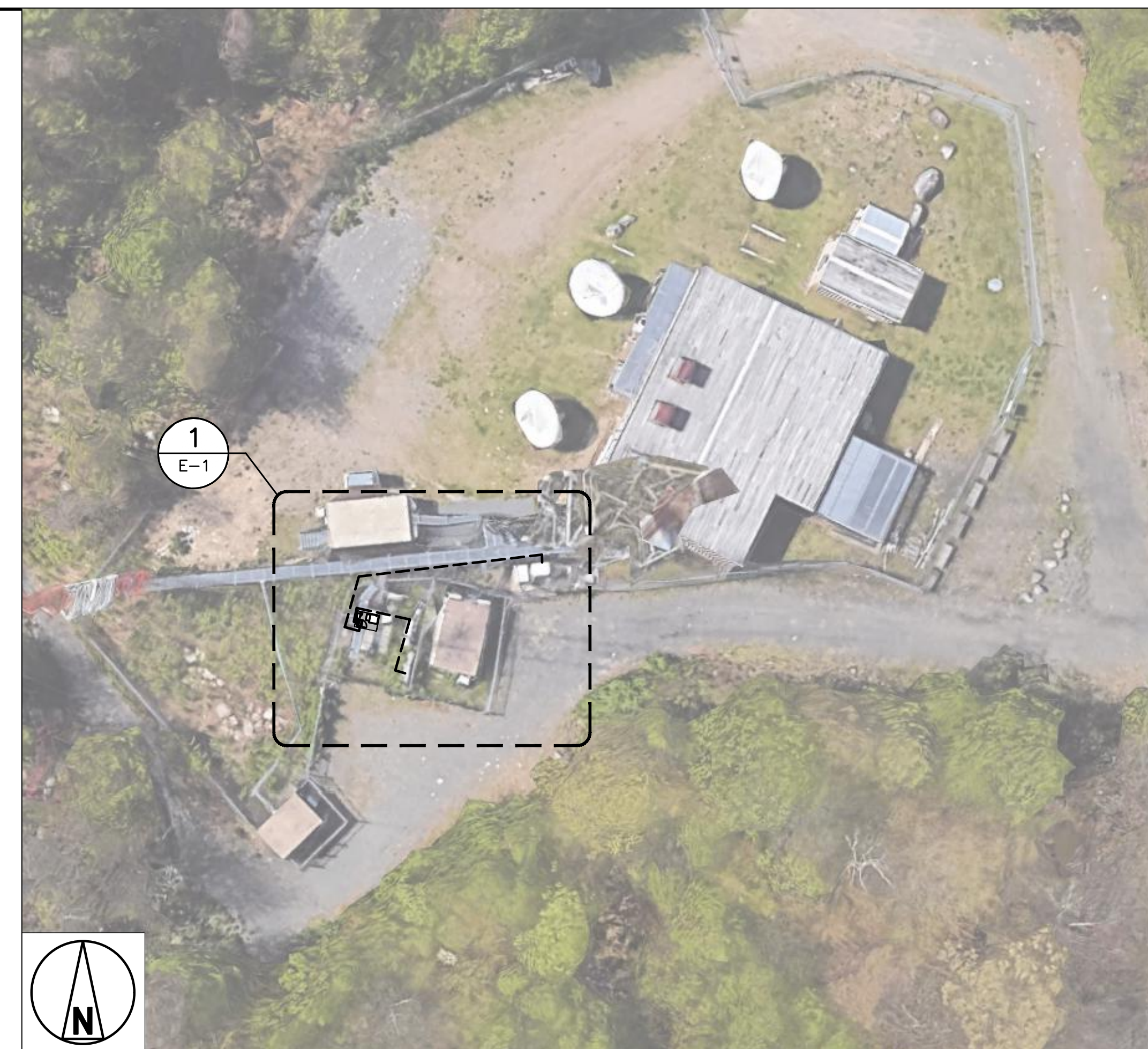

CONDUIT ROUTING AERIAL VIEW PLAN

NO SCALE

2

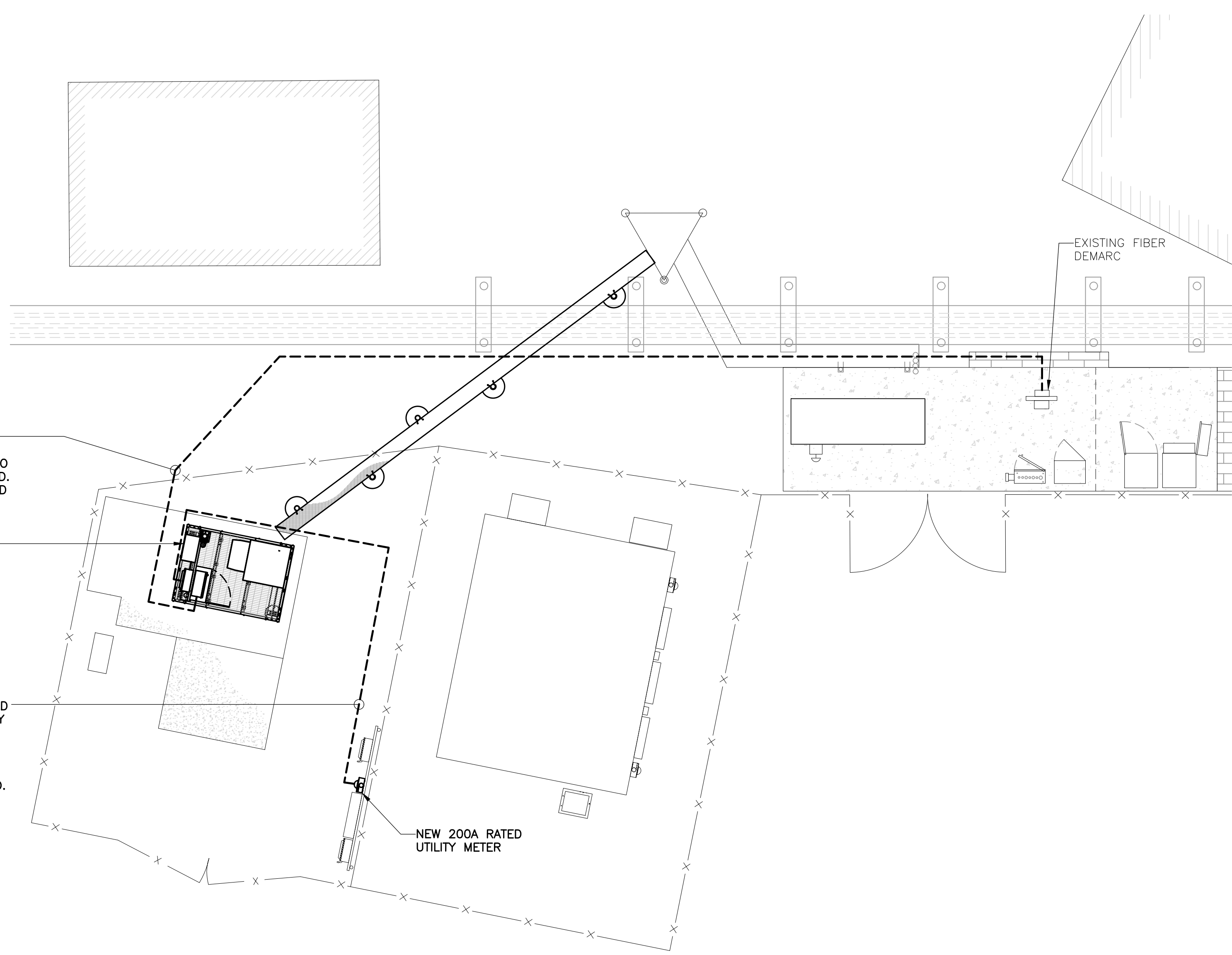

UTILITY ROUTING PLAN

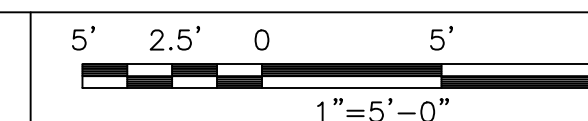

1



5701 SOUTH SANTA FE DRIVE
LITTLETON, CO 80120



CEN TEK engineering
Centered on Solutions™

(203) 488-0580
(203) 488-8587 Fax
63-2 North Branford Road
Branford, CT 06405

www.CentekEng.com



IT IS A VIOLATION OF LAW FOR ANY PERSON, UNLESS THEY ARE ACTING UNDER THE DIRECTION OF A LICENSED PROFESSIONAL ENGINEER, TO ALTER THIS DOCUMENT

DRAWN BY:	CHECKED BY:	APPROVED BY:
RTS	TJR	

RFDS REV #: 1 - 12/14/2022

CONSTRUCTION DOCUMENTS

SUBMITTALS		
REV	DATE	DESCRIPTION
A	03/29/23	ISSUED FOR CLIENT REVIEW
B	04/13/23	REVISED PER CLIENT COMMENTS
0	07/24/23	ISSUED FOR CONSTRUCTION
1	07/27/23	REVISED PER CLIENT COMMENTS
2	08/08/23	REVISED PER CLIENT COMMENTS

CEN TEK PROJECT NUMBER
23009.03

DISH Wireless L.L.C.
PROJECT INFORMATION
BOHVN00186A
0 CLARK HILL ROAD
NAUGATUCK CT, 06770

SHEET TITLE
ELECTRICAL AND FIBER
ROUTING PLAN WITH NOTES

SHEET NUMBER

E-1

DC POWER WIRING SHALL BE COLOR CODED AT EACH END FOR IDENTIFYING +24V AND -48V CONDUCTORS. RED MARKINGS SHALL IDENTIFY +24V AND BLUE MARKINGS SHALL IDENTIFY -48V.

- CONTRACTOR SHALL INSPECT THE EXISTING CONDITIONS PRIOR TO SUBMITTING A BID. ANY QUESTIONS ARISING DURING THE BID PERIOD IN REGARDS TO THE CONTRACTOR'S FUNCTIONS, THE SCOPE OF WORK, OR ANY OTHER ISSUE RELATED TO THIS PROJECT SHALL BE BROUGHT UP DURING THE BID PERIOD WITH THE PROJECT MANAGER FOR CLARIFICATION, NOT AFTER THE CONTRACT HAS BEEN AWARDED.
- ALL ELECTRICAL WORK SHALL BE DONE IN ACCORDANCE WITH CURRENT NATIONAL ELECTRICAL CODES AND ALL STATE AND LOCAL CODES, LAWS, AND ORDINANCES. PROVIDE ALL COMPONENTS AND WIRING SIZES AS REQUIRED TO MEET NEC STANDARDS.
- LOCATION OF EQUIPMENT, CONDUIT AND DEVICES SHOWN ON THE DRAWINGS ARE APPROXIMATE AND SHALL BE COORDINATED WITH FIELD CONDITIONS PRIOR TO CONSTRUCTION.
- CONDUIT ROUGH-IN SHALL BE COORDINATED WITH THE MECHANICAL EQUIPMENT TO AVOID LOCATION CONFLICTS. VERIFY WITH THE MECHANICAL EQUIPMENT CONTRACTOR AND COMPLY AS REQUIRED.
- CONTRACTOR SHALL PROVIDE ALL BREAKERS, CONDUITS AND CIRCUITS AS REQUIRED FOR A COMPLETE SYSTEM.
- CONTRACTOR SHALL PROVIDE PULL BOXES AND JUNCTION BOXES AS REQUIRED BY THE NEC ARTICLE 314.
- CONTRACTOR SHALL PROVIDE ALL STRAIN RELIEF AND CABLE SUPPORTS FOR ALL CABLE ASSEMBLIES. INSTALLATION SHALL BE IN ACCORDANCE WITH MANUFACTURER'S SPECIFICATIONS AND RECOMMENDATIONS.
- ALL DISCONNECTS AND CONTROLLING DEVICES SHALL BE PROVIDED WITH ENGRAVED PHENOLIC NAMEPLATES INDICATING EQUIPMENT CONTROLLED, BRANCH CIRCUITS INSTALLED ON, AND PANEL FIELD LOCATIONS FED FROM.
- INSTALL AN EQUIPMENT GROUNDING CONDUCTOR IN ALL CONDUITS PER THE SPECIFICATIONS AND NEC 250. THE EQUIPMENT GROUNDING CONDUCTORS SHALL BE BONDED AT ALL JUNCTION BOXES, PULL BOXES, AND ALL DISCONNECT SWITCHES, AND EQUIPMENT CABINETS.
- ALL NEW MATERIAL SHALL HAVE A U.L. LABEL.
- PANEL SCHEDULE LOADING AND CIRCUIT ARRANGEMENTS REFLECT POST-CONSTRUCTION EQUIPMENT.
- CONTRACTOR SHALL BE RESPONSIBLE FOR AS-BUILT PANEL SCHEDULE AND SITE DRAWINGS.

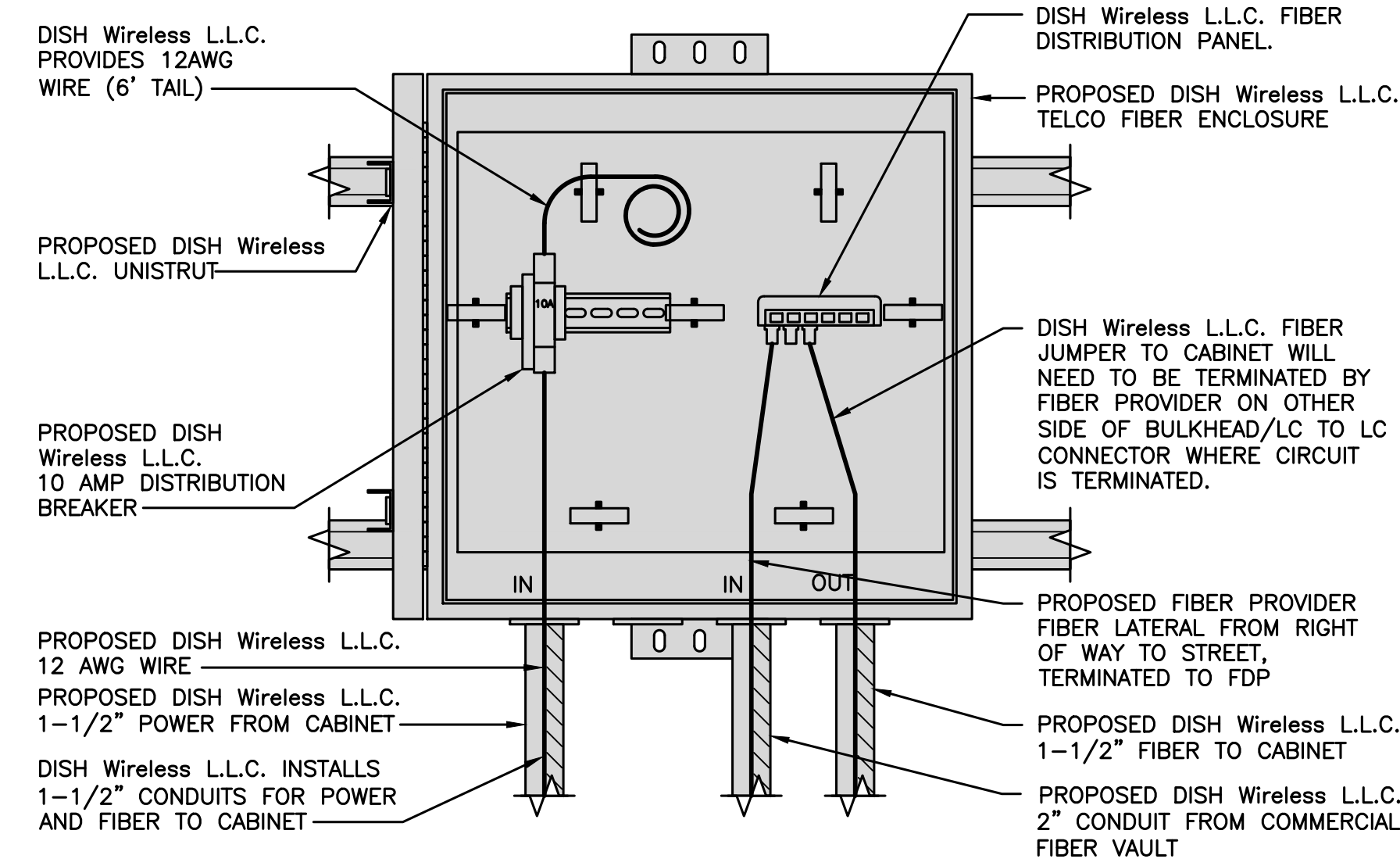

DARK TELCO BOX - INTERIOR WIRING LAYOUT

NO SCALE

2

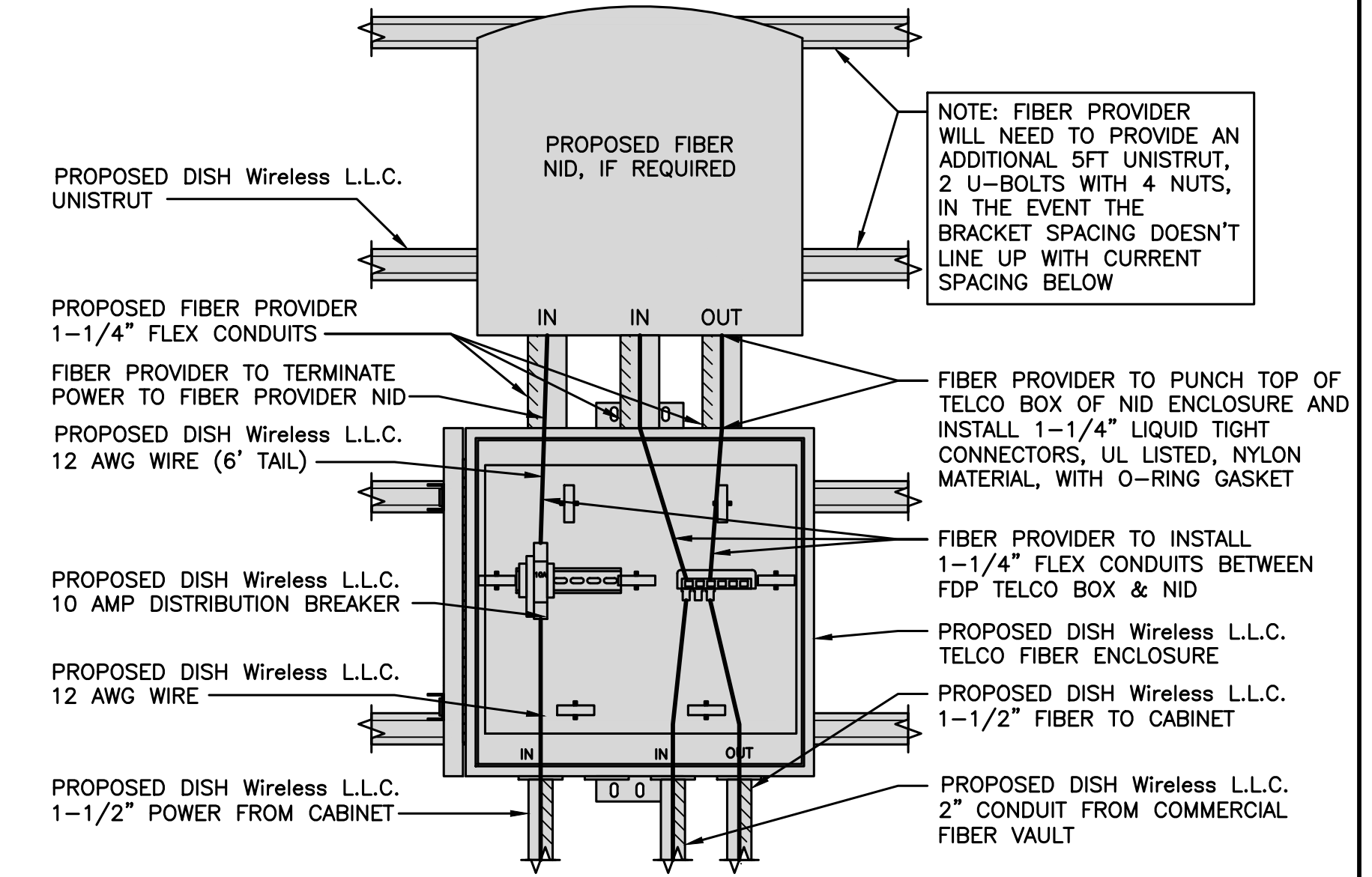

LIT TELCO BOX - INTERIOR WIRING LAYOUT (OPTIONAL)

NO SCALE

3

ELECTRICAL NOTES

NO SCALE

1

NOT USED

NO SCALE

4

NOT USED

NO SCALE

5

NOT USED

NO SCALE

6

NOT USED

NO SCALE

7

NOT USED

NO SCALE

8



5701 SOUTH SANTA FE DRIVE
LITTLETON, CO 80120



CEN TEK engineering
Centered on Solutions™

(203) 488-0580
(203) 488-8587 Fax
63-2 North Branford Road
Branford, CT 06405

www.CentekEng.com

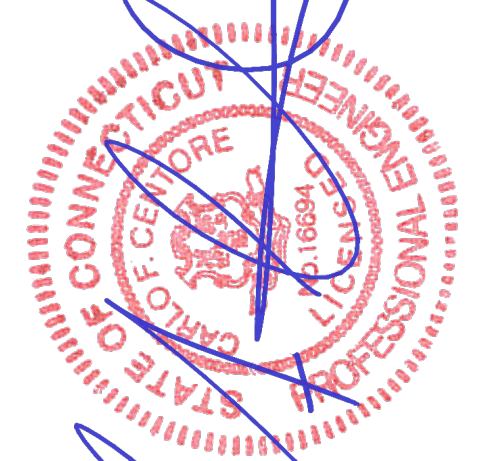

IT IS A VIOLATION OF LAW FOR ANY PERSON, UNLESS THEY ARE ACTING UNDER THE DIRECTION OF A LICENSED PROFESSIONAL ENGINEER, TO ALTER THIS DOCUMENT

DRAWN BY:	CHECKED BY:	APPROVED BY:
RTS	TJR	

RFDS REV #: 1 - 12/14/2022

CONSTRUCTION DOCUMENTS

SUBMITTALS		
REV	DATE	DESCRIPTION
A	03/29/23	ISSUED FOR CLIENT REVIEW
B	04/13/23	REVISED PER CLIENT COMMENTS
0	07/24/23	ISSUED FOR CONSTRUCTION
1	07/27/23	REVISED PER CLIENT COMMENTS
2	08/08/23	REVISED PER CLIENT COMMENTS

CEN TEK PROJECT NUMBER
23009.03

DISH Wireless L.L.C.
PROJECT INFORMATION
BOHVN00186A
0 CLARK HILL ROAD
NAUGATUCK CT, 06770

SHEET TITLE
TELCO CABINET
DETAILS

SHEET NUMBER

E-2

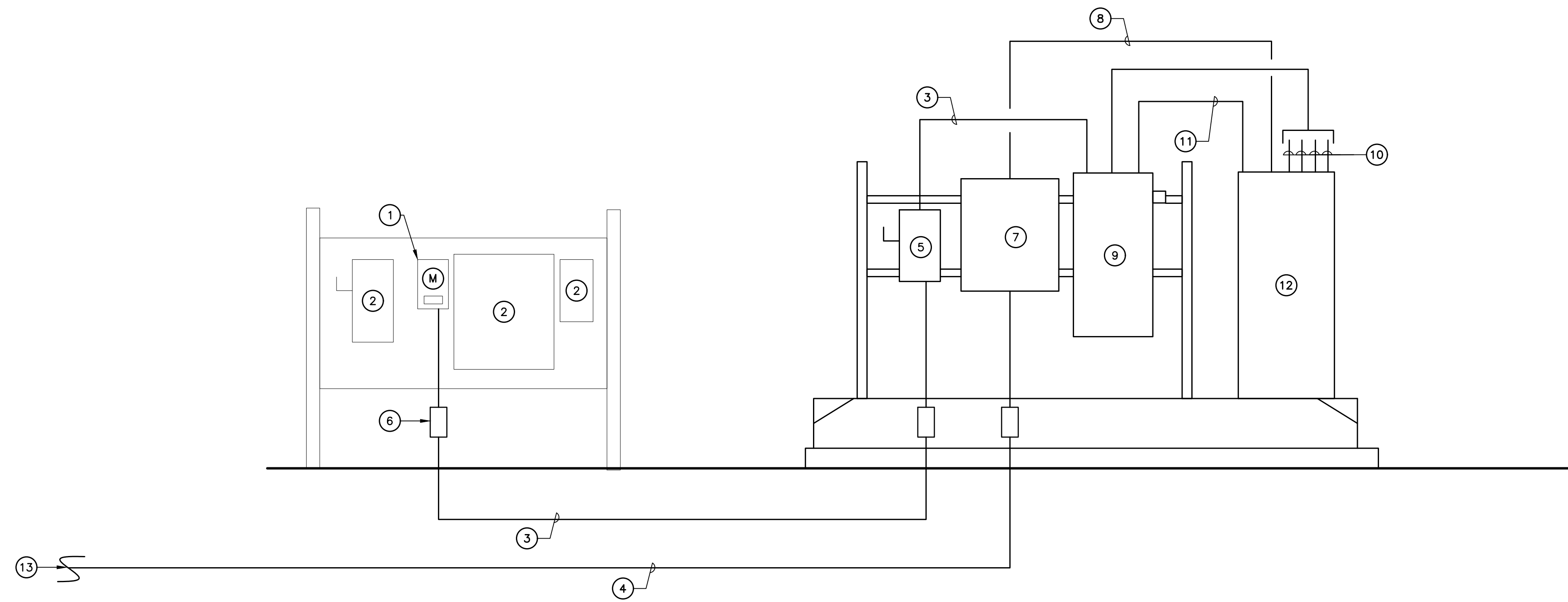

- ### RISER NOTES
- ① EXISTING UTILITY METER SOCKET WITH NEW 200A, SINGLE PHASE, 240V RATED UTILITY METER. ALL EQUIPMENT TO BE UTILITY APPROVED.
 - ② EXISTING EQUIPMENT TO REMAIN.
 - ③ (3) 3/0 AWG, (1) #6 AWG GROUND, 2" CONDUIT. CONTRACTOR MAY REUSE EXISTING CONDUITS AND CONDUCTOR PROVIDED THEY ARE IN PROPER WORKING CONDITION AND MEET THIS PROJECTS REQUIREMENTS. CONTRACTOR TO VERIFY AND REPORT ALL DEFICIENCIES TO ENGINEER OF RECORD.
 - ④ (1) 4" CONDUIT WITH PULL ROPES FOR TELEPHONE COMPANY CONDUCTORS. CONDUCTORS PROVIDED BY TELEPHONE COMPANY FROM EXISTING DEMARC TO EQUIPMENT PLATFORM. PROVIDE ALL COUPLINGS, ADAPTERS, SWEEPS, AND ASSOCIATED HARDWARE. MATERIAL SHALL BE PER TELEPHONE COMPANY SPECIFICATIONS.
 - ⑤ NEW HEAVY DUTY NEMA-3R, 200A/240V, NON FUSED DISCONNECT.
 - ⑥ EXPANSION COUPLING TYP.
 - ⑦ NEW DISH Wireless L.L.C. TELCO/FIBER CABINET.
 - ⑧ CONDUITS AND CONDUCTORS FOR TELCO CONNECTION TO EQUIPMENT CABINET AS REQUIRED BY MANUFACTURER AND CONSTRUCTION MANAGER FOR PROPER OPERATION OF EQUIPMENT
 - ⑨ NEW 120/240V, 200A/2P, SINGLE PHASE PPC CABINET.
 - ⑩ 4 SETS OF (3) #10 AWG, (1) #10 AWG GROUND, 3/4" CONDUIT.
 - ⑪ (1) #12 AWG, (1) #10 AWG GROUND, 3/4" CONDUIT. FOR CONVENIENCE OUTLET
 - ⑫ NEW DISH Wireless L.L.C. EQUIPMENT CABINET.
 - ⑬ EXISTING FIBER DEMARC. CONTRACTOR TO VERIFY LOCATION IN FIELD.

ELECTRICAL RISER DIAGRAM

NO SCALE 1

VOLTAGE:		120/240		PHASE:	1	WIRE:	3	PANEL NO.	MDP			
MAIN BUS:		200		AMPS			TOTAL WATTS, L1	11,700				
MAIN BREAKER:		200		A FRAME	200	A TRIP	TOTAL WATTS, L2	11,700	LOC:	EQUIPMENT FRAME		
MOUNTING:		SURFACE				TOTAL WATTS	23,400					
NOTES:												
A) PPC SHALL BE 200A, 120/240V, SINGLE PHASE, 3W, 65 KAIC, 200A MCB, 24 POSITION, NEMA 3R ENCLOSURE, LAMINATED ENGRAVED BAKELITE NAMEPLATE, COPPER EQUIPMENT GROUND KIT, INSULATED COPPER SOLID NEUTRAL BAR.												
B) BRANCH CIRCUIT BREAKER AND CONDUCTOR SIZE BASED ON SPECIFIC EQUIPMENT. CONFIRM ELECTRICAL REQUIREMENTS PRIOR TO INSTALLATION.												
DIRECTORY	WIRE & CONDUIT	WATTS LOAD		CKT.	AMPS	L1	L2	AMPS	CKT.	WATTS LOAD		DIRECTORY
RECTIFIER #1	3/4" C, 2 #10, #10GND	2,880	2,880	1	30/2P			20	2	180	3/4" C, 2 #12, #12GND	CONVENIENCE GFCI OUTLET
RECTIFIER #2	3/4" C, 2 #10, #10GND	2,880	2,880	3	30/2P			20	4	180	3/4" C, 2 #12, #12GND	PPC GFCI OUTLET
RECTIFIER #3	3/4" C, 2 #10, #10GND	2,880	2,880	5	30/2P			8	6	-	-	SPACE
RECTIFIER #4	3/4" C, 2 #10, #10GND	2,880	2,880	7	30/2P			8	8	-	-	SPACE
SPACE	-	2,880	2,880	9	30/2P			10	10	-	-	SPACE
SPACE	-	2,880	2,880	11	30/2P			12	12	-	-	SPACE
SPACE	-	2,880	2,880	13	30/2P			14	14	-	-	SPACE
SPACE	-	2,880	2,880	15	30/2P			16	16	-	-	SPACE
SPACE	-	-	-	17	-			18	18	-	-	SPACE
SPACE	-	-	-	19	-			20	20	-	-	SPACE
SPACE	-	-	-	21	-			22	22	-	-	SPACE
SPACE	-	-	-	23	-			24	24	-	-	SPACE

ELECTRICAL PANEL SCHEDULE

NO SCALE 2

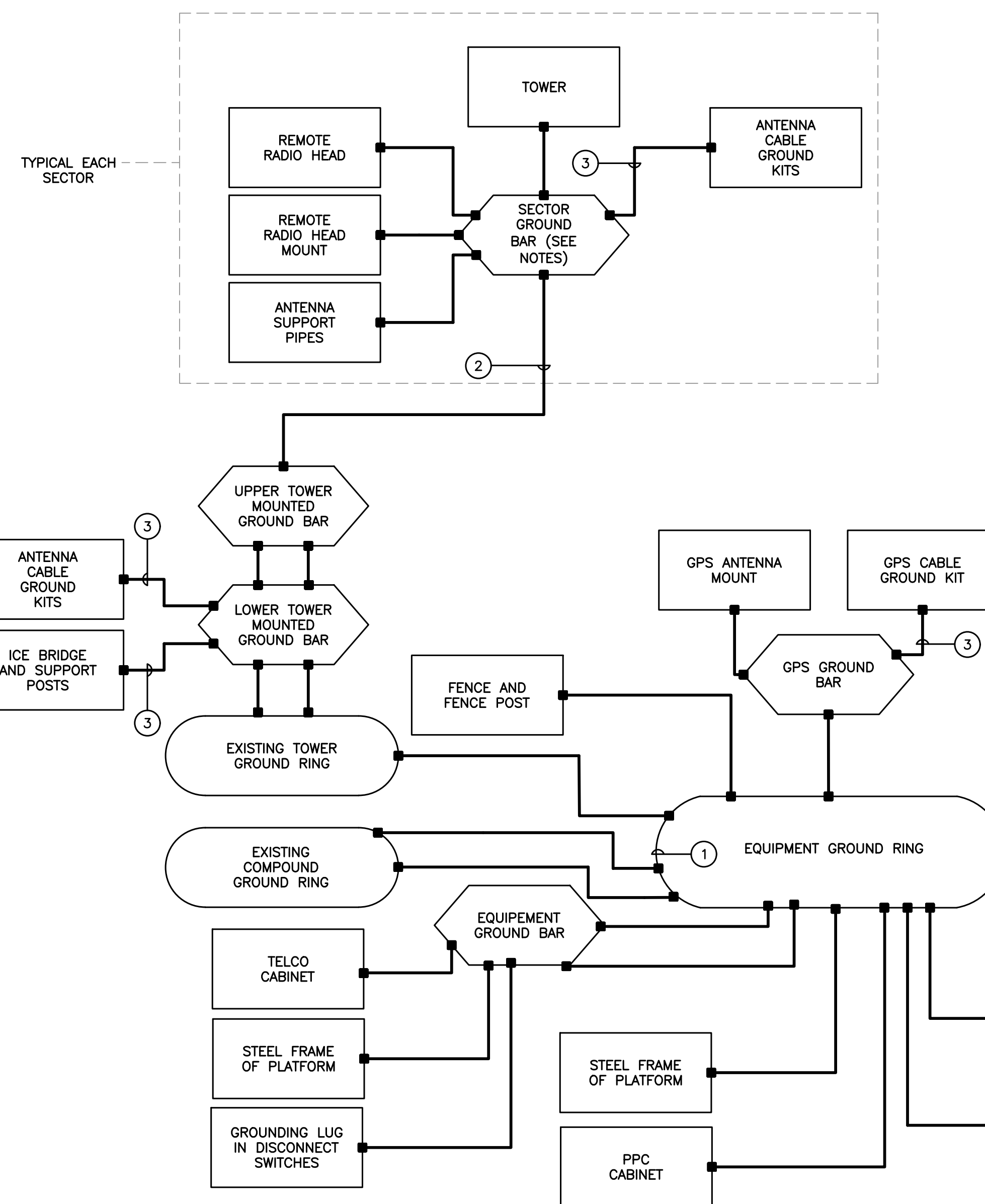

- ### GROUNDING SCHEMATIC NOTES
- ① GROUND RING, #2 AWG BCW
 - ② #2/0 GREEN INSULATED
 - ③ #6 AWG
- GENERAL NOTES:
1. ALL SURGE SUPPRESSION EQUIPMENT SHALL BE BONDED TO GROUND PER MANUFACTURER'S SPECIFICATIONS
 2. UNLESS OTHERWISE NOTED OR REQUIRED BY CODE, GROUND CONDUCTORS SHOWN SHALL BE #2 AWG (SOLID TINNED BCW - EXTERIOR; STRANDED GREEN INSULATED - INTERIOR).
 3. BOND CABLE TRAY AND ICE BRIDGE SECTIONS TOGETHER WITH #6 AWG STRANDED GREEN INSULATED JUMPERS.
 4. ALL SECTOR GROUND BARS SHALL BE BONDED TOGETHER WITH #2 AWG SOLID TINNED BCW.
 5. BOND ALL EQUIPMENT CABINETS AND BATTERY CABINETS TO GROUND PER MANUFACTURER'S SPECIFICATIONS.
 6. ALL BONDS TO TOWER SHALL BE MADE IN STRICT ACCORDANCE WITH SPECIFICATIONS OF TOWER MANUFACTURER OR STRUCTURAL ENGINEER.
 7. REFER TO GROUNDING PLAN FOR LOCATION OF GROUNDING DEVICES.
 8. REFER TO ALL ELECTRICAL AND GROUNDING DETAILS.
 9. COORDINATE ALL TOWER MOUNTED EQUIPMENT WITH OWNER.
 10. ALL TOWER MOUNTED AMPLIFIERS AND ASSOCIATED EQUIPMENT SHALL BE BONDED TO THE SECTOR GROUND BAR PER MANUFACTURER'S SPECIFICATIONS.
 11. ALL GROUNDING SHALL BE IN ACCORDANCE WITH NEC AND OWNER'S REQUIREMENTS.
 12. COORDINATE WITH TOWER OWNER BEFORE INSTALLING ANY GROUNDING ELEMENTS ON TOWER OR BONDING TO EXISTING TOWER GROUND RING.

ELECTRICAL SCHEMATIC DIAGRAM

NO SCALE 3



5701 SOUTH SANTA FE DRIVE
LITTLETON, CO 80120



CEN TEK engineering
Centered on Solutions™

(203) 488-0580
(203) 488-8587 Fax
63-2 North Branford Road
Branford, CT 06405

www.CentekEng.com

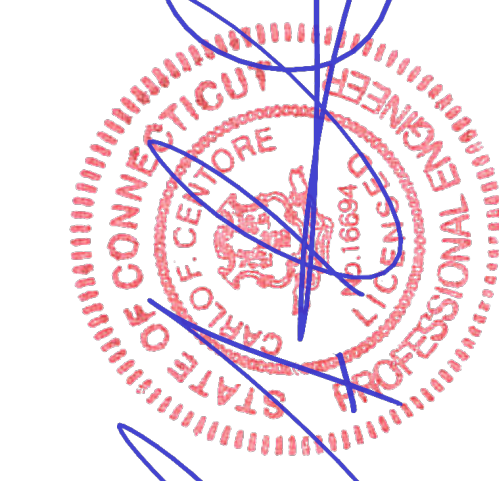

IT IS A VIOLATION OF LAW FOR ANY PERSON, UNLESS THEY ARE ACTING UNDER THE DIRECTION OF A LICENSED PROFESSIONAL ENGINEER, TO ALTER THIS DOCUMENT

DRAWN BY:	CHECKED BY:	APPROVED BY:
RTS	TJR	

RFDS REV #: 1 - 12/14/2022

CONSTRUCTION DOCUMENTS

SUBMITTALS

REV	DATE	DESCRIPTION
A	03/29/23	ISSUED FOR CLIENT REVIEW
B	04/13/23	REVISED PER CLIENT COMMENTS
0	07/24/23	ISSUED FOR CONSTRUCTION
1	07/27/23	REVISED PER CLIENT COMMENTS
2	08/08/23	REVISED PER CLIENT COMMENTS

CEN TEK PROJECT NUMBER
23009.03

DISH Wireless L.L.C.
PROJECT INFORMATION

BOHVN00186A
0 CLARK HILL ROAD
NAUGATUCK CT, 06770

SHEET TITLE
ELECTRICAL RISER, PANEL
SCHEDULE, AND SCHEMATIC

SHEET NUMBER

E-3



IT IS A VIOLATION OF LAW FOR ANY PERSON, UNLESS THEY ARE ACTING UNDER THE DIRECTION OF A LICENSED PROFESSIONAL ENGINEER, TO ALTER THIS DOCUMENT

DRAWN BY:	CHECKED BY:	APPROVED BY:
RTS	TJR	

RFDS REV #: 1 - 12/14/2022

CONSTRUCTION DOCUMENTS

SUBMITTALS		
REV	DATE	DESCRIPTION
A	03/29/23	ISSUED FOR CLIENT REVIEW
B	04/13/23	REVISED PER CLIENT COMMENTS
0	07/24/23	ISSUED FOR CONSTRUCTION
1	07/27/23	REVISED PER CLIENT COMMENTS
2	08/08/23	REVISED PER CLIENT COMMENTS

CEN TEK PROJECT NUMBER
23009.03

DISH Wireless L.L.C.
PROJECT INFORMATION
BOHVN00186A
0 CLARK HILL ROAD
NAUGATUCK CT, 06770

SHEET TITLE
COMPOUND/ANTENNA
GROUNDING PLAN AND NOTES

SHEET NUMBER

G-1

GROUNDING PLAN NOTES:

- ① LOWER TOWER MOUNTED GROUND BAR.
- ② UPPER TOWER MOUNTED GROUND BAR.
- ③ BOND LOWER TOWER MOUNTED GROUND BAR TO UPPER TOWER MOUNTED GROUND BAR TYP. 2 LEADS.
- ④ BOND LOWER TOWER MOUNTED GROUND TO TOWER STEEL.
- ⑤ BOND LOWER TOWER MOUNTED GROUND BAR TO ICE-BRIDGE POST.
- ⑥ CONNECT LOWER TOWER MOUNTED GROUND BAR TO TOWER GROUND RING TYP. 2 LEADS.
- ⑦ BOND EQUIPMENT GROUND RING TO TOWER GROUND RING.
- ⑧ ICE BRIDGE POST AND COVER. BOND EACH SECTION AND SUPPORT TO GROUND RING.
- ⑨ #2 SOLID TINNED BCW GROUND RING (2'-0" FROM OUTSIDE EDGE OF EQUIPMENT PLATFORM FOUNDATION WHEN ROUTED ALONG PLATFORM PERIMETER.) (TYP.).
- ⑩ GROUNDING ROD WITH ACCESS (TYP.).
- ⑪ GROUNDING ROD (TYP.).
- ⑫ MAIN EQUIPMENT GROUND BAR.
- ⑬ BOND MAIN GROUND BAR TO GROUND RING.
- ⑭ CONNECT FENCE TO GROUNDING RING (TYP. EACH POST WITHIN 6' OF GROUND RING).
- ⑮ BOND EQUIPMENT CABINETS TO GROUND RING PER NEC AND MANUFACTURER REQUIREMENTS
- ⑯ BOND EQUIPMENT TO GROUND BAR PER NEC AND MANUFACTURER REQUIREMENTS
- ⑰ BOND GROUND BAR TO EQUIPMENT PLATFORM STEEL TYP.
- ⑱ BOND EQUIPMENT PLATFORM TO GROUND RING TYP. EACH CORNER
- ⑲ CONNECT UPPER TOWER MOUNTED GROUND BAR TO SECTOR GROUND BAR TYP.
- ⑳ SECTOR GROUND BAR TYP.
- ㉑ BOND SECTOR GROUND BAR TO STEEL ANTENNA FRAME.
- ㉒ BOND ANTENNA AND ANTENNA APPURTENANCES MOUNTING PIPES TO SECTOR GROUND BAR. (TYPICAL).
- ㉓ ALL SECTOR GROUND BARS SHALL BE BONDED TOGETHER WITH #2 AWG SOLID TINNED BCW.
- ㉔ CONNECT EQUIPMENT GROUND RING TO EXISTING COMPOUND GROUND RING. CONTRACTOR TO VERIFY LOCATION COMPOUND GROUND RING IN FIELD

GROUNDING PLAN NOTES

NO SCALE

2

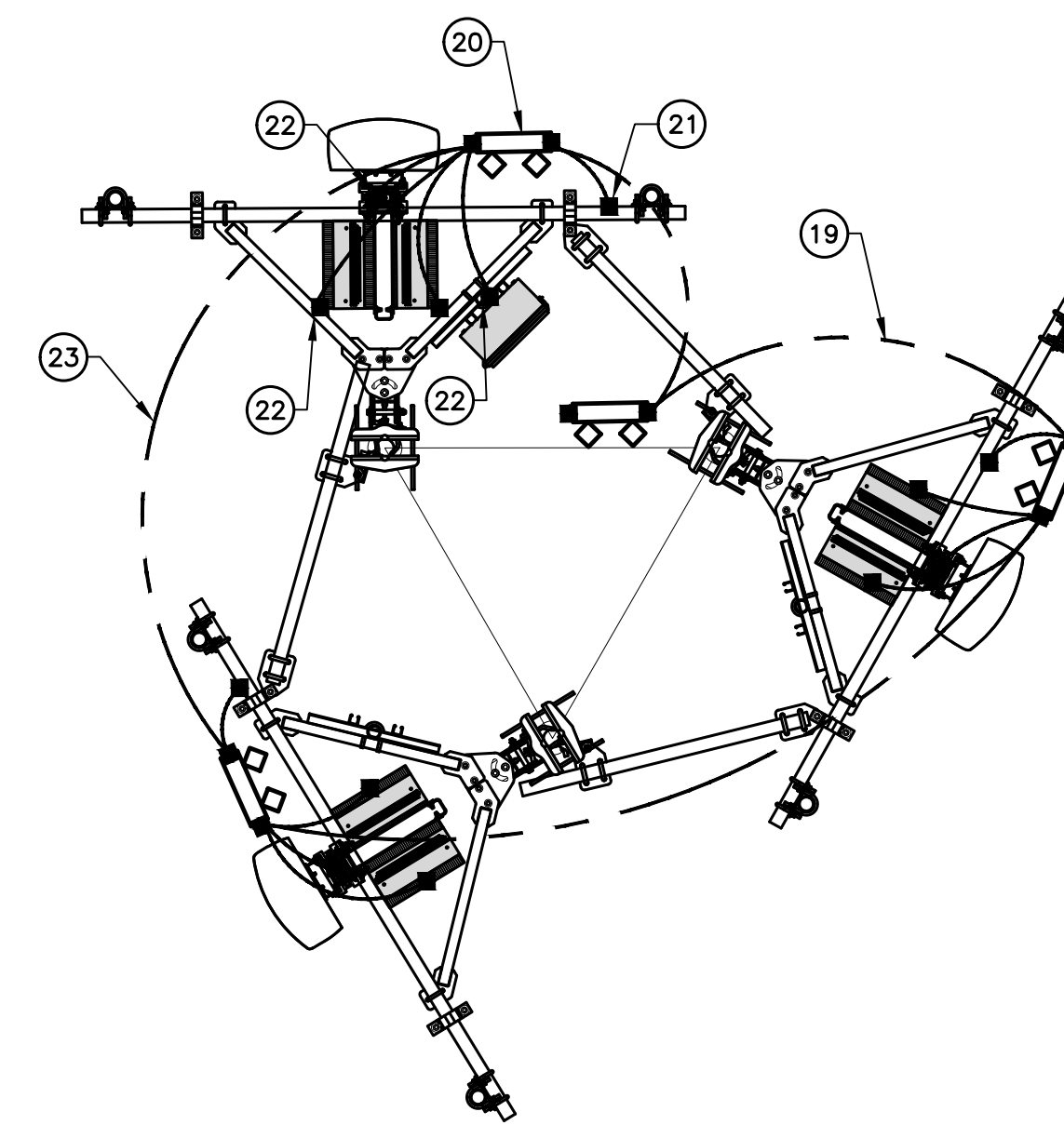

ANTENNA GROUNDING PLAN

NO SCALE

3

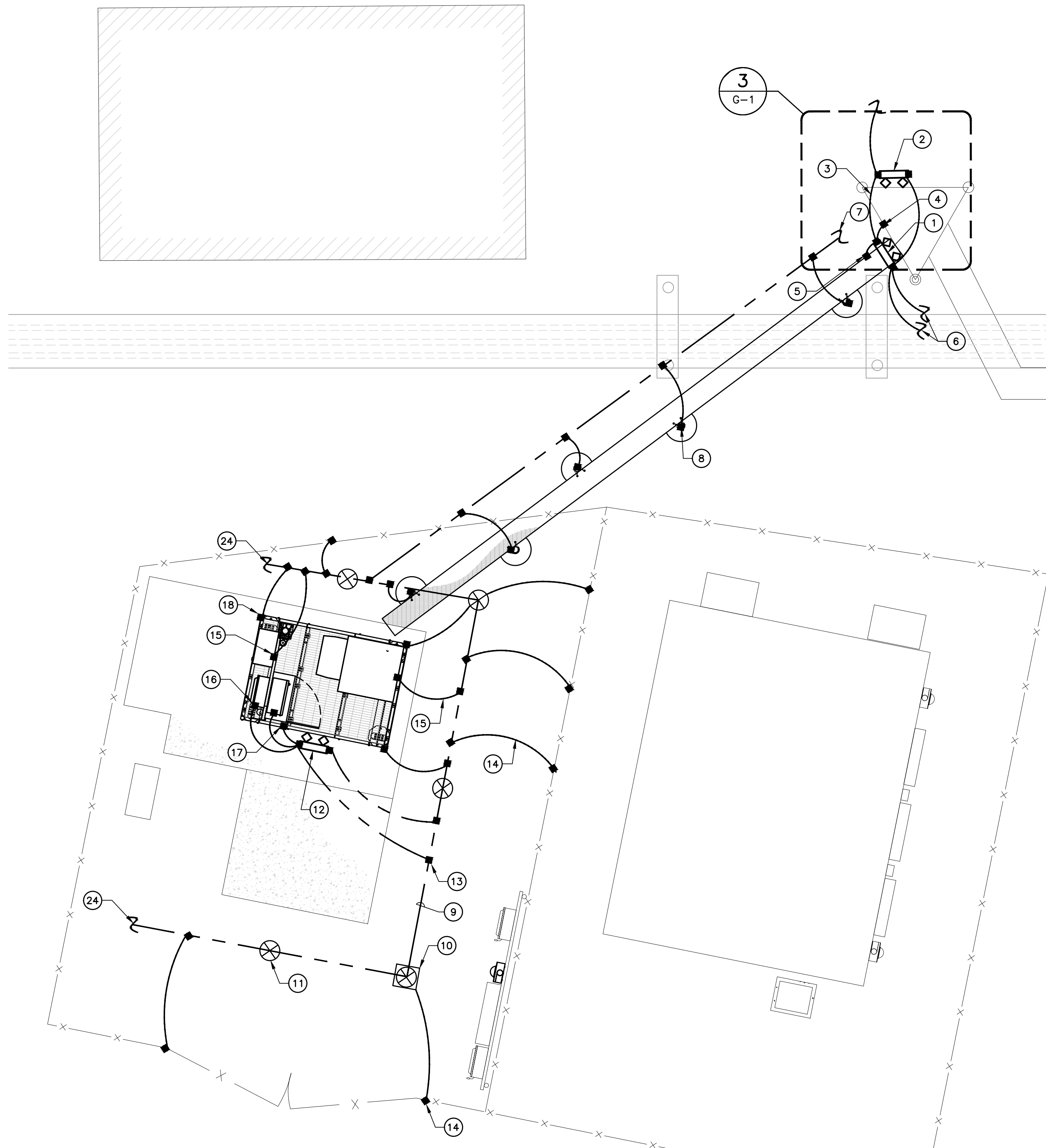

COMPOUND GROUNDING PLAN

NO SCALE

1

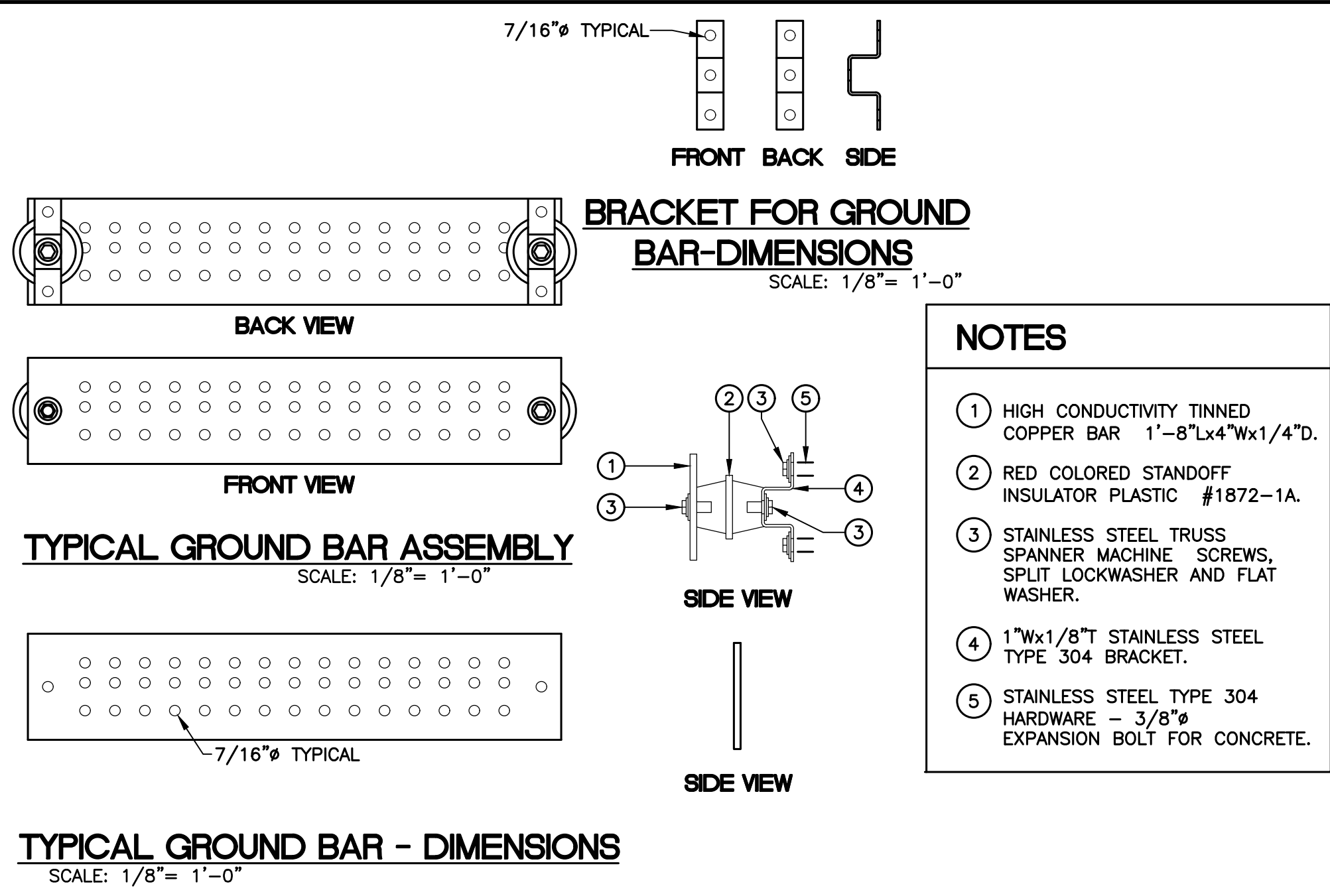

- NOTES**
- HIGH CONDUCTIVITY TINNED COPPER BAR 1'-8"Lx4"Wx1/4"D.
 - RED COLORED STANDOFF INSULATOR PLASTIC #1872-1A.
 - STAINLESS STEEL TRUSS SPANNER MACHINE SCREWS, SPLIT LOCKWASHER AND FLAT WASHER.
 - 1"Wx1/8" STAINLESS STEEL TYPE 304 BRACKET.
 - STAINLESS STEEL TYPE 304 HARDWARE - 3/8" EXPANSION BOLT FOR CONCRETE.

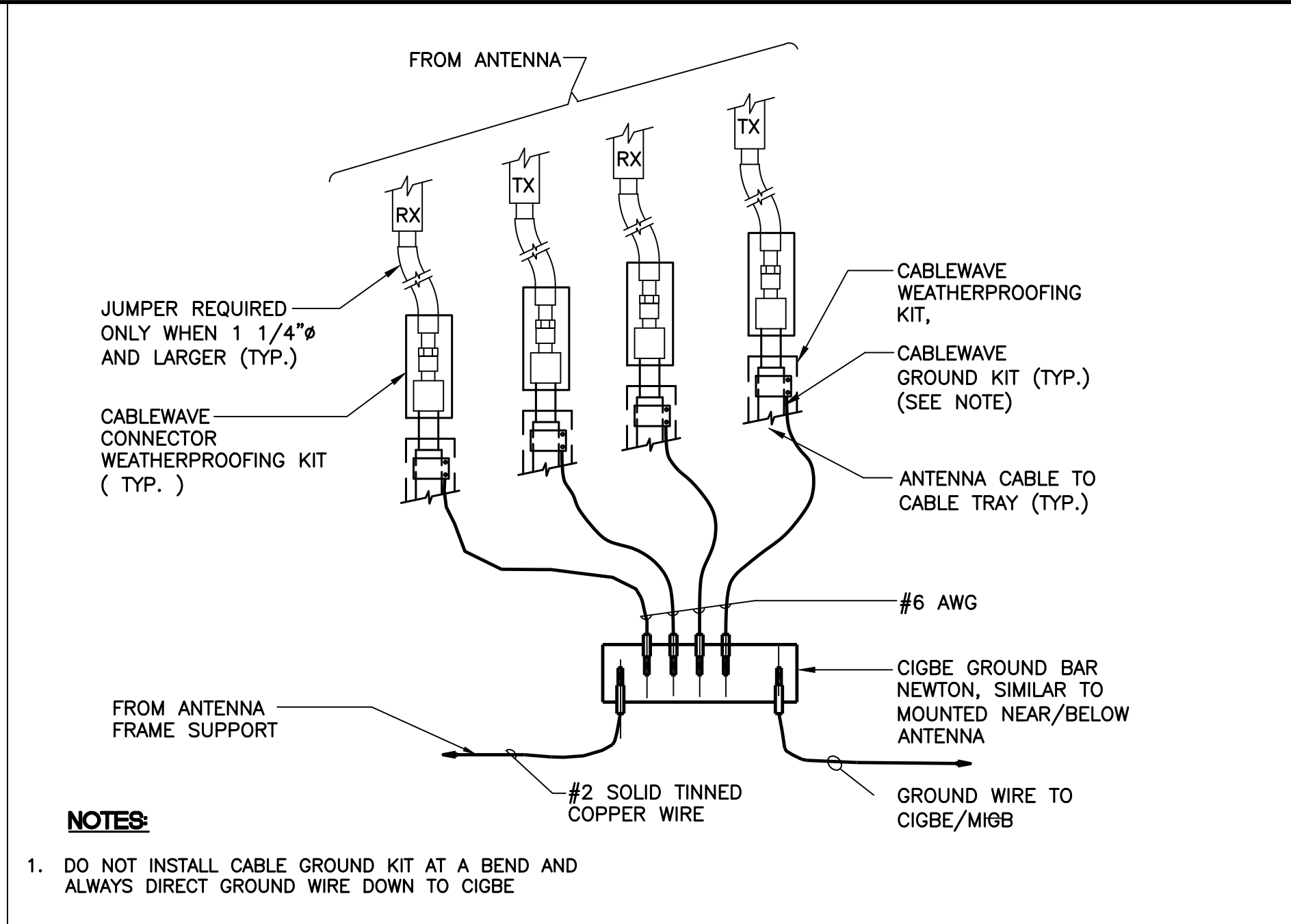

- NOTES:**
- DO NOT INSTALL CABLE GROUND KIT AT A BEND AND ALWAYS DIRECT GROUND WIRE DOWN TO CIGBE

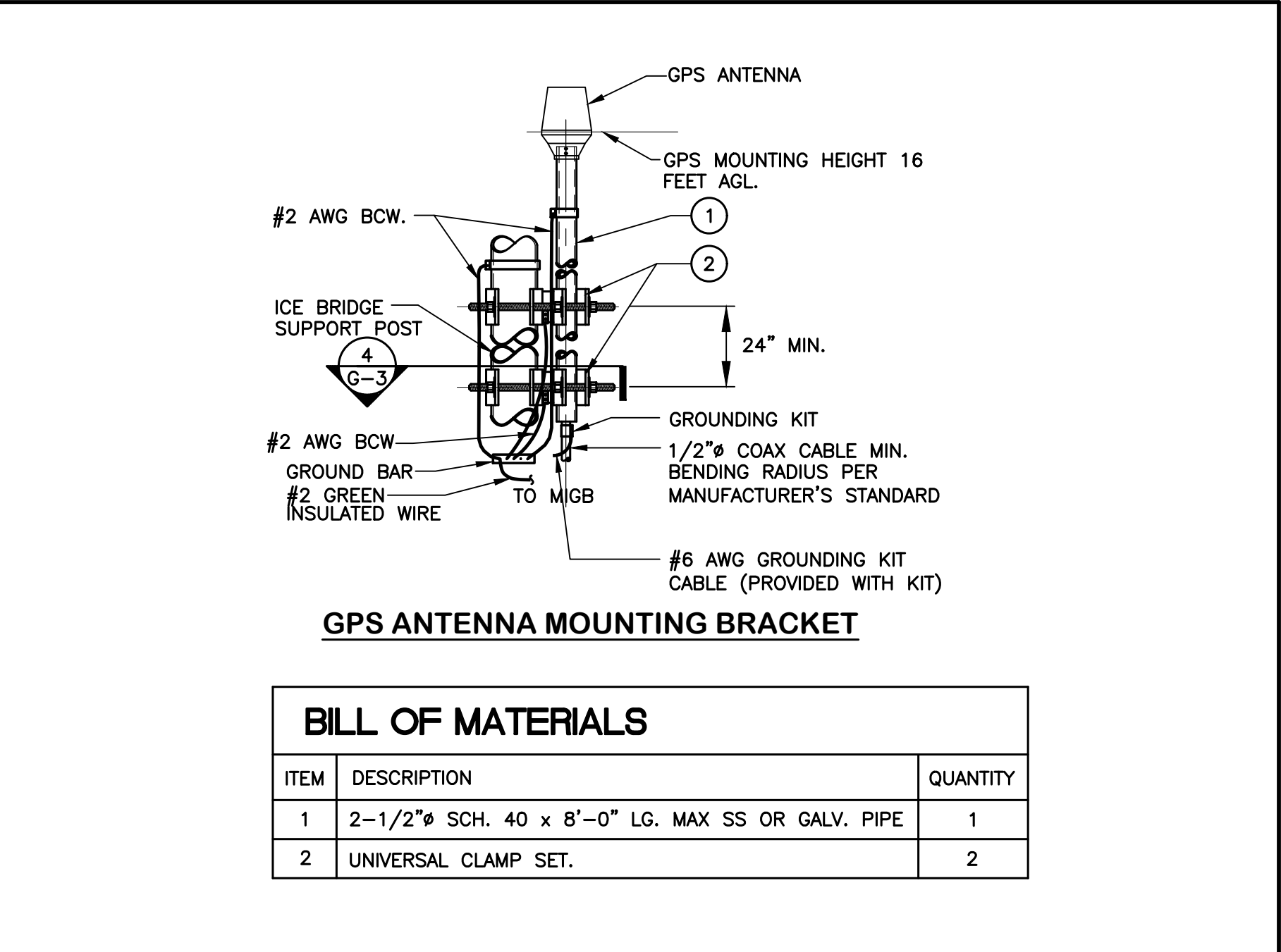

GPS GROUNDING/MOUNTING BRACKET DETAIL
NO SCALE

MASTER/EQUIPMENT GROUND BAR DETAIL
NO SCALE

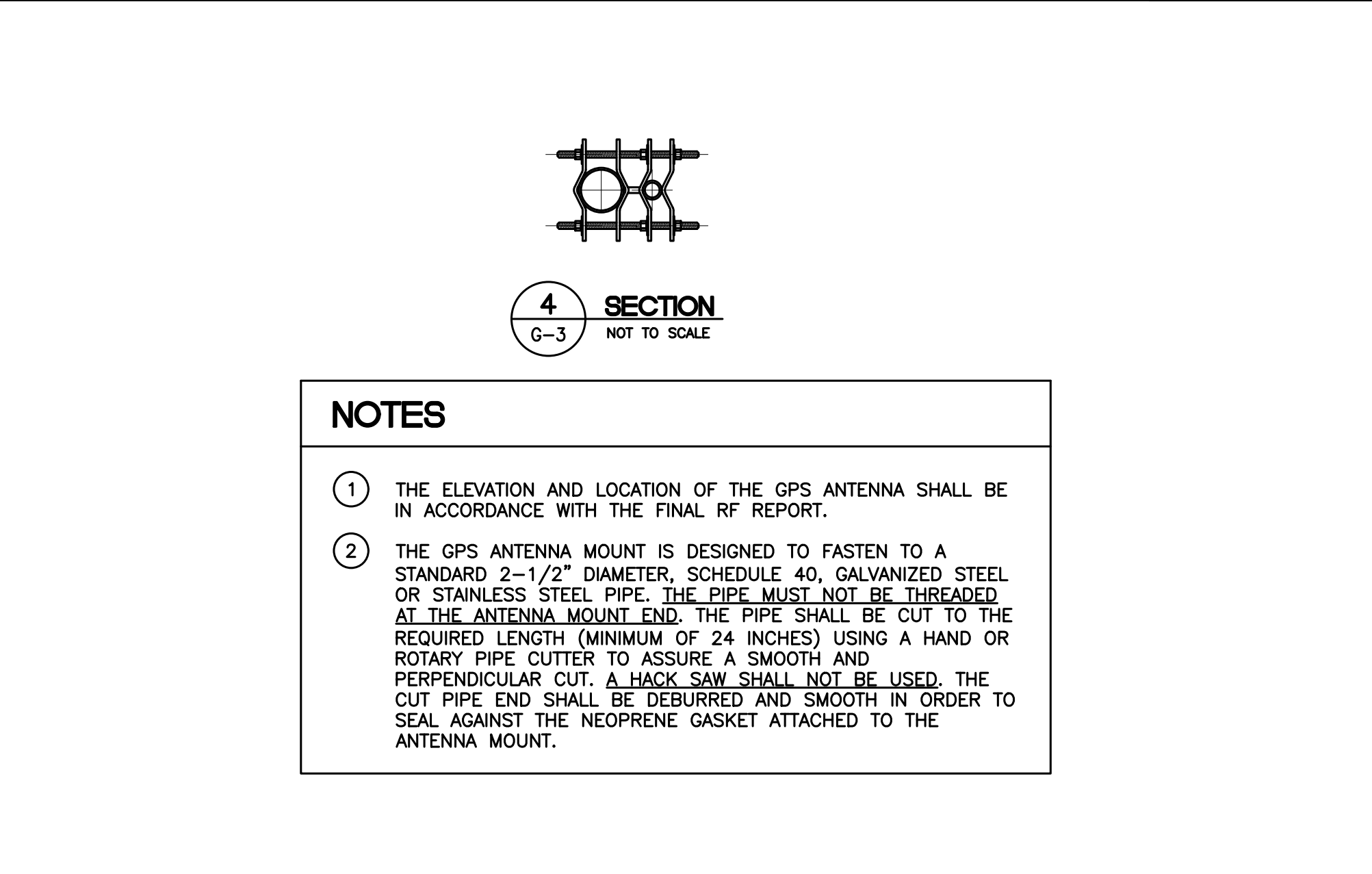

CONNECTION OF GROUND WIRES TO GROUND BAR
NO SCALE

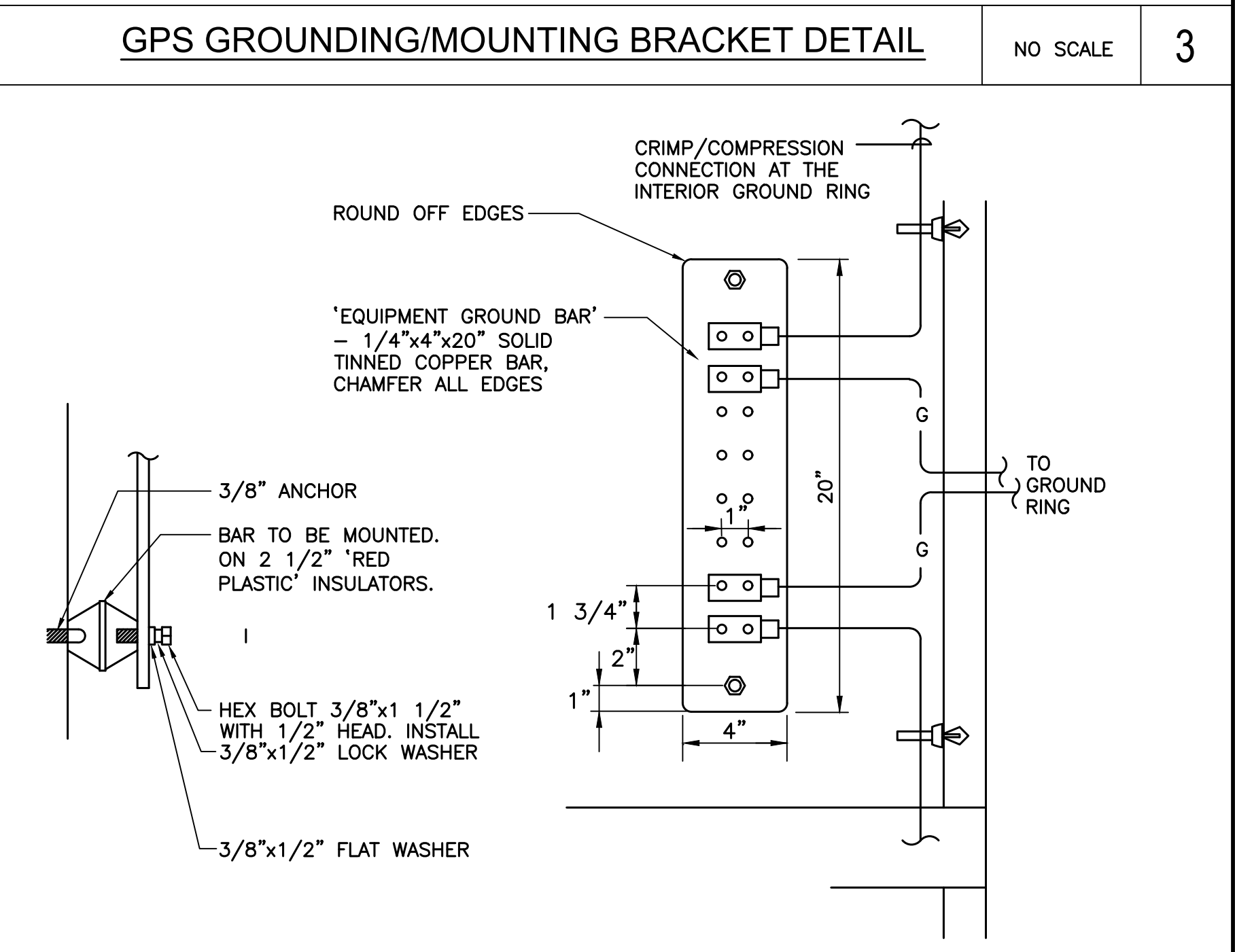
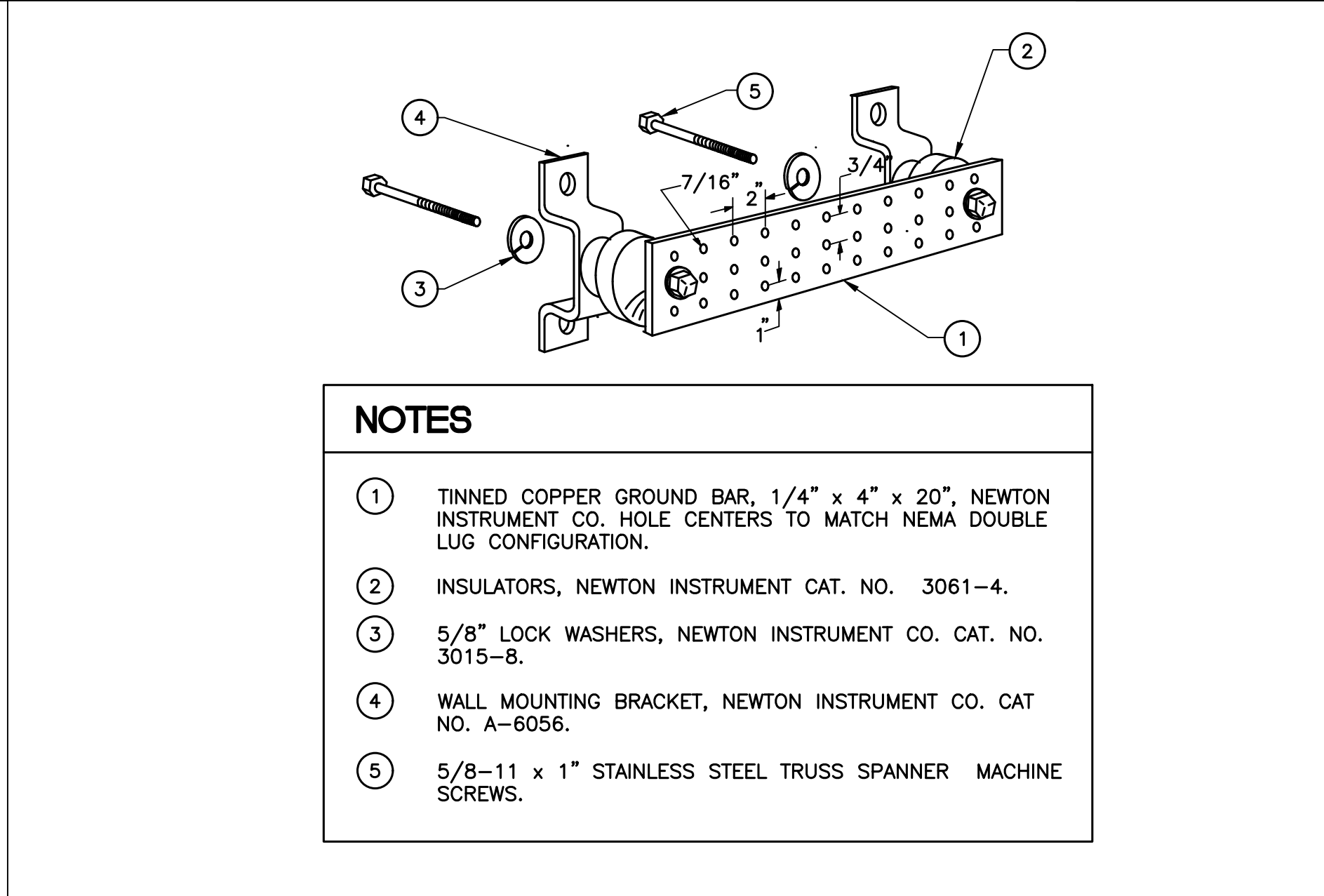

GPS GROUNDING/MOUNTING BRACKET DETAIL
NO SCALE

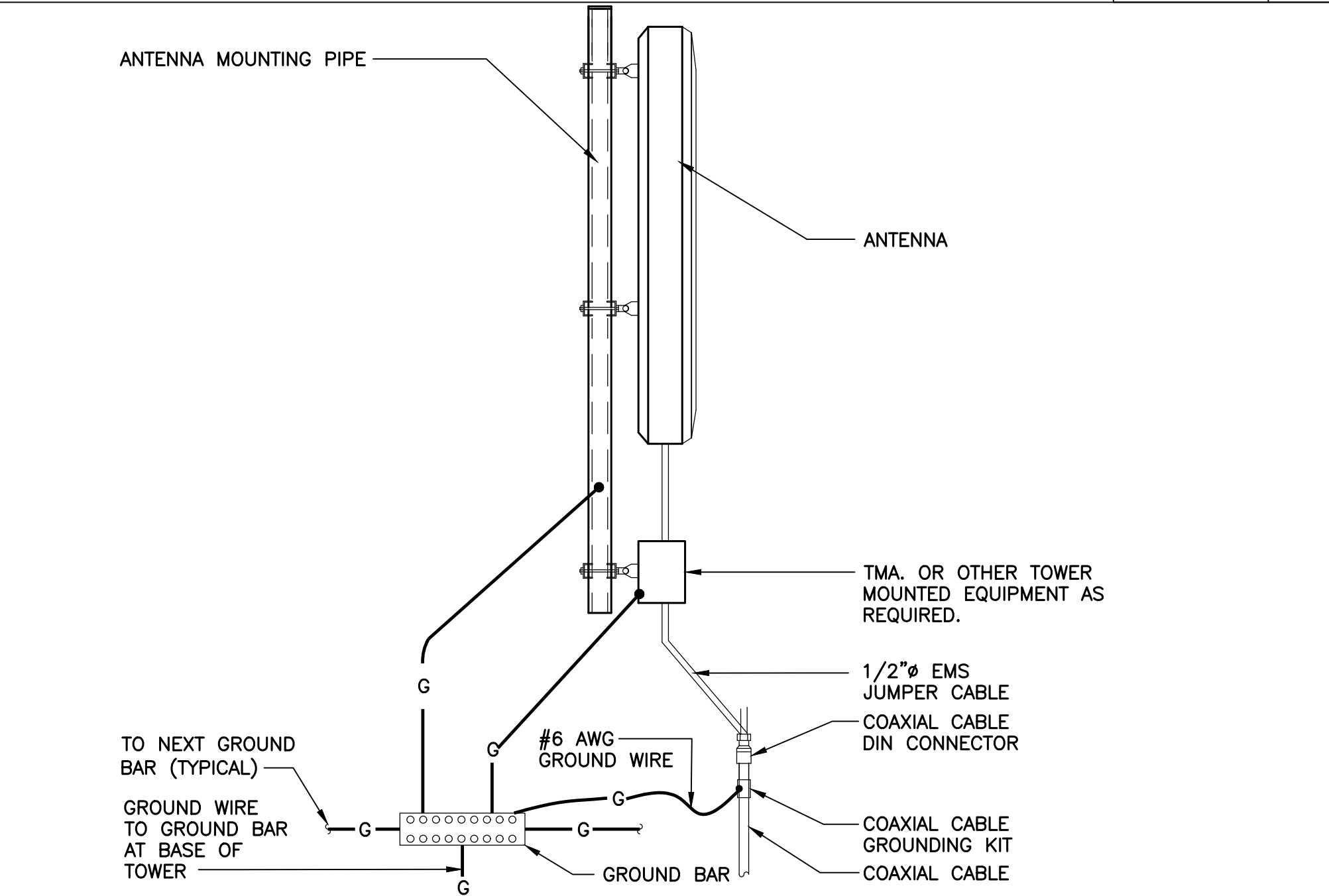

GROUND BAR DETAIL
NO SCALE

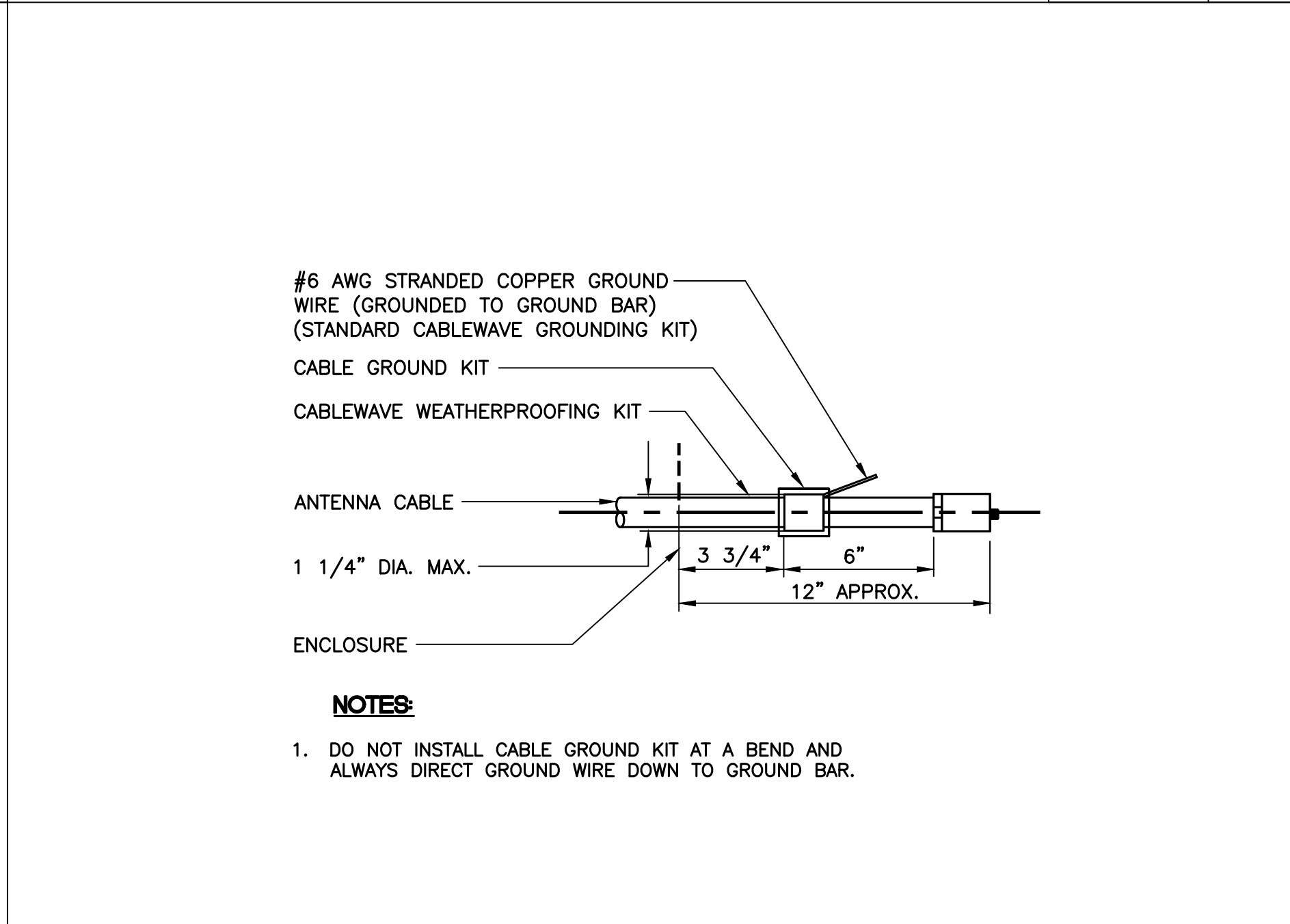

EQUIPMENT GROUND BAR DETAIL
NO SCALE

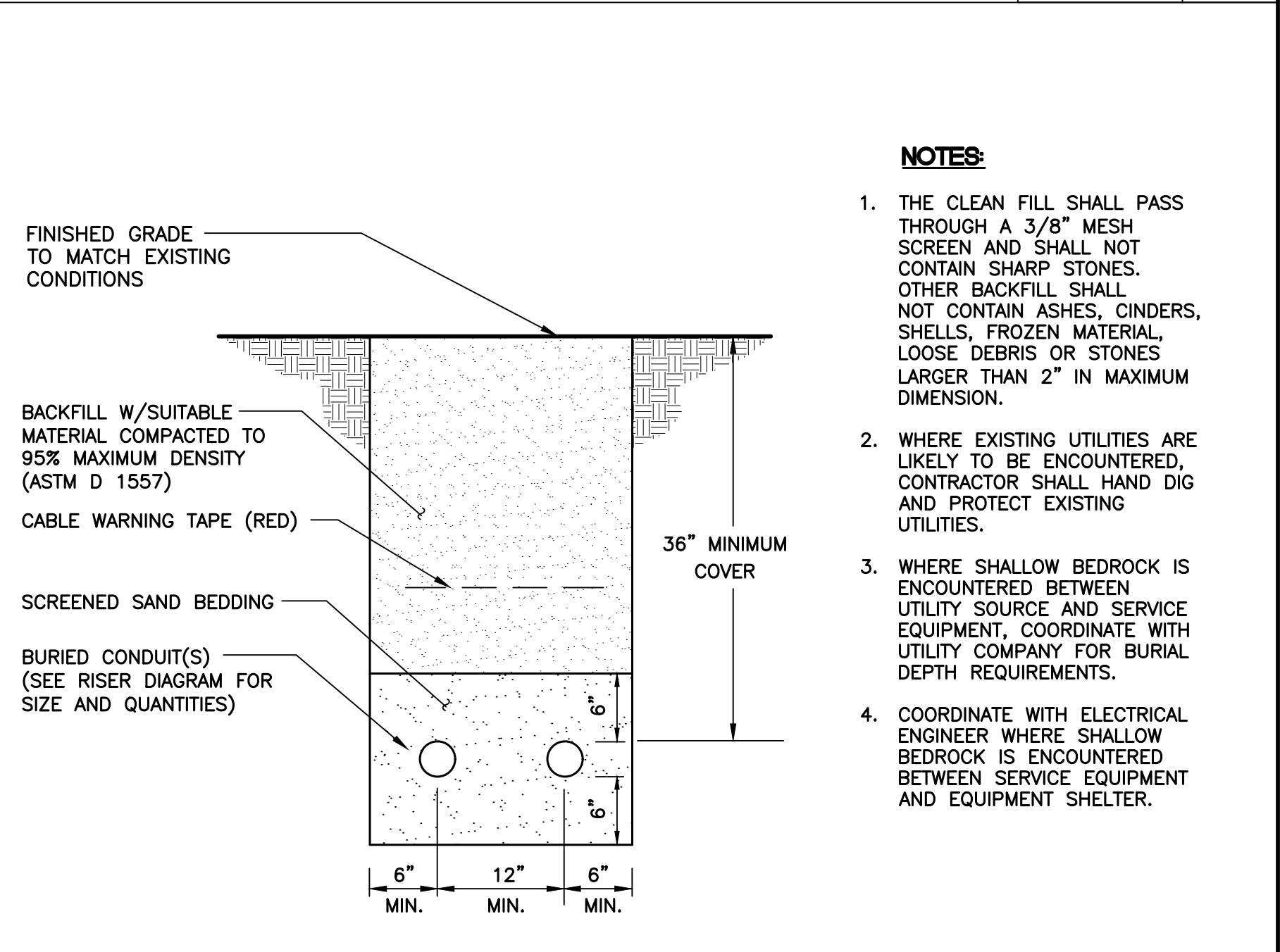

TYPICAL ANTENNA GROUNDING DETAIL
NO SCALE

ANTENNA CABLE GROUNDING DETAIL
NO SCALE

TYPICAL ELECTRICAL TRENCH DETAIL
NO SCALE

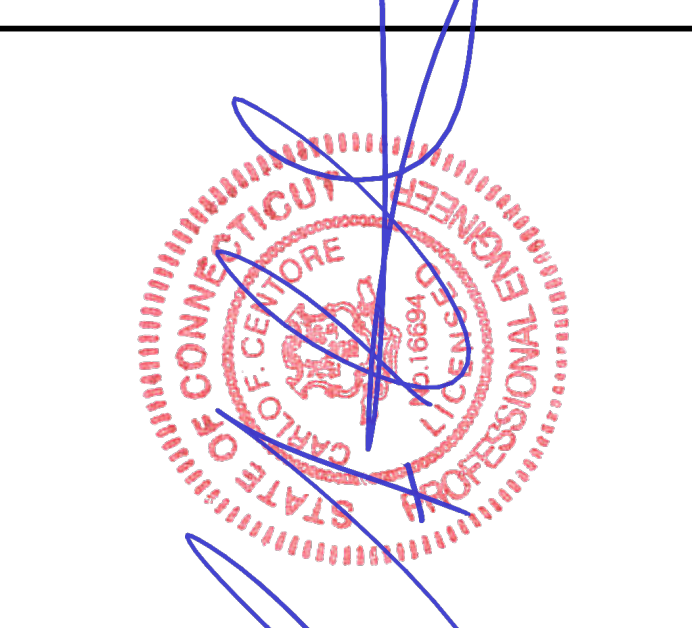

IT IS A VIOLATION OF LAW FOR ANY PERSON, UNLESS THEY ARE ACTING UNDER THE DIRECTION OF A LICENSED PROFESSIONAL ENGINEER, TO ALTER THIS DOCUMENT

DRAWN BY:	CHECKED BY:	APPROVED BY:
RTS	TJR	

RFDS REV #: 1 - 12/14/2022

CONSTRUCTION DOCUMENTS

SUBMITTALS

REV	DATE	DESCRIPTION
A	03/29/23	ISSUED FOR CLIENT REVIEW
B	04/13/23	REVISED PER CLIENT COMMENTS
0	07/24/23	ISSUED FOR CONSTRUCTION
1	07/27/23	REVISED PER CLIENT COMMENTS
2	08/08/23	REVISED PER CLIENT COMMENTS

CEN TEK PROJECT NUMBER
23009.03

DISH Wireless L.L.C.
PROJECT INFORMATION
BOHVN00186A
0 CLARK HILL ROAD
NAUGATUCK CT, 06770

SHEET TITLE
TYPICAL GROUNDING
DETAILS
SHEET NUMBER

G-2

NOTES:

1. USE GROUND PLATE DETAIL IF 10 FT. GROUND ROD DEPTH CANNOT BE ACHIEVED DUE TO LEDGE CONDITION OR IF EXISTING TOWER FOUNDATION IS ENCOUNTERED.

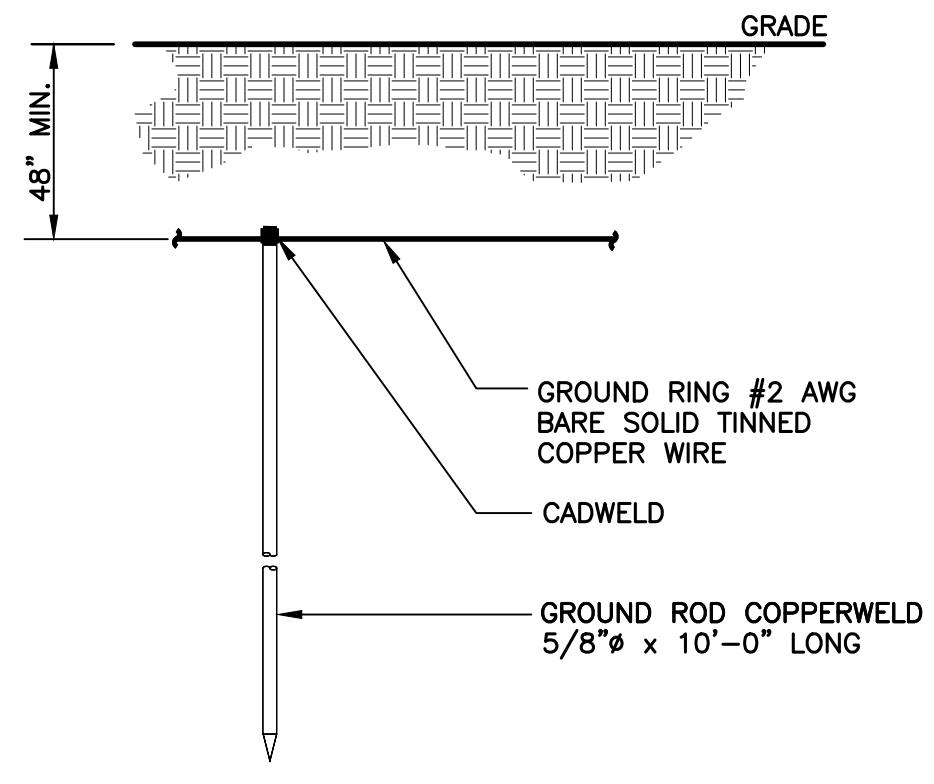

GROUND ROD DETAIL

NO SCALE 1

NOTES:

1. INSPECTION HAND HOLE MAY BE CONCRETE OR PVC AND SHALL BE A MINIMUM OF 12" DIA x 18" DEEP.

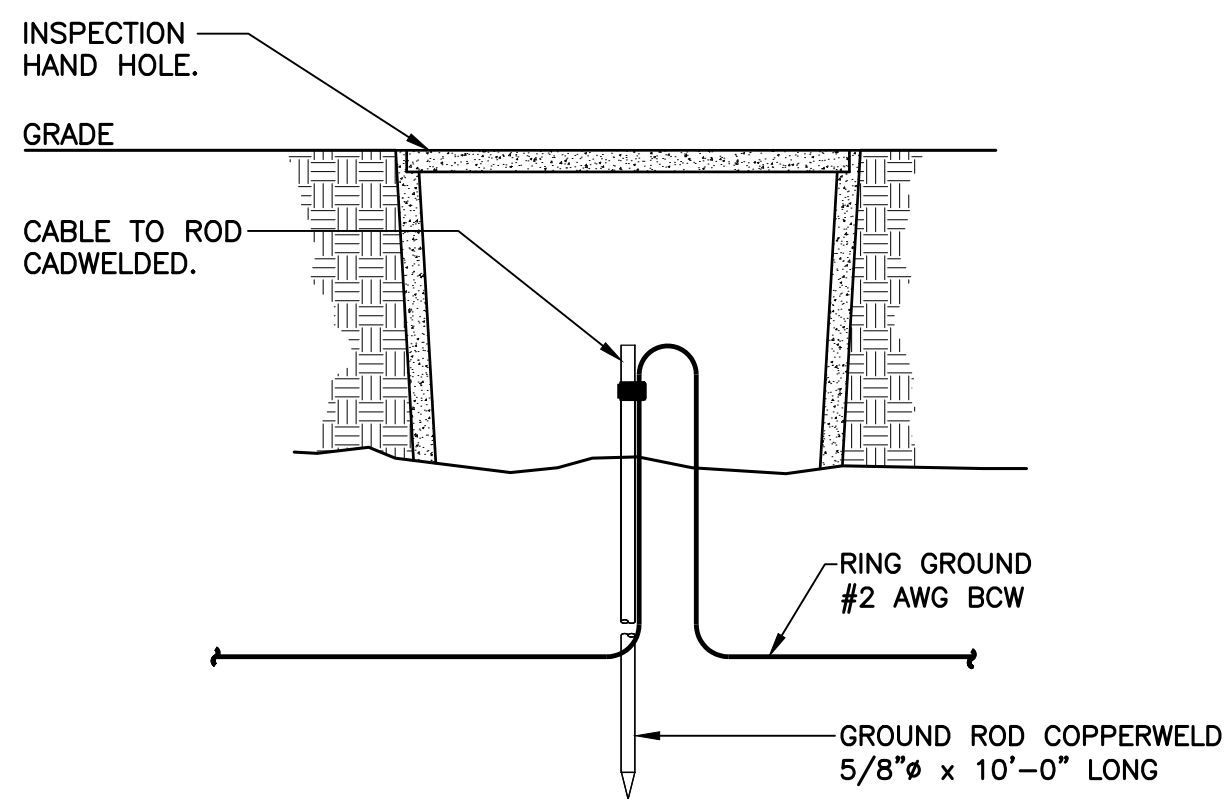

GROUND ROD WITH ACCESS DETAIL

NO SCALE 2

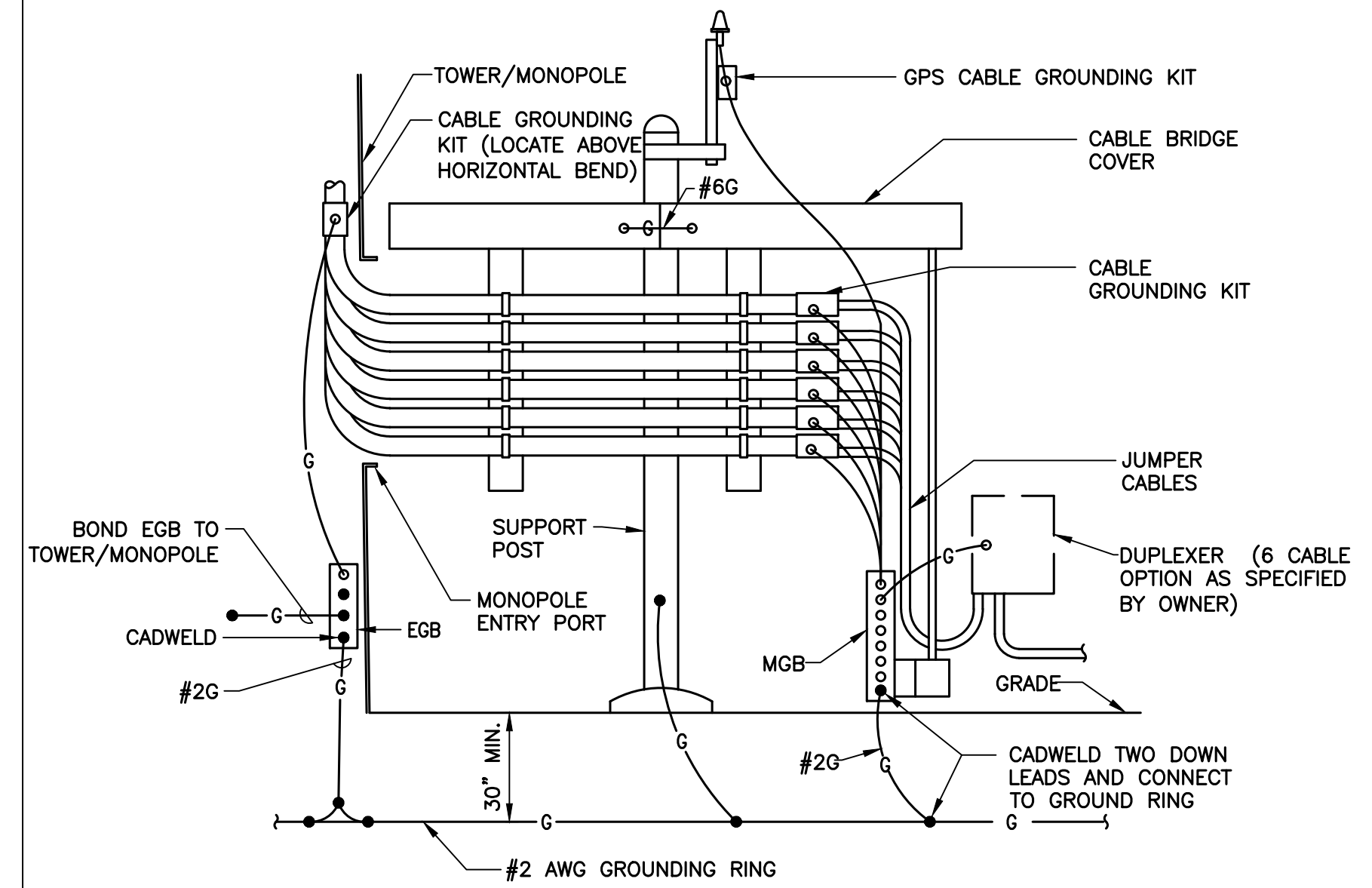

ICE-BRIDGE GROUNDING DETAIL

NO SCALE 3

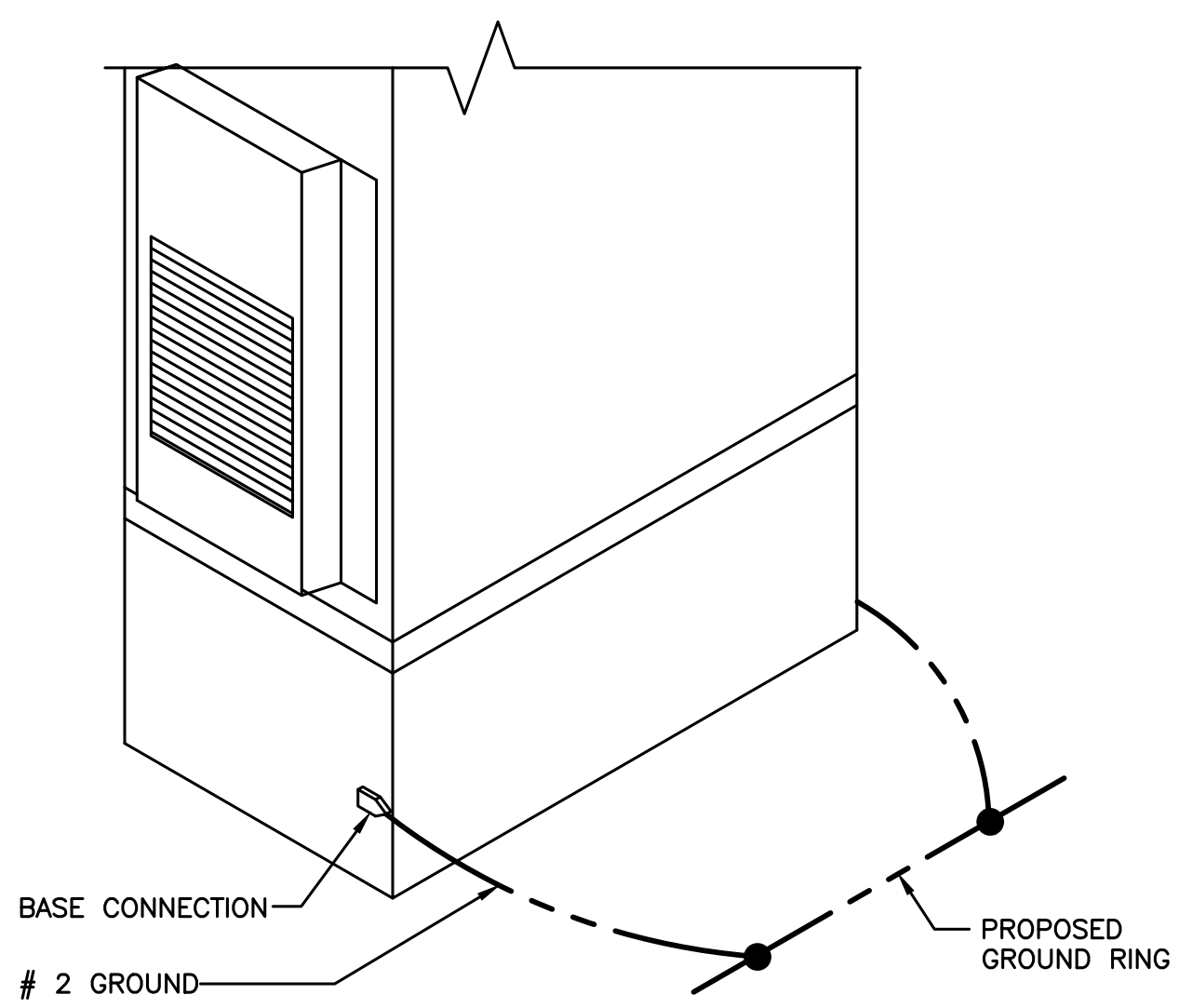

OUTDOOR CABINET GROUNDING

NO SCALE 4



5701 SOUTH SANTA FE DRIVE
LITTLETON, CO 80120



CEN TEK engineering
Centered on Solutions™

(203) 488-0580
(203) 488-8587 Fax
63-2 North Branford Road
Branford, CT 06405

www.CentekEng.com



IT IS A VIOLATION OF LAW FOR ANY PERSON, UNLESS THEY ARE ACTING UNDER THE DIRECTION OF A LICENSED PROFESSIONAL ENGINEER, TO ALTER THIS DOCUMENT

DRAWN BY: RTS	CHECKED BY: TJR	APPROVED BY:
------------------	--------------------	--------------

RFDS REV #: 1 - 12/14/2022

CONSTRUCTION DOCUMENTS

SUBMITTALS

REV	DATE	DESCRIPTION
A	03/29/23	ISSUED FOR CLIENT REVIEW
B	04/13/23	REVISED PER CLIENT COMMENTS
0	07/24/23	ISSUED FOR CONSTRUCTION
1	07/27/23	REVISED PER CLIENT COMMENTS
2	08/08/23	REVISED PER CLIENT COMMENTS

CEN TEK PROJECT NUMBER
23009.03

DISH Wireless L.L.C.
PROJECT INFORMATION

BOHVN00186A
0 CLARK HILL ROAD
NAUGATUCK CT, 06770

SHEET TITLE
TYPICAL GROUNDING
DETAILS

SHEET NUMBER
G-3

NOT USED

NO SCALE 7

NOT USED

NO SCALE 8

NOT USED

NO SCALE 9

ELECTRICAL SPECIFICATIONS

SECTION 16010

- 1.01. SCOPE OF WORK
- A. WORK SHALL INCLUDE ALL LABOR, EQUIPMENT AND SERVICES REQUIRED TO COMPLETE (MAKE READY FOR OPERATION) ALL THE ELECTRICAL WORK INCLUDING, BUT NOT LIMITED TO, THE FOLLOWING:
- 200A, 240/120V, 1P, 3 WIRE ELECTRIC SERVICE METER FOR OWNER AND ASSOCIATED DISTRIBUTION EQUIPMENT. (AS REQUIRED BY UTILITY CO.)
 - NEW SITE TELEPHONE SERVICE AS SPECIFIED BY TELEPHONE COMPANY.
 - CELLULAR GROUNDING SYSTEMS, CONSISTING OF ANTENNA GROUNDING, GROUND RING, GROUND BARS, ETC.
 - FIELD MEASURE EXISTING ELECTRICAL SERVICES TO CONFIRM AVAILABLE EXISTING POWER.
 - COORDINATE ALL WORK SHOWN, ON THESE PLANS WITH LOCAL UTILITY COMPANIES.
- B. LOCAL UTILITY COMPANIES SHALL PROVIDE THE FOLLOWING:
- TELEPHONE CABLES.
 - SHUTDOWN OF SERVICE (COORDINATE WITH OWNER).
- C. CONTRACTOR SHALL CONFER WITH LOCAL UTILITY COMPANIES TO ASCERTAIN THE LIMITS OF THEIR WORK AND SHALL INCLUDE IN BID ANY CHARGES OR FEES MADE BY THE UTILITY COMPANIES FOR THEIR PORTION OF THE WORK AND SHALL PROVIDE AND INSTALL ALL ITEMS REQUIRED, BUT NOT PROVIDED BY UTILITY COMPANY.
- D. ELECTRICAL CONTRACTOR SHALL COORDINATE ELECTRICAL INSTALLATION WITH ELECTRIC UTILITY CO. PRIOR TO INSTALLATION.
- E. CONTRACTOR SHALL COORDINATE WITH TELEPHONE UTILITY COMPANY FOR LOCATION OF TELEPHONE SERVICE AND TO DETERMINE ANY REQUIRED EQUIPMENT TO BE INSTALLED BY CONTRACTOR.

1.02. GENERAL REQUIREMENTS

- A. THE ENTIRE ELECTRICAL INSTALLATION SHALL BE MADE IN STRICT ACCORDANCE WITH ALL LOCAL, STATE AND NATIONAL CODES AND REGULATIONS WHICH MAY APPLY AND NOTHING IN THE DRAWINGS OR SPECIFICATIONS SHALL BE INTERPRETED AS AN INFRINGEMENT OF SUCH CODES OR REGULATIONS.
- B. THE ELECTRICAL CONTRACTOR IS TO BE RESPONSIBLE FOR THE COMPLETE INSTALLATION AND COORDINATION OF THE ENTIRE ELECTRICAL SERVICE. ALL ACTIVITIES TO BE COORDINATED THROUGH OWNERS REPRESENTATIVE, DESIGN ENGINEER AND OTHER AUTHORITIES HAVING JURISDICTION OF TRADES.
- C. THE CONTRACTOR SHALL BE RESPONSIBLE FOR OBTAINING ALL PERMITS AND PAY ALL FEES THAT MAY BE REQUIRED FOR THE ELECTRICAL WORK AND FOR SCHEDULING OF ALL INSPECTIONS THAT MAY BE REQUIRED BY THE LOCAL AUTHORITY.
- D. THE CONTRACTOR SHALL BE RESPONSIBLE FOR COORDINATION WITH THE BUILDING OWNER FOR NEW AND/OR DEMOLITION WORK INVOLVED.
- E. THE CONTRACTOR SHALL BE RESPONSIBLE FOR COORDINATION WITH LOCAL TELEPHONE COMPANY THAT MAY BE REQUIRED FOR THE INSTALLATION OF TELEPHONE SERVICE TO THE PROPOSED CELLULAR SITE.
- F. NO MATERIAL OTHER THAN THAT CONTAINED IN THE "LATEST LIST OF ELECTRICAL FITTINGS" APPROVED BY THE UNDERWRITERS' LABORATORIES, SHALL BE USED IN ANY PART OF THE WORK. ALL MATERIAL FOR WHICH LABEL SERVICE HAS BEEN ESTABLISHED SHALL BEAR THE U.L. LABEL.
- G. THE CONTRACTOR SHALL GUARANTEE ALL NEW WORK FOR A PERIOD OF ONE YEAR FROM THE ACCEPTANCE DATE BY THE OWNER. THE CONTRACTOR SHALL BE RESPONSIBLE FOR OBTAINING WARRANTIES FROM ALL EQUIPMENT MANUFACTURERS FOR SUBMISSION TO THE OWNER.
- H. DRAWINGS INDICATE GENERAL ARRANGEMENT OF WORK INCLUDED IN CONTRACT. CONTRACTOR SHALL, WITHOUT EXTRA CHARGE, MAKE MODIFICATIONS TO THE LAYOUT OF THE WORK TO PREVENT CONFLICT WITH WORK OF OTHER TRADES AND FOR THE PROPER INSTALLATION OF WORK. CHECK ALL DRAWINGS AND VISIT JOB SITE TO VERIFY SPACE AND TYPE OF EXISTING CONDITIONS IN WHICH WORK WILL BE DONE, PRIOR TO SUBMITTAL OF BID.
- I. THE ELECTRICAL CONTRACTOR SHALL SUPPLY THREE (3) COMPLETE SETS OF APPROVED DRAWINGS, ENGINEERING DATA SHEETS, MAINTENANCE AND OPERATING INSTRUCTION MANUALS FOR ALL SYSTEMS AND THEIR RESPECTIVE EQUIPMENT. THESE MANUALS SHALL BE INSERTED IN VINYL COVERED 3-RING BINDERS AND TURNED OVER TO OWNER'S REPRESENTATIVE ONE (1) WEEK PRIOR TO FINAL PUNCH LIST.
- J. ALL WORK SHALL BE INSTALLED IN A NEAT AND WORKMAN LIKE MANNER AND WILL BE SUBJECT TO THE APPROVAL OF THE OWNER'S REPRESENTATIVE.
- K. ALL EQUIPMENT AND MATERIALS TO BE INSTALLED SHALL BE NEW, UNLESS OTHERWISE NOTED.
- L. BEFORE FINAL PAYMENT, THE CONTRACTOR SHALL PROVIDE A COMPLETE SET OF PRINTS (AS-BUILTS), LEGIBLY MARKED IN RED PENCIL TO SHOW ALL CHANGES FROM THE ORIGINAL PLANS.
- M. PROVIDE TEMPORARY POWER AND LIGHTING IN WORK AREAS AS REQUIRED.
- N. SHOP DRAWINGS:

- CONTRACTOR SHALL SUBMIT SIX (6) COPIES OF SHOP DRAWINGS ON ALL EQUIPMENT AND MATERIALS PROPOSED FOR USE ON THIS PROJECT, GIVING ALL DETAILS, WHICH INCLUDE DIMENSIONS, CAPACITIES, ETC.
- CONTRACTOR SHALL SUBMIT SIX (6) COPIES OF ALL TEST REPORTS CALLED FOR IN THE SPECIFICATIONS AND DRAWINGS.

- O. ENTIRE ELECTRICAL INSTALLATION SHALL BE IN ACCORDANCE WITH OWNER'S SPECIFICATIONS, AND REQUIREMENTS OF ALL LOCAL AUTHORITIES HAVING JURISDICTION. IT IS THE CONTRACTOR'S RESPONSIBILITY TO COORDINATE WITH APPROPRIATE INDIVIDUALS TO OBTAIN ALL SUCH SPECIFICATIONS AND REQUIREMENTS. NOTHING CONTAINED IN, OR OMITTED FROM, THESE DOCUMENTS SHALL RELIEVE CONTRACTOR FROM THIS OBLIGATION.

SECTION 16111

- 1.01. CONDUIT
- A. MINIMUM CONDUIT SIZE FOR BRANCH CIRCUITS, LOW VOLTAGE CONTROL AND ALARM CIRCUITS SHALL BE 3/4". CONDUITS SHALL BE PROPERLY FASTENED AS REQUIRED BY THE N.E.C.
- B. THE INTERIOR OF RACEWAYS/ ENCLOSURES INSTALLED UNDERGROUND SHALL BE CONSIDERED TO BE WET LOCATION, INSULATED CONDUCTORS SHALL BE LISTED FOR USE IN WET LOCATIONS. PROVIDE WEATHERPROOF CONSTRUCTION IN WET LOCATIONS.
- C. CONDUIT INSTALLED UNDERGROUND SHALL BE INSTALLED TO MEET MINIMUM COVER REQUIREMENTS OF TABLE 300.5.
- D. PROVIDE RIGID GALVANIZED STEEL CONDUIT (RMC) FOR THE FIRST 10 FOOT SECTION WHEN LEAVING A BUILDING OR SECTIONS PASSING THROUGH FLOOR SLABS
- E. ONLY LISTED PVC CONDUIT AND FITTINGS ARE PERMITTED FOR THE INSTALLATION OF ELECTRICAL CONDUCTORS, SUITABLE FOR UNDERGROUND APPLICATIONS.

CONDUIT SCHEDULE SECTION 16111			
CONDUIT TYPE	NEC REFERENCE	APPLICATION	MIN. BURIAL DEPTH (PER NEC TABLE 300.5) ^{2,3}
EMT	ARTICLE 358	INTERIOR CIRCUITING, EQUIPMENT ROOMS, SHELTERS	N/A
RMC, RIGID GALV. STEEL	ARTICLE 344, 300.5, 300.50	ALL INTERIOR/ EXTERIOR CIRCUITING, ALL UNDERGROUND INSTALLATIONS.	6 INCHES
PVC, SCHEDULE 40	ARTICLE 352, 300.5, 300.50	INTERIOR/ EXTERIOR CIRCUITING AND GROUNDING SYSTEMS, UNDERGROUND INSTALLATIONS, WHERE NOT SUBJECT TO PHYSICAL DAMAGE. ¹	18 INCHES
PVC, SCHEDULE 80	ARTICLE 352, 300.5, 300.50	INTERIOR/ EXTERIOR CIRCUITING AND GROUNDING SYSTEMS, UNDERGROUND INSTALLATIONS, WHERE SUBJECT TO PHYSICAL DAMAGE. ¹	18 INCHES
LIQUID TIGHT FLEX. METAL	ARTICLE 350	SHORT LENGTHS (MAX. 3FT.) WIRING TO VIBRATING EQUIPMENT IN WET LOCATIONS.	N/A
FLEX. METAL	ARTICLE 348	SHORT LENGTHS (MAX. 3FT.) WIRING TO VIBRATING EQUIPMENT IN WET LOCATIONS.	N/A

¹ PHYSICAL DAMAGE IS SUBJECT TO THE AUTHORITY HAVING JURISDICTION.
² UNDERGROUND CONDUIT INSTALLED UNDER ROADS, HIGHWAYS, DRIVEWAYS, PARKING LOTS SHALL HAVE MINIMUM DEPTH OF 24".
³ WHERE SOLID ROCK PREVENTS COMPLIANCE WITH MINIMUM COVER DEPTHS, WIRING SHALL BE INSTALLED IN PERMITTED RACEWAY FOR DIRECT BURIAL. THE RACEWAY SHALL BE COVERED BY A MINIMUM OF 2" OF CONCRETE EXTENDING DOWN TO ROCK.

SECTION 16123

- 1.01. CONDUCTORS
- A. ALL CONDUCTORS SHALL BE TYPE THWN (INT. APPLICATION) AND XHHW (EXT. APPLICATION), 75 DEGREE C, 600 VOLT INSULATION, SOFT ANNEALED STRANDED COPPER, #10 AWG AND SMALLER SHALL BE SPLICED USING ACCEPTABLE SOLDERLESS PRESSURE CONNECTORS. #8 AWG AND LARGER SHALL BE SPLICED USING COMPRESSION SPLIT-BOLT TYPE CONNECTORS. #12 AWG SHALL BE THE MINIMUM SIZE CONDUCTOR FOR LINE VOLTAGE BRANCH CIRCUITS. REFER TO PANEL SCHEDULE FOR BRANCH CIRCUIT CONDUCTOR SIZE(S). CONDUCTORS SHALL BE COLOR CODED FOR CONSISTENT PHASE IDENTIFICATION:
- | | | |
|------|------------------|--------------------------|
| LINE | 120/208/240V | 277/480V |
| A | BLACK | BROWN |
| B | RED | ORANGE |
| C | BLUE | YELLOW |
| N | CONTINUOUS WHITE | GREY |
| G | CONTINUOUS GREEN | GREEN WITH YELLOW STRIPE |
- B. MINIMUM BENDING RADIUS FOR CONDUCTORS SHALL BE 12 TIMES THE LARGEST DIAMETER OF BRANCH CIRCUIT CONDUCTOR.

SECTION 16130

- 1.01. BOXES
- A. FURNISH AND INSTALL OUTLET BOXES FOR ALL DEVICES, SWITCHES, RECEPTACLES, ETC.. BOXES TO BE ZINC COATED STEEL.
- B. FURNISH AND INSTALL PULL BOXES IN MAIN FEEDERS RUNS WHERE REQUIRED. PULL BOXES SHALL BE GALVANIZED STEEL WITH SCREW REMOVABLE COVERS, SIZE AND QUANTITY AS REQUIRED. PROVIDE WEATHERPROOF CONSTRUCTION IN WET LOCATIONS.

SECTION 16140

- 1.01. WIRING DEVICES
- A. THE FOLLOWING LIST IS PROVIDED TO CONVEY THE QUALITY AND RATING OF WIRING DEVICES WHICH ARE TO BE INSTALLED. A COMPLETE LIST OF ALL DEVICES MUST BE SUBMITTED BEFORE INSTALLATION FOR APPROVAL.
- 1.5 MINUTE TIMER SWITCH – INTERMATIC #FF15M (INTERIOR LIGHTS)
 - DUPLEX RECEPTACLE – P&S #2095 (GFCI) SPECIFICATION GRADE
 - SINGLE POLE SWITCH – P&S #CSB20AC2 (20A-120V HARD USE) SPECIFICATION GRADE
 - DUPLEX RECEPTACLE – P&S #5362 (20A-120V HARD USE) SPECIFICATION GRADE
- B. PLATES – ALL PLATES USED SHALL BE CORROSION RESISTANT TYPE 304 STAINLESS STEEL. PLATES SHALL BE FROM SAME MANUFACTURER AS SWITCHES AND RECEPTACLES. PROVIDE WEATHERPROOF HOUSING FOR DEVICES LOCATED IN WET LOCATIONS.
- C. OTHER MANUFACTURERS OF THE SWITCHES, RECEPTACLES AND PLATES MAY BE SUBMITTED FOR APPROVAL BY THE ENGINEER.

SECTION 16170

- 1.01. DISCONNECT SWITCHES
- A. FUSIBLE AND NON-FUSIBLE, 600V, HEAVY DUTY DISCONNECT SWITCHES SHALL BE AS MANUFACTURED BY SQUARE "D". PROVIDE FUSES AS CALLED FOR ON THE CONTRACT DRAWINGS. AMPERE RATING SHALL BE CONSISTENT WITH LOAD BEING SERVED. DISCONNECT SWITCH COVER SHALL BE MECHANICALLY INTERLOCKED TO PREVENT COVER FROM OPENING WHEN THE SWITCH IS IN THE "ON" POSITION. EXTERIOR APPLICATIONS SHALL BE NEMA 3R CONSTRUCTION WITH PADLOCK FEATURE.

SECTION 16190

- 1.01. SEISMIC RESTRAINT
- A. ALL DEVICES SHALL BE INSTALLED IN ACCORDANCE WITH ZONE 2 SEISMIC REQUIREMENTS.

SECTION 16195

- 1.01. LABELING AND IDENTIFICATION NOMENCLATURE FOR ELECTRICAL EQUIPMENT
- A. CONTRACTOR SHALL FURNISH AND INSTALL NON-METALLIC ENGRAVED BACK-LIT NAMEPLATES ON ALL PANELS AND MAJOR ITEMS OF ELECTRICAL EQUIPMENT.
- B. LETTERS TO BE WHITE ON BLACK BACKGROUND WITH LETTERS 1-1/2 INCH HIGH WITH 1/4 INCH MARGIN.
- C. IDENTIFICATION NOMENCLATURE SHALL BE IN ACCORDANCE WITH OWNER'S STANDARDS.

SECTION 16450

- 1.01. GROUNDING
- A. ALL NON-CURRENT CARRYING PARTS OF THE ELECTRICAL AND TELEPHONE CONDUIT SYSTEMS SHALL BE MECHANICALLY AND ELECTRICALLY CONNECTED TO PROVIDE AN INDEPENDENT RETURN PATH TO THE EQUIPMENT GROUNDING SOURCES.
- B. GROUNDING SYSTEM WILL BE IN ACCORDANCE WITH THE LATEST ACCEPTABLE EDITION OF THE NATIONAL ELECTRICAL CODE AND REQUIREMENTS PER LOCAL INSPECTOR HAVING JURISDICTION.
- C. GROUNDING OF PANELBOARDS:
- PANELBOARD SHALL BE GROUNDED BY TERMINATING THE PANELBOARD FEEDER'S EQUIPMENT GROUND CONDUCTOR TO THE EQUIPMENT GROUND BAR KIT(S) LUGGED TO THE CABINET. ENSURE THAT THE SURFACE BETWEEN THE KIT AND CABINET ARE BARE METAL TO BARE METAL. PRIME AND PAINT OVER TO PREVENT CORROSION.
 - CONDUIT(S) TERMINATING INTO THE PANELBOARD SHALL HAVE GROUNDING TYPE BUSHINGS. THE BUSHINGS SHALL BE BONDED TOGETHER WITH BARE #10 AWG COPPER CONDUCTOR WHICH IN TURN IS TERMINATED INTO THE PANELBOARD'S EQUIPMENT GROUND BAR KIT(S).
- D. EQUIPMENT GROUNDING CONDUCTOR:
- EACH EQUIPMENT GROUND CONDUCTOR SHALL BE SIZED IN ACCORDANCE WITH THE N.E.C. ARTICLE 250.
 - THE MINIMUM SIZE OF EQUIPMENT GROUND CONDUCTOR SHALL BE #12 AWG COPPER.
 - EACH FEEDER OR BRANCH CIRCUIT SHALL HAVE EQUIPMENT GROUND CONDUCTOR(S) INSTALLED IN THE SAME RACEWAY(S).
- E. CELLULAR GROUNDING SYSTEM:
- CONTRACTOR SHALL PROVIDE A CELLULAR GROUNDING SYSTEM WITH THE MAXIMUM AC RESISTANCE TO GROUND OF 10 OHM BETWEEN ANY POINT ON THE GROUNDING SYSTEM AS MEASURED BY 3-POINT GROUNDING TEST. (REFER TO SECTION 16960).

- PROVIDE THE CELLULAR GROUNDING SYSTEM AS SPECIFIED ON DRAWINGS, INCLUDING, BUT NOT LIMITED TO:
- GROUND BARS
 - INTERIOR GROUND RING
 - EXTERIOR GROUNDING (WHERE REQUIRED DUE TO MEASURED AC RESISTANCE GREATER THAN SPECIFIED).
 - ANTENNA GROUND CONNECTIONS AND PLATES.

- F. CONTRACTOR, AFTER COMPLETION OF THE COMPLETE GROUNDING SYSTEM BUT PRIOR TO CONCEALMENT/BURIAL OF SAME, SHALL NOTIFY OWNER'S PROJECT ENGINEER WHO WILL HAVE A DESIGN ENGINEER VISIT SITE AND MAKE A VISUAL INSPECTION OF THE GROUNDING GRID AND CONNECTIONS OF THE SYSTEM.
- G. ALL EQUIPMENT SHALL BE BONDED TO GROUND AS REQUIRED BY N.E.C., MFG. SPECIFICATIONS, AND OWNER'S SPECIFICATIONS.

SECTION 16470

- 1.01. DISTRIBUTION EQUIPMENT
- A. REFER TO CONTRACT DRAWINGS FOR DETAILS AND SCHEDULES.

SECTION 16477

- 1.01. FUSES
- A. FUSES SHALL BE NONRENEWABLE TYPE AS MANUFACTURED BY "BUSSMAN" OR APPROVED EQUAL. FUSES RATED TO 1/10 AMPERE UP TO 600 AMPERES SHALL BE EQUIVALENT TO BUSSMAN TYPE LPN-RK (250V) UL CLASS RK1, LOW PEAK, DUAL ELEMENT, TIME-DELAY FUSES. FUSES SHALL HAVE SEPARATE SHORT CIRCUIT AND OVERLOAD ELEMENTS AND HAVE AN INTERRUPTING RATING OF 200 KAIC. UPON COMPLETION OF WORK, PROVIDE ONE SPARE SET OF FUSES FOR EACH TYPE INSTALLED.

SECTION 16960

- 1.01. TESTS BY INDEPENDENT ELECTRICAL TESTING FIRM
- A. CONTRACTOR SHALL RETAIN THE SERVICES OF A LOCAL INDEPENDENT ELECTRICAL TESTING FIRM (WITH MINIMUM 5 YEARS COMMERCIAL EXPERIENCE IN THE ELECTRICAL TESTING INDUSTRY) AS SPECIFIED BY OWNER TO PERFORM:
- TEST 1: THERMAL OVERLOAD AND MAGNETIC TRIP TEST, AND CABLE INSULATION TEST FOR ALL CIRCUIT BREAKERS RATED 100 AMPS OR GREATER.
- TEST 2: RESISTANCE TO GROUND TEST ON THE CELLULAR GROUNDING SYSTEM.
- THE TESTING FIRM SHALL INCLUDE THE FOLLOWING INFORMATION WITH THE REPORT:
- TESTING PROCEDURE INCLUDING THE MAKE AND MODEL OF TEST EQUIPMENT.
 - CERTIFICATION OF TESTING EQUIPMENT CALIBRATION WITHIN SIX (6) MONTHS OF DATE OF TESTING. INCLUDE CERTIFICATION LAB ADDRESS AND TELEPHONE NUMBER.
 - GRAPHICAL DESCRIPTION OF TESTING METHOD ACTUALLY IMPLEMENTED.
- B. THESE TESTS SHALL BE PERFORMED IN THE PRESENCE AND TO THE SATISFACTION OF OWNER'S CONSTRUCTION REPRESENTATIVE. TESTING DATA SHALL BE INITIALED AND DATED BY THE CONSTRUCTION REPRESENTATIVE AND INCLUDED WITH THE WRITTEN REPORT/ANALYSIS.
- C. THE CONTRACTOR SHALL FORWARD SIX (6) COPIES OF THE INDEPENDENT ELECTRICAL TESTING FIRM'S REPORT/ANALYSIS TO ENGINEER A MINIMUM OF TEN (10) WORKING DAYS PRIOR TO THE JOB TURNOVER.
- D. CONTRACTOR TO PROVIDE A MINIMUM OF ONE (1) WEEK NOTICE TO OWNER AND ENGINEER FOR ALL TESTS REQUIRING WITNESSING.

SECTION 16961

- 1.01. TESTS BY CONTRACTOR
- A. ALL TESTS AS REQUIRED UPON COMPLETION OF WORK, SHALL BE MADE BY THIS CONTRACTOR. THESE SHALL BE CONTINUITY AND INSULATION TESTS; TEST TO DETERMINE THE QUALITY OF MATERIALS, ETC. AND SHALL BE MADE IN ACCORDANCE WITH N.E.C. RECOMMENDATIONS. ALL FEEDERS AND BRANCH CIRCUIT WIRING (EXCEPT CLASS 2 SIGNAL CIRCUITS) MUST BE TESTED FREE FROM SHORT CIRCUIT AND GROUND FAULT CONDITIONS AT 500V IN A REASONABLY DRY AMBIENT OF APPROXIMATELY 70 DEGREES F.
- B. CONTRACTOR SHALL PERFORM LOAD PHASE BALANCING TESTS. CIRCUITS SHALL BE SO CONNECTED TO THE PANELBOARDS SUCH THAT THE NEW LOAD IS DISTRIBUTED AS EQUALLY AS POSSIBLE BETWEEN EACH LOAD AND NEUTRAL. 10% SHALL BE CONSIDERED AS A REASONABLE AND ACCEPTABLE ALLOWANCE. BRANCH CIRCUITS SHALL BE BALANCED ON THEIR OWN PANELBOARDS; FEEDER LOADS SHALL, IN TURN, BE BALANCED ON THE SERVICE EQUIPMENT. REASONABLE LOAD TEST SHALL BE ARRANGED TO VERIFY LOAD BALANCE IF REQUESTED BY THE ENGINEER.
- C. ALL TESTS, UPON REQUEST, SHALL BE REPEATED IN THE PRESENCE OF OWNER'S REPRESENTATIVE. ALL TESTS SHALL BE DOCUMENTED AND TURNED OVER TO OWNER. OWNER SHALL HAVE THE AUTHORITY TO STOP ANY OF THE WORK NOT BEING PROPERLY INSTALLED. ALL SUCH DETECTED WORK SHALL BE REPAIRED OR REPLACED AT NO ADDITIONAL EXPENSE TO THE OWNER AND THE TESTS SHALL BE REPEATED.



5701 SOUTH SANTA FE DRIVE
LITTLETON, CO 80120



(203) 488-0580
(203) 488-8587 Fax
63-2 North Branford Road
Branford, CT 06405

www.CentekEng.com

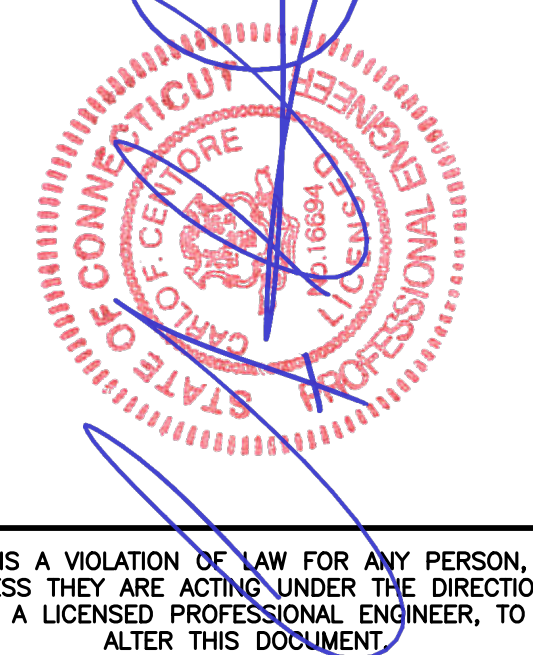

IT IS A VIOLATION OF LAW FOR ANY PERSON, UNLESS THEY ARE ACTING UNDER THE DIRECTION OF A LICENSED PROFESSIONAL ENGINEER, TO ALTER THIS DOCUMENT

DRAWN BY:	CHECKED BY:	APPROVED BY:
RTS	TJR	

RFDS REV #: 1 - 12/14/2022

CONSTRUCTION DOCUMENTS

SUBMITTALS		
REV	DATE	DESCRIPTION
A	03/29/23	ISSUED FOR CLIENT REVIEW
B	04/13/23	REVISED PER CLIENT COMMENTS
0	07/24/23	ISSUED FOR CONSTRUCTION
1	07/27/23	REVISED PER CLIENT COMMENTS
2	08/08/23	REVISED PER CLIENT COMMENTS

CENTEK PROJECT NUMBER
23009.03

DISH Wireless L.L.C.
PROJECT INFORMATION

BOHVN00186A
0 CLARK HILL ROAD
NAUGATUCK CT, 06770

SHEET TITLE
ELECTRICAL
SPECIFICATIONS

SHEET NUMBER

G-4

NOTES AND SPECIFICATIONS:

DESIGN BASIS:

GOVERNING CODE: 2021 INTERNATIONAL BUILDING CODE (IBC) AS MODIFIED BY THE 2022 CONNECTICUT STATE BUILDING CODE.

1. DESIGN CRITERIA:

- RISK CATEGORY II (BASED ON IBC TABLE 1604.5)
- NOMINAL/ULTIMATE DESIGN SPEED: 97 MPH (V_{asd}) (EXPOSURE C/ IMPORTANCE FACTOR 1.0 BASED ON ASCE 7-16).

SITE NOTES

- THE CONTRACTOR SHALL CALL UTILITIES PRIOR TO THE START OF CONSTRUCTION.
- ACTIVE EXISTING UTILITIES, WHERE ENCOUNTERED IN THE WORK, SHALL BE PROTECTED AT ALL TIMES. THE ENGINEER SHALL BE NOTIFIED IMMEDIATELY, PRIOR TO PROCEEDING, SHOULD ANY UNCOVERED EXISTING UTILITY PRECLUDE COMPLETION OF THE WORK IN ACCORDANCE WITH THE CONTRACT DOCUMENTS.
- THE AREAS OF THE COMPOUND DISTURBED BY THE WORK SHALL BE RETURNED TO THEIR ORIGINAL CONDITION.
- CONTRACTOR SHALL MINIMIZE DISTURBANCE TO EXISTING SITE DURING CONSTRUCTION. EROSION CONTROL MEASURES, SHALL BE IN CONFORMANCE WITH THE LOCAL GUIDELINES FOR EROSION AND SEDIMENT CONTROL.
- IF ANY FIELD CONDITIONS EXIST WHICH PRECLUDE COMPLIANCE WITH THE DRAWINGS, THE CONTRACTOR SHALL IMMEDIATELY NOTIFY THE ENGINEER AND SHALL PROCEED WITH AFFECTED WORK AFTER CONFLICT IS SATISFACTORILY RESOLVED.

GENERAL NOTES

- ALL WORK SHALL BE IN ACCORDANCE WITH THE 2021 INTERNATIONAL BUILDING CODE AS MODIFIED BY THE 2022 CONNECTICUT SUPPLEMENT, INCLUDING THE TIA/EIA-222 REVISION "H" "STRUCTURAL STANDARDS FOR STEEL ANTENNA TOWERS AND SUPPORTING STRUCTURES." 2022 CONNECTICUT FIRE SAFETY CODE, NATIONAL ELECTRICAL CODE AND LOCAL CODES.
- SHOULD ANY FIELD CONDITIONS PRECLUDE COMPLIANCE WITH THE DRAWINGS, THE CONTRACTOR SHALL IMMEDIATELY NOTIFY THE ENGINEER AND SHALL NOT PROCEED WITH ANY AFFECTED WORK.
- CONTRACTOR SHALL REVIEW ALL DRAWINGS AND SPECIFICATIONS IN THE CONTRACT DOCUMENT SET. CONTRACTOR SHALL COORDINATE ALL WORK SHOWN IN THE SET OF DRAWINGS. THE CONTRACTOR SHALL PROVIDE A COMPLETE SET OF DRAWINGS TO ALL SUBCONTRACTORS AND ALL RELATED PARTIES. THE SUBCONTRACTORS SHALL EXAMINE ALL THE DRAWINGS AND SPECIFICATIONS FOR THE INFORMATION THAT AFFECTS THEIR WORK.
- BEFORE BEGINNING THE WORK, THE CONTRACTOR IS RESPONSIBLE FOR MAKING SUCH INVESTIGATIONS CONCERNING PHYSICAL CONDITIONS (SURFACE AND SUBSURFACE) AT OR CONTIGUOUS TO THE SITE, WHICH MAY AFFECT PERFORMANCE AND COST OF THE WORK.
- ALL DIMENSIONS, ELEVATIONS, AND OTHER REFERENCES TO EXISTING STRUCTURES, SURFACE, AND SUBSURFACE CONDITIONS ARE APPROXIMATE. NO GUARANTEE IS MADE FOR THE ACCURACY OR COMPLETENESS OF THE INFORMATION SHOWN. THE CONTRACTOR SHALL VERIFY AND COORDINATE ALL DIMENSIONS, ELEVATIONS AND ANGLES WITH EXISTING CONDITIONS AND WITH ARCHITECTURAL AND SITE DRAWINGS BEFORE PROCEEDING WITH ANY WORK.
- AS THE WORK PROGRESSES, THE CONTRACTOR SHALL NOTIFY THE OWNER OF ANY CONDITIONS WHICH ARE IN CONFLICT OR OTHERWISE NOT CONSISTENT WITH THE CONSTRUCTION DOCUMENTS, AND SHALL NOT PROCEED WITH SUCH WORK UNTIL THE CONFLICT IS SATISFACTORILY RESOLVED.
- CONTRACTOR SHALL PROVIDE A COMPLETE BUILD-OUT WITH ALL FINISHES, STRUCTURAL, MECHANICAL, AND ELECTRICAL COMPONENTS AND PROVIDE ALL ITEMS AS SHOWN OR INDICATED ON THE DRAWINGS OR IN THE WRITTEN SPECIFICATIONS.
- CONTRACTOR SHALL FURNISH ALL MATERIAL, LABOR AND EQUIPMENT TO COMPLETE THE WORK AND FURNISH A COMPLETED JOB ALL IN ACCORDANCE WITH LOCAL AND STATE GOVERNING AUTHORITIES AND OTHER AUTHORITIES HAVING LAWFUL JURISDICTION OVER THE WORK.
- CONTRACTOR SHALL SECURE AND PAY FOR ALL PERMITS AND ALL INSPECTIONS REQUIRED AND SHALL ALSO PAY FEES REQUIRED FOR THE GENERAL CONSTRUCTION, PLUMBING, ELECTRICAL, AND HVAC. PERMITS SHALL BE PAID FOR BY THE RESPECTIVE SUBCONTRACTORS.
- CONTRACTOR SHALL MAINTAIN A CURRENT SET OF DRAWINGS AND SPECIFICATIONS ON SITE AT ALL TIMES AND INSURE DISTRIBUTION OF NEW DRAWINGS TO SUBCONTRACTORS AND OTHER RELEVANT PARTIES AS SOON AS THEY ARE MADE AVAILABLE. ALL OLD DRAWINGS SHALL BE MARKED VOID AND REMOVED FROM THE CONTRACT AREA. THE CONTRACTOR SHALL FURNISH AN 'AS-BUILT' SET OF DRAWINGS TO OWNER UPON COMPLETION OF PROJECT.
- LOCATION OF EQUIPMENT AND WORK SUPPLIED BY OTHERS THAT IS DIAGRAMMATICALLY INDICATED ON THE DRAWINGS, SHALL BE DETERMINED BY THE CONTRACTOR. THE CONTRACTOR SHALL DETERMINE LOCATIONS AND DIMENSIONS SUBJECT TO STRUCTURAL CONDITIONS AND WORK OF THE SUBCONTRACTORS.
- THE CONTRACTOR IS SOLELY RESPONSIBLE TO DETERMINE CONSTRUCTION PROCEDURE AND SEQUENCE AND TO ENSURE THE SAFETY OF THE EXISTING STRUCTURES AND ITS COMPONENT PARTS DURING CONSTRUCTION. THIS INCLUDES THE ADDITION OF WHATEVER SHORING, BRACING, UNDERPINNING, ETC. THAT MAY BE NECESSARY.
- ALL EQUIPMENT AND PRODUCTS PURCHASED ARE TO BE REVIEWED BY CONTRACTOR AND ALL APPLICABLE SUB-CONTRACTORS FOR ANY CONDITION PER THE MANUFACTURER'S RECOMMENDATIONS. CONTRACTOR TO SUPPLY THESE ITEMS AT NO COST TO OWNER OR CONSTRUCTION MANAGER.

- DRAWINGS INDICATE THE MINIMUM STANDARDS, BUT IF ANY WORK SHOULD BE INDICATED TO BE SUBSTANDARD TO ANY ORDINANCES, LAWS, CODES, RULES, OR REGULATIONS BEARING ON THE WORK, THE CONTRACTOR SHALL INCLUDE IN HIS WORK AND SHALL EXECUTE THE WORK CORRECTLY IN ACCORDANCE WITH SUCH ORDINANCES, LAWS, CODES, RULES OR REGULATIONS WITH NO INCREASE IN COSTS.
- ALL UTILITY WORK SHALL BE IN ACCORDANCE WITH LOCAL UTILITY COMPANY REQUIREMENTS AND SPECIFICATIONS.
- ALL EQUIPMENT AND PRODUCTS PURCHASED ARE TO BE REVIEWED BY CONTRACTOR AND ALL APPLICABLE SUBCONTRACTORS FOR ANY CONDITION PER MANUFACTURER'S RECOMMENDATIONS. CONTRACTOR TO SUPPLY THESE ITEMS AT NO COST TO OWNER OR CONSTRUCTION MANAGER.
- ANY AND ALL ERRORS, DISCREPANCIES, AND 'MISSED' ITEMS ARE TO BE BROUGHT TO THE ATTENTION OF THE DISH Wireless L.L.C. CONSTRUCTION MANAGER DURING THE BIDDING PROCESS BY THE CONTRACTOR. ALL THESE ITEMS ARE TO BE INCLUDED IN THE BID. NO 'EXTRA' WILL BE ALLOWED FOR MISSED ITEMS.
- CONTRACTOR SHALL BE RESPONSIBLE FOR ALL ON-SITE SAFETY FROM THE TIME THE JOB IS AWARDED UNTIL ALL WORK IS COMPLETE AND ACCEPTED BY THE OWNER.
- CONTRACTOR TO REVIEW ALL SHOP DRAWINGS AND SUBMIT COPY TO ENGINEER FOR APPROVAL. DRAWINGS MUST BEAR THE CHECKER'S INITIALS BEFORE SUBMITTING TO THE CONSTRUCTION MANAGER FOR REVIEW.
- THE CONTRACTOR SHALL FIELD VERIFY ALL DIMENSIONS, ELEVATIONS, ANGLES AND EXISTING CONDITIONS AT THE SITE, PRIOR TO FABRICATION AND/OR INSTALLATION OF ANY WORK IN THE CONTRACT AREA.
- COORDINATION, LAYOUT, FURNISHING AND INSTALLATION OF CONDUITS AND ALL APURTENANCES REQUIRED FOR PROPER INSTALLATION OF ELECTRICAL AND TELECOMMUNICATION SERVICE SHALL BE THE SOLE RESPONSIBILITY OF THE CONTRACTOR AND CONFIRMED WITH THE PROJECT MANAGER AND OWNER PRIOR TO THE COMMENCEMENT OF ANY WORK
- ALL DAMAGE CAUSED TO ANY EXISTING STRUCTURE SHALL BE THE SOLE RESPONSIBILITY OF THE CONTRACTOR. THE CONTRACTOR WILL BE HELD LIABLE FOR ALL REPAIRS REQUIRED FOR EXISTING STRUCTURES IF DAMAGED DURING CONSTRUCTION ACTIVITIES.
- THE CONTRACTOR SHALL CONTACT 'CALL BEFORE YOU DIG' AT LEAST 48 HOURS PRIOR TO ANY EXCAVATIONS AT 1-800-922-4455. ALL UTILITIES SHALL BE IDENTIFIED AND CLEARLY MARKED. CONTRACTOR SHALL MAINTAIN AND PROTECT MARKED UTILITIES THROUGHOUT PROJECT COMPLETION.
- CONTRACTOR SHALL COMPLY WITH THE OWNER'S ENVIRONMENTAL ENGINEER ON ALL METHODS AND PROVISIONS FOR ALL EXCAVATION ACTIVITIES INCLUDING SOIL DISPOSAL. ALL BACKFILL MATERIALS TO BE PROVIDED BY THE CONTRACTOR.
- THE COUNTY/CITY/TOWN MAY MAKE PERIODIC FIELD INSPECTIONS TO ENSURE COMPLIANCE WITH THE DESIGN PLANS, SPECIFICATIONS, AND CONTRACT DOCUMENTS.
- THE COUNTY/CITY/TOWN MUST BE NOTIFIED (2) WORKING DAYS PRIOR TO CONCEALMENT/BURIAL OF ANY SYSTEM OR MATERIAL THAT WILL PREVENT THE DIRECT INSPECTION OF MATERIALS, METHODS OR WORKMANSHIP. EXAMPLES OF THESE PROCESSES ARE BACKFILLING A GROUND RING OR TOWER FOUNDATION, POURING TOWER FOUNDATIONS, BURYING GROUND RODS, PLATES OR GRIDS, ETC. THE CONTRACTOR MAY PROCEED WITH THE SCHEDULED PROCESS (2) WORKING DAYS AFTER PROVIDING NOTICE UNLESS NOTIFIED OTHERWISE BY THE COUNTY/CITY/TOWN.
- PRIOR TO THE SUBMISSION OF BIDS, THE CONTRACTOR SHALL VISIT THE SITE TO FAMILIARIZE WITH THE EXISTING CONDITIONS AND TO CONFIRM THAT THE WORK CAN BE ACCOMPLISHED AS SHOWN ON THE CONSTRUCTION DRAWINGS. ANY DISCREPANCY FOUND SHALL BE BROUGHT TO THE ATTENTION OF ENGINEER ON RECORD, PRIOR TO THE COMMENCEMENT OF ANY WORK.

STRUCTURAL STEEL

- ALL STRUCTURAL STEEL IS DESIGNED BY ALLOWABLE STRESS DESIGN (ASD)
 - STRUCTURAL STEEL (W SHAPES)---ASTM A992 (FY = 50 KSI)
 - STRUCTURAL STEEL (OTHER SHAPES)---ASTM A36 (FY = 36 KSI)
 - STRUCTURAL HSS (RECTANGULAR SHAPES)---ASTM A500 GRADE B, (FY = 46 KSI)
 - STRUCTURAL HSS (ROUND SHAPES)---ASTM A500 GRADE B, (FY = 42 KSI)
 - PIPE---ASTM A53 (FY = 35 KSI)
 - CONNECTION BOLTS---ASTM A325-N
 - U-BOLTS---ASTM A36
 - ANCHOR RODS---ASTM F 1554
 - WELDING ELECTRODE---ASTM E 70XX
- CONTRACTOR TO REVIEW ALL SHOP DRAWINGS AND SUBMIT COPY TO ENGINEER FOR APPROVAL. DRAWINGS MUST BEAR THE CHECKER'S INITIALS BEFORE SUBMITTING TO THE ENGINEER FOR REVIEW. SHOP DRAWINGS SHALL INCLUDE THE FOLLOWING: SECTION PROFILES, SIZES, CONNECTION ATTACHMENTS, REINFORCING, ANCHORAGE, SIZE AND TYPE OF FASTENERS AND ACCESSORIES. INCLUDE ERECTION DRAWINGS, ELEVATIONS AND DETAILS.
- STRUCTURAL STEEL SHALL BE DETAILED, FABRICATED AND ERECTED IN ACCORDANCE WITH THE LATEST PROVISIONS OF AISC MANUAL OF STEEL CONSTRUCTION.
- PROVIDE ALL PLATES, CLIP ANGLES, CLOSURE PIECES, STRAP ANCHORS, MISCELLANEOUS PIECES AND HOLES REQUIRED TO COMPLETE THE STRUCTURE.
- FIT AND SHOP ASSEMBLE FABRICATIONS IN THE LARGEST PRACTICAL SECTIONS FOR DELIVERY TO SITE.
- INSTALL FABRICATIONS PLUMB AND LEVEL, ACCURATELY FITTED, AND FREE FROM DISTORTIONS OR DEFECTS.
- AFTER ERECTION OF STRUCTURES, TOUCHUP ALL WELDS, ABRASIONS AND NON-GALVANIZED SURFACES WITH A 95% ORGANIC ZINC RICH PAINT IN ACCORDANCE WITH ASTM 780.
- ALL STEEL MATERIAL (EXPOSED TO WEATHER) SHALL BE GALVANIZED AFTER FABRICATION IN ACCORDANCE WITH ASTM A123 "ZINC (HOT DIPPED GALVANIZED) COATINGS" ON IRONS AND STEEL PRODUCTS.
- ALL BOLTS, ANCHORS AND MISCELLANEOUS HARDWARE SHALL BE GALVANIZED IN ACCORDANCE WITH ASTM A153 "ZINC COATING (HOT-DIP) ON IRON AND STEEL HARDWARE".
- THE ENGINEER SHALL BE NOTIFIED OF ANY INCORRECTLY FABRICATED, DAMAGED OR OTHERWISE MISFITTING OR NON CONFORMING MATERIALS OR CONDITIONS TO REMEDIAL OR CORRECTIVE ACTION. ANY SUCH ACTION SHALL REQUIRE ENGINEER REVIEW.
- CONNECTION ANGLES SHALL HAVE A MINIMUM THICKNESS OF 1/4 INCHES.
- STRUCTURAL CONNECTION BOLTS SHALL CONFORM TO ASTM A325. ALL BOLTS SHALL BE 3/4" DIAMETER MINIMUM AND SHALL HAVE A MINIMUM OF TWO BOLTS, UNLESS OTHERWISE ON THE DRAWINGS.
- LOCK WASHER ARE NOT PERMITTED FOR A325 STEEL ASSEMBLIES.
- SHOP CONNECTIONS SHALL BE WELDED OR HIGH STRENGTH BOLTED.
- MILL BEARING ENDS OF COLUMNS, STIFFENERS, AND OTHER BEARING SURFACES TO TRANSFER LOAD OVER ENTIRE CROSS SECTION.
- FABRICATE BEAMS WITH MILL CAMBER UP.
- LEVEL AND PLUMB INDIVIDUAL MEMBERS OF THE STRUCTURE TO AN ACCURACY OF 1:500, BUT NOT TO EXCEED 1/4" IN THE FULL HEIGHT OF THE COLUMN.
- COMMENCEMENT OF STRUCTURAL STEEL WORK WITHOUT NOTIFYING THE ENGINEER OF ANY DISCREPANCIES WILL BE CONSIDERED ACCEPTANCE OF PRECEDING WORK.
- INSPECTION AND TESTING OF ALL WELDING AND HIGH STRENGTH BOLTING SHALL BE PERFORMED BY AN INDEPENDENT TESTING LABORATORY.
- FOUR COPIES OF ALL INSPECTION TEST REPORTS SHALL BE SUBMITTED TO THE ENGINEER WITHIN TEN (10) WORKING DAYS OF THE DATE OF INSPECTION.



5701 SOUTH SANTA FE DRIVE
LITTLETON, CO 80120



CEN TEK engineering
Centered on Solutions™

(203) 488-0580
(203) 488-8587 Fax
63-2 North Branford Road
Branford, CT 06405

www.CentekEng.com

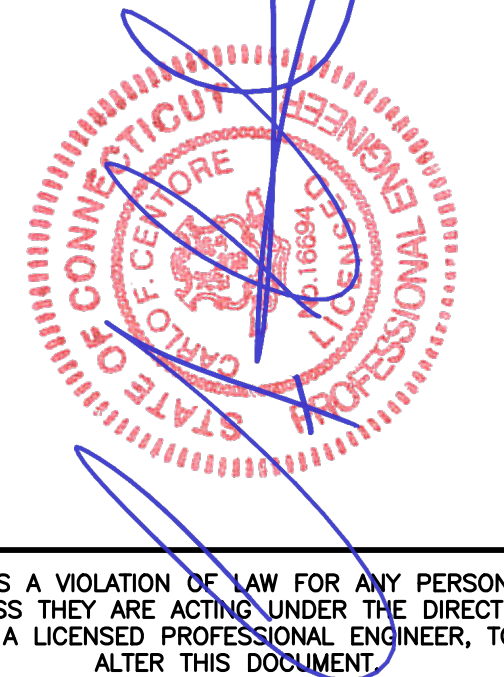

IT IS A VIOLATION OF LAW FOR ANY PERSON, UNLESS THEY ARE ACTING UNDER THE DIRECTION OF A LICENSED PROFESSIONAL ENGINEER, TO ALTER THIS DOCUMENT

DRAWN BY:	CHECKED BY:	APPROVED BY:
RTS	TJR	

RFDS REV #: 1 - 12/14/2022

CONSTRUCTION DOCUMENTS

SUBMITTALS		
REV	DATE	DESCRIPTION
A	03/29/23	ISSUED FOR CLIENT REVIEW
B	04/13/23	REVISED PER CLIENT COMMENTS
0	07/24/23	ISSUED FOR CONSTRUCTION
1	07/27/23	REVISED PER CLIENT COMMENTS
2	08/08/23	REVISED PER CLIENT COMMENTS

CEN TEK PROJECT NUMBER
23009.03

DISH Wireless L.L.C.
PROJECT INFORMATION
BOHVN00186A
0 CLARK HILL ROAD
NAUGATUCK CT, 06770

SHEET TITLE
SPECIFICATIONS AND NOTES

SHEET NUMBER
GN-1

RF COLOR CODING

RF Cable Color Codes

Low Bands (N71-N29) Optional - (N29) **ORANGE** AWS (N66-N70) **PURPLE** CORE Tech (3 GHz) **YELLOW** Negative Start Port on Ant/RRH **WHITE**

RF Jumper Color Coding 3/4" legs widths with 3/4" spacing

Low-Band RRH - (600MHz N71 baseband) + (800MHz N29 band) + (700MHz N29 band) - optional per market

Add Frequency Color to Sector Band (CORES will use Yellow bands)

Mid-Band RRH - (AWS bands N66-N70)

Add Frequency Color to Sector Band (CORES will use Yellow bands)

Hybrid/Discret Cables

Example 1: Hybrid of 400MHz (purple) and 800MHz (red) with 400MHz and 800MHz bands

Example 2: Hybrid of 400MHz (purple) and 800MHz (red) with 400MHz and 800MHz bands

Example 3: Hybrid of 400MHz (purple) and 800MHz (red) with 400MHz and 800MHz bands

Example 4: Hybrid of 400MHz (purple) and 800MHz (red) with 400MHz and 800MHz bands

Fiber Jumpers to RRHs

Low Band RRH fiber cables have sector stripe only

Power Cables to RRHs

Low Band RRH power cables have sector stripe only

RET meters at Antennas

RET control is handled by the Mid-Band RRH and not all RET ports exist on antennas

Repeat RET cables are used when antenna ports provide inputs for both CORE and Mid-Band

Microwave Radio Links

Cables will have a 1/2 inch white wrap with the primary color overlapping in the middle. Add additional sector color bands to each additional RRH radio

Microwave cables will require 3/4 inch labels inside the cabinet to identify the local and remote RRH IDs



5701 SOUTH SANTA FE DRIVE
LITTLETON, CO 80120



CEN TEK engineering
Centered on Solutions™

(203) 488-0580
(203) 488-5587 Fax
63-2 North Branford Road
Branford, CT 06405

www.CentekEng.com

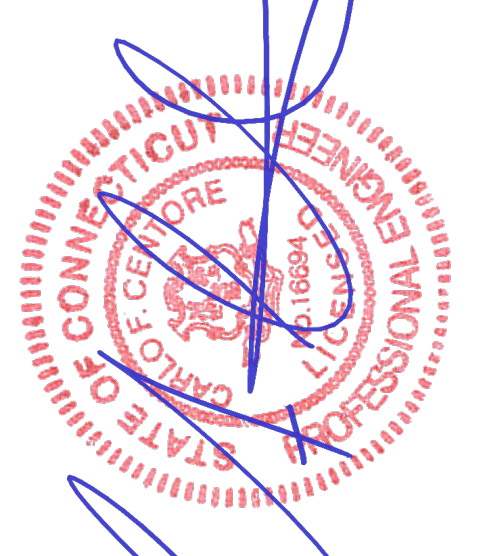

IT IS A VIOLATION OF LAW FOR ANY PERSON, UNLESS THEY ARE ACTING UNDER THE DIRECTION OF A LICENSED PROFESSIONAL ENGINEER, TO ALTER THIS DOCUMENT

DRAWN BY:	CHECKED BY:	APPROVED BY:
RTS	TJR	

RFDS REV #: 1 - 12/14/2022

CONSTRUCTION DOCUMENTS

SUBMITTALS		
REV	DATE	DESCRIPTION
A	03/29/23	ISSUED FOR CLIENT REVIEW
B	04/13/23	REVISED PER CLIENT COMMENTS
0	07/24/23	ISSUED FOR CONSTRUCTION
1	07/27/23	REVISED PER CLIENT COMMENTS
2	08/08/23	REVISED PER CLIENT COMMENTS

CEN TEK PROJECT NUMBER
23009.03

DISH Wireless L.L.C.
PROJECT INFORMATION

BOHVN00186A
0 CLARK HILL ROAD
NAUGATUCK CT, 06770

SHEET TITLE
RF CABLE
COLOR CODES

SHEET NUMBER

RF-1

Exhibit D

Structural Analysis Report

Structural Analysis Report

276-ft Existing Guyed Lattice Tower

*Proposed DISH
Antenna Installation*

DISH Site Ref: BOHVN00186A

*0 Clark Hill Road
Naugatuck, CT*

Centek Project No. 23009.03

Rev 2: September 14, 2023

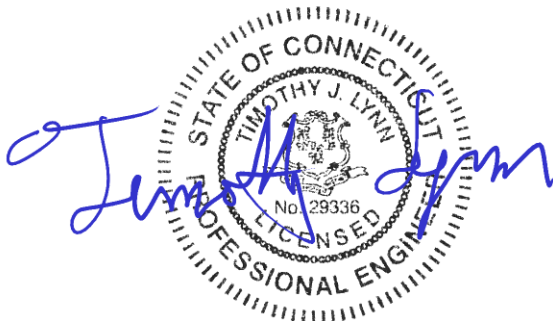

Prepared for:
DISH Wireless, L.L.C.
5701 South Santa Fe Drive,
Littleton, CO 80120

Table of Contents

SECTION 1 - REPORT

- INTRODUCTION
- ANTENNA AND APPURTENANCE SUMMARY
- PRIMARY ASSUMPTIONS USED IN THE ANALYSIS
- ANALYSIS
- TOWER LOADING
- TOWER CAPACITY
- FOUNDATION AND ANCHORS
- CONCLUSION

SECTION 2 – CONDITIONS & SOFTWARE

- STANDARD ENGINEERING CONDITIONS
- GENERAL DESCRIPTION OF STRUCTURAL ANALYSIS PROGRAM

SECTION 3 – CALCULATIONS

- tnxDTower INPUT/OUTPUT SUMMARY
- tnxDTower DETAILED OUTPUT
- FOUNDATION ANALYSIS

SECTION 4 – REFERENCE MATERIAL

- RFDS

Introduction

The purpose of this report is to summarize the results of the non-linear, P- Δ structural analysis of the antenna installation proposed by DISH on the existing guyed lattice tower located in Naugatuck, CT.

The host tower is a 276-ft tall, guyed lattice tower. The manufacturer's drawings and calculations were unavailable for use in this report. The tower geometry, structure member sizes and foundation system information, and all existing antenna and appurtenance information, were obtained from a previous structural analysis report prepared by Fullerton Engineering, P.C.; job no; 2021.0215.0004, dated July 15, 2022 and tower mapping report prepared by FDH dated June 27, 2022. The proposed antenna and appurtenance information was obtained from an RF Data Sheet provided by DISH.

The tower consists of vertical sections constructed of steel pipe legs conforming to ASTM A572-50. Diagonal and horizontal lateral support bracing consists of steel angle construction conforming to ASTM A36. The vertical tower sections are connected by bolted flange plates with the diagonal and horizontal bracing to pipe legs consisting of bolted connections. The width of the tower face is 4-ft throughout its length with the exception of a tapered base section.

Antenna and Appurtenance Summary

- **T-MOBILE (Existing):**
Antennas: Three (3) RFS APXVAARR24 43 panel antennas, three (3) Ericsson AIR 32 panel antennas, three (3) Ericsson AIR6449 panel antennas, three (3) Ericsson 4415 remote radio heads and three (3) Ericsson 4449 remote radio heads mounted on three (3) 12-ft V-Frames with a RAD center elevation of 236-ft above the existing tower base.
Cables: Three (3) 1-5/8" dia. Hybriflex Fiber feeder cables running on the exterior of the existing tower.
- **AT&T (Existing):**
Antennas: Three (3) Ericsson Air6449 B77D panel antennas, three (3) Ericsson Air6419 B77G panel antennas, one (1) CCI DMP65R-BU8DA-K panel antenna, two CCI DMP65R-BU6DA panel antennas, two (2) Kathrein 800-10966 panel antennas, one (1) Kathrein 800-10965 panel antennas, three (3) Ericsson 4449 remote radio heads, three (3) Ericsson RRUS-32 B2 remote radio heads, three (3) Ericsson RRUS-32 B30 remote radio heads, three (3) Ericsson RRUS 4478 B14 remote radio heads, Ericsson 4426 B66 remote radio heads, and three (3) Raycap DC6-48-60-18-8F surges mounted on three (3) Sitepro1 VFA12-HD Sector Frames with a RAD center elevation of 220-ft above the existing tower base.
Coax Cables: Two (2) RG6-Fiber cables and four (4) DC Trunk cables running on the exterior of the existing tower.
- **DISH (Proposed):**
Antenna: Three (3) JMA MX08FRO665-21 panel antennas, three (3) Fujitsu TA08025-B605 remote radio heads, three (3) Fujitsu TA08025-B604 remote radio heads and one (1) Raycap RDIDC-9181-PF-48 OVP mounted on three (3) Commscope V-Frame Sector Frames with a RAD center elevation of 170-ft above the existing tower base.
Coax Cables: One (1) 1.75" Cables Unlimited CU12PSM6P4XXX_4AWG Hybrid cable running on the exterior of the existing tower.

Primary Assumptions Used in the Analysis

- The tower structure's theoretical capacity not including any assessment of the condition of the tower.
- The tower carries the horizontal and vertical loads due to the weight of antennas, ice load and wind.
- Tower is properly installed and maintained.
- Tower is in plumb condition.
- Tower loading for antennas and mounts as listed in this report.
- All bolts are appropriately tightened providing the necessary connection continuity.
- All welds are fabricated with ER-70S-6 electrodes.
- All members are assumed to be as specified in the original tower design documents or reinforcement drawings.
- All members are "hot dipped" galvanized in accordance with ASTM A123 and ASTM A153 Standards.
- All member protective coatings are in good condition.
- All tower members were properly designed, detailed, fabricated, installed and have been properly maintained since erection.
- Any deviation from the analyzed antenna loading will require a new analysis for verification of structural adequacy.
- All coax cables to be installed as indicated in this report.

A n a l y s i s

The existing tower was analyzed using a comprehensive computer program entitled tnxTower. The program analyzes the tower, considering the worst case loading condition. The tower is considered as loaded by concentric forces along the tower, and the model assumes that the tower members are subjected to bending, axial, and shear forces.

The existing tower was analyzed for the controlling basic wind speed (3-second gust) with no ice and the applicable wind and ice combination to determine stresses in members as per guidelines of TIA-222-H entitled “Structural Standard for Antenna Support Structures and Antennas”, the American Institute of Steel Construction (AISC) and the Manual of Steel Construction; Load and Resistance Factor Design (LRFD).

The controlling wind speed is determined by evaluating the local available wind speed data as provided in Appendix P of the CSBC¹ and the wind speed data available in the TIA-222-H Standard.

T o w e r L o a d i n g

Tower loading was determined by the basic wind speed as applied to projected surface areas with modification factors per TIA-222-H, gravity loads of the tower structure and its components, and the application of 1.00” radial ice on the tower structure and its components.

Load Cases:	<u>Load Case 1</u> ; 120 mph (Ultimate) wind speed w/ no ice plus gravity load – used in calculation of tower stresses and rotation.	<i>[Appendix P of the 2022 CT Building Code]</i>
	<u>Load Case 2</u> ; 50 mph wind speed w/ 1.00” radial ice plus gravity load – used in calculation of tower stresses.	<i>[Annex B of TIA-222-H]</i>

¹ The 2021 International Building Code as amended by the 2022 Connecticut State Building Code (CSBC).

Tower Capacity

- Calculated stresses **were found** to be within allowable limits.

Tower Section	Elevation	Stress Ratio (percentage of capacity)	Result
Leg (T18)	162' - 182'	74.1%	PASS
Diagonal (T2)	261.75' – 265.5'	85.0%	PASS
Guy A (T15)	202'	66.8%	PASS
Guy B (T15)	202'	64.9%	PASS
Guy C (T15)	202'	62.9%	PASS

Foundations and Anchorage

The existing tower base foundation consists of a 3'-0" dia. x 5'-6" long reinforced circular concrete pedestal with a 8'-2" x 6'-2" x 1'-6" thick reinforced concrete pad bearing directly on the existing sub grade. Additionally, guy wire loading is transferred to six (6) existing 11-ft x 4.5-ft x 3-ft reinforced concrete anchor support blocks. The foundation information was obtained from the structural analysis report document prepared by Fullerton Engineering, PC dated by 07/15/2022.

The worst case tower base and guy anchor reactions developed from the governing Load Case were used in the verification of the anchorage foundations:

Tower Guy Reactions			
Vector	Guy A	Guy B	Guy C
Horizontal (In Plane of GW)	54 kips	52 kips	54 kips
Horizontal (Out of Plane of GW)	1 kips	1 kips	1 kips
Vertical	55 kips	60 kips	55 kips
Resultant Force at end of Guy Wire	77 kips	79 kips	77 kips
Tower Base Reactions			
Vector	Proposed Reaction		
Horizontal Shear	1 kips		
Axial Compression	164 kips		

Foundation	Design Limit	TIA-222-H ⁽¹⁾	Proposed Loading (FS) ⁽¹⁾	Result
Reinf. Conc. Anchor Block (A)	Uplift	1.0	2.41	PASS
	Sliding	1.0	1.02	PASS
		Ultimate Bearing	Proposed	
Base Foundation	Bearing	12.0 ksf	3.63 ksf	PASS

Note 1: FS denotes 'Factor of Safety'.

Conclusion

This analysis shows that the subject tower **is structurally adequate** to support the proposed modified antenna configuration.

The analysis is based, in part, on the information provided to this office by DISH. If the existing conditions are different than the information in this report, Centek Engineering, Inc. must be contacted for resolution of any potential issues.

Please feel free to call with any questions or comments.

Respectfully Submitted by:

Timothy J. Lynn, PE
 Structural Engineer

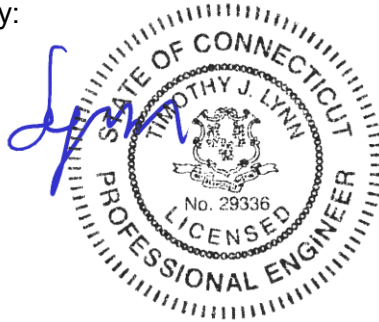

*Standard Conditions for Furnishing of
Professional Engineering Services on
Existing Structures*

All engineering services are performed on the basis that the information used is current and correct. This information may consist of, but is not necessarily limited to:

- Information supplied by the client regarding the structure itself, its foundations, the soil conditions, the antenna and feed line loading on the structure and its components, or other relevant information.
- Information from the field and/or drawings in the possession of Centek Engineering, Inc. or generated by field inspections or measurements of the structure.
- It is the responsibility of the client to ensure that the information provided to Centek Engineering, Inc. and used in the performance of our engineering services is correct and complete. In the absence of information to the contrary, we assume that all structures were constructed in accordance with the drawings and specifications and are in an un-corroded condition and have not deteriorated. It is therefore assumed that its capacity has not significantly changed from the “as new” condition.
- All services will be performed to the codes specified by the client, and we do not imply to meet any other codes or requirements unless explicitly agreed in writing. If wind and ice loads or other relevant parameters are to be different from the minimum values recommended by the codes, the client shall specify the exact requirement. In the absence of information to the contrary, all work will be performed in accordance with the latest revision of ANSI/ASCE10 & ANSI/EIA-222
- All services performed, results obtained, and recommendations made are in accordance with generally accepted engineering principles and practices. Centek Engineering, Inc. is not responsible for the conclusions, opinions and recommendations made by others based on the information we supply.

GENERAL DESCRIPTION OF STRUCTURAL ANALYSIS PROGRAM

TnxTower, is an integrated structural analysis and design software package for Designed specifically for the telecommunications industry, TnxTower, formerly ERITower, automates much of the tower analysis and design required by the TIA/EIA 222 Standard.

TnxTower Features:

- TnxTower can analyze and design 3- and 4-sided guyed towers, 3- and 4-sided self-supporting towers and either round or tapered ground mounted poles with or without guys.
- The program analyzes towers using the TIA-222-H standard or any of the previous TIA/EIA standards back to RS-222 (1959). Steel design is checked using the AISC ASD or the AISC LRFD specifications.
- Linear and non-linear (P-delta) analyses can be used in determining displacements and forces in the structure. Wind pressures and forces are automatically calculated.
- Extensive graphics plots include material take-off, shear-moment, leg compression, displacement, twist, feed line, guy anchor and stress plots.
- TnxTower contains unique features such as True Cable behavior, hog rod take-up, foundation stiffness and much more.

Section	T1	T2	T3	T4	T5	T6	T7	T8	T9	T10	T11	T12	T13	T14	T15	T16	T17	T18	T19	T20	T21	T22	T23	T24	T25	T26	T27	T28	T29	T30	T31	T32	T33	T34	T35	T36	T37	T38	T39	T40	T41	T42	T43	T44	T45	T46	T47	T48	T49	T50	T51	T52	T53	T54	T55	T56	T57	T58
Legs	SR 1 3/4																																																									
Leg Grade	A572-50																																																									
Diagonals	L1 3/4x1 3/4x3/16														L2 1/2x2 1/2x3/8														L2 1/2x2 1/2x1/4														L2x2x3/8															
Diagonal Grade	L2x2x3/16														L2x2x3/16														L2x2x3/16														L2x2x3/16															
Top Girts	N.A.														L2x2x3/16														N.A.														L2x2x3/16															
Horizontals	L2x2x3/16														N.A.														L2x2x3/16														L2x2x3/16															
Sec. Horizontals	N.A.														L2x2x3/16														N.A.														L2x2x3/16															
Top Guy Pull-Offs	N.A.														L2x2x3/16														N.A.														L2x2x3/16															
Face Width (ft)	N.A.														L2x2x3/16														N.A.														L2x2x3/16															
# Panels @ (ft)	N.A.														L2x2x3/16														N.A.														L2x2x3/16															
Weight (K)	18.7														0.3														0.3														0.3															
	3 @ 3.5														2 @ 3.75														0.2														0.5															

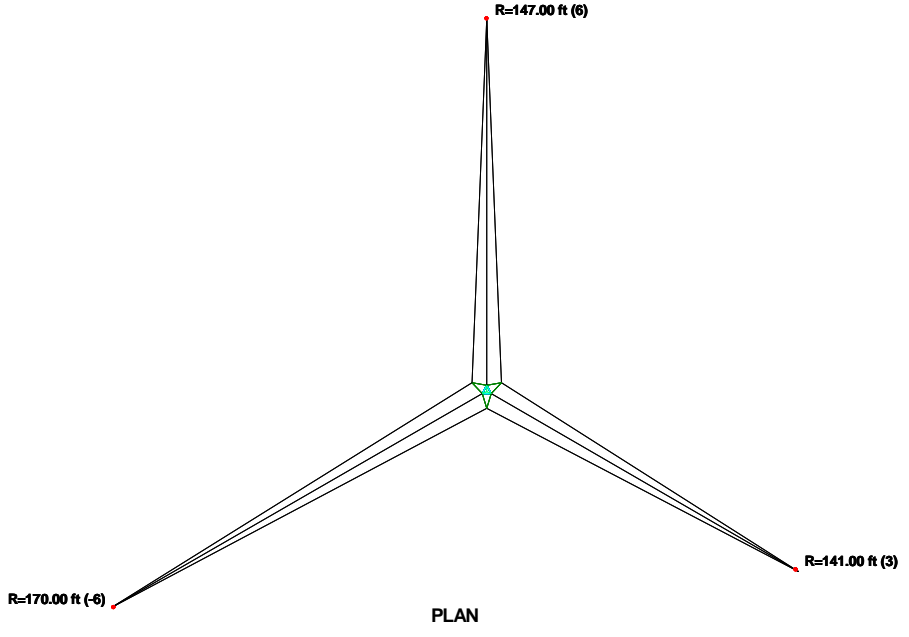
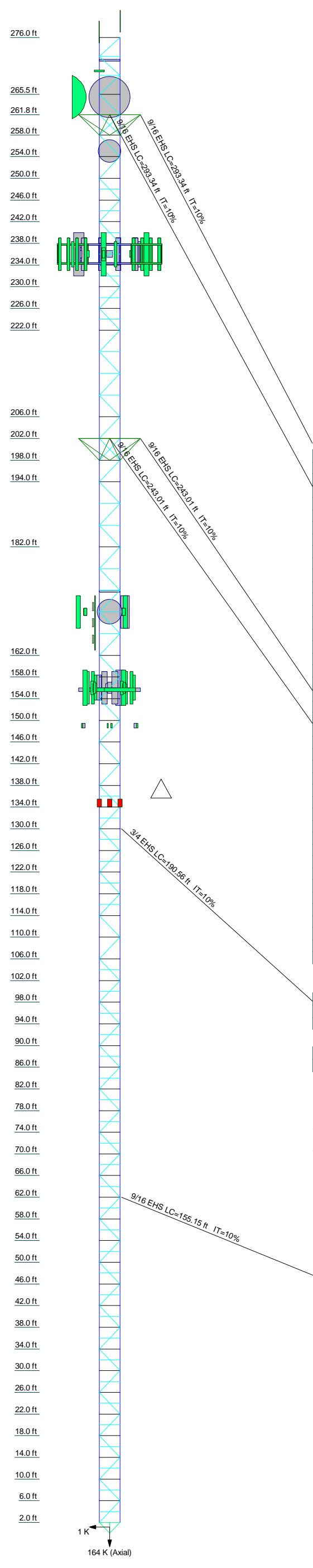

DESIGNED APPURTENANCE LOADING

TYPE	ELEVATION	TYPE	ELEVATION
Flash Beacon Lighting	277	HPA-65R-BUU-H6 (ATI)	156
4-ft Lightning Rod	277	HPA-65R-BUU-H6 (ATI)	156
6' Dish Ice Shield	274 - 270	QS66512-2 (ATI)	156
6' Dish Ice Shield	270	QS66512-2 (ATI)	156
8' Dish	265	QS66512-2 (ATI)	156
8' Dish	265	80010965 (ATI)	156
PR-460	255	80010965 (ATI)	156
APXVAARR24-43	236	80010965 (ATI)	156
APXVAARR24-43	236	7770.00 w/ mount pipe (ATI)	156
APXVAARR24-43	236	7770.00 w/ mount pipe (ATI)	156
AIR32	236	7770.00 w/ mount pipe (ATI)	156
AIR32	236	RRUS-32 (ATI)	156
AIR32	236	RRUS-32 (ATI)	156
AIR6449	236	RRUS-32 (ATI)	156
AIR6449	236	LGP21401 TMA (ATI)	156
AIR6449	236	LGP21401 TMA (ATI)	156
4415 B25	236	LGP21401 TMA (ATI)	156
4415 B25	236	TPX-070821 (ATI)	156
4415 B25	236	TPX-070821 (ATI)	156
4449 B12,B71	236	TPX-070821 (ATI)	156
4449 B12,B71	236	4478 B14 (ATI)	156
4449 B12,B71	236	4478 B14 (ATI)	156
12' V-Frame	236	4478 B14 (ATI)	156
12' V-Frame	236	RRUS-11 (ATI)	156
12' V-Frame	236	RRUS-11 (ATI)	156
F24x18	196	RRUS-11 (ATI)	156
6' Dish Ice Shield	174	DC6-48-60-18-8F Surge Arrestor (ATI)	156
MX08FRO665-21 (DISH)	170	DC6-48-60-18-8F Surge Arrestor (ATI)	156
MX08FRO665-21 (DISH)	170	DC6-48-60-18-8F Surge Arrestor (ATI)	156
MX08FRO665-21 (DISH)	170	Valmont 13' Lightweight T-Frame (ATI)	156
TA08025-B605 (DISH)	170	Valmont 13' Lightweight T-Frame (ATI)	156
TA08025-B605 (DISH)	170	Valmont 13' Lightweight T-Frame (ATI)	156
TA08025-B605 (DISH)	170	HPA-65R-BUU-H6 (ATI)	156
TA08025-B604 (DISH)	170	(2) DBCT108F1V92-1 (ATI)	149
TA08025-B604 (DISH)	170	(2) DBCT108F1V92-1 (ATI)	149
TA08025-B604 (DISH)	170	(2) DBCT108F1V92-1 (ATI)	149
RD1DC-9181-PF-48 (DISH)	170	Beacon	134
VFA8-SD-S (DISH)	170	Beacon	134
VFA8-SD-S (DISH)	170	Beacon	134
VFA8-SD-S (DISH)	170	DB222-A	115
GHF4-23A	170	Weather Equipment	52
4 Bay DiPole	163	alarm	20

SYMBOL LIST

MARK	SIZE	MARK	SIZE
A	L2 1/2x2 1/2x1/4	C	L2 1/2x2 1/2x3/8
B	L2x2x3/16		

MATERIAL STRENGTH

GRADE	Fy	Fu	GRADE	Fy	Fu
A572-50	50 ksi	65 ksi	A36	36 ksi	58 ksi

TOWER DESIGN NOTES

1. Tower is located in New Haven County, Connecticut.
2. Tower designed for Exposure B to the TIA-222-H Standard.
3. Tower designed for a 120 mph basic wind in accordance with the TIA-222-H Standard.
4. Tower is also designed for a 50 mph basic wind with 1.00 in ice. Ice is considered to increase in thickness with height.
5. Deflections are based upon a 60 mph wind.
6. Tower Risk Category II.
7. Topographic Category 1 with Crest Height of 0.00 ft
8. TOWER RATING: 85%

ALL REACTIONS ARE FACTORED

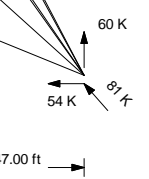

Centek Engineering Inc.
 63-2 North Branford Rd.
 Branford, CT 06405
 Phone: (203) 488-0580
 FAX: (203) 488-8587

Job: **23009.03 - BOHVN00186A**
 Project: **276' Guyed Lattice Tower - 0 Clark Hill Rd., Naugatuck, CT**
 Client: DISH
 Code: TIA-222-H
 Path: J:\2009\230090\W03_BOHVN00186A\05_Structural\Structural Analysis\Calc\Rev 2\276' Guyed Lattice Tower_BOHVN00186A_CT.dwg

Drawn by: T.JL
 Date: 09/14/23
 App'd:
 Scale: NTS
 Dwg No. E-1

Feed Line Distribution Chart

2' - 276'

— Round
 — Flat
 — App In Face
 — App Out Face
 — Truss Leg

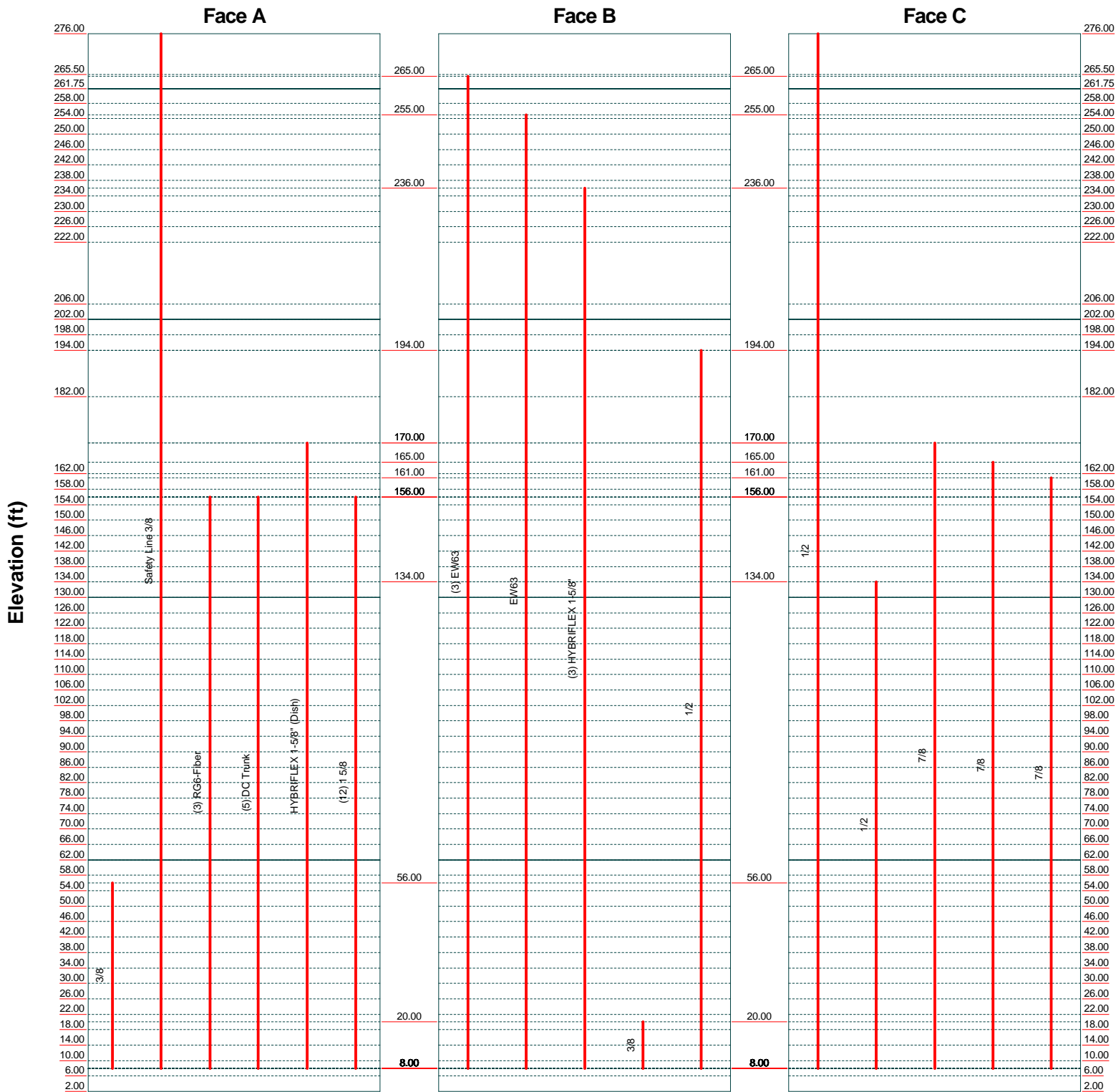

Centek Engineering Inc.		
63-2 North Branford Rd. Branford, CT 06405 Phone: (203) 488-0580 FAX: (203) 488-8587		
Job: 23009.03 - BOHVN00186A	Project: 276' Guyed Lattice Tower - 0 Clark Hill Rd., Naugatuck, CT	Client: DISH
Code: TIA-222-H	Date: 09/14/23	App'd: TJL
Path: <small>J:\Jobs\23009000\W03_BOHVN00186A\05_Structural\Structural Analysis\Calc\Rev 230716 Guyed Lattice Tower_BOHVN00186A.ctb</small>	Scale: NTS	Dwg No: E-7

Feed Line Plan

— Round
 — Flat
 — App In Face
 — App Out Face

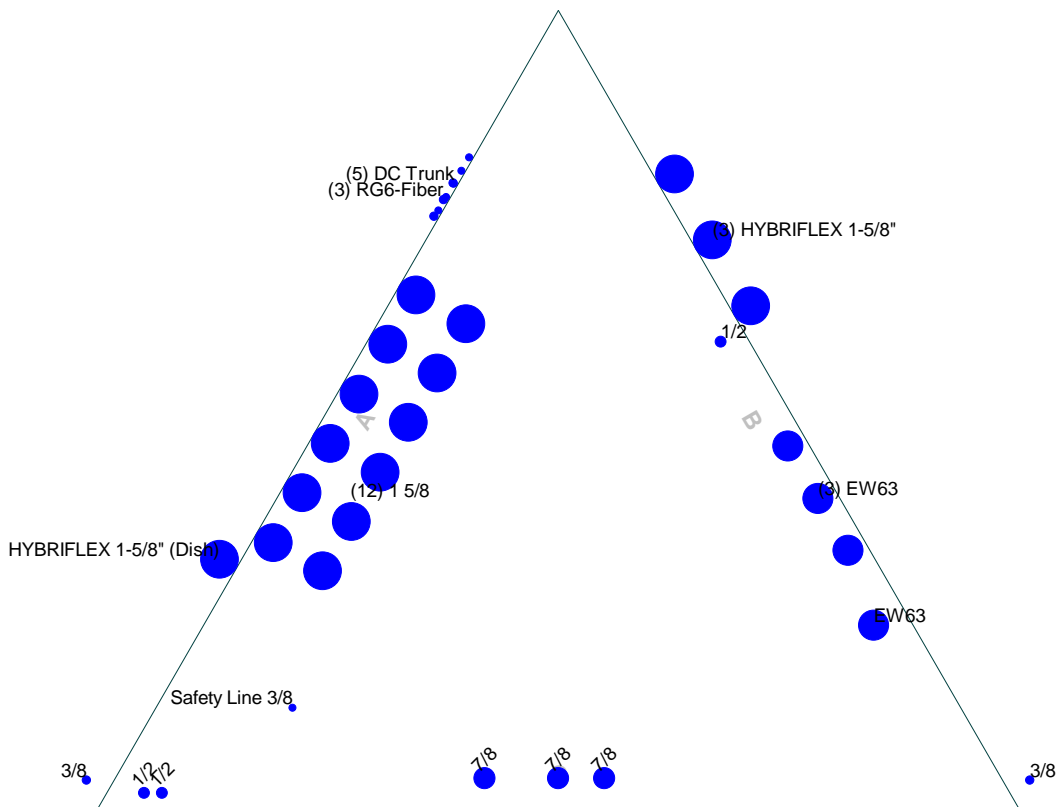

Centek Engineering Inc. 63-2 North Branford Rd. Branford, CT 06405 Phone: (203) 488-0580 FAX: (203) 488-8587		Job: 23009.03 - BOHVN00186A	
		Project: 276' Guyed Lattice Tower - 0 Clark Hill Rd., Naugatuck, CT	
Client: DISH	Drawn by: T.JL	App'd:	
Code: TIA-222-H	Date: 09/14/23	Scale: NTS	
Path:	Dwg No: E-7		

J:\Jobs\23009.03 - BOHVN00186A\05 - Structural\Structural Analysis\Calc\Rev 2023\H Guyed Lattice Tower - BOHVN00186A - CT.dwg

tnxTower Centek Engineering Inc. 63-2 North Branford Rd. Branford, CT 06405 Phone: (203) 488-0580 FAX: (203) 488-8587	Job 23009.03 - BOHVN00186A	Page 1 of 162
	Project 276' Guyed Lattice Tower - 0 Clark Hill Rd., Naugatuck, CT	Date 16:33:12 09/14/23
	Client DISH	Designed by TJL

Tower Input Data

The main tower is a 3x guyed tower with an overall height of 276.00 ft above the ground line.

The base of the tower is set at an elevation of 0.00 ft above the ground line.

The face width of the tower is 4.00 ft at the top and 4.00 ft at the base.

This tower is designed using the TIA-222-H standard.

The following design criteria apply:

Tower is located in New Haven County, Connecticut.

Tower base elevation above sea level: 0.00 ft.

Basic wind speed of 120 mph.

Risk Category II.

Exposure Category B.

Simplified Topographic Factor Procedure for wind speed-up calculations is used.

Topographic Category: 1.

Crest Height: 0.00 ft.

Nominal ice thickness of 1.0000 in.

Ice thickness is considered to increase with height.

Ice density of 56 pcf.

A wind speed of 50 mph is used in combination with ice.

Temperature drop of 50 °F.

Deflections calculated using a wind speed of 60 mph.

I-Beam base is 2.00 ft above the pivot.

Pressures are calculated at each section.

Stress ratio used in tower member design is 1.

Safety factor used in guy design is 1.

Local bending stresses due to climbing loads, feed line supports, and appurtenance mounts are not considered.

Options

Consider Moments - Legs Consider Moments - Horizontals Consider Moments - Diagonals Use Moment Magnification ✓ Use Code Stress Ratios ✓ Use Code Safety Factors - Guys Escalate Ice Always Use Max Kz Use Special Wind Profile ✓ Include Bolts In Member Capacity ✓ Leg Bolts Are At Top Of Section ✓ Secondary Horizontal Braces Leg Use Diamond Inner Bracing (4 Sided) ✓ SR Members Have Cut Ends SR Members Are Concentric	Distribute Leg Loads As Uniform Assume Legs Pinned ✓ Assume Rigid Index Plate ✓ Use Clear Spans For Wind Area ✓ Use Clear Spans For KL/r ✓ Retension Guys To Initial Tension ✓ Bypass Mast Stability Checks ✓ Use Azimuth Dish Coefficients ✓ Project Wind Area of Appurt. ✓ Autocalc Torque Arm Areas Add IBC .6D+W Combination ✓ Sort Capacity Reports By Component Triangulate Diamond Inner Bracing Treat Feed Line Bundles As Cylinder Ignore KL/ry For 60 Deg. Angle Legs	Use ASCE 10 X-Brace Ly Rules ✓ Calculate Redundant Bracing Forces Ignore Redundant Members in FEA SR Leg Bolts Resist Compression All Leg Panels Have Same Allowable Offset Girt At Foundation ✓ Consider Feed Line Torque Include Angle Block Shear Check Use TIA-222-H Bracing Resist. Exemption Use TIA-222-H Tension Splice Exemption <div style="background-color: #e0e0e0; text-align: center; padding: 2px;">Poles</div> Include Shear-Torsion Interaction Always Use Sub-Critical Flow Use Top Mounted Sockets Pole Without Linear Attachments Pole With Shroud Or No Appurtenances Outside and Inside Corner Radii Are Known
--	---	---

Job	23009.03 - BOHVN00186A	Page	2 of 162
Project	276' Guyed Lattice Tower - 0 Clark Hill Rd., Naugatuck, CT	Date	16:33:12 09/14/23
Client	DISH	Designed by	TJL

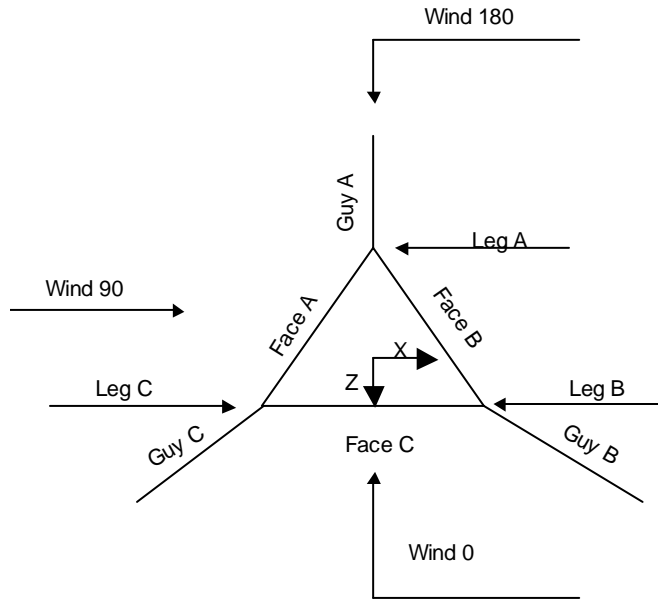

Corner & Starmount Guyed Tower

tnxTower Centek Engineering Inc. 63-2 North Branford Rd. Branford, CT 06405 Phone: (203) 488-0580 FAX: (203) 488-8587	Job 23009.03 - BOHVN00186A	Page 3 of 162
	Project 276' Guyed Lattice Tower - 0 Clark Hill Rd., Naugatuck, CT	Date 16:33:12 09/14/23
	Client DISH	Designed by TJL

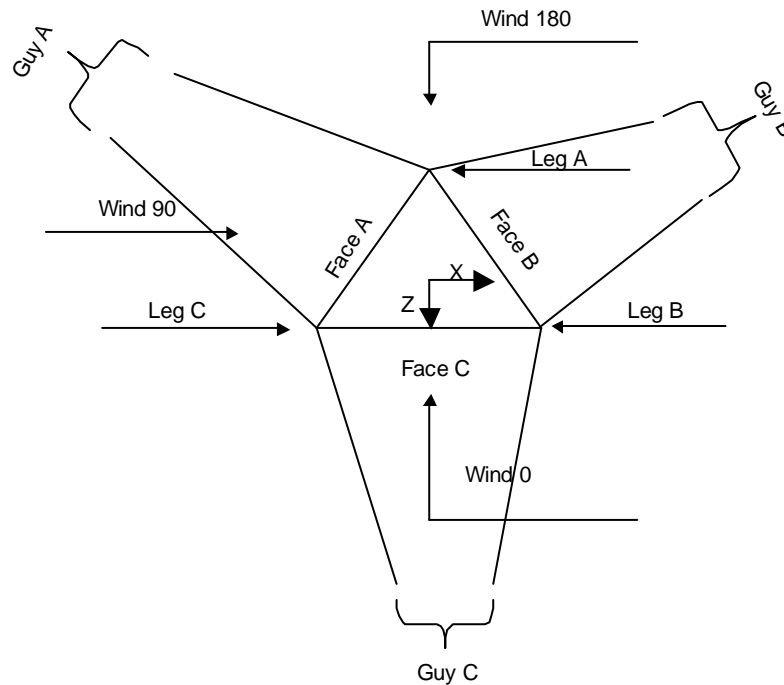

Face Guyed

Tower Section Geometry

Tower Section	Tower Elevation	Assembly Database	Description	Section Width	Number of Sections	Section Length
	ft			ft		ft
T1	276.00-265.50			4.00	1	10.50
T2	265.50-261.75			4.00	1	3.75
T3	261.75-258.00			4.00	1	3.75
T4	258.00-254.00			4.00	1	4.00
T5	254.00-250.00			4.00	1	4.00
T6	250.00-246.00			4.00	1	4.00
T7	246.00-242.00			4.00	1	4.00
T8	242.00-238.00			4.00	1	4.00
T9	238.00-234.00			4.00	1	4.00
T10	234.00-230.00			4.00	1	4.00
T11	230.00-226.00			4.00	1	4.00
T12	226.00-222.00			4.00	1	4.00
T13	222.00-206.00			4.00	1	16.00
T14	206.00-202.00			4.00	1	4.00
T15	202.00-198.00			4.00	1	4.00
T16	198.00-194.00			4.00	1	4.00

Exhibit E

Mount Analysis

INFINIGY

MOUNT ANALYSIS REPORT

March 14, 2023

Dish Wireless Site Number	BOHVN00186A
Infinigy Job Number	1197-F0001-B
Client	Northeast Site Solutions
Carrier	Dish Wireless
Site Location	0 Clark Hill Road Naugatuck, CT 06770 New Haven County 41° 31' 04.6" N NAD83 73° 01' 06.4" W NAD83
Structure Type	Guyed Tower
Structure Height	276.0 ft
Mount Type	10.0 ft Sector Frames
Mount Elevation	170.0 ft AGL
Structural Usage Ratio	39.1%
Overall Result	Pass

The enclosed structural analysis has been performed in accordance with the 2022 Connecticut State Building Code (2021 IBC) based on an ultimate 3-second gust wind speed of 118 mph. The evaluation criteria and applicable standards are presented in the next section of this report.

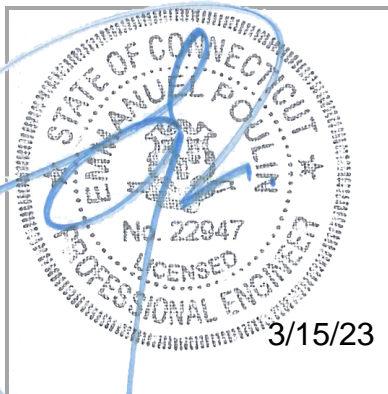

structural@infinigy.com

CONTENTS

1. Introduction
2. Design/Analysis Parameters
3. Proposed Loading Configuration
4. Supporting Documentation
5. Results
6. Recommendations
7. Assumptions
8. Liability Waiver and Limitations
9. Calculations

1. INTRODUCTION

Infinigy performed a structural analysis on the Dish Wireless proposed telecommunication equipment supporting Sector Frames mounted to the existing structure located at the aforementioned address. All referenced supporting documents have been obtained from the client and are assumed to be accurate and applicable to this site. The mount was analyzed using RISA-3D version 20.0.6 analysis software.

2. DESIGN/ANALYSIS PARAMETERS

Wind Speed	118 mph (3-Second Gust)
Wind Speed w/ ice	50 mph (3-Second Gust) w/ 1.0" ice
Adopted Code	2022 Connecticut State Building Code (2021 IBC)
Standard(s)	TIA-222-H
Risk Category	II
Exposure Category	B
Topographic Factor	1.0
Seismic Spectral Response	$S_s = 0.196 \text{ g} / S_1 = 0.054 \text{ g}$
Live Load Wind Speed	30 mph
Man Live Load at Mid/End Points	250 lbs
Man Live Load at Mount Pipes	500 lbs
Ground Elevation (HMSL)	750.5 ft

3. PROPOSED LOADING CONFIGURATION - 170.0 ft. AGL Sector Frames

Centerline (ft)	Qty.	Appurtenance Manufacturers	Appurtenance Models
170.0	3	JMA WIRELESS	MX08FRO665-21
	3	FUJITSU	TA08025-B604
	3	FUJITSU	TA08025-B605
	1	RAYCAP	RDIDC-9181-PF-48

4. SUPPORTING DOCUMENTATION

Construction Drawings	Infinigy dated May 03, 2021
Dish Wireless Proposed Loading	RFDS dated April 23, 2021
Mount Specifications	Sabre Industries: C10837002C-32788

5. RESULTS

Components	Capacity (%)	Pass/Fail
Horizontal	37.8	Pass
Arms	11.8	Pass
Mount Pipe	15.1	Pass
Bracing	13.8	Pass
Connections	39.1	Pass
RATING =	39.1	Pass

Notes:

- See additional documentation in Appendix for calculations supporting the capacity consumed and detailed mount connection calculations.
- Results reflect worst case sector (alpha).

6. RECOMMENDATIONS

Infinigy recommends installing Dish Wireless's proposed equipment loading configuration on the proposed Sector Frames at 170.0 ft. The installation shall be performed in accordance with the construction documents issued by Infinigy for this site.

If you have any questions, require additional information, or believe the actual conditions differ from those detailed in this report, please contact us immediately.

Robert Faber
Project Engineer I | **INFINIGY**

7. ASSUMPTIONS

The antenna mounting system was properly fabricated, installed and maintained in accordance with its original design and manufacturer's specifications.	
The configuration of antennas, mounts, and other appurtenances are as specified in the proposed loading configuration table.	
All member connections are assumed to have been designed to meet or exceed the load carrying capacity of the connected member unless otherwise specified in this report.	
The analysis will require revisions if the existing conditions in the field differ from those shown in the above-referenced documents or assumed in this analysis. No allowance was made for any damaged, missing, or rusted members.	
Steel grades have been assumed as follows, unless noted otherwise:	
Channel, Solid Round, Angle, Plate	ASTM A36
HSS (Rectangular)	ASTM A500-B GR 46
HSS (Circular)	ASTM A500-B GR 42
Pipe	ASTM A53-B GR 35
Connection Bolts	ASTM A325
U-Bolts / Threaded Rods	ASTM A307
All bolted connections are pretensioned in accordance with Table 8.2 of the RCSC 2014 Standard.	

8. LIABILITY WAIVER AND LIMITATIONS

Our structural calculations are completed assuming all information provided to Infinigy is accurate and applicable to this site. For the purposes of calculations, we assume an overall structure condition as erected and all members and connections to be free of corrosion and/or structural defects. The structure owner and/or contractor shall verify the structure's condition prior to installation of any proposed equipment. If actual conditions differ from those described in this report, Infinigy should be notified immediately to assess the impact on the results of this report.

Our evaluation is completed using industry standard methods and procedures. The structural results, conclusions and recommendations contained in this report are proprietary and should not be used by others as their own. Infinigy is not responsible for decisions made by others that are or are not based on the stated assumptions and conclusions in this report.

This report is an evaluation of the mount structure only and does not determine the adequacy of the supporting structure, other carrier mounts or cable mounting attachments. The analysis of these elements is outside the scope of this analysis, are assumed to be adequate for the purpose of this report and to have been installed per their manufacturer requirements. This document is not for construction purposes.

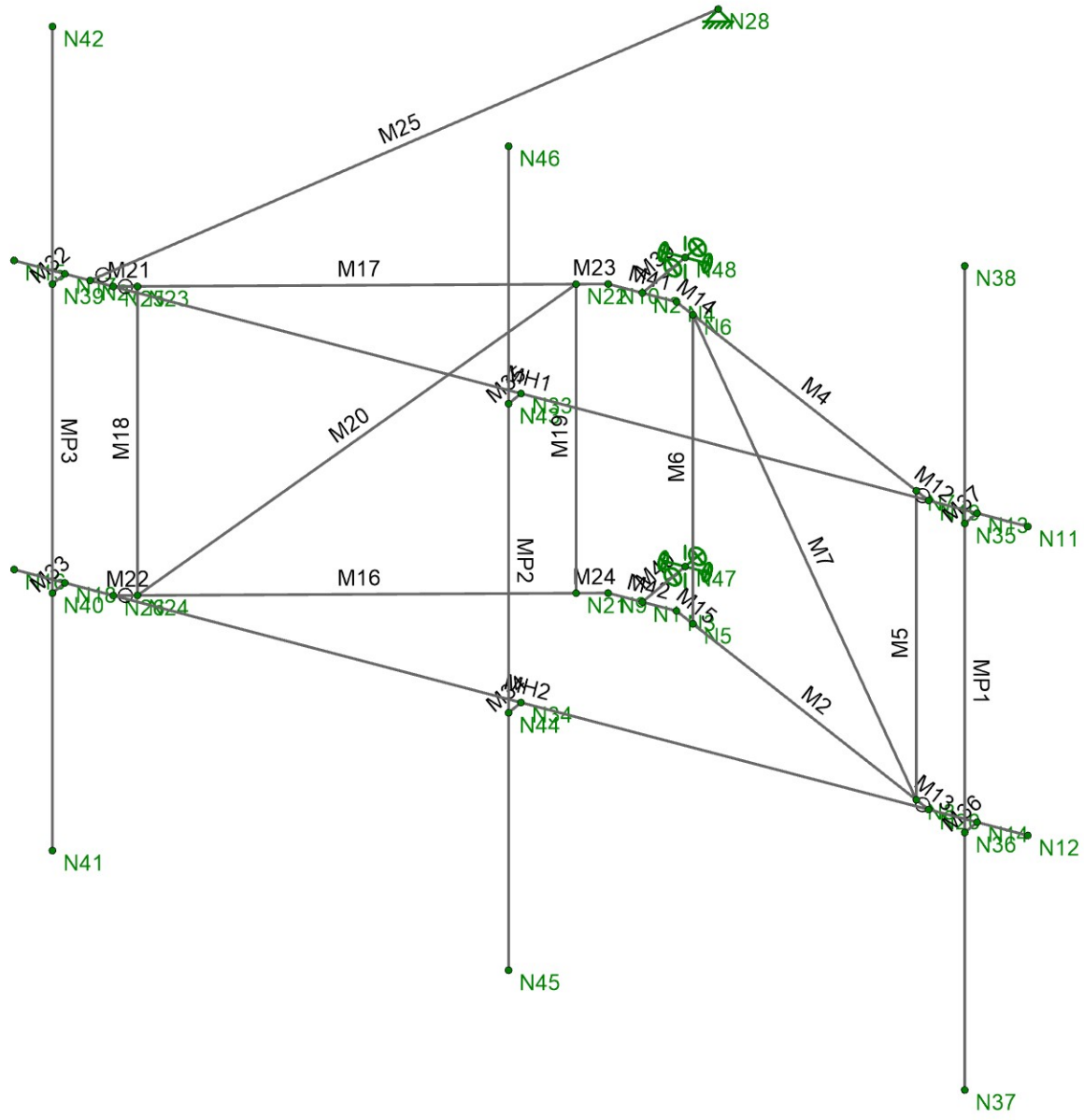
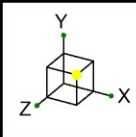

Infinigy	BOHVN00186A	Wireframe1
RF		Mar 15, 2023
1197-F0001-B		BOHVN00186A_loaded.r3d

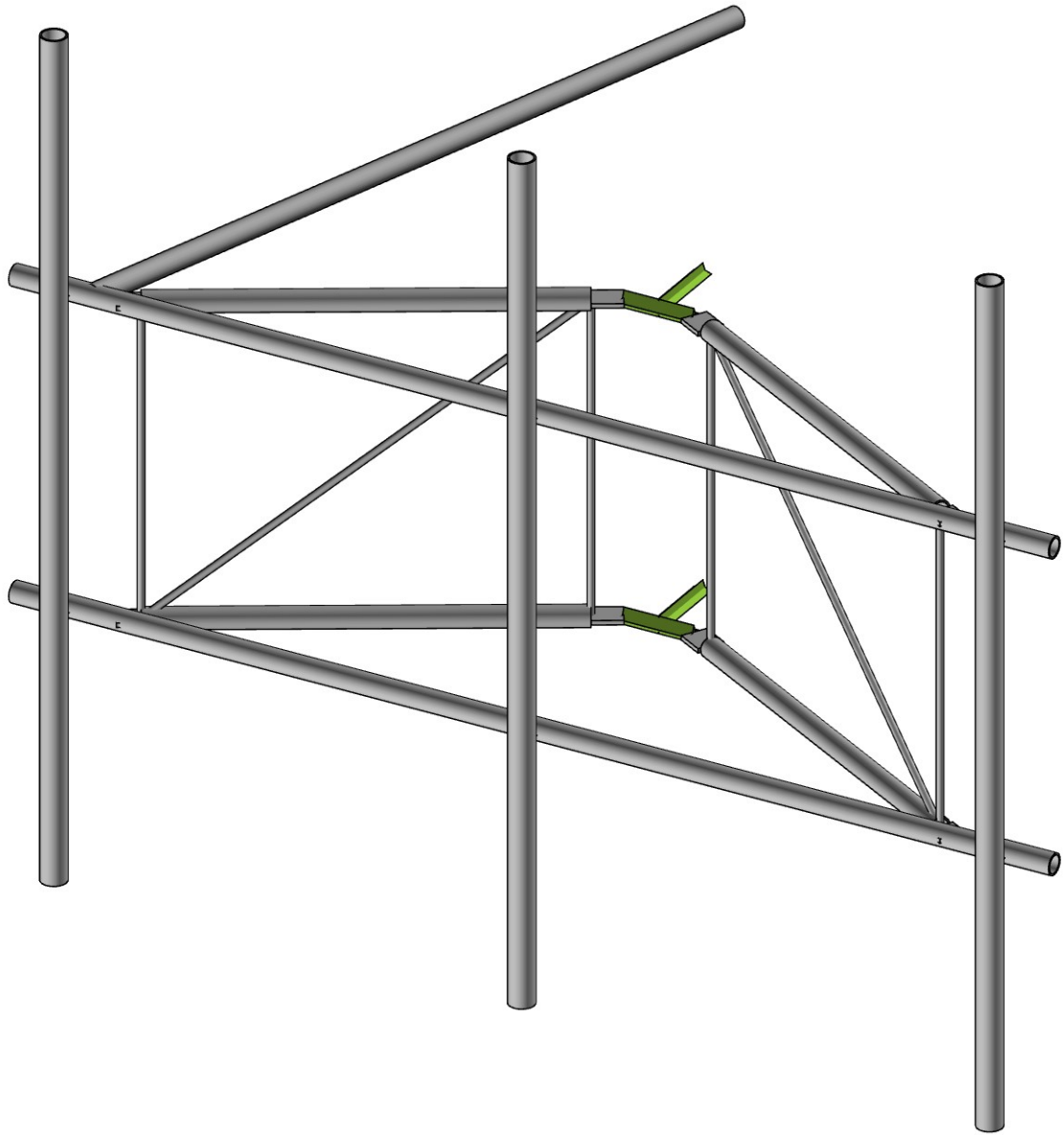
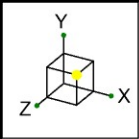

Infinigy	BOHVN00186A	Render2
RF		Mar 15, 2023
1197-F0001-B		BOHVN00186A_loaded.r3d

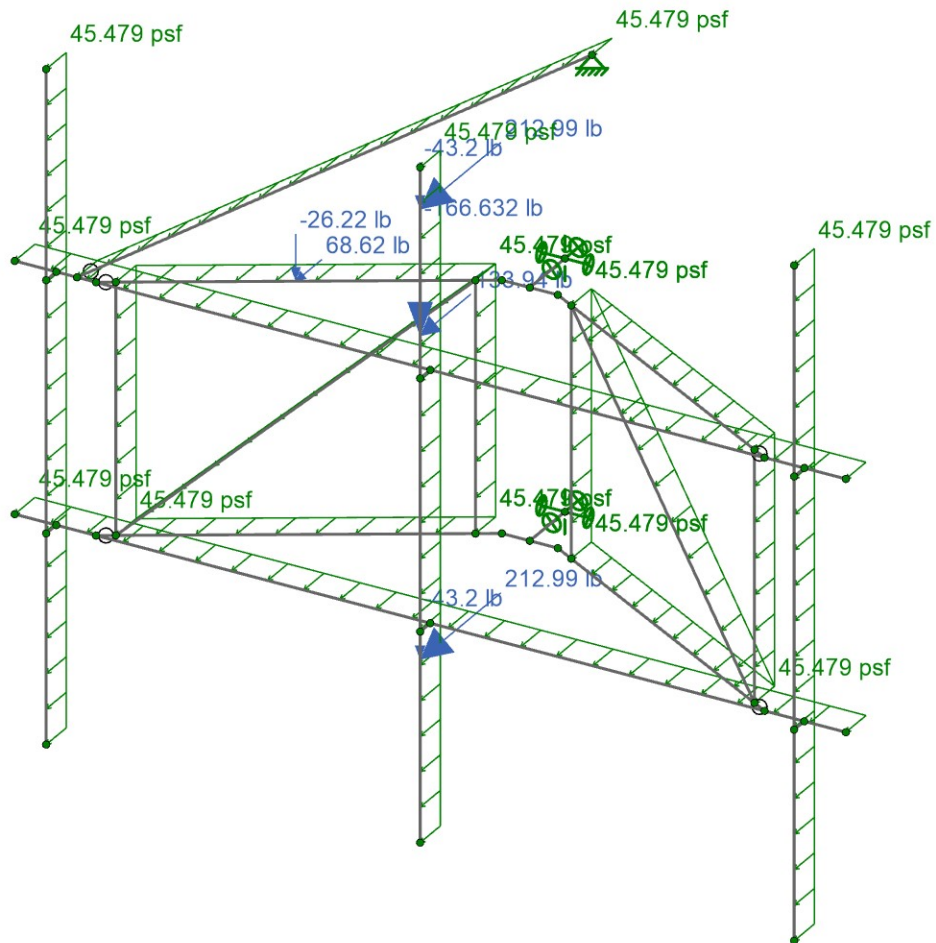
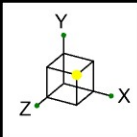

Loads: LC 8, 1.2DL + 1WL AZI 180

Infinigy
RF
1197-F0001-B

BOHVN00186A

3
Mar 15, 2023
BOHVN00186A_loaded.r3d

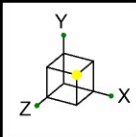

Code Check (Env)	
Black	No Calc
Red	> 1.0
Magenta	.90-1.0
Green	.75-.90
Cyan	.50-.75
Blue	0.-.50

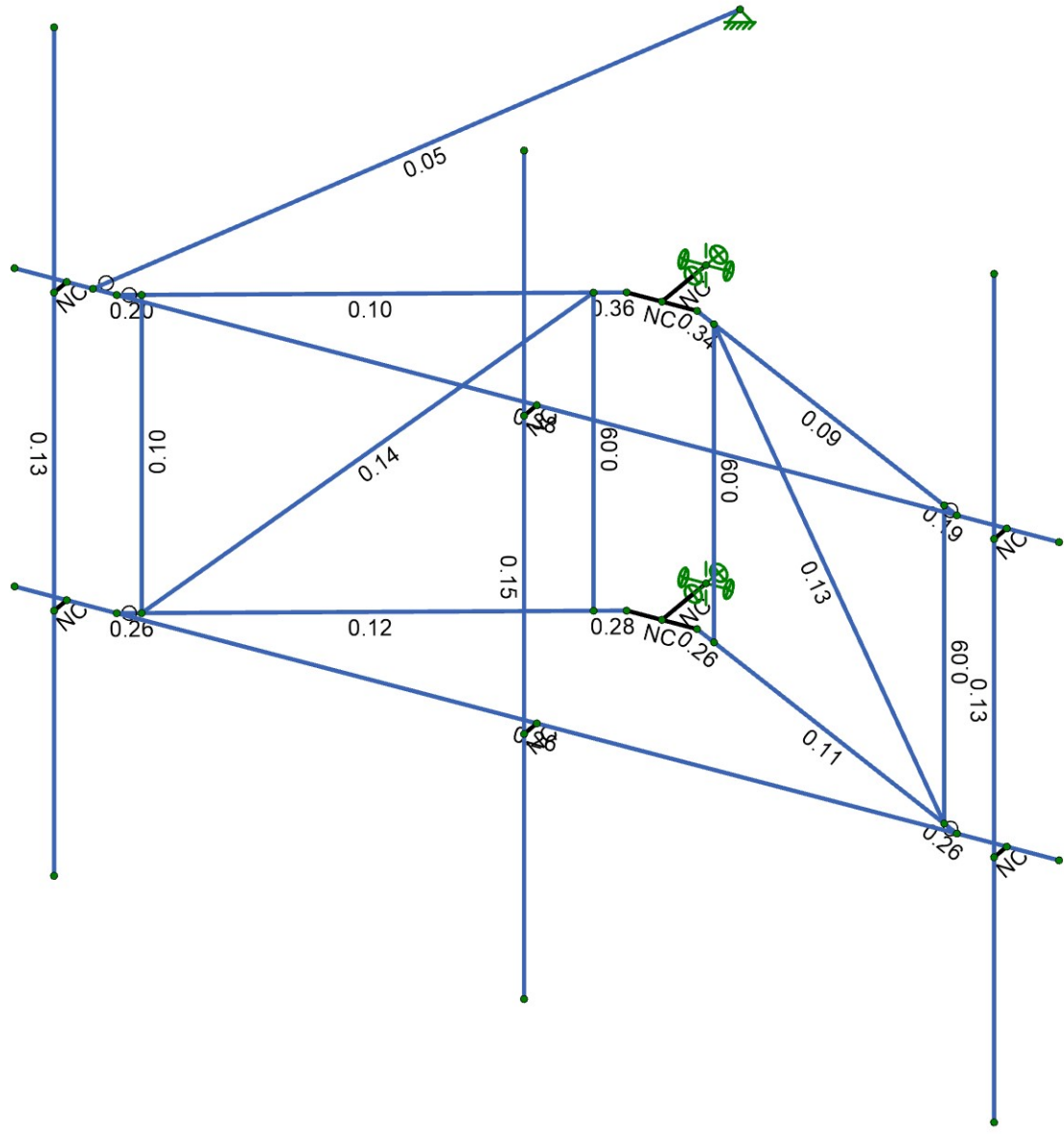

Member Code Checks Displayed (Enveloped)

Infinigy	BOHVN00186A	4
RF		Mar 15, 2023
1197-F0001-B		BOHVN00186A_loaded.r3d

Program Inputs

PROJECT INFORMATION	
Site #:	BOHVN00186A
Carrier:	Dish
Engineer:	Robert Faber

SITE INFORMATION	
Risk Category:	II
Exposure Category:	B
Topo Factor Procedure:	Method 1, Category 1
Site Class:	D - Stiff Soil (Assumed)
Ground Elevation:	750.50 ft *Rev H

MOUNT INFORMATION	
Mount Type:	Sector Frame
Num Sectors:	3
Centerline AGL:	170.00 ft
Tower Height AGL:	276.00 ft

TOPOGRAPHIC DATA	
Topo Feature:	N/A
Slope Distance:	N/A ft
Crest Distance:	N/A ft
Crest Height:	N/A ft

FACTORS	
Directionality Fact. (K_d):	0.950
Ground Ele. Factor (K_e):	0.973 *Rev H Only
Rooftop Speed-Up (K_s):	1.000 *Rev H Only
Topographic Factor (K_{zt}):	1.000
Height Esc. Fact. (K_{iz}):	1.178
Gust Effect Factor (G_h):	1.000
Shielding Factor (K_a):	0.900
Velocity Pressure Co. (K_z):	1.150 (Mount Elev)

CODE STANDARDS	
Building Code:	2021 IBC
TIA Standard:	TIA-222-H
ASCE Standard:	ASCE 7-16

WIND AND ICE DATA	
Ultimate Wind (V_{ult}):	118 mph
Design Wind (V):	N/A mph
Ice Wind (V_{ice}):	50 mph
Base Ice Thickness (t_i):	1 in
Radial Ice Thickness (t_{iz}):	1.178 in
Flat Pressure:	75.798 psf
Round Pressure:	45.479 psf
Ice Wind Pressure:	8.166 psf

2Gh*qz
1.2Gh*qz

SEISMIC DATA	
Short-Period Accel. (S_s):	0.196 g
1-Second Accel. (S_1):	0.054 g
Short-Period Design (S_{DS}):	0.209
1-Second Design (S_{D1}):	0.086
Short-Period Coeff. (F_a):	1.600
1-Second Coeff. (F_v):	2.400
Amplification Factor (A_s):	3.000
Response Mod. Coeff. (R):	2.000
Seismic Importance (I_e):	1.000
Seismic Response Co. (C_s):	0.105
Total App. Weight:	232.710 lb
Total Shear Force (V_s):	24.326 lb
Hor. Seismic Load (E_h):	24.326 lb
Vert. Seismic Load (E_v):	9.730 lb *

*For reference only. Per TIA rev H section 16.7, E_v is not applicable to mounts

$$qz = 0.00256 * Kz * Kzt * Ks * Ke * Kd * V^2$$

Program Inputs

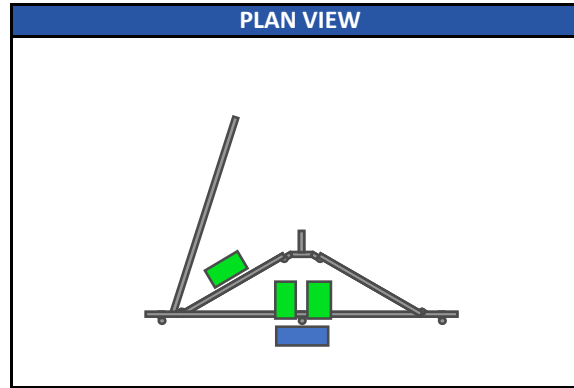
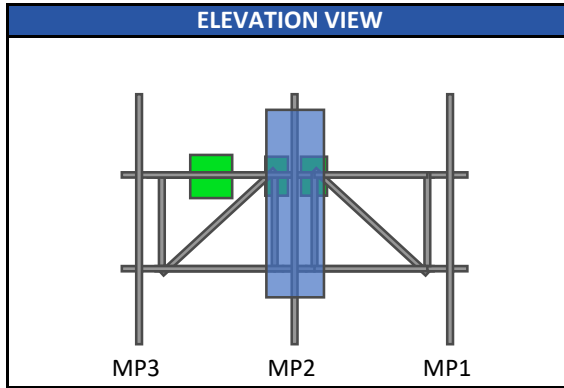

APPURTENANCE INFORMATION									
Appurtenance Name	Elevation	Qty./ Sector	Height (in)	Width (in)	Depth (in)	Weight (lbs)	EPA _N (ft ²)	EPA _T (ft ²)	Member (α sector)
JMA WIRELESS MX08FRO665-21	170.0	1	72.00	20.00	8.00	72.00	12.49	5.87	MP2
FUJITSU TA08025-B604	170.0	1	14.96	15.75	7.87	63.90	1.96	0.98	MP2
FUJITSU TA08025-B605	170.0	1	14.96	15.75	9.06	74.96	1.96	1.13	MP2
RAYCAP RDIDC-9181-PF-48	170.0	1	16.57	14.57	8.46	21.85	2.01	1.17	M17

ASCE 7 Hazards Report

Address:
No Address at This Location

Standard: ASCE/SEI 7-16
Risk Category: II
Soil Class: D - Default (see Section 11.4.3)

Latitude: 41.517944
Longitude: -73.018444
Elevation: 750.4865430969335 ft (NAVD 88)

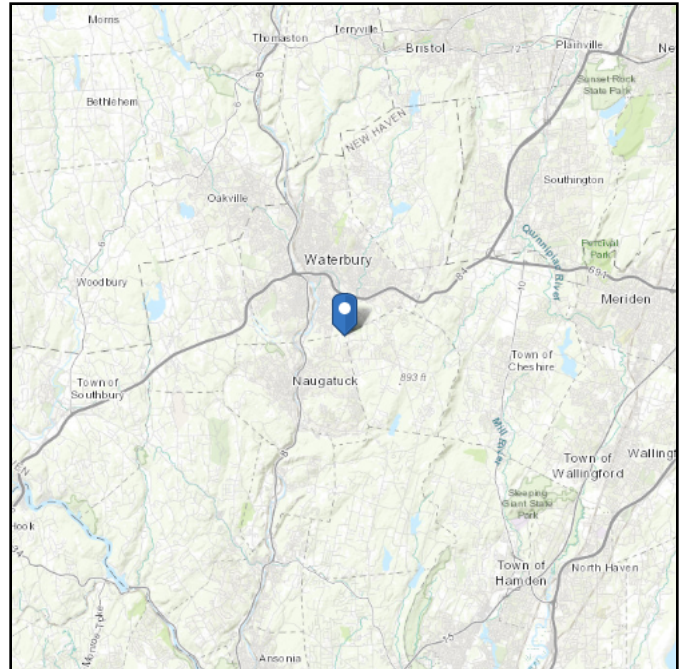
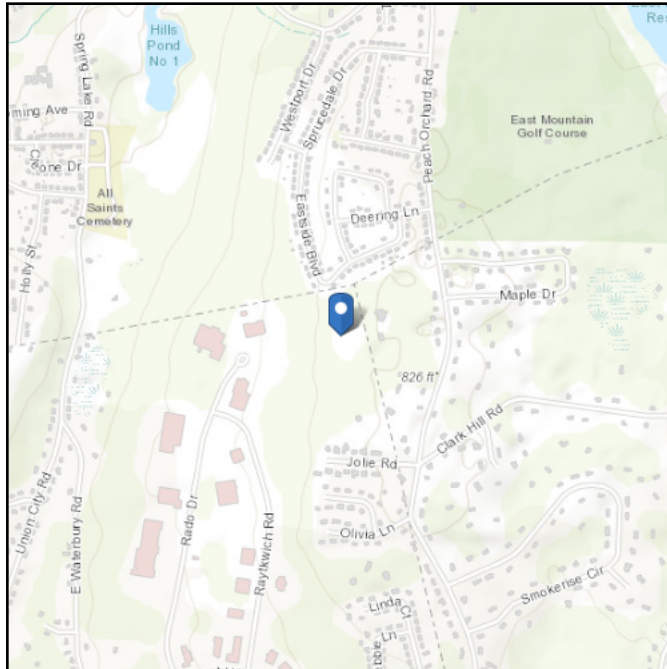

Wind

Results:

Wind Speed	118 Vmph
10-year MRI	75 Vmph
25-year MRI	84 Vmph
50-year MRI	90 Vmph
100-year MRI	97 Vmph

Data Source: ASCE/SEI 7-16, Fig. 26.5-1B and Figs. CC.2-1–CC.2-4, and Section 26.5.2

Date Accessed: Tue Mar 14 2023

Value provided is 3-second gust wind speeds at 33 ft above ground for Exposure C Category, based on linear interpolation between contours. Wind speeds are interpolated in accordance with the 7-16 Standard. Wind speeds correspond to approximately a 7% probability of exceedance in 50 years (annual exceedance probability = 0.00143, MRI = 700 years).

Site is in a hurricane-prone region as defined in ASCE/SEI 7-16 Section 26.2. Glazed openings need not be protected against wind-borne debris.

Site Soil Class:

Results:

S_s :	0.196	S_{D1} :	0.087
S_1 :	0.054	T_L :	6
F_a :	1.6	PGA :	0.108
F_v :	2.4	PGA _M :	0.171
S_{MS} :	0.313	F_{PGA} :	1.584
S_{M1} :	0.13	I_e :	1
S_{DS} :	0.209	C_v :	0.7

Seismic Design Category: B

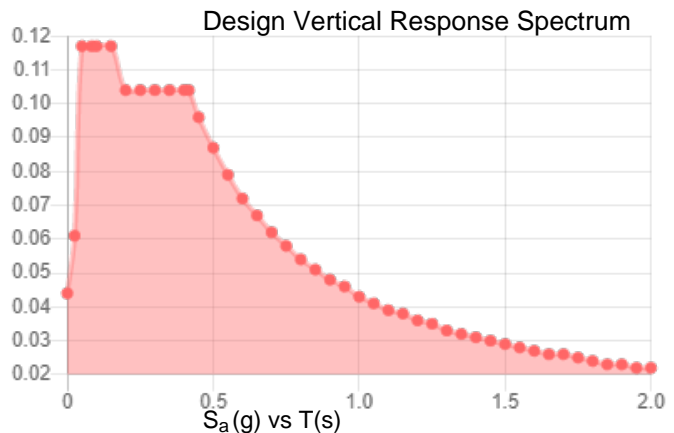
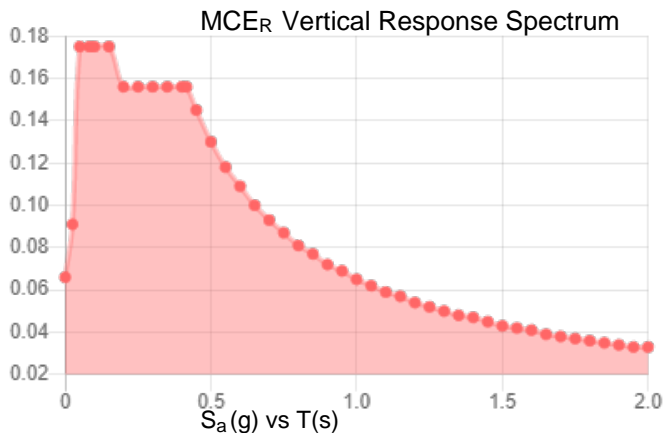
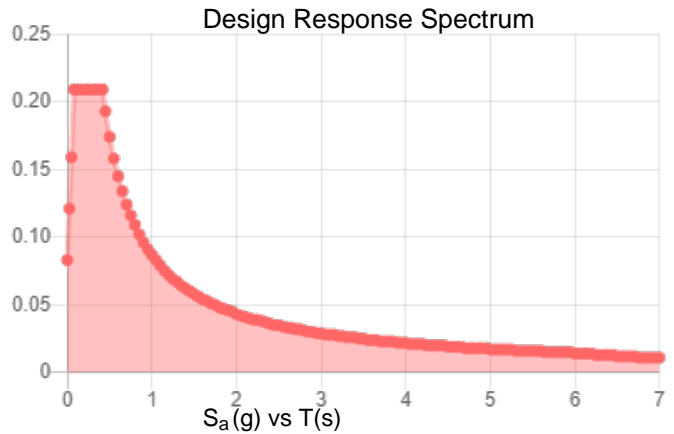
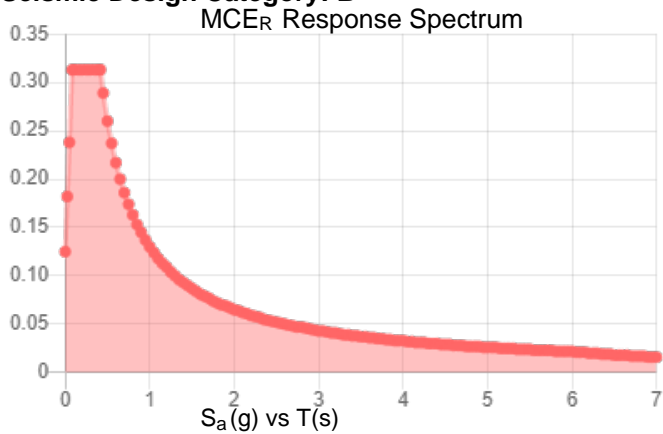

Data Accessed:

Tue Mar 14 2023

Date Source:

USGS Seismic Design Maps based on ASCE/SEI 7-16 and ASCE/SEI 7-16 Table 1.5-2. Additional data for site-specific ground motion procedures in accordance with ASCE/SEI 7-16 Ch. 21 are available from USGS.

Ice

Results:

Ice Thickness: 1.00 in.
Concurrent Temperature: 15 F
Gust Speed 50 mph

Data Source: Standard ASCE/SEI 7-16, Figs. 10-2 through 10-8

Date Accessed: Tue Mar 14 2023

Ice thicknesses on structures in exposed locations at elevations higher than the surrounding terrain and in valleys and gorges may exceed the mapped values.

Values provided are equivalent radial ice thicknesses due to freezing rain with concurrent 3-second gust speeds, for a 500-year mean recurrence interval, and temperatures concurrent with ice thicknesses due to freezing rain. Thicknesses for ice accretions caused by other sources shall be obtained from local meteorological studies. Ice thicknesses in exposed locations at elevations higher than the surrounding terrain and in valleys and gorges may exceed the mapped values.

The ASCE 7 Hazard Tool is provided for your convenience, for informational purposes only, and is provided “as is” and without warranties of any kind. The location data included herein has been obtained from information developed, produced, and maintained by third party providers; or has been extrapolated from maps incorporated in the ASCE 7 standard. While ASCE has made every effort to use data obtained from reliable sources or methodologies, ASCE does not make any representations or warranties as to the accuracy, completeness, reliability, currency, or quality of any data provided herein. Any third-party links provided by this Tool should not be construed as an endorsement, affiliation, relationship, or sponsorship of such third-party content by or from ASCE.

ASCE does not intend, nor should anyone interpret, the results provided by this Tool to replace the sound judgment of a competent professional, having knowledge and experience in the appropriate field(s) of practice, nor to substitute for the standard of care required of such professionals in interpreting and applying the contents of this Tool or the ASCE 7 standard.

In using this Tool, you expressly assume all risks associated with your use. Under no circumstances shall ASCE or its officers, directors, employees, members, affiliates, or agents be liable to you or any other person for any direct, indirect, special, incidental, or consequential damages arising from or related to your use of, or reliance on, the Tool or any information obtained therein. To the fullest extent permitted by law, you agree to release and hold harmless ASCE from any and all liability of any nature arising out of or resulting from any use of data provided by the ASCE 7 Hazard Tool.

Hot Rolled Steel Properties

	Label	E [ksi]	G [ksi]	Nu	Therm. Coeff. [1e ⁵ F ⁻¹]	Density [lb/ft ³]	Yield [ksi]	Ry	Fu [ksi]	Rt
1	A992	29000	11154	0.3	0.65	490	50	1.1	65	1.1
2	A36 Gr.36	29000	11154	0.3	0.65	490	36	1.5	58	1.2
3	A572 Gr.50	29000	11154	0.3	0.65	490	50	1.1	65	1.1
4	A500 Gr.B RND	29000	11154	0.3	0.65	527	42	1.4	58	1.3
5	A500 Gr.B Rect	29000	11154	0.3	0.65	527	46	1.4	58	1.3
6	A53 Gr.B	29000	11154	0.3	0.65	490	35	1.6	60	1.2
7	A1085	29000	11154	0.3	0.65	490	50	1.4	65	1.3
8	A500 Gr.C	29000	11154	0.3	0.65	527	46	1.4	62	1.3

Hot Rolled Steel Section Sets

	Label	Shape	Type	Design List	Material	Design Rule Area [in ²]	Iyy [in ⁴]	Izz [in ⁴]	J [in ⁴]	
1	Mount Pipe	PIPE 2.5	Column	HSS Pipe	A53 Gr.B	Typical	1.61	1.45	1.45	2.89
2	Tieback	PIPE 2.0	HBrace	Pipe	A53 Gr.B	Typical	1.02	0.627	0.627	1.25
3	Bracing	0.75" SR	VBrace	BAR	A36 Gr.36	Typical	0.442	0.016	0.016	0.031
4	Arms	PIPE 2.0X	Beam	Pipe	A53 Gr.B	Typical	1.4	0.827	0.827	1.65
5	Horizontal	PIPE 2.0X	Beam	Pipe	A53 Gr.B	Typical	1.4	0.827	0.827	1.65
6	Plates	3"x.5"	Beam	BAR	A36 Gr.36	Typical	1.5	0.031	1.125	0.112

Hot Rolled Steel Design Parameters

	Label	Shape	Length [in]	Lcomp top [in]	K y-y	K z-z	Channel Conn.	a [in]	Function
1	M2	Arms	45.25	Lbyy			N/A	N/A	Lateral
2	M4	Arms	45.25	Lbyy			N/A	N/A	Lateral
3	M5	Bracing	36		0.7	0.7	N/A	N/A	Lateral
4	M6	Bracing	36		0.7	0.7	N/A	N/A	Lateral
5	M7	Bracing	57.824		0.7	0.7	N/A	N/A	Lateral
6	MH2	Horizontal	120	Lbyy			N/A	N/A	Lateral
7	MH1	Horizontal	120	Lbyy			N/A	N/A	Lateral
8	M12	Plates	2.5	Lbyy			N/A	N/A	Lateral
9	M13	Plates	2.5	Lbyy			N/A	N/A	Lateral
10	M14	Plates	3.313	Lbyy			N/A	N/A	Lateral
11	M15	Plates	3.313	Lbyy			N/A	N/A	Lateral
12	M16	Arms	45.25	Lbyy			N/A	N/A	Lateral
13	M17	Arms	45.25	Lbyy			N/A	N/A	Lateral
14	M18	Bracing	36		0.7	0.7	N/A	N/A	Lateral
15	M19	Bracing	36		0.7	0.7	N/A	N/A	Lateral
16	M20	Bracing	57.824		0.7	0.7	N/A	N/A	Lateral
17	M21	Plates	2.5	Lbyy			N/A	N/A	Lateral
18	M22	Plates	2.5	Lbyy			N/A	N/A	Lateral
19	M23	Plates	3.313	Lbyy			N/A	N/A	Lateral
20	M24	Plates	3.313	Lbyy			N/A	N/A	Lateral
21	M25	Tieback	88.334				N/A	N/A	Lateral
22	MP1	Mount Pipe	96	Lbyy			N/A	N/A	Lateral
23	MP2	Mount Pipe	96	Lbyy			N/A	N/A	Lateral
24	MP3	Mount Pipe	96	Lbyy			N/A	N/A	Lateral

Member Primary Data

	Label	I Node	J Node	Rotate(deg)	Section/Shape	Type	Design List	Material	Design Rule
1	M2	N5	N8		Arms	Beam	Pipe	A53 Gr.B	Typical
2	M4	N6	N7		Arms	Beam	Pipe	A53 Gr.B	Typical
3	M5	N8	N7	270	Bracing	VBrace	BAR	A36 Gr.36	Typical
4	M6	N5	N6	270	Bracing	VBrace	BAR	A36 Gr.36	Typical

Member Primary Data (Continued)

	Label	I Node	J Node	Rotate(deg)	Section/Shape	Type	Design List	Material	Design Rule
5	M7	N6	N8		Bracing	VBrace	BAR	A36 Gr.36	Typical
6	MH2	N16	N12		Horizontal	Beam	Pipe	A53 Gr.B	Typical
7	MH1	N15	N11		Horizontal	Beam	Pipe	A53 Gr.B	Typical
8	M12	N7	N19	90	Plates	Beam	BAR	A36 Gr.36	Typical
9	M13	N8	N20	90	Plates	Beam	BAR	A36 Gr.36	Typical
10	M14	N4	N6	90	Plates	Beam	BAR	A36 Gr.36	Typical
11	M15	N3	N5	90	Plates	Beam	BAR	A36 Gr.36	Typical
12	M16	N21	N24		Arms	Beam	Pipe	A53 Gr.B	Typical
13	M17	N22	N23		Arms	Beam	Pipe	A53 Gr.B	Typical
14	M18	N24	N23	270	Bracing	VBrace	BAR	A36 Gr.36	Typical
15	M19	N21	N22	270	Bracing	VBrace	BAR	A36 Gr.36	Typical
16	M20	N22	N24		Bracing	VBrace	BAR	A36 Gr.36	Typical
17	M21	N23	N25	90	Plates	Beam	BAR	A36 Gr.36	Typical
18	M22	N24	N26	90	Plates	Beam	BAR	A36 Gr.36	Typical
19	M23	N10	N22	90	Plates	Beam	BAR	A36 Gr.36	Typical
20	M24	N9	N21	90	Plates	Beam	BAR	A36 Gr.36	Typical
21	M25	N28	N27		Tieback	HBrace	Pipe	A53 Gr.B	Typical
22	M32	N17	N39		RIGID	None	None	RIGID	Typical
23	M33	N18	N40		RIGID	None	None	RIGID	Typical
24	M34	N34	N44		RIGID	None	None	RIGID	Typical
25	M35	N33	N43		RIGID	None	None	RIGID	Typical
26	M36	N14	N36		RIGID	None	None	RIGID	Typical
27	M37	N13	N35		RIGID	None	None	RIGID	Typical
28	M39	N48	N2		RIGID	None	None	RIGID	Typical
29	M40	N47	N1		RIGID	None	None	RIGID	Typical
30	M41	N10	N4		RIGID	None	None	RIGID	Typical
31	M42	N9	N3		RIGID	None	None	RIGID	Typical
32	MP1	N38	N37	90	Mount Pipe	Column	HSS Pipe	A53 Gr.B	Typical
33	MP2	N46	N45	90	Mount Pipe	Column	HSS Pipe	A53 Gr.B	Typical
34	MP3	N42	N41	90	Mount Pipe	Column	HSS Pipe	A53 Gr.B	Typical

Member Point Loads (BLC 1 : Self Weight)

	Member Label	Direction	Magnitude [lb, lb-ft]	Location [(in, %)]
1	MP2	Y	-36	6
2	MP2	Y	-36	70
3	MP2	Y	-63.9	%25
4	MP2	Y	-74.96	%25
5	M17	Y	-21.85	%50

Member Point Loads (BLC 2 : Wind Load AZI 0)

	Member Label	Direction	Magnitude [lb, lb-ft]	Location [(in, %)]
1	MP2	X	0	6
2	MP2	Z	-212.99	6
3	MP2	X	0	70
4	MP2	Z	-212.99	70
5	MP2	X	0	%25
6	MP2	Z	-66.97	%25
7	MP2	X	0	%25
8	MP2	Z	-66.97	%25
9	M17	X	0	%50
10	M17	Z	-68.62	%50

Member Point Loads (BLC 3 : Wind Load AZI 30)

	Member Label	Direction	Magnitude [lb, lb-ft]	Location [(in, %)]
1	MP2	X	-92.38	6
2	MP2	Z	-160.01	6
3	MP2	X	-92.38	70
4	MP2	Z	-160.01	70
5	MP2	X	-29.3	%25
6	MP2	Z	-50.75	%25
7	MP2	X	-29.93	%25
8	MP2	Z	-51.84	%25
9	M17	X	-30.71	%50
10	M17	Z	-53.2	%50

Member Point Loads (BLC 4 : Wind Load AZI 60)

	Member Label	Direction	Magnitude [lb, lb-ft]	Location [(in, %)]
1	MP2	X	-111.1	6
2	MP2	Z	-64.14	6
3	MP2	X	-111.1	70
4	MP2	Z	-64.14	70
5	MP2	X	-36.24	%25
6	MP2	Z	-20.92	%25
7	MP2	X	-39.52	%25
8	MP2	Z	-22.82	%25
9	M17	X	-40.74	%50
10	M17	Z	-23.52	%50

Member Point Loads (BLC 5 : Wind Load AZI 90)

	Member Label	Direction	Magnitude [lb, lb-ft]	Location [(in, %)]
1	MP2	X	-100.05	6
2	MP2	Z	0	6
3	MP2	X	-100.05	70
4	MP2	Z	0	70
5	MP2	X	-33.47	%25
6	MP2	Z	0	%25
7	MP2	X	-38.53	%25
8	MP2	Z	0	%25
9	M17	X	-39.85	%50
10	M17	Z	0	%50

Member Point Loads (BLC 6 : Wind Load AZI 120)

	Member Label	Direction	Magnitude [lb, lb-ft]	Location [(in, %)]
1	MP2	X	-111.1	6
2	MP2	Z	64.14	6
3	MP2	X	-111.1	70
4	MP2	Z	64.14	70
5	MP2	X	-36.24	%25
6	MP2	Z	20.92	%25
7	MP2	X	-39.52	%25
8	MP2	Z	22.82	%25
9	M17	X	-40.74	%50
10	M17	Z	23.52	%50

Member Point Loads (BLC 7 : Wind Load AZI 150)

	Member Label	Direction	Magnitude [lb, lb-ft]	Location [(in, %)]
1	MP2	X	-92.38	6
2	MP2	Z	160.01	6
3	MP2	X	-92.38	70
4	MP2	Z	160.01	70
5	MP2	X	-29.3	%25
6	MP2	Z	50.75	%25
7	MP2	X	-29.93	%25
8	MP2	Z	51.84	%25
9	M17	X	-30.71	%50
10	M17	Z	53.2	%50

Member Point Loads (BLC 8 : Wind Load AZI 180)

	Member Label	Direction	Magnitude [lb, lb-ft]	Location [(in, %)]
1	MP2	X	0	6
2	MP2	Z	212.99	6
3	MP2	X	0	70
4	MP2	Z	212.99	70
5	MP2	X	0	%25
6	MP2	Z	66.97	%25
7	MP2	X	0	%25
8	MP2	Z	66.97	%25
9	M17	X	0	%50
10	M17	Z	68.62	%50

Member Point Loads (BLC 9 : Wind Load AZI 210)

	Member Label	Direction	Magnitude [lb, lb-ft]	Location [(in, %)]
1	MP2	X	92.38	6
2	MP2	Z	160.01	6
3	MP2	X	92.38	70
4	MP2	Z	160.01	70
5	MP2	X	29.3	%25
6	MP2	Z	50.75	%25
7	MP2	X	29.93	%25
8	MP2	Z	51.84	%25
9	M17	X	30.71	%50
10	M17	Z	53.2	%50

Member Point Loads (BLC 10 : Wind Load AZI 240)

	Member Label	Direction	Magnitude [lb, lb-ft]	Location [(in, %)]
1	MP2	X	111.1	6
2	MP2	Z	64.14	6
3	MP2	X	111.1	70
4	MP2	Z	64.14	70
5	MP2	X	36.24	%25
6	MP2	Z	20.92	%25
7	MP2	X	39.52	%25
8	MP2	Z	22.82	%25
9	M17	X	40.74	%50
10	M17	Z	23.52	%50

Member Point Loads (BLC 11 : Wind Load AZI 270)

	Member Label	Direction	Magnitude [lb, lb-ft]	Location [(in, %)]
1	MP2	X	100.05	6
2	MP2	Z	0	6
3	MP2	X	100.05	70
4	MP2	Z	0	70
5	MP2	X	33.47	%25
6	MP2	Z	0	%25
7	MP2	X	38.53	%25
8	MP2	Z	0	%25
9	M17	X	39.85	%50
10	M17	Z	0	%50

Member Point Loads (BLC 12 : Wind Load AZI 300)

	Member Label	Direction	Magnitude [lb, lb-ft]	Location [(in, %)]
1	MP2	X	111.1	6
2	MP2	Z	-64.14	6
3	MP2	X	111.1	70
4	MP2	Z	-64.14	70
5	MP2	X	36.24	%25
6	MP2	Z	-20.92	%25
7	MP2	X	39.52	%25
8	MP2	Z	-22.82	%25
9	M17	X	40.74	%50
10	M17	Z	-23.52	%50

Member Point Loads (BLC 13 : Wind Load AZI 330)

	Member Label	Direction	Magnitude [lb, lb-ft]	Location [(in, %)]
1	MP2	X	92.38	6
2	MP2	Z	-160.01	6
3	MP2	X	92.38	70
4	MP2	Z	-160.01	70
5	MP2	X	29.3	%25
6	MP2	Z	-50.75	%25
7	MP2	X	29.93	%25
8	MP2	Z	-51.84	%25
9	M17	X	30.71	%50
10	M17	Z	-53.2	%50

Member Point Loads (BLC 16 : Ice Weight)

	Member Label	Direction	Magnitude [lb, lb-ft]	Location [(in, %)]
1	MP2	Y	-92.288	6
2	MP2	Y	-92.288	70
3	MP2	Y	-43.813	%25
4	MP2	Y	-46.818	%25
5	M17	Y	-46.101	%50

Member Point Loads (BLC 17 : Ice Wind Load AZI 0)

	Member Label	Direction	Magnitude [lb, lb-ft]	Location [(in, %)]
1	MP2	X	0	6
2	MP2	Z	-18.32	6

Member Point Loads (BLC 17 : Ice Wind Load AZI 0) (Continued)

	Member Label	Direction	Magnitude [lb, lb-ft]	Location [(in, %)]
3	MP2	X	0	70
4	MP2	Z	-18.32	70
5	MP2	X	0	%25
6	MP2	Z	-6.67	%25
7	MP2	X	0	%25
8	MP2	Z	-6.67	%25
9	M17	X	0	%50
10	M17	Z	-6.97	%50

Member Point Loads (BLC 18 : Ice Wind Load AZI 30)

	Member Label	Direction	Magnitude [lb, lb-ft]	Location [(in, %)]
1	MP2	X	-8.41	6
2	MP2	Z	-14.57	6
3	MP2	X	-8.41	70
4	MP2	Z	-14.57	70
5	MP2	X	-3.11	%25
6	MP2	Z	-5.39	%25
7	MP2	X	-3.15	%25
8	MP2	Z	-5.46	%25
9	M17	X	-3.3	%50
10	M17	Z	-5.72	%50

Member Point Loads (BLC 19 : Ice Wind Load AZI 60)

	Member Label	Direction	Magnitude [lb, lb-ft]	Location [(in, %)]
1	MP2	X	-11.97	6
2	MP2	Z	-6.91	6
3	MP2	X	-11.97	70
4	MP2	Z	-6.91	70
5	MP2	X	-4.64	%25
6	MP2	Z	-2.68	%25
7	MP2	X	-4.82	%25
8	MP2	Z	-2.78	%25
9	M17	X	-5.1	%50
10	M17	Z	-2.95	%50

Member Point Loads (BLC 20 : Ice Wind Load AZI 90)

	Member Label	Direction	Magnitude [lb, lb-ft]	Location [(in, %)]
1	MP2	X	-12.32	6
2	MP2	Z	0	6
3	MP2	X	-12.32	70
4	MP2	Z	0	70
5	MP2	X	-4.92	%25
6	MP2	Z	0	%25
7	MP2	X	-5.2	%25
8	MP2	Z	0	%25
9	M17	X	-5.53	%50
10	M17	Z	0	%50

Member Point Loads (BLC 21 : Ice Wind Load AZI 120)

	Member Label	Direction	Magnitude [lb, lb-ft]	Location [(in, %)]
1	MP2	X	-11.97	6
2	MP2	Z	6.91	6
3	MP2	X	-11.97	70
4	MP2	Z	6.91	70
5	MP2	X	-4.64	%25
6	MP2	Z	2.68	%25
7	MP2	X	-4.82	%25
8	MP2	Z	2.78	%25
9	M17	X	-5.1	%50
10	M17	Z	2.95	%50

Member Point Loads (BLC 22 : Ice Wind Load AZI 150)

	Member Label	Direction	Magnitude [lb, lb-ft]	Location [(in, %)]
1	MP2	X	-8.41	6
2	MP2	Z	14.57	6
3	MP2	X	-8.41	70
4	MP2	Z	14.57	70
5	MP2	X	-3.11	%25
6	MP2	Z	5.39	%25
7	MP2	X	-3.15	%25
8	MP2	Z	5.46	%25
9	M17	X	-3.3	%50
10	M17	Z	5.72	%50

Member Point Loads (BLC 23 : Ice Wind Load AZI 180)

	Member Label	Direction	Magnitude [lb, lb-ft]	Location [(in, %)]
1	MP2	X	0	6
2	MP2	Z	18.32	6
3	MP2	X	0	70
4	MP2	Z	18.32	70
5	MP2	X	0	%25
6	MP2	Z	6.67	%25
7	MP2	X	0	%25
8	MP2	Z	6.67	%25
9	M17	X	0	%50
10	M17	Z	6.97	%50

Member Point Loads (BLC 24 : Ice Wind Load AZI 210)

	Member Label	Direction	Magnitude [lb, lb-ft]	Location [(in, %)]
1	MP2	X	8.41	6
2	MP2	Z	14.57	6
3	MP2	X	8.41	70
4	MP2	Z	14.57	70
5	MP2	X	3.11	%25
6	MP2	Z	5.39	%25
7	MP2	X	3.15	%25
8	MP2	Z	5.46	%25
9	M17	X	3.3	%50
10	M17	Z	5.72	%50

Member Point Loads (BLC 25 : Ice Wind Load AZI 240)

	Member Label	Direction	Magnitude [lb, lb-ft]	Location [(in, %)]
1	MP2	X	11.97	6
2	MP2	Z	6.91	6
3	MP2	X	11.97	70
4	MP2	Z	6.91	70
5	MP2	X	4.64	%25
6	MP2	Z	2.68	%25
7	MP2	X	4.82	%25
8	MP2	Z	2.78	%25
9	M17	X	5.1	%50
10	M17	Z	2.95	%50

Member Point Loads (BLC 26 : Ice Wind Load AZI 270)

	Member Label	Direction	Magnitude [lb, lb-ft]	Location [(in, %)]
1	MP2	X	12.32	6
2	MP2	Z	0	6
3	MP2	X	12.32	70
4	MP2	Z	0	70
5	MP2	X	4.92	%25
6	MP2	Z	0	%25
7	MP2	X	5.2	%25
8	MP2	Z	0	%25
9	M17	X	5.53	%50
10	M17	Z	0	%50

Member Point Loads (BLC 27 : Ice Wind Load AZI 300)

	Member Label	Direction	Magnitude [lb, lb-ft]	Location [(in, %)]
1	MP2	X	11.97	6
2	MP2	Z	-6.91	6
3	MP2	X	11.97	70
4	MP2	Z	-6.91	70
5	MP2	X	4.64	%25
6	MP2	Z	-2.68	%25
7	MP2	X	4.82	%25
8	MP2	Z	-2.78	%25
9	M17	X	5.1	%50
10	M17	Z	-2.95	%50

Member Point Loads (BLC 28 : Ice Wind Load AZI 330)

	Member Label	Direction	Magnitude [lb, lb-ft]	Location [(in, %)]
1	MP2	X	8.41	6
2	MP2	Z	-14.57	6
3	MP2	X	8.41	70
4	MP2	Z	-14.57	70
5	MP2	X	3.11	%25
6	MP2	Z	-5.39	%25
7	MP2	X	3.15	%25
8	MP2	Z	-5.46	%25
9	M17	X	3.3	%50
10	M17	Z	-5.72	%50

Member Point Loads (BLC 31 : Seismic Load Z)

	Member Label	Direction	Magnitude [lb, lb-ft]	Location [(in, %)]
1	MP2	Z	-11.29	6
2	MP2	Z	-11.29	70
3	MP2	Z	-20.039	%25
4	MP2	Z	-23.507	%25
5	M17	Z	-6.852	%50

Member Point Loads (BLC 32 : Seismic Load X)

	Member Label	Direction	Magnitude [lb, lb-ft]	Location [(in, %)]
1	MP2	X	-11.29	6
2	MP2	X	-11.29	70
3	MP2	X	-20.039	%25
4	MP2	X	-23.507	%25
5	M17	X	-6.852	%50

Member Distributed Loads (BLC 14 : Distr. Wind Load Z)

	Member Label	Direction	Start Magnitude [lb/ft, F, psf, lb-ft/in]	End Magnitude [lb/ft, F, psf, lb-ft/in]	Start Location [(in, %)]	End Location [(in, %)]
1	M2	SZ	-45.479	-45.479	0	%100
2	M4	SZ	-45.479	-45.479	0	%100
3	M5	SZ	-45.479	-45.479	0	%100
4	M6	SZ	-45.479	-45.479	0	%100
5	M7	SZ	-45.479	-45.479	0	%100
6	MH2	SZ	-45.479	-45.479	0	%100
7	MH1	SZ	-45.479	-45.479	0	%100
8	M12	SZ	0	0	0	%100
9	M13	SZ	0	0	0	%100
10	M14	SZ	0	0	0	%100
11	M15	SZ	0	0	0	%100
12	M16	SZ	-45.479	-45.479	0	%100
13	M17	SZ	-45.479	-45.479	0	%100
14	M18	SZ	-45.479	-45.479	0	%100
15	M19	SZ	-45.479	-45.479	0	%100
16	M20	SZ	-45.479	-45.479	0	%100
17	M21	SZ	0	0	0	%100
18	M22	SZ	0	0	0	%100
19	M23	SZ	0	0	0	%100
20	M24	SZ	0	0	0	%100
21	M25	SZ	-45.479	-45.479	0	%100
22	M32	SZ	0	0	0	%100
23	M33	SZ	0	0	0	%100
24	M34	SZ	0	0	0	%100
25	M35	SZ	0	0	0	%100
26	M36	SZ	0	0	0	%100
27	M37	SZ	0	0	0	%100
28	M39	SZ	0	0	0	%100
29	M40	SZ	0	0	0	%100
30	M41	SZ	0	0	0	%100
31	M42	SZ	0	0	0	%100
32	MP1	SZ	-45.479	-45.479	0	%100
33	MP2	SZ	-45.479	-45.479	0	%100
34	MP3	SZ	-45.479	-45.479	0	%100

Member Distributed Loads (BLC 15 : Distr. Wind Load X)

Member	Label	Direction	Start Magnitude [lb/ft, F, psf, lb-ft/in]	End Magnitude [lb/ft, F, psf, lb-ft/in]	Start Location [(in, %)]	End Location [(in, %)]
1	M2	SX	-45.479	-45.479	0	%100
2	M4	SX	-45.479	-45.479	0	%100
3	M5	SX	-45.479	-45.479	0	%100
4	M6	SX	-45.479	-45.479	0	%100
5	M7	SX	-45.479	-45.479	0	%100
6	MH2	SX	-45.479	-45.479	0	%100
7	MH1	SX	-45.479	-45.479	0	%100
8	M12	SX	0	0	0	%100
9	M13	SX	0	0	0	%100
10	M14	SX	0	0	0	%100
11	M15	SX	0	0	0	%100
12	M16	SX	-45.479	-45.479	0	%100
13	M17	SX	-45.479	-45.479	0	%100
14	M18	SX	-45.479	-45.479	0	%100
15	M19	SX	-45.479	-45.479	0	%100
16	M20	SX	-45.479	-45.479	0	%100
17	M21	SX	0	0	0	%100
18	M22	SX	0	0	0	%100
19	M23	SX	0	0	0	%100
20	M24	SX	0	0	0	%100
21	M25	SX	-45.479	-45.479	0	%100
22	M32	SX	0	0	0	%100
23	M33	SX	0	0	0	%100
24	M34	SX	0	0	0	%100
25	M35	SX	0	0	0	%100
26	M36	SX	0	0	0	%100
27	M37	SX	0	0	0	%100
28	M39	SX	0	0	0	%100
29	M40	SX	0	0	0	%100
30	M41	SX	0	0	0	%100
31	M42	SX	0	0	0	%100
32	MP1	SX	-45.479	-45.479	0	%100
33	MP2	SX	-45.479	-45.479	0	%100
34	MP3	SX	-45.479	-45.479	0	%100

Member Distributed Loads (BLC 16 : Ice Weight)

Member	Label	Direction	Start Magnitude [lb/ft, F, psf, lb-ft/in]	End Magnitude [lb/ft, F, psf, lb-ft/in]	Start Location [(in, %)]	End Location [(in, %)]
1	M2	Y	-5.114	-5.114	0	%100
2	M4	Y	-5.114	-5.114	0	%100
3	M5	Y	-2.775	-2.775	0	%100
4	M6	Y	-2.775	-2.775	0	%100
5	M7	Y	-2.775	-2.775	0	%100
6	MH2	Y	-5.114	-5.114	0	%100
7	MH1	Y	-5.114	-5.114	0	%100
8	M12	Y	-1.696	-1.696	0	%100
9	M13	Y	-1.696	-1.696	0	%100
10	M14	Y	-1.696	-1.696	0	%100
11	M15	Y	-1.696	-1.696	0	%100
12	M16	Y	-5.114	-5.114	0	%100
13	M17	Y	-5.114	-5.114	0	%100
14	M18	Y	-2.775	-2.775	0	%100
15	M19	Y	-2.775	-2.775	0	%100
16	M20	Y	-2.775	-2.775	0	%100
17	M21	Y	-1.696	-1.696	0	%100



Company : Infinigy
 Designer : RF
 Job Number : 1197-F0001-B
 Model Name : BOHVN00186A

3/15/2023
 12:00:57 AM
 Checked By : _____

Member Distributed Loads (BLC 16 : Ice Weight) (Continued)

Member Label	Direction	Start Magnitude [lb/ft, F, psf, lb-ft/in]	End Magnitude [lb/ft, F, psf, lb-ft/in]	Start Location [(in, %)]	End Location [(in, %)]
18	M22	Y	-1.696	-1.696	0 %100
19	M23	Y	-1.696	-1.696	0 %100
20	M24	Y	-1.696	-1.696	0 %100
21	M25	Y	-5.114	-5.114	0 %100
22	M32	Y	-1.696	-1.696	0 %100
23	M33	Y	-1.696	-1.696	0 %100
24	M34	Y	-1.696	-1.696	0 %100
25	M35	Y	-1.696	-1.696	0 %100
26	M36	Y	-1.696	-1.696	0 %100
27	M37	Y	-1.696	-1.696	0 %100
28	M39	Y	-1.696	-1.696	0 %100
29	M40	Y	-1.696	-1.696	0 %100
30	M41	Y	-1.696	-1.696	0 %100
31	M42	Y	-1.696	-1.696	0 %100
32	MP1	Y	-5.834	-5.834	0 %100
33	MP2	Y	-5.834	-5.834	0 %100
34	MP3	Y	-5.834	-5.834	0 %100

Member Distributed Loads (BLC 29 : Distr. Ice Wind Load Z)

Member Label	Direction	Start Magnitude [lb/ft, F, psf, lb-ft/in]	End Magnitude [lb/ft, F, psf, lb-ft/in]	Start Location [(in, %)]	End Location [(in, %)]
1	M2	SZ	-16.267	-16.267	0 %100
2	M4	SZ	-16.267	-16.267	0 %100
3	M5	SZ	-33.819	-33.819	0 %100
4	M6	SZ	-33.819	-33.819	0 %100
5	M7	SZ	-33.819	-33.819	0 %100
6	MH2	SZ	-16.267	-16.267	0 %100
7	MH1	SZ	-16.267	-16.267	0 %100
8	M12	SZ	0	0	0 %100
9	M13	SZ	0	0	0 %100
10	M14	SZ	0	0	0 %100
11	M15	SZ	0	0	0 %100
12	M16	SZ	-16.267	-16.267	0 %100
13	M17	SZ	-16.267	-16.267	0 %100
14	M18	SZ	-33.819	-33.819	0 %100
15	M19	SZ	-33.819	-33.819	0 %100
16	M20	SZ	-33.819	-33.819	0 %100
17	M21	SZ	0	0	0 %100
18	M22	SZ	0	0	0 %100
19	M23	SZ	0	0	0 %100
20	M24	SZ	0	0	0 %100
21	M25	SZ	-16.267	-16.267	0 %100
22	M32	SZ	0	0	0 %100
23	M33	SZ	0	0	0 %100
24	M34	SZ	0	0	0 %100
25	M35	SZ	0	0	0 %100
26	M36	SZ	0	0	0 %100
27	M37	SZ	0	0	0 %100
28	M39	SZ	0	0	0 %100
29	M40	SZ	0	0	0 %100
30	M41	SZ	0	0	0 %100
31	M42	SZ	0	0	0 %100
32	MP1	SZ	-14.858	-14.858	0 %100
33	MP2	SZ	-14.858	-14.858	0 %100
34	MP3	SZ	-14.858	-14.858	0 %100

Member Distributed Loads (BLC 30 : Distr. Ice Wind Load X)

Member	Label	Direction	Start Magnitude [lb/ft, F, psf, lb-ft/in]	End Magnitude [lb/ft, F, psf, lb-ft/in]	Start Location [(in, %)]	End Location [(in, %)]
1	M2	SX	-16.267	-16.267	0	%100
2	M4	SX	-16.267	-16.267	0	%100
3	M5	SX	-33.819	-33.819	0	%100
4	M6	SX	-33.819	-33.819	0	%100
5	M7	SX	-33.819	-33.819	0	%100
6	MH2	SX	-16.267	-16.267	0	%100
7	MH1	SX	-16.267	-16.267	0	%100
8	M12	SX	0	0	0	%100
9	M13	SX	0	0	0	%100
10	M14	SX	0	0	0	%100
11	M15	SX	0	0	0	%100
12	M16	SX	-16.267	-16.267	0	%100
13	M17	SX	-16.267	-16.267	0	%100
14	M18	SX	-33.819	-33.819	0	%100
15	M19	SX	-33.819	-33.819	0	%100
16	M20	SX	-33.819	-33.819	0	%100
17	M21	SX	0	0	0	%100
18	M22	SX	0	0	0	%100
19	M23	SX	0	0	0	%100
20	M24	SX	0	0	0	%100
21	M25	SX	-16.267	-16.267	0	%100
22	M32	SX	0	0	0	%100
23	M33	SX	0	0	0	%100
24	M34	SX	0	0	0	%100
25	M35	SX	0	0	0	%100
26	M36	SX	0	0	0	%100
27	M37	SX	0	0	0	%100
28	M39	SX	0	0	0	%100
29	M40	SX	0	0	0	%100
30	M41	SX	0	0	0	%100
31	M42	SX	0	0	0	%100
32	MP1	SX	-14.858	-14.858	0	%100
33	MP2	SX	-14.858	-14.858	0	%100
34	MP3	SX	-14.858	-14.858	0	%100

Node Loads and Enforced Displacements (BLC 33 : Service Live Loads)

Node	Label	L, D, M	Direction	Magnitude [(lb, lb-ft), (in, rad), (lb*s ² /in, lb*s ² *in)]
1	N16	L	Y	-250

Node Loads and Enforced Displacements (BLC 34 : Maintenance Load Lm1)

Node	Label	L, D, M	Direction	Magnitude [(lb, lb-ft), (in, rad), (lb*s ² /in, lb*s ² *in)]
1	N14	L	Y	-500

Node Loads and Enforced Displacements (BLC 35 : Maintenance Load Lm2)

Node	Label	L, D, M	Direction	Magnitude [(lb, lb-ft), (in, rad), (lb*s ² /in, lb*s ² *in)]
1	N34	L	Y	-500



Node Loads and Enforced Displacements (BLC 36 : Maintenance Load Lm3)

Node Label	L, D, M	Direction	Magnitude [(lb, lb-ft), (in, rad), (lb*s ² /in, lb*s ² *in)]
1	N18	L	Y -500

Member Area Loads

No Data to Print...

Basic Load Cases

	BLC Description	Category	X Gravity	Y Gravity	Z Gravity	Nodal	Point	Distributed
1	Self Weight	DL		-1			5	
2	Wind Load AZI 0	WLZ					10	
3	Wind Load AZI 30	None					10	
4	Wind Load AZI 60	None					10	
5	Wind Load AZI 90	WLX					10	
6	Wind Load AZI 120	None					10	
7	Wind Load AZI 150	None					10	
8	Wind Load AZI 180	None					10	
9	Wind Load AZI 210	None					10	
10	Wind Load AZI 240	None					10	
11	Wind Load AZI 270	None					10	
12	Wind Load AZI 300	None					10	
13	Wind Load AZI 330	None					10	
14	Distr. Wind Load Z	WLZ						34
15	Distr. Wind Load X	WLX						34
16	Ice Weight	OL1					5	34
17	Ice Wind Load AZI 0	OL2					10	
18	Ice Wind Load AZI 30	None					10	
19	Ice Wind Load AZI 60	None					10	
20	Ice Wind Load AZI 90	OL3					10	
21	Ice Wind Load AZI 120	None					10	
22	Ice Wind Load AZI 150	None					10	
23	Ice Wind Load AZI 180	None					10	
24	Ice Wind Load AZI 210	None					10	
25	Ice Wind Load AZI 240	None					10	
26	Ice Wind Load AZI 270	None					10	
27	Ice Wind Load AZI 300	None					10	
28	Ice Wind Load AZI 330	None					10	
29	Distr. Ice Wind Load Z	OL2						34
30	Distr. Ice Wind Load X	OL3						34
31	Seismic Load Z	ELZ			-0.314		5	
32	Seismic Load X	ELX	-0.314				5	
33	Service Live Loads	LL				1		
34	Maintenance Load Lm1	LL				1		
35	Maintenance Load Lm2	LL				1		
36	Maintenance Load Lm3	LL				1		

Load Combinations

	Description	Solve P-Delta	BLC Factor	BLC Factor	BLC Factor	BLC Factor	BLC Factor	BLC Factor	BLC Factor	BLC Factor	BLC Factor
1	1.4DL	Yes	Y	1	1.4						
2	1.2DL + 1WL AZI 0	Yes	Y	1	1.2	2	1	14	1	15	
3	1.2DL + 1WL AZI 30	Yes	Y	1	1.2	3	1	14	0.866	15	0.5
4	1.2DL + 1WL AZI 60	Yes	Y	1	1.2	4	1	14	0.5	15	0.866
5	1.2DL + 1WL AZI 90	Yes	Y	1	1.2	5	1	14		15	1
6	1.2DL + 1WL AZI 120	Yes	Y	1	1.2	6	1	14	-0.5	15	0.866

Load Combinations (Continued)

	Description	Solve	P-Delta	BLC	Factor	BLC	Factor	BLC	Factor	BLC	Factor	BLC	Factor
7	1.2DL + 1WL AZI 150	Yes	Y	1	1.2	7	1	14	-0.866	15	0.5		
8	1.2DL + 1WL AZI 180	Yes	Y	1	1.2	8	1	14	-1	15			
9	1.2DL + 1WL AZI 210	Yes	Y	1	1.2	9	1	14	-0.866	15	-0.5		
10	1.2DL + 1WL AZI 240	Yes	Y	1	1.2	10	1	14	-0.5	15	-0.866		
11	1.2DL + 1WL AZI 270	Yes	Y	1	1.2	11	1	14		15	-1		
12	1.2DL + 1WL AZI 300	Yes	Y	1	1.2	12	1	14	0.5	15	-0.866		
13	1.2DL + 1WL AZI 330	Yes	Y	1	1.2	13	1	14	0.866	15	-0.5		
14	0.9DL + 1WL AZI 0	Yes	Y	1	0.9	2	1	14	1	15			
15	0.9DL + 1WL AZI 30	Yes	Y	1	0.9	3	1	14	0.866	15	0.5		
16	0.9DL + 1WL AZI 60	Yes	Y	1	0.9	4	1	14	0.5	15	0.866		
17	0.9DL + 1WL AZI 90	Yes	Y	1	0.9	5	1	14		15	1		
18	0.9DL + 1WL AZI 120	Yes	Y	1	0.9	6	1	14	-0.5	15	0.866		
19	0.9DL + 1WL AZI 150	Yes	Y	1	0.9	7	1	14	-0.866	15	0.5		
20	0.9DL + 1WL AZI 180	Yes	Y	1	0.9	8	1	14	-1	15			
21	0.9DL + 1WL AZI 210	Yes	Y	1	0.9	9	1	14	-0.866	15	-0.5		
22	0.9DL + 1WL AZI 240	Yes	Y	1	0.9	10	1	14	-0.5	15	-0.866		
23	0.9DL + 1WL AZI 270	Yes	Y	1	0.9	11	1	14		15	-1		
24	0.9DL + 1WL AZI 300	Yes	Y	1	0.9	12	1	14	0.5	15	-0.866		
25	0.9DL + 1WL AZI 330	Yes	Y	1	0.9	13	1	14	0.866	15	-0.5		
26	1.2D + 1.0Di	Yes	Y	1	1.2	16	1						
27	1.2D + 1.0Di + 1.0Wi AZI 0	Yes	Y	1	1.2	16	1	17	1	29	1	30	
28	1.2D + 1.0Di + 1.0Wi AZI 30	Yes	Y	1	1.2	16	1	18	1	29	0.866	30	0.5
29	1.2D + 1.0Di + 1.0Wi AZI 60	Yes	Y	1	1.2	16	1	19	1	29	0.5	30	0.866
30	1.2D + 1.0Di + 1.0Wi AZI 90	Yes	Y	1	1.2	16	1	20	1	29		30	1
31	1.2D + 1.0Di + 1.0Wi AZI 120	Yes	Y	1	1.2	16	1	21	1	29	-0.5	30	0.866
32	1.2D + 1.0Di + 1.0Wi AZI 150	Yes	Y	1	1.2	16	1	22	1	29	-0.866	30	0.5
33	1.2D + 1.0Di + 1.0Wi AZI 180	Yes	Y	1	1.2	16	1	23	1	29	-1	30	
34	1.2D + 1.0Di + 1.0Wi AZI 210	Yes	Y	1	1.2	16	1	24	1	29	-0.866	30	-0.5
35	1.2D + 1.0Di + 1.0Wi AZI 240	Yes	Y	1	1.2	16	1	25	1	29	-0.5	30	-0.866
36	1.2D + 1.0Di + 1.0Wi AZI 270	Yes	Y	1	1.2	16	1	26	1	29		30	-1
37	1.2D + 1.0Di + 1.0Wi AZI 300	Yes	Y	1	1.2	16	1	27	1	29	0.5	30	-0.866
38	1.2D + 1.0Di + 1.0Wi AZI 330	Yes	Y	1	1.2	16	1	28	1	29	0.866	30	-0.5
39	(1.2 + 0.2Sds)DL + 1.0E AZI 0	Yes	Y	1	1.242	31	1	32					
40	(1.2 + 0.2Sds)DL + 1.0E AZI 30	Yes	Y	1	1.242	31	0.866	32	0.5				
41	(1.2 + 0.2Sds)DL + 1.0E AZI 60	Yes	Y	1	1.242	31	0.5	32	0.866				
42	(1.2 + 0.2Sds)DL + 1.0E AZI 90	Yes	Y	1	1.242	31		32	1				
43	(1.2 + 0.2Sds)DL + 1.0E AZI 120	Yes	Y	1	1.242	31	-0.5	32	0.866				
44	(1.2 + 0.2Sds)DL + 1.0E AZI 150	Yes	Y	1	1.242	31	-0.866	32	0.5				
45	(1.2 + 0.2Sds)DL + 1.0E AZI 180	Yes	Y	1	1.242	31	-1	32					
46	(1.2 + 0.2Sds)DL + 1.0E AZI 210	Yes	Y	1	1.242	31	-0.866	32	-0.5				
47	(1.2 + 0.2Sds)DL + 1.0E AZI 240	Yes	Y	1	1.242	31	-0.5	32	-0.866				
48	(1.2 + 0.2Sds)DL + 1.0E AZI 270	Yes	Y	1	1.242	31		32	-1				
49	(1.2 + 0.2Sds)DL + 1.0E AZI 300	Yes	Y	1	1.242	31	0.5	32	-0.866				
50	(1.2 + 0.2Sds)DL + 1.0E AZI 330	Yes	Y	1	1.242	31	0.866	32	-0.5				
51	(0.9 - 0.2Sds)DL + 1.0E AZI 0	Yes	Y	1	0.858	31	1	32					
52	(0.9 - 0.2Sds)DL + 1.0E AZI 30	Yes	Y	1	0.858	31	0.866	32	0.5				
53	(0.9 - 0.2Sds)DL + 1.0E AZI 60	Yes	Y	1	0.858	31	0.5	32	0.866				
54	(0.9 - 0.2Sds)DL + 1.0E AZI 90	Yes	Y	1	0.858	31		32	1				
55	(0.9 - 0.2Sds)DL + 1.0E AZI 120	Yes	Y	1	0.858	31	-0.5	32	0.866				
56	(0.9 - 0.2Sds)DL + 1.0E AZI 150	Yes	Y	1	0.858	31	-0.866	32	0.5				
57	(0.9 - 0.2Sds)DL + 1.0E AZI 180	Yes	Y	1	0.858	31	-1	32					
58	(0.9 - 0.2Sds)DL + 1.0E AZI 210	Yes	Y	1	0.858	31	-0.866	32	-0.5				
59	(0.9 - 0.2Sds)DL + 1.0E AZI 240	Yes	Y	1	0.858	31	-0.5	32	-0.866				
60	(0.9 - 0.2Sds)DL + 1.0E AZI 270	Yes	Y	1	0.858	31		32	-1				
61	(0.9 - 0.2Sds)DL + 1.0E AZI 300	Yes	Y	1	0.858	31	0.5	32	-0.866				

Load Combinations (Continued)

	Description	Solve	P-Delta	BLC	Factor	BLC	Factor	BLC	Factor	BLC	Factor	BLC	Factor
62	(0.9 - 0.2Sds)DL + 1.0E AZI 330	Yes	Y	1	0.858	31	0.866	32	-0.5				
63	1.0DL + 1.5LL + 1.0SWL (60 mph) AZI 0	Yes	Y	1	1	2	0.259	14	0.259	15		33	1.5
64	1.0DL + 1.5LL + 1.0SWL (60 mph) AZI 30	Yes	Y	1	1	3	0.259	14	0.224	15	0.129	33	1.5
65	1.0DL + 1.5LL + 1.0SWL (60 mph) AZI 60	Yes	Y	1	1	4	0.259	14	0.129	15	0.224	33	1.5
66	1.0DL + 1.5LL + 1.0SWL (60 mph) AZI 90	Yes	Y	1	1	5	0.259	14		15	0.259	33	1.5
67	1.0DL + 1.5LL + 1.0SWL (60 mph) AZI 120	Yes	Y	1	1	6	0.259	14	-0.129	15	0.224	33	1.5
68	1.0DL + 1.5LL + 1.0SWL (60 mph) AZI 150	Yes	Y	1	1	7	0.259	14	-0.224	15	0.129	33	1.5
69	1.0DL + 1.5LL + 1.0SWL (60 mph) AZI 180	Yes	Y	1	1	8	0.259	14	-0.259	15		33	1.5
70	1.0DL + 1.5LL + 1.0SWL (60 mph) AZI 210	Yes	Y	1	1	9	0.259	14	-0.224	15	-0.129	33	1.5
71	1.0DL + 1.5LL + 1.0SWL (60 mph) AZI 240	Yes	Y	1	1	10	0.259	14	-0.129	15	-0.224	33	1.5
72	1.0DL + 1.5LL + 1.0SWL (60 mph) AZI 270	Yes	Y	1	1	11	0.259	14		15	-0.259	33	1.5
73	1.0DL + 1.5LL + 1.0SWL (60 mph) AZI 300	Yes	Y	1	1	12	0.259	14	0.129	15	-0.224	33	1.5
74	1.0DL + 1.5LL + 1.0SWL (60 mph) AZI 330	Yes	Y	1	1	13	0.259	14	0.224	15	-0.129	33	1.5
75	1.2DL + 1.5LL	Yes	Y	1	1.2	33	1.5						
76	1.2DL + 1.5LM-MP1 + 1SWL (30 mph) AZI 0	Yes	Y	1	1.2	34	1.5	2	0.065	14	0.065	15	
77	1.2DL + 1.5LM-MP1 + 1SWL (30 mph) AZI 30	Yes	Y	1	1.2	34	1.5	3	0.065	14	0.056	15	0.032
78	1.2DL + 1.5LM-MP1 + 1SWL (30 mph) AZI 60	Yes	Y	1	1.2	34	1.5	4	0.065	14	0.032	15	0.056
79	1.2DL + 1.5LM-MP1 + 1SWL (30 mph) AZI 90	Yes	Y	1	1.2	34	1.5	5	0.065	14		15	0.065
80	1.2DL + 1.5LM-MP1 + 1SWL (30 mph) AZI 120	Yes	Y	1	1.2	34	1.5	6	0.065	14	-0.032	15	0.056
81	1.2DL + 1.5LM-MP1 + 1SWL (30 mph) AZI 150	Yes	Y	1	1.2	34	1.5	7	0.065	14	-0.056	15	0.032
82	1.2DL + 1.5LM-MP1 + 1SWL (30 mph) AZI 180	Yes	Y	1	1.2	34	1.5	8	0.065	14	-0.065	15	
83	1.2DL + 1.5LM-MP1 + 1SWL (30 mph) AZI 210	Yes	Y	1	1.2	34	1.5	9	0.065	14	-0.056	15	-0.032
84	1.2DL + 1.5LM-MP1 + 1SWL (30 mph) AZI 240	Yes	Y	1	1.2	34	1.5	10	0.065	14	-0.032	15	-0.056
85	1.2DL + 1.5LM-MP1 + 1SWL (30 mph) AZI 270	Yes	Y	1	1.2	34	1.5	11	0.065	14		15	-0.065
86	1.2DL + 1.5LM-MP1 + 1SWL (30 mph) AZI 300	Yes	Y	1	1.2	34	1.5	12	0.065	14	0.032	15	-0.056
87	1.2DL + 1.5LM-MP1 + 1SWL (30 mph) AZI 330	Yes	Y	1	1.2	34	1.5	13	0.065	14	0.056	15	-0.032
88	1.2DL + 1.5LM-MP2 + 1SWL (30 mph) AZI 0	Yes	Y	1	1.2	35	1.5	2	0.065	14	0.065	15	
89	1.2DL + 1.5LM-MP2 + 1SWL (30 mph) AZI 30	Yes	Y	1	1.2	35	1.5	3	0.065	14	0.056	15	0.032
90	1.2DL + 1.5LM-MP2 + 1SWL (30 mph) AZI 60	Yes	Y	1	1.2	35	1.5	4	0.065	14	0.032	15	0.056
91	1.2DL + 1.5LM-MP2 + 1SWL (30 mph) AZI 90	Yes	Y	1	1.2	35	1.5	5	0.065	14		15	0.065
92	1.2DL + 1.5LM-MP2 + 1SWL (30 mph) AZI 120	Yes	Y	1	1.2	35	1.5	6	0.065	14	-0.032	15	0.056
93	1.2DL + 1.5LM-MP2 + 1SWL (30 mph) AZI 150	Yes	Y	1	1.2	35	1.5	7	0.065	14	-0.056	15	0.032
94	1.2DL + 1.5LM-MP2 + 1SWL (30 mph) AZI 180	Yes	Y	1	1.2	35	1.5	8	0.065	14	-0.065	15	
95	1.2DL + 1.5LM-MP2 + 1SWL (30 mph) AZI 210	Yes	Y	1	1.2	35	1.5	9	0.065	14	-0.056	15	-0.032
96	1.2DL + 1.5LM-MP2 + 1SWL (30 mph) AZI 240	Yes	Y	1	1.2	35	1.5	10	0.065	14	-0.032	15	-0.056
97	1.2DL + 1.5LM-MP2 + 1SWL (30 mph) AZI 270	Yes	Y	1	1.2	35	1.5	11	0.065	14		15	-0.065
98	1.2DL + 1.5LM-MP2 + 1SWL (30 mph) AZI 300	Yes	Y	1	1.2	35	1.5	12	0.065	14	0.032	15	-0.056
99	1.2DL + 1.5LM-MP2 + 1SWL (30 mph) AZI 330	Yes	Y	1	1.2	35	1.5	13	0.065	14	0.056	15	-0.032
100	1.2DL + 1.5LM-MP3 + 1SWL (30 mph) AZI 0	Yes	Y	1	1.2	36	1.5	2	0.065	14	0.065	15	
101	1.2DL + 1.5LM-MP3 + 1SWL (30 mph) AZI 30	Yes	Y	1	1.2	36	1.5	3	0.065	14	0.056	15	0.032
102	1.2DL + 1.5LM-MP3 + 1SWL (30 mph) AZI 60	Yes	Y	1	1.2	36	1.5	4	0.065	14	0.032	15	0.056
103	1.2DL + 1.5LM-MP3 + 1SWL (30 mph) AZI 90	Yes	Y	1	1.2	36	1.5	5	0.065	14		15	0.065
104	1.2DL + 1.5LM-MP3 + 1SWL (30 mph) AZI 120	Yes	Y	1	1.2	36	1.5	6	0.065	14	-0.032	15	0.056
105	1.2DL + 1.5LM-MP3 + 1SWL (30 mph) AZI 150	Yes	Y	1	1.2	36	1.5	7	0.065	14	-0.056	15	0.032
106	1.2DL + 1.5LM-MP3 + 1SWL (30 mph) AZI 180	Yes	Y	1	1.2	36	1.5	8	0.065	14	-0.065	15	
107	1.2DL + 1.5LM-MP3 + 1SWL (30 mph) AZI 210	Yes	Y	1	1.2	36	1.5	9	0.065	14	-0.056	15	-0.032
108	1.2DL + 1.5LM-MP3 + 1SWL (30 mph) AZI 240	Yes	Y	1	1.2	36	1.5	10	0.065	14	-0.032	15	-0.056
109	1.2DL + 1.5LM-MP3 + 1SWL (30 mph) AZI 270	Yes	Y	1	1.2	36	1.5	11	0.065	14		15	-0.065
110	1.2DL + 1.5LM-MP3 + 1SWL (30 mph) AZI 300	Yes	Y	1	1.2	36	1.5	12	0.065	14	0.032	15	-0.056
111	1.2DL + 1.5LM-MP3 + 1SWL (30 mph) AZI 330	Yes	Y	1	1.2	36	1.5	13	0.065	14	0.056	15	-0.032

Envelope Node Reactions

Node Label	X [lb]	LC	Y [lb]	LC	Z [lb]	LC	MX [lb-ft]	LC	MY [lb-ft]	LC	MZ [lb-ft]	LC
1 N28 max	168.968	22	34.189	36	614.856	16	0	111	0	111	0	111
2 min	-168.716	16	10.95	54	-617.341	22	0	1	0	1	0	1

Envelope Node Reactions (Continued)

Node Label		X [lb]	LC	Y [lb]	LC	Z [lb]	LC	MX [lb-ft]	LC	MY [lb-ft]	LC	MZ [lb-ft]	LC	
3	N47	max	935.545	79	611.439	33	1008.606	27	-180.376	62	0	111	195.095	79
4		min	-1000.022	109	209.291	14	-31.22	20	-526.262	32	0	1	-227.206	109
5	N48	max	1032.957	103	869.212	88	709.174	25	-250.089	59	0	111	290.655	79
6		min	-968.448	85	291.954	57	-1493.029	7	-748.297	90	0	1	-311.069	109
7	Totals:	max	752.228	5	1469.172	101	1231.699	14						
8		min	-752.228	11	514.319	59	-1231.702	20						

Envelope AISC 15TH (360-16): LRFD Member Steel Code Checks

Member	Shape	Code Check	Loc[in]	LC	Shear	Check	Loc[in]	Dir	LC	phi*Pnc [lb]	phi*Pnt [lb]	phi*Mn y-y [lb-ft]	phi*Mn z-z [lb-ft]	Cb	Eqn
1	MH1	PIPE 2.0X	0.378	60	8	0.075	12.5	8	12974.268	44100	2530.5	2530.5	1	H1-1b	
2	M23	3"x.5"	0.358	0	104	0.079	3.313	y	80	47260.401	48600	507.6	3037.5	1.031	H1-1b
3	M14	3"x.5"	0.341	0	84	0.083	3.313	y	108	47260.401	48600	507.6	3037.5	1.031	H1-1b
4	M24	3"x.5"	0.28	0	110	0.075	3.313	y	79	47260.401	48600	507.6	3037.5	1.026	H1-1b
5	M15	3"x.5"	0.263	0	78	0.079	3.313	y	109	47260.401	48600	507.6	3037.5	1.026	H1-1b
6	M22	3"x.5"	0.261	0	107	0.059	2.5	y	90	47832.381	48600	507.6	3037.5	1.667	H1-1b
7	M13	3"x.5"	0.26	0	81	0.06	2.5	y	98	47832.381	48600	507.6	3037.5	1.667	H1-1b
8	MH2	PIPE 2.0X	0.26	60	98	0.064	11.25	107	12974.268	44100	2530.5	2530.5	1	H1-1b	
9	M21	3"x.5"	0.2	0	100	0.062	2.5	y	93	47832.381	48600	507.6	3037.5	1.667	H1-1b
10	M12	3"x.5"	0.193	0	76	0.063	2.5	y	95	47832.381	48600	507.6	3037.5	1.667	H1-1b
11	MP2	PIPE 2.5	0.151	30	8	0.026	30	13	30038.461	50715	3596.25	3596.25	1	H1-1b	
12	M20	0.75" SR	0.138	0	109	0.005	57.824	4	2206.248	14320.8	184.32	184.32	1	H1-1b*	
13	M7	0.75" SR	0.135	0	79	0.005	57.824	12	2206.248	14320.8	184.32	184.32	1	H1-1b*	
14	MP3	PIPE 2.5	0.127	30	97	0.035	30	3	30038.461	50715	3596.25	3596.25	1	H1-1b	
15	MP1	PIPE 2.5	0.126	30	91	0.033	30	88	30038.461	50715	3596.25	3596.25	1	H1-1b	
16	M16	PIPE 2.0X	0.118	0	110	0.015	45.25	79	36930.95	44100	2530.5	2530.5	1	H1-1b	
17	M2	PIPE 2.0X	0.111	0	78	0.016	45.25	109	36930.95	44100	2530.5	2530.5	1	H1-1b	
18	M17	PIPE 2.0X	0.097	0	104	0.014	45.25	81	36930.95	44100	2530.5	2530.5	1	H1-1b	
19	M18	0.75" SR	0.097	0	100	0.014	36	102	5686.943	14320.8	184.32	184.32	1	H1-1b*	
20	M4	PIPE 2.0X	0.093	0	102	0.014	45.25	107	36930.95	44100	2530.5	2530.5	1	H1-1b	
21	M5	0.75" SR	0.091	0	76	0.013	36	84	5686.943	14320.8	184.32	184.32	1	H1-1b*	
22	M19	0.75" SR	0.091	0	108	0.028	36	101	5686.943	14320.8	184.32	184.32	1	H1-1b*	
23	M6	0.75" SR	0.085	0	80	0.028	0	101	5686.943	14320.8	184.32	184.32	1	H1-1b*	
24	M25	PIPE 2.0	0.052	44.167	5	0.004	88.334	36	16778.481	32130	1871.625	1871.625	1	H1-1b	

Envelope Member End Reactions

Member	Member End		Axial[lb]	LC y Shear[lb]	LC z Shear[lb]	LC Torque[lb-ft]	LC y-y Moment[lb-ft]	LC z-z Moment[lb-ft]	LC
1	M25	I	max 636.999	16 34.153	38 30.034	11 0	111 0	111 0	111
2			min -639.442	22 10.963	51 -30.034	17 0	1 0	1 0	1
3		J	max 649.024	17 -10.963	62 30.034	5 0	111 0	111 0	111
4			min -649.851	23 -34.153	26 -30.034	23 0	1 0	1 0	1

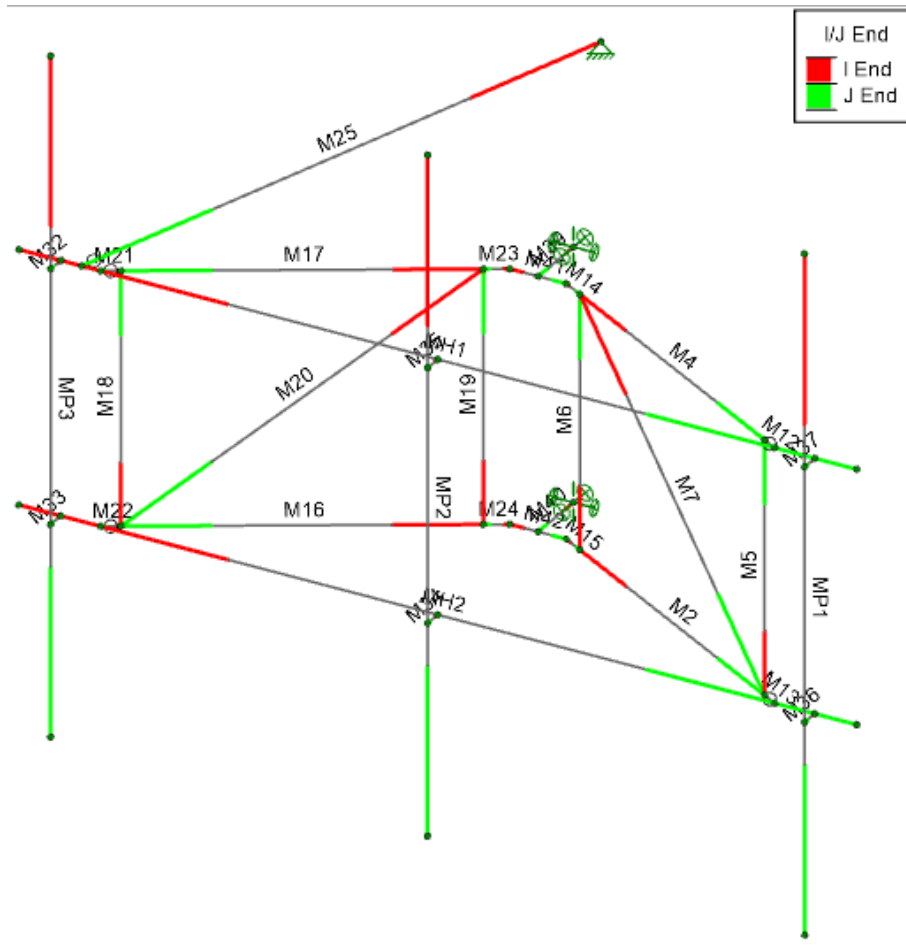

INFINIGY⁸

Bolt Calculation Tool, V1.6.4

PROJECT DATA	
Site Name:	N/A
Site Number:	BOHVN00186A
Connection Description:	Frame to Tower

ENVELOPE BOLT LOADS		
(LC93 M39) Bolt Tension:	2498.10	lbs
(LC102 M39) Bolt Shear:	604.78	lbs

MAX BOLT USAGE LOADS ¹		
Bolt Tension:	2498.10	lbs
Bolt Shear:	226.01	lbs

BOLT PROPERTIES		
Bolt Type:	Threaded Rod	-
Bolt Diameter:	0.5	in
Bolt Grade:	A307	-
# of Threaded Rods:	4	-
Threads Excluded?	No	-

¹ Max bolt usage loads correspond to Load combination #93 on member M39 in RISA-3D, which causes the maximum demand on the bolts.

Member Information
I nodes of M39, M40,

BOLT CHECK	
Tensile Strength	6385.43
Shear Strength	4417.86
Max Tensile Usage	39.1%
Max Shear Usage	13.7%
Interaction Check (Max Usage)	0.16
Result	Pass

≤1.05



wireless



THD 10' V-Boom Assembly with Tieback (Tier 1, 2, 3)

C10837002C



• **Sector Frame Option 2**- This is a secondary approved mount if the primary is not available*

- **C10837002C-32788 V-Boom Sector Frame**
- 10' THD V-Boom Sector Mount with Tieback
- Face Width = 10', Stiff Arm = 1
- Includes (3) 2-7/8" OD x 8' Antenna
- Mounting Pipes and all associated hardware
- Kit weight – 610 lbs

Exhibit F

Power Density/RF Emissions Report



Radio Frequency Emissions Analysis Report



Site ID: BOHVN00186A

0 Clark Hill Road
Naugatuck, CT 06770

September 19, 2023

Fox Hill Telecom Project Number: 230986

Site Compliance Summary	
Compliance Status:	COMPLIANT
Site total MPE% of FCC general population allowable limit:	6.27 %

September 19, 2023

Dish Wireless
5701 South Santa Fe Drive
Littleton, CO 80120

Emissions Analysis for Site: **BOHVN00186A**

Fox Hill Telecom, Inc (“Fox Hill”) was directed to analyze the proposed radio installation for Dish Wireless, LLC (Dish) facility located at **0 Clark Hill Road, Naugatuck, CT**, for the purpose of determining whether the emissions from the Proposed Dish radio and antenna installation located on this property are within specified federal limits.

All information used in this report was analyzed as a percentage of current Maximum Permissible Exposure (% MPE) as listed in the FCC OET Bulletin 65 Edition 97-01 and ANSI/IEEE Std C95.1. The FCC regulates Maximum Permissible Exposure in units of microwatts per square centimeter ($\mu\text{W}/\text{cm}^2$). The number of $\mu\text{W}/\text{cm}^2$ calculated at each sample point is called the power density. The exposure limit for power density varies depending upon the frequencies being utilized. Wireless Carriers and Paging Services use different frequency bands each with different exposure limits, therefore it is necessary to report results and limits in terms of percent MPE rather than power density.

All results were compared to the FCC (Federal Communications Commission) radio frequency exposure rules, 47 CFR 1.1307(b)(1) – (b)(3), to determine compliance with the Maximum Permissible Exposure (MPE) limits for General Population/Uncontrolled environments as defined below.

General population/uncontrolled exposure limits apply to situations in which the general population may be exposed or in which persons who are exposed as a consequence of their employment may not be made fully aware of the potential for exposure or cannot exercise control over their exposure. Therefore, members of the general population would always be considered under this category when exposure is not employment related, for example, in the case of a telecommunications tower that exposes persons in a nearby residential area.

Population exposure to radio frequencies is regulated and enforced in units of microwatts per square centimeter ($\mu\text{W}/\text{cm}^2$). The general population exposure limit for the 600 MHz band is approximately $400 \mu\text{W}/\text{cm}^2$. The general population exposure limit for the 1900 MHz (PCS) and 2100 MHz (AWS / AWS-4) bands is $1000 \mu\text{W}/\text{cm}^2$. Because each carrier will be using different frequency bands, and each frequency band has different exposure limits, it is necessary to report percent of MPE rather than power density.

Occupational/controlled exposure limits apply to situations in which persons are exposed as a consequence of their employment and in which those persons who are exposed have been made fully aware of the potential for exposure and can exercise control over their exposure. Occupational/controlled exposure limits also apply where exposure is of a transient nature as a result of incidental passage through a location where exposure levels may be above general population/uncontrolled limits (see below), as long as the exposed person has been made fully aware of the potential for exposure and can exercise control over his or her exposure by leaving the area or by some other appropriate means.

Additional details can be found in FCC OET 65.



CALCULATIONS

Calculations were performed for the proposed upgrades to the Dish Wireless antenna facility located at **0 Clark Hill Road, Naugatuck, CT**, using the equipment information listed below. All calculations were performed per the specifications under FCC OET 65 for far field modeling calculations.

In OET-65, plane wave power densities in the Far Field of an antenna are calculated by considering antenna gain and reflective waves that would contribute to exposure.

Since the radiation pattern of an antenna has developed in the **Far Field** region the power gain in specific directions needs to be considered in exposure predictions to yield an Effective Radiated Power (ERP) in each specific direction from the antenna. Also, since the vertical radiation pattern of the antenna is considered, the exposure calculations would most likely be reduced significantly at ground level, resulting in a more realistic estimate of the actual exposure levels. To determine a worst-case scenario at each point along the calculation radials, each point was calculated using the antenna gain value at each angle of incident and compared against the result using an isotropic radiator at the antenna height with the greater of the two used to yield the more pessimistic far field value for each point along the calculation radial.

Additionally, to model a truly "worst case" prediction of exposure levels at or near a surface, such as at ground-level or on a rooftop, reflection off the surface of antenna radiation power can be assumed, resulting in a potential 1.6 times increase in power density in calculating far field power density values.

With these factors Considered, the worst case **Far Field prediction model** utilized in this analysis is determined by the following equation:

Equation 9 per FCC OET65 for Far Field Modeling

$$S = \frac{33.4 \text{ ERP}}{R^2}$$

S = Power Density (in $\mu\text{w}/\text{cm}^2$)

ERP = Effective Radiated Power from antenna (watts)

R = Distance from the antenna (meters)

Predicted far field power density values for all carriers identified in this report were calculated 6 feet above the ground level and are displayed as a percentage of the applicable FCC standards. All emissions values for other carriers were calculated using the same Far Field model outlined above, using industry standard radio configurations and frequency band selection based upon available licenses in this geographic area for emissions contribution estimates.

For each Dish sector the following channel counts, frequency bands and power levels were utilized as shown in *Table 1*:

Technology	Frequency Band	Channel Count	Transmit Power per Channel (W)
5G	n71 (600 MHz)	4	61.5
5G	n70 (AWS-4 / 1995-2020)	4	40
5G	n66 (AWS-4 / 2180-2200)	4	40

Table 1: Channel Data Table



The following **Dish** antennas listed in *Table 2* were used in the modeling for transmission in the 600 MHz (n71) frequency band and the 2100 MHz (AWS 4) frequency bands at 1995-2020 MHz (n70) and 2180-2200 MHz (n66). This is based on feedback from Dish regarding anticipated antenna selection. Maximum gain values for all antennas are listed in the Inventory and Power Data table below.

Sector	Antenna Number	Antenna Make / Model	Antenna Centerline (ft)
A	1	JMA MX08FRO665-21	170
B	1	JMA MX08FRO665-21	170
C	1	JMA MX08FRO665-21	170

Table 2: Antenna Data

All calculations were done with respect to uncontrolled / general population threshold limits.

RESULTS

Per the calculations completed for the proposed **Dish** configurations *Table 3* shows resulting emissions power levels and percentages of the FCC’s allowable general population limit.

Antenna ID	Antenna Make / Model	Frequency Bands	Antenna Gain (dBd)	Channel Count	Total TX Power (W)	ERP (W)	MPE %
Antenna A1	JMA MX08FRO665-21	n71 (600 MHz) / n70 (AWS-4 / 1995-2020) / n66 (AWS-4 / 2180-2200)	11.45 / 16.15 / 16.65	12	566	17,426.72	1.26
Sector A Composite MPE%							1.26
Antenna B1	JMA MX08FRO665-21	n71 (600 MHz) / n70 (AWS-4 / 1995-2020) / n66 (AWS-4 / 2180-2200)	11.45 / 16.15 / 16.65	12	566	17,426.72	1.26
Sector B Composite MPE%							1.26
Antenna C1	JMA MX08FRO665-21	n71 (600 MHz) / n70 (AWS-4 / 1995-2020) / n66 (AWS-4 / 2180-2200)	11.45 / 16.15 / 16.65	12	566	17,426.72	1.26
Sector C Composite MPE%							1.26

Table 3: Dish Emissions Levels

The Following table (*Table 4*) shows all additional carriers on site and their emissions contribution estimates, along with the newly calculated **Dish** far field emissions contributions per this report. FCC OET 65 specifies that for carriers utilizing directional antennas that the highest recorded sector value be used for composite site emissions values due to their greatly reduced emissions contributions in the directions of the adjacent sectors. For this site, all three sectors have the same configuration yielding the same results for all three sectors. *Table 5* below shows a summary for each **Dish** Sector as well as the composite emissions value for the site.

Site Composite MPE%	
Carrier	MPE%
Dish – Max Per Sector Value	1.26 %
T-Mobile	0.98 %
AT&T	4.02 %
Microwave Dishes (265')	0.01 %
Site Total MPE %:	6.27 %

Table 4: All Carrier MPE Contributions

Dish Sector A Total:	1.26 %
Dish Sector B Total:	1.26 %
Dish Sector C Total:	1.26 %
Site Total:	6.27 %

Table 5: Site MPE Summary



Table 6 below details a breakdown by frequency band and technology for the MPE power values for the maximum calculated **Dish** sector(s). For this site, all three sectors have the same configuration yielding the same results for all three sectors.

Dish _ Frequency Band / Technology Max Power Values (Per Sector)	# Channels	Watts ERP (Per Channel)	Height (feet)	Total Power Density ($\mu\text{W}/\text{cm}^2$)	Frequency (MHz)	Allowable MPE ($\mu\text{W}/\text{cm}^2$)	Calculated % MPE
Dish n71 (600 MHz) 5G	4	858.77	170	3.36	n71 (600 MHz)	400	0.84%
Dish n70 (AWS-4 / 1995-2020) 5G	4	1,648.39	170	2.10	n70 (AWS-4 / 1995-2020)	1000	0.21%
Dish n66 (AWS-4 / 2180-2200) 5G	4	1,849.52	170	2.10	n66 (AWS-4 / 2180-2200)	1000	0.21%
						Total:	1.26 %

Table 6: Dish Maximum Sector MPE Power Values



Summary

All calculations performed for this analysis yielded results that were **within** the allowable limits for general population exposure to RF Emissions.

The anticipated maximum composite contributions from the Dish facility as well as the site composite emissions value with regards to compliance with FCC's allowable limits for general population exposure to RF Emissions are shown here:

Dish Sector	Power Density Value (%)
Sector A:	1.26 %
Sector B:	1.26 %
Sector C:	1.26 %
Dish Maximum Total (per sector):	1.26 %
Site Total:	6.27 %
Site Compliance Status:	COMPLIANT

The anticipated composite emissions value for this site, assuming all carriers present, is **6.27 %** of the allowable FCC established general population limit sampled at the ground level. This is based upon the far field calculations performed for all carriers identified in this report.

FCC guidelines state that if a site is found to be out of compliance (over allowable thresholds), that carriers over a 5% contribution to the composite value will require measures to bring the site into compliance. For this facility, the composite values calculated were well within the allowable 100% threshold standard per the federal government.

Scott Heffernan
Principal RF Engineer
Fox Hill Telecom, Inc
Worcester, MA 01609
(978)660-3998

Exhibit G

Letter of Authorization



Dish Wireless, LLC Letter of Authorization

Dish Wireless Site ID: BOHVN00186A
Site Address: 0 Clark Hill Road, Naugatuck, CT
RE: Zoning and Permitting Application

This letter authorizes Dish Wireless LLC and its authorized agents from Northeast Site Solutions, LLC to file all necessary administrative approvals, zoning approvals and building permits for the purposes of installing antenna and associated equipment on the rooftop at the location referenced above.

DocuSigned by:
By: *Mike Navin*
2395EC2BB36C42F...

Title: Head of Technology

Printed Name: Mike Navin

Date: 7/21/2023

420 Main Street, Unit 1 Box 2, Sturbridge, MA 01566

Exhibit H

Recipient Mailings



N. WARREN HESS, III
MAYOR-BOROUGH OF NAUGATUCK
229 CHURCH ST
NAUGATUCK CT 06770-4145

Expected Delivery Date: 09/22/23
Ref#: DAD-
0001

C004

DEBORAH CHASE
NORTHEAST SITE SOLUTIONS
STE 1
420 MAIN ST
STURBRIDGE MA 01566-1359

Expected Delivery Date: 09/22/23
Ref#: DAD-
0001

P

PRIORITY MAIL®

Click-N-Ship®

U.S. POSTAGE PAID

Flat Rate Envoy

\$9.65

09/20/2023

Mailed from 01566 986747399314611

Click-N-Ship®

U.S. POSTAGE PAID

Flat Rate Envoy

\$9.65

09/20/2023

Mailed from 01566 986747399314611

Click-N-Ship®

U.S. POSTAGE PAID

Flat Rate Envoy

\$9.65

09/20/2023

Mailed from 01566 986747399314611

Click-N-Ship®

U.S. POSTAGE PAID

Flat Rate Envoy

\$9.65

09/20/2023

Mailed from 01566 986747399314611



Cut on dotted line.

Instructions

1. Each Click-N-Ship® label is unique. Labels are to be used as printed and used only once. DO NOT PHOTO COPY OR ALTER LABEL.
2. Place your label so it does not wrap around the edge of the package.
3. Adhere your label to the package. A self-adhesive label is recommended. If tape or glue is used, DO NOT TAPE OVER BARCODE. Be sure all edges are secure.
4. To mail your package with PC Postage®, you may schedule a Package Pickup online, hand to your letter carrier, take to a Post Office™, or drop in a USPS collection box.
5. Mail your package on the "Ship Date" you selected when creating this label.

Click-N-Ship® Label Record

USPS TRACKING # :
9405 5036 9930 0605 4684 88

Trans. #: 595051071	Priority Mail® Postage: \$9.65
Print Date: 09/20/2023	Total: \$9.65
Ship Date: 09/20/2023	
Expected Delivery Date: 09/22/2023	

From: DEBORAH CHASE Ref#: DAD-
NORTHEAST SITE SOLUTIONS
STE 1
420 MAIN ST
STURBRIDGE MA 01566-1359

To: N. WARREN HESS, III
MAYOR-BOROUGH OF NAUGATUCK
229 CHURCH ST
NAUGATUCK CT 06770-4145

* Retail Pricing Priority Mail rates apply. There is no fee for USPS Tracking® service on Priority Mail service with use of this electronic rate shipping label. Refunds for unused postage paid labels can be requested online 30 days from the print date.



Thank you for shipping with the United States Postal Service!
Check the status of your shipment on the USPS Tracking® page at usps.com



LORI ROTELLA
TOWN PLANNER- NAUGATUCK ZONING
229 CHURCH ST
NAUGATUCK CT 06770-4145

USPS TRACKING #

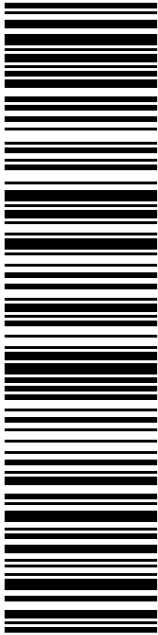

9405 5036 9930 0605 4685 18

DEBORAH CHASE
NORTHEAST SITE SOLUTIONS
STE 1
420 MAIN ST
STURBRIDGE MA 01566-1359

PRIORITY MAIL®

Expected Delivery Date: 09/22/23
Ref#: DD-00186A
0001

C004

P

usps.com 9405 5036 9930 0605 4685 18 0096 5000 0020 6770
US POSTAGE
Flat Rate Envoy

U.S. POSTAGE PAID
Click-N-Ship®

Mailed from 01566 98674739931 1261

09/20/2023



UNITED STATES POSTAL SERVICE®

Click-N-Ship®

Electronic Rate Approved #038555749





Cut on dotted line.

Instructions

- Each Click-N-Ship® label is unique. Labels are to be used as printed and used only once. DO NOT PHOTO COPY OR ALTER LABEL.
- Place your label so it does not wrap around the edge of the package.
- Adhere your label to the package. A self-adhesive label is recommended. If tape or glue is used, DO NOT TAPE OVER BARCODE. Be sure all edges are secure.
- To mail your package with PC Postage®, you may schedule a Package Pickup online, hand to your letter carrier, take to a Post Office™, or drop in a USPS collection box.
- Mail your package on the "Ship Date" you selected when creating this label.

Click-N-Ship® Label Record

USPS TRACKING # :
9405 5036 9930 0605 4685 18

Trans. #: 595051071	Priority Mail® Postage: \$9.65
Print Date: 09/20/2023	Total: \$9.65
Ship Date: 09/20/2023	
Expected Delivery Date: 09/22/2023	

From: DEBORAH CHASE
NORTHEAST SITE SOLUTIONS
STE 1
420 MAIN ST
STURBRIDGE MA 01566-1359

Ref#: DD-00186A

To: LORI ROTELLA
TOWN PLANNER- NAUGATUCK ZONING DEPARTMENT
229 CHURCH ST
NAUGATUCK CT 06770-4145

* Retail Pricing Priority Mail rates apply. There is no fee for USPS Tracking® service on Priority Mail service with use of this electronic rate shipping label. Refunds for unused postage paid labels can be requested online 30 days from the print date.



Thank you for shipping with the United States Postal Service!
Check the status of your shipment on the USPS Tracking® page at usps.com



TEGNA BROADCAST HOLDINGS LLC
8350 BROAD ST
TYSONS VA 22102-5150

USPS TRACKING #

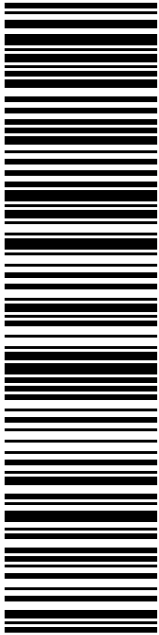

9405 5036 9930 0605 4685 32

P

usps.com 9405 5036 9930 0605 4685 32 0096 5000 0042 2102
US POSTAGE
 Flat Rate Envoy

U.S. POSTAGE PAID
 Click-N-Ship®

Mailed from 01566 986747399308965

DEBORAH CHASE
NORTHEAST SITE SOLUTIONS
STE 1
420 MAIN ST
STURBRIDGE MA 01566-1359

PRIORITY MAIL®

Expected Delivery Date: 09/22/23
 Ref#: DD-00186A
0001

C013

Electronic Rate Approved #038555749





Cut on dotted line.

Instructions

1. Each Click-N-Ship® label is unique. Labels are to be used as printed and used only once. DO NOT PHOTO COPY OR ALTER LABEL.
2. Place your label so it does not wrap around the edge of the package.
3. Adhere your label to the package. A self-adhesive label is recommended. If tape or glue is used, DO NOT TAPE OVER BARCODE. Be sure all edges are secure.
4. To mail your package with PC Postage®, you may schedule a Package Pickup online, hand to your letter carrier, take to a Post Office™, or drop in a USPS collection box.
5. Mail your package on the "Ship Date" you selected when creating this label.

Click-N-Ship® Label Record

USPS TRACKING # :
9405 5036 9930 0605 4685 32

Trans. #: 595051071	Priority Mail® Postage: \$9.65
Print Date: 09/20/2023	Total: \$9.65
Ship Date: 09/20/2023	
Expected Delivery Date: 09/22/2023	

From: DEBORAH CHASE Ref#: DD-00186A
 NORTHEAST SITE SOLUTIONS
 STE 1
 420 MAIN ST
 STURBRIDGE MA 01566-1359

To: TEGNA BROADCAST HOLDINGS LLC
 8350 BROAD ST
 TYSONS VA 22102-5150

* Retail Pricing Priority Mail rates apply. There is no fee for USPS Tracking® service on Priority Mail service with use of this electronic rate shipping label. Refunds for unused postage paid labels can be requested online 30 days from the print date.



Thank you for shipping with the United States Postal Service!
 Check the status of your shipment on the USPS Tracking® page at usps.com



FISKDALE
 458 MAIN ST
 FISKDALE, MA 01518-9998
 (800)275-8777

09/20/2023 12:53 PM

Product	Qty	Unit Price	Price
---------	-----	------------	-------

Prepaid Mail	1		\$0.00
Naugatuck, CT 06770			
Weight: 1 lb 0.80 oz			
Acceptance Date:			
Wed 09/20/2023			
Tracking #:			
9405 5036 9930 0605 4684 88			

Prepaid Mail	1		\$0.00
Naugatuck, CT 06770			
Weight: 1 lb 10.20 oz			
Acceptance Date:			
Wed 09/20/2023			
Tracking #:			
9405 5036 9930 0605 4685 18			

Prepaid Mail	1		\$0.00
McLean, VA 22102			
Weight: 1 lb 0.80 oz			
Acceptance Date:			
Wed 09/20/2023			
Tracking #:			
9405 5036 9930 0605 4685 32			

Grand Total: \$0.00

Text your tracking number to 28777 (2USPS) to get the latest status. Standard Message and Data rates may apply. You may also visit www.usps.com USPS Tracking or call 1-800-222-1811.

Preview your Mail
 Track your Packages
 Sign up for FREE @
<https://informedelivery.usps.com>

All sales final on stamps and postage.
 Refunds for guaranteed services only.
 Thank you for your business.

Tell us about your experience.
 Go to: <https://postalexperience.com/Pos>
 or scan this code with your mobile device,



or call 1-800-410-7420.

UFN: 242703-0518
 Receipt #: 840-50180227-2-3289031-1
 Clerk: 1