



QC Development

PO Box 916

Storrs, CT 06268

860-670-9068

Mark.Roberts@QCDevelopment.net

March 8, 2019

Melanie A. Bachman
Executive Director
Connecticut Siting Council
10 Franklin Square
New Britain, CT 06051

Notice of Exempt Modification – New Cingular Wireless PCS, LLC (AT&T) – CT5737
1334 Route 85, Montville, CT 06353
N 41.41769444
W 72.19813889

Dear Ms. Bachman:

AT&T currently maintains six (6) antennas at the 190-foot level of the existing 1089-foot Guyed Lattice tower at 1334 Route 85, Montville, CT. The tower is owned by American Tower and the property is owned by the City of New London Water Department. AT&T now intends to remove three (3) KMW antennas and add (2) Kathrein 800-10965 and (4) Kathrein 800-10966 antennas. AT&T will also swap (3) Ericsson RRUS-11 for (3) Ericsson 4449-B5/B12s, add (3) Ericsson B25/B66 8843 and add (3) Ericsson B14 4478 Remote Radio Units (RRU). The new Antennas and RRUs will also be installed at the 190-foot level of the tower.

AT&T's use of this facility was approved by the Siting Council on September 5, 2002. This approval included no condition(s) that could feasibly be violated by this modification, including total facility height or mounting restrictions. This modification therefore complies with the aforementioned approval.

Please accept this letter as notification pursuant to Regulations of Connecticut State Agencies § 16-50j-73, for construction that constitutes an exempt modification pursuant to R.C.S.A. § 16-50j-72(b)(2). In accordance with R.C.S.A. § 16-50j-73, a copy of this letter is being sent to Ronald K. McDaniel, Mayor of the Town of Montville, and the Montville Planning Department as well as the

property and tower owner.

The planned modifications to the facility fall squarely within those activities explicitly provided for in R.C.S.A. § 16-50j-72(b)(2).

1. The proposed modifications will not result in an increase in the height of the existing structure.
2. The proposed modifications will not require the extension of the site boundary.
3. The proposed modifications will not increase noise levels at the facility by six decibels or more, or to levels that exceed state and local criteria.
4. The operation of the replacement antennas will not increase radio frequency emissions at the facility to a level at or above the Federal Communications Commission safety standard.
5. The proposed modifications will not cause a change or alteration in the physical or environmental characteristics of the site.
6. The existing structure and its foundation can support the proposed loading.

For the foregoing reasons, AT&T respectfully submits that the proposed modifications to the above-referenced telecommunications facility constitute an exempt modification under R.C.S.A. § 16-50j-72(b)(2).

Please feel free to call me at (860) 670-9068 with any questions regarding this matter. Thank you for your consideration.

Sincerely,



Mark Roberts
QC Development
Consultant for AT&T

Attachments

Cc: Mayor Ronald K. McDaniel - Elected Official
Marcia A. Vlaun – Town Planner
City of New London Water Department – Property Owner
American Tower – Tower Owner (via e-mail)

Power Density

Existing Loading on Tower

Carrier	# of Channels	ERP/Ch (W)	Antenna Centerline Height (ft)	Power Density (mW/cm ²)	Freq. Band (MHz ^{**})	Limit S (mW/cm ²)	%MPE
Other Carriers*							0.49%
AT&T GSM	1	283	190	0.0030	880	0.5867	0.05%
AT&T UMTS	2	565	190	0.0120	880	0.5867	0.20%
AT&T UMTS	4	525	190	0.0223	1900	1.0000	0.22%
AT&T LTE	1	1615	190	0.0172	734	0.4893	0.35%
AT&T LTE	2	875	190	0.0186	1900	1.0000	0.19%
Site Total							1.50%

*Per CSC Records (available upon request, includes calculation formulas)

** If a range of frequencies are used, such as 880-894, enter the lowest value, i.e. 880

Proposed Loading on Tower

Carrier	# of Channels	ERP/Ch (W)	Antenna Centerline Height (ft)	Power Density (mW/cm ²)	Freq. Band (MHz ^{**})	Limit S (mW/cm ²)	%MPE
Other Carriers*							0.49%
AT&T UMTS	1	565	190	0.0060	850	0.5667	0.11%
AT&T LTE	2	2951	190	0.0627	700	0.4667	1.34%
AT&T LTE	1	1000	190	0.0106	850	0.5667	0.19%
AT&T 5G	1	1000	190	0.0106	850	0.5667	0.19%
AT&T LTE	2	3664	190	0.0778	1900	1.0000	0.78%
AT&T LTE	2	3837	190	0.0815	2100	1.0000	0.82%
Site Total							3.90%

*Per CSC Records (available upon request, includes calculation formulas)

** If a range of frequencies are used, such as 880-894, enter the lowest value, i.e. 880

PROJECT INFORMATION

SCOPE OF WORK: ITEMS TO BE MOUNTED ON THE EXISTING GUYED TOWER:

- PROPOSED NEW 12' HD V-BOOM SECTOR MOUNT (SABRE PART# C10857001C) (TYP. OF 1 PER SECTOR, TOTAL OF 3).
- INSTALL NEW ADDITIONAL 2" STD. (2.38" O.D.) PIPE BRACE, SECURED TO THE PROPOSED MOUNT AND EXISTING TOWER (TYP. OF 1 PER SECTOR, TOTAL OF 3).
- INSTALL NEW 2-1/2" STD (2.88" O.D.) (10'-0" LONG) PIPE MASTS @ POS. 3 & @ POS. 4 (TYP. OF 2 PER SECTOR, TOTAL OF 6).
- INSTALL NEW 2-1/2" STD (2.88" O.D.) (6'-0" LONG) PIPE MASTS @ POS. 1 (TYP. OF 1 PER SECTOR, TOTAL OF 3).
- NEW AT&T ANTENNAS: (800-10965) (TOTAL OF 2 PER ALPHA SECTOR).
- NEW AT&T ANTENNAS: (800-10966) (TYP. OF 2 PER BETA & GAMMA SECTORS, TOTAL OF 4).
- NEW AT&T RRUS: B14 4478 (700) (TYP. OF 1 PER SECTOR, TOTAL OF 3).
- NEW AT&T RRUS: B2/B66A 8843 (1900/AWS) (TYP. OF 1 PER SECTOR, TOTAL OF 3).
- NEW AT&T RRUS: B5/B12 4449 (850/700) (TYP. OF 1 PER SECTOR, TOTAL OF 3).
- NEW AT&T SURGE ARRESTOR: DC6-48-60-18-8C (TOTAL OF 1) WITH (2) DC POWER & (1) FIBER CABLE.
- NEW AT&T SURGE ARRESTOR: DC6-48-60-0-8C-EV (TOTAL OF 1) WITH (2) DC POWER ONLY.

ITEMS TO BE MOUNTED AT EQUIPMENT LOCATION:

- SWAP BASEBAND FOR RBS 6630.
- ADD 5G RBS 6630.
- ADD (1) XMU.

SITE ADDRESS: BUTLERTOWN RD AND 61 MONTVILLE, CT 06370

LATITUDE: 41.418390 N, 41' 25' 06.20" N

LONGITUDE: 72.198600 W, 72' 11' 54.96" W

TYPE OF SITE: GUYED TOWER / OUTDOOR EQUIPMENT

STRUCTURE HEIGHT: 1089'-0"±

RAD CENTER: 190'-0"±

CURRENT USE: TELECOMMUNICATIONS FACILITY

PROPOSED USE: TELECOMMUNICATIONS FACILITY

DRAWING INDEX

SHEET NO.	DESCRIPTION	REV.
T-1	TITLE SHEET	1
GN-1	GENERAL NOTES	1
A-1	COMPOUND & EQUIPMENT PLANS	1
A-2	ANTENNA LAYOUTS & ELEVATION	1
A-3	DETAILS	1
SN-1	STRUCTURAL NOTES	1
S-1	STRUCTURAL DETAILS	1
RF-1	RF PLUMBING DIAGRAM	1
G-1	GROUNDING DETAILS	1

ATC SITE NAME: HARTFORD CT2
ATC SITE #: 302534



SITE NUMBER: CT5737

SITE NAME: EAST LYME NORTH

FA CODE: 10071018

PACE ID: MRCTB035143, MRCTB035157, MRCTB035203, MRCTB035218

PROJECT: LTE 2C_3C_4C_5C 2019 UPGRADE

VICINITY MAP

DIRECTION TO SITE:

START GOING NORTHEAST ON ENTERPRISE DRIVE - TURN LEFT ON CAPITOL BLVD - TURN LEFT ON WEST ST - TURN LEFT TO TAKE RAMP ONTO I-91 N TOWARD HARTFORD - TAKE EXIT #25-26/GLASTONBURY/OLD WETHERSFIELD ONTO CT-3 N TOWARD #25/GLASTONBURY - TAKE THE NORWICH EXIT ONTO CT-2 E - TAKE RIGHT FORK ONTO CT-11 S TOWARD NEW LONDON - TAKE EXIT #4/SALEM/HADLYME - TURN LEFT ON E HADDAM RD. (CT-82) - TURN RIGHT ON NEW LONDON RD. (CT-85) - CONTINUE TO FOLLOW CT-85 - SITE ENTRANCE WILL BE ON THE RIGHT.



GENERAL NOTES

1. THIS DOCUMENT IS THE CREATION, DESIGN, PROPERTY AND COPYRIGHTED WORK OF AT&T. ANY DUPLICATION OR USE WITHOUT EXPRESS WRITTEN CONSENT IS STRICTLY PROHIBITED. DUPLICATION AND USE BY GOVERNMENT AGENCIES FOR THE PURPOSES OF CONDUCTING THEIR LAWFULLY AUTHORIZED REGULATORY AND ADMINISTRATIVE FUNCTIONS IS SPECIFICALLY ALLOWED.
2. THE FACILITY IS AN UNMANNED PRIVATE AND SECURED EQUIPMENT INSTALLATION. IT IS ONLY ACCESSED BY TRAINED TECHNICIANS FOR PERIODIC ROUTINE MAINTENANCE AND THEREFORE DOES NOT REQUIRE ANY WATER OR SANITARY SEWER SERVICE. THE FACILITY IS NOT GOVERNED BY REGULATIONS REQUIRING PUBLIC ACCESS PER ADA REQUIREMENTS.
3. CONTRACTOR SHALL VERIFY ALL PLANS AND EXISTING DIMENSIONS AND CONDITIONS ON THE JOB SITE AND SHALL IMMEDIATELY NOTIFY THE AT&T MOBILITY REPRESENTATIVE IN WRITING OF DISCREPANCIES BEFORE PROCEEDING WITH THE WORK OR BE RESPONSIBLE FOR SAME.
4. CONSTRUCTION DRAWINGS ARE VALID FOR SIX MONTHS AFTER ENGINEER OF RECORD'S STAMPED AND SIGNED SUBMITTAL DATE LISTED HEREIN.

72 HOURS



CALL BEFORE YOU DIG

CALL TOLL FREE 1-800-922-4455
 OR CALL 811

UNDERGROUND SERVICE ALERT

HGD HUDSON Design Group LLC
 45 BEECHWOOD DRIVE NORTH ANDOVER, MA 01845
 TEL: (978) 557-5553 FAX: (978) 336-5586

SAI
 12 INDUSTRIAL WAY SALEM, NH 03079

SITE NUMBER: CT5737
SITE NAME: EAST LYME NORTH
ATC SITE #: 302534
 BUTLERTOWN RD AND 61 MONTVILLE, CT 06370
 NEW LONDON COUNTY

at&t
 500 ENTERPRISE DRIVE, SUITE 3A ROCKY HILL, CT 06067

NO.	DATE	REVISIONS	BY	CHK	APP'D
1	03/05/19	ISSUED FOR CONSTRUCTION	AM	AT	DJC
A	12/26/18	ISSUED FOR REVIEW	AM	AT	DJC

SCALE: AS SHOWN DESIGNED BY: AT DRAWN BY: AM

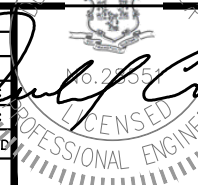

AT&T	
TITLE SHEET (LTE 2C_3C_4C_5C)	
SITE NUMBER	DRAWING NUMBER
CT5737	T-1
	1

GROUNDING NOTES

1. THE SUBCONTRACTOR SHALL REVIEW AND INSPECT THE EXISTING FACILITY GROUNDING SYSTEM AND LIGHTNING PROTECTION SYSTEM (AS DESIGNED AND INSTALLED) FOR STRICT COMPLIANCE WITH THE NEC (AS ADOPTED BY THE AHJ), THE SITE-SPECIFIC (UL, LPI, OR NFPA) LIGHTING PROTECTION CODE, AND GENERAL COMPLIANCE WITH TELCORDIA AND TIA GROUNDING STANDARDS. THE SUBCONTRACTOR SHALL REPORT ANY VIOLATIONS OR ADVERSE FINDINGS TO THE CONTRACTOR FOR RESOLUTION.
2. ALL GROUND ELECTRODE SYSTEMS (INCLUDING TELECOMMUNICATION, RADIO, LIGHTNING PROTECTION, AND AC POWER GES'S) SHALL BE BONDED TOGETHER, AT OR BELOW GRADE, BY TWO OR MORE COPPER BONDING CONDUCTORS IN ACCORDANCE WITH THE NEC.
3. THE SUBCONTRACTOR SHALL PERFORM IEEE FALL-OF-POTENTIAL RESISTANCE TO EARTH TESTING (PER IEEE 1100 AND 81) FOR NEW GROUND ELECTRODE SYSTEMS. THE SUBCONTRACTOR SHALL FURNISH AND INSTALL SUPPLEMENTAL GROUND ELECTRODES AS NEEDED TO ACHIEVE A TEST RESULT OF 5 OHMS OR LESS.
4. METAL RACEWAY SHALL NOT BE USED AS THE NEC REQUIRED EQUIPMENT GROUND CONDUCTOR. STRANDED COPPER CONDUCTORS WITH GREEN INSULATION, SIZED IN ACCORDANCE WITH THE NEC, SHALL BE FURNISHED AND INSTALLED WITH THE POWER CIRCUITS TO BTS EQUIPMENT.
5. EACH BTS CABINET FRAME SHALL BE DIRECTLY CONNECTED TO THE MASTER GROUND BAR WITH GREEN INSULATED SUPPLEMENTAL EQUIPMENT GROUND WIRES, 6 AWG STRANDED COPPER OR LARGER FOR INDOOR BTS 2 AWG STRANDED COPPER FOR OUTDOOR BTS.
6. EXOTHERMIC WELDS SHALL BE USED FOR ALL GROUNDING CONNECTIONS BELOW GRADE.
7. APPROVED ANTIOXIDANT COATINGS (I.E., CONDUCTIVE GEL OR PASTE) SHALL BE USED ON ALL COMPRESSION AND BOLTED GROUND CONNECTIONS.
8. ICE BRIDGE BONDING CONDUCTORS SHALL BE EXOTHERMICALLY BONDED OR BOLTED TO GROUND BAR.
9. ALUMINUM CONDUCTOR OR COPPER CLAD STEEL CONDUCTOR SHALL NOT BE USED FOR GROUNDING CONNECTIONS.
10. MISCELLANEOUS ELECTRICAL AND NON-ELECTRICAL METAL BOXES, FRAMES AND SUPPORTS SHALL BE BONDED TO THE GROUND RING, IN ACCORDANCE WITH THE NEC.
11. METAL CONDUIT SHALL BE MADE ELECTRICALLY CONTINUOUS WITH LISTED BONDING FITTINGS OR BY BONDING ACROSS THE DISCONTINUITY WITH 6 AWS COPPER WIRE UL APPROVED GROUNDING TYPE CONDUIT CLAMPS.
12. ALL NEW STRUCTURES WITH A FOUNDATION AND/OR FOOTING HAVING 20 FT. OR MORE OF 1/2 IN. OR GREATER ELECTRICALLY CONDUCTIVE REINFORCING STEEL MUST HAVE IT BONDED TO THE GROUND RING USING AN EXOTHERMIC WELD CONNECTION USING #2 AWG SOLID BARE TINNED COPPER GROUND WIRE, PER NEC 250.50

GENERAL NOTES

1. FOR THE PURPOSE OF CONSTRUCTION DRAWING, THE FOLLOWING DEFINITIONS SHALL APPLY:
 CONTRACTOR – SAI
 SUBCONTRACTOR – GENERAL CONTRACTOR (CONSTRUCTION)
 OWNER – AT&T MOBILITY
2. PRIOR TO THE SUBMISSION OF BIDS, THE BIDDING SUBCONTRACTOR SHALL VISIT THE CELL SITE TO FAMILIARIZE WITH THE EXISTING CONDITIONS AND TO CONFIRM THAT THE WORK CAN BE ACCOMPLISHED AS SHOWN ON THE CONSTRUCTION DRAWINGS. ANY DISCREPANCY FOUND SHALL BE BROUGHT TO THE ATTENTION OF CONTRACTOR.
3. ALL MATERIALS FURNISHED AND INSTALLED SHALL BE IN STRICT ACCORDANCE WITH ALL APPLICABLE CODES, REGULATIONS, AND ORDINANCES. SUBCONTRACTOR SHALL ISSUE ALL APPROPRIATE NOTICES AND COMPLY WITH ALL LAWS, ORDINANCES, RULES, REGULATIONS, AND LAWFUL ORDERS OF ANY PUBLIC AUTHORITY REGARDING THE PERFORMANCE OF THE WORK. ALL WORK CARRIED OUT SHALL COMPLY WITH ALL APPLICABLE MUNICIPAL AND UTILITY COMPANY SPECIFICATIONS AND LOCAL JURISDICTIONAL CODES, ORDINANCES AND APPLICABLE REGULATIONS.
4. DRAWINGS PROVIDED HERE ARE NOT TO BE SCALED AND ARE INTENDED TO SHOW OUTLINE ONLY.
5. UNLESS NOTED OTHERWISE, THE WORK SHALL INCLUDE FURNISHING MATERIALS, EQUIPMENT, APPURTENANCES, AND LABOR NECESSARY TO COMPLETE ALL INSTALLATIONS AS INDICATED ON THE DRAWINGS.
6. "KITTING LIST" SUPPLIED WITH THE BID PACKAGE IDENTIFIES ITEMS THAT WILL BE SUPPLIED BY CONTRACTOR. ITEMS NOT INCLUDED IN THE BILL OF MATERIALS AND KITTING LIST SHALL BE SUPPLIED BY THE SUBCONTRACTOR.
7. THE SUBCONTRACTOR SHALL INSTALL ALL EQUIPMENT AND MATERIALS IN ACCORDANCE WITH MANUFACTURER'S RECOMMENDATIONS UNLESS SPECIFICALLY STATED OTHERWISE.
8. IF THE SPECIFIED EQUIPMENT CANNOT BE INSTALLED AS SHOWN ON THESE DRAWINGS, THE SUBCONTRACTOR SHALL PROPOSE AN ALTERNATIVE INSTALLATION SPACE FOR APPROVAL BY THE CONTRACTOR.
9. SUBCONTRACTOR SHALL DETERMINE ACTUAL ROUTING OF CONDUIT, POWER AND T1 CABLES, GROUNDING CABLES AS SHOWN ON THE POWER, GROUNDING AND TELCO PLAN DRAWING. SUBCONTRACTOR SHALL UTILIZE EXISTING TRAYS AND/OR SHALL ADD NEW TRAYS AS NECESSARY. SUBCONTRACTOR SHALL CONFIRM THE ACTUAL ROUTING WITH THE CONTRACTOR.
10. THE SUBCONTRACTOR SHALL PROTECT EXISTING IMPROVEMENTS, PAVEMENTS, CURBS, LANDSCAPING AND STRUCTURES. ANY DAMAGED PART SHALL BE REPAIRED AT SUBCONTRACTOR'S EXPENSE TO THE SATISFACTION OF OWNER.
11. SUBCONTRACTOR SHALL LEGALLY AND PROPERLY DISPOSE OF ALL SCRAP MATERIALS SUCH AS COAXIAL CABLES AND OTHER ITEMS REMOVED FROM THE EXISTING FACILITY. ANTENNAS REMOVED SHALL BE RETURNED TO THE OWNER'S DESIGNATED LOCATION.
12. SUBCONTRACTOR SHALL LEAVE PREMISES IN CLEAN CONDITION.
13. ALL CONCRETE REPAIR WORK SHALL BE DONE IN ACCORDANCE WITH AMERICAN CONCRETE INSTITUTE (ACI) 301.

14. ANY NEW CONCRETE NEEDED FOR THE CONSTRUCTION SHALL BE AIR-ENTRAINED AND SHALL HAVE 4000 PSI STRENGTH AT 28 DAYS. ALL CONCRETE WORK SHALL BE DONE IN ACCORDANCE WITH ACI 318 CODE REQUIREMENTS.
15. ALL STRUCTURAL STEEL WORK SHALL BE DETAILED, FABRICATED AND ERECTED IN ACCORDANCE WITH AISC SPECIFICATIONS. ALL STRUCTURAL STEEL SHALL BE ASTM A36 (Fy = 36 ksi) UNLESS OTHERWISE NOTED. PIPES SHALL BE ASTM A53 TYPE E (Fy = 36 ksi). ALL STEEL EXPOSED TO WEATHER SHALL BE HOT DIPPED GALVANIZED. TOUCHUP ALL SCRATCHES AND OTHER MARKS IN THE FIELD AFTER STEEL IS ERECTED USING A COMPATIBLE ZINC RICH PAINT.
16. CONSTRUCTION SHALL COMPLY WITH SPECIFICATIONS AND "GENERAL CONSTRUCTION SERVICES FOR CONSTRUCTION OF AT&T SITES."
17. SUBCONTRACTOR SHALL VERIFY ALL EXISTING DIMENSIONS AND CONDITIONS PRIOR TO COMMENCING ANY WORK. ALL DIMENSIONS OF EXISTING CONSTRUCTION SHOWN ON THE DRAWINGS MUST BE VERIFIED. SUBCONTRACTOR SHALL NOTIFY THE CONTRACTOR OF ANY DISCREPANCIES PRIOR TO ORDERING MATERIAL OR PROCEEDING WITH CONSTRUCTION.
18. THE EXISTING CELL SITE IS IN FULL COMMERCIAL OPERATION. ANY CONSTRUCTION WORK BY SUBCONTRACTOR SHALL NOT DISRUPT THE EXISTING NORMAL OPERATION. ANY WORK ON EXISTING EQUIPMENT MUST BE COORDINATED WITH CONTRACTOR. ALSO, WORK SHOULD BE SCHEDULED FOR AN APPROPRIATE MAINTENANCE WINDOW USUALLY IN LOW TRAFFIC PERIODS AFTER MIDNIGHT.
19. SINCE THE CELL SITE IS ACTIVE, ALL SAFETY PRECAUTIONS MUST BE TAKEN WHEN WORKING AROUND HIGH LEVELS OF ELECTROMAGNETIC RADIATION. EQUIPMENT SHOULD BE SHUTDOWN PRIOR TO PERFORMING ANY WORK THAT COULD EXPOSE THE WORKERS TO DANGER. PERSONAL RF EXPOSURE MONITORS ARE ADVISED TO BE WORN TO ALERT OF ANY DANGEROUS EXPOSURE LEVELS.
20. APPLICABLE BUILDING CODES:
 SUBCONTRACTOR'S WORK SHALL COMPLY WITH ALL APPLICABLE NATIONAL, STATE, AND LOCAL CODES AS ADOPTED BY THE LOCAL AUTHORITY HAVING JURISDICTION (AHJ) FOR THE LOCATION. THE EDITION OF THE AHJ ADOPTED CODES AND STANDARDS IN EFFECT ON THE DATE OF CONTRACT AWARD SHALL GOVERN THE DESIGN.

BUILDING CODE: IBC 2015 WITH 2018 CT STATE BUILDING CODE AMENDMENTS
 ELECTRICAL CODE: 2017 NATIONAL ELECTRICAL CODE (NFPA 70-2017)

SUBCONTRACTOR'S WORK SHALL COMPLY WITH THE LATEST EDITION OF THE FOLLOWING STANDARDS:

AMERICAN CONCRETE INSTITUTE (ACI) 318; BUILDING CODE REQUIREMENTS FOR STRUCTURAL CONCRETE;

AMERICAN INSTITUTE OF STEEL CONSTRUCTION (AISC) MANUAL OF STEEL CONSTRUCTION, ASD, FOURTEENTH EDITION;

TELECOMMUNICATIONS INDUSTRY ASSOCIATION (TIA) 222-G, STRUCTURAL STANDARDS FOR STEEL

FOR ANY CONFLICTS BETWEEN SECTIONS OF LISTED CODES AND STANDARDS REGARDING MATERIAL, METHODS OF CONSTRUCTION, OR OTHER REQUIREMENTS, THE MOST RESTRICTIVE REQUIREMENT SHALL GOVERN. WHERE THERE IS CONFLICT BETWEEN A GENERAL REQUIREMENT AND A SPECIFIC REQUIREMENT, THE SPECIFIC REQUIREMENT SHALL GOVERN.

ABBREVIATIONS					
AGL	ABOVE GRADE LEVEL	EQ	EQUAL	REQ	REQUIRED
AWG	AMERICAN WIRE GAUGE	GC	GENERAL CONTRACTOR	RF	RADIO FREQUENCY
BBU	BATTERY BACKUP UNIT	GRC	GALVANIZED RIGID CONDUIT	TBD	TO BE DETERMINED
BTCW	BARE TINNED SOLID COPPER WIRE	MGB	MASTER GROUND BAR	TBR	TO BE REMOVED
BGR	BURIED GROUND RING	MIN	MINIMUM	TBRR	TO BE REMOVED AND REPLACED
BTS	BASE TRANSCEIVER STATION	P	PROPOSED	TYP	TYPICAL
E	EXISTING	NTS	NOT TO SCALE	UG	UNDER GROUND
EGB	EQUIPMENT GROUND BAR	RAD	RADIATION CENTER LINE (ANTENNA)	VIF	VERIFY IN FIELD
EGR	EQUIPMENT GROUND RING	REF	REFERENCE		

45 BEECHWOOD DRIVE
NORTH ANDOVER, MA 01845
TEL: (978) 557-5553
FAX: (978) 336-5586

12 INDUSTRIAL WAY
SALEM, NH 03079

SITE NUMBER: CT5737
 SITE NAME: EAST LYME NORTH
 ATC SITE #: 302534
 BUTLERTOWN RD AND 61
 MONTVILLE, CT 06370
 NEW LONDON COUNTY

500 ENTERPRISE DRIVE, SUITE 3A
ROCKY HILL, CT 06067

NO.	DATE	REVISIONS	BY	CHK	APP'D
1	03/05/19	ISSUED FOR CONSTRUCTION	AM	AT	AM
A	12/26/18	ISSUED FOR REVIEW	AM	AT	AM

SCALE: AS SHOWN DESIGNED BY: AT DRAWN BY: AM

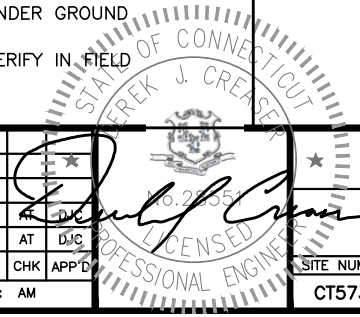

AT&T
 GENERAL NOTES
 (LTE 2C_3C_4C_5C)

SITE NUMBER	DRAWING NUMBER	REV
CT5737	GN-1	1

NOTE:
REFER TO STRUCTURAL ANALYSIS BY: STAINLESS A BUSINESS OF FDH INFRASTRUCTURE SERVICES, LLC, DATED: JANUARY 31, 2019, FOR THE CAPACITY OF THE EXISTING STRUCTURES TO SUPPORT THE PROPOSED EQUIPMENT.

NOTE:
REFER TO THE FINAL RF DATA SHEET FOR FINAL ANTENNA SETTINGS.

NOTE:
AN ANALYSIS FOR THE CAPACITY OF THE EXISTING ANTENNA MOUNT TO SUPPORT THE PROPOSED LOADING HAS BEEN COMPLETED BY: HUDSON DESIGN GROUP, LLC. DATED: DECEMBER 18, 2018

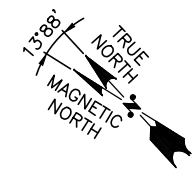
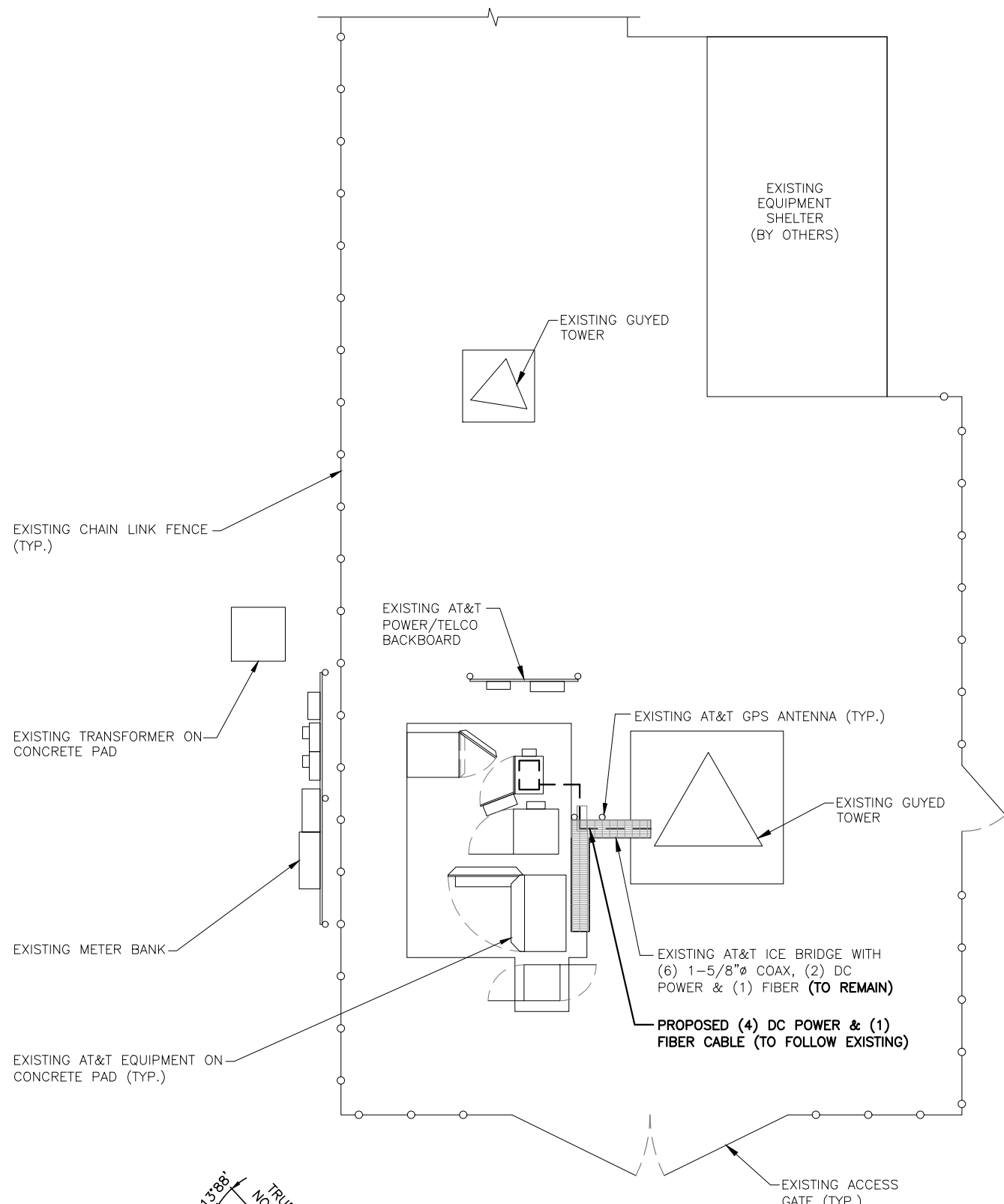

COMPOUND PLAN
22x34 SCALE: 1/4"=1'-0"
11x17 SCALE: 1/8"=1'-0"
1
A-1
0 2'-0" 4'-0" 8'-0" 12'-0"

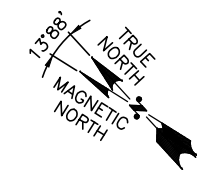
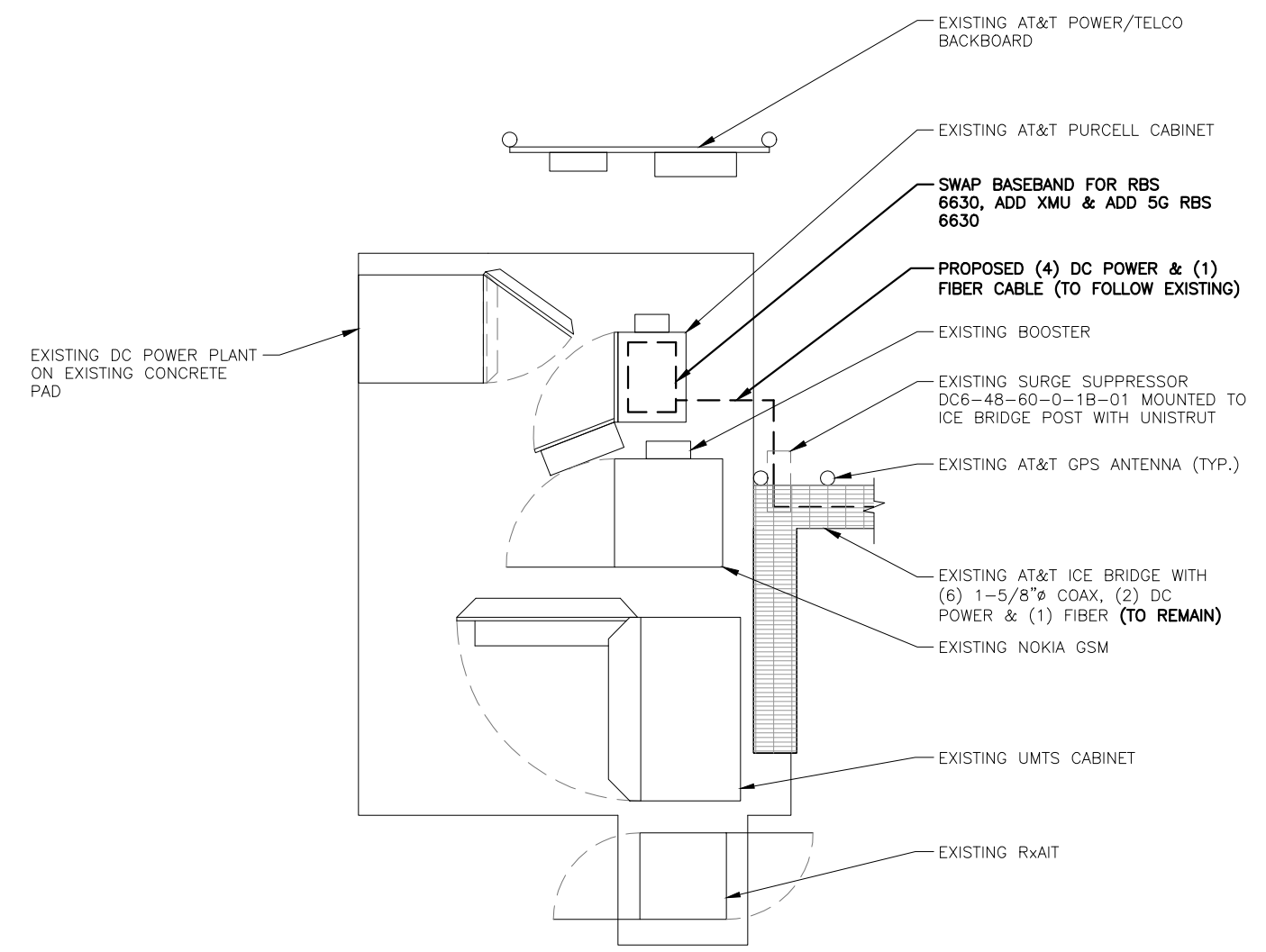

EQUIPMENT PLAN
22x34 SCALE: 1/2"=1'-0"
11x17 SCALE: 1/4"=1'-0"
2
A-1
0 1'-0" 2'-0" 4'-0" 6'-0"

HGD HUDSON Design Group LLC
45 BEECHWOOD DRIVE NORTH ANDOVER, MA 01845
TEL: (978) 557-5553 FAX: (978) 336-5586

SAI
12 INDUSTRIAL WAY SALEM, NH 03079

SITE NUMBER: CT5737
SITE NAME: EAST LYME NORTH
ATC SITE #: 302534
BUTLERTOWN RD AND 61 MONTVILLE, CT 06370
NEW LONDON COUNTY

at&t
500 ENTERPRISE DRIVE, SUITE 3A
ROCKY HILL, CT 06067

NO.	DATE	REVISIONS	BY	CHK	APP'D
1	03/05/19	ISSUED FOR CONSTRUCTION	AM	AT	DJC
A	12/26/18	ISSUED FOR REVIEW	AM	AT	DJC

SCALE: AS SHOWN DESIGNED BY: AT DRAWN BY: AM

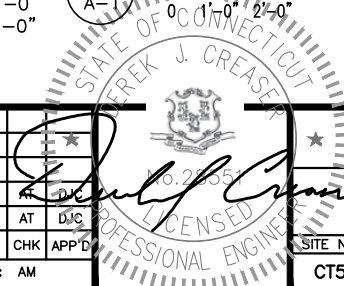

AT&T
COMPOUND & EQUIPMENT PLAN
(LTE 2C_3C_4C_5C)
SITE NUMBER: CT5737
DRAWING NUMBER: A-1
REV: 1

TOP OF EXISTING GUYED TOWER
ELEV. 1089'-0"± (AGL)

NOTE:
REFER TO THE FINAL RF DATA SHEET FOR FINAL ANTENNA SETTINGS.

NOTE:
AN ANALYSIS FOR THE CAPACITY OF THE EXISTING ANTENNA MOUNT TO SUPPORT THE PROPOSED LOADING HAS BEEN COMPLETED BY: HUDSON DESIGN GROUP, LLC. DATED: DECEMBER 18, 2018

NOTE:
REFER TO STRUCTURAL ANALYSIS BY: STAINLESS A BUSINESS OF FDH INFRASTRUCTURE SERVICES, LLC, DATED: JANUARY 31, 2019, FOR THE CAPACITY OF THE EXISTING STRUCTURES TO SUPPORT THE PROPOSED EQUIPMENT.

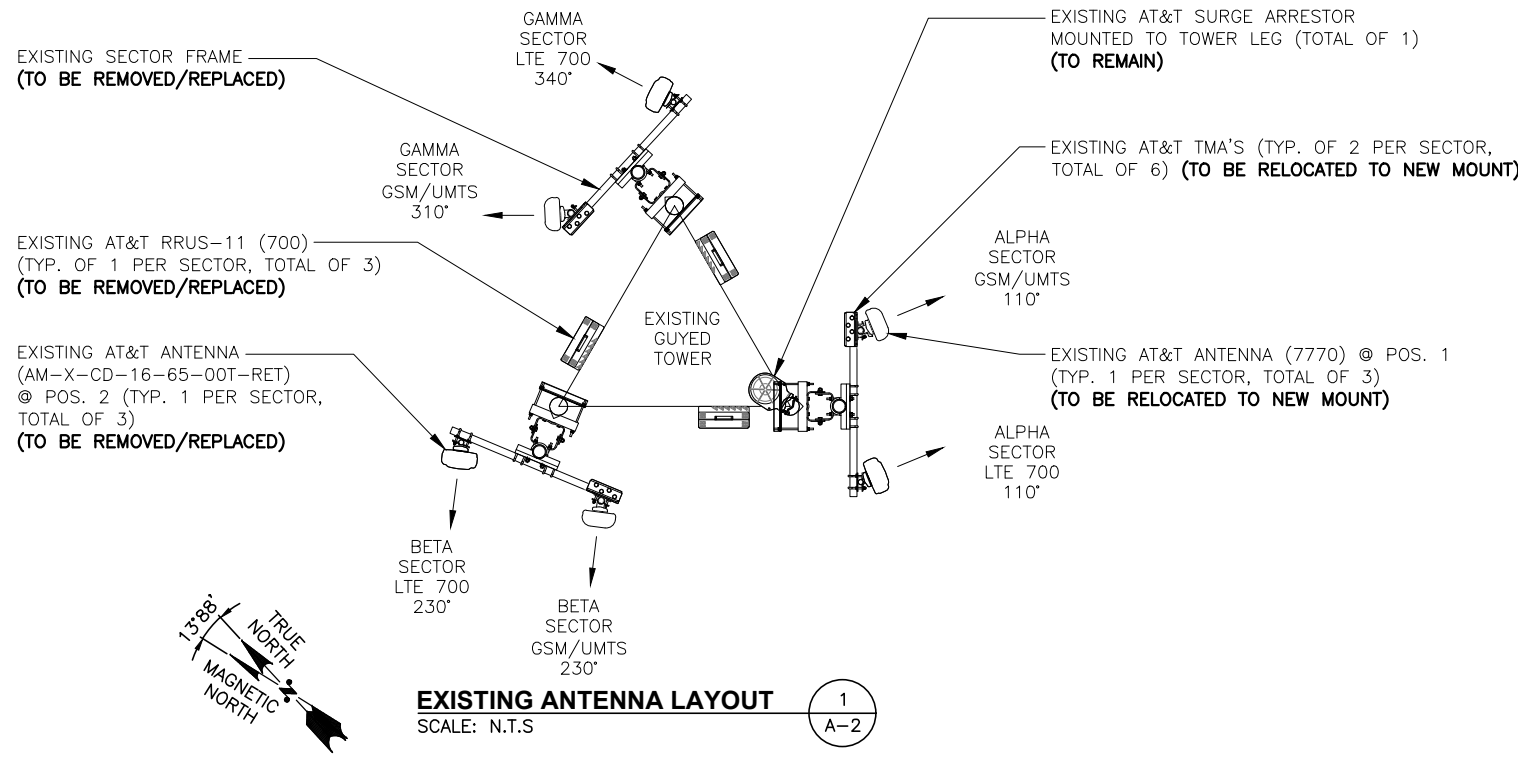

EXISTING ANTENNA LAYOUT
SCALE: N.T.S.

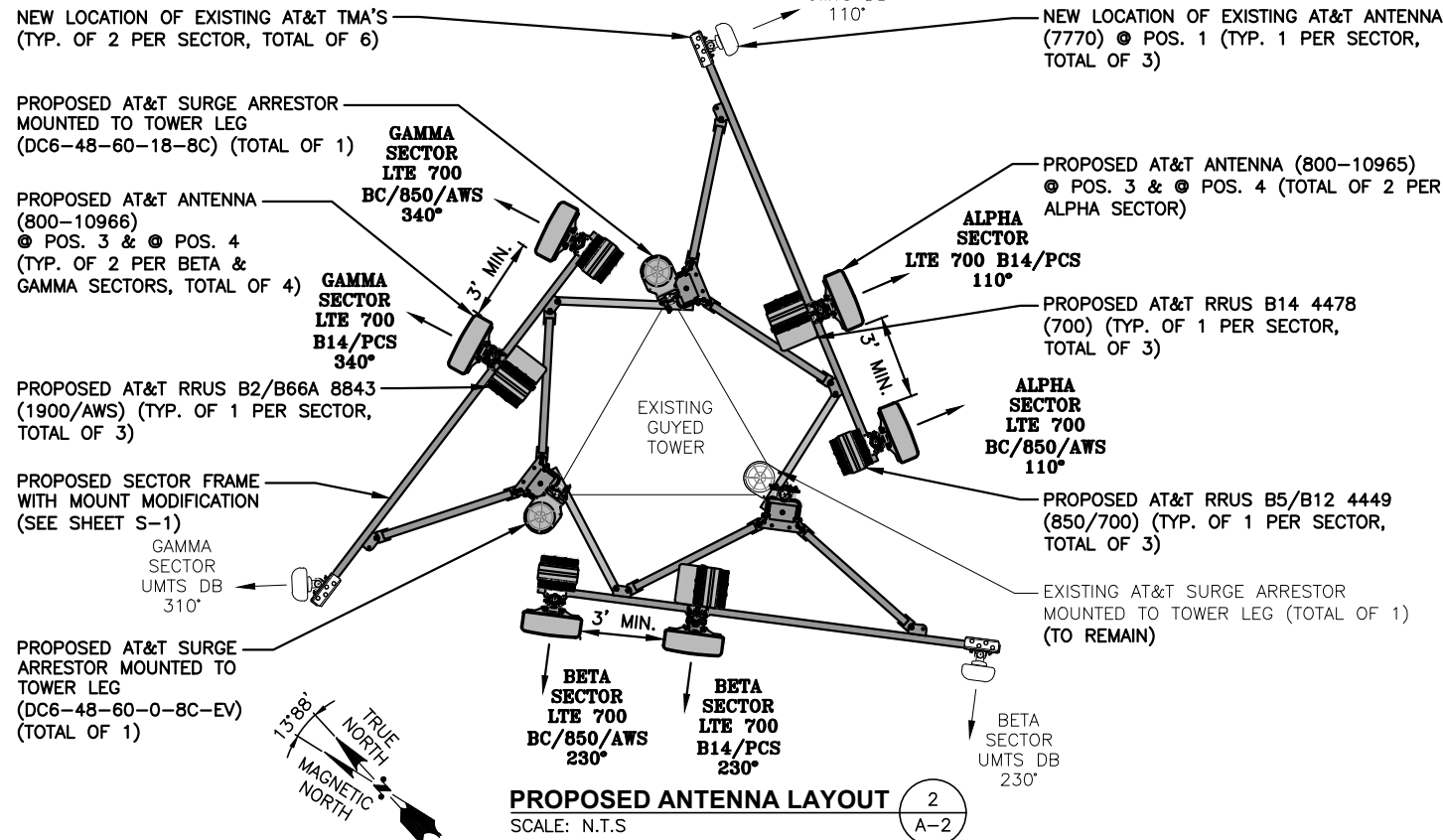

PROPOSED ANTENNA LAYOUT
SCALE: N.T.S.

CL OF PROPOSED & EXISTING AT&T ANTENNAS
ELEV. 190'-0"± (A.G.L.)

PROPOSED AT&T RRUS B14 4478 (700) (TYP. OF 1 PER SECTOR, TOTAL OF 3)
PROPOSED AT&T RRUS B2/B66A 8843 (1900/AWS) (TYP. OF 1 PER SECTOR, TOTAL OF 3)

PROPOSED AT&T RRUS B5/B12 4449 (850/700) (TYP. OF 1 PER SECTOR, TOTAL OF 3)
PROPOSED AT&T SURGE ARRESTOR MOUNTED TO TOWER LEG (DC6-48-60-18-8C) (TOTAL OF 1)

PROPOSED AT&T ANTENNA @ POS. 3 & @ POS. 4 (TYP. OF 2 PER SECTOR, TOTAL OF 6)
PROPOSED SECTOR FRAME WITH MOUNT MODIFICATION (SEE SHEET S-1)
NEW LOCATION OF EXISTING AT&T ANTENNA (7770) @ POS. 1 (TYP. 1 PER SECTOR, TOTAL OF 3)
NEW LOCATION OF EXISTING AT&T TMA'S (TYP. OF 2 PER SECTOR, TOTAL OF 6)

PROPOSED AT&T SURGE ARRESTOR MOUNTED TO TOWER LEG (DC6-48-60-0-8C-EV) (TOTAL OF 1)

EXISTING AT&T ICE BRIDGE WITH (6) 1-5/8"Ø COAX, (2) DC POWER & (1) FIBER (TO REMAIN)

PROPOSED (4) DC POWER & (1) FIBER CABLE (TO FOLLOW EXISTING)

NOTE:
EXISTING GROUND EQUIPMENT NOT SHOWN FOR CLARITY

NOTE:
ANTENNAS AND MOUNTS TO BE ADJUSTED AS REQUIRED TO ACHIEVE A 3'-0" MINIMUM SEPARATION BETWEEN ANTENNAS

NOTE:
PROPOSED ANTENNA MOUNT TO BE ROTATED TO MATCH LTE AZIMUTHS

GROUND LEVEL
ELEV. 0'-0"± (A.G.L.)

ELEVATION
22x34 SCALE: 1/8" = 1'-0"
11x17 SCALE: 1/16" = 1'-0"

HGD HUDSON Design Group LLC
45 BEECHWOOD DRIVE
NORTH ANDOVER, MA 01845
TEL: (978) 557-5553
FAX: (978) 336-5586

SAI
12 INDUSTRIAL WAY
SALEM, NH 03079

SITE NUMBER: CT5737
SITE NAME: EAST LYME NORTH
ATC SITE #: 302534
BUTLERTOWN RD AND 61
MONTVILLE, CT 06370
NEW LONDON COUNTY

at&t
500 ENTERPRISE DRIVE, SUITE 3A
ROCKY HILL, CT 06067

1	03/05/19	ISSUED FOR CONSTRUCTION	AM	AT	DJC
A	12/26/18	ISSUED FOR REVIEW	AM	AT	DJC
NO.	DATE	REVISIONS	BY	CHK	APP'D
SCALE: AS SHOWN		DESIGNED BY: AT	DRAWN BY: AM		

AT&T
ANTENNA LAYOUTS & ELEVATION
(LTE 2C_3C_4C_5C)
SITE NUMBER: CT5737
DRAWING NUMBER: A-2
REV: 1

NOTE:
REFER TO THE FINAL RF DATA SHEET FOR FINAL ANTENNA SETTINGS.

NOTE:
REFER TO STRUCTURAL ANALYSIS BY: STAINLESS A BUSINESS OF FDH INFRASTRUCTURE SERVICES, LLC, DATED: JANUARY 31, 2019, FOR THE CAPACITY OF THE EXISTING STRUCTURES TO SUPPORT THE PROPOSED EQUIPMENT.

NOTE:
AN ANALYSIS FOR THE CAPACITY OF THE EXISTING ANTENNA MOUNT TO SUPPORT THE PROPOSED LOADING HAS BEEN COMPLETED BY: HUDSON DESIGN GROUP, LLC. DATED: DECEMBER 18, 2018

ANTENNA SCHEDULE											
SECTOR	EXISTING/PROPOSED	BAND	ANTENNA	SIZE (INCHES) (L x W x D)	ANTENNA CL. HEIGHT	AZIMUTH	TMA/DIPLEXER	RRU	SIZE (INCHES) (L x W x D)	FEEDER	RAYCAP
A1	EXISTING	UMTS DB	7770	55X11X5	±190'	110°	(E)(2)(G) POWERWAVE LGP 21901 (E)(2) POWERWAVE LGP 21401	--	--	(2) 1-5/8" (225'±)	(E) (1) RAYCAP DC6-48-60-18-8C
A2	--	--	--	--	--	--	--	--	--	--	
A3	PROPOSED	LTE 700 B14/PCS	800-10965	78.7x20x6.9	±190'	110°	--	(P) (1) B14 4478 (700) (P) (1) B2/B66A 8843 (1900/AWS)	18.1X13.4X8.3 14.9X13.2X10.9	--	
A4	PROPOSED	LTE 700 BC/850/AWS	800-10965	78.7x20x6.9	±190'	110°	--	(P) (1) B5/B12 4449 (850/700)	14.9X13.2X10.4	--	
B1	EXISTING	UMTS DB	7770	55X11X5	±190'	230°	(E)(2)(G) POWERWAVE LGP 21901 (E)(2) POWERWAVE LGP 21401	--	--	(2) 1-5/8" COAX (225'±)	(P) (1) RAYCAP DC6-48-60-18-8C
B2	--	--	--	--	--	--	--	--	--	--	
B3	PROPOSED	LTE 700 B14/PCS	800-10966	96X20X6.9	±190'	230°	--	(P) (1) B14 4478 (700) (P) (1) B2/B66A 8843 (1900/AWS)	18.1X13.4X8.3 14.9X13.2X10.9	--	
B4	PROPOSED	LTE 700 BC/850/AWS	800-10966	96X20X6.9	±190'	230°	--	(P) (1) B5/B12 4449 (850/700)	14.9X13.2X10.4	--	
C1	EXISTING	UMTS DB	7770	55X11X5	±190'	310°	(E)(2)(G) POWERWAVE LGP 21901 (E)(2) POWERWAVE LGP 21401	--	--	(2) 1-5/8" COAX (225'±)	(P) (1) RAYCAP DC6-48-60-0-8C-EV
C2	--	--	--	--	--	--	--	--	--	--	
C3	PROPOSED	LTE 700 B14/PCS	800-10966	96X20X6.9	±190'	340°	--	(P) (1) B14 4478 (700) (P) (1) B2/B66A 8843 (1900/AWS)	18.1X13.4X8.3 14.9X13.2X10.9	--	
C4	PROPOSED	LTE 700 BC/850/AWS	800-10966	96X20X6.9	±190'	340°	--	(P) (1) B5/B12 4449 (850/700)	14.9X13.2X10.4	--	

PROPOSED RRU BACK TO BACK TO BACK MOUNT BRACKET PART# SXX1250461/1 (OR APPROVAL EQUAL)

PROPOSED AT&T RRUS B14 4478 (700) (TYP. OF 1 PER SECTOR, TOTAL OF 3)

PROPOSED AT&T RRUS B2/B66A 8843 (1900/AWS) (TYP. OF 1 PER SECTOR, TOTAL OF 3)

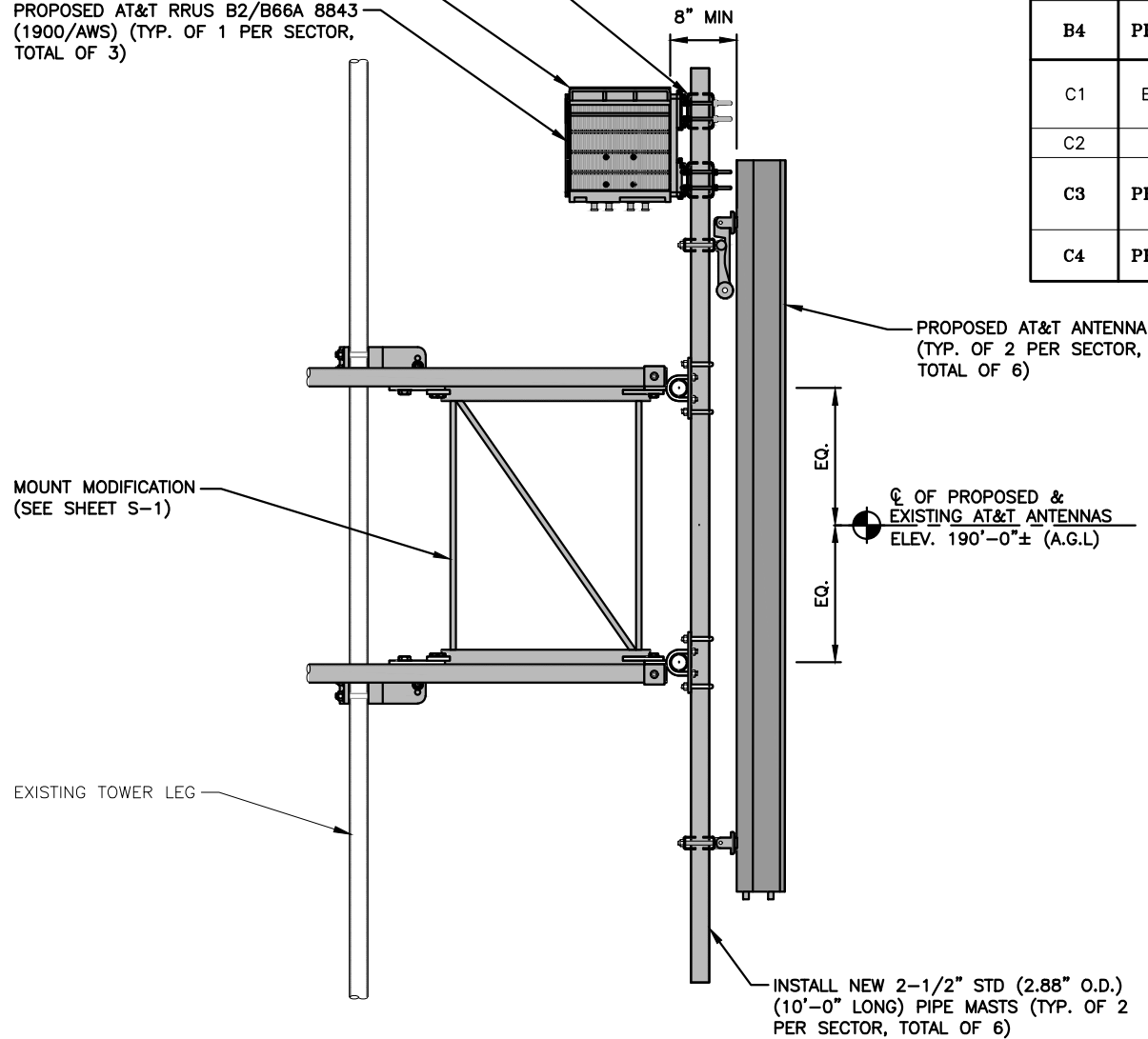

FINAL ANTENNA SCHEDULE 3 A-3
SCALE: N.T.S.

RRU CHART				
QUANTITY	MODEL	L	W	D
3(P)	B14 4478 (700)	18.1"	13.4"	8.3"
3(P)	B2/B66A 8843 (1900/AWS)	14.9"	13.2"	10.9"
3(P)	B5/B12 4449 (700/850)	14.9"	13.2"	10.4"

NOTE:
MOUNT PER MANUFACTURER'S SPECIFICATIONS

NOTE:
SEE RFDS FOR RRU FREQUENCY AND MODEL NUMBER

PROPOSED RRU REFER TO THE FINAL RFDS AND CHART FOR QUANTITY, MODEL AND DIMENSIONS

NOTE:
MOUNT PER MANUFACTURER'S SPECIFICATIONS.

PROPOSED RRUS DETAIL 2 A-3
SCALE: N.T.S.

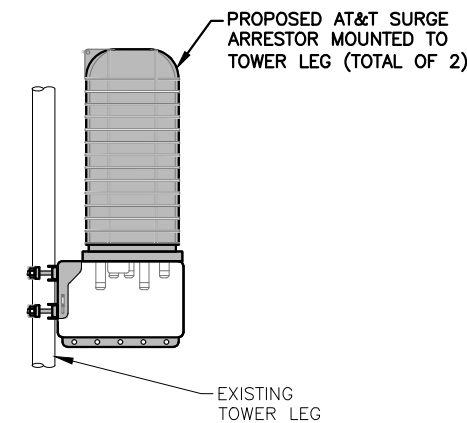

PROPOSED SURGE ARRESTOR MOUNTING DETAIL 4 A-3
SCALE: N.T.S.

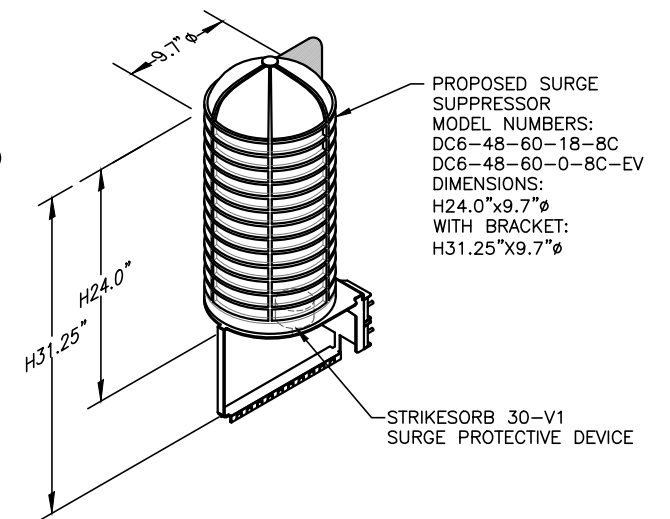

NOTE:
MOUNT PER MANUFACTURER'S SPECIFICATIONS.

PROPOSED SURGE SUPPRESSOR DETAIL 5 A-3
SCALE: N.T.S.

STRUCTURAL NOTES:

- DESIGN REQUIREMENTS ARE PER STATE BUILDING CODE AND APPLICABLE SUPPLEMENTS, INTERNATIONAL BUILDING CODE, EIA/TIA-222-G STRUCTURAL STANDARDS FOR STEEL ANTENNA, TOWERS AND ANTENNA SUPPORTING STRUCTURES.
- CONTRACTOR SHALL VERIFY ALL DIMENSIONS AND CONDITIONS IN THE FIELD PRIOR TO FABRICATION AND ERECTION OF ANY MATERIAL. ANY UNUSUAL CONDITIONS SHALL BE REPORTED TO THE ATTENTION OF THE CONSTRUCTION MANAGER AND ENGINEER OF RECORD.
- DESIGN AND CONSTRUCTION OF STRUCTURAL STEEL SHALL CONFORM TO THE AMERICAN INSTITUTE OF STEEL CONSTRUCTION "SPECIFICATION FOR THE DESIGN, FABRICATION AND ERECTION OF STRUCTURAL STEEL FOR BUILDINGS".
- STRUCTURAL STEEL SHALL CONFORM TO ASTM A992 (Fy=50 ksi), MISCELLANEOUS STEEL SHALL CONFORM TO ASTM A36 UNLESS OTHERWISE INDICATED.
- STEEL PIPE SHALL CONFORM TO ASTM A500 "COLD-FORMED WELDED & SEAMLESS CARBON STEEL STRUCTURAL TUBING", GRADE B, OR ASTM A53 PIPE STEEL BLACK AND HOT-DIPPED ZINC-COATED WELDED AND SEAMLESS TYPE E OR S, GRADE B. PIPE SIZES INDICATED ARE NOMINAL. ACTUAL OUTSIDE DIAMETER IS LARGER.
- STRUCTURAL CONNECTION BOLTS SHALL BE HIGH STRENGTH BOLTS (BEARING TYPE) AND CONFORM TO ASTM A325 TYPE-X "HIGH STRENGTH BOLTS FOR STRUCTURAL JOINTS, INCLUDING SUITABLE NUTS AND PLAIN HARDENED WASHERS". ALL BOLTS SHALL BE 3/4" DIA UON.
- ALL STEEL MATERIALS SHALL BE GALVANIZED AFTER FABRICATION IN ACCORDANCE WITH ASTM A123 "ZINC (HOT-DIP GALVANIZED) COATINGS ON IRON AND STEEL PRODUCTS", UNLESS OTHERWISE NOTED.
- ALL BOLTS, ANCHORS AND MISCELLANEOUS HARDWARE SHALL BE GALVANIZED IN ACCORDANCE WITH ASTM A153 "ZINC-COATING (HOT-DIP) ON IRON AND STEEL HARDWARE", UNLESS OTHERWISE NOTED.
- FIELD WELDS, DRILL HOLES, SAW CUTS AND ALL DAMAGED GALVANIZED SURFACES SHALL BE REPAIRED WITH AN ORGANIC ZINC REPAIR PAINT COMPLYING WITH REQUIREMENTS OF ASTM A780. GALVANIZING REPAIR PAINT SHALL HAVE 65 PERCENT ZINC BY WEIGHT, ZIRP BY DUNCAN GALVANIZING, GALVA BRIGHT PREMIUM BY CROWN OR EQUAL. THICKNESS OF APPLIED GALVANIZING REPAIR PAINT SHALL BE NOT LESS THAN 4 COATS (ALLOW TIME TO DRY BETWEEN COATS) WITH A RESULTING COATING THICKNESS REQUIRED BY ASTM A123 OR A153 AS APPLICABLE.
- CONTRACTOR SHALL COMPLY WITH AWS CODE FOR PROCEDURES, APPEARANCE AND QUALITY OF WELDS, AND FOR METHODS USED IN CORRECTING WELDING. ALL WELDERS AND WELDING PROCESSES SHALL BE QUALIFIED IN ACCORDANCE WITH AWS "STANDARD QUALIFICATION PROCEDURES". ALL WELDING SHALL BE DONE USING E70XX ELECTRODES AND WELDING SHALL CONFORM TO AISC AND D.I.I. WHERE FILLET WELD SIZES ARE NOT SHOWN, PROVIDE THE MINIMUM SIZE PER TABLE J2.4 IN THE AISC "STEEL CONSTRUCTION MANUAL". 14TH EDITION.
- INCORRECTLY FABRICATED, DAMAGED OR OTHERWISE MISFITTING OR NON-CONFORMING MATERIALS OR CONDITIONS SHALL BE REPORTED TO THE CONSTRUCTION MANAGER PRIOR TO REMEDIAL OR CORRECTIVE ACTION. ANY SUCH ACTION SHALL REQUIRE CONSTRUCTION MANAGER APPROVAL.
- UNISTRUT SHALL BE FORMED STEEL CHANNEL STRUT FRAMING AS MANUFACTURED BY UNISTRUT CORP., WAYNE, MI OR EQUAL. STRUT MEMBERS SHALL BE 1 5/8"x1 5/8"x12GA, UNLESS OTHERWISE NOTED, AND SHALL BE HOT-DIP GALVANIZED AFTER FABRICATION.
- EPOXY ANCHOR ASSEMBLY SHALL CONSIST OF STAINLESS STEEL ANCHOR ROD WITH NUTS & WASHERS. AN INTERNALLY THREADED INSERT, A SCREEN TUBE AND A EPOXY ADHESIVE. THE ANCHORING SYSTEM SHALL BE THE HILTI-HIT HY-270 AND OR HY-200 SYSTEMS (AS SPECIFIED IN DWG.) OR ENGINEERS APPROVED EQUAL.
- EXPANSION BOLTS SHALL CONFORM TO FEDERAL SPECIFICATION FF-S-325, GROUP II, TYPE 4, CLASS I, HILTI KWIK BOLT III OR APPROVED EQUAL. INSTALLATION SHALL BE IN ACCORDANCE WITH THE MANUFACTURER'S RECOMMENDATIONS.
- LUMBER SHALL COMPLY WITH THE REQUIREMENTS OF THE AMERICAN INSTITUTE OF TIMBER CONSTRUCTION AND THE NATIONAL FOREST PRODUCTS ASSOCIATION'S NATIONAL DESIGN SPECIFICATION FOR WOOD CONSTRUCTION. ALL LUMBER SHALL BE PRESSURE TREATED AND SHALL BE STRUCTURAL GRADE NO. 2 OR BETTER.
- WHERE ROOF PENETRATIONS ARE REQUIRED, THE CONTRACTOR SHALL CONTACT AND COORDINATE RELATED WORK WITH THE BUILDING OWNER AND THE EXISTING ROOF INSTALLER. WORK SHALL BE PERFORMED IN SUCH A MANNER AS TO NOT VOID THE EXISTING ROOF WARRANTY. ROOF SHALL BE WATERTIGHT.
- ALL FIBERGLASS MEMBERS USED ARE AS MANUFACTURED BY STRONGWELL COMPANY OF BRISTOL, VA 24203. ALL DESIGN CRITERIA FOR THESE MEMBERS IS BASED ON INFORMATION PROVIDED IN THE DESIGN MANUAL. ALL REQUIREMENTS PUBLISHED IN SAID MANUAL MUST BE STRICTLY ADHERED TO.
- NO MATERIALS TO BE ORDERED AND NO WORK TO BE COMPLETED UNTIL SHOP DRAWINGS HAVE BEEN REVIEWED AND APPROVED IN WRITING.
- SUBCONTRACTOR SHALL FIREPROOF ALL STEEL TO PRE-EXISTING CONDITIONS.

SPECIAL INSPECTIONS (REFERENCE IBC CHAPTER 17):

GENERAL: WHERE APPLICATION IS MADE FOR CONSTRUCTION, THE OWNER OR THE REGISTERED DESIGN PROFESSIONAL IN RESPONSIBLE CHARGE ACTING AS THE OWNER'S AGENT SHALL EMPLOY ONE OR MORE APPROVED AGENCIES TO PERFORM INSPECTIONS DURING CONSTRUCTION ON THE TYPES OF WORK LISTED IN THE INSPECTION CHECKLIST ABOVE.

THE REGISTERED DESIGN PROFESSIONAL IN RESPONSIBLE CHARGE AND ENGINEERS OF RECORD INVOLVED IN THE DESIGN OF THE PROJECT ARE PERMITTED TO ACT AS THE APPROVED AGENCY AND THEIR PERSONNEL ARE PERMITTED TO ACT AS THE SPECIAL INSPECTOR FOR THE WORK DESIGNED BY THEM, PROVIDED THOSE PERSONNEL MEET THE QUALIFICATION REQUIREMENTS.

STATEMENT OF SPECIAL INSPECTIONS: THE APPLICANT SHALL SUBMIT A STATEMENT OF SPECIAL INSPECTIONS PREPARED BY THE REGISTERED DESIGN PROFESSIONAL IN RESPONSIBLE CHARGE IN ACCORDANCE WITH SECTION 107.1 AS A CONDITION FOR ISSUANCE. THIS STATEMENT SHALL BE IN ACCORDANCE WITH SECTION 1705.

REPORT REQUIREMENT: SPECIAL INSPECTORS SHALL KEEP RECORDS OF INSPECTIONS. THE SPECIAL INSPECTOR SHALL FURNISH INSPECTION REPORTS TO THE BUILDING OFFICIAL, AND TO THE REGISTERED DESIGN PROFESSIONAL IN RESPONSIBLE CHARGE. REPORTS SHALL INDICATE THAT WORK INSPECTED WAS OR WAS NOT COMPLETED IN CONFORMANCE TO APPROVED CONSTRUCTION DOCUMENTS. DISCREPANCIES SHALL BE BROUGHT TO THE IMMEDIATE ATTENTION OF THE CONTRACTOR FOR CORRECTION. IF THEY ARE NOT CORRECTED, THE DISCREPANCIES SHALL BE BROUGHT TO THE ATTENTION OF THE BUILDING OFFICIAL AND TO THE REGISTERED DESIGN PROFESSIONAL IN RESPONSIBLE CHARGE. A FINAL REPORT DOCUMENTING REQUIRED SPECIAL INSPECTIONS SHALL BE SUBMITTED.

SPECIAL INSPECTION CHECKLIST	
BEFORE CONSTRUCTION	
CONSTRUCTION/INSTALLATION INSPECTIONS AND TESTING REQUIRED (COMPLETED BY ENGINEER OF RECORD)	REPORT ITEM
N/A	ENGINEER OF RECORD APPROVED SHOP DRAWINGS ¹
N/A	MATERIAL SPECIFICATIONS REPORT ²
N/A	FABRICATOR NDE INSPECTION
N/A	PACKING SLIPS ³
ADDITIONAL TESTING AND INSPECTIONS:	
DURING CONSTRUCTION	
CONSTRUCTION/INSTALLATION INSPECTIONS AND TESTING REQUIRED (COMPLETED BY ENGINEER OF RECORD)	REPORT ITEM
REQUIRED	STEEL INSPECTIONS
N/A	HIGH STRENGTH BOLT INSPECTIONS
N/A	HIGH WIND ZONE INSPECTIONS ⁴
N/A	FOUNDATION INSPECTIONS
N/A	CONCRETE COMP. STRENGTH, SLUMP TESTS AND PLACEMENT
N/A	POST INSTALLED ANCHOR VERIFICATION ⁵
N/A	GROUT VERIFICATION
N/A	CERTIFIED WELD INSPECTION
N/A	EARTHWORK: LIFT AND DENSITY
N/A	ON SITE COLD GALVANIZING VERIFICATION
N/A	GUY WIRE TENSION REPORT
ADDITIONAL TESTING AND INSPECTIONS:	
AFTER CONSTRUCTION	
CONSTRUCTION/INSTALLATION INSPECTIONS AND TESTING REQUIRED (COMPLETED BY ENGINEER OF RECORD)	REPORT ITEM
REQUIRED	MODIFICATION INSPECTOR REDLINE OR RECORD DRAWINGS ⁶
N/A	POST INSTALLED ANCHOR PULL-OUT TESTING
REQUIRED	PHOTOGRAPHS
ADDITIONAL TESTING AND INSPECTIONS:	

NOTES:

- REQUIRED FOR ANY NEW SHOP FABRICATED FRP OR STEEL.
- PROVIDED BY MANUFACTURER, REQUIRED IF HIGH STRENGTH BOLTS OR STEEL.
- PROVIDED BY GENERAL CONTRACTOR; PROOF OF MATERIALS.
- HIGH WIND ZONE INSPECTION CATB 120MPH OR CAT C,D 110MPH INSPECT FRAMING OF WALLS, ANCHORING, FASTENING SCHEDULE.
- ADHESIVE FOR REBAR AND ANCHORS SHALL HAVE BEEN TESTED IN ACCORDANCE WITH ACI 355.4 AND ICC-ES AC308 FOR CRACKED CONCRETE AND SEISMIC APPLICATIONS. DESIGN ADHESIVE BOND STRENGTH HAS BEEN BASED ON ACI 355.4 TEMPERATURE CATEGORY B WITH INSTALLATIONS INTO DRY HOLES DRILLED USING A CARBIDE BIT INTO CRACKED CONCRETE THAT HAS CURED FOR AT LEAST 21 DAYS. ADHESIVE ANCHORS REQUIRING CERTIFIED INSTALLATIONS SHALL BE INSTALLED BY A CERTIFIED ADHESIVE ANCHOR INSTALLER PER ACI 318-11 D.9.2.2. INSTALLATIONS REQUIRING CERTIFIED INSTALLERS SHALL BE INSPECTED PER ACI 318-11 D.8.2.4.
- AS REQUIRED; FOR ANY FIELD CHANGES TO THE ITEMS IN THIS TABLE.

NOTES:

- ALL CONNECTIONS TO BE SHOP WELDED & FIELD BOLTED USING 3/4"Ø A325-X BOLTS, UNLESS OTHERWISE NOTIFIED.
- SHOP DRAWING ENGINEER REVIEW & APPROVAL REQUIRED BEFORE ORDERING MATERIAL.
- SHOP DRAWING ENGINEER REVIEW & APPROVAL REQUIRED PRIOR TO STEEL FABRICATION.
- VERIFICATION OF EXISTING ROOF CONSTRUCTION IS REQUIRED PRIOR TO THE INSTALLATION OF THE ROOF PLATFORM. ENGINEER OF RECORD IS TO APPROVE EXISTING CONDITIONS IN ORDER TO MOVE FORWARD.
- CENTERLINE OF PROPOSED STEEL PLATFORM SUPPORT COLUMNS TO BE CENTRALLY LOCATED OVER THE EXISTING BUILDING COLUMNS.
- EXISTING BRICK MASONRY COLUMNS/BEARING TO BE REPAIRED/REPLACED AT ALL PROPOSED PLATFORM SUPPORT POINTS. ENGINEER OF RECORD TO REVIEW AND APPROVE.



SITE NUMBER: CT5737
SITE NAME: EAST LYME NORTH
ATC SITE #: 302534

BUTLERTOWN RD AND 61
MONTVILLE, CT 06370
NEW LONDON COUNTY



NO.	DATE	REVISIONS	BY	CHK	APP'D
1	03/05/19	ISSUED FOR CONSTRUCTION	AM	AT	DJC
A	12/26/18	ISSUED FOR REVIEW	AM	AT	DJC

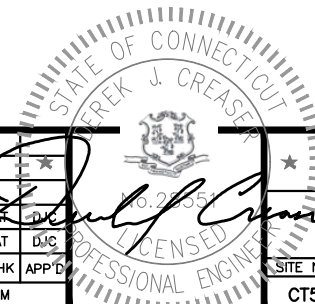

AT&T	
STRUCTURAL NOTES (LTE 2C_3C_4C_5C)	
SITE NUMBER	DRAWING NUMBER
CT5737	SN-1
REV	1

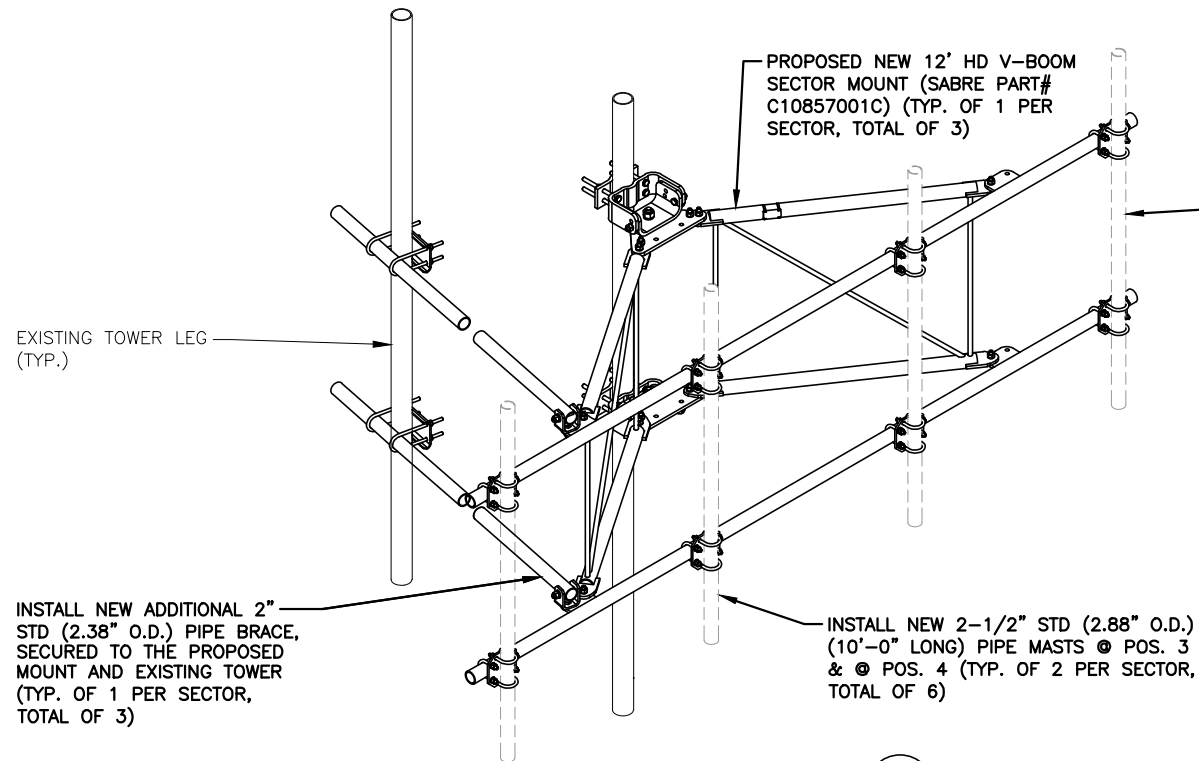

12' HD V-BOOM DETAIL (1) S-1
SCALE: N.T.S.

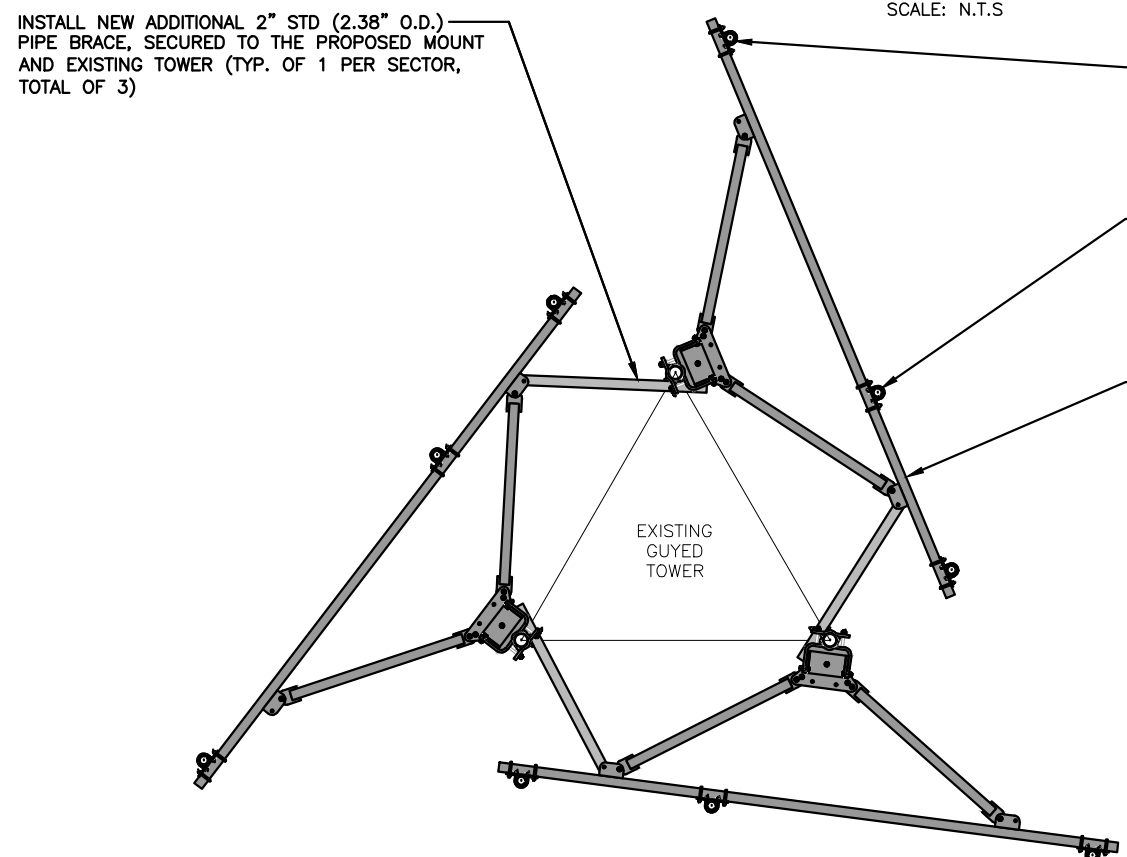

PROPOSED REINFORCEMENT PLAN (2) S-1
22x34 SCALE: 1/2"=1'-0"
11x17 SCALE: 1/4"=1'-0"



INSTALL NEW 2-1/2" STD (2.88" O.D.) (6'-0" LONG) PIPE MASTS @ POS. 1 (TYP. OF 1 PER SECTOR, TOTAL OF 3)

INSTALL NEW 2-1/2" STD (2.88" O.D.) PIPE MASTS @ POS. 3 & @ POS. 4 (TYP. OF 3 PER SECTOR, TOTAL OF 9)

PROPOSED RRU BACK TO BACK TO BACK MOUNT BRACKET PART# SXK1250461/1 (OR APPROVAL EQUAL)

PROPOSED AT&T RRUS B14 4478 (700) (TYP. OF 1 PER SECTOR, TOTAL OF 3)

PROPOSED AT&T RRUS B2/B66A 8843 (1900/AWS) (TYP. OF 1 PER SECTOR, TOTAL OF 3)

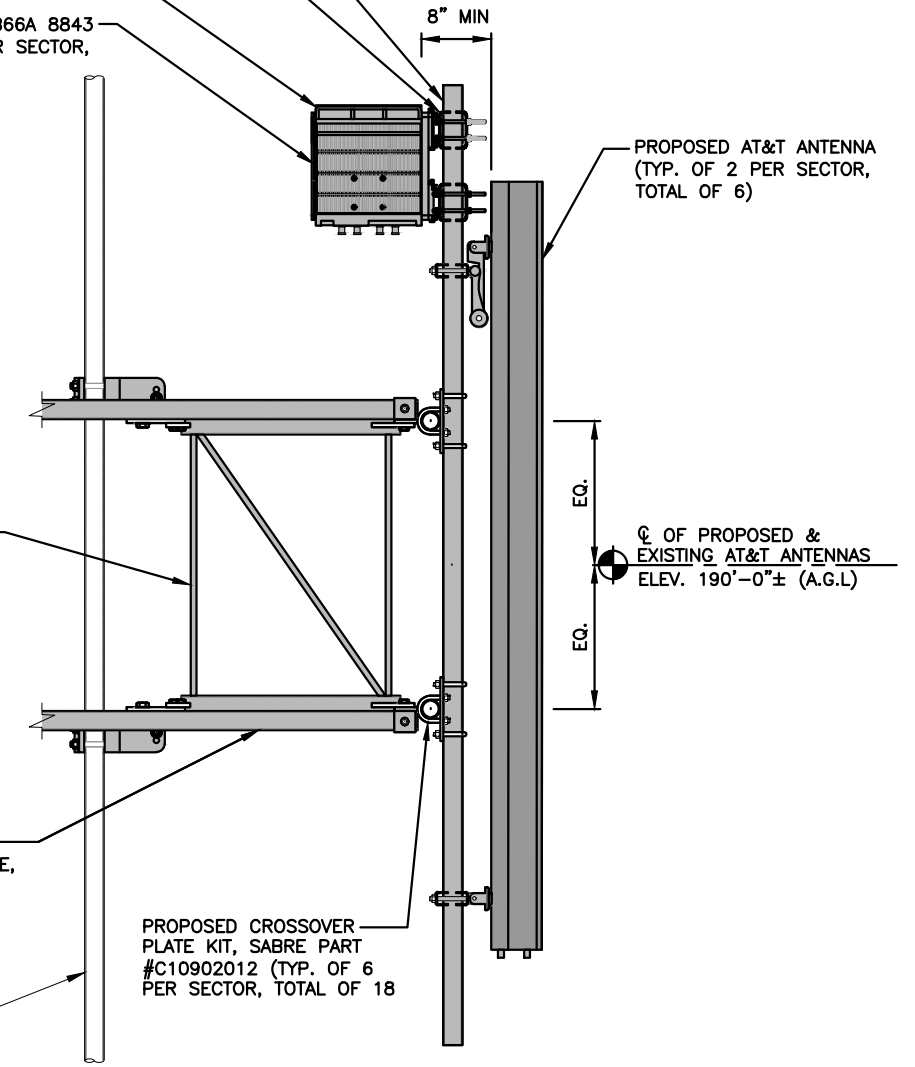

PROPOSED NEW 12' HD V-BOOM SECTOR MOUNT (SABRE PART# C10857001C) (TYP. OF 1 PER SECTOR, TOTAL OF 3)

INSTALL NEW ADDITIONAL 2" STD (2.38" O.D.) PIPE BRACE, SECURED TO THE PROPOSED MOUNT AND EXISTING TOWER (TYP. OF 1 PER SECTOR, TOTAL OF 3)

PROPOSED CROSSOVER PLATE KIT, SABRE PART #C10902012 (TYP. OF 6 PER SECTOR, TOTAL OF 18)

EXISTING TOWER LEG

NOTE:
REFER TO STRUCTURAL ANALYSIS BY: STAINLESS A BUSINESS OF HD INFRASTRUCTURE SERVICES, LLC, DATED: JANUARY 31, 2019, FOR THE CAPACITY OF THE EXISTING STRUCTURES TO SUPPORT THE PROPOSED EQUIPMENT.

NOTE:
REFER TO THE FINAL RF DATA SHEET FOR FINAL ANTENNA SETTINGS.

NOTE:
AN ANALYSIS FOR THE CAPACITY OF THE EXISTING ANTENNA MOUNT TO SUPPORT THE PROPOSED LOADING HAS BEEN COMPLETED BY: HUDSON DESIGN GROUP, LLC. DATED: DECEMBER 18, 2018

PROPOSED MOUNT MODIFICATIONS DETAILS (3) S-1
22x34 SCALE: 1"=1'-0"
11x17 SCALE: 1/2"=1'-0"

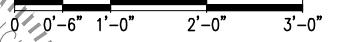

1	03/05/19	ISSUED FOR CONSTRUCTION	AM	AT	DJC
A	12/26/18	ISSUED FOR REVIEW	AM	AT	DJC
NO.	DATE	REVISIONS	BY	CHK	APP'D
SCALE: AS SHOWN		DESIGNED BY: AT	DRAWN BY: AM		



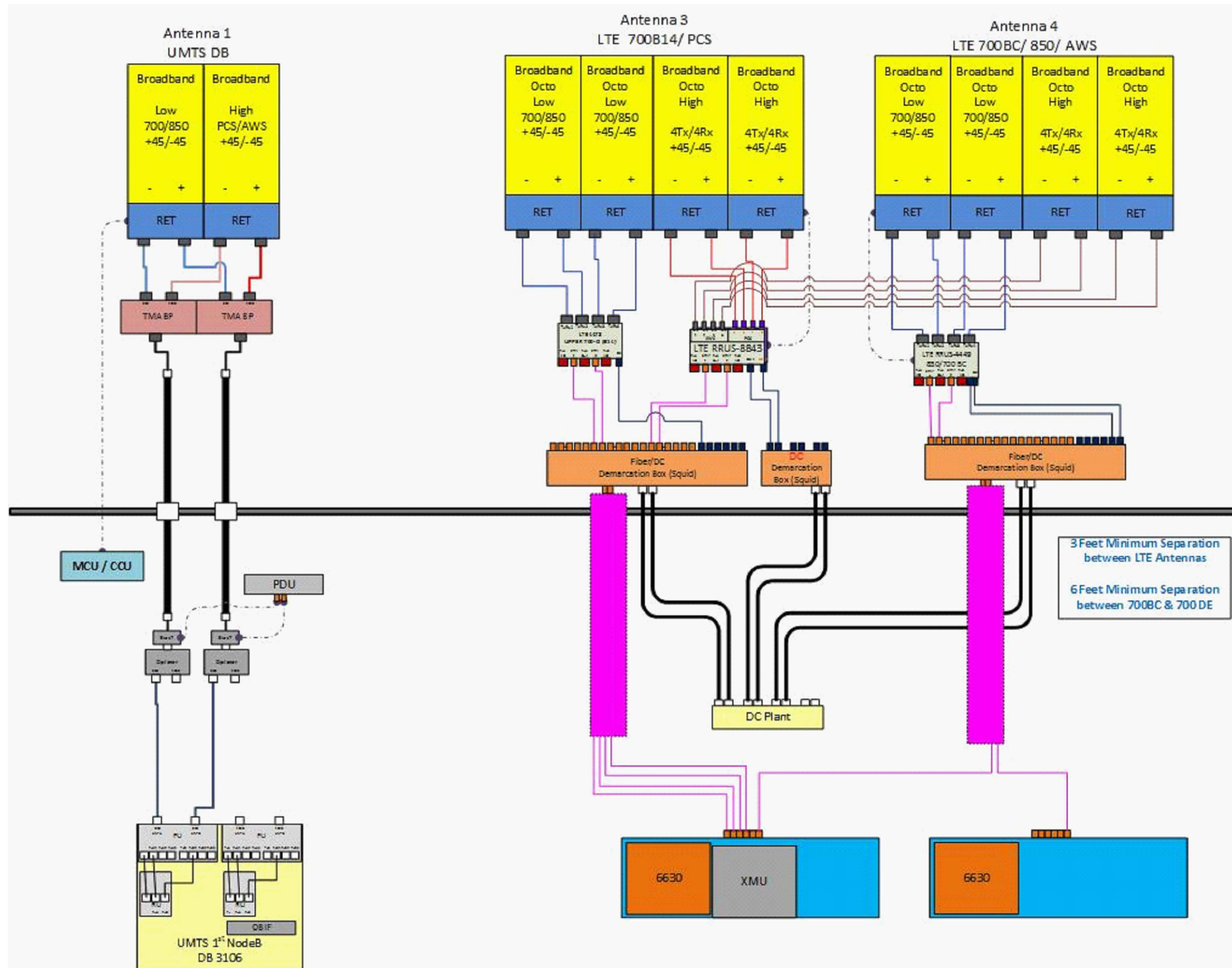

RF PLUMBING DIAGRAM
SCALE: N.T.S

1
RF-1

NOTE:
1. CONTRACTOR TO CONFIRM ALL PARTS.
2. INSTALL ALL EQUIPMENT TO MANUFACTURER'S RECOMMENDATIONS

NOTE:
REFER TO THE FINAL RF DATA SHEET FOR FINAL ANTENNA SETTINGS.

NO.	DATE	REVISIONS	BY	CHK	APP'D
1	03/05/19	ISSUED FOR CONSTRUCTION	AM		
A	12/26/18	ISSUED FOR REVIEW	AM	AT	DJC

SCALE: AS SHOWN DESIGNED BY: AT DRAWN BY: AM

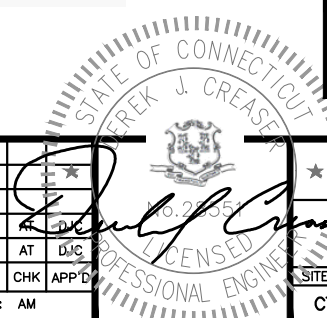

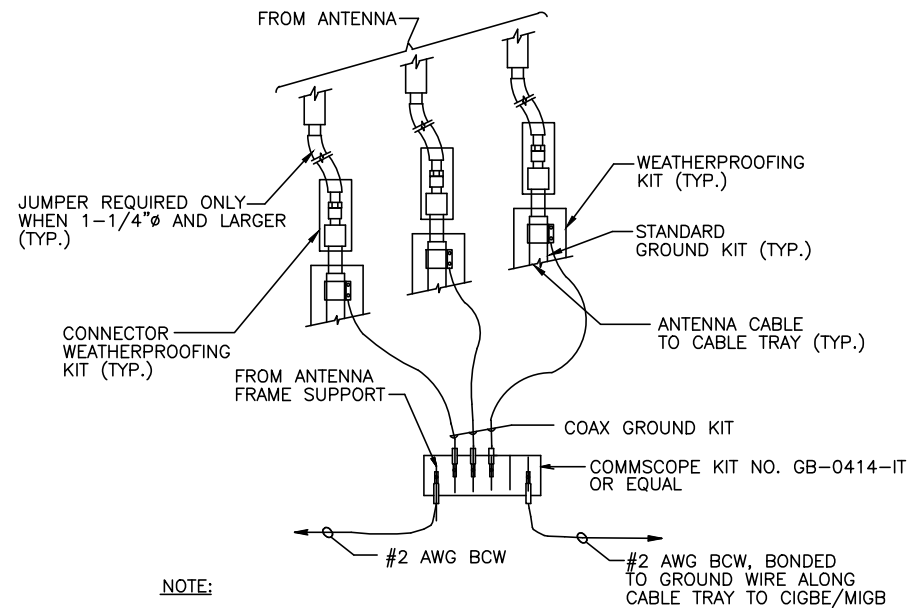

NOTE:
 1. DO NOT INSTALL CABLE GROUND KIT AT A BEND AND ALWAYS DIRECT GROUND WIRE DOWN TO CIGBE.

GROUND WIRE TO GROUND BAR CONNECTION DETAIL 1
 SCALE: N.T.S. G-1

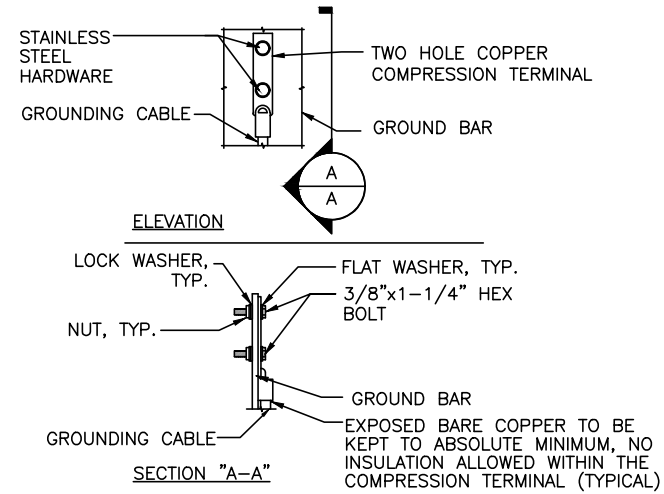

NOTE:
 1. "DOUBLING UP" OR "STACKING" OF CONNECTION IS NOT PERMITTED.
 2. OXIDE INHIBITING COMPOUND TO BE USED AT ALL LOCATION.
 3. CADWELD DOWNLEADS FROM UPPER EGB, LOWER EGB, AND MGB

TYPICAL GROUND BAR CONNECTION DETAIL 3
 SCALE: N.T.S. G-1

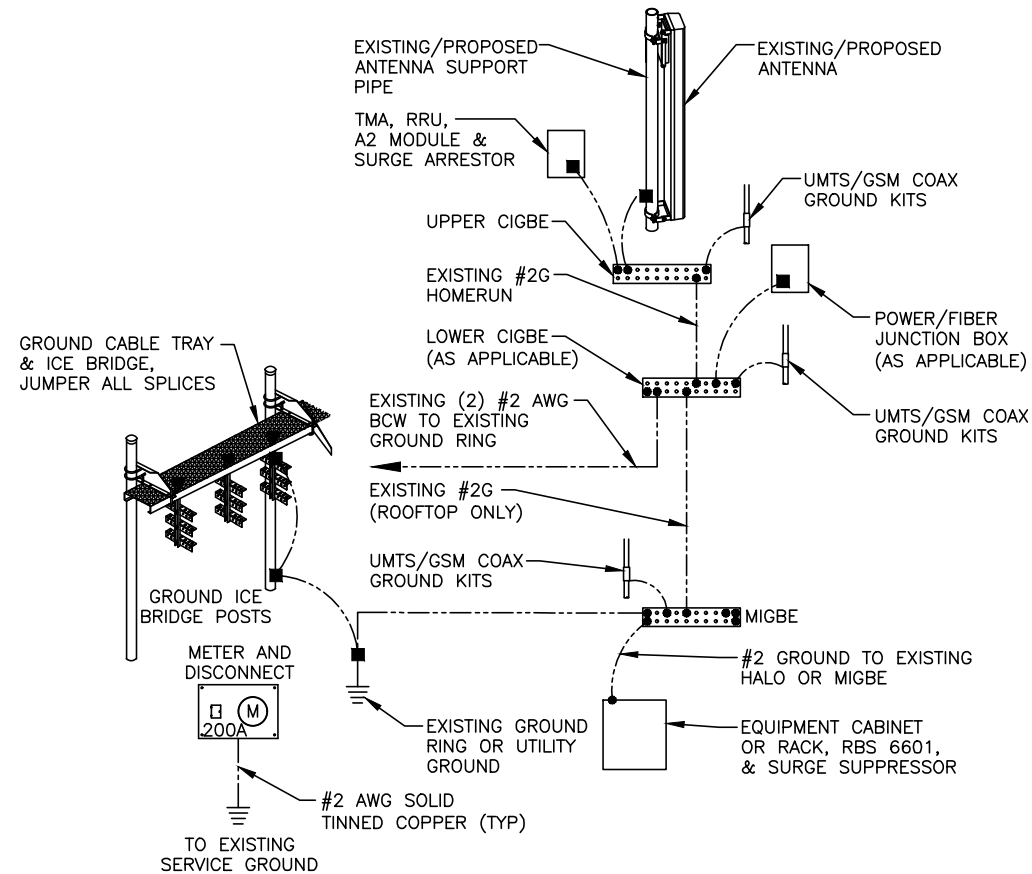

GROUNDING RISER DIAGRAM 2
 SCALE: N.T.S. G-1

EACH GROUND CONDUCTOR TERMINATING ON ANY GROUND BAR SHALL HAVE AN IDENTIFICATION TAG ATTACHED AT EACH END THAT WILL IDENTIFY ITS ORIGIN AND DESTINATION.

SECTION "P" - SURGE PRODUCERS

- CABLE ENTRY PORTS (HATCH PLATES) (#2)
- GENERATOR FRAMEWORK (IF AVAILABLE) (#2)
- TELCO GROUND BAR
- COMMERCIAL POWER COMMON NEUTRAL/GROUND BOND (#2)
- +24V POWER SUPPLY RETURN BAR (#2)
- 48V POWER SUPPLY RETURN BAR (#2)
- RECTIFIER FRAMES.

SECTION "A" - SURGE ABSORBERS

- INTERIOR GROUND RING (#2)
- EXTERNAL EARTH GROUND FIELD (BURIED GROUND RING) (#2)
- METALLIC COLD WATER PIPE (IF AVAILABLE) (#2)
- BUILDING STEEL (IF AVAILABLE) (#2)

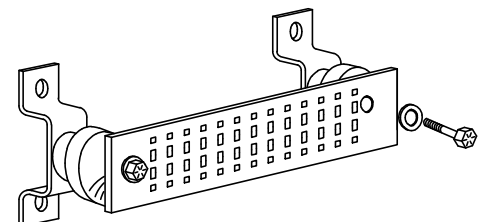

GROUND BAR - DETAIL 4
 SCALE: N.T.S. G-1

1	03/05/19	ISSUED FOR CONSTRUCTION	AM	AT	CHK
A	12/26/18	ISSUED FOR REVIEW	AM	AT	DJC
NO.	DATE	REVISIONS	BY	CHK	APP'D
SCALE: AS SHOWN		DESIGNED BY: AT	DRAWN BY: AM		

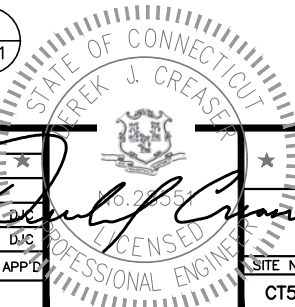

AT&T	
GROUNDING DETAILS (LTE 2C_3C_4C_5C)	
SITE NUMBER	DRAWING NUMBER
CT5737	G-1
	REV 1



REPORT T017213

ATC Site: 302534 Hartford CT 2
ATC Engineering No: OAA745012_C3_01
ATC Customer: AT&T Mobility

DATE: 1/31/2019

FEASIBILITY STRUCTURAL ANALYSIS
FOR A 1202' OVERALL HEIGHT G-8 GUYED TOWER
NEW LONDON, CT

PREPARED BY: CD
CHECKED BY: TM

APPROVED: KMP



□□□□	□□□□□□	□□□ r□□□
2 2 2 1 □□	□□	□□□□□□□□□□ d□□□□□ r□□ □□□□□□
□		
□		
□		

Rev.	Date	Description
00	2/2/19	00000d0000r0 00000

<u>SECTION</u>	<u>PAGE</u>
A. AUTHORIZATION/PURPOSE	1
B. TOWER HISTORY	1
C. CONDITIONS INVESTIGATED	2
D. LOADS AND STRESSES	4
E. METHOD OF ANALYSIS	4
F. RESULTS	5
G. CONCLUSIONS AND RECOMMENDATIONS	6
H. PROVISIONS OF ANALYSIS.....	7
 <u>APPENDIX</u>	
GENERAL ARRANGEMENT	E-1, E-2
LINEAR APPURTENANCES	A-2

Rev.	Date	Description
00	2/2/19	00000d00000r000000

A. AUTHORIZATION/PURPOSE

As authorized by Geoff Middlebrooks of American Tower Corporation (ATC), a feasibility structural analysis was performed to investigate the adequacy of a 1202' overall height G-8 guyed tower in New London, Connecticut to support specified equipment.

B. TOWER HISTORY

The tower was originally designed and furnished in 2000 by Central Tower, Inc. It was designed in accordance with ANSI/EIA/TIA Standard 222-F for a wind speed rating of 90 mph with 1/2" radial ice while supporting the following equipment:

1. One (1) TFU 31JTT-R antenna mounted on top of a support pole at the top of the tower, fed by one (1) DTW1500.
2. One (1) TFU 18DSC-R antenna side mounted on the support pole at the top of the tower, fed by one (1) 6-1/8" rigid coax.
3. One (1) DB809 antenna at the 1001' level, fed by one (1) 7/8" heliax.
4. One (1) ASP705 antenna at the 1001' level, fed by one (1) 7/8" heliax.
5. One (1) 4' dish with ice shield at the 875' level, fed by one (1) EW63 waveguide.
6. Two (2) HMD24VO antennas at the 850' level, each fed by one (1) EW20 waveguide.
7. One (1) DB809 antenna at the 850' level, fed by one (1) 1-1/4" heliax.
8. One (1) ASP705 antenna at the 850' level, fed by one (1) 1-1/4" heliax.
9. Eighteen (18) whip antennas between the 400' and 800' levels, each fed by one (1) 1-5/8" heliax.
10. One (1) DB809 antenna at the 708' level, fed by one (1) 1-1/4" heliax.
11. One (1) SRL210 antenna at the 708' level, fed by one (1) 1/2" heliax.
12. Two (2) 8' dishes with ice shields at the 500' level, each fed by one (1) 1-5/8" heliax.
13. Two (2) 8' dishes with ice shields at the 350' level, each fed by one (1) 1-5/8" heliax.
14. One (1) 8' dish with ice shield at the 350' level, fed by one (1) EW63 waveguide.
15. Four (4) ASP950 antennas at the 270' level, each fed by one (1) 1-1/4" heliax.
16. Twelve (12) panel antennas at the 200' level, each fed by one (1) 1-5/8" heliax.
17. Twelve (12) panel antennas at the 150' level, each fed by one (1) 1-5/8" heliax.
18. Two (2) 8' dishes with ice shields at the 125' level, each fed by one (1) 1-5/8" heliax.
19. One (1) waveguide rack on the tower face to the 1001' level.
20. One (1) 2" conduit for lighting system for the full height of the tower.
21. One (1) climbing ladder with safety device for the full height of the tower.

Rev.	Date	Description
00	2/2/10	00000d0000r0 00000

- ❖ In 2009, the tower was modified per Stainless Report T017209. The modifications consisted of the following:
 - a. Field welded stiffener plates to the existing top and bottom vertical leg flanges at the 960', 980', 1000', 1020', 1040' and 1060' flange levels.
 - b. Field drilled and installed 2 additional stitch bolts, one on each side of the existing center stitch bolt on the horizontal members at the following locations:

Location	No. of levels
713.8' – 1083.8'	74
558.8' – 628.8'	14
378.8' – 448.8'	14
218.8' – 288.8'	14
63.8' – 123.8'	12

- c. Field drilled and installed 2 additional stitch bolts, one on each side of the existing center stitch bolt on all K-bracing diagonal members.
- ❖ In 2013, the tower was modified per Stainless Report T017212. The modifications consisted of the following:
 - a. Adjusted initial tensions in all guy levels.
 - b. Reinforced the head plates of the outer anchor arms.
- ❖ Stainless has no record of any other modifications to the tower. If there have been other modifications, Stainless should be notified in order to include these modifications in the analysis.

C. CONDITIONS INVESTIGATED

The analysis was performed for wind speed and tower equipment based upon the following sources:

- Stainless Proposal P19_T0172_001 dated 1/25/2019
- Stainless Report T017211 Revision A dated 7/25/2013.
- Emails from Christina Minor of ATC, dated 1/25/2019, 1/29/2019 and 1/30/2019 with details of proposed equipment and existing equipment.
- LoadList_AT&T MOBILITY@302534_OAA745012_011819114311.xls
- 302534_CAP_OAA745012_012419.PDF

APPURTENANCE	ELEVATION, ft.	FEED LINE
TFU 31JTT-R mounted on top of a support pole	Tower top	6-1/8" rigid
MRC ProScan III	1073'	7/8" 11/16"

Rev.	Date	Description
00	2/2/19	

Ice shield	1003'	--
MRC ProScan III	996'	7/8" 11/16"
Ice shield	889'	--
8' dish with radome	878'	EW63
Ice shield	356'	--
8' dish with radome	349'	EW63
(6) Powerwave Allgon LGP21401 TTA	192'	(6) 1-5/8"
(1) Raycap DC6-48-60-18-8F (3) Ericsson RRUS 8843 B2, B66A (Proposed) (1) Raycap DC6-48-60-18-8C (Proposed) (3) Ericsson RRUS 4449 B5, B12 (Proposed) (3) Ericsson RRUS 4478 B14 (Proposed) (3) Ericsson RRUS-11 800 MHz (1) Raycap DC6-48-60-18-8C-EV (Proposed) (3) Powerwave Allgon 7770 panel antennas (2) Kathrein Scala 80010965 (Proposed) (4) Kathrein Scala 80010966 (Proposed) (3) 12' HD V-Boom sector mounts – Sabre P/N C10857001C (Proposed)	190'	(1) 0.33" Fiber (1) 0.39" Fiber (Proposed) (2) 0.65" 8AWG 2C (4) 0.78" 8AWG 6
FAA lighting system	Full height of the tower	1" conduit
Inside climbing ladder with safety device	Full height of the tower	3/8" cable
Support Conduit	1068'	3/4"
Support Conduit	995'	2"
Support Conduit	880'	1 1/2"
Support Conduit	192'	2"
Support Conduit	185'	(1) 2 1/2" (1) 2"

Rev.	Date	Description
00	2/2/19	00000d0000r0 00000

The tower cross section was based upon Inspection Report prepared by FDH Velocitel dated 7/14/2017. The locations of the existing and proposed transmission lines are shown on Page A-2 of this Report. Deviating from the line locations as shown may invalidate the results of this analysis.

D. LOADS AND STRESSES

The analysis was performed using the following design parameters in accordance with the 2018 Connecticut State Building Code, based on the 2015 IBC, and ANSI/TIA 222-G-2005, Structural Standard for Antenna Supporting Structures and Antennas, including addenda 1 & 2, dated 2007 and 2009:

- Risk Category II
- 135 mph ultimate design wind speed with no ice
- 50 mph nominal wind speed with 3/4" design ice thickness
- Exposure Category B
- Topographic Category 1
- 0.17 earthquake spectral response acceleration at short periods (S_s)
- Earthquake Site Class D

The ultimate design wind speed is converted to a nominal design wind speed for use in ANSI/TIA 222-G based upon the following formula:

$$\begin{aligned} V_{asd} &= V_{ult} * (0.6)^{1/2} \\ &= 135 * (0.6)^{1/2} \\ &= 105 \text{ mph} \end{aligned}$$

Seismic effects need not be considered as the value of S_s is less than 1.0 per Section 2.7.3 of ANSI/TIA 222-G. Load and resistance factors used to evaluate the adequacy of the structure were in accordance with ANSI/TIA 222-G.

Foundations were reviewed based upon the recommendations of Report 862-05163: Proposed TV Transmission Tower, New London, Connecticut dated 10/26/2000, prepared by Professional Service Industries, Inc. of Canton, MA.

E. METHOD OF ANALYSIS

The analysis was performed using tnxTower, a computer-aided finite element program for analysis of towers subject to simultaneous transverse and axial loads.

Rev.	Date	Description
00	2/2019	00000d0000r0 00000

F. RESULTS

The results of the analysis show the following ratings:

COMPONENT	SPAN	RATING %
Tower top	--	44
Leg Compression	7	55
	6	73
	5	73
	4	62
	3	63
	2	65
	1	71
Leg tension	7	78
	6	--
	5	--
	4	--
	3	--
	2	--
	1	--
Diagonals	7	40
	6	44
	5	31
	4	32
	3	28
	2	39
	1	33
Horizontals	7	41
	6	45
	5	32
	4	33
	3	28
	2	39
	1	27
Guys	7	63
	6	61
	5	54
	4	46
	3	44
	2	41
	1	32

Rev.	Date	Description
00	2/20/10	00000d00000r0 00000

Foundations	Base	89
	Inner Anchors	22
	Outer Anchors	46

The rating is defined as the percentage of the component design capacity that is used up in supporting itself and the loading from the antennas and transmission lines under the design wind and ice loading conditions. Ratings of up to 105% for tower members, and up to 110% for foundations are considered acceptable due to tolerances in calculating the applied loads on the tower as well as component design capacities.

However, the state of Connecticut mandates a maximum rating of 100%, and the tower has been reviewed based on 100% maximum rating.

G. CONCLUSIONS AND RECOMMENDATIONS

Based on the preceding results, the following conclusions may be drawn:

1. The tower, supporting the equipment as specified in section C of this report, is adequate to achieve an ultimate wind speed of 135 mph with no ice, and 50 mph nominal wind speed with 3/4" design ice thickness in accordance with the 2018 Connecticut State Building Code, based on the 2015 IBC, and ANSI/TIA 222-G and the analysis parameters of Section D.
2. Due to lack of information, the following assumptions have been made to complete the analysis.
 - a. Guy lug connections are adequate to develop the design strength of the guy wires.
 - b. End connections of all main horizontal, diagonal and top bay K-bracing members are adequate to develop the maximum allowable capacities of the members.
 - c. The top bay horizontal and diagonal members are adequate to resist the loads, including the load increase factor, from the top antenna.
 - d. The first bay main diagonals, redundant horizontals and sub-diagonals are adequate to resist the loads.
 - e. Guy pull off members at guy levels are adequate to resist the imposed loads from the guy wires.
3. In view of the lack of information and assumptions made in order to complete the analysis, this analysis has been classified as a feasibility analysis in which primarily the main tower members have been checked for strength and stability. According to Section 15.5 of ANSI/TIA 222-G, a rigorous structural analysis determines the overall strength and stability of the tower members, tower foundations and all connection details to accommodate changed tower conditions and/or modifications to the tower. The Code stipulates that final acceptance of changed tower conditions and/or modifications to the

Rev.	Date	Description
00	2/2/19	00000d0000r0 00000

tower shall be based upon a rigorous structural analysis. Stainless recommends that the required information be obtained in order to complete the structural review.

H. PROVISIONS OF ANALYSIS

The analysis performed and the conclusions contained herein are based on the assumption that the tower has been properly installed and maintained, including, but not limited to the following:

1. Proper alignment and plumbness.
2. Correct guy tensions.
3. Correct bolt tightness.
4. No significant deterioration or damage to any component.

Furthermore, the information and conclusions contained in this Report were determined by application of the current "state-of-the-arts" engineering and analysis procedures and formulae, and Stainless assumes no obligations to revise any of the information or conclusions contained in this Report in the event that such engineering and analysis procedures and formulae are hereafter modified or revised. In addition, under no circumstances will Stainless have any obligation or responsibility whatsoever for or on account of consequential or incidental damages sustained by any person, firm or organization as a result of any information or conclusions contained in the Report, and the maximum liability of Stainless, if any, pursuant to this Report shall be limited to the total funds actually received by Stainless for preparation of this Report.

Customer has requested Stainless to prepare and submit to Customer an engineering analysis with respect to the Subject Tower and has further requested Stainless to make appropriate recommendations regarding suggested structural modifications and changes to the Subject Tower. In making such request of Stainless, Customer has informed Stainless that Customer will make a determination as to whether or not to implement any of the changes or modifications which may be suggested by Stainless and that Customer will have any such changes or modifications made by riggers, erectors and other subcontractors of Customer's choice.

Customer hereby agrees and acknowledges that Stainless shall have no liability whatsoever to Customer or to others for any work or services performed by any persons other than Stainless in connection with the implementation of any structural changes or modifications recommended by Stainless including but not limited to any services rendered for Customer or for others by riggers, erectors or other subcontractors. Customer acknowledges and agrees that any riggers, erectors or subcontractors retained or employed by Customer shall be solely responsible to Customer and to others for the quality of work performed by them and that Stainless shall have no liability or responsibility whatsoever as a result of any negligence or breach of contract by any such rigger, erector or subcontractor.

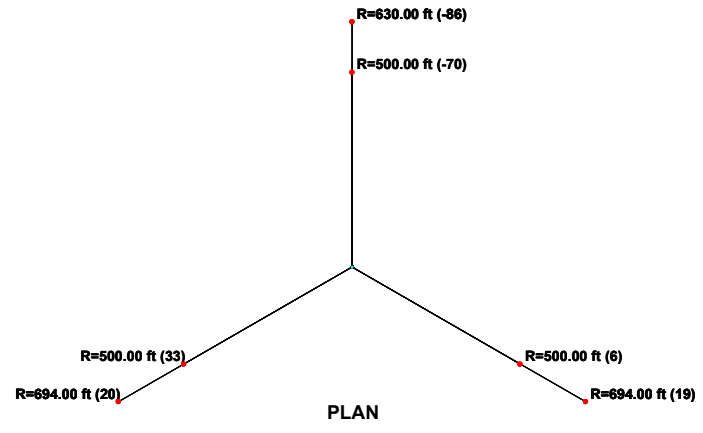
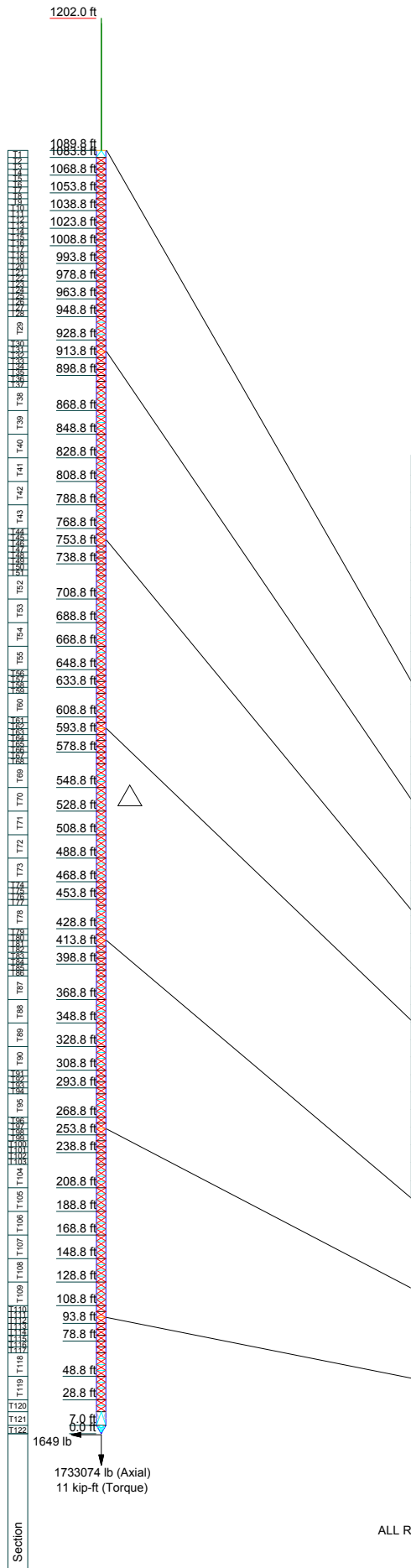

DESIGNED APPURTENANCE LOADING

TYPE	ELEVATION	TYPE	ELEVATION
Ice shield for strobe	1087	Ice shield for strobe	295.5
Ice shield for strobe	1087	Ice shield for strobe	295.5
Ice shield for strobe	1087	Flash tech Beacon	291.5
Flash tech Beacon	1083	Flash tech Beacon	291.5
Flash tech Beacon	1083	Strobe	286.5
Strobe	1077	Strobe	286.5
Strobe	1077	Strobe	286.5
Strobe	1077	(2) LGP21401	192
MRC Proscan III	1073	(2) LGP21401	192
Ice shield	1003	(2) LGP21401	192
MRC Proscan III	996	Sector frame	192
Sidemarker	969	Sector frame	192
Sidemarker	969	Sector frame	192
Sidemarker	969	RRUS 4449 B5 B12 (Proposed)	190
Ice shield	889	RRUS 4449 B5 B12 (Proposed)	190
8 FT DISH	878	RRUS 4449 B5 B12 (Proposed)	190
Ice shield for strobe	839.5	RRUS 4478 B14(Proposed)	190
Ice shield for strobe	839.5	RRUS 4478 B14(Proposed)	190
Ice shield for strobe	839.5	RRUS 4478 B14(Proposed)	190
Flash tech Beacon	837	RRUS-11 800MHz	190
Flash tech Beacon	837	RRUS-11 800MHz	190
Strobe	832	RRUS-11 800MHz	190
Strobe	832	DC6-48-60-18-8C- EV (Proposed)	190
Strobe	832	7770 w/Mount Pipe	190
Sidemarker	696	7770 w/Mount Pipe	190
Sidemarker	696	7770 w/Mount Pipe	190
Sidemarker	696	800 10965 w/ Mount Pipe (Proposed)	190
Ice shield for strobe	569.5	800 10965 w/ Mount Pipe (Proposed)	190
Ice shield for strobe	569.5	(2) 800 10966 w/ Mount Pipe (Proposed)	190
Ice shield for strobe	569.5	(2) 800 10966 w/ Mount Pipe (Proposed)	190
Flash tech Beacon	565.5	(2) 800 10966 w/ Mount Pipe (Proposed)	190
Flash tech Beacon	565.5	DC6-48-60-18-8F (23.5"x9.7" 20lbs)	190
Strobe	560.5	RRU 8843 B2 B66A (Proposed)	190
Strobe	560.5	RRU 8843 B2 B66A (Proposed)	190
Strobe	560.5	RRU 8843 B2 B66A (Proposed)	190
Sidemarker	425	RRU 8843 B2 B66A (Proposed)	190
Sidemarker	425	DC6-48-60-18-8C (Proposed)	190
Sidemarker	425	Sidemarker	155
Ice shield	356	Sidemarker	155
8 FT DISH	349	Sidemarker	155
Ice shield for strobe	295.5	Sidemarker	155

1649 lb
1733074 lb (Axial)
11 kip-ft (Torque)

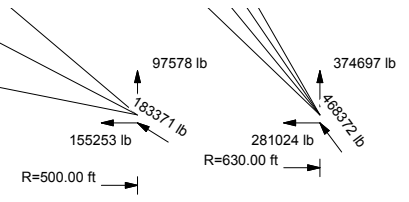

ALL REACTIONS ARE FACTORED

<p>STAINLESS A BUSINESS OF FDH INFRASTRUCTURE SERVICES Tower Engineers</p>	<p>STAINLESS 100 West Main Street, Suite 400 Lansdale, PA - 19446 Phone: 215-372-1378 FAX:</p>	<p>Job: T017213 New London, CT</p>			
		<p>Project: 1089.8' Steel Height Tower</p>			
		<p>Client: American Tower Corporation</p>	<p>Drawn by: CD</p>	<p>App'd:</p>	
		<p>Code: TIA-222-G</p>	<p>Date: 02/01/19</p>	<p>Scale: NTS</p>	
		<p>Path: \\192.168.4.90\Project\T017213\eng\ltnxTower\T017213.eri</p>			<p>Dwg No. E-1</p>

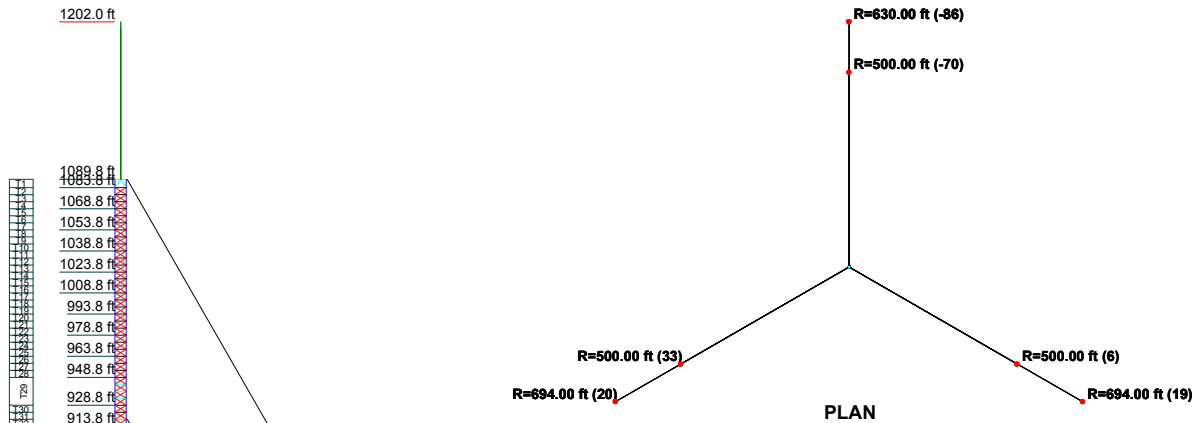

PLAN

TOWER DESIGN NOTES

1. Tower designed for Exposure B to the TIA-222-G Standard.
2. Tower designed for a 105 mph basic wind in accordance with the TIA-222-G Standard.
3. Tower is also designed for a 50 mph basic wind with 0.75 in ice. Ice is considered to increase in thickness with height.
4. Deflections are based upon a 60 mph wind.
5. Tower Structure Class II.
6. Topographic Category 1 with Crest Height of 0.00 ft
7. 112.2 ft TFU-31JTT-R + Pole is included for load transfer only.

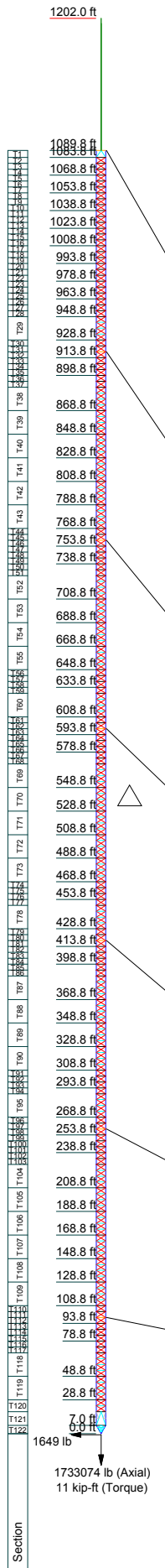

1733074 lb (Axial)
11 kip-ft (Torque)

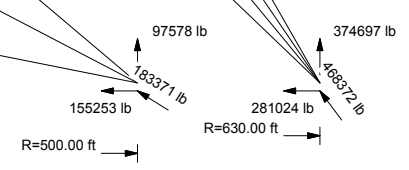

ALL REACTIONS ARE FACTORED

 <p>STAINLESS A BUSINESS OF FDH INFRASTRUCTURE SERVICES Tower Engineers</p>	<p>STAINLESS</p> <p>100 West Main Street, Suite 400 Lansdale, PA - 19446 Phone: 215-372-1378 FAX:</p>		<p>Job: T017213 New London, CT</p>	
	<p>Project: 1089.8' Steel Height Tower</p>		<p>Client: American Tower Corporation</p>	<p>Drawn by: CD</p>
	<p>Code: TIA-222-G</p>		<p>Date: 02/01/19</p>	<p>App'd: NTS</p>
	<p>Path: \\192.168.4.90\Project\T017213\enq\ltx\Tower\T017213.eri</p>		<p>Dwg No: E-2</p>	
	<p>Scale: NTS</p>			

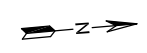
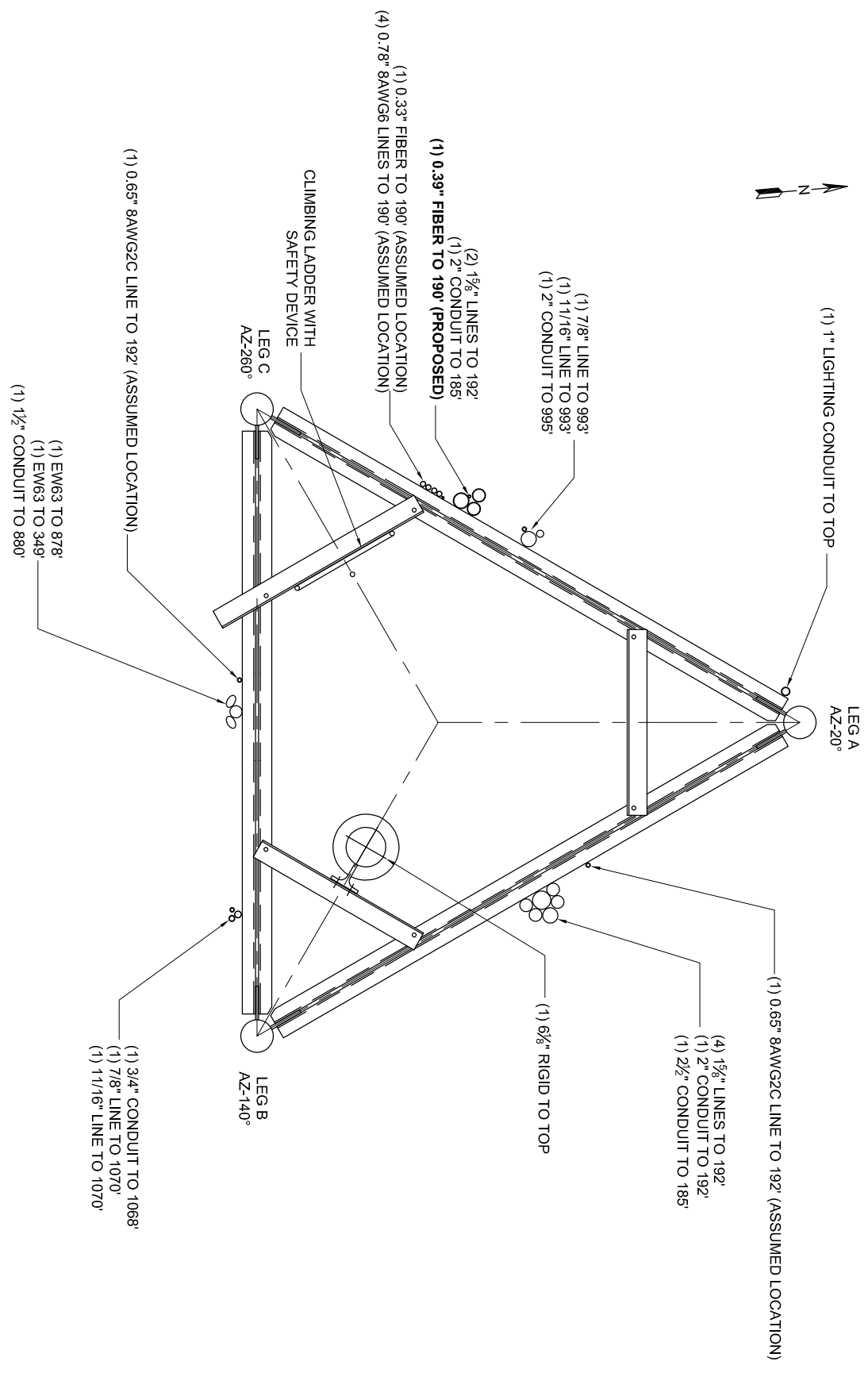

LINEAR APPURTENANCES
NEW LONDON, CT

THIS DRAWING IS THE PROPERTY OF STAINLESS AND TRANSMITTED IN CONFIDENCE, AND THE REPRODUCTION, USE OR DISCLOSURE, IN WHOLE OR IN PART, OF THE DESIGN AND DETAILS CONTAINED HEREIN IS PROHIBITED WITHOUT THE PRIOR WRITTEN PERMISSION OF STAINLESS.

REV	BY	DATE	REVISION DESCRIPTION	D,C,K	DATE	E,C,K	DATE	PREPARED BY	CD	1/30/2019
								CHECKED BY		
								ENGINEER REVIEW		
								PROJECT NUMBER	T017213	
								DRAWING NUMBER	A-2	

December 18, 2018



SAI Communications
 12 Industrial Way
 Salem NH, 03079

RE: Site Number: CT5737 (LTE 2C/3C/4C/5C)
 FA Number: 10071018
 PACE Number: MRCTB035157
 PT Number: 2051 AOKPHD
 Site Name: EAST LYME NORTH
 Site Address: Butlertown Road and 61
 Montville, CT 06370

To Whom It May Concern:

Hudson Design Engineering PLLC (HDG) has been authorized by SAI Communications to perform a mount analysis on the proposed AT&T antenna mounts to determine their capability of supporting the following equipment loading:

- (3) 7770 Antennas (55.0"x11.0"x5.0" - Wt. = 35 lbs. /each)
- (6) LGP21401 TMA's (14.4"x9.0"x2.7" - Wt. = 19 lbs. /each)
- (1) Squid Surge Arrestor (24.0"x9.7"Φ - Wt. = 33 lbs.) (tower mounted)
- **(4) 800-10966 Antennas (96.0"x20.0"x6.9" - Wt. = 115 lbs. /each)**
- **(2) 800-10965 Antennas (78.7"x20.0"x6.9" - Wt. = 109 lbs. /each)**
- **(3) B14 4478 RRH's (18.1"x13.4"x8.3" - Wt. = 60 lbs. /each)**
- **(3) B5/B12 4449 RRH's (18.0"x13.2"x9.5" - Wt. = 71 lbs. /each)**
- **(3) B2/B66A 8843 RRH's (14.9"x13.2"x10.9" - Wt. = 72 lbs. /each)**
- **(2) Squid Surge Arrestors (24.0"x9.7"Φ - Wt. = 33 lbs.) (tower mounted)**

**Proposed equipment shown in bold*

A survey climb and mapping of the antenna mount was not performed at this site. Mount fabrication drawings prepared by Sabre Industries Towers & Poles (P/N C10857001C-MC) dated January 20, 2017 were used to perform this analysis. HDG conducted a ground audit of the existing AT&T antenna mounts on November 9, 2018.

Mount Analysis Methods:

- This analysis was conducted in accordance with EIA/TIA-222-G, Structural Standards for Steel Antenna Towers and Antenna Supporting Structures, the International Building Code 2015 with 2018 Connecticut State Building Code Amendments and AT&T Mount Technical Directive – R11.
- HDG considers this mount to be asymmetrical and has applied wind loads in 30 degree increments all around the mount. Per TIA-222-G Annex B, the max basic wind speed for this site is equal to 120 mph with a max basic wind speed with ice of 50 mph and a max ice thickness of 0.75 in. Per the AT&T Mount Technical Directive and Appendix N of the Connecticut State Building Code, an ultimate wind speed of 135 mph converted to a nominal wind speed of 105 mph and an escalated ice thickness of 2.60 in was used for this analysis.
- HDG considers this site to be exposure category C; tower is located large, flat, open, terrain/grasslands.
- HDG considers this site to be topographic category 1; tower is located in flat terrain.
- The mount has been analyzed with load combinations consisting of 250 lbs live load using a service wind speed of 30 mph wind on the worst case antenna. Analysis performed on each antenna pipe to determine worst case location; worst case location was antenna position 4.
- The mount has been analyzed with load combinations consisting of a 250 lbs live load in a worst case location on the mount.

Based on our evaluation, we have determined that the new Sabre Industries C10857001C-MC mounts **ARE CAPABLE** of supporting the proposed installation with the following modifications:

- **Install new additional 2" std. (2.38" O.D.) pipe brace secured to the proposed mount and existing tower (typ. of 1 per sector, total of 3).**
- **Install new 2-1/2" std. (2.88" O.D.) pipe masts behind new 800-10966 and 800-10965 antennas secured to the proposed mount (typ. of 2 per sector, total of 6).**

	Component	Controlling Load Case	Stress Ratio	Pass/Fail
Proposed (LTE 2C/3C/4C/5C) Mount Rating	28	LC7	123%	FAIL
Modified (LTE 2C/3C/4C/5C) Mount Rating	13	LC25	81%	PASS

Reference Documents:

- Fabrication drawings prepared by Sabre Industries Towers & Poles dated January 20, 2017.

This determination was based on the following limitations and assumptions:

1. HDG is not responsible for any modifications completed prior to and hereafter which HDG was not directly involved.
2. All structural members and their connections are assumed to be in good condition and are free from defects with no deterioration to its member capacities.
3. All antennas, coax cables and waveguide cables are assumed to be properly installed and supported as per the manufacturer's requirements.
4. The existing mount has been adequately secured to the tower structure per the mount manufacturer's specifications.
5. All components pertaining to AT&T's mounts must be tightened and re-plumbed prior to the installation of new appurtenances.
6. HDG performed a localized analysis on the mount itself and not on the supporting tower structure.

Please feel free to contact our office should you have any questions.

Respectfully Submitted,
Hudson Design Group LLC



Michael Cabral
Structural Dept. Head



Daniel P. Hamm, PE
Principal

FIELD PHOTOS:
(Existing mounts to be removed)

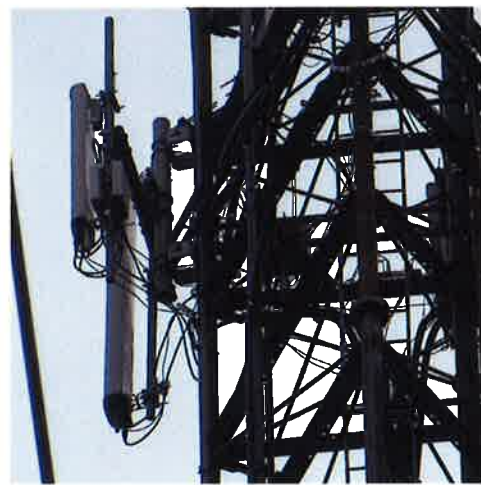



HUDSON
Design Group LLC

Wind & Ice Calculations

Date: 12/18/2018
 Project Name: EAST LYME NORTH
 Project Number: CT5737
 Designed By: JN Checked By: MSC



2.6.5.2 Velocity Pressure Coeff:

$$K_z = 2.01 (z/z_g)^{2/\alpha}$$

$K_z =$ **1.449** $z =$ 190 (ft)
 $z_g =$ 900 (ft)
 $\alpha =$ 9.5

$K_{zmin} \leq K_z \leq 2.01$

Table 2-4

Exposure	Z_g	α	K_{zmin}	K_e
B	1200 ft	7.0	0.70	0.9
C	900 ft	9.5	0.85	1.0
D	700 ft	11.5	1.03	1.1

2.6.6.4 Topographic Factor:

Table 2-5

Topo. Category	K_t	f
2	0.43	1.25
3	0.53	2.0
4	0.72	1.5

$$K_{zt} = [1 + (K_e K_t / K_h)]^2$$

$$K_h = e^{(fz/H)}$$

$K_{zt} =$ **#DIV/0!**

$K_h =$ **#DIV/0!**

(If Category 1 then $K_{zt} = 1.0$)

$K_e =$ 0 (from Table 2-4)

$K_t =$ 0 (from Table 2-5)

$f =$ 0 (from Table 2-5)

$z =$ 190

$H =$ 0 (Ht. of the crest above surrounding terrain)

$K_{zt} =$ 1.00

$K_{iz} =$ 1.19 (from Sec. 2.6.8)

Category = 1

2.6.8 Design Ice Thickness

Max Ice Thickness =

$t_i =$ 0.75 in

$$t_{iz} = 2.0 * t_i * I * K_{iz} * (K_z t)^{0.35}$$

$t_{iz} =$ 1.79 in

Date: 12/18/2018
 Project Name: EAST LYME NORTH
 Project Number: CT5737
 Designed By: JN Checked By: MSC



2.6.7 Gust Effect Factor

2.6.7.1 Self Supporting Lattice Structures

Gh = 1.0 Latticed Structures > 600 ft

Gh = 0.85 Latticed Structures 450 ft or less

Gh = 0.85 + 0.15 [h/150 - 3.0]

h= ht. of structure

h= 1089

Gh= 1.49

2.6.7.2 Guyed Masts

Gh= 0.85

2.6.7.3 Pole Structures

Gh= 1.1

2.6.9 Appurtenances

Gh= 1.0

2.6.7.4 Structures Supported on Other Structures

(Cantilevered tubular or latticed spines, pole, structures on buildings (ht. : width ratio > 5)

Gh= 1.35

Gh= 1.00

2.6.9.2 Design Wind Force on Appurtenances

State Code Ultimate Design Wind Speed:

V_{ult} = 135 mph

Nomial Design Wind Speed,

V_{asd} = V_{ult} v(0.6)

V_{asd} = 105 mph

V_{asd} per the AT&T Mount Technical Directive and Connecticut Supplement, Latest Addition.

Per TIA-222-G,

V_{min} = 105 mph

V_{max} = 120 mph

F = q_z * Gh * (EPA)_A

q_z = 0.00256 * K_z * K_{zt} * K_d * V_{max}² * I

q_z = 38.84

q_{z (ice)} = 8.81

q_{z (30)} = 3.17

K_z = 1.449

K_{zt} = 1.0

K_d = 0.95

V_{asd} = 105 mph

V_{max (ice)} = 50 mph

V₃₀ = 30 mph

I = 1.0

Table 2-2

Structure Type	Wind Direction Probability Factor, Kd
Latticed structures with triangular, square or rectangular cross sections	0.85
Tubular pole structures, latticed structures with other cross sections, appurtenances	0.95

Determine Ca:

Table 2-8

Force Coefficients (Ca) for Appurtenances				
Member Type		Aspect Ratio ≤ 2.5	Aspect Ratio = 7	Aspect Ratio ≥ 25
		Ca	Ca	Ca
Flat		1.2	1.4	2.0
Round	C < 32 (Subcritical)	0.7	0.8	1.2
	32 ≤ C ≤ 64 (Transitional)	$3.76/(C^{0.485})$	$3.37/(C^{0.415})$	$38.4/(C^{1.0})$
	C > 64 (Supercritical)	0.5	0.6	0.6

Aspect Ratio is the overall length/width ratio in the plane normal to the wind direction.
 (Aspect ratio is independent of the spacing between support points of a linear appurtenance,
 Note: Linear interpolation may be used for aspect ratios other than those shown.

Ice Thickness =

1.79 in

Angle = 0 (deg)

Equivalent Angle = 180 (deg)

Appurtenances	Height	Width	Depth	Flat Area	Aspect Ratio	Ca	Force (lbs)	Force (lbs) (w/ Ice)	Force (lbs) (30 mph)
7770 Antenna	55.0	11.0	5.0	4.20	5.00	1.31	214	68	17
800-10966 Antenna	96.0	20.0	6.9	13.33	4.80	1.30	674	187	55
800-10965 Antenna	78.7	20.0	6.9	10.93	3.94	1.26	537	150	44
B14 4478 RRH	18.1	13.4	8.3	1.68	1.35	1.20	79	27	6
B14 4478 RRH (Shielded)	18.1	0.0	8.3	0.00	0.00	1.20	0	0	0
B5/B12 4449 RRH	18.0	9.5	13.2	1.19	1.89	1.20	55	21	5
B5/B12 4449 RRH (Shielded)	18.0	4.8	13.2	0.59	3.79	1.26	29	14	2
B2/B66A 8843 RRH	14.9	10.9	13.2	1.13	1.37	1.20	53	20	4
B2/B66A 8843 RRH (Shielded)	14.9	5.5	13.2	0.56	2.73	1.21	27	12	2
LGP21401 TMA	14.4	9.0	2.7	0.90	1.60	1.20	42	17	3
Surge Arrestor	24.0	9.7	9.7	1.62	2.47	0.70	44	16	4

Date: 12/18/2018

Project Name: EAST LYME NORTH

Project Number: CT5737

Designed By: JN Checked By: MSC



WIND LOADS

Angle = 30 (deg)

Ice Thickness = 1.79 in.

Equivalent Angle = 210 (deg)

WIND LOADS WITH NO ICE:

Appurtenances	Height	Width	Depth	Flat Area (normal)	Flat Area (side)	Aspect Ratio	Aspect Ratio	Ca (normal)	Ca (side)	Force (lbs) (normal)	Force (lbs) (side)	Force (lbs) (angle)
7770 Antenna	55.0	11.0	5.0	4.20	1.91	5.00	11.00	1.31	1.53	214	114	189
800-10966 Antenna	96.0	20.0	6.9	13.33	4.60	4.80	13.91	1.30	1.63	674	291	579
800-10965 Antenna	78.7	20.0	6.9	10.93	3.77	3.94	11.41	1.26	1.55	537	227	459
B14 4478 RRH	18.1	13.4	8.3	1.68	1.04	1.35	2.18	1.20	1.20	79	49	71
B14 4478 RRH (Shielded)	18.1	6.7	8.3	0.84	1.04	2.70	2.18	1.21	1.20	40	49	42
B5/B12 4449 RRH	18.0	9.5	13.2	1.19	1.65	1.89	1.36	1.20	1.20	55	77	61
B5/B12 4449 RRH (Shielded)	18.0	4.8	13.2	0.59	1.65	3.79	1.36	1.26	1.20	29	77	41
B2/B66A 8843 RRH	14.9	10.9	13.2	1.13	1.37	1.37	1.13	1.20	1.20	53	64	55
B2/B66A 8843 RRH (Shielded)	14.9	5.5	13.2	0.56	1.37	2.73	1.13	1.21	1.20	27	64	36
LGP21401 TMA	14.4	9.0	2.7	0.90	0.27	1.60	5.33	1.20	1.33	42	14	35

WIND LOADS WITH ICE:

7770 Antenna	58.6	14.6	8.6	5.93	3.49	4.02	6.83	1.27	1.39	66	43	60
800-10966 Antenna	99.6	23.6	10.5	16.30	7.24	4.22	9.51	1.28	1.48	183	95	161
800-10965 Antenna	82.3	23.6	10.5	13.47	5.98	3.49	7.86	1.24	1.43	148	75	130
B14 4478 RRH	21.7	17.0	11.9	2.55	1.79	1.28	1.83	1.20	1.20	27	19	25
B14 4478 RRH (Shielded)	21.7	8.5	11.9	1.28	1.79	2.55	1.83	1.20	1.20	14	19	15
B5/B12 4449 RRH	21.6	13.1	16.8	1.96	2.51	1.65	1.29	1.20	1.20	21	27	22
B5/B12 4449 RRH (Shielded)	21.6	6.5	16.8	0.98	2.51	3.30	1.29	1.24	1.20	11	27	15
B2/B66A 8843 RRH	18.5	14.5	16.8	1.86	2.15	1.28	1.10	1.20	1.20	20	23	20
B2/B66A 8843 RRH (Shielded)	18.5	7.2	16.8	0.93	2.15	2.55	1.10	1.20	1.20	10	23	13
LGP21401 TMA	18.0	12.6	6.3	1.57	0.78	1.43	2.86	1.20	1.22	17	8	15

WIND LOADS AT 30 MPH:

7770 Antenna	55.0	11.0	5.0	4.20	1.91	5.00	11.00	1.31	1.53	17	9	15
800-10966 Antenna	96.0	20.0	6.9	13.33	4.60	4.80	13.91	1.30	1.63	55	24	47
800-10965 Antenna	78.7	20.0	6.9	10.93	3.77	3.94	11.41	1.26	1.55	44	18	37
B14 4478 RRH	18.1	13.4	8.3	1.68	1.04	1.35	2.18	1.20	1.20	6	4	6
B14 4478 RRH (Shielded)	18.1	6.7	8.3	0.84	1.04	2.70	2.18	1.21	1.20	3	4	3
B5/B12 4449 RRH	18.0	9.5	13.2	1.19	1.65	1.89	1.36	1.20	1.20	5	6	5
B5/B12 4449 RRH (Shielded)	18.0	4.8	13.2	0.59	1.65	3.79	1.36	1.26	1.20	2	6	3
B2/B66A 8843 RRH	14.9	10.9	13.2	1.13	1.37	1.37	1.13	1.20	1.20	4	5	5
B2/B66A 8843 RRH (Shielded)	14.9	5.5	13.2	0.56	1.37	2.73	1.13	1.21	1.20	2	5	3
LGP21401 TMA	14.4	9.0	2.7	0.90	0.27	1.60	5.33	1.20	1.33	3	1	3

Date: 12/18/2018

Project Name: EAST LYME NORTH

Project Number: CT5737

Designed By: JN Checked By: MSC



WIND LOADS

Angle = 60 (deg)

Ice Thickness = 1.79 in.

Equivalent Angle = 240 (deg)

WIND LOADS WITH NO ICE:

Appurtenances	Height	Width	Depth	Flat Area (normal)	Flat Area (side)	Ratio (normal)	Ratio (side)	Ca (normal)	Ca (side)	Force (lbs) (normal)	Force (lbs) (side)	Force (lbs) (angle)
7770 Antenna	55.0	11.0	5.0	4.20	1.91	5.00	11.00	1.31	1.53	214	114	139
800-10966 Antenna	96.0	20.0	6.9	13.33	4.60	4.80	13.91	1.30	1.63	674	291	387
800-10965 Antenna	78.7	20.0	6.9	10.93	3.77	3.94	11.41	1.26	1.55	537	227	304
B14 4478 RRH	18.1	13.4	8.3	1.68	1.04	1.35	2.18	1.20	1.20	79	49	56
B14 4478 RRH (Shielded)	18.1	10.1	8.3	1.26	1.04	1.80	2.18	1.20	1.20	59	49	51
B5/B12 4449 RRH	18.0	9.5	13.2	1.19	1.65	1.89	1.36	1.20	1.20	55	77	72
B5/B12 4449 RRH (Shielded)	18.0	7.1	13.2	0.89	1.65	2.53	1.36	1.20	1.20	42	77	68
B2/B66A 8843 RRH	14.9	10.9	13.2	1.13	1.37	1.37	1.13	1.20	1.20	53	64	61
B2/B66A 8843 RRH (Shielded)	14.9	8.2	13.2	0.85	1.37	1.82	1.13	1.20	1.20	39	64	58
LGP21401 TMA	14.4	9.0	2.7	0.90	0.27	1.60	5.33	1.20	1.33	42	14	21

WIND LOADS WITH ICE:

7770 Antenna	58.6	14.6	8.6	5.93	3.49	4.02	6.83	1.27	1.39	66	43	49
800-10966 Antenna	99.6	23.6	10.5	16.30	7.24	4.22	9.51	1.28	1.48	183	95	117
800-10965 Antenna	82.3	23.6	10.5	13.47	5.98	3.49	7.86	1.24	1.43	148	75	93
B14 4478 RRH	21.7	17.0	11.9	2.55	1.79	1.28	1.83	1.20	1.20	27	19	21
B14 4478 RRH (Shielded)	21.7	12.7	11.9	1.92	1.79	1.70	1.83	1.20	1.20	20	19	19
B5/B12 4449 RRH	21.6	13.1	16.8	1.96	2.51	1.65	1.29	1.20	1.20	21	27	25
B5/B12 4449 RRH (Shielded)	21.6	9.8	16.8	1.47	2.51	2.20	1.29	1.20	1.20	16	27	24
B2/B66A 8843 RRH	18.5	14.5	16.8	1.86	2.15	1.28	1.10	1.20	1.20	20	23	22
B2/B66A 8843 RRH (Shielded)	18.5	10.9	16.8	1.39	2.15	1.70	1.10	1.20	1.20	15	23	21
LGP21401 TMA	18.0	12.6	6.3	1.57	0.78	1.43	2.86	1.20	1.22	17	8	10

WIND LOADS AT 30 MPH:

7770 Antenna	55.0	11.0	5.0	4.20	1.91	5.00	11.00	1.31	1.53	17	9	11
800-10966 Antenna	96.0	20.0	6.9	13.33	4.60	4.80	13.91	1.30	1.63	55	24	32
800-10965 Antenna	78.7	20.0	6.9	10.93	3.77	3.94	11.41	1.26	1.55	44	18	25
B14 4478 RRH	18.1	13.4	8.3	1.68	1.04	1.35	2.18	1.20	1.20	6	4	5
B14 4478 RRH (Shielded)	18.1	10.1	8.3	1.26	1.04	1.80	2.18	1.20	1.20	5	4	4
B5/B12 4449 RRH	18.0	9.5	13.2	1.19	1.65	1.89	1.36	1.20	1.20	5	6	6
B5/B12 4449 RRH (Shielded)	18.0	7.1	13.2	0.89	1.65	2.53	1.36	1.20	1.20	3	6	6
B2/B66A 8843 RRH	14.9	10.9	13.2	1.13	1.37	1.37	1.13	1.20	1.20	4	5	5
B2/B66A 8843 RRH (Shielded)	14.9	8.2	13.2	0.85	1.37	1.82	1.13	1.20	1.20	3	5	5
LGP21401 TMA	14.4	9.0	2.7	0.90	0.27	1.60	5.33	1.20	1.33	3	1	2

Date: 12/18/2018
 Project Name: EAST LYME NORTH
 Project Number: CT5737
 Designed By: JN Checked By: MSC



WIND LOADS

Angle = 90 (deg) Ice Thickness = 1.79 in. Equivalent Angle = 270 (deg)

WIND LOADS WITH NO ICE:

Appurtenances	Height	Width	Depth	Flat Area (normal)	Flat Area (side)	Ratio (normal)	Ratio (side)	Ca (normal)	Ca (side)	Force (lbs) (normal)	Force (lbs) (side)	Force (lbs) (angle)
7770 Antenna	55.0	11.0	5.0	4.20	1.91	5.00	11.00	1.31	1.53	214	114	114
800-10966 Antenna	96.0	20.0	6.9	13.33	4.60	4.80	13.91	1.30	1.63	674	291	291
800-10965 Antenna	78.7	20.0	6.9	10.93	3.77	3.94	11.41	1.26	1.55	537	227	227
B14 4478 RRH	18.1	13.4	8.3	1.68	1.04	1.35	2.18	1.20	1.20	79	49	49
B14 4478 RRH (Shielded)	18.1	0.0	8.3	0.00	1.04	0.00	2.18	1.20	1.20	0	49	49
B5/B12 4449 RRH	18.0	9.5	13.2	1.19	1.65	1.89	1.36	1.20	1.20	55	77	77
B5/B12 4449 RRH (Shielded)	18.0	4.8	13.2	0.59	1.65	3.79	1.36	1.26	1.20	29	77	77
B2/B66A 8843 RRH	14.9	10.9	13.2	1.13	1.37	1.37	1.13	1.20	1.20	53	64	64
B2/B66A 8843 RRH (Shielded)	14.9	5.5	13.2	0.56	1.37	2.73	1.13	1.21	1.20	27	64	64
LGP21401 TMA	14.4	9.0	2.7	0.90	0.27	1.60	5.33	1.20	1.33	42	14	14

WIND LOADS WITH ICE:

7770 Antenna	58.6	14.6	8.6	5.93	3.49	4.02	6.83	1.27	1.39	66	43	43
800-10966 Antenna	99.6	23.6	10.5	16.30	7.24	4.22	9.51	1.28	1.48	183	95	95
800-10965 Antenna	82.3	23.6	10.5	13.47	5.98	3.49	7.86	1.24	1.43	148	75	75
B14 4478 RRH	21.7	17.0	11.9	2.55	1.79	1.28	1.83	1.20	1.20	27	19	19
B14 4478 RRH (Shielded)	21.7	3.6	11.9	0.54	1.79	6.06	1.83	1.36	1.20	6	19	19
B5/B12 4449 RRH	21.6	13.1	16.8	1.96	2.51	1.65	1.29	1.20	1.20	21	27	27
B5/B12 4449 RRH (Shielded)	21.6	8.3	16.8	1.25	2.51	2.59	1.29	1.20	1.20	13	27	27
B2/B66A 8843 RRH	18.5	14.5	16.8	1.86	2.15	1.28	1.10	1.20	1.20	20	23	23
B2/B66A 8843 RRH (Shielded)	18.5	9.0	16.8	1.16	2.15	2.05	1.10	1.20	1.20	12	23	23
LGP21401 TMA	18.0	12.6	6.3	1.57	0.78	1.43	2.86	1.20	1.22	17	8	8

WIND LOADS AT 30 MPH:

7770 Antenna	55.0	11.0	5.0	4.20	1.91	5.00	11.00	1.31	1.53	17	9	9
800-10966 Antenna	96.0	20.0	6.9	13.33	4.60	4.80	13.91	1.30	1.63	55	24	24
800-10965 Antenna	78.7	20.0	6.9	10.93	3.77	3.94	11.41	1.26	1.55	44	18	18
B14 4478 RRH	18.1	13.4	8.3	1.68	1.04	1.35	2.18	1.20	1.20	6	4	4
B14 4478 RRH (Shielded)	18.1	0.0	8.3	0.00	1.04	0.00	2.18	1.20	1.20	0	4	4
B5/B12 4449 RRH	18.0	9.5	13.2	1.19	1.65	1.89	1.36	1.20	1.20	5	6	6
B5/B12 4449 RRH (Shielded)	18.0	4.8	13.2	0.59	1.65	3.79	1.36	1.26	1.20	2	6	6
B2/B66A 8843 RRH	14.9	10.9	13.2	1.13	1.37	1.37	1.13	1.20	1.20	4	5	5
B2/B66A 8843 RRH (Shielded)	14.9	5.5	13.2	0.56	1.37	2.73	1.13	1.21	1.20	2	5	5
LGP21401 TMA	14.4	9.0	2.7	0.90	0.27	1.60	5.33	1.20	1.33	3	1	1

Date: 12/18/2018
 Project Name: EAST LYME NORTH
 Project Number: CT5737
 Designed By: JN Checked By: MSC



WIND LOADS

Angle = 120 (deg)

Ice Thickness = 1.79 in.

Equivalent Angle = 300 (deg)

WIND LOADS WITH NO ICE:

Appurtenances	Height	Width	Depth	Flat Area (normal)	Flat Area (side)	Ratio (normal)	Ratio (side)	Ca (normal)	Ca (side)	Force (lbs) (normal)	Force (lbs) (side)	Force (lbs) (angle)
7770 Antenna	55.0	11.0	5.0	4.20	1.91	5.00	11.00	1.31	1.53	214	114	139
800-10966 Antenna	96.0	20.0	6.9	13.33	4.60	4.80	13.91	1.30	1.63	674	291	387
800-10965 Antenna	78.7	20.0	6.9	10.93	3.77	3.94	11.41	1.26	1.55	537	227	304
B14 4478 RRH	18.1	13.4	8.3	1.68	1.04	1.35	2.18	1.20	1.20	79	49	56
B14 4478 RRH (Shielde	18.1	10.1	8.3	1.26	1.04	1.80	2.18	1.20	1.20	59	49	51
B5/B12 4449 RRH	18.0	9.5	13.2	1.19	1.65	1.89	1.36	1.20	1.20	55	77	72
B5/B12 4449 RRH (Shi	18.0	7.1	13.2	0.89	1.65	2.53	1.36	1.20	1.20	42	77	68
B2/B66A 8843 RRH	14.9	10.9	13.2	1.13	1.37	1.37	1.13	1.20	1.20	53	64	61
B2/B66A 8843 RRH (Sh	14.9	8.2	13.2	0.85	1.37	1.82	1.13	1.20	1.20	39	64	58
LGP21401 TMA	14.4	9.0	2.7	0.90	0.27	1.60	5.33	1.20	1.33	42	14	21

WIND LOADS WITH ICE:

7770 Antenna	58.6	14.6	8.6	5.93	3.49	4.02	6.83	1.27	1.39	66	43	49
800-10966 Antenna	99.6	23.6	10.5	16.30	7.24	4.22	9.51	1.28	1.48	183	95	117
800-10965 Antenna	82.3	23.6	10.5	13.47	5.98	3.49	7.86	1.24	1.43	148	75	93
B14 4478 RRH	21.7	17.0	11.9	2.55	1.79	1.28	1.83	1.20	1.20	27	19	21
B14 4478 RRH (Shielde	21.7	12.7	11.9	1.92	1.79	1.70	1.83	1.20	1.20	20	19	19
B5/B12 4449 RRH	21.6	13.1	16.8	1.96	2.51	1.65	1.29	1.20	1.20	21	27	25
B5/B12 4449 RRH (Shi	21.6	9.8	16.8	1.47	2.51	2.20	1.29	1.20	1.20	16	27	24
B2/B66A 8843 RRH	18.5	14.5	16.8	1.86	2.15	1.28	1.10	1.20	1.20	20	23	22
B2/B66A 8843 RRH (Sh	18.5	10.9	16.8	1.39	2.15	1.70	1.10	1.20	1.20	15	23	21
LGP21401 TMA	18.0	12.6	6.3	1.57	0.78	1.43	2.86	1.20	1.22	17	8	10

WIND LOADS AT 30 MPH:

7770 Antenna	55.0	11.0	5.0	4.20	1.91	5.00	11.00	1.31	1.53	17	9	11
800-10966 Antenna	96.0	20.0	6.9	13.33	4.60	4.80	13.91	1.30	1.63	55	24	32
800-10965 Antenna	78.7	20.0	6.9	10.93	3.77	3.94	11.41	1.26	1.55	44	18	25
B14 4478 RRH	18.1	13.4	8.3	1.68	1.04	1.35	2.18	1.20	1.20	6	4	5
B14 4478 RRH (Shielde	18.1	10.1	8.3	1.26	1.04	1.80	2.18	1.20	1.20	5	4	4
B5/B12 4449 RRH	18.0	9.5	13.2	1.19	1.65	1.89	1.36	1.20	1.20	5	6	6
B5/B12 4449 RRH (Shi	18.0	7.1	13.2	0.89	1.65	2.53	1.36	1.20	1.20	3	6	6
B2/B66A 8843 RRH	14.9	10.9	13.2	1.13	1.37	1.37	1.13	1.20	1.20	4	5	5
B2/B66A 8843 RRH (Sh	14.9	8.2	13.2	0.85	1.37	1.82	1.13	1.20	1.20	3	5	5
LGP21401 TMA	14.4	9.0	2.7	0.90	0.27	1.60	5.33	1.20	1.33	3	1	2

Date: 12/18/2018
 Project Name: EAST LYME NORTH
 Project Number: CT5737
 Designed By: JN Checked By: MSC



WIND LOADS

Angle = 150 (deg)

Ice Thickness = 1.79 in.

Equivalent Angle = 330 (deg)

WIND LOADS WITH NO ICE:

Appurtenances	Height	Width	Depth	Flat Area (normal)	Flat Area (side)	Ratio (normal)	Ratio (side)	Ca (normal)	Ca (side)	Force (lbs) (normal)	Force (lbs) (side)	Force (lbs) (angle)
7770 Antenna	55.0	11.0	5.0	4.20	1.91	5.00	11.00	1.31	1.53	214	114	189
800-10966 Antenna	96.0	20.0	6.9	13.33	4.60	4.80	13.91	1.30	1.63	674	291	579
800-10965 Antenna	78.7	20.0	6.9	10.93	3.77	3.94	11.41	1.26	1.55	537	227	459
B14 4478 RRH	18.1	13.4	8.3	1.68	1.04	1.35	2.18	1.20	1.20	79	49	71
B14 4478 RRH (Shielde	18.1	6.7	8.3	0.84	1.04	2.70	2.18	1.21	1.20	40	49	42
B5/B12 4449 RRH	18.0	9.5	13.2	1.19	1.65	1.89	1.36	1.20	1.20	55	77	61
B5/B12 4449 RRH (Shi	18.0	4.8	13.2	0.59	1.65	3.79	1.36	1.26	1.20	29	77	41
B2/B66A 8843 RRH	14.9	10.9	13.2	1.13	1.37	1.37	1.13	1.20	1.20	53	64	55
B2/B66A 8843 RRH (Sh	14.9	5.5	13.2	0.56	1.37	2.73	1.13	1.21	1.20	27	64	36
LGP21401 TMA	14.4	9.0	2.7	0.90	0.27	1.60	5.33	1.20	1.33	42	14	35

WIND LOADS WITH ICE:

7770 Antenna	58.6	14.6	8.6	5.93	3.49	4.02	6.83	1.27	1.39	66	43	60
800-10966 Antenna	99.6	23.6	10.5	16.30	7.24	4.22	9.51	1.28	1.48	183	95	161
800-10965 Antenna	82.3	23.6	10.5	13.47	5.98	3.49	7.86	1.24	1.43	148	75	130
B14 4478 RRH	21.7	17.0	11.9	2.55	1.79	1.28	1.83	1.20	1.20	27	19	25
B14 4478 RRH (Shielde	21.7	8.5	11.9	1.28	1.79	2.55	1.83	1.20	1.20	14	19	15
B5/B12 4449 RRH	21.6	13.1	16.8	1.96	2.51	1.65	1.29	1.20	1.20	21	27	22
B5/B12 4449 RRH (Shi	21.6	6.5	16.8	0.98	2.51	3.30	1.29	1.24	1.20	11	27	15
B2/B66A 8843 RRH	18.5	14.5	16.8	1.86	2.15	1.28	1.10	1.20	1.20	20	23	20
B2/B66A 8843 RRH (Sh	18.5	7.2	16.8	0.93	2.15	2.55	1.10	1.20	1.20	10	23	13
LGP21401 TMA	18.0	12.6	6.3	1.57	0.78	1.43	2.86	1.20	1.22	17	8	15

WIND LOADS AT 30 MPH:

7770 Antenna	55.0	11.0	5.0	4.20	1.91	5.00	11.00	1.31	1.53	17	9	15
800-10966 Antenna	96.0	20.0	6.9	13.33	4.60	4.80	13.91	1.30	1.63	55	24	47
800-10965 Antenna	78.7	20.0	6.9	10.93	3.77	3.94	11.41	1.26	1.55	44	18	37
B14 4478 RRH	18.1	13.4	8.3	1.68	1.04	1.35	2.18	1.20	1.20	6	4	6
B14 4478 RRH (Shielde	18.1	6.7	8.3	0.84	1.04	2.70	2.18	1.21	1.20	3	4	3
B5/B12 4449 RRH	18.0	9.5	13.2	1.19	1.65	1.89	1.36	1.20	1.20	5	6	5
B5/B12 4449 RRH (Shi	18.0	4.8	13.2	0.59	1.65	3.79	1.36	1.26	1.20	2	6	3
B2/B66A 8843 RRH	14.9	10.9	13.2	1.13	1.37	1.37	1.13	1.20	1.20	4	5	5
B2/B66A 8843 RRH (Sh	14.9	5.5	13.2	0.56	1.37	2.73	1.13	1.21	1.20	2	5	3
LGP21401 TMA	14.4	9.0	2.7	0.90	0.27	1.60	5.33	1.20	1.33	3	1	3

Date: 12/18/2018
 Project Name: EAST LYME NORTH
 Project Number: CT5737
 Designed By: JN Checked By: MSC



ICE WEIGHT CALCULATIONS

Thickness of ice: 1.79 in.
 Density of ice: 56 pcf

7770 Antenna

Weight of ice based on total radial SF area:
 Height (in): 55.0
 Width (in): 11.0
 Depth (in): 5.0
 Total weight of ice on object: 139 lbs
 Weight of object: 35 lbs
Combined weight of ice and object: 174 lbs

800-10966 Antenna

Weight of ice based on total radial SF area:
 Height (in): 96.0
 Width (in): 20.0
 Depth (in): 6.9
 Total weight of ice on object: 401 lbs
 Weight of object: 115 lbs
Combined weight of ice and object: 516 lbs

800-10965 Antenna

Weight of ice based on total radial SF area:
 Height (in): 78.7
 Width (in): 20.0
 Depth (in): 6.9
 Total weight of ice on object: 329 lbs
 Weight of object: 109 lbs
Combined weight of ice and object: 438 lbs

B14 4478 RRH

Weight of ice based on total radial SF area:
 Height (in): 18.1
 Width (in): 13.4
 Depth (in): 8.3
 Total weight of ice on object: 58 lbs
 Weight of object: 60 lbs
Combined weight of ice and object: 118 lbs

B5/B12 4449 RRH

Weight of ice based on total radial SF area:
 Height (in): 18.0
 Width (in): 13.2
 Depth (in): 9.5
 Total weight of ice on object: 59 lbs
 Weight of object: 71 lbs
Combined weight of ice and object: 130 lbs

B2/B66A 8843 RRH

Weight of ice based on total radial SF area:
 Height (in): 14.9
 Width (in): 13.2
 Depth (in): 10.9
 Total weight of ice on object: 51 lbs
 Weight of object: 72 lbs
Combined weight of ice and object: 123 lbs

LGP21401 TMA

Weight of ice based on total radial SF area:
 Height (in): 14.4
 Width (in): 9.0
 Depth (in): 2.7
 Total weight of ice on object: 29 lbs
 Weight of object: 19 lbs
Combined weight of ice and object: 48 lbs

Squid Surge Arrestor

Weight of ice based on total radial SF area:
 Depth (in): 24.0
 Diameter(in): 9.7
 Total weight of ice on object: 50 lbs
 Weight of object: 33 lbs
Combined weight of ice and object: 83 lbs

3/4" Round Bar

Per foot weight of ice:
 diameter (in): 0.75
Per foot weight of ice on object: 6 plf

2" pipe

Per foot weight of ice:
 diameter (in): 2.38
Per foot weight of ice on object: 9 plf

2-1/2" pipe

Per foot weight of ice:
 diameter (in): 2.88
Per foot weight of ice on object: 10 plf



HUDSON
Design Group LLC

**Mount Calculations
(Proposed Conditions)**

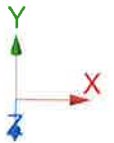
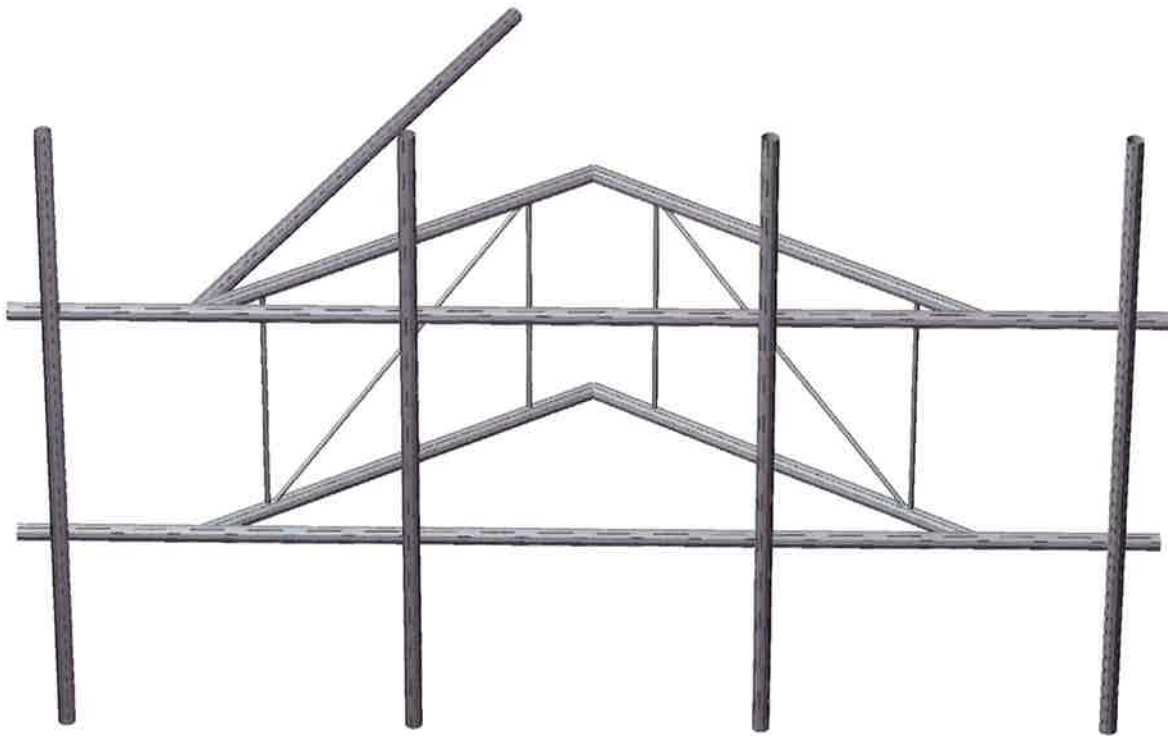

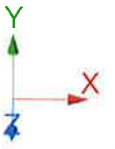
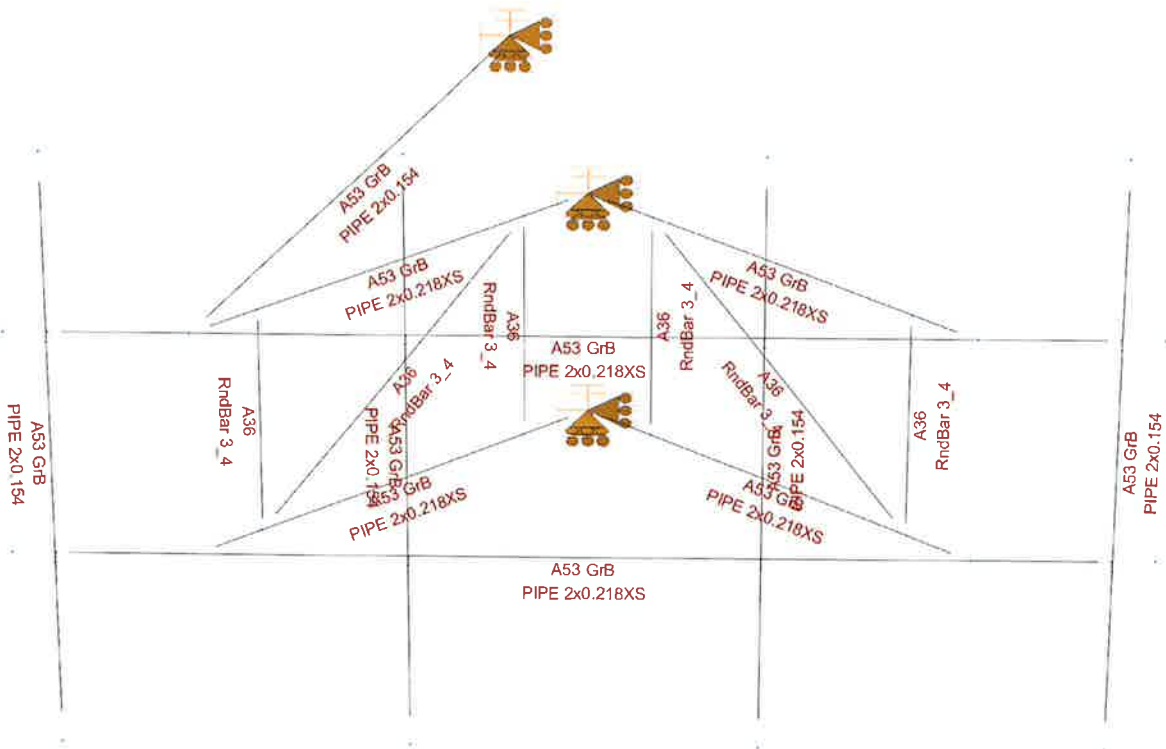

Design status

- Not designed
- Error on design
- Design O.K.
- With warnings

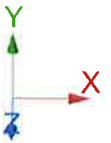
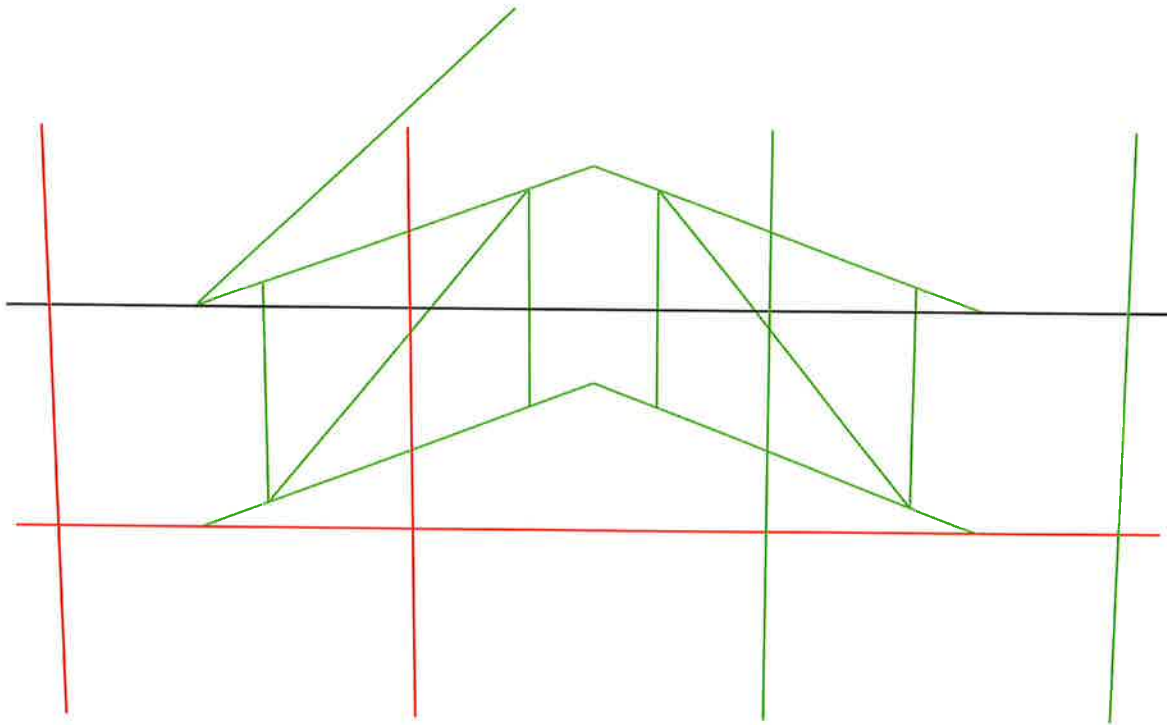

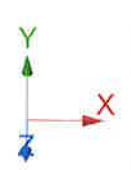
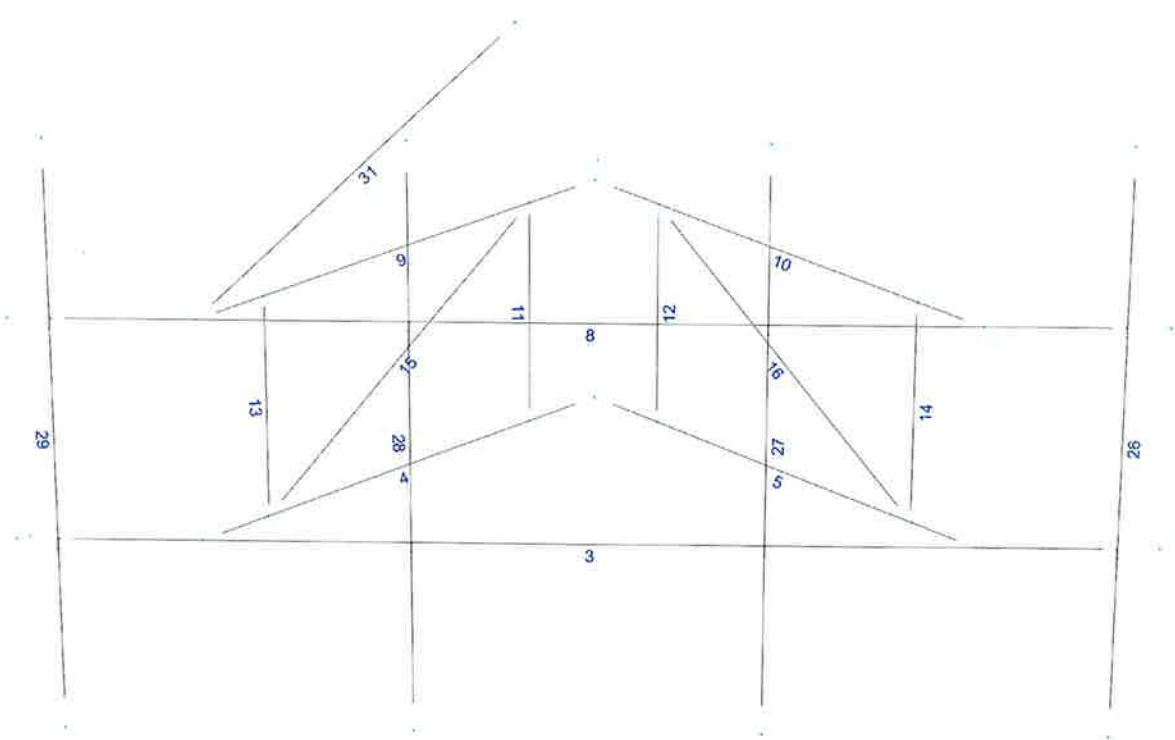

Current Date: 12/18/2018 3:07 PM

Units system: English

File name: W:\STRUCTURAL DEPARTMENT\ANALYSIS SOFTWARE\RAM Elements\RAM Projects\AT&T\CT\CT5737\LTE 2C-3C-4C-5C\CT5737 (LT 2C-3C-4C-5C).etx\

Load data

GLOSSARY

Comb : Indicates if load condition is a load combination

Load Conditions

Condition	Description	Comb.	Category
D	Dead Load	No	DL
Wo	Wind Load (NO ICE)	No	WIND
W30	WL 30deg	No	WIND
W60	WL 60deg	No	WIND
W90	WL 90deg	No	WIND
W120	WL 120deg	No	WIND
W150	WL 150deg	No	WIND
Di	Ice Load	No	LL
WI0	WL ICE 0deg	No	WIND
WI30	WL ICE 30deg	No	WIND
WI60	WL ICE 60deg	No	WIND
WI90	WL ICE 90deg	No	WIND
WI120	WL ICE 120deg	No	WIND
WI150	WL ICE 150deg	No	WIND
WL0	WL 30 mph 0deg	No	WIND
WL30	WL 30 mph 30deg	No	WIND
WL60	WL 30 mph 60deg	No	WIND
WL90	WL 30 mph 90deg	No	WIND
WL120	WL 30 mph 120deg	No	WIND
WL150	WL 30 mph 150deg	No </td <td>WIND</td>	WIND
LL1	250 lb Live Load on Left End	No	LL
LL2	250 lb Live Load on Center	No	LL
LL3	250 lb Live Load on Right End	No	LL
LLa1	250 lb Live Load on Antenna 1	No	LL
LLa2	250 lb Live Load on Antenna 2	No	LL
LLa3	250 lb Live Load on Antenna 3	No	LL

Distributed force on members

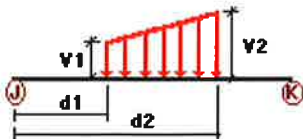

Condition	Member	Dir1	Val1 [Kip/ft]	Val2 [Kip/ft]	Dist1 [ft]	%	Dist2 [ft]	%
Wo	3	z	-0.009	0.00	0.00	No	0.00	No
	4	z	-0.009	0.00	0.00	No	0.00	No
	5	z	-0.009	0.00	0.00	No	0.00	No
	8	z	-0.009	0.00	0.00	No	0.00	No
	9	z	-0.009	0.00	0.00	No	0.00	No
	10	z	-0.009	0.00	0.00	No	0.00	No
	11	z	-0.003	0.00	0.00	No	0.00	No
	12	z	-0.003	0.00	0.00	No	0.00	No
	13	z	-0.003	0.00	0.00	No	0.00	No
	14	z	-0.003	0.00	0.00	No	0.00	No
	15	z	-0.003	0.00	0.00	No	0.00	No
	16	z	-0.003	0.00	0.00	No	0.00	No
	27	z	-0.009	0.00	0.00	No	0.00	No
	31	z	-0.009	0.00	0.00	No	0.00	No
W30	3	z	-0.009	0.00	0.00	No	0.00	No
	4	z	-0.009	0.00	0.00	No	0.00	No
	5	z	-0.009	0.00	0.00	No	0.00	No
	8	z	-0.009	0.00	0.00	No	0.00	No
	9	z	-0.009	0.00	0.00	No	0.00	No
	10	z	-0.009	0.00	0.00	No	0.00	No
	11	z	-0.003	0.00	0.00	No	0.00	No
	12	z	-0.003	0.00	0.00	No	0.00	No
	13	z	-0.003	0.00	0.00	No	0.00	No
	14	z	-0.003	0.00	0.00	No	0.00	No
	15	z	-0.003	0.00	0.00	No	0.00	No
	16	z	-0.003	0.00	0.00	No	0.00	No
	26	z	-0.009	0.00	0.00	No	0.00	No
	27	z	-0.009	0.00	0.00	No	0.00	No
28	z	-0.009	0.00	0.00	No	0.00	No	
29	z	-0.009	0.00	0.00	No	0.00	No	
31	z	-0.009	0.00	0.00	No	0.00	No	
W60	3	x	-0.009	0.00	0.00	No	0.00	No
	4	x	-0.009	0.00	0.00	No	0.00	No
	5	x	-0.009	0.00	0.00	No	0.00	No
	8	x	-0.009	0.00	0.00	No	0.00	No
	9	x	-0.009	0.00	0.00	No	0.00	No
	10	x	-0.009	0.00	0.00	No	0.00	No
	11	x	-0.003	0.00	0.00	No	0.00	No
	12	x	-0.003	0.00	0.00	No	0.00	No
	13	x	-0.003	0.00	0.00	No	0.00	No
	14	x	-0.003	0.00	0.00	No	0.00	No
	15	x	-0.003	0.00	0.00	No	0.00	No
	16	x	-0.003	0.00	0.00	No	0.00	No
	26	x	-0.009	0.00	0.00	No	0.00	No
	27	x	-0.009	0.00	0.00	No	0.00	No
28	x	-0.009	0.00	0.00	No	0.00	No	
29	x	-0.009	0.00	0.00	No	0.00	No	
31	x	-0.009	0.00	0.00	No	0.00	No	
W90	4	x	-0.009	0.00	0.00	No	0.00	No
	5	x	-0.009	0.00	0.00	No	0.00	No
	9	x	-0.009	0.00	0.00	No	0.00	No
	10	x	-0.009	0.00	0.00	No	0.00	No
	11	x	-0.003	0.00	0.00	No	0.00	No
	12	x	-0.003	0.00	0.00	No	0.00	No
	13	x	-0.003	0.00	0.00	No	0.00	No
	14	x	-0.003	0.00	0.00	No	0.00	No
	15	x	-0.003	0.00	0.00	No	0.00	No
	16	x	-0.003	0.00	0.00	No	0.00	No
	26	x	-0.009	0.00	0.00	No	0.00	No
27	x	-0.009	0.00	0.00	No	0.00	No	

	28	x	-0.009	0.00	0.00	No	0.00	No
	29	x	-0.009	0.00	0.00	No	0.00	No
	31	x	-0.009	0.00	0.00	No	0.00	No
W120	3	x	-0.009	0.00	0.00	No	0.00	No
	4	x	-0.009	0.00	0.00	No	0.00	No
	5	x	-0.009	0.00	0.00	No	0.00	No
	8	x	-0.009	0.00	0.00	No	0.00	No
	9	x	-0.009	0.00	0.00	No	0.00	No
	10	x	-0.009	0.00	0.00	No	0.00	No
	11	x	-0.003	0.00	0.00	No	0.00	No
	12	x	-0.003	0.00	0.00	No	0.00	No
	13	x	-0.003	0.00	0.00	No	0.00	No
	14	x	-0.003	0.00	0.00	No	0.00	No
	15	x	-0.003	0.00	0.00	No	0.00	No
	16	x	-0.003	0.00	0.00	No	0.00	No
	26	x	-0.009	0.00	0.00	No	0.00	No
	27	x	-0.009	0.00	0.00	No	0.00	No
	28	x	-0.009	0.00	0.00	No	0.00	No
	29	x	-0.009	0.00	0.00	No	0.00	No
	31	x	-0.009	0.00	0.00	No	0.00	No
W150	3	z	0.009	0.00	0.00	No	0.00	No
	4	z	0.009	0.00	0.00	No	0.00	No
	5	z	0.009	0.00	0.00	No	0.00	No
	8	z	0.009	0.00	0.00	No	0.00	No
	9	z	0.009	0.00	0.00	No	0.00	No
	10	z	0.009	0.00	0.00	No	0.00	No
	11	z	0.003	0.00	0.00	No	0.00	No
	12	z	0.003	0.00	0.00	No	0.00	No
	13	z	0.003	0.00	0.00	No	0.00	No
	14	z	0.003	0.00	0.00	No	0.00	No
	15	z	0.003	0.00	0.00	No	0.00	No
	16	z	0.003	0.00	0.00	No	0.00	No
	26	z	0.009	0.00	0.00	No	0.00	No
	27	z	0.009	0.00	0.00	No	0.00	No
	28	z	0.009	0.00	0.00	No	0.00	No
	29	z	0.009	0.00	0.00	No	0.00	No
	31	z	0.009	0.00	0.00	No	0.00	No
Di	3	y	-0.009	0.00	0.00	No	0.00	No
	4	y	-0.009	0.00	0.00	No	0.00	No
	5	y	-0.009	0.00	0.00	No	0.00	No
	8	y	-0.009	0.00	0.00	No	0.00	No
	9	y	-0.009	0.00	0.00	No	0.00	No
	10	y	-0.009	0.00	0.00	No	0.00	No
	11	y	-0.006	0.00	0.00	No	0.00	No
	12	y	-0.006	0.00	0.00	No	0.00	No
	13	y	-0.006	0.00	0.00	No	0.00	No
	14	y	-0.006	0.00	0.00	No	0.00	No
	15	y	-0.006	0.00	0.00	No	0.00	No
	16	y	-0.006	0.00	0.00	No	0.00	No
	26	y	-0.009	0.00	0.00	No	0.00	No
	27	y	-0.009	0.00	0.00	No	0.00	No
	28	y	-0.009	0.00	0.00	No	0.00	No
	29	y	-0.009	0.00	0.00	No	0.00	No
	31	y	-0.009	0.00	0.00	No	0.00	No

Concentrated forces on members

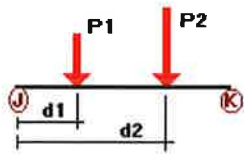

Condition	Member	Dir1	Value1 [Kip]	Dist1 [ft]	%
D	26	y	-0.018	2.00	No
		y	-0.018	6.00	No
		y	-0.038	4.50	No
	28	y	-0.058	0.50	No
		y	-0.058	7.50	No
		y	-0.06	1.50	No
	29	y	-0.058	0.50	No
		y	-0.058	7.50	No
		y	-0.071	1.25	No
Wo	26	y	-0.072	1.75	No
		z	-0.107	2.00	No
		z	-0.107	6.00	No
	28	z	-0.338	0.50	No
		z	-0.338	7.50	No
		z	-0.338	0.50	No
	29	z	-0.338	7.50	No
		z	-0.029	1.25	No
		z	-0.027	1.75	No
W30	26	2	-0.095	2.00	No
		2	-0.095	6.00	No
		2	-0.035	4.50	No
	28	2	-0.29	0.50	No
		2	-0.29	7.50	No
		2	-0.042	1.50	No
	29	2	-0.29	0.50	No
		2	-0.29	7.50	No
		2	-0.041	1.25	No
W60	26	2	-0.07	2.00	No
		2	-0.07	6.00	No
		2	-0.021	4.50	No
	28	2	-0.194	0.50	No
		2	-0.194	7.50	No
		2	-0.051	1.50	No
	29	2	-0.194	0.50	No
		2	-0.194	7.50	No
		2	-0.068	1.25	No
W90	26	x	-0.057	2.00	No
		x	-0.057	6.00	No
		x	-0.014	4.50	No
	28	x	-0.146	0.50	No
		x	-0.146	7.50	No
		x	-0.049	1.50	No
	29	x	-0.146	0.50	No
		x	-0.146	7.50	No
		x	-0.077	1.25	No
W120	26	3	0.07	2.00	No
		3	0.07	6.00	No
		3	0.021	4.50	No
	28	3	0.194	0.50	No
		3	0.194	7.50	No
		3	0.051	1.50	No
	29	3	0.194	0.50	No
		3	0.194	7.50	No
		3	0.068	1.25	No

W150	26	3	0.095	2.00	No
		3	0.095	6.00	No
		3	0.035	4.50	No
	28	3	0.29	0.50	No
		3	0.29	7.50	No
		3	0.042	1.50	No
	29	3	0.29	0.50	No
		3	0.29	7.50	No
		3	0.041	1.25	No
Di	26	y	-0.07	2.00	No
		y	-0.07	6.00	No
		y	-0.058	4.50	No
	28	y	-0.201	0.50	No
		y	-0.201	7.50	No
		y	-0.058	1.50	No
	29	y	-0.201	0.50	No
		y	-0.201	7.50	No
		y	-0.059	1.25	No
W10	26	z	-0.051	1.75	No
		z	-0.035	2.00	No
		z	-0.035	6.00	No
	28	z	-0.017	4.50	No
		z	-0.094	0.50	No
		z	-0.094	7.50	No
	29	z	-0.027	1.50	No
		z	-0.094	0.50	No
		z	-0.094	7.50	No
W130	26	z	-0.021	1.25	No
		z	-0.02	1.75	No
		2	-0.031	2.00	No
	28	2	-0.031	6.00	No
		2	-0.015	4.50	No
		2	-0.081	0.50	No
	29	2	-0.081	7.50	No
		2	-0.025	1.50	No
		2	-0.081	0.50	No
W160	26	2	-0.081	7.50	No
		2	-0.022	1.25	No
		2	-0.025	2.00	No
	28	2	-0.025	6.00	No
		2	-0.01	4.50	No
		2	-0.059	0.50	No
	29	2	-0.059	7.50	No
		2	-0.021	1.50	No
		2	-0.059	0.50	No
W190	26	2	-0.059	7.50	No
		2	-0.025	1.25	No
		x	-0.022	2.00	No
	28	x	-0.022	6.00	No
		x	-0.008	4.50	No
		x	-0.048	0.50	No
	29	x	-0.048	7.50	No
		x	-0.019	1.50	No
		x	-0.048	0.50	No
W1120	26	x	-0.048	7.50	No
		x	-0.027	1.25	No
		3	0.025	2.00	No
	28	3	0.025	6.00	No
		3	0.01	4.50	No
3	0.059	0.50	No		

		3	0.059	7.50	No
		3	0.021	1.50	No
	29	3	0.059	0.50	No
		3	0.059	7.50	No
		3	0.025	1.25	No
WI150	26	3	0.031	2.00	No
		3	0.031	6.00	No
		3	0.015	4.50	No
	28	3	0.081	0.50	No
		3	0.081	7.50	No
		3	0.025	1.50	No
	29	3	0.081	0.50	No
		3	0.081	7.50	No
		3	0.022	1.25	No
WL0	26	z	-0.009	2.00	No
		z	-0.009	6.00	No
		z	-0.004	4.50	No
	28	z	-0.028	0.50	No
		z	-0.028	7.50	No
		z	-0.007	1.50	No
	29	z	-0.028	0.50	No
		z	-0.028	7.50	No
		z	-0.005	1.25	No
		z	-0.005	1.75	No
WL30	26	2	-0.008	2.00	No
		2	-0.008	6.00	No
		2	-0.003	4.50	No
	28	2	-0.024	0.50	No
		2	-0.024	7.50	No
		2	-0.006	1.50	No
	29	2	-0.024	0.50	No
		2	-0.024	7.50	No
		2	-0.005	1.25	No
WL60	26	2	-0.006	2.00	No
		2	-0.006	6.00	No
		2	-0.002	4.50	No
	28	2	-0.016	0.50	No
		2	-0.016	7.50	No
		2	-0.005	1.50	No
	29	2	-0.016	0.50	No
		2	-0.016	7.50	No
		2	-0.006	1.25	No
WL90	26	x	-0.005	2.00	No
		x	-0.005	6.00	No
		x	-0.002	4.50	No
	28	x	-0.012	0.50	No
		x	-0.012	7.50	No
		x	-0.004	1.50	No
	29	x	-0.012	0.50	No
		x	-0.012	7.50	No
		x	-0.007	1.25	No
WL120	26	3	0.006	2.00	No
		3	0.006	6.00	No
		3	0.002	4.50	No
	28	3	0.016	0.50	No
		3	0.016	7.50	No
		3	0.005	1.50	No
	29	3	0.016	0.50	No
		3	0.016	7.50	No
		3	0.006	1.25	No

WL150	26	3	0.008	2.00	No
		3	0.008	6.00	No
		3	0.003	4.50	No
	28	3	0.024	0.50	No
		3	0.024	7.50	No
		3	0.006	1.50	No
	29	3	0.024	0.50	No
		3	0.024	7.50	No
		3	0.005	1.25	No
LL1	8	y	-0.25	0.00	Yes
LL2	8	y	-0.25	50.00	Yes
LL3	8	y	-0.25	100.00	Yes
LLa1	26	y	-0.25	50.00	Yes
LLa2	28	y	-0.25	50.00	Yes
LLa3	29	y	-0.25	50.00	Yes

Self weight multipliers for load conditions

Condition	Description	Self weight multiplier			
		Comb.	MultX	MultY	MultZ
D	Dead Load	No	0.00	-1.00	0.00
Wo	Wind Load (NO ICE)	No	0.00	0.00	0.00
W30	WL 30deg	No	0.00	0.00	0.00
W60	WL 60deg	No	0.00	0.00	0.00
W90	WL 90deg	No	0.00	0.00	0.00
W120	WL 120deg	No	0.00	0.00	0.00
W150	WL 150deg	No	0.00	0.00	0.00
Di	Ice Load	No	0.00	0.00	0.00
WI0	WL ICE 0deg	No	0.00	0.00	0.00
WI30	WL ICE 30deg	No	0.00	0.00	0.00
WI60	WL ICE 60deg	No	0.00	0.00	0.00
WI90	WL ICE 90deg	No	0.00	0.00	0.00
WI120	WL ICE 120deg	No	0.00	0.00	0.00
WI150	WL ICE 150deg	No	0.00	0.00	0.00
WL0	WL 30 mph 0deg	No	0.00	0.00	0.00
WL30	WL 30 mph 30deg	No	0.00	0.00	0.00
WL60	WL 30 mph 60deg	No	0.00	0.00	0.00
WL90	WL 30 mph 90deg	No	0.00	0.00	0.00
WL120	WL 30 mph 120deg	No	0.00	0.00	0.00
WL150	WL 30 mph 150deg	No	0.00	0.00	0.00
LL1	250 lb Live Load on Left End	No	0.00	0.00	0.00
LL2	250 lb Live Load on Center	No	0.00	0.00	0.00
LL3	250 lb Live Load on Right End	No	0.00	0.00	0.00
LLa1	250 lb Live Load on Antenna 1	No	0.00	0.00	0.00
LLa2	250 lb Live Load on Antenna 2	No	0.00	0.00	0.00
LLa3	250 lb Live Load on Antenna 3	No	0.00	0.00	0.00

Earthquake (Dynamic analysis only)

Condition	a/g	Ang. [Deg]	Damp. [%]
D	0.00	0.00	0.00
Wo	0.00	0.00	0.00
W30	0.00	0.00	0.00
W60	0.00	0.00	0.00
W90	0.00	0.00	0.00
W120	0.00	0.00	0.00
W150	0.00	0.00	0.00
Di	0.00	0.00	0.00
WI0	0.00	0.00	0.00
WI30	0.00	0.00	0.00
WI60	0.00	0.00	0.00
WI90	0.00	0.00	0.00
WI120	0.00	0.00	0.00
WI150	0.00	0.00	0.00
WL0	0.00	0.00	0.00
WL30	0.00	0.00	0.00
WL60	0.00	0.00	0.00
WL90	0.00	0.00	0.00
WL120	0.00	0.00	0.00
WL150	0.00	0.00	0.00
LL1	0.00	0.00	0.00
LL2	0.00	0.00	0.00
LL3	0.00	0.00	0.00
LLa1	0.00	0.00	0.00
LLa2	0.00	0.00	0.00
LLa3	0.00	0.00	0.00

Current Date: 12/18/2018 3:07 PM

Units system: English

File name: W:\STRUCTURAL DEPARTMENT\ANALYSIS SOFTWARE\RAM Elements\RAM Projects\AT&T\CT\CT5737\LTE 2C-3C-4C-5C\CT5737 (LT 2C-3C-4C-5C).etx\

Steel Code Check

Report: Summary - Group by member

Load conditions to be included in design :

LC1=1.2D+1.6Wo
LC2=1.2D+1.6W30
LC3=1.2D+1.6W60
LC4=1.2D+1.6W90
LC5=1.2D+1.6W120
LC6=1.2D+1.6W150
LC7=1.2D-1.6Wo
LC8=1.2D-1.6W30
LC9=1.2D-1.6W60
LC10=1.2D-1.6W90
LC11=1.2D-1.6W120
LC12=1.2D-1.6W150
LC13=0.9D+1.6Wo
LC14=0.9D+1.6W30
LC15=0.9D+1.6W60
LC16=0.9D+1.6W90
LC17=0.9D+1.6W120
LC18=0.9D+1.6W150
LC19=0.9D-1.6Wo
LC20=0.9D-1.6W30
LC21=0.9D-1.6W60
LC22=0.9D-1.6W90
LC23=0.9D-1.6W120
LC24=0.9D-1.6W150
LC25=1.2D+Di+W10
LC26=1.2D+Di+W130
LC27=1.2D+Di+W160
LC28=1.2D+Di+W190
LC29=1.2D+Di+W1120
LC30=1.2D+Di+W1150
LC31=1.2D+Di-W10
LC32=1.2D+Di-W130
LC33=1.2D+Di-W160
LC34=1.2D+Di-W190
LC35=1.2D+Di-W1120
LC36=1.2D+Di-W1150
LC37=0.9D
LC38=1.2D+1.6LL1
LC39=1.2D+1.6LL2
LC40=1.2D+1.6LL3
LC41=1.2D+W10+LLa1
LC42=1.2D+W130+LLa1
LC43=1.2D+W160+LLa1
LC44=1.2D+W190+LLa1
LC45=1.2D+W1120+LLa1
LC46=1.2D+W1150+LLa1
LC47=1.2D-W10+LLa1
LC48=1.2D-W130+LLa1
LC49=1.2D-W160+LLa1
LC50=1.2D-W190+LLa1
LC51=1.2D-W1120+LLa1
LC52=1.2D-W1150+LLa1

LC53=1.2D+WL0+LLa2
 LC54=1.2D+WL30+LLa2
 LC55=1.2D+WL60+LLa2
 LC56=1.2D+WL90+LLa2
 LC57=1.2D+WL120+LLa2
 LC58=1.2D+WL150+LLa2
 LC59=1.2D-WL0+LLa2
 LC60=1.2D-WL30+LLa2
 LC61=1.2D-WL60+LLa2
 LC62=1.2D-WL90+LLa2
 LC63=1.2D-WL120+LLa2
 LC64=1.2D-WL150+LLa2
 LC65=1.2D+WL0+LLa3
 LC66=1.2D+WL30+LLa3
 LC67=1.2D+WL60+LLa3
 LC68=1.2D+WL90+LLa3
 LC69=1.2D+WL120+LLa3
 LC70=1.2D+WL150+LLa3
 LC71=1.2D-WL0+LLa3
 LC72=1.2D-WL30+LLa3
 LC73=1.2D-WL60+LLa3
 LC74=1.2D-WL90+LLa3
 LC75=1.2D-WL120+LLa3
 LC76=1.2D-WL150+LLa3

Description	Section	Member	Ctrl Eq.	Ratio	Status	Reference
	PIPE 2x0.154	26	LC40 at 31.25%	0.36	OK	Eq. H1-1b
		27	LC2 at 31.25%	0.39	OK	Eq. H1-1b
		28	LC7 at 68.75%	1.23	N.G.	Eq. H1-1b
		29	LC1 at 68.75%	1.23	N.G.	Eq. H1-1b
		31	LC3 at 0.00%	0.39	OK	Eq. H1-1a
	PIPE 2x0.218XS	3	LC7 at 16.96%	1.09	N.G.	Eq. H1-1a
		4	LC7 at 0.00%	0.48	OK	Eq. H1-1b
		5	LC2 at 100.00%	0.37	OK	Eq. H1-1b
		8	LC1 at 16.96%	0.87	With warnings	Eq. H1-1b
		9	LC31 at 100.00%	0.47	OK	Eq. H1-1b
		10	LC26 at 100.00%	0.23	OK	Eq. H1-1b
	RndBar 3_4	11	LC31 at 0.00%	0.59	OK	Eq. H1-1a
		12	LC40 at 100.00%	0.27	OK	Eq. H1-1a
		13	LC25 at 100.00%	0.85	OK	Eq. H1-1a
		14	LC26 at 0.00%	0.34	OK	Eq. H1-1a
		15	LC25 at 100.00%	0.49	OK	Eq. H1-1a
		16	LC25 at 100.00%	0.18	OK	Eq. H1-1b

Current Date: 12/18/2018 3:07 PM

Units system: English

File name: W:\STRUCTURAL DEPARTMENT\ANALYSIS SOFTWARE\RAM Elements\RAM Projects\AT&T\CT\CT5737\LTE 2C-3C-4C-5C\CT5737 (LT 2C-3C-4C-5C).etx\

Geometry data

GLOSSARY

Cb22, Cb33	: Moment gradient coefficients
Cm22, Cm33	: Coefficients applied to bending term in interaction formula
d0	: Tapered member section depth at J end of member
DJX	: Rigid end offset distance measured from J node in axis X
DJY	: Rigid end offset distance measured from J node in axis Y
DJZ	: Rigid end offset distance measured from J node in axis Z
DKX	: Rigid end offset distance measured from K node in axis X
DKY	: Rigid end offset distance measured from K node in axis Y
DKZ	: Rigid end offset distance measured from K node in axis Z
dL	: Tapered member section depth at K end of member
Ig factor	: Inertia reduction factor (Effective Inertia/Gross Inertia) for reinforced concrete members
K22	: Effective length factor about axis 2
K33	: Effective length factor about axis 3
L22	: Member length for calculation of axial capacity
L33	: Member length for calculation of axial capacity
LB pos	: Lateral unbraced length of the compression flange in the positive side of local axis 2
LB neg	: Lateral unbraced length of the compression flange in the negative side of local axis 2
RX	: Rotation about X
RY	: Rotation about Y
RZ	: Rotation about Z
TO	: 1 = Tension only member 0 = Normal member
TX	: Translation in X
TY	: Translation in Y
TZ	: Translation in Z

Nodes

Node	X [ft]	Y [ft]	Z [ft]	Rigid Floor
2	6.50	0.00	0.00	0
3	-6.50	0.00	0.00	0
8	-4.40	0.00	0.00	0
9	4.40	0.00	0.00	0
10	0.00	0.00	-3.00	0
11	-3.6667	0.00	-0.50	0
12	3.6667	0.00	-0.50	0
13	0.7333	0.00	-2.50	0
14	-0.7333	0.00	-2.50	0
16	6.50	3.00	0.00	0
17	-6.50	3.00	0.00	0
22	-4.40	3.00	0.00	0
23	4.40	3.00	0.00	0
24	0.00	3.00	-3.00	0
25	-3.6667	3.00	-0.50	0
26	3.6667	3.00	-0.50	0
27	0.7333	3.00	-2.50	0
28	-0.7333	3.00	-2.50	0
33	-6.00	5.50	0.20	0
34	6.00	5.50	0.20	0
35	-6.00	-2.50	0.20	0

36	6.00	-2.50	0.20	0
42	2.00	5.50	0.20	0
43	2.00	-2.50	0.20	0
48	-2.00	5.50	0.20	0
49	-2.00	-2.50	0.20	0
51	-1.00	3.00	-6.50	0

Restraints

Node	TX	TY	TZ	RX	RY	RZ
10	1	1	1	1	1	1
24	1	1	1	1	1	1
51	1	1	1	1	1	1

Members

Member	NJ	NK	Description	Section	Material	d0 [in]	dL [in]	Ig factor
3	3	2		PIPE 2x0.218XS	A53 GrB	0.00	0.00	0.00
4	8	10		PIPE 2x0.218XS	A53 GrB	0.00	0.00	0.00
5	9	10		PIPE 2x0.218XS	A53 GrB	0.00	0.00	0.00
8	17	16		PIPE 2x0.218XS	A53 GrB	0.00	0.00	0.00
9	22	24		PIPE 2x0.218XS	A53 GrB	0.00	0.00	0.00
10	23	24		PIPE 2x0.218XS	A53 GrB	0.00	0.00	0.00
11	14	28		RndBar 3_4	A36	0.00	0.00	0.00
12	27	13		RndBar 3_4	A36	0.00	0.00	0.00
13	25	11		RndBar 3_4	A36	0.00	0.00	0.00
14	12	26		RndBar 3_4	A36	0.00	0.00	0.00
15	28	11		RndBar 3_4	A36	0.00	0.00	0.00
16	27	12		RndBar 3_4	A36	0.00	0.00	0.00
26	34	36		PIPE 2x0.154	A53 GrB	0.00	0.00	0.00
27	42	43		PIPE 2x0.154	A53 GrB	0.00	0.00	0.00
28	48	49		PIPE 2x0.154	A53 GrB	0.00	0.00	0.00
29	33	35		PIPE 2x0.154	A53 GrB	0.00	0.00	0.00
31	22	51		PIPE 2x0.154	A53 GrB	0.00	0.00	0.00

Orientation of local axes

Member	Rotation [Deg]	Axes23	NX	NY	NZ
26	45.00	0	0.00	0.00	0.00
27	45.00	0	0.00	0.00	0.00
28	45.00	0	0.00	0.00	0.00
29	45.00	0	0.00	0.00	0.00

Hinges

Member	Node-J				Node-K				TOR	AXL	Axial rigidity
	M33	M22	V3	V2	M33	M22	V3	V2			
15	0	0	0	0	0	0	0	0	0	0	Tension only
16	0	0	0	0	0	0	0	0	0	0	Tension only



HUDSON
Design Group LLC

**Mount Calculations
(Modified Conditions)**

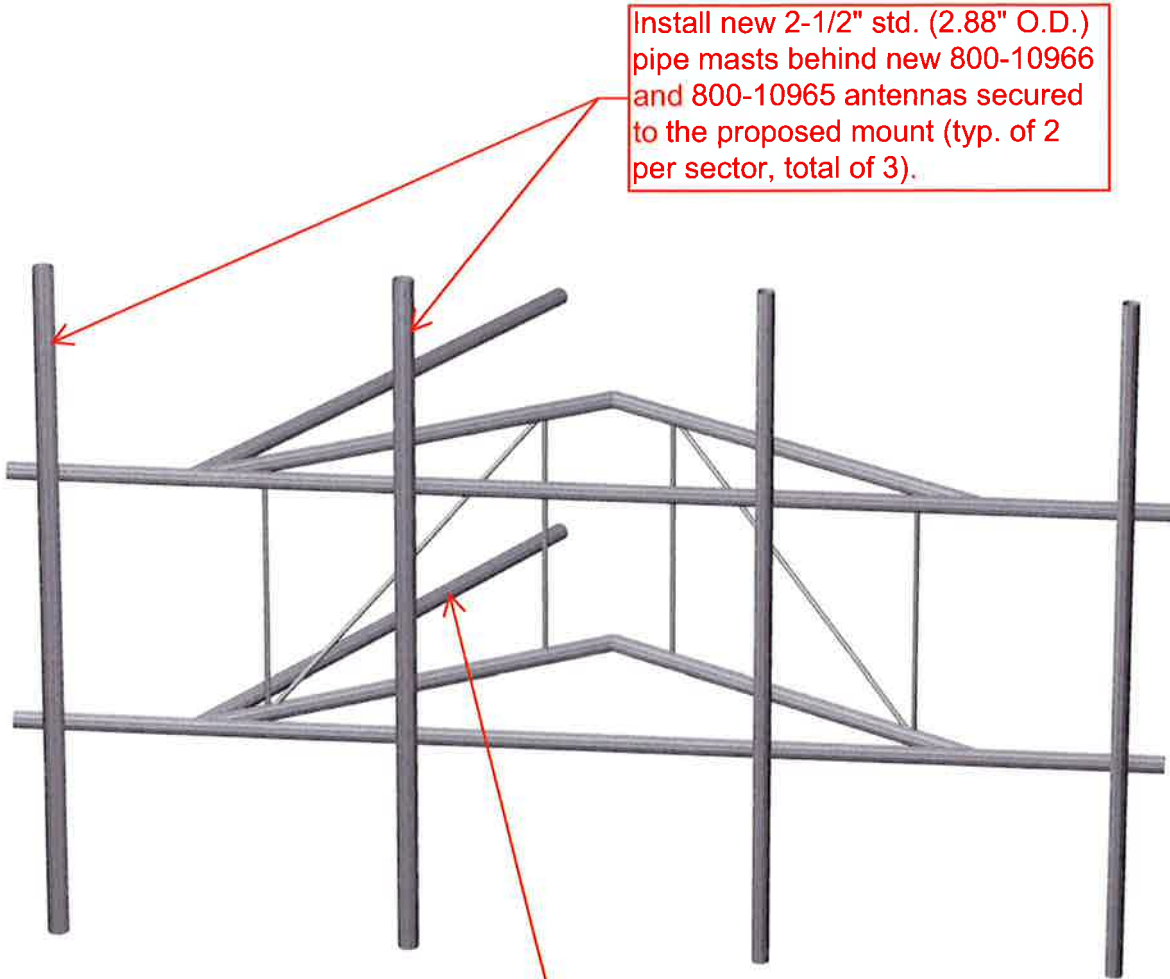



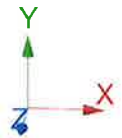
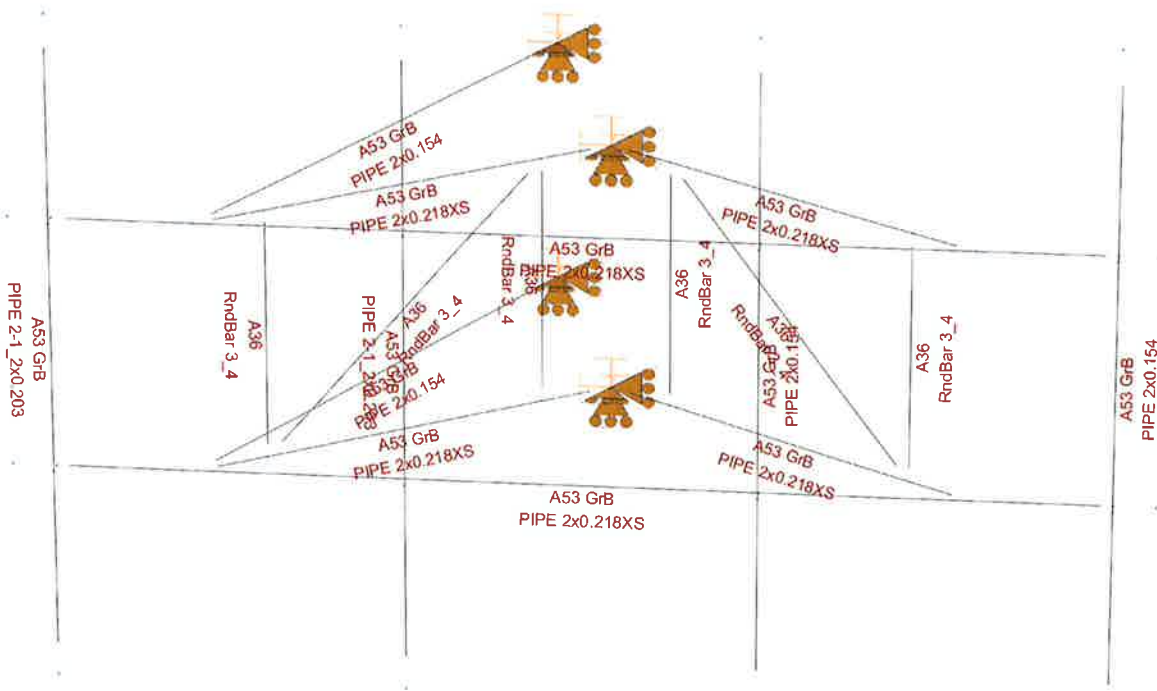

Install new 2-1/2" std. (2.88" O.D.) pipe masts behind new 800-10966 and 800-10965 antennas secured to the proposed mount (typ. of 2 per sector, total of 3).

Install new additional 2" std. (2.38" O.D.) pipe brace secured to the proposed mount and existing tower (typ. of 1 per sector, total of 3).





Design status

-  Not designed
-  Error on design
-  Design O.K.
-  With warnings

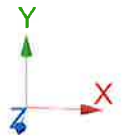
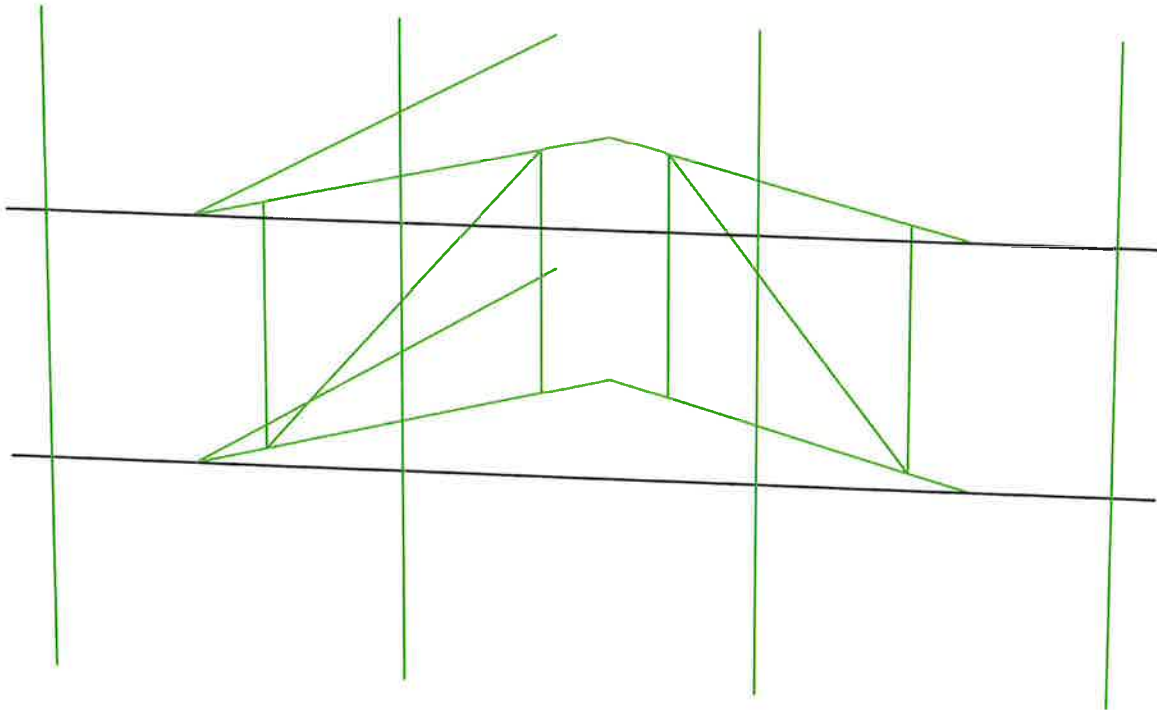

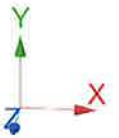
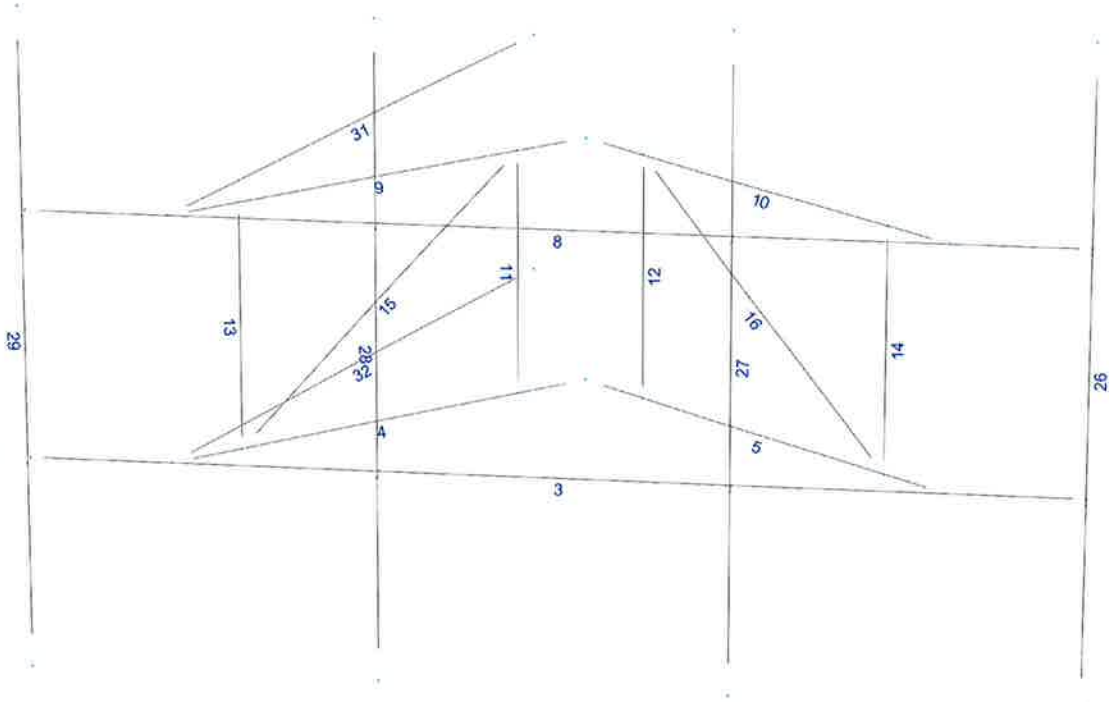

Current Date: 12/18/2018 3:08 PM

Units system: English

File name: W:\STRUCTURAL DEPARTMENT\ANALYSIS SOFTWARE\RAM Elements\RAM Projects\AT&T\CT\CT5737\LTE 2C-3C-4C-5C\CT5737 (LT 2C-3C-4C-5C) (MOD).etzl

Steel Code Check

Report: Summary - Group by member

Load conditions to be included in design :

LC1=1.2D+1.6Wo
LC2=1.2D+1.6W30
LC3=1.2D+1.6W60
LC4=1.2D+1.6W90
LC5=1.2D+1.6W120
LC6=1.2D+1.6W150
LC7=1.2D-1.6Wo
LC8=1.2D-1.6W30
LC9=1.2D-1.6W60
LC10=1.2D-1.6W90
LC11=1.2D-1.6W120
LC12=1.2D-1.6W150
LC13=0.9D+1.6Wo
LC14=0.9D+1.6W30
LC15=0.9D+1.6W60
LC16=0.9D+1.6W90
LC17=0.9D+1.6W120
LC18=0.9D+1.6W150
LC19=0.9D-1.6Wo
LC20=0.9D-1.6W30
LC21=0.9D-1.6W60
LC22=0.9D-1.6W90
LC23=0.9D-1.6W120
LC24=0.9D-1.6W150
LC25=1.2D+Di+W10
LC26=1.2D+Di+W130
LC27=1.2D+Di+W160
LC28=1.2D+Di+W190
LC29=1.2D+Di+W120
LC30=1.2D+Di+W150
LC31=1.2D+Di-W10
LC32=1.2D+Di-W130
LC33=1.2D+Di-W160
LC34=1.2D+Di-W190
LC35=1.2D+Di-W120
LC36=1.2D+Di-W150
LC37=0.9D
LC38=1.2D+1.6LL1
LC39=1.2D+1.6LL2
LC40=1.2D+1.6LL3
LC41=1.2D+WL0+LLa1
LC42=1.2D+WL30+LLa1
LC43=1.2D+WL60+LLa1
LC44=1.2D+WL90+LLa1
LC45=1.2D+WL120+LLa1
LC46=1.2D+WL150+LLa1
LC47=1.2D-WL0+LLa1
LC48=1.2D-WL30+LLa1
LC49=1.2D-WL60+LLa1
LC50=1.2D-WL90+LLa1
LC51=1.2D-WL120+LLa1
LC52=1.2D-WL150+LLa1

LC53=1.2D+WL0+LLa2
 LC54=1.2D+WL30+LLa2
 LC55=1.2D+WL60+LLa2
 LC56=1.2D+WL90+LLa2
 LC57=1.2D+WL120+LLa2
 LC58=1.2D+WL150+LLa2
 LC59=1.2D-WL0+LLa2
 LC60=1.2D-WL30+LLa2
 LC61=1.2D-WL60+LLa2
 LC62=1.2D-WL90+LLa2
 LC63=1.2D-WL120+LLa2
 LC64=1.2D-WL150+LLa2
 LC65=1.2D+WL0+LLa3
 LC66=1.2D+WL30+LLa3
 LC67=1.2D+WL60+LLa3
 LC68=1.2D+WL90+LLa3
 LC69=1.2D+WL120+LLa3
 LC70=1.2D+WL150+LLa3
 LC71=1.2D-WL0+LLa3
 LC72=1.2D-WL30+LLa3
 LC73=1.2D-WL60+LLa3
 LC74=1.2D-WL90+LLa3
 LC75=1.2D-WL120+LLa3
 LC76=1.2D-WL150+LLa3

Description	Section	Member	Ctrl Eq.	Ratio	Status	Reference
	PIPE 2-1_2x0.203	28	LC1 at 68.75%	0.64	OK	Eq. H1-1b
		29	LC1 at 68.75%	0.64	OK	Eq. H1-1b
	PIPE 2x0.154	26	LC40 at 31.25%	0.37	OK	Eq. H1-1b
		27	LC39 at 31.25%	0.18	OK	Eq. H1-1b
		31	LC9 at 0.00%	0.21	OK	Eq. H1-1b
		32	LC3 at 0.00%	0.21	OK	Eq. H1-1b
	PIPE 2x0.218XS	3	LC7 at 16.96%	0.78	With warnings	Eq. H1-1b
		4	LC36 at 100.00%	0.42	OK	Eq. H1-1b
		5	LC40 at 16.67%	0.20	OK	Eq. H1-1b
		8	LC1 at 16.96%	0.76	With warnings	Eq. H1-1b
		9	LC30 at 100.00%	0.49	OK	Eq. H1-1b
		10	LC26 at 100.00%	0.22	OK	Eq. H1-1b
	RndBar 3_4	11	LC26 at 100.00%	0.61	OK	Eq. H1-1a
		12	LC40 at 100.00%	0.26	OK	Eq. H1-1a
		13	LC25 at 100.00%	0.81	OK	Eq. H1-1a
		14	LC40 at 0.00%	0.33	OK	Eq. H1-1a
		15	LC26 at 100.00%	0.50	OK	Eq. H1-1a
		16	LC25 at 100.00%	0.18	OK	Eq. H1-1b

Current Date: 12/18/2018 3:08 PM

Units system: English

File name: W:\STRUCTURAL DEPARTMENT\ANALYSIS SOFTWARE\RAM Elements\RAM Projects\AT&T\CT\CT5737\LTE 2C-3C-4C-5C\CT5737 (LT 2C-3C-4C-5C) (MOD).etzl

Geometry data

GLOSSARY

Cb22, Cb33	: Moment gradient coefficients
Cm22, Cm33	: Coefficients applied to bending term in interaction formula
d0	: Tapered member section depth at J end of member
DJX	: Rigid end offset distance measured from J node in axis X
DJY	: Rigid end offset distance measured from J node in axis Y
DJZ	: Rigid end offset distance measured from J node in axis Z
DKX	: Rigid end offset distance measured from K node in axis X
DKY	: Rigid end offset distance measured from K node in axis Y
DKZ	: Rigid end offset distance measured from K node in axis Z
dL	: Tapered member section depth at K end of member
Ig factor	: Inertia reduction factor (Effective Inertia/Gross Inertia) for reinforced concrete members
K22	: Effective length factor about axis 2
K33	: Effective length factor about axis 3
L22	: Member length for calculation of axial capacity
L33	: Member length for calculation of axial capacity
LB pos	: Lateral unbraced length of the compression flange in the positive side of local axis 2
LB neg	: Lateral unbraced length of the compression flange in the negative side of local axis 2
RX	: Rotation about X
RY	: Rotation about Y
RZ	: Rotation about Z
TO	: 1 = Tension only member 0 = Normal member
TX	: Translation in X
TY	: Translation in Y
TZ	: Translation in Z

Nodes

Node	X [ft]	Y [ft]	Z [ft]	Rigid Floor
2	6.50	0.00	0.00	0
3	-6.50	0.00	0.00	0
8	-4.40	0.00	0.00	0
9	4.40	0.00	0.00	0
10	0.00	0.00	-3.00	0
11	-3.6667	0.00	-0.50	0
12	3.6667	0.00	-0.50	0
13	0.7333	0.00	-2.50	0
14	-0.7333	0.00	-2.50	0
16	6.50	3.00	0.00	0
17	-6.50	3.00	0.00	0
22	-4.40	3.00	0.00	0
23	4.40	3.00	0.00	0
24	0.00	3.00	-3.00	0
25	-3.6667	3.00	-0.50	0
26	3.6667	3.00	-0.50	0
27	0.7333	3.00	-2.50	0
28	-0.7333	3.00	-2.50	0
33	-6.00	5.50	0.20	0
34	6.00	5.50	0.20	0
35	-6.00	-2.50	0.20	0

36	6.00	-2.50	0.20	0
42	2.00	5.50	0.20	0
43	2.00	-2.50	0.20	0
48	-2.00	5.50	0.20	0
49	-2.00	-2.50	0.20	0
51	-1.00	3.00	-6.50	0
52	-1.00	0.00	-6.50	0

Restraints

Node	TX	TY	TZ	RX	RY	RZ
10	1	1	1	1	1	1
24	1	1	1	1	1	1
51	1	1	1	1	1	1
52	1	1	1	1	1	1

Members

Member	NJ	NK	Description	Section	Material	d0 [in]	dL [in]	Ig factor
3	3	2		PIPE 2x0.218XS	A53 GrB	0.00	0.00	0.00
4	8	10		PIPE 2x0.218XS	A53 GrB	0.00	0.00	0.00
5	9	10		PIPE 2x0.218XS	A53 GrB	0.00	0.00	0.00
8	17	16		PIPE 2x0.218XS	A53 GrB	0.00	0.00	0.00
9	22	24		PIPE 2x0.218XS	A53 GrB	0.00	0.00	0.00
10	23	24		PIPE 2x0.218XS	A53 GrB	0.00	0.00	0.00
11	14	28		RndBar 3_4	A36	0.00	0.00	0.00
12	27	13		RndBar 3_4	A36	0.00	0.00	0.00
13	25	11		RndBar 3_4	A36	0.00	0.00	0.00
14	12	26		RndBar 3_4	A36	0.00	0.00	0.00
15	28	11		RndBar 3_4	A36	0.00	0.00	0.00
16	27	12		RndBar 3_4	A36	0.00	0.00	0.00
26	34	36		PIPE 2x0.154	A53 GrB	0.00	0.00	0.00
27	42	43		PIPE 2x0.154	A53 GrB	0.00	0.00	0.00
28	48	49		PIPE 2-1_2x0.203	A53 GrB	0.00	0.00	0.00
29	33	35		PIPE 2-1_2x0.203	A53 GrB	0.00	0.00	0.00
31	22	51		PIPE 2x0.154	A53 GrB	0.00	0.00	0.00
32	8	52		PIPE 2x0.154	A53 GrB	0.00	0.00	0.00

Orientation of local axes

Member	Rotation [Deg]	Axis23	NX	NY	NZ
26	45.00	0	0.00	0.00	0.00
27	45.00	0	0.00	0.00	0.00
28	45.00	0	0.00	0.00	0.00
29	45.00	0	0.00	0.00	0.00

Hinges

Member	Node-J				Node-K				TOR	AXL	Axial rigidity
	M33	M22	V3	V2	M33	M22	V3	V2			
15	0	0	0	0	0	0	0	0	0	0	Tension only
16	0	0	0	0	0	0	0	0	0	0	Tension only

The Assessor's office is responsible for the maintenance of records on the ownership of properties. Assessments are computed at 70% of the estimated market value of real property at the time of the last revaluation which was 2016.



Information on the Property Records for the Municipality of Montville was last updated on 3/6/2019.

Property Summary Information

Parcel Data And Values	Sales
------------------------	-------

Parcel Information

Location:	1334 ROUTE 85	Property Use:	Vacant Land	Primary Use:	Residential
Unique ID:	Z0477310	Map Block Lot:	002/003/000	Acres:	78.70
490 Acres:	75.03	Zone:	R80	Volume / Page:	0001/0001
Developers Map / Lot:		Census:	695202		

Value Information

	Appraised Value	Assessed Value
Land	111,070	77,750
Buildings	0	0
Detached Outbuildings	0	0
Total	111,070	77,750

Owner's Information

Owner's Data

NEW LONDON CITY OF
WATER DEPT
120 BROAD ST
NEW LONDON, CT 06320

[Back To Search \(JavaScript>window.history.back\(1\);\)](#)

[Print View \(PrintPage.aspx?towncode=086&uniqueid=Z0477310\)](#)

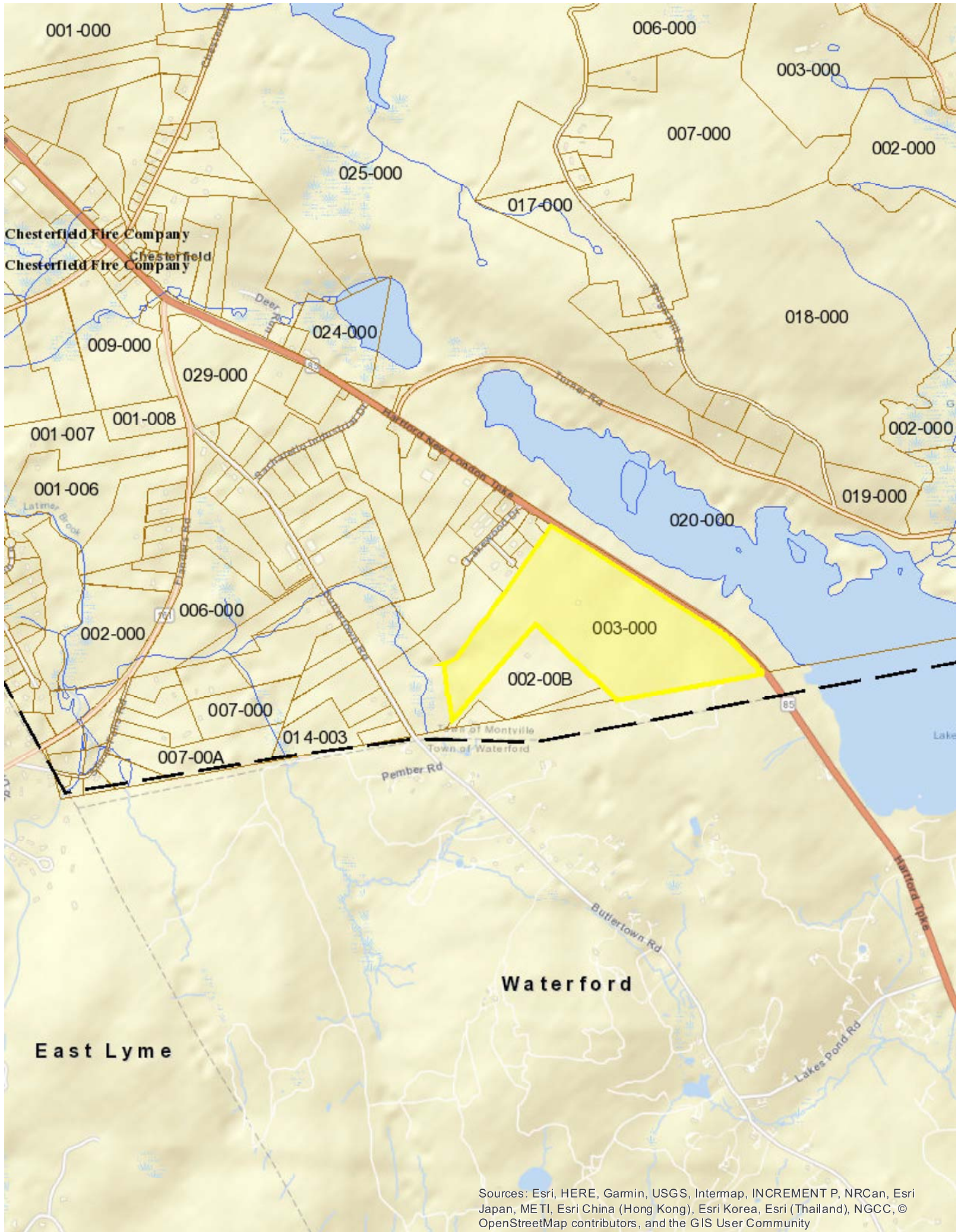



**UNITED STATES
POSTAL SERVICE®**

Click-N-Ship®

P

usps.com
US POSTAGE \$7.35
 Flat Rate Env



03/09/2019 Mailed from 06268 062S0000000101

PRIORITY MAIL 1-DAY™

Expected Delivery Date: 03/11/19

MARK J ROBERTS
 QC DEVELOPMENT
 PO BOX 916
 STORRS CT 06268-0916

0024

Carrier -- Leave if No Response

C020

SHIP TO: CITY OF NEW LONDON
 WATER DEPARTMENT
 120 BROAD ST
 NEW LONDON CT 06320-5724

USPS TRACKING #



9405 5036 9930 0439 9676 90

Electronic Rate Approved #038555749



Cut on dotted line.

Instructions

1. Each Click-N-Ship® label is unique. Labels are to be used as printed and used only once. DO NOT PHOTO COPY OR ALTER LABEL.
2. Place your label so it does not wrap around the edge of the package.
3. Adhere your label to the package. A self-adhesive label is recommended. If tape or glue is used, DO NOT TAPE OVER BARCODE. Be sure all edges are secure.
4. To mail your package with PC Postage®, you may schedule a Package Pickup online, hand to your letter carrier, take to a Post Office™, or drop in a USPS collection box.
5. Mail your package on the "Ship Date" you selected when creating this label.

Click-N-Ship® Label Record

USPS TRACKING # :
9405 5036 9930 0439 9676 90

Trans. #: 458534482	Priority Mail® Postage: \$7.35
Print Date: 03/06/2019	Total: \$7.35
Ship Date: 03/09/2019	
Expected Delivery Date: 03/11/2019	

From: MARK J ROBERTS
 QC DEVELOPMENT
 PO BOX 916
 STORRS CT 06268-0916

To: CITY OF NEW LONDON
 WATER DEPARTMENT
 120 BROAD ST
 NEW LONDON CT 06320-5724

* Retail Pricing Priority Mail rates apply. There is no fee for USPS Tracking® service on Priority Mail service with use of this electronic rate shipping label. Refunds for unused postage paid labels can be requested online 30 days from the print date.



Thank you for shipping with the United States Postal Service!
 Check the status of your shipment on the USPS Tracking® page at usps.com



**UNITED STATES
POSTAL SERVICE®**

Click-N-Ship®

P

usps.com
US POSTAGE 9405 5036 9930 0439 9677 06 0073 5000 0010 6382
 Flat Rate Env
 03/09/2019



Mailed from 06268 062S0000000313

PRIORITY MAIL 1-DAY™

Expected Delivery Date: 03/11/19

MARK J ROBERTS
 QC DEVELOPMENT
 PO BOX 916
 STORRS CT 06268-0916

0024

SHIP TO: MAYOR RONALD K MCDANIEL
 TOWN OF MONTVILLE
 310 NORWICH NEW LONDON TPKE
 CC: MS MARCIA VLAUN, TOWN PLANNER
 UNCASVILLE CT 06382-2523

USPS TRACKING #

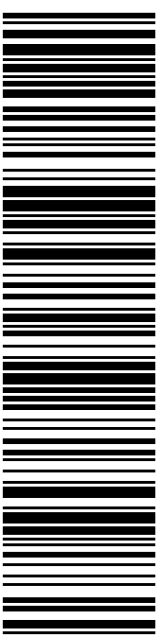

9405 5036 9930 0439 9677 06

Electronic Rate Approved #038555749



Cut on dotted line.

Instructions

1. Each Click-N-Ship® label is unique. Labels are to be used as printed and used only once. DO NOT PHOTO COPY OR ALTER LABEL.
2. Place your label so it does not wrap around the edge of the package.
3. Adhere your label to the package. A self-adhesive label is recommended. If tape or glue is used, DO NOT TAPE OVER BARCODE. Be sure all edges are secure.
4. To mail your package with PC Postage®, you may schedule a Package Pickup online, hand to your letter carrier, take to a Post Office™, or drop in a USPS collection box.
5. Mail your package on the "Ship Date" you selected when creating this label.

Click-N-Ship® Label Record

USPS TRACKING # :
9405 5036 9930 0439 9677 06

Trans. #: 458534482	Priority Mail® Postage: \$7.35
Print Date: 03/06/2019	Total: \$7.35
Ship Date: 03/09/2019	
Expected Delivery Date: 03/11/2019	

From: MARK J ROBERTS
 QC DEVELOPMENT
 PO BOX 916
 STORRS CT 06268-0916

To: MAYOR RONALD K MCDANIEL
 TOWN OF MONTVILLE
 310 NORWICH NEW LONDON TPKE
 CC: MS MARCIA VLAUN, TOWN PLANNER
 UNCASVILLE CT 06382-2523

* Retail Pricing Priority Mail rates apply. There is no fee for USPS Tracking® service on Priority Mail service with use of this electronic rate shipping label. Refunds for unused postage paid labels can be requested online 30 days from the print date.



Thank you for shipping with the United States Postal Service!
 Check the status of your shipment on the USPS Tracking® page at usps.com