

Pinnacle Wireless

RECEIVED
OCT 23 2014

CONNECTICUT
SITING COUNCIL

800 Marshall Phelps Rd
Building 2A
Windsor, CT 06095

ORIGINAL

October 23, 2014

Melanie Bachman
Acting Executive Director
Connecticut Siting Council
Ten Franklin Square
New Britain, CT 06051

RE: **EM-CING-086-130130**— New Cingular Wireless PCS, LLC notification of completion of construction at 57 Cook Drive, Uncasville, Connecticut.

Dear Ms. Bachman:

This letter is submitted on behalf of New Cingular Wireless PCS, LLC ("AT&T"), whose notice of intent to modify an existing telecommunications facility was acknowledged by the Connecticut Siting Council ("Council") on February 20, 2013.

Please accept this letter as notification of completion of construction by AT&T as required as a condition of the Council's acknowledgement. In addition, please refer to the attached documentation from AT&T's Engineer confirming that the installation was completed as designed.

Respectfully Yours,

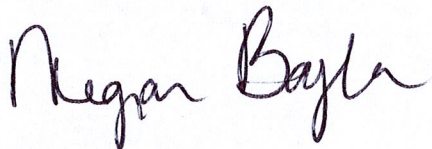

Megan Boylan
Project Coordinator

Cc: Kevin Mason, AT&T



Final Report of Special Inspections

Project: CT2171 Uncasville, AT&T Mobility Telecommunication Facility Upgrade (LTE)

Location: 57 Cook Drive, Uncasville, CT 06382

Owner: AT&T Wireless (New Cingular Wireless)

Engineer of Record: Daniel P. Hamm, P.E.
Hudson Design Group, LLC.

To the best of my information, knowledge and belief, the Special Inspections required for this project, and itemized in the *Statement of Special Inspections* submitted for permit, have been performed and all discovered discrepancies have been reported and resolved.

Representatives of Hudson Design Group LLC performed inspections during the construction of the AT&T telecommunications facility at the above-referenced address. The Final Inspection has been conducted on March 21, 2014.

Comments: Based on my knowledge, information and belief the completed construction substantially conforms to the approved plans, Connecticut State Building Code, Structural Standards for Steel Antenna Towers and Antenna Supporting Structures (ANSI/TIA/EIA-222-F), the equipment manufacturer's installation guidelines, and the following:

1. Final LTE Construction Drawings dated 03-14-2013, prepared by Hudson Design Group LLC, entitled "Uncasville".
2. Structural Analysis (Rev3) dated 03-14-13 prepared by Hudson Design Group LLC.

All deviations from the approved plans do not endanger the intended occupancy of the facility and equipment substitutions are approved as equivalent to the original specifications. Construction has been satisfactorily completed.

Respectfully submitted,
Special Inspector

Daniel P. Hamm, P.E.
(Type or print name)

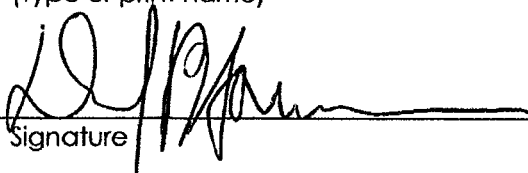
Signature

04-07-14
Date

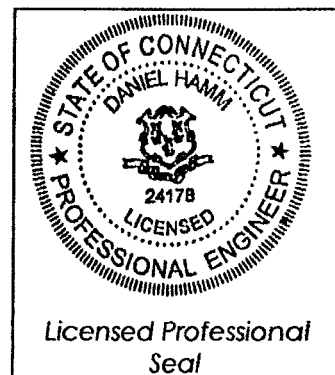



STATE OF CONNECTICUT

CONNECTICUT SITING COUNCIL

Ten Franklin Square, New Britain, CT 06051

Phone: (860) 827-2935 Fax: (860) 827-2950

E-Mail: siting.council@ct.gov

www.ct.gov/csc

February 20, 2013

Christopher Bisson
New Cingular Wireless PCS, LLC
154 General Patton Drive
Naugatuck, CT 06770

RE: **EM-CING-086-130130** – New Cingular Wireless PCS, LLC notice of intent to modify an existing telecommunications facility located at 57 Cook Drive, Uncasville, Connecticut.

Dear Mr. Bisson:

The Connecticut Siting Council (Council) hereby acknowledges your notice to modify this existing telecommunications facility, pursuant to Section 16-50j-73 of the Regulations of Connecticut State Agencies with the following conditions:

- Prior to antenna installation, the modifications identified in the (Revised) Structural Analysis Report prepared by Hudson Design Group dated January 18, 2013, and stamped by Gi Kai Wang shall be implemented;
- Within 45 days following completion of the antenna installation, a signed letter from a Professional Engineer duly licensed in the State of Connecticut shall be submitted to the Council to certify that the recommended modifications have been completed and the structure and foundation do not exceed 100 percent of the post-construction structural rating.
- Any deviation from the proposed modification as specified in this notice and supporting materials with Council shall render this acknowledgement invalid;
- Any material changes to this modification as proposed shall require the filing of a new notice with the Council;
- Within 45 days after completion of construction, the Council shall be notified in writing that construction has been completed;
- The validity of this action shall expire one year from the date of this letter; and
- The applicant may file a request for an extension of time beyond the one year deadline provided that such request is submitted to the Council not less than 60 days prior to the expiration;

The proposed modifications including the placement of all necessary equipment and shelters within the tower compound are to be implemented as specified here and in your notice dated January 23, 2013. The modifications are in compliance with the exception criteria in Section 16-50j-72 (b) of the Regulations of Connecticut State Agencies as changes to an existing facility site that would not increase tower height, extend the boundaries of the tower site, increase noise levels at the tower site boundary by six decibels, and increase the total radio frequencies electromagnetic radiation power density measured at the tower site boundary to or above the standard adopted by the State Department of Environmental Protection pursuant to General

Statutes § 22a-162. This facility has also been carefully modeled to ensure that radio frequency emissions are conservatively below State and federal standards applicable to the frequencies now used on this tower.

This decision is under the exclusive jurisdiction of the Council. Please be advised that the validity of this action shall expire one year from the date of this letter. Any additional change to this facility will require explicit notice to this agency pursuant to Regulations of Connecticut State Agencies Section 16-50j-73. Such notice shall include all relevant information regarding the proposed change with cumulative worst-case modeling of radio frequency exposure at the closest point of uncontrolled access to the tower base, consistent with Federal Communications Commission, Office of Engineering and Technology, Bulletin 65. Thank you for your attention and cooperation.

Very truly yours,



Linda Roberts
Executive Director

LR/CDM/cm

c: The Honorable Ronald K. McDaniel, Mayor, Town of Montville
Marcia Vlaun, Town Planner, Town of Montville

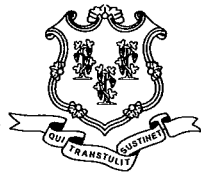

STATE OF CONNECTICUT

CONNECTICUT SITING COUNCIL

Ten Franklin Square, New Britain, CT 06051

Phone: (860) 827-2935 Fax: (860) 827-2950

E-Mail: siting.council@ct.gov

www.ct.gov/csc

January 31, 2013

The Honorable Ronald K. McDaniel
Mayor
Town of Montville
310 Norwich New London Turnpike
Uncasville, CT 06382

RE: **EM-CING-086-130130** – New Cingular Wireless PCS, LLC notice of intent to modify an existing telecommunications facility located at 57 Cook Drive, Uncasville, Connecticut.

Dear Mayor McDaniel:

The Connecticut Siting Council (Council) received a request to modify an existing telecommunications facility, pursuant to Regulations of Connecticut State Agencies Section 16-50j-72, a copy of which has already been provided to you.

If you have any questions or comments regarding the proposal, please call me or inform the Council by February 14, 2013.

Thank you for your cooperation and consideration.

Very truly yours,

Linda Roberts
Executive Director

LR/cm

c: Marcia Vlaun, Town Planner, Town of Montville



EM-CING-086-130130

New Cingular Wireless PCS, LLC
154 General Patton Dr.
Naugatuck, CT 06770
Phone: (203)-217-6200
Christopher Bisson
Real Estate Consultant

January 23, 2013

Hand Delivered

Ms. Linda Roberts
Executive Director
Connecticut Siting Council
10 Franklin Square
New Britain, CT 06051

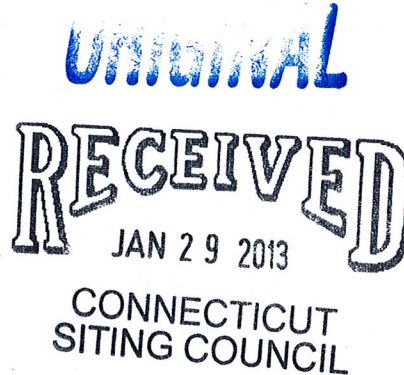

RE: New Cingular Wireless PCS, LLC notice of intent to modify an existing telecommunications facility located at 57 Cook Drive, Uncasville, CT 06382, know to AT&T as site CT2171.

Dear Ms. Roberts:

In order to accommodate technological changes, implement Uniform Mobile Telecommunications System ("UMTS") and/or Long Term Evolution ("LTE") capabilities, and enhance system performance in the state of Connecticut, New Cingular Wireless PCS, LLC ("AT&T") plans to modify the equipment configurations at many of its existing cell sites. Please accept this letter and attachments as notification, pursuant to R.C.S.A. Section 16-50j-73, of construction which constitutes an exempt modification pursuant to R.C.S.A. Section 16-50j-72(b)(2). In compliance with R.C.S.A. Section 16-50j-73, a copy of this letter and its attachments is being sent to the chief elected official of the municipality in which affected cell site is located.

UMTS offers services to mobile computer and phone users anywhere in the world. Based on the Global System for Mobile ("GSM") communication standard, UMTS is the planned worldwide standard for mobile users. UMTS, fully implemented, gives computer and phone users high-speed access to the internet as they travel. They have the same capabilities even when they roam, through both terrestrial wireless and satellite transmissions.

LTE is a new high-performance air interface for cellular mobile communications. It is designed to increase the capacity and speed of mobile telephone networks.

Attached is a summary of the planned modifications, including power density calculations reflecting the change in AT&T's operations at the site. Also included is documentation of the structural sufficiency of the tower to accommodate the revised antenna configuration based on the supplied structural modification plan dated 4/26/2012 requiring the restacking of the existing coaxial cables.

The changes to the facility do not constitute modification as defined Connecticut General Statutes ("C.G.S.") Section 16-50i(d) because the general physical characteristics of the facility will not be significantly changed or altered. Rather, the planned changes to the facility fall squarely within those activities explicitly provided for the R.C.S.A. Section 16-50j-72(b)(2).

1. The height of the overall structure will not be affected.
2. The proposed changes will not extend the site boundaries. There will be no effect on the site compound as all proposed equipment will be located in the existing AT&T equipment shelter.
3. The proposed changes will not increase the noise level at the existing facility by 6 decibels or more.
4. Radio Frequency power density may increase due to the use of one or more GSM channels for UMTS transmissions. Moreover, LTE will utilize additional radio frequencies newly licensed by the FCC for cellular mobile communications. However, the changes will not increase the calculated "worst case" power density for the combined operations at the site to a level at or above the applicable standard for uncontrolled environments as calculated for a mixed frequency site.

For the foregoing reasons New Cingular Wireless PCS, LLC respectfully submits that the proposed changes at the referenced site constitute exempt modifications under R.C.S.A. Section 16-50j-72(b)(2).

Please feel free to call me at (203)-217-6200 or email CBisson@Transcendwireless.com with questions concerning this matter.
Thank you for your consideration.

Sincerely,

Christopher Bisson
Real Estate Consultant

(Revised)
STRUCTURAL ANALYSIS REPORT

For

CT2171
UNCASVILLE

57 COOK DRIVE
UNCASVILLE, CT 06382

Antennas Mounted to the Tower



Prepared for:

Pinnacle
Wireless



500 ENTERPRISE DRIVE, SUITE 3A
ROCKY HILL, CT 06067

Dated: January 18, 2013

Prepared by:



1600 Osgood Street Building 20 North, Suite 3090
North Andover, MA 01845
Phone: (978) 557-5553

www.hudsondesigngroupllc.com



Gi Kai Wang 1/18/13

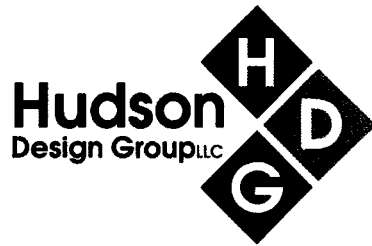

SCOPE OF WORK:

Hudson Design Group LLC (HDG) has been authorized by AT&T to conduct a structural evaluation of the 193' guyed tower supporting the proposed AT&T antennas located at elevation 180' above the ground level.

This report represents this office's findings, conclusions and recommendations pertaining to the support of AT&T's existing and proposed antennas listed below.

Record drawings of the existing tower were not available for our use. The previous structural analysis report prepared by All-Points Technology Corporation, P.C., dated July 30, 2009 was available and obtained for our use. The previous structural analysis report prepared by Centek Engineering Inc., dated December 8, 2011 was also available and obtained for our use.

This office conducted an on-site visual survey and tower mapping on October 15, 2012 to record dimensional properties of the existing tower and its appurtenances. Attendees included Nick Bestor (HDG - Associate) and Jay Lee (HDG - Associate).

CONCLUSION SUMMARY:

HDG performed structural analysis of the existing tower with the following modifications:

1. **Strengthen tower legs from El.140' to El.180'.**
2. **Add horizontals from El.100' to El.120' and from El.140' to El.180'.**
3. **Replace tower diagonals from El.140' to El.160'.**
4. **Replace guy wires at El.162.6'.**
5. **Replace torque arm at El.102.6' and at El.162.6'.**

Based on our evaluation, we have determined that the existing tower and foundation **are in conformance** with the ANSI/TIA-222-F Standard for the loading considered under the criteria listed in this report. The tower structure is rated at **95.7%** - (Leg at Tower Section T6 from EL.80' to EL.100' Controlling).



APPURTENANCES CONFIGURATION:

Tenant	Appurtenances	Elev.	Mount
	(3) APX16DWV-16DWVS Antennas	192.7'	12' T-Frame
	(3) TMAs	191.5'	12' T-Frame
	20' Omni	188'	14' T-Frame
	6' Omni	181'	14' T-Frame
AT&T	(6) Powerwave 7770 Antennas	180'	14' T-Frame
AT&T	(6) TT19-08BP111 TMAs	180'	14' T-Frame
AT&T	SBNH-1D6565C Antenna	180'	14' T-Frame
AT&T	AM-X-CD-16-65-00 Antenna	180'	14' T-Frame
AT&T	P65-17-XLH-RR Antenna	180'	14' T-Frame
AT&T	(6) RRUs	180'	14' T-Frame
AT&T	Surge Arrestor DC6-48-60-18-8F	180'	Tower Leg
	(3) LPA-80080 Antennas	168'	14' T-Frame
	(3) BXA-171085 Antennas	168'	14' T-Frame
	(3) BXA-80063 Antennas	168'	14' T-Frame
	7' Dipoles	154.5'	14' T-Frame
	(6) DB980H90E-M Antennas	151'	14' T-Frame
	(12) DB844H90E-XY Antennas	142'	14' T-Frame
	(3) Kathrein 800 10504 Antennas	130'	10' T-Frame
	10' Dipoles	124'	4' Side Mount Standoff
	Junction Box	119'	Tower Leg
	(2) 20' Omni	117'	4' Side Mount Standoff
	(3) LLPX310R Antennas	116.3'	1' Side Mount Standoff
	(3) RRHs	114.5'	1' Side Mount Standoff
	6' Yagi	110'	Tower Leg
	GPS	105'	3' Side Mount Standoff

***Proposed AT&T Appurtenances shown in Bold.**

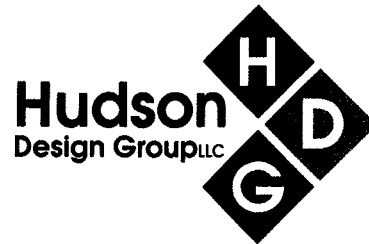

AT&T EXISTING/PROPOSED COAX CABLES:

Tenant	Coax Cables	Elev.	Mount
AT&T	(12) 1 5/8" Cables	180'	Face of Tower
AT&T	Fiber Cable	180'	Face of Tower
AT&T	(2) DC Power Cables	180'	Face of Tower

**Proposed AT&T Coax Cables shown in Bold.*

ANALYSIS RESULTS SUMMARY:

Component	Max. Stress Ratio	Elev. of Component (ft)	Pass/Fail	Comments
Legs	95.7 %	80 – 100	PASS	Controlling
Diagonals	76.7 %	20 – 40	PASS	
Horizontals	3.9 %	0 – 5	PASS	
Sec. Horizontals	35.0 %	160 – 180	PASS	
Top Girt	22.0 %	0 – 5	PASS	
Bottom Girt	57.5 %	5 – 20	PASS	
Guy	92.7 %	162.6	PASS	
Torque Arm	88.5 %	162.6	PASS	

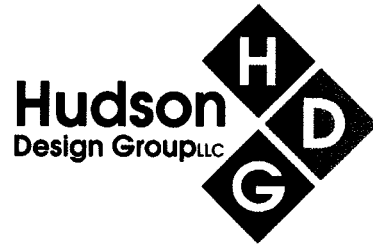

DESIGN CRITERIA:

1. EIA/TIA-222-F Structural Standards for Steel Antenna Towers and Antenna Supporting Structures

City/Town: Montville
County: New London
Wind Load: 95 mph (fastest mile)
 115 mph (3 second gust)
Nominal Ice Thickness: 1/2 inch

2. Approximate height above grade to proposed antennas: 180'

***Calculations and referenced documents are attached.**

ASSUMPTIONS:

1. Material strength of the existing structure was not available for structural analysis, and was assumed as follows:
Tower Legs (Pipes): $F_y=50$ ksi
Tower Diagonals (Pipes): $F_y=42$ ksi
Angles and Channels: $F_y=36$ ksi
2. The appurtenances configuration is as stated in this report. All antennas, coax cables and waveguide cables are assumed to be properly installed and supported as per the manufacturer requirements.
3. The tower and foundation are properly constructed and maintained. All structural members and their connections are assumed to be in good condition and are free from defects with no deterioration to its member capacities.
4. The support mounts and platforms are not analyzed and are considered adequate to support the loading. The analysis is limited to the primary support structure itself.
5. All prior structural modification, if any, are assumed to be as per the data supplied (if available), and installed properly.

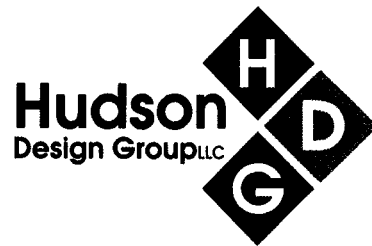

SUPPORT RECOMMENDATIONS:

HDG recommends that the proposed antennas and RRHs be mounted on the existing T-frame supported by the tower; the proposed surge arrestor be mounted on the tower leg.

Reference HDG's Latest Construction Drawings for all component and connection requirements (attached).

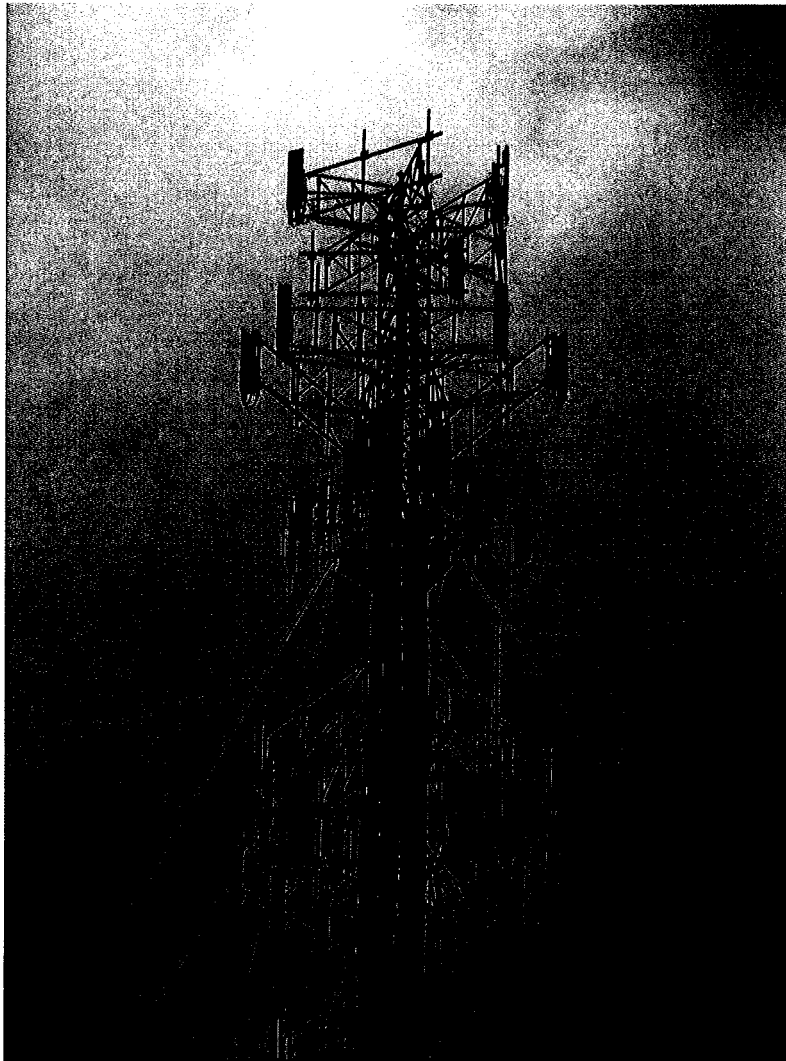
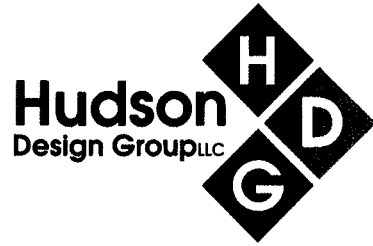
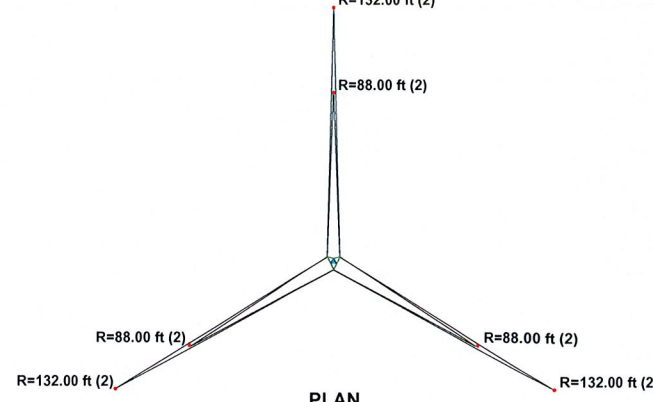
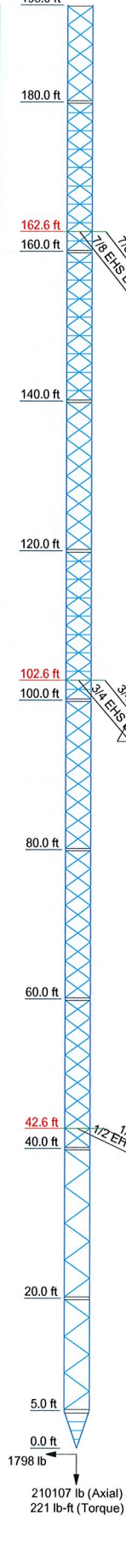

Photo 1: Photo illustrating the Tower with Appurtenances shown.



CALCULATIONS

Legs	ROHN 2.5 EH (CT2171)	ROHN 2.5 EH	ROHN 2.5 EH	ROHN 3 EH	ROHN 2.5 EH	ROHN 2.5 EH
Leg Grade	L2x2x1/4	L2x2x1/4	L2x2x1/4	L1 3/4x1 3/4x3/16	L2x2x1/4	L2x2x1/4
Diagonals	A36	A53-B-42	A36	A36	A53-B-42	A36
Diagonal Grade	ROHN TSI.5x11 ga	ROHN TSI.5x16 ga	ROHN TSI.5x11 ga	ROHN TSI.5x11 ga	ROHN TSI.5x16 ga	ROHN TSI.5x11 ga
Top Girts	L2x2x1/4	L2x2x1/4	L2x2x1/4	ROHN TSI.5x11 ga	L2x2x1/4	L2x2x1/4
Bottom Girts	L2x2x1/4	L2x2x1/4	L2x2x1/4	ROHN TSI.5x11 ga	L2x2x1/4	L2x2x1/4
Horizontals	N.A.	N.A.	N.A.	ROHN TSI.5x11 ga	N.A.	N.A.
Sec. Horizontals	N.A.	N.A.	N.A.	N.A.	L2x2x1/4	N.A.
Face Width (ft)	5 @ 2.53333	5 @ 2.53333	5 @ 2.53333	64 @ 2.45833	64 @ 2.45833	64 @ 2.45833
# Panels @ (ft)	1578.8	1578.8	1578.8	1086.8	1086.8	1086.8
Weight (lb)	2709.0	2709.0	2709.0	1386.7	1386.7	1386.7
	779.8	779.8	779.8	726.3	726.3	726.3
	540.3	540.3	540.3	540.3	540.3	540.3
	327.8	327.8	327.8	327.8	327.8	327.8



SYMBOL LIST

MARK	SIZE	MARK	SIZE
A	L4x4x1/4	B	4 @ 1.16667

MATERIAL STRENGTH

GRADE	Fy	Fu	GRADE	Fy	Fu
A572-50	50 ksi	65 ksi	A53-B-42	42 ksi	63 ksi
A36	36 ksi	58 ksi			

TOWER DESIGN NOTES

1. Tower is located in New London County, Connecticut.
2. Tower designed for a 95 mph basic wind in accordance with the TIA/EIA-222-F Standard.
3. Tower is also designed for a 82 mph basic wind with 0.50 in ice.
4. Deflections are based upon a 50 mph wind.
5. TOWER RATING: 95.7%



Hudson Design Group, LLC		Job: CT 2171 Modification Uncasville, CT	
1600 Osgood Street, Building 20 North, Suite 3090		Project: 193 ft Guyed Tower	
North Andover, MA 01845		Client: AT&T	Drawn by: kw
Phone: (978) 557-5553		Code: TIA/EIA-222-F	Date: 01/17/13
FAX: (978) 226-5586		Path: C:\Users\kwang\Documents\Hudson\AAA\CT 2171 Mod - GT (AT&T)\CT 2171 - Mod\CT 2171 - Mod.dwg	App'd: _____
			Scale: N
			Dwg No. _____

tnxTower Hudson Design Group, LLC 1600 Osgood Street, Building 20 North, Suite 3090 North Andover, MA 01845 Phone: (978) 557-5553 FAX: (978) 226-5586	Job CT 2171 Modification Uncasville, CT	Page 1 of 13
	Project 193 ft Guyed Tower	Date 17:13:52 01/17/13
	Client AT&T	Designed by kw

Tower Input Data

The main tower is a 3x guyed tower with an overall height of 193.00 ft above the ground line.

The base of the tower is set at an elevation of 0.00 ft above the ground line.

The face width of the tower is 3.50 ft at the top and tapered at the base.

This tower is designed using the TIA/EIA-222-F standard.

The following design criteria apply:

Tower is located in New London County, Connecticut.

Basic wind speed of 95 mph.

Nominal ice thickness of 0.5000 in.

Ice density of 56 pcf.

A wind speed of 82 mph is used in combination with ice.

Temperature drop of 50 °F.

Deflections calculated using a wind speed of 50 mph.

Pressures are calculated at each section.

Safety factor used in guy design is 2.

Stress ratio used in tower member design is 1.333.

Local bending stresses due to climbing loads, feedline supports, and appurtenance mounts are not considered.

Tower Section Geometry

Tower Section	Tower Elevation	Assembly Database	Description	Section Width	Number of Sections	Section Length
	ft			ft		ft
T1	193.00-180.00			3.50	1	13.00
T2	180.00-160.00			3.50	1	20.00
T3	160.00-140.00			3.50	1	20.00
T4	140.00-120.00			3.50	1	20.00
T5	120.00-100.00			3.50	1	20.00
T6	100.00-80.00			3.50	1	20.00
T7	80.00-60.00			3.50	1	20.00
T8	60.00-40.00			3.50	1	20.00
T9	40.00-20.00			3.50	1	20.00
T10	20.00-5.00			3.50	1	15.00
T11	5.00-0.00			3.50	1	5.00

Tower Section Geometry (cont'd)

Tower Section	Tower Elevation	Diagonal Spacing	Bracing Type	Has K Brace End Panels	Has Horizontals	Top Girt Offset	Bottom Girt Offset
	ft	ft				in	in
T1	193.00-180.00	2.53	CX Brace	No	No	2.0000	2.0000
T2	180.00-160.00	2.46	X Brace	No	Yes	2.0000	2.0000
T3	160.00-140.00	2.46	X Brace	No	Yes	2.0000	2.0000
T4	140.00-120.00	2.46	CX Brace	No	No	2.0000	2.0000
T5	120.00-100.00	2.46	X Brace	No	Yes	2.0000	2.0000
T6	100.00-80.00	2.46	CX Brace	No	No	2.0000	2.0000
T7	80.00-60.00	2.46	CX Brace	No	No	2.0000	2.0000
T8	60.00-40.00	2.46	CX Brace	No	No	2.0000	2.0000
T9	40.00-20.00	2.46	K Brace Left	No	No	2.0000	2.0000

tnxTower Hudson Design Group, LLC 1600 Osgood Street, Building 20 North, Suite 3090 North Andover, MA 01845 Phone: (978) 557-5553 FAX: (978) 226-5586	Job CT 2171 Modification Uncasville, CT	Page 2 of 13
	Project 193 ft Guyed Tower	Date 17:13:52 01/17/13
	Client AT&T	Designed by kw

Tower Section	Tower Elevation	Diagonal Spacing	Bracing Type	Has K Brace End Panels	Has Horizontals	Top Girt Offset	Bottom Girt Offset
	ft	ft				in	in
T10	20.00-5.00	2.44	K Brace Left	No	No	2.0000	2.0000
T11	5.00-0.00	1.17	X Brace	No	Yes	4.0000	0.0000

Tower Section Geometry (cont'd)

Tower Elevation	Leg Type	Leg Size	Leg Grade	Diagonal Type	Diagonal Size	Diagonal Grade
ft						
T1 193.00-180.00	Pipe	ROHN 2.5 EH	A572-50 (50 ksi)	Equal Angle	L2x2x1/4	A36 (36 ksi)
T2 180.00-160.00	Pipe	ROHN 2.5 EH (CT2171)	A572-50 (50 ksi)	Equal Angle	L2x2x1/4	A36 (36 ksi)
T3 160.00-140.00	Pipe	ROHN 2.5 EH (CT2171)	A572-50 (50 ksi)	Equal Angle	L2x2x1/4	A36 (36 ksi)
T4 140.00-120.00	Pipe	ROHN 2.5 EH	A572-50 (50 ksi)	Pipe	ROHN TS1.5x11 ga	A53-B-42 (42 ksi)
T5 120.00-100.00	Pipe	ROHN 3 EH	A572-50 (50 ksi)	Equal Angle	L2x2x1/4	A36 (36 ksi)
T6 100.00-80.00	Pipe	ROHN 3 EH	A572-50 (50 ksi)	Pipe	ROHN TS1.5x16 ga	A53-B-42 (42 ksi)
T7 80.00-60.00	Pipe	ROHN 3 EH	A572-50 (50 ksi)	Equal Angle	L1 3/4x1 3/4x3/16	A36 (36 ksi)
T8 60.00-40.00	Pipe	ROHN 3 EH	A572-50 (50 ksi)	Pipe	ROHN TS1.5x16 ga	A53-B-42 (42 ksi)
T9 40.00-20.00	Pipe	ROHN 3 EH	A572-50 (50 ksi)	Pipe	ROHN TS1.5x16 ga	A53-B-42 (42 ksi)
T10 20.00-5.00	Pipe	ROHN 3 EH	A572-50 (50 ksi)	Pipe	ROHN TS1.5x16 ga	A53-B-42 (42 ksi)
T11 5.00-0.00	Pipe	ROHN 3 EH	A572-50 (50 ksi)	Equal Angle		A36 (36 ksi)

Tower Section Geometry (cont'd)

Tower Elevation	Top Girt Type	Top Girt Size	Top Girt Grade	Bottom Girt Type	Bottom Girt Size	Bottom Girt Grade
ft						
T1 193.00-180.00	Equal Angle	L2x2x1/4	A36 (36 ksi)	Equal Angle	L2x2x1/4	A36 (36 ksi)
T2 180.00-160.00	Equal Angle	L2x2x1/4	A36 (36 ksi)	Equal Angle	L2x2x1/4	A36 (36 ksi)
T3 160.00-140.00	Pipe	ROHN TS1.5x11 ga	A53-B-42 (42 ksi)	Pipe	ROHN TS1.5x11 ga	A53-B-42 (42 ksi)
T4 140.00-120.00	Pipe	ROHN TS1.5x16 ga	A53-B-42 (42 ksi)	Pipe	ROHN TS1.5x16 ga	A53-B-42 (42 ksi)
T5 120.00-100.00	Equal Angle	L2x2x1/4	A36 (36 ksi)	Equal Angle	L2x2x1/4	A36 (36 ksi)
T6 100.00-80.00	Pipe	ROHN TS1.5x11 ga	A53-B-42 (42 ksi)	Pipe	ROHN TS1.5x11 ga	A53-B-42 (42 ksi)
T7 80.00-60.00	Pipe	ROHN TS1.5x11 ga	A53-B-42 (42 ksi)	Pipe	ROHN TS1.5x11 ga	A53-B-42 (42 ksi)
T8 60.00-40.00	Pipe	ROHN TS1.5x11 ga	A53-B-42 (42 ksi)	Pipe	ROHN TS1.5x11 ga	A53-B-42 (42 ksi)
T9 40.00-20.00	Pipe	ROHN TS1.5x16 ga	A53-B-42	Pipe	ROHN TS1.5x16 ga	A53-B-42

tnxTower Hudson Design Group, LLC 1600 Osgood Street, Building 20 North, Suite 3090 North Andover, MA 01845 Phone: (978) 557-5553 FAX: (978) 226-5586	Job CT 2171 Modification Uncasville, CT	Page 3 of 13
	Project 193 ft Guyed Tower	Date 17:13:52 01/17/13
	Client AT&T	Designed by kw

Tower Elevation ft	Top Girt Type	Top Girt Size	Top Girt Grade	Bottom Girt Type	Bottom Girt Size	Bottom Girt Grade
T10 20.00-5.00	Pipe	ROHN TS1.5x16 ga	(42 ksi) A53-B-42	Pipe	ROHN TS1.5x16 ga	(42 ksi) A53-B-42
T11 5.00-0.00	Equal Angle	L4x4x1/4	A36 (36 ksi)	Equal Angle	L4x4x1/4	A36 (36 ksi)

Tower Section Geometry (cont'd)

Tower Elevation ft	No. of Mid Girts	Mid Girt Type	Mid Girt Size	Mid Girt Grade	Horizontal Type	Horizontal Size	Horizontal Grade
T11 5.00-0.00	None	Solid Round		A572-50 (50 ksi)	Equal Angle	L4x4x1/4	A36 (36 ksi)

Tower Section Geometry (cont'd)

Tower Elevation ft	Secondary Horizontal Type	Secondary Horizontal Size	Secondary Horizontal Grade	Inner Bracing Type	Inner Bracing Size	Inner Bracing Grade
T2 180.00-160.00	Equal Angle	L2x2x1/4	A36 (36 ksi)	Solid Round		A572-50 (50 ksi)
T3 160.00-140.00	Equal Angle	L2x2x1/4	A36 (36 ksi)	Solid Round		A572-50 (50 ksi)
T5 120.00-100.00	Equal Angle	L2x2x1/4	A36 (36 ksi)	Solid Round		A572-50 (50 ksi)

Guy Data

Guy Elevation ft	Guy Grade	Guy Size	Initial Tension lb	%	Guy Modulus ksi	Guy Weight plf	L _u ft	Anchor Radius ft	Anchor Azimuth Adj. °	Anchor Elevation ft	End Fitting Efficiency %	
162.625	EHS	A	7/8	7970.00	10%	19000	1.581	206.41	132.00	0.0000	2.00	100%
		B	7/8	7970.00	10%	19000	1.581	206.41	132.00	0.0000	2.00	100%
		C	7/8	7970.00	10%	19000	1.581	206.41	132.00	0.0000	2.00	100%
102.625	EHS	A	3/4	5830.00	10%	19000	1.155	132.22	88.00	0.0000	2.00	100%
		B	3/4	5830.00	10%	19000	1.155	132.22	88.00	0.0000	2.00	100%
		C	3/4	5830.00	10%	19000	1.155	132.22	88.00	0.0000	2.00	100%
42.625	EHS	A	1/2	2690.00	10%	21000	0.517	95.00	88.00	0.0000	2.00	100%
		B	1/2	2690.00	10%	21000	0.517	95.00	88.00	0.0000	2.00	100%
		C	1/2	2690.00	10%	21000	0.517	95.00	88.00	0.0000	2.00	100%

Guy Data(cont'd)

tnxTower Hudson Design Group, LLC 1600 Osgood Street, Building 20 North, Suite 3090 North Andover, MA 01845 Phone: (978) 557-5553 FAX: (978) 226-5586	Job CT 2171 Modification Uncasville, CT	Page 4 of 13
	Project 193 ft Guyed Tower	Date 17:13:52 01/17/13
	Client AT&T	Designed by kw

Guy Elevation ft	Mount Type	Torque-Arm Spread ft	Torque-Arm Leg Angle °	Torque-Arm Style	Torque-Arm Grade	Torque-Arm Type	Torque-Arm Size
162.625	Torque Arm	7.33	0.0000	Channel	A36 (36 ksi)	Channel	C15x50
102.625	Torque Arm	7.33	0.0000	Channel	A36 (36 ksi)	Channel	MC12x31
42.625	Torque Arm	7.33	0.0000	Channel	A36 (36 ksi)	Channel	C12x25

Feed Line/Linear Appurtenances - Entered As Round Or Flat

Description	Face or Leg	Allow Shield	Component Type	Placement ft	Total Number	Number Per Row	Clear Spacing in	Width or Diameter in	Perimeter in	Weight plf
1 5/8	C	Yes	Ar (CaAa)	192.00 - 8.00	12	6	1.8000	1.8000		1.04
7/8	C	Yes	Ar (CaAa)	178.00 - 8.00	2	1	1.1100	1.1100		0.54
1 5/8 (AT&T - Existing)	C	Yes	Ar (CaAa)	180.00 - 8.00	12	6	1.8000	1.8000		1.04
1 5/8	B	Yes	Ar (CaAa)	168.00 - 8.00	12	6	1.8000	1.8000		1.04
1 5/8	B	Yes	Ar (CaAa)	151.00 - 8.00	7	7	1.8000	1.8000		1.04
1 5/8	A	Yes	Ar (CaAa)	141.00 - 8.00	12	6	1.8000	1.8000		1.04
1 5/8	A	Yes	Ar (CaAa)	129.00 - 8.00	6	6	1.8000	1.8000		1.04
1 5/8	C	Yes	Ar (CaAa)	120.00 - 8.00	1	1	1.8000	1.8000		1.04
2" Rigid Conduit	B	Yes	Ar (CaAa)	114.50 - 8.00	1	1	2.0000	2.0000		2.80
1 5/8	A	Yes	Ar (CaAa)	107.00 - 8.00	1	1	1.8000	1.8000		1.04
1/2	A	Yes	Ar (CaAa)	108.00 - 8.00	1	1	0.5800	0.5800		0.25
1/2	A	Yes	Ar (CaAa)	104.00 - 8.00	1	1	0.5800	0.5800		0.25
1/2	C	Yes	Ar (CaAa)	108.00 - 8.00	1	1	0.5800	0.5800		0.25
***** FB-L98B-002 (AT&T - proposed)	C	Yes	Ar (CaAa)	180.00 - 8.00	1	1	0.4000	0.4000		0.25
WR-VG122ST-BRDA (AT&T - proposed)	C	Yes	Ar (CaAa)	180.00 - 8.00	2	2	0.4000	0.4000		0.25

Discrete Tower Loads

Description	Face or Leg	Offset Type	Offsets: Horz Lateral Vert ft ft ft	Azimuth Adjustment °	Placement ft	C _A A _A Front ft ²	C _A A _A Side ft ²	Weight lb	
PiROD 12' T-Frame	A	From Leg	2.50	0.0000	192.00	No Ice	12.20	12.20	360.00
			0.00						
			0.00						
PiROD 12' T-Frame	B	From Leg	2.50	0.0000	192.00	No Ice	12.20	12.20	360.00
			0.00						
			0.00						
PiROD 12' T-Frame	C	From Leg	2.50	0.0000	192.00	No Ice	12.20	12.20	360.00
			0.00						
			0.00						
APX16DWV-16DWVS w/mount pipe	A	From Leg	5.00	0.0000	192.70	No Ice	10.00	6.39	40.40
			0.00						
			0.00						

tnxTower Hudson Design Group, LLC 1600 Osgood Street, Building 20 North, Suite 3090 North Andover, MA 01845 Phone: (978) 557-5553 FAX: (978) 226-5586	Job		CT 2171 Modification Uncasville, CT		Page	5 of 13
	Project		193 ft Guyed Tower		Date	17:13:52 01/17/13
	Client		AT&T		Designed by	kw

Description	Face or Leg	Offset Type	Offsets: Horz Lateral Vert ft ft ft	Azimuth Adjustment °	Placement ft	C _{AA} Front ft ²	C _{AA} Side ft ²	Weight lb
APX16DWV-16DWVS w/mount pipe	B	From Leg	5.00 0.00 0.00	0.0000	192.70	No Ice 1/2" Ice 10.59	6.39 7.30	40.40 110.14
APX16DWV-16DWVS w/mount pipe	C	From Leg	5.00 0.00 0.00	0.0000	192.70	No Ice 1/2" Ice 10.59	6.39 7.30	40.40 110.14
Gen. TMA	A	From Leg	5.00 0.00 0.00	0.0000	191.50	No Ice 1/2" Ice 0.80	0.45 0.56	13.20 18.38
Gen. TMA	B	From Leg	5.00 0.00 0.00	0.0000	191.50	No Ice 1/2" Ice 0.80	0.45 0.56	13.20 18.38
Gen. TMA	C	From Leg	5.00 0.00 0.00	0.0000	191.50	No Ice 1/2" Ice 0.80	0.45 0.56	13.20 18.38

Omni 3"x20'	C	From Leg	5.00 0.00 0.00	0.0000	188.00	No Ice 1/2" Ice 8.03	6.00 8.03	50.00 93.17
Omni 3"x6'	B	From Leg	5.00 0.00 0.00	0.0000	181.00	No Ice 1/2" Ice 2.13	1.77 2.13	20.00 33.24

PiROD 14' T-Frame (AT&T - Existing)	A	From Leg	2.50 0.00 0.00	0.0000	179.00	No Ice 1/2" Ice 20.60	15.00 20.60	500.00 650.00
PiROD 14' T-Frame (AT&T - Existing)	B	From Leg	2.50 0.00 0.00	0.0000	179.00	No Ice 1/2" Ice 20.60	15.00 20.60	500.00 650.00
PiROD 14' T-Frame (AT&T - Existing)	C	From Leg	2.50 0.00 0.00	0.0000	179.00	No Ice 1/2" Ice 20.60	15.00 20.60	500.00 650.00
(2) Powerwave 7770 w/mount pipe (AT&T - Existing)	A	From Leg	5.00 0.00 0.00	0.0000	180.00	No Ice 1/2" Ice 6.47	4.10 4.75	57.25 101.14
(2) Powerwave 7770 w/mount pipe (AT&T - Existing)	B	From Leg	5.00 0.00 0.00	0.0000	180.00	No Ice 1/2" Ice 6.47	4.10 4.75	57.25 101.14
(2) Powerwave 7770 w/mount pipe (AT&T - Existing)	C	From Leg	5.00 0.00 0.00	0.0000	180.00	No Ice 1/2" Ice 6.47	4.10 4.75	57.25 101.14
(2) Powerwave TT19-08BP111-001 (AT&T - Existing)	A	From Leg	5.00 0.00 0.00	0.0000	180.00	No Ice 1/2" Ice 0.76	0.52 0.62	16.00 21.80
(2) Powerwave TT19-08BP111-001 (AT&T - Existing)	B	From Leg	5.00 0.00 0.00	0.0000	180.00	No Ice 1/2" Ice 0.76	0.52 0.62	16.00 21.80
(2) Powerwave TT19-08BP111-001 (AT&T - Existing)	C	From Leg	5.00 0.00 0.00	0.0000	180.00	No Ice 1/2" Ice 0.76	0.52 0.62	16.00 21.80

SBNH-1D6565C w/mount pipe (AT&T - Proposed) KMW	A	From Leg	5.00 0.00 0.00	0.0000	180.00	No Ice 1/2" Ice 12.40	10.29 11.81	113.11 203.89
AM-X-CD-16-65-00T-RET w/mount pipe	B	From Leg	5.00 0.00 0.00	0.0000	180.00	No Ice 1/2" Ice 9.15	6.30 7.48	74.05 136.21

tnxTower Hudson Design Group, LLC 1600 Osgood Street, Building 20 North, Suite 3090 North Andover, MA 01845 Phone: (978) 557-5553 FAX: (978) 226-5586	Job		CT 2171 Modification Uncasville, CT		Page	6 of 13
	Project		193 ft Guyed Tower		Date	17:13:52 01/17/13
	Client		AT&T		Designed by	kw

Description	Face or Leg	Offset Type	Offsets: Horz Lateral Vert ft ft ft	Azimuth Adjustment °	Placement ft	C _{MA} Front ft ²	C _{MA} Side ft ²	Weight lb	
(AT&T - Proposed)									
Powerwave P65-17-XLH-RR w/mount pipe	C	From Leg	5.00 0.00	0.0000	180.00	No Ice 1/2" Ice	11.75 12.47	9.39 10.90	122.11 209.23
(AT&T - Proposed)			0.00						
(2) Ericsson RRU (AT&T - Proposed)	A	From Leg	4.00 0.00	0.0000	180.00	No Ice 1/2" Ice	2.07 2.26	1.08 1.23	44.00 58.64
(2) Ericsson RRU (AT&T - Proposed)	B	From Leg	4.00 0.00	0.0000	180.00	No Ice 1/2" Ice	2.07 2.26	1.08 1.23	44.00 58.64
(2) Ericsson RRU (AT&T - Proposed)	C	From Leg	4.00 0.00	0.0000	180.00	No Ice 1/2" Ice	2.07 2.26	1.08 1.23	44.00 58.64
Surge Arrestor (DC6-48-60-18-8F) w/mount pipe	A	From Leg	0.50 0.00	0.0000	180.00	No Ice 1/2" Ice	2.45 2.95	2.45 2.95	38.25 64.62
(AT&T - Proposed)			0.00						

PiROD 14' T-Frame	A	From Leg	1.50 0.00	0.0000	168.00	No Ice 1/2" Ice	15.00 20.60	15.00 20.60	500.00 650.00
PiROD 14' T-Frame	B	From Leg	1.50 0.00	0.0000	168.00	No Ice 1/2" Ice	15.00 20.60	15.00 20.60	500.00 650.00
PiROD 14' T-Frame	C	From Leg	1.50 0.00	0.0000	168.00	No Ice 1/2" Ice	15.00 20.60	15.00 20.60	500.00 650.00
LPA-80080-4CF w/mount pipe	A	From Leg	2.50 0.00	0.0000	168.00	No Ice 1/2" Ice	2.87 3.24	7.24 7.95	30.25 74.63
BXA-171085-8BF-EDIN w/mount pipe	A	From Leg	2.50 0.00	0.0000	168.00	No Ice 1/2" Ice	3.17 3.54	3.34 3.95	28.75 58.78
BXA-80063/6CF w/Mount Pipe	A	From Leg	2.50 0.00	0.0000	168.00	No Ice 1/2" Ice	8.00 8.65	5.42 6.59	40.45 96.77
LPA-80080-4CF w/mount pipe	B	From Leg	2.50 0.00	0.0000	168.00	No Ice 1/2" Ice	2.87 3.24	7.24 7.95	30.25 74.63
BXA-171085-8BF-EDIN w/mount pipe	B	From Leg	2.50 0.00	0.0000	168.00	No Ice 1/2" Ice	3.17 3.54	3.34 3.95	28.75 58.78
BXA-80063/6CF w/Mount Pipe	B	From Leg	2.50 0.00	0.0000	168.00	No Ice 1/2" Ice	8.00 8.65	5.42 6.59	40.45 96.77
LPA-80080-4CF w/mount pipe	C	From Leg	2.50 0.00	0.0000	168.00	No Ice 1/2" Ice	2.87 3.24	7.24 7.95	30.25 74.63
BXA-171085-8BF-EDIN w/mount pipe	C	From Leg	2.50 0.00	0.0000	168.00	No Ice 1/2" Ice	3.17 3.54	3.34 3.95	28.75 58.78
BXA-80063/6CF w/Mount Pipe	C	From Leg	2.50 0.00	0.0000	168.00	No Ice 1/2" Ice	8.00 8.65	5.42 6.59	40.45 96.77

PiROD 14' T-Frame	A	From Leg	2.50 0.00	0.0000	151.00	No Ice 1/2" Ice	15.00 20.60	15.00 20.60	500.00 650.00

tnxTower Hudson Design Group, LLC 1600 Osgood Street, Building 20 North, Suite 3090 North Andover, MA 01845 Phone: (978) 557-5553 FAX: (978) 226-5586	Job CT 2171 Modification Uncasville, CT	Page 7 of 13
	Project 193 ft Guyed Tower	Date 17:13:52 01/17/13
	Client AT&T	Designed by kw

Description	Face or Leg	Offset Type	Offsets: Horz Lateral Vert ft ft ft	Azimuth Adjustment °	Placement ft	C _A A ₁ Front ft ²	C _A A ₁ Side ft ²	Weight lb
PiROD 14' T-Frame	B	From Leg	0.00 2.50 0.00	0.0000	151.00	No Ice 1/2" Ice 20.60	15.00 20.60	500.00 650.00
PiROD 14' T-Frame	C	From Leg	0.00 2.50 0.00	0.0000	151.00	No Ice 1/2" Ice 20.60	15.00 20.60	500.00 650.00
(2) DB980H90E-M w/Mount Pipe	A	From Leg	0.00 5.00 0.00	0.0000	151.00	No Ice 1/2" Ice 4.86	3.86 4.95	34.05 69.84
(2) DB980H90E-M w/Mount Pipe	B	From Leg	0.00 5.00 0.00	0.0000	151.00	No Ice 1/2" Ice 4.86	3.86 4.95	34.05 69.84
(2) DB980H90E-M w/Mount Pipe	C	From Leg	0.00 5.00 0.00	0.0000	151.00	No Ice 1/2" Ice 4.86	3.86 4.95	34.05 69.84
7' Dipole	C	From Leg	0.00 5.00 0.00	0.0000	154.50	No Ice 1/2" Ice 2.64	2.10 2.64	20.00 35.37

PiROD 14' T-Frame	A	From Leg	0.00 2.50 0.00	0.0000	141.00	No Ice 1/2" Ice 20.60	15.00 20.60	500.00 650.00
PiROD 14' T-Frame	B	From Leg	0.00 2.50 0.00	0.0000	141.00	No Ice 1/2" Ice 20.60	15.00 20.60	500.00 650.00
PiROD 14' T-Frame	C	From Leg	0.00 2.50 0.00	0.0000	141.00	No Ice 1/2" Ice 20.60	15.00 20.60	500.00 650.00
(4) DB844H90E-XY w/Mount Pipe	A	From Leg	0.00 5.00 0.00	0.0000	142.00	No Ice 1/2" Ice 3.48	4.92 5.60	28.25 64.88
(4) DB844H90E-XY w/Mount Pipe	B	From Leg	0.00 5.00 0.00	0.0000	142.00	No Ice 1/2" Ice 3.48	4.92 5.60	28.25 64.88
(4) DB844H90E-XY w/Mount Pipe	C	From Leg	0.00 5.00 0.00	0.0000	142.00	No Ice 1/2" Ice 3.48	4.92 5.60	28.25 64.88

PiROD 10' Lightweight T-Frame	A	From Leg	0.00 1.50 0.00	0.0000	129.00	No Ice 1/2" Ice 14.50	9.30 14.50	251.00 344.00
PiROD 10' Lightweight T-Frame	B	From Leg	0.00 1.50 0.00	0.0000	129.00	No Ice 1/2" Ice 14.50	9.30 14.50	251.00 344.00
PiROD 10' Lightweight T-Frame	C	From Leg	0.00 1.50 0.00	0.0000	129.00	No Ice 1/2" Ice 14.50	9.30 14.50	251.00 344.00
Kathrein 800 10504 w/mount pipe	A	From Leg	0.00 3.00 0.00	0.0000	130.00	No Ice 1/2" Ice 4.18	3.29 4.11	41.90 73.39
Kathrein 800 10504 w/mount pipe	B	From Leg	0.00 3.00 0.00	0.0000	130.00	No Ice 1/2" Ice 4.18	3.29 4.11	41.90 73.39
Kathrein 800 10504 w/mount pipe	C	From Leg	0.00 3.00 0.00	0.0000	130.00	No Ice 1/2" Ice 4.18	3.29 4.11	41.90 73.39

tnxTower Hudson Design Group, LLC 1600 Osgood Street, Building 20 North, Suite 3090 North Andover, MA 01845 Phone: (978) 557-5553 FAX: (978) 226-5586	Job		CT 2171 Modification Uncasville, CT		Page	8 of 13
	Project		193 ft Guyed Tower		Date	17:13:52 01/17/13
	Client		AT&T		Designed by	kw

Description	Face or Leg	Offset Type	Offsets: Horz Lateral Vert ft ft ft	Azimuth Adjustment °	Placement ft		C _A A _A Front ft ²	C _A A _A Side ft ²	Weight lb

Pirot 4' Side Mount Standoff (1)	B	From Leg	2.00 0.00 0.00	0.0000	119.50	No Ice 1/2" Ice	2.72 4.91	2.72 4.91	50.00 89.00
10' Dipole	B	From Leg	4.00 0.00 0.00	0.0000	124.00	No Ice 1/2" Ice	4.00 4.97	4.00 4.97	25.00 53.13

1' Standoff T-Arm (6' face width)	A	From Leg	0.50 0.00 0.00	0.0000	114.50	No Ice 1/2" Ice	3.50 4.20	3.50 4.20	85.00 110.00
1' Standoff T-Arm (6' face width)	B	From Leg	0.50 0.00 0.00	0.0000	114.50	No Ice 1/2" Ice	3.50 4.20	3.50 4.20	85.00 110.00
1' Standoff T-Arm (6' face width)	C	From Leg	0.50 0.00 0.00	0.0000	114.50	No Ice 1/2" Ice	3.50 4.20	3.50 4.20	85.00 110.00
Argus LLPX310R w/mount pipe	A	From Leg	1.00 0.00 0.00	0.0000	116.30	No Ice 1/2" Ice	4.94 5.32	2.81 3.32	43.60 78.53
Argus LLPX310R w/mount pipe	B	From Leg	1.00 0.00 0.00	0.0000	116.30	No Ice 1/2" Ice	4.94 5.32	2.81 3.32	43.60 78.53
Argus LLPX310R w/mount pipe	C	From Leg	1.00 0.00 0.00	0.0000	116.30	No Ice 1/2" Ice	4.94 5.32	2.81 3.32	43.60 78.53
RRH	A	From Leg	1.00 0.00 0.00	0.0000	114.50	No Ice 1/2" Ice	2.79 3.02	1.69 1.87	51.00 72.75
RRH	B	From Leg	1.00 0.00 0.00	0.0000	114.50	No Ice 1/2" Ice	2.79 3.02	1.69 1.87	51.00 72.75
RRH	C	From Leg	1.00 0.00 0.00	0.0000	114.50	No Ice 1/2" Ice	2.79 3.02	1.69 1.87	51.00 72.75
Junction Box 2'x2'	A	From Leg	0.50 0.00 0.00	0.0000	119.00	No Ice 1/2" Ice	5.60 5.92	1.40 1.60	15.00 44.78

6' Yagi	C	From Leg	1.00 0.00 0.00	0.0000	110.00	No Ice 1/2" Ice	1.40 1.88	0.35 0.48	35.00 85.85
3' Side Mount Standoff	B	From Leg	1.50 0.00 0.00	0.0000	104.00	No Ice 1/2" Ice	1.90 3.30	1.90 3.30	40.00 70.00
GPS	B	From Leg	3.00 0.00 0.00	0.0000	105.00	No Ice 1/2" Ice	0.21 0.32	0.21 0.32	5.00 7.52
Pirot 4' Side Mount Standoff (1)	B	From Leg	2.00 0.00 0.00	0.0000	108.00	No Ice 1/2" Ice	2.72 4.91	2.72 4.91	50.00 89.00
Omni 3"x20'	B	From Leg	4.00 0.00 0.00	0.0000	117.00	No Ice 1/2" Ice	6.00 8.03	6.00 8.03	50.00 93.17
Pirot 4' Side Mount Standoff (1)	A	From Leg	2.00 0.00 0.00	0.0000	108.00	No Ice 1/2" Ice	2.72 4.91	2.72 4.91	50.00 89.00

tnxTower Hudson Design Group, LLC 1600 Osgood Street, Building 20 North, Suite 3090 North Andover, MA 01845 Phone: (978) 557-5553 FAX: (978) 226-5586	Job CT 2171 Modification Uncasville, CT	Page 9 of 13
	Project 193 ft Guyed Tower	Date 17:13:52 01/17/13
	Client AT&T	Designed by kw

Description	Face or Leg	Offset Type	Offsets: Horz Lateral Vert ft ft ft	Azimuth Adjustment °	Placement ft	C _{AA} Front	C _{AA} Side	Weight lb
Omni 3"x20"	A	From Leg	4.00	0.0000	117.00	No Ice	6.00	50.00
			0.00			1/2" Ice	8.03	93.17
			0.00					

Load Combinations

Comb. No.	Description
1	Dead Only
2	Dead+Wind 0 deg - No Ice+Guy
3	Dead+Wind 90 deg - No Ice+Guy
4	Dead+Wind 180 deg - No Ice+Guy
5	Dead+Ice+Temp+Guy
6	Dead+Wind 0 deg+Ice+Temp+Guy
7	Dead+Wind 90 deg+Ice+Temp+Guy
8	Dead+Wind 180 deg+Ice+Temp+Guy
9	Dead+Wind 0 deg - Service+Guy
10	Dead+Wind 90 deg - Service+Guy
11	Dead+Wind 180 deg - Service+Guy

Maximum Reactions

Location	Condition	Gov. Load Comb.	Vertical lb	Horizontal, X lb	Horizontal, Z lb
Mast	Max. Vert	6	210107.08	-3.15	227.35
	Max. H _x	4	142838.30	3.64	-1798.28
	Max. H _z	9	108781.88	-0.54	593.09
	Max. M _x	1	0.00	-0.20	-0.16
	Max. M _z	1	0.00	-0.20	-0.16
	Max. Torsion	11	-97.70	0.07	-579.51
	Min. Vert	1	108040.90	-0.20	-0.16
	Min. H _x	3	183043.66	-977.98	486.31
	Min. H _z	4	142838.30	3.64	-1798.28
	Min. M _x	1	0.00	-0.20	-0.16
	Min. M _z	1	0.00	-0.20	-0.16
	Min. Torsion	6	-221.46	-3.15	227.35
	Guy C @ 132 ft Elev 2 ft Azimuth 240 deg	Max. Vert	4	-4683.43	-3507.24
Max. H _x		4	-4683.43	-3507.24	1428.69
Max. H _z		3	-55719.11	-40294.80	22537.34
Min. Vert		3	-55719.11	-40294.80	22537.34
Min. H _x		3	-55719.11	-40294.80	22537.34
Min. H _z		4	-4683.43	-3507.24	1428.69
Guy B @ 132 ft Elev 2 ft Azimuth 120 deg	Max. Vert	3	-1319.99	645.29	657.25
	Max. H _x	2	-48082.27	33933.67	20691.57
	Max. H _z	2	-48082.27	33933.67	20691.57

tnxTower Hudson Design Group, LLC 1600 Osgood Street, Building 20 North, Suite 3090 North Andover, MA 01845 Phone: (978) 557-5553 FAX: (978) 226-5586	Job CT 2171 Modification Uncasville, CT	Page 10 of 13
	Project 193 ft Guyed Tower	Date 17:13:52 01/17/13
	Client AT&T	Designed by kw

Location	Condition	Gov. Load Comb.	Vertical lb	Horizontal, X lb	Horizontal, Z lb
Guy A @ 132 ft Elev 2 ft Azimuth 0 deg	Min. Vert	2	-48082.27	33933.67	20691.57
	Min. H _x	3	-1319.99	645.29	657.25
	Min. H _z	3	-1319.99	645.29	657.25
	Max. Vert	2	-633.91	-0.02	-316.98
	Max. H _x	4	-51751.87	3.24	-42912.51
	Max. H _z	2	-633.91	-0.02	-316.98
	Min. Vert	4	-51751.87	3.24	-42912.51
Guy C @ 88 ft Elev 2 ft Azimuth 240 deg	Min. H _x	7	-26430.45	-1159.32	-21848.69
	Min. H _z	4	-51751.87	3.24	-42912.51
	Max. Vert	4	-3816.40	-3997.95	1905.93
	Max. H _x	4	-3816.40	-3997.95	1905.93
	Max. H _z	3	-38587.84	-36644.32	20778.84
	Min. Vert	3	-38587.84	-36644.32	20778.84
	Min. H _x	3	-38587.84	-36644.32	20778.84
Guy B @ 88 ft Elev 2 ft Azimuth 120 deg	Min. H _z	4	-3816.40	-3997.95	1905.93
	Max. Vert	3	-894.09	722.51	600.16
	Max. H _x	2	-33119.96	30932.43	18498.77
	Max. H _z	2	-33119.96	30932.43	18498.77
	Min. Vert	2	-33119.96	30932.43	18498.77
	Min. H _x	3	-894.09	722.51	600.16
	Min. H _z	3	-894.09	722.51	600.16
Guy A @ 88 ft Elev 2 ft Azimuth 0 deg	Max. Vert	2	-381.33	0.03	-361.34
	Max. H _x	9	-5125.59	0.77	-6084.64
	Max. H _z	2	-381.33	0.03	-361.34
	Min. Vert	4	-36197.80	-7.44	-39787.12
	Min. H _x	7	-18083.62	-856.13	-20171.59
	Min. H _z	4	-36197.80	-7.44	-39787.12

Tower Mast Reaction Summary

Load Combination	Vertical lb	Shear _x lb	Shear _z lb	Overturning Moment, M _x lb-ft	Overturning Moment, M _z lb-ft	Torque lb-ft
Dead Only	108040.90	0.20	0.16	0.00	0.00	100.65
Dead+Wind 0 deg - No Ice+Guy	201714.24	2.62	-523.14	0.00	0.00	209.58
Dead+Wind 90 deg - No Ice+Guy	183043.66	977.98	-486.31	0.00	0.00	200.44
Dead+Wind 180 deg - No Ice+Guy	142838.30	-3.64	1798.28	0.00	0.00	104.86
Dead+Ice+Temp+Guy	142893.78	0.72	0.29	0.00	0.00	132.54
Dead+Wind 0 deg+Ice+Temp+Guy	210107.08	3.15	-227.35	0.00	0.00	221.46
Dead+Wind 90 deg+Ice+Temp+Guy	198599.60	605.43	-448.41	0.00	0.00	177.66
Dead+Wind 180 deg+Ice+Temp+Guy	177092.06	-2.00	1233.80	0.00	0.00	137.07
Dead+Wind 0 deg -	108781.88	0.54	-593.09	0.00	0.00	104.85

tnxTower Hudson Design Group, LLC 1600 Osgood Street, Building 20 North, Suite 3090 North Andover, MA 01845 Phone: (978) 557-5553 FAX: (978) 226-5586	Job CT 2171 Modification Uncasville, CT	Page 11 of 13
	Project 193 ft Guyed Tower	Date 17:13:52 01/17/13
	Client AT&T	Designed by kw

Load Combination	Vertical lb	Shear _x lb	Shear _z lb	Overturning Moment, M _x lb-ft	Overturning Moment, M _z lb-ft	Torque lb-ft
Service+Guy						
Dead+Wind 90 deg - Service+Guy	108762.12	583.77	1.67	0.00	0.00	98.59
Dead+Wind 180 deg - Service+Guy	108787.07	-0.07	579.51	0.00	0.00	97.70

Maximum Tower Deflections - Service Wind

Section No.	Elevation ft	Horz. Deflection in	Gov. Load Comb.	Tilt °	Twist °
T1	193 - 180	4.033	9	0.2414	0.0221
T2	180 - 160	3.379	9	0.2301	0.0190
T3	160 - 140	2.559	9	0.1306	0.0099
T4	140 - 120	2.132	9	0.1026	0.0024
T5	120 - 100	1.652	11	0.1221	0.0115
T6	100 - 80	1.207	11	0.0717	0.0093
T7	80 - 60	1.014	11	0.0514	0.0068
T8	60 - 40	0.771	11	0.0655	0.0057
T9	40 - 20	0.481	11	0.0564	0.0019
T10	20 - 5	0.290	11	0.0597	0.0128
T11	5 - 0	0.076	11	0.0699	0.0011

Critical Deflections and Radius of Curvature - Service Wind

Elevation ft	Appurtenance	Gov. Load Comb.	Deflection in	Tilt °	Twist °	Radius of Curvature ft
192.70	APX16DWV-16DWVS w/mount pipe	9	4.017	0.2414	0.0221	82800
192.00	PiROD 12' T-Frame	9	3.982	0.2415	0.0219	82800
191.50	Gen. TMA	9	3.956	0.2416	0.0218	82800
188.00	Omni 3"x20'	9	3.778	0.2414	0.0211	82800
181.00	Omni 3"x6'	9	3.428	0.2328	0.0193	33362
180.00	(2) Powerwave 7770 w/mount pipe	9	3.379	0.2301	0.0190	29965
179.00	PiROD 14' T-Frame	9	3.331	0.2269	0.0187	26866
168.00	PiROD 14' T-Frame	9	2.839	0.1723	0.0141	11189
162.63	Guy	9	2.642	0.1429	0.0114	8762
154.50	7' Dipole	9	2.417	0.1120	0.0067	12731
151.00	PiROD 14' T-Frame	9	2.342	0.1049	0.0049	21256
142.00	(4) DB844H90E-XY w/Mount Pipe	9	2.172	0.1011	0.0023	28989
141.00	PiROD 14' T-Frame	9	2.152	0.1018	0.0023	24629
130.00	Kathrein 800 10504 w/mount pipe	10	1.908	0.1167	0.0063	37272
129.00	PiROD 10' Lightweight T-Frame	10	1.883	0.1181	0.0069	41585
124.00	10' Dipole	10	1.756	0.1227	0.0098	98773
119.50	PiROD 4' Side Mount Standoff (1)	11	1.639	0.1217	0.0117	164942
119.00	Junction Box 2'x2'	11	1.627	0.1212	0.0118	126306
117.00	Omni 3"x20'	11	1.575	0.1183	0.0121	63045
116.30	Argus LLPX310R w/mount pipe	11	1.557	0.1171	0.0122	53247
114.50	1' Standoff T-Arm (6' face width)	11	1.512	0.1133	0.0123	37859
110.00	6' Yagi	11	1.403	0.1014	0.0118	21953
108.00	PiROD 4' Side Mount Standoff (1)	11	1.358	0.0954	0.0114	18499
105.00	GPS	11	1.295	0.0861	0.0106	14966
104.00	3' Side Mount Standoff	11	1.276	0.0830	0.0103	14084

tnxTower Hudson Design Group, LLC 1600 Osgood Street, Building 20 North, Suite 3090 North Andover, MA 01845 Phone: (978) 557-5553 FAX: (978) 226-5586	Job CT 2171 Modification Uncasville, CT	Page 12 of 13
	Project 193 ft Guyed Tower	Date 17:13:52 01/17/13
	Client AT&T	Designed by kw

Elevation	Appurtenance	Gov. Load	Deflection	Tilt	Twist	Radius of Curvature
ft		Comb.	in	°	°	ft
102.63	Guy	11	1.251	0.0789	0.0100	13158
42.63	Guy	11	0.513	0.0577	0.0010	25641

Section Capacity Table

Section No.	Elevation ft	Component Type	Size	Critical Element	P lb	SF*P _{allow} lb	% Capacity	Pass Fail
T1	193 - 180	Leg	ROHN 2.5 EH	3	-17953.20	80468.01	22.3	Pass
T2	180 - 160	Leg	ROHN 2.5 EH (CT2171)	42	-100430.00	115924.20	86.6	Pass
T3	160 - 140	Leg	ROHN 2.5 EH (CT2171)	123	-90759.60	113280.33	80.1	Pass
T4	140 - 120	Leg	ROHN 2.5 EH	204	-52894.90	78691.25	67.2	Pass
T5	120 - 100	Leg	ROHN 3 EH	261	-107317.00	112344.04	95.5	Pass
T6	100 - 80	Leg	ROHN 3 EH	342	-103760.00	108371.83	95.7	Pass
T7	80 - 60	Leg	ROHN 3 EH	399	-74845.40	106297.95	70.4	Pass
T8	60 - 40	Leg	ROHN 3 EH	456	-90727.00	106795.02	85.0	Pass
T9	40 - 20	Leg	ROHN 3 EH	513	-87696.40	96680.09	90.7	Pass
T10	20 - 5	Leg	ROHN 3 EH	545	-71197.80	96867.11	73.5	Pass
T11	5 - 0	Leg	ROHN 3 EH	571	-77153.30	111258.84	69.3	Pass
T1	193 - 180	Diagonal	L2x2x1/4	11	-2509.19	12217.93	20.5	Pass
T2	180 - 160	Diagonal	L2x2x1/4	54	-11922.70	19784.12	60.3	Pass
T3	160 - 140	Diagonal	L2x2x1/4	195	-7515.19	19784.12	38.0	Pass
T4	140 - 120	Diagonal	ROHN TS1.5x11 ga	212	-3113.85	9932.49	31.4	Pass
T5	120 - 100	Diagonal	L2x2x1/4	273	-7513.78	19867.03	37.8	Pass
T6	100 - 80	Diagonal	ROHN TS1.5x16 ga	391	-3653.35	5323.86	68.6	Pass
T7	80 - 60	Diagonal	L1 3/4x1 3/4x3/16	453	-2036.79	6588.45	30.9	Pass
T8	60 - 40	Diagonal	ROHN TS1.5x16 ga	468	-3819.76	5323.86	71.7	Pass
T9	40 - 20	Diagonal	ROHN TS1.5x16 ga	543	-4082.19	5323.86	76.7	Pass
T10	20 - 5	Diagonal	ROHN TS1.5x16 ga	570	-1378.82	5333.43	25.9	Pass
T11	5 - 0	Horizontal	L4x4x1/4	583	-1536.85	39735.26	3.9	Pass
T2	180 - 160	Secondary Horizontal	L2x2x1/4	55	-6028.44	17227.69	35.0	Pass
T3	160 - 140	Secondary Horizontal	L2x2x1/4	199	1875.09	27007.65	6.9	Pass
T5	120 - 100	Secondary Horizontal	L2x2x1/4	283	6372.18	27007.65	23.6	Pass
T1	193 - 180	Top Girt	L2x2x1/4	4	-269.64	14588.62	1.8	Pass
T2	180 - 160	Top Girt	L2x2x1/4	43	-596.38	14610.08	4.1	Pass
T3	160 - 140	Top Girt	ROHN TS1.5x11 ga	124	1916.23	17475.90	11.0	Pass
T4	140 - 120	Top Girt	ROHN TS1.5x16 ga	205	620.90	8826.21	7.0	Pass
T5	120 - 100	Top Girt	L2x2x1/4	264	860.96	27007.65	3.2	Pass
T6	100 - 80	Top Girt	ROHN TS1.5x11 ga	343	1808.81	17475.90	10.4	Pass
T7	80 - 60	Top Girt	ROHN TS1.5x11 ga	401	896.20	17475.90	5.1	Pass
T8	60 - 40	Top Girt	ROHN TS1.5x11 ga	458	702.23	17475.90	4.0	Pass
T9	40 - 20	Top Girt	ROHN TS1.5x16 ga	516	1282.65	8826.21	14.5	Pass
T10	20 - 5	Top Girt	ROHN TS1.5x16 ga	549	274.70	8826.21	3.1	Pass
T11	5 - 0	Top Girt	L4x4x1/4	574	12261.20	55858.03	22.0	Pass
T1	193 - 180	Bottom Girt	L2x2x1/4	7	-293.02	14588.62	2.0	Pass
T2	180 - 160	Bottom Girt	L2x2x1/4	46	-5167.21	14610.08	35.4	Pass
T3	160 - 140	Bottom Girt	ROHN TS1.5x11 ga	127	706.29	17475.90	4.0	Pass
T4	140 - 120	Bottom Girt	ROHN TS1.5x16 ga	210	595.62	8826.21	6.7	Pass
T5	120 - 100	Bottom Girt	L2x2x1/4	265	-2354.28	14722.85	16.0	Pass
T6	100 - 80	Bottom Girt	ROHN TS1.5x11 ga	347	684.02	17475.90	3.9	Pass
T7	80 - 60	Bottom Girt	ROHN TS1.5x11 ga	404	890.69	17475.90	5.1	Pass
T8	60 - 40	Bottom Girt	ROHN TS1.5x11 ga	461	1228.46	17475.90	7.0	Pass
T9	40 - 20	Bottom Girt	ROHN TS1.5x16 ga	517	318.60	8826.21	3.6	Pass
T10	20 - 5	Bottom Girt	ROHN TS1.5x16 ga	550	5075.85	8826.21	57.5	Pass
T2	180 - 160	Guy A@162.625	7/8	595	33946.40	39850.00	85.2	Pass
T5	120 - 100	Guy A@102.625	3/4	606	19887.20	29150.00	68.2	Pass
T8	60 - 40	Guy A@42.625	1/2	618	7750.26	13450.00	57.6	Pass
T2	180 - 160	Guy B@162.625	7/8	590	32186.80	39850.00	80.8	Pass

tnxTower Hudson Design Group, LLC 1600 Osgood Street, Building 20 North, Suite 3090 North Andover, MA 01845 Phone: (978) 557-5553 FAX: (978) 226-5586	Job CT 2171 Modification Uncasville, CT	Page 13 of 13
	Project 193 ft Guyed Tower	Date 17:13:52 01/17/13
	Client AT&T	Designed by kw

Section No.	Elevation ft	Component Type	Size	Critical Element	P lb	SF*P _{allow} lb	% Capacity	Pass Fail	
T5	120 - 100	Guy B@102.625	3/4	602	18539.60	29150.00	63.6	Pass	
T8	60 - 40	Guy B@42.625	1/2	614	6792.41	13450.00	50.5	Pass	
T2	180 - 160	Guy C@162.625	7/8	586	36938.50	39850.00	92.7	Pass	
T5	120 - 100	Guy C@102.625	3/4	598	21568.60	29150.00	74.0	Pass	
T8	60 - 40	Guy C@42.625	1/2	610	8019.12	13450.00	59.6	Pass	
T2	180 - 160	Torque Arm Top@162.625	C15x50	593	-13515.10	168624.49	88.5	Pass	
T5	120 - 100	Torque Arm Top@102.625	MC12x31	605	-8437.53	137872.18	75.2	Pass	
T8	60 - 40	Torque Arm Top@42.625	C12x25	617	-4504.67	109746.02	24.5	Pass	
							Summary		
							Leg (T6)	95.7	Pass
							Diagonal (T9)	76.7	Pass
							Horizontal (T11)	3.9	Pass
							Secondary Horizontal (T2)	35.0	Pass
							Top Girt (T11)	22.0	Pass
							Bottom Girt (T10)	57.5	Pass
							Guy A (T2)	85.2	Pass
							Guy B (T2)	80.8	Pass
							Guy C (T2)	92.7	Pass
							Torque Arm Top (T2)	88.5	Pass
							RATING =	95.7	Pass

DATE: 1/17/2013

Project Name: CT2171

Project No.: _____

Design By: KW Chk'd By: _____ Page 2 of 5



NEGLECT SOIL PRESSURE & HORIZONTAL REACTION

$$W_1 = 0.15 \times 7 \times 7 \times 1.75 = 12.9 \text{ kips}$$

$$W_2 = 0.15 \times 2.5 \times 2.5 \times 3.75 = 3.5 \text{ kips}$$

$$W_3 = 0.125 \times (7 \times 7 - 2.5 \times 2.5) \times 3.25 = 17.4 \text{ kips}$$

$$\Sigma W = 33.8 \text{ kips}$$

$$F.S. (\text{SLIDING}) = \frac{0.45 \times (210.1 + 33.8)}{0.23} = 477.2 \quad \text{OK}$$

$$\text{BEARING PRESSURE} = \frac{210.1 + 33.8}{7 \times 7} = 4.98 \text{ ksf} \quad \text{OK}$$



GUY ANCHOR (@ 88' RADIUS)

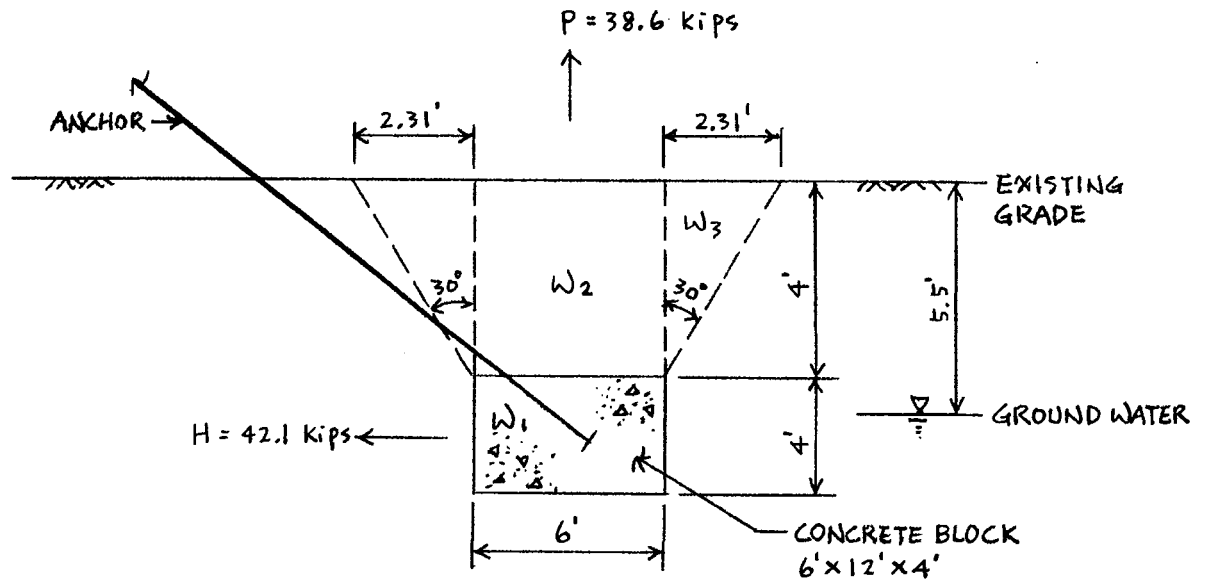

MAXIMUM REACTIONS AT GUY ANCHOR

$P = 38.6$ kips

$H = 42.1$ kips

$W_1 = 0.15 \times 6 \times 12 \times 1.5 + 0.088 \times 6 \times 12 \times 2.5 = 32.0$ kips

$W_2 = 0.125 \times 6 \times 12 \times 4 = 36.0$ kips

$W_3 = 0.125 \times (8.31 \times 14.31 - 6 \times 12) \times 4 = 23.5$ kips

SOIL PRESSURE

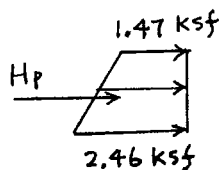

$H_p = \frac{1}{2} \times (1.47 + 2.46) \times 4 \times 12 = 94.3$ kips

F.S. (SLIDING) = $\frac{0.45 \times (91.5 - 38.6) + 94.3}{42.1} = 2.8$ OK

DATE: 1/17/2013
Project Name: CT2171
Project No.: _____
Design By: KW Chk'd By: _____

Page 4 of 5



CHECK UPLIFT

$$\frac{W_R}{2} + \frac{W_c}{1.25} = \frac{59.5}{2} + \frac{32.0}{1.25} = 55.4 \text{ kips} > 38.6 \text{ kips} \quad \text{OK}$$

$$\frac{W_R + W_c}{1.5} = \frac{91.5}{1.5} = 61.0 \text{ kips} > 38.6 \text{ kips} \quad \text{OK}$$



GUY ANCHOR (@ 132' RADIUS)

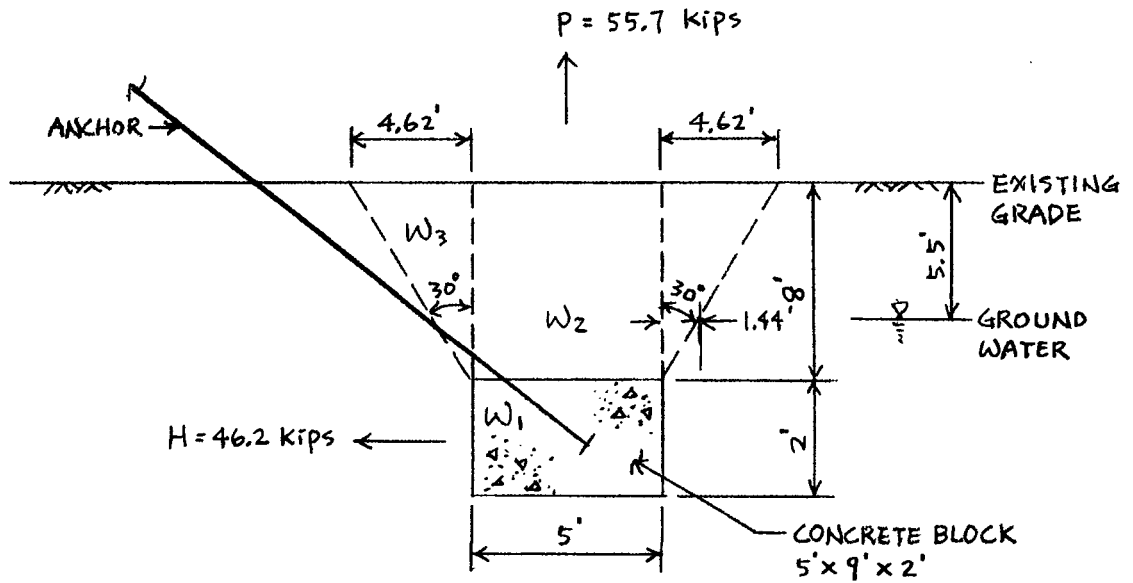

MAXIMUM REACTIONS AT GUY ANCHOR

$P = 55.7 \text{ kips}$

$H = 46.2 \text{ kips}$

$W_1 = 0.088 \times 5 \times 9 \times 2 = 7.9 \text{ kips}$

$W_2 = 0.125 \times 5 \times 9 \times 8 = 45.0 \text{ kips}$

$W_3 = 0.125 \times (11.06 \times 15.06 - 5 \times 9) \times 5.5 = 83.6 \text{ kips}$
 $= 0.06 \times (6.44 \times 10.44 - 5 \times 9) \times 2.5 = 3.3 \text{ kips}$

SOIL PRESSURE

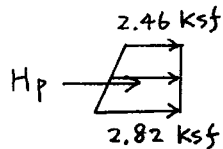

$H_p = \frac{1}{2} \times (2.46 + 2.82) \times 2 \times 9 = 47.5 \text{ kips}$

F.S. (SLIDING) = $\frac{0.45 \times (139.8 - 55.7) + 47.5}{46.2} = 1.8 \text{ OK}$

CHECK UPLIFT

$\frac{131.9}{2} + \frac{7.9}{1.25} = 72.3 \text{ kips} > 55.7 \text{ kips} \text{ OK}$

$\frac{131.9 + 7.9}{1.5} = 93.2 \text{ kips} > 55.7 \text{ kips} \text{ OK}$



C Squared Systems, LLC
65 Dartmouth Drive, Unit A3
Auburn, NH 03032
(603) 644-2800
support@csquaredsystems.com

Calculated Radio Frequency Emissions



CT2171

(Uncasville)

57 Cook Drive, Uncasville, CT 06382

a.k.a. (Montville – 57 Cook Street)

January 23, 2013

Table of Contents

1. Introduction.....	1
2. FCC Guidelines for Evaluating RF Radiation Exposure Limits.....	1
3. RF Exposure Prediction Methods	2
4. Calculation Results	3
5. Conclusion	4
6. Statement of Certification	4
Attachment A: References	5
Attachment B: FCC Limits for Maximum Permissible Exposure (MPE).....	6
Attachment C: AT&T Antenna Data Sheets and Electrical Patterns.....	8

List of Tables

Table 1: Carrier Information	3
Table 2: FCC Limits for Maximum Permissible Exposure (MPE)	6

List of Figures

Figure 1: Graph of FCC Limits for Maximum Permissible Exposure (MPE).....	7
---	---

1. Introduction

The purpose of this report is to investigate compliance with applicable FCC regulations for the proposed modifications to the existing AT&T antenna arrays mounted on the guyed wire tower located at 57 Cook Drive in Uncasville, CT. The coordinates of the tower are 41° 28' 29.9" N, 72° 06' 18.0" W.

AT&T is proposing the following modifications:

- 1) Install three multi-band (700/850/1900/2100 MHz) antennas for their LTE network (one per sector).

2. FCC Guidelines for Evaluating RF Radiation Exposure Limits

In 1985, the FCC established rules to regulate radio frequency (RF) exposure from FCC licensed antenna facilities. In 1996, the FCC updated these rules, which were further amended in August 1997 by OET Bulletin 65 Edition 97-01. These new rules include Maximum Permissible Exposure (MPE) limits for transmitters operating between 300 kHz and 100 GHz. The FCC MPE limits are based upon those recommended by the National Council on Radiation Protection and Measurements (NCRP), developed by the Institute of Electrical and Electronics Engineers, Inc., (IEEE) and adopted by the American National Standards Institute (ANSI).

The FCC general population/uncontrolled limits set the maximum exposure to which most people may be subjected. General population/uncontrolled exposures apply in situations in which the general public may be exposed, or in which persons that are exposed as a consequence of their employment may not be fully aware of the potential for exposure or cannot exercise control over their exposure.

Public exposure to radio frequencies is regulated and enforced in units of milliwatts per square centimeter (mW/cm^2). The general population exposure limits for the various frequency ranges are defined in the attached "FCC Limits for Maximum Permissible Exposure (MPE)" in Attachment B of this report.

Higher exposure limits are permitted under the occupational/controlled exposure category, but only for persons who are exposed as a consequence of their employment and who have been made fully aware of the potential for exposure, and they must be able to exercise control over their exposure. General population/uncontrolled limits are five times more stringent than the levels that are acceptable for occupational, or radio frequency trained individuals. Attachment B contains excerpts from OET Bulletin 65 and defines the Maximum Exposure Limit.

Finally, it should be noted that the MPE limits adopted by the FCC for both general population/uncontrolled exposure and for occupational/controlled exposure incorporate a substantial margin of safety and have been established to be well below levels generally accepted as having the potential to cause adverse health effects.

3. RF Exposure Prediction Methods

The emission field calculation results displayed in the following figures were generated using the following formula as outlined in FCC bulletin OET 65:

$$\text{Power Density} = \left(\frac{1.6^2 \times \text{EIRP}}{4\pi \times R^2} \right) \times \text{Off Beam Loss}$$

Where:

EIRP = Effective Isotropic Radiated Power

$$R = \text{Radial Distance} = \sqrt{(H^2 + V^2)}$$

H = Horizontal Distance from antenna in meters

V = Vertical Distance from radiation center of antenna in meters

Ground reflection factor of 1.6

Off Beam Loss is determined by the selected antenna pattern

These calculations assume that the antennas are operating at 100 percent capacity and power, and that all channels are transmitting simultaneously. Obstructions (trees, buildings, etc.) that would normally attenuate the signal are not taken into account. The calculations assume even terrain in the area of study and do not take into account actual terrain elevations which could attenuate the signal. As a result, the predicted signal levels reported below are much higher than the actual signal levels will be from the finished modifications.

4. Calculation Results

Table 1 below outlines the power density information for the site. Because the proposed AT&T antennas are directional in nature, the majority of the RF power is focused out towards the horizon. As a result, there will be less RF power directed below the antennas relative to the horizon, and consequently lower power density levels around the base of the tower. Please refer to Attachment C for the vertical patterns of the proposed AT&T antennas. The calculated results for AT&T in Table 1 include a nominal 10 dB off-beam pattern loss to account for the lower relative gain below the antennas.

Carrier	Antenna Height (Feet)	Operating Frequency (MHz)	Number of Trans.	ERP Per Transmitter (Watts)	Power Density (mw/cm ²)	Limit	%MPE
Cingular UMTS	177	880	1	500	0.0057	0.5867	0.98%
Cingular GSM	177	880	4	296	0.0136	0.5867	2.32%
Cingular GSM	177	1900	2	427	0.0098	1.0000	0.98%
Clearwire	120	2500	6	285.76	0.0428	1.0000	4.28%
MetroPCS	130	2140	3	443.61	0.0283	1.0000	2.83%
Nextel	134	851	12	100	0.0240	0.5673	4.24%
Verizon cellular	169	869	9	288	0.0326	0.5793	5.63%
Verizon PCS	169	1970	7	233	0.0205	1.0000	2.05%
Verizon AWS	169	2145	1	583	0.0073	1.0000	0.73%
Verizon LTE	169	698	1	760	0.0096	0.4653	2.06%
Sprint	160	1962.5	3	200	0.0084	1.0000	0.84%
T-Mobile	192	1935	8	157	0.0123	1.0000	1.23%
AT&T UMTS	180	880	2	565	0.0013	0.5867	0.21%
AT&T UMTS	180	1900	2	875	0.0019	1.0000	0.19%
AT&T LTE	180	734	1	1615	0.0018	0.4893	0.37%
AT&T GSM	180	880	1	283	0.0003	0.5867	0.05%
AT&T GSM	180	1900	4	525	0.0023	1.0000	0.23%
Total						24.95%	

Table 1: Carrier Information^{1 2 3}

¹ The existing CSC filing for Cingular should be removed and replaced with the updated AT&T technologies and values provided in Table 1. The power density information for carriers other than AT&T was taken directly from the CSC database dated 1/14/2013. Please note that %MPE values listed are rounded to two decimal points. The total %MPE listed is a summation of each unrounded contribution. Therefore, summing each rounded value may not reflect the total value listed in the table.

² In the case where antenna models are not uniform across all 3 sectors for the same frequency band, the antenna model with the highest gain was used for the calculations to present a worse-case scenario.

³ Antenna height listed for AT&T is in reference to the Hudson Design Group Structural Analysis dated January 18, 2013.

5. Conclusion

The above analysis verifies that emissions from the existing site will be below the maximum power density levels as outlined by the FCC in the OET Bulletin 65 Ed. 97-01. Even when using conservative methods, the cumulative power density from the proposed transmit antennas at the existing facility is well below the limits for the general public. The highest expected percent of Maximum Permissible Exposure at ground level is **24.95% of the FCC limit**.

As noted previously, obstructions (trees, buildings, etc.) that would normally attenuate the signal are not taken into account. As a result, the predicted signal levels are more conservative (higher) than the actual signal levels will be from the finished modifications.

6. Statement of Certification

I certify to the best of my knowledge that the statements in this report are true and accurate. The calculations follow guidelines set forth in ANSI/IEEE Std. C95.3, ANSI/IEEE Std. C95.1 and FCC OET Bulletin 65 Edition 97-01.

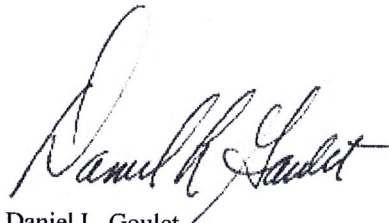

Daniel L. Goulet
C Squared Systems, LLC

January 23, 2013

Date

Attachment A: References

OET Bulletin 65 - Edition 97-01 - August 1997 Federal Communications Commission Office of Engineering & Technology

ANSI C95.1-1982, American National Standard Safety Levels With Respect to Human Exposure to Radio Frequency Electromagnetic Fields, 300 kHz to 100 GHz. IEEE-SA Standards Board

IEEE Std C95.3-1991 (Reaff 1997), IEEE Recommended Practice for the Measurement of Potentially Hazardous Electromagnetic Fields - RF and Microwave. IEEE-SA Standards Board

Attachment B: FCC Limits for Maximum Permissible Exposure (MPE)

(A) Limits for Occupational/Controlled Exposure⁴

Frequency Range (MHz)	Electric Field Strength (E) (V/m)	Magnetic Field Strength (E) (A/m)	Power Density (S) (mW/cm ²)	Averaging Time E ² , H ² or S (minutes)
0.3-3.0	614	1.63	(100)*	6
3.0-30	1842/f	4.89/f	(900/f ²)*	6
30-300	61.4	0.163	1.0	6
300-1500	-	-	f/300	6
1500-100,000	-	-	5	6

(B) Limits for General Population/Uncontrolled Exposure⁵

Frequency Range (MHz)	Electric Field Strength (E) (V/m)	Magnetic Field Strength (E) (A/m)	Power Density (S) (mW/cm ²)	Averaging Time E ² , H ² or S (minutes)
0.3-1.34	614	1.63	(100)*	30
1.34-30	824/f	2.19/f	(180/f ²)*	30
30-300	27.5	0.073	0.2	30
300-1500	-	-	f/1500	30
1500-100,000	-	-	1.0	30

f = frequency in MHz * Plane-wave equivalent power density

Table 2: FCC Limits for Maximum Permissible Exposure (MPE)

⁴ Occupational/controlled limits apply in situations in which persons are exposed as a consequence of their employment provided those persons are fully aware of the potential for exposure and can exercise control over their exposure. Limits for occupational/controlled exposure also apply in situations when an individual is transient through a location where occupational/controlled limits apply provided he or she is made aware of the potential for exposure.

⁵ General population/uncontrolled exposures apply in situations in which the general public may be exposed, or in which persons that are exposed as a consequence of their employment may not be fully aware of the potential for exposure or cannot exercise control over their exposure.

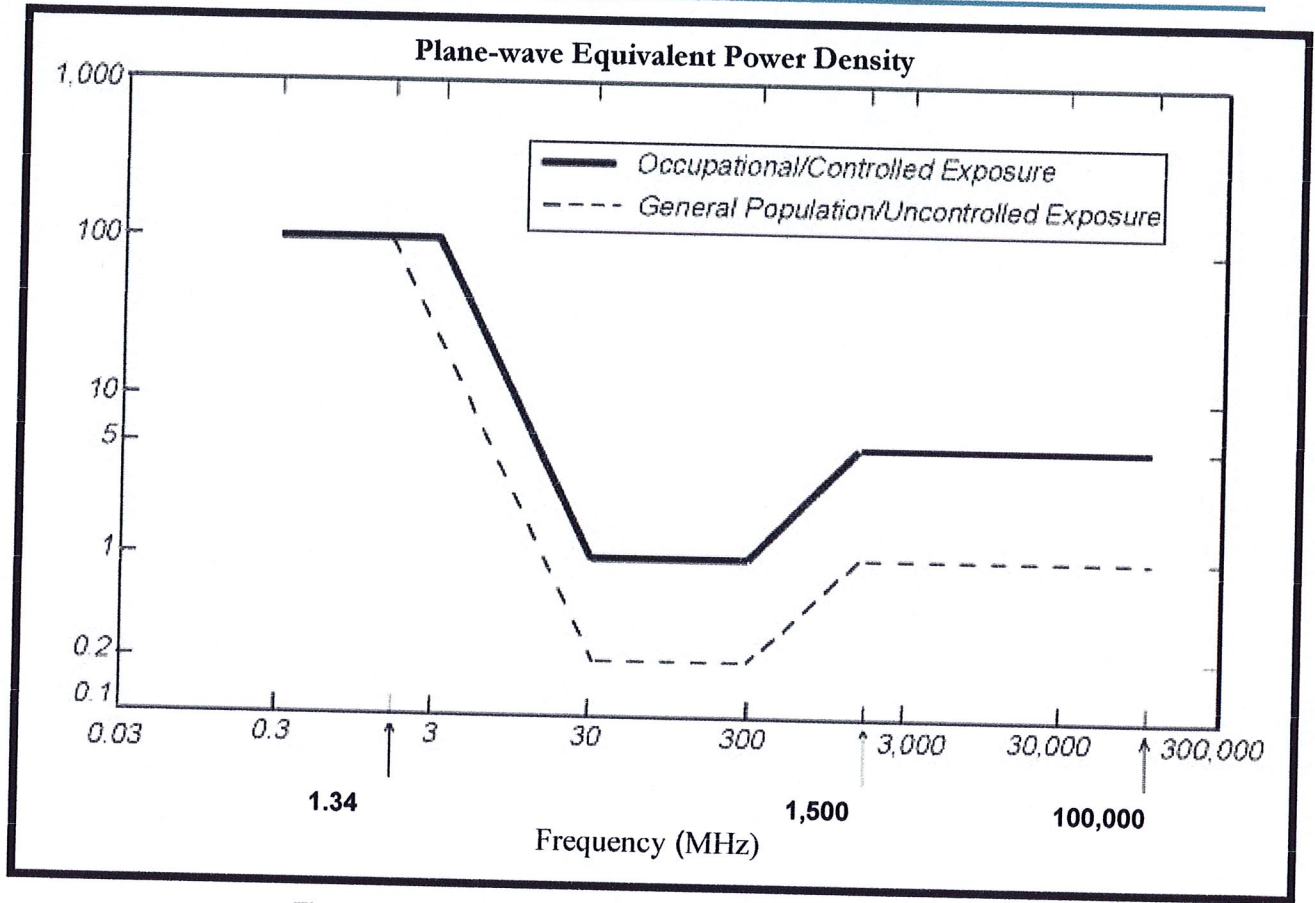
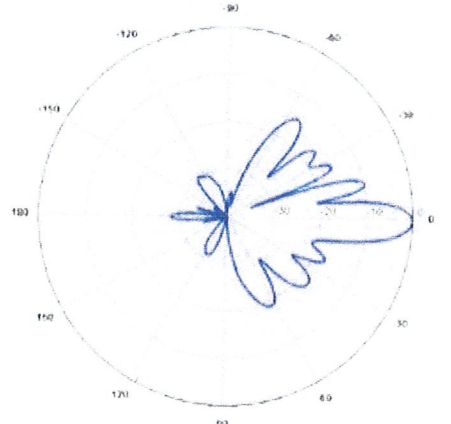
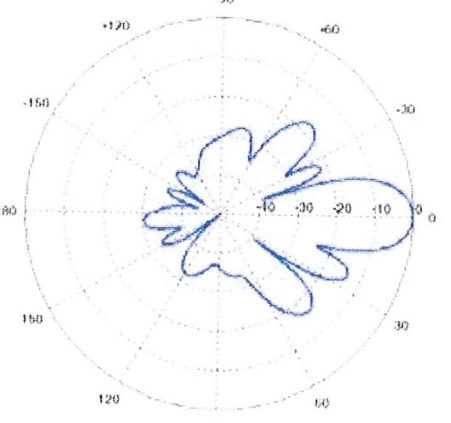
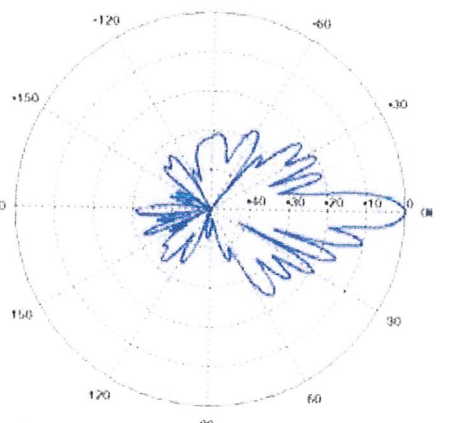

Figure 1: Graph of FCC Limits for Maximum Permissible Exposure (MPE)

Attachment C: AT&T Antenna Data Sheets and Electrical Patterns

<p>700 MHz</p> <p>Manufacturer: Powerwave Model #: P65-17-XLH-RR Frequency Band: 698-806 MHz Gain: 14.3 dBd Vertical Beamwidth: 8.4° Horizontal Beamwidth: 70° Polarization: Dual Linear $\pm 45^\circ$ Size L x W x D: 96.0" x 12.0" x 6.0"</p>	
<p>850 MHz</p> <p>Manufacturer: Powerwave Model #: 7770.00 Frequency Band: 824-896 MHz Gain: 11.5 dBd Vertical Beamwidth: 15° Horizontal Beamwidth: 82° Polarization: Dual Linear $\pm 45^\circ$ Size L x W x D: 55.0" x 11.0" x 5.0"</p>	
<p>1900 MHz</p> <p>Manufacturer: Powerwave Model #: 7770.00 Frequency Band: 1850-1990 MHz Gain: 13.4 dBd Vertical Beamwidth: 7° Horizontal Beamwidth: 86° Polarization: Dual Linear $\pm 45^\circ$ Size L x W x D: 55.0" x 11.0" x 5.0"</p>	

PROJECT INFORMATION

SCOPE OF WORK: TELECOMMUNICATIONS FACILITY UPGRADE (LTE):
 1. INSTALL (3) NEW LTE ANTENNAS, (6) RRR'S, (1) SURGE ARRESTOR, (1) FIBER LINE, (2) DC POWER LINES & (1) GPS ANTENNA
 2. INSTALL (1) LTE 6601 CABINET

SITE ADDRESS: 57 COOK DRIVE
 UNCASVILLE, CT 06382

LATITUDE: 41.47499 N 41° 28' 29.9" N
 LONGITUDE: 72.10502 W 72° 06' 18.0" W

CURRENT USE: TELECOMMUNICATIONS FACILITY
 PROPOSED USE: TELECOMMUNICATIONS FACILITY



SITE NUMBER: CT2171
SITE NAME: UNCASVILLE

DRAWING INDEX

REV

VICINITY MAP

GENERAL NOTES

- T-1 TITLE SHEET
- GN-1 GENERAL NOTES
- A-1 COMPOUND PLAN & EQUIPMENT PLAN
- A-2 ANTENNA PLAN & ELEVATION
- A-3 DETAILS
- S-1 TOWER MODIFICATION ELEVATION & GUY WIRE PLAN
- S-2 TOWER MODIFICATION DETAILS
- S-3 TOWER MODIFICATION DETAILS
- G-1 PLUMBING DIAGRAM & GROUNDING DETAILS

- 1
- 1
- 1
- 1
- 1
- 1
- 1
- 1
- 1

DIRECTIONS TO SITE:
 START OUT GOING NORTHEAST ON ENTERPRISE DR TOWARD CAPITOL BLVD. 0.4 MI. TURN LEFT ONTO CAPITOL BLVD. 0.3 MI. TURN LEFT ONTO WEST ST. 0.3 MI. TURN LEFT TO MERGE ONTO I-91 N. 4.3 MI. TAKE EXIT 25-26 FOR STATE HWY 3 N. 0.3 MI. TAKE EXIT 25 ON THE LEFT TO MERGE ONTO CT-3 N TOWARD GLASTONBURY. 2.1 MI. TAKE THE STATE HWY 2 E EXIT TOWARD NORWICH. 0.4 MI. MERGE ONTO CT-2 E. 19.6 MI. SLIGHT RIGHT TO STAY ON CT-2 E. 12.5 MI. TAKE THE I-395 S/STATE HWY 2A S RAMP TO NEW HAVEN. 0.3 MI. MERGE ONTO I-395 S. 3.5 MI. TAKE EXIT 79A FOR STATE HWY 2A E TOWARD PRESTON/LEDYARD. 0.8 MI. MERGE ONTO CT-2A E. 0.3 MI. TAKE THE STATE HWY 32 RAMP TO NORWICH/UNCASVILLE. 0.4 MI. TURN RIGHT AT CT-32/NORWICH - NEW LONDON RD/NORWICH NEW LONDON TURNPIKE. 0.4 MI. TURN RIGHT AT COOK DR. 0.3 MI. ARRIVE AT 57 COOK DR, UNCASVILLE, CT 06382.

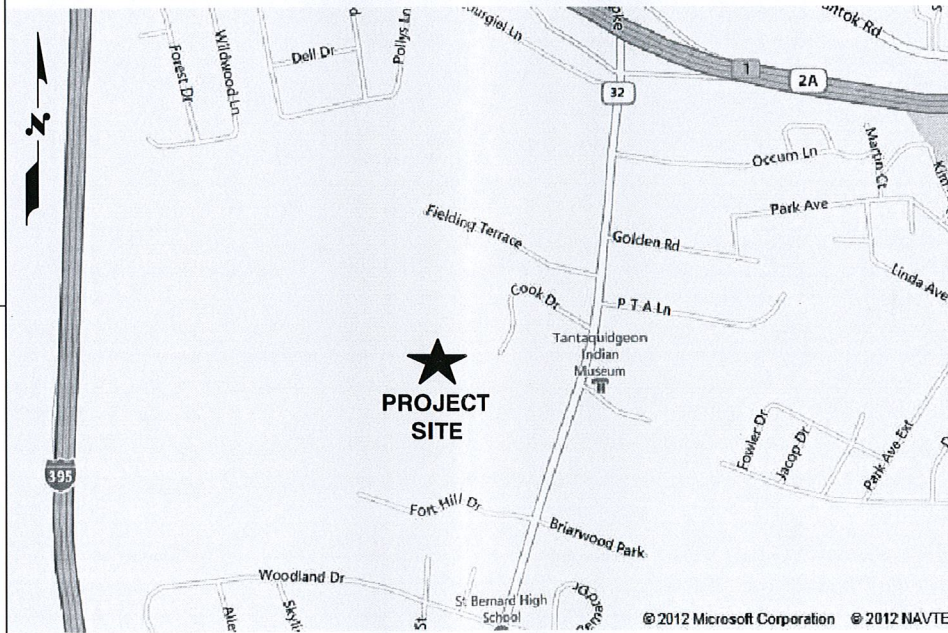

1. THIS DOCUMENT IS THE CREATION, DESIGN, PROPERTY AND COPYRIGHTED WORK OF AT&T. ANY DUPLICATION OR USE WITHOUT EXPRESS WRITTEN CONSENT IS STRICTLY PROHIBITED. DUPLICATION AND USE BY GOVERNMENT AGENCIES FOR THE PURPOSES OF CONDUCTING THEIR LAWFULLY AUTHORIZED REGULATORY AND ADMINISTRATIVE FUNCTIONS IS SPECIFICALLY ALLOWED.
2. THE FACILITY IS AN UNMANNED PRIVATE AND SECURED EQUIPMENT INSTALLATION. IT IS ONLY ACCESSED BY TRAINED TECHNICIANS FOR PERIODIC ROUTINE MAINTENANCE AND THEREFORE DOES NOT REQUIRE ANY WATER OR SANITARY SEWER SERVICE. THE FACILITY IS NOT GOVERNED BY REGULATIONS REQUIRING PUBLIC ACCESS PER ADA REQUIREMENTS.
3. CONTRACTOR SHALL VERIFY ALL PLANS AND EXISTING DIMENSIONS AND CONDITIONS ON THE JOB SITE AND SHALL IMMEDIATELY NOTIFY THE AT&T REPRESENTATIVE IN WRITING OF DISCREPANCIES BEFORE PROCEEDING WITH THE WORK OR BE RESPONSIBLE FOR SAME.

CALL
 BEFORE YOU DIG
 CALL TOLL FREE 1-800-922-4455 OR DIAL 811

UNDERGROUND SERVICE ALERT

1600 OSGOOD STREET
 BUILDING 20 NORTH, SUITE 3090
 N. ANDOVER, MA 01845
 TEL: (978) 557-5553
 FAX: (978) 336-5586

a UniTek GLOBAL SERVICES company
 800 MARSHALL PHELPS ROAD UNIT# 2A
 WINDSOR, CT 06095

SITE NUMBER: CT2171
SITE NAME: UNCASVILLE
 57 COOK DRIVE
 UNCASVILLE, CT 06382
 NEW LONDON COUNTY

500 ENTERPRISE DRIVE
 ROCKY HILL, CT 06067

								AT&T	
								TITLE SHEET (LTE)	
NO.	DATE	REVISIONS	BY	CHK	DATE	JOB NUMBER	DRAWING NUMBER	REV	
1	01/21/13	ISSUED FOR CONSTRUCTION	MJS	DC		2171.01	T-1	1	
0	07/12/12	ISSUED FOR REVIEW	MJS	DC					
SCALE: AS SHOWN		DESIGNED BY: DC		DRAWN BY: MJS					

GROUNDING NOTES

1. THE SUBCONTRACTOR SHALL REVIEW AND INSPECT THE EXISTING FACILITY GROUNDING SYSTEM AND LIGHTNING PROTECTION SYSTEM (AS DESIGNED AND INSTALLED) FOR STRICT COMPLIANCE WITH THE NEC (AS ADOPTED BY THE AHJ), THE SITE-SPECIFIC (UL, LPI, OR NFPA) LIGHTNING PROTECTION CODE, AND GENERAL COMPLIANCE WITH TELCORDIA AND TIA GROUNDING STANDARDS. THE SUBCONTRACTOR SHALL REPORT ANY VIOLATIONS OR ADVERSE FINDINGS TO THE CONTRACTOR FOR RESOLUTION.
2. ALL GROUND ELECTRODE SYSTEMS (INCLUDING TELECOMMUNICATION, RADIO, LIGHTNING PROTECTION, AND AC POWER GES'S) SHALL BE BONDED TOGETHER, AT OR BELOW GRADE, BY TWO OR MORE COPPER BONDING CONDUCTORS IN ACCORDANCE WITH THE NEC.
3. THE SUBCONTRACTOR SHALL PERFORM IEEE FALL-OF-POTENTIAL RESISTANCE TO EARTH TESTING (PER IEEE 1100 AND 81) FOR NEW GROUND ELECTRODE SYSTEMS. THE SUBCONTRACTOR SHALL FURNISH AND INSTALL SUPPLEMENTAL GROUND ELECTRODES AS NEEDED TO ACHIEVE A TEST RESULT OF 5 OHMS OR LESS.
4. METAL RACEWAY SHALL NOT BE USED AS THE NEC REQUIRED EQUIPMENT GROUND CONDUCTOR. STRANDED COPPER CONDUCTORS WITH GREEN INSULATION, SIZED IN ACCORDANCE WITH THE NEC, SHALL BE FURNISHED AND INSTALLED WITH THE POWER CIRCUITS TO BTS EQUIPMENT.
5. EACH BTS CABINET FRAME SHALL BE DIRECTLY CONNECTED TO THE MASTER GROUND BAR WITH GREEN INSULATED SUPPLEMENTAL EQUIPMENT GROUND WIRES, 6 AWG STRANDED COPPER OR LARGER FOR INDOOR BTS 2 AWG STRANDED COPPER FOR OUTDOOR BTS.
6. EXOTHERMIC WELDS SHALL BE USED FOR ALL GROUNDING CONNECTIONS BELOW GRADE.
7. APPROVED ANTIOXIDANT COATINGS (I.E., CONDUCTIVE GEL OR PASTE) SHALL BE USED ON ALL COMPRESSION AND BOLTED GROUND CONNECTIONS.
8. ICE BRIDGE BONDING CONDUCTORS SHALL BE EXOTHERMICALLY BONDED OR BOLTED TO THE BRIDGE AND THE TOWER GROUND BAR.
9. ALUMINUM CONDUCTOR OR COPPER CLAD STEEL CONDUCTOR SHALL NOT BE USED FOR GROUNDING CONNECTIONS.
10. MISCELLANEOUS ELECTRICAL AND NON-ELECTRICAL METAL BOXES, FRAMES AND SUPPORTS SHALL BE BONDED TO THE GROUND RING, IN ACCORDANCE WITH THE NEC.
11. METAL CONDUIT SHALL BE MADE ELECTRICALLY CONTINUOUS WITH LISTED BONDING FITTINGS OR BY BONDING ACROSS THE DISCONTINUITY WITH 6 AWS COPPER WIRE UL APPROVED GROUNDING TYPE CONDUIT CLAMPS.
12. ALL NEW STRUCTURES WITH A FOUNDATION AND/OR FOOTING HAVING 20 FT. OR MORE OF 1/2 IN. OR GREATER ELECTRICALLY CONDUCTIVE REINFORCING STEEL MUST HAVE IT BONDED TO THE GROUND RING USING AN EXOTHERMIC WELD CONNECTION USING #2 AWG SOLID BARE TINNED COPPER GROUND WIRE, PER NEC 250.50

GENERAL NOTES

1. FOR THE PURPOSE OF CONSTRUCTION DRAWING, THE FOLLOWING DEFINITIONS SHALL APPLY:
 CONTRACTOR - PINNACLE WIRELESS
 SUBCONTRACTOR - GENERAL CONTRACTOR (CONSTRUCTION)
 OWNER - AT&T MOBILITY
 2. PRIOR TO THE SUBMISSION OF BIDS, THE BIDDING SUBCONTRACTOR SHALL VISIT THE CELL SITE TO FAMILIARIZE WITH THE EXISTING CONDITIONS AND TO CONFIRM THAT THE WORK CAN BE ACCOMPLISHED AS SHOWN ON THE CONSTRUCTION DRAWINGS. ANY DISCREPANCY FOUND SHALL BE BROUGHT TO THE ATTENTION OF CONTRACTOR.
 3. ALL MATERIALS FURNISHED AND INSTALLED SHALL BE IN STRICT ACCORDANCE WITH ALL APPLICABLE CODES, REGULATIONS, AND ORDINANCES. SUBCONTRACTOR SHALL ISSUE ALL APPROPRIATE NOTICES AND COMPLY WITH ALL LAWS, ORDINANCES, RULES, REGULATIONS, AND LAWFUL ORDERS OF ANY PUBLIC AUTHORITY REGARDING THE PERFORMANCE OF THE WORK. ALL WORK CARRIED OUT SHALL COMPLY WITH ALL APPLICABLE MUNICIPAL AND UTILITY COMPANY SPECIFICATIONS AND LOCAL JURISDICTIONAL CODES, ORDINANCES AND APPLICABLE REGULATIONS.
 4. DRAWINGS PROVIDED HERE ARE NOT TO BE SCALED AND ARE INTENDED TO SHOW OUTLINE ONLY.
 5. UNLESS NOTED OTHERWISE, THE WORK SHALL INCLUDE FURNISHING MATERIALS, EQUIPMENT, APPURTENANCES, AND LABOR NECESSARY TO COMPLETE ALL INSTALLATIONS AS INDICATED ON THE DRAWINGS.
 6. "KITTING LIST" SUPPLIED WITH THE BID PACKAGE IDENTIFIES ITEMS THAT WILL BE SUPPLIED BY CONTRACTOR. ITEMS NOT INCLUDED IN THE BILL OF MATERIALS AND KITTING LIST SHALL BE SUPPLIED BY THE SUBCONTRACTOR.
 7. THE SUBCONTRACTOR SHALL INSTALL ALL EQUIPMENT AND MATERIALS IN ACCORDANCE WITH MANUFACTURER'S RECOMMENDATIONS UNLESS SPECIFICALLY STATED OTHERWISE.
 8. IF THE SPECIFIED EQUIPMENT CANNOT BE INSTALLED AS SHOWN ON THESE DRAWINGS, THE SUBCONTRACTOR SHALL PROPOSE AN ALTERNATIVE INSTALLATION SPACE FOR APPROVAL BY THE CONTRACTOR.
 9. SUBCONTRACTOR SHALL DETERMINE ACTUAL ROUTING OF CONDUIT, POWER AND T1 CABLES, GROUNDING CABLES AS SHOWN ON THE POWER, GROUNDING AND TELCO PLAN DRAWING. SUBCONTRACTOR SHALL UTILIZE EXISTING TRAYS AND/OR SHALL ADD NEW TRAYS AS NECESSARY. SUBCONTRACTOR SHALL CONFIRM THE ACTUAL ROUTING WITH THE CONTRACTOR.
 10. THE SUBCONTRACTOR SHALL PROTECT EXISTING IMPROVEMENTS, PAVEMENTS, CURBS, LANDSCAPING AND STRUCTURES. ANY DAMAGED PART SHALL BE REPAIRED AT SUBCONTRACTOR'S EXPENSE TO THE SATISFACTION OF OWNER.
 11. SUBCONTRACTOR SHALL LEGALLY AND PROPERLY DISPOSE OF ALL SCRAP MATERIALS SUCH AS COAXIAL CABLES AND OTHER ITEMS REMOVED FROM THE EXISTING FACILITY. ANTENNAS REMOVED SHALL BE RETURNED TO THE OWNER'S DESIGNATED LOCATION.
 12. SUBCONTRACTOR SHALL LEAVE PREMISES IN CLEAN CONDITION.
 13. ALL CONCRETE REPAIR WORK SHALL BE DONE IN ACCORDANCE WITH AMERICAN CONCRETE INSTITUTE (ACI) 301.
 14. ANY NEW CONCRETE NEEDED FOR THE CONSTRUCTION SHALL BE AIR-ENTRAINED AND SHALL HAVE 4000 PSI STRENGTH AT 28 DAYS. ALL CONCRETE WORK SHALL BE DONE IN ACCORDANCE WITH ACI 318 CODE REQUIREMENTS.
 15. ALL STRUCTURAL STEEL WORK SHALL BE DETAILED, FABRICATED AND ERECTED IN ACCORDANCE WITH AISC SPECIFICATIONS. ALL STRUCTURAL STEEL SHALL BE ASTM A36 (Fy = 36 ksi) UNLESS OTHERWISE NOTED. PIPES SHALL BE ASTM A53 TYPE E (Fy = 36 ksi). ALL STEEL EXPOSED TO WEATHER SHALL BE HOT DIPPED GALVANIZED. TOUCHUP ALL SCRATCHES AND OTHER MARKS IN THE FIELD AFTER STEEL IS ERECTED USING A COMPATIBLE ZINC RICH PAINT.
 16. CONSTRUCTION SHALL COMPLY WITH UMS SPECIFICATIONS AND "GENERAL CONSTRUCTION SERVICES FOR CONSTRUCTION OF AT&T MOBILITY SITES."
 17. SUBCONTRACTOR SHALL VERIFY ALL EXISTING DIMENSIONS AND CONDITIONS PRIOR TO COMMENCING ANY WORK. ALL DIMENSIONS OF EXISTING CONSTRUCTION SHOWN ON THE DRAWINGS MUST BE VERIFIED. SUBCONTRACTOR SHALL NOTIFY THE CONTRACTOR OF ANY DISCREPANCIES PRIOR TO ORDERING MATERIAL OR PROCEEDING WITH CONSTRUCTION.
 18. THE EXISTING CELL SITE IS IN FULL COMMERCIAL OPERATION. ANY CONSTRUCTION WORK BY SUBCONTRACTOR SHALL NOT DISRUPT THE EXISTING NORMAL OPERATION. ANY WORK ON EXISTING EQUIPMENT MUST BE COORDINATED WITH CONTRACTOR. ALSO, WORK SHOULD BE SCHEDULED FOR AN APPROPRIATE MAINTENANCE WINDOW USUALLY IN LOW TRAFFIC PERIODS AFTER MIDNIGHT.
 19. SINCE THE CELL SITE IS ACTIVE, ALL SAFETY PRECAUTIONS MUST BE TAKEN WHEN WORKING AROUND HIGH LEVELS OF ELECTROMAGNETIC RADIATION. EQUIPMENT SHOULD BE SHUTDOWN PRIOR TO PERFORMING ANY WORK THAT COULD EXPOSE THE WORKERS TO DANGER. PERSONAL RF EXPOSURE MONITORS ARE ADVISED TO BE WORN TO ALERT OF ANY DANGEROUS EXPOSURE LEVELS.
 20. APPLICABLE BUILDING CODES:
 SUBCONTRACTOR'S WORK SHALL COMPLY WITH ALL APPLICABLE NATIONAL, STATE, AND LOCAL CODES AS ADOPTED BY THE LOCAL AUTHORITY HAVING JURISDICTION (AHJ) FOR THE LOCATION. THE EDITION OF THE AHJ ADOPTED CODES AND STANDARDS IN EFFECT ON THE DATE OF CONTRACT AWARD SHALL GOVERN THE DESIGN.
 BUILDING CODE: 2003 IBC WITH 2005 CT SUPPLEMENT & 2009 CT AMENDMENTS
 ELECTRICAL CODE: REFER TO ELECTRICAL DRAWINGS
 LIGHTNING CODE: REFER TO ELECTRICAL DRAWINGS
- SUBCONTRACTOR'S WORK SHALL COMPLY WITH THE LATEST EDITION OF THE FOLLOWING STANDARDS:
- AMERICAN CONCRETE INSTITUTE (ACI) 318; BUILDING CODE REQUIREMENTS FOR STRUCTURAL CONCRETE;
 - AMERICAN INSTITUTE OF STEEL CONSTRUCTION (AISC) MANUAL OF STEEL CONSTRUCTION, ASD, NINTH EDITION;
 - TELECOMMUNICATIONS INDUSTRY ASSOCIATION (TIA) 222-F, STRUCTURAL STANDARDS FOR STEEL
 - ANTENNA TOWER AND ANTENNA SUPPORTING STRUCTURES; REFER TO ELECTRICAL DRAWINGS FOR SPECIFIC ELECTRICAL STANDARDS.
- FOR ANY CONFLICTS BETWEEN SECTIONS OF LISTED CODES AND STANDARDS REGARDING MATERIAL, METHODS OF CONSTRUCTION, OR OTHER REQUIREMENTS, THE MOST RESTRICTIVE REQUIREMENT SHALL GOVERN. WHERE THERE IS CONFLICT BETWEEN A GENERAL REQUIREMENT AND A SPECIFIC REQUIREMENT, THE SPECIFIC REQUIREMENT SHALL GOVERN.

ABBREVIATIONS

AGL	ABOVE GRADE LEVEL	G.C.	GENERAL CONTRACTOR	RF	RADIO FREQUENCY
AWG	AMERICAN WIRE GAUGE	MGB	MASTER GROUND BUS		
BCW	BARE COPPER WIRE	MIN	MINIMUM	TBD	TO BE DETERMINED
BTS	BASE TRANSCEIVER STATION	PROPOSED	NEW	TBR	TO BE REMOVED
EXISTING	EXISTING	N.T.S.	NOT TO SCALE	TBRR	TO BE REMOVED AND REPLACED
EG	EQUIPMENT GROUND		REFERENCE		
EGR	EQUIPMENT GROUND		REQUIRED	TYP	TYPICAL

1600 OSGOOD STREET
BUILDING 20 NORTH, SUITE 3090
N. ANDOVER, MA 01845
TEL: (978) 557-5553
FAX: (978) 336-5586

a UniTek GLOBAL SERVICES company
800 MARSHALL PHELPS ROAD UNIT# 2A
WINDSOR, CT 06095

SITE NUMBER: CT2171
SITE NAME: UNCASVILLE
 57 COOK DRIVE
 UNCASVILLE, CT 06382
 NEW LONDON COUNTY

500 ENTERPRISE DRIVE
 ROCKY HILL, CT 06067

1 01/21/13 ISSUED FOR CONSTRUCTION		MJS	EC	DPH	
0 07/12/12 ISSUED FOR REVIEW		MJS	EC	DPH	
NO.	DATE	REVISIONS	BY	CHKD	
SCALE: AS SHOWN		DESIGNED BY: DC	DRAWN BY: MJS		
				JOB NUMBER	DRAWING NUMBER
				2171.01	GN-1
					REV
					1



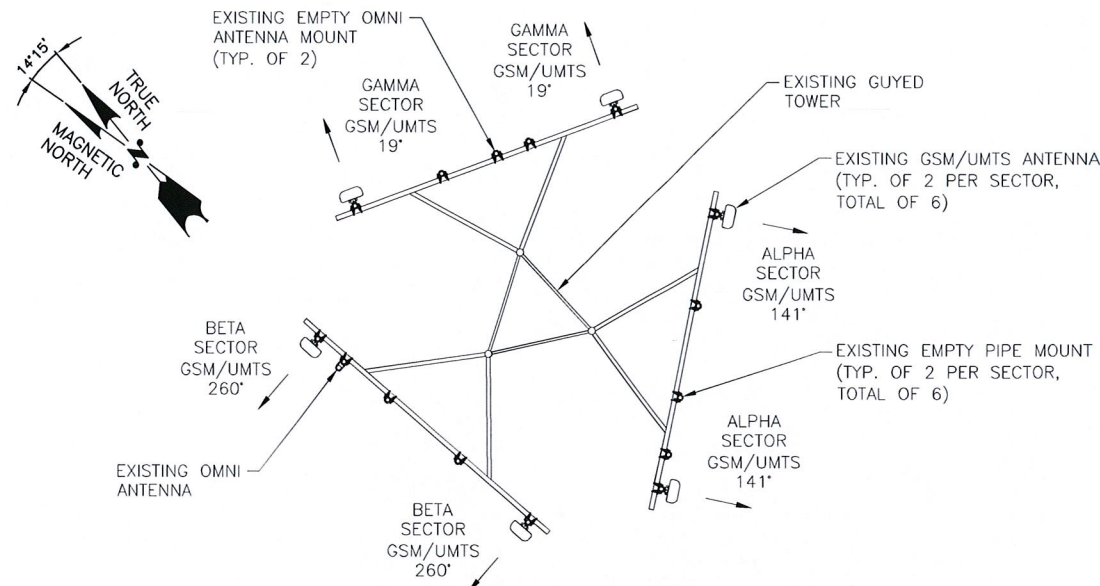

EXISTING GSM/UMTS ANTENNA PLAN
SCALE: N.T.S.

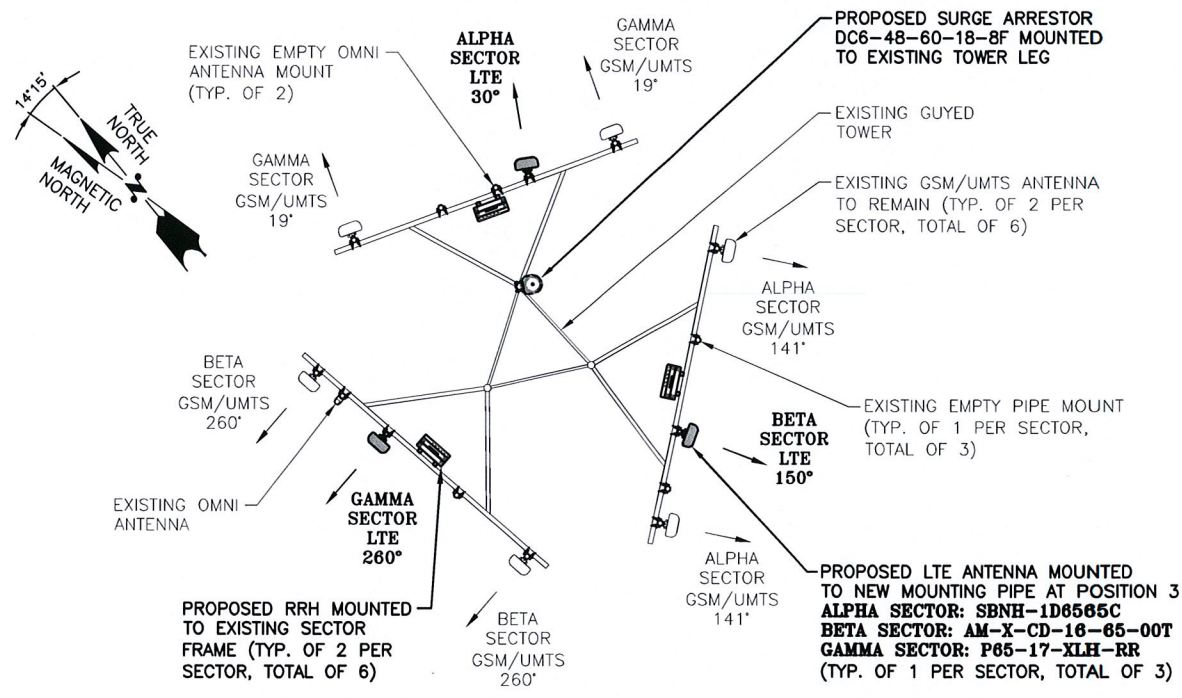

PROPOSED LTE ANTENNA PLAN
SCALE: N.T.S.

- TOP OF EXISTING TOWER
ELEV. 193'-0"± (AGL)
- CENTER OF PROPOSED AT&T LTE ANTENNAS
ELEV. 180'-0"± (AGL)
- PROPOSED AT&T RRH'S & SURGE ARRESTOR
ELEV. 180'-0"± (AGL)
- PROPOSED LTE ANTENNA MOUNTED TO NEW MOUNTING PIPE AT POSITION 3
ALPHA SECTOR: SBNH-1D8585C
BETA SECTOR: AM-X-CD-16-85-00T
GAMMA SECTOR: P85-17-XLH-RR
(TYP. OF 1 PER SECTOR, TOTAL OF 3)
- PROPOSED RRH MOUNTED TO EXISTING SECTOR FRAME (TYP. OF 2 PER SECTOR, TOTAL OF 6)

NOTE:
REFER TO THE FINAL RF DATA SHEET FOR FINAL ANTENNA SETTINGS.

NOTE:
REFER TO STRUCTURAL ANALYSIS BY: HUDSON DESIGN GROUP, LLC DATED: JANUARY 18, 2013 (REV1) FOR THE CAPACITY OF THE EXISTING STRUCTURES TO SUPPORT THE PROPOSED EQUIPMENT.

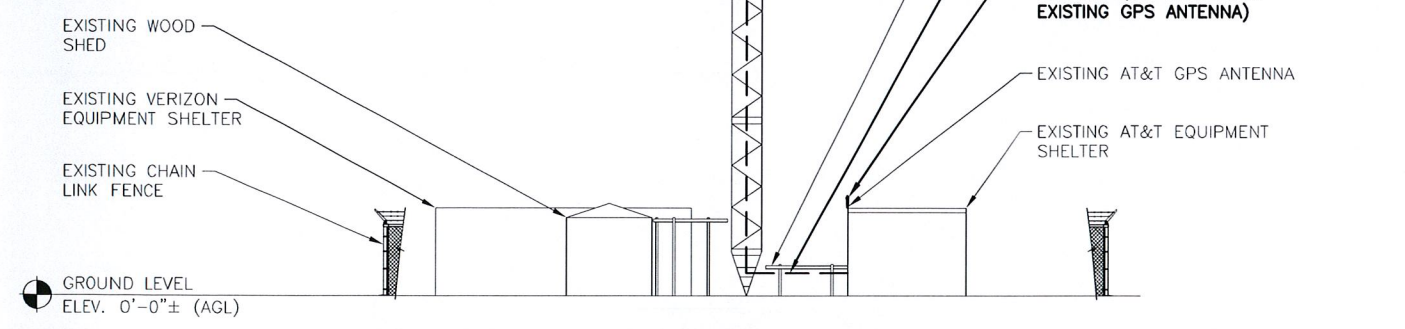

Hudson Design Group, LLC
1600 OSGOOD STREET
BUILDING 20 NORTH, SUITE 3090
N. ANDOVER, MA 01845
TEL: (978) 557-5553
FAX: (978) 336-5586

Pinnacle Wireless
a UniTek GLOBAL SERVICES company
800 MARSHALL PHELPS ROAD UNIT# 2A
WINDSOR, CT 06095

SITE NUMBER: CT2171
SITE NAME: UNCASVILLE
57 COOK DRIVE
UNCASVILLE, CT 06382
NEW LONDON COUNTY

at&t
500 ENTERPRISE DRIVE
ROCKY HILL, CT 06067

										AT&T	
										ANTENNA PLAN & ELEVATION (LTE)	
NO.	DATE	REVISIONS	BY	CHECKED	DATE	DRAWING NUMBER	SCALE	DESIGNED BY	DRAWN BY	DATE	REV
1	01/21/13	ISSUED FOR CONSTRUCTION	MJS	DC		A-2	AS SHOWN	DC	MJS	1/21/13	1
0	07/12/12	ISSUED FOR REVIEW	MJS	DC		A-2					

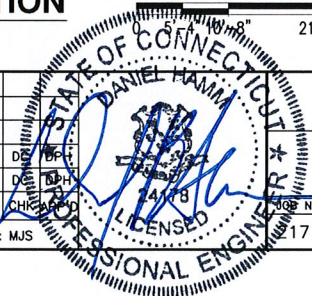

NOTE:
REFER TO THE FINAL RF DATA SHEET FOR FINAL ANTENNA SETTINGS.

NOTE:
REFER TO STRUCTURAL ANALYSIS BY: HUDSON DESIGN GROUP, LLC DATED: JANUARY 18, 2013 (REV1) FOR THE CAPACITY OF THE EXISTING STRUCTURES TO SUPPORT THE PROPOSED EQUIPMENT.

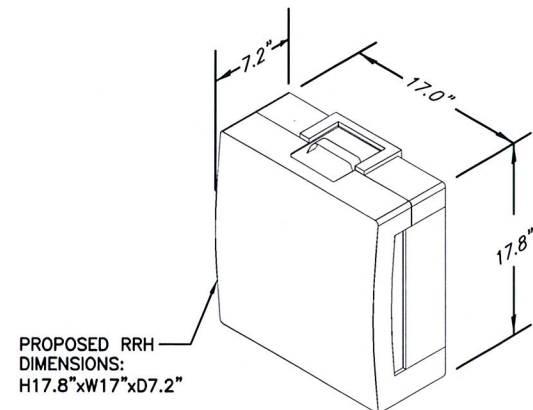

PROPOSED RRH DIMENSIONS: H17.8"xW17"xD7.2"

NOTE:
MOUNT PER MANUFACTURER'S SPECIFICATIONS.

RRH DETAIL

SCALE: N.T.S.

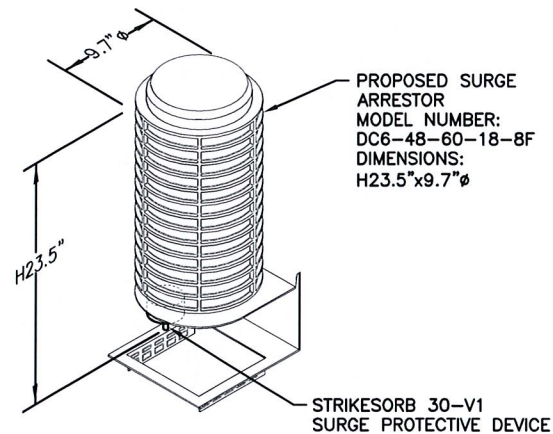

PROPOSED SURGE ARRESTOR MODEL NUMBER: DC6-48-60-18-8F DIMENSIONS: H23.5"x9.7"φ

NOTE:
MOUNT PER MANUFACTURER'S SPECIFICATIONS.

DC SURGE ARRESTOR DETAIL

SCALE: N.T.S.

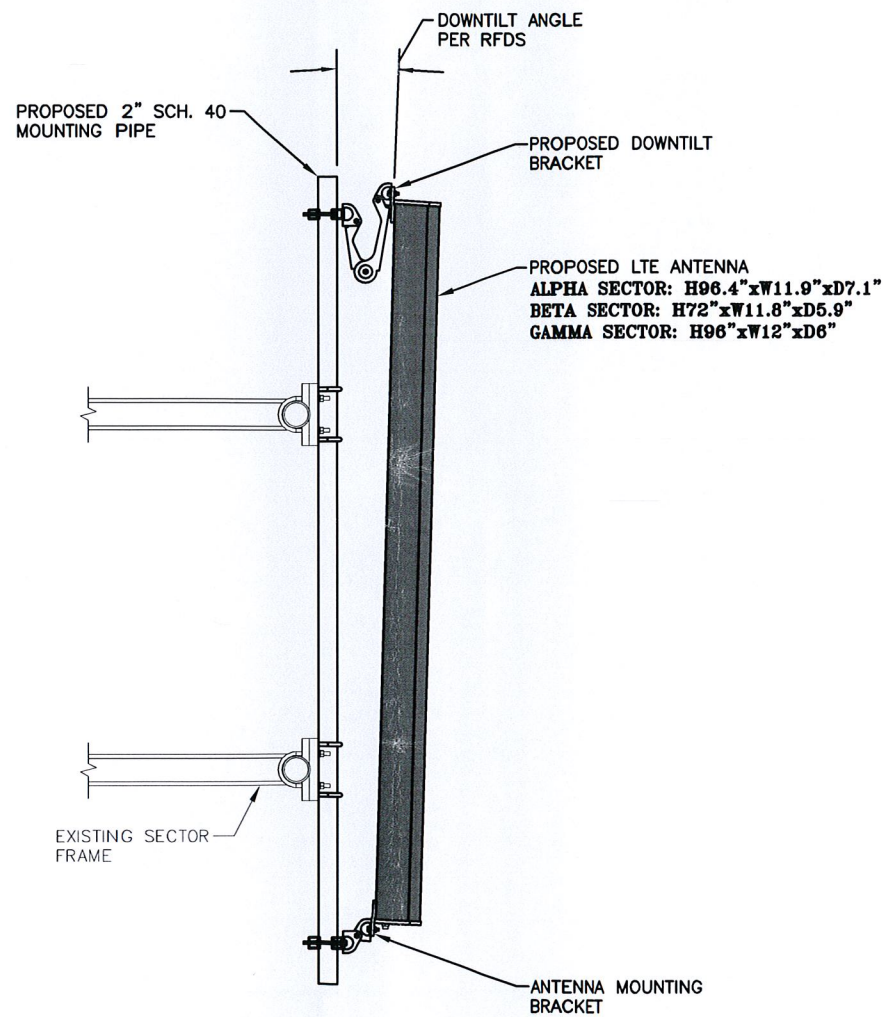

PROPOSED 2" SCH. 40 MOUNTING PIPE

DOWNTILT ANGLE PER RFDS

PROPOSED DOWNTILT BRACKET

PROPOSED LTE ANTENNA ALPHA SECTOR: H96.4"xW11.9"xD7.1" BETA SECTOR: H72"xW11.8"xD5.9" GAMMA SECTOR: H96"xW12"xD6"

EXISTING SECTOR FRAME

ANTENNA MOUNTING BRACKET

PROPOSED LTE ANTENNA DETAIL

SCALE: N.T.S.

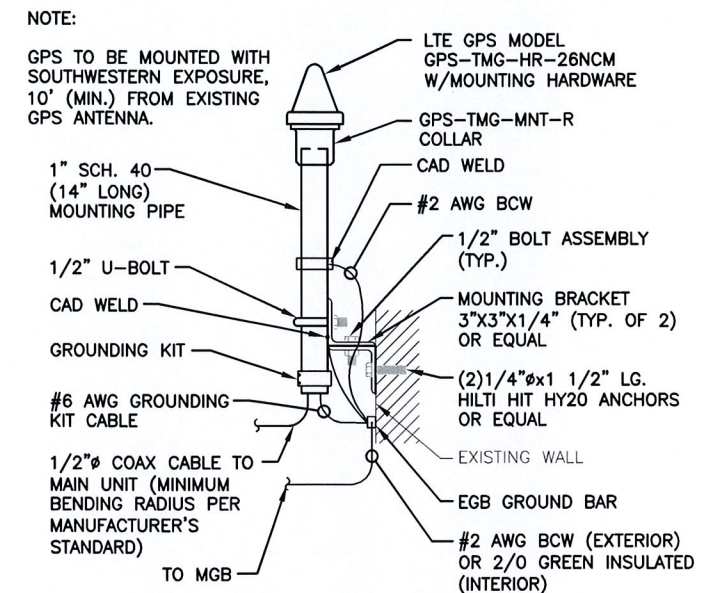

NOTE:

GPS TO BE MOUNTED WITH SOUTHWESTERN EXPOSURE, 10' (MIN.) FROM EXISTING GPS ANTENNA.

LTE GPS MODEL GPS-TMG-HR-26NCM W/MOUNTING HARDWARE

GPS-TMG-MNT-R COLLAR

CAD WELD

#2 AWG BCW

1/2" BOLT ASSEMBLY (TYP.)

MOUNTING BRACKET 3"x3"x1/4" (TYP. OF 2) OR EQUAL

(2) 1/4"φ x 1 1/2" LG. HILTI HIT HY20 ANCHORS OR EQUAL

EXISTING WALL

EGB GROUND BAR

#2 AWG BCW (EXTERIOR) OR 2/0 GREEN INSULATED (INTERIOR)

1" SCH. 40 (14" LONG) MOUNTING PIPE

1/2" U-BOLT

CAD WELD

GROUNDING KIT

#6 AWG GROUNDING KIT CABLE

1/2"φ COAX CABLE TO MAIN UNIT (MINIMUM BENDING RADIUS PER MANUFACTURER'S STANDARD)

TO MGB

GPS MOUNTING DETAIL

SCALE: N.T.S.

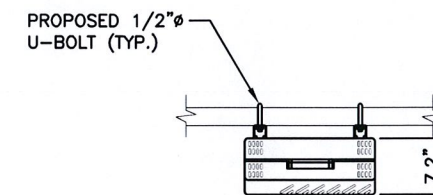

PROPOSED 1/2"φ U-BOLT (TYP.)

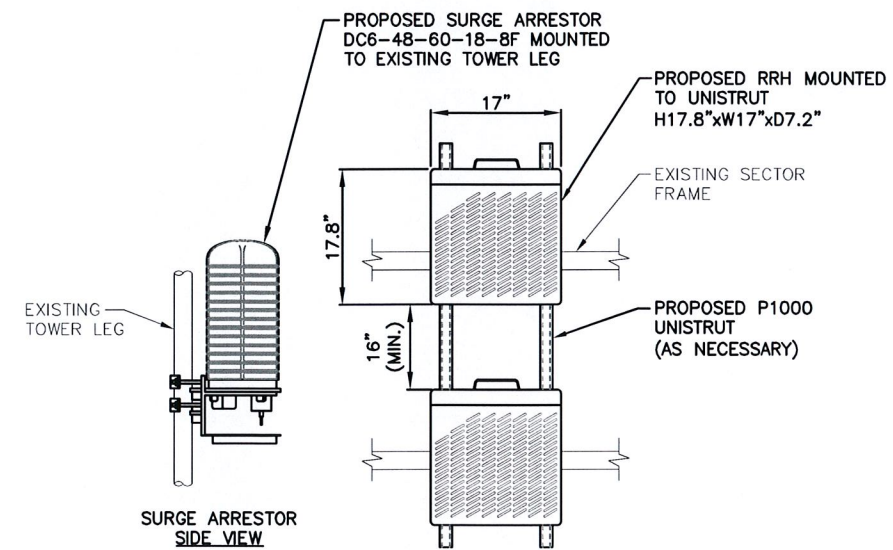

PROPOSED SURGE ARRESTOR DC6-48-60-18-8F MOUNTED TO EXISTING TOWER LEG

PROPOSED RRH MOUNTED TO UNISTRUT H17.8"xW17"xD7.2"

EXISTING SECTOR FRAME

PROPOSED P1000 UNISTRUT (AS NECESSARY)

EXISTING TOWER LEG

SURGE ARRESTOR SIDE VIEW

PROPOSED RRH & SURGE ARRESTOR MOUNTING DETAIL

SCALE: N.T.S.

Hudson Design Group, LLC
1600 OSGOOD STREET
BUILDING 20 NORTH, SUITE 3090
N. ANDOVER, MA 01845
TEL: (978) 557-5553
FAX: (978) 336-5586

Pinnacle Wireless
a UniTek GLOBAL SERVICES company
800 MARSHALL PHELPS ROAD UNIT# 2A
WINDSOR, CT 06095

SITE NUMBER: CT2171
SITE NAME: UNCASVILLE

57 COOK DRIVE
UNCASVILLE, CT 06382
NEW LONDON COUNTY

at&t
500 ENTERPRISE DRIVE
ROCKY HILL, CT 06067

		STATE OF CONNECTICUT		AT&T	
		DANIEL HAMM		DETAILS	
		LICENSED PROFESSIONAL ENGINEER		(LTE)	
NO.	DATE	REVISIONS	BY	JOB NUMBER	DRAWING NUMBER
1	01/21/13	ISSUED FOR CONSTRUCTION	M.H. DC DPH	2171.01	A-3
0	07/12/12	ISSUED FOR REVIEW	M.H. DC DPH		
SCALE: AS SHOWN		DESIGNED BY: DC		DRAWN BY: [Signature]	
		DRAWN BY: [Signature]		REV	
				1	

- TOP OF EXISTING TOWER
ELEV. 193'-0"
- TOWER SECTION
ELEV. 180'-0"
- PROPOSED L2"x2"x1/4" HORIZONTAL
ELEV. 160'-0" - 180'-0"
(SEE DETAIL 1 ON SHEET S-3)
- TOWER SECTION
ELEV. 160'-0"
- PROPOSED L2"x2"x1/4" HORIZONTAL
ELEV. 140'-0" - 160'-0"
(SEE DETAIL 4 ON SHEET S-2)
- TOWER SECTION
ELEV. 140'-0"
- TOWER SECTION
ELEV. 120'-0"
- PROPOSED L2"x2"x1/4" HORIZONTAL
ELEV. 100'-0" - 120'-0"
(SEE DETAIL 1 ON SHEET S-2)
- TOWER SECTION
ELEV. 100'-0"
- EXISTING GUY WIRE (TYP.)
- TOWER SECTION
ELEV. 80'-0"
- EXISTING GUYED TOWER
- TOWER SECTION
ELEV. 60'-0"
- EXISTING TORQUE ARM
- TOWER SECTION
ELEV. 40'-0"
- TOWER SECTION
ELEV. 20'-0"
- TOWER SECTION
ELEV. 5'-0"
- BASE OF EXISTING TOWER
ELEV. 0'-0"

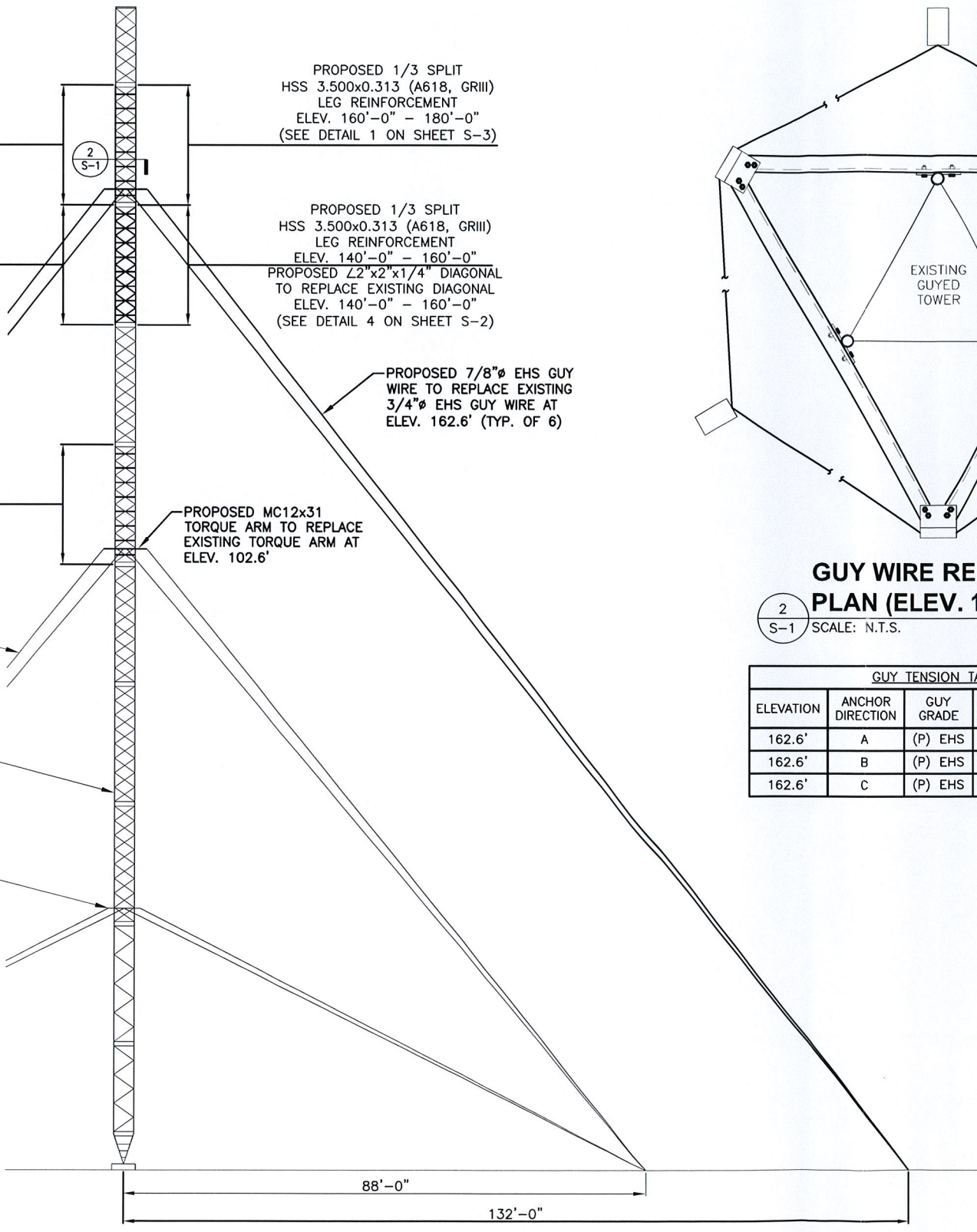

1 TOWER ELEVATION
S-1 SCALE: N.T.S.

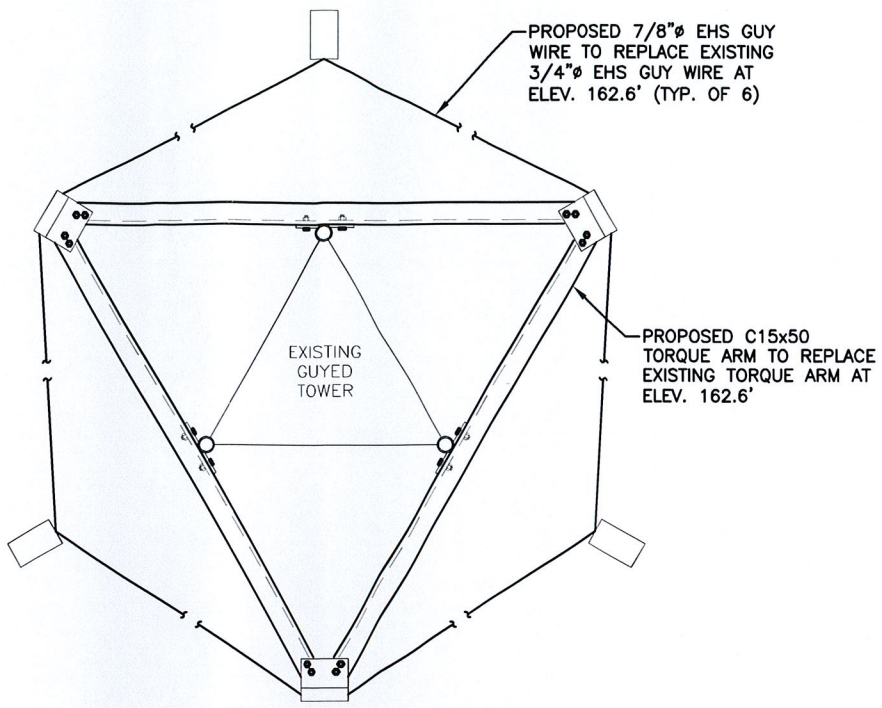

2 GUY WIRE REPLACEMENT PLAN (ELEV. 162.6')
S-1 SCALE: N.T.S.

GUY TENSION TABLE				
ELEVATION	ANCHOR DIRECTION	GUY GRADE	GUY SIZE	10% INITIAL TENSION (LBS)
162.6'	A	(P) EHS	7/8"	7,979
162.6'	B	(P) EHS	7/8"	7,979
162.6'	C	(P) EHS	7/8"	7,979

ALL DIMENSIONS, MEASUREMENTS, QUANTITIES, PART NUMBERS, AND COAX/ANTENNA PLACEMENTS TO BE FIELD VERIFIED BY CONTRACTOR PRIOR TO MATERIAL ORDERS AND CONSTRUCTION.

NOTE:
REFER TO STRUCTURAL ANALYSIS BY: HUDSON DESIGN GROUP, LLC DATED: JANUARY 18, 2013 (REV1) FOR THE CAPACITY OF THE EXISTING STRUCTURES TO SUPPORT THE PROPOSED EQUIPMENT.

GENERAL NOTES:

- ALL WORK SHALL BE DONE IN ACCORDANCE WITH ALL APPLICABLE FEDERAL, STATE, AND LOCAL CODES AND ORDINANCES. IT IS THE CONTRACTORS RESPONSIBILITY TO OBTAIN ALL PERMITS NECESSARY TO COMPLETE THE PROJECT AND ABIDE BY ALL CONDITIONS AND REQUIREMENTS OF THE PERMITS.
- THE CONTRACTOR SHALL BE RESPONSIBLE FOR VERIFICATION OF ALL DIMENSIONS, ELEVATIONS, AND EXISTING CONDITIONS AT THE SITE BEFORE ORDERING ANY MATERIALS OR DOING ANY WORK. NO EXTRA CHARGE OR COMPENSATION SHALL BE ALLOWED DUE TO DIFFERENCE BETWEEN ACTUAL DIMENSIONS AND DIMENSIONS INDICATED ON THE CONSTRUCTION DRAWINGS. ANY SUCH DISCREPANCY IN DIMENSION WHICH MAY BE FOUND SHALL BE SUBMITTED TO HUDSON DESIGN GROUP FOR CONSIDERATION BEFORE THE CONTRACTOR PROCEEDS WITH THE WORK IN THE AFFECTED AREA.
- INCORRECTLY FABRICATED, DAMAGED, OTHERWISE MISFITTING, OR NON-CONFORMING MATERIALS AND CONDITIONS SHALL BE REPORTED TO HUDSON DESIGN GROUP PRIOR TO ANY REMEDIAL OR CORRECTIVE ACTION. ALL ACTIONS SHALL REQUIRE HUDSON DESIGN GROUP, LLC APPROVAL.
- IT IS THE CONTRACTORS SOLE RESPONSIBILITY TO DETERMINE ERECTION PROCEDURE AND SEQUENCE TO INSURE THE SAFETY OF THE STRUCTURE AND ITS COMPONENT PARTS DURING ERECTION AND/OR FIELD MODIFICATIONS. THIS INCLUDES, BUT IS NOT LIMITED TO, THE ADDITION OF TEMPORARY BRACING, GUYS OR TIE DOWNS THAT MAY BE NECESSARY. SUCH MATERIAL SHALL BE REMOVED AFTER COMPLETION OF THE PROJECT.
- CONTRACTOR SHALL PROMPTLY REMOVE ANY AND ALL DEBRIS FROM SITE AND RESTORE AS BEST AS POSSIBLE TO PRE-CONSTRUCTION CONDITION.

STEEL:

- ALL STRUCTURAL STEEL SHALL BE FABRICATED AND ERECTED IN ACCORDANCE WITH THE LATEST AISC CODE AND ASTM SPECIFICATIONS.
- ALL CONNECTIONS OF STRUCTURAL STEEL MEMBERS SHALL BE MADE USING SPECIFIED WELDS WITH WELDING ELECTRODES E-70XX OR SPECIFIED HIGH STRENGTH BOLTS TO BE ASTM A325N, THREAD INCLUDED WITH SHEAR PLANE UNLESS OTHERWISE NOTED.
- ALL BOLTED CONNECTIONS TO BE INSTALLED TO A SNUG-TIGHTENED CONDITION IN ACCORDANCE WITH AISC 13 PART 16.2, "SPECIFICATION FOR STRUCTURAL JOINTS USING ASTM A325 OR A490 BOLTS", SECTION 8.1, UNLESS OTHERWISE NOTED.
- ALL STEEL (EXCEPT A490 BOLTS), AFTER FABRICATION, SHALL BE HOT DIPPED GALVANIZED PER ASTM A-123. ALL DAMAGED SURFACES, WELDED AREAS AND AUTHORIZED NON-GALVANIZED MEMBERS OR PARTS (EXISTING OR NEW) SHALL BE PAINTED WITH 2 COATS OF ZRC COLD GALVANIZING COMPOUND.
- ALL SHOP AND FIELD WELDING SHALL BE DONE BY WELDERS QUALIFIED AS DESCRIBED IN THE "AMERICAN WELDING SOCIETY'S STANDARD QUALIFICATION PROCEDURE" TO PERFORM THE TYPE OF WORK REQUIRED.
- STRUCTURAL STEEL MAY NOT BE TORCH CUT FOR FABRICATION. ALL STEEL FABRICATION MUST FOLLOW AISC STANDARDS.
- NEW STEEL MEMBERS AND CONNECTIONS SHALL BE PAINTED TO MATCH EXISTING TOWER.

MISC. NOTES:

- ALL MODIFICATIONS ARE ASSUMED TO BE MADE ON AN EMPTY TOWER. CONTRACTOR IS RESPONSIBLE TO MAKE PROVISIONS TO SUPPORT OR WORK AROUND EXISTING ANTENNAS AND TRANSMISSION LINES. MODIFICATIONS MUST BE CONTINUOUS THROUGH ALL AREAS SHOWN.
- CONTRACTOR SHALL FIELD VERIFY ALL DIMENSIONS PRIOR TO CONSTRUCTION.

FABRICATION NOTES:

- ALL DIMENSIONS ARE PRELIMINARY UNTIL FIELD VERIFIED BY CONTRACTOR. ANY CHANGES MUST BE APPROVED BY ENGINEER OF RECORD IN WRITING PRIOR TO FABRICATION AND INSTALLATION.
- NEW STEEL MEMBERS MUST HAVE SINGLE DRILLED HOLES. SLOTTED AND DOUBLE DRILLED HOLES ARE NOT ACCEPTABLE MEANS OF FABRICATION.

CONTRACTOR QUALIFICATION NOTES:

- ALL REPAIRS SHALL BE PERFORMED BY A TOWER CONTRACTOR WITH A MINIMUM OF 5 YEARS EXPERIENCE IN TOWER ERECTION AND RETROFIT AND WITH WORKING KNOWLEDGE OF THE ANS/TIA-222-G "STRUCTURAL STANDARD FOR ANTENNA SUPPORTING STRUCTURES AND ANTENNAS".
- CONTRACTOR IS RESPONSIBLE FOR ALL CONSTRUCTION MEANS AND METHODS. SHOULD THE CONTRACTOR REQUIRE DIRECT CONSULTATION, HUDSON DESIGN GROUP, LLC IS WILLING TO OFFER SERVICES BASED UPON AN AGREED FEE FOR THE WORK REQUIRED.
- ALL SUBMITTAL INFORMATION MUST BE SENT TO HUDSON DESIGN GROUP, LLC 1600 OSGOOD ST. BUILDING 204, SUITE 3090, NORTH ANDOVER, MA 01845 TEL: (978)557-5553, FAX: (978)336-5586. ANY VARIATION OF THESE SPECIFICATIONS OR DRAWINGS WITHOUT CONSENT FROM HUDSON DESIGN GROUP WILL VOID ANY RESPONSIBILITY OR LIABILITY FOR DAMAGE (MATERIAL OR PHYSICAL) TOWARDS HUDSON DESIGN GROUP, LLC.

JOB SITE SAFETY AND NOTES:

NEITHER THE PROFESSIONAL ACTIVITIES OF HUDSON DESIGN GROUP, LLC NOR THE PRESENCE OF HUDSON DESIGN GROUP, LLC OR EMPLOYEES AND SUB-CONSULTANTS AT THE CONSTRUCTION SITE, SHALL RELIEVE THE GENERAL CONTRACTOR AND/OR SUBCONTRACTORS AND ANY OTHER ENTITY OF THEIR OBLIGATIONS, DUTIES AND RESPONSIBILITIES INCLUDING, BUT NOT LIMITED TO, CONSTRUCTION MEANS, METHODS, SEQUENCE, TECHNIQUES, OR PROCEDURES NECESSARY FOR PERFORMING, SUPERINTENDING OR COORDINATING ALL PORTIONS OF THE WORK OF CONSTRUCTION IN ACCORDANCE WITH THE CONTRACT DOCUMENTS AND ANY HEALTH OR SAFETY PRECAUTIONS REQUIRED BY ANY REGULATORY AGENCIES. THE GENERAL CONTRACTOR AND/OR SUBCONTRACTOR IS SOLELY RESPONSIBLE FOR JOB SAFETY, AND WARRANTS THAT THIS INTENT IS EVIDENT BY ACCEPTING THIS WORK.

SUBSTITUTES AND/OR EQUALS:

IF CONTRACTOR WISHES TO FURNISH OR USE A SUBSTITUTE ITEM OF MATERIAL OR EQUIPMENT, CONTRACTOR SHALL MAKE WRITTEN APPLICATION TO ENGINEER FOR ACCEPTANCE THEREOF, CERTIFYING THAT THE PROPOSED SUBSTITUTE WILL ADEQUATELY PERFORM THE FUNCTIONS AND ACHIEVE THE RESULTS CALLED FOR BY THE GENERAL DESIGN, BE SIMILAR IN SUBSTANCE TO THAT SPECIFIED, AND SUITED TO THE SAME USE AS THAT SPECIFIED. ALL VARIATIONS OF THE PROPOSED SUBSTITUTE FROM THAT SPECIFIED WILL BE IDENTIFIED IN THE APPLICATION AND AVAILABLE MAINTENANCE, REPAIR, AND REPLACEMENT SERVICE WILL BE INDICATED. THE APPLICATION WILL ALSO CONTAIN AN ITEMIZED ESTIMATE OF ALL COSTS OR CREDITS THAT WILL RESULT DIRECTLY OR INDIRECTLY FROM ACCEPTANCE OF SUCH SUBSTITUTE INCLUDING COSTS OF REDESIGN AND CLAIMS OF OTHER CONTRACTORS AFFECTED BY THE RESULTING CHANGE, ALL OF WHICH WILL BE CONSIDERED BY ENGINEER IN EVALUATION OF THE PROPOSED SUBSTITUTE. ENGINEER MAY REQUIRE CONTRACTOR TO FURNISH ADDITIONAL DATA ABOUT THE PROPOSED SUBSTITUTE.

Hudson Design Group, LLC
1600 OSGOOD STREET
BUILDING 20 NORTH, SUITE 3090
N. ANDOVER, MA 01845
TEL: (978) 557-5553
FAX: (978) 336-5586

Pinnacle Wireless
a UniTek GLOBAL SERVICES company
800 MARSHALL PHELPS ROAD UNIT# 2A
WINDSOR, CT 06095

SITE NUMBER: CT2171
SITE NAME: UNCASVILLE
57 COOK DRIVE
UNCASVILLE, CT 06382
NEW LONDON COUNTY

at&t
500 ENTERPRISE DRIVE
ROCKY HILL, CT 06067

NO.	DATE	REVISIONS	BY	DATE	SCALE	DESIGNED BY	DRAWN BY	DRAWING NUMBER	REV
1	01/21/13	ISSUED FOR CONSTRUCTION	MJS	DC	AS SHOWN	DC	MJS	171.01	1
0	07/12/12	ISSUED FOR REVIEW	MJS	DC				S-1	

AT&T
TOWER MODIFICATION ELEVATION & GUY WIRE PLAN (LTE)

Professional Engineer Seal: DANIEL HANN, LICENSED PROFESSIONAL ENGINEER, STATE OF CONNECTICUT, LICENSE NO. 171.01

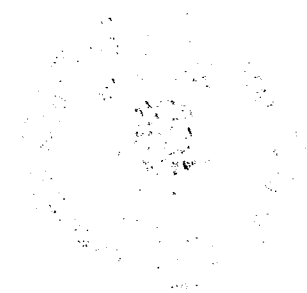

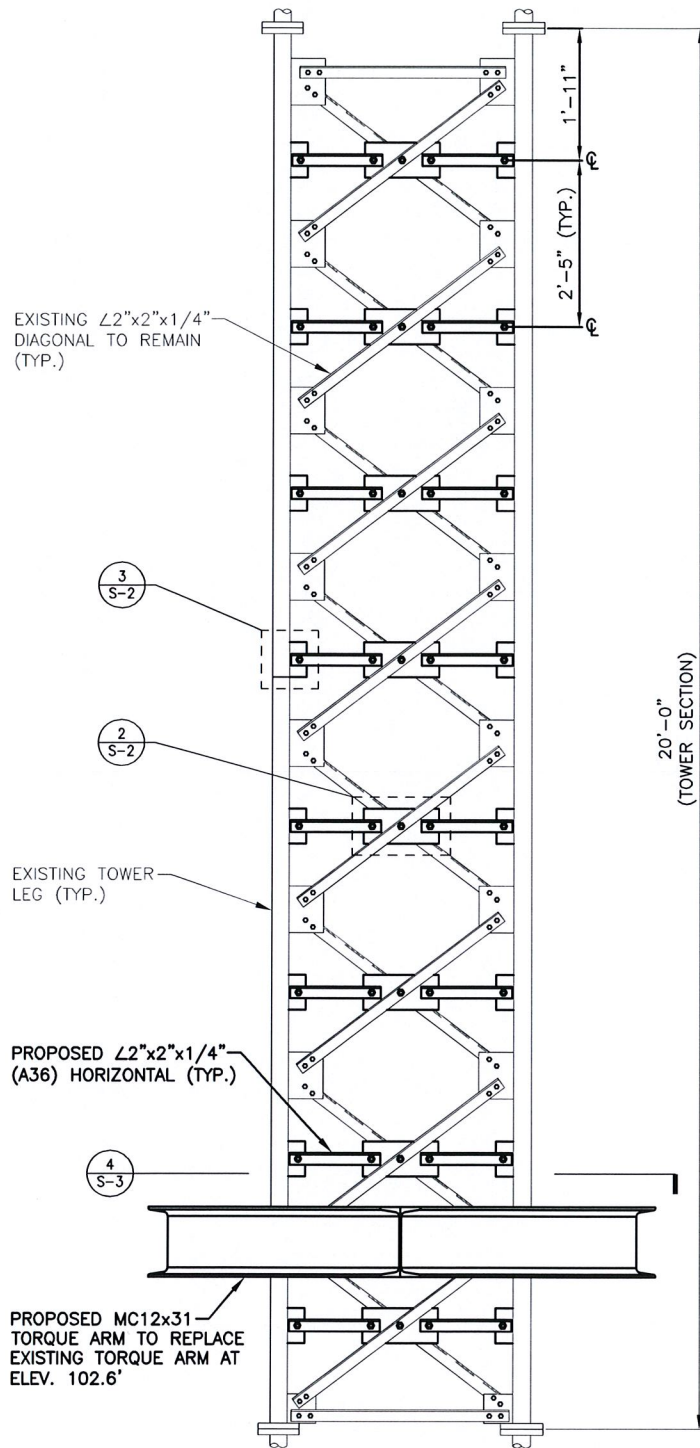

TOWER REINFORCEMENT ELEVATION (ELEV. 100' - 120')

1 S-2 SCALE: 3/4"=1'-0"



NOTE:
REFER TO STRUCTURAL ANALYSIS BY: HUDSON DESIGN GROUP, LLC DATED: JANUARY 18, 2013 (REV1) FOR THE CAPACITY OF THE EXISTING STRUCTURES TO SUPPORT THE PROPOSED EQUIPMENT.

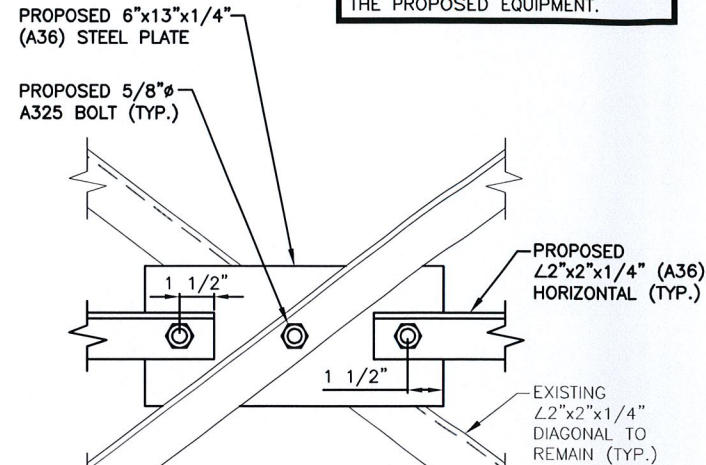

2 CONNECTION DETAIL

2 S-2 SCALE: 3"=1'-0"

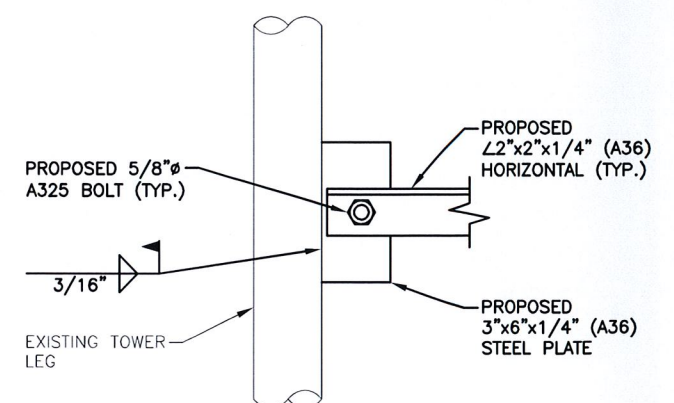

3 CONNECTION DETAIL

3 S-2 SCALE: 3"=1'-0"

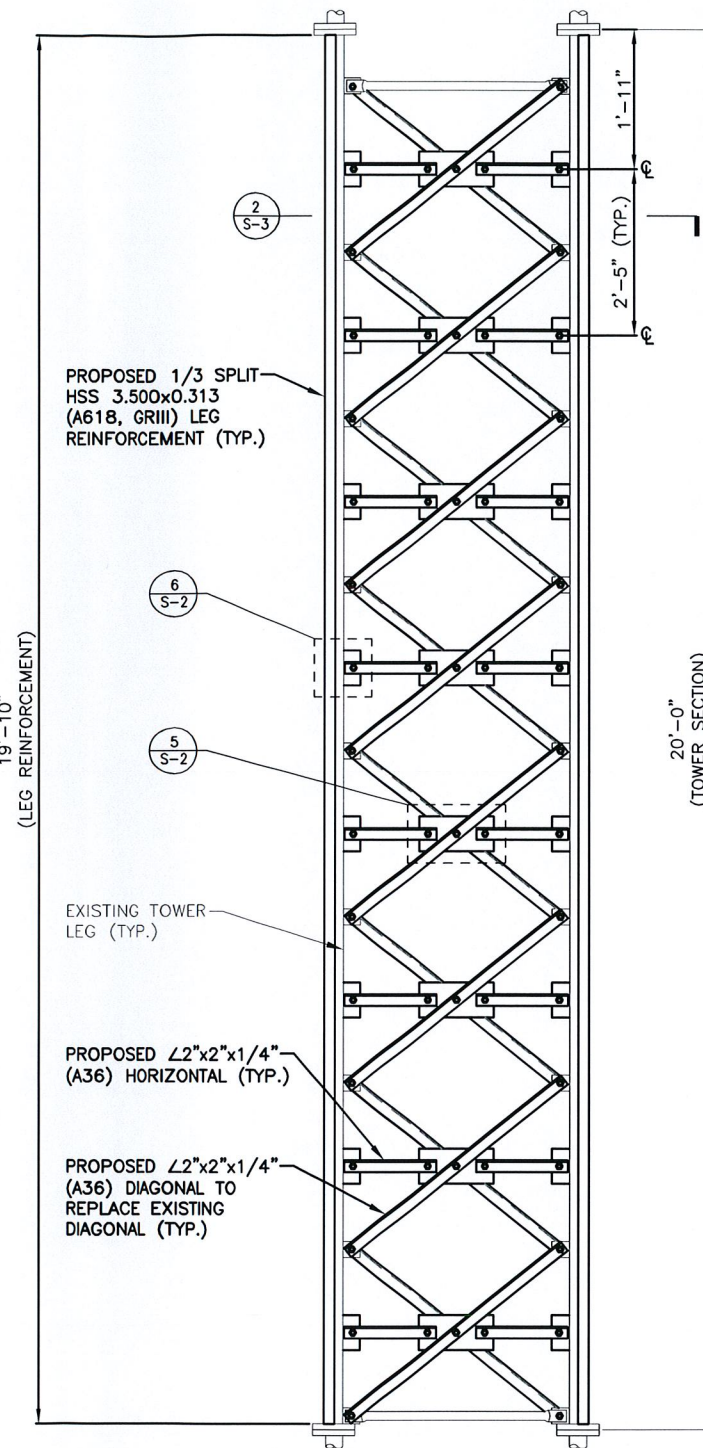

TOWER REINFORCEMENT ELEVATION (ELEV. 140' - 160')

4 S-2 SCALE: 3/4"=1'-0"



ALL DIMENSIONS, MEASUREMENTS, QUANTITIES, PART NUMBERS, AND COAX/ANTENNA PLACEMENTS TO BE FIELD VERIFIED BY CONTRACTOR PRIOR TO MATERIAL ORDERS AND CONSTRUCTION.

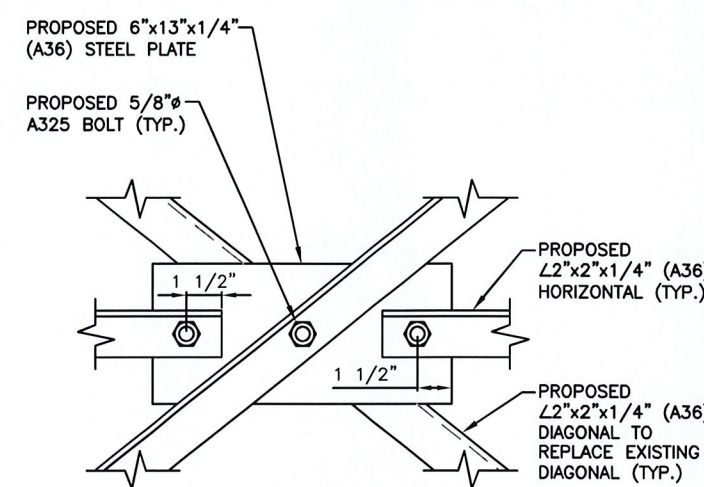

5 CONNECTION DETAIL

5 S-2 SCALE: 3"=1'-0"

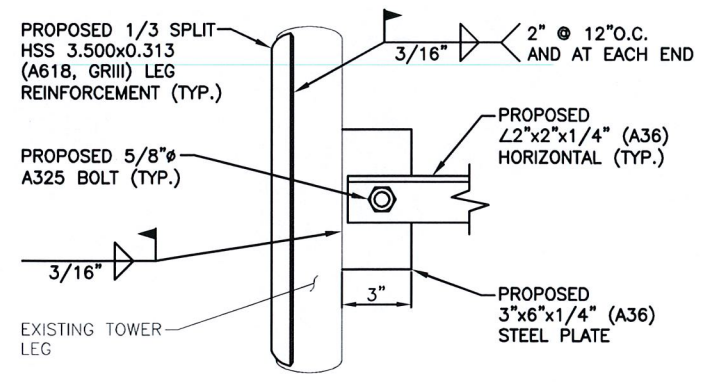

6 CONNECTION DETAIL

6 S-2 SCALE: 3"=1'-0"



Hudson Design Group, LLC
1600 OSGOOD STREET
BUILDING 20 NORTH SUITE 3090
N. ANDOVER, MA 01845
TEL: (978) 557-5553
FAX: (978) 336-5586

Pinnacle Wireless
a UniTek GLOBAL SERVICES company
800 MARSHALL PHELPS ROAD UNIT# 2A
WINDSOR, CT 06095

SITE NUMBER: CT2171
SITE NAME: UNCASVILLE
57 COOK DRIVE
UNCASVILLE, CT 06382
NEW LONDON COUNTY

at&t
500 ENTERPRISE DRIVE
ROCKY HILL, CT 06067

NO.	DATE	REVISIONS	BY
1	01/21/13	ISSUED FOR CONSTRUCTION	MJS
0	07/12/12	ISSUED FOR REVIEW	MJS

SCALE: AS SHOWN DESIGNED BY: DC DRAWN BY: MJS



AT&T
TOWER MODIFICATION DETAILS (LTE)

JOB NUMBER	DRAWING NUMBER	REV
2171.01	S-2	1

NOTE:
 REFER TO STRUCTURAL ANALYSIS
 BY: HUDSON DESIGN GROUP, LLC
 DATED: JANUARY 18, 2013 (REV1)
 FOR THE CAPACITY OF THE
 EXISTING STRUCTURES TO SUPPORT
 THE PROPOSED EQUIPMENT.

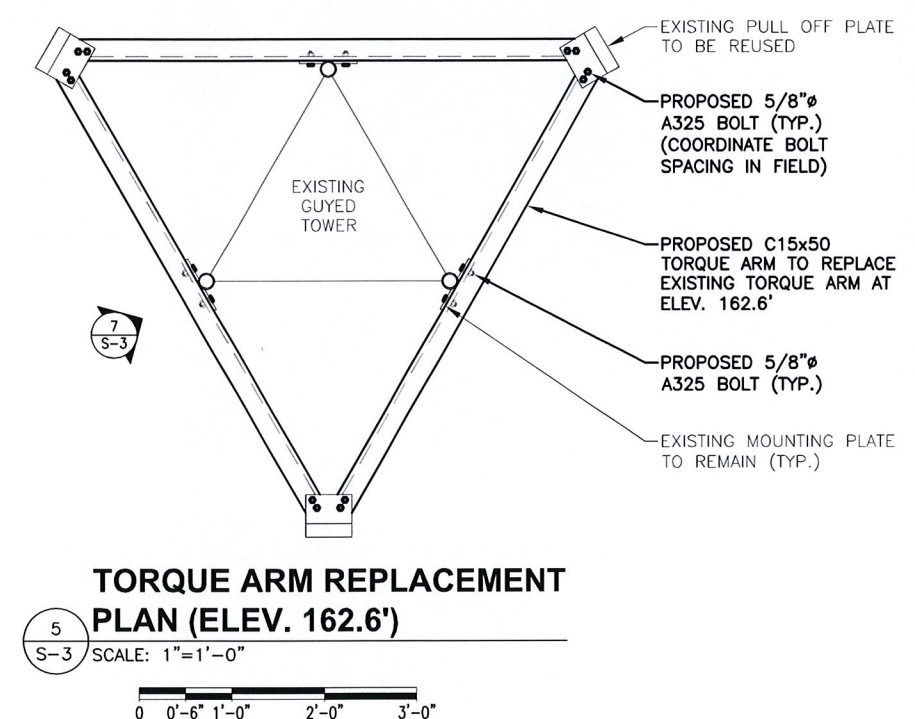
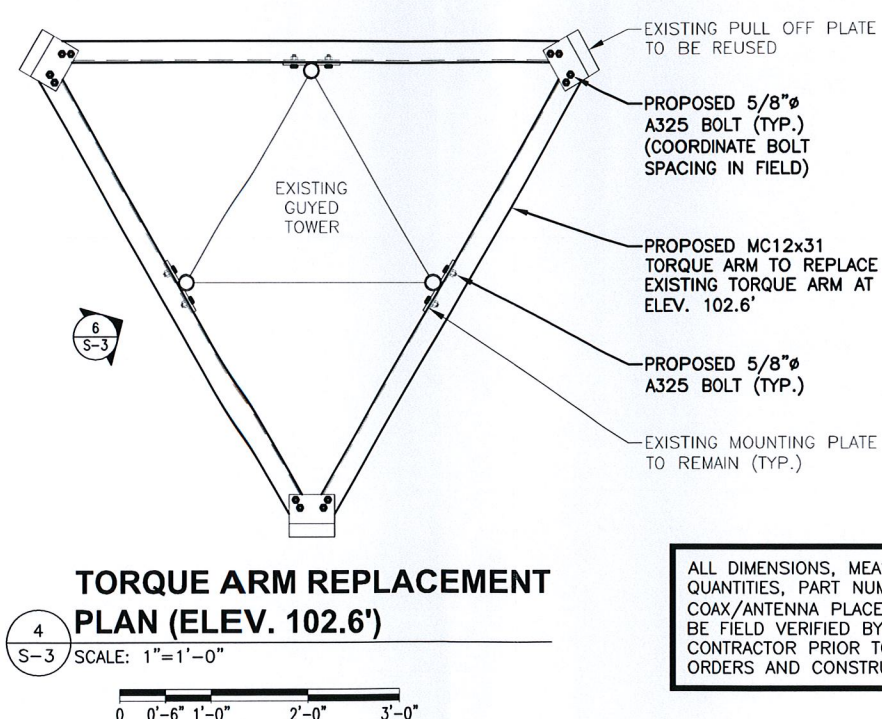
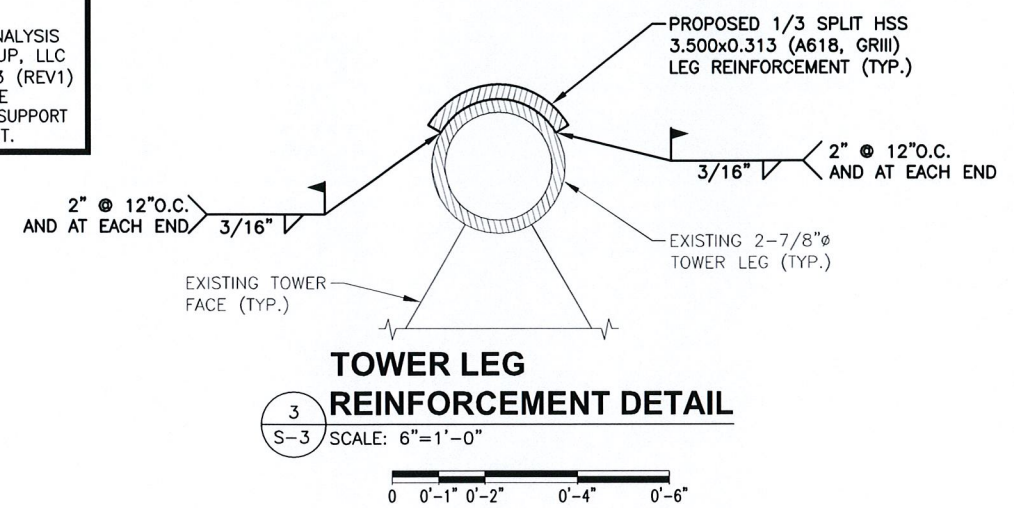
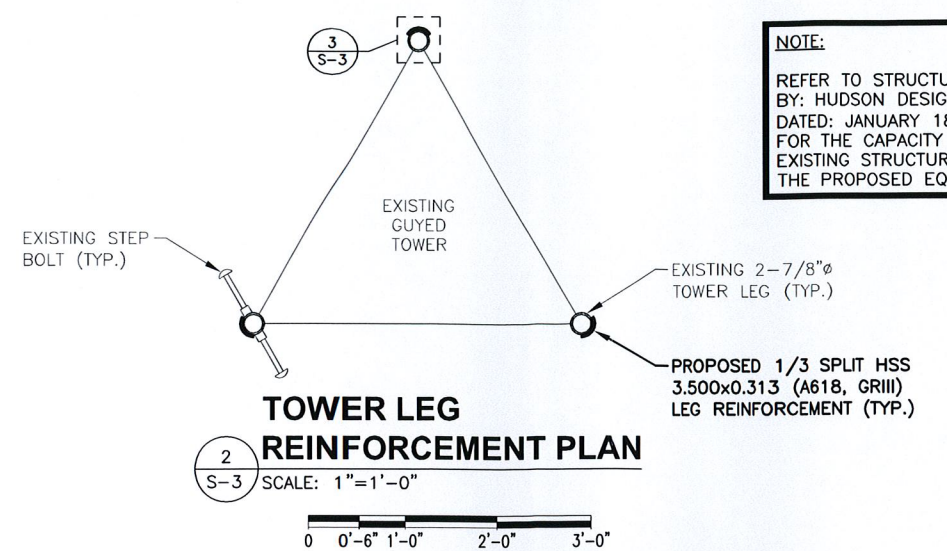
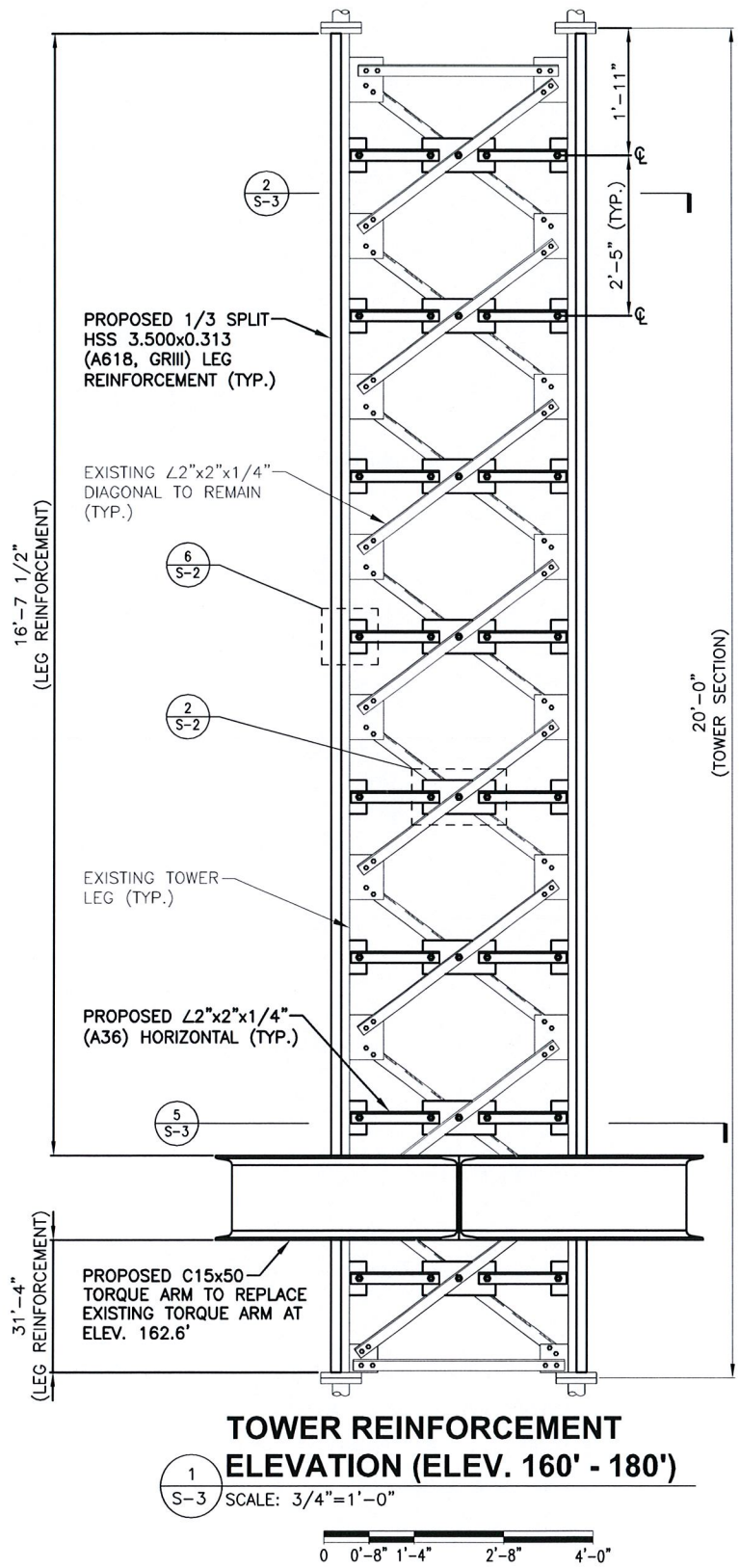

ALL DIMENSIONS, MEASUREMENTS, QUANTITIES, PART NUMBERS, AND COAX/ANTENNA PLACEMENTS TO BE FIELD VERIFIED BY CONTRACTOR PRIOR TO MATERIAL ORDERS AND CONSTRUCTION.

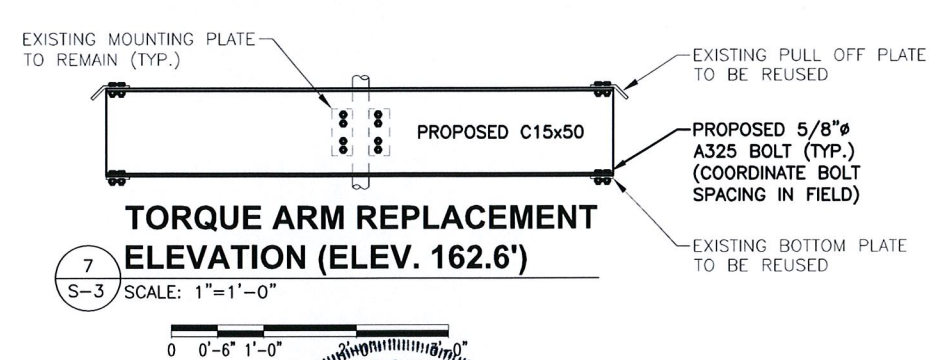
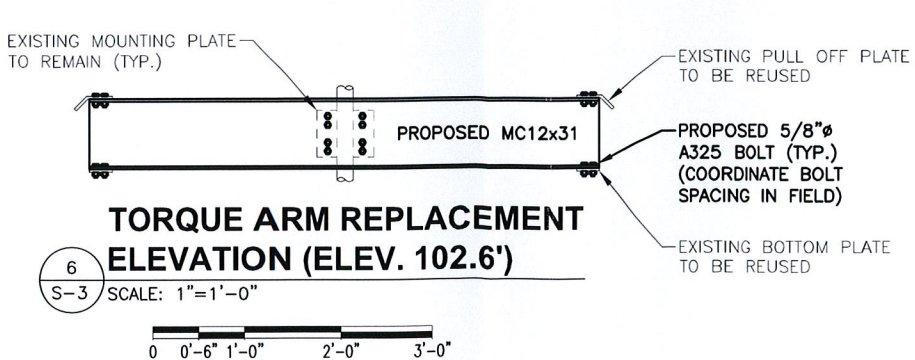

Hudson Design Group, LLC

1600 OSGOOD STREET
 BUILDING 20 NORTH, SUITE 3090
 N. ANDOVER, MA 01845

TEL: (978) 557-5553
 FAX: (978) 336-5586

Pinnacle Wireless

a UniTek GLOBAL SERVICES company

800 MARSHALL PHELPS ROAD UNIT# 2A
 WINDSOR, CT 06095

SITE NUMBER: CT2171
SITE NAME: UNCASVILLE

57 COOK DRIVE
 UNCASVILLE, CT 06382
 NEW LONDON COUNTY

at&t

500 ENTERPRISE DRIVE
 ROCKY HILL, CT 06067

NO.	DATE	REVISIONS	DESIGNED BY: DC	DRAWN BY: M...
1	01/21/13	ISSUED FOR CONSTRUCTION		
0	07/12/12	ISSUED FOR REVIEW		

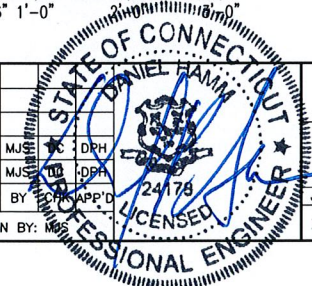

AT&T	
TOWER MODIFICATION DETAILS (LTE)	
JOB NUMBER	DRAWING NUMBER
2171.01	S-3
REV	1

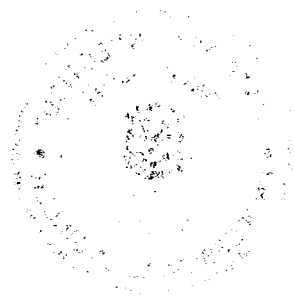

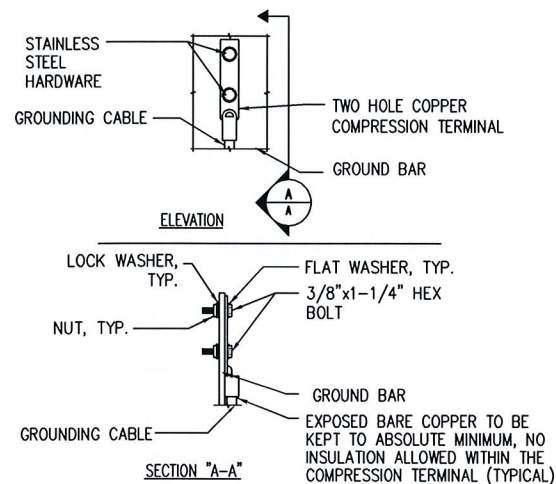

NOTE:
 1. "DOUBLING UP" OR "STACKING" OF CONNECTION IS NOT PERMITTED.
 2. OXIDE INHIBITING COMPOUND TO BE USED AT ALL LOCATIONS.
 3. CADWELD DOWNLEADS FROM UPPER EGB, LOWER EGB, AND MGB.

TYPICAL GROUND BAR CONNECTION DETAIL



N.T.S.

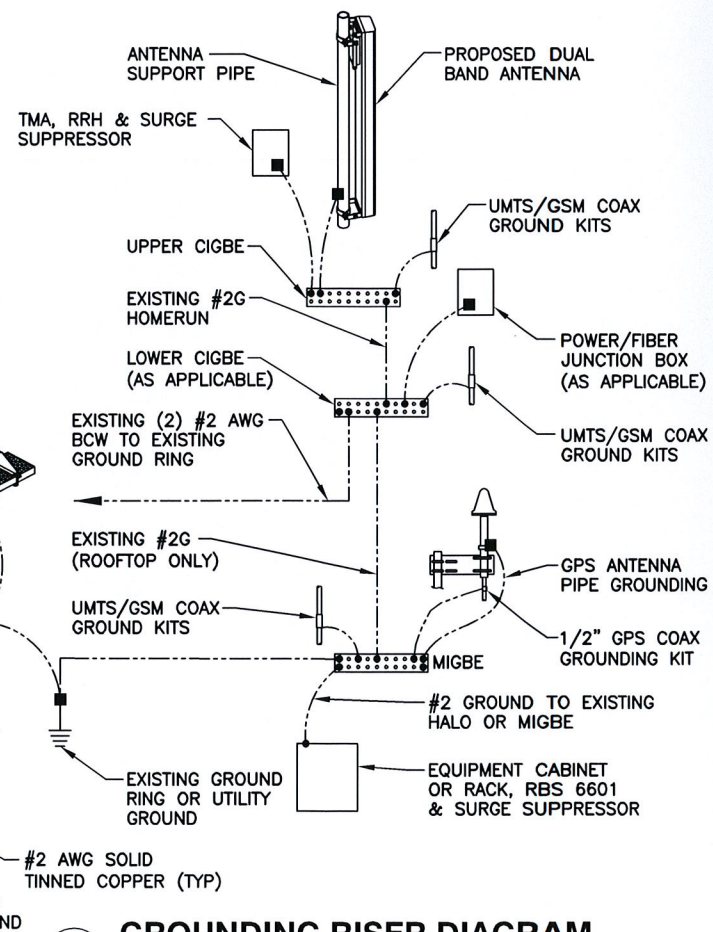

GROUNDING RISER DIAGRAM



N.T.S.

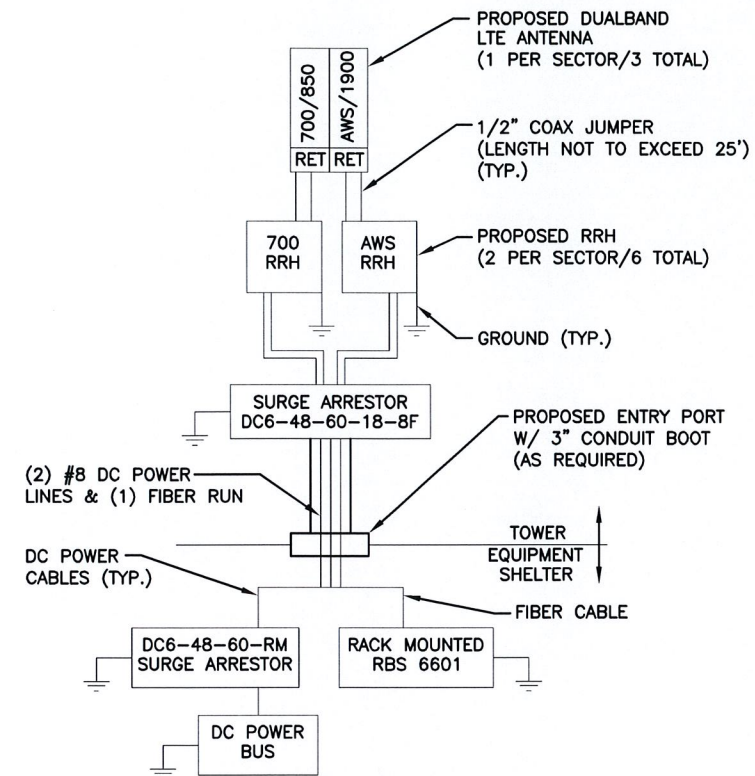

PLUMBING DIAGRAM



N.T.S.

WIRELESS SOLUTIONS INC.			
NO.	REQ.	PART NO.	DESCRIPTION
①	1	HLGB-0420-IS	SOLID GND. BAR (20"x4"x1/4")
②	2		WALL MTG. BRKT.
③	2		INSULATORS
④	4		5/8"-11x1" H.H.C.S.
⑤	4		5/8 LOCKWASHER

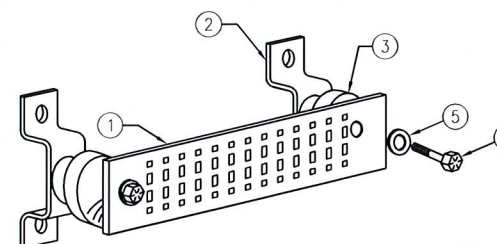

GROUND BAR DETAIL



N.T.S.

EACH GROUND CONDUCTOR TERMINATING ON ANY GROUND BAR SHALL HAVE AN IDENTIFICATION TAG ATTACHED AT EACH END THAT WILL IDENTIFY ITS ORIGIN AND DESTINATION.

SECTION "P" - SURGE PRODUCERS

- CABLE ENTRY PORTS (HATCH PLATES) (#2)
- GENERATOR FRAMEWORK (IF AVAILABLE) (#2)
- TELCO GROUND BAR
- COMMERCIAL POWER COMMON NEUTRAL/GROUND BOND (#2)
- +24V POWER SUPPLY RETURN BAR (#2)
- 48V POWER SUPPLY RETURN BAR (#2)
- RECTIFIER FRAMES.

SECTION "A" - SURGE ABSORBERS

- INTERIOR GROUND RING (#2)
- EXTERNAL EARTH GROUND FIELD (BURIED GROUND RING) (#2)
- METALLIC COLD WATER PIPE (IF AVAILABLE) (#2)
- BUILDING STEEL (IF AVAILABLE) (#2)

Hudson Design Group, Inc.
 1600 OSGOOD STREET
 BUILDING 20 NORTH, SUITE 309D
 N. ANDOVER, MA 01845
 TEL: (978) 557-5553
 FAX: (978) 336-5586

Pinnacle Wireless
 a UniTek GLOBAL SERVICES company
 800 MARSHALL PHELPS ROAD UNIT# 2A
 WINDSOR, CT 06095

SITE NUMBER: CT2171
SITE NAME: UNCASVILLE

57 COOK DRIVE
 UNCASVILLE, CT 06382
 NEW LONDON COUNTY

at&t
 500 ENTERPRISE DRIVE
 ROCKY HILL, CT 06067

NO.	DATE	REVISIONS	DESIGNED BY:	DRAWN BY:
1	01/21/13	ISSUED FOR CONSTRUCTION	MJS	DC
0	07/12/12	ISSUED FOR REVIEW	MJS	DC

SCALE: AS SHOWN

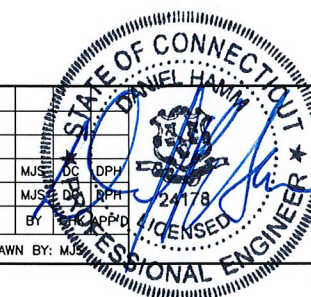

AT&T	
PLUMBING DIAGRAM & GROUNDING DETAILS (LTE)	
JOB NUMBER	DRAWING NUMBER
2171.01	G-1
REV	
1	

