

Date: **September 29, 2016**

Sean Dempsey
Crown Castle
3530 Toringdon Way Suite 300
Charlotte, NC 28277



2000 Corporate Dr.
Canonsburg PA 15317
(724) 416-9125

Subject: Structural Analysis Report

Carrier Designation: *T-Mobile Co-Locate*
Carrier Site Number: CTNH032H

Crown Castle Designation: **Crown Castle BU Number:** 876370
Crown Castle Site Name: MAYBROOK / BOND
Crown Castle JDE Job Number: 382811
Crown Castle Work Order Number: 1306197
Crown Castle Application Number: 345818 Rev. 17

Engineering Firm Designation: **Crown Castle Project Number:** 1306197

Site Data: **41 Beckwith Rd., MONTVILLE, New London County, CT**
Latitude 41° 26' 7.66", Longitude -72° 13' 15.07"
180 Foot - Monopole Tower

Dear Sean Dempsey,

Crown Castle is pleased to submit this "**Structural Analysis Report**" to determine the structural integrity of the above mentioned tower. This analysis has been performed in accordance with the Crown Castle Structural 'Statement of Work' and the terms of Crown Castle Purchase Order Number 1306197, in accordance with application 345818, revision 17.

The purpose of the analysis is to determine acceptability of the tower stress level. Based on our analysis we have determined the tower stress level for the structure and foundation, under the following load case, to be:

LC5: Existing + Proposed Equipment

Sufficient Capacity

Note: See Table I and Table II for the proposed and existing loading, respectively.

This analysis has been performed in accordance with the 2016 Connecticut State Building Code based upon an ultimate 3-second gust wind speed of 135 mph converted to a nominal 3-second gust wind speed of 105 mph per Section 1609.3 and Appendix N as required for use in the TIA-222-G Standard per Exception #5 of Section 1609.1.1. Exposure Category B and Risk Category II were used in this analysis.

All modifications and equipment proposed in this report shall be installed in accordance with the attached drawings for the determined available structural capacity to be effective.

We at Crown Castle appreciate the opportunity of providing our continuing professional services to you and Crown Castle. If you have any questions or need further assistance on this or any other projects, please give us a call.

Structural analysis prepared by: Dolly Hsu, E.I.T. / Shan

Respectfully submitted by:

Terry P. Styran, P.E.
Senior Project Engineer

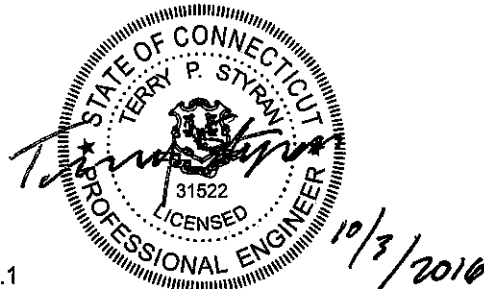

TABLE OF CONTENTS

1) INTRODUCTION

2) ANALYSIS CRITERIA

Table 1 - Proposed Antenna and Cable Information

Table 2 - Existing Antenna and Cable Information

Table 3 - Design Antenna and Cable Information

3) ANALYSIS PROCEDURE

Table 4 - Documents Provided

3.1) Analysis Method

3.2) Assumptions

4) ANALYSIS RESULTS

Table 5 - Section Capacity (Summary)

Table 6 – Tower Component Stresses vs. Capacity – LC5

4.1) Recommendations

5) APPENDIX A

tnxTower Output

6) APPENDIX B

Base Level Drawing

7) APPENDIX C

Additional Calculations

1) INTRODUCTION

This tower is a 180 ft. Monopole tower designed by ENGINEERED ENDEAVORS, INC. in September of 2000. The tower was originally designed for a wind speed of 90 mph per TIA/EIA-222-F.

2) ANALYSIS CRITERIA

The structural analysis was performed for this tower in accordance with the requirements of TIA-222-G Structural Standards for Steel Antenna Towers and Antenna Supporting Structures using a 3-second gust wind speed of 105 mph with no ice, 50 mph with 0.75 inch ice thickness and 60 mph under service loads, and exposure category B.

Table 1 - Proposed Antenna and Cable Information

Mounting Level (ft)	Center Line Elevation (ft)	Number of Antennas	Antenna Manufacturer	Antenna Model	Number of Feed Lines	Feed Line Size (in)	Note
175.0	175.0	3	commscope	LNX-6515DS-A1M	1	1-5/8	-
		3	ericsson	RRUS 11 B12			
		6	ericsson	RRUS 11 B4			
		3	rfs celwave	APX16DWV-16DWV-S-E-A20			
		1	tower mounts	Platform Mount [LP 301-1]			

Table 2 - Existing Antenna and Cable Information

Mounting Level (ft)	Center Line Elevation (ft)	Number of Antennas	Antenna Manufacturer	Antenna Model	Number of Feed Lines	Feed Line Size (in)	Note
180.0	181.0	6	decibel	DB980H90E-M w/ Mount Pipe	6	1-5/8	1
	180.0	1	tower mounts	Platform Mount [LP 601-1]			
167.0	167.0	3	antel	BXA-171085-8BF-EDIN-2 w/ Mount Pipe	12	1-5/8	1
		3	antel	BXA-70063-6CF-2 w/ Mount Pipe			
		6	antel	LPA-80080/4CF w/ Mount Pipe			
		6	rfs celwave	FD9R6004/2C-3L			
		1	tower mounts	Side Arm Mount [SO 202-3]			
75.0	76.0	1	lucent	KS24019-L112A	1	1/2	1
	75.0	1	tower mounts	Side Arm Mount [SO 701-1]			

Notes:

- Existing Equipment

Table 3 - Design Antenna and Cable Information

Mounting Level (ft)	Center Line Elevation (ft)	Number of Antennas	Antenna Manufacturer	Antenna Model	Number of Feed Lines	Feed Line Size (in)
180	180	12	DAPA	48000	-	-
170	170	12	DAPA	48000	-	-
160	160	12	DAPA	48000	-	-
150	150	12	DAPA	48000	-	-
140	140	12	DAPA	48000	-	-

3) ANALYSIS PROCEDURE

Table 4 - Documents Provided

Document	Remarks	Reference	Source
4-TOWER MANUFACTURER DRAWINGS	Engineered Endeavors, Inc.	1532099	CCSITES

3.1) Analysis Method

tnxTower (version 7.0.5.1), a commercially available analysis software package, was used to create a three-dimensional model of the tower and calculate member stresses for various loading cases. Selected output from the analysis is included in Appendix A.

3.2) Assumptions

- 1) Tower and structures were built in accordance with the manufacturer's specifications.
- 2) The tower and structures have been maintained in accordance with the manufacturer's specification.
- 3) The configuration of antennas, transmission cables, mounts and other appurtenances are as specified in Tables 1 and 2 and the referenced drawings.

This analysis may be affected if any assumptions are not valid or have been made in error. Crown Castle should be notified to determine the effect on the structural integrity of the tower.

4) ANALYSIS RESULTS

Table 5 - Section Capacity (Summary)

Section No.	Elevation (ft)	Component Type	Size	Critical Element	P (K)	SF*P_allow (K)	% Capacity	Pass / Fail
L1	180 - 133	Pole	TP27.51x15.5x0.25	1	-8.54	1527.84	58.9	Pass
L2	133 - 87.3333	Pole	TP38.56x25.9879x0.375	2	-16.78	3257.30	49.1	Pass
L3	87.3333 - 42.6667	Pole	TP49.1x36.46x0.4375	3	-29.22	4757.64	45.7	Pass
L4	42.6667 - 0	Pole	TP59x46.5397x0.4375	4	-47.13	5529.76	49.9	Pass
							Summary	
						Pole (L1)	58.9	Pass
						Rating =	58.9	Pass

Table 6 - Tower Component Stresses vs. Capacity – LC5

Notes	Component	Elevation (ft)	% Capacity	Pass / Fail
1	Anchor Rods	0	46.3	Pass
1	Base Plate	0	63.8	Pass
1, 2	Base Foundation (Compared w/ Design Loads)	0	57.8	Pass

Structure Rating (max from all components) =	63.8%
---	--------------

Notes:

- 1) See additional documentation in "Appendix C – Additional Calculations" for calculations supporting the % capacity consumed.
- 2) Foundation capacity determined by comparing analysis reactions to original design reactions.

4.1) Recommendations

The tower and its foundation have sufficient capacity to carry the existing and proposed loads. No modifications are required at this time.

APPENDIX A
TNXTOWER OUTPUT

Section	1	2	3	4	
Length (ft)	47'	49'8-1/32"	50'	49'3-31/32"	
Number of Sides	18	18	18	18	
Thickness (in)	0.2500	0.3750	0.4375	0.4375	
Socket Length (ft)	4'	5'3-31/32"	6'8-1/32"	46.5397	
Top Dia (in)	15.5000	25.9879	36.4600	46.5397	
Bot Dia (in)	27.5100	38.5600	49.1000	59.0000	
Grade		A572-65			
Weight (K)	2.7	6.4	10.0	12.2	31.3

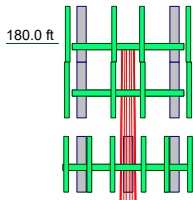

180.0 ft

133.0 ft

87.3 ft

42.7 ft

0.0 ft

DESIGNED APPURTENANCE LOADING

TYPE	ELEVATION	TYPE	ELEVATION
(2) DB980H90E-M w/ Mount Pipe	180	(2) LPA-80080/4CF w/ Mount Pipe	167
(2) DB980H90E-M w/ Mount Pipe	180	(2) LPA-80080/4CF w/ Mount Pipe	167
(2) DB980H90E-M w/ Mount Pipe	180	BXA-70063-6CF-2 w/ Mount Pipe	167
Platform Mount [LP 601-1]	180	BXA-70063-6CF-2 w/ Mount Pipe	167
10' Climbing Ladder (Flat)	180	BXA-70063-6CF-2 w/ Mount Pipe	167
APX16DWV-16DWV-S-E-A20	175	BXA-171085-8BF-EDIN-2 w/ Mount Pipe	167
APX16DWV-16DWV-S-E-A20	175		
APX16DWV-16DWV-S-E-A20	175	BXA-171085-8BF-EDIN-2 w/ Mount Pipe	167
LNX-6515DS-A1M	175	BXA-171085-8BF-EDIN-2 w/ Mount Pipe	167
LNX-6515DS-A1M	175		
LNX-6515DS-A1M	175	(2) FD9R6004/2C-3L	167
(2) RRUS 11 B4	175	(2) FD9R6004/2C-3L	167
(2) RRUS 11 B4	175	(2) FD9R6004/2C-3L	167
(2) RRUS 11 B4	175	Side Arm Mount [SO 202-3]	167
RRUS 11 B12	175	T-Arm Mount [TA 602-3]	167
RRUS 11 B12	175	KS24019-L112A	75
Platform Mount [LP 301-1]	175	Side Arm Mount [SO 701-1]	75
(2) LPA-80080/4CF w/ Mount Pipe	167		

MATERIAL STRENGTH

GRADE	Fy	Fu	GRADE	Fy	Fu
A572-65	65 ksi	80 ksi			

TOWER DESIGN NOTES

1. Tower is located in New London County, Connecticut.
2. Tower designed for Exposure B to the TIA-222-G Standard.
3. Tower designed for a 105 mph basic wind in accordance with the TIA-222-G Standard.
4. Tower is also designed for a 50 mph basic wind with 0.75 in ice. Ice is considered to increase in thickness with height.
5. Deflections are based upon a 60 mph wind.
6. Tower Structure Class II.
7. Topographic Category 1 with Crest Height of 0'
8. TOWER RATING: 58.9%

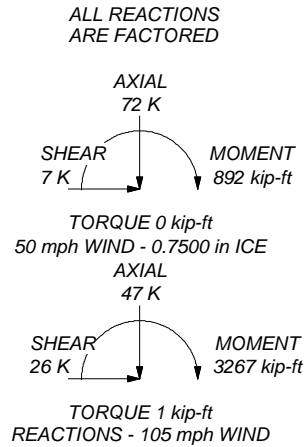

<p>CROWN CASTLE The Foundation for a Wireless World</p>	Crown Castle 2000 Corporate Dr. Canonsburg PA 15317 Phone: (724) 416-9125 FAX: (724) 416-4623		Job: BU# 876370
	Project:		
	Client: Crown Castle	Drawn by: Dolly Hsu	App'd:
	Code: TIA-222-G	Date: 09/29/16	Scale: NTS
	Path: X:\ENG Work Area\DHsu\WIP\876370.WO 1306197\876370.dwg		

Tower Input Data

There is a pole section.

This tower is designed using the TIA-222-G standard.

The following design criteria apply:

- 2) Tower is located in New London County, Connecticut.
- 3) Basic wind speed of 105 mph.
- 4) Structure Class II.
- 5) Exposure Category B.
- 6) Topographic Category 1.
- 7) Crest Height 0'.
- 8) Nominal ice thickness of 0.7500 in.
- 9) Ice thickness is considered to increase with height.
- 10) Ice density of 56.00 pcf.
- 11) A wind speed of 50 mph is used in combination with ice.
- 12) Temperature drop of 50 °F.
- 13) Deflections calculated using a wind speed of 60 mph.
- 14) A non-linear (P-delta) analysis was used.
- 15) Pressures are calculated at each section.
- 16) Stress ratio used in pole design is 1.
- 17) Local bending stresses due to climbing loads, feed line supports, and appurtenance mounts are not considered.

Options

- | | | |
|--|--|---|
| Consider Moments - Legs
Consider Moments - Horizontals
Consider Moments - Diagonals
Use Moment Magnification
✓ Use Code Stress Ratios
✓ Use Code Safety Factors - Guys
Escalate Ice
Always Use Max Kz
Use Special Wind Profile

Include Bolts In Member Capacity

Leg Bolts Are At Top Of Section
Secondary Horizontal Braces Leg
Use Diamond Inner Bracing (4 Sided)
SR Members Have Cut Ends
SR Members Are Concentric | Distribute Leg Loads As Uniform
Assume Legs Pinned
✓ Assume Rigid Index Plate
✓ Use Clear Spans For Wind Area
Use Clear Spans For KL/r
Retension Guys To Initial Tension
✓ Bypass Mast Stability Checks
✓ Use Azimuth Dish Coefficients
✓ Project Wind Area of Appurt.

Autocalc Torque Arm Areas

Add IBC .6D+W Combination
✓ Sort Capacity Reports By Component
Triangulate Diamond Inner Bracing
Treat Feed Line Bundles As Cylinder | Use ASCE 10 X-Brace Ly Rules
Calculate Redundant Bracing Forces
Ignore Redundant Members in FEA
SR Leg Bolts Resist Compression
All Leg Panels Have Same Allowable
Offset Girt At Foundation
✓ Consider Feed Line Torque
Include Angle Block Shear Check
Use TIA-222-G Bracing Resist.
Exemption
Use TIA-222-G Tension Splice
Exemption

<div style="text-align: center; background-color: #e0e0e0; padding: 2px;">Poles</div> ✓ Include Shear-Torsion Interaction
Always Use Sub-Critical Flow
Use Top Mounted Sockets |
|--|--|---|

Tapered Pole Section Geometry

Section	Elevation <small>ft</small>	Section Length <small>ft</small>	Splice Length <small>ft</small>	Number of Sides	Top Diameter <small>in</small>	Bottom Diameter <small>in</small>	Wall Thickness <small>in</small>	Bend Radius <small>in</small>	Pole Grade
L1	180'-133'	47'	4'	18	15.5000	27.5100	0.2500	1.0000	A572-65 (65 ksi)
L2	133'-87'3-31/32"	49'8-1/32"	5'3-31/32"	18	25.9879	38.5600	0.3750	1.5000	A572-65 (65 ksi)
L3	87'3-31/32"-42'8-1/32"	50'	6'8-1/32"	18	36.4600	49.1000	0.4375	1.7500	A572-65 (65 ksi)
L4	42'8-1/32"-0'	49'3-31/32"		18	46.5397	59.0000	0.4375	1.7500	A572-65 (65 ksi)

Tapered Pole Properties

Section	Tip Dia. in	Area in ²	I in ⁴	r in	C in	I/C in ³	J in ⁴	It/Q in ²	w in	w/t
L1	15.7391	12.1009	355.5445	5.4138	7.8740	45.1542	711.5567	6.0516	2.2880	9.152
	27.9344	21.6308	2030.7756	9.6773	13.9751	145.3141	4064.2233	10.8175	4.4018	17.607
L2	27.4169	30.4857	2526.6814	9.0926	13.2018	191.3886	5056.6874	15.2458	3.9139	10.437
	39.1549	45.4497	8372.4782	13.5557	19.5885	427.4185	16755.973	22.7292	6.1266	16.337
L3	38.3915	50.0217	8200.5504	12.7880	18.5217	442.7545	16411.891	25.0156	5.6470	12.907
							1			
	49.8574	67.5740	20216.486	17.2752	24.9428	810.5139	40459.574	33.7934	7.8716	17.992
L4	48.9674	64.0186	17190.414	16.3663	23.6421	727.1088	34403.447	32.0154	7.4210	16.962
			0				6			
	59.9102	81.3214	35235.566	20.7897	29.9720	1175.6161	70517.496	40.6684	9.6140	21.975
		2				3				

Tower Elevation	Gusset Area (per face)	Gusset Thickness	Gusset Grade	Adjust. Factor A _r	Adjust. Factor A _r	Weight Mult.	Double Angle Stitch Bolt Spacing Diagonals	Double Angle Stitch Bolt Spacing Horizontals	Double Angle Stitch Bolt Spacing Redundants
ft	ft ²	in					in	in	in
L1 180'-133'				1	1	1			
L2 133'-87'3-31/32"				1	1	1			
L3 87'3-31/32"-42'8-1/32"				1	1	1			
L4 42'8-1/32"-0'				1	1	1			

Feed Line/Linear Appurtenances - Entered As Round Or Flat

Description	Face or Leg	Allow Shield	Component Type	Placement	Total Number	Number Per Row	Clear Spacing	Width or Diameter	Perimeter	Weight
				ft			in	r in	r in	plf

Feed Line/Linear Appurtenances - Entered As Area

Description	Face or Leg	Allow Shield	Component Type	Placement	Total Number	C _A A _A	Weight
				ft		ft ² /ft	plf
LDF7-50A(1-5/8")	B	No	Inside Pole	180' - 0'	6	No Ice 1/2" Ice 1" Ice	0.00 0.00 0.82
* LDF7-50A(1-5/8")	A	No	Inside Pole	167' - 0'	12	No Ice 1/2" Ice 1" Ice	0.82 0.82 0.82
* LDF4-50A(1/2")	A	No	Inside Pole	75' - 0'	1	No Ice 1/2" Ice 1" Ice	0.15 0.15 0.15
* MLE Hybrid 9Power/18Fiber RL 2(1-5/8")	B	No	Inside Pole	175' - 0'	1	No Ice 1/2" Ice 1" Ice	1.07 1.07 1.07

Feed Line/Linear Appurtenances Section Areas

Tower Section	Tower Elevation ft	Face	A_R ft ²	A_F ft ²	C_{AA} In Face ft ²	C_{AA} Out Face ft ²	Weight K
L1	180'-133'	A	0.000	0.000	0.000	0.000	0.33
		B	0.000	0.000	0.000	0.000	0.28
		C	0.000	0.000	0.000	0.000	0.00
L2	133'-87'3-31/32"	A	0.000	0.000	0.000	0.000	0.45
		B	0.000	0.000	0.000	0.000	0.27
		C	0.000	0.000	0.000	0.000	0.00
L3	87'3-31/32"-42'8-1/32"	A	0.000	0.000	0.000	0.000	0.44
		B	0.000	0.000	0.000	0.000	0.27
		C	0.000	0.000	0.000	0.000	0.00
L4	42'8-1/32"-0'	A	0.000	0.000	0.000	0.000	0.43
		B	0.000	0.000	0.000	0.000	0.26
		C	0.000	0.000	0.000	0.000	0.00

Feed Line/Linear Appurtenances Section Areas - With Ice

Tower Section	Tower Elevation ft	Face or Leg	Ice Thickness in	A_R ft ²	A_F ft ²	C_{AA} In Face ft ²	C_{AA} Out Face ft ²	Weight K
L1	180'-133'	A	1.750	0.000	0.000	0.000	0.000	0.33
		B		0.000	0.000	0.000	0.000	0.28
		C		0.000	0.000	0.000	0.000	0.00
L2	133'-87'3-31/32"	A	1.691	0.000	0.000	0.000	0.000	0.45
		B		0.000	0.000	0.000	0.000	0.27
		C		0.000	0.000	0.000	0.000	0.00
L3	87'3-31/32"-42'8-1/32"	A	1.604	0.000	0.000	0.000	0.000	0.44
		B		0.000	0.000	0.000	0.000	0.27
		C		0.000	0.000	0.000	0.000	0.00
L4	42'8-1/32"-0'	A	1.432	0.000	0.000	0.000	0.000	0.43
		B		0.000	0.000	0.000	0.000	0.26
		C		0.000	0.000	0.000	0.000	0.00

Feed Line Center of Pressure

Section	Elevation ft	CP_x in	CP_z in	CP_x Ice in	CP_z Ice in
L1	180'-133'	0.0000	0.0000	0.0000	0.0000
L2	133'-87'3-31/32"	0.0000	0.0000	0.0000	0.0000
L3	87'3-31/32"-42'8-1/32"	0.0000	0.0000	0.0000	0.0000
L4	42'8-1/32"-0'	0.0000	0.0000	0.0000	0.0000

Shielding Factor Ka

Tower Section	Feed Line Record No.	Description	Feed Line Segment Elev.	K_a No Ice	K_a Ice

Discrete Tower Loads

Description	Face or Leg	Offset Type	Offsets:		Azimuth Adjustment	Placement	C _A A _A		Weight	
			Horz	Lateral			Front	Side		
			ft	ft	°	ft	ft ²	ft ²	K	
(2) DB980H90E-M w/ Mount Pipe	A	From Leg	4.00		0.000	180'	No Ice	4.04	3.62	0.03
			0'				1/2"	4.50	4.48	0.07
			1'				Ice	4.95	5.22	0.11
(2) DB980H90E-M w/ Mount Pipe	B	From Leg	4.00		0.000	180'	No Ice	4.04	3.62	0.03
			0'				1/2"	4.50	4.48	0.07
			1'				Ice	4.95	5.22	0.11
(2) DB980H90E-M w/ Mount Pipe	C	From Leg	4.00		0.000	180'	No Ice	4.04	3.62	0.03
			0'				1/2"	4.50	4.48	0.07
			1'				Ice	4.95	5.22	0.11
Platform Mount [LP 601-1]	C	None			0.000	180'	No Ice	28.47	28.47	1.12
							1/2"	33.59	33.59	1.51
							Ice	38.71	38.71	1.91
10' Climbing Ladder (Flat)	B	From Leg	2.00		0.000	180'	No Ice	5.84	5.84	0.05
			0'				1/2"	10.30	10.30	0.07
			-5'				Ice	14.76	14.76	0.09
* APX16DWV-16DWV-S-E-A20	A	From Leg	4.00		0.000	175'	No Ice	6.59	2.15	0.04
			0'				1/2"	6.96	2.49	0.07
			0'				Ice	7.34	2.84	0.11
APX16DWV-16DWV-S-E-A20	B	From Leg	4.00		0.000	175'	No Ice	6.59	2.15	0.04
			0'				1/2"	6.96	2.49	0.07
			0'				Ice	7.34	2.84	0.11
APX16DWV-16DWV-S-E-A20	C	From Leg	4.00		0.000	175'	No Ice	6.59	2.15	0.04
			0'				1/2"	6.96	2.49	0.07
			0'				Ice	7.34	2.84	0.11
LNX-6515DS-A1M	A	From Leg	4.00		0.000	175'	No Ice	11.45	7.70	0.05
			0'				1/2"	12.06	8.29	0.12
			0'				Ice	12.69	8.89	0.19
LNX-6515DS-A1M	B	From Leg	4.00		0.000	175'	No Ice	11.45	7.70	0.05
			0'				1/2"	12.06	8.29	0.12
			0'				Ice	12.69	8.89	0.19
LNX-6515DS-A1M	C	From Leg	4.00		0.000	175'	No Ice	11.45	7.70	0.05
			0'				1/2"	12.06	8.29	0.12
			0'				Ice	12.69	8.89	0.19
(2) RRUS 11 B4	A	From Leg	4.00		0.000	175'	No Ice	2.83	1.18	0.05
			0'				1/2"	3.04	1.33	0.07
			0'				Ice	3.26	1.48	0.10
(2) RRUS 11 B4	B	From Leg	4.00		0.000	175'	No Ice	2.83	1.18	0.05
			0'				1/2"	3.04	1.33	0.07
			0'				Ice	3.26	1.48	0.10
(2) RRUS 11 B4	C	From Leg	4.00		0.000	175'	No Ice	2.83	1.18	0.05
			0'				1/2"	3.04	1.33	0.07
			0'				Ice	3.26	1.48	0.10
RRUS 11 B12	A	From Leg	4.00		0.000	175'	No Ice	2.83	1.18	0.05
			0'				1/2"	3.04	1.33	0.07
			0'				Ice	3.26	1.48	0.10
RRUS 11 B12	B	From Leg	4.00		0.000	175'	No Ice	2.83	1.18	0.05
			0'				1/2"	3.04	1.33	0.07
			0'				Ice	3.26	1.48	0.10
RRUS 11 B12		From Leg	4.00		0.000	175'	No Ice	2.83	1.18	0.05
			0'				1/2"	3.04	1.33	0.07
			0'				Ice	3.26	1.48	0.10

Description	Face or Leg	Offset Type	Offsets:		Azimuth Adjustment	Placement	C _{AA} _{Front}	C _{AA} _{Side}	Weight	
			Horz	Lateral						Vert
			ft	ft						
RRUS 11 B12	C	From Leg	4.00	0.000		175'	No Ice	2.83	1.18	0.05
			0'				1/2"	3.04	1.33	0.07
			0'				Ice	3.26	1.48	0.10
							1" Ice			
Platform Mount [LP 301-1]	C	None		0.000		175'	No Ice	30.10	30.10	1.59
							1/2"	40.80	40.80	2.03
							Ice	51.50	51.50	2.47
							1" Ice			
*										
(2) LPA-80080/4CF w/ Mount Pipe	A	From Leg	4.00	0.000		167'	No Ice	2.86	6.57	0.03
			0'				1/2"	3.22	7.19	0.08
			0'				Ice	3.59	7.84	0.13
							1" Ice			
(2) LPA-80080/4CF w/ Mount Pipe	B	From Leg	4.00	0.000		167'	No Ice	2.86	6.57	0.03
			0'				1/2"	3.22	7.19	0.08
			0'				Ice	3.59	7.84	0.13
							1" Ice			
(2) LPA-80080/4CF w/ Mount Pipe	C	From Leg	4.00	0.000		167'	No Ice	2.86	6.57	0.03
			0'				1/2"	3.22	7.19	0.08
			0'				Ice	3.59	7.84	0.13
							1" Ice			
BXA-70063-6CF-2 w/ Mount Pipe	A	From Leg	4.00	0.000		167'	No Ice	7.81	5.80	0.04
			0'				1/2"	8.36	6.95	0.10
			0'				Ice	8.87	7.82	0.17
							1" Ice			
BXA-70063-6CF-2 w/ Mount Pipe	B	From Leg	4.00	0.000		167'	No Ice	7.81	5.80	0.04
			0'				1/2"	8.36	6.95	0.10
			0'				Ice	8.87	7.82	0.17
							1" Ice			
BXA-70063-6CF-2 w/ Mount Pipe	C	From Leg	4.00	0.000		167'	No Ice	7.81	5.80	0.04
			0'				1/2"	8.36	6.95	0.10
			0'				Ice	8.87	7.82	0.17
							1" Ice			
BXA-171085-8BF-EDIN-2 w/ Mount Pipe	A	From Leg	4.00	0.000		167'	No Ice	3.18	3.35	0.03
			0'				1/2"	3.56	3.97	0.06
			0'				Ice	3.93	4.60	0.10
							1" Ice			
BXA-171085-8BF-EDIN-2 w/ Mount Pipe	B	From Leg	4.00	0.000		167'	No Ice	3.18	3.35	0.03
			0'				1/2"	3.56	3.97	0.06
			0'				Ice	3.93	4.60	0.10
							1" Ice			
BXA-171085-8BF-EDIN-2 w/ Mount Pipe	C	From Leg	4.00	0.000		167'	No Ice	3.18	3.35	0.03
			0'				1/2"	3.56	3.97	0.06
			0'				Ice	3.93	4.60	0.10
							1" Ice			
(2) FD9R6004/2C-3L	A	From Leg	4.00	0.000		167'	No Ice	0.31	0.08	0.00
			0'				1/2"	0.39	0.12	0.01
			0'				Ice	0.47	0.17	0.01
							1" Ice			
(2) FD9R6004/2C-3L	B	From Leg	4.00	0.000		167'	No Ice	0.31	0.08	0.00
			0'				1/2"	0.39	0.12	0.01
			0'				Ice	0.47	0.17	0.01
							1" Ice			
(2) FD9R6004/2C-3L	C	From Leg	4.00	0.000		167'	No Ice	0.31	0.08	0.00
			0'				1/2"	0.39	0.12	0.01
			0'				Ice	0.47	0.17	0.01
							1" Ice			
Side Arm Mount [SO 202-3]	C	None		0.000		167'	No Ice	6.18	6.18	0.33
							1/2"	8.56	8.56	0.40
							Ice	10.94	10.94	0.47
							1" Ice			
T-Arm Mount [TA 602-3]	C	None		0.000		167'	No Ice	11.59	11.59	0.77
							1/2"	15.44	15.44	0.99
							Ice	19.29	19.29	1.21
							1" Ice			

Description	Face or Leg	Offset Type	Offsets: Horz Lateral Vert ft ft ft	Azimuth Adjustment °	Placement ft		C _A A _A Front ft ²	C _A A _A Side ft ²	Weight K
*									
KS24019-L112A	A	From Leg	1.50 0' 1'	0.000	75'	No Ice 1/2" Ice 1" Ice	0.10 0.18 0.26	0.10 0.18 0.26	0.01 0.01 0.01
Side Arm Mount [SO 701-1]	A	From Leg	0.75 0' 0'	0.000	75'	No Ice 1/2" Ice 1" Ice	0.85 1.14 1.43	1.67 2.34 3.01	0.07 0.08 0.09

Load Combinations

Comb. No.	Description
1	Dead Only
2	1.2 Dead+1.6 Wind 0 deg - No Ice
3	0.9 Dead+1.6 Wind 0 deg - No Ice
4	1.2 Dead+1.6 Wind 30 deg - No Ice
5	0.9 Dead+1.6 Wind 30 deg - No Ice
6	1.2 Dead+1.6 Wind 60 deg - No Ice
7	0.9 Dead+1.6 Wind 60 deg - No Ice
8	1.2 Dead+1.6 Wind 90 deg - No Ice
9	0.9 Dead+1.6 Wind 90 deg - No Ice
10	1.2 Dead+1.6 Wind 120 deg - No Ice
11	0.9 Dead+1.6 Wind 120 deg - No Ice
12	1.2 Dead+1.6 Wind 150 deg - No Ice
13	0.9 Dead+1.6 Wind 150 deg - No Ice
14	1.2 Dead+1.6 Wind 180 deg - No Ice
15	0.9 Dead+1.6 Wind 180 deg - No Ice
16	1.2 Dead+1.6 Wind 210 deg - No Ice
17	0.9 Dead+1.6 Wind 210 deg - No Ice
18	1.2 Dead+1.6 Wind 240 deg - No Ice
19	0.9 Dead+1.6 Wind 240 deg - No Ice
20	1.2 Dead+1.6 Wind 270 deg - No Ice
21	0.9 Dead+1.6 Wind 270 deg - No Ice
22	1.2 Dead+1.6 Wind 300 deg - No Ice
23	0.9 Dead+1.6 Wind 300 deg - No Ice
24	1.2 Dead+1.6 Wind 330 deg - No Ice
25	0.9 Dead+1.6 Wind 330 deg - No Ice
26	1.2 Dead+1.0 Ice+1.0 Temp
27	1.2 Dead+1.0 Wind 0 deg+1.0 Ice+1.0 Temp
28	1.2 Dead+1.0 Wind 30 deg+1.0 Ice+1.0 Temp
29	1.2 Dead+1.0 Wind 60 deg+1.0 Ice+1.0 Temp
30	1.2 Dead+1.0 Wind 90 deg+1.0 Ice+1.0 Temp
31	1.2 Dead+1.0 Wind 120 deg+1.0 Ice+1.0 Temp
32	1.2 Dead+1.0 Wind 150 deg+1.0 Ice+1.0 Temp
33	1.2 Dead+1.0 Wind 180 deg+1.0 Ice+1.0 Temp
34	1.2 Dead+1.0 Wind 210 deg+1.0 Ice+1.0 Temp
35	1.2 Dead+1.0 Wind 240 deg+1.0 Ice+1.0 Temp
36	1.2 Dead+1.0 Wind 270 deg+1.0 Ice+1.0 Temp
37	1.2 Dead+1.0 Wind 300 deg+1.0 Ice+1.0 Temp
38	1.2 Dead+1.0 Wind 330 deg+1.0 Ice+1.0 Temp
39	Dead+Wind 0 deg - Service
40	Dead+Wind 30 deg - Service
41	Dead+Wind 60 deg - Service
42	Dead+Wind 90 deg - Service
43	Dead+Wind 120 deg - Service
44	Dead+Wind 150 deg - Service

Comb. No.	Description
45	Dead+Wind 180 deg - Service
46	Dead+Wind 210 deg - Service
47	Dead+Wind 240 deg - Service
48	Dead+Wind 270 deg - Service
49	Dead+Wind 300 deg - Service
50	Dead+Wind 330 deg - Service

Maximum Member Forces

Section No.	Elevation ft	Component Type	Condition	Gov. Load Comb.	Axial K	Major Axis Moment kip-ft	Minor Axis Moment kip-ft
L1	180 - 133	Pole	Max Tension	1	0.00	0.00	0.00
			Max. Compression	26	-21.44	-0.32	-0.19
			Max. Mx	8	-8.54	-480.15	-0.06
			Max. My	14	-8.54	-0.10	-480.08
			Max. Vy	8	14.28	-480.15	-0.06
			Max. Vx	14	14.28	-0.10	-480.08
			Max. Torque	4			-0.86
L2	133 - 87.3333	Pole	Max Tension	1	0.00	0.00	0.00
			Max. Compression	26	-32.74	-0.32	-0.19
			Max. Mx	8	-16.78	-1195.04	-0.06
			Max. My	14	-16.78	-0.13	-1194.96
			Max. Vy	8	18.06	-1195.04	-0.06
			Max. Vx	2	-18.06	-0.13	1194.80
			Max. Torque	4			-0.85
L3	87.3333 - 42.6667	Pole	Max Tension	1	0.00	0.00	0.00
			Max. Compression	26	-49.12	-0.32	0.15
			Max. Mx	8	-29.22	-2068.20	0.14
			Max. My	2	-29.22	-0.14	2067.25
			Max. Vy	8	22.18	-2068.20	0.14
			Max. Vx	2	-22.15	-0.14	2067.25
			Max. Torque	4			-0.85
L4	42.6667 - 0	Pole	Max Tension	1	0.00	0.00	0.00
			Max. Compression	26	-71.90	-0.32	0.15
			Max. Mx	8	-47.13	-3266.96	0.14
			Max. My	2	-47.13	-0.14	3264.26
			Max. Vy	8	26.36	-3266.96	0.14
			Max. Vx	2	-26.33	-0.14	3264.26
			Max. Torque	4			-0.75

Maximum Reactions

Location	Condition	Gov. Load Comb.	Vertical K	Horizontal, X K	Horizontal, Z K
Pole	Max. Vert	30	71.90	-7.06	0.00
	Max. H _x	20	47.14	26.34	-0.00
	Max. H _z	2	47.14	-0.00	26.30
	Max. M _x	2	3264.26	-0.00	26.30
	Max. M _z	8	3266.96	-26.34	-0.00
	Max. Torsion	16	0.75	13.17	-22.78
	Min. Vert	17	35.36	13.17	-22.78
	Min. H _x	8	47.14	-26.34	-0.00
	Min. H _z	14	47.14	-0.00	-26.30
	Min. M _x	14	-3263.99	-0.00	-26.30
	Min. M _z	20	-3266.67	26.34	-0.00
	Min. Torsion	4	-0.75	-13.17	22.78

Tower Mast Reaction Summary

Load Combination	Vertical K	Shear _x K	Shear _z K	Overturning Moment, M _x kip-ft	Overturning Moment, M _z kip-ft	Torque kip-ft
Dead Only	39.29	0.00	0.00	-0.11	-0.11	0.00
1.2 Dead+1.6 Wind 0 deg - No Ice	47.14	0.00	-26.30	-3264.26	-0.14	0.74
0.9 Dead+1.6 Wind 0 deg - No Ice	35.36	0.00	-26.30	-3230.07	-0.10	0.73
1.2 Dead+1.6 Wind 30 deg - No Ice	47.14	13.17	-22.78	-2826.97	-1633.55	0.75
0.9 Dead+1.6 Wind 30 deg - No Ice	35.36	13.17	-22.78	-2797.34	-1616.43	0.75
1.2 Dead+1.6 Wind 60 deg - No Ice	47.14	22.81	-13.15	-1632.21	-2829.30	0.57
0.9 Dead+1.6 Wind 60 deg - No Ice	35.36	22.81	-13.15	-1615.09	-2799.66	0.57
1.2 Dead+1.6 Wind 90 deg - No Ice	47.14	26.34	0.00	-0.14	-3266.96	0.23
0.9 Dead+1.6 Wind 90 deg - No Ice	35.36	26.34	0.00	-0.11	-3232.75	0.23
1.2 Dead+1.6 Wind 120 deg - No Ice	47.14	22.81	13.15	1631.93	-2829.30	-0.17
0.9 Dead+1.6 Wind 120 deg - No Ice	35.36	22.81	13.15	1614.88	-2799.66	-0.16
1.2 Dead+1.6 Wind 150 deg - No Ice	47.14	13.17	22.78	2826.69	-1633.56	-0.52
0.9 Dead+1.6 Wind 150 deg - No Ice	35.36	13.17	22.78	2797.14	-1616.43	-0.52
1.2 Dead+1.6 Wind 180 deg - No Ice	47.14	0.00	26.30	3263.99	-0.14	-0.74
0.9 Dead+1.6 Wind 180 deg - No Ice	35.36	0.00	26.30	3229.87	-0.10	-0.73
1.2 Dead+1.6 Wind 210 deg - No Ice	47.14	-13.17	22.78	2826.69	1633.28	-0.75
0.9 Dead+1.6 Wind 210 deg - No Ice	35.36	-13.17	22.78	2797.13	1616.23	-0.75
1.2 Dead+1.6 Wind 240 deg - No Ice	47.14	-22.81	13.15	1631.93	2829.02	-0.57
0.9 Dead+1.6 Wind 240 deg - No Ice	35.36	-22.81	13.15	1614.88	2799.46	-0.57
1.2 Dead+1.6 Wind 270 deg - No Ice	47.14	-26.34	0.00	-0.14	3266.67	-0.23
0.9 Dead+1.6 Wind 270 deg - No Ice	35.36	-26.34	0.00	-0.11	3232.54	-0.23
1.2 Dead+1.6 Wind 300 deg - No Ice	47.14	-22.81	-13.15	-1632.20	2829.02	0.17
0.9 Dead+1.6 Wind 300 deg - No Ice	35.36	-22.81	-13.15	-1615.09	2799.45	0.16
1.2 Dead+1.6 Wind 330 deg - No Ice	47.14	-13.17	-22.78	-2826.96	1633.28	0.52
0.9 Dead+1.6 Wind 330 deg - No Ice	35.36	-13.17	-22.78	-2797.34	1616.22	0.52
1.2 Dead+1.0 Ice+1.0 Temp	71.90	0.00	0.00	-0.15	-0.32	0.00
1.2 Dead+1.0 Wind 0 deg+1.0 Ice+1.0 Temp	71.90	0.00	-7.05	-890.62	-0.39	0.40
1.2 Dead+1.0 Wind 30 deg+1.0 Ice+1.0 Temp	71.90	3.53	-6.10	-771.32	-446.12	0.42
1.2 Dead+1.0 Wind 60 deg+1.0 Ice+1.0 Temp	71.90	6.11	-3.52	-445.38	-772.42	0.34
1.2 Dead+1.0 Wind 90 deg+1.0 Ice+1.0 Temp	71.90	7.06	0.00	-0.14	-891.86	0.16
1.2 Dead+1.0 Wind 120 deg+1.0 Ice+1.0 Temp	71.90	6.11	3.52	445.10	-772.42	-0.06
1.2 Dead+1.0 Wind 150 deg+1.0 Ice+1.0 Temp	71.90	3.53	6.10	771.05	-446.12	-0.26
1.2 Dead+1.0 Wind 180 deg+1.0 Ice+1.0 Temp	71.90	0.00	7.05	890.35	-0.39	-0.40
1.2 Dead+1.0 Wind 210 deg+1.0 Ice+1.0 Temp	71.90	-3.53	6.10	771.04	445.34	-0.42

Load Combination	Vertical	Shear _x	Shear _z	Overturning Moment, M _x	Overturning Moment, M _z	Torque
	K	K	K	kip-ft	kip-ft	kip-ft
1.2 Dead+1.0 Wind 240 deg+1.0 Ice+1.0 Temp	71.90	-6.11	3.52	445.10	771.64	-0.34
1.2 Dead+1.0 Wind 270 deg+1.0 Ice+1.0 Temp	71.90	-7.06	0.00	-0.14	891.07	-0.16
1.2 Dead+1.0 Wind 300 deg+1.0 Ice+1.0 Temp	71.90	-6.11	-3.52	-445.38	771.64	0.06
1.2 Dead+1.0 Wind 330 deg+1.0 Ice+1.0 Temp	71.90	-3.53	-6.10	-771.32	445.34	0.26
Dead+Wind 0 deg - Service	39.29	0.00	-4.80	-592.88	-0.12	0.14
Dead+Wind 30 deg - Service	39.29	2.40	-4.16	-513.47	-296.75	0.14
Dead+Wind 60 deg - Service	39.29	4.16	-2.40	-296.50	-513.90	0.11
Dead+Wind 90 deg - Service	39.29	4.81	0.00	-0.11	-593.38	0.04
Dead+Wind 120 deg - Service	39.29	4.16	2.40	296.27	-513.90	-0.03
Dead+Wind 150 deg - Service	39.29	2.40	4.16	513.24	-296.75	-0.10
Dead+Wind 180 deg - Service	39.29	0.00	4.80	592.66	-0.12	-0.14
Dead+Wind 210 deg - Service	39.29	-2.40	4.16	513.24	296.51	-0.14
Dead+Wind 240 deg - Service	39.29	-4.16	2.40	296.27	513.66	-0.11
Dead+Wind 270 deg - Service	39.29	-4.81	0.00	-0.11	593.14	-0.04
Dead+Wind 300 deg - Service	39.29	-4.16	-2.40	-296.50	513.66	0.03
Dead+Wind 330 deg - Service	39.29	-2.40	-4.16	-513.47	296.51	0.10

Solution Summary

Load Comb.	Sum of Applied Forces			Sum of Reactions			% Error
	PX K	PY K	PZ K	PX K	PY K	PZ K	
1	0.00	-39.29	0.00	0.00	39.29	0.00	0.000%
2	0.00	-47.14	-26.30	-0.00	47.14	26.30	0.000%
3	0.00	-35.36	-26.30	-0.00	35.36	26.30	0.000%
4	13.17	-47.14	-22.78	-13.17	47.14	22.78	0.000%
5	13.17	-35.36	-22.78	-13.17	35.36	22.78	0.000%
6	22.81	-47.14	-13.15	-22.81	47.14	13.15	0.000%
7	22.81	-35.36	-13.15	-22.81	35.36	13.15	0.000%
8	26.34	-47.14	0.00	-26.34	47.14	-0.00	0.000%
9	26.34	-35.36	0.00	-26.34	35.36	0.00	0.000%
10	22.81	-47.14	13.15	-22.81	47.14	-13.15	0.000%
11	22.81	-35.36	13.15	-22.81	35.36	-13.15	0.000%
12	13.17	-47.14	22.78	-13.17	47.14	-22.78	0.000%
13	13.17	-35.36	22.78	-13.17	35.36	-22.78	0.000%
14	0.00	-47.14	26.30	-0.00	47.14	-26.30	0.000%
15	0.00	-35.36	26.30	-0.00	35.36	-26.30	0.000%
16	-13.17	-47.14	22.78	13.17	47.14	-22.78	0.000%
17	-13.17	-35.36	22.78	13.17	35.36	-22.78	0.000%
18	-22.81	-47.14	13.15	22.81	47.14	-13.15	0.000%
19	-22.81	-35.36	13.15	22.81	35.36	-13.15	0.000%
20	-26.34	-47.14	0.00	26.34	47.14	-0.00	0.000%
21	-26.34	-35.36	0.00	26.34	35.36	0.00	0.000%
22	-22.81	-47.14	-13.15	22.81	47.14	13.15	0.000%
23	-22.81	-35.36	-13.15	22.81	35.36	13.15	0.000%
24	-13.17	-47.14	-22.78	13.17	47.14	22.78	0.000%
25	-13.17	-35.36	-22.78	13.17	35.36	22.78	0.000%
26	0.00	-71.90	0.00	0.00	71.90	0.00	0.000%
27	0.00	-71.90	-7.05	-0.00	71.90	7.05	0.000%
28	3.53	-71.90	-6.10	-3.53	71.90	6.10	0.000%
29	6.11	-71.90	-3.52	-6.11	71.90	3.52	0.000%
30	7.06	-71.90	0.00	-7.06	71.90	0.00	0.000%
31	6.11	-71.90	3.52	-6.11	71.90	-3.52	0.000%
32	3.53	-71.90	6.10	-3.53	71.90	-6.10	0.000%

Load Comb.	Sum of Applied Forces			Sum of Reactions			% Error
	PX K	PY K	PZ K	PX K	PY K	PZ K	
33	0.00	-71.90	7.05	-0.00	71.90	-7.05	0.000%
34	-3.53	-71.90	6.10	3.53	71.90	-6.10	0.000%
35	-6.11	-71.90	3.52	6.11	71.90	-3.52	0.000%
36	-7.06	-71.90	0.00	7.06	71.90	0.00	0.000%
37	-6.11	-71.90	-3.52	6.11	71.90	3.52	0.000%
38	-3.53	-71.90	-6.10	3.53	71.90	6.10	0.000%
39	0.00	-39.29	-4.80	0.00	39.29	4.80	0.000%
40	2.40	-39.29	-4.16	-2.40	39.29	4.16	0.000%
41	4.16	-39.29	-2.40	-4.16	39.29	2.40	0.000%
42	4.81	-39.29	0.00	-4.81	39.29	0.00	0.000%
43	4.16	-39.29	2.40	-4.16	39.29	-2.40	0.000%
44	2.40	-39.29	4.16	-2.40	39.29	-4.16	0.000%
45	0.00	-39.29	4.80	0.00	39.29	-4.80	0.000%
46	-2.40	-39.29	4.16	2.40	39.29	-4.16	0.000%
47	-4.16	-39.29	2.40	4.16	39.29	-2.40	0.000%
48	-4.81	-39.29	0.00	4.81	39.29	0.00	0.000%
49	-4.16	-39.29	-2.40	4.16	39.29	2.40	0.000%
50	-2.40	-39.29	-4.16	2.40	39.29	4.16	0.000%

Non-Linear Convergence Results

Load Combination	Converged?	Number of Cycles	Displacement Tolerance	Force Tolerance
1	Yes	4	0.00000001	0.00000001
2	Yes	4	0.00000001	0.00058854
3	Yes	4	0.00000001	0.00029235
4	Yes	5	0.00000001	0.00074295
5	Yes	5	0.00000001	0.00032188
6	Yes	5	0.00000001	0.00071977
7	Yes	5	0.00000001	0.00031057
8	Yes	4	0.00000001	0.00046926
9	Yes	4	0.00000001	0.00018440
10	Yes	5	0.00000001	0.00072916
11	Yes	5	0.00000001	0.00031513
12	Yes	5	0.00000001	0.00073722
13	Yes	5	0.00000001	0.00031907
14	Yes	4	0.00000001	0.00058858
15	Yes	4	0.00000001	0.00029236
16	Yes	5	0.00000001	0.00071765
17	Yes	5	0.00000001	0.00030962
18	Yes	5	0.00000001	0.00074032
19	Yes	5	0.00000001	0.00032063
20	Yes	4	0.00000001	0.00046905
21	Yes	4	0.00000001	0.00018435
22	Yes	5	0.00000001	0.00073044
23	Yes	5	0.00000001	0.00031583
24	Yes	5	0.00000001	0.00072289
25	Yes	5	0.00000001	0.00031217
26	Yes	4	0.00000001	0.00000001
27	Yes	5	0.00000001	0.00038251
28	Yes	5	0.00000001	0.00047774
29	Yes	5	0.00000001	0.00047083
30	Yes	5	0.00000001	0.00038281
31	Yes	5	0.00000001	0.00047366
32	Yes	5	0.00000001	0.00047592
33	Yes	5	0.00000001	0.00038288
34	Yes	5	0.00000001	0.00046956
35	Yes	5	0.00000001	0.00047615
36	Yes	5	0.00000001	0.00038175
37	Yes	5	0.00000001	0.00047224
38	Yes	5	0.00000001	0.00047030
39	Yes	4	0.00000001	0.00002876
40	Yes	4	0.00000001	0.00013336
41	Yes	4	0.00000001	0.00011824
42	Yes	4	0.00000001	0.00002514

43	Yes	4	0.00000001	0.00012380
44	Yes	4	0.00000001	0.00012915
45	Yes	4	0.00000001	0.00002877
46	Yes	4	0.00000001	0.00011698
47	Yes	4	0.00000001	0.00013147
48	Yes	4	0.00000001	0.00002510
49	Yes	4	0.00000001	0.00012449
50	Yes	4	0.00000001	0.00011976

Maximum Tower Deflections - Service Wind

Section No.	Elevation ft	Horz. Deflection in	Gov. Load Comb.	Tilt °	Twist °
L1	180 - 133	21.850	42	1.304	0.004
L2	137 - 87.3333	11.429	42	0.907	0.001
L3	92.6667 - 42.6667	4.809	42	0.517	0.000
L4	49.3333 - 0	1.315	42	0.248	0.000

Critical Deflections and Radius of Curvature - Service Wind

Elevation ft	Appurtenance	Gov. Load Comb.	Deflection in	Tilt °	Twist °	Radius of Curvature ft
180'	(2) DB980H90E-M w/ Mount Pipe	42	21.850	1.304	0.004	35919
175'	APX16DWV-16DWV-S-E-A20	42	20.537	1.258	0.004	35919
167'	(2) LPA-80080/4CF w/ Mount Pipe	42	18.456	1.184	0.003	13815
75'	KS24019-L112A	42	3.078	0.395	0.000	8948

Maximum Tower Deflections - Design Wind

Section No.	Elevation ft	Horz. Deflection in	Gov. Load Comb.	Tilt °	Twist °
L1	180 - 133	120.229	8	7.174	0.022
L2	137 - 87.3333	62.949	8	4.996	0.005
L3	92.6667 - 42.6667	26.494	8	2.850	0.001
L4	49.3333 - 0	7.245	8	1.366	0.001

Critical Deflections and Radius of Curvature - Design Wind

Elevation ft	Appurtenance	Gov. Load Comb.	Deflection in	Tilt °	Twist °	Radius of Curvature ft
180'	(2) DB980H90E-M w/ Mount Pipe	8	120.229	7.174	0.022	6699
175'	APX16DWV-16DWV-S-E-A20	8	113.012	6.922	0.019	6699
167'	(2) LPA-80080/4CF w/ Mount Pipe	8	101.579	6.519	0.016	2574
75'	KS24019-L112A	8	16.955	2.178	0.001	1627

Compression Checks

Pole Design Data

Section No.	Elevation ft	Size	L ft	L _u ft	Kl/r	A in ²	P _u K	φP _n K	Ratio P _u / φP _n
L1	180 - 133 (1)	TP27.51x15.5x0.25	47'	0'	0.0	20.819 8	-8.54	1527.84	0.006
L2	133 - 87.3333 (2)	TP38.56x25.9879x0.375	49'8- 1/32"	0'	0.0	43.842 8	-16.78	3257.30	0.005
L3	87.3333 - 42.6667 (3)	TP49.1x36.46x0.4375	50'	0'	0.0	65.233 7	-29.22	4757.64	0.006
L4	42.6667 - 0 (4)	TP59x46.5397x0.4375	49'3- 31/32"	0'	0.0	81.321 4	-47.13	5529.76	0.009

Pole Bending Design Data

Section No.	Elevation ft	Size	M _{ux} kip-ft	φM _{nx} kip-ft	Ratio M _{ux} / φM _{nx}	M _{uy} kip-ft	φM _{ny} kip-ft	Ratio M _{uy} / φM _{ny}
L1	180 - 133 (1)	TP27.51x15.5x0.25	480.17	822.96	0.583	0.00	822.96	0.000
L2	133 - 87.3333 (2)	TP38.56x25.9879x0.375	1195.06	2461.57	0.485	0.00	2461.57	0.000
L3	87.3333 - 42.6667 (3)	TP49.1x36.46x0.4375	2068.20	4589.28	0.451	0.00	4589.28	0.000
L4	42.6667 - 0 (4)	TP59x46.5397x0.4375	3266.96	6661.72	0.490	0.00	6661.72	0.000

Pole Shear Design Data

Section No.	Elevation ft	Size	Actual V _u K	φV _n K	Ratio V _u / φV _n	Actual T _u kip-ft	φT _n kip-ft	Ratio T _u / φT _n
L1	180 - 133 (1)	TP27.51x15.5x0.25	14.28	763.92	0.019	0.00	1647.94	0.000
L2	133 - 87.3333 (2)	TP38.56x25.9879x0.375	18.06	1628.65	0.011	0.00	4929.16	0.000
L3	87.3333 - 42.6667 (3)	TP49.1x36.46x0.4375	22.18	2378.82	0.009	0.23	9189.83	0.000
L4	42.6667 - 0 (4)	TP59x46.5397x0.4375	26.36	2764.88	0.010	0.23	13339.75	0.000

Pole Interaction Design Data

Section No.	Elevation ft	Ratio P _u / φP _n	Ratio M _{ux} / φM _{nx}	Ratio M _{uy} / φM _{ny}	Ratio V _u / φV _n	Ratio T _u / φT _n	Comb. Stress Ratio	Allow. Stress Ratio	Criteria
L1	180 - 133 (1)	0.006	0.583	0.000	0.019	0.000	0.589	1.000	4.8.2 ✓
L2	133 - 87.3333 (2)	0.005	0.485	0.000	0.011	0.000	0.491	1.000	4.8.2 ✓
L3	87.3333 - 42.6667 (3)	0.006	0.451	0.000	0.009	0.000	0.457	1.000	4.8.2 ✓

Section No.	Elevation ft	Ratio P_u	Ratio M_{ux}	Ratio M_{uy}	Ratio V_u	Ratio T_u	Comb. Stress Ratio	Allow. Stress Ratio	Criteria
L4	42.6667 - 0 (4)	0.009	0.490	0.000	0.010	0.000	0.499 ✓	1.000	4.8.2 ✓

Section Capacity Table

Section No.	Elevation ft	Component Type	Size	Critical Element	P K	ϕP_{allow} K	% Capacity	Pass Fail
L1	180 - 133	Pole	TP27.51x15.5x0.25	1	-8.54	1527.84	58.9	Pass
L2	133 - 87.3333	Pole	TP38.56x25.9879x0.375	2	-16.78	3257.30	49.1	Pass
L3	87.3333 - 42.6667	Pole	TP49.1x36.46x0.4375	3	-29.22	4757.64	45.7	Pass
L4	42.6667 - 0	Pole	TP59x46.5397x0.4375	4	-47.13	5529.76	49.9	Pass
Summary								
Pole (L1)							58.9	Pass
RATING =							58.9	Pass

APPENDIX B
BASE LEVEL DRAWING

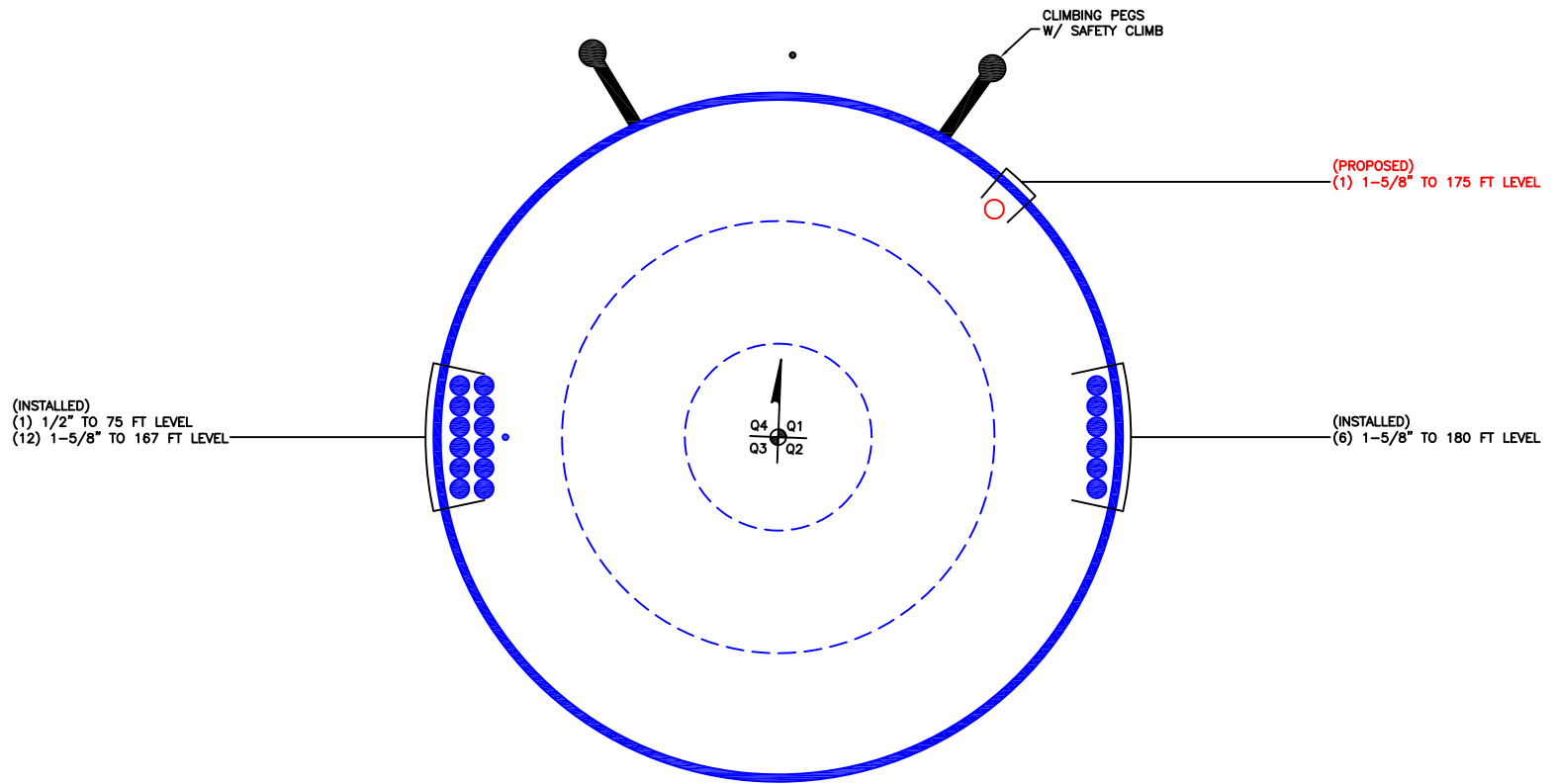

APPENDIX C
ADDITIONAL CALCULATIONS

CCISeismic - Design Category

Per 2012/2015 IBC

Site BU: 876370
 Work Order: 1306197
 Application: 345818 Rev. 17



	Degrees	Minutes	Seconds		
Site Latitude =	41	46	7.66	41.7688	degrees
Site Longitude =	-72	13	15.07	-72.2209	degrees
Ground Supported Structure =	Yes				
Structure Class =	II				(Table 2-1)
Site Class =	D - Stiff Soil				(Table 2-11)
Spectral response acceleration short periods, S_s =	0.165				USGS Seismic Tool
Spectral response acceleration 1 s period, S_1 =	0.059				
Importance Factor, I =	1.0				(Table 2-3)
Acceleration-based site coefficient, F_a =	1.6				(Table 2-12)
Velocity-based site coefficient, F_v =	2.4				(Table 2-13)
Design spectral response acceleration short period, S_{DS} =	0.176				(2.7.6)
Design spectral response acceleration 1 s period, S_{D1} =	0.094				(2.7.6)
Seismic Design Category - Short Period Response =	B				ASCE 7-05 Table 11.6-1
Seismic Design Category - 1s Period Response =	B				ASCE 7-05 Table 11.6-2
Worst Case Seismic Design Category =	B				ASCE 7-05 Tables 11.6-1 and 6-2

Stiffened or Unstiffened, UngROUTed, Circular Base Plate - Any Rod Material

TIA Rev G

Assumption: Clear space between bottom of leveling nut and top of concrete **not** exceeding (1)*(Rod Diameter)

Site Data

BU#: 876370

Site Name: MAYBROOK / BOND

App #: 345818 Rev. 17

Pole Manufacturer: *Other*

Anchor Rod Data

Qty:	20	
Diam:	2.25	in
Rod Material:	A615-J	
Strength (Fu):	100	ksi
Yield (Fy):	75	ksi
Bolt Circle:	68	in

Plate Data

Diam:	74	in
Thick:	2	in
Grade:	60	ksi
Single-Rod B-eff:	9.36	in

Stiffener Data (Welding at both sides)

Config:	0	*
Weld Type:		
Groove Depth:		<-- Disregard
Groove Angle:		<-- Disregard
Fillet H. Weld:		in
Fillet V. Weld:		in
Width:		in
Height:		in
Thick:		in
Notch:		in
Grade:		ksi
Weld str.:		ksi

Pole Data

Diam:	59	in
Thick:	0.4375	in
Grade:	65	ksi
# of Sides:	18	"0" IF Round
Fu	80	ksi
Reinf. Fillet Weld	0	"0" if None

Reactions

Mu:	3267	ft-kips
Axial, Pu:	47	kips
Shear, Vu:	26	kips
Eta Factor, η	0.5	TIA G (Fig. 4-4)

If No stiffeners, Criteria: **AISC LRFD** <-Only Applicable to Unstiffened Cases

Anchor Rod Results

Max Rod (Cu+ Vu/η):	120.3 Kips
Allowable Axial, Φ*Fu*Anet:	260.0 Kips
Anchor Rod Stress Ratio:	46.3% Pass

Rigid

AISC LRFD

φ*Tn

Base Plate Results

Base Plate Stress:	34.5 ksi
Allowable Plate Stress:	54.0 ksi
Base Plate Stress Ratio:	63.8% Pass

Flexural Check

Rigid

AISC LRFD

φ*Fy

Y.L. Length:

33.81

n/a

Stiffener Results

Horizontal Weld :	n/a
Vertical Weld:	n/a
Plate Flex+Shear, fb/Fb+(fv/Fv)^2:	n/a
Plate Tension+Shear, ft/Ft+(fv/Fv)^2:	n/a
Plate Comp. (AISC Bracket):	n/a

Pole Results

Pole Punching Shear Check: n/a

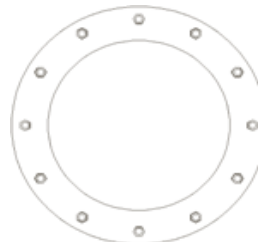

* 0 = none, 1 = every bolt, 2 = every 2 bolts, 3 = 2 per bolt

** Note: for complete joint penetration groove welds the groove depth must be exactly 1/2 the stiffener thickness for calculation purposes

FOUNDATION REACTION COMPARISON

BU# 876370
WO# 1306197

REACTIONS	DESIGN REACTIONS	*MODIFIED DESIGN REACTIONS	CURRENT REACTIONS	% CAPACITY
MOMENT (kip-ft)	4315.6	5826.1	3267.0	56.1%
SHEAR (kips)	33.3	45.0	26.0	57.8%

Design loads from: CClsites Doc #1532099

* Design loads were multiplied by 1.35 for comparison as allowed by TIA-222-G, Section 15.5.