

July 1, 2016

Melanie A. Bachman  
Acting Executive Director  
Connecticut Siting Council  
10 Franklin Square  
New Britain, CT 06051

Re: **Notice of Exempt Modification – Facility Modification  
1430 Monroe Turnpike, Monroe, Connecticut**

Dear Ms. Bachman:

Cellco Partnership d/b/a Verizon Wireless (“Cellco”) currently maintains twelve (12) wireless telecommunications antennas at the 131-foot level on the existing 159-foot tower at 1430 Monroe Turnpike in Monroe, Connecticut (the “Property”). The tower is owned by SBA. The Council approved Cellco’s use of this tower in 2005. Cellco now intends to modify its facility by adding three (3) model 7420213V01, 2100 MHz antennas, for a total of fifteen (15) antennas, all at the 138-foot level on the tower. Cellco also intends to install three (3) remote radio heads (“RRHs”) behind its 2100 MHz antennas and one (1) HYBRIFLEX™ antenna cable. Included in Attachment 1 are specifications for Cellco’s replacement antennas, RRHs and HYBRIFLEX™ cable.<sup>1</sup>

Please accept this letter as notification pursuant to R.C.S.A. § 16-50j-73, for construction that constitutes an exempt modification pursuant to R.C.S.A. § 16-50j-72(b)(2). In accordance with R.C.S.A. § 16-50j-73, a copy of this letter is being sent to Steve Vavrek, First Selectman for the Town of Monroe. A copy of this letter is also being sent to Sisters of the Holy Family of Nazareth, the owner of the Property.

The planned modifications to the facility fall squarely within those activities explicitly provided for in R.C.S.A. § 16-50j-72(b)(2).

---

<sup>1</sup> This same notice of exempt modification was acknowledged by the Council on September 2, 2014 (EM-VER-085-140814). Cellco’s modifications were not completed and the acknowledgement expired on or about September 2, 2015.

Melanie A. Bachman  
July 1, 2016  
Page 2

1. The proposed modifications will not result in an increase in the height of the existing tower. Cellco's new antennas and RRHs will be installed on Cellco's existing platform at the 131-foot level of the existing 159-foot tower.
2. The proposed modifications will not involve any change to ground-mounted equipment and, therefore, will not require the extension of the site boundary.
3. The proposed modifications will not increase noise levels at the facility by six decibels or more, or to levels that exceed state and local criteria.
4. The operation of the replacement antennas will not increase radio frequency (RF) emissions at the facility to a level at or above the Federal Communications Commission (FCC) safety standard. A cumulative General Power Density table for Cellco's modified facility is included in Attachment 2.
5. The proposed modifications will not cause a change or alteration in the physical or environmental characteristics of the site.
6. The tower and its foundation, with certain modifications, can support Cellco's proposed modifications. (See Structural Analysis and Modification Drawings included in Attachment 3).

Lastly, included in Attachment 4 is a copy of the Town of Monroe's Assessor's map and owner's information.

For the foregoing reasons, Cellco respectfully submits that the proposed modifications to the above-referenced telecommunications facility constitutes an exempt modification under R.C.S.A. § 16-50j-72(b)(2).

Sincerely,



Kenneth C. Baldwin

Enclosures

Copy to:

Steve Vavrek, Monroe First Selectman  
Sisters of the Holy Family of Nazareth  
Tim Parks

# **ATTACHMENT 1**

# KATHREIN SCALA DIVISION

742 213V01

65° Panel Antenna

Kathrein's X-polarized adjustable electrical downtilt antennas offer the wireless carrier the ability to tailor polarization diversity sites for optimum performance. Using variable downtilt, only a few models need be procured to accommodate the needs of widely varying conditions. Remotely controlled downtilt is available as a retrofitable option.

- 0-6° downtilt range.
- UV resistant pulltruded fiberglass radome.
- DC Grounded metallic parts for impulse suppression.
- No moving electrical connections.
- Wideband vector dipole technology.
- Optional remote downtilt Control.
- Will accommodate future 3G / UMTS applications.

### General specifications:

Frequency range	1710-2200 MHz	
VSWR	< 1.5:1	
Impedance	50 ohms	
Intermodulation (2x20w)	IM3: <-150 dBc	
Polarization	+45° and -45°	
Front-to-back ratio (180°±30°)	>30 dB (co-polar) >25 dB (total power)	
Maximum input power	300 watts per input (at 50°C)	
Electrical downtilt continuously adjustable	0-6 degrees	
Connector	2 x 7-16 DIN female	
Isolation	>30 dB	
Cross polar ratio		
Main direction 0°	25 dB (typical)	
Sector ±60°	>10 dB	
Tracking, average	0.5 dB	
Squint	±2.0°	
Weight	19.8 lb (9 kg) 24.3 lb (11 kg) clamps included	
Dimensions	76.9 x 6.1 x 2.8 inches (1954 x 155 x 70 mm)	
Wind load	at 93 mph (150kph)	
Front/Side/Rear	115 lbf / 32 lbf / 115 lbf (510 N) / (140 N) / (510 N)	
Mounting category	M (Medium)	
Wind survival rating*	120 mph (200 kph)	
Shipping dimensions	88 x 6.8 x 3.6 inches (2235 x 172 x 92 mm)	
Shipping weight	28.7 lb (13 kg)	
Mounting	Fixed mounts for 2 to 4.6 inch (50 to 115 mm) OD masts are included and tilt options are available.	

See reverse for order information.

Specifications:	1710-1880 MHz	1850-1990 MHz	1920-2200 MHz
Gain	19 dBi	19.2 dBi	19.5 dBi
+45° and -45° polarization horizontal beamwidth	67° (half-power)	65° (half-power)	63° (half-power)
+45° and -45° polarization vertical beamwidth	4.7° (half-power)	4.5° (half-power)	4.3° (half-power)
Sidelobe suppression for first sidelobe above main beam	0° 2° 4° 6° T 18 18 16 15 dB	0° 2° 4° 6° T 18 18 17 16 dB	0° 2° 4° 6° T 18 18 18 18 dB

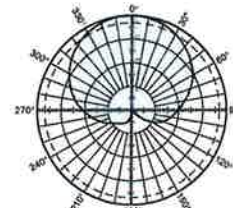

Horizontal pattern  
±45°- polarization

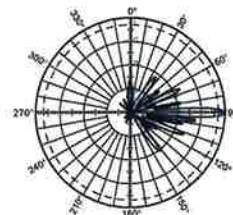

Vertical pattern  
±45°- polarization  
0°-6° electrical downtilt



11271-B  
936.3740/b



\*Mechanical design is based on environmental conditions as stipulated in TIA-222-G-2 (December 2009) and/or ETS 300 019-1-4 which include the static mechanical load imposed on an antenna by wind at maximum velocity. See the Engineering Section of the catalog for further details.

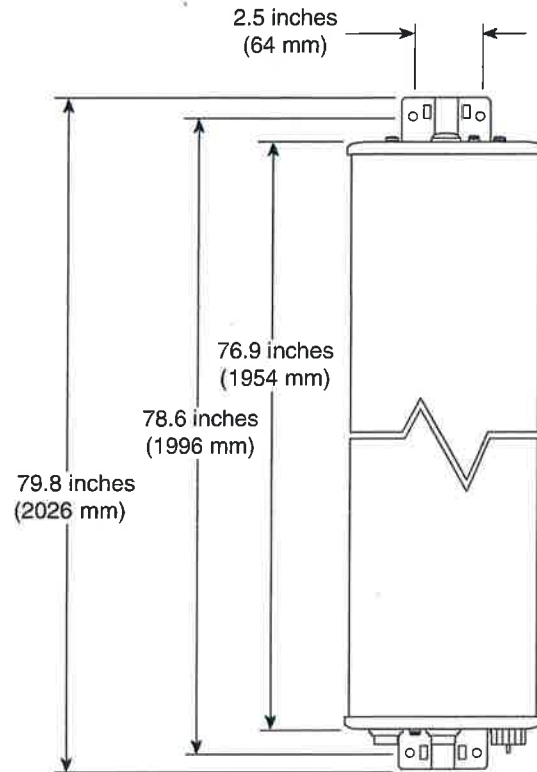
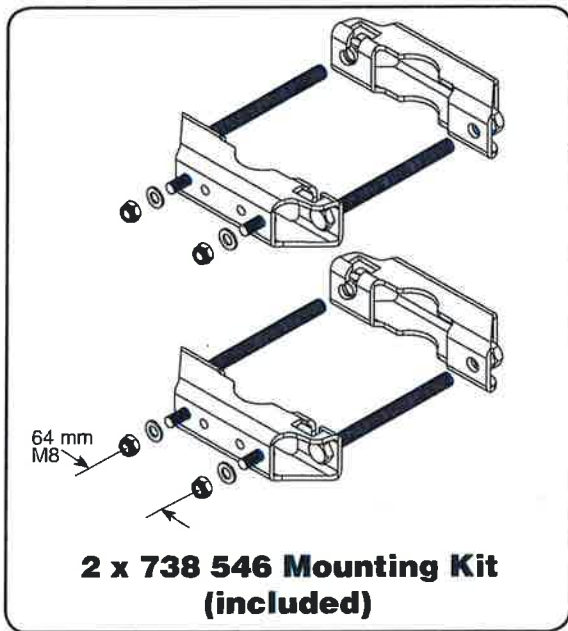

**Mounting Options:**

Model	Description
2 x 738 546 (included)	Mounting Kit for 2 to 4.6 inch (50 to 115 mm) OD mast. 4.4 lb (2 kg)
850 10013	Tilt Mount Kit 0–11 degrees downtilt angle. 7.4 lb (3.7 kg)
742 263	Three-panel Sector Mounting Kit (120 deg. ea.) for 3.5 inch (89 mm) OD mast.

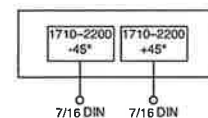
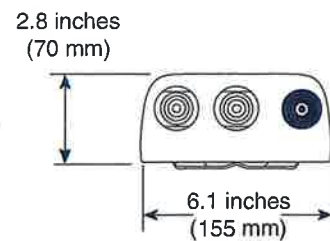

**Order Information:**

Model	Description
742 213V01	Antenna with 7-16 DIN connectors 0°–6° adjustable electrical downtilt

All specifications are subject to change without notice. The latest specifications are available at [www.kathrein-scala.com](http://www.kathrein-scala.com).

## Alcatel-Lucent RRH2x40-AWS

### REMOTE RADIO HEAD

The Alcatel-Lucent RRH2x40-AWS is a high-power, small form-factor Remote Radio Head (RRH) operating in the AWS frequency band (1700/2100MHz - 3GPP Band 4). The Alcatel-Lucent RRH2x40-AWS is designed with an eco-efficient approach, providing operators with the means to achieve high quality and capacity coverage with minimum site requirements.

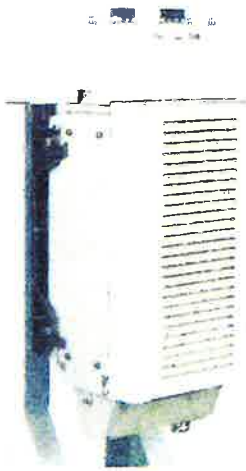

A distributed eNodeB expands deployment options by using two components, a Base Band Unit (BBU) containing the digital assets and a separate RRH containing the radio-frequency (RF) elements. This modular design optimizes available space and allows the main components of an eNodeB to be installed separately, within the same site or several kilometres apart.

The Alcatel-Lucent RRH2x40-AWS is linked to the BBU by an optical-fiber connection carrying downlink and uplink digital radio signals along with operations, administration and maintenance (OA&M) information. The Alcatel-Lucent RRH2x40-AWS has two transmit RF paths, 40 W RF output power per transmit path, and is designed to manage up to four-way receive diversity. The device is ideally suited to support macro coverage, with multiple-input multiple-output (MIMO) 2x2 operation in up to 20 MHz of bandwidth.

The Alcatel-Lucent RRH2x40-AWS is designed to make available all the benefits of a distributed eNodeB, with excellent RF characteristics, with low

capital expenditures (CAPEX) and low operating expenditures (OPEX). The limited space available in some sites may prevent the installation of traditional single-cabinet BTS equipment or require costly cranes to be employed, leaving coverage holes. However, many of these sites can host an Alcatel-Lucent RRH2x40-AWS installation, providing more flexible site selection and improved network quality along with greatly reduced installation time and costs.

#### Fast, low-cost installation and deployment

The Alcatel-Lucent RRH2x40-AWS is a zero-footprint solution and operates noise-free, simplifying negotiations with site property owners and minimizing environmental impacts. Installation can easily be done by a single person because the Alcatel-Lucent RRH2x40-AWS is compact and weighs less than 20 kg (44 lb), eliminating the need for a crane to hoist the BTS cabinet to the rooftop. A site can be in operation in less than one day — a fraction of the time required for a traditional BTS.



## Excellent RF performance

Because of its small size and weight, the Alcatel-Lucent RRH2x40-AWS can be installed close to the antenna. Operators can therefore locate the Alcatel-Lucent RRH2x40-AWS where RF engineering is deemed ideal, minimizing trade-offs between available sites and RF optimum sites. The RF feeder cost and installation costs are reduced or eliminated, and there is no need for a Tower Mounted Amplifier (TMA) because losses introduced by the RF feeder are greatly reduced. The Alcatel-Lucent RRH2x40-AWS provides more RF power while at the same time consuming less electricity.

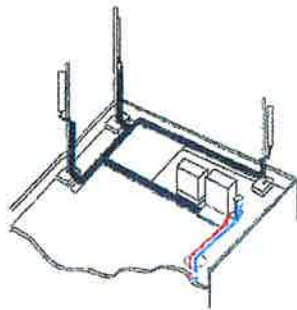

Macro

## Features

- Zero-footprint deployment
- Easy installation, with a lightweight unit can be carried and set up by one person
- Optimized RF power, with flexible site selection and elimination of a TMA
- Convection-cooled (fanless)
- Noise-free
- Best-in-class power efficiency, with significantly reduced energy consumption

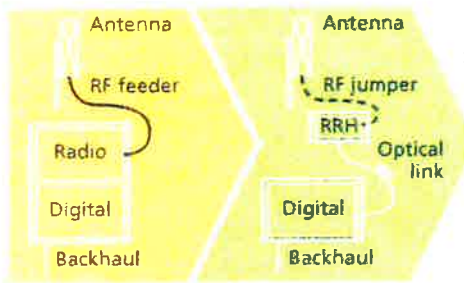

RRH for space-constrained cell sites

## Benefits

- Leverages existing real estate with lower site costs
- Reduces installation costs, with fewer installation materials and simplified logistics
- Decreases power costs and minimizes environmental impacts, with the potential for eco-sustainable power options
- Improves RF performance and adds flexibility to network planning

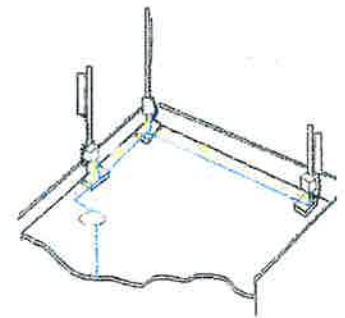

Distributed

## Technical specifications

### Physical dimensions

- Height: 620 mm (24.4 in.)
- Width: 270 mm (10.63 in.)
- Depth: 170mm (6.7 in.)
- Weight (without mounting kit): less than 20 kg (44 lb)

### Power

- Power supply: -48VDC

### Operating environment

- Outdoor temperature range:
  - With solar load: -40°C to +50°C (-40°F to +122°F)
  - Without solar load: -40°C to +55°C (-40°F to +131°F)

- Passive convection cooling (no fans)
- Enclosure protection
  - IP65 (International Protection rating)

### RF characteristics

- Frequency band: 1700/2100 MHz (AWS); 3GPP Band 4
- Bandwidth: up to 20 MHz
- RF output power at antenna port: 40 W nominal RF power for each Tx port
- Rx diversity: 2-way or 4-way with optional Rx Diversity module
- Noise figure: below 2.0 dB typical
- Antenna Line Device features
  - TMA and Remote electrical tilt (RET) support via AISG v2.0

### Optical characteristics

#### Type/number of fibers

- Single-mode variant
  - One Single Mode Single Fiber per RRH2x, carrying UL and DL using CWDM
  - Single mode dual fiber (SM/DF)
- Multi-mode variant
  - Two Multi-mode fibers per RRH2x: one carrying UL, the other carrying DL

### Optical fiber length

- Up to 500 m (0.31 mi), using MM fiber
- Up to 20 km (12.43 mi), using SM fiber

### Digital Ports and Alarms

- Two optical ports to support daisy-chaining
- Six external alarms

[www.alcatel-lucent.com](http://www.alcatel-lucent.com) Alcatel, Lucent, Alcatel-Lucent and the Alcatel-Lucent logo are trademarks of Alcatel-Lucent. All other trademarks are the property of their respective owners. The information presented is subject to change without notice. Alcatel-Lucent assumes no responsibility for inaccuracies contained herein. Copyright © 2010 Alcatel-Lucent. All rights reserved. CPG2809100912 (09)



**HYBRIFLEX™ RRH Hybrid Feeder Cabling Solution, 1-5/8", Single-Mode Fiber**

**Product Description**

RFS' HYBRIFLEX Remote Radio Head (RRH) hybrid feeder cabling solution combines optical fiber and DC power for RRHs in a single lightweight aluminum corrugated cable, making it the world's most innovative solution for RRH deployments.

It was developed to reduce installation complexity and costs at Cellular sites. HYBRIFLEX allows mobile operators deploying an RRH architecture to standardize the RRH installation process and eliminate the need for and cost of cable grounding. HYBRIFLEX combines optical fiber (multi-mode or single-mode) and power in a single corrugated cable. It eliminates the need for junction boxes and can connect multiple RRHs with a single feeder. Standard RFS CELLFLEX® accessories can be used with HYBRIFLEX cable. Both pre-connectorized and on-site options are available.

**Features/Benefits**

- Aluminum corrugated armor with outstanding bending characteristics – minimizes installation time and enables mechanical protection and shielding
- Same accessories as 1 5/8" coaxial cable
- Outer conductor grounding – Eliminates typical grounding requirements and saves on installation costs
- Lightweight solution and compact design – Decreases tower loading
- Robust cabling – Eliminates need for expensive cable trays and ducts
- Installation of tight bundled fiber optic cable pairs directly to the RRH – Reduces CAPEX and wind load by eliminating need for interconnection
- Optical fiber and power cables housed in single corrugated cable – Saves CAPEX by standardizing RRH cable installation and reducing installation requirements
- Outdoor polyethylene jacket – Ensures long-lasting cable protection



Figure 1: HYBRIFLEX Series

**Technical Specifications**

Outer Conductor Armor	Corrugated Aluminum	[mm (in.)]	46.5 (1.83)
Jacket	Polyethylene, PE	[mm (in.)]	50.3 (1.98)
UV-Protection	Individual and External Jacket		Yes
Weight, Approximate		[kg/m (lb/ft)]	1.9 (1.30)
Minimum Bending Radius, Single Bending		[mm (in.)]	200 (8)
Minimum Bending Radius, Repeated Bending		[mm (in.)]	500 (20)
Recommended/Maximum Clamp Spacing		[m (ft)]	1.0 / 1.2 (3.25 / 4.0)
DC-Resistance Outer Conductor Armor		[Ω/km (Ω/1000ft)]	068 (0.205)
DC-Resistance Power Cable, 8.4mm²(8AWG)		[Ω/km (Ω/1000ft)]	2.1 (0.307)
Version			Single-mode OM3
Quantity, Fiber Count			16 (8 pairs)
Core/Clad		[μm]	50/125
Primary Coating (Acrylate)		[μm]	245
Buffer Diameter, Nominal		[μm]	900
Secondary Protection, Jacket, Nominal		[mm (in.)]	2.0 (0.08)
Minimum Bending Radius		[mm (in.)]	104 (4.1)
Insertion Loss @ wavelength 850nm		dB/km	3.0
Insertion Loss @ wavelength 1310nm		dB/km	1.0
Standards (Meets or exceeds)			UL94-V0 UL1666 RoHS Compliant
Size (Power)		[mm (AWG)]	8.4 (8)
Quantity, Wire Count (Power)			16 (8 pairs)
Size (Alarm)		[mm (AWG)]	0.8 (18)
Quantity, Wire Count (Alarm)			4 (2 pairs)
Type			UV protected
Strands			19
Primary Jacket Diameter, Nominal		[mm (in.)]	6.8 (0.27)
Standards (Meets or exceeds)			NFPA 130, ICEA S-95-658 UL Type XHHW-2, UL 44 UL-LS Limited Smoke, UL VW-1 IEEE-383 (1974), IEEE1202/FT4 RoHS Compliant
Installation Temperature		[°C (°F)]	-40 to +65 (-40 to 149)
Operation Temperature		[°C (°F)]	-40 to +65 (-40 to 149)

\* This data is provisional and subject to change

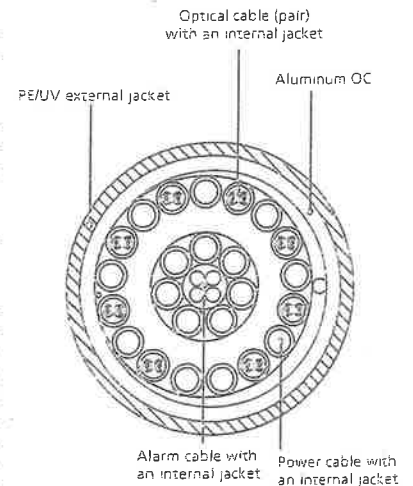

Figure 2: Construction Detail

All information contained in the present datasheet is subject to confirmation at time of ordering



# **ATTACHMENT 2**

Site Name: Monroe NE Tower Height: 159ft	General		Power		Density		CALC. POWER DENS	FREQ.	MAX. PERMISS. EXP.	FRACTION MPE	Total
	CARRIER	# OF CHAN.	WATTS ERP	HEIGHT							
*AT&T UMTS	1	500	160	0.0070	880	0.5867	1.20%				
*AT&T UMTS	1	500	160	0.0070	1900	1.0000	0.70%				
*AT&T GSM	4	296	160	0.0166	880	0.5867	2.83%				
*AT&T GSM	2	427	160	0.0120	1900	1.0000	1.20%				
*AT&T LTE	1	500	160	0.0070	740	0.4933	1.42%				
*T-Mobile	8	309.48	140	0.0454	1935	1.0000	4.54%				
*Sprint CDMA/LTE	3	347	151	0.0164	1900	1.0000	1.64%				
*Sprint CDMA/LTE	1	195	151	0.0031	850	0.5667	0.54%				
*Sprint CDMA/LTE	2	347	151	0.0109	2500	1.0000	1.09%				
*Town of Monroe	1	104	157	0.0015	453.6125	0.3024	0.50%				
*Town of Monroe	1	104	95	0.0041	460.2875	0.3069	1.35%				
*Town of Monroe	1	90	85	0.0045	453.7625	0.3025	1.48%				
<b>Verizon</b>	<b>15</b>	<b>428</b>	<b>130</b>	<b>0.1366</b>	<b>1970</b>	<b>1.0000</b>	<b>13.66%</b>				
<b>Verizon</b>	<b>9</b>	<b>397</b>	<b>130</b>	<b>0.0760</b>	<b>869</b>	<b>0.5793</b>	<b>13.12%</b>				
<b>Verizon</b>	<b>1</b>	<b>1750</b>	<b>130</b>	<b>0.0372</b>	<b>2145</b>	<b>1.0000</b>	<b>3.72%</b>				
<b>Verizon</b>	<b>1</b>	<b>824</b>	<b>130</b>	<b>0.0175</b>	<b>698</b>	<b>0.4653</b>	<b>3.77%</b>				
<b>52.78%</b>											
* Source: Siting Council											

# **ATTACHMENT 3**



FDH Engineering, Inc., 6521 Meridien Drive Raleigh, NC 27616, Ph. 919.755.1012

**Structural Analysis for  
SBA Network Services, Inc.**

**159' Monopole Tower**

**SBA Site Name: Monroe Turnpike  
SBA Site ID: CT13055-A-04  
Verizon Site Name: Monroe NE**

FDH Project Number 14252L1400

**Analysis Results**

Tower Components	92.0 %	Sufficient
Foundation	96.6 %	Sufficient

Prepared By:

Cary J. Webb, PE  
Project Engineer

Reviewed By:

Bradley R. Newman, PE  
Senior Project Engineer  
CT PE License No. 29630

**FDH Engineering, Inc.**  
6521 Meridien Drive  
Raleigh, NC 27616  
(919) 755-1012  
info@fdh-inc.com



March 28, 2014

*Prepared pursuant to TIA/EIA-222-F Structural Standards for Steel Antenna Towers and Antenna Supporting Structures and the 2005 Connecticut State Building Code*

**TABLE OF CONTENTS**

EXECUTIVE SUMMARY ..... 3

    Conclusions..... 3

    Recommendations ..... 3

APPURTENANCE LISTING ..... 4

RESULTS ..... 5

GENERAL COMMENTS ..... 6

LIMITATIONS..... 6

APPENDIX ..... 7



## EXECUTIVE SUMMARY

At the request of SBA Network Services, Inc., FDH Engineering, Inc. performed a structural analysis of the monopole located in Monroe, CT to determine whether the tower is structurally adequate to support both the existing and proposed loads pursuant to the *Structural Standards for Steel Antenna Towers and Antenna Supporting Structures, TIA/EIA-222-F* and the *2005 Connecticut State Building Code (CSBC)*. Information pertaining to the existing/proposed antenna loading, foundation dimensions, current tower geometry, soil parameters, and member sizes was obtained from:

- Sabre Communications Corporation (Job No. 04-05018) Stamped Permit Drawings dated August 18, 2003
- Clarence Welti Associates, Inc. (Tower CT54XC771) Geotechnical Study dated April 25, 2003
- FDH, Inc. (Job No. 08-07120T) TIA Inspection Report dated August 22, 2008
- FDH Engineering, Inc. (Project No. 14252L1400) Modification Drawings for a 159' Monopole dated March 28, 2014
- SBA Network Services, Inc.

The *basic design wind speed* per the *TIA/EIA-222-F* standards and the *2005 CSBC* is 85 mph without ice and 38 mph with 3/4" radial ice. Ice is considered to increase in thickness with height.

## Conclusions

With the existing and proposed antennas from Verizon in place at 131 ft, the tower meets the requirements of the *TIA/EIA-222-F* standards and the *2005 CSBC* provided the **Recommendations** listed below are satisfied. Furthermore, provided the foundation was designed and constructed to support the original design reactions (see Sabre Job No. 04-05018), the foundation should have the necessary capacity to support the existing and proposed loading. For a more detailed description of the analysis of the tower, see the **Results** section of this report.

Our structural analysis has been performed assuming all information provided to FDH Engineering, Inc. is accurate (i.e., the steel data, tower layout, existing antenna loading, and proposed antenna loading) and that the tower has been properly erected and maintained per the original design drawings.

## Recommendations

To ensure the requirements of the *TIA/EIA-222-F* standards and the *2005 CSBC* are met with the existing and proposed loading in place, we have the following recommendations:

1. The proposed coax should be installed inside the pole's shaft.
2. The existing diplexers should be installed directly behind the existing/proposed panel antennas.
3. RRU/RRH Stipulation: The proposed equipment may be installed in any configuration as determined by the client.
4. The modifications outlined in FDH Engineering, Inc. (Project No. 14252L1400) Modification Drawings for a 159' Monopole dated March 28, 2014 must be correctly installed for this analysis to be valid.

## APPURTENANCE LISTING

The proposed and existing antennas with their corresponding cables/coax lines are shown in **Table 1**. *If the actual layout determined in the field deviates from the layout, FDH Engineering, Inc. should be contacted to perform a revised analysis.*

**Table 1 - Appurtenance Loading**

### Existing Loading:

Antenna Elevation (ft)	Description	Coax and Lines <sup>1</sup>	Carrier	Mount Elevation (ft)	Mount Type
162	(3) Powerwave 7770 (3) Powerwave P65-16-XLH-RR (6) Powerwave LGP21401 TMAs (6) Ericsson RRUS-11 RRHs (1) Raycap DC6-48-60-18-8F Surge Suppressor	(6) 1-5/8" (1) 0.393" Fiber (1) 0.645" DC	New Cingular	159	(1) 12.5' Low Profile Platform
	(1) Decibel DB404-B	(1) 7/8"	Town		
151	(3) RFS APXVSP18-C-A20 (3) Alcatel Lucent 1900 MHz RRHs (3) Alcatel Lucent 800 MHz RRHs (3) Alcatel Lucent 800 MHz Filters (4) RFS ACU-A20-N RETs	(3) 1-1/4" Fiber	Sprint	149	(1) 12.5' Low Profile Platform
142.5	(12) EMS FR65-17-04DP (6) Remec S20057A1 TMAs	(12) 1-1/4"	T-Mobile	140	(1) 12.5' Low Profile Platform
131	(3) Antel BXA-70063/6CF (3) Antel BXA-171063-12BF (6) Antel LPA-80063-6CF (6) RFS FD9R6004/2C-3L Diplexers	(12) 1-5/8"	Verizon	130	(1) 12.5' Low Profile Platform
110	(1) Sinclair SCL329-HL Omni	(1) 7/8" <sup>2</sup>	Town	110	(1) 4' Standoff
80	(1) Sinclair SCL329-HL Omni	(1) 7/8" <sup>2</sup>		80	(1) 4' Standoff
50	(1) Decibel 26DB GPS	(1) 1/2" <sup>3</sup>		Sprint	47

1. Coax installed inside the pole's shaft unless otherwise noted.
2. Town has (2) 7/8" coax installed outside the pole's shaft in a single row to 110 ft and 80 ft.
3. Sprint has (1) 1/2" coax installed outside the pole's shaft to 47 ft.

### Proposed Loading:

Antenna Elevation (ft)	Description	Feed Lines	Carrier	Mount Elevation (ft)	Mount Type
131	(3) Kathrein 742 213_2110_P45_02.0 (3) Antel BXA-70063/6CF (3) Antel BXA-171063-12BF (6) Antel LPA-80063-6CF (3) Alcatel Lucent RRH2x40-AWS RRHs (6) RFS FD9R6004/2C-3L Diplexers (1) RFS DB-T1-6Z-8AB-0Z Distribution Box	(12) 1-5/8" (1) 1-5/8" Fiber	Verizon	130	(1) 12.5' Low Profile Platform

## RESULTS

The following yield strength of steel for individual members was used for analysis:

**Table 2 - Material Strength**

Member Type	Yield Strength
Tower Shaft Sections	65 ksi
Base Plate	60 ksi
Anchor Bolts	75 ksi

**Table 3** displays the summary of the ratio (as a percentage) of force in the member to their capacities. Values greater than 100 % indicate locations where the maximum force in the member exceeds its capacity. *Note: Capacities up to 100% are considered acceptable.* **Table 4** displays the maximum foundation reactions.

If the assumptions outlined in this report differ from actual field conditions, FDH Engineering, Inc. should be contacted to perform a revised analysis. Furthermore, as no information pertaining to the allowable twist and sway requirements for the existing or proposed appurtenances was provided, deflection and rotation were not taken into consideration when performing this analysis.

See the **Appendix** for detailed modeling information

**Table 3 - Summary of Working Percentage of Structural Components**

Section No.	Elevation ft	Component Type	Size	% Capacity*	Pass Fail
L1	159 - 149	Pole	TP14.93x12x0.1875	37.0	Pass
L2	149 - 119.5	Pole	TP29.64x13.969x0.3125	90.8	Pass
	119.5 - 97.5	Modified Pole	TP29.64x13.969x0.3125 w/ Flat Plate	92.0	Pass
L3	97.5 - 47.75	Pole	TP43.6x27.9166x0.375	96.0	Pass
L4	47.75 - 0	Pole	TP56.84x41.189x0.375	96.4	Pass
		Anchor Bolts	(14) 2.25" Ø w/ BC = 64"	96.0	Pass
		Base Plate	PL 70" Ø x 2.25" thk	69.9	Pass

\*Capacities include a 1/3 allowable stress increase for wind per TIA/EIA-222-F standards.

**Table 4 - Maximum Base Reactions**

Base Reactions	Current Analysis (TIA/EIA-222-F)	Original Design (TIA/EIA-222-F)
Axial	35 k	41 k
Shear	30 k	31 k
Moment	3,541 k-ft	3,665 k-ft

## **GENERAL COMMENTS**

This engineering analysis is based upon the theoretical capacity of the structure. It is not a condition assessment of the tower and its foundation. It is the responsibility of SBA Network Services, Inc. to verify that the tower modeled and analyzed is the correct structure (with accurate antenna loading information) modeled. If there are substantial modifications to be made or the assumptions made in this analysis are not accurate, FDH Engineering, Inc. should be notified immediately to perform a revised analysis.

## **LIMITATIONS**

All opinions and conclusions are considered accurate to a reasonable degree of engineering certainty based upon the evidence available at the time of this report. All opinions and conclusions are subject to revision based upon receipt of new or additional/updated information. All services are provided exercising a level of care and diligence equivalent to the standard and care of our profession. No other warranty or guarantee, expressed or implied, is offered. Our services are confidential in nature and we will not release this report to any other party without the client's consent. The use of this engineering work is limited to the express purpose for which it was commissioned and it may not be reused, copied, or distributed for any other purpose without the written consent of FDH Engineering, Inc.

## **APPENDIX**



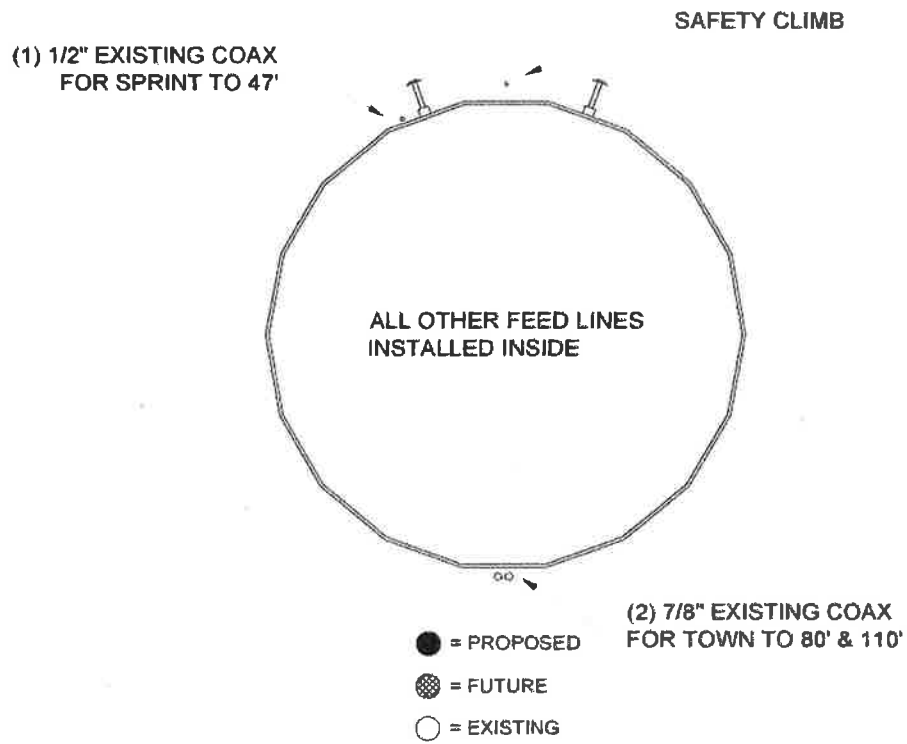
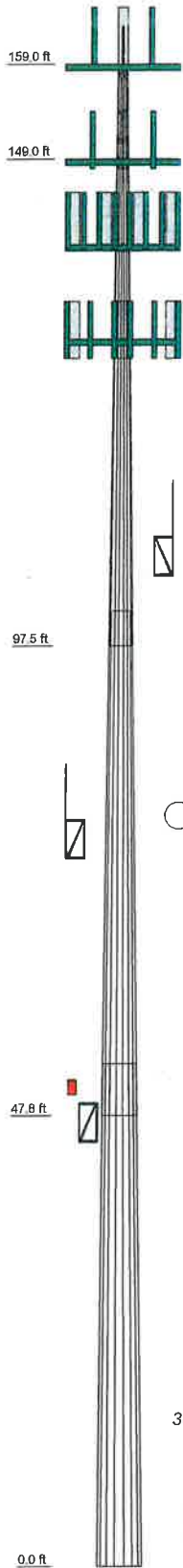

Figure 1 – Feed Line Layout

Section	1	2	3	4
Length (ft)	10.00	53.50	53.50	53.25
Number of Sides	18	18	18	18
Thickness (in)	0.1875	0.3125	0.3750	0.3750
Socket Length (ft)	2.00	3.75	5.50	41.2377
Top Dia (in)	12.0000	13.9690	27.9166	56.8400
Bot Dia (in)	14.9300	29.6400	43.6000	10.5
Grade		A572-65		
Weight (K)	0.3	3.9	7.7	22.3



### DESIGNED APPURTENANCE LOADING

TYPE	ELEVATION	TYPE	ELEVATION
Lightning Rod	159	(1) 12.5' Low Profile Platform	149
7770.00 w/Mount Pipe	159	(4) FR85-17-04DP w/Mount Pipe	140
7770.00 w/Mount Pipe	159	(4) FR85-17-04DP w/Mount Pipe	140
7770.00 w/Mount Pipe	159	(4) FR85-17-04DP w/Mount Pipe	140
P65-16-XLH-RR w/Mount Pipe	159	(2) S20057A1 TMA	140
P65-16-XLH-RR w/Mount Pipe	159	(2) S20057A1 TMA	140
P65-16-XLH-RR w/Mount Pipe	159	(2) S20057A1 TMA	140
(2) LGP21401 TMA	159	(1) 12.5' Low Profile Platform	140
(2) LGP21401 TMA	159	742 213 2110_P45_02.0 w/Mount Pipe	130
(2) LGP21401 TMA	159	742 213 2110_P45_02.0 w/Mount Pipe	130
(2) RRUS-11	159	742 213 2110_P45_02.0 w/Mount Pipe	130
(2) RRUS-11	159	BXA-70063/6CF w/Mount Pipe	130
(2) RRUS-11	159	BXA-70063/6CF w/Mount Pipe	130
DC6-48-60-18-BF Surge Arrestor	159	BXA-70063/6CF w/Mount Pipe	130
(1) 12.5' Low Profile Platform	159	BXA-171063-12BF w/ Mount Pipe	130
DB404-B	159	BXA-171063-12BF w/ Mount Pipe	130
APXVSP18-C-A20 w/Mount Pipe	149	BXA-171063-12BF w/ Mount Pipe	130
APXVSP18-C-A20 w/Mount Pipe	149	(2) LPA-80063/6CF w/ Mount Pipe	130
APXVSP18-C-A20 w/Mount Pipe	149	(2) LPA-80063/6CF w/ Mount Pipe	130
1900 MHz RRH	149	(2) LPA-80063/6CF w/ Mount Pipe	130
1900 MHz RRH	149	(2) FD9R6004/2C-3L Diplexer	130
1900 MHz RRH	149	(2) FD9R6004/2C-3L Diplexer	130
800 MHz RRH	149	(2) FD9R6004/2C-3L Diplexer	130
800 MHz RRH	149	RRH2X40-AWS	130
800 MHz RRH	149	RRH2X40-AWS	130
800 MHz Filter	149	RRH2X40-AWS	130
800 MHz Filter	149	DB-T1-6Z-8AB-0Z	130
800 MHz Filter	149	(1) 12.5' Low Profile Platform	130
ACU-A20-N RET	149	SCL329-HL Omni	110
ACU-A20-N RET	149	(1) 4' Standoff	110
(2) ACU-A20-N RET	149	SCL329-HL Omni	80
(2) Empty Mount Pipe	149	(1) 4' Standoff	80
(2) Empty Mount Pipe	149	Decibel 26DB GPS	47
(2) Empty Mount Pipe	149	(1) 4' Standoff	47

### MATERIAL STRENGTH

GRADE	Fy	Fu	GRADE	Fy	Fu
A572-65	65 ksi	80 ksi			

### TOWER DESIGN NOTES

1. Tower is located in Fairfield County, Connecticut.
2. Tower designed for a 85 mph basic wind in accordance with the TIA/EIA-222-F Standard.
3. Tower is also designed for a 38 mph basic wind with 0.75 in ice. Ice is considered to increase in thickness with height.
4. Deflections are based upon a 50 mph wind.

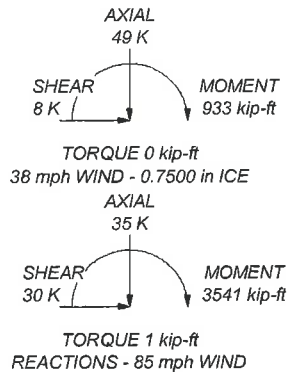

 Tower Analysis	<b>FDH Engineering, Inc.</b> 6521 Meridian Drive, Suite 107 Raleigh, NC 27616 Phone: 9197551012 FAX: 9197551031		<b>Job: Monroe Turnpike, CT13055-A</b>		
	Project: 14252L1400			Drawn by: Cary Webb	
	Client: SBA Network Services, Inc.		Date: 03/28/14		App'd:
	Code: TIA/EIA-222-F		Scale: NTS		Dwg No. E-1
	Path:				



**POST CONSTRUCTION INSPECTION NOTES:**

**GENERAL**

1. THE POST CONSTRUCTION INSPECTION (PCI) IS A VISUAL INSPECTION OF TOWER MODIFICATIONS AND A REVIEW OF CONSTRUCTION INSPECTIONS AND OTHER REPORTS TO VERIFY THAT THE CONSTRUCTION WAS PERFORMED IN ACCORDANCE WITH THE CONTRACT DOCUMENTS, NAMELY THE MODIFICATION DRAWINGS, AS DESIGNED BY THE ENGINEER OF RECORD (EOR).
2. THE PCI IS TO CONFIRM INSTALLATION CONFIGURATION AND WORKMANSHIP ONLY AND IS NOT TO BE USED TO DETERMINE THE RELIABILITY OF THE STRUCTURE. THE EOR OR TAKE OWNERSHIP OF THE MODIFICATION DESIGN. OWNERSHIP OF THE STRUCTURAL MODIFICATION DESIGN EFFECTIVENESS AND INTEGRITY RESIDES WITH THE EOR AT ALL TIMES.
3. ALL PCIS SHALL BE CONDUCTED BY A PCI INSPECTOR THAT IS APPROVED TO PERFORM ELEVATED WORK FOR FDH ENGINEERING, INC.
4. TO ENSURE THAT THE REQUIREMENTS OF THE PCI ARE MET, IT IS VITAL THAT THE GENERAL CONTRACTOR (GC) AND THE PCI INSPECTOR BEGIN COMMUNICATING AND COORDINATING AS SOON AS POSSIBLE. IT IS EXPECTED THAT EACH PARTY WILL BE RESPONSIBLE FOR PROVIDING THE OTHER WITH ALL NECESSARY INFORMATION IS NOT KNOWN, CONTACT YOUR FDH POINT OF CONTACT (POC).
5. REFER TO COR-01 : CONTRACTOR CLOSEOUT REQUIREMENTS FOR FURTHER DETAILS AND REQUIREMENTS.

**PCI INSPECTOR**

1. THE PCI INSPECTOR IS REQUIRED TO CONTACT THE GC AS SOON AS RECEIVING A PO FOR THE PCI TO, AT A MINIMUM:
  - REVIEW THE REQUIREMENTS OF THE PCI CHECKLIST
  - WORK WITH THE GC TO DEVELOP A SCHEDULE TO CONDUCT ON-SITE INSPECTIONS, INCLUDING FOUNDATION INSPECTIONS
2. THE PCI INSPECTOR IS RESPONSIBLE FOR COLLECTING ALL GENERAL CONTRACTOR (GC) PHOTOGRAPHS DURING THE REINFORCEMENT MODIFICATION CONSTRUCTION/ERECTION AND SUBMITTING THE CONTRACT DOCUMENTS, CONDUCTING THE IN-FIELD INSPECTIONS, AND SUBMITTING THE PCI REPORT TO FDH.

**CORRECTION OF FAILING PCIS**

1. IF THE MODIFICATION INSTALLATION WOULD FAIL THE PCI (FAILED PCI), THE GC SHALL WORK WITH FDH TO COORDINATE A REMEDIATION PLAN IN ONE OF TWO WAYS:
  - CORRECT FAILING ISSUES TO COMPLY WITH THE SPECIFICATIONS CONTAINED IN THE ORIGINAL CONTRACT DOCUMENTS AND COORDINATE A SUPPLEMENT PCI.
  - OR, WITH FDH'S APPROVAL, THE GC MAY WORK WITH THE EOR TO RE-ANALYZE THE MODIFICATION/REINFORCEMENT USING THE AS-BUILT CONDITION.

**REQUIRED PHOTOS**

1. BETWEEN THE GC AND THE PCI INSPECTOR THE FOLLOWING PHOTOGRAPHS, AT A MINIMUM, ARE TO BE TAKEN AND INCLUDED IN THE PCI REPORT:
  - PRE-CONSTRUCTION GENERAL SITE CONDITION
  - PHOTOGRAPHS DURING THE REINFORCEMENT MODIFICATION CONSTRUCTION/ERECTION AND INSPECTION
    - \*\* RAW MATERIALS
    - \*\* PHOTOS OF ALL CRITICAL DETAILS
    - \*\* PHOTOGRAPHS OF ALL CONNECTIONS
    - \*\* WELD PREPARATION
    - \*\* BOLT INSTALLATION AND TORQUE
    - \*\* FINAL INSTALLED CONDITION
    - \*\* SURFACE COATING REPAIR
    - \*\* POST CONSTRUCTION PHOTOGRAPHS
    - \*\* FINAL INFIELD CONDITION
2. PHOTOS OF ELEVATED MODIFICATIONS TAKEN FROM THE GROUND SHALL BE CONSIDERED INADEQUATE.

**PCI CHECKLIST**

CONSTRUCTION/INSTALLATION INSPECTIONS AND TESTING REQUIRED	REPORT ITEM
<b>PRE-CONSTRUCTION</b>	
X	PCI CHECKLIST DRAWING
N/A	EOR APPROVED SHOP DRAWINGS
N/A	FABRICATION INSPECTION
N/A	FABRICATOR CERTIFIED WELD INSPECTION
X	MATERIAL TEST REPORT (MTR)
N/A	FABRICATOR WDE INSPECTION
N/A	NDE REPORT OF MONOPOLE BASE PLATE (AS REQUIRED)
X	PACKING SLIPS
<b>ADDITIONAL TESTING AND INSPECTIONS:</b>	
<b>CONSTRUCTION</b>	
X	CONSTRUCTION INSPECTIONS
N/A	FOUNDATION INSPECTIONS
N/A	CONCRETE COMP. STRENGTH AND SLUMP TESTS
N/A	POST INSTALLED ANCHOR ROD VERIFICATION
N/A	BASE PLATE GROUT VERIFICATION
N/A	CONTRACTOR'S CERTIFIED WELD INSPECTION
N/A	EARTHWORK: LIFT AND DENSITY
X	ON SITE COLD GALVANIZING VERIFICATION
N/A	GUY WIRE TENSION REPORT
X	GC AS-BUILT DOCUMENTS
<b>ADDITIONAL TESTING AND INSPECTIONS:</b>	
<b>POST-CONSTRUCTION</b>	
X	PCI INSPECTOR REDLINE OR RECORD DRAWING(S)
N/A	POST INSTALLED ANCHOR ROD PULL-OUT TESTING
X	PHOTOGRAPHS
<b>ADDITIONAL TESTING AND INSPECTIONS:</b>	

NOTE: X DENOTES A DOCUMENT NEEDED FOR THE PCI REPORT  
 N/A DENOTES A DOCUMENT THAT IS NOT REQUIRED FOR THE PCI REPORT

PREPARED BY:  

 625 MEMORIAL DRIVE  
 RALEIGH, NC 27618  
 PHONE: 919-855-2222  
 FAX: 919-855-2221  
 ENGINEERING INNOVATION

PREPARED BY:  
**SBA**  
 5000 BROOKHOLD DRIVE  
 ROCKY HAVEN, N. CAROLINA  
 (800) 487-8111

BRADLEY R. NEWMAN, P.E.  
 CONNECTICUT LIC. NO. 28830  
 03/28/14

WJD  
 DRAWN BY:  
 C/JW  
 CHECKED BY:  
 BRN  
 ENG APP'D:  
 PROJECT NO:  
 142252L1400

SUBMITTALS		
DATE	DESCRIPTION	NO.
03/28/14	CONSTRUCTION	0

THE INFORMATION CONTAINED IN THIS SET OF DOCUMENTS IS PROPRIETARY BY NATURE. REPRODUCTION OR CAUSING TO BE REPRODUCED IN ANY MANNER WITHOUT THE PERMISSION OF FDH ENGINEERING, INC. IS PROHIBITED.

SITE NAME:  
**MONROE TURNPIKE**

SITE NUMBER:  
**CT13055-A-04**

SITE ADDRESS:  
 1428 MONROE TURNPIKE  
 MONROE, CT 06488

SHEET TITLE  
**POST CONSTRUCTION INSPECTION NOTES**

SHEET NUMBER  
**N-1**

**GENERAL NOTES:**

1. ALL WORK SHALL BE DONE IN ACCORDANCE WITH ALL APPLICABLE FEDERAL, STATE AND LOCAL CODES AND ORDINANCES. IT IS THE CONTRACTOR'S RESPONSIBILITY TO OBTAIN ALL NECESSARY PERMITS TO COMPLETE THE PROJECT AND ABIDE BY ALL CONDITIONS AND REQUIREMENTS OF THE PERMITS.
2. THE CONTRACTOR SHALL BE RESPONSIBLE FOR VERIFICATION OF FEDERAL, STATE AND LOCAL CODES AND ORDINANCES. IT IS THE CONTRACTOR'S RESPONSIBILITY TO OBTAIN ALL NECESSARY PERMITS TO COMPLETE THE PROJECT AND ABIDE BY ALL CONDITIONS AND REQUIREMENTS OF THE PERMITS.
3. THE CONTRACTOR SHALL BE RESPONSIBLE FOR VERIFICATION OF FEDERAL, STATE AND LOCAL CODES AND ORDINANCES. IT IS THE CONTRACTOR'S RESPONSIBILITY TO OBTAIN ALL NECESSARY PERMITS TO COMPLETE THE PROJECT AND ABIDE BY ALL CONDITIONS AND REQUIREMENTS OF THE PERMITS.
4. IT IS THE CONTRACTOR'S SOLE RESPONSIBILITY TO DETERMINE ERECTION PROCEDURE AND SEQUENCE TO ENSURE THE SAFETY OF THE STRUCTURE AND ITS COMPONENT PARTS DURING ERECTION AND/OR FIELD MODIFICATIONS. THIS INCLUDES, BUT IS NOT LIMITED TO, THE ADDITION OF TEMPORARY BRACING, GUYS OR TIE DOWNS THAT MAY BE NECESSARY. SUCH MATERIAL SHALL BE REMOVED AFTER THE COMPLETION OF THE PROJECT.
5. CONTRACTOR SHALL PROMPTLY REMOVE ANY & ALL DEBRIS FROM SITE AND RESTORE AS BEST AS POSSIBLE TO PRECONSTRUCTION CONDITION.

**CONTRACTOR QUALIFICATION NOTES:**

1. ALL REPAIRS SHALL BE PERFORMED BY A TOWER CONTRACTOR WITH A MINIMUM 5 YEARS EXPERIENCE IN TOWER ERECTION AND RETROFIT AND WITH WORKING KNOWLEDGE OF THE TIA/EIA 222-F STRUCTURAL STANDARDS FOR STEEL ANTENNA TOWERS AND ANTENNA SUPPORTING STRUCTURES.
2. CONTRACTOR IS RESPONSIBLE FOR ALL CONSTRUCTION MEANS AND METHODS. SHOULD THE CONTRACTOR REQUIRE DIRECT CONSULTATION, FDH ENGINEERING, INC. IS WILLING TO OFFER SERVICES BASED UPON AN AGREED FEE FOR THE WORK REQUIRED.
3. ALL SUBMITTAL INFORMATION MUST BE SENT TO FDH ENGINEERING, INC. 6521 MERIDIAN DRIVE, RALEIGH NC, 27616, TEL. (919) 755-1012, FAX. (919) 755-1031, E-MAIL INFO@FDH-INC.COM. CONFIRMATION OF THESE SPECIFICATIONS OR DRAWINGS WITHOUT RESPONSIBILITY OR LIABILITY FOR DAMAGE (MATERIAL OR PHYSICAL) TOWARDS FDH ENGINEERING, INC.
4. ALL CONSTRUCTION TO BE IN ACCORDANCE WITH THE TIA-1019-A STANDARD.

**JOB SITE SAFETY & NOTES:**

1. NEITHER THE PROFESSIONAL ACTIVITIES OF FDH ENGINEERING, INC. NOR THE PRESENCE OF FDH ENGINEERING, INC. OR EMPLOYEES SHALL RELIEVE THE GENERAL CONTRACTOR AND/OR SUBCONTRACTORS AND ANY OTHER ENTITY OF THEIR OBLIGATIONS, DUTIES AND RESPONSIBILITIES INCLUDING, BUT NOT LIMITED TO, CONSTRUCTION SAFETY PROCEDURES, ACCESS, ERECTION, AND DEMONSTRATION PROCEDURES NECESSARY FOR PROTECTION OF PERSONNEL AND PROPERTY. ALL PORTIONS OF THE WORK OF CONSTRUCTION IN ACCORDANCE WITH THE CONTRACT DOCUMENTS AND ANY HEALTH OR SAFETY PRECAUTIONS REQUIRED BY ANY REGULATORY AGENCIES, THE CONTRACTOR SHALL BE RESPONSIBLE FOR. THE CONTRACTOR IS SOLELY RESPONSIBLE FOR JOB SAFETY AND WARRANTS THAT THIS INTENT IS EMBODIED IN ACCEPTING THIS WORK.

**STEEL:**

1. ALL STRUCTURAL STEEL SHALL BE FABRICATED AND ERECTED IN ACCORDANCE WITH THE LATEST AISC CODE AND ASTM SPECIFICATIONS.
- \*ALL STEEL FLAT PLATE SHALL BE ASTM A372-65 (Fy=65KSI) UNLESS OTHERWISE SPECIFIED.
- ALL CONNECTIONS OF STRUCTURAL STEEL MEMBERS SHALL BE MADE USING SPECIFIED WELDS WITH WELDING ELECTRODES E-60XX OR SPECIFIED HIGH STRENGTH BOLTS TO BE ASTM A325N. THREAD INCLUDED WITH SHEAR PLANE (UNLESS OTHERWISE NOTED).
- ALL BOLTED CONNECTIONS TO BE INSTALLED TO A SNUG-TIGHTENED CONDITION IN ACCORDANCE WITH AISC 13 PART 16.2. SPECIFICATION FOR STRUCTURAL JOINTS USING ASTM A325 OR A490 BOLTS", SECTION B.1. UNLESS OTHERWISE SPECIFIED, WHEN "X" TYPE BOLTS ARE USED, CONTRACTOR MAY BE REQUIRED TO STACK ADDITIONAL NUTS TO TO THE TOP OF THE UPPER NUT. UNLESS OTHERWISE NOTED, ALL NUTS SHALL BE HEAVY HEX UNLESS OTHERWISE NOTED.
- ALL STEEL, AFTER FABRICATION, SHALL BE HOT DIPPED GALVANIZED PER ASTM A-123. ALL DAMAGED SURFACES, INCLUDING CORROSION AND DISCOLORATION, SHALL BE REPAIRED OR PARTS (EXISTING OR NEW) SHALL BE BURNED WITH MULTIPLE COATS OF ZRC COLD GALVANIZING COMPOUND ACHIEVING A MINIMUM OF 4 MILS DRY FILM PER ASTM A 780.
- ALL SHOP AND FIELD WELDING SHALL BE DONE BY WELDERS QUALIFIED TO THE AISC 308. CONTRACTOR SHALL FOLLOW THE SOCIETY'S STANDARD QUALIFICATION PROCEDURE TO PERFORM THE TYPE OF WORK REQUIRED. CONTRACTOR IS REQUIRED TO PROVIDE FDH ENGINEERING, INC. WITH A PASSING CERTIFIED WELDING INSPECTION FOR ALL WELDS.
- STRUCTURAL STEEL MAY NOT BE TORCH CUT FOR FABRICATION. ALL STEEL FABRICATION MUST FOLLOW AISC STANDARDS.

**MISC. NOTES:**

1. ALL MODIFICATIONS ARE ASSUMED TO BE MADE ON AN EMPTY TOWER. CONTRACTOR IS RESPONSIBLE TO MAKE PROVISIONS TO SUPPORT OR WORK AROUND EXISTING ANTENNAS AND TRANSMISSION LINES. MODIFICATIONS MUST BE CONTINUOUS THROUGH ALL AREAS SHOWN.
- CONTRACTOR FIELD VERIFY ALL DIMENSIONS PRIOR TO CONSTRUCTION.

**FABRICATION NOTES:**

1. ALL DIMENSIONS ARE PRELIMINARY UNTIL FIELD VERIFIED BY CONTRACTOR. ANY CHANGES MUST BE APPROVED BY ENGINEER OF RECORD IN WRITING PRIOR TO FABRICATION AND INSTALLATION.
  - NEW STEEL MEMBERS MUST HAVE SINGLE DRILLED HOLES; SLOTTED AND DOUBLE DRILLED HOLES ARE NOT ACCEPTABLE MEANS OF FABRICATION.
- SUBSTITUTES AND/OR EQUALS:**
1. IF CONTRACTOR WISHES TO FURNISH OR USE A SUBSTITUTE ITEM OF MATERIAL OR EQUIPMENT, CONTRACTOR SHALL FIRST MAKE WRITTEN APPLICATION TO ENGINEER OF RECORD FOR APPROVAL. CONTRACTOR SHALL SUBMIT THE FOLLOWING INFORMATION TO THE ENGINEER OF RECORD TO ACHIEVE THE RESULTS CALLED FOR BY THE GENERAL DESIGN. THE SUBSTITUTE WILL PERFORM IDENTICALLY THE FUNCTIONS AND BE SIMILAR IN SUBSTANCE TO THAT SPECIFIED AND SUITED TO THE SAME USE AS THAT SPECIFIED. ALL VARIATIONS OF THE SUBSTITUTE MATERIALS, EQUIPMENT AND METHODS WILL BE IDENTIFIED IN THE APPLICATION AND APPROVAL WILL BE OBTAINED FROM THE ENGINEER OF RECORD. CONTRACTOR SHALL REPAIR AND REPLACEMENT SERVICE WILL BE INDICATED. THE APPLICATION WILL ALSO CONTAIN AN ITEMIZED ESTIMATE OF ALL COSTS OR CREDITS THAT WILL RESULT DIRECTLY OR INDIRECTLY FROM THE SUBSTITUTION OF SUCH SUBSTITUTE INCLUDING COSTS OF DESIGN AND CONSTRUCTION. CONTRACTORS AFFECTED BY THE RESULTING CHANGE, ALL OF WHICH WILL BE CONSIDERED BY ENGINEER OF RECORD IN EVALUATION OF THE PROPOSED SUBSTITUTE. ENGINEER OF RECORD SHALL BE RESPONSIBLE TO FURNISH ADDITIONAL DATA ABOUT THE PROPOSED SUBSTITUTE.

**NEW FLAT PLATE REINFORCEMENT NOTES:**

1. CONTRACTOR TO FIELD VERIFY PROPOSED LOCATION OF FLAT PLATE TO ENSURE THAT PROPER SPACING CAN BE MET.
- CONTRACTOR TO REPLACE AND/OR RELOCATE ANY CLIMBING PEGS THAT INTERFERE WITH THE INSTALLATION OF FLAT PLATE.
- ALL AJAX CONNECTIONS TO USE HIGH TENSILE SLEEVE PROVIDED BY MANUFACTURER. AJAX BOLT ASSEMBLY TO BE INSTALLED PER MANUFACTURER SPECIFICATIONS. SEE AJAX BOLT ASSEMBLY DETAIL BELOW.
- ALL SHEAR SLEEVES TO BE HOT DIPPED GALVANIZED PRIOR TO INSTALLATION.
- NEW FLAT PLATES TO BE INSTALLED ON THE CENTER OF THE PROPOSED SIDE UNLESS OTHERWISE NOTED.
- PRIOR TO FLAT PLATE INSTALLATION, SLIP JOINTS MUST BE TIGHTENED WITH A MINIMUM JACKING FORCE OF 6000 LBS.
- EXISTING COAX BANDS TO BE REPLACED AFTER FLAT PLATE INSTALLATION. NEW FLAT PLATE TO BE INSTALLED BENEATH EXISTING COAX BANDS.

**PRETENSION BOLTS:**

1. ALL DIRECT TENSION INDICATOR (DTI) WASHERS SHALL BE THE "SQUIRRELER STYLE" AS MANUFACTURED BY: APPLIED BOLTING TECHNOLOGY PRODUCTS, INC. 1413 ROCKINGHAM ROAD, BELLWALLS FALLS, VERMONT 05101, USA PHONE: 1-800-505-1999 WEBSITE: WWW.APPLIEDBOLTING.COM
- USE DIRECT TENSION INDICATOR (DTI) WASHERS COMPATIBLE WITH 3/4" NOMINAL A325 BOLTS FOR THE AJAX N20 BOLTS. DTI'S SHALL NOT BE HOT-DIP GALVANIZED. DTI'S SHALL BE MECHANICALLY GALVANIZED (MG) BY THE COLD MECHANICAL PROCESS ONLY AS PROVIDED BY THE DTI MANUFACTURER.
- USE HARDENED WASHER FOR A 3/4" NOMINAL BOLT BETWEEN THE TOP OF DIRECT TENSION INDICATOR (DTI) WASHER AND THE NUT OF ASTM F436 AND HAVE A MINIMUM HARDNESS OF RE 38 OR HIGHER. THE HARDENED WASHERS SHALL BE MECHANICALLY GALVANIZED (MG) BY THE COLD MECHANICAL PROCESS ONLY AS PROVIDED BY THE DTI MANUFACTURER. CONTRACTOR SHALL PROVIDE DOCUMENTATION OF WASHER SPECIFICATION AND HARDNESS.
- CONTRACTOR SHALL FOLLOW DTI MANUFACTURER'S INSTRUCTION FOR INSTALLATION, LUBRICATION, TIGHTENING AND INSPECTION.

**INSPECTION REQUIRED:** ALL AJAX BOLTS SHALL BE INSPECTED ACCORDING TO THE REQUIREMENTS OF THE AISC "SPECIFICATION FOR STRUCTURAL BOLTS AND BOLTED CONNECTIONS" (AISC 308) BY A QUALIFIED BOLT INSPECTOR DURING INSTALLATION. THE BOLT INSPECTOR SHALL VERIFY AND DOCUMENT THE SHOP-DRILL AND FIELD-DRILLED HOLE SIZES. THE INSTALLATION OF THE AJAX BOLT ASSEMBLY, INCLUDING THE SHEAR SLEEVE PLACEMENT AND BUTT LUBRICATION AND CONTRACTOR'S TENSIONING PROCEDURE SHALL BE VISUALLY INSPECTED ACCORDING TO THE DTI MANUFACTURER'S INSTRUCTIONS. THE BOLT INSPECTOR SHALL PROVIDE PHOTO DOCUMENTATION OF ALL BOLTS AFTER TIGHTENING CLEARLY SHOWING THE CONDITION OF THE DTI'S.

**COLD GALVANIZATION/SURFACE PREPARATION NOTES:**

1. CONTRACTOR TO USE ZINCA OR ZRC COLD GALVANIZATION COMPOUNDS OR APPROVED EQUIVALENT.
- PREPARE RUSTED/CORRODED SURFACE FOR TREATMENT ACCORDING TO MANUFACTURER'S RECOMMENDATIONS.
- CONTRACTOR TO APPLY (2) COATS OF COLD GALVANIZATION COMPOUND PER MANUFACTURER'S RECOMMENDATION. DRYING AND CURING TIMES MUST BE UTILIZED PER MANUFACTURER'S RECOMMENDATION.
- APPLY ALL COATINGS BY BRUSH IN CALM WIND CONDITIONS. IF THE TOWER IS PAINTED, BRUSH PAINT ALL TREATED AREAS TO MATCH TOWER AFTER COLD GALVANIZATION COMPOUND IS ALLOWED TO CURE.

PREPARED BY:  
  
 601 VERMONT AVENUE  
 SUITE 200  
 FARMINGTON, CT 06030  
 PHONE: 860-255-0112  
 FAX: 860-255-1011  
**ENGINEERING INNOVATION**

PREPARED FOR:  
  
**SBA**  
 5600 BROOKER SOUND PARKWAY, NW  
 SUITE 3340  
 (800) 497-9171

STATE OF CONNECTICUT  
  
**BRADLEY R. NEWMAN, P.E.**  
 03/28/14  
 CONNECTICUT LIC. NO. 29530  
 DRAWN BY: WJD  
 CHECKED BY: CJW  
 ENG. APPROV.: BRN  
 PROJECT NO.: 14252L1400

DATE	DESCRIPTION	REV
03/29/14	CONSTRUCTION	0

THE INFORMATION CONTAINED IN THIS SET OF DOCUMENTS IS PROPRIETARY TO FDH ENGINEERING, INC. AND IS TO BE REPRODUCED IN WHOLE OR IN PART OF THESE DRAWINGS WITHOUT THE PERMISSION OF FDH ENGINEERING, INC. IS PROHIBITED.

SITE NAME: <b>MONROE TURNPIKE</b>
SITE NUMBER: <b>CT13055-A-04</b>
SITE ADDRESS: <b>1428 MONROE TURNPIKE MONROE, CT 06468</b>
SHEET TITLE <b>GENERAL NOTES</b>
SHEET NUMBER <b>N-2</b>

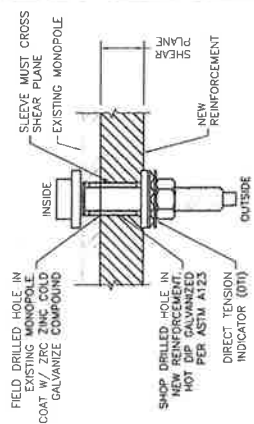

**AJAX BOLT ASSEMBLY**  
SCALE: NTS



# TOWER MODIFICATION SCHEDULE

NO.	TYPE OF MODIFICATION	BOTTOM ELEV. (FT)	TOP ELEV. (FT)
1	INSTALLATION OF NEW FLAT PLATE REINFORCEMENT. SEE S-2 FOR DETAILS.	99.3±	119.7±

- APURTENANCES MAY INTERFERE WITH PROPOSED MODIFICATIONS.
- ALL MODIFICATIONS TO BE INSTALLED CONTINUOUSLY THROUGH EXISTING EQUIPMENT. ALL EXISTING EQUIPMENT NOT TO BE DAMAGED OR TAKEN OFF AIR DURING INSTALLATION.
- ANTENNA GRAPHICS NOT SHOWN FOR CLARITY. SEE STRUCTURAL ANALYSIS REPORT FOR EXISTING ANTENNA LOADING.



LENGTH (FT)	# OF SIDES	THICKNESS (IN)	SOCKET LENGTH (FT)	TOP DIAMETER (IN)	BOT DIAMETER (IN)	TOWER FINISH
10.00	53.50	0.3125	2.00	12.0000	14.9300	
53.25	18	0.3750	N/A	41.2377	58.8400	
93.50		0.2750	5.50	27.9166	43.6000	GALVANIZED

**PREPARED BY:**  
  
**ENGINEERING INNOVATION**  
 825 AMERICAN DRIVE  
 SUITE 100  
 MONROE, CT 06468  
 PHONE: 860-487-5152  
 FAX: 860-487-5151

**PREPARED FOR:**  
  
**SBA**  
 5000 BROKEN SOUND PARKWAY, NW  
 SUITE 100  
 WEST PALM BEACH, FL 33411  
 (800) 487-5151

**BRADLEY R. NEWMAN, P.E.**  
 CONNECTICUT LIC. NO. 29839  
 03/28/14

**DRAWN BY:** WJD  
**CHECKED BY:** CJW  
**ENG APP'D:** BRN  
**PROJECT NO.:** 14252L1400

SUBMITTALS		
DATE	DESCRIPTION	REV
03/28/14	CONSTRUCTION	0

THE INFORMATION CONTAINED IN THIS SET OF DOCUMENTS IS PROPRIETARY BY FDH ENGINEERING INNOVATION. IT IS TO BE REPRODUCED THE WHOLE OR ANY PART OF THESE DRAWINGS WITHOUT THE PERMISSION OF FDH ENGINEERING, INC. IS PROHIBITED.

**SITE NAME:**  
 MONROE TURNPIKE  
**SITE NUMBER:**  
 CT13055-A-04  
**SITE ADDRESS:**  
 1428 MONROE TURNPIKE  
 MONROE, CT 06468

**SHEET TITLE**  
 MODIFICATION SCHEDULE

**SHEET NUMBER**  
 S-1

SUBMITTALS		
DATE	DESCRIPTION	NO.
03/28/14	CONSTRUCTION	0

THE INFORMATION CONTAINED IN THIS SET OF DOCUMENTS IS PROPRIETARY TO SBA ENGINEERING INNOVATION. NO PART OF THESE DRAWINGS WITHOUT THE PERMISSION OF FDH ENGINEERING, INC. IS PROHIBITED.

SITE NAME:  
**MONROE TURNPIKE**

SITE NUMBER:  
**CT13055-A-04**

SITE ADDRESS:  
**1428 MONROE TURNPIKE  
 MONROE, CT 06468**

SHEET TITLE  
**FLAT PLATE INSTALLATION  
 DETAILS**

SHEET NUMBER  
**S-2**

FLAT PLATE INSTALLATION SCHEDULE				
PART #	QTY.	DESCRIPTION	ELEVATION	FLATS
MK-1	3	FLAT PLATE REINFORCEMENT	99'-4" ± TO 119'-4" ±	6 - 12 - 18
-	66	20MM AJAX BOLTS	VARIES	-

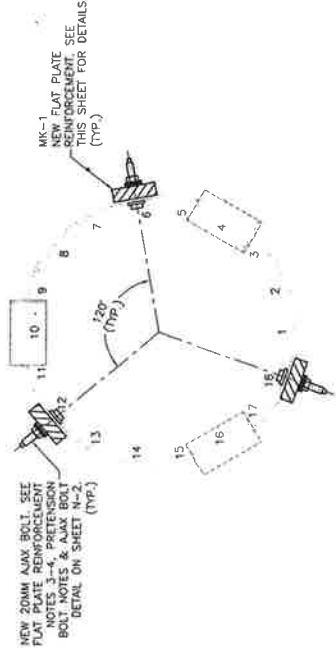

2  
**S-2**  
 FLAT PLATE REINFORCEMENT LAYOUT  
 PLAN VIEW  
 SCALE: 1" = 1'-0"

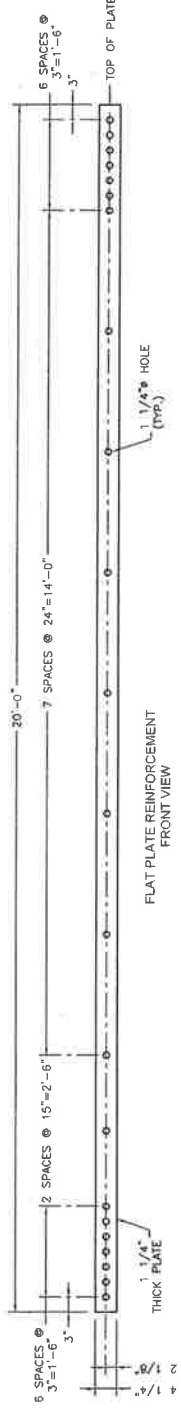
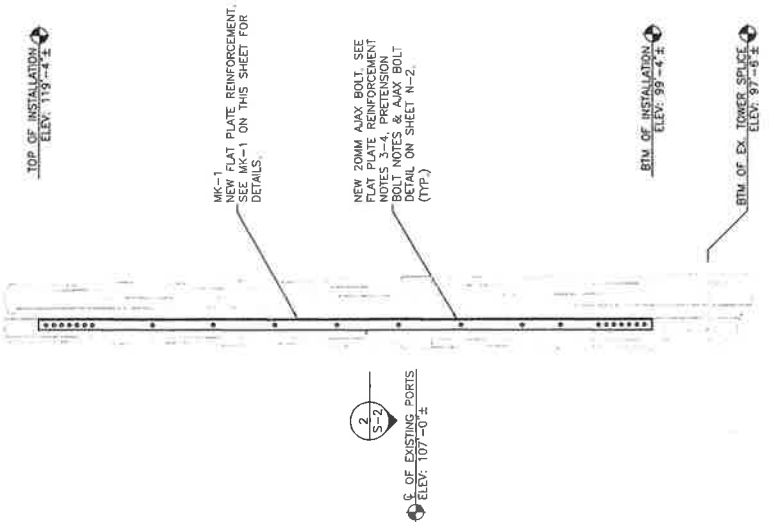

MK-1  
**S-2**  
 FLAT PLATE REINFORCEMENT  
 FRONT VIEW  
 SCALE: 1/2" = 1'-0"

# **ATTACHMENT 4**

# 1430 MONROE TPKE

**Location** 1430 MONROE TPKE

**Map/Lot** 145/ 024/ 00/ /

**Acct#** 14502400

**Owner** SISTERS OF THE HOLY FAMILY OF NAZARETH

**Assessment** \$6,295,700

**Appraisal** \$8,993,700

**PID** 17241

**Building Count** 2

**Survey** 3089

## Current Value

Appraisal			
Valuation Year	Improvements	Land	Total
2015	\$7,597,800	\$1,395,900	\$8,993,700

Assessment			
Valuation Year	Improvements	Land	Total
2015	\$5,318,600	\$977,100	\$6,295,700

## Owner of Record

**Owner** SISTERS OF THE HOLY FAMILY OF NAZARETH

**Sale Price** \$0

**Co-Owner**

**Certificate**

**Address** 310 NORTH RIVER RD  
DES PLAINES, IL 60016

**Book & Page** 1603/14-1

**Sale Date** 07/10/2009

**Instrument** 0

## Ownership History

Ownership History					
Owner	Sale Price	Certificate	Book & Page	Instrument	Sale Date
SISTERS OF THE HOLY FAMILY OF NAZARETH	\$0		1603/14-1	0	07/10/2009
SISTERS OF THE HOLF FAMILY OF NAZARETH	\$0		86/ 395		02/14/1967

## Building Information

### Building 1 : Section 1

**Year Built:** 2015

**Living Area:** 16,970

Building Attributes	
Field	Description

Style	Other
Model	Residential
Stories:	1
Occupancy	28
Exterior Wall 1	Brick
Heat Fuel	Typical
Heat Type:	Hot Air
AC Type:	Central AC
Total Bedrooms:	28
Total Bthrms:	30
Total Half Baths:	
Total Rooms:	35
Fireplaces	
Basement Gar.	3
Basement	Full
In Law Apt	

## Building Photo

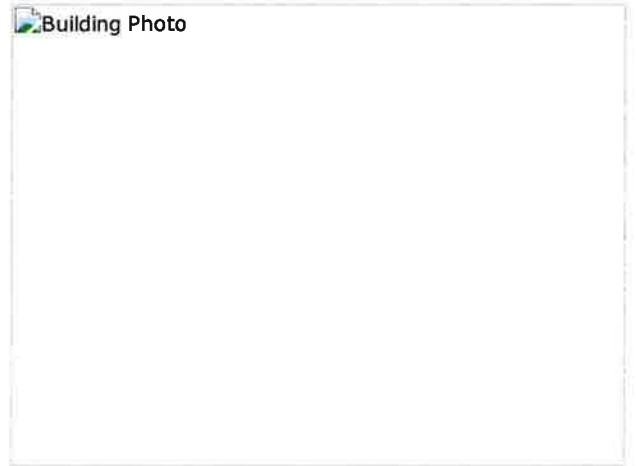

(<http://images.vgsi.com/photos/MonroeCTPhotos//\00\00\68\9>)

## Building Layout

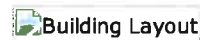

Building Sub-Areas (sq ft)			Legend
Code	Description	Gross Area	Living Area
BAS	First Floor	16,970	16,970
CRL	Crawl	5,270	0
CTH	Cathedral Ceiling	1,816	0
FBM	Finished Basement	12,116	0
FOP	Open Porch	120	0
PTO	Patio	348	0
		36,640	16,970

## Building 2 : Section 1

**Year Built:** 1965  
**Living Area:** 85,709

Building Attributes : Bldg 2 of 2	
Field	Description
STYLE	Church
MODEL	Commercial
Grade	C
Stories:	
Occupancy	
Exterior Wall 1	Brick/Stone
Exterior Wall 2	
Heating Fuel	Typical
Heating Type	Hw/Steam
AC Type	None
Bldg Use	Church

## Building Photo

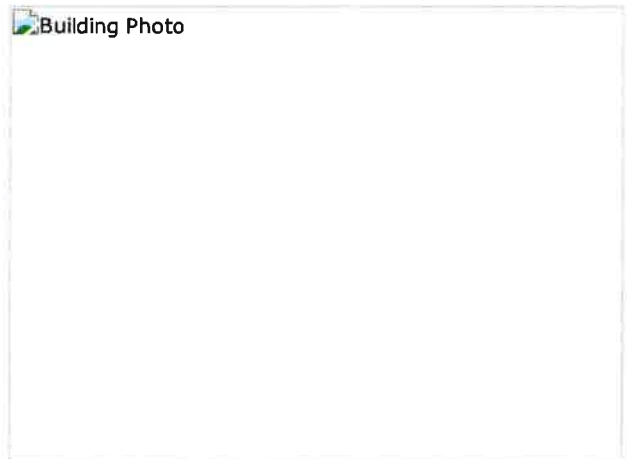

(<http://images.vgsi.com/photos/MonroeCTPhotos//\00\00\68\9>)

## Building Layout

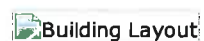



Total Rooms	
Total Bedrms	
Total Baths	
Fireplace	
Xtra Fireplaces	
1st Floor Use:	
Heat/AC	Typical
Frame Type	Fireresist
Baths/Plumbing	Normal
Ceiling/Wall	Ceil and Wall
Rooms/Prtns	Average
Wall Height	9
% Comn Wall	

Building Sub-Areas (sq ft)			Legend
Code	Description	Gross Area	Living Area
FUS	Finished Upper Story	55,828	55,828
BAS	First Floor	29,881	29,881
SLB	Slab	29,881	0
		115,590	85,709

### Extra Features

Extra Features						Legend
Code	Description	Size	Value	Bldg #	Comment	
ELEV	Elevator	3 STOP	\$60,000	1		
GEN	Generator	0	\$90,000	1		
CRP5	PORCH COVRD	2047 S.F.	\$17,900	2		
CRS1	UTIL FRAME	165 S.F.	\$800	2		

### Land

#### Land Use

**Use Code** 906R  
**Description** Church  
**Zone** RF2

#### Neighborhood

**Alt Land Approved** No  
**Category**

#### Land Line Valuation

**Size (Acres)** 124.21  
**Appraised Value** \$1,395,900

### Outbuildings

Outbuildings							Legend
Code	Description	Sub Code	Sub Description	Size	Value	Bldg #	
PA1	ASPHALT PARKING			50000 S.F.	\$50,000	2	
RG4	Garage Fin Attic			1525 S.F.	\$30,500	2	
RG4	Garage Fin Attic			1736 S.F.	\$34,700	2	
SC1	COM SWIM POOL			1920 S.F.	\$86,400	2	

### Valuation History

Appraisal

No Data for Appraisal History

**Assessment**

No Data for Assessment History

(c) 2016 Vision Government Solutions, Inc. All rights reserved.



1430 MONROE TPKE  
Field Card  
Zoom to Feature  
Buffer Feature



Parcel ID: 145 024 00



1430 MONROE TPKE

Field Card  
Zoom to Feature  
Buffer Feature

Remove From Selected | View Additional Details