

STATE OF CONNECTICUT
CONNECTICUT SITING COUNCIL

Ten Franklin Square, New Britain, CT 06051
Phone: (860) 827-2935 Fax: (860) 827-2950
E-Mail: siting.council@ct.gov
www.ct.gov/csc

September 10, 2009

Thomas F. Flynn III
UMTS Project Manager
T-Mobile USA, Inc.
35 Griffin Rd. S
Bloomfield, CT 06002

RE: **EM-T-MOBILE-085-090803** – Omnipoint Communications, as subsidiary of T-Mobile USA, Inc.
notice of intent to modify an existing telecommunications facility located at 88 Main Street, Monroe,
Connecticut.

Dear Mr. Flynn:

The Connecticut Siting Council (Council) hereby acknowledges your notice to modify this existing telecommunications facility, pursuant to Section 16-50j-73 of the Regulations of Connecticut State Agencies.

The proposed modifications are to be implemented as specified here and in your notice dated July 31, 2009, including the placement of all necessary equipment and shelters within the tower compound. The modifications are in compliance with the exception criteria in Section 16-50j-72 (b) of the Regulations of Connecticut State Agencies as changes to an existing facility site that would not increase tower height, extend the boundaries of the tower site, increase noise levels at the tower site boundary by six decibels, and increase the total radio frequencies electromagnetic radiation power density measured at the tower site boundary to or above the standard adopted by the State Department of Environmental Protection pursuant to General Statutes § 22a-162. This facility has also been carefully modeled to ensure that radio frequency emissions are conservatively below State and federal standards applicable to the frequencies now used on this tower.

This decision is under the exclusive jurisdiction of the Council. Please be advised that the validity of this action shall expire one year from the date of this letter. Any additional change to this facility will require explicit notice to this agency pursuant to Regulations of Connecticut State Agencies Section 16-50j-73. Such notice shall include all relevant information regarding the proposed change with cumulative worst-case modeling of radio frequency exposure at the closest point of uncontrolled access to the tower base, consistent with Federal Communications Commission, Office of Engineering and Technology, Bulletin 65. Any deviation from this format may result in the Council implementing enforcement proceedings pursuant to General Statutes § 16-50u including, without limitation, imposition of expenses resulting from such failure and of civil penalties in an amount not less than one thousand dollars per day for each day of construction or operation in material violation.

Thank you for your attention and cooperation.

Very truly yours,

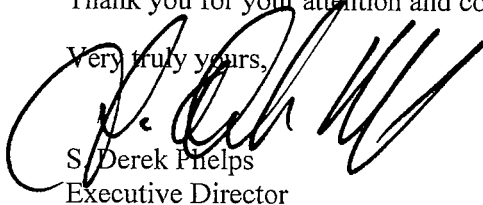

S/Derek Phelps
Executive Director

SDP/MP/laf

c: The Honorable Tom Buzi, First Selectman, Town of Monroe
Daniel A. Tuba, Planning Administrator, Town of Monroe

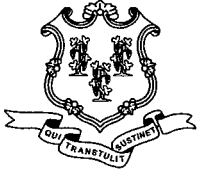

STATE OF CONNECTICUT

CONNECTICUT SITING COUNCIL

Ten Franklin Square, New Britain, CT 06051

Phone: (860) 827-2935 Fax: (860) 827-2950

E-Mail: siting.council@ct.gov

www.ct.gov/csc

August 3, 2009

The Honorable Tom Buzi
First Selectman
Town of Monroe
Town Hall
7 Fan Hill Road
Monroe, CT 06468-1800

RE: **EM-T-MOBILE-085-090803** – Omnipoint Communications, as subsidiary of T-Mobile USA, Inc. notice of intent to modify an existing telecommunications facility located at 88 Main Street, Monroe, Connecticut.

Dear Mr. Buzi:

The Connecticut Siting Council (Council) received this request to modify an existing telecommunications facility, pursuant to Regulations of Connecticut State Agencies Section 16-50j-72.

If you have any questions or comments regarding this proposal, please call me or inform the Council by August 17, 2009.

Thank you for your cooperation and consideration.

Very truly yours,



S. Derek Phelps
Executive Director

SDP/jb

Enclosure: Notice of Intent

c: Daniel A. Tuba, Planning Administrator, Town of Monroe

July 31, 2009

Via Federal Express

S. Derek Phelps, Executive Director
Connecticut Siting Council
Ten Franklin Square
New Britain, CT 06051

ORIGINAL
RECEIVED
AUG - 3 2009
CONNECTICUT
SITING COUNCIL

**Re: Notice of Exempt Modification
T-Mobile USA, Inc. Telecommunications Facility
88 Main Street, Monroe, Connecticut
T-Mobile Site CT11215A**

Dear Mr. Phelps:

Omnipoint Communications, a subsidiary of T-Mobile USA, Inc. ("T-Mobile"), intends to replace existing antennas with new antennas, and supplement existing ground equipment at a 195-foot self-supporting monopole facility owned by T-Mobile USA, Inc. and located at Stepney Fire Department, 88 Main Street, Monroe, Connecticut, ("Facility"). T-Mobile is licensed by the Federal Communications Commission ("FCC") to provide PCS wireless telecommunications service in the State of Connecticut, which includes the area to be served by the proposed installation. This installation constitutes an exempt modification pursuant to the Public Utility Environmental Standards Act, Connecticut General Statutes Section 16-50g *et. seq.* ("PUESA"), and Section 16-50j-72(b)(2) of the Regulations of the Connecticut State Agencies adopted pursuant to PUESA. In accordance with R.C.S.A. Section 16-50j-73, a copy of this notice has been sent to Tom Buzi, First Selectman, Town of Monroe.

The existing Facility consists of a 195-foot self-supporting monopole capable of supporting multiple carriers within a fenced compound. The coordinates for the Facility are **Lat: 41°-17'-59"** and **Long: 73°-14'-58"**. The Facility is located in the south central portion of town, in the Stepney area of Monroe. The Facility is behind the Stepney Volunteer Fire Company station, approximately 300 feet east of Main Street (Route 25) and roughly 600 feet west of Maple Drive (see Site Map, attached as Exhibit A). The tower currently supports Verizon antennas at the one hundred sixty five foot (165') level centerline AGL (above ground level), and Cingular/AT&T antennas at the one hundred seventy five foot (175') level centerline AGL. The current T-Mobile antenna configuration is two antennas per sector in the alpha and gamma sectors and four antennas in the beta sector for a total of eight. T-Mobile proposes to replace three existing antennas at the one hundred ninety five foot level (195') with three new APX18206516S antennas (one in each sector) and also proposes to swap out two ddTMA's with one RFS twin PCS and one RFS twin AWS TMA per sector. The other T-Mobile antennas will remain, all at a centerline of hundred ninety five feet (195') AGL. T-Mobile's installation constitutes a total of eight antennas. T-Mobile also intends to replace an existing S8000 equipment cabinet with a new UMTS 3106 BTS equipment cabinet. This will supplement two other existing to its current configuration of one existing S8000 equipment cabinets. The three cabinets will be mounted on an existing concrete pad, located within the compound. T-Mobile's

equipment will be contained within it's existing lease area. T-Mobile intends to run new coaxial cable on its existing ice bridges from its current equipment pad to the existing tower. Utilities will be run from existing utility sources at the Facility (See Design Drawings and Equipment Specifications, attached as Exhibits B and C respectively).

For the following reasons, the proposed modifications to the Main Street Facility meet the exempt modification criteria set forth in R.C.S.A. Section 16-50j-72(b)(2):

1. The proposed modification will not increase the height of the tower as T-Mobile seeks to install replacement antennas (total of six), at a center line height of 195 feet.
2. The installation and replacement of T-Mobile's antennas and ground equipment will not require an extension of the site boundaries.
3. The proposed modifications will not increase the noise levels at the existing Facility by six decibels or more.
4. The operation of the additional antennas will not increase the total radio frequency (RF) power density, measured at the site boundary, to a level at or above the standard adopted by the Connecticut Department of Environmental Protection as set forth in Section 22a-162 of the Connecticut General Statutes and MPE limits established by the Federal Communications Commission. The worst-case RF power density calculations for the proposed T-Mobile antennas would be 9.38% of the FCC standard (see general power density calculations table, attached as Exhibit D).

Also attached, Exhibit E, is a structural analysis confirming that the tower can support the existing and proposed antennas and associated equipment.

For the foregoing reasons, T-Mobile respectfully submits that the proposed antenna installation and equipment at the Monroe Facility constitutes an exempt modification under R.C.S.A. Section 16-50j-72(b)(2).

Respectfully Submitted,

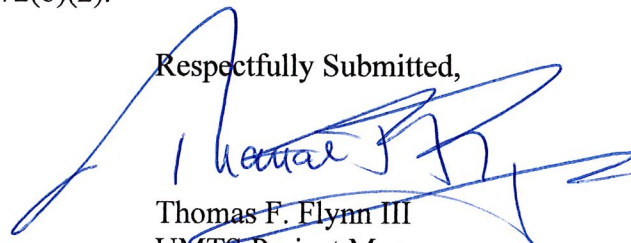

Thomas F. Flynn III
UMTS Project Manager
Agent for T-Mobile

cc: Tom Buzi, First Selectman, Town of Monroe
Stepney Volunteer Fire Company, underlying property owners

Hartford/72800.55/KSHEATHELM/381104v1

Exhibit A

Site Map

T-Mobile Site CT11215A

88 Main Road

Monroe, Connecticut

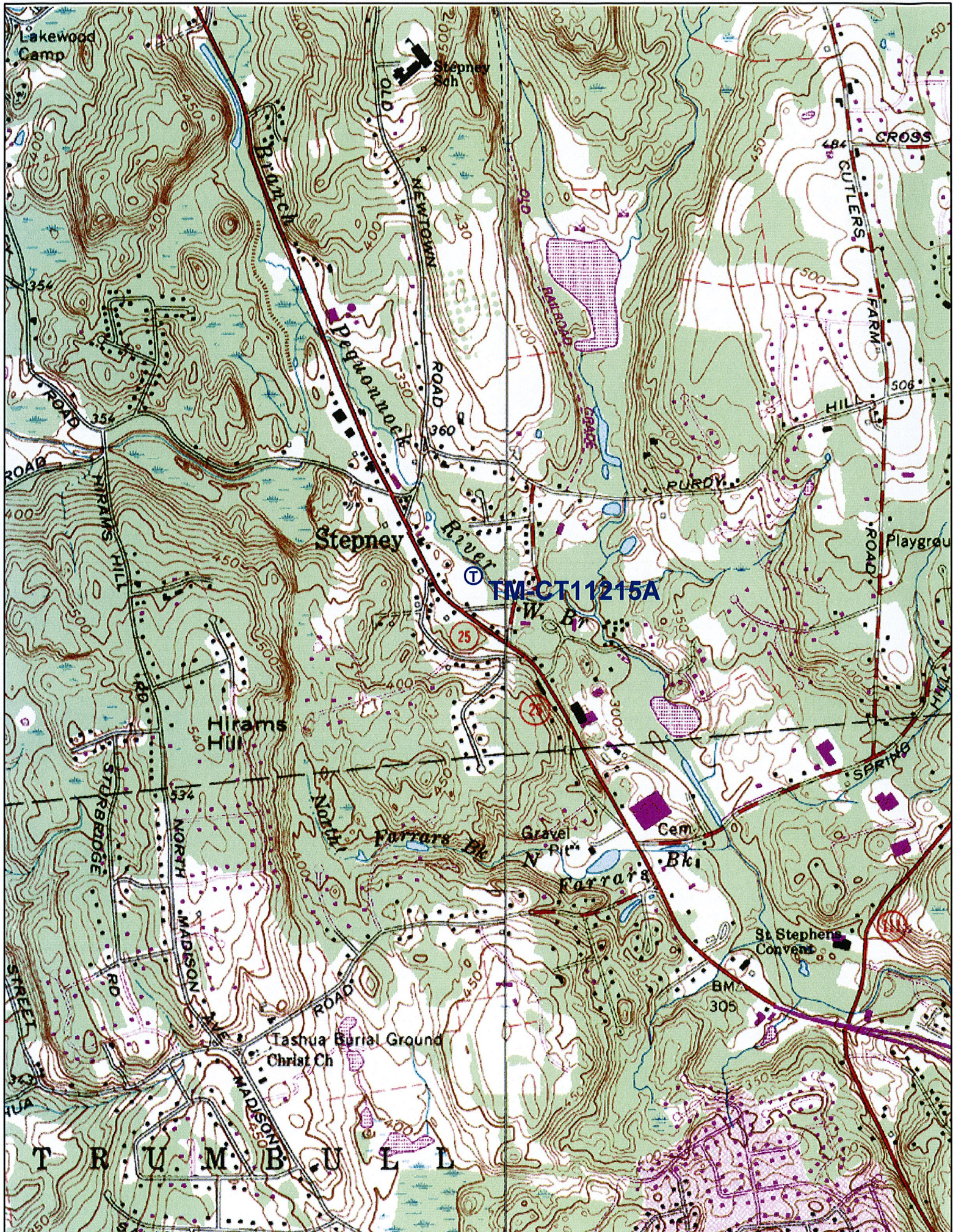

Exhibit B

Design Drawings

T-Mobile Site CT11215A

88 Main Road

Monroe, Connecticut

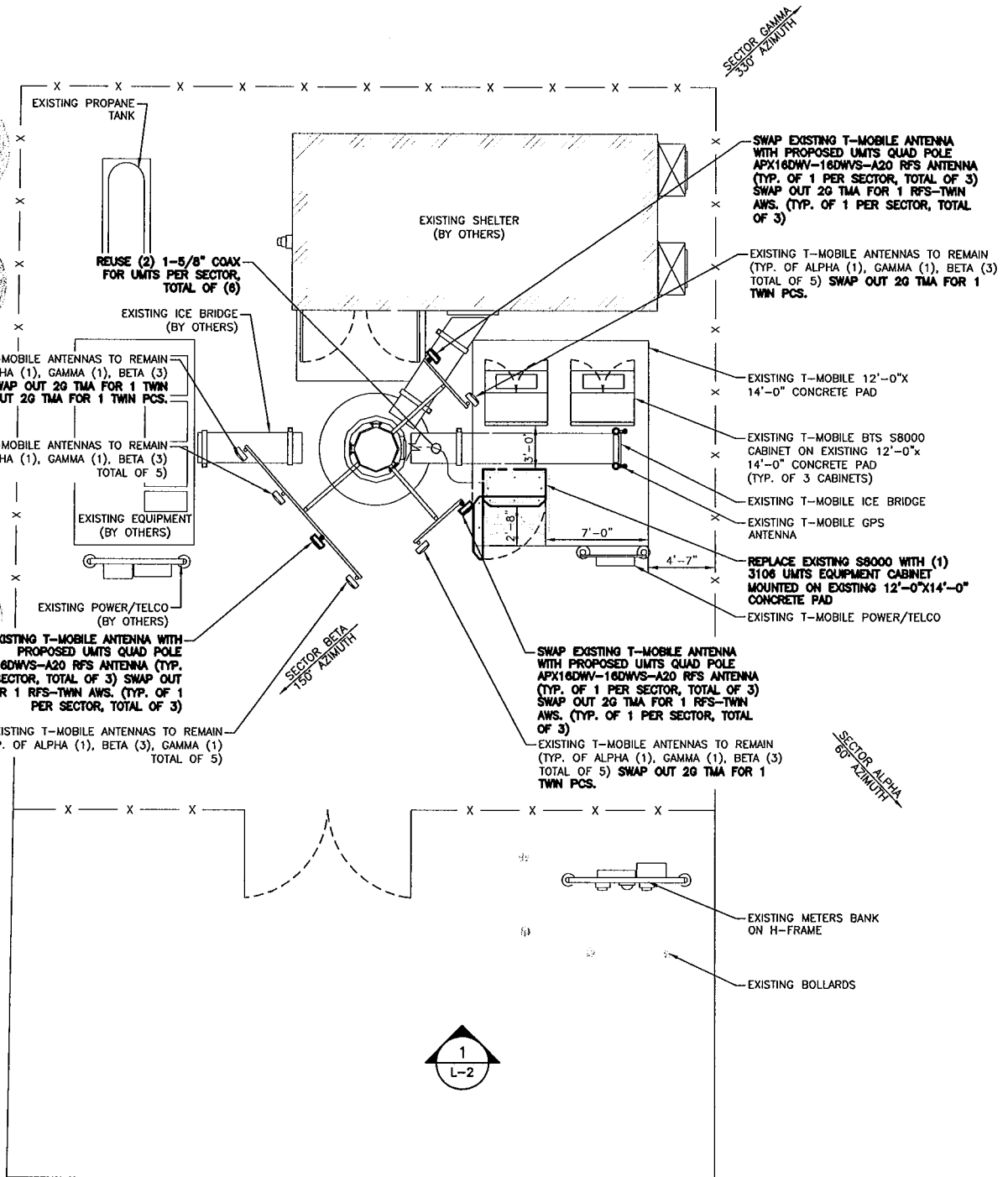

COMPOUND LAYOUT PLAN

1

SCALE: NTS

T-Mobile
35 GRIFFIN ROAD SOUTH
BLOOMFIELD, CT 06002



50 Eastman St.
South Easton, MA 02375
Phone: (508) 938-8393
Fax: (508) 936-8365

PROJECT LOCATION:
MONROE-1/RT-25
CT11215A
88 MAIN STREET
MONROE, CT 06468

PROJECT MANAGER:
KB

DRAWN BY:
MK

BSDA PROJ. #:
2898.417

APPROVED BY:

07/08/09
06/13/09
05/13/09

**COMPOUND
LAYOUT
PLAN**

SHEET:

L1

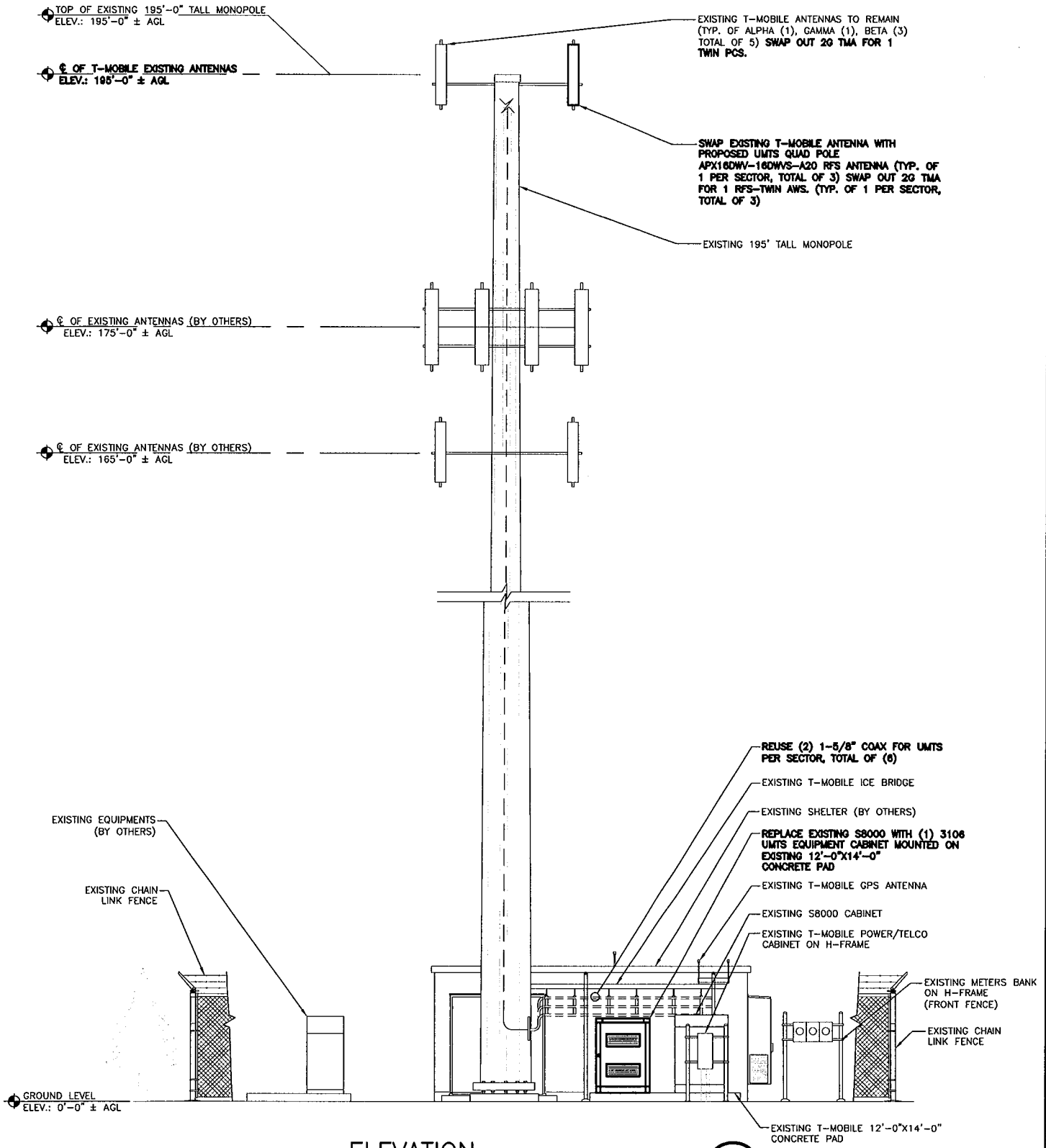

ELEVATION

SCALE: N.T.S.

1

T-Mobile
 35 GRIFFIN ROAD SOUTH
 BLOOMFIELD, CT 06002



50 Eastman St.
 South Easton, MA 02375
 Phone: (508) 936-6393
 Fax: (508) 936-6395

PROJECT LOCATION:
 MONROE-1/RT-25
 CT11215A
 88 MAIN STREET
 MONROE, CT 06468

PROJECT MANAGER:
 KB

DRAWN BY:
 MK

BSDA PROJ. #:
 2898.417

APPROVED BY:
 07/08/09
 06/13/09
 05/13/09

ELEVATION

SHEET:
L2

Exhibit C

Equipment Specifications

T-Mobile Site CT11215A

88 Main Road

Monroe, Connecticut



Optimizer® Panel Dual Polarized Antenna equipped with (2) ACU motors

Product Description

Gathering two X-Polarized antennas in a single radome this pair of variable tilt antenna provides exceptional suppression of all upper sidelobes at all downtilt angles. It also features a wide downtilt range with optional remote tilt.

This antenna is optimized for performance across the entire AWS frequency band (1710-2170 MHz). The antenna comes pre-connected with the antenna control unit (ACU).

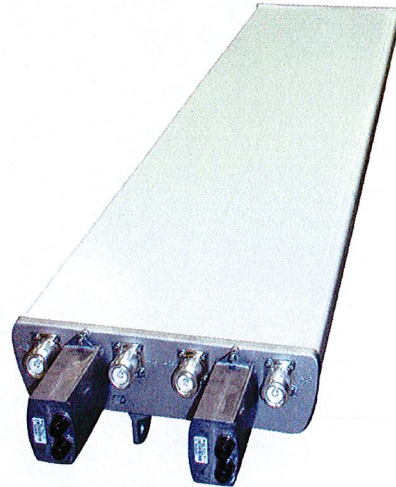

Features/Benefits

- Variable electrical downtilt - provides enhanced precision in controlling intercell interference. The tilt is infield adjustable 0-10 deg.
- High Suppression of all Upper Sidelobes (Typically <-20dB).
- Gain difference between UL and DL <1dB.
- Two X-Polarised panels in a single radome.
- Azimuth horizontal beamwidth difference <7deg between UL and DL (1710-1755 & 2110-2155).
- Low profile for low visual impact.
- Dual polarization; Broadband design.

Technical Features

Frequency Band	3G/UMTS
Horizontal Pattern	Directional
Antenna Type	Panel Dual Polarized
Electrical Down Tilt Option	Variable
Gain, dBi (dBd)	18.0 (16.0) Avg. across band
Frequency Range, MHz	1710-2170

All information contained in the present datasheet is subject to confirmation at time of ordering.



Optimizer® Panel Dual Polarized Antenna equipped with (2) ACU motors

Connector Type	(4) 7-16 DIN Female
Connector Location	Bottom
Mount Type	Downtilt Kit w/Scissor Kit
Electrical Downtilt, deg	0-10 , 0-10
Horizontal Beamwidth, deg	65 ±5 (65.9 average across band)
Mounting Hardware	APM40-2 + APM40-E2
Rated Wind Speed, km/h (mph)	160 (100)
VSWR	< 1.4:1
Vertical Beamwidth, deg	5.8 to 7.8 across band
1st Upper Sidelobe Suppression, dB	> 18 (typically > 20)
Upper Sidelobe Suppression, dB	> 18 all (typically > 20)
Polarization	Dual pol +/-45°
Front-To-Back Ratio, dB	>28
Maximum Power Input, W	300
Isolation between Ports, dB	> 30
Lightning protection	Direct Ground
3rd Order IMP @ 2 x 43 dBm, dBc	> 150 (155 Typical)
Overall Length, m (ft)	1.35 (4.42)
Dimensions - HxWxD, mm (in)	1349 x 330 x 80 (53 x 13 x 3.15)
Radiating Element Material	Brass
Radome Material	Fiberglass
Reflector Material	Aluminum
Max Wind Loading Area, m ² (ft ²)	0.64 (6.6)
Survival Wind Speed, km/h (mph)	200 (125)
Maximum Thrust @ Rated Wind, N (lbf)	787 (177)
Front Thrust @ Rated Wind, N (lbf)	787 (177)
Shipping Weight, kg (lb)	24.1 (52.7)
Packing Dimensions, HxWxD, mm (in)	1550 x 420 x 210 (61 x 16.5 x 8.3)
Weight w/o Mtg Hardware, kg (lb)	18.0 (39.6)

Note

This data is provisional and subject to change.

All information contained in the present datasheet is subject to confirmation at time of ordering.



Vertical Pattern

(This is a general representation of the antenna family pattern. For the latest detailed pattern contact Applications Engineering. You may also download the CELplot(TM) pattern reader and antenna pattern data fields from our website.)

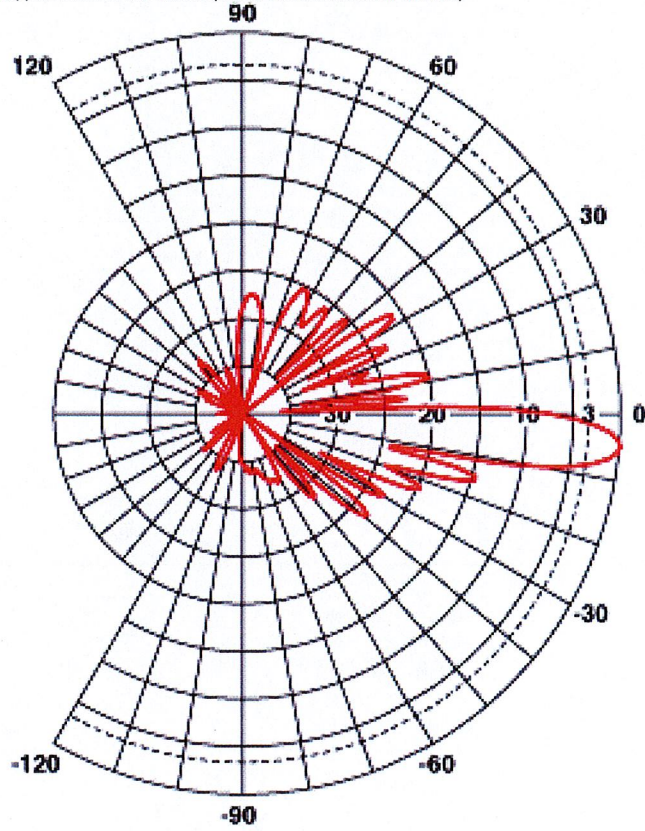

All information contained in the present datasheet is subject to confirmation at time of ordering.



Optimizer® Panel Dual Polarized Antenna equipped with (2) ACU motors

Horizontal Pattern

(This is a general representation of the antenna family pattern. For the latest detailed pattern contact Applications Engineering. You may also download the CELplot(TM) pattern reader and antenna pattern data fields from our website.)

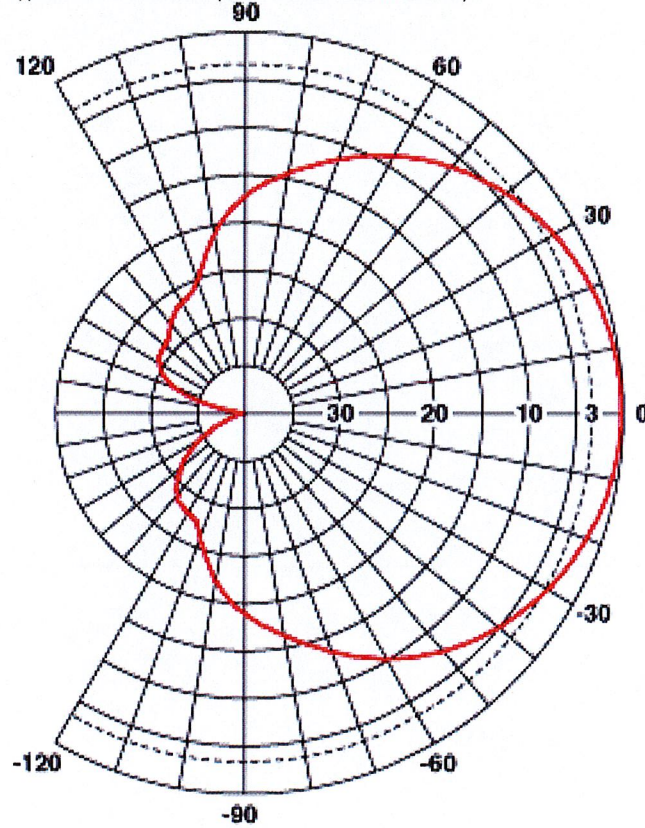

All information contained in the present datasheet is subject to confirmation at time of ordering.

2 Product Overview

The RBS 3106 is an outdoor macro RBS, based on the RBS 3000 R3 hardware, and a member of the RBS 3000 family.

The figure below shows the RBS.

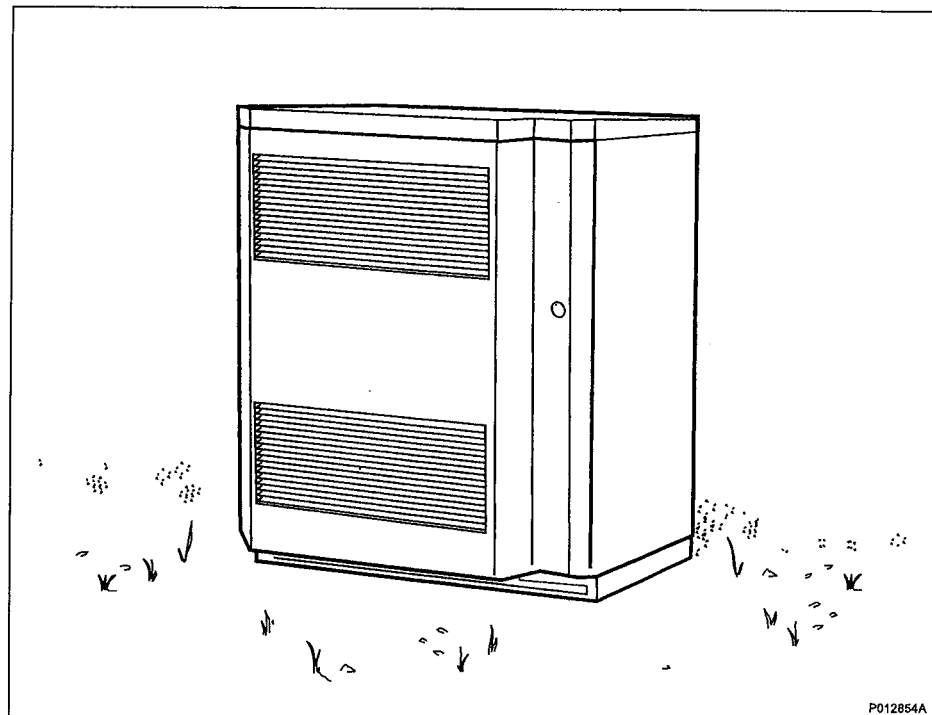

Figure 1 RBS 3106

2.1 Main Features

Not all features are supported by all RBS configurations. For current RBS configurations, see Section 6 on page 21.

The main features of RBS 3106 are the following:

- A complete RBS in a four-subrack cabinet with a standard footprint
- Can be equipped with various Radio Units (RU)
- Can be equipped with transport network interface boards, which support E1, T1, J1, E3, T3, STM-1/OC-3c, STM-1/OC-3, or Ethernet 10/100/1000 Mbps

- Ethernet (optical or electrical) can be used along with the other transmission types in Dual Stack configurations
- Can perform antenna sharing with Global System for Mobile Communications (GSM) and Time-Division Multiple Access (TDMA) systems
- Variable baseband capacity of up to 1536 Channel Elements (CE) uplink and downlink
- Supports High-Speed Downlink Packet Access (HSDPA)–enhanced uplink, up to 180 HS codes
- Power supply: 100 to 250 V AC or –40.0 to –57.6 V DC
- Two-way RX diversity, two-way TX diversity (optional), and four-way RX diversity (optional)
- Can be equipped and configured to support multiple frequency bands
- Can be configured for 1 – 6 sectors, with up to four carriers per sector
- Supports external alarm equipment
- Supports the Global Positioning System (GPS) as a synchronization source
- Supports Ethernet-based site Local Area Networks (LAN) (optional)
- Supports GSM or WCDMA Tower-Mounted Amplifiers (TMA) and Remote Electrical Tilt Units (RETU)

2.2 Optional Equipment

The following equipment is optional and can be ordered separately. It is not necessary for basic RBS functions.

The optional equipment presented in this section is located outside the RBS. Optional equipment located inside the RBS is described in Section 7.2 on page 30.

RBS Base Frame and Battery Base Unit (BBU)

The RBS 3106 is mounted on its installation frame and the frame can be installed to either the ground, an RBS base frame, or a battery base unit.

ASC, TMA, RETU, and RIU

The GSM or WCDMA TMA, the Antenna System Controller (ASC), the RETU, and the RET Interface Unit (RIU), are mast-mounted units placed close to the antenna.

The TMA and the ASC are uplink amplifiers and improve the RX sensitivity.

The RETU enables remote tilt of the antenna system. An ASC or a RIU is required to enable the RBS to communicate with the RETU.

There also exist 3GPP/AISG defined components as ATMA and ARET. These components are supported for P6.

External Battery Backup

Battery backup can be achieved with an external battery cabinet. The external batteries are connected to an optional DC filter (DCF) inside the RBS.

3 Dimensions

This section describes the physical characteristics of the RBS, that is, dimensions, weight, and color.

Table 1 RBS 3106 Dimensions

Unit	Dimensions (mm)
Height (including installation frame)	1626
Width	1300
Depth	710
Depth including door	926

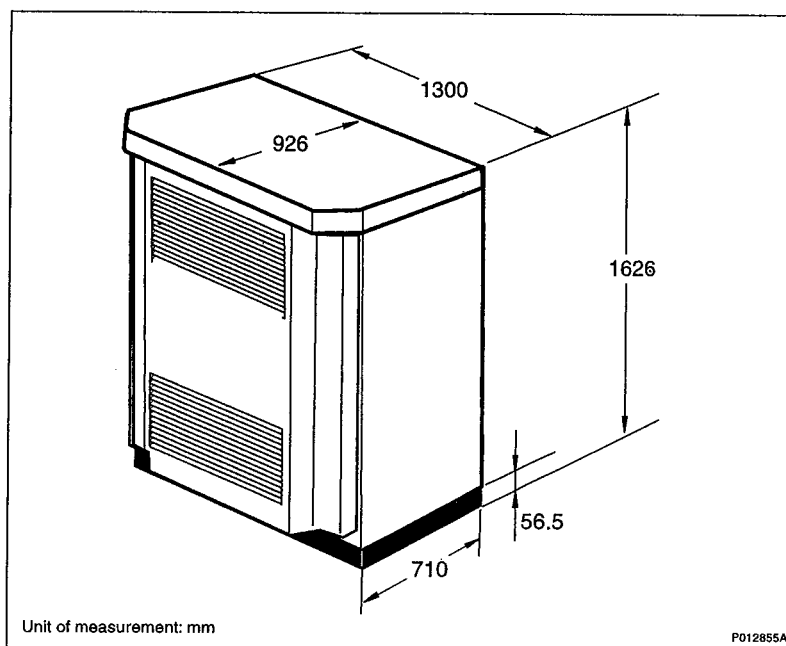

Figure 2 RBS 3106 Dimensions

The various weights of the RBS 3106 are shown in the table below.

Table 2 RBS 3106 Weights

Unit	Type	Weight (kg)
RBS fully equipped excluding batteries	AC-powered	560
RBS fully equipped including batteries	AC-powered	850

Unit	Type	Weight (kg)
RBS fully equipped including batteries and future expansion of hardware (not yet available)	AC-powered	875
RBS fully equipped	DC-powered	510
Installation frame	AC- and DC-powered	12

The color of RBS 3106 is shown in the table below.

Table 3 RBS 3106 Color

Color	Color Standard
Gray	RAL 7035
Green	NCS 8010-G 10 Y

Exhibit D

Power Density Calculations

T-Mobile Site CT11215A

88 Main Road

Monroe, Connecticut

Technical Memo

To: Maxton
From: Farid Marbough - Radio Frequency Engineer
cc: Jason Overbey
Subject: Power Density Report for CT11215A
Date: July 8, 2009

1. Introduction:

This report is the result of an Electromagnetic Field Intensities (EMF - Power Densities) study for the T-Mobile antenna installation on a Monopole at 88 Main Street, Monroe, CT. This study incorporates the most conservative consideration for determining the practical combined worst case power density levels that would be theoretically encountered from locations surrounding the transmitting location.

2. Discussion:

The following assumptions were used in the calculations:

- 1) The emissions from T-Mobile transmitters are in the (1940-1949.8), (2140-2145), (2110-2120)MHz frequency Band.
- 2) The antenna array consists of three sectors, with 2, 4 and 2 antennas per sector respectively.
- 3) The model numbers for GSM antennas are DR65-18-02DPL2Q, RR90-16-02DP, DR65-18-02DPL2Q.
- 3) The model number for UMTS antenna is APX16DWV-16DWV.
- 4) GSM antenna center line height is 195 ft.
- 4) UMTS antenna center line height is 195 ft.
- 5) The maximum transmit power from any GSM sector is 1649.38 Watts Effective Radiated Power (EiRP) assuming 8 channels per sector.
- 5) The maximum transmit power from any UMTS sector is 1933.26 Watts Effective Radiated Power (EiRP) assuming 2 channels per sector.
- 6) All the antennas are simultaneously transmitting and receiving, 24 hours a day.
- 7) Power levels emitting from the antennas are increased by a factor of 2.56 to account for possible in-phase reflections from the surrounding environment. This is rarely the case, and if so, is never continuous.
- 8) The average ground level of the studied area does not change significantly with respect to the transmitting location.

Equations given in "FCC OET Bulletin 65, Edition 97-01" were then used with the above information to perform the calculations.

3. Conclusion:

Based on the above worst case assumptions, the power density calculation from the T-Mobile antenna installation on a Monopole at 88 Main Street, Monroe, CT, is 0.022 mW/cm². This value represents 2.2% of the Maximum Permissible Exposure (MPE) standard of 1 milliwatt per square centimeter (mW/cm²) set forth in the FCC/ANSI/IEEE C95.1-1991. Furthermore, the proposed antenna location for T-Mobile will not interfere with existing public safety communications, AM or FM radio broadcasts, TV, Police Communications, HAM Radio communications or any other signals in the area. The combined Power Density from other carriers is 7.18%. The combined Power Density for the site is 9.38% of the M.P.E. standard.

Connecticut Market

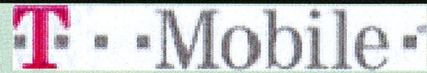

Worst Case Power Density

Site: CT11215A
Site Address: 88 Main Street
Town: Monroe
Tower Height: 195 ft.
Tower Style: Monopole

GSM Data		UMTS Data	
Base Station TX output	20 W	Base Station TX output	40 W
Number of channels	8	Number of channels	2
Antenna Model	DR65-18-02DPL2Q	Antenna Model	APX16DWV-16DWV
Cable Size	1 5/8 in.	Cable Size	1 5/8 in.
Cable Length	230 ft.	Cable Length	230 ft.
Antenna Height	195.0 ft.	Antenna Height	195.0 ft.
Ground Reflection	1.6	Ground Reflection	1.6
Frequency	1945.0 MHz	Frequency	2.1 GHz
Jumper & Connector loss	4.50 dB	Jumper & Connector loss	1.50 dB
Antenna Gain	17.3 dBi	Antenna Gain	18.0 dBi
Cable Loss per foot	0.0116 dB	Cable Loss per foot	0.0116 dB
Total Cable Loss	2.6680 dB	Total Cable Loss	2.6680 dB
Total Attenuation	7.1680 dB	Total Attenuation	4.1680 dB
Total EIRP per Channel (In Watts)	53.14 dBm 206.17 W	Total EIRP per Channel (In Watts)	59.85 dBm 966.63 W
Total EIRP per Sector (In Watts)	62.17 dBm 1649.38 W	Total EIRP per Sector (In Watts)	62.86 dBm 1933.26 W
nsg	10.1320	nsg	13.8320
Power Density (S) = 0.010130 mW/cm ²		Power Density (S) = 0.011874 mW/cm ²	
T-Mobile Worst Case % MPE =		2.2004%	
Equation Used:			
$S = \frac{(1000)(grf)^2 (Power)^{nsg}}{4\pi (R)^2}$			
Office of Engineering and Technology (OET) Bulletin 65, Edition 97-01, August 1997			

Co-Location Total

Carrier	% of Standard
Verizon	5.1800 %
Cingular	2.0000 %
Sprint	
AT&T Wireless	
Nextel	
MetroPCS	
Other Antenna Systems	
Total Excluding T-Mobile	7.1800 %
T-Mobile	2.2004
Total % MPE for Site	9.3804%

Exhibit E

Structural Analysis

T-Mobile Site CT11215A

88 Main Road

Monroe, Connecticut



June 30, 2009

Mr. Hans Fiedler
UMTS Development Project Manager
T-Mobile, USA
35 Griffin Rd South
Bloomfield, CT 06002

Ref: T-Mobile Site CT11215A
Monroe-1/Rt 25
88 Main St
Monroe, CT 06468

Dear Mr. Fiedler:

As requested, Bay State Design, Inc. performed the structural analysis of swapping one GSM quad pole antenna with on new APX16DWV-16DWVS-A20 antenna per sector; swapping two ddTMA's with one RFS twin PCS and one RFS twin AWS TMA's per sector; and swapping one GSM S-8000 cabinet with one RBS 3106 cabinet on the existing concrete pad. Based on the structural analysis, field survey report, and the site file review completed for this site, it is concluded that the structure is adequate to support the additional loads imposed by the proposed changes including the foundation.

This analysis is based on T-Mobile's RF data sheet Rev 2.0 dated 05/26/09. BSDI shall be notified if there any changes.

Please feel free to contact this office if you have any questions.

Sincerely yours,

Trichur Venkataraman, P.E.
Bay State Design, Inc.

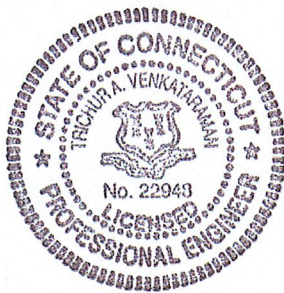

**BAY STATE
DESIGN**

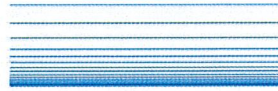

STRUCTURAL ANALYSIS REPORT

CT11215A

**Monroe-1/Rt 25
88 Main St
Monroe, CT 06468**

Submitted to T- MOBILE Wireless

July 1, 2009

I. INTRODUCTION

This monopole analysis was performed by Bay State Design with the intent of determining the structural adequacies of the existing 195 ft monopole to support all existing and proposed equipment, as shown on the data sheets. The site is located at 88 Main St, Monroe, CT 06468.

For the purpose of the assessment, all structural main and secondary members, and their connections, are assumed to be in good condition and free of defects. A tower inventory was performed on June 29, 2009 by Bay State Design, Inc.

Existing equipment information was obtained from the tower mapping notes and the T-Mobile RFDS Rev 2 dated 05/26/09.

II. SCOPE OF WORK

The scope of work required determining the structural adequacies of the existing 195 ft monopole to support all the existing equipment along with the following proposed changes:

1. Swap one GSM quad pole antenna with one new APX16DWV-16DWVS-A20 antenna for UMTS per sector.
2. Swap two ddTMA's with one RFS twin PCS TMA and one RFS twin AWS TMA per sector.
3. Use existing coax for UMTS.

III. ASSESSMENT RESULTS

This assessment was performed by Bay State Design, Inc. to determine if the monopole is capable of accommodating the proposed changes to be installed by T-Mobile in accordance with TIA/EIA-222-F specification.

The monopole was analyzed using RISA Tower, version 5.3 a commercially available structural analysis and design software package. Loads were calculated in accordance with TIA/EIA-222-F specification including wind and ice loading.

TOWER: The assessment indicates that the existing monopole does meet the structural requirements as specified by TIA/EIA-222-F.

IV. FOUNDATION

The tower is stressed only to 85.2%. Hence, it is reasonable to assume that the foundation is adequate.

Section	Length (ft)	Number of Sides	Thickness (in)	Top Dia (in)	Bot Dia (in)	Grade	Weight (lb)
1	37.67	18	0.2500	25.8000	34.4000	A572-65	3188.0
2	40.67	18	0.2500	34.4000	40.1000	A572-65	4266.3
3	39.66	18	0.4375	40.1000	47.3000	A572-65	8512.8
4	39.00	18	0.4375	47.3000	54.4000	A572-65	9754.7
5	38.17	18	0.4375	54.4000	61.6000	A572-65	10901.1
							36622.8

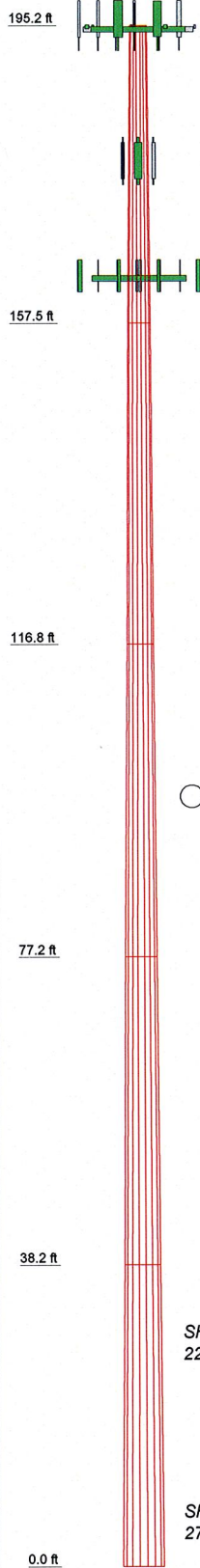

DESIGNED APPURTENANCE LOADING

TYPE	ELEVATION	TYPE	ELEVATION
T-arm (15' width)	195	(2) TMA KRY 112114	195
T-arm (7' width)	195	4"x6' pipe	178
T-arm (7' width)	195	4"x6' pipe	178
2" dia. pipe (6' long)	195	4"x6' pipe	178
2" dia. pipe (6' long)	195	7770.00	178
2" dia. pipe (6' long)	195	7770.00	178
2" dia. pipe (6' long)	195	7770.00	178
RR90-16-DP	195	PIROD 15' Low Profile Platform (Monopole)	163.5
RR90-16-DP	195	DB844H90E-XY w/Mount Pipe	163.5
RR90-16-DP	195	DB844H90E-XY w/Mount Pipe	163.5
2" dia. pipe (6' long)	195	DB844H90E-XY w/Mount Pipe	163.5
2" dia. pipe (6' long)	195	DB844H90E-XY w/Mount Pipe	163.5
DR65-18-02DPL2Q	195	DB844H90E-XY w/Mount Pipe	163.5
2" dia. pipe (6' long)	195	DB844H90E-XY w/Mount Pipe	163.5
2" dia. pipe (6' long)	195	DB844H90E-XY w/Mount Pipe	163.5
DR65-18-02DPL2Q	195	DB948F85E-M w/Mount Pipe	163.5
APX16DWW-16DWVS-C-A20	195	DB948F85E-M w/Mount Pipe	163.5
APX16DWW-16DWVS-C-A20	195	DB948F85E-M w/Mount Pipe	163.5
APX16DWW-16DWVS-C-A20	195	DB948F85E-M w/Mount Pipe	163.5
(2) TMA KRY 112114	195	DB948F85E-M w/Mount Pipe	163.5
(2) TMA KRY 112114	195	DB948F85E-M w/Mount Pipe	163.5

MATERIAL STRENGTH

GRADE	Fy	Fu	GRADE	Fy	Fu
A572-65	65 ksi	80 ksi			

TOWER DESIGN NOTES

1. Tower is located in Fairfield County, Connecticut.
2. Tower designed for a 85 mph basic wind in accordance with the TIA/EIA-222-F Standard.
3. Tower is also designed for a 74 mph basic wind with 0.50 in ice.
4. Deflections are based upon a 60 mph wind.
5. TOWER RATING: 85.2%

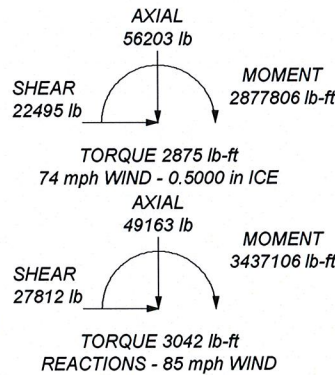

Bay State Design		Job: CT11215A	
241 Boston Post Road West		Project: 195' Monopole	
Marlborough, MA 01752		Client: T-Mobile	Drawn by: kw
Phone: (508) 229-4100		Code: TIA/EIA-222-F	Date: 07/02/09
FAX: (508) 485-5321		Path: N:\PROJECTS\T-Mobile NLP3 MA Sites\CT11215A\CT11215A.dwg	App'd: NTS
		Dwg No. E-1	

BSD Bay State Design 241 Boston Post Road West Marlborough, MA 01752 Phone: (508) 229-4100 FAX: (508) 485-5321	Job CT11215A	Page 1 of 13
	Project 195' Monopole	Date 12:12:49 07/02/09
	Client T-Mobile	Designed by kw

Tower Input Data

There is a pole section.
This tower is designed using the TIA/EIA-222-F standard.
The following design criteria apply:
Tower is located in Fairfield County, Connecticut.
Basic wind speed of 85 mph.
Nominal ice thickness of 0.5000 in.
Ice density of 56 pcf.
A wind speed of 74 mph is used in combination with ice.
Temperature drop of 50 °F.
Deflections calculated using a wind speed of 60 mph.
A non-linear (P-delta) analysis was used.
Pressures are calculated at each section.
Stress ratio used in pole design is 1.333.
Local bending stresses due to climbing loads, feedline supports, and appurtenance mounts are not considered.

Tapered Pole Section Geometry

Section	Elevation <i>ft</i>	Section Length <i>ft</i>	Splice Length <i>ft</i>	Number of Sides	Top Diameter <i>in</i>	Bottom Diameter <i>in</i>	Wall Thickness <i>in</i>	Bend Radius <i>in</i>	Pole Grade
L1	195.17-157.50	37.67	0.00	18	25.8000	34.4000	0.2500	1.0000	A572-65 (65 ksi)
L2	157.50-116.83	40.67	0.00	18	34.4000	40.1000	0.2500	1.0000	A572-65 (65 ksi)
L3	116.83-77.17	39.66	0.00	18	40.1000	47.3000	0.4375	1.7500	A572-65 (65 ksi)
L4	77.17-38.17	39.00	0.00	18	47.3000	54.4000	0.4375	1.7500	A572-65 (65 ksi)
L5	38.17-0.00	38.17		18	54.4000	61.6000	0.4375	1.7500	A572-65 (65 ksi)

Tapered Pole Properties

Section	Tip Dia. <i>in</i>	Area <i>in²</i>	<i>I</i> <i>in⁴</i>	<i>r</i> <i>in</i>	<i>C</i> <i>in</i>	<i>I/C</i> <i>in³</i>	<i>J</i> <i>in⁴</i>	<i>I/Q</i> <i>in²</i>	<i>w</i> <i>in</i>	<i>w/t</i>
L1	26.1980	20.2739	1672.0802	9.0702	13.1064	127.5774	3346.3605	10.1389	4.1008	16.403
	34.9307	27.0980	3992.6065	12.1233	17.4752	228.4727	7990.4665	13.5516	5.6144	22.458
L2	34.9307	27.0980	3992.6065	12.1233	17.4752	228.4727	7990.4665	13.5516	5.6144	22.458
	40.7186	31.6210	6344.0903	14.1467	20.3708	311.4306	12696.5284	15.8135	6.6176	26.47
L3	40.7186	55.0763	10946.1825	14.0802	20.3708	537.3467	21906.7683	27.5434	6.2876	14.372
	48.0297	65.0744	18055.0539	16.6362	24.0284	751.4048	36133.8652	32.5434	7.5548	17.268
L4	48.0297	65.0744	18055.0539	16.6362	24.0284	751.4048	36133.8652	32.5434	7.5548	17.268
	55.2392	74.9337	27567.5782	19.1567	27.6352	997.5531	55171.4305	37.4740	8.8044	20.124
L5	55.2392	74.9337	27567.5782	19.1567	27.6352	997.5531	55171.4305	37.4740	8.8044	20.124
	62.5503	84.9318	40140.0691	21.7127	31.2928	1282.7254	80332.9556	42.4740	10.0716	23.021

BSD Bay State Design 241 Boston Post Road West Marlborough, MA 01752 Phone: (508) 229-4100 FAX: (508) 485-5321	Job CT11215A	Page 2 of 13
	Project 195' Monopole	Date 12:12:49 07/02/09
	Client T-Mobile	Designed by kw

Tower Elevation	Gusset Area (per face)	Gusset Thickness	Gusset Grade	Adjust. Factor A_f	Adjust. Factor A_r	Weight Mult.	Double Angle Stitch Bolt Spacing Diagonals	Double Angle Stitch Bolt Spacing Horizontals
ft	ft ²	in					in	in
L1 195.17-157.50				1	1	1.05		
L2 157.50-116.83				1	1	1.05		
L3 116.83-77.17				1	1	1.05		
L4 77.17-38.17				1	1	1.05		
L5 38.17-0.00				1	1	1.05		

Monopole Base Plate Data

Base Plate Data	
Base plate is square	√
Base plate is grouted	
Anchor bolt grade	A615-75
Anchor bolt size	2.0000 in
Number of bolts	20
Embedment length	96.0000 in
f_c	4 ksi
Grout space	4.5000 in
Base plate grade	A572-50
Base plate thickness	3.0000 in
Bolt circle diameter	68.6000 in
Outer diameter	68.0000 in
Inner diameter	52.0000 in
Corner clipped	10.0000 in
Base plate type	Plain Plate

Feed Line/Linear Appurtenances - Entered As Area

Description	Face or Leg	Allow Shield	Component Type	Placement	Total Number	C_{AA}	Weight	
				ft		ft ² /ft	plf	
1 5/8	A	No	Inside Pole	195.00 - 10.00	24	No Ice 1/2" Ice	0.00 0.00	1.04 1.04
1 5/8	A	No	Inside Pole	178.00 - 10.00	6	No Ice 1/2" Ice	0.00 0.00	1.04 1.04
1 5/8	A	No	Inside Pole	163.50 - 10.00	24	No Ice 1/2" Ice	0.00 0.00	1.04 1.04

Feed Line/Linear Appurtenances Section Areas

Tower Section	Tower Elevation	Face	A_R	A_F	C_{AA} In Face	C_{AA} Out Face	Weight
	ft		ft ²	ft ²	ft ²	ft ²	lb
L1	195.17-157.50	A	0.000	0.000	0.000	0.000	1213.68
		B	0.000	0.000	0.000	0.000	0.00
		C	0.000	0.000	0.000	0.000	0.00
L2	157.50-116.83	A	0.000	0.000	0.000	0.000	2284.03

BSD Bay State Design 241 Boston Post Road West Marlborough, MA 01752 Phone: (508) 229-4100 FAX: (508) 485-5321	Job	CT11215A	Page	3 of 13
	Project	195' Monopole	Date	12:12:49 07/02/09
	Client	T-Mobile	Designed by	kw

Tower Section	Tower Elevation ft	Face	A _R ft ²	A _F ft ²	C _A A _A In Face ft ²	C _A A _A Out Face ft ²	Weight lb
L3	116.83-77.17	B	0.000	0.000	0.000	0.000	0.00
		C	0.000	0.000	0.000	0.000	0.00
		A	0.000	0.000	0.000	0.000	2227.31
L4	77.17-38.17	B	0.000	0.000	0.000	0.000	0.00
		C	0.000	0.000	0.000	0.000	0.00
		A	0.000	0.000	0.000	0.000	2190.24
L5	38.17-0.00	B	0.000	0.000	0.000	0.000	0.00
		C	0.000	0.000	0.000	0.000	0.00
		A	0.000	0.000	0.000	0.000	1582.03
		B	0.000	0.000	0.000	0.000	0.00
		C	0.000	0.000	0.000	0.000	0.00

Feed Line/Linear Appurtenances Section Areas - With Ice

Tower Section	Tower Elevation ft	Face or Leg	Ice Thickness in	A _R ft ²	A _F ft ²	C _A A _A In Face ft ²	C _A A _A Out Face ft ²	Weight lb
L1	195.17-157.50	A	0.500	0.000	0.000	0.000	0.000	1213.68
		B		0.000	0.000	0.000	0.000	0.00
		C		0.000	0.000	0.000	0.000	0.00
L2	157.50-116.83	A	0.500	0.000	0.000	0.000	0.000	2284.03
		B		0.000	0.000	0.000	0.000	0.00
		C		0.000	0.000	0.000	0.000	0.00
L3	116.83-77.17	A	0.500	0.000	0.000	0.000	0.000	2227.31
		B		0.000	0.000	0.000	0.000	0.00
		C		0.000	0.000	0.000	0.000	0.00
L4	77.17-38.17	A	0.500	0.000	0.000	0.000	0.000	2190.24
		B		0.000	0.000	0.000	0.000	0.00
		C		0.000	0.000	0.000	0.000	0.00
L5	38.17-0.00	A	0.500	0.000	0.000	0.000	0.000	1582.03
		B		0.000	0.000	0.000	0.000	0.00
		C		0.000	0.000	0.000	0.000	0.00

Discrete Tower Loads

Description	Face or Leg	Offset Type	Offsets: Horz Lateral Vert ft ft ft	Azimuth Adjustment °	Placement ft	C _A A _A Front ft ²	C _A A _A Side ft ²	Weight lb	
T-arm (15' width)	A	From Face	3.50	0.0000	195.00	No Ice	5.50	5.50	129.00
			0.00			1/2" Ice	6.90	6.90	170.00
T-arm (7' width)	B	From Face	3.50	0.0000	195.00	No Ice	2.50	2.50	100.00
			0.00			1/2" Ice	3.50	3.50	130.00
T-arm (7' width)	C	From Face	3.50	0.0000	195.00	No Ice	2.50	2.50	100.00
			0.00			1/2" Ice	3.50	3.50	130.00
2" dia. pipe (6' long)	A	From Face	3.50	0.0000	195.00	No Ice	2.85	2.85	22.90
			7.10			1/2" Ice	3.85	3.85	47.21
			0.00						

BSD Bay State Design 241 Boston Post Road West Marlborough, MA 01752 Phone: (508) 229-4100 FAX: (508) 485-5321	Job CT11215A	Page 4 of 13
	Project 195' Monopole	Date 12:12:49 07/02/09
	Client T-Mobile	Designed by kw

Description	Face or Leg	Offset Type	Offsets:			Azimuth Adjustment	Placement	C _{AA} Front	C _{AA} Side	Weight
			Horz	Lateral	Vert					
			ft	ft	ft					
2" dia. pipe (6' long)	A	From Face	3.50	0.0000	195.00	No Ice	2.85	2.85	22.90	
			2.30			1/2" Ice	3.85	3.85	47.21	
			0.00							
2" dia. pipe (6' long)	A	From Face	3.50	0.0000	195.00	No Ice	2.85	2.85	22.90	
			-2.30			1/2" Ice	3.85	3.85	47.21	
			0.00							
2" dia. pipe (6' long)	A	From Face	3.50	0.0000	195.00	No Ice	2.85	2.85	22.90	
			-7.10			1/2" Ice	3.85	3.85	47.21	
			0.00							
RR90-16-DP	A	From Face	3.50	0.0000	195.00	No Ice	4.36	1.97	18.00	
			7.10			1/2" Ice	4.77	2.31	40.42	
			1.00							
RR90-16-DP	A	From Face	3.50	0.0000	195.00	No Ice	4.36	1.97	18.00	
			-2.30			1/2" Ice	4.77	2.31	40.42	
			1.00							
RR90-16-DP	A	From Face	3.50	0.0000	195.00	No Ice	4.36	1.97	18.00	
			-7.10			1/2" Ice	4.77	2.31	40.42	
			1.00							
2" dia. pipe (6' long)	B	From Face	3.50	0.0000	195.00	No Ice	2.85	2.85	22.90	
			2.50			1/2" Ice	3.85	3.85	47.21	
			0.00							
2" dia. pipe (6' long)	B	From Face	3.50	0.0000	195.00	No Ice	2.85	2.85	22.90	
			-2.50			1/2" Ice	3.85	3.85	47.21	
			0.00							
DR65-18-02DPL2Q	B	From Face	3.50	0.0000	195.00	No Ice	6.30	2.42	24.00	
			-2.50			1/2" Ice	6.73	2.76	55.86	
			1.00							
2" dia. pipe (6' long)	C	From Face	3.50	0.0000	195.00	No Ice	2.85	2.85	22.90	
			2.50			1/2" Ice	3.85	3.85	47.21	
			0.00							
2" dia. pipe (6' long)	C	From Face	3.50	0.0000	195.00	No Ice	2.85	2.85	22.90	
			-2.50			1/2" Ice	3.85	3.85	47.21	
			0.00							
DR65-18-02DPL2Q	C	From Face	3.50	0.0000	195.00	No Ice	6.30	2.42	24.00	
			-2.50			1/2" Ice	6.73	2.76	55.86	
			1.00							
APX16DWV-16DWVS-C-A 20	A	From Face	3.50	0.0000	195.00	No Ice	7.23	2.15	48.20	
			2.30			1/2" Ice	7.68	2.49	81.74	
			1.00							
APX16DWV-16DWVS-C-A 20	B	From Face	3.50	0.0000	195.00	No Ice	7.23	2.15	48.20	
			2.50			1/2" Ice	7.68	2.49	81.74	
			1.00							
APX16DWV-16DWVS-C-A 20	C	From Face	3.50	0.0000	195.00	No Ice	7.23	2.15	48.20	
			2.50			1/2" Ice	7.68	2.49	81.74	
			1.00							
(2) TMA KRY 112114	A	From Face	3.50	0.0000	195.00	No Ice	0.41	0.19	11.00	
			1.30			1/2" Ice	0.50	0.26	14.09	
			0.00							
(2) TMA KRY 112114	B	From Face	3.50	0.0000	195.00	No Ice	0.41	0.19	11.00	
			1.50			1/2" Ice	0.50	0.26	14.09	
			0.00							
(2) TMA KRY 112114	C	From Face	3.50	0.0000	195.00	No Ice	0.41	0.19	11.00	
			1.50			1/2" Ice	0.50	0.26	14.09	
			0.00							
4"x6' pipe	A	From Face	1.00	0.0000	178.00	No Ice	2.25	2.25	65.00	
			0.00			1/2" Ice	2.62	2.62	84.10	
			0.00							

BSD <i>Bay State Design</i> 241 Boston Post Road West Marlborough, MA 01752 Phone: (508) 229-4100 FAX: (508) 485-3321	Job CT11215A	Page 5 of 13
	Project 195' Monopole	Date 12:12:49 07/02/09
	Client T-Mobile	Designed by kw

Description	Face or Leg	Offset Type	Offsets:		Azimuth Adjustment	Placement	C _{AA} Front	C _{AA} Side	Weight
			Horz	Lateral					
			ft	ft	°	ft	ft ²	ft ²	lb
4"x6' pipe	B	From Face	1.00	0.0000	178.00	No Ice	2.25	2.25	65.00
			0.00	1/2" Ice		2.62	2.62	84.10	
4"x6' pipe	C	From Face	1.00	0.0000	178.00	No Ice	2.25	2.25	65.00
			0.00	1/2" Ice		2.62	2.62	84.10	
7770.00	A	From Face	1.00	0.0000	178.00	No Ice	5.88	2.93	35.00
			0.00	1/2" Ice		6.31	3.27	67.63	
7770.00	B	From Face	1.00	0.0000	178.00	No Ice	5.88	2.93	35.00
			0.00	1/2" Ice		6.31	3.27	67.63	
7770.00	C	From Face	1.00	0.0000	178.00	No Ice	5.88	2.93	35.00
			0.00	1/2" Ice		6.31	3.27	67.63	
PiROD 15' Low Profile Platform (Monopole)	A	None		0.0000	163.50	No Ice	17.30	17.30	1500.00
DB844H90E-XY w/Mount Pipe	A	From Face	3.20	0.0000	163.50	No Ice	22.10	22.10	2030.00
			7.50	1/2" Ice		3.58	5.40	35.55	
DB844H90E-XY w/Mount Pipe	A	From Face	3.20	0.0000	163.50	No Ice	3.58	5.40	35.55
			-7.50	1/2" Ice		4.20	6.49	76.59	
DB844H90E-XY w/Mount Pipe	B	From Face	3.20	0.0000	163.50	No Ice	3.58	5.40	35.55
			7.50	1/2" Ice		4.20	6.49	76.59	
DB844H90E-XY w/Mount Pipe	B	From Face	3.20	0.0000	163.50	No Ice	3.58	5.40	35.55
			-7.50	1/2" Ice		4.20	6.49	76.59	
DB844H90E-XY w/Mount Pipe	C	From Face	3.20	0.0000	163.50	No Ice	3.58	5.40	35.55
			7.50	1/2" Ice		4.20	6.49	76.59	
DB844H90E-XY w/Mount Pipe	C	From Face	3.20	0.0000	163.50	No Ice	3.58	5.40	35.55
			-7.50	1/2" Ice		4.20	6.49	76.59	
DB948F85E-M w/Mount Pipe	A	From Face	3.20	0.0000	163.50	No Ice	2.62	4.92	34.05
			2.50	1/2" Ice		3.23	6.01	68.79	
DB948F85E-M w/Mount Pipe	A	From Face	3.20	0.0000	163.50	No Ice	2.62	4.92	34.05
			-2.50	1/2" Ice		3.23	6.01	68.79	
DB948F85E-M w/Mount Pipe	B	From Face	3.20	0.0000	163.50	No Ice	2.62	4.92	34.05
			2.50	1/2" Ice		3.23	6.01	68.79	
DB948F85E-M w/Mount Pipe	B	From Face	3.20	0.0000	163.50	No Ice	2.62	4.92	34.05
			-2.50	1/2" Ice		3.23	6.01	68.79	
DB948F85E-M w/Mount Pipe	C	From Face	3.20	0.0000	163.50	No Ice	2.62	4.92	34.05
			2.50	1/2" Ice		3.23	6.01	68.79	
DB948F85E-M w/Mount Pipe	C	From Face	3.20	0.0000	163.50	No Ice	2.62	4.92	34.05
			-2.50	1/2" Ice		3.23	6.01	68.79	

BSD Bay State Design 241 Boston Post Road West Marlborough, MA 01752 Phone: (508) 229-4100 FAX: (508) 485-5321	Job CT11215A	Page 6 of 13
	Project 195' Monopole	Date 12:12:49 07/02/09
	Client T-Mobile	Designed by kw

Tower Pressures - No Ice

$G_H = 1.690$

Section Elevation	z	K _Z	q _z	A _G	F a c e	A _F	A _R	A _{leg}	Leg %	C _A A _A In Face	C _A A _A Out Face
ft	ft		psf	ft ²		ft ²	ft ²	ft ²		ft ²	ft ²
L1 195.17-157.50	175.58	1.612	31	94.489	A	0.000	94.489	94.489	100.00	0.000	0.000
					B	0.000	94.489	100.00	0.000	0.000	
					C	0.000	94.489	100.00	0.000	0.000	
L2 157.50-116.83	136.86	1.501	29	126.246	A	0.000	126.246	126.246	100.00	0.000	0.000
					B	0.000	126.246	100.00	0.000	0.000	
					C	0.000	126.246	100.00	0.000	0.000	
L3 116.83-77.17	96.75	1.36	26	144.429	A	0.000	144.429	144.429	100.00	0.000	0.000
					B	0.000	144.429	100.00	0.000	0.000	
					C	0.000	144.429	100.00	0.000	0.000	
L4 77.17-38.17	57.69	1.173	23	165.262	A	0.000	165.262	165.262	100.00	0.000	0.000
					B	0.000	165.262	100.00	0.000	0.000	
					C	0.000	165.262	100.00	0.000	0.000	
L5 38.17-0.00	18.69	1	19	184.488	A	0.000	184.488	184.488	100.00	0.000	0.000
					B	0.000	184.488	100.00	0.000	0.000	
					C	0.000	184.488	100.00	0.000	0.000	

Tower Pressure - With Ice

$G_H = 1.690$

Section Elevation	z	K _Z	q _z	t _z	A _G	F a c e	A _F	A _R	A _{leg}	Leg %	C _A A _A In Face	C _A A _A Out Face
ft	ft		psf	in	ft ²		ft ²	ft ²	ft ²		ft ²	ft ²
L1 195.17-157.50	175.58	1.612	23	0.5000	97.628	A	0.000	97.628	97.628	100.00	0.000	0.000
						B	0.000	97.628	100.00	0.000	0.000	
						C	0.000	97.628	100.00	0.000	0.000	
L2 157.50-116.83	136.86	1.501	22	0.5000	129.636	A	0.000	129.636	129.636	100.00	0.000	0.000
						B	0.000	129.636	100.00	0.000	0.000	
						C	0.000	129.636	100.00	0.000	0.000	
L3 116.83-77.17	96.75	1.36	20	0.5000	147.733	A	0.000	147.733	147.733	100.00	0.000	0.000
						B	0.000	147.733	100.00	0.000	0.000	
						C	0.000	147.733	100.00	0.000	0.000	
L4 77.17-38.17	57.69	1.173	17	0.5000	168.512	A	0.000	168.512	168.512	100.00	0.000	0.000
						B	0.000	168.512	100.00	0.000	0.000	
						C	0.000	168.512	100.00	0.000	0.000	
L5 38.17-0.00	18.69	1	15	0.5000	187.669	A	0.000	187.669	187.669	100.00	0.000	0.000
						B	0.000	187.669	100.00	0.000	0.000	
						C	0.000	187.669	100.00	0.000	0.000	

Tower Pressure - Service

$G_H = 1.690$

BSD Bay State Design 241 Boston Post Road West Marlborough, MA 01752 Phone: (508) 229-4100 FAX: (508) 485-5321	Job CT11215A	Page 7 of 13
	Project 195' Monopole	Date 12:12:49 07/02/09
	Client T-Mobile	Designed by kw

Section Elevation	z	K _Z	q _z	A _G	F _a c e	A _F	A _R	A _{leg}	Leg %	C _A A _A In Face ft ²	C _A A _A Out Face ft ²
ft	ft		psf	ft ²		ft ²	ft ²	ft ²			
L1 195.17-157.50	175.58	1.612	16	94.489	A	0.000	94.489	94.489	100.00	0.000	0.000
					B	0.000	94.489		100.00	0.000	0.000
					C	0.000	94.489		100.00	0.000	0.000
L2 157.50-116.83	136.86	1.501	15	126.246	A	0.000	126.246	126.246	100.00	0.000	0.000
					B	0.000	126.246		100.00	0.000	0.000
					C	0.000	126.246		100.00	0.000	0.000
L3 116.83-77.17	96.75	1.36	13	144.429	A	0.000	144.429	144.429	100.00	0.000	0.000
					B	0.000	144.429		100.00	0.000	0.000
					C	0.000	144.429		100.00	0.000	0.000
L4 77.17-38.17	57.69	1.173	11	165.262	A	0.000	165.262	165.262	100.00	0.000	0.000
					B	0.000	165.262		100.00	0.000	0.000
					C	0.000	165.262		100.00	0.000	0.000
L5 38.17-0.00	18.69	1	10	184.488	A	0.000	184.488	184.488	100.00	0.000	0.000
					B	0.000	184.488		100.00	0.000	0.000
					C	0.000	184.488		100.00	0.000	0.000

Force Totals

Load Case	Vertical Forces	Sum of Forces X	Sum of Forces Z	Sum of Overturning Moments, M _x	Sum of Overturning Moments, M _z	Sum of Torques
	lb	lb	lb	lb-ft	lb-ft	lb-ft
Leg Weight	36622.84					
Bracing Weight	0.00					
Total Member Self-Weight	36622.84					
Total Weight	49162.52					
Wind 0 deg - No Ice		-77.34	-27678.39	-3304473.77	15570.97	-2525.40
Wind 30 deg - No Ice		13816.87	-23931.52	-2854211.95	-1647326.21	-3046.07
Wind 60 deg - No Ice		24008.86	-13772.22	-1639231.66	-2868712.97	-2750.54
Wind 90 deg - No Ice		27767.69	77.34	14914.11	-3321319.72	-1718.01
Wind 120 deg - No Ice		24086.20	13906.17	1664998.34	-2883870.84	-225.14
Wind 150 deg - No Ice		13950.82	24008.86	2868882.30	-1673580.42	1328.06
Wind 180 deg - No Ice		77.34	27678.39	3303986.24	-14744.78	2525.40
Wind 210 deg - No Ice		-13816.87	23931.52	2853724.42	1648152.39	3046.07
Wind 240 deg - No Ice		-24008.86	13772.22	1638744.13	2869539.15	2750.54
Wind 270 deg - No Ice		-27767.69	-77.34	-15401.64	3322145.90	1718.01
Wind 300 deg - No Ice		-24086.20	-13906.17	-1665485.87	2884697.03	225.14
Wind 330 deg - No Ice		-13950.82	-24008.86	-2869369.82	1674406.60	-1328.06
Member Ice	5354.88					
Total Weight Ice	56202.83					
Wind 0 deg - Ice		-60.56	-22389.86	-2746211.34	12648.58	-2393.37
Wind 30 deg - Ice		11177.45	-19359.91	-2372418.42	-1368660.49	-2860.89
Wind 60 deg - Ice		19420.47	-11142.49	-1363066.14	-2383029.19	-2561.83
Wind 90 deg - Ice		22459.79	60.56	11390.36	-2758658.25	-1576.33
Wind 120 deg - Ice		19481.02	11247.37	1382666.58	-2394898.17	-168.46
Wind 150 deg - Ice		11282.34	19420.47	2383330.16	-1389218.17	1284.55
Wind 180 deg - Ice		60.56	22389.86	2745254.10	-11089.39	2393.37
Wind 210 deg - Ice		-11177.45	19359.91	2371461.18	1370219.68	2860.89
Wind 240 deg - Ice		-19420.47	11142.49	1362108.90	2384588.38	2561.83
Wind 270 deg - Ice		-22459.79	-60.56	-12347.60	2760217.44	1576.33
Wind 300 deg - Ice		-19481.02	-11247.37	-1383623.82	2396457.36	168.46
Wind 330 deg - Ice		-11282.34	-19420.47	-2384287.40	1390777.36	-1284.55
Total Weight	49162.52					
Wind 0 deg - Service		-38.53	-13791.31	-1646642.10	7965.80	-1258.33
Wind 30 deg - Service		6884.53	-11924.36	-1422290.19	-820605.80	-1517.77
Wind 60 deg - Service		11962.89	-6862.28	-816902.09	-1429186.05	-1370.51
Wind 90 deg - Service		13835.81	38.53	7308.95	-1654706.37	-856.03

BSD Bay State Design 241 Boston Post Road West Marlborough, MA 01752 Phone: (508) 229-4100 FAX: (508) 485-5321	Job CT11215A	Page 8 of 13
	Project 195' Monopole	Date 12:12:49 07/02/09
	Client T-Mobile	Designed by kw

Load Case	Vertical Forces lb	Sum of Forces X lb	Sum of Forces Z lb	Sum of Overturning Moments, M_x lb-ft	Sum of Overturning Moments, M_z lb-ft	Sum of Torques lb-ft
Wind 120 deg - Service		12001.43	6929.03	829496.25	-1436738.77	-112.18
Wind 150 deg - Service		6951.27	11962.89	1429355.38	-833687.48	661.73
Wind 180 deg - Service		38.53	13791.31	1646154.58	-7139.62	1258.33
Wind 210 deg - Service		-6884.53	11924.36	1421802.67	821431.98	1517.77
Wind 240 deg - Service		-11962.89	6862.28	816414.56	1430012.24	1370.51
Wind 270 deg - Service		-13835.81	-38.53	-7796.48	1655532.55	856.03
Wind 300 deg - Service		-12001.43	-6929.03	-829983.78	1437564.95	112.18
Wind 330 deg - Service		-6951.27	-11962.89	-1429842.91	834513.66	-661.73

Load Combinations

Comb. No.	Description
1	Dead Only
2	Dead+Wind 0 deg - No Ice
3	Dead+Wind 30 deg - No Ice
4	Dead+Wind 60 deg - No Ice
5	Dead+Wind 90 deg - No Ice
6	Dead+Wind 120 deg - No Ice
7	Dead+Wind 150 deg - No Ice
8	Dead+Wind 180 deg - No Ice
9	Dead+Wind 210 deg - No Ice
10	Dead+Wind 240 deg - No Ice
11	Dead+Wind 270 deg - No Ice
12	Dead+Wind 300 deg - No Ice
13	Dead+Wind 330 deg - No Ice
14	Dead+Ice+Temp
15	Dead+Wind 0 deg+Ice+Temp
16	Dead+Wind 30 deg+Ice+Temp
17	Dead+Wind 60 deg+Ice+Temp
18	Dead+Wind 90 deg+Ice+Temp
19	Dead+Wind 120 deg+Ice+Temp
20	Dead+Wind 150 deg+Ice+Temp
21	Dead+Wind 180 deg+Ice+Temp
22	Dead+Wind 210 deg+Ice+Temp
23	Dead+Wind 240 deg+Ice+Temp
24	Dead+Wind 270 deg+Ice+Temp
25	Dead+Wind 300 deg+Ice+Temp
26	Dead+Wind 330 deg+Ice+Temp
27	Dead+Wind 0 deg - Service
28	Dead+Wind 30 deg - Service
29	Dead+Wind 60 deg - Service
30	Dead+Wind 90 deg - Service
31	Dead+Wind 120 deg - Service
32	Dead+Wind 150 deg - Service
33	Dead+Wind 180 deg - Service
34	Dead+Wind 210 deg - Service
35	Dead+Wind 240 deg - Service
36	Dead+Wind 270 deg - Service
37	Dead+Wind 300 deg - Service
38	Dead+Wind 330 deg - Service

Maximum Reactions

BSD Bay State Design 241 Boston Post Road West Marlborough, MA 01752 Phone: (508) 229-4100 FAX: (508) 485-5321	Job CT11215A	Page 9 of 13
	Project 195' Monopole	Date 12:12:49 07/02/09
	Client T-Mobile	Designed by kw

Location	Condition	Gov. Load Comb.	Vertical lb	Horizontal, X lb	Horizontal, Z lb
Pole	Max. Vert	24	56202.83	22459.80	60.56
	Max. H _x	11	49162.52	27767.70	77.34
	Max. H _z	2	49162.52	77.34	27678.39
	Max. M _x	2	3409634.55	77.34	27678.39
	Max. M _z	5	3427081.94	-27767.70	-77.34
	Max. Torsion	3	3042.44	-13816.87	23931.52
	Min. Vert	1	49162.52	0.00	0.00
	Min. H _x	5	49162.52	-27767.70	-77.34
	Min. H _z	8	49162.52	-77.34	-27678.40
	Min. M _x	8	-3409113.09	-77.34	-27678.40
	Min. M _z	11	-3427956.71	27767.70	77.34
	Min. Torsion	9	-3042.46	13816.87	-23931.52

Tower Mast Reaction Summary

Load Combination	Vertical lb	Shear _x lb	Shear _z lb	Overturning Moment, M _x lb-ft	Overturning Moment, M _z lb-ft	Torque lb-ft
Dead Only	49162.52	0.00	0.00	-243.76	413.09	0.00
Dead+Wind 0 deg - No Ice	49162.52	-77.34	-27678.39	-3409634.55	16175.91	-2524.81
Dead+Wind 30 deg - No Ice	49162.52	13816.87	-23931.52	-2944998.83	-1699726.27	-3042.44
Dead+Wind 60 deg - No Ice	49162.52	24008.86	-13772.22	-1691294.37	-2960051.03	-2744.54
Dead+Wind 90 deg - No Ice	49162.52	27767.70	77.34	15500.59	-3427081.94	-1712.67
Dead+Wind 120 deg - No Ice	49162.52	24086.20	13906.17	1718042.15	-2975743.48	-223.64
Dead+Wind 150 deg - No Ice	49162.52	13950.82	24008.86	2960186.86	-1726970.51	1325.24
Dead+Wind 180 deg - No Ice	49162.52	77.34	27678.40	3409113.09	-15325.18	2520.88
Dead+Wind 210 deg - No Ice	49162.52	-13816.87	23931.52	2944497.17	1700575.85	3042.46
Dead+Wind 240 deg - No Ice	49162.52	-24008.86	13772.22	1690801.23	2960912.67	2748.49
Dead+Wind 270 deg - No Ice	49162.52	-27767.70	-77.34	-15999.96	3427956.71	1716.66
Dead+Wind 300 deg - No Ice	49162.52	-24086.20	-13906.17	-1718556.14	2976619.33	223.66
Dead+Wind 330 deg - No Ice	49162.52	-13950.82	-24008.86	-2960709.37	1727834.30	-1329.24
Dead+Ice+Temp	56202.83	-0.00	-0.00	-480.30	782.33	0.00
Dead+Wind 0 deg+Ice+Temp	56202.83	-60.56	-22389.87	-2855810.13	13275.83	-2407.25
Dead+Wind 30 deg+Ice+Temp	56202.83	11177.46	-19359.92	-2467051.73	-1423232.47	-2875.47
Dead+Wind 60 deg+Ice+Temp	56202.83	19420.48	-11142.49	-1417371.02	-2478148.94	-2573.03
Dead+Wind 90 deg+Ice+Temp	56202.83	22459.80	60.56	11940.88	-2868806.45	-1582.06
Dead+Wind 120 deg+Ice+Temp	56202.83	19481.03	11247.38	1437896.18	-2490560.51	-168.34
Dead+Wind 150 deg+Ice+Temp	56202.83	11282.34	19420.48	2478443.61	-1444769.54	1290.44
Dead+Wind 180 deg+Ice+Temp	56202.83	60.56	22389.87	2854779.37	-11620.83	2404.65
Dead+Wind 210 deg+Ice+Temp	56202.83	-11177.45	19359.92	2466035.26	1424886.67	2875.49
Dead+Wind 240 deg+Ice+Temp	56202.83	-19420.48	11142.49	1416362.64	2479814.99	2575.61
Dead+Wind 270 deg+Ice+Temp	56202.83	-22459.80	-60.56	-12955.48	2870485.15	1584.65
Dead+Wind 300 deg+Ice+Temp	56202.83	-19481.03	-11247.38	-1438925.07	2492240.00	168.36
Dead+Wind 330 deg+Ice+Temp	56202.83	-11282.34	-19420.48	-2479480.57	1446437.18	-1293.07
Dead+Wind 0 deg - Service	49162.52	-38.53	-13791.31	-1700048.15	8291.13	-1264.34
Dead+Wind 30 deg - Service	49162.52	6884.53	-11924.36	-1468394.95	-847193.56	-1524.13
Dead+Wind 60 deg - Service	49162.52	11962.89	-6862.28	-843349.69	-1475552.86	-1375.49
Dead+Wind 90 deg - Service	49162.52	13835.81	38.53	7597.80	-1708414.95	-858.63
Dead+Wind 120 deg - Service	49162.52	12001.43	6929.03	856435.95	-1483399.67	-112.06
Dead+Wind 150 deg - Service	49162.52	6951.27	11962.89	1475726.27	-860793.26	664.52
Dead+Wind 180 deg - Service	49162.52	38.53	13791.31	1699529.76	-7418.69	1263.43
Dead+Wind 210 deg - Service	49162.52	-6884.53	11924.36	1467880.22	848065.70	1524.13
Dead+Wind 240 deg - Service	49162.52	-11962.89	6862.28	842837.08	1476428.01	1376.40
Dead+Wind 270 deg - Service	49162.52	-13835.81	-38.53	-8111.95	1709293.38	859.53
Dead+Wind 300 deg - Service	49162.52	-12001.43	-6929.03	-856953.76	1484278.37	112.06
Dead+Wind 330 deg - Service	49162.52	-6951.27	-11962.89	-1476246.21	861668.95	-665.43

BSD Bay State Design 241 Boston Post Road West Marlborough, MA 01752 Phone: (508) 229-4100 FAX: (508) 485-5321	Job CT11215A	Page 10 of 13
	Project 195' Monopole	Date 12:12:49 07/02/09
	Client T-Mobile	Designed by kw

Solution Summary

Load Comb.	Sum of Applied Forces			Sum of Reactions			% Error
	PX lb	PY lb	PZ lb	PX lb	PY lb	PZ lb	
1	0.00	-49162.52	0.00	0.00	49162.52	0.00	0.000%
2	-77.34	-49162.52	-27678.39	77.34	49162.52	27678.39	0.000%
3	13816.87	-49162.52	-23931.52	-13816.87	49162.52	23931.52	0.000%
4	24008.86	-49162.52	-13772.22	-24008.86	49162.52	13772.22	0.000%
5	27767.69	-49162.52	77.34	-27767.70	49162.52	-77.34	0.000%
6	24086.20	-49162.52	13906.17	-24086.20	49162.52	-13906.17	0.000%
7	13950.82	-49162.52	24008.86	-13950.82	49162.52	-24008.86	0.000%
8	77.34	-49162.52	27678.39	-77.34	49162.52	-27678.40	0.000%
9	-13816.87	-49162.52	23931.52	13816.87	49162.52	-23931.52	0.000%
10	-24008.86	-49162.52	13772.22	24008.86	49162.52	-13772.22	0.000%
11	-27767.69	-49162.52	-77.34	27767.70	49162.52	77.34	0.000%
12	-24086.20	-49162.52	-13906.17	24086.20	49162.52	13906.17	0.000%
13	-13950.82	-49162.52	-24008.86	13950.82	49162.52	24008.86	0.000%
14	0.00	-56202.83	0.00	0.00	56202.83	0.00	0.000%
15	-60.56	-56202.83	-22389.86	60.56	56202.83	22389.87	0.000%
16	11177.45	-56202.83	-19359.91	-11177.46	56202.83	19359.92	0.000%
17	19420.47	-56202.83	-11142.49	-19420.48	56202.83	11142.49	0.000%
18	22459.79	-56202.83	60.56	-22459.80	56202.83	-60.56	0.000%
19	19481.02	-56202.83	11247.37	-19481.03	56202.83	-11247.38	0.000%
20	11282.34	-56202.83	19420.47	-11282.34	56202.83	-19420.48	0.000%
21	60.56	-56202.83	22389.86	-60.56	56202.83	-22389.87	0.000%
22	-11177.45	-56202.83	19359.91	11177.45	56202.83	-19359.92	0.000%
23	-19420.47	-56202.83	11142.49	19420.48	56202.83	-11142.49	0.000%
24	-22459.79	-56202.83	-60.56	22459.80	56202.83	60.56	0.000%
25	-19481.02	-56202.83	-11247.37	19481.03	56202.83	11247.38	0.000%
26	-11282.34	-56202.83	-19420.47	11282.34	56202.83	19420.48	0.000%
27	-38.53	-49162.52	-13791.31	38.53	49162.52	13791.31	0.000%
28	6884.53	-49162.52	-11924.36	-6884.53	49162.52	11924.36	0.000%
29	11962.89	-49162.52	-6862.28	-11962.89	49162.52	6862.28	0.000%
30	13835.81	-49162.52	38.53	-13835.81	49162.52	-38.53	0.000%
31	12001.43	-49162.52	6929.03	-12001.43	49162.52	-6929.03	0.000%
32	6951.27	-49162.52	11962.89	-6951.27	49162.52	-11962.89	0.000%
33	38.53	-49162.52	13791.31	-38.53	49162.52	-13791.31	0.000%
34	-6884.53	-49162.52	11924.36	6884.53	49162.52	-11924.36	0.000%
35	-11962.89	-49162.52	6862.28	11962.89	49162.52	-6862.28	0.000%
36	-13835.81	-49162.52	-38.53	13835.81	49162.52	38.53	0.000%
37	-12001.43	-49162.52	-6929.03	12001.43	49162.52	6929.03	0.000%
38	-6951.27	-49162.52	-11962.89	6951.27	49162.52	11962.89	0.000%

Non-Linear Convergence Results

Load Combination	Converged?	Number of Cycles	Displacement Tolerance	Force Tolerance
1	Yes	4	0.00000001	0.00000001
2	Yes	5	0.00000001	0.00004535
3	Yes	5	0.00000001	0.00031530
4	Yes	5	0.00000001	0.00036418
5	Yes	4	0.00000001	0.00063667
6	Yes	5	0.00000001	0.00034640
7	Yes	5	0.00000001	0.00033698
8	Yes	4	0.00000001	0.00098378

BSD Bay State Design 241 Boston Post Road West Marlborough, MA 01752 Phone: (508) 229-4100 FAX: (508) 485-5321	Job	CT11215A	Page	11 of 13
	Project	195' Monopole	Date	12:12:49 07/02/09
	Client	T-Mobile	Designed by	kw

9	Yes	5	0.00000001	0.00036583
10	Yes	5	0.00000001	0.00031767
11	Yes	4	0.00000001	0.00088885
12	Yes	5	0.00000001	0.00035086
13	Yes	5	0.00000001	0.00035943
14	Yes	4	0.00000001	0.00000001
15	Yes	5	0.00000001	0.00021754
16	Yes	5	0.00000001	0.00053326
17	Yes	5	0.00000001	0.00058348
18	Yes	5	0.00000001	0.00021075
19	Yes	5	0.00000001	0.00056714
20	Yes	5	0.00000001	0.00055702
21	Yes	5	0.00000001	0.00021455
22	Yes	5	0.00000001	0.00058619
23	Yes	5	0.00000001	0.00053573
24	Yes	5	0.00000001	0.00021292
25	Yes	5	0.00000001	0.00057242
26	Yes	5	0.00000001	0.00058268
27	Yes	4	0.00000001	0.00036484
28	Yes	5	0.00000001	0.00005240
29	Yes	5	0.00000001	0.00006662
30	Yes	4	0.00000001	0.00022371
31	Yes	5	0.00000001	0.00005982
32	Yes	5	0.00000001	0.00005721
33	Yes	4	0.00000001	0.00032692
34	Yes	5	0.00000001	0.00006730
35	Yes	5	0.00000001	0.00005286
36	Yes	4	0.00000001	0.00026127
37	Yes	5	0.00000001	0.00006124
38	Yes	5	0.00000001	0.00006402

Base Plate Design Data

Plate Thickness	Number of Anchor Bolts	Anchor Bolt Size	Actual	Actual	Actual	Actual	Controlling Condition	Ratio
			Allowable Ratio Bolt Tension	Allowable Ratio Bolt Compression	Allowable Ratio Plate Stress	Allowable Ratio Stiffener Stress		
in		in	lb	lb	ksi	ksi		
3.0000	20	2.0000	117791.05	122706.17	29.590		Bolt T	1.14
			103672.56	172096.45	37.500			✓
			1.14	0.71	0.79			

Compression Checks

Pole Design Data

Section No.	Elevation	Size	L	L _u	Kl/r	F _a	A	Actual P	Allow. P _a	Ratio P
	ft		ft	ft		ksi	in ²	lb	lb	P _a
L1	195.17 - 157.5 (1)	TP34.4x25.8x0.25	37.67	195.17	193.2	4.001	27.0980	-6614.67	108427.00	0.061
L2	157.5 - 116.83	TP40.1x34.4x0.25	40.67	195.17	165.6	5.448	31.6210	-13192.10	172286.00	0.077

BSD Bay State Design 241 Boston Post Road West Marlborough, MA 01752 Phone: (508) 229-4100 FAX: (508) 485-5321	Job CT11215A	Page 12 of 13
	Project 195' Monopole	Date 12:12:49 07/02/09
	Client T-Mobile	Designed by kw

Section No.	Elevation ft	Size	L ft	L _u ft	Kl/r	F _a ksi	A in ²	Actual P lb	Allow. P _a lb	Ratio P P _a
L3	116.83 - 77.17 (2)	TP47.3x40.1x0.4375	39.66	195.17	140.8	7.535	65.0744	-24048.80	490321.00	0.049
L4	77.17 - 38.17 (4)	TP54.4x47.3x0.4375	39.00	195.17	122.3	9.991	74.9337	-36269.00	748653.00	0.048
L5	38.17 - 0 (5)	TP61.6x54.4x0.4375	38.17	195.17	107.9	12.835	84.9318	-49151.20	1090080.00	0.045

Pole Bending Design Data

Section No.	Elevation ft	Size	Actual M _x lb-ft	Actual f _{bx} ksi	Allow. F _{bx} ksi	Ratio f _{bx} F _{bx}	Actual M _y lb-ft	Actual f _{by} ksi	Allow. F _{by} ksi	Ratio f _{by} F _{by}
L1	195.17 - 157.5 (1)	TP34.4x25.8x0.25	253585.83	-13.319	39.000	0.342	0.00	0.000	39.000	0.000
L2	157.5 - 116.83 (2)	TP40.1x34.4x0.25	828869.17	-31.938	37.956	0.841	0.00	0.000	37.956	0.000
L3	116.83 - 77.17 (3)	TP47.3x40.1x0.4375	1559400.00	-24.904	39.000	0.639	0.00	0.000	39.000	0.000
L4	77.17 - 38.17 (4)	TP54.4x47.3x0.4375	2439441.67	-29.345	39.000	0.752	0.00	0.000	39.000	0.000
L5	38.17 - 0 (5)	TP61.6x54.4x0.4375	3437108.33	-32.154	39.000	0.824	0.00	0.000	39.000	0.000

Pole Interaction Design Data

Section No.	Elevation ft	Size	Ratio P P _a	Ratio f _{bx} F _{bx}	Ratio f _{by} F _{by}	Comb. Stress Ratio	Allow. Stress Ratio	Criteria
L1	195.17 - 157.5 (1)	TP34.4x25.8x0.25	0.061	0.342	0.000	0.403	1.333	H1-3 ✓
L2	157.5 - 116.83 (2)	TP40.1x34.4x0.25	0.077	0.841	0.000	0.918	1.333	H1-3 ✓
L3	116.83 - 77.17 (3)	TP47.3x40.1x0.4375	0.049	0.639	0.000	0.688	1.333	H1-3 ✓
L4	77.17 - 38.17 (4)	TP54.4x47.3x0.4375	0.048	0.752	0.000	0.801	1.333	H1-3 ✓
L5	38.17 - 0 (5)	TP61.6x54.4x0.4375	0.045	0.824	0.000	0.870	1.333	H1-3 ✓

Section Capacity Table

Section No.	Elevation ft	Component Type	Size	Critical Element	P lb	SF*P _{allow} lb	% Capacity	Pass Fail
L1	195.17 - 157.5	Pole	TP34.4x25.8x0.25	1	-6614.67	144533.19	30.2	Pass
L2	157.5 - 116.83	Pole	TP40.1x34.4x0.25	2	-13192.10	229657.23	68.9	Pass
L3	116.83 - 77.17	Pole	TP47.3x40.1x0.4375	3	-24048.80	653597.87	51.6	Pass
L4	77.17 - 38.17	Pole	TP54.4x47.3x0.4375	4	-36269.00	997954.41	60.1	Pass
L5	38.17 - 0	Pole	TP61.6x54.4x0.4375	5	-49151.20	1453076.58	65.2	Pass

BSD <i>Bay State Design</i> 241 Boston Post Road West Marlborough, MA 01752 Phone: (508) 229-4100 FAX: (508) 485-5321	Job CT11215A	Page 13 of 13
	Project 195' Monopole	Date 12:12:49 07/02/09
	Client T-Mobile	Designed by kw

Section No.	Elevation ft	Component Type	Size	Critical Element	P lb	SF*P _{allow} lb	% Capacity	Pass Fail	
							Summary		
						Pole (L2)	68.9	Pass	
						Base Plate	85.2	Pass	
							RATING =	85.2	Pass