



October 22, 2014

David Martin and
Members of the Siting Council
Connecticut Siting Council
Ten Franklin Square
New Britain, CT 06051

RE: Notice of Exempt Modification
160 Wampus Lane
Milford, CT 06460
Sprint Site #: NV2.5_CT81XC005
N 41° 13' 30.6"
W -73° 02' 32.5"

Dear Mr. Martin and Members of the Siting Council:

On behalf of Sprint Spectrum, SBA Communications is submitting an exempt modification application to the Connecticut Siting Council for modification of existing equipment at a tower facility located at 160 Wampus Lane, Milford, CT.

The 160 Wampus Lane facility consists of a 120' MONOPOLE Tower owned and operated by SBA 2012 TC Assets, LLC. In order to accommodate technological changes and enhance system performance in the State of Connecticut, Sprint Spectrum plans to modify the equipment configurations at many of its existing cell sites. Please accept this letter and attachments as notification, pursuant to R.C.S.A. Section 16-50j-73, of construction which constitutes an exempt modification pursuant to R.C.S.A. Section 16-50j-72(b)(2). In compliance with R.C.S.A. Section 16-50j-73, a copy of this letter and attachments is being sent to the chief elected official of the municipality in which the affected cell site is located.

As part of Sprint's Network Vision modification project, Sprint desires to upgrade their equipment to meet the new standards of 4G technology. The new equipment will allow customers to download files and browse the internet at a high rate of speed while also allowing their phones to be compatible with the latest 4G technology.

Attached is a summary of the planned modifications, including power density calculations reflecting the change in Sprint's operations at the site along with the required fee of \$625.

The changes to the facility do not constitute modifications as defined in Connecticut General Statutes ("C.G.S.") Section 16-50i(d) because the general physical characteristics of the facility will not be



significantly changed or altered. Rather, the planned changes to the facility fall squarely within those activities explicitly provided for in R.C.S.A. Section 16-50j-72(b)(2).

1. The overall height of the structure will be unaffected.
2. The proposed changes will not extend the site boundaries. There will be no effect on the site compound other than the new equipment cabinets.
3. The proposed changes will not increase the noise level at the existing facility by six decibels or more.
4. The changes in radio frequency power density will not increase the calculated "worst case" power density for the combined operations at the site to a level at or above the applicable standard for uncontrolled environments as calculated for a mixed frequency site.

For the foregoing reasons, SBA Communications on behalf of Sprint Spectrum, respectfully submits that the proposed changes at the referenced site constitute exempt modifications under R.C.S.A. Section 16-50j-72(b)(2).

Please feel free to call me at (508) 251-0720 x 3804 with any questions you may have concerning this matter.

Thank you,

Kri Pelletier
SBA Communications Corporation
33 Boston Post Road West Suite 320
Marlborough, MA 01752
508-251-0720 x 3804 + T
508-251-1755 + F
203-446-7700 + C
kpelletier@sbsite.com



**Sprint Spectrum
Equipment Modification**

160 Wampus Lane, Milford, CT 06460
Site number CT81XC005

Tower Owner: SBA 2012 TC Assets, LLC

Equipment Configuration: MONOPOLE Tower

Current and/or approved:

Clearwire

- (3) Argus LLPX310R
- (3) Samsung FDD-R6-RRH
- (3) Dragonwave A-ANT-23G-2-C
- (6) 5/16" lines
- (3) 1/2" lines

Sprint

- (6) Andrew LBX-6513DS-A1M
- (3) Andrew HBX-9014DS-R2M
- (9) 7/8" Lines
- (6) 1-5/8" Lines

Planned Modifications:

Clearwire

- (3) Dragonwave A-ANT-23G-2-C
- (3) 1/2" lines

Sprint

- (3) RFS APXVSP18-C-A20
- (3) RFS APXV9TM14-ALU-I20
- (3) ALU TD-RRH8x20-25
- (3) ALU 1900 MHz RRU
- (3) ALU 800 MHz RRU
- (3) ALU 800 MHz External Notch Filter
- (4) RFS ACU-A-20-N
- (4) 1-1/4" Fiber

Structural Information:

The attached structural analysis demonstrates that the tower and foundation will have adequate structural capacity to accommodate the proposed modifications.



Power Density:

The anticipated Maximum Composite contributions from the Sprint facility are .003% of the allowable FCC established general public limit. The anticipated composite MPE value for this site assuming all carriers present is 22.793% of the allowable FCC established general public limit sampled at the ground level.

Site Composite MPE %	
Carrier	MPE %
Sprint	0.003%
T-Mobile	0.270%
Metro PCS	8.790%
Clearwire	1.380%
On Site Measurements per CSC MPE Database	12.350%
Total Site MPE %	22.793%



October 22, 2014

Mayor Benjamin G. Blake
City of Milford
110 River Street
Milford, CT 06460

RE: Telecommunications Facility @ 160 Wampus Lane, Milford, CT 06460

Dear Mayor Blake,

In order to accommodate technological changes and enhance system performance in the State of Connecticut, Sprint Spectrum will be changing its equipment configuration at certain cell sites.

As required by Regulations of Connecticut State Agencies (R.C.S.A.) Section 16-50j-73, the Connecticut Siting Council has been notified of the changes and will review Sprint's proposal. Please accept this letter as notification under Section 16-50j-73 of construction which constitutes an exempt modification pursuant to R.C.S.A. Section 16-50j-72(b)(2).

The accompanying letter to the Siting Council fully describes Sprint's proposal for the referenced cell site. However, if you have any questions or require any further information on our plans or the Siting Council's procedures, please call me at (508) 251-0720 x 3804.

Thank you,

A handwritten signature in black ink, appearing to read "Kri Pelletier", written in a cursive style.

Kri Pelletier
SBA Communications Company
33 Boston Post Road West, Suite 320
Marlborough, MA 01752
508-251-0720 x 3804 + T
508-251-1755 + F
203-446-7700 + C
kpelletier@sbsite.com

October 22, 2014

President / Manager
Cutting Edge Technologies, LLC
160 Wampus Lane
Milford, CT 06460

RE: Telecommunications Facility @ 160 Wampus Lane, Milford, CT 06460

To Whom It May Concern:

In order to accommodate technological changes and enhance system performance in the State of Connecticut, Sprint Spectrum will be changing its equipment configuration at certain cell sites.

As required by Regulations of Connecticut State Agencies (R.C.S.A.) Section 16-50j-73, the Connecticut Siting Council has been notified of the changes and will review Sprint's proposal. Please accept this letter as notification under Section 16-50j-73 of construction which constitutes an exempt modification pursuant to R.C.S.A. Section 16-50j-72(b)(2).

The accompanying letter to the Siting Council fully describes Sprint's proposal for the referenced cell site. However, if you have any questions or require any further information on our plans or the Siting Council's procedures, please call me at (508) 251-0720 x 3804.

Thank you,



Kri Pelletier
SBA Communications Company
33 Boston Post Road West, Suite 320
Marlborough, MA 01752
508-251-0720 x 3804 + T
508-251-1755 + F
203-446-7700 + C
kpelletier@sbsite.com

RADIO FREQUENCY FCC REGULATORY COMPLIANCE
MAXIMUM PERMISSIBLE EXPOSURE (MPE) ASSESSMENT

Sprint Existing Facility

Site ID: CT81XC005

Milford West
160 Wampus Lane
Milford, CT 06460

January 14, 2014

January 14, 2014

Sprint
Attn: RF Engineering Manager
1 International Boulevard, Suite 800
Mahwah, NJ 07495

Re: Radio Frequency Maximum Permissible Exposure (MPE) Assessment for Site:
CT81XC005 – Milford West

Site Total: 22.793% - MPE % in full compliance

EBI Consulting was directed to analyze the proposed upgrades to the existing Sprint facility located at 160 Wampus Lane, Milford, CT, for the purpose of determining whether the radio frequency (RF) exposure levels from the proposed Sprint equipment upgrades on this property are within specified federal limits.

All information used in this report was analyzed as a percentage of current Maximum Permissible Exposure (% MPE) as listed in the FCC OET Bulletin 65 Edition 97-01 and ANSI/IEEE Std C95.1. The FCC regulates Maximum Permissible Exposure in units of microwatts per square centimeter ($\mu\text{W}/\text{cm}^2$). The number of $\mu\text{W}/\text{cm}^2$ calculated at each sample point is called the power density. The exposure limit for power density varies depending upon the frequencies being utilized. Wireless Carriers and Paging Services use different frequency bands each with different exposure limits, therefore it is necessary to report results and limits in terms of percent MPE rather than power density.

All results were compared to the FCC (Federal Communications Commission) radio frequency exposure rules, 47 CFR 1.1307(b)(1) – (b)(3), to determine compliance with the Maximum Permissible Exposure (MPE) limits for General Population/Uncontrolled environments as defined below.

General population/uncontrolled exposure limits apply to situations in which the general public may be exposed or in which persons who are exposed as a consequence of their employment may not be made fully aware of the potential for exposure or cannot exercise control over their exposure. Therefore, members of the general public would always be considered under this category when exposure is not employment related, for example, in the case of a telecommunications tower that exposes persons in a nearby residential area.

Public exposure to radio frequencies is regulated and enforced in units of microwatts per square centimeter ($\mu\text{W}/\text{cm}^2$). The general population exposure limit for the cellular band is approximately $567 \mu\text{W}/\text{cm}^2$, and the general population exposure limit for the 1900 MHz and 2500 MHz bands band is $1000 \mu\text{W}/\text{cm}^2$. Because each carrier will be using different frequency bands, and each frequency band has different exposure limits, it is necessary to report percent of MPE rather than power density.

Occupational/controlled exposure limits apply to situations in which persons are exposed as a consequence of their employment and in which those persons who are exposed have been made fully aware of the potential for exposure and can exercise control over their exposure. Occupational/controlled exposure limits also apply where exposure is of a transient nature as a result of incidental passage through a location where exposure levels may be above general population/uncontrolled limits (see below), as long as the exposed person has been made fully aware of the potential for exposure and can exercise control over his or her exposure by leaving the area or by some other appropriate means.

Additional details can be found in FCC OET 65.

CALCULATIONS

Calculations were done for the proposed upgrades to the existing Sprint Wireless antenna facility located at 160 Wampus Lane, Milford, CT, using the equipment information listed below. All calculations were performed per the specifications under FCC OET 65. For this report the sample point is the top of a 6 foot person standing at the base of the tower. The actual gain value of the antenna vertical broadcast pattern, per the antenna manufactures supplied specifications, was used in this direction. This value will be much lower than the maximum gain value for these antennas in this direction based upon their directivity.

For all calculations, all emissions were calculated using the following assumptions:

- 1) 3 channels in the 1900 MHz Band were considered for each sector of the proposed installation.
- 2) 1 channel in the 800 MHz Band was considered for each sector of the proposed installation
- 3) 1 channel in the 2500 MHz Band was considered for each sector of the proposed installation.
- 4) All radios at the proposed installation were considered to be running at full power and were uncombined in their RF transmissions paths per carrier prescribed configuration. Per FCC OET Bulletin No. 65 - Edition 97-01 recommendations to achieve the maximum anticipated value at each sample point, all power levels emitting from the proposed antenna installation are increased by a factor of 2.56 to account for possible in-phase reflections from the surrounding environment. This is rarely the case, and if so, is never continuous.
- 5) For the following calculations the sample point was the top of a six foot person standing at the base of the tower. The actual gain value of the antenna vertical broadcast pattern, per the antenna manufactures supplied specifications, was used in this direction. This value will be much lower than the maximum gain value for these antennas in this direction based upon their directivity.

- 6) The antennas used in this modeling are the RFS APXVSPP18-C-A20 and the RFS APXVTMM-C-120. This is based on feedback from the carrier with regards to anticipated antenna selection. The RFS APXVSPP18-C-A20 has a 15.9 dBd gain value at its main lobe at 1900 MHz and 13.4 dBd at its main lobe for 850 MHz. The RFS APXVTMM-C-120 has a 15.9 dBd gain value at its main lobe at 2500 MHz. All calculations were performed assuming the main lobe of the antenna was focused at the base of the tower to present a worst case scenario.
- 7) The antenna mounting height centerline for the existing proposed antennas is **116.5 feet** above ground level (AGL).
- 8) Emissions values for additional carriers were taken from the Connecticut Siting Council active database. Values in this database are provided by the individual carriers themselves.

All calculation were done with respect to uncontrolled / general public threshold limits

Site ID	CT81XC005 - Milford West
Site Address	160 Wampus Lane, Milford, CT 06460
Site Type	Monopole

Sector 1

Antenna Number	Antenna Make	Antenna Model	Radio Type	Frequency Band	Technology	Power Out Per Channel (Watts)	Number of Channels	Composite Power	Antenna Gain in direction of sample point (dBd)	Antenna Height (ft)	analysis height	Cable Size	Cable Loss (dB)	Additional Loss	ERP	Power Density Value	Power Density Percentage
1a	RFS	APXVSP18-C-A20	RRH	1900 MHz	CDMA / LTE	20	3	60	-26.21	116.5	110.5	1/2 "	0.5	0	0.1279827	0.003768	0.00038%
1a	RFS	APXVSP18-C-A20	RRH	850 MHz	CDMA / LTE	20	1	20	-28.71	116.5	110.5	1/2 "	0.5	0	0.02399	0.000706	0.00012%
1B	RFS	APXVTMM14-C-120	RRH	2500 MHz	CDMA / LTE	40	1	40	-26.21	116.5	110.5	1/2 "	0.5	0	0.0853218	0.002512	0.00044%
Sector total Power Density Value:																0.0009%	

Sector 2

Antenna Number	Antenna Make	Antenna Model	Radio Type	Frequency Band	Technology	Power Out Per Channel (Watts)	Number of Channels	Composite Power	Antenna Gain in direction of sample point (dBd)	Antenna Height (ft)	analysis height	Cable Size	Cable Loss (dB)	Additional Loss	ERP	Power Density Value	Power Density Percentage
2a	RFS	APXVSP18-C-A20	RRH	1900 MHz	CDMA / LTE	20	3	60	-26.21	116.5	110.5	1/2 "	0.5	0	0.1279827	0.003768	0.00038%
2a	RFS	APXVSP18-C-A20	RRH	850 MHz	CDMA / LTE	20	1	20	-28.71	116.5	110.5	1/2 "	0.5	0	0.02399	0.000706	0.00012%
2B	RFS	APXVTMM14-C-120	RRH	2500 MHz	CDMA / LTE	40	1	40	-26.21	116.5	110.5	1/2 "	0.5	0	0.0853218	0.002512	0.00044%
Sector total Power Density Value:																0.001%	

Sector 3

Antenna Number	Antenna Make	Antenna Model	Radio Type	Frequency Band	Technology	Power Out Per Channel (Watts)	Number of Channels	Composite Power	Antenna Gain in direction of sample point (dBd)	Antenna Height (ft)	analysis height	Cable Size	Cable Loss (dB)	Additional Loss	ERP	Power Density Value	Power Density Percentage
3a	RFS	APXVSP18-C-A20	RRH	1900 MHz	CDMA / LTE	20	3	60	-26.21	116.5	110.5	1/2 "	0.5	0	0.1279827	0.003768	0.00038%
3a	RFS	APXVSP18-C-A20	RRH	850 MHz	CDMA / LTE	20	1	20	-28.71	116.5	110.5	1/2 "	0.5	0	0.02399	0.000706	0.00012%
3B	RFS	APXVTMM14-C-120	RRH	2500 MHz	CDMA / LTE	40	1	40	-26.21	116.5	110.5	1/2 "	0.5	0	0.0853218	0.002512	0.00044%
Sector total Power Density Value:																0.001%	

Site Composite MPE %	
Carrier	MPE %
Sprint	0.003%
T-Mobile	0.270%
Metro PCS	8.790%
Clearwire	1.380%
On Site Measurements per CSC MPE Database	12.350%
Total Site MPE %	22.793%

Summary

All calculations performed for this analysis yielded results that were well within the allowable limits for general public Maximum Permissible Exposure (MPE) to radio frequency energy.

The anticipated Maximum Composite contributions from the Sprint facility are **0.003% (0.001% from each sector)** of the allowable FCC established general public limit considering all three sectors simultaneously sampled at the ground level.

The anticipated composite MPE value for this site assuming all carriers present is **22.793%** of the allowable FCC established general public limit sampled at 6 feet above ground level. This total composite site value is based upon MPE values listed in the Connecticut Siting Council database for existing carrier emissions.

FCC guidelines state that if a site is found to be out of compliance (over allowable thresholds), that carriers over a 5% contribution to the composite value will require measures to bring the site into compliance. For this facility, the composite values calculated were well within the allowable 100% threshold standard per the federal government.



Scott Heffernan
RF Engineering Director

EBI Consulting
21 B Street
Burlington, MA 01803



FDH Engineering, Inc., 6521 Meriden Drive Raleigh, NC 27616, Ph. 919.755.1012

**Structural Analysis for
SBA Network Services, Inc.**

120' Monopole Tower

**SBA Site Name: Milford West
SBA Site ID: CT46128-A-02
Sprint Site ID: CT81XC005**

FDH Project Number 146ED31400

Analysis Results

Tower Components	99.1%	Sufficient
Foundation	89.3%	Sufficient

Prepared By:

Drew Alexander, EI
Project Engineer

Reviewed By:

Bradley R. Newman, PE
Senior Project Engineer
CT PE License No. 29630

FDH Engineering, Inc.
6521 Meriden Drive
Raleigh, NC 27616
(919) 755-1012
info@fdh-inc.com

October 8, 2014

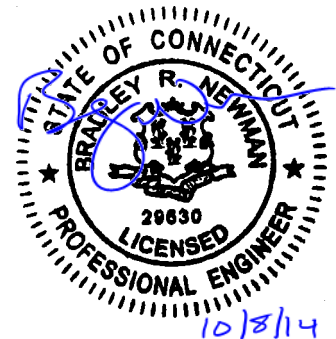

Prepared pursuant to TIA/EIA-222-F Structural Standards for Steel Antenna Towers and Antenna Supporting Structures and the 2005 Connecticut State Building Code

TABLE OF CONTENTS

EXECUTIVE SUMMARY 3

 Conclusions..... 3

 Recommendations 3

APPURTENANCE LISTING 4

RESULTS 5

GENERAL COMMENTS 6

LIMITATIONS 6

APPENDIX 7

EXECUTIVE SUMMARY

At the request of SBA Network Services, Inc., FDH Engineering, Inc. performed a structural analysis of the monopole located in Milford, CT to determine whether the tower is structurally adequate to support both the existing and proposed loads pursuant to the *Structural Standards for Steel Antenna Towers and Antenna Supporting Structures, TIA/EIA-222-F* and the *2005 Connecticut State Building Code (CSBC)*. Information pertaining to the existing/proposed antenna loading, current tower geometry, geotechnical data, foundation dimensions, and member sizes was obtained from:

- Rohn (Eng. File No. 51361AE) original design drawings dated April 3, 2002
- Clarence Welti Assoc., Inc. (Site No. CT-0638) Geotechnical Study dated June 19, 2001
- Vertical Solutions (Project No. 110520.01 Rev00) Rigorous Structural Analysis dated May 11, 2011
- SBA Network Services, Inc.

The *basic design wind speed* per the *TIA/EIA-222-F* standards and the *2005 CSBC* is 85 mph without ice and 38 mph with 3/4" radial ice. Ice is considered to increase in thickness with height.

Conclusions

With the existing and proposed antennas from Sprint in place at 116.5 ft, the tower does meet the requirements of the *TIA/EIA-222-F* standards and the *2005 CSBC* provided the **Recommendations** listed below are satisfied. Furthermore, provided the foundation was designed and constructed to support the original design reactions (see Rohn Eng. File No. 51361AE), the foundation should have the necessary capacity to support both the proposed and existing loading. For a more detailed description of the analysis of the tower, see the **Results** section of this report.

Our structural analysis has been performed assuming all information provided to FDH Engineering, Inc. is accurate (i.e., the steel data, tower layout, existing antenna loading, and proposed antenna loading) and that the tower has been properly erected and maintained per the original design drawings.

Recommendations

To ensure the requirements of the *TIA/EIA-222-F* standards and the *2005 CSBC* are met with the existing and proposed loading in place, we have the following recommendations:

1. The proposed coax should be installed inside the pole's shaft.
2. RRU/RRH Stipulation: The equipment may be installed in any arrangement as determined by the client.

APPURTENANCE LISTING

The proposed and existing antennas with their corresponding cables/coax lines are shown in **Table 1**. *If the actual layout determined in the field deviates from the layout, FDH Engineering, Inc. should be contacted to perform a revised analysis.*

Table 1 - Appurtenance Loading

Existing Loading:

Antenna Elevation (ft)	Description	Coax and Lines ¹	Carrier	Mount Elevation (ft)	Mount Type
116.5	(3) Argus LLPX310R ² (3) Samsung FDD-R6-RRH ² (3) Dragonwave A-ANT-23G-2-C	(6) 5/16" ² (3) 1/2"	Clearwire	116.5	(1) Low Profile Platform
	(6) Andrew LBX-6513DS-A1M ² (3) Andrew HBX-9014DS-R2M ²	(9) 7/8" ² (6) 1-5/8" ²	Sprint		
105	(3) Ericsson AIR B2A/B4P (3) Ericsson AIR B4A/B2P (3) Ericsson KRY 112 144/1 Double TMA 17/21	(12) 1-5/8" (1) 1-5/8" Fiber	T-Mobile	105	(1) Platform w/ Handrails
88	(3) RFS APXV18-206517S-C	(6) 1-5/8"	Metro PCS	88	Flush Mount
78	(2) GPS	---	---	78	(2) Standoffs

1. Coax installed inside the pole's shaft unless otherwise noted.
2. Existing equipment to be removed; not considered.

Proposed Carrier – Final Loading:

Antenna Elevation (ft)	Description	Coax and Lines	Carrier	Mount Elevation (ft)	Mount Type
116.5	(3) Dragonwave A-ANT-23G-2-C	(3) 1/2"	Clearwire	116.5	(1) Low Profile Platform
	(3) RFS APXVSP18-C-A20 (3) RFS APXV9TM14-ALU-I20 (3) ALU TD-RRH8x20-25 (3) ALU 1900 MHz RRU (3) ALU 800 MHz RRU (3) ALU 800 MHz External Notch Filter (4) RFS ACU-A-20-N	(4) 1-1/4" Fiber	Sprint		

RESULTS

The following yield strength of steel for individual members was used for analysis:

Table 2 - Material Strength

Member Type	Yield Strength
Tower Shaft Sections	65 ksi
Base Plate	50 ksi (assumed)
Anchor Bolts	75 ksi (assumed)

Table 3 displays the summary of the ratio (as a percentage) of force in the member to their capacities. Values greater than 100% indicate locations where the maximum force in the member exceeds its capacity. **Table 4** displays the maximum foundation reactions. **Table 5** displays the maximum antenna rotations at service wind speeds.

If the assumptions outlined in this report differ from actual field conditions, FDH Engineering, Inc. should be contacted to perform a revised analysis. Furthermore, as no information pertaining to the allowable twist and sway requirements for the existing or proposed appurtenances was provided, deflection and rotation were not taken into consideration when performing this analysis.

See the **Appendix** for detailed modeling information

Table 3 - Summary of Working Percentage of Structural Components

Section No.	Elevation ft	Component Type	Size	% Capacity*	Pass Fail
L1	120 - 100	Pole	TP23.183x20x0.1875	23.9	Pass
L2	100 - 54.9167	Pole	TP29.87x22.3438x0.1875	99.1	Pass
L3	54.9167 - 44.1667	Pole	TP31.093x28.907x0.25	84.3	Pass
L4	44.1667 - 0	Pole	TP37.5x30.0151x0.3125	89.0	Pass
		Anchor Bolts	(8) 2.25" \varnothing w/ B.C.=43.5"	90.3	Pass
		Base Plate	PL 49.5" \varnothing x 2" Thick	81.1	Pass

*Capacities include 1/3 allowable stress increase for wind per TIA/EIA-222-F standards.

Table 4 - Maximum Base Reactions

Base Reactions	Current Analysis (TIA/EIA-222-F)	Original Design (TIA/EIA-222-F)
Axial	17 k	30 k
Shear	15 k	17 k
Moment	1,291 k-ft	1,446 k-ft

Table 5 - Maximum Antenna Rotations at Service Wind Speed

Centerline Elevation	Dish	Tilt (deg)*	Twist (deg)*
116.5	(3) Dragonwave A-ANT-23G-2-C Dishes	2.0824	0.0001

*Allowable Tilt and Twist to be reviewed by others.

GENERAL COMMENTS

This engineering analysis is based upon the theoretical capacity of the structure. It is not a condition assessment of the tower and its foundation. It is the responsibility of SBA Network Services, Inc. to verify that the tower modeled and analyzed is the correct structure (with accurate antenna loading information) modeled. If there are substantial modifications to be made or the assumptions made in this analysis are not accurate, FDH Engineering, Inc. should be notified immediately to perform a revised analysis.

LIMITATIONS

All opinions and conclusions are considered accurate to a reasonable degree of engineering certainty based upon the evidence available at the time of this report. All opinions and conclusions are subject to revision based upon receipt of new or additional/updated information. All services are provided exercising a level of care and diligence equivalent to the standard and care of our profession. No other warranty or guarantee, expressed or implied, is offered. Our services are confidential in nature and we will not release this report to any other party without the client's consent. The use of this engineering work is limited to the express purpose for which it was commissioned and it may not be reused, copied, or distributed for any other purpose without the written consent of FDH Engineering, Inc.

APPENDIX

Section	1	2	3	4	
Length (ft)	20.00	48.00	14.50	48.00	
Number of Sides	18	18	18	18	
Thickness (in)	0.1875	0.1875	0.2500	0.3125	
Socket Length (ft)	2.92	3.75	3.83	30.0151	
Top Dia (in)	20.0000	22.3438	28.9070	37.5000	
Bot Dia (in)	23.1830	29.8700	31.0930		
Grade	A572-65				
Weight (K)	0.9	2.5	1.2	5.4	10.0

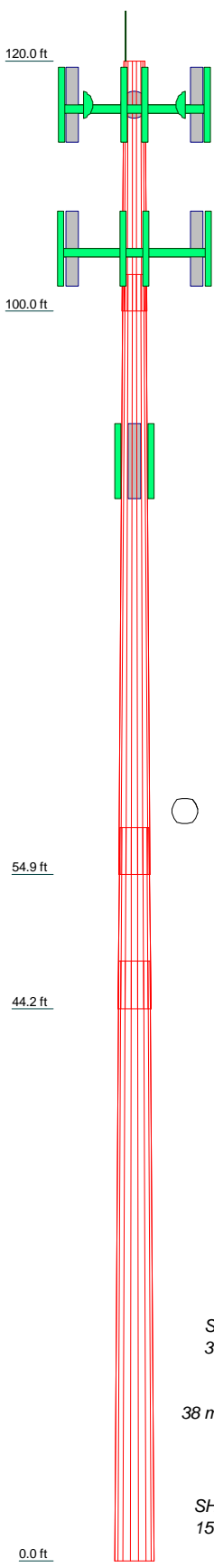

DESIGNED APPURTENANCE LOADING

TYPE	ELEVATION	TYPE	ELEVATION
Lightning Rod	120	Low Profile Platform	116.5
APXVSP18-C-A20 w/Mount Pipe	116.5	A-ANT-23G-2-C	116.5
APXVSP18-C-A20 w/Mount Pipe	116.5	A-ANT-23G-2-C	116.5
APXVSP18-C-A20 w/Mount Pipe	116.5	A-ANT-23G-2-C	116.5
APXV9TM14-ALU-I20 w/ Mount Pipe	116.5	AIR B4A/B2P	105
APXV9TM14-ALU-I20 w/ Mount Pipe	116.5	AIR B4A/B2P	105
APXV9TM14-ALU-I20 w/ Mount Pipe	116.5	AIR B4A/B2P	105
TD-RRH8x20-25	116.5	KRY 112 144/1 Double TMA 17/21	105
TD-RRH8x20-25	116.5	KRY 112 144/1 Double TMA 17/21	105
TD-RRH8x20-25	116.5	KRY 112 144/1 Double TMA 17/21	105
1900 MHz RRU	116.5	Platform w/ Handrails	105
1900 MHz RRU	116.5	AIR B2A/B4P	105
1900 MHz RRU	116.5	AIR B2A/B4P	105
800 MHz RRU	116.5	AIR B2A/B4P	105
800 MHz RRU	116.5	APXV18-206517S-C w/Mount Pipe	88
800 MHz RRU	116.5	APXV18-206517S-C w/Mount Pipe	88
ACU-A20-N RET	116.5	APXV18-206517S-C w/Mount Pipe	88
ACU-A20-N RET	116.5	Standoff	78
(2) ACU-A20-N RET	116.5	GPS	78
800 MHz External Notch Filter	116.5	GPS	78
800 MHz External Notch Filter	116.5	Standoff	78
800 MHz External Notch Filter	116.5	Standoff	78

MATERIAL STRENGTH

GRADE	Fy	Fu	GRADE	Fy	Fu
A572-65	65 ksi	80 ksi			

TOWER DESIGN NOTES

1. Tower is located in New Haven County, Connecticut.
2. Tower designed for a 85 mph basic wind in accordance with the TIA/EIA-222-F Standard.
3. Tower is also designed for a 38 mph basic wind with 0.75 in ice. Ice is considered to increase in thickness with height.
4. Deflections are based upon a 50 mph wind.
5. TOWER RATING: 99.1%

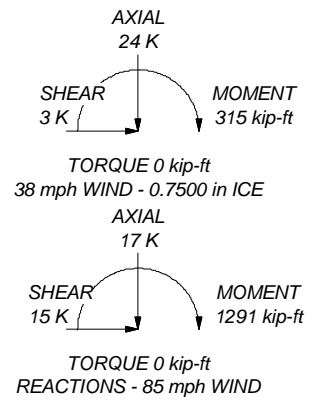

 FDH Engineering, Inc. 6521 Meridien Drive, Suite 107 Raleigh, North Carolina 27616 Phone: 9197551012 FAX: 9197551031 Tower Analysis	Job: Milford West - CT46128-A-02		
	Project: 146ED31400		
	Client: SBA Network Services, Inc.	Drawn by: DAlexander	App'd:
	Code: TIA/EIA-222-F	Date: 10/08/14	Scale: NTS
	Path:		Dwg No. E-1

SPECIAL CONSTRUCTION NOTE:
 SPRINT TOWER TOP WORK FOR NEW EQUIPMENT INSTALLATION IS CONTINGENT ON THE FOLLOWING:
 • COMPLETION OF AN ANTENNA/RRH MOUNT LOCAL STRUCTURE ASSESSMENT (PROVIDED BY A&E VENDOR). GC SHALL FURNISH ALL REQUIRED ANTENNA/RRH MOUNT STRUCTURAL MODIFICATIONS AS INDICATED HEREIN BEFORE INSTALLATION OF NEW ANTENNAS/RRH AND OTHER TOWER TOP EQUIPMENT.
 • COMPLETION OF A TOWER GLOBAL STRUCTURAL ANALYSIS (PROVIDED BY SBA). GC SHALL INSTALL NEW HYBRID TRUNK(S) WITHIN EXISTING SPRINT CABLE-WAYS (UNLESS NOTED OTHERWISE), INCLUDING ALL REQUIRED CABLE HANGERS AND SUPPORTS, WITH ALL EXISTING AND NEW SPRINT CABLES STACKED AND BUNDLED IN ACCORDANCE WITH THE SBA-PROVIDED GLOBAL STRUCTURAL ANALYSIS.
 • FOR OVERSTRESSED SBA TOWERS (FAILING TOWER GLOBAL STRUCTURAL ANALYSIS); SBA NETWORK SERVICES (UNDER A SEPARATE CONSTRUCTION PO ISSUED BY SPRINT) SHALL FURNISH, INSTALL AND COMPLETE ALL REQUIRED TOWER/FOUNDATION STRUCTURAL MODIFICATIONS, ENGINEERING CONSTRUCTION CONTROL INSPECTIONS, FINAL ENGINEERING AFFIDAVIT, INCLUDING FINAL ACCEPTANCE BY SBA.

RAD CENTER FOOTNOTE:
 SPRINT RAD CENTER SHOWN IN RED TEXT BASED ON SBA-PROVIDED COLLOCATION APPLICATION, EQUIPMENT DATABASE, AND STRUCTURAL ANALYSIS. THE SBA-PROVIDED ANTENNA RAD CENTER SHALL SUPERSEDE ANY CONFLICTING INFORMATION DERIVED FROM THE SPRINT NV AND NV 2.5 RFDS.

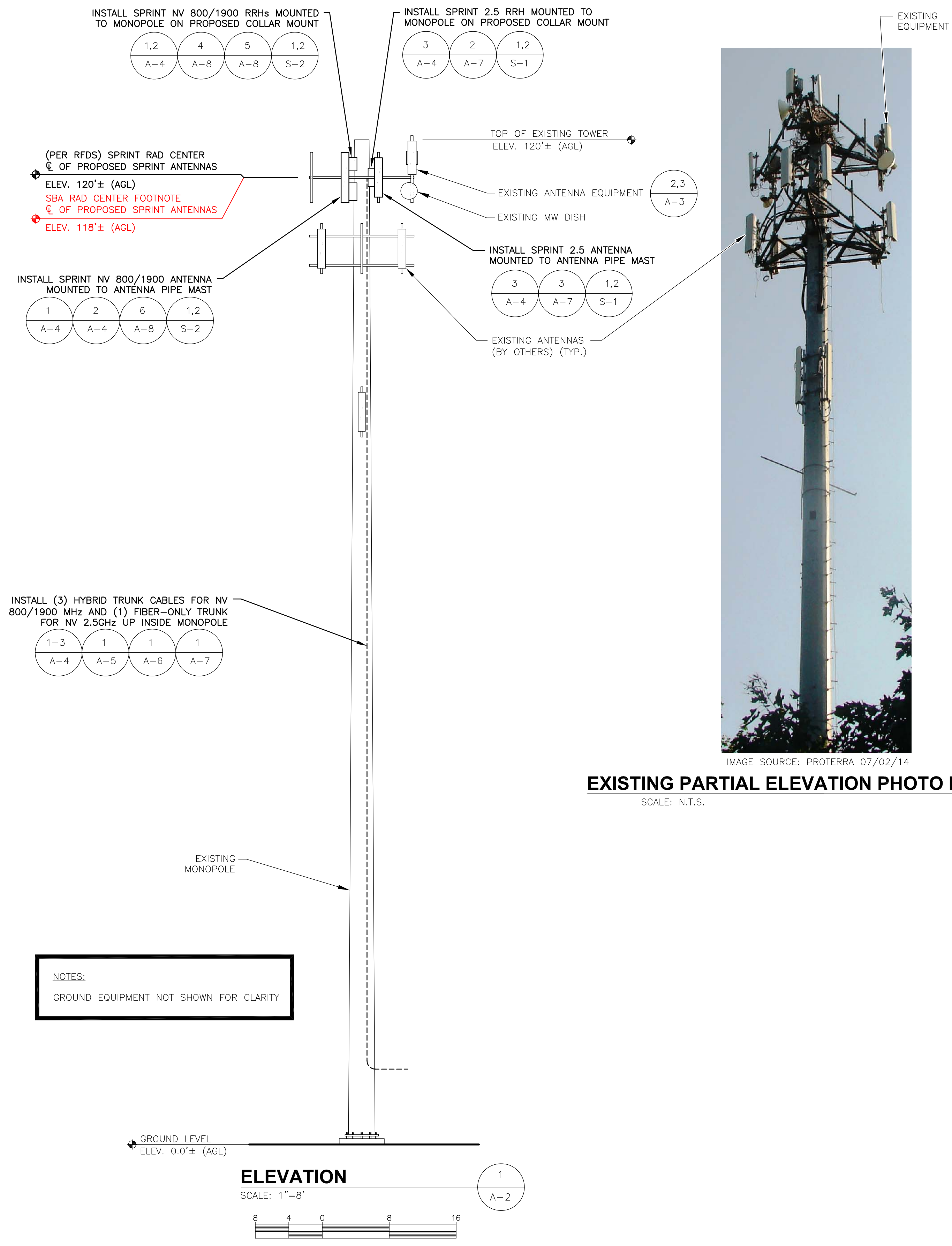

IMAGE SOURCE: PROTERRA 07/02/14

EXISTING PARTIAL ELEVATION PHOTO DETAIL

SCALE: N.T.S.

NOTES:
 GROUND EQUIPMENT NOT SHOWN FOR CLARITY

Sprint
 1 INTERNATIONAL BLVD, SUITE 800
 MAHWAH, NJ 07495
 TEL: (800) 357-7641

SBA
 SBA COMMUNICATIONS CORP.
 33 BOSTON POST ROAD WEST, SUITE 320
 MARLBOROUGH, MA 01752 TEL: (508) 251-0720

ProTerra
 DESIGN GROUP, LLC
 4 Bay Road, Bldg A
 Suite 200
 Hadley, MA 01035 Ph: (413)320-4918
 Fax: (413)320-4917

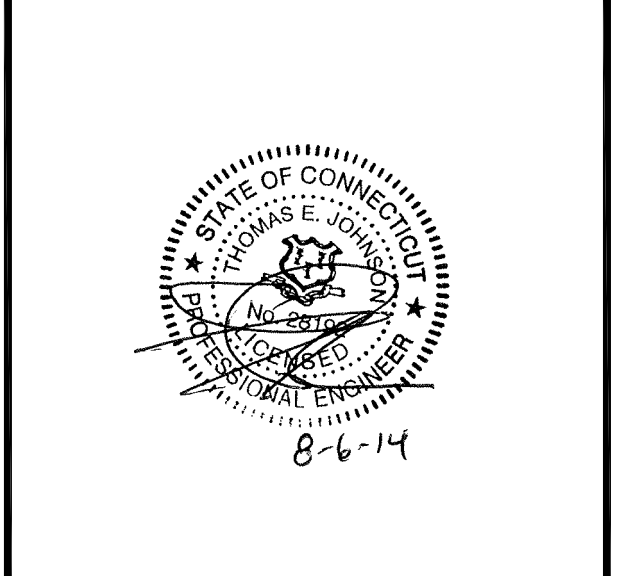

CHECKED BY: JMM/TEJ

APPROVED BY: JMM/TEJ

SUBMITTALS

REV.	DATE	DESCRIPTION	BY
2	08/06/14	ISSUED FOR CONSTRUCTION	JEB
1	08/01/14	ISSUED FOR CONSTRUCTION	JEB
0	07/17/14	ISSUED FOR BP	JEB

SITE NUMBER:
 CT81XC005-A
 SITE NAME:
 MILFORD WEST
 SITE ADDRESS:
 160 WAMPUS LANE
 MILFORD, CT 06460

SHEET TITLE
 ELEVATION PLAN

SHEET NUMBER
 A-2

SPECIAL CONSTRUCTION NOTE:
 SPRINT TOWER TOP WORK FOR NEW EQUIPMENT INSTALLATION IS CONTINGENT ON THE FOLLOWING:
 * COMPLETION OF AN ANTENNA/RRH MOUNT LOCAL STRUCTURE ASSESSMENT (PROVIDED BY A&E VENDOR). GC SHALL FURNISH ALL REQUIRED ANTENNA/RRH MOUNT STRUCTURAL MODIFICATIONS AS INDICATED HEREIN BEFORE INSTALLATION OF NEW ANTENNAS/RRH AND OTHER TOWER TOP EQUIPMENT.
 * COMPLETION OF A TOWER GLOBAL STRUCTURAL ANALYSIS (PROVIDED BY SBA). GC SHALL INSTALL NEW HYBRID TRUNK(S) WITHIN EXISTING SPRINT CABLE-WAYS (UNLESS NOTED OTHERWISE), INCLUDING ALL REQUIRED CABLE HANGERS AND SUPPORTS, WITH ALL EXISTING AND NEW SPRINT CABLES STACKED AND BUNDLED IN ACCORDANCE WITH THE SBA-PROVIDED GLOBAL STRUCTURAL ANALYSIS.
 * FOR OVERSTRESSED SBA TOWERS (FAILING TOWER GLOBAL STRUCTURAL ANALYSIS); SBA NETWORK SERVICES (UNDER A SEPARATE CONSTRUCTION PO ISSUED BY SPRINT) SHALL FURNISH, INSTALL AND COMPLETE ALL REQUIRED TOWER/FOUNDATION STRUCTURAL MODIFICATIONS, ENGINEERING CONSTRUCTION CONTROL INSPECTIONS, FINAL ENGINEERING AFFIDAVIT, INCLUDING FINAL ACCEPTANCE BY SBA.

NOTE:
 EXISTING AZIMUTHS FROM RECORD CONSTRUCTION DRAWINGS DATED 08/31/10, LAST REVISED 12/01/10

Sprint
 1 INTERNATIONAL BLVD, SUITE 800
 MAHWAH, NJ 07495
 TEL: (800) 357-7641

SBA

SBA COMMUNICATIONS CORP.
 33 BOSTON POST ROAD WEST, SUITE 320
 MARLBOROUGH, MA 01752 TEL: (508) 251-0720

ProTerra
 DESIGN GROUP, LLC

4 Bay Road, Bldg A
 Suite 200 Ph: (413)320-4918
 Hadley, MA 01035 Fax: (413)320-4917

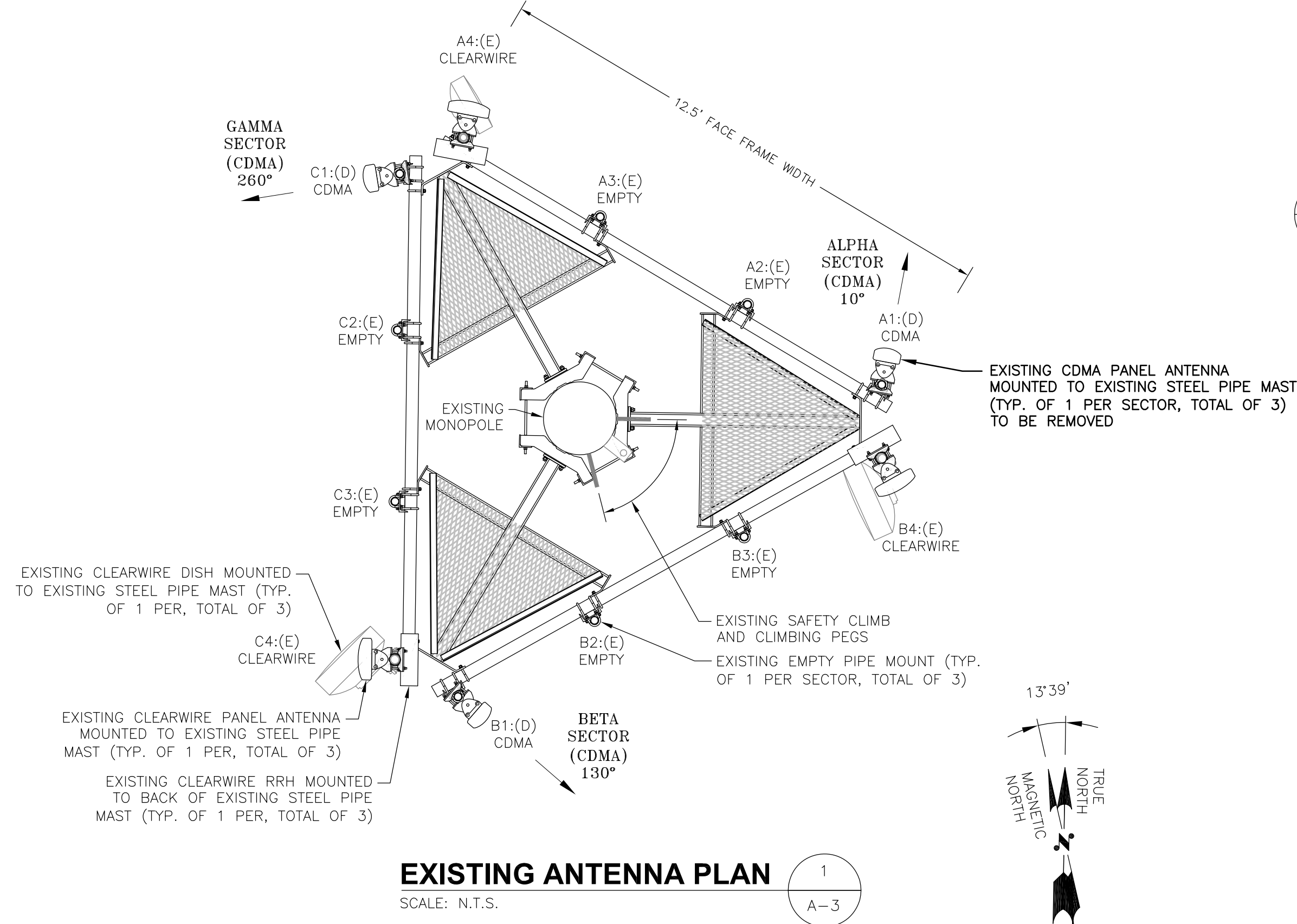
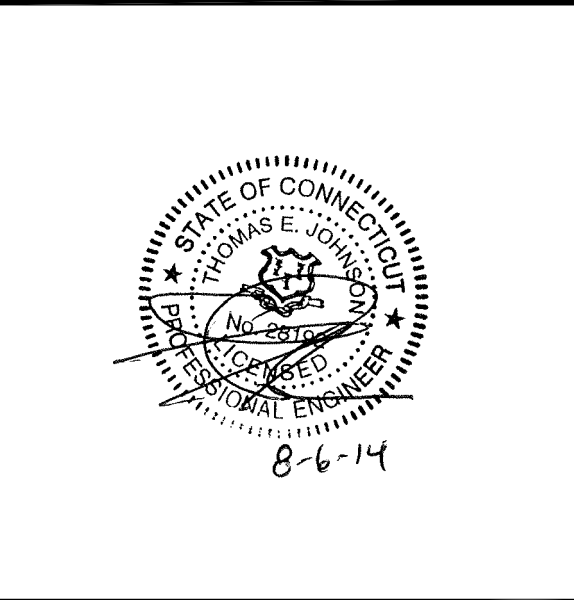

EXISTING ANTENNA PLAN 1
 SCALE: N.T.S. A-3

ANTENNA STATUS LEGEND:
 EMPTY – EMPTY PIPE
 (E) – EXISTING
 (P) – INSTALL
 (R) – RELOCATE
 (D) – DECOMMISSION AND REMOVE
 NV – SPRINT ANTENNA
 2.5 – SPRINT ANTENNA

SPECIAL CONSTRUCTION NOTE:
 PER SBA MASTER LEASE AGREEMENT, REMOVE ALL EXISTING CDMA ANTENNAS AND RELATED COAX CABLE BEFORE INSTALLING NV 2.5 GHZ TOWER TOP EQUIPMENT

SPECIAL INSTALLATION NOTE:
 JUMPERS (COAX/AISG) FROM 2.5 RRH TO 2.5 ANTENNA AND FROM 800/1900 RRH TO 800/1900 ANTENNA SHALL NOT EXCEED 15'. NOTIFY SPRINT CONSTRUCTION MANAGER OF ANY DISCREPANCY

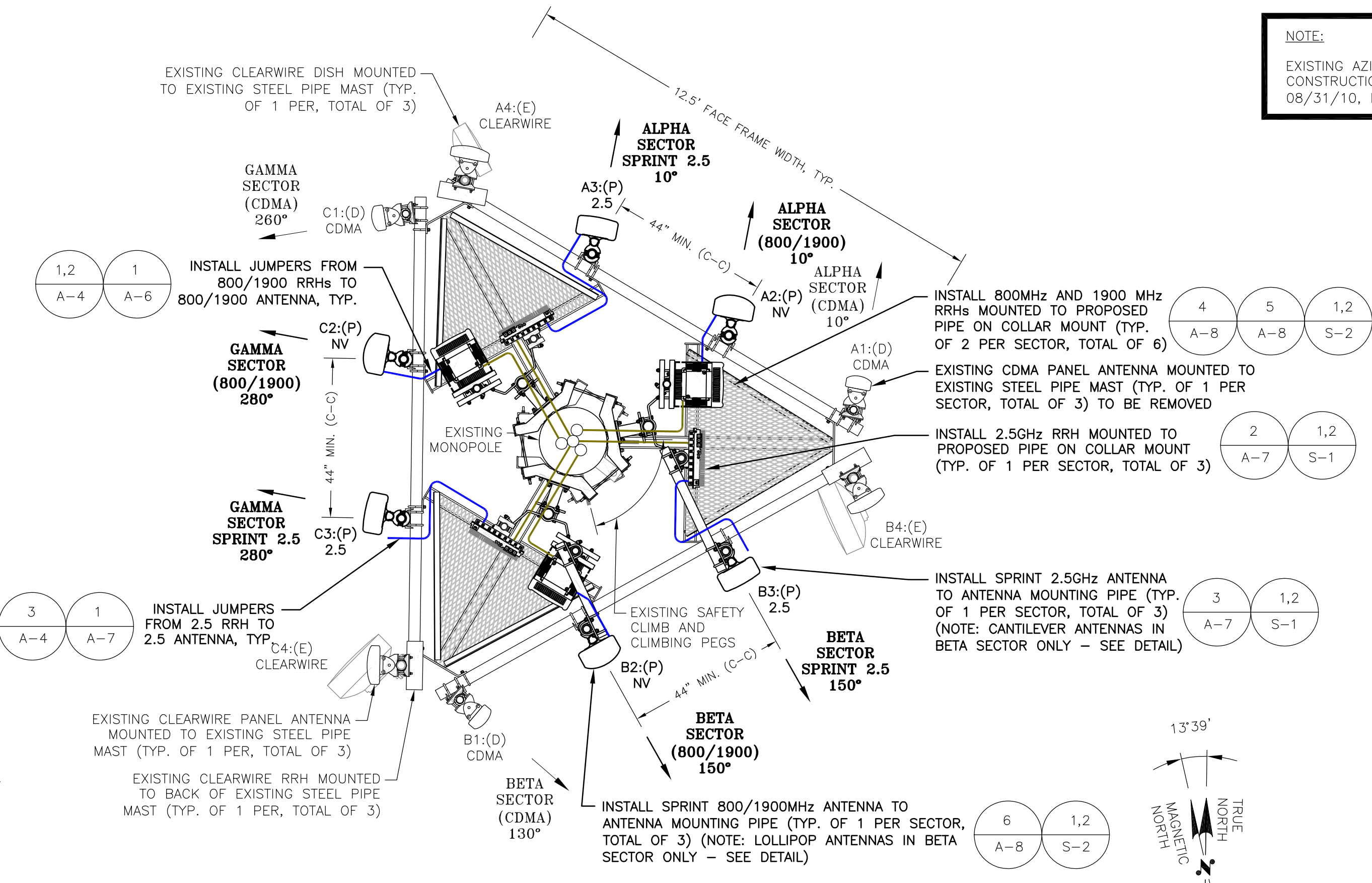

INTERIM ANTENNA PLAN 2
 SCALE: N.T.S. A-3

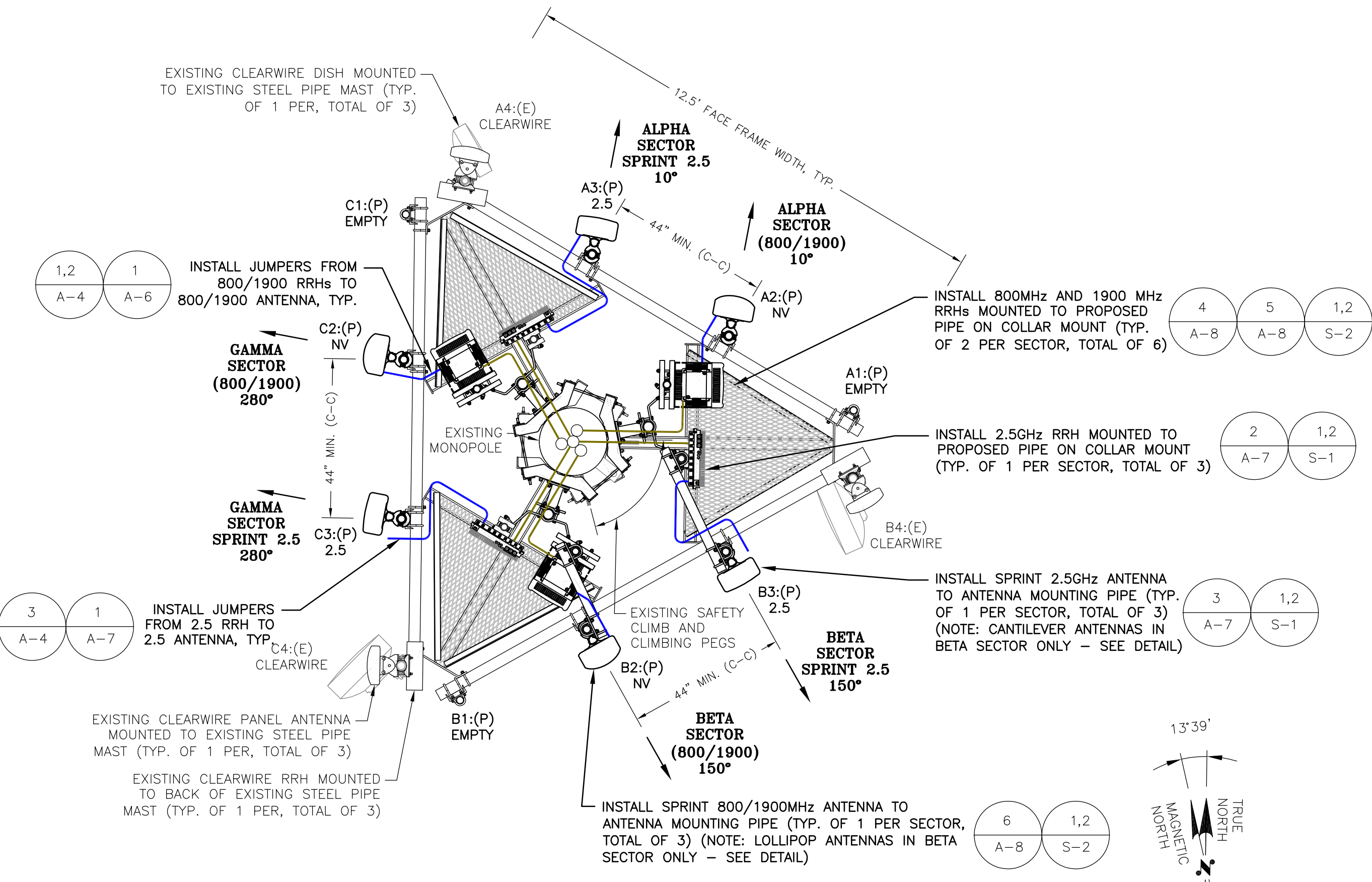

FINAL ANTENNA PLAN 3
 SCALE: N.T.S. A-3

NOTES:
 1) VERIFY PROPOSED AZIMUTHS WITH RF ENGINEER PRIOR TO INSTALLATION

CHECKED BY: JMM/TEJ

APPROVED BY: JMM/TEJ

SUBMITTALS

REV.	DATE	DESCRIPTION	BY
2	08/06/14	ISSUED FOR CONSTRUCTION	JEB
1	08/01/14	ISSUED FOR CONSTRUCTION	JEB
0	07/17/14	ISSUED FOR BP	JEB

SITE NUMBER:
 CT81XC005-A
 SITE NAME:
 MILFORD WEST
 SITE ADDRESS:
 160 WAMPUS LANE
 MILFORD, CT 06460

SHEET TITLE
 ANTENNA PLANS

SHEET NUMBER
 A-3