



**Crown Castle**  
3530 Torington Way, Suite 300  
Charlotte, NC 28277

September 17, 2014

Melanie A. Bachman  
Connecticut Siting Council  
10 Franklin Square  
New Britain, CT 06051

**RE: Sprint PCS-Exempt Modification - Crown Site BU: 876342**  
**Sprint PCS Site ID: CT03XC171**  
**Located at: 111 Schoolhouse Road, Milford, CT 06460**

Dear Ms. Bachman:

This letter and exhibits are submitted on behalf of Sprint PCS (Sprint). Sprint is making modifications to certain existing sites in its Connecticut system in order to implement their 2.5GHz LTE technology. Please accept this letter and exhibits as notification, pursuant to § 16-50j-73 of the Regulations of Connecticut State Agencies (“R.C.S.A.”), of construction that constitutes an exempt modification pursuant to R.C.S.A. § 16-50j-72(b)(2). In compliance with R.C.S.A. § 16-50j-73, a copy of this letter is being sent to the Honorable Benjamin G. Blake, Mayor for City of Milford, and Milford FFI, LLC, Property Owner.

Sprint plans to modify the existing wireless communications facility owned by Crown Castle and located at **111 Schoolhouse Road, Milford, CT 06460**. Attached are a compound plan and elevation depicting the planned changes (Exhibit-1), and documentation of the structural sufficiency of the structure to accommodate the revised antenna configuration (Exhibit-2). Also included is a power density table report reflecting the modification to Sprint’s operations at the site (Exhibit-3).

The changes to the facility do not constitute a modification as defined in Connecticut General Statutes (“C.G.S.”) § 16-50i(d) because the general physical characteristics of the facility will not be significantly changed. Rather, the planned changes to the facility fall squarely within those activities explicitly provided for in the R.C.S.A. § 16-50j-72(b)(2).

1. The proposed modifications will not result in an increase in the height of the existing tower. Sprint’s additional antennas will be located at the same elevation on the existing tower.
2. There will be no proposed modifications to the ground and no extension of boundaries.
3. The proposed modifications will not increase noise levels at the facility by six decibels or more.

4. A Structural Modification Report confirming that the tower and foundation can support Sprint's proposed modifications is included as Exhibit-2.
5. The operation of the additional antennas will not increase radio frequency (RF) emissions at the facility to a level at or above the Federal Communications Commission (FCC) adopted safety standard. A cumulative General Power Density table report for Sprint's modified facility is included as Exhibit-3.

For the foregoing reasons, Sprint respectfully submits the proposed modifications to the above-reference telecommunications facility constitutes an exempt modification under R.C.S.A. § 16-50j-72(b)(2). Please send approval/rejection letter to Attn: Donna Neal.

Sincerely,



Raymond Perry  
Real Estate Specialist

Enclosures

Tab 1: Exhibit-1: Compound plan and elevation depicting the planned changes

Tab 2: Exhibit-2: Structural Modification Report

Tab 3: Exhibit-3: General Power Density Table Report (RF Emissions Analysis Report)

cc: Honorable Benjamin G. Blake, Mayor  
City of Milford  
70 West River Street  
Milford, CT 06460

Milford FFI, LLC  
111 School House Road  
Fairfield Inn Milford  
Milford, CT 06460

# Sprint

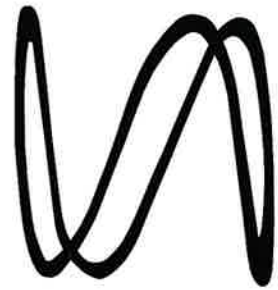

# CROWN CASTLE

PROJECT: 2.5 EQUIPMENT DEPLOYMENT  
 SITE NAME: BIC DRIVE (SSUSA)  
 SITE CASCADE: CT03XC171  
 SITE NUMBER: 876342  
 SITE ADDRESS: 111 SCHOOL HOUSE RD, AKA BIC DRIVE MILFORD, CT 06460  
 SITE TYPE: MONOPOLE TOWER  
 MARKET: SOUTHERN CONNECTICUT

PLANS PREPARED FOR:

6580 Sprint Parkway  
Overland Park, Kansas 66251

PLANS PREPARED BY:

Design. Build. Deliver.  
 1033 Watervliet Shaker Rd  
Albany, NY 12205  
Office # (518) 690-0790  
Fax # (518) 690-0793  
 JOB NUMBER 353-1000X

MLA PARTNER:

ENGINEERING LICENSE:

DRAWING NOTICE:  
 THESE DOCUMENTS ARE CONFIDENTIAL AND ARE THE SOLE PROPERTY OF SPRINT AND MAY NOT BE REPRODUCED, DISSEMINATED OR REDISTRIBUTED WITHOUT THE EXPRESS WRITTEN CONSENT OF SPRINT.

REVISIONS:

DESCRIPTION	DATE	BY	REV
ISSUED FOR PERMIT	9/16/14	JLM	0

SITE NAME:  
**BIC DRIVE (SSUSA)**

SITE CASCADE:  
**CT03XC171**

SITE ADDRESS:  
 111 SCHOOL HOUSE RD,  
 AKA BIC DRIVE  
 MILFORD, CT 06460

SHEET DESCRIPTION:  
**TITLE SHEET & PROJECT DATA**

SHEET NUMBER:  
**T-1**

**SITE INFORMATION**

**TOWER OWNER:**  
 CROWN CASTLE CORP.  
 2000 CORPORATE DRIVE  
 CANONSBURG, PA 15317  
 (704) 405-6555

**LATITUDE (NAD83):**  
 41° 12' 45.06" N  
 41.212794°

**LONGITUDE (NAD83):**  
 73° 5' 7.1" W  
 -73.085306°

**COUNTY:**  
 NEW HAVEN

**ZONING JURISDICTION:**  
 CITY OF MILFORD

**ZONING DISTRICT:**  
 U

**POWER COMPANY:**  
 THE UNITED ILLUMINATING COMPANY  
 (800) 7-CALL UI

**AAV PROVIDER:**  
 VERIZON  
 (855) 277-5195

**SPRINT CM:**  
 GARY WOOD  
 GARY.WOOD@SPRINT.COM

**CROWN CASTLE CM:**  
 HARRY ATHAN  
 (518) 380-0041  
 HTAMANAGEMENT@NYCAP.RR.COM

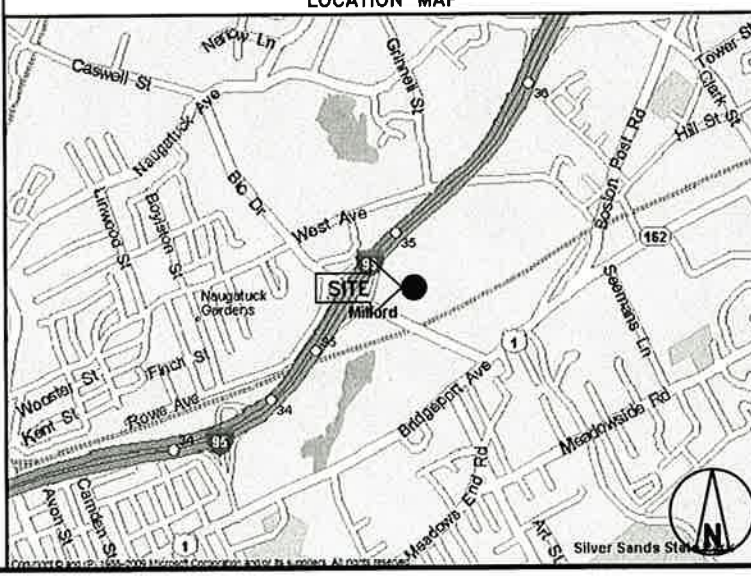
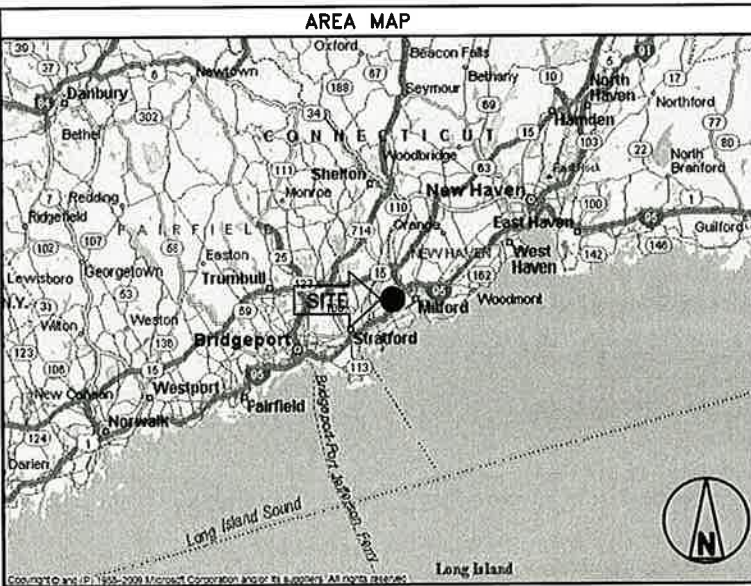

**PROJECT DESCRIPTION**

SPRINT PROPOSES TO MODIFY AN EXISTING UNMANNED TELECOMMUNICATIONS FACILITY.

- INSTALL (3) PANEL ANTENNAS
- INSTALL (3) RRU'S TO TOWER
- INSTALL (27) JUMPER CABLES
- INSTALL (1) HYBRID CABLE
- INSTALL (8) NEW BATTERIES IN EXISTING BATTERY CABINET
- INSTALL 2.5 EQUIPMENT IN EXISTING N.V. MMBS CABINET
- REMOVE CLEARWIRE & METRICOMM TOWER APPURTANCES

THESE PLANS HAVE BEEN DEVELOPED FOR THE MODIFICATION OF AN EXISTING UNMANNED TELECOMMUNICATIONS FACILITY OWNED OR LEASED BY SPRINT IN ACCORDANCE WITH THE SCOPE OF WORK PROVIDED BY SPRINT. INFINIGY HAS INCORPORATED THIS SCOPE OF WORK IN THE PLANS. THESE PLANS ARE NOT FOR CONSTRUCTION UNLESS ACCOMPANIED BY A PASSING STRUCTURAL STABILITY ANALYSIS PREPARED BY A LICENSED STRUCTURAL ENGINEER. STRUCTURAL ANALYSIS MUST INCLUDE BOTH TOWER AND MOUNT.

**APPLICABLE CODES**

ALL WORK SHALL BE PERFORMED AND MATERIALS INSTALL IN ACCORDANCE WITH THE CURRENT EDITIONS OF THE FOLLOWING CODES AS ADOPTED BY THE LOCAL GOVERNING AUTHORITIES. NOTHING IN THESE PLANS IS TO BE CONSTRUED TO PERMIT WORK NOT CONFORMING TO THESE CODES.

- INTERNATIONAL BUILDING CODE (2012 IBC)
- TIA-EIA-222-F OR LATEST EDITION
- NFPA 780 - LIGHTNING PROTECTION CODE
- 2011 NATIONAL ELECTRIC CODE OR LATEST EDITION
- ANY OTHER NATIONAL OR LOCAL APPLICABLE CODES, MOST RECENT EDITIONS
- CT BUILDING CODE
- LOCAL BUILDING CODE
- CITY/COUNTY ORDINANCES

**DRAWING INDEX**

SHEET NO:	SHEET TITLE	REV
T-1	TITLE SHEET & PROJECT DATA	0
SP-1	SPRINT SPECIFICATIONS	0
SP-2	SPRINT SPECIFICATIONS	0
SP-3	SPRINT SPECIFICATIONS	0
A-1	SITE PLAN	0
A-2	TOWER ELEVATION & CABLE PLAN	0
A-3	ANTENNA LAYOUT & MOUNTING DETAILS	0
A-4	COLOR CODING & NOTES	0
A-5	EQUIPMENT & MOUNTING DETAILS	0
A-6	CIVIL DETAILS	0
A-7	PLUMBING DIAGRAM	0
E-1	ELECTRICAL & GROUNDING PLAN	0
E-2	ELECTRICAL & GROUNDING DETAILS	0

THESE OUTLINE SPECIFICATIONS IN CONJUNCTION WITH THE SPRINT STANDARD CONSTRUCTION SPECIFICATIONS, INCLUDING CONTRACT DOCUMENTS AND THE CONSTRUCTION DRAWINGS DESCRIBE THE WORK TO BE PERFORMED BY THE CONTRACTOR.

**SECTION 01 100 - SCOPE OF WORK**

**PART 1 - GENERAL**

- 1.1 THE WORK: THESE STANDARD CONSTRUCTION SPECIFICATIONS IN CONJUNCTION WITH THE SPRINT CONSTRUCTION STANDARDS FOR WIRELESS SITES, CONTRACT DOCUMENTS AND THE CONSTRUCTION DRAWINGS DESCRIBE THE WORK TO BE PERFORMED BY THE CONTRACTOR.
- 1.2 RELATED DOCUMENTS:
  - A. THE REQUIREMENTS OF THIS SECTION APPLY TO ALL SECTIONS IN THIS SPECIFICATION.
  - B. SPRINT "STANDARD CONSTRUCTION DETAILS FOR WIRELESS SITES" ARE INCLUDED IN AND MADE A PART OF THESE SPECIFICATIONS HEREWITH.
- 1.3 PRECEDENCE: SHOULD CONFLICTS OCCUR BETWEEN THE STANDARD CONSTRUCTION SPECIFICATIONS FOR WIRELESS SITES INCLUDING THE STANDARD CONSTRUCTION DETAILS FOR WIRELESS SITES AND THE CONSTRUCTION DRAWINGS, INFORMATION ON THE CONSTRUCTION DRAWINGS SHALL TAKE PRECEDENCE. NOTIFY SPRINT CONSTRUCTION MANAGER IF THIS OCCURS.
- 1.4 NATIONALLY RECOGNIZED CODES AND STANDARDS:
  - A. THE WORK SHALL COMPLY WITH APPLICABLE NATIONAL AND LOCAL CODES AND STANDARDS, LATEST EDITION, AND PORTIONS THEREOF, INCLUDED BUT NOT LIMITED TO THE FOLLOWING:
    - 1. GR-63-CORE NEBS REQUIREMENTS: PHYSICAL PROTECTION
    - 5. GR-78-CORE GENERIC REQUIREMENTS FOR THE PHYSICAL DESIGN AND MANUFACTURE OF TELECOMMUNICATIONS EQUIPMENT.
    - 3. GR-1089 CORE, ELECTROMAGNETIC COMPATIBILITY AND ELECTRICAL SAFETY -GENERIC CRITERIA FOR NETWORK TELECOMMUNICATIONS EQUIPMENT.
    - 4. NATIONAL FIRE PROTECTION ASSOCIATION CODES AND STANDARDS (NFPA) INCLUDING NFPA 70 (NATIONAL ELECTRICAL CODE - "NEC") AND NFPA 101 (LIFE SAFETY CODE).
    - 5. AMERICAN SOCIETY FOR TESTING OF MATERIALS (ASTM)
    - 6. INSTITUTE OF ELECTRONIC AND ELECTRICAL ENGINEERS (IEEE)
    - 7. AMERICAN CONCRETE INSTITUTE (ACI)
    - 8. AMERICAN WIRE PRODUCERS ASSOCIATION (AWPA)
    - 9. CONCRETE REINFORCING STEEL INSTITUTE (CRSI)
    - 10. AMERICAN ASSOCIATION OF STATE HIGHWAY AND TRANSPORTATION OFFICIALS (AASHTO)
    - 11. PORTLAND CEMENT ASSOCIATION (PCA)
    - 12. NATIONAL CONCRETE MASONRY ASSOCIATION (NCMA)
    - 13. BRICK INDUSTRY ASSOCIATION (BIA)
    - 14. AMERICAN WELDING SOCIETY (AWS)
    - 15. NATIONAL ROOFING CONTRACTORS ASSOCIATION (NRCA)
    - 16. SHEET METAL AND AIR CONDITIONING CONTRACTORS' NATIONAL ASSOCIATION (SMACNA)
    - 17. DOOR AND HARDWARE INSTITUTE (DHI)
    - 18. OCCUPATIONAL SAFETY AND HEALTH ACT (OSHA)
    - 19. APPLICABLE BUILDING CODES INCLUDING UNIFORM BUILDING CODE, SOUTHERN BUILDING CODE, BOCA, AND THE INTERNATIONAL BUILDING CODE.
- 1.5 DEFINITIONS:
  - A. WORK: THE SUM OF TASKS AND RESPONSIBILITIES IDENTIFIED IN THE CONTRACT DOCUMENTS.
  - B. COMPANY: SPRINT CORPORATION
  - C. ENGINEER: SYNONYMOUS WITH ARCHITECT & ENGINEER AND "A&E". THE DESIGN PROFESSIONAL HAVING PROFESSIONAL RESPONSIBILITY FOR DESIGN OF THE PROJECT.
  - D. CONTRACTOR: CONSTRUCTION CONTRACTOR; CONSTRUCTION VENDOR; INDIVIDUAL OR ENTITY WHO AFTER EXECUTION OF A CONTRACT IS BOUND TO ACCOMPLISH THE WORK.
  - E. THIRD PARTY VENDOR OR AGENCY: A VENDOR OR AGENCY ENGAGED SEPARATELY BY THE COMPANY, A&E, OR CONTRACTOR TO PROVIDE MATERIALS OR TO ACCOMPLISH SPECIFIC TASKS RELATED TO BUT NOT INCLUDED IN THE WORK.
  - F. OFCI: OWNER FURNISHED, CONTRACTOR INSTALLED EQUIPMENT.
  - G. CONSTRUCTION MANAGER - ALL PROJECTS RELATED COMMUNICATION TO FLOW THROUGH SPRINT REPRESENTATIVE IN CHARGE OF PROJECT...

- 1.6 SITE FAMILIARITY: CONTRACTOR SHALL BE RESPONSIBLE FOR FAMILIARIZING HIMSELF WITH ALL CONTRACT DOCUMENTS, FIELD CONDITIONS AND DIMENSIONS PRIOR TO PROCEEDING WITH CONSTRUCTION. ANY DISCREPANCIES SHALL BE BROUGHT TO THE ATTENTION OF THE SPRINT CONSTRUCTION MANAGER PRIOR TO THE COMMENCEMENT OF WORK. NO COMPENSATION WILL BE AWARDED BASED ON CLAIM OF LACK OF KNOWLEDGE OR FIELD CONDITIONS.
- 1.7 POINT OF CONTACT: COMMUNICATION BETWEEN SPRINT AND THE CONTRACTOR SHALL FLOW THROUGH THE SINGLE SPRINT CONSTRUCTION MANAGER APPOINTED TO MANAGE THE PROJECT FOR SPRINT.
- 1.8 ON-SITE SUPERVISION: THE CONTRACTOR SHALL SUPERVISE AND DIRECT THE WORK AND SHALL BE RESPONSIBLE FOR CONSTRUCTION MEANS, METHODS, TECHNIQUES, SEQUENCES, AND PROCEDURES IN ACCORDANCE WITH THE CONTRACT DOCUMENTS. THE CONTRACTOR SHALL EMPLOY A COMPETENT SUPERINTENDENT WHO SHALL BE IN ATTENDANCE AT THE SITE AT ALL TIMES DURING PERFORMANCE OF THE WORK.
- 1.9 DRAWINGS, SPECIFICATIONS AND DETAILS REQUIRED AT JOBSITE: THE CONSTRUCTION CONTRACTOR SHALL MAINTAIN A FULL SET OF THE CONSTRUCTION DRAWINGS, STANDARD CONSTRUCTION DETAILS FOR WIRELESS SITES AND THE STANDARD CONSTRUCTION SPECIFICATIONS FOR WIRELESS SITES AT THE JOBSITE FROM MOBILIZATION THROUGH CONSTRUCTION COMPLETION.
  - A. THE JOBSITE DRAWINGS, SPECIFICATIONS AND DETAILS SHALL BE CLEARLY MARKED DAILY IN RED PENCIL WITH ANY CHANGES IN CONSTRUCTION OVER WHAT IS DEPICTED IN THE DOCUMENTS. AT CONSTRUCTION COMPLETION, THIS JOBSITE MARKUP SET SHALL BE DELIVERED TO THE COMPANY OR COMPANY'S DESIGNATED REPRESENTATIVE TO BE FORWARDED TO THE COMPANY'S A&E VENDOR FOR PRODUCTION OF "AS-BUILT" DRAWINGS.
  - B. DETAILS ARE INTENDED TO SHOW DESIGN INTENT. MODIFICATIONS MAY BE REQUIRED TO SUIT JOB DIMENSIONS OR CONDITIONS, AND SUCH MODIFICATIONS SHALL BE INCLUDED AS PART OF THE WORK. CONTRACTOR SHALL NOTIFY SPRINT CONSTRUCTION MANAGER OF ANY VARIATIONS PRIOR TO PROCEEDING WITH THE WORK.
  - C. DIMENSIONS SHOWN ARE TO FINISH SURFACES UNLESS NOTED OTHERWISE. SPACING BETWEEN EQUIPMENT IS THE REQUIRED CLEARANCE. SHOULD THERE BE ANY QUESTIONS REGARDING THE CONTRACT DOCUMENTS, EXISTING CONDITIONS AND/OR DESIGN INTENT, THE CONTRACTOR SHALL BE RESPONSIBLE FOR OBTAINING A CLARIFICATION FROM THE SPRINT CONSTRUCTION MANAGER PRIOR TO PROCEEDING WITH THE WORK.
- 1.10 USE OF JOB SITE: THE CONTRACTOR SHALL CONFINE ALL CONSTRUCTION AND RELATED OPERATIONS INCLUDING STAGING AND STORAGE OF MATERIALS AND EQUIPMENT, PARKING, TEMPORARY FACILITIES, AND WASTE STORAGE TO THE LEASE PARCEL UNLESS OTHERWISE PERMITTED BY THE CONTRACT DOCUMENTS.
- 1.11 UTILITIES SERVICES: WHERE NECESSARY TO CUT EXISTING PIPES, ELECTRICAL WIRES, CONDUITS, CABLES, ETC., OF UTILITY SERVICES, OR OF FIRE PROTECTION OR COMMUNICATIONS SYSTEMS, THEY SHALL BE CUT AND CAPPED AT SUITABLE PLACES OR WHERE SHOWN. ALL SUCH ACTIONS SHALL BE COORDINATED WITH THE UTILITY COMPANY INVOLVED.
- 1.12 PERMITS / FEES: WHEN REQUIRED THAT A PERMIT OR CONNECTION FEE BE PAID TO A PUBLIC UTILITY PROVIDER FOR NEW SERVICE TO THE CONSTRUCTION PROJECT, PAYMENT OF SUCH FEE SHALL BE THE RESPONSIBILITY OF THE CONTRACTOR.
- 1.13 CONTRACTOR SHALL TAKE ALL MEASURES AND PROVIDE ALL MATERIAL NECESSARY FOR PROTECTING EXISTING EQUIPMENT AND PROPERTY.
- 1.14 METHODS OF PROCEDURE (MOPS) FOR CONSTRUCTION: CONTRACTOR SHALL PERFORM WORK AS DESCRIBED IN THE FOLLOWING INSTALLATION AND COMMISSIONING MOPS.
 

NOTE: IN SHORT-FORM SPECIFICATIONS ON THE DRAWINGS, A/E TO INSERT LIST OF APPLICABLE MOPS INCLUDING EN-2012-001, EN-2013-002, EL-0568, AND TS-0193
- 1.15 USE OF ELECTRONIC PROJECT MANAGEMENT SYSTEMS:

**PART 2 - PRODUCTS (NOT USED)**

**PART 3 - EXECUTION**

- 3.1 TEMPORARY UTILITIES AND FACILITIES: THE CONTRACTOR SHALL BE RESPONSIBLE FOR ALL TEMPORARY UTILITIES AND FACILITIES NECESSARY EXCEPT AS OTHERWISE INDICATED IN THE CONSTRUCTION DOCUMENTS. TEMPORARY UTILITIES AND FACILITIES INCLUDE POTABLE WATER, HEAT, HVAC, ELECTRICITY, SANITARY FACILITIES, WASTE DISPOSAL FACILITIES, AND TELEPHONE/COMMUNICATION SERVICES. PROVIDE TEMPORARY UTILITIES AND FACILITIES IN ACCORDANCE WITH OSHA AND THE AUTHORITY HAVING JURISDICTION. CONTRACTOR MAY UTILIZE THE COMPANY ELECTRICAL SERVICE IN THE COMPLETION OF THE WORK WHEN IT BECOMES AVAILABLE. USE OF THE LESSORS OR SITE OWNER'S UTILITIES OR FACILITIES IS EXPRESSLY FORBIDDEN EXCEPT AS OTHERWISE ALLOWED IN THE CONTRACT DOCUMENTS.
- 3.2 ACCESS TO WORK: THE CONTRACTOR SHALL PROVIDE ACCESS TO THE JOB SITE FOR AUTHORIZED COMPANY PERSONNEL AND AUTHORIZED REPRESENTATIVES OF THE ARCHITECT/ENGINEER DURING ALL PHASES OF THE WORK.
- 3.3 TESTING: REQUIREMENTS FOR TESTING BY THIS CONTRACTOR SHALL BE AS INDICATED HEREWITH, ON THE CONSTRUCTION DRAWINGS, AND IN THE INDIVIDUAL SECTIONS OF THESE SPECIFICATIONS. SHOULD COMPANY CHOOSE TO ENGAGE ANY THIRD-PARTY TO CONDUCT ADDITIONAL TESTING, THE CONTRACTOR SHALL COOPERATE WITH AND PROVIDE A WORK AREA FOR COMPANY'S TEST AGENCY.
- 3.4 DIMENSIONS: VERIFY DIMENSIONS INDICATED ON DRAWINGS WITH FIELD DIMENSIONS BEFORE FABRICATION OR ORDERING OF MATERIALS. DO NOT SCALE DRAWINGS.

3.5 EXISTING CONDITIONS: NOTIFY THE SPRINT CONSTRUCTION MANAGER OF EXISTING CONDITIONS DIFFERING FROM THOSE INDICATED ON THE DRAWINGS. DO NOT REMOVE OR ALTER STRUCTURAL COMPONENTS WITHOUT PRIOR WRITTEN APPROVAL FROM THE ARCHITECT AND ENGINEER.

**SECTION 01 200 - COMPANY FURNISHED MATERIAL AND EQUIPMENT**

**PART 1 - GENERAL**

- 1.1 THE WORK: THESE STANDARD CONSTRUCTION SPECIFICATIONS IN CONJUNCTION WITH THE OTHER CONTRACT DOCUMENTS AND THE CONSTRUCTION DRAWINGS DESCRIBE THE WORK TO BE PERFORMED BY THE CONTRACTOR.
- 1.2 RELATED DOCUMENTS:
  - A. THE REQUIREMENTS OF THIS SECTION APPLY TO ALL SECTIONS IN THIS SPECIFICATION.
  - B. SPRINT "STANDARD CONSTRUCTION DETAILS FOR WIRELESS SITES" ARE INCLUDED IN AND MADE A PART OF THESE SPECIFICATIONS HEREWITH.
- PART 2 - PRODUCTS (NOT USED)**
- PART 3 - EXECUTION**
  - 3.1 RECEIPT OF MATERIAL AND EQUIPMENT:
    - A. A COMPANY FURNISHED MATERIAL AND EQUIPMENT IS IDENTIFIED ON THE RF DATA SHEET IN THE CONSTRUCTION DOCUMENTS.
    - B. THE CONTRACTOR IS RESPONSIBLE FOR SPRINT PROVIDED MATERIAL AND EQUIPMENT AND UPON RECEIPT SHALL:
      - 1. ACCEPT DELIVERIES AS SHIPPED AND TAKE RECEIPT.
      - 2. VERIFY COMPLETENESS AND CONDITION OF ALL DELIVERIES.
      - 3. TAKE RESPONSIBILITY FOR EQUIPMENT AND PROVIDE INSURANCE PROTECTION AS REQUIRED IN AGREEMENT.
      - 4. RECORD ANY DEFECTS OR DAMAGES AND WITHIN TWENTY-FOUR HOURS AFTER RECEIPT, REPORT TO SPRINT OR ITS DESIGNATED PROJECT REPRESENTATIVE OF SUCH.
      - 5. PROVIDE SECURE AND NECESSARY WEATHER PROTECTED WAREHOUSING.
      - 6. COORDINATE SAFE AND SECURE TRANSPORTATION OF MATERIAL AND EQUIPMENT, DELIVERING AND OFF-LOADING FROM CONTRACTOR'S WAREHOUSE TO SITE.

- 3.2 DELIVERABLES:
  - A. COMPLETE SHIPPING AND RECEIPT DOCUMENTATION IN ACCORDANCE WITH COMPANY PRACTICE.
  - B. IF APPLICABLE, COMPLETE LOST/STOLEN/DAMAGED DOCUMENTATION REPORT AS NECESSARY IN ACCORDANCE WITH COMPANY PRACTICE, AND AS DIRECTED BY COMPANY.
  - C. UPLOAD DOCUMENTATION INTO SPRINT SITE MANAGEMENT SYSTEM (SMS) AND/OR PROVIDE HARD COPY DOCUMENTATION AS REQUESTED.

**SECTION 01 300 - CELL SITE CONSTRUCTION CO.**

**PART 1 - GENERAL**

- 1.1 THE WORK: THESE STANDARD CONSTRUCTION SPECIFICATIONS IN CONJUNCTION WITH THE OTHER CONTRACT DOCUMENTS AND THE CONSTRUCTION DRAWINGS DESCRIBE THE WORK TO BE PERFORMED BY THE CONTRACTOR.
- 1.2 RELATED DOCUMENTS:
  - A. THE REQUIREMENTS OF THIS SECTION APPLY TO ALL SECTIONS IN THIS SPECIFICATION.
  - B. SPRINT "STANDARD CONSTRUCTION DETAILS FOR WIRELESS SITES" ARE INCLUDED IN AND MADE A PART OF THESE SPECIFICATIONS HEREWITH.
- 1.3 NOTICE TO PROCEED
  - A. NO WORK SHALL COMMENCE PRIOR TO COMPANY'S WRITTEN NOTICE TO PROCEED AND THE ISSUANCE OF THE WORK ORDER.
  - B. UPON RECEIVING NOTICE TO PROCEED, CONTRACTOR SHALL FULLY PERFORM ALL WORK NECESSARY TO PROVIDE SPRINT WITH AN OPERATIONAL WIRELESS FACILITY.

**TOWER OWNER NOTIFICATION**  
 ONCE THE CONTRACTOR HAS RECEIVED AND ACCEPTED THE NOTICE TO PROCEED, CONTRACTOR WILL CONTACT THE CROWN CASTLE CONSTRUCTION MANAGER OF RECORD (NOTED ON THE FIRST PAGE ON THIS CONSTRUCTION DRAWING) A MINIMUM OF 48 HOURS PRIOR TO WORK START. UPON ARRIVAL TO THE JOB SITE, CONTRACTOR CREW IS REQUIRED CALL 1-800-788-7011 TO NOTIFY THE CROWN CASTLE NOC WORK HAS BEGUN.

**PART 2 - PRODUCTS (NOT USED)**

**PART 3 - EXECUTION**

- 3.1 FUNCTIONAL REQUIREMENTS:
  - A. THE ACTIVITIES DESCRIBED IN THIS PARAGRAPH REPRESENT MINIMUM ACTIONS AND PROCESSES REQUIRED TO SUCCESSFULLY COMPLETE THE WORK. THE ACTIVITIES DESCRIBED ARE NOT EXHAUSTIVE, AND CONTRACTOR SHALL TAKE ANY AND ALL ACTIONS AS NECESSARY TO SUCCESSFULLY COMPLETE THE CONSTRUCTION OF A FULLY FUNCTIONING WIRELESS FACILITY AT THE SITE IN ACCORDANCE WITH COMPANY PROCESSES.
  - B. SUBMIT SPECIFIC DOCUMENTATION AS INDICATED HEREIN, AND OBTAIN REQUIRED APPROVALS WHILE THE WORK IS BEING PERFORMED.
  - C. MANAGE AND CONDUCT ALL FIELD CONSTRUCTION SERVICE RELATED ACTIVITIES
  - D. PROVIDE CONSTRUCTION ACTIVITIES TO THE EXTENT REQUIRED BY THE CONTRACT DOCUMENTS, INCLUDING BUT NOT LIMITED TO THE FOLLOWING:

PLANS PREPARED FOR:



PLANS PREPARED BY:



MLA PARTNER:



ENGINEERING LICENSE:



DRAWING NOTICE:

THESE DOCUMENTS ARE CONFIDENTIAL AND ARE THE SOLE PROPERTY OF SPRINT AND MAY NOT BE REPRODUCED, DISSEMINATED OR REDISTRIBUTED WITHOUT THE EXPRESS WRITTEN CONSENT OF SPRINT.

REVISIONS:

DESCRIPTION	DATE	BY	REV
ISSUED FOR PERMIT	9/16/14	JLM	0

SITE NAME:

**BIC DRIVE (SSUSA)**

SITE CASCADE:

**CT03XC171**

SITE ADDRESS:

111 SCHOOL HOUSE RD,  
 AKA BIC DRIVE  
 MILFORD, CT 06460

SHEET DESCRIPTION:

**SPRINT SPECIFICATIONS**

SHEET NUMBER:

**SP-1**

CONTINUE FROM SP-1

1. PERFORM ANY REQUIRED SITE ENVIRONMENTAL MITIGATION.
  2. PREPARE GROUND SITES; PROVIDE DE-GRUBBING; AND ROUGH AND FINAL GRADING, AND COMPOUND SURFACE TREATMENTS.
  3. MANAGE AND CONDUCT ALL ACTIVITIES FOR INSTALLATION OF UTILITIES INCLUDING ELECTRICAL AND TELCO BACKHAUL.
  4. INSTALL UNDERGROUND FACILITIES INCLUDING UNDERGROUND POWER AND COMMUNICATIONS CONDUITS, AND UNDERGROUND GROUNDING SYSTEM.
  5. INSTALL ABOVE GROUND GROUNDING SYSTEMS.
  6. PROVIDE NEW HVAC INSTALLATIONS AND MODIFICATIONS.
  7. INSTALL "H-FRAMES", CABINETS AND SHELTERS AS INDICATED.
  8. INSTALL ROADS, ACCESS WAYS, CURBS AND DRAINS AS INDICATED.
  9. ACCOMPLISH REQUIRED MODIFICATION OF EXISTING FACILITIES.
  10. PROVIDE ANTENNA SUPPORT STRUCTURE FOUNDATIONS.
  11. PROVIDE SLABS AND EQUIPMENT PLATFORMS.
  12. INSTALL COMPOUND FENCING, SIGHT SHIELDING, LANDSCAPING AND ACCESS BARRIERS.
  13. PERFORM INSPECTION AND MATERIAL TESTING AS REQUIRED HEREINAFTER.
  14. CONDUCT SITE RESISTANCE TO EARTH TESTING AS REQUIRED HEREINAFTER.
  15. INSTALL FIXED GENERATOR SETS AND OTHER STANDBY POWER SOLUTIONS.
  16. INSTALL TOWERS, ANTENNA SUPPORT STRUCTURES AND PLATFORMS ON EXISTING TOWERS AS REQUIRED.
  17. INSTALL CELL SITE RADIOS, MICROWAVE, GPS, COAXIAL MAINLINE, ANTENNAS, CROSS BAND COUPLERS, TOWER TOP AMPLIFIERS, LOW NOISE AMPLIFIERS AND RELATED EQUIPMENT.
  18. PERFORM, DOCUMENT, AND CLOSE OUT ANY CONSTRUCTION CONTROL DOCUMENTS THAT MAY BE REQUIRED BY GOVERNMENT AGENCIES AND LANDLORDS.
  19. PERFORM ANTENNA AND COAX SWEEP TESTING AND MAKE ANY AND ALL NECESSARY CORRECTIONS.
  20. REMAIN ON SITE MOBILIZED THROUGHOUT HAND-OFF AND INTEGRATION TO ASSIST AS NEEDED UNTIL SITE IS DEEMED SUBSTANTIALLY COMPLETE AND PLACED "ON AIR."
- 3.2 GENERAL REQUIREMENTS FOR CIVIL CONSTRUCTION:
- A. CONTRACTOR SHALL KEEP THE SITE FREE FROM ACCUMULATING WASTE MATERIAL, DEBRIS, AND TRASH. AT THE COMPLETION OF THE WORK, CONTRACTOR SHALL REMOVE FROM THE SITE ALL REMAINING RUBBISH, IMPLEMENTS, TEMPORARY FACILITIES, AND SURPLUS MATERIALS.
  - B. EQUIPMENT ROOMS SHALL AT ALL TIMES BE MAINTAINED "BROOM CLEAN" AND CLEAR OF DEBRIS.
  - C. CONTRACTOR SHALL TAKE ALL REASONABLE PRECAUTIONS TO DISCOVER AND LOCATE ANY HAZARDOUS CONDITION.
    1. IN THE EVENT CONTRACTOR ENCOUNTERS ANY HAZARDOUS CONDITION WHICH HAS NOT BEEN ABATED OR OTHERWISE MITIGATED, CONTRACTOR AND ALL OTHER PERSONS SHALL IMMEDIATELY STOP WORK IN THE AFFECTED AREA AND NOTIFY COMPANY IN WRITING. THE WORK IN THE AFFECTED AREA SHALL NOT BE RESUMED EXCEPT BY WRITTEN NOTIFICATION BY COMPANY.
    2. CONTRACTOR AGREES TO USE CARE WHILE ON THE SITE AND SHALL NOT TAKE ACTION THAT WILL OR MAY RESULT IN OR CAUSE THE HAZARDOUS CONDITION TO BE FURTHER RELEASED IN THE ENVIRONMENT, OR TO FURTHER EXPOSE INDIVIDUALS TO THE HAZARD.
  - D. CONTRACTOR'S ACTIVITIES SHALL BE RESTRICTED TO THE PROJECT LIMITS. SHOULD AREAS OUTSIDE THE PROJECT LIMITS BE AFFECTED BY CONTRACTOR'S ACTIVITIES, CONTRACTOR SHALL IMMEDIATELY RETURN THEM TO ORIGINAL CONDITION.
  - E. CONDUCT TESTING AS REQUIRED HEREIN.
- 3.3 DELIVERABLES:
- A. CONTRACTOR SHALL REVIEW, APPROVE, AND SUBMIT TO SPRINT SHOP DRAWINGS, PRODUCT DATA, SAMPLES, AND SIMILAR SUBMITTALS AS REQUIRED HEREINAFTER.
  - B. PROVIDE DOCUMENTATION INCLUDING, BUT NOT LIMITED TO, THE FOLLOWING. DOCUMENTATION SHALL BE FORWARDED IN ORIGINAL FORMAT AND/OR UPLOADED INTO SMS.
    1. ALL CORRESPONDENCE AND PRELIMINARY CONSTRUCTION REPORTS.
    2. PROJECT PROGRESS REPORTS.
    3. CIVIL CONSTRUCTION START DATE (POPULATE FIELD IN SMS AND/OR FORWARD NOTIFICATION).
    4. ELECTRICAL SERVICE COMPLETION DATE (POPULATE FIELD IN SMS AND/OR FORWARD NOTIFICATION).

5. LINES AND ANTENNA INSTALL DATE (POPULATE FIELD IN SMS AND/OR FORWARD NOTIFICATION).
6. POWER INSTALL DATE (POPULATE FIELD IN SMS AND/OR FORWARD NOTIFICATION).
7. TELCO READY DATE (POPULATE FIELD IN SMS AND/OR FORWARD NOTIFICATION).
8. PPC (OR SHELTER) INSTALL DATE (POPULATE FIELD IN SMS AND/OR FORWARD NOTIFICATION).
9. TOWER CONSTRUCTION START DATE (POPULATE FIELD IN SMS AND/OR FORWARD NOTIFICATION).
10. TOWER CONSTRUCTION COMPLETE DATE (POPULATE FIELD IN SMS AND/OR FORWARD NOTIFICATION).
11. BTS AND RADIO EQUIPMENT DELIVERED AT SITE DATE (POPULATE FIELD IN SMS AND/OR FORWARD NOTIFICATION).
12. NETWORK OPERATIONS HANDOFF CHECKLIST (HOC WALK) COMPLETE (UPLOAD FORM IN SMS)
13. CIVIL CONSTRUCTION COMPLETE DATE (POPULATE FIELD IN SMS AND/OR FORWARD NOTIFICATION).
14. SITE CONSTRUCTION PROGRESS PHOTOS UNLOADED INTO SMS.

SECTION 01 400 - SUBMITTALS & TESTS

PART 1 - GENERAL

- 1.1 THE WORK: THESE STANDARD CONSTRUCTION SPECIFICATIONS IN CONJUNCTION WITH THE OTHER CONTRACT DOCUMENTS AND THE CONSTRUCTION DRAWINGS DESCRIBE THE WORK TO BE PERFORMED BY THE CONTRACTOR.
- 1.2 RELATED DOCUMENTS:
  - A. THE REQUIREMENTS OF THIS SECTION APPLY TO ALL SECTIONS IN THIS SPECIFICATION.
  - B. SPRINT STANDARD CONSTRUCTION DETAILS FOR WIRELESS SITES ARE INCLUDED IN AND MADE A PART OF THESE SPECIFICATIONS HERewith.
- 1.3 SUBMITTALS:
  - A. THE WORK IN ALL ASPECTS SHALL COMPLY WITH THE CONSTRUCTION DRAWINGS AND THESE SPECIFICATIONS.
  - B. SUBMIT THE FOLLOWING TO COMPANY REPRESENTATIVE FOR APPROVAL.
    1. CONCRETE MIX-DESIGNS FOR TOWER FOUNDATIONS, ANCHORS PIERS, AND CONCRETE PAVING.
    2. CONCRETE BREAK TESTS AS SPECIFIED HEREIN.
    3. SPECIAL FINISHES FOR INTERIOR SPACES, IF ANY.
    4. ALL EQUIPMENT AND MATERIALS SO IDENTIFIED ON THE CONSTRUCTION DRAWINGS.
    5. CHEMICAL GROUNDING DESIGN
  - D. ALTERNATES: AT THE COMPANY'S REQUEST, ANY ALTERNATIVES TO THE MATERIALS OR METHODS SPECIFIED SHALL BE SUBMITTED TO SPRINT'S CONSTRUCTION MANAGER FOR APPROVAL PRIOR TO BEING SHIPPED TO SITE. SPRINT WILL REVIEW AND APPROVE ONLY THOSE REQUESTS MADE IN WRITING. NO VERBAL APPROVALS WILL BE CONSIDERED. SUBMITTAL FOR APPROVAL SHALL INCLUDE A STATEMENT OF COST REDUCTION PROPOSED FOR USE OF ALTERNATE PRODUCT.
- 1.4 TESTS AND INSPECTIONS:
  - A. THE CONTRACTOR SHALL BE RESPONSIBLE FOR ALL CONSTRUCTION TESTS, INSPECTIONS AND PROJECT DOCUMENTATION.
  - B. CONTRACTOR SHALL ACCOMPLISH TESTING INCLUDING BUT NOT LIMITED TO THE FOLLOWING:
    1. COAX SWEEPS AND FIBER TESTS PER TS-0200 REV 4 ANTENNA LINE ACCEPTANCE STANDARDS.
    2. AGL, AZIMUTH AND DOWNTILT USING ELECTRONIC COMMERCIAL MADE-FOR-THE-PURPOSE ANTENNA ALIGNMENT TOOL.
    3. CONTRACTOR SHALL BE RESPONSIBLE FOR ANY AND ALL CORRECTIONS TO ANY WORK IDENTIFIED AS UNACCEPTABLE IN SITE INSPECTION ACTIVITIES AND/OR AS A RESULT OF TESTING.
  - C. REQUIRED CLOSEOUT DOCUMENTATION INCLUDES, BUT IS NOT LIMITED TO THE FOLLOWING:
    1. AZIMUTH, DOWNTILT, AGL - UPLOAD REPORT FROM ANTENNA ALIGNMENT TOOL TO SITERRA TASK 465. INSTALLED AZIMUTH, DOWNTILT, AND AGL MUST CONFORM TO THE RF DATA SHEETS. SWEEP AND FIBER TESTS
    2. SCANABLE BARCODE PHOTOGRAPHS OF TOWER TOP AND INACCESSIBLE SERIALIZED EQUIPMENT
    3. ALL AVAILABLE JURISDICTIONAL INFORMATION
    4. PDF SCAN OF REDLINES PRODUCED IN FIELD

5. ELECTRONIC AS-BUILT DRAWINGS IN AUTOCAD AND PDF FORMATS. ANY FIELD CHANGE MUST BE REFLECTED BY MODIFYING THE PLANS, ELEVATIONS, AND DETAILS IN THE DRAWING SETS. GENERAL NOTES INDICATING MODIFICATIONS WILL NOT BE ACCEPTED. CHANGES SHALL BE HIGHLIGHTED AS "CLOUDS" IDENTIFIED AS THE "AS-BUILT" CONDITION.
  6. LIEN WAIVERS
  7. FINAL PAYMENT APPLICATION
  8. REQUIRED FINAL CONSTRUCTION PHOTOS
  9. CONSTRUCTION AND COMMISSIONING CHECKLIST COMPLETE WITH NO DEFICIENT ITEMS
  10. ALL POST NTP TASKS INCLUDING DOCUMENT UPLOADS COMPLETED IN SITERRA (SPRINTS DOCUMENT REPOSITORY OF RECORD).
- 1.5 COMMISSIONING: PERFORM ALL COMMISSIONING AS REQUIRED BY APPLICABLE MOPs
- 1.6 INTEGRATION: PERFORM ALL INTEGRATION ACTIVITIES AS REQUIRED BY APPLICABLE MOPs

PART 2 - PRODUCTS (NOT USED)

PART 3 - EXECUTION

- 3.1 REQUIREMENTS FOR TESTING:
- A. THIRD PARTY TESTING AGENCY:
    1. WHEN THE USE OF A THIRD PARTY INDEPENDENT TESTING AGENCY IS REQUIRED, THE AGENCY THAT IS SELECTED MUST PERFORM SUCH WORK ON A REGULAR BASIS IN THE STATE WHERE THE PROJECT IS LOCATED AND HAVE A THOROUGH UNDERSTANDING OF LOCAL AVAILABLE MATERIALS, INCLUDING THE SOIL, ROCK, AND GROUNDWATER CONDITIONS.
    2. THE THIRD PARTY TESTING AGENCY IS TO BE FAMILIAR WITH THE APPLICABLE REQUIREMENTS FOR THE TESTS TO BE DONE, EQUIPMENT TO BE USED, AND ASSOCIATED HEALTH AND SAFETY ISSUES.
    3. EXPERIENCE IN SOILS, CONCRETE, MASONRY, AGGREGATE, AND ASPHALT TESTING USING ASTM, AASJTO, AND OTHER METHODS IS NEEDED.
    4. EXPERIENCE IN SOILS, CONCRETE, MASONRY, AGGREGATE, AND ASPHALT TESTING USING ASTM, AASJTO, AND OTHER METHODS IS NEEDED.
- 3.2 REQUIRED TESTS:
- A. CONTRACTOR SHALL ACCOMPLISH TESTING INCLUDING BUT NOT LIMITED TO THE FOLLOWING:
    1. CONCRETE CYLINDER BREAK TESTS FOR THE TOWER AND ANCHOR FOUNDATIONS AS SPECIFIED IN SECTION: PORTLAND CEMENT CONCRETE PAVING.
    2. ASPHALT ROADWAY COMPACTED THICKNESS, SURFACE SMOOTHNESS, AND COMPACTED DENSITY TESTING AS SPECIFIED IN SECTION: HOT MIX ASPHALT PAVING.
    3. FIELD QUALITY CONTROL TESTING AS SPECIFIED IN SECTION: PORTLAND CEMENT CONCRETE PAVING.
    4. TESTING REQUIRED UNDER SECTION: AGGREGATE BASE FOR ACCESS ROADS, PADS AND ANCHOR LOCATIONS
    5. STRUCTURAL BACKFILL COMPACTION TESTS FOR THE TOWER FOUNDATION.
    6. SITE RESISTANCE TO EARTH TESTING PER EXHIBIT: CELL SITE GROUNDING SYSTEM DESIGN.
    7. ANTENNA AND COAX SWEEP TESTS PER EXHIBIT: ANTENNA TRANSMISSION LINE ACCEPTANCE STANDARDS.
    8. GROUNDING AT ANTENNA MASTS FOR GPS AND ANTENNAS
    9. ALL OTHER TESTS REQUIRED BY COMPANY OR JURISDICTION.
- 3.3 REQUIRED INSPECTIONS
- A. SCHEDULE INSPECTIONS WITH COMPANY REPRESENTATIVE.
  - B. CONDUCT INSPECTIONS INCLUDING BUT NOT LIMITED TO THE FOLLOWING:
    1. GROUNDING SYSTEM INSTALLATION PRIOR TO EARTH CONCEALMENT DOCUMENTED WITH DIGITAL PHOTOGRAPHS BY CONTRACTOR, APPROVED BY A&E OR SPRINT REPRESENTATIVE.
    2. FORMING FOR CONCRETE AND REBAR PLACEMENT PRIOR TO POUR DOCUMENTED WITH DIGITAL PHOTOGRAPHS BY CONTRACTOR, APPROVED BY A&E OR SPRINT REPRESENTATIVE.
    3. COMPACTION OF BACKFILL MATERIALS; AGGREGATE BASE FOR ROADS, PADS, AND ANCHORS; ASPHALT PAVING; AND SHAFT BACKFILL FOR CONCRETE AND WOOD POLES, BY INDEPENDENT THIRD PARTY AGENCY.
    4. PRE- AND POST-CONSTRUCTION ROOFTOP AND STRUCTURAL INSPECTIONS ON EXISTING FACILITIES.
    5. TOWER ERECTION SECTION STACKING AND PLATFORM ATTACHMENT DOCUMENTED BY DIGITAL PHOTOGRAPHS BY THIRD PARTY AGENCY.
    6. ANTENNA AZIMUTH, DOWN TILT AND PER SUNLIGHT TOOL SUNSIGHT INSTRUMENTS - ANTENNA ALIGNMENT TOOL (AAT)

PLANS PREPARED FOR:



PLANS PREPARED BY:



MLA PARTNER:



ENGINEERING LICENSE:



DRAWING NOTICE:

THESE DOCUMENTS ARE CONFIDENTIAL AND ARE THE SOLE PROPERTY OF SPRINT AND MAY NOT BE REPRODUCED, DISSEMINATED OR REDISTRIBUTED WITHOUT THE EXPRESS WRITTEN CONSENT OF SPRINT.

REVISIONS:

DESCRIPTION	DATE	BY	REV
ISSUED FOR PERMIT	9/16/14	JLM	0

SITE NAME:

BIC DRIVE (SSUSA)

SITE CASCADE:

CT03XC171

SITE ADDRESS:

111 SCHOOL HOUSE RD,  
AKA BIC DRIVE  
MILFORD, CT 06460

SHEET DESCRIPTION:

SPRINT SPECIFICATIONS

SHEET NUMBER:

SP-2

CONTINUE FROM SP--2

7. VERIFICATION DOCUMENTED WITH THE ANTENNA CHECKLIST REPORT, BY A&E, SITE DEVELOPMENT REP, OR RF REP.
  8. FINAL INSPECTION CHECKLIST AND HANDOFF WALK (HOC). SIGNED FORM SHOWING ACCEPTANCE BY FIELD OPS IS TO BE UPLOADED INTO SMS.
  9. COAX SWEEP AND FIBER TESTING DOCUMENTS SUBMITTED VIA SMS FOR RF APPROVAL.
  10. SCAN-ABLE BARCODE PHOTOGRAPHS OF TOWER TOP AND INACCESSIBLE SERIALIZED EQUIPMENT
  11. ALL AVAILABLE JURISDICTIONAL INFORMATION
  12. PDF SCAN OF REDLINES PRODUCED IN FIELD
- C. THE CONTRACTOR SHALL BE RESPONSIBLE FOR ANY AND ALL CORRECTIONS TO ANY WORK IDENTIFIED AS UNACCEPTABLE IN SITE INSPECTION ACTIVITIES AND/OR AS A RESULT OF TESTING.
- D. CONSTRUCTION INSPECTIONS AND CORRECTIVE MEASURES SHALL BE DOCUMENTED BY THE CONTRACTOR WITH WRITTEN REPORTS AND PHOTOGRAPHS. PHOTOGRAPHS MUST BE DIGITAL AND OF SUFFICIENT QUALITY TO CLEARLY SHOW THE SITE CONSTRUCTION. PHOTOGRAPHS MUST CLEARLY IDENTIFY THE PHOTOGRAPHED ITEM AND BE LABELED WITH THE SITE CASCADE NUMBER, SITE NAME, DESCRIPTION, AND DATE.
- 3.4 DELIVERABLES: TEST AND INSPECTION REPORTS AND CLOSEOUT DOCUMENTATION SHALL BE UPLOADED TO THE SMS AND/OR FORWARDED TO SPRINT FOR INCLUSION INTO THE PERMANENT SITE FILES.
- A. THE FOLLOWING TEST AND INSPECTION REPORTS SHALL BE PROVIDED AS APPLICABLE.
1. CONCRETE MIX AND CYLINDER BREAK REPORTS.
  2. STRUCTURAL BACKFILL COMPACTION REPORTS.
  3. SITE RESISTANCE TO EARTH TEST.
  4. ANTENNA AZIMUTH AND DOWN TILT VERIFICATION
  5. TOWER ERECTION INSPECTIONS AND MEASUREMENTS DOCUMENTING TOWER INSTALLED PER SUPPLIER'S REQUIREMENTS AND THE APPLICABLE SECTIONS HEREIN.
  6. COAX CABLE SWEEP TESTS PER COMPANY'S "ANTENNA LINE ACCEPTANCE STANDARDS".
- B. REQUIRED CLOSEOUT DOCUMENTATION INCLUDES THE FOLLOWING;
1. TEST WELLS AND TRENCHES: PHOTOGRAPHS OF ALL TEST WELLS; PHOTOGRAPHS SHOWING ALL OPEN EXCAVATIONS AND TRENCHING PRIOR TO BACKFILLING SHOWING A TAPE MEASURE VISIBLE IN THE EXCAVATIONS INDICATING DEPTH.
  2. CONDUITS, CONDUCTORS AND GROUNDING: PHOTOGRAPHS SHOWING TYPICAL INSTALLATION OF CONDUCTORS AND CONNECTORS; PHOTOGRAPHS SHOWING TYPICAL BEND RADIUS OF INSTALLED GROUND WIRES AND GROUND ROD SPACING;
  3. CONCRETE FORMS AND REINFORCING: CONCRETE FORMING AT TOWER AND EQUIPMENT/SHELTER PAD/FOUNDATIONS - PHOTOGRAPHS SHOWING ALL REINFORCING STEEL, UTILITY AND CONDUIT STUB OUTS; PHOTOGRAPHS SHOWING CONCRETE POUR OF SHELTER SLAB/FOUNDATION, TOWER FOUNDATION AND GUY ANCHORS WITH VIBRATOR IN USE; PHOTOGRAPHS SHOWING EACH ANCHOR ON GUYED TOWERS, BEFORE CONCRETE POUR.
  4. TOWER, ANTENNAS AND MAINLINE: INSPECTION AND PHOTOGRAPHS OF SECTION STACKING; INSPECTION AND PHOTOGRAPHS OF PLATFORM COMPONENT ATTACHMENT POINTS; PHOTOGRAPHS OF TOWER TOP GROUNDING; PHOTOS OF TOWER COAX LINE COLOR CODING AT THE TOP AND AT GROUND LEVEL; INSPECTION AND PHOTOGRAPHS OF OPERATIONAL OF TOWER LIGHTING, AND PLACEMENT OF FAA REGISTRATION SIGN; PHOTOGRAPHS SHOWING ADDITIONAL GROUNDING POINTS FOR TOWERS GREATER THAN 200 FEET.; PHOTOS OF ANTENNA GROUND BAR, EQUIPMENT GROUND BAR, AND MASTER GROUND BAR; PHOTOS OF GPS ANTENNA(S); PHOTOS OF EACH SECTOR OF ANTENNAS; ONE PHOTOGRAPH LOOKING AT THE SECTOR AND ONE FROM BEHIND SHOWING THE PROJECTED COVERAGE AREA; PHOTOS OF COAX WEATHERPROOFING - TOP AND BOTTOM; PHOTOS OF COAX GROUNDING--TOP AND BOTTOM; PHOTOS OF ANTENNA AND MAST GROUNDING; PHOTOS OF COAX CABLE ENTRY INTO SHELTER; PHOTOS OF PLATFORM MECHANICAL CONNECTIONS TO TOWER/MONOPOLE.
  5. ROOF TOPS: PRE-CONSTRUCTION AND POST-CONSTRUCTION VISUAL INSPECTION AND PHOTOGRAPHS OF THE ROOF AND INTERIOR TO DETERMINE AND DOCUMENT CONDITIONS; ROOF TOP CONSTRUCTION INSPECTIONS AS REQUIRED BY THE JURISDICTION; PHOTOGRAPHS OF CABLE TRAY AND/OR ICE BRIDGE; PHOTOGRAPHS OF DOGHOUSE/CABLE EXIT FROM ROOF;
  6. SITE LAYOUT - PHOTOGRAPHS OF THE OVERALL COMPOUND, INCLUDING EQUIPMENT PLATFORM FROM ALL FOUR CORNERS.
  7. FINISHED UTILITIES: CLOSE-UP PHOTOGRAPHS OF THE PPC BREAKER PANEL; CLOSE-UP PHOTOGRAPH OF THE INSIDE OF THE TELCO PANEL AND NIU; CLOSE-UP PHOTOGRAPH OF THE POWER METER AND DISCONNECT; PHOTOS OF POWER AND TELCO ENTRANCE TO COMPANY ENCLOSURE; PHOTOGRAPHS AT METER BOX AND/OR FACILITY DISTRIBUTION PANEL.
  8. REQUIRED MATERIALS CERTIFICATIONS: CONCRETE MIX DESIGNS; MILL CERTIFICATION FOR ALL REINFORCING AND STRUCTURAL STEEL; AND ASPHALT PAVING MIX DESIGN.
  9. ANY AND ALL SUBMITTALS BY THE JURISDICTION OR COMPANY.

SECTION 01 400 - SUBMITTALS & TESTS

PART 1 - GENERAL

- 1.1 THE WORK: THESE STANDARD CONSTRUCTION SPECIFICATIONS IN CONJUNCTION WITH THE OTHER CONTRACT DOCUMENTS AND THE CONSTRUCTION DRAWINGS DESCRIBE THE WORK TO BE PERFORMED BY THE CONTRACTOR.
- 1.2 RELATED DOCUMENTS:
  - A. THE REQUIREMENTS OF THIS SECTION APPLY TO ALL SECTIONS IN THIS SPECIFICATION.
  - B. SPRINT "STANDARD CONSTRUCTION DETAILS FOR WIRELESS SITES" ARE INCLUDED IN AND MADE A PART OF THESE SPECIFICATIONS HEREWITH.

PART 2 - PRODUCTS (NOT USED)

PART 3 - EXECUTION

- 3.1 WEEKLY REPORTS:
  - A. CONTRACTOR SHALL PROVIDE SPRINT WITH WEEKLY REPORTS SHOWING PROJECT STATUS. THIS STATUS REPORT FORMAT WILL BE PROVIDED TO THE CONTRACTOR BY SPRINT. THE REPORT WILL CONTAIN SITE ID NUMBER, THE MILESTONES FOR EACH SITE, INCLUDING THE BASELINE DATE, ESTIMATED COMPLETION DATE AND ACTUAL COMPLETION DATE.
  - B. REPORT INFORMATION WILL BE TRANSMITTED TO SPRINT VIA ELECTRONIC MEANS AS REQUIRED. THIS INFORMATION WILL PROVIDE A BASIS FOR PROGRESS MONITORING AND PAYMENT.
- 3.2 PROJECT CONFERENCE CALLS:
  - A. SPRINT MAY HOLD WEEKLY PROJECT CONFERENCE CALLS. CONTRACTOR WILL BE REQUIRED TO COMMUNICATE SITE STATUS, MILESTONE COMPLETIONS AND UPCOMING MILESTONE PROJECTIONS, AND ANSWER ANY OTHER SITE STATUS QUESTIONS AS NECESSARY.
- 3.3 PROJECT TRACKING IN SMS:
  - A. CONTRACTOR SHALL PROVIDE SCHEDULE UPDATES AND PROJECTIONS IN THE SMS SYSTEM ON A WEEKLY BASIS.
- 3.4 ADDITIONAL REPORTING:
  - A. ADDITIONAL OR ALTERNATE REPORTING REQUIREMENTS MAY BE ADDED TO THE REPORT AS DETERMINED TO BE REASONABLY NECESSARY BY COMPANY.
- 3.5 PROJECT PHOTOGRAPHS:
  - A. FILE DIGITAL PHOTOGRAPHS OF COMPLETED SITE IN JPEG FORMAT IN THE SMS PHOTO LIBRARY FOR THE RESPECTIVE SITE. PHOTOGRAPHS SHALL BE CLEARLY LABELED WITH SITE NUMBER, NAME AND DESCRIPTION, AND SHALL INCLUDE AT A MINIMUM THE FOLLOWING AS APPLICABLE:
    1. SHELTER AND TOWER OVERVIEW.
    2. TOWER FOUNDATION(S) - FORMS AND STEEL BEFORE POUR (EACH ANCHOR ON GUYED TOWERS).
    3. TOWER FOUNDATION(S) POUR WITH VIBRATOR IN USE (EACH ANCHOR ON GUYED TOWERS).
    4. TOWER STEEL AS BEING INSTALLED INTO HOLE (SHOW ANCHOR STEEL ON GUYED TOWERS).
    5. PHOTOS OF TOWER SECTION STACKING.
    6. CONCRETE TESTING / SAMPLES.
    7. PLACING OF ANCHOR BOLTS IN TOWER FOUNDATION.
    8. BUILDING/WATER TANK FROM ROAD FOR TENANT IMPROVEMENTS OR COMMENTS.
    9. SHELTER FOUNDATION--FORMS AND STEEL BEFORE POURING.
    10. SHELTER FOUNDATION POUR WITH VIBRATOR IN USE.
    11. COAX CABLE ENTRY INTO SHELTER.
    12. PLATFORM MECHANICAL CONNECTIONS TO TOWER/MONOPOLE.
    13. ROOFTOP PRE AND POST CONSTRUCTION PHOTOS TO INCLUDE PENETRATIONS AND INTERIOR CEILING.
    14. PHOTOS OF TOWER TOP COAX LINE COLOR CODING AND COLOR CODING AT GROUND LEVEL.
    15. PHOTOS OF ALL APPROPRIATE COMPANY OR REGULATORY SIGNAGE.
    16. PHOTOS OF EQUIPMENT BOLT DOWN INSIDE SHELTER.
    17. POWER AND TELCO ENTRANCE TO COMPANY ENCLOSURE AND POWER AND TELCO SUPPLY LOCATIONS INCLUDING METER/DISCONNECT.
    18. ELECTRICAL TRENCH(S) WITH ELECTRICAL / CONDUIT BEFORE BACKFILL.
    19. ELECTRICAL TRENCH(S) WITH FOIL-BACKED TAPE BEFORE FURTHER BACKFILL.
    20. TELCO TRENCH WITH TELEPHONE / CONDUIT BEFORE BACKFILL.
    21. TELCO TRENCH WITH FOIL-BACKED TAPE BEFORE FURTHER BACKFILL.
    22. SHELTER GROUND-RING TRENCH WITH GROUND-WIRE BEFORE BACKFILL (SHOW ALL CAD WELDS AND BEND RADII).
    23. TOWER GROUND-RING TRENCH WITH GROUND-WIRE BEFORE BACKFILL (SHOW ALL CAD WELDS AND BEND RADII).

24. FENCE GROUND-RING TRENCH WITH GROUND-WIRE BEFORE BACKFILL (SHOW ALL CAD WELDS AND BEND RADII).
25. ALL BTS GROUND CONNECTIONS.
26. ALL GROUND TEST WELLS.
27. ANTENNA GROUND BAR AND EQUIPMENT GROUND BAR.
28. ADDITIONAL GROUNDING POINTS ON TOWERS ABOVE 200'.
29. HVAC UNITS INCLUDING CONDENSERS ON SPLIT SYSTEMS.
30. GPS ANTENNAS.
31. CABLE TRAY AND/OR WAVEGUIDE BRIDGE.
32. DOGHOUSE/CABLE EXIT FROM ROOF.
33. EACH SECTOR OF ANTENNAS; ONE PHOTOGRAPH LOOKING AT THE SECTOR AND ONE FROM BEHIND SHOWING THE PROJECTED COVERAGE AREA.
34. MASTER BUS BAR.
35. TELCO BOARD AND NIU.
36. ELECTRICAL DISTRIBUTION WALL.
37. CABLE ENTRY WITH SURGE SUPPRESSION.
38. ENTRANCE TO EQUIPMENT ROOM.
39. COAX WEATHERPROOFING--TOP AND BOTTOM OF TOWER.
40. COAX GROUNDING --TOP AND BOTTOM OF TOWER.
41. ANTENNA AND MAST GROUNDING.
42. LANDSCAPING - WHERE APPLICABLE.

3.6 FINAL PROJECT ACCEPTANCE: COMPLETE ALL REQUIRED REPORTING TASKS PER CONTRACT, CONTRACT DOCUMENTS OR THE SPRINT INTEGRATED CONSTRUCTION STANDARDS FOR WIRELESS SITES AND UPLOAD INTO SITERRA.

PLANS PREPARED FOR:



PLANS PREPARED BY:



MLA PARTNER:



ENGINEERING LICENSE:



DRAWING NOTICE:

THESE DOCUMENTS ARE CONFIDENTIAL AND ARE THE SOLE PROPERTY OF SPRINT AND MAY NOT BE REPRODUCED, DISSEMINATED OR REDISTRIBUTED WITHOUT THE EXPRESS WRITTEN CONSENT OF SPRINT.

REVISIONS:

DESCRIPTION	DATE	BY	REV
ISSUED FOR PERMIT	9/16/14	J.M	0

SITE NAME:

BIC DRIVE (SSUSA)

SITE CASCADE:

CT03XC171

SITE ADDRESS:

111 SCHOOL HOUSE RD,  
AKA BIC DRIVE  
MILFORD, CT 06460

SHEET DESCRIPTION:

SPRINT SPECIFICATIONS

SHEET NUMBER:

SP-3

INFORMATION CONTAINED WITHIN DRAWINGS ARE BASED ON PROVIDED INFORMATION AND ARE NOT THE RESULT OF A FIELD SURVEY.

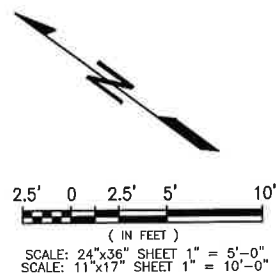
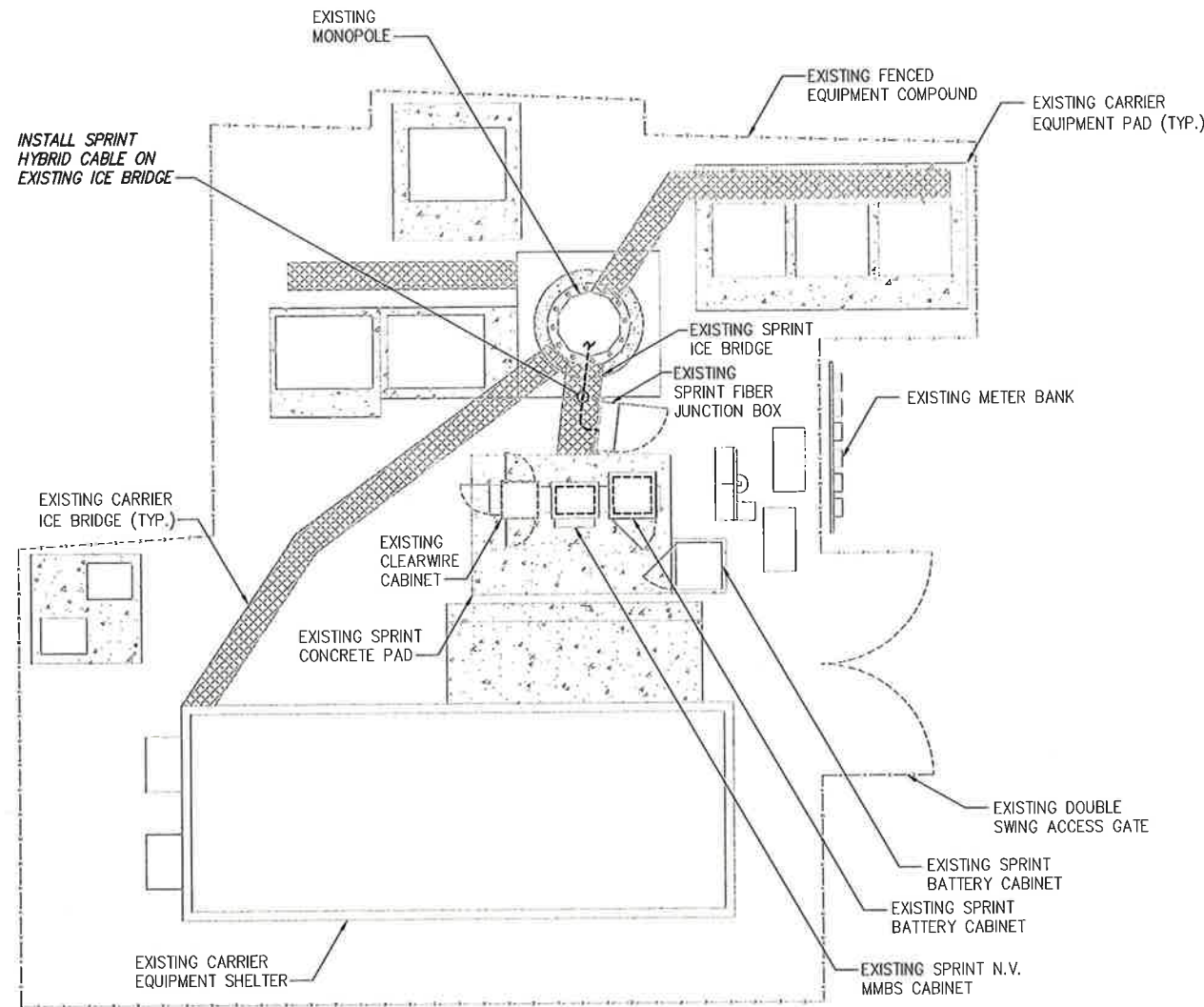

OVERALL SITE PLAN

SCALE AS NOTED

1

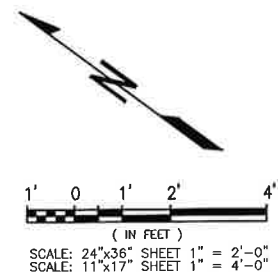
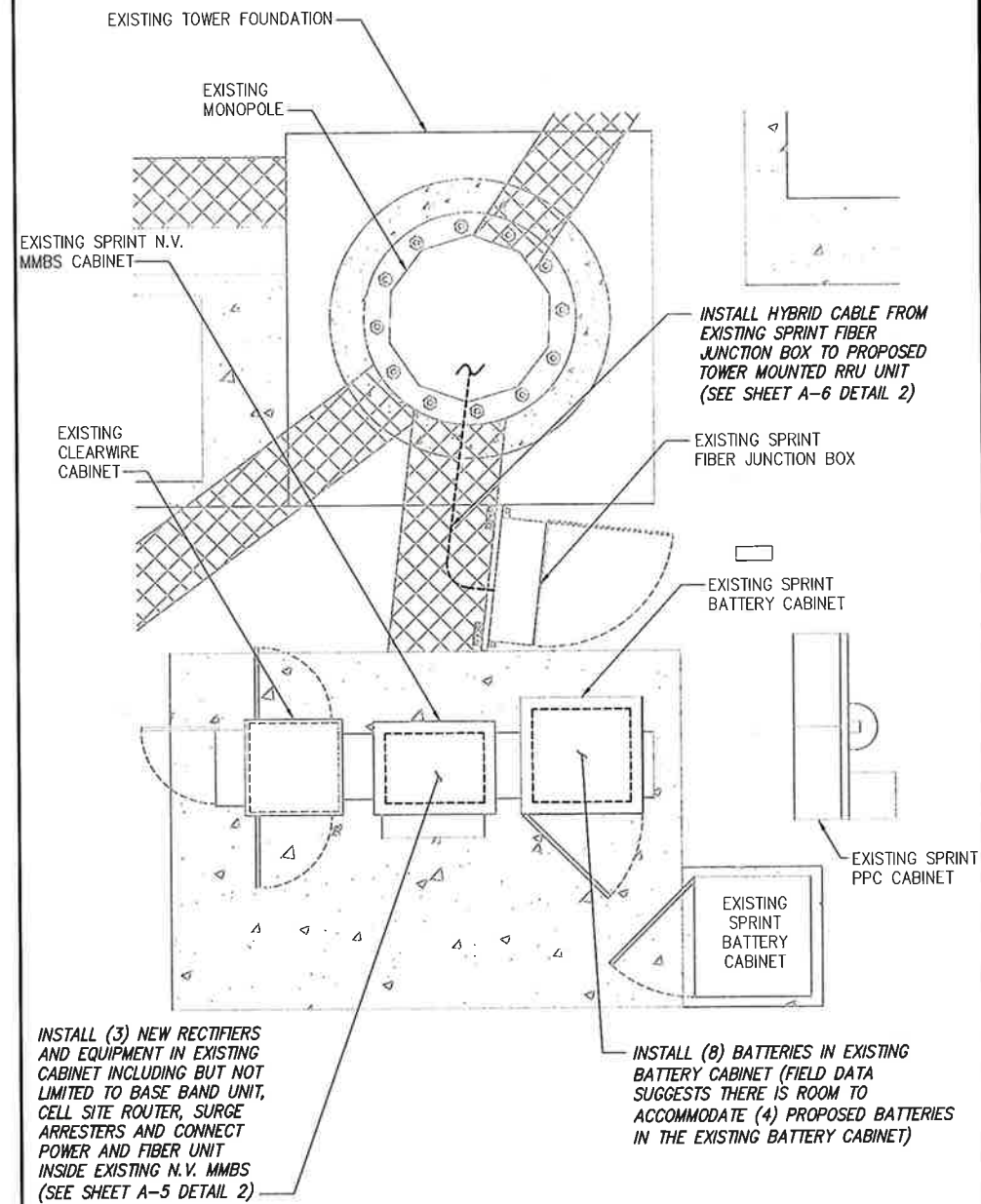

SPRINT EQUIPMENT PLAN

SCALE AS NOTED

2

PLANS PREPARED FOR:

**Sprint**  
 6580 Sprint Parkway  
 Overland Park, Kansas 66251

PLANS PREPARED BY:

**INFINIGY** Design. Build. Deliver.  
 1033 Watervliet Shaker Rd  
 Albany, NY 12205  
 Office # (518) 690-0790  
 Fax # (518) 690-0793  
 JOB NUMBER 353-XXXX

MLA PARTNER:

**CROWN CASTLE**

ENGINEERING LICENSE:

DRAWING NOTICE:

THESE DOCUMENTS ARE CONFIDENTIAL AND ARE THE SOLE PROPERTY OF SPRINT AND MAY NOT BE REPRODUCED, DISSEMINATED OR REDISTRIBUTED WITHOUT THE EXPRESS WRITTEN CONSENT OF SPRINT.

REVISIONS:

DESCRIPTION	DATE	BY	REV
ISSUED FOR PERMIT	9/16/14	JLM	0

SITE NAME:

BIC DRIVE (SSUSA)

SITE CASCADE:

CT03XC171

SITE ADDRESS:

111 SCHOOL HOUSE RD,  
 AKA BIC DRIVE  
 MILFORD, CT 06460

SHEET DESCRIPTION:

SITE PLAN

SHEET NUMBER:

A-1

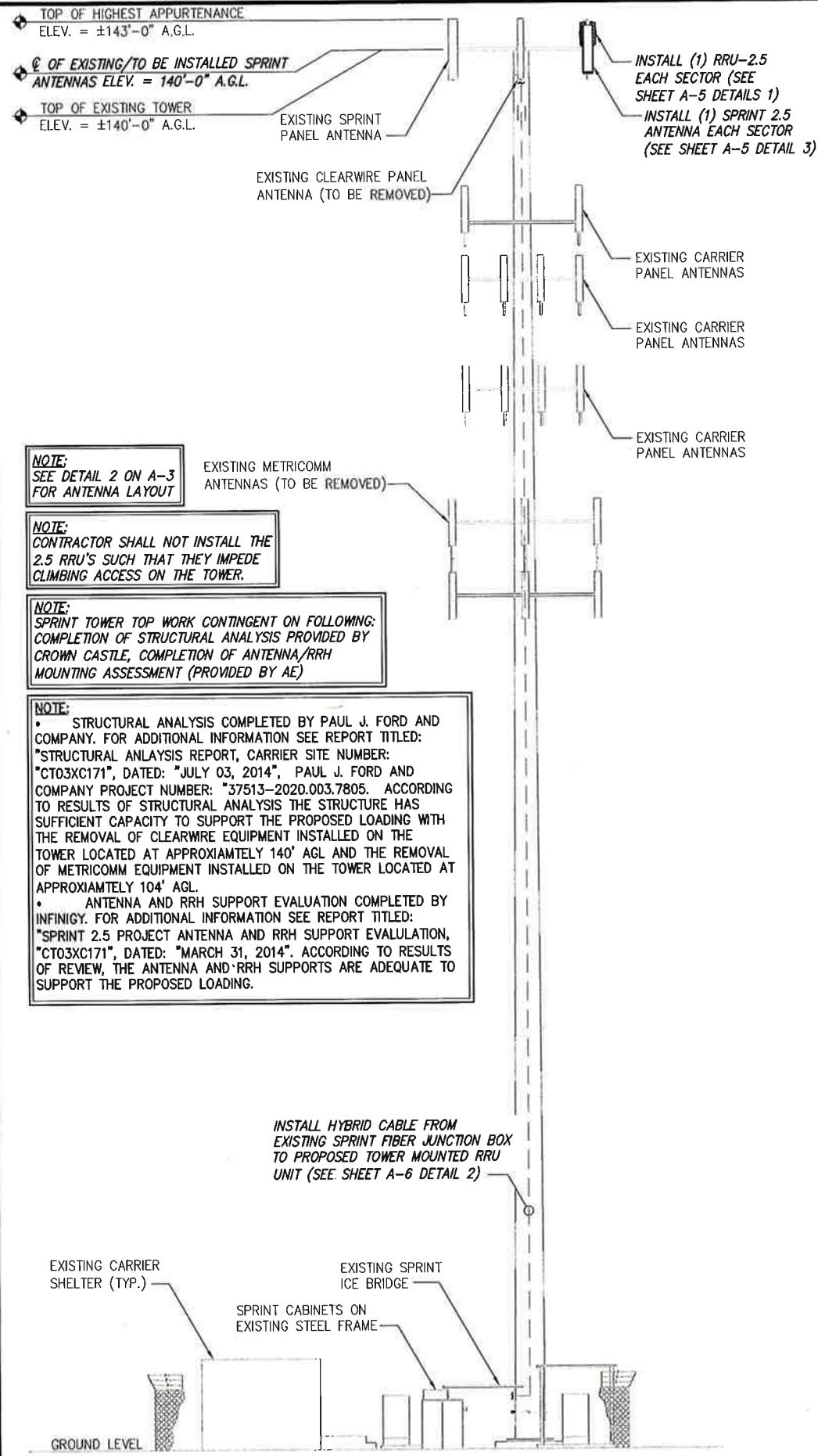

**NOTE:**  
SEE DETAIL 2 ON A-3  
FOR ANTENNA LAYOUT

**NOTE:**  
CONTRACTOR SHALL NOT INSTALL THE  
2.5 RRU'S SUCH THAT THEY IMPEDE  
CLIMBING ACCESS ON THE TOWER.

**NOTE:**  
SPRINT TOWER TOP WORK CONTINGENT ON FOLLOWING:  
COMPLETION OF STRUCTURAL ANALYSIS PROVIDED BY  
CROWN CASTLE, COMPLETION OF ANTENNA/RRH  
MOUNTING ASSESSMENT (PROVIDED BY AE)

**NOTE:**  
• STRUCTURAL ANALYSIS COMPLETED BY PAUL J. FORD AND  
COMPANY. FOR ADDITIONAL INFORMATION SEE REPORT TITLED:  
"STRUCTURAL ANALYSIS REPORT, CARRIER SITE NUMBER:  
"CT03XC171", DATED: "JULY 03, 2014", PAUL J. FORD AND  
COMPANY PROJECT NUMBER: "37513-2020.003.7805. ACCORDING  
TO RESULTS OF STRUCTURAL ANALYSIS THE STRUCTURE HAS  
SUFFICIENT CAPACITY TO SUPPORT THE PROPOSED LOADING WITH  
THE REMOVAL OF CLEARWIRE EQUIPMENT INSTALLED ON THE  
TOWER LOCATED AT APPROXIMATELY 140' AGL AND THE REMOVAL  
OF METRICOMM EQUIPMENT INSTALLED ON THE TOWER LOCATED AT  
APPROXIMATELY 104' AGL.  
• ANTENNA AND RRH SUPPORT EVALUATION COMPLETED BY  
INFINIGY. FOR ADDITIONAL INFORMATION SEE REPORT TITLED:  
"SPRINT 2.5 PROJECT ANTENNA AND RRH SUPPORT EVALUATION,  
"CT03XC171", DATED: "MARCH 31, 2014". ACCORDING TO RESULTS  
OF REVIEW, THE ANTENNA AND RRH SUPPORTS ARE ADEQUATE TO  
SUPPORT THE PROPOSED LOADING.

DETAIL NOT USED

NO SCALE

2

TOWER ELEVATION

NO SCALE

1

DETAIL NOT USED

NO SCALE

3

DETAIL NOT USED

NO SCALE

4

PLANS PREPARED FOR:

**Sprint**  
6580 Sprint Parkway  
Overland Park, Kansas 66251

PLANS PREPARED BY:

**INFINIGY** Design.  
Build.  
Deliver.  
1033 Watervliet Shaker Rd  
Albany, NY 12205  
Office # (518) 690-0790  
Fax # (518) 690-0793  
JOB NUMBER 353-XXXX

MLA PARTNER:

**CROWN  
CASTLE**

ENGINEERING LICENSE:

STATE OF CONNECTICUT  
JOHN S. STEVENS  
No. 24705  
LICENSED PROFESSIONAL ENGINEER

DRAWING NOTICE:

THESE DOCUMENTS ARE CONFIDENTIAL AND ARE  
THE SOLE PROPERTY OF SPRINT AND MAY NOT BE  
REPRODUCED, DISSEMINATED OR REDISTRIBUTED  
WITHOUT THE EXPRESS WRITTEN CONSENT OF  
SPRINT.

REVISIONS:

DESCRIPTION	DATE	BY	REV
ISSUED FOR PERMIT	9/16/14	JLM	0

SITE NAME:

BIC DRIVE (SSUSA)

SITE CASCADE:

CT03XC171

SITE ADDRESS:

111 SCHOOL HOUSE RD,  
AKA BIC DRIVE  
MILFORD, CT 06460

SHEET DESCRIPTION:

TOWER ELEVATION  
& CABLE PLAN

SHEET NUMBER:

A-2



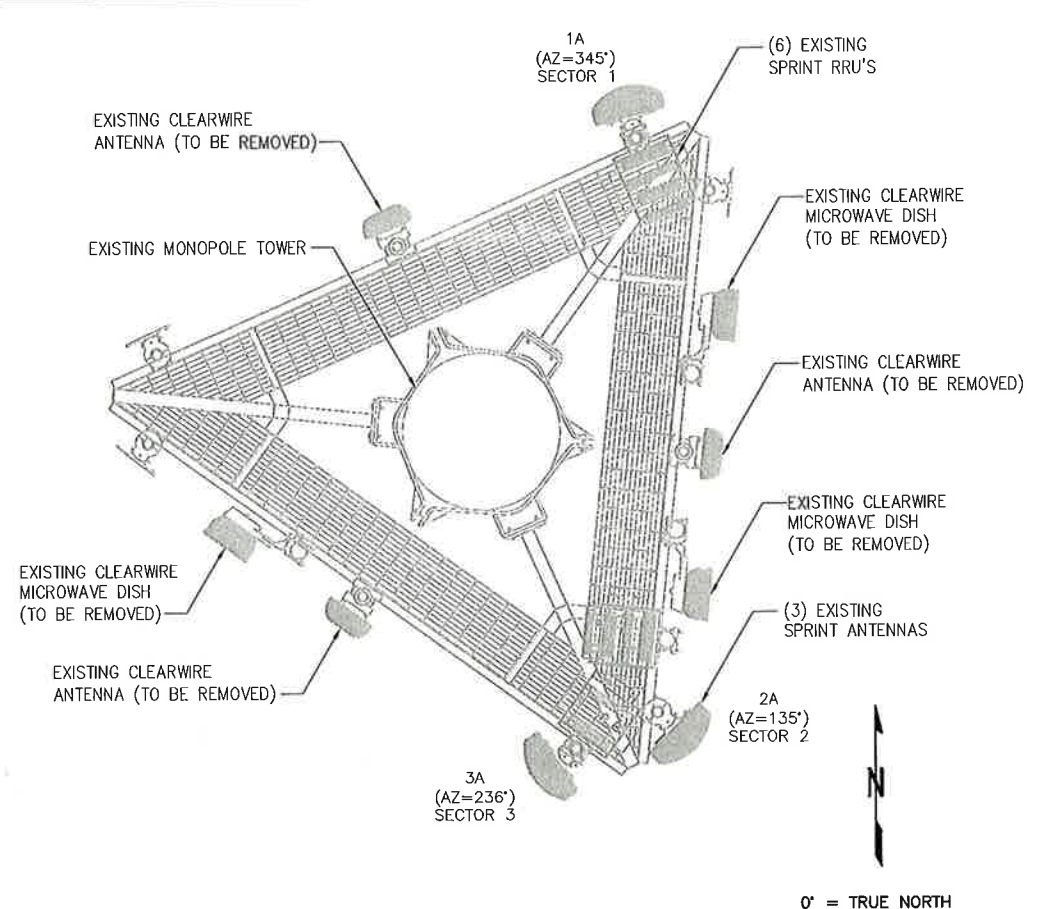

EXISTING ANTENNA & RRU LAYOUT

NO SCALE 1

THE CONFIGURATION PLANS ARE BASED ON PROVIDED INFORMATION AND ARE FOR CONCEPTUAL PURPOSES ONLY. CONTRACTOR TO VERIFY FIELD CONDITIONS PRIOR TO CONSTRUCTION.

NOTE: JUMPERS FROM 2.5 RRU TO THE 2.5 ANTENNA CANNOT EXCEED 15 FEET

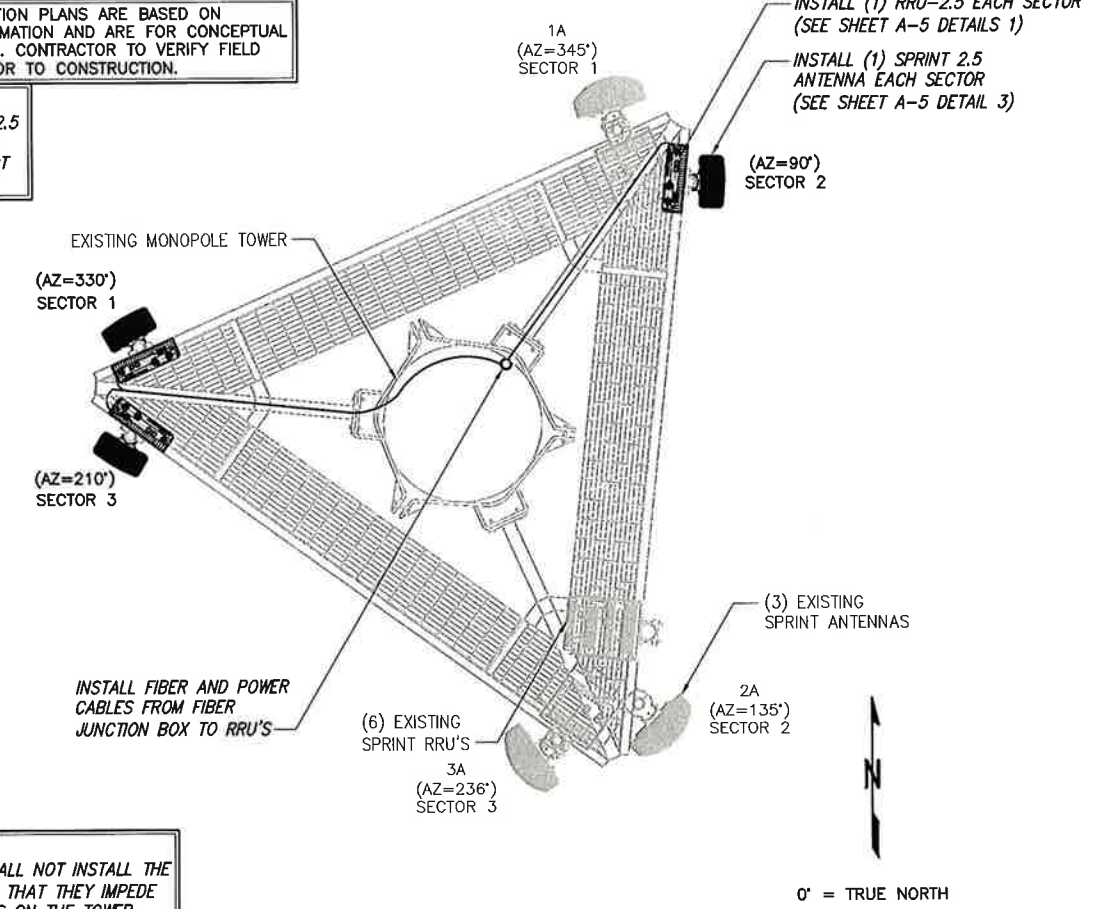

FINAL ANTENNA LAYOUT

NO SCALE 2

NOTE: CONTRACTOR SHALL NOT INSTALL THE 2.5 RRU'S SUCH THAT THEY IMPEDE CLIMBING ACCESS ON THE TOWER.

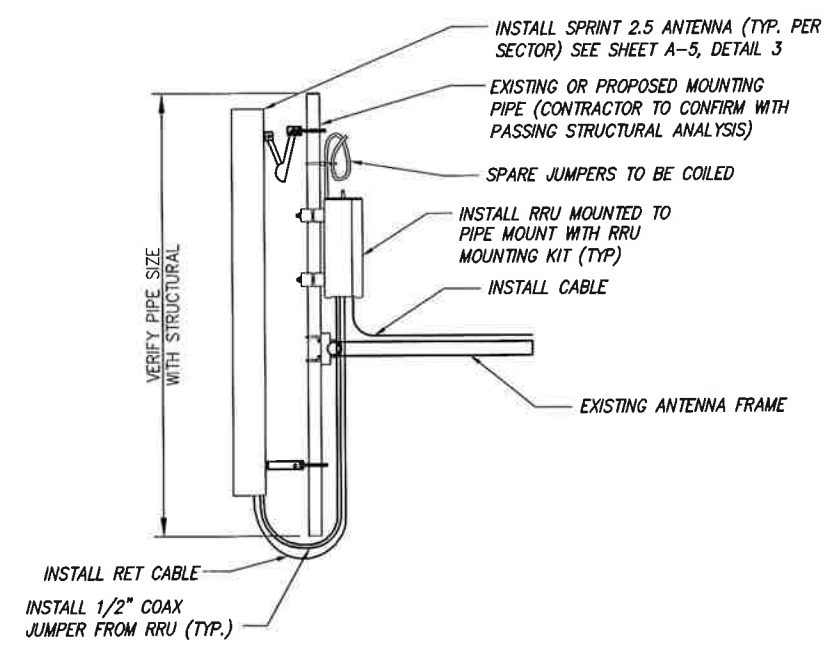

- NOTES:
- CUT DC CONDUCTORS TO LENGTH.
  - COIL FIBER CABLE AND SECURE AT SIDE OF RRU.
  - DO NOT EXCEED BEND RADIUS.

NOTE: CONTRACTOR TO POSITION RRU ON MOUNT BEHIND ANTENNA SUCH THAT THE RRU DOES NOT INTERFERE WITH THE EXISTING PLATFORM/T-ARM MOUNTING HARDWARE.

NOTE: SPARE DC CABLES ARE COILED UP ON NV RRHS AT SPRINT ARRAY. THESE ARE TO BE USED TO POWER UP THE 2.5 RRHS AND TIED INTO EXISTING DC BREAKERS INSIDE THE FIBER JUNCTION BOX LOCATED AT EQUIPMENT.

NOTE: THE DIAGRAM IS FOR CONCEPTUAL PURPOSES ONLY. CONTRACTOR IS TO REFER TO PASSING STRUCTURAL ANALYSIS FOR ANTENNA AND RRU MOUNTING DETAILS.

DETAIL NOT USED

NO SCALE 3

TYPICAL ANTENNA & RRU MOUNTING DETAILS

NO SCALE 4

PLANS PREPARED FOR:

6580 Sprint Parkway  
Overland Park, Kansas 66251

PLANS PREPARED BY:

Design. Build. Deliver.  
1033 Watervliet Shaker Rd  
Albany, NY 12205  
Office # (518) 690-0790  
Fax # (518) 690-0793  
JOB NUMBER 353-XXXX

MLA PARTNER:

ENGINEERING LICENSE:

DRAWING NOTICE:  
THESE DOCUMENTS ARE CONFIDENTIAL AND ARE THE SOLE PROPERTY OF SPRINT AND MAY NOT BE REPRODUCED, DISSEMINATED OR REDISTRIBUTED WITHOUT THE EXPRESS WRITTEN CONSENT OF SPRINT.

REVISIONS:

DESCRIPTION	DATE	BY	REV

ISSUED FOR PERMIT: 9/16/14 JLM 0

SITE NAME:  
BIC DRIVE (SSUSA)

SITE CASCADE:  
CT03XC171

SITE ADDRESS:  
111 SCHOOL HOUSE RD,  
AKA BIC DRIVE  
MILFORD, CT 06460

SHEET DESCRIPTION:  
ANTENNA LAYOUT  
& MOUNTING DETAILS

SHEET NUMBER:  
A-3

NV CABLES			
BAND	INDICATOR	PORT	COLOR
800-1	YEL GRN	NV-1	GRN
1900-1	YEL RED	NV-2	BLU
1900-2	YEL BRN	NV-3	BRN
1900-3	YEL BLU	NV-4	WHT
1900-4	YEL SLT	NV-5	RED
800-2	YEL ORG	NV-6	SLT
SPARE	YEL WHT	NV-7	PPL
2500	YEL PPL	NV-8	ORG

HYBRID	
HYBRID	COLOR
1	GRN
2	BLU
3	BRN
4	WHT
5	RED
6	SLT
7	PPL
8	ORG

2.5 Band		
2500 Radio 1	COLOR	
YEL WHT	GRN	
YEL WHT	BLU	
YEL WHT	BRN	
YEL WHT	WHT	
YEL WHT	RED	
YEL WHT	SLT	
YEL WHT	PPL	
YEL WHT	ORG	

Figure 1: Antenna Orientation

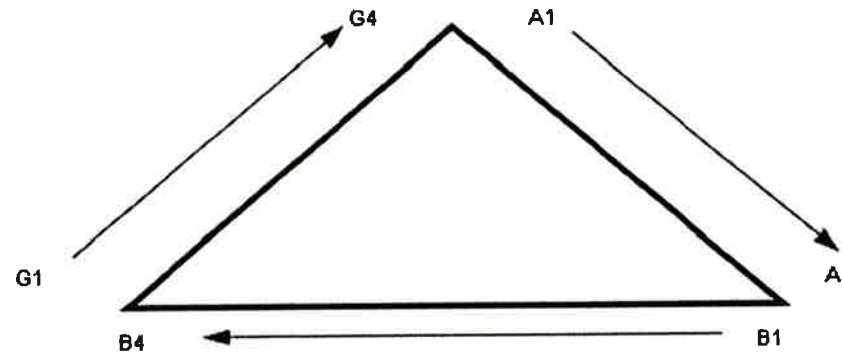

NOTES:

- ALL CABLES SHALL BE MARKED WITH 2" WIDE, UV STABILIZED, UL APPROVED TAPE.
- THE FIRST RING SHALL BE CLOSEST TO THE END OF THE CABLE AND SPACED APPROXIMATELY 2" FROM THE END CONNECTOR, WEATHERPROOFING, OR BREAK-OUT CYLINDER. THERE SHALL BE A 1" SPACE BETWEEN EACH RING FOR THE CABLE IDENTIFIER, AND NO SPACES BETWEEN THE FREQUENCY BANDS.
- A 2" GAP SHALL SEPARATE THE CABLE COLOR CODE FROM THE FREQUENCY COLOR CODE. THE 2" COLOR RINGS FOR THE FREQUENCY CODE SHALL BE PLACED NEXT TO EACH OTHER WITH NO SPACES.
- THE 2" COLORED TAPE(S) SHALL EACH BE WRAPPED A MINIMUM OF 3 TIMES AROUND THE INDIVIDUAL CABLES, AND THE TAPE SHALL BE KEPT IN THE SAME LOCATION AS MUCH AS POSSIBLE.
- SITES WITH MORE THAN FOUR (4) SECTORS WILL REQUIRE ADDITIONAL RINGS FOR EACH SECTOR, FOLLOWING THE PATTERN. HIGH CAPACITY SITES WILL USE THE NEXT COLOR IN THE SEQUENCE FOR ADDITIONAL CABLES IN EACH SECTOR.
- HYBRID FIBER CABLE SHALL BE SECTOR IDENTIFIED INSIDE THE CABINET ON FREQUENCY BUNDLES, ON THE SEALTITE, ON THE MAIN LINE UPON EXIT OF SEALTITE, AND BEFORE AND AFTER THE BREAKOUT UNIT (MEDUSA), AS WELL AS BEFORE AND AFTER ANY ENTRANCE OR EXIT.
- HFC "MAIN TRUNK" WILL NOT BE MARKED WITH THE FREQUENCY CODES, AS IT CONTAINS ALL FREQUENCIES.
- INDIVIDUAL POWER PAIRS AND FIBER BUNDLES SHALL BE LABELED WITH BOTH THE CABLE AND FREQUENCY.

Sector	Cable	First Ring	Second Ring	Third Ring
1 Alpha	1	Green	No Tape	No Tape
	2		No Tape	No Tape
	3	Brown	No Tape	No Tape
	4	White	No Tape	No Tape
	5	Red	No Tape	No Tape
	6	Grey	No Tape	No Tape
	7	Purple	No Tape	No Tape
	8	Orange	No Tape	No Tape
2 Beta	1	Green	Green	No Tape
	2			No Tape
	3	Brown	Brown	No Tape
	4	White	White	No Tape
	5	Red	Red	No Tape
	6	Grey	Grey	No Tape
	7	Purple	Purple	No Tape
	8	Orange	Orange	No Tape
3 Gamma	1	Green	Green	Green
	2			
	3	Brown	Brown	Brown
	4	White	White	White
	5	Red	Red	Red
	6	Grey	Grey	Grey
	7	Purple	Purple	Purple
	8	Orange	Orange	Orange

NV FREQUENCY	INDICATOR	ID
800-1	YEL GRN	GRN
1900-1	YEL RED	RED
1900-2	YEL BRN	BRN
1900-3	YEL BLU	BLU
1900-4	YEL SLT	SLT
800-1	YEL ORG	ORG
RESERVED	YEL WHT	WHT
RESERVED	YEL PPL	PPL

2.5 FREQUENCY	INDICATOR		ID
2500 -1	YEL	WHT	GRN
2500 -2	YEL	WHT	RED
2500 -3	YEL	WHT	BRN
2500 -4	YEL	WHT	BLU
2500 -5	YEL	WHT	SLT
2500 -6	YEL	WHT	ORG
2500 -7	YEL	WHT	WHT
2500 -8	YEL	WHT	PPL

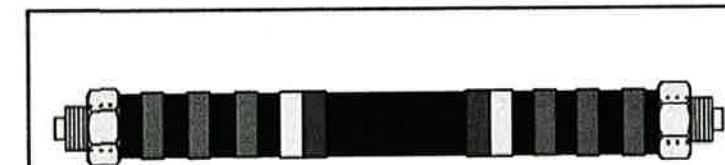

PLANS PREPARED FOR:

6580 Sprint Parkway  
Overland Park, Kansas 66251

PLANS PREPARED BY:

1033 Watervliet Shaker Rd  
Albany, NY 12205  
Office # (518) 690-0790  
Fax # (518) 690-0793  
JOB NUMBER 353-100X

MLA PARTNER:

ENGINEERING LICENSE:

DRAWING NOTICE:  
THESE DOCUMENTS ARE CONFIDENTIAL AND ARE THE SOLE PROPERTY OF SPRINT AND MAY NOT BE REPRODUCED, DISSEMINATED OR REDISTRIBUTED WITHOUT THE EXPRESS WRITTEN CONSENT OF SPRINT.

REVISIONS:	DESCRIPTION	DATE	BY	REV
ISSUED FOR PERMIT		9/16/14	JLM	0

SITE NAME:  
BIC DRIVE (SSUSA)

SITE CASCADE:  
CT03XC171

SITE ADDRESS:  
111 SCHOOL HOUSE RD,  
AKA BIC DRIVE  
MILFORD, CT 06460

SHEET DESCRIPTION:  
COLOR CODING AND NOTES

SHEET NUMBER:  
A-4

RRU: ALCATEL LUCENT TD-RRH8X20  
 COLOR: LIGHT GREY  
 WEIGHT: 70 LBS.

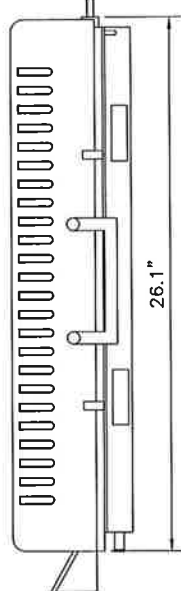

SIDE VIEW

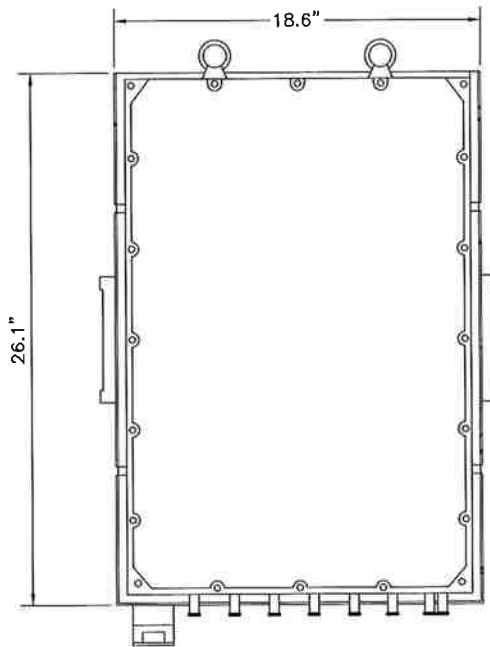

FRONT VIEW

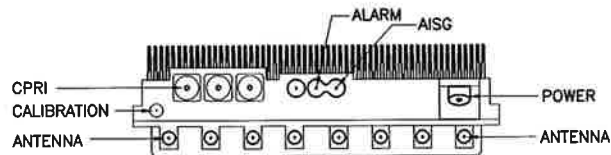

NOTES:  
 COMPLY WITH MANUFACTURERS INSTRUCTIONS TO ENSURE THAT ALL RRU'S RECEIVE ELECTRICAL POWER WITHIN 24 HOURS OF BEING REMOVED FROM THE MANUFACTURER'S PACKAGING. DO NOT OPEN RRU PACKAGES IN THE RAIN

2.5 RRU'S

NO SCALE

1

2.5 EQUIPMENT IN EXISTING CABINET

NO SCALE

2

- DS3 SURGE PROTECTOR
- POWER INJECTOR 5-8
- POWER INJECTOR 1-4
- 7210 SAS-M 2
- 7210 SAS-M 1
- 7205 SAR-8
- LTE-BBU 2.5GHz
- LTE-BBU FDD
- CDMA MT-BBU GROWTH
- CDMA MT-BBU PRIMARY
- PDP1
- PDP2
- 15MHz SPLITTER
- ETHERNET HUB SEC-B
- PRIMARY PROTECTION T1
- SEC-B #1, #1 & #3
- RECTIFIER SHELF PRIMARY
- RECTIFIER SHELF 2.5GHz

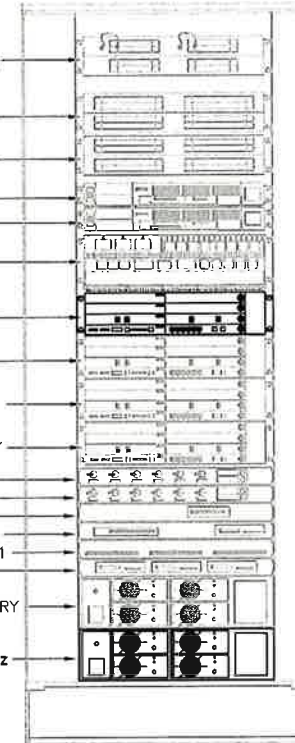

FRONT VIEW

ANTENNA RFS APXVTM14-C-I20

RADOME MATERIAL: ASA  
 RADOME COLOR: LIGHT GRAY  
 DIMENSIONS, HxWxD.in(mim): 56.3"x12.6"x6.3" (1430x320x160mm)  
 WEIGHT: 52.9 lbs  
 CONNECTORS: (8) 4.1/9.5 DIN FEMALE  
 (1) NF - CALIBRATION CONNECTOR

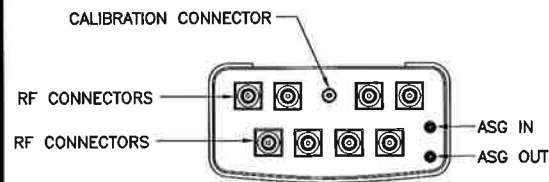

PLAN VIEW

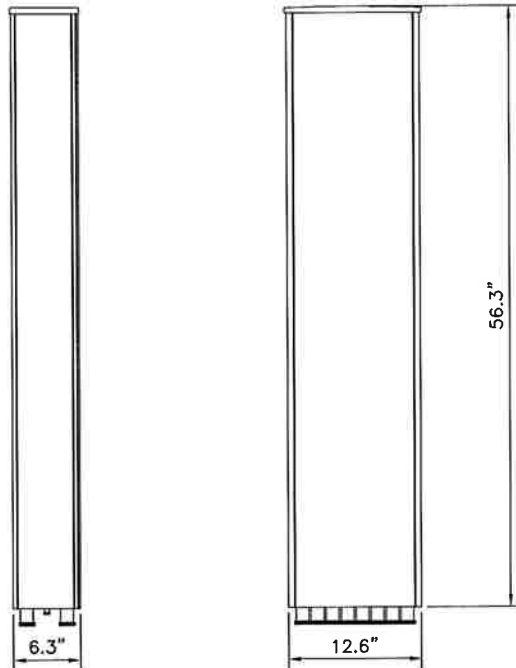

2.5 ANTENNA

NO SCALE

3

DETAIL NOT USED

NO SCALE

4

PLANS PREPARED FOR:



PLANS PREPARED BY:



MLA PARTNER:



ENGINEERING LICENSE:



DRAWING NOTICE:

THESE DOCUMENTS ARE CONFIDENTIAL AND ARE THE SOLE PROPERTY OF SPRINT AND MAY NOT BE REPRODUCED, DISSEMINATED OR REDISTRIBUTED WITHOUT THE EXPRESS WRITTEN CONSENT OF SPRINT.

REVISIONS:

DESCRIPTION	DATE	BY	REV
ISSUED FOR PERMIT	9/16/14	JLM	0

SITE NAME:

BIC DRIVE (SSUSA)

SITE CASCADE:

CT03XC171

SITE ADDRESS:

111 SCHOOL HOUSE RD,  
 AKA BIC DRIVE  
 MILFORD, CT 06460

SHEET DESCRIPTION:

EQUIPMENT &  
 MOUNTING DETAILS

SHEET NUMBER:

A-5

**RFS HYBRIFLEX RISER CABLE SCHEDULE**

Fiber Only (Existing DC Power)	Hybrid cable MN: HB058-M12-050F 12x multi-mode fiber pairs, Top: Outdoor protected connectors, Bottom: LC Connectors, 5/8 cable, 50 ft	50 ft
	MN: HB058-M12-075F	75 ft
	MN: HB058-M12-100F	100 ft
	MN: HB058-M12-125F	125 ft
	MN: HB058-M12-150F	150 ft
	MN: HB058-M12-175F	175 ft
	MN: HB058-M12-200F	200 ft
8 AWG Power	Hybrid cable MN: HB114-08U3M12-050F 3x 8 AWG power pairs, 12x multi-mode fiber pairs, Outdoor rated connectors & LC Connectors, 1 1/4 cable, 50 ft	50 ft
	MN: HB114-08U3M12-075F	75 ft
	MN: HB114-08U3M12-100F	100 ft
	MN: HB114-08U3M12-125F	125 ft
	MN: HB114-08U3M12-150F	150 ft
	MN: HB114-08U3M12-175F	175 ft
	MN: HB114-08U3M12-200F	200 ft
6 AWG Power	Hybrid cable MN: HB114-13U3M12-225F 3x 6 AWG power pair, 12x multi-mode fiber pairs, Outdoor rated connectors & LC Connectors, 1 1/4 cable, 225 ft	225 ft
	MN: HB114-13U3M12-250F	250 ft
	MN: HB114-13U3M12-275F	275 ft
	MN: HB114-13U3M12-300F	300 ft
4 AWG Power	Hybrid cable MN: HB114-21U3M12-325F 3x 4 AWG power pair, 12x multi-mode fiber pairs, Outdoor rated connectors & LC Connectors, 1 1/4 cable, 325 ft	325 ft
	MN: HB114-21U3M12-350F	350 ft
	MN: HB114-21U3M12-375F	375 ft

**RFS HYBRIFLEX JUMPER CABLE SCHEDULE**

Fiber Only	Hybrid Jumper cable MN: HBF012-M3-SF1 5 ft, 3x multi-mode fiber pairs, Outdoor & LC connectors, 1/2 cable	5 ft
	MN: HBF012-M3-10F1	10 ft
	MN: HBF012-M3-15F1	15 ft
	MN: HBF012-M3-20F1	20 ft
	MN: HBF012-M3-25F1	25 ft
	MN: HBF012-M3-30F1	30 ft
8 AWG Power	Hybrid Jumper cable MN: HBF058-08U1M3-SF1 5 ft, 3x 8 AWG power pair, 3x multi-mode fiber pairs, Outdoor & LC Connectors, 5/8 cable	5 ft
	MN: HBF058-08U1M3-10F1	10 ft
	MN: HBF058-08U1M3-15F1	15 ft
	MN: HBF058-08U1M3-20F1	20 ft
	MN: HBF058-08U1M3-25F1	25 ft
	MN: HBF058-08U1M3-30F1	30 ft
6 AWG Power	Hybrid Jumper cable MN: HBF058-13U1M3-SF1 5 ft, 1x 6 AWG power pair, 3x multi-mode fiber pairs, Outdoor & LC Connectors, 5/8 cable	5 ft
	MN: HBF058-13U1M3-10F1	10 ft
	MN: HBF058-13U1M3-15F1	15 ft
	MN: HBF058-13U1M3-20F1	20 ft
	MN: HBF058-13U1M3-25F1	25 ft
	MN: HBF058-13U1M3-30F1	30 ft
4 AWG Power	Hybrid Jumper cable MN: HBF078-21U1M3-SF1 5 ft, 3x 4 AWG power pair, 3x multi-mode fiber pairs, Outdoor & LC Connectors, 7/8 cable	5 ft
	MN: HBF078-21U1M3-10F1	10 ft
	MN: HBF078-21U1M3-15F1	15 ft
	MN: HBF078-21U1M3-20F1	20 ft
	MN: HBF078-21U1M3-25F1	25 ft
	MN: HBF078-21U1M3-30F1	30 ft

NOTE:  
SPRINT CM TO CONFIRM HYBRID OR FIBER RISER CABLE  
AND HYBRID OR FIBER JUMPER CABLE MODEL NUMBERS IF  
HYBRID CABLES ARE REQUIRED BEFORE PREPARING BOM.

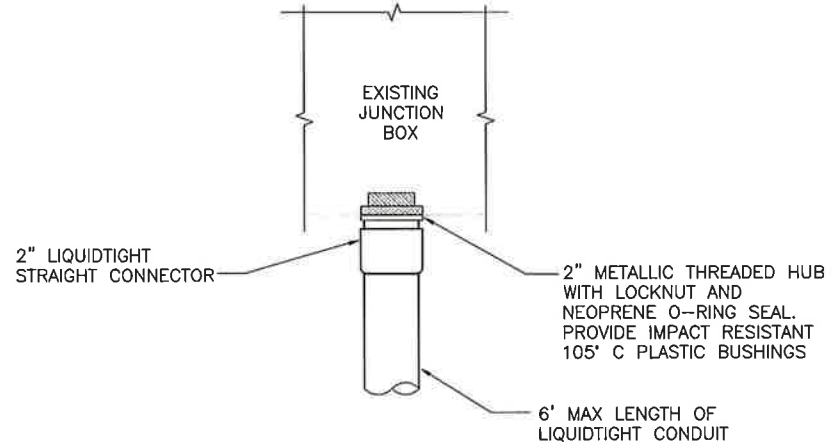
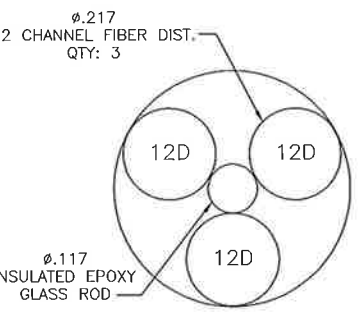
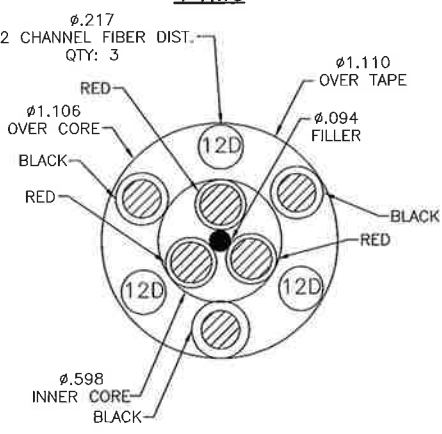
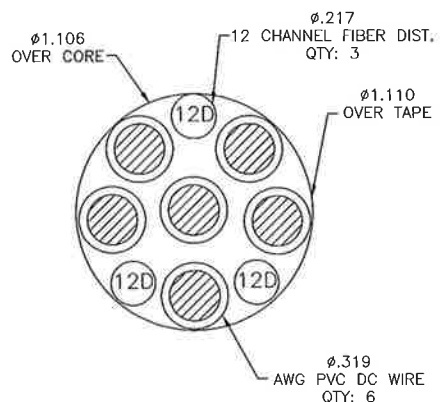

**FIBER JUNCTION BOX PENETRATION**

NO SCALE 2

**2.5 CABLE CROSS SECTION DATA**

NO SCALE 1

**DETAIL NOT USED**

NO SCALE 3

PLANS PREPARED FOR:

6580 Sprint Parkway  
Overland Park, Kansas 66251

PLANS PREPARED BY:

Design. Build. Deliver.  
1033 Watervliet Shaker Rd  
Albany, NY 12205  
Office # (518) 690-0790  
Fax # (518) 690-0793  
JOB NUMBER 353-XXXX

MLA PARTNER:

ENGINEERING LICENSE:

DRAWING NOTICE:  
THESE DOCUMENTS ARE CONFIDENTIAL AND ARE THE SOLE PROPERTY OF SPRINT AND MAY NOT BE REPRODUCED, DISSEMINATED OR REDISTRIBUTED WITHOUT THE EXPRESS WRITTEN CONSENT OF SPRINT.

REVISIONS:

DESCRIPTION	DATE	BY	REV
ISSUED FOR PERMIT	9/16/14	JLM	0

SITE NAME:  
**BIC DRIVE (SSUSA)**

SITE CASCADE:  
**CT03XC171**

SITE ADDRESS:  
111 SCHOOL HOUSE RD,  
AKA BIC DRIVE  
MILFORD, CT 06460

SHEET DESCRIPTION:  
**CIVIL DETAILS**

SHEET NUMBER:  
**A-6**

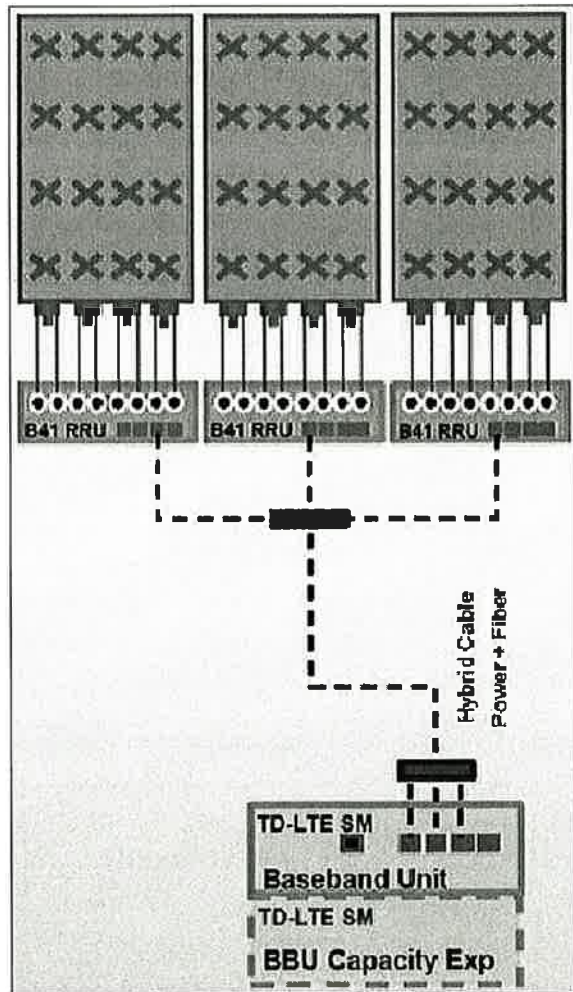

ALU 2.5 ALU SCENARIO 1

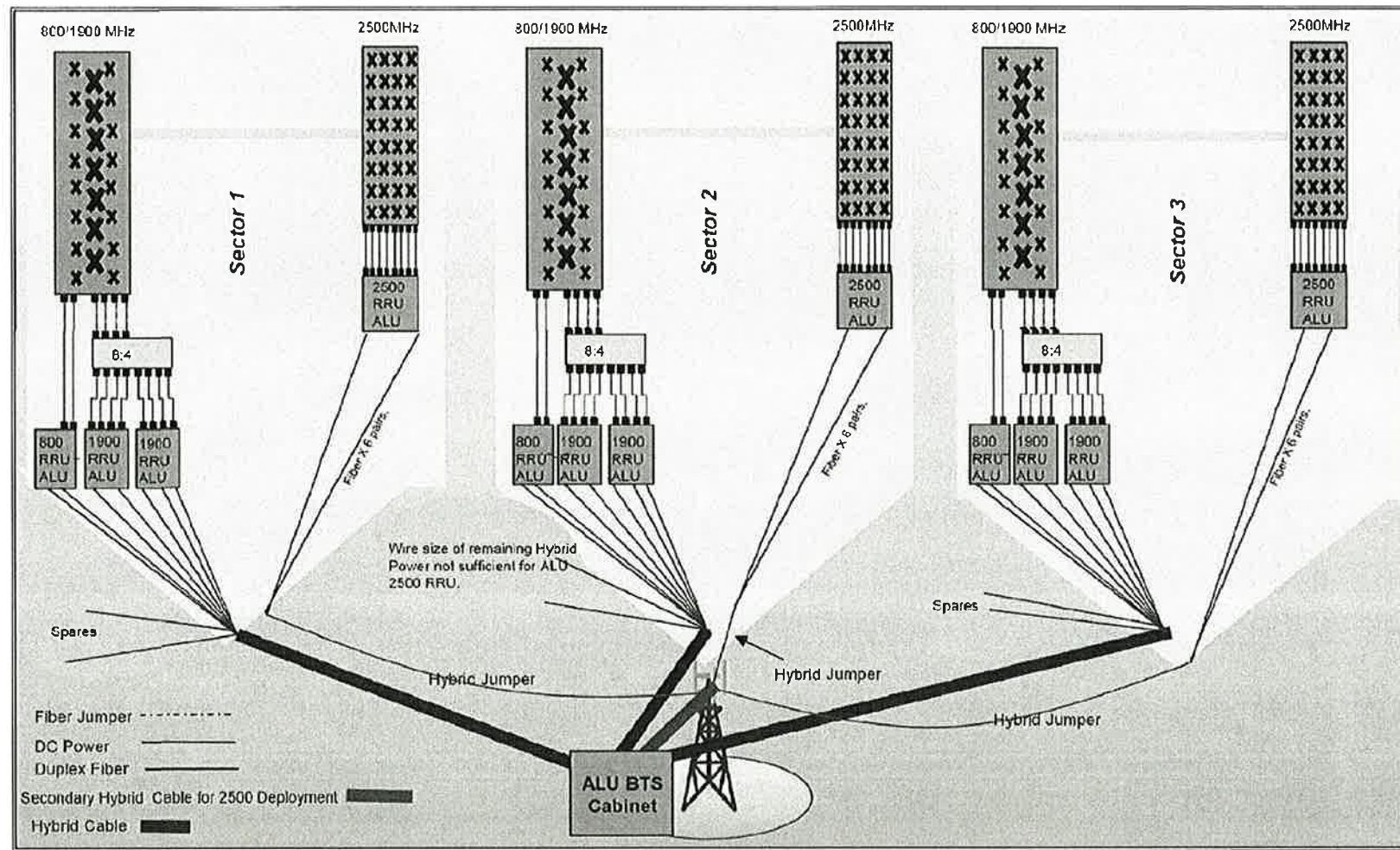

RAN WIRING DIAGRAM

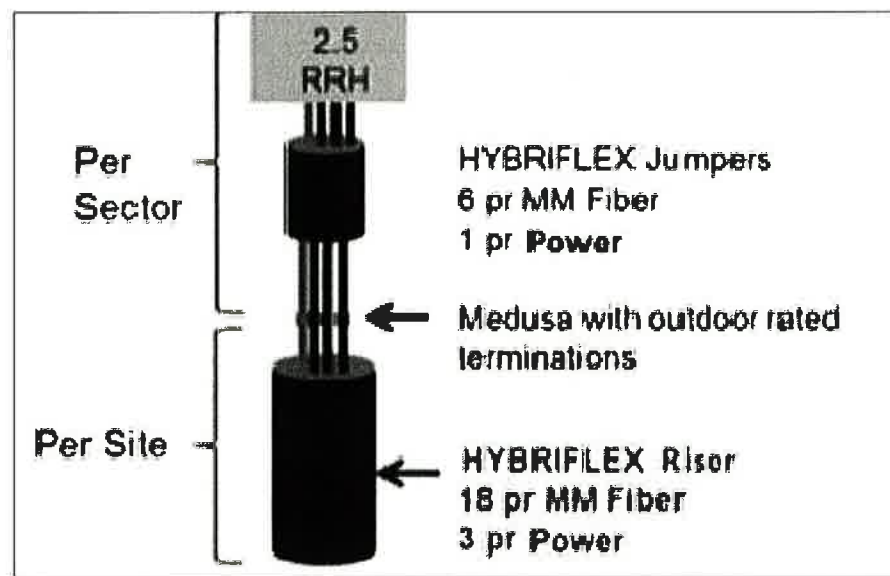

RF 2.5 ALU SCENARIO 1

PLANS PREPARED FOR:

**Sprint**  
6580 Sprint Parkway  
Overland Park, Kansas 66251

PLANS PREPARED BY:

**INFINIGY** Design. Build. Deliver.  
1033 Watervliet Shaker Rd  
Albany, NY 12205  
Office # (518) 690-0790  
Fax # (518) 690-0793  
JOB NUMBER 353-XXXX

MLA PARTNER:

**CROWN CASTLE**

ENGINEERING LICENSE:



DRAWING NOTICE:

THESE DOCUMENTS ARE CONFIDENTIAL AND ARE THE SOLE PROPERTY OF SPRINT AND MAY NOT BE REPRODUCED, DISSEMINATED OR REDISTRIBUTED WITHOUT THE EXPRESS WRITTEN CONSENT OF SPRINT.

REVISIONS:

DESCRIPTION	DATE	BY	REV
ISSUED FOR PERMIT	9/16/14	JLM	0

SITE NAME:

BIC DRIVE (SSUSA)

SITE CASCADE:

CT03XC171

SITE ADDRESS:

111 SCHOOL HOUSE RD,  
AKA BIC DRIVE  
MILFORD, CT 06460

SHEET DESCRIPTION:

PLUMBING DIAGRAM

SHEET NUMBER:

A-7

PLANS PREPARED FOR:



PLANS PREPARED BY:



MLA PARTNER:



ENGINEERING LICENSE:



DRAWING NOTICE:

THESE DOCUMENTS ARE CONFIDENTIAL AND ARE THE SOLE PROPERTY OF SPRINT AND MAY NOT BE REPRODUCED, DISSEMINATED OR REDISTRIBUTED WITHOUT THE EXPRESS WRITTEN CONSENT OF SPRINT.

REVISIONS:

DESCRIPTION	DATE	BY	REV
ISSUED FOR PERMIT	9/16/14	JLM	0

SITE NAME:

BIC DRIVE (SSUSA)

SITE CASCADE:

CT03XC171

SITE ADDRESS:

111 SCHOOL HOUSE RD,  
AKA BIC DRIVE  
MILFORD, CT 06460

SHEET DESCRIPTION:

ELECTRICAL &  
GROUNDING PLAN

SHEET NUMBER:

E-1

PLAN NOT USED

NO SCALE 1

- LEGEND:**
- G — EXISTING GROUND RING
  - CADWELD CONNECTION (EXOTHERMIC WELD)
  - ▲ MECHANICAL CONNECTION
  - ⊗ GROUND ROD
  - CABLE GROUND KIT

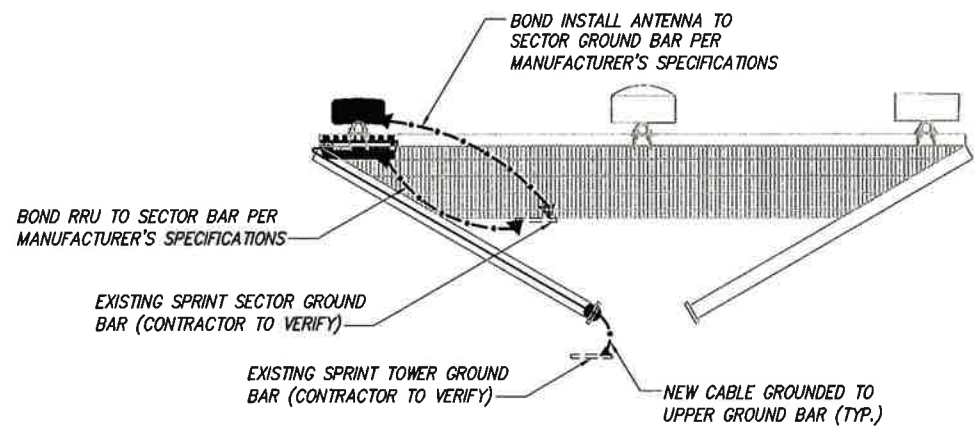

TYPICAL ANTENNA GROUNDING PLAN

NO SCALE 2

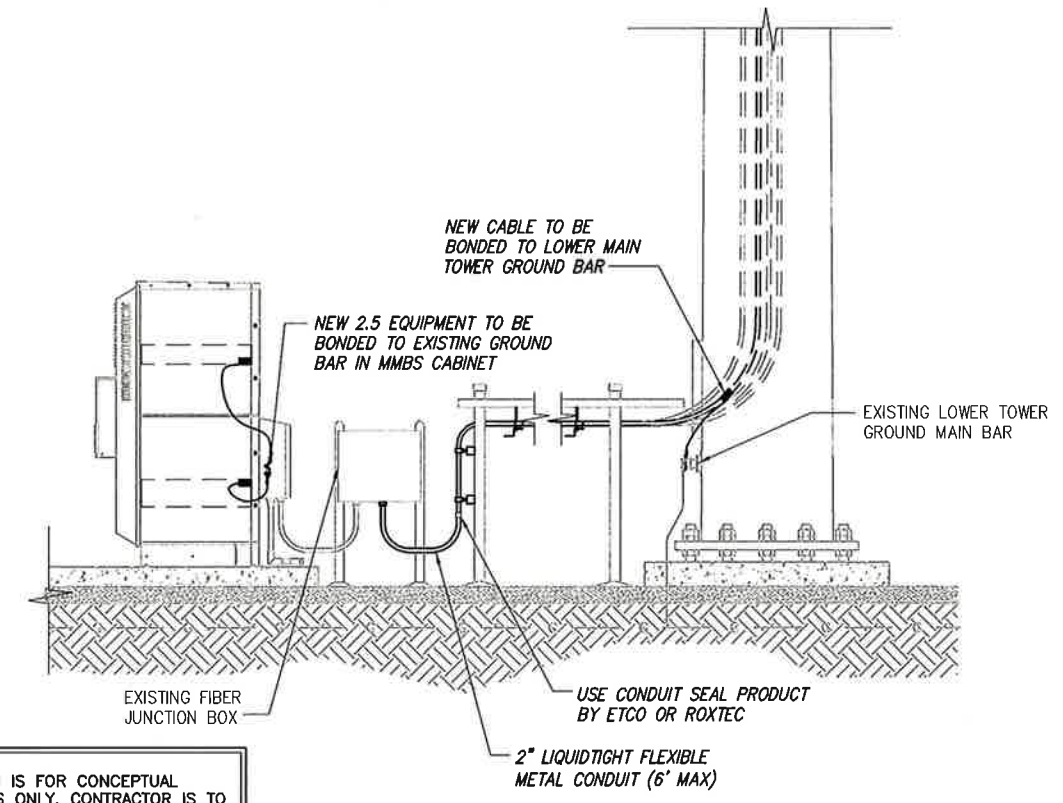

**NOTE:**  
DEPICTION IS FOR CONCEPTUAL PURPOSES ONLY. CONTRACTOR IS TO FIELD VERIFY PRIOR TO CONSTRUCTION

TYPICAL EQUIPMENT GROUNDING PLAN (ELEVATION)

NO SCALE 3

**NOTES**  
 CG SHALL REFERENCE ALL SPECS FOR "CONNECTING THE POWER SUPPLY" OF THE NEW INSTALLATION DOCUMENTS, FOR ALL CONNECTION SPECIFICATIONS.

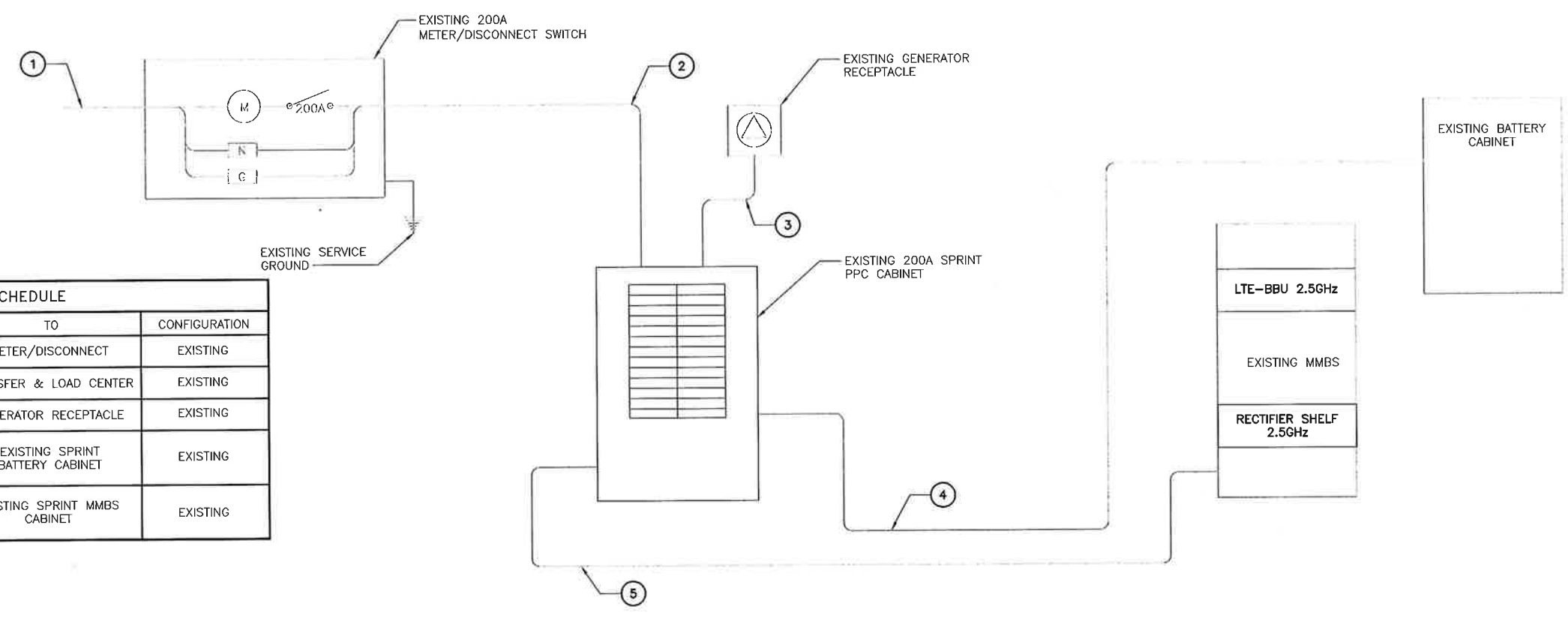

CIRCUIT SCHEDULE			
NO	FROM	TO	CONFIGURATION
①	UTILITY SOURCE	METER/DISCONNECT	EXISTING
②	METER/DISCONNECT	TRANSFER & LOAD CENTER	EXISTING
③	TRANSFER & LOAD CENTER	GENERATOR RECEPTACLE	EXISTING
④	TRANSFER & LOAD CENTER	EXISTING SPRINT BATTERY CABINET	EXISTING
⑤	TRANSFER & LOAD CENTER	EXISTING SPRINT MMBS CABINET	EXISTING

ELECTRICAL ONE-LINE DIAGRAM

NO SCALE 1

PLANS PREPARED FOR:

6580 Sprint Parkway  
 Overland Park, Kansas 66251

PLANS PREPARED BY:

Design. Build. Deliver.  
 1033 Watervliet Shaker Rd  
 Albany, NY 12205  
 Office # (518) 690-0790  
 Fax # (518) 690-0793  
 JOB NUMBER 353-XXXX

MLA PARTNER:

ENGINEERING LICENSE:

DRAWING NOTICE:  
 THESE DOCUMENTS ARE CONFIDENTIAL AND ARE THE SOLE PROPERTY OF SPRINT AND MAY NOT BE REPRODUCED, DISSEMINATED OR REDISTRIBUTED WITHOUT THE EXPRESS WRITTEN CONSENT OF SPRINT.

REVISIONS:

DESCRIPTION	DATE	BY	REV

ISSUED FOR PERMIT: 9/16/14 J.M. 0

SITE NAME:  
**BIC DRIVE (SSUSA)**

SITE CASCADE:  
**CT03XC171**

SITE ADDRESS:  
 111 SCHOOL HOUSE RD,  
 AKA BIC DRIVE  
 MILFORD, CT 06460

SHEET DESCRIPTION:  
**ELECTRICAL & GROUNDING DETAILS**

SHEET NUMBER:  
**E-2**

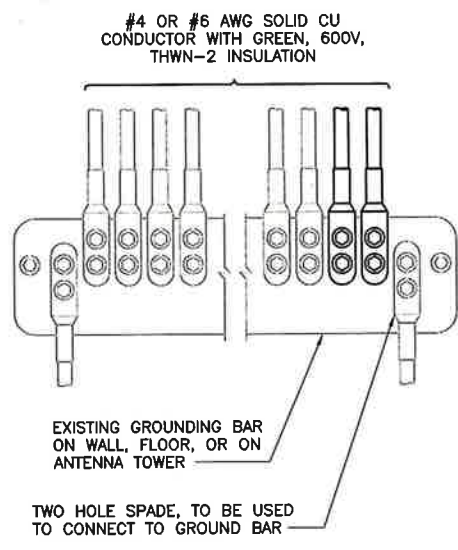

**NOTES**  
 1. APPLY NO-OX TO LUG AND BAR CONTACT SURFACE. DO NOT COAT INLINE LUG.  
 2. IF STOLEN GROUND BARS ARE ENCOUNTERED, CONTACT SPRINT CM FOR REPLACEMENT THREADED ROD KIT.

INSTALLATION OF GROUNDING CONDUCTOR TO GROUNDING BAR

NO SCALE 2

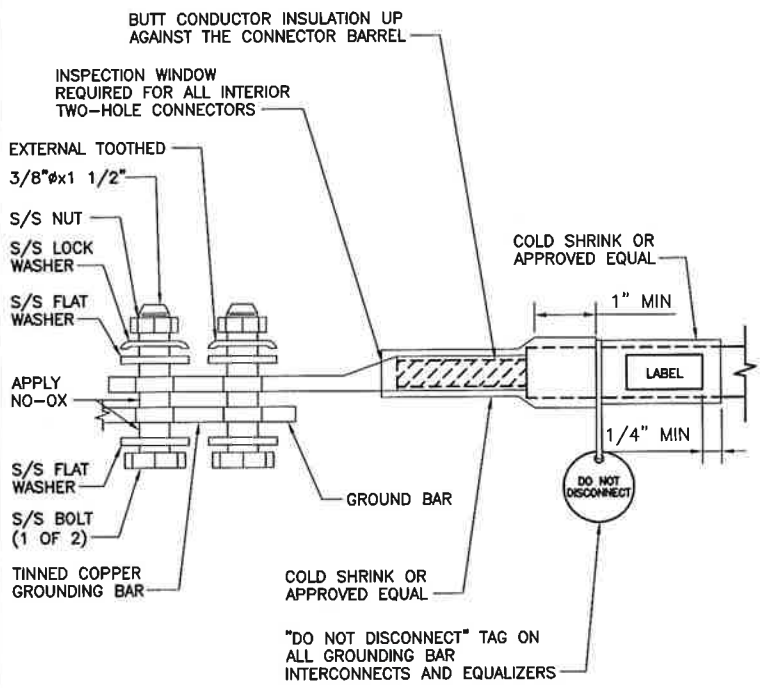

TWO HOLE LUG

NO SCALE 3

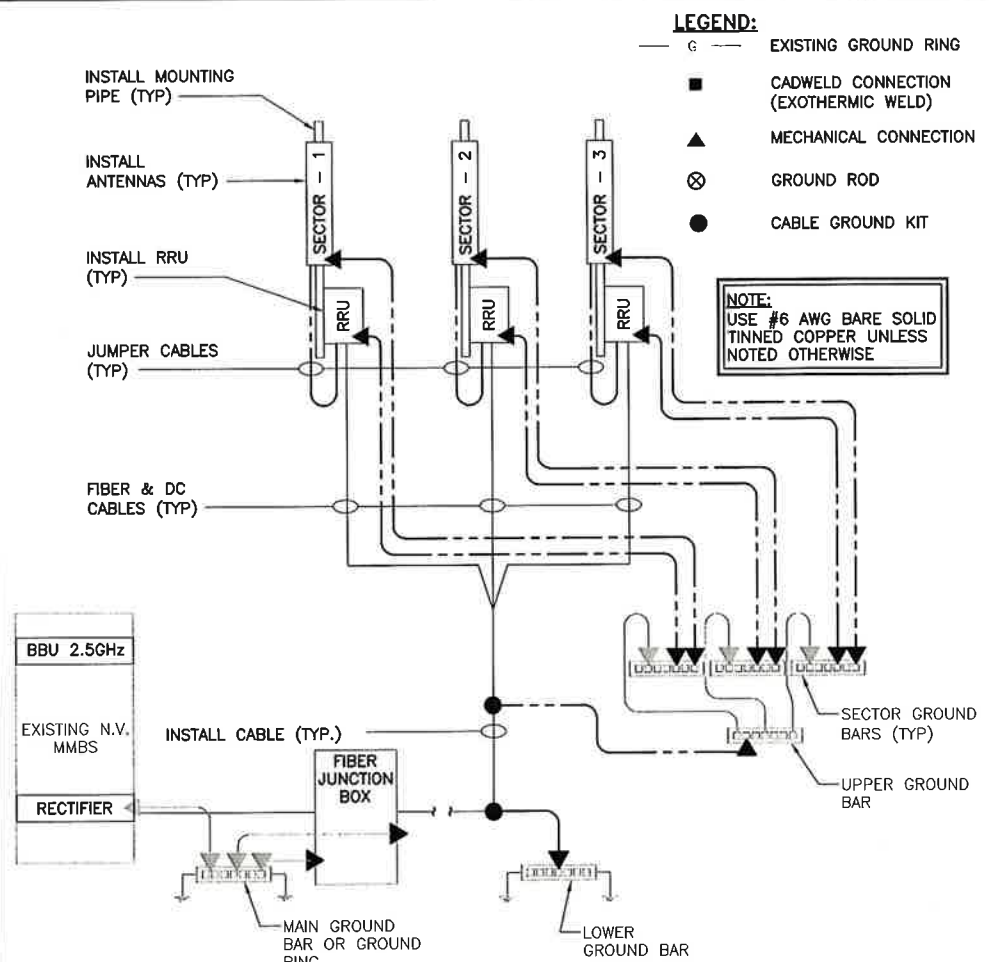

GROUNDING RISER DIAGRAM

NO SCALE 4



**PAUL J. FORD AND COMPANY**  
**STRUCTURAL ENGINEERS**  
 250 East Broad Street • Suite 600 • Columbus, Ohio 43215-3708

Date: July 03, 2014

Patrick Byrum  
 Crown Castle  
 3530 Toringdon Way Suite 300  
 Charlotte, NC 28277

Paul J Ford and Company  
 250 E. Broad Street Suite 600  
 Columbus, OH 43215  
 614.221.6679

**Subject: Structural Analysis Report**

<b>Carrier Designation:</b>	<b>Sprint PCS Co-Locate</b>	SCENARIO 2.5B
	<b>Carrier Site Number:</b>	CT03XC171
	<b>Carrier Site Name:</b>	BIC DRIVE (SSUSA)
<b>Crown Castle Designation:</b>	<b>Crown Castle BU Number:</b>	876342
	<b>Crown Castle Site Name:</b>	BIC DRIVE (SSUSA)
	<b>Crown Castle JDE Job Number:</b>	252284
	<b>Crown Castle Work Order Number:</b>	795506
	<b>Crown Castle Application Number:</b>	207193 Rev. 5
<b>Engineering Firm Designation:</b>	<b>Paul J Ford and Company Project Number:</b>	37513-2020.003.7805
<b>Site Data:</b>	<b>111 School House Road, a/k/a Bic Drive, MILFORD, New Haven County, CT</b>	
	<b>Latitude 41° 12' 46.06", Longitude -73° 5' 7.1"</b>	
	<b>140 Foot - Monopole Tower</b>	

Dear Patrick Byrum,

Paul J Ford and Company is pleased to submit this "Structural Analysis Report" to determine the structural integrity of the above mentioned tower. This analysis has been performed in accordance with the Crown Castle Structural 'Statement of Work' and the terms of Crown Castle Purchase Order Number 664932, in accordance with application 207193, revision 5.

The purpose of the analysis is to determine acceptability of the tower stress level. Based on our analysis we have determined the tower stress level for the structure and foundation, under the following load case, to be:

LC7: Existing + Reserved + Proposed Equipment **Sufficient Capacity**  
 Note: See Table I and Table II for the proposed and existing/reserved loading, respectively.

The structural analysis was performed for this tower in accordance with the requirements of TIA/EIA-222-F Structural Standards for Steel Antenna Towers and Antenna Supporting Structures using a fastest mile wind speed of 85 mph with no ice, 37.6 mph with 0.75 inch ice thickness and 50 mph under service loads.

We at Paul J Ford and Company appreciate the opportunity of providing our continuing professional services to you and Crown Castle. If you have any questions or need further assistance on this or any other projects please give us a call.

Respectfully submitted by:

*Seth Tschanen*

Seth Tschanen  
 Structural Designer

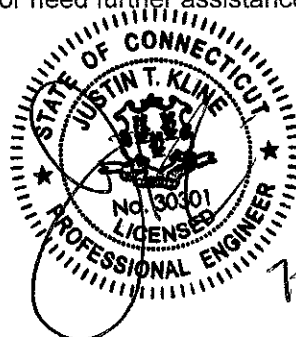

7-9-14





PAUL J. FORD AND COMPANY  
STRUCTURAL ENGINEERS  
250 East Broad Street • Suite 600 • Columbus, Ohio 43215-3708

Date: **July 03, 2014**

Patrick Byrum  
Crown Castle  
3530 Toringdon Way Suite 300  
Charlotte, NC 28277

Paul J Ford and Company  
250 E. Broad Street Suite 600  
Columbus, OH 43215  
614.221.6679

**Subject: Structural Analysis Report**

**Carrier Designation:** **Sprint PCS Co-Locate** SCENARIO 2.5B  
**Carrier Site Number:** CT03XC171  
**Carrier Site Name:** BIC DRIVE (SSUSA)

**Crown Castle Designation:** **Crown Castle BU Number:** 876342  
**Crown Castle Site Name:** BIC DRIVE (SSUSA)  
**Crown Castle JDE Job Number:** 252284  
**Crown Castle Work Order Number:** 795506  
**Crown Castle Application Number:** 207193 Rev. 5

**Engineering Firm Designation:** **Paul J Ford and Company Project Number:** 37513-2020.003.7805

**Site Data:** 111 School House Road, a/k/a Bic Drive, MILFORD, New Haven  
County, CT  
Latitude 41° 12' 46.06", Longitude -73° 5' 7.1"  
140 Foot - Monopole Tower

Dear Patrick Byrum,

*Paul J Ford and Company* is pleased to submit this "**Structural Analysis Report**" to determine the structural integrity of the above mentioned tower. This analysis has been performed in accordance with the Crown Castle Structural 'Statement of Work' and the terms of Crown Castle Purchase Order Number 664932, in accordance with application 207193, revision 5.

The purpose of the analysis is to determine acceptability of the tower stress level. Based on our analysis we have determined the tower stress level for the structure and foundation, under the following load case, to be:

LC7: Existing + Reserved + Proposed Equipment

**Sufficient Capacity**

Note: See Table I and Table II for the proposed and existing/reserved loading, respectively.

The structural analysis was performed for this tower in accordance with the requirements of TIA/EIA-222-F Structural Standards for Steel Antenna Towers and Antenna Supporting Structures using a fastest mile wind speed of 85 mph with no ice, 37.6 mph with 0.75 inch ice thickness and 50 mph under service loads.

We at *Paul J Ford and Company* appreciate the opportunity of providing our continuing professional services to you and Crown Castle. If you have any questions or need further assistance on this or any other projects please give us a call.

Respectfully submitted by:

Seth Tschanen  
Structural Designer

## TABLE OF CONTENTS

### 1) INTRODUCTION

### 2) ANALYSIS CRITERIA

Table 1 - Proposed Antenna and Cable Information

Table 2 - Existing and Reserved Antenna and Cable Information

Table 3 - Design Antenna and Cable Information

### 3) ANALYSIS PROCEDURE

Table 4 - Documents Provided

3.1) Analysis Method

3.2) Assumptions

### 4) ANALYSIS RESULTS

Table 5 - Section Capacity (Summary)

Table 6 – Tower Components vs. Capacity

4.1) Recommendations

### 5) APPENDIX A

tnxTower Output

### 6) APPENDIX B

Base Level Drawing

### 7) APPENDIX C

Additional Calculations

## 1) INTRODUCTION

This tower is a 140 ft Monopole tower designed by SUMMIT in October of 1999. The tower was originally designed for a wind speed of 85 mph per TIA/EIA-222-F.

## 2) ANALYSIS CRITERIA

The structural analysis was performed for this tower in accordance with the requirements of TIA/EIA-222-F Structural Standards for Steel Antenna Towers and Antenna Supporting Structures using a fastest mile wind speed of 85 mph with no ice, 37.6 mph with 0.75 inch ice thickness and 50 mph under service loads.

**Table 1 - Proposed Antenna and Cable Information**

Mounting Level (ft)	Center Line Elevation (ft)	Number of Antennas	Antenna Manufacturer	Antenna Model	Number of Feed Lines	Feed Line Size (in)	Note
140.0	140.0	3	alcatel lucent	TD-RRH8x20-25	1	1 1/4	--
		3	rfs celwave	APXVTM14-C-120 w/ Mount Pipe			
		1	misc	Handrail Kit [NA 507-1]			

**Table 2 - Existing and Reserved Antenna and Cable Information**

Mounting Level (ft)	Center Line Elevation (ft)	Number of Antennas	Antenna Manufacturer	Antenna Model	Number of Feed Lines	Feed Line Size (in)	Note	
140.0	142.0	1	andrew	VHLP1-23	6 3	5/16 1/2	3	
		1	andrew	VHLP2-11				
		1	andrew	VHLP2-23				
		3	argus technologies	LLPX310R w/ Mount Pipe				
		3	samsung	FDD_R6_RRH				
	140.0	140.0	3	alcatel lucent	1900MHz RRH (65MHz)	3	1 1/4	1
			3	alcatel lucent	800 EXTERNAL NOTCH FILTER			
			3	alcatel lucent	800MHZ RRH			
			9	rfs celwave	ACU-A20-N			
			3	rfs celwave	APXVSP18-C-A20 w/ Mount Pipe			
123.0	123.0	6	ericsson	TME-RRUS-11	--	--	1	
		1	tower mounts	Side Arm Mount [SO 102-3]				
121.0	125.0	3	kmw	AM-X-CD-16-65-00T-RET w/ Mount Pipe	1 2 14	3/8 7/16 1 5/8	1	
		1	raycap	DC6-48-60-18-8F				
	123.0	6	powerwave	7770.00 w/ Mount Pipe				
		6	powerwave	LGP21401				
		6	powerwave	LGP21901				
121.0	1	tower mounts	Platform Mount [LP 401-1]					

Mounting Level (ft)	Center Line Elevation (ft)	Number of Antennas	Antenna Manufacturer	Antenna Model	Number of Feed Lines	Feed Line Size (in)	Note	
115.0	116.0	3	andrew	ETW200VS12UB	6 12	1 5/8 1 1/4	1	
		6	ems wireless	RR90-17-02DP w/ Mount Pipe				
		6	remec	S20070A1				
		3	rfs celwave	APX16DWV-16DWV-S-E-A20 w/ Mount Pipe				
	115.0	1	tower mounts	Platform Mount [LP 401-1]				
104.0	107.0	1	trimble	ACUTIME 2000	--	--	1	
	106.0	3	rfs celwave	FD9R6004/2C-3L				
	105.0	3	rfs celwave	FD9R6004/2C-3L				
		3	rymsa wireless	MG D3-800Tx w/ Mount Pipe				
	104.0	104.0	4	decibel	DB846F65ZAXY w/ Mount Pipe	--	--	3
			2	decibel	DB846H80E-SX w/ Mount Pipe			
			3	andrew	LNx-6514DS-VTM w/ Mount Pipe	--	--	2
			3	antel	BXA-171063-8BF-EDIN-0 w/ Mount Pipe			
			2	antel	BXA-70063/6CF w/ Mount Pipe			
			1	powerwave	P65.16.XL.2 w/ Mount Pipe			
1	tower mounts	Platform Mount [LP 303-1]						
95.0	95.0	3	rfs celwave	APXV18-206517S-C w/ Mount Pipe	6	1 5/8	1	
		1	tower mounts	Pipe Mount [PM 601-3]				
87.0	91.0	8	andrew	931LG65R1E-B w/ Mount Pipe	12	1 5/8	1	
		6	powerwave	TS07-AWDB111-001				
	87.0	1	tower mounts	Sector Mount [SM 802-3]				
	83.0	4	andrew	931LG65R1E-B w/ Mount Pipe				
80.0	82.0	1	kathrein	OG-860/1920/GPS-A	1	1/2	1	
	80.0	1	tower mounts	Side Arm Mount [SO 202-1]				

- Notes:  
 1) Existing Equipment  
 2) Reserved Equipment  
 3) Equipment To Be Removed

**Table 3 - Design Antenna and Cable Information**

Mounting Level (ft)	Center Line Elevation (ft)	Number of Antennas	Antenna Manufacturer	Antenna Model	Number of Feed Lines	Feed Line Size (in)
--	--	--	--	--	--	--

### 3) ANALYSIS PROCEDURE

**Table 4 - Documents Provided**

Document	Remarks	Reference	Source
4-GEOTECHNICAL REPORTS	FDH, 08-12040E G1, 12/05/2008	1531894	CCSITES
4-POST-MODIFICATION INSPECTION	PJF, 41709-0132, 12/04/2009	2547672	CCSITES
4-TOWER FOUNDATION DRAWINGS/DESIGN/SPECS	Summit, 5403, 09/29/1999	1631615	CCSITES
4-TOWER MANUFACTURER DRAWINGS	Summit, 5403, 10/29/1999	1630877	CCSITES

#### 3.1) Analysis Method

tnxTower (version 6.1.4.1), a commercially available analysis software package, was used to create a three-dimensional model of the tower and calculate member stresses for various loading cases. Selected output from the analysis is included in Appendix A.

#### 3.2) Assumptions

- 1) Tower and structures were built in accordance with the manufacturer's specifications.
- 2) The tower and structures have been maintained in accordance with the manufacturer's specification.
- 3) The configuration of antennas, transmission cables, mounts and other appurtenances are as specified in Tables 1 and 2 and the referenced drawings.
- 4) Monopole was reinforced in conformance with the referenced modification drawings.
- 5) Clearwire equipment at the 140' level and associated feed lines are to be removed.

This analysis may be affected if any assumptions are not valid or have been made in error. Paul J Ford and Company should be notified to determine the effect on the structural integrity of the tower.

#### 4) ANALYSIS RESULTS

**Table 5 - Section Capacity (Summary)**

Section No.	Elevation (ft)	Component Type	Size	Critical Element	P (K)	SF*P_allow (K)	% Capacity	Pass / Fail
L1	140 - 98.5	Pole	TP24.4257x16x0.25	1	-10.61	1011.74	97.6	Pass
L2	98.5 - 88.5	Pole	TP26.456x24.4257x0.4933	2	-12.09	1851.64	66.8	Pass
L3	88.5 - 71.75	Pole	TP29.3572x24.8095x0.5231	3	-18.05	2253.49	89.0	Pass
L4	71.75 - 47.25	Pole	TP34.332x29.3572x0.5889	4	-23.47	2890.54	92.5	Pass
L5	47.25 - 41.75	Pole	TP34.8235x32.2913x0.6414	5	-27.27	3279.23	92.3	Pass
L6	41.75 - 23.5	Pole	TP38.5288x34.8235x0.6656	6	-33.39	3807.13	92.8	Pass
L7	23.5 - 20.75	Pole	TP39.0872x38.5288x0.7405	7	-34.43	4146.31	87.3	Pass
L8	20.75 - 0	Pole	TP43.3x39.0872x0.6628	8	-42.11	4334.21	95.1	Pass
							Summary	
						Pole (L1)	97.6	Pass
						Rating =	97.6	Pass

**Table 6 - Tower Component Stresses vs. Capacity – LC7**

Notes	Component	Elevation (ft)	% Capacity	Pass / Fail
1	Anchor Rods	0	98.8	Pass
1	Base Plate	0	76.9	Pass
1	Base Foundation Steel	0	62.8	Pass
1	Base Foundation Soil Interaction	0	72.0	Pass

<b>Structure Rating (max from all components) =</b>	<b>98.8%</b>
---	--------------

Notes:

- 1) See additional documentation in "Appendix C – Additional Calculations" for calculations supporting the % capacity consumed.

#### 4.1) Recommendations

- Remove Clearwire equipment at 140' level.

**APPENDIX A**  
**TNXTOWER OUTPUT**

## Tower Input Data

There is a pole section.

This tower is designed using the TIA/EIA-222-F standard.

The following design criteria apply:

- 1) Tower is located in New Haven County, Connecticut.
- 2) Basic wind speed of 85 mph.
- 3) Nominal ice thickness of 0.7500 in.
- 4) Ice density of 56.00 pcf.
- 5) A wind speed of 38 mph is used in combination with ice.
- 6) Temperature drop of 50 °F.
- 7) Deflections calculated using a wind speed of 50 mph.
- 8) A non-linear (P-delta) analysis was used.
- 9) Pressures are calculated at each section.
- 10) Stress ratio used in pole design is 1.333.
- 11) Local bending stresses due to climbing loads, feed line supports, and appurtenance mounts are not considered.

## Options

Consider Moments - Legs Consider Moments - Horizontals Consider Moments - Diagonals Use Moment Magnification ✓ Use Code Stress Ratios ✓ Use Code Safety Factors - Guys Escalate Ice Always Use Max Kz Use Special Wind Profile Include Bolts In Member Capacity Leg Bolts Are At Top Of Section Secondary Horizontal Braces Leg Use Diamond Inner Bracing (4 Sided) Add IBC .6D+W Combination	Distribute Leg Loads As Uniform Assume Legs Pinned ✓ Assume Rigid Index Plate ✓ Use Clear Spans For Wind Area Use Clear Spans For KL/r Retension Guys To Initial Tension ✓ Bypass Mast Stability Checks ✓ Use Azimuth Dish Coefficients ✓ Project Wind Area of Appurt. Autocalc Torque Arm Areas SR Members Have Cut Ends Sort Capacity Reports By Component Triangulate Diamond Inner Bracing Use TIA-222-G Tension Splice Capacity Exemption	✓ Treat Feedline Bundles As Cylinder Use ASCE 10 X-Brace Ly Rules Calculate Redundant Bracing Forces Ignore Redundant Members in FEA SR Leg Bolts Resist Compression All Leg Panels Have Same Allowable Offset Girt At Foundation ✓ Consider Feedline Torque Include Angle Block Shear Check <div style="text-align: center; background-color: #e0e0e0; padding: 2px;">Poles</div> ✓ Include Shear-Torsion Interaction Always Use Sub-Critical Flow Use Top Mounted Sockets
--	--	--

## Tapered Pole Section Geometry

Section	Elevation <i>ft</i>	Section Length <i>ft</i>	Splice Length <i>ft</i>	Number of Sides	Top Diameter <i>in</i>	Bottom Diameter <i>in</i>	Wall Thickness <i>in</i>	Bend Radius <i>in</i>	Pole Grade
L1	140.0000- 98.5000	41.5000	0.00	12	16.0000	24.4257	0.2500	1.0000	A607-65 (65 ksi)
L2	98.5000- 88.5000	10.0000	3.25	12	24.4257	26.4560	0.4933	1.9733	Reinf 57.60 ksi (58 ksi)
L3	88.5000- 71.7500	20.0000	0.00	12	24.8095	29.3572	0.5231	2.0925	Reinf 58.01 ksi (58 ksi)
L4	71.7500- 47.2500	24.5000	4.25	12	29.3572	34.3320	0.5888	2.3554	Reinf 57.97 ksi (58 ksi)
L5	47.2500- 41.7500	9.7500	0.00	12	32.2913	34.8235	0.6414	2.5655	Reinf 58.08 ksi (58 ksi)
L6	41.7500- 23.5000	18.2500	0.00	12	34.8235	38.5288	0.6656	2.6623	Reinf 58.66 ksi (59 ksi)
L7	23.5000- 20.7500	2.7500	0.00	12	38.5288	39.0872	0.7405	2.9619	Reinf 56.70 ksi (57 ksi)
L8	20.7500-0.0000	20.7500		12	39.0872	43.3000	0.6628	2.6513	Reinf 59.55 ksi (60 ksi)



### Tapered Pole Properties

Section	Tip Dia. in	Area in <sup>2</sup>	I in <sup>4</sup>	r in	C in	I/C in <sup>3</sup>	J in <sup>4</sup>	It/Q in <sup>2</sup>	w in	w/t
L1	16.5644	12.6788	401.4426	5.6385	8.2880	48.4366	813.4316	6.2401	3.6180	14.472
	25.2874	19.4614	1451.8426	8.6549	12.6525	114.7473	2941.8268	9.5783	5.8761	23.504
L2	25.2874	38.0164	2779.2573	8.5678	12.6525	219.6604	5631.5288	18.7105	5.2240	10.589
	27.3893	41.2415	3548.2900	9.2946	13.7042	258.9197	7189.7975	20.2978	5.7681	11.692
L3	26.4498	40.9099	3079.9249	8.6945	12.8513	239.6581	6240.7629	20.1346	5.2470	10.03
	30.3928	48.5704	5154.3114	10.3226	15.2070	338.9423	10444.0322	23.9049	6.4657	12.36
L4	30.3928	54.5476	5762.2583	10.2991	15.2070	378.9203	11675.8975	26.8467	6.2896	10.681
	35.5431	63.9803	9298.2960	12.0800	17.7840	522.8469	18840.8687	31.4892	7.6229	12.945
L5	34.5732	65.3639	8357.3764	11.3307	16.7269	499.6366	16934.3103	32.1701	6.9352	10.813
	36.0520	70.5934	10528.0750	12.2372	18.0386	583.6418	21332.7343	34.7439	7.6138	11.871
L6	36.0520	73.2062	10902.2837	12.2285	18.0386	604.3867	22090.9826	36.0299	7.5490	11.342
	39.8880	81.1473	14848.9385	13.5550	19.9579	744.0120	30087.9751	39.9382	8.5420	12.834
L7	39.8880	90.1005	16422.0964	13.5282	19.9579	822.8357	33275.6196	44.3447	8.3412	11.265
	40.4660	91.4317	17160.8234	13.7281	20.2471	847.5676	34772.4808	44.9999	8.4909	11.467
L8	40.4660	82.0095	15454.7701	13.7559	20.2471	763.3062	31315.5543	40.3626	8.6990	13.124
	44.8275	91.0010	21115.8755	15.2641	22.4294	941.4374	42786.4885	44.7879	9.8280	14.827

Tower Elevation	Gusset Area (per face)	Gusset Thickness	Gusset Grade	Adjust. Factor A <sub>r</sub>	Adjust. Factor A <sub>r</sub>	Weight Mult.	Double Angle Stitch Bolt Spacing Diagonals	Double Angle Stitch Bolt Spacing Horizontals
ft	ft <sup>2</sup>	in					in	in
L1 140.0000-98.5000				1	1	1		
L2 98.5000-88.5000				1	1	1		
L3 88.5000-71.7500				1	1	1		
L4 71.7500-47.2500				1	1	1		
L5 47.2500-41.7500				1	1	1		
L6 41.7500-23.5000				1	1	1		
L7 23.5000-20.7500				1	1	1		
L8 20.7500-0.0000				1	1	1		

### Feed Line/Linear Appurtenances - Entered As Area

Description	Face or Leg	Allow Shield	Component Type	Placement	Total Number	C <sub>A</sub> A <sub>A</sub>	Weight
				ft		ft <sup>2</sup> /ft	plf
HB114-1-0813U4-M5J(1 1/4")	C	No	CaAa (Out Of Face)	140.0000 - 0.0000	3	No Ice	0.0000
						1/2" Ice	0.0000
						1" Ice	0.0000
HB114-13U3M12-XXXX(1-1/4")	C	No	CaAa (Out Of Face)	115.0000 - 0.0000	1	No Ice	0.0000
						1/2" Ice	0.0000
						1" Ice	0.0000
HB114-13U3M12-XXXX(1-1/4")	C	No	CaAa (Out Of Face)	140.0000 - 115.0000	1	No Ice	0.1540
						1/2" Ice	0.2540
						1" Ice	0.3540
*****							
LDF7-50A(1-5/8")	C	No	Inside Pole	121.0000 - 0.0000	14	No Ice	0.0000
						1/2" Ice	0.0000
						1" Ice	0.0000
FB-L98B-002-75000(3/8")	C	No	Inside Pole	121.0000 - 0.0000	1	No Ice	0.0000
						1/2" Ice	0.0000
						1" Ice	0.0000
WR-VG122ST-BRDA(7/16)	C	No	Inside Pole	121.0000 - 0.0000	2	No Ice	0.0000
						1/2" Ice	0.0000
						1" Ice	0.0000

Description	Face or Leg	Allow Shield	Component Type	Placement ft	Total Number		C <sub>AA</sub> ft <sup>2</sup> /ft	Weight plf
*****								
HJ7-50A(1-5/8")	C	No	CaAa (Out Of Face)	115.0000 - 0.0000	5	No Ice	0.0000	1.04
						1/2" Ice	0.0000	2.55
						1" Ice	0.0000	4.68
LDF6-50A(1-1/4")	C	No	Inside Pole	115.0000 - 0.0000	12	No Ice	0.0000	0.66
						1/2" Ice	0.0000	0.66
						1" Ice	0.0000	0.66
HJ7-50A(1-5/8")	C	No	CaAa (Out Of Face)	115.0000 - 0.0000	1	No Ice	0.1980	1.04
						1/2" Ice	0.2980	2.55
						1" Ice	0.3980	4.68
*****								
LDF4-50A(1/2")	C	No	Inside Pole	104.0000 - 0.0000	1	No Ice	0.0000	0.15
						1/2" Ice	0.0000	0.15
						1" Ice	0.0000	0.15
*****								
CR 50 1873(1-5/8")	C	No	CaAa (Out Of Face)	95.0000 - 0.0000	1	No Ice	0.1980	0.83
						1/2" Ice	0.2980	2.34
						1" Ice	0.3980	4.47
CR 50 1873(1-5/8")	C	No	CaAa (Out Of Face)	95.0000 - 0.0000	5	No Ice	0.0000	0.83
						1/2" Ice	0.0000	2.34
						1" Ice	0.0000	4.47
*****								
LDF7-50A(1-5/8")	C	No	Inside Pole	87.0000 - 0.0000	12	No Ice	0.0000	0.82
						1/2" Ice	0.0000	0.82
						1" Ice	0.0000	0.82
*****								
LDF4-50A(1/2")	C	No	Inside Pole	80.0000 - 0.0000	1	No Ice	0.0000	0.15
						1/2" Ice	0.0000	0.15
						1" Ice	0.0000	0.15
*****								
Aero MP3-08	C	No	CaAa (Out Of Face)	41.7500 - 0.0000	2	No Ice	0.4667	0.00
						1/2" Ice	0.5778	0.00
						1" Ice	0.6889	0.00
Aero MP3-06	C	No	CaAa (Out Of Face)	71.7500 - 41.7500	1	No Ice	0.4343	0.00
						1/2" Ice	0.5454	0.00
						1" Ice	0.6566	0.00
Aero MP3-05	C	No	CaAa (Out Of Face)	100.7500 - 71.7500	1	No Ice	0.3478	0.00
						1/2" Ice	0.4001	0.00
						1" Ice	0.6566	0.00
1 1/4" Flat Reinforcement	C	No	CaAa (Out Of Face)	107.0000 - 100.7500	1	No Ice	0.2083	0.00
						1/2" Ice	0.3194	0.00
						1" Ice	0.4306	0.00

**Feed Line/Linear Appurtenances Section Areas**

Tower Section	Tower Elevation ft	Face	A <sub>R</sub> ft <sup>2</sup>	A <sub>F</sub> ft <sup>2</sup>	C <sub>AA</sub> In Face ft <sup>2</sup>	C <sub>AA</sub> Out Face ft <sup>2</sup>	Weight K
L1	140.0000-98.5000	A	0.000	0.000	0.000	0.000	0.00
		B	0.000	0.000	0.000	0.000	0.00
		C	0.000	0.000	0.000	9.202	0.69
L2	98.5000-88.5000	A	0.000	0.000	0.000	0.000	0.00
		B	0.000	0.000	0.000	0.000	0.00
		C	0.000	0.000	0.000	6.745	0.34
L3	88.5000-71.7500	A	0.000	0.000	0.000	0.000	0.00
		B	0.000	0.000	0.000	0.000	0.00
		C	0.000	0.000	0.000	12.459	0.75
L4	71.7500-47.2500	A	0.000	0.000	0.000	0.000	0.00
		B	0.000	0.000	0.000	0.000	0.00
		C	0.000	0.000	0.000	20.343	1.12
L5	47.2500-41.7500	A	0.000	0.000	0.000	0.000	0.00
		B	0.000	0.000	0.000	0.000	0.00
		C	0.000	0.000	0.000	4.567	0.25
L6	41.7500-23.5000	A	0.000	0.000	0.000	0.000	0.00
		B	0.000	0.000	0.000	0.000	0.00
		C	0.000	0.000	0.000	24.260	0.84
L7	23.5000-20.7500	A	0.000	0.000	0.000	0.000	0.00

Tower Section	Tower Elevation ft	Face	A <sub>R</sub> ft <sup>2</sup>	A <sub>F</sub> ft <sup>2</sup>	C <sub>AA</sub> In Face ft <sup>2</sup>	C <sub>AA</sub> Out Face ft <sup>2</sup>	Weight K
L8	20.7500-0.0000	B	0.000	0.000	0.000	0.000	0.00
		C	0.000	0.000	0.000	3.656	0.13
		A	0.000	0.000	0.000	0.000	0.00
		B	0.000	0.000	0.000	0.000	0.00
		C	0.000	0.000	0.000	27.584	0.95

### Feed Line/Linear Appurtenances Section Areas - With Ice

Tower Section	Tower Elevation ft	Face or Leg	Ice Thickness in	A <sub>R</sub> ft <sup>2</sup>	A <sub>F</sub> ft <sup>2</sup>	C <sub>AA</sub> In Face ft <sup>2</sup>	C <sub>AA</sub> Out Face ft <sup>2</sup>	Weight K
L1	140.0000-98.5000	A	0.750	0.000	0.000	0.000	0.000	0.00
		B		0.000	0.000	0.000	0.000	0.00
		C		0.000	0.000	0.000	16.875	1.31
L2	98.5000-88.5000	A	0.750	0.000	0.000	0.000	0.000	0.00
		B		0.000	0.000	0.000	0.000	0.00
		C		0.000	0.000	0.000	11.025	0.68
L3	88.5000-71.7500	A	0.750	0.000	0.000	0.000	0.000	0.00
		B		0.000	0.000	0.000	0.000	0.00
		C		0.000	0.000	0.000	20.507	1.42
L4	71.7500-47.2500	A	0.750	0.000	0.000	0.000	0.000	0.00
		B		0.000	0.000	0.000	0.000	0.00
		C		0.000	0.000	0.000	31.777	2.10
L5	47.2500-41.7500	A	0.750	0.000	0.000	0.000	0.000	0.00
		B		0.000	0.000	0.000	0.000	0.00
		C		0.000	0.000	0.000	7.134	0.47
L6	41.7500-23.5000	A	0.750	0.000	0.000	0.000	0.000	0.00
		B		0.000	0.000	0.000	0.000	0.00
		C		0.000	0.000	0.000	35.819	1.56
L7	23.5000-20.7500	A	0.750	0.000	0.000	0.000	0.000	0.00
		B		0.000	0.000	0.000	0.000	0.00
		C		0.000	0.000	0.000	5.397	0.24
L8	20.7500-0.0000	A	0.750	0.000	0.000	0.000	0.000	0.00
		B		0.000	0.000	0.000	0.000	0.00
		C		0.000	0.000	0.000	40.725	1.77

### Feed Line Center of Pressure

Section	Elevation ft	CP <sub>x</sub> in	CP <sub>z</sub> in	CP <sub>x</sub> Ice in	CP <sub>z</sub> Ice in
L1	140.0000-98.5000	-0.2669	0.1541	-0.4178	0.2412
L2	98.5000-88.5000	-0.6665	0.3848	-0.9096	0.5252
L3	88.5000-71.7500	-0.7292	0.4210	-1.0004	0.5776
L4	71.7500-47.2500	-0.8216	0.4743	-1.0970	0.6334
L5	47.2500-41.7500	-0.8348	0.4820	-1.1230	0.6484
L6	41.7500-23.5000	-1.2034	0.6948	-1.5148	0.8746
L7	23.5000-20.7500	-1.2238	0.7066	-1.5494	0.8945
L8	20.7500-0.0000	-1.2448	0.7187	-1.5854	0.9153

### Discrete Tower Loads

Description	Face or Leg	Offset Type	Offsets: Horz Lateral Vert ft ft ft	Azimuth Adjustment °	Placement ft	C <sub>AA</sub> Front ft <sup>2</sup>	C <sub>AA</sub> Side ft <sup>2</sup>	Weight K	
APXVSPP18-C-A20 w/ Mount Pipe	A	From Leg	4.0000	0.00	140.0000	No Ice	8.4975	6.9458	0.08
			0.00			1/2" Ice	9.1490	8.1266	0.15
			0.00			1" Ice	9.7672	9.0212	0.23
APXVSPP18-C-A20 w/ Mount Pipe	B	From Leg	4.0000	0.00	140.0000	No Ice	8.4975	6.9458	0.08
			0.00			1/2" Ice	9.1490	8.1266	0.15

Description	Face or Leg	Offset Type	Offsets: Horz Lateral Vert ft ft	Azimuth Adjustment °	Placement ft	C <sub>AA</sub> Front ft <sup>2</sup>	C <sub>AA</sub> Side ft <sup>2</sup>	Weight K	
			0.00			1" Ice	9.7672	9.0212	0.23
APXVSPP18-C-A20 w/ Mount Pipe	C	From Leg	4.0000	0.00	140.0000	No Ice	8.4975	6.9458	0.08
			0.00			1/2" Ice	9.1490	8.1266	0.15
			0.00			1" Ice	9.7672	9.0212	0.23
800 EXTERNAL NOTCH FILTER	A	From Leg	4.0000	0.00	140.0000	No Ice	0.7701	0.3747	0.01
			0.00			1/2" Ice	0.8898	0.4647	0.02
			0.00			1" Ice	1.0181	0.5634	0.02
800 EXTERNAL NOTCH FILTER	B	From Leg	4.0000	0.00	140.0000	No Ice	0.7701	0.3747	0.01
			0.00			1/2" Ice	0.8898	0.4647	0.02
			0.00			1" Ice	1.0181	0.5634	0.02
800 EXTERNAL NOTCH FILTER	C	From Leg	4.0000	0.00	140.0000	No Ice	0.7701	0.3747	0.01
			0.00			1/2" Ice	0.8898	0.4647	0.02
			0.00			1" Ice	1.0181	0.5634	0.02
800MHZ RRH	A	From Leg	4.0000	0.00	140.0000	No Ice	2.4899	2.0685	0.05
			0.00			1/2" Ice	2.7061	2.2705	0.07
			0.00			1" Ice	2.9310	2.4812	0.10
800MHZ RRH	B	From Leg	4.0000	0.00	140.0000	No Ice	2.4899	2.0685	0.05
			0.00			1/2" Ice	2.7061	2.2705	0.07
			0.00			1" Ice	2.9310	2.4812	0.10
800MHZ RRH	C	From Leg	4.0000	0.00	140.0000	No Ice	2.4899	2.0685	0.05
			0.00			1/2" Ice	2.7061	2.2705	0.07
			0.00			1" Ice	2.9310	2.4812	0.10
1900MHz RRH (65MHz)	A	From Leg	4.0000	0.00	140.0000	No Ice	2.7087	2.6087	0.06
			0.00			1/2" Ice	2.9477	2.8450	0.08
			0.00			1" Ice	3.1953	3.0899	0.11
1900MHz RRH (65MHz)	B	From Leg	4.0000	0.00	140.0000	No Ice	2.7087	2.6087	0.06
			0.00			1/2" Ice	2.9477	2.8450	0.08
			0.00			1" Ice	3.1953	3.0899	0.11
1900MHz RRH (65MHz)	C	From Leg	4.0000	0.00	140.0000	No Ice	2.7087	2.6087	0.06
			0.00			1/2" Ice	2.9477	2.8450	0.08
			0.00			1" Ice	3.1953	3.0899	0.11
(3) ACU-A20-N	A	From Leg	4.0000	0.00	140.0000	No Ice	0.0778	0.1361	0.00
			0.00			1/2" Ice	0.1210	0.1890	0.00
			0.00			1" Ice	0.1728	0.2506	0.00
(3) ACU-A20-N	B	From Leg	4.0000	0.00	140.0000	No Ice	0.0778	0.1361	0.00
			0.00			1/2" Ice	0.1210	0.1890	0.00
			0.00			1" Ice	0.1728	0.2506	0.00
(3) ACU-A20-N	C	From Leg	4.0000	0.00	140.0000	No Ice	0.0778	0.1361	0.00
			0.00			1/2" Ice	0.1210	0.1890	0.00
			0.00			1" Ice	0.1728	0.2506	0.00
APXVTM14-C-120 w/ Mount Pipe	A	From Leg	4.0000	0.00	140.0000	No Ice	7.1342	4.9591	0.08
			0.00			1/2" Ice	7.6618	5.7544	0.13
			0.00			1" Ice	8.1830	6.4723	0.19
APXVTM14-C-120 w/ Mount Pipe	B	From Leg	4.0000	0.00	140.0000	No Ice	7.1342	4.9591	0.08
			0.00			1/2" Ice	7.6618	5.7544	0.13
			0.00			1" Ice	8.1830	6.4723	0.19
APXVTM14-C-120 w/ Mount Pipe	C	From Leg	4.0000	0.00	140.0000	No Ice	7.1342	4.9591	0.08
			0.00			1/2" Ice	7.6618	5.7544	0.13
			0.00			1" Ice	8.1830	6.4723	0.19
TD-RRH8x20-25	A	From Leg	4.0000	0.00	140.0000	No Ice	4.7198	1.7027	0.07
			0.00			1/2" Ice	5.0138	1.9196	0.10
			0.00			1" Ice	5.3165	2.1453	0.13
TD-RRH8x20-25	B	From Leg	4.0000	0.00	140.0000	No Ice	4.7198	1.7027	0.07
			0.00			1/2" Ice	5.0138	1.9196	0.10
			0.00			1" Ice	5.3165	2.1453	0.13
TD-RRH8x20-25	C	From Leg	4.0000	0.00	140.0000	No Ice	4.7198	1.7027	0.07
			0.00			1/2" Ice	5.0138	1.9196	0.10
			0.00			1" Ice	5.3165	2.1453	0.13
Handrail Kit [NA 507-1]	C	None		0.00	140.0000	No Ice	4.8000	4.8000	0.25
						1/2" Ice	6.7000	6.7000	0.29
						1" Ice	8.6000	8.6000	0.34
Platform Mount [LP 401-1]	C	None		0.00	140.0000	No Ice	24.3300	24.3300	1.65
						1/2" Ice	30.2200	30.2200	2.03
						1" Ice	36.1100	36.1100	2.41

\*\*\*\*\*

Description	Face or Leg	Offset Type	Offsets: Horz Lateral Vert ft ft ft	Azimuth Adjustment °	Placement ft	C <sub>AA</sub> Front ft <sup>2</sup>	C <sub>AA</sub> Side ft <sup>2</sup>	Weight K	
(2) TME-RRUS-11	A	From Leg	2.0000 0.00 0.00	0.00	123.0000	No Ice 3.2486 1/2" Ice 3.4905 1" Ice 3.7411	1.3726 1.5510 1.7380	0.05 0.07 0.09	
(2) TME-RRUS-11	B	From Leg	2.0000 0.00 0.00	0.00	123.0000	No Ice 3.2486 1/2" Ice 3.4905 1" Ice 3.7411	1.3726 1.5510 1.7380	0.05 0.07 0.09	
(2) TME-RRUS-11	C	From Leg	2.0000 0.00 0.00	0.00	123.0000	No Ice 3.2486 1/2" Ice 3.4905 1" Ice 3.7411	1.3726 1.5510 1.7380	0.05 0.07 0.09	
Side Arm Mount [SO 102-3]	C	None		0.00	123.0000	No Ice 3.0000 1/2" Ice 3.4800 1" Ice 3.9600	3.0000 3.4800 3.9600	0.08 0.11 0.14	
*****									
(2) 7770.00 w/ Mount Pipe	A	From Leg	4.0000 0.00 2.00	0.00	121.0000	No Ice 6.1194 1/2" Ice 6.6258 1" Ice 7.1283	4.2543 5.0137 5.7109	0.06 0.10 0.16	
(2) 7770.00 w/ Mount Pipe	B	From Leg	4.0000 0.00 2.00	0.00	121.0000	No Ice 6.1194 1/2" Ice 6.6258 1" Ice 7.1283	4.2543 5.0137 5.7109	0.06 0.10 0.16	
(2) 7770.00 w/ Mount Pipe	C	From Leg	4.0000 0.00 2.00	0.00	121.0000	No Ice 6.1194 1/2" Ice 6.6258 1" Ice 7.1283	4.2543 5.0137 5.7109	0.06 0.10 0.16	
(2) LGP21401	A	From Leg	4.0000 0.00 2.00	0.00	121.0000	No Ice 1.2880 1/2" Ice 1.4453 1" Ice 1.6112	0.3640 0.4785 0.6017	0.01 0.02 0.03	
(2) LGP21401	B	From Leg	4.0000 0.00 2.00	0.00	121.0000	No Ice 1.2880 1/2" Ice 1.4453 1" Ice 1.6112	0.3640 0.4785 0.6017	0.01 0.02 0.03	
(2) LGP21401	C	From Leg	4.0000 0.00 2.00	0.00	121.0000	No Ice 1.2880 1/2" Ice 1.4453 1" Ice 1.6112	0.3640 0.4785 0.6017	0.01 0.02 0.03	
(2) LGP21901	A	From Leg	4.0000 0.00 2.00	0.00	121.0000	No Ice 0.2695 1/2" Ice 0.3432 1" Ice 0.4255	0.1838 0.2483 0.3216	0.01 0.01 0.01	
(2) LGP21901	B	From Leg	4.0000 0.00 2.00	0.00	121.0000	No Ice 0.2695 1/2" Ice 0.3432 1" Ice 0.4255	0.1838 0.2483 0.3216	0.01 0.01 0.01	
(2) LGP21901	C	From Leg	4.0000 0.00 2.00	0.00	121.0000	No Ice 0.2695 1/2" Ice 0.3432 1" Ice 0.4255	0.1838 0.2483 0.3216	0.01 0.01 0.01	
AM-X-CD-16-65-00T-RET w/ Mount Pipe	A	From Leg	4.0000 0.00 4.00	0.00	121.0000	No Ice 8.4975 1/2" Ice 9.1490 1" Ice 9.7672	6.3042 7.4790 8.3676	0.07 0.14 0.21	
AM-X-CD-16-65-00T-RET w/ Mount Pipe	B	From Leg	4.0000 0.00 4.00	0.00	121.0000	No Ice 8.4975 1/2" Ice 9.1490 1" Ice 9.7672	6.3042 7.4790 8.3676	0.07 0.14 0.21	
AM-X-CD-16-65-00T-RET w/ Mount Pipe	C	From Leg	4.0000 0.00 4.00	0.00	121.0000	No Ice 8.4975 1/2" Ice 9.1490 1" Ice 9.7672	6.3042 7.4790 8.3676	0.07 0.14 0.21	
DC6-48-60-18-8F	B	From Leg	4.0000 0.00 4.00	0.00	121.0000	No Ice 2.5667 1/2" Ice 2.7978 1" Ice 3.0377	2.5667 2.7978 3.0377	0.02 0.04 0.07	
Platform Mount [LP 401-1]	C	None		0.00	121.0000	No Ice 24.3300 1/2" Ice 30.2200 1" Ice 36.1100	24.3300 30.2200 36.1100	1.65 2.03 2.41	
*****									
(2) RR90-17-02DP w/ Mount Pipe	A	From Leg	4.0000 0.00 1.00	0.00	115.0000	No Ice 4.5931 1/2" Ice 5.0883 1" Ice 5.5778	3.3194 4.0888 4.7844	0.03 0.07 0.12	
(2) RR90-17-02DP w/ Mount Pipe	B	From Leg	4.0000 0.00 1.00	0.00	115.0000	No Ice 4.5931 1/2" Ice 5.0883 1" Ice 5.5778	3.3194 4.0888 4.7844	0.03 0.07 0.12	
(2) RR90-17-02DP w/ Mount Pipe	C	From Leg	4.0000 0.00 1.00	0.00	115.0000	No Ice 4.5931 1/2" Ice 5.0883 1" Ice 5.5778	3.3194 4.0888 4.7844	0.03 0.07 0.12	

Description	Face or Leg	Offset Type	Offsets:		Azimuth Adjustment	Placement	C <sub>AA</sub>		Weight	
			Horz	Lateral			Front	Side		
			ft	ft	°	ft	ft <sup>2</sup>	ft <sup>2</sup>	K	
APX16DWV-16DWV-S-E-A20 w/ Mount Pipe	A	From Leg	4.0000		0.00	115.0000	No Ice	7.4657	3.4938	0.06
			0.00				1/2" Ice	7.9944	4.2631	0.11
			1.00				1" Ice	8.5176	4.9598	0.16
APX16DWV-16DWV-S-E-A20 w/ Mount Pipe	B	From Leg	4.0000		0.00	115.0000	No Ice	7.4657	3.4938	0.06
			0.00				1/2" Ice	7.9944	4.2631	0.11
			1.00				1" Ice	8.5176	4.9598	0.16
APX16DWV-16DWV-S-E-A20 w/ Mount Pipe	C	From Leg	4.0000		0.00	115.0000	No Ice	7.4657	3.4938	0.06
			0.00				1/2" Ice	7.9944	4.2631	0.11
			1.00				1" Ice	8.5176	4.9598	0.16
(2) S20070A1	A	From Leg	4.0000		0.00	115.0000	No Ice	0.7653	0.3588	0.01
			0.00				1/2" Ice	0.8909	0.4622	0.01
			1.00				1" Ice	1.0250	0.5744	0.02
(2) S20070A1	B	From Leg	4.0000		0.00	115.0000	No Ice	0.7653	0.3588	0.01
			0.00				1/2" Ice	0.8909	0.4622	0.01
			1.00				1" Ice	1.0250	0.5744	0.02
(2) S20070A1	C	From Leg	4.0000		0.00	115.0000	No Ice	0.7653	0.3588	0.01
			0.00				1/2" Ice	0.8909	0.4622	0.01
			1.00				1" Ice	1.0250	0.5744	0.02
ETW200VS12UB	A	From Leg	4.0000		0.00	115.0000	No Ice	0.4716	0.1899	0.01
			0.00				1/2" Ice	0.5667	0.2551	0.01
			1.00				1" Ice	0.6704	0.3290	0.02
ETW200VS12UB	B	From Leg	4.0000		0.00	115.0000	No Ice	0.4716	0.1899	0.01
			0.00				1/2" Ice	0.5667	0.2551	0.01
			1.00				1" Ice	0.6704	0.3290	0.02
ETW200VS12UB	C	From Leg	4.0000		0.00	115.0000	No Ice	0.4716	0.1899	0.01
			0.00				1/2" Ice	0.5667	0.2551	0.01
			1.00				1" Ice	0.6704	0.3290	0.02
Platform Mount [LP 401-1]	C	None			0.00	115.0000	No Ice	24.3300	24.3300	1.65
							1/2" Ice	30.2200	30.2200	2.03
							1" Ice	36.1100	36.1100	2.41
*****										
MG D3-800Tx w/ Mount Pipe	A	From Leg	4.0000		0.00	104.0000	No Ice	3.5703	3.4178	0.03
			0.00				1/2" Ice	3.9790	4.1193	0.07
			1.00				1" Ice	4.3870	4.7842	0.11
MG D3-800Tx w/ Mount Pipe	B	From Leg	4.0000		0.00	104.0000	No Ice	3.5703	3.4178	0.03
			0.00				1/2" Ice	3.9790	4.1193	0.07
			1.00				1" Ice	4.3870	4.7842	0.11
MG D3-800Tx w/ Mount Pipe	C	From Leg	4.0000		0.00	104.0000	No Ice	3.5703	3.4178	0.03
			0.00				1/2" Ice	3.9790	4.1193	0.07
			1.00				1" Ice	4.3870	4.7842	0.11
P65.16.XL.2 w/ Mount Pipe	A	From Leg	4.0000		0.00	104.0000	No Ice	8.6375	5.7792	0.06
			0.00				1/2" Ice	9.2903	6.9491	0.12
			0.00				1" Ice	9.9098	7.8329	0.19
BXA-70063/6CF w/ Mount Pipe	B	From Leg	4.0000		0.00	104.0000	No Ice	7.9795	5.4071	0.04
			0.00				1/2" Ice	8.6208	6.5581	0.10
			0.00				1" Ice	9.2281	7.4216	0.17
BXA-70063/6CF w/ Mount Pipe	C	From Leg	4.0000		0.00	104.0000	No Ice	7.9795	5.4071	0.04
			0.00				1/2" Ice	8.6208	6.5581	0.10
			0.00				1" Ice	9.2281	7.4216	0.17
ACUTIME 2000	A	From Leg	4.0000		0.00	104.0000	No Ice	0.2975	0.2975	0.00
			0.00				1/2" Ice	0.3739	0.3739	0.00
			3.00				1" Ice	0.4589	0.4589	0.01
FD9R6004/2C-3L	A	From Leg	4.0000		0.00	104.0000	No Ice	0.3665	0.0846	0.00
			0.00				1/2" Ice	0.4506	0.1362	0.01
			1.00				1" Ice	0.5433	0.1965	0.01
FD9R6004/2C-3L	B	From Leg	4.0000		0.00	104.0000	No Ice	0.3665	0.0846	0.00
			0.00				1/2" Ice	0.4506	0.1362	0.01
			1.00				1" Ice	0.5433	0.1965	0.01
FD9R6004/2C-3L	C	From Leg	4.0000		0.00	104.0000	No Ice	0.3665	0.0846	0.00
			0.00				1/2" Ice	0.4506	0.1362	0.01
			1.00				1" Ice	0.5433	0.1965	0.01
FD9R6004/2C-3L	A	From Leg	4.0000		0.00	104.0000	No Ice	0.3665	0.0846	0.00
			0.00				1/2" Ice	0.4506	0.1362	0.01
			2.00				1" Ice	0.5433	0.1965	0.01
FD9R6004/2C-3L	B	From Leg	4.0000		0.00	104.0000	No Ice	0.3665	0.0846	0.00

Description	Face or Leg	Offset Type	Offsets: Horz Lateral Vert ft ft	Azimuth Adjustment °	Placement ft	C <sub>AA</sub> Front ft <sup>2</sup>	C <sub>AA</sub> Side ft <sup>2</sup>	Weight K	
FD9R6004/2C-3L	C	From Leg	0.00	0.00	104.0000	1/2" Ice	0.4506	0.1362	0.01
			2.00			1" Ice	0.5433	0.1965	0.01
			4.0000			No Ice	0.3665	0.0846	0.00
LNx-6514DS-VTM w/ Mount Pipe	A	From Leg	0.00	0.00	104.0000	1/2" Ice	0.4506	0.1362	0.01
			2.00			1" Ice	0.5433	0.1965	0.01
			4.0000			No Ice	8.6346	7.0679	0.06
LNx-6514DS-VTM w/ Mount Pipe	B	From Leg	0.00	0.00	104.0000	1/2" Ice	9.2852	8.2532	0.13
			0.00			1" Ice	9.9050	9.1523	0.21
			4.0000			No Ice	8.6346	7.0679	0.06
LNx-6514DS-VTM w/ Mount Pipe	C	From Leg	0.00	0.00	104.0000	1/2" Ice	9.2852	8.2532	0.13
			0.00			1" Ice	9.9050	9.1523	0.21
			4.0000			No Ice	8.6346	7.0679	0.06
BXA-171063-8BF-EDIN-0 w/ Mount Pipe	A	From Leg	0.00	0.00	104.0000	1/2" Ice	9.2852	8.2532	0.13
			0.00			1" Ice	9.9050	9.1523	0.21
			4.0000			No Ice	3.1789	3.3530	0.03
BXA-171063-8BF-EDIN-0 w/ Mount Pipe	B	From Leg	0.00	0.00	104.0000	1/2" Ice	3.5550	3.9709	0.06
			0.00			1" Ice	3.9637	4.5951	0.10
			4.0000			No Ice	3.1789	3.3530	0.03
BXA-171063-8BF-EDIN-0 w/ Mount Pipe	C	From Leg	0.00	0.00	104.0000	1/2" Ice	3.5550	3.9709	0.06
			0.00			1" Ice	3.9637	4.5951	0.10
			4.0000			No Ice	3.1789	3.3530	0.03
Platform Mount [LP 303-1]	C	None	0.00	0.00	104.0000	1/2" Ice	14.6600	14.6600	1.25
			0.00			1" Ice	18.8700	18.8700	1.48
			0.00			1" Ice	23.0800	23.0800	1.71
*****									
APXV18-206517S-C w/ Mount Pipe	A	From Leg	1.0000	0.00	95.0000	No Ice	5.4042	4.7000	0.05
			0.00			1/2" Ice	5.9597	5.8600	0.10
			0.00			1" Ice	6.4808	6.7338	0.15
APXV18-206517S-C w/ Mount Pipe	B	From Leg	1.0000	0.00	95.0000	No Ice	5.4042	4.7000	0.05
			0.00			1/2" Ice	5.9597	5.8600	0.10
			0.00			1" Ice	6.4808	6.7338	0.15
APXV18-206517S-C w/ Mount Pipe	C	From Leg	1.0000	0.00	95.0000	No Ice	5.4042	4.7000	0.05
			0.00			1/2" Ice	5.9597	5.8600	0.10
			0.00			1" Ice	6.4808	6.7338	0.15
Pipe Mount [PM 601-3]	C	None	0.00	0.00	95.0000	No Ice	4.3900	4.3900	0.20
			0.00			1/2" Ice	5.4800	5.4800	0.24
			0.00			1" Ice	6.5700	6.5700	0.28
*****									
(2) 931LG65R1E-B w/ Mount Pipe	A	From Leg	4.0000	0.00	87.0000	No Ice	4.2042	4.4542	0.03
			0.00			1/2" Ice	4.6363	5.1231	0.08
			4.00			1" Ice	5.0778	5.8041	0.12
(3) 931LG65R1E-B w/ Mount Pipe	B	From Leg	4.0000	0.00	87.0000	No Ice	4.2042	4.4542	0.03
			0.00			1/2" Ice	4.6363	5.1231	0.08
			4.00			1" Ice	5.0778	5.8041	0.12
(3) 931LG65R1E-B w/ Mount Pipe	C	From Leg	4.0000	0.00	87.0000	No Ice	4.2042	4.4542	0.03
			0.00			1/2" Ice	4.6363	5.1231	0.08
			4.00			1" Ice	5.0778	5.8041	0.12
931LG65R1E-B w/ Mount Pipe	A	From Leg	4.0000	0.00	87.0000	No Ice	4.2042	4.4542	0.03
			0.00			1/2" Ice	4.6363	5.1231	0.08
			-4.00			1" Ice	5.0778	5.8041	0.12
931LG65R1E-B w/ Mount Pipe	B	From Leg	4.0000	0.00	87.0000	No Ice	4.2042	4.4542	0.03
			0.00			1/2" Ice	4.6363	5.1231	0.08
			-4.00			1" Ice	5.0778	5.8041	0.12
(2) 931LG65R1E-B w/ Mount Pipe	C	From Leg	4.0000	0.00	87.0000	No Ice	4.2042	4.4542	0.03
			0.00			1/2" Ice	4.6363	5.1231	0.08
			-4.00			1" Ice	5.0778	5.8041	0.12
(3) TS07-AWDB111-001	A	From Leg	4.0000	0.00	87.0000	No Ice	1.4000	0.5833	0.03
			0.00			1/2" Ice	1.5599	0.6978	0.04
			4.00			1" Ice	1.7284	0.8210	0.05
(3) TS07-AWDB111-001	B	From Leg	4.0000	0.00	87.0000	No Ice	1.4000	0.5833	0.03
			0.00			1/2" Ice	1.5599	0.6978	0.04
			4.00			1" Ice	1.7284	0.8210	0.05
Sector Mount [SM 802-3]	C	None		0.00	87.0000	No Ice	24.4100	24.4100	0.93

Description	Face or Leg	Offset Type	Offsets: Horz Lateral Vert ft ft ft	Azimuth Adjustment °	Placement ft	C <sub>AA</sub> Front ft <sup>2</sup>	C <sub>AA</sub> Side ft <sup>2</sup>	Weight K	
						1/2" Ice	31.3900	31.3900	1.36
						1" Ice	38.3700	38.3700	1.79
*****									
OG-860/1920/GPS-A	A	From Leg	2.0000 0.00 2.00	0.00	80.0000	No Ice	0.3286	0.4044	0.00
						1/2" Ice	0.4340	0.5138	0.01
						1" Ice	0.5481	0.6317	0.01
Side Arm Mount [SO 202-1]	A	None		0.00	80.0000	No Ice	2.9600	2.5300	0.11
						1/2" Ice	4.1000	3.5100	0.13
						1" Ice	5.2400	4.4900	0.16

**Tower Pressures - No Ice**

$G_H = 1.690$

Section Elevation ft	z ft	K <sub>Z</sub>	q <sub>z</sub> psf	A <sub>G</sub> ft <sup>2</sup>	F a c e e	A <sub>F</sub> ft <sup>2</sup>	A <sub>R</sub> ft <sup>2</sup>	A <sub>leg</sub> ft <sup>2</sup>	Leg %	C <sub>AA</sub> In Face ft <sup>2</sup>	C <sub>AA</sub> Out Face ft <sup>2</sup>
L1 140.0000-98.5000	118.0637	1.439	26.58 6	69.903	A	0.000	69.903	69.903	100.00	0.000	0.000
					B	0.000	69.903		100.00	0.000	0.000
					C	0.000	69.903		100.00	0.000	9.202
L2 98.5000-88.5000	93.4335	1.346	24.90 1	21.201	A	0.000	21.201	21.201	100.00	0.000	0.000
					B	0.000	21.201		100.00	0.000	0.000
					C	0.000	21.201		100.00	0.000	6.745
L3 88.5000-71.7500	79.9313	1.288	23.81 5	38.320	A	0.000	38.320	38.320	100.00	0.000	0.000
					B	0.000	38.320		100.00	0.000	0.000
					C	0.000	38.320		100.00	0.000	12.459
L4 71.7500-47.2500	59.1811	1.182	21.85 5	65.016	A	0.000	65.016	65.016	100.00	0.000	0.000
					B	0.000	65.016		100.00	0.000	0.000
					C	0.000	65.016		100.00	0.000	20.343
L5 47.2500-41.7500	44.4808	1.089	20.14 3	15.633	A	0.000	15.633	15.633	100.00	0.000	0.000
					B	0.000	15.633		100.00	0.000	0.000
					C	0.000	15.633		100.00	0.000	4.567
L6 41.7500-23.5000	32.4714	1	18.49 6	55.778	A	0.000	55.778	55.778	100.00	0.000	0.000
					B	0.000	55.778		100.00	0.000	0.000
					C	0.000	55.778		100.00	0.000	24.260
L7 23.5000-20.7500	22.1217	1	18.49 6	8.893	A	0.000	8.893	8.893	100.00	0.000	0.000
					B	0.000	8.893		100.00	0.000	0.000
					C	0.000	8.893		100.00	0.000	3.656
L8 20.7500-0.0000	10.1982	1	18.49 6	71.231	A	0.000	71.231	71.231	100.00	0.000	0.000
					B	0.000	71.231		100.00	0.000	0.000
					C	0.000	71.231		100.00	0.000	27.584

**Tower Pressure - With Ice**

$G_H = 1.690$

Section Elevation ft	z ft	K <sub>Z</sub>	q <sub>z</sub> psf	t <sub>z</sub> in	A <sub>G</sub> ft <sup>2</sup>	F a c e e	A <sub>F</sub> ft <sup>2</sup>	A <sub>R</sub> ft <sup>2</sup>	A <sub>leg</sub> ft <sup>2</sup>	Leg %	C <sub>AA</sub> In Face ft <sup>2</sup>	C <sub>AA</sub> Out Face ft <sup>2</sup>
L1 140.0000-98.5000	118.0637	1.439	5.202	0.7500	75.090	A	0.000	75.090	75.090	100.00	0.000	0.000
						B	0.000	75.090		100.00	0.000	0.000
						C	0.000	75.090		100.00	0.000	16.875
L2 98.5000-88.5000	93.4335	1.346	4.873	0.7500	22.451	A	0.000	22.451	22.451	100.00	0.000	0.000
						B	0.000	22.451		100.00	0.000	0.000
						C	0.000	22.451		100.00	0.000	11.025
L3 88.5000-71.7500	79.9313	1.288	4.660	0.7500	40.413	A	0.000	40.413	40.413	100.00	0.000	0.000
						B	0.000	40.413		100.00	0.000	0.000
						C	0.000	40.413		100.00	0.000	20.507
L4 71.7500-	59.1811	1.182	4.277	0.7500	68.079	A	0.000	68.079	68.079	100.00	0.000	0.000



Section Elevation ft	z ft	K <sub>Z</sub>	q <sub>z</sub> psf	t <sub>z</sub> in	A <sub>G</sub> ft <sup>2</sup>	F a c e F <sub>F</sub> ft <sup>2</sup>	A <sub>R</sub> ft <sup>2</sup>	A <sub>leg</sub> ft <sup>2</sup>	Leg %	C <sub>AA</sub> In Face ft <sup>2</sup>	C <sub>AA</sub> Out Face ft <sup>2</sup>
47.2500						B	0.000	68.079	100.00	0.000	0.000
L5 47.2500-41.7500	44.4808	1.089	3.941	0.7500	16.321	C	0.000	68.079	100.00	0.000	31.777
						A	0.000	16.321	100.00	0.000	0.000
						B	0.000	16.321	100.00	0.000	0.000
L6 41.7500-23.5000	32.4714	1	3.619	0.7500	58.060	C	0.000	16.321	100.00	0.000	7.134
						A	0.000	58.060	100.00	0.000	0.000
						B	0.000	58.060	100.00	0.000	0.000
L7 23.5000-20.7500	22.1217	1	3.619	0.7500	9.237	C	0.000	58.060	100.00	0.000	35.819
						A	0.000	9.237	100.00	0.000	0.000
						B	0.000	9.237	100.00	0.000	0.000
L8 20.7500-0.0000	10.1982	1	3.619	0.7500	73.824	C	0.000	9.237	100.00	0.000	5.397
						A	0.000	73.824	100.00	0.000	0.000
						B	0.000	73.824	100.00	0.000	0.000
						C	0.000	73.824	100.00	0.000	40.725

**Tower Pressure - Service**

$G_H = 1.690$

Section Elevation ft	z ft	K <sub>Z</sub>	q <sub>z</sub> psf	A <sub>G</sub> ft <sup>2</sup>	F a c e F <sub>F</sub> ft <sup>2</sup>	A <sub>R</sub> ft <sup>2</sup>	A <sub>leg</sub> ft <sup>2</sup>	Leg %	C <sub>AA</sub> In Face ft <sup>2</sup>	C <sub>AA</sub> Out Face ft <sup>2</sup>	
L1 140.0000-98.5000	118.0637	1.439	9.199	69.903	A	0.000	69.903	69.903	100.00	0.000	0.000
					B	0.000	69.903	69.903	100.00	0.000	0.000
					C	0.000	69.903	69.903	100.00	0.000	9.202
L2 98.5000-88.5000	93.4335	1.346	8.616	21.201	A	0.000	21.201	21.201	100.00	0.000	0.000
					B	0.000	21.201	21.201	100.00	0.000	0.000
					C	0.000	21.201	21.201	100.00	0.000	6.745
L3 88.5000-71.7500	79.9313	1.288	8.240	38.320	A	0.000	38.320	38.320	100.00	0.000	0.000
					B	0.000	38.320	38.320	100.00	0.000	0.000
					C	0.000	38.320	38.320	100.00	0.000	12.459
L4 71.7500-47.2500	59.1811	1.182	7.562	65.016	A	0.000	65.016	65.016	100.00	0.000	0.000
					B	0.000	65.016	65.016	100.00	0.000	0.000
					C	0.000	65.016	65.016	100.00	0.000	20.343
L5 47.2500-41.7500	44.4808	1.089	6.970	15.633	A	0.000	15.633	15.633	100.00	0.000	0.000
					B	0.000	15.633	15.633	100.00	0.000	0.000
					C	0.000	15.633	15.633	100.00	0.000	4.567
L6 41.7500-23.5000	32.4714	1	6.400	55.778	A	0.000	55.778	55.778	100.00	0.000	0.000
					B	0.000	55.778	55.778	100.00	0.000	0.000
					C	0.000	55.778	55.778	100.00	0.000	24.260
L7 23.5000-20.7500	22.1217	1	6.400	8.893	A	0.000	8.893	8.893	100.00	0.000	0.000
					B	0.000	8.893	8.893	100.00	0.000	0.000
					C	0.000	8.893	8.893	100.00	0.000	3.656
L8 20.7500-0.0000	10.1982	1	6.400	71.231	A	0.000	71.231	71.231	100.00	0.000	0.000
					B	0.000	71.231	71.231	100.00	0.000	0.000
					C	0.000	71.231	71.231	100.00	0.000	27.584

**Load Combinations**

Comb. No.	Description
1	Dead Only
2	Dead+Wind 0 deg - No Ice
3	Dead+Wind 30 deg - No Ice
4	Dead+Wind 60 deg - No Ice
5	Dead+Wind 90 deg - No Ice
6	Dead+Wind 120 deg - No Ice
7	Dead+Wind 150 deg - No Ice
8	Dead+Wind 180 deg - No Ice
9	Dead+Wind 210 deg - No Ice
10	Dead+Wind 240 deg - No Ice
11	Dead+Wind 270 deg - No Ice
12	Dead+Wind 300 deg - No Ice

Comb. No.	Description
13	Dead+Wind 330 deg - No Ice
14	Dead+Ice+Temp
15	Dead+Wind 0 deg+Ice+Temp
16	Dead+Wind 30 deg+Ice+Temp
17	Dead+Wind 60 deg+Ice+Temp
18	Dead+Wind 90 deg+Ice+Temp
19	Dead+Wind 120 deg+Ice+Temp
20	Dead+Wind 150 deg+Ice+Temp
21	Dead+Wind 180 deg+Ice+Temp
22	Dead+Wind 210 deg+Ice+Temp
23	Dead+Wind 240 deg+Ice+Temp
24	Dead+Wind 270 deg+Ice+Temp
25	Dead+Wind 300 deg+Ice+Temp
26	Dead+Wind 330 deg+Ice+Temp
27	Dead+Wind 0 deg - Service
28	Dead+Wind 30 deg - Service
29	Dead+Wind 60 deg - Service
30	Dead+Wind 90 deg - Service
31	Dead+Wind 120 deg - Service
32	Dead+Wind 150 deg - Service
33	Dead+Wind 180 deg - Service
34	Dead+Wind 210 deg - Service
35	Dead+Wind 240 deg - Service
36	Dead+Wind 270 deg - Service
37	Dead+Wind 300 deg - Service
38	Dead+Wind 330 deg - Service

### Maximum Member Forces

Section No.	Elevation ft	Component Type	Condition	Gov. Load Comb.	Force K	Major Axis Moment kip-ft	Minor Axis Moment kip-ft
L1	140 - 98.5	Pole	Max Tension	14	0.00	-0.00	0.00
			Max. Compression	14	-19.80	0.53	-0.44
			Max. Mx	11	-10.61	479.23	-0.09
			Max. My	8	-10.61	0.18	-479.22
			Max. Vy	11	-20.61	479.23	-0.09
			Max. Vx	2	-20.62	0.22	479.10
			Max. Torque	3			-0.54
			Max Tension	1	0.00	0.00	0.00
L2	98.5 - 88.5	Pole	Max. Compression	14	-21.95	0.85	-0.63
			Max. Mx	11	-12.09	623.85	-0.15
			Max. My	8	-12.09	0.26	-623.88
			Max. Vy	11	-22.28	623.85	-0.15
			Max. Vx	2	-22.29	0.32	623.67
			Max. Torque	3			-0.45
			Max Tension	1	0.00	0.00	0.00
			Max. Compression	14	-30.79	1.84	-1.70
L3	88.5 - 71.75	Pole	Max. Mx	11	-18.07	1152.83	0.67
			Max. My	8	-18.06	-0.65	-1154.45
			Max. Vy	11	-28.41	1152.83	0.67
			Max. Vx	2	-28.49	1.27	1153.92
			Max. Torque	11			1.48
			Max Tension	1	0.00	0.00	0.00
			Max. Compression	14	-37.16	3.18	-2.48
			Max. Mx	11	-23.48	1753.03	1.44
L4	71.75 - 47.25	Pole	Max. My	8	-23.47	-1.28	-1756.01
			Max. Vy	11	-30.88	1753.03	1.44
			Max. Vx	2	-30.96	2.67	1755.09
			Max. Torque	12			1.58
			Max Tension	1	0.00	0.00	0.00
			Max. Compression	14	-41.48	3.83	-2.85
			Max. Mx	11	-27.28	2060.70	1.82
			Max. My	8	-27.27	-1.58	-2064.33
L5	47.25 - 41.75	Pole	Max. Vy	11	-32.14	2060.70	1.82
			Max. Vx	2	-32.21	3.35	2063.22
			Max. Torque	12			1.67
			Max Tension	1	0.00	0.00	0.00
			Max. Compression	14	-41.48	3.83	-2.85
			Max. Mx	11	-27.28	2060.70	1.82
			Max. My	8	-27.27	-1.58	-2064.33
			Max. Vy	11	-32.14	2060.70	1.82
L6	41.75 - 23.5	Pole	Max. Vx	2	-32.21	3.35	2063.22
			Max. Torque	12			1.67
L6	41.75 - 23.5	Pole	Max Tension	1	0.00	0.00	0.00

Section No.	Elevation ft	Component Type	Condition	Gov. Load Comb.	Force K	Major Axis Moment kip-ft	Minor Axis Moment kip-ft
L7	23.5 - 20.75	Pole	Max. Compression	14	-48.48	5.15	-3.60
			Max. Mx	11	-33.39	2667.25	2.50
			Max. My	8	-33.39	-2.10	-2672.08
			Max. Vy	11	-34.34	2667.25	2.50
			Max. Vx	2	-34.42	4.65	2670.56
			Max. Torque	12			1.92
			Max Tension	1	0.00	0.00	0.00
			Max. Compression	14	-49.67	5.36	-3.73
			Max. Mx	11	-34.43	2762.18	2.60
			Max. My	8	-34.43	-2.17	-2767.19
			Max. Vy	11	-34.69	2762.18	2.60
			Max. Vx	2	-34.77	4.84	2765.61
L8	20.75 - 0	Pole	Max. Torque	12			1.96
			Max Tension	1	0.00	0.00	0.00
			Max. Compression	14	-58.37	7.05	-4.69
			Max. Mx	11	-42.11	3508.19	3.34
			Max. My	8	-42.11	-2.70	-3514.52
			Max. Vy	11	-37.23	3508.19	3.34
			Max. Vx	2	-37.30	6.36	3512.43
			Max. Torque	12			2.29

### Maximum Reactions

Location	Condition	Gov. Load Comb.	Vertical K	Horizontal, X K	Horizontal, Z K
Pole	Max. Vert	14	58.37	-0.00	0.00
	Max. H <sub>x</sub>	11	42.12	37.21	0.05
	Max. H <sub>z</sub>	2	42.12	0.05	37.28
	Max. M <sub>x</sub>	2	3512.43	0.05	37.28
	Max. M <sub>z</sub>	5	3504.55	-37.21	-0.05
	Max. Torsion	12	2.29	32.25	18.68
	Min. Vert	8	42.12	-0.05	-37.28
	Min. H <sub>x</sub>	5	42.12	-37.21	-0.05
	Min. H <sub>z</sub>	8	42.12	-0.05	-37.28
	Min. M <sub>x</sub>	8	-3514.52	-0.05	-37.28
	Min. M <sub>z</sub>	11	-3508.19	37.21	0.05
	Min. Torsion	6	-2.28	-32.25	-18.68

### Tower Mast Reaction Summary

Load Combination	Vertical K	Shear <sub>x</sub> K	Shear <sub>z</sub> K	Overturning Moment, M <sub>x</sub> kip-ft	Overturning Moment, M <sub>z</sub> kip-ft	Torque kip-ft
Dead Only	42.12	-0.00	0.00	1.17	1.78	0.00
Dead+Wind 0 deg - No Ice	42.12	-0.05	-37.28	-3512.43	6.36	-1.15
Dead+Wind 30 deg - No Ice	42.12	18.56	-32.27	-3039.61	-1747.52	-0.01
Dead+Wind 60 deg - No Ice	42.12	32.20	-18.60	-1751.81	-3032.68	1.12
Dead+Wind 90 deg - No Ice	42.12	37.21	0.05	5.72	-3504.55	1.96
Dead+Wind 120 deg - No Ice	42.12	32.25	18.68	1762.03	-3037.19	2.28
Dead+Wind 150 deg - No Ice	42.12	18.65	32.31	3046.51	-1755.36	1.99
Dead+Wind 180 deg - No Ice	42.12	0.05	37.28	3514.52	-2.70	1.17
Dead+Wind 210 deg - No Ice	42.12	-18.56	32.27	3042.00	1751.18	0.03
Dead+Wind 240 deg - No Ice	42.12	-32.20	18.60	1754.19	3036.34	-1.12
Dead+Wind 270 deg - No Ice	42.12	-37.21	-0.05	-3.34	3508.19	-1.97
Dead+Wind 300 deg - No Ice	42.12	-32.25	-18.68	-1759.64	3040.84	-2.29
Dead+Wind 330 deg - No Ice	42.12	-18.65	-32.31	-3044.11	1759.01	-1.99
Dead+Ice+Temp	58.37	0.00	-0.00	4.69	7.05	0.00
Dead+Wind 0 deg+Ice+Temp	58.37	-0.01	-8.84	-853.86	8.36	-0.35
Dead+Wind 30 deg+Ice+Temp	58.37	4.40	-7.65	-738.29	-420.20	-0.05
Dead+Wind 60 deg+Ice+Temp	58.37	7.63	-4.41	-423.57	-734.22	0.26
Dead+Wind 90 deg+Ice+Temp	58.37	8.82	0.01	5.95	-849.53	0.51
Dead+Wind 120 deg+Ice+Temp	58.37	7.65	4.43	435.18	-735.30	0.61
Dead+Wind 150 deg+Ice+Temp	58.37	4.42	7.66	749.11	-422.07	0.56

Load Combination	Vertical	Shear <sub>x</sub>	Shear <sub>z</sub>	Overturning Moment, M <sub>x</sub>	Overturning Moment, M <sub>z</sub>	Torque
	K	K	K	kip-ft	kip-ft	kip-ft
Dead+Wind 180 deg+Ice+Temp	58.37	0.01	8.84	863.60	6.21	0.35
Dead+Wind 210 deg+Ice+Temp	58.37	-4.40	7.65	748.03	434.77	0.05
Dead+Wind 240 deg+Ice+Temp	58.37	-7.63	4.41	433.31	748.78	-0.26
Dead+Wind 270 deg+Ice+Temp	58.37	-8.82	-0.01	3.79	864.09	-0.51
Dead+Wind 300 deg+Ice+Temp	58.37	-7.65	-4.43	-425.44	749.86	-0.61
Dead+Wind 330 deg+Ice+Temp	58.37	-4.42	-7.66	-739.37	436.63	-0.56
Dead+Wind 0 deg - Service	42.12	-0.02	-12.90	-1216.47	3.40	-0.40
Dead+Wind 30 deg - Service	42.12	6.42	-11.16	-1052.69	-604.47	-0.00
Dead+Wind 60 deg - Service	42.12	11.14	-6.44	-606.35	-1049.88	0.39
Dead+Wind 90 deg - Service	42.12	12.87	0.02	2.77	-1213.32	0.69
Dead+Wind 120 deg - Service	42.12	11.16	6.47	611.48	-1051.45	0.79
Dead+Wind 150 deg - Service	42.12	6.45	11.18	1056.67	-607.18	0.69
Dead+Wind 180 deg - Service	42.12	0.02	12.90	1218.88	0.26	0.40
Dead+Wind 210 deg - Service	42.12	-6.42	11.16	1055.10	608.13	0.01
Dead+Wind 240 deg - Service	42.12	-11.14	6.44	608.76	1053.54	-0.39
Dead+Wind 270 deg - Service	42.12	-12.87	-0.02	-0.36	1216.98	-0.69
Dead+Wind 300 deg - Service	42.12	-11.16	-6.47	-609.07	1055.11	-0.80
Dead+Wind 330 deg - Service	42.12	-6.45	-11.18	-1054.25	610.84	-0.69

## Solution Summary

Load Comb.	Sum of Applied Forces			Sum of Reactions			% Error
	PX K	PY K	PZ K	PX K	PY K	PZ K	
1	0.00	-42.12	0.00	0.00	42.12	-0.00	0.000%
2	-0.05	-42.12	-37.29	0.05	42.12	37.28	0.003%
3	18.56	-42.12	-32.27	-18.56	42.12	32.27	0.000%
4	32.20	-42.12	-18.60	-32.20	42.12	18.60	0.000%
5	37.21	-42.12	0.05	-37.21	42.12	-0.05	0.003%
6	32.25	-42.12	18.68	-32.25	42.12	-18.68	0.000%
7	18.65	-42.12	32.31	-18.65	42.12	-32.31	0.000%
8	0.05	-42.12	37.29	-0.05	42.12	-37.28	0.008%
9	-18.56	-42.12	32.27	18.56	42.12	-32.27	0.000%
10	-32.20	-42.12	18.60	32.20	42.12	-18.60	0.000%
11	-37.21	-42.12	-0.05	37.21	42.12	0.05	0.003%
12	-32.25	-42.12	-18.68	32.25	42.12	18.68	0.000%
13	-18.65	-42.12	-32.31	18.65	42.12	32.31	0.000%
14	0.00	-58.37	0.00	-0.00	58.37	0.00	0.003%
15	-0.01	-58.37	-8.84	0.01	58.37	8.84	0.000%
16	4.40	-58.37	-7.65	-4.40	58.37	7.65	0.000%
17	7.63	-58.37	-4.41	-7.63	58.37	4.41	0.000%
18	8.82	-58.37	0.01	-8.82	58.37	-0.01	0.000%
19	7.65	-58.37	4.43	-7.65	58.37	-4.43	0.000%
20	4.42	-58.37	7.66	-4.42	58.37	-7.66	0.000%
21	0.01	-58.37	8.84	-0.01	58.37	-8.84	0.000%
22	-4.40	-58.37	7.65	4.40	58.37	-7.65	0.000%
23	-7.63	-58.37	4.41	7.63	58.37	-4.41	0.000%
24	-8.82	-58.37	-0.01	8.82	58.37	0.01	0.000%
25	-7.65	-58.37	-4.43	7.65	58.37	4.43	0.000%
26	-4.42	-58.37	-7.66	4.42	58.37	7.66	0.000%
27	-0.02	-42.12	-12.90	0.02	42.12	12.90	0.004%
28	6.42	-42.12	-11.16	-6.42	42.12	11.16	0.001%
29	11.14	-42.12	-6.44	-11.14	42.12	6.44	0.001%
30	12.88	-42.12	0.02	-12.87	42.12	-0.02	0.004%
31	11.16	-42.12	6.47	-11.16	42.12	-6.47	0.001%
32	6.45	-42.12	11.18	-6.45	42.12	-11.18	0.001%
33	0.02	-42.12	12.90	-0.02	42.12	-12.90	0.004%
34	-6.42	-42.12	11.16	6.42	42.12	-11.16	0.001%
35	-11.14	-42.12	6.44	11.14	42.12	-6.44	0.001%
36	-12.88	-42.12	-0.02	12.87	42.12	0.02	0.004%
37	-11.16	-42.12	-6.47	11.16	42.12	6.47	0.001%
38	-6.45	-42.12	-11.18	6.45	42.12	11.18	0.001%

### Non-Linear Convergence Results

Load Combination	Converged?	Number of Cycles	Displacement Tolerance	Force Tolerance
1	Yes	6	0.00000001	0.00000001
2	Yes	14	0.00003428	0.00006464
3	Yes	18	0.00000001	0.00006848
4	Yes	18	0.00000001	0.00006724
5	Yes	14	0.00003429	0.00013043
6	Yes	18	0.00000001	0.00007003
7	Yes	18	0.00000001	0.00006757
8	Yes	13	0.00008856	0.00013305
9	Yes	18	0.00000001	0.00006808
10	Yes	18	0.00000001	0.00006934
11	Yes	14	0.00003429	0.00011508
12	Yes	18	0.00000001	0.00006728
13	Yes	18	0.00000001	0.00006972
14	Yes	7	0.00000001	0.00003551
15	Yes	15	0.00000001	0.00013477
16	Yes	16	0.00000001	0.00006720
17	Yes	16	0.00000001	0.00006698
18	Yes	15	0.00000001	0.00013442
19	Yes	16	0.00000001	0.00006841
20	Yes	16	0.00000001	0.00006792
21	Yes	15	0.00000001	0.00013631
22	Yes	16	0.00000001	0.00006893
23	Yes	16	0.00000001	0.00006911
24	Yes	15	0.00000001	0.00013639
25	Yes	16	0.00000001	0.00006807
26	Yes	16	0.00000001	0.00006861
27	Yes	13	0.00009532	0.00005633
28	Yes	15	0.00000001	0.00007586
29	Yes	15	0.00000001	0.00007194
30	Yes	13	0.00009534	0.00007154
31	Yes	15	0.00000001	0.00008042
32	Yes	15	0.00000001	0.00007250
33	Yes	13	0.00009532	0.00005580
34	Yes	15	0.00000001	0.00007464
35	Yes	15	0.00000001	0.00007876
36	Yes	13	0.00009532	0.00007021
37	Yes	15	0.00000001	0.00007163
38	Yes	15	0.00000001	0.00007937

### Maximum Tower Deflections - Service Wind

Section No.	Elevation ft	Horz. Deflection in	Gov. Load Comb.	Tilt °	Twist °
L1	140 - 98.5	37.92	33	2.52	0.00
L2	98.5 - 88.5	18.18	33	1.80	0.00
L3	91.75 - 71.75	15.71	33	1.68	0.00
L4	71.75 - 47.25	9.41	33	1.29	0.00
L5	51.5 - 41.75	4.80	33	0.88	0.00
L6	41.75 - 23.5	3.13	33	0.73	0.00
L7	23.5 - 20.75	0.98	33	0.40	0.00
L8	20.75 - 0	0.76	33	0.35	0.00

### Critical Deflections and Radius of Curvature - Service Wind

Elevation ft	Appurtenance	Gov. Load Comb.	Deflection in	Tilt °	Twist °	Radius of Curvature ft
140.0000	APXVSPP18-C-A20 w/ Mount Pipe	33	37.92	2.52	0.00	15009
123.0000	(2) TME-RRUS-11	33	29.18	2.23	0.00	4413
121.0000	(2) 7770.00 w/ Mount Pipe	33	28.19	2.19	0.00	3949
115.0000	(2) RR90-17-02DP w/ Mount Pipe	33	25.30	2.09	0.00	3000

Elevation ft	Appurtenance	Gov. Load Comb.	Deflection in	Tilt °	Twist °	Radius of Curvature ft
104.0000	MG D3-800Tx w/ Mount Pipe	33	20.39	1.90	0.00	2083
95.0000	APXV18-206517S-C w/ Mount Pipe	33	16.87	1.74	0.00	2536
87.0000	(2) 931LG65R1E-B w/ Mount Pipe	33	14.08	1.60	0.00	3509
80.0000	OG-860/1920/GPS-A	33	11.81	1.46	0.00	2911

### Maximum Tower Deflections - Design Wind

Section No.	Elevation ft	Horz. Deflection in	Gov. Load Comb.	Tilt °	Twist °
L1	140 - 98.5	109.04	8	7.24	0.01
L2	98.5 - 88.5	52.34	8	5.20	0.01
L3	91.75 - 71.75	45.25	8	4.85	0.01
L4	71.75 - 47.25	27.11	7	3.72	0.00
L5	51.5 - 41.75	13.83	7	2.54	0.00
L6	41.75 - 23.5	9.02	7	2.11	0.00
L7	23.5 - 20.75	2.81	7	1.15	0.00
L8	20.75 - 0	2.19	7	1.02	0.00

### Critical Deflections and Radius of Curvature - Design Wind

Elevation ft	Appurtenance	Gov. Load Comb.	Deflection in	Tilt °	Twist °	Radius of Curvature ft
140.0000	APXVSPP18-C-A20 w/ Mount Pipe	8	109.04	7.24	0.01	5360
123.0000	(2) TME-RRUS-11	8	83.96	6.41	0.01	1574
121.0000	(2) 7770.00 w/ Mount Pipe	8	81.11	6.32	0.01	1407
115.0000	(2) RR90-17-02DP w/ Mount Pipe	8	72.79	6.02	0.01	1068
104.0000	MG D3-800Tx w/ Mount Pipe	8	58.68	5.48	0.01	739
95.0000	APXV18-206517S-C w/ Mount Pipe	8	48.58	5.02	0.01	895
87.0000	(2) 931LG65R1E-B w/ Mount Pipe	8	40.55	4.59	0.01	1234
80.0000	OG-860/1920/GPS-A	7	34.03	4.20	0.00	1021

### Compression Checks

### Pole Design Data

Section No.	Elevation ft	Size	L ft	L <sub>u</sub> ft	Kl/r	F <sub>a</sub> ksi	A in <sup>2</sup>	Actual P K	Allow. P <sub>a</sub> K	Ratio P P <sub>a</sub>
L1	140 - 98.5 (1)	TP24.4257x16x0.25	41.5000	0.0000	0.0	39.00	19.4614	-10.61	759.00	0.014
L2	98.5 - 88.5 (2)	TP26.456x24.4257x0.4933	10.0000	0.0000	0.0	34.56	40.1933	-12.09	1389.08	0.009
L3	88.5 - 71.75 (3)	TP29.3572x24.8095x0.5231	20.0000	0.0000	0.0	34.81	48.5704	-18.05	1690.54	0.011
L4	71.75 - 47.25 (4)	TP34.332x29.3572x0.5889	24.5000	0.0000	0.0	34.78	62.3440	-23.47	2168.45	0.011
L5	47.25 - 41.75 (5)	TP34.8235x32.2913x0.6414	9.7500	0.0000	0.0	34.85	70.5934	-27.27	2460.04	0.011
L6	41.75 - 23.5 (6)	TP38.5288x34.8235x0.6656	18.2500	0.0000	0.0	35.20	81.1473	-33.39	2856.06	0.012
L7	23.5 - 20.75 (7)	TP39.0872x38.5288x0.7405	2.7500	0.0000	0.0	34.02	91.4317	-34.43	3110.51	0.011
L8	20.75 - 0 (8)	TP43.3x39.0872x0.6628	20.7500	0.0000	0.0	35.73	91.0011	-42.11	3251.47	0.013

### Pole Bending Design Data

Section No.	Elevation ft	Size	Actual M <sub>x</sub> kip-ft	Actual f <sub>bx</sub> ksi	Allow. F <sub>bx</sub> ksi	Ratio f <sub>bx</sub> F <sub>bx</sub>	Actual M <sub>y</sub> kip-ft	Actual f <sub>by</sub> ksi	Allow. F <sub>by</sub> ksi	Ratio f <sub>by</sub> F <sub>by</sub>
L1	140 - 98.5 (1)	TP24.4257x16x0.25	479.31	50.13	39.00	1.285	0.00	0.00	39.00	0.000
L2	98.5 - 88.5 (2)	TP26.456x24.4257x0.4933	624.00	30.46	34.56	0.881	0.00	0.00	34.56	0.000
L3	88.5 - 71.75 (3)	TP29.3572x24.8095x0.5231	1154.82	40.89	34.81	1.175	0.00	0.00	34.81	0.000
L4	71.75 - 47.25 (4)	TP34.332x29.3572x0.5889	1756.73	42.48	34.78	1.221	0.00	0.00	34.78	0.000

Section No.	Elevation ft	Size	Actual $M_x$ kip-ft	Actual $f_{bx}$ ksi	Allow. $F_{bx}$ ksi	Ratio $\frac{f_{bx}}{F_{bx}}$	Actual $M_y$ kip-ft	Actual $f_{by}$ ksi	Allow. $F_{by}$ ksi	Ratio $\frac{f_{by}}{F_{by}}$
L5	47.25 - 41.75 (5)	TP34.8235x32.2913x0.6414	2065.22	42.46	34.85	1.218	0.00	0.00	34.85	0.000
L6	41.75 - 23.5 (6)	TP38.5288x34.8235x0.6656	2673.26	43.12	35.20	1.225	0.00	0.00	35.20	0.000
L7	23.5 - 20.75 (7)	TP39.0872x38.5288x0.7405	2768.41	39.20	34.02	1.152	0.00	0.00	34.02	0.000
L8	20.75 - 0 (8)	TP43.3x39.0872x0.6628	3516.04	44.82	35.73	1.254	0.00	0.00	35.73	0.000

### Pole Shear Design Data

Section No.	Elevation ft	Size	Actual $V$ K	Actual $f_v$ ksi	Allow. $F_v$ ksi	Ratio $\frac{f_v}{F_v}$	Actual $T$ kip-ft	Actual $f_{vt}$ ksi	Allow. $F_{vt}$ ksi	Ratio $\frac{f_{vt}}{F_{vt}}$
L1	140 - 98.5 (1)	TP24.4257x16x0.25	20.62	1.06	26.00	0.083	0.45	0.02	26.00	0.001
L2	98.5 - 88.5 (2)	TP26.456x24.4257x0.4933	22.29	0.55	23.04	0.049	0.42	0.01	23.04	0.000
L3	88.5 - 71.75 (3)	TP29.3572x24.8095x0.5231	28.51	0.59	23.20	0.051	0.96	0.02	23.20	0.001
L4	71.75 - 47.25 (4)	TP34.332x29.3572x0.5889	30.99	0.50	23.19	0.044	1.17	0.01	23.19	0.001
L5	47.25 - 41.75 (5)	TP34.8235x32.2913x0.6414	32.24	0.46	23.23	0.040	1.27	0.01	23.23	0.001
L6	41.75 - 23.5 (6)	TP38.5288x34.8235x0.6656	34.44	0.42	23.46	0.037	1.56	0.01	23.46	0.001
L7	23.5 - 20.75 (7)	TP39.0872x38.5288x0.7405	34.79	0.38	22.68	0.034	1.61	0.01	22.68	0.000
L8	20.75 - 0 (8)	TP43.3x39.0872x0.6628	37.33	0.41	23.82	0.035	1.99	0.01	23.82	0.000

### Pole Interaction Design Data

Section No.	Elevation ft	Ratio $P$ $P_a$	Ratio $f_{bx}$ $F_{bx}$	Ratio $f_{by}$ $F_{by}$	Ratio $f_v$ $F_v$	Ratio $f_{vt}$ $F_{vt}$	Comb. Stress Ratio	Allow. Stress Ratio	Criteria
L1	140 - 98.5 (1)	0.014	1.285	0.000	0.083	0.001	1.301 ✓	1.333	H1-3+VT ✓
L2	98.5 - 88.5 (2)	0.009	0.881	0.000	0.049	0.000	0.891 ✓	1.333	H1-3+VT ✓
L3	88.5 - 71.75 (3)	0.011	1.175	0.000	0.051	0.001	1.186 ✓	1.333	H1-3+VT ✓
L4	71.75 - 47.25 (4)	0.011	1.221	0.000	0.044	0.001	1.233 ✓	1.333	H1-3+VT ✓
L5	47.25 - 41.75 (5)	0.011	1.218	0.000	0.040	0.001	1.230 ✓	1.333	H1-3+VT ✓
L6	41.75 - 23.5 (6)	0.012	1.225	0.000	0.037	0.001	1.237 ✓	1.333	H1-3+VT ✓
L7	23.5 - 20.75 (7)	0.011	1.152	0.000	0.034	0.000	1.163 ✓	1.333	H1-3+VT ✓
L8	20.75 - 0 (8)	0.013	1.254	0.000	0.035	0.000	1.268 ✓	1.333	H1-3+VT ✓

### Section Capacity Table

Section No.	Elevation ft	Component Type	Size	Critical Element	$P$ K	$SF * P_{allow}$ K	% Capacity	Pass Fail
L1	140 - 98.5	Pole	TP24.4257x16x0.25	1	-10.61	1011.74	97.6	Pass
L2	98.5 - 88.5	Pole	TP26.456x24.4257x0.4933	2	-12.09	1851.64	66.8	Pass
L3	88.5 - 71.75	Pole	TP29.3572x24.8095x0.5231	3	-18.05	2253.49	89.0	Pass
L4	71.75 - 47.25	Pole	TP34.332x29.3572x0.5889	4	-23.47	2890.54	92.5	Pass
L5	47.25 - 41.75	Pole	TP34.8235x32.2913x0.6414	5	-27.27	3279.23	92.3	Pass
L6	41.75 - 23.5	Pole	TP38.5288x34.8235x0.6656	6	-33.39	3807.13	92.8	Pass
L7	23.5 - 20.75	Pole	TP39.0872x38.5288x0.7405	7	-34.43	4146.31	87.3	Pass
L8	20.75 - 0	Pole	TP43.3x39.0872x0.6628	8	-42.11	4334.21	95.1	Pass
Summary								
Pole (L1)							97.6	Pass
<b>RATING =</b>							<b>97.6</b>	<b>Pass</b>

## APPENDIX B

### BASE LEVEL DRAWING

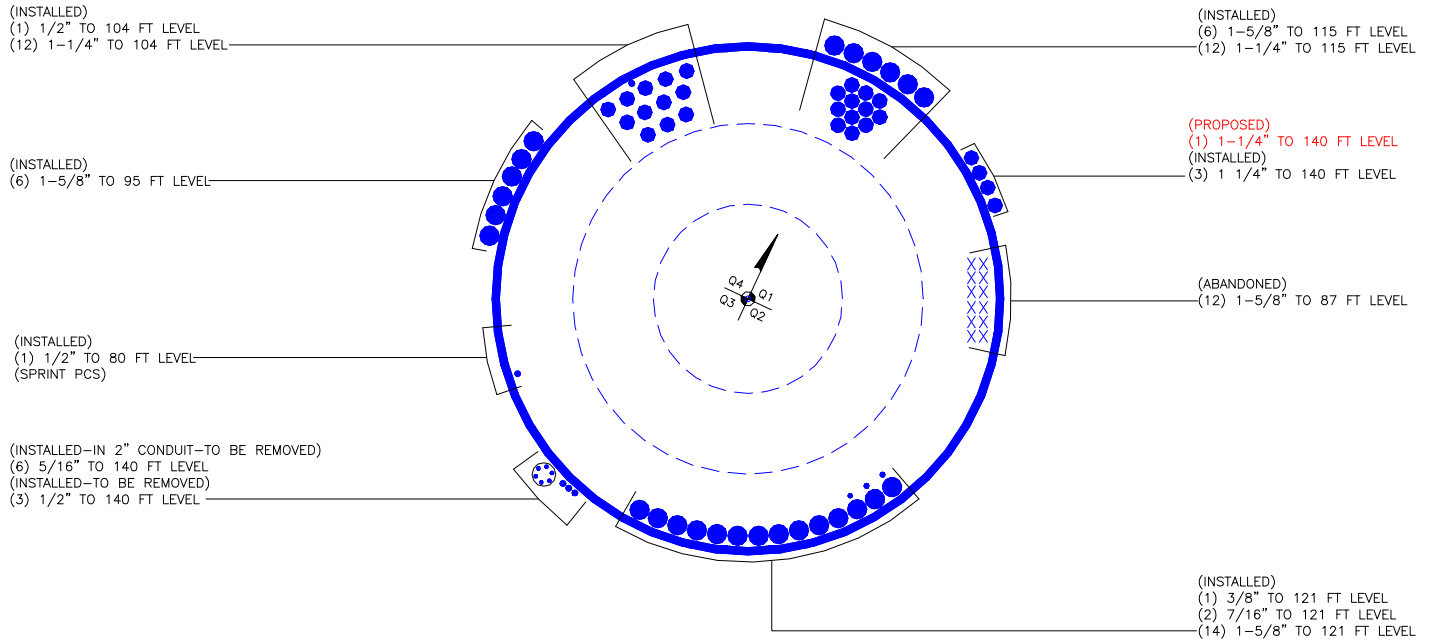



**APPENDIX C**  
**ADDITIONAL CALCULATIONS**

Section	1	2	3	4	5	6	7	8	25.6
Length (ft)	41.5000	10.0000	20.0000	24.5000	9.7500	18.2500	2.7500	20.7500	
Number of Sides	12	12	12	12	12	12	12	12	
Thickness (in)	0.2500	0.4933	0.5231	0.5888	0.6414	0.6656	0.7405	0.6628	
Socket Length (ft)		3.2500		4.2500					
Top Dia (in)	16.0000	24.4257	24.8095	29.3572	32.2913	34.8235	38.5288	39.0872	
Bot Dia (in)	24.4257	26.4560	29.3572	34.3320	34.8235	38.5288	39.0872	43.3000	
Grade	A607-65	Reinf 57.60 ksi	Reinf 58.01 ksi	Reinf 57.97 ksi	Reinf 58.08 ksi	Reinf 58.66 ksi	Reinf 56.70 ksi	Reinf 58.58 ksi	
Weight (K)	2.3	1.3	3.0	4.9	2.3	4.8	0.8	6.1	

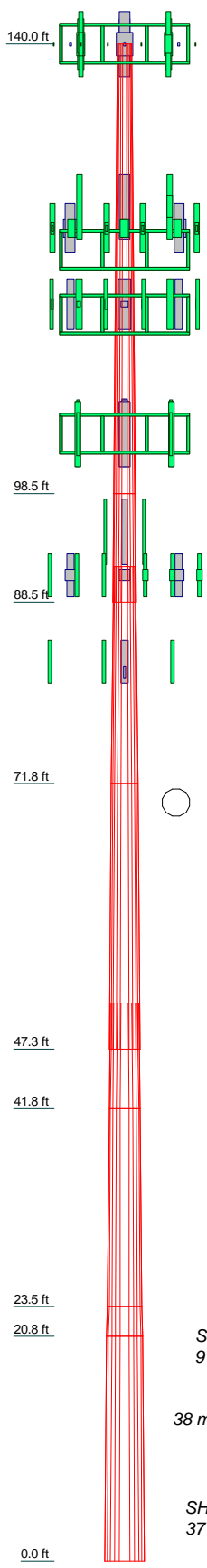

### DESIGNED APPURTENANCE LOADING

TYPE	ELEVATION	TYPE	ELEVATION
APXVSP18-C-A20 w/ Mount Pipe	140	APX16DWV-16DWV-S-E-A20 w/ Mount Pipe	115
APXVSP18-C-A20 w/ Mount Pipe	140	APX16DWV-16DWV-S-E-A20 w/ Mount Pipe	115
APXVSP18-C-A20 w/ Mount Pipe	140	APX16DWV-16DWV-S-E-A20 w/ Mount Pipe	115
800 EXTERNAL NOTCH FILTER	140	(2) S20070A1	115
800 EXTERNAL NOTCH FILTER	140	(2) S20070A1	115
800 EXTERNAL NOTCH FILTER	140	(2) S20070A1	115
800MHZ RRH	140	ETW200VS12UB	115
800MHZ RRH	140	ETW200VS12UB	115
800MHZ RRH	140	ETW200VS12UB	115
1900MHZ RRH (65MHz)	140	ETW200VS12UB	115
1900MHZ RRH (65MHz)	140	Platform Mount [LP 401-1]	115
1900MHZ RRH (65MHz)	140	MG D3-800Tx w/ Mount Pipe	104
(3) ACU-A20-N	140	MG D3-800Tx w/ Mount Pipe	104
(3) ACU-A20-N	140	MG D3-800Tx w/ Mount Pipe	104
(3) ACU-A20-N	140	P65.16.XL.2 w/ Mount Pipe	104
APXVTM14-C-120 w/ Mount Pipe	140	BXA-70063/6CF w/ Mount Pipe	104
APXVTM14-C-120 w/ Mount Pipe	140	BXA-70063/6CF w/ Mount Pipe	104
APXVTM14-C-120 w/ Mount Pipe	140	ACUTIME 2000	104
TD-RRH8x20-25	140	FD9R6004/2C-3L	104
TD-RRH8x20-25	140	FD9R6004/2C-3L	104
TD-RRH8x20-25	140	FD9R6004/2C-3L	104
Handrail Kit [NA 507-1]	140	FD9R6004/2C-3L	104
Platform Mount [LP 401-1]	140	FD9R6004/2C-3L	104
(2) TME-RRUS-11	123	LNx-6514DS-VTM w/ Mount Pipe	104
(2) TME-RRUS-11	123	LNx-6514DS-VTM w/ Mount Pipe	104
(2) TME-RRUS-11	123	LNx-6514DS-VTM w/ Mount Pipe	104
Side Arm Mount [SO 102-3]	123	BXA-171063-8BF-EDIN-0 w/ Mount Pipe	104
(2) 7770.00 w/ Mount Pipe	121	BXA-171063-8BF-EDIN-0 w/ Mount Pipe	104
(2) 7770.00 w/ Mount Pipe	121	BXA-171063-8BF-EDIN-0 w/ Mount Pipe	104
(2) 7770.00 w/ Mount Pipe	121	BXA-171063-8BF-EDIN-0 w/ Mount Pipe	104
(2) LGP21401	121	BXA-171063-8BF-EDIN-0 w/ Mount Pipe	104
(2) LGP21401	121	Platform Mount [LP 303-1]	104
(2) LGP21401	121	APXV18-206517S-C w/ Mount Pipe	95
(2) LGP21901	121	APXV18-206517S-C w/ Mount Pipe	95
(2) LGP21901	121	APXV18-206517S-C w/ Mount Pipe	95
AM-X-CD-16-65-00T-RET w/ Mount Pipe	121	Pipe Mount [PM 601-3]	95
AM-X-CD-16-65-00T-RET w/ Mount Pipe	121	(2) 931LG65R1E-B w/ Mount Pipe	87
AM-X-CD-16-65-00T-RET w/ Mount Pipe	121	(3) 931LG65R1E-B w/ Mount Pipe	87
AM-X-CD-16-65-00T-RET w/ Mount Pipe	121	(3) 931LG65R1E-B w/ Mount Pipe	87
AM-X-CD-16-65-00T-RET w/ Mount Pipe	121	931LG65R1E-B w/ Mount Pipe	87
DC6-48-60-18-8F	121	931LG65R1E-B w/ Mount Pipe	87
Platform Mount [LP 401-1]	121	(2) 931LG65R1E-B w/ Mount Pipe	87
(2) RR90-17-02DP w/ Mount Pipe	115	(3) TS07-AWDB111-001	87
(2) RR90-17-02DP w/ Mount Pipe	115	(3) TS07-AWDB111-001	87
(2) RR90-17-02DP w/ Mount Pipe	115	Sector Mount [SM 802-3]	87
APX16DWV-16DWV-S-E-A20 w/ Mount Pipe	115	OG-860/1920/GPS-A	80
		Side Arm Mount [SO 202-1]	80

### MATERIAL STRENGTH

GRADE	Fy	Fu	GRADE	Fy	Fu
A607-65	65 ksi	80 ksi	Reinf 58.08 ksi	58 ksi	73 ksi
Reinf 57.60 ksi	58 ksi	72 ksi	Reinf 58.66 ksi	59 ksi	74 ksi
Reinf 58.01 ksi	58 ksi	73 ksi	Reinf 56.70 ksi	57 ksi	71 ksi
Reinf 57.97 ksi	58 ksi	73 ksi	Reinf 59.55 ksi	60 ksi	75 ksi

### TOWER DESIGN NOTES

1. Tower is located in New Haven County, Connecticut.
2. Tower is designed for a 85 mph basic wind in accordance with the TIA/EIA-222-F Standard.
3. Tower is also designed for a 38 mph basic wind with 0.75 in ice.
4. Deflections are based upon a 50 mph wind.
5. TOWER RATING: 97.6%

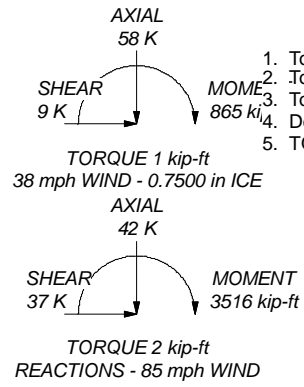



**Paul J Ford and Company**  
250 E. Broad Street Suite 600  
Columbus, OH 43215  
Phone: 614.221.6679  
FAX: 614.448.4105

Job: **140' Monopole / Bic Drive (SSUSA)**  
Project: **37513-2020.003.7805 / BU 876342**

Client: Crown Castle	Drawn by: Seth Tschanen	App'd:
Code: TIA/EIA-222-F	Date: 07/09/14	Scale: NTS
Path:		Dwg No. E-1

## Square, Stiffened / Unstiffened Base Plate, Any Rod Material - Rev. F /G

- Assumptions: 1) Rod groups at corners. Total # rods divisible by 4. Maximum total # of rods = 48 (12 per Corner).  
 2) Rod Spacing = Straight Center-to-Center distance between any (2) adjacent rods (same corner)  
 3) Clear space between bottom of leveling nut and top of concrete **not** exceeding (1)\*(Rod Diameter)

Site Data		
BU#:	876342	
Site Name:	Bic Drive (SSUSA)	
App #:		
Anchor Rod Data		
Qty:	16	
Diam:	2.25	in
Rod Material:	A615-J	
Yield, Fy:	75	ksi
Strength, Fu:	100	ksi
Bolt Circle:	54	in
Anchor Spacing:	6	in

Plate Data		
W=Side:	56	in
Thick:	3	in
Grade:	50	ksi
Clip Distance:	0	in

Stiffener Data (Welding at both sides)		
Configuration:	Stiffened	
Weld Type:	Both	**
Groove Depth:	0.5	in **
Groove Angle:	45	degrees
Fillet H. Weld:	0.5	in
Fillet V. Weld:	0.3125	in
Width:	7.75	in
Height:	18	in
Thick:	1.25	in
Notch:	0.75	in
Grade:	65	ksi
Weld str.:	70	ksi

Pole Data		
Diam:	43.3	in
Thick:	0.375	in
Grade:	65	ksi
# of Sides:	12	"0" IF Round

Stress Increase Factor		
ASD ASIF:	1.333	

\*\* Note: for complete joint penetration groove welds the groove depth must be exactly 1/2 the stiffener thickness for calculation purposes

Base Reactions		
TIA Revision:	F	
Unfactored Moment, M:	3516	ft-kips
Unfactored Axial, P:	42	kips
Unfactored Shear, V:	37	kips

### Anchor Rod Results

TIA F --> Maximum Rod Tension: 192.7 Kips  
 Allowable Tension: 195.0 Kips  
 Anchor Rod Stress Ratio: 98.8% **Pass**

### Base Plate Results

Base Plate Stress: 4.3 ksi  
 Allowable PL Bending Stress: 26.7 ksi  
 Base Plate Stress Ratio: 16.0% **Pass**

### Shear Check Only

PL Ref. Data
Yield Line (in):
N/A, Roark
Max PL Length:
35.90

### Stiffener Results

Horizontal Weld : 69.3% **Pass**  
 Vertical Weld: 76.9% **Pass**  
 Plate Flex+Shear,  $f_b/F_b + (f_v/F_v)^2$ : 11.5% **Pass**  
 Plate Tension+Shear,  $f_t/F_t + (f_v/F_v)^2$ : 32.4% **Pass**  
 Plate Comp. (AISC Bracket): 41.0% **Pass**

### Pole Results

Pole Punching Shear Check: 20.6% **Pass**

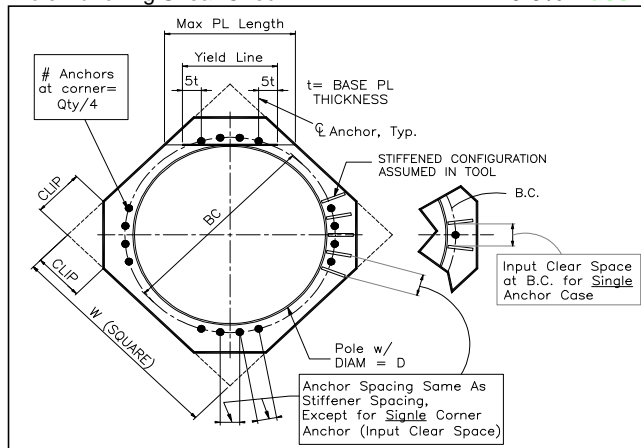

Foundation Loads:

Pole weight or tower leg compression = 42 (kips)  
 Horizontal load at top of pier = 37 (kips)  
 Overturning moment at top of pier = 3516 (ft-kips)

Design criteria:

Safety factor against overturning = 1.5

Soil Properties:

Soil density = 120 (pcf)  
 Allowable soil bearing = 10 (ksf)  
 Depth to water table = 99 (ft)

Dimensions:

Pier shape (round or square) = S ("R" or "S")  
 Pier width = 7 (ft)  
 Pier height above grade = 0.5 (ft)  
 depth to bottom of footing = 10 (ft)  
 Footing thickness = 4 (ft)  
 Footing width = 22.5 (ft)  
 Footing length = 22.5 (ft)

Concrete:

Concrete strength = 3 (ksi)  
 Rebar strength = 60 (ksi)  
 ultimate load factor = 1.3

Reinforcing Steel:

Pad  
 minimum cover over rebar = 3 inches  
 size of pad rebar = #11 bar  
 quantity of pad rebar = 23 (ea direction)

Reinforcing Steel:

Pier  
 size of vert rebar in pier = #11 bar  
 vertical rebar quantity = 32  
 size of pier ties = #5 bar  
 minimum cover over rebar = 3 inches  
 Total volume of concrete = 86.8 cu yd

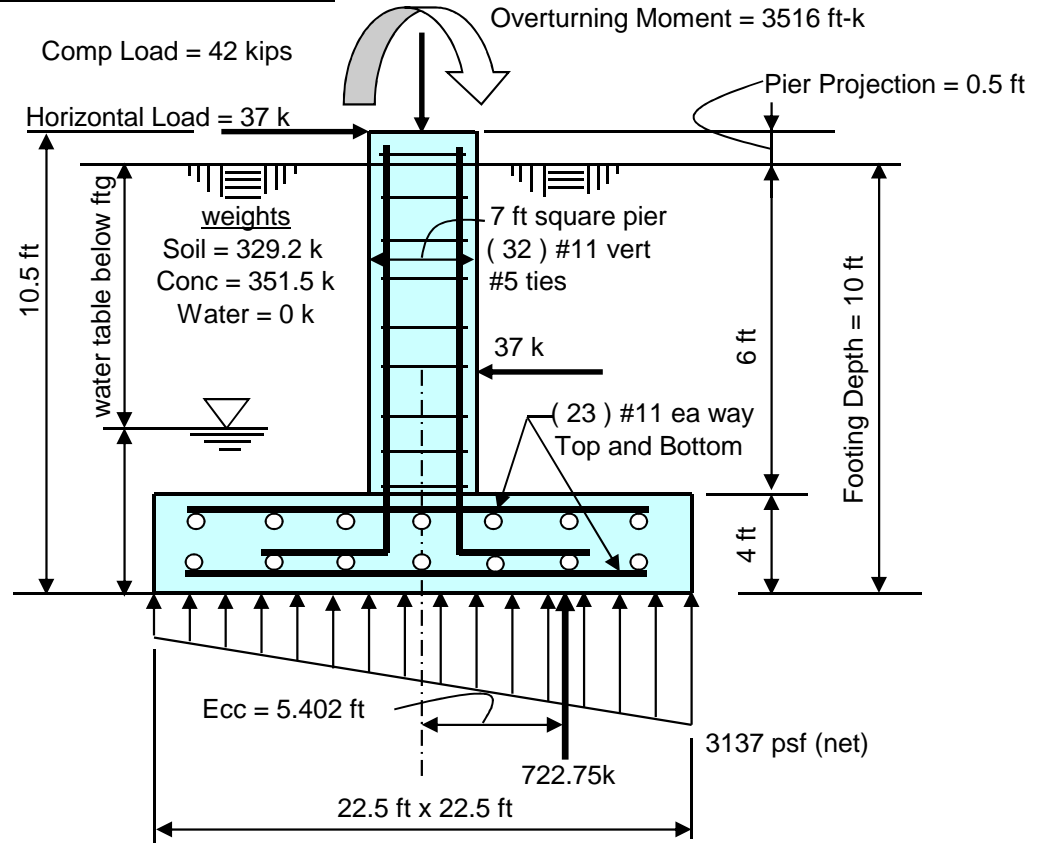

Summary of analysis results	
Maximum Net Soil Bearing = 3.137 ksf Allowable Net Soil Bearing = 10 ksf <b>Soil Bearing Stress Ratio = 0.31 Okay</b>	Ult Bending Shear Capacity = 110 psi Ult Bending Shear Stress = 30 psi <b>Bending Shear Stress Ratio = 0.28 Okay</b>
Ftg Overturning Resistance = 8131 ft-kips Overturning Moment = 3905 ft-kips Required Overturning Safety Factor = 1.5 Overturning Safety Factor = 2.082 <b>Ratio = 0.72 Okay</b>	Pad Bending Moment Capacity = 6680 ft-k Pad Bending Moment = 1584 ft-k <b>Bending Moment Stress Ratio = 0.24 OK</b>

```

                000000                o
                oo  oo                oo
00000  000000  oo                00000  oo  oo  o 0000000000  o 00000
oo  o  oo  oo  oo                oo  oo  oo                oo  oo  oo  oo  oo  oo
oo                oo  oo  oo                oo  oo  oo                oo  oo  oo  oo  oo
 00000  oo  oo                oo                oo  oo  oo                oo  oo  oo  oo  oo
o  oo  oo                oo  oo                oo  oo  oo  o  oo  oo  oo  oo  oo  oo
00000  oo                000000  00000  000  00000 o  oo  oo  oo  oo  oo  oo (TM)

```

```

=====
                        spColumn v4.80 (TM)
Computer program for the Strength Design of Reinforced Concrete Sections
Copyright © 1988-2011, STRUCTUREPOINT, LLC.
All rights reserved
=====

```

Licensee stated above acknowledges that STRUCTUREPOINT (SP) is not and cannot be responsible for either the accuracy or adequacy of the material supplied as input for processing by the spColumn computer program. Furthermore, STRUCTUREPOINT neither makes any warranty expressed nor implied with respect to the correctness of the output prepared by the spColumn program. Although STRUCTUREPOINT has endeavored to produce spColumn error free the program is not and cannot be certified infallible. The final and only responsibility for analysis, design and engineering documents is the licensee's. Accordingly, STRUCTUREPOINT disclaims all responsibility in contract, negligence or other tort for any analysis, design or engineering documents prepared in connection with the use of the spColumn program.

General Information:

=====  
 File Name: g:\tower\375\_crown\_castle\2013\37513-2020 bu 876342\wo 795506 ... \37513-2020.003.7805.col  
 Project: 37513-2020.003  
 Column: Engineer: SJT  
 Code: ACI 318-02 Units: English  
 Run Option: Investigation Slenderness: Not considered  
 Run Axis: X-axis Column Type: Architectural

Material Properties:

=====  
 f'c = 3 ksi fy = 60 ksi  
 Ec = 3122.02 ksi Es = 29000 ksi  
 Ultimate strain = 0.003 in/in  
 Beta1 = 0.85

Section:

=====  
 Rectangular: Width = 84 in Depth = 84 in  
 Gross section area, Ag = 7056 in^2  
 Ix = 4.14893e+006 in^4 Iy = 4.14893e+006 in^4  
 rx = 24.2487 in ry = 24.2487 in  
 Xo = 0 in Yo = 0 in

Reinforcement:

=====  
 Bar Set: ASTM A615

Size	Diam (in)	Area (in^2)	Size	Diam (in)	Area (in^2)	Size	Diam (in)	Area (in^2)
# 3	0.38	0.11	# 4	0.50	0.20	# 5	0.63	0.31
# 6	0.75	0.44	# 7	0.88	0.60	# 8	1.00	0.79
# 9	1.13	1.00	# 10	1.27	1.27	# 11	1.41	1.56
# 14	1.69	2.25	# 18	2.26	4.00			

Confinement: Tied; #5 ties with #10 bars, #5 with larger bars.  
 phi(a) = 0.8, phi(b) = 0.9, phi(c) = 0.65

Layout: Circular  
 Pattern: All Sides Equal (Cover to longitudinal reinforcement)  
 Total steel area: As = 49.92 in^2 at rho = 0.71% (Note: rho < 1.0%)  
 Minimum clear spacing = 6.10 in

32 #11 Cover = 3 in

Factored Loads and Moments with Corresponding Capacities:

=====  

No.	Pu kip	Mux k-ft	PhiMnx k-ft	PhiMn/Mu NA	depth in	Dt in	depth in	eps_t	Phi
1	42.00	5075.85	8083.79	1.593	13.43	80.29	0.01493	0.900	

\*\*\* End of output \*\*\*

RADIO FREQUENCY FCC REGULATORY COMPLIANCE  
MAXIMUM PERMISSIBLE EXPOSURE (MPE) ASSESSMENT

Sprint Existing Facility

Site ID: CT03XC171

Bic Drive

111 School House Road  
Milford, CT 06460

**March 8, 2014**

**EBI Project Number: 62140950**

March 8, 2014

Sprint  
Attn: RF Engineering Manager  
1 International Boulevard, Suite 800  
Mahwah, NJ 07495

Re: Radio Frequency Maximum Permissible Exposure (MPE) Assessment for Site:  
**CT03XC171 - Bic Drive**

**Site Total: 79.402% - MPE % in full compliance**

EBI Consulting was directed to analyze the proposed upgrades to the existing Sprint facility located at 111 School House Road, Milford, CT, for the purpose of determining whether the radio frequency (RF) exposure levels from the proposed Sprint equipment upgrades on this property are within specified federal limits.

All information used in this report was analyzed as a percentage of current Maximum Permissible Exposure (% MPE) as listed in the FCC OET Bulletin 65 Edition 97-01 and ANSI/IEEE Std C95.1. The FCC regulates Maximum Permissible Exposure in units of microwatts per square centimeter ( $\mu\text{W}/\text{cm}^2$ ). The number of  $\mu\text{W}/\text{cm}^2$  calculated at each sample point is called the power density. The exposure limit for power density varies depending upon the frequencies being utilized. Wireless Carriers and Paging Services use different frequency bands each with different exposure limits, therefore it is necessary to report results and limits in terms of percent MPE rather than power density.

All results were compared to the FCC (Federal Communications Commission) radio frequency exposure rules, 47 CFR 1.1307(b)(1) – (b)(3), to determine compliance with the Maximum Permissible Exposure (MPE) limits for General Population/Uncontrolled environments as defined below.

General population/uncontrolled exposure limits apply to situations in which the general public may be exposed or in which persons who are exposed as a consequence of their employment may not be made fully aware of the potential for exposure or cannot exercise control over their exposure. Therefore, members of the general public would always be considered under this category when exposure is not employment related, for example, in the case of a telecommunications tower that exposes persons in a nearby residential area.

Public exposure to radio frequencies is regulated and enforced in units of microwatts per square centimeter ( $\mu\text{W}/\text{cm}^2$ ). The general population exposure limit for the cellular band (850 MHz Band) is approximately  $567 \mu\text{W}/\text{cm}^2$ , and the general population exposure limit for the 1900 MHz and 2500 MHz bands band is  $1000 \mu\text{W}/\text{cm}^2$ . Because each carrier will be using different frequency bands, and each frequency band has different exposure limits, it is necessary to report percent of MPE rather than power density.



Occupational/controlled exposure limits apply to situations in which persons are exposed as a consequence of their employment and in which those persons who are exposed have been made fully aware of the potential for exposure and can exercise control over their exposure. Occupational/controlled exposure limits also apply where exposure is of a transient nature as a result of incidental passage through a location where exposure levels may be above general population/uncontrolled limits (see below), as long as the exposed person has been made fully aware of the potential for exposure and can exercise control over his or her exposure by leaving the area or by some other appropriate means.

Additional details can be found in FCC OET 65.

## **CALCULATIONS**

Calculations were done for the proposed upgrades to the existing Sprint Wireless antenna facility located at 111 School House Road, Milford, CT, using the equipment information listed below. All calculations were performed per the specifications under FCC OET 65. All calculations were performed assuming the main lobe of the antenna was focused at the base of the tower to present a worst case scenario. Actual values seen from this site will be dramatically less than those shown in this report. For this report the sample point is the top of a 6 foot person standing at the base of the tower.

For all calculations, all emissions were calculated using the following assumptions:

- 1) 4 channels in the 1900 MHz Band were considered for each sector of the proposed installation.
- 2) 1 channel in the 800 MHz Band was considered for each sector of the proposed installation
- 3) 2 channels in the 2500 MHz Band were considered for each sector of the proposed installation.
- 4) All radios at the proposed installation were considered to be running at full power and were uncombined in their RF transmissions paths per carrier prescribed configuration. Per FCC OET Bulletin No. 65 - Edition 97-01 recommendations to achieve the maximum anticipated value at each sample point, all power levels emitting from the proposed antenna installation are increased by a factor of 2.56 to account for possible in-phase reflections from the surrounding environment. This is rarely the case, and if so, is never continuous.
- 5) For the following calculations the sample point was the top of a six foot person standing at the base of the tower. The maximum gain of the antenna per the antenna manufactures supplied specifications was used in this direction.

- 6) The antennas used in this modeling are the RFS APXVSPP18-C-A20 and the RFS APXVTMM-C-120. This is based on feedback from the carrier with regards to anticipated antenna selection. The RFS APXVSPP18-C-A20 has a 15.9 dBd gain value at its main lobe at 1900 MHz and 13.4 dBd at its main lobe for 850 MHz. The RFS APXVTMM-C-120 has a 15.9 dBd gain value at its main lobe at 2500 MHz. All calculations were performed assuming the main lobe of the antenna was focused at the base of the tower to present a worst case scenario.
- 7) The antenna mounting height centerline for the proposed antennas is **140 feet** above ground level (AGL).
- 8) Emissions values for additional carriers were taken from the Connecticut Siting Council active database. Values in this database are provided by the individual carriers themselves.

All calculation were done with respect to uncontrolled / general public threshold limits

Site ID	CT03XC171 - Bic Drive
Site Address	111 School House Road, Milford, CT 06460
Site Type	Monopole

**Sector 1**

Antenna Number	Antenna Make	Antenna Model	Radio Type	Frequency Band	Technology	Power Out Per Channel (Watts)	Number of Channels	Composite Power	Antenna Gain in direction of sample point (dBd)	Antenna Height (ft)	analysis height	Antenna Height Meters	Cable Size	Cable Loss (dB)	Additional Loss (dB)	Gain Factor	ERP	Power Density Value	Power Density Percentage
1a	RFS	APXVSPP18-C-A20	RRH	1900 MHz	CDMA / LTE	20	4	80	15.9	140	134	40.8437	1/2 "	0.5	3	17.378008	1390.2407	27.83469	2.78347%
1a	RFS	APXVSPP18-C-A20	RRH	850 MHz	CDMA / LTE	20	1	20	13.4	140	134	40.8437	1/2 "	0.5	3	9.7723722	195.44744	3.913149	0.69015%
1B	RFS	APXVTMM14-C-120	RRH	2500 MHz	CDMA / LTE	20	2	40	13.4	140	134	40.8437	1/2 "	0.5	3	9.7723722	390.89489	7.826298	1.38030%
Sector total Power Density Value:																	4.854%		

**Sector 2**

Antenna Number	Antenna Make	Antenna Model	Radio Type	Frequency Band	Technology	Power Out Per Channel (Watts)	Number of Channels	Composite Power	Antenna Gain in direction of sample point (dBd)	Antenna Height (ft)	analysis height	Antenna Height Meters	Cable Size	Cable Loss (dB)	Additional Loss (dB)	Gain Factor	ERP	Power Density Value	Power Density Percentage
2a	RFS	APXVSPP18-C-A20	RRH	1900 MHz	CDMA / LTE	20	4	80	15.9	140	134	40.8437	1/2 "	0.5	3	17.378008	1390.2407	27.83469	2.78347%
2a	RFS	APXVSPP18-C-A20	RRH	850 MHz	CDMA / LTE	20	1	20	13.4	140	134	40.8437	1/2 "	0.5	3	9.7723722	195.44744	3.913149	0.69015%
2B	RFS	APXVTMM14-C-120	RRH	2500 MHz	CDMA / LTE	20	2	40	13.4	140	134	40.8437	1/2 "	0.5	3	9.7723722	390.89489	7.826298	1.38030%
Sector total Power Density Value:																	4.854%		

**Sector 3**

Antenna Number	Antenna Make	Antenna Model	Radio Type	Frequency Band	Technology	Power Out Per Channel (Watts)	Number of Channels	Composite Power	Antenna Gain in direction of sample point (dBd)	Antenna Height (ft)	analysis height	Antenna Height Meters	Cable Size	Cable Loss (dB)	Additional Loss (dB)	Gain Factor	ERP	Power Density Value	Power Density Percentage
3a	RFS	APXVSPP18-C-A20	RRH	1900 MHz	CDMA / LTE	20	4	80	15.9	140	134	40.8437	1/2 "	0.5	3	17.378008	1390.2407	27.83469	2.78347%
3a	RFS	APXVSPP18-C-A20	RRH	850 MHz	CDMA / LTE	20	1	20	13.4	140	134	40.8437	1/2 "	0.5	3	9.7723722	195.44744	3.913149	0.69015%
3B	RFS	APXVTMM14-C-120	RRH	2500 MHz	CDMA / LTE	20	2	40	13.4	140	134	40.8437	1/2 "	0.5	3	9.7723722	390.89489	7.826298	1.38030%
Sector total Power Density Value:																	4.854%		

Site Composite MPE %	
Carrier	MPE %
Sprint	14.562%
Verizon Wireless	28.930%
MetroPCS	7.540%
Clearwire	0.950%
AT&T	20.580%
T-Mobile	6.840%
<b>Total Site MPE %</b>	<b>79.402%</b>

## Summary

All calculations performed for this analysis yielded results that were well within the allowable limits for general public Maximum Permissible Exposure (MPE) to radio frequency energy.

The anticipated Maximum Composite contributions from the Sprint facility are **14.562% (4.854% from each sector)** of the allowable FCC established general public limit considering all three sectors simultaneously sampled at the ground level.

The anticipated composite MPE value for this site assuming all carriers present is **79.402%** of the allowable FCC established general public limit sampled at 6 feet above ground level. This total composite site value is based upon MPE values listed in the Connecticut Siting Council database for existing carrier emissions.

FCC guidelines state that if a site is found to be out of compliance (over allowable thresholds), that carriers over a 5% contribution to the composite value will require measures to bring the site into compliance. For this facility, the composite values calculated were well within the allowable 100% threshold standard per the federal government.



**Scott Heffernan**  
RF Engineering Director

**EBI Consulting**  
21 B Street  
Burlington, MA 01803