

**From:** Mary Caulfield [mailto:mcaulfield@clinellc.com]  
**Sent:** Monday, March 19, 2018 12:37 PM  
**To:** CSC-DL Siting Council  
**Subject:** RE: AT&T CT2111 / 10034978 // 438 Bridgeport Ave., Milford, CT // Notice of Exempt Mod

Good Afternoon,

Please find attached the updated soft copy for AT&T for an exempt modification at 438 Bridgeport Ave., Milford, CT, which contains the required proof the filings have been sent to the chief elected official, zoning official, underlying property and tower owner.

Please let me know should anything additional be needed.

Thanks,  
Mary

**Mary Caulfield**  
Site Acquisition Consultant  
978.994.0252  
[mcaulfield@clinellc.com](mailto:mcaulfield@clinellc.com)

**From:** Mary Caulfield  
**Sent:** Wednesday, March 7, 2018 1:21 PM  
**To:** 'siting.council@ct.gov' <[siting.council@ct.gov](mailto:siting.council@ct.gov)>  
**Subject:** AT&T CT2111 / 10034978 // 438 Bridgeport Ave, CT // Notice of Exempt Mod

Good Afternoon,

Please find attached a soft copy of a filing for AT&T for an exempt modification at 438 Bridgeport Avenue., CT. Hard copies are in route to you and should arrive by close of business Thursday, 3/8.

Please let me know should anything additional be needed.

Thanks,  
Mary



**Mary Caulfield** | Site Acquisition Consultant  
95 Ryan Drive, Suite 1 | Raynham, MA 02767  
Cell: 978.994.0252 | Fax: 508.819.3017  
[mcaulfield@clinellc.com](mailto:mcaulfield@clinellc.com) | [www.centerlinecommunications.com](http://www.centerlinecommunications.com)

1 OF 1

1 LBS

MARY CAULFIELD  
978-994-0252  
USER ADDRESS  
95 RYAN DRIVE SUITE 1  
RAYNHAM MA 02767

**SHIP TO:**

BENJAMIN G. BLAKE - MAYOR  
203-783-3201  
CITY OF MILFORD  
110 RIVER STREET  
**MILFORD CT 06460-3318**

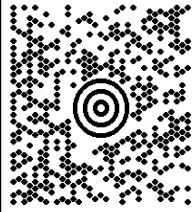

**CT 066 9-05**



**UPS GROUND**

TRACKING #: 1Z 9Y4 503 03 0957 3629

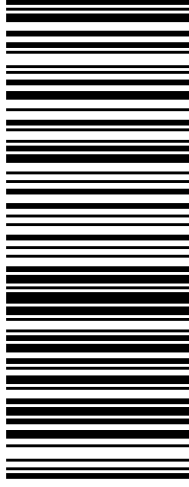

BILLING: P/P

Reference#1: CT2111/MRCTB026729 - CSC to Mayor

UIS 20.0.32. WNTNVS0 97.04.01./2018



1 OF 1

1 LBS

MARY CAULFIELD  
978-994-0252  
USER ADDRESS  
95 RYAN DRIVE SUITE 1  
RAYNHAM MA 02767

**SHIP TO:**

DAVID SULKIS - PLANNING & ZONING  
203-783-3245  
CITY OF MILFORD  
70 WEST RIVER STREET

**MILFORD CT 06460-3317**

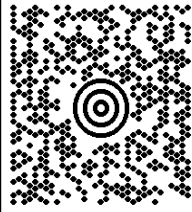

**CT 066 9-05**



**UPS GROUND**

TRACKING #: 1Z 9Y4 503 03 1984 8617

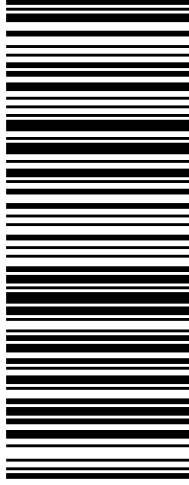

BILLING: P/P

Reference#1: CT2111/MRCTB026729 - CSC to P&Z

UIS 20.0.32. WNTNVS0 97.04.01./2018



1 OF 1

1 LBS

MARY CAULFIELD  
978-994-0252  
USER ADDRESS  
95 RYAN DRIVE SUITE 1  
RAYNHAM MA 02767

**SHIP TO:**

HENRY & GENEVIEVE CHARCHENKO  
438 BRIDGEPORT AVENUE  
**MILFORD CT 06460-4106**

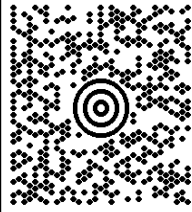

**CT 066 9-05**



**UPS GROUND**

TRACKING #: 1Z 9Y4 503 03 0442 9642

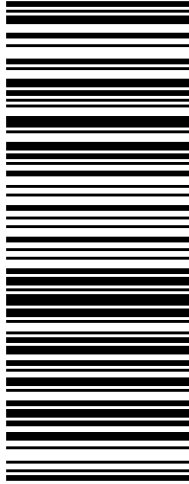

BILLING: P/P

Reference#1: CT2111- CSC to Property Owner



UIS 20.0.32. WNTNVS0 97.04.01./2018

1 OF 1

1 LBS

MARY CAULFIELD  
978-994-0252  
USER ADDRESS  
95 RYAN DRIVE SUITE 1  
RAYNHAM MA 02767

**SHIP TO:**

SHAWN DUNN  
781-926-7061  
AMERICAN TOWER CORPORATION  
10 PRESIDENTIAL WAY

**WOBURN MA 01801-1053**

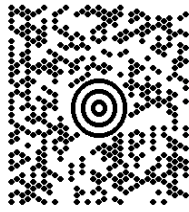

**MA 018 9-04**



**UPS GROUND**

TRACKING #: 1Z 9Y4 503 03 1472 5606

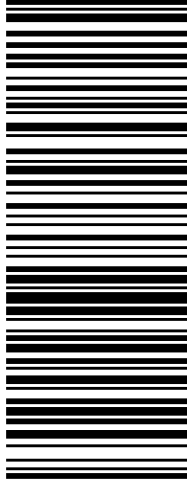

BILLING: P/P

Reference#1: CT2111/MRCTB026729 - CSC to ATC

UIS 20.0.32. WNTNVS0 97.04.01/2018



Mary Caulfield, Site Acquisition Consultant  
c/o New Cingular Wireless, PCS LLC (AT&T)  
Centerline Communications, LLC  
95 Ryan Drive, Suite 1  
Raynham, MA 02767  
Mobile: (978) 994-0252  
[MCaulfield@centerlinecommunications.com](mailto:MCaulfield@centerlinecommunications.com)

March 6, 2018

Melanie A. Bachman  
Acting Executive Director  
Connecticut Siting Council  
10 Franklin Square  
New Britain, CT 06051

**RE: Notice of Exempt Modification**  
**Site Number: CT2111 (Name: Milford Bridgeport Ave)**  
**438 Bridgeport Ave, Milford, CT 06460**  
**N 41.206561 // W -73.093372**

Dear Ms. Bachman:

New Cingular Wireless, PCS, LLC (“AT&T”) currently maintains 9 total antennas at the 102-foot level on the existing 100-foot monopole tower, located at 438 Bridgeport Avenue, Milford, CT. The tower is owned by American Tower. The property is owned by Henry and Genevieve Charchenko. AT&T now intends to add three (3) new LTE (700/2200 band) antennas for its LTE upgrade. AT&T also intends to install six (6) new remote radios; and certain in-cabinet upgrades at the base.

Note that this facility was originally approved by the Connecticut Siting Council on July 4, 1984, Docket No. 44.

Please accept this letter as notification pursuant to Regulations of Connecticut State Agencies §16-50j-73, for construction that constitutes an exempt modification pursuant to R.C.S.A. § 16-50j-72(b)(2). In accordance with R.C.S.A. § 16-50j-73, a copy of this letter is being sent to Benjamin G. Blake, Mayor for the City of Milford, David Sulkis, City Planner - Executive Secretary of Planning & Zoning Board for the City of Milford, as well as the tower owner, American Tower, and the ground owner, Henry and Genevieve Charchenko.

The planned modifications to the facility fall squarely within those activities explicitly provided for in R.C.S.A. § 16-50j-72(b)(2).

Attached to accommodate this filing are construction drawings dated March 1, 2018 by Hudson Design Group LLC, a structural analysis dated January 29, 2018 by American Tower Corporation and an Emissions Analysis Report dated February 26, 2018 by Centerline Communications, LLC.

1. The proposed modifications will not result in an increase in the height of the existing structure.
2. The proposed modifications will not require the extension of the site boundary.
3. The proposed modifications will not increase noise levels at the facility by six decibels or more, or to levels that exceed state and local criteria.
4. The operation of the replacement antennas will not increase radio frequency emissions at the facility to a level at or above the Federal Communications Commission safety standard.
5. The proposed modifications will not cause an ineligible change or alteration in the physical or environmental characteristics of the site.
6. The existing structure and its foundation can support the proposed loading, pursuant to the structural analysis by American Tower Corporation, dated January 29, 2018.

For the foregoing reasons, AT&T respectfully submits that the proposed modifications to the above referenced telecommunications facility constitute an exempt modification under R.C.S.A. § 16-50j-72(b)(2).

Sincerely,

---

Mary Caulfield, Site Acquisition Consultant  
c/o New Cingular Wireless, PCS LLC (AT&T)  
Centerline Communications, LLC  
95 Ryan Drive, Suite 1  
Raynham, MA 02767  
Mobile: (978) 994-0252  
[MCaulfield@centerlinecommunications.com](mailto:MCaulfield@centerlinecommunications.com)

cc: Benjamin G. Blake, Mayor, City of Milford  
David Sulkis, City Planner, City of Milford  
American Tower, Tower Owner  
Henry and Genevieve Charchenko, Property Owner



**AMERICAN TOWER®**  
CORPORATION

---

## Structural Analysis Report

**Structure** : 100.6 ft Monopole  
**ATC Site Name** : Mlfd - Milford, CT  
**ATC Site Number** : 302516  
**Engineering Number** : OAA720687\_C3\_01  
**Proposed Carrier** : AT&T Mobility  
**Carrier Site Name** : Milford Bridgeport Ave  
**Carrier Site Number** : CTL02111 / 10034978  
**Site Location** : 438 Bridgeport Ave  
Milford, CT 06460-4105  
41.206600,-73.093400  
**County** : New Haven  
**Date** : January 29, 2018  
**Max Usage** : 78%  
**Result** : Pass

Prepared By:  
Nicole Davis  
Engineer Intern

Reviewed By:

**COA: PEC.0001553**





**Table of Contents**

Introduction .....	1
Supporting Documents .....	1
Analysis .....	1
Conclusion.....	1
Existing and Reserved Equipment.....	2
Equipment to be Removed.....	2
Proposed Equipment .....	2
Structure Usages .....	3
Foundations .....	3
Deflection, Twist, and Sway.....	3
Standard Conditions .....	4
Calculations .....	Attached



## Introduction

The purpose of this report is to summarize results of a structural analysis performed on the 100.6 ft monopole to reflect the change in loading by AT&T Mobility.

## Supporting Documents

<b>Tower Drawings</b>	Mapping by Smith Cullum, SpectraSite #CT-0052, dated May 31, 2002 ITT Meyer Specification #AT-8935, Type D, dated April 13, 1984
<b>Foundation Drawing</b>	Mapping by FDH Project #02-1210, dated January 9, 2003
<b>Geotechnical Report</b>	AET Job #002GT03, dated January 7, 2003
<b>Modifications</b>	American Tower #27094034, dated April 21, 2008

## Analysis

The tower was analyzed using American Tower Corporation's tower analysis software. This program considers an elastic three-dimensional model and second-order effects per ANSI/TIA-222.

<b>Basic Wind Speed:</b>	97 mph (3-Second Gust Vasd)/ 125 mph (3-second Gust Vult)
<b>Basic Wind Speed w/ Ice:</b>	50 mph (3-Second Gust) w/ 3/4" radial ice concurrent
<b>Code:</b>	ANSI/TIA-222-G / 2012 IBC / 2016 Connecticut State Building Code
<b>Structure Class:</b>	II
<b>Exposure Category:</b>	B
<b>Topographic Category:</b>	1
<b>Crest Height:</b>	0 ft
<b>Spectral Response:</b>	$S_s = 0.20$ , $S_1 = 0.06$
<b>Site Class:</b>	D - Stiff Soil

## Conclusion

Based on the analysis results, the structure meets the requirements per the applicable codes listed above. The tower and foundation can support the equipment as described in this report.

If you have any questions or require additional information, please contact American Tower via email at [Engineering@americantower.com](mailto:Engineering@americantower.com). Please include the American Tower site name, site number, and engineering number in the subject line for any questions.



**Existing and Reserved Equipment**

Elevation <sup>1</sup> (ft)		Qty	Antenna	Mount Type	Lines	Carrier
Mount	RAD					
100.0	102.0	2	Commscope WCS-IMFQ-AMT	Platform w/ Handrails	(12) 1 5/8" Coax (4) 0.78" 8 AWG 6 (2) 0.39" Fiber Trunk (2) 3" Conduit	AT&T Mobility
		6	Powerwave LGP21401			
		2	Raycap DC6-48-60-18-8F			
		3	Ericsson RRUS 11 (Band 12)			
		3	Ericsson RRUS 32 (50.8 lbs)			
		3	Ericsson RRUS 32 B2			
		3	Powerwave 7770.00			
		3	Commscope SBNHH-1D65A			
		3	CCI OPA-65R-LCUU-H4			
	108.0	1	10' Omni			Other
93.0	93.0	3	48" x 12" Panel	Flush	(6) 7/8" Coax	Sprint Nextel
83.0	83.0	6	RFS APX86-909014L-CT0-00	Flush	(9) 7/8" Coax	
73.0	73.0	3	Kathrein Smart Bias Tee	Flush	(18) 7/8" Coax	T-Mobile
		3	Ericsson KRY 112 489/2			
		3	RFS ATMAA1412D-1A20			
		3	RFS APX16PV-16PVL-A			
		3	Commscope LNX-6515DS-VTM			

**Equipment to be Removed**

Elevation <sup>1</sup> (ft)		Qty	Antenna	Mount Type	Lines	Carrier
Mount	RAD					
102.0	102.0	3	Ericsson RRUS 11 (Band 12)	-	-	AT&T Mobility

**Proposed Equipment**

Elevation <sup>1</sup> (ft)		Qty	Antenna	Mount Type	Lines	Carrier
Mount	RAD					
100.0	102.0	3	Kaelus DBC0061F1V51-2	Platform w/ Handrails	(2) 0.78" 8 AWG 6 (1) 2" Conduit	AT&T Mobility
		3	Ericsson RRUS 4478 B14			
		3	Ericsson RRUS 32 B66			
		1	Raycap DC6-48-60-18-8C			
		3	Kathrein 80010964			

<sup>1</sup>Mount elevation is defined as height above bottom of steel structure to the bottom of mount, RAD elevation is defined as center of antenna above ground level (AGL).

Install proposed coax inside the pole shaft.



**Structure Usages**

Structural Component	Controlling Usage	Pass/Fail
Anchor Bolts	28%	Pass
Shaft	55%	Pass
Base Plate	34%	Pass
Reinforcement	60%	Pass

**Foundations**

Reaction Component	Analysis Reactions	% of Usage
Moment (Kips-Ft)	1,197.4	78%
Axial (Kips)	40.9	2%
Shear (Kips)	16.7	42%

The structure base reactions resulting from this analysis were found to be acceptable through analysis based on geotechnical and foundation information, therefore no modification or reinforcement of the foundation will be required.

**Deflection and Sway\***

Antenna Elevation (ft)	Antenna	Carrier	Deflection (ft)	Sway (Rotation) (°)
100.0	Kaelus DBC0061F1V51-2	AT&T Mobility	0.856	0.926
	Ericsson RRUS 4478 B14			
	Ericsson RRUS 32 B66			
	Raycap DC6-48-60-18-8C			
	Kathrein Scala 80010964			

\*Deflection and Sway was evaluated considering a design wind speed of 60 mph (3-Second Gust) per ANSI/TIA-222-G



## **Standard Conditions**

All engineering services performed by A.T. Engineering Service, PLLC are prepared on the basis that the information used is current and correct. This information may consist of, but is not limited to the following:

- Information supplied by the client regarding antenna, mounts and feed line loading
- Information from drawings, design and analysis documents, and field notes in the possession of A.T. Engineering Service, PLLC

It is the responsibility of the client to ensure that the information provided to A.T. Engineering Service, PLLC and used in the performance of our engineering services is correct and complete.

All assets of American Tower Corporation, its affiliates and subsidiaries (collectively "American Tower") are inspected at regular intervals. Based upon these inspections and in the absence of information to the contrary, American Tower assumes that all structures were constructed in accordance with the drawings and specifications.

Unless explicitly agreed by both the client and A.T. Engineering Service, PLLC, all services will be performed in accordance with the current revision of ANSI/TIA-222.

All services are performed, results obtained, and recommendations made in accordance with generally accepted engineering principles and practices. A.T. Engineering Service, PLLC is not responsible for the conclusions, opinions and recommendations made by others based on the information supplied herein.

© 2007 - 2018 by ATC IP LLC. All rights reserved.

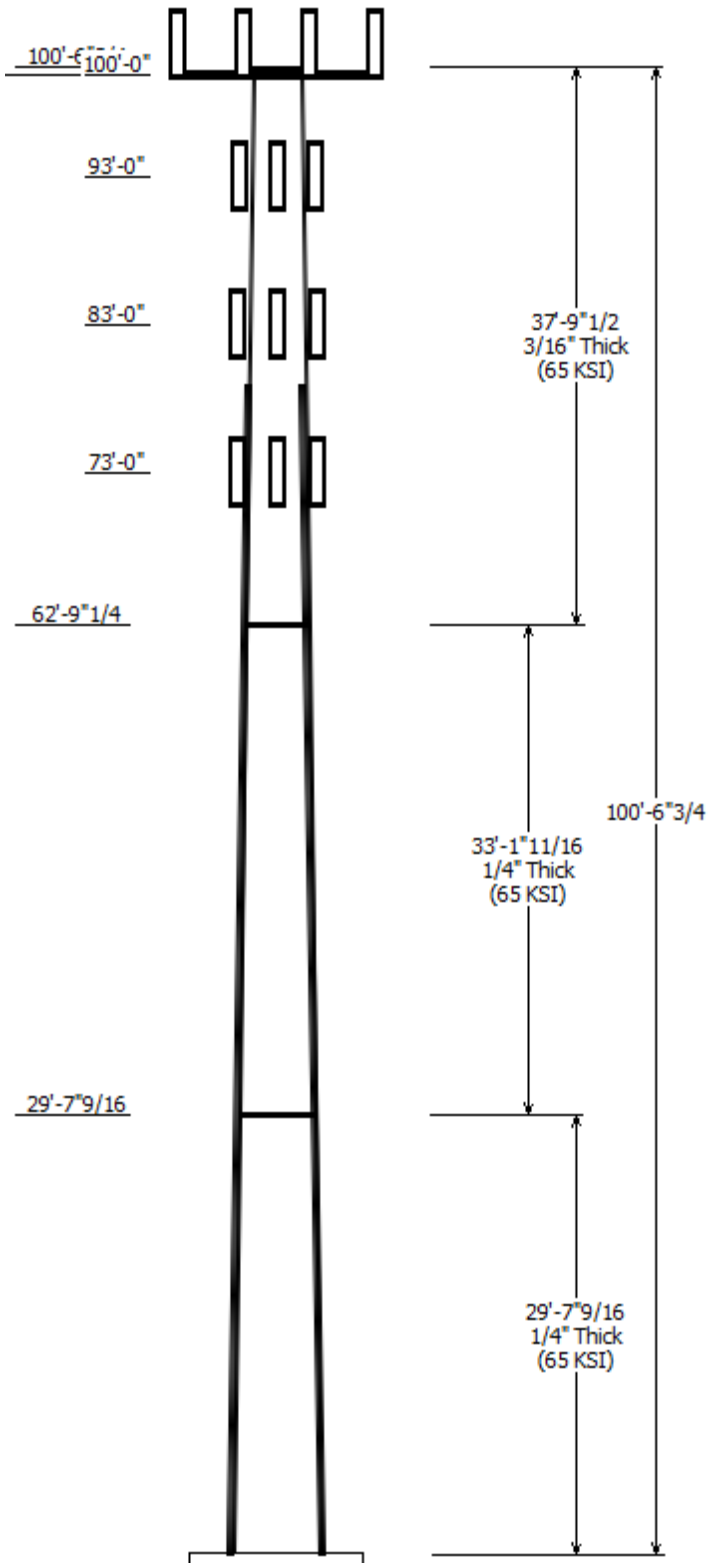

Job Information	
Pole : 302516	Code: ANSI/TIA-222-G
Location : Mlfd - Milford, CT	
Description : 100 ft ITT Meyer Type "D" Monopole	
Client : AT&T Mobility	Struct Class : II
Shape : 12 Sides	Exposure : B
Height : 100.56 (ft)	Topo : 1
Base Elev (ft): 0.00	
Taper: 0.169053in/ft	

Sections Properties						
Shaft Section	Length (ft)	Diameter (in)		Thick Joint (in)	Overlap Length (in)	Steel Grade
		Top	Bottom			
1	29.630	26.99	32.00	0.250	0.000	12 Sides 65
2	33.140	21.38	26.99	0.250	0.000	12 Sides 65
3	37.790	15.00	21.38	0.188	0.000	12 Sides 65

Discrete Appurtenance			
Attach Elev (ft)	Force Elev (ft)	Qty	Description
100.000	102.000	3	Ericsson RRUS 11 (Band 12)
100.000	102.000	3	Commscope SBNHH-1D65A
100.000	102.000	3	Kathrein Scala 80010964
100.000	102.000	3	Ericsson RRUS 32 B66
100.000	102.000	3	Ericsson RRUS 4478 B14
100.000	102.000	3	Kaelus DBC0061F1V51-2
100.000	102.000	3	Ericsson RRUS 32 B2
100.000	102.000	1	Raycap DC6-48-60-18-8C
100.000	102.000	2	Commscope WCS-IMFQ-AMT
100.000	108.000	1	10' Omni
100.000	102.000	3	CCI OPA-65R-LCUU-H4
100.000	102.000	3	Ericsson RRUS 32 (50.8 lbs)
100.000	102.000	3	Powerwave Allgon 7770.00
100.000	102.000	6	Powerwave Allgon LGP21401
100.000	102.000	2	Raycap DC6-48-60-18-8F
100.000	100.000	1	Flat Platform w/ Handrails
93.000	93.000	3	48" x 12" Panel
83.000	83.000	6	RFS APX86-909014L-CT0-00
73.000	73.000	3	Commscope LNX-6515DS-VTM
73.000	73.000	3	RFS ATMAA1412D-1A20
73.000	73.000	3	Ericsson KRY 112 489/2
73.000	73.000	3	Kathrein Scala Smart Bias Tee
73.000	73.000	3	RFS APX16PV-16PVL-A

Linear Appurtenance			
Elev (ft)		Description	Exposed To Wind
From	To		
85.000	93.000	7/8" Coax	Yes
0.000	100.0	0.39" Fiber Trunk	No
0.000	100.0	0.78" 8 AWG 6	No
0.000	100.0	0.78" 8 AWG 6	No
0.000	100.0	1 5/8" Coax	No
0.000	100.0	2" Conduit	No
0.000	100.0	3" Conduit	No
0.000	73.000	7/8" Coax	Yes
0.000	83.000	7/8" Coax	Yes
0.000	85.000	#20 DYWIDAG	Yes

Load Cases	
1.2D + 1.6W	97 mph with No Ice

0.9D + 1.6W	97 mph with No Ice (Reduced DL)
1.2D + 1.0Di + 1.0Wi	50 mph with 0.75 in Radial Ice
(1.2 + 0.2Sds) * DL + E	Seismic Equivalent Lateral Forces Method
(1.2 + 0.2Sds) * DL + E	Seismic Equivalent Modal Analysis Method
(0.9 - 0.2Sds) * DL + E	Seismic (Reduced DL) Equivalent Lateral
(0.9 - 0.2Sds) * DL + E	Seismic (Reduced DL) Equivalent Modal
1.0D + 1.0W	Serviceability 60 mph

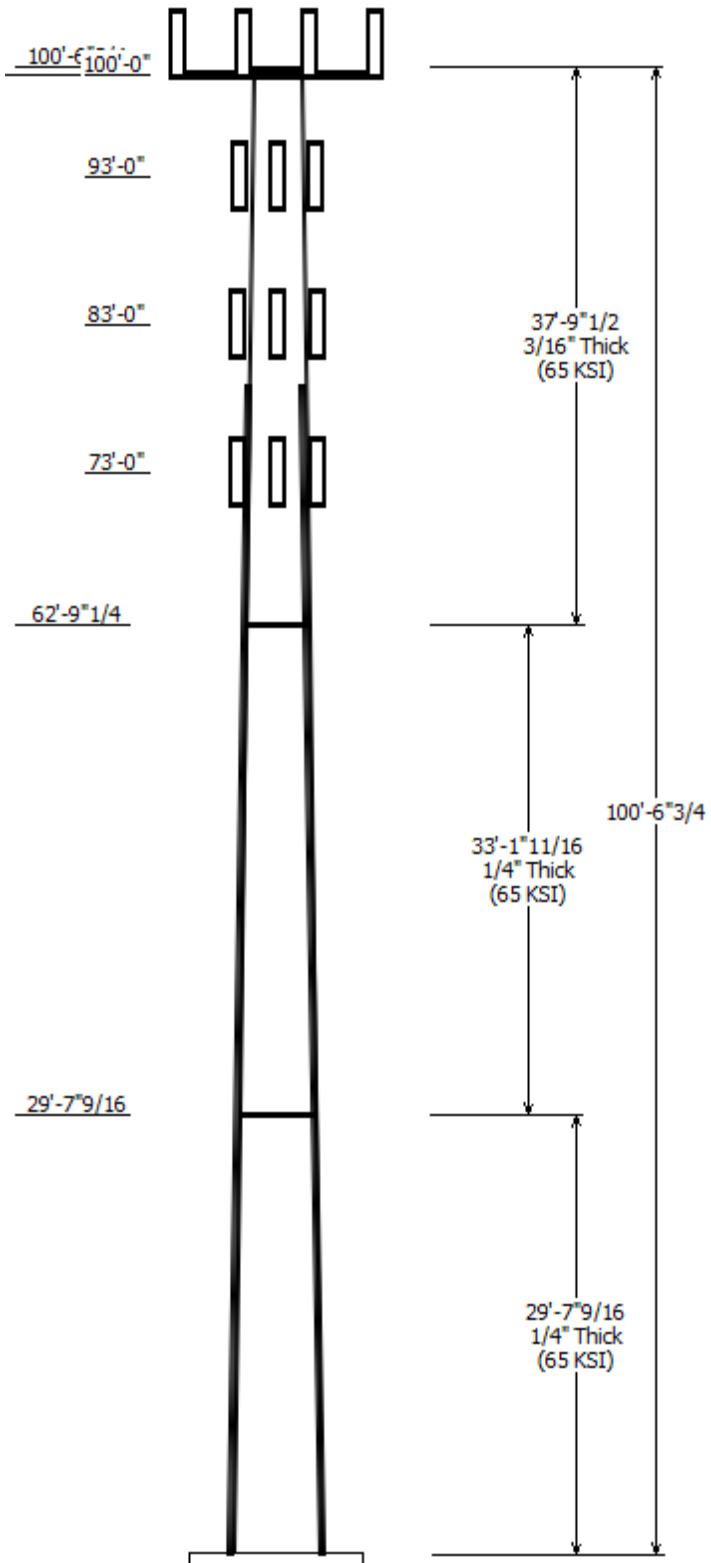

Reactions			
Load Case	Moment (kip-ft)	Shear (kip)	Axial (kip)
1.2D + 1.6W	1197.40	16.75	23.33
0.9D + 1.6W	1177.60	16.62	17.49
1.2D + 1.0Di + 1.0Wi	273.52	3.67	40.95
(1.2 + 0.2Sds) * DL + E ELFM	65.81	0.81	22.98
(1.2 + 0.2Sds) * DL + E EMAM	123.45	1.39	22.98
(0.9 - 0.2Sds) * DL + E ELFM	65.19	0.81	15.87
(0.9 - 0.2Sds) * DL + E EMAM	122.19	1.39	15.87
1.0D + 1.0W	290.70	4.15	19.47

Dish Deflections			
Load Case	Attach Elev (ft)	Deflection (in)	Rotation (deg)
	0.00	0.000	0.000

Load Case : 1.2D + 1.6W  
Max Ratio 54.60% at 0.0 ft

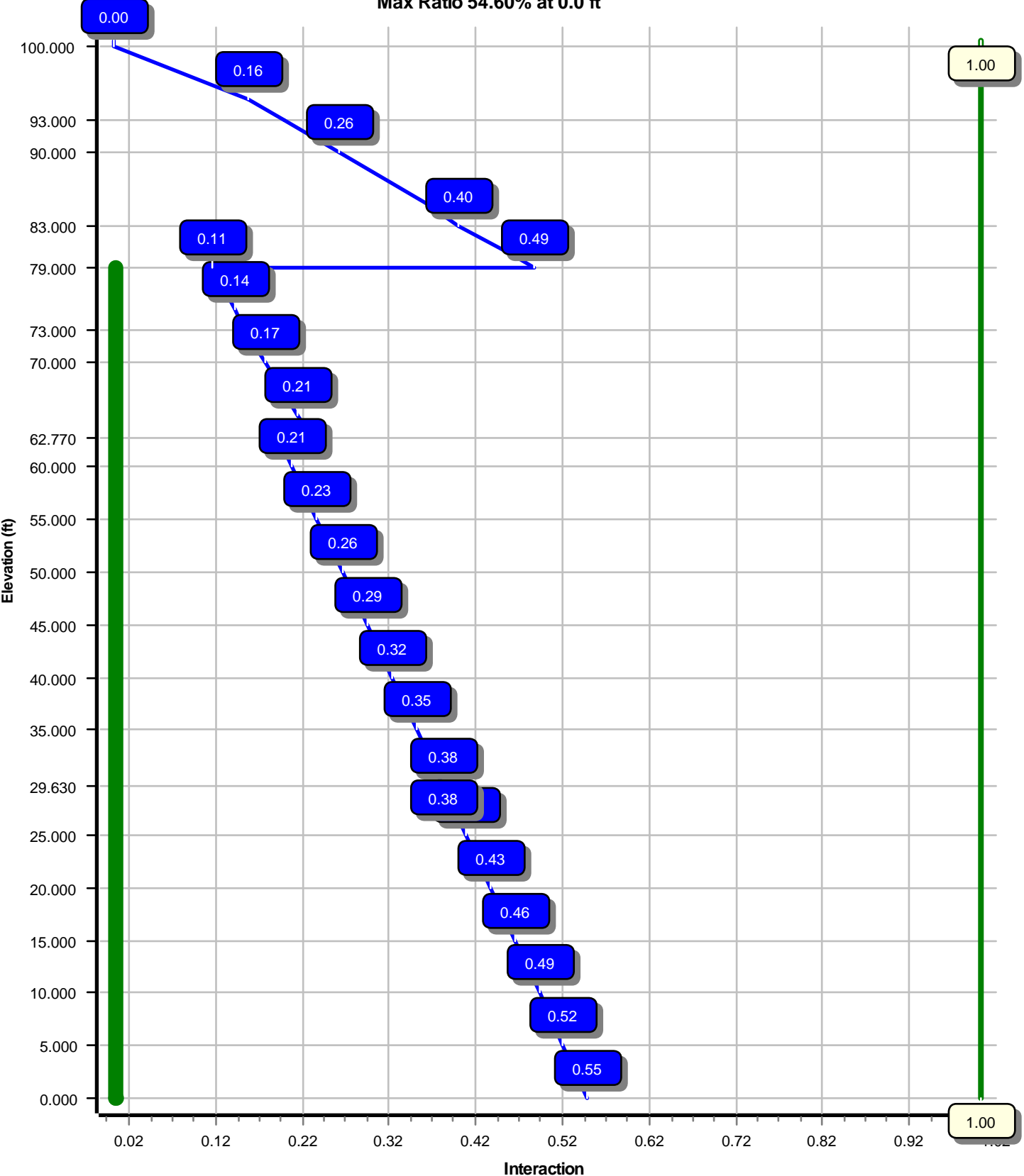



Site Number: 302516

Code: ANSI/TIA-222-G

© 2007 - 2018 by ATC IP LLC. All rights reserved.

Site Name: Mlfd - Milford, CT

Engineering Number: OAA720687\_C3\_01

1/29/2018 9:08:29 AM

Customer: AT&T Mobility

Analysis Parameters

Location :	New Haven County, CT	Height (ft) :	100.56
Code :	ANSI/TIA-222-G	Base Diameter (in) :	32.00
Shape :	12 Sides	Top Diameter (in) :	15.00
Pole Type :	Taper	Taper (in/ft) :	0.169
Pole Manufacturer :	ITT Meyer	Rotation (deg) :	0.00

Ice & Wind Parameters

Structure Class:	II	Design Wind Speed Without Ice:	97 mph
Exposure Category:	B	Design Wind Speed With Ice:	50 mph
Topographic Category:	1	Operational Wind Speed:	60 mph
Crest Height:	0 ft	Design Ice Thickness:	0.75 in

Seismic Parameters

Analysis Method:	Equivalent Modal Analysis & Equivalent Lateral Force Methods		
Site Class:	D - Stiff Soil		
Period Based on Rayleigh Method (sec):	1.62		
T <sub>L</sub> (sec):	6	p:	1
S <sub>s</sub> :	0.197	S <sub>1</sub> :	0.063
F <sub>a</sub> :	1.600	F <sub>v</sub> :	2.400
S <sub>ds</sub> :	0.210	S <sub>d1</sub> :	0.101
		C <sub>s</sub> :	0.042
		C <sub>s</sub> Max:	0.042
		C <sub>s</sub> Min:	0.030

Load Cases

1.2D + 1.6W	97 mph with No Ice
0.9D + 1.6W	97 mph with No Ice (Reduced DL)
1.2D + 1.0Di + 1.0Wi	50 mph with 0.75 in Radial Ice
(1.2 + 0.2Sds) * DL + E ELFM	Seismic Equivalent Lateral Forces Method
(1.2 + 0.2Sds) * DL + E EMAM	Seismic Equivalent Modal Analysis Method
(0.9 - 0.2Sds) * DL + E ELFM	Seismic (Reduced DL) Equivalent Lateral Forces Method
(0.9 - 0.2Sds) * DL + E EMAM	Seismic (Reduced DL) Equivalent Modal Analysis Method
1.0D + 1.0W	Serviceability 60 mph

Site Number: 302516

Code: ANSI/TIA-222-G

© 2007 - 2018 by ATC IP LLC. All rights reserved.

Site Name: Mlfd - Milford, CT

Engineering Number: OAA720687\_C3\_01

1/29/2018 9:08:29 AM

Customer: AT&T Mobility

**Shaft Section Properties**

Sect Info	Length (ft)	Thick (in)	Fy (ksi)	Joint Type	Slip Joint Len (in)	Weight (lb)	Bottom				Top				Taper (in/ft)				
							Dia (in)	Elev (ft)	Area (in <sup>2</sup> )	Ix (in <sup>4</sup> )	W/t Ratio	D/t Ratio	Dia (in)	Elev (ft)		Area (in <sup>2</sup> )	Ix (in <sup>4</sup> )	W/t Ratio	D/t Ratio
1-12	29.630	0.2500	65		0.00	2,374	32.00	0.00	25.56	3288.6	31.62	128.00	26.99	29.63	21.53	1964.8	26.25	107.96	0.169053
2-12	33.140	0.2500	65	Butt	0.00	2,173	26.99	29.63	21.53	1964.8	26.25	107.96	21.38	62.77	17.02	970.5	20.24	85.55	0.169053
3-12	37.790	0.1875	65	Butt	0.00	1,398	21.38	62.77	12.80	734.4	27.89	114.07	15.00	100.56	8.94	250.5	18.76	80.00	0.169053
Shaft Weight						5,945													

**Discrete Appurtenance Properties**

Attach Elev (ft)	Description	Qty	Distance From Face (ft)	Vert Ecc (ft)	Weight (lb)	No Ice EPAa (sf)	Orientation Factor
100.00	10' Omni	1	0.000	8.000	25.00	3.000	0.75
100.00	CCI OPA-65R-LCUU-H4	3	0.000	2.000	57.00	6.080	0.75
100.00	Commscope SBNHH-1D65A	3	0.000	2.000	33.50	5.880	0.75
100.00	Commscope WCS-IMFQ-AMT	2	0.000	2.000	29.50	0.990	0.75
100.00	Ericsson RRUS 11 (Band 12)	3	0.000	2.000	50.00	2.570	0.75
100.00	Ericsson RRUS 32 (50.8 lbs)	3	0.000	2.000	50.80	2.690	0.75
100.00	Ericsson RRUS 32 B2	3	0.000	2.000	53.00	2.740	0.75
100.00	Ericsson RRUS 32 B66	3	0.000	2.000	53.00	2.740	0.75
100.00	Ericsson RRUS 4478 B14	3	0.000	2.000	59.40	2.020	0.75
100.00	Flat Platform w/ Handrails	1	0.000	0.000	2000.00	42.400	1.00
100.00	Kaelus DBC0061F1V51-2	3	0.000	2.000	25.50	0.510	0.75
100.00	Kathrein Scala 80010964	3	0.000	2.000	81.60	10.000	0.75
100.00	Powerwave Allgon 7770.00	3	0.000	2.000	35.00	5.510	0.75
100.00	Powerwave Allgon LGP21401	6	0.000	2.000	14.10	1.100	0.75
100.00	Raycap DC6-48-60-18-8C	1	0.000	2.000	16.00	3.050	0.75
100.00	Raycap DC6-48-60-18-8F	2	0.000	2.000	20.00	1.110	0.75
93.00	48" x 12" Panel	3	0.000	0.000	30.00	5.070	0.73
83.00	RFS APX86-909014L-CT0-00	6	0.000	0.000	24.20	8.470	0.68
73.00	Commscope LNX-6515DS-VTM	3	0.000	0.000	50.30	11.450	0.70
73.00	Ericsson KRY 112 489/2	3	0.000	0.000	15.40	0.650	0.50
73.00	Kathrein Scala Smart Bias Tee	3	0.000	0.000	3.30	0.090	0.50
73.00	RFS APX16PV-16PVL-A	3	0.000	0.000	39.60	6.040	0.60
73.00	RFS ATMAA1412D-1A20	3	0.000	0.000	13.00	1.000	0.50
Totals	Num Loadings:23	67			4321.00		

**Linear Appurtenance Properties**

Elev From (ft)	Elev To (ft)	Qty	Description	Coax Diameter (in)	Coax Weight (lb/ft)	Projected Flat	Projected Width (in)	Exposed To Wind	Carrier
0.00	100.00	2	0.39" Fiber Trunk	0.39	0.06	N	0.00	N	AT&T Mobility
0.00	100.00	4	0.78" 8 AWG 6	0.78	0.59	N	0.00	N	AT&T Mobility
0.00	100.00	2	0.78" 8 AWG 6	0.78	0.59	N	0.00	N	AT&T Mobility
0.00	100.00	12	1 5/8" Coax	1.98	0.82	N	0.00	N	AT&T Mobility
0.00	100.00	1	2" Conduit	2.38	3.65	N	0.00	N	AT&T Mobility
0.00	100.00	2	3" Conduit	3.50	7.58	N	0.00	N	AT&T Mobility
85.00	93.00	6	7/8" Coax	1.09	0.33	N	3.27	Y	Sprint Nextel
0.00	85.00	4	#20 DYWIDAG	2.50	0.00	N	8.00	Y	--
0.00	83.00	9	7/8" Coax	1.09	0.33	N	0.00	Y	Sprint Nextel
0.00	73.00	18	7/8" Coax	1.09	0.33	N	0.00	Y	T-Mobile

Site Number: 302516

Code: ANSI/TIA-222-G

© 2007 - 2018 by ATC IP LLC. All rights reserved.

Site Name: Mlfd - Milford, CT

Engineering Number: OAA720687\_C3\_01

1/29/2018 9:08:29 AM

Customer: AT&T Mobility

Additional Steel

Elev From (ft)	Elev To (ft)	Qty	Description	Fy (ksi)	Offset (in)	<del>Intermediate Connections</del> Description	Spacing (in)	Len (in)	Connectors	Continuation?
0.00	79.00	4	SOL #20 All Thread	80	2.19	6" Angle Bracket	30.0	3.31	5/8" A36 U-Bolt	No

Segment Properties (Max Len : 5. ft)

Seg Top Elev (ft)	Description	Thick (in)	Flat Dia (in)	Area (in <sup>2</sup> )	Ix (in <sup>4</sup> )	W/t Ratio	D/t Ratio	F'y (ksi)	S (in <sup>3</sup> )	Z (in <sup>3</sup> )	Weight (lb)	Additional Reinforcing		
												Area (in <sup>2</sup> )	Ix (in <sup>4</sup> )	Weight (lb)
0.00		0.2500	32.000	25.559	3,288.6	31.62	128.00	70.2	198.5	0.0	0.0	19.64	3,718	0.0
5.00		0.2500	31.155	24.878	3,032.9	30.71	124.62	71.2	188.1	0.0	429.1	19.64	3,559	334.0
10.00		0.2500	30.309	24.198	2,790.8	29.81	121.24	72.2	177.9	0.0	417.5	19.64	3,403	334.0
15.00		0.2500	29.464	23.517	2,561.9	28.90	117.86	73.2	168.0	0.0	405.9	19.64	3,250	334.0
20.00		0.2500	28.619	22.837	2,345.9	27.99	114.48	74.2	158.4	0.0	394.3	19.64	3,101	334.0
25.00		0.2500	27.774	22.157	2,142.4	27.09	111.09	75.2	149.0	0.0	382.8	19.64	2,955	334.0
29.63	Top - Section 1	0.2500	26.991	21.526	1,964.8	26.25	107.96	76.1	140.6	0.0	344.1	19.64	2,824	309.3
29.63	Bot - Section 2	0.2500	26.991	21.526	1,964.8	26.25	107.96	76.1	140.6	0.0		19.64	2,824	
30.00		0.2500	26.928	21.476	1,951.0	26.18	107.71	76.2	140.0	0.0	27.1	19.64	2,813	24.7
35.00		0.2500	26.083	20.796	1,771.4	25.28	104.33	77.1	131.2	0.0	359.6	19.64	2,675	334.0
40.00		0.2500	25.238	20.115	1,603.1	24.37	100.95	78.1	122.7	0.0	348.0	19.64	2,540	334.0
45.00		0.2500	24.393	19.435	1,445.9	23.46	97.57	79.1	114.5	0.0	336.4	19.64	2,408	334.0
50.00		0.2500	23.547	18.754	1,299.3	22.56	94.19	80.1	106.6	0.0	324.9	19.64	2,280	334.0
55.00		0.2500	22.702	18.074	1,162.9	21.65	90.81	81.1	99.0	0.0	313.3	19.64	2,156	334.0
60.00		0.2500	21.857	17.393	1,036.5	20.75	87.43	81.9	91.6	0.0	301.7	19.64	2,035	334.0
62.77	Top - Section 2	0.2500	21.389	17.017	970.5	20.24	85.55	81.9	87.7	0.0	162.2	19.64	1,969	185.0
62.77	Bot - Section 3	0.1875	21.389	12.800	734.4	27.89	114.07	74.3	66.3	0.0		19.64	1,969	
65.00		0.1875	21.012	12.573	695.9	27.35	112.06	74.9	64.0	0.0	96.3	19.64	1,917	149.0
70.00		0.1875	20.166	12.062	614.5	26.14	107.55	76.2	58.9	0.0	209.6	19.64	1,803	334.0
73.00		0.1875	19.659	11.756	568.9	25.41	104.85	77.0	55.9	0.0	121.6	19.64	1,736	200.4
75.00		0.1875	19.321	11.552	539.8	24.93	103.05	77.5	54.0	0.0	79.3	19.64	1,693	133.6
79.00	Reinf. Top	0.1875	18.645	11.144	484.6	23.97	99.44	78.6	50.2	0.0	154.5	19.64	1,607	267.2
80.00		0.1875	18.476	11.042	471.4	23.72	98.54	78.8	49.3	0.0	37.7			
83.00		0.1875	17.969	10.735	433.2	23.00	95.83	79.6	46.6	0.0	111.2			
85.00		0.1875	17.630	10.531	409.0	22.52	94.03	80.2	44.8	0.0	72.4			
90.00		0.1875	16.785	10.021	352.4	21.31	89.52	81.5	40.6	0.0	174.8			
93.00		0.1875	16.278	9.715	321.0	20.58	86.82	81.9	38.1	0.0	100.7			
95.00		0.1875	15.940	9.511	301.2	20.10	85.01	81.9	36.5	0.0	65.4			
100.0		0.1875	15.095	9.000	255.3	18.89	80.50	81.9	32.7	0.0	157.5			
100.5		0.1875	15.000	8.943	250.5	18.76	80.00	81.9	32.3	0.0	17.1			
											5,944.9			
												5,277.2		

<b>Load Case:</b> 1.2D + 1.6W	97 mph with No Ice	22 Iterations
Gust Response Factor :1.10		Wind Importance Factor :1.00
Dead Load Factor :1.20		
Wind Load Factor :1.60		

Applied Segment Forces Summary

Seg Elev	Description	Shaft Forces		Discrete Forces			Linear Forces		Sum of Forces				
		Wind FX (lb)	Dead Load (lb)	Wind FX (lb)	Torsion MY (lb-ft)	Moment MZ (lb-ft)	Dead Load (lb)	Wind FX (lb)	Dead Load (lb)	Wind FX (lb)	Dead Load (lb)	Torsion MY (lb-ft)	Moment MZ (lb)
0.00		230.4	0.0					0.0	0.0	230.4	0.0	0.0	0.0
5.00		454.6	514.9					66.7	648.1	521.3	1,163.0	0.0	0.0
10.00		442.3	501.0					66.7	648.1	509.0	1,149.1	0.0	0.0
15.00		430.0	487.1					66.7	648.1	496.7	1,135.2	0.0	0.0
20.00		417.6	473.2					66.7	648.1	484.3	1,121.3	0.0	0.0
25.00		390.7	459.3					66.7	648.1	457.4	1,107.4	0.0	0.0
29.63	Top - Section 1	199.6	412.9					61.8	600.2	261.3	1,013.1	0.0	0.0
30.00		212.6	32.5					4.9	48.0	217.5	80.4	0.0	0.0
35.00		397.8	431.5					67.5	648.1	465.3	1,079.6	0.0	0.0
40.00		399.9	417.6					68.9	648.1	468.8	1,065.7	0.0	0.0
45.00		399.8	403.7					70.1	648.1	469.9	1,051.9	0.0	0.0
50.00		397.8	389.8					71.3	648.1	469.0	1,038.0	0.0	0.0
55.00		394.1	376.0					72.3	648.1	466.4	1,024.1	0.0	0.0
60.00		303.3	362.1					73.2	648.1	376.5	1,010.2	0.0	0.0
62.77	Top - Section 2	193.0	194.6					40.9	359.1	234.0	553.7	0.0	0.0
65.00		275.2	115.5					33.2	289.1	308.4	404.6	0.0	0.0
70.00		301.4	251.5					74.9	648.1	376.3	899.6	0.0	0.0
73.00	Appurtenance(s)	185.5	145.9	1,365.1	0.0	0.0	437.8	45.3	388.9	1,596.0	972.5	0.0	0.0
75.00		218.9	95.2					30.4	245.0	249.2	340.2	0.0	0.0
79.00	Reinf. Top	181.0	185.3					61.1	490.0	242.1	675.3	0.0	0.0
80.00		142.0	45.3					15.3	42.3	157.4	87.6	0.0	0.0
83.00	Appurtenance(s)	176.0	133.4	1,304.1	0.0	0.0	174.2	46.2	127.0	1,526.3	434.6	0.0	0.0
85.00		247.6	86.8					30.9	77.5	278.5	164.4	0.0	0.0
90.00		283.5	209.8					0.0	205.7	283.5	415.5	0.0	0.0
93.00	Appurtenance(s)	160.0	120.9	432.8	0.0	0.0	108.0	0.0	123.4	592.9	352.3	0.0	0.0
95.00		186.6	78.5					0.0	77.5	186.6	156.0	0.0	0.0
100.00	Appurtenance(s)	146.7	189.0	4,842.6	0.0	6,859.4	4,465.2	0.0	193.9	4,989.3	4,848.0	0.0	0.0
100.56		14.5	20.5					0.0	0.0	14.5	20.5	0.0	0.0
<b>Totals:</b>										16,928.6	23,364.0	0.00	0.00

Site Number: 302516

Code: ANSI/TIA-222-G

© 2007 - 2018 by ATC IP LLC. All rights reserved.

Site Name: Mlfd - Milford, CT

Engineering Number: OAA720687\_C3\_01

1/29/2018 9:08:31 AM

Customer: AT&T Mobility

Load Case: 1.2D + 1.6W

97 mph with No Ice

22 Iterations

Gust Response Factor :1.10

Wind Importance Factor :1.00

Dead Load Factor :1.20

Wind Load Factor :1.60

Calculated Forces

Seg Elev (ft)	Pu FY (-) (kips)	Vu FX (-) (kips)	Tu MY (ft-kips)	Mu MZ (ft-kips)	Mu MX (ft-kips)	Resultant Moment (ft-kips)	phi Pn (kips)	phi Vn (kips)	phi Tn (ft-kips)	phi Mn (ft-kips)	Total Deflect (in)	Rotation (deg)	Ratio
0.00	-23.33	-16.75	0.00	-1,197.40	0.00	1,197.40	1,615.50	807.75	2,117.47	1,045.74	0.00	0.00	0.546
5.00	-22.10	-16.31	0.00	-1,113.67	0.00	1,113.67	1,594.62	797.31	2,034.02	1,004.53	0.13	-0.23	0.518
10.00	-20.89	-15.88	0.00	-1,032.10	0.00	1,032.10	1,572.52	786.26	1,950.54	963.30	0.50	-0.47	0.490
15.00	-19.70	-15.45	0.00	-952.69	0.00	952.69	1,549.22	774.61	1,867.15	922.11	1.11	-0.69	0.463
20.00	-18.53	-15.02	0.00	-875.44	0.00	875.44	1,524.70	762.35	1,783.98	881.04	1.96	-0.92	0.435
25.00	-17.38	-14.61	0.00	-800.33	0.00	800.33	1,498.98	749.49	1,701.17	840.14	3.04	-1.14	0.407
29.63	-16.34	-14.36	0.00	-732.69	0.00	732.69	1,474.07	737.04	1,624.90	802.48	4.24	-1.33	0.381
29.63	-16.34	-14.36	0.00	-732.69	0.00	732.69	1,474.07	737.04	1,624.90	802.48	4.24	-1.33	0.381
30.00	-16.24	-14.17	0.00	-727.38	0.00	727.38	1,472.04	736.02	1,618.83	799.48	4.34	-1.35	0.379
35.00	-15.12	-13.73	0.00	-656.54	0.00	656.54	1,443.89	721.95	1,537.10	759.12	5.87	-1.56	0.350
40.00	-14.03	-13.28	0.00	-587.90	0.00	587.90	1,414.54	707.27	1,456.10	719.12	7.61	-1.76	0.322
45.00	-12.95	-12.82	0.00	-521.51	0.00	521.51	1,383.97	691.99	1,375.97	679.54	9.55	-1.95	0.293
50.00	-11.89	-12.35	0.00	-457.43	0.00	457.43	1,352.19	676.10	1,296.83	640.45	11.69	-2.13	0.264
55.00	-10.85	-11.87	0.00	-395.70	0.00	395.70	1,319.21	659.60	1,218.80	601.92	14.01	-2.30	0.235
60.00	-9.83	-11.47	0.00	-336.34	0.00	336.34	1,282.07	641.04	1,139.41	562.71	16.50	-2.45	0.206
62.77	-9.28	-11.23	0.00	-304.56	0.00	304.56	1,254.29	627.14	1,090.28	538.45	17.95	-2.54	0.190
62.77	-9.28	-11.23	0.00	-304.56	0.00	304.56	855.95	427.98	748.44	369.63	17.95	-2.54	0.229
65.00	-8.87	-10.92	0.00	-279.52	0.00	279.52	847.38	423.69	727.65	359.36	19.15	-2.60	0.212
70.00	-7.97	-10.51	0.00	-224.93	0.00	224.93	827.29	413.64	681.30	336.47	21.95	-2.74	0.174
73.00	-7.06	-8.88	0.00	-193.39	0.00	193.39	814.65	407.33	653.71	322.84	23.70	-2.81	0.152
75.00	-6.73	-8.62	0.00	-175.63	0.00	175.63	805.98	402.99	635.42	313.81	24.88	-2.86	0.139
79.00	-6.06	-8.35	0.00	-141.14	0.00	141.14	788.07	394.03	599.12	295.88	27.31	-2.94	0.114
79.00	-6.06	-8.35	0.00	-141.14	0.00	141.14	788.07	394.03	599.12	295.88	27.31	-2.94	0.485
80.00	-5.96	-8.20	0.00	-132.79	0.00	132.79	783.47	391.73	590.11	291.44	27.93	-2.95	0.464
83.00	-5.59	-6.67	0.00	-108.18	0.00	108.18	769.38	384.69	563.27	278.18	29.86	-3.17	0.396
85.00	-5.42	-6.40	0.00	-94.84	0.00	94.84	759.75	379.87	545.53	269.42	31.22	-3.31	0.359
90.00	-5.00	-6.11	0.00	-62.82	0.00	62.82	734.81	367.41	501.78	247.81	34.83	-3.58	0.261
93.00	-4.67	-5.51	0.00	-44.48	0.00	44.48	716.07	358.03	473.88	234.03	37.12	-3.71	0.197
95.00	-4.52	-5.32	0.00	-33.46	0.00	33.46	701.02	350.51	454.06	224.24	38.69	-3.78	0.156
100.00	-0.02	-0.02	0.00	-0.01	0.00	0.01	663.41	331.70	406.37	200.69	42.71	-3.87	0.000
100.56	0.00	-0.01	0.00	0.00	0.00	0.00	659.19	329.60	401.19	198.13	43.17	-3.87	0.000

<b>Load Case:</b> 0.9D + 1.6W	97 mph with No Ice (Reduced DL)	22 Iterations
Gust Response Factor :1.10		Wind Importance Factor :1.00
Dead Load Factor :0.90		
Wind Load Factor :1.60		

**Applied Segment Forces Summary**

Seg Elev (ft)	Description	Shaft Forces		Discrete Forces			Linear Forces		Sum of Forces				
		Wind FX (lb)	Dead Load (lb)	Wind FX (lb)	Torsion MY (lb-ft)	Moment MZ (lb-ft)	Dead Load (lb)	Wind FX (lb)	Dead Load (lb)	Wind FX (lb)	Dead Load (lb)	Torsion MY (lb-ft)	Moment MZ (lb)
0.00		230.4	0.0					0.0	0.0	230.4	0.0	0.0	0.0
5.00		454.6	386.2					66.7	486.1	521.3	872.2	0.0	0.0
10.00		442.3	375.7					66.7	486.1	509.0	861.8	0.0	0.0
15.00		430.0	365.3					66.7	486.1	496.7	851.4	0.0	0.0
20.00		417.6	354.9					66.7	486.1	484.3	841.0	0.0	0.0
25.00		390.7	344.5					66.7	486.1	457.4	830.6	0.0	0.0
29.63	Top - Section 1	199.6	309.7					61.8	450.1	261.3	759.8	0.0	0.0
30.00		212.6	24.4					4.9	36.0	217.5	60.3	0.0	0.0
35.00		397.8	323.6					67.5	486.1	465.3	809.7	0.0	0.0
40.00		399.9	313.2					68.9	486.1	468.8	799.3	0.0	0.0
45.00		399.8	302.8					70.1	486.1	469.9	788.9	0.0	0.0
50.00		397.8	292.4					71.3	486.1	469.0	778.5	0.0	0.0
55.00		394.1	282.0					72.3	486.1	466.4	768.1	0.0	0.0
60.00		303.3	271.5					73.2	486.1	376.5	757.6	0.0	0.0
62.77	Top - Section 2	193.0	146.0					40.9	269.3	234.0	415.2	0.0	0.0
65.00		275.2	86.6					33.2	216.8	308.4	303.4	0.0	0.0
70.00		301.4	188.6					74.9	486.1	376.3	674.7	0.0	0.0
73.00	Appurtenance(s)	185.5	109.4	1,365.1	0.0	0.0	328.3	45.3	291.7	1,596.0	729.4	0.0	0.0
75.00		218.9	71.4					30.4	183.7	249.2	255.1	0.0	0.0
79.00	Reinf. Top	181.0	139.0					61.1	367.5	242.1	506.5	0.0	0.0
80.00		142.0	34.0					15.3	31.8	157.4	65.7	0.0	0.0
83.00	Appurtenance(s)	176.0	100.0	1,304.1	0.0	0.0	130.7	46.2	95.3	1,526.3	326.0	0.0	0.0
85.00		212.0	65.1					30.9	58.2	242.9	123.3	0.0	0.0
90.00		225.2	157.4					0.0	154.3	225.2	311.7	0.0	0.0
93.00	Appurtenance(s)	137.4	90.7	432.8	0.0	0.0	81.0	0.0	92.6	570.2	264.2	0.0	0.0
95.00		186.6	58.9					0.0	58.2	186.6	117.0	0.0	0.0
100.00	Appurtenance(s)	146.7	141.7	4,842.6	0.0	6,859.4	3,348.9	0.0	145.4	4,989.3	3,636.0	0.0	0.0
100.56		14.5	15.4					0.0	0.0	14.5	15.4	0.0	0.0
<b>Totals:</b>										16,812.0	17,523.0	0.00	0.00

Site Number: 302516

Code: ANSI/TIA-222-G

© 2007 - 2018 by ATC IP LLC. All rights reserved.

Site Name: Mlfd - Milford, CT

Engineering Number: OAA720687\_C3\_01

1/29/2018 9:08:33 AM

Customer: AT&T Mobility

**Load Case: 0.9D + 1.6W**

97 mph with No Ice (Reduced DL)

22 Iterations

Gust Response Factor :1.10

Wind Importance Factor :1.00

Dead Load Factor :0.90

Wind Load Factor :1.60

**Calculated Forces**

Seg Elev (ft)	Pu FY (-) (kips)	Vu FX (-) (kips)	Tu MY (ft-kips)	Mu MZ (ft-kips)	Mu MX (ft-kips)	Resultant Moment (ft-kips)	phi Pn (kips)	phi Vn (kips)	phi Tn (ft-kips)	phi Mn (ft-kips)	Total Deflect (in)	Rotation (deg)	Ratio
0.00	-17.49	-16.62	0.00	-1,177.60	0.00	1,177.60	1,615.50	807.75	2,117.47	1,045.74	0.00	0.00	0.535
5.00	-16.55	-16.16	0.00	-1,094.51	0.00	1,094.51	1,594.62	797.31	2,034.02	1,004.53	0.12	-0.23	0.508
10.00	-15.63	-15.71	0.00	-1,013.71	0.00	1,013.71	1,572.52	786.26	1,950.54	963.30	0.49	-0.46	0.480
15.00	-14.73	-15.26	0.00	-935.17	0.00	935.17	1,549.22	774.61	1,867.15	922.11	1.09	-0.68	0.453
20.00	-13.84	-14.82	0.00	-858.87	0.00	858.87	1,524.70	762.35	1,783.98	881.04	1.92	-0.90	0.425
25.00	-12.96	-14.39	0.00	-784.78	0.00	784.78	1,498.98	749.49	1,701.17	840.14	2.98	-1.12	0.397
29.63	-12.18	-14.14	0.00	-718.15	0.00	718.15	1,474.07	737.04	1,624.90	802.48	4.16	-1.31	0.372
29.63	-12.18	-14.14	0.00	-718.15	0.00	718.15	1,474.07	737.04	1,624.90	802.48	4.16	-1.31	0.372
30.00	-12.10	-13.94	0.00	-712.92	0.00	712.92	1,472.04	736.02	1,618.83	799.48	4.27	-1.33	0.370
35.00	-11.26	-13.49	0.00	-643.22	0.00	643.22	1,443.89	721.95	1,537.10	759.12	5.77	-1.53	0.342
40.00	-10.43	-13.04	0.00	-575.75	0.00	575.75	1,414.54	707.27	1,456.10	719.12	7.47	-1.72	0.314
45.00	-9.61	-12.57	0.00	-510.57	0.00	510.57	1,383.97	691.99	1,375.97	679.54	9.38	-1.91	0.286
50.00	-8.82	-12.10	0.00	-447.70	0.00	447.70	1,352.19	676.10	1,296.83	640.45	11.48	-2.09	0.257
55.00	-8.03	-11.63	0.00	-387.18	0.00	387.18	1,319.21	659.60	1,218.80	601.92	13.75	-2.25	0.229
60.00	-7.27	-11.24	0.00	-329.02	0.00	329.02	1,282.07	641.04	1,139.41	562.71	16.20	-2.41	0.200
62.77	-6.85	-11.00	0.00	-297.89	0.00	297.89	1,254.29	627.14	1,090.28	538.45	17.62	-2.49	0.185
62.77	-6.85	-11.00	0.00	-297.89	0.00	297.89	855.95	427.98	748.44	369.63	17.62	-2.49	0.223
65.00	-6.54	-10.69	0.00	-273.37	0.00	273.37	847.38	423.69	727.65	359.36	18.79	-2.55	0.206
70.00	-5.87	-10.29	0.00	-219.94	0.00	219.94	827.29	413.64	681.30	336.47	21.54	-2.68	0.169
73.00	-5.21	-8.67	0.00	-189.07	0.00	189.07	814.65	407.33	653.71	322.84	23.25	-2.75	0.147
75.00	-4.95	-8.41	0.00	-171.74	0.00	171.74	805.98	402.99	635.42	313.81	24.41	-2.80	0.135
79.00	-4.45	-8.15	0.00	-138.10	0.00	138.10	788.07	394.03	599.12	295.88	26.79	-2.88	0.111
79.00	-4.45	-8.15	0.00	-138.10	0.00	138.10	788.07	394.03	599.12	295.88	26.79	-2.88	0.473
80.00	-4.38	-8.00	0.00	-129.95	0.00	129.95	783.47	391.73	590.11	291.44	27.40	-2.90	0.452
83.00	-4.12	-6.47	0.00	-105.97	0.00	105.97	769.38	384.69	563.27	278.18	29.29	-3.11	0.387
85.00	-3.98	-6.23	0.00	-93.03	0.00	93.03	759.75	379.87	545.53	269.42	30.62	-3.24	0.351
90.00	-3.67	-6.00	0.00	-61.88	0.00	61.88	734.81	367.41	501.78	247.81	34.16	-3.51	0.255
93.00	-3.43	-5.42	0.00	-43.87	0.00	43.87	716.07	358.03	473.88	234.03	36.41	-3.64	0.192
95.00	-3.31	-5.23	0.00	-33.03	0.00	33.03	701.02	350.51	454.06	224.24	37.95	-3.71	0.152
100.00	-0.01	-0.02	0.00	-0.01	0.00	0.01	663.41	331.70	406.37	200.69	41.89	-3.80	0.000
100.56	0.00	-0.01	0.00	0.00	0.00	0.00	659.19	329.60	401.19	198.13	42.33	-3.80	0.000



<b>Load Case:</b> 1.2D + 1.0Di + 1.0Wi	50 mph with 0.75 in Radial Ice	21 Iterations
Gust Response Factor :1.10	Ice Dead Load Factor :1.00	Wind Importance Factor :1.00
Dead Load Factor :1.20		Ice Importance Factor :1.00
Wind Load Factor :1.00		

Applied Segment Forces Summary

Seg Elev (ft)	Description	Shaft Forces		Discrete Forces			Linear Forces		Sum of Forces				
		Wind FX (lb)	Dead Load (lb)	Wind FX (lb)	Torsion MY (lb-ft)	Moment MZ (lb-ft)	Dead Load (lb)	Wind FX (lb)	Dead Load (lb)	Wind FX (lb)	Dead Load (lb)	Torsion MY (lb-ft)	Moment MZ (lb)
0.00		41.0	0.0					0.0	0.0	41.0	0.0	0.0	0.0
5.00		81.2	757.3					24.2	874.2	105.4	1,631.6	0.0	0.0
10.00		79.7	765.6					24.8	900.9	104.4	1,666.5	0.0	0.0
15.00		77.9	758.7					25.1	914.6	103.0	1,673.3	0.0	0.0
20.00		76.0	746.8					25.3	924.1	101.3	1,670.9	0.0	0.0
25.00		71.5	732.3					25.5	931.5	96.9	1,663.7	0.0	0.0
29.63	Top - Section 1	36.6	664.0					23.7	868.0	60.3	1,531.9	0.0	0.0
30.00		39.2	52.7					1.9	69.6	41.1	122.2	0.0	0.0
35.00		73.4	698.8					26.4	942.7	99.8	1,641.5	0.0	0.0
40.00		74.2	680.6					27.6	947.2	101.7	1,627.8	0.0	0.0
45.00		74.5	661.8					28.7	951.2	103.2	1,613.0	0.0	0.0
50.00		74.5	642.4					29.7	954.8	104.2	1,597.3	0.0	0.0
55.00		74.2	622.6					30.6	958.1	104.9	1,580.8	0.0	0.0
60.00		57.4	602.5					31.5	961.2	88.9	1,563.6	0.0	0.0
62.77	Top - Section 2	36.7	326.0					17.8	533.7	54.5	859.7	0.0	0.0
65.00		52.5	220.0					14.5	430.3	67.1	650.3	0.0	0.0
70.00		57.7	478.4					33.1	966.6	90.9	1,444.9	0.0	0.0
73.00	Appurtenance(s)	35.7	279.7	263.8	0.0	0.0	1,696.1	20.3	581.1	319.8	2,556.9	0.0	0.0
75.00		42.3	183.3					13.6	314.0	56.0	497.2	0.0	0.0
79.00	Reinf. Top	35.1	356.5					27.6	628.6	62.7	985.1	0.0	0.0
80.00		27.7	87.9					7.0	77.1	34.7	165.0	0.0	0.0
83.00	Appurtenance(s)	34.4	258.3	250.5	0.0	0.0	1,255.4	21.1	231.6	306.0	1,745.3	0.0	0.0
85.00		47.3	168.9					14.2	114.0	61.5	282.9	0.0	0.0
90.00		53.3	406.8					0.0	267.5	53.3	674.3	0.0	0.0
93.00	Appurtenance(s)	32.7	236.4	97.2	0.0	0.0	522.1	0.0	160.7	129.9	919.2	0.0	0.0
95.00		44.8	154.3					0.0	77.5	44.8	231.8	0.0	0.0
100.00	Appurtenance(s)	35.3	370.0	1,112.5	0.0	1,594.6	9,747.2	0.0	193.9	1,147.8	10,311.1	0.0	0.0
100.56		3.5	40.7					0.0	0.0	3.5	40.7	0.0	0.0
<b>Totals:</b>										3,688.60	40,948.6	0.00	0.00

Site Number: 302516

Code: ANSI/TIA-222-G

© 2007 - 2018 by ATC IP LLC. All rights reserved.

Site Name: Mlfd - Milford, CT

Engineering Number: OAA720687\_C3\_01

1/29/2018 9:08:36 AM

Customer: AT&T Mobility

**Load Case: 1.2D + 1.0Di + 1.0Wi**

50 mph with 0.75 in Radial Ice

21 Iterations

Gust Response Factor :1.10

Ice Dead Load Factor :1.00

Wind Importance Factor :1.00

Dead Load Factor :1.20

Ice Importance Factor :1.00

Wind Load Factor :1.00

**Calculated Forces**

Seg Elev (ft)	Pu FY (-) (kips)	Vu FX (-) (kips)	Tu MY (ft-kips)	Mu MZ (ft-kips)	Mu MX (ft-kips)	Resultant Moment (ft-kips)	phi Pn (kips)	phi Vn (kips)	phi Tn (ft-kips)	phi Mn (ft-kips)	Total Deflect (in)	Rotation (deg)	Ratio
0.00	-40.95	-3.67	0.00	-273.52	0.00	273.52	1,615.50	807.75	2,117.47	1,045.74	0.00	0.00	0.137
5.00	-39.31	-3.60	0.00	-255.18	0.00	255.18	1,594.62	797.31	2,034.02	1,004.53	0.03	-0.05	0.131
10.00	-37.64	-3.53	0.00	-237.19	0.00	237.19	1,572.52	786.26	1,950.54	963.30	0.11	-0.11	0.124
15.00	-35.97	-3.45	0.00	-219.57	0.00	219.57	1,549.22	774.61	1,867.15	922.11	0.25	-0.16	0.118
20.00	-34.29	-3.38	0.00	-202.31	0.00	202.31	1,524.70	762.35	1,783.98	881.04	0.45	-0.21	0.111
25.00	-32.63	-3.30	0.00	-185.44	0.00	185.44	1,498.98	749.49	1,701.17	840.14	0.70	-0.26	0.104
29.63	-31.09	-3.24	0.00	-170.16	0.00	170.16	1,474.07	737.04	1,624.90	802.48	0.97	-0.31	0.098
29.63	-31.09	-3.24	0.00	-170.16	0.00	170.16	1,474.07	737.04	1,624.90	802.48	0.97	-0.31	0.098
30.00	-30.97	-3.22	0.00	-168.96	0.00	168.96	1,472.04	736.02	1,618.83	799.48	1.00	-0.31	0.098
35.00	-29.33	-3.13	0.00	-152.88	0.00	152.88	1,443.89	721.95	1,537.10	759.12	1.35	-0.36	0.091
40.00	-27.70	-3.04	0.00	-137.23	0.00	137.23	1,414.54	707.27	1,456.10	719.12	1.75	-0.41	0.084
45.00	-26.08	-2.95	0.00	-122.02	0.00	122.02	1,383.97	691.99	1,375.97	679.54	2.20	-0.45	0.077
50.00	-24.48	-2.85	0.00	-107.30	0.00	107.30	1,352.19	676.10	1,296.83	640.45	2.70	-0.49	0.070
55.00	-22.90	-2.74	0.00	-93.07	0.00	93.07	1,319.21	659.60	1,218.80	601.92	3.23	-0.53	0.063
60.00	-21.34	-2.65	0.00	-79.36	0.00	79.36	1,282.07	641.04	1,139.41	562.71	3.81	-0.57	0.055
62.77	-20.48	-2.59	0.00	-72.03	0.00	72.03	1,254.29	627.14	1,090.28	538.45	4.15	-0.59	0.052
62.77	-20.48	-2.59	0.00	-72.03	0.00	72.03	855.95	427.98	748.44	369.63	4.15	-0.59	0.062
65.00	-19.83	-2.53	0.00	-66.25	0.00	66.25	847.38	423.69	727.65	359.36	4.43	-0.60	0.058
70.00	-18.38	-2.43	0.00	-53.62	0.00	53.62	827.29	413.64	681.30	336.47	5.08	-0.64	0.049
73.00	-15.83	-2.08	0.00	-46.34	0.00	46.34	814.65	407.33	653.71	322.84	5.48	-0.65	0.043
75.00	-15.33	-2.02	0.00	-42.17	0.00	42.17	805.98	402.99	635.42	313.81	5.76	-0.66	0.040
79.00	-14.35	-1.95	0.00	-34.08	0.00	34.08	788.07	394.03	599.12	295.88	6.32	-0.68	0.033
79.00	-14.35	-1.95	0.00	-34.08	0.00	34.08	788.07	394.03	599.12	295.88	6.32	-0.68	0.133
80.00	-14.18	-1.92	0.00	-32.12	0.00	32.12	783.47	391.73	590.11	291.44	6.47	-0.69	0.128
83.00	-12.44	-1.61	0.00	-26.35	0.00	26.35	769.38	384.69	563.27	278.18	6.92	-0.74	0.111
85.00	-12.16	-1.55	0.00	-23.14	0.00	23.14	759.75	379.87	545.53	269.42	7.24	-0.77	0.102
90.00	-11.48	-1.50	0.00	-15.38	0.00	15.38	734.81	367.41	501.78	247.81	8.08	-0.84	0.078
93.00	-10.56	-1.36	0.00	-10.89	0.00	10.89	716.07	358.03	473.88	234.03	8.62	-0.87	0.061
95.00	-10.33	-1.31	0.00	-8.17	0.00	8.17	701.02	350.51	454.06	224.24	8.99	-0.89	0.051
100.00	-0.04	0.00	0.00	0.00	0.00	0.00	663.41	331.70	406.37	200.69	9.94	-0.91	0.000
100.56	0.00	0.00	0.00	0.00	0.00	0.00	659.19	329.60	401.19	198.13	10.05	-0.91	0.000

<b>Load Case:</b> 1.0D + 1.0W	Serviceability 60 mph	20 Iterations
Gust Response Factor :1.10		Wind Importance Factor :1.00
Dead Load Factor :1.00		
Wind Load Factor :1.00		

Applied Segment Forces Summary

Seg Elev (ft)	Description	Shaft Forces		Discrete Forces			Linear Forces		Sum of Forces				
		Wind FX (lb)	Dead Load (lb)	Wind FX (lb)	Torsion MY (lb-ft)	Moment MZ (lb-ft)	Dead Load (lb)	Wind FX (lb)	Dead Load (lb)	Wind FX (lb)	Dead Load (lb)	Torsion MY (lb-ft)	Moment MZ (lb)
0.00		55.1	0.0					0.0	0.0	55.1	0.0	0.0	0.0
5.00		108.7	429.1					25.8	540.1	134.5	969.2	0.0	0.0
10.00		105.8	417.5					25.8	540.1	131.6	957.6	0.0	0.0
15.00		102.8	405.9					25.8	540.1	128.6	946.0	0.0	0.0
20.00		99.9	394.3					25.8	540.1	125.7	934.4	0.0	0.0
25.00		93.4	382.8					25.8	540.1	119.2	922.9	0.0	0.0
29.63	Top - Section 1	47.7	344.1					23.9	500.1	71.6	844.2	0.0	0.0
30.00		50.8	27.1					1.9	40.0	52.7	67.0	0.0	0.0
35.00		95.1	359.6					26.1	540.1	121.2	899.7	0.0	0.0
40.00		95.6	348.0					26.6	540.1	122.3	888.1	0.0	0.0
45.00		95.6	336.4					27.1	540.1	122.7	876.5	0.0	0.0
50.00		95.1	324.9					27.5	540.1	122.7	865.0	0.0	0.0
55.00		94.2	313.3					27.9	540.1	122.2	853.4	0.0	0.0
60.00		72.5	301.7					28.3	540.1	100.8	841.8	0.0	0.0
62.77	Top - Section 2	46.2	162.2					15.8	299.2	62.0	461.4	0.0	0.0
65.00		65.8	96.3					12.8	240.9	78.6	337.2	0.0	0.0
70.00		72.1	209.6					29.0	540.1	101.0	749.7	0.0	0.0
73.00	Appurtenance(s)	44.4	121.6	326.4	0.0	0.0	364.8	17.5	324.1	388.3	810.4	0.0	0.0
75.00		52.3	79.3					11.7	204.2	64.1	283.5	0.0	0.0
79.00	Reinf. Top	43.3	154.5					23.6	408.3	66.9	562.8	0.0	0.0
80.00		34.0	37.7					5.9	35.3	39.9	73.0	0.0	0.0
83.00	Appurtenance(s)	42.1	111.2	311.8	0.0	0.0	145.2	17.9	105.8	371.8	362.2	0.0	0.0
85.00		50.7	72.4					12.0	64.6	62.6	137.0	0.0	0.0
90.00		53.9	174.8					0.0	171.5	53.9	346.3	0.0	0.0
93.00	Appurtenance(s)	32.8	100.7	103.5	0.0	0.0	90.0	0.0	102.9	136.4	293.6	0.0	0.0
95.00		44.6	65.4					0.0	64.6	44.6	130.0	0.0	0.0
100.00	Appurtenance(s)	35.1	157.5	1,158.0	0.0	1,640.3	3,721.0	0.0	161.6	1,193.1	4,040.0	0.0	0.0
100.56		3.5	17.1					0.0	0.0	3.5	17.1	0.0	0.0
Totals:										4,197.50	19,470.0	0.00	0.00

Site Number: 302516

Code: ANSI/TIA-222-G

© 2007 - 2018 by ATC IP LLC. All rights reserved.

Site Name: Mlfd - Milford, CT

Engineering Number: OAA720687\_C3\_01

1/29/2018 9:08:38 AM

Customer: AT&T Mobility

Load Case: 1.0D + 1.0W

Serviceability 60 mph

20 Iterations

Gust Response Factor :1.10

Wind Importance Factor :1.00

Dead Load Factor :1.00

Wind Load Factor :1.00

Calculated Forces

Seg Elev (ft)	Pu FY (-) (kips)	Vu FX (-) (kips)	Tu MY (ft-kips)	Mu MZ (ft-kips)	Mu MX (ft-kips)	Resultant Moment (ft-kips)	phi Pn (kips)	phi Vn (kips)	phi Tn (ft-kips)	phi Mn (ft-kips)	Total Deflect (in)	Rotation (deg)	Ratio
0.00	-19.47	-4.15	0.00	-290.70	0.00	290.70	1,615.50	807.75	2,117.47	1,045.74	0.00	0.00	0.137
5.00	-18.49	-4.03	0.00	-269.94	0.00	269.94	1,594.62	797.31	2,034.02	1,004.53	0.03	-0.06	0.130
10.00	-17.53	-3.92	0.00	-249.77	0.00	249.77	1,572.52	786.26	1,950.54	963.30	0.12	-0.11	0.123
15.00	-16.58	-3.80	0.00	-230.18	0.00	230.18	1,549.22	774.61	1,867.15	922.11	0.27	-0.17	0.116
20.00	-15.65	-3.69	0.00	-211.16	0.00	211.16	1,524.70	762.35	1,783.98	881.04	0.47	-0.22	0.109
25.00	-14.72	-3.58	0.00	-192.72	0.00	192.72	1,498.98	749.49	1,701.17	840.14	0.74	-0.27	0.102
29.63	-13.88	-3.51	0.00	-176.15	0.00	176.15	1,474.07	737.04	1,624.90	802.48	1.03	-0.32	0.095
29.63	-13.88	-3.51	0.00	-176.15	0.00	176.15	1,474.07	737.04	1,624.90	802.48	1.03	-0.32	0.095
30.00	-13.81	-3.46	0.00	-174.85	0.00	174.85	1,472.04	736.02	1,618.83	799.48	1.05	-0.33	0.094
35.00	-12.91	-3.35	0.00	-157.54	0.00	157.54	1,443.89	721.95	1,537.10	759.12	1.42	-0.38	0.087
40.00	-12.02	-3.23	0.00	-140.80	0.00	140.80	1,414.54	707.27	1,456.10	719.12	1.84	-0.42	0.080
45.00	-11.14	-3.11	0.00	-124.67	0.00	124.67	1,383.97	691.99	1,375.97	679.54	2.31	-0.47	0.073
50.00	-10.27	-2.98	0.00	-109.13	0.00	109.13	1,352.19	676.10	1,296.83	640.45	2.82	-0.51	0.066
55.00	-9.42	-2.86	0.00	-94.21	0.00	94.21	1,319.21	659.60	1,218.80	601.92	3.38	-0.55	0.058
60.00	-8.58	-2.76	0.00	-79.90	0.00	79.90	1,282.07	641.04	1,139.41	562.71	3.98	-0.59	0.051
62.77	-8.11	-2.69	0.00	-72.27	0.00	72.27	1,254.29	627.14	1,090.28	538.45	4.33	-0.61	0.047
62.77	-8.11	-2.69	0.00	-72.27	0.00	72.27	855.95	427.98	748.44	369.63	4.33	-0.61	0.057
65.00	-7.78	-2.61	0.00	-66.27	0.00	66.27	847.38	423.69	727.65	359.36	4.62	-0.62	0.053
70.00	-7.03	-2.51	0.00	-53.21	0.00	53.21	827.29	413.64	681.30	336.47	5.29	-0.66	0.043
73.00	-6.22	-2.11	0.00	-45.69	0.00	45.69	814.65	407.33	653.71	322.84	5.71	-0.67	0.038
75.00	-5.94	-2.04	0.00	-41.47	0.00	41.47	805.98	402.99	635.42	313.81	6.00	-0.69	0.035
79.00	-5.38	-1.97	0.00	-33.29	0.00	33.29	788.07	394.03	599.12	295.88	6.58	-0.70	0.029
79.00	-5.38	-1.97	0.00	-33.29	0.00	33.29	788.07	394.03	599.12	295.88	6.58	-0.70	0.119
80.00	-5.30	-1.93	0.00	-31.32	0.00	31.32	783.47	391.73	590.11	291.44	6.73	-0.71	0.114
83.00	-4.94	-1.56	0.00	-25.52	0.00	25.52	769.38	384.69	563.27	278.18	7.19	-0.76	0.098
85.00	-4.81	-1.50	0.00	-22.40	0.00	22.40	759.75	379.87	545.53	269.42	7.52	-0.79	0.089
90.00	-4.46	-1.45	0.00	-14.90	0.00	14.90	734.81	367.41	501.78	247.81	8.38	-0.86	0.066
93.00	-4.17	-1.31	0.00	-10.56	0.00	10.56	716.07	358.03	473.88	234.03	8.93	-0.89	0.051
95.00	-4.04	-1.26	0.00	-7.95	0.00	7.95	701.02	350.51	454.06	224.24	9.31	-0.90	0.041
100.00	-0.02	0.00	0.00	0.00	0.00	0.00	663.41	331.70	406.37	200.69	10.27	-0.93	0.000
100.56	0.00	0.00	0.00	0.00	0.00	0.00	659.19	329.60	401.19	198.13	10.38	-0.93	0.000

### Equivalent Lateral Forces Method Analysis

(Based on ASCE7-10 Chapters 11, 12, 15)

Spectral Response Acceleration for Short Period ( $S_s$ ):	0.20
Spectral Response Acceleration at 1.0 Second Period ( $S_1$ ):	0.06
Long-Period Transition Period ( $T_L$ ):	6
Importance Factor ( $I_E$ ):	1.00
Site Coefficient $F_a$ :	1.60
Site Coefficient $F_v$ :	2.40
Response Modification Coefficient (R):	1.50
Design Spectral Response Acceleration at Short Period ( $S_{ds}$ ):	0.21
Design Spectral Response Acceleration at 1.0 Second Period ( $S_{d1}$ ):	0.10
Seismic Response Coefficient ( $C_s$ ):	0.04
Upper Limit $C_s$	0.04
Lower Limit $C_s$	0.03
Period based on Rayleigh Method (sec):	1.62
Redundancy Factor ( $\rho$ ):	1.00
Seismic Force Distribution Exponent (k):	1.56
Total Unfactored Dead Load:	19.47 k
Seismic Base Shear (E):	0.81 k

#### Load Case (1.2 + 0.2Sds) \* DL + E ELFM      Seismic Equivalent Lateral Forces Method

Segment	Height Above Base (ft)	Weight (lb)	$W_z$ (lb-ft)	$C_{vx}$	Horizontal Force (lb)	Vertical Force (lb)
27	100.28	17	23	0.002	2	21
26	97.50	319	402	0.035	28	396
25	94.00	130	155	0.013	11	162
24	91.50	204	232	0.020	16	253
23	87.50	346	369	0.032	26	430
22	84.00	137	137	0.012	10	170
21	81.50	217	207	0.018	14	270
20	79.50	73	67	0.006	5	91
19	77.00	563	491	0.043	34	699
18	74.00	283	232	0.020	16	352
17	71.50	446	346	0.030	24	553
16	67.50	750	532	0.046	37	931
15	63.88	337	220	0.019	15	419
14	61.38	461	283	0.024	20	573
13	57.50	842	466	0.040	33	1,046
12	52.50	853	410	0.036	29	1,060
11	47.50	865	355	0.031	25	1,074
10	42.50	877	303	0.026	21	1,089
9	37.50	888	252	0.022	18	1,103
8	32.50	900	205	0.018	14	1,117
7	29.81	67	13	0.001	1	83
6	27.31	844	146	0.013	10	1,049
5	22.50	923	118	0.010	8	1,146

Site Number: 302516

Code: ANSI/TIA-222-G

© 2007 - 2018 by ATC IP LLC. All rights reserved.

Site Name: Mlfd - Milford, CT

Engineering Number: OAA720687\_C3\_01

1/29/2018 9:08:38 AM

Customer: AT&T Mobility

4	17.50	934	81	0.007	6	1,161
3	12.50	946	48	0.004	3	1,175
2	7.50	958	22	0.002	2	1,189
1	2.50	969	4	0.000	0	1,204
Kaelus DBC0061F1V51-	100.00	76	100	0.009	7	95
Commscope WCS-IMFQ-A	100.00	59	77	0.007	5	73
Powerwave Allgon LGP	100.00	85	111	0.010	8	105
Raycap DC6-48-60-18-	100.00	40	52	0.005	4	50
Ericsson RRUS 4478 B	100.00	178	234	0.020	16	221
Ericsson RRUS 11 (Ba	100.00	150	197	0.017	14	186
Ericsson RRUS 32 (50	100.00	152	200	0.017	14	189
Ericsson RRUS 32 B2	100.00	159	208	0.018	15	197
Ericsson RRUS 32 B66	100.00	159	208	0.018	15	197
10' Omni	100.00	25	33	0.003	2	31
Raycap DC6-48-60-18-	100.00	16	21	0.002	1	20
Powerwave Allgon 777	100.00	105	138	0.012	10	130
Commscope SBNHH-1D65	100.00	101	132	0.011	9	125
CCI OPA-65R-LCUU-H4	100.00	171	224	0.019	16	212
Kathrein Scala 80010	100.00	245	321	0.028	22	304
Flat Platform w/ Han	100.00	2,000	2,622	0.227	184	2,484
48" x 12" Panel	93.00	90	105	0.009	7	112
RFS APX86-909014L-CT	83.00	145	142	0.012	10	180
Kathrein Scala Smart	73.00	10	8	0.001	1	12
Ericsson KRY 112 489	73.00	46	37	0.003	3	57
RFS ATMAA1412D-1A20	73.00	39	31	0.003	2	48
RFS APX16PV-16PVL-A	73.00	119	95	0.008	7	148
Commscope LNX-6515DS	73.00	151	121	0.010	8	187
		19,470	11,537	1.000	809	24,182

Load Case (0.9 - 0.2Sds) \* DL + E ELFM

Seismic (Reduced DL) Equivalent Lateral Forces Method

Segment	Height Above Base (ft)	Weight (lb)	W <sub>z</sub> (lb-ft)	C <sub>vx</sub>	Horizontal Force (lb)	Vertical Force (lb)
27	100.28	17	23	0.002	2	15
26	97.50	319	402	0.035	28	274
25	94.00	130	155	0.013	11	112
24	91.50	204	232	0.020	16	175
23	87.50	346	369	0.032	26	297
22	84.00	137	137	0.012	10	118
21	81.50	217	207	0.018	14	186
20	79.50	73	67	0.006	5	63
19	77.00	563	491	0.043	34	483
18	74.00	283	232	0.020	16	243
17	71.50	446	346	0.030	24	382
16	67.50	750	532	0.046	37	643
15	63.88	337	220	0.019	15	289
14	61.38	461	283	0.024	20	396
13	57.50	842	466	0.040	33	722
12	52.50	853	410	0.036	29	732
11	47.50	865	355	0.031	25	742
10	42.50	877	303	0.026	21	752
9	37.50	888	252	0.022	18	762
8	32.50	900	205	0.018	14	772
7	29.81	67	13	0.001	1	58
6	27.31	844	146	0.013	10	724
5	22.50	923	118	0.010	8	792
4	17.50	934	81	0.007	6	802
3	12.50	946	48	0.004	3	812
2	7.50	958	22	0.002	2	822
1	2.50	969	4	0.000	0	832

Site Number: 302516

Code: ANSI/TIA-222-G

© 2007 - 2018 by ATC IP LLC. All rights reserved.

Site Name: Mlfd - Milford, CT

Engineering Number: OAA720687\_C3\_01

1/29/2018 9:08:38 AM

Customer: AT&T Mobility

Kaelus DBC0061F1V51-	100.00	76	100	0.009	7	66
Commscope WCS-IMFQ-A	100.00	59	77	0.007	5	51
Powerwave Allgon LGP	100.00	85	111	0.010	8	73
Raycap DC6-48-60-18-	100.00	40	52	0.005	4	34
Ericsson RRUS 4478 B	100.00	178	234	0.020	16	153
Ericsson RRUS 11 (Ba	100.00	150	197	0.017	14	129
Ericsson RRUS 32 (50	100.00	152	200	0.017	14	131
Ericsson RRUS 32 B2	100.00	159	208	0.018	15	136
Ericsson RRUS 32 B66	100.00	159	208	0.018	15	136
10' Omni	100.00	25	33	0.003	2	21
Raycap DC6-48-60-18-	100.00	16	21	0.002	1	14
Powerwave Allgon 777	100.00	105	138	0.012	10	90
Commscope SBNHH-1D65	100.00	101	132	0.011	9	86
CCI OPA-65R-LCUU-H4	100.00	171	224	0.019	16	147
Kathrein Scala 80010	100.00	245	321	0.028	22	210
Flat Platform w/ Han	100.00	2,000	2,622	0.227	184	1,716
48" x 12" Panel	93.00	90	105	0.009	7	77
RFS APX86-909014L-CT	83.00	145	142	0.012	10	125
Kathrein Scala Smart	73.00	10	8	0.001	1	8
Ericsson KRY 112 489	73.00	46	37	0.003	3	40
RFS ATMAA1412D-1A20	73.00	39	31	0.003	2	33
RFS APX16PV-16PVL-A	73.00	119	95	0.008	7	102
Commscope LNX-6515DS	73.00	151	121	0.010	8	129
		19,470	11,537	1.000	809	16,705

Load Case (1.2 + 0.2Sds) \* DL + E ELFM Seismic Equivalent Lateral Forces Method

Calculated Forces

Seg Elev (ft)	Pu FY (-) (kips)	Vu FX (-) (kips)	Tu MY (ft-kips)	Mu MZ (ft-kips)	Mu MX (ft-kips)	Resultant Moment (ft-kips)	phi Pn (kips)	phi Vn (kips)	phi Tn (ft-kips)	phi Mn (ft-kips)	Total Deflect (in)	Rotation (deg)	Ratio
0.00	-22.98	-0.81	0.00	-65.81	0.00	65.81	1,615.50	807.75	2,117.47	1,045.74	0.00	0.00	0.038
5.00	-21.79	-0.81	0.00	-61.76	0.00	61.76	1,594.62	797.31	2,034.02	1,004.53	0.01	-0.01	0.036
10.00	-20.61	-0.81	0.00	-57.69	0.00	57.69	1,572.52	786.26	1,950.54	963.30	0.03	-0.03	0.034
15.00	-19.45	-0.81	0.00	-53.62	0.00	53.62	1,549.22	774.61	1,867.15	922.11	0.06	-0.04	0.032
20.00	-18.31	-0.81	0.00	-49.56	0.00	49.56	1,524.70	762.35	1,783.98	881.04	0.11	-0.05	0.031
25.00	-17.26	-0.80	0.00	-45.52	0.00	45.52	1,498.98	749.49	1,701.17	840.14	0.17	-0.06	0.029
29.63	-17.17	-0.80	0.00	-41.82	0.00	41.82	1,474.07	737.04	1,624.90	802.48	0.24	-0.07	0.027
29.63	-17.17	-0.80	0.00	-41.82	0.00	41.82	1,474.07	737.04	1,624.90	802.48	0.24	-0.07	0.027
30.00	-16.06	-0.79	0.00	-41.53	0.00	41.53	1,472.04	736.02	1,618.83	799.48	0.24	-0.08	0.027
35.00	-14.95	-0.77	0.00	-37.59	0.00	37.59	1,443.89	721.95	1,537.10	759.12	0.33	-0.09	0.025
40.00	-13.86	-0.75	0.00	-33.74	0.00	33.74	1,414.54	707.27	1,456.10	719.12	0.43	-0.10	0.023
45.00	-12.79	-0.73	0.00	-30.00	0.00	30.00	1,383.97	691.99	1,375.97	679.54	0.54	-0.11	0.021
50.00	-11.73	-0.70	0.00	-26.37	0.00	26.37	1,352.19	676.10	1,296.83	640.45	0.66	-0.12	0.019
55.00	-10.68	-0.66	0.00	-22.89	0.00	22.89	1,319.21	659.60	1,218.80	601.92	0.79	-0.13	0.017
60.00	-10.11	-0.64	0.00	-19.57	0.00	19.57	1,282.07	641.04	1,139.41	562.71	0.93	-0.14	0.015
62.77	-9.69	-0.63	0.00	-17.79	0.00	17.79	1,254.29	627.14	1,090.28	538.45	1.01	-0.14	0.014
62.77	-9.69	-0.63	0.00	-17.79	0.00	17.79	855.95	427.98	748.44	369.63	1.01	-0.14	0.018
65.00	-8.76	-0.59	0.00	-16.39	0.00	16.39	847.38	423.69	727.65	359.36	1.08	-0.15	0.016
70.00	-8.21	-0.56	0.00	-13.45	0.00	13.45	827.29	413.64	681.30	336.47	1.24	-0.16	0.014
73.00	-7.40	-0.53	0.00	-11.75	0.00	11.75	814.65	407.33	653.71	322.84	1.34	-0.16	0.012
75.00	-6.70	-0.49	0.00	-10.70	0.00	10.70	805.98	402.99	635.42	313.81	1.41	-0.16	0.011
79.00	-6.61	-0.49	0.00	-8.74	0.00	8.74	788.07	394.03	599.12	295.88	1.55	-0.17	0.010
79.00	-6.61	-0.49	0.00	-8.74	0.00	8.74	788.07	394.03	599.12	295.88	1.55	-0.17	0.038
80.00	-6.34	-0.47	0.00	-8.26	0.00	8.26	783.47	391.73	590.11	291.44	1.58	-0.17	0.036
83.00	-5.99	-0.45	0.00	-6.85	0.00	6.85	769.38	384.69	563.27	278.18	1.69	-0.18	0.032
85.00	-5.56	-0.43	0.00	-5.94	0.00	5.94	759.75	379.87	545.53	269.42	1.77	-0.19	0.029
90.00	-5.31	-0.41	0.00	-3.82	0.00	3.82	734.81	367.41	501.78	247.81	1.98	-0.21	0.023
93.00	-5.04	-0.39	0.00	-2.59	0.00	2.59	716.07	358.03	473.88	234.03	2.11	-0.22	0.018
95.00	-4.64	-0.36	0.00	-1.81	0.00	1.81	701.02	350.51	454.06	224.24	2.21	-0.22	0.015
100.00	0.00	0.00	0.00	0.00	0.00	0.00	663.41	331.70	406.37	200.69	2.44	-0.22	0.000
100.56	0.00	0.00	0.00	0.00	0.00	0.00	659.19	329.60	401.19	198.13	2.47	-0.22	0.000



Site Number: 302516

Code: ANSI/TIA-222-G

© 2007 - 2018 by ATC IP LLC. All rights reserved.

Site Name: Mlfd - Milford, CT

Engineering Number: OAA720687\_C3\_01

1/29/2018 9:08:38 AM

Customer: AT&T Mobility

Load Case (0.9 - 0.2Sds) \* DL + E ELMF

Seismic (Reduced DL) Equivalent Lateral Forces Method

Calculated Forces

Seg Elev (ft)	Pu FY (-) (kips)	Vu FX (-) (kips)	Tu MY (ft-kips)	Mu MZ (ft-kips)	Mu MX (ft-kips)	Resultant Moment (ft-kips)	phi Pn (kips)	phi Vn (kips)	phi Tn (ft-kips)	phi Mn (ft-kips)	Total Deflect (in)	Rotation (deg)	Ratio
0.00	-15.87	-0.81	0.00	-65.19	0.00	65.19	1,615.50	807.75	2,117.47	1,045.74	0.00	0.00	0.035
5.00	-15.05	-0.81	0.00	-61.15	0.00	61.15	1,594.62	797.31	2,034.02	1,004.53	0.01	-0.01	0.033
10.00	-14.24	-0.81	0.00	-57.09	0.00	57.09	1,572.52	786.26	1,950.54	963.30	0.03	-0.03	0.032
15.00	-13.44	-0.81	0.00	-53.04	0.00	53.04	1,549.22	774.61	1,867.15	922.11	0.06	-0.04	0.030
20.00	-12.65	-0.80	0.00	-49.00	0.00	49.00	1,524.70	762.35	1,783.98	881.04	0.11	-0.05	0.028
25.00	-11.92	-0.79	0.00	-44.99	0.00	44.99	1,498.98	749.49	1,701.17	840.14	0.17	-0.06	0.027
29.63	-11.86	-0.79	0.00	-41.32	0.00	41.32	1,474.07	737.04	1,624.90	802.48	0.23	-0.07	0.025
29.63	-11.86	-0.79	0.00	-41.32	0.00	41.32	1,474.07	737.04	1,624.90	802.48	0.23	-0.07	0.025
30.00	-11.09	-0.78	0.00	-41.03	0.00	41.03	1,472.04	736.02	1,618.83	799.48	0.24	-0.08	0.025
35.00	-10.33	-0.76	0.00	-37.13	0.00	37.13	1,443.89	721.95	1,537.10	759.12	0.32	-0.09	0.023
40.00	-9.58	-0.74	0.00	-33.32	0.00	33.32	1,414.54	707.27	1,456.10	719.12	0.42	-0.10	0.021
45.00	-8.84	-0.72	0.00	-29.61	0.00	29.61	1,383.97	691.99	1,375.97	679.54	0.53	-0.11	0.020
50.00	-8.10	-0.69	0.00	-26.03	0.00	26.03	1,352.19	676.10	1,296.83	640.45	0.65	-0.12	0.018
55.00	-7.38	-0.66	0.00	-22.59	0.00	22.59	1,319.21	659.60	1,218.80	601.92	0.78	-0.13	0.016
60.00	-6.98	-0.64	0.00	-19.31	0.00	19.31	1,282.07	641.04	1,139.41	562.71	0.92	-0.14	0.014
62.77	-6.70	-0.62	0.00	-17.55	0.00	17.55	1,254.29	627.14	1,090.28	538.45	1.00	-0.14	0.013
62.77	-6.70	-0.62	0.00	-17.55	0.00	17.55	855.95	427.98	748.44	369.63	1.00	-0.14	0.016
65.00	-6.05	-0.58	0.00	-16.17	0.00	16.17	847.38	423.69	727.65	359.36	1.07	-0.15	0.015
70.00	-5.67	-0.56	0.00	-13.26	0.00	13.26	827.29	413.64	681.30	336.47	1.23	-0.15	0.013
73.00	-5.11	-0.52	0.00	-11.59	0.00	11.59	814.65	407.33	653.71	322.84	1.32	-0.16	0.011
75.00	-4.63	-0.48	0.00	-10.55	0.00	10.55	805.98	402.99	635.42	313.81	1.39	-0.16	0.010
79.00	-4.57	-0.48	0.00	-8.62	0.00	8.62	788.07	394.03	599.12	295.88	1.53	-0.17	0.009
79.00	-4.57	-0.48	0.00	-8.62	0.00	8.62	788.07	394.03	599.12	295.88	1.53	-0.17	0.035
80.00	-4.38	-0.46	0.00	-8.14	0.00	8.14	783.47	391.73	590.11	291.44	1.56	-0.17	0.034
83.00	-4.14	-0.45	0.00	-6.74	0.00	6.74	769.38	384.69	563.27	278.18	1.67	-0.18	0.030
85.00	-3.84	-0.42	0.00	-5.85	0.00	5.85	759.75	379.87	545.53	269.42	1.75	-0.19	0.027
90.00	-3.67	-0.40	0.00	-3.76	0.00	3.76	734.81	367.41	501.78	247.81	1.96	-0.21	0.020
93.00	-3.48	-0.38	0.00	-2.55	0.00	2.55	716.07	358.03	473.88	234.03	2.09	-0.21	0.016
95.00	-3.21	-0.36	0.00	-1.78	0.00	1.78	701.02	350.51	454.06	224.24	2.18	-0.22	0.013
100.00	0.00	0.00	0.00	0.00	0.00	0.00	663.41	331.70	406.37	200.69	2.41	-0.22	0.000
100.56	0.00	0.00	0.00	0.00	0.00	0.00	659.19	329.60	401.19	198.13	2.44	-0.22	0.000

### Equivalent Modal Forces Analysis

(Based on ASCE7-10 Chapters 11, 12 & 15 and ANSI/TIA-G, section 2.7)

Spectral Response Acceleration for Short Period ( $S_s$ ):	0.20
Spectral Response Acceleration at 1.0 Second Period ( $S_1$ ):	0.06
Importance Factor ( $I_E$ ):	1.00
Site Coefficient $F_a$ :	1.60
Site Coefficient $F_v$ :	2.40
Response Modification Coefficient (R):	1.50
Design Spectral Response Acceleration at Short Period ( $S_{ds}$ ):	0.21
Design Spectral Response Acceleration at 1.0 Second Period ( $S_{d1}$ ):	0.10
Period Based on Rayleigh Method (sec):	1.62
Redundancy Factor ( $\rho$ ):	1.00

**Load Case (1.2 + 0.2Sds) \* DL + E EMAM**      Seismic Equivalent Modal Analysis Method

Segment	Height Above Base (ft)	Weight (lb)	a	b	c	Saz	Horizontal Force (lb)	Vertical Force (lb)
27	100.28	17	1.879	1.925	1.120	0.400	5	21
26	97.50	319	1.777	1.435	0.938	0.330	70	396
25	94.00	130	1.651	0.947	0.742	0.252	22	162
24	91.50	204	1.565	0.674	0.623	0.202	27	253
23	87.50	346	1.431	0.345	0.464	0.133	31	430
22	84.00	137	1.319	0.147	0.353	0.083	8	170
21	81.50	217	1.241	0.047	0.287	0.054	8	270
20	79.50	73	1.181	-0.012	0.241	0.034	2	91
19	77.00	563	1.108	-0.065	0.192	0.013	5	699
18	74.00	283	1.023	-0.103	0.143	-0.006	-1	352
17	71.50	446	0.955	-0.118	0.110	-0.016	-5	553
16	67.50	750	0.852	-0.119	0.070	-0.023	-12	931
15	63.88	337	0.763	-0.104	0.044	-0.021	-5	419
14	61.38	461	0.704	-0.088	0.031	-0.016	-5	573
13	57.50	842	0.618	-0.059	0.017	-0.003	-2	1,046
12	52.50	853	0.515	-0.022	0.008	0.016	9	1,060
11	47.50	865	0.422	0.011	0.006	0.033	19	1,074
10	42.50	877	0.338	0.036	0.009	0.044	26	1,089
9	37.50	888	0.263	0.053	0.016	0.050	29	1,103
8	32.50	900	0.197	0.063	0.024	0.051	30	1,117
7	29.81	67	0.166	0.066	0.028	0.050	2	83
6	27.31	844	0.139	0.069	0.032	0.049	28	1,049
5	22.50	923	0.095	0.071	0.038	0.047	29	1,146
4	17.50	934	0.057	0.071	0.041	0.045	28	1,161
3	12.50	946	0.029	0.068	0.040	0.041	26	1,175
2	7.50	958	0.011	0.056	0.032	0.034	22	1,189
1	2.50	969	0.001	0.026	0.014	0.017	11	1,204
Kaelus DBC0061F1V51-	100.00	76	1.869	1.871	1.101	0.392	20	95
Commscope WCS-	100.00	59	1.869	1.871	1.101	0.392	15	73
Powerwave Allgon LGP	100.00	85	1.869	1.871	1.101	0.392	22	105
Raycap DC6-48-60-18-	100.00	40	1.869	1.871	1.101	0.392	10	50
Ericsson RRUS 4478 B	100.00	178	1.869	1.871	1.101	0.392	47	221
Ericsson RRUS 11 (Ba	100.00	150	1.869	1.871	1.101	0.392	39	186
Ericsson RRUS 32 (50	100.00	152	1.869	1.871	1.101	0.392	40	189

Ericsson RRUS 32 B2	100.00	159	1.869	1.871	1.101	0.392	42	197
Ericsson RRUS 32 B66	100.00	159	1.869	1.871	1.101	0.392	42	197
10' Omni	100.00	25	1.869	1.871	1.101	0.392	7	31
Raycap DC6-48-60-18-	100.00	16	1.869	1.871	1.101	0.392	4	20
Powerwave Allgon 777	100.00	105	1.869	1.871	1.101	0.392	27	130
Commscope SBNHH-	100.00	101	1.869	1.871	1.101	0.392	26	125
CCI OPA-65R-LCUU-H4	100.00	171	1.869	1.871	1.101	0.392	45	212
Kathrein Scala 80010	100.00	245	1.869	1.871	1.101	0.392	64	304
Flat Platform w/ Han	100.00	2,000	1.869	1.871	1.101	0.392	523	2,484
48" x 12" Panel	93.00	90	1.617	0.830	0.693	0.231	14	112
RFS APX86-909014L-CT	83.00	145	1.288	0.104	0.325	0.071	7	180
Kathrein Scala Smart	73.00	10	0.996	-0.111	0.129	-0.010	0	12
Ericsson KRY 112 489	73.00	46	0.996	-0.111	0.129	-0.010	0	57
RFS ATMAA1412D-1A20	73.00	39	0.996	-0.111	0.129	-0.010	0	48
RFS APX16PV-16PVL-A	73.00	119	0.996	-0.111	0.129	-0.010	-1	148
Commscope LNX-	73.00	151	0.996	-0.111	0.129	-0.010	-1	187
		19,470	58.090	35.736	24.938	8.419	1,398	24,182

Load Case (0.9 - 0.2Sds) \* DL + E EMAM Seismic (Reduced DL) Equivalent Modal Analysis Method

Segment	Height Above Base (ft)	Weight (lb)	a	b	c	Saz	Horizontal Force (lb)	Vertical Force (lb)
27	100.28	17	1.879	1.925	1.120	0.400	5	15
26	97.50	319	1.777	1.435	0.938	0.330	70	274
25	94.00	130	1.651	0.947	0.742	0.252	22	112
24	91.50	204	1.565	0.674	0.623	0.202	27	175
23	87.50	346	1.431	0.345	0.464	0.133	31	297
22	84.00	137	1.319	0.147	0.353	0.083	8	118
21	81.50	217	1.241	0.047	0.287	0.054	8	186
20	79.50	73	1.181	-0.012	0.241	0.034	2	63
19	77.00	563	1.108	-0.065	0.192	0.013	5	483
18	74.00	283	1.023	-0.103	0.143	-0.006	-1	243
17	71.50	446	0.955	-0.118	0.110	-0.016	-5	382
16	67.50	750	0.852	-0.119	0.070	-0.023	-12	643
15	63.88	337	0.763	-0.104	0.044	-0.021	-5	289
14	61.38	461	0.704	-0.088	0.031	-0.016	-5	396
13	57.50	842	0.618	-0.059	0.017	-0.003	-2	722
12	52.50	853	0.515	-0.022	0.008	0.016	9	732
11	47.50	865	0.422	0.011	0.006	0.033	19	742
10	42.50	877	0.338	0.036	0.009	0.044	26	752
9	37.50	888	0.263	0.053	0.016	0.050	29	762
8	32.50	900	0.197	0.063	0.024	0.051	30	772
7	29.81	67	0.166	0.066	0.028	0.050	2	58
6	27.31	844	0.139	0.069	0.032	0.049	28	724
5	22.50	923	0.095	0.071	0.038	0.047	29	792
4	17.50	934	0.057	0.071	0.041	0.045	28	802
3	12.50	946	0.029	0.068	0.040	0.041	26	812
2	7.50	958	0.011	0.056	0.032	0.034	22	822
1	2.50	969	0.001	0.026	0.014	0.017	11	832
Kaelus DBC0061F1V51-	100.00	76	1.869	1.871	1.101	0.392	20	66
Commscope WCS-	100.00	59	1.869	1.871	1.101	0.392	15	51
Powerwave Allgon LGP	100.00	85	1.869	1.871	1.101	0.392	22	73
Raycap DC6-48-60-18-	100.00	40	1.869	1.871	1.101	0.392	10	34
Ericsson RRUS 4478 B	100.00	178	1.869	1.871	1.101	0.392	47	153
Ericsson RRUS 11 (Ba	100.00	150	1.869	1.871	1.101	0.392	39	129
Ericsson RRUS 32 (50	100.00	152	1.869	1.871	1.101	0.392	40	131
Ericsson RRUS 32 B2	100.00	159	1.869	1.871	1.101	0.392	42	136
Ericsson RRUS 32 B66	100.00	159	1.869	1.871	1.101	0.392	42	136
10' Omni	100.00	25	1.869	1.871	1.101	0.392	7	21

Site Number: 302516

Code: ANSI/TIA-222-G

© 2007 - 2018 by ATC IP LLC. All rights reserved.

Site Name: Mlfd - Milford, CT

Engineering Number: OAA720687\_C3\_01

1/29/2018 9:08:38 AM

Customer: AT&T Mobility

Raycap DC6-48-60-18-	100.00	16	1.869	1.871	1.101	0.392	4	14
Powerwave Allgon 777	100.00	105	1.869	1.871	1.101	0.392	27	90
Commscope SBNHH-	100.00	101	1.869	1.871	1.101	0.392	26	86
CCI OPA-65R-LCUU-H4	100.00	171	1.869	1.871	1.101	0.392	45	147
Kathrein Scala 80010	100.00	245	1.869	1.871	1.101	0.392	64	210
Flat Platform w/ Han	100.00	2,000	1.869	1.871	1.101	0.392	523	1,716
48" x 12" Panel	93.00	90	1.617	0.830	0.693	0.231	14	77
RFS APX86-909014L-CT	83.00	145	1.288	0.104	0.325	0.071	7	125
Kathrein Scala Smart	73.00	10	0.996	-0.111	0.129	-0.010	0	8
Ericsson KRY 112 489	73.00	46	0.996	-0.111	0.129	-0.010	0	40
RFS ATMAA1412D-1A20	73.00	39	0.996	-0.111	0.129	-0.010	0	33
RFS APX16PV-16PVL-A	73.00	119	0.996	-0.111	0.129	-0.010	-1	102
Commscope LNX-	73.00	151	0.996	-0.111	0.129	-0.010	-1	129
		19,470	58.090	35.736	24.938	8.419	1,398	16,705

Load Case (1.2 + 0.2Sds) \* DL + E EMAM Seismic Equivalent Modal Analysis Method

Calculated Forces

Seg Elev (ft)	Pu FY (-) (kips)	Vu FX (-) (kips)	Tu MY (ft-kips)	Mu MZ (ft-kips)	Mu MX (ft-kips)	Resultant Moment (ft-kips)	phi Pn (kips)	phi Vn (kips)	phi Tn (ft-kips)	phi Mn (ft-kips)	Total Deflect (in)	Rotation (deg)	Ratio
0.00	-22.98	-1.39	0.00	-123.45	0.00	123.45	1,615.50	807.75	2,117.47	1,045.74	0.00	0.00	0.063
5.00	-21.79	-1.38	0.00	-116.49	0.00	116.49	1,594.62	797.31	2,034.02	1,004.53	0.01	-0.02	0.061
10.00	-20.61	-1.36	0.00	-109.60	0.00	109.60	1,572.52	786.26	1,950.54	963.30	0.05	-0.05	0.059
15.00	-19.45	-1.34	0.00	-102.79	0.00	102.79	1,549.22	774.61	1,867.15	922.11	0.12	-0.07	0.056
20.00	-18.30	-1.32	0.00	-96.09	0.00	96.09	1,524.70	762.35	1,783.98	881.04	0.21	-0.10	0.053
25.00	-17.26	-1.29	0.00	-89.51	0.00	89.51	1,498.98	749.49	1,701.17	840.14	0.32	-0.12	0.051
29.63	-17.17	-1.30	0.00	-83.51	0.00	83.51	1,474.07	737.04	1,624.90	802.48	0.45	-0.14	0.049
29.63	-17.17	-1.30	0.00	-83.51	0.00	83.51	1,474.07	737.04	1,624.90	802.48	0.45	-0.14	0.049
30.00	-16.05	-1.27	0.00	-83.03	0.00	83.03	1,472.04	736.02	1,618.83	799.48	0.46	-0.15	0.048
35.00	-14.95	-1.24	0.00	-76.70	0.00	76.70	1,443.89	721.95	1,537.10	759.12	0.63	-0.17	0.046
40.00	-13.86	-1.22	0.00	-70.50	0.00	70.50	1,414.54	707.27	1,456.10	719.12	0.82	-0.19	0.043
45.00	-12.79	-1.20	0.00	-64.42	0.00	64.42	1,383.97	691.99	1,375.97	679.54	1.03	-0.22	0.040
50.00	-11.73	-1.19	0.00	-58.43	0.00	58.43	1,352.19	676.10	1,296.83	640.45	1.27	-0.24	0.037
55.00	-10.68	-1.19	0.00	-52.48	0.00	52.48	1,319.21	659.60	1,218.80	601.92	1.53	-0.26	0.034
60.00	-10.11	-1.20	0.00	-46.53	0.00	46.53	1,282.07	641.04	1,139.41	562.71	1.82	-0.28	0.032
62.77	-9.69	-1.20	0.00	-43.22	0.00	43.22	1,254.29	627.14	1,090.28	538.45	1.99	-0.29	0.030
62.77	-9.69	-1.20	0.00	-43.22	0.00	43.22	855.95	427.98	748.44	369.63	1.99	-0.29	0.036
65.00	-8.76	-1.21	0.00	-40.54	0.00	40.54	847.38	423.69	727.65	359.36	2.13	-0.30	0.034
70.00	-8.20	-1.21	0.00	-34.49	0.00	34.49	827.29	413.64	681.30	336.47	2.45	-0.32	0.030
73.00	-7.40	-1.21	0.00	-30.85	0.00	30.85	814.65	407.33	653.71	322.84	2.66	-0.33	0.027
75.00	-6.70	-1.21	0.00	-28.42	0.00	28.42	805.98	402.99	635.42	313.81	2.80	-0.34	0.025
79.00	-6.61	-1.21	0.00	-23.60	0.00	23.60	788.07	394.03	599.12	295.88	3.10	-0.36	0.022
79.00	-6.61	-1.21	0.00	-23.60	0.00	23.60	788.07	394.03	599.12	295.88	3.10	-0.36	0.088
80.00	-6.34	-1.20	0.00	-22.39	0.00	22.39	783.47	391.73	590.11	291.44	3.17	-0.36	0.085
83.00	-5.99	-1.18	0.00	-18.80	0.00	18.80	769.38	384.69	563.27	278.18	3.41	-0.40	0.075
85.00	-5.56	-1.15	0.00	-16.43	0.00	16.43	759.75	379.87	545.53	269.42	3.58	-0.42	0.068
90.00	-5.30	-1.13	0.00	-10.66	0.00	10.66	734.81	367.41	501.78	247.81	4.05	-0.47	0.050
93.00	-5.03	-1.09	0.00	-7.28	0.00	7.28	716.07	358.03	473.88	234.03	4.35	-0.49	0.038
95.00	-4.63	-1.02	0.00	-5.09	0.00	5.09	701.02	350.51	454.06	224.24	4.55	-0.50	0.029
100.00	0.00	0.00	0.00	0.00	0.00	0.00	663.41	331.70	406.37	200.69	5.08	-0.51	0.000
100.56	0.00	0.00	0.00	0.00	0.00	0.00	659.19	329.60	401.19	198.13	5.14	-0.51	0.000

Site Number: 302516

Code: ANSI/TIA-222-G

© 2007 - 2018 by ATC IP LLC. All rights reserved.

Site Name: Mlfd - Milford, CT

Engineering Number: OAA720687\_C3\_01

1/29/2018 9:08:38 AM

Customer: AT&T Mobility

Load Case (0.9 - 0.2Sds) \* DL + E EMAM Seismic (Reduced DL) Equivalent Modal Analysis Method

Calculated Forces

Seg Elev (ft)	Pu FY (-) (kips)	Vu FX (-) (kips)	Tu MY (ft-kips)	Mu MZ (ft-kips)	Mu MX (ft-kips)	Resultant Moment (ft-kips)	phi Pn (kips)	phi Vn (kips)	phi Tn (ft-kips)	phi Mn (ft-kips)	Total Deflect (in)	Rotation (deg)	Ratio
0.00	-15.87	-1.39	0.00	-122.19	0.00	122.19	1,615.50	807.75	2,117.47	1,045.74	0.00	0.00	0.060
5.00	-15.05	-1.37	0.00	-115.24	0.00	115.24	1,594.62	797.31	2,034.02	1,004.53	0.01	-0.02	0.058
10.00	-14.24	-1.35	0.00	-108.37	0.00	108.37	1,572.52	786.26	1,950.54	963.30	0.05	-0.05	0.056
15.00	-13.44	-1.33	0.00	-101.60	0.00	101.60	1,549.22	774.61	1,867.15	922.11	0.11	-0.07	0.053
20.00	-12.64	-1.31	0.00	-94.94	0.00	94.94	1,524.70	762.35	1,783.98	881.04	0.20	-0.10	0.051
25.00	-11.92	-1.28	0.00	-88.41	0.00	88.41	1,498.98	749.49	1,701.17	840.14	0.32	-0.12	0.048
29.63	-11.86	-1.28	0.00	-82.48	0.00	82.48	1,474.07	737.04	1,624.90	802.48	0.44	-0.14	0.046
29.63	-11.86	-1.28	0.00	-82.48	0.00	82.48	1,474.07	737.04	1,624.90	802.48	0.44	-0.14	0.046
30.00	-11.09	-1.25	0.00	-82.00	0.00	82.00	1,472.04	736.02	1,618.83	799.48	0.46	-0.14	0.046
35.00	-10.33	-1.22	0.00	-75.74	0.00	75.74	1,443.89	721.95	1,537.10	759.12	0.62	-0.17	0.043
40.00	-9.57	-1.20	0.00	-69.62	0.00	69.62	1,414.54	707.27	1,456.10	719.12	0.81	-0.19	0.041
45.00	-8.83	-1.18	0.00	-63.62	0.00	63.62	1,383.97	691.99	1,375.97	679.54	1.02	-0.21	0.038
50.00	-8.10	-1.17	0.00	-57.71	0.00	57.71	1,352.19	676.10	1,296.83	640.45	1.26	-0.24	0.036
55.00	-7.38	-1.17	0.00	-51.84	0.00	51.84	1,319.21	659.60	1,218.80	601.92	1.52	-0.26	0.033
60.00	-6.98	-1.18	0.00	-45.97	0.00	45.97	1,282.07	641.04	1,139.41	562.71	1.80	-0.28	0.030
62.77	-6.69	-1.18	0.00	-42.70	0.00	42.70	1,254.29	627.14	1,090.28	538.45	1.96	-0.29	0.029
62.77	-6.69	-1.18	0.00	-42.70	0.00	42.70	855.95	427.98	748.44	369.63	1.96	-0.29	0.034
65.00	-6.05	-1.19	0.00	-40.06	0.00	40.06	847.38	423.69	727.65	359.36	2.10	-0.30	0.032
70.00	-5.66	-1.20	0.00	-34.08	0.00	34.08	827.29	413.64	681.30	336.47	2.43	-0.32	0.028
73.00	-5.11	-1.20	0.00	-30.49	0.00	30.49	814.65	407.33	653.71	322.84	2.63	-0.33	0.026
75.00	-4.63	-1.19	0.00	-28.09	0.00	28.09	805.98	402.99	635.42	313.81	2.77	-0.34	0.024
79.00	-4.56	-1.19	0.00	-23.31	0.00	23.31	788.07	394.03	599.12	295.88	3.06	-0.35	0.020
79.00	-4.56	-1.19	0.00	-23.31	0.00	23.31	788.07	394.03	599.12	295.88	3.06	-0.35	0.085
80.00	-4.38	-1.18	0.00	-22.12	0.00	22.12	783.47	391.73	590.11	291.44	3.13	-0.35	0.082
83.00	-4.13	-1.17	0.00	-18.57	0.00	18.57	769.38	384.69	563.27	278.18	3.37	-0.39	0.072
85.00	-3.84	-1.14	0.00	-16.23	0.00	16.23	759.75	379.87	545.53	269.42	3.54	-0.41	0.065
90.00	-3.66	-1.11	0.00	-10.52	0.00	10.52	734.81	367.41	501.78	247.81	4.00	-0.46	0.047
93.00	-3.47	-1.08	0.00	-7.18	0.00	7.18	716.07	358.03	473.88	234.03	4.29	-0.48	0.036
95.00	-3.20	-1.01	0.00	-5.03	0.00	5.03	701.02	350.51	454.06	224.24	4.50	-0.49	0.027
100.00	0.00	0.00	0.00	0.00	0.00	0.00	663.41	331.70	406.37	200.69	5.02	-0.50	0.000
100.56	0.00	0.00	0.00	0.00	0.00	0.00	659.19	329.60	401.19	198.13	5.08	-0.50	0.000

Site Number: 302516

Code: ANSI/TIA-222-G

© 2007 - 2018 by ATC IP LLC. All rights reserved.

Site Name: Mlfd - Milford, CT

Engineering Number: OAA720687\_C3\_01

1/29/2018 9:08:38 AM

Customer: AT&T Mobility

Analysis Summary

Load Case	Reactions						Max Usage	
	Shear FX (kips)	Shear FZ (kips)	Axial FY (kips)	Moment MX (ft-kips)	Moment MY (ft-kips)	Moment MZ (ft-kips)	Elev (ft)	Interaction Ratio
1.2D + 1.6W	16.75	0.00	23.33	0.00	0.00	1197.40	0.00	0.55
0.9D + 1.6W	16.62	0.00	17.49	0.00	0.00	1177.60	0.00	0.54
1.2D + 1.0Di + 1.0Wi	3.67	0.00	40.95	0.00	0.00	273.52	0.00	0.14
(1.2 + 0.2Sds) * DL + E ELFM	0.81	0.00	22.98	0.00	0.00	65.81	79.00	0.04
(1.2 + 0.2Sds) * DL + E EMAM	1.39	0.00	22.98	0.00	0.00	123.45	79.00	0.09
(0.9 - 0.2Sds) * DL + E ELFM	0.81	0.00	15.87	0.00	0.00	65.19	0.00	0.03
(0.9 - 0.2Sds) * DL + E EMAM	1.39	0.00	15.87	0.00	0.00	122.19	79.00	0.08
1.0D + 1.0W	4.15	0.00	19.47	0.00	0.00	290.70	0.00	0.14

Additional Steel Summary

Elev From (ft)	Elev To (ft)	Member	Intermediate Connectors			Upper Termination Connectors				Lower Termination Connectors				Max Member		
			VQ/I (lb/in)	Applied (kips)	phiVn (kips)	MQ/I (kips)	phiVn (kips)	Num Reqd	Num Actual	MQ/I (kips)	phiVn (kips)	Num Reqd	Num Actual	Pu (kip)	phiPn (kip)	Ratio
0.00	79.0	(4) SOL-#20 All Thre	288.7	8.7	16.8	50.7	12.0	5	12	0.0	12.0	0	0	198.3	330.5	0.600

<b>Base/Flange Plate</b>	Plate Type	<b>Baseplate</b>
	Pole Diameter	30 in
	Pole Thickness	0.25 in
	Plate Length	44 in
	Plate Thickness	2 in
	Plate Fy	60 ksi
	Weld Length	0.1875 in
	$\phi_s$ Resistance	2414.58 k-in
	Applied	816.13 k-in
<b>Stiffeners</b>	#	<b>12</b> <i>Show</i>
	Thickness	0.5 in
	Length	5.5 in
	Height	10 in
	Chamfer	0.25 in
	Offset Angle	0°
	Fy	36 ksi

<b>Bolts</b>	#	<b>8</b>
	Bolt Circle	44 in
	(R)adial / (S)quare	S
	Bolt Gap	6 in
	Diameter	2.25 in
	Hole Diameter	2.5 in
	Type	18J
	Fy	75 ksi
	Fu	100 ksi
	$\phi_s$ Resistance	259.82 k
Applied	73.36 k	

<b>Reinforcement</b>	#	<b>4</b>
	DYW. Circle	36.875 in
	Offset Angle	0°
	Type	#20
	Diameter	2.5 in
	Fu	100 ksi
$\phi_s$ Resistance	392.70 k	
Applied	155.06 k	

<b>Extra Bolts O</b>	#	<b>0</b>
----------------------	---	----------

Code Rev. **G**

Date **1/29/2018**  
 Engineer **A. Black**  
 Site # **302516**  
 Carrier **AT&T Mobility**

Moment **1197.4 k-ft**  
 Axial **23.3 k**

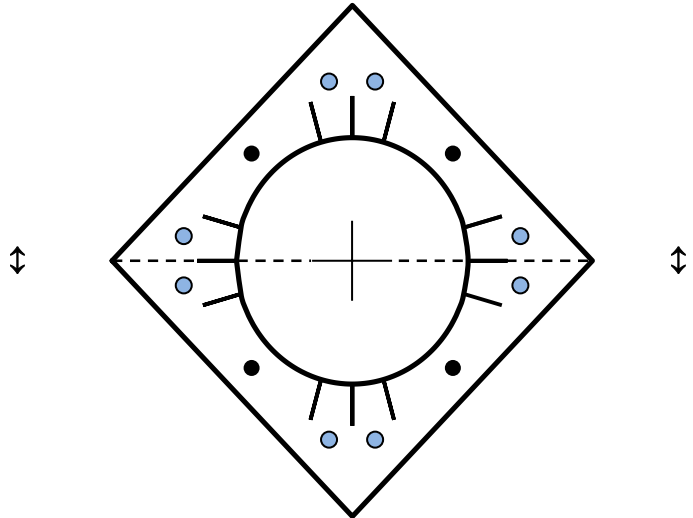

Plate Stress Ratio:  
**0.34** (Pass)

Bolt Stress Ratio:  
**0.28** (Pass)

Reinforcement Stress Ratio:  
**0.39** (Pass)



Site Name:	<b>Mlfd-Milford</b>
Site Number:	<b>302516</b>
Engineering Number:	<b>OAA720687_C3_01</b>
Engineer:	<b>Nicole.Davis</b>
Date:	<b>1/29/2018</b>

**Design Base Loads (Factored) - Design per TIA-222-G Standard**

Moment (Overturning) ( $M_u$ ):	1197.4	k-ft
Shear/Leg ( $V_u$ ):	16.8	k
Compression/Leg ( $P_u$ ):	23.3	k
Uplift/Leg ( $T_u$ ):	0.0	k
Tower Type (GT / SST / MP):	MP	
Length / Width of Block:	8.0	ft
Thickness of Block:	6.5	ft
Block Height Above Ground:	1.0	ft
Depth Below Ground Surface to Water Table (w):	99.0	ft
Unit Weight of Concrete:	150.0	pcf
Unit Weight of Soil:	130.0	pcf
Unit Weight of Water:	62.4	pcf
Ultimate Compressive Bearing Pressure:	50000	psf
Capacity Increase (Due to Transient Loads):	1.00	
Pullout Angle:	45.0	degrees
Rod Diameter:	2.25	in
Rod Ultimate Strength:	100	ksi
Rod Net Area:	2.65	in <sup>2</sup>
Number of Rods:	16	
Diameter of Cored Hole:	3.50	in
Ultimate Grout / Rock Interface Bond Strength:	150	psi
Ultimate Grout / Rock Anchor Interface Bond Strength:	450	psi
Overall Rod Embedment Length:	72	in
Rod Exposure Above Lock Off Nut in Foundation:	0	in
Rod Embedment Circle:	84	in
Free Stress Length:	0	in
Soil / Concrete Friction Coefficient:	0.30	
Rock Anchor Design Plastic or Elastic:	Plastic	
Ignore Pullout Weight Resistance (Y/N):	Y	
Weight of Concrete (Buoyancy Effect Considered):	62.4	k
Compressive Bearing Resistance:	2513.3	k
Pullout Weight / Rod:		k - Ignored
Rock / Grout Bond Strength / Rod:	118.8	k
Grout / Rod Bond Strength / Rod:	229.0	k
Rod Mechanical Strength / Rod:	60.0	k
Soil Strength Reduction Factor ( $\phi_s$ ):	0.75	
Factored Nominal Moment Capacity per Leg ( $\phi_s M_n$ ):	1665.0	k
Factored Nominal Uplift Capacity per Leg ( $\phi_s T_n$ ):	1498.7	k
Factored Nominal Compressive Capacity per Leg ( $\phi_s P_n$ ):	1885.0	k
Factored Nominal Shear Capacity per Leg ( $\phi_s V_n$ ):	1908.0	k
$M_u$ :	1306.3	k-ft
$T_u$ :	0.0	k
$P_u$ :	31.8	k
$V_u$ :	16.8	k
$T_u/\phi_s T_n + M_u/\phi_s M_n$ :	0.78	Result: OK
$P_u/\phi_s P_n$ :	0.02	Result: OK
$V_u/\phi_s V_n$ :	0.01	Result: OK

### Caisson Strength Capacity

Concrete Compressive Strength ( $f'_c$ ):	4000 psi
Vertical Steel Rebar Size #:	11
Vertical Steel Rebar Area:	1.56 in <sup>2</sup>
# of Vertical Steel Rebars:	52 Minimum # of vertical rebar met
Vertical Steel Rebar Yield Strength ( $F_y$ ):	60 ksi
Horizontal Tie / Stirrup Size #:	4
Horizontal Tie / Stirrup Area:	0.20 in <sup>2</sup>
Horizontal Tie / Stirrup Spacing:	12.0 in
Horizontal Tie / Stirrup Steel Yield Strength ( $F_y$ ):	40 ksi
Rod Bearing Plate Diameter:	8.0 in
Rod Bearing Plate Thickness:	1.0 in
Anchor Bearing Plate Yield Strength:	36 ksi
Anchor Rod Nut Diameter:	4.00 in
Rebar Cage Diameter:	88.0 in
Strength Bending/Tension Reduction Factor ( $\phi_B$ ):	0.90 ACI318-05 - 9.3.2.1
Strength Shear Reduction Factor ( $\phi_V$ ):	0.75 ACI318-05 - 9.3.2.3
Strength Compression/Bearing Reduction Factor ( $\phi_{P/B}$ ):	0.65 ACI318-05 - 9.3.2.2
Steel Elastic Modulus:	29000 ksi
Design Moment ( $M_u$ ):	1306.3 k-ft
Factored Nominal Moment Capacity ( $\phi_B M_n$ ):	15706.9 k-ft - ACI318-05 - 10.2
$M_u / \phi_B M_n$ :	0.08 Result: OK
Design Shear ( $V_u$ ):	282.4 k
Factored Nominal Shear Capacity ( $\phi_V V_n$ ):	673.9 k - ACI318-05 - 11.3.1.1 or 11.5.7.2
$V_u / \phi_V V_n$ :	0.42 Result: OK
Design Tension ( $T_u$ ):	0.0 k
Factored Nominal Tension Capacity ( $\phi_T T_n$ ):	4380.5 k - ACI318-05 - 10.2
$T_u / \phi_T T_n$ :	0.00 Result: OK
Design Compression ( $P_u$ ):	23.3 k
Factored Nominal Compression Capacity ( $\phi_P P_n$ ):	14886.8 k - ACI318-05 - 10.3.6.2
$P_u / \phi_P P_n$ :	0.00 Result: OK

### Bearing Plate Design

Plate Bearing Design Load ( $P_u$ ):	35.3 k
Plate Shear Design Load ( $V_u$ ):	35.3 k
Factored Rod Bearing Plate Capacity of a Single Anchor ( $\phi_B P_n$ ):	204.6 k
Bearing Plate Pressure:	0.9 ksi
Plate Design Moment ( $M_u$ ):	10.2 k-in
Critical Length:	5.63 in
Plastic Modulus:	1.41 in <sup>3</sup>
Factored Nominal Plate Flexural Resistance ( $\phi_B M_n$ ):	45.6 k-in
Factored Nominal Plate Shear Resistance ( $\phi_V V_n$ ):	244.3 k
Factored Punch Shear Capacity Resisting Plate Load ( $\phi_P P_n$ ):	514.4 k - ACI318-05 - 11.11.2.1
Interaction Equation:	0.22 Result: OK



# Radio Frequency Emissions Analysis Report

AT&T Existing Facility

Site ID: CT2111

FA#: 10034978

Milford - Bridgeport Ave

438 Bridgeport Avenue

Milford, CT 06460

**February 26, 2018**

**Centerline Communications Project Number: 950012-029**

Site Compliance Summary	
Compliance Status:	<b>COMPLIANT</b>
Site total MPE% of FCC general population allowable limit:	<b>22.14 %</b>



February 26, 2018

AT&T Mobility – New England  
Attn: John Benedetto, RF Manager  
550 Cochituate Road  
Suite 550 – 13&14  
Framingham, MA 06040

### Emissions Analysis for Site: **CT2111 – Milford - Bridgeport Ave**

Centerline Communications, LLC (“Centerline”) was directed to analyze the proposed AT&T facility located at **438 Bridgeport Avenue, Milford, CT**, for the purpose of determining whether the emissions from the Proposed AT&T Antenna Installation located on this property are within specified federal limits.

All information used in this report was analyzed as a percentage of current Maximum Permissible Exposure (% MPE) as listed in the FCC OET Bulletin 65 Edition 97-01 and ANSI/IEEE Std C95.1. The FCC regulates Maximum Permissible Exposure in units of microwatts per square centimeter ( $\mu\text{W}/\text{cm}^2$ ). The number of  $\mu\text{W}/\text{cm}^2$  calculated at each sample point is called the power density. The exposure limit for power density varies depending upon the frequencies being utilized. Wireless Carriers and Paging Services use different frequency bands each with different exposure limits, therefore it is necessary to report results and limits in terms of percent MPE rather than power density.

All results were compared to the FCC (Federal Communications Commission) radio frequency exposure rules, 47 CFR 1.1307(b)(1) – (b)(3), to determine compliance with the Maximum Permissible Exposure (MPE) limits for General Population/Uncontrolled environments as defined below.

General population/uncontrolled exposure limits apply to situations in which the general population may be exposed or in which persons who are exposed as a consequence of their employment may not be made fully aware of the potential for exposure or cannot exercise control over their exposure. Therefore, members of the general population would always be considered under this category when exposure is not employment related, for example, in the case of a telecommunications tower that exposes persons in a nearby residential area.

Population exposure to radio frequencies is regulated and enforced in units of microwatts per square centimeter ( $\mu\text{W}/\text{cm}^2$ ). The general population exposure limits for the 700 and 850 MHz Bands are approximately  $467 \mu\text{W}/\text{cm}^2$  and  $567 \mu\text{W}/\text{cm}^2$  respectively. The general population exposure limit for the 1900 MHz (PCS), 2100 MHz (AWS) and 2300 MHz (WCS) bands is  $1000 \mu\text{W}/\text{cm}^2$ . Because each carrier will be using different frequency bands, and each frequency band has different exposure limits, it is necessary to report percent of MPE rather than power density.



Occupational/controlled exposure limits apply to situations in which persons are exposed as a consequence of their employment and in which those persons who are exposed have been made fully aware of the potential for exposure and can exercise control over their exposure. Occupational/controlled exposure limits also apply where exposure is of a transient nature as a result of incidental passage through a location where exposure levels may be above general population/uncontrolled limits (see below), as long as the exposed person has been made fully aware of the potential for exposure and can exercise control over his or her exposure by leaving the area or by some other appropriate means.

Additional details can be found in FCC OET 65.



## CALCULATIONS

Calculations were performed for the proposed AT&T Wireless antenna facility located at **438 Bridgeport Avenue, Milford, CT**, using the equipment information listed below. All calculations were performed per the specifications under FCC OET 65. Since AT&T is proposing highly focused directional panel antennas, which project most of the emitted energy out toward the horizon, all calculations were performed assuming a lobe representing the maximum gain of the antenna per the antenna manufactures supplied specifications, minus 10 dB, was focused at the base of the tower. For this report the sample point is the top of a 6-foot person standing at the base of the tower.

Per FCC OET Bulletin No. 65 - Edition 97-01 recommendations to achieve the maximum anticipated value at each sample point, all power levels emitting from the proposed antenna installation are increased by a factor of 2.56 to account for possible in-phase reflections from the surrounding environment. All power values expressed and analyzed are maximum power levels expected to be used on all radios.

All emissions values for additional carriers were taken from the Connecticut Siting Council (CSC) active MPE database. Values in this database are provided by the individual carriers themselves

For each sector the following channel counts, frequency bands and power levels were utilized as shown in *Table 1*:

Technology	Frequency Band	Channel Count	Transmit Power per Channel (W)
UMTS	850 MHz	2	30
LTE	850 MHz	2	40
LTE	700 MHz	2	60
LTE	2300 MHz (WCS)	4	30
LTE	700 MHz (Band 14)	4	60
LTE	2100 MHz (AWS)	4	30
LTE	700 MHz	2	60
LTE	1900 MHz (PCS)	4	60

*Table 1: Channel Data Table*



The following antennas listed in *Table 2* were used in the modeling for transmission in the 700 MHz, 850 MHz, 1900 MHz (PCS), 2100 MHz (AWS) and 2300 MHz (WCS) frequency bands. This is based on feedback from the carrier with regards to anticipated antenna selection. Maximum gain values for all antennas are listed in the Inventory and Power Data table below. The maximum gain of the antenna per the antenna manufactures supplied specifications, minus 10 dB, was used for all calculations. This value is a very conservative estimate as gain reductions for these particular antennas are typically much higher in this direction.

Sector	Antenna Number	Antenna Make / Model	Antenna Centerline (ft)
A	1	Powerwave 7770	103
A	2	CCI OPA-65R-LCUU-H4	103
A	3	Kathrein 800-10964	103
A	4	Commscope SBNHH-1D65A	103
B	1	Powerwave 7770	103
B	2	CCI OPA-65R-LCUU-H4	103
B	3	Kathrein 800-10964	103
B	4	Commscope SBNHH-1D65A	103
C	1	Powerwave 7770	103
C	2	CCI OPA-65R-LCUU-H4	103
C	3	Kathrein 800-10964	103
C	4	Commscope SBNHH-1D65A	103

*Table 2: Antenna Data*

All calculations were done with respect to uncontrolled / general population threshold limits.



## RESULTS

Per the calculations completed for the proposed AT&T configurations *Table 3* shows resulting emissions power levels and percentages of the FCC’s allowable general population limit.

Antenna ID	Antenna Make / Model	Frequency Bands	Antenna Gain (dBd)	Channel Count	Total TX Power (W)	ERP (W)	MPE %
Antenna A1	Powerwave 7770	850 MHz	11.4	2	60	828.23	0.56
Antenna A2	CCI OPA-65R-LCUU-H4	850 MHz / 700 MHz / 2300 MHz (WCS)	11.15 / 10.55 / 14.65	8	320	5,905.46	3.15
Antenna A3	Kathrein 800-10964	700 MHz / 2100 MHz (AWS)	11.45 / 15.35	8	360	7,464.50	4.31
Antenna A4	Commscope SBNHH-1D65A	700 MHz / 1900 MHz (PCS)	10.85 / 14.55	6	360	8,301.87	3.81
Sector A Composite MPE%							<b>11.83</b>
Antenna B1	Powerwave 7770	850 MHz	11.4	2	60	828.23	0.56
Antenna B2	CCI OPA-65R-LCUU-H4	850 MHz / 700 MHz / 2300 MHz (WCS)	11.15 / 10.55 / 14.65	8	320	5,905.46	3.15
Antenna B3	Kathrein 800-10964	700 MHz / 2100 MHz (AWS)	11.45 / 15.35	8	360	7,464.50	4.31
Antenna B4	Commscope SBNHH-1D65A	700 MHz / 1900 MHz (PCS)	10.85 / 14.55	6	360	8,301.87	3.81
Sector B Composite MPE%							<b>11.83</b>
Antenna C1	Powerwave 7770	850 MHz	11.4	2	60	828.23	0.56
Antenna C2	CCI OPA-65R-LCUU-H4	850 MHz / 700 MHz / 2300 MHz (WCS)	11.15 / 10.55 / 14.65	8	320	5,905.46	3.15
Antenna C3	Kathrein 800-10964	700 MHz / 2100 MHz (AWS)	11.45 / 15.35	8	360	7,464.50	4.31
Antenna C4	Commscope SBNHH-1D65A	700 MHz / 1900 MHz (PCS)	10.85 / 14.55	6	360	8,301.87	3.81
Sector C Composite MPE%							<b>11.83</b>

*Table 3: AT&T Emissions Levels*





The Following table (*table 4*) shows all additional carriers on site and their MPE% as recorded in the CSC active MPE database for this facility along with the newly calculated maximum AT&T MPE contributions per this report. FCC OET 65 specifies that for carriers utilizing directional antennas that the highest recorded sector value be used for composite site MPE values due to their greatly reduced emissions contributions in the directions of the adjacent sectors. For this site, all three sectors have the same configuration yielding the same results on all three sectors. *Table 5* below shows a summary for each AT&T Sector as well as the composite MPE value for the site.

<b>Site Composite MPE%</b>	
<b>Carrier</b>	<b>MPE%</b>
AT&T – Max Sector Value	<b>11.83 %</b>
Sprint	3.97 %
T-Mobile	6.34 %
<b>Site Total MPE %:</b>	<b>22.14 %</b>

*Table 4: All Carrier MPE Contributions*

AT&T Sector A Total:	11.83 %
AT&T Sector B Total:	11.83 %
AT&T Sector C Total:	11.83 %
<b>Site Total:</b>	<b>22.14 %</b>

*Table 5: Site MPE Summary*



FCC OET 65 specifies that for carriers utilizing directional antennas that the highest recorded sector value be used for composite site MPE values due to their greatly reduced emissions contributions in the directions of the adjacent sectors. *Table 6* below details a breakdown by frequency band and technology for the MPE power values for the maximum calculated AT&T sector(s). For this site, all three sectors have the same configuration yielding the same results on all three sectors.

AT&T _ Frequency Band / Technology Max Power Values (All Sectors)	# Channels	Watts ERP (Per Channel)	Height (feet)	Total Power Density ( $\mu\text{W}/\text{cm}^2$ )	Frequency (MHz)	Allowable MPE ( $\mu\text{W}/\text{cm}^2$ )	Calculated % MPE
AT&T 850 MHz UMTS (antenna 1)	2	414.12	103	3.16	850 MHz	567	0.56%
AT&T 850 MHz LTE (antenna 2)	2	521.27	103	3.98	850 MHz	567	0.70%
AT&T 700 MHz LTE (antenna 2)	2	681.01	103	5.20	700 MHz	467	1.11%
AT&T 2300 MHz (WCS) LTE (antenna 2)	4	875.23	103	13.38	2300 MHz (WCS)	1000	1.34%
AT&T 700 MHz LTE – BAND 14 (antenna 3)	4	837.82	103	12.80	700 MHz	467	2.74%
AT&T 2100 MHz (AWS) LTE (antenna 3)	4	1,028.30	103	15.72	2100 MHz (AWS)	1000	1.57%
AT&T 700 MHz LTE (antenna 4)	2	729.71	103	5.58	700 MHz	467	1.19%
AT&T 1900 MHz (PCS) LTE (antenna 4)	4	1,710.61	103	26.14	1900 MHz (PCS)	1000	2.61%
						<b>Total:</b>	<b>11.83%</b>

*Table 6: AT&T Maximum Sector MPE Power Values*



## Summary

All calculations performed for this analysis yielded results that were **within** the allowable limits for general population exposure to RF Emissions.

The anticipated maximum composite contributions from the AT&T facility as well as the site composite emissions value with regards to compliance with FCC's allowable limits for general population exposure to RF Emissions are shown here:

AT&T Sector	Power Density Value (%)
Sector A:	11.83 %
Sector B:	11.83 %
Sector C:	11.83 %
AT&T Maximum Total (per sector):	11.83 %
Site Total:	22.14 %
Site Compliance Status:	<b>COMPLIANT</b>

The anticipated composite MPE value for this site assuming all carriers present is **22.14 %** of the allowable FCC established general population limit sampled at the ground level. This is based upon values listed in the Connecticut Siting Council database for existing carrier emissions.

FCC guidelines state that if a site is found to be out of compliance (over allowable thresholds), that carriers over a 5% contribution to the composite value will require measures to bring the site into compliance. For this facility, the composite values calculated were well within the allowable 100% threshold standard per the federal government.

A handwritten signature in black ink, appearing to read 'Scott Heffernan', is written over a light blue horizontal line.

Scott Heffernan  
RF Engineering Director  
**Centerline Communications, LLC**  
95 Ryan Drive, Suite 1  
Raynham, MA 02767



**City of Milford, Connecticut. Assessment Parcel Map**

Parcel ID: **4835**

Address: **438 BRIDGEPORT AVE**

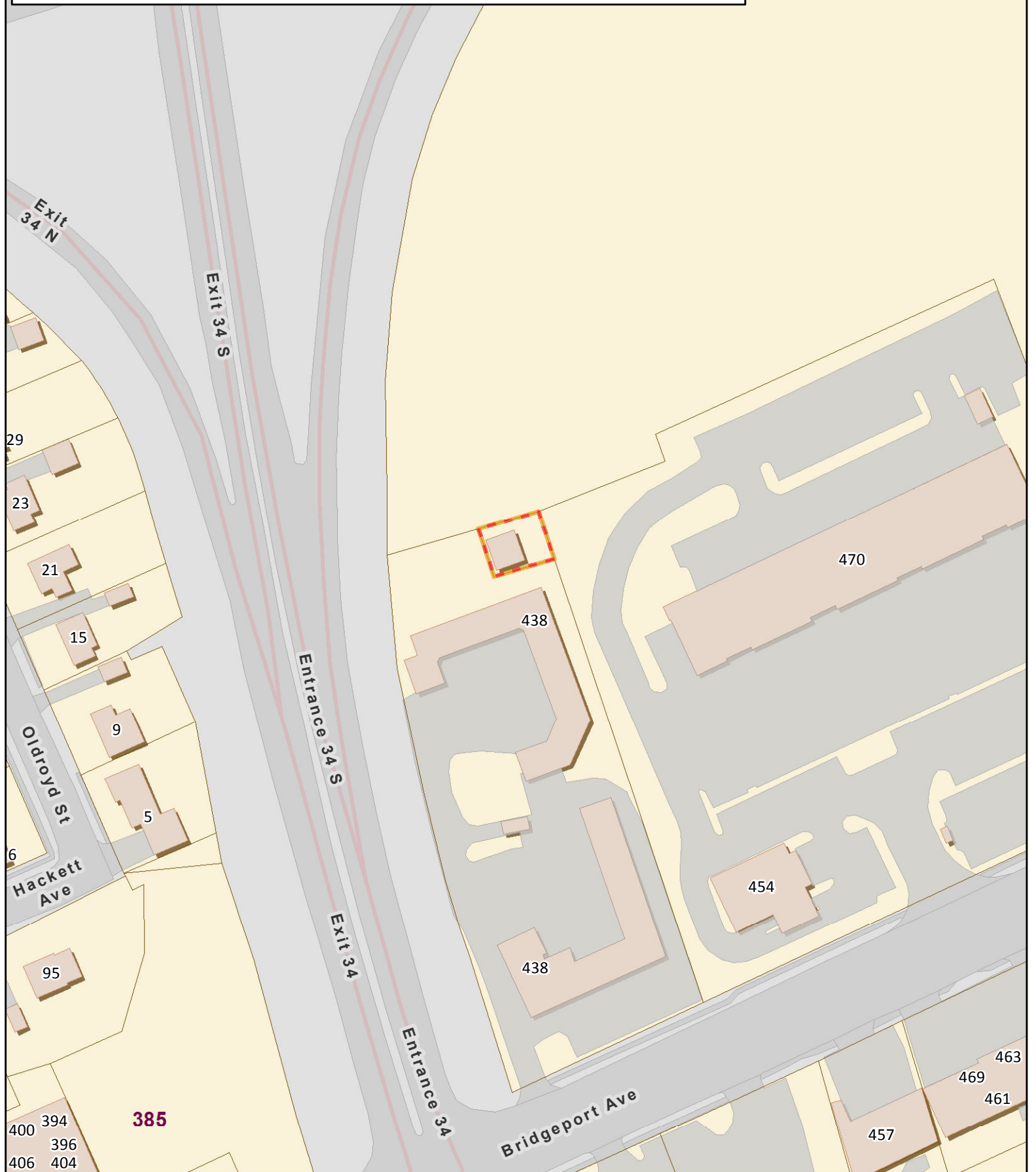

**1 inch = 100 feet**

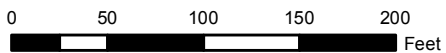

Disclaimer: This map is for informational purposes only. All information is subject to verification by any user. The City of Milford and its mapping contractors assume no legal responsibility for the information contained herein.

Map Produced: July 2016

# 438 BRIDGEPORT AVE

**Location** 438 BRIDGEPORT AVE

**Mblu** 24/ 385/ 3/A /

**Acct#** 003195

**Owner** CHARCHENKO HENRY &  
GENEVIEVE &

**Assessment** \$318,090

**Appraisal** \$454,410

**PID** 4835

**Building Count** 1

## Current Value

Appraisal			
Valuation Year	Improvements	Land	Total
2016	\$426,060	\$28,350	\$454,410

Assessment			
Valuation Year	Improvements	Land	Total
2016	\$298,240	\$19,850	\$318,090

## Owner of Record

**Owner** CHARCHENKO HENRY & GENEVIEVE &  
**Other** C/O SPECTRASITE COMMUNICATIONS  
**Address** P O BOX 723597 PROP TAX DEPT  
ATLANTA, GA 31139

**Sale Price** \$0  
**Certificate**  
**Book & Page** 00549/1620  
**Sale Date** 05/18/1965

## Ownership History

Ownership History				
Owner	Sale Price	Certificate	Book & Page	Sale Date
CHARCHENKO HENRY & GENEVIEVE &	\$0		00549/1620	05/18/1965

## Building Information

### Building 1 : Section 1

**Year Built:**  
**Living Area:** 0  
**Replacement Cost:** \$0  
**Building Percent**  
**Good:**  
**Replacement Cost**  
**Less Depreciation:** \$0

Building Attributes	
Field	Description

Style	Outbuildings
Model	
Grade:	
Stories:	
Occupancy	
Exterior Wall 1	
Exterior Wall 2	
Roof Structure:	
Roof Cover	
Interior Wall 1	
Interior Wall 2	
Interior Flr 1	
Interior Flr 2	
Heat Fuel	
Heat Type:	
AC Type:	
Total Bedrooms:	
Total Bthrms:	
Total Half Baths:	
Total Xtra Fixtrs:	
Total Rooms:	
Bath Description:	
Kitchen Descrip:	
Int Condition:	
Solar Panels	
House Generator	

### Building Photo



(<http://images.vgsi.com/photos/MilfordCTPhotos//\00\05\48\32.j>)

### Building Layout

Building Layout

(<http://images.vgsi.com/photos/MilfordCTPhotos//Sketches/4835>)

Building Sub-Areas (sq ft)	Legend
No Data for Building Sub-Areas	

### Extra Features

Extra Features	Legend
No Data for Extra Features	

### Land

#### Land Use

<b>Use Code</b>	434V
<b>Description</b>	CELL TOWER MDL-00
<b>Zone</b>	CDD3
<b>Neighborhood</b>	B
<b>Alt Land Appr Category</b>	No

#### Land Line Valuation

<b>Size (Acres)</b>	0.05
<b>Frontage</b>	0
<b>Depth</b>	0
<b>Assessed Value</b>	\$19,850
<b>Appraised Value</b>	\$28,350

## Outbuildings

Outbuildings						<u>Legend</u>
Code	Description	Sub Code	Sub Description	Size	Value	Bldg #
FN4	FENCE-8' CHAIN			176 L.F.	\$1,060	1
	RADBLD			550	\$55,000	1
	RADELD			200	\$20,000	1
CEL1	CEL TWR SITE			1 UNITS	\$350,000	1

## Valuation History

Appraisal			
Valuation Year	Improvements	Land	Total
2016	\$412,760	\$28,350	\$441,110
2013	\$412,760	\$28,350	\$441,110
2012	\$412,760	\$28,350	\$441,110

Assessment			
Valuation Year	Improvements	Land	Total
2016	\$288,930	\$19,850	\$308,780
2013	\$288,930	\$19,850	\$308,780
2012	\$288,930	\$19,850	\$308,780

(c) 2016 Vision Government Solutions, Inc. All rights reserved.

**PROJECT INFORMATION**

SCOPE OF WORK: ITEMS TO BE MOUNTED ON THE EXISTING TOWER:

- INSTALL NEW ANTENNA (80010964) (TYP. OF 1 PER SECTORS, TOTAL OF 3).
- INSTALL NEW SURGE ARRESTOR (DC6-48-60-18-8C)
- INSTALL NEW AT&T RRUS-32 B66 (TYP. OF 1 PER SECTOR, TOTAL OF 3)
- INSTALL NEW AT&T B14 4478 (TYP. OF 1 PER SECTOR, TOTAL OF 3)
- INSTALL NEW (2) DC POWER

ITEMS TO BE MOUNTED INSIDE EXISTING EQUIPMENT SHELTER:

- REPLACE EXISTING (2) DUS WITH (2) 5216& REPLACE EXISTING IDL2 WITH IDLE.
- INSTALL AT&T RRUS-E2 (TYP. OF 1 PER SECTOR, TOTAL OF 3)
- REPLACE EXISTING DIPLEXERS WITH LOW BAND COMBINERS

ITEMS TO REMAIN:

- (9) ANTENNAS, (9) RRU'S, (2) SURGE ARRESTOR, (12) 1-1/4"Ø LINES COAX (2) DC POWER CABLES, & (1) FIBER RUN.

SITE ADDRESS: 438 BRIDGEPORT AVE  
MILFORD, CT 06460

SITE OWNER: AMERICAN TOWER CORPORATION  
116 HUNTINGTON AVE. 11TH FLOOR  
BOSTON, MA 02116

FA #: 10034978

LATITUDE: 41.206603° N 41° 12' 23.77" N  
LONGITUDE: 73.093388° W 73° 05' 36.19" W

TYPE OF SITE: MONOPOLE / INDOOR EQUIPMENT

TOWER HEIGHT: 100'-0"±  
RAD CENTER: 102'-0"±

JURISDICTION: NATIONAL, STATE & LOCAL CODES OR ORDINANCES

CURRENT USE: TELECOMMUNICATIONS FACILITY  
PROPOSED USE: TELECOMMUNICATIONS FACILITY



**SITE NUMBER: CT2111**

**SITE NAME: MILFORD-BRIDGEPORT AVE**

**PROJECT: LTE 5C/6C/7C 2018 UPGRADE**

**DRAWING INDEX**

SHEET NO.	DESCRIPTION	REV.
T-1	TITLE SHEET	B
GN-1	GENERAL NOTES	B
A-1	COMPOUND & EQUIPMENT PLANS	B
A-2	ANTENNA LAYOUTS & ELEVATION	B
A-3	DETAILS	B
RF-1	RF PLUMBING DIAGRAM	B
G-1	GROUNDING DETAILS	B

**VICINITY MAP**

**DIRECTIONS TO SITE:**

START OUT GOING NORTHEAST ON ENTERPRISE DR TOWARD CAPITOL BLVD. 0.4 MI. TURN LEFT ONTO CAPITOL BLVD. 0.3 MI. TURN LEFT ONTO WEST ST. 0.2 MI. MERGE ONTO I-91 N VIA THE RAMP ON THE LEFT TOWARD HARTFORD. 10.6 MI. TAKE THE JENNINGS ROAD EXIT, EXIT 33. 0.3 MI. TURN RIGHT ONTO JENNINGS RD. 0.1 MI. TURN LEFT TO STAY ON JENNINGS RD. 0.4 MI. TURN LEFT ONTO WESTON ST. 0.1 MI. END AT 92 WESTON ST HARTFORD, CT 06120.

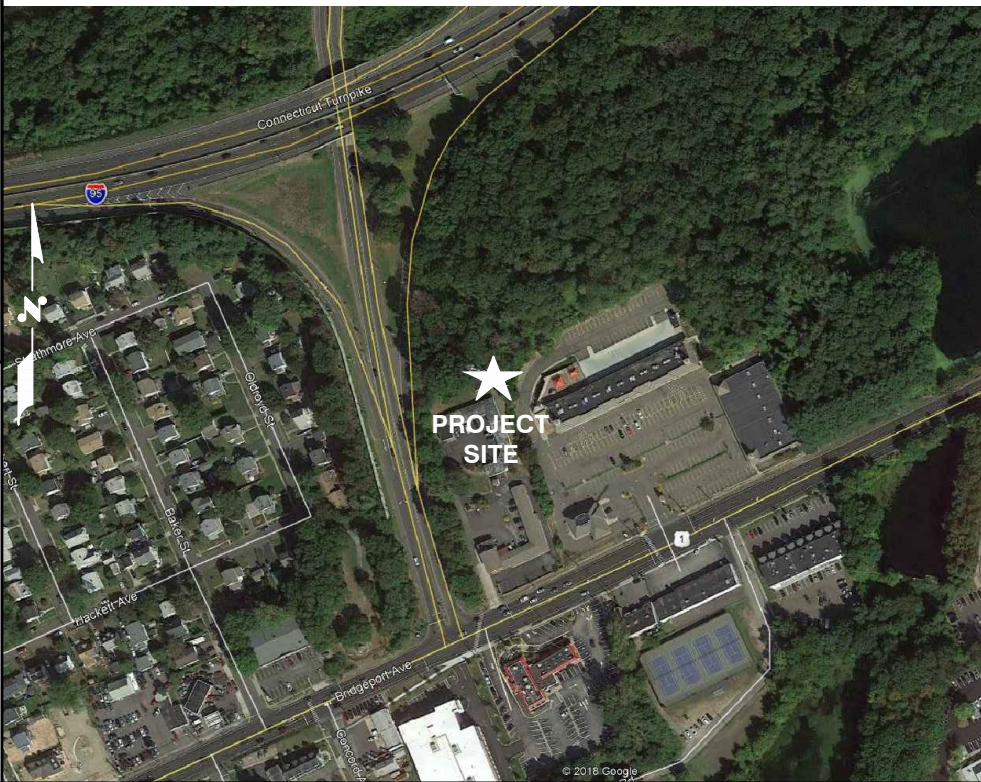

**GENERAL NOTES**

1. THIS DOCUMENT IS THE CREATION, DESIGN, PROPERTY AND COPYRIGHTED WORK OF AT&T. ANY DUPLICATION OR USE WITHOUT EXPRESS WRITTEN CONSENT IS STRICTLY PROHIBITED. DUPLICATION AND USE BY GOVERNMENT AGENCIES FOR THE PURPOSES OF CONDUCTING THEIR LAWFULLY AUTHORIZED REGULATORY AND ADMINISTRATIVE FUNCTIONS IS SPECIFICALLY ALLOWED.
2. THE FACILITY IS AN UNMANNED PRIVATE AND SECURED EQUIPMENT INSTALLATION. IT IS ONLY ACCESSED BY TRAINED TECHNICIANS FOR PERIODIC ROUTINE MAINTENANCE AND THEREFORE DOES NOT REQUIRE ANY WATER OR SANITARY SEWER SERVICE. THE FACILITY IS NOT GOVERNED BY REGULATIONS REQUIRING PUBLIC ACCESS PER ADA REQUIREMENTS.
3. CONTRACTOR SHALL VERIFY ALL PLANS AND EXISTING DIMENSIONS AND CONDITIONS ON THE JOB SITE AND SHALL IMMEDIATELY NOTIFY THE AT&T MOBILITY REPRESENTATIVE IN WRITING OF DISCREPANCIES BEFORE PROCEEDING WITH THE WORK OR BE RESPONSIBLE FOR SAME.
4. CONSTRUCTION DRAWINGS ARE VALID FOR SIX MONTHS AFTER ENGINEER OF RECORD'S STAMPED AND SIGNED SUBMITTAL DATE LISTED HEREIN.

**AMERICAN TOWER SITE ID: MLFD-MILFORD**  
**SITE NAME: 302516**

**72 HOURS**  
**CALL BEFORE YOU DIG**  
CALL TOLL FREE 1-800-922-4455  
OR CALL 811

**UNDERGROUND SERVICE ALERT**

<p>45 BEECHWOOD DRIVE NORTH ANDOVER, MA 01845 TEL: (978) 557-5553 FAX: (978) 336-5586</p>	<p>95 RYAN DRIVE RAYNHAM, MA 02767</p>	<p>SITE NUMBER: CT2111 SITE NAME: MILFORD-BRIDGEPORT AVE ATC SITE ID: 302516</p> <p>438 BRIDGEPORT AVE MILFORD, CT 06460 NEW HAVEN COUNTY</p>	<p>500 ENTERPRISE DRIVE, SUITE 3A ROCKY HILL, CT 06067</p>	<p>NO. DATE REVISIONS BY CHK APP'D</p> <p>B 03/01/18 ISSUED FOR PERMITTING SB AT DJC</p> <p>A 02/01/18 ISSUED FOR REVIEW RB AT DJC</p>		<p>AT&amp;T</p> <p>TITLE SHEET (LTE 5C/6C/7C)</p>
				<p>SCALE: AS SHOWN DESIGNED BY: AT DRAWN BY: RB</p>		<p>SITE NUMBER: CT2111 DRAWING NUMBER: T-1 REV: B</p>



**GROUNDING NOTES**

- THE SUBCONTRACTOR SHALL REVIEW AND INSPECT THE EXISTING FACILITY GROUNDING SYSTEM AND LIGHTNING PROTECTION SYSTEM (AS DESIGNED AND INSTALLED) FOR STRICT COMPLIANCE WITH THE NEC (AS ADOPTED BY THE AHJ), THE SITE-SPECIFIC (UL, LPI, OR NFPA) LIGHTING PROTECTION CODE, AND GENERAL COMPLIANCE WITH TELCORDIA AND TIA GROUNDING STANDARDS. THE SUBCONTRACTOR SHALL REPORT ANY VIOLATIONS OR ADVERSE FINDINGS TO THE CONTRACTOR FOR RESOLUTION.
- ALL GROUND ELECTRODE SYSTEMS (INCLUDING TELECOMMUNICATION, RADIO, LIGHTNING PROTECTION, AND AC POWER GES'S) SHALL BE BONDED TOGETHER, AT OR BELOW GRADE, BY TWO OR MORE COPPER BONDING CONDUCTORS IN ACCORDANCE WITH THE NEC.
- THE SUBCONTRACTOR SHALL PERFORM IEEE FALL-OF-POTENTIAL RESISTANCE TO EARTH TESTING (PER IEEE 1100 AND 81) FOR NEW GROUND ELECTRODE SYSTEMS. THE SUBCONTRACTOR SHALL FURNISH AND INSTALL SUPPLEMENTAL GROUND ELECTRODES AS NEEDED TO ACHIEVE A TEST RESULT OF 5 OHMS OR LESS.
- METAL RACEWAY SHALL NOT BE USED AS THE NEC REQUIRED EQUIPMENT GROUND CONDUCTOR. STRANDED COPPER CONDUCTORS WITH GREEN INSULATION, SIZED IN ACCORDANCE WITH THE NEC, SHALL BE FURNISHED AND INSTALLED WITH THE POWER CIRCUITS TO BTS EQUIPMENT.
- EACH BTS CABINET FRAME SHALL BE DIRECTLY CONNECTED TO THE MASTER GROUND BAR WITH GREEN INSULATED SUPPLEMENTAL EQUIPMENT GROUND WIRES, 6 AWG STRANDED COPPER OR LARGER FOR INDOOR BTS 2 AWG STRANDED COPPER FOR OUTDOOR BTS.
- EXOTHERMIC WELDS SHALL BE USED FOR ALL GROUNDING CONNECTIONS BELOW GRADE.
- APPROVED ANTIOXIDANT COATINGS (I.E., CONDUCTIVE GEL OR PASTE) SHALL BE USED ON ALL COMPRESSION AND BOLTED GROUND CONNECTIONS.
- ICE BRIDGE BONDING CONDUCTORS SHALL BE EXOTHERMICALLY BONDED OR BOLTED TO GROUND BAR.
- ALUMINUM CONDUCTOR OR COPPER CLAD STEEL CONDUCTOR SHALL NOT BE USED FOR GROUNDING CONNECTIONS.
- MISCELLANEOUS ELECTRICAL AND NON-ELECTRICAL METAL BOXES, FRAMES AND SUPPORTS SHALL BE BONDED TO THE GROUND RING, IN ACCORDANCE WITH THE NEC.
- METAL CONDUIT SHALL BE MADE ELECTRICALLY CONTINUOUS WITH LISTED BONDING FITTINGS OR BY BONDING ACROSS THE DISCONTINUITY WITH 6 AWS COPPER WIRE UL APPROVED GROUNDING TYPE CONDUIT CLAMPS.
- ALL NEW STRUCTURES WITH A FOUNDATION AND/OR FOOTING HAVING 20 FT. OR MORE OF 1/2 IN. OR GREATER ELECTRICALLY CONDUCTIVE REINFORCING STEEL MUST HAVE IT BONDED TO THE GROUND RING USING AN EXOTHERMIC WELD CONNECTION USING #2 AWG SOLID BARE TINNED COPPER GROUND WIRE, PER NEC 250.50

**GENERAL NOTES**

- FOR THE PURPOSE OF CONSTRUCTION DRAWING, THE FOLLOWING DEFINITIONS SHALL APPLY:  
CONTRACTOR – CENTERLINE  
SUBCONTRACTOR – GENERAL CONTRACTOR (CONSTRUCTION)  
OWNER – AT&T MOBILITY
- PRIOR TO THE SUBMISSION OF BIDS, THE BIDDING SUBCONTRACTOR SHALL VISIT THE CELL SITE TO FAMILIARIZE WITH THE EXISTING CONDITIONS AND TO CONFIRM THAT THE WORK CAN BE ACCOMPLISHED AS SHOWN ON THE CONSTRUCTION DRAWINGS. ANY DISCREPANCY FOUND SHALL BE BROUGHT TO THE ATTENTION OF CONTRACTOR.
- ALL MATERIALS FURNISHED AND INSTALLED SHALL BE IN STRICT ACCORDANCE WITH ALL APPLICABLE CODES, REGULATIONS, AND ORDINANCES. SUBCONTRACTOR SHALL ISSUE ALL APPROPRIATE NOTICES AND COMPLY WITH ALL LAWS, ORDINANCES, RULES, REGULATIONS, AND LAWFUL ORDERS OF ANY PUBLIC AUTHORITY REGARDING THE PERFORMANCE OF THE WORK. ALL WORK CARRIED OUT SHALL COMPLY WITH ALL APPLICABLE MUNICIPAL AND UTILITY COMPANY SPECIFICATIONS AND LOCAL JURISDICTIONAL CODES, ORDINANCES AND APPLICABLE REGULATIONS.
- DRAWINGS PROVIDED HERE ARE NOT TO BE SCALED AND ARE INTENDED TO SHOW OUTLINE ONLY.
- UNLESS NOTED OTHERWISE, THE WORK SHALL INCLUDE FURNISHING MATERIALS, EQUIPMENT, APPURTENANCES, AND LABOR NECESSARY TO COMPLETE ALL INSTALLATIONS AS INDICATED ON THE DRAWINGS.
- "KITTING LIST" SUPPLIED WITH THE BID PACKAGE IDENTIFIES ITEMS THAT WILL BE SUPPLIED BY CONTRACTOR. ITEMS NOT INCLUDED IN THE BILL OF MATERIALS AND KITTING LIST SHALL BE SUPPLIED BY THE SUBCONTRACTOR.
- THE SUBCONTRACTOR SHALL INSTALL ALL EQUIPMENT AND MATERIALS IN ACCORDANCE WITH MANUFACTURER'S RECOMMENDATIONS UNLESS SPECIFICALLY STATED OTHERWISE.
- IF THE SPECIFIED EQUIPMENT CANNOT BE INSTALLED AS SHOWN ON THESE DRAWINGS, THE SUBCONTRACTOR SHALL PROPOSE AN ALTERNATIVE INSTALLATION SPACE FOR APPROVAL BY THE CONTRACTOR.
- SUBCONTRACTOR SHALL DETERMINE ACTUAL ROUTING OF CONDUIT, POWER AND T1 CABLES, GROUNDING CABLES AS SHOWN ON THE POWER, GROUNDING AND TELCO PLAN DRAWING. SUBCONTRACTOR SHALL UTILIZE EXISTING TRAYS AND/OR SHALL ADD NEW TRAYS AS NECESSARY. SUBCONTRACTOR SHALL CONFIRM THE ACTUAL ROUTING WITH THE CONTRACTOR.
- THE SUBCONTRACTOR SHALL PROTECT EXISTING IMPROVEMENTS, PAVEMENTS, CURBS, LANDSCAPING AND STRUCTURES. ANY DAMAGED PART SHALL BE REPAIRED AT SUBCONTRACTOR'S EXPENSE TO THE SATISFACTION OF OWNER.
- SUBCONTRACTOR SHALL LEGALLY AND PROPERLY DISPOSE OF ALL SCRAP MATERIALS SUCH AS COAXIAL CABLES AND OTHER ITEMS REMOVED FROM THE EXISTING FACILITY. ANTENNAS REMOVED SHALL BE RETURNED TO THE OWNER'S DESIGNATED LOCATION.
- SUBCONTRACTOR SHALL LEAVE PREMISES IN CLEAN CONDITION.
- ALL CONCRETE REPAIR WORK SHALL BE DONE IN ACCORDANCE WITH AMERICAN CONCRETE INSTITUTE (ACI) 301.

- ANY NEW CONCRETE NEEDED FOR THE CONSTRUCTION SHALL BE AIR-ENTRAINED AND SHALL HAVE 4000 PSI STRENGTH AT 28 DAYS. ALL CONCRETE WORK SHALL BE DONE IN ACCORDANCE WITH ACI 318 CODE REQUIREMENTS.
- ALL STRUCTURAL STEEL WORK SHALL BE DETAILED, FABRICATED AND ERECTED IN ACCORDANCE WITH AISC SPECIFICATIONS. ALL STRUCTURAL STEEL SHALL BE ASTM A36 (Fy = 36 ksi) UNLESS OTHERWISE NOTED. PIPES SHALL BE ASTM A53 TYPE E (Fy = 36 ksi). ALL STEEL EXPOSED TO WEATHER SHALL BE HOT DIPPED GALVANIZED. TOUCHUP ALL SCRATCHES AND OTHER MARKS IN THE FIELD AFTER STEEL IS ERECTED USING A COMPATIBLE ZINC RICH PAINT.
- CONSTRUCTION SHALL COMPLY WITH LTE SPECIFICATIONS AND "GENERAL CONSTRUCTION SERVICES FOR CONSTRUCTION OF AT&T SITES."
- SUBCONTRACTOR SHALL VERIFY ALL EXISTING DIMENSIONS AND CONDITIONS PRIOR TO COMMENCING ANY WORK. ALL DIMENSIONS OF EXISTING CONSTRUCTION SHOWN ON THE DRAWINGS MUST BE VERIFIED. SUBCONTRACTOR SHALL NOTIFY THE CONTRACTOR OF ANY DISCREPANCIES PRIOR TO ORDERING MATERIAL OR PROCEEDING WITH CONSTRUCTION.
- THE EXISTING CELL SITE IS IN FULL COMMERCIAL OPERATION. ANY CONSTRUCTION WORK BY SUBCONTRACTOR SHALL NOT DISRUPT THE EXISTING NORMAL OPERATION. ANY WORK ON EXISTING EQUIPMENT MUST BE COORDINATED WITH CONTRACTOR. ALSO, WORK SHOULD BE SCHEDULED FOR AN APPROPRIATE MAINTENANCE WINDOW USUALLY IN LOW TRAFFIC PERIODS AFTER MIDNIGHT.
- SINCE THE CELL SITE IS ACTIVE, ALL SAFETY PRECAUTIONS MUST BE TAKEN WHEN WORKING AROUND HIGH LEVELS OF ELECTROMAGNETIC RADIATION. EQUIPMENT SHOULD BE SHUTDOWN PRIOR TO PERFORMING ANY WORK THAT COULD EXPOSE THE WORKERS TO DANGER. PERSONAL RF EXPOSURE MONITORS ARE ADVISED TO BE WORN TO ALERT OF ANY DANGEROUS EXPOSURE LEVELS.
- APPLICABLE BUILDING CODES:  
SUBCONTRACTOR'S WORK SHALL COMPLY WITH ALL APPLICABLE NATIONAL, STATE, AND LOCAL CODES AS ADOPTED BY THE LOCAL AUTHORITY HAVING JURISDICTION (AHJ) FOR THE LOCATION. THE EDITION OF THE AHJ ADOPTED CODES AND STANDARDS IN EFFECT ON THE DATE OF CONTRACT AWARD SHALL GOVERN THE DESIGN.  
BUILDING CODE: IBC 2012 WITH 2016 CT BUILDING CODE AMENDMENTS  
ELECTRICAL CODE: REFER TO ELECTRICAL DRAWINGS  
LIGHTENING CODE: REFER TO ELECTRICAL DRAWINGS  
  
SUBCONTRACTOR'S WORK SHALL COMPLY WITH THE LATEST EDITION OF THE FOLLOWING STANDARDS:  
  
AMERICAN CONCRETE INSTITUTE (ACI) 318; BUILDING CODE REQUIREMENTS FOR STRUCTURAL CONCRETE;  
  
AMERICAN INSTITUTE OF STEEL CONSTRUCTION (AISC)  
MANUAL OF STEEL CONSTRUCTION, ASD, FOURTEENTH EDITION;  
  
TELECOMMUNICATIONS INDUSTRY ASSOCIATION (TIA) 222-G,  
STRUCTURAL STANDARDS FOR STEEL  
  
EQUIPMENT AND ANTENNA SUPPORTING STRUCTURES; REFER TO ELECTRICAL DRAWINGS FOR SPECIFIC ELECTRICAL STANDARDS.  
  
FOR ANY CONFLICTS BETWEEN SECTIONS OF LISTED CODES AND STANDARDS REGARDING MATERIAL, METHODS OF CONSTRUCTION, OR OTHER REQUIREMENTS, THE MOST RESTRICTIVE REQUIREMENT SHALL GOVERN. WHERE THERE IS CONFLICT BETWEEN A GENERAL REQUIREMENT AND A SPECIFIC REQUIREMENT, THE SPECIFIC REQUIREMENT SHALL GOVERN.

ABBREVIATIONS					
AGL	ABOVE GRADE LEVEL	EQ	EQUAL	REQ	REQUIRED
AWG	AMERICAN WIRE GAUGE	GC	GENERAL CONTRACTOR	RF	RADIO FREQUENCY
BBU	BATTERY BACKUP UNIT	GRC	GALVANIZED RIGID CONDUIT	TBD	TO BE DETERMINED
BTCW	BARE TINNED SOLID COPPER WIRE	MGB	MASTER GROUND BAR	TBR	TO BE REMOVED
BGR	BURIED GROUND RING	MIN	MINIMUM	TBRR	TO BE REMOVED AND REPLACED
BTS	BASE TRANSCEIVER STATION	P	PROPOSED	TYP	TYPICAL
E	EXISTING	NTS	NOT TO SCALE	UG	UNDER GROUND
EGB	EQUIPMENT GROUND BAR	RAD	RADIATION CENTER LINE (ANTENNA)	VIF	VERIFY IN FIELD
EGR	EQUIPMENT GROUND RING	REF	REFERENCE		

45 BEECHWOOD DRIVE  
NORTH ANDOVER, MA 01845  
TEL: (978) 557-5553  
FAX: (978) 336-5586

95 RYAN DRIVE  
RAYNHAM, MA 02767

SITE NUMBER: CT2111  
SITE NAME: MILFORD-BRIDGEPORT AVE  
ATC SITE ID: 302516  
  
438 BRIDGEPORT AVE  
MILFORD, CT 06460  
NEW HAVEN COUNTY

500 ENTERPRISE DRIVE, SUITE 3A  
ROCKY HILL, CT 06067

B	03/01/18	ISSUED FOR PERMITTING	SB	AT	DJC
A	02/01/18	ISSUED FOR REVIEW	RB	AT	DJC
NO.	DATE	REVISIONS	BY	CHK	APP'D
SCALE: AS SHOWN		DESIGNED BY: AT		DRAWN BY: RB	

AT&T		
GENERAL NOTES (LTE 5C/6C/7C)		
SITE NUMBER	DRAWING NUMBER	REV
CT2111	GN-1	B

**NOTE:**

AN ANALYSIS FOR THE CAPACITY OF THE EXISTING MOUNT TO SUPPORT THE PROPOSED EQUIPMENT SHALL BE DETERMINED PRIOR TO CONSTRUCTION.

**NOTE:**

ALL ANTENNAS AND COAX TO BE INSTALLED IN ACCORDANCE WITH STRUCTURAL ANALYSIS PROVIDED BY AMERICAN TOWER CORP. AND FINAL AT&T RF DATA SHEET.

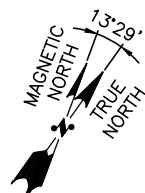
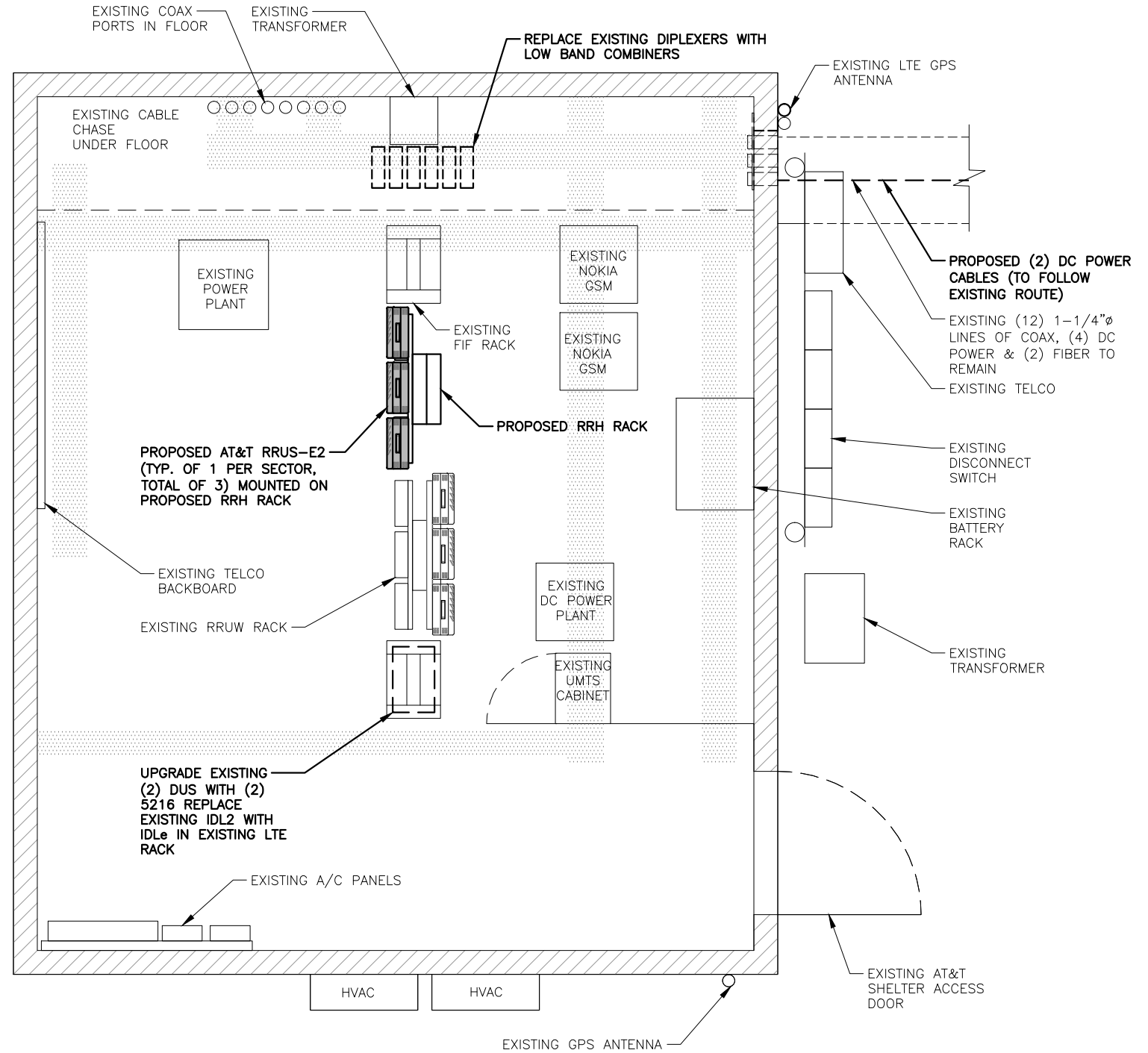
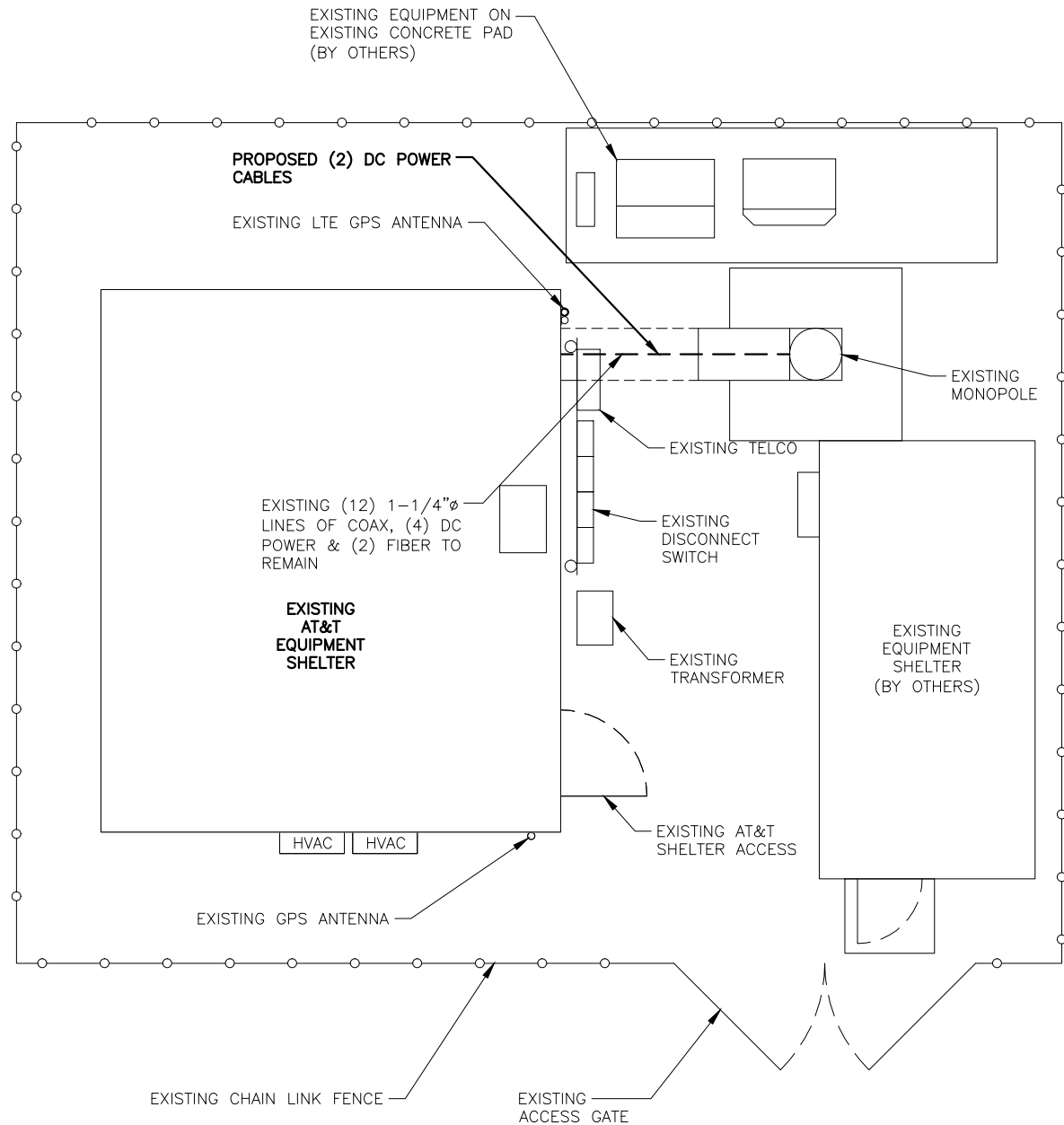

**COMPOUND PLAN**  
22x34 SCALE: 1/4"=1'-0"  
11x17 SCALE: 1/8"=1'-0"

1  
A-1

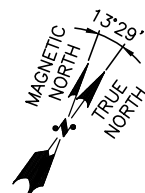

**EQUIPMENT PLAN**  
22x34 SCALE: 1/2"=1'-0"  
11x17 SCALE: 1/4"=1'-0"

2  
A-1



45 BEECHWOOD DRIVE  
NORTH ANDOVER, MA 01845  
TEL: (978) 557-5553  
FAX: (978) 336-5586



95 RYAN DRIVE  
RAYNHAM, MA 02767

SITE NUMBER: CT2111  
SITE NAME: MILFORD-BRIDGEPORT AVE  
ATC SITE ID: 302516

438 BRIDGEPORT AVE  
MILFORD, CT 06460  
NEW HAVEN COUNTY



500 ENTERPRISE DRIVE, SUITE 3A  
ROCKY HILL, CT 06067

				AT&T			
				COMPOUND & EQUIPMENT PLANS (LTE 5C/6C/7C)			
NO.		DATE		REVISIONS		BY	
B	03/01/18	ISSUED FOR PERMITTING	SB	AT	DJC		
A	02/01/18	ISSUED FOR REVIEW	RB	AT	DJC		
SCALE: AS SHOWN		DESIGNED BY: AT		DRAWN BY: RB			
SITE NUMBER		DRAWING NUMBER		REV			
CT2111		A-1		B			

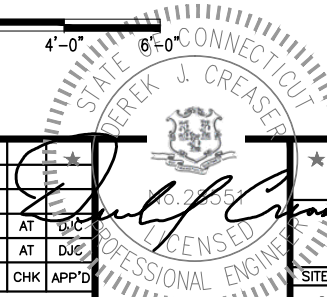

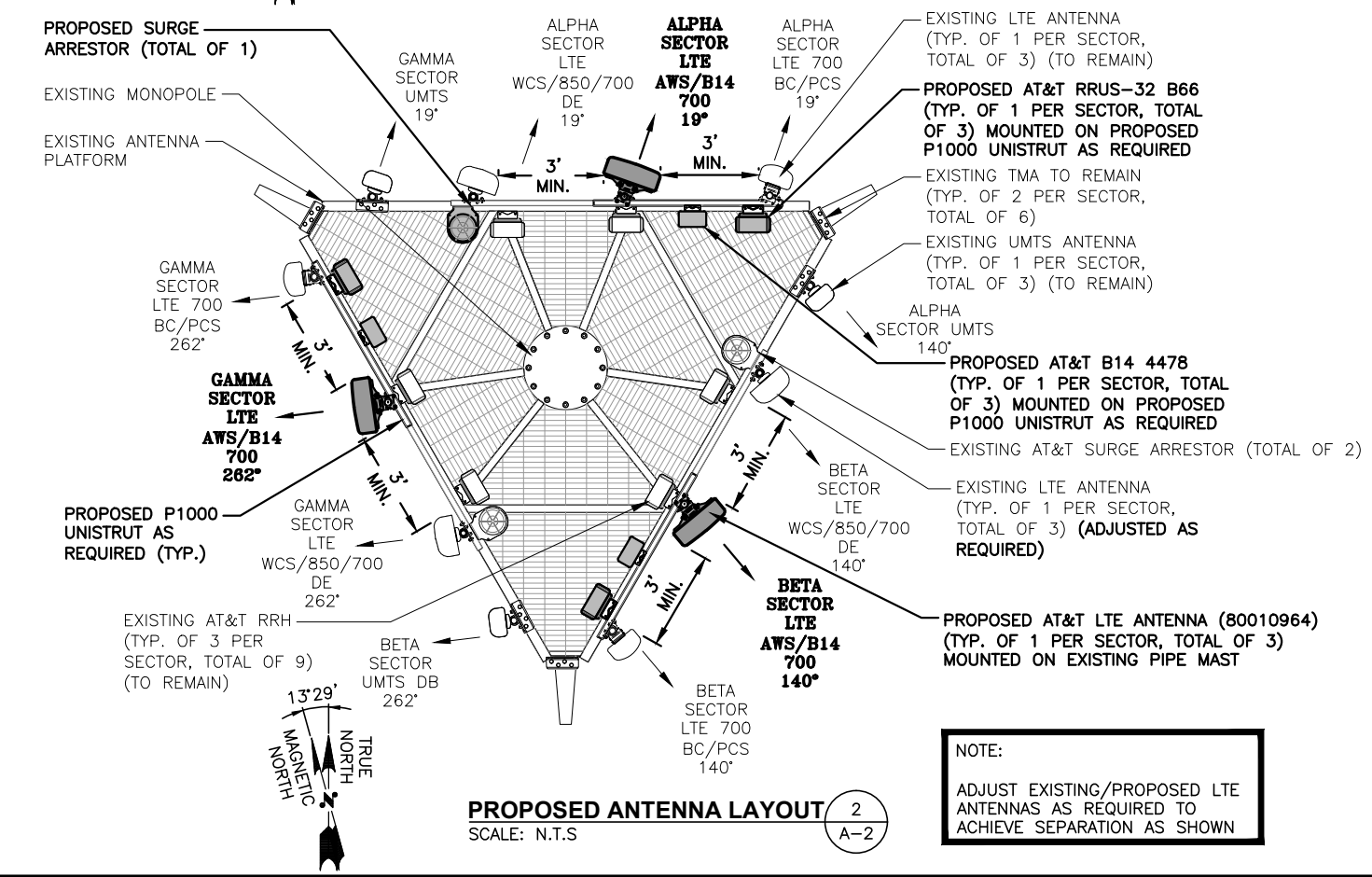
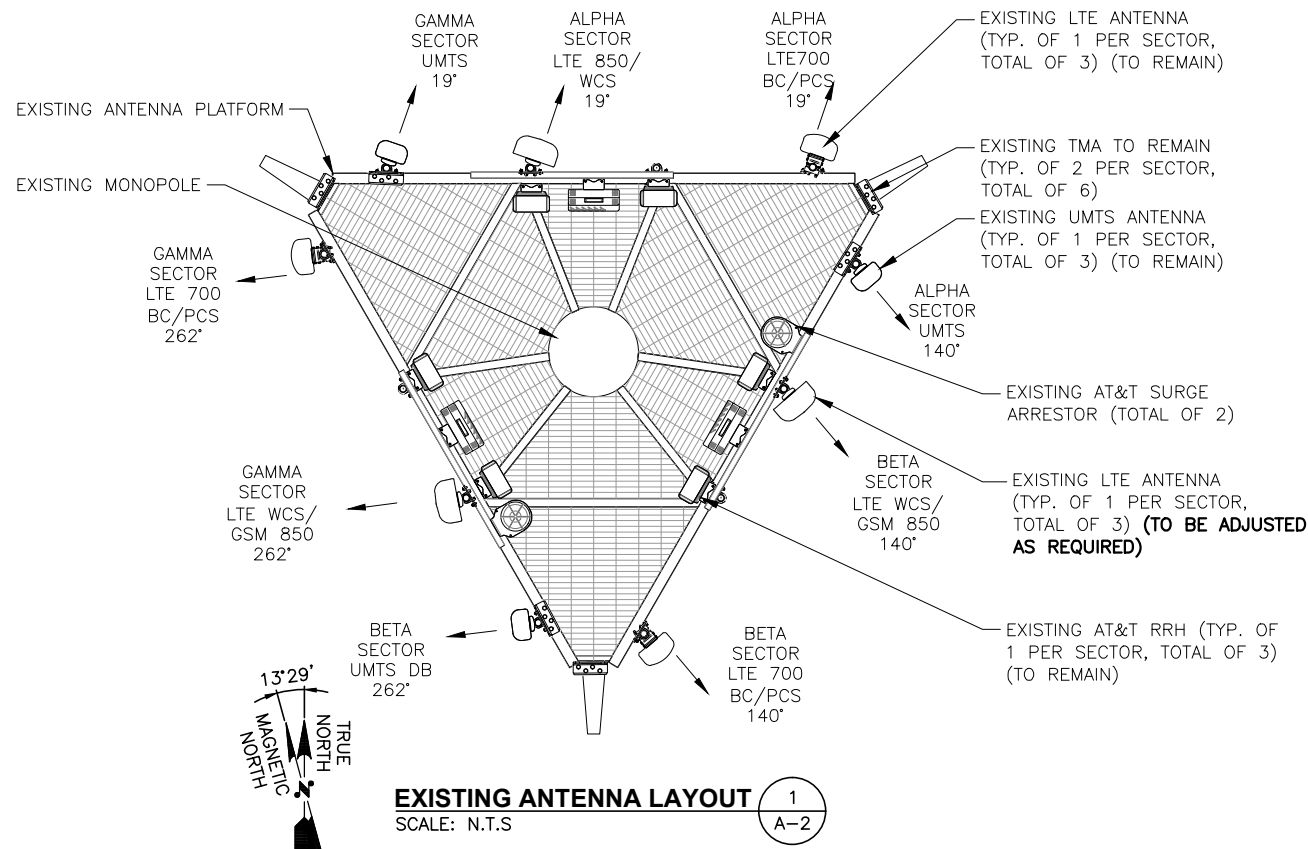

**NOTE:**  
ADJUST EXISTING/PROPOSED LTE ANTENNAS AS REQUIRED TO ACHIEVE SEPARATION AS SHOWN

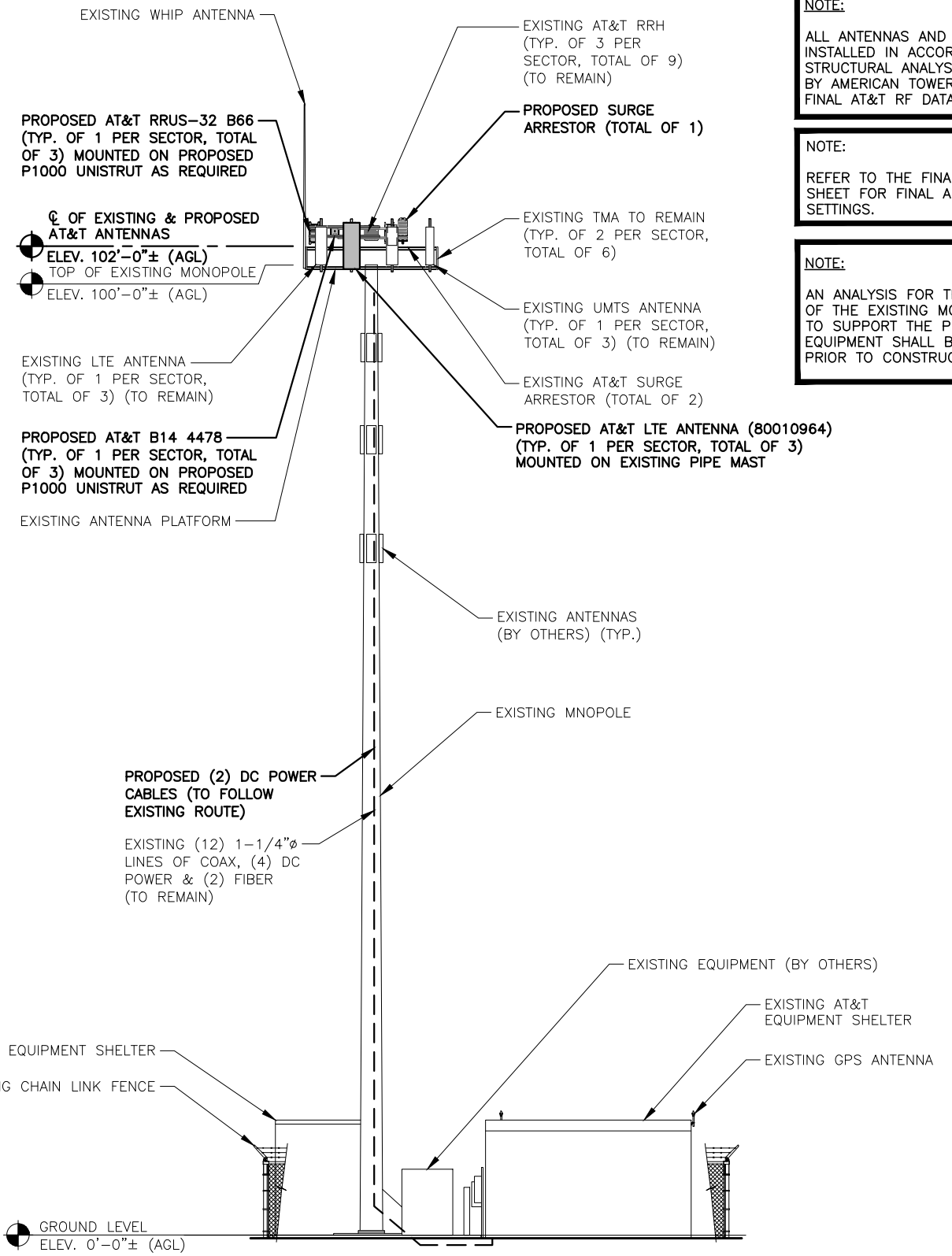

**NOTE:**  
ALL ANTENNAS AND COAX TO BE INSTALLED IN ACCORDANCE WITH STRUCTURAL ANALYSIS PROVIDED BY AMERICAN TOWER CORP. AND FINAL AT&T RF DATA SHEET.

**NOTE:**  
REFER TO THE FINAL RF DATA SHEET FOR FINAL ANTENNA SETTINGS.

**NOTE:**  
AN ANALYSIS FOR THE CAPACITY OF THE EXISTING MOUNT TO SUPPORT THE PROPOSED EQUIPMENT SHALL BE DETERMINED PRIOR TO CONSTRUCTION.

B		03/01/18	ISSUED FOR PERMITTING	SB	AT	DJC
A		02/01/18	ISSUED FOR REVIEW	RB	AT	DJC
NO.	DATE	REVISIONS		BY	CHK	APP'D
SCALE: AS SHOWN		DESIGNED BY: AT		DRAWN BY: RB		
SITE NUMBER		DRAWING NUMBER		REV		
CT2111		A-2		B		

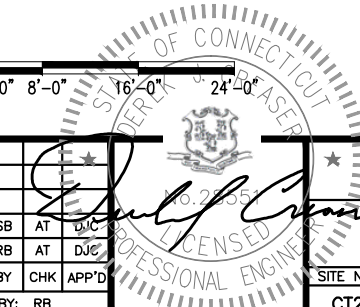

**NOTE:**  
ALL ANTENNAS AND COAX TO BE INSTALLED IN ACCORDANCE WITH STRUCTURAL ANALYSIS PROVIDED BY AMERICAN TOWER CORP. AND FINAL AT&T RF DATA SHEET.

**NOTE:**  
REFER TO THE FINAL RF DATA SHEET FOR FINAL ANTENNA SETTINGS.

**NOTE:**  
AN ANALYSIS FOR THE CAPACITY OF THE EXISTING MOUNT TO SUPPORT THE PROPOSED EQUIPMENT SHALL BE DETERMINED PRIOR TO CONSTRUCTION.

**FINAL ANTENNA SCHEDULE**

SECTOR	BAND	ANTENNA	SIZE (INCHES) (L X W X D)	RAD CENTER	AZIMUTH	TMA	TMA/DIPLEXER	RRU	SIZE (INCHES) (L X W X D)	COAX JUMPERS	FIBER JUMPERS	COAX
ALPHA	UMTS 850	EXISTING	7770	55X11X5	102'-0"±	140'	EXISTING LGP12104	EXISTING 782-10250	-	-	-	(2) 1-1/4"
	LTE WCS/850/700DE	EXISTING	OPA-65R-LCUU-H4	48X14.4X7.3	102'-0"±	19'	-	EXISTING DBC0061F1V51-2	EXISTING RRUS-32 (WCS)	-	-	(2) 1-1/4"
	LTE AWS/B14 700	PROPOSED	80010964	59X20X6.9	102'-0"±	19'	-	PROPOSED RRUS-32 B66 (AWS)	15.0x13.2x7.4	1*	1**	-
	LTE 700 BC/PCS	EXISTING	SBNHH-1D65A	55.0x11.9x7.1	102'-0"±	19'	-	EXISTING LGP21901	EXISTING RRUS-11 (700) EXISTING RRUS-32 B2 (PCS)	-	-	-
BETA	UMTS 850	EXISTING	7770	55X11X5	102'-0"±	262'	EXISTING LGP12104	EXISTING 782-10250	-	-	-	(2) 1-1/4"
	LTE WCS/850/700DE	EXISTING	OPA-65R-LCUU-H4	48X14.4X7.3	102'-0"±	140'	-	EXISTING DBC0061F1V51-2	EXISTING RRUS-32 (WCS)	-	-	(2) 1-1/4"
	LTE AWS/B14 700	PROPOSED	80010964	59X20X6.9	102'-0"±	140'	-	PROPOSED RRUS-32 B66 (AWS)	15.0x13.2x7.4	1*	1**	-
	LTE 700 BC/PCS	EXISTING	SBNHH-1D65A	55.0x11.9x7.1	102'-0"±	140'	-	EXISTING LGP21901	EXISTING RRUS-11 (700) EXISTING RRUS-32 B2 (PCS)	-	-	-
GAMMA	UMTS 850	EXISTING	7770	55X11X5	102'-0"±	19'	EXISTING LGP12104	EXISTING 782-10250	-	-	-	(2) 1-1/4"
	LTE WCS/850/700DE	EXISTING	OPA-65R-LCUU-H4	48X14.4X7.3	102'-0"±	262'	-	EXISTING DBC0061F1V51-2	EXISTING RRUS-32 (WCS)	-	-	(2) 1-1/4"
	LTE AWS/B14 700	PROPOSED	80010964	59X20X6.9	102'-0"±	262'	-	PROPOSED RRUS-32 B66 (AWS)	15.0x13.2x7.4	1*	1**	-
	LTE 700 BC/PCS	EXISTING	SBNHH-1D65A	55.0x11.9x7.1	102'-0"±	262'	-	EXISTING LGP21901	EXISTING RRUS-11 (700) EXISTING RRUS-32 B2 (PCS)	-	-	-

EXISTING ANTENNA PIPE MAST

**FINAL ANTENNA CONFIGURATION TABLE**

5  
A-3

**\*COAX JUMPER NOTE:**  
COAX JUMPERS (2) PER SECTOR, FROM EACH RRU (TOTAL OF 6).

**\*\*FIBER JUMPER NOTE:**  
FIBER JUMPERS (3) PER SECTOR, FROM THE SQUID TO RRU (TOTAL OF 9).

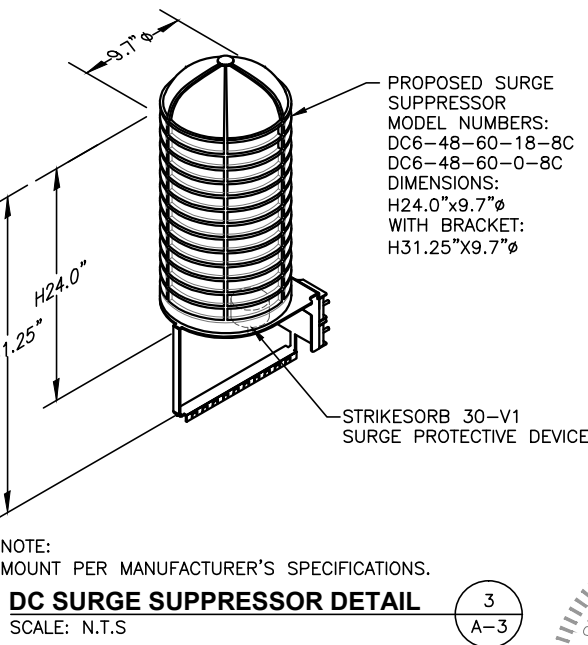
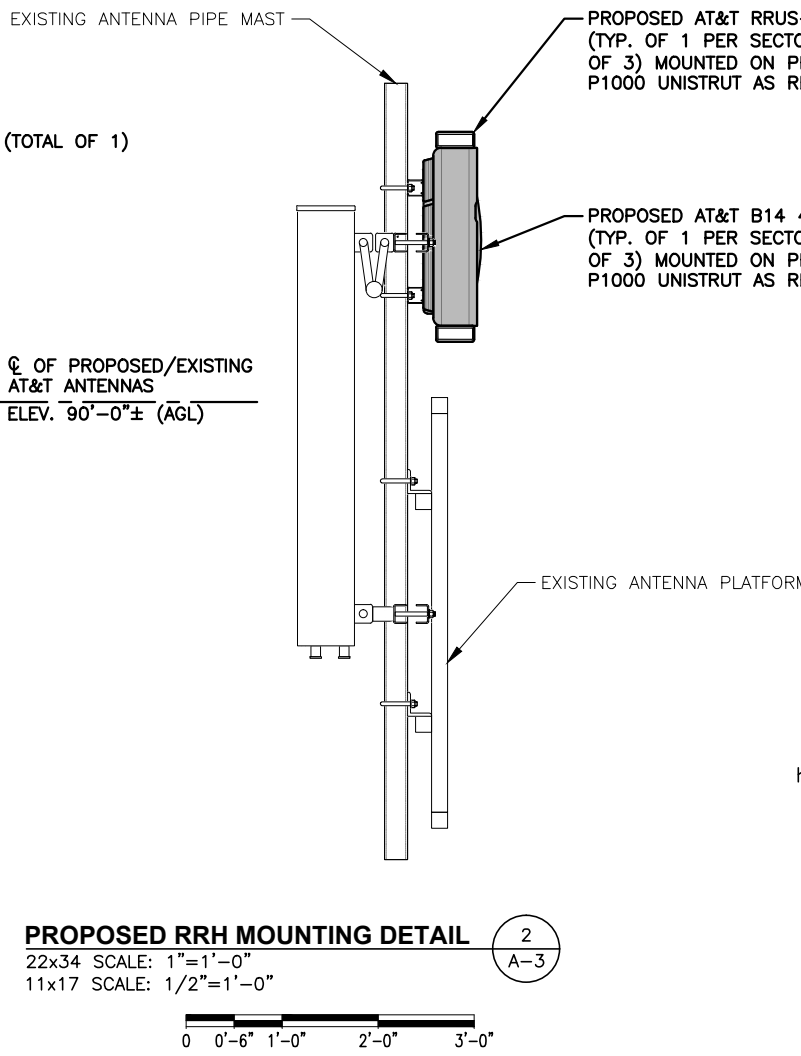
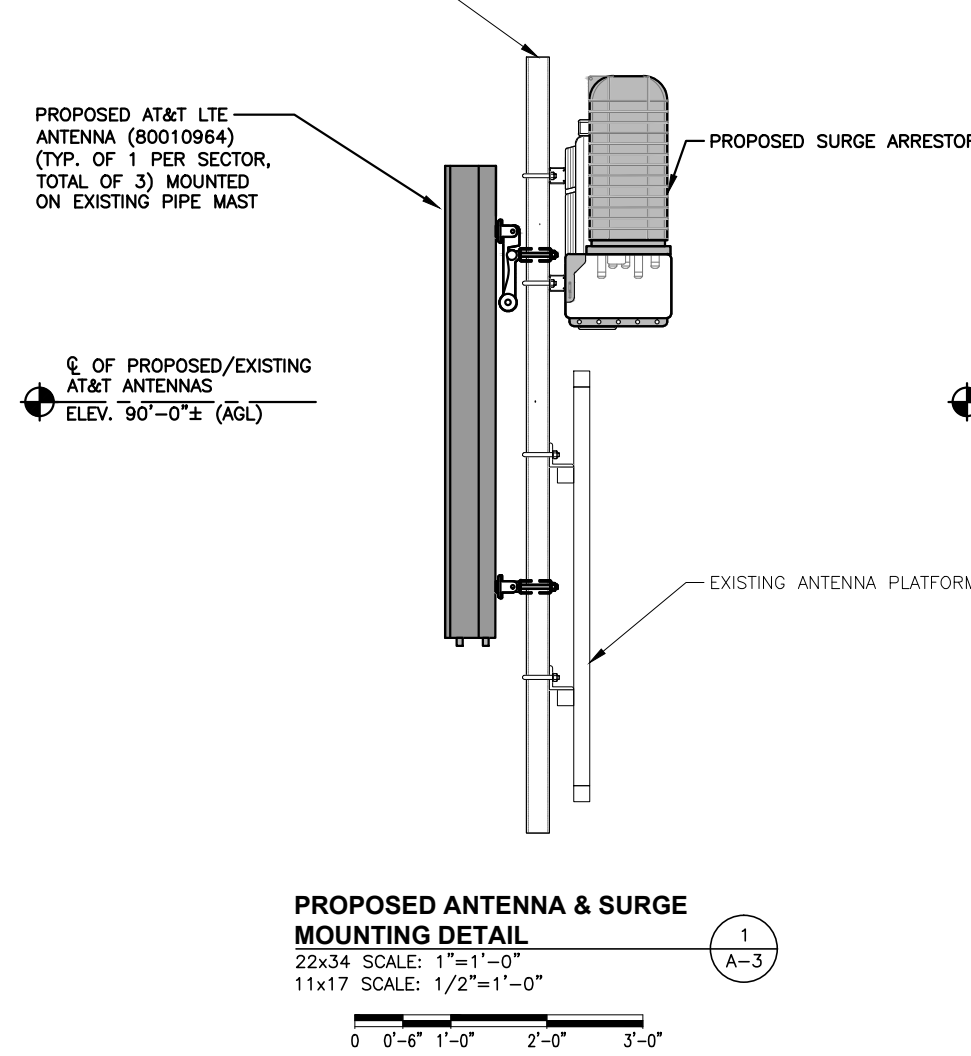

RRU CHART				
QUANTITY	MODEL	L	W	D
3(E)	RRUS-11	19.7"	17.0"	7.2"
6(E), 3(P)	RRUS-32	27.2"	12.1"	7.0"
3(P)	4478 B14	15.0"	13.2"	7.4"

**NOTE:**  
MOUNT PER MANUFACTURER'S SPECIFICATIONS

**NOTE:**  
SEE RFDS FOR RRH FREQUENCY AND MODEL NUMBER

PROPOSED RRU REFER TO THE FINAL RFDS AND CHART FOR QUANTITY, MODEL AND DIMENSIONS

**NOTE:**  
MOUNT PER MANUFACTURER'S SPECIFICATIONS.

**NOTE:**  
MOUNT PER MANUFACTURER'S SPECIFICATIONS.

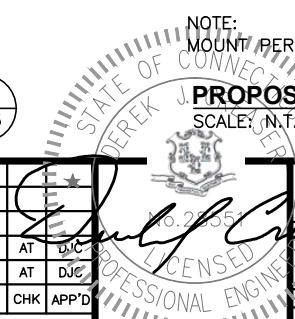

**HGD HUDSON Design Group LLC**  
45 BEECHWOOD DRIVE NORTH ANDOVER, MA 01845  
TEL: (978) 557-5553 FAX: (978) 336-5586

**CENTERLINE COMMUNICATIONS**  
95 RYAN DRIVE RAYNHAM, MA 02767

**SITE NUMBER: CT2111**  
**SITE NAME: MILFORD-BRIDGEPORT AVE**  
**ATC SITE ID: 302516**  
438 BRIDGEPORT AVE MILFORD, CT 06460 NEW HAVEN COUNTY

**at&t**  
500 ENTERPRISE DRIVE, SUITE 3A ROCKY HILL, CT 06067

B	03/01/18	ISSUED FOR PERMITTING	SB	AT	DJC
A	02/01/18	ISSUED FOR REVIEW	RB	AT	DJC
NO.	DATE	REVISIONS	BY	CHK	APP'D
SCALE: AS SHOWN			DESIGNED BY: AT	DRAWN BY: RB	

**AT&T**  
DETAILS (LTE 5C/6C/7C)

SITE NUMBER	DRAWING NUMBER	REV
CT2111	A-3	B

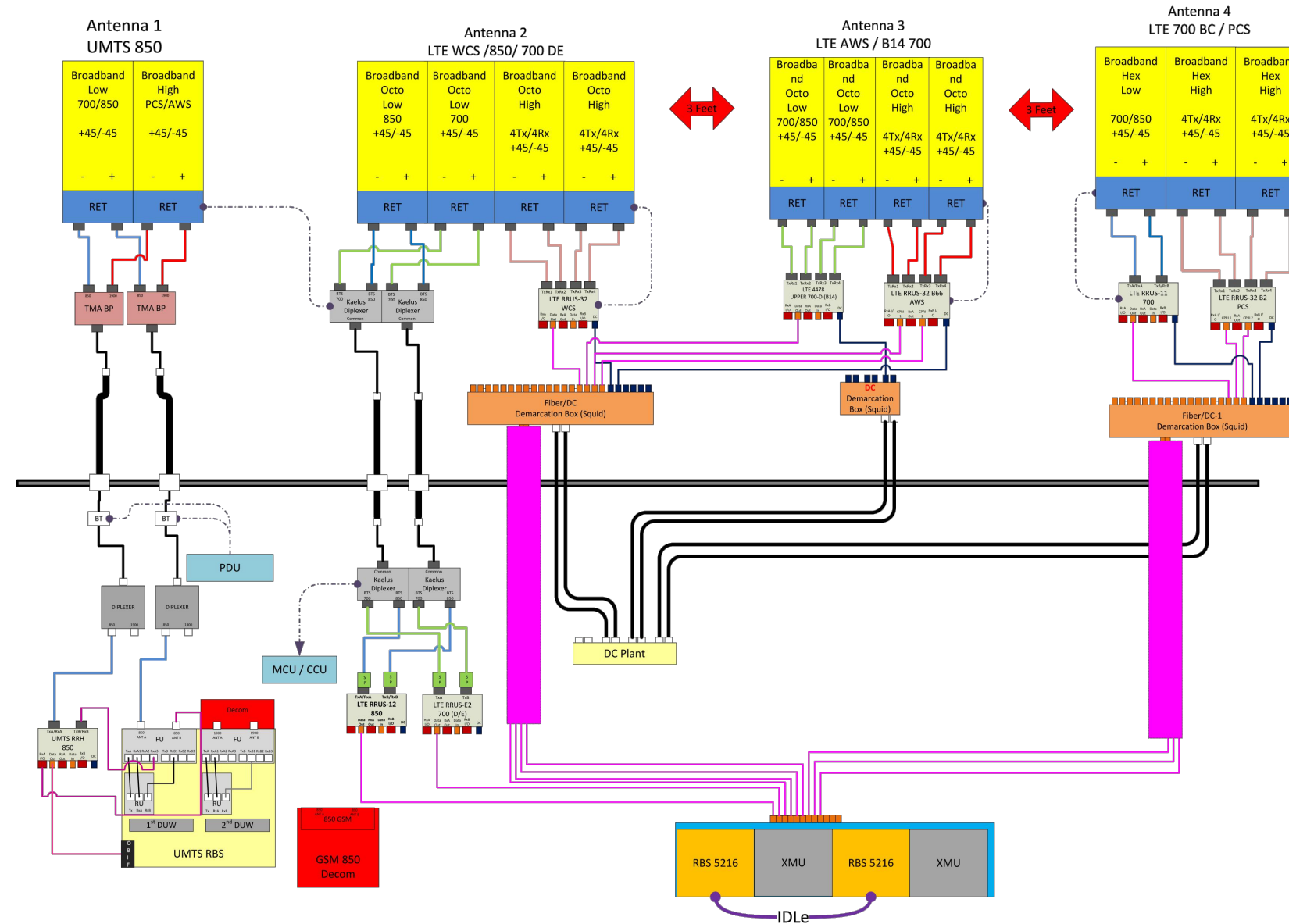

**RF PLUMBING DIAGRAM** 1  
SCALE: N.T.S. RF-1

**NOTE:**  
1. CONTRACTOR TO CONFIRM ALL PARTS.  
2. INSTALL ALL EQUIPMENT TO MANUFACTURER'S RECOMMENDATIONS

**NOTE:**  
REFER TO THE FINAL RF DATA SHEET FOR FINAL ANTENNA SETTINGS.

NO.	DATE	REVISIONS	BY	CHK	APP'D
B	03/01/18	ISSUED FOR PERMITTING	SB	AT	DJC
A	02/01/18	ISSUED FOR REVIEW	RB	AT	DJC
SCALE: AS SHOWN		DESIGNED BY: AT	DRAWN BY: RB		

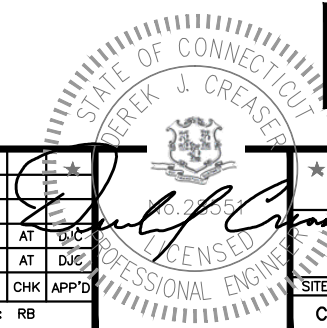

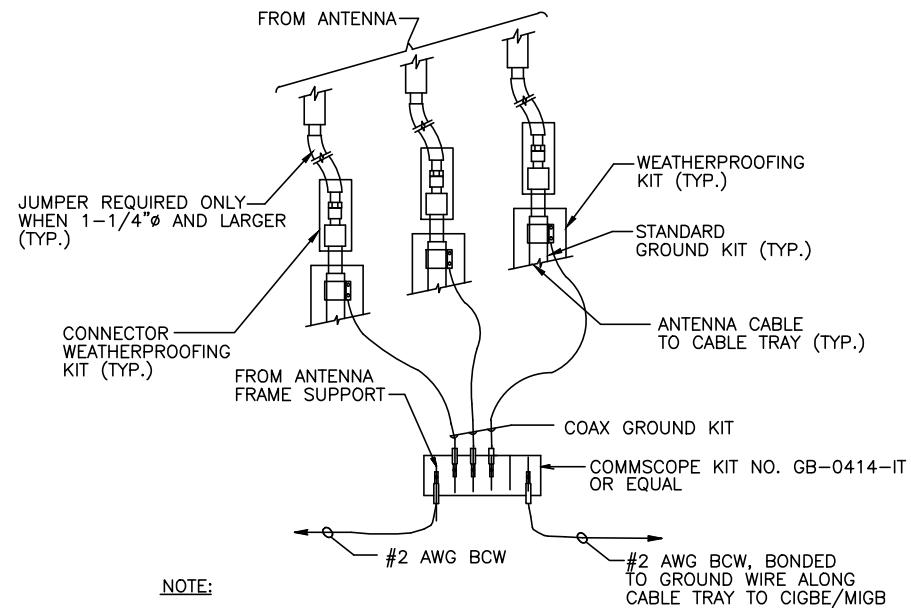

NOTE:  
 1. DO NOT INSTALL CABLE GROUND KIT AT A BEND AND ALWAYS DIRECT GROUND WIRE DOWN TO CIGBE.

**GROUND WIRE TO GROUND BAR CONNECTION DETAIL**

SCALE: N.T.S

1  
G-1

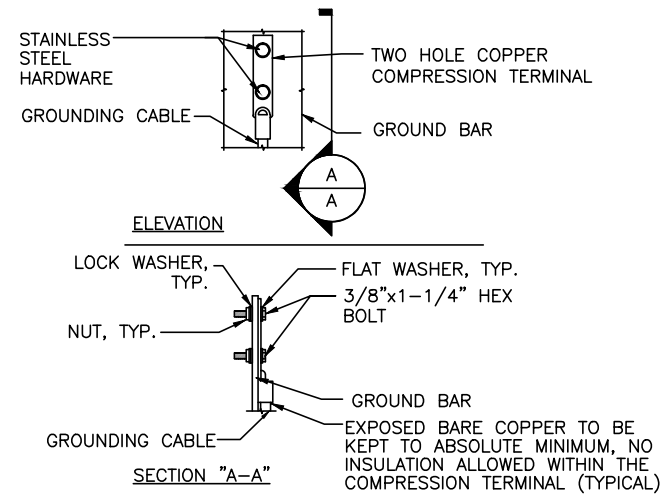

NOTE:  
 1. "DOUBLING UP" OR "STACKING" OF CONNECTION IS NOT PERMITTED.  
 2. OXIDE INHIBITING COMPOUND TO BE USED AT ALL LOCATION.  
 3. CADWELD DOWNLEADS FROM UPPER EGB, LOWER EGB, AND MGB

**TYPICAL GROUND BAR CONNECTION DETAIL**

SCALE: N.T.S

3  
G-1

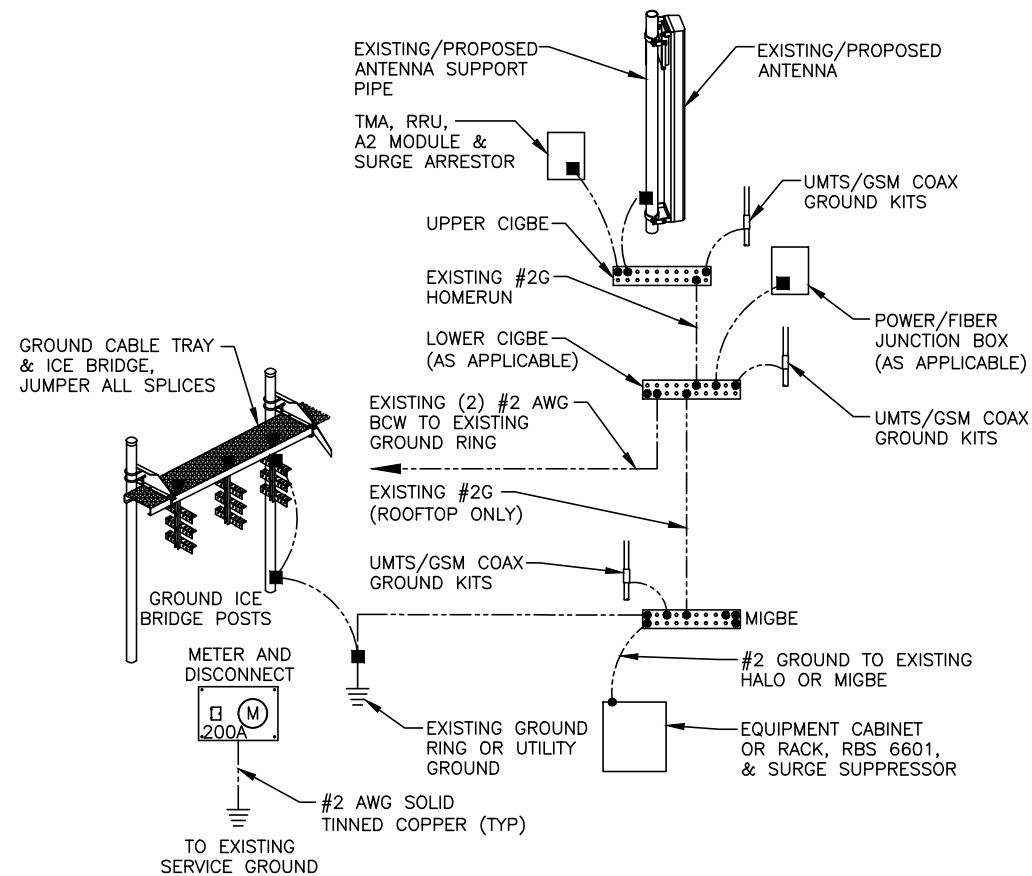

**GROUNDING RISER DIAGRAM**

SCALE: N.T.S

2  
G-1

EACH GROUND CONDUCTOR TERMINATING ON ANY GROUND BAR SHALL HAVE AN IDENTIFICATION TAG ATTACHED AT EACH END THAT WILL IDENTIFY ITS ORIGIN AND DESTINATION.

**SECTION "P" - SURGE PRODUCERS**

- CABLE ENTRY PORTS (HATCH PLATES) (#2)
- GENERATOR FRAMEWORK (IF AVAILABLE) (#2)
- TELCO GROUND BAR
- COMMERCIAL POWER COMMON NEUTRAL/GROUND BOND (#2)
- +24V POWER SUPPLY RETURN BAR (#2)
- 48V POWER SUPPLY RETURN BAR (#2)
- RECTIFIER FRAMES.

**SECTION "A" - SURGE ABSORBERS**

- INTERIOR GROUND RING (#2)
- EXTERNAL EARTH GROUND FIELD (BURIED GROUND RING) (#2)
- METALLIC COLD WATER PIPE (IF AVAILABLE) (#2)
- BUILDING STEEL (IF AVAILABLE) (#2)

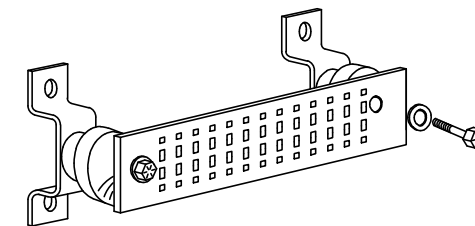

**GROUND BAR - DETAIL**

SCALE: N.T.S

4  
G-1

								AT&T	
								GROUNDING DETAILS (LTE 5C/6C/7C)	
B	03/01/18	ISSUED FOR PERMITTING	SB	AT	DJC			SITE NUMBER	
A	02/01/18	ISSUED FOR REVIEW	RB	AT	DJC			DRAWING NUMBER	
NO.	DATE	REVISIONS	BY	CHK	APP'D			REV	
SCALE: AS SHOWN		DESIGNED BY: AT		DRAWN BY: RB				CT2111	
								G-1	
								B	