

JULIE D. KOHLER

PLEASE REPLY TO: Bridgeport
WRITER'S DIRECT DIAL: (203) 337-4157
E-Mail Address: jkohler@cohenandwolf.com

September 17, 2014

Attorney Melanie Bachman
Acting Executive Director
Connecticut Siting Council
Ten Franklin Square
New Britain, CT 06051

**Re: Notice of Exempt Modification
CL&P/T-Mobile co-location
Site ID CT111832C
701 Bartholomew Street, Middletown CT**

Dear Attorney Bachman:

This office represents T-Mobile Northeast LLC ("T-Mobile") and has been retained to file exempt modification filings with the Connecticut Siting Council on its behalf.

In this case, the Connecticut Light and Power Company ("CL&P") owns the existing wood utility pole and related facility at 701 Bartholomew Street, Middletown Connecticut (latitude 41.52074953/longitude -72.6083121). T-Mobile intends to add three antennas and related equipment at this existing telecommunications facility in Middletown ("Middletown Facility"). Please accept this letter as notification, pursuant to R.C.S.A. § 16-50j-73, of construction which constitutes an exempt modification pursuant to R.C.S.A. § 16-50j-72(b)(2). In accordance with R.C.S.A. § 16-50j-73, a copy of this letter is being sent to the Mayor, Daniel T. Drew. CL&P is also the property owner. See attached letter of authorization from CL&P dated September 17, 2014, provided as Exhibit A.

The existing Middletown Facility consists of a 95 foot tall utility pole structure. T-Mobile plans to add three antennas at a centerline of 83 feet. T-Mobile will also replace an equipment cabinet on the existing concrete pad, install three RRUs (remote radio units) on a proposed H-frame, add coax cable and reuse existing coax cable all within the compound area. See the plans revised to August 22, 2014 attached hereto as Exhibit B. The existing Facility is structurally capable of supporting T-Mobile's proposed modifications, as indicated in the structural analysis dated September 5, 2014 attached hereto as Exhibit C.

The planned modifications to the Middletown Facility fall squarely within those activities

September 17, 2014
Site ID CTHA056J
Page 2

explicitly provided for in R.C.S.A. § 16-50j-72(b)(2).

1. The proposed modification will not increase the height of the tower. T-Mobile's proposed antennas will be installed at the 83 foot level of the 95 foot utility pole. The enclosed tower drawing confirms that the proposed modification will not increase the height of the tower.
2. The installation of the T-Mobile equipment in the existing compound, as reflected on page 1 of Exhibit B, will not require an extension of the site boundaries. T-Mobile's proposed equipment will be located entirely within the existing compound area.
3. The proposed modification to the Facility will not increase the noise levels at the existing facility by six decibels or more.
4. The operation of the proposed antennas will not increase the total radio frequency (RF) power density, measured at the base of the tower, to a level at or above the applicable standard. According to a Radio Frequency Emissions Analysis Report prepared by EBI dated September 16, 2014 T-Mobile's operations would add 15.39% of the FCC Standard. Therefore, the calculated "worst case" power density for the planned combined operation at the site including all of the proposed antennas would be 52.56% of the FCC Standard as calculated for a mixed frequency site as evidenced by the engineering exhibit attached hereto as Exhibit C.

For the foregoing reasons, T-Mobile respectfully submits that the proposed antennas and equipment at the Middletown Facility constitutes an exempt modification under R.C.S.A. § 16-50j-72(b)(2). Upon acknowledgement by the Council of this proposed exempt modification, T-Mobile shall commence construction approximately sixty days from the date of the Council's notice of acknowledgement.

Sincerely,

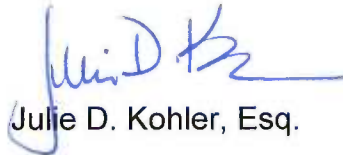

Julie D. Kohler, Esq.

cc: City of Middletown, Mayor Daniel T. Drew
CL&P
Sheldon Freinckle, NSS

EXHIBIT A



**Northeast
Utilities System**

56 Prospect Street, Hartford, CT 06103

Northeast Utilities Service Company
P.O. Box 270
Hartford, CT 06141-0270
(203) 665-5000

September 17, 2014

Mr. Mark Richard
T-Mobile
35 Griffin Rd.
Bloomfield, CT 06002

RE: T-Mobile Antenna Site, CT-11 832C, 701 Bartholomew Rd., Middletown CT, structure 14027.

Dear Mr. Richard:

Based on our reviews of the site drawings, the structural analysis provided by Laminated Wood Pole, along with a third party review performed Matthew Young we have reviewed for acceptance this modification.

Since there are no outstanding structural or site related issues to resolve at this time, construction at these locations may begin as soon as scheduling allows. You may contact Mr. O'Brien (860-665-6987); once the lease issues are secured you may then contact Mr. John Landry directly (860-665-5425) to begin the construction arrangements

Sincerely,

Robert Gray
Transmission Line Engineering

Ref: CT11832C-L700-CD-V1.pdf

Ref: CT11832C-L700-SA Summary letter-V1.pdf

EXHIBIT B

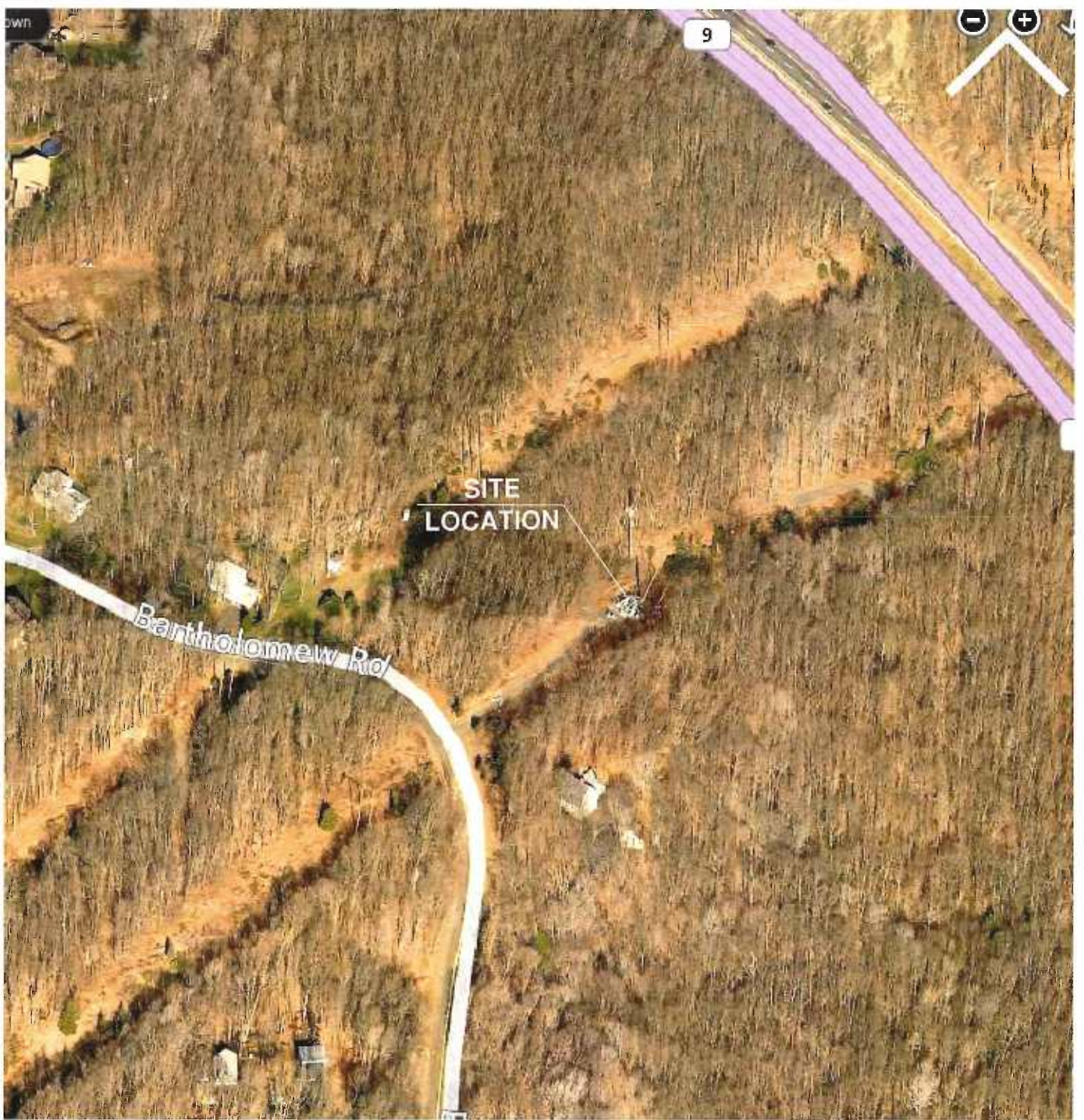

ALL EQUIPMENT LOCATIONS ARE APPROXIMATE AND ARE SUBJECT TO APPROVAL BY LESSEE/LICENSEE'S STRUCTURAL & RF ENGINEERS. LOCATIONS OF POWER & TELEPHONE FACILITIES ARE SUBJECT TO APPROVAL BY UTILITY COMPANIES.

KEY MAP
N.T.S.



PROJECT : L700

CONFIGURATION

704G

SUBMITTALS

LE REV A	08.21.14
LE REV 0	08.22.14

ATLANTIS GROUP
1340 Centre Street
Suite 212
Newton, MA 02459
Office: 617-965-0789
Fax: 617-213-5056

LEASE EXHIBIT

SITE NUMBER:
CT11832B

SITE NAME:
CT832/CL&P MIDDLETOWN
SITE ADDRESS:
701 BARTHOLOMEW ST
MIDDLETOWN, CT 06457

NORTHEAST SITE SOLUTIONS
54 MAIN STREET, UNIT 3
STURBRIDGE, MA 01566
(508) 434-5237

FOR
T-MOBILE NORTHEAST, LLC
35 GRIFFIN ROAD SOUTH
BLOOMFIELD, CT 06002
OFFICE: (860) 692-7100
FAX: (860) 692-7159

DRAWN BY: FG

CHECKED BY: SM

PAGE 1 OF 3

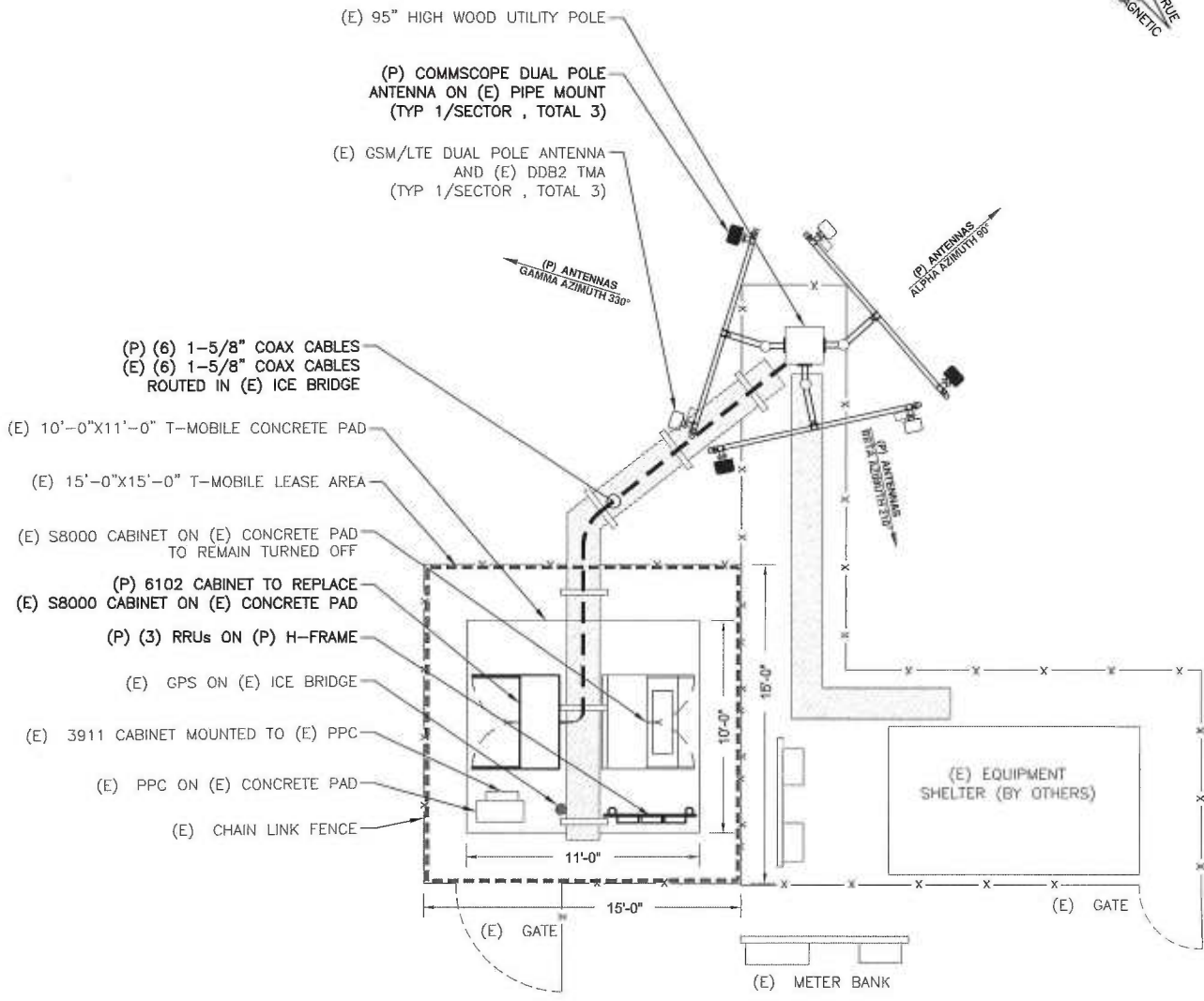
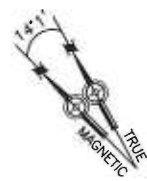

SITE PLAN

SCALE: 1/8" = 1'-0" (8.5x11)

1
LE-2

PROJECT : L700
 CONFIGURATION
704G

SUBMITTALS	
LE REV A	08.21.14
LE REV 0	08.22.14

ATLANTIS GROUP
 1340 Centre Street
 Suite 212
 Newton, MA 02459
 Office: 617-965-0789
 Fax: 617-213-5056

LEASE EXHIBIT
 SITE NUMBER:
 CT11832B
 SITE NAME:
 CT832/CL&P MIDDLETOWN
 SITE ADDRESS:
 701 BARTHOLOMEW ST
 MIDDLETOWN, CT 06457

NORTHEAST SITE SOLUTIONS
 54 MAIN STREET, UNIT 3
 STURBRIDGE, MA 01566
 (508) 434-5237
 FOR
T-MOBILE NORTHEAST, LLC
 35 GRIFFIN ROAD SOUTH
 BLOOMFIELD, CT 06002
 OFFICE: (860) 692-7100
 FAX: (860) 692-7159

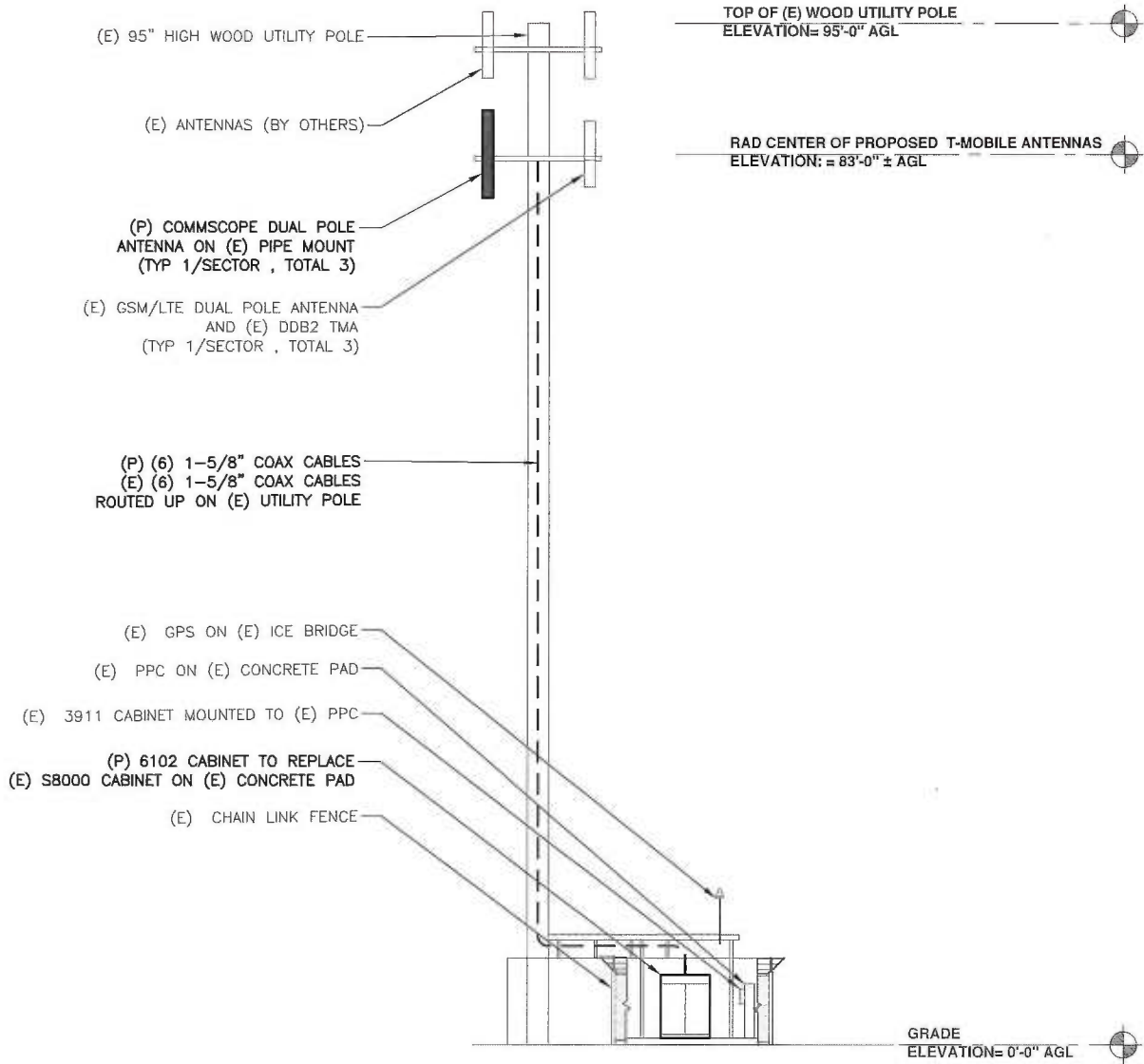

ELEVATION VIEW

SCALE: 1/16" = 1'-0" (8.5x11)

1
LE-3

PROJECT : L700
 CONFIGURATION
704G

SUBMITTALS	
LE REV A	08.21.14
LE REV 0	08.22.14

ATLANTIS GROUP
 1340 Centre Street
 Suite 212
 Newton, MA 02459
 Office: 617-965-0789
 Fax: 617-213-5056

LEASE EXHIBIT
 SITE NUMBER:
 CT11832B
 SITE NAME:
 CT832/CL&P MIDDLETOWN
 SITE ADDRESS:
 701 BARTHOLOMEW ST
 MIDDLETOWN, CT 06457

NORTHEAST SITE SOLUTIONS
 54 MAIN STREET, UNIT 3
 STURBRIDGE, MA 01566
 (508) 434-5237
 FOR
T-MOBILE NORTHEAST, LLC
 35 GRIFFIN ROAD SOUTH
 BLOOMFIELD, CT 06002
 OFFICE: (860) 692-7100
 FAX: (860) 692-7159

EXHIBIT C

Matthew J. Young – Professional Engineer

P.O. Box 277 – Story, WY 82842

Telephone: 402-643-4708

e-mail: myoung@lwsinc.com

September 5, 2014

RE: Northeast Utilities – Middletown Site # CT5436/CT0436/CT11832 – Str. # 14027

Northeast Site Solutions
ATTN: Sheldon Freinckle

I have reviewed the laminated wood pole that is located at the Middletown, CT site. I understand that the proposed modification involves adding (3) additional panel antennas and (6) 1 5/8" coax to the T-Mobile array, which is centered at approximately 83' AGL. The AT&T antennas, which are centered at approximately 93' AGL will remain unchanged from the 2012 installation. Northeast Utilities' conductor loading is also unchanged and is consistent with the values that were provided for the original design in 2002.

Based on this information, the existing laminated wood structure does have adequate capacity to support the proposed loads.

The analysis was based on the following parameters:

Load Conditions Checked:

- 1) NESC Extreme Wind = 110 MPH with no ice (31.2 psf) – transverse and longitudinal
- 2) NESC "Heavy" – combined wind and ice

Minimum existing pole groundline dimensions = 22 1/4" x 23 3/8"

Maximum Element Usage = **88%** (pole - Extreme Wind (L))

Proposed Loading:

AT&T –

- (3) 55" x 11" x 5" panels – centerline height = 93 ft. AGL
- + (6) TMA's (mounted behind antennas) – existing
- (3) 54" x 12.6" x 7.9" panels – centerline height = 93 ft. AGL - existing

Total AT&T EPA = 39.1 sq. ft.

T-Mobile –

- (3) 56" x 8" x 2.8" panels – centerline height = 83 ft. AGL - existing
- (3) 96.4" x 11.9" x 7.1" panels – centerline height = 83 ft. AGL - proposed

Total T-Mobile EPA = 39.8 sq. ft.

Coax Cables –

Maximum projection for all cables = 2" from any one pole face

This analysis considers that the pole, its foundation, and all attachments were constructed and remain as originally specified.

If you have any questions, please call or e-mail.

Sincerely,

Matthew J. Young, P.E.

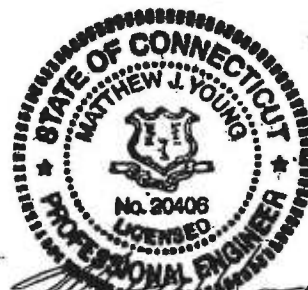

9-5-2014

Matthew J. Young – Professional Engineer
P.O. Box 277 – Story, WY 82842
Telephone: 402-643-4708
e-mail: myoung@lwsinc.com

Pole Analysis

E-LAM[®] Laminated Wood Pole

Northeast Utilities/T-Mobile
Middletown CT Site
Site # CT5436/CT0436/CT11832
Str. # 14027
Middletown, CT

Drawings and Calculations
(8 Pages + Cover Sheet)



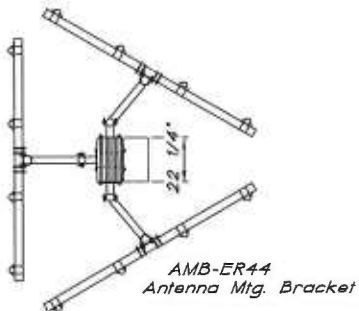
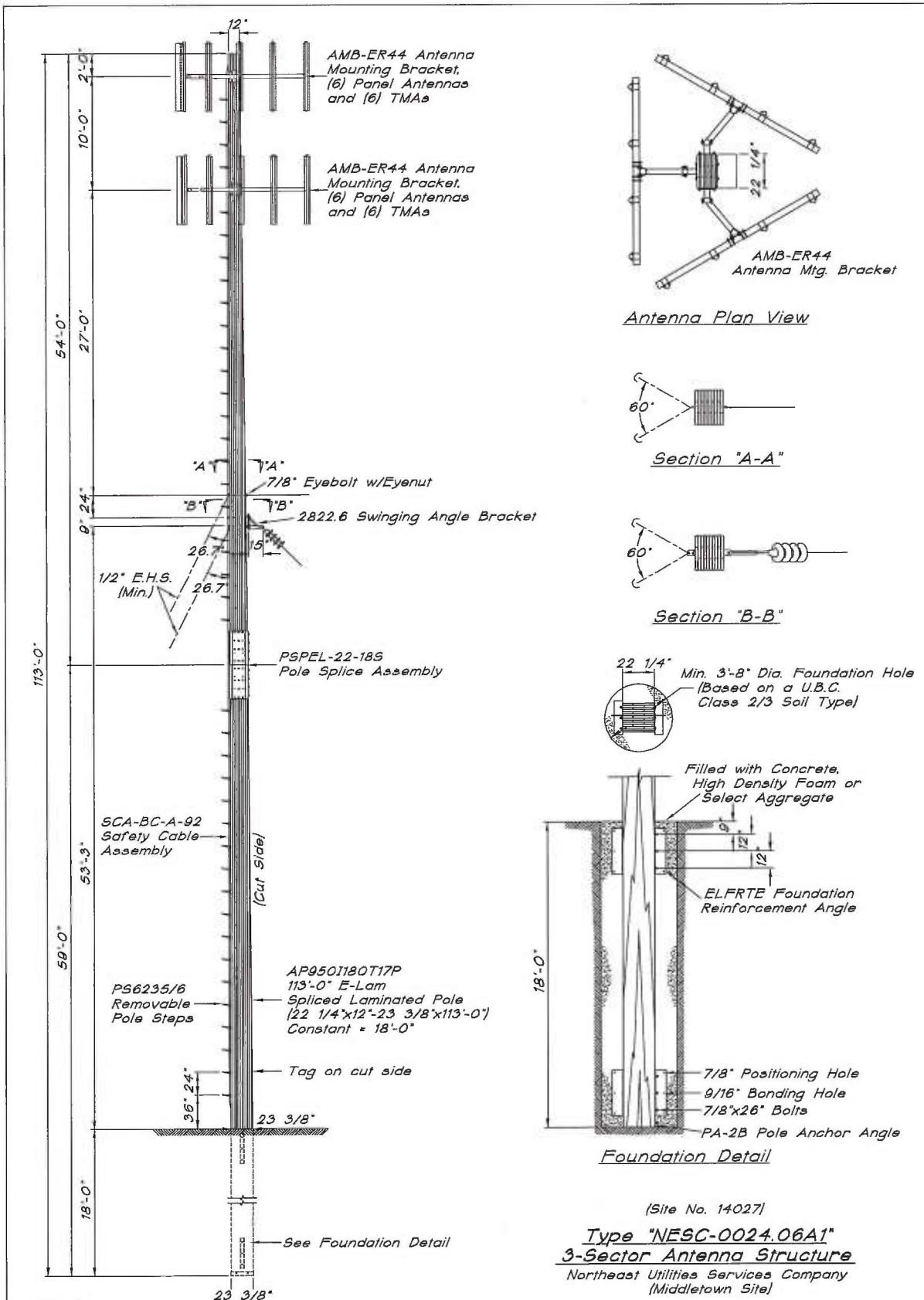

Antenna Plan View

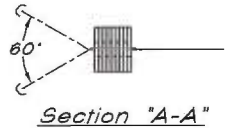

Section "A-A"



Section "B-B"

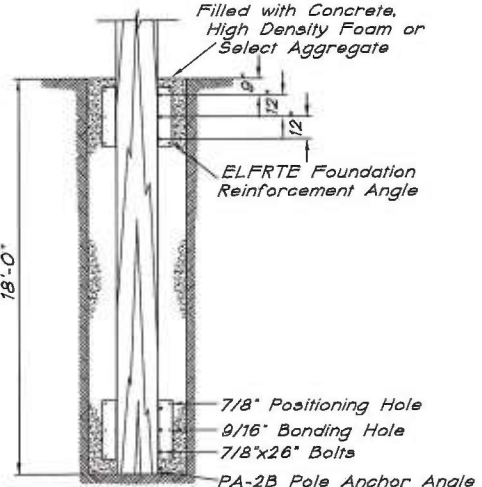
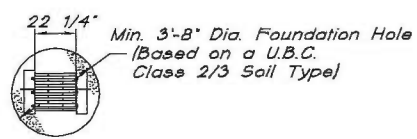

Foundation Detail

(Site No. 14027)

Type "NESC-0024.06A1"
3-Sector Antenna Structure
 Northeast Utilities Services Company
 (Middletown Site)

©LWS 11/02

9.		9-3-14	
7. & 8.	updated antennas	5/1&8/18-12	
5. & 6.		9/3&9/8-08	
4.		9-2-03	
3.	Added Pole Steps	8-27-03	
2.	Increased Embedded Depth due to Soil Report.	7-22-03	
1.		12-10-02	
NO.	REVISION	DATE	CK.

Laminated Wood Systems, Inc.

E-LAM

P.O. BOX 386, SEWARD, NE 68434 1-800-949-ELAM

DRAWN: J. Baack DATE: 11-26-02 DWG. NO.: NESC-0024.06A1

ACAD DWG. FILE: NESC2406A1

Type "PSPeL-22-18S"
Pole Splice Detail
 (for 22 1/4"x18" Section)

PSPeL-22-18-SP
 5/16" Splice
 Side Plate

PSPeL-22-1
 1/4" Splice
 Channel

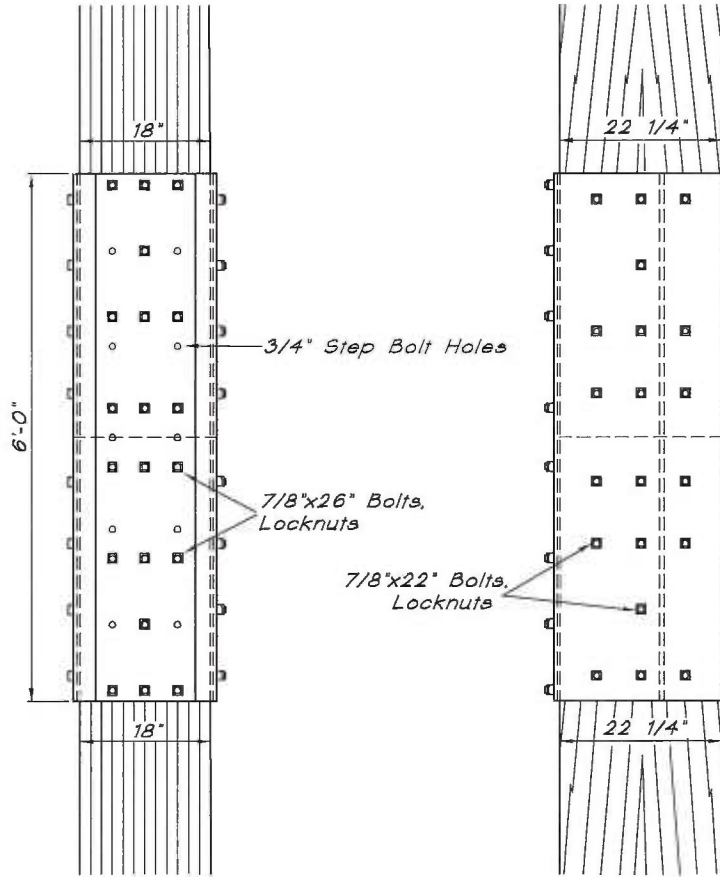
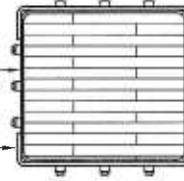

© LWS 10/02

				Laminated Wood Systems, Inc.		
				E-LAM		
				P.O. BOX 386, SEWARD, NE 68434		1-800-949-ELAM
NO.	REVISION	DATE	CK.	DRAWN	DATE	DWG. NO.
				J. Baack	10-18-02	PSPeL-22-18S
ACAD DWG. FILE: PSPeL2218S						

AT&T Antennas - 93' AGL (existing)

Site # 5436 - Str. # 14027 - Middletown, CT Site

Wind Load Calculation

Ext. Wind Speed = 110 MPH					
Ext. Wind	Height Above Ground (ft.)	Kz	Grf-Str	Shape Factor	Wind Pressure (p.s.f.)
O.L.F.	93.00	1.15	0.88	1.6	49.77
1.00					
				Projected Area (sq. ft.)	Equiv. Point Load (lbs.)
existing antennas & bracket				39.1	1,946
NESC Zone		Basic Pressure (p.s.f.)	O.L.F.	Shape Factor	
		4.00	2.50	1.60	16.0
				Projected Area (sq. ft.)	Equiv. Point Load (lbs.)
existing antennas & bracket				39.1	626
0.00					

T-Mobile Antennas - 83' AGL (prop. Sept. 2014)

Site # 5436 - Str. # 14027 - Middletown, CT Site

Wind Load Calculation

Ext. Wind Speed =		110	MPH		
Ext. Wind	Height Above Ground (ft.)	Kz	Grf-Str	Shape Factor	Wind Pressure (p.s.f.)
O.L.F.					
1.00	83.00	1.12	0.89	1.6	49.11
				Projected Area (sq. ft.)	Equiv. Point Load (lbs.)
(3) RR90-17 + (3) LNX-6515DS + Brkt.				39.8	1,955
NESC Zone		Basic Pressure (p.s.f.)	O.L.F.	Shape Factor	
		4.00	2.50	1.60	16.0
				Projected Area (sq. ft.)	Equiv. Point Load (lbs.)
(3) RR90-17 + (3) LNX-6515DS + Brkt. 0.00				39.8	637

Cables

Site # 5436 - Str. # 14027 - Middletown, CT Site

Wind Load Calculation

Ext. Wind Speed = 110 MPH					
Ext. Wind	Height Above Ground (ft.)	Kz	Grf-Str	Shape Factor	Wind Pressure (p.s.f.)
O.L.F.					
1.00	47.50	0.99	0.93	1.6	45.88
				Projected Area (sq. ft.)	Equiv. Point Load (lbs.)
max. projection = 2"				15.8	726
NESC Zone		Basic Pressure (p.s.f.)	O.L.F.	Shape Factor	
		4.00	2.50	1.60	16.0
				Projected Area (sq. ft.)	Equiv. Point Load (lbs.)
max. projection = 2"				15.8	253
0.00					

Project Name : NESC/AT&T/T-Mobile - Str. # 14027
 Project Notes: Middletown, CT
 Project File : h:\pls\examples\old_files\pls\pls_pole\projects\nesc\nesc14027sept2014.pol
 Date run : 10:08:41 AM Friday, September 05, 2014
 by : PLS-POLE Version 13.01

Successfully performed nonlinear analysis

The model has 0 warnings.

Loads from file: h:\pls\examples\old_files\pls\pls_pole\projects\nesc\nesc14027sept2014.lca

*** Analysis Results:

Maximum element usage is 88.15% for Laminated Wood Pole "Pole" in load case "Ext. Wind 1"
 Maximum insulator usage is 5.99% for Suspen "SUSWIRE" in load case "NESC HVY t"

Summary of Joint Support Reactions For All Load Cases:

Load Case	Joint Label	Long. Force (kips)	Tran. Force (kips)	Vert. Force (kips)	Shear Force (kips)	Tran. Moment (ft-k)	Long. Bending Moment (ft-k)	Bending Moment (ft-k)	Vert. Moment (ft-k)	Found. Usage %
Ext. Wind t	Pole:g	-0.08	-0.02	-54.10	0.08	-66.68	-13.32	67.99	-0.04	0.00
Ext. Wind t	\$Gnd1	2.29	8.80	17.76	9.09	0.00	0.00	0.00	0.00	0.00
Ext. Wind t	\$Gnd2	-2.23	8.44	17.07	8.73	0.00	0.00	0.00	0.00	0.00
Ext. Wind l	Pole:g	-10.91	-2.39	-24.14	11.17	142.51	-694.04	708.52	0.78	0.00
Ext. Wind l	\$Gnd1	-0.03	0.08	0.14	0.08	0.00	0.00	0.00	0.00	0.00
Ext. Wind l	\$Gnd2	-0.86	2.29	4.79	2.44	0.00	0.00	0.00	0.00	0.00
NESC HVY t	Pole:g	-0.03	0.73	-39.06	0.73	-56.71	-5.96	57.02	-0.01	0.00
NESC HVY t	\$Gnd1	1.22	4.64	9.47	4.80	0.00	0.00	0.00	0.00	0.00
NESC HVY t	\$Gnd2	-1.21	4.57	9.31	4.72	0.00	0.00	0.00	0.00	0.00
NESC HVY l	Pole:g	-3.56	-0.87	-21.97	3.67	51.12	-225.37	231.10	0.10	0.00
NESC HVY l	\$Gnd1	-0.00	0.05	0.08	0.05	0.00	0.00	0.00	0.00	0.00
NESC HVY l	\$Gnd2	-0.25	0.79	1.63	0.83	0.00	0.00	0.00	0.00	0.00
Hvy Ice	Pole:g	-0.01	0.52	-27.22	0.52	-25.34	-1.58	25.39	0.00	0.00
Hvy Ice	\$Gnd1	0.38	1.43	2.94	1.49	0.00	0.00	0.00	0.00	0.00
Hvy Ice	\$Gnd2	-0.40	1.48	3.03	1.53	0.00	0.00	0.00	0.00	0.00

Summary of Tip Deflections For All Load Cases:

Note: positive tip load results in positive deflection

Load Case	Joint Label	Long. Defl. (in)	Tran. Defl. (in)	Vert. Defl. (in)	Resultant Defl. (in)	Long. Rot. (deg)	Tran. Rot. (deg)	Twist (deg)
Ext. Wind t	Pole:t	1.55	-28.85	-0.65	28.90	0.11	3.28	-0.00
Ext. Wind l	Pole:t	67.97	12.73	-2.51	69.20	4.98	-0.85	-0.02
NESC HVY t	Pole:t	0.72	-11.78	-0.12	11.80	0.05	1.21	-0.00
NESC HVY l	Pole:t	22.05	4.59	-0.28	22.52	1.61	-0.31	-0.00
Hvy Ice	Pole:t	0.20	-1.74	-0.02	1.76	0.01	0.10	0.00

*** Overall summary for all load cases - Usage = Maximum Stress / Allowable Stress

Summary of Laminated Wood Pole Usages:

Laminated Wood Pole Label	Maximum Usage %	Load Case	Segment Number	Weight (lbs)
Pole	88.15	Ext. Wind 1	22	14933.6

Summary of Davit Usages:

Davit Label	Maximum Usage %	Load Case	Segment Number	Weight (lbs)
SWF	0.03	Hvy Ice	1	12.0
SWGUY	0.03	Hvy Ice	1	12.0
WIRE	0.03	Hvy Ice	1	12.0

GUY 0.03 Hvy Ice 1 12.0

Summary of Guy Usages:

Guy Label	Maximum Usage %	Load Case	Weight (lbs)	Unstressed Length (ft)
sw	74.29	Ext. Wind t	32.4	62.62
wire	71.38	Ext. Wind t	30.8	59.55

*** Maximum Stress Summary for Each Load Case

Summary of Maximum Usages by Load Case:

Load Case	Maximum Usage %	Element Label	Element Type
Ext. Wind t	74.29	sw	Guy
Ext. Wind l	88.15	Pole Laminated Wood	
NESC HVY t	39.56	sw	Guy
NESC HVY l	34.17	Pole Laminated Wood	
Hvy Ice	12.72	wire	Guy

Summary of Laminated Wood Pole Usages by Load Case:

Load Case	Maximum Usage %	Laminated Wood Pole Label	Segment Number
Ext. Wind t	42.29	Pole	9
Ext. Wind l	88.15	Pole	22
NESC HVY t	16.18	Pole	9
NESC HVY l	34.17	Pole	22
Hvy Ice	3.80	Pole	22

Summary of Davit Usages by Load Case:

Load Case	Maximum Usage %	Davit Label	Segment Number
Ext. Wind t	0.03	WIRE	1
Ext. Wind l	0.03	WIRE	1
NESC HVY t	0.03	GUY	1
NESC HVY l	0.03	WIRE	1
Hvy Ice	0.03	WIRE	1

Summary of Guy Usages by Load Case:

Load Case	Maximum Usage %	Guy Label
Ext. Wind t	74.29	sw
Ext. Wind l	20.08	wire
NESC HVY t	39.56	sw
NESC HVY l	6.90	wire
Hvy Ice	12.72	wire

Summary of Insulator Usages:

Insulator Label	Insulator Type	Maximum Usage %	Load Case	Weight (lbs)
SUSSW	Suspension	3.71	NESC HVY t	3.0
SUSWIRE	Suspension	5.99	NESC HVY t	3.0
ANT1	Suspension	4.65	Ext. Wind t	3.0
ANT2	Suspension	4.66	Ext. Wind t	3.0
cables	Suspension	4.34	Ext. Wind t	3.0

*** Weight of structure (lbs):
Weight of Guys: 63.2
Weight of Davit Arms: 48.0
Weight of Laminated Wood Poles: 14933.6
Weight of Suspensions: 15.0
Total: 15059.8

*** End of Report

nesc14027sept2014

EXHIBIT D

RADIO FREQUENCY EMISSIONS ANALYSIS REPORT
EVALUATION OF HUMAN EXPOSURE POTENTIAL
TO NON-IONIZING EMISSIONS

T-Mobile Existing Facility

Site ID: CT11832C

CL&P Middletown

701 Bartholomew Street
Middletown, CT 06457

September 16, 2014

EBI Project Number: 62144663

Site Compliance Summary	
Compliance Status:	COMPLIANT
Site total MPE% of FCC general public allowable limit:	52.56 %

September 16, 2014

T-Mobile USA
Attn: Jason Overbey, RF Manager
35 Griffin Road South
Bloomfield, CT 06002

Emissions Analysis for Site: **CT11832C – CL&P Middletown**

EBI Consulting was directed to analyze the proposed T-Mobile facility located at **701 Bartholomew Street, Middletown, CT**, for the purpose of determining whether the emissions from the Proposed T-Mobile Antenna Installation located on this property are within specified federal limits.

All information used in this report was analyzed as a percentage of current Maximum Permissible Exposure (% MPE) as listed in the FCC OET Bulletin 65 Edition 97-01 and ANSI/IEEE Std C95.1. The FCC regulates Maximum Permissible Exposure in units of microwatts per square centimeter ($\mu\text{W}/\text{cm}^2$). The number of $\mu\text{W}/\text{cm}^2$ calculated at each sample point is called the power density. The exposure limit for power density varies depending upon the frequencies being utilized. Wireless Carriers and Paging Services use different frequency bands each with different exposure limits, therefore it is necessary to report results and limits in terms of percent MPE rather than power density.

All results were compared to the FCC (Federal Communications Commission) radio frequency exposure rules, 47 CFR 1.1307(b)(1) – (b)(3), to determine compliance with the Maximum Permissible Exposure (MPE) limits for General Population/Uncontrolled environments as defined below.

General population/uncontrolled exposure limits apply to situations in which the general public may be exposed or in which persons who are exposed as a consequence of their employment may not be made fully aware of the potential for exposure or cannot exercise control over their exposure. Therefore, members of the general public would always be considered under this category when exposure is not employment related, for example, in the case of a telecommunications tower that exposes persons in a nearby residential area.

Public exposure to radio frequencies is regulated and enforced in units of microwatts per square centimeter ($\mu\text{W}/\text{cm}^2$). The general population exposure limit for the 700 MHz Band is $467 \mu\text{W}/\text{cm}^2$, and the general population exposure limit for the PCS and AWS bands is $1000 \mu\text{W}/\text{cm}^2$. Because each carrier will be using different frequency bands, and each frequency band has different exposure limits, it is necessary to report percent of MPE rather than power density.

Occupational/controlled exposure limits apply to situations in which persons are exposed as a consequence of their employment and in which those persons who are exposed have been made fully aware of the potential for exposure and can exercise control over their exposure. Occupational/controlled exposure limits also apply where exposure is of a transient nature as a result of incidental passage through a location where exposure levels may be above general population/uncontrolled limits (see below), as long as the exposed person has been made fully aware of the potential for exposure and can exercise control over his or her exposure by leaving the area or by some other appropriate means.

Additional details can be found in FCC OET 65.

CALCULATIONS

Calculations were done for the proposed T-Mobile Wireless antenna facility located at **701 Bartholomew Street, Middletown, CT**, using the equipment information listed below. All calculations were performed per the specifications under FCC OET 65. Since T-Mobile is proposing highly focused directional panel antennas, which project most of the emitted energy out toward the horizon, all calculations were performed assuming a lobe representing the maximum gain of the antenna per the antenna manufactures supplied specifications, minus 10 dB, was focused at the base of the tower. For this report the sample point is the top of a 6 foot person standing at the base of the tower.

For all calculations, all equipment was calculated using the following assumptions:

- 1) 2 GSM channels (PCS Band - 1900 MHz) were considered for each sector of the proposed installation. These Channels have a transmit power of 30 Watts per Channel
- 2) 2 UMTS channels (PCS Band - 1900 MHz) were considered for each sector of the proposed installation. These Channels have a transmit power of 30 Watts per Channel.
- 3) 2 LTE channels (PCS Band - 1900 MHz) were considered for each sector of the proposed installation. These Channels have a transmit power of 60 Watts per Channel.
- 4) 1 LTE channel (700 MHz Band) was considered for each sector of the proposed installation. This channel has a transmit power of 30 Watts.
- 5) All radios at the proposed installation were considered to be running at full power and were uncombined in their RF transmissions paths per carrier prescribed configuration. Per FCC OET Bulletin No. 65 - Edition 97-01 recommendations to achieve the maximum anticipated value at each sample point, all power levels emitting from the proposed antenna installation are increased by a factor of 2.56 to account for possible in-phase reflections from the surrounding environment. This is rarely the case, and if so, is never continuous.

- 6) For the following calculations the sample point was the top of a six foot person standing at the base of the tower. The maximum gain of the antenna per the antenna manufactures supplied specifications minus 10 dB was used in this direction. This value is a very conservative estimate as gain reductions for these particular antennas are typically much higher in this direction.
- 7) The antennas used in this modeling are the **Andrew RR90_17_02DP** for 1900 MHz (PCS) channels and the **Commscope LNX-6515DS-VTM** for 700 MHz channels. This is based on feedback from the carrier with regards to anticipated antenna selection. The **Andrew RR90_17_02DP** has a maximum gain of **14.4 dBd** at its main lobe. The **Commscope LNX-6515DS-VTM** has a maximum gain of **14.6 dBd** at its main lobe. The maximum gain of the antenna per the antenna manufactures supplied specifications, minus 10 dB, was used for all calculations. This value is a very conservative estimate as gain reductions for these particular antennas are typically much higher in this direction.
- 8) The antenna mounting height centerline of the proposed antennas is **83 feet** above ground level (AGL).
- 9) Emissions values for additional carriers were taken from the Connecticut Siting Council active database. Values in this database are provided by the individual carriers themselves.

All calculations were done with respect to uncontrolled / general public threshold limits.

T-Mobile Site Inventory and Power Data

Sector:	A	Sector:	B	Sector:	C
Antenna #:	1	Antenna #:	1	Antenna #:	1
Make / Model:	Andrew RR90_17_02DP	Make / Model:	Andrew RR90_17_02DP	Make / Model:	Andrew RR90_17_02DP
Gain:	14.4 dBd	Gain:	14.4 dBd	Gain:	14.4 dBd
Height (AGL):	83	Height (AGL):	83	Height (AGL):	83
Frequency Bands	1900 MHz(PCS)	Frequency Bands	1900 MHz(PCS)	Frequency Bands	1900 MHz(PCS)
Channel Count	6	Channel Count	6	# PCS Channels:	6
Total TX Power:	240	Total TX Power:	240	# AWS Channels:	240
ERP (W):	3,505.81	ERP (W):	3,505.81	ERP (W):	3,505.81
Antenna A1 MPE%	4.01	Antenna B1 MPE%	4.01	Antenna C1 MPE%	4.01
Antenna #:	2	Antenna #:	2	Antenna #:	2
Make / Model:	Commscope LNX-6515DS-VTM	Make / Model:	Commscope LNX-6515DS-VTM	Make / Model:	Commscope LNX-6515DS-VTM
Gain:	14.6 dBd	Gain:	14.6 dBd	Gain:	14.6 dBd
Height (AGL):	83	Height (AGL):	83	Height (AGL):	83
Frequency Bands	700 Mhz	Frequency Bands	700 Mhz	Frequency Bands	700 Mhz
Channel Count	1	Channel Count	1	Channel Count	1
Total TX Power:	30	Total TX Power:	30	Total TX Power:	30
ERP (W):	445.37	ERP (W):	445.37	ERP (W):	445.37
Antenna A2 MPE%	1.12	Antenna B2 MPE%	1.12	Antenna C2 MPE%	1.12

Site Composite MPE %	
Carrier	MPE %
T-Mobile	15.39
AT&T	37.17 %
Site Total MPE %:	52.56 %

T-Mobile Sector 1 Total:	5.13 %
T-Mobile Sector 2 Total:	5.13 %
T-Mobile Sector 3 Total:	5.13 %
Site Total:	52.56 %

Summary

All calculations performed for this analysis yielded results that were **within** the allowable limits for general public exposure to RF Emissions.

The anticipated maximum composite contributions from the T-Mobile facility as well as the site composite emissions value with regards to compliance with FCC's allowable limits for general public exposure to RF Emissions are shown here:

T-Mobile Sector	Power Density Value (%)
Sector 1:	5.13 %
Sector 2:	5.13 %
Sector 3 :	5.13 %
T-Mobile Total:	15.39 %
Site Total:	52.56 %
Site Compliance Status:	COMPLIANT

The anticipated composite MPE value for this site assuming all carriers present is **52.56%** of the allowable FCC established general public limit sampled at the ground level. This is based upon values listed in the Connecticut Siting Council database for existing carrier emissions.

FCC guidelines state that if a site is found to be out of compliance (over allowable thresholds), that carriers over a 5% contribution to the composite value will require measures to bring the site into compliance. For this facility, the composite values calculated were well within the allowable 100% threshold standard per the federal government.



Scott Heffernan
RF Engineering Director

EBI Consulting
21 B Street
Burlington, MA 01803`