



NORTHEAST
SITE SOLUTIONS

Turnkey Wireless Development

Northeast Site Solutions
Victoria Masse
420 Main Street, Unit 2
Sturbridge, MA 01566
860-306-2326
victoria@northeastitesolutions.com

June 30, 2020

Members of the Siting Council
Connecticut Siting Council
Ten Franklin Square
New Britain, CT 06051

RE: Notice of Exempt Modification
33 Mitchell Drive, Manchester CT 06040
Latitude: 41.79730280
Longitude: -72.51194400
T-Mobile Site#: CTHA174A_Anchor

Dear Ms. Bachman:

T-Mobile is requesting to file an exempt modification for an existing 170-foot Lattice Tower located at 33 Mitchell Drive, Manchester CT. T-Mobile currently maintains twelve (12) antennas at the 140-foot level of the existing 170-foot tower. The tower and property are owned by the Mitchell Drive LLC. T-Mobile now intends to add four (4) new 2500 MHz antenna, four (4) RRU and (4) new hybrid lines. The new antennas would be installed at the 140-foot and level of the tower.

Planned Modifications:

Remove: NONE

Remove and Replace: NONE

Install New:

(4) AIR6449 B41 -2500MHz Antenna

(4) RRU4415 B25

(4) Hybrid Lines

Existing to Remain:

(8) 1-5/8" Coax

(4) Hybrid Lines

(4) AIR21 B2A_B4P Antenna

(4) APXVAARR24-43-U-NA20 Antenna

(4) AIR32DB B66Aa B2a Antenna

(4) TMA

(4) RRU 4449

This facility was first approved by the Town of Manchester – A Special Exception Application was approved November 19, 2012. Please see attached.

Please accept this letter as notification pursuant to Regulations of Connecticut State Agencies § 16-50j-73, for construction that constitutes an exempt modification pursuant to R.C.S.A. § 16-50j-72(b)(2). In accordance with R.C.S.A. § 16-50j-73, a copy of this letter is being sent to Mayor Jay Moran, as Elected Official for the Town of Manchester and James Davis, Zoning Enforcement Officer as well as the property owner and the tower owner.

The planned modifications to the facility fall squarely within those activities explicitly provided for in R.C.S.A. § 16-50j-72(b)(2).

1. The proposed modifications will not result in an increase in the height of the existing structure.
2. The proposed modifications will not require the extension of the site boundary.
3. The proposed modifications will not increase noise levels at the facility by six decibels or more, or to levels that exceed state and local criteria.
4. The operation of the replacement antennas will not increase radio frequency emissions at the facility to a level at or above the Federal Communications Commission safety standard.
5. The proposed modifications will not cause a change or alteration in the physical or environmental characteristics of the site.
6. The existing structure and its foundation can support the proposed loading.

For the foregoing reasons, T-Mobile respectfully submits that the proposed modifications to the above referenced telecommunications facility constitute an exempt modification under R.C.S.A. § 16-50j-72(b)(2).

Sincerely,

Victoria Masse
Mobile: 860-209-4690
Fax: 413-521-0558
Office: 420 Main Street, Sturbridge MA 01566
Email: victoria@northeastitesolutions.com

Attachments

cc: Mayor Jay Moran - as elected official
James Davis – Zoning Enforcement Officer
Mitchell Drive LLC - Tower and property owner

NORTHEAST SITE SOLUTIONS, LLC
420 MAIN ST. BUILDING #4, 2nd FLOOR
Sturbridge, MA 01566

WEBSTER BANK
51-7010/2111

4090

06/25/2020

PAY TO THE ORDER OF Connecticut Siting Council

*625.00

\$

EXACTLY SIX HUNDRED TWENTY-FIVE DOLLARS

DOLLARS

Connecticut Siting Council
10 Franklin Square
New Britain CT 06051

MEMO

CTHA174A Anchor

Lisa Linn Allen
AUTHORIZED SIGNATURE

⑈004090⑈ ⑆211170101⑆ 0010608887⑈

Check#: 4090 Date: 06/25/2020 Vendor#: 10023 Connecticut Siting Co Check Total: *625.00 4090

Invoice#	Invoice Date	Job/Description	Balance	Retain	Discount	This Check
CTHA174A CSC	06/25/2020	2 TMO Anchor Program	625.00			625.00

Check#: 4090 Date: 06/25/2020 Vendor#: 10023 Connecticut Siting Co Check Total: *625.00 4090

Invoice#	Invoice Date	Job/Description	Balance	Retain	Discount	This Check
CTHA174A CSC	06/25/2020	2 TMO Anchor Program	625.00			625.00

Exhibit A



SCOTT SHANLEY, GENERAL MANAGER

Town of Manchester

41 Center Street • P.O. Box 191
Manchester, Connecticut 06045-0191
www.manchesterct.gov

LEO V. DIANA, MAYOR
JAY MORAN, DEPUTY MAYOR
LISA P. O'NEILL, SECRETARY

DIRECTORS
STEVE GATES
SUSAN HOLMES
RUDY C. KISSMANN
CHERI A. PELLETIER
JOHN D. TOPPING
MARK D. TWEDIE

CERTIFIED LETTER
November 21, 2012

Todd Stacy
Marcus Communications, LLC
33 Mitchell Drive
Manchester, CT 06045

Re: Marcus Communication, LLC – 33 Mitchell Drive & 184 Sheldon Road
Special Exception (2012-106)

Dear Mr. Stacy:

As agent for the applicant, please be advised that at its meeting of November 19, 2012, the Planning and Zoning Commission approved with modifications the above referenced application. The approval is for activities as shown on plans entitled, "SITE PLAN #33 MITCHELL DRIVE & #184 SHELDON ROAD, PREPARED FOR MARCUS COMMUNICATIONS, MANCHESTER, CONN", by Aeschliman Land Surveying, PC, Map No. 212007-1A, dated 08/27/2012, revised 11/09/2012.

The specific approval granted is as follows:

Special Exception (2012-106) – approved the special exception under Article II Section 16.15.02(o) to construct a 170' self-supporting telecommunications tower and related appurtenances with modifications as outlined in a memorandum from Derrick Gregor, Assistant Town Engineer to Renata Bertotti, Senior Planner, dated November 19, 2012.

All site work related to the above approvals must be completed by November 19, 2017 in accordance with the Connecticut General Statutes, Section 8-3. Failure to complete all work within the specified time period will result in automatic expiration of the approval.

Please submit one set of sealed and signed washoff or fixed line mylar plans and five (5) paper copies of the plans incorporating the modifications listed above, sealed and signed, to this office for stamping and signature.

To speed the endorsement of final plans staff requests the following block be added to the lower right of each page of the plans above or to the left of the title block: Please do not reduce this block to less than 2" X 3".

An equal opportunity Employer



<p style="text-align: center;">A P P R O V E D</p> <p style="text-align: center;">PLANNING AND ZONING COMMISSION MANCHESTER, CT</p> <p>DATE: _____</p> <p>SIGNED: _____</p>

You are also required to submit a fee of \$50.00 for the above referenced plan to cover digital GIS conversion costs incurred by the Town. The payment for GIS conversion should accompany the final mylar and paper copies. A copy of the GIS Conversion Fee Requirement is enclosed.

A Certificate of Approval of this decision will be forwarded to you immediately following the expiration of the Superior Court appeal period (i.e., 15 days after the legal decision notice is published in the newspaper). Upon receipt, you must file the Certificate of Approval with the Town Clerk and pay the required recording fee. The approval of your petition by the Planning and Zoning Commission will not be effective until the Certificate has been recorded on the land records in the Town Clerk's office. You are hereby advised not to engage in any activity concerning your petition until the Certificate has been recorded. We also remind you to obtain a building permit for this work before you start construction.

NOTE: No changes to the approved site plans, or to the building elevations, materials or colors, are to be made until the proposed changes are submitted to the Planning Department and it is determined whether the changes can be approved administratively or will need Planning and Zoning Commission approval.

Sincerely,

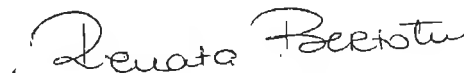

Renata Bertotti, AICP
Senior Planner

RB/lg

R:\PLANNING\PZC\2012\11 - NOVEMBER 19\DECISION LETTERS\2012-106 MARCUS COMMUNICATIONS.DOC

Encls.

- cc: Engineering Department (w/out encl.)
John Rainaldi, Director of Assessment & Collection (w/out encl.)
James A. Davis, Zoning Enforcement Officer (w/out encl.)
Richard Gallacher, GIS Coordinator (w/out encl.)
Greg Smith, Chief Building Official (w/out encl.)

Exhibit B

33 MITCHELL DRIVE

Location 33 MITCHELL DRIVE

Mblu 90/ 4000/ 33/ /

Acct# 400000033

Owner MITCHELL DRIVE LLC

Assessment \$951,600

Appraisal \$1,359,400

PID 11439

Building Count 1

DISTRICT T

CONCRETE

Current Value

Appraisal			
Valuation Year	Improvements	Land	Total
2016	\$1,051,100	\$308,300	\$1,359,400

Assessment			
Valuation Year	Improvements	Land	Total
2016	\$735,800	\$215,800	\$951,600

Owner of Record

Owner	MITCHELL DRIVE LLC	Sale Price	\$710,000
Address	PO BOX 1498 MANCHESTER, CT 06045-1498	Certificate	
		Book & Page	3918/ 222
		Sale Date	12/30/2011
		Instrument	33

Ownership History

Ownership History					
Owner	Sale Price	Certificate	Book & Page	Instrument	Sale Date
MITCHELL DRIVE LLC	\$710,000		3918/ 222	33	12/30/2011
GREAT OAK WAY INC	\$0		3815/ 185	31	11/12/2010
MITCHELL DRIVE ASSOC LLC	\$0	C	1865/ 337		12/13/1996

Building Information

Building 1 : Section 1

Year Built: 1967

Building Photo

Living Area: 33,898
Replacement Cost: \$1,539,539
Replacement Cost
Less Depreciation: \$785,200



(<http://images.vgsi.com/photos2/ManchesterCTPhotos//00\03\31\69.jpg>)

Building Attributes	
Field	Description
STYLE	Light Indust
MODEL	Ind/Comm
Grade	Average
Stories:	1
Occupancy	4
Exterior Wall 1	Pre-finish Metl
Exterior Wall 2	Concr/Cinder
Roof Structure	Flat
Roof Cover	Tar + Gravel
Interior Wall 1	Minim/Masonry
Interior Wall 2	
Interior Floor 1	Concr-Finished
Interior Floor 2	
Heating Fuel	Solar Assisted
Heating Type	Hot Air-no Duc
AC Type	Partial
Bldg Use	Industrial 96
Total Rooms	
Total Bedrms	00
Total Baths	0
1st Floor Use:	300
Heat/AC	Heat AC Split
Frame Type	Steel
Baths/Plumbing	Average
Ceiling/Wall	Ceil & Min WI
Rooms/Prtns	Average
Wall Height	20
% Comn Wall	0

Building Layout

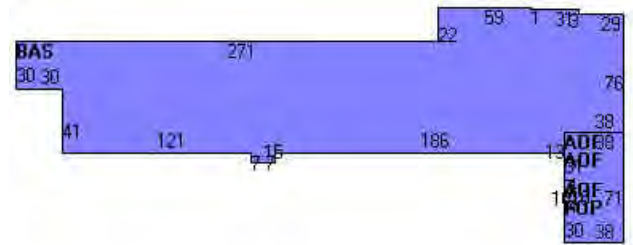

(http://images.vgsi.com/photos2/ManchesterCTPhotos//Sketches/11439_1)

Building Sub-Areas (sq ft)			Legend
Code	Description	Gross Area	Living Area
BAS	First Floor	28,542	28,542
AOF	Office, (Average)	5,356	5,356
FOP	Porch, Open	40	0
		33,938	33,898

Extra Features

Extra Features				Legend
Code	Description	Size	Value	Bldg #
SPR1	Sprinklers-Wet	2700 S.F.	\$2,100	1
A/C	Partial AC	5356 S.F.	\$5,500	1
SOL	Solar Panels	750 UNIT	\$150,000	1

Land**Land Use**

Use Code 300
Description Industrial 96
Zone IND
Neighborhood 4000
Alt Land Appr No
Category

Land Line Valuation

Size (Acres) 4.49
Frontage 0
Depth 0
Assessed Value \$215,800
Appraised Value \$308,300

Outbuildings

Outbuildings						<u>Legend</u>
Code	Description	Sub Code	Sub Description	Size	Value	Bldg #
PAV1	Paving Asphalt			24000 S.F.	\$30,000	1
PAV2	Paving Concrete			48 S.F.	\$100	1
SHD1	Shed			200 S.F.	\$1,800	1
SHD1	Shed			240 S.F.	\$2,200	1
SHD1	Shed			240 S.F.	\$2,200	1
SPNL	Solar Pan Comm			72 EACH	\$72,000	1

Valuation History

Appraisal			
Valuation Year	Improvements	Land	Total
2015	\$686,400	\$308,300	\$994,700
2010	\$1,083,000	\$495,000	\$1,578,000
2005	\$781,800	\$538,800	\$1,320,600

Assessment			
Valuation Year	Improvements	Land	Total
2015	\$480,500	\$215,800	\$696,300
2010	\$758,100	\$346,500	\$1,104,600
2005	\$547,400	\$377,200	\$924,600



TOWN OF MANCHESTER PROPERTY MAP

TILE 90

Legend

- Property Line
- Road Right of Way
- Building
- Road, Driveway or Parking Lot
- Bridge
- Railroad Right of Way
- Access Easement
- Townline
- River or Stream
- Water Body
- Parcel Hook

- 02517 RPKEY
- 0477 Acreage
- 127 Street Address
- 155 Developer Lot Number
- 127.6(P) Dimension (Plan Source)
- (127.6) Dimension (Scaled)
- 127.6(D) Dimension (Deed Source)

Key Map

73	89	105
74	90	106
75	91	107

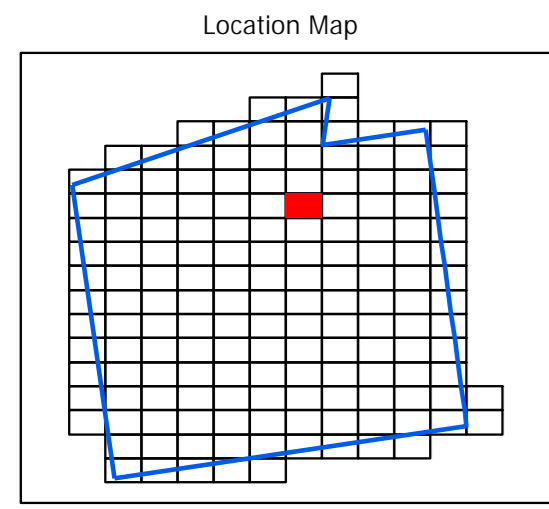

DISCLAIMER:
Please be advised that all information presented in this map is provided "as-is" without warranty of any kind, either expressed or implied. Real property is compiled from recorded deeds, subdivision plans, and other public records and data. Users of these map data are hereby notified that the aforementioned public primary information sources should be consulted for verification of the information contained in these map data. This map is intended for informational purposes only and does not meet the accuracy requirements of survey data.

NOTE: The GIS parcel layer acreages are NOT used and should NOT be used for property assessment purposes.

This tax map is formatted for 24" x 36" (Arch D) paper size only. Printing these maps on smaller paper will render the map scale (1" = 100') inaccurate.

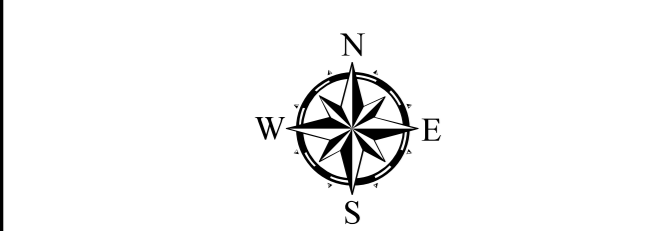

DATE PRINTED: 14-Jun-19
0 50 100 200 Feet
1 Inch = 100 Feet

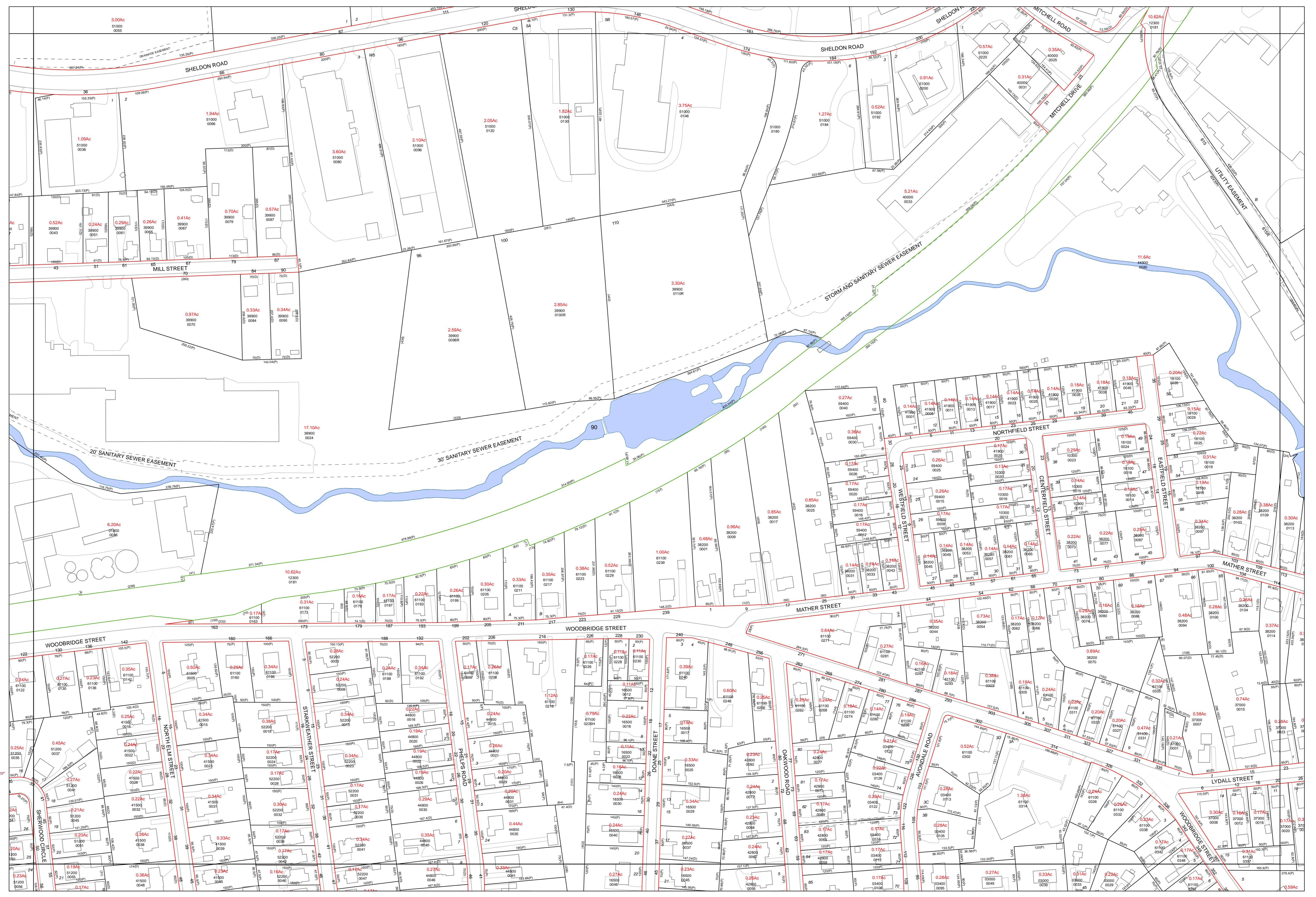

Exhibit C

MODIFICATION OF EXISTING WIRELESS FACILITY BY



T-MOBILE NORTHEAST LLC

PROJECT: ANCHOR

SITE NUMBER: CTHA174A

SITE NAME: MANCHESTER

SITE ADDRESS: 33 MITCHELL DRIVE

MANCHESTER, CT 06040

(RF CONFIG: 4Sec-67D5992DB_3xAIR+1OP)

PROJECT NOTES:

1. THIS IS AN UNMANNED TELECOMMUNICATION FACILITY AND NOT FOR HUMAN HABITATION:
HANDICAPPED ACCESS IS NOT REQUIRED.
POTABLE WATER OR SANITARY SERVICE IS NOT REQUIRED.
NO OUTDOOR STORAGE OR ANY SOLID WASTE RECEPTACLES REQUIRED.
2. CONTRACTOR SHALL VERIFY ALL PLANS, EXISTING DIMENSIONS, AND CONDITIONS ON THE JOB SITE. CONTRACTOR SHALL IMMEDIATELY NOTIFY THE ARCHITECT/ENGINEER IN WRITING OF ANY DISCREPANCIES BEFORE PROCEEDING WITH THE WORK. FAILURE TO NOTIFY THE ARCHITECT/ENGINEER PLACES THE RESPONSIBILITY ON THE CONTRACTOR TO CORRECT THE DISCREPANCIES AT THE CONTRACTOR'S EXPENSE.
3. DEVELOPMENT AND USE OF THE SITE WILL CONFORM TO ALL APPLICABLE CODES, ORDINANCES AND SPECIFICATIONS.

STRUCTURE NOTE:

REFER TO STRUCTURAL ANALYSIS REPORT TITLED "STRUCTURAL ANALYSIS REPORT - SELF SUPPORT TOWER" SITE ID: CTHA174A, DATED JUN 15, 2020, PREPARED BY EFI GLOBAL INC.

APPLICABLE STATE ADOPTION CODES:

LATEST EDITION OF:
CONNECTICUT STATE BUILDING CODE (CSBC).
ANSI/TIA-222-G STRUCTURAL STANDARD FOR ANTENNA SUPPORTING STRUCTURES AND ANTENNAS.
NATIONAL ELECTRICAL CODE (NEC) FOR POWER AND GROUNDING REQUIREMENTS.
OCCUPATIONAL SAFETY AND HEALTH ACT (OSHA).
NFPA - NATIONAL FIRE PROTECTION ASSOCIATION.

APPROVALS:

FSA CM	DATE
RF ENGINEER	DATE
FOPS	DATE
T-MOBILE ENGINEERING AND DEVELOPMENT	DATE
	DATE
	DATE

SITE IMAGE:



VICINITY MAP:

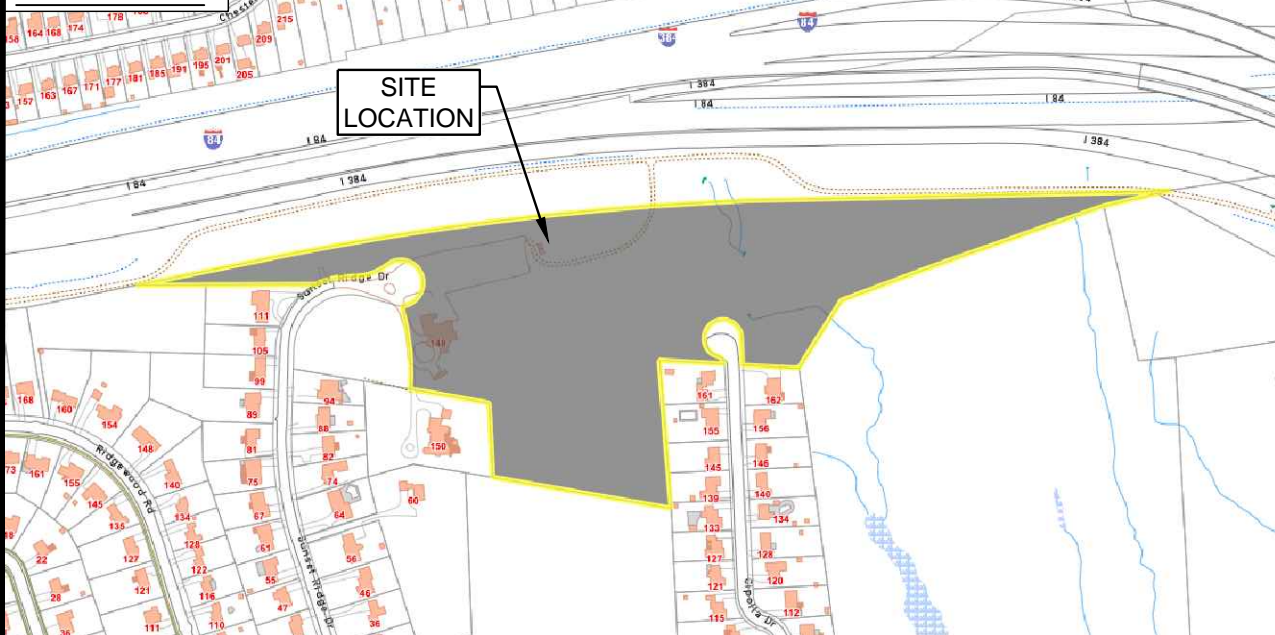

PROJECT SCOPE:

UPGRADE OF EXISTING WIRELESS FACILITY AS FOLLOWS:
UPGRADE EXISTING RBS 6102 CABINET INTERNALLY.
ADD (3) ANTENNAS FOR A TOTAL OF (12).
ADD (3) REMOTE RADIO UNITS.
ADD (1) 6160 AND (1) B160 CABINETS ON NEW CONCRETE PAD.
ADD (4) 6X12 HCS HYBRID, FOR FINAL CONFIGURATION OF (8) 6X12 HCS HYBRID AND (8) 1-5/8" COAX CABLES.

PROJECT INFORMATION:

ADDRESS: 33 MITCHELL DRIVE
MANCHESTER, CT 06040
STRUCTURE TYPE: LATTICE TOWER
COORDINATES: 41° 47' 50.20" N 72°30' 42.97" W
GROUND ELEVATION: 228.7± AMSL
ZONING DISTRICT: R2
PARCEL ID: 13740
TOWER HEIGHT: 170± AGL

PROJECT TEAM:

APPLICANT: T-MOBILE NORTHEAST, LLC.
35 GRIFFIN ROAD SOUTH
BLOOMFIELD, CT 06002
860-692-7100
LANDLORD: TOWN OF EAST HARTFORD
EAST HARTFORD
CT 06108
PROJECT MANAGER: NORTHEAST SITE SOLUTIONS
420 MAIN STREET, BLDG 4
STURBRIDGE, MA 01566
SHELDON FREINCLE
SHELDON@NORTHEASTSITESOLUTIONS.COM
201-776-8521
CONSULTANTS: FORESITE LLC
462 WALNUT ST
NEWTON, MA 02460
SAEED MOSSAVAT
SMOSSAVAT@FORESITELLC.COM
617-212-3123

SHEET INDEX:

T-1: TITLE SHEET
N-1: GENERAL NOTES
A-1: PLAN
A-2: ELEVATION
A-3: EQUIPMENT DETAILS
E-1: GROUNDING DETAILS

APPLICANT:
T-Mobile
T-MOBILE NORTHEAST LLC

35 GRIFFIN ROAD SOUTH
BLOOMFIELD, CT 06002
860-692-7100

PROJECT MANAGER
NSS NORTHEAST
SITE SOLUTIONS
Turkey Wireless Development
420 MAIN STREET, BLDG 4
STURBRIDGE, MA 01566
203-275-6669

CONSULTANT:
FORESITE LLC
Architects . Engineers . Surveyors
462 WALNUT STREET
NEWTON, MA 02460
617-212-3123

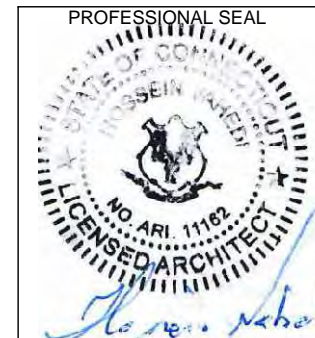

THIS DOCUMENT IS THE DESIGN PROPERTY AND COPYRIGHT OF FORESITE, LLC. AND FOR THE EXCLUSIVE USE BY THE TITLE CLIENT. DUPLICATION OR USE WITHOUT THE EXPRESS WRITTEN CONSENT OF THE CREATOR IS STRICTLY PROHIBITED. DRAWING SCALES ARE INTENDED FOR 11"x17" SIZE PRINTED MEDIA ONLY. ALL OTHER PRINTED SIZES ARE DEEMED "NOT TO SCALE".

REV	DESCRIPTION	DATE
A	PRELIMINARY	06/21/20
A	REVISED CABLE COUNTS	06/30/20

SITE NUMBER: CTHA174A
SITE NAME: MANCHESTER
SITE ADDRESS: 33 MITCHELL DRIVE
MANCHESTER, CT 06040

SHEET TITLE:
T-1: TITLE SHEET

Copyright © 2018 Foresite LLC all rights reserved. The details, templates, drawing formats or any portion of this document generated by Foresite LLC may not be duplicated, traced or used otherwise for any profit-driven enterprise.

GENERAL NOTES:

1. THE CONTRACTOR SHALL GIVE ALL NOTICES AND COMPLY WITH ALL LAWS, ORDINANCES, RULES, REGULATIONS AND LAWFUL ORDERS OF ANY PUBLIC AUTHORITY, MUNICIPAL AND UTILITY COMPANY SPECIFICATIONS, AND LOCAL AND STATE JURISDICTIONAL CODES BEARING ON THE PERFORMANCE OF THE WORK. THE WORK PERFORMED ON THE PROJECT AND THE MATERIALS INSTALLED SHALL BE IN STRICT ACCORDANCE WITH ALL APPLICABLE CODES, REGULATIONS, AND ORDINANCES.
2. THE ARCHITECT/ENGINEER HAS MADE EVERY EFFORT TO SET FORTH IN THE CONSTRUCTION AND CONTRACT DOCUMENTS THE COMPLETE SCOPE OF WORK. THE CONTRACTOR BIDDING THE JOB IS NEVERTHELESS CAUTIONED THAT MINOR OMISSIONS OR ERRORS IN THE DRAWINGS AND OR SPECIFICATIONS SHALL NOT EXCUSE SAID CONTRACTOR FROM COMPLETING THE PROJECT AND IMPROVEMENTS IN ACCORDANCE WITH THE INTENT OF THESE DOCUMENTS.
3. THE CONTRACTOR OR BIDDER SHALL BEAR THE RESPONSIBILITY OF NOTIFYING (IN WRITING) THE CLIENT'S REPRESENTATIVE OF ANY CONFLICTS, ERRORS, OR OMISSIONS PRIOR TO THE SUBMISSION OF CONTRACTOR'S PROPOSAL OR PERFORMANCE OF WORK.
5. THE CONTRACTOR SHALL VISIT THE JOB SITE PRIOR TO THE SUBMISSION OF BIDS OR PERFORMING WORK TO FAMILIARIZE HIMSELF WITH THE FIELD CONDITIONS AND TO VERIFY THAT THE PROJECT CAN BE CONSTRUCTED IN ACCORDANCE WITH THE CONSTRUCTION DOCUMENTS.
6. THE CONTRACTOR SHALL INSTALL ALL EQUIPMENT AND MATERIALS ACCORDING TO THE MANUFACTURER'S / VENDOR'S SPECIFICATIONS UNLESS NOTED OTHERWISE OR WHERE LOCAL CODES OR ORDINANCES TAKE PRECEDENCE.
7. THE CONTRACTOR SHALL MAKE NECESSARY PROVISIONS TO PROTECT EXISTING IMPROVEMENTS DURING CONSTRUCTION.
8. THE CONTRACTOR SHALL COMPLY WITH ALL PERTINENT SECTIONS OF THE BASIC STATE BUILDING CODE, LATEST EDITION, AND ALL OSHA REQUIREMENTS AS THEY APPLY TO THIS PROJEC
9. THE CONTRACTOR SHALL NOTIFY THE CLIENT'S REPRESENTATIVE IN WRITING WHERE A CONFLICT OCCURS ON ANY OF THE CONTRACT DOCUMENTS. THE CONTRACTOR IS NOT TO ORDER MATERIAL OR CONSTRUCT ANY PORTION OF THE WORK THAT IS IN CONFLICT UNTIL CONFLICT IS RESOLVED BY THE CLIENT'S REPRESENTATIVE.
10. THE WORK SHALL CONFORM TO THE CODES AND STANDARDS OF THE FOLLOWING AGENCIES AS FURTHER CITED HEREIN:
 - A. ASTM: AMERICAN SOCIETY FOR TESTING AND MATERIALS, AS PUBLISHED IN "COMPILATION OF ASTM STANDARDS BUILDING CODES" OR LATEST EDITION.
 - B. AWS: AMERICAN WELDING SOCIETY INC. AS PUBLISHED IN "STANDARD D1.1-08, STRUCTURAL WELDING CODE" OR LATEST EDITION.
 - C. AISC: AMERICAN INSTITUTE FOR STEEL CONSTRUCTION AS PUBLISHED IN "CODE FOR STANDARD PRACTICE FOR STEEL BUILDINGS AND BRIDGES"; "SPECIFICATIONS FOR THE DESIGN, FABRICATION AND ERECTION OF STRUCTURAL STEEL FOR BUILDINGS" (LATEST EDITION).
11. BOLTING:
 - A. BOLTS SHALL BE CONFORMING TO ASTM A325 HIGH STRENGTH, HOT DIP GALVANIZED WITH ASTM A153 HEAVY HEX TYPE NUTS.
 - B. BOLTS SHALL BE 3/4"Ø MINIMUM (UNLESS OTHERWISE NOTED)
 - C. ALL CONNECTIONS SHALL BE 2 BOLTS MINIMUM.
12. FABRICATION:
 - A. FABRICATION OF STEEL SHALL CONFORM TO THE AISC AND AWS STANDARDS AND CODES (LATEST EDITION).
 - B. ALL STRUCTURAL STEEL SHALL BE HOT-DIP GALVANIZED AFTER FABRICATION IN ACCORDANCE WITH ASTM A123 (LATEST EDITION), UNLESS OTHERWISE NOTED.
13. ERECTION OF STEEL:
 - A. PROVIDE ALL ERECTION EQUIPMENT, BRACING, PLANKING, FIELD BOLTS, NUTS, WASHERS, DRIFT PINS, AND SIMILAR MATERIALS WHICH DO NOT FORM A PART OF THE COMPLETED CONSTRUCTION BUT ARE NECESSARY FOR ITS PROPER ERECTION.
 - B. ERECT AND ANCHOR ALL STRUCTURAL STEEL IN ACCORDANCE WITH AISC REFERENCE STANDARDS. ALL WORK SHALL BE ACCURATELY SET TO ESTABLISHED LINES AND ELEVATIONS AND RIGIDLY FASTENED IN PLACE WITH SUITABLE ATTACHMENTS TO THE CONSTRUCTION OF THE BUILDING.
 - C. TEMPORARY BRACING, GUYING AND SUPPORT SHALL BE PROVIDED TO KEEP THE STRUCTURE SAFE AND ALIGNED AT ALL TIMES DURING CONSTRUCTION, AND TO PREVENT DANGER TO PERSONS AND PROPERTY. CHECK ALL TEMPORARY LOADS AND STAY WITHIN SAFE CAPACITY OF ALL BUILDING COMPONENTS.
14. ANTENNA INSTALLATION:
 - A. INSTALL ANTENNAS AS INDICATED ON DRAWINGS AND CLIENT'S REPRESENTATIVE SPECIFICATIONS.
 - B. INSTALL GALVANIZED STEEL ANTENNA MOUNTS AS INDICATED ON DRAWINGS.

- C. INSTALL COAXIAL / FIBER CABLES AND TERMINATIONS BETWEEN ANTENNAS AND EQUIPMENT PER MANUFACTURER'S RECOMMENDATIONS. WEATHERPROOF ALL CONNECTORS BETWEEN THE ANTENNA AND EQUIPMENT PER MANUFACTURER'S REQUIREMENTS.
15. ANTENNA AND COAXIAL / FIBER CABLE GROUNDING:
 - A. ALL EXTERIOR #6 GREEN GROUND WIRE "DAISY CHAIN" CONNECTIONS ARE TO BE WEATHER SEALED WITH ANDREWS CONNECTOR/SPLICE WEATHERPROOFING KIT TYPE #221213 OR EQUAL.
 - B. ALL COAXIAL / FIBER CABLE GROUNDING KITS ARE TO BE INSTALLED ON STRAIGHT RUNS OF COAXIAL / FIBER CABLE (NOT WITHIN BENDS).
16. RELATED WORK, FURNISH THE FOLLOWING WORK AS SPECIFIED UNDER CONSTRUCTION DOCUMENTS, BUT COORDINATE WITH OTHER TRADES PRIOR TO BID:
 - A. FLASHING OF OPENING INTO OUTSIDE WALLS
 - B. SEALING AND CAULKING ALL OPENINGS
 - C. PAINTING
 - D. CUTTING AND PATCHING
17. REQUIREMENTS OF REGULATORY AGENCIES:
 - A. FURNISH U.L. LISTED EQUIPMENT WHERE SUCH LABEL IS AVAILABLE. INSTALL IN CONFORMANCE WITH U.L. STANDARDS WHERE APPLICABLE.
 - B. INSTALL ANTENNA, ANTENNA CABLES, GROUNDING SYSTEM IN ACCORDANCE WITH DRAWINGS AND SPECIFICATION IN EFFECT AT PROJECT LOCATION AND RECOMMENDATIONS OF STATE AND LOCAL BUILDING CODES, AND SPECIAL CODES HAVING JURISDICTION OVER SPECIFIC PORTIONS OF WORK. THIS WORK INCLUDES BUT IS NOT LIMITED TO THE FOLLOWING:
 - C. TIA-EIA - 222 (LATEST EDITION). STRUCTURAL STANDARDS FOR STEEL ANTENNA TOWERS AND ANTENNA SUPPORTING STRUCTURES.
 - D. FAA - FEDERAL AVIATION ADMINISTRATION ADVISORY CIRCULAR AC 70/7460-IH, OBSTRUCTION MARKING AND LIGHTING.
 - E. FCC - FEDERAL COMMUNICATIONS COMMISSION RULES AND REGULATIONS FORM 715, OBSTRUCTION MARKING AND LIGHTING SPECIFICATION FOR ANTENNA STRUCTURES AND FORM 715A, HIGH INTENSITY OBSTRUCTION LIGHTING SPECIFICATIONS FOR ANTENNA STRUCTURES.
 - F. AISC - AMERICAN INSTITUTE OF STEEL CONSTRUCTION SPECIFICATION FOR STRUCTURAL JOINTS USING ASTM A325 BOLTS (LATEST EDITION).
 - G. NEC - NATIONAL ELECTRICAL CODE - ON TOWER LIGHTING KITS.
 - H. UL - UNDERWRITER'S LABORATORIES APPROVED ELECTRICAL PRODUCTS.
 - I. IN ALL CASES, PART 77 OF THE FAA RULES AND PARTS 17 AND 22 OF THE FCC RULES ARE APPLICABLE AND IN THE EVENT OF CONFLICT, SUPERSEDE ANY OTHER STANDARDS OR SPECIFICATIONS.
 - J. 2009 LIFE SAFETY CODE NFPA - 101.

APPLICANT:

T-MOBILE NORTHEAST LLC
 35 GRIFFIN ROAD SOUTH
 BLOOMFIELD, CT 06002
 860-692-7100

PROJECT MANAGER

NSS NORTHEAST
 SITE SOLUTIONS
Turnkey Wireless Development
 420 MAIN STREET, BLDG 4
 STURBRIDGE, MA 01566
 203-275-6669

CONSULTANT:

Architects . Engineers . Surveyors
 462 WALNUT STREET
 NEWTON, MA 02460
 617-212-3123



THIS DOCUMENT IS THE DESIGN PROPERTY AND COPYRIGHT OF FORESITE, LLC. AND FOR THE EXCLUSIVE USE BY THE TITLE CLIENT. DUPLICATION OR USE WITHOUT THE EXPRESS WRITTEN CONSENT OF THE CREATOR IS STRICTLY PROHIBITED. DRAWING SCALES ARE INTENDED FOR 11"x17" SIZE PRINTED MEDIA ONLY. ALL OTHER PRINTED SIZES ARE DEEMED "NOT TO SCALE".

REV	DESCRIPTION	DATE
A	PRELIMINARY	06/21/20
A	REVISED CABLE COUNTS	06/30/20

SITE NUMBER: CTHA174A
SITE NAME: MANCHESTER
 SITE ADDRESS: 33 MITCHELL DRIVE
 MANCHESTER, CT 06040

SHEET TITLE:
N-1: NOTES AND DISCLAIMERS

Copyright © 2018 Foresite LLC all rights reserved. The details, templates, drawing formats or any portion of this document generated by Foresite LLC may not be duplicated, traced or used otherwise for any profit-driven enterprise.

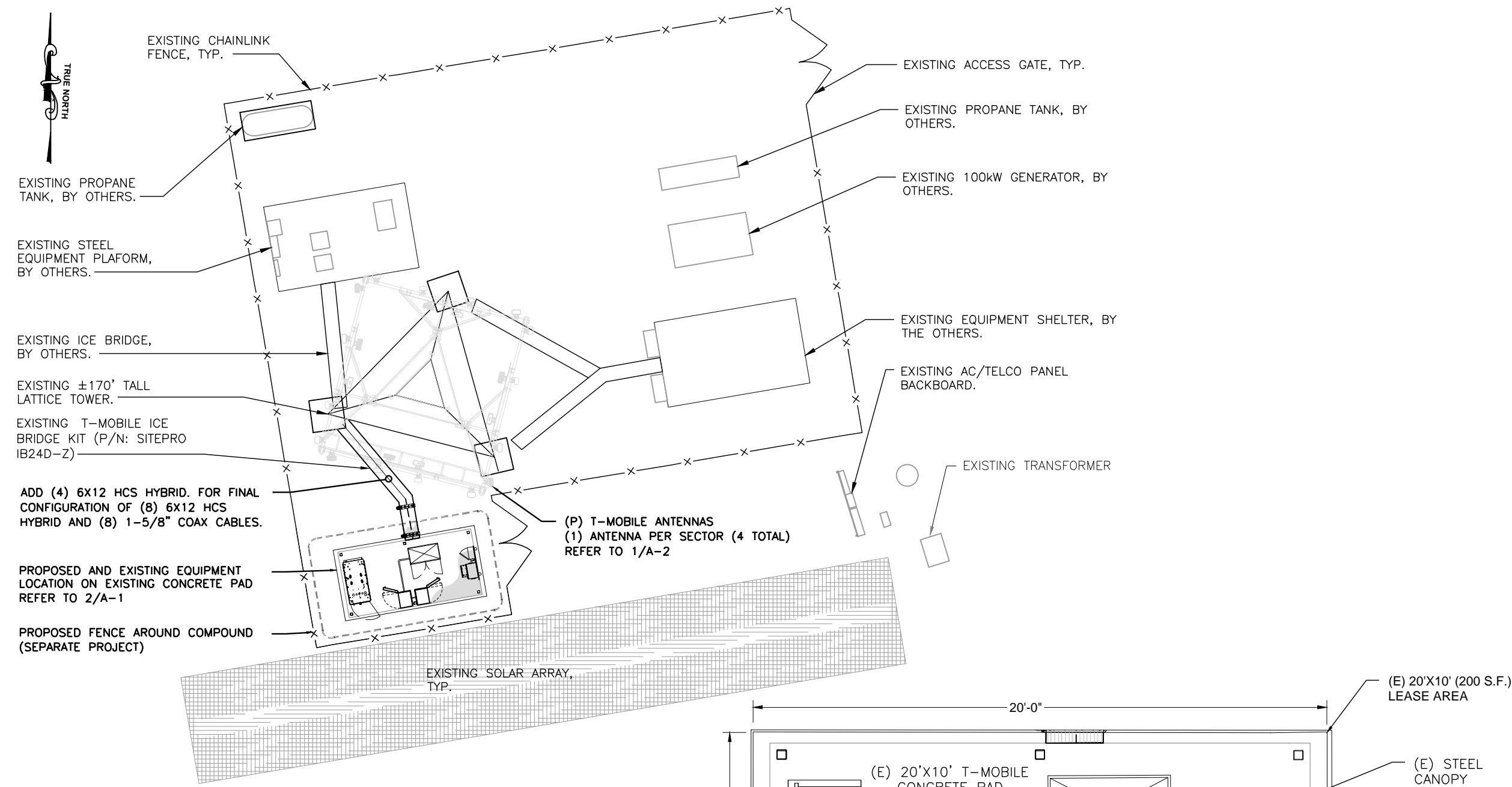

PLAN
SCALE: 1/16" = 1'-0" 1
A-1

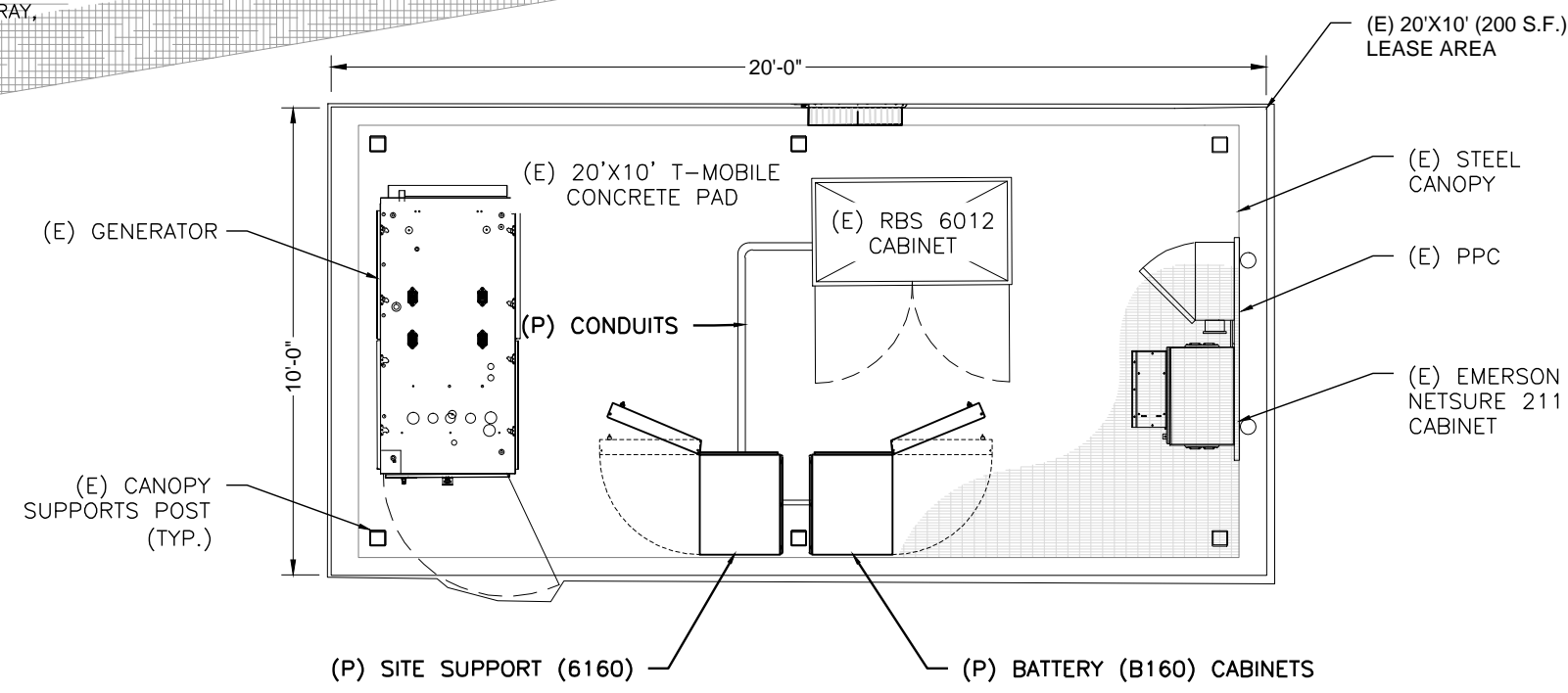

EQUIPMENT LAYOUT
SCALE: 1/4" = 1'-0" 2
A-1

APPLICANT:
T-Mobile
T-MOBILE NORTHEAST LLC
35 GRIFFIN ROAD SOUTH
BLOOMFIELD, CT 06002
860-692-7100

PROJECT MANAGER
NSS NORTHEAST
SITE SOLUTIONS
Turnkey Wireless Development
420 MAIN STREET, BLDG 4
STURBRIDGE, MA 01566
203-275-6669

CONSULTANT:
FORESITE LLC
Architects . Engineers . Surveyors
462 WALNUT STREET
NEWTON, MA 02460
617-212-3123

PROFESSIONAL SEAL
STATE OF CONNECTICUT
NO. ARI. 11162
LICENSED ARCHITECT
Thomas Nebel

THIS DOCUMENT IS THE DESIGN PROPERTY AND COPYRIGHT OF FORESITE, LLC. AND FOR THE EXCLUSIVE USE BY THE TITLE CLIENT. DUPLICATION OR USE WITHOUT THE EXPRESS WRITTEN CONSENT OF THE CREATOR IS STRICTLY PROHIBITED. DRAWING SCALES ARE INTENDED FOR 11"x17" SIZE PRINTED MEDIA ONLY. ALL OTHER PRINTED SIZES ARE DEEMED "NOT TO SCALE".

REV	DESCRIPTION	DATE
A	PRELIMINARY	06/21/20
A	REVISED CABLE COUNTS	06/30/20

SITE NUMBER: CTHA174A
SITE NAME: MANCHESTER
SITE ADDRESS: 33 MITCHELL DRIVE
MANCHESTER, CT 06040

SHEET TITLE:
A-1: PLAN

Copyright © 2018 Foresite LLC all rights reserved. The details, templates, drawing formats or any portion of this document generated by Foresite LLC may not be duplicated, traced or used otherwise for any profit-driven enterprise.

STRUCTURAL NOTES:

PRIOR TO COMMENCING CONSTRUCTION, GC SHALL REFER TO TOWER STRUCTURAL ANALYSIS TO DETERMINE IF THERE ARE ANY SUPPLEMENTAL OR SPECIAL REQUIREMENTS FOR TOWER TOP EQUIPMENT AND FOR CABLE BUNDLING, SHIELDING, MOUNTING OR RELOCATION ARRANGEMENTS.

REFER TO STRUCTURAL ANALYSIS REPORT TITLED " STRUCTURAL ANALYSIS REPORT - SELF SUPPORT TOWER " SITE ID: CTHA174A, DATED JUN 15, 2020, PREPARED BY EFI GLOBAL INC.

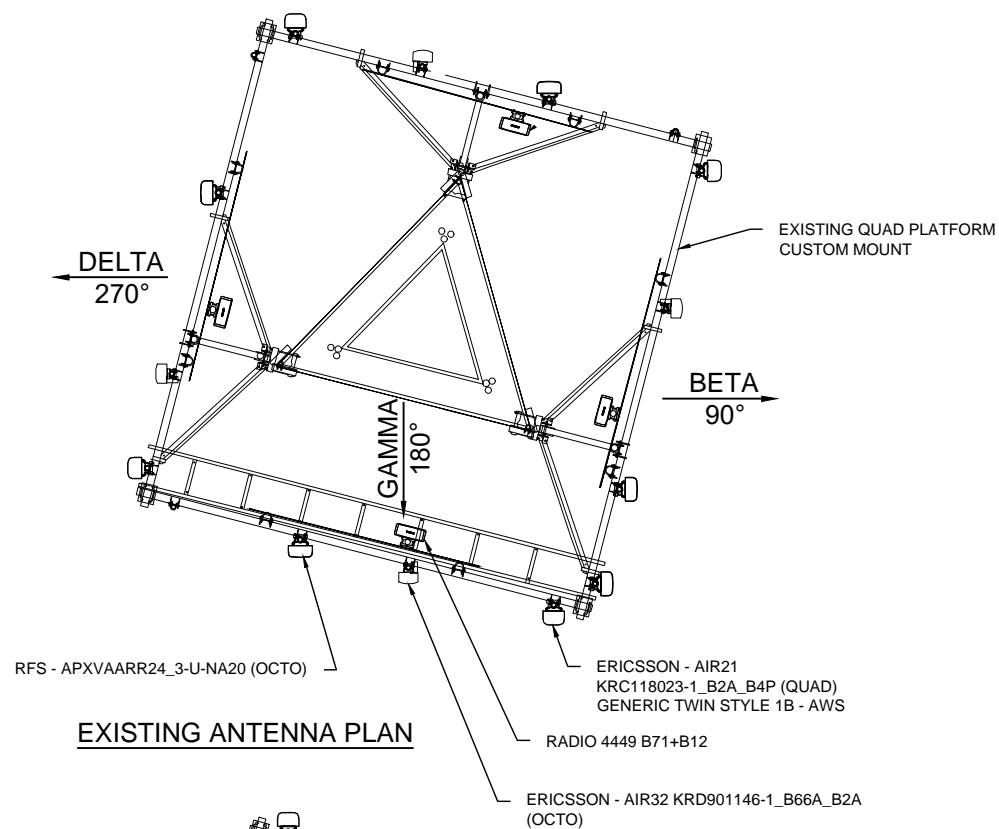

EXISTING ANTENNA PLAN

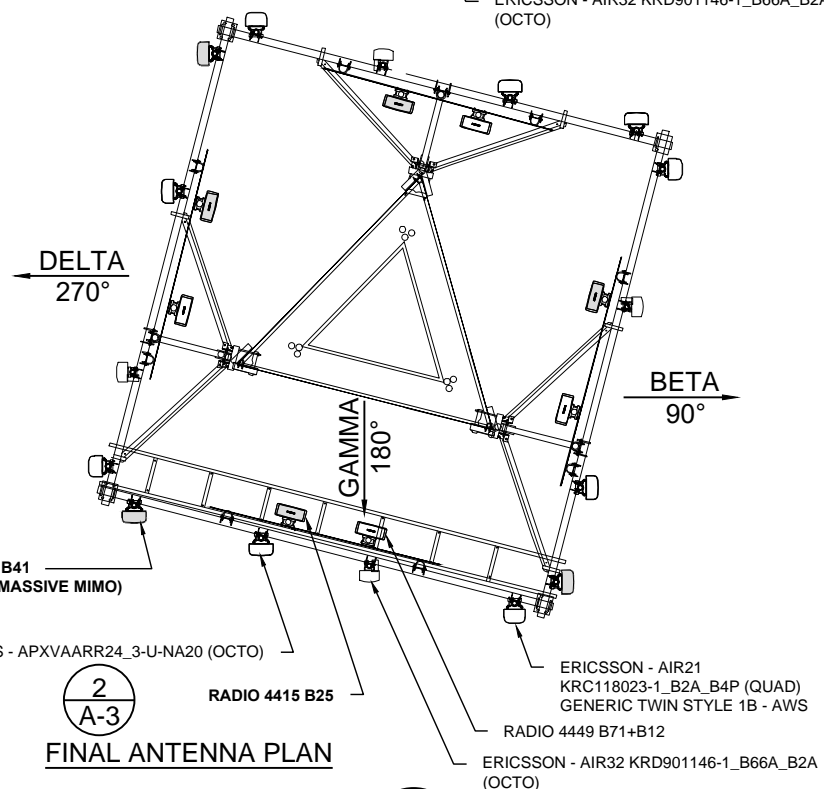

FINAL ANTENNA PLAN

ANTENNA PLAN
SCALE: NTS

TOP OF EXISTING LATTICE TOWER
ELEV: 170'-0"± (AGL)

(P) T-MOBILE ANTENNA
(1) ANTENNA PER SECTOR (4 TOTAL)
REFER TO A-4

CENTER OF (E) & (P) T-MOBILE ANTENNAS
ELEV: 140'-0"± (AGL)

CENTER OF (E) VERIZON WIRELESS ANTENNAS
ELEV: 120'-0"± (AGL)

ADD (4) 6X12 HCS HYBRID. FOR
FINAL CONFIGURATION OF
(8) 6X12 HCS HYBRID AND
(8) 1-5/8" COAX CABLES.

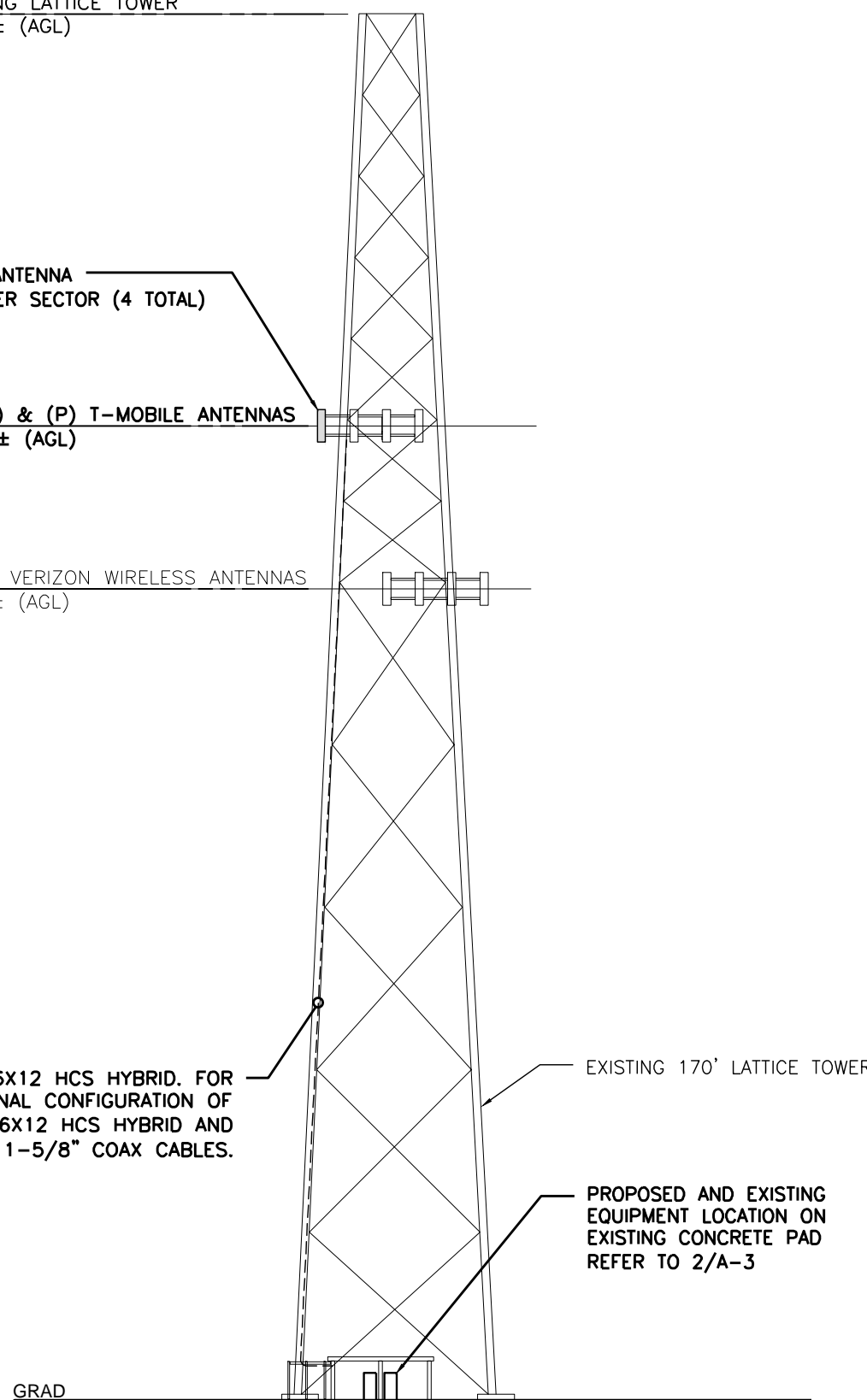

ELEVATION
SCALE: 1" = 20'-0"

APPLICANT:
T-Mobile
T-MOBILE NORTHEAST LLC

35 GRIFFIN ROAD SOUTH
BLOOMFIELD, CT 06002
860-692-7100

PROJECT MANAGER

NSS NORTHEAST
SITE SOLUTIONS
Turnkey Wireless Development
420 MAIN STREET, BLDG 4
STURBRIDGE, MA 01566
203-275-6669

CONSULTANT:

FORESITE LLC

Architects . Engineers . Surveyors
462 WALNUT STREET
NEWTON, MA 02460
617-212-3123



THIS DOCUMENT IS THE DESIGN PROPERTY AND COPYRIGHT OF FORESITE, LLC. AND FOR THE EXCLUSIVE USE BY THE TITLE CLIENT. DUPLICATION OR USE WITHOUT THE EXPRESS WRITTEN CONSENT OF THE CREATOR IS STRICTLY PROHIBITED. DRAWING SCALES ARE INTENDED FOR 11"x17" SIZE PRINTED MEDIA ONLY. ALL OTHER PRINTED SIZES ARE DEEMED "NOT TO SCALE".

REV	DESCRIPTION	DATE
A	PRELIMINARY	06/21/20
A	REVISED CABLE COUNTS	06/30/20

SITE NUMBER: CTHA174A
SITE NAME: MANCHESTER
SITE ADDRESS: 33 MITCHELL DRIVE
MANCHESTER, CT 06040

SHEET TITLE:
A-2: ELEVATION

Copyright © 2018 Foresite LLC all rights reserved. The details, templates, drawing formats or any portion of this document generated by Foresite LLC may not be duplicated, traced or used otherwise for any profit-driven enterprise.

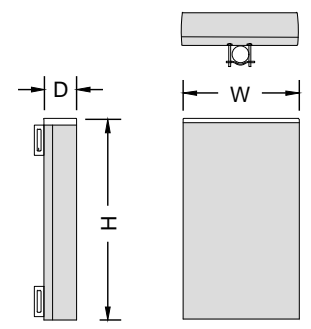

ERICSSON ANTENNA SPECIFICATIONS	
MODEL #	AIR6449 B41
MANUF.	ERICSSON
HEIGHT	33.1"
WIDTH	20.5"
DEPTH	8.3"
WEIGHT	103 LB

ERICSSON ANTENNA
N.T.S. 1
A-3

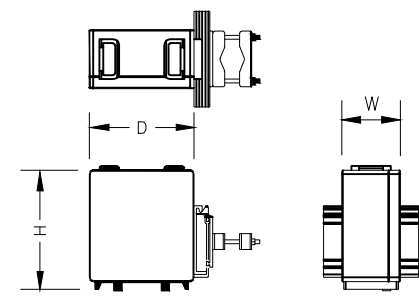

REMOTE RADIO UNIT SPECIFICATIONS	
MODEL #	RADIO 4415 B25
MANUF.	ERICSSON
HEIGHT	14.9"
WIDTH	13.2"
DEPTH	5.4"
WEIGHT	46.3 LB

REMOTE RADIO UNIT
N.T.S. 2
A-3

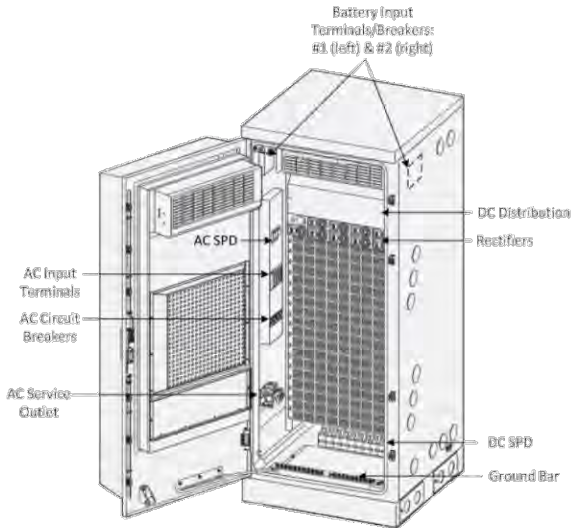

SITE SUPPORT CABINET SPECIFICATIONS	
MODEL #	6160
MANUF.	ERICSSON
HEIGHT	63"
WIDTH	25.6"
DEPTH	33.5"
WEIGHT	605 lbs

SITE SUPPORT CABINET
N.T.S. 3
A-3



BATTERY CABINET SPECIFICATIONS	
MODEL #	B160
MANUF.	ERICSSON
HEIGHT	63"
WIDTH	26"
DEPTH	26"
WEIGHT	1883 lbs

BATTERY CABINET
N.T.S. 4
A-3

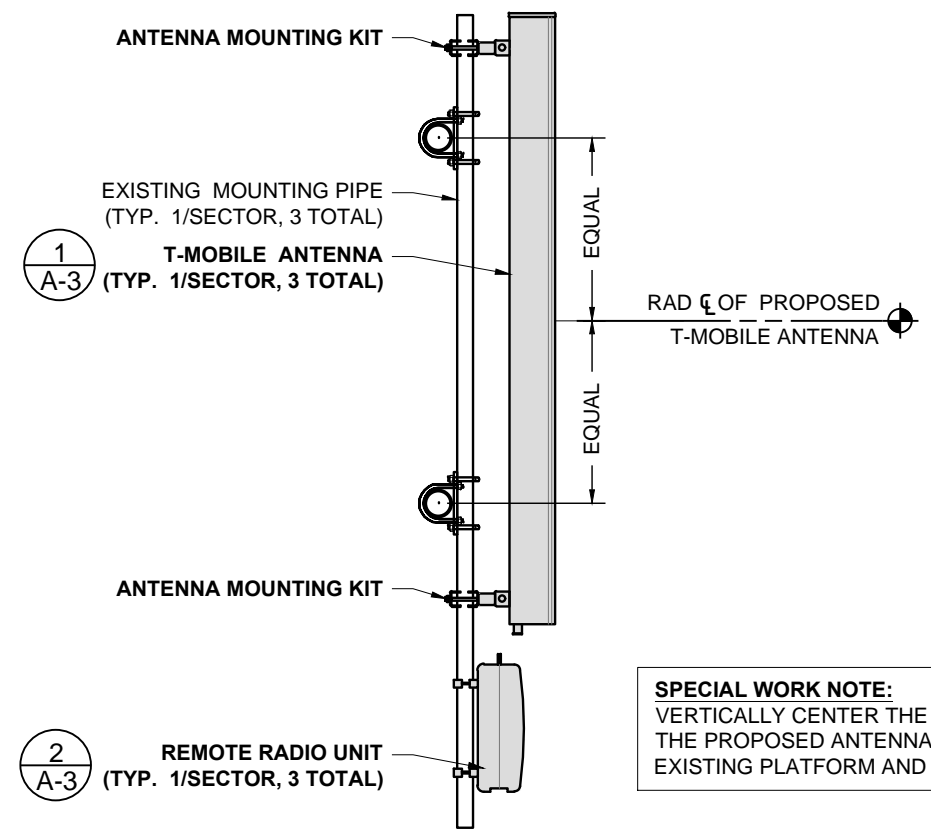

SPECIAL WORK NOTE:
VERTICALLY CENTER THE PIPE MAST AND THE PROPOSED ANTENNAS BETWEEN THE EXISTING PLATFORM AND HANDRAIL

APPLICANT:
T-Mobile
T-MOBILE NORTHEAST LLC
35 GRIFFIN ROAD SOUTH
BLOOMFIELD, CT 06002
860-692-7100

PROJECT MANAGER
NSS NORTHEAST
SITE SOLUTIONS
Turnkey Wireless Development
420 MAIN STREET, BLDG 4
STURBRIDGE, MA 01566
203-275-6669

CONSULTANT:
FORESITE LLC
Architects . Engineers . Surveyors
462 WALNUT STREET
NEWTON, MA 02460
617-212-3123



THIS DOCUMENT IS THE DESIGN PROPERTY AND COPYRIGHT OF FORESITE, LLC. AND FOR THE EXCLUSIVE USE BY THE TITLE CLIENT. DUPLICATION OR USE WITHOUT THE EXPRESS WRITTEN CONSENT OF THE CREATOR IS STRICTLY PROHIBITED. DRAWING SCALES ARE INTENDED FOR 11"x17" SIZE PRINTED MEDIA ONLY. ALL OTHER PRINTED SIZES ARE DEEMED "NOT TO SCALE".

REV	DESCRIPTION	DATE
A	PRELIMINARY	06/21/20
A	REVISED CABLE COUNTS	06/30/20

SITE NUMBER: CTHA174A
SITE NAME: MANCHESTER
SITE ADDRESS: 33 MITCHELL DRIVE
MANCHESTER, CT 06040

SHEET TITLE:
A-3: EQUIPMENT DETAILS

Copyright © 2018 Foresite LLC all rights reserved. The details, templates, drawing formats or any portion of this document generated by Foresite LLC may not be duplicated, traced or used otherwise for any profit-driven enterprise.

ELECTRICAL & GROUNDING NOTES

1. ALL ELECTRICAL WORK SHALL CONFORM TO THE REQUIREMENTS OF THE NATIONAL ELECTRICAL CODE (NEC) AS WELL AS APPLICABLE STATE AND LOCAL CODES.
2. ALL ELECTRICAL ITEMS SHALL BE U.L. APPROVED OR LISTED AND PRODUCED PER SPECIFICATION REQUIREMENTS.
3. THE ELECTRICAL WORK INCLUDES ALL LABOR AND MATERIAL DESCRIBED BY DRAWINGS AND SPECIFICATION INCLUDING INCIDENTAL WORK TO PROVIDE COMPLETE OPERATING AND APPROVED ELECTRICAL SYSTEM.
4. GENERAL CONTRACTOR SHALL PAY FEES FOR PERMITS, AND RESPONSIBLE FOR OBTAINING SAID PERMITS AND COORDINATION OF INSPECTIONS.
5. ELECTRICAL AND TELCO WIRING OUTSIDE A BUILDING AND EXPOSED TO WEATHER SHALL BE IN WATER TIGHT GALVANIZED RIGID STEEL CONDUITS OR SCHEDULE 80 PVC (AS PERMITTED BY CODE) AND WHERE REQUIRED IN LIQUID TIGHT FLEXIBLE METAL OR NONMETALLIC CONDUITS.
6. RIGID STEEL CONDUITS SHALL BE GROUNDED AT BOTH ENDS.
7. ELECTRICAL WIRING SHALL BE COPPER WITH TYPE XHHW, THWN, OR THIN INSULATION.
8. RUN ELECTRICAL CONDUIT OR CABLING BETWEEN ELECTRICAL ROOM AND PROPOSED CELL SITE ARE PEDESTAL AS INDICATED ON THIS DRAWING. PROVIDE FULL LENGTH PULL ROPE. COORDINATE INSTALLATION WITH UTILITY COMPANY.
9. RUN TELCO CONDUIT OR CABLE BETWEEN TELEPHONE UTILITY DEMARCATION POINT AND PROPOSED CELL SITE TELECOM CABINET AND RBS CABINET AS INDICATED ON DRAWING A -1. PROVIDE FULL LENGTH PULL ROPE INSTALLED TELCO CONDUIT. PROVIDE GREENLEE CONDUIT MEASURING TAPE AT EACH END.
10. ALL EQUIPMENT LOCATED OUTSIDE SHALL HAVE NAME 3R ENCLOSURE.
11. GROUNDING SHALL COMPLY WITH NEC ART. 250.
12. GROUNDING COAX CABLE SHIELDS MINIMUM AT BOTH ENDS USING MANUFACTURERS COAX CABLE GROUNDING KITS SUPPLIED BY PROJECT OWNER.
13. USE #6 COPPER STRANDED WIRE WITH GREEN COLOR INSTALLATION FOR ABOVE GRADE GROUNDING (UNLESS OTHERWISE SPECIFIED) AND #2 SOLID TINNED BARE COPPER WIRE FOR BELOW GRADE GROUNDING AS INDICATED ON THE GROUND.
14. ALL GROUND CONNECTION TO BE BURNDY HYGROUND COMPRESSION TYPE CONNECTORS OR CADWELD EXOTHERMIC WELD. DO NOT ALLOW BARE COPPER WIRE TO BE IN CONTACT WITH GALVANIZED STEEL.
15. ROUTE GROUNDING CONDUCTORS ALONG THE SHORTEST AND STRAIGHTEST PATH POSSIBLE, EXCEPT AS OTHERWISE INDICATED. GROUNDING LEADS SHOULD NEVER BE BENT AS RIGHT ANGLE. ALWAYS MAKE AT LEAST 12" RADIUS BENDS. #6 WIRE CAN BE BENT AT 6" RADIUS WHEN NECESSARY BOND ANY METER OBJECTS WITHIN 7 FEET OF PROPOSED EQUIPMENT OR CABINET TO MASTER GROUND BAR.
16. CONNECTIONS TO MGB SHALL BE ARRANGED IN THREE MAIN GROUPS: SURGE PROCEDURES (COAXIAL CABLE GROUND KITS, TELCO AND POWER PANEL GROUND); (GROUNDING ELECTRODE RING OR BUILDING STEEL); NON-SURGING OBJECTS (EGB GROUND IN RBS UNIT).
17. CONNECTIONS TO GROUND BARS SHALL BE MADE WITH TWO HOLE COMPRESSION TYPE COPPER LUGS. APPLY OXIDE INHIBITING COMPOUND TO ALL CONNECTIONS.
18. APPLY OXIDE INHIBITING COMPOUND TO ALL COMPRESSION TYPE GROUND CONNECTION.
19. BOND ANTENNA MOUNTING BRACKETS, COAXIAL CABLE GROUND KITS, AND ALNA TO EGB PLACED NEAR THE ANTENNA LOCATION.
20. BOND ANTENNA EGB'S AND MGB TO WATER MAIN.
21. TEST COMPLETED GROUND SYSTEM AND RECORD RESULTS FOR PROJECT CLOSE-OUT DOCUMENTATION.
22. BOND ANY METAL OBJECTS WITHIN 7 FEET OF PROPOSED EQUIPMENT OR CABINET TO MASTER GROUND BAR.
23. VERIFY PROPOSED SERVICE UPGRADE WITH LOCAL UTILITY COMPANY PRIOR TO CONSTRUCTION.

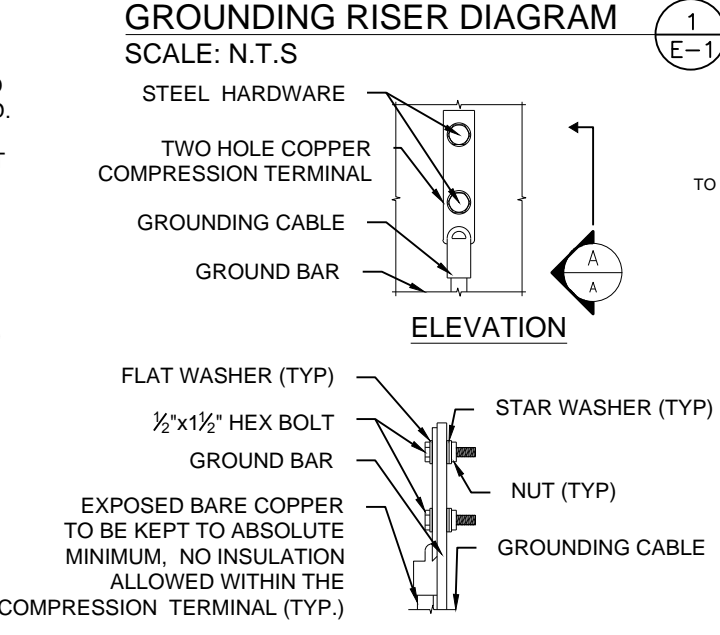
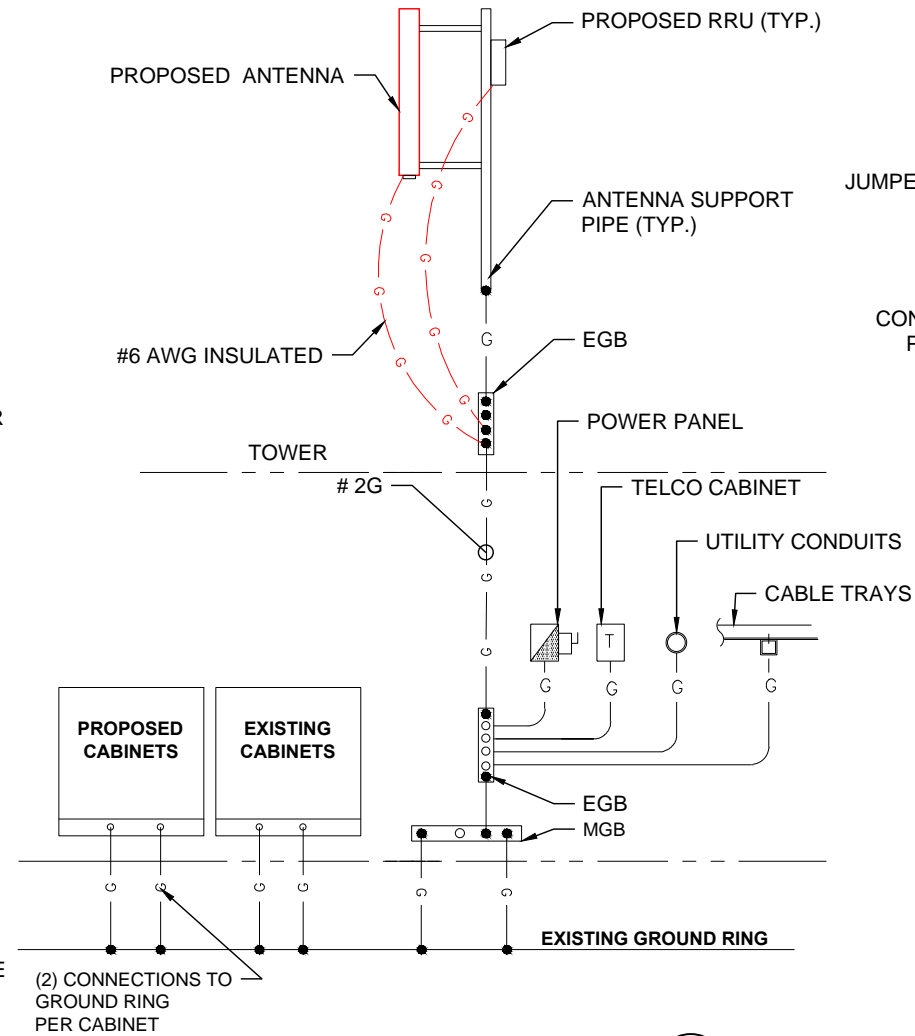

- NOTES:**
1. "DOUBLING UP" OR "STACKING" OF CONNECTIONS IS NOT PERMITTED.
 2. OXIDE INHIBITING COMPOUND TO BE USED AT ALL LOCATIONS.

TYPICAL GROUND BAR CONNECTIONS DETAIL
SCALE: N.T.S.

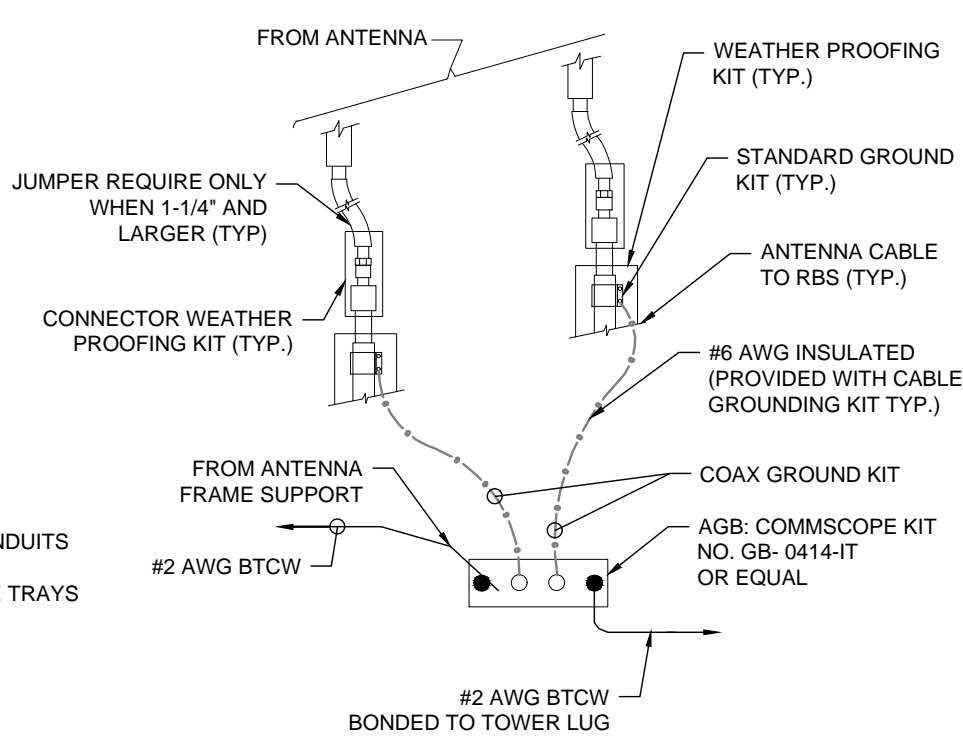

- NOTES:**
- INSTALL CABLE GROUND KIT ABOVE HORIZONTAL BEND AND ALWAYS DIRECT GROUND WIRE DOWN TO AGB/EGB

TOWER TOP CABLE GROUNDING DETAIL
SCALE: N.T.S.

- SPECIAL CONTRACTOR NOTES:**
- CONTRACTOR TO VERIFY THE POWER FEED & PHASE OF METER BANK AND THAT THE EXISTING AND PROPOSED CONDUITS AND WIRE SIZES ARE ADEQUATE FOR THE PROPOSED LOADING IN ACCORDANCE WITH NEC AND INCLUDE ELECTRICAL UPGRADES IN THE SCOPE OF WORK AS REQUIRED.

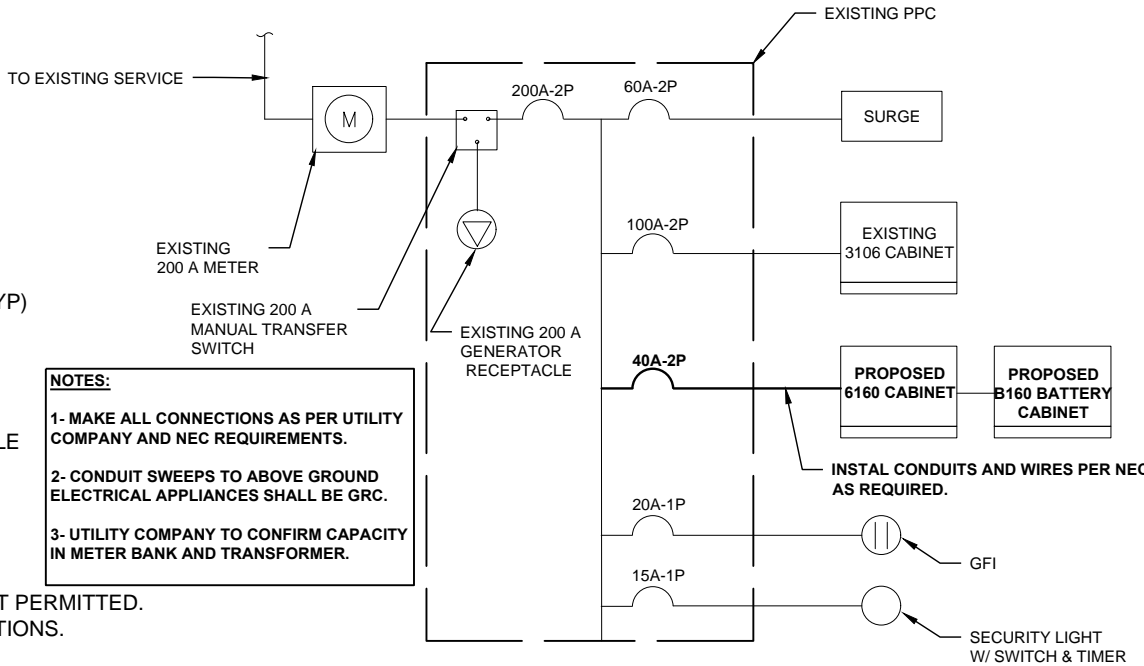

- NOTES:**
1. MAKE ALL CONNECTIONS AS PER UTILITY COMPANY AND NEC REQUIREMENTS.
 2. CONDUIT SWEEPS TO ABOVE GROUND ELECTRICAL APPLIANCES SHALL BE GRC.
 3. UTILITY COMPANY TO CONFIRM CAPACITY IN METER BANK AND TRANSFORMER.

ONE LINE DIAGRAM
N.T.S.

APPLICANT:
T-Mobile
T-MOBILE NORTHEAST LLC
35 GRIFFIN ROAD SOUTH
BLOOMFIELD, CT 06002
860-692-7100

PROJECT MANAGER
NSS NORTHEAST
SITE SOLUTIONS
Turnkey Wireless Development
420 MAIN STREET, BLDG 4
STURBRIDGE, MA 01566
203-275-6669

CONSULTANT:
FORESITE LLC
Architects . Engineers . Surveyors
462 WALNUT STREET
NEWTON, MA 02460
617-212-3123

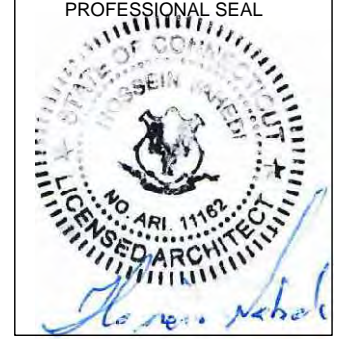

THIS DOCUMENT IS THE DESIGN PROPERTY AND COPYRIGHT OF FORESITE, LLC. AND FOR THE EXCLUSIVE USE BY THE TITLE CLIENT. DUPLICATION OR USE WITHOUT THE EXPRESS WRITTEN CONSENT OF THE CREATOR IS STRICTLY PROHIBITED. DRAWING SCALES ARE INTENDED FOR 11"x17" SIZE PRINTED MEDIA ONLY. ALL OTHER PRINTED SIZES ARE DEEMED "NOT TO SCALE".

REV	DESCRIPTION	DATE
A	PRELIMINARY	06/21/20
A	REVISED CABLE COUNTS	06/30/20

SITE NUMBER: CTHA174A
SITE NAME: MANCHESTER
SITE ADDRESS: 33 MITCHELL DRIVE
MANCHESTER, CT 06040

SHEET TITLE:
E-1: GROUNDING AND ELECTRICAL DETAILS

Exhibit D

Prepared For:



**T-Mobile Northeast, LLC
35 Griffin Road South
Bloomfield, CT 06002**



Structure Rating

Tower:	Pass (93.3%)
Anchor rods:	Pass (51.7%)
Foundation:	Pass (59.4%)

Sincerely,
EFI Global, Inc.
License No: PEC0001429



Ahmet Colakoglu, PE
Connecticut Professional Engineer
License No: 27057

**Site ID: CTHA174A
Site Name: MANCHESTER
33 Mitchell Dr,
Manchester, CT 06040**

CONTENTS

1.0 – SUBJECT AND REFERENCES

1.1 – STRUCTURE

2.0 – EXISTING AND PROPOSED APPURTENANCES

3.0 - CODES AND LOADING

4.0 - STANDARD CONDITIONS FOR ENGINEERING SERVICES ON EXISTING
STRUCTURES

5.0 - ANALYSIS AND ASSUMPTIONS

6.0 – RESULTS AND CONCLUSION

APPENDIX

A –SOFTWARE OUTPUT

1.0 SUBJECT AND REFERENCES

The purpose of this analysis is to evaluate the structural capacity of the existing 170 feet tall self-support tower, located at 33 Mitchell Dr, Manchester, CT 06040 for the additions and alterations proposed by T-Mobile.

The structural analysis of the site is based on the following documents provided to EFI Global, Inc. (EFI):

- Structural Analysis Report prepared by Centek Engineering, Inc., dated 03/06/2018.
- Construction Drawings prepared by Centek Engineering, Inc., dated 07/18/2018.
- RFDS prepared by T-Mobile, dated 05/19/2020.
- Site Audit pictures, dated 05/02/2020.

1.1 STRUCTURE

The subject structure is a 170 ft. tall self-support tower. Truss Legs are X-Braced with single and double angle members throughout the length of the tower. The tower is 24.0 ft wide at the base and 7.0 ft at the top. Please refer to the software output in Appendix A for tower geometry, member sizes, and other details.

2.0 EXISTING AND PROPOSED APPURTENANCES

This analysis was based on the following existing and proposed appurtenances:

Existing Configuration of T-MOBILE Appurtenances:

Rad Center (Ft)	Antenna & TMA	Coax	Mount
140	(4) AIR21 KRC118023-1_B2A_B4P (4) AIR32 KRD901146-1_B66A_B2A (4) APXVAARR24_43-U-NA20 (4) Ericsson Radio 4449 B71+B85 (4) Generic Twin Style 1B – AWS (1) 2' MW Dish	(8) 1-5/8" (4) 6X12 HCS	(1) Custom Sector Mount

Proposed and Final Configuration of T-MOBILE Appurtenances:

Rad Center (Ft)	Antenna & TMA	Coax	Mount
140	(4) AIR21 KRC118023-1_B2A_B4P (4) AIR32 KRD901146-1_B66A_B2A (4) APXVAARR24_43-U-NA20 (4) Ericsson AIR6449 B41 (4) Ericsson Radio 4449 B71+B85 (4) Ericsson Radio 4415 B25 (4) Generic Twin Style 1B – AWS (1) 2' MW Dish	(8) 1-5/8" (8) 6X12 HCS	(1) Custom Sector Mount

Existing and Remaining Appurtenances by Others:

Rad Center (Ft)	Antenna & TMA	Coax	Mount
170	(12) 6'x1' Panel Antennas	(12) 1-5/8"	(3) 12 ft Sector Mounts
165	(3) 6' MW Dishes	(3) 1-5/8"	Leg Mounted
160	(1) Shively Labs 6812	(1) 1-5/8"	Leg Mounted
155	(1) Shively Labs 6812	(1) 1-5/8"	Leg Mounted
150	(2) 4' MW Dishes (1) 2' MW Dish	(3) 1-5/8"	Leg Mounted
110	(1) 2' Dish	-	Leg Mounted
100	(12) Andrew SBNHH-1D65B (3) Alcatel lucent RRH2x60-07-U (3) Alcatel lucent RRH2x60-PCS (3) Alcatel lucent RRH4x45/2x90-AWS (2) Commscope DB-T1-6Z-8AB-0Z	(2) 1-5/8"	(3) Sector Mounts

3.0 CODES AND LOADING

The tower was analyzed per *ANSI/TIA-222-G* as referenced by the *2018 Connecticut State Building Code* with all of the adopted Addendums and Supplements. The following wind loading was used in compliance with the standard for Hartford County, CT:

- Basic wind speed 97 mph without ice (W_0)
- Basic wind speed 50 mph with 1" escalating ice (W_i)
- Exposure Category C
- Topographic Category 1
- Structure Class II

The following load combinations were used with wind blowing at 0°, 30°, 45°, 60°, and 90° measured from a line normal to the face of the tower.

- $1.2 D + 1.6 W_0$
- $0.9 D + 1.6 W_0$
- $1.2 D + 1.0 D_i + 1.0 W_i + 1.0 T_i$

D: Dead Load of structure and appurtenances

T_i : Load effects due to temperature

W_0 : Wind Load, without ice (based upon V)

W_i : Wind Load, with ice (based upon V_i)

D_i : Weight of Ice

4.0 STANDARD CONDITIONS FOR ENGINEERING SERVICES ON EXISTING STRUCTURES

The analysis is based on the information provided to EFI and is assumed to be current and correct. Unless otherwise noted, the structure and the foundation system are assumed to be in good condition, free of defects and can achieve theoretical strength.

It is assumed that the structure has been maintained and shall be maintained during its service. The superstructure and the foundation system are assumed to be designed with proper engineering practice and fabricated, constructed and erected in accordance with the design documents. EFI will accept no liability which may arise due to any existing deficiency in design, material, fabrication, erection, construction, etc. or lack of maintenance.

The analysis does not include a qualification of the mounts attached on the structure or their connections. The analysis is performed to verify the capacity of the main structural members, which is the current practice in the tower industry.

The analysis results presented in this report are only applicable for the previously mentioned existing and proposed additions and alterations. Any deviation of the proposed equipment and placement, etc., will require EFI to generate an additional structural analysis.

5.0 ANALYSIS AND ASSUMPTIONS

The tower was analyzed by utilizing tnxTower, a non-linear, three-dimensional, finite element-analysis software package, a product of Tower Numerics, Inc. Software output for this analysis is provided in Appendix A of this report.

6.0 **RESULTS AND CONCLUSION**

Based on a structural analysis per ANSI/TIA-222-G, the existing self-support tower is found to have **adequate** structural capacity for the proposed changes by T-Mobile. For the code specified load combinations and as a maximum, the diagonals between the elevations 40 ft. and 60 ft. are stressed to **93.3%** its structural capacity. The legs, horizontals and anchor bolts are stressed to 61.2%, 10.3% and 51.7% of their structural capacities.

The existing base foundation is found to have **adequate** structural capacity for the proposed changes by T-Mobile. As a maximum, the foundation is stressed to **59.4%** of its structural capacity.

Therefore, the proposed additions and alterations by T-Mobile **can** be implemented as intended and with the conditions outlined in this report.

Should you have any questions about this report, please contact EFI at telecom@efiglobal.com.

APPENDIX A
SOFTWARE OUTPUT

DESIGNED APPURTENANCE LOADING

TYPE	ELEVATION	TYPE	ELEVATION
15' Lighting Rod	170	(2) Radio 4449 B71+B85_T-Mobile	140
Beacon	170	Radio 4449 B71+B85_T-Mobile	140
(4) 6'x1' Panel Antenna	170	Radio 4449 B71+B85_T-Mobile	140
(4) 6'x1' Panel Antenna	170	RRUS 4415 B25	140
(4) 6'x1' Panel Antenna	170	RRUS 4415 B25	140
10.5'-P2x0.154 H	170	(2) RRUS 4415 B25	140
10.5'-P2x0.154 H	170	KRY 112 144/1	140
10.5'-P2x0.154 H	170	KRY 112 144/1	140
Sector Mount [SM 502-3]	170	(2) KRY 112 144/1	140
6' Dish	165	Custom 4-Sided Sector Mount	140
6' Dish	165	SC2-W100AB	140
6' Dish	165	2' Dish	110
6812	160	RRH2x60-PCS	100
6812	155	RRH4x45/2x90-AWS	100
4' Dish	150		
4' Dish	150	RRH4x45/2x90-AWS	100
2' Dish	150		
AIR 21 B2A/B4P w/ Mount Pipe	140	RRH4x45/2x90-AWS	100
AIR 21 B2A/B4P w/ Mount Pipe	140		
(2) AIR 21 B2A/B4P w/ Mount Pipe	140	DB-T1-6Z-8AB-0Z	100
AIR 32 B2a/B66Aa w/ Mount Pipe	140	DB-T1-6Z-8AB-0Z	100
AIR 32 B2a/B66Aa w/ Mount Pipe	140	10.5'-P2x0.154 H	100
(2) AIR 32 B2a/B66Aa w/ Mount Pipe	140	10.5'-P2x0.154 H	100
(2) APXVAARR24_43-U-NA20 w/ Mount Pipe	140	10.5'-P2x0.154 H	100
APXVAARR24_43-U-NA20 w/ Mount Pipe	140	Sector Mount [SM 502-3]	100
APXVAARR24_43-U-NA20 w/ Mount Pipe	140	RRH2x60-700	100
Ericsson AIR6449 B41 w/ Mount Pipe	140	(4) SBNHH-1D65B w/ Mount Pipe	100
Ericsson AIR6449 B41 w/ Mount Pipe	140	(4) SBNHH-1D65B w/ Mount Pipe	100
(2) Ericsson AIR6449 B41 w/ Mount Pipe	140	(4) SBNHH-1D65B w/ Mount Pipe	100
		RRH2x60-700	100
		RRH2x60-PCS	100
		RRH2x60-PCS	100
		RRH2x60-700	100

SYMBOL LIST

MARK	SIZE	MARK	SIZE
A	L2 1/2x2 1/2x3/16		

MATERIAL STRENGTH

GRADE	Fy	Fu	GRADE	Fy	Fu
A572-50	50 ksi	65 ksi	A36	36 ksi	58 ksi

TOWER DESIGN NOTES

1. Tower is located in Hartford County, Connecticut.
2. Tower designed for Exposure C to the TIA-222-G Standard.
3. Tower designed for a 97 mph basic wind in accordance with the TIA-222-G Standard.
4. Tower is also designed for a 50 mph basic wind with 1.00 in ice. Ice is considered to increase in thickness with height.
5. Wind Effects are based upon a 60 mph wind.
6. Tower Structure Class II.
7. Topographic Category 1 with Crest Height of 0.0000 ft
8. **WIND RATING: 93.3%**

PLIFF: 250 K

SHEAR: 31 K

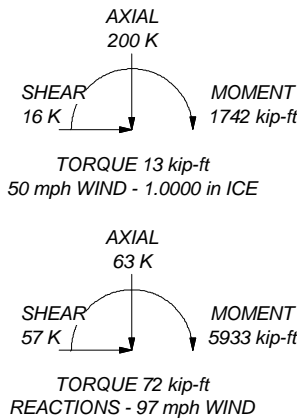

Section	T1	T2	T3	T4	T5	T6	T7	T8	T9
Legs	Pirod 207628	Pirod 207629	Pirod 207629	Pirod 195557	Pirod 211843	Pirod 208333	Pirod 208334	Pirod 208335	Pirod 208335
Leg Grade			L2 1/2x2 1/2x3/16						
Diagonals			L3x3x3/16						
Diagonal Grade				L3x3x5/16		2L3x3x3/16			2L3 1/2x3 1/2x1/4
Top Girts									
Sec. Horizontals	A								
Face Width (ft)	7	8	10	12	14	16	18	20	22
# Panels @ (ft)			7 @ 10				5 @ 20		
Weight (K)	0.9	2.2	2.4	3.4	4.3	4.4	5.0	5.8	6.5

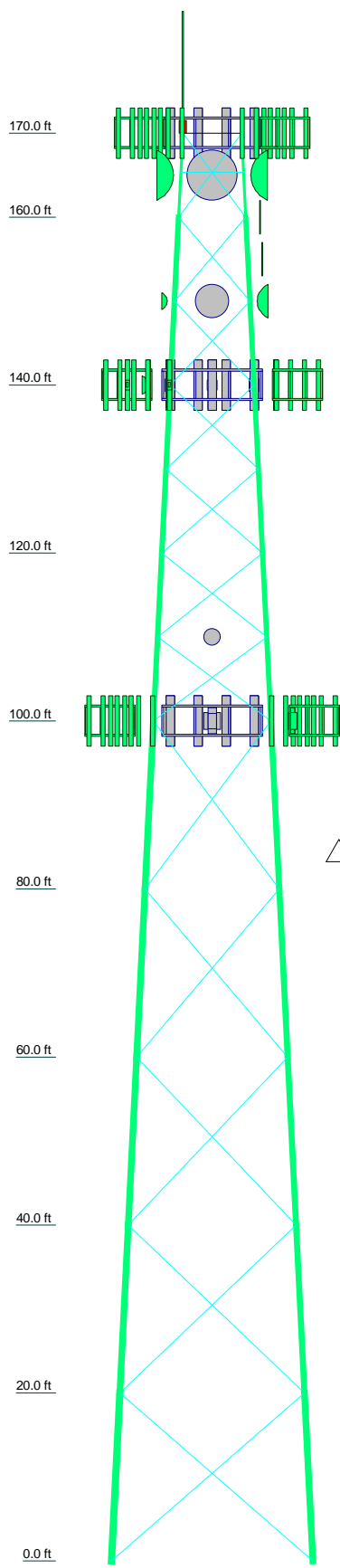

EFI Global, Inc.
 efi global 1117 Perimeter Center West, Suite E500
 Atlanta, GA 30338
 Phone: (770) 693-0835
 FAX:

Job: **CTHA174A**
 Project: **049.00427 - 2075022**
 Client: **Foresite LLC** Drawn by: **Ahmet Colakoglu** App'd:
 Code: **TIA-222-G** Date: **06/15/20** Scale: **NTS**
 Path: Dwg No. **E-1**

SYMBOL LIST

MARK	SIZE	MARK	SIZE
A	L2 1/2x2 1/2x3/16		

MATERIAL STRENGTH

GRADE	Fy	Fu	GRADE	Fy	Fu
A572-50	50 ksi	65 ksi	A36	36 ksi	58 ksi

TOWER DESIGN NOTES

1. Tower is located in Hartford County, Connecticut.
2. Tower designed for Exposure C to the TIA-222-G Standard.
3. Tower designed for a 97 mph basic wind in accordance with the TIA-222-G Standard.
4. Tower is also designed for a 50 mph basic wind with 1.00 in ice. Ice is considered to increase in thickness with height.
5. Deflections are based upon a 60 mph wind.
6. Tower Structure Class II.
7. Topographic Category 1 with Crest Height of 0.0000 ft
8. TOWER RATING: 93.3%

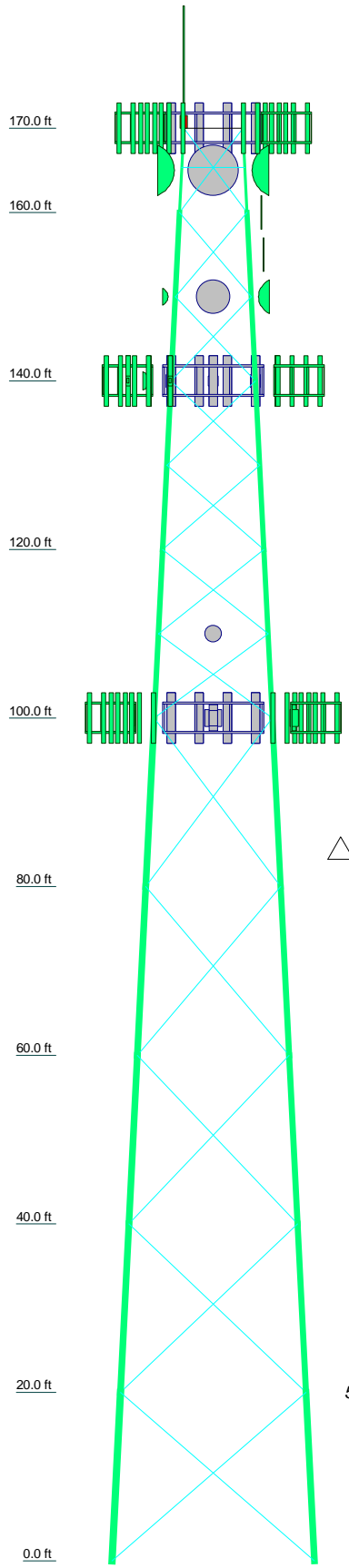

ALL REACTIONS
ARE FACTORED

MAX. CORNER REACTIONS AT BASE:

DOWN: 306 K
SHEAR: 35 K

UPLIFT: -256 K
SHEAR: 31 K

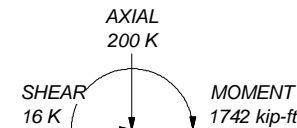

TORQUE 13 kip-ft
50 mph WIND - 1.0000 in ICE

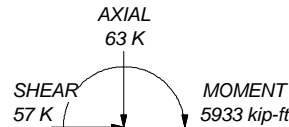

TORQUE 72 kip-ft
REACTIONS - 97 mph WIND

Section	T1	T2	T3	T4	T5	T6	T7	T8	T9
Legs	Pirolod 207628	Pirolod 207629	Pirolod 195557	Pirolod 211843	Pirolod 208333	Pirolod 208334	Pirolod 208335		
Leg Grade			L3x3x3/16	L3x3x5/16	2L3x3x3/16	2L3x3x3/16	2L3 1/2x3 1/2x1/4		
Diagonals					A572-50				
Diagonal Grade					A36				
Top Girts	A				N.A.				
Sec. Horizontals	A				N.A.				
Face Width (ft)	7	8	10	12	14	16	18	20	22
# Panels @ (ft)			7 @ 10				5 @ 20		
Weight (K)	0.9	2.2	2.4	3.4	4.3	4.4	5.0	5.8	6.5

EFI Global, Inc.
 efi global 1117 Perimeter Center West, Suite E500
 Atlanta, GA 30338
 Phone: (770) 693-0835
 FAX:

Job: **CTHA174A**
 Project: **049.00427 - 2075022**
 Client: **Foresite LLC** Drawn by: **Ahmet Colakoglu** App'd:
 Code: **TIA-222-G** Date: **06/15/20** Scale: **NTS**
 Path: **Dwg No. E-1**

tnxTower EFI Global, Inc. 1117 Perimeter Center West, Suite E500 Atlanta, GA 30338 Phone: (770) 693-0835 FAX:	Job	CTHA174A	Page	1 of 27
	Project	049.00427 - 2075022	Date	15:52:55 06/15/20
	Client	Foresite LLC	Designed by	Ahmet Colakoglu

Tower Input Data

The main tower is a 3x free standing tower with an overall height of 170.0000 ft above the ground line.

The base of the tower is set at an elevation of 0.0000 ft above the ground line.

The face width of the tower is 7.0000 ft at the top and 24.0000 ft at the base.

This tower is designed using the TIA-222-G standard.

The following design criteria apply:

Tower is located in Hartford County, Connecticut.

Basic wind speed of 97 mph.

Structure Class II.

Exposure Category C.

Topographic Category 1.

Crest Height 0.0000 ft.

Nominal ice thickness of 1.0000 in.

Ice thickness is considered to increase with height.

Ice density of 56.0000 pcf.

A wind speed of 50 mph is used in combination with ice.

Deflections calculated using a wind speed of 60 mph.

A non-linear (P-delta) analysis was used.

Pressures are calculated at each section.

Stress ratio used in tower member design is 1.

Local bending stresses due to climbing loads, feed line supports, and appurtenance mounts are not considered.

Options

<ul style="list-style-type: none"> Consider Moments - Legs Consider Moments - Horizontals Consider Moments - Diagonals Use Moment Magnification √ Use Code Stress Ratios √ Use Code Safety Factors - Guys Escalate Ice Always Use Max Kz Use Special Wind Profile √ Include Bolts In Member Capacity Leg Bolts Are At Top Of Section √ Secondary Horizontal Braces Leg Use Diamond Inner Bracing (4 Sided) √ SR Members Have Cut Ends SR Members Are Concentric 	<ul style="list-style-type: none"> Distribute Leg Loads As Uniform Assume Legs Pinned √ Assume Rigid Index Plate √ Use Clear Spans For Wind Area √ Use Clear Spans For KL/r Retension Guys To Initial Tension √ Bypass Mast Stability Checks √ Use Azimuth Dish Coefficients √ Project Wind Area of Appurt. Autocalc Torque Arm Areas Add IBC .6D+W Combination √ Sort Capacity Reports By Component Triangulate Diamond Inner Bracing Treat Feed Line Bundles As Cylinder Ignore KL/ry For 60 Deg. Angle Legs 	<ul style="list-style-type: none"> Use ASCE 10 X-Brace Ly Rules √ Calculate Redundant Bracing Forces Ignore Redundant Members in FEA √ SR Leg Bolts Resist Compression All Leg Panels Have Same Allowable Offset Girt At Foundation √ Consider Feed Line Torque √ Include Angle Block Shear Check Use TIA-222-G Bracing Resist. Exemption Use TIA-222-G Tension Splice Exemption <li style="text-align: center;">Poles Include Shear-Torsion Interaction Always Use Sub-Critical Flow Use Top Mounted Sockets Pole Without Linear Attachments Pole With Shroud Or No Appurtenances Outside and Inside Corner Radii Are Known
--	---	---

tnxTower EFI Global, Inc. 1117 Perimeter Center West, Suite E500 Atlanta, GA 30338 Phone: (770) 693-0835 FAX:	Job CTHA174A	Page 2 of 27
	Project 049.00427 - 2075022	Date 15:52:55 06/15/20
	Client Foresite LLC	Designed by Ahmet Colakoglu

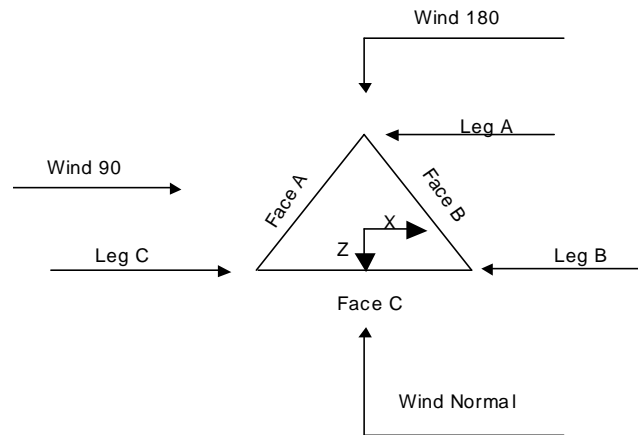

Triangular Tower

Tower Section Geometry

Tower Section	Tower Elevation	Assembly Database	Description	Section Width	Number of Sections	Section Length
	ft			ft		ft
T1	170.0000-160.0000			7.0000	1	10.0000
T2	160.0000-140.0000			8.0000	1	20.0000
T3	140.0000-120.0000			10.0000	1	20.0000
T4	120.0000-100.0000			12.0000	1	20.0000
T5	100.0000-80.0000			14.0000	1	20.0000
T6	80.0000-60.0000			16.0000	1	20.0000
T7	60.0000-40.0000			18.0000	1	20.0000
T8	40.0000-20.0000			20.0000	1	20.0000
T9	20.0000-0.0000			22.0000	1	20.0000

Tower Section Geometry (cont'd)

Tower Section	Tower Elevation	Diagonal Spacing	Bracing Type	Has K Brace End Panels	Has Horizontals	Top Girt Offset	Bottom Girt Offset
	ft	ft				in	in
T1	170.0000-160.0000	10.0000	X Brace	No	Yes	0.0000	0.0000

tnxTower EFI Global, Inc. 1117 Perimeter Center West, Suite E500 Atlanta, GA 30338 Phone: (770) 693-0835 FAX:	Job CTHA174A	Page 3 of 27
	Project 049.00427 - 2075022	Date 15:52:55 06/15/20
	Client Foresite LLC	Designed by Ahmet Colakoglu

Tower Section	Tower Elevation ft	Diagonal Spacing ft	Bracing Type	Has K Brace End Panels	Has Horizontals	Top Girt Offset in	Bottom Girt Offset in
T2	160.0000-140.0000	10.0000	X Brace	No	No	0.0000	0.0000
T3	140.0000-120.0000	10.0000	X Brace	No	No	0.0000	0.0000
T4	120.0000-100.0000	10.0000	X Brace	No	No	0.0000	0.0000
T5	100.0000-80.0000	20.0000	X Brace	No	No	0.0000	0.0000
T6	80.0000-60.0000	20.0000	X Brace	No	No	0.0000	0.0000
T7	60.0000-40.0000	20.0000	X Brace	No	No	0.0000	0.0000
T8	40.0000-20.0000	20.0000	X Brace	No	No	0.0000	0.0000
T9	20.0000-0.0000	20.0000	X Brace	No	No	0.0000	0.0000

Tower Section Geometry (cont'd)

Tower Elevation ft	Leg Type	Leg Size	Leg Grade	Diagonal Type	Diagonal Size	Diagonal Grade
T1 170.0000-160.0000	Truss Leg	Pirod 207628	A572-50 (50 ksi)	Single Angle	L2 1/2x2 1/2x3/16	A36 (36 ksi)
T2 160.0000-140.0000	Truss Leg	Pirod 207629	A572-50 (50 ksi)	Single Angle	L2 1/2x2 1/2x3/16	A36 (36 ksi)
T3 140.0000-120.0000	Truss Leg	Pirod 207629	A572-50 (50 ksi)	Single Angle	L3x3x3/16	A36 (36 ksi)
T4 120.0000-100.0000	Truss Leg	Pirod 195557	A572-50 (50 ksi)	Single Angle	L3x3x5/16	A36 (36 ksi)
T5 100.0000-80.0000	Truss Leg	Pirod 211843	A572-50 (50 ksi)	Double Angle	2L3x3x3/16	A36 (36 ksi)
T6 80.0000-60.0000	Truss Leg	Pirod 208333	A572-50 (50 ksi)	Double Angle	2L3x3x3/16	A36 (36 ksi)
T7 60.0000-40.0000	Truss Leg	Pirod 208334	A572-50 (50 ksi)	Double Angle	2L3x3x3/16	A36 (36 ksi)
T8 40.0000-20.0000	Truss Leg	Pirod 208334	A572-50 (50 ksi)	Double Angle	2L3 1/2x3 1/2x1/4	A36 (36 ksi)
T9 20.0000-0.0000	Truss Leg	Pirod 208335	A572-50 (50 ksi)	Double Angle	2L3 1/2x3 1/2x1/4	A36 (36 ksi)

Tower Section Geometry (cont'd)

Tower Elevation ft	Top Girt Type	Top Girt Size	Top Girt Grade	Bottom Girt Type	Bottom Girt Size	Bottom Girt Grade
T1 170.0000-160.0000	Single Angle	L2 1/2x2 1/2x3/16	A36 (36 ksi)	Single Angle		A36 (36 ksi)

tnxTower EFI Global, Inc. 1117 Perimeter Center West, Suite E500 Atlanta, GA 30338 Phone: (770) 693-0835 FAX:	Job	CTHA174A	Page	4 of 27
	Project	049.00427 - 2075022	Date	15:52:55 06/15/20
	Client	Foresite LLC	Designed by	Ahmet Colakoglu

Tower Section Geometry (cont'd)

Tower Elevation	Secondary Horizontal Type	Secondary Horizontal Size	Secondary Horizontal Grade	Inner Bracing Type	Inner Bracing Size	Inner Bracing Grade
<i>ft</i>						
T1 170.0000-160.00 00	Equal Angle	L2 1/2x2 1/2x3/16	A36 (36 ksi)	Solid Round		A572-50 (50 ksi)

Tower Section Geometry (cont'd)

Tower Elevation	Gusset Area (per face)	Gusset Thickness	Gusset Grade	Adjust. Factor A_f	Adjust. Factor A_r	Weight Mult.	Double Angle Stitch Bolt Spacing Diagonals	Double Angle Stitch Bolt Spacing Horizontals	Double Angle Stitch Bolt Spacing Redundants
<i>ft</i>	<i>ft²</i>	<i>in</i>					<i>in</i>	<i>in</i>	<i>in</i>
T1 170.0000-160.0000	0.0000	0.0000	A36 (36 ksi)	1.03	1	1.05	30.0000	30.0000	36.0000
T2 160.0000-140.0000	0.0000	0.0000	A36 (36 ksi)	1.03	1	1.05	36.0000	36.0000	36.0000
T3 140.0000-120.0000	0.0000	0.0000	A36 (36 ksi)	1.03	1	1.05	36.0000	0.0000	36.0000
T4 120.0000-100.0000	0.0000	0.0000	A36 (36 ksi)	1.03	1	1.05	36.0000	0.0000	36.0000
T5 100.0000-80.0000	0.0000	0.0000	A36 (36 ksi)	1.03	1	1.05	36.0000	0.0000	36.0000
T6 80.0000-60.0000	0.0000	0.0000	A36 (36 ksi)	1.03	1	1.05	36.0000	0.0000	36.0000
T7 60.0000-40.0000	0.0000	0.0000	A36 (36 ksi)	1.03	1	1.05	36.0000	0.0000	36.0000
T8 40.0000-20.0000	0.0000	0.0000	A36 (36 ksi)	1.03	1	1.05	36.0000	0.0000	36.0000
T9 20.0000-0.0000 0	0.0000	0.0000	A36 (36 ksi)	1.03	1	1.05	36.0000	0.0000	36.0000

Tower Section Geometry (cont'd)

K Factors¹

tnxTower EFI Global, Inc. 1117 Perimeter Center West, Suite E500 Atlanta, GA 30338 Phone: (770) 693-0835 FAX:	Job	CTHA174A	Page	5 of 27
	Project	049.00427 - 2075022	Date	15:52:55 06/15/20
	Client	Foresite LLC	Designed by	Ahmet Colakoglu

Tower Elevation	Calc K Single Angles	Calc K Solid Rounds	Legs	X Brace Diags X Y	K Brace Diags X Y	Single Diags X Y	Girts X Y	Horiz. X Y	Sec. Horiz. X Y	Inner Brace X Y
T1 170.0000-160.0000	Yes	Yes	1	1 1	1 1	1 1	1 1	1 1	1 0.5	1 1
T2 160.0000-140.0000	Yes	Yes	1	1 1	1 1	1 1	1 1	1 1	1 1	1 1
T3 140.0000-120.0000	Yes	Yes	1	1 1	1 1	1 1	1 1	1 1	1 1	1 1
T4 120.0000-100.0000	Yes	Yes	1	1 1	1 1	1 1	1 1	1 1	1 1	1 1
T5 100.0000-80.0000	Yes	Yes	1	1 1	1 1	1 1	1 1	1 1	1 1	1 1
T6 80.0000-60.0000	Yes	Yes	1	1 1	1 1	1 1	1 1	1 1	1 1	1 1
T7 60.0000-40.0000	Yes	Yes	1	1 1	1 1	1 1	1 1	1 1	1 1	1 1
T8 40.0000-20.0000	Yes	Yes	1	1 1	1 1	1 1	1 1	1 1	1 1	1 1
T9 20.0000-0.0000	Yes	Yes	1	1 1	1 1	1 1	1 1	1 1	1 1	1 1

¹Note: K factors are applied to member segment lengths. K-braces without inner supporting members will have the K factor in the out-of-plane direction applied to the overall length.

Tower Section Geometry (cont'd)

Tower Elevation ft	Truss-Leg K Factors					
	Truss-Legs Used As Leg Members			Truss-Legs Used As Inner Members		
	Leg Panels	X Brace Diagonals	Z Brace Diagonals	Leg Panels	X Brace Diagonals	Z Brace Diagonals
T1 170.0000-160.0000	1	0.5	0.85	1	0.5	0.85
T2 160.0000-140.0000	1	0.5	0.85	1	0.5	0.85
T3 140.0000-120.0000	1	0.5	0.85	1	0.5	0.85
T4 120.0000-100.0000	1	0.5	0.85	1	0.5	0.85
T5 100.0000-80.0000	1	0.5	0.85	1	0.5	0.85
T6 80.0000-60.0000	1	0.5	0.85	1	0.5	0.85

tnxTower EFI Global, Inc. 1117 Perimeter Center West, Suite E500 Atlanta, GA 30338 Phone: (770) 693-0835 FAX:	Job	CTHA174A	Page	6 of 27
	Project	049.00427 - 2075022	Date	15:52:55 06/15/20
	Client	Foresite LLC	Designed by	Ahmet Colakoglu

Truss-Leg K Factors						
Tower Elevation ft	Truss-Legs Used As Leg Members			Truss-Legs Used As Inner Members		
	Leg Panels	X Brace Diagonals	Z Brace Diagonals	Leg Panels	X Brace Diagonals	Z Brace Diagonals
60.0000-40.0000 T7	1	0.5	0.85	1	0.5	0.85
40.0000-20.0000 T8	1	0.5	0.85	1	0.5	0.85
20.0000-0.0000 T9	1	0.5	0.85	1	0.5	0.85

Tower Section Geometry (cont'd)

Tower Elevation ft	Leg		Diagonal		Top Girt		Bottom Girt		Mid Girt		Long Horizontal		Short Horizontal	
	Net Width Deduct in	U	Net Width Deduct in	U	Net Width Deduct in	U	Net Width Deduct in	U	Net Width Deduct in	U	Net Width Deduct in	U	Net Width Deduct in	U
170.0000-160.0000 T1	0.0000	1	0.0000	1	0.0000	1	0.0000	1	0.0000	0.75	0.0000	1	0.0000	1
160.0000-140.0000 T2	0.0000	1	0.0000	1	0.0000	1	0.0000	1	0.0000	0.75	0.0000	1	0.0000	1
140.0000-120.0000 T3	0.0000	1	0.0000	1	0.0000	1	0.0000	1	0.0000	0.75	0.0000	1	0.0000	1
120.0000-100.0000 T4	0.0000	1	0.0000	1	0.0000	1	0.0000	1	0.0000	0.75	0.0000	0.75	0.0000	0.75
100.0000-80.0000 T5	0.0000	1	0.0000	1	0.0000	1	0.0000	1	0.0000	0.75	0.0000	0.75	0.0000	0.75
80.0000-60.0000 T6	0.0000	1	0.0000	1	0.0000	1	0.0000	1	0.0000	0.75	0.0000	0.75	0.0000	0.75
60.0000-40.0000 T7	0.0000	1	0.0000	1	0.0000	1	0.0000	1	0.0000	0.75	0.0000	0.75	0.0000	0.75
40.0000-20.0000 T8	0.0000	1	0.0000	1	0.0000	1	0.0000	1	0.0000	0.75	0.0000	0.75	0.0000	0.75
20.0000-0.0000 T9	0.0000	1	0.0000	1	0.0000	1	0.0000	1	0.0000	0.75	0.0000	0.75	0.0000	0.75

Tower Section Geometry (cont'd)

<p style="text-align: center;">tnxTower</p> <p style="text-align: center;">EFI Global, Inc. 1117 Perimeter Center West, Suite E500 Atlanta, GA 30338 Phone: (770) 693-0835 FAX:</p>	Job	CTHA174A	Page	7 of 27
	Project	049.00427 - 2075022	Date	15:52:55 06/15/20
	Client	Foresite LLC	Designed by	Ahmet Colakoglu

Tower Elevation ft	Leg Connection Type	Leg		Diagonal		Top Girt		Bottom Girt		Mid Girt		Long Horizontal		Short Horizontal	
		Bolt Size in	No.	Bolt Size in	No.	Bolt Size in	No.	Bolt Size in	No.	Bolt Size in	No.	Bolt Size in	No.	Bolt Size in	No.
T1 170.0000-160.0000	Flange	1.0000 A325N	6	1.0000 A325N	1	1.0000 A325N	1	0.0000 A325N	0	0.6250 A325N	0	0.6250 A325N	0	1.0000 A325N	0
T2 160.0000-140.0000	Flange	1.0000 A325N	6	1.0000 A325N	1	0.6250 A325N	0	0.0000 A325N	0	0.6250 A325N	0	0.6250 A325N	0	1.0000 A325N	0
T3 140.0000-120.0000	Flange	1.0000 A325N	6	1.0000 A325N	1	0.6250 A325N	0	0.0000 A325N	0	0.6250 A325N	0	0.6250 A325N	0	1.0000 A325N	0
T4 120.0000-100.0000	Flange	1.0000 A325N	6	1.0000 A325N	1	0.6250 A325N	0	0.0000 A325N	0	0.6250 A325N	0	0.6250 A325N	0	1.0000 A325N	0
T5 100.0000-80.0000	Flange	1.0000 A325N	12	0.8750 A325N	1	0.6250 A325N	0	0.0000 A325N	0	0.6250 A325N	0	0.6250 A325N	0	1.0000 A325N	0
T6 80.0000-60.0000	Flange	1.0000 A325N	12	0.8750 A325N	1	1.0000 A325N	0	0.0000 A325N	0	1.0000 A325N	1	0.6250 A325N	0	1.0000 A325N	0
T7 60.0000-40.0000	Flange	1.0000 A325N	12	0.8750 A325N	1	1.2500 A325N	0	0.0000 A325N	0	1.2500 A325N	1	0.6250 A325N	0	1.0000 A325N	0
T8 40.0000-20.0000	Flange	1.0000 A325N	12	0.8750 A325N	1	1.2500 A325N	0	0.0000 A325N	0	0.6250 A325N	0	0.6250 A325N	0	1.0000 A325N	0
T9 20.0000-0.0000	Flange	0.0000 A325N	0	0.8750 A325N	1	0.6250 A325N	0	0.0000 A325N	0	0.6250 A325N	0	0.6250 A325N	0	1.0000 A325N	0

Feed Line/Linear Appurtenances - Entered As Round Or Flat

Description	Face or Leg	Allow Shield	Exclude From Torque Calculation	Component Type	Placement ft	Face Offset in	Lateral Offset (Frac FW)	#	# Per Row	Clear Spacing in	Width or Diameter in	Perimeter in	Weight plf
170ft													
LDF7-50A(1-5/8)	A	No	No	Ar (CaAa)	170.0000 - 0.0000	-6.0000	0.45	12	6	1.9800 0.5000	1.9800		0.8200
LDF7-50A(1-5/8)	B	No	No	Ar (CaAa)	165.0000 - 160.0000	-6.0000	0.45	3	3	1.9800 0.5000	1.9800		0.8200
LDF7-50A(1-5/8)	B	No	No	Ar (CaAa)	160.0000 - 155.0000	-6.0000	0.45	4	4	1.9800 0.5000	1.9800		0.8200
LDF7-50A(1-5/8)	B	No	No	Ar (CaAa)	155.0000 - 150.0000	-6.0000	0.45	5	5	1.9800 0.5000	1.9800		0.8200
LDF7-50A(1-5/8)	B	No	No	Ar (CaAa)	150.0000 - 0.0000	-6.0000	0.45	8	4	1.9800 0.5000	1.9800		0.8200
100ft Verizon													
LDF7-50A(1-5/8)	C	No	No	Ar (CaAa)	100.0000 - 0.0000	-6.0000	0.47	2	2	1.9800 0.5000	1.9800		0.8200
140ft T-Mobile													
(8) 1-5/8" + (8) 6x12	C	No	No	Ar (CaAa)	140.0000 - 0.0000	0.0000	-0.4	16	8	1.0000 0.5000	1.9800		0.8200

tnxTower EFI Global, Inc. 1117 Perimeter Center West, Suite E500 Atlanta, GA 30338 Phone: (770) 693-0835 FAX:	Job	CTHA174A	Page	8 of 27
	Project	049.00427 - 2075022	Date	15:52:55 06/15/20
	Client	Foresite LLC	Designed by	Ahmet Colakoglu

Feed Line/Linear Appurtenances Section Areas

Tower Section	Tower Elevation ft	Face	A_R ft ²	A_F ft ²	C_{AA} In Face ft ²	C_{AA} Out Face ft ²	Weight K
T1	170.0000-160.0000 0	A	0.000	0.000	23.760	0.000	0.0984
		B	0.000	0.000	2.970	0.000	0.0123
		C	0.000	0.000	0.000	0.000	0.0000
T2	160.0000-140.0000 0	A	0.000	0.000	47.520	0.000	0.1968
		B	0.000	0.000	24.750	0.000	0.1025
		C	0.000	0.000	0.000	0.000	0.0000
T3	140.0000-120.0000 0	A	0.000	0.000	47.520	0.000	0.1968
		B	0.000	0.000	31.680	0.000	0.1312
		C	0.000	0.000	63.360	0.000	0.2624
T4	120.0000-100.0000 0	A	0.000	0.000	47.520	0.000	0.1968
		B	0.000	0.000	31.680	0.000	0.1312
		C	0.000	0.000	63.360	0.000	0.2624
T5	100.0000-80.0000	A	0.000	0.000	47.520	0.000	0.1968
		B	0.000	0.000	31.680	0.000	0.1312
		C	0.000	0.000	71.280	0.000	0.2952
T6	80.0000-60.0000	A	0.000	0.000	47.520	0.000	0.1968
		B	0.000	0.000	31.680	0.000	0.1312
		C	0.000	0.000	71.280	0.000	0.2952
T7	60.0000-40.0000	A	0.000	0.000	47.520	0.000	0.1968
		B	0.000	0.000	31.680	0.000	0.1312
		C	0.000	0.000	71.280	0.000	0.2952
T8	40.0000-20.0000	A	0.000	0.000	47.520	0.000	0.1968
		B	0.000	0.000	31.680	0.000	0.1312
		C	0.000	0.000	71.280	0.000	0.2952
T9	20.0000-0.0000	A	0.000	0.000	47.520	0.000	0.1968
		B	0.000	0.000	31.680	0.000	0.1312
		C	0.000	0.000	71.280	0.000	0.2952

Feed Line/Linear Appurtenances Section Areas - With Ice

Tower Section	Tower Elevation ft	Face or Leg	Ice Thickness in	A_R ft ²	A_F ft ²	C_{AA} In Face ft ²	C_{AA} Out Face ft ²	Weight K
T1	170.0000-160.0000 0	A	2.349	0.000	0.000	35.022	0.000	0.8606
		B		0.000	0.000	10.033	0.000	0.1653
		C		0.000	0.000	0.000	0.000	0.0000
T2	160.0000-140.0000 0	A	2.327	0.000	0.000	69.902	0.000	1.7098
		B		0.000	0.000	52.731	0.000	1.0643
		C		0.000	0.000	0.000	0.000	0.0000
T3	140.0000-120.0000 0	A	2.294	0.000	0.000	69.692	0.000	1.6930
		B		0.000	0.000	51.368	0.000	1.1658
		C		0.000	0.000	72.204	0.000	1.7374
T4	120.0000-100.0000 0	A	2.256	0.000	0.000	69.451	0.000	1.6737
		B		0.000	0.000	51.114	0.000	1.1513
		C		0.000	0.000	71.964	0.000	1.7175
T5	100.0000-80.0000	A	2.211	0.000	0.000	69.167	0.000	1.6511
		B		0.000	0.000	50.814	0.000	1.1342
		C		0.000	0.000	102.132	0.000	2.1266
T6	80.0000-60.0000	A	2.156	0.000	0.000	68.819	0.000	1.6236
		B		0.000	0.000	50.447	0.000	1.1134
		C		0.000	0.000	101.409	0.000	2.0863
T7	60.0000-40.0000	A	2.085	0.000	0.000	68.368	0.000	1.5880

tnxTower EFI Global, Inc. 1117 Perimeter Center West, Suite E500 Atlanta, GA 30338 Phone: (770) 693-0835 FAX:	Job CTHA174A	Page 9 of 27
	Project 049.00427 - 2075022	Date 15:52:55 06/15/20
	Client Foresite LLC	Designed by Ahmet Colakoglu

Tower Section	Tower Elevation ft	Face or Leg	Ice Thickness in	A _R ft ²	A _F ft ²	C _{AA} In Face ft ²	C _{AA} Out Face ft ²	Weight K
T8	40.0000-20.0000	B		0.000	0.000	49.971	0.000	1.0866
		C		0.000	0.000	100.470	0.000	2.0343
		A	1.981	0.000	0.000	67.712	0.000	1.5367
		B		0.000	0.000	49.280	0.000	1.0481
T9	20.0000-0.0000	C		0.000	0.000	99.106	0.000	1.9596
		A	1.775	0.000	0.000	66.415	0.000	1.4364
		B		0.000	0.000	47.910	0.000	0.9732
		C		0.000	0.000	96.405	0.000	1.8143

Feed Line Center of Pressure

Section	Elevation ft	CP _X in	CP _Z in	CP _X Ice in	CP _Z Ice in
T1	170.0000-160.0000	1.9202	-12.7618	1.2032	-4.7854
T2	160.0000-140.0000	5.0553	-9.7940	3.7650	-4.7254
T3	140.0000-120.0000	17.7530	-7.2365	13.0287	-3.5886
T4	120.0000-100.0000	19.7790	-8.2646	15.5458	-4.4707
T5	100.0000-80.0000	20.0172	-8.7057	12.0480	-3.3808
T6	80.0000-60.0000	22.1594	-9.7667	13.3405	-3.8738
T7	60.0000-40.0000	23.8812	-10.6186	14.5377	-4.3659
T8	40.0000-20.0000	24.8385	-11.1686	15.4694	-4.8407
T9	20.0000-0.0000	26.2415	-11.8656	16.6410	-5.5444

Shielding Factor Ka

Tower Section	Feed Line Record No.	Description	Feed Line Segment Elev.	K _a No Ice	K _a Ice
T1	2	LDF7-50A(1-5/8)	160.00 - 170.00	0.6000	0.4025
T1	3	LDF7-50A(1-5/8)	160.00 - 165.00	0.6000	0.4025
T2	2	LDF7-50A(1-5/8)	140.00 - 160.00	0.6000	0.4970
T2	4	LDF7-50A(1-5/8)	155.00 - 160.00	0.6000	0.4970
T2	5	LDF7-50A(1-5/8)	150.00 - 155.00	0.6000	0.4970
T2	6	LDF7-50A(1-5/8)	140.00 - 150.00	0.6000	0.4970
T3	2	LDF7-50A(1-5/8)	120.00 - 140.00	0.6000	0.5553
T3	6	LDF7-50A(1-5/8)	120.00 - 140.00	0.6000	0.5553
T3	10	(8) 1-5/8" + (8) 6x12	120.00 - 140.00	0.6000	0.5553
T4	2	LDF7-50A(1-5/8)	100.00 - 120.00	0.6000	0.6000
T4	6	LDF7-50A(1-5/8)	100.00 - 120.00	0.6000	0.6000
T4	10	(8) 1-5/8" + (8) 6x12	100.00 - 120.00	0.6000	0.6000

tnxTower EFI Global, Inc. 1117 Perimeter Center West, Suite E500 Atlanta, GA 30338 Phone: (770) 693-0835 FAX:	Job CTHA174A	Page 10 of 27
	Project 049.00427 - 2075022	Date 15:52:55 06/15/20
	Client Foresite LLC	Designed by Ahmet Colakoglu

Tower Section	Feed Line Record No.	Description	Feed Line Segment Elev.	K _a No Ice	K _a Ice
			120.00		
T5	2	LDF7-50A(1-5/8)	80.00 - 100.00	0.6000	0.6000
T5	6	LDF7-50A(1-5/8)	80.00 - 100.00	0.6000	0.6000
T5	8	LDF7-50A(1-5/8)	80.00 - 100.00	0.6000	0.6000
T5	10	(8) 1-5/8" + (8) 6x12	80.00 - 100.00	0.6000	0.6000
T6	2	LDF7-50A(1-5/8)	60.00 - 80.00	0.6000	0.6000
T6	6	LDF7-50A(1-5/8)	60.00 - 80.00	0.6000	0.6000
T6	8	LDF7-50A(1-5/8)	60.00 - 80.00	0.6000	0.6000
T6	10	(8) 1-5/8" + (8) 6x12	60.00 - 80.00	0.6000	0.6000
T7	2	LDF7-50A(1-5/8)	40.00 - 60.00	0.6000	0.6000
T7	6	LDF7-50A(1-5/8)	40.00 - 60.00	0.6000	0.6000
T7	8	LDF7-50A(1-5/8)	40.00 - 60.00	0.6000	0.6000
T7	10	(8) 1-5/8" + (8) 6x12	40.00 - 60.00	0.6000	0.6000
T8	2	LDF7-50A(1-5/8)	20.00 - 40.00	0.6000	0.6000
T8	6	LDF7-50A(1-5/8)	20.00 - 40.00	0.6000	0.6000
T8	8	LDF7-50A(1-5/8)	20.00 - 40.00	0.6000	0.6000
T8	10	(8) 1-5/8" + (8) 6x12	20.00 - 40.00	0.6000	0.6000
T9	2	LDF7-50A(1-5/8)	0.00 - 20.00	0.6000	0.6000
T9	6	LDF7-50A(1-5/8)	0.00 - 20.00	0.6000	0.6000
T9	8	LDF7-50A(1-5/8)	0.00 - 20.00	0.6000	0.6000
T9	10	(8) 1-5/8" + (8) 6x12	0.00 - 20.00	0.6000	0.6000

Discrete Tower Loads

Description	Face or Leg	Offset Type	Offsets: Horz Lateral Vert	Azimuth Adjustment	Placement	C _{AA} Front	C _{AA} Side	Weight
			ft ft ft	°	ft	ft ²	ft ²	K

15' Lighting Rod	C	From Leg	0.0000 0.0000 7.0000	0.0000	170.0000	No Ice 4.5000 1/2" Ice 6.0300 1" Ice 7.5800	4.5000 6.0300 7.5800	0.0500 0.0800 0.1200
Beacon	C	From Leg	0.0000 0.0000 0.0000	0.0000	170.0000	No Ice 1.2000 1/2" Ice 1.3900 1" Ice 1.5900	1.2000 1.3900 1.5900	0.0300 0.0400 0.0600
170ft								
(4) 6'x1' Panel Antenna	A	From Leg	3.0000 0.0000 0.0000	0.0000	170.0000	No Ice 8.1300 1/2" Ice 8.5900 1" Ice 9.0500	8.1300 8.5900 9.0500	0.0400 0.0800 0.1300
(4) 6'x1' Panel Antenna	B	From Leg	3.0000 0.0000 0.0000	0.0000	170.0000	No Ice 8.1300 1/2" Ice 8.5900 1" Ice 9.0500	8.1300 8.5900 9.0500	0.0400 0.0800 0.1300
(4) 6'x1' Panel Antenna	C	From Leg	3.0000 0.0000 0.0000	0.0000	170.0000	No Ice 8.1300 1/2" Ice 8.5900 1" Ice 9.0500	8.1300 8.5900 9.0500	0.0400 0.0800 0.1300
10.5'-P2x0.154 H	A	From Leg	3.0000 0.0000 0.0000	0.0000	170.0000	No Ice 2.4937 1/2" Ice 3.5719 1" Ice 4.6667	0.0149 0.0212 0.0275	0.0380 0.0572 0.0827
10.5'-P2x0.154 H	B	From Leg	3.0000 0.0000 0.0000	0.0000	170.0000	No Ice 2.4937 1/2" Ice 3.5719 1" Ice 4.6667	0.0149 0.0212 0.0275	0.0380 0.0572 0.0827
10.5'-P2x0.154 H	C	From Leg	3.0000 0.0000 0.0000	0.0000	170.0000	No Ice 2.4937	0.0149	0.0380

tnxTower EFI Global, Inc. 1117 Perimeter Center West, Suite E500 Atlanta, GA 30338 Phone: (770) 693-0835 FAX:	Job	CTHA174A	Page	11 of 27
	Project	049.00427 - 2075022	Date	15:52:55 06/15/20
	Client	Foresite LLC	Designed by	Ahmet Colakoglu

Description	Face or Leg	Offset Type	Offsets: Horz Lateral Vert ft ft ft	Azimuth Adjustment °	Placement ft	C _{AA} Front ft ²	C _{AA} Side ft ²	Weight K
			0.0000			1/2" Ice 3.5719	0.0212	0.0572
			0.0000			1" Ice 4.6667	0.0275	0.0827
Sector Mount [SM 502-3]	C	None		0.0000	170.0000	No Ice 29.8200	29.8200	1.6731
						1/2" Ice 42.2100	42.2100	2.2663
						1" Ice 54.4300	54.4300	3.0515

100ft Verizon								
(4) SBNHH-1D65B w/ Mount Pipe	A	From Leg	3.0000	0.0000	100.0000	No Ice 4.0946	3.2958	0.0665
			0.0000			1/2" Ice 4.4861	3.6763	0.1297
			0.0000			1" Ice 4.8867	4.0660	0.2038
(4) SBNHH-1D65B w/ Mount Pipe	B	From Leg	3.0000	0.0000	100.0000	No Ice 4.0946	3.2958	0.0665
			0.0000			1/2" Ice 4.4861	3.6763	0.1297
			0.0000			1" Ice 4.8867	4.0660	0.2038
(4) SBNHH-1D65B w/ Mount Pipe	C	From Leg	3.0000	0.0000	100.0000	No Ice 4.0946	3.2958	0.0665
			0.0000			1/2" Ice 4.4861	3.6763	0.1297
			0.0000			1" Ice 4.8867	4.0660	0.2038
RRH2x60-700	A	From Leg	3.0000	0.0000	100.0000	No Ice 3.5002	1.8157	0.0600
			0.0000			1/2" Ice 3.7609	2.0519	0.0827
			0.0000			1" Ice 4.0285	2.2894	0.1091
RRH2x60-700	B	From Leg	3.0000	0.0000	100.0000	No Ice 3.5002	1.8157	0.0600
			0.0000			1/2" Ice 3.7609	2.0519	0.0827
			0.0000			1" Ice 4.0285	2.2894	0.1091
RRH2x60-700	C	From Leg	3.0000	0.0000	100.0000	No Ice 3.5002	1.8157	0.0600
			0.0000			1/2" Ice 3.7609	2.0519	0.0827
			0.0000			1" Ice 4.0285	2.2894	0.1091
RRH2X60-PCS	A	From Leg	3.0000	0.0000	100.0000	No Ice 2.2000	1.7233	0.0550
			0.0000			1/2" Ice 2.3926	1.9015	0.0754
			0.0000			1" Ice 2.5926	2.0870	0.0987
RRH2X60-PCS	B	From Leg	3.0000	0.0000	100.0000	No Ice 2.2000	1.7233	0.0550
			0.0000			1/2" Ice 2.3926	1.9015	0.0754
			0.0000			1" Ice 2.5926	2.0870	0.0987
RRH2X60-PCS	C	From Leg	3.0000	0.0000	100.0000	No Ice 2.2000	1.7233	0.0550
			0.0000			1/2" Ice 2.3926	1.9015	0.0754
			0.0000			1" Ice 2.5926	2.0870	0.0987
RRH4x45/2x90-AWS	A	From Leg	3.0000	0.0000	100.0000	No Ice 2.2000	1.8333	0.0650
			0.0000			1/2" Ice 2.3926	2.0148	0.0860
			0.0000			1" Ice 2.5926	2.2037	0.1101
RRH4x45/2x90-AWS	B	From Leg	3.0000	0.0000	100.0000	No Ice 2.2000	1.8333	0.0650
			0.0000			1/2" Ice 2.3926	2.0148	0.0860
			0.0000			1" Ice 2.5926	2.2037	0.1101
RRH4x45/2x90-AWS	C	From Leg	3.0000	0.0000	100.0000	No Ice 2.2000	1.8333	0.0650
			0.0000			1/2" Ice 2.3926	2.0148	0.0860
			0.0000			1" Ice 2.5926	2.2037	0.1101
DB-T1-6Z-8AB-0Z	A	From Leg	3.0000	0.0000	100.0000	No Ice 4.8000	2.0000	0.0440
			0.0000			1/2" Ice 5.0704	2.1926	0.0801
			0.0000			1" Ice 5.3481	2.3926	0.1202
DB-T1-6Z-8AB-0Z	B	From Leg	3.0000	0.0000	100.0000	No Ice 4.8000	2.0000	0.0440
			0.0000			1/2" Ice 5.0704	2.1926	0.0801
			0.0000			1" Ice 5.3481	2.3926	0.1202
10.5'-P2x0.154 H	A	From Leg	3.0000	0.0000	100.0000	No Ice 2.4937	0.0149	0.0380
			0.0000			1/2" Ice 3.5719	0.0212	0.0572
			0.0000			1" Ice 4.6667	0.0275	0.0827
10.5'-P2x0.154 H	B	From Leg	3.0000	0.0000	100.0000	No Ice 2.4937	0.0149	0.0380
			0.0000			1/2" Ice 3.5719	0.0212	0.0572
			0.0000			1" Ice 4.6667	0.0275	0.0827
10.5'-P2x0.154 H	C	From Leg	3.0000	0.0000	100.0000	No Ice 2.4937	0.0149	0.0380
			0.0000			1/2" Ice 3.5719	0.0212	0.0572

tnxTower EFI Global, Inc. 1117 Perimeter Center West, Suite E500 Atlanta, GA 30338 Phone: (770) 693-0835 FAX:	Job	CTHA174A	Page	12 of 27
	Project	049.00427 - 2075022	Date	15:52:55 06/15/20
	Client	Foresite LLC	Designed by	Ahmet Colakoglu

Description	Face or Leg	Offset Type	Offsets: Horz Lateral Vert ft ft ft	Azimuth Adjustment °	Placement ft	C _{AA} Front ft ²	C _{AA} Side ft ²	Weight K
Sector Mount [SM 502-3]	C	None	0.0000	0.0000	100.0000	1" Ice 4.6667 No Ice 29.8200 1/2" Ice 42.2100 1" Ice 54.4300	0.0275 29.8200 42.2100 54.4300	0.0827 1.6731 2.2663 3.0515
***** ***160ft & 155ft***								
6812	B	From Leg	2.0000 0.0000 0.0000	0.0000	160.0000	No Ice 0.2000 1/2" Ice 0.3600 1" Ice 0.5200	0.2000 0.3600 0.5200	0.0030 0.0039 0.0048
6812	B	From Leg	2.0000 0.0000 0.0000	0.0000	155.0000	No Ice 0.2000 1/2" Ice 0.3600 1" Ice 0.5200	0.2000 0.3600 0.5200	0.0030 0.0039 0.0048
***** **140ft T-Mobile**								
AIR 21 B2A/B4P w/ Mount Pipe	A	From Leg	3.0000 0.0000 0.0000	0.0000	140.0000	No Ice 6.1619 1/2" Ice 6.6000 1" Ice 7.0327	5.5453 6.3031 6.9984	0.1034 0.1592 0.2216
AIR 21 B2A/B4P w/ Mount Pipe	B	From Leg	3.0000 0.0000 0.0000	0.0000	140.0000	No Ice 6.1619 1/2" Ice 6.6000 1" Ice 7.0327	5.5453 6.3031 6.9984	0.1034 0.1592 0.2216
(2) AIR 21 B2A/B4P w/ Mount Pipe	C	From Leg	3.0000 0.0000 0.0000	0.0000	140.0000	No Ice 6.1619 1/2" Ice 6.6000 1" Ice 7.0327	5.5453 6.3031 6.9984	0.1034 0.1592 0.2216
AIR 32 B2a/B66Aa w/ Mount Pipe	A	From Leg	3.0000 0.0000 0.0000	0.0000	140.0000	No Ice 6.7474 1/2" Ice 7.2017 1" Ice 7.6475	6.0700 6.8671 7.5828	0.1531 0.2140 0.2819
AIR 32 B2a/B66Aa w/ Mount Pipe	B	From Leg	3.0000 0.0000 0.0000	0.0000	140.0000	No Ice 6.7474 1/2" Ice 7.2017 1" Ice 7.6475	6.0700 6.8671 7.5828	0.1531 0.2140 0.2819
(2) AIR 32 B2a/B66Aa w/ Mount Pipe	C	From Leg	3.0000 0.0000 0.0000	0.0000	140.0000	No Ice 6.7474 1/2" Ice 7.2017 1" Ice 7.6475	6.0700 6.8671 7.5828	0.1531 0.2140 0.2819
(2) APXVAARR24_43-U-NA20 w/ Mount Pipe	A	From Leg	3.0000 0.0000 0.0000	0.0000	140.0000	No Ice 14.6935 1/2" Ice 15.4553 1" Ice 16.2297	6.8734 7.5537 8.2466	0.1862 0.3147 0.4577
APXVAARR24_43-U-NA20 w/ Mount Pipe	B	From Leg	3.0000 0.0000 0.0000	0.0000	140.0000	No Ice 14.6935 1/2" Ice 15.4553 1" Ice 16.2297	6.8734 7.5537 8.2466	0.1862 0.3147 0.4577
APXVAARR24_43-U-NA20 w/ Mount Pipe	C	From Leg	3.0000 0.0000 0.0000	0.0000	140.0000	No Ice 14.6935 1/2" Ice 15.4553 1" Ice 16.2297	6.8734 7.5537 8.2466	0.1862 0.3147 0.4577
Ericsson AIR6449 B41 w/ Mount Pipe	A	From Leg	3.0000 0.0000 0.0000	0.0000	140.0000	No Ice 6.8995 1/2" Ice 7.7436 1" Ice 8.4932	4.3156 5.3695 6.2751	0.1322 0.1917 0.2576
Ericsson AIR6449 B41 w/ Mount Pipe	B	From Leg	3.0000 0.0000 0.0000	0.0000	140.0000	No Ice 6.8995 1/2" Ice 7.7436 1" Ice 8.4932	4.3156 5.3695 6.2751	0.1322 0.1917 0.2576
(2) Ericsson AIR6449 B41 w/ Mount Pipe	C	From Leg	3.0000 0.0000 0.0000	0.0000	140.0000	No Ice 6.8995 1/2" Ice 7.7436 1" Ice 8.4932	4.3156 5.3695 6.2751	0.1322 0.1917 0.2576
(2) Radio 4449 B71+B85_T-Mobile	A	From Leg	3.0000 0.0000 0.0000	0.0000	140.0000	No Ice 1.9701 1/2" Ice 2.1466 1" Ice 2.3306	1.5865 1.7488 1.9185	0.0732 0.0930 0.1156
Radio 4449 B71+B85_T-Mobile	B	From Leg	3.0000 0.0000 0.0000	0.0000	140.0000	No Ice 1.9701 1/2" Ice 2.1466 1" Ice 2.3306	1.5865 1.7488 1.9185	0.0732 0.0930 0.1156
Radio 4449	C	From Leg	3.0000	0.0000	140.0000	No Ice 1.9701	1.5865	0.0732

tnxTower EFI Global, Inc. 1117 Perimeter Center West, Suite E500 Atlanta, GA 30338 Phone: (770) 693-0835 FAX:	Job	CTHA174A	Page	13 of 27
	Project	049.00427 - 2075022	Date	15:52:55 06/15/20
	Client	Foresite LLC	Designed by	Ahmet Colakoglu

Description	Face or Leg	Offset Type	Offsets:		Azimuth Adjustment	Placement	CAAA Front	CAAA Side	Weight	
			Horz	Lateral Vert						
			ft	ft	°	ft	ft ²	ft ²	K	
B71+B85_T-Mobile			0.0000			1/2" Ice	2.1466	1.7488	0.0930	
			0.0000			1" Ice	2.3306	1.9185	0.1156	
RRUS 4415 B25	A	From Leg	3.0000		0.0000	140.0000	No Ice	1.6444	0.6788	0.0440
			0.0000				1/2" Ice	1.8044	0.7911	0.0564
			0.0000				1" Ice	1.9719	0.9129	0.0712
RRUS 4415 B25	B	From Leg	3.0000		0.0000	140.0000	No Ice	1.6444	0.6788	0.0440
			0.0000				1/2" Ice	1.8044	0.7911	0.0564
			0.0000				1" Ice	1.9719	0.9129	0.0712
(2) RRUS 4415 B25	C	From Leg	3.0000		0.0000	140.0000	No Ice	1.6444	0.6788	0.0440
			0.0000				1/2" Ice	1.8044	0.7911	0.0564
			0.0000				1" Ice	1.9719	0.9129	0.0712
KRY 112 144/1	A	From Leg	3.0000		0.0000	140.0000	No Ice	0.3500	0.1750	0.0110
			0.0000				1/2" Ice	0.4259	0.2343	0.0142
			0.0000				1" Ice	0.5093	0.3009	0.0186
KRY 112 144/1	B	From Leg	3.0000		0.0000	140.0000	No Ice	0.3500	0.1750	0.0110
			0.0000				1/2" Ice	0.4259	0.2343	0.0142
			0.0000				1" Ice	0.5093	0.3009	0.0186
(2) KRY 112 144/1	C	From Leg	3.0000		0.0000	140.0000	No Ice	0.3500	0.1750	0.0110
			0.0000				1/2" Ice	0.4259	0.2343	0.0142
			0.0000				1" Ice	0.5093	0.3009	0.0186
Custom 4-Sided Sector Mount	C	None			0.0000	140.0000	No Ice	36.0000	36.0000	3.0000
							1/2" Ice	42.0000	42.0000	3.3000
							1" Ice	48.0000	48.0000	3.6000

Dishes

Description	Face or Leg	Dish Type	Offset Type	Offsets:		Azimuth Adjustment	3 dB Beam Width	Elevation	Outside Diameter	Aperture Area	Weight	
				Horz	Lateral Vert							
			ft	ft	°	°	ft	ft	ft ²	K		
SC2-W100AB	C	Paraboloid w/o Radome	From Leg	3.0000		0.0000		140.0000	2.2000	No Ice	3.8000	0.0100
				0.0000						1/2" Ice	4.0900	0.0300
				0.0000						1" Ice	4.3900	0.0500
6' Dish	A	Paraboloid w/o Radome	From Leg	1.0000		0.0000		165.0000	6.0000	No Ice	28.2740	0.3800
				0.0000						1/2" Ice	29.0650	0.4500
				0.0000						1" Ice	29.8560	0.5200
6' Dish	B	Paraboloid w/o Radome	From Leg	1.0000		0.0000		165.0000	6.0000	No Ice	28.2740	0.3800
				0.0000						1/2" Ice	29.0650	0.4500
				0.0000						1" Ice	29.8560	0.5200
6' Dish	C	Paraboloid w/o Radome	From Leg	1.0000		0.0000		165.0000	6.0000	No Ice	28.2740	0.3800
				0.0000						1/2" Ice	29.0650	0.4500
				0.0000						1" Ice	29.8560	0.5200
4' Dish	A	Paraboloid w/o Radome	From Leg	1.0000		0.0000		150.0000	4.0000	No Ice	12.5660	0.1400
				0.0000						1/2" Ice	13.0950	0.2820
				0.0000						1" Ice	13.6240	0.4240
4' Dish	B	Paraboloid w/o Radome	From Leg	1.0000		0.0000		150.0000	4.0000	No Ice	12.5660	0.1400
				0.0000						1/2" Ice	13.0950	0.2820
				0.0000						1" Ice	13.6240	0.4240
2' Dish	C	Paraboloid w/o Radome	From Leg	1.0000		0.0000		150.0000	2.0000	No Ice	3.1420	0.0700
				0.0000						1/2" Ice	3.4090	0.2820

tnxTower EFI Global, Inc. 1117 Perimeter Center West, Suite E500 Atlanta, GA 30338 Phone: (770) 693-0835 FAX:	Job	CTHA174A	Page	14 of 27
	Project	049.00427 - 2075022	Date	15:52:55 06/15/20
	Client	Foresite LLC	Designed by	Ahmet Colakoglu

Description	Face or Leg	Dish Type	Offset Type	Offsets: Horz Lateral Vert ft	Azimuth Adjustment °	3 dB Beam Width °	Elevation ft	Outside Diameter ft	Aperture Area ft ²	Weight K
2' Dish	A	Paraboloid w/Shroud (HP)	From Leg	0.0000 0.0000 0.0000 0.0000	0.0000		110.0000	2.0000	1" Ice No Ice 1/2" Ice 1" Ice	0.4940 0.0700 0.2820 0.4940

Truss-Leg Properties

Section Designation	Area in ²	Area Ice in ²	Self Weight K	Ice Weight K	Equiv. Diameter in	Equiv. Diameter Ice in	Leg Area in ²
Pirod 207628	1223.0016	5703.8061	0.3486	1.7328	4.2465	19.8049	3.6816
Pirod 207629	2288.0928	6636.4847	0.5754	1.8976	7.9448	23.0433	5.3014
Pirod 207629	2288.0928	6612.9668	0.5754	1.8525	7.9448	22.9617	5.3014
Pirod 195557	2415.7954	6657.9346	0.7105	1.7196	8.3882	23.1178	7.2158
Pirod 211843	2561.1191	6698.0542	1.0496	1.8683	8.8928	23.2571	9.4248
Pirod 208333	2561.1191	6659.0197	1.0496	1.7934	8.8928	23.1216	9.4248
Pirod 208334	2696.6490	6680.2711	1.2271	1.7214	9.3634	23.1954	11.9282
Pirod 208334	2696.6490	6606.4167	1.2271	1.5867	9.3634	22.9389	11.9282
Pirod 208335	2836.8087	6531.8043	1.4257	1.3559	9.8500	22.6799	14.7262

Load Combinations

Comb. No.	Description
1	Dead Only
2	1.2 Dead+1.6 Wind 0 deg - No Ice
3	0.9 Dead+1.6 Wind 0 deg - No Ice
4	1.2 Dead+1.6 Wind 30 deg - No Ice
5	0.9 Dead+1.6 Wind 30 deg - No Ice
6	1.2 Dead+1.6 Wind 60 deg - No Ice
7	0.9 Dead+1.6 Wind 60 deg - No Ice
8	1.2 Dead+1.6 Wind 90 deg - No Ice
9	0.9 Dead+1.6 Wind 90 deg - No Ice
10	1.2 Dead+1.6 Wind 120 deg - No Ice
11	0.9 Dead+1.6 Wind 120 deg - No Ice
12	1.2 Dead+1.6 Wind 150 deg - No Ice
13	0.9 Dead+1.6 Wind 150 deg - No Ice
14	1.2 Dead+1.6 Wind 180 deg - No Ice
15	0.9 Dead+1.6 Wind 180 deg - No Ice
16	1.2 Dead+1.6 Wind 210 deg - No Ice
17	0.9 Dead+1.6 Wind 210 deg - No Ice
18	1.2 Dead+1.6 Wind 240 deg - No Ice
19	0.9 Dead+1.6 Wind 240 deg - No Ice
20	1.2 Dead+1.6 Wind 270 deg - No Ice
21	0.9 Dead+1.6 Wind 270 deg - No Ice
22	1.2 Dead+1.6 Wind 300 deg - No Ice
23	0.9 Dead+1.6 Wind 300 deg - No Ice
24	1.2 Dead+1.6 Wind 330 deg - No Ice
25	0.9 Dead+1.6 Wind 330 deg - No Ice
26	1.2 Dead+1.0 Ice
27	1.2 Dead+1.0 Wind 0 deg+1.0 Ice
28	1.2 Dead+1.0 Wind 30 deg+1.0 Ice

tnxTower EFI Global, Inc. 1117 Perimeter Center West, Suite E500 Atlanta, GA 30338 Phone: (770) 693-0835 FAX:	Job	CTHA174A	Page	15 of 27
	Project	049.00427 - 2075022	Date	15:52:55 06/15/20
	Client	Foresite LLC	Designed by	Ahmet Colakoglu

<i>Comb. No.</i>	<i>Description</i>
29	1.2 Dead+1.0 Wind 60 deg+1.0 Ice
30	1.2 Dead+1.0 Wind 90 deg+1.0 Ice
31	1.2 Dead+1.0 Wind 120 deg+1.0 Ice
32	1.2 Dead+1.0 Wind 150 deg+1.0 Ice
33	1.2 Dead+1.0 Wind 180 deg+1.0 Ice
34	1.2 Dead+1.0 Wind 210 deg+1.0 Ice
35	1.2 Dead+1.0 Wind 240 deg+1.0 Ice
36	1.2 Dead+1.0 Wind 270 deg+1.0 Ice
37	1.2 Dead+1.0 Wind 300 deg+1.0 Ice
38	1.2 Dead+1.0 Wind 330 deg+1.0 Ice
39	Dead+Wind 0 deg - Service
40	Dead+Wind 30 deg - Service
41	Dead+Wind 60 deg - Service
42	Dead+Wind 90 deg - Service
43	Dead+Wind 120 deg - Service
44	Dead+Wind 150 deg - Service
45	Dead+Wind 180 deg - Service
46	Dead+Wind 210 deg - Service
47	Dead+Wind 240 deg - Service
48	Dead+Wind 270 deg - Service
49	Dead+Wind 300 deg - Service
50	Dead+Wind 330 deg - Service

Maximum Member Forces

<i>Section No.</i>	<i>Elevation ft</i>	<i>Component Type</i>	<i>Condition</i>	<i>Gov. Load Comb.</i>	<i>Axial K</i>	<i>Major Axis Moment kip-ft</i>	<i>Minor Axis Moment kip-ft</i>	
T1	170 - 160	Leg	Max Tension	22	3.9642	0.0000	0.0000	
			Max. Compression	27	-7.1871	-0.2949	-0.0152	
			Max. Mx	14	2.5944	-0.7884	0.0134	
			Max. My	10	1.1325	0.3448	-0.8797	
			Max. Vy	6	-1.8651	0.0000	0.0000	
			Max. Vx	12	-1.8783	0.0000	0.0000	
		Diagonal	Max Tension	13	4.1301	0.0045	-0.0003	
			Max. Compression	10	-4.3307	0.0000	0.0000	
			Max. Mx	29	-1.3763	0.0669	-0.0038	
			Max. My	27	-0.3339	0.0661	0.0059	
			Max. Vy	32	0.0515	0.0667	-0.0042	
			Max. Vx	27	0.0027	0.0000	0.0000	
		Secondary Horizontal	Max Tension	22	0.9204	0.0000	0.0000	
			Max. Compression	11	-0.9923	0.0119	0.0037	
			Max. Mx	33	0.0813	0.0361	0.0149	
			Max. My	28	0.0755	0.0353	0.0153	
			Max. Vy	33	0.0484	0.0361	0.0149	
			Max. Vx	38	-0.0053	0.0000	0.0000	
			Top Girt	Max Tension	11	0.9444	0.0000	0.0000
				Max. Compression	22	-0.9480	0.0000	0.0000
Max. Mx	26	-0.0522		-0.1271	0.0000			
Max. My	34	-0.0481		0.0000	0.0037			
Max. Vy	26	0.0726		0.0000	0.0000			
Max. Vx	34	-0.0021		0.0000	0.0000			
T2	160 - 140	Leg	Max Tension	23	27.7267	-0.5446	0.0475	
			Max. Compression	10	-33.6581	1.5113	0.3007	
			Max. Mx	10	-33.6581	1.5113	0.3007	
			Max. My	4	-4.3903	0.0122	-1.3608	
			Max. Vy	14	-0.4730	-0.5459	-0.0991	
			Max. Vx	20	-0.6985	-0.0087	-1.2331	

<p>tnxTower</p> <p>EFI Global, Inc. 1117 Perimeter Center West, Suite E500 Atlanta, GA 30338 Phone: (770) 693-0835 FAX:</p>	Job	CTHA174A	Page	16 of 27
	Project	049.00427 - 2075022	Date	15:52:55 06/15/20
	Client	Foresite LLC	Designed by	Ahmet Colakoglu

Section No.	Elevation ft	Component Type	Condition	Gov. Load Comb.	Axial K	Major Axis Moment kip-ft	Minor Axis Moment kip-ft
T3	140 - 120	Diagonal	Max Tension	22	5.5877	0.0000	0.0000
			Max. Compression	10	-5.9081	0.0000	0.0000
			Max. Mx	30	1.2251	0.0920	0.0148
			Max. My	31	0.0359	0.0902	0.0153
			Max. Vy	30	0.0641	0.0920	0.0148
			Max. Vx	31	0.0044	0.0000	0.0000
		Leg	Max Tension	23	59.9637	-1.2314	-0.0124
			Max. Compression	10	-73.2860	2.8943	0.2266
			Max. Mx	11	-71.6418	2.9001	0.2277
			Max. My	20	-10.7891	0.1185	-2.8172
			Max. Vy	6	-2.1441	-1.2150	-0.1124
			Max. Vx	12	-1.8164	0.2006	0.2991
T4	120 - 100	Diagonal	Max Tension	12	8.0430	0.0000	0.0000
			Max. Compression	12	-8.0602	0.0000	0.0000
			Max. Mx	29	1.7838	0.1360	-0.0199
			Max. My	31	0.2095	0.1217	0.0209
			Max. Vy	29	0.0861	0.1360	-0.0199
			Max. Vx	31	0.0054	0.0000	0.0000
		Leg	Max Tension	23	93.5989	-2.0497	-0.0100
			Max. Compression	10	-111.6322	2.8417	0.1675
			Max. Mx	11	-89.9965	2.9001	0.2277
			Max. My	20	-11.6996	0.1185	-2.8172
			Max. Vy	22	0.2494	-2.8440	-0.1567
			Max. Vx	16	0.4006	0.1155	2.7563
T5	100 - 80	Diagonal	Max Tension	12	8.8702	0.0000	0.0000
			Max. Compression	12	-8.8660	0.0000	0.0000
			Max. Mx	29	1.9939	0.1892	0.0253
			Max. My	28	-0.8834	0.1642	-0.0283
			Max. Vy	29	0.1112	0.1892	0.0253
			Max. Vx	28	-0.0065	0.0000	0.0000
		Leg	Max Tension	23	118.3510	-2.8233	-0.1556
			Max. Compression	10	-140.7476	3.3487	0.3890
			Max. Mx	22	113.8154	-3.6194	-0.3649
			Max. My	16	-17.8410	-0.1172	5.4886
			Max. Vy	22	-1.4538	-2.8440	-0.1567
			Max. Vx	4	-1.4016	0.0404	-1.9390
T6	80 - 60	Diagonal	Max Tension	13	14.3715	0.0000	0.0000
			Max. Compression	12	-14.8750	0.0000	0.0000
			Max. Mx	29	2.4246	-0.4176	0.0736
			Max. My	32	-4.6716	-0.3188	-0.0845
			Max. Vy	29	-0.1576	-0.4176	0.0736
			Max. Vx	33	-0.0125	0.0000	0.0000
		Leg	Max Tension	23	152.5603	-3.5552	-0.3630
			Max. Compression	10	-181.9272	3.5712	0.2637
			Max. Mx	22	148.3204	-3.7637	-0.2564
			Max. My	16	-20.1652	-0.1172	5.4886
			Max. Vy	22	0.3492	-3.7637	-0.2564
			Max. Vx	16	0.5658	-0.1172	5.4886
T7	60 - 40	Diagonal	Max Tension	24	14.7147	0.0000	0.0000
			Max. Compression	12	-14.9546	0.0000	0.0000
			Max. Mx	29	3.0493	-0.4860	0.0781
			Max. My	27	0.0112	-0.4752	0.0794
			Max. Vy	29	-0.1738	-0.4860	0.0781
			Max. Vx	27	0.0121	0.0000	0.0000
		Leg	Max Tension	23	184.0517	-3.7141	-0.2552
			Max. Compression	10	-218.4544	5.5360	0.4086
			Max. Mx	10	-218.4544	5.5360	0.4086
			Max. My	16	-22.7090	-0.0581	4.0002
			Max. Vy	22	0.4067	-5.0110	-0.3902
			Max. Vx	4	-0.5134	-0.0904	-3.9990
Diagonal	Max Tension	24	14.5838	0.0000	0.0000		

tnxTower EFI Global, Inc. 1117 Perimeter Center West, Suite E500 Atlanta, GA 30338 Phone: (770) 693-0835 FAX:	Job	CTHA174A	Page	17 of 27
	Project	049.00427 - 2075022	Date	15:52:55 06/15/20
	Client	Foresite LLC	Designed by	Ahmet Colakoglu

Section No.	Elevation ft	Component Type	Condition	Gov. Load Comb.	Axial K	Major Axis Moment kip-ft	Minor Axis Moment kip-ft
T8	40 - 20	Leg	Max. Compression	24	-15.1083	0.0000	0.0000
			Max. Mx	29	2.6618	-0.5478	-0.0868
			Max. My	34	-3.2947	-0.5257	-0.0898
			Max. Vy	29	-0.1875	-0.5478	-0.0868
			Max. Vx	34	-0.0125	0.0000	0.0000
			Max Tension	23	214.6624	-5.0367	-0.3895
			Max. Compression	10	-255.3700	3.2449	0.2987
		Diagonal	Max. Mx	10	-253.6742	5.5360	0.4086
			Max. My	16	-27.8770	-0.4859	8.1076
			Max. Vy	3	0.3736	5.4890	-0.5873
			Max. Vx	4	0.6759	-0.5143	-8.1067
			Max Tension	24	14.7705	0.0000	0.0000
			Max. Compression	24	-15.2200	0.0000	0.0000
			Max. Mx	29	2.6429	-0.7548	0.1069
T9	20 - 0	Leg	Max. My	33	-3.6458	-0.7078	-0.1193
			Max. Vy	29	-0.2489	-0.7548	0.1069
			Max. Vx	33	-0.0159	0.0000	0.0000
			Max Tension	23	241.8201	-4.0404	-0.2723
			Max. Compression	10	-288.7554	-0.0000	-0.0001
			Max. Mx	22	237.2457	-4.1884	-0.2753
			Max. My	16	-29.2176	-0.4859	8.1076
		Diagonal	Max. Vy	22	-0.5114	-4.1884	-0.2753
			Max. Vx	16	0.7920	-0.4859	8.1076
			Max Tension	24	15.3273	0.0000	0.0000
			Max. Compression	24	-15.9002	0.0000	0.0000
			Max. Mx	30	2.6182	-0.8187	-0.1262
			Max. My	31	2.4062	-0.7412	-0.1282
			Max. Vy	30	-0.2525	-0.8187	-0.1262
Max. Vx	31	-0.0158	0.0000	0.0000			

Maximum Reactions

Location	Condition	Gov. Load Comb.	Vertical K	Horizontal, X K	Horizontal, Z K
Leg C	Max. Vert	18	295.0815	29.4952	-16.2099
	Max. H _x	18	295.0815	29.4952	-16.2099
	Max. H _z	7	-245.5401	-25.6524	13.9899
	Min. Vert	7	-245.5401	-25.6524	13.9899
	Min. H _x	7	-245.5401	-25.6524	13.9899
	Min. H _z	18	295.0815	29.4952	-16.2099
Leg B	Max. Vert	10	306.4710	-29.6884	-18.3411
	Max. H _x	23	-255.6683	25.9116	16.1783
	Max. H _z	25	-227.2680	22.2627	16.4081
	Min. Vert	23	-255.6683	25.9116	16.1783
	Min. H _x	10	306.4710	-29.6884	-18.3411
	Min. H _z	10	306.4710	-29.6884	-18.3411
Leg A	Max. Vert	2	304.8731	1.4125	35.1239
	Max. H _x	20	30.3608	4.5521	2.3498
	Max. H _z	2	304.8731	1.4125	35.1239
	Min. Vert	15	-255.6188	-1.4215	-30.8211
	Min. H _x	11	-129.0174	-4.5066	-15.7217
	Min. H _z	15	-255.6188	-1.4215	-30.8211

<p>tnxTower</p> <p>EFI Global, Inc. 1117 Perimeter Center West, Suite E500 Atlanta, GA 30338 Phone: (770) 693-0835 FAX:</p>	<p>Job</p> <p>CTHA174A</p>	<p>Page</p> <p>18 of 27</p>
	<p>Project</p> <p>049.00427 - 2075022</p>	<p>Date</p> <p>15:52:55 06/15/20</p>
	<p>Client</p> <p>Foresite LLC</p>	<p>Designed by</p> <p>Ahmet Colakoglu</p>

Tower Mast Reaction Summary

Load Combination	Vertical	Shear _x	Shear _z	Overturing Moment, M _x	Overturing Moment, M _z	Torque
	K	K	K	kip-ft	kip-ft	kip-ft
Dead Only	52.5841	0.0000	0.0000	-0.0417	-15.6528	-0.0000
1.2 Dead+1.6 Wind 0 deg - No Ice	63.1009	-0.2532	-56.5303	-5899.4915	20.0348	58.4152
0.9 Dead+1.6 Wind 0 deg - No Ice	47.3257	-0.2532	-56.5303	-5895.0052	24.7081	58.3975
1.2 Dead+1.6 Wind 30 deg - No Ice	63.1009	26.9464	-44.8082	-4650.5180	-2883.5750	71.0625
0.9 Dead+1.6 Wind 30 deg - No Ice	47.3257	26.9464	-44.8082	-4646.9909	-2876.6563	71.0580
1.2 Dead+1.6 Wind 60 deg - No Ice	63.1009	44.1831	-25.6850	-2729.0101	-4705.5012	29.7867
0.9 Dead+1.6 Wind 60 deg - No Ice	47.3257	44.1831	-25.6850	-2726.9001	-4697.1925	29.7843
1.2 Dead+1.6 Wind 90 deg - No Ice	63.1009	52.6591	-1.0888	-176.2479	-5590.3133	-29.5303
0.9 Dead+1.6 Wind 90 deg - No Ice	47.3257	52.6591	-1.0888	-176.0650	-5581.3395	-29.5334
1.2 Dead+1.6 Wind 120 deg - No Ice	63.1009	48.2605	28.3625	3011.7512	-5111.6612	-42.6925
0.9 Dead+1.6 Wind 120 deg - No Ice	47.3257	48.2605	28.3625	3009.4577	-5103.0652	-42.6792
1.2 Dead+1.6 Wind 150 deg - No Ice	63.1009	26.4034	48.4733	5089.8932	-2707.9111	-44.4280
0.9 Dead+1.6 Wind 150 deg - No Ice	47.3257	26.4034	48.4733	5086.0275	-2701.1878	-44.4098
1.2 Dead+1.6 Wind 180 deg - No Ice	63.1009	0.0049	53.9509	5645.1018	-18.8427	-58.9314
0.9 Dead+1.6 Wind 180 deg - No Ice	47.3257	0.0049	53.9509	5640.8190	-14.1284	-58.9226
1.2 Dead+1.6 Wind 210 deg - No Ice	63.1009	-25.0329	46.0626	4851.0678	2536.4761	-71.6615
0.9 Dead+1.6 Wind 210 deg - No Ice	47.3257	-25.0329	46.0626	4847.3784	2539.2865	-71.6565
1.2 Dead+1.6 Wind 240 deg - No Ice	63.1009	-46.6041	27.1138	2876.0690	4916.6495	-29.8758
0.9 Dead+1.6 Wind 240 deg - No Ice	47.3257	-46.6041	27.1139	2873.8933	4917.6115	-29.8701
1.2 Dead+1.6 Wind 270 deg - No Ice	63.1009	-52.7605	-1.2116	-193.8609	5568.6170	30.1541
0.9 Dead+1.6 Wind 270 deg - No Ice	47.3257	-52.7605	-1.2116	-193.6581	5569.0557	30.1564
1.2 Dead+1.6 Wind 300 deg - No Ice	63.1009	-46.1346	-26.8174	-2846.6175	4871.4586	43.2958
0.9 Dead+1.6 Wind 300 deg - No Ice	47.3257	-46.1346	-26.8174	-2844.4161	4872.4196	43.2898
1.2 Dead+1.6 Wind 330 deg - No Ice	63.1009	-28.5059	-47.2270	-4890.7998	3009.0914	44.4032
0.9 Dead+1.6 Wind 330 deg - No Ice	47.3257	-28.5059	-47.2270	-4887.0897	3011.4758	44.3853
1.2 Dead+1.0 Ice	199.9941	0.0000	0.0000	-15.1902	-113.8296	0.0040
1.2 Dead+1.0 Wind 0 deg+1.0 Ice	199.9941	-0.0483	-15.6480	-1657.0741	-106.6661	10.2571
1.2 Dead+1.0 Wind 30 deg+1.0 Ice	199.9941	7.6371	-12.8769	-1362.7164	-926.3390	13.2564
1.2 Dead+1.0 Wind 60 deg+1.0 Ice	199.9941	12.8094	-7.4291	-804.7741	-1473.9481	7.1656
1.2 Dead+1.0 Wind 90 deg+1.0 Ice	199.9941	14.9222	-0.2056	-48.8808	-1695.2138	-3.7350

tnxTower EFI Global, Inc. 1117 Perimeter Center West, Suite E500 Atlanta, GA 30338 Phone: (770) 693-0835 FAX:	Job	CTHA174A	Page	19 of 27
	Project	049.00427 - 2075022	Date	15:52:55 06/15/20
	Client	Foresite LLC	Designed by	Ahmet Colakoglu

Load Combination	Vertical	Shear _x	Shear _z	Overturning Moment, M _x	Overturning Moment, M _z	Torque
	K	K	K	kip-ft	kip-ft	kip-ft
1.2 Dead+1.0 Wind 120 deg+1.0 Ice	199.9941	13.4696	7.8732	820.0942	-1537.1478	-8.0637
1.2 Dead+1.0 Wind 150 deg+1.0 Ice	199.9941	7.4760	13.4729	1403.6785	-885.3557	-7.4352
1.2 Dead+1.0 Wind 180 deg+1.0 Ice	199.9941	0.0079	15.2891	1590.0745	-115.1732	-10.3413
1.2 Dead+1.0 Wind 210 deg+1.0 Ice	199.9941	-7.2660	13.1176	1370.8500	637.5938	-13.3510
1.2 Dead+1.0 Wind 240 deg+1.0 Ice	199.9941	-13.1517	7.6339	795.9476	1281.9866	-7.1866
1.2 Dead+1.0 Wind 270 deg+1.0 Ice	199.9941	-14.9386	-0.2398	-53.8259	1469.5054	3.8356
1.2 Dead+1.0 Wind 300 deg+1.0 Ice	199.9941	-13.1752	-7.6495	-825.8620	1280.1291	8.1686
1.2 Dead+1.0 Wind 330 deg+1.0 Ice	199.9941	-7.8777	-13.2335	-1395.7533	722.3224	7.4290
Dead+Wind 0 deg - Service	52.5841	-0.0605	-13.5183	-1410.1236	-6.3876	13.9671
Dead+Wind 30 deg - Service	52.5841	6.4438	-10.7151	-1111.5842	-700.3695	16.9879
Dead+Wind 60 deg - Service	52.5841	10.5656	-6.1421	-652.3062	-1135.8499	7.1231
Dead+Wind 90 deg - Service	52.5841	12.5925	-0.2604	-42.1264	-1347.3064	-7.0596
Dead+Wind 120 deg - Service	52.5841	11.5407	6.7824	719.8336	-1232.9603	-10.2081
Dead+Wind 150 deg - Service	52.5841	6.3139	11.5915	1216.4966	-658.4035	-10.6215
Dead+Wind 180 deg - Service	52.5841	0.0012	12.9014	1349.2205	-15.6682	-14.0924
Dead+Wind 210 deg - Service	52.5841	-5.9862	11.0151	1159.4220	595.0973	-17.1310
Dead+Wind 240 deg - Service	52.5841	-11.1446	6.4838	687.4003	1163.9908	-7.1444
Dead+Wind 270 deg - Service	52.5841	-12.6168	-0.2897	-46.3343	1319.7566	7.2086
Dead+Wind 300 deg - Service	52.5841	-11.0323	-6.4129	-680.3965	1153.1642	10.3535
Dead+Wind 330 deg - Service	52.5841	-6.8166	-11.2935	-1168.9838	708.0152	10.6156

Solution Summary

Load Comb.	Sum of Applied Forces			Sum of Reactions			% Error
	PX K	PY K	PZ K	PX K	PY K	PZ K	
1	0.0000	-52.5841	0.0000	0.0000	52.5841	0.0000	0.000%
2	-0.2532	-63.1009	-56.5303	0.2532	63.1009	56.5303	0.000%
3	-0.2532	-47.3257	-56.5303	0.2532	47.3257	56.5303	0.000%
4	26.9464	-63.1009	-44.8082	-26.9464	63.1009	44.8082	0.000%
5	26.9464	-47.3257	-44.8082	-26.9464	47.3257	44.8082	0.000%
6	44.1831	-63.1009	-25.6850	-44.1831	63.1009	25.6850	0.000%
7	44.1831	-47.3257	-25.6850	-44.1831	47.3257	25.6850	0.000%
8	52.6590	-63.1009	-1.0888	-52.6591	63.1009	1.0888	0.000%
9	52.6590	-47.3257	-1.0888	-52.6591	47.3257	1.0888	0.000%
10	48.2605	-63.1009	28.3625	-48.2605	63.1009	-28.3625	0.000%
11	48.2605	-47.3257	28.3625	-48.2605	47.3257	-28.3625	0.000%
12	26.4034	-63.1009	48.4733	-26.4034	63.1009	-48.4733	0.000%
13	26.4034	-47.3257	48.4733	-26.4034	47.3257	-48.4733	0.000%
14	0.0049	-63.1009	53.9509	-0.0049	63.1009	-53.9509	0.000%
15	0.0049	-47.3257	53.9509	-0.0049	47.3257	-53.9509	0.000%
16	-25.0329	-63.1009	46.0626	25.0329	63.1009	-46.0626	0.000%
17	-25.0329	-47.3257	46.0626	25.0329	47.3257	-46.0626	0.000%
18	-46.6041	-63.1009	27.1139	46.6041	63.1009	-27.1138	0.000%
19	-46.6041	-47.3257	27.1139	46.6041	47.3257	-27.1139	0.000%
20	-52.7605	-63.1009	-1.2116	52.7605	63.1009	1.2116	0.000%
21	-52.7605	-47.3257	-1.2116	52.7605	47.3257	1.2116	0.000%
22	-46.1346	-63.1009	-26.8174	46.1346	63.1009	26.8174	0.000%
23	-46.1346	-47.3257	-26.8174	46.1346	47.3257	26.8174	0.000%
24	-28.5059	-63.1009	-47.2270	28.5059	63.1009	47.2270	0.000%

tnxTower EFI Global, Inc. 1117 Perimeter Center West, Suite E500 Atlanta, GA 30338 Phone: (770) 693-0835 FAX:	Job	CTHA174A	Page	20 of 27
	Project	049.00427 - 2075022	Date	15:52:55 06/15/20
	Client	Foresite LLC	Designed by	Ahmet Colakoglu

Load Comb.	Sum of Applied Forces			Sum of Reactions			% Error
	PX K	PY K	PZ K	PX K	PY K	PZ K	
25	-28.5059	-47.3257	-47.2270	28.5059	47.3257	47.2270	0.000%
26	0.0000	-199.9941	0.0000	-0.0000	199.9941	0.0000	0.000%
27	-0.0483	-199.9941	-15.6480	0.0483	199.9941	15.6480	0.000%
28	7.6371	-199.9941	-12.8769	-7.6371	199.9941	12.8769	0.000%
29	12.8094	-199.9941	-7.4291	-12.8094	199.9941	7.4291	0.000%
30	14.9222	-199.9941	-0.2056	-14.9222	199.9941	0.2056	0.000%
31	13.4696	-199.9941	7.8732	-13.4696	199.9941	-7.8732	0.000%
32	7.4760	-199.9941	13.4729	-7.4760	199.9941	-13.4729	0.000%
33	0.0079	-199.9941	15.2891	-0.0079	199.9941	-15.2891	0.000%
34	-7.2660	-199.9941	13.1176	7.2660	199.9941	-13.1176	0.000%
35	-13.1517	-199.9941	7.6339	13.1517	199.9941	-7.6339	0.000%
36	-14.9386	-199.9941	-0.2398	14.9386	199.9941	0.2398	0.000%
37	-13.1752	-199.9941	-7.6495	13.1752	199.9941	7.6495	0.000%
38	-7.8777	-199.9941	-13.2335	7.8777	199.9941	13.2335	0.000%
39	-0.0605	-52.5841	-13.5183	0.0605	52.5841	13.5183	0.000%
40	6.4438	-52.5841	-10.7151	-6.4438	52.5841	10.7151	0.000%
41	10.5656	-52.5841	-6.1421	-10.5656	52.5841	6.1421	0.000%
42	12.5925	-52.5841	-0.2604	-12.5925	52.5841	0.2604	0.000%
43	11.5407	-52.5841	6.7824	-11.5407	52.5841	-6.7824	0.000%
44	6.3139	-52.5841	11.5916	-6.3139	52.5841	-11.5915	0.000%
45	0.0012	-52.5841	12.9014	-0.0012	52.5841	-12.9014	0.000%
46	-5.9862	-52.5841	11.0151	5.9862	52.5841	-11.0151	0.000%
47	-11.1446	-52.5841	6.4838	11.1446	52.5841	-6.4838	0.000%
48	-12.6168	-52.5841	-0.2897	12.6168	52.5841	0.2897	0.000%
49	-11.0323	-52.5841	-6.4129	11.0323	52.5841	6.4129	0.000%
50	-6.8167	-52.5841	-11.2935	6.8166	52.5841	11.2935	0.000%

Non-Linear Convergence Results

Load Combination	Converged?	Number of Cycles	Displacement Tolerance	Force Tolerance
1	Yes	4	0.0000001	0.0000001
2	Yes	4	0.0000001	0.00000144
3	Yes	4	0.0000001	0.00000126
4	Yes	4	0.0000001	0.00000001
5	Yes	4	0.0000001	0.00000001
6	Yes	4	0.0000001	0.00000001
7	Yes	4	0.0000001	0.00000001
8	Yes	4	0.0000001	0.00000001
9	Yes	4	0.0000001	0.00000001
10	Yes	4	0.0000001	0.00000133
11	Yes	4	0.0000001	0.00000001
12	Yes	4	0.0000001	0.00000001
13	Yes	4	0.0000001	0.00000001
14	Yes	4	0.0000001	0.00000001
15	Yes	4	0.0000001	0.00000001
16	Yes	4	0.0000001	0.00000001
17	Yes	4	0.0000001	0.00000001
18	Yes	4	0.0000001	0.00000001
19	Yes	4	0.0000001	0.00000001
20	Yes	4	0.0000001	0.00000001
21	Yes	4	0.0000001	0.00000001
22	Yes	4	0.0000001	0.00000001
23	Yes	4	0.0000001	0.00000001
24	Yes	4	0.0000001	0.00000001
25	Yes	4	0.0000001	0.00000001

tnxTower EFI Global, Inc. 1117 Perimeter Center West, Suite E500 Atlanta, GA 30338 Phone: (770) 693-0835 FAX:	Job	CTHA174A	Page	21 of 27
	Project	049.00427 - 2075022	Date	15:52:55 06/15/20
	Client	Foresite LLC	Designed by	Ahmet Colakoglu

26	Yes	4	0.0000001	0.0000001
27	Yes	4	0.0000001	0.0000001
28	Yes	4	0.0000001	0.0000001
29	Yes	4	0.0000001	0.0000001
30	Yes	4	0.0000001	0.0000001
31	Yes	4	0.0000001	0.0000001
32	Yes	4	0.0000001	0.0000001
33	Yes	4	0.0000001	0.0000001
34	Yes	4	0.0000001	0.0000001
35	Yes	4	0.0000001	0.0000001
36	Yes	4	0.0000001	0.0000001
37	Yes	4	0.0000001	0.0000001
38	Yes	4	0.0000001	0.0000001
39	Yes	4	0.0000001	0.0000001
40	Yes	4	0.0000001	0.0000001
41	Yes	4	0.0000001	0.0000001
42	Yes	4	0.0000001	0.0000001
43	Yes	4	0.0000001	0.0000001
44	Yes	4	0.0000001	0.0000001
45	Yes	4	0.0000001	0.0000001
46	Yes	4	0.0000001	0.0000001
47	Yes	4	0.0000001	0.0000001
48	Yes	4	0.0000001	0.0000001
49	Yes	4	0.0000001	0.0000001
50	Yes	4	0.0000001	0.0000001

Maximum Tower Deflections - Service Wind

Section No.	Elevation ft	Horz. Deflection in	Gov. Load Comb.	Tilt °	Twist °
T1	170 - 160	2.3622	43	0.1114	0.0171
T2	160 - 140	2.1204	43	0.1107	0.0172
T3	140 - 120	1.6458	43	0.1038	0.0163
T4	120 - 100	1.2092	43	0.0892	0.0151
T5	100 - 80	0.8477	43	0.0734	0.0131
T6	80 - 60	0.5415	43	0.0589	0.0101
T7	60 - 40	0.3074	43	0.0422	0.0069
T8	40 - 20	0.1381	43	0.0280	0.0039
T9	20 - 0	0.0348	39	0.0126	0.0019

Critical Deflections and Radius of Curvature - Service Wind

Elevation ft	Appurtenance	Gov. Load Comb.	Deflection in	Tilt °	Twist °	Radius of Curvature ft
170.0000	15' Lighting Rod	43	2.3622	0.1114	0.0171	765941
165.0000	6' Dish	43	2.2412	0.1111	0.0172	765941
160.0000	6812	43	2.1204	0.1107	0.0172	399960
155.0000	6812	43	2.0001	0.1097	0.0171	307573
150.0000	4' DIsh	43	1.8807	0.1083	0.0169	239878
140.0000	SC2-W100AB	43	1.6458	0.1038	0.0163	146656
110.0000	2' Dish	43	1.0201	0.0811	0.0142	71884
100.0000	(4) SBNHH-1D65B w/ Mount Pipe	43	0.8477	0.0734	0.0131	113145

tnxTower EFI Global, Inc. 1117 Perimeter Center West, Suite E500 Atlanta, GA 30338 Phone: (770) 693-0835 FAX:	Job	CTHA174A	Page	22 of 27
	Project	049.00427 - 2075022	Date	15:52:55 06/15/20
	Client	Foresite LLC	Designed by	Ahmet Colakoglu

Maximum Tower Deflections - Design Wind

Section No.	Elevation ft	Horz. Deflection in	Gov. Load Comb.	Tilt °	Twist °
T1	170 - 160	9.8458	10	0.4654	0.0714
T2	160 - 140	8.8354	10	0.4624	0.0722
T3	140 - 120	6.8533	10	0.4333	0.0682
T4	120 - 100	5.0324	10	0.3715	0.0631
T5	100 - 80	3.5273	10	0.3053	0.0547
T6	80 - 60	2.2534	10	0.2448	0.0422
T7	60 - 40	1.2796	10	0.1755	0.0291
T8	40 - 20	0.5751	10	0.1165	0.0162
T9	20 - 0	0.1459	2	0.0524	0.0080

Critical Deflections and Radius of Curvature - Design Wind

Elevation ft	Appurtenance	Gov. Load Comb.	Deflection in	Tilt °	Twist °	Radius of Curvature ft
170.0000	15' Lighting Rod	10	9.8458	0.4654	0.0714	185538
165.0000	6' Dish	10	9.3401	0.4644	0.0720	185538
160.0000	6812	10	8.8354	0.4624	0.0722	96839
155.0000	6812	10	8.3329	0.4585	0.0718	74344
150.0000	4' DIsh	10	7.8340	0.4524	0.0708	57663
140.0000	SC2-W100AB	10	6.8533	0.4333	0.0682	34190
110.0000	2' Dish	10	4.2448	0.3375	0.0594	17132
100.0000	(4) SBNHH-1D65B w/ Mount Pipe	10	3.5273	0.3053	0.0547	27031

Bolt Design Data

Section No.	Elevation ft	Component Type	Bolt Grade	Bolt Size in	Number Of Bolts	Maximum Load per Bolt K	Allowable Load per Bolt K	Ratio Load Allowable	Allowable Ratio	Criteria
T1	170	Leg	A325N	1.0000	6	0.5801	53.0144	0.011	1	Bolt Tension
		Diagonal	A325N	1.0000	1	4.1301	9.1441	0.452	1	Member Block Shear
		Top Girt	A325N	1.0000	1	0.9444	9.1441	0.103	1	Member Block Shear
T2	160	Leg	A325N	1.0000	6	4.6036	53.0144	0.087	1	Bolt Tension
		Diagonal	A325N	1.0000	1	5.5877	9.1441	0.611	1	Member Block Shear
T3	140	Leg	A325N	1.0000	6	9.9940	53.0144	0.189	1	Bolt Tension
		Diagonal	A325N	1.0000	1	8.0430	10.1637	0.791	1	Member Block Shear
T4	120	Leg	A325N	1.0000	6	15.6001	53.0144	0.294	1	Bolt Tension
		Diagonal	A325N	1.0000	1	8.8702	16.9395	0.524	1	Member Block Shear
T5	100	Leg	A325N	1.0000	12	9.8626	53.0144	0.186	1	Bolt Tension
		Diagonal	A325N	0.8750	1	14.3715	20.1867	0.712	1	Member Block Shear

tnxTower EFI Global, Inc. 1117 Perimeter Center West, Suite E500 Atlanta, GA 30338 Phone: (770) 693-0835 FAX:	Job	CTHA174A	Page	23 of 27
	Project	049.00427 - 2075022	Date	15:52:55 06/15/20
	Client	Foresite LLC	Designed by	Ahmet Colakoglu

Section No.	Elevation ft	Component Type	Bolt Grade	Bolt Size in	Number Of Bolts	Maximum Load per Bolt K	Allowable Load per Bolt K	Ratio Load Allowable	Allowable Ratio	Criteria
T6	80	Leg Diagonal	A325N A325N	1.0000 0.8750	12 1	12.7134 14.7147	53.0144 20.1867	0.240 0.729	1 1	Bolt Tension Member Block Shear
T7	60	Leg Diagonal	A325N A325N	1.0000 0.8750	12 1	15.3376 14.5838	53.0144 20.1867	0.289 0.722	1 1	Bolt Tension Member Block Shear
T8	40	Leg Diagonal	A325N A325N	1.0000 0.8750	12 1	17.8885 14.7705	53.0144 29.5800	0.337 0.499	1 1	Bolt Tension Member Bearing
T9	20	Diagonal	A325N	0.8750	1	15.3273	29.5800	0.518	1	Member Bearing

Compression Checks

Leg Design Data (Compression)

Section No.	Elevation ft	Size	L ft	L _u ft	Kl/r	A in ²	P _u K	φP _n K	Ratio $\frac{P_u}{\phi P_n}$
T1	170 - 160	Pirod 207628	10.0167	5.3422	45.0 K=1.00	3.6816	-7.1871	142.8700	0.050 ¹
T2	160 - 140	Pirod 207629	20.0333	10.0167	37.5 K=1.00	5.3014	-33.6581	215.2540	0.156 ¹
T3	140 - 120	Pirod 207629	20.0333	10.0167	37.5 K=1.00	5.3014	-73.2860	215.2540	0.340 ¹
T4	120 - 100	Pirod 195557	20.0333	10.0167	32.1 K=1.00	7.2158	-111.6320	301.0870	0.371 ¹
T5	100 - 80	Pirod 211843	20.0333	20.0333	48.8 K=1.00	9.4248	-140.7480	356.2930	0.395 ¹
T6	80 - 60	Pirod 208333	20.0333	20.0333	48.8 K=1.00	9.4248	-181.9270	356.2930	0.511 ¹
T7	60 - 40	Pirod 208334	20.0333	20.0333	48.8 K=1.00	11.9282	-218.4540	451.1480	0.484 ¹
T8	40 - 20	Pirod 208334	20.0333	20.0333	48.8 K=1.00	11.9282	-255.3700	451.1480	0.566 ¹
T9	20 - 0	Pirod 208335	20.0333	20.0333	48.7 K=1.00	14.7262	-288.7550	557.2670	0.518 ¹

¹ P_u / φP_n controls

Truss-Leg Diagonal Data

Section No.	Elevation ft	Diagonal Size	L _d ft	Kl/r	φP _n K	A in ²	V _u K	φV _n K	Stress Ratio
T1	170 - 160	0.5	1.4751	120.4	165.6700	0.1963	1.9419	3.4444	0.564
T2	160 - 140	0.5	1.4625	119.3	238.5650	0.1963	0.3428	3.5038	0.098
T3	140 - 120	0.5	1.4625	119.3	238.5650	0.1963	2.1459	3.5038	0.612
T4	120 - 100	0.5	1.4501	118.3	324.7130	0.1963	0.4017	3.5639	0.113
T5	100 - 80	0.5	1.3875	113.2	424.1150	0.1963	1.4854	4.0160	0.370

tnxTower EFI Global, Inc. 1117 Perimeter Center West, Suite E500 Atlanta, GA 30338 Phone: (770) 693-0835 FAX:	Job CTHA174A	Page 24 of 27
	Project 049.00427 - 2075022	Date 15:52:55 06/15/20
	Client Foresite LLC	Designed by Ahmet Colakoglu

Section No.	Elevation ft	Diagonal Size	L_d ft	Kl/r	ϕP_n K	A in ²	V_u K	ϕV_n K	Stress Ratio
T6	80 - 60	0.5	1.3875	113.2	424.1150	0.1963	0.5675	4.0160	0.141
T7	60 - 40	0.5	1.3751	112.2	536.7710	0.1963	0.5176	4.0836	0.127
T8	40 - 20	0.5	1.3751	112.2	536.7710	0.1963	0.6815	4.0836	0.167
T9	20 - 0	0.5	1.3629	111.2	662.6800	0.1963	0.7960	4.1506	0.192

Diagonal Design Data (Compression)

Section No.	Elevation ft	Size	L ft	L_u ft	Kl/r	A in ²	P_u K	ϕP_n K	Ratio $\frac{P_u}{\phi P_n}$
T1	170 - 160	L2 1/2x2 1/2x3/16	12.5033	5.6688	137.4	0.9020	-4.3307	10.7896	0.401 ¹
T2	160 - 140	L2 1/2x2 1/2x3/16	13.7962	6.3687	K=1.00 154.4	0.9020	-5.9080	8.5486	0.691 ¹
T3	140 - 120	L3x3x3/16	15.2425	7.1234	K=1.00 143.4	1.0900	-8.0602	11.9707	0.673 ¹
T4	120 - 100	L3x3x5/16	16.8027	7.9237	K=1.00 161.4	1.7800	-8.8660	15.4302	0.575 ¹
T5	100 - 80	2L3x3x3/16	25.0067	12.3529	K=1.00 157.9	2.1800	-14.8750	19.7618	0.753 ¹
T6	80 - 60	2L3x3x3/16	26.2552	12.9770	K=1.00 165.8	2.1800	-14.9546	17.9068	0.835 ¹
T7	60 - 40	2L3x3x3/16	27.5922	13.6454	K=1.00 174.4	2.1800	-15.1083	16.1954	0.933 ¹
T8	40 - 20	2L3 1/2x3 1/2x1/4	29.0058	14.3521	K=1.00 158.0	3.3800	-15.2200	30.5856	0.498 ¹
T9	20 - 0	2L3 1/2x3 1/2x1/4	30.4850	15.0917	K=1.00 166.1	3.3800	-15.9002	27.6614	0.575 ¹

¹ $P_u / \phi P_n$ controls

Secondary Horizontal Design Data (Compression)

Section No.	Elevation ft	Size	L ft	L_u ft	Kl/r	A in ²	P_u K	ϕP_n K	Ratio $\frac{P_u}{\phi P_n}$
T1	170 - 160	L2 1/2x2 1/2x3/16	7.4667	3.2333	99.2	0.9020	-0.9923	17.4100	0.057 ¹
					K=1.27				

¹ $P_u / \phi P_n$ controls

Top Girt Design Data (Compression)

Section No.	Elevation ft	Size	L ft	L_u ft	Kl/r	A in ²	P_u K	ϕP_n K	Ratio $\frac{P_u}{\phi P_n}$
T1	170 - 160	L2 1/2x2 1/2x3/16	7.0000	5.6667	137.4	0.9020	-0.9480	10.7979	0.088 ¹
					K=1.00				

tnxTower EFI Global, Inc. 1117 Perimeter Center West, Suite E500 Atlanta, GA 30338 Phone: (770) 693-0835 FAX:	Job	CTHA174A	Page	25 of 27
	Project	049.00427 - 2075022	Date	15:52:55 06/15/20
	Client	Foresite LLC	Designed by	Ahmet Colakoglu

Section No.	Elevation ft	Size	L ft	L _u ft	Kl/r	A in ²	P _u K	φP _n K	Ratio $\frac{P_u}{\phi P_n}$
-------------	-----------------	------	---------	----------------------	------	----------------------	---------------------	----------------------	---------------------------------

¹ P_u / φP_n controls

Tension Checks

Leg Design Data (Tension)

Section No.	Elevation ft	Size	L ft	L _u ft	Kl/r	A in ²	P _u K	φP _n K	Ratio $\frac{P_u}{\phi P_n}$
T1	170 - 160	Pirod 207628	10.0167	4.6744	45.0	3.6816	3.9642	165.6700	0.024 ¹
T2	160 - 140	Pirod 207629	20.0333	10.0167	37.5	5.3014	27.6214	238.5650	0.116 ¹
T3	140 - 120	Pirod 207629	20.0333	10.0167	37.5	5.3014	59.9637	238.5650	0.251 ¹
T4	120 - 100	Pirod 195557	20.0333	10.0167	32.1	7.2158	93.6006	324.7130	0.288 ¹
T5	100 - 80	Pirod 211843	20.0333	20.0333	48.8	9.4248	118.3510	424.1150	0.279 ¹
T6	80 - 60	Pirod 208333	20.0333	20.0333	48.8	9.4248	152.5600	424.1150	0.360 ¹
T7	60 - 40	Pirod 208334	20.0333	20.0333	48.8	11.9282	184.0520	536.7710	0.343 ¹
T8	40 - 20	Pirod 208334	20.0333	20.0333	48.8	11.9282	214.6620	536.7710	0.400 ¹
T9	20 - 0	Pirod 208335	20.0333	20.0333	48.7	14.7262	241.8200	662.6800	0.365 ¹

¹ P_u / φP_n controls

Truss-Leg Diagonal Data

Section No.	Elevation ft	Diagonal Size	L _d ft	Kl/r	φP _n K	A in ²	V _u K	φV _n K	Stress Ratio
T1	170 - 160	0.5	1.4751	120.4	165.6700	0.1963	1.9419	3.4444	0.564
T2	160 - 140	0.5	1.4625	119.3	238.5650	0.1963	0.3428	3.5038	0.098
T3	140 - 120	0.5	1.4625	119.3	238.5650	0.1963	2.1459	3.5038	0.612
T4	120 - 100	0.5	1.4501	118.3	324.7130	0.1963	0.4017	3.5639	0.113
T5	100 - 80	0.5	1.3875	113.2	424.1150	0.1963	1.4854	4.0160	0.370
T6	80 - 60	0.5	1.3875	113.2	424.1150	0.1963	0.5675	4.0160	0.141
T7	60 - 40	0.5	1.3751	112.2	536.7710	0.1963	0.5176	4.0836	0.127
T8	40 - 20	0.5	1.3751	112.2	536.7710	0.1963	0.6815	4.0836	0.167
T9	20 - 0	0.5	1.3629	111.2	662.6800	0.1963	0.7960	4.1506	0.192

Diagonal Design Data (Tension)

Section No.	Elevation ft	Size	L ft	L _u ft	Kl/r	A in ²	P _u K	φP _n K	Ratio $\frac{P_u}{\phi P_n}$
T1	170 - 160	L2 1/2x2 1/2x3/16	12.5033	5.6688	90.0	0.9020	4.1301	29.2248	0.141 ¹
T2	160 - 140	L2 1/2x2 1/2x3/16	13.7962	6.3687	100.8	0.9020	5.5877	29.2248	0.191 ¹
T3	140 - 120	L3x3x3/16	15.2425	7.1234	93.2	1.0900	8.0430	35.3160	0.228 ¹
T4	120 - 100	L3x3x5/16	16.8027	7.9237	105.3	1.7800	8.8702	57.6720	0.154 ¹

tnxTower EFI Global, Inc. 1117 Perimeter Center West, Suite E500 Atlanta, GA 30338 Phone: (770) 693-0835 FAX:	Job CTHA174A	Page 26 of 27
	Project 049.00427 - 2075022	Date 15:52:55 06/15/20
	Client Foresite LLC	Designed by Ahmet Colakoglu

Section No.	Elevation ft	Size	L ft	L _u ft	Kl/r	A in ²	P _u K	φP _n K	Ratio $\frac{P_u}{\phi P_n}$
T5	100 - 80	2L3x3x3/16	25.0067	12.3529	159.8	2.1800	14.3715	70.6320	0.203 ¹
T6	80 - 60	2L3x3x3/16	26.2552	12.9770	167.8	2.1800	14.7147	70.6320	0.208 ¹
T7	60 - 40	2L3x3x3/16	27.5922	13.6454	176.3	2.1800	14.5838	70.6320	0.206 ¹
T8	40 - 20	2L3 1/2x3 1/2x1/4	29.0058	14.3521	159.7	3.3800	14.7705	109.5120	0.135 ¹
T9	20 - 0	2L3 1/2x3 1/2x1/4	30.4850	15.0917	167.8	3.3800	15.3273	109.5120	0.140 ¹

¹ P_u / φP_n controls

Secondary Horizontal Design Data (Tension)

Section No.	Elevation ft	Size	L ft	L _u ft	Kl/r	A in ²	P _u K	φP _n K	Ratio $\frac{P_u}{\phi P_n}$
T1	170 - 160	L2 1/2x2 1/2x3/16	7.4667	3.2333	99.7	0.9020	0.9204	29.2248	0.031 ¹

¹ P_u / φP_n controls

Top Girt Design Data (Tension)

Section No.	Elevation ft	Size	L ft	L _u ft	Kl/r	A in ²	P _u K	φP _n K	Ratio $\frac{P_u}{\phi P_n}$
T1	170 - 160	L2 1/2x2 1/2x3/16	7.0000	5.6667	92.5	0.9020	0.9444	29.2248	0.032 ¹

¹ P_u / φP_n controls

Section Capacity Table

Section No.	Elevation ft	Component Type	Size	Critical Element	P K	φP _{allow} K	% Capacity	Pass Fail
T1	170 - 160	Leg	Pirod 207628	1	-5.4549	142.8700	56.4	Pass
T2	160 - 140	Leg	Pirod 207629	17	-33.6581	215.2540	15.6	Pass
T3	140 - 120	Leg	Pirod 207629	31	-52.0353	215.2540	61.2	Pass
T4	120 - 100	Leg	Pirod 195557	47	-111.6320	301.0870	37.1	Pass
T5	100 - 80	Leg	Pirod 211843	62	-140.7480	356.2930	39.5	Pass
T6	80 - 60	Leg	Pirod 208333	71	-181.9270	356.2930	51.1	Pass
T7	60 - 40	Leg	Pirod 208334	80	-218.4540	451.1480	48.4	Pass
T8	40 - 20	Leg	Pirod 208334	89	-255.3700	451.1480	56.6	Pass
T9	20 - 0	Leg	Pirod 208335	98	-288.7550	557.2670	51.8	Pass
T1	170 - 160	Diagonal	L2 1/2x2 1/2x3/16	9	-4.3307	10.7896	40.1	Pass
							45.2 (b)	
T2	160 - 140	Diagonal	L2 1/2x2 1/2x3/16	21	-5.9080	8.5486	69.1	Pass
T3	140 - 120	Diagonal	L3x3x3/16	36	-8.0602	11.9707	67.3	Pass
							79.1 (b)	
T4	120 - 100	Diagonal	L3x3x5/16	51	-8.8660	15.4302	57.5	Pass
T5	100 - 80	Diagonal	2L3x3x3/16	66	-14.8750	19.7618	75.3	Pass
T6	80 - 60	Diagonal	2L3x3x3/16	75	-14.9546	17.9068	83.5	Pass

<p>tnxTower</p> <p>EFI Global, Inc. 1117 Perimeter Center West, Suite E500 Atlanta, GA 30338 Phone: (770) 693-0835 FAX:</p>	Job	CTHA174A	Page	27 of 27
	Project	049.00427 - 2075022	Date	15:52:55 06/15/20
	Client	Foresite LLC	Designed by	Ahmet Colakoglu

Section No.	Elevation ft	Component Type	Size	Critical Element	P K	ϕP_{allow} K	% Capacity	Pass Fail
T7	60 - 40	Diagonal	2L3x3x3/16	85	-15.1083	16.1954	93.3	Pass
T8	40 - 20	Diagonal	2L3 1/2x3 1/2x1/4	94	-15.2200	30.5856	49.8	Pass
T9	20 - 0	Diagonal	2L3 1/2x3 1/2x1/4	103	-15.9002	27.6614	57.5	Pass
T1	170 - 160	Secondary Horizontal	L2 1/2x2 1/2x3/16	14	-0.9923	17.4100	5.7	Pass
T1	170 - 160	Top Girt	L2 1/2x2 1/2x3/16	6	-0.9480	10.7979	8.8	Pass
							10.3 (b)	
							Summary	
						Leg (T3)	61.2	Pass
						Diagonal (T7)	93.3	Pass
						Secondary Horizontal (T1)	5.7	Pass
						Top Girt (T1)	10.3	Pass
						Bolt Checks	79.1	Pass
						RATING =	93.3	Pass

Project Information	
Site #	CTHA174A

Tower Information	
Tower Type	Self Support
TIA-222 Rev	G

Load Z Normalization

Applied Loads		
	Comp.	Uplift
Axial (k)	306.00	256.00
Shear (k)	35.00	31.00

Anchor Rod Data	
Quantity:	12
Diameter (in):	1
<u>Material Grade:</u>	F1554-105
Grout Considered:	No
l_{ar} (in):	1
Eta Factor, η :	0.5
Thread Type:	N-Included
Configuration:	Symmetrical

Fy=105 ksi Fu=125 ksi

Anchor Rod Results	
Axial, Pu_c (kips)	25.50
Shear, Vu (kips)	2.92
Moment, Mu (kip-in)	-
Axial Cap., ϕPn_t (kips)	60.60
Shear Cap., ϕVn (kips)	-
Moment Cap., ϕMn (kip-in)	-
Stress Rating	51.7%

Pass

SST Unit Base Foundation

Site #:

TIA-222 Revision:

Top & Bot. Pad Rein. Different?:

Tower Centroid Offset?:

Block Foundation?:

Superstructure Analysis Reactions		
Global Moment, M :	5933	ft-kips
Global Axial, P :	63	kips
Global Shear, V :	57	kips
Leg Compression, P_{comp} :	306	kips
Leg Comp. Shear, V_{u,comp} :	35	kips
Leg Uplift, P_{uplift} :	256	kips
Leg Uplift. Shear, V_{u,uplift} :	31	kips
Tower Height, H :	170	ft
Base Face Width, BW :	24	ft
BP Dist. Above Fdn, bp_{dist} :	3	in

Foundation Analysis Checks				
	Capacity	Demand	Rating	Check
<i>Lateral (Sliding) (kips)</i>	309.12	57.00	18.4%	Pass
<i>Bearing Pressure (ksf)</i>	9.45	1.83	19.4%	Pass
<i>Overturning (kip*ft)</i>	11098.86	6587.42	59.4%	Pass
<i>Pier Flexure (Comp.) (kip*ft)</i>	1875.55	166.25	8.9%	Pass
<i>Pier Flexure (Tension) (kip*ft)</i>	1051.59	147.25	14.0%	Pass
<i>Pier Compression (kip)</i>	8998.02	319.60	3.6%	Pass
<i>Pad Flexure (kip*ft)</i>	2609.92	266.32	10.2%	Pass
<i>Pad Shear - 1-way (kips)</i>	607.92	93.91	15.4%	Pass
<i>Pad Shear - Comp 2-way (ksi)</i>	0.190	0.090	47.6%	Pass

Pier Properties		
Pier Shape:	Circular	
Pier Diameter, dpier :	4.5	ft
Ext. Above Grade, E :	0.50	ft
Pier Rebar Size, Sc :	7	
Pier Rebar Quantity, mc :	24	
Pier Tie/Spiral Size, St :	4	
Pier Tie/Spiral Quantity, mt :	5	
Pier Reinforcement Type:	Tie	
Pier Clear Cover, cc_{pier} :	3	in

Soil Rating:	59.4%
Structural Rating:	47.6%

Pad Properties		
Depth, D :	6.00	ft
Pad Width, W :	32.00	ft
Pad Thickness, T :	1.75	ft
Pad Rebar Size (Bottom), Sp :	7	
Pad Rebar Quantity (Bottom), mp :	61	
Pad Clear Cover, cc_{pad} :	3	in

Material Properties		
Rebar Grade, Fy :	60	ksi
Concrete Compressive Strength, F_c :	4	ksi
Dry Concrete Density, δ_c :	150	pcf

Soil Properties		
Total Soil Unit Weight, γ :	100	pcf
Ultimate Net Bearing, Q_{net} :	12.000	ksf
Cohesion, Cu :	0.000	ksf
Friction Angle, φ :	30	degrees
SPT Blow Count, N_{blows} :		
Base Friction, μ :	0.45	
Neglected Depth, N :	3.3	ft
Foundation Bearing on Rock?	No	
Groundwater Depth, gw :	N/A	ft

<-- Toggle between Gross and Net

Exhibit E

1) ANALYSIS CRITERIA

The analysis was performed for the existing and proposed appurtenances as specified in the loading information referenced below, and per the following loading criteria of Table 1.

Table 1 – Loading and Analysis Criteria

Rad Center	140'
Structure Type	Self Support Tower
Exposure Category	B
Basic Wind Speed (3-Second Gust)	125 * $\sqrt{0.6}$ = 97 mph (Nominal)
Ice Loading	1.00" with 50 mph Wind
Risk Category	II
Topographic Factor	Kzt = 1.0

Table 1.1 – Existing Appurtenance Configuration

Qty	Model
4	Ericsson AIR21 B2A B4P – Antennas
4	Ericsson AIR32 B66A B2A – Antennas
4	RFS APXVAARR24-43-U-NA20 – Antennas
4	Generic Twin Style 1B AWS – TMAs
4	Radio 4449 B71 + B85 – RRHs

Table 1.2 – Proposed and Final Appurtenance Configuration

Qty	Model
4	Ericsson AIR21 B2A B4P – Antennas
4	Ericsson AIR32 B66A B2A – Antennas
4	RFS APXVAARR24-43-U-NA20 – Antennas
4	Ericsson AIR6449 B41 – Antennas
4	Generic Twin Style 1B AWS – TMAs*
4	Radio 4449 B71 + B85 – RRHs*
4	Radio 4415 B25 – RRHs*

* Existing/Proposed equipment are assumed to be mounted behind antenna.

Table 1.3 – Assumed Material Properties

Member Type	ASTM Material Designation	Fy (ksi)	Fu (ksi)
Pipes	A53 Gr. B	35	60
Angles/Channels	A36	36	58
Rectangular HSS	A500 Gr. B - 46	46	58
Round HSS	A500 Gr. B - 42	42	58
Others (UNO)	A572 Gr. 50	50	65

2) ANALYSIS PROCEDURE

The analysis is based on the following information:

Table 2 – Documents

Document	Provided By	Date
RFDS	T-Mobile	05/19/2020
Construction Drawings	Centek Engineering	07/18/2018
Site Photos	-	05/02/2020

2.1) Analysis Method

Risa-3D, a commercially available analysis software package, was used to create a three-dimensional model of the mount and calculate member stresses for various loading cases. Selected output from the analysis is included in the Appendix.

2.2) Analysis Conditions and Assumptions

- 1) The mount was built and installed in accordance with the manufacturer's specifications.
- 2) The mount has been maintained and will be maintained in accordance with the manufacturer's specifications. All structural members and connections of the mount are in good condition and can achieve theoretical strength.
- 3) The configuration of antennas is as specified in "1) Analysis Criteria".
- 4) The analysis was performed for the subject mount only. It does not include an evaluation of the other mounts or the tower, which should be analyzed by others.
- 5) The evaluation does not include any antenna rigging loads. The equipment should not be rigged using the subject antenna mount as the support.
- 6) The analysis includes a minimum 250 lbf maintenance point load at the worst-case location on the mount, as well as a minimum 500 lbf maintenance point load at each antenna location in conjunction with a 30 mph wind load.
- 7) Any steel grating represented in this model is for loading purposes only and it is not considered to provide any structural restraint or support.
- 8) Member sizes per construction drawings, site photos and assumed based on our experience with similar structures. Please refer to calculation output in the appendix of this report for sizes and lengths assumed.
- 9) All member connections are assumed to have been designed to meet or exceed the load carrying capacity of the connected member unless otherwise specified in this report.

EFI Global, Inc. (EFI), must be notified immediately if any of these assumptions are discovered to be incorrect. The results of this analysis may be affected if any of the assumptions are not valid or have been made in error.

3) ANALYSIS RESULTS AND CONCLUSION

The analysis results are shown on the table below.

Table 3.1 – Mount Component Stresses vs. Capacity

Component	% Capacity	Pass / Fail
Horizontal Face Pipe	70.6	Pass
Antenna Mount Pipe	89.1	Pass
Vertical Standoff Pipe	29.3	Pass
Vertical Face Pipe	47.2	Pass
Pipe Kicker	<20.0	Pass

Sector Mounts: The existing sector mounts have **adequate** capacity for the proposed changes by T-Mobile. For the code specified load combinations and as a maximum, the mount members are stressed to **89.1%** of their structural capacity.

APPENDIX
INPUT LOADS
ANALYSIS OUTPUT

CLIENT: ForeSite LLC - T-Mobile
 PROJECT: CTHA174A
 SUBJECT: Antenna Loads -TIA 222 G Standard (chapter 16 revisions)

Tower Height 170.00 ft Type of Mount Sector
 Basic Wind Speed, V 97 mph (=Ultimate Speed* $\sqrt{0.6}$)
 Basic Wind Speed with Ice, V_i 50 mph
 Maintenance Load Factor, L_{FM} 0.0957 Load Factor for Maint. Load Cases (Basic Wind Speed=30 mph)
 Design Ice Thickness, t_i 1 inches

Table 2-3 Importance Factors

Structure Classification	Wind Load Without Ice	Wind Load With Ice	Ice Thickness	Earthquake
II	1	1	1	1

Table 2-4 Exposure Category Coefficients

Exposure Category	Z_g	α	K_{zmin}	K_e	m
B	1200	7	0.7	0.9	0.55

Table 2-5 Topographic Categories
 K_{zt} 1.000

Table 2-2 Wind Directionality Factor, K_d

Structure Type	K_d
Lattice Tower	0.95 DOES NOT CHANGE

Gust Effect Factor G_h

Structure Type	G_h
Lattice Tower	1.00 DOES NOT CHANGE

Shielding Factor, K_a

Structure Type	K_a
Lattice Tower	0.90 DOES NOT CHANGE

Seismic Factors

S_s	0.178
S_1	0.064
F_a	1.6
F_v	2.4
R	3 Truss or Pole

CLIENT: ForeSite LLC - T-Mobile
 PROJECT: CTHA174A
 SUBJECT: Antenna Loads -TIA 222 G Standard (chapter 16 revisions)

Rad Center 140.00 ft

Antenna AND Mount Without Ice

Mounting Pole	Height (ft)	Model Number	#	Weight (lbs)	H (in)	*W (in)	D (in)	Ka	**A _N (ft2)	***A _T (ft2)	Aspect (FRONT)	Aspect (SIDE)	Ca (FRONT)	Ca (SIDE)	K _z	q _z (psf)	Pounds							
																	Wind Load (Front)	Wind Load (Side)	Dead Load	Total Wind Load (Front)	Total Wind Load (Side)	Total Dead Load	Lateral Load (Seismic)	Vertical Load (Seismic)
Pos. 1	140.00	Ericsson AIR21 B2A B4P	1	91.5	56.0	12.1	7.9	0.90	4.71	3.06	4.63	7.12	1.29	1.40	1.088	24.9	136.5	96.3	91.5	136	102	100	4	4
	140.00	Generic Twin Style 1B -AWS (ATMAP	1	8.4	10.1	N/A	2.8	0.90	-	0.20	-	3.61	-	1.25	1.088	24.9	0.0	5.5	8.4					
		Empty		0.0	-	-	-	0.90	-	-	-	-	-	-	-	-	0.0	0.0	0					
		Empty		0.0	-	-	-	0.90	-	-	-	-	-	-	-	-	0.0	0.0	0					
		Empty		0.0	-	-	-	0.90	-	-	-	-	-	-	-	-	0.0	0.0	0	69	51	50	2	2
Pos.2	140.00	Ericsson AIR32 B66A B2A	1	132.2	56.6	12.9	8.7	0.90	5.07	3.42	4.39	6.51	1.28	1.38	1.088	24.9	145.8	105.6	132.2	146	106	132	5	5
	140.00	Empty	1	0.0	-	-	-	0.90	-	-	-	-	-	-	-	-	0.0	0.0	0					
		Empty		0.0	-	-	-	0.90	-	-	-	-	-	-	-	-	0.0	0.0	0					
		Empty		0.0	-	-	-	0.90	-	-	-	-	-	-	-	-	0.0	0.0	0					
		Empty		0.0	-	-	-	0.90	-	-	-	-	-	-	-	-	0.0	0.0	0	73	53	67	2	3
Pos.3	140.00	RFS APXVAARR24-43-U-NA20	1	153.3	95.9	24.0	8.7	0.90	15.98	5.79	4.00	11.02	1.27	1.53	1.088	24.9	453.5	199.1	153.3	454	246	271	10	10
	140.00	Radio 4449 B71+B85	1	73.2	17.9	N/A	9.4	0.90	-	1.17	-	1.91	-	1.20	1.088	24.9	0.0	31.4	73.21					
	140.00	Radio 4415 B25	1	44.0	15.0	N/A	5.4	0.90	-	0.56	-	2.78	-	1.21	1.088	24.9	0.0	15.2	44					
		Empty		0.0	-	-	-	0.90	-	-	-	-	-	-	-	-	0.0	0.0	0					
		Empty		0.0	-	-	-	0.90	-	-	-	-	-	-	-	-	0.0	0.0	0	227	123	136	5	5
Pos.4	140.00	Ericsson AIR6449 B41	1	103.0	33.1	20.5	8.3	0.90	4.71	1.91	1.61	3.99	1.20	1.27	1.088	24.9	126.7	54.1	103	127	54	103	4	4
		Empty		0.0	-	-	-	0.90	-	-	-	-	-	-	-	-	0.0	0.0	0					
		Empty		0.0	-	-	-	0.90	-	-	-	-	-	-	-	-	0.0	0.0	0					
		Empty		0.0	-	-	-	0.90	-	-	-	-	-	-	-	-	0.0	0.0	0					
		Empty		0.0	-	-	-	0.90	-	-	-	-	-	-	-	-	0.0	0.0	0	64	28	52	2	2

* Enter N/A in the W column for front shielded apertures.

** A_N is the product of H and W

*** A_T is the product of H and D

DL 606

Mount	Height (ft)	Member	*L (in)	**W (in)	D (in)	Weight (lb/ft)	*** Ca	K _z	q _z (psf)	Wind Load (PLF)	Lateral Load (Seismic)	Vertical Load (Seismic)
	140.00	2 STD Pipe	12.00	2.38	0.00		1.20	1.088	22.4	5	-	-
	140.00	3 STD Pipe	12.00	3.50	0.00		1.20	1.088	22.4	8	-	-
	140.00	4 STD Pipe	12.00	4.50	0.00		1.20	1.088	22.4	10	-	-
	140.00	Angle Horizontal	0.00	0.00	0.00		-	-	-	-	-	-
	140.00	Angle Vertical	0.00	0.00	0.00		-	-	-	-	-	-
	140.00	Angle Diagonal	0.00	0.00	0.00		-	-	-	-	-	-
	140.00	Tube Standoff (4x4)	0.00	4.00	4.00		-	-	-	-	-	-
	140.00	Tube Horizontal	0.00	0.00	0.00		-	-	-	-	-	-
	140.00	Plate	0.00	0.00	0.00		-	-	-	-	-	-
	140.00	Double Angle	0.00	0.00	0.00		-	-	-	-	-	-
	140.00	Double Angle	0.00	0.00	0.00		-	-	-	-	-	-
	140.00	Channel (Weak Axis Bending)	0.00	0.00	0.00		-	-	-	-	-	-
	140.00	Channel (Strong Axis Bending)	0.00	0.00	0.00		-	-	-	-	-	-

* The dimension L is the longest dimension of the member

** The dimension W is the height or width of the member that resists wind load

*** Ca will equal 1.2 for round members and 2.0 for flat members

CLIENT: ForeSite LLC - T-Mobile
 PROJECT: CTHA174A
 SUBJECT: Antenna Loads -TIA 222 G Standard (chapter 16 revisions)

ti (in) 2.310955 Kiz 1.1554773 reduction 0.2657

Antenna AND Mount With Ice

Mounting Pole	Height (ft)	Model Number	#	H (in)	W (in)	D (in)	Ka	*A _N (ft2)	*A _T (ft2)	*Volume Ice (ft3)	*Weight Ice (lbs)	**Ca (FRONT)	**Ca (SIDE)	Kz	q _z (psf)	Pounds							
																Ice Wind Load (Front)	Ice Wind Load (Side)	Combined Wind Load (Front)	Combined Wind Load (Side)	Ice Dead Load	**Total Wind Load (Front)	**Total Wind Load (Side)	Total Ice Load
Pos. 1	140.00	Ericsson AIR21 B2A B4P	1	56.0	12.1	7.9	0.90	2.33	2.20	4.24	237.56	0.72	0.75	1.088	6.6	10.1	9.8	46.3	35.4	238	46	39	277
	140.00	Generic Twin Style 1B -AWS (ATMAP	1	10.1	8.7	2.8	0.90	-	0.56	0.70	39.20	0.70	0.70	1.088	6.6	0.0	2.3	0.0	3.8	39			
		Empty		-	-	-	0.90	-	-	-	0.00	-	-	-	-	0.0	0.0	0.0	0.0	0			
		Empty		-	-	-	0.90	-	-	-	0.00	-	-	-	-	0.0	0.0	0.0	0.0	0			
		Empty		-	-	-	0.90	-	-	-	0.00	-	-	-	-	0.0	0.0	0.0	0.0	0			
Pos.2	140.00	Ericsson AIR32 B66A B2A	1	56.6	12.9	8.7	0.90	2.38	2.24	4.59	257.27	0.72	0.75	1.088	6.6	10.2	10.0	49.0	38.0	257	49	38	257
	140.00	Empty	1	-	-	-	0.90	-	-	-	0.00	-	-	-	-	0.0	0.0	0.0	0.0	0			
		Empty		-	-	-	0.90	-	-	-	0.00	-	-	-	-	0.0	0.0	0.0	0.0	0			
		Empty		-	-	-	0.90	-	-	-	0.00	-	-	-	-	0.0	0.0	0.0	0.0	0			
		Empty		-	-	-	0.90	-	-	-	0.00	-	-	-	-	0.0	0.0	0.0	0.0	0			
Pos.3	140.00	RFS APXVAARR24-43-U-NA20	1	95.9	24.0	8.7	0.90	4.00	3.51	10.59	593.22	0.72	0.81	1.088	6.6	17.2	16.9	137.7	69.9	593	138	90	782
	140.00	Radio 4449 B71+B85	1	17.9	13.2	9.4	0.90	-	1.02	1.97	110.46	0.70	0.70	1.088	6.6	0.0	4.3	0.0	12.6	110			
	140.00	Radio 4415 B25	1	15.0	13.2	5.4	0.90	-	0.80	1.41	78.70	0.70	0.70	1.088	6.6	0.0	3.3	0.0	7.4	79			
		Empty		-	-	-	0.90	-	-	-	0.00	-	-	-	-	0.0	0.0	0.0	0.0	0			
		Empty		-	-	-	0.90	-	-	-	0.00	-	-	-	-	0.0	0.0	0.0	0.0	0			
Pos.4	140.00	Ericsson AIR6449 B41	1	33.1	20.5	8.3	0.90	1.87	1.48	3.83	214.32	0.70	0.71	1.088	6.6	7.8	6.2	41.5	20.6	214	41	21	214
		Empty		-	-	-	0.90	-	-	-	0.00	-	-	-	-	0.0	0.0	0.0	0.0	0			
		Empty		-	-	-	0.90	-	-	-	0.00	-	-	-	-	0.0	0.0	0.0	0.0	0			
		Empty		-	-	-	0.90	-	-	-	0.00	-	-	-	-	0.0	0.0	0.0	0.0	0			
		Empty		-	-	-	0.90	-	-	-	0.00	-	-	-	-	0.0	0.0	0.0	0.0	0			
																					21	11	108

* A_N, A_T, Volume Ice and Weight Ice are calculated per unit
 ** Ca will equal 1.2 for all ice load calculations

Mount	Height (ft)	Member	*L (in)	**W (in)	D (in)	***A _N (ft2)	Volume Ice (ft3)	Weight Ice (lbs)	****Ca (FRONT)	Kz	q _z (psf)	PLF		
												Ice Wind Load (Front)	Combined Wind Load (Front)	Ice Dead Load
	140.00	2 STD Pipe	12.00	2.38	0.00	0.61	0.24	13.24	1.20	1.088	6.0	4.4	5.8	13
	140.00	3 STD Pipe	12.00	3.50	0.00	0.65	0.29	16.41	1.20	1.088	6.0	4.6	6.7	16
	140.00	4 STD Pipe	12.00	4.50	0.00	0.68	0.34	19.23	1.20	1.088	6.0	4.8	7.5	19
	140.00	Angle Horizontal	0.00	0.00	0.00	-	-	-	-	-	-	-	-	-
	140.00	Angle Vertical	0.00	0.00	0.00	-	-	-	-	-	-	-	-	-
	140.00	Angle Diagonal	0.00	0.00	0.00	-	-	-	-	-	-	-	-	-
	140.00	Tube Standoff (4x4)	0.00	4.00	4.00	-	-	-	-	-	-	-	-	-
	140.00	Tube Horizontal	0.00	0.00	0.00	-	-	-	-	-	-	-	-	-
	140.00	Plate	0.00	0.00	0.00	-	-	-	-	-	-	-	-	-
	140.00	Double Angle	0.00	0.00	0.00	-	-	-	-	-	-	-	-	-
	140.00	Double Angle	0.00	0.00	0.00	-	-	-	-	-	-	-	-	-
	140.00	Channel (Weak Axis Bending)	0.00	0.00	0.00	-	-	-	-	-	-	-	-	-
	140.00	Channel (Strong Axis Bending)	0.00	0.00	0.00	-	-	-	-	-	-	-	-	-

* The dimension L is the longest dimension of the member
 ** The dimension W is the height or width of the member that resists wind load
 *** A_N is the area of ice built up on the LW plane
 **** Ca will equal 1.2 for all ice load calculations

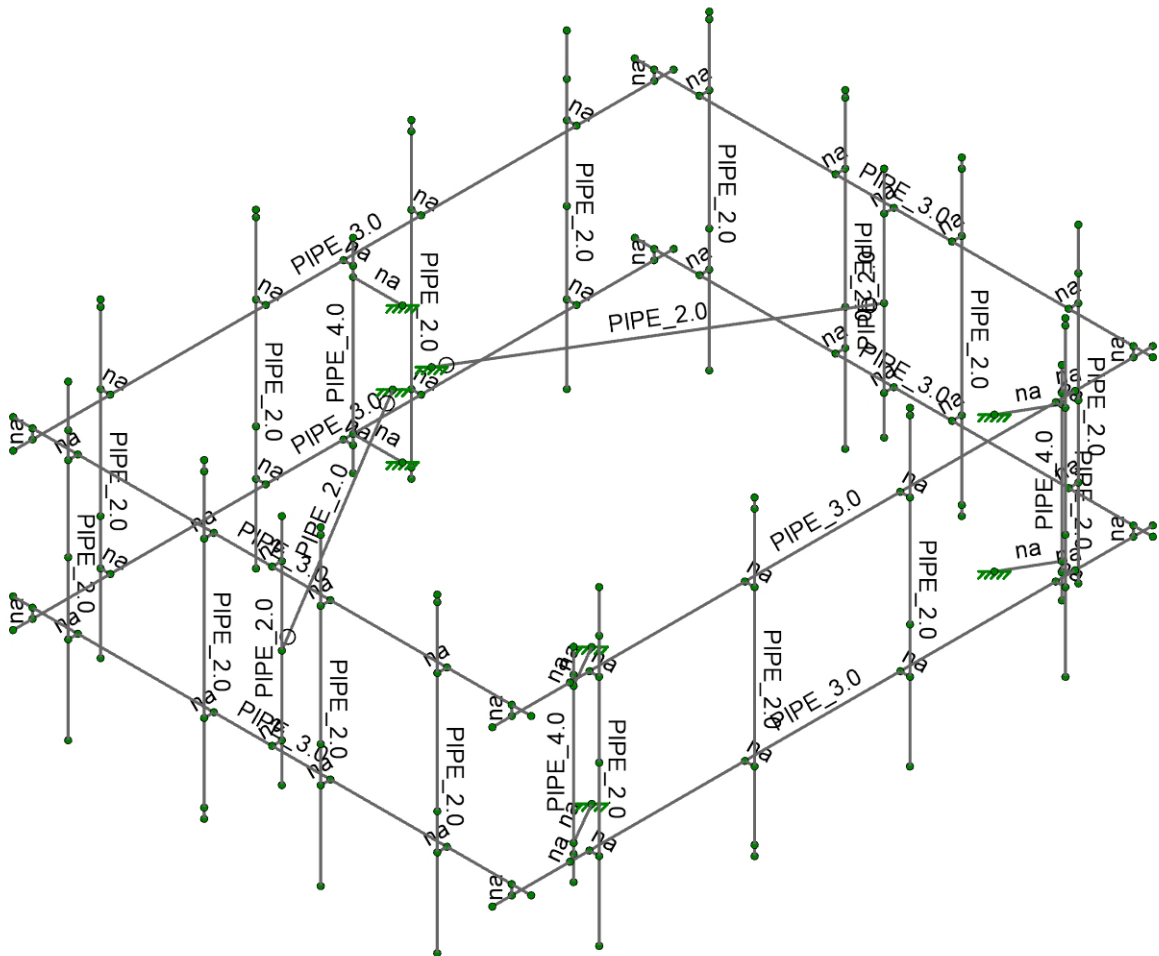
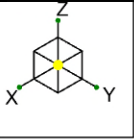

Envelope Only Solution

T-Mobile / EFI Global Inc

GHK

049.00427 - 2075022

CTHA174A

SK-1

Jun 15, 2020

CTHA174A Mount G-Code with Se...

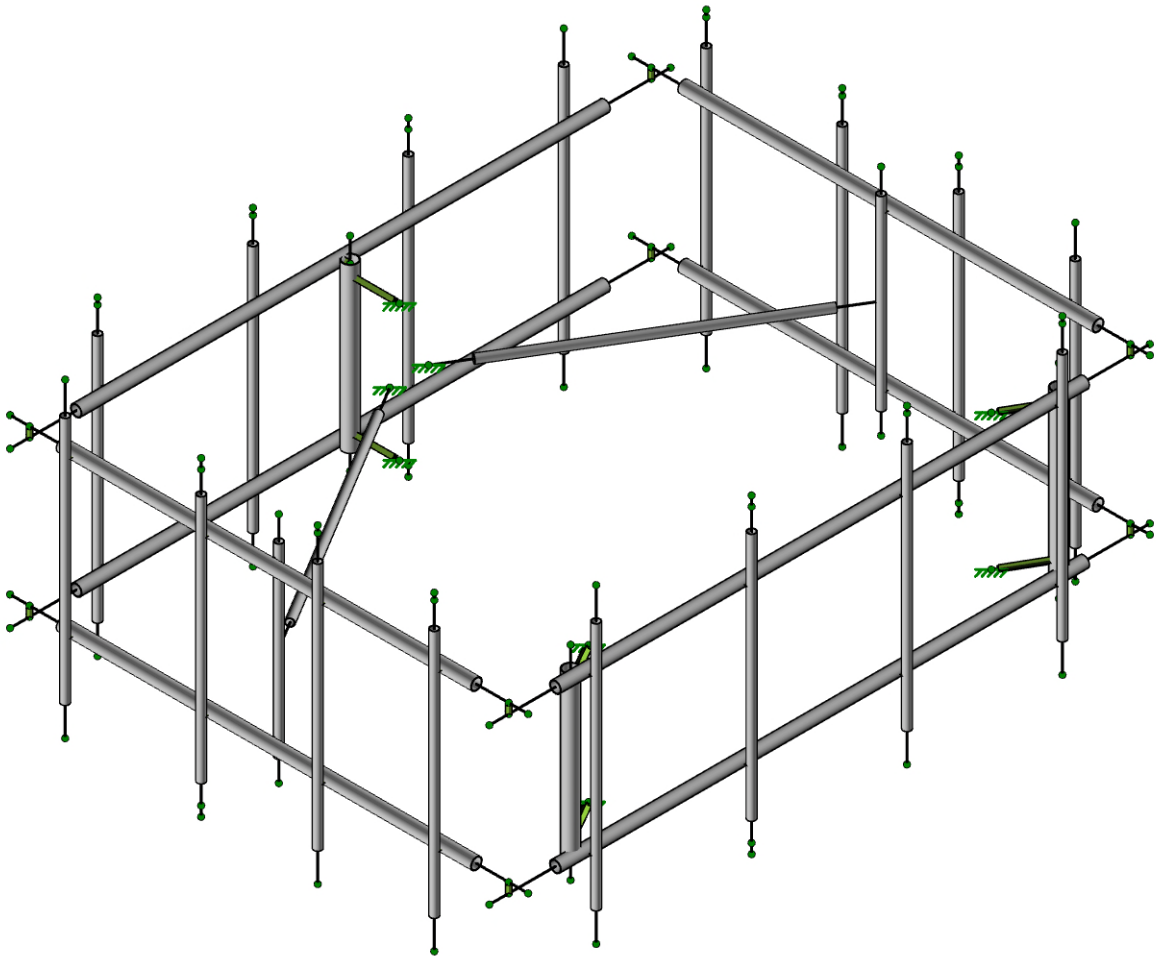
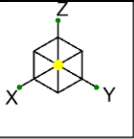

Envelope Only Solution

T-Mobile / EFI Global Inc

GHK

049.00427 - 2075022

CTHA174A

SK-3

Jun 15, 2020

CTHA174A Mount G-Code with Se...

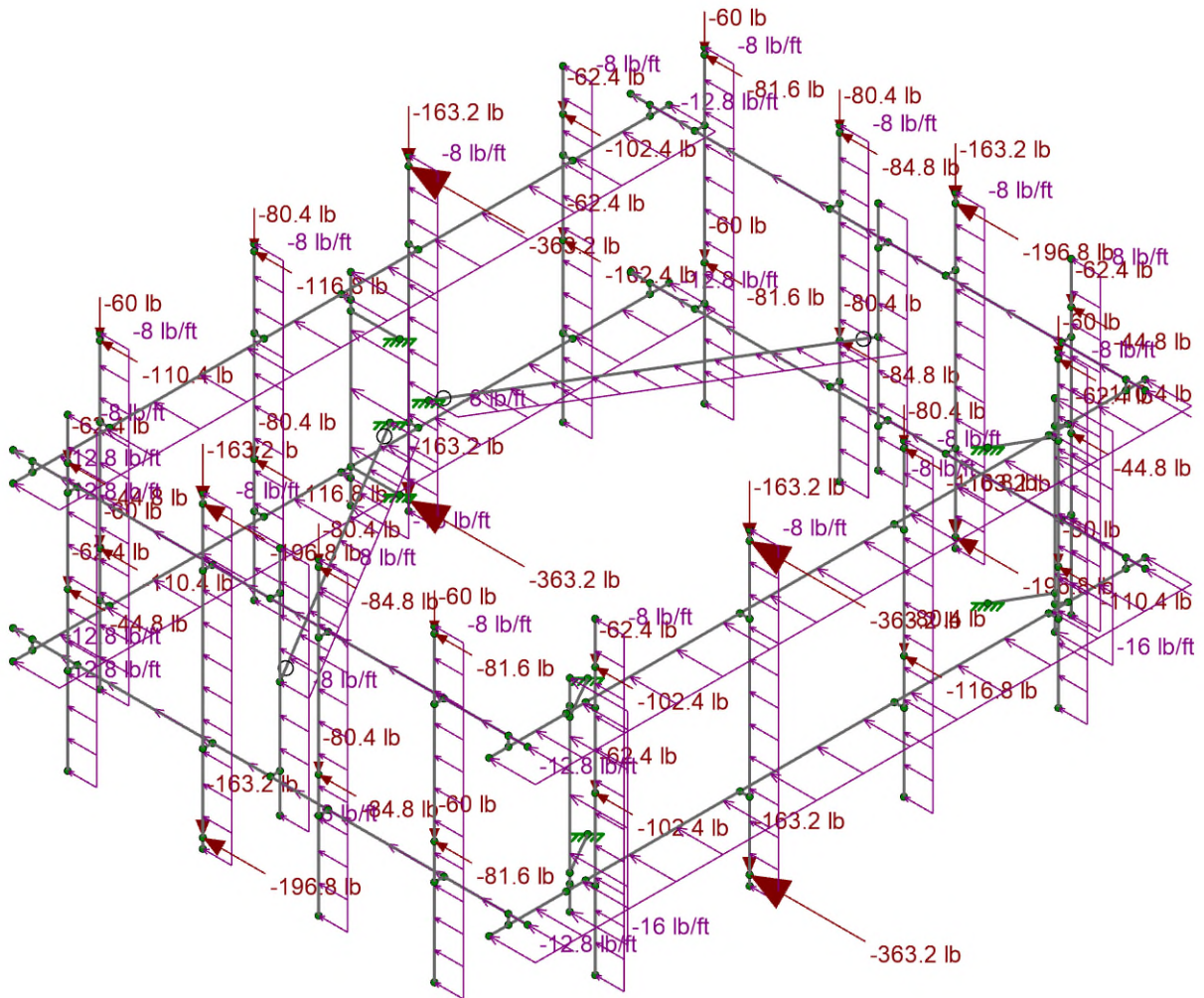

Loads: LC 1, DL + WL (NO ICE) 0 Degree
Envelope Only Solution

T-Mobile / EFI Global Inc

CTHA174A

SK-4

GHK

Jun 15, 2020

049.00427 - 2075022

CTHA174A Mount G-Code with Se...

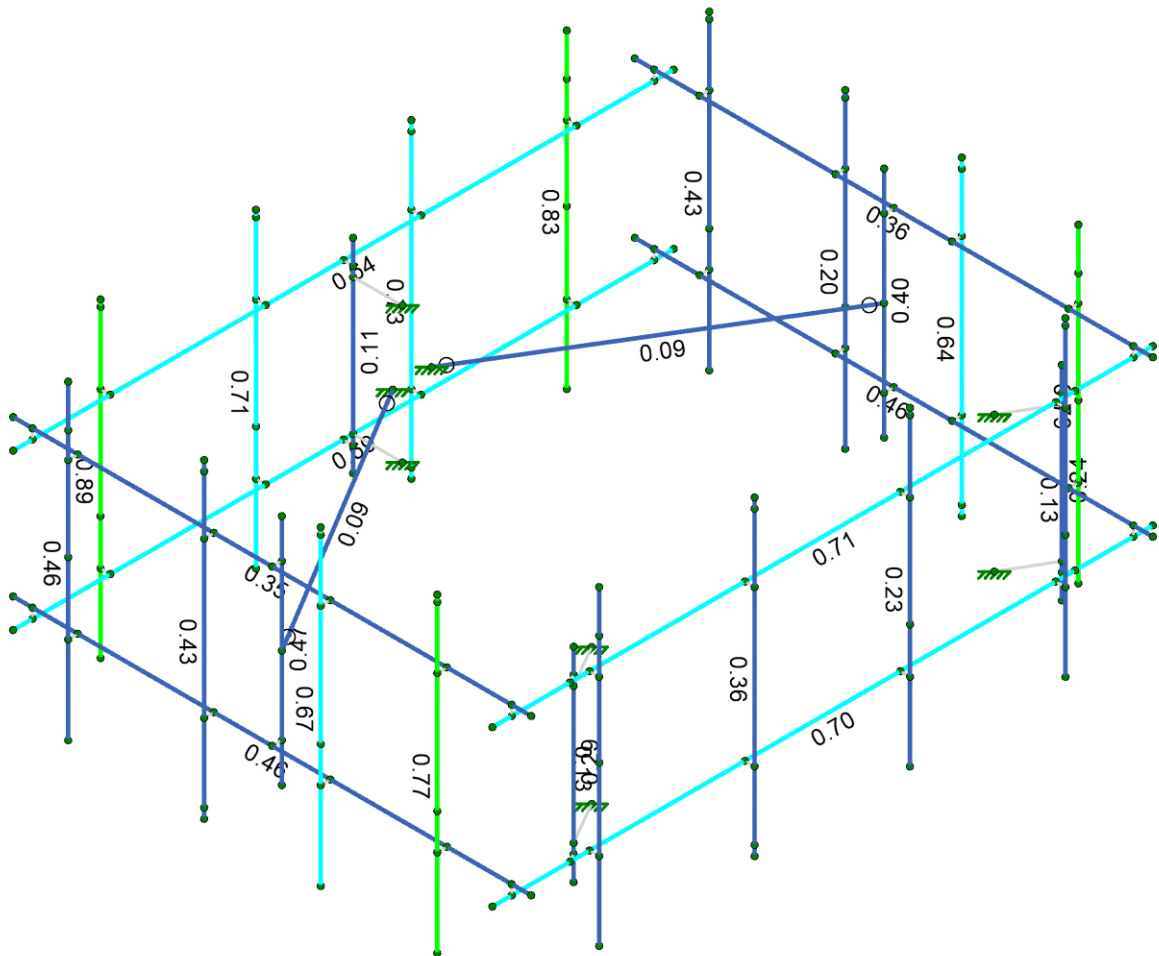
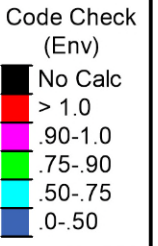
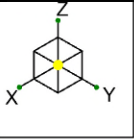

Member Code Checks Displayed (Enveloped)
Envelope Only Solution

T-Mobile / EFI Global Inc

GHK

049.00427 - 2075022

CTHA174A

SK-5

Jun 15, 2020

CTHA174A Mount G-Code with Se...

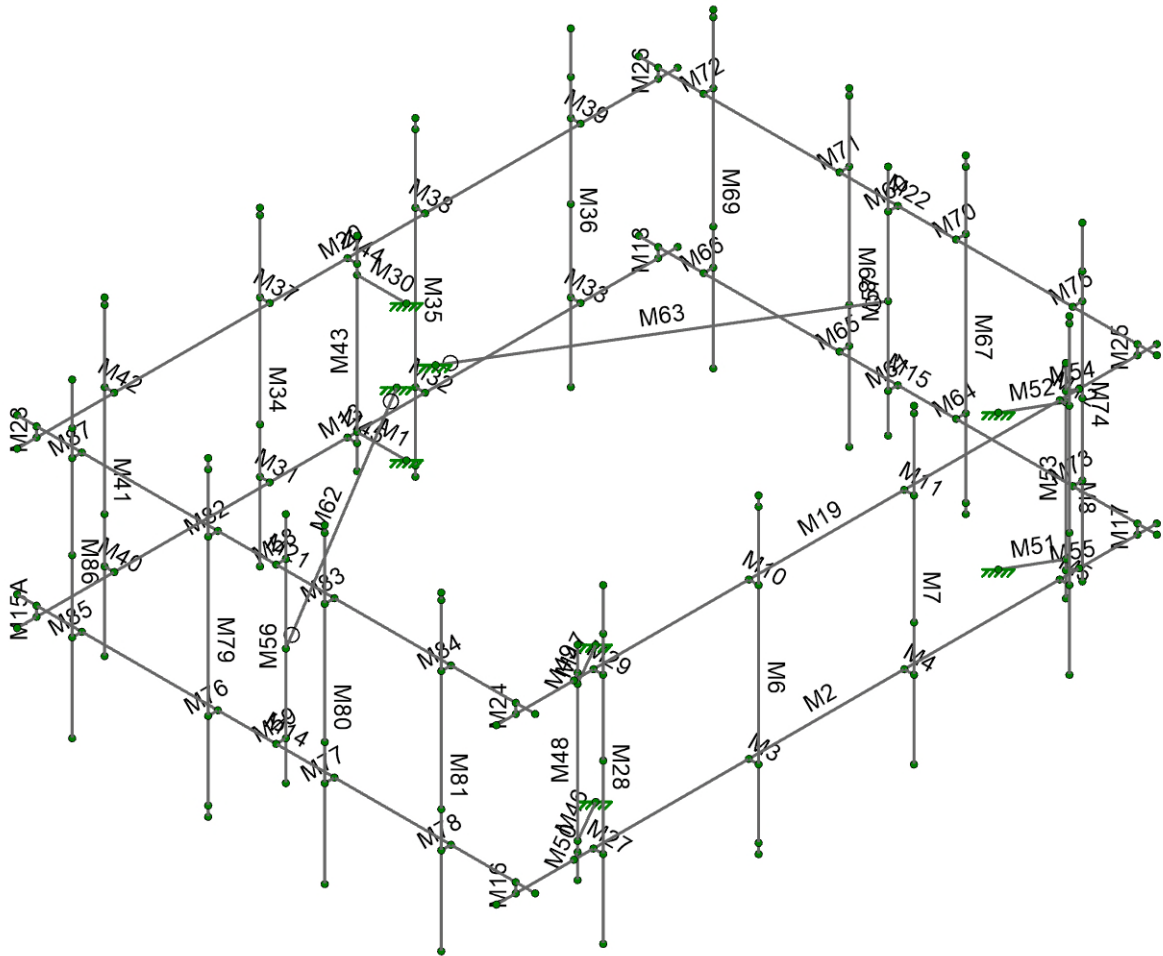
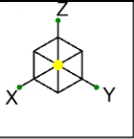

Envelope Only Solution

T-Mobile / EFI Global Inc

GHK

049.00427 - 2075022

CTHA174A

SK-7

Jun 15, 2020

CTHA174A Mount G-Code with Se...

Hot Rolled Steel Properties

	Label	E [ksi]	G [ksi]	Nu	Therm. C...	Density [k...	Yield [ksi]	Ry	Fu [ksi]	Rt
1	A36 Gr.36	29000	11154	0.3	0.65	0.49	36	1.5	58	1.2
2	A572 Gr.50	29000	11154	0.3	0.65	0.49	50	1.1	65	1.2
3	A992	29000	11154	0.3	0.65	0.49	50	1.1	65	1.2
4	A500 Gr.42	29000	11154	0.3	0.65	0.49	42	1.3	58	1.1
5	A500 Gr.46	29000	11154	0.3	0.65	0.49	46	1.2	58	1.1
6	A53 Gr.B	29000	11154	0.3	0.65	0.49	35	1.5	60	1.2
7	A529 Gr.50	29000	11154	0.3	0.65	0.49	50	1.1	65	1.2

Cold Formed Steel Properties

	Label	E [ksi]	G [ksi]	Nu	Therm. Coeff...	Density [k/ft³]	Yield [ksi]	Fu [ksi]
1	A570 33	29500	11346	0.3	0.65	0.49	33	52
2	A607 C1 55	29500	11346	0.3	0.65	0.49	55	70

Hot Rolled Steel Section Sets

	Label	Shape	Type	Design List	Material	Design Rule	Area [in²]	Iyy [in⁴]	Izz [in⁴]	J [in⁴]
1	Standoff T...	HSS4X4X4	Beam	None	A500 Gr.46	Typical	3.37	7.8	7.8	12.8
2	Face Pipe...	PIPE_3.0	Beam	None	A53 Gr.B	Typical	2.07	2.85	2.85	5.69
3	Antenna...	PIPE_2.5	Column	None	A53 Gr.B	Typical	1.61	1.45	1.45	2.89
4	Pipe Rail	PIPE_2.5	Beam	None	A53 Gr.B	Typical	1.61	1.45	1.45	2.89
5	Pipe Rail...	PIPE_2.5	VBrace	None	A53 Gr.B	Typical	1.61	1.45	1.45	2.89

Cold Formed Steel Section Sets

	Label	Shape	Type	Design List	Material	Design Rule	Area [in²]	Iyy [in⁴]	Izz [in⁴]	J [in⁴]
1	CF1A	1.5CU1.2...	Beam	CU	A570_33	Typical	0.131	0.022	0.052	5.4e-05

General Section Sets

	Label	Shape	Type	Material	Area [in²]	Iyy [in⁴]	Izz [in⁴]	J [in⁴]
1	GEN1A	RE4X4	Beam	gen_Conc3NW	16	21.333	21.333	31.573
2	RIGID		None	LINK	1e+06	1e+06	1e+06	1e+06

Primary Member Properties

	Label	I Node	J Node	K Node	Rotate(deg)	Section/S...	Type	Design List	Material	Design Rule
1	M1	N2	N1			RIGID	None	None	LINK	Typical
2	M3	N4	N11			RIGID	None	None	LINK	Typical
3	M4	N5	N12			RIGID	None	None	LINK	Typical
4	M5	N6	N13			RIGID	None	None	LINK	Typical
5	M10	N17	N20			RIGID	None	None	LINK	Typical
6	M11	N18	N21			RIGID	None	None	LINK	Typical
7	M12	N19	N22			RIGID	None	None	LINK	Typical
8	M15A	N30	N36			RIGID	None	None	LINK	Typical
9	M16	N24	N34			RIGID	None	None	LINK	Typical
10	M17	N23	N33			RIGID	None	None	LINK	Typical
11	M18	N29	N35			RIGID	None	None	LINK	Typical
12	M23	N46	N52			RIGID	None	None	LINK	Typical
13	M24	N40	N50			RIGID	None	None	LINK	Typical
14	M25	N39	N49			RIGID	None	None	LINK	Typical
15	M26	N45	N51			RIGID	None	None	LINK	Typical
16	M27	N53	N55			RIGID	None	None	LINK	Typical
17	M29	N57	N58			RIGID	None	None	LINK	Typical
18	M30	N60	N59			RIGID	None	None	LINK	Typical
19	M31	N61	N67			RIGID	None	None	LINK	Typical
20	M32	N62	N68			RIGID	None	None	LINK	Typical
21	M33	N63	N69			RIGID	None	None	LINK	Typical
22	M37	N73	N76			RIGID	None	None	LINK	Typical
23	M38	N74	N77			RIGID	None	None	LINK	Typical
24	M39	N75	N78			RIGID	None	None	LINK	Typical

Primary Member Properties (Continued)

	Label	I Node	J Node	K Node	Rotate(deg)	Section/S...	Type	Design List	Material	Design Rule
25	M40	N79	N81			RIGID	None	None	LINK	Typical
26	M42	N83	N84			RIGID	None	None	LINK	Typical
27	M44	N87	N89			RIGID	None	None	LINK	Typical
28	M45	N88	N90			RIGID	None	None	LINK	Typical
29	M46	N92	N91			RIGID	None	None	LINK	Typical
30	M47	N94	N93			RIGID	None	None	LINK	Typical
31	M49	N97	N99			RIGID	None	None	LINK	Typical
32	M50	N98	N100			RIGID	None	None	LINK	Typical
33	M51	N102	N101			RIGID	None	None	LINK	Typical
34	M52	N104	N103			RIGID	None	None	LINK	Typical
35	M54	N107	N109			RIGID	None	None	LINK	Typical
36	M55	N108	N110			RIGID	None	None	LINK	Typical
37	M58	N116	N114			RIGID	None	None	LINK	Typical
38	M59	N115	N112			RIGID	None	None	LINK	Typical
39	M60	N113	N118			RIGID	None	None	LINK	Typical
40	M61	N111	N117			RIGID	None	None	LINK	Typical
41	M64	N127	N133			RIGID	None	None	LINK	Typical
42	M65	N128	N134			RIGID	None	None	LINK	Typical
43	M66	N129	N135			RIGID	None	None	LINK	Typical
44	M70	N139	N142			RIGID	None	None	LINK	Typical
45	M71	N140	N143			RIGID	None	None	LINK	Typical
46	M72	N141	N144			RIGID	None	None	LINK	Typical
47	M73	N145	N147			RIGID	None	None	LINK	Typical
48	M75	N149	N150			RIGID	None	None	LINK	Typical
49	M76	N151	N157			RIGID	None	None	LINK	Typical
50	M77	N152	N158			RIGID	None	None	LINK	Typical
51	M78	N153	N159			RIGID	None	None	LINK	Typical
52	M82	N163	N166			RIGID	None	None	LINK	Typical
53	M83	N164	N167			RIGID	None	None	LINK	Typical
54	M84	N165	N168			RIGID	None	None	LINK	Typical
55	M85	N169	N171			RIGID	None	None	LINK	Typical
56	M87	N173	N174			RIGID	None	None	LINK	Typical
57	M43	N86	N85			PIPE 4.0	Beam	Wide Flan...	A53 Gr.B	Typical
58	M48	N96	N95			PIPE 4.0	Beam	Wide Flan...	A53 Gr.B	Typical
59	M53	N106	N105			PIPE 4.0	Beam	Wide Flan...	A53 Gr.B	Typical
60	M2	N3	N7			PIPE 3.0	Beam	Wide Flan...	A53 Gr.B	Typical
61	M13	N31	N32			PIPE 3.0	Beam	Wide Flan...	A53 Gr.B	Typical
62	M14	N28	N26			PIPE 3.0	Beam	Wide Flan...	A53 Gr.B	Typical
63	M15	N27	N25			PIPE 3.0	Beam	Wide Flan...	A53 Gr.B	Typical
64	M19	N37	N38			PIPE 3.0	Beam	Wide Flan...	A53 Gr.B	Typical
65	M20	N47	N48			PIPE 3.0	Beam	Wide Flan...	A53 Gr.B	Typical
66	M21	N44	N42			PIPE 3.0	Beam	Wide Flan...	A53 Gr.B	Typical
67	M22	N43	N41			PIPE 3.0	Beam	Wide Flan...	A53 Gr.B	Typical
68	M6	N8	N14			PIPE 2.0	Beam	None	A53 Gr.B	Typical
69	M7	N9	N15			PIPE 2.0	Beam	None	A53 Gr.B	Typical
70	M8	N10	N16			PIPE 2.0	Beam	None	A53 Gr.B	Typical
71	M28	N54	N56			PIPE 2.0	Beam	None	A53 Gr.B	Typical
72	M34	N64	N70			PIPE 2.0	Beam	None	A53 Gr.B	Typical
73	M35	N65	N71			PIPE 2.0	Beam	None	A53 Gr.B	Typical
74	M36	N66	N72			PIPE 2.0	Beam	None	A53 Gr.B	Typical
75	M41	N80	N82			PIPE 2.0	Beam	None	A53 Gr.B	Typical
76	M56	N121	N119			PIPE 2.0	Beam	Wide Flan...	A53 Gr.B	Typical
77	M57	N122	N120			PIPE 2.0	Beam	Wide Flan...	A53 Gr.B	Typical
78	M62	N125	N124			PIPE 2.0	Beam	Wide Flan...	A53 Gr.B	Typical
79	M63	N123	N126			PIPE 2.0	Beam	Wide Flan...	A53 Gr.B	Typical
80	M67	N130	N136			PIPE 2.0	Beam	None	A53 Gr.B	Typical
81	M68	N131	N137			PIPE 2.0	Beam	None	A53 Gr.B	Typical
82	M69	N132	N138			PIPE 2.0	Beam	None	A53 Gr.B	Typical

Primary Member Properties (Continued)

	Label	I Node	J Node	K Node	Rotate(deg)	Section/S...	Type	Design List	Material	Design Rule
83	M74	N146	N148			PIPE 2.0	Beam	None	A53 Gr.B	Typical
84	M79	N154	N160			PIPE 2.0	Beam	None	A53 Gr.B	Typical
85	M80	N155	N161			PIPE 2.0	Beam	None	A53 Gr.B	Typical
86	M81	N156	N162			PIPE 2.0	Beam	None	A53 Gr.B	Typical
87	M86	N170	N172			PIPE 2.0	Beam	None	A53 Gr.B	Typical

Advanced Member Properties

	Label	I Release	J Release	I Offset [in]	J Offset [in]	T/C Only	Physical	Deflectio...	Analysis...	Activation	Seismic...
1	M1						Yes	** NA **			None
2	M3						Yes	** NA **			None
3	M4						Yes	** NA **			None
4	M5						Yes	** NA **			None
5	M10						Yes	** NA **			None
6	M11						Yes	** NA **			None
7	M12						Yes	** NA **			None
8	M15A						Yes	** NA **			None
9	M16						Yes	** NA **			None
10	M17						Yes	** NA **			None
11	M18						Yes	** NA **			None
12	M23						Yes	** NA **			None
13	M24						Yes	** NA **			None
14	M25						Yes	** NA **			None
15	M26						Yes	** NA **			None
16	M27						Yes	** NA **			None
17	M29						Yes	** NA **			None
18	M30						Yes	** NA **			None
19	M31						Yes	** NA **			None
20	M32						Yes	** NA **			None
21	M33						Yes	** NA **			None
22	M37						Yes	** NA **			None
23	M38						Yes	** NA **			None
24	M39						Yes	** NA **			None
25	M40						Yes	** NA **			None
26	M42						Yes	** NA **			None
27	M44						Yes	** NA **			None
28	M45						Yes	** NA **			None
29	M46						Yes	** NA **			None
30	M47						Yes	** NA **			None
31	M49						Yes	** NA **			None
32	M50						Yes	** NA **			None
33	M51						Yes	** NA **			None
34	M52						Yes	** NA **			None
35	M54						Yes	** NA **			None
36	M55						Yes	** NA **			None
37	M58						Yes	** NA **			None
38	M59						Yes	** NA **			None
39	M60						Yes	** NA **			None
40	M61						Yes	** NA **			None
41	M64						Yes	** NA **			None
42	M65						Yes	** NA **			None
43	M66						Yes	** NA **			None
44	M70						Yes	** NA **			None
45	M71						Yes	** NA **			None
46	M72						Yes	** NA **			None
47	M73						Yes	** NA **			None
48	M75						Yes	** NA **			None
49	M76						Yes	** NA **			None
50	M77						Yes	** NA **			None

Advanced Member Properties (Continued)

	Label	I Release	J Release	I Offset [in]	J Offset [in]	T/C Only	Physical	Deflectio...	Analysis...	Activation	Seismic...
51	M78						Yes	** NA **			None
52	M82						Yes	** NA **			None
53	M83						Yes	** NA **			None
54	M84						Yes	** NA **			None
55	M85						Yes	** NA **			None
56	M87						Yes	** NA **			None
57	M43						Yes				None
58	M48						Yes				None
59	M53						Yes				None
60	M2						Yes				None
61	M13						Yes				None
62	M14						Yes				None
63	M15						Yes				None
64	M19						Yes				None
65	M20						Yes				None
66	M21						Yes				None
67	M22						Yes				None
68	M6						Yes				None
69	M7						Yes				None
70	M8						Yes				None
71	M28						Yes				None
72	M34						Yes				None
73	M35						Yes				None
74	M36						Yes				None
75	M41						Yes				None
76	M56						Yes				None
77	M57						Yes				None
78	M62	BenPIN	BenPIN				Yes				None
79	M63	BenPIN	BenPIN				Yes				None
80	M67						Yes				None
81	M68						Yes				None
82	M69						Yes				None
83	M74						Yes				None
84	M79						Yes				None
85	M80						Yes				None
86	M81						Yes				None
87	M86						Yes				None

Hot Rolled Member Properties

	Label	Shape	Length [in]	Lb y-y [in]	Lb z-z [in]	Lcomp t...	Lcomp...	L-Torqu...	K y-y	K z-z	Cb	Function
1	M43	PIPE_4.0	63			Lbyy						Lateral
2	M48	PIPE_4.0	63			Lbyy						Lateral
3	M53	PIPE_4.0	63			Lbyy						Lateral
4	M2	PIPE_3.0	204			Lbyy						Lateral
5	M13	PIPE_3.0	204			Lbyy						Lateral
6	M14	PIPE_3.0	160			Lbyy						Lateral
7	M15	PIPE_3.0	160			Lbyy						Lateral
8	M19	PIPE_3.0	204			Lbyy						Lateral
9	M20	PIPE_3.0	204			Lbyy						Lateral
10	M21	PIPE_3.0	160			Lbyy						Lateral
11	M22	PIPE_3.0	160			Lbyy						Lateral
12	M6	PIPE_2.0	96									Lateral
13	M7	PIPE_2.0	96									Lateral
14	M8	PIPE_2.0	96									Lateral
15	M28	PIPE_2.0	96									Lateral
16	M34	PIPE_2.0	96									Lateral
17	M35	PIPE_2.0	96									Lateral
18	M36	PIPE_2.0	96									Lateral

Hot Rolled Member Properties (Continued)

Label	Shape	Length [in]	Lb y-y [in]	Lb z-z [in]	Lcomp t...	Lcomp...	L-Torqu...	K y-y	K z-z	Cb	Function
19	M41	PIPE 2.0	96								Lateral
20	M56	PIPE 2.0	72			Lbyy					Lateral
21	M57	PIPE 2.0	72			Lbyy					Lateral
22	M62	PIPE 2.0	101.743			Lbyy					Lateral
23	M63	PIPE 2.0	101.743			Lbyy					Lateral
24	M67	PIPE 2.0	96								Lateral
25	M68	PIPE 2.0	96								Lateral
26	M69	PIPE 2.0	96								Lateral
27	M74	PIPE 2.0	96								Lateral
28	M79	PIPE 2.0	96								Lateral
29	M80	PIPE 2.0	96								Lateral
30	M81	PIPE 2.0	96								Lateral
31	M86	PIPE 2.0	96								Lateral

Cold Formed Member Properties

No Data to Print...											
---------------------	--	--	--	--	--	--	--	--	--	--	--

Nodes

	Label	X [in]	Y [in]	Z [in]	Temp [deg F]	Detach From Dia...
1	N1	0	-109	3		
2	N2	0	-93.75	3		
3	N3	102	36	0		
4	N4	24	36	0		
5	N5	-24	36	0		
6	N6	-72	36	0		
7	N7	-102	36	0		
8	N8	24	39	72		
9	N9	-24	39	72		
10	N10	-72	39	72		
11	N11	24	39	0		
12	N12	-24	39	0		
13	N13	-72	39	0		
14	N14	24	39	-24		
15	N15	-24	39	-24		
16	N16	-72	39	-24		
17	N17	24	36	48		
18	N18	-24	36	48		
19	N19	-72	36	48		
20	N20	24	39	48		
21	N21	-24	39	48		
22	N22	-72	39	48		
23	N23	-96	36	0		
24	N24	96	36	0		
25	N25	-96	42	3		
26	N26	96	42	3		
27	N27	-96	-118	3		
28	N28	96	-118	3		
29	N29	-96	-112	0		
30	N30	96	-112	0		
31	N31	102	-112	0		
32	N32	-102	-112	0		
33	N33	-96	36	3		
34	N34	96	36	3		
35	N35	-96	-112	3		
36	N36	96	-112	3		
37	N37	102	36	48		
38	N38	-102	36	48		



Nodes (Continued)

	Label	X [in]	Y [in]	Z [in]	Temp [deg F]	Detach From Dia...
39	N39	-96	36	48		
40	N40	96	36	48		
41	N41	-96	42	51		
42	N42	96	42	51		
43	N43	-96	-118	51		
44	N44	96	-118	51		
45	N45	-96	-112	48		
46	N46	96	-112	48		
47	N47	102	-112	48		
48	N48	-102	-112	48		
49	N49	-96	36	51		
50	N50	96	36	51		
51	N51	-96	-112	51		
52	N52	96	-112	51		
53	N53	72	36	0		
54	N54	72	39	72		
55	N55	72	39	0		
56	N56	72	39	-24		
57	N57	72	36	48		
58	N58	72	39	48		
59	N59	0	-109	45		
60	N60	0	-93.75	45		
61	N61	24	-112	0		
62	N62	-24	-112	0		
63	N63	-72	-112	0		
64	N64	24	-115	72		
65	N65	-24	-115	72		
66	N66	-72	-115	72		
67	N67	24	-115	0		
68	N68	-24	-115	0		
69	N69	-72	-115	0		
70	N70	24	-115	-24		
71	N71	-24	-115	-24		
72	N72	-72	-115	-24		
73	N73	24	-112	48		
74	N74	-24	-112	48		
75	N75	-72	-112	48		
76	N76	24	-115	48		
77	N77	-24	-115	48		
78	N78	-72	-115	48		
79	N79	72	-112	0		
80	N80	72	-115	72		
81	N81	72	-115	0		
82	N82	72	-115	-24		
83	N83	72	-112	48		
84	N84	72	-115	48		
85	N85	0	-109	55.5		
86	N86	0	-109	-7.5		
87	N87	0	-109	48		
88	N88	0	-109	0		
89	N89	0	-112	48		
90	N90	0	-112	0		
91	N91	75.401887	34.5	3		
92	N92	62.195	26.875	3		
93	N93	75.401887	34.5	45		
94	N94	62.195	26.875	45		
95	N95	75.401887	34.5	55.5		
96	N96	75.401887	34.5	-7.5		

Nodes (Continued)

	Label	X [in]	Y [in]	Z [in]	Temp [deg F]	Detach From Dia...
97	N97	75.401887	34.5	48		
98	N98	75.401887	34.5	0		
99	N99	77.999964	36	48		
100	N100	77.999964	36	0		
101	N101	-75.401887	34.5	3		
102	N102	-62.195	26.875	3		
103	N103	-75.401887	34.5	45		
104	N104	-62.195	26.875	45		
105	N105	-75.401887	34.5	55.5		
106	N106	-75.401887	34.5	-7.5		
107	N107	-75.401887	34.5	48		
108	N108	-75.401887	34.5	0		
109	N109	-77.999964	36	48		
110	N110	-77.999964	36	0		
111	N111	-96	-38	3		
112	N112	96	-38	3		
113	N113	-96	-38	51		
114	N114	96	-38	51		
115	N115	93	-38	3		
116	N116	93	-38	51		
117	N117	-93	-38	3		
118	N118	-93	-38	51		
119	N119	93	-38	63		
120	N120	-93	-38	63		
121	N121	93	-38	-9		
122	N122	-93	-38	-9		
123	N123	-6	-90.75	27		
124	N124	6	-90.75	27		
125	N125	93	-38	27		
126	N126	-93	-38	27		
127	N127	-96	-20	3		
128	N128	-96	-56	3		
129	N129	-96	-98	3		
130	N130	-99	-20	72		
131	N131	-99	-56	72		
132	N132	-99	-98	72		
133	N133	-99	-20	3		
134	N134	-99	-56	3		
135	N135	-99	-98	3		
136	N136	-99	-20	-24		
137	N137	-99	-56	-24		
138	N138	-99	-98	-24		
139	N139	-96	-20	51		
140	N140	-96	-56	51		
141	N141	-96	-98	51		
142	N142	-99	-20	51		
143	N143	-99	-56	51		
144	N144	-99	-98	51		
145	N145	-96	16	3		
146	N146	-99	16	72		
147	N147	-99	16	3		
148	N148	-99	16	-24		
149	N149	-96	16	51		
150	N150	-99	16	51		
151	N151	96	-56	3		
152	N152	96	-20	3		
153	N153	96	16	3		
154	N154	99	-56	72		

Nodes (Continued)

	Label	X [in]	Y [in]	Z [in]	Temp [deg F]	Detach From Dia...
155	N155	99	-20	72		
156	N156	99	16	72		
157	N157	99	-56	3		
158	N158	99	-20	3		
159	N159	99	16	3		
160	N160	99	-56	-24		
161	N161	99	-20	-24		
162	N162	99	16	-24		
163	N163	96	-56	51		
164	N164	96	-20	51		
165	N165	96	16	51		
166	N166	99	-56	51		
167	N167	99	-20	51		
168	N168	99	16	51		
169	N169	96	-98	3		
170	N170	99	-98	72		
171	N171	99	-98	3		
172	N172	99	-98	-24		
173	N173	96	-98	51		
174	N174	99	-98	51		
175	N175	-72	39	70		
176	N176	72	-115	70		
177	N177	-99	-98	70		
178	N178	99	16	70		
179	N179	-72	39	14		
180	N180	72	-115	14		
181	N181	-99	-98	14		
182	N182	99	16	14		
183	N183	-24	39	70		
184	N184	24	-115	70		
185	N185	-99	-56	70		
186	N186	99	-20	70		
187	N187	-24	39	14		
188	N188	24	-115	14		
189	N189	-99	-56	14		
190	N190	99	-20	14		
191	N191	24	39	69		
192	N192	-24	-115	69		
193	N193	-99	-20	69		
194	N194	99	-56	69		
195	N195	24	39	-21		
196	N196	-24	-115	-21		
197	N197	-99	-20	-21		
198	N198	99	-56	-21		
199	N199	72	39	59		
200	N200	-72	-115	59		
201	N201	-99	16	59		
202	N202	99	-98	59		
203	N203	72	39	25		
204	N204	-72	-115	25		
205	N205	-99	16	25		
206	N206	99	-98	25		

Boundary Conditions

	Node Label	X [k/in]	Y [k/in]	Z [k/in]	X Rot [k-ft/rad]	Y Rot [k-ft/rad]	Z Rot [k-ft/rad]
1	N2	Reaction	Reaction	Reaction	Reaction	Reaction	Reaction
2	N60	Reaction	Reaction	Reaction	Reaction	Reaction	Reaction
3	N92	Reaction	Reaction	Reaction	Reaction	Reaction	Reaction

Boundary Conditions (Continued)

	Node Label	X [k/in]	Y [k/in]	Z [k/in]	X Rot [k-ft/rad]	Y Rot [k-ft/rad]	Z Rot [k-ft/rad]
4	N94	Reaction	Reaction	Reaction	Reaction	Reaction	Reaction
5	N102	Reaction	Reaction	Reaction	Reaction	Reaction	Reaction
6	N104	Reaction	Reaction	Reaction	Reaction	Reaction	Reaction
7	N123	Reaction	Reaction	Reaction	Reaction	Reaction	Reaction
8	N124	Reaction	Reaction	Reaction	Reaction	Reaction	Reaction

Basic Load Cases

	BLC Desc...	Category	X Gravity	Y Gravity	Z Gravity	Nodal	Point	Distributed	Area(Me...	Surface(P...
1	DEAD LO...	None			-1	32				
2	DEAD LO...	None				32		31		
3	WIND LO...	None				32		31		
4	WIND LO...	None				32		31		
5	WIND LO...	None				32		31		
6	WIND LO...	None				32		31		
7	LIVE LOA...	None				1				
8	LIVE LOA...	None				1				
9	LIVE LOA...	None								
10	MAINTEN...	None				1				
11	MAINTEN...	None				1				
12	MAINTEN...	None				1				
13	MAINTEN...	None				1				

Load Combinations

	De...	So...	PD...	SR...	BLC Fa...	BLC Fa...	BLC Fa...	BLC Fa...	BLC Fa...	BLC Fa...	BLC Fa...	BLC Fa...	BLC Fa...	BLC Fa...
1	DL...	Yes	Y		1	1.2		3	1.6					
2	DL...	Yes	Y		1	1.2		3	1.3...	4	0.8			
3	DL...	Yes	Y		1	1.2		3	0.8	4	1.3...			
4	DL...	Yes	Y		1	1.2				4	1.6			
5	DL...	Yes	Y		1	1.2		3	-0.8	4	1.3...			
6	DL...	Yes	Y		1	1.2		3	-1...	4	0.8			
7	DL...	Yes	Y		1	1.2		3	-1.6					
8	DL...	Yes	Y		1	1.2		3	-1...	4	-0.8			
9	DL...	Yes	Y		1	1.2		3	-0.8	4	-1...			
10	DL...	Yes	Y		1	1.2				4	-1.6			
11	DL...	Yes	Y		1	1.2		3	0.8	4	-1...			
12	DL...	Yes	Y		1	1.2		3	1.3...	4	-0.8			
13	DL...	Yes	Y		1	1.2	2	1	5	1				
14	DL...	Yes	Y		1	1.2	2	1	5	0.8...	6	0.5		
15	DL...	Yes	Y		1	1.2	2	1	5	0.5	6	0.8...		
16	DL...	Yes	Y		1	1.2	2	1		6	1			
17	DL...	Yes	Y		1	1.2	2	1	5	-0.5	6	0.8...		
18	DL...	Yes	Y		1	1.2	2	1	5	-0...	6	0.5		
19	DL...	Yes	Y		1	1.2	2	1	5	-1				
20	DL...	Yes	Y		1	1.2	2	1	5	-0...	6	-0.5		
21	DL...	Yes	Y		1	1.2	2	1	5	-0.5	6	-0...		
22	DL...	Yes	Y		1	1.2	2	1		6	-1			
23	DL...	Yes	Y		1	1.2	2	1	5	0.5	6	-0...		
24	DL...	Yes	Y		1	1.2	2	1	5	0.8...	6	-0.5		
25	DE...	Yes	Y		1	1.2				7	1.5			
26	DE...	Yes	Y		1	1.2				8	1.5			
27	DE...	Yes	Y		1	1.2				9	1.5			
28	DL...	Yes	Y		1	1.2	10	1.5	3	0.0...				
29	DL...	Yes	Y		1	1.2	11	1.5	3	0.0...				
30	DL...	Yes	Y		1	1.2	12	1.5	3	0.0...				
31	DL...	Yes	Y		1	1.2	13	1.5	3	0.0...				
32	DL...	Yes	Y		1	1.2	10	1.5	4	0.0...				
33	DL...	Yes	Y		1	1.2	11	1.5	4	0.0...				

Load Combinations (Continued)

De...	So...	PD...	SR...	BLC Fa...	BLC Fa...	BLC Fa...	BLC Fa...	BLC Fa...	BLC Fa...	BLC Fa...	BLC Fa...	BLC Fa...	BLC Fa...	BLC Fa...	BLC Fa...
34	DL...	Yes	Y	1	1.2	12	1.5	4	0.0...						
35	DL...	Yes	Y	1	1.2	13	1.5	4	0.0...						
36	DL...	Yes	Y	1	1.2	10	1.5	3	-0....						
37	DL...	Yes	Y	1	1.2	11	1.5	3	-0....						
38	DL...	Yes	Y	1	1.2	12	1.5	3	-0....						
39	DL...	Yes	Y	1	1.2	13	1.5	3	-0....						
40	DL...	Yes	Y	1	1.2	10	1.5	4	-0....						
41	DL...	Yes	Y	1	1.2	11	1.5	4	-0....						
42	DL...	Yes	Y	1	1.2	12	1.5	4	-0....						
43	DL...	Yes	Y	1	1.2	13	1.5	4	-0....						
44	DL...		Y	1	1	2	0.7	5	-0.7						

Node Reactions

Node...	X [lbs]	LC	Y [lbs]	LC	Z [lbs]	LC	MX [k-ft]	LC	MY [k-ft]	LC	MZ [k-ft]	LC		
1	N2	max	897.066	4	633.662	1	2934.4...	14	-1.136	11	0.304	23	1.603	4
2		min	-859.553	10	-667.092	7	660.007	8	-4.518	17	-0.067	6	-1.536	10
3	N60	max	1379.2...	4	829.021	1	2956.8...	20	-0.92	6	0.333	5	2.387	4
4		min	-1415....	10	-755.824	7	714.164	2	-4.657	24	-0.207	11	-2.45	10
5	N92	max	363.912	4	624.034	1	2525.3...	19	0.39	31	-0.802	2	0.313	12
6		min	-574.828	10	-2127....	19	430.505	1	-0.291	19	-3.476	19	-4.197	18
7	N94	max	748.401	4	2167.7...	13	2328.4...	13	0.322	6	-0.623	5	4.283	24
8		min	-575.668	10	-942.941	6	397.818	7	-0.826	24	-2.99	23	-0.862	6
9	N102	max	632.487	4	564.504	1	2452.4...	19	0.368	36	3.692	20	3.982	20
10		min	-420.847	10	-2020....	19	479.262	1	-0.357	17	0.863	1	-0.457	2
11	N104	max	629.309	4	2060.9...	13	2251.1...	13	0.272	7	3.258	15	0.946	8
12		min	-802.357	10	-877.65	8	436.744	7	-0.894	13	0.497	9	-4.055	14
13	N123	max	956.063	4	560.981	11	75.771	16	0	10	0.003	15	0	43
14		min	-938.16	10	-572.285	5	15.187	10	-0.005	15	0	10	0	1
15	N124	max	921.651	4	548.497	4	75.844	22	0.001	4	0	4	0	43
16		min	-941.269	10	-559.498	10	15.231	3	-0.003	23	-0.002	23	0	1
17	Totals:	max	6528.1...	4	6761.6...	1	15222....	24						
18		min	-6528....	10	-6761....	7	4797.7...	5						

Node Displacements

Node...	X [in]	LC	Y [in]	LC	Z [in]	LC	X Rota...	LC	Y Rota...	LC	Z Rota...	LC		
1	N1	max	0	10	0	7	0	12	0	18	0	6	0	11
2		min	0	4	0	1	0	18	0	12	0	23	0	5
3	N2	max	0	10	0	7	0	8	0	17	0	6	0	10
4		min	0	4	0	1	0	14	0	11	0	23	0	4
5	N3	max	0	10	0.055	19	-0.014	5	6.904e...	24	2.858e...	23	2.158e...	20
6		min	-0.001	16	-0.003	1	-0.058	23	1.538e...	5	7.025e...	5	-3.554...	2
7	N4	max	0	10	0.124	7	-0.047	2	2.512e...	7	-2.765...	4	1.932e...	1
8		min	0	4	-0.131	1	-0.185	20	-2.965...	1	-2.474...	22	-1.908...	7
9	N5	max	0	10	0.105	7	-0.045	2	7.413e...	7	2.71e-03	21	2.202e...	7
10		min	0	4	-0.112	1	-0.163	20	-1.098...	1	6.095e...	3	-2.232...	1
11	N6	max	0	21	0.003	7	0	2	1.912e...	16	1.082e...	20	6.746e...	7
12		min	0	33	-0.003	1	-0.003	37	-8.603...	40	2.574e...	2	-9.035...	1
13	N7	max	0.001	21	0.052	18	-0.016	33	7.078e...	14	-8.266...	4	5.585e...	12
14		min	0	3	-0.006	12	-0.06	23	1.553e...	9	-2.964...	23	-2.035...	18
15	N8	max	0.044	10	0.332	7	-0.054	3	8.9e-03	1	2.662e...	10	2.229e...	1
16		min	-0.08	4	-0.314	1	-0.187	21	-9.327...	7	-4.161...	4	-2.249...	7
17	N9	max	0.071	23	0.227	7	-0.048	3	4.188e...	1	3.086e...	22	2.476e...	7
18		min	-0.01	5	-0.212	1	-0.164	21	-4.52e...	7	-7.67e...	4	-2.449...	1
19	N10	max	0.037	10	0.045	7	0	2	2.447e...	1	1.972e...	10	1.072e...	7
20		min	-0.021	4	-0.049	1	-0.003	37	-2.306...	7	-1.246...	4	-8.476...	1
21	N11	max	0.006	7	0.124	7	-0.054	3	2.512e...	7	-2.765...	4	1.932e...	1
22		min	-0.006	1	-0.131	1	-0.186	21	-2.965...	1	-2.474...	22	-1.908...	7

Node Displacements (Continued)

Node...		X [in]	LC	Y [in]	LC	Z [in]	LC	X Rota...	LC	Y Rota...	LC	Z Rota...	LC	
23	N12	max	0.007	1	0.105	7	-0.048	3	7.413e...	7	2.71e-03	21	2.202e...	7
24		min	-0.006	7	-0.112	1	-0.164	21	-1.098...	1	6.095e...	3	-2.232...	1
25	N13	max	0.003	1	0.003	7	0	2	1.912e...	16	1.082e...	20	6.746e...	7
26		min	-0.002	7	-0.003	1	-0.003	37	-8.603...	40	2.574e...	2	-9.035...	1
27	N14	max	0.083	10	0.28	7	-0.054	3	8.107e...	7	2.808e...	4	1.932e...	1
28		min	-0.047	4	-0.299	1	-0.187	21	-8.559...	1	-4.31e...	10	-1.908...	7
29	N15	max	-0.01	1	0.125	7	-0.048	3	8.469e...	7	2.706e...	17	2.202e...	7
30		min	-0.066	19	-0.141	1	-0.164	21	-1.204...	1	6.847e...	2	-2.232...	1
31	N16	max	-0.004	1	0.006	19	0	2	2.6e-04	19	1.129e...	17	6.746e...	7
32		min	-0.025	17	-0.003	1	-0.003	37	-8.9e-05	28	2.479e...	12	-9.035...	1
33	N17	max	0	10	0.146	7	-0.047	6	3.271e...	1	-4.31e...	10	2.229e...	1
34		min	0	4	-0.139	1	-0.185	24	-3.697...	7	-2.424...	16	-2.249...	7
35	N18	max	0	10	0.133	7	-0.045	6	2.135e...	1	2.678e...	24	2.476e...	7
36		min	0	4	-0.126	1	-0.163	24	-2.466...	7	6.71e-04	6	-2.449...	1
37	N19	max	0	10	0.004	7	0	5	5.03e-04	1	1.161e...	23	1.072e...	7
38		min	0	15	-0.004	1	-0.003	23	-3.619...	7	1.959e...	5	-8.476...	1
39	N20	max	0.007	7	0.146	7	-0.054	3	3.271e...	1	-4.31e...	10	2.229e...	1
40		min	-0.007	1	-0.139	1	-0.186	21	-3.697...	7	-2.424...	16	-2.249...	7
41	N21	max	0.007	1	0.133	7	-0.048	3	2.135e...	1	2.678e...	24	2.476e...	7
42		min	-0.007	7	-0.126	1	-0.164	21	-2.466...	7	6.71e-04	6	-2.449...	1
43	N22	max	0.002	1	0.004	7	0	2	5.03e-04	1	1.161e...	23	1.072e...	7
44		min	-0.003	7	-0.004	1	-0.003	37	-3.619...	7	1.959e...	5	-8.476...	1
45	N23	max	0.001	21	0.04	19	-0.011	33	7.078e...	14	-8.262...	4	5.58e-04	12
46		min	0	3	-0.003	12	-0.042	24	1.553e...	9	-2.963...	23	-2.035...	18
47	N24	max	0	10	0.043	19	-0.01	5	6.904e...	24	2.857e...	23	2.158e...	20
48		min	-0.001	16	-0.001	1	-0.04	23	1.538e...	5	7.021e...	5	-3.549...	2
49	N25	max	0.007	6	0.02	19	0.004	3	7.077e...	14	-8.262...	4	5.577e...	12
50		min	-0.006	12	-0.01	1	-0.015	26	1.552e...	9	-2.963...	23	-2.035...	18
51	N26	max	0.004	2	0.023	19	0.002	30	6.903e...	24	2.857e...	23	2.158e...	20
52		min	-0.006	8	-0.009	1	-0.014	25	1.537e...	5	7.021e...	5	-3.546...	2
53	N27	max	-0.005	5	0.022	19	-0.278	9	2.739e...	9	-2.184...	10	6.633e...	5
54		min	-0.032	23	-0.011	1	-0.944	15	-3.949...	3	-8.181...	16	-1.777...	23
55	N28	max	0.035	15	0.025	19	-0.277	5	3.255e...	4	8.715e...	24	1.975e...	15
56		min	0.003	9	-0.009	1	-0.976	23	-6.496...	22	2.508e...	6	-9.694...	10
57	N29	max	0.003	22	0.021	7	-0.276	9	2.735e...	9	-2.184...	10	6.639e...	5
58		min	0	4	-0.012	1	-0.946	15	-3.953...	3	-8.181...	16	-1.778...	23
59	N30	max	0	10	0.023	19	-0.276	5	3.251e...	4	8.715e...	24	1.975e...	15
60		min	-0.003	16	-0.01	1	-0.98	23	-6.507...	22	2.508e...	6	-9.7e-04	10
61	N31	max	0	10	0.032	18	-0.291	5	3.251e...	4	8.716e...	24	1.975e...	15
62		min	-0.003	16	-0.008	12	-1.032	23	-6.507...	22	2.508e...	6	-9.7e-04	10
63	N32	max	0.003	22	0.029	20	-0.29	9	2.735e...	9	-2.185...	10	6.636e...	5
64		min	0	4	-0.007	2	-0.995	15	-3.953...	3	-8.182...	16	-1.777...	23
65	N33	max	-0.002	33	0.02	19	-0.011	33	7.078e...	14	-8.262...	4	5.58e-04	12
66		min	-0.008	14	-0.01	1	-0.042	24	1.553e...	9	-2.963...	23	-2.035...	18
67	N34	max	0.008	23	0.023	19	-0.01	5	6.904e...	24	2.857e...	23	2.158e...	20
68		min	0.002	4	-0.009	1	-0.04	23	1.538e...	5	7.021e...	5	-3.549...	2
69	N35	max	-0.005	10	0.022	19	-0.276	9	2.735e...	9	-2.184...	10	6.639e...	5
70		min	-0.023	16	-0.011	1	-0.946	15	-3.953...	3	-8.181...	16	-1.778...	23
71	N36	max	0.024	23	0.025	19	-0.276	5	3.251e...	4	8.715e...	24	1.975e...	15
72		min	0.006	5	-0.009	1	-0.98	23	-6.507...	22	2.508e...	6	-9.7e-04	10
73	N37	max	0.001	22	0.008	7	-0.004	4	7.965e...	13	2.765e...	22	6.838e...	8
74		min	0	4	-0.055	13	-0.053	22	1.836e...	7	6.754e...	4	-2.123...	14
75	N38	max	0	10	0.012	6	-0.005	10	8.037e...	13	-8.269...	10	1.997e...	24
76		min	-0.001	15	-0.052	24	-0.057	16	2.027e...	7	-2.941...	16	-8.752...	6
77	N39	max	0	10	0.007	7	-0.004	10	8.037e...	13	-8.23e...	10	1.997e...	24
78		min	-0.001	15	-0.04	13	-0.039	16	2.027e...	7	-2.94e...	16	-8.747...	6
79	N40	max	0.001	22	0.005	7	-0.004	4	7.965e...	13	2.764e...	22	6.833e...	8
80		min	0	4	-0.042	13	-0.036	22	1.836e...	7	6.716e...	4	-2.123...	14

Node Displacements (Continued)

Node...	X [in]	LC	Y [in]	LC	Z [in]	LC	X Rota...	LC	Y Rota...	LC	Z Rota...	LC		
81	N41	max	0.001	6	0	7	0.012	23	8.036e...	13	-8.23e...	10	1.996e...	24
82		min	-0.021	24	-0.064	13	-0.005	5	2.027e...	7	-2.94e...	16	-8.744...	6
83	N42	max	0.021	13	0	7	0.014	15	7.964e...	13	2.764e...	22	6.83e-04	8
84		min	0	7	-0.066	13	-0.004	9	1.836e...	7	6.716e...	4	-2.122...	14
85	N43	max	0	6	0.002	7	-0.268	9	5.15e-04	2	-1.627...	9	2.071e...	5
86		min	-0.02	23	-0.066	13	-0.951	15	-4.794...	8	-8.701...	15	-1.098...	11
87	N44	max	0.021	15	0	7	-0.266	5	4.763e...	10	9.311e...	22	1.309e...	3
88		min	0	9	-0.068	13	-0.984	23	-5.877...	4	1.749e...	4	-2.347...	9
89	N45	max	0	10	0	7	-0.271	9	5.146e...	2	-1.627...	9	2.072e...	5
90		min	-0.003	16	-0.066	13	-0.95	15	-4.798...	8	-8.701...	15	-1.099...	11
91	N46	max	0.003	22	0	7	-0.27	5	4.759e...	10	9.311e...	22	1.309e...	3
92		min	-0.001	4	-0.069	13	-0.985	23	-5.881...	4	1.749e...	4	-2.348...	9
93	N47	max	0.003	22	-0.004	6	-0.281	5	4.759e...	10	9.312e...	22	1.309e...	3
94		min	-0.001	4	-0.078	24	-1.04	23	-5.881...	4	1.75e-03	4	-2.348...	9
95	N48	max	0	10	-0.007	7	-0.28	9	5.146e...	2	-1.628...	9	2.072e...	5
96		min	-0.003	16	-0.074	14	-1.003	15	-4.798...	8	-8.702...	15	-1.098...	11
97	N49	max	0	10	0	7	-0.004	10	8.037e...	13	-8.23e...	10	1.997e...	24
98		min	-0.01	16	-0.064	13	-0.039	16	2.027e...	7	-2.94e...	16	-8.747...	6
99	N50	max	0.009	22	0	7	-0.004	4	7.965e...	13	2.764e...	22	6.833e...	8
100		min	0	4	-0.066	13	-0.036	22	1.836e...	7	6.716e...	4	-2.123...	14
101	N51	max	-0.004	10	0.002	7	-0.271	9	5.146e...	2	-1.627...	9	2.072e...	5
102		min	-0.029	16	-0.066	13	-0.95	15	-4.798...	8	-8.701...	15	-1.099...	11
103	N52	max	0.031	22	0	7	-0.27	5	4.759e...	10	9.311e...	22	1.309e...	3
104		min	0.004	4	-0.068	13	-0.985	23	-5.881...	4	1.749e...	4	-2.348...	9
105	N53	max	0	42	0.004	7	0	1	2.572e...	7	-2.54e...	12	1.188e...	1
106		min	0	16	-0.004	1	-0.004	19	-1.562...	1	-1.384...	18	-9.454...	7
107	N54	max	0	8	0.024	7	0	1	1.027e...	1	-1.356...	9	1.056e...	1
108		min	-0.035	15	-0.027	1	-0.004	19	-9.039...	7	-1.532...	15	-1.294...	7
109	N55	max	0.003	7	0.004	7	0	11	2.572e...	7	-2.54e...	12	1.188e...	1
110		min	-0.004	1	-0.004	1	-0.004	17	-1.562...	1	-1.384...	18	-9.454...	7
111	N56	max	0.032	20	0.012	7	0	11	3.628e...	7	-2.585...	2	1.188e...	1
112		min	0.002	1	-0.01	1	-0.004	17	-2.618...	1	-1.423...	21	-9.454...	7
113	N57	max	0	22	0.005	7	0	7	4.948e...	1	-2.752...	7	1.056e...	1
114		min	0	4	-0.004	1	-0.004	13	-3.722...	7	-1.447...	13	-1.294...	7
115	N58	max	0.004	7	0.005	7	0	1	4.948e...	1	-2.752...	7	1.056e...	1
116		min	-0.003	1	-0.004	1	-0.004	19	-3.722...	7	-1.447...	13	-1.294...	7
117	N59	max	0	10	0	7	0	6	0	13	0	11	0	10
118		min	0	4	0	1	0	24	0	7	0	5	0	4
119	N60	max	0	10	0	7	0	2	0	24	0	11	0	10
120		min	0	4	0	1	0	20	0	6	0	5	0	4
121	N61	max	0	11	0.012	8	-0.037	5	2.822e...	2	8.795e...	23	6.607e...	8
122		min	-0.001	16	-0.014	2	-0.13	24	-1.23e...	8	2.46e-03	5	-8.671...	2
123	N62	max	0.001	22	0.021	6	-0.036	7	1.903e...	7	-2.373...	6	1.2e-03	12
124		min	0	5	-0.023	12	-0.138	13	-1.625...	1	-8.945...	23	-1.013...	6
125	N63	max	0.002	22	0.033	6	-0.209	8	6.299e...	8	-2.858...	10	5.009e...	6
126		min	0	5	-0.036	12	-0.715	14	-4.616...	2	-1.028...	16	-6.414...	12
127	N64	max	0.219	22	0.064	7	-0.037	6	2.839e...	1	9.213e...	22	1.036e...	8
128		min	0.032	4	-0.07	1	-0.131	24	-2.633...	7	1.013e...	4	-1.122...	2
129	N65	max	-0.004	10	0.163	7	-0.041	7	7.711e...	1	6.086e...	10	1.383e...	12
130		min	-0.23	16	-0.172	1	-0.139	13	-7.394...	7	-9.756...	16	-1.286...	6
131	N66	max	-0.06	9	0.061	6	-0.211	8	1.625e...	1	-2.546...	9	9.589e...	18
132		min	-0.25	15	-0.087	12	-0.715	14	-1.326...	7	-1.042...	15	-4.549...	12
133	N67	max	0.002	9	0.012	8	-0.037	6	2.822e...	2	8.795e...	23	6.607e...	8
134		min	-0.003	3	-0.014	2	-0.13	24	-1.23e...	8	2.46e-03	5	-8.671...	2
135	N68	max	0.004	12	0.021	6	-0.041	7	1.903e...	7	-2.373...	6	1.2e-03	12
136		min	-0.003	6	-0.023	12	-0.139	24	-1.625...	1	-8.945...	23	-1.013...	6
137	N69	max	0.002	19	0.033	6	-0.211	8	6.299e...	8	-2.858...	10	5.009e...	6
138		min	0	1	-0.036	12	-0.715	14	-4.616...	2	-1.028...	16	-6.414...	12

Node Displacements (Continued)

Node...		X [in]	LC	Y [in]	LC	Z [in]	LC	X Rota...	LC	Y Rota...	LC	Z Rota...	LC	
139	N70	max	-0.06	7	0.01	8	-0.037	6	2.953e...	18	8.79e-03	15	6.607e...	8
140		min	-0.214	14	-0.009	2	-0.13	24	-6.29e...	9	2.527e...	6	-8.671...	2
141	N71	max	0.228	22	0.163	7	-0.042	7	7.499e...	7	5.609e...	4	1.2e-03	12
142		min	0.006	4	-0.158	1	-0.139	24	-7.222...	1	-9.6e-03	22	-1.013...	6
143	N72	max	0.247	19	0.046	7	-0.211	8	7.213e...	8	-2.963...	10	5.009e...	6
144		min	0.071	11	-0.045	1	-0.715	14	-5.53e...	2	-1.022...	20	-6.414...	12
145	N73	max	0.001	10	0.018	8	-0.038	5	7.869e...	1	8.769e...	22	1.036e...	8
146		min	0	4	-0.02	2	-0.129	23	-5.815...	7	2.517e...	5	-1.122...	2
147	N74	max	0	10	0.025	6	-0.039	1	2.085e...	1	-2.47e...	11	1.383e...	12
148		min	-0.001	4	-0.027	12	-0.138	19	-1.769...	7	-8.918...	17	-1.286...	6
149	N75	max	0	10	0.037	6	-0.213	8	1.093e...	1	-2.749...	8	9.589e...	18
150		min	-0.003	16	-0.055	12	-0.714	14	-7.938...	7	-1.032...	14	-4.549...	12
151	N76	max	0.004	9	0.018	8	-0.037	6	7.869e...	1	8.769e...	22	1.036e...	8
152		min	-0.004	3	-0.02	2	-0.131	24	-5.815...	7	2.517e...	5	-1.122...	2
153	N77	max	0.005	12	0.025	6	-0.041	7	2.085e...	1	-2.47e...	11	1.383e...	12
154		min	-0.005	6	-0.027	12	-0.139	13	-1.769...	7	-8.918...	17	-1.286...	6
155	N78	max	0.002	8	0.037	6	-0.211	8	1.093e...	1	-2.749...	8	9.589e...	18
156		min	-0.002	2	-0.055	12	-0.715	14	-7.938...	7	-1.032...	14	-4.549...	12
157	N79	max	0	10	0.028	8	-0.207	5	4.917e...	3	1.093e...	23	4.898e...	3
158		min	-0.003	16	-0.031	2	-0.733	23	-4.286...	9	3.023e...	5	-3.136...	9
159	N80	max	0.272	22	0.072	7	-0.208	5	2.732e...	1	1.146e...	22	2.332e...	2
160		min	0.043	4	-0.095	1	-0.733	23	-2.527...	7	1.404e...	4	-9.891...	20
161	N81	max	0	1	0.028	8	-0.208	5	4.917e...	3	1.093e...	23	4.898e...	3
162		min	-0.002	19	-0.031	2	-0.733	23	-4.286...	9	3.023e...	5	-3.136...	9
163	N82	max	-0.075	5	0.021	8	-0.208	5	4.388e...	3	1.089e...	14	4.898e...	3
164		min	-0.262	13	-0.023	2	-0.733	23	-3.758...	9	3.114e...	5	-3.136...	9
165	N83	max	0.003	22	0.033	8	-0.209	5	8.543e...	12	1.101e...	23	2.332e...	2
166		min	0	4	-0.052	2	-0.731	23	-6.495...	6	2.83e-03	5	-9.891...	20
167	N84	max	0.001	12	0.033	8	-0.208	5	8.543e...	12	1.101e...	23	2.332e...	2
168		min	-0.002	6	-0.052	2	-0.733	23	-6.495...	6	2.83e-03	5	-9.891...	20
169	N85	max	0	11	0	7	0	2	2.161e...	13	2.059e...	12	1.603e...	11
170		min	0	17	-0.002	13	0	20	-7.319...	7	-6.616...	17	-1.561...	5
171	N86	max	0	23	0.002	19	0	8	1.962e...	19	1.246e...	7	1.269e...	11
172		min	0	6	0	1	0	14	-2.362...	1	-6.558...	24	-1.315...	5
173	N87	max	0	10	0	7	0	2	2.158e...	13	2.03e-05	12	1.603e...	11
174		min	0	4	0	1	0	20	-7.26e...	7	-6.592...	17	-1.561...	5
175	N88	max	0	10	0	19	0	8	1.959e...	19	1.261e...	8	1.269e...	11
176		min	0	4	0	1	0	14	-2.303...	1	-6.544...	24	-1.315...	5
177	N89	max	0	11	0	7	0	7	2.158e...	13	2.03e-05	12	1.603e...	11
178		min	0	5	0	1	0	13	-7.26e...	7	-6.592...	17	-1.561...	5
179	N90	max	0	11	0	19	0	1	1.959e...	19	1.261e...	8	1.269e...	11
180		min	0	5	0	1	0	19	-2.303...	1	-6.544...	24	-1.315...	5
181	N91	max	0	12	0	18	0	34	0	19	0	19	0	18
182		min	0	18	0	12	0	21	0	30	0	30	0	12
183	N92	max	0	10	0	19	0	1	0	19	0	19	0	18
184		min	0	4	0	1	0	19	0	31	0	2	0	12
185	N93	max	0	24	0	6	0	2	0	24	0	24	0	6
186		min	0	6	0	24	0	20	0	6	0	38	0	24
187	N94	max	0	10	0	6	0	7	0	24	0	23	0	6
188		min	0	4	0	13	0	13	0	6	0	5	0	24
189	N95	max	0.001	21	0	7	0	7	4.652e...	13	1.187e...	21	-8.081...	4
190		min	0	34	-0.005	13	0	13	8.484e...	7	-8.456...	34	-4.749...	23
191	N96	max	0	38	0.004	19	0	1	3.739e...	20	1.826e...	13	4.782e...	18
192		min	-0.002	14	0	1	0	19	7.668e...	31	-6.108...	38	9.767e...	9
193	N97	max	0	10	0	7	0	7	4.649e...	13	1.184e...	21	-8.081...	4
194		min	0	4	-0.001	13	0	13	9.076e...	7	-8.452...	34	-4.749...	23
195	N98	max	0	42	0	19	0	1	3.736e...	20	1.826e...	13	4.782e...	18
196		min	0	25	0	1	0	19	7.672e...	31	-6.108...	38	9.767e...	9

Node Displacements (Continued)

Node...	X [in]	LC	Y [in]	LC	Z [in]	LC	X Rota...	LC	Y Rota...	LC	Z Rota...	LC		
197	N99	max	0	22	0	6	0	30	4.649e...	13	1.184e...	21	-8.081...	4
198		min	0	4	-0.002	24	0	8	9.076e...	7	-8.452...	34	-4.749...	23
199	N100	max	0	42	0.002	18	0	38	3.736e...	20	1.826e...	13	4.782e...	18
200		min	0	16	0	12	0	25	7.672e...	31	-6.108...	38	9.767e...	9
201	N101	max	0	20	0	20	0	29	0	19	0	29	0	2
202		min	0	2	0	2	0	21	0	29	0	20	0	20
203	N102	max	0	10	0	19	0	1	0	17	0	1	0	2
204		min	0	4	0	1	0	19	0	36	0	20	0	20
205	N103	max	0	8	0	8	0	11	0	14	0	9	0	14
206		min	0	14	0	14	0	17	0	8	0	15	0	8
207	N104	max	0	10	0	8	0	7	0	13	0	9	0	14
208		min	0	4	0	13	0	13	0	7	0	15	0	8
209	N105	max	0	41	0	7	0	7	4.726e...	13	6.711e...	41	4.477e...	14
210		min	-0.002	16	-0.005	13	0	13	2.072e...	7	-1.914...	16	8.191e...	8
211	N106	max	0.002	23	0.004	18	0	1	3.829e...	16	4.231e...	37	-1.018...	2
212		min	0	33	0	28	0	19	8.117e...	40	-2.411...	24	-4.54e...	20
213	N107	max	0	10	0	7	0	7	4.723e...	13	6.708e...	41	4.477e...	14
214		min	0	4	-0.001	13	0	13	2.131e...	7	-1.911...	16	8.191e...	8
215	N108	max	0	22	0	19	0	1	3.829e...	16	4.231e...	37	-1.018...	2
216		min	0	33	0	1	0	19	8.117e...	40	-2.409...	24	-4.54e...	20
217	N109	max	0	10	0	8	0	29	4.723e...	13	6.708e...	41	4.477e...	14
218		min	0	15	-0.002	14	0	6	2.131e...	7	-1.911...	16	8.191e...	8
219	N110	max	0	21	0.002	20	0	33	3.829e...	16	4.231e...	37	-1.018...	2
220		min	0	33	0	1	0	26	8.117e...	40	-2.409...	24	-4.54e...	20
221	N111	max	0.075	10	0.022	19	-0.237	9	5.911e...	16	5.133e...	4	6.876e...	19
222		min	-0.054	4	-0.01	1	-0.795	14	1.741e...	9	-3.04e...	22	-2.789...	10
223	N112	max	0.059	10	0.025	19	-0.227	6	7.054e...	22	3.125e...	16	5.262e...	10
224		min	-0.08	4	-0.009	1	-0.816	24	1.736e...	4	-4.993...	10	-9.827...	4
225	N113	max	0.072	10	0.001	7	-0.229	9	5.88e-03	21	1.639e...	10	-2.062...	5
226		min	-0.111	4	-0.066	13	-0.797	15	1.828e...	26	-3.33e...	16	-1.061...	14
227	N114	max	0.115	10	0	7	-0.222	5	6.987e...	16	3.414e...	22	1.308e...	23
228		min	-0.076	4	-0.068	13	-0.817	23	1.987e...	10	-1.627...	4	-3.373...	4
229	N115	max	0.059	10	0.027	19	-0.223	6	7.054e...	22	3.125e...	16	5.262e...	10
230		min	-0.08	4	-0.009	1	-0.808	24	1.736e...	4	-4.993...	10	-9.827...	4
231	N116	max	0.115	10	0	7	-0.224	6	6.987e...	16	3.414e...	22	1.308e...	23
232		min	-0.076	4	-0.072	13	-0.808	24	1.987e...	10	-1.627...	4	-3.373...	4
233	N117	max	0.075	10	0.024	19	-0.231	9	5.911e...	16	5.133e...	4	6.876e...	19
234		min	-0.054	4	-0.01	1	-0.788	15	1.741e...	9	-3.04e...	22	-2.789...	10
235	N118	max	0.072	10	0	7	-0.233	9	5.88e-03	21	1.639e...	10	-2.062...	5
236		min	-0.111	4	-0.069	13	-0.788	15	1.828e...	26	-3.33e...	16	-1.061...	14
237	N119	max	0.156	10	-0.026	7	-0.224	6	6.987e...	16	3.424e...	22	1.308e...	23
238		min	-0.096	4	-0.155	13	-0.808	24	1.987e...	10	-1.64e...	4	-3.373...	4
239	N120	max	0.092	10	-0.022	7	-0.233	9	5.878e...	22	1.652e...	10	-2.062...	5
240		min	-0.151	4	-0.139	13	-0.788	15	1.828e...	26	-3.339...	16	-1.061...	14
241	N121	max	0.065	10	0.111	19	-0.223	6	7.054e...	22	3.135e...	16	5.262e...	10
242		min	-0.107	4	0.018	1	-0.808	24	1.736e...	4	-5.125...	10	-9.827...	4
243	N122	max	0.101	10	0.094	19	-0.231	9	5.911e...	16	5.265e...	4	6.876e...	19
244		min	-0.061	4	0.013	12	-0.788	15	1.748e...	9	-3.05e...	22	-2.789...	10
245	N123	max	0	10	0	5	0	10	0	15	0	10	0	43
246		min	0	4	0	11	0	16	0	10	0	15	0	1
247	N124	max	0	10	0	10	0	3	0	23	0	23	0	43
248		min	0	4	0	4	0	22	0	4	0	4	0	1
249	N125	max	0.028	11	0.026	5	-0.224	6	-5.282...	2	1.761e...	22	7.85e-04	10
250		min	-0.02	5	-0.04	11	-0.808	24	-7.489...	20	-2.365...	4	-6.6e-04	4
251	N126	max	0.015	9	0.018	9	-0.232	9	7.29e-06	12	4.801e...	10	1.114e...	5
252		min	-0.024	3	-0.033	15	-0.788	15	-4.227...	18	-1.708...	16	-2.303...	14
253	N127	max	0.072	10	0.022	19	-0.186	9	9.092e...	21	1.249e...	4	1.092e...	21
254		min	-0.061	4	-0.01	1	-0.661	15	2.225e...	3	-2.88e...	22	-6.02e...	3

Node Displacements (Continued)

Node...		X [in]	LC	Y [in]	LC	Z [in]	LC	X Rota...	LC	Y Rota...	LC	Z Rota...	LC	
255	N128	max	0.071	10	0.022	19	-0.256	9	3.609e...	16	-6.2e-04	4	4.647e...	3
256		min	-0.047	4	-0.011	1	-0.883	15	6.139e...	9	-3.506...	22	-5.588...	9
257	N129	max	0.018	10	0.022	19	-0.273	9	2.937e...	10	-1.613...	11	7.803e...	4
258		min	-0.018	4	-0.011	1	-0.95	15	-1.453...	4	-5.674...	18	-1.907...	22
259	N130	max	0.181	10	-0.019	7	-0.192	9	9.58e-03	13	6.072e...	10	2.27e-04	9
260		min	-0.237	4	-0.259	13	-0.668	15	3.612e...	7	-7.531...	4	-1.397...	15
261	N131	max	0.106	10	-0.001	7	-0.259	9	3.785e...	24	2.472e...	10	5.374e...	4
262		min	-0.197	4	-0.143	13	-0.893	15	-1.651...	6	-4.631...	4	-7.111...	10
263	N132	max	0.024	10	0.02	7	-0.278	9	1.544e...	1	9.388e...	10	2.217e...	4
264		min	-0.195	16	-0.082	13	-0.968	15	-1.303...	7	-6.586...	16	-1.365...	10
265	N133	max	0.072	10	0.019	7	-0.193	9	9.092e...	21	1.249e...	4	1.092e...	21
266		min	-0.061	4	-0.011	1	-0.667	15	2.225e...	3	-2.88e...	22	-6.02e...	3
267	N134	max	0.071	10	0.022	19	-0.26	9	3.609e...	16	-6.2e-04	4	4.647e...	3
268		min	-0.047	4	-0.011	1	-0.893	15	6.139e...	9	-3.506...	22	-5.588...	9
269	N135	max	0.018	10	0.026	19	-0.278	9	2.937e...	10	-1.613...	11	7.803e...	4
270		min	-0.018	4	-0.009	1	-0.967	15	-1.453...	4	-5.674...	18	-1.907...	22
271	N136	max	0.287	10	0.279	19	-0.193	9	9.901e...	19	8.569e...	4	1.092e...	21
272		min	-0.236	4	-0.021	1	-0.668	15	-1.549...	1	-1.008...	10	-6.02e...	3
273	N137	max	0.154	22	0.119	18	-0.26	9	3.638e...	17	-4.696...	4	4.647e...	3
274		min	-0.034	4	0.016	12	-0.893	15	6.267e...	10	-3.613...	22	-5.588...	9
275	N138	max	0.161	22	0.033	20	-0.278	9	3.36e-04	9	-1.717...	1	7.803e...	4
276		min	0.03	4	-0.011	2	-0.967	15	-1.882...	3	-5.77e...	22	-1.907...	22
277	N139	max	0.077	10	0	7	-0.197	8	9.092e...	16	1.947e...	10	2.27e-04	9
278		min	-0.102	4	-0.066	13	-0.659	14	2.143e...	10	-3.404...	4	-1.397...	15
279	N140	max	0.063	10	0.001	7	-0.261	9	3.538e...	23	9.498e...	10	5.374e...	4
280		min	-0.109	4	-0.066	13	-0.881	14	7.376e...	5	-3.945...	16	-7.111...	10
281	N141	max	0.013	10	0.002	7	-0.276	9	5.675e...	2	-5.023...	10	2.217e...	4
282		min	-0.059	16	-0.066	13	-0.949	15	-3.275...	8	-6.22e...	16	-1.365...	10
283	N142	max	0.077	10	0.002	6	-0.192	9	9.092e...	16	1.947e...	10	2.27e-04	9
284		min	-0.102	4	-0.062	13	-0.667	15	2.143e...	10	-3.404...	4	-1.397...	15
285	N143	max	0.063	10	0.002	7	-0.259	9	3.538e...	23	9.498e...	10	5.374e...	4
286		min	-0.109	4	-0.065	13	-0.893	15	7.376e...	5	-3.945...	16	-7.111...	10
287	N144	max	0.013	10	0	7	-0.278	9	5.675e...	2	-5.023...	10	2.217e...	4
288		min	-0.059	16	-0.07	13	-0.967	15	-3.275...	8	-6.22e...	16	-1.365...	10
289	N145	max	0.021	11	0.021	19	-0.062	9	1.098e...	15	-3.676...	4	1.634e...	10
290		min	-0.032	5	-0.01	1	-0.24	15	2.802e...	9	-2.285...	22	-1.463...	4
291	N146	max	0.057	10	-0.06	6	-0.066	9	1.098e...	24	1.084e...	10	1.843e...	10
292		min	-0.082	4	-0.295	24	-0.246	15	3.018e...	6	-2.266...	16	-2.065...	4
293	N147	max	0.021	11	0.021	6	-0.066	9	1.098e...	15	-3.676...	4	1.634e...	10
294		min	-0.032	5	-0.012	12	-0.246	15	2.802e...	9	-2.285...	22	-1.463...	4
295	N148	max	0.059	10	0.315	18	-0.066	9	1.097e...	17	1.136e...	4	1.634e...	10
296		min	-0.033	4	0.071	11	-0.246	15	2.844e...	10	-2.393...	22	-1.463...	4
297	N149	max	0.036	11	0	7	-0.068	8	1.092e...	23	7.881e...	10	1.843e...	10
298		min	-0.037	5	-0.065	13	-0.24	14	3.108e...	5	-2.167...	16	-2.065...	4
299	N150	max	0.036	11	0.004	6	-0.066	9	1.092e...	23	7.881e...	10	1.843e...	10
300		min	-0.037	5	-0.064	24	-0.246	15	3.108e...	5	-2.167...	16	-2.065...	4
301	N151	max	0.066	10	0.025	19	-0.251	5	4.331e...	21	4.138e...	16	1.85e-04	17
302		min	-0.091	4	-0.009	1	-0.921	23	4.751e...	3	-1.011...	10	-8.765...	12
303	N152	max	0.05	10	0.025	19	-0.179	5	9.741e...	15	2.443e...	15	5.431e...	11
304		min	-0.061	4	-0.009	1	-0.662	24	2.567e...	9	3.717e...	9	-1.252...	17
305	N153	max	0.026	21	0.024	19	-0.058	5	1.084e...	23	2.076e...	14	1.028e...	10
306		min	-0.014	3	-0.009	1	-0.235	23	2.807e...	5	5.648e...	7	-1.185...	4
307	N154	max	0.274	10	0.013	7	-0.258	5	4.71e-03	13	8.182e...	10	4.205e...	17
308		min	-0.177	4	-0.163	13	-0.932	24	-1.201...	7	-5.847...	4	-1.622...	11
309	N155	max	0.171	10	-0.042	7	-0.181	5	9.987e...	24	4.089e...	10	1.559e...	23
310		min	-0.116	4	-0.271	13	-0.669	24	1.57e-03	6	-2.698...	4	-6.31e...	4
311	N156	max	0.089	10	-0.043	7	-0.06	5	1.117e...	13	3.277e...	10	1.727e...	10
312		min	-0.067	4	-0.299	13	-0.241	24	1.79e-03	7	-2.219...	4	-1.515...	4

Node Displacements (Continued)

Node...		X [in]	LC	Y [in]	LC	Z [in]	LC	X Rota...	LC	Y Rota...	LC	Z Rota...	LC	
313	N157	max	0.066	10	0.025	19	-0.259	5	4.331e...	21	4.138e...	16	1.85e-04	17
314		min	-0.091	4	-0.009	1	-0.931	24	4.751e...	3	-1.011...	10	-8.765...	12
315	N158	max	0.05	10	0.021	19	-0.182	6	9.741e...	15	2.443e...	15	5.431e...	11
316		min	-0.061	4	-0.009	1	-0.669	24	2.567e...	9	3.717e...	9	-1.252...	17
317	N159	max	0.026	21	0.023	19	-0.06	5	1.084e...	23	2.076e...	14	1.028e...	10
318		min	-0.014	3	-0.009	1	-0.241	24	2.807e...	5	5.648e...	7	-1.185...	4
319	N160	max	0.234	10	0.159	19	-0.26	5	5.774e...	7	1.059e...	4	1.85e-04	17
320		min	-0.32	4	-0.064	1	-0.932	24	-3.189...	1	-8.333...	10	-8.765...	12
321	N161	max	0.043	10	0.282	18	-0.182	6	9.736e...	17	2.542e...	16	5.431e...	11
322		min	-0.103	16	0.073	12	-0.669	24	2.642e...	9	2.414e...	9	-1.252...	17
323	N162	max	0.012	9	0.314	20	-0.06	5	1.081e...	21	2.172e...	16	1.028e...	10
324		min	-0.047	15	0.077	3	-0.241	24	2.882e...	5	4.778e...	9	-1.185...	4
325	N163	max	0.126	10	0	7	-0.26	6	4.198e...	15	4.422e...	22	4.205e...	17
326		min	-0.078	4	-0.068	13	-0.919	24	8.119e...	9	-1.723...	4	-1.622...	11
327	N164	max	0.094	10	0	7	-0.182	6	9.755e...	22	2.675e...	22	1.559e...	23
328		min	-0.069	4	-0.068	13	-0.662	24	2.36e-03	4	-1.176...	4	-6.31e...	4
329	N165	max	0.031	9	0	7	-0.061	6	1.085e...	13	2.035e...	22	1.727e...	10
330		min	-0.031	3	-0.067	13	-0.235	24	2.872e...	7	-7.769...	4	-1.515...	4
331	N166	max	0.126	10	0	7	-0.258	5	4.198e...	15	4.422e...	22	4.205e...	17
332		min	-0.078	4	-0.067	13	-0.931	24	8.119e...	9	-1.723...	4	-1.622...	11
333	N167	max	0.094	10	0	7	-0.181	5	9.755e...	22	2.675e...	22	1.559e...	23
334		min	-0.069	4	-0.064	13	-0.669	24	2.36e-03	4	-1.176...	4	-6.31e...	4
335	N168	max	0.031	9	0.001	8	-0.06	5	1.085e...	13	2.035e...	22	1.727e...	10
336		min	-0.031	3	-0.066	13	-0.241	24	2.872e...	7	-7.769...	4	-1.515...	4
337	N169	max	0.026	10	0.025	19	-0.273	5	4.11e-04	3	6.163e...	15	2.341e...	4
338		min	-0.026	4	-0.009	1	-0.988	23	-3.964...	9	1.486e...	9	-1.357...	10
339	N170	max	0.204	22	0.005	6	-0.28	5	6.257e...	10	6.732e...	22	1.841e...	4
340		min	-0.012	4	-0.076	24	-1.006	23	-5.102...	4	2.815e...	4	-2.734...	10
341	N171	max	0.026	10	0.029	18	-0.28	5	4.11e-04	3	6.163e...	15	2.341e...	4
342		min	-0.026	4	-0.009	12	-1.006	23	-3.964...	9	1.486e...	9	-1.357...	10
343	N172	max	-0.012	10	0.03	18	-0.28	5	3.961e...	4	6.262e...	16	2.341e...	4
344		min	-0.176	16	-0.014	11	-1.006	23	-3.81e...	10	1.355e...	9	-1.357...	10
345	N173	max	0.063	22	0	7	-0.277	5	6.255e...	10	6.631e...	22	1.841e...	4
346		min	-0.019	4	-0.068	13	-0.987	23	-5.101...	4	5.775e...	4	-2.734...	10
347	N174	max	0.063	22	0	6	-0.28	5	6.255e...	10	6.631e...	22	1.841e...	4
348		min	-0.019	4	-0.072	13	-1.006	23	-5.101...	4	5.775e...	4	-2.734...	10
349	N175	max	0.033	10	0.041	7	0	2	2.447e...	1	1.972e...	10	1.072e...	7
350		min	-0.018	4	-0.044	1	-0.003	37	-2.306...	7	-1.246...	4	-8.476...	1
351	N176	max	0.249	22	0.066	7	-0.208	5	2.732e...	1	1.146e...	22	2.332e...	2
352		min	0.04	4	-0.09	1	-0.733	23	-2.527...	7	1.404e...	4	-9.891...	20
353	N177	max	0.022	10	0.018	7	-0.278	9	1.544e...	1	9.387e...	10	2.217e...	4
354		min	-0.182	16	-0.081	13	-0.968	15	-1.303...	7	-6.586...	16	-1.365...	10
355	N178	max	0.082	10	-0.04	7	-0.06	5	1.117e...	13	3.277e...	10	1.727e...	10
356		min	-0.062	4	-0.277	13	-0.241	24	1.79e-03	7	-2.219...	4	-1.515...	4
357	N179	max	0.006	23	0.005	7	0	2	5.101e...	1	6.035e...	10	7.905e...	7
358		min	-0.001	5	-0.005	1	-0.003	37	-1.035...	19	-3.976...	16	-8.872...	1
359	N180	max	0.044	23	0.033	8	-0.208	5	6.446e...	15	-7.061...	8	4.091e...	3
360		min	0.01	5	-0.04	2	-0.733	23	-2.44e...	9	-2.449...	15	-4.338...	9
361	N181	max	0.01	11	0.019	7	-0.278	9	1.806e...	24	-1.26e...	12	1.11e-03	4
362		min	-0.039	16	-0.014	1	-0.967	15	3.538e...	5	-7.677...	18	-1.619...	10
363	N182	max	0.033	21	0.005	7	-0.06	5	1.215e...	24	1.193e...	25	1.188e...	10
364		min	-0.013	3	-0.049	13	-0.241	24	1.673e...	6	-4.254...	17	-1.261...	4
365	N183	max	0.065	23	0.217	7	-0.048	3	4.188e...	1	3.086e...	22	2.476e...	7
366		min	-0.009	5	-0.203	1	-0.164	21	-4.52e...	7	-7.669...	4	-2.449...	1
367	N184	max	0.201	22	0.058	7	-0.037	6	2.839e...	1	9.213e...	22	1.036e...	8
368		min	0.03	4	-0.065	1	-0.131	24	-2.633...	7	1.013e...	4	-1.122...	2
369	N185	max	0.101	10	-0.002	7	-0.259	9	3.785e...	24	2.472e...	10	5.374e...	4
370		min	-0.188	4	-0.135	13	-0.893	15	-1.65e...	6	-4.63e...	4	-7.111...	10

Node Displacements (Continued)

Node...		X [in]	LC	Y [in]	LC	Z [in]	LC	X Rota...	LC	Y Rota...	LC	Z Rota...	LC	
371	N186	max	0.162	10	-0.039	7	-0.181	5	9.987e...	24	4.089e...	10	1.559e...	23
372		min	-0.111	4	-0.251	13	-0.669	24	1.57e-03	6	-2.698...	4	-6.31e...	4
373	N187	max	0.013	24	0.102	7	-0.048	3	-3.207...	8	-3.327...	10	2.282e...	7
374		min	-0.003	6	-0.105	1	-0.164	21	-4.78e...	15	-6.637...	16	-2.295...	1
375	N188	max	0.036	21	0.015	8	-0.037	6	1.443e...	2	-4.636...	10	7.7e-04	8
376		min	0.005	4	-0.018	2	-0.131	24	-2.025...	8	-1.946...	16	-9.415...	2
377	N189	max	0.06	10	0.016	7	-0.26	9	1.54e-03	14	-5.872...	11	4.797e...	3
378		min	-0.056	4	-0.022	1	-0.893	15	1.557e...	8	-2.248...	22	-5.918...	9
379	N190	max	0.056	10	0.006	8	-0.182	5	1.242e...	14	1.186e...	13	7.406e...	11
380		min	-0.055	4	-0.045	13	-0.669	24	-3.424...	9	2.446e...	4	-1.043...	5
381	N191	max	0.036	10	0.304	7	-0.054	3	8.9e-03	1	2.662e...	10	2.229e...	1
382		min	-0.067	4	-0.288	1	-0.187	21	-9.327...	7	-4.161...	4	-2.249...	7
383	N192	max	-0.005	10	0.14	7	-0.041	7	7.711e...	1	6.084e...	10	1.383e...	12
384		min	-0.201	16	-0.149	1	-0.139	13	-7.394...	7	-9.756...	16	-1.286...	6
385	N193	max	0.162	10	-0.018	7	-0.192	9	9.58e-03	13	6.071e...	10	2.27e-04	9
386		min	-0.214	4	-0.231	13	-0.668	15	3.614e...	7	-7.531...	4	-1.397...	15
387	N194	max	0.25	10	0.01	7	-0.258	5	4.71e-03	13	8.182e...	10	4.205e...	17
388		min	-0.16	4	-0.149	13	-0.932	24	-1.201...	7	-5.847...	4	-1.622...	11
389	N195	max	0.07	10	0.256	7	-0.054	3	8.106e...	7	2.807e...	4	1.932e...	1
390		min	-0.039	4	-0.273	1	-0.187	21	-8.559...	1	-4.31e...	10	-1.908...	7
391	N196	max	0.2	22	0.14	7	-0.042	7	7.499e...	7	5.607e...	4	1.2e-03	12
392		min	0.008	4	-0.136	1	-0.139	24	-7.222...	1	-9.6e-03	22	-1.013...	6
393	N197	max	0.257	10	0.249	19	-0.193	9	9.901e...	19	8.569e...	4	1.092e...	21
394		min	-0.21	4	-0.016	1	-0.668	15	-1.548...	1	-1.008...	10	-6.02e...	3
395	N198	max	0.209	10	0.143	19	-0.26	5	5.774e...	7	1.059e...	4	1.85e-04	17
396		min	-0.288	4	-0.055	1	-0.932	24	-3.188...	1	-8.333...	10	-8.765...	12
397	N199	max	0.001	8	0.013	7	0	1	1.01e-03	1	-1.502...	9	1.056e...	1
398		min	-0.015	14	-0.014	1	-0.004	19	-8.871...	7	-1.522...	15	-1.294...	7
399	N200	max	-0.027	8	0.047	6	-0.211	8	1.608e...	1	-2.56e...	9	9.589e...	18
400		min	-0.114	15	-0.069	12	-0.715	14	-1.309...	7	-1.041...	15	-4.549...	12
401	N201	max	0.043	10	-0.02	6	-0.066	9	1.097e...	24	1.068e...	10	1.843e...	10
402		min	-0.053	4	-0.152	24	-0.246	15	3.032e...	5	-2.254...	16	-2.065...	4
403	N202	max	0.117	22	0.001	6	-0.28	5	6.256e...	10	6.72e-03	22	1.841e...	4
404		min	-0.016	4	-0.073	24	-1.006	23	-5.101...	4	2.983e...	4	-2.734...	10
405	N203	max	0.004	9	0.005	7	0	1	1.697e...	39	7.846e...	17	1.119e...	1
406		min	-0.003	3	-0.005	1	-0.004	19	-1.26e...	13	2.178e...	25	-1.127...	7
407	N204	max	0.007	22	0.033	6	-0.211	8	6.567e...	23	4.886e...	15	7.264e...	6
408		min	-0.002	5	-0.043	12	-0.715	14	-6.896...	5	1.374e...	9	-5.442...	12
409	N205	max	0.021	11	0.012	7	-0.066	9	-7.494...	11	1.419e...	23	1.73e-03	10
410		min	-0.03	5	-0.036	13	-0.246	15	-2.973...	17	3.064e...	5	-1.739...	4
411	N206	max	0.036	22	0.016	7	-0.28	5	2.748e...	14	-3.101...	8	2.112e...	4
412		min	-0.016	4	-0.025	1	-1.006	23	6.564e...	8	-1.317...	13	-1.988...	10

LRFD

Member	Shape	Code...	Loc [in]	LC	Shear...	Loc [in]	Dir	LC	phi*P...	phi*P...	phi*M...	phi*M...	Cb	Eqn
1	M43	PIPE...	0.112	52.5	13	0.118	52.5	10	85371...	93240	10.631	10.631	3	H1-1b
2	M48	PIPE...	0.293	10.5	18	0.287	10.5	18	85371...	93240	10.631	10.631	3	H3-6
3	M53	PIPE...	0.242	52.5	14	0.273	10.5	20	85371...	93240	10.631	10.631	3	H1-1b
4	M2	PIPE...	0.697	180.625	19	0.492	180.625	17	15471...	65205	5.749	5.749	3	H3-6
5	M13	PIPE...	0.690	102	15	0.108	102	1	15471...	65205	5.749	5.749	2.239	H1-1b
6	M14	PIPE...	0.462	153.333	18	0.235	6.667	22	25150...	65205	5.749	5.749	2.593	H1-1b
7	M15	PIPE...	0.463	153.333	20	0.215	6.667	16	25150...	65205	5.749	5.749	2.704	H1-1b
8	M19	PIPE...	0.706	23.375	13	0.549	180.625	13	15471...	65205	5.749	5.749	3	H3-6
9	M20	PIPE...	0.639	102	21	0.112	102	1	15471...	65205	5.749	5.749	2.674	H1-1b
10	M21	PIPE...	0.353	153.333	23	0.238	6.667	14	25150...	65205	5.749	5.749	2.617	H1-1b
11	M22	PIPE...	0.356	153.333	15	0.222	6.667	23	25150...	65205	5.749	5.749	2.731	H1-1b
12	M6	PIPE...	0.360	24	1	0.044	24	7	14916...	32130	1.872	1.872	1.328	H1-1b
13	M7	PIPE...	0.230	24	22	0.025	72	17	14916...	32130	1.872	1.872	1.468	H1-1b



LRFD (Continued)

Member	Shape	Code...	Loc [in]	LC	Shear...	Loc [in]	Dir	LC	phi*P...	phi*P...	phi*M...	phi*M...	Cb	Eqn	
14	M8	PIPE...	0.129	24	7	0.023	72		17	14916...	32130	1.872	1.872	1.88	H1-1b
15	M28	PIPE...	0.133	24	15	0.025	72		21	14916...	32130	1.872	1.872	1.715	H1-1b
16	M34	PIPE...	0.713	24	22	0.073	24		22	14916...	32130	1.872	1.872	1.495	H1-1b
17	M35	PIPE...	0.730	24	15	0.072	24		16	14916...	32130	1.872	1.872	1.524	H1-1b
18	M36	PIPE...	0.834	24	15	0.096	24		16	14916...	32130	1.872	1.872	1.805	H1-1b
19	M41	PIPE...	0.891	24	22	0.103	72		16	14916...	32130	1.872	1.872	1.536	H1-1b
20	M56	PIPE...	0.472	60	22	0.079	36		22	20866...	32130	1.872	1.872	1.787	H1-1b
21	M57	PIPE...	0.396	60	16	0.071	36		4	20866...	32130	1.872	1.872	1.792	H1-1b
22	M62	PIPE...	0.095	50.871	16	0.010	101.743		24	13570...	32130	1.872	1.872	1.136	H1-1b
23	M63	PIPE...	0.095	50.871	22	0.011	101.743		14	13570...	32130	1.872	1.872	1.136	H1-1b
24	M67	PIPE...	0.638	21	15	0.091	69		18	14916...	32130	1.872	1.872	2.177	H1-1b
25	M68	PIPE...	0.196	21	15	0.022	69		20	14916...	32130	1.872	1.872	2.158	H1-1b
26	M69	PIPE...	0.426	21	16	0.084	21		16	14916...	32130	1.872	1.872	2.251	H1-1b
27	M74	PIPE...	0.789	69	18	0.087	21		15	14916...	32130	1.872	1.872	2.24	H1-1b
28	M79	PIPE...	0.426	69	10	0.043	69		4	14916...	32130	1.872	1.872	2.37	H1-1b
29	M80	PIPE...	0.672	21	23	0.099	69		19	14916...	32130	1.872	1.872	2.22	H1-1b
30	M81	PIPE...	0.774	21	24	0.085	21		23	14916...	32130	1.872	1.872	2.209	H1-1b
31	M86	PIPE...	0.459	21	22	0.089	21		22	14916...	32130	1.872	1.872	2.254	H1-1b

Cold Formed Steel Code Checks

No Data to Print...

Exhibit F

RADIO FREQUENCY EMISSIONS ANALYSIS REPORT
EVALUATION OF HUMAN EXPOSURE POTENTIAL
TO NON-IONIZING EMISSIONS

T-Mobile Existing Facility

Site ID: CTHA174A

Manchester
33 Mitchell Drive
Manchester, Connecticut 06040

June 29, 2020

EBI Project Number: 6220002750

Site Compliance Summary	
Compliance Status:	COMPLIANT
Site total MPE% of FCC general population allowable limit:	17.21%

June 29, 2020

T-Mobile
Attn: Jason Overbey, RF Manager
35 Griffin Road South
Bloomfield, Connecticut 06002

Emissions Analysis for Site: CTHA174A - Manchester

EBI Consulting was directed to analyze the proposed T-Mobile facility located at **33 Mitchell Drive in Manchester, Connecticut** for the purpose of determining whether the emissions from the Proposed T-Mobile Antenna Installation located on this property are within specified federal limits.

All information used in this report was analyzed as a percentage of current Maximum Permissible Exposure (% MPE) as listed in the FCC OET Bulletin 65 Edition 97-01 and ANSI/IEEE Std C95.1. The FCC regulates Maximum Permissible Exposure in units of microwatts per square centimeter ($\mu\text{W}/\text{cm}^2$). The number of $\mu\text{W}/\text{cm}^2$ calculated at each sample point is called the power density. The exposure limit for power density varies depending upon the frequencies being utilized. Wireless Carriers and Paging Services use different frequency bands each with different exposure limits; therefore, it is necessary to report results and limits in terms of percent MPE rather than power density.

All results were compared to the FCC (Federal Communications Commission) radio frequency exposure rules, 47 CFR 1.1307(b)(1) – (b)(3), to determine compliance with the Maximum Permissible Exposure (MPE) limits for General Population/Uncontrolled environments as defined below.

General population/uncontrolled exposure limits apply to situations in which the general population may be exposed or in which persons who are exposed as a consequence of their employment may not be made fully aware of the potential for exposure or cannot exercise control over their exposure. Therefore, members of the general population would always be considered under this category when exposure is not employment related, for example, in the case of a telecommunications tower that exposes persons in a nearby residential area.

Public exposure to radio frequencies is regulated and enforced in units of microwatts per square centimeter ($\mu\text{W}/\text{cm}^2$). The general population exposure limits for the 600 MHz and 700 MHz frequency bands are approximately $400 \mu\text{W}/\text{cm}^2$ and $467 \mu\text{W}/\text{cm}^2$, respectively. The general population exposure limit for the 1900 MHz (PCS), 2100 MHz (AWS) and 11 GHz frequency bands is $1000 \mu\text{W}/\text{cm}^2$. Because each carrier will be using different frequency bands, and each frequency band has different exposure limits, it is necessary to report percent of MPE rather than power density.

Occupational/controlled exposure limits apply to situations in which persons are exposed as a consequence of their employment and in which those persons who are exposed have been made fully aware of the potential for exposure and can exercise control over their exposure. Occupational/controlled exposure limits also apply where exposure is of a transient nature as a result of incidental passage through a location where exposure levels may be above general population/uncontrolled limits (see below), as long as the exposed person has been made fully aware of the potential for exposure and can exercise control over his or her exposure by leaving the area or by some other appropriate means.

Additional details can be found in FCC OET 65.

CALCULATIONS

Calculations were done for the proposed T-Mobile Wireless antenna facility located at 33 Mitchell Drive in Manchester, Connecticut using the equipment information listed below. All calculations were performed per the specifications under FCC OET 65. Since T-Mobile is proposing highly focused directional panel antennas, which project most of the emitted energy out toward the horizon, all calculations were performed assuming a lobe representing the maximum gain of the antenna per the antenna manufacturer's supplied specifications, minus 10 dB for directional panel antennas and 20 dB for highly focused parabolic microwave dishes, was focused at the base of the tower. For this report, the sample point is the top of a 6-foot person standing at the base of the tower.

For all calculations, all equipment was calculated using the following assumptions:

- 1) 2 LTE channels (600 MHz Band) were considered for each sector of the proposed installation. These Channels have a transmit power of 30 Watts per Channel.
- 2) 1 NR channel (600 MHz Band) was considered for each sector of the proposed installation. This Channel has a transmit power of 80 Watts.
- 3) 2 LTE channels (700 MHz Band) were considered for each sector of the proposed installation. These Channels have a transmit power of 30 Watts per Channel.
- 4) 4 GSM channels (PCS Band - 1900 MHz) were considered for each sector of the proposed installation. These Channels have a transmit power of 30 Watts per Channel.
- 5) 4 LTE channels (PCS Band - 1900 MHz) were considered for each sector of the proposed installation. These Channels have a transmit power of 60 Watts per Channel.

- 6) 2 UMTS channels (AWS Band - 2100 MHz) were considered for each sector of the proposed installation. These Channels have a transmit power of 30 Watts per Channel.
- 7) 2 LTE channels (AWS Band – 2100 MHz) were considered for each sector of the proposed installation. These Channels have a transmit power of 60 Watts per Channel.
- 8) 2 LTE channels (BRS Band - 2500 MHz) were considered for each sector of the proposed installation. These Channels have a transmit power of 40 Watts per Channel.
- 9) 2 NR channels (BRS Band - 2500 MHz) were considered for each sector of the proposed installation. These Channels have a transmit power of 40 Watts per Channel.
- 10) All radios at the proposed installation were considered to be running at full power and were uncombined in their RF transmissions paths per carrier prescribed configuration. Per FCC OET Bulletin No. 65 - Edition 97-01 recommendations to achieve the maximum anticipated value at each sample point, all power levels emitting from the proposed antenna installation are increased by a factor of 2.56 to account for possible in-phase reflections from the surrounding environment. This is rarely the case, and if so, is never continuous.
- 11) For the following calculations, the sample point was the top of a 6-foot person standing at the base of the tower. The maximum gain of the antenna per the antenna manufacturer's supplied specifications, minus 10 dB for directional panel antennas and 20 dB for highly focused parabolic microwave dishes, was used in this direction. This value is a very conservative estimate as gain reductions for these particular antennas are typically much higher in this direction.
- 12) The antennas used in this modeling are the Ericsson AIR 21 for the 1900 MHz / 2100 MHz channel(s), the Ericsson AIR 32 for the 1900 MHz / 2100 MHz channel(s), the RFS APXVAARR24_43-UNA20 for the 600 MHz / 600 MHz / 700 MHz / 1900 MHz channel(s), the Ericsson AIR 6449 for the 2500 MHz / 2500 MHz channel(s) in Sector A, the Ericsson AIR 21 for the 1900 MHz / 2100 MHz channel(s), the Ericsson AIR 32 for the 1900 MHz / 2100 MHz channel(s), the RFS APXVAARR24_43-UNA20 for the 600 MHz / 600 MHz / 700 MHz / 1900 MHz channel(s), the Ericsson AIR 6449 for the 2500 MHz / 2500 MHz channel(s) in Sector B, the Ericsson AIR 21 for the 1900 MHz / 2100 MHz channel(s), the Ericsson AIR 32 for the 1900 MHz / 2100 MHz channel(s), the RFS APXVAARR24_43-UNA20 for the 600 MHz / 600 MHz / 700 MHz / 1900 MHz channel(s), the Ericsson AIR 6449 for the 2500 MHz / 2500 MHz channel(s) in Sector C. This is based on feedback from the carrier with regard to anticipated antenna selection. All Antenna gain values and associated transmit power levels are shown in the Site Inventory and Power Data table below. The maximum gain of the antenna per the antenna manufacturer's supplied specifications, minus 10 dB for directional

panel antennas and 20 dB for highly focused parabolic microwave dishes, was used for all calculations. This value is a very conservative estimate as gain reductions for these particular antennas are typically much higher in this direction.

- 13) The antenna mounting height centerline of the proposed antennas is 140 feet above ground level (AGL).
- 14) Emissions values for additional carriers were taken from the Connecticut Siting Council active database. Values in this database are provided by the individual carriers themselves.
- 15) All calculations were done with respect to uncontrolled / general population threshold limits.

T-Mobile Site Inventory and Power Data

Sector:	A	Sector:	B	Sector:	C
Antenna #:	1	Antenna #:	1	Antenna #:	1
Make / Model:	Ericsson AIR 21	Make / Model:	Ericsson AIR 21	Make / Model:	Ericsson AIR 21
Frequency Bands:	1900 MHz / 2100 MHz	Frequency Bands:	1900 MHz / 2100 MHz	Frequency Bands:	1900 MHz / 2100 MHz
Gain:	15.35 dBd / 15.35 dBd	Gain:	15.35 dBd / 15.35 dBd	Gain:	15.35 dBd / 15.35 dBd
Height (AGL):	140 feet	Height (AGL):	140 feet	Height (AGL):	140 feet
Channel Count:	6	Channel Count:	6	Channel Count:	6
Total TX Power (W):	180 Watts	Total TX Power (W):	180 Watts	Total TX Power (W):	180 Watts
ERP (W):	6,169.82	ERP (W):	6,169.82	ERP (W):	6,169.82
Antenna A1 MPE %:	1.13%	Antenna B1 MPE %:	1.13%	Antenna C1 MPE %:	1.13%
Antenna #:	2	Antenna #:	2	Antenna #:	2
Make / Model:	Ericsson AIR 32	Make / Model:	Ericsson AIR 32	Make / Model:	Ericsson AIR 32
Frequency Bands:	1900 MHz / 2100 MHz	Frequency Bands:	1900 MHz / 2100 MHz	Frequency Bands:	1900 MHz / 2100 MHz
Gain:	15.35 dBd / 15.85 dBd	Gain:	15.35 dBd / 15.85 dBd	Gain:	15.35 dBd / 15.85 dBd
Height (AGL):	140 feet	Height (AGL):	140 feet	Height (AGL):	140 feet
Channel Count:	4	Channel Count:	4	Channel Count:	4
Total TX Power (W):	240 Watts	Total TX Power (W):	240 Watts	Total TX Power (W):	240 Watts
ERP (W):	8,728.31	ERP (W):	8,728.31	ERP (W):	8,728.31
Antenna A2 MPE %:	1.60%	Antenna B2 MPE %:	1.60%	Antenna C2 MPE %:	1.60%
Antenna #:	3	Antenna #:	3	Antenna #:	3
Make / Model:	RFS APXVAARR24_43-UNA20	Make / Model:	RFS APXVAARR24_43-UNA20	Make / Model:	RFS APXVAARR24_43-UNA20
Frequency Bands:	600 MHz / 600 MHz / 700 MHz / 1900 MHz	Frequency Bands:	600 MHz / 600 MHz / 700 MHz / 1900 MHz	Frequency Bands:	600 MHz / 600 MHz / 700 MHz / 1900 MHz
Gain:	12.95 dBd / 12.95 dBd / 13.35 dBd / 15.65 dBd	Gain:	12.95 dBd / 12.95 dBd / 13.35 dBd / 15.65 dBd	Gain:	12.95 dBd / 12.95 dBd / 13.35 dBd / 15.65 dBd
Height (AGL):	140 feet	Height (AGL):	140 feet	Height (AGL):	140 feet
Channel Count:	7	Channel Count:	7	Channel Count:	7
Total TX Power (W):	320 Watts	Total TX Power (W):	320 Watts	Total TX Power (W):	320 Watts
ERP (W):	8,466.41	ERP (W):	8,466.41	ERP (W):	8,466.41
Antenna A3 MPE %:	2.58%	Antenna B3 MPE %:	2.58%	Antenna C3 MPE %:	2.58%
Antenna #:	4	Antenna #:	4	Antenna #:	4
Make / Model:	Ericsson AIR 6449	Make / Model:	Ericsson AIR 6449	Make / Model:	Ericsson AIR 6449
Frequency Bands:	2500 MHz / 2500 MHz	Frequency Bands:	2500 MHz / 2500 MHz	Frequency Bands:	2500 MHz / 2500 MHz
Gain:	22.05 dBd / 22.05 dBd	Gain:	22.05 dBd / 22.05 dBd	Gain:	22.05 dBd / 22.05 dBd
Height (AGL):	140 feet	Height (AGL):	140 feet	Height (AGL):	140 feet
Channel Count:	4	Channel Count:	4	Channel Count:	4
Total TX Power (W):	160 Watts	Total TX Power (W):	160 Watts	Total TX Power (W):	160 Watts
ERP (W):	25,651.93	ERP (W):	25,651.93	ERP (W):	25,651.93
Antenna A4 MPE %:	4.71%	Antenna B4 MPE %:	4.71%	Antenna C4 MPE %:	4.71%

Site Composite MPE %	
Carrier	MPE %
T-Mobile (Max at Sector A):	10.02%
T-Mobile Microwave	0.34%
Verizon	6.85%
Site Total MPE % :	17.21%

T-Mobile MPE % Per Sector	
T-Mobile Sector A Total:	10.02%
T-Mobile Sector B Total:	10.02%
T-Mobile Sector C Total:	10.02%
Site Total MPE % :	17.21%

T-Mobile Maximum MPE Power Values (Sector A)							
T-Mobile Frequency Band / Technology (Sector A)	# Channels	Watts ERP (Per Channel)	Height (feet)	Total Power Density ($\mu\text{W}/\text{cm}^2$)	Frequency (MHz)	Allowable MPE ($\mu\text{W}/\text{cm}^2$)	Calculated % MPE
T-Mobile 1900 MHz GSM	4	1028.30	140.0	7.54	1900 MHz GSM	1000	0.75%
T-Mobile 2100 MHz UMTS	2	1028.30	140.0	3.77	2100 MHz UMTS	1000	0.38%
T-Mobile 1900 MHz LTE	2	2056.61	140.0	7.54	1900 MHz LTE	1000	0.75%
T-Mobile 2100 MHz LTE	2	2307.55	140.0	8.47	2100 MHz LTE	1000	0.85%
T-Mobile 600 MHz LTE	2	591.73	140.0	2.17	600 MHz LTE	400	0.54%
T-Mobile 600 MHz NR	1	1577.94	140.0	2.89	600 MHz NR	400	0.72%
T-Mobile 700 MHz LTE	2	648.82	140.0	2.38	700 MHz LTE	467	0.51%
T-Mobile 1900 MHz LTE	2	2203.69	140.0	8.08	1900 MHz LTE	1000	0.81%
T-Mobile 2500 MHz LTE	2	6412.98	140.0	23.53	2500 MHz LTE	1000	2.35%
T-Mobile 2500 MHz NR	2	6412.98	140.0	23.53	2500 MHz NR	1000	2.35%
						Total:	10.02%

• NOTE: Totals may vary by approximately 0.01% due to summation of remainders in calculations.

Summary

All calculations performed for this analysis yielded results that were **within** the allowable limits for general population exposure to RF Emissions.

The anticipated maximum composite contributions from the T-Mobile facility as well as the site composite emissions value with regards to compliance with FCC's allowable limits for general population exposure to RF Emissions are shown here:

T-Mobile Sector	Power Density Value (%)
Sector A:	10.02%
Sector B:	10.02%
Sector C:	10.02%
T-Mobile Maximum MPE % (Sector A):	10.02%
Site Total:	17.21%
Site Compliance Status:	COMPLIANT

The anticipated composite MPE value for this site assuming all carriers present is **17.21%** of the allowable FCC established general population limit sampled at the ground level. This is based upon values listed in the Connecticut Siting Council database for existing carrier emissions.

FCC guidelines state that if a site is found to be out of compliance (over allowable thresholds), that carriers over a 5% contribution to the composite value will require measures to bring the site into compliance. For this facility, the composite values calculated were well within the allowable 100% threshold standard per the federal government.

Exhibit G

From: [Deborah Chase](#)
To: ["sshanley@manchesterct.gov"](mailto:sshanley@manchesterct.gov)
Cc: ["mpilla@manchesterct.gov"](mailto:mpilla@manchesterct.gov); ["ganderson@manchesterct.gov"](mailto:ganderson@manchesterct.gov)
Subject: 33 MITCHELL DRIVE, MANCHESTER, CT 06042-2317 T-MOBILE EM APPLICATION (CTHA174A-ANCHOR)
Date: Tuesday, June 30, 2020 4:14:00 PM
Attachments: [image001.png](#)

Good afternoon,

On behalf of our client, (T-Mobile), I am forwarding copies of T-Mobile's Exempt Modification Request to

collocate on a wireless telecommunications facility located at 33 Mitchell Drive in Manchester.

Hard copies will be sent as well for your records.

Please do not hesitate to contact me with any questions regarding T-Mobile's Exempt Modification Request.

Thank you very much

Deborah Chase

Senior Project Coordinator & Analyst

Mobile: 860-490-8839



 Save a tree. Refuse.Reduce. Reuse. Recycle.

Exhibit H



**UNITED STATES
POSTAL SERVICE®**

Click-N-Ship®

P

usps.com
US POSTAGE \$7.75
 Flat Rate Enviv



07/02/2020 Mailed from 01566 062S0000001309

PRIORITY MAIL 2-DAY™

Expected Delivery Date: 07/08/20

DEBORAH CHASE
 NORTHEAST SITE SOLUTIONS, LLC
 420 MAIN ST STE 2
 STURBRIDGE MA 01566-1359

0006

Carrier -- Leave if No Response

C006

SHIP TO: LISA A MATTHEWS
 CT SITING COUNCIL
 10 FRANKLIN SQ
 NEW BRITAIN CT 06051-2655

USPS TRACKING #



9405 5036 9930 0440 6786 60

Electronic Rate Approved #038555749



Cut on dotted line.

Instructions

1. Each Click-N-Ship® label is unique. Labels are to be used as printed and used only once. DO NOT PHOTO COPY OR ALTER LABEL.
2. Place your label so it does not wrap around the edge of the package.
3. Adhere your label to the package. A self-adhesive label is recommended. If tape or glue is used, DO NOT TAPE OVER BARCODE. Be sure all edges are secure.
4. To mail your package with PC Postage®, you may schedule a Package Pickup online, hand to your letter carrier, take to a Post Office™, or drop in a USPS collection box.
5. Mail your package on the "Ship Date" you selected when creating this label.

Click-N-Ship® Label Record

USPS TRACKING # :
9405 5036 9930 0440 6786 60

Trans. #: 498636869	Priority Mail® Postage: \$7.75
Print Date: 07/02/2020	Total: \$7.75
Ship Date: 07/02/2020	
Expected Delivery Date: 07/08/2020	

From: DEBORAH CHASE
 NORTHEAST SITE SOLUTIONS, LLC
 420 MAIN ST STE 2
 STURBRIDGE MA 01566-1359

To: LISA A MATTHEWS
 CT SITING COUNCIL
 10 FRANKLIN SQ
 NEW BRITAIN CT 06051-2655

* Retail Pricing Priority Mail rates apply. There is no fee for USPS Tracking® service on Priority Mail service with use of this electronic rate shipping label. Refunds for unused postage paid labels can be requested online 30 days from the print date.



Thank you for shipping with the United States Postal Service!
 Check the status of your shipment on the USPS Tracking® page at usps.com