



Denise Sabo
420 Main Street, Box 2
Sturbridge MA 01566
860-209-4690
denise@northeastitesolutions.com

June 13, 2018

Members of the Siting Council
Connecticut Siting Council
Ten Franklin Square
New Britain, CT 06051

RE: Exempt Modification Application
239 East Middle Turnpike, Manchester CT 06040
Latitude: 41.78438900
Longitude: -72.51177100
T-Mobile Site#: CT11365D-L700 4x2

Dear Ms. Bachman:

T-Mobile is requesting to file an exempt modification for an existing 184-foot monopole tower located at 239 East Middle Turnpike, Manchester CT 06040. T-Mobile currently has approval for nine (9) antennas at the 163-foot level of the existing 184-foot tower. The tower and property are owned by Town of Manchester. T-Mobile now intends to install one (1) IBR1300 Dish and replace existing antenna equipment. The new dish would be installed at the 163-foot level of the tower.

Planned Modifications:

Remove:
NONE

Remove and Replace:

(3) LNX6515 Antenna (remove) - (3) APXAARR24 Antenna 600-700 Mhz (replace)
(3) AIR21 Antenna (remove) - (3) AIR3246 B66 Antenna 1900-2100 Mhz (replace)
(3) TMA (remove) – TMA KRY112 144/2 (replace)
(3) RRU (remove) – RRU -4449 B71 B12 (replace)

Install New:

(1) IBR1300 Dish
(1) Fiber line
(2) CAT6 Cables

Existing to Remain:

(21) 1-5/8" Coax
(2) Hybrid line
(3) AIR32 Antenna – 1900-2100 Mhz

"This facility was first approved by the Town of Manchester P&Z – Approved in 2002 to erect telecommunication tower.
"Please see attached.

Please accept this letter as notification pursuant to Regulations of Connecticut State Agencies § 16- SOj-73, for construction that constitutes an exempt modification pursuant to R.C.S.A. § 16-50j-72(b)(2). In accordance with R.C.S.A. § 16-SOj-73, a copy of this letter is being sent to Mayor Jay Moran, Elected Official and Matthew Bordeaux, Planning Director for the Town of Manchester, as well as the property owner and the tower owner.

The planned modifications to the facility fall squarely within those activities explicitly provided for in R.C.S.A. § 16-50j-72(b)(2).

1. The proposed modifications will not result in an increase in the height of the existing structure.
2. The proposed modifications will not require the extension of the site boundary.
3. The proposed modifications will not increase noise levels at the facility by six decibels or more, or to levels that exceed state and local criteria.
4. The operation of the replacement antennas will not increase radio frequency emissions at the facility to a level at or above the Federal Communications Commission safety standard.
5. The proposed modifications will not cause a change or alteration in the physical or environmental characteristics of the site. .
6. The existing structure and its foundation can support the proposed loading.

For the foregoing reasons, T-Mobile respectfully submits that the proposed modifications to the above referenced telecommunications facility constitute an exempt modification under R.C.S.A. § 16-50j-72(b)(2).

Sincerely,

Denise Sabo
Mobile: 860-209-4690
Fax: 413-521-0558
Office: 4 Angela's Way, Burlington CT 06013
Email: denise@northeastsitesolutions.com

Attachments

cc: Jay Moran, Mayor- as elected official
Matthew Bordeaux, Zoning Director
Town of Manchester - as property & tower owner

Exhibit A



Town of Manchester

41 Center Street • P.O. Box 191
Manchester, Connecticut 06045-0191
www.ci.manchester.ct.us

STEPHEN T. CASSANO, MAYOR
JOSH M. HOWROYD, DEPUTY MAYOR
CHRISTY SCOTT, SECRETARY

DIRECTORS
TIMOTHY H. BECKER
THOMAS P. CROCKETT
JOSEPH S. HACHEY
DAVID M. SHERIDAN
LOUIS A. SPADACCINI
KEVIN L. ZINGLER

STEVEN R. WERBNER, GENERAL MANAGER

June 14, 2002

Mr. Wayne Medlin
Sprint PCS
Crossroads Corporate Center – Suite 800
1 International Blvd.
Mahwah, NJ 07495

Re: Manchester Police Antenna

Dear Mr. Medlin:

We understand that an agreement between the Town of Manchester and Sprint PCS has been executed, and that Sprint PCS will construct a monopole tower at the Manchester Police Headquarters for its communications needs and build a new parking lot as part of that arrangement.

The police station's monopole tower is considered an accessory municipal structure and is permitted by the Town of Manchester zoning regulations. In Connecticut, before such an improvement project can be carried out, the Planning and Zoning Commission must issue a report on that project. Our PZC issued such a report on March 18, 2002. I have enclosed a memorandum dated March 21, 2002 relaying that report, and my supporting memorandum dated March 14, 2002.

At this stage Sprint PCS and the Town will need to secure the necessary building permits from the town building department and a zoning certificate from the zoning officer before construction can proceed.

Very truly yours,

Mark Pellegrini, AICP
Director of Neighborhood Services and
Economic Development

MP/s

R:\SHARON09\MARK\LETTERS\SPRINT PCS.DOC

cc: Mr. William Bellock
Timothy O'Neil, Assistant Town Attorney

An Equal Opportunity Employer



**TOWN OF MANCHESTER
PLANNING DEPARTMENT**

TO: Steven R. Werbner, General Manager

FROM: Mark Pellegrini, Director of Neighborhood Services
and Economic Development



DATE: March 21, 2002

RE: Mandatory Referral Report
Police Station Radio Tower and Parking Lot Expansion (MR-0201)

At its meeting of March 18, 2002 the Planning and Zoning Commission voted unanimously to endorse the proposal to construct a monopole tower at the Manchester Police Headquarters, dismantle the existing tower, and build a new parking lot as shown on plans submitted by the Manchester Police Department dated September 11, 2001 and amended to September 26, 2001. In making this decision the Planning and Zoning Commission considered my memorandum of March 14, 2002 (copy attached) as well as a review of the site plan and photo simulations of the proposed new tower presented by Lt. Marc Montminy at their meeting.

MP/s

R:\SHARON09\MARK\MEMOS\Werbner-MR0102.doc

Attach.

**TOWN OF MANCHESTER
PLANNING DEPARTMENT**

TO: Planning and Zoning Commission

FROM: Mark Pellegrini, Director of Neighborhood Services
And Economic Development 

DATE: March 14, 2002

RE: Mandatory Referral Report
Police Station Radio Tower and Parking Lot Expansion (MR-0201)

The Planning and Zoning Commission is being asked to report on a proposal developed by the Manchester Police Department to replace its current radio tower and build a new parking lot in the location of the current tower at the Police Headquarters.

Description of Project

The police department has an existing 190' high lattice-type radio tower to serve its radio communications needs. The department wishes to replace this tower and equipment. They also have experienced parking problems, especially on Princeton Street, during daytime hours. The activity at the department's headquarters has created a greater demand for daytime parking than originally anticipated. Relocating the tower would provide room to add parking in front of the garage along Middle Turnpike. Attached is a site plan showing the proposed new tower location and the new parking lot, as well as a series of photo simulations showing the potential visual impact of the new monopole tower proposed to be constructed here.

There is no PZC approval aside from this mandatory referral report required for this project. The parking lot is less than one-half acre and therefore no erosion control plan will be needed. The new monopole tower is a permitted accessory structure and will only require a building permit and zoning permit from the Zoning Enforcement Officer.

Construction and Other Uses

The Police Department, through the Town, issued a request for proposals for the construction of the replacement tower. The proposal favored by the department was received from Sprint PCS. Under this proposal Sprint would pay for the construction of the new tower, provide new radio and related equipment to allow for a "hot" transfer so there will be no interruption in police communication during the switch-over from one tower to the other. Sprint PCS will also construct the parking lot and landscaping as proposed on the attached plans. In exchange for

these services, the police department will allow Sprint to locate a personal communications system antenna array on the tower and related hardware on the ground near the tower. The tower will also be capable of holding additional PCS arrays at the discretion of the Town.

Recommendation

The proposed improvements to the police department's headquarters site would be generally consistent with our Plan of Conservation and Development. The police department does require a tall communications antenna for its communication needs, which has become more sophisticated as communications and computing technology have evolved. It would also be beneficial to have more on-site parking at the police department to relieve the traffic problems experienced on Princeton Street and to a lesser extent on Middle Turnpike during certain times of the day.

The construction of a 190±' monopole in this location will have some visual impact. It is possible through the proposed planting around the base of the unit and equipment cabinets to minimize the view of the lowest portions of the tower from passing motorists, but this area would primarily be visible to people driving into the Illing Middle School. The upper portions of the tower will be visible from various locations in the vicinity as shown on the attached photo simulations. The only alternative to a monopole tower would be a lattice-type tower, which in some respects is less intrusive since there is so much open air around the structure itself. However, we have been advised that such towers may become less attractive if multiple antenna arrays are placed on them and increased cabling is run up to the arrays. Lattice towers also require a larger footprint.

MP/s

R:\SHARON09\PZCMEMOS\18MAR02-PZC memos\MR-0201.doc

Attach.

Exhibit B

239 MIDDLE TURNPIKE EAST

Location 239 MIDDLE TURNPIKE EAST

Mblu 92/ 3950/ 239/ /

Acct# 395000239

Owner MANCHESTER TOWN OF

Assessment \$4,243,700

Appraisal \$6,062,100

PID 10705

Building Count 2

Current Value

Appraisal			
Valuation Year	Improvements	Land	Total
2016	\$5,573,900	\$488,200	\$6,062,100

Assessment			
Valuation Year	Improvements	Land	Total
2016	\$3,901,900	\$341,800	\$4,243,700

Owner of Record

Owner MANCHESTER TOWN OF
Address 41 CENTER ST
MANCHESTER, CT 06040-5096

Sale Price \$0
Certificate C
Book & Page
Sale Date

Ownership History

Ownership History				
Owner	Sale Price	Certificate	Book & Page	Sale Date
MANCHESTER TOWN OF	\$0	C		

Building Information

Building 1 : Section 1

Year Built: 1995
Living Area: 46,701
Replacement Cost: \$6,306,043
**Replacement Cost
Less Depreciation:** \$5,044,800

Building Attributes	
Field	Description
STYLE	Other Municip
MODEL	Ind/Comm

Grade	Average +10
Stories:	2
Occupancy	1
Exterior Wall 1	Brick Veneer
Exterior Wall 2	Stucco/Masonry
Roof Structure	Flat
Roof Cover	Tar + Gravel
Interior Wall 1	Minim/Masonry
Interior Wall 2	Drywall/Sheetr
Interior Floor 1	Carpet
Interior Floor 2	Tile/Vinyl Cmp
Heating Fuel	Gas
Heating Type	Forced Air-Duc
AC Type	Central
Bldg Use	Municipal 96
Total Rooms	
Total Bedrms	00
Total Baths	0
1st Floor Use:	901I
Heat/AC	Heat/AC Packag
Frame Type	Steel
Baths/Plumbing	Average
Ceiling/Wall	Susp Ceil & WI
Rooms/Prtns	Average
Wall Height	10
% Comn Wall	0

Building Photo



(http://images.vgsi.com/photos2/ManchesterCTPhotos//\00\03\2

Building Layout

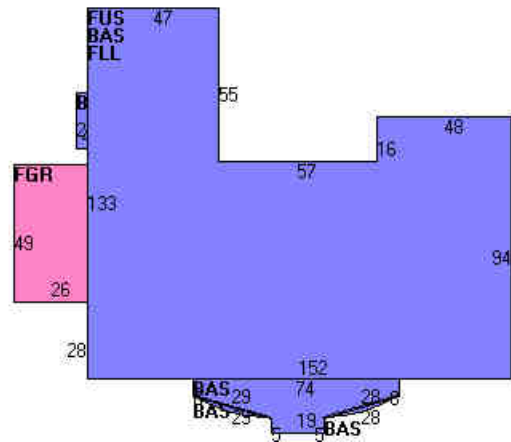

Building Sub-Areas (sq ft)			Legend
Code	Description	Gross Area	Living Area
BAS	First Floor	16,283	16,283
FLL	Finished Lower Level	15,209	15,209
FUS	Upper Story, Finished	15,209	15,209
FGR	Garage	1,274	0
		47,975	46,701

Building 2 : Section 1

Year Built: 1975
Living Area: 7,000
Replacement Cost: \$506,690
Replacement Cost Less Depreciation: \$309,100

Building Attributes : Bldg 2 of 2	
Field	Description
STYLE	Service Shop
MODEL	Ind/Comm

Grade	Average
Stories:	1
Occupancy	1
Exterior Wall 1	Brick Veneer
Exterior Wall 2	
Roof Structure	Gable/Hip
Roof Cover	Asphalt Shingl
Interior Wall 1	Minim/Masonry
Interior Wall 2	
Interior Floor 1	Concr-Finished
Interior Floor 2	
Heating Fuel	Gas
Heating Type	Forced Air-Duc
AC Type	None
Bldg Use	Municipal 96
Total Rooms	
Total Bedrms	00
Total Baths	0
1st Floor Use:	901I
Heat/AC	Heat/AC Packag
Frame Type	Masonry
Baths/Plumbing	Average
Ceiling/Wall	Ceil & Min WI
Rooms/Prtns	Average
Wall Height	19
% Comn Wall	0

Building Photo



(<http://images.vgsi.com/photos2/ManchesterCTPhotos//\00\03\2>)

Building Layout

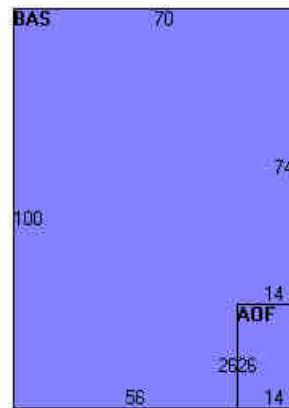

Building Sub-Areas (sq ft)			Legend
Code	Description	Gross Area	Living Area
BAS	First Floor	6,636	6,636
AOF	Office, (Average)	364	364
		7,000	7,000

Extra Features

Extra Features				Legend
Code	Description	Size	Value	Bldg #
MEZ1	Mezzanine-Unfin	1900 S.F.	\$13,300	2
SPR1	Sprinklers-Wet	47975 S.F.	\$54,000	1

Land

Land Use

Use Code 901I

Land Line Valuation

Size (Acres) 3.97

Description Municipal 96
Zone RA
Neighborhood 4000
Alt Land Appr No
Category

Frontage 0
Depth 0
Assessed Value \$341,800
Appraised Value \$488,200

Outbuildings

Outbuildings						Legend
Code	Description	Sub Code	Sub Description	Size	Value	Bldg #
PAV1	Paving Asphalt			97700 S.F.	\$122,100	1
FN4	Fence 8' Chain			128 L.F.	\$1,900	1
LT1	Lights 1Fix			15 UNITS	\$12,900	1
CNP1	Canopy Ave			360 S.F.	\$7,800	1
SHD2	Shed W/Imp			120 S.F.	\$1,300	1
SHD1	Shed			168 S.F.	\$1,500	1
FN3	Fence 6' Chain			160 L.F.	\$3,700	1
SHD2	Shed W/Imp			140 S.F.	\$1,500	1

Valuation History

Appraisal			
Valuation Year	Improvements	Land	Total
2015	\$4,365,100	\$488,200	\$4,853,300
2010	\$4,125,100	\$423,400	\$4,548,500
2005	\$3,622,600	\$380,200	\$4,002,800

Assessment			
Valuation Year	Improvements	Land	Total
2015	\$3,055,600	\$341,800	\$3,397,400
2010	\$2,887,500	\$296,400	\$3,183,900
2005	\$2,535,800	\$266,200	\$2,802,000

Exhibit C

Copyright © 2016 Foresite LLC all rights reserved. The details, templates, drawing formats or any portion of this document generated by Foresite LLC may not be duplicated, traced or used otherwise for any profit-driven enterprise.

ANTENNA UPGRADES BY
T-Mobile
T-MOBILE NORTHEAST LLC

SITE NUMBER: CT11365D
 SITE NAME: CT365/Manchester PD_MP
 SITE ADDRESS: 239 E. MIDDLE TPK
 MANCHESTER, CT 06040
 (RF CONFIGURATION 67D92DB)

APPLICANT:
T-Mobile
T-MOBILE NORTHEAST LLC
 35 GRIFFIN ROAD SOUTH
 BLOOMFIELD, CT 06002
 860-692-7100

PROJECT MANGER
NSS NORTHEAST
 SITE SOLUTIONS
Turnkey Wireless Development
 420 MAIN STREET, BLDG 4
 STURBRIDGE, MA 01566
 203-275-6669

CONSULTANT:
FORESITE LLC
 Architects . Engineers . Surveyors
 462 WALNUT STREET
 NEWTON, MA 02460
 617-212-3123

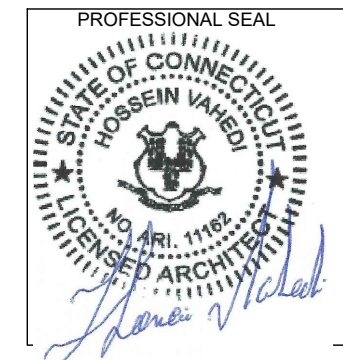

THIS DOCUMENT IS THE DESIGN PROPERTY AND COPYRIGHT OF FORESITE, LLC. AND FOR THE EXCLUSIVE USE BY THE TITLE CLIENT. DUPLICATION OR USE WITHOUT THE EXPRESS WRITTEN CONSENT OF THE CREATOR IS STRICTLY PROHIBITED. DRAWING SCALES ARE INTENDED FOR 11"x17" SIZE PRINTED MEDIA ONLY. ALL OTHER PRINTED SIZES ARE DEEMED "NOT TO SCALE".

REV	DESCRIPTION	DATE
A	PRELIMINARY	03/19/18
0	ISSUED FOR PERMIT	04/02/18
1	BACKHAUL ADDED	05/07/18
2	ISSUED FOR PERMIT	05/07/18

SITE NUMBER: CT11365D
 SITE NAME: CT365/Manchester PD_MP
 SITE ADDRESS: 239 E. MIDDLE TPK
 MANCHESTER, CT 06040

SHEET TITLE:

PROJECT SCOPE:

T-MOBILE, A WIRELESS TELECOMMUNICATIONS PROVIDER PROPOSES TO UPGRADE AN EXISTING FACILITY AS FOLLOWS:
 REPLACE (6) EXISTING ANTENNAS ON EXISTING TOWER,
 REPLACE (3) EXISTING REMOTE RADIO UNITS,
 REPLACE (3) EXISTING TOWER MOUNTED AMPLIFIER,
 ADD (1) BACKHAUL RADIO,
 ADD (1) HYBRID CABLE AND (2) CAT6 CABLES .

PROJECT NOTES:

1. THIS IS AN UNMANNED TELECOMMUNICATION FACILITY AND NOT FOR HUMAN HABITATION: HANDICAPPED ACCESS IS NOT REQUIRED. POTABLE WATER OR SANITARY SERVICE IS NOT REQUIRED. NO OUTDOOR STORAGE OR ANY SOLID WASTE RECEPTACLES REQUIRED.
2. CONTRACTOR SHALL VERIFY ALL PLANS, EXISTING DIMENSIONS, AND CONDITIONS ON THE JOB SITE. CONTRACTOR SHALL IMMEDIATELY NOTIFY THE ARCHITECT/ENGINEER IN WRITING OF ANY DISCREPANCIES BEFORE PROCEEDING WITH THE WORK. FAILURE TO NOTIFY THE ARCHITECT/ENGINEER PLACES THE RESPONSIBILITY ON THE CONTRACTOR TO CORRECT THE DISCREPANCIES AT THE CONTRACTOR'S EXPENSE.
3. DEVELOPMENT AND USE OF THE SITE WILL CONFORM TO ALL APPLICABLE CODES, ORDINANCES AND SPECIFICATIONS.
4. REFER TO STRUCTURAL ANALYSIS REPORT TITLED "STRUCTURAL ANALYSIS REPORT - REVISION 2 - MONOPOLE, DATED MAY 02, 2018 PREPARED BY DESTEK ENGINEERING.

APPLICABLE STATE ADOPTION CODES:

- 2016 CONNECTICUT STATE BUILDING CODE (CSBC).
- ANSI/TIA-222-G-2005 STRUCTURAL STANDARD FOR ANTENNA SUPPORTING STRUCTURES AND ANTENNAS.
- 2014 NATIONAL ELECTRICAL CODE (NFPA 70) FOR POWER AND GROUNDING REQUIREMENTS.

SITE IMAGE:



VICINITY MAP:

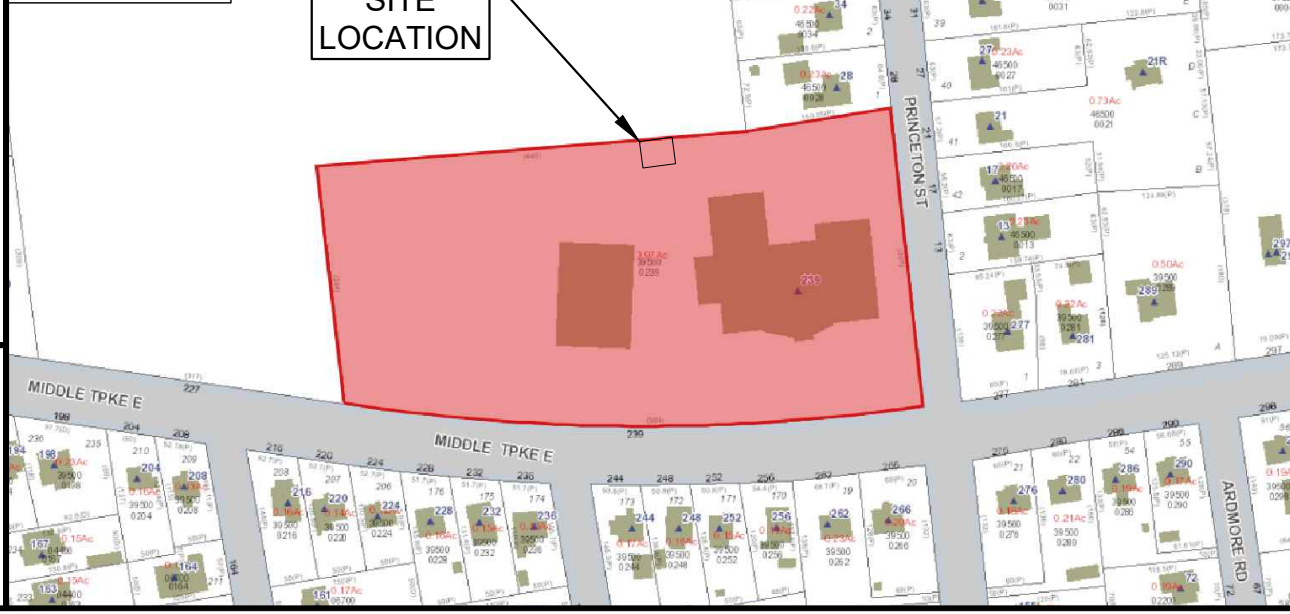

PROJECT INFORMATION:

ADDRESS: MANCHESTER POLICE DEPARTMENT
 239 E. MIDDLE TPK
 MANCHESTER, CT 06040

STRUCTURE TYPE: MONOPOLE

ZONING DISTRICT: RA

PARCEL ID: 10705

COORDINATES: N 4178438900 / W -72.51177100

ANTENNA HEIGHT: 163'

PROJECT TEAM:

APPLICANT: T-MOBILE NORTHEAST, LLC.
 35 GRIFFIN ROAD SOUTH
 BLOOMFIELD, CT 06002
 860-692-7100

LANDLORD: TOWN OF MANCHESTER
 41 CENTER STREET
 MANCHESTER, CT 06040

PROJECT MANGER: NORTHEAST SITE SOLUTIONS
 420 MAIN STREET, BLDG 4
 STURBRIDGE, MA 01566
 SHELDON FREINCLE
 SHELDON@NORTHEASTSITE
 SOLUTIONS.COM
 201-776-8521

CONSULTANTS: FORESITE LLC
 462 WALNUT ST
 NEWTON, MA 02460
 SAEED MOSSAVAT
 SMOSSAVAT@FORESITELLC.COM
 617-212-3123

SHEET INDEX:

- T-1: TITLE SHEET
- N-1: GENERAL NOTES
- A-1: PLAN
- A-2: ELEVATION
- A-3: ANTENNA PLAN
- A-4: ANTENNA DETAILS
- E-1: GROUNDING DETAILS

Copyright © 2016 Foresite LLC all rights reserved. The details, templates, drawing formats or any portion of this document generated by Foresite LLC may not be duplicated, traced or used otherwise for any profit-driven enterprise.

GENERAL NOTES:

1. THE CONTRACTOR SHALL GIVE ALL NOTICES AND COMPLY WITH ALL LAWS, ORDINANCES, RULES, REGULATIONS AND LAWFUL ORDERS OF ANY PUBLIC AUTHORITY, MUNICIPAL AND UTILITY COMPANY SPECIFICATIONS, AND LOCAL AND STATE JURISDICTIONAL CODES BEARING ON THE PERFORMANCE OF THE WORK. THE WORK PERFORMED ON THE PROJECT AND THE MATERIALS INSTALLED SHALL BE IN STRICT ACCORDANCE WITH ALL APPLICABLE CODES, REGULATIONS, AND ORDINANCES.
2. THE ARCHITECT/ENGINEER HAS MADE EVERY EFFORT TO SET FORTH IN THE CONSTRUCTION AND CONTRACT DOCUMENTS THE COMPLETE SCOPE OF WORK. THE CONTRACTOR BIDDING THE JOB IS NEVERTHELESS CAUTIONED THAT MINOR OMISSIONS OR ERRORS IN THE DRAWINGS AND OR SPECIFICATIONS SHALL NOT EXCUSE SAID CONTRACTOR FROM COMPLETING THE PROJECT AND IMPROVEMENTS IN ACCORDANCE WITH THE INTENT OF THESE DOCUMENTS.
3. THE CONTRACTOR OR BIDDER SHALL BEAR THE RESPONSIBILITY OF NOTIFYING (IN WRITING) THE CLIENT'S REPRESENTATIVE OF ANY CONFLICTS, ERRORS, OR OMISSIONS PRIOR TO THE SUBMISSION OF CONTRACTOR'S PROPOSAL OR PERFORMANCE OF WORK.
5. THE CONTRACTOR SHALL VISIT THE JOB SITE PRIOR TO THE SUBMISSION OF BIDS OR PERFORMING WORK TO FAMILIARIZE HIMSELF WITH THE FIELD CONDITIONS AND TO VERIFY THAT THE PROJECT CAN BE CONSTRUCTED IN ACCORDANCE WITH THE CONSTRUCTION DOCUMENTS.
6. THE CONTRACTOR SHALL INSTALL ALL EQUIPMENT AND MATERIALS ACCORDING TO THE MANUFACTURER'S / VENDOR'S SPECIFICATIONS UNLESS NOTED OTHERWISE OR WHERE LOCAL CODES OR ORDINANCES TAKE PRECEDENCE.
7. THE CONTRACTOR SHALL MAKE NECESSARY PROVISIONS TO PROTECT EXISTING IMPROVEMENTS DURING CONSTRUCTION.
8. THE CONTRACTOR SHALL COMPLY WITH ALL PERTINENT SECTIONS OF THE BASIC STATE BUILDING CODE, LATEST EDITION, AND ALL OSHA REQUIREMENTS AS THEY APPLY TO THIS PROJEC
9. THE CONTRACTOR SHALL NOTIFY THE CLIENT'S REPRESENTATIVE IN WRITING WHERE A CONFLICT OCCURS ON ANY OF THE CONTRACT DOCUMENTS. THE CONTRACTOR IS NOT TO ORDER MATERIAL OR CONSTRUCT ANY PORTION OF THE WORK THAT IS IN CONFLICT UNTIL CONFLICT IS RESOLVED BY THE CLIENT'S REPRESENTATIVE.
10. THE WORK SHALL CONFORM TO THE CODES AND STANDARDS OF THE FOLLOWING AGENCIES AS FURTHER CITED HEREIN:
 - A. ASTM: AMERICAN SOCIETY FOR TESTING AND MATERIALS, AS PUBLISHED IN "COMPILATION OF ASTM STANDARDS BUILDING CODES" OR LATEST EDITION.
 - B. AWS: AMERICAN WELDING SOCIETY INC. AS PUBLISHED IN "STANDARD D1.1-08, STRUCTURAL WELDING CODE" OR LATEST EDITION.
 - C. AISC: AMERICAN INSTITUTE FOR STEEL CONSTRUCTION AS PUBLISHED IN "CODE FOR STANDARD PRACTICE FOR STEEL BUILDINGS AND BRIDGES"; "SPECIFICATIONS FOR THE DESIGN, FABRICATION AND ERECTION OF STRUCTURAL STEEL FOR BUILDINGS" (LATEST EDITION).
11. BOLTING:
 - A. BOLTS SHALL BE CONFORMING TO ASTM A325 HIGH STRENGTH, HOT DIP GALVANIZED WITH ASTM A153 HEAVY HEX TYPE NUTS.
 - B. BOLTS SHALL BE 3/4"Ø MINIMUM (UNLESS OTHERWISE NOTED)
 - C. ALL CONNECTIONS SHALL BE 2 BOLTS MINIMUM.
12. FABRICATION:
 - A. FABRICATION OF STEEL SHALL CONFORM TO THE AISC AND AWS STANDARDS AND CODES (LATEST EDITION).
 - B. ALL STRUCTURAL STEEL SHALL BE HOT-DIP GALVANIZED AFTER FABRICATION IN ACCORDANCE WITH ASTM A123 (LATEST EDITION), UNLESS OTHERWISE NOTED.
13. ERECTION OF STEEL:
 - A. PROVIDE ALL ERECTION EQUIPMENT, BRACING, PLANKING, FIELD BOLTS, NUTS, WASHERS, DRIFT PINS, AND SIMILAR MATERIALS WHICH DO NOT FORM A PART OF THE COMPLETED CONSTRUCTION BUT ARE NECESSARY FOR ITS PROPER ERECTION.
 - B. ERECT AND ANCHOR ALL STRUCTURAL STEEL IN ACCORDANCE WITH AISC REFERENCE STANDARDS. ALL WORK SHALL BE ACCURATELY SET TO ESTABLISHED LINES AND ELEVATIONS AND RIGIDLY FASTENED IN PLACE WITH SUITABLE ATTACHMENTS TO THE CONSTRUCTION OF THE BUILDING.
 - C. TEMPORARY BRACING, GUYING AND SUPPORT SHALL BE PROVIDED TO KEEP THE STRUCTURE SAFE AND ALIGNED AT ALL TIMES DURING CONSTRUCTION, AND TO PREVENT DANGER TO PERSONS AND PROPERTY. CHECK ALL TEMPORARY LOADS AND STAY WITHIN SAFE CAPACITY OF ALL BUILDING COMPONENTS.

14. ANTENNA INSTALLATION:
 - A. INSTALL ANTENNAS AS INDICATED ON DRAWINGS AND CLIENT'S REPRESENTATIVE SPECIFICATIONS.
 - B. INSTALL GALVANIZED STEEL ANTENNA MOUNTS AS INDICATED ON DRAWINGS.
 - C. INSTALL COAXIAL / FIBER CABLES AND TERMINATIONS BETWEEN ANTENNAS AND EQUIPMENT PER MANUFACTURER'S RECOMMENDATIONS. WEATHERPROOF ALL CONNECTORS BETWEEN THE ANTENNA AND EQUIPMENT PER MANUFACTURER'S REQUIREMENTS.
15. ANTENNA AND COAXIAL / FIBER CABLE GROUNDING:
 - A. ALL EXTERIOR #6 GREEN GROUND WIRE "DAISY CHAIN" CONNECTIONS ARE TO BE WEATHER SEALED WITH ANDREWS CONNECTOR/SPLICE WEATHERPROOFING KIT TYPE #221213 OR EQUAL.
 - B. ALL COAXIAL / FIBER CABLE GROUNDING KITS ARE TO BE INSTALLED ON STRAIGHT RUNS OF COAXIAL / FIBER CABLE (NOT WITHIN BENDS).
16. RELATED WORK, FURNISH THE FOLLOWING WORK AS SPECIFIED UNDER CONSTRUCTION DOCUMENTS, BUT COORDINATE WITH OTHER TRADES PRIOR TO BID:
 - A. FLASHING OF OPENING INTO OUTSIDE WALLS
 - B. SEALING AND CAULKING ALL OPENINGS
 - C. PAINTING
 - D. CUTTING AND PATCHING
17. REQUIREMENTS OF REGULATORY AGENCIES:
 - A. FURNISH U.L. LISTED EQUIPMENT WHERE SUCH LABEL IS AVAILABLE. INSTALL IN CONFORMANCE WITH U.L. STANDARDS WHERE APPLICABLE.
 - B. INSTALL ANTENNA, ANTENNA CABLES, GROUNDING SYSTEM IN ACCORDANCE WITH DRAWINGS AND SPECIFICATION IN EFFECT AT PROJECT LOCATION AND RECOMMENDATIONS OF STATE AND LOCAL BUILDING CODES, AND SPECIAL CODES HAVING JURISDICTION OVER SPECIFIC PORTIONS OF WORK. THIS WORK INCLUDES BUT IS NOT LIMITED TO THE FOLLOWING:
 - C. TIA-EIA - 222 (LATEST EDITION). STRUCTURAL STANDARDS FOR STEEL ANTENNA TOWERS AND ANTENNA SUPPORTING STRUCTURES.
 - D. FAA - FEDERAL AVIATION ADMINISTRATION ADVISORY CIRCULAR AC 70/7460-IH, OBSTRUCTION MARKING AND LIGHTING.
 - E. FCC - FEDERAL COMMUNICATIONS COMMISSION RULES AND REGULATIONS FORM 715, OBSTRUCTION MARKING AND LIGHTING SPECIFICATION FOR ANTENNA STRUCTURES AND FORM 715A, HIGH INTENSITY OBSTRUCTION LIGHTING SPECIFICATIONS FOR ANTENNA STRUCTURES.
 - F. AISC - AMERICAN INSTITUTE OF STEEL CONSTRUCTION SPECIFICATION FOR STRUCTURAL JOINTS USING ASTM A325 BOLTS (LATEST EDITION).
 - G. NEC - NATIONAL ELECTRICAL CODE - ON TOWER LIGHTING KITS.
 - H. UL - UNDERWRITER'S LABORATORIES APPROVED ELECTRICAL PRODUCTS.
 - I. IN ALL CASES, PART 77 OF THE FAA RULES AND PARTS 17 AND 22 OF THE FCC RULES ARE APPLICABLE AND IN THE EVENT OF CONFLICT, SUPERSEDE ANY OTHER STANDARDS OR SPECIFICATIONS.
 - J. 2009 LIFE SAFETY CODE NFPA - 101.

APPLICANT:

T-MOBILE NORTHEAST LLC
 35 GRIFFIN ROAD SOUTH
 BLOOMFIELD, CT 06002
 860-692-7100

 **PROJECT MANGER**
NSS NORTHEAST
SITE SOLUTIONS
Turnkey Wireless Development
 420 MAIN STREET, BLDG 4
 STURBRIDGE, MA 01566
 203-275-6669

CONSULTANT:
 **LLC**
 Architects . Engineers . Surveyors
 462 WALNUT STREET
 NEWTON, MA 02460
 617-212-3123

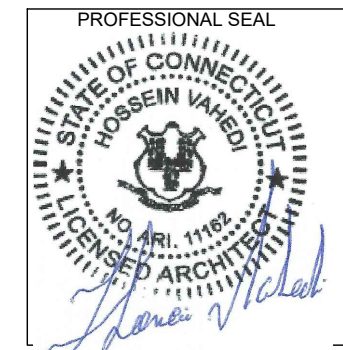

THIS DOCUMENT IS THE DESIGN PROPERTY AND COPYRIGHT OF FORESITE, LLC. AND FOR THE EXCLUSIVE USE BY THE TITLE CLIENT. DUPLICATION OR USE WITHOUT THE EXPRESS WRITTEN CONSENT OF THE CREATOR IS STRICTLY PROHIBITED. DRAWING SCALES ARE INTENDED FOR 11"x17" SIZE PRINTED MEDIA ONLY. ALL OTHER PRINTED SIZES ARE DEEMED "NOT TO SCALE".

REV	DESCRIPTION	DATE
A	PRELIMINARY	03/19/18
0	ISSUED FOR PERMIT	04/02/18
1	BACKHAUL ADDED	05/07/18
2	ISSUED FOR PERMIT	05/07/18

SITE NUMBER: CT11365D
 SITE NAME: CT365/Manchester PD_MP
 SITE ADDRESS: 239 E. MIDDLE TPK
 MANCHESTER, CT 06040

SHEET TITLE:
N-1: NOTES AND DISCLAIMERS

Copyright © 2016 Foresite LLC all rights reserved. The details, templates, drawing formats or any portion of this document generated by Foresite LLC may not be duplicated, traced or used otherwise for any profit-driven enterprise.

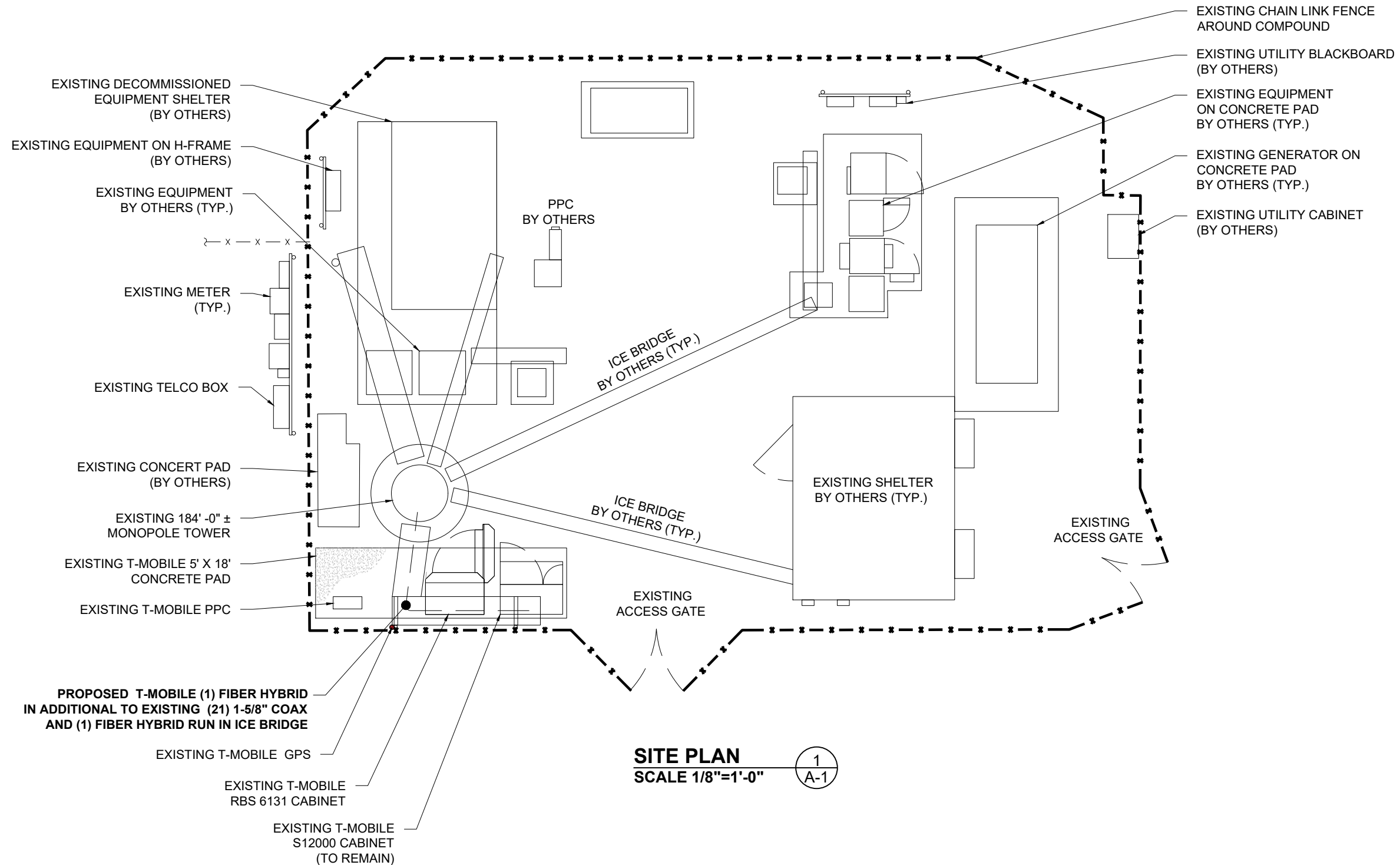

PROPOSED T-MOBILE (1) FIBER HYBRID IN ADDITIONAL TO EXISTING (21) 1-5/8" COAX AND (1) FIBER HYBRID RUN IN ICE BRIDGE

SITE PLAN
SCALE 1/8"=1'-0" 1
A-1

APPLICANT:
T-Mobile
T-MOBILE NORTHEAST LLC
35 GRIFFIN ROAD SOUTH
BLOOMFIELD, CT 06002
860-692-7100

PROJECT MANGER
NSS NORTHEAST
SITE SOLUTIONS
Turnkey Wireless Development
420 MAIN STREET, BLDG 4
STURBRIDGE, MA 01566
203-275-6669

CONSULTANT:
FORESITE LLC
Architects . Engineers . Surveyors
462 WALNUT STREET
NEWTON, MA 02460
617-212-3123

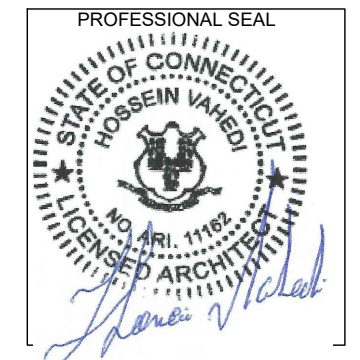

THIS DOCUMENT IS THE DESIGN PROPERTY AND COPYRIGHT OF FORESITE, LLC. AND FOR THE EXCLUSIVE USE BY THE TITLE CLIENT. DUPLICATION OR USE WITHOUT THE EXPRESS WRITTEN CONSENT OF THE CREATOR IS STRICTLY PROHIBITED. DRAWING SCALES ARE INTENDED FOR 11"x17" SIZE PRINTED MEDIA ONLY. ALL OTHER PRINTED SIZES ARE DEEMED "NOT TO SCALE".

REV	DESCRIPTION	DATE
A	PRELIMINARY	03/19/18
0	ISSUED FOR PERMIT	04/02/18
1	BACKHAUL ADDED	05/07/18
2	ISSUED FOR PERMIT	05/07/18

SITE NUMBER: CT11365D
SITE NAME: CT365/Manchester PD_MP
SITE ADDRESS: 239 E. MIDDLE TPK
MANCHESTER, CT 06040

SHEET TITLE:
A-1: PLAN

Copyright © 2016 Foresite LLC all rights reserved. The details, templates, drawing formats or any portion of this document generated by Foresite LLC may not be duplicated, traced or used otherwise for any profit-driven enterprise.

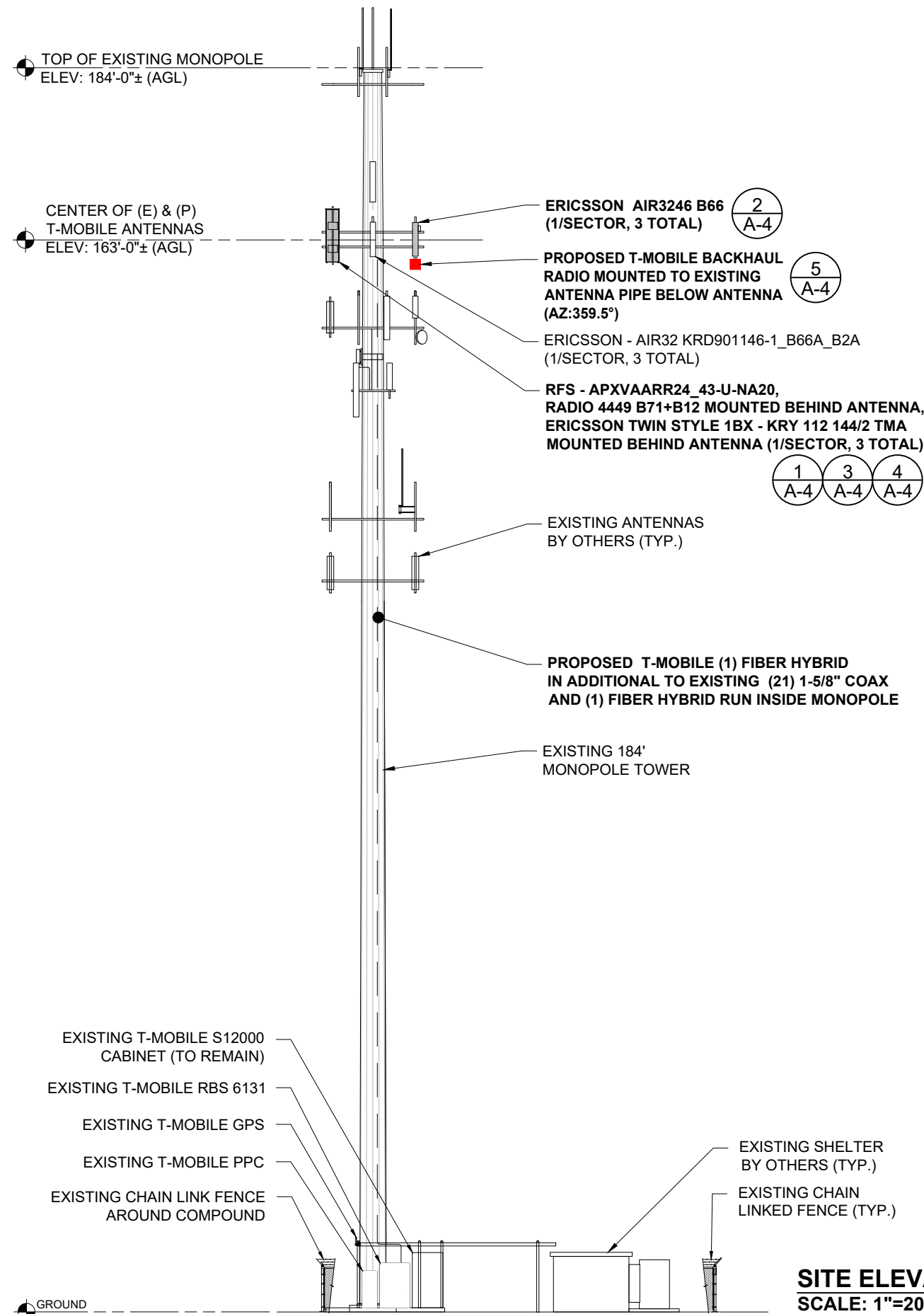

STRUCTURAL NOTES:
 PRIOR TO COMMENCING CONSTRUCTION, GC SHALL REFER TO TOWER STRUCTURAL ANALYSIS PROVIDED BY OTHERS TO DETERMINE IF THERE ARE ANY SUPPLEMENTAL OR SPECIAL REQUIREMENTS FOR TOWER TOP EQUIPMENT AND FOR CABLE BUNDLING, SHIELDING, MOUNTING OR RELOCATION ARRANGEMENTS.



SITE ELEVATION
 SCALE: 1"=20' 1/A-2

ELEVATION PHOTO DETAIL
 SCALE: NTS 2/A-2

APPLICANT:
T-Mobile
T-MOBILE NORTHEAST LLC
 35 GRIFFIN ROAD SOUTH
 BLOOMFIELD, CT 06002
 860-692-7100

PROJECT MANGER
NSS NORTHEAST
 SITE SOLUTIONS
Turnkey Wireless Development
 420 MAIN STREET, BLDG 4
 STURBRIDGE, MA 01566
 203-275-6669

CONSULTANT:
FORESITE LLC
 Architects . Engineers . Surveyors
 462 WALNUT STREET
 NEWTON, MA 02460
 617-212-3123

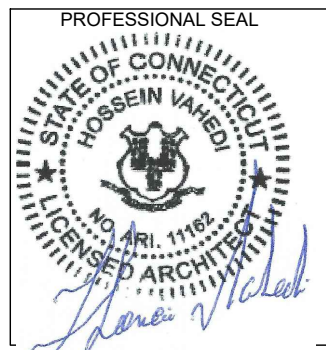

THIS DOCUMENT IS THE DESIGN PROPERTY AND COPYRIGHT OF FORESITE, LLC. AND FOR THE EXCLUSIVE USE BY THE TITLE CLIENT. DUPLICATION OR USE WITHOUT THE EXPRESS WRITTEN CONSENT OF THE CREATOR IS STRICTLY PROHIBITED. DRAWING SCALES ARE INTENDED FOR 11"x17" SIZE PRINTED MEDIA ONLY. ALL OTHER PRINTED SIZES ARE DEEMED "NOT TO SCALE".

REV	DESCRIPTION	DATE
A	PRELIMINARY	03/19/18
0	ISSUED FOR PERMIT	04/02/18
1	BACKHAUL ADDED	05/07/18
2	ISSUED FOR PERMIT	05/07/18

SITE NUMBER: CT11365D
 SITE NAME: CT365/Manchester PD_MP
 SITE ADDRESS: 239 E. MIDDLE TPK
 MANCHESTER, CT 06040

SHEET TITLE:
 A-2: ELEVATION

Copyright © 2016 Foresite LLC all rights reserved. The details, templates, drawing formats or any portion of this document generated by Foresite LLC may not be duplicated, traced or used otherwise for any profit-driven enterprise.

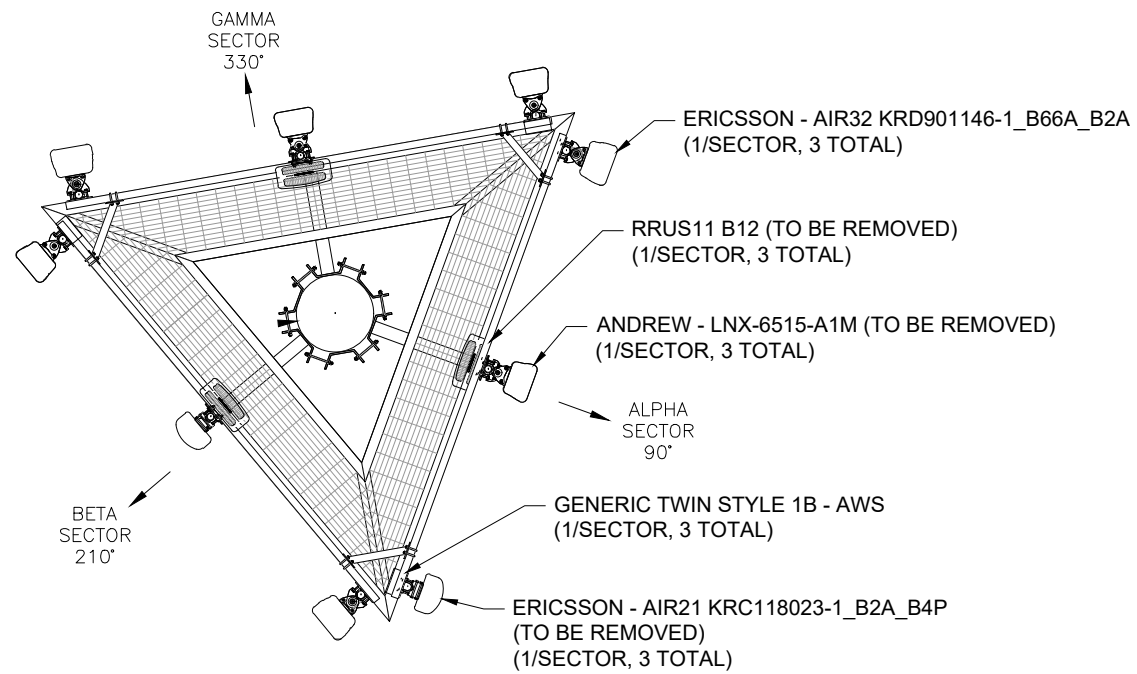

EXISTING ANTENNA PLAN
SCALE: NTS

1
A-3

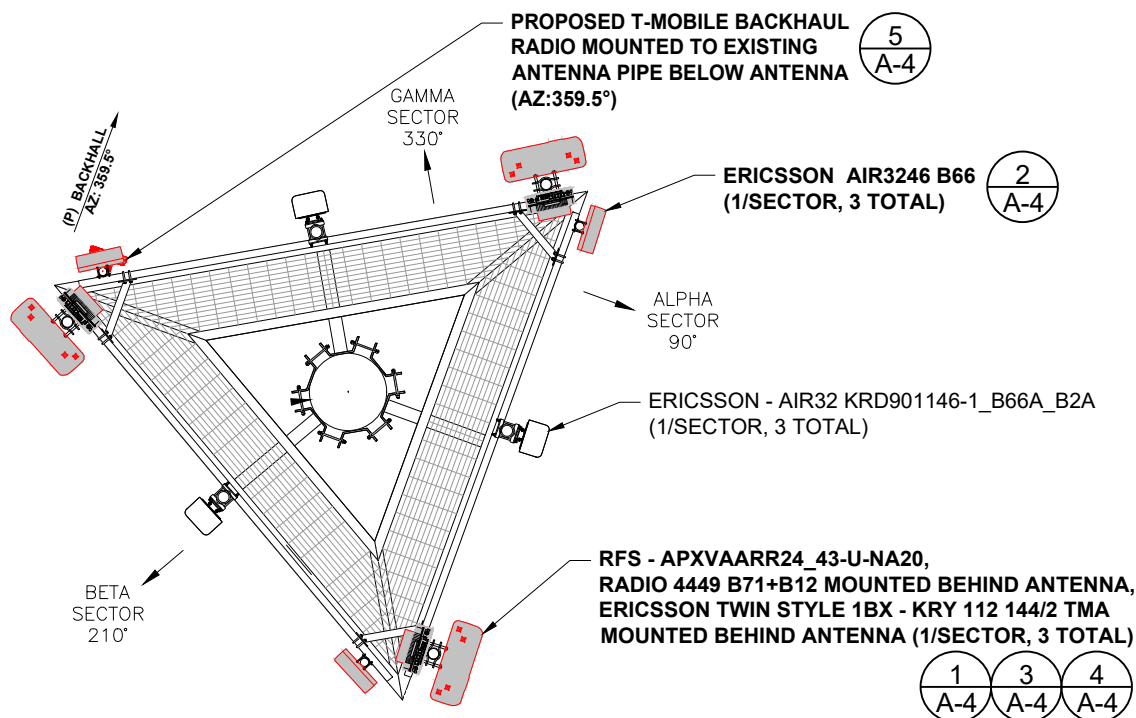

PROPOSED ANTENNA PLAN
SCALE: NTS

2
A-3

CENTER OF (E) & (P) T-MOBILE ANTENNAS
ELEV: 163'-0"± (AGL)

PROPOSED T-MOBILE BACKHAUL RADIO MOUNTED TO EXISTING ANTENNA PIPE BELOW ANTENNA (AZ:359.5°)

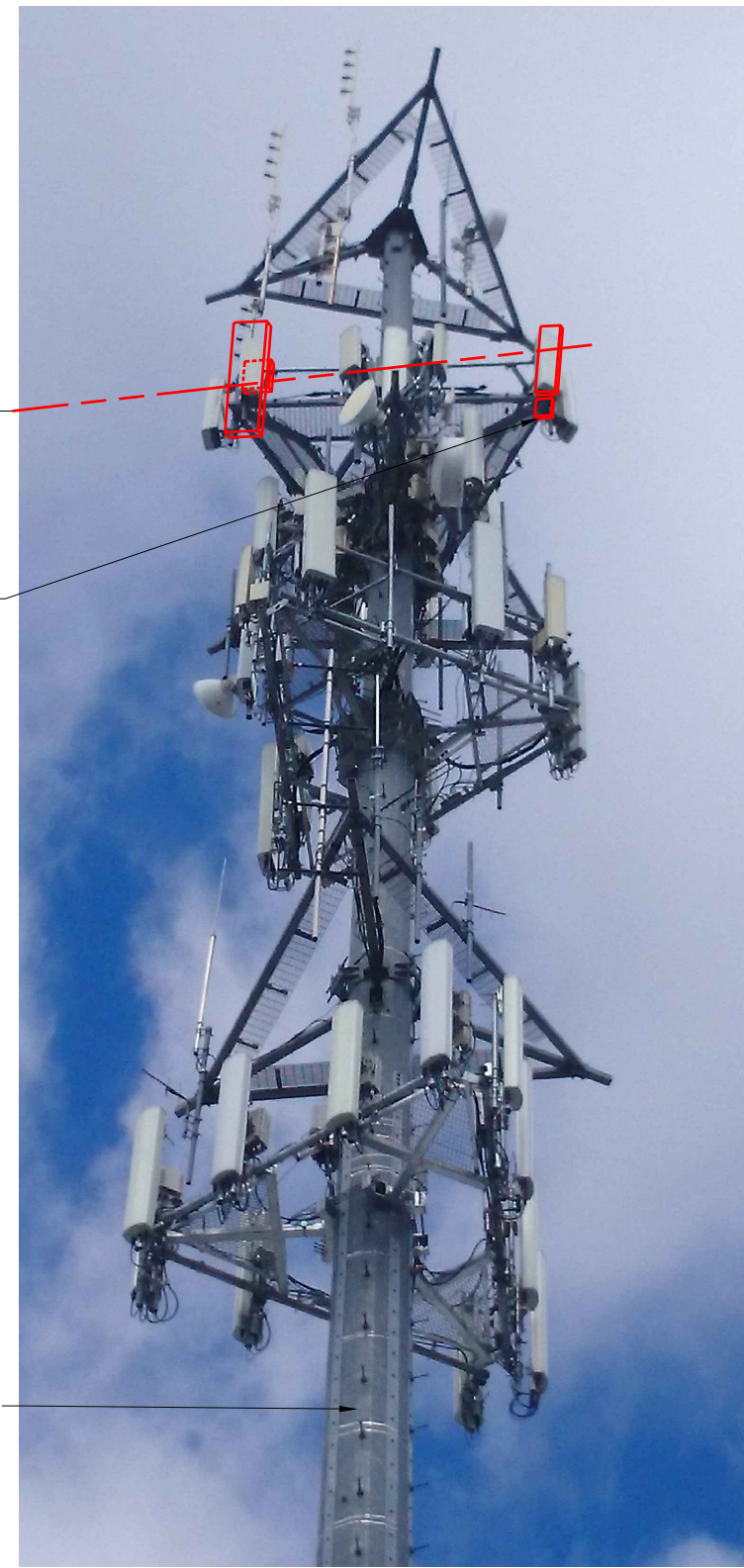

SITE PHOTO DETAIL
SCALE: NTS

3
A-3

APPLICANT:
T-Mobile
T-MOBILE NORTHEAST LLC
35 GRIFFIN ROAD SOUTH
BLOOMFIELD, CT 06002
860-692-7100

PROJECT MANGER
NSS NORTHEAST
SITE SOLUTIONS
Turnkey Wireless Development
420 MAIN STREET, BLDG 4
STURBRIDGE, MA 01566
203-275-6669

CONSULTANT:
FORESITE LLC
Architects . Engineers . Surveyors
462 WALNUT STREET
NEWTON, MA 02460
617-212-3123

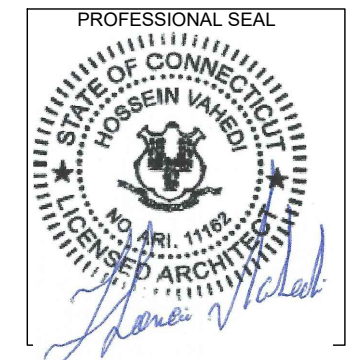

THIS DOCUMENT IS THE DESIGN PROPERTY AND COPYRIGHT OF FORESITE, LLC. AND FOR THE EXCLUSIVE USE BY THE TITLE CLIENT. DUPLICATION OR USE WITHOUT THE EXPRESS WRITTEN CONSENT OF THE CREATOR IS STRICTLY PROHIBITED. DRAWING SCALES ARE INTENDED FOR 11"x17" SIZE PRINTED MEDIA ONLY. ALL OTHER PRINTED SIZES ARE DEEMED "NOT TO SCALE".

REV	DESCRIPTION	DATE
A	PRELIMINARY	03/19/18
0	ISSUED FOR PERMIT	04/02/18
1	BACKHAUL ADDED	05/07/18
2	ISSUED FOR PERMIT	05/07/18

SITE NUMBER: CT11365D
SITE NAME: CT365/Manchester PD_MP
SITE ADDRESS: 239 E. MIDDLE TPK
MANCHESTER, CT 06040

SHEET TITLE:
A-3: ANTENNA PLAN AND DETAILS

Copyright © 2016 Foresite LLC all rights reserved. The details, templates, drawing formats or any portion of this document generated by Foresite LLC may not be duplicated, traced or used otherwise for any profit-driven enterprise.

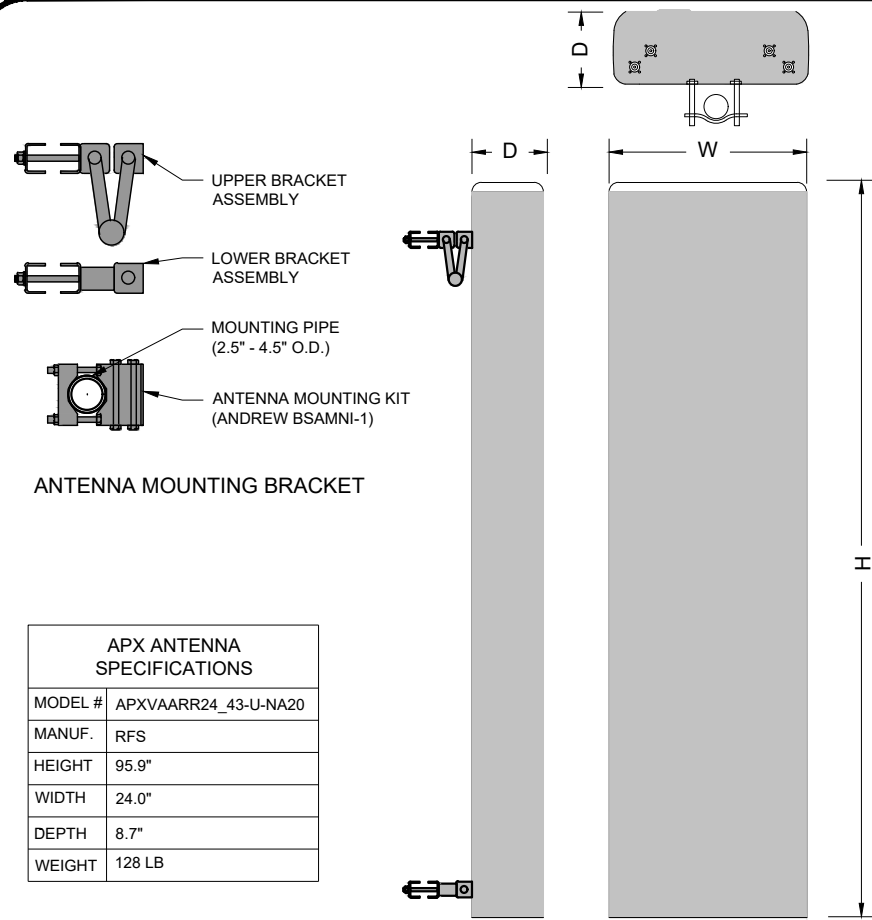

- UPPER BRACKET ASSEMBLY
- LOWER BRACKET ASSEMBLY
- MOUNTING PIPE (2.5" - 4.5" O.D.)
- ANTENNA MOUNTING KIT (ANDREW BSAMNI-1)

ANTENNA MOUNTING BRACKET

APX ANTENNA SPECIFICATIONS	
MODEL #	APXVAARR24_43-U-NA20
MANUF.	RFS
HEIGHT	95.9"
WIDTH	24.0"
DEPTH	8.7"
WEIGHT	128 LB

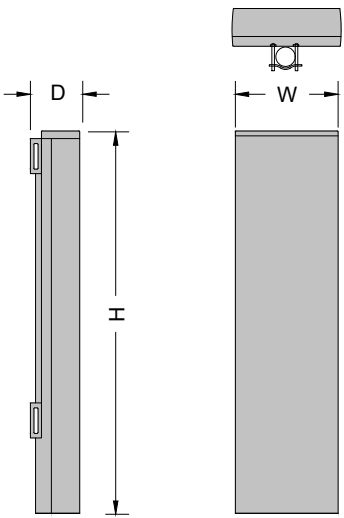

ERICSSON ANTENNA SPECIFICATIONS	
MODEL #	AIR3246 B66
MANUF.	ERICSSON
HEIGHT	58.1"
WIDTH	15.7"
DEPTH	9.4"
WEIGHT	180 LB

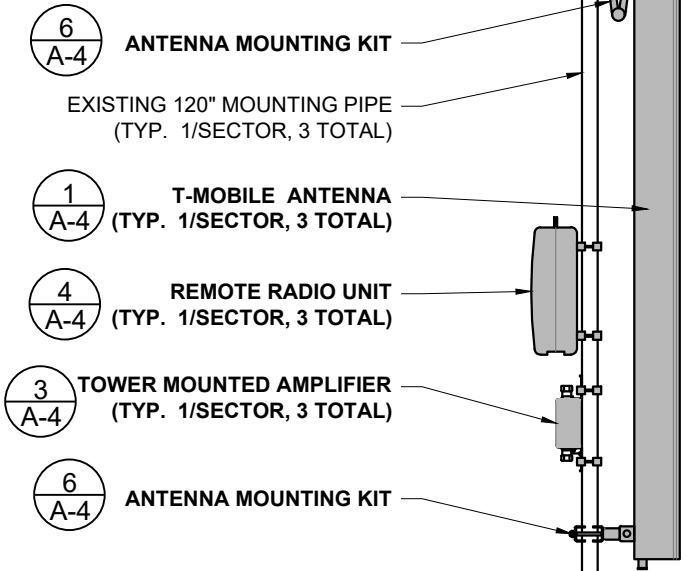

- ANTENNA MOUNTING KIT (TYP. 1/SECTOR, 3 TOTAL)
- EXISTING 120" MOUNTING PIPE (TYP. 1/SECTOR, 3 TOTAL)
- T-MOBILE ANTENNA (TYP. 1/SECTOR, 3 TOTAL)
- REMOTE RADIO UNIT (TYP. 1/SECTOR, 3 TOTAL)
- TOWER MOUNTED AMPLIFIER (TYP. 1/SECTOR, 3 TOTAL)
- ANTENNA MOUNTING KIT (TYP. 1/SECTOR, 3 TOTAL)

APX ANTENNA
N.T.S

ERICSSON ANTENNA
N.T.S

ANTENNA MOUNTING DETAIL
N.T.S

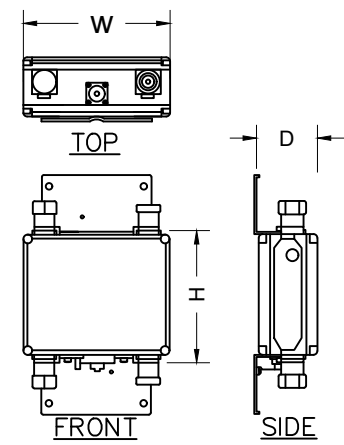

TOWER MOUNTED AMPLIFIER SPECIFICATIONS	
MODEL #	KRY 112 144/1
MANUF.	ERICSSON
HEIGHT	6.9"
WIDTH	6.1"
DEPTH	2.8"
WEIGHT	11.02 LB

TOWER MOUNTED AMPLIFIER
N.T.S

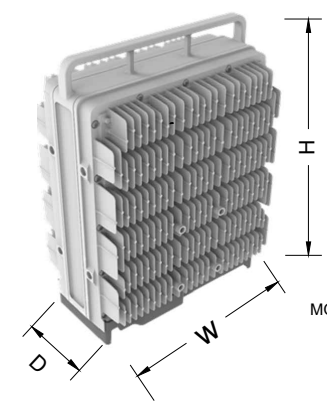

REMOTE RADIO UNIT SPECIFICATIONS	
MODEL #	RADIO 4449 B71+B12
MANUF.	ERICSSON
HEIGHT	14.9"
WIDTH	13.2"
DEPTH	10.4"
WEIGHT	74 LB

REMOTE RADIO UNIT
N.T.S

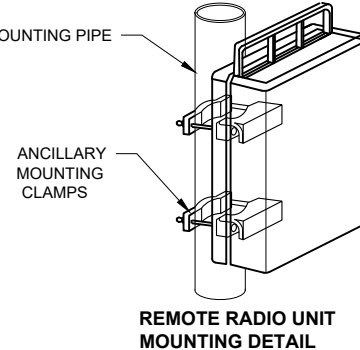

REMOTE RADIO UNIT MOUNTING DETAIL

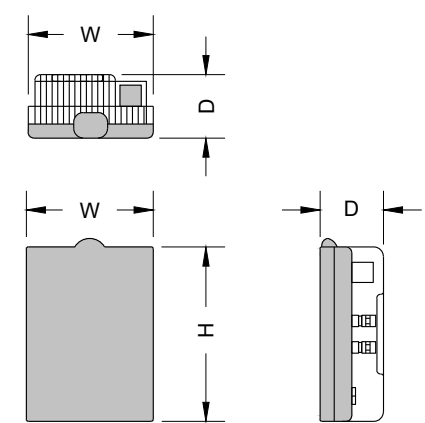

RRU DIMENSIONS	
MODEL #	IBR 1300
MANUF.	FASTBACK
HEIGHT	10.24"
WIDTH	7.87"
DEPTH	3.54"
WEIGHT	8.82 LB

BACKHALL RADIO UNIT
N.T.S

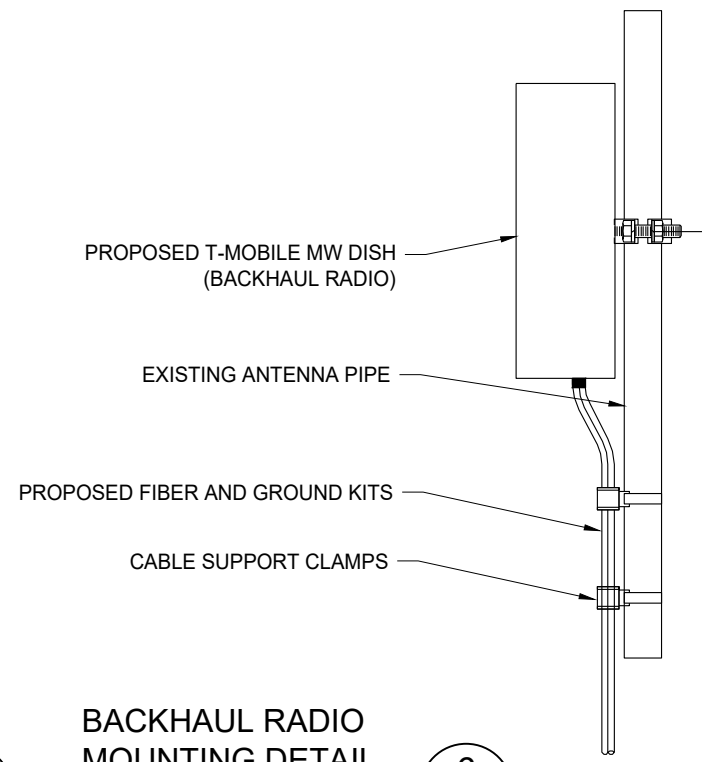

BACKHAUL RADIO MOUNTING DETAIL
N.T.S

APPLICANT:
T-Mobile
T-MOBILE NORTHEAST LLC
 35 GRIFFIN ROAD SOUTH
 BLOOMFIELD, CT 06002
 860-692-7100

PROJECT MANGER
NSS NORTHEAST
 SITE SOLUTIONS
Turnkey Wireless Development
 420 MAIN STREET, BLDG 4
 STURBRIDGE, MA 01566
 203-275-6669

CONSULTANT:
FORESITE LLC
 Architects . Engineers . Surveyors
 462 WALNUT STREET
 NEWTON, MA 02460
 617-212-3123

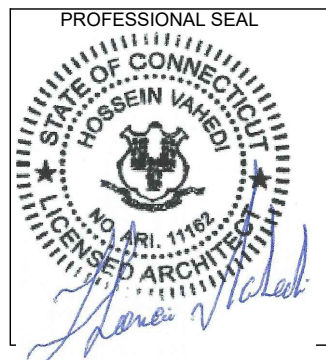

THIS DOCUMENT IS THE DESIGN PROPERTY AND COPYRIGHT OF FORESITE, LLC. AND FOR THE EXCLUSIVE USE BY THE TITLE CLIENT. DUPLICATION OR USE WITHOUT THE EXPRESS WRITTEN CONSENT OF THE CREATOR IS STRICTLY PROHIBITED. DRAWING SCALES ARE INTENDED FOR 11"x17" SIZE PRINTED MEDIA ONLY. ALL OTHER PRINTED SIZES ARE DEEMED "NOT TO SCALE".

REV	DESCRIPTION	DATE
A	PRELIMINARY	03/19/18
0	ISSUED FOR PERMIT	04/02/18
1	BACKHAUL ADDED	05/07/18
2	ISSUED FOR PERMIT	05/07/18

SITE NUMBER: CT11365D
 SITE NAME: CT365/Manchester PD_MP
 SITE ADDRESS: 239 E. MIDDLE TPK
 MANCHESTER, CT 06040

SHEET TITLE:
 A-4: ANTENNA DETAILS

Copyright © 2016 Foresite LLC all rights reserved. The details, templates, drawing formats or any portion of this document generated by Foresite LLC may not be duplicated, traced or used otherwise for any profit-driven enterprise.

ELECTRICAL & GROUNDING NOTES

1. ALL ELECTRICAL WORK SHALL CONFORM TO THE REQUIREMENTS OF THE NATIONAL ELECTRICAL CODE (NEC) AS WELL AS APPLICABLE STATE AND LOCAL CODES.
2. ALL ELECTRICAL ITEMS SHALL BE U.L. APPROVED OR LISTED AND PRODUCED PER SPECIFICATION REQUIREMENTS.
3. THE ELECTRICAL WORK INCLUDES ALL LABOR AND MATERIAL DESCRIBED BY DRAWINGS AND SPECIFICATION INCLUDING INCIDENTAL WORK TO PROVIDE COMPLETE OPERATING AND APPROVED ELECTRICAL SYSTEM.
4. GENERAL CONTRACTOR SHALL PAY FEES FOR PERMITS, AND RESPONSIBLE FOR OBTAINING SAID PERMITS AND COORDINATION OF INSPECTIONS.
5. ELECTRICAL AND TELCO WIRING OUTSIDE A BUILDING AND EXPOSED TO WEATHER SHALL BE IN WATER TIGHT GALVANIZED RIGID STEEL CONDUITS OR SCHEDULE 80 PVC (AS PERMITTED BY CODE) ND WHERE REQUIRED IN LIQUID TIGHT FLEXIBLE METAL OR NONMETALLIC CONDUITS.
6. RIGID STEEL CONDUITS SHALL BE GROUNDED AT BOTH ENDS.
7. ELECTRICAL WIRING SHALL BE COPPER WITH TYPE XHHW, THWN, OR THIN INSULATION.
8. RUN ELECTRICAL CONDUIT OR CABLING BETWEEN ELECTRICAL ROOM AND PROPOSED CELL SITE ARE PEDESTAL AS INDICATED ON THIS DRAWING. PROVIDE FULL LENGTH PULL ROPE. COORDINATE INSTALLATION WITH UTILITY COMPANY.
9. RUN TELCO CONDUIT OR CABLE BETWEEN TELEPHONE UTILITY DEMARCATION POINT AND PROPOSED CELL SITE TELECOM CABINET AND RBS CABINET AS INDICATED ON DRAWING A -1. PROVIDE FULL LENGTH PULL ROPE INSTALLED TELCO CONDUIT. PROVIDE GREENLEE CONDUIT MEASURING TAPE AT EACH END.
10. ALL EQUIPMENT LOCATED OUTSIDE SHALL HAVE NAME 3R ENCLOSURE.
11. GROUNDING SHALL COMPLY WITH NEC ART. 250.
12. GROUNDING COAX CABLE SHIELDS MINIMUM AT BOTH ENDS USING MANUFACTURES COAX CABLE GROUNDING KITS SUPPLIED BY PROJECT OWNER.
13. USE #6 COPPER STRANDED WIRE WITH GREEN COLOR INSTALLATION FOR ABOVE GRADE GROUNDING (UNLESS OTHERWISE SPECIFIED) AND #2 SOLID TINNED BARE COPPER WIRE FOR BELOW GRADE GROUNDING AS INDICATED ON THE GROUND.
14. ALL GROUND CONNECTION TO BE BURNDY HYGROUND COMPRESSION TYPE CONNECTORS OR CADWELD EXOTHERMIC WELD. DO NOT ALLOW BARE COPPER WIRE TO BE IN CONTACT WITH GALVANIZED STEEL.
15. ROUTE GROUNDING CONDUCTORS ALONG THE SHORTEST AND STRAIGHTEST PATH POSSIBLE, EXCEPT AS OTHERWISE INDICATED. GROUNDING LEADS SHOULD NEVER BE BENT AS RIGHT ANGLE. ALWAYS MAKE AT LEAST 12" RADIUS BENDS. #6 WIRE CAN BE BENT AT 6" RADIUS WHEN NECESSARY BOND ANY METER OBJECTS WITHIN 7 FEET OF PROPOSED EQUIPMENT OR CABINET TO MASTER GROUND BAR.
16. CONNECTIONS TO MGB SHALL BE ARRANGED IN THREE MAIN GROUPS: SURGE PROCEDURES (COAXIAL CABLE GROUND KITS, TELCO AND POWER PANEL GROUND); (GROUNDING ELECTRODE RING OR BUILDING STEEL); NON-SURGING OBJECTS (EGB GROUND IN RBS UNIT).
17. CONNECTIONS TO GROUND BARS SHALL BE MADE WITH TWO HOLE COMPRESSION TYPE COPPER LUGS. APPLY OXIDE INHIBITING COMPOUND TO ALL LOCATIONS.
18. APPLY OXIDE INHIBITING COMPOUND TO ALL COMPRESSION TYPE GROUND CONNECTION.
19. BOND ANTENNA MOUNTING BRACKETS, COAXIAL CABLE GROUND KITS, AND ALNA TO EGB PLACED NEAR THE ANTENNA LOCATION.
20. BOND ANTENNA EGB'S AND MGB TO WATER MAIN.
21. TEST COMPLETED GROUND SYSTEM AND RECORD RESULTS FOR PROJECT CLOSE-OUT DOCUMENTATION.
22. BOND ANY METAL OBJECTS WITHIN 7 FEET OF PROPOSED EQUIPMENT OR CABINET TO MASTER GROUND BAR.
23. VERIFY PROPOSED SERVICE UPGRADE WITH LOCAL UTILITY COMPANY PRIOR TO CONSTRUCTION.

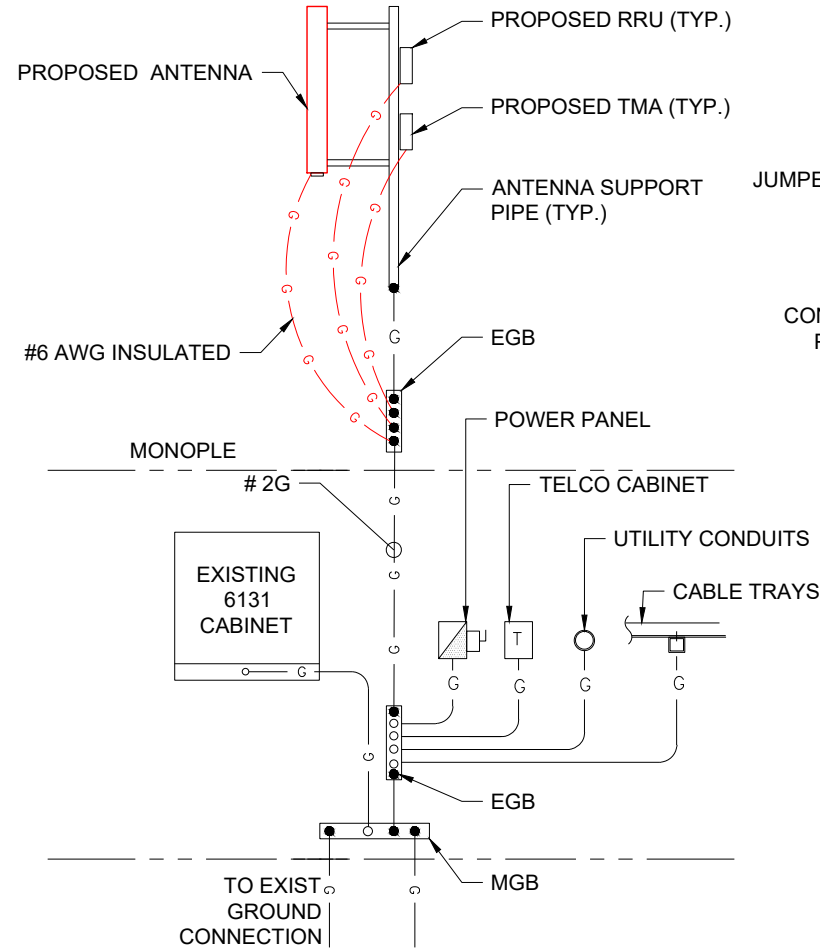

GROUNDING RISER DIAGRAM

SCALE: N.T.S

1
E-1

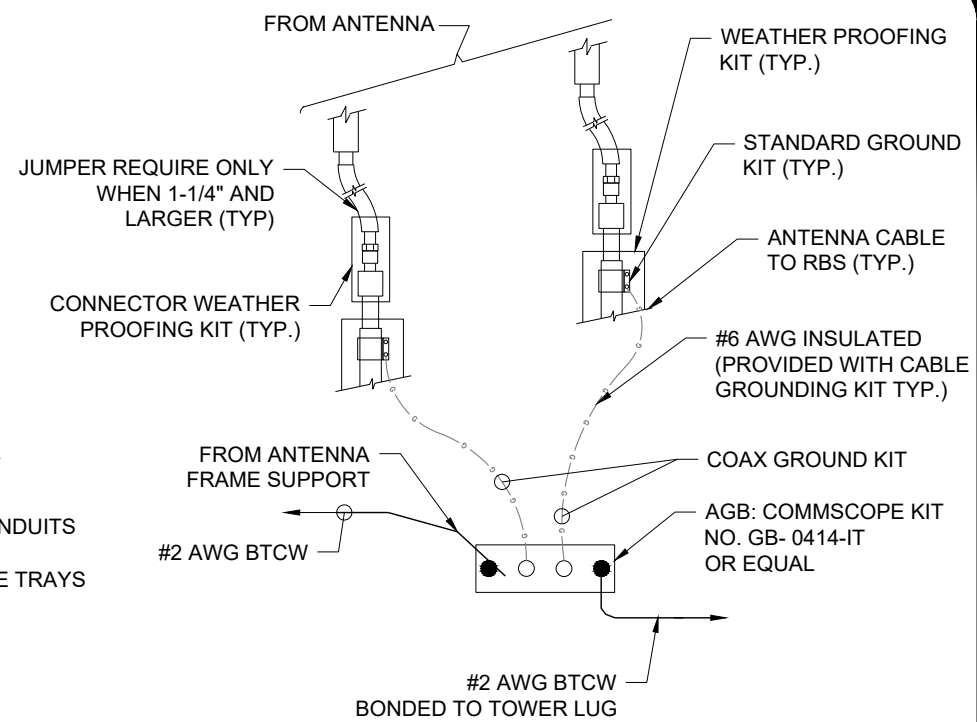

NOTES:
INSTALL CABLE GROUND KIT ABOVE HORIZONTAL BEND AND ALWAYS DIRECT GROUND WIRE DOWN TO AGB/EGB

TOWER TOP CABLE GROUNDING DETAIL

SCALE: N.T.S

2
E-1

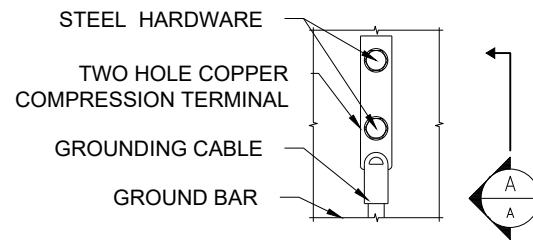

ELEVATION

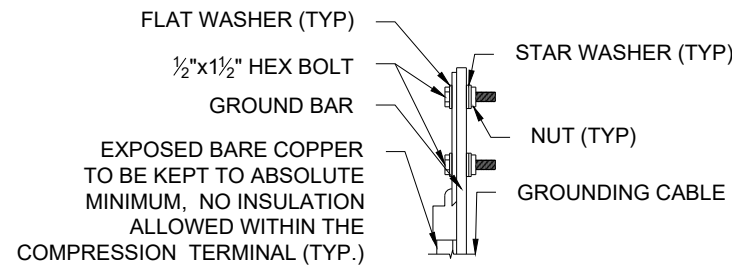

SECTION A-A

- NOTES:**
1. "DOUBLING UP" OR "STACKING " OF CONNECTION IS NOT PERMITTED.
 2. OXIDE INHIBITING COMPOUND TO BE USED AT ALL LOCATIONS.

TYPICAL GROUND BAR CONNECTIONS DETAIL

SCALE: N.T.S

3
E-1

APPLICANT:

T-MOBILE NORTHEAST LLC
 35 GRIFFIN ROAD SOUTH
 BLOOMFIELD, CT 06002
 860-692-7100

PROJECT MANGER

NSS NORTHEAST
 SITE SOLUTIONS
 Turnkey Wireless Development
 420 MAIN STREET, BLDG 4
 STURBRIDGE, MA 01566
 203-275-6669

CONSULTANT:

FORESITE LLC
 Architects . Engineers . Surveyors
 462 WALNUT STREET
 NEWTON, MA 02460
 617-212-3123

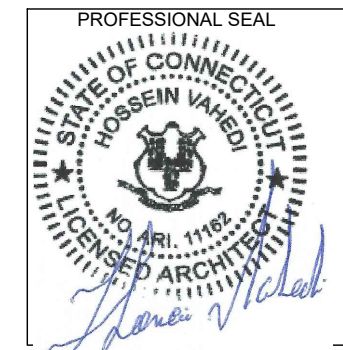

THIS DOCUMENT IS THE DESIGN PROPERTY AND COPYRIGHT OF FORESITE, LLC. AND FOR THE EXCLUSIVE USE BY THE TITLE CLIENT. DUPLICATION OR USE WITHOUT THE EXPRESS WRITTEN CONSENT OF THE CREATOR IS STRICTLY PROHIBITED. DRAWING SCALES ARE INTENDED FOR 11"x17" SIZE PRINTED MEDIA ONLY. ALL OTHER PRINTED SIZES ARE DEEMED "NOT TO SCALE".

REV	DESCRIPTION	DATE
A	PRELIMINARY	03/19/18
0	ISSUED FOR PERMIT	04/02/18
1	BACKHAUL ADDED	05/07/18
2	ISSUED FOR PERMIT	05/07/18

SITE NUMBER: CT11365D
 SITE NAME: CT365/Manchester PD_MP
 SITE ADDRESS: 239 E. MIDDLE TPK
 MANCHESTER, CT 06040

SHEET TITLE:
 E-1: GROUNDING AND ELECTRICAL DETAILS

Exhibit D

**STRUCTURAL ANALYSIS REPORT - REVISION 2
MONOPOLE**



Prepared For:



**T-Mobile Northeast, LLC
35 Griffin Road South
Bloomfield, CT 06002**



Structure Rating

Monopole:	Pass (98.6%)
Anchor Rods:	Pass (94.2%)
Foundation	Pass (87.6%)

Sincerely,
Destek Engineering, LLC
License No: PEC0001429

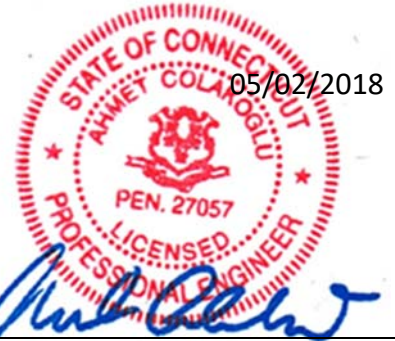

Ahmet Colakoglu, PE
Connecticut Professional Engineer
License No: 27057

**Site ID: CT11365D
Site Name: CT365/Manchester PD_MP
239 E.Middle Tpk
Manchester, CT 06040**

CONTENTS

1.0 – SUBJECT AND REFERENCES

1.1 – STRUCTURE

2.0 – EXISTING AND PROPOSED APPURTENANCES

3.0 - CODES AND LOADING

4.0 - STANDARD CONDITIONS FOR ENGINEERING SERVICES ON EXISTING
STRUCTURES

5.0 - ANALYSIS AND ASSUMPTIONS

6.0 – RESULTS AND CONCLUSION

APPENDIX

A –CALCULATIONS

1.0 SUBJECT AND REFERENCES

The purpose of this analysis is to evaluate the structural capacity of the wireless telecommunication installation on the existing monopole located at 239 East Middle Tpk, Manchester, CT 06040 for additions and alterations proposed by T-Mobile.

The structural analysis is based on the following documentation provided to Destek Engineering, LLC (Destek):

- RFDS provided by T-Mobile, dated 04/05/2018.
- Structural Analysis Report prepared by Tectonic, dated 07/21/2016.
- Structural Analysis Report prepared by Malouf Engineering Intl.,Inc. , dated 03/18/2009.
- Structural Analysis report prepared by ComEX, dated 08/01/2017.

1.1 STRUCTURE

The structure is a 184'-0" (18) sided monopole, which is attached to the foundation with anchor bolts and a base plate. Please refer to the software output in Appendix A, for tower geometry, member sizes, and other details.

Section Length (ft)	Lap Splice (in)	Shaft Thickness (in)	Top Dia/Bottom Dia (in/in)	Steel Yield Strength (ksi)
17.38	2.92	0.1875	15.500/19.399	65
36.36	3.80	0.2500	18.369/26.401	65
48.89	4.99	0.3750	25.061/35.892	65
49.05	6.11	0.4375	34.037/44.903	65
49.14	-	0.4375	42.674/53.500	65

- The monopole is 18 sided.

- It is connected to the foundation with anchor bolts and a base plate.

2.0 EXISTING AND PROPOSED APPURTENANCES

Existing Configuration of T-Mobile Appurtenances:

RAD CENTER (FT)	ANTENNA & TMA	COAX	MOUNT
163	(3) AIR32 KRD901146-1_B66A_B2A (3) AIR21 KRC118023-1_B2A_B4P (3) LNX-6515DS-A1M (3) Generic Twin Style 1B -AWS (3) RRUS 11 B12	(21) 1-5/8 (1) 9x18 Hybrid (1) 6X12 Hybrid	(1) Platform w/Hand Rail

Proposed and Final Configuration of T-Mobile Appurtenances:

RAD CENTER (FT)	ANTENNA & TMA	COAX*	MOUNT
163	(3) AIR32 KRD901146-1_B66A_B2A (3) AIR3246 B66 (3) APXVAARR24_43-U-NA20 (3) KRY 112 144/2 (3) Radio 4449 B71+B12 (1) IBR 1300 radio	(21) 1-5/8 (1) 9x18 Hybrid (2) 6X12 Hybrid (2) Cat 6 (1) Fiber	(1) Platform w/Hand Rail

*: Feedlines located inside the monopole

Existing and Reserved Appurtenances by Others:

CARRIER	RAD CENTER (FT)	ANTENNA & TMA	COAX	MOUNT
Unknown	184	(1) Lightning Rod 2" x 21" (2) 20'-4 Bay Dipole (2) 2' Dish	(4) 7/8"	(1) Platform
Sprint	154	(3) APXVSP18-C (6) RRH 1900MHz (3) RRH 800 MHz (3) APXVTM14-ALU-120 (3) TD-RRH8x20-25	(3) 3/8" (3) 1-1/4" (2) 2" Rigid Conduit (3) 1/2"	(1) Platform (1) Ring Mount
Unknown	151	(3) VHLP2-11 Dish	-	(3) Pipe Mount
Unknown	144	(3) 800 10121 (3) RRUS 11 (2) DC6-48-60-18-8F (2) OPA-65R-LCUU-H6 (4) OPA-65R-LCUU-H8 (3) RRUS 32 (3) RRUS 12 (3) RRUS E2 (3) RRUS A2	(6) 1-5/8" (3) 3/8" (6) 7/16"	(1) Platform
Unknown	124	(1) 20'-4 Bay Dipole (2) 10'x2" Omni (2) 3' Yagi	(5) 1/2"	(1) Platform
Verizon	111	(6) LNX-6514DS-VTM (6) HBX-6517DS-VTM (3) RRH2X40-AWS w/RDEM (3) RRH2x40-07U (3) RRH2x40- PCS	(2) 1-5/8"	(1) Platform

		(2) RFS DB-T1-6Z-8AB-0Z		
Unknown	55	(1) GPS_A	(1) 1/2"	(1) Stand Off Mount
Unknown	38.9	(4) VHLPX2-18-2WH/B	(4) 1/2"	(3) Stand Off Mounts

3.0 CODES AND LOADING

The monopole was analyzed per *TIA/EIA-222-G* as referenced by the *2016 Connecticut State Building Code* with all of the adopted Addendums and Supplements. The following wind loading was used in compliance with the standard for Manchester, CT:

- Basic wind speed 105 mph without ice (W_0 , Equivalent to 98mph including $I_w=1.15$)
- Basic wind speed 50 mph with 1.00" escalating ice (W_i)
- Exposure Category C
- Topographic Category 1
- Structure Class III

The following load combinations were used with wind blowing at 0°, 30°, 45°, 60°, and 90° measured from a line normal to the face of the monopole.

- $1.2 D + 1.6 W_0$
- $0.9 D + 1.6 W_0$
- $1.2 D + 1.0 D_i + 1.0 W_i$

D: Dead Load of structure and appurtenances

W_0 : Wind Load, without ice

W_i : Wind Load, with ice

D_i : Weight of Ice

4.0 STANDARD CONDITIONS FOR ENGINEERING SERVICES ON EXISTING STRUCTURES

The analysis is based on the information provided to Destek and is assumed to be current and correct. Unless otherwise noted, the structure and the foundation system are assumed to be in good condition, free of defects and can achieve theoretical strength.

It is assumed that the structure has been maintained and shall be maintained during its service. The superstructure and the foundation system are assumed to be designed with proper engineering practice and fabricated, constructed and erected in accordance with the design documents. Destek will accept no liability which may arise due to any existing deficiency in design, material, fabrication, erection, construction, etc. or lack of maintenance.

The analysis results presented in this report are only applicable for the previously mentioned existing and proposed additions and alterations. Any deviation of the proposed equipment and placement, etc., will require Destek to generate an additional structural analysis.

5.0 ANALYSIS AND ASSUMPTIONS

The Monopole was analyzed by utilizing tnxTower, a non-linear, three-dimensional, finite element-analysis software package, a product of Tower Numerics, Inc. Software output for this analysis is provided in Appendix A of this report.

6.0 RESULTS AND CONCLUSION

Based on analysis, per TIA-222-G, the existing monopole **has adequate** structural capacity for the proposed changes by T-Mobile. As a maximum, the monopole shaft between 1 feet and 44.03 feet is stressed to **98.6%** of its capacity. The anchor rods also **have adequate** structural capacity for the proposed changes by T-Mobile. As a maximum, the anchor rods are stressed to **94.2%** of its capacity.

The existing tower foundation has **adequate** structural capacity to support the proposed installation by T-Mobile. As a maximum, the foundation is stressed to **87.6%** of its capacity.

Therefore, the proposed additions and alterations by T-Mobile **can** be implemented as intended with the conditions outlined in this report.

Should you have any questions about this report, please contact us at (770) 693-0835.

**APPENDIX A
CALCULATIONS**

DESIGNED APPURTENANCE LOADING

TYPE	ELEVATION	TYPE	ELEVATION
Lightning Rod 2"x21"	184	RRUS 11	144
13' Low Profile Platform	184	RRUS 12	144
20' 4-Bay Dipole	184	RRUS 12	144
20' 4-Bay Dipole	184	RRUS 12	144
9' x 2" Pipe Mount	184	DC6-48-60-18-8F	144
9' x 2" Pipe Mount	184	(2) OPA-65R-LCUU-H6 w/ Mount Pipe	144
9' x 2" Pipe Mount	184	(2) OPA-65R-LCUU-H8 w/ Mount Pipe	144
5'x2.5" Pipe	184	(2) OPA-65R-LCUU-H8 w/ Mount Pipe	144
5'x2.5" Pipe	184	RRUS 32	144
APXVAARR24_43-U-NA20 w/ Mount Pipe	163	RRUS 32	144
APXVAARR24_43-U-NA20 w/ Mount Pipe	163	RRUS 32	144
APXVAARR24_43-U-NA20 w/ Mount Pipe	163	RRUS E2 B29	144
APXVAARR24_43-U-NA20 w/ Mount Pipe	163	RRUS E2 B29	144
APXVAARR24_43-U-NA20 w/ Mount Pipe	163	RRUS E2 B29	144
RADIO 4449	163	RRUS A2	144
RADIO 4449	163	RRUS A2	144
RADIO 4449	163	RRUS A2	144
AIR 32 B2a/B66Aa B2a w/ Mount Pipe	163	13' Low Profile Platform	144
AIR 32 B2a/B66Aa B2a w/ Mount Pipe	163	800 10121 w/ Mount Pipe	144
AIR 32 B2a/B66Aa B2a w/ Mount Pipe	163	800 10121 w/ Mount Pipe	144
AIR 3246 B66	163	2" Dia 10' Omni	124
AIR 3246 B66	163	2" Dia 10' Omni	124
AIR 3246 B66	163	3' Yagi with Mount Pipe	124
AIR 3246 B66	163	3' Yagi with Mount Pipe	124
KRY 112 144/2	163	13' Low Profile Platform	124
KRY 112 144/2	163	20' 4-Bay Dipole	124
KRY 112 144/2	163	9' x 2" Pipe Mount	124
IBR 1300 Series	163	(2) LNX-6514DS-VTM w/ Mount Pipe	111
14 ft Handrail kit	163	(2) LNX-6514DS-VTM w/ Mount Pipe	111
14' Platform	163	(2) LNX-6514DS-VTM w/ Mount Pipe	111
APXVSPP18-C w/ Mount Pipe	154	RRH2X40-AWS w/RDEM	111
APXVSPP18-C w/ Mount Pipe	154	RRH2X40-AWS w/RDEM	111
APXVSPP18-C w/ Mount Pipe	154	RRH2X40-AWS w/RDEM	111
(2) RRH1900MHz	154	RRH2x40-07U	111
(2) RRH1900MHz	154	RRH2x40-07U	111
(2) RRH1900MHz	154	RRH2x40-07U	111
RRH800MHz	154	RRH2x40- PCS	111
RRH800MHz	154	RRH2x40- PCS	111
RRH800MHz	154	RRH2x40- PCS	111
13' Low Profile Platform	154	RFS DB-T1-6Z-8AB-0Z	111
APXVTM14-ALU-I20 w/ Mount Pipe	154	RFS DB-T1-6Z-8AB-0Z	111
APXVTM14-ALU-I20 w/ Mount Pipe	154	Pirot 13' Platform	111
APXVTM14-ALU-I20 w/ Mount Pipe	154	(2) HBX-6517DS-VTM w/ Mount Pipe	111
TD-RRH8x20-25	154	(2) HBX-6517DS-VTM w/ Mount Pipe	111
TD-RRH8x20-25	154	(2) HBX-6517DS-VTM w/ Mount Pipe	111
TD-RRH8x20-25	154	Side Arm Mount [SO 301-1]	55
Ring Mount	154	GPS_A	55
VHLP2-11	151	1ft Side Mount Standoff	39.9
VHLP2-11	151	1ft Side Mount Standoff	39.9
VHLP2-11	151	1ft Side Mount Standoff	39.9
800 10121 w/ Mount Pipe	144	2' Dish	39.9
RRUS 11	144	2' Dish	39.9
RRUS 11	144	(2) 2' Dish	39.9

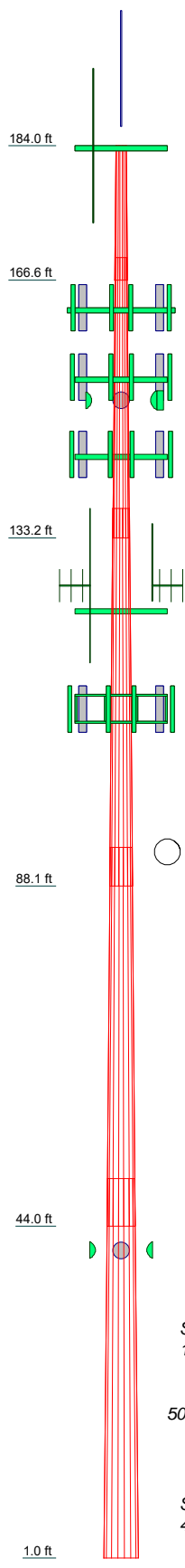

ALL REACTIONS ARE FACTORED

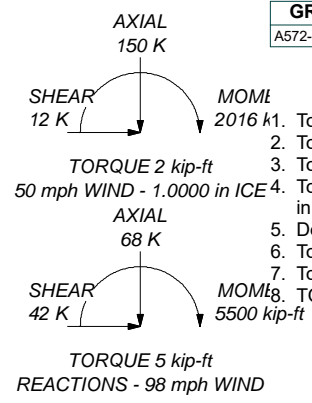

MATERIAL STRENGTH

GRADE	Fy	Fu	GRADE	Fy	Fu
A572-65	65 ksi	80 ksi			

TOWER DESIGN NOTES

1. Tower is located in Hartford County, Connecticut.
 2. Tower designed for Exposure B to the TIA-222-G Standard.
 3. Tower designed for a 98 mph basic wind in accordance with the TIA-222-G Standard.
 4. Tower is also designed for a 50 mph basic wind with 1.00 in ice. Ice is considered to increase in thickness with height.
 5. Deflections are based upon a 60 mph wind.
 6. Tower Structure Class III.
 7. Topographic Category 1 with Crest Height of 0.0000 ft
- TOWER RATING: 98.6%

Section	Length (ft)	Number of Sides	Thickness (in)	Socket Length (ft)	Top Dia (in)	Bot Dia (in)	Grade	Weight (K)
1	17.3800	18	0.1875	2.9200	15.5000	19.3990	A572-65	0.6
2	36.3600	18	0.2500	3.8000	18.3689	26.4007	A572-65	2.2
3	48.8900	18	0.3750	4.9900	25.0613	35.8924	A572-65	6.0
4	49.0500	18	0.4375	6.1100	34.0369	44.9030	A572-65	9.0
5	49.1400	18	0.4375	42.6744	53.5000		A572-65	11.1
								28.9

Destek Engineering LLC
 1281 Kennestone Circle, Suite 100
 Marietta, GA 30066
 Phone: 770693-0835
 FAX:

Job: **CT11365D**
 Project: **1875007**
 Client: Foresite/T-Mobile
 Code: TIA-222-G
 Path: Z:\Projects\201875 - ForeSite LLC\1875007 - CT11365D\TNR\Rev 2\CT11365D-Rev 2.dwg
 Drawn by: Ahmet Colakoglu
 Date: 05/02/18
 App'd:
 Scale: NTS
 Dwg No. E-1

tnxTower Destek Engineering LLC 1281 Kennestone Circle, Suite 100 Marietta, GA 30066 Phone: 770693-0835 FAX:	Job CT11365D	Page 1 of 20
	Project 1875007	Date 09:35:33 05/02/18
	Client Foresite/T-Mobile	Designed by Ahmet Colakoglu

Tower Input Data

There is a pole section.

This tower is designed using the TIA-222-G standard.

The following design criteria apply:

Tower is located in Hartford County, Connecticut.

Basic wind speed of 98 mph.

Structure Class III.

Exposure Category B.

Topographic Category 1.

Crest Height 0.0000 ft.

Nominal ice thickness of 1.0000 in.

Ice thickness is considered to increase with height.

Ice density of 56.00 pcf.

A wind speed of 50 mph is used in combination with ice.

Temperature drop of 50 °F.

Deflections calculated using a wind speed of 60 mph.

A non-linear (P-delta) analysis was used.

Pressures are calculated at each section.

Stress ratio used in pole design is 1.

Local bending stresses due to climbing loads, feed line supports, and appurtenance mounts are not considered.

Options

<ul style="list-style-type: none"> Consider Moments - Legs Consider Moments - Horizontals Consider Moments - Diagonals Use Moment Magnification √ Use Code Stress Ratios √ Use Code Safety Factors - Guys Escalate Ice Always Use Max Kz Use Special Wind Profile Include Bolts In Member Capacity Leg Bolts Are At Top Of Section Secondary Horizontal Braces Leg Use Diamond Inner Bracing (4 Sided) SR Members Have Cut Ends SR Members Are Concentric 	<ul style="list-style-type: none"> Distribute Leg Loads As Uniform Assume Legs Pinned √ Assume Rigid Index Plate √ Use Clear Spans For Wind Area Use Clear Spans For KL/r Retention Guys To Initial Tension √ Bypass Rigid Stability Checks √ Use Azimuth Dish Coefficients √ Project Wind Area of Appurt. Autocalc Torque Arm Areas Add IBC .6D+W Combination Sort Capacity Reports By Component Triangulate Diamond Inner Bracing Treat Feed Line Bundles As Cylinder 	<ul style="list-style-type: none"> Use ASCE 10 X-Brace Ly Rules Calculate Redundant Bracing Forces Ignore Redundant Members in FEA SR Leg Bolts Resist Compression All Leg Panels Have Same Allowable Offset Girt At Foundation √ Consider Feed Line Torque Include Angle Block Shear Check Use TIA-222-G Bracing Resist. Exemption Use TIA-222-G Tension Splice Exemption <li style="text-align: center;">Poles √ Include Shear-Torsion Interaction Always Use Sub-Critical Flow Use Top Mounted Sockets
--	---	---

Tapered Pole Section Geometry

Section	Elevation ft	Section Length ft	Splice Length ft	Number of Sides	Top Diameter in	Bottom Diameter in	Wall Thickness in	Bend Radius in	Pole Grade
L1	184.0000-166.6 200	17.3800	2.92	18	15.5000	19.3990	0.1875	0.7500	A572-65 (65 ksi)
L2	166.6200-133.1 800	36.3600	3.80	18	18.3689	26.4007	0.2500	1.0000	A572-65 (65 ksi)

tnxTower Destek Engineering LLC 1281 Kennestone Circle, Suite 100 Marietta, GA 30066 Phone: 770693-0835 FAX:	Job	CT11365D	Page	2 of 20
	Project	1875007	Date	09:35:33 05/02/18
	Client	Foresite/T-Mobile	Designed by	Ahmet Colakoglu

Section	Elevation	Section Length	Splice Length	Number of Sides	Top Diameter	Bottom Diameter	Wall Thickness	Bend Radius	Pole Grade
	ft	ft	ft		in	in	in	in	
L3	133.1800-88.0000	48.8900	4.99	18	25.0613	35.8924	0.3750	1.5000	A572-65 (65 ksi)
L4	88.0900-44.0300	49.0500	6.11	18	34.0369	44.9030	0.4375	1.7500	A572-65 (65 ksi)
L5	44.0300-1.0000	49.1400		18	42.6744	53.5000	0.4375	1.7500	A572-65 (65 ksi)

Tapered Pole Properties

Section	Tip Dia.	Area	I	r	C	I/C	J	It/Q	w	w/t
	in	in ²	in ⁴	in	in	in ³	in ⁴	in ²	in	
L1	15.7391	9.1129	269.9504	5.4359	7.8740	34.2838	540.2560	4.5573	2.3980	12.789
	19.6983	11.4332	533.1255	6.8201	9.8547	54.0986	1066.9525	5.7177	3.0842	16.449
L2	19.3073	14.3774	596.3238	6.4322	9.3314	63.9050	1193.4323	7.1901	2.7929	11.172
	26.8080	20.7506	1792.8103	9.2835	13.4116	133.6765	3587.9796	10.3773	4.2065	16.826
L3	26.3027	29.3829	2262.2648	8.7636	12.7311	177.6954	4527.5063	14.6942	3.7508	10.002
	36.4461	42.2746	6737.5056	12.6087	18.2333	369.5157	13483.8766	21.1413	5.6571	15.085
L4	35.6845	46.6570	6654.5323	11.9278	17.2908	384.8608	13317.8209	23.3329	5.2205	11.933
	45.5957	61.7459	15423.8208	15.7853	22.8107	676.1653	30867.9366	30.8788	7.1329	16.304
L5	44.6996	58.6513	13219.0421	14.9941	21.6786	609.7733	26455.4782	29.3312	6.7407	15.407
	54.3253	73.6839	26211.1184	18.8372	27.1780	964.4241	52456.7261	36.8490	8.6460	19.762

Tower Elevation	Gusset Area	Gusset Thickness	Gusset Grade	Adjust. Factor	Adjust. Factor	Weight Mult.	Double Angle	Double Angle	Double Angle
ft	ft ²	in		A _f	A _r		Stitch Bolt Spacing Diagonals	Stitch Bolt Spacing Horizontals	Stitch Bolt Spacing Redundants
							in	in	in
L1				1	1	1			
184.0000-166.6200									
L2				1	1	1			
166.6200-133.1800									
L3				1	1	1			
133.1800-88.0900									
L4				1	1	1			
88.0900-44.0300									
L5				1	1	1			
44.0300-1.0000									

Feed Line/Linear Appurtenances - Entered As Round Or Flat

Description	Sector	Component Type	Placement	Total Number	Number Per Row	Start/End Position	Width or Diameter	Perimeter	Weight
			ft				in	in	klf
LDF4-50A(1/2)	A	Surface Ar (CaAa)	155.0000 - 7.0000	3	3	0.000	0.6250		0.00
2" (Nominal) Conduit	A	Surface Ar (CaAa)	155.0000 - 7.0000	2	2	0.000	2.3750		0.00

tnxTower Destek Engineering LLC 1281 Kennestone Circle, Suite 100 Marietta, GA 30066 Phone: 770693-0835 FAX:	Job	CT11365D	Page	3 of 20
	Project	1875007	Date	09:35:33 05/02/18
	Client	Foresite/T-Mobile	Designed by	Ahmet Colakoglu

Description	Sector	Component Type	Placement ft	Total Number	Number Per Row	Start/End Position	Width or Diameter in	Perimeter in	Weight klf
Step Pegs (Surface Ar)	C	Surface Ar (CaAa)	184.0000 - 2.0000	1	1	0.000 0.000	0.8000		0.00
Safety Line 3/8	C	Surface Ar (CaAa)	184.0000 - 7.0000	1	1	0.000 0.000	0.3750		0.00

Feed Line/Linear Appurtenances - Entered As Area

Description	Face or Leg	Allow Shield	Component Type	Placement ft	Total Number		C _{AA} ft ² /ft	Weight klf

LDF5-50A(7/8)	B	No	Inside Pole	184.0000 - 7.0000	4	No Ice 1/2" Ice 1" Ice	0.0000 0.0000 0.0000	0.00 0.00 0.00
LDF7-50A(1-5/8)	B	No	Inside Pole	164.0000 - 7.0000	21	No Ice 1/2" Ice 1" Ice	0.0000 0.0000 0.0000	0.00 0.00 0.00
CAT6(1/4)	C	No	Inside Pole	164.0000 - 7.0000	2	No Ice 1/2" Ice 1" Ice	0.0000 0.0000 0.0000	0.00 0.00 0.00
3/8" Fiber Cable	C	No	Inside Pole	164.0000 - 7.0000	1	No Ice 1/2" Ice 1" Ice	0.0000 0.0000 0.0000	0.00 0.00 0.00
LDF2-50A(3/8")	A	No	Inside Pole	154.0000 - 7.0000	3	No Ice 1/2" Ice 1" Ice	0.0000 0.0000 0.0000	0.00 0.00 0.00
LDF6-50A(1-1/4)	B	No	Inside Pole	154.0000 - 7.0000	3	No Ice 1/2" Ice 1" Ice	0.0000 0.0000 0.0000	0.00 0.00 0.00

CAT6(1/4)	C	No	Inside Pole	163.0000 - 7.0000	2	No Ice 1/2" Ice 1" Ice	0.0000 0.0000 0.0000	0.00 0.00 0.00

LDF7-50A(1-5/8)	B	No	Inside Pole	144.0000 - 7.0000	6	No Ice 1/2" Ice 1" Ice	0.0000 0.0000 0.0000	0.00 0.00 0.00
FB-L98-002-XXX(3/8)	B	No	Inside Pole	144.0000 - 7.0000	3	No Ice 1/2" Ice 1" Ice	0.0000 0.0000 0.0000	0.00 0.00 0.00
WR-VG122ST-BRDA(7/16)	B	No	Inside Pole	144.0000 - 7.0000	6	No Ice 1/2" Ice 1" Ice	0.0000 0.0000 0.0000	0.00 0.00 0.00

LDF4-50A(1/2)	B	No	Inside Pole	124.0000 - 7.0000	5	No Ice 1/2" Ice 1" Ice	0.0000 0.0000 0.0000	0.00 0.00 0.00

LDF7-50A(1-5/8)	B	No	Inside Pole	111.0000 - 7.0000	2	No Ice 1/2" Ice 1" Ice	0.0000 0.0000 0.0000	0.00 0.00 0.00

LDF4-50A(1/2)	B	No	Inside Pole	55.0000 - 7.0000	1	No Ice 1/2" Ice 1" Ice	0.0000 0.0000 0.0000	0.00 0.00 0.00
LDF4-50A(1/2)	B	No	Inside Pole	39.9000 - 7.0000	4	No Ice 1/2" Ice 1" Ice	0.0000 0.0000 0.0000	0.00 0.00 0.00

tnxTower Destek Engineering LLC 1281 Kennestone Circle, Suite 100 Marietta, GA 30066 Phone: 770693-0835 FAX:	Job CT11365D	Page 4 of 20
	Project 1875007	Date 09:35:33 05/02/18
	Client Foresite/T-Mobile	Designed by Ahmet Colakoglu

Description	Face or Leg	Allow Shield	Component Type	Placement ft	Total Number		C _{AA} ft ² /ft	Weight klf

7"x1/2"	A	No	Inside Pole	44.9000 - 2.0000	2	No Ice	0.0000	0.01
						1/2" Ice	0.0000	0.01
						1" Ice	0.0000	0.01
7"x1/2"	B	No	Inside Pole	44.9000 - 2.0000	2	No Ice	0.0000	0.01
						1/2" Ice	0.0000	0.01
						1" Ice	0.0000	0.01
7"x1/2"	C	No	Inside Pole	44.9000 - 2.0000	2	No Ice	0.0000	0.01
						1/2" Ice	0.0000	0.01
						1" Ice	0.0000	0.01
6"x1/4"	A	No	Inside Pole	89.0000 - 44.9000	2	No Ice	0.0000	0.01
						1/2" Ice	0.0000	0.01
						1" Ice	0.0000	0.01
6"x1/4"	B	No	Inside Pole	89.0000 - 44.9000	2	No Ice	0.0000	0.01
						1/2" Ice	0.0000	0.01
						1" Ice	0.0000	0.01
6"x1/4"	C	No	Inside Pole	89.0000 - 44.9000	2	No Ice	0.0000	0.01
						1/2" Ice	0.0000	0.01
						1" Ice	0.0000	0.01
5"x1/4"	A	No	Inside Pole	119.0000 - 89.0000	2	No Ice	0.0000	0.00
						1/2" Ice	0.0000	0.00
						1" Ice	0.0000	0.00
5"x1/4"	B	No	Inside Pole	119.0000 - 89.0000	2	No Ice	0.0000	0.00
						1/2" Ice	0.0000	0.00
						1" Ice	0.0000	0.00
5"x1/4"	C	No	Inside Pole	119.0000 - 89.0000	2	No Ice	0.0000	0.00
						1/2" Ice	0.0000	0.00
						1" Ice	0.0000	0.00
Hybrid for TMO - 32 mm	C	No	Inside Pole	164.0000 - 7.0000	3	No Ice	0.0000	0.00
						1/2" Ice	0.0000	0.00
						1" Ice	0.0000	0.00
CAT6(1/4)	C	No	Inside Pole	163.0000 - 7.0000	2	No Ice	0.0000	0.00
						1/2" Ice	0.0000	0.00
						1" Ice	0.0000	0.00
CAT6(1/4)	C	No	Inside Pole	163.0000 - 7.0000	2	No Ice	0.0000	0.00
						1/2" Ice	0.0000	0.00
						1" Ice	0.0000	0.00
3/8" Fiber Cable	C	No	Inside Pole	163.0000 - 7.0000	1	No Ice	0.0000	0.00
						1/2" Ice	0.0000	0.00
						1" Ice	0.0000	0.00

Feed Line/Linear Appurtenances Section Areas

Tower Section	Tower Elevation ft	Face	A _R ft ²	A _F ft ²	C _{AA} In Face ft ²	C _{AA} Out Face ft ²	Weight K
L1	184.0000-166.6200	A	0.000	0.000	0.000	0.000	0.00
		B	0.000	0.000	0.000	0.000	0.02
		C	0.000	0.000	2.042	0.000	0.05
L2	166.6200-133.1800	A	0.000	0.000	14.456	0.000	0.05
		B	0.000	0.000	0.000	0.000	0.68
		C	0.000	0.000	3.929	0.000	0.20
L3	133.1800-88.0900	A	0.000	0.000	29.872	0.000	0.35
		B	0.000	0.000	0.000	0.000	1.50
		C	0.000	0.000	5.298	0.000	0.54
L4	88.0900-44.0300	A	0.000	0.000	29.190	0.000	0.55
		B	0.000	0.000	0.000	0.000	1.72
		C	0.000	0.000	5.177	0.000	0.73

tnxTower Destek Engineering LLC 1281 Kennestone Circle, Suite 100 Marietta, GA 30066 Phone: 770693-0835 FAX:	Job	CT11365D	Page	5 of 20
	Project	1875007	Date	09:35:33 05/02/18
	Client	Foresite/T-Mobile	Designed by	Ahmet Colakoglu

Tower Section	Tower Elevation ft	Face	A _R ft ²	A _F ft ²	C _{AA} In Face ft ²	C _{AA} Out Face ft ²	Weight K
L5	44.0300-1.0000	A	0.000	0.000	24.532	0.000	1.09
		B	0.000	0.000	0.000	0.000	2.10
		C	0.000	0.000	4.751	0.000	1.26

Feed Line/Linear Appurtenances Section Areas - With Ice

Tower Section	Tower Elevation ft	Face or Leg	Ice Thickness in	A _R ft ²	A _F ft ²	C _{AA} In Face ft ²	C _{AA} Out Face ft ²	Weight K
L1	184.0000-166.6200	A	2.954	0.000	0.000	0.000	0.000	0.00
		B		0.000	0.000	0.000	0.000	0.02
		C		0.000	0.000	22.577	0.000	0.50
L2	166.6200-133.1800	A	2.907	0.000	0.000	50.296	0.000	0.94
		B		0.000	0.000	0.000	0.000	0.68
		C		0.000	0.000	43.440	0.000	1.06
L3	133.1800-88.0900	A	2.819	0.000	0.000	102.878	0.000	2.15
		B		0.000	0.000	0.000	0.000	1.50
		C		0.000	0.000	57.729	0.000	1.66
L4	88.0900-44.0300	A	2.678	0.000	0.000	98.594	0.000	2.23
		B		0.000	0.000	0.000	0.000	1.72
		C		0.000	0.000	54.863	0.000	1.77
L5	44.0300-1.0000	A	2.400	0.000	0.000	80.252	0.000	2.40
		B		0.000	0.000	0.000	0.000	2.10
		C		0.000	0.000	47.099	0.000	2.11

Feed Line Center of Pressure

Section	Elevation ft	CP _x in	CP _z in	CP _x Ice in	CP _z Ice in
L1	184.0000-166.6200	0.0000	0.1669	0.0000	0.8966
L2	166.6200-133.1800	-0.4899	-0.1439	-0.6494	0.2139
L3	133.1800-88.0900	-0.6925	-0.2633	-0.9466	0.0472
L4	88.0900-44.0300	-0.7212	-0.2730	-1.1061	0.0543
L5	44.0300-1.0000	-0.6417	-0.2293	-1.1150	0.1007

Shielding Factor Ka

Tower Section	Feed Line Record No.	Description	Feed Line Segment Elev.	K _a No Ice	K _a Ice
L1	3	Step Pegs (Surface Ar)	166.62 - 184.00	1.0000	1.0000
L1	4	Safety Line 3/8	166.62 - 184.00	1.0000	1.0000
L1	1	LDF4-50A(1/2)	166.62 - 155.00	1.0000	1.0000
L1	2	2" (Nominal) Conduit	166.62 - 155.00	1.0000	1.0000

tnxTower Destek Engineering LLC 1281 Kennestone Circle, Suite 100 Marietta, GA 30066 Phone: 770693-0835 FAX:	Job CT11365D	Page 6 of 20
	Project 1875007	Date 09:35:33 05/02/18
	Client Foresite/T-Mobile	Designed by Ahmet Colakoglu

Tower Section	Feed Line Record No.	Description	Feed Line Segment Elev.	K _a No Ice	K _a Ice
L2	1	LDF4-50A(1/2)	133.18 - 155.00	1.0000	1.0000
L2	2	2" (Nominal) Conduit	133.18 - 155.00	1.0000	1.0000
L2	3	Step Pegs (Surface Ar)	133.18 - 166.62	1.0000	1.0000
L2	4	Safety Line 3/8	133.18 - 166.62	1.0000	1.0000
L3	1	LDF4-50A(1/2)	88.09 - 133.18	1.0000	1.0000
L3	2	2" (Nominal) Conduit	88.09 - 133.18	1.0000	1.0000
L3	3	Step Pegs (Surface Ar)	88.09 - 133.18	1.0000	1.0000
L3	4	Safety Line 3/8	88.09 - 133.18	1.0000	1.0000
L4	1	LDF4-50A(1/2)	44.03 - 88.09	1.0000	1.0000
L4	2	2" (Nominal) Conduit	44.03 - 88.09	1.0000	1.0000
L4	3	Step Pegs (Surface Ar)	44.03 - 88.09	1.0000	1.0000
L4	4	Safety Line 3/8	44.03 - 88.09	1.0000	1.0000

Discrete Tower Loads

Description	Face or Leg	Offset Type	Offsets: Horz Lateral Vert	Azimuth Adjustment °	Placement ft	C _A A _A Front	C _A A _A Side	Weight K
			ft ft ft			ft ²	ft ²	K
Lightning Rod 2"x21"	A	From Leg	1.0000 0.00 10.00	0.0000	184.0000	No Ice 4.3400 1/2" Ice 6.4500 1" Ice 8.5600	4.3400 6.4500 8.5600	0.08 0.11 0.15
13' Low Profile Platform	C	None		0.0000	184.0000	No Ice 24.3300 1/2" Ice 30.2200 1" Ice 36.1100	24.3300 30.2200 36.1100	1.65 2.03 2.42
20' 4-Bay Dipole	C	From Leg	3.5000 0.00 0.00	0.0000	184.0000	No Ice 4.0000 1/2" Ice 6.0000 1" Ice 8.0000	4.0000 6.0000 8.0000	0.06 0.10 0.14
20' 4-Bay Dipole	C	From Leg	3.5000 0.00 0.00	0.0000	184.0000	No Ice 4.0000 1/2" Ice 6.0000 1" Ice 8.0000	4.0000 6.0000 8.0000	0.06 0.10 0.14
9' x 2" Pipe Mount	A	From Leg	3.5000 0.00 0.00	0.0000	184.0000	No Ice 2.1375 1/2" Ice 3.0656 1" Ice 4.0104	2.1375 3.0656 4.0104	0.03 0.05 0.07
9' x 2" Pipe Mount	C	From Leg	3.5000 0.00 0.00	0.0000	184.0000	No Ice 2.1375 1/2" Ice 3.0656 1" Ice 4.0104	2.1375 3.0656 4.0104	0.03 0.05 0.07
9' x 2" Pipe Mount	C	From Leg	3.5000 0.00 0.00	0.0000	184.0000	No Ice 2.1375 1/2" Ice 3.0656 1" Ice 4.0104	2.1375 3.0656 4.0104	0.03 0.05 0.07
5'x2.5" Pipe	C	From Leg	3.5000 0.00 0.00	0.0000	184.0000	No Ice 1.3280 1/2" Ice 1.6320 1" Ice 1.9360	1.3280 1.6320 1.9360	0.03 0.04 0.05
5'x2.5" Pipe	B	From Leg	3.5000 0.00 0.00	0.0000	184.0000	No Ice 1.3280 1/2" Ice 1.6320 1" Ice 1.9360	1.3280 1.6320 1.9360	0.03 0.04 0.05
****Client**								
APXVAARR24_43-U-NA20	A	From Leg	3.5000	0.0000	163.0000	No Ice 20.4801	11.0240	0.16

tnxTower Destek Engineering LLC 1281 Kennestone Circle, Suite 100 Marietta, GA 30066 Phone: 770693-0835 FAX:	Job	CT11365D	Page	7 of 20
	Project	1875007	Date	09:35:33 05/02/18
	Client	Foresite/T-Mobile	Designed by	Ahmet Colakoglu

Description	Face or Leg	Offset Type	Offsets:		Azimuth Adjustment	Placement	C _{AA} Front	C _{AA} Side	Weight
			Horz	Lateral					
w/ Mount Pipe			0.00			1/2" Ice	21.2306	12.5496	0.30
			0.00			1" Ice	21.9900	14.0992	0.44
APXVAARR24_43-U-NA20	B	From Leg	3.5000	0.0000	163.0000	No Ice	20.4801	11.0240	0.16
w/ Mount Pipe			0.00			1/2" Ice	21.2306	12.5496	0.30
			0.00			1" Ice	21.9900	14.0992	0.44
APXVAARR24_43-U-NA20	C	From Leg	3.5000	0.0000	163.0000	No Ice	20.4801	11.0240	0.16
w/ Mount Pipe			0.00			1/2" Ice	21.2306	12.5496	0.30
			0.00			1" Ice	21.9900	14.0992	0.44
RADIO 4449	A	From Leg	3.5000	0.0000	163.0000	No Ice	3.5000	2.3593	0.09
			0.00			1/2" Ice	3.7426	2.5658	0.11
			0.00			1" Ice	3.9926	2.7794	0.15
RADIO 4449	B	From Leg	3.5000	0.0000	163.0000	No Ice	3.5000	2.3593	0.09
			0.00			1/2" Ice	3.7426	2.5658	0.11
			0.00			1" Ice	3.9926	2.7794	0.15
RADIO 4449	C	From Leg	3.5000	0.0000	163.0000	No Ice	3.5000	2.3593	0.09
			0.00			1/2" Ice	3.7426	2.5658	0.11
			0.00			1" Ice	3.9926	2.7794	0.15
AIR 32 B2a/B66Aa B2a w/	A	From Leg	3.5000	0.0000	163.0000	No Ice	6.8150	6.1370	0.15
Mount Pipe			0.00			1/2" Ice	7.2990	6.9930	0.22
			0.00			1" Ice	7.7830	7.8490	0.28
AIR 32 B2a/B66Aa B2a w/	B	From Leg	3.5000	0.0000	163.0000	No Ice	6.8150	6.1370	0.15
Mount Pipe			0.00			1/2" Ice	7.2990	6.9930	0.22
			0.00			1" Ice	7.7830	7.8490	0.28
AIR 32 B2a/B66Aa B2a w/	C	From Leg	3.5000	0.0000	163.0000	No Ice	6.8150	6.1370	0.15
Mount Pipe			0.00			1/2" Ice	7.2990	6.9930	0.22
			0.00			1" Ice	7.7830	7.8490	0.28
AIR 3246 B66	A	From Leg	0.0000	0.0000	163.0000	No Ice	8.0958	6.4779	0.20
			0.00			1/2" Ice	8.5429	7.2440	0.27
			0.00			1" Ice	8.9901	7.9590	0.35
AIR 3246 B66	B	From Leg	0.0000	0.0000	163.0000	No Ice	8.0958	6.4779	0.20
			0.00			1/2" Ice	8.5429	7.2440	0.27
			0.00			1" Ice	8.9901	7.9590	0.35
AIR 3246 B66	C	From Leg	0.0000	0.0000	163.0000	No Ice	8.0958	6.4779	0.20
			0.00			1/2" Ice	8.5429	7.2440	0.27
			0.00			1" Ice	8.9901	7.9590	0.35
KRY 112 144/2	A	From Leg	3.0000	0.0000	163.0000	No Ice	0.4794	0.2317	0.01
			0.00			1/2" Ice	0.5681	0.2994	0.01
			0.00			1" Ice	0.6642	0.3763	0.02
KRY 112 144/2	B	From Leg	3.0000	0.0000	163.0000	No Ice	0.4794	0.2317	0.01
			0.00			1/2" Ice	0.5681	0.2994	0.01
			0.00			1" Ice	0.6642	0.3763	0.02
KRY 112 144/2	C	From Leg	3.0000	0.0000	163.0000	No Ice	0.4794	0.2317	0.01
			0.00			1/2" Ice	0.5681	0.2994	0.01
			0.00			1" Ice	0.6642	0.3763	0.02
IBR 1300 Series	A	From Leg	3.0000	0.0000	163.0000	No Ice	0.6709	0.2322	0.01
			0.00			1/2" Ice	0.7752	0.2993	0.01
			0.00			1" Ice	0.8868	0.3738	0.02
14 ft Handrail kit	C	None		0.0000	163.0000	No Ice	6.0000	8.5000	0.26
						1/2" Ice	9.0000	12.7500	0.34
						1" Ice	12.0000	17.0000	0.42
14' Platform	C	None		0.0000	163.0000	No Ice	23.1000	23.1000	2.10
						1/2" Ice	26.8000	26.8000	2.50
						1" Ice	30.5000	30.5000	2.90
153									
APXVSP18-C w/ Mount	A	From Leg	3.5000	0.0000	154.0000	No Ice	8.2619	6.9458	0.08
Pipe			0.00			1/2" Ice	8.8215	8.1266	0.15
			0.00			1" Ice	9.3462	9.0212	0.23

tnxTower Destek Engineering LLC 1281 Kennestone Circle, Suite 100 Marietta, GA 30066 Phone: 770693-0835 FAX:	Job	CT11365D	Page	8 of 20
	Project	1875007	Date	09:35:33 05/02/18
	Client	Foresite/T-Mobile	Designed by	Ahmet Colakoglu

Description	Face or Leg	Offset Type	Offsets:		Azimuth Adjustment	Placement	CAAA Front	CAAA Side	Weight
			Horz	Lateral Vert					
APXVSPP18-C w/ Mount Pipe	B	From Leg	3.5000	0.0000	154.0000	No Ice	8.2619	6.9458	0.08
			0.00			1/2" Ice	8.8215	8.1266	0.15
			0.00			1" Ice	9.3462	9.0212	0.23
APXVSPP18-C w/ Mount Pipe	C	From Leg	3.5000	0.0000	154.0000	No Ice	8.2619	6.9458	0.08
			0.00			1/2" Ice	8.8215	8.1266	0.15
			0.00			1" Ice	9.3462	9.0212	0.23
(2) RRH1900MHz	A	From Leg	1.0000	0.0000	154.0000	No Ice	2.5985	3.7161	0.06
			0.00			1/2" Ice	2.8392	4.1008	0.10
			0.00			1" Ice	3.0895	4.5022	0.14
(2) RRH1900MHz	B	From Leg	1.0000	0.0000	154.0000	No Ice	2.5985	3.7161	0.06
			0.00			1/2" Ice	2.8392	4.1008	0.10
			0.00			1" Ice	3.0895	4.5022	0.14
(2) RRH1900MHz	C	From Leg	1.0000	0.0000	154.0000	No Ice	2.5985	3.7161	0.06
			0.00			1/2" Ice	2.8392	4.1008	0.10
			0.00			1" Ice	3.0895	4.5022	0.14
RRH800MHz	A	From Leg	1.0000	0.0000	154.0000	No Ice	2.2433	2.4095	0.05
			0.00			1/2" Ice	2.4881	2.7501	0.08
			0.00			1" Ice	2.7439	3.1073	0.11
RRH800MHz	B	From Leg	1.0000	0.0000	154.0000	No Ice	2.2433	2.4095	0.05
			0.00			1/2" Ice	2.4881	2.7501	0.08
			0.00			1" Ice	2.7439	3.1073	0.11
RRH800MHz	C	From Leg	1.0000	0.0000	154.0000	No Ice	2.2433	2.4095	0.05
			0.00			1/2" Ice	2.4881	2.7501	0.08
			0.00			1" Ice	2.7439	3.1073	0.11
13' Low Profile Platform	C	None		0.0000	154.0000	No Ice	24.3300	24.3300	1.65
						1/2" Ice	30.2200	30.2200	2.03
						1" Ice	36.1100	36.1100	2.42
APXVTM14-ALU-I20 w/ Mount Pipe	A	From Leg	3.5000	0.0000	154.0000	No Ice	6.5799	4.9591	0.08
			0.00			1/2" Ice	7.0306	5.7544	0.13
			0.00			1" Ice	7.4733	6.4723	0.19
APXVTM14-ALU-I20 w/ Mount Pipe	B	From Leg	3.5000	0.0000	154.0000	No Ice	6.5799	4.9591	0.08
			0.00			1/2" Ice	7.0306	5.7544	0.13
			0.00			1" Ice	7.4733	6.4723	0.19
APXVTM14-ALU-I20 w/ Mount Pipe	C	From Leg	3.5000	0.0000	154.0000	No Ice	6.5799	4.9591	0.08
			0.00			1/2" Ice	7.0306	5.7544	0.13
			0.00			1" Ice	7.4733	6.4723	0.19
***151									
TD-RRH8x20-25	A	From Leg	1.0000	0.0000	154.0000	No Ice	4.0455	1.5345	0.07
			0.00			1/2" Ice	4.2975	1.7142	0.10
			0.00			1" Ice	4.5570	1.9008	0.13
TD-RRH8x20-25	B	From Leg	1.0000	0.0000	154.0000	No Ice	4.0455	1.5345	0.07
			0.00			1/2" Ice	4.2975	1.7142	0.10
			0.00			1" Ice	4.5570	1.9008	0.13
TD-RRH8x20-25	C	From Leg	1.0000	0.0000	154.0000	No Ice	4.0455	1.5345	0.07
			0.00			1/2" Ice	4.2975	1.7142	0.10
			0.00			1" Ice	4.5570	1.9008	0.13
Ring Mount	C	None		0.0000	154.0000	No Ice	4.3900	4.3900	0.20
						1/2" Ice	5.4800	5.4800	0.24
						1" Ice	6.5700	6.5700	0.28

143									
13' Low Profile Platform	A	None		0.0000	144.0000	No Ice	24.3300	24.3300	1.65
						1/2" Ice	30.2200	30.2200	2.03
						1" Ice	36.1100	36.1100	2.42
800 10121 w/ Mount Pipe	A	From Leg	3.5000	0.0000	144.0000	No Ice	5.3879	4.5996	0.07
			0.00			1/2" Ice	5.8131	5.3507	0.11
			0.00			1" Ice	6.2340	6.0464	0.17

tnxTower Destek Engineering LLC 1281 Kennestone Circle, Suite 100 Marietta, GA 30066 Phone: 770693-0835 FAX:	Job	CT11365D	Page	9 of 20
	Project	1875007	Date	09:35:33 05/02/18
	Client	Foresite/T-Mobile	Designed by	Ahmet Colakoglu

Description	Face or Leg	Offset Type	Offsets:		Azimuth Adjustment	Placement	CAAA Front	CAAA Side	Weight
			Horz	Lateral Vert					
800 10121 w/ Mount Pipe	B	From Leg	3.5000	0.0000	144.0000	No Ice	5.3879	4.5996	0.07
			0.00			1/2" Ice	5.8131	5.3507	0.11
			0.00			1" Ice	6.2340	6.0464	0.17
800 10121 w/ Mount Pipe	C	From Leg	3.5000	0.0000	144.0000	No Ice	5.3879	4.5996	0.07
			0.00			1/2" Ice	5.8131	5.3507	0.11
			0.00			1" Ice	6.2340	6.0464	0.17
RRUS 11	A	From Leg	2.5000	0.0000	144.0000	No Ice	2.7845	1.1872	0.05
			0.00			1/2" Ice	2.9919	1.3342	0.07
			0.00			1" Ice	3.2066	1.4897	0.10
RRUS 11	B	From Leg	2.5000	0.0000	144.0000	No Ice	2.7845	1.1872	0.05
			0.00			1/2" Ice	2.9919	1.3342	0.07
			0.00			1" Ice	3.2066	1.4897	0.10
RRUS 11	C	From Leg	2.5000	0.0000	144.0000	No Ice	2.7845	1.1872	0.05
			0.00			1/2" Ice	2.9919	1.3342	0.07
			0.00			1" Ice	3.2066	1.4897	0.10
RRUS 12	A	From Leg	2.5000	0.0000	144.0000	No Ice	3.1450	1.2854	0.06
			0.00			1/2" Ice	3.3648	1.4379	0.08
			0.00			1" Ice	3.5920	1.5998	0.11
RRUS 12	B	From Leg	2.5000	0.0000	144.0000	No Ice	3.1450	1.2854	0.06
			0.00			1/2" Ice	3.3648	1.4379	0.08
			0.00			1" Ice	3.5920	1.5998	0.11
RRUS 12	C	From Leg	2.5000	0.0000	144.0000	No Ice	3.1450	1.2854	0.06
			0.00			1/2" Ice	3.3648	1.4379	0.08
			0.00			1" Ice	3.5920	1.5998	0.11
DC6-48-60-18-8F	C	From Leg	2.0000	0.0000	144.0000	No Ice	0.7915	0.7915	0.02
			0.00			1/2" Ice	1.2743	1.2743	0.03
			0.00			1" Ice	1.4503	1.4503	0.05
(2) OPA-65R-LCUU-H6 w/ Mount Pipe	A	From Leg	3.5000	0.0000	144.0000	No Ice	9.8953	7.1792	0.10
			0.00			1/2" Ice	10.4700	8.3621	0.18
			0.00			1" Ice	11.0098	9.2588	0.26
(2) OPA-65R-LCUU-H8 w/ Mount Pipe	B	From Leg	3.5000	0.0000	144.0000	No Ice	12.9838	9.3187	0.12
			0.00			1/2" Ice	13.6685	10.7901	0.21
			0.00			1" Ice	14.3572	12.2416	0.32
(2) OPA-65R-LCUU-H8 w/ Mount Pipe	C	From Leg	3.5000	0.0000	144.0000	No Ice	12.9838	9.3187	0.12
			0.00			1/2" Ice	13.6685	10.7901	0.21
			0.00			1" Ice	14.3572	12.2416	0.32
RRUS 32	A	From Leg	2.5000	0.0000	144.0000	No Ice	2.8571	1.7766	0.06
			0.00			1/2" Ice	3.0830	1.9677	0.08
			0.00			1" Ice	3.3163	2.1658	0.10
RRUS 32	B	From Leg	2.5000	0.0000	144.0000	No Ice	2.8571	1.7766	0.06
			0.00			1/2" Ice	3.0830	1.9677	0.08
			0.00			1" Ice	3.3163	2.1658	0.10
RRUS 32	C	From Leg	2.5000	0.0000	144.0000	No Ice	2.8571	1.7766	0.06
			0.00			1/2" Ice	3.0830	1.9677	0.08
			0.00			1" Ice	3.3163	2.1658	0.10
RRUS E2 B29	A	From Leg	2.5000	0.0000	144.0000	No Ice	3.1450	1.2854	0.06
			0.00			1/2" Ice	3.3648	1.4379	0.08
			0.00			1" Ice	3.5920	1.5998	0.11
RRUS E2 B29	B	From Leg	2.5000	0.0000	144.0000	No Ice	3.1450	1.2854	0.06
			0.00			1/2" Ice	3.3648	1.4379	0.08
			0.00			1" Ice	3.5920	1.5998	0.11
RRUS E2 B29	C	From Leg	2.5000	0.0000	144.0000	No Ice	3.1450	1.2854	0.06
			0.00			1/2" Ice	3.3648	1.4379	0.08
			0.00			1" Ice	3.5920	1.5998	0.11
RRUS A2	A	From Leg	2.5000	0.0000	144.0000	No Ice	2.0663	0.5050	0.02
			0.00			1/2" Ice	2.2451	0.6151	0.03
			0.00			1" Ice	2.4313	0.7322	0.05

tnxTower Destek Engineering LLC 1281 Kennestone Circle, Suite 100 Marietta, GA 30066 Phone: 770693-0835 FAX:	Job	CT11365D	Page	10 of 20
	Project	1875007	Date	09:35:33 05/02/18
	Client	Foresite/T-Mobile	Designed by	Ahmet Colakoglu

Description	Face or Leg	Offset Type	Offsets:		Azimuth Adjustment	Placement	CAAA Front	CAAA Side	Weight
			Horz	Lateral					
RRUS A2	B	From Leg	2.5000	0.0000	144.0000	No Ice	2.0663	0.5050	0.02
			0.00			1/2" Ice	2.2451	0.6151	0.03
			0.00			1" Ice	2.4313	0.7322	0.05
RRUS A2	C	From Leg	2.5000	0.0000	144.0000	No Ice	2.0663	0.5050	0.02
			0.00			1/2" Ice	2.2451	0.6151	0.03
			0.00			1" Ice	2.4313	0.7322	0.05
123									
13' Low Profile Platform	A	None		0.0000	124.0000	No Ice	24.3300	24.3300	1.65
						1/2" Ice	30.2200	30.2200	2.03
						1" Ice	36.1100	36.1100	2.42
20' 4-Bay Dipole	C	From Leg	3.5000	0.0000	124.0000	No Ice	4.0000	4.0000	0.06
			0.00			1/2" Ice	6.0000	6.0000	0.10
			3.00			1" Ice	8.0000	8.0000	0.14
9' x 2" Pipe Mount	C	From Leg	3.5000	0.0000	124.0000	No Ice	2.1375	2.1375	0.03
			0.00			1/2" Ice	3.0656	3.0656	0.05
			0.00			1" Ice	4.0104	4.0104	0.07
2" Dia 10' Omni	B	From Leg	3.5000	0.0000	124.0000	No Ice	2.5830	2.5830	0.04
			0.00			1/2" Ice	3.7950	3.7950	0.07
			6.00			1" Ice	5.0070	5.0070	0.09
2" Dia 10' Omni	B	From Leg	3.5000	0.0000	124.0000	No Ice	2.5830	2.5830	0.04
			0.00			1/2" Ice	3.7950	3.7950	0.07
			6.00			1" Ice	5.0070	5.0070	0.09
3' Yagi with Mount Pipe	B	From Leg	3.5000	0.0000	124.0000	No Ice	1.1850	1.1850	0.02
			0.00			1/2" Ice	1.5610	1.5600	0.04
			3.00			1" Ice	1.9370	1.9350	0.05
3' Yagi with Mount Pipe	C	From Leg	3.5000	0.0000	124.0000	No Ice	1.1850	1.1850	0.02
			0.00			1/2" Ice	1.5610	1.5600	0.04
			3.00			1" Ice	1.9370	1.9350	0.05
***111**									
(2) HBX-6517DS-VTM w/ Mount Pipe	A	From Leg	3.5000	0.0000	111.0000	No Ice	5.5412	5.0210	0.05
			0.00			1/2" Ice	6.1121	6.2225	0.09
			0.00			1" Ice	6.6539	7.1672	0.15
(2) HBX-6517DS-VTM w/ Mount Pipe	B	From Leg	3.5000	0.0000	111.0000	No Ice	5.5412	5.0210	0.05
			0.00			1/2" Ice	6.1121	6.2225	0.09
			0.00			1" Ice	6.6539	7.1672	0.15
(2) HBX-6517DS-VTM w/ Mount Pipe	C	From Leg	3.5000	0.0000	111.0000	No Ice	5.5412	5.0210	0.05
			0.00			1/2" Ice	6.1121	6.2225	0.09
			0.00			1" Ice	6.6539	7.1672	0.15
(2) LNX-6514DS-VTM w/ Mount Pipe	A	From Leg	3.5000	0.0000	111.0000	No Ice	8.4106	7.0817	0.06
			0.00			1/2" Ice	8.9745	8.2729	0.13
			0.00			1" Ice	9.5048	9.1847	0.21
(2) LNX-6514DS-VTM w/ Mount Pipe	B	From Leg	3.5000	0.0000	111.0000	No Ice	8.4106	7.0817	0.06
			0.00			1/2" Ice	8.9745	8.2729	0.13
			0.00			1" Ice	9.5048	9.1847	0.21
(2) LNX-6514DS-VTM w/ Mount Pipe	C	From Leg	3.5000	0.0000	111.0000	No Ice	8.4106	7.0817	0.06
			0.00			1/2" Ice	8.9745	8.2729	0.13
			0.00			1" Ice	9.5048	9.1847	0.21
RRH2X40-AWS w/RDEM	A	From Leg	2.5000	0.0000	111.0000	No Ice	3.7700	2.2300	0.05
			0.00			1/2" Ice	4.0400	2.4600	0.07
			0.00			1" Ice	4.3100	2.6900	0.10
RRH2X40-AWS w/RDEM	B	From Leg	2.5000	0.0000	111.0000	No Ice	3.7700	2.2300	0.05
			0.00			1/2" Ice	4.0400	2.4600	0.07
			0.00			1" Ice	4.3100	2.6900	0.10
RRH2X40-AWS w/RDEM	C	From Leg	2.5000	0.0000	111.0000	No Ice	3.7700	2.2300	0.05
			0.00			1/2" Ice	4.0400	2.4600	0.07
			0.00			1" Ice	4.3100	2.6900	0.10
RRH2x40-07U	A	From Leg	2.5000	0.0000	111.0000	No Ice	2.2900	1.2100	0.05

tnxTower Destek Engineering LLC 1281 Kennestone Circle, Suite 100 Marietta, GA 30066 Phone: 770693-0835 FAX:	Job	CT11365D	Page	11 of 20
	Project	1875007	Date	09:35:33 05/02/18
	Client	Foresite/T-Mobile	Designed by	Ahmet Colakoglu

Description	Face or Leg	Offset Type	Offsets:		Azimuth Adjustment	Placement	C _{AA} Front	C _{AA} Side	Weight	
			Horz	Lateral						Vert
RRH2x40-07U	B	From Leg	0.00		0.0000	111.0000	1/2" Ice	2.4900	1.3600	0.07
			0.00				1" Ice	2.6900	1.5100	0.09
			2.5000				No Ice	2.2900	1.2100	0.05
RRH2x40-07U	C	From Leg	0.00		0.0000	111.0000	1/2" Ice	2.4900	1.3600	0.07
			0.00				1" Ice	2.6900	1.5100	0.09
			2.5000				No Ice	2.2900	1.2100	0.05
RRH2x40- PCS	A	From Leg	0.00		0.0000	111.0000	1/2" Ice	2.4900	1.3600	0.07
			0.00				1" Ice	2.6900	1.5100	0.09
			2.5000				No Ice	2.5700	2.0200	0.05
RRH2x40- PCS	B	From Leg	0.00		0.0000	111.0000	1/2" Ice	2.7900	2.2300	0.07
			0.00				1" Ice	3.0100	2.4400	0.09
			2.5000				No Ice	2.5700	2.0200	0.05
RRH2x40- PCS	C	From Leg	0.00		0.0000	111.0000	1/2" Ice	2.7900	2.2300	0.07
			0.00				1" Ice	3.0100	2.4400	0.09
			2.5000				No Ice	2.5700	2.0200	0.05
RFS DB-T1-6Z-8AB-0Z	B	From Leg	0.00		0.0000	111.0000	1/2" Ice	5.6000	2.3300	0.04
			0.00				1" Ice	5.9200	2.5600	0.09
			1.5000				No Ice	6.2400	2.7900	0.13
RFS DB-T1-6Z-8AB-0Z	C	From Leg	0.00		0.0000	111.0000	1/2" Ice	5.6000	2.3300	0.04
			0.00				1" Ice	5.9200	2.5600	0.09
			1.5000				No Ice	6.2400	2.7900	0.13
Pirod 13' Platform	C	None			0.0000	111.0000	No Ice	15.7000	15.7000	1.30
							1/2" Ice	20.1000	20.1000	1.76
							1" Ice	24.5000	24.5000	2.23
55										
Side Arm Mount [SO 301-1]	C	None			0.0000	55.0000	No Ice	1.0000	0.9000	0.02
							1/2" Ice	1.3900	1.4200	0.03
							1" Ice	1.7800	1.9400	0.04
GPS_A	C	From Leg	1.0000		0.0000	55.0000	No Ice	0.2550	0.2550	0.00
			0.00				1/2" Ice	0.3205	0.3205	0.00
			0.00				1" Ice	0.3934	0.3934	0.01
40										
1ft Side Mount Standoff	A	From Leg	0.5000		0.0000	39.9000	No Ice	1.0000	1.0000	0.03
			0.00				1/2" Ice	1.5000	1.5000	0.05
			0.00				1" Ice	2.0000	2.0000	0.07
1ft Side Mount Standoff	B	From Leg	0.5000		0.0000	39.9000	No Ice	1.0000	1.0000	0.03
			0.00				1/2" Ice	1.5000	1.5000	0.05
			0.00				1" Ice	2.0000	2.0000	0.07
1ft Side Mount Standoff	C	From Leg	0.5000		0.0000	39.9000	No Ice	1.0000	1.0000	0.03
			0.00				1/2" Ice	1.5000	1.5000	0.05
			0.00				1" Ice	2.0000	2.0000	0.07

Dishes

Description	Face or Leg	Dish Type	Offset Type	Offsets:		Azimuth Adjustment	3 dB Beam Width	Elevation	Outside Diameter	Aperture Area	Weight
				Horz	Lateral						

tnxTower Destek Engineering LLC 1281 Kennestone Circle, Suite 100 Marietta, GA 30066 Phone: 770693-0835 FAX:	Job	CT11365D	Page	12 of 20
	Project	1875007	Date	09:35:33 05/02/18
	Client	Foresite/T-Mobile	Designed by	Ahmet Colakoglu

Description	Face or Leg	Dish Type	Offset Type	Offsets: Horz Lateral Vert ft	Azimuth Adjustment °	3 dB Beam Width °	Elevation ft	Outside Diameter ft	Aperture Area ft ²	Weight K	
VHLP2-11	A	Paraboloid w/o Radome	From Leg	3.5000 0.00 0.00	0.0000		151.0000	2.1750	No Ice 1/2" Ice 1" Ice	3.7150 4.0060 4.2960	0.03 0.05 0.07
VHLP2-11	B	Paraboloid w/Shroud (HP)	From Leg	3.5000 0.00 0.00	0.0000		151.0000	2.5000	No Ice 1/2" Ice 1" Ice	3.1420 3.4090 3.6760	0.07 0.28 0.49
VHLP2-11	C	Paraboloid w/o Radome	From Leg	3.5000 0.00 0.00	0.0000		151.0000	2.1750	No Ice 1/2" Ice 1" Ice	3.7150 4.0060 4.2960	0.03 0.05 0.07

2' Dish	A	Paraboloid w/o Radome	From Leg	2.0000 0.00 1.00	0.0000		39.9000	2.1750	No Ice 1/2" Ice 1" Ice	3.7200 4.0100 4.3000	0.03 0.05 0.07
2' Dish	B	Paraboloid w/o Radome	From Leg	2.0000 0.00 1.00	0.0000		39.9000	2.1750	No Ice 1/2" Ice 1" Ice	3.7200 4.0100 4.3000	0.03 0.05 0.07
(2) 2' Dish	C	Paraboloid w/o Radome	From Leg	2.0000 0.00 1.00	0.0000		39.9000	2.1750	No Ice 1/2" Ice 1" Ice	3.7200 4.0100 4.3000	0.03 0.05 0.07

Load Combinations

Comb. No.	Description
1	Dead Only
2	1.2 Dead+1.6 Wind 0 deg - No Ice
3	0.9 Dead+1.6 Wind 0 deg - No Ice
4	1.2 Dead+1.6 Wind 30 deg - No Ice
5	0.9 Dead+1.6 Wind 30 deg - No Ice
6	1.2 Dead+1.6 Wind 60 deg - No Ice
7	0.9 Dead+1.6 Wind 60 deg - No Ice
8	1.2 Dead+1.6 Wind 90 deg - No Ice
9	0.9 Dead+1.6 Wind 90 deg - No Ice
10	1.2 Dead+1.6 Wind 120 deg - No Ice
11	0.9 Dead+1.6 Wind 120 deg - No Ice
12	1.2 Dead+1.6 Wind 150 deg - No Ice
13	0.9 Dead+1.6 Wind 150 deg - No Ice
14	1.2 Dead+1.6 Wind 180 deg - No Ice
15	0.9 Dead+1.6 Wind 180 deg - No Ice
16	1.2 Dead+1.6 Wind 210 deg - No Ice
17	0.9 Dead+1.6 Wind 210 deg - No Ice
18	1.2 Dead+1.6 Wind 240 deg - No Ice
19	0.9 Dead+1.6 Wind 240 deg - No Ice
20	1.2 Dead+1.6 Wind 270 deg - No Ice
21	0.9 Dead+1.6 Wind 270 deg - No Ice
22	1.2 Dead+1.6 Wind 300 deg - No Ice
23	0.9 Dead+1.6 Wind 300 deg - No Ice
24	1.2 Dead+1.6 Wind 330 deg - No Ice
25	0.9 Dead+1.6 Wind 330 deg - No Ice
26	1.2 Dead+1.0 Ice+1.0 Temp
27	1.2 Dead+1.0 Wind 0 deg+1.0 Ice+1.0 Temp
28	1.2 Dead+1.0 Wind 30 deg+1.0 Ice+1.0 Temp
29	1.2 Dead+1.0 Wind 60 deg+1.0 Ice+1.0 Temp
30	1.2 Dead+1.0 Wind 90 deg+1.0 Ice+1.0 Temp
31	1.2 Dead+1.0 Wind 120 deg+1.0 Ice+1.0 Temp
32	1.2 Dead+1.0 Wind 150 deg+1.0 Ice+1.0 Temp

tnxTower Destek Engineering LLC 1281 Kennestone Circle, Suite 100 Marietta, GA 30066 Phone: 770693-0835 FAX:	Job	CT11365D	Page	13 of 20
	Project	1875007	Date	09:35:33 05/02/18
	Client	Foresite/T-Mobile	Designed by	Ahmet Colakoglu

<i>Comb. No.</i>	<i>Description</i>
33	1.2 Dead+1.0 Wind 180 deg+1.0 Ice+1.0 Temp
34	1.2 Dead+1.0 Wind 210 deg+1.0 Ice+1.0 Temp
35	1.2 Dead+1.0 Wind 240 deg+1.0 Ice+1.0 Temp
36	1.2 Dead+1.0 Wind 270 deg+1.0 Ice+1.0 Temp
37	1.2 Dead+1.0 Wind 300 deg+1.0 Ice+1.0 Temp
38	1.2 Dead+1.0 Wind 330 deg+1.0 Ice+1.0 Temp
39	Dead+Wind 0 deg - Service
40	Dead+Wind 30 deg - Service
41	Dead+Wind 60 deg - Service
42	Dead+Wind 90 deg - Service
43	Dead+Wind 120 deg - Service
44	Dead+Wind 150 deg - Service
45	Dead+Wind 180 deg - Service
46	Dead+Wind 210 deg - Service
47	Dead+Wind 240 deg - Service
48	Dead+Wind 270 deg - Service
49	Dead+Wind 300 deg - Service
50	Dead+Wind 330 deg - Service

Maximum Member Forces

<i>Section No.</i>	<i>Elevation ft</i>	<i>Component Type</i>	<i>Condition</i>	<i>Gov. Load Comb.</i>	<i>Axial K</i>	<i>Major Axis Moment kip-ft</i>	<i>Minor Axis Moment kip-ft</i>
L1	184 - 166.62	Pole	Max Tension	1	0.00	0.00	0.00
			Max. Compression	26	-7.95	3.48	-1.78
			Max. Mx	20	-2.34	52.25	-0.16
			Max. My	14	-2.34	0.31	-51.80
			Max. Vy	20	-3.83	52.25	-0.16
			Max. Vx	14	3.83	0.31	-51.80
			Max. Torque	12			-2.64
L2	166.62 - 133.18	Pole	Max Tension	1	0.00	0.00	0.00
			Max. Compression	26	-58.94	1.63	-7.08
			Max. Mx	20	-15.28	535.06	0.35
			Max. My	14	-15.27	-0.13	-536.70
			Max. Vy	8	25.22	-534.33	1.05
			Max. Vx	14	25.23	-0.13	-536.70
			Max. Torque	12			-3.34
L3	133.18 - 88.09	Pole	Max Tension	1	0.00	0.00	0.00
			Max. Compression	26	-94.96	5.26	-13.20
			Max. Mx	8	-30.07	-1881.42	5.34
			Max. My	14	-30.09	-1.37	-1882.99
			Max. Vy	8	35.97	-1881.42	5.34
			Max. Vx	14	35.85	-1.37	-1882.99
			Max. Torque	10			-4.42
L4	88.09 - 44.03	Pole	Max Tension	1	0.00	0.00	0.00
			Max. Compression	26	-117.99	8.82	-15.18
			Max. Mx	8	-45.38	-3492.73	10.07
			Max. My	14	-45.39	-2.66	-3489.54
			Max. Vy	8	38.94	-3492.73	10.07
			Max. Vx	14	38.82	-2.66	-3489.54
			Max. Torque	10			-4.39
L5	44.03 - 1	Pole	Max Tension	1	0.00	0.00	0.00
			Max. Compression	26	-150.35	12.42	-16.50
			Max. Mx	8	-68.27	-5486.73	23.67
			Max. My	14	-68.27	-3.15	-5475.97
			Max. Vy	8	41.56	-5486.73	23.67
			Max. Vx	2	-41.47	-30.43	5474.17

tnxTower Destek Engineering LLC 1281 Kennestone Circle, Suite 100 Marietta, GA 30066 Phone: 770693-0835 FAX:	Job	CT11365D	Page	14 of 20
	Project	1875007	Date	09:35:33 05/02/18
	Client	Foresite/T-Mobile	Designed by	Ahmet Colakoglu

Section No.	Elevation ft	Component Type	Condition	Gov. Load Comb.	Axial K	Major Axis Moment kip-ft	Minor Axis Moment kip-ft
			Max. Torque	22			4.65

Maximum Reactions

Location	Condition	Gov. Load Comb.	Vertical K	Horizontal, X K	Horizontal, Z K
Pole	Max. Vert	26	150.35	-0.00	0.00
	Max. H _x	21	51.24	41.36	0.16
	Max. H _z	3	51.24	-0.33	41.39
	Max. M _x	2	5474.17	-0.33	41.39
	Max. M _z	8	5486.73	-41.47	0.32
	Max. Torsion	22	4.64	35.86	20.59
	Min. Vert	9	51.24	-41.48	0.32
	Min. H _x	9	51.24	-41.48	0.32
	Min. H _z	15	51.24	-0.01	-41.30
	Min. M _x	14	-5475.97	-0.01	-41.30
	Min. M _z	20	-5479.48	41.36	0.16
	Min. Torsion	12	-4.58	-20.49	-35.75

Tower Mast Reaction Summary

Load Combination	Vertical K	Shear _x K	Shear _z K	Overturning Moment, M _x kip-ft	Overturning Moment, M _z kip-ft	Torque kip-ft
Dead Only	56.93	0.00	-0.00	1.68	1.02	0.00
1.2 Dead+1.6 Wind 0 deg - No Ice	68.32	0.33	-41.39	-5474.17	-30.43	-2.79
0.9 Dead+1.6 Wind 0 deg - No Ice	51.24	0.33	-41.39	-5354.61	-30.17	-2.76
1.2 Dead+1.6 Wind 30 deg - No Ice	68.32	21.09	-35.62	-4720.97	-2778.71	-0.50
0.9 Dead+1.6 Wind 30 deg - No Ice	51.24	21.09	-35.62	-4617.85	-2718.16	-0.48
1.2 Dead+1.6 Wind 60 deg - No Ice	68.32	36.06	-20.69	-2732.77	-4767.06	1.50
0.9 Dead+1.6 Wind 60 deg - No Ice	51.24	36.06	-20.69	-2673.38	-4662.85	1.51
1.2 Dead+1.6 Wind 90 deg - No Ice	68.32	41.47	-0.32	-23.67	-5486.73	3.17
0.9 Dead+1.6 Wind 90 deg - No Ice	51.24	41.48	-0.32	-23.82	-5367.23	3.16
1.2 Dead+1.6 Wind 120 deg - No Ice	68.32	36.13	20.56	2737.19	-4770.69	4.47
0.9 Dead+1.6 Wind 120 deg - No Ice	51.24	36.13	20.56	2676.46	-4666.43	4.44
1.2 Dead+1.6 Wind 150 deg - No Ice	68.32	20.49	35.75	4741.93	-2722.15	4.58
0.9 Dead+1.6 Wind 150 deg - No Ice	51.24	20.49	35.75	4637.22	-2662.67	4.54
1.2 Dead+1.6 Wind 180 deg - No Ice	68.32	0.01	41.30	5475.97	-3.15	3.14
0.9 Dead+1.6 Wind 180 deg - No Ice	51.24	0.01	41.30	5355.45	-3.38	3.11

<p style="text-align: center;">tnxTower</p> <p style="text-align: center;">Destek Engineering LLC 1281 Kennestone Circle, Suite 100 Marietta, GA 30066 Phone: 770693-0835 FAX:</p>	<p>Job</p> <p style="text-align: center;">CT11365D</p>	<p>Page</p> <p style="text-align: center;">15 of 20</p>
	<p>Project</p> <p style="text-align: center;">1875007</p>	<p>Date</p> <p style="text-align: center;">09:35:33 05/02/18</p>
	<p>Client</p> <p style="text-align: center;">Foresite/T-Mobile</p>	<p>Designed by</p> <p style="text-align: center;">Ahmet Colakoglu</p>

Load Combination	Vertical K	Shear _x K	Shear _z K	Overturning Moment, M _x kip-ft	Overturning Moment, M _z kip-ft	Torque kip-ft
No Ice						
1.2 Dead+1.6 Wind 210 deg - No Ice	68.32	-20.51	35.89	4756.78	2722.35	0.76
0.9 Dead+1.6 Wind 210 deg - No Ice	51.24	-20.51	35.89	4651.73	2662.23	0.74
1.2 Dead+1.6 Wind 240 deg - No Ice	68.32	-35.94	20.83	2762.16	4753.07	-1.68
0.9 Dead+1.6 Wind 240 deg - No Ice	51.24	-35.94	20.83	2700.92	4648.45	-1.68
1.2 Dead+1.6 Wind 270 deg - No Ice	68.32	-41.36	-0.16	-11.45	5479.48	-3.84
0.9 Dead+1.6 Wind 270 deg - No Ice	51.24	-41.36	-0.16	-11.80	5358.88	-3.82
1.2 Dead+1.6 Wind 300 deg - No Ice	68.32	-35.86	-20.59	-2726.60	4750.06	-4.64
0.9 Dead+1.6 Wind 300 deg - No Ice	51.24	-35.86	-20.59	-2667.26	4645.49	-4.61
1.2 Dead+1.6 Wind 330 deg - No Ice	68.32	-20.79	-35.52	-4712.76	2751.49	-4.17
0.9 Dead+1.6 Wind 330 deg - No Ice	51.24	-20.79	-35.52	-4609.76	2690.79	-4.14
1.2 Dead+1.0 Ice+1.0 Temp	150.35	0.00	-0.00	16.50	12.42	0.01
1.2 Dead+1.0 Wind 0 deg+1.0 Ice+1.0 Temp	150.35	0.06	-11.87	-1898.93	5.32	-1.74
1.2 Dead+1.0 Wind 30 deg+1.0 Ice+1.0 Temp	150.35	6.26	-10.68	-1707.63	-993.33	-0.72
1.2 Dead+1.0 Wind 60 deg+1.0 Ice+1.0 Temp	150.35	10.30	-5.93	-940.22	-1649.04	0.43
1.2 Dead+1.0 Wind 90 deg+1.0 Ice+1.0 Temp	150.35	12.20	-0.06	10.88	-1974.21	1.48
1.2 Dead+1.0 Wind 120 deg+1.0 Ice+1.0 Temp	150.35	10.31	5.91	973.80	-1649.81	2.22
1.2 Dead+1.0 Wind 150 deg+1.0 Ice+1.0 Temp	150.35	5.89	10.26	1674.78	-940.16	2.37
1.2 Dead+1.0 Wind 180 deg+1.0 Ice+1.0 Temp	150.35	0.00	11.85	1931.70	11.29	1.83
1.2 Dead+1.0 Wind 210 deg+1.0 Ice+1.0 Temp	150.35	-6.15	10.73	1748.20	1004.75	0.78
1.2 Dead+1.0 Wind 240 deg+1.0 Ice+1.0 Temp	150.35	-10.28	5.96	979.41	1670.16	-0.45
1.2 Dead+1.0 Wind 270 deg+1.0 Ice+1.0 Temp	150.35	-12.18	-0.03	13.47	1996.90	-1.60
1.2 Dead+1.0 Wind 300 deg+1.0 Ice+1.0 Temp	150.35	-10.26	-5.91	-939.03	1669.56	-2.24
1.2 Dead+1.0 Wind 330 deg+1.0 Ice+1.0 Temp	150.35	-5.94	-10.22	-1635.92	971.13	-2.28
Dead+Wind 0 deg - Service	56.93	0.06	-7.54	-986.34	-4.56	-0.53
Dead+Wind 30 deg - Service	56.93	3.84	-6.49	-850.30	-500.44	-0.09
Dead+Wind 60 deg - Service	56.93	6.57	-3.77	-491.58	-859.23	0.28
Dead+Wind 90 deg - Service	56.93	7.56	-0.06	-2.76	-989.30	0.60
Dead+Wind 120 deg - Service	56.93	6.58	3.75	495.40	-859.88	0.84
Dead+Wind 150 deg - Service	56.93	3.73	6.52	857.09	-490.21	0.86
Dead+Wind 180 deg - Service	56.93	0.00	7.53	989.67	0.37	0.59
Dead+Wind 210 deg - Service	56.93	-3.74	6.54	859.77	492.12	0.14
Dead+Wind 240 deg - Service	56.93	-6.55	3.80	499.90	858.53	-0.32
Dead+Wind 270 deg - Service	56.93	-7.54	-0.03	-0.55	989.72	-0.72
Dead+Wind 300 deg - Service	56.93	-6.53	-3.75	-490.43	857.98	-0.88
Dead+Wind 330 deg - Service	56.93	-3.79	-6.47	-848.77	497.37	-0.79

tnxTower Destek Engineering LLC 1281 Kennestone Circle, Suite 100 Marietta, GA 30066 Phone: 770693-0835 FAX:	Job	CT11365D	Page	16 of 20
	Project	1875007	Date	09:35:33 05/02/18
	Client	Foresite/T-Mobile	Designed by	Ahmet Colakoglu

Solution Summary

Load Comb.	Sum of Applied Forces			Sum of Reactions			% Error
	PX K	PY K	PZ K	PX K	PY K	PZ K	
1	0.00	-56.93	0.00	-0.00	56.93	0.00	0.002%
2	0.33	-68.32	-41.39	-0.33	68.32	41.39	0.006%
3	0.33	-51.24	-41.39	-0.33	51.24	41.39	0.007%
4	21.09	-68.32	-35.62	-21.09	68.32	35.62	0.000%
5	21.09	-51.24	-35.62	-21.09	51.24	35.62	0.000%
6	36.06	-68.32	-20.69	-36.06	68.32	20.69	0.000%
7	36.06	-51.24	-20.69	-36.06	51.24	20.69	0.000%
8	41.48	-68.32	-0.32	-41.47	68.32	0.32	0.010%
9	41.48	-51.24	-0.32	-41.48	51.24	0.32	0.007%
10	36.13	-68.32	20.56	-36.13	68.32	-20.56	0.000%
11	36.13	-51.24	20.56	-36.13	51.24	-20.56	0.000%
12	20.49	-68.32	35.75	-20.49	68.32	-35.75	0.000%
13	20.49	-51.24	35.75	-20.49	51.24	-35.75	0.000%
14	0.01	-68.32	41.30	-0.01	68.32	-41.30	0.006%
15	0.01	-51.24	41.30	-0.01	51.24	-41.30	0.004%
16	-20.51	-68.32	35.89	20.51	68.32	-35.89	0.000%
17	-20.51	-51.24	35.89	20.51	51.24	-35.89	0.000%
18	-35.94	-68.32	20.83	35.94	68.32	-20.83	0.000%
19	-35.94	-51.24	20.83	35.94	51.24	-20.83	0.000%
20	-41.37	-68.32	-0.16	41.36	68.32	0.16	0.006%
21	-41.37	-51.24	-0.16	41.36	51.24	0.16	0.007%
22	-35.86	-68.32	-20.59	35.86	68.32	20.59	0.000%
23	-35.86	-51.24	-20.59	35.86	51.24	20.59	0.000%
24	-20.79	-68.32	-35.52	20.79	68.32	35.52	0.000%
25	-20.79	-51.24	-35.52	20.79	51.24	35.52	0.000%
26	0.00	-150.35	0.00	-0.00	150.35	0.00	0.000%
27	0.06	-150.35	-11.87	-0.06	150.35	11.87	0.002%
28	6.26	-150.35	-10.68	-6.26	150.35	10.68	0.002%
29	10.30	-150.35	-5.93	-10.30	150.35	5.93	0.002%
30	12.21	-150.35	-0.06	-12.20	150.35	0.06	0.002%
31	10.32	-150.35	5.91	-10.31	150.35	-5.91	0.002%
32	5.89	-150.35	10.26	-5.89	150.35	-10.26	0.002%
33	0.00	-150.35	11.85	-0.00	150.35	-11.85	0.002%
34	-6.15	-150.35	10.73	6.15	150.35	-10.73	0.002%
35	-10.28	-150.35	5.96	10.28	150.35	-5.96	0.002%
36	-12.18	-150.35	-0.03	12.18	150.35	0.03	0.002%
37	-10.27	-150.35	-5.91	10.26	150.35	5.91	0.002%
38	-5.94	-150.35	-10.22	5.94	150.35	10.22	0.002%
39	0.06	-56.93	-7.55	-0.06	56.93	7.54	0.003%
40	3.85	-56.93	-6.49	-3.84	56.93	6.49	0.003%
41	6.57	-56.93	-3.77	-6.57	56.93	3.77	0.003%
42	7.56	-56.93	-0.06	-7.56	56.93	0.06	0.003%
43	6.58	-56.93	3.75	-6.58	56.93	-3.75	0.003%
44	3.74	-56.93	6.52	-3.73	56.93	-6.52	0.003%
45	0.00	-56.93	7.53	-0.00	56.93	-7.53	0.003%
46	-3.74	-56.93	6.54	3.74	56.93	-6.54	0.003%
47	-6.55	-56.93	3.80	6.55	56.93	-3.80	0.003%
48	-7.54	-56.93	-0.03	7.54	56.93	0.03	0.003%
49	-6.54	-56.93	-3.75	6.53	56.93	3.75	0.003%
50	-3.79	-56.93	-6.48	3.79	56.93	6.47	0.003%

Non-Linear Convergence Results

tnxTower Destek Engineering LLC 1281 Kennestone Circle, Suite 100 Marietta, GA 30066 Phone: 770693-0835 FAX:	Job CT11365D	Page 17 of 20
	Project 1875007	Date 09:35:33 05/02/18
	Client Foresite/T-Mobile	Designed by Ahmet Colakoglu

Load Combination	Converged?	Number of Cycles	Displacement Tolerance	Force Tolerance
1	Yes	6	0.00000001	0.00000341
2	Yes	22	0.00006507	0.00011322
3	Yes	21	0.00006452	0.00013368
4	Yes	29	0.00000001	0.00009347
5	Yes	28	0.00000001	0.00009380
6	Yes	29	0.00000001	0.00009367
7	Yes	28	0.00000001	0.00009398
8	Yes	21	0.00010464	0.00012987
9	Yes	21	0.00006450	0.00009702
10	Yes	29	0.00000001	0.00009745
11	Yes	28	0.00000001	0.00009792
12	Yes	28	0.00000001	0.00014807
13	Yes	28	0.00000001	0.00009082
14	Yes	22	0.00006503	0.00014114
15	Yes	22	0.00003936	0.00010237
16	Yes	29	0.00000001	0.00009524
17	Yes	28	0.00000001	0.00009557
18	Yes	29	0.00000001	0.00009543
19	Yes	28	0.00000001	0.00009569
20	Yes	22	0.00006507	0.00010187
21	Yes	21	0.00006453	0.00012004
22	Yes	28	0.00000001	0.00014878
23	Yes	28	0.00000001	0.00009125
24	Yes	29	0.00000001	0.00009693
25	Yes	28	0.00000001	0.00009750
26	Yes	21	0.00000001	0.00000225
27	Yes	28	0.00011052	0.00002147
28	Yes	28	0.00010931	0.00009929
29	Yes	28	0.00010961	0.00009308
30	Yes	28	0.00011022	0.00001792
31	Yes	28	0.00010946	0.00010753
32	Yes	28	0.00010950	0.00009148
33	Yes	28	0.00011039	0.00002281
34	Yes	28	0.00010913	0.00011795
35	Yes	28	0.00010942	0.00010390
36	Yes	28	0.00011021	0.00001864
37	Yes	28	0.00010959	0.00008958
38	Yes	28	0.00010958	0.00010506
39	Yes	20	0.00014459	0.00003359
40	Yes	20	0.00014427	0.00004263
41	Yes	20	0.00014427	0.00004460
42	Yes	20	0.00014458	0.00003213
43	Yes	20	0.00014427	0.00005692
44	Yes	20	0.00014429	0.00003836
45	Yes	20	0.00014461	0.00003428
46	Yes	20	0.00014429	0.00005083
47	Yes	20	0.00014427	0.00004869
48	Yes	20	0.00014459	0.00003272
49	Yes	20	0.00014428	0.00003880
50	Yes	20	0.00014428	0.00005658

Maximum Tower Deflections - Service Wind

Section No.	Elevation ft	Horz. Deflection in	Gov. Load Comb.	Tilt °	Twist °
L1	184 - 166.62	43.45	47	2.1245	0.0177

tnxTower Destek Engineering LLC 1281 Kennestone Circle, Suite 100 Marietta, GA 30066 Phone: 770693-0835 FAX:	Job	CT11365D	Page	18 of 20
	Project	1875007	Date	09:35:33 05/02/18
	Client	Foresite/T-Mobile	Designed by	Ahmet Colakoglu

Section No.	Elevation ft	Horz. Deflection in	Gov. Load Comb.	Tilt °	Twist °
L2	169.54 - 133.18	37.08	47	2.0679	0.0108
L3	136.98 - 88.09	23.83	47	1.7421	0.0050
L4	93.08 - 44.03	10.51	47	1.1136	0.0020
L5	50.14 - 1	2.93	47	0.5549	0.0008

Critical Deflections and Radius of Curvature - Service Wind

Elevation ft	Appurtenance	Gov. Load Comb.	Deflection in	Tilt °	Twist °	Radius of Curvature ft
184.0000	Lightning Rod 2"x21"	47	43.45	2.1245	0.0177	32865
163.0000	APXVAARR24_43-U-NA20 w/ Mount Pipe	47	34.26	2.0241	0.0086	8275
154.0000	APXVSP18-C w/ Mount Pipe	47	30.49	1.9432	0.0067	6022
151.0000	VHLP2-11	47	29.27	1.9117	0.0063	5521
144.0000	13' Low Profile Platform	47	26.49	1.8310	0.0056	4623
124.0000	13' Low Profile Platform	47	19.30	1.5636	0.0040	4045
111.0000	(2) HBX-6517DS-VTM w/ Mount Pipe	47	15.27	1.3747	0.0031	4119
55.0000	Side Arm Mount [SO 301-1]	47	3.51	0.6135	0.0009	3855
40.9000	2' Dish	47	2.03	0.4459	0.0006	4695
39.9000	1ft Side Mount Standoff	47	1.94	0.4343	0.0006	4815

Maximum Tower Deflections - Design Wind

Section No.	Elevation ft	Horz. Deflection in	Gov. Load Comb.	Tilt °	Twist °
L1	184 - 166.62	238.78	14	11.7002	0.0954
L2	169.54 - 133.18	204.04	10	11.4199	0.0575
L3	136.98 - 88.09	131.50	10	9.6424	0.0263
L4	93.08 - 44.03	58.14	10	6.1719	0.0106
L5	50.14 - 1	16.22	10	3.0749	0.0041

Critical Deflections and Radius of Curvature - Design Wind

Elevation ft	Appurtenance	Gov. Load Comb.	Deflection in	Tilt °	Twist °	Radius of Curvature ft
184.0000	Lightning Rod 2"x21"	14	238.78	11.7002	0.0954	6851
163.0000	APXVAARR24_43-U-NA20 w/ Mount Pipe	10	188.65	11.1875	0.0459	1671
154.0000	APXVSP18-C w/ Mount Pipe	10	168.01	10.7477	0.0356	1188
151.0000	VHLP2-11	10	161.31	10.5755	0.0332	1082
144.0000	13' Low Profile Platform	10	146.09	10.1327	0.0292	894
124.0000	13' Low Profile Platform	10	106.61	8.6580	0.0215	766
111.0000	(2) HBX-6517DS-VTM w/ Mount Pipe	10	84.39	7.6148	0.0166	772
55.0000	Side Arm Mount [SO 301-1]	10	19.41	3.4002	0.0046	700

tnxTower Destek Engineering LLC 1281 Kennestone Circle, Suite 100 Marietta, GA 30066 Phone: 770693-0835 FAX:	Job	CT11365D	Page	19 of 20
	Project	1875007	Date	09:35:33 05/02/18
	Client	Foresite/T-Mobile	Designed by	Ahmet Colakoglu

Elevation	Appurtenance	Gov. Load Comb.	Deflection in	Tilt °	Twist °	Radius of Curvature ft
40.9000	2' Dish	10	11.23	2.4709	0.0033	850
39.9000	1ft Side Mount Standoff	10	10.76	2.4065	0.0032	871

Compression Checks

Pole Design Data

Section No.	Elevation ft	Size	L ft	L _u ft	Kl/r	A in ²	P _u K	φP _n K	Ratio $\frac{P_u}{\phi P_n}$
L1	184 - 166.62 (1)	TP19.399x15.5x0.1875	17.3800	0.0000	0.0	11.0434	-2.34	820.47	0.003
L2	166.62 - 133.18 (2)	TP26.4007x18.3689x0.25	36.3600	0.0000	0.0	20.0845	-15.25	1487.75	0.010
L3	133.18 - 88.09 (3)	TP35.8924x25.0613x0.375	48.8900	0.0000	0.0	40.9588	-30.06	3043.03	0.010
L4	88.09 - 44.03 (4)	TP44.903x34.0369x0.4375	49.0500	0.0000	0.0	59.8663	-45.37	4447.77	0.010
L5	44.03 - 1 (5)	TP53.5x42.6744x0.4375	49.1400	0.0000	0.0	73.6839	-68.27	5183.00	0.013

Pole Bending Design Data

Section No.	Elevation ft	Size	M _{ux} kip-ft	φM _{ux} kip-ft	Ratio $\frac{M_{ux}}{\phi M_{ux}}$	M _{uy} kip-ft	φM _{uy} kip-ft	Ratio $\frac{M_{uy}}{\phi M_{uy}}$
L1	184 - 166.62 (1)	TP19.399x15.5x0.1875	52.34	312.38	0.168	0.00	312.38	0.000
L2	166.62 - 133.18 (2)	TP26.4007x18.3689x0.25	537.14	772.80	0.695	0.00	772.80	0.000
L3	133.18 - 88.09 (3)	TP35.8924x25.0613x0.375	1887.47	2146.85	0.879	0.00	2146.85	0.000
L4	88.09 - 44.03 (4)	TP44.903x34.0369x0.4375	3501.55	3934.12	0.890	0.00	3934.12	0.000
L5	44.03 - 1 (5)	TP53.5x42.6744x0.4375	5500.16	5653.21	0.973	0.00	5653.21	0.000

Pole Shear Design Data

Section No.	Elevation ft	Size	Actual V _u K	φV _n K	Ratio $\frac{V_u}{\phi V_n}$	Actual T _u kip-ft	φT _n kip-ft	Ratio $\frac{T_u}{\phi T_n}$
L1	184 - 166.62 (1)	TP19.399x15.5x0.1875	3.84	410.24	0.009	0.53	625.52	0.001
L2	166.62 - 133.18 (2)	TP26.4007x18.3689x0.25	25.29	743.88	0.034	0.18	1547.50	0.000
L3	133.18 - 88.09 (3)	TP35.8924x25.0613x0.375	36.03	1521.52	0.024	4.40	4298.94	0.001

tnxTower Destek Engineering LLC 1281 Kennestone Circle, Suite 100 Marietta, GA 30066 Phone: 770693-0835 FAX:	Job	CT11365D	Page	20 of 20
	Project	1875007	Date	09:35:33 05/02/18
	Client	Foresite/T-Mobile	Designed by	Ahmet Colakoglu

Section No.	Elevation ft	Size	Actual V_u K	ϕV_n K	Ratio $\frac{V_u}{\phi V_n}$	Actual T_u kip-ft	ϕT_n kip-ft	Ratio $\frac{T_u}{\phi T_n}$
L4	88.09 - 44.03 (4)	TP44.903x34.0369x0.4375	39.00	2223.88	0.018	4.39	7877.86	0.001
L5	44.03 - 1 (5)	TP53.5x42.6744x0.4375	41.65	2591.50	0.016	4.47	11320.25	0.000

Pole Interaction Design Data

Section No.	Elevation ft	Ratio P_u ϕP_n	Ratio M_{ux} ϕM_{nx}	Ratio M_{uy} ϕM_{ny}	Ratio V_u ϕV_n	Ratio T_u ϕT_n	Comb. Stress Ratio	Allow. Stress Ratio	Criteria
L1	184 - 166.62 (1)	0.003	0.168	0.000	0.009	0.001	0.171	1.000	4.8.2
L2	166.62 - 133.18 (2)	0.010	0.695	0.000	0.034	0.000	0.706	1.000	4.8.2
L3	133.18 - 88.09 (3)	0.010	0.879	0.000	0.024	0.001	0.890	1.000	4.8.2
L4	88.09 - 44.03 (4)	0.010	0.890	0.000	0.018	0.001	0.901	1.000	4.8.2
L5	44.03 - 1 (5)	0.013	0.973	0.000	0.016	0.000	0.986	1.000	4.8.2

Section Capacity Table

Section No.	Elevation ft	Component Type	Size	Critical Element	P K	ϕP_{allow} K	% Capacity	Pass Fail
L1	184 - 166.62	Pole	TP19.399x15.5x0.1875	1	-2.34	820.47	17.1	Pass
L2	166.62 - 133.18	Pole	TP26.4007x18.3689x0.25	2	-15.25	1487.75	70.6	Pass
L3	133.18 - 88.09	Pole	TP35.8924x25.0613x0.375	3	-30.06	3043.03	89.0	Pass
L4	88.09 - 44.03	Pole	TP44.903x34.0369x0.4375	4	-45.37	4447.77	90.1	Pass
L5	44.03 - 1	Pole	TP53.5x42.6744x0.4375	5	-68.27	5183.00	98.6	Pass
Summary								
Pole (L5)							98.6	Pass
RATING =							98.6	Pass

Stiffened or Unstiffened, Ungrouted, Circular Base Plate - Any Rod Material

TIA Rev G

Assumption: Clear space between bottom of leveling nut and top of concrete **not** exceeding (1)*(Rod Diameter)

Site Data	
BU#:	
Site Name:	CT35/Manchester PD_MP
App #:	
Pole Manufacturer:	Other

Reactions		
Mu:	5500	ft-kips
Axial, Pu:	68	kips
Shear, Vu:	42	kips
Eta Factor, η	0.5	TIA G (Fig. 4-4)

Anchor Rod Data		
Qty:	18	
Diam:	2.25	in
Rod Material:	A615-J	
Strength (Fu):	100	ksi
Yield (Fy):	75	ksi
Bolt Circle:	62	in

If No stiffeners, Criteria: **AISC LRFD** <-Only Applicable to Unstiffened Cases

Anchor Rod Results

Max Rod (Cu+ Vu/η): 245.0 Kips
 Allowable Axial, Φ*Fu*Anet: 260.0 Kips
 Anchor Rod Stress Ratio: 94.2% **Pass**

Stiffened
AISC LRFD
φ*Tn

Plate Data		
Diam:	68	in
Thick:	2	in
Grade:	60	ksi
Single-Rod B-eff:	9.43	in

Base Plate Results

Base Plate Stress: 41.8 ksi
 Allowable Plate Stress: 54.0 ksi
 Base Plate Stress Ratio: 77.4% **Pass**

Flexural Check

Stiffened
AISC LRFD
φ*Fy
Y.L. Length:
N/A, Roark

Stiffener Data (Welding at both sides)		
Config:	1	*
Weld Type:	Both	
Groove Depth:	0.375	in **
Groove Angle:	45	degrees
Fillet H. Weld:	0.375	in
Fillet V. Weld:	0.375	in
Width:	6.5	in
Height:	15	in
Thick:	0.75	in
Notch:	1	in
Grade:	50	ksi
Weld str.:	70	ksi

Stiffener Results

Horizontal Weld : 90.4% **Pass**
 Vertical Weld: 72.2% **Pass**
 Plate Flex+Shear, fb/Fb+(fv/Fv)^2: 44.3% **Pass**
 Plate Tension+Shear, ft/Ft+(fv/Fv)^2: 96.1% **Pass**
 Plate Comp. (AISC Bracket): 96.3% **Pass**

Pole Results

Pole Punching Shear Check: 22.5% **Pass**

Pole Data		
Diam:	53.5	in
Thick:	0.4375	in
Grade:	65	ksi
# of Sides:	18	"0" IF Round
Fu	80	ksi
Reinf. Fillet Weld	0	"0" if None

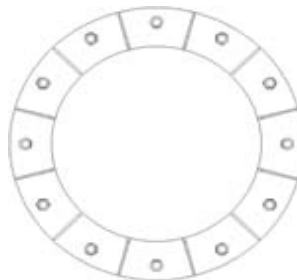

* 0 = none, 1 = every bolt, 2 = every 2 bolts, 3 = 2 per bolt

** Note: for complete joint penetration groove welds the groove depth must be exactly 1/2 the stiffener thickness for calculation purposes

Drilled Pier Foundation

BU #:
 Site Name:
 App. Number:

TIA-222 Revison:
 Tower Type:

Applied Loads		
	Comp.	Uplift
Moment (kip-ft)	5500	
Axial Force (kips)	68	
Shear Force (kips)	42	

Material Properties		
Concrete Strength, f _c :	3	ksi
Rebar Strength, F _y :	60	ksi

Pier Design Data		
Depth	31	ft
Ext. Above Grade	1	ft
Pier Section 1		
<i>From 1' above grade to 31' below grade</i>		
Pier Diameter	7	ft
Rebar Quantity	27	
Rebar Size	11	
Clear Cover to Ties	3	in
Tie Size	5	

Analysis Results		
Soil Lateral Capacity	Compression	Uplift
D _{v=0} (ft from TOC)	6.94	-
Soil Safety Factor	1.74	-
Max Moment (kip-ft)	5785.36	-
Rating	76.4%	-

Reinforced Concrete Capacity	Compression	Uplift
Critical Depth (ft from TOC)	7.18	-
Critical Moment (kip-ft)	5784.78	-
Critical Moment Capacity	6602.15	-
Rating	87.6%	-

Soil Interaction Rating	76.4%
Structural Foundation Rating	87.6%

Soil Profile			
Groundwater Depth	6	ft	# of Layers
			4

Layer	Top (ft)	Bottom (ft)	Thickness (ft)	γ _{soil} (pcf)	γ _{concrete} (pcf)	Cohesion (ksf)	Angle of Friction (degrees)	Calculated Ultimate Skin Friction Comp (ksf)	Calculated Ultimate Skin Friction Uplift (ksf)	Ultimate Skin Friction Comp Override (ksf)	Ultimate Skin Friction Uplift Override (ksf)	Ult. Gross Bearing Capacity (ksf)	SPT Blow Count	Soil Type
1	0	3.5	3.5	100	150	0	0	0.000	0.000					Cohesionless
2	3.5	6	2.5	100	150	0	30	0.000	0.000	0.35	0.35			Cohesionless
3	6	16	10	37.6	87.6	0	30	0.000	0.000	0.35	0.35			Cohesionless
4	16	31	15	37.6	87.6	0	30	0.000	0.000	0.35	0.35	1.54		Cohesionless

Exhibit E



RADIO FREQUENCY EMISSIONS ANALYSIS REPORT EVALUATION OF HUMAN EXPOSURE POTENTIAL TO NON-IONIZING EMISSIONS

T-Mobile Existing Facility

Site ID: CT11365D

CT365/Manchester PD_MP
239 E. Middle Turnpike
Manchester, CT 06040

May 22, 2018

EBI Project Number: 6218004013

Site Compliance Summary	
Compliance Status:	COMPLIANT
Site total MPE% of FCC general population allowable limit:	14.684%



May 22, 2018

T-Mobile USA
Attn: Jason Overbey, RF Manager
35 Griffin Road South
Bloomfield, CT 06002

Emissions Analysis for Site: **CT11365D – CT365/Manchester PD_MP**

EBI Consulting was directed to analyze the proposed T-Mobile facility located at **239 E. Middle Turnpike, Manchester, CT**, for the purpose of determining whether the emissions from the Proposed T-Mobile Antenna Installation located on this property are within specified federal limits.

All information used in this report was analyzed as a percentage of current Maximum Permissible Exposure (% MPE) as listed in the FCC OET Bulletin 65 Edition 97-01 and ANSI/IEEE Std C95.1. The FCC regulates Maximum Permissible Exposure in units of microwatts per square centimeter ($\mu\text{W}/\text{cm}^2$). The number of $\mu\text{W}/\text{cm}^2$ calculated at each sample point is called the power density. The exposure limit for power density varies depending upon the frequencies being utilized. Wireless Carriers and Paging Services use different frequency bands each with different exposure limits, therefore it is necessary to report results and limits in terms of percent MPE rather than power density.

All results were compared to the FCC (Federal Communications Commission) radio frequency exposure rules, 47 CFR 1.1307(b)(1) – (b)(3), to determine compliance with the Maximum Permissible Exposure (MPE) limits for General Population/Uncontrolled environments as defined below.

General population/uncontrolled exposure limits apply to situations in which the general population may be exposed or in which persons who are exposed as a consequence of their employment may not be made fully aware of the potential for exposure or cannot exercise control over their exposure. Therefore, members of the general population would always be considered under this category when exposure is not employment related, for example, in the case of a telecommunications tower that exposes persons in a nearby residential area.

Public exposure to radio frequencies is regulated and enforced in units of microwatts per square centimeter ($\mu\text{W}/\text{cm}^2$). The general population exposure limits for the 600 MHz and 700 MHz Band are approximately $400 \mu\text{W}/\text{cm}^2$ and $467 \mu\text{W}/\text{cm}^2$ respectively. The general population exposure limit for the 1900 MHz (PCS), 2100 MHz (AWS) and 5 GHz Microwave bands is $1000 \mu\text{W}/\text{cm}^2$. Because each carrier will be using different frequency bands, and each frequency band has different exposure limits, it is necessary to report percent of MPE rather than power density.



Occupational/controlled exposure limits apply to situations in which persons are exposed as a consequence of their employment and in which those persons who are exposed have been made fully aware of the potential for exposure and can exercise control over their exposure. Occupational/controlled exposure limits also apply where exposure is of a transient nature as a result of incidental passage through a location where exposure levels may be above general population/uncontrolled limits (see below), as long as the exposed person has been made fully aware of the potential for exposure and can exercise control over his or her exposure by leaving the area or by some other appropriate means.

Additional details can be found in FCC OET 65.

CALCULATIONS

Calculations were done for the proposed T-Mobile Wireless antenna facility located at **239 E. Middle Turnpike, Manchester, CT**, using the equipment information listed below. All calculations were performed per the specifications under FCC OET 65. Since T-Mobile is proposing highly focused directional panel antennas, which project most of the emitted energy out toward the horizon, all calculations were performed assuming a lobe representing the maximum gain of the antenna per the antenna manufactures supplied specifications, minus 10 dB for directional panel antennas for broadcast and microwave backhaul, was focused at the base of the tower. For this report the sample point is the top of a 6-foot person standing at the base of the tower.

For all calculations, all equipment was calculated using the following assumptions:

- 1) 4 LTE channels (PCS Band - 1900 MHz) were considered for each sector of the proposed installation. These Channels have a transmit power of 40 Watts per Channel.
- 2) 5 LTE channels (AWS Band – 2100 MHz) were considered for each sector of the proposed installation. These Channels have a transmit power of 40 Watts per Channel
- 3) 4 LTE channel (600 MHz Band) was considered for each sector of the proposed installation. This channel has a transmit power of 40 Watts.
- 4) 4 LTE channel (700 MHz Band) was considered for each sector of the proposed installation. This channel has a transmit power of 40 Watts.
- 5) 1 microwave backhaul channel (5 GHz) was considered for the proposed facility. This channel has a transmit power of 1 Watt.



- 6) All radios at the proposed installation were considered to be running at full power and were uncombined in their RF transmissions paths per carrier prescribed configuration. Per FCC OET Bulletin No. 65 - Edition 97-01 recommendations to achieve the maximum anticipated value at each sample point, all power levels emitting from the proposed antenna installation are increased by a factor of 2.56 to account for possible in-phase reflections from the surrounding environment. This is rarely the case, and if so, is never continuous.
- 7) For the following calculations the sample point was the top of a 6-foot person standing at the base of the tower. The maximum gain of the antenna per the antenna manufactures supplied specifications, minus 10 dB for directional panel antennas for broadcast and microwave backhaul, was used in this direction. This value is a very conservative estimate as gain reductions for these particular antennas are typically much higher in this direction.
- 8) The antennas used in this modeling are the **Ericsson AIR32 B66A/B2A** & **Ericsson AIR3246_B66** for 1900 MHz (PCS) and 2100 MHz (AWS) channels, the **RFS APXVAAR24-43-U-NA20** for 600 MHz and 700 MHz channels and the **Fastback IBR1300** for the proposed 5 GHz microwave backhaul. This is based on feedback from the carrier with regard to anticipated antenna selection. The **Ericsson AIR32 B66A/B2A** has a maximum gain of **15.9 dBd** at its main lobe at 1900 MHz and 2100 MHz. The **Ericsson AIR3246_B66** has a maximum gain of **15.9 dBd** at its main lobe at 1900 MHz and 2100 MHz. The **RFS APXVAAR24-43-U-NA20** has a maximum gain of **12.65/ 12.95 dBd** at its main lobe at 600 MHz and 700 MHz respectively. The **Fastback IBR1300** has a maximum gain of **10 dBd** at its main lobe at 5 GHz. The maximum gain of the antenna per the antenna manufactures supplied specifications, minus 10 dB for directional panel antennas for broadcast and microwave backhaul, was used for all calculations. This value is a very conservative estimate as gain reductions for these particular antennas are typically much higher in this direction.
- 9) The antenna mounting height centerline of the proposed antennas (both panel antennas and microwave antenna) is **163 feet** above ground level (AGL).
- 10) Emissions values for additional carriers were taken from the Connecticut Siting Council active database. Values in this database are provided by the individual carriers themselves.
- 11) All calculations were done with respect to uncontrolled / general population threshold limits.



T-Mobile Site Inventory and Power Data

Sector:	A	Sector:	B	Sector:	C
Antenna #:	1	Antenna #:	1	Antenna #:	1
Make / Model:	Ericsson AIR32 B66A/B2A	Make / Model:	Ericsson AIR32 B66A/B2A	Make / Model:	Ericsson AIR32 B66A/B2A
Gain:	15.9 dBd	Gain:	15.9 dBd	Gain:	15.9 dBd
Height (AGL):	163	Height (AGL):	163	Height (AGL):	163
Frequency Bands	1900 MHz (PCS)	Frequency Bands	1900 MHz (PCS)	Frequency Bands	1900 MHz (PCS)
Channel Count	4	Channel Count	4	Channel Count	4
Total TX Power(W):	160	Total TX Power(W):	160	Total TX Power(W):	160
ERP (W):	6,224.72	ERP (W):	6,224.72	ERP (W):	6,224.72
Antenna A1 MPE%	0.908	Antenna B1 MPE%	0.908	Antenna C1 MPE%	0.908
Antenna #:	2	Antenna #:	2	Antenna #:	2
Make / Model:	Ericsson AIR3246_B66	Make / Model:	Ericsson AIR3246_B66	Make / Model:	Ericsson AIR3246_B66
Gain:	15.9 dBd	Gain:	15.9 dBd	Gain:	15.9 dBd
Height (AGL):	163	Height (AGL):	163	Height (AGL):	163
Frequency Bands	2100 MHz (AWS)	Frequency Bands	2100 MHz (AWS)	Frequency Bands	2100 MHz (AWS)
Channel Count	5	Channel Count	5	Channel Count	5
Total TX Power(W):	200	Total TX Power(W):	200	Total TX Power(W):	200
ERP (W):	7,780.90	ERP (W):	7,780.90	ERP (W):	7,780.90
Antenna A2 MPE%	1.135	Antenna B2 MPE%	1.135	Antenna C2 MPE%	1.135
Antenna #:	3	Antenna #:	3	Antenna #:	3
Make / Model:	RFS APXVAAR24-43-U-NA20	Make / Model:	RFS APXVAAR24-43-U-NA20	Make / Model:	RFS APXVAAR24-43-U-NA20
Gain:	12.65/ 12.95 dBd	Gain:	12.65/ 12.95 dBd	Gain:	12.65/ 12.95 dBd
Height (AGL):	163	Height (AGL):	163	Height (AGL):	163
Frequency Bands	600 MHz / 700 MHz	Frequency Bands	600 MHz / 700 MHz	Frequency Bands	600 MHz / 700 MHz
Channel Count	8	Channel Count	8	Channel Count	8
Total TX Power(W):	320	Total TX Power(W):	320	Total TX Power(W):	320
ERP (W):	6,101.11	ERP (W):	6,101.11	ERP (W):	6,101.11
Antenna A3 MPE%	2.060	Antenna B3 MPE%	2.060	Antenna C3 MPE%	2.060

Microwave Backhaul Data

Make / Model:	Gain	Height (AGL):	Frequency Bands	Channel Count	Total TX Power(W)	ERP (W)	MPE %	Sector
Fastback IBR1300	10 dBd	163	5 GHz	1	1	10	0.002	C



Site Summary Tables

Site Composite MPE%	
Carrier	MPE%
T-Mobile (Sector C)	4.104 %
Town MFRE	0.110%
Town MPD - ch 1	0.010%
Town MPD - ch 2	0.020%
Town MFD	0.030%
Town services intercity	0.060%
RAFS I/2	0.190%
Town public works	0.080%
Town Services EOC	0.080%
Town FD	0.080%
town SP hotline	0.110%
Town Vol FD	0.070%
Town Service - School	0.020%
Htfd City FD	0.080%
Tolland MUT	0.080%
Sprint	2.46%
Clearwire	0.09%
Verizon Wireless	3.51%
AT&T	3.50%
Site Total MPE %:	14.684%

T-Mobile Sector A Total:	4.102 %
T-Mobile Sector B Total:	4.102 %
T-Mobile Sector C Total:	4.104 %
<hr/>	
Site Total:	14.684%

T-Mobile Max Power Values (Sector C)

T-Mobile_Max Power Values (Sector C)	# Channels	Watts ERP (Per Channel)	Height (feet)	Total Power Density ($\mu\text{W}/\text{cm}^2$)	Frequency (MHz)	Allowable MPE ($\mu\text{W}/\text{cm}^2$)	Calculated % MPE
T-Mobile PCS - 1900 MHz LTE	4	1,556.18	163	9.08	PCS - 1900 MHz	1000	0.908%
T-Mobile AWS - 2100 MHz LTE	5	1,556.18	163	11.35	AWS - 2100 MHz	1000	1.135%
T-Mobile 600 MHz LTE	4	736.31	163	4.30	600 MHz	1000	1.074%
T-Mobile 700 MHz LTE	4	788.97	163	4.60	700 MHz	400	0.986%
T-Mobile 5 GHz Microwave	1	10	163	0.020	10 GHz	1000	0.002%
						Total:	4.104%

Summary

All calculations performed for this analysis yielded results that were **within** the allowable limits for general population exposure to RF Emissions.

The anticipated maximum composite contributions from the T-Mobile facility as well as the site composite emissions value with regards to compliance with FCC's allowable limits for general population exposure to RF Emissions are shown here:

T-Mobile Sector	Power Density Value (%)
Sector A:	4.102 %
Sector B:	4.102 %
Sector C:	4.104 %
T-Mobile Per Sector Maximum (Sector C):	4.104 %
Site Total:	14.684 %
Site Compliance Status:	COMPLIANT

The anticipated composite MPE value for this site assuming all carriers present is **14.684%** of the allowable FCC established general population limit sampled at the ground level. This is based upon values listed in the Connecticut Siting Council database for existing carrier emissions.

FCC guidelines state that if a site is found to be out of compliance (over allowable thresholds), that carriers over a 5% contribution to the composite value will require measures to bring the site into compliance. For this facility, the composite values calculated were well within the allowable 100% threshold standard per the federal government.

Exhibit F



**UNITED STATES
POSTAL SERVICE®**

Click-N-Ship®

P

usps.com
US POSTAGE
 Flat Rate Env
 \$6.70

9405 5036 9930 0250 3766 71 0067 0000 0010 6040



06/15/2018

Mailed from 06002 062S00000001311

PRIORITY MAIL 1-DAY™

DEBORAH CHASE
 T-MOBILE USA- NSS
 35 GRIFFIN RD S
 BLOOMFIELD CT 06002-1351

Expected Delivery Date: 06/16/18
 Ref#: 3654X2ZAP
0024

Carrier -- Leave if No Response

C004

SHIP TO: JAY MORAN
 MAYOR-TOWN OF MANCHESTER
 41 CENTER ST
 MANCHESTER CT 06040-5090

USPS TRACKING #

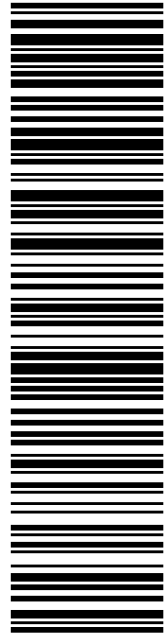

9405 5036 9930 0250 3766 71

Electronic Rate Approved #038555749



Cut on dotted line.

Instructions

1. Each Click-N-Ship® label is unique. Labels are to be used as printed and used only once. DO NOT PHOTO COPY OR ALTER LABEL.
2. Place your label so it does not wrap around the edge of the package.
3. Adhere your label to the package. A self-adhesive label is recommended. If tape or glue is used, DO NOT TAPE OVER BARCODE. Be sure all edges are secure.
4. To mail your package with PC Postage®, you may schedule a Package Pickup online, hand to your letter carrier, take to a Post Office™, or drop in a USPS collection box.
5. Mail your package on the "Ship Date" you selected when creating this label.

Click-N-Ship® Label Record

USPS TRACKING # :
9405 5036 9930 0250 3766 71

Trans. #: 437308562	Priority Mail® Postage: \$6.70
Print Date: 06/14/2018	Total: \$6.70
Ship Date: 06/15/2018	
Expected Delivery Date: 06/16/2018	

From: DEBORAH CHASE
 T-MOBILE USA- NSS
 35 GRIFFIN RD S
 BLOOMFIELD CT 06002-1351

Ref#: 3654X2ZAP

To: JAY MORAN
 MAYOR-TOWN OF MANCHESTER
 41 CENTER ST
 MANCHESTER CT 06040-5090

* Retail Pricing Priority Mail rates apply. There is no fee for USPS Tracking® service on Priority Mail service with use of this electronic rate shipping label. Refunds for unused postage paid labels can be requested online 30 days from the print date.



Thank you for shipping with the United States Postal Service!
 Check the status of your shipment on the USPS Tracking® page at usps.com

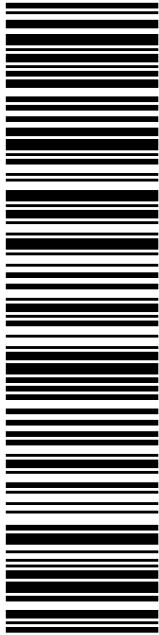

USPS TRACKING #

9405 5036 9930 0250 3766 88

Electronic Rate Approved #038555749

P

06/15/2018

PRIORITY MAIL 1-DAY™

Expected Delivery Date: 06/16/18

Ref#: 365-4X2ZAP

0024



usps.com 9405 5036 9930 0250 3766 88 0067 0000 0010 6040

US POSTAGE

Flat Rate Env

Mailed from 06002 062S00000001311

SHIP MATTHEW BORDEAU
TO: ZONING DIRECTOR- TOWN OF MANCHESTER
 494 MAIN ST
 LINCOLN CENTER-2ND FLOOR
 MANCHESTER CT 06040-4102

Carrier -- Leave if No Response

C009

DEBORAH CHASE
 T-MOBILE USA- NSS
 35 GRIFFIN RD S
 BLOOMFIELD CT 06002-1351



Click-N-Ship®



Cut on dotted line.

Instructions

1. Each Click-N-Ship® label is unique. Labels are to be used as printed and used only once. DO NOT PHOTO COPY OR ALTER LABEL.
2. Place your label so it does not wrap around the edge of the package.
3. Adhere your label to the package. A self-adhesive label is recommended. If tape or glue is used, DO NOT TAPE OVER BARCODE. Be sure all edges are secure.
4. To mail your package with PC Postage®, you may schedule a Package Pickup online, hand to your letter carrier, take to a Post Office™, or drop in a USPS collection box.
5. Mail your package on the "Ship Date" you selected when creating this label.

Click-N-Ship® Label Record

USPS TRACKING # :

9405 5036 9930 0250 3766 88

<p>Trans. #: 437308562 Print Date: 06/14/2018 Ship Date: 06/15/2018 Expected Delivery Date: 06/16/2018</p>	<p>Priority Mail® Postage: \$6.70</p> <p>Total: \$6.70</p>
---	--

From: DEBORAH CHASE
 T-MOBILE USA- NSS
 35 GRIFFIN RD S
 BLOOMFIELD CT 06002-1351

Ref#: 365-4X2ZAP

To: MATTHEW BORDEAU
 ZONING DIRECTOR- TOWN OF MANCHESTER
 494 MAIN ST
 LINCOLN CENTER-2ND FLOOR
 MANCHESTER CT 06040-4102

* Retail Pricing Priority Mail rates apply. There is no fee for USPS Tracking® service on Priority Mail service with use of this electronic rate shipping label. Refunds for unused postage paid labels can be requested online 30 days from the print date.



Thank you for shipping with the United States Postal Service!
 Check the status of your shipment on the USPS Tracking® page at usps.com



**UNITED STATES
POSTAL SERVICE®**





usps.com
US POSTAGE
 Flat Rate Env
 \$6.70
 9405 5036 9930 0250 3766 95 0067 0000 0010 6040

06/15/2018



Mailed from 06002 062S00000001311

PRIORITY MAIL 1-DAY™

Expected Delivery Date: 06/16/18

DEBORAH CHASE
 T-MOBILE USA- NSS
 35 GRIFFIN RD S
 BLOOMFIELD CT 06002-1351

0024

Carrier -- Leave if No Response

C004

SHIP TO: JOSEPH CAMPOSEO
 TOWN CLERK- TOWN OF MANCHESTER
 41 CENTER ST
 MANCHESTER CT 06040-5090

USPS TRACKING #

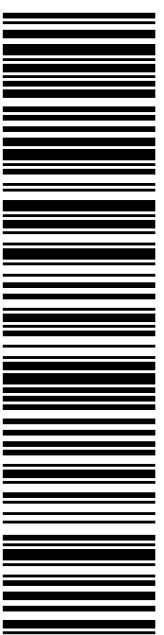

9405 5036 9930 0250 3766 95

Electronic Rate Approved #038555749



Cut on dotted line.

Instructions

1. Each Click-N-Ship® label is unique. Labels are to be used as printed and used only once. DO NOT PHOTO COPY OR ALTER LABEL.
2. Place your label so it does not wrap around the edge of the package.
3. Adhere your label to the package. A self-adhesive label is recommended. If tape or glue is used, DO NOT TAPE OVER BARCODE. Be sure all edges are secure.
4. To mail your package with PC Postage®, you may schedule a Package Pickup online, hand to your letter carrier, take to a Post Office™, or drop in a USPS collection box.
5. Mail your package on the "Ship Date" you selected when creating this label.

Click-N-Ship® Label Record

USPS TRACKING # :
9405 5036 9930 0250 3766 95

Trans. #: 437308562	Priority Mail® Postage: \$6.70
Print Date: 06/14/2018	Total: \$6.70
Ship Date: 06/15/2018	
Expected Delivery Date: 06/16/2018	

From: DEBORAH CHASE
 T-MOBILE USA- NSS
 35 GRIFFIN RD S
 BLOOMFIELD CT 06002-1351

To: JOSEPH CAMPOSEO
 TOWN CLERK- TOWN OF MANCHESTER
 41 CENTER ST
 MANCHESTER CT 06040-5090

* Retail Pricing Priority Mail rates apply. There is no fee for USPS Tracking® service on Priority Mail service with use of this electronic rate shipping label. Refunds for unused postage paid labels can be requested online 30 days from the print date.



Thank you for shipping with the United States Postal Service!

Check the status of your shipment on the USPS Tracking® page at usps.com