



Northeast Site Solutions  
Victoria Masse  
420 Main Street #2, Sturbridge, MA 01566  
860-306-2326  
victoria@northeastsitesolutions.com

June 15, 2021

Members of the Siting Council  
Connecticut Siting Council  
Ten Franklin Square  
New Britain, CT 06051

RE: Exempt Modification Application  
239 East Middle Turnpike, Manchester CT 06040  
Latitude: 41.78438900  
Longitude: -72.51177100  
T-Mobile Site#: CT11365D\_Anchor

Dear Ms. Bachman:

T-Mobile currently maintains nine (9) antennas at the 163-foot level of the existing 183-foot tower. The tower and property are owned by Town of Manchester. T-Mobile now intends to add three (3) new 2500 MHz 5G capable antenna. The new antenna would be installed at the 163-foot level of the tower. T-Mobile also intends to make the following modifications on the mounts referenced in our attached engineering documents.

**T-Mobile Planned Modifications:**

Remove:

- (3) KRY 112 144/2
- (1) IBR 1300 Radio

Remove and Replace:

Install New:

- (3) AIR6449 B41 2500 MHz Antenna
- (3) Radio 4415 B25
- (1) Hybrid cable
- (5) 1-5/8" Coax

Existing to Remain:

- (3) APXVAARR24\_43-U-NA20 600/700/1900 MHz Antenna
- (3) AIR32 KRD901146-1\_B66A\_B2A 1900/2100 MHz Antenna
- (3) AIR3246 B66 Antenna
- (3) Radio 449 B71+B85
- (16) 1-5/8" Coax
- (3) Hybrid cables



Ground:

- (1) Nortel Cabinet (to be removed)
- (1) Battery Cabinet (on existing concrete pad)
- (1) Support Cabinet (on existing concrete pad)

This facility was first approved by the Town of Manchester P&Z – Approved in 2002 to erect telecommunication tower. Please see attached.

Please accept this letter as notification pursuant to Regulations of Connecticut State Agencies § 16- SOj-73, for construction that constitutes an exempt modification pursuant to R.C.S.A. § 16-50j-72(b)(2). In accordance with R.C.S.A. § 16-SOj-73, a copy of this letter is being sent to Scott Shanley, General Manager and James Davis, Zoning Enforcement Officer for the Town of Manchester, as well as the property owner and the tower owner.

The planned modifications to the facility fall squarely within those activities explicitly provided for in R.C.S.A. § 16-50j-72(b)(2).

1. The proposed modifications will not result in an increase in the height of the existing structure.
2. The proposed modifications will not require the extension of the site boundary.
3. The proposed modifications will not increase noise levels at the facility by six decibels or more, or to levels that exceed state and local criteria.
4. The operation of the replacement antennas will not increase radio frequency emissions at the facility to a level at or above the Federal Communications Commission safety standard.
5. The proposed modifications will not cause a change or alteration in the physical or environmental characteristics of the site.
6. The existing structure and its foundation can support the proposed loading.

For the foregoing reasons, T-Mobile respectfully submits that the proposed modifications to the above referenced telecommunications facility constitute an exempt modification under R.C.S.A. § 16-50j-72(b)(2).

Sincerely,

Victoria Masse  
Mobile: 860-306-2326  
Fax: 413-521-0558  
Office: 420 Main Street, Unit 2, Sturbridge MA 01566  
Email: [victoria@northeastitesolutions.com](mailto:victoria@northeastitesolutions.com)



**NSS** **NORTHEAST**  
SITE SOLUTIONS  
*Turnkey Wireless Development*

Attachments

cc: Scott Shanley, General Manager (*email only at [sshanley@manchesterct.gov](mailto:sshanley@manchesterct.gov)*)

James Davis, Zoning Enforcement Officer (*email only at [jdavis@manchesterct.gov](mailto:jdavis@manchesterct.gov)*)

Town of Manchester - as property & tower owner (*email only at [jcampose@manchesterct.gov](mailto:jcampose@manchesterct.gov)*)

NORTHEAST SITE SOLUTIONS, LLC  
420 MAIN ST. BUILDING #4, 2nd FLOOR  
Sturbridge, MA 01566

WEBSTER BANK  
51-7010/2111

4401

06/07/2021

PAY TO THE ORDER OF Connecticut Siting Council

\$ \*625.00

EXACTLY SIX HUNDRED TWENTY-FIVE DOLLARS

DOLLARS

Connecticut Siting Council  
10 Franklin Square  
New Britain CT 06051

MEMO

*Lisa Jun Allen*  
AUTHORIZED SIGNATURE

⑈004401⑈ ⑆211170101⑆10 0010608887⑈

<b>Check#:</b> 4401	<b>Date:</b> 06/07/2021	<b>Vendor#:</b> 10023 Connecticut Siting Co	<b>Check Total:</b> *625.00	4401		
<i>Invoice#</i>	<i>Invoice Date</i>	<i>Job/Description</i>	<i>Balance</i>	<i>Retain</i>	<i>Discount</i>	<i>This Check</i>
CT11365D Zoning	06/08/2021	2 TMO Anchor Program	625.00			625.00

# Exhibit A



# Town of Manchester

41 Center Street • P.O. Box 191  
Manchester, Connecticut 06045-0191  
[www.ci.manchester.ct.us](http://www.ci.manchester.ct.us)

STEPHEN T. CASSANO, MAYOR  
JOSH M. HOWROYD, DEPUTY MAYOR  
CHRISTY SCOTT, SECRETARY

DIRECTORS  
TIMOTHY H. BECKER  
THOMAS P. CROCKETT  
JOSEPH S. HACHEY  
DAVID M. SHERIDAN  
LOUIS A. SPADACCINI  
KEVIN L. ZINGLER

STEVEN R. WERBNER, GENERAL MANAGER

June 14, 2002

Mr. Wayne Medlin  
Sprint PCS  
Crossroads Corporate Center – Suite 800  
1 International Blvd.  
Mahwah, NJ 07495

Re: Manchester Police Antenna

Dear Mr. Medlin:

We understand that an agreement between the Town of Manchester and Sprint PCS has been executed, and that Sprint PCS will construct a monopole tower at the Manchester Police Headquarters for its communications needs and build a new parking lot as part of that arrangement.

The police station's monopole tower is considered an accessory municipal structure and is permitted by the Town of Manchester zoning regulations. In Connecticut, before such an improvement project can be carried out, the Planning and Zoning Commission must issue a report on that project. Our PZC issued such a report on March 18, 2002. I have enclosed a memorandum dated March 21, 2002 relaying that report, and my supporting memorandum dated March 14, 2002.

At this stage Sprint PCS and the Town will need to secure the necessary building permits from the town building department and a zoning certificate from the zoning officer before construction can proceed.

Very truly yours,

Mark Pellegrini, AICP  
Director of Neighborhood Services and  
Economic Development

MP/s

R:\SHARON09\MARK\LETTERS\SPRINT PCS.DOC

cc: Mr. William Bellock  
Timothy O'Neil, Assistant Town Attorney

An Equal Opportunity Employer



**TOWN OF MANCHESTER  
PLANNING DEPARTMENT**

**TO:** Steven R. Werbner, General Manager

**FROM:** Mark Pellegrini, Director of Neighborhood Services  
and Economic Development



**DATE:** March 21, 2002

**RE:** Mandatory Referral Report  
Police Station Radio Tower and Parking Lot Expansion (MR-0201)

At its meeting of March 18, 2002 the Planning and Zoning Commission voted unanimously to endorse the proposal to construct a monopole tower at the Manchester Police Headquarters, dismantle the existing tower, and build a new parking lot as shown on plans submitted by the Manchester Police Department dated September 11, 2001 and amended to September 26, 2001. In making this decision the Planning and Zoning Commission considered my memorandum of March 14, 2002 (copy attached) as well as a review of the site plan and photo simulations of the proposed new tower presented by Lt. Marc Montminy at their meeting.

MP/s

R:\SHARON09\MARK\MEMOS\Werbner-MR0102.doc

Attach.

**TOWN OF MANCHESTER  
PLANNING DEPARTMENT**

**TO:** Planning and Zoning Commission

**FROM:** Mark Pellegrini, Director of Neighborhood Services  
And Economic Development 

**DATE:** March 14, 2002

**RE:** Mandatory Referral Report  
Police Station Radio Tower and Parking Lot Expansion (MR-0201)

The Planning and Zoning Commission is being asked to report on a proposal developed by the Manchester Police Department to replace its current radio tower and build a new parking lot in the location of the current tower at the Police Headquarters.

***Description of Project***

The police department has an existing 190' high lattice-type radio tower to serve its radio communications needs. The department wishes to replace this tower and equipment. They also have experienced parking problems, especially on Princeton Street, during daytime hours. The activity at the department's headquarters has created a greater demand for daytime parking than originally anticipated. Relocating the tower would provide room to add parking in front of the garage along Middle Turnpike. Attached is a site plan showing the proposed new tower location and the new parking lot, as well as a series of photo simulations showing the potential visual impact of the new monopole tower proposed to be constructed here.

There is no PZC approval aside from this mandatory referral report required for this project. The parking lot is less than one-half acre and therefore no erosion control plan will be needed. The new monopole tower is a permitted accessory structure and will only require a building permit and zoning permit from the Zoning Enforcement Officer.

***Construction and Other Uses***

The Police Department, through the Town, issued a request for proposals for the construction of the replacement tower. The proposal favored by the department was received from Sprint PCS. Under this proposal Sprint would pay for the construction of the new tower, provide new radio and related equipment to allow for a "hot" transfer so there will be no interruption in police communication during the switch-over from one tower to the other. Sprint PCS will also construct the parking lot and landscaping as proposed on the attached plans. In exchange for



these services, the police department will allow Sprint to locate a personal communications system antenna array on the tower and related hardware on the ground near the tower. The tower will also be capable of holding additional PCS arrays at the discretion of the Town.

### ***Recommendation***

The proposed improvements to the police department's headquarters site would be generally consistent with our Plan of Conservation and Development. The police department does require a tall communications antenna for its communication needs, which has become more sophisticated as communications and computing technology have evolved. It would also be beneficial to have more on-site parking at the police department to relieve the traffic problems experienced on Princeton Street and to a lesser extent on Middle Turnpike during certain times of the day.

The construction of a 190±' monopole in this location will have some visual impact. It is possible through the proposed planting around the base of the unit and equipment cabinets to minimize the view of the lowest portions of the tower from passing motorists, but this area would primarily be visible to people driving into the Illing Middle School. The upper portions of the tower will be visible from various locations in the vicinity as shown on the attached photo simulations. The only alternative to a monopole tower would be a lattice-type tower, which in some respects is less intrusive since there is so much open air around the structure itself. However, we have been advised that such towers may become less attractive if multiple antenna arrays are placed on them and increased cabling is run up to the arrays. Lattice towers also require a larger footprint.

MP/s

R:\SHARON09\PZCMEMOS\18MAR02-PZC memos\MR-0201.doc

Attach.

# Exhibit B

# 239 MIDDLE TURNPIKE EAST

**Location** 239 MIDDLE TURNPIKE EAST

**Mblu** 92/ 3950/ 239/ /

**Acct#** 395000239

**Owner** MANCHESTER TOWN OF

**Assessment** \$4,243,700

**Appraisal** \$6,062,100

**PID** 10705

**Building Count** 2

## Current Value

Appraisal			
Valuation Year	Improvements	Land	Total
2016	\$5,573,900	\$488,200	\$6,062,100

Assessment			
Valuation Year	Improvements	Land	Total
2016	\$3,901,900	\$341,800	\$4,243,700

## Owner of Record

**Owner** MANCHESTER TOWN OF

**Sale Price** \$0

**Address** 41 CENTER ST

**Certificate** C

MANCHESTER, CT 06040-5096

**Book & Page**

**Sale Date**

## Ownership History

Ownership History				
Owner	Sale Price	Certificate	Book & Page	Sale Date
MANCHESTER TOWN OF	\$0	C		

## Building Information

### Building 1 : Section 1

**Year Built:** 1995

**Living Area:** 46,701

**Replacement Cost:** \$6,306,043

**Replacement Cost**

**Less Depreciation:** \$5,044,800

Building Attributes	
Field	Description
STYLE	Other Municip
MODEL	Ind/Comm

Grade	Average +10
Stories:	2
Occupancy	1
Exterior Wall 1	Brick Veneer
Exterior Wall 2	Stucco/Masonry
Roof Structure	Flat
Roof Cover	Tar + Gravel
Interior Wall 1	Minim/Masonry
Interior Wall 2	Drywall/Sheetr
Interior Floor 1	Carpet
Interior Floor 2	Tile/Vinyl Cmp
Heating Fuel	Gas
Heating Type	Forced Air-Duc
AC Type	Central
Bldg Use	Municipal 96
Total Rooms	
Total Bedrms	00
Total Baths	0
1st Floor Use:	901I
Heat/AC	Heat/AC Packag
Frame Type	Steel
Baths/Plumbing	Average
Ceiling/Wall	Susp Ceil & WI
Rooms/Prtns	Average
Wall Height	10
% Comn Wall	0

### Building Photo



(http://images.vgsi.com/photos2/ManchesterCTPhotos//\00\03\2

### Building Layout

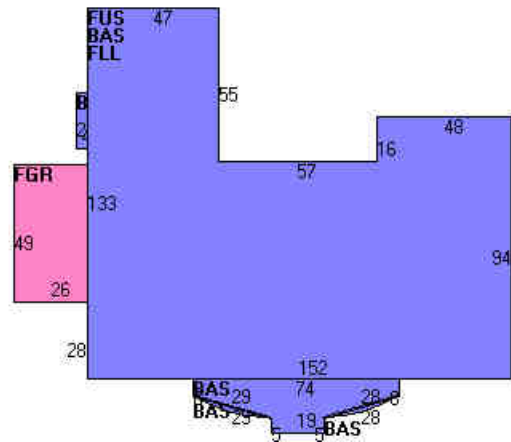

Building Sub-Areas (sq ft)			Legend
Code	Description	Gross Area	Living Area
BAS	First Floor	16,283	16,283
FLL	Finished Lower Level	15,209	15,209
FUS	Upper Story, Finished	15,209	15,209
FGR	Garage	1,274	0
		47,975	46,701

### Building 2 : Section 1

**Year Built:** 1975  
**Living Area:** 7,000  
**Replacement Cost:** \$506,690  
**Replacement Cost Less Depreciation:** \$309,100

Building Attributes : Bldg 2 of 2	
Field	Description
STYLE	Service Shop
MODEL	Ind/Comm

Grade	Average
Stories:	1
Occupancy	1
Exterior Wall 1	Brick Veneer
Exterior Wall 2	
Roof Structure	Gable/Hip
Roof Cover	Asphalt Shingl
Interior Wall 1	Minim/Masonry
Interior Wall 2	
Interior Floor 1	Concr-Finished
Interior Floor 2	
Heating Fuel	Gas
Heating Type	Forced Air-Duc
AC Type	None
Bldg Use	Municipal 96
Total Rooms	
Total Bedrms	00
Total Baths	0
1st Floor Use:	901I
Heat/AC	Heat/AC Packag
Frame Type	Masonry
Baths/Plumbing	Average
Ceiling/Wall	Ceil & Min WI
Rooms/Prtns	Average
Wall Height	19
% Comn Wall	0

### Building Photo



(<http://images.vgsi.com/photos2/ManchesterCTPhotos//\00\03\2>)

### Building Layout

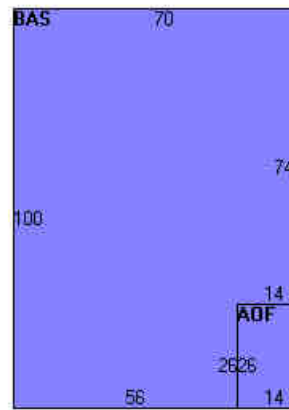

Building Sub-Areas (sq ft)			<u>Legend</u>
Code	Description	Gross Area	Living Area
BAS	First Floor	6,636	6,636
AOF	Office, (Average)	364	364
		7,000	7,000

### Extra Features

Extra Features				<u>Legend</u>
Code	Description	Size	Value	Bldg #
MEZ1	Mezzanine-Unfin	1900 S.F.	\$13,300	2
SPR1	Sprinklers-Wet	47975 S.F.	\$54,000	1

### Land

#### Land Use

Use Code 901I

#### Land Line Valuation

Size (Acres) 3.97

**Description** Municipal 96  
**Zone** RA  
**Neighborhood** 4000  
**Alt Land Appr** No  
**Category**

**Frontage** 0  
**Depth** 0  
**Assessed Value** \$341,800  
**Appraised Value** \$488,200

**Outbuildings**

<b>Outbuildings</b>						<b>Legend</b>
<b>Code</b>	<b>Description</b>	<b>Sub Code</b>	<b>Sub Description</b>	<b>Size</b>	<b>Value</b>	<b>Bldg #</b>
PAV1	Paving Asphalt			97700 S.F.	\$122,100	1
FN4	Fence 8' Chain			128 L.F.	\$1,900	1
LT1	Lights 1Fix			15 UNITS	\$12,900	1
CNP1	Canopy Ave			360 S.F.	\$7,800	1
SHD2	Shed W/Imp			120 S.F.	\$1,300	1
SHD1	Shed			168 S.F.	\$1,500	1
FN3	Fence 6' Chain			160 L.F.	\$3,700	1
SHD2	Shed W/Imp			140 S.F.	\$1,500	1

**Valuation History**

<b>Appraisal</b>			
<b>Valuation Year</b>	<b>Improvements</b>	<b>Land</b>	<b>Total</b>
2015	\$4,365,100	\$488,200	\$4,853,300
2010	\$4,125,100	\$423,400	\$4,548,500
2005	\$3,622,600	\$380,200	\$4,002,800

<b>Assessment</b>			
<b>Valuation Year</b>	<b>Improvements</b>	<b>Land</b>	<b>Total</b>
2015	\$3,055,600	\$341,800	\$3,397,400
2010	\$2,887,500	\$296,400	\$3,183,900
2005	\$2,535,800	\$266,200	\$2,802,000

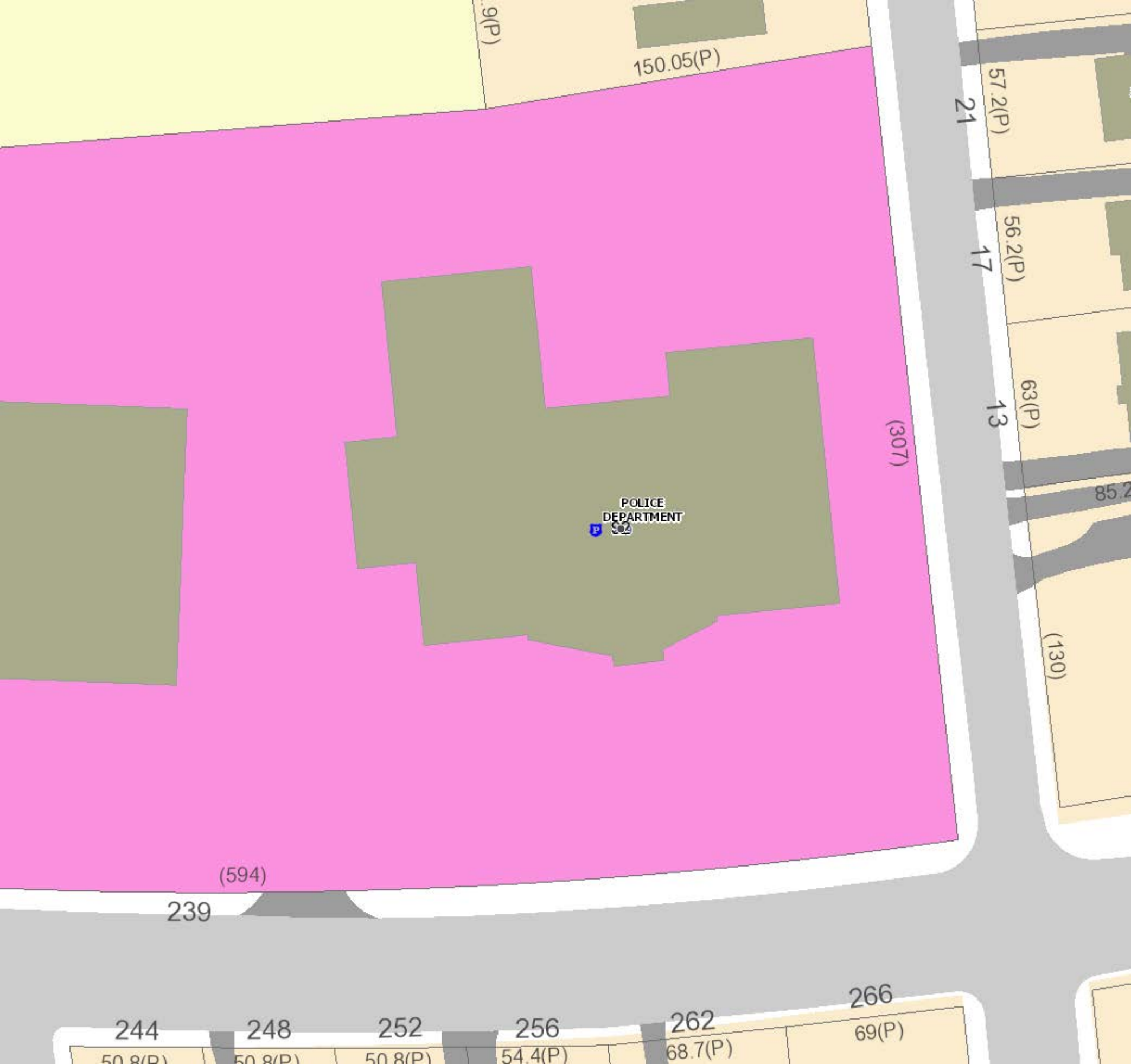

.9(P)

150.05(P)

57.2(P)  
21

56.2(P)  
17

63(P)  
13

85.2

(130)

(307)

POLICE DEPARTMENT

(594)

239

244

50.8(P)

248

50.8(P)

252

50.8(P)

256

54.4(P)

262

68.7(P)

266

69(P)

# Exhibit C



UPGRADE OF EXISTING WIRELESS FACILITY BY



**T-MOBILE NORTHEAST LLC**

PROJECT: ANCHOR

SITE NUMBER: CT11365D

SITE NAME: CT365/Manchester PD\_MP

SITE ADDRESS: 239 E. MIDDLE TPK

MANCHESTER, CT 06040

(RF CONFIGURATION 67D5992M\_3xAIR+1OP)

**APPLICANT:**  
  
**T-MOBILE NORTHEAST LLC**  
 35 GRIFFIN ROAD SOUTH  
 BLOOMFIELD, CT 06002  
 860-692-7100

**PROJECT MANGER**  
  
**NSS NORTHEAST**  
 SITE SOLUTIONS  
*Turnkey Wireless Development*  
 420 MAIN STREET, BLDG 4  
 STURBRIDGE, MA 01566  
 203-275-6669

**CONSULTANT:**  
  
**FORESITE** LLC  
 Architects . Engineers . Surveyors  
 462 WALNUT STREET  
 NEWTON, MA 02460  
 617-212-3123

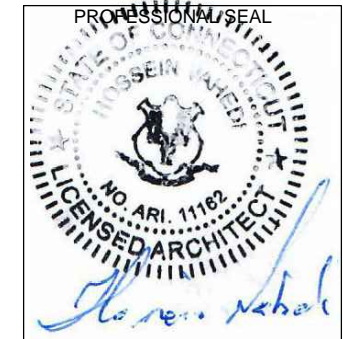

THIS DOCUMENT IS THE DESIGN PROPERTY AND COPYRIGHT OF FORESITE, LLC. AND FOR THE EXCLUSIVE USE BY THE TITLE CLIENT. DUPLICATION OR USE WITHOUT THE EXPRESS WRITTEN CONSENT OF THE CREATOR IS STRICTLY PROHIBITED.  
 DRAWING SCALES ARE INTENDED FOR 11"x17" SIZE PRINTED MEDIA ONLY. ALL OTHER PRINTED SIZES ARE DEEMED "NOT TO SCALE".

REV	DESCRIPTION	DATE
A	PRELIMINARY	06/24/20
B	ADDED AT&T INFO	08/03/20
0	FINAL ISSUED	08/03/20
1	UPDATED PER NEW SA	03/08/21
2	REVISIONS- PER NEW SA	06/11/21
3	REVISIONS- CABLES	06/15/21

SITE NUMBER: CT11365D  
 SITE NAME: CT365/Manchester PD\_MP  
 SITE ADDRESS: 239 E. MIDDLE TPK  
 MANCHESTER, CT 06040

SHEET TITLE:

**PROJECT NOTES:**

- THIS IS AN UNMANNED TELECOMMUNICATION FACILITY AND NOT FOR HUMAN HABITATION:  
 HANDICAPPED ACCESS IS NOT REQUIRED.  
 POTABLE WATER OR SANITARY SERVICE IS NOT REQUIRED.  
 NO OUTDOOR STORAGE OR ANY SOLID WASTE RECEPTACLES REQUIRED.
- CONTRACTOR SHALL VERIFY ALL PLANS, EXISTING DIMENSIONS, AND CONDITIONS ON THE JOB SITE. CONTRACTOR SHALL IMMEDIATELY NOTIFY THE ARCHITECT/ENGINEER IN WRITING OF ANY DISCREPANCIES BEFORE PROCEEDING WITH THE WORK. FAILURE TO NOTIFY THE ARCHITECT/ENGINEER PLACES THE RESPONSIBILITY ON THE CONTRACTOR TO CORRECT THE DISCREPANCIES AT THE CONTRACTOR'S EXPENSE.
- DEVELOPMENT AND USE OF THE SITE WILL CONFORM TO ALL APPLICABLE CODES, ORDINANCES AND SPECIFICATIONS.

**STRUCTURAL NOTES:**  
 REFER TO STRUCTURAL ANALYSIS REPORT TITLED " STRUCTURAL ANALYSIS REPORT MONOPOLE " SITE ID: CT11365D -REV. 7, DATED MAY 21, 2021 AND "MOUNT STRUCTURAL ANALYSIS REPORT-UPGRADE" DATED JUNE 19, 2020 BOTH PREPARED BY EFI GLOBAL INC.

**CODE COMPLIANCE:**  
 ALL WORK SHALL COMPLY WITH THE CURRENT NATIONAL AND CONNECTICUT STATE BUILDING AND LIFE SAFETY CODES, SUPPLEMENTS AND AMENDMENTS INCLUDING BUT NOT LIMITED TO THE LATEST EDITION OF:  
 CONNECTICUT STATE BUILDING CODE (CSBC).  
 ANSII/TIA-222-G STRUCTURAL STANDARD FOR ANTENNA SUPPORTING STRUCTURES AND ANTENNAS.  
 NATIONAL ELECTRICAL CODE (NEC) FOR POWER AND GROUNDING REQUIREMENTS.  
 OCCUPATIONAL SAFETY AND HEALTH ACT (OSHA).  
 NFPA - NATIONAL FIRE PROTECTION ASSOCIATION.

Connecticut - Call Before You Dig  
 811 or 1-800-922-4455  
**Advance Notice:**  
 Minimum of 2 working days in advance, no more than 30 days in advance

**APPROVALS:**

FSA CM	DATE
RF ENGINEER	DATE
FOPS	DATE
T-MOBILE ENGINEERING AND DEVELOPMENT	DATE
	DATE
	DATE

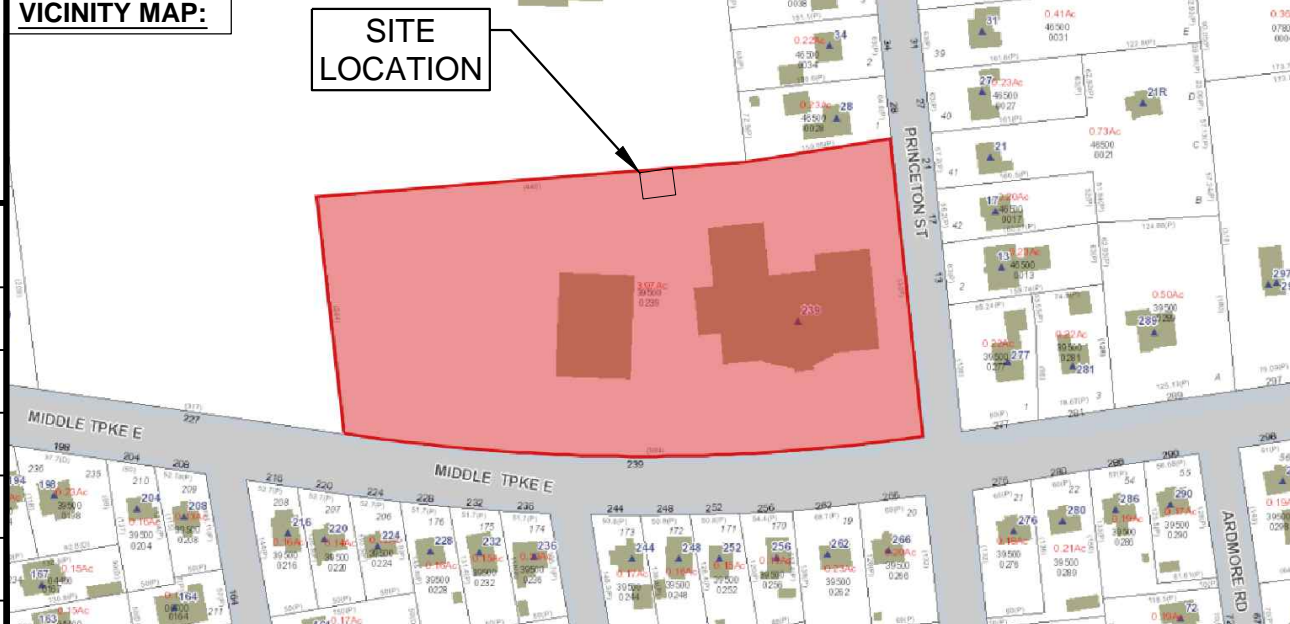

**PROJECT SCOPE:**  
 UPGRADE OF EXISTING WIRELESS FACILITY AS FOLLOWS:  
 ADD (3) NEW ANTENNAS FOR TOTAL OF (12).  
 ADD (3) REMOTE RADIO UNITS AT ANTENNAS. REMOVE (3) TMAS AT ANTENNAS.  
 REMOVE (1) EXISTING NORTEL CABINET.  
 ADD (1) ENCLOSURE 6160.  
 ADD (1) BATTERY CABINET B160  
 FINAL CABLE CONFIGURATION: (16) 1-5/8", (5) 1-5/8 (FUTURE ENTITLEMENT), (1) 9X18 HSC AND (3) 6X12 HSC

**PROJECT INFORMATION:**  
 ADDRESS: MANCHESTER POLICE DEPARTMENT  
 239 E. MIDDLE TPK  
 MANCHESTER, CT 06040  
 STRUCTURE TYPE: MONOPOLE  
 ZONING DISTRICT: RA  
 PARCEL ID: 10705  
 COORDINATES: N 4178438900 / W -72.51177100

**PROJECT TEAM:**  
 APPLICANT: T-MOBILE NORTHEAST, LLC.  
 35 GRIFFIN ROAD SOUTH  
 BLOOMFIELD, CT 06002  
 860-692-7100  
 LANDLORD: TOWN OF MANCHESTER  
 41 CENTER STREET  
 MANCHESTER, CT 06040  
 PROJECT MANGER: NORTHEAST SITE SOLUTIONS  
 420 MAIN STREET, BLDG 4  
 STURBRIDGE, MA 01566  
 SHELDON FREINCLE  
 SHELDON@NORTHEASTSITESOLUTIONS.COM  
 201-776-8521  
 CONSULTANTS: FORESITE LLC  
 462 WALNUT ST  
 NEWTON, MA 02460  
 SAEED MOSSAVAT  
 SMOSSAVAT@FORESITELLC.COM  
 617-212-3123

**SHEET INDEX:**  
 T-1: TITLE SHEET  
 N-1: GENERAL NOTES  
 A-1: SITE PLAN  
 A-2: ELEVATION AND ANTENNA PLAN  
 A-3: EQUIPMENT LAYOUT PLAN  
 A-4: EQUIPMENT SPECIFICATIONS  
 S-1: STRUCTURAL DETAILS  
 S-2: STRUCTURAL DETAILS  
 E-1: GROUNDING DETAILS

Copyright © 2016 Foresite LLC all rights reserved. The details, templates, drawing formats or any portion of this document generated by Foresite LLC may not be duplicated, traced or used otherwise for any profit-driven enterprise.

Copyright © 2016 Foresite LLC all rights reserved. The details, templates, drawing formats or any portion of this document generated by Foresite LLC may not be duplicated, traced or used otherwise for any profit-driven enterprise.

**GENERAL NOTES:**

1. THE CONTRACTOR SHALL GIVE ALL NOTICES AND COMPLY WITH ALL LAWS, ORDINANCES, RULES, REGULATIONS AND LAWFUL ORDERS OF ANY PUBLIC AUTHORITY, MUNICIPAL AND UTILITY COMPANY SPECIFICATIONS, AND LOCAL AND STATE JURISDICTIONAL CODES BEARING ON THE PERFORMANCE OF THE WORK. THE WORK PERFORMED ON THE PROJECT AND THE MATERIALS INSTALLED SHALL BE IN STRICT ACCORDANCE WITH ALL APPLICABLE CODES, REGULATIONS, AND ORDINANCES.
2. THE ARCHITECT/ENGINEER HAS MADE EVERY EFFORT TO SET FORTH IN THE CONSTRUCTION AND CONTRACT DOCUMENTS THE COMPLETE SCOPE OF WORK. THE CONTRACTOR BIDDING THE JOB IS NEVERTHELESS CAUTIONED THAT MINOR OMISSIONS OR ERRORS IN THE DRAWINGS AND OR SPECIFICATIONS SHALL NOT EXCUSE SAID CONTRACTOR FROM COMPLETING THE PROJECT AND IMPROVEMENTS IN ACCORDANCE WITH THE INTENT OF THESE DOCUMENTS.
3. THE CONTRACTOR OR BIDDER SHALL BEAR THE RESPONSIBILITY OF NOTIFYING (IN WRITING) THE CLIENT'S REPRESENTATIVE OF ANY CONFLICTS, ERRORS, OR OMISSIONS PRIOR TO THE SUBMISSION OF CONTRACTOR'S PROPOSAL OR PERFORMANCE OF WORK.
5. THE CONTRACTOR SHALL VISIT THE JOB SITE PRIOR TO THE SUBMISSION OF BIDS OR PERFORMING WORK TO FAMILIARIZE HIMSELF WITH THE FIELD CONDITIONS AND TO VERIFY THAT THE PROJECT CAN BE CONSTRUCTED IN ACCORDANCE WITH THE CONSTRUCTION DOCUMENTS.
6. THE CONTRACTOR SHALL INSTALL ALL EQUIPMENT AND MATERIALS ACCORDING TO THE MANUFACTURER'S / VENDOR'S SPECIFICATIONS UNLESS NOTED OTHERWISE OR WHERE LOCAL CODES OR ORDINANCES TAKE PRECEDENCE.
7. THE CONTRACTOR SHALL MAKE NECESSARY PROVISIONS TO PROTECT EXISTING IMPROVEMENTS DURING CONSTRUCTION.
8. THE CONTRACTOR SHALL COMPLY WITH ALL PERTINENT SECTIONS OF THE BASIC STATE BUILDING CODE, LATEST EDITION, AND ALL OSHA REQUIREMENTS AS THEY APPLY TO THIS PROJEC
9. THE CONTRACTOR SHALL NOTIFY THE CLIENT'S REPRESENTATIVE IN WRITING WHERE A CONFLICT OCCURS ON ANY OF THE CONTRACT DOCUMENTS. THE CONTRACTOR IS NOT TO ORDER MATERIAL OR CONSTRUCT ANY PORTION OF THE WORK THAT IS IN CONFLICT UNTIL CONFLICT IS RESOLVED BY THE CLIENT'S REPRESENTATIVE.
10. THE WORK SHALL CONFORM TO THE CODES AND STANDARDS OF THE FOLLOWING AGENCIES AS FURTHER CITED HEREIN:
  - A. ASTM: AMERICAN SOCIETY FOR TESTING AND MATERIALS, AS PUBLISHED IN "COMPILATION OF ASTM STANDARDS BUILDING CODES" OR LATEST EDITION.
  - B. AWS: AMERICAN WELDING SOCIETY INC. AS PUBLISHED IN "STANDARD D1.1-08, STRUCTURAL WELDING CODE" OR LATEST EDITION.
  - C. AISC: AMERICAN INSTITUTE FOR STEEL CONSTRUCTION AS PUBLISHED IN "CODE FOR STANDARD PRACTICE FOR STEEL BUILDINGS AND BRIDGES"; "SPECIFICATIONS FOR THE DESIGN, FABRICATION AND ERECTION OF STRUCTURAL STEEL FOR BUILDINGS" (LATEST EDITION).
11. BOLTING:
  - A. BOLTS SHALL BE CONFORMING TO ASTM A325 HIGH STRENGTH, HOT DIP GALVANIZED WITH ASTM A153 HEAVY HEX TYPE NUTS.
  - B. BOLTS SHALL BE 3/4"Ø MINIMUM (UNLESS OTHERWISE NOTED)
  - C. ALL CONNECTIONS SHALL BE 2 BOLTS MINIMUM.
12. FABRICATION:
  - A. FABRICATION OF STEEL SHALL CONFORM TO THE AISC AND AWS STANDARDS AND CODES (LATEST EDITION).
  - B. ALL STRUCTURAL STEEL SHALL BE HOT-DIP GALVANIZED AFTER FABRICATION IN ACCORDANCE WITH ASTM A123 (LATEST EDITION), UNLESS OTHERWISE NOTED.
13. ERECTION OF STEEL:
  - A. PROVIDE ALL ERECTION EQUIPMENT, BRACING, PLANKING, FIELD BOLTS, NUTS, WASHERS, DRIFT PINS, AND SIMILAR MATERIALS WHICH DO NOT FORM A PART OF THE COMPLETED CONSTRUCTION BUT ARE NECESSARY FOR ITS PROPER ERECTION.
  - B. ERECT AND ANCHOR ALL STRUCTURAL STEEL IN ACCORDANCE WITH AISC REFERENCE STANDARDS. ALL WORK SHALL BE ACCURATELY SET TO ESTABLISHED LINES AND ELEVATIONS AND RIGIDLY FASTENED IN PLACE WITH SUITABLE ATTACHMENTS TO THE CONSTRUCTION OF THE BUILDING.
  - C. TEMPORARY BRACING, GUYING AND SUPPORT SHALL BE PROVIDED TO KEEP THE STRUCTURE SAFE AND ALIGNED AT ALL TIMES DURING CONSTRUCTION, AND TO PREVENT DANGER TO PERSONS AND PROPERTY. CHECK ALL TEMPORARY LOADS AND STAY WITHIN SAFE CAPACITY OF ALL BUILDING COMPONENTS.
14. ANTENNA INSTALLATION:
  - A. INSTALL ANTENNAS AS INDICATED ON DRAWINGS AND CLIENT'S REPRESENTATIVE SPECIFICATIONS.

- B. INSTALL GALVANIZED STEEL ANTENNA MOUNTS AS INDICATED ON DRAWINGS.
- C. INSTALL COAXIAL / FIBER CABLES AND TERMINATIONS BETWEEN ANTENNAS AND EQUIPMENT PER MANUFACTURER'S RECOMMENDATIONS. WEATHERPROOF ALL CONNECTORS BETWEEN THE ANTENNA AND EQUIPMENT PER MANUFACTURER'S REQUIREMENTS.
15. ANTENNA AND COAXIAL / FIBER CABLE GROUNDING:
  - A. ALL EXTERIOR #6 GREEN GROUND WIRE "DAISY CHAIN" CONNECTIONS ARE TO BE WEATHER SEALED WITH ANDREWS CONNECTOR/SPLICE WEATHERPROOFING KIT TYPE #221213 OR EQUAL.
  - B. ALL COAXIAL / FIBER CABLE GROUNDING KITS ARE TO BE INSTALLED ON STRAIGHT RUNS OF COAXIAL / FIBER CABLE (NOT WITHIN BENDS).
16. RELATED WORK, FURNISH THE FOLLOWING WORK AS SPECIFIED UNDER CONSTRUCTION DOCUMENTS, BUT COORDINATE WITH OTHER TRADES PRIOR TO BID:
  - A. FLASHING OF OPENING INTO OUTSIDE WALLS
  - B. SEALING AND CAULKING ALL OPENINGS
  - C. PAINTING
  - D. CUTTING AND PATCHING
17. REQUIREMENTS OF REGULATORY AGENCIES:
  - A. FURNISH U.L. LISTED EQUIPMENT WHERE SUCH LABEL IS AVAILABLE. INSTALL IN CONFORMANCE WITH U.L. STANDARDS WHERE APPLICABLE.
  - B. INSTALL ANTENNA, ANTENNA CABLES, GROUNDING SYSTEM IN ACCORDANCE WITH DRAWINGS AND SPECIFICATION IN EFFECT AT PROJECT LOCATION AND RECOMMENDATIONS OF STATE AND LOCAL BUILDING CODES, AND SPECIAL CODES HAVING JURISDICTION OVER SPECIFIC PORTIONS OF WORK. THIS WORK INCLUDES BUT IS NOT LIMITED TO THE FOLLOWING:
    - C. TIA-EIA - 222 (LATEST EDITION). STRUCTURAL STANDARDS FOR STEEL ANTENNA TOWERS AND ANTENNA SUPPORTING STRUCTURES.
    - D. FAA - FEDERAL AVIATION ADMINISTRATION ADVISORY CIRCULAR AC 70/7460-IH, OBSTRUCTION MARKING AND LIGHTING.
    - E. FCC - FEDERAL COMMUNICATIONS COMMISSION RULES AND REGULATIONS FORM 715, OBSTRUCTION MARKING AND LIGHTING SPECIFICATION FOR ANTENNA STRUCTURES AND FORM 715A, HIGH INTENSITY OBSTRUCTION LIGHTING SPECIFICATIONS FOR ANTENNA STRUCTURES.
    - F. AISC - AMERICAN INSTITUTE OF STEEL CONSTRUCTION SPECIFICATION FOR STRUCTURAL JOINTS USING ASTM A325 BOLTS (LATEST EDITION).
    - G. NEC - NATIONAL ELECTRICAL CODE - ON TOWER LIGHTING KITS.
    - H. UL - UNDERWRITER'S LABORATORIES APPROVED ELECTRICAL PRODUCTS.
  - I. IN ALL CASES, PART 77 OF THE FAA RULES AND PARTS 17 AND 22 OF THE FCC RULES ARE APPLICABLE AND IN THE EVENT OF CONFLICT, SUPERSEDE ANY OTHER STANDARDS OR SPECIFICATIONS.
  - J. 2018 LIFE SAFETY CODE NFPA - 101.

**APPLICANT:**  
  
**T-MOBILE NORTHEAST LLC**  
 35 GRIFFIN ROAD SOUTH  
 BLOOMFIELD, CT 06002  
 860-692-7100

  
**PROJECT MANGER**  
**NSS NORTHEAST**  
 SITE SOLUTIONS  
*Turnkey Wireless Development*  
 420 MAIN STREET, BLDG 4  
 STURBRIDGE, MA 01566  
 203-275-6669

**CONSULTANT:**  
  
 Architects . Engineers . Surveyors  
 462 WALNUT STREET  
 NEWTON, MA 02460  
 617-212-3123

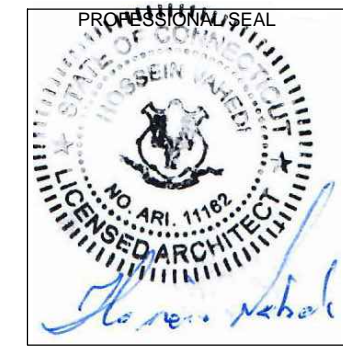

THIS DOCUMENT IS THE DESIGN PROPERTY AND COPYRIGHT OF FORESITE, LLC. AND FOR THE EXCLUSIVE USE BY THE TITLE CLIENT. DUPLICATION OR USE WITHOUT THE EXPRESS WRITTEN CONSENT OF THE CREATOR IS STRICTLY PROHIBITED. DRAWING SCALES ARE INTENDED FOR 11"x17" SIZE PRINTED MEDIA ONLY. ALL OTHER PRINTED SIZES ARE DEEMED "NOT TO SCALE".

REV	DESCRIPTION	DATE
A	PRELIMINARY	06/24/20
B	ADDED AT&T INFO	08/03/20
0	FINAL ISSUED	08/03/20
1	UPDATED PER NEW SA	03/08/21
2	REVISIONS- PER NEW SA	06/11/21
3	REVISIONS- CABLES	06/15/21

SITE NUMBER: CT11365D  
 SITE NAME: CT365/Manchester\_PD\_MP  
 SITE ADDRESS: 239 E. MIDDLE TPK  
 MANCHESTER, CT 06040

SHEET TITLE:  
**N-1: NOTES AND DISCLAIMERS**

Copyright © 2016 Foresite LLC all rights reserved. The details, templates, drawing formats or any portion of this document generated by Foresite LLC may not be duplicated, traced or used otherwise for any profit-driven enterprise.

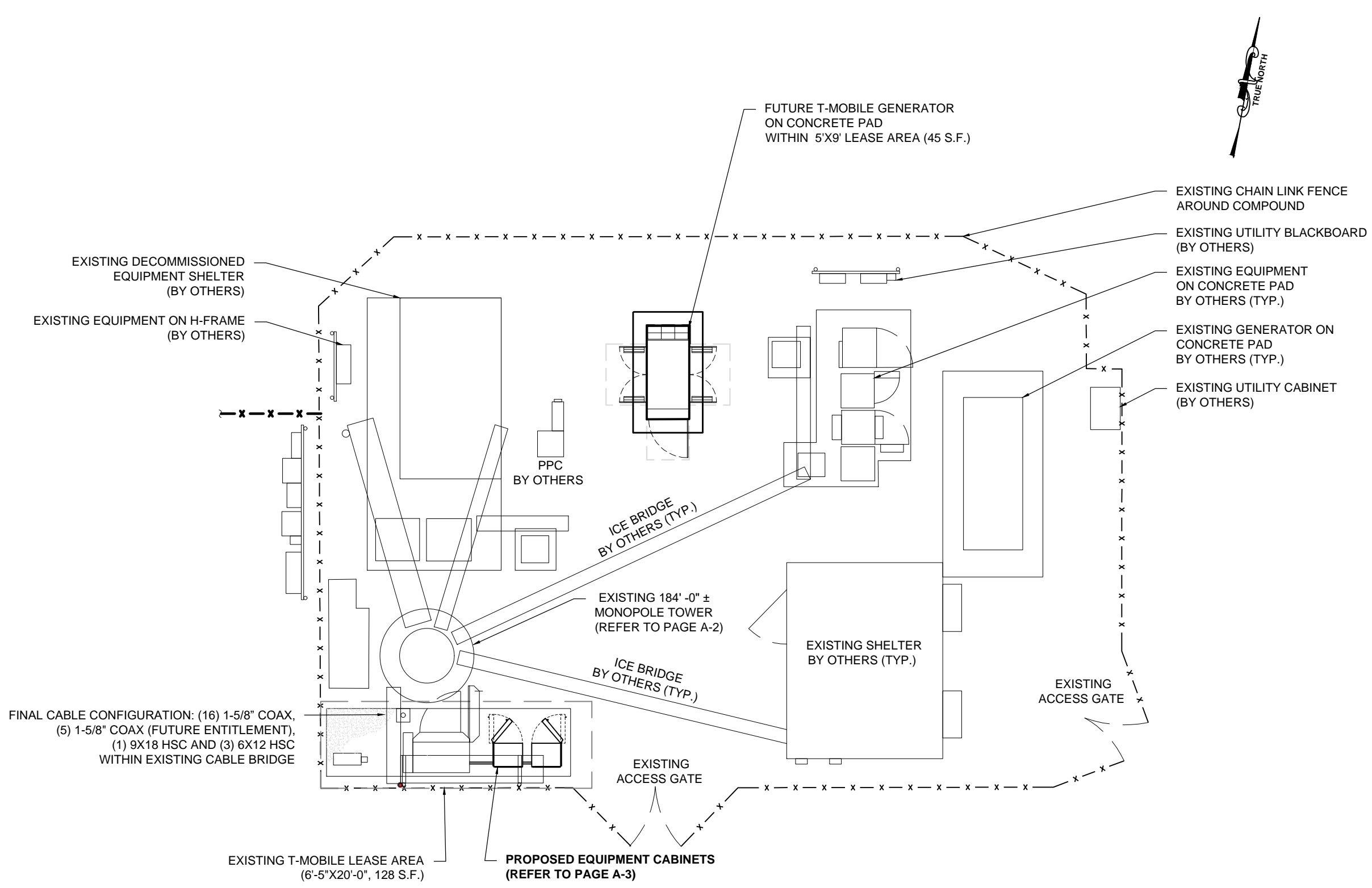

**SITE PLAN**  
SCALE 1/8"=1'-0" 1  
A-1

**APPLICANT:**  
**T-Mobile**  
**T-MOBILE NORTHEAST LLC**  
35 GRIFFIN ROAD SOUTH  
BLOOMFIELD, CT 06002  
860-692-7100

**PROJECT MANGER**  
**NSS NORTHEAST**  
SITE SOLUTIONS  
*Turnkey Wireless Development*  
420 MAIN STREET, BLDG 4  
STURBRIDGE, MA 01566  
203-275-6669

**CONSULTANT:**  
**FORESITE** LLC  
Architects . Engineers . Surveyors  
462 WALNUT STREET  
NEWTON, MA 02460  
617-212-3123



THIS DOCUMENT IS THE DESIGN PROPERTY AND COPYRIGHT OF FORESITE, LLC. AND FOR THE EXCLUSIVE USE BY THE TITLE CLIENT. DUPLICATION OR USE WITHOUT THE EXPRESS WRITTEN CONSENT OF THE CREATOR IS STRICTLY PROHIBITED.  
DRAWING SCALES ARE INTENDED FOR 11"x17" SIZE PRINTED MEDIA ONLY. ALL OTHER PRINTED SIZES ARE DEEMED "NOT TO SCALE".

REV	DESCRIPTION	DATE
A	PRELIMINARY	06/24/20
B	ADDED AT&T INFO	08/03/20
0	FINAL ISSUED	08/03/20
1	UPDATED PER NEW SA	03/08/21
2	REVISIONS- PER NEW SA	06/11/21
3	REVISIONS- CABLES	06/15/21

SITE NUMBER: CT11365D  
SITE NAME: CT365/Manchester PD\_MP  
SITE ADDRESS: 239 E. MIDDLE TPK  
MANCHESTER, CT 06040

SHEET TITLE:  
A-1: SITE PLAN

Copyright © 2016 Foresite LLC all rights reserved. The details, templates, drawing formats or any portion of this document generated by Foresite LLC may not be duplicated, traced or used otherwise for any profit-driven enterprise.

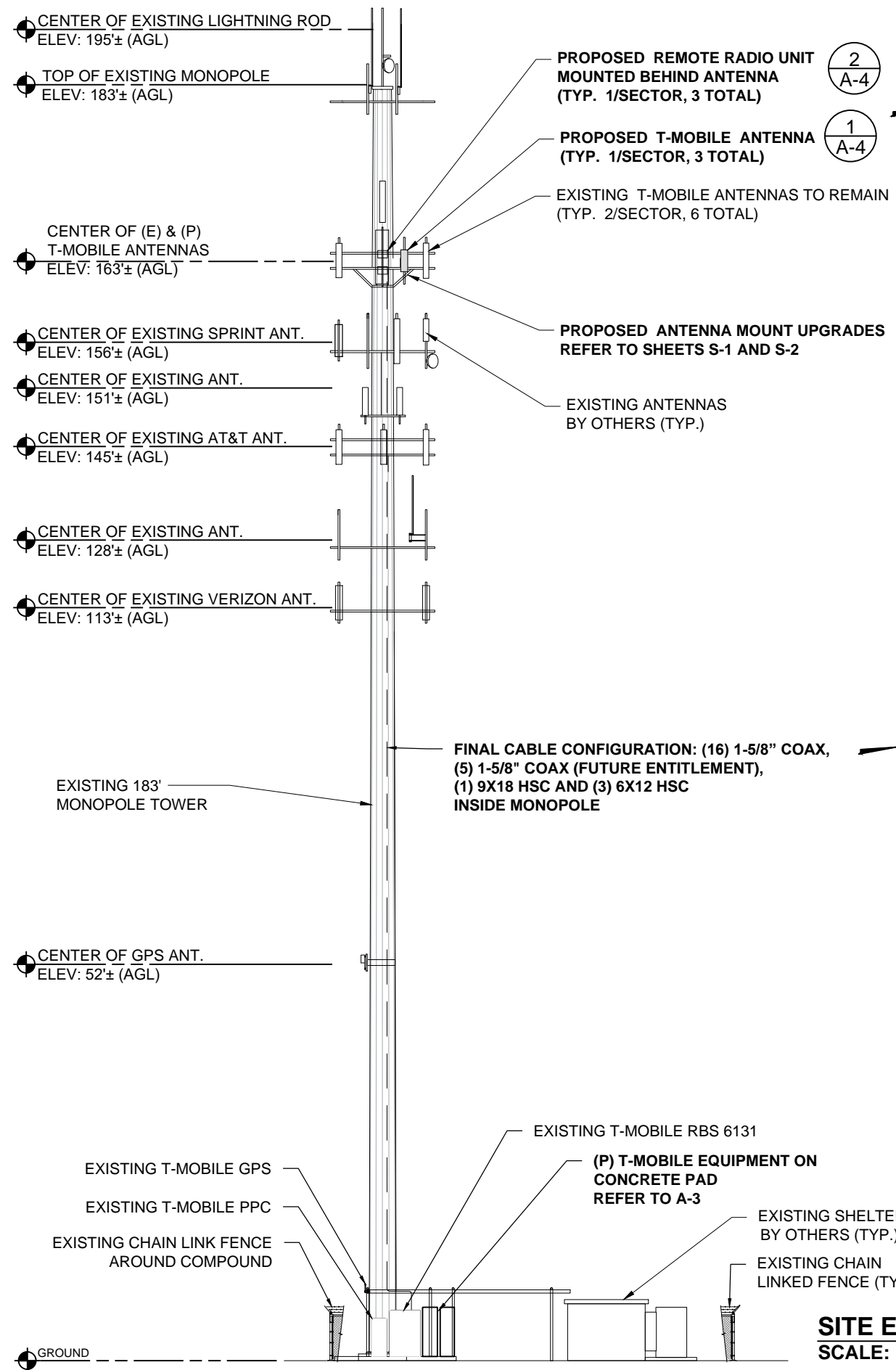

- PROPOSED REMOTE RADIO UNIT MOUNTED BEHIND ANTENNA (TYP. 1/SECTOR, 3 TOTAL)** (2/A-4)
- PROPOSED T-MOBILE ANTENNA (TYP. 1/SECTOR, 3 TOTAL)** (1/A-4)
- EXISTING T-MOBILE ANTENNAS TO REMAIN (TYP. 2/SECTOR, 6 TOTAL)**
- PROPOSED ANTENNA MOUNT UPGRADES REFER TO SHEETS S-1 AND S-2**
- EXISTING ANTENNAS BY OTHERS (TYP.)**

**FINAL CABLE CONFIGURATION: (16) 1-5/8" COAX, (5) 1-5/8" COAX (FUTURE ENTITLEMENT), (1) 9X18 HSC AND (3) 6X12 HSC INSIDE MONOPOLE**

REFER TO STRUCTURAL ANALYSIS REPORT TITLED "STRUCTURAL ANALYSIS REPORT MONOPOLE" SITE ID: CT11365D -REV. 7, DATED MAY 21, 2021 AND "MOUNT STRUCTURAL ANALYSIS REPORT-UPGRADE" DATED JUNE 19, 2020 BOTH PREPARED BY EFI GLOBAL INC.

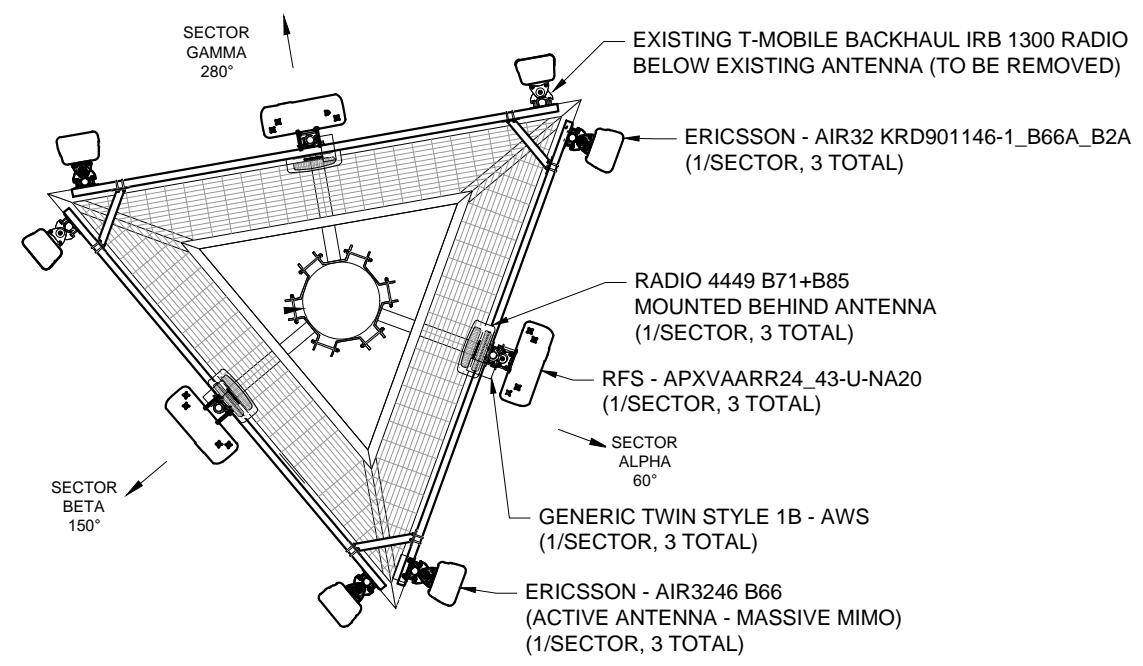

**EXISTING ANTENNA PLAN** (2/A-2)  
SCALE: NTS

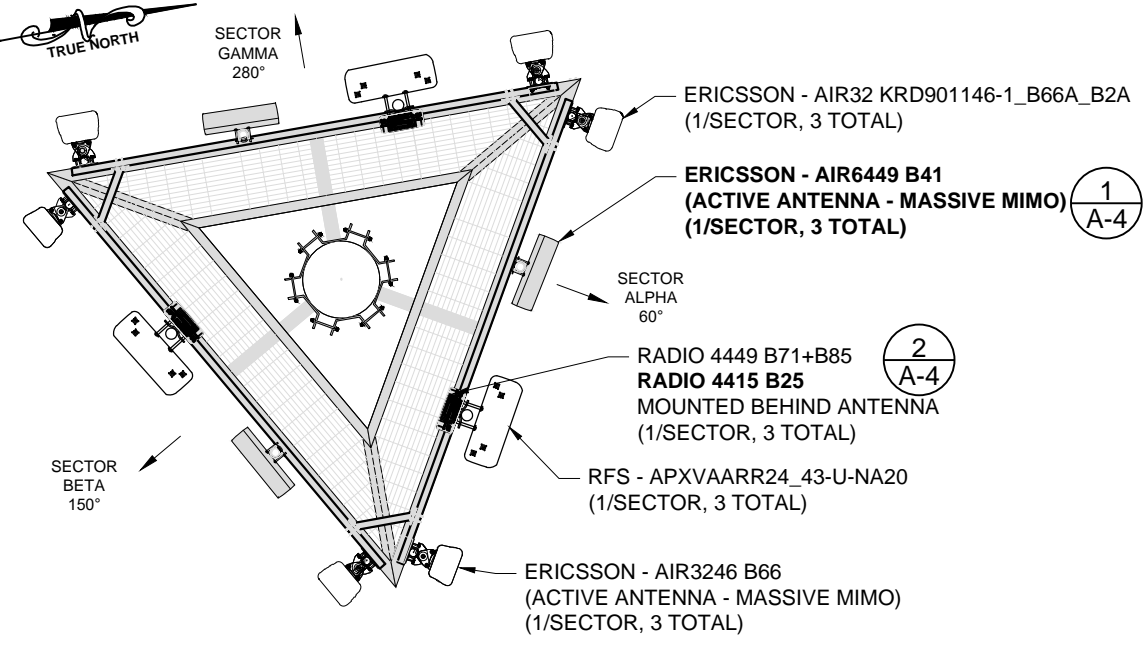

**FINAL ANTENNA PLAN** (3/A-2)  
SCALE: NTS

**SITE ELEVATION** (1/A-2)  
SCALE: 1"=20'

**APPLICANT:**  
**T-Mobile**  
**T-MOBILE NORTHEAST LLC**  
35 GRIFFIN ROAD SOUTH  
BLOOMFIELD, CT 06002  
860-692-7100

**PROJECT MANGER**  
**NSS NORTHEAST**  
SITE SOLUTIONS  
Turnkey Wireless Development  
420 MAIN STREET, BLDG 4  
STURBRIDGE, MA 01566  
203-275-6669

**CONSULTANT:**  
**FORESITE LLC**  
Architects . Engineers . Surveyors  
462 WALNUT STREET  
NEWTON, MA 02460  
617-212-3123



THIS DOCUMENT IS THE DESIGN PROPERTY AND COPYRIGHT OF FORESITE, LLC. AND FOR THE EXCLUSIVE USE BY THE TITLE CLIENT. DUPLICATION OR USE WITHOUT THE EXPRESS WRITTEN CONSENT OF THE CREATOR IS STRICTLY PROHIBITED. DRAWING SCALES ARE INTENDED FOR 11"x17" SIZE PRINTED MEDIA ONLY. ALL OTHER PRINTED SIZES ARE DEEMED "NOT TO SCALE".

REV	DESCRIPTION	DATE
A	PRELIMINARY	06/24/20
B	ADDED AT&T INFO	08/03/20
0	FINAL ISSUED	08/03/20
1	UPDATED PER NEW SA	03/08/21
2	REVISIONS- PER NEW SA	06/11/21
3	REVISIONS- CABLES	06/15/21

SITE NUMBER: CT11365D  
SITE NAME: CT365/Manchester PD\_MP  
SITE ADDRESS: 239 E. MIDDLE TPK  
MANCHESTER, CT 06040

SHEET TITLE:  
A-2: ELEVATION AND ANTENNA PLANS

Copyright © 2016 Foresite LLC all rights reserved. The details, templates, drawing formats or any portion of this document generated by Foresite LLC may not be duplicated, traced or used otherwise for any profit-driven enterprise.

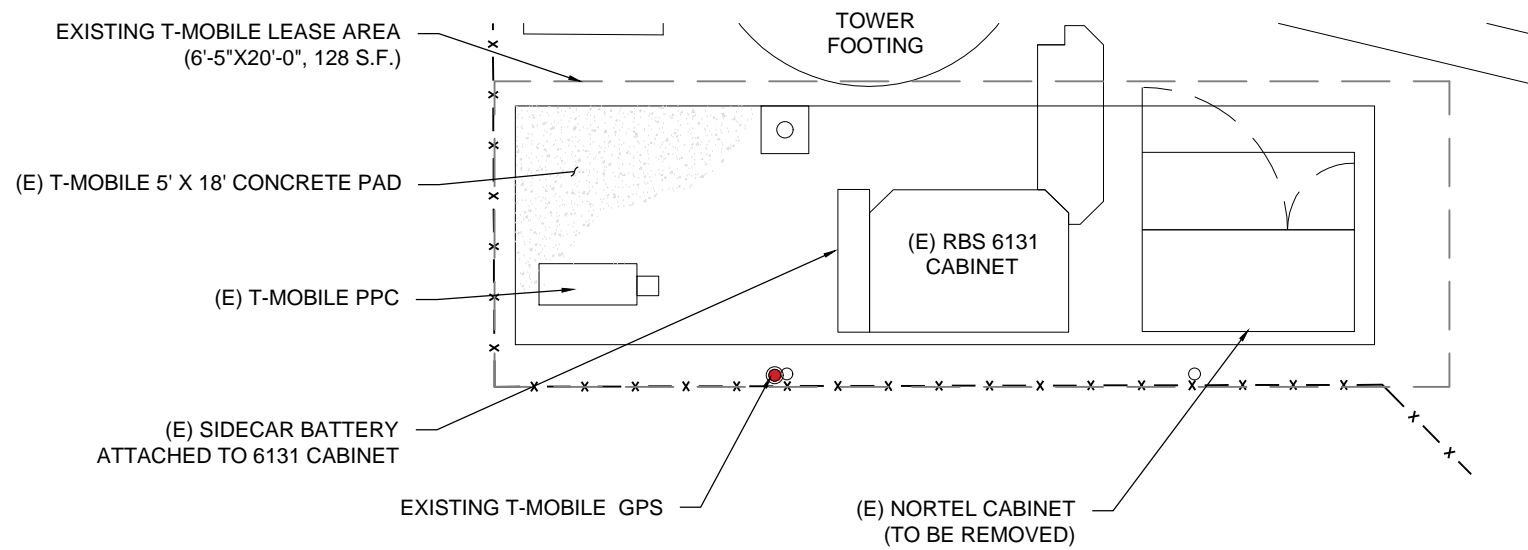

**EXISTING EQUIPMENT LAYOUT**

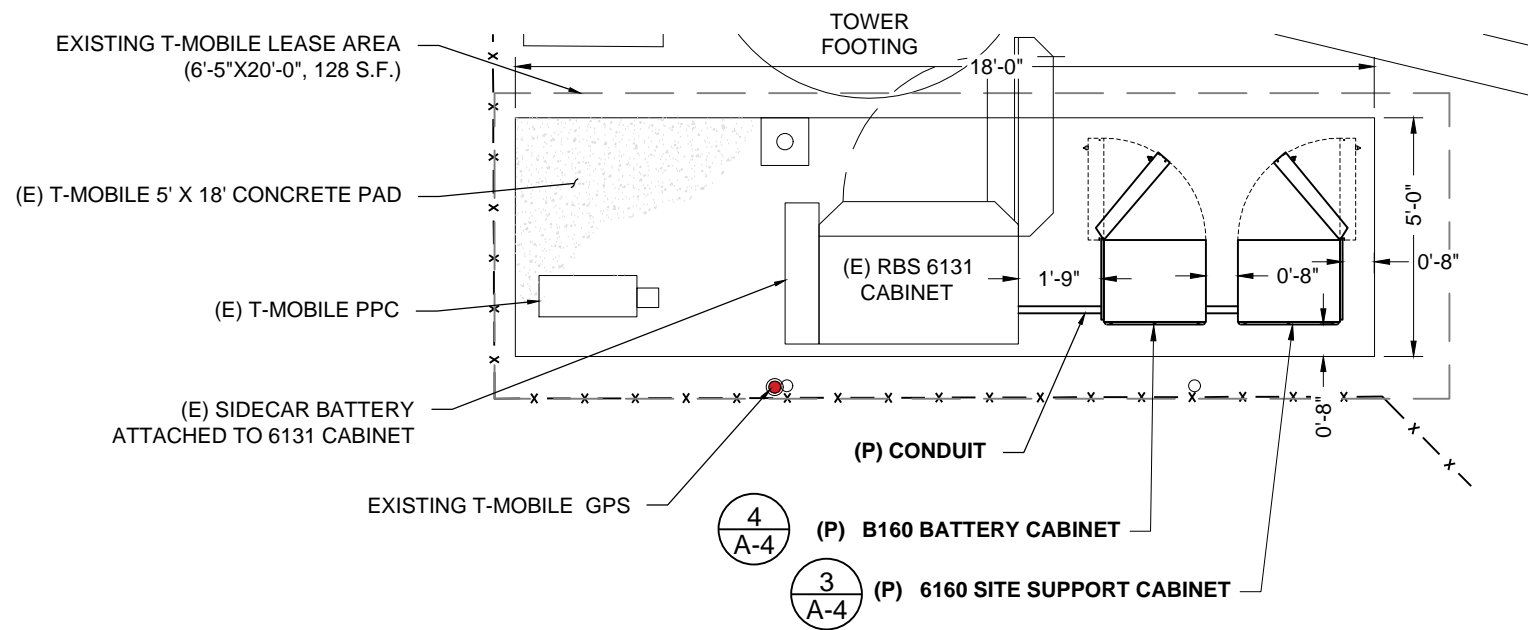

**FINAL EQUIPMENT LAYOUT**

**EQUIPMENT LAYOUT**  
**SCALE: 1"=4'**

1  
A-3

**APPLICANT:**  
**T-Mobile**  
**T-MOBILE NORTHEAST LLC**  
 35 GRIFFIN ROAD SOUTH  
 BLOOMFIELD, CT 06002  
 860-692-7100

**PROJECT MANGER**  
**NSS NORTHEAST**  
 SITE SOLUTIONS  
*Turnkey Wireless Development*  
 420 MAIN STREET, BLDG 4  
 STURBRIDGE, MA 01566  
 203-275-6669

**CONSULTANT:**  
**FORESITE LLC**  
 Architects . Engineers . Surveyors  
 462 WALNUT STREET  
 NEWTON, MA 02460  
 617-212-3123



THIS DOCUMENT IS THE DESIGN PROPERTY AND COPYRIGHT OF FORESITE, LLC. AND FOR THE EXCLUSIVE USE BY THE TITLE CLIENT. DUPLICATION OR USE WITHOUT THE EXPRESS WRITTEN CONSENT OF THE CREATOR IS STRICTLY PROHIBITED.  
 DRAWING SCALES ARE INTENDED FOR 11"x17" SIZE PRINTED MEDIA ONLY. ALL OTHER PRINTED SIZES ARE DEEMED "NOT TO SCALE".

REV	DESCRIPTION	DATE
A	PRELIMINARY	06/24/20
B	ADDED AT&T INFO	08/03/20
0	FINAL ISSUED	08/03/20
1	UPDATED PER NEW SA	03/08/21
2	REVISIONS- PER NEW SA	06/11/21
3	REVISIONS- CABLES	06/15/21

SITE NUMBER: CT11365D  
 SITE NAME: CT365/Manchester\_PD\_MP  
 SITE ADDRESS: 239 E. MIDDLE TPK  
 MANCHESTER, CT 06040

SHEET TITLE:  
**A-3: EQUIPMENT LAYOUT PLANS**

Copyright © 2016 Foresite LLC all rights reserved. The details, templates, drawing formats or any portion of this document generated by Foresite LLC may not be duplicated, traced or used otherwise for any profit-driven enterprise.

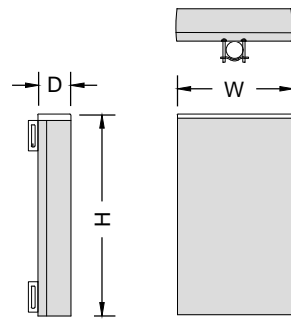

ERICSSON ANTENNA SPECIFICATIONS	
MODEL #	AIR6449 B41
MANUF.	ERICSSON
HEIGHT	33.1"
WIDTH	20.5"
DEPTH	8.3"
WEIGHT	103 LB

**ERICSSON ANTENNA** 1  
N.T.S. A-4

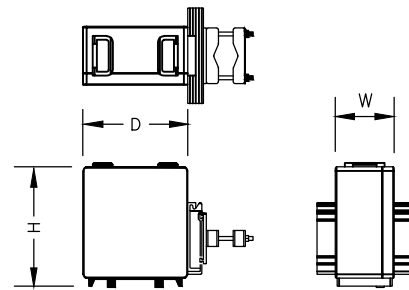

REMOTE RADIO UNIT SPECIFICATIONS	
MODEL #	RADIO 4415 B25
MANUF.	ERICSSON
HEIGHT	14.9"
WIDTH	13.2"
DEPTH	5.4"
WEIGHT	46.3 LB

**REMOTE RADIO UNIT** 2  
N.T.S. A-4

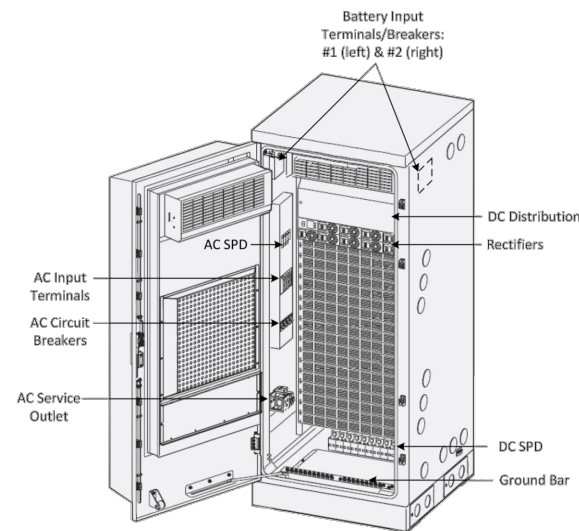

SITE SUPPORT CABINET SPECIFICATIONS	
MODEL #	6160
MANUF.	ERICSSON
HEIGHT	63"
WIDTH	25.6"
DEPTH	33.5"
WEIGHT	605 lbs

**SITE SUPPORT CABINET** 3  
N.T.S. A-4



BATTERY CABINET SPECIFICATIONS	
MODEL #	B160
MANUF.	ERICSSON
HEIGHT	63"
WIDTH	26"
DEPTH	26"
WEIGHT	1883 lbs

**BATTERY CABINET** 4  
N.T.S. A-4

**APPLICANT:**  
**T-Mobile**  
**T-MOBILE NORTHEAST LLC**

35 GRIFFIN ROAD SOUTH  
BLOOMFIELD, CT 06002  
860-692-7100

**PROJECT MANGER**  
**NSS NORTHEAST**  
SITE SOLUTIONS  
*Turnkey Wireless Development*  
420 MAIN STREET, BLDG 4  
STURBRIDGE, MA 01566  
203-275-6669

**CONSULTANT:**  
**FORESITE** LLC  
Architects . Engineers . Surveyors  
462 WALNUT STREET  
NEWTON, MA 02460  
617-212-3123

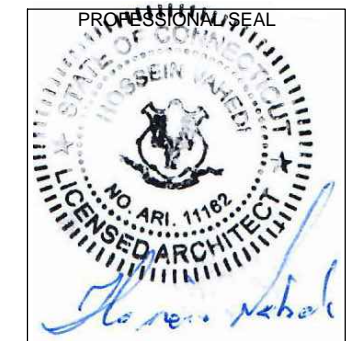

THIS DOCUMENT IS THE DESIGN PROPERTY AND COPYRIGHT OF FORESITE, LLC. AND FOR THE EXCLUSIVE USE BY THE TITLE CLIENT. DUPLICATION OR USE WITHOUT THE EXPRESS WRITTEN CONSENT OF THE CREATOR IS STRICTLY PROHIBITED. DRAWING SCALES ARE INTENDED FOR 11"x17" SIZE PRINTED MEDIA ONLY. ALL OTHER PRINTED SIZES ARE DEEMED "NOT TO SCALE".

REV	DESCRIPTION	DATE
A	PRELIMINARY	06/24/20
B	ADDED AT&T INFO	08/03/20
0	FINAL ISSUED	08/03/20
1	UPDATED PER NEW SA	03/08/21
2	REVISIONS- PER NEW SA	06/11/21
3	REVISIONS- CABLES	06/15/21

SITE NUMBER: CT11365D  
SITE NAME: CT365/Manchester PD\_MP  
SITE ADDRESS: 239 E. MIDDLE TPK  
MANCHESTER, CT 06040

SHEET TITLE:  
A-4: EQUIPMENT SPECIFICATIONS

Copyright © 2016 Foresite LLC all rights reserved. The details, templates, drawing formats or any portion of this document generated by Foresite LLC may not be duplicated, traced or used otherwise for any profit-driven enterprise.

**1.0 DESIGN INFORMATION AND GENERAL REQUIREMENTS**

**1.0 GENERAL**  
 ALL DIMENSIONS ARE APPROXIMATE, CONTRACTOR SHOULD VERIFY ALL DIMENSIONS BEFORE FABRICATION OF STEEL AND COMMENCEMENT OF WORK.

**1.1 CODES**  
 a. 2018 CONNECTICUT STATE BUILDING CODE (2015 IBC)  
 b. MINIMUM DESIGN LOADS FOR BUILDINGS AND OTHER STRUCTURES, ASCE/SEI 7-10, AMERICAN SOCIETY OF CIVIL ENGINEERS  
 c. STEEL CONSTRUCTION MANUAL, 14TH EDITION, AMERICAN INSTITUTE OF STEEL CONSTRUCTION  
 d. STRUCTURAL STANDARDS FOR ANTENNA SUPPORTING STRUCTURES, ANSI/TIA-222-G, TELECOMMUNICATIONS INDUSTRY ASSOCIATION

**1.2 LOADS AND DESIGN CRITERIA**  
 a. BASIC WIND SPEED (3-SECOND GUST): V: 97 MPH (ASD), EXPOSURE B, RISK CATEGORY II  
 b. EQUIPMENT AS LISTED IN MOUNT STRUCTURAL ANALYSIS REPORT - UPGRADE PREPARED BY EFI GLOBAL, INC, DATED 06/19/2020.

**1.3 NOTES**  
 a. PRIOR TO PURCHASE OR FABRICATION OF MATERIAL, THE CONTRACTOR SHALL PERFORM AN INSPECTION VERIFYING MEMBER AND BOLT SIZES. SHOULD THE CONTRACTOR DISCOVER ANY DAMAGED OR MISSING MEMBERS OR THE MEMBER OR BOLT SIZES DO NOT MATCH THOSE LISTED, EFI GLOBAL, INC, SHALL BE NOTIFIED IMMEDIATELY.  
 b. CONTRACTOR TO REPLACE ALL BOLTS REMOVED WITH NEW BOLTS OF SAME TYPE, UNLESS NOTED OTHERWISE.

**2.0 STRUCTURAL STEEL**

**2.1 MATERIALS**  
 a. STRUCTURAL STEEL . . . . . ASTM A992  
 MISC ANGLE & PLATE . . . . . ASTM A36  
 PIPE . . . . . ASTM A53 GR. B  
 RODS . . . . . ASTM A572-50 (MINIMUM)  
 HSS . . . . . ASTM A500, GR. B, Fy=46 KSI  
 b. BOLTS . . . . . ASTM A325 U.N.O.  
 c. WELDING ELECTRODES . . . . . AWS A5.1 (E70XX)  
 d. STEEL CONSTRUCTION SHALL CONFORM TO "SPECIFICATION FOR STRUCTURAL STEEL BUILDINGS, ANSI/AISC 360-16"  
 e. WELDING SHALL CONFORM TO AWS D1.1/D1.3/D1.7 AS APPLICABLE.  
 f. THE FABRICATOR SHALL FURNISH CHECKED SHOP AND ERECTION DRAWINGS TO THE ENGINEER, AND OBTAIN APPROVAL PRIOR TO FABRICATING ANY STRUCTURAL STEEL. SHOP DRAWINGS SHALL CONFORM TO "DETAILING FOR STEEL CONSTRUCTION, 2ND EDITION"  
 g. POOR MATCHING OF HOLES SHALL BE CORRECTED BY DRILLING TO THE NEXT LARGER SIZE. WELDING FOR REDRILLING WILL NOT BE PERMITTED.

**2.2 CONNECTIONS**  
 a. SHOP CONNECTIONS MAY BE BOLTED OR WELDED  
 b. CONNECTIONS WHERE THE BEAM SHEAR (V) IS NOT NOTED ON THE DRAWINGS, SIMPLE SHEAR CONNECTIONS SHALL BE DESIGNED TO DEVELOP 1/2 OF THE MAXIMUM TOTAL UNIFORM LOAD CAPACITY OF THE BEAM.  
 c. FIELD CONNECTIONS SHALL BE MADE WITH A325 BOLTS AND HARDENED WASHERS EXCEPT AS INDICATED ON THE DESIGN DRAWINGS  
 d. CONNECTIONS NOT SHOWN ON DRAWINGS SHALL BE DESIGNED BY THE STEEL FABRICATOR. CONNECTIONS SHALL BE DESIGNED IN ACCORDANCE WITH AISC "SPECIFICATIONS FOR STRUCTURAL JOINTS USING ASTM A325 OR A490 BOLTS" AND "AISC CODE OF STANDARD PRACTICE FOR STEEL BUILDINGS AND BRIDGES".  
 e. DO NOT FIELD CUT OR ALTER STRUCTURAL MEMBERS WITHOUT PRIOR WRITTEN APPROVAL OF ENGINEER.  
 f. BOLT HOLES SHALL BE CUT, DRILLED OR PUNCHED AT RIGHT ANGLES TO THE SURFACE OF THE METAL AND SHALL NOT BE MADE OR ENLARGED BY BURNING. HOLES SHALL BE CLEAN CUT WITHOUT TORN OR RAGGED EDGES. OUTSIDE BURRS RESULTING FROM DRILLING OR REAMING OPERATION SHALL BE REMOVED WITH A TOOL MAKING A 1/16 INCH BEVEL. BOLT HOLES SHALL BE 1/16 INCH OVERSIZE.

**2.3 FINISHES**  
 a. STRUCTURAL STEEL SHALL BE HOT DIP GALVANIZED AFTER FABRICATION PER ASTM A123  
 b. BOLTS AND NUTS SHALL BE HOT DIP GALVANIZED PER ASTM A153.  
 c. ALL SURFACES DAMAGED BY FIELD WELDING OR CUTTING SHALL BE PAINTED WITH COLD GALVANIZING COMPOUND TWICE. THE PAINT SHOULD BE AT LEAST 93% PURE ZINC. RUST-OLEUM PROFESSIONAL, (MODEL# 7585838) OR SIMILAR.

**2.4 WELDING**  
 a. CONTRACTOR TO TAKE ALL NECESSARY PRECAUTIONS FOR FIRE PREVENTION DURING WELDING, SUCH AS: INSTALLING 3000 (NFPA 701) FIRE BLANKET AROUND COAX. MORE SPATTER AND SPARKS SHOULD BE ANTICIPATED WHILE WELDING ON GALVANIZED SURFACE. COAX IS FLAMMABLE AND SHALL CATCH FIRE IF NOT PROTECTED. WATER SHALL BE ON SITE OF ADEQUATE AMOUNT AND AVAILABLE AT SHORT NOTICE AT ALL TIMES DURING WELDING ACTIVITY. CONTRACTOR SHOULD BE ABLE TO TRANSPORT THE WATER TO THE HEIGHT WELDING BEING PERFORMED.  
 b. WELDING ON GALVANIZED SURFACE SHOULD BE DONE WITH EXTREME CAUTION. IF THE WELD MATERIAL IS CONTAMINATED WITH ZINC, IT DOES NOT PROVIDE A STRUCTURAL WELD. GROUND GALVANIZING BEFORE WELDING.  
 c. WELDING CERTIFICATE MUST BE PROVIDED PRIOR TO WELDING. ALL WELDING SHALL BE PERFORMED BY AWS QUALIFIED WELDER WHO HAS EXPERIENCE WITH GALVANIZED SURFACES.

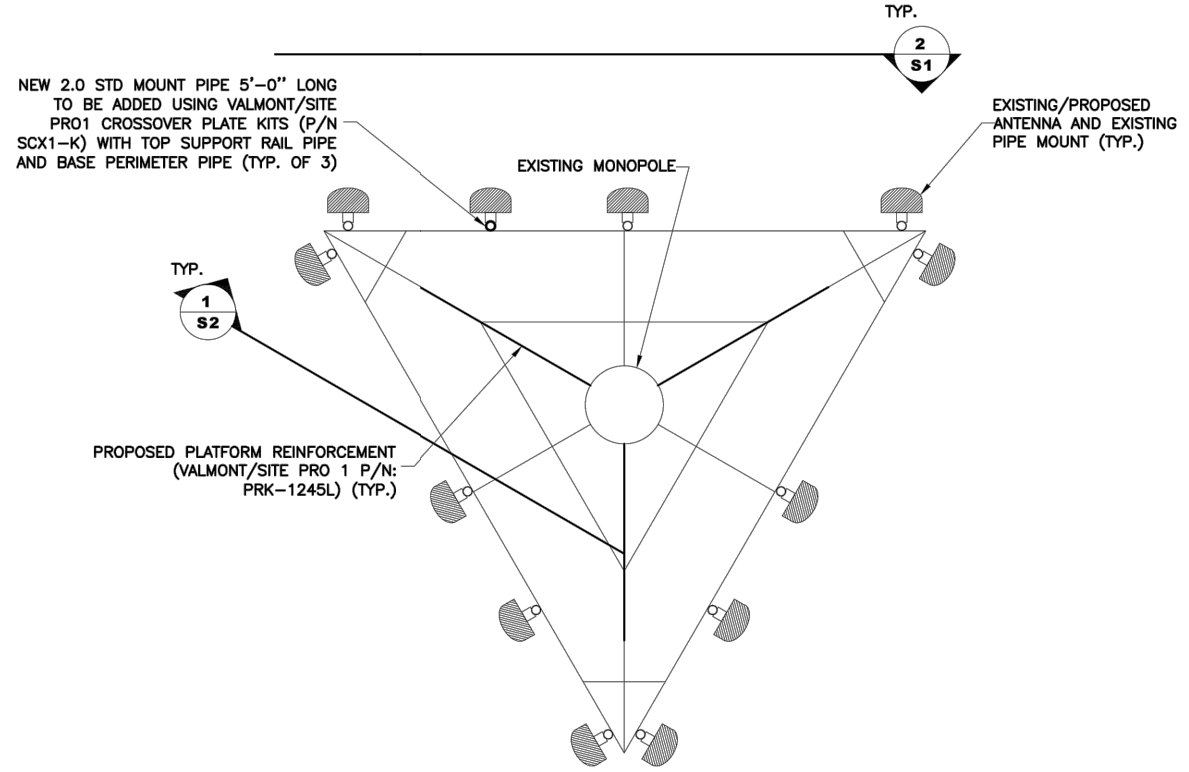

**1 PLATFORM MOUNT @ 163' PLAN**  
 1/4" = 1'-0"

**NOTE:**  
 - ADDITIONAL EQUIPMENT AND MOUNTING HARDWARE NOT SHOWN FOR CLARITY

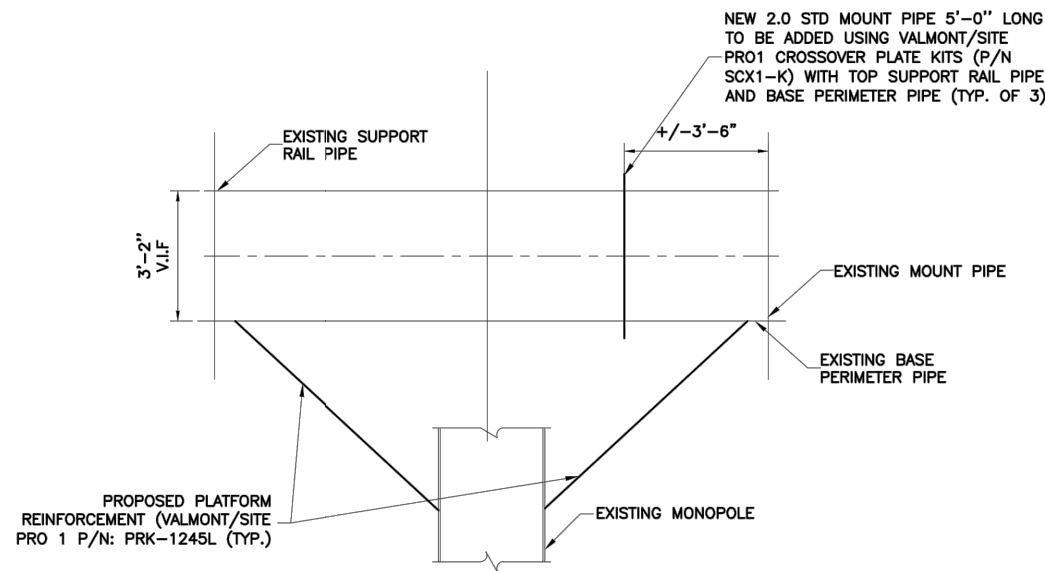

**2 PLATFORM MOUNT @ 163' ELEVATION**  
 N.T.S.

**NOTE:**  
 - ADDITIONAL EQUIPMENT AND MOUNTING HARDWARE NOT SHOWN FOR CLARITY

**APPLICANT:**  
**T-Mobile**  
**T-MOBILE NORTHEAST LLC**  
 35 GRIFFIN ROAD SOUTH  
 BLOOMFIELD, CT 06002  
 860-692-7100

**PROJECT MANGER**  
**NSS NORTHEAST**  
 SITE SOLUTIONS  
*Turnkey Wireless Development*  
 420 MAIN STREET, BLDG 4  
 STURBRIDGE, MA 01566  
 203-275-6669

**CONSULTANT:**  
**FORESITE** LLC  
 Architects . Engineers . Surveyors  
 462 WALNUT STREET  
 NEWTON, MA 02460  
 617-212-3123



THIS DOCUMENT IS THE DESIGN PROPERTY AND COPYRIGHT OF FORESITE, LLC, AND FOR THE EXCLUSIVE USE BY THE TITLE CLIENT. DUPLICATION OR USE WITHOUT THE EXPRESS WRITTEN CONSENT OF THE CREATOR IS STRICTLY PROHIBITED.  
 DRAWING SCALES ARE INTENDED FOR 11"x17" SIZE PRINTED MEDIA ONLY. ALL OTHER PRINTED SIZES ARE DEEMED "NOT TO SCALE".

REV	DESCRIPTION	DATE
A	PRELIMINARY	06/24/20
B	ADDED AT&T INFO	08/03/20
0	FINAL ISSUED	08/03/20
1	UPDATED PER NEW SA	03/08/21
2	REVISIONS- PER NEW SA	06/11/21
3	REVISIONS- CABLES	06/15/21

SITE NUMBER: CT11365D  
 SITE NAME: CT365/Manchester PD\_MP  
 SITE ADDRESS: 239 E. MIDDLE TPK  
 MANCHESTER, CT 06040

SHEET TITLE:  
**S-1: STRUCTURAL DETAILS**

Copyright © 2016 Foresite LLC all rights reserved. The details, templates, drawing formats or any portion of this document generated by Foresite LLC may not be duplicated, traced or used otherwise for any profit-driven enterprise.

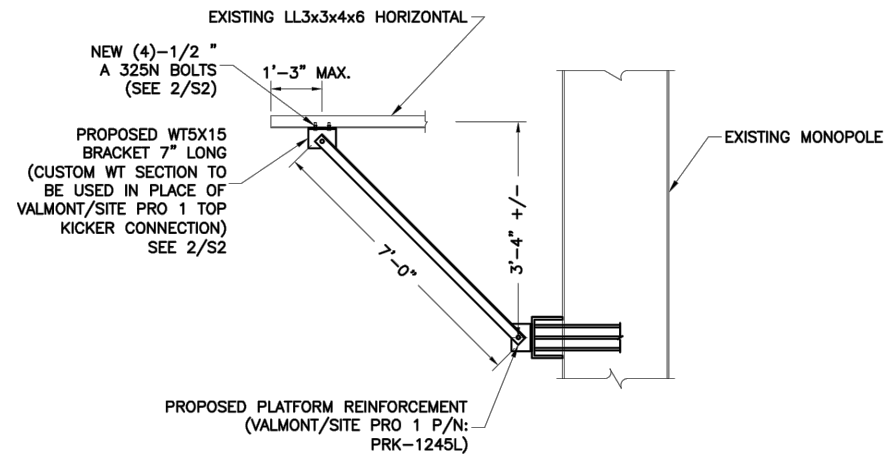

**1**  
**S2** **PLATFORM MOUNT KICKER CONNECTION**

1/4" = 1'-0"

**NOTE:**  
- ADDITIONAL EQUIPMENT AND MOUNTING HARDWARE NOT SHOWN FOR CLARITY

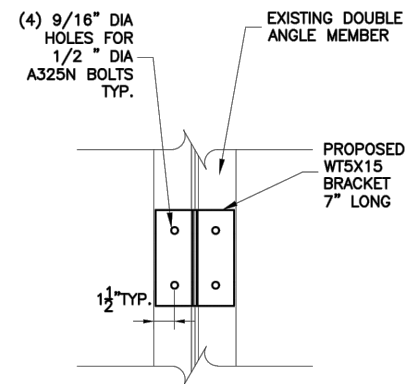
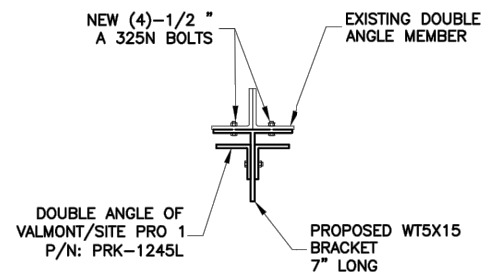

**2**  
**S2** **CONNECTION DETAIL**

1" = 1'-0"

**NOTE:**  
- MODIFICATIONS SHOULD BE DONE AT ALL SECTORS

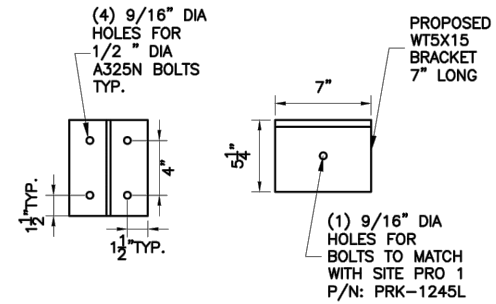

PROPOSED MODIFICATION TO BE INSTALLED AT ALL CORNERS.

**APPLICANT:**  
**T-Mobile**  
**T-MOBILE NORTHEAST LLC**  
35 GRIFFIN ROAD SOUTH  
BLOOMFIELD, CT 06002  
860-692-7100

**PROJECT MANGER**  
**NSS NORTHEAST**  
SITE SOLUTIONS  
*Turnkey Wireless Development*  
420 MAIN STREET, BLDG 4  
STURBRIDGE, MA 01566  
203-275-6669

**CONSULTANT:**  
**FORESITE** LLC  
Architects . Engineers . Surveyors  
462 WALNUT STREET  
NEWTON, MA 02460  
617-212-3123



THIS DOCUMENT IS THE DESIGN PROPERTY AND COPYRIGHT OF FORESITE, LLC. AND FOR THE EXCLUSIVE USE BY THE TITLE CLIENT. DUPLICATION OR USE WITHOUT THE EXPRESS WRITTEN CONSENT OF THE CREATOR IS STRICTLY PROHIBITED. DRAWING SCALES ARE INTENDED FOR 11"x17" SIZE PRINTED MEDIA ONLY. ALL OTHER PRINTED SIZES ARE DEEMED "NOT TO SCALE".

REV	DESCRIPTION	DATE
A	PRELIMINARY	06/24/20
B	ADDED AT&T INFO	08/03/20
0	FINAL ISSUED	08/03/20
1	UPDATED PER NEW SA	03/08/21
2	REVISIONS- PER NEW SA	06/11/21
3	REVISIONS- CABLES	06/15/21

SITE NUMBER: CT11365D  
SITE NAME: CT365/Manchester PD\_MP  
SITE ADDRESS: 239 E. MIDDLE TPK  
MANCHESTER, CT 06040

SHEET TITLE:  
**S-2: STRUCTURAL DETAILS**



Copyright © 2016 Foresite LLC all rights reserved. The details, templates, drawing formats or any portion of this document generated by Foresite LLC may not be duplicated, traced or used otherwise for any profit-driven enterprise.

**ELECTRICAL & GROUNDING NOTES**

1. ALL ELECTRICAL WORK SHALL CONFORM TO THE REQUIREMENTS OF THE NATIONAL ELECTRICAL CODE (NEC) AS WELL AS APPLICABLE STATE AND LOCAL CODES.
2. ALL ELECTRICAL ITEMS SHALL BE U.L. APPROVED OR LISTED AND PRODUCED PER SPECIFICATION REQUIREMENTS.
3. THE ELECTRICAL WORK INCLUDES ALL LABOR AND MATERIAL DESCRIBED BY DRAWINGS AND SPECIFICATION INCLUDING INCIDENTAL WORK TO PROVIDE COMPLETE OPERATING AND APPROVED ELECTRICAL SYSTEM.
4. GENERAL CONTRACTOR SHALL PAY FEES FOR PERMITS, AND RESPONSIBLE FOR OBTAINING SAID PERMITS AND COORDINATION OF INSPECTIONS.
5. ELECTRICAL AND TELCO WIRING OUTSIDE A BUILDING AND EXPOSED TO WEATHER SHALL BE IN WATER TIGHT GALVANIZED RIGID STEEL CONDUITS OR SCHEDULE 80 PVC (AS PERMITTED BY CODE) ND WHERE REQUIRED IN LIQUID TIGHT FLEXIBLE METAL OR NONMETALLIC CONDUITS.
6. RIGID STEEL CONDUITS SHALL BE GROUNDED AT BOTH ENDS.
7. ELECTRICAL WIRING SHALL BE COPPER WITH TYPE XHHW, THWN, OR THIN INSULATION.
8. RUN ELECTRICAL CONDUIT OR CABLING BETWEEN ELECTRICAL ROOM AND PROPOSED CELL SITE ARE PEDESTAL AS INDICATED ON THIS DRAWING. PROVIDE FULL LENGTH PULL ROPE. COORDINATE INSTALLATION WITH UTILITY COMPANY.
9. RUN TELCO CONDUIT OR CABLE BETWEEN TELEPHONE UTILITY DEMARCATION POINT AND PROPOSED CELL SITE TELECOM CABINET AND RBS CABINET AS INDICATED ON DRAWING A -1. PROVIDE FULL LENGTH PULL ROPE INSTALLED TELCO CONDUIT. PROVIDE GREENLEE CONDUIT MEASURING TAPE AT EACH END.
10. ALL EQUIPMENT LOCATED OUTSIDE SHALL HAVE NAME 3R ENCLOSURE.
11. GROUNDING SHALL COMPLY WITH NEC ART. 250.
12. GROUNDING COAX CABLE SHIELDS MINIMUM AT BOTH ENDS USING MANUFACTURERS COAX CABLE GROUNDING KITS SUPPLIED BY PROJECT OWNER.
13. USE #6 COPPER STRANDED WIRE WITH GREEN COLOR INSTALLATION FOR ABOVE GRADE GROUNDING (UNLESS OTHERWISE SPECIFIED) AND #2 SOLID TINNED BARE COPPER WIRE FOR BELOW GRADE GROUNDING AS INDICATED ON THE GROUND.
14. ALL GROUND CONNECTION TO BE BURNDY HYGROUND COMPRESSION TYPE CONNECTORS OR CADWELD EXOTHERMIC WELD. DO NOT ALLOW BARE COPPER WIRE TO BE IN CONTACT WITH GALVANIZED STEEL.
15. ROUTE GROUNDING CONDUCTORS ALONG THE SHORTEST AND STRAIGHTEST PATH POSSIBLE, EXCEPT AS OTHERWISE INDICATED. GROUNDING LEADS SHOULD NEVER BE BENT AS RIGHT ANGLE. ALWAYS MAKE AT LEAST 12" RADIUS BENDS. #6 WIRE CAN BE BENT AT 6" RADIUS WHEN NECESSARY BOND ANY METER OBJECTS WITHIN 7 FEET OF PROPOSED EQUIPMENT OR CABINET TO MASTER GROUND BAR.
16. CONNECTIONS TO MGB SHALL BE ARRANGED IN THREE MAIN GROUPS: SURGE PROCEDURES (COAXIAL CABLE GROUND KITS, TELCO AND POWER PANEL GROUND); (GROUNDING ELECTRODE RING OR BUILDING STEEL); NON-SURGING OBJECTS (EGB GROUND IN RBS UNIT).
17. CONNECTIONS TO GROUND BARS SHALL BE MADE WITH TWO HOLE COMPRESSION TYPE COPPER LUGS. APPLY OXIDE INHIBITING COMPOUND TO ALL LOCATIONS.
18. APPLY OXIDE INHIBITING COMPOUND TO ALL COMPRESSION TYPE GROUND CONNECTION.
19. BOND ANTENNA MOUNTING BRACKETS, COAXIAL CABLE GROUND KITS, AND ALNA TO EGB PLACED NEAR THE ANTENNA LOCATION.
20. BOND ANTENNA EGB'S AND MGB TO WATER MAIN.
21. TEST COMPLETED GROUND SYSTEM AND RECORD RESULTS FOR PROJECT CLOSE-OUT DOCUMENTATION.
22. BOND ANY METAL OBJECTS WITHIN 7 FEET OF PROPOSED EQUIPMENT OR CABINET TO MASTER GROUND BAR.
23. VERIFY PROPOSED SERVICE UPGRADE WITH LOCAL UTILITY COMPANY PRIOR TO CONSTRUCTION.

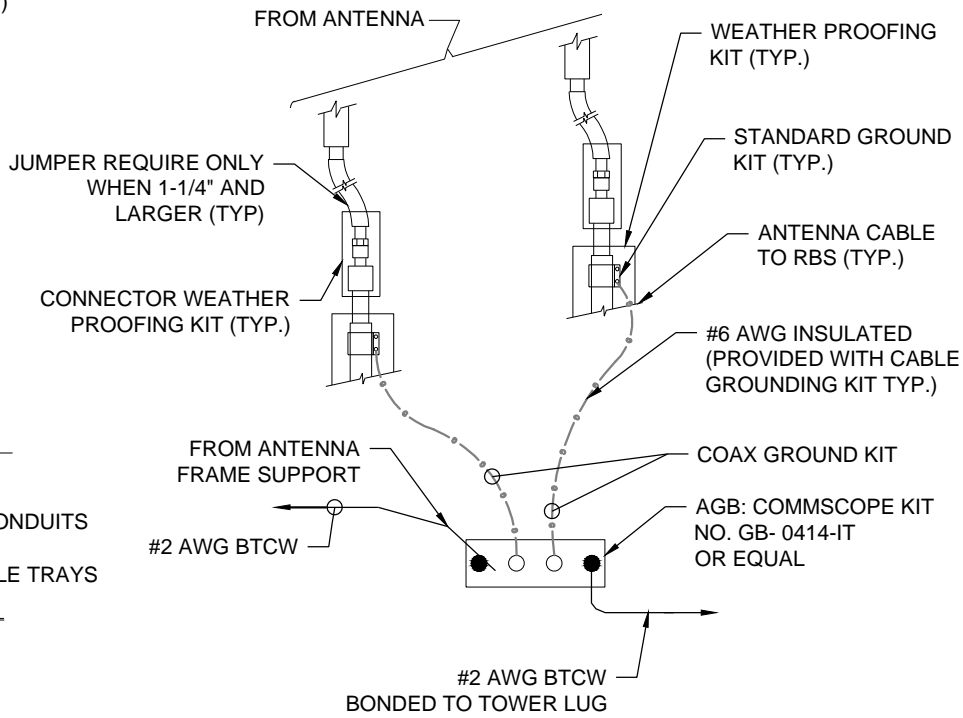
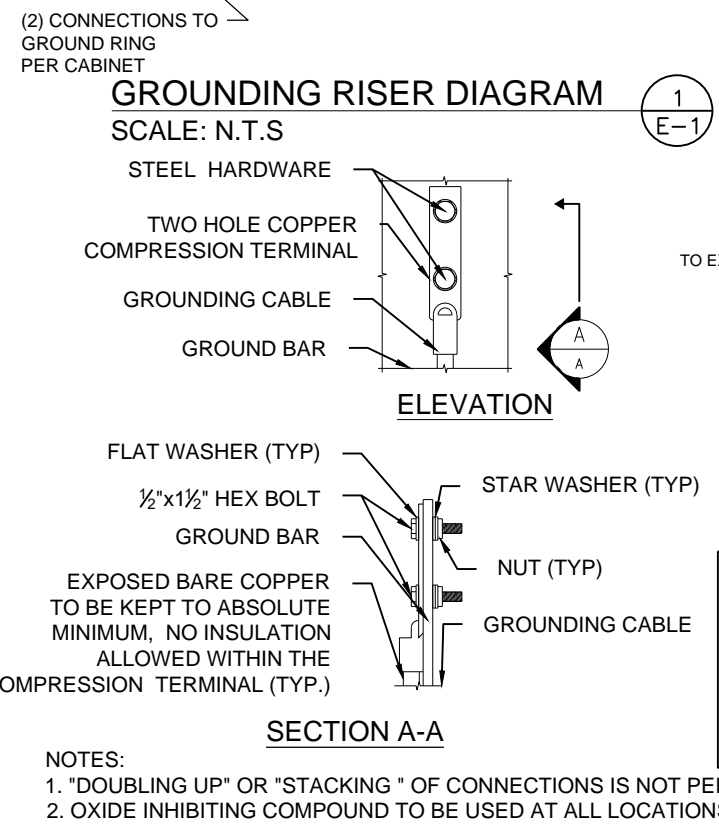
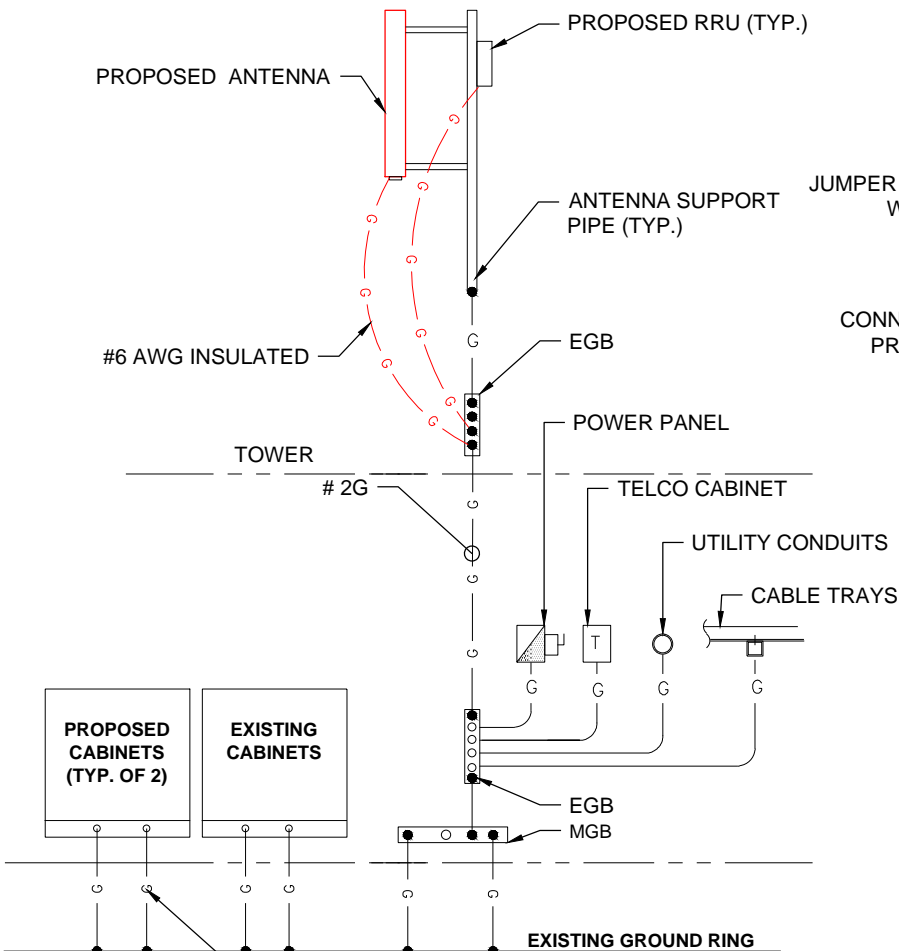

**NOTES:**  
INSTALL CABLE GROUND KIT ABOVE HORIZONTAL BEND AND ALWAYS DIRECT GROUND WIRE DOWN TO AGB/EGB

**TOWER TOP CABLE GROUNDING DETAIL**  
SCALE: N.T.S

**SPECIAL CONTRACTOR NOTES:**  
CONTRACTOR TO VERIFY THE POWER FEED & PHASE OF METER BANK AND THAT THE EXISTING AND PROPOSED CONDUITS AND WIRE SIZES ARE ADEQUATE FOR THE PROPOSED LOADING IN ACCORDANCE WITH NEC AND INCLUDE ELECTRICAL UPGRADES IN THE SCOPE OF WORK AS REQUIRED.

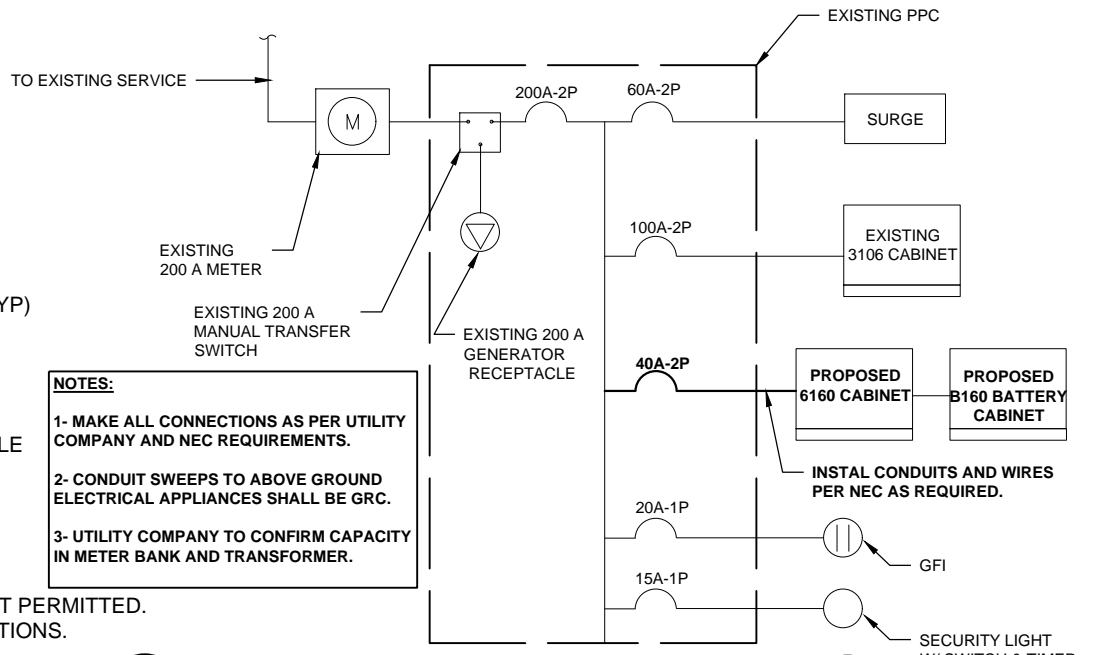

**NOTES:**  
1- MAKE ALL CONNECTIONS AS PER UTILITY COMPANY AND NEC REQUIREMENTS.  
2- CONDUIT SWEEPS TO ABOVE GROUND ELECTRICAL APPLIANCES SHALL BE GRC.  
3- UTILITY COMPANY TO CONFIRM CAPACITY IN METER BANK AND TRANSFORMER.

**APPLICANT:**  
**T-Mobile**  
**T-MOBILE NORTHEAST LLC**  
35 GRIFFIN ROAD SOUTH  
BLOOMFIELD, CT 06002  
860-692-7100

**PROJECT MANGER**  
**NSS NORTHEAST**  
SITE SOLUTIONS  
Turnkey Wireless Development  
420 MAIN STREET, BLDG 4  
STURBRIDGE, MA 01566  
203-275-6669

**CONSULTANT:**  
**FORESITE** LLC  
Architects . Engineers . Surveyors  
462 WALNUT STREET  
NEWTON, MA 02460  
617-212-3123

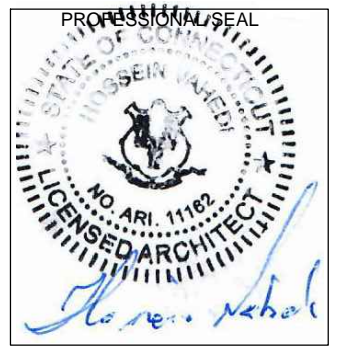

THIS DOCUMENT IS THE DESIGN PROPERTY AND COPYRIGHT OF FORESITE, LLC. AND FOR THE EXCLUSIVE USE BY THE TITLE CLIENT. DUPLICATION OR USE WITHOUT THE EXPRESS WRITTEN CONSENT OF THE CREATOR IS STRICTLY PROHIBITED. DRAWING SCALES ARE INTENDED FOR 11"x17" SIZE PRINTED MEDIA ONLY. ALL OTHER PRINTED SIZES ARE DEEMED "NOT TO SCALE".

REV	DESCRIPTION	DATE
A	PRELIMINARY	06/24/20
B	ADDED AT&T INFO	08/03/20
0	FINAL ISSUED	08/03/20
1	UPDATED PER NEW SA	03/08/21
2	REVISIONS- PER NEW SA	06/11/21
3	REVISIONS- CABLES	06/15/21

SITE NUMBER: CT11365D  
SITE NAME: CT365/Manchester PD\_MP  
SITE ADDRESS: 239 E. MIDDLE TPK  
MANCHESTER, CT 06040

SHEET TITLE:  
E-1: GROUNDING AND ELECTRICAL DETAILS

# Exhibit D

Prepared For:



**T-Mobile Northeast, LLC**  
**35 Griffin Road South**  
**Bloomfield, CT 06002**



**Structure Rating**

<b>Monopole:</b>	<b>Pass (94.4%)</b>
<b>Anchor Rods:</b>	<b>Pass (90.1%)</b>
<b>Base Plate:</b>	<b>Pass (92.2%)</b>
<b>Foundation</b>	<b>Pass (81.0%)</b>

Sincerely,  
EFI Global, Inc.  
License No: PEC0001429



Ahmet Colakoglu, PE  
Connecticut Professional Engineer  
License No: 27057

**T-Mobile Site ID: CT11365D**  
**T-Mobile Site Name: CT365/Manchester PD\_MP**  
**AT&T Site ID: CT5448**  
**AT&T Site Name: Manchester Central**  
**FA Location Code: 10071105**  
**239 E. Middle Tpk**  
**Manchester, CT 06040**

## **CONTENTS**

1.0 – SUBJECT AND REFERENCES

1.1 – STRUCTURE

2.0 – EXISTING AND PROPOSED APPURTENANCES

3.0 - CODES AND LOADING

4.0 - STANDARD CONDITIONS FOR ENGINEERING SERVICES ON EXISTING  
STRUCTURES

5.0 - ANALYSIS AND ASSUMPTIONS

6.0 – RESULTS AND CONCLUSION

APPENDIX

A - CALCULATIONS

B - MOUNT STRUCTURAL ANALYSIS REPORT – UPGRADE (DATED 06/19/2020)

## 1.0 SUBJECT AND REFERENCES

The purpose of this analysis is to evaluate the structural capacity of the wireless telecommunication installation on the existing monopole located at 239 East Middle Tpk, Manchester, CT 06040 for additions and alterations proposed by T-Mobile and AT&T.

The structural analysis is based on the following documentation provided to EFI Global, Inc. (EFI):

- RFDS provided by T-Mobile, dated 05/05/2020.
- Tower Mapping Report prepared by Hightower Solutions, Inc., dated 2/10/2021.
- ANSI/TIA-222-G-2005 Inspection Report prepared by Hightower Solutions, Inc., dated 2/10/2021.
- Structural Analysis Report prepared by Hudson Design Group, LLC., dated 12/10/2019.
- Construction Drawings prepared by Hudson Design Group, LLC, dated 10/28/2019.
- Structure and Foundation Design Calculations prepared by Engineered Endeavors Incorporated, dated 10/16/2002.

## 1.1 STRUCTURE

The structure is a 183 ft. (18) sided monopole, which is attached to the foundation with anchor bolts and a base plate. Please refer to the software output in Appendix A, for tower geometry, member sizes, and other details.

Section Length (ft)	Lap Splice (in)	Shaft Thickness (in)	Top Diameter (in)	Bottom Diameter (in)	Steel Yield Strength (ksi)
17.50	36.00	0.1875	15.50	19.42	65
36.42	46.00	0.2500	18.37	26.41	65
48.92	60.00	0.3750	25.06	35.88	65
49.08	74.00	0.4375	34.02	44.88	65
49.08	--	0.4375	42.64	53.50	65

**2.0 EXISTING AND PROPOSED APPURTENANCES**

**Existing Configuration of T-Mobile Appurtenances:**

<b>RAD CENTER (FT)</b>	<b>ANTENNA &amp; TMA</b>	<b>COAX*</b>	<b>MOUNT</b>
163	(3) AIR32 KRD901146-1_B66A_B2A (3) AIR3246 B66 (3) APXVAARR24_43-U-NA20 (3) KRY 112 144/2 (3) Radio 4449 B71+B12 (1) IBR 1300 radio	(16) 1-5/8" (1) 9x18 HSC (2) 6x12 HSC (2) 0.2"	(1) Platform w/ Handrail

**\*Feedlines located inside the monopole**

**Existing Configuration of AT&T Appurtenances:**

<b>RAD CENTER (FT)</b>	<b>ANTENNA &amp; TMA</b>	<b>COAX*</b>	<b>MOUNT</b>
145	(4) CCI OPA-65R-LCUU-H8 (2) CCI OPA-65R-LCUU-H6 (3) Kathrein 80010121 (6) LGP21401 TMA (6) LGP21901 Diplexers (3) RRUS 11 B12 (3) RRUS 32 B66A (3) RRUS 32 B30 (3) Radio 4478 B5 (2) DC6-48-60-18-8C (2) CCI HPA-65R-BUU-H8 (1) CCI HPA-65R-BUU-H6 (3) RRUS 32 B2	(6) 1-5/8" (4) DC Power Cables (2) Fiber Cables	(1) Platform w/ Handrails

**\*Feedlines located inside the monopole**

**Proposed and Final Configuration of T-Mobile Appurtenances:**

RAD CENTER (FT)	ANTENNA & TMA	COAX*	MOUNT
163	(3) AIR32 KRD901146-1_B66A_B2A*** (3) AIR6449 B41 (3) AIR3246 B66 (3) APXVAARR24_43-U-NA20*** (3) Radio 4449 B71+B85 (3) Radio 4415 B25	(16) 1-5/8" (5) 1-5/8"*** (1) 9x18 HSC (3) 6X12 HSC	(1) Platform w/ Handrail + Proposed Modifications

\*Feedlines located inside the monopole

\*\* Future feedline entitlement considered in analysis.

\*\*\* Reduced wind area considered per CFD analysis.

**Proposed and Final Configuration of AT&T Appurtenances:**

RAD CENTER (FT)	ANTENNA & TMA	COAX*	MOUNT
145	(4) CCI OPA-65R-LCUU-H8*** (2) CCI OPA-65R-LCUU-H6*** (3) Kathrein 80010121*** (6) LGP21401 TMA (6) LGP21901 Diplexers (3) RRUS 11 B12 (3) RRUS 32 B66A (3) RRUS 32 B30 (3) Radio 4478 B5 (2) DC6-48-60-18-8C (1) NNH4-65B-R6*** (2) NNH4-65C-R6*** (3) RRUS E2 B29 (3) RRUS 12 B2 (3) Radio 4478 B14 (3) A2 Modules (2) DC6-48-60-0-8C-EV	(6) 1-5/8" (8) DC Power Cables (2) Fiber Cables	(1) Platform w/ Handrails

\*Feedlines located inside the monopole

\*\*\* Reduced wind area considered per CFD analysis.

**Existing Appurtenances by Others:**

CARRIER	RAD CENTER (FT)	ANTENNA & TMA	COAX*	MOUNT
Unknown	195.75	(1) Lightning Rod	(4) 7/8" (1) 1/2" (2) 0.32"	(1) Low Profile Platform
	194.25	(2) 12' Dipole		
	189.5	(2) HPD2-18RS (2' Dish) (2) 9" x 9" x 3.5" TMA		
	172.25	(2) 12' Dipole		
Sprint	158.5	(6) RRH1900-4x45 (1) Junction Box	(4) 1-1/4" (2) 2.42" Flex Conduit**	(1) Ring Mount
		(3) RRH8x20 (3) RRH2x50-800		
Unknown	156	(3) RFS APXVTM14*** (3) RFS APXVSP18***	(2) 0.2" (1) 1/2"*** (2) 1/2"***	(1) Low Profile Platform
	153.83	(1) Motorola MTI1669		
	151.5	(1) VHLP2-23-DW1 (2' Dish)		
Unknown	150.5	(1) 3' Dish (1) VHLP2-18-DW1 (2' Dish)	(7) 1/2"	(1) Low Profile Platform
	132.08	(1) 15' Whip		
	129.42	(1) 5'-6" Whip		
	128.5	(1) Yagi		
	128.17	(1) 20' Dipole		
	125.08	(1) Yagi		
Verizon	115.42	(2) RRFDC-3315-PF-48	(2) 1-1/4"***	(1) Low Profile Platform
	113	(6) HBXX-6517DS-A2M*** (6) LNX-6514DS-A1M*** (3) B25 RRH 4x30 (3) B13 RRH4x30 (3) B4 RRH2x60-4R		
Unknown	51.75	(1) GPS (1) 12" x 2.5" x 1.5" TMA	(1) 1/2" (2) 0.2"	(1) Stand Off Mount

**\*All feedlines are inside shaft unless otherwise noted**

**\*\*Outside Shaft**

**\*\*\* Reduced wind area considered per CFD analysis.**



### 3.0 CODES AND LOADING

The tower was analyzed per *ANSI/TIA-222-G* as referenced by the *2018 Connecticut State Building Code* with all of the adopted Addendums and Supplements. The following wind loading was used in compliance with the standard for Manchester, CT:

- Basic wind speed 105 mph without ice ( $W_0$ )
- Basic wind speed 50 mph with 1" escalating ice ( $W_i$ )
- Exposure Category B
- Topographic Category 1
- Structure Class III

The following load combinations were used with wind blowing at 0°, 30°, 45°, 60°, and 90° measured from a line normal to the face of the tower.

- $1.2 D + 1.6 W_0$
- $0.9 D + 1.6 W_0$
- $1.2 D + 1.0 D_i + 1.0 W_i$

D: Dead Load of structure and appurtenances

$W_0$ : Wind Load, without ice

$W_i$ : Wind Load, with ice

$D_i$ : Weight of Ice

### 4.0 STANDARD CONDITIONS FOR ENGINEERING SERVICES ON EXISTING STRUCTURES

The analysis is based on the information provided to EFI and is assumed to be current and correct. Unless otherwise noted, the structure and the foundation system are assumed to be in good condition, free of defects and can achieve theoretical strength.

It is assumed that the structure has been maintained and shall be maintained during its service. The superstructure and the foundation system are assumed to be designed with proper engineering practice and fabricated, constructed and erected in accordance with the design documents. EFI will accept no liability which may arise due to any existing deficiency in design, material, fabrication, erection, construction, etc. or lack of maintenance.

The analysis does not include a qualification of the mounts attached on the structure or their connections. The analysis is performed to verify the capacity of the main structural members, which is the current practice in the tower industry.

The analysis results presented in this report are only applicable for the previously mentioned existing and proposed additions and alterations. Any deviation of the proposed equipment and placement, etc., will require EFI to generate an additional structural analysis.

## 5.0 **ANALYSIS AND ASSUMPTIONS**

The Monopole was analyzed by utilizing tnxTower, a non-linear, three-dimensional, finite element-analysis software package, a product of Tower Numerics, Inc. Software output for this analysis is provided in Appendix A of this report.

The structural monopole shaft reinforcement modifications shown in the referenced Tower Mapping Report prepared by Hightower Solutions, Inc., dated 2/10/2021, have been incorporated into our analysis. After analyzing the upgraded structure, EFI has deemed the modifications to be ineffective due to weak compressive capacity in the reinforcement plates. The added wind area of the reinforcement has been considered in this analysis.

## 6.0 **RESULTS AND CONCLUSION**

Based on structural analysis per TIA-222-G, the existing monopole is found to have **adequate** structural capacity for the proposed changes by T-Mobile and AT&T. For the code specified load combinations and as a maximum, the monopole shaft is stressed to **94.4%** of its structural capacity. The anchor rods and base plate are stressed to **90.1%** and **92.2%** of their structural capacities, respectively.

The existing base foundation is found to have **adequate** structural capacity for the proposed changes by T-Mobile and AT&T. For the code specified load combinations and as a maximum, the foundation is stressed to **81.0%** of its structural capacity.

Therefore, the proposed additions and alterations by T-Mobile and AT&T **can** be implemented as intended with the conditions outlined in this report.

Should you have any questions about this report, please contact EFI at [telecom@efiglobal.com](mailto:telecom@efiglobal.com).

**APPENDIX A  
CALCULATIONS**

# Panel Antennas

## TIA Design Wind Force on Appurtenances

Per section 2.6.11.2 of TIA-222-H

$$F_A = q_z G_h (EPA)_A$$

$$(EPA)_A = K_a[(EPA)_N \cos^2(\theta) + (EPA)_T \sin^2(\theta)]$$

$$(EPA)_N = \sum(C_a A_a)_N$$

$$(EPA)_T = \sum(C_a A_a)_T$$



# Panel Antennas

## TIA Design Wind Force on Appurtenances

Per section 2.6.11.2 of TIA-222-H, in the absence of more accurate data, EPAs consist of flat and round components

- Panel Antennas are considered to be flat,  $C_a$  = force coefficient from table 2-9,  $A_a$ =projected area
- Antenna manufacturers typically design antennas to be aerodynamic
  - Wind tunnel testing
  - Whitepapers
  - Evidence points to wind load reductions from TIA prescribed values

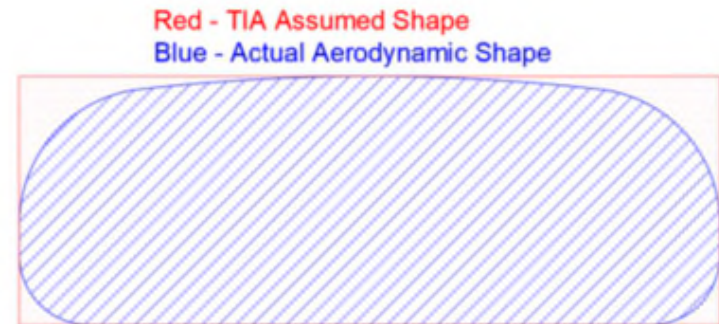

# TIA response regarding Computational Fluid Dynamics (CFD)

## FAQ TIA-222

### Question:

*Can I use loading that is less than the values prescribed by the written TIA-222-G and claim compliance with the standard? If so, under what conditions?*

### Answer:

*The standard provides force coefficients for basic appurtenance shapes as provided in Table 2-8 and for generic microwave antennas as provided in Annex C. **Antennas and other discrete appurtenances with complex shapes may be idealized by the simple shapes provided in the standard or may be determined using Wind Tunnel testing, CFD computations or other rational methods that may result in lower force coefficients.** TIA-222-G specifically provides standard prescribed methods to calculate the Effective Projected Area of combinations of appurtenances commonly used for antennas supporting structures. These methods include the many factors not easily taken into consideration in design such as shielding, dynamic loads, etc. The intent of the Standard is not to allow the use of other methods that result in less loading than these prescribed methods.*

# Antenna Manufacturer Information

## Specification Sheets

Wind Load values differ in wind speed

How are the load values determined?

Wind Load (@100mph), Front / Side / Rear	842N / 421.0N / 842N (189.4lbf / 94.7lbf / 189.4lbf)
--	--

Wind Loading, maximum

1791.0 N @ 150 km/h

402.6 lbf @ 150 km/h

Wind Speed, maximum

241 km/h | 150 mph

Frontal, lateral, and rear wind loading @ 150 km/h, lbf (N)	208 (925), 98 (435), 212 (943)
---	--------------------------------

# Software Decision

## CFD Software

- ANSYS
- Reviewed additionally:
  - Autodesk Robot
  - Solidworks Flow

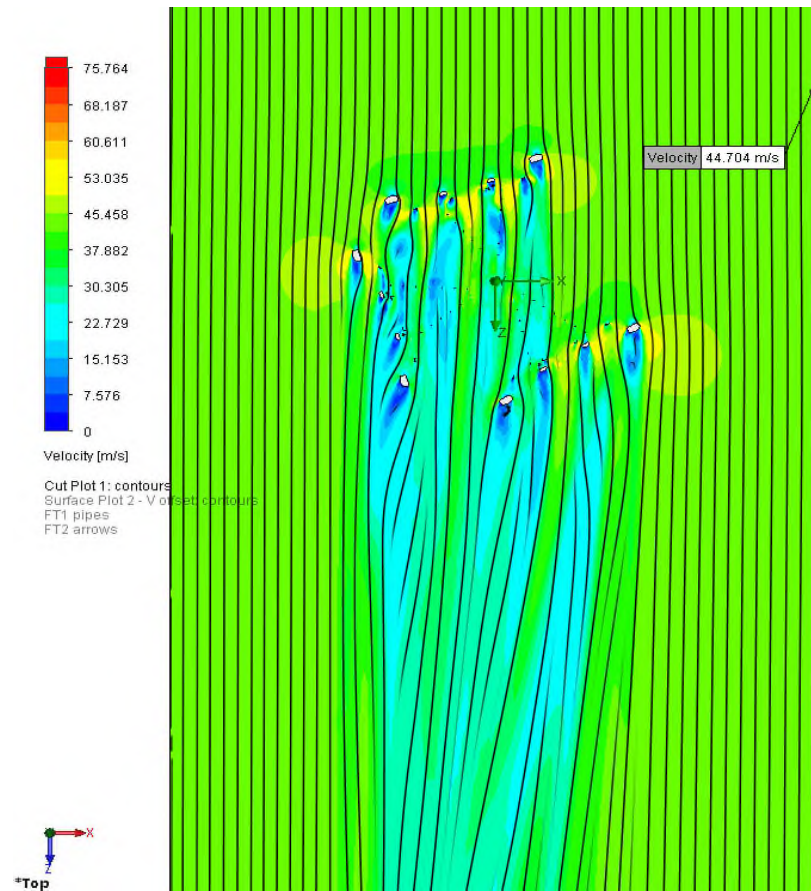



# CFD Process

## CFD Benchmarking

- Software within ANSYS – CFX vs. Fluent (using version 19.2 currently)
- Compared CFX results to known wind tunnel testing results
- Enclosure Dimensions – wind tunnel and real world
- Fluid model
- Reviewed antenna tilt
- 0-180 degree wind directions simulated
- Adjustment factor
- Antenna with mount pipe

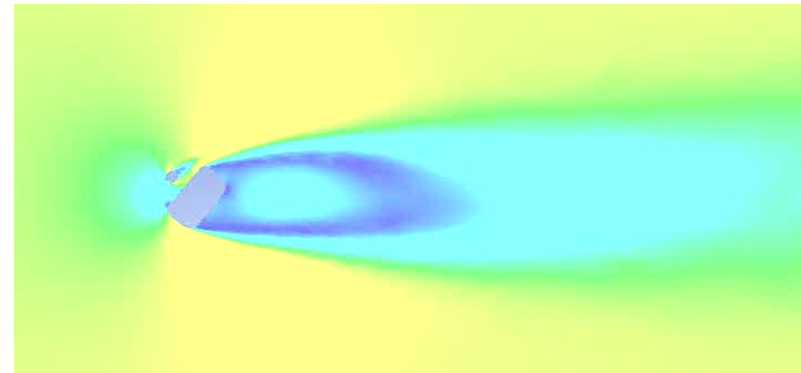

# CFD Process

## CFD Procedure/Software

- Obtain additional dimensional information from Antenna Manufacturer (3D file, 2D cross section file, 2D drawing with radius of curvature details)

Software	Description
ANSYS SpaceClaim	Software used for refining antenna model geometry
ANSYS Workbench	Software used to manage CFD analysis process
ANSYS Meshing	Software used to create meshes within the enclosures
ANSYS CFX	Software used to perform the CFD analysis
ANSYS CFD-Post	Software used to view results from ANSYS CFX
Crown CFD EPA Calculator	Supplemental tool used to analyze CFX data, generate EPA graphs, and determine antenna EPA values

# CFD Process

## EPA Tool

Import From CSV    Generate Report

Engineer Information	
Prepared By:	
Checked By:	
Engineer of Record:	
EOR Title:	Project Engineer

Antenna Information	
Manufacturer:	Commscope
Model:	SBNH-1D65658
Height (in):	72.7
Width (in):	11.9
Depth (in):	7.1
Weight (lbs):	47.4

Pipe Information	
Diameter (in):	2.375
Thickness (in):	0.154
Length (in):	84.7

Parameters	
Windspeed (mph):	90
Calibration Factor:	1.1

Total Projected Area		
degree	Antenna w/ MP (ft <sup>2</sup> )	Antenna (ft <sup>2</sup> )
0	6.27	6.07
90	5.04	3.64

CFD Results		
Degree	Antenna w/ MP Force (lb)	Antenna Force (lb)
0	58	60
10		
20	65	63
30	63	58
40	56	49
50	51	43
60		
70		
80		
90	30	20
100		
110		
120		
130	58	47
140	63	54
150	66	60
160	71	69
170		
180		

## CFD EPA Calculator

Configuration	Results															
	C <sub>d</sub> A <sub>Front</sub> (ft <sup>2</sup> )								C <sub>d</sub> A <sub>Side</sub> (ft <sup>2</sup> )							
Ice Thickness	0	0.5	1	2	4	0	0.5	1	2	4	0	0.5	1	2	4	
Antenna	4.16	4.57	4.98	5.85	7.69	2.49	2.88	3.27	4.09	5.84	47.40	97.91	154.55	287.03	634.20	
Antenna w/ MP	4.09	4.49	4.89	5.71	7.47	3.30	3.68	4.06	4.87	6.59	73.21	136.26	210.15	391.86	900.68	

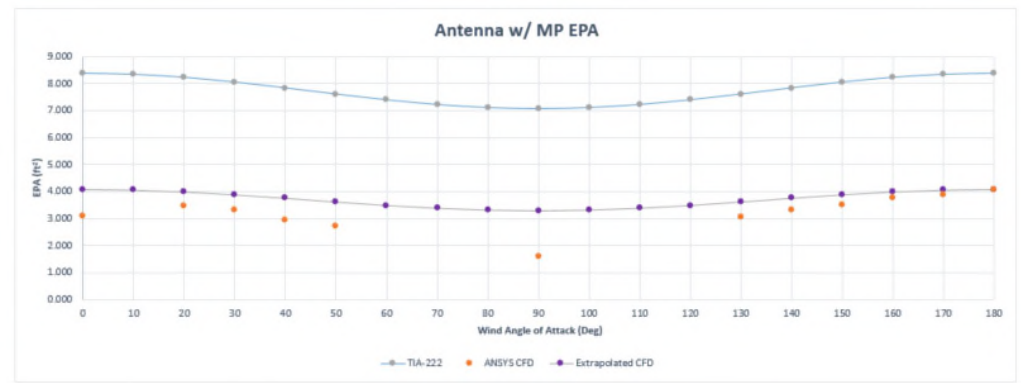
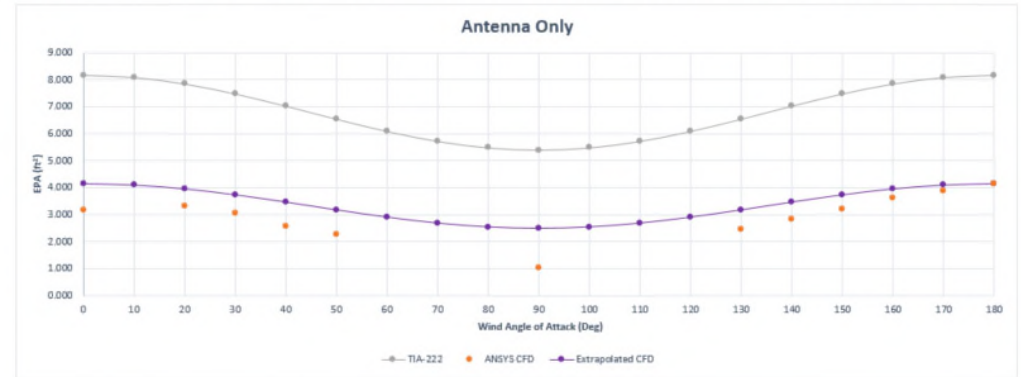

# CFD Process

- EPA Tool
- TIA-222 and tnx  $\rightarrow (EPA)_A = K_a [(EPA)_N \cos^2(\theta) + (EPA)_T \sin^2(\theta)]$
  - Extrapolate CFD results to follow the TIA trigonometric formula

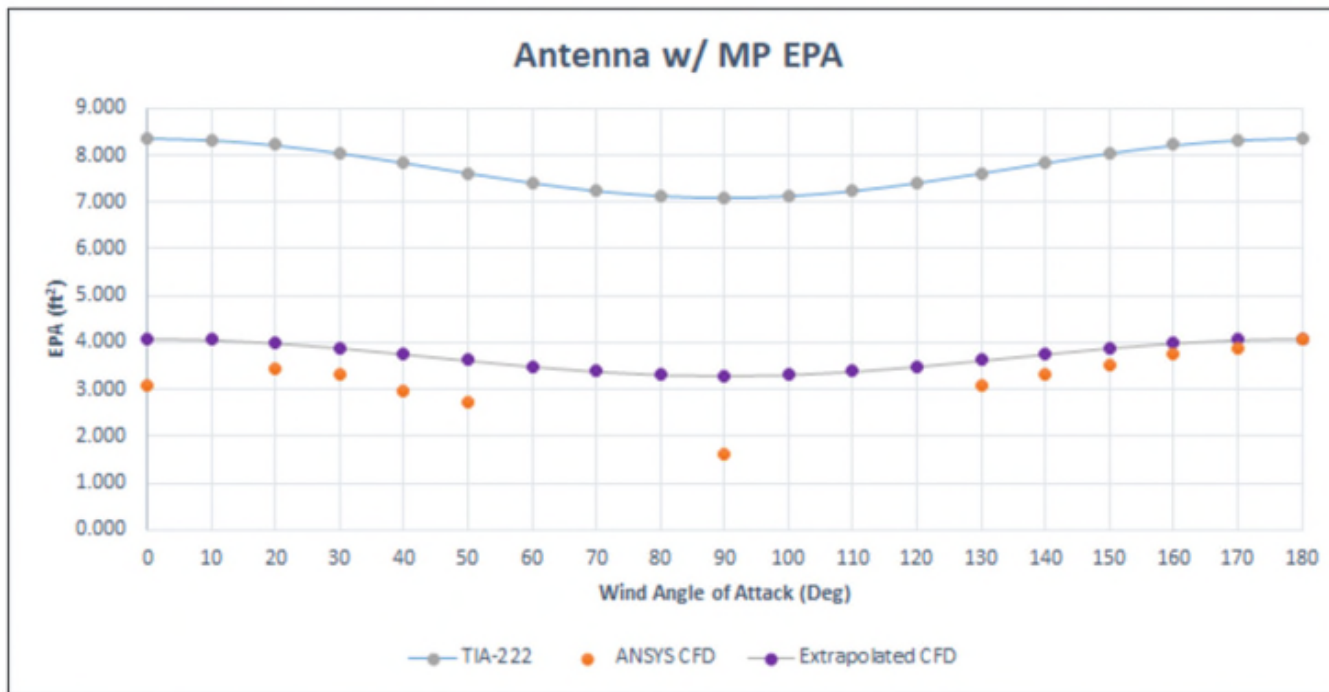

# CFD Process

## EPA Tool

- $EPA_A \text{ curve} = K_a * [(EPA)_N \cos^2(\theta) + (EPA)_T \sin^2(\theta)]$

*TIA-222 section 2.6.11.2*

- $PA \text{ curve} = [(PA)_N \cos^2(\theta) + (PA)_T \sin^2(\theta)]$

*created from PAs at 0° and 90°*

- $ANSYS \text{ CFD EPA} = CFDDragforce / (.00256 * V^2)$

*ANSYS CFD EPA points are back calculated from CFDDragforce values using the force equation from TIA-222 2.6.11.2*

- $Extrapolation \text{ factor}(EF) = ANSYS \text{ CFD EPA} / PA$

*determined at all degrees a CFD point exists*

- $Extrapolated \text{ CFD EPA curve} = MaxEF * [(PA)_N \cos^2(\theta) + (PA)_T \sin^2(\theta)]$

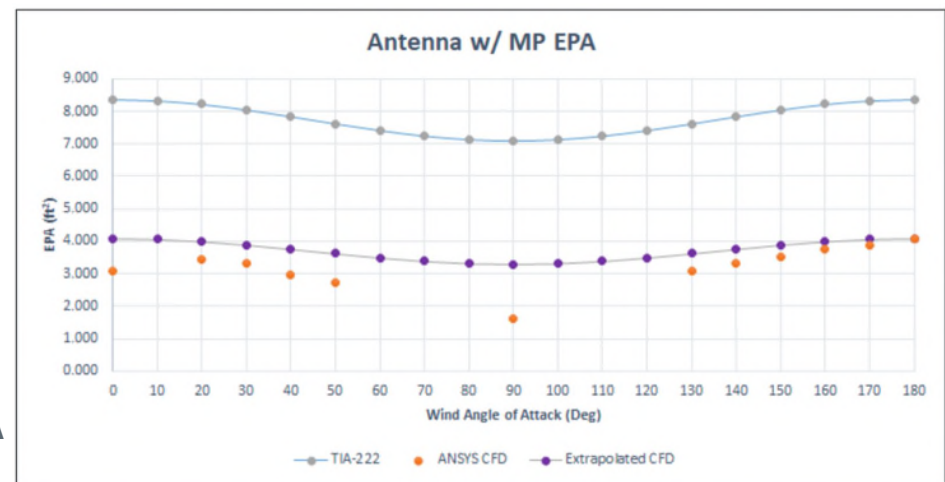

# CFD Process Report

Date: 3/11/2019

Subject: Computational Fluid Dynamics Analysis Report

Antenna Manufacturer: Commscope  
 Model Number: SBNH-1D6565B  
 Antenna Height: 72.7 in.  
 Antenna Width: 11.9 in.  
 Antenna Depth: 7.1 in.

Based on our analysis, using the procedure outlined in ENG-PRC-10367 Antenna EPA Determination using Computational Fluid Dynamics, we have determined the EPA and weight of the antenna to be the following values:

Table 1 – Antenna EPA for tnxTower Input

	C <sub>d</sub> A <sub>s</sub> Front (ft <sup>2</sup> )					C <sub>d</sub> A <sub>s</sub> Side (ft <sup>2</sup> )				
	No Ice	1/2" Ice	1" Ice	2" Ice	4" Ice	No Ice	1/2" Ice	1" Ice	2" Ice	4" Ice
Antenna	4.16	4.57	4.98	5.85	7.69	2.49	2.88	3.27	4.09	5.84
Antenna with Mount Pipe	4.09	4.49	4.89	5.71	7.47	3.3	3.68	4.06	4.87	6.59

Table 2 – Antenna Weight for tnxTower Input

	Weight (lbs)				
	No Ice	1/2" Ice	1" Ice	2" Ice	4" Ice
Antenna	47.4	97.91	154.55	287.03	634.2
Antenna with Mount Pipe	73.21	136.26	210.15	391.86	900.68

CFD analysis prepared by: \_\_\_\_\_

Respectfully Submitted by: \_\_\_\_\_

CFD Analysis of Antenna EPA  
 Commscope SBNH-1D6565B

3/11/2019  
 Page 2

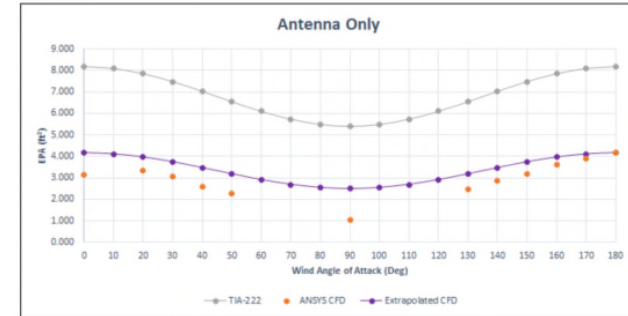

Figure 1 – EPA Graph for Antenna

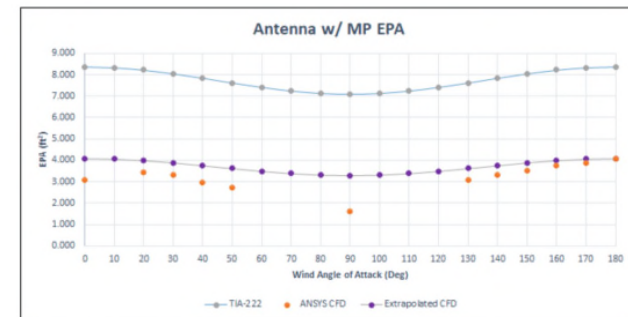

Figure 2 – EPA Graph for Antenna with Mount Pipe

# tnxTower Input

- tnxTower Database will need updated with new EPA values
- Proposing to update the existing antenna model number entry with the new EPA , and create a new entry corresponding to the TIA calculated EPA and tag with“\_TIA” at the end

**Table 1 – Antenna EPA for tnxTower Input**

	C <sub>a</sub> A <sub>a</sub> Front (ft <sup>2</sup> )					C <sub>a</sub> A <sub>a</sub> Side (ft <sup>2</sup> )				
	No Ice	1/2" Ice	1" Ice	2" Ice	4" Ice	No Ice	1/2" Ice	1" Ice	2" Ice	4" Ice
Antenna	4.16	4.57	4.98	5.85	7.69	2.49	2.88	3.27	4.09	5.84
Antenna with Mount Pipe	4.09	4.49	4.89	5.71	7.47	3.3	3.68	4.06	4.87	6.59

## DESIGNED APPURTENANCE LOADING

TYPE	ELEVATION	TYPE	ELEVATION
Lightning Rod w/ Pipe Extension	189.75	RRUS 32 B30	145
HPD2-18RS	189.5	RRUS 32 B30	145
HPD2-18RS	189.5	RRUS 32 B30	145
24' 4-Bay Dipole	184	DC6-48-60-18-8C	145
9" x 9" x 3.5" TMA	184	DC6-48-60-18-8C	145
9" x 9" x 3.5" TMA	184	RRUS 11 B12	145
14' Low Profile Platform	184	RRUS 11 B12	145
24' 4-Bay Dipole	184	RRUS 11 B12	145
AIR 32 B2a/B66Aa w/ Mount Pipe	163	RRUS 4478 B5	145
Ericsson AIR6449 B41 w/ Mount Pipe	163	RRUS 4478 B5	145
Ericsson AIR6449 B41 w/ Mount Pipe	163	RRUS 4478 B5	145
Ericsson AIR6449 B41 w/ Mount Pipe	163	RRUS 4478 B5	145
Ericsson AIR6449 B41 w/ Mount Pipe	163	RRUS 4478 B5	145
AIR 3246 B66 w/ Mount Pipe	163	RRUS 4478 B5	145
AIR 3246 B66 w/ Mount Pipe	163	RRUS 4478 B5	145
APXVAARR24_43-U-NA20 w/ Mount Pipe	163	RRUS 4478 B5	145
APXVAARR24_43-U-NA20 w/ Mount Pipe	163	RRUS 4478 B5	145
APXVAARR24_43-U-NA20 w/ Mount Pipe	163	RRUS 4478 B5	145
APXVAARR24_43-U-NA20 w/ Mount Pipe	163	RRUS 4478 B5	145
APXVAARR24_43-U-NA20 w/ Mount Pipe	163	RRUS 4478 B5	145
APXVAARR24_43-U-NA20 w/ Mount Pipe	163	RRUS 4478 B5	145
Radio 4449 B71+B85_T-Mobile	163	RRUS 4478 B14	145
Radio 4449 B71+B85_T-Mobile	163	RRUS 4478 B14	145
Radio 4449 B71+B85_T-Mobile	163	RRUS 4478 B14	145
RRUS 4415 B25	163	RRU A2	145
RRUS 4415 B25	163	RRU A2	145
RRUS 4415 B25	163	RRU A2	145
Platform Mount [LP 1201-1_HR-1]	163	DC6-48-60-0-8C	145
Site Pro 1 (P/N: PRK-1245L)	163	DC6-48-60-0-8C	145
AIR 32 B2a/B66Aa w/ Mount Pipe	163	Platform Mount [LP 301-1_KCKR]	145
AIR 32 B2a/B66Aa w/ Mount Pipe	163	800 10121	145
Ring Mount	159	800 10121	145
APXVTM14-C-120 w/ Mount Pipe	154	(2) OPA-65R-LCUU-H6	145
APXVTM14-C-120 w/ Mount Pipe	154	800 10121	145
APXVTM14-C-120 w/ Mount Pipe	154	(2) OPA-65R-LCUU-H8	145
RRH2X50-800	154	15' Whip	132.08
RRH2X50-800	154	5'-6" Whip	129.42
RRH2X50-800	154	24" Yagi	128.5
TD-RRH8x20	154	20' 4-Bay Dipole	128.17
TD-RRH8x20	154	15" Yagi	125.08
TD-RRH8x20	154	13' Low Profile Platform	123
TD-RRH8x20	154	26" Yagi	121.75
(2) PCS 1900MHz 4x45W-65MHz	154	(2) HBXX-6517DS-A2M w/ Mount Pipe	111
(2) PCS 1900MHz 4x45W-65MHz	154	RRFDC-3315-PF-48	111
(2) PCS 1900MHz 4x45W-65MHz	154	RRFDC-3315-PF-48	111
18" x 18" x 6.5" Junction Box	154	B25 RRH4X30	111
13' Low Profile Platform	154	B25 RRH4X30	111
APXVSP18-C w/ Mount Pipe	154	B25 RRH4X30	111
APXVSP18-C w/ Mount Pipe	154	B13 RRH 4X30	111
APXVSP18-C w/ Mount Pipe	154	B13 RRH 4X30	111
MTI1669	153.83	B13 RRH 4X30	111
Andrew VHLP2-23	151.5	B4 RRH2X60-4R	111
3' Dish w/ Randome	150.5	B4 RRH2X60-4R	111
Andrew VHLP2-18	150.5	B4 RRH2X60-4R	111
(2) OPA-65R-LCUU-H8	145	RMQP 12' Platform w/ handrails	111
(2) LGP21401	145	(2) LNX-6514DS-A1M w/ Mount Pipe	111
(2) LGP21401	145	(2) HBXX-6517DS-A2M w/ Mount Pipe	111
(2) LGP21401	145	(2) HBXX-6517DS-A2M w/ Mount Pipe	111
(2) LGP21901	145	(2) LNX-6514DS-A1M w/ Mount Pipe	111
(2) LGP21901	145	(2) LNX-6514DS-A1M w/ Mount Pipe	111
(2) LGP21901	145	(2) LNX-6514DS-A1M w/ Mount Pipe	111
RRUS 32 B66	145	12" x 2.5" x 1.5" TMA	51.75
RRUS 32 B66	145	3' Side Mount Standoff	51.75
RRUS 32 B66	145	GPS	51.75

### MATERIAL STRENGTH

GRADE	Fy	Fu	GRADE	Fy	Fu
A572-65	65 ksi	80 ksi			

### TOWER DESIGN NOTES

1. Tower is located in Hartford County, Connecticut.
2. Tower designed for Exposure B to the TIA-222-G Standard.
3. Tower designed for a 105 mph basic wind in accordance with the TIA-222-G Standard.
4. Tower is also designed for a 50 mph basic wind with 1.00 in ice. Ice is considered to increase in thickness with height.
5. Deflections are based upon a 60 mph wind.
6. Tower Structure Class III.
7. Topographic Category 1 with Crest Height of 0.0000 ft
8. TOWER RATING: 94.4%

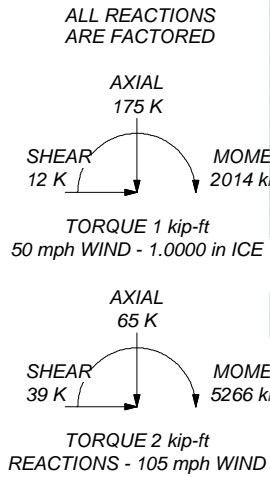

Section	Length (ft)	Number of Sides	Thickness (in)	Socket Length (ft)	Top Dia (in)	Bot Dia (in)	Grade	Weight (K)
1	17.5000	18	0.1875	3.0000	15.5000	19.4200		0.6
2	36.4200	18	0.2500	3.8300	18.3730	26.4100		2.2
3	48.9200	18	0.3750	5.0000	25.0648	35.8800	A572-65	6.0
4	49.0800	18	0.4375	6.1700	34.0246	44.8800		9.0
5	49.0800	18	0.4375	42.6403	53.5000			11.0
								28.8

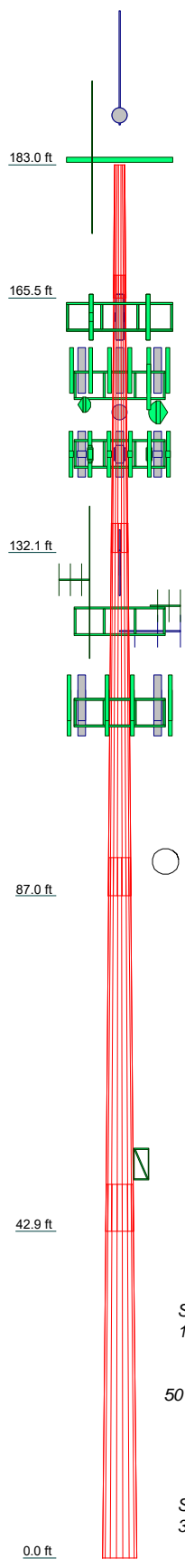

**EFI Global, Inc.**  
1117 Perimeter Center West, Suite E500  
Atlanta, GA 30338  
Phone: (470) 990-6593  
FAX:

Job: <b>CT11365D</b>		
Project: <b>049.00421 - 2075019</b>		
Client: <b>Foresite LLC</b>	Drawn by: <b>Evan.Martin</b>	App'd:
Code: <b>TIA-222-G</b>	Date: <b>04/21/21</b>	Scale: <b>NTS</b>
Path:		Dwg No. <b>E-1</b>



<b>tnxTower</b>  <b>EFI Global, Inc.</b> 1117 Perimeter Center West, Suite E500 Atlanta, GA 30338 Phone: (470) 990-6593 FAX:	<b>Job</b> CT11365D	<b>Page</b> 1 of 34
	<b>Project</b> 049.00421 - 2075019	<b>Date</b> 14:16:25 04/21/21
	<b>Client</b> Foresite LLC	<b>Designed by</b> Evan.Martin

## Tower Input Data

The tower is a monopole.

This tower is designed using the TIA-222-G standard.

The following design criteria apply:

- Tower is located in Hartford County, Connecticut.
- ASCE 7-10 Wind Data is used (wind speeds converted to nominal values).
- Basic wind speed of 105 mph.
- Structure Class III.
- Exposure Category B.
- Topographic Category 1.
- Crest Height 0.0000 ft.
- Nominal ice thickness of 1.0000 in.
- Ice thickness is considered to increase with height.
- Ice density of 56.00 pcf.
- A wind speed of 50 mph is used in combination with ice.
- Temperature drop of 50 °F.
- Deflections calculated using a wind speed of 60 mph.
- A non-linear (P-delta) analysis was used.
- Pressures are calculated at each section.
- Stress ratio used in pole design is 1.
- Local bending stresses due to climbing loads, feed line supports, and appurtenance mounts are not considered.

## Options

- |  |   |   |
|--|---|---|
| <ul style="list-style-type: none"> <li>Consider Moments - Legs</li> <li>Consider Moments - Horizontals</li> <li>Consider Moments - Diagonals</li> <li>Use Moment Magnification</li> <li>√ Use Code Stress Ratios</li> <li>√ Use Code Safety Factors - Guys</li> <li>Escalate Ice</li> <li>Always Use Max Kz</li> <li>Use Special Wind Profile</li> <li>Include Bolts In Member Capacity</li> <li>Leg Bolts Are At Top Of Section</li> <li>Secondary Horizontal Braces Leg</li> <li>Use Diamond Inner Bracing (4 Sided)</li> <li>SR Members Have Cut Ends</li> <li>SR Members Are Concentric</li> </ul> | <ul style="list-style-type: none"> <li>Distribute Leg Loads As Uniform</li> <li>Assume Legs Pinned</li> <li>√ Assume Rigid Index Plate</li> <li>√ Use Clear Spans For Wind Area</li> <li>Use Clear Spans For KL/r</li> <li>Retension Guys To Initial Tension</li> <li>√ Bypass Mast Stability Checks</li> <li>√ Use Azimuth Dish Coefficients</li> <li>√ Project Wind Area of Appurt.</li> <li>Autocalc Torque Arm Areas</li> <li>Add IBC .6D+W Combination</li> <li>Sort Capacity Reports By Component</li> <li>Triangulate Diamond Inner Bracing</li> <li>Treat Feed Line Bundles As Cylinder</li> <li>Ignore KL/ry For 60 Deg. Angle Legs</li> </ul> | <ul style="list-style-type: none"> <li>Use ASCE 10 X-Brace Ly Rules</li> <li>Calculate Redundant Bracing Forces</li> <li>Ignore Redundant Members in FEA</li> <li>SR Leg Bolts Resist Compression</li> <li>All Leg Panels Have Same Allowable</li> <li>Offset Girt At Foundation</li> <li>√ Consider Feed Line Torque</li> <li>Include Angle Block Shear Check</li> <li>Use TIA-222-G Bracing Resist. Exemption</li> <li>Use TIA-222-G Tension Splice Exemption</li> <li style="text-align: center;">Poles</li> <li>√ Include Shear-Torsion Interaction</li> <li>Always Use Sub-Critical Flow</li> <li>Use Top Mounted Sockets</li> <li>Pole Without Linear Attachments</li> <li>Pole With Shroud Or No Appurtenances</li> <li>Outside and Inside Corner Radii Are Known</li> </ul> |
|--|---|---|

## Tapered Pole Section Geometry

Section	Elevation	Section Length	Splice Length	Number of Sides	Top Diameter	Bottom Diameter	Wall Thickness	Bend Radius	Pole Grade
	ft	ft	ft		in	in	in	in	

<b>tnxTower</b>  <b>EFI Global, Inc.</b> 1117 Perimeter Center West, Suite E500 Atlanta, GA 30338 Phone: (470) 990-6593 FAX:	<b>Job</b> CT11365D	<b>Page</b> 2 of 34
	<b>Project</b> 049.00421 - 2075019	<b>Date</b> 14:16:25 04/21/21
	<b>Client</b> Foresite LLC	<b>Designed by</b> Evan.Martin

Section	Elevation ft	Section Length ft	Splice Length ft	Number of Sides	Top Diameter in	Bottom Diameter in	Wall Thickness in	Bend Radius in	Pole Grade
L1	183.0000-165.5000	17.5000	3.00	18	15.5000	19.4200	0.1875	0.7500	A572-65 (65 ksi)
L2	165.5000-132.8000	36.4200	3.83	18	18.3730	26.4100	0.2500	1.0000	A572-65 (65 ksi)
L3	132.0800-86.9900	48.9200	5.00	18	25.0648	35.8800	0.3750	1.5000	A572-65 (65 ksi)
L4	86.9900-42.9100	49.0800	6.17	18	34.0246	44.8800	0.4375	1.7500	A572-65 (65 ksi)
L5	42.9100-0.0000	49.0800		18	42.6403	53.5000	0.4375	1.7500	A572-65 (65 ksi)

### Tapered Pole Properties

Section	Tip Dia. in	Area in <sup>2</sup>	I in <sup>4</sup>	r in	C in	I/C in <sup>3</sup>	J in <sup>4</sup>	It/Q in <sup>2</sup>	w in	w/t
L1	15.7102	9.1129	269.9504	5.4359	7.8740	34.2838	540.2560	4.5573	2.3980	12.789
	19.6907	11.4457	534.8757	6.8275	9.8654	54.2176	1070.4552	5.7240	3.0879	16.469
L2	19.2901	14.3806	596.7256	6.4337	9.3335	63.9339	1194.2363	7.1917	2.7936	11.175
	26.7789	20.7580	1794.7237	9.2868	13.4163	133.7721	3591.8090	10.3810	4.2082	16.833
L3	26.2534	29.3870	2263.2318	8.7649	12.7329	177.7464	4529.4417	14.6963	3.7514	10.004
	36.3757	42.2598	6730.4514	12.6043	18.2270	369.2564	13469.7589	21.1339	5.6549	15.08
L4	35.6049	46.6399	6647.2213	11.9234	17.2845	384.5770	13303.1892	23.3244	5.2183	11.928
	45.5049	61.7140	15399.8990	15.7771	22.7990	675.4626	30820.0616	30.8628	7.1289	16.295
L5	44.6169	58.6039	13187.0389	14.9820	21.6613	608.7836	26391.4297	29.3075	6.7347	15.394
	54.2578	73.6839	26211.1184	18.8372	27.1780	964.4241	52456.7261	36.8490	8.6460	19.762

Tower Elevation ft	Gusset Area (per face) ft <sup>2</sup>	Gusset Thickness in	Gusset Grade	Adjust. Factor A <sub>f</sub>	Adjust. Factor A <sub>r</sub>	Weight Mult.	Double Angle Stitch Bolt Spacing Diagonals in	Double Angle Stitch Bolt Spacing Horizontals in	Double Angle Stitch Bolt Spacing Redundants in
L1 183.0000-165.5000				1	1	1			
L2 165.5000-132.8000				1	1	1			
L3 132.0800-86.9900				1	1	1			
L4 86.9900-42.9100				1	1	1			
L5 42.9100-0.0000				1	1	1			

### Feed Line/Linear Appurtenances - Entered As Round Or Flat

<b>tnxTower</b>  <b>EFI Global, Inc.</b> 1117 Perimeter Center West, Suite E500 Atlanta, GA 30338 Phone: (470) 990-6593 FAX:	<b>Job</b>	CT11365D	<b>Page</b>	3 of 34
	<b>Project</b>	049.00421 - 2075019	<b>Date</b>	14:16:25 04/21/21
	<b>Client</b>	Foresite LLC	<b>Designed by</b>	Evan.Martin

Description	Sector	Exclude From Torque Calculation	Component Type	Placement ft	Total Number	Number Per Row	Start/End Position	Width or Diameter in	Perimeter in	Weight klf
LDF4P-50A(1/2")	A	No	Surface Ar (CaAa)	156.0000 - 5.0000	3	3	0.000 0.000	0.6300		0.00
2-1/2"	A	No	Surface Ar (CaAa)	156.0000 - 5.0000	2	2	0.000 0.000	2.3800		0.00
***										
LDF7-50A(1-5/8")	B	No	Surface Ar (CaAa)	113.0000 - 5.0000	2	2	0.000 0.000	1.9800		0.00
****										
*****										
7" x 0.5" Flat	A	No	Surface Af (CaAa)	43.0800 - 0.0000	1	1	-0.250 -0.083	7.0000	15.0000	0.00
7" x 0.5" Flat	A	No	Surface Af (CaAa)	43.0800 - 0.0000	1	1	0.250 0.417	7.0000	15.0000	0.00
7" x 0.5" Flat	B	No	Surface Af (CaAa)	43.0800 - 0.0000	1	1	-0.417 -0.250	7.0000	15.0000	0.00
7" x 0.5" Flat	B	No	Surface Af (CaAa)	43.0800 - 0.0000	1	1	0.250 0.417	7.0000	15.0000	0.00
7" x 0.5" Flat	C	No	Surface Af (CaAa)	43.0800 - 0.0000	1	1	-0.250 -0.083	7.0000	15.0000	0.00
7" x 0.5" Flat	C	No	Surface Af (CaAa)	43.0800 - 0.0000	1	1	0.083 0.250	7.0000	15.0000	0.00
6" x 0.25" Flat	A	No	Surface Af (CaAa)	87.6700 - 43.0800	1	1	-0.250 -0.083	6.0000	12.5000	0.00
6" x 0.25" Flat	A	No	Surface Af (CaAa)	87.6700 - 43.0800	1	1	0.250 0.417	6.0000	12.5000	0.00
6" x 0.25" Flat	B	No	Surface Af (CaAa)	87.6700 - 43.0800	1	1	-0.417 -0.250	6.0000	12.5000	0.00
6" x 0.25" Flat	B	No	Surface Af (CaAa)	87.6700 - 43.0800	1	1	0.250 0.417	6.0000	12.5000	0.00
6" x 0.25" Flat	C	No	Surface Af (CaAa)	87.6700 - 43.0800	1	1	-0.250 -0.083	6.0000	12.5000	0.00
6" x 0.25" Flat	C	No	Surface Af (CaAa)	87.6700 - 43.0800	1	1	0.083 0.250	6.0000	12.5000	0.00
5" x 0.25" Flat	A	No	Surface Af (CaAa)	117.5800 - 87.6700	1	1	-0.250 -0.083	5.0000	10.5000	0.00
5" x 0.25" Flat	A	No	Surface Af (CaAa)	117.5800 - 87.6700	1	1	0.250 0.417	5.0000	10.5000	0.00
5" x 0.25" Flat	B	No	Surface Af (CaAa)	117.5800 - 87.6700	1	1	-0.417 -0.250	5.0000	10.5000	0.00
5" x 0.25" Flat	B	No	Surface Af (CaAa)	117.5800 - 87.6700	1	1	0.250 0.417	5.0000	10.5000	0.00
5" x 0.25" Flat	C	No	Surface Af (CaAa)	117.5800 - 87.6700	1	1	-0.250 -0.083	5.0000	10.5000	0.00
5" x 0.25" Flat	C	No	Surface Af (CaAa)	117.5800 - 87.6700	1	1	0.083 0.250	5.0000	10.5000	0.00

### Feed Line/Linear Appurtenances - Entered As Area

Description	Face or Leg	Allow Shield	Exclude From Torque Calculation	Component Type	Placement ft	Total Number	CAAA	Weight
							ft <sup>2</sup> /ft	klf
LDF5-50A(7/8")	B	No	No	Inside Pole	183.0000 - 5.0000	4	No Ice 1/2" Ice 1" Ice	0.0000 0.0000 0.0000
LDF2-50A(3/8")	B	No	No	Inside Pole	183.0000 - 5.0000	2	No Ice 1/2" Ice	0.0000 0.0000

<b>tnxTower</b>  <b>EFI Global, Inc.</b> 1117 Perimeter Center West, Suite E500 Atlanta, GA 30338 Phone: (470) 990-6593 FAX:	<b>Job</b>	CT11365D	<b>Page</b>	4 of 34
	<b>Project</b>	049.00421 - 2075019	<b>Date</b>	14:16:25 04/21/21
	<b>Client</b>	Foresite LLC	<b>Designed by</b>	Evan.Martin

Description	Face or Leg	Allow Shield	Exclude From Torque Calculation	Component Type	Placement ft	Total Number		C <sub>AA</sub> ft <sup>2</sup> /ft	Weight klf
LCF12-50J-P7(5/8")	B	No	No	Inside Pole	184.2500 - 5.0000	1	1" Ice No Ice 1/2" Ice 1" Ice	0.0000 0.0000 0.0000 0.0000	0.00 0.00 0.00 0.00
***									
LDF6-50A(1-1/4")	A	No	No	Inside Pole	156.0000 - 5.0000	4	No Ice 1/2" Ice 1" Ice	0.0000 0.0000 0.0000	0.00 0.00 0.00
LDF4P-50A(1/2")	A	No	No	Inside Pole	156.0000 - 5.0000	2	No Ice 1/2" Ice 1" Ice	0.0000 0.0000 0.0000	0.00 0.00 0.00
***									
LDF7-50A(1-5/8")	B	No	No	Inside Pole	145.0000 - 5.0000	6	No Ice 1/2" Ice 1" Ice	0.0000 0.0000 0.0000	0.00 0.00 0.00
DC Power Cables	B	No	No	Inside Pole	145.0000 - 5.0000	2	No Ice 1/2" Ice 1" Ice	0.0000 0.0000 0.0000	0.00 0.00 0.00
Fiber Cables	B	No	No	Inside Pole	145.0000 - 5.0000	8	No Ice 1/2" Ice 1" Ice	0.0000 0.0000 0.0000	0.00 0.00 0.00
***									
LCF12-50J-P7(5/8")	B	No	No	Inside Pole	124.0000 - 5.0000	7	No Ice 1/2" Ice 1" Ice	0.0000 0.0000 0.0000	0.00 0.00 0.00
***									
LDF4P-50A(1/2")	A	No	No	Inside Pole	51.7500 - 5.0000	1	No Ice 1/2" Ice 1" Ice	0.0000 0.0000 0.0000	0.00 0.00 0.00
0.2" Cable	A	No	No	Inside Pole	51.7500 - 5.0000	2	No Ice 1/2" Ice 1" Ice	0.0000 0.0000 0.0000	0.00 0.00 0.00
***T-Mobile***									
LDF7-50A(1-5/8")	C	No	No	Inside Pole	163.0000 - 5.0000	21	No Ice 1/2" Ice 1" Ice	0.0000 0.0000 0.0000	0.00 0.00 0.00
9x18 MLE Hybrid Line - 40mm	C	No	No	Inside Pole	163.0000 - 5.0000	1	No Ice 1/2" Ice 1" Ice	0.0000 0.0000 0.0000	0.00 0.00 0.00
HCS 6X12 4AWG (1-5/8")	C	No	No	Inside Pole	163.0000 - 5.0000	3	No Ice 1/2" Ice 1" Ice	0.0000 0.0000 0.0000	0.00 0.00 0.00
****									

### Feed Line/Linear Appurtenances Section Areas

Tower Section	Tower Elevation ft	Face	A <sub>R</sub> ft <sup>2</sup>	A <sub>F</sub> ft <sup>2</sup>	C <sub>AA</sub> In Face ft <sup>2</sup>	C <sub>AA</sub> Out Face ft <sup>2</sup>	Weight K
L1	183.0000-165.500 0	A	0.000	0.000	0.000	0.000	0.00
		B	0.000	0.000	0.000	0.000	0.03
		C	0.000	0.000	0.000	0.000	0.00
L2	165.5000-132.080 0	A	0.000	0.000	15.907	0.000	0.14
		B	0.000	0.000	0.000	0.000	0.24

<b>tnxTower</b>  <b>EFI Global, Inc.</b> 1117 Perimeter Center West, Suite E500 Atlanta, GA 30338 Phone: (470) 990-6593 FAX:	<b>Job</b>	CT11365D	<b>Page</b>	5 of 34
	<b>Project</b>	049.00421 - 2075019	<b>Date</b>	14:16:25 04/21/21
	<b>Client</b>	Foresite LLC	<b>Designed by</b>	Evan.Martin

Tower Section	Tower Elevation ft	Face	A <sub>R</sub> ft <sup>2</sup>	A <sub>F</sub> ft <sup>2</sup>	C <sub>AA</sub> In Face ft <sup>2</sup>	C <sub>AA</sub> Out Face ft <sup>2</sup>	Weight K
L3	132.0800-86.9900	C	0.000	0.000	0.000	0.000	0.68
		A	0.000	0.000	81.195	0.000	0.26
		B	0.000	0.000	61.510	0.000	0.80
L4	86.9900-42.9100	C	0.000	0.000	51.210	0.000	0.99
		A	0.000	0.000	117.530	0.000	0.25
		B	0.000	0.000	105.672	0.000	0.82
L5	42.9100-0.0000	C	0.000	0.000	88.217	0.000	0.96
		A	0.000	0.000	125.333	0.000	0.23
		B	0.000	0.000	115.136	0.000	0.71
		C	0.000	0.000	100.123	0.000	0.83

### Feed Line/Linear Appurtenances Section Areas - With Ice

Tower Section	Tower Elevation ft	Face or Leg	Ice Thickness in	A <sub>R</sub> ft <sup>2</sup>	A <sub>F</sub> ft <sup>2</sup>	C <sub>AA</sub> In Face ft <sup>2</sup>	C <sub>AA</sub> Out Face ft <sup>2</sup>	Weight K
L1	183.0000-165.5000 0	A	2.952	0.000	0.000	0.000	0.000	0.00
		B		0.000	0.000	0.000	0.000	0.03
		C		0.000	0.000	0.000	0.000	0.00
L2	165.5000-132.0800 0	A	2.905	0.000	0.000	55.190	0.000	1.12
		B		0.000	0.000	0.000	0.000	0.24
		C		0.000	0.000	0.000	0.000	0.68
L3	132.0800-86.9900	A	2.816	0.000	0.000	189.724	0.000	3.55
		B		0.000	0.000	118.517	0.000	2.86
		C		0.000	0.000	86.753	0.000	2.47
L4	86.9900-42.9100	A	2.674	0.000	0.000	236.590	0.000	4.18
		B		0.000	0.000	190.731	0.000	3.99
		C		0.000	0.000	137.875	0.000	3.20
L5	42.9100-0.0000	A	2.388	0.000	0.000	228.206	0.000	3.81
		B		0.000	0.000	190.119	0.000	3.69
		C		0.000	0.000	146.014	0.000	3.07

### Feed Line Center of Pressure

Section	Elevation ft	CP <sub>x</sub> in	CP <sub>z</sub> in	CP <sub>x</sub> Ice in	CP <sub>z</sub> Ice in
L1	183.0000-165.5000	0.0000	0.0000	0.0000	0.0000
L2	165.5000-132.0800	-3.0674	-1.7710	-3.0951	-1.7870
L3	132.0800-86.9900	-1.2643	-0.7788	-1.6295	-1.3479
L4	86.9900-42.9100	-0.9004	-0.5505	-1.1906	-1.3131
L5	42.9100-0.0000	-0.9494	-0.3005	-1.2512	-1.1592

Note: For pole sections, center of pressure calculations do not consider feed line shielding.

### Shielding Factor Ka

<b>tnxTower</b>  <b>EFI Global, Inc.</b> 1117 Perimeter Center West, Suite E500 Atlanta, GA 30338 Phone: (470) 990-6593 FAX:	<b>Job</b> CT11365D	<b>Page</b> 6 of 34
	<b>Project</b> 049.00421 - 2075019	<b>Date</b> 14:16:25 04/21/21
	<b>Client</b> Foresite LLC	<b>Designed by</b> Evan.Martin

Tower Section	Feed Line Record No.	Description	Feed Line Segment Elev.	K <sub>a</sub> No Ice	K <sub>a</sub> Ice
L1	7	LDF4P-50A(1/2")	165.50 - 156.00	1.0000	1.0000
L1	8	2-1/2"	165.50 - 156.00	1.0000	1.0000
L2	7	LDF4P-50A(1/2")	132.08 - 156.00	1.0000	1.0000
L2	8	2-1/2"	132.08 - 156.00	1.0000	1.0000
L2	16	LDF7-50A(1-5/8")	132.08 - 113.00	1.0000	1.0000
L2	32	6" x 0.25" Flat	132.08 - 87.67	1.0000	1.0000
L2	33	6" x 0.25" Flat	132.08 - 87.67	1.0000	1.0000
L2	34	6" x 0.25" Flat	132.08 - 87.67	1.0000	1.0000
L2	35	6" x 0.25" Flat	132.08 - 87.67	1.0000	1.0000
L2	36	6" x 0.25" Flat	132.08 - 87.67	1.0000	1.0000
L2	37	6" x 0.25" Flat	132.08 - 87.67	1.0000	1.0000
L2	38	5" x 0.25" Flat	132.08 - 117.58	1.0000	1.0000
L2	39	5" x 0.25" Flat	132.08 - 117.58	1.0000	1.0000
L2	40	5" x 0.25" Flat	132.08 - 117.58	1.0000	1.0000
L2	41	5" x 0.25" Flat	132.08 - 117.58	1.0000	1.0000
L2	42	5" x 0.25" Flat	132.08 - 117.58	1.0000	1.0000
L2	43	5" x 0.25" Flat	132.08 - 117.58	1.0000	1.0000
L3	7	LDF4P-50A(1/2")	86.99 - 132.08	1.0000	1.0000
L3	8	2-1/2"	86.99 - 132.08	1.0000	1.0000
L3	16	LDF7-50A(1-5/8")	86.99 - 113.00	1.0000	1.0000
L3	26	7" x 0.5" Flat	86.99 - 43.08	1.0000	1.0000
L3	27	7" x 0.5" Flat	86.99 - 43.08	1.0000	1.0000
L3	28	7" x 0.5" Flat	86.99 - 43.08	1.0000	1.0000
L3	29	7" x 0.5" Flat	86.99 - 43.08	1.0000	1.0000
L3	30	7" x 0.5" Flat	86.99 - 43.08	1.0000	1.0000
L3	31	7" x 0.5" Flat	86.99 - 43.08	1.0000	1.0000
L3	32	6" x 0.25" Flat	86.99 - 87.67	1.0000	1.0000
L3	33	6" x 0.25" Flat	86.99 - 87.67	1.0000	1.0000
L3	34	6" x 0.25" Flat	86.99 - 87.67	1.0000	1.0000
L3	35	6" x 0.25" Flat	86.99 - 87.67	1.0000	1.0000
L3	36	6" x 0.25" Flat	86.99 - 87.67	1.0000	1.0000
L3	37	6" x 0.25" Flat	86.99 - 87.67	1.0000	1.0000
L4	7	LDF4P-50A(1/2")	42.91 - 86.99	1.0000	1.0000
L4	8	2-1/2"	42.91 - 86.99	1.0000	1.0000
L4	16	LDF7-50A(1-5/8")	42.91 - 86.99	1.0000	1.0000
L4	26	7" x 0.5" Flat	42.91 - 43.08	1.0000	1.0000
L4	27	7" x 0.5" Flat	42.91 - 43.08	1.0000	1.0000
L4	28	7" x 0.5" Flat	42.91 - 43.08	1.0000	1.0000
L4	29	7" x 0.5" Flat	42.91 - 43.08	1.0000	1.0000
L4	30	7" x 0.5" Flat	42.91 - 43.08	1.0000	1.0000
L4	31	7" x 0.5" Flat	42.91 - 43.08	1.0000	1.0000

**Discrete Tower Loads**

<b>tnxTower</b>  <b>EFI Global, Inc.</b> 1117 Perimeter Center West, Suite E500 Atlanta, GA 30338 Phone: (470) 990-6593 FAX:	<b>Job</b>	CT11365D	<b>Page</b>	7 of 34
	<b>Project</b>	049.00421 - 2075019	<b>Date</b>	14:16:25 04/21/21
	<b>Client</b>	Foresite LLC	<b>Designed by</b>	Evan.Martin

Description	Face or Leg	Offset Type	Offsets:		Azimuth Adjustment	Placement	CAAA Front	CAAA Side	Weight	
			Horz	Lateral Vert						
			ft	ft	°	ft	ft <sup>2</sup>	ft <sup>2</sup>	K	
Lightning Rod w/ Pipe Extension	A	From Leg	1.0000	0.0000	0.0000	189.7500	No Ice	2.5800	2.5800	0.05
			0.00				1/2" Ice	4.0200	4.0200	0.08
			6.00				1" Ice	5.4600	5.4600	0.11
14' Low Profile Platform	A	None			0.0000	184.0000	No Ice	15.7000	15.7000	1.30
							1/2" Ice	20.1000	20.1000	1.76
							1" Ice	24.5000	24.5000	2.23
24' 4-Bay Dipole	C	From Leg	3.5000	0.0000	0.0000	184.0000	No Ice	4.7500	4.7500	0.05
			0.00				1/2" Ice	6.2500	6.2500	0.08
			0.00				1" Ice	7.7500	7.7500	0.11
24' 4-Bay Dipole	C	From Leg	3.5000	0.0000	0.0000	184.0000	No Ice	4.7500	4.7500	0.05
			0.00				1/2" Ice	6.2500	6.2500	0.08
			0.00				1" Ice	7.7500	7.7500	0.11
9" x 9" x 3.5" TMA	A	From Leg	3.5000	0.0000	0.0000	184.0000	No Ice	0.6750	0.2632	0.01
			0.00				1/2" Ice	0.7787	0.3356	0.02
			5.50				1" Ice	0.8898	0.4162	0.02
9" x 9" x 3.5" TMA	C	From Leg	3.5000	0.0000	0.0000	184.0000	No Ice	0.6750	0.2632	0.01
			0.00				1/2" Ice	0.7787	0.3356	0.02
			5.50				1" Ice	0.8898	0.4162	0.02
***163***										
AIR 32 B2a/B66Aa w/ Mount Pipe	A	From Leg	3.5000	0.0000	0.0000	163.0000	No Ice	3.7600	3.1500	0.19
			0.00				1/2" Ice	4.1200	3.4900	0.25
			0.00				1" Ice	4.4800	3.8400	0.32
AIR 32 B2a/B66Aa w/ Mount Pipe	B	From Leg	3.5000	0.0000	0.0000	163.0000	No Ice	3.7600	3.1500	0.19
			0.00				1/2" Ice	4.1200	3.4900	0.25
			0.00				1" Ice	4.4800	3.8400	0.32
AIR 32 B2a/B66Aa w/ Mount Pipe	C	From Leg	3.5000	0.0000	0.0000	163.0000	No Ice	3.7600	3.1500	0.19
			0.00				1/2" Ice	4.1200	3.4900	0.25
			0.00				1" Ice	4.4800	3.8400	0.32
Ericsson AIR6449 B41 w/ Mount Pipe	A	From Leg	3.5000	0.0000	0.0000	163.0000	No Ice	6.8995	4.3156	0.13
			0.00				1/2" Ice	7.7436	5.3695	0.19
			0.00				1" Ice	8.4932	6.2751	0.26
Ericsson AIR6449 B41 w/ Mount Pipe	B	From Leg	3.5000	0.0000	0.0000	163.0000	No Ice	6.8995	4.3156	0.13
			0.00				1/2" Ice	7.7436	5.3695	0.19
			0.00				1" Ice	8.4932	6.2751	0.26
Ericsson AIR6449 B41 w/ Mount Pipe	C	From Leg	3.5000	0.0000	0.0000	163.0000	No Ice	6.8995	4.3156	0.13
			0.00				1/2" Ice	7.7436	5.3695	0.19
			0.00				1" Ice	8.4932	6.2751	0.26
AIR 3246 B66 w/ Mount Pipe	A	From Leg	3.5000	0.0000	0.0000	163.0000	No Ice	8.1769	6.5590	0.20
			0.00				1/2" Ice	8.6563	7.3933	0.27
			0.00				1" Ice	9.1243	8.1279	0.35
AIR 3246 B66 w/ Mount Pipe	B	From Leg	3.5000	0.0000	0.0000	163.0000	No Ice	8.1769	6.5590	0.20
			0.00				1/2" Ice	8.6563	7.3933	0.27
			0.00				1" Ice	9.1243	8.1279	0.35
AIR 3246 B66 w/ Mount Pipe	C	From Leg	3.5000	0.0000	0.0000	163.0000	No Ice	8.1769	6.5590	0.20
			0.00				1/2" Ice	8.6563	7.3933	0.27
			0.00				1" Ice	9.1243	8.1279	0.35
APXVAARR24_43-U-NA20 w/ Mount Pipe	A	From Leg	3.5000	0.0000	0.0000	163.0000	No Ice	14.6900	6.8700	0.19
			0.00				1/2" Ice	15.4600	7.5500	0.31
			0.00				1" Ice	16.2300	8.2500	0.46
APXVAARR24_43-U-NA20 w/ Mount Pipe	B	From Leg	3.5000	0.0000	0.0000	163.0000	No Ice	14.6900	6.8700	0.19
			0.00				1/2" Ice	15.4600	7.5500	0.31
			0.00				1" Ice	16.2300	8.2500	0.46
APXVAARR24_43-U-NA20 w/ Mount Pipe	C	From Leg	3.5000	0.0000	0.0000	163.0000	No Ice	14.6900	6.8700	0.19
			0.00				1/2" Ice	15.4600	7.5500	0.31
			0.00				1" Ice	16.2300	8.2500	0.46
Radio 4449 B71+B85_T-Mobile	A	From Leg	3.5000	0.0000	0.0000	163.0000	No Ice	1.9701	1.5865	0.07
			0.00				1/2" Ice	2.1466	1.7488	0.09

<b>tnxTower</b>  <b>EFI Global, Inc.</b> 1117 Perimeter Center West, Suite E500 Atlanta, GA 30338 Phone: (470) 990-6593 FAX:	<b>Job</b>	CT11365D	<b>Page</b>	8 of 34
	<b>Project</b>	049.00421 - 2075019	<b>Date</b>	14:16:25 04/21/21
	<b>Client</b>	Foresite LLC	<b>Designed by</b>	Evan.Martin

Description	Face or Leg	Offset Type	Offsets:		Azimuth Adjustment	Placement	CAAA Front	CAAA Side	Weight	
			Horz	Vert						
			ft	ft	°	ft	ft <sup>2</sup>	ft <sup>2</sup>	K	
Radio 4449 B71+B85_T-Mobile	B	From Leg	0.00		0.0000	163.0000	1" Ice	2.3306	1.9185	0.12
			3.5000				No Ice	1.9701	1.5865	0.07
			0.00				1/2" Ice	2.1466	1.7488	0.09
Radio 4449 B71+B85_T-Mobile	C	From Leg	0.00		0.0000	163.0000	1" Ice	2.3306	1.9185	0.12
			3.5000				No Ice	1.9701	1.5865	0.07
			0.00				1/2" Ice	2.1466	1.7488	0.09
RRUS 4415 B25	A	From Leg	0.00		0.0000	163.0000	1" Ice	2.3306	1.9185	0.12
			3.5000				No Ice	1.6444	0.6788	0.04
			0.00				1/2" Ice	1.8044	0.7911	0.06
RRUS 4415 B25	B	From Leg	0.00		0.0000	163.0000	1" Ice	1.9719	0.9129	0.07
			3.5000				No Ice	1.6444	0.6788	0.04
			0.00				1/2" Ice	1.8044	0.7911	0.06
RRUS 4415 B25	C	From Leg	0.00		0.0000	163.0000	1" Ice	1.9719	0.9129	0.07
			3.5000				No Ice	1.6444	0.6788	0.04
			0.00				1/2" Ice	1.8044	0.7911	0.06
Platform Mount [LP 1201-1_HR-1]	C	None	0.00		0.0000	163.0000	1" Ice	1.9719	0.9129	0.07
							No Ice	26.3900	26.3900	2.36
							1/2" Ice	31.4000	31.4000	3.06
Site Pro 1 (P/N: PRK-1245L)	C	None	0.00		0.0000	163.0000	1" Ice	36.2000	36.2000	3.86
							No Ice	6.3200	4.8500	0.28
							1/2" Ice	7.7900	6.3600	0.42
***153*** APXVSPP18-C w/ Mount Pipe	A	From Leg	0.00		0.0000	154.0000	1" Ice	9.3600	7.9400	0.60
			3.5000				No Ice	4.6000	4.0100	0.09
			2.00				1/2" Ice	5.0500	4.4500	0.15
APXVSPP18-C w/ Mount Pipe	B	From Leg	0.00		0.0000	154.0000	1" Ice	5.5000	4.8900	0.23
			3.5000				No Ice	4.6000	4.0100	0.09
			2.00				1/2" Ice	5.0500	4.4500	0.15
APXVSPP18-C w/ Mount Pipe	C	From Leg	0.00		0.0000	154.0000	1" Ice	5.5000	4.8900	0.23
			3.5000				No Ice	4.6000	4.0100	0.09
			2.00				1/2" Ice	5.0500	4.4500	0.15
APXVTM14-C-120 w/ Mount Pipe	A	From Leg	0.00		0.0000	154.0000	1" Ice	5.5000	4.8900	0.23
			3.5000				No Ice	4.0900	2.8600	0.08
			2.00				1/2" Ice	4.4800	3.2300	0.13
APXVTM14-C-120 w/ Mount Pipe	B	From Leg	0.00		0.0000	154.0000	1" Ice	4.8800	3.6100	0.19
			3.5000				No Ice	4.0900	2.8600	0.08
			2.00				1/2" Ice	4.4800	3.2300	0.13
APXVTM14-C-120 w/ Mount Pipe	C	From Leg	0.00		0.0000	154.0000	1" Ice	4.8800	3.6100	0.19
			3.5000				No Ice	4.0900	2.8600	0.08
			2.00				1/2" Ice	4.4800	3.2300	0.13
RRH2X50-800	A	From Leg	0.00		0.0000	154.0000	1" Ice	4.8800	3.6100	0.19
			3.5000				No Ice	1.7008	1.2822	0.05
			2.00				1/2" Ice	1.8640	1.4275	0.07
RRH2X50-800	B	From Leg	0.00		0.0000	154.0000	1" Ice	2.0345	1.5803	0.09
			3.5000				No Ice	1.7008	1.2822	0.05
			2.00				1/2" Ice	1.8640	1.4275	0.07
RRH2X50-800	C	From Leg	0.00		0.0000	154.0000	1" Ice	2.0345	1.5803	0.09
			3.5000				No Ice	1.7008	1.2822	0.05
			2.00				1/2" Ice	1.8640	1.4275	0.07
TD-RRH8x20	A	From Leg	0.00		0.0000	154.0000	1" Ice	2.0345	1.5803	0.09
			3.5000				No Ice	3.7042	1.2939	0.07
			4.50				1/2" Ice	3.9462	1.4646	0.09
TD-RRH8x20	B	From Leg	0.00		0.0000	154.0000	1" Ice	4.1956	1.6424	0.12
			3.5000				No Ice	3.7042	1.2939	0.07
			4.50				1/2" Ice	3.9462	1.4646	0.09
TD-RRH8x20	C	From Leg	0.00		0.0000	154.0000	1" Ice	4.1956	1.6424	0.12
			3.5000				No Ice	3.7042	1.2939	0.07
			4.50				1/2" Ice	3.9462	1.4646	0.09



<b>tnxTower</b>  <b>EFI Global, Inc.</b> 1117 Perimeter Center West, Suite E500 Atlanta, GA 30338 Phone: (470) 990-6593 FAX:	<b>Job</b>	CT11365D	<b>Page</b>	9 of 34
	<b>Project</b>	049.00421 - 2075019	<b>Date</b>	14:16:25 04/21/21
	<b>Client</b>	Foresite LLC	<b>Designed by</b>	Evan.Martin

Description	Face or Leg	Offset Type	Offsets:		Azimuth Adjustment	Placement	CAAA Front	CAAA Side	Weight
			Horz	Lateral					
			0.00			1/2" Ice	3.9462	1.4646	0.09
			4.50			1" Ice	4.1956	1.6424	0.12
(2) PCS 1900MHz	A	From Leg	1.0000	0.0000	154.0000	No Ice	2.3218	2.2381	0.06
4x45W-65MHz			0.00			1/2" Ice	2.5266	2.4407	0.08
			4.50			1" Ice	2.7388	2.6507	0.11
(2) PCS 1900MHz	B	From Leg	1.0000	0.0000	154.0000	No Ice	2.3218	2.2381	0.06
4x45W-65MHz			0.00			1/2" Ice	2.5266	2.4407	0.08
			4.50			1" Ice	2.7388	2.6507	0.11
(2) PCS 1900MHz	C	From Leg	1.0000	0.0000	154.0000	No Ice	2.3218	2.2381	0.06
4x45W-65MHz			0.00			1/2" Ice	2.5266	2.4407	0.08
			4.50			1" Ice	2.7388	2.6507	0.11
18" x 18" x 6.5" Junction Box	A	From Leg	1.0000	0.0000	154.0000	No Ice	2.7000	1.0528	0.05
			0.00			1/2" Ice	3.1148	1.3424	0.07
			0.00			1" Ice	3.5296	1.6320	0.09
13' Low Profile Platform	A	None		0.0000	154.0000	No Ice	15.7000	15.7000	1.30
						1/2" Ice	20.1000	20.1000	1.76
						1" Ice	24.5000	24.5000	2.23
Ring Mount	C	None		0.0000	159.0000	No Ice	1.4000	1.4000	0.09
						1/2" Ice	2.4000	2.4000	0.13
						1" Ice	3.4000	3.4000	0.17
***154***									
MT11669	B	From Leg	3.5000	0.0000	153.8300	No Ice	1.7521	0.5236	0.05
			0.00			1/2" Ice	2.0213	0.7236	0.07
			0.00			1" Ice	2.2905	0.9236	0.09
**146**									
800 10121	A	From Leg	3.5000	0.0000	145.0000	No Ice	3.7400	2.1700	0.05
			0.00			1/2" Ice	4.1800	2.5800	0.08
			0.00			1" Ice	4.6300	3.0000	0.12
800 10121	B	From Leg	3.5000	0.0000	145.0000	No Ice	3.7400	2.1700	0.05
			0.00			1/2" Ice	4.1800	2.5800	0.08
			0.00			1" Ice	4.6300	3.0000	0.12
800 10121	C	From Leg	3.5000	0.0000	145.0000	No Ice	3.7400	2.1700	0.05
			0.00			1/2" Ice	4.1800	2.5800	0.08
			0.00			1" Ice	4.6300	3.0000	0.12
(2) OPA-65R-LCUU-H6	A	From Leg	3.5000	0.0000	145.0000	No Ice	9.2000	4.6300	0.08
			0.00			1/2" Ice	9.9700	5.3400	0.14
			0.00			1" Ice	10.7600	6.0700	0.20
(2) OPA-65R-LCUU-H8	B	From Leg	3.5000	0.0000	145.0000	No Ice	11.9500	6.0300	0.07
			0.00			1/2" Ice	12.9200	6.9300	0.14
			0.00			1" Ice	13.9000	7.8500	0.22
(2) OPA-65R-LCUU-H8	C	From Leg	3.5000	0.0000	145.0000	No Ice	11.9500	6.0300	0.07
			0.00			1/2" Ice	12.9200	6.9300	0.14
			0.00			1" Ice	13.9000	7.8500	0.22
(2) LGP21401	A	From Leg	3.5000	0.0000	145.0000	No Ice	1.1040	0.2070	0.01
			0.00			1/2" Ice	1.2388	0.2738	0.02
			0.00			1" Ice	1.3810	0.3475	0.03
(2) LGP21401	B	From Leg	3.5000	0.0000	145.0000	No Ice	1.1040	0.2070	0.01
			0.00			1/2" Ice	1.2388	0.2738	0.02
			0.00			1" Ice	1.3810	0.3475	0.03
(2) LGP21401	C	From Leg	3.5000	0.0000	145.0000	No Ice	1.1040	0.2070	0.01
			0.00			1/2" Ice	1.2388	0.2738	0.02
			0.00			1" Ice	1.3810	0.3475	0.03
(2) LGP21901	A	From Leg	3.5000	0.0000	145.0000	No Ice	0.2310	0.1575	0.01
			0.00			1/2" Ice	0.2941	0.2129	0.01
			0.00			1" Ice	0.3647	0.2756	0.01
(2) LGP21901	B	From Leg	3.5000	0.0000	145.0000	No Ice	0.2310	0.1575	0.01
			0.00			1/2" Ice	0.2941	0.2129	0.01

<b>tnxTower</b>  <b>EFI Global, Inc.</b> 1117 Perimeter Center West, Suite E500 Atlanta, GA 30338 Phone: (470) 990-6593 FAX:	<b>Job</b>	CT11365D	<b>Page</b>	10 of 34
	<b>Project</b>	049.00421 - 2075019	<b>Date</b>	14:16:25 04/21/21
	<b>Client</b>	Foresite LLC	<b>Designed by</b>	Evan.Martin

Description	Face or Leg	Offset Type	Offsets:		Azimuth Adjustment	Placement	CAAA Front	CAAA Side	Weight
			Horz	Lateral					
(2) LGP21901	C	From Leg	0.00	3.5000	0.0000	145.0000	1" Ice 0.3647	0.2756	0.01
			0.00	0.00			No Ice 0.2310	0.1575	0.01
			0.00	0.00			1/2" Ice 0.2941	0.2129	0.01
RRUS 32 B66	A	From Leg	0.00	3.5000	0.0000	145.0000	1" Ice 0.3647	0.2756	0.01
			0.00	0.00			No Ice 2.7427	1.6681	0.05
			0.00	0.00			1/2" Ice 2.9647	1.8552	0.07
RRUS 32 B66	B	From Leg	0.00	3.5000	0.0000	145.0000	1" Ice 3.1941	2.0493	0.10
			0.00	0.00			No Ice 2.7427	1.6681	0.05
			0.00	0.00			1/2" Ice 2.9647	1.8552	0.07
RRUS 32 B66	C	From Leg	0.00	3.5000	0.0000	145.0000	1" Ice 3.1941	2.0493	0.10
			0.00	0.00			No Ice 2.7427	1.6681	0.05
			0.00	0.00			1/2" Ice 2.9647	1.8552	0.07
RRUS 32 B30	A	From Leg	0.00	3.5000	0.0000	145.0000	1" Ice 3.1941	2.0493	0.10
			0.00	0.00			No Ice 2.6923	1.5727	0.06
			0.00	0.00			1/2" Ice 2.9115	1.7556	0.08
RRUS 32 B30	B	From Leg	0.00	3.5000	0.0000	145.0000	1" Ice 3.1382	1.9455	0.10
			0.00	0.00			No Ice 2.6923	1.5727	0.06
			0.00	0.00			1/2" Ice 2.9115	1.7556	0.08
RRUS 32 B30	C	From Leg	0.00	3.5000	0.0000	145.0000	1" Ice 3.1382	1.9455	0.10
			0.00	0.00			No Ice 2.6923	1.5727	0.06
			0.00	0.00			1/2" Ice 2.9115	1.7556	0.08
DC6-48-60-18-8C	A	From Leg	0.00	3.5000	0.0000	145.0000	1" Ice 3.1382	1.9455	0.10
			0.00	0.00			No Ice 1.1450	1.1450	0.03
			0.00	0.00			1/2" Ice 1.7924	1.7924	0.05
DC6-48-60-18-8C	B	From Leg	0.00	3.5000	0.0000	145.0000	1" Ice 2.0024	2.0024	0.07
			0.00	0.00			No Ice 1.1450	1.1450	0.03
			0.00	0.00			1/2" Ice 1.7924	1.7924	0.05
RRUS 11 B12	A	From Leg	0.00	3.5000	0.0000	145.0000	1" Ice 2.0024	2.0024	0.07
			0.00	0.00			No Ice 2.8333	1.1821	0.05
			0.00	0.00			1/2" Ice 3.0426	1.3299	0.07
RRUS 11 B12	B	From Leg	0.00	3.5000	0.0000	145.0000	1" Ice 3.2593	1.4848	0.10
			0.00	0.00			No Ice 2.8333	1.1821	0.05
			0.00	0.00			1/2" Ice 3.0426	1.3299	0.07
RRUS 11 B12	C	From Leg	0.00	3.5000	0.0000	145.0000	1" Ice 3.2593	1.4848	0.10
			0.00	0.00			No Ice 2.8333	1.1821	0.05
			0.00	0.00			1/2" Ice 3.0426	1.3299	0.07
RRUS 4478 B5	A	From Leg	0.00	3.5000	0.0000	145.0000	1" Ice 3.2593	1.4848	0.10
			0.00	0.00			No Ice 1.8425	1.0588	0.06
			0.00	0.00			1/2" Ice 2.0123	1.1969	0.08
RRUS 4478 B5	B	From Leg	0.00	3.5000	0.0000	145.0000	1" Ice 2.1895	1.3425	0.09
			0.00	0.00			No Ice 1.8425	1.0588	0.06
			0.00	0.00			1/2" Ice 2.0123	1.1969	0.08
RRUS 4478 B5	C	From Leg	0.00	3.5000	0.0000	145.0000	1" Ice 2.1895	1.3425	0.09
			0.00	0.00			No Ice 1.8425	1.0588	0.06
			0.00	0.00			1/2" Ice 2.0123	1.1969	0.08
NNH4-65B-R6	A	From Leg	0.00	3.5000	0.0000	145.0000	1" Ice 2.1895	1.3425	0.09
			0.00	0.00			No Ice 7.6200	3.0100	0.10
			0.00	0.00			1/2" Ice 8.1200	3.4500	0.17
NNH4-65C-R6	B	From Leg	0.00	3.5000	0.0000	145.0000	1" Ice 8.6300	3.9000	0.25
			0.00	0.00			No Ice 9.7500	3.9600	0.10
			0.00	0.00			1/2" Ice 10.3600	4.5000	0.19
NNH4-65C-R6	C	From Leg	0.00	3.5000	0.0000	145.0000	1" Ice 10.9700	5.0600	0.30
			0.00	0.00			No Ice 9.7500	3.9600	0.10
			0.00	0.00			1/2" Ice 10.3600	4.5000	0.19
RRUS E2 B29	A	From Leg	0.00	3.5000	0.0000	145.0000	1" Ice 10.9700	5.0600	0.30
			0.00	0.00			No Ice 3.1450	1.2854	0.06
			0.00	0.00			1/2" Ice 3.3648	1.4379	0.08

<b>tnxTower</b>  <b>EFI Global, Inc.</b> 1117 Perimeter Center West, Suite E500 Atlanta, GA 30338 Phone: (470) 990-6593 FAX:	<b>Job</b>	CT11365D	<b>Page</b>	11 of 34
	<b>Project</b>	049.00421 - 2075019	<b>Date</b>	14:16:25 04/21/21
	<b>Client</b>	Foresite LLC	<b>Designed by</b>	Evan.Martin

Description	Face or Leg	Offset Type	Offsets:		Azimuth Adjustment	Placement	CAAA Front	CAAA Side	Weight					
			Horz	Lateral						Vert	°	ft	ft <sup>2</sup>	ft <sup>2</sup>
RRUS E2 B29	B	From Leg	0.00		0.0000	145.0000	1" Ice	3.5920	1.5998	0.11				
			3.5000								No Ice	3.1450	1.2854	0.06
			0.00								1/2" Ice	3.3648	1.4379	0.08
RRUS E2 B29	C	From Leg	0.00		0.0000	145.0000	1" Ice	3.5920	1.5998	0.11				
			3.5000								No Ice	3.1450	1.2854	0.06
			0.00								1/2" Ice	3.3648	1.4379	0.08
RRUS 12 B2	A	From Leg	0.00		0.0000	145.0000	1" Ice	3.5920	1.5998	0.11				
			3.5000								No Ice	3.1435	1.2816	0.05
			0.00								1/2" Ice	3.3632	1.4340	0.07
RRUS 12 B2	B	From Leg	0.00		0.0000	145.0000	1" Ice	3.5904	1.5955	0.10				
			3.5000								No Ice	3.1435	1.2816	0.05
			0.00								1/2" Ice	3.3632	1.4340	0.07
RRUS 12 B2	C	From Leg	0.00		0.0000	145.0000	1" Ice	3.5904	1.5955	0.10				
			3.5000								No Ice	3.1435	1.2816	0.05
			0.00								1/2" Ice	3.3632	1.4340	0.07
RRUS 4478 B14	A	From Leg	0.00		0.0000	145.0000	1" Ice	3.5904	1.5955	0.10				
			3.5000								No Ice	1.8425	1.0588	0.06
			0.00								1/2" Ice	2.0123	1.1969	0.08
RRUS 4478 B14	B	From Leg	0.00		0.0000	145.0000	1" Ice	2.1895	1.3425	0.09				
			3.5000								No Ice	1.8425	1.0588	0.06
			0.00								1/2" Ice	2.0123	1.1969	0.08
RRUS 4478 B14	C	From Leg	0.00		0.0000	145.0000	1" Ice	2.1895	1.3425	0.09				
			3.5000								No Ice	1.8425	1.0588	0.06
			0.00								1/2" Ice	2.0123	1.1969	0.08
RRU A2	A	From Leg	0.00		0.0000	145.0000	1" Ice	2.1895	1.3425	0.09				
			3.5000								No Ice	2.0637	0.5047	0.02
			0.00								1/2" Ice	2.2424	0.6147	0.03
RRU A2	B	From Leg	0.00		0.0000	145.0000	1" Ice	2.4285	0.7318	0.05				
			3.5000								No Ice	2.0637	0.5047	0.02
			0.00								1/2" Ice	2.2424	0.6147	0.03
RRU A2	C	From Leg	0.00		0.0000	145.0000	1" Ice	2.4285	0.7318	0.05				
			3.5000								No Ice	2.0637	0.5047	0.02
			0.00								1/2" Ice	2.2424	0.6147	0.03
DC6-48-60-0-8C	A	From Leg	0.00		0.0000	145.0000	1" Ice	2.4285	0.7318	0.05				
			3.5000								No Ice	0.8498	0.8498	0.02
			0.00								1/2" Ice	1.3563	1.3563	0.04
DC6-48-60-0-8C	B	From Leg	0.00		0.0000	145.0000	1" Ice	1.5325	1.5325	0.05				
			3.5000								No Ice	0.8498	0.8498	0.02
			0.00								1/2" Ice	1.3563	1.3563	0.04
Platform Mount [LP 301-1_KCKR]	A	None	0.00		0.0000	145.0000	1" Ice	1.5325	1.5325	0.05				
											No Ice	35.0300	35.0300	1.86
											1/2" Ice	44.4600	44.4600	2.52
**123**														
20' 4-Bay Dipole	C	From Leg	0.00		0.0000	128.1700	1" Ice	53.7200	53.7200	3.33				
			3.5000								No Ice	4.7500	4.7500	0.05
			0.00								1/2" Ice	6.2500	6.2500	0.08
15' Whip	A	From Leg	0.00		0.0000	132.0800	1" Ice	7.7500	7.7500	0.11				
			3.5000								No Ice	3.7500	3.7500	0.04
			0.00								1/2" Ice	4.5000	4.5000	0.07
5'-6" Whip	A	From Leg	0.00		0.0000	129.4200	1" Ice	5.2500	5.2500	0.10				
			3.5000								No Ice	1.2000	1.2000	0.03
			0.00								1/2" Ice	1.8000	1.8000	0.03
24" Yagi	C	From Leg	0.00		0.0000	128.5000	1" Ice	2.4000	2.4000	0.04				
			3.5000								No Ice	1.5000	1.5000	0.01
			0.00								1/2" Ice	2.2500	2.2500	0.02
15" Yagi	B	From Leg	0.00		0.0000	125.0800	1" Ice	3.0000	3.0000	0.03				
			3.5000								No Ice	0.7500	0.7500	0.01
			0.00								1/2" Ice	2.2500	2.2500	0.02

<b>tnxTower</b>  <b>EFI Global, Inc.</b> 1117 Perimeter Center West, Suite E500 Atlanta, GA 30338 Phone: (470) 990-6593 FAX:	<b>Job</b>	CT11365D	<b>Page</b>	12 of 34
	<b>Project</b>	049.00421 - 2075019	<b>Date</b>	14:16:25 04/21/21
	<b>Client</b>	Foresite LLC	<b>Designed by</b>	Evan.Martin

Description	Face or Leg	Offset Type	Offsets:		Azimuth Adjustment	Placement	CAAA Front	CAAA Side	Weight	
			Horz	Lateral Vert						
			ft	ft	°	ft	ft <sup>2</sup>	ft <sup>2</sup>	K	
			0.00			1/2" Ice	1.2500	1.2500	0.01	
			0.00			1" Ice	1.7500	1.7500	0.01	
2'6" Yagi	A	From Leg	3.5000		0.0000	121.7500	No Ice	1.5000	1.5000	0.01
			0.00				1/2" Ice	2.2500	2.2500	0.02
			0.00				1" Ice	3.0000	3.0000	0.03
13' Low Profile Platform	A	None			0.0000	123.0000	No Ice	15.7000	15.7000	1.30
							1/2" Ice	20.1000	20.1000	1.76
							1" Ice	24.5000	24.5000	2.23
***112***										
(2) LNX-6514DS-A1M w/ Mount Pipe	A	From Leg	3.5000		0.0000	111.0000	No Ice	4.0900	3.3000	0.06
			0.00				1/2" Ice	4.4900	3.6800	0.13
			0.00				1" Ice	4.8900	4.0600	0.20
(2) LNX-6514DS-A1M w/ Mount Pipe	B	From Leg	3.5000		0.0000	111.0000	No Ice	4.0900	3.3000	0.06
			0.00				1/2" Ice	4.4900	3.6800	0.13
			0.00				1" Ice	4.8900	4.0600	0.20
(2) LNX-6514DS-A1M w/ Mount Pipe	C	From Leg	3.5000		0.0000	111.0000	No Ice	4.0900	3.3000	0.06
			0.00				1/2" Ice	4.4900	3.6800	0.13
			0.00				1" Ice	4.8900	4.0600	0.20
(2) HBXX-6517DS-A2M w/ Mount Pipe	A	From Leg	3.5000		0.0000	111.0000	No Ice	7.9700	5.9900	0.08
			0.00				1/2" Ice	8.7300	6.7200	0.14
			2.00				1" Ice	9.5000	7.4700	0.22
(2) HBXX-6517DS-A2M w/ Mount Pipe	B	From Leg	3.5000		0.0000	111.0000	No Ice	7.9700	5.9900	0.08
			0.00				1/2" Ice	8.7300	6.7200	0.14
			2.00				1" Ice	9.5000	7.4700	0.22
(2) HBXX-6517DS-A2M w/ Mount Pipe	C	From Leg	3.5000		0.0000	111.0000	No Ice	7.9700	5.9900	0.08
			0.00				1/2" Ice	8.7300	6.7200	0.14
			2.00				1" Ice	9.5000	7.4700	0.22
RRFDC-3315-PF-48	B	From Leg	1.0000		0.0000	111.0000	No Ice	3.7079	2.1921	0.02
			0.00				1/2" Ice	3.9505	2.3950	0.05
			4.42				1" Ice	4.2005	2.6056	0.09
RRFDC-3315-PF-48	C	From Leg	1.0000		0.0000	111.0000	No Ice	3.7079	2.1921	0.02
			0.00				1/2" Ice	3.9505	2.3950	0.05
			4.42				1" Ice	4.2005	2.6056	0.09
B25 RRH4X30	A	From Leg	3.5000		0.0000	111.0000	No Ice	2.2000	1.7417	0.06
			0.00				1/2" Ice	2.3926	1.9204	0.08
			2.00				1" Ice	2.5926	2.1065	0.10
B25 RRH4X30	B	From Leg	3.5000		0.0000	111.0000	No Ice	2.2000	1.7417	0.06
			0.00				1/2" Ice	2.3926	1.9204	0.08
			2.00				1" Ice	2.5926	2.1065	0.10
B25 RRH4X30	C	From Leg	3.5000		0.0000	111.0000	No Ice	2.2000	1.7417	0.06
			0.00				1/2" Ice	2.3926	1.9204	0.08
			2.00				1" Ice	2.5926	2.1065	0.10
B13 RRH 4X30	A	From Leg	3.5000		0.0000	111.0000	No Ice	2.0552	1.3201	0.06
			0.00				1/2" Ice	2.2405	1.4754	0.07
			2.00				1" Ice	2.4333	1.6376	0.09
B13 RRH 4X30	B	From Leg	3.5000		0.0000	111.0000	No Ice	2.0552	1.3201	0.06
			0.00				1/2" Ice	2.2405	1.4754	0.07
			2.00				1" Ice	2.4333	1.6376	0.09
B13 RRH 4X30	C	From Leg	3.5000		0.0000	111.0000	No Ice	2.0552	1.3201	0.06
			0.00				1/2" Ice	2.2405	1.4754	0.07
			2.00				1" Ice	2.4333	1.6376	0.09
B4 RRH2X60-4R	A	From Leg	3.5000		0.0000	111.0000	No Ice	3.3554	2.0048	0.06
			0.00				1/2" Ice	3.6120	2.2369	0.08
			2.00				1" Ice	3.8757	2.4759	0.10
B4 RRH2X60-4R	B	From Leg	3.5000		0.0000	111.0000	No Ice	3.3554	2.0048	0.06
			0.00				1/2" Ice	3.6120	2.2369	0.08
			2.00				1" Ice	3.8757	2.4759	0.10

<b>tnxTower</b>  <b>EFI Global, Inc.</b> 1117 Perimeter Center West, Suite E500 Atlanta, GA 30338 Phone: (470) 990-6593 FAX:	<b>Job</b>	CT11365D	<b>Page</b>	13 of 34
	<b>Project</b>	049.00421 - 2075019	<b>Date</b>	14:16:25 04/21/21
	<b>Client</b>	Foresite LLC	<b>Designed by</b>	Evan.Martin

Description	Face or Leg	Offset Type	Offsets: Horz Lateral Vert	Azimuth Adjustment	Placement	CAAA Front	CAAA Side	Weight
			ft ft ft	°	ft	ft <sup>2</sup>	ft <sup>2</sup>	K
B4 RRH2X60-4R	C	From Leg	3.5000 0.00 2.00	0.0000	111.0000	No Ice 3.3554 1/2" Ice 3.6120 1" Ice 3.8757	2.0048 2.2369 2.4759	0.06 0.08 0.10
RMQP 12' Platform w/ handrails	C	None		0.0000	111.0000	No Ice 26.3000 1/2" Ice 35.6000 1" Ice 44.9000	26.3000 35.6000 44.9000	1.92 2.34 2.76
***55***								
3' Side Mount Standoff	B	From Leg	1.5000 0.00 0.00	0.0000	51.7500	No Ice 1.5000 1/2" Ice 2.2000 1" Ice 2.9000	1.5000 2.2000 2.9000	0.04 0.07 0.10
GPS	B	From Leg	3.0000 0.00 0.00	0.0000	51.7500	No Ice 0.2100 1/2" Ice 0.3100 1" Ice 0.4100	0.2100 0.3100 0.4100	0.01 0.01 0.01
12" x 2.5" x 1.5" TMA	B	From Leg	3.0000 0.00 0.00	0.0000	51.7500	No Ice 0.5602 1/2" Ice 0.6590 1" Ice 0.7652	0.3658 0.4493 0.5429	0.02 0.02 0.03

## Dishes

Description	Face or Leg	Dish Type	Offset Type	Offsets: Horz Lateral Vert	Azimuth Adjustment	3 dB Beam Width	Elevation	Outside Diameter	Aperture Area	Weight
				ft ft ft	°	°	ft	ft	ft <sup>2</sup>	K
HPD2-18RS	A	Paraboloid w/Shroud (HP)	From Leg	3.0000 0.00 0.00	70.0000		189.5000	2.0000	No Ice 3.1400 1/2" Ice 3.4100 1" Ice 3.6800	0.03 0.04 0.06
HPD2-18RS	A	Paraboloid w/Shroud (HP)	From Leg	3.0000 0.00 0.00	-60.0000		189.5000	2.0000	No Ice 3.1400 1/2" Ice 3.4100 1" Ice 3.6800	0.03 0.04 0.06
3' Dish w/ Randome	B	Paraboloid w/Radome	From Leg	3.5000 0.00 0.00	-10.0000		150.5000	3.0000	No Ice 7.1000 1/2" Ice 7.9000 1" Ice 8.7000	0.05 0.08 0.11
Andrew VHLP2-23	C	Paraboloid w/Radome	From Leg	3.5000 0.00 0.00	10.0000		151.5000	2.0000	No Ice 3.1400 1/2" Ice 6.4100 1" Ice 9.6800	0.03 0.04 0.05
Andrew VHLP2-18	A	Paraboloid w/Radome	From Leg	3.5000 0.00 0.00	-40.0000		150.5000	2.0000	No Ice 3.1400 1/2" Ice 6.4100 1" Ice 9.6800	0.03 0.04 0.05

## Load Combinations

Comb. No.	Description
1	Dead Only
2	1.2 Dead+1.6 Wind 0 deg - No Ice
3	0.9 Dead+1.6 Wind 0 deg - No Ice
4	1.2 Dead+1.6 Wind 30 deg - No Ice

<b>tnxTower</b>  <b>EFI Global, Inc.</b> 1117 Perimeter Center West, Suite E500 Atlanta, GA 30338 Phone: (470) 990-6593 FAX:	<b>Job</b>	CT11365D	<b>Page</b>	14 of 34
	<b>Project</b>	049.00421 - 2075019	<b>Date</b>	14:16:25 04/21/21
	<b>Client</b>	Foresite LLC	<b>Designed by</b>	Evan.Martin

<i>Comb. No.</i>	<i>Description</i>
5	0.9 Dead+1.6 Wind 30 deg - No Ice
6	1.2 Dead+1.6 Wind 60 deg - No Ice
7	0.9 Dead+1.6 Wind 60 deg - No Ice
8	1.2 Dead+1.6 Wind 90 deg - No Ice
9	0.9 Dead+1.6 Wind 90 deg - No Ice
10	1.2 Dead+1.6 Wind 120 deg - No Ice
11	0.9 Dead+1.6 Wind 120 deg - No Ice
12	1.2 Dead+1.6 Wind 150 deg - No Ice
13	0.9 Dead+1.6 Wind 150 deg - No Ice
14	1.2 Dead+1.6 Wind 180 deg - No Ice
15	0.9 Dead+1.6 Wind 180 deg - No Ice
16	1.2 Dead+1.6 Wind 210 deg - No Ice
17	0.9 Dead+1.6 Wind 210 deg - No Ice
18	1.2 Dead+1.6 Wind 240 deg - No Ice
19	0.9 Dead+1.6 Wind 240 deg - No Ice
20	1.2 Dead+1.6 Wind 270 deg - No Ice
21	0.9 Dead+1.6 Wind 270 deg - No Ice
22	1.2 Dead+1.6 Wind 300 deg - No Ice
23	0.9 Dead+1.6 Wind 300 deg - No Ice
24	1.2 Dead+1.6 Wind 330 deg - No Ice
25	0.9 Dead+1.6 Wind 330 deg - No Ice
26	1.2 Dead+1.0 Ice+1.0 Temp
27	1.2 Dead+1.0 Wind 0 deg+1.0 Ice+1.0 Temp
28	1.2 Dead+1.0 Wind 30 deg+1.0 Ice+1.0 Temp
29	1.2 Dead+1.0 Wind 60 deg+1.0 Ice+1.0 Temp
30	1.2 Dead+1.0 Wind 90 deg+1.0 Ice+1.0 Temp
31	1.2 Dead+1.0 Wind 120 deg+1.0 Ice+1.0 Temp
32	1.2 Dead+1.0 Wind 150 deg+1.0 Ice+1.0 Temp
33	1.2 Dead+1.0 Wind 180 deg+1.0 Ice+1.0 Temp
34	1.2 Dead+1.0 Wind 210 deg+1.0 Ice+1.0 Temp
35	1.2 Dead+1.0 Wind 240 deg+1.0 Ice+1.0 Temp
36	1.2 Dead+1.0 Wind 270 deg+1.0 Ice+1.0 Temp
37	1.2 Dead+1.0 Wind 300 deg+1.0 Ice+1.0 Temp
38	1.2 Dead+1.0 Wind 330 deg+1.0 Ice+1.0 Temp
39	Dead+Wind 0 deg - Service
40	Dead+Wind 30 deg - Service
41	Dead+Wind 60 deg - Service
42	Dead+Wind 90 deg - Service
43	Dead+Wind 120 deg - Service
44	Dead+Wind 150 deg - Service
45	Dead+Wind 180 deg - Service
46	Dead+Wind 210 deg - Service
47	Dead+Wind 240 deg - Service
48	Dead+Wind 270 deg - Service
49	Dead+Wind 300 deg - Service
50	Dead+Wind 330 deg - Service

### Maximum Member Forces

<i>Section No.</i>	<i>Elevation ft</i>	<i>Component Type</i>	<i>Condition</i>	<i>Gov. Load Comb.</i>	<i>Axial K</i>	<i>Major Axis Moment kip-ft</i>	<i>Minor Axis Moment kip-ft</i>
L1	183 - 165.5	Pole	Max Tension	8	0.00	0.00	-0.00
			Max. Compression	26	-7.11	2.06	0.42
			Max. Mx	20	-1.89	45.59	0.03
			Max. My	2	-1.92	0.21	42.71
			Max. Vy	20	-3.13	45.59	0.03
			Max. Vx	14	3.02	-0.27	-42.69
			Max. Torque	16			-2.39

<b>tnxTower</b>  <b>EFI Global, Inc.</b> 1117 Perimeter Center West, Suite E500 Atlanta, GA 30338 Phone: (470) 990-6593 FAX:	<b>Job</b>	CT11365D	<b>Page</b>	15 of 34
	<b>Project</b>	049.00421 - 2075019	<b>Date</b>	14:16:25 04/21/21
	<b>Client</b>	Foresite LLC	<b>Designed by</b>	Evan.Martin

Section No.	Elevation ft	Component Type	Condition	Gov. Load Comb.	Axial K	Major Axis Moment kip-ft	Minor Axis Moment kip-ft
L2	165.5 - 132.08	Pole	Max Tension	1	0.00	0.00	0.00
			Max. Compression	26	-70.99	0.93	0.32
			Max. Mx	20	-16.75	521.23	1.11
			Max. My	2	-16.87	1.19	511.74
			Max. Vy	8	24.44	-521.13	-1.94
			Max. Vx	2	-24.03	1.19	511.74
			Max. Torque	16			-2.48
L3	132.08 - 86.99	Pole	Max Tension	1	0.00	0.00	0.00
			Max. Compression	26	-111.25	4.31	3.71
			Max. Mx	20	-31.76	1829.42	3.09
			Max. My	2	-31.86	4.69	1800.48
			Max. Vy	8	34.56	-1828.65	-4.90
			Max. Vx	2	-34.09	4.69	1800.48
			Max. Torque	16			-2.48
L4	86.99 - 42.91	Pole	Max Tension	1	0.00	0.00	0.00
			Max. Compression	26	-139.49	4.96	6.88
			Max. Mx	20	-45.95	3375.47	4.79
			Max. My	2	-46.00	7.61	3326.74
			Max. Vy	8	37.42	-3375.15	-7.95
			Max. Vx	2	-36.96	7.61	3326.74
			Max. Torque	16			-2.36
L5	42.91 - 0	Pole	Max Tension	1	0.00	0.00	0.00
			Max. Compression	26	-175.12	5.94	10.47
			Max. Mx	20	-65.06	5266.41	6.96
			Max. My	2	-65.06	11.16	5195.84
			Max. Vy	8	39.43	-5265.98	-11.19
			Max. Vx	2	-39.00	11.16	5195.84
			Max. Torque	16			-2.05

### Maximum Reactions

Location	Condition	Gov. Load Comb.	Vertical K	Horizontal, X K	Horizontal, Z K
Pole	Max. Vert	26	175.12	-0.00	-0.00
	Max. H <sub>x</sub>	21	48.83	39.35	0.04
	Max. H <sub>z</sub>	3	48.83	0.07	38.92
	Max. M <sub>x</sub>	2	5195.84	0.07	38.92
	Max. M <sub>z</sub>	8	5265.98	-39.36	-0.07
	Max. Torsion	2	1.88	0.07	38.92
	Min. Vert	21	48.83	39.35	0.04
	Min. H <sub>x</sub>	9	48.83	-39.36	-0.07
	Min. H <sub>z</sub>	15	48.83	-0.05	-38.89
	Min. M <sub>x</sub>	14	-5189.32	-0.05	-38.89
	Min. M <sub>z</sub>	20	-5266.41	39.35	0.04
	Min. Torsion	16	-2.04	19.67	-33.65

### Tower Mast Reaction Summary

Load Combination	Vertical K	Shear <sub>x</sub> K	Shear <sub>z</sub> K	Overturning Moment, M <sub>x</sub> kip-ft	Overturning Moment, M <sub>z</sub> kip-ft	Torque kip-ft
Dead Only	54.25	0.00	0.00	-0.73	0.23	0.00

<p style="text-align: center;"><b>tnxTower</b></p> <p style="text-align: center;"><b>EFI Global, Inc.</b> 1117 Perimeter Center West, Suite E500 Atlanta, GA 30338 Phone: (470) 990-6593 FAX:</p>	<b>Job</b>	CT11365D	<b>Page</b>	16 of 34
	<b>Project</b>	049.00421 - 2075019	<b>Date</b>	14:16:25 04/21/21
	<b>Client</b>	Foresite LLC	<b>Designed by</b>	Evan.Martin

Load Combination	Vertical	Shear <sub>x</sub>	Shear <sub>z</sub>	Overturning Moment, M <sub>x</sub>	Overturning Moment, M <sub>z</sub>	Torque
	K	K	K	kip-ft	kip-ft	kip-ft
1.2 Dead+1.6 Wind 0 deg - No Ice	65.10	-0.07	-38.92	-5195.84	11.16	-1.88
0.9 Dead+1.6 Wind 0 deg - No Ice	48.83	-0.07	-38.92	-5076.87	10.82	-1.87
1.2 Dead+1.6 Wind 30 deg - No Ice	65.10	19.55	-33.66	-4491.90	-2613.28	-1.82
0.9 Dead+1.6 Wind 30 deg - No Ice	48.83	19.55	-33.66	-4389.03	-2553.57	-1.80
1.2 Dead+1.6 Wind 60 deg - No Ice	65.10	34.00	-19.35	-2576.42	-4547.61	-1.06
0.9 Dead+1.6 Wind 60 deg - No Ice	48.83	34.00	-19.35	-2517.42	-4443.64	-1.04
1.2 Dead+1.6 Wind 90 deg - No Ice	65.10	39.36	0.07	11.19	-5265.98	-0.11
0.9 Dead+1.6 Wind 90 deg - No Ice	48.83	39.36	0.07	11.14	-5145.64	-0.09
1.2 Dead+1.6 Wind 120 deg - No Ice	65.10	34.14	19.54	2607.82	-4570.67	0.43
0.9 Dead+1.6 Wind 120 deg - No Ice	48.83	34.14	19.54	2548.51	-4466.16	0.45
1.2 Dead+1.6 Wind 150 deg - No Ice	65.10	19.75	33.74	4503.01	-2648.02	0.96
0.9 Dead+1.6 Wind 150 deg - No Ice	48.83	19.75	33.74	4400.37	-2587.42	0.96
1.2 Dead+1.6 Wind 180 deg - No Ice	65.10	0.05	38.89	5189.32	-7.97	1.68
0.9 Dead+1.6 Wind 180 deg - No Ice	48.83	0.05	38.89	5070.98	-7.82	1.67
1.2 Dead+1.6 Wind 210 deg - No Ice	65.10	-19.67	33.65	4487.33	2636.51	2.04
0.9 Dead+1.6 Wind 210 deg - No Ice	48.83	-19.67	33.65	4385.04	2576.03	2.02
1.2 Dead+1.6 Wind 240 deg - No Ice	65.10	-34.06	19.45	2593.86	4559.43	1.09
0.9 Dead+1.6 Wind 240 deg - No Ice	48.83	-34.06	19.45	2534.86	4455.01	1.07
1.2 Dead+1.6 Wind 270 deg - No Ice	65.10	-39.35	-0.04	-6.96	5266.41	-0.01
0.9 Dead+1.6 Wind 270 deg - No Ice	48.83	-39.35	-0.04	-6.54	5145.89	-0.02
1.2 Dead+1.6 Wind 300 deg - No Ice	65.10	-34.13	-19.49	-2600.07	4569.21	-0.80
0.9 Dead+1.6 Wind 300 deg - No Ice	48.83	-34.13	-19.49	-2540.48	4464.56	-0.81
1.2 Dead+1.6 Wind 330 deg - No Ice	65.10	-19.71	-33.79	-4511.56	2639.00	-1.39
0.9 Dead+1.6 Wind 330 deg - No Ice	48.83	-19.71	-33.79	-4408.22	2578.52	-1.39
1.2 Dead+1.0 Ice+1.0 Temp	175.12	0.00	0.00	-10.47	5.94	0.00
1.2 Dead+1.0 Wind 0 deg+1.0 Ice+1.0 Temp	175.12	-0.00	-11.52	-1998.35	6.63	-1.18
1.2 Dead+1.0 Wind 30 deg+1.0 Ice+1.0 Temp	175.12	5.79	-9.97	-1731.18	-994.46	-1.23
1.2 Dead+1.0 Wind 60 deg+1.0 Ice+1.0 Temp	175.12	10.05	-5.74	-998.88	-1733.30	-0.82
1.2 Dead+1.0 Wind 90 deg+1.0 Ice+1.0 Temp	175.12	11.65	0.02	-5.93	-2011.37	-0.26
1.2 Dead+1.0 Wind 120 deg+1.0 Ice+1.0 Temp	175.12	10.10	5.80	990.88	-1744.33	0.28
1.2 Dead+1.0 Wind 150 deg+1.0 Ice+1.0 Temp	175.12	5.84	10.00	1715.46	-1006.15	0.71



<b>tnxTower</b>  <b>EFI Global, Inc.</b> 1117 Perimeter Center West, Suite E500 Atlanta, GA 30338 Phone: (470) 990-6593 FAX:	<b>Job</b> CT11365D	<b>Page</b> 17 of 34
	<b>Project</b> 049.00421 - 2075019	<b>Date</b> 14:16:25 04/21/21
	<b>Client</b> Foresite LLC	<b>Designed by</b> Evan.Martin

Load Combination	Vertical K	Shear <sub>x</sub> K	Shear <sub>z</sub> K	Overturning Moment, M <sub>x</sub> kip-ft	Overturning Moment, M <sub>z</sub> kip-ft	Torque kip-ft
1.2 Dead+1.0 Wind 180 deg+1.0 Ice+1.0 Temp	175.12	0.02	11.52	1978.47	1.39	1.10
1.2 Dead+1.0 Wind 210 deg+1.0 Ice+1.0 Temp	175.12	-5.79	9.96	1708.53	1007.19	1.17
1.2 Dead+1.0 Wind 240 deg+1.0 Ice+1.0 Temp	175.12	-10.03	5.77	984.89	1740.19	0.76
1.2 Dead+1.0 Wind 270 deg+1.0 Ice+1.0 Temp	175.12	-11.59	-0.01	-12.89	2011.50	0.14
1.2 Dead+1.0 Wind 300 deg+1.0 Ice+1.0 Temp	175.12	-10.05	-5.76	-1004.74	1744.94	-0.32
1.2 Dead+1.0 Wind 330 deg+1.0 Ice+1.0 Temp	175.12	-5.79	-10.00	-1736.65	1007.15	-0.83
Dead+Wind 0 deg - Service	54.25	-0.01	-7.11	-939.02	2.24	-0.36
Dead+Wind 30 deg - Service	54.25	3.57	-6.15	-811.76	-471.66	-0.35
Dead+Wind 60 deg - Service	54.25	6.21	-3.53	-465.91	-821.00	-0.22
Dead+Wind 90 deg - Service	54.25	7.19	0.01	1.38	-951.06	-0.02
Dead+Wind 120 deg - Service	54.25	6.23	3.57	470.34	-825.23	0.10
Dead+Wind 150 deg - Service	54.25	3.61	6.16	812.54	-477.96	0.20
Dead+Wind 180 deg - Service	54.25	0.01	7.10	936.56	-1.21	0.32
Dead+Wind 210 deg - Service	54.25	-3.59	6.14	809.67	476.31	0.37
Dead+Wind 240 deg - Service	54.25	-6.22	3.55	467.79	823.61	0.19
Dead+Wind 270 deg - Service	54.25	-7.19	-0.01	-1.89	951.57	-0.00
Dead+Wind 300 deg - Service	54.25	-6.23	-3.56	-470.20	825.39	-0.13
Dead+Wind 330 deg - Service	54.25	-3.60	-6.17	-815.35	476.78	-0.25

## Solution Summary

Load Comb.	Sum of Applied Forces			Sum of Reactions			% Error
	PX K	PY K	PZ K	PX K	PY K	PZ K	
1	0.00	-54.25	0.00	-0.00	54.25	-0.00	0.000%
2	-0.07	-65.10	-38.93	0.07	65.10	38.92	0.007%
3	-0.07	-48.83	-38.93	0.07	48.83	38.92	0.008%
4	19.55	-65.10	-33.66	-19.55	65.10	33.66	0.000%
5	19.55	-48.83	-33.66	-19.55	48.83	33.66	0.000%
6	34.00	-65.10	-19.35	-34.00	65.10	19.35	0.000%
7	34.00	-48.83	-19.35	-34.00	48.83	19.35	0.000%
8	39.36	-65.10	0.07	-39.36	65.10	-0.07	0.011%
9	39.36	-48.83	0.07	-39.36	48.83	-0.07	0.013%
10	34.14	-65.10	19.54	-34.14	65.10	-19.54	0.000%
11	34.14	-48.83	19.54	-34.14	48.83	-19.54	0.000%
12	19.75	-65.10	33.74	-19.75	65.10	-33.74	0.000%
13	19.75	-48.83	33.74	-19.75	48.83	-33.74	0.000%
14	0.05	-65.10	38.90	-0.05	65.10	-38.89	0.007%
15	0.05	-48.83	38.90	-0.05	48.83	-38.89	0.008%
16	-19.67	-65.10	33.65	19.67	65.10	-33.65	0.000%
17	-19.67	-48.83	33.65	19.67	48.83	-33.65	0.000%
18	-34.06	-65.10	19.45	34.06	65.10	-19.45	0.000%
19	-34.06	-48.83	19.45	34.06	48.83	-19.45	0.000%
20	-39.36	-65.10	-0.04	39.35	65.10	0.04	0.011%
21	-39.36	-48.83	-0.04	39.35	48.83	0.04	0.013%
22	-34.13	-65.10	-19.49	34.13	65.10	19.49	0.000%
23	-34.13	-48.83	-19.49	34.13	48.83	19.49	0.000%
24	-19.71	-65.10	-33.79	19.71	65.10	33.79	0.000%
25	-19.71	-48.83	-33.79	19.71	48.83	33.79	0.000%
26	0.00	-175.12	0.00	-0.00	175.12	-0.00	0.000%
27	-0.00	-175.12	-11.52	0.00	175.12	11.52	0.002%
28	5.79	-175.12	-9.97	-5.79	175.12	9.97	0.002%

<b>tnxTower</b>  <b>EFI Global, Inc.</b> 1117 Perimeter Center West, Suite E500 Atlanta, GA 30338 Phone: (470) 990-6593 FAX:	<b>Job</b>	CT11365D	<b>Page</b>	18 of 34
	<b>Project</b>	049.00421 - 2075019	<b>Date</b>	14:16:25 04/21/21
	<b>Client</b>	Foresite LLC	<b>Designed by</b>	Evan.Martin

Load Comb.	Sum of Applied Forces			Sum of Reactions			% Error
	PX K	PY K	PZ K	PX K	PY K	PZ K	
29	10.06	-175.12	-5.74	-10.05	175.12	5.74	0.002%
30	11.65	-175.12	0.02	-11.65	175.12	-0.02	0.002%
31	10.11	-175.12	5.80	-10.10	175.12	-5.80	0.002%
32	5.84	-175.12	10.00	-5.84	175.12	-10.00	0.002%
33	0.02	-175.12	11.53	-0.02	175.12	-11.52	0.002%
34	-5.79	-175.12	9.97	5.79	175.12	-9.96	0.002%
35	-10.03	-175.12	5.77	10.03	175.12	-5.77	0.002%
36	-11.60	-175.12	-0.01	11.59	175.12	0.01	0.002%
37	-10.05	-175.12	-5.76	10.05	175.12	5.76	0.002%
38	-5.79	-175.12	-10.00	5.79	175.12	10.00	0.002%
39	-0.01	-54.25	-7.11	0.01	54.25	7.11	0.002%
40	3.57	-54.25	-6.15	-3.57	54.25	6.15	0.002%
41	6.21	-54.25	-3.53	-6.21	54.25	3.53	0.002%
42	7.19	-54.25	0.01	-7.19	54.25	-0.01	0.002%
43	6.23	-54.25	3.57	-6.23	54.25	-3.57	0.002%
44	3.61	-54.25	6.16	-3.61	54.25	-6.16	0.002%
45	0.01	-54.25	7.10	-0.01	54.25	-7.10	0.002%
46	-3.59	-54.25	6.14	3.59	54.25	-6.14	0.002%
47	-6.22	-54.25	3.55	6.22	54.25	-3.55	0.002%
48	-7.19	-54.25	-0.01	7.19	54.25	0.01	0.002%
49	-6.23	-54.25	-3.56	6.23	54.25	3.56	0.002%
50	-3.60	-54.25	-6.17	3.60	54.25	6.17	0.002%

## Non-Linear Convergence Results

Load Combination	Converged?	Number of Cycles	Displacement Tolerance	Force Tolerance
1	Yes	6	0.0000001	0.0000001
2	Yes	22	0.00007158	0.00012411
3	Yes	21	0.00007024	0.00014512
4	Yes	29	0.00000001	0.00009240
5	Yes	28	0.00000001	0.00009176
6	Yes	29	0.00000001	0.00009558
7	Yes	28	0.00000001	0.00009504
8	Yes	21	0.00011410	0.00008927
9	Yes	20	0.00011363	0.00010804
10	Yes	29	0.00000001	0.00009650
11	Yes	28	0.00000001	0.00009587
12	Yes	29	0.00000001	0.00009492
13	Yes	28	0.00000001	0.00009428
14	Yes	22	0.00007160	0.00009574
15	Yes	21	0.00007026	0.00011346
16	Yes	29	0.00000001	0.00009713
17	Yes	28	0.00000001	0.00009669
18	Yes	29	0.00000001	0.00009420
19	Yes	28	0.00000001	0.00009349
20	Yes	21	0.00011409	0.00009572
21	Yes	20	0.00011362	0.00011461
22	Yes	29	0.00000001	0.00009523
23	Yes	28	0.00000001	0.00009449
24	Yes	29	0.00000001	0.00009690
25	Yes	28	0.00000001	0.00009633
26	Yes	20	0.00000001	0.00000156
27	Yes	30	0.00012600	0.00001541
28	Yes	30	0.00012488	0.00009078
29	Yes	30	0.00012485	0.00009792

<b>tnxTower</b>  <b>EFI Global, Inc.</b> 1117 Perimeter Center West, Suite E500 Atlanta, GA 30338 Phone: (470) 990-6593 FAX:	<b>Job</b>	CT11365D	<b>Page</b>	19 of 34
	<b>Project</b>	049.00421 - 2075019	<b>Date</b>	14:16:25 04/21/21
	<b>Client</b>	Foresite LLC	<b>Designed by</b>	Evan.Martin

30	Yes	30	0.00012593	0.00001169
31	Yes	30	0.00012481	0.00009693
32	Yes	30	0.00012486	0.00009233
33	Yes	30	0.00012604	0.00001459
34	Yes	30	0.00012487	0.00009937
35	Yes	30	0.00012484	0.00009314
36	Yes	30	0.00012593	0.00001177
37	Yes	30	0.00012478	0.00009668
38	Yes	30	0.00012480	0.00010074
39	Yes	21	0.00009658	0.00002071
40	Yes	21	0.00009638	0.00002422
41	Yes	21	0.00009638	0.00003022
42	Yes	21	0.00009657	0.00001991
43	Yes	21	0.00009637	0.00002883
44	Yes	21	0.00009637	0.00002586
45	Yes	21	0.00009658	0.00002040
46	Yes	21	0.00009637	0.00003170
47	Yes	21	0.00009637	0.00002573
48	Yes	21	0.00009657	0.00001994
49	Yes	21	0.00009637	0.00002713
50	Yes	21	0.00009637	0.00003044

### Maximum Tower Deflections - Service Wind

Section No.	Elevation ft	Horz. Deflection in	Gov. Load Comb.	Tilt °	Twist °
L1	183 - 165.5	41.85	48	2.0395	0.0126
L2	168.5 - 132.08	35.72	48	1.9876	0.0065
L3	135.91 - 86.99	22.94	48	1.6802	0.0025
L4	91.99 - 42.91	10.09	48	1.0723	0.0010
L5	49.08 - 0	2.80	48	0.5325	0.0003

### Critical Deflections and Radius of Curvature - Service Wind

Elevation ft	Appurtenance	Gov. Load Comb.	Deflection in	Tilt °	Twist °	Radius of Curvature ft
189.7500	Lightning Rod w/ Pipe Extension	48	41.85	2.0395	0.0126	37706
189.5000	HPD2-18RS	48	41.85	2.0395	0.0126	37706
184.0000	14' Low Profile Platform	48	41.85	2.0395	0.0126	37706
163.0000	AIR 32 B2a/B66Aa w/ Mount Pipe	48	33.44	1.9543	0.0050	9535
159.0000	Ring Mount	48	31.80	1.9244	0.0042	7986
154.0000	APXVSPP18-C w/ Mount Pipe	48	29.79	1.8810	0.0035	6638
153.8300	MTI1669	48	29.72	1.8794	0.0035	6600
151.5000	Andrew VHLP2-23	48	28.80	1.8570	0.0032	6122
150.5000	3' Dish w/ Randome	48	28.41	1.8470	0.0032	5937
145.0000	800 10121	48	26.28	1.7884	0.0028	5091
132.0800	15' Whip	48	21.60	1.6313	0.0024	4132
129.4200	5'-6" Whip	48	20.70	1.5964	0.0023	4147
128.5000	24" Yagi	48	20.39	1.5842	0.0023	4152
128.1700	20' 4-Bay Dipole	48	20.28	1.5798	0.0023	4154
125.0800	15" Yagi	48	19.26	1.5382	0.0022	4172
123.0000	13' Low Profile Platform	48	18.59	1.5097	0.0021	4184
121.7500	2'6" Yagi	48	18.20	1.4925	0.0021	4191
111.0000	(2) LNX-6514DS-A1M w/ Mount	48	14.98	1.3411	0.0016	4251

<b>tnxTower</b>  <b>EFI Global, Inc.</b> 1117 Perimeter Center West, Suite E500 Atlanta, GA 30338 Phone: (470) 990-6593 FAX:	<b>Job</b> CT11365D	<b>Page</b> 20 of 34
	<b>Project</b> 049.00421 - 2075019	<b>Date</b> 14:16:25 04/21/21
	<b>Client</b> Foresite LLC	<b>Designed by</b> Evan.Martin

Elevation	Appurtenance	Gov. Load Comb.	Deflection in	Tilt °	Twist °	Radius of Curvature ft
51.7500	Pipe 3' Side Mount Standoff	48	3.10	0.5634	0.0003	3989

### Maximum Tower Deflections - Design Wind

Section No.	Elevation ft	Horz. Deflection in	Gov. Load Comb.	Tilt °	Twist °
L1	183 - 165.5	231.12	20	11.2789	0.0647
L2	168.5 - 132.08	197.42	20	11.0124	0.0324
L3	135.91 - 86.99	126.94	20	9.3177	0.0131
L4	91.99 - 42.91	55.89	20	5.9466	0.0051
L5	49.08 - 0	15.54	20	2.9514	0.0018

### Critical Deflections and Radius of Curvature - Design Wind

Elevation ft	Appurtenance	Gov. Load Comb.	Deflection in	Tilt °	Twist °	Radius of Curvature ft
189.7500	Lightning Rod w/ Pipe Extension	20	231.12	11.2789	0.0647	7687
189.5000	HPD2-18RS	20	231.12	11.2789	0.0647	7687
184.0000	14' Low Profile Platform	20	231.12	11.2789	0.0647	7687
163.0000	AIR 32 B2a/B66Aa w/ Mount Pipe	20	184.84	10.8326	0.0265	1895
159.0000	Ring Mount	20	175.82	10.6691	0.0225	1569
154.0000	APXVSPP18-C w/ Mount Pipe	20	164.72	10.4303	0.0189	1290
153.8300	MT11669	20	164.35	10.4215	0.0188	1283
151.5000	Andrew VHLP2-23	20	159.27	10.2978	0.0176	1185
150.5000	3' Dish w/ Randome	20	157.10	10.2426	0.0171	1147
145.0000	800 10121	20	145.40	9.9181	0.0152	976
132.0800	15' Whip	20	119.54	9.0465	0.0126	782
129.4200	5'-6" Whip	20	114.53	8.8531	0.0122	783
128.5000	24" Yagi	20	112.83	8.7853	0.0121	784
128.1700	20' 4-Bay Dipole	20	112.22	8.7609	0.0120	784
125.0800	15" Yagi	20	106.61	8.5299	0.0115	785
123.0000	13' Low Profile Platform	20	102.92	8.3721	0.0112	786
121.7500	2'6" Yagi	20	100.74	8.2765	0.0109	787
111.0000	(2) LNX-6514DS-A1M w/ Mount Pipe	20	82.96	7.4375	0.0088	792
51.7500	3' Side Mount Standoff	20	17.18	3.1230	0.0019	723

### Compression Checks

### Pole Design Data

<b>tnxTower</b>  <b>EFI Global, Inc.</b> 1117 Perimeter Center West, Suite E500 Atlanta, GA 30338 Phone: (470) 990-6593 FAX:	<b>Job</b>	CT11365D	<b>Page</b>	21 of 34
	<b>Project</b>	049.00421 - 2075019	<b>Date</b>	14:16:25 04/21/21
	<b>Client</b>	Foresite LLC	<b>Designed by</b>	Evan.Martin

Section No.	Elevation ft	Size	L ft	L <sub>u</sub> ft	Kl/r	A in <sup>2</sup>	P <sub>u</sub> K	φP <sub>n</sub> K	Ratio $\frac{P_u}{\phi P_n}$					
L1	183 - 181.964	TP19.42x15.5x0.1875	17.5000	0.0000	0.0	9.2509	-1.44	687.30	0.002					
	181.964 - 180.929					9.3890	-1.47	697.55	0.002					
	180.929 - 179.893					9.5271	-1.50	707.81	0.002					
	179.893 - 178.857					9.6651	-1.53	718.07	0.002					
	178.857 - 177.821					9.8032	-1.56	728.33	0.002					
	177.821 - 176.786					9.9413	-1.60	738.59	0.002					
	176.786 - 175.75					10.0793	-1.63	748.84	0.002					
	175.75 - 174.714					10.2174	-1.67	759.10	0.002					
	174.714 - 173.679					10.3555	-1.70	769.36	0.002					
	173.679 - 172.643					10.4935	-1.74	779.62	0.002					
	172.643 - 171.607					10.6316	-1.77	789.88	0.002					
	171.607 - 170.571					10.7697	-1.81	800.13	0.002					
	170.571 - 169.536					10.9077	-1.85	810.39	0.002					
	169.536 - 168.5					11.0458	-1.89	820.65	0.002					
	168.5 - 165.5					11.4457	-0.94	845.01	0.001					
	L2					168.5 - 165.5	TP26.41x18.373x0.25	36.4200	0.0000	0.0	14.9059	-1.24	1107.44	0.001
						165.5 - 163.856					15.1938	-2.32	1128.82	0.002
163.856 - 162.212		15.4816	-7.40	1150.21	0.006									
162.212 - 160.568		15.7695	-7.55	1171.59	0.006									
160.568 - 158.924		16.0573	-7.80	1192.98	0.007									
158.924 - 157.281		16.3452	-7.96	1214.37	0.007									
157.281 - 155.637		16.6330	-8.12	1235.75	0.007									
155.637 - 153.993		16.9209	-10.78	1257.14	0.009									
153.993 - 152.349		17.2088	-11.00	1278.52	0.009									
152.349 - 150.705		17.4966	-11.19	1299.91	0.009									
150.705 - 149.061		17.7845	-11.40	1321.30	0.009									
149.061 - 147.417		18.0723	-11.59	1342.68	0.009									
147.417 - 145.773		18.3602	-11.78	1364.07	0.009									
145.773 - 144.129		18.6480	-15.63	1385.46	0.011									
144.129 - 142.486		18.9359	-15.84	1406.84	0.011									
142.486 - 140.842		19.2237	-16.06	1428.23	0.011									
140.842 -		19.5116	-16.29	1449.61	0.011									

<b>tnxTower</b>  <b>EFI Global, Inc.</b> 1117 Perimeter Center West, Suite E500 Atlanta, GA 30338 Phone: (470) 990-6593 FAX:	<b>Job</b>	CT11365D	<b>Page</b>	22 of 34
	<b>Project</b>	049.00421 - 2075019	<b>Date</b>	14:16:25 04/21/21
	<b>Client</b>	Foresite LLC	<b>Designed by</b>	Evan.Martin

Section No.	Elevation ft	Size	L ft	L <sub>u</sub> ft	Kl/r	A in <sup>2</sup>	P <sub>u</sub> K	φP <sub>n</sub> K	Ratio $\frac{P_u}{\phi P_n}$
	139.198								
	139.198 - 137.554					19.7994	-16.52	1471.00	0.011
	137.554 - 135.91					20.0873	-16.75	1487.91	0.011
	135.91 - 132.08					20.7580	-7.21	1524.51	0.005
L3	135.91 - 132.08	TP35.88x25.0648x0.375	48.9200	0.0000	0.0	30.3949	-10.48	2258.19	0.005
	132.08 - 129.853					30.9809	-18.15	2301.73	0.008
	129.853 - 127.626					31.5670	-18.63	2345.27	0.008
	127.626 - 125.398					32.1531	-19.09	2388.81	0.008
	125.398 - 123.171					32.7392	-19.55	2432.36	0.008
	123.171 - 120.944					33.3252	-21.46	2475.90	0.009
	120.944 - 118.717					33.9113	-21.94	2519.44	0.009
	118.717 - 116.489					34.4974	-22.42	2562.98	0.009
	116.489 - 114.262					35.0834	-22.92	2606.52	0.009
	114.262 - 112.035					35.6695	-23.42	2650.07	0.009
	112.035 - 109.808					36.2556	-27.30	2693.61	0.010
	109.808 - 107.581					36.8416	-27.83	2737.15	0.010
	107.581 - 105.353					37.4277	-28.37	2780.69	0.010
	105.353 - 103.126					38.0138	-28.92	2824.23	0.010
	103.126 - 100.899					38.5998	-29.48	2867.78	0.010
	100.899 - 98.6717					39.1859	-30.04	2911.32	0.010
	98.6717 - 96.4444					39.7720	-30.61	2954.86	0.010
	96.4444 - 94.2172					40.3581	-31.18	2998.40	0.010
	94.2172 - 91.99					40.9441	-31.76	3041.94	0.010
	91.99 - 86.99					42.2598	-15.91	3139.69	0.005
L4	91.99 - 86.99	TP44.88x34.0246x0.4375	49.0800	0.0000	0.0	48.1756	-18.00	3579.20	0.005
	86.99 - 84.8839					48.8224	-34.54	3627.26	0.010
	84.8839 - 82.7778					49.4693	-35.16	3675.32	0.010
	82.7778 - 80.6717					50.1161	-35.78	3723.38	0.010
	80.6717 - 78.5656					50.7630	-36.42	3771.44	0.010
	78.5656 - 76.4594					51.4098	-37.05	3819.49	0.010
	76.4594 - 74.3533					52.0567	-37.70	3867.55	0.010
	74.3533 -					52.7035	-38.35	3915.61	0.010

<b>tnxTower</b>  <b>EFI Global, Inc.</b> 1117 Perimeter Center West, Suite E500 Atlanta, GA 30338 Phone: (470) 990-6593 FAX:	<b>Job</b>	CT11365D	<b>Page</b>	23 of 34
	<b>Project</b>	049.00421 - 2075019	<b>Date</b>	14:16:25 04/21/21
	<b>Client</b>	Foresite LLC	<b>Designed by</b>	Evan.Martin

Section No.	Elevation ft	Size	L ft	L <sub>u</sub> ft	Kl/r	A in <sup>2</sup>	P <sub>u</sub> K	φP <sub>n</sub> K	Ratio $\frac{P_u}{\phi P_n}$
	72.2472								
	72.2472 -					53.3504	-39.00	3963.67	0.010
	70.1411								
	70.1411 -					53.9973	-39.66	4011.73	0.010
	68.035								
	68.035 -					54.6441	-40.33	4059.78	0.010
	65.9289								
	65.9289 -					55.2910	-41.00	4107.84	0.010
	63.8228								
	63.8228 -					55.9378	-41.68	4155.90	0.010
	61.7167								
	61.7167 -					56.5847	-42.37	4203.96	0.010
	59.6106								
	59.6106 -					57.2315	-43.06	4252.02	0.010
	57.5044								
	57.5044 -					57.8784	-43.75	4300.08	0.010
	55.3983								
	55.3983 -					58.5252	-44.45	4348.13	0.010
	53.2922								
	53.2922 -					59.1721	-45.24	4396.19	0.010
	51.1861								
	51.1861 -					59.8190	-45.95	4444.25	0.010
	49.08								
	49.08 - 42.91					61.7140	-25.03	4567.55	0.005
L5	49.08 - 42.91	TP53.5x42.6403x0.4375	49.0800	0.0000	0.0	60.4997	-24.38	4494.82	0.005
	42.91 -					61.1936	-50.19	4538.80	0.011
	40.6516								
	40.6516 -					61.8875	-50.97	4577.10	0.011
	38.3932								
	38.3932 -					62.5814	-51.75	4615.11	0.011
	36.1347								
	36.1347 -					63.2753	-52.54	4652.81	0.011
	33.8763								
	33.8763 -					63.9692	-53.33	4690.23	0.011
	31.6179								
	31.6179 -					64.6631	-54.13	4727.34	0.011
	29.3595								
	29.3595 -					65.3570	-54.93	4764.17	0.012
	27.1011								
	27.1011 -					66.0509	-55.74	4800.69	0.012
	24.8426								
	24.8426 -					66.7448	-56.56	4836.92	0.012
	22.5842								
	22.5842 -					67.4387	-57.38	4872.86	0.012
	20.3258								
	20.3258 -					68.1327	-58.21	4908.50	0.012
	18.0674								
	18.0674 -					68.8266	-59.05	4943.85	0.012
	15.8089								
	15.8089 -					69.5205	-59.89	4978.90	0.012
	13.5505								
	13.5505 -					70.2144	-60.73	5013.65	0.012
	11.2921								
	11.2921 -					70.9083	-61.59	5048.11	0.012
	9.03368								
	9.03368 -					71.6022	-62.44	5082.28	0.012
	6.77526								
	6.77526 -					72.2961	-63.31	5116.15	0.012
	4.51684								
	4.51684 -					72.9900	-64.18	5149.72	0.012

<b>tnxTower</b>  <b>EFI Global, Inc.</b> 1117 Perimeter Center West, Suite E500 Atlanta, GA 30338 Phone: (470) 990-6593 FAX:	<b>Job</b>	CT11365D	<b>Page</b>	24 of 34
	<b>Project</b>	049.00421 - 2075019	<b>Date</b>	14:16:25 04/21/21
	<b>Client</b>	Foresite LLC	<b>Designed by</b>	Evan.Martin

Section No.	Elevation ft	Size	L ft	L <sub>u</sub> ft	Kl/r	A in <sup>2</sup>	P <sub>u</sub> K	φP <sub>n</sub> K	Ratio $\frac{P_u}{\phi P_n}$
	2.25842					73.6839	-65.06	5183.00	0.013
	2.25842 - 0								

### Pole Bending Design Data

Section No.	Elevation ft	Size	M <sub>ux</sub> kip-ft	φM <sub>ux</sub> kip-ft	Ratio $\frac{M_{ux}}{\phi M_{ux}}$	M <sub>uy</sub> kip-ft	φM <sub>uy</sub> kip-ft	Ratio $\frac{M_{uy}}{\phi M_{uy}}$		
L1	183 - 181.964	TP19.42x15.5x0.1875	8.89	218.78	0.041	0.00	218.78	0.000		
	181.964 - 180.929		11.35	225.40	0.050	0.00	225.40	0.000		
	180.929 - 179.893		13.86	232.12	0.060	0.00	232.12	0.000		
	179.893 - 178.857		16.44	238.93	0.069	0.00	238.93	0.000		
	178.857 - 177.821		19.07	245.85	0.078	0.00	245.85	0.000		
	177.821 - 176.786		21.76	252.86	0.086	0.00	252.86	0.000		
	176.786 - 175.75		24.52	259.97	0.094	0.00	259.97	0.000		
	175.75 - 174.714		27.34	267.18	0.102	0.00	267.18	0.000		
	174.714 - 173.679		30.22	274.49	0.110	0.00	274.49	0.000		
	173.679 - 172.643		33.16	281.90	0.118	0.00	281.90	0.000		
	172.643 - 171.607		36.17	289.41	0.125	0.00	289.41	0.000		
	171.607 - 170.571		39.24	297.01	0.132	0.00	297.01	0.000		
	170.571 - 169.536		42.39	304.71	0.139	0.00	304.71	0.000		
	169.536 - 168.5		45.59	312.52	0.146	0.00	312.52	0.000		
	L2		168.5 - 165.5	TP26.41x18.373x0.25	24.70	333.56	0.074	0.00	333.56	0.000
			165.5 - 163.856		30.62	425.48	0.072	0.00	425.48	0.000
			163.856 - 162.212		60.94	442.18	0.138	0.00	442.18	0.000
162.212 - 160.568		72.04	459.21		0.157	0.00	459.21	0.000		
160.568 - 158.924		89.05	476.55		0.187	0.00	476.55	0.000		
158.924 - 157.281		106.26	494.22		0.215	0.00	494.22	0.000		
157.281 - 155.637		123.82	512.21		0.242	0.00	512.21	0.000		
155.637 - 153.993		141.58	530.52		0.267	0.00	530.52	0.000		
153.993 - 152.349		165.97	549.15		0.302	0.00	549.15	0.000		
152.349 - 150.705		189.72	568.10		0.334	0.00	568.10	0.000		
150.705 -		214.13	587.38		0.365	0.00	587.38	0.000		
		239.05	606.97		0.394	0.00	606.97	0.000		



<b>tnxTower</b>  <b>EFI Global, Inc.</b> 1117 Perimeter Center West, Suite E500 Atlanta, GA 30338 Phone: (470) 990-6593 FAX:	<b>Job</b>	CT11365D	<b>Page</b>	25 of 34
	<b>Project</b>	049.00421 - 2075019	<b>Date</b>	14:16:25 04/21/21
	<b>Client</b>	Foresite LLC	<b>Designed by</b>	Evan.Martin

Section No.	Elevation ft	Size	$M_{ux}$ kip-ft	$\phi M_{rx}$ kip-ft	Ratio $\frac{M_{ux}}{\phi M_{rx}}$	$M_{uy}$ kip-ft	$\phi M_{ry}$ kip-ft	Ratio $\frac{M_{uy}}{\phi M_{ry}}$
	149.061							
	149.061 - 147.417		264.48	626.89	0.422	0.00	626.89	0.000
	147.417 - 145.773		290.10	647.13	0.448	0.00	647.13	0.000
	145.773 - 144.129		322.75	667.69	0.483	0.00	667.69	0.000
	144.129 - 142.486		362.09	688.57	0.526	0.00	688.57	0.000
	142.486 - 140.842		401.61	709.78	0.566	0.00	709.78	0.000
	140.842 - 139.198		441.31	731.30	0.603	0.00	731.30	0.000
	139.198 - 137.554		481.18	753.15	0.639	0.00	753.15	0.000
	137.554 - 135.91		521.23	772.99	0.674	0.00	772.99	0.000
	135.91 - 132.08		257.18	818.71	0.314	0.00	818.71	0.000
L3	135.91 - 132.08	TP35.88x25.0648x0.375	358.27	1177.83	0.304	0.00	1177.83	0.000
	132.08 - 129.853		671.30	1224.03	0.548	0.00	1224.03	0.000
	129.853 - 127.626		728.13	1271.11	0.573	0.00	1271.11	0.000
	127.626 - 125.398		785.59	1319.08	0.596	0.00	1319.08	0.000
	125.398 - 123.171		843.48	1367.94	0.617	0.00	1367.94	0.000
	123.171 - 120.944		903.88	1417.69	0.638	0.00	1417.69	0.000
	120.944 - 118.717		964.94	1468.33	0.657	0.00	1468.33	0.000
	118.717 - 116.489		1026.36	1519.86	0.675	0.00	1519.86	0.000
	116.489 - 114.262		1088.13	1572.28	0.692	0.00	1572.28	0.000
	114.262 - 112.035		1150.28	1625.58	0.708	0.00	1625.58	0.000
	112.035 - 109.808		1224.76	1679.77	0.729	0.00	1679.77	0.000
	109.808 - 107.581		1299.20	1734.85	0.749	0.00	1734.85	0.000
	107.581 - 105.353		1373.97	1790.82	0.767	0.00	1790.82	0.000
	105.353 - 103.126		1449.08	1847.68	0.784	0.00	1847.68	0.000
	103.126 - 100.899		1524.51	1905.43	0.800	0.00	1905.43	0.000
	100.899 - 98.6717		1600.26	1964.06	0.815	0.00	1964.06	0.000
	98.6717 - 96.4444		1676.33	2023.58	0.828	0.00	2023.58	0.000
	96.4444 - 94.2172		1752.72	2084.00	0.841	0.00	2084.00	0.000
	94.2172 - 91.99		1829.43	2145.30	0.853	0.00	2145.30	0.000
	91.99 - 86.99		959.89	2286.16	0.420	0.00	2286.16	0.000
L4	91.99 - 86.99	TP44.88x34.0246x0.4375	1043.43	2541.43	0.411	0.00	2541.43	0.000
	86.99 -		2077.29	2610.57	0.796	0.00	2610.57	0.000

<b>tnxTower</b>  <b>EFI Global, Inc.</b> 1117 Perimeter Center West, Suite E500 Atlanta, GA 30338 Phone: (470) 990-6593 FAX:	<b>Job</b>	CT11365D	<b>Page</b>	26 of 34
	<b>Project</b>	049.00421 - 2075019	<b>Date</b>	14:16:25 04/21/21
	<b>Client</b>	Foresite LLC	<b>Designed by</b>	Evan.Martin

Section No.	Elevation ft	Size	$M_{ux}$ kip-ft	$\phi M_{rx}$ kip-ft	Ratio $\frac{M_{ux}}{\phi M_{rx}}$	$M_{uy}$ kip-ft	$\phi M_{ry}$ kip-ft	Ratio $\frac{M_{uy}}{\phi M_{ry}}$
	84.8839							
	84.8839 - 82.7778		2151.53	2680.63	0.803	0.00	2680.63	0.000
	82.7778 - 80.6717		2226.06	2751.63	0.809	0.00	2751.63	0.000
	80.6717 - 78.5656		2300.86	2823.54	0.815	0.00	2823.54	0.000
	78.5656 - 76.4594		2375.93	2896.39	0.820	0.00	2896.39	0.000
	76.4594 - 74.3533		2451.28	2970.17	0.825	0.00	2970.17	0.000
	74.3533 - 72.2472		2526.88	3044.88	0.830	0.00	3044.88	0.000
	72.2472 - 70.1411		2602.76	3120.51	0.834	0.00	3120.51	0.000
	70.1411 - 68.035		2678.89	3197.07	0.838	0.00	3197.07	0.000
	68.035 - 65.9289		2755.29	3274.55	0.841	0.00	3274.55	0.000
	65.9289 - 63.8228		2831.95	3352.97	0.845	0.00	3352.97	0.000
	63.8228 - 61.7167		2908.86	3432.32	0.847	0.00	3432.32	0.000
	61.7167 - 59.6106		2986.02	3512.58	0.850	0.00	3512.58	0.000
	59.6106 - 57.5044		3063.43	3593.78	0.852	0.00	3593.78	0.000
	57.5044 - 55.3983		3141.08	3675.91	0.855	0.00	3675.91	0.000
	55.3983 - 53.2922		3218.98	3758.97	0.856	0.00	3758.97	0.000
	53.2922 - 51.1861		3296.90	3842.95	0.858	0.00	3842.95	0.000
	51.1861 - 49.08		3375.47	3927.87	0.859	0.00	3927.87	0.000
	49.08 - 42.91		1858.63	4166.01	0.446	0.00	4166.01	0.000
L5	49.08 - 42.91	TP53.5x42.6403x0.4375	1749.15	4018.22	0.435	0.00	4018.22	0.000
	42.91 - 40.6516		3693.53	4104.54	0.900	0.00	4104.54	0.000
	40.6516 - 38.3932		3779.46	4186.57	0.903	0.00	4186.57	0.000
	38.3932 - 36.1347		3865.56	4269.13	0.905	0.00	4269.13	0.000
	36.1347 - 33.8763		3951.83	4352.18	0.908	0.00	4352.18	0.000
	33.8763 - 31.6179		4038.29	4435.75	0.910	0.00	4435.75	0.000
	31.6179 - 29.3595		4124.92	4519.81	0.913	0.00	4519.81	0.000
	29.3595 - 27.1011		4211.71	4604.35	0.915	0.00	4604.35	0.000
	27.1011 - 24.8426		4298.68	4689.37	0.917	0.00	4689.37	0.000
	24.8426 - 22.5842		4385.82	4774.85	0.919	0.00	4774.85	0.000
	22.5842 - 20.3258		4473.13	4860.78	0.920	0.00	4860.78	0.000
	20.3258 - 18.0674		4560.61	4947.17	0.922	0.00	4947.17	0.000
	18.0674 -		4648.25	5033.98	0.923	0.00	5033.98	0.000

<b>tnxTower</b>  <b>EFI Global, Inc.</b> 1117 Perimeter Center West, Suite E500 Atlanta, GA 30338 Phone: (470) 990-6593 FAX:	<b>Job</b> CT11365D	<b>Page</b> 27 of 34
	<b>Project</b> 049.00421 - 2075019	<b>Date</b> 14:16:25 04/21/21
	<b>Client</b> Foresite LLC	<b>Designed by</b> Evan.Martin

Section No.	Elevation ft	Size	$M_{ux}$ kip-ft	$\phi M_{rx}$ kip-ft	Ratio $\frac{M_{ux}}{\phi M_{rx}}$	$M_{uy}$ kip-ft	$\phi M_{ry}$ kip-ft	Ratio $\frac{M_{uy}}{\phi M_{ry}}$
	15.8089							
	15.8089 - 13.5505		4736.07	5121.23	0.925	0.00	5121.23	0.000
	13.5505 - 11.2921		4824.05	5208.90	0.926	0.00	5208.90	0.000
	11.2921 - 9.03368		4912.19	5296.98	0.927	0.00	5296.98	0.000
	9.03368 - 6.77526		5000.50	5385.46	0.929	0.00	5385.46	0.000
	6.77526 - 4.51684		5088.98	5474.33	0.930	0.00	5474.33	0.000
	4.51684 - 2.25842		5177.62	5563.58	0.931	0.00	5563.58	0.000
	2.25842 - 0		5266.42	5653.21	0.932	0.00	5653.21	0.000

### Pole Shear Design Data

Section No.	Elevation ft	Size	Actual $V_u$ K	$\phi V_n$ K	Ratio $\frac{V_u}{\phi V_n}$	Actual $T_u$ kip-ft	$\phi T_n$ kip-ft	Ratio $\frac{T_u}{\phi T_n}$
L1	183 - 181.964	TP19.42x15.5x0.1875	2.34	343.65	0.007	0.57	438.89	0.001
	181.964 - 180.929		2.40	348.78	0.007	0.57	452.15	0.001
	180.929 - 179.893		2.46	353.91	0.007	0.57	465.62	0.001
	179.893 - 178.857		2.51	359.04	0.007	0.57	479.28	0.001
	178.857 - 177.821		2.57	364.16	0.007	0.57	493.14	0.001
	177.821 - 176.786		2.63	369.29	0.007	0.57	507.19	0.001
	176.786 - 175.75		2.69	374.42	0.007	0.57	521.45	0.001
	175.75 - 174.714		2.75	379.55	0.007	0.57	535.90	0.001
	174.714 - 173.679		2.81	384.68	0.007	0.57	550.55	0.001
	173.679 - 172.643		2.87	389.81	0.007	0.57	565.39	0.001
	172.643 - 171.607		2.94	394.94	0.007	0.57	580.44	0.001
	171.607 - 170.571		3.00	400.07	0.008	0.57	595.68	0.001
	170.571 - 169.536		3.07	405.20	0.008	0.57	611.12	0.001
	169.536 - 168.5		3.13	410.32	0.008	0.57	626.75	0.001
L2	168.5 - 165.5	TP26.41x18.373x0.25	1.55	422.50	0.004	0.25	668.92	0.000
	165.5 - 163.856		1.81	553.72	0.003	0.32	853.71	0.000
	163.856 - 162.212		3.48	564.41	0.006	0.57	887.18	0.001
	162.212 - 160.568		10.29	575.10	0.018	0.57	921.31	0.001
	160.568 -		10.41	585.80	0.018	0.57	956.08	0.001
			10.62	596.49	0.018	0.57	991.48	0.001

<b>tnxTower</b>  <b>EFI Global, Inc.</b> 1117 Perimeter Center West, Suite E500 Atlanta, GA 30338 Phone: (470) 990-6593 FAX:	<b>Job</b>	CT11365D	<b>Page</b>	28 of 34
	<b>Project</b>	049.00421 - 2075019	<b>Date</b>	14:16:25 04/21/21
	<b>Client</b>	Foresite LLC	<b>Designed by</b>	Evan.Martin

Section No.	Elevation ft	Size	Actual $V_u$ K	$\phi V_n$ K	Ratio $\frac{V_u}{\phi V_n}$	Actual $T_u$ kip-ft	$\phi T_n$ kip-ft	Ratio $\frac{T_u}{\phi T_n}$
	158.924							
	158.924 - 157.281		10.74	607.18	0.018	0.57	1027.54	0.001
	157.281 - 155.637		10.86	617.88	0.018	0.57	1064.24	0.001
	155.637 - 153.993		14.46	628.57	0.023	0.67	1101.58	0.001
	153.993 - 152.349		14.66	639.26	0.023	0.67	1139.57	0.001
	152.349 - 150.705		14.89	649.96	0.023	0.60	1178.20	0.001
	150.705 - 149.061		15.42	660.65	0.023	0.36	1217.47	0.000
	149.061 - 147.417		15.53	671.34	0.023	0.14	1257.39	0.000
	147.417 - 145.773		15.65	682.03	0.023	0.14	1297.95	0.000
	145.773 - 144.129		23.89	692.73	0.034	0.38	1339.16	0.000
	144.129 - 142.486		24.00	703.42	0.034	0.38	1381.01	0.000
	142.486 - 140.842		24.11	714.11	0.034	0.38	1423.50	0.000
	140.842 - 139.198		24.22	724.81	0.033	0.38	1466.64	0.000
	139.198 - 137.554		24.33	735.50	0.033	0.38	1510.42	0.000
	137.554 - 135.91		24.43	743.95	0.033	0.38	1550.18	0.000
	135.91 - 132.08		10.45	762.25	0.014	0.16	1641.78	0.000
L3	135.91 - 132.08	TP35.88x25.0648x0.375	14.36	1129.09	0.013	0.22	2363.74	0.000
	132.08 - 129.853		25.18	1150.86	0.022	0.51	2456.35	0.000
	129.853 - 127.626		25.74	1172.64	0.022	0.51	2550.73	0.000
	127.626 - 125.398		25.91	1194.41	0.022	0.08	2646.90	0.000
	125.398 - 123.171		26.12	1216.18	0.021	0.08	2744.84	0.000
	123.171 - 120.944		27.36	1237.95	0.022	0.33	2844.57	0.000
	120.944 - 118.717		27.53	1259.72	0.022	0.33	2946.07	0.000
	118.717 - 116.489		27.69	1281.49	0.022	0.33	3049.35	0.000
	116.489 - 114.262		27.85	1303.26	0.021	0.33	3154.41	0.000
	114.262 - 112.035		28.02	1325.03	0.021	0.33	3261.25	0.000
	112.035 - 109.808		33.39	1346.80	0.025	0.33	3369.88	0.000
	109.808 - 107.581		33.54	1368.57	0.025	0.14	3480.28	0.000
	107.581 - 105.353		33.69	1390.35	0.024	0.14	3592.45	0.000
	105.353 - 103.126		33.84	1412.12	0.024	0.14	3706.41	0.000
	103.126 -		33.99	1433.89	0.024	0.14	3822.15	0.000

<b>tnxTower</b>  <b>EFI Global, Inc.</b> 1117 Perimeter Center West, Suite E500 Atlanta, GA 30338 Phone: (470) 990-6593 FAX:	<b>Job</b>	CT11365D	<b>Page</b>	29 of 34
	<b>Project</b>	049.00421 - 2075019	<b>Date</b>	14:16:25 04/21/21
	<b>Client</b>	Foresite LLC	<b>Designed by</b>	Evan.Martin

Section No.	Elevation ft	Size	Actual $V_u$ K	$\phi V_n$ K	Ratio $\frac{V_u}{\phi V_n}$	Actual $T_u$ kip-ft	$\phi T_n$ kip-ft	Ratio $\frac{T_u}{\phi T_n}$
	100.899							
	100.899 - 98.6717		34.13	1455.66	0.023	0.14	3939.67	0.000
	98.6717 - 96.4444		34.28	1477.43	0.023	0.14	4058.97	0.000
	96.4444 - 94.2172		34.42	1499.20	0.023	0.14	4180.04	0.000
	94.2172 - 91.99		34.56	1520.97	0.023	0.14	4302.90	0.000
	91.99 - 86.99		16.94	1569.85	0.011	0.07	4585.19	0.000
L4	91.99 - 86.99	TP44.88x34.0246x0.4375	18.17	1789.60	0.010	0.07	5098.73	0.000
	86.99 - 84.8839		35.23	1813.63	0.019	0.14	5237.30	0.000
	84.8839 - 82.7778		35.37	1837.66	0.019	0.14	5377.73	0.000
	82.7778 - 80.6717		35.50	1861.69	0.019	0.14	5520.02	0.000
	80.6717 - 78.5656		35.63	1885.72	0.019	0.14	5664.17	0.000
	78.5656 - 76.4594		35.76	1909.75	0.019	0.14	5810.17	0.000
	76.4594 - 74.3533		35.89	1933.78	0.019	0.14	5958.04	0.000
	74.3533 - 72.2472		36.02	1957.81	0.018	0.14	6107.77	0.000
	72.2472 - 70.1411		36.14	1981.83	0.018	0.14	6259.35	0.000
	70.1411 - 68.035		36.27	2005.86	0.018	0.14	6412.79	0.000
	68.035 - 65.9289		36.39	2029.89	0.018	0.14	6568.09	0.000
	65.9289 - 63.8228		36.51	2053.92	0.018	0.14	6725.24	0.000
	63.8228 - 61.7167		36.63	2077.95	0.018	0.14	6884.26	0.000
	61.7167 - 59.6106		36.75	2101.98	0.017	0.14	7045.13	0.000
	59.6106 - 57.5044		36.87	2126.01	0.017	0.14	7207.86	0.000
	57.5044 - 55.3983		36.99	2150.04	0.017	0.14	7372.45	0.000
	55.3983 - 53.2922		37.10	2174.07	0.017	0.14	7538.90	0.000
	53.2922 - 51.1861		37.31	2198.10	0.017	0.14	7707.20	0.000
	51.1861 - 49.08		37.42	2222.12	0.017	0.01	7877.37	0.000
	49.08 - 42.91		19.73	2283.78	0.009	0.00	8354.58	0.000
L5	49.08 - 42.91	TP53.5x42.6403x0.4375	18.29	2247.41	0.008	0.00	8058.44	0.000
	42.91 - 40.6516		38.08	2269.40	0.017	0.01	8231.41	0.000
	40.6516 - 38.3932		38.16	2288.55	0.017	0.01	8395.75	0.000
	38.3932 - 36.1347		38.23	2307.55	0.017	0.01	8561.17	0.000
	36.1347 - 33.8763		38.31	2326.41	0.016	0.01	8727.67	0.000
	33.8763 - 31.6179		38.39	2345.11	0.016	0.01	8895.08	0.000
	31.6179 -		38.46	2363.67	0.016	0.01	9063.50	0.000

<b>tnxTower</b>  <b>EFI Global, Inc.</b> 1117 Perimeter Center West, Suite E500 Atlanta, GA 30338 Phone: (470) 990-6593 FAX:	<b>Job</b>	CT11365D	<b>Page</b>	30 of 34
	<b>Project</b>	049.00421 - 2075019	<b>Date</b>	14:16:25 04/21/21
	<b>Client</b>	Foresite LLC	<b>Designed by</b>	Evan.Martin

Section No.	Elevation ft	Size	Actual $V_u$ K	$\phi V_n$ K	Ratio $\frac{V_u}{\phi V_n}$	Actual $T_u$ kip-ft	$\phi T_n$ kip-ft	Ratio $\frac{T_u}{\phi T_n}$
	29.3595							
	29.3595 - 27.1011		38.54	2382.08	0.016	0.01	9232.92	0.000
	27.1011 - 24.8426		38.62	2400.35	0.016	0.01	9403.25	0.000
	24.8426 - 22.5842		38.69	2418.46	0.016	0.01	9574.50	0.000
	22.5842 - 20.3258		38.77	2436.43	0.016	0.01	9746.67	0.000
	20.3258 - 18.0674		38.84	2454.25	0.016	0.01	9919.75	0.000
	18.0674 - 15.8089		38.92	2471.92	0.016	0.01	10093.67	0.000
	15.8089 - 13.5505		38.99	2489.45	0.016	0.01	10268.50	0.000
	13.5505 - 11.2921		39.06	2506.83	0.016	0.01	10444.17	0.000
	11.2921 - 9.03368		39.14	2524.06	0.016	0.01	10620.67	0.000
	9.03368 - 6.77526		39.21	2541.14	0.015	0.01	10797.92	0.000
	6.77526 - 4.51684		39.28	2558.07	0.015	0.01	10975.92	0.000
	4.51684 - 2.25842		39.36	2574.86	0.015	0.01	11154.75	0.000
	2.25842 - 0		39.43	2591.50	0.015	0.01	11334.33	0.000

### Pole Interaction Design Data

Section No.	Elevation ft	Ratio $P_u$ $\phi P_n$	Ratio $M_{ux}$ $\phi M_{nx}$	Ratio $M_{uy}$ $\phi M_{ny}$	Ratio $V_u$ $\phi V_n$	Ratio $T_u$ $\phi T_n$	Comb. Stress Ratio	Allow. Stress Ratio	Criteria
L1	183 - 181.964	0.002	0.041	0.000	0.007	0.001	0.043	1.000	4.8.2
	181.964 - 180.929	0.002	0.050	0.000	0.007	0.001	0.053	1.000	4.8.2
	180.929 - 179.893	0.002	0.060	0.000	0.007	0.001	0.062	1.000	4.8.2
	179.893 - 178.857	0.002	0.069	0.000	0.007	0.001	0.071	1.000	4.8.2
	178.857 - 177.821	0.002	0.078	0.000	0.007	0.001	0.080	1.000	4.8.2
	177.821 - 176.786	0.002	0.086	0.000	0.007	0.001	0.088	1.000	4.8.2
	176.786 - 175.75	0.002	0.094	0.000	0.007	0.001	0.097	1.000	4.8.2
	175.75 - 174.714	0.002	0.102	0.000	0.007	0.001	0.105	1.000	4.8.2
	174.714 - 173.679	0.002	0.110	0.000	0.007	0.001	0.112	1.000	4.8.2
	173.679 - 172.643	0.002	0.118	0.000	0.007	0.001	0.120	1.000	4.8.2
	172.643 - 171.607	0.002	0.125	0.000	0.007	0.001	0.127	1.000	4.8.2
	171.607 - 170.571	0.002	0.132	0.000	0.008	0.001	0.134	1.000	4.8.2

<b>tnxTower</b>  <b>EFI Global, Inc.</b> 1117 Perimeter Center West, Suite E500 Atlanta, GA 30338 Phone: (470) 990-6593 FAX:	<b>Job</b>	CT11365D	<b>Page</b>	31 of 34
	<b>Project</b>	049.00421 - 2075019	<b>Date</b>	14:16:25 04/21/21
	<b>Client</b>	Foresite LLC	<b>Designed by</b>	Evan.Martin

Section No.	Elevation ft	Ratio $P_u$ $\phi P_n$	Ratio $M_{ux}$ $\phi M_{nx}$	Ratio $M_{uy}$ $\phi M_{ny}$	Ratio $V_u$ $\phi V_n$	Ratio $T_u$ $\phi T_n$	Comb. Stress Ratio	Allow. Stress Ratio	Criteria
	170.571 - 169.536	0.002	0.139	0.000	0.008	0.001	0.141	1.000	4.8.2
	169.536 - 168.5	0.002	0.146	0.000	0.008	0.001	0.148	1.000	4.8.2
L2	168.5 - 165.5	0.001	0.074	0.000	0.004	0.000	0.075	1.000	4.8.2
	168.5 - 165.5	0.001	0.072	0.000	0.003	0.000	0.073	1.000	4.8.2
	165.5 - 163.856	0.002	0.138	0.000	0.006	0.001	0.140	1.000	4.8.2
	163.856 - 162.212	0.006	0.157	0.000	0.018	0.001	0.164	1.000	4.8.2
	162.212 - 160.568	0.006	0.187	0.000	0.018	0.001	0.194	1.000	4.8.2
	160.568 - 158.924	0.007	0.215	0.000	0.018	0.001	0.222	1.000	4.8.2
	158.924 - 157.281	0.007	0.242	0.000	0.018	0.001	0.249	1.000	4.8.2
	157.281 - 155.637	0.007	0.267	0.000	0.018	0.001	0.274	1.000	4.8.2
	155.637 - 153.993	0.009	0.302	0.000	0.023	0.001	0.311	1.000	4.8.2
	153.993 - 152.349	0.009	0.334	0.000	0.023	0.001	0.343	1.000	4.8.2
	152.349 - 150.705	0.009	0.365	0.000	0.023	0.001	0.374	1.000	4.8.2
	150.705 - 149.061	0.009	0.394	0.000	0.023	0.000	0.403	1.000	4.8.2
	149.061 - 147.417	0.009	0.422	0.000	0.023	0.000	0.431	1.000	4.8.2
	147.417 - 145.773	0.009	0.448	0.000	0.023	0.000	0.457	1.000	4.8.2
	145.773 - 144.129	0.011	0.483	0.000	0.034	0.000	0.496	1.000	4.8.2
	144.129 - 142.486	0.011	0.526	0.000	0.034	0.000	0.538	1.000	4.8.2
	142.486 - 140.842	0.011	0.566	0.000	0.034	0.000	0.578	1.000	4.8.2
	140.842 - 139.198	0.011	0.603	0.000	0.033	0.000	0.616	1.000	4.8.2
139.198 - 137.554	0.011	0.639	0.000	0.033	0.000	0.651	1.000	4.8.2	
137.554 - 135.91	0.011	0.674	0.000	0.033	0.000	0.687	1.000	4.8.2	
135.91 - 132.08	0.005	0.314	0.000	0.014	0.000	0.319	1.000	4.8.2	
L3	135.91 - 132.08	0.005	0.304	0.000	0.013	0.000	0.309	1.000	4.8.2
	132.08 - 129.853	0.008	0.548	0.000	0.022	0.000	0.557	1.000	4.8.2
	129.853 - 127.626	0.008	0.573	0.000	0.022	0.000	0.581	1.000	4.8.2
	127.626 - 125.398	0.008	0.596	0.000	0.022	0.000	0.604	1.000	4.8.2
	125.398 - 123.171	0.008	0.617	0.000	0.021	0.000	0.625	1.000	4.8.2
	123.171 - 120.944	0.009	0.638	0.000	0.022	0.000	0.647	1.000	4.8.2
	120.944 - 118.717	0.009	0.657	0.000	0.022	0.000	0.666	1.000	4.8.2
	118.717 - 116.489	0.009	0.675	0.000	0.022	0.000	0.685	1.000	4.8.2

<b>tnxTower</b>  <b>EFI Global, Inc.</b> 1117 Perimeter Center West, Suite E500 Atlanta, GA 30338 Phone: (470) 990-6593 FAX:	<b>Job</b>	CT11365D	<b>Page</b>	32 of 34
	<b>Project</b>	049.00421 - 2075019	<b>Date</b>	14:16:25 04/21/21
	<b>Client</b>	Foresite LLC	<b>Designed by</b>	Evan.Martin

Section No.	Elevation ft	Ratio	Ratio	Ratio	Ratio	Ratio	Comb. Stress Ratio	Allow. Stress Ratio	Criteria
		$P_u$	$M_{ux}$	$M_{uy}$	$V_u$	$T_u$			
	116.489 - 114.262	0.009	0.692	0.000	0.021	0.000	0.701	1.000	4.8.2
	114.262 - 112.035	0.009	0.708	0.000	0.021	0.000	0.717	1.000	4.8.2
	112.035 - 109.808	0.010	0.729	0.000	0.025	0.000	0.740	1.000	4.8.2
	109.808 - 107.581	0.010	0.749	0.000	0.025	0.000	0.760	1.000	4.8.2
	107.581 - 105.353	0.010	0.767	0.000	0.024	0.000	0.778	1.000	4.8.2
	105.353 - 103.126	0.010	0.784	0.000	0.024	0.000	0.795	1.000	4.8.2
	103.126 - 100.899	0.010	0.800	0.000	0.024	0.000	0.811	1.000	4.8.2
	100.899 - 98.6717	0.010	0.815	0.000	0.023	0.000	0.826	1.000	4.8.2
	98.6717 - 96.4444	0.010	0.828	0.000	0.023	0.000	0.839	1.000	4.8.2
	96.4444 - 94.2172	0.010	0.841	0.000	0.023	0.000	0.852	1.000	4.8.2
	94.2172 - 91.99	0.010	0.853	0.000	0.023	0.000	0.864	1.000	4.8.2
	91.99 - 86.99	0.005	0.420	0.000	0.011	0.000	0.425	1.000	4.8.2
L4	91.99 - 86.99	0.005	0.411	0.000	0.010	0.000	0.416	1.000	4.8.2
	86.99 - 84.8839	0.010	0.796	0.000	0.019	0.000	0.806	1.000	4.8.2
	84.8839 - 82.7778	0.010	0.803	0.000	0.019	0.000	0.813	1.000	4.8.2
	82.7778 - 80.6717	0.010	0.809	0.000	0.019	0.000	0.819	1.000	4.8.2
	80.6717 - 78.5656	0.010	0.815	0.000	0.019	0.000	0.825	1.000	4.8.2
	78.5656 - 76.4594	0.010	0.820	0.000	0.019	0.000	0.830	1.000	4.8.2
	76.4594 - 74.3533	0.010	0.825	0.000	0.019	0.000	0.835	1.000	4.8.2
	74.3533 - 72.2472	0.010	0.830	0.000	0.018	0.000	0.840	1.000	4.8.2
	72.2472 - 70.1411	0.010	0.834	0.000	0.018	0.000	0.844	1.000	4.8.2
	70.1411 - 68.035	0.010	0.838	0.000	0.018	0.000	0.848	1.000	4.8.2
	68.035 - 65.9289	0.010	0.841	0.000	0.018	0.000	0.852	1.000	4.8.2
	65.9289 - 63.8228	0.010	0.845	0.000	0.018	0.000	0.855	1.000	4.8.2
	63.8228 - 61.7167	0.010	0.847	0.000	0.018	0.000	0.858	1.000	4.8.2
	61.7167 - 59.6106	0.010	0.850	0.000	0.017	0.000	0.860	1.000	4.8.2
	59.6106 - 57.5044	0.010	0.852	0.000	0.017	0.000	0.863	1.000	4.8.2
	57.5044 - 55.3983	0.010	0.855	0.000	0.017	0.000	0.865	1.000	4.8.2
	55.3983 - 53.2922	0.010	0.856	0.000	0.017	0.000	0.867	1.000	4.8.2
	53.2922 - 51.1861	0.010	0.858	0.000	0.017	0.000	0.868	1.000	4.8.2
	51.1861 - 49.08	0.010	0.859	0.000	0.017	0.000	0.870	1.000	4.8.2



<b>tnxTower</b>  <b>EFI Global, Inc.</b> 1117 Perimeter Center West, Suite E500 Atlanta, GA 30338 Phone: (470) 990-6593 FAX:	<b>Job</b> CT11365D	<b>Page</b> 33 of 34
	<b>Project</b> 049.00421 - 2075019	<b>Date</b> 14:16:25 04/21/21
	<b>Client</b> Foresite LLC	<b>Designed by</b> Evan.Martin

Section No.	Elevation ft	Ratio $P_u$ $\phi P_n$	Ratio $M_{ux}$ $\phi M_{nx}$	Ratio $M_{uy}$ $\phi M_{ny}$	Ratio $V_u$ $\phi V_n$	Ratio $T_u$ $\phi T_n$	Comb. Stress Ratio	Allow. Stress Ratio	Criteria
L5	49.08 - 42.91	0.005	0.446	0.000	0.009	0.000	0.452	1.000	4.8.2
	49.08 - 42.91	0.005	0.435	0.000	0.008	0.000	0.441	1.000	4.8.2
	42.91 - 40.6516	0.011	0.900	0.000	0.017	0.000	0.911	1.000	4.8.2
	40.6516 - 38.3932	0.011	0.903	0.000	0.017	0.000	0.914	1.000	4.8.2
	38.3932 - 36.1347	0.011	0.905	0.000	0.017	0.000	0.917	1.000	4.8.2
	36.1347 - 33.8763	0.011	0.908	0.000	0.016	0.000	0.920	1.000	4.8.2
	33.8763 - 31.6179	0.011	0.910	0.000	0.016	0.000	0.922	1.000	4.8.2
	31.6179 - 29.3595	0.011	0.913	0.000	0.016	0.000	0.924	1.000	4.8.2
	29.3595 - 27.1011	0.012	0.915	0.000	0.016	0.000	0.927	1.000	4.8.2
	27.1011 - 24.8426	0.012	0.917	0.000	0.016	0.000	0.929	1.000	4.8.2
	24.8426 - 22.5842	0.012	0.919	0.000	0.016	0.000	0.930	1.000	4.8.2
	22.5842 - 20.3258	0.012	0.920	0.000	0.016	0.000	0.932	1.000	4.8.2
	20.3258 - 18.0674	0.012	0.922	0.000	0.016	0.000	0.934	1.000	4.8.2
	18.0674 - 15.8089	0.012	0.923	0.000	0.016	0.000	0.936	1.000	4.8.2
	15.8089 - 13.5505	0.012	0.925	0.000	0.016	0.000	0.937	1.000	4.8.2
	13.5505 - 11.2921	0.012	0.926	0.000	0.016	0.000	0.938	1.000	4.8.2
	11.2921 - 9.03368	0.012	0.927	0.000	0.016	0.000	0.940	1.000	4.8.2
9.03368 - 6.77526	0.012	0.929	0.000	0.015	0.000	0.941	1.000	4.8.2	
6.77526 - 4.51684	0.012	0.930	0.000	0.015	0.000	0.942	1.000	4.8.2	
4.51684 - 2.25842	0.012	0.931	0.000	0.015	0.000	0.943	1.000	4.8.2	
2.25842 - 0	0.013	0.932	0.000	0.015	0.000	0.944	1.000	4.8.2	

### Section Capacity Table

Section No.	Elevation ft	Component Type	Size	Critical Element	P K	$\phi P_{allow}$ K	% Capacity	Pass Fail	
L1	183 - 165.5	Pole	TP19.42x15.5x0.1875	1	-1.89	820.65	14.8	Pass	
L2	165.5 - 132.08	Pole	TP26.41x18.373x0.25	2	-16.75	1487.91	68.7	Pass	
L3	132.08 - 86.99	Pole	TP35.88x25.0648x0.375	3	-31.76	3041.94	86.4	Pass	
L4	86.99 - 42.91	Pole	TP44.88x34.0246x0.4375	4	-45.95	4444.25	87.0	Pass	
L5	42.91 - 0	Pole	TP53.5x42.6403x0.4375	5	-65.06	5183.00	94.4	Pass	
							Summary		
							Pole (L5)	94.4	Pass
							<b>RATING =</b>	<b>94.4</b>	<b>Pass</b>

<b><i>tnxTower</i></b>  <b><i>EFI Global, Inc.</i></b> <i>1117 Perimeter Center West, Suite E500</i> <i>Atlanta, GA 30338</i> <i>Phone: (470) 990-6593</i> <i>FAX:</i>	<b>Job</b> CT11365D	<b>Page</b> 34 of 34
	<b>Project</b> 049.00421 - 2075019	<b>Date</b> 14:16:25 04/21/21
	<b>Client</b> Foresite LLC	<b>Designed by</b> Evan.Martin

# Monopole Base Plate Connection

Site Info	
Site Name	CT11365D

Analysis Considerations	
TIA-222 Revision	G
Grout Considered:	No
$I_{gr}$ (in)	1
Eta Factor, $\eta$	0.5

Applied Loads	
Moment (kip-ft)	5266.42
Axial Force (kips)	65.06
Shear Force (kips)	39.43

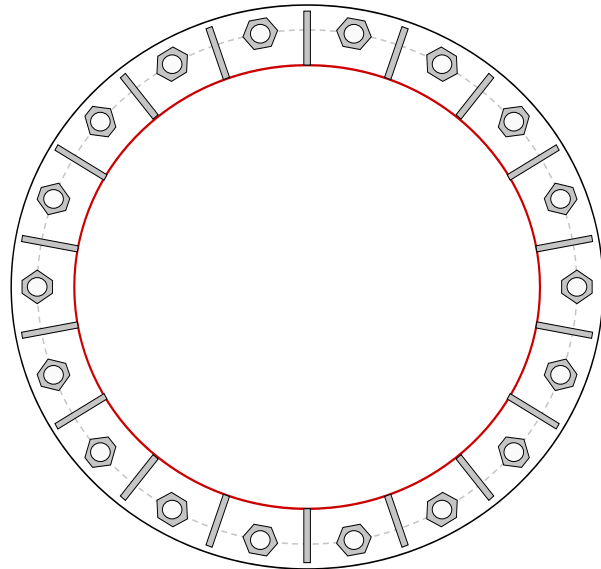

Connection Properties	Analysis Results	
<b>Anchor Rod Data</b>	<b>Anchor Rod Summary</b> <i>(units of kips, kip-in)</i>	
(18) 2-1/4" $\phi$ bolts (A615-75 N; $F_y=75$ ksi, $F_u=100$ ksi) on 62" BC	$Pu\_c = 230$	$\phi Pn\_t = 260$ <b>Stress Rating</b>
<b>Base Plate Data</b>	$Vu = 2.19$	$\phi Vn = n/a$ <b>90.1%</b>
68" OD x 2" Plate (A572-60; $F_y=60$ ksi, $F_u=75$ ksi)	$Mu = n/a$	$\phi Mn = n/a$ <b>Pass</b>
<b>Stiffener Data</b>	<b>Base Plate Summary</b>	
(18) 15"H x 6.5"W x 0.75"T, Notch: 1" plate: $F_y= 50$ ksi ; weld: $F_y= 70$ ksi horiz. weld: 0.375" groove, 45° dbl bevel, 0.375" fillet vert. weld: 0.375" fillet	Max Stress (ksi): 40.44	(Roark's Flexural)
<b>Pole Data</b>	Allowable Stress (ksi): 54	
53.5" x 0.4375" 18-sided pole (A572-65; $F_y=65$ ksi, $F_u=80$ ksi)	Stress Rating: <b>74.9%</b>	<b>Pass</b>
	<b>Stiffener Summary</b>	
	Horizontal Weld: <b>85.9%</b>	<b>Pass</b>
	Vertical Weld: <b>69.2%</b>	<b>Pass</b>
	Plate Flexure+Shear: <b>41.5%</b>	<b>Pass</b>
	Plate Tension+Shear: <b>91.1%</b>	<b>Pass</b>
	Plate Compression: <b>92.2%</b>	<b>Pass</b>
	<b>Pole Summary</b>	
	Punching Shear: <b>21.6%</b>	<b>Pass</b>

## Drilled Pier Foundation

BU #:	
Site Name:	CT11365D
Order Number:	
TIA-222 Revisor:	G
Tower Type:	Monopole

Applied Loads		
	Comp.	Uplift
Moment (kip-ft)	5266	
Axial Force (kips)	65	
Shear Force (kips)	39	

Material Properties		
Concrete Strength, f <sub>c</sub> :	4	ksi
Rebar Strength, F <sub>y</sub> :	60	ksi

Pier Design Data		
Depth	31	ft
Ext. Above Grade	1	ft
Pier Section 1		
<i>From 1' above grade to 31' below grade</i>		
Pier Diameter	7	ft
Rebar Quantity	27	
Rebar Size	11	
Clear Cover to Ties	3	in
Tie Size	5	

Analysis Results		
Soil Lateral Capacity		
	Compression	Uplift
D <sub>v=0</sub> (ft from TOC)	7.17	-
Soil Safety Factor	3.68	-
Max Moment (kip-ft)	5498.84	-
Rating	36.1%	-
Soil Vertical Capacity		
	Compression	Uplift
Skin Friction (kips)	415.61	-
End Bearing (kips)	202.04	-
Weight of Concrete (kips)	146.75	-
Total Capacity (kips)	617.65	-
Axial (kips)	211.75	-
Rating	34.3%	-
Reinforced Concrete Capacity		
	Compression	Uplift
Critical Depth (ft from TOC)	7.26	-
Critical Moment (kip-ft)	5498.75	-
Critical Moment Capacity	6789.77	-
Rating	81.0%	-
<b>Soil Interaction Rating</b>		<b>36.1%</b>
<b>Structural Foundation Rating</b>		<b>81.0%</b>

Check Limitation	
N/A	<input checked="" type="checkbox"/>
Load Z Normalization:	<input type="checkbox"/>

Soil Profile			
Groundwater Depth	5	ft	# of Layers
			4

Layer	Top (ft)	Bottom (ft)	Thickness (ft)	γ <sub>soil</sub> (pcf)	γ <sub>concrete</sub> (pcf)	Cohesion (ksf)	Angle of Friction (degrees)	Calculated Ultimate Skin Friction Comp (ksf)	Calculated Ultimate Skin Friction Uplift (ksf)	Ultimate Skin Friction Comp Override (ksf)	Ultimate Skin Friction Uplift Override (ksf)	Ult. Gross Bearing Capacity (ksf)	SPT Blow Count	Soil Type
1	0	3.5	3.5	130	150	0	0	0.000	0.000					Cohesionless
2	3.5	5	1.5	130	150	0	38	0.450	0.450				10	Cohesionless
3	5	15	10	70	87.6	0	38	0.715	0.715				10	Cohesionless
4	15	31	16	70	87.6	0	38	1.086	1.086			7	10	Cohesionless

**APPENDIX B**  
**MOUNT STRUCTURAL ANALYSIS REPORT – UPGRADE (DATED 06/19/2020)**

Date: 6/19/2020

To: T-Mobile Northeast, LLC  
35 Griffin Road South  
Bloomfield, CT 06002

**Subject: Mount Structural Analysis Report - Upgrade**

**T-Mobile Designation:**                      **Site Name:**                      CT365/Manchester PD\_MP  
**Site ID:**    CT11365D

**EFI Designation:**                              **Project Number:** 049.00421 - 2075019

**Site Data:**    **239 E.Middle Tpk, Manchester, CT 06040**  
**Latitude 41.78438900°, Longitude -72.51177100°**

EFI Global, Inc. is pleased to submit this “**Mount Structural Analysis Report - Upgrade**” to determine the structural capacity of the antenna mounts utilized by T-Mobile at the above referenced site.

The purpose of the analysis is to determine acceptability of the mount stress level for the changes proposed by T-Mobile. Under the following load case we have determined the mounts to have:

Existing + Proposed Equipment                              **Adequate Capacity/ with Modifications (71.6%)**  
Note: See Analysis Criteria for loading configuration

The analysis has been performed in accordance with the TIA-222-G Standard and 2018 Connecticut State Building Code (2015 IBC).

We at *EFI Global, Inc.* appreciate the opportunity of providing our continuing professional services to you. If you have any questions or need further assistance on this or any other projects, please give us a call.

Sincerely,  
EFI Global, Inc.  
License No: PEC0001245

6/19/2020  
  

Ahmet Colakoglu, PE  
Connecticut Professional Engineer  
License No: 27057

## 1) ANALYSIS CRITERIA

The analysis was performed for the existing and proposed appurtenances as specified in the loading information referenced below, and per the following loading criteria of Table 1.

**Table 1 – Loading and Analysis Criteria**

<b>Rad Center</b>	163'
<b>Structure Type</b>	Monopole
<b>Exposure Category</b>	B
<b>Basic Wind Speed (3-Second Gust)</b>	125 * $\sqrt{0.6}$ = 97 mph (ASD)
<b>Ice Loading</b>	1.00" with 50 mph Wind
<b>Risk Category</b>	II
<b>Topographic Factor</b>	Kzt = 1.0

**Table 1.1 – Existing Appurtenance Configuration**

Qty	Model
3	Ericsson AIR32 KRD901146-1_B66A_B2A – Antennas
3	RFS APXVAARR24_43-U-NA20 – Antennas
3	Ericsson AIR3246 B66 – Antennas
3	Generic Twin Style 1B-AWS – TMAs
3	Radio 4449 B71+B85 – RRUs

**Table 1.2 – Proposed and Final Appurtenance Configuration**

Qty	Model
3	Ericsson AIR32 KRD901146-1_B66A_B2A – Antennas
3	Ericsson AIR6449 B41 – Antennas
3	RFS APXVAARR24_43-U-NA20 – Antennas
3	Ericsson AIR3246 B66 – Antennas
3	Radio 4449 B71+B85 – RRUs*
3	Radio 4415 B25 – RRUs*

\* To be mounted behind the antenna

**Table 1.3 – Assumed Material Properties**

Member Type	ASTM Material Designation	Fy (ksi)	Fu (ksi)
Pipes	A53 Gr. B	35	60
Angles/Channels	A36	36	58
Rectangular HSS	A500 Gr. B - 46	46	58
Round HSS	A500 Gr. B - 42	42	58
Others (UNO)	A572 Gr. 50	50	65

## 2) ANALYSIS PROCEDURE

The analysis is based on the following information:

**Table 2 – Documents**

Document	Provided By	Date
RFDS	T-Mobile	05/19/2020
Structural Analysis Report	Tectonic	07/21/2016
Mount Assessment Letter	Destek Engineering, LLC	05/02/2018
Construction Drawings	Northeast Site Solutions	07/12/2018
Site Photos	-	04/23/2020

### 2.1) Analysis Method

Risa-3D, a commercially available analysis software package, was used to create a three-dimensional model of the mount and calculate member stresses for various loading cases. Selected output from the analysis is included in the Appendix.



## 2.2) Analysis Conditions and Assumptions

- 1) The mount was built and installed in accordance with the manufacturer's specifications.
- 2) The mount has been maintained and will be maintained in accordance with the manufacturer's specifications. All structural members and connections of the mount are in good condition and can achieve theoretical strength.
- 3) The configuration of antennas is as specified in "1) Analysis Criteria".
- 4) The analysis was performed for the subject mount only. It does not include an evaluation of the other mounts or the tower, which should be analyzed by others.
- 5) The evaluation does not include any antenna rigging loads. The equipment should not be rigged using the subject antenna mount as the support.
- 6) The analysis includes a minimum 250 lbf maintenance point load at the worst-case location on the mount, as well as a minimum 250 lbf maintenance point load at each antenna location in conjunction with a 30 mph wind load.
- 7) Any steel grating represented in this model is for loading purposes only and it is not considered to provide any structural restraint or support.
- 8) Member sizes per the structural analysis report, site photos and assumed based on our experience with similar structures. Please refer to calculation output in the appendix of this report for sizes and lengths assumed.
- 9) All member connections are assumed to have been designed to meet or exceed the load carrying capacity of the connected member unless otherwise specified in this report.

EFI Global, Inc. (EFI), must be notified immediately if any of these assumptions are discovered to be incorrect. The results of this analysis may be affected if any of the assumptions are not valid or have been made in error.

### 3) ANALYSIS RESULTS AND CONCLUSION

The analysis results are shown on the table below.

**Table 3.1 – Mount Component Stresses vs. Capacity**

Component	% Capacity	Pass / Fail
Horizontal Face Angles	55.0	Fail
Support Rail Pipes	38.0	Pass
Platform Support Double Angle	46.0	Pass
Standoff Tube Arm	49.0	Pass
Grating Angles	29.0	Pass
Support Rail Bracing Angles	37.0	Pass
Antenna Mount Pipe	71.6	Pass

**Platform Mount:** The existing platform mount **will have adequate** capacity for the proposed changes by T-Mobile, **once the mount is upgraded as per the attached EFI drawings, dated 06/19/2020**. For the code specified load combinations and as a maximum, the mount members are stressed to **71.6%** of their structural capacity.

**APPENDIX**

**INPUT LOADS  
ANALYSIS OUTPUT  
UPGRADE DRAWINGS**

CLIENT: ForeSite LLC - T-Mobile  
 PROJECT: CT11365D  
 SUBJECT: Antenna Loads -TIA 222 G Stanadard (chapter 16 revisions)

Tower Height 184.00 ft Type of Mount Platform  
 Basic Wind Speed, V 97 mph (=Ultimate Speed\*sqrt(0.6))  
 Basic Wind Speed with Ice, V<sub>i</sub> 50 mph  
 Maintenance Load Factor, L<sub>FM</sub> 0.0957 Load Factor for Maint. Load Cases (Basic Wind Speed=30 mph)  
 Design Ice Thickness, t<sub>i</sub> 1 inches

Table 2-3 Importance Factors

Structure Classification	Wind Load Without Ice	Wind Load With Ice	Ice Thickness	Earthquake
II	1	1	1	1

Table 2-4 Exposure Category Coefficients

Exposure Category	Z <sub>g</sub>	α	K <sub>zmin</sub>	K <sub>e</sub>	m
B	1200	7	0.7	0.9	0.55

Table 2-5 Topographic Categories  
 K<sub>zt</sub> 1.000

Table 2-2 Wind Directionality Factor, K<sub>d</sub>

Structure Type	K <sub>d</sub>
Monopole	0.95 DOES NOT CHANGE

Gust Effect Factor G<sub>h</sub>

Structure Type	G <sub>h</sub>
Monopole	1.00 DOES NOT CHANGE

Shielding Factor, K<sub>a</sub>

Structure Type	K <sub>a</sub>
Monopole	0.90 DOES NOT CHANGE

Seismic Factors

S <sub>s</sub>	0.178
S <sub>1</sub>	0.064
F <sub>a</sub>	1.6
F <sub>v</sub>	2.4
R	1.5 Truss or Pole

CLIENT: ForeSite LLC - T-Mobile  
 PROJECT: CT11365D  
 SUBJECT: Antenna Loads -TIA 222 G Stanadard (chapter 16 revisions)

Rad Center 163.00 ft

**Antenna AND Mount Without Ice**

Mounting Pole	Height (ft)	Model Number	#	Weight (lbs)	H (in)	*W (in)	D (in)	Ka	**A <sub>N</sub> (ft <sup>2</sup> )	***A <sub>T</sub> (ft <sup>2</sup> )	Aspect (FRONT)	Aspect (SIDE)	Ca (FRONT)	Ca (SIDE)	K <sub>z</sub>	q <sub>z</sub> (psf)	Pounds							
																	Wind Load (Front)	Wind Load (Side)	Dead Load	Total Wind Load (Front)	Total Wind Load (Side)	Total Dead Load	Lateral Load (Seismic)	Vertical Load (Seismic)
Pos. 1	163.00	Ericsson AIR32 KRD 901 146-1 B66A-B2A	1	143.0	59.3	12.9	8.7	0.90	5.30	3.56	4.60	6.84	1.29	1.39	1.136	26.0	160.3	116.1	143	160	116	143	10	5
		Empty		0.0	-	-	-	0.90	-	-	-	-	-	-	-	-	0.0	0.0	0					
		Empty		0.0	-	-	-	0.90	-	-	-	-	-	-	-	-	0.0	0.0	0					
		Empty		0.0	-	-	-	0.90	-	-	-	-	-	-	-	-	0.0	0.0	0					
		Empty		0.0	-	-	-	0.90	-	-	-	-	-	-	-	-	0.0	0.0	0	81	59	72	5	3
Pos.2	163.00	Ericsson AIR6449 B41	1	103.0	33.1	20.5	8.3	0.90	4.71	1.91	1.61	3.99	1.20	1.27	1.136	26.0	132.3	56.5	103	132	57	103	7	4
		Empty		0.0	-	-	-	0.90	-	-	-	-	-	-	-	-	0.0	0.0	0					
		Empty		0.0	-	-	-	0.90	-	-	-	-	-	-	-	-	0.0	0.0	0					
		Empty		0.0	-	-	-	0.90	-	-	-	-	-	-	-	-	0.0	0.0	0					
		Empty		0.0	-	-	-	0.90	-	-	-	-	-	-	-	-	0.0	0.0	0	67	29	52	4	2
Pos.3	163.00	RFS APXVAARR24_43-U-NA20	1	153.3	95.9	24.0	8.7	0.90	15.98	5.79	4.00	11.02	1.27	1.53	1.136	26.0	473.7	208.0	153.3	474	261	273	19	10
		Radio 4449 B71+B85	1	73.2	17.9	N/A	10.6	0.90	-	1.32	-	1.68	-	1.20	1.136	26.0	0.0	37.1	73.21					
		Radio 4415 B25	1	46.3	14.9	N/A	5.4	0.90	-	0.56	-	2.76	-	1.21	1.136	26.0	0.0	15.8	46.3					
		Empty		0.0	-	-	-	0.90	-	-	-	-	-	-	-	-	0.0	0.0	0					
		Empty		0.0	-	-	-	0.90	-	-	-	-	-	-	-	-	0.0	0.0	0	237	131	137	9	5
Pos.4	163.00	Ericsson AIR3246 B66	1	226.0	58.7	15.7	9.4	0.90	6.40	3.83	3.74	6.24	1.26	1.37	1.136	26.0	188.0	122.5	226	188	123	226	15	9
		Empty		0.0	-	-	-	0.90	-	-	-	-	-	-	-	-	0.0	0.0	0					
		Empty		0.0	-	-	-	0.90	-	-	-	-	-	-	-	-	0.0	0.0	0					
		Empty		0.0	-	-	-	0.90	-	-	-	-	-	-	-	-	0.0	0.0	0					
		Empty		0.0	-	-	-	0.90	-	-	-	-	-	-	-	-	0.0	0.0	0	94	62	113	8	4

\* Enter N/A in the W column for front shielded apurtanances.

\*\* A<sub>N</sub> is the product of H and W

\*\*\* A<sub>T</sub> is the product of H and D

DL 745

Mount	Height (ft)	Member	*L (in)	**W (in)	D (in)	Weight (lb/ft)	*** Ca	K <sub>z</sub>	q <sub>z</sub> (psf)	Wind Load (PLF)	Lateral Load (Seismic)	Vertical Load (Seismic)
	163.00	2 STD Pipe	12.00	2.38	0.00		1.20	1.136	23.4	6	-	-
	163.00	2.5 STD Pipe	0.00	2.88	0.00		-	-	-	-	-	-
	163.00	3 STD Pipe	0.00	3.50	0.00		-	-	-	-	-	-
	163.00	Angle Horizontal	0.00	0.00	0.00		-	-	-	-	-	-
	163.00	Angle (L3x3x4)	12.00	3.00	3.00		2.00	1.136	23.4	12	-	-
	163.00	Angle Diagonal	0.00	0.00	0.00		-	-	-	-	-	-
	163.00	Tube Standoff (4x4x4)	12.00	4.00	4.00		2.00	1.136	23.4	16	-	-
	163.00	Tube Horizontal	0.00	0.00	0.00		-	-	-	-	-	-
	163.00	Plate	0.00	0.00	0.00		-	-	-	-	-	-
	163.00	Double Angle (LL2.5x2.5x3)	12.00	2.50	2.50		2.00	1.136	23.4	10	-	-
	163.00	Double Angle	0.00	0.00	0.00		-	-	-	-	-	-
	163.00	Channel (Weak Axis Bending)	0.00	0.00	0.00		-	-	-	-	-	-
	163.00	Channel (Strong Axis Bending)	0.00	0.00	0.00		-	-	-	-	-	-

\* The dimension L is the longest dimension of the member

\*\* The dimension W is the height or width of the member that resists wind load

\*\*\* Ca will equal 1.2 for round members and 2.0 for flat members

CLIENT: ForeSite LLC - T-Mobile  
 PROJECT: CT11365D  
 SUBJECT: Antenna Loads -TIA 222 G Stanadard (chapter 16 revisions)

ti (in) 2.346375 Kiz 1.1731873 reduction 0.2657

**Antenna AND Mount With Ice**

Mounting Pole	Height (ft)	Model Number	#	H (in)	W (in)	D (in)	Ka	*A <sub>N</sub> (ft2)	*A <sub>T</sub> (ft2)	*Volume Ice (ft3)	*Weight Ice (lbs)	**Ca (FRONT)	**Ca (SIDE)	Kz	q <sub>z</sub> (psf)	Pounds							
																Ice Wind Load (Front)	Ice Wind Load (Side)	Combined Wind Load (Front)	Combined Wind Load (Side)	Ice Dead Load	**Total Wind Load (Front)	**Total Wind Load (Side)	Total Ice Load
Pos. 1	163.00	Ericsson AIR32 KRD 901 146-1 B66A-B2A	1	59.3	12.9	8.7	0.90	2.50	2.37	4.86	271.95	0.73	0.75	1.136	6.9	11.3	11.0	53.9	41.9	272	54	42	272
		Empty		-	-	-	0.90	-	-	-	0.00	-	-	-	-	0.0	0.0	0.0	0.0	0			
		Empty		-	-	-	0.90	-	-	-	0.00	-	-	-	-	0.0	0.0	0.0	0.0	0			
		Empty		-	-	-	0.90	-	-	-	0.00	-	-	-	-	0.0	0.0	0.0	0.0	0			
		Empty		-	-	-	0.90	-	-	-	0.00	-	-	-	-	0.0	0.0	0.0	0.0	0			
Pos.2	163.00	Ericsson AIR6449 B41	1	33.1	20.5	8.3	0.90	1.90	1.50	3.90	218.38	0.70	0.71	1.136	6.9	8.3	6.6	43.4	21.6	218	43	22	218
		Empty		-	-	-	0.90	-	-	-	0.00	-	-	-	-	0.0	0.0	0.0	0.0	0			
		Empty		-	-	-	0.90	-	-	-	0.00	-	-	-	-	0.0	0.0	0.0	0.0	0			
		Empty		-	-	-	0.90	-	-	-	0.00	-	-	-	-	0.0	0.0	0.0	0.0	0			
		Empty		-	-	-	0.90	-	-	-	0.00	-	-	-	-	0.0	0.0	0.0	0.0	0			
Pos.3	163.00	RFS APXVAARR24_43-U-NA20	1	95.9	24.0	8.7	0.90	4.06	3.56	10.78	603.79	0.72	0.81	1.136	6.9	18.2	18.0	144.1	73.2	604	144	96	803
		Radio 4449 B71+B85	1	17.9	13.2	10.6	0.90	-	1.08	2.13	119.38	0.70	0.70	1.136	6.9	0.0	4.7	0.0	14.6	119			
		Radio 4415 B25	1	14.9	13.2	5.4	0.90	-	0.81	1.43	80.24	0.70	0.70	1.136	6.9	0.0	3.5	0.0	7.8	80			
		Empty		-	-	-	0.90	-	-	-	0.00	-	-	-	-	0.0	0.0	0.0	0.0	0			
		Empty		-	-	-	0.90	-	-	-	0.00	-	-	-	-	0.0	0.0	0.0	0.0	0			
Pos.4	163.00	Ericsson AIR3246 B66	1	58.7	15.7	9.4	0.90	2.58	2.37	5.53	309.67	0.71	0.74	1.136	6.9	11.4	11.0	61.4	43.5	310	61	44	310
		Empty		-	-	-	0.90	-	-	-	0.00	-	-	-	-	0.0	0.0	0.0	0.0	0			
		Empty		-	-	-	0.90	-	-	-	0.00	-	-	-	-	0.0	0.0	0.0	0.0	0			
		Empty		-	-	-	0.90	-	-	-	0.00	-	-	-	-	0.0	0.0	0.0	0.0	0			
		Empty		-	-	-	0.90	-	-	-	0.00	-	-	-	-	0.0	0.0	0.0	0.0	0			

\* A<sub>N</sub>, A<sub>T</sub>, Volume Ice and Weight Ice are calculated per unit  
 \*\* Ca will equal 1.2 for all ice load calculations

Mount	Height (ft)	Member	*L (in)	**W (in)	D (in)	***A <sub>N</sub> (ft2)	Volume Ice (ft3)	Weight Ice (lbs)	****Ca (FRONT)	Kz	q <sub>z</sub> (psf)	PLF		
												Ice Wind Load (Front)	Combined Wind Load (Front)	Ice Dead Load
	163.00	2 STD Pipe	12.00	2.38	0.00	0.62	0.24	13.55	1.20	1.136	6.2	4.6	6.1	14
	163.00	2.5 STD Pipe	0.00	2.88	0.00	-	-	-	-	-	-	-	-	-
	163.00	3 STD Pipe	0.00	3.50	0.00	-	-	-	-	-	-	-	-	-
	163.00	Angle Horizontal	0.00	0.00	0.00	-	-	-	-	-	-	-	-	-
	163.00	Angle (L3x3x4)	12.00	3.00	3.00	0.64	0.20	10.95	1.20	1.136	6.2	4.8	7.9	11
	163.00	Angle Diagonal	0.00	0.00	0.00	-	-	-	-	-	-	-	-	-
	163.00	Tube Standoff (4x4x4)	12.00	4.00	4.00	0.67	0.62	34.66	1.20	1.136	6.2	5.0	9.2	35
	163.00	Tube Horizontal	0.00	0.00	0.00	-	-	-	-	-	-	-	-	-
	163.00	Plate	0.00	0.00	0.00	-	-	-	-	-	-	-	-	-
	163.00	Double Angle (LL2.5x2.5x3)	12.00	2.50	2.50	0.63	0.24	13.69	1.20	1.136	6.2	4.7	7.3	14
	163.00	Double Angle	0.00	0.00	0.00	-	-	-	-	-	-	-	-	-
	163.00	Channel (Weak Axis Bending)	0.00	0.00	0.00	-	-	-	-	-	-	-	-	-
	163.00	Channel (Strong Axis Bending)	0.00	0.00	0.00	-	-	-	-	-	-	-	-	-

\* The dimension L is the longest dimension of the member  
 \*\* The dimension W is the height or width of the member that resists wind load  
 \*\*\* A<sub>N</sub> is the area of ice built up on the LW plane  
 \*\*\*\* Ca will equal 1.2 for all ice load calculations

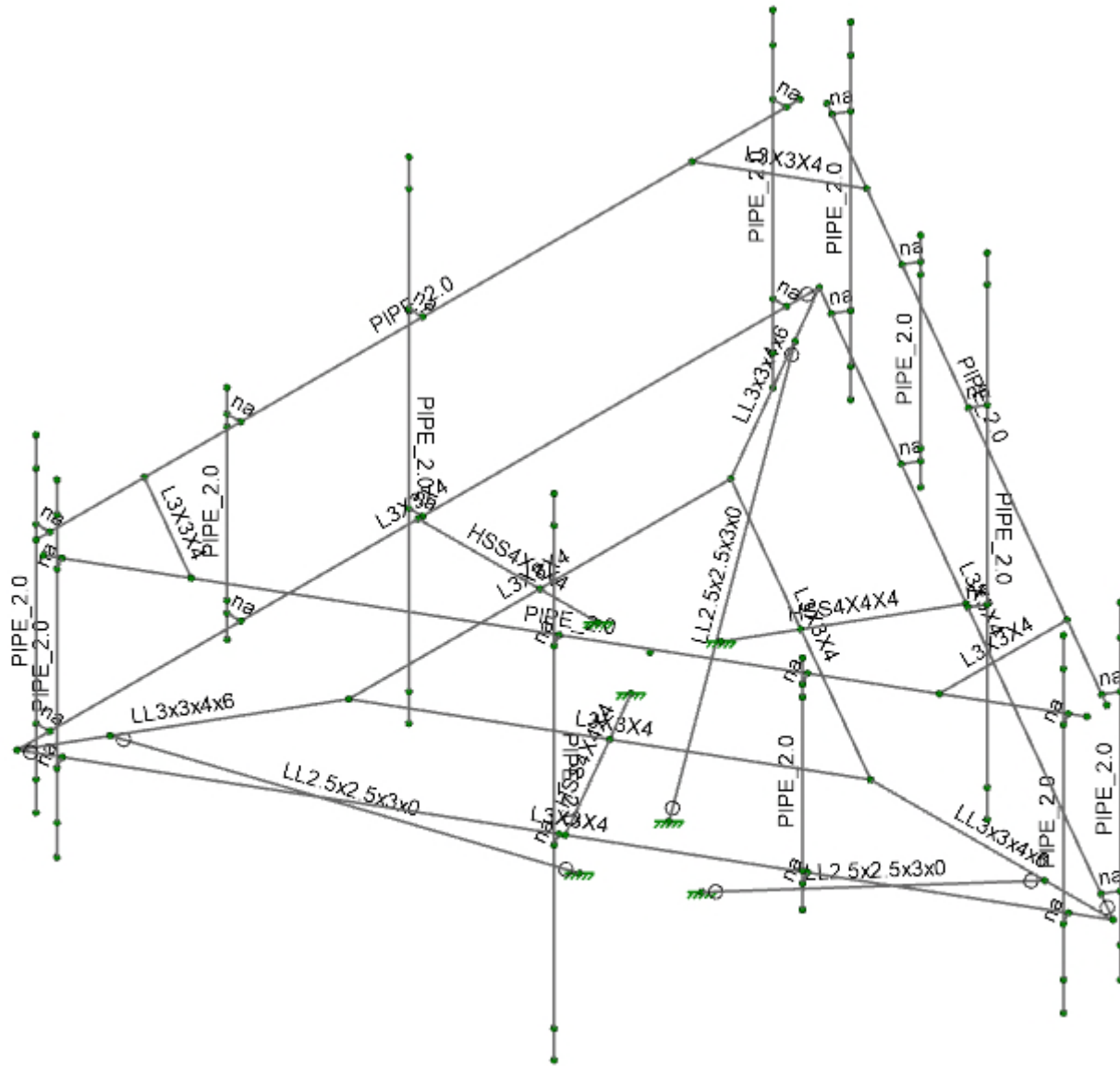

Envelope Only Solution

Foresite/ EFI Global

SK

049.00421 - 2075019

CT11365D - Upgrade

SK-1

Jun 18, 2020

CT11365D - Upgrade.r3d





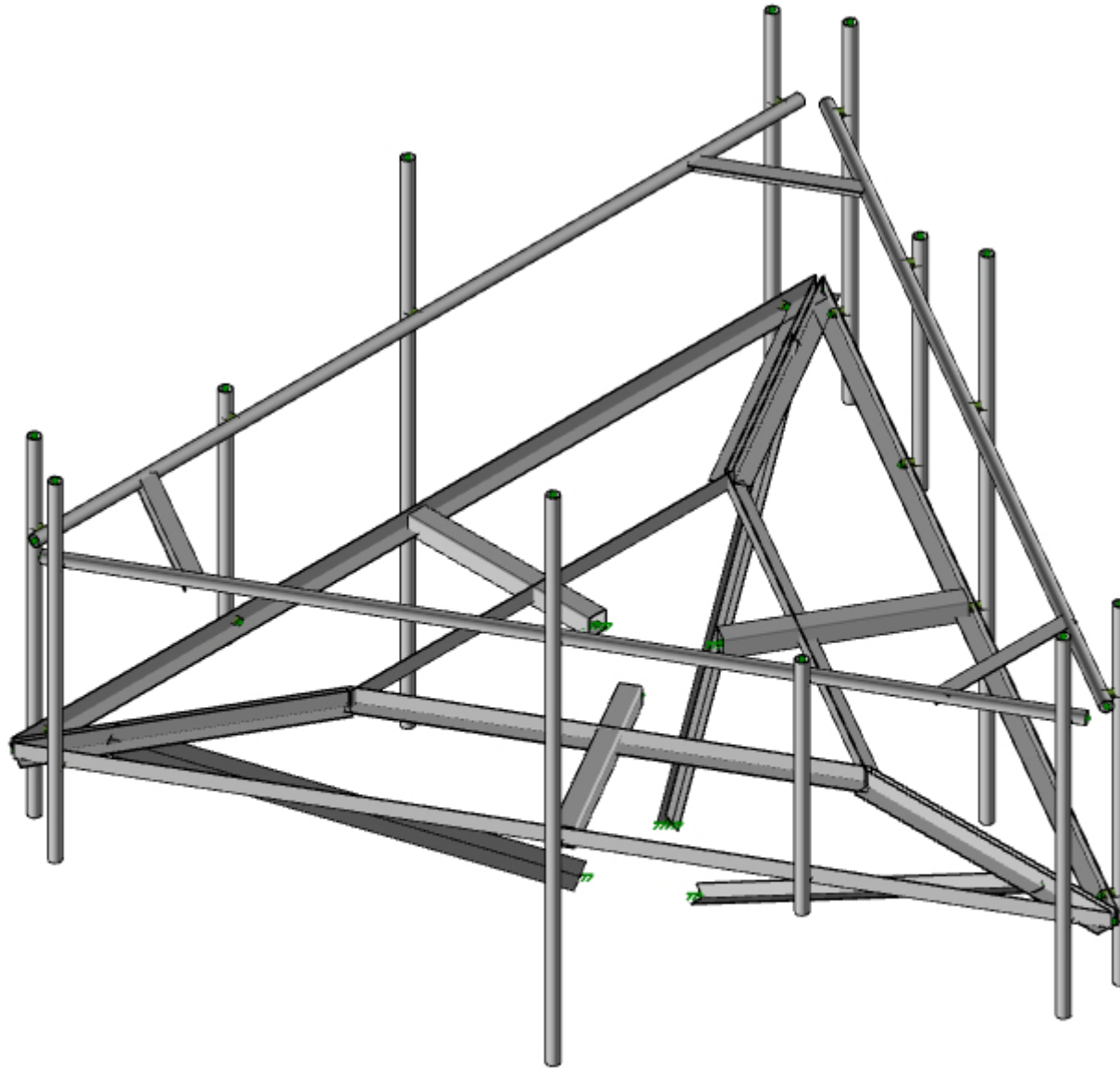
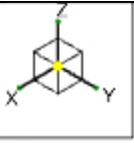

Member Length (in) Displayed  
Envelope Only Solution

Foresite/ EFI Global  
SK  
049.00421 - 2075019

CT11365D - Upgrade

SK-3  
Jun 18, 2020  
CT11365D - Upgrade.r3d

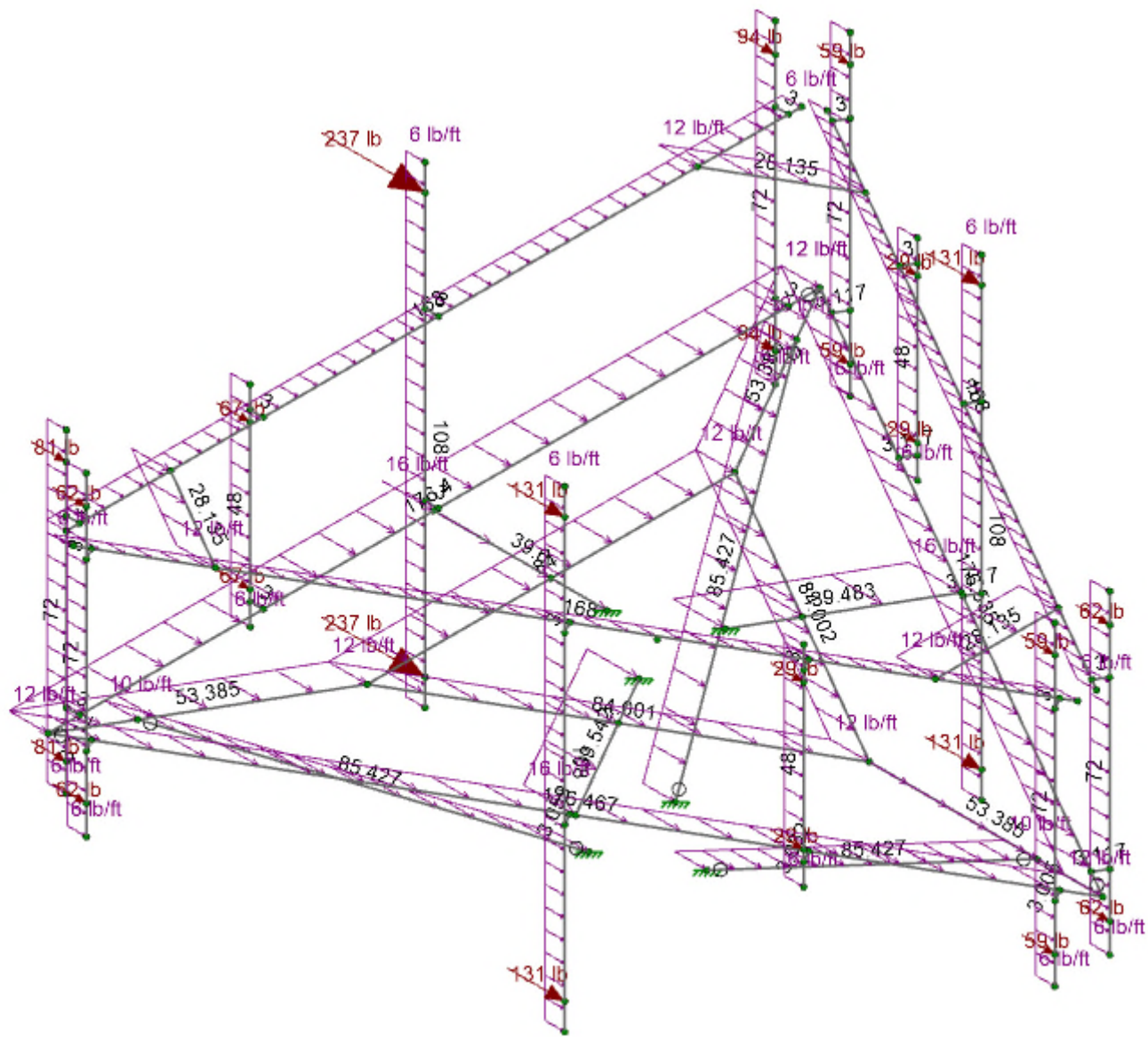



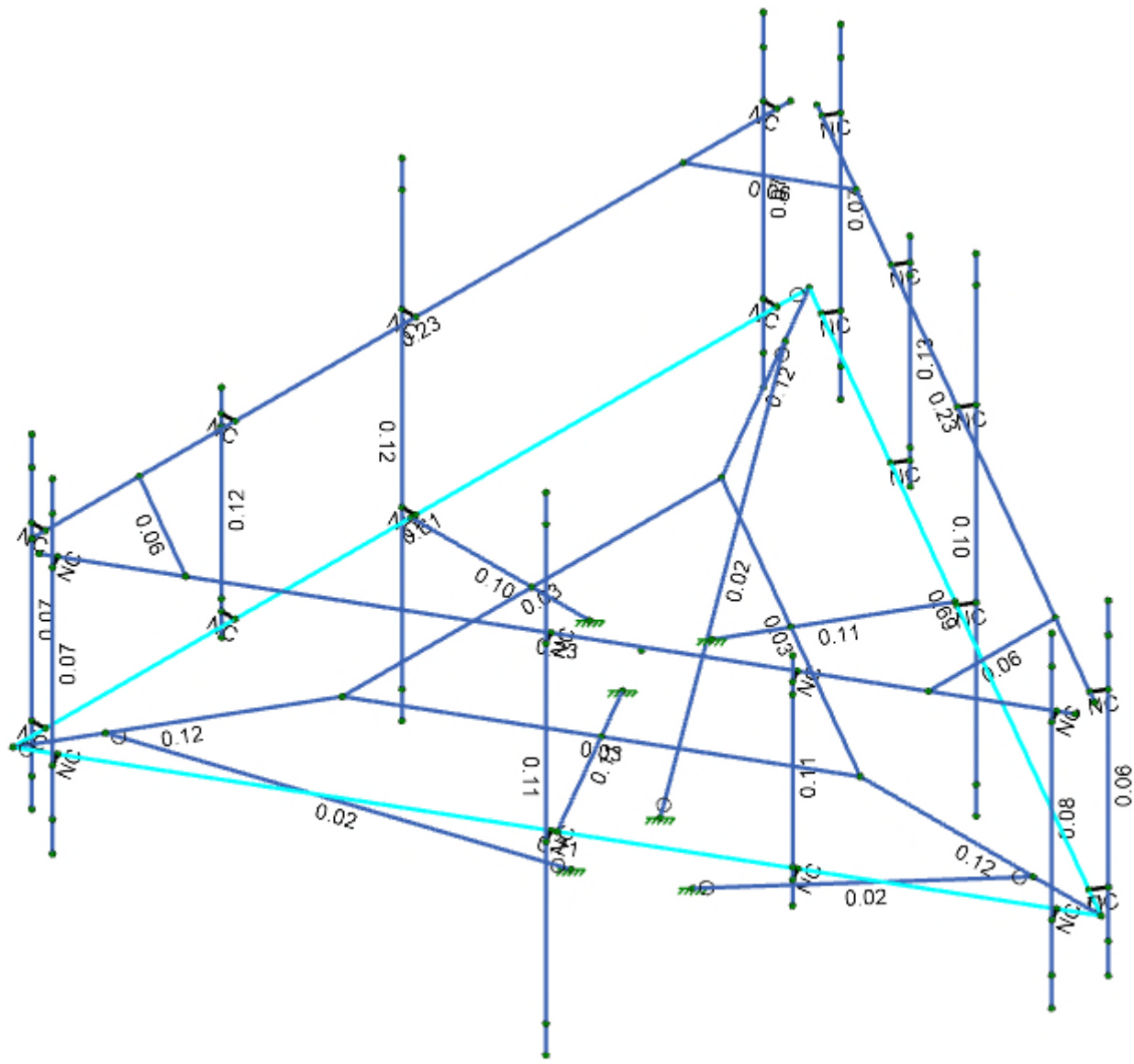
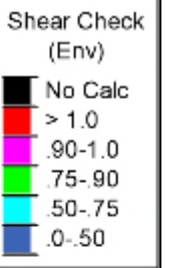
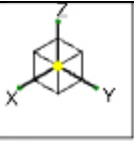

Member Shear Checks Displayed (Enveloped)  
Envelope Only Solution

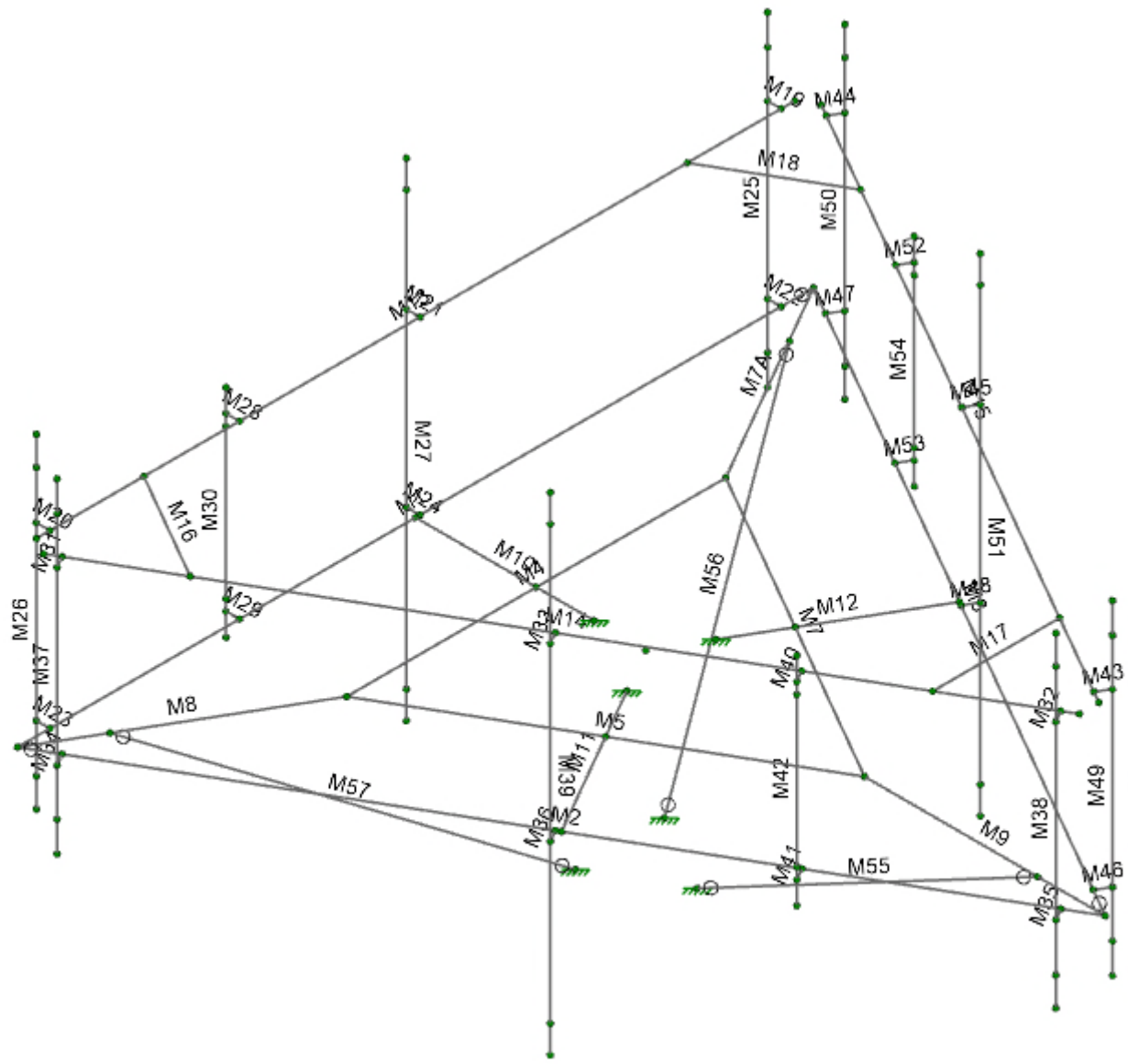

Envelope Only Solution

Foresite/ EFI Global  
SK  
049.00421 - 2075019

CT11365D - Upgrade

SK-7  
Jun 18, 2020  
CT11365D - Upgrade.r3d

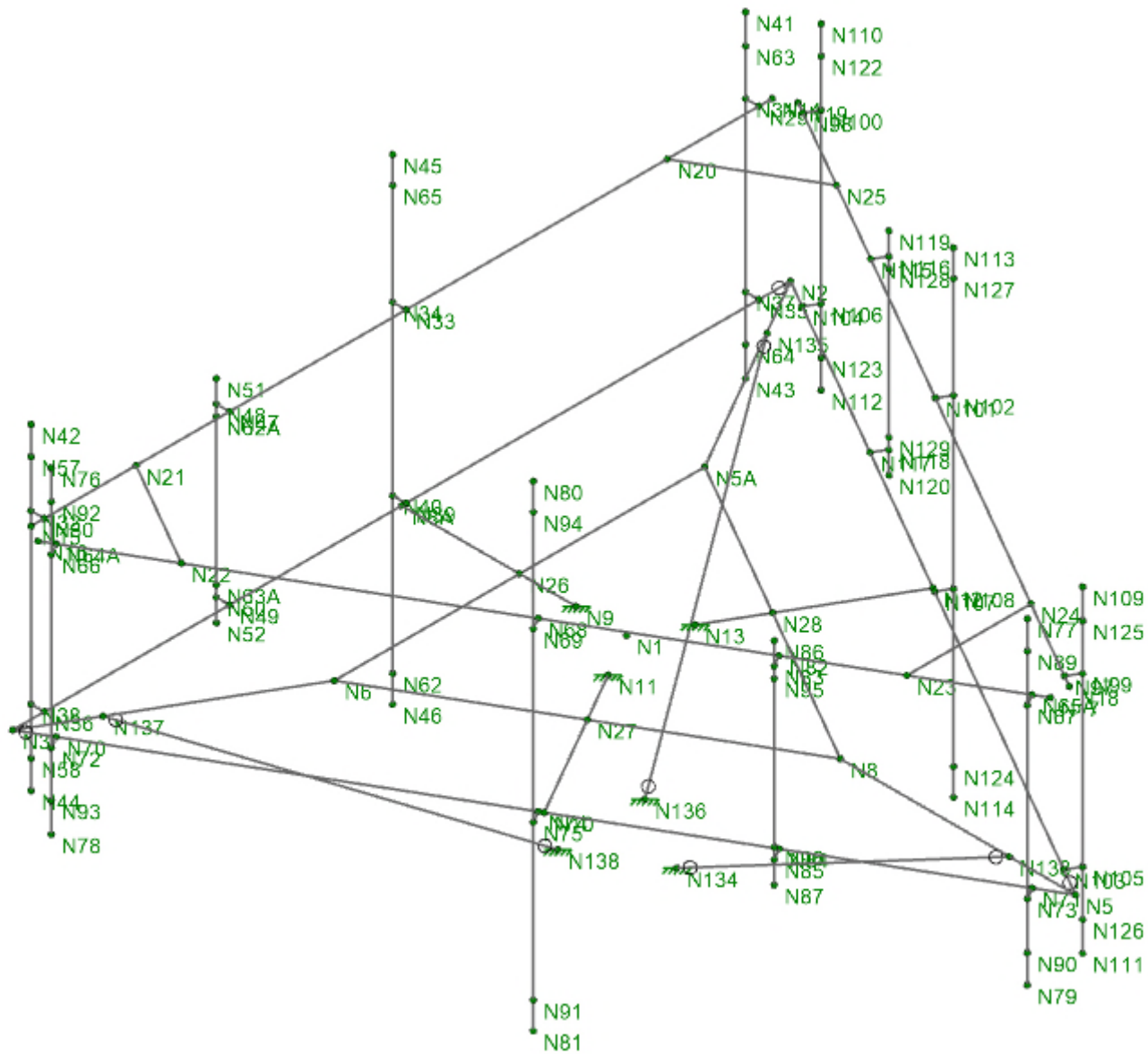

Envelope Only Solution

Foresite/ EFI Global  
SK  
049.00421 - 2075019

CT11365D - Upgrade

SK-8  
Jun 18, 2020  
CT11365D - Upgrade.r3d

**Model Settings**

Number of Reported Sections	5
Number of Internal Sections	97
Member Area Load Mesh Size (in <sup>2</sup> )	144
Consider Shear Deformation	Yes
Consider Torsional Warping	Yes
Approximate Mesh Size (in)	12
Transfer Forces Between Intersecting Wood Walls	No
Increase Wood Wall Nailing Capacity for Wind Loads	Yes
Include P-Delta for Walls	Yes
Optimize Masonry and Wood Walls	Yes
Maximum Number of Iterations	3
Single	No
Multiple (Optimum)	Yes
Maximum	No
Global Axis corresponding to vertical direction	Z
Convert Existing Data	Yes
Default Global Plane for z-axis	XZ
Plate Local Axis Orientation	Nodal
Hot Rolled Steel	AISC 14th (360-10): LRFD
Stiffness Adjustment	Yes (Iterative)
Notional Annex	None
Connections	AISC 14th (360-10): LRFD
Cold Formed Steel	AISI NAS-01: ASD
Stiffness Adjustment	Yes (Iterative)
Wood	AF&PA NDS-05/08: ASD
Temperature	< 100F
Concrete	ACI 318-05
Masonry	ACI 530-05: ASD
Aluminum	AA ADM1-05: ASD
Structure Type	Building
Stiffness Adjustment	Yes (Iterative)
Stainless	AISC 14th (360-10): ASD
Stiffness Adjustment	Yes (Iterative)
Analysis Methodology	Exact Integration Method
Paralle Beta Factor	0.65
Compression Stress Block	Rectangular Stress Block
Analyze using Cracked Sections	Yes
Leave room for horizontal rebar splices (2*d bar spacing)	No
List forces which were ignored for design in the Detail Report	Yes
Column Min Steel	1
Column Max Steel	8
Rebar Material Spec	ASTM A615
Warn if beam-column framing arrangement is not understood	No
Number of Shear Regions	4
Region 2 & 3 Spacing Increase Increment (in)	4
Code	ASCE 7-05
Risk Category	I
Drift Cat	Other
Base Elevation (ft)	-999999
Include the weight of the structure in base shear calcs	Yes
S <sub>v</sub> (g)	1
SD <sub>v</sub> (g)	1
SD <sub>h</sub> (g)	1
T <sub>v</sub> (sec)	-1
T (sec)	
T (sec)	
C <sub>v</sub>	0.035
C <sub>h</sub>	0.035
C <sub>v</sub> Exp.	0.75
C <sub>h</sub> Exp.	0.75
R	8.5
R	8.5
Ω <sub>v</sub>	1
Ω <sub>h</sub>	1
C <sub>v</sub>	4
C <sub>h</sub>	4
ρ	1
ρ	1

**Line Project Grid**

No Data to Print...

**Hot Rolled Steel Properties**

	Label	E [ksi]	G [ksi]	Nu	Therm. Coeff. [...]	Density [k/ft³]	Yield [ksi]	Ry	Fu [ksi]	Rt
1	A36 Gr.36	29000	11154	0.3	0.65	0.49	36	1.5	58	1.2
2	A572 Gr.50	29000	11154	0.3	0.65	0.49	50	1.1	65	1.2
3	A992	29000	11154	0.3	0.65	0.49	50	1.1	65	1.2
4	A500 Gr.42	29000	11154	0.3	0.65	0.49	42	1.3	58	1.1
5	A500 Gr.46	29000	11154	0.3	0.65	0.49	46	1.2	58	1.1
6	A53 Gr.B	29000	11154	0.3	0.65	0.49	35	1.5	60	1.2
7	A529 Gr.50	29000	11154	0.3	0.65	0.49	50	1.1	65	1.2

**Hot Rolled Steel Section Sets**

	Label	Shape	Type	Design List	Material	Design Rule	Area [in²]	Iyy [in⁴]	Izz [in⁴]	J [in⁴]
1	Standoff Tube...	HSS4X4X4	Beam	None	A500 Gr.46	Typical	3.37	7.8	7.8	12.8
2	Face Pipe Hori...	PIPE_3.0	Beam	None	A53 Gr.B	Typical	2.07	2.85	2.85	5.69
3	Antenna Pipe...	PIPE_2.5	Column	None	A53 Gr.B	Typical	1.61	1.45	1.45	2.89
4	Pipe Rail	PIPE_2.5	Beam	None	A53 Gr.B	Typical	1.61	1.45	1.45	2.89
5	Pipe Rail Brace	PIPE_2.5	VBrace	None	A53 Gr.B	Typical	1.61	1.45	1.45	2.89

**Primary Member Properties**

	Label	I Node	J Node	K Node	Rotate(deg)	Section/Shape	Type	Design List	Material	Design Rule
1	M19	N29	N31			RIGID	None	None	LINK	Typical
2	M20	N30	N32			RIGID	None	None	LINK	Typical
3	M21	N33	N34			RIGID	None	None	LINK	Typical
4	M22	N35	N37			RIGID	None	None	LINK	Typical
5	M23	N36	N38			RIGID	None	None	LINK	Typical
6	M24	N39	N40			RIGID	None	None	LINK	Typical
7	M28	N47	N48			RIGID	None	None	LINK	Typical
8	M29	N49	N50			RIGID	None	None	LINK	Typical
9	M31	N64A	N66			RIGID	None	None	LINK	Typical
10	M32	N65A	N67			RIGID	None	None	LINK	Typical
11	M33	N68	N69			RIGID	None	None	LINK	Typical
12	M34	N70	N72			RIGID	None	None	LINK	Typical
13	M35	N71	N73			RIGID	None	None	LINK	Typical
14	M36	N74	N75			RIGID	None	None	LINK	Typical
15	M40	N82	N83			RIGID	None	None	LINK	Typical
16	M41	N84	N85			RIGID	None	None	LINK	Typical
17	M43	N97	N99			RIGID	None	None	LINK	Typical
18	M44	N98	N100			RIGID	None	None	LINK	Typical
19	M45	N101	N102			RIGID	None	None	LINK	Typical
20	M46	N103	N105			RIGID	None	None	LINK	Typical
21	M47	N104	N106			RIGID	None	None	LINK	Typical
22	M48	N107	N108			RIGID	None	None	LINK	Typical
23	M52	N115	N116			RIGID	None	None	LINK	Typical
24	M53	N117	N118			RIGID	None	None	LINK	Typical
25	M13	N14	N15			PIPE_2.0	Beam	Wide Flange	A53 Gr.B	Typical
26	M14	N16	N17			PIPE_2.0	Beam	Wide Flange	A53 Gr.B	Typical
27	M15	N18	N19			PIPE_2.0	Beam	Wide Flange	A53 Gr.B	Typical
28	M25	N43	N41			PIPE_2.0	Beam	Wide Flange	A53 Gr.B	Typical
29	M26	N44	N42			PIPE_2.0	Beam	Wide Flange	A53 Gr.B	Typical
30	M27	N45	N46			PIPE_2.0	Beam	Wide Flange	A53 Gr.B	Typical
31	M30	N52	N51			PIPE_2.0	Beam	Wide Flange	A53 Gr.B	Typical
32	M37	N78	N76			PIPE_2.0	Beam	Wide Flange	A53 Gr.B	Typical
33	M38	N79	N77			PIPE_2.0	Beam	Wide Flange	A53 Gr.B	Typical
34	M39	N80	N81			PIPE_2.0	Beam	Wide Flange	A53 Gr.B	Typical
35	M42	N87	N86			PIPE_2.0	Beam	Wide Flange	A53 Gr.B	Typical
36	M49	N111	N109			PIPE_2.0	Beam	Wide Flange	A53 Gr.B	Typical
37	M50	N112	N110			PIPE_2.0	Beam	Wide Flange	A53 Gr.B	Typical
38	M51	N113	N114			PIPE_2.0	Beam	Wide Flange	A53 Gr.B	Typical
39	M54	N120	N119			PIPE_2.0	Beam	Wide Flange	A53 Gr.B	Typical
40	M7A	N2	N5A		270	LL3x3x4x6	Beam	Wide Flange	A36 Gr.36	Typical
41	M8	N3	N6		90	LL3x3x4x6	Beam	Wide Flange	A36 Gr.36	Typical
42	M9	N5	N8		90	LL3x3x4x6	Beam	Wide Flange	A36 Gr.36	Typical
43	M1	N2	N3			L3X3X4	Beam	Wide Flange	A36 Gr.36	Typical
44	M2	N3	N5		180	L3X3X4	Beam	Wide Flange	A36 Gr.36	Typical
45	M3	N5	N2		180	L3X3X4	Beam	Wide Flange	A36 Gr.36	Typical
46	M4	N5A	N6		90	L3X3X4	Beam	Wide Flange	A36 Gr.36	Typical
47	M5	N6	N8		270	L3X3X4	Beam	Wide Flange	A36 Gr.36	Typical
48	M7	N8	N5A		270	L3X3X4	Beam	Wide Flange	A36 Gr.36	Typical
49	M16	N22	N21			L3X3X4	Beam	Wide Flange	A36 Gr.36	Typical
50	M17	N23	N24			L3X3X4	Beam	Wide Flange	A36 Gr.36	Typical
51	M18	N20	N25			L3X3X4	Beam	Wide Flange	A36 Gr.36	Typical
52	M10	N8A	N9			HSS4X4X4	Beam	Wide Flange	A500 Gr.46	Typical
53	M11	N10	N11			HSS4X4X4	Beam	Wide Flange	A500 Gr.46	Typical
54	M12	N12	N13			HSS4X4X4	Beam	Wide Flange	A500 Gr.46	Typical
55	M55	N133	N134			LL2.5x2.5x3x0	Beam	Double Angle (...)	A36 Gr.36	Typical
56	M56	N135	N136			LL2.5x2.5x3x0	Beam	Double Angle (...)	A36 Gr.36	Typical
57	M57	N137	N138			LL2.5x2.5x3x0	Beam	Double Angle (...)	A36 Gr.36	Typical

**Advanced Member Properties**

	Label	I Release	J Release	I Offset [in]	J Offset [in]	T/C Only	Physical	Deflection Ra...	Analysis Offs...	Activation	Seismic DR
1	M19						Yes	** NA **			None
2	M20						Yes	** NA **			None
3	M21						Yes	** NA **			None
4	M22						Yes	** NA **			None
5	M23						Yes	** NA **			None
6	M24						Yes	** NA **			None
7	M28						Yes	** NA **			None
8	M29						Yes	** NA **			None
9	M31						Yes	** NA **			None
10	M32						Yes	** NA **			None
11	M33						Yes	** NA **			None
12	M34						Yes	** NA **			None
13	M35						Yes	** NA **			None
14	M36						Yes	** NA **			None



**Advanced Member Properties (Continued)**

	Label	I Release	J Release	I Offset [in]	J Offset [in]	T/C Only	Physical	Deflection Ra...	Analysis Offs...	Activation	Seismic DR
15	M40						Yes	** NA **			None
16	M41						Yes	** NA **			None
17	M43						Yes	** NA **			None
18	M44						Yes	** NA **			None
19	M45						Yes	** NA **			None
20	M46						Yes	** NA **			None
21	M47						Yes	** NA **			None
22	M48						Yes	** NA **			None
23	M52						Yes	** NA **			None
24	M53						Yes	** NA **			None
25	M13						Yes				None
26	M14						Yes				None
27	M15						Yes				None
28	M25						Yes				None
29	M26						Yes				None
30	M27						Yes				None
31	M30						Yes				None
32	M37						Yes				None
33	M38						Yes				None
34	M39						Yes				None
35	M42						Yes				None
36	M49						Yes				None
37	M50						Yes				None
38	M51						Yes				None
39	M54						Yes				None
40	M7A						Yes				None
41	M8						Yes				None
42	M9						Yes				None
43	M1	BenPIN					Yes				None
44	M2	BenPIN					Yes				None
45	M3	BenPIN					Yes				None
46	M4						Yes				None
47	M5						Yes				None
48	M7						Yes				None
49	M16						Yes				None
50	M17						Yes				None
51	M18						Yes				None
52	M10						Yes				None
53	M11						Yes				None
54	M12						Yes				None
55	M55	BenPIN	BenPIN				Yes	Default			None
56	M56	BenPIN	BenPIN				Yes	Default			None
57	M57	BenPIN	BenPIN				Yes	Default			None

**Hot Rolled Member Properties**

	Label	Shape	Length [in]	Lb y-y [in]	Lb z-z [in]	Lcomp top [in]	Lcomp bot [in]	L-Torque [in]	K y-y	K z-z	Cb	Function
1	M13	PIPE_2.0	168			Lbyy						Lateral
2	M14	PIPE_2.0	168			Lbyy						Lateral
3	M15	PIPE_2.0	168			Lbyy						Lateral
4	M25	PIPE_2.0	72			Lbyy						Lateral
5	M26	PIPE_2.0	72			Lbyy						Lateral
6	M27	PIPE_2.0	108			Lbyy						Lateral
7	M30	PIPE_2.0	48			Lbyy						Lateral
8	M37	PIPE_2.0	72			Lbyy						Lateral
9	M38	PIPE_2.0	72			Lbyy						Lateral
10	M39	PIPE_2.0	108			Lbyy						Lateral
11	M42	PIPE_2.0	48			Lbyy						Lateral
12	M49	PIPE_2.0	72			Lbyy						Lateral
13	M50	PIPE_2.0	72			Lbyy						Lateral
14	M51	PIPE_2.0	108			Lbyy						Lateral
15	M54	PIPE_2.0	48			Lbyy						Lateral
16	M7A	LL3x3x4x6	53.385			Lbyy						Lateral
17	M8	LL3x3x4x6	53.385			Lbyy						Lateral
18	M9	LL3x3x4x6	53.385			Lbyy						Lateral
19	M1	L3X3X4	176.4			Lbyy						Lateral
20	M2	L3X3X4	176.467			Lbyy						Lateral
21	M3	L3X3X4	176.535			Lbyy						Lateral
22	M4	L3X3X4	84			Lbyy						Lateral
23	M5	L3X3X4	84.001			Lbyy						Lateral
24	M7	L3X3X4	84.002			Lbyy						Lateral
25	M16	L3X3X4	28.135			Lbyy						Lateral
26	M17	L3X3X4	28.135			Lbyy						Lateral
27	M18	L3X3X4	28.135			Lbyy						Lateral
28	M10	HSS4X4X4	39.6			Lbyy						Lateral
29	M11	HSS4X4X4	39.542			Lbyy						Lateral
30	M12	HSS4X4X4	39.483			Lbyy						Lateral
31	M55	LL2.5x2.5x3x0	85.427			Lbyy						Lateral
32	M56	LL2.5x2.5x3x0	85.427			Lbyy						Lateral
33	M57	LL2.5x2.5x3x0	85.427			Lbyy						Lateral

**Nodes**

	Label	X [in]	Y [in]	Z [in]	Temp [deg F]	Detach From Diaphragm
1	N1	0	0	0		
2	N2	-88.2	-51	0		
3	N3	88.2	-51	0		
4	N5	0.067296	101.883441	0		
5	N5A	-42	-24.25	0		
6	N6	42	-24.25	0		
7	N8	0.001116	48.498067	0		
8	N8A	0	-51	0		
9	N9	0	-11.4	0		
10	N10	44.116843	25.470871	0		
11	N11	9.87269	5.7	0		
12	N12	-44.066352	25.44172	0		
13	N13	-9.87269	5.7	0		
14	N14	-84	-51	38		

Nodes (Continued)

	Label	X [in]	Y [in]	Z [in]	Temp [deg F]	Detach From Diaphragm
15	N15	84	-51	38		
16	N16	86.167296	-47.246134	38		
17	N17	2.167296	98.246134	38		
18	N18	-2.167296	98.246134	38		
19	N19	-86.167296	-47.246134	38		
20	N20	-60.2	-51	38		
21	N21	60.2	-51	38		
22	N22	74.267296	-26.634729	38		
23	N23	14.067296	77.634729	38		
24	N24	-14.067296	77.634729	38		
25	N25	-74.267296	-26.634729	38		
26	N26	0	-24.25	0		
27	N27	21.000279	12.124517	0		
28	N28	-20.999442	12.124033	0		
29	N29	-81	-51	38		
30	N30	81	-51	38		
31	N31	-81	-54	38		
32	N32	81	-54	38		
33	N33	-1	-51	38		
34	N34	-1	-54	38		
35	N35	-81	-51	0		
36	N36	81	-51	0		
37	N37	-81	-54	0		
38	N38	81	-54	0		
39	N39	-1	-51	0		
40	N40	-1	-54	0		
41	N41	-81	-54	55		
42	N42	81	-54	55		
43	N43	-81	-54	-17		
44	N44	81	-54	-17		
45	N45	-1	-54	67		
46	N46	-1	-54	-41		
47	N47	39	-51	38		
48	N48	39	-54	38		
49	N49	39	-51	0		
50	N50	39	-54	0		
51	N51	39	-54	43		
52	N52	39	-54	-5		
53	N57	81	-54	48.65		
54	N58	81	-54	-10.65		
55	N62	-1	-54	-34.95		
56	N63	-81	-54	48.35		
57	N64	-81	-54	-10.35		
58	N65	-1	-54	60.95		
59	N62A	39	-54	35.55		
60	N63A	39	-54	2.45		
61	N64A	84.667296	-44.648058	38		
62	N65A	3.667296	95.648058	38		
63	N66	87.265372	-43.148058	38		
64	N67	6.265372	97.148058	38		
65	N68	44.667296	24.633975	38		
66	N69	47.265372	26.133975	38		
67	N70	84.570509	-44.703937	0		
68	N71	3.663177	95.64568	0		
69	N72	87.265372	-43.148058	0		
70	N73	6.265372	97.148058	0		
71	N74	44.616271	24.604516	0		
72	N75	47.265372	26.133975	0		
73	N76	87.265372	-43.148058	55		
74	N77	6.265372	97.148058	55		
75	N78	87.265372	-43.148058	-17		
76	N79	6.265372	97.148058	-17		
77	N80	47.265372	26.133975	67		
78	N81	47.265372	26.133975	-41		
79	N82	24.667296	59.274991	38		
80	N83	27.265372	60.774991	38		
81	N84	24.639152	59.258742	0		
82	N85	27.265372	60.774991	0		
83	N86	27.265372	60.774991	43		
84	N87	27.265372	60.774991	-5		
85	N89	6.265372	97.148058	48.65		
86	N90	6.265372	97.148058	-10.65		
87	N91	47.265372	26.133975	-34.95		
88	N92	87.265372	-43.148058	48.35		
89	N93	87.265372	-43.148058	-10.35		
90	N94	47.265372	26.133975	60.95		
91	N95	27.265372	60.774991	35.55		
92	N96	27.265372	60.774991	2.45		
93	N97	-3.667296	95.648058	38		
94	N98	-84.667296	-44.648058	38		
95	N99	-6.265372	97.148058	38		
96	N100	-87.265372	-43.148058	38		
97	N101	-43.667296	26.366025	38		
98	N102	-46.265372	27.866025	38		
99	N103	-3.566352	95.589778	0		
100	N104	-84.566352	-44.706337	0		
101	N105	-6.265372	97.148058	0		
102	N106	-87.265372	-43.148058	0		
103	N107	-43.566352	26.307746	0		
104	N108	-46.265372	27.866025	0		
105	N109	-6.265372	97.148058	55		
106	N110	-87.265372	-43.148058	55		
107	N111	-6.265372	97.148058	-17		
108	N112	-87.265372	-43.148058	-17		
109	N113	-46.265372	27.866025	67		
110	N114	-46.265372	27.866025	-41		
111	N115	-63.667296	-8.274991	38		

**Nodes (Continued)**

	Label	X [in]	Y [in]	Z [in]	Temp [deg F]	Detach From Diaphragm
112	N116	-66.265372	-6.774991	38		
113	N117	-63.566352	-8.33327	0		
114	N118	-66.265372	-6.774991	0		
115	N119	-66.265372	-6.774991	43		
116	N120	-66.265372	-6.774991	-5		
117	N122	-87.265372	-43.148058	48.65		
118	N123	-87.265372	-43.148058	-10.65		
119	N124	-46.265372	27.866025	-34.95		
120	N125	-6.265372	97.148058	48.35		
121	N126	-6.265372	97.148058	-10.35		
122	N127	-46.265372	27.866025	60.95		
123	N128	-66.265372	-6.774991	35.55		
124	N129	-66.265372	-6.774991	2.45		
125	N133	0.067296	86.883441	0		
126	N134	0	11.4	-40		
127	N135	-75.276915	-43.383441	0		
128	N136	-9.87269	-5.7	-40		
129	N137	75.209619	-43.5	0		
130	N138	9.87269	-5.7	-40		

**Boundary Conditions**

	Node Label	X [k/in]	Y [k/in]	Z [k/in]	X Rot [k-ft/rad]	Y Rot [k-ft/rad]	Z Rot [k-ft/rad]
1	N13	Reaction	Reaction	Reaction	Reaction	Reaction	Reaction
2	N11	Reaction	Reaction	Reaction	Reaction	Reaction	Reaction
3	N9	Reaction	Reaction	Reaction	Reaction	Reaction	Reaction
4	N134	Reaction	Reaction	Reaction	Reaction	Reaction	Reaction
5	N136	Reaction	Reaction	Reaction	Reaction	Reaction	Reaction
6	N138	Reaction	Reaction	Reaction	Reaction	Reaction	Reaction

**Basic Load Cases**

	BLC Description	Category	X Gravity	Y Gravity	Z Gravity	Nodal	Point	Distributed	Area(Member)	Surface(Plate/...
1	DEAD LOAD	None			-1	24			3	
2	DEAD LOAD ICE	None				24		33	3	
3	WIND LOAD (...)	None				24		33		
4	WIND LOAD (...)	None				24		33		
5	WIND LOAD (I...)	None				24		33		
6	WIND LOAD (I...)	None				24		31		
7	LIVE LOAD1	None				1				
8	LIVE LOAD2	None				1				
9	LIVE LOAD3	None				1				
10	MAINTENANC...	None				1				
11	MAINTENANC...	None				1				
12	MAINTENANC...	None				1				
13	MAINTENANC...	None				1				
14	BLC 1 Transien...	None						36		
15	BLC 2 Transien...	None						36		

**Node Loads and Enforced Displacements (BLC 1 : DEAD LOAD)**

	Node Label	L, D, M	Direction	Magnitude [(lb, k-ft), (in, rad), (l... Inactive [(lb, k-ft), (in, rad), (lb*...
1	N57	L	Z	-72 Active
2	N58	L	Z	-72 Active
3	N122	L	Z	-72 Active
4	N123	L	Z	-72 Active
5	N89	L	Z	-72 Active
6	N90	L	Z	-72 Active
7	N62A	L	Z	-52 Active
8	N63A	L	Z	-52 Active
9	N128	L	Z	-52 Active
10	N129	L	Z	-52 Active
11	N95	L	Z	-52 Active
12	N96	L	Z	-52 Active
13	N65	L	Z	-137 Active
14	N62	L	Z	-137 Active
15	N127	L	Z	-137 Active
16	N124	L	Z	-137 Active
17	N94	L	Z	-137 Active
18	N91	L	Z	-137 Active
19	N63	L	Z	-113 Active
20	N64	L	Z	-113 Active
21	N125	L	Z	-113 Active
22	N126	L	Z	-113 Active
23	N92	L	Z	-113 Active
24	N93	L	Z	-113 Active

**Node Loads and Enforced Displacements (BLC 2 : DEAD LOAD ICE)**

	Node Label	L, D, M	Direction	Magnitude [(lb, k-ft), (in, rad), (l... Inactive [(lb, k-ft), (in, rad), (lb*...
1	N57	L	Z	-136 Active
2	N58	L	Z	-136 Active
3	N122	L	Z	-136 Active
4	N123	L	Z	-136 Active
5	N89	L	Z	-136 Active
6	N90	L	Z	-136 Active
7	N62A	L	Z	-110 Active
8	N63A	L	Z	-110 Active
9	N128	L	Z	-110 Active
10	N129	L	Z	-110 Active
11	N95	L	Z	-110 Active
12	N96	L	Z	-110 Active
13	N65	L	Z	-402 Active
14	N62	L	Z	-402 Active
15	N127	L	Z	-402 Active
16	N124	L	Z	-402 Active
17	N94	L	Z	-402 Active
18	N91	L	Z	-402 Active
19	N63	L	Z	-155 Active



**Node Loads and Enforced Displacements (BLC 2 : DEAD LOAD ICE) (Continued)**

	Node Label	L, D, M	Direction	Magnitude [(lb, k-ft), (in, rad), (l... Inactive [(lb, k-ft), (in, rad), (lb*...
20	N64	L	Z	-155 Active
21	N125	L	Z	-155 Active
22	N126	L	Z	-155 Active
23	N92	L	Z	-155 Active
24	N93	L	Z	-155 Active

**Node Loads and Enforced Displacements (BLC 6 : WIND LOAD (ICE) SIDE)**

	Node Label	L, D, M	Direction	Magnitude [(lb, k-ft), (in, rad), (l... Inactive [(lb, k-ft), (in, rad), (lb*...
7	N62A	L	X	11 Active
8	N63A	L	X	11 Active
9	N128	L	X	22 Active
10	N129	L	X	22 Active
11	N95	L	X	22 Active
12	N96	L	X	22 Active
13	N65	L	X	48 Active
14	N62	L	X	48 Active
15	N127	L	X	73 Active
16	N124	L	X	73 Active
17	N94	L	X	73 Active
18	N91	L	X	73 Active
19	N63	L	X	22 Active
20	N64	L	X	22 Active
21	N125	L	X	31 Active
22	N126	L	X	31 Active
23	N92	L	X	31 Active
24	N93	L	X	31 Active

**Member Distributed Loads (BLC 2 : DEAD LOAD ICE)**

	Member Label	Direction	Start Magnitude [lb/ft,...	End Magnitude [lb/ft,...	Start Location [(in, %)]	End Location [(in, %)]	Inactive [(lb, k-ft), (in, r...
1	M13	Z	-14	-14	0	%100	Active
2	M14	Z	-14	-14	0	%100	Active
3	M15	Z	-14	-14	0	%100	Active
4	M25	Z	-14	-14	0	%100	Active
5	M26	Z	-14	-14	0	%100	Active
6	M27	Z	-14	-14	0	%100	Active
7	M30	Z	-14	-14	0	%100	Active
8	M37	Z	-14	-14	0	%100	Active
9	M38	Z	-14	-14	0	%100	Active
10	M39	Z	-14	-14	0	%100	Active
11	M42	Z	-14	-14	0	%100	Active
12	M49	Z	-14	-14	0	%100	Active
13	M50	Z	-14	-14	0	%100	Active
14	M51	Z	-14	-14	0	%100	Active
15	M54	Z	-14	-14	0	%100	Active
16	M7A	Z	-16	-16	0	%100	Active
17	M8	Z	-16	-16	0	%100	Active
18	M9	Z	-16	-16	0	%100	Active
19	M1	Z	-11	-11	0	%100	Active
20	M2	Z	-11	-11	0	%100	Active
21	M3	Z	-11	-11	0	%100	Active
22	M4	Z	-11	-11	0	%100	Active
23	M5	Z	-11	-11	0	%100	Active
24	M7	Z	-11	-11	0	%100	Active
25	M16	Z	-11	-11	0	%100	Active
26	M17	Z	-11	-11	0	%100	Active
27	M18	Z	-11	-11	0	%100	Active
28	M10	Z	-35	-35	0	%100	Active
29	M11	Z	-35	-35	0	%100	Active
30	M12	Z	-35	-35	0	%100	Active
31	M57	Z	-14	-14	0	%100	Active
32	M55	Z	-14	-14	0	%100	Active
33	M56	Z	-14	-14	0	%100	Active

**Member Distributed Loads (BLC 3 : WIND LOAD (NO ICE) FRONT)**

	Member Label	Direction	Start Magnitude [lb/ft,...	End Magnitude [lb/ft,...	Start Location [(in, %)]	End Location [(in, %)]	Inactive [(lb, k-ft), (in, r...
1	M13	PY	6	6	0	%100	Active
2	M14	PY	6	6	0	%100	Active
3	M15	PY	6	6	0	%100	Active
4	M25	PY	6	6	0	%100	Active
5	M26	PY	6	6	0	%100	Active
6	M27	PY	6	6	0	%100	Active
7	M30	PY	6	6	0	%100	Active
8	M37	PY	6	6	0	%100	Active
9	M38	PY	6	6	0	%100	Active
10	M39	PY	6	6	0	%100	Active
11	M42	PY	6	6	0	%100	Active
12	M49	PY	6	6	0	%100	Active
13	M50	PY	6	6	0	%100	Active
14	M51	PY	6	6	0	%100	Active
15	M54	PY	6	6	0	%100	Active
16	M7A	PY	12	12	0	%100	Active
17	M8	PY	12	12	0	%100	Active
18	M9	PY	12	12	0	%100	Active
19	M1	PY	12	12	0	%100	Active
20	M2	PY	12	12	0	%100	Active
21	M3	PY	12	12	0	%100	Active
22	M4	PY	12	12	0	%100	Active
23	M5	PY	12	12	0	%100	Active
24	M7	PY	12	12	0	%100	Active
25	M16	PY	12	12	0	%100	Active
26	M17	PY	12	12	0	%100	Active
27	M18	PY	12	12	0	%100	Active
28	M10	PY	16	16	0	%100	Active
29	M11	PY	16	16	0	%100	Active
30	M12	PY	16	16	0	%100	Active
31	M57	PY	10	10	0	%100	Active
32	M56	PY	10	10	0	%100	Active
33	M55	PY	10	10	0	%100	Active



**Member Distributed Loads (BLC 3 : WIND LOAD (NO ICE) FRONT) (Continued)**

	Member Label	Direction	Start Magnitude [lb/ft,...	End Magnitude [lb/ft,...	Start Location [(in, %)]	End Location [(in, %)]	Inactive [(lb, k-ft), (in, r...
8	M37	PY	6	6	0	%100	Active
9	M38	PY	6	6	0	%100	Active
10	M39	PY	6	6	0	%100	Active
11	M42	PY	6	6	0	%100	Active
12	M49	PY	6	6	0	%100	Active
13	M50	PY	6	6	0	%100	Active
14	M51	PY	6	6	0	%100	Active
15	M54	PY	6	6	0	%100	Active
16	M7A	PY	12	12	0	%100	Active
17	M8	PY	12	12	0	%100	Active
18	M9	PY	12	12	0	%100	Active
19	M1	PY	12	12	0	%100	Active
20	M2	PY	12	12	0	%100	Active
21	M3	PY	12	12	0	%100	Active
22	M4	PY	12	12	0	%100	Active
23	M5	PY	12	12	0	%100	Active
24	M7	PY	12	12	0	%100	Active
25	M16	PY	12	12	0	%100	Active
26	M17	PY	12	12	0	%100	Active
27	M18	PY	12	12	0	%100	Active
28	M10	PY	16	16	0	%100	Active
29	M11	PY	16	16	0	%100	Active
30	M12	PY	16	16	0	%100	Active
31	M57	PY	10	10	0	%100	Active
32	M56	PY	10	10	0	%100	Active
33	M55	PY	10	10	0	%100	Active



**Member Distributed Loads (BLC 5 : WIND LOAD (ICE) FRONT)**

	Member Label	Direction	Start Magnitude [lb/ft,...	End Magnitude [lb/ft,...	Start Location [(in, %)]	End Location [(in, %)]	Inactive [(lb, k-ft), (in, r...
32	M56	PY	7.3	7.3	0	%100	Active
33	M55	PY	7.3	7.3	0	%100	Active

**Member Distributed Loads (BLC 15 : BLC 2 Transient Area Loads)**

	Member Label	Direction	Start Magnitude [lb/ft, ...]	End Magnitude [lb/ft, ...]	Start Location [(in, %)]	End Location [(in, %)]	Inactive [(lb, k-ft), (in, r...)]
18	M1	Z	-6.724	-9.014	29.4	58.8	Active
19	M1	Z	-9.014	-9.342	58.8	88.2	Active
20	M1	Z	-9.342	-9.014	88.2	117.6	Active
21	M1	Z	-9.014	-6.724	117.6	147	Active
22	M1	Z	-6.724	-2.799	147	176.4	Active
23	M4	Z	-17.633	-4.409	0	28	Active
24	M4	Z	-4.409	-4.407	28	56	Active
25	M4	Z	-4.407	-17.628	56	84	Active
26	M10	Z	-19.641	-19.641	0	26.75	Active
27	M2	Z	-2.793	-6.706	0	29.411	Active
28	M2	Z	-6.706	-8.991	29.411	58.822	Active
29	M2	Z	-8.991	-9.321	58.822	88.234	Active
30	M2	Z	-9.321	-8.997	88.234	117.645	Active
31	M2	Z	-8.997	-6.713	117.645	147.056	Active
32	M2	Z	-6.713	-2.795	147.056	176.467	Active
33	M5	Z	-17.57	-4.391	0	28	Active
34	M5	Z	-4.391	-4.402	28	56.001	Active
35	M5	Z	-4.402	-17.604	56.001	84.001	Active
36	M11	Z	-19.648	-19.648	0.004	26.693	Active

**Member Area Loads (BLC 1 : DEAD LOAD)**

	Node A	Node B	Node C	Node D	Direction	Load Direction	Magnitude [psf]	Inactive [(lb, k-ft), (i...)]
1	N5	N2	N5A	N8	Z	Two Way	-5	Active
2	N5A	N2	N3	N6	Z	Two Way	-5	Active
3	N5	N8	N6	N3	Z	Two Way	-5	Active

**Member Area Loads (BLC 2 : DEAD LOAD ICE)**

	Node A	Node B	Node C	Node D	Direction	Load Direction	Magnitude [psf]	Inactive [(lb, k-ft), (i...)]
1	N5	N2	N5A	N8	Z	Two Way	-10.95	Active
2	N5A	N2	N3	N6	Z	Two Way	-10.95	Active
3	N5	N8	N6	N3	Z	Two Way	-10.95	Active

**Load Combinations**

Desc...	Solve	PDelta	SRSS	BLC	Factor	BLC	Factor	BLC	Factor	BLC	Factor	BLC	Factor	BLC	Factor	BLC	Factor	BLC	Factor	BLC	Factor	BLC	Factor	
1	DL+...	Yes	Y	1	1.2			3	1.6															
2	DL+...	Yes	Y	1	1.2			3	1.386	4	0.8													
3	DL+...	Yes	Y	1	1.2			3	0.8	4	1.386													
4	DL+...	Yes	Y	1	1.2					4	1.6													
5	DL+...	Yes	Y	1	1.2			3	-0.8	4	1.386													
6	DL+...	Yes	Y	1	1.2			3	-1.386	4	0.8													
7	DL+...	Yes	Y	1	1.2			3	-1.6															
8	DL+...	Yes	Y	1	1.2			3	-1.386	4	-0.8													
9	DL+...	Yes	Y	1	1.2			3	-0.8	4	-1.386													
10	DL+...	Yes	Y	1	1.2					4	-1.6													
11	DL+...	Yes	Y	1	1.2			3	0.8	4	-1.386													
12	DL+...	Yes	Y	1	1.2			3	1.386	4	-0.8													
13	DL+...	Yes	Y	1	1.2	2	1	5	1															
14	DL+...	Yes	Y	1	1.2	2	1	5	0.866	6	0.5													
15	DL+...	Yes	Y	1	1.2	2	1	5	0.5	6	0.866													
16	DL+...	Yes	Y	1	1.2	2	1			6	1													
17	DL+...	Yes	Y	1	1.2	2	1	5	-0.5	6	0.866													
18	DL+...	Yes	Y	1	1.2	2	1	5	-0.866	6	0.5													
19	DL+...	Yes	Y	1	1.2	2	1	5	-1															
20	DL+...	Yes	Y	1	1.2	2	1	5	-0.866	6	-0.5													
21	DL+...	Yes	Y	1	1.2	2	1	5	-0.5	6	-0.866													
22	DL+...	Yes	Y	1	1.2	2	1			6	-1													
23	DL+...	Yes	Y	1	1.2	2	1	5	0.5	6	-0.866													
24	DL+...	Yes	Y	1	1.2	2	1	5	0.866	6	-0.5													
25	DEA...	Yes	Y	1	1.2					7	1.5													
26	DEA...	Yes	Y	1	1.2					8	1.5													
27	DEA...	Yes	Y	1	1.2					9	1.5													
28	DL+...	Yes	Y	1	1.2	10	1.5	3	0.082															
29	DL+...	Yes	Y	1	1.2	11	1.5	3	0.082															
30	DL+...	Yes	Y	1	1.2	12	1.5	3	0.082															
31	DL+...	Yes	Y	1	1.2	13	1.5	3	0.082															
32	DL+...	Yes	Y	1	1.2	10	1.5	4	0.082															
33	DL+...	Yes	Y	1	1.2	11	1.5	4	0.082															
34	DL+...	Yes	Y	1	1.2	12	1.5	4	0.082															
35	DL+...	Yes	Y	1	1.2	13	1.5	4	0.082															
36	DL+...	Yes	Y	1	1.2	10	1.5	3	-0.082															
37	DL+...	Yes	Y	1	1.2	11	1.5	3	-0.082															
38	DL+...	Yes	Y	1	1.2	12	1.5	3	-0.082															
39	DL+...	Yes	Y	1	1.2	13	1.5	3	-0.082															
40	DL+...	Yes	Y	1	1.2	10	1.5	4	-0.082															
41	DL+...	Yes	Y	1	1.2	11	1.5	4	-0.082															
42	DL+...	Yes	Y	1	1.2	12	1.5	4	-0.082															
43	DL+...	Yes	Y	1	1.2	13	1.5	4	-0.082															
44	DL+...	Yes	Y	1	1	2	0.7	5	-0.7															

**Node Reactions**

No Data to Print...

**Node Reactions (Continued)**

	Node Label		X [lbs]	LC	Y [lbs]	LC	Z [lbs]	LC	MX [k-ft]	LC	MY [k-ft]	LC	MZ [k-ft]	LC
1	N13	max	2432.825	9	3515.497	8	2012.4	14	3.351	13	5.825	13	3.474	2
2		min	-2618.236	3	-3418.001	2	367.327	8	0.584	7	0.96	7	-3.461	8
3	N11	max	2681.774	11	3604.846	6	2012.215	17	3.375	17	-0.93	11	3.612	5
4		min	-2499.898	5	-3501.174	12	342.791	11	0.49	11	-5.823	17	-3.612	11
5	N9	max	3469.639	10	1061.886	7	2003.54	22	-1.155	3	0.051	5	2.241	10
6		min	-3464	4	-1269.989	1	375.829	3	-6.703	21	-0.154	41	-2.229	4
7	N134	max	56.933	10	4962.543	13	2708.988	13	0	8	0	8	0	8
8		min	-54.45	4	657.612	6	362.656	6	0	14	-0.003	14	-0.002	14
9	N136	max	-485.739	3	-286.865	3	2718.515	21	0.003	22	0.002	22	0	4
10		min	-4325.789	21	-2481.28	21	304.014	3	0	4	0	4	-0.002	22



**Node Reactions (Continued)**

Node Label	X [lbs]	LC	Y [lbs]	LC	Z [lbs]	LC	MX [k-ft]	LC	MY [k-ft]	LC	MZ [k-ft]	LC
11 N138	max 4291.784	17	-295.473	10	2709.37	17	0	12	0.002	18	0	12
12	min 525.629	11	-2486.379	16	328.703	11	-0.003	18	0	12	-0.002	18
13 Totals:	max 6317.925	10	5794.924	7	13389.997	24						
14	min -6317.92	4	-5794.931	1	4488.824	5						

**Node Displacements**

Node Label	X [in]	LC	Y [in]	LC	Z [in]	LC	X Rotation...	LC	Y Rotation...	LC	Z Rotation...	LC
1 N1	max 0	43	0	43	0	43	0	43	0	43	0	43
2	min 0	1	0	1	0	1	0	1	0	1	0	1
3 N2	max 0.006	10	0.049	3	0.041	3	-2.424e-03	5	-1.297e-03	3	1.09e-03	10
4	min -0.008	4	-0.05	9	-0.203	21	-1.5e-02	23	-2.138e-02	21	-1.067e-03	4
5 N3	max 0.008	11	0.05	11	0.04	11	2.562e-02	18	1.936e-03	4	9.238e-04	10
6	min -0.007	5	-0.052	5	-0.202	17	3.489e-03	12	-3.303e-03	10	-9.088e-04	4
7 N5	max 0.082	4	0.019	1	0.032	7	3.877e-04	7	2.33e-02	14	6.816e-04	10
8	min -0.081	10	-0.016	7	-0.202	13	-1.117e-02	13	3.894e-03	8	-6.65e-04	4
9 N5A	max 0.01	4	0.015	2	0.041	43	4.289e-04	9	1.396e-03	20	4.882e-04	9
10	min -0.011	10	-0.016	8	-0.01	3	-1.329e-03	15	2.526e-04	3	-5.219e-04	3
11 N6	max 0.011	4	0.016	12	0.04	32	2.951e-04	5	-4.903e-04	1	5.779e-04	11
12	min -0.01	10	-0.017	6	-0.009	11	-7.428e-04	24	-1.669e-03	21	-6.052e-04	5
13 N8	max 0.023	4	0.016	1	0.037	13	1.801e-03	19	1.321e-03	4	1.044e-03	10
14	min -0.023	10	-0.014	7	-0.007	7	3.591e-04	1	-1.122e-03	10	-1.074e-03	4
15 N8A	max 0.005	40	0	1	-0.04	3	8.814e-03	20	6.939e-04	29	6.12e-04	10
16	min -0.005	35	0	7	-0.238	21	1.42e-03	3	-2.852e-04	39	-6.17e-04	4
17 N9	max 0	4	0	1	0	3	0	21	0	41	0	4
18	min 0	10	0	7	0	22	0	3	0	5	0	10
19 N10	max 0.022	5	0.038	11	-0.036	10	-4.902e-04	10	7.65e-03	16	1.143e-03	10
20	min -0.022	11	-0.038	5	-0.238	16	-4.447e-03	16	1.141e-03	10	-1.15e-03	4
21 N11	max 0	5	0	12	0	11	0	11	0	17	0	11
22	min 0	11	0	6	0	17	0	17	0	11	0	5
23 N12	max 0.022	3	0.036	3	-0.038	7	-4.6e-04	6	-1.165e-03	7	1.122e-03	10
24	min -0.021	9	-0.036	9	-0.237	13	-4.449e-03	24	-7.617e-03	13	-1.132e-03	4
25 N13	max 0	3	0	2	0	8	0	7	0	7	0	8
26	min 0	9	0	8	0	14	0	13	0	13	0	2
27 N14	max 0.212	4	0.339	1	0.024	3	7.802e-03	7	5.15e-03	4	4.395e-03	11
28	min -0.215	10	-0.334	7	-0.243	21	-8.951e-03	1	-5.657e-03	10	-4.139e-03	5
29 N15	max 0.211	4	0.349	1	0.029	11	8.569e-03	7	5.106e-03	4	3.452e-03	9
30	min -0.215	10	-0.367	7	-0.234	17	-9.174e-03	1	-5.622e-03	10	-4.079e-03	3
31 N16	max 0.287	3	0.288	1	0.023	11	7.405e-03	7	6.926e-03	3	4.098e-03	8
32	min -0.29	9	-0.292	7	-0.243	17	-6.402e-03	1	-7.636e-03	9	-3.869e-03	2
33 N17	max 0.428	4	0.235	1	0.023	7	5.302e-03	7	9.166e-03	4	2.823e-03	4
34	min -0.41	10	-0.228	7	-0.234	13	-4.57e-03	1	-9.393e-03	10	-3.518e-03	10
35 N18	max 0.425	4	0.222	1	0.014	7	4.988e-03	7	9.445e-03	4	3.425e-03	4
36	min -0.422	10	-0.221	7	-0.241	13	-4.923e-03	1	-8.31e-03	10	-3.112e-03	10
37 N19	max 0.294	5	0.284	1	0.032	3	6.846e-03	7	7.786e-03	5	3.277e-03	12
38	min -0.31	11	-0.273	7	-0.236	21	-6.977e-03	1	-7.056e-03	11	-3.866e-03	6
39 N20	max 0.212	4	0.417	1	-0.012	1	6.505e-03	7	1.794e-03	2	6.652e-03	12
40	min -0.215	10	-0.408	7	-0.24	19	-7.537e-03	1	-1.749e-03	8	-6.729e-03	6
41 N21	max 0.211	4	0.445	1	-0.029	1	7.203e-03	7	5.11e-04	5	7.029e-03	8
42	min -0.215	10	-0.453	7	-0.272	19	-7.432e-03	1	-3.48e-03	41	-6.805e-03	2
43 N22	max 0.371	3	0.339	1	-0.006	9	3.115e-03	8	6.222e-03	3	6.615e-03	8
44	min -0.376	9	-0.346	7	-0.241	15	-2.641e-03	2	-7.075e-03	9	-6.752e-03	2
45 N23	max 0.513	4	0.258	2	-0.019	9	4.552e-03	9	6.157e-03	3	6.521e-03	4
46	min -0.504	10	-0.255	8	-0.274	15	-3.219e-03	3	-5.571e-03	9	-6.381e-03	10
47 N24	max 0.513	4	0.237	12	0.005	5	4.873e-03	5	5.416e-03	5	5.884e-03	4
48	min -0.504	10	-0.238	6	-0.244	23	-4.459e-03	11	-4.783e-03	11	-5.942e-03	10
49 N25	max 0.39	5	0.325	1	-0.023	5	2.876e-03	6	6.909e-03	5	6.863e-03	11
50	min -0.399	11	-0.317	7	-0.273	23	-4.016e-03	12	-6.064e-03	11	-6.569e-03	5
51 N26	max 0.008	4	0	1	-0.006	3	4.807e-03	21	1.66e-04	41	3.232e-04	4
52	min -0.008	10	0	7	-0.034	21	8.146e-04	3	-5.494e-05	5	-3.309e-04	10
53 N27	max 0.007	5	0.013	11	-0.005	11	-3.325e-04	11	4.172e-03	17	1.233e-03	11
54	min -0.008	11	-0.013	5	-0.034	17	-2.424e-03	16	6.631e-04	11	-1.235e-03	5
55 N28	max 0.007	3	0.012	3	-0.006	7	-4.114e-04	6	-6.676e-04	7	1.167e-03	9
56	min -0.007	9	-0.012	8	-0.034	13	-2.399e-03	13	-4.178e-03	13	-1.179e-03	3
57 N29	max 0.212	4	0.347	1	0.011	3	7.802e-03	7	5.151e-03	4	4.395e-03	11
58	min -0.215	10	-0.341	7	-0.238	20	-8.951e-03	1	-5.657e-03	10	-4.139e-03	5
59 N30	max 0.211	4	0.358	1	0.015	11	8.569e-03	7	5.106e-03	4	3.452e-03	9
60	min -0.215	10	-0.374	7	-0.233	17	-9.174e-03	1	-5.622e-03	10	-4.079e-03	3
61 N31	max 0.202	4	0.347	1	0.031	2	7.802e-03	7	5.151e-03	4	4.395e-03	11
62	min -0.204	10	-0.341	7	-0.238	20	-8.951e-03	1	-5.657e-03	10	-4.139e-03	5
63 N32	max 0.202	4	0.358	1	0.027	11	8.569e-03	7	5.106e-03	4	3.452e-03	9
64	min -0.207	10	-0.374	7	-0.235	18	-9.174e-03	1	-5.622e-03	10	-4.079e-03	3
65 N33	max 0.211	4	0.637	1	-0.028	6	2.416e-02	7	4.648e-03	4	2.937e-03	4
66	min -0.215	10	-0.687	7	-0.261	23	-2.449e-02	1	-4.193e-03	10	-3.103e-03	10
67 N34	max 0.22	4	0.637	1	-0.036	2	2.416e-02	7	4.648e-03	4	2.937e-03	4
68	min -0.224	10	-0.687	7	-0.266	20	-2.449e-02	1	-4.193e-03	10	-3.103e-03	10
69 N35	max 0.005	10	0.046	2	0.015	2	7.448e-03	7	4.547e-03	5	2.324e-03	12
70	min -0.008	4	-0.057	8	-0.229	20	-6.618e-03	1	-2.125e-03	11	-3.391e-03	6
71 N36	max 0.008	11	0.046	11	0.019	11	9.461e-03	7	1.908e-03	4	1.466e-03	9
72	min -0.006	5	-0.049	5	-0.219	17	-7.249e-03	1	-3.621e-03	22	-1.226e-03	3
73 N37	max 0.01	11	0.046	2	0.031	2	7.448e-03	7	4.547e-03	5	2.324e-03	12
74	min -0.016	5	-0.057	8	-0.237	20	-6.618e-03	1	-2.125e-03	11	-3.391e-03	6
75 N38	max 0.01	10	0.046	11	0.027	11	9.461e-03	7	1.908e-03	4	1.466e-03	9
76	min -0.008	4	-0.049	5	-0.234	18	-7.249e-03	1	-3.621e-03	22	-1.226e-03	3
77 N39	max 0.005	40	0	2	-0.039	3	9.281e-03	19	5.247e-04	29	5.046e-04	10
78	min -0.005	35	0	8	-0.238	21	-2.338e-03	1	-4.409e-04	39	-4.301e-04	4
79 N40	max 0.005	10	0	2	-0.036	2	9.281e-03	19	5.247e-04	29	5.046e-04	10
80	min -0.006	4	0	8	-0.265	20	-2.338e-03	1	-4.409e-04	39	-4.301e-04	4
81 N41	max 0.295	4	0.507	1	0.031	2	8.405e-03	7	5.564e-03	4	4.395e-03	11
82	min -0.306	10	-0.482	7	-0.238	20	-9.555e-03	1	-6.071e-03	10	-4.139e-03	5
83 N42	max 0.294	4	0.522	1	0.027	11	9.123e-03	7	5.521e-03	4	3.452e-03	9
84	min -0.308	10	-0.527	7	-0.235	18	-9.728e-03	1	-6.037e-03	10	-4.079e-03	3
85 N43	max 0.042	11	0.087	6	0.031	2	6.845e-03	7	4.2e-03	17	2.324e-03	12
86	min -0.088	5	-0.084	12	-0.237	20	-6.016e-03	1	-1.768e-03	11	-3.391e-03	6
87 N44	max 0.065	22	0.132	8	0.027	11	8.907e-03	7	1.494e-03	4	1.466e-03	9
88	min -0.035	4	-0.097	2	-0.234	18	-6.696e-03	1	-3.507e-03	22	-1.226e-03	3
89 N45	max 0.442	4	1.503	1	-0.036	2	3.133e-02	7	8.69e-03	4	2.937e-03	4

**Node Displacements (Continued)**

Node Label		X [in]	LC	Y [in]	LC	Z [in]	LC	X Rotation...	LC	Y Rotation...	LC	Z Rotation...	LC	
90		min	-0.433	10	-1.542	7	-0.267	20	-3.167e-02	1	-8.232e-03	10	-3.103e-03	10
91	N46	max	0.271	4	0.392	1	-0.036	2	1.415e-02	1	9.253e-03	10	5.046e-04	10
92		min	-0.267	10	-0.228	7	-0.266	20	-1.016e-02	7	-9.364e-03	4	-4.301e-04	4
93	N47	max	0.211	4	0.56	1	-0.061	1	1.351e-02	7	2.292e-03	5	5.017e-03	7
94		min	-0.214	10	-0.583	7	-0.306	19	-1.36e-02	1	-2.414e-03	11	-4.119e-03	1
95	N48	max	0.213	4	0.56	1	-0.02	1	1.351e-02	7	2.292e-03	5	5.017e-03	7
96		min	-0.214	10	-0.583	7	-0.319	19	-1.36e-02	1	-2.414e-03	11	-4.119e-03	1
97	N49	max	0.006	11	0.034	12	-0.061	1	1.416e-02	7	3.015e-03	4	9.952e-04	11
98		min	-0.005	5	-0.056	7	-0.302	19	-1.375e-02	1	-2.754e-03	10	-1.025e-03	5
99	N50	max	0.009	11	0.034	12	-0.02	1	1.416e-02	7	3.015e-03	4	9.952e-04	11
100		min	-0.008	5	-0.056	7	-0.319	19	-1.375e-02	1	-2.754e-03	10	-1.025e-03	5
101	N51	max	0.222	4	0.628	1	-0.02	1	1.351e-02	7	2.293e-03	5	5.017e-03	7
102		min	-0.223	10	-0.651	7	-0.319	19	-1.36e-02	1	-2.415e-03	11	-4.119e-03	1
103	N52	max	0.022	10	0.025	9	-0.02	1	1.416e-02	7	3.014e-03	4	9.952e-04	11
104		min	-0.022	4	-0.046	3	-0.319	19	-1.375e-02	1	-2.753e-03	10	-1.025e-03	5
105	N57	max	0.259	4	0.46	1	0.027	11	9.121e-03	7	5.519e-03	4	3.452e-03	9
106		min	-0.27	10	-0.469	7	-0.235	18	-9.725e-03	1	-6.035e-03	10	-4.079e-03	3
107	N58	max	0.045	10	0.08	8	0.027	11	8.91e-03	7	1.497e-03	4	1.466e-03	9
108		min	-0.025	4	-0.06	2	-0.234	18	-6.699e-03	1	-3.508e-03	22	-1.226e-03	3
109	N62	max	0.215	4	0.306	1	-0.036	2	1.415e-02	1	9.251e-03	10	5.046e-04	10
110		min	-0.211	10	-0.167	7	-0.266	20	-1.016e-02	7	-9.362e-03	4	-4.301e-04	4
111	N63	max	0.258	4	0.444	1	0.031	2	8.403e-03	7	5.561e-03	4	4.395e-03	11
112		min	-0.266	10	-0.426	7	-0.238	20	-9.552e-03	1	-6.068e-03	10	-4.139e-03	5
113	N64	max	0.03	11	0.049	5	0.031	2	6.848e-03	7	4.202e-03	17	2.324e-03	12
114		min	-0.06	5	-0.051	11	-0.237	20	-6.019e-03	1	-1.77e-03	11	-3.391e-03	6
115	N65	max	0.39	4	1.311	1	-0.036	2	3.133e-02	7	8.688e-03	4	2.937e-03	4
116		min	-0.383	10	-1.352	7	-0.267	20	-3.167e-02	1	-8.23e-03	10	-3.103e-03	10
117	N62A	max	0.207	4	0.527	1	-0.02	1	1.353e-02	7	3.281e-03	5	4.674e-03	7
118		min	-0.207	10	-0.55	7	-0.319	19	-1.364e-02	1	-3.419e-03	11	-3.836e-03	1
119	N63A	max	0.008	28	0.067	1	-0.02	1	1.416e-02	7	4.159e-03	4	9.352e-04	10
120		min	-0.005	39	-0.091	7	-0.319	19	-1.384e-02	1	-3.961e-03	10	-9.085e-04	4
121	N64A	max	0.295	3	0.294	1	0.012	10	7.405e-03	7	6.926e-03	3	4.098e-03	8
122		min	-0.298	9	-0.298	7	-0.238	16	-6.403e-03	1	-7.636e-03	9	-3.869e-03	2
123	N65A	max	0.435	4	0.235	1	0.01	7	5.302e-03	7	9.166e-03	4	2.823e-03	4
124		min	-0.419	10	-0.229	7	-0.233	13	-4.57e-03	1	-9.393e-03	10	-3.518e-03	10
125	N66	max	0.3	3	0.284	1	0.033	10	7.405e-03	7	6.926e-03	3	4.098e-03	8
126		min	-0.303	9	-0.288	7	-0.238	16	-6.403e-03	1	-7.636e-03	9	-3.869e-03	2
127	N67	max	0.431	4	0.234	1	0.018	7	5.302e-03	7	9.166e-03	4	2.823e-03	4
128		min	-0.414	10	-0.23	7	-0.234	14	-4.57e-03	1	-9.393e-03	10	-3.518e-03	10
129	N68	max	0.626	3	0.374	2	-0.044	2	1.127e-02	8	2.042e-02	3	4.057e-03	11
130		min	-0.579	9	-0.352	8	-0.26	19	-1.151e-02	2	-2.089e-02	9	-4.178e-03	5
131	N69	max	0.628	3	0.377	2	-0.028	10	1.127e-02	8	2.042e-02	3	4.057e-03	11
132		min	-0.581	9	-0.354	8	-0.268	16	-1.151e-02	2	-2.089e-02	9	-4.178e-03	5
133	N70	max	0.024	2	0.05	11	0.017	10	4.277e-03	8	5.996e-03	3	1.991e-03	8
134		min	-0.013	8	-0.047	5	-0.229	16	-6.886e-03	2	-6.432e-03	9	-3.08e-03	2
135	N71	max	0.082	4	0.02	1	0.013	7	4.207e-03	8	9.209e-03	4	4.666e-04	16
136		min	-0.08	10	-0.017	7	-0.219	13	-3.972e-03	2	-6.455e-03	10	-1.202e-04	10
137	N72	max	0.029	2	0.05	11	0.033	10	4.277e-03	8	5.996e-03	3	1.991e-03	8
138		min	-0.016	8	-0.049	5	-0.237	16	-6.886e-03	2	-6.432e-03	9	-3.08e-03	2
139	N73	max	0.081	4	0.02	1	0.018	7	4.207e-03	8	9.209e-03	4	4.666e-04	16
140		min	-0.08	10	-0.017	7	-0.233	14	-3.972e-03	2	-6.455e-03	10	-1.202e-04	10
141	N74	max	0.021	5	0.038	11	-0.036	10	2.034e-03	9	8.342e-03	15	1.253e-03	11
142		min	-0.021	11	-0.039	5	-0.238	17	-4.629e-03	15	-3.162e-03	9	-1.177e-03	5
143	N75	max	0.023	5	0.042	11	-0.028	10	2.034e-03	9	8.342e-03	15	1.253e-03	11
144		min	-0.023	11	-0.042	5	-0.266	16	-4.629e-03	15	-3.162e-03	9	-1.177e-03	5
145	N76	max	0.425	3	0.399	1	0.033	10	7.819e-03	7	7.449e-03	3	4.098e-03	8
146		min	-0.44	9	-0.42	7	-0.238	16	-6.816e-03	1	-8.159e-03	9	-3.869e-03	2
147	N77	max	0.595	4	0.318	1	0.018	7	5.717e-03	7	9.719e-03	4	2.823e-03	4
148		min	-0.581	10	-0.326	7	-0.234	14	-4.985e-03	1	-9.947e-03	10	-3.518e-03	10
149	N78	max	0.09	9	0.074	9	0.033	10	3.919e-03	8	5.475e-03	3	1.991e-03	8
150		min	-0.07	3	-0.118	3	-0.237	16	-6.527e-03	2	-5.91e-03	9	-3.08e-03	2
151	N79	max	0.029	9	0.059	9	0.018	7	3.848e-03	8	8.655e-03	4	4.666e-04	16
152		min	-0.097	15	-0.052	3	-0.233	14	-3.613e-03	2	-5.903e-03	10	-1.202e-04	10
153	N80	max	1.354	3	0.786	2	-0.028	10	1.48e-02	8	2.678e-02	4	4.057e-03	11
154		min	-1.321	9	-0.757	8	-0.268	16	-1.504e-02	2	-2.729e-02	10	-4.178e-03	5
155	N81	max	0.3	5	0.226	12	-0.028	10	6.945e-03	12	1.438e-02	10	1.253e-03	11
156		min	-0.443	11	-0.303	6	-0.267	16	-8.803e-03	6	-1.081e-02	4	-1.177e-03	5
157	N82	max	0.611	4	0.31	2	-0.052	9	8.026e-03	9	1.108e-02	3	4.491e-03	3
158		min	-0.59	10	-0.301	8	-0.308	15	-7.941e-03	3	-1.107e-02	9	-3.572e-03	9
159	N83	max	0.606	4	0.321	2	-0.011	9	8.026e-03	9	1.108e-02	3	4.491e-03	3
160		min	-0.586	10	-0.31	8	-0.321	15	-7.941e-03	3	-1.107e-02	9	-3.572e-03	9
161	N84	max	0.088	4	0.025	1	-0.054	9	6.882e-03	9	1.332e-02	4	6.636e-04	8
162		min	-0.069	10	-0.014	7	-0.303	15	-7.364e-03	3	-1.311e-02	10	-6.942e-04	2
163	N85	max	0.089	4	0.024	1	-0.011	9	6.882e-03	9	1.332e-02	4	6.636e-04	8
164		min	-0.069	10	-0.012	7	-0.321	15	-7.364e-03	3	-1.311e-02	10	-6.942e-04	2
165	N86	max	0.661	4	0.356	2	-0.011	9	8.026e-03	9	1.108e-02	3	4.491e-03	3
166		min	-0.642	10	-0.345	8	-0.321	15	-7.942e-03	3	-1.108e-02	9	-3.572e-03	9
167	N87	max	0.029	18	0.036	10	-0.011	9	6.881e-03	9	1.332e-02	4	6.636e-04	8
168		min	-0.01	12	-0.026	4	-0.321	15	-7.363e-03	3	-1.311e-02	10	-6.942e-04	2
169	N89	max	0.533	4	0.286	1	0.018	7	5.715e-03	7	9.717e-03	4	2.823e-03	4
170		min	-0.518	10	-0.29	7	-0.234	14	-4.983e-03	1	-9.945e-03	10	-3.518e-03	10
171	N90	max	0.003	7	0.035	9	0.018	7	3.85e-03	8	8.658e-03	4	4.666e-04	16
172		min	-0.054	14	-0.029	3	-0.233	14	-3.615e-03	2	-5.905e-03	10	-1.202e-04	10
173	N91	max	0.235	5	0.184	12	-0.028	10	6.943e-03	12	1.438e-02	10	1.253e-03	11
174		min	-0.357	11	-0.249	6	-0.267	16	-8.801e-03	6	-1.08e-02	4	-1.177e-03	5
175	N92	max	0.376	3	0.353	1	0.033	10	7.817e-03	7	7.446e-03	3	4.098e-03	8
176		min	-0.386	9	-0.368	7	-0.238	16	-6.814e-03	1	-8.157e-03	9	-3.869e-03	2
177	N93	max	0.051	10	0.055	9	0.033	10	3.922e-03	8	5.477e-03	3	1.991e-03	8
178		min	-0.034	4	-0.081	3	-0.237	16	-6.529e-03	2	-5.912e-03	9	-3.08e-03	2
179	N94	max	1.193	3	0.696	2	-0.028							

**Node Displacements (Continued)**

Node Label		X [in]	LC	Y [in]	LC	Z [in]	LC	X Rotation...	LC	Y Rotation...	LC	Z Rotation...	LC	
187	N98	max	0.303	5	0.288	1	0.017	3	6.846e-03	7	7.786e-03	5	3.277e-03	12
188		min	-0.317	11	-0.278	7	-0.235	21	-6.977e-03	1	-7.056e-03	11	-3.866e-03	6
189	N99	max	0.429	4	0.22	1	0.029	6	4.988e-03	7	9.445e-03	4	3.425e-03	4
190		min	-0.425	10	-0.22	7	-0.238	24	-4.923e-03	1	-8.31e-03	10	-3.112e-03	10
191	N100	max	0.308	5	0.282	1	0.03	4	6.846e-03	7	7.786e-03	5	3.277e-03	12
192		min	-0.322	11	-0.269	7	-0.236	22	-6.977e-03	1	-7.056e-03	11	-3.866e-03	6
193	N101	max	0.584	4	0.364	12	-0.026	9	1.101e-02	6	2.09e-02	5	3.389e-03	8
194		min	-0.627	11	-0.335	6	-0.263	15	-1.049e-02	11	-2.097e-02	11	-3.582e-03	2
195	N102	max	0.588	4	0.368	12	-0.029	6	1.101e-02	6	2.09e-02	5	3.389e-03	8
196		min	-0.63	10	-0.338	6	-0.268	24	-1.049e-02	11	-2.097e-02	11	-3.582e-03	2
197	N103	max	0.094	4	0.025	12	0.013	6	4.052e-03	6	6.882e-03	4	1.847e-03	4
198		min	-0.103	10	-0.017	6	-0.229	24	-2.383e-03	12	-8.916e-03	10	-2.903e-03	10
199	N104	max	0.003	36	0.046	3	0.021	3	3.884e-03	6	6.798e-03	5	1.516e-03	11
200		min	-0.007	23	-0.046	9	-0.22	21	-6.398e-03	12	-8.007e-03	11	-1.255e-03	5
201	N105	max	0.091	4	0.029	12	0.028	6	4.052e-03	6	6.882e-03	4	1.847e-03	4
202		min	-0.098	10	-0.019	6	-0.237	24	-2.383e-03	12	-8.916e-03	10	-2.903e-03	10
203	N106	max	0.004	6	0.048	3	0.029	4	3.884e-03	6	6.798e-03	5	1.516e-03	11
204		min	-0.009	23	-0.049	9	-0.235	22	-6.398e-03	12	-8.007e-03	11	-1.255e-03	5
205	N107	max	0.023	3	0.036	3	-0.038	7	2.162e-03	5	2.886e-03	6	1.396e-03	10
206		min	-0.022	9	-0.036	9	-0.238	13	-5.042e-03	23	-8.186e-03	23	-1.327e-03	4
207	N108	max	0.025	3	0.039	3	-0.029	6	2.162e-03	5	2.886e-03	6	1.396e-03	10
208		min	-0.025	9	-0.039	9	-0.266	24	-5.042e-03	23	-8.186e-03	23	-1.327e-03	4
209	N109	max	0.598	4	0.31	1	0.028	6	5.401e-03	7	1.005e-02	4	3.425e-03	4
210		min	-0.575	10	-0.311	7	-0.238	24	-5.336e-03	1	-8.913e-03	10	-3.112e-03	10
211	N110	max	0.447	5	0.406	1	0.03	4	7.261e-03	7	8.266e-03	5	3.277e-03	12
212		min	-0.448	11	-0.392	7	-0.236	22	-7.393e-03	1	-7.535e-03	11	-3.866e-03	6
213	N111	max	0.046	11	0.065	19	0.028	6	3.694e-03	6	6.28e-03	4	1.847e-03	4
214		min	-0.018	5	-0.008	1	-0.237	24	-2.026e-03	12	-8.313e-03	10	-2.903e-03	10
215	N112	max	0.122	11	0.076	5	0.029	4	3.525e-03	6	6.319e-03	5	1.516e-03	11
216		min	-0.106	5	-0.12	11	-0.236	22	-6.038e-03	12	-7.527e-03	11	-1.255e-03	5
217	N113	max	1.336	4	0.748	12	-0.029	6	1.453e-02	6	2.764e-02	4	3.389e-03	8
218		min	-1.378	10	-0.733	6	-0.268	24	-1.401e-02	12	-2.762e-02	10	-3.582e-03	2
219	N114	max	0.475	3	0.209	2	-0.029	6	6.584e-03	2	1.158e-02	9	1.396e-03	10
220		min	-0.335	9	-0.295	8	-0.267	24	-8.668e-03	8	-1.503e-02	4	-1.327e-03	4
221	N115	max	0.495	5	0.356	1	-0.054	5	5.727e-03	6	1.24e-02	5	5.385e-03	10
222		min	-0.518	11	-0.341	7	-0.307	23	-5.805e-03	12	-1.238e-02	11	-4.488e-03	4
223	N116	max	0.502	5	0.352	1	-0.014	5	5.727e-03	6	1.24e-02	5	5.385e-03	10
224		min	-0.526	11	-0.34	7	-0.32	23	-5.805e-03	12	-1.238e-02	11	-4.488e-03	4
225	N117	max	0.021	5	0.042	2	-0.057	5	7.627e-03	6	1.231e-02	5	4.366e-04	2
226		min	-0.041	11	-0.032	8	-0.301	23	-7.647e-03	12	-1.294e-02	11	-4.672e-04	8
227	N118	max	0.021	5	0.041	2	-0.014	5	7.627e-03	6	1.231e-02	5	4.366e-04	2
228		min	-0.041	11	-0.031	8	-0.319	23	-7.647e-03	12	-1.294e-02	11	-4.672e-04	8
229	N119	max	0.564	5	0.376	1	-0.014	5	5.728e-03	6	1.24e-02	5	5.385e-03	10
230		min	-0.588	11	-0.363	7	-0.32	23	-5.806e-03	12	-1.238e-02	11	-4.488e-03	4
231	N120	max	0.024	11	0.05	4	-0.014	5	7.626e-03	6	1.23e-02	5	4.366e-04	2
232		min	-0.041	5	-0.039	10	-0.319	23	-7.646e-03	12	-1.294e-02	11	-4.672e-04	8
233	N122	max	0.395	5	0.359	1	0.03	4	7.259e-03	7	8.264e-03	5	3.277e-03	12
234		min	-0.401	11	-0.345	7	-0.236	22	-7.391e-03	1	-7.533e-03	11	-3.866e-03	6
235	N123	max	0.074	11	0.058	5	0.029	4	3.527e-03	6	6.321e-03	5	1.516e-03	11
236		min	-0.066	5	-0.085	11	-0.236	22	-6.04e-03	12	-7.529e-03	11	-1.255e-03	5
237	N124	max	0.384	3	0.169	2	-0.029	6	6.582e-03	2	1.158e-02	9	1.396e-03	10
238		min	-0.265	9	-0.242	8	-0.267	24	-8.666e-03	8	-1.503e-02	4	-1.327e-03	4
239	N125	max	0.531	4	0.274	1	0.028	6	5.398e-03	7	1.005e-02	4	3.425e-03	4
240		min	-0.516	10	-0.275	7	-0.238	24	-5.333e-03	1	-8.911e-03	10	-3.112e-03	10
241	N126	max	0.025	3	0.042	19	0.028	6	3.696e-03	6	6.283e-03	4	1.847e-03	4
242		min	-0.011	9	0.002	2	-0.237	24	-2.029e-03	12	-8.316e-03	10	-2.903e-03	10
243	N127	max	1.169	4	0.663	12	-0.029	6	1.453e-02	6	2.764e-02	4	3.389e-03	8
244		min	-1.211	10	-0.646	6	-0.268	24	-1.401e-02	12	-2.762e-02	10	-3.582e-03	2
245	N128	max	0.471	5	0.34	1	-0.014	5	6.39e-03	6	1.248e-02	5	5.02e-03	10
246		min	-0.496	11	-0.327	7	-0.32	23	-6.474e-03	12	-1.242e-02	11	-4.183e-03	4
247	N129	max	0.051	5	0.052	2	-0.014	5	8.083e-03	6	1.245e-02	5	4.27e-04	1
248		min	-0.073	11	-0.042	8	-0.32	23	-8.116e-03	12	-1.297e-02	11	-3.963e-04	7
249	N133	max	0.069	4	0.018	1	0.026	7	5.674e-04	7	1.628e-02	14	1.03e-03	10
250		min	-0.068	10	-0.016	7	-0.048	1	-8.262e-03	13	2.6e-03	8	-1.029e-03	4
251	N134	max	0	4	0	6	0	6	0	14	0	14	0	14
252		min	0	10	0	13	0	13	0	8	0	8	0	8
253	N135	max	0.003	36	0.037	3	0.029	3	-1.687e-03	6	-7.305e-04	3	8.903e-04	10
254		min	-0.006	31	-0.038	9	-0.051	9	-1.031e-02	24	-1.529e-02	21	-8.865e-04	4
255	N136	max	0	21	0	21	0	3	0	4	0	4	0	22
256		min	0	3	0	3	0	21	0	22	0	22	0	4
257	N137	max	0.006	1	0.04	11	0.029	11	1.812e-02	18	1.782e-03	4	8.318e-04	10
258		min	-0.004	7	-0.042	5	-0.051	5	2.19e-03	11	-2.533e-03	10	-8.295e-04	4
259	N138	max	0	11	0	16	0	11	0	18	0	12	0	18
260		min	0	17	0	10	0	17	0	12	0	18	0	12

**LRFD**

Member	Shape	Code Ch...	Loc [in]	LC	Shear Ch...	Loc [in]	Dir	LC	phi*Pnc [lb]	phi*Pnt [lb]	phi*Mnyy...	phi*Mnzz...	Cb	Eqn
1	M13	PIPE_2.0	0.326	84	9	0.229	143.5	7	5018.672	32130	1.872	1.872	1.972	H1-1b
2	M14	PIPE_2.0	0.383	84	5	0.235	143.5	3	5018.672	32130	1.872	1.872	1.892	H1-1b
3	M15	PIPE_2.0	0.359	82.25	9	0.226	143.5	11	5018.672	32130	1.872	1.872	1.78	H1-1b
4	M25	PIPE_2.0	0.298	17.25	21	0.069	17.25	10	20866.733	32130	1.872	1.872	1.345	H1-1b
5	M26	PIPE_2.0	0.286	17.25	16	0.072	17.25	3	20866.733	32130	1.872	1.872	1.571	H1-1b
6	M27	PIPE_2.0	0.709	66.375	1	0.116	66.375	10	12143.947	32130	1.872	1.872	1.494	H1-1b
7	M30	PIPE_2.0	0.358	43	10	0.119	5	6	26521.424	32130	1.872	1.872	1.466	H1-1b
8	M37	PIPE_2.0	0.307	17.25	17	0.067	17.25	6	20866.733	32130	1.872	1.872	1.632	H1-1b
9	M38	PIPE_2.0	0.298	17.25	24	0.077	17.25	11	20866.733	32130	1.872	1.872	1.532	H1-1b
10	M39	PIPE_2.0	0.665	66.375	10	0.110	66.375	6	12143.947	32130	1.872	1.872	2.4	H1-1b
11	M42	PIPE_2.0	0.383	43	6	0.112	5	4	26521.424	32130	1.872	1.872	1.963	H1-1b
12	M49	PIPE_2.0	0.300	17.25	13	0.055	17.25	15	20866.733	32130	1.872	1.872	1.606	H1-1b
13	M50	PIPE_2.0	0.313	17.25	9	0.069	17.25	7	20866.733	32130	1.872	1.872	1.595	H1-1b
14	M51	PIPE_2.0	0.716	66.375	4	0.101	66.375	2	12143.947	32130	1.872			



**LRFD (Continued)**

Member	Shape	Code Ch...	Loc [in]	LC	Shear Ch...	Loc [in]	Dir	LC	phi*Pnc [lb]	phi*Pnt [lb]	phi*Mnyy...	phi*Mnzz...	Cb	Eqn	
20	M2	L3X3X4	0.590	5.515	4	0.708	88.234	y	8	3575.077	46656	1.688	2.688	1.5	H2-1
21	M3	L3X3X4	0.539	5.517	12	0.685	88.267	y	5	3572.354	46656	1.688	2.688	1.5	H2-1
22	M4	L3X3X4	0.231	42	21	0.032	0	y	21	15778.129	46656	1.688	3.345	1.5	H2-1
23	M5	L3X3X4	0.282	41.126	11	0.033	0	y	17	15777.71	46656	1.688	3.345	1.5	H2-1
24	M7	L3X3X4	0.288	42.001	3	0.032	0	y	13	15777.29	46656	1.688	3.345	1.5	H2-1
25	M16	L3X3X4	0.374	0	8	0.057	28.135	y	2	41307.194	46656	1.688	3.756	1.391	H2-1
26	M17	L3X3X4	0.238	0	9	0.063	28.135	z	10	41307.194	46656	1.688	3.756	1.5	H2-1
27	M18	L3X3X4	0.375	0	11	0.058	0	z	6	41307.194	46656	1.688	3.756	1.317	H2-1
28	M10	HSS4X4X4	0.461	39.6	22	0.096	39.6	y	10	133302.091	139518	16.181	16.181	2.565	H1-1b
29	M11	HSS4X4X4	0.487	39.542	17	0.113	39.542	y	6	133319.954	139518	16.181	16.181	3	H1-1b
30	M12	HSS4X4X4	0.485	39.483	14	0.113	39.483	y	2	133337.808	139518	16.181	16.181	3	H1-1b
31	M55	LL2.5x2.5...	0.185	85.427	13	0.019	85.427	y	14	30558.737	58320	3.3	2.55	1.136	H1-1b*
32	M56	LL2.5x2.5...	0.186	85.427	21	0.019	85.427	z	22	30558.737	58320	3.3	2.55	1.136	H1-1b*
33	M57	LL2.5x2.5...	0.185	85.427	17	0.019	85.427	z	18	30558.737	58320	3.3	2.55	1.136	H1-1b*

**1.0 DESIGN INFORMATION AND GENERAL REQUIREMENTS**

1.0 GENERAL  
ALL DIMENSIONS ARE APPROXIMATE, CONTRACTOR SHOULD VERIFY ALL DIMENSIONS BEFORE FABRICATION OF STEEL AND COMMENCEMENT OF WORK.

- 1.1 CODES  
a. 2018 CONNECTICUT STATE BUILDING CODE (2015 IBC)  
b. MINIMUM DESIGN LOADS FOR BUILDINGS AND OTHER STRUCTURES, ASCE/SEI 7-10, AMERICAN SOCIETY OF CIVIL ENGINEERS  
c. STEEL CONSTRUCTION MANUAL, 14TH EDITION, AMERICAN INSTITUTE OF STEEL CONSTRUCTION  
d. STRUCTURAL STANDARDS FOR ANTENNA SUPPORTING STRUCTURES, ANSI/TIA-222-G, TELECOMMUNICATIONS INDUSTRY ASSOCIATION

- 1.2 LOADS AND DESIGN CRITERIA  
a. BASIC WIND SPEED (3-SECOND GUST): V: 97 MPH (ASD), EXPOSURE B, RISK CATEGORY II  
b. EQUIPMENT AS LISTED IN MOUNT STRUCTURAL ANALYSIS REPORT - UPGRADE PREPARED BY EFI GLOBAL, INC, DATED 06/19/2020.

- 1.3 NOTES  
a. PRIOR TO PURCHASE OR FABRICATION OF MATERIAL, THE CONTRACTOR SHALL PERFORM AN INSPECTION VERIFYING MEMBER AND BOLT SIZES. SHOULD THE CONTRACTOR DISCOVER ANY DAMAGED OR MISSING MEMBERS OR THE MEMBER OR BOLT SIZES DO NOT MATCH THOSE LISTED, EFI GLOBAL, INC, SHALL BE NOTIFIED IMMEDIATELY.  
b. CONTRACTOR TO REPLACE ALL BOLTS REMOVED WITH NEW BOLTS OF SAME TYPE, UNLESS NOTED OTHERWISE.

**2.0 STRUCTURAL STEEL**

- 2.1 MATERIALS  
a. STRUCTURAL STEEL . . . . . ASTM A992  
MISC ANGLE & PLATE . . . . . ASTM A36  
PIPE . . . . . ASTM A53 GR. B  
RODS . . . . . ASTM A572-50 (MINIMUM)  
HSS. . . . . ASTM A500, GR. B, Fy=46 KSI  
b. BOLTS . . . . . ASTM A325 U.N.O.  
c. WELDING ELECTRODES . . . . . AWS A5.1 (E70XX)  
d. STEEL CONSTRUCTION SHALL CONFORM TO "SPECIFICATION FOR STRUCTURAL STEEL BUILDINGS, ANSI/AISC 360-16"  
e. WELDING SHALL CONFORM TO AWS D1.1/D1.3/D1.7 AS APPLICABLE.  
f. THE FABRICATOR SHALL FURNISH CHECKED SHOP AND ERECTION DRAWINGS TO THE ENGINEER, AND OBTAIN APPROVAL PRIOR TO FABRICATING ANY STRUCTURAL STEEL. SHOP DRAWINGS SHALL CONFORM TO "DETAILING FOR STEEL CONSTRUCTION, 2ND EDITION"  
g. POOR MATCHING OF HOLES SHALL BE CORRECTED BY DRILLING TO THE NEXT LARGER SIZE. WELDING FOR REDRILLING WILL NOT BE PERMITTED.

- 2.2 CONNECTIONS  
a. SHOP CONNECTIONS MAY BE BOLTED OR WELDED  
b. CONNECTIONS WHERE THE BEAM SHEAR (V) IS NOT NOTED ON THE DRAWINGS, SIMPLE SHEAR CONNECTIONS SHALL BE DESIGNED TO DEVELOP 1/2 OF THE MAXIMUM TOTAL UNIFORM LOAD CAPACITY OF THE BEAM.  
c. FIELD CONNECTIONS SHALL BE MADE WITH A325 BOLTS AND HARDENED WASHERS EXCEPT AS INDICATED ON THE DESIGN DRAWINGS  
d. CONNECTIONS NOT SHOWN ON DRAWINGS SHALL BE DESIGNED BY THE STEEL FABRICATOR. CONNECTIONS SHALL BE DESIGNED IN ACCORDANCE WITH AISC "SPECIFICATIONS FOR STRUCTURAL JOINTS USING ASTM A325 OR A490 BOLTS" AND "AISC CODE OF STANDARD PRACTICE FOR STEEL BUILDINGS AND BRIDGES".  
e. DO NOT FIELD CUT OR ALTER STRUCTURAL MEMBERS WITHOUT PRIOR WRITTEN APPROVAL OF ENGINEER.  
f. BOLT HOLES SHALL BE CUT, DRILLED OR PUNCHED AT RIGHT ANGLES TO THE SURFACE OF THE METAL AND SHALL NOT BE MADE OR ENLARGED BY BURNING. HOLES SHALL BE CLEAN CUT WITHOUT TORN OR RAGGED EDGES. OUTSIDE BURRS RESULTING FROM DRILLING OR REAMING OPERATION SHALL BE REMOVED WITH A TOOL MAKING A 1/16 INCH BEVEL. BOLT HOLES SHALL BE 1/16 INCH OVERSIZE.

- 2.3 FINISHES  
a. STRUCTURAL STEEL SHALL BE HOT DIP GALVANIZED AFTER FABRICATION PER ASTM A123  
b. BOLTS AND NUTS SHALL BE HOT DIP GALVANIZED PER ASTM A153.  
c. ALL SURFACES DAMAGED BY FIELD WELDING OR CUTTING SHALL BE PAINTED WITH COLD GALVANIZING COMPOUND TWICE. THE PAINT SHOULD BE AT LEAST 93% PURE ZINC. RUST-OLEUM PROFESSIONAL, (MODEL# 7585838) OR SIMILAR.

- 2.4 WELDING  
a. CONTRACTOR TO TAKE ALL NECESSARY PRECAUTIONS FOR FIRE PREVENTION DURING WELDING, SUCH AS; INSTALLING 3000 (NFPA 701) FIRE BLANKET AROUND COAX. MORE SPLATTER AND SPARKS SHOULD BE ANTICIPATED WHILE WELDING ON GALVANIZED SURFACE. COAX IS FLAMMABLE AND SHALL CATCH FIRE IF NOT PROTECTED. WATER SHALL BE ON SITE OF ADEQUATE AMOUNT AND AVAILABLE AT SHORT NOTICE AT ALL TIMES DURING WELDING ACTIVITY. CONTRACTOR SHOULD BE ABLE TO TRANSPORT THE WATER TO THE HEIGHT WELDING BEING PERFORMED.  
b. WELDING ON GALVANIZED SURFACE SHOULD BE DONE WITH EXTREME CAUTION. IF THE WELD MATERIAL IS CONTAMINATED WITH ZINC, IT DOES NOT PROVIDE A STRUCTURAL WELD. GROUND GALVANIZING BEFORE WELDING.  
c. WELDING CERTIFICATE MUST BE PROVIDED PRIOR TO WELDING. ALL WELDING SHALL BE PERFORMED BY AWS QUALIFIED WELDER WHO HAS EXPERIENCE WITH GALVANIZED SURFACES.

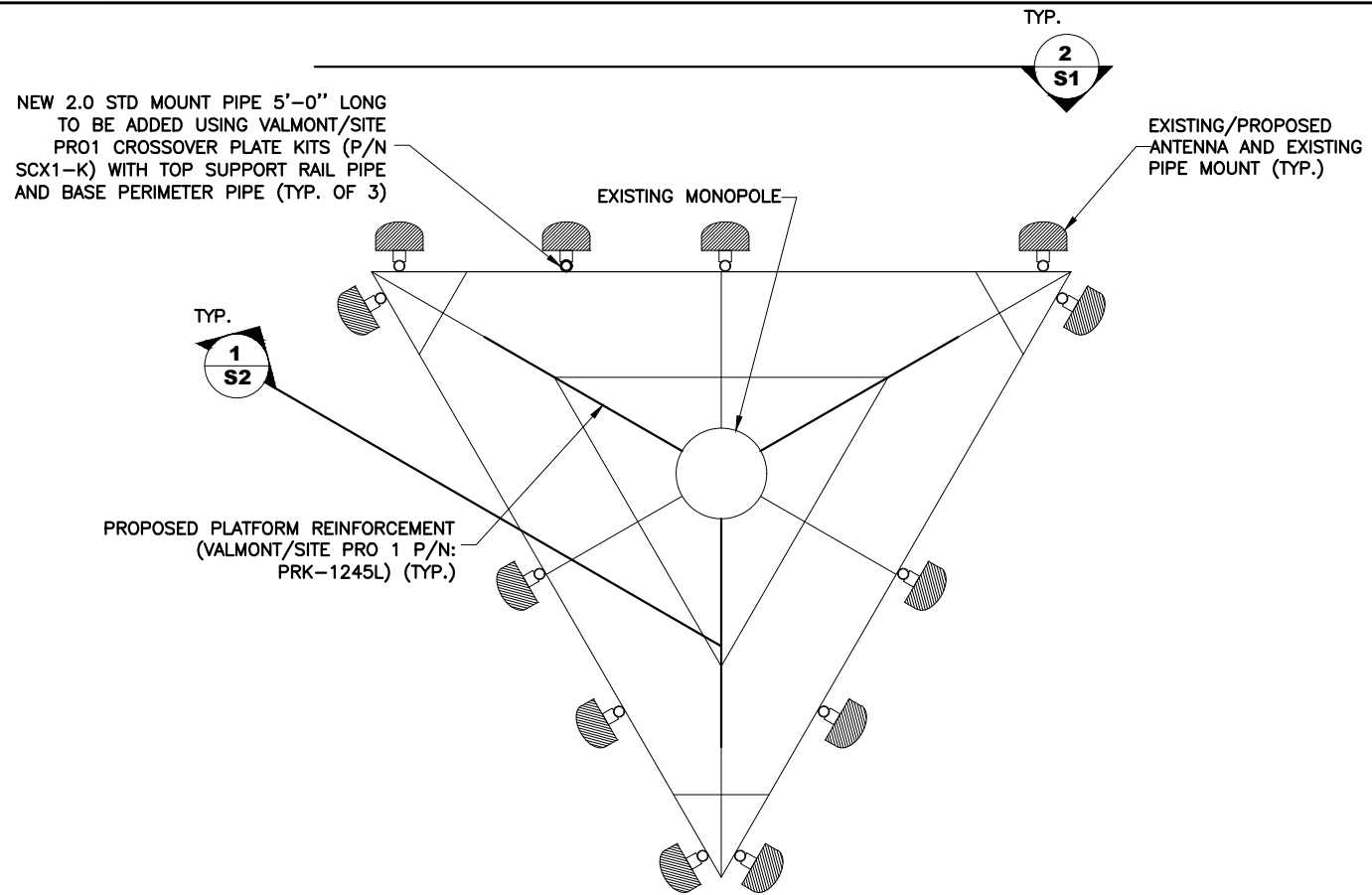

**1 PLATFORM MOUNT @ 163' PLAN**  
1/4" = 1'-0"

**NOTE:**  
- ADDITIONAL EQUIPMENT AND MOUNTING HARDWARE NOT SHOWN FOR CLARITY

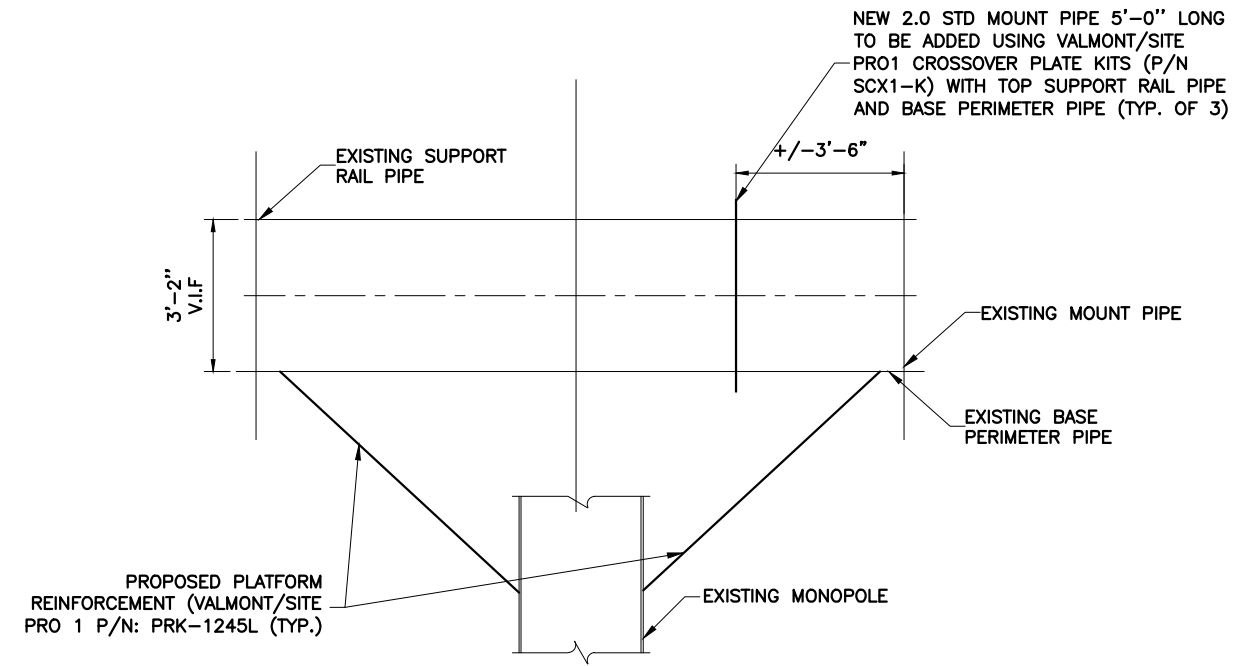

**2 PLATFORM MOUNT @ 163' ELEVATION**  
N.T.S

**NOTE:**  
- ADDITIONAL EQUIPMENT AND MOUNTING HARDWARE NOT SHOWN FOR CLARITY

PROPOSED MODIFICATION TO BE INSTALLED AT ALL CORNERS.



PREPARED FOR:  
T-Mobile Northeast, LLC  
35 Griffin Road South  
Bloomfield, CT 06002

NUM	DATE	DESCRIPTION:
A	06/19/20	ISSUED FOR CONSTRUCTION

CT11365D  
239E MIDDLE TPK,  
MANCHESTER, CT 06040  
ADDRESS:

DESIGNED: SK  
DRAWN: SK  
CHECKED: AC

JOB #: 049.00421  
2075019

**S1 UPGRADE DRAWINGS**



Ahmet Colakoglu, PE  
CT License No: 27057

PROPOSED MODIFICATION  
TO BE INSTALLED AT ALL  
CORNERS.

T-Mobile Northeast, LLC  
35 Griffin Road South  
Bloomfield, CT 06002

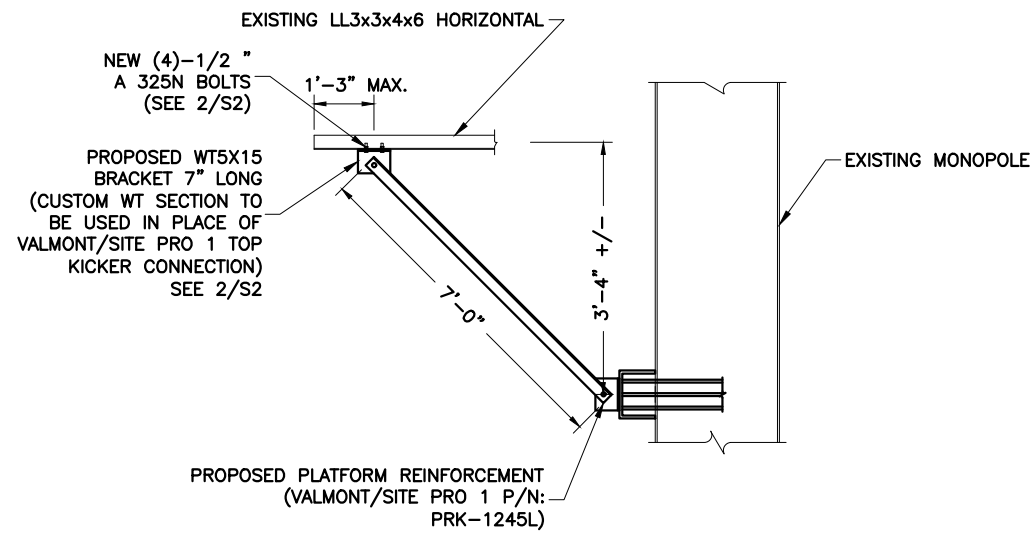

**1**  
**S2** **PLATFORM MOUNT KICKER CONNECTION**  
1/4" = 1'-0"

**NOTE:**  
- ADDITIONAL EQUIPMENT AND MOUNTING HARDWARE NOT SHOWN FOR CLARITY

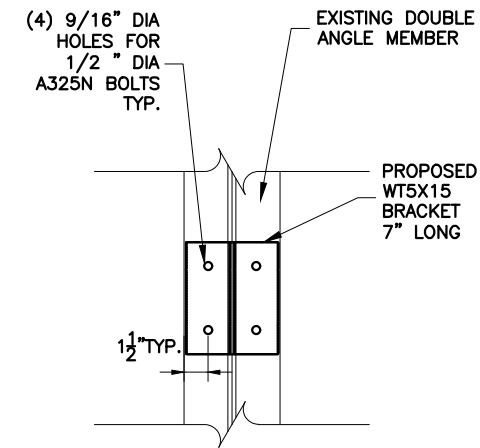
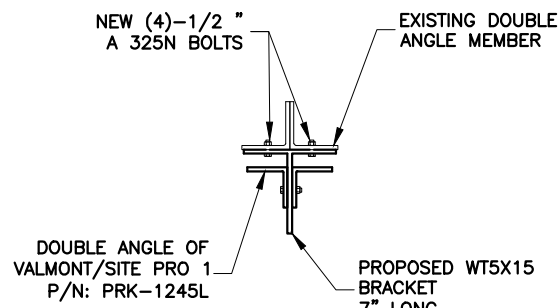

**2**  
**S2** **CONNECTION DETAIL**  
1" = 1'-0"

**NOTE:**  
- MODIFICATIONS SHOULD BE DONE AT ALL SECTORS

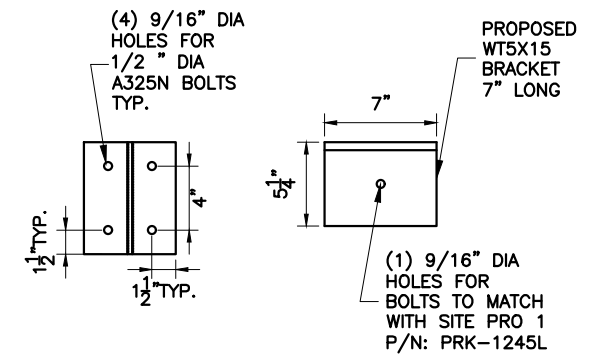

PREPARED FOR:

NUM	DATE	DESCRIPTION:
A	06/19/20	ISSUED FOR CONSTRUCTION

CT11365D

239E MIDDLE TPK,  
MANCHESTER, CT 06040

ADDRESS:

DESIGNED: SK  
DRAWN: SK  
CHECKED: AC

JOB #: 049.00421  
2075019

**S2**  
**UPGRADE**  
**DRAWINGS**



Ahmet Colakoglu, PE  
CT License No: 27057

# Exhibit E

RADIO FREQUENCY EMISSIONS ANALYSIS REPORT  
EVALUATION OF HUMAN EXPOSURE POTENTIAL  
TO NON-IONIZING EMISSIONS

T-Mobile Existing Facility

Site ID: CT11365D

CT365/Manchester PD\_MP  
239 E. Middle Turnpike  
Manchester, Connecticut 06040

**July 9, 2020**

**EBI Project Number: 6220002988**

Site Compliance Summary	
Compliance Status:	<b>COMPLIANT</b>
Site total MPE% of FCC general population allowable limit:	<b>40.04%</b>



July 9, 2020

T-Mobile

Attn: Jason Overbey, RF Manager  
35 Griffin Road South  
Bloomfield, Connecticut 06002

Emissions Analysis for Site: CT11365D - CT365/Manchester PD\_MP

EBI Consulting was directed to analyze the proposed T-Mobile facility located at **239 E. Middle Turnpike in Manchester, Connecticut** for the purpose of determining whether the emissions from the Proposed T-Mobile Antenna Installation located on this property are within specified federal limits.

All information used in this report was analyzed as a percentage of current Maximum Permissible Exposure (% MPE) as listed in the FCC OET Bulletin 65 Edition 97-01 and ANSI/IEEE Std C95.1. The FCC regulates Maximum Permissible Exposure in units of microwatts per square centimeter ( $\mu\text{W}/\text{cm}^2$ ). The number of  $\mu\text{W}/\text{cm}^2$  calculated at each sample point is called the power density. The exposure limit for power density varies depending upon the frequencies being utilized. Wireless Carriers and Paging Services use different frequency bands each with different exposure limits; therefore, it is necessary to report results and limits in terms of percent MPE rather than power density.

All results were compared to the FCC (Federal Communications Commission) radio frequency exposure rules, 47 CFR 1.1307(b)(1) – (b)(3), to determine compliance with the Maximum Permissible Exposure (MPE) limits for General Population/Uncontrolled environments as defined below.

General population/uncontrolled exposure limits apply to situations in which the general population may be exposed or in which persons who are exposed as a consequence of their employment may not be made fully aware of the potential for exposure or cannot exercise control over their exposure. Therefore, members of the general population would always be considered under this category when exposure is not employment related, for example, in the case of a telecommunications tower that exposes persons in a nearby residential area.

Public exposure to radio frequencies is regulated and enforced in units of microwatts per square centimeter ( $\mu\text{W}/\text{cm}^2$ ). The general population exposure limits for the 600 MHz and 700 MHz frequency bands are approximately  $400 \mu\text{W}/\text{cm}^2$  and  $467 \mu\text{W}/\text{cm}^2$ , respectively. The general population exposure limit for the 1900 MHz (PCS), 2100 MHz (AWS) and 11 GHz frequency bands is  $1000 \mu\text{W}/\text{cm}^2$ . Because each carrier will be using different frequency bands, and each frequency band has different exposure limits, it is necessary to report percent of MPE rather than power density.

Occupational/controlled exposure limits apply to situations in which persons are exposed as a consequence of their employment and in which those persons who are exposed have been made fully aware of the potential for exposure and can exercise control over their exposure. Occupational/controlled exposure limits also apply where exposure is of a transient nature as a result of incidental passage through a location where exposure levels may be above general population/uncontrolled limits (see below), as long as the exposed person has been made fully aware of the potential for exposure and can exercise control over his or her exposure by leaving the area or by some other appropriate means.

Additional details can be found in FCC OET 65.

## **CALCULATIONS**

Calculations were done for the proposed T-Mobile Wireless antenna facility located at 239 E. Middle Turnpike in Manchester, Connecticut using the equipment information listed below. All calculations were performed per the specifications under FCC OET 65. Since T-Mobile is proposing highly focused directional panel antennas, which project most of the emitted energy out toward the horizon, all calculations were performed assuming a lobe representing the maximum gain of the antenna per the antenna manufacturer's supplied specifications, minus 10 dB for directional panel antennas and 20 dB for highly focused parabolic microwave dishes, was focused at the base of the tower. For this report, the sample point is the top of a 6-foot person standing at the base of the tower.

For all calculations, all equipment was calculated using the following assumptions:

- 1) 2 LTE channels (600 MHz Band) were considered for each sector of the proposed installation. These Channels have a transmit power of 30 Watts per Channel.
- 2) 1 NR channel (600 MHz Band) was considered for each sector of the proposed installation. This Channel has a transmit power of 80 Watts.
- 3) 2 LTE channels (700 MHz Band) were considered for each sector of the proposed installation. These Channels have a transmit power of 30 Watts per Channel.
- 4) 4 GSM channels (PCS Band - 1900 MHz) were considered for each sector of the proposed installation. These Channels have a transmit power of 30 Watts per Channel.
- 5) 4 LTE channels (PCS Band - 1900 MHz) were considered for each sector of the proposed installation. These Channels have a transmit power of 60 Watts per Channel.

- 6) 2 UMTS channels (AWS Band - 2100 MHz) were considered for each sector of the proposed installation. These Channels have a transmit power of 30 Watts per Channel.
- 7) 4 LTE channels (AWS Band – 2100 MHz) were considered for each sector of the proposed installation. These Channels have a transmit power of 40 Watts per Channel.
- 8) 2 LTE channels (BRS Band - 2500 MHz) were considered for each sector of the proposed installation. These Channels have a transmit power of 40 Watts per Channel.
- 9) 2 NR channels (BRS Band - 2500 MHz) were considered for each sector of the proposed installation. These Channels have a transmit power of 40 Watts per Channel.
- 10) All radios at the proposed installation were considered to be running at full power and were uncombined in their RF transmissions paths per carrier prescribed configuration. Per FCC OET Bulletin No. 65 - Edition 97-01 recommendations to achieve the maximum anticipated value at each sample point, all power levels emitting from the proposed antenna installation are increased by a factor of 2.56 to account for possible in-phase reflections from the surrounding environment. This is rarely the case, and if so, is never continuous.
- 11) For the following calculations, the sample point was the top of a 6-foot person standing at the base of the tower. The maximum gain of the antenna per the antenna manufacturer's supplied specifications, minus 10 dB for directional panel antennas and 20 dB for highly focused parabolic microwave dishes, was used in this direction. This value is a very conservative estimate as gain reductions for these particular antennas are typically much higher in this direction.
- 12) The antennas used in this modeling are the Ericsson AIR 32 for the 1900 MHz / 1900 MHz / 2100 MHz channel(s), the Ericsson AIR 6449 for the 2500 MHz / 2500 MHz channel(s), the RFS APXVAARR24\_43-U-NA20 for the 600 MHz / 600 MHz / 700 MHz / 1900 MHz channel(s), the Ericsson AIR 3246 for the 2100 MHz channel(s) in Sector A, the Ericsson AIR 32 for the 1900 MHz / 1900 MHz / 2100 MHz channel(s), the Ericsson AIR 6449 for the 2500 MHz / 2500 MHz channel(s), the RFS APXVAARR24\_43-U-NA20 for the 600 MHz / 600 MHz / 700 MHz / 1900 MHz channel(s), the Ericsson AIR 3246 for the 2100 MHz channel(s) in Sector B, the Ericsson AIR 32 for the 1900 MHz / 1900 MHz / 2100 MHz channel(s), the Ericsson AIR 6449 for the 2500 MHz / 2500 MHz channel(s), the RFS APXVAARR24\_43-U-NA20 for the 600 MHz / 600 MHz / 700 MHz / 1900 MHz channel(s), the Ericsson AIR 3246 for the 2100 MHz channel(s) in Sector C. This is based on feedback from the carrier with regard to anticipated antenna selection. All Antenna gain values and associated transmit power levels are shown in the Site Inventory and Power Data table below. The maximum gain of the antenna per the antenna manufacturer's supplied specifications, minus 10 dB for directional

panel antennas and 20 dB for highly focused parabolic microwave dishes, was used for all calculations. This value is a very conservative estimate as gain reductions for these particular antennas are typically much higher in this direction.

- 13) The antenna mounting height centerline of the proposed antennas is 163 feet above ground level (AGL).
- 14) Emissions values for additional carriers were taken from the Connecticut Siting Council active database. Values in this database are provided by the individual carriers themselves.
- 15) All calculations were done with respect to uncontrolled / general population threshold limits.

## T-Mobile Site Inventory and Power Data

Sector:	A	Sector:	B	Sector:	C
Antenna #:	1	Antenna #:	1	Antenna #:	1
Make / Model:	Ericsson AIR 32	Make / Model:	Ericsson AIR 32	Make / Model:	Ericsson AIR 32
Frequency Bands:	1900 MHz / 1900 MHz / 2100 MHz	Frequency Bands:	1900 MHz / 1900 MHz / 2100 MHz	Frequency Bands:	1900 MHz / 1900 MHz / 2100 MHz
Gain:	15.35 dBd / 15.35 dBd / 15.85 dBd	Gain:	15.35 dBd / 15.35 dBd / 15.85 dBd	Gain:	15.35 dBd / 15.35 dBd / 15.85 dBd
Height (AGL):	163 feet	Height (AGL):	163 feet	Height (AGL):	163 feet
Channel Count:	8	Channel Count:	8	Channel Count:	8
Total TX Power (W):	300 Watts	Total TX Power (W):	300 Watts	Total TX Power (W):	300 Watts
ERP (W):	10,533.98	ERP (W):	10,533.98	ERP (W):	10,533.98
Antenna A1 MPE %:	<b>1.43%</b>	Antenna B1 MPE %:	<b>1.43%</b>	Antenna C1 MPE %:	<b>1.43%</b>
Antenna #:	2	Antenna #:	2	Antenna #:	2
Make / Model:	Ericsson AIR 6449	Make / Model:	Ericsson AIR 6449	Make / Model:	Ericsson AIR 6449
Frequency Bands:	2500 MHz / 2500 MHz	Frequency Bands:	2500 MHz / 2500 MHz	Frequency Bands:	2500 MHz / 2500 MHz
Gain:	22.05 dBd / 22.05 dBd	Gain:	22.05 dBd / 22.05 dBd	Gain:	22.05 dBd / 22.05 dBd
Height (AGL):	163 feet	Height (AGL):	163 feet	Height (AGL):	163 feet
Channel Count:	4	Channel Count:	4	Channel Count:	4
Total TX Power (W):	160 Watts	Total TX Power (W):	160 Watts	Total TX Power (W):	160 Watts
ERP (W):	25,651.93	ERP (W):	25,651.93	ERP (W):	25,651.93
Antenna A2 MPE %:	<b>3.47%</b>	Antenna B2 MPE %:	<b>3.47%</b>	Antenna C2 MPE %:	<b>3.47%</b>
Antenna #:	3	Antenna #:	3	Antenna #:	3
Make / Model:	RFS APXVAARR24_43-U-NA20	Make / Model:	RFS APXVAARR24_43-U-NA20	Make / Model:	RFS APXVAARR24_43-U-NA20
Frequency Bands:	600 MHz / 600 MHz / 700 MHz / 1900 MHz	Frequency Bands:	600 MHz / 600 MHz / 700 MHz / 1900 MHz	Frequency Bands:	600 MHz / 600 MHz / 700 MHz / 1900 MHz
Gain:	12.95 dBd / 12.95 dBd / 13.35 dBd / 15.65 dBd	Gain:	12.95 dBd / 12.95 dBd / 13.35 dBd / 15.65 dBd	Gain:	12.95 dBd / 12.95 dBd / 13.35 dBd / 15.65 dBd
Height (AGL):	163 feet	Height (AGL):	163 feet	Height (AGL):	163 feet
Channel Count:	7	Channel Count:	7	Channel Count:	7
Total TX Power (W):	320 Watts	Total TX Power (W):	320 Watts	Total TX Power (W):	320 Watts
ERP (W):	8,466.41	ERP (W):	8,466.41	ERP (W):	8,466.41
Antenna A3 MPE %:	<b>1.91%</b>	Antenna B3 MPE %:	<b>1.91%</b>	Antenna C3 MPE %:	<b>1.91%</b>
Antenna #:	4	Antenna #:	4	Antenna #:	4
Make / Model:	Ericsson AIR 3246	Make / Model:	Ericsson AIR 3246	Make / Model:	Ericsson AIR 3246
Frequency Bands:	2100 MHz	Frequency Bands:	2100 MHz	Frequency Bands:	2100 MHz
Gain:	15.85 dBd	Gain:	15.85 dBd	Gain:	15.85 dBd
Height (AGL):	163 feet	Height (AGL):	163 feet	Height (AGL):	163 feet
Channel Count:	4	Channel Count:	4	Channel Count:	4
Total TX Power (W):	160 Watts	Total TX Power (W):	160 Watts	Total TX Power (W):	160 Watts
ERP (W):	6,153.47	ERP (W):	6,153.47	ERP (W):	6,153.47
Antenna A4 MPE %:	<b>0.83%</b>	Antenna B4 MPE %:	<b>0.83%</b>	Antenna C4 MPE %:	<b>0.83%</b>

Site Composite MPE %	
Carrier	MPE %
<b>T-Mobile (Max at Sector A):</b>	<b>7.64%</b>
RAFS I/2	0.19%
Town	0.67%
Htfd City FD	0.08%
Tolland MUT	0.08%
Sprint	2.46%
Clearwire	0.09%
AT&T	21.18%
Verizon	7.65%
<b>Site Total MPE % :</b>	<b>40.04%</b>

T-Mobile MPE % Per Sector	
T-Mobile Sector A Total:	7.64%
T-Mobile Sector B Total:	7.64%
T-Mobile Sector C Total:	7.64%
<b>Site Total MPE % :</b>	<b>40.04%</b>

T-Mobile Maximum MPE Power Values (Sector A)							
T-Mobile Frequency Band / Technology (Sector A)	# Channels	Watts ERP (Per Channel)	Height (feet)	Total Power Density ( $\mu\text{W}/\text{cm}^2$ )	Frequency (MHz)	Allowable MPE ( $\mu\text{W}/\text{cm}^2$ )	Calculated % MPE
T-Mobile 1900 MHz GSM	4	1028.30	163.0	5.57	1900 MHz GSM	1000	0.56%
T-Mobile 1900 MHz LTE	2	2056.61	163.0	5.57	1900 MHz LTE	1000	0.56%
T-Mobile 2100 MHz UMTS	2	1153.78	163.0	3.12	2100 MHz UMTS	1000	0.31%
T-Mobile 2500 MHz LTE	2	6412.98	163.0	17.36	2500 MHz LTE	1000	1.74%
T-Mobile 2500 MHz NR	2	6412.98	163.0	17.36	2500 MHz NR	1000	1.74%
T-Mobile 600 MHz LTE	2	591.73	163.0	1.60	600 MHz LTE	400	0.40%
T-Mobile 600 MHz NR	1	1577.94	163.0	2.14	600 MHz NR	400	0.53%
T-Mobile 700 MHz LTE	2	648.82	163.0	1.76	700 MHz LTE	467	0.38%
T-Mobile 1900 MHz LTE	2	2203.69	163.0	5.96	1900 MHz LTE	1000	0.60%
T-Mobile 2100 MHz LTE	4	1538.37	163.0	8.33	2100 MHz LTE	1000	0.83%
						<b>Total:</b>	<b>7.64%</b>

• NOTE: Totals may vary by approximately 0.01% due to summation of remainders in calculations.

## Summary

All calculations performed for this analysis yielded results that were **within** the allowable limits for general population exposure to RF Emissions.

The anticipated maximum composite contributions from the T-Mobile facility as well as the site composite emissions value with regards to compliance with FCC's allowable limits for general population exposure to RF Emissions are shown here:

T-Mobile Sector	Power Density Value (%)
Sector A:	7.64%
Sector B:	7.64%
Sector C:	7.64%
T-Mobile Maximum MPE % (Sector A):	7.64%
Site Total:	40.04%
Site Compliance Status:	<b>COMPLIANT</b>

The anticipated composite MPE value for this site assuming all carriers present is **40.04%** of the allowable FCC established general population limit sampled at the ground level. This is based upon values listed in the Connecticut Siting Council database for existing carrier emissions.

FCC guidelines state that if a site is found to be out of compliance (over allowable thresholds), that carriers over a 5% contribution to the composite value will require measures to bring the site into compliance. For this facility, the composite values calculated were well within the allowable 100% threshold standard per the federal government.

# Exhibit F



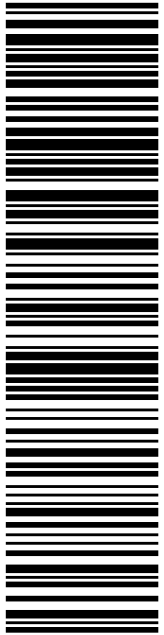

**USPS TRACKING #**

**9405 5036 9930 0417 1115 03**

Electronic Rate Approved #038555749

**SHIP**

TO: LISA MATTHEWS  
CT SITING COUNCIL  
10 FRANKLIN SQ  
NEW BRITAIN CT 06051-2655

**P**

**PRIORITY MAIL 2-DAY™**

DEBORAH CHASE  
NORTHEAST SITE SOLUTIONS, LLC  
420 MAIN ST STE 2  
STURBRIDGE MA 01566-1359

**C006**

**Click-N-Ship®**

**U.S. POSTAGE PAID**

Flat Rate Env  
US POSTAGE \$7.95  
usps.com 9405 5036 9930 0417 1115 03 0079 5000 0010 6051

Mailed from 01566  
06/18/2021



Cut on dotted line.

### Instructions

1. Each Click-N-Ship® label is unique. Labels are to be used as printed and used only once. DO NOT PHOTO COPY OR ALTER LABEL.
2. Place your label so it does not wrap around the edge of the package.
3. Adhere your label to the package. A self-adhesive label is recommended. If tape or glue is used, DO NOT TAPE OVER BARCODE. Be sure all edges are secure.
4. To mail your package with PC Postage®, you may schedule a Package Pickup online, hand to your letter carrier, take to a Post Office™, or drop in a USPS collection box.
5. Mail your package on the "Ship Date" you selected when creating this label.

### Click-N-Ship® Label Record

**USPS TRACKING # :**  
**9405 5036 9930 0417 1115 03**

Trans. #: 536143964	Priority Mail® Postage: <b>\$7.95</b>
Print Date: 06/15/2021	Total: <b>\$7.95</b>
Ship Date: 06/18/2021	
Expected Delivery Date: 06/21/2021	

**From:** DEBORAH CHASE      Ref#: 365D-ANCH  
NORTHEAST SITE SOLUTIONS, LLC  
420 MAIN ST STE 2  
STURBRIDGE MA 01566-1359

**To:** LISA MATTHEWS  
CT SITING COUNCIL  
10 FRANKLIN SQ  
NEW BRITAIN CT 06051-2655

\* Retail Pricing Priority Mail rates apply. There is no fee for USPS Tracking® service on Priority Mail service with use of this electronic rate shipping label. Refunds for unused postage paid labels can be requested online 30 days from the print date.



Thank you for shipping with the United States Postal Service!  
Check the status of your shipment on the USPS Tracking® page at usps.com

# Exhibit G

## Deborah Chase

---

**From:** Deborah Chase  
**Sent:** Thursday, June 17, 2021 11:38 AM  
**To:** 'sshanley@manchesterct.gov'  
**Subject:** 239 East Middle Turnpike, Manchester CT 06040 T-MOBIL EM APPLICATION (CT11365D-ANCHOR)  
**Attachments:** 239 EAST MIDDLE TURNPIKE MANCHESTER CT 06040 T-MOBILE EM APPLICATION (CT11365D-ANCHOR).pdf

Dear Mr. Shanley

Attached please find T-Mobile's exempt modification application that is being submitted to the Connecticut Siting Council today, June 17, 2021 for the above referenced address.

In light of the present circumstances with Covid-19, the Council has advised that electronic notification of this filing is acceptable.

If you could kindly confirm receipt.

Thank you very much

**Deborah Chase**

Senior Project Coordinator & Analyst

Mobile: 860-490-8839



🌱 Save a tree. Refuse. Reduce. Reuse. Recycle.

## Deborah Chase

---

**From:** Deborah Chase  
**Sent:** Thursday, June 17, 2021 11:40 AM  
**To:** 'jdavis@manchesterct.gov'  
**Subject:** 239 East Middle Turnpike, Manchester CT 06040 T-MOBILE EM APPLICATION ( CT11365D-ANCHOR)  
**Attachments:** 239 EAST MIDDLE TURNPIKE MANCHESTER CT 06040 T-MOBILE EM APPLICATION (CT11365D-ANCHOR).pdf

Dear Mr. Davis,

Attached please find T-Mobile's exempt modification application that is being submitted to the Connecticut Siting Council today, June 17, 2021 for the above referenced address.

In light of the present circumstances with Covid-19, the Council has advised that electronic notification of this filing is acceptable.

If you could kindly confirm receipt.

Thank you very much

### Deborah Chase

Senior Project Coordinator & Analyst

Mobile: 860-490-8839



🌳 Save a tree. Refuse. Reduce. Reuse. Recycle.

## Deborah Chase

---

**From:** Deborah Chase  
**Sent:** Thursday, June 17, 2021 11:43 AM  
**To:** 'jcampose@manchesterct.gov'  
**Subject:** 239 East Middle Turnpike, Manchester CT 06040 T-MOBIL EM APPLICATION (CT11365D-ANCHOR)  
**Attachments:** 239 EAST MIDDLE TURNPIKE MANCHESTER CT 06040 T-MOBILE EM APPLICATION (CT11365D-ANCHOR).pdf

Dear Mr. Camposeo

Attached please find T-Mobile's exempt modification application that is being submitted to the Connecticut Siting Council today, June 17, 2021 for the above referenced address.

In light of the present circumstances with Covid-19, the Council has advised that electronic notification of this filing is acceptable.

If you could kindly confirm receipt.

Thank you very much

### Deborah Chase

Senior Project Coordinator & Analyst

Mobile: 860-490-8839



🌱 Save a tree. Refuse.Reduce. Reuse. Recycle.