



20 Commercial St
Branford, CT 06405
Phone: (203) 208-0806
Fax: (203) 488-4820

May 22, 2015

Connecticut Siting Council
Ten Franklin Square
New Britain, CT 06051
Attn: Ms. Melanie Bachman, Executive Director

**Re: Notice of Exempt Modification Application
Manchester Police Department Tower**
239 Middle Turnpike East
Manchester, CT 06040

Dear Ms. Bachman,

On behalf of New Cingular Wireless PCS, LLC ("AT&T"), enclosed for filing are an original and two (2) copies of AT&T's Notice of Exempt Modification for Proposed Modifications to an Existing Telecommunications Facility located at the above-referenced site.

I also enclose herewith a check in the amount of \$625.00 representing the fee for the Notice of Exempt Modification.

If you have any questions, please feel free to contact me.

Thank you,

By: Paul F. Sagristano

Name: Paul Sagristano
Vertical Development LLC
Phone- 917-841-0247
Fax- 401-633-6202
psagristano@verticaldevelopmentllc.com

cc:

Scott Shanley Town General Manager 41 Center Street Manchester, CT 06040 860-647-5235		
---	--	--

siting.council@ct.gov (electronic copy)

Notice of Exempt Modification
239 Middle Turnpike East
Manchester, CT 06040

New Cingular Wireless PCS, LLC ("AT&T") submits this Notice of Exempt Modification to the Connecticut Siting Council ("Council") pursuant to Sections 16-50j-73 and 16-50j-72(b) of the Regulations of Connecticut State Agencies ("Regulations") in connection with AT&T's planned modification of antennas and associated equipment on an existing 184' monopole located at 239 Middle Turnpike East (Manchester Police Department), in the Town of Manchester, Connecticut. More particularly, AT&T plans to upgrade this site by adding LTE technology to its facilities. The proposed modifications will not increase the tower height, cause a significant adverse change or alteration in the physical or environmental characteristics of the site, extend the boundaries of the tower site, increase noise levels at the tower site boundary by six (6) decibels, add radio frequency sending or receiving capability which increases the total radio frequency electromagnetic radiation power density measured at the tower site boundary to or above the standard adopted by the Federal Communications Commission pursuant to Section 704 of the Telecommunications Act of 1996, as amended, and the State Department of Energy and Environmental Protection, pursuant to Section 22a-162 of the Connecticut General Statutes, or impair the structural integrity of the facility, as determined in a certification provided by a professional engineer licensed in Connecticut.

To better meet the growing voice and data demands of its wireless customers, AT&T is upgrading their network nationwide to include LTE technology, which will provide faster service and better overall performance. Pursuant to the LTE technology upgrade at this site, AT&T will add panel antennas, install RRHs, and install related equipment to its equipment area within the fenced tower compound.

The monopole tower located at 239 Middle Turnpike East, in the Town of Manchester, Connecticut (lat. 41.7843919°, long. -72.5116989°) is owned and operated by SBA Towers, LLC, a Florida limited liability company ("Landlord"). AT&T's existing facility is located within the Landlord's existing fenced compound. AT&T currently has Six (6) panel antennas (Two (2) per sector) with a centerline of 143' installed on the tower. AT&T's base station equipment is located adjacent to the base of the tower within the fenced compound. A site plan depicting this is attached.

AT&T plans to remove all existing equipment and install a new Commscope MTC3607 platform mount. AT&T will relocate to the new platform the following existing antennas and equipment with a proposed centerline of 143' installed on the tower: three (3) existing Kathrein 800-10121 panel antennas (one (1) per sector), three (3) Ericsson RRUS-11 (one (1) per sector) which will be connected and located behind the Kathrein 800-10121 panel antennas, and one (1) DC-6 Surge Suppressor.

AT&T plans to add to the new platform Three (2) CCI OPA-65R-LCUU-H6 panel antennas, Four (4) CCI OPA-65R-LCUU H8 antennas, , three (3) RRUS-12 (1 per sector), three (3) Ericsson A2 modules (1 per sector (attached behind each respective RRU-12), three (3) RRUS-32 (1 per sector), and three (3) RRUS-E2 (1 per sector) and will add one (1) new Raycap DC-6 Surge Suppressors. The height of the tower will not be increased and all antennas, surge suppressors, and RRHs will be installed at the existing 143' centerline.

Within the existing equipment shelter AT&T also plans replace an existing Ericsson RBS 6601 cabinet with a new Ericsson RBS 6601 and replace Six (6) existing Diplexers with Six (6) new Kaelus Diplexers and 1 Raycap DC-6 on the ice Bridge. Finally, AT&T will be adding one (1) fiber trunks and two (2) DC trunks from the ground equipment to the AT&T Rad Center outside the monopole following existing DC Trunks and existing Fiber Trunk. The compound's boundaries will not need to be extended. The proposed modifications will not cause a significant adverse change or alteration in the physical or environmental characteristics of the site, since it is already a

telecommunications installation and the modifications will be compatible with this. Other than brief, construction-related noise, these modifications will not increase noise levels at the tower site boundary by six (6) decibels.

The proposed modifications will not add radio frequency sending or receiving capability which increases the total radio frequency electromagnetic radiation power density measured at the tower site boundary to or above the standard adopted by the Federal Communications Commission pursuant to Section 704 of the Telecommunications Act of 1996, as amended, and the State Department of Energy and Environmental Protection, pursuant to Section 22a-162 of the Connecticut General Statutes. A radio frequency emissions analysis prepared by EBI Consulting concludes that the proposed final configuration (including other carriers on the tower) will emit 68.61% of the allowable FCC established general public limits sampled at the ground level (see page 1 and the 6th page of Radio Frequency Emissions Analysis Report Evaluation of Human Exposure Potential to Non-Ionizing Emissions (the "MPE" Assessment) dated May 19, 2015). Emissions values for additional carriers were based upon values listed in Connecticut Siting Council active database (see the 2nd and 6 page of the MPE Assessment dated May 19, 2015). The information used in the report was analyzed as a percentage of current Maximum Permissible Exposure (%MPE) as listed in the FCC OET Bulletin 65 Edition 97-01 and ANSI/IEEE Std C95.1 (see the 2nd page of the MPE Assessment).

The proposed modifications will not impair the structural integrity of the facility. Hudson Design Services performed a structural analysis of the tower on April 10, 2015 to verify that it can support the proposed loading. The report was commissioned by Sprint in cooperation with the other 3 carriers proposing modifications. An initial structural analysis capturing all proposed carriers modifications found the foundation to pass to and the tower to fail to meet the specified ANSI/TIA/222-G requirements and deemed inadequate to support the proposed loading. Metro PCS elected to decommission its site and remove all equipment from the tower which resulted in a revised tower modification to address the failing tower analysis for which a tower structural modification

was undertaken. Hudson design group thereafter designed modification drawings (“Modification Drawings”) dated April 10, 2015, which depict a flat Steel plate reinforcement (of varying sizes) to the Monopole from 1’ through 88’ so that the monopole will comply with the specified ANSI-TIA-222-G requirements and adequately structurally support the proposed loading. The Structural Analysis specifically states that the modifications presented on these drawings are based on the AT&T Structural Analysis Report dated October 14, 2014 by Des Tek and that satisfactory completion of the work indicated on the Modification Drawings will result in the structure meeting the requirements of the specifications under which the structural was completed (see page 9 of the construction drawings (page 1 of the Modification Drawings)).

In conclusion, AT&T’s proposed modifications do not constitute a modification subject to the Council’s review because AT&T will not change the height of the tower, will not extend the boundaries of the compound, will not cause a significant adverse change or alteration in the physical or environmental characteristics of the site, will not increase the noise levels at the site, will not increase the total radio frequency electromagnetic radiation power density at the site to levels above applicable standards, and will not impair the structural integrity of the facility. Therefore, AT&T respectfully requests that the Council acknowledge that this Notice of Exempt Modification meets the Council’s exemption criteria.

PROJECT INFORMATION

- SCOPE OF WORK:
- REMOVE ALL TOWER TOP EQUIPMENT & REPLACE SECTOR FRAMES.
 - AT&T ANTENNAS: (2) NEW LTE ANTENNAS PER SECTOR WITH (3) SECTORS, FOR A TOTAL OF (6) NEW LTE ANTENNAS; (3) EXISTING UMTS ANTENNAS & TMAS TO BE RE-USED (1 PER SECTOR)
 - AT&T RRUS: (3) NEW RRUS PER SECTOR WITH (3) SECTORS, FOR A TOTAL OF (9) NEW RRUS; (1) EXISTING RRU PER SECTOR TO BE REUSED, FOR A TOTAL OF (3) EXISTING RRUS.
 - (1) NEW A2 MODULES PER SECTOR WITH (3) SECTORS, FOR A TOTAL OF (3) A2 MODULES.
 - (1) NEW AT&T DC6 SURGE SUPPRESSORS; (1) EXISTING DC6 TO BE REUSED.
 - NEW LTE RBS-6601 & DC-DC CONVERTER INSTALLED IN NEW PURCELL CABINET.
 - NEW DC-6 SURGE BOX MOUNTED TO EXISTING ICE BRIDGE.
 - (2) NEW FIBER TRUNKS & (4) NEW DC TRUNKS TOTAL.
 - UPGRADE BREAKER IN EXISTING 6601 CABINET.
 - REPLACE (6) EXISTING DIPLEXERS AT AT&T EQUIPMENT PAD.

SITE ADDRESS: 239 MIDDLE TURNPIKE EAST
MANCHESTER, CT 06040

LATITUDE: 41.7843919 41° 47' 3.8"N
LONGITUDE: -72.5116989 72° 30' 42.1"W

USID: 26172

TOWER OWNER: TOWN OF MANCHESTER
41 CENTER STREET
MANCHESTER, CT 06040

TYPE OF SITE: MONOPOLE/OUTDOOR EQUIPMENT

MONOPOLE HEIGHT: 184'-0"±

RAD CENTER: 143'-0"±

CURRENT USE: UNMANNED WIRELESS TELECOMMUNICATIONS FACILITY
PROPOSED USE: UNMANNED WIRELESS TELECOMMUNICATIONS FACILITY



at&t
MOBILITY

FA CODE: 10071105
SITE NUMBER: CT5448
SITE NAME: MANCHESTER CENTRAL

PROJECT TEAM

CLIENT REPRESENTATIVE

COMPANY: EMPIRE TELECOM
ADDRESS: 16 ESQUIRE ROAD
BILLERICA, MA 01821
CONTACT: DAVID COOPER
PHONE: 617-639-4908
EMAIL: dcooper@empiretelecomm.com

SITE ACQUISITION:

COMPANY: VERTICAL DEVELOPMENT, LLC
ADDRESS: 7 SYCAMORE WAY
BRANFORD, CT 06405
CONTACT: DAVID BASS
PHONE: 203-826-5857
EMAIL: dbass@verticaldevelopmentllc.com

ZONING:

COMPANY: VERTICAL DEVELOPMENT, LLC
ADDRESS: 7 SYCAMORE WAY
BRANFORD, CT 06405
CONTACT: DAVID BASS
PHONE: 203-826-5857
EMAIL: dbass@verticaldevelopmentllc.com

ENGINEERING:

COMPANY: COM-EX CONSULTANTS, LLC
ADDRESS: 4 SECOND AVENUE
SUITE 204
DENVER, NJ 07834
CONTACT: NICHOLAS D. BARILE, P.E.
PHONE: 862-209-4300
EMAIL: nbarile@comexconsultants.com

RF ENGINEER:

COMPANY: AT&T MOBILITY – NEW ENGLAND
ADDRESS: 550 COCHITUATE ROAD
SUITE 550 13 & 14
FRAMINGHAM, MA 01701
CONTACT: CAMERON SYME
PHONE: 508-596-7146
EMAIL: cs6970@att.com

CONSTRUCTION MANAGEMENT:

COMPANY: EMPIRE TELECOM
ADDRESS: 16 ESQUIRE ROAD
BILLERICA, MA 01821
CONTACT: GRZEGORZ "GREG" DORMAN
PHONE: 484-683-1750
EMAIL: gdorman@empiretelecomm.com

DRAWING INDEX

REV.

T-1	TITLE SHEET	0
GN-1	GROUNDING & GENERAL NOTES	0
A-1	COMPOUND LAYOUTS	0
A-2	EQUIPMENT LAYOUTS	0
A-3	ANTENNA LAYOUTS & ELEVATIONS	0
A-4	DETAILS	0
A-5	ANTENNA MOUNTING DETAILS	0
G-1	GROUNDING, ONE-LINE DIAGRAM & DETAILS	0

VICINITY MAP

1. HEAD WEST ON COCHITUATE RD TOWARD BURR ST (0.3 MI) 2. TURN LEFT ONTO SHOPPERS WORLD DR (230 FT) 3. MAKE A U-TURN AT RING RD (138 FT) 4. TAKE THE 1ST RIGHT ONTO COCHITUATE RD. (0.3 MI) 5. TAKE THE RAMP TO I-90 E/MASSPIKE W/SPRINGFIELD/BOSTON. TOLL ROAD (0.6 MI) 6. KEEP LEFT AT THE FORK, FOLLOW SIGNS FOR INTERSTATE 90 W/MASSACHUSETTS TURNPIKE/WORCHESTER/SPRINGFIELD AND MERGE ONTO I-90 W/MASSACHUSETTS TURNPIKE. PARTIAL TOLL ROAD (38.3 MI) 7. TAKE EXIT 9 TO MERGE ONTO I-84 TOWARD US-20/HARTFORD/NEW YORK CITY. PARTIAL TOLL ROAD. ENTERING CONNECTICUT (34.7 MI) 8. TAKE EXIT 63 FOR CT-30 TOWARD CT-83/S WINDSOR/MANCHESTER (0.2 MI) 9. KEEP RIGHT AT THE FORK, FOLLOW SIGNS FOR CONNECTICUT 30 N/COMMECTICUT 83 AND MERGE ONTO CT-30 N/DEMING ST (0.4 MI) 10. TURN RIGHT ONTO CT-83 S/OAKLAND ST. CONTINUE TO FOLLOW OAKLAND ST (1.2 MI) 11. CONTINUE ONTO SUMMIT ST (0.7 MI) 12. TURN LEFT ONTO MIDDLE TURNPIKE E. DESTINATION WILL BE ON THE LEFT

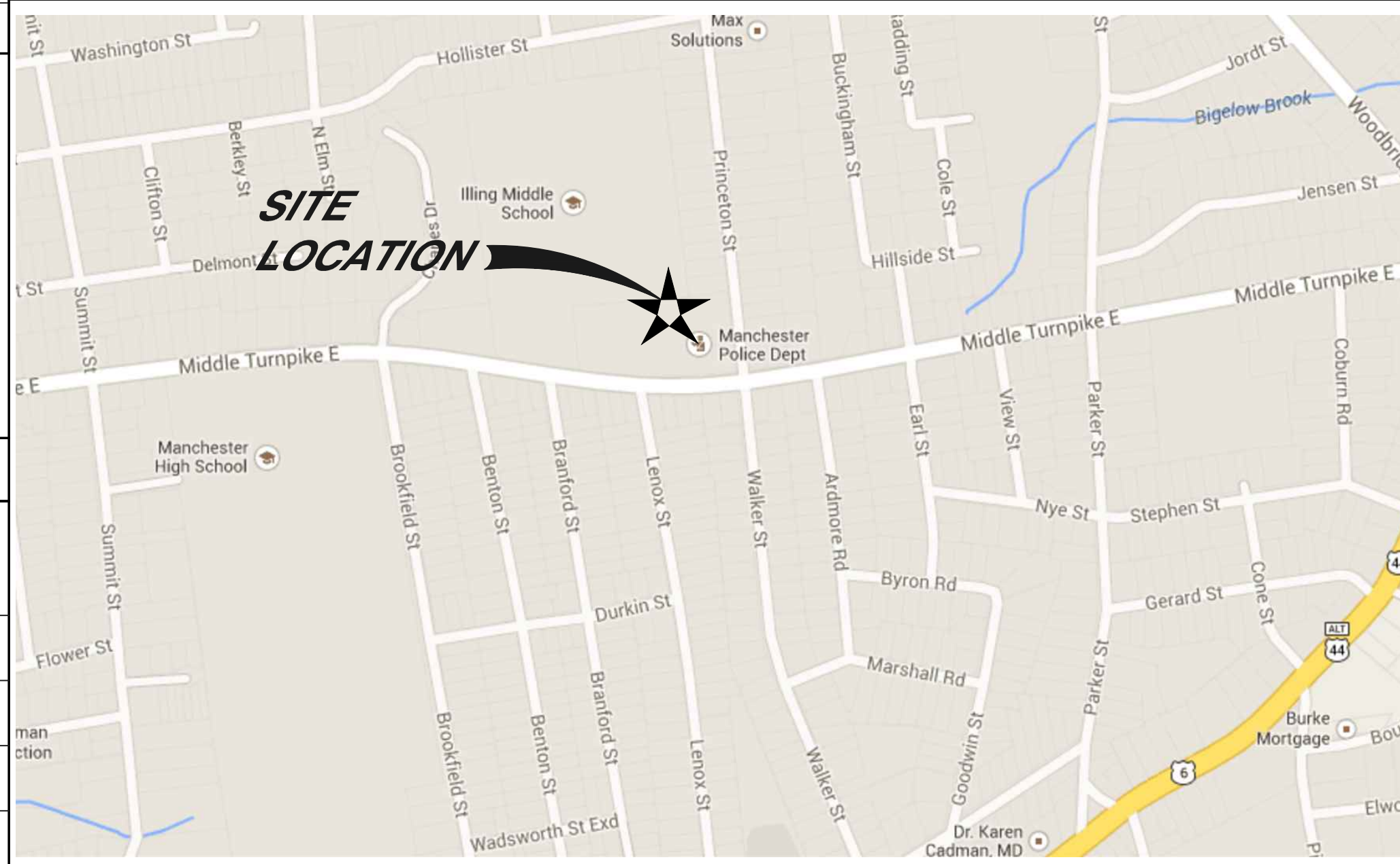

GENERAL NOTES

- THIS DOCUMENT IS THE CREATION, DESIGN, PROPERTY, AND COPYRIGHTED WORK OF AT&T. ANY DUPLICATION OR USE WITHOUT EXPRESS WRITTEN CONSENT IS STRICTLY PROHIBITED. DUPLICATION AND USE BY GOVERNMENT AGENCIES FOR THE PURPOSES OF CONDUCTING THEIR LAWFULLY AUTHORIZED REGULATORY AND ADMINISTRATIVE FUNCTIONS IS SPECIFICALLY ALLOWED.
- THE FACILITY IS AN UNMANNED PRIVATE AND SECURED EQUIPMENT INSTALLATION. IT IS ONLY ACCESSED BY TRAINED TECHNICIANS FOR PERIODIC ROUTINE MAINTENANCE AND THEREFORE DOES NOT REQUIRE ANY WATER OR SANITARY SEWER SERVICE. THE FACILITY IS NOT GOVERNED BY REGULATIONS REQUIRING PUBLIC ACCESS PER ADA REQUIREMENTS.
- CONTRACTOR SHALL VERIFY ALL PLANS AND EXISTING DIMENSIONS AND CONDITIONS ON THE JOB SITE AND SHALL IMMEDIATELY NOTIFY THE AT&T REPRESENTATIVE IN WRITING OF DISCREPANCIES BEFORE PROCEEDING WITH THE WORK OR BE RESPONSIBLE FOR SAME.

APPROVALS

THE FOLLOWING PARTIES HEREBY APPROVE AND ACCEPT THESE DOCUMENTS AND AUTHORIZE THE SUBCONTRACTOR TO PROCEED WITH THE CONSTRUCTION DESCRIBED HEREIN, ALL DOCUMENTS ARE SUBJECT TO REVIEW BY THE LOCAL BUILDING DEPARTMENT AND MAY IMPOSE CHANGES OR SITE MODIFICATIONS.

DISCIPLINE:	DISCIPLINE:	DATE:
SITE ACQUISITION:		
CONSTRUCTION MANAGER:		
AT&T PROJECT MANAGER:		



CONNECTICUT LAW REQUIRES TWO WORKING DAYS NOTICE PRIOR TO ANY EARTH MOVING ACTIVITIES BY CALLING 800-922-4455 OR DIAL 811



SITE NUMBER: CT5448
SITE NAME: MANCHESTER CENTRAL
239 MIDDLE TURNPIKE EAST
MANCHESTER, CT 06040
HARTFORD COUNTY



NO.	DATE	REVISIONS	BY	CHK	APP'D
0	05/21/15	INITIAL SUBMISSION	CJT	NDB	NDB
SCALE: AS SHOWN		DESIGNED BY: CJT	DRAWN BY: PAV		05/21/15

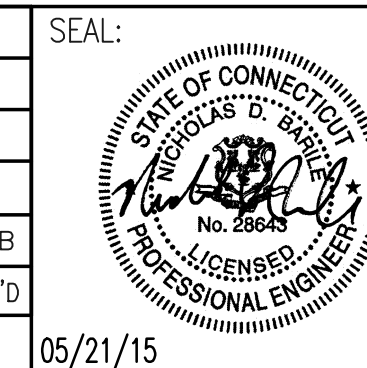

AT&T		
DRAWING TITLE: TITLE SHEET		
JOB NUMBER: 14025-EMP	DRAWING NUMBER: T-1	REV: 0

GROUNDING NOTES:

1. THE SUBCONTRACTOR SHALL REVIEW AND INSPECT THE EXISTING FACILITY GROUNDING SYSTEM AND LIGHTNING PROTECTION SYSTEM (AS DESIGNED AND INSTALLED) FOR STRICT COMPLIANCE WITH THE NEC (AS ADOPTED BY THE AHJ), THE SITE-SPECIFIC (UL, LPI, OR NFPA) LIGHTING PROTECTION CODE, AND GENERAL COMPLIANCE WITH TELCORDIA AND TIA GROUNDING STANDARDS. THE SUBCONTRACTOR SHALL REPORT ANY VIOLATIONS OR ADVERSE FINDINGS TO THE CONTRACTOR FOR RESOLUTION.
2. ALL GROUND ELECTRODE SYSTEMS (INCLUDING TELECOMMUNICATION, RADIO, LIGHTNING PROTECTION, AND AC POWER GES'S) SHALL BE BONDED TOGETHER, AT OR BELOW GRADE, BY TWO OR MORE COPPER BONDING CONDUCTORS IN ACCORDANCE WITH THE NEC.
3. THE SUBCONTRACTOR SHALL PERFORM IEEE FALL-OF-POTENTIAL RESISTANCE TO EARTH TESTING (PER IEEE 1100 AND 81) FOR NEW GROUND ELECTRODE SYSTEMS. THE SUBCONTRACTOR SHALL FURNISH AND INSTALL SUPPLEMENTAL GROUND ELECTRODES AS NEEDED TO ACHIEVE A TEST RESULT OF 5 OHMS OR LESS. TESTS SHALL BE PERFORMED IN ACCORDANCE WITH 25471-000-3PS-EG00-0001, DESIGN & TESTING OF FACILITY GROUNDING FOR CELL SITES.
4. METAL RACEWAY SHALL NOT BE USED AS THE NEC REQUIRED EQUIPMENT GROUND CONDUCTOR. STRANDED COPPER CONDUCTORS WITH GREEN INSULATION, SIZED IN ACCORDANCE WITH THE NEC, SHALL BE FURNISHED AND INSTALLED WITH THE POWER CIRCUITS TO BTS EQUIPMENT.
5. EACH BTS CABINET FRAME SHALL BE DIRECTLY CONNECTED TO THE MASTER GROUND BAR WITH GREEN INSULATED SUPPLEMENTAL EQUIPMENT GROUND WIRES, 6 AWG STRANDED COPPER OR LARGER FOR INDOOR BTS; 2 AWG STRANDED COPPER FOR OUTDOOR BTS.
6. EXOTHERMIC WELDS SHALL BE USED FOR ALL GROUNDING CONNECTIONS BELOW GRADE.
7. APPROVED ANTIOXIDANT COATINGS (I.E., CONDUCTIVE GEL OR PASTE) SHALL BE USED ON ALL COMPRESSION AND BOLTED GROUND CONNECTIONS.
8. ICE BRIDGE BONDING CONDUCTORS SHALL BE EXOTHERMICALLY BONDED OR BOLTED WITH STAINLESS STEEL HARDWARE TO THE BRIDGE AND THE TOWER GROUND BAR.
9. ALUMINUM CONDUCTOR OR COPPER CLAD STEEL CONDUCTOR SHALL NOT BE USED FOR GROUNDING CONNECTIONS.
10. MISCELLANEOUS ELECTRICAL AND NON-ELECTRICAL METAL BOXES, FRAMES AND SUPPORTS SHALL BE BONDED TO THE GROUND RING, IN ACCORDANCE WITH THE NEC.
11. METAL CONDUIT AND TRAY SHALL BE GROUNDED AND MADE ELECTRICALLY CONTINUOUS WITH LISTED BONDING FITTINGS OR BY BONDING ACROSS THE DISCONTINUITY WITH 6 AWG COPPER WIRE UL APPROVED GROUNDING TYPE CONDUIT CLAMPS.
12. GROUND CONDUCTORS USED IN THE FACILITY GROUND AND LIGHTNING PROTECTION SYSTEMS SHALL NOT BE ROUTED THROUGH METALLIC OBJECTS THAT FORM A RING AROUND THE CONDUCTOR, SUCH AS METALLIC CONDUITS, METAL SUPPORT CLIPS OR SLEEVES THROUGH WALLS OR FLOORS. WHEN IT IS REQUIRED TO BE HOUSED IN CONDUIT TO MEET CODE REQUIREMENTS OR LOCAL CONDITIONS, NON-METALLIC MATERIAL SUCH AS PVC PLASTIC CONDUIT SHALL BE USED. WHERE USE OF METAL CONDUIT IS UNAVOIDABLE (E.G., NON-METALLIC CONDUIT PROHIBITED BY LOCAL CODE) THE GROUND CONDUCTOR SHALL BE BONDED TO EACH END OF THE METAL CONDUIT.
13. ALL TOWER GROUNDING SYSTEMS SHALL COMPLY WITH THE REQUIREMENTS OF ANSI/TIA 222. FOR TOWERS BEING BUILT TO REV-G OF THE STANDARD, THE WIRE SIZE OF THE BURIED GROUND RING AND CONNECTIONS BETWEEN THE TOWER AND THE BURIED GROUND RING SHALL BE CHANGED FROM 2 AWG TO 2/0 AWG. IN ADDITION, THE MINIMUM LENGTH OF THE GROUND RODS SHALL BE INCREASED FROM EIGHT FEET (8') TO TEN FEET (10').
14. ALL NEW STRUCTURES WITH A FOUNDATION AND/OR FOOTING HAVING 20 FT. OR MORE 1/2" OR GREATER ELECTRICALLY CONDUCTIVE REINFORCING STEEL MUST HAVE IT BONDED TO THE GROUND RING USING AN EXOTHERMIC WELD CONNECTION USING #2 AWG SOLID TINNED COPPER GROUND WIRE, PER NEC 250.50.

GENERAL NOTES:

1. FOR THE PURPOSE OF CONSTRUCTION DRAWING, THE FOLLOWING DEFINITIONS SHALL APPLY:
 CONTRACTOR - EMPIRE TELECOM
 SUBCONTRACTOR - GENERAL CONTRACTOR (CONSTRUCTION)
 OWNER - AT&T MOBILITY
 OEM - ORIGINAL EQUIPMENT MANUFACTURER
2. PRIOR TO THE SUBMISSION OF BIDS, THE BIDDING SUBCONTRACTOR SHALL VISIT THE CELL SITE TO FAMILIARIZE WITH THE EXISTING CONDITIONS AND TO CONFIRM THAT THE WORK CAN BE ACCOMPLISHED AS SHOWN ON THE CONSTRUCTION DRAWINGS. ANY DISCREPANCY FOUND SHALL BE BROUGHT TO THE ATTENTION OF CONTRACTOR.
3. ALL MATERIALS FURNISHED AND INSTALLED SHALL BE IN STRICT ACCORDANCE WITH ALL APPLICABLE CODES, REGULATIONS, AND ORDINANCES. SUBCONTRACTOR SHALL ISSUE ALL APPROPRIATE NOTICES AND COMPLY WITH ALL LAWS, ORDINANCES, RULES, REGULATIONS, AND LAWFUL ORDERS OF ANY PUBLIC AUTHORITY REGARDING THE PERFORMANCE OF THE WORK. ALL WORK CARRIED OUT SHALL COMPLY WITH ALL APPLICABLE MUNICIPAL AND UTILITY COMPANY SPECIFICATIONS AND LOCAL JURISDICTIONAL CODES, ORDINANCES AND APPLICABLE REGULATIONS.
4. DRAWINGS PROVIDED HERE ARE NOT TO BE SCALED AND ARE INTENDED TO SHOW OUTLINE ONLY.
5. UNLESS NOTED OTHERWISE, THE WORK SHALL INCLUDE FURNISHING MATERIALS, EQUIPMENT, APPURTENANCES, AND LABOR NECESSARY TO COMPLETE ALL INSTALLATIONS AS INDICATED ON THE DRAWINGS.
6. THE SUBCONTRACTOR SHALL INSTALL ALL EQUIPMENT AND MATERIALS IN ACCORDANCE WITH MANUFACTURER'S RECOMMENDATIONS UNLESS SPECIFICALLY STATED OTHERWISE.
7. IF THE SPECIFIED EQUIPMENT CANNOT BE INSTALLED AS SHOWN ON THESE DRAWINGS, THE SUBCONTRACTOR SHALL PROPOSE AN ALTERNATIVE INSTALLATION SPACE FOR APPROVAL BY THE CONTRACTOR.
8. SUBCONTRACTOR SHALL DETERMINE ACTUAL ROUTING OF CONDUIT, POWER AND T1 CABLES, GROUNDING CABLES AS SHOWN ON THE POWER, GROUNDING AND TELCO PLAN DRAWING. SUBCONTRACTOR SHALL UTILIZE EXISTING TRAYS AND/OR SHALL ADD NEW TRAYS AS NECESSARY. SUBCONTRACTOR SHALL CONFIRM THE ACTUAL ROUTING WITH THE CONTRACTOR. ROUTING OF TRENCHING SHALL BE APPROVED BY CONTRACTOR
9. THE SUBCONTRACTOR SHALL PROTECT EXISTING IMPROVEMENTS, PAVEMENTS, CURBS, LANDSCAPING AND STRUCTURES. ANY DAMAGED PART SHALL BE REPAIRED AT SUBCONTRACTOR'S EXPENSE TO THE SATISFACTION OF OWNER.
10. SUBCONTRACTOR SHALL LEGALLY AND PROPERLY DISPOSE OFF ALL SCRAP MATERIALS SUCH AS COAXIAL CABLES AND OTHER ITEMS REMOVED FROM THE EXISTING FACILITY. ANTENNAS REMOVED SHALL BE RETURNED TO THE OWNER'S DESIGNATED LOCATION.
11. SUBCONTRACTOR SHALL LEAVE PREMISES IN CLEAN CONDITION.
12. ALL CONCRETE REPAIR WORK SHALL BE DONE IN ACCORDANCE WITH AMERICAN CONCRETE INSTITUTE (ACI) 301.
13. ANY NEW CONCRETE NEEDED FOR THE CONSTRUCTION SHALL HAVE 4000 PSI STRENGTH AT 28 DAYS UNLESS OTHERWISE SPECIFIED. ALL CONCRETING WORK SHALL BE DONE IN ACCORDANCE WITH ACI 318 CODE REQUIREMENTS.
14. ALL STRUCTURAL STEEL WORK SHALL BE DETAILED, FABRICATED AND ERECTED IN ACCORDANCE WITH AISC SPECIFICATIONS. ALL STRUCTURAL STEEL SHALL BE ASTM A36 (Fy=36 ksi). ALL STEEL EXPOSED TO WEATHER SHALL BE HOT DIPPED GALVANIZED. TOUCH UP ALL SCRATCHES AND OTHER MARKS IN THE FIELD AFTER STEEL IS ERECTED USING A COMPATIBLE ZINC RICH PAINT.
15. CONSTRUCTION SHALL COMPLY WITH SPECIFICATION 25741-000-3APS-A00Z-00002, "GENERAL CONSTRUCTION SERVICES FOR CONSTRUCTION OF AT&T MOBILITY SITES."
16. SUBCONTRACTOR SHALL VERIFY ALL EXISTING DIMENSIONS AND CONDITIONS PRIOR TO COMMENCING ANY WORK. ALL DIMENSIONS OF EXISTING CONSTRUCTION SHOWN ON THE DRAWINGS MUST BE VERIFIED. SUBCONTRACTOR SHALL NOTIFY THE CONTRACTOR OF ANY DISCREPANCIES PRIOR TO ORDERING MATERIAL OR PROCEEDING WITH CONSTRUCTION.
17. THE EXISTING CELL SITE IS IN FULL COMMERCIAL OPERATION. ANY CONSTRUCTION WORK BY SUBCONTRACTOR SHALL NOT DISRUPT THE EXISTING NORMAL OPERATION. ANY WORK ON EXISTING EQUIPMENT MUST BE COORDINATED WITH CONTRACTOR. ALSO, WORK MAY NEED TO BE SCHEDULED FOR AN APPROPRIATE MAINTENANCE WINDOW USUALLY IN LOW TRAFFIC PERIODS AFTER MIDNIGHT.
18. SINCE THE CELL SITE MAY BE ACTIVE, ALL SAFETY PRECAUTIONS MUST BE TAKEN WHEN WORKING AROUND HIGH LEVELS OF ELECTROMAGNETIC RADIATION. EQUIPMENT SHOULD BE SHUTDOWN PRIOR TO PERFORMING ANY WORK THAT COULD EXPOSE THE WORKERS TO DANGER. PERSONAL RF EXPOSURE MONITORS ARE REQUIRED TO BE WORN TO ALERT OF ANY DANGEROUS EXPOSURE LEVELS.

19. SUBCONTRACTOR'S WORK SHALL COMPLY WITH ALL APPLICABLE NATIONAL, STATE, AND LOCAL CODES AS ADOPTED BY THE LOCAL AUTHORITY HAVING JURISDICTION (AHJ) FOR THE LOCATION. THE EDITION OF THE AHJ ADOPTED CODES AND STANDARDS IN EFFECT ON THE DATE OF CONTRACT AWARD SHALL GOVERN THE DESIGN.
 - INTERNATIONAL BUILDING CODE: IBC 2009 WITH LOCAL & COUNTY AMENDMENTS
 - NATIONAL ELECTRICAL CODE: NEC 2011 WITH LOCAL & COUNTY AMENDMENTS
 - FIRE/LIFE SAFETY CODE: NFPA-101 2009 WITH LOCAL & COUNTY AMENDMENTS
20. SUBCONTRACTOR'S WORK SHALL COMPLY WITH THE LATEST EDITION OF THE FOLLOWING STANDARDS:
 - AMERICAN CONCRETE INSTITUTE (ACI) 318, BUILDING CODE REQUIREMENTS FOR STRUCTURAL CONCRETE
 - AMERICAN INSTITUTE OF STEEL CONSTRUCTION (AISC), MANUAL OF STEEL CONSTRUCTION, THIRTEENTH EDITION
 - AMERICAN SOCIETY OF TESTING OF MATERIALS, ASTM
 - TELECOMMUNICATIONS INDUSTRY ASSOCIATION (ANSI/TIA-222-G-1), STRUCTURAL STANDARDS FOR STEEL ANTENNA TOWER AND ANTENNA SUPPORTING STRUCTURES:
 - TIA 607, COMMERCIAL BUILDING GROUNDING AND BONDING REQUIREMENTS FOR TELECOMMUNICATIONS
 - OCCUPATIONAL SAFETY AND HEALTH ADMINISTRATION, OSHA
 - INSTITUTE FOR ELECTRICAL AND ELECTRONICS ENGINEERS (IEEE) 81, GUIDE FOR MEASURING EARTH RESISTIVELY, GROUND IMPEDANCE, AND EARTH SURFACE POTENTIALS OF A GROUND SYSTEM IEEE 1100 (1999) RECOMMENDED PRACTICE FOR POWERING AND GROUNDING OF ELECTRONIC EQUIPMENT
 - TELCORDIA GR-1503, COAXIAL CABLE CONNECTIONS
21. FOR ANY CONFLICTS BETWEEN SECTIONS OF LISTED CODES AND STANDARDS REGARDING MATERIAL, METHODS OF CONSTRUCTION, OR OTHER REQUIREMENTS, THE MOST RESTRICTIVE REQUIREMENT SHALL GOVERN. WHERE THERE IS CONFLICT BETWEEN A GENERAL REQUIREMENT AND A SPECIFIC REQUIREMENT, THE SPECIFIC REQUIREMENT SHALL GOVERN.



SITE NUMBER: CT5448
SITE NAME: MANCHESTER CENTRAL
 239 MIDDLE TURNPIKE EAST
 MANCHESTER, CT 06040
 HARTFORD COUNTY



0	05/21/15	INITIAL SUBMISSION	CJT	NDB	NDB
NO.	DATE	REVISIONS	BY	CHK	APP'D
SCALE: AS SHOWN			DESIGNED BY: CJT	DRAWN BY: PAV	

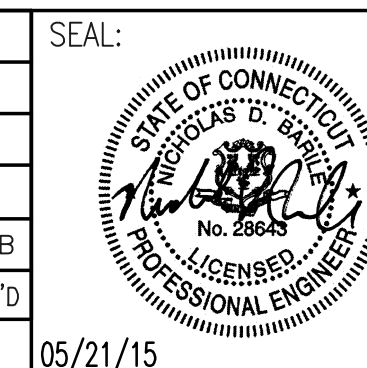

AT&T		
DRAWING TITLE: GROUNDING NOTES & GENERAL NOTES		
JOB NUMBER 14025-EMP	DRAWING NUMBER GN-1	REV 0

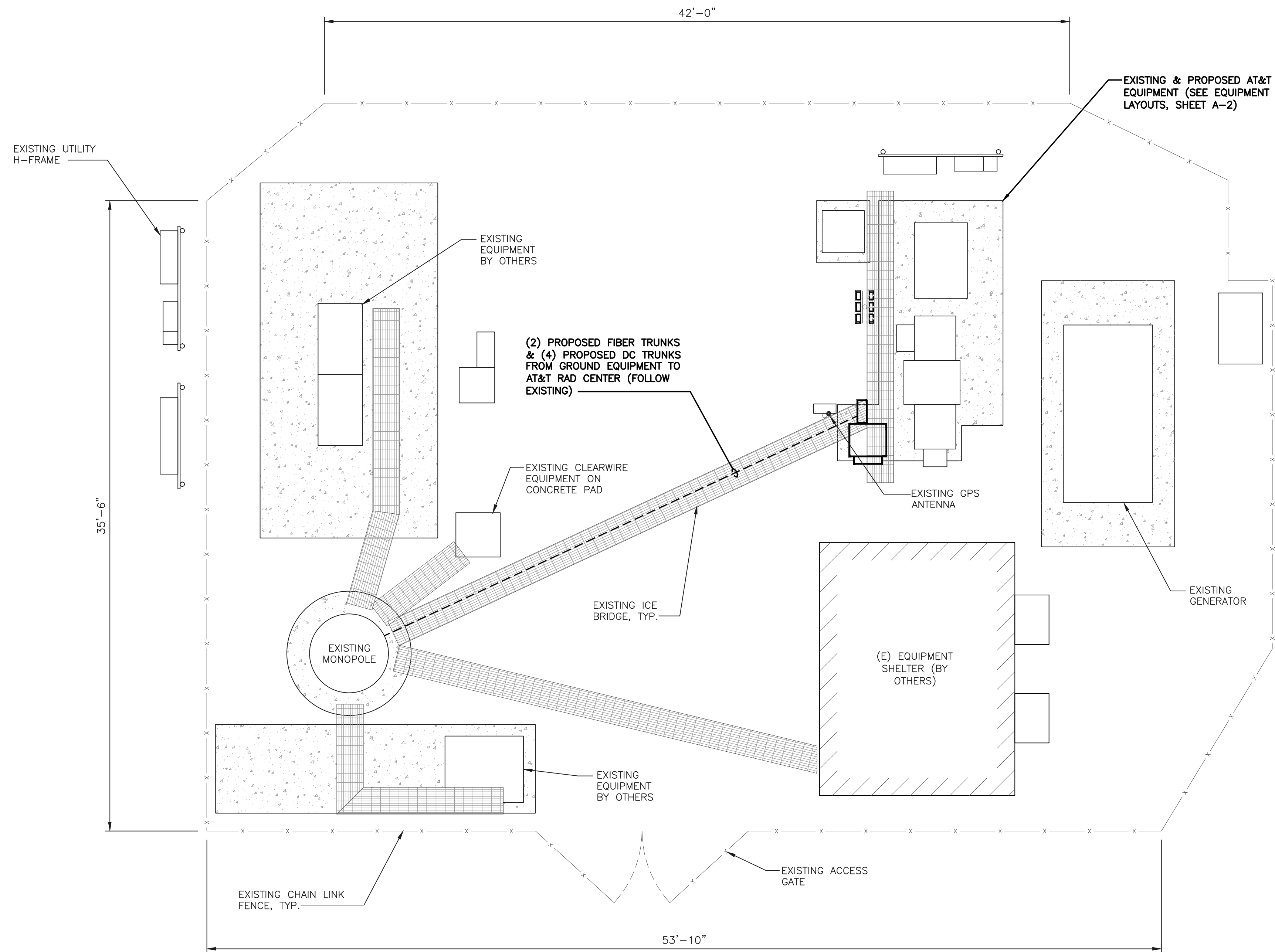

COMPOUND LAYOUT

SCALE: 1" = 4'-0"



(IN FEET)
1/4 Inch = 1 Foot

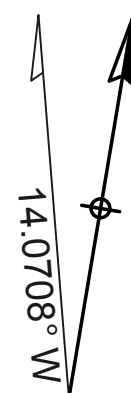

NORTH

COM-EX
Consultants
4 SECOND AVENUE
SUITE 204
DENVER, NJ 07834
PHONE: 862.209.4300
FAX: 862.209.4301

EMPIRE
telecom
16 ESQUIRE ROAD
BILLERICA, MA 01821

SITE NUMBER: CT5448
SITE NAME: MANCHESTER CENTRAL
239 MIDDLE TURNPIKE EAST
MANCHESTER, CT 06040
HARTFORD COUNTY

at&t
MOBILITY
550 COCHITUATE ROAD
FRAMINGHAM, MA 01701

0	05/21/15	INITIAL SUBMISSION	CJT	NDB	NDB
NO.	DATE	REVISIONS	BY	CHK	APP'D
SCALE: AS SHOWN		DESIGNED BY: CJT	DRAWN BY: PAV		

SEAL:

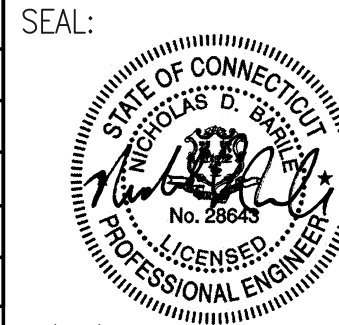

AT&T		
DRAWING TITLE: COMPOUND LAYOUT		
JOB NUMBER 14025-EMP	DRAWING NUMBER A-1	REV 0

05/21/15

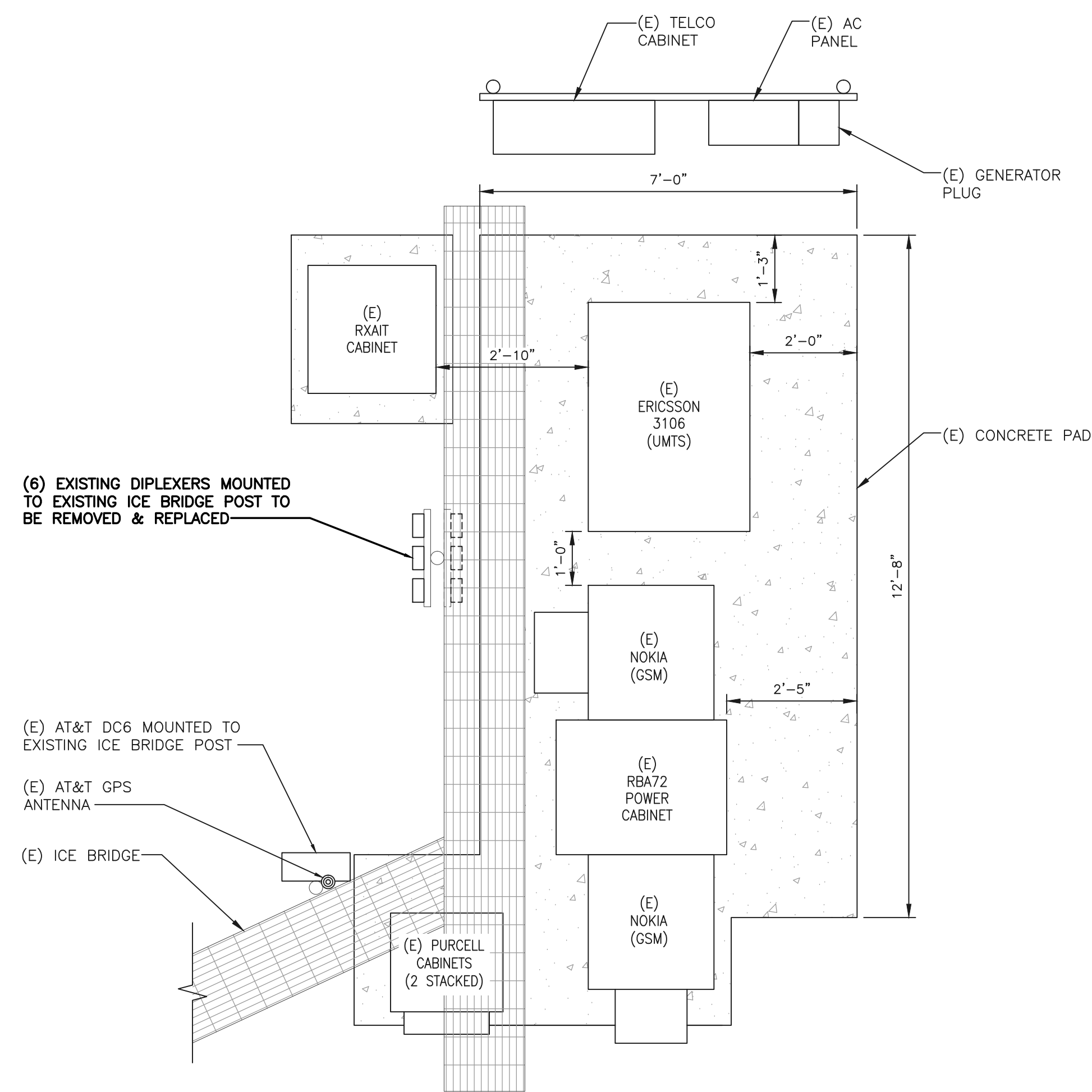

EXISTING EQUIPMENT LAYOUT

SCALE: 1" = 2'-0"



(IN FEET)
1/2 Inch = 1 Foot

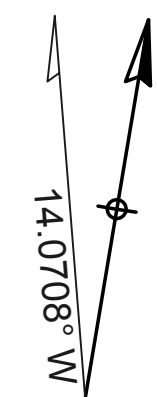

NORTH

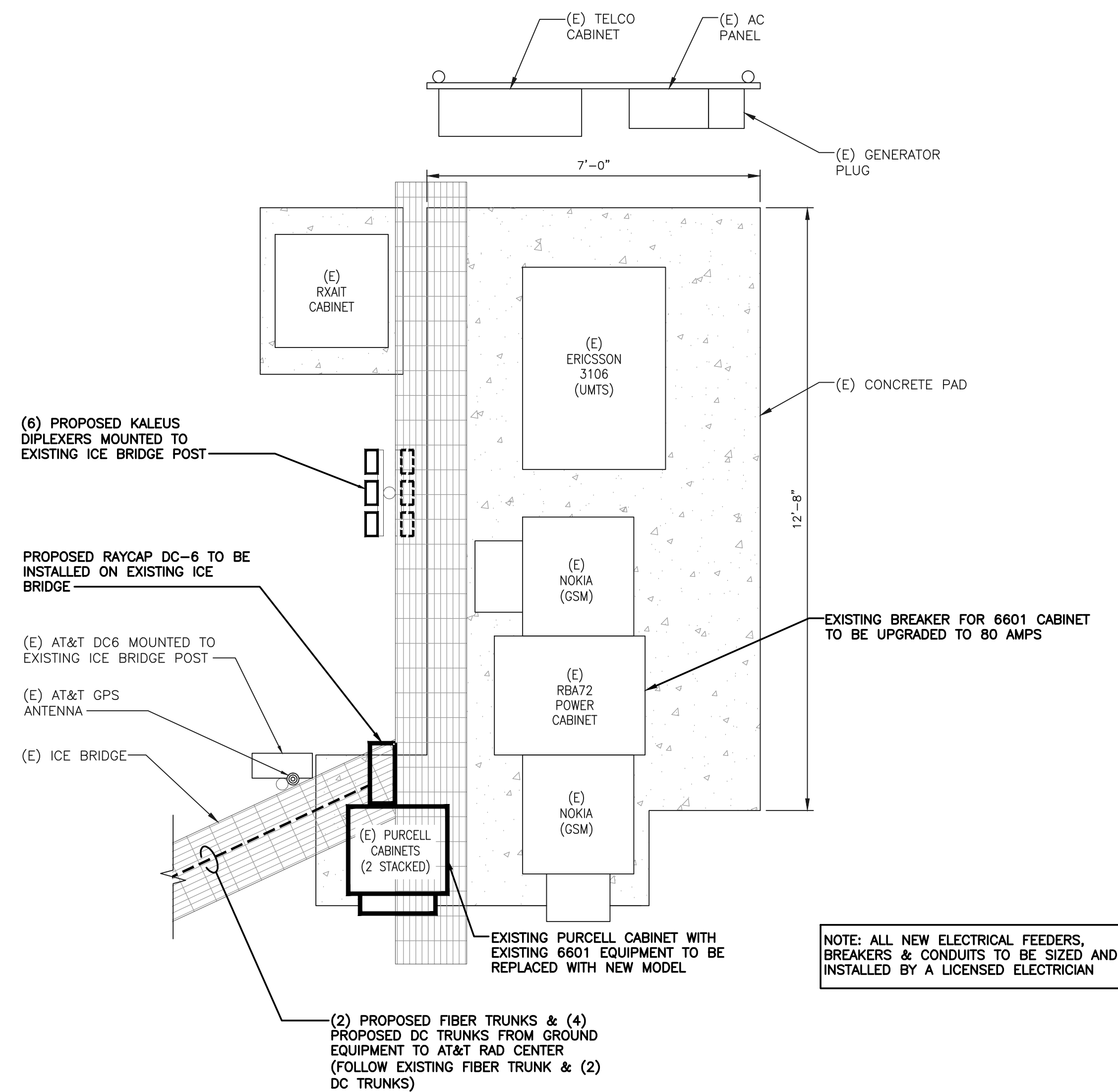

PROPOSED EQUIPMENT LAYOUT

SCALE: 1" = 2'-0"

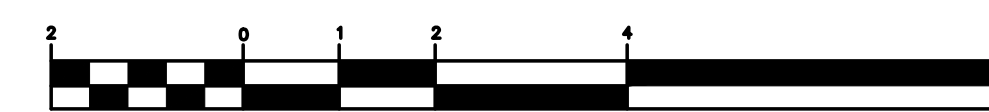

(IN FEET)
1/2 Inch = 1 Foot

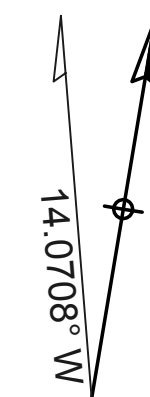

NORTH

0	05/21/15	INITIAL SUBMISSION	CJT	NDB	NDB
NO.	DATE	REVISIONS	BY	CHK	APP'D
SCALE: AS SHOWN		DESIGNED BY: CJT	DRAWN BY: PAV		05/21/15

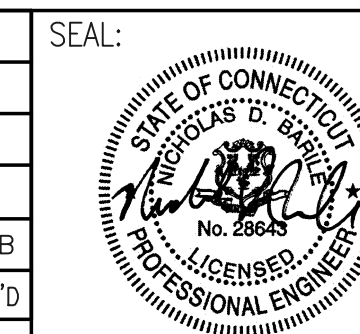

AT&T		
DRAWING TITLE: EQUIPMENT LAYOUTS		
JOB NUMBER 14025-EMP	DRAWING NUMBER A-2	REV 0

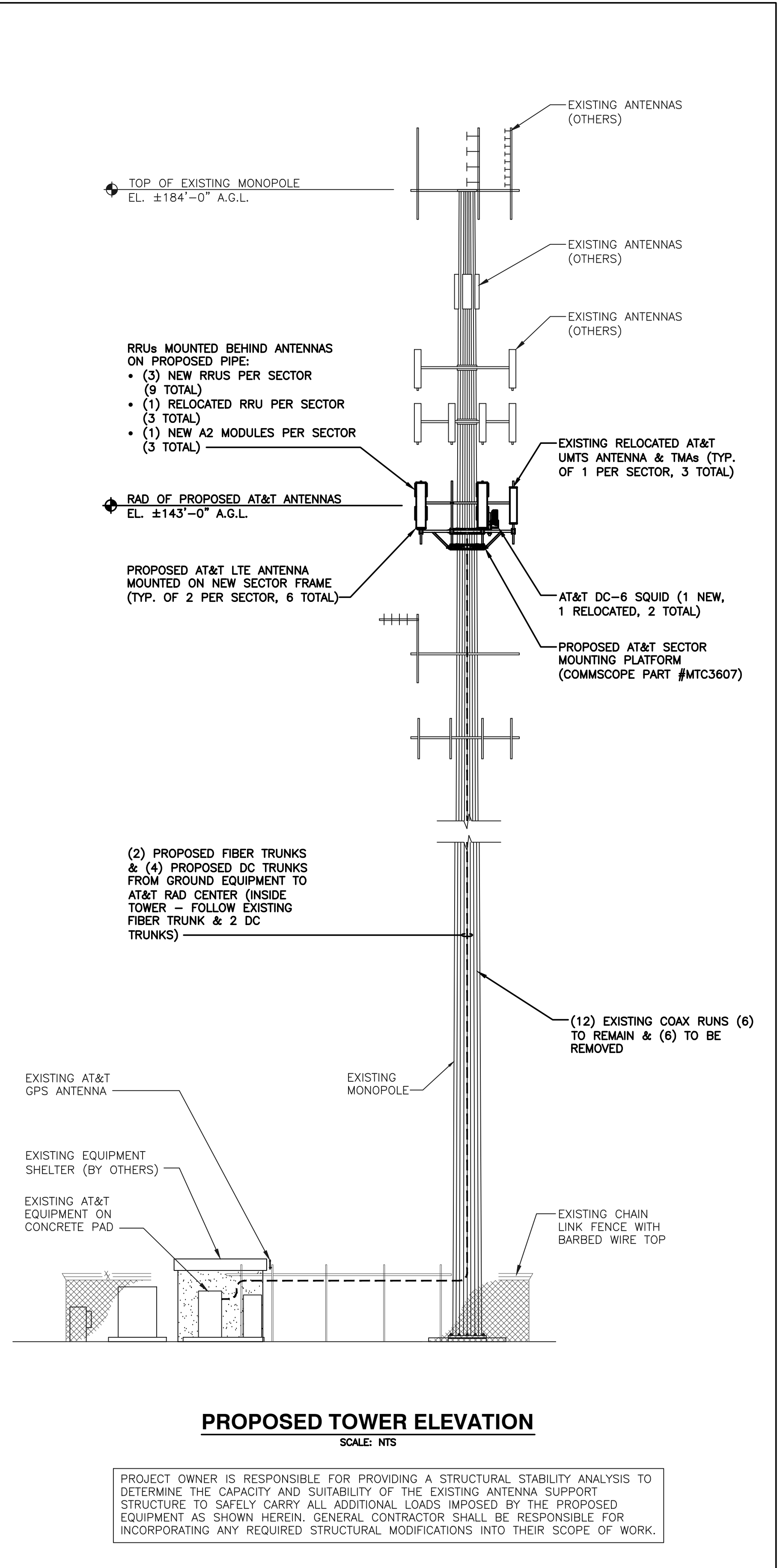
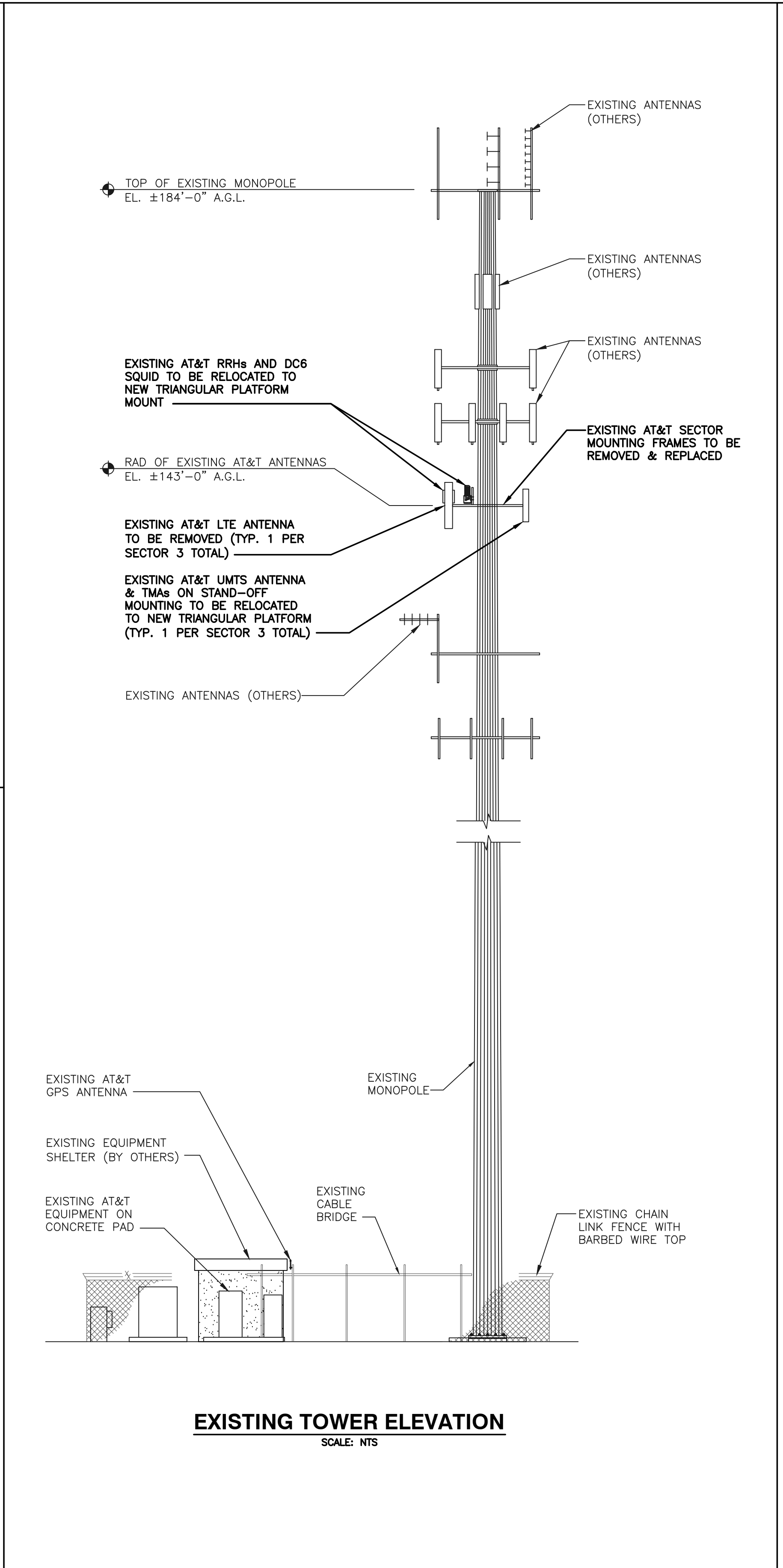
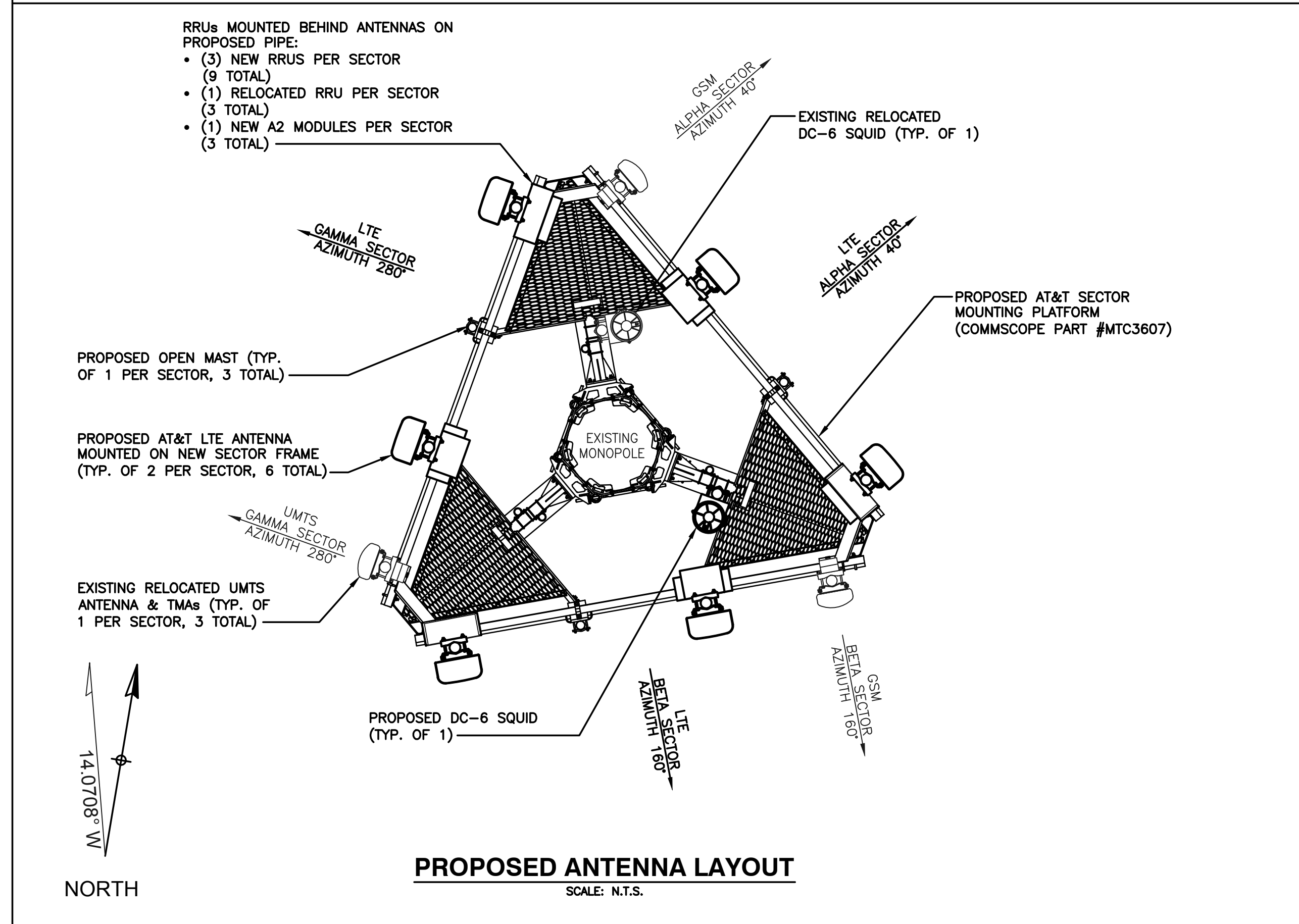
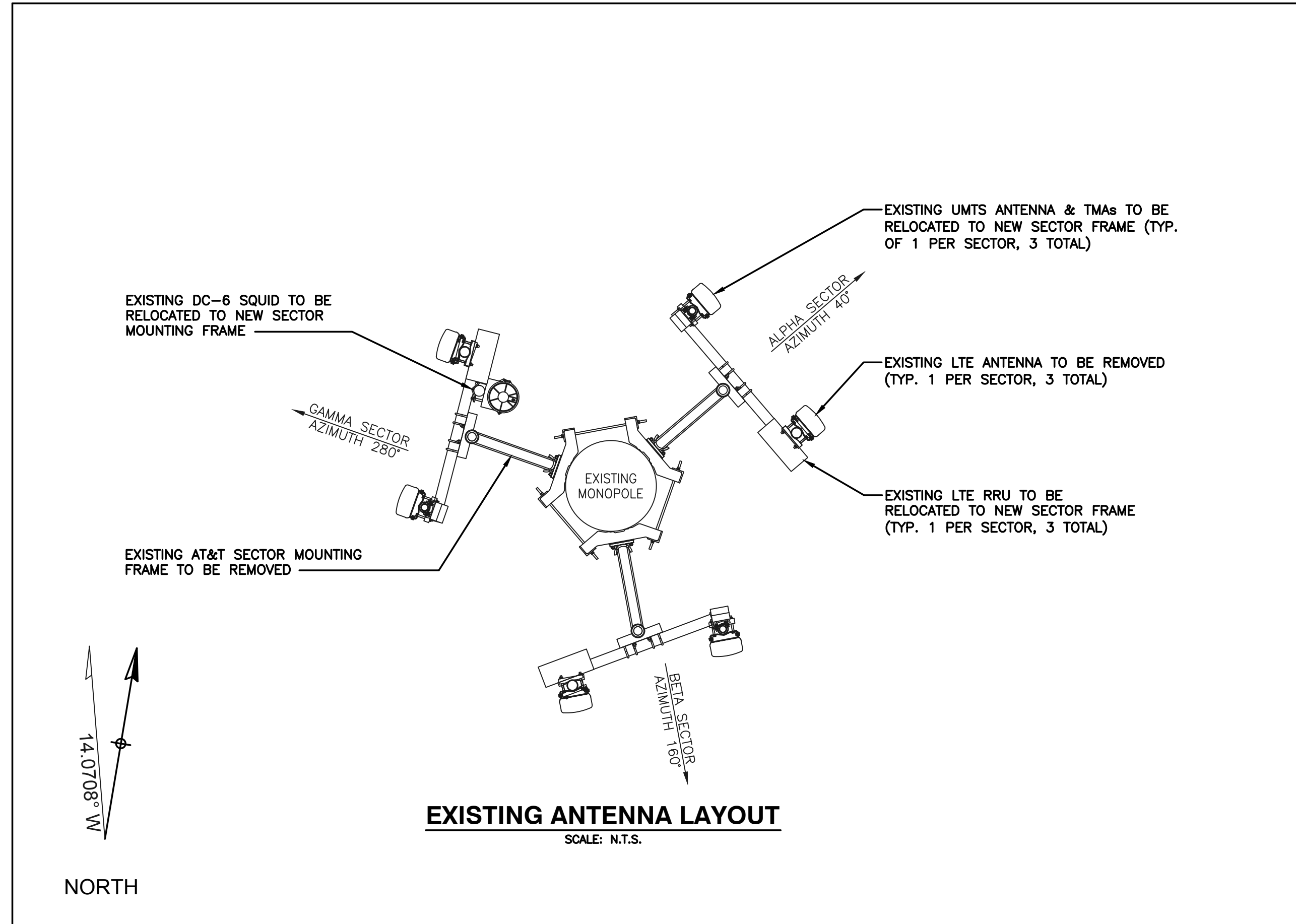

COM-EX
Consultants
4 SECOND AVENUE
SUITE 204
DENVER, NJ 07834
PHONE: 862.209.4300
FAX: 862.209.4301

EMPIRE
telecom
16 ESQUIRE ROAD
BILLERICA, MA 01821

SITE NUMBER: CT5448
SITE NAME: MANCHESTER CENTRAL
239 MIDDLE TURNPIKE EAST
MANCHESTER, CT 06040
HARTFORD COUNTY

at&t
MOBILITY
550 COCHITUATE ROAD
FRAMINGHAM, MA 01701

0	05/21/15	INITIAL SUBMISSION	CJT	NDB	NDB
NO.	DATE	REVISIONS	BY	CHK	APP'D
SCALE: AS SHOWN		DESIGNED BY: CJT	DRAWN BY: PAV		05/21/15

SEAL:
STATE OF CONNECTICUT
PROFESSIONAL ENGINEER
No. 2664

AT&T
DRAWING TITLE:
ANTENNA LAYOUTS & ELEVATIONS

JOB NUMBER	DRAWING NUMBER	REV
14025-EMP	A-3	0

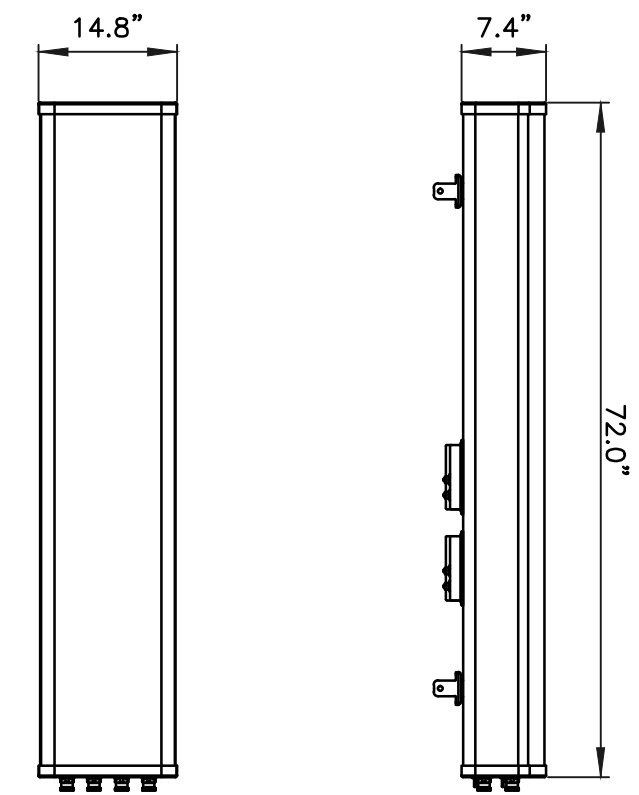

FRONT VIEW SIDE VIEW

MANUFACTURER	CCI
MODEL	OPA-65R-LCUU-H6
WEIGHT	73.0 LBS

6' LTE ANTENNA DETAIL
SCALE: N.T.S.

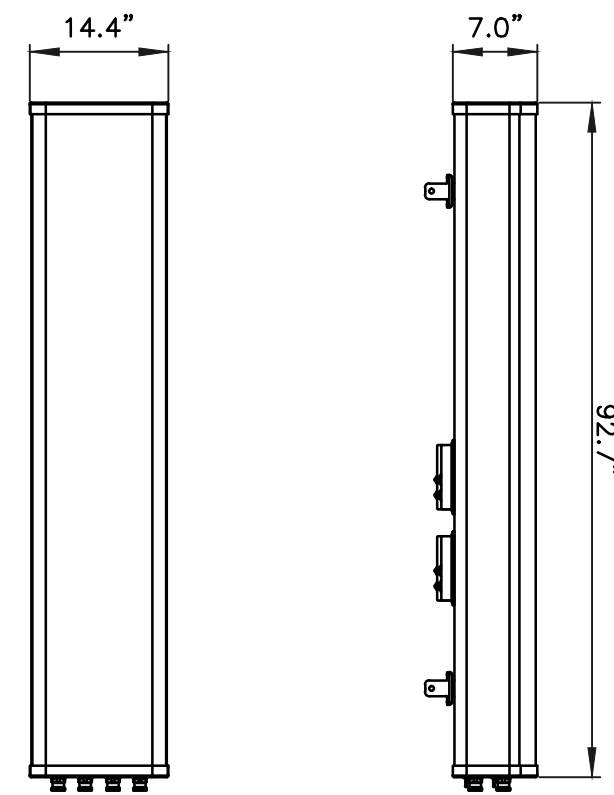

FRONT VIEW SIDE VIEW

MANUFACTURER	CCI
MODEL	OPA-65R-LCUU-H8
WEIGHT	88.0 LBS

8' LTE ANTENNA DETAIL
SCALE: N.T.S.

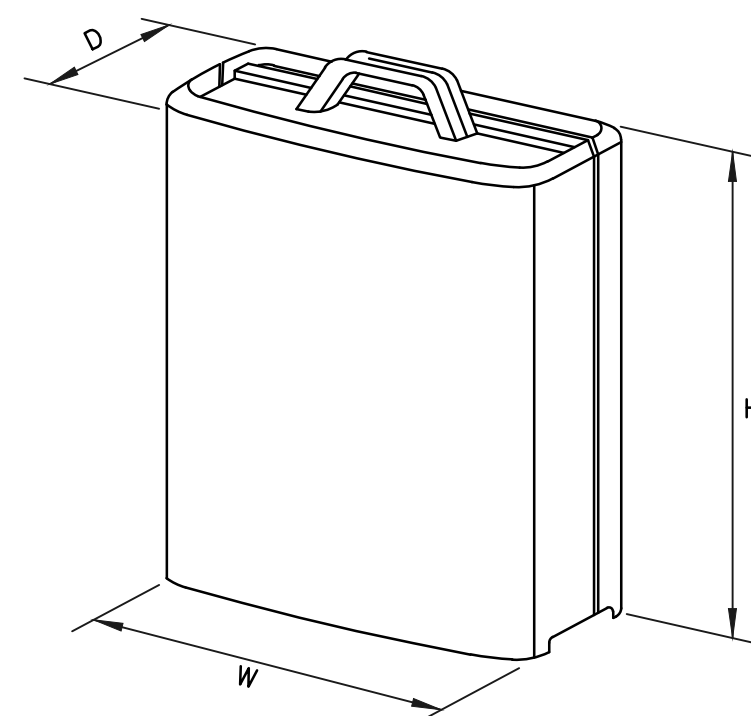

MODEL	L x W x H	WEIGHT
RRUS-11	19.69" x 16.97" x 7.17"	50.7 LBS
RRUS-12	20.4" x 18.5" x 7.5"	58 LBS
RRUS-32	29.9" x 13.3" x 9.5"	77 LBS
RRUS-E2	20.4" x 18.5" x 7.5"	58 LBS
A2 MODULE	16.4" x 15.2" x 3.4"	22 LBS

RRUS DETAIL
SCALE: N.T.S.

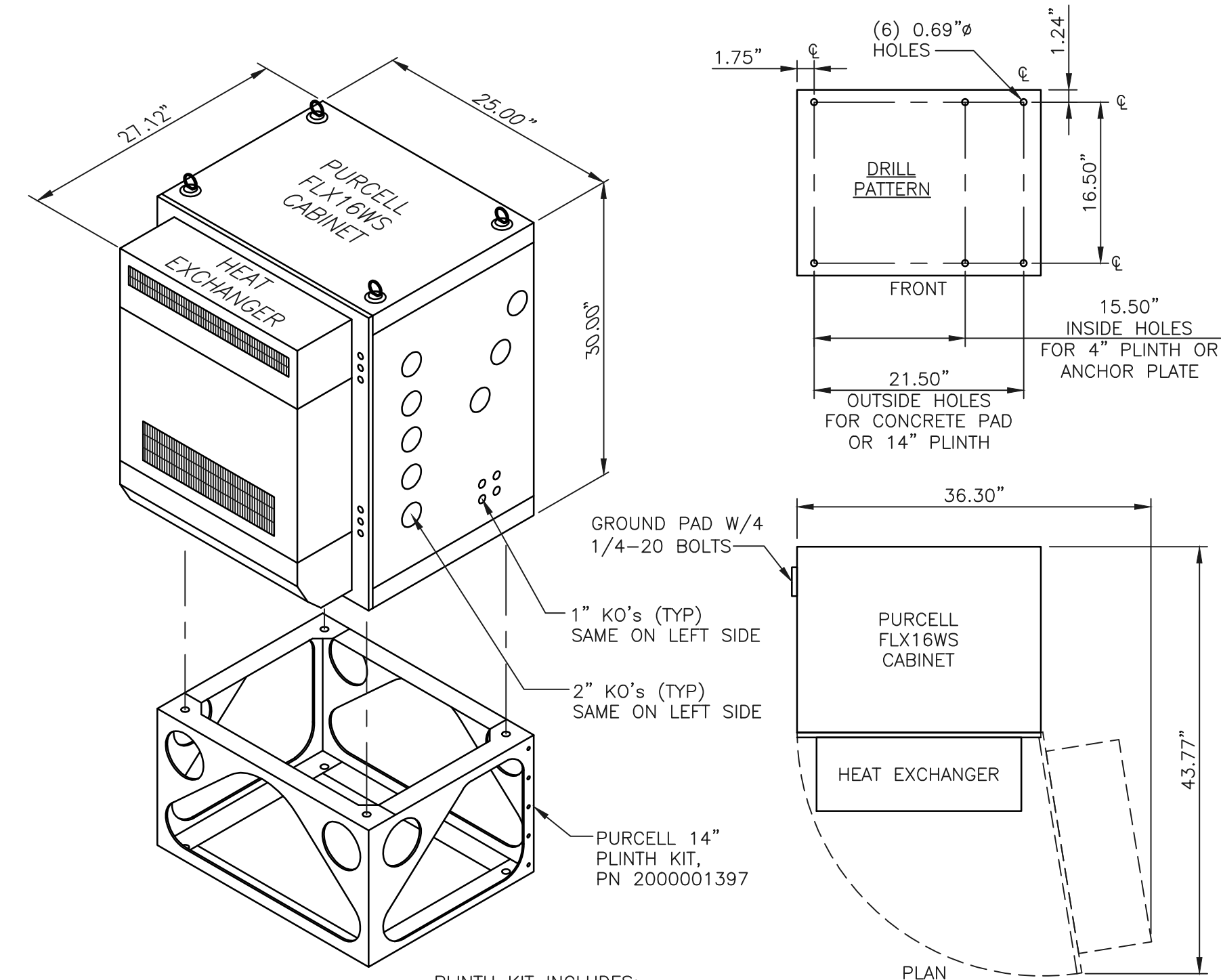

- PLINTH KIT INCLUDES:**
- (1) 14", HIGH PLINTH ASSEMBLY
 - (8) 1/2-13, 1.25" LONG STAINLESS STEEL HEX BOLTS
 - (16) 1/2 STAINLESS STEEL FLAT WASHERS
 - (12) 1.2 STAINLESS STEEL SPLIT LOCK WASHERS
 - (4) 1/2-13, 1.5" LONG STAINLESS STEEL HEX BOLTS
 - (8) LOAD SPREADING WASHERS

WEIGHT:

- EMPTY W/BLANK DOOR = 80lbs
- EMPTY W/ HEAT EXCHANGER = 120lbs
- EQUIPMENT (VARIES) = 400/lbs MAX
- CABINET TOTAL (MAX) = 600lbs

NOTES:

1. DOOR HINGE MAY BE REVERSED
2. MINIMUM ANCHOR SIZE MUST BE 1/2"DIA.
3. AN ISOLATOR BASE IS REQUIRED WHEN MOUNTING CABINET DIRECTLY ON CONCRETE PAD.

PURCELL CABINET DETAIL
SCALE: N.T.S.

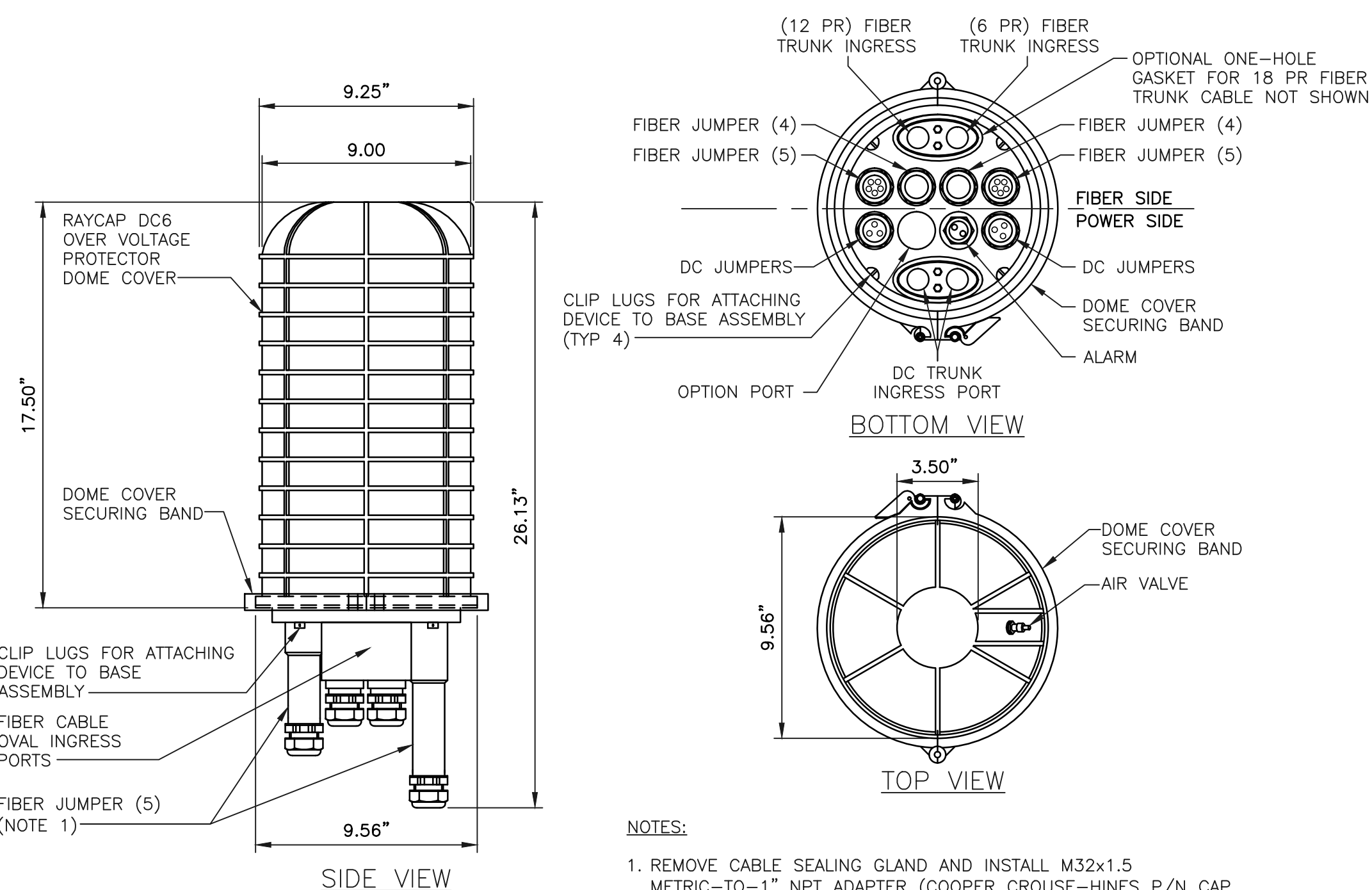

NOTES:

1. REMOVE CABLE SEALING GLAND AND INSTALL M32x1.5 METRIC-TO-1" NPT ADAPTER (COOPER CROUSE-HINES P/N CAP 740 994 OR EQUIVALENT MFR) WHEN CONNECTING CONDUIT TO OVP.

DC-6 SURGE SUPPRESSOR DETAIL
SCALE: N.T.S.

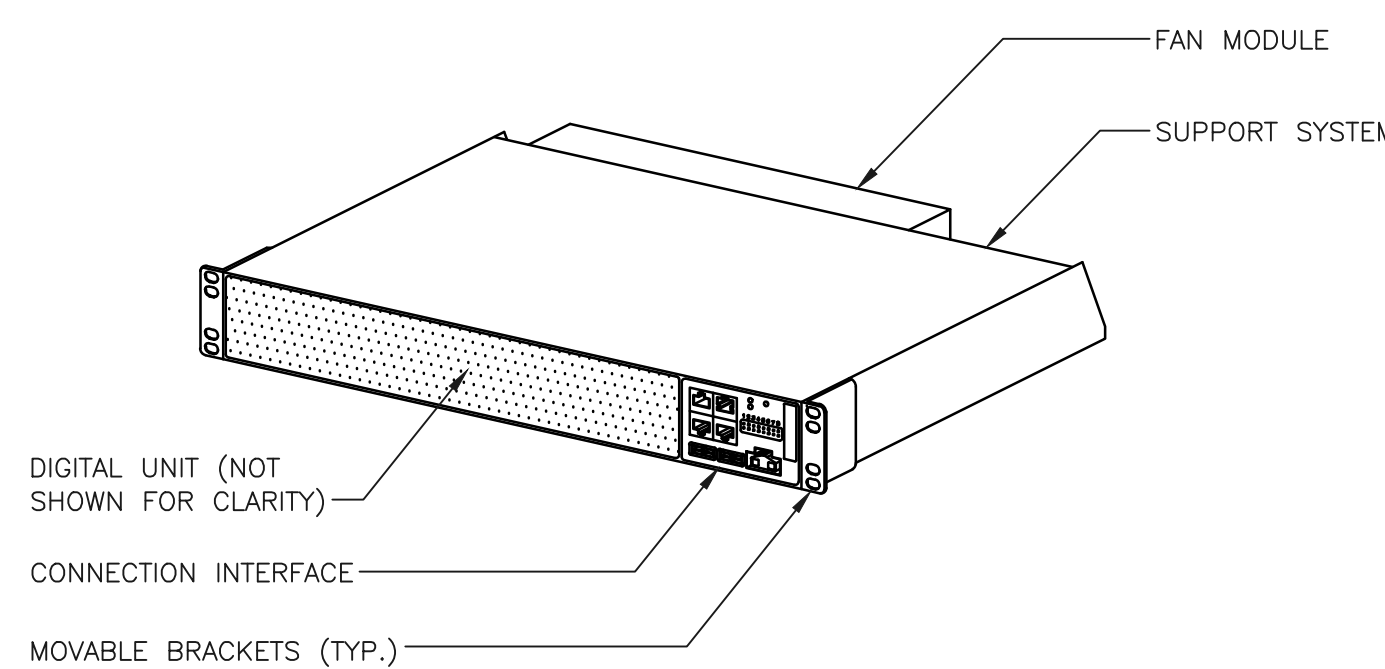

PHYSICAL CHARACTERISTICS	
HEIGHT	2.59" (1.5 U)
WIDTH	19"
DEPTH	13.77"
WEIGHT (FULLY EQUIPPED)	<22 LBS.
COLOR	WHITE

DC POWER SUPPLY	
NOMINAL VOLTAGE	-48VDC
OPERATING VOLTAGE RANGE	-40.0 TO -57.6 VDC
NON-DESTRUCTIVE VOLTAGE RANGE	0 TO -60 VDC

RBS 6601 DETAIL
SCALE: N.T.S.

MINIMUM SEPARATION OF 6'-0" TO BE MAINTAINED BETWEEN ALL PROPOSED AT&T LTE ANTENNAS

PROPOSED LTE ANTENNA MOUNTED TO PROPOSED SECTOR FRAME (TYP. FOR 2 PER SECTOR, TOTAL OF 6)

RRUs MOUNTED BEHIND ANTENNAS ON PROPOSED PIPE:
 • (3) NEW RRUs PER SECTOR (9 TOTAL)
 • (1) RELOCATED RRU PER SECTOR (3 TOTAL)
 • (1) NEW A2 MODULE PER SECTOR (3 TOTAL)

EXISTING RELOCATED UMTS ANTENNA & TMAs MOUNTED TO PROPOSED SECTOR FRAME (TYP. FOR 1 PER SECTOR, TOTAL OF 3)

PROPOSED AT&T SECTOR MOUNTING PLATFORM (COMMSCOPE PART #MTC3607)

DC-6 SQUID MOUNTED TO PROPOSED VERTICAL PIPE (1 NEW, 1 RELOCATED, 2 TOTAL)

PROPOSED ANTENNA MOUNTING DETAIL (FRONT VIEW)

SCALE: N.T.S.

AT&T ANTENNA MOUNTED TO PROPOSED SECTOR FRAME (TYP. FOR 3 PER SECTOR, TOTAL OF 9)

RRUs MOUNTED BEHIND ANTENNAS ON PROPOSED PIPE:
 • (3) NEW RRUs PER SECTOR (9 TOTAL)
 • (1) RELOCATED RRU PER SECTOR (3 TOTAL)
 • (1) NEW A2 MODULE PER SECTOR (3 TOTAL)

DC-6 SQUID MOUNTED TO PROPOSED VERTICAL PIPE (1 NEW, 1 RELOCATED, 2 TOTAL)

EXISTING MONOPOLE

PROPOSED AT&T SECTOR MOUNTING PLATFORM (COMMSCOPE PART #MTC3607)

PROPOSED ANTENNA MOUNTING DETAIL (SIDE VIEW)

SCALE: N.T.S.

EXISTING ANTENNA SCHEDULE

SECTOR	POSITION	MAKE	MODEL	SIZE (INCHES)
ALPHA	A1	KATHREIN	800-10121	54.5"x10.3"x5.9"
	A2	-	-	-
	A3	-	-	-
	A4	KMW	AM-X-CD-16-65-00T-RET	72"x11.8"x5.9"
BETA	B1	KATHREIN	800-10121	54.5"x10.3"x5.9"
	B2	-	-	-
	B3	-	-	-
	B4	ANDREW	SBNH-1D6565C	96.4"x11.9"x7.1"
GAMMA	G1	KATHREIN	800-10121	54.5"x10.3"x5.9"
	G2	-	-	-
	G3	-	-	-
	G4	ANDREW	SBNH-1D6565C	96.4"x11.9"x7.1"

PROPOSED ANTENNA SCHEDULE

SECTOR	POSITION	MAKE	MODEL	SIZE (INCHES)
ALPHA	A1	KATHREIN	800-10121	54.5"x10.3"x5.9"
	A2	CCI	OPA-65R-LCUU-H6	72"x14.8"x7.4"
	A3	-	-	-
	A4	CCI	OPA-65R-LCUU-H6	72"x14.8"x7.4"
BETA	B1	KATHREIN	800-10121	54.5"x10.3"x5.9"
	B2	CCI	OPA-65R-LCUU-H8	92.7"x14.4"x7.0"
	B3	-	-	-
	B4	CCI	OPA-65R-LCUU-H8	92.7"x14.4"x7.0"
GAMMA	G1	KATHREIN	800-10121	54.5"x10.3"x5.9"
	G2	CCI	OPA-65R-LCUU-H8	92.7"x14.4"x7.0"
	G3	-	-	-
	G4	CCI	OPA-65R-LCUU-H8	92.7"x14.4"x7.0"

PROPOSED RRH SCHEDULE

SECTOR	MAKE	MODEL	SIZE (INCHES)	ADDITIONAL COMPONENT	SIZE (INCHES)
ALPHA	ERICSSON	RRUS-12	20.4"x18.5"x7.5"	ERICSSON A2 MODULE	16.4"x15.2"x3.4"
	ERICSSON	RRUS-11 (RELOCATED)	19.7"x16.9"x7.2"		
	ERICSSON	RRUS-32	29.9"x13.3"x9.5"		
	ERICSSON	RRUS-E2	20.4"x18.5"x7.5"		
BETA	ERICSSON	RRUS-12	20.4"x18.5"x7.5"	ERICSSON A2 MODULE	16.4"x15.2"x3.4"
	ERICSSON	RRUS-11 (RELOCATED)	19.7"x16.9"x7.2"		
	ERICSSON	RRUS-32	29.9"x13.3"x9.5"		
	ERICSSON	RRUS-E2	20.4"x18.5"x7.5"		
GAMMA	ERICSSON	RRUS-12	20.4"x18.5"x7.5"	ERICSSON A2 MODULE	16.4"x15.2"x3.4"
	ERICSSON	RRUS-11 (RELOCATED)	19.7"x16.9"x7.2"		
	ERICSSON	RRUS-32	29.9"x13.3"x9.5"		
	ERICSSON	RRUS-E2	20.4"x18.5"x7.5"		

PROJECT OWNER IS RESPONSIBLE FOR PROVIDING A STRUCTURAL STABILITY ANALYSIS TO DETERMINE THE CAPACITY AND SUITABILITY OF THE EXISTING ANTENNA SUPPORT STRUCTURE TO SAFELY CARRY ALL ADDITIONAL LOADS IMPOSED BY THE PROPOSED EQUIPMENT AS SHOWN HEREIN. GENERAL CONTRACTOR SHALL BE RESPONSIBLE FOR INCORPORATING ANY REQUIRED STRUCTURAL MODIFICATIONS INTO THEIR SCOPE OF WORK.

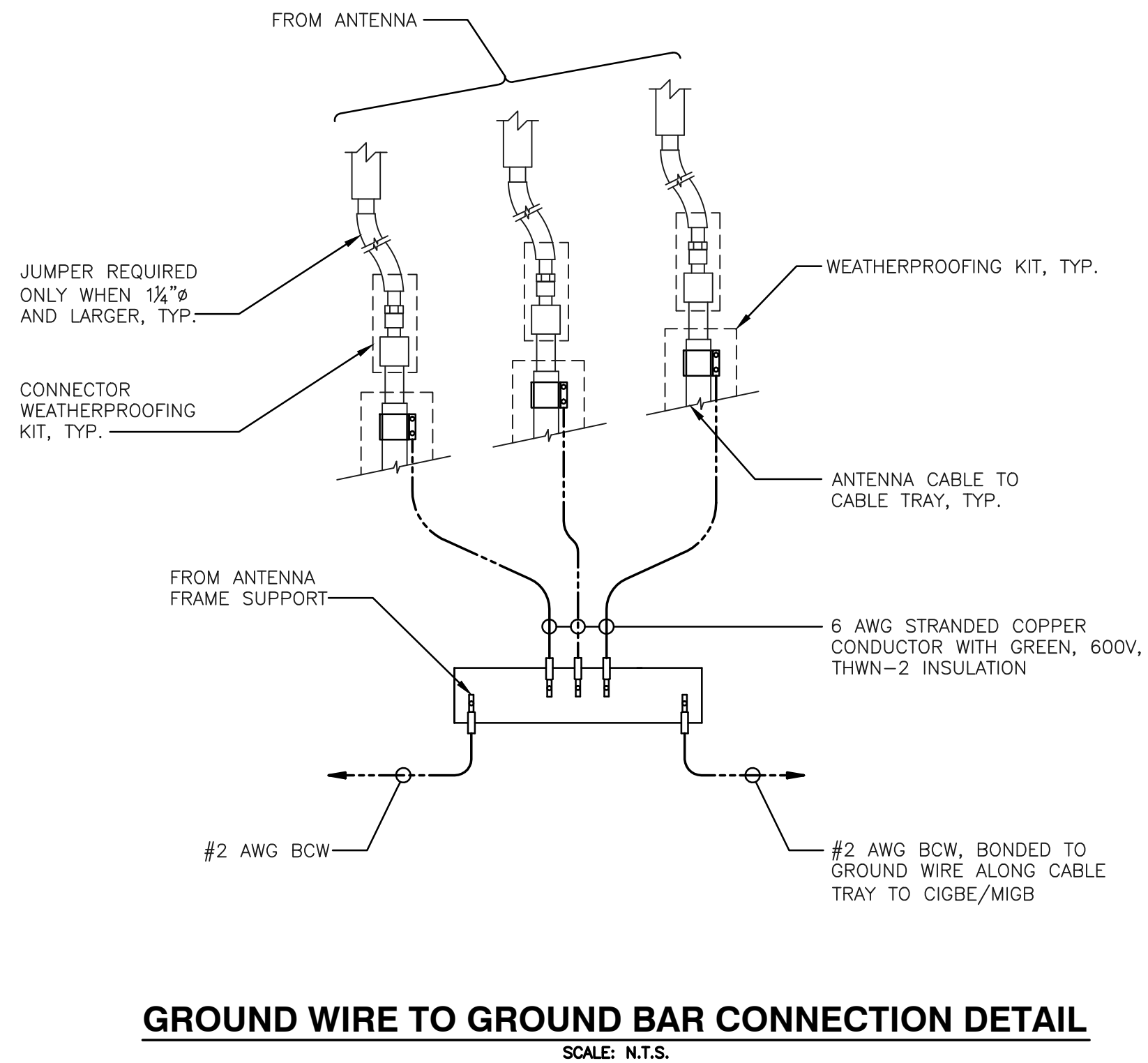

GROUND WIRE TO GROUND BAR CONNECTION DETAIL
SCALE: N.T.S.

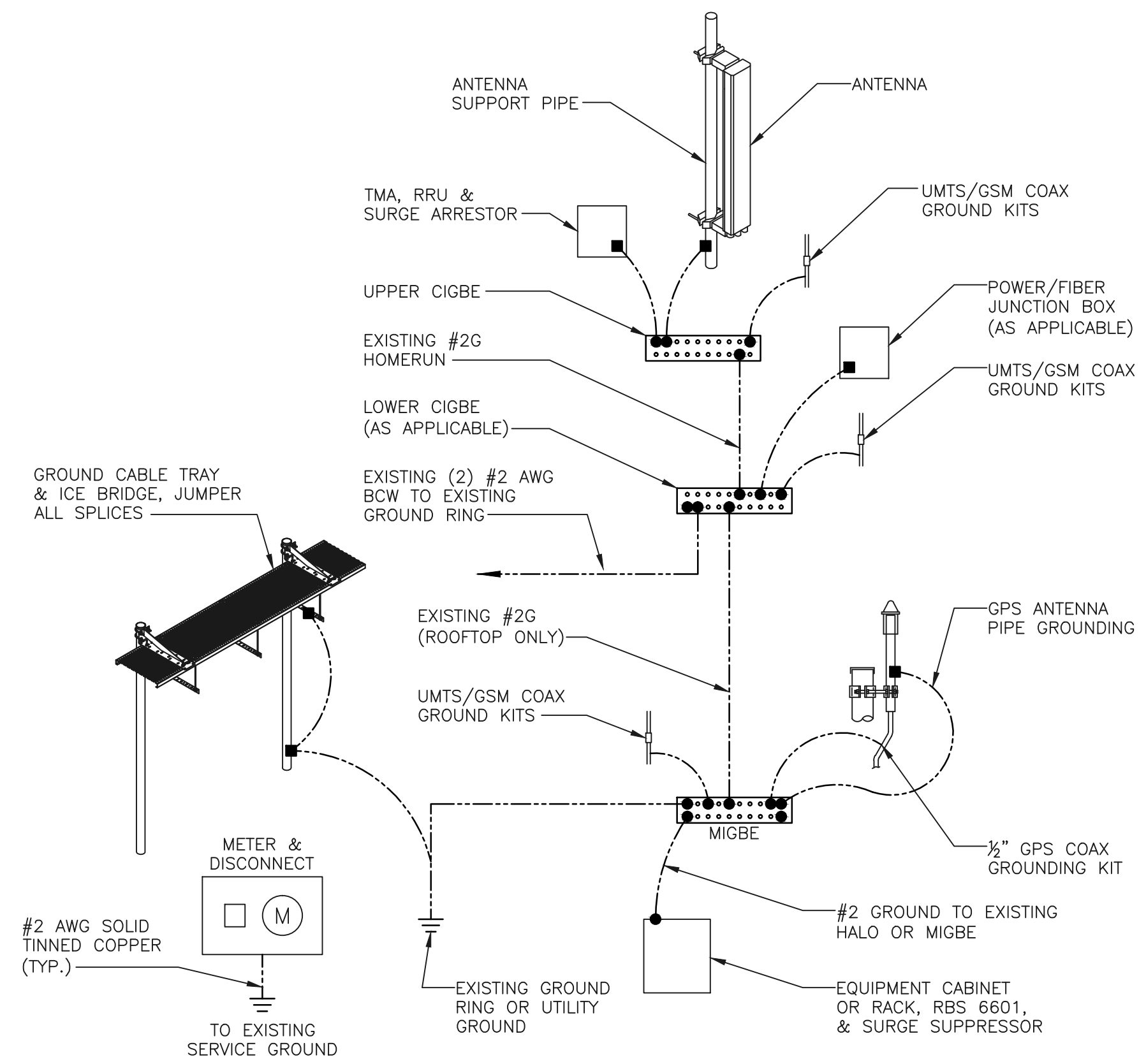

GROUNDING RISER DIAGRAM
SCALE: N.T.S.

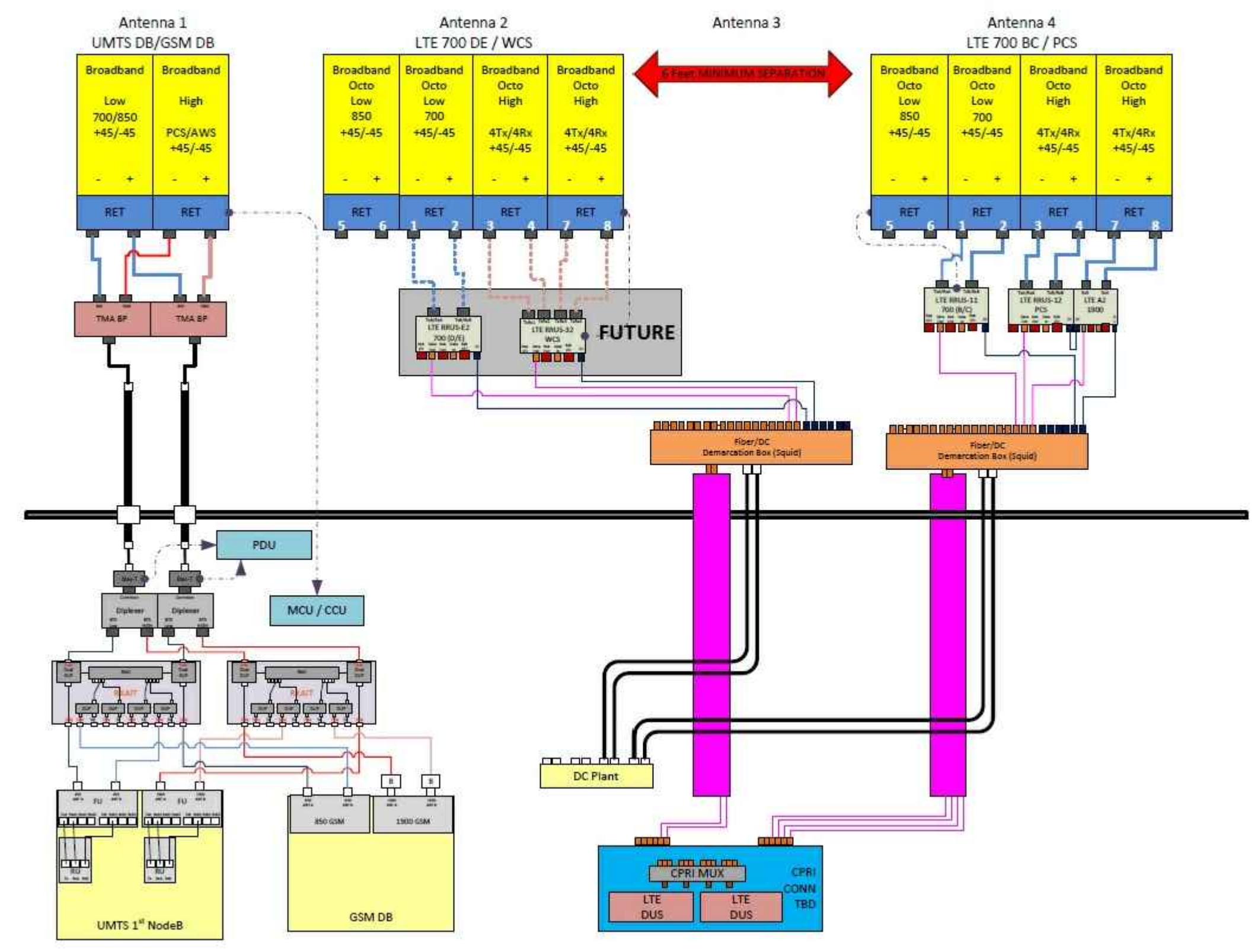

PLUMBING DIAGRAM
SCALE: N.T.S.

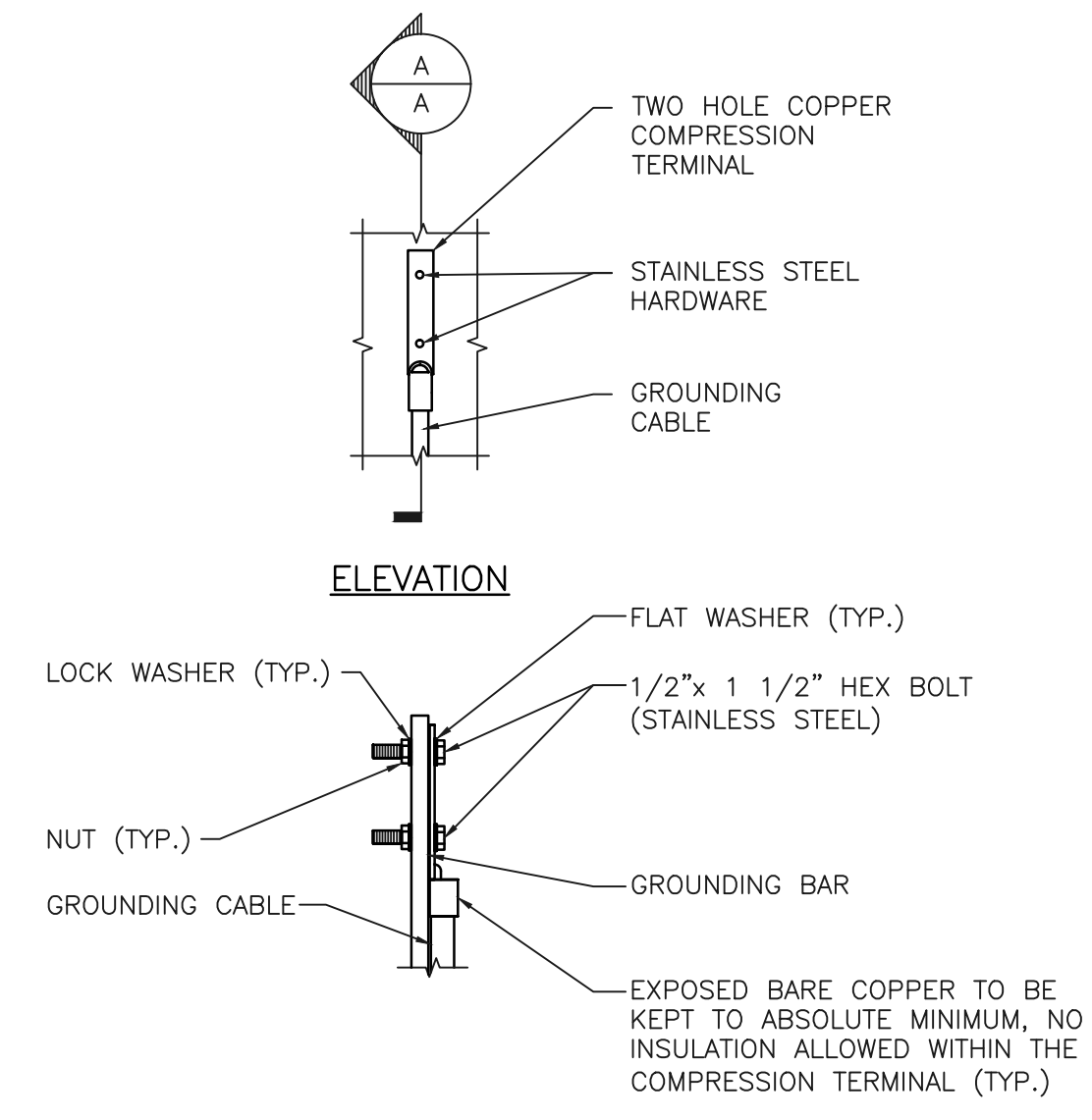

TYPICAL GROUND BAR CONNECTION DETAIL
SCALE: N.T.S.

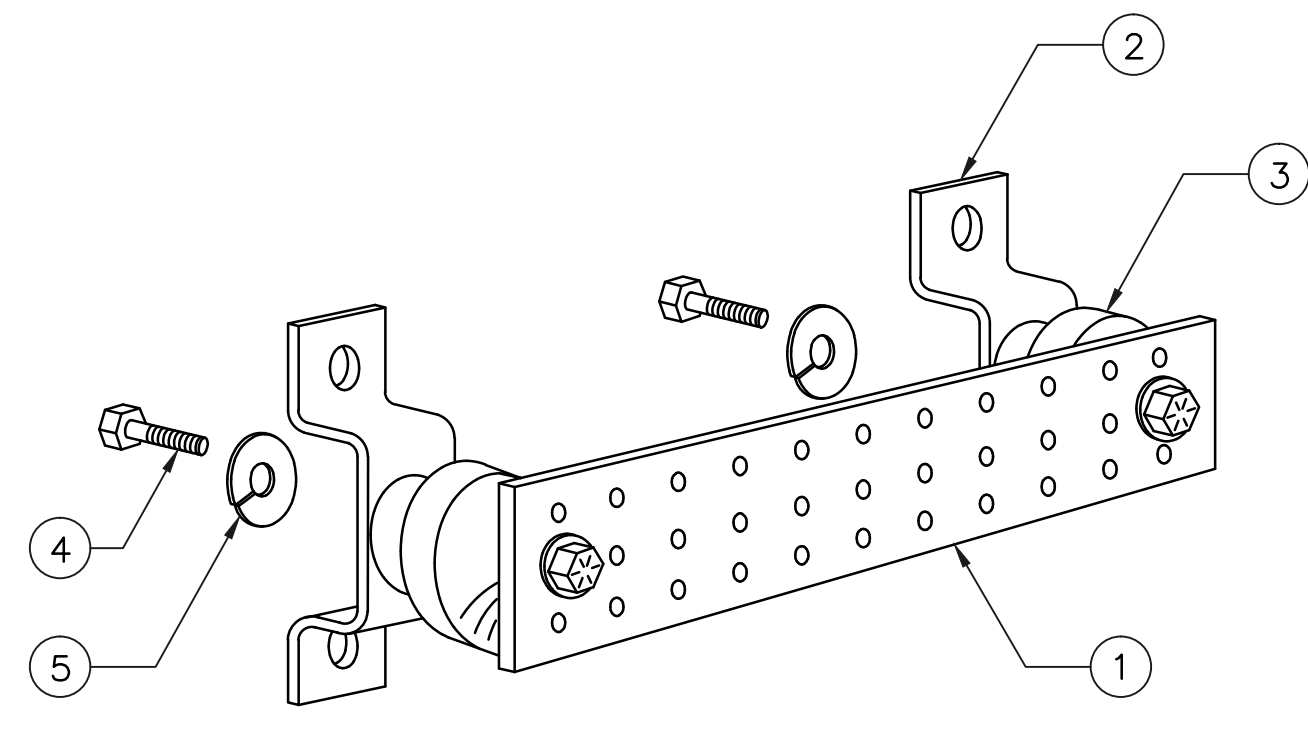

ITEM NO.	QTY.	DESCRIPTION
1	1	SOLID GROUND BAR (20"x 4"x 1/4")
2	2	WALL MOUNTING BRACKET
3	2	INSULATORS
4	4	5/8"-11x1" H.H.C.S.
5	4	5/8" LOCK WASHER

- NOTES:
- EACH GROUND CONDUCTOR TERMINATING ON ANY GROUND BAR SHALL HAVE AN IDENTIFICATION TAG ATTACHED AT EACH END THAT WILL IDENTIFY ITS ORIGIN AND DESTINATION
- SECTION "P" - SURGE PRODUCERS**
- CABLE ENTRY PORTS (HATCH PLATES) (#2)
 - GENERATOR FRAMEWORK (IF AVAILABLE) (#2)
 - TELCO GROUND BAR
 - COMMERCIAL POWER COMMON NEUTRAL/GROUND BOND (#2)
 - +24V POWER SUPPLY RETURN BAR (#2)
 - 48V POWER SUPPLY RETURN BAR (#2)
 - RECTIFIER FRAMES
- SECTION "A" - SURGE ABSORBERS**
- INTERIOR GROUND RING (#2)
 - EXTERNAL EARTH GROUND FIELD (BURIED GROUND RING) (#2)
 - METALLIC COLD WATER PIPE (IF AVAILABLE) (#2)
 - BUILDING STEEL (IF AVAILABLE) (#2)

GROUND BAR DETAIL
SCALE: N.T.S.

**STRUCTURAL ANALYSIS REPORT – REVISION 2
MONOPOLE**



Prepared For:
Com-Ex Consultants, LLC
4 Second Avenue – Suite 204
Denville, NJ 07834



AT&T FA Number/Site Number: FA10071105/CT5448
AT&T Site Name: Manchester Central
239 Middle Turnpike East
Manchester, Hartford County, CT 06040

CONTENTS

1.0 – SUBJECT AND REFERENCES

1.1 – STRUCTURE

2.0 – EXISTING AND PROPOSED APPURTENANCES

3.0 – CODES AND LOADING

4.0 – STANDARD CONDITIONS FOR ENGINEERING SERVICES ON EXISTING STRUCTURES

5.0 – ANALYSIS

6.0 – RESULTS AND CONCLUSION

APPENDIX

A – SOFTWARE OUTPUT

1.0 SUBJECT AND REFERENCES

The purpose of this analysis is to evaluate the structural capacity of the existing 184'-0" galvanized structural steel monopole located at 6239 Middle Turnpike East, Manchester, CT 06040 for the addition and alteration of wireless telecommunication appurtenances proposed by AT&T Mobility (AT&T).

The structural analysis is based on the following documentation:

- Construction Drawings prepared by Com-Ex Consultants, Job Number 14025-EMP dated October 3, 2014
- RFDS for CTV5448 prepared by AT&T, dated August 5, 2014
- "Rigorous Structural Analysis Report" prepared by Malouf Engineering International, Inc., Project ID CT00813M-07Vo dated July 18, 2007

1.1 STRUCTURE

The structure is an approximately 184'-0" 18-sided, galvanized structural steel monopole, attached to its foundation via anchor bolts and a stiffened base plate. The structure is comprised of the following sections:

Section Length (ft)	Lap Splice (ft)	Shaft Thickness (in)	Diameter Top/Bottom (in)	Yield Strength (ksi)
17.38	2.92	0.1875	15.5000/19.399	65
36.36	3.80	0.2500	18.3689/26.4007	65
48.89	4.99	0.3750	25.0613/35.8924	65
49.05	6.11	0.4375	34.0369/44.9030	65
49.14	n/a	0.4375	42.6744/53.5000	65

2.0 EXISTING AND PROPOSED APPURTENANCES

This analysis is based on the following existing and proposed appurtenances:

Existing Appurtenances by Others

Rad. Center (ft)	Antenna & TMA	Mount	Cables
184	(1) Omni Whip Antenna (2) 4 Element Dipole Antenna (2) 8 Element Dipole Antenna	Low Profile Platform	(4) 7/8"
161	(6) RR90-17-02DP	Low Profile Platform	(12) 1-5/8"
154	(6) DB980-F65T4E-M (6) APVX86-906513-C	Low Profile Platform	(15) 1-5/8"
124	(2) Yagi Antenna 1 Omni Whip Antenna	Low Profile Platform	(3) 1/2"
53	(1) GPS Antenna	Side Arm	(1) 1/2"

Existing Configuration of AT&T Appurtenances:

Rad. Center (ft)	Antenna & TMA	Mount	Cables
143	(3) Kathrein Scala 800-10121 (2) Commscope/Andrew SBNH-1D6565C (1) KMW Antenna AM-X-CD-16-00T-RET (3) LTE RRH units (1) Raycap DC6-48-60-18-8F	Low Profile Platform	(12) 1-5/8" (2) Hybrid DC/Fiber cable

Final Configuration of AT&T Appurtenances:

Rad. Center (ft)	Antenna & TMA	Mount	Cables
143	(3) Kathrein Scala 800-10121 (4) CCI Antenna OPA-65R-LCUU-H8 (2) CCI Antenna OPA-65R-LCUU-H6 (3) Ericsson RRUS-12 (3) Ericsson RRUS-11 (3) Ericsson RRUS-32 (3) Ericsson RRUS-E2 (3) Ericsson A2 Module (2) Raycap DC6-48-60-18-8F	(1) Commscope MTC3607	(6) 1-5/8" (4) Hybrid DC/Fiber cable

3.0 **CODES AND LOADING**

The tower was analyzed per *TIA/EIA-222-F* as referenced by *2003 International Building Code*. The following wind loading was used in compliance with the standard for Hartford County:

- Basic wind speed: 80 mph
- Basic wind speed: 69 mph with 1/2" radial ice
- Basic wind speed: 50 mph for service loads

The following load combinations were used with wind blowing at 0°, 60°, and 90° measured from a line normal to the face of the tower:

- $D + W_o$
- $D + 0.75W_i + I$

D: Dead Load of structure and appurtenances, W_o : Wind Load, without ice

W_i : Wind Load with ice, I: Weight of ice

4.0 **STANDARD CONDITIONS FOR ENGINEERING SERVICES ON EXISTING STRUCTURES**

The analysis is based on the information provided to Destek and is assumed to be current and correct. Unless otherwise noted, the structure is assumed to be in good condition, free of defects, and can achieve theoretical strength.

It is assumed that the structure has been maintained and shall be maintained during its service. The superstructure and the foundation system are assumed to be designed with proper engineering practice and fabricated, constructed and erected in accordance with the design documents. Destek will accept no liability which may arise due to any existing deficiency in design, material, fabrication, erection, construction, etc., or lack of maintenance. The analysis does not include a qualification of the mounts attached on the structure or their connections. The analysis is performed to verify the capacity of the main structural members, which is the current practice in the tower industry.

The analysis results presented in this report are only applicable for the previously mentioned existing and proposed appurtenances. Any deviation of the appurtenances and placement, etc., will require Destek to generate an additional structural analysis. Additionally, the proposed linear appurtenances should be placed per any recommendations specified in this report.

5.0 **ANALYSIS and ASSUMPTIONS**

The tower was analyzed using RISA Tower, a three-dimensional, non-linear, finite element-analysis software package produced by RISA Technologies. Software output for this analysis is provided in Appendix A of this report.

6.0 RESULTS AND CONCLUSION

Based on an analysis per *TIA/EIA-222-F*, the existing monopole is found to have **adequate** structural capacity for the proposed installation by AT&T. For the aforementioned load combinations, the monopole shaft section between grade and 44.03' and the baseplate will be stressed to a maximum of **84.9%** and **94.7%** of their respective allowable capacities.

Information regarding the existing soils and foundation system was not available at the time of this analysis, thus a foundation analysis could not be completed. Assuming that the foundation was designed at least to the capacity of the superstructure, the monopole foundation is considered to have adequate structural capacity.

Reactions

	Malouf Analysis	Destek Analysis
Moment (ft-kips)	2551.5	3341.0
Shear (kips)	21.8	26.9

Should you need any clarifications or have any questions about this report, please contact Destek at (770) 693-0835 or acolakoglu@destekengineering.com.

Sincerely,
Destek Engineering, LLC

10/14/2014



Ahmet Colakoglu, P.E.
Connecticut Professional Engineer
License Num. 27057

APPENDIX A
SOFTWARE OUTPUT

DESIGNED APPURTENANCE LOADING

TYPE	ELEVATION	TYPE	ELEVATION
Lightning Rod	186	RRUS-32 (ATI)	146
Omni Whip Antenna	186	RRUS-E2 (ATI)	146
4 Element Dipole Antenna	186	DC6-48-60-0-8F (ATI)	144
8 Element Dipole Antenna	186	DC6-48-60-0-8F (ATI)	144
Low Profile Platform	186	Commscope MTC3607 (ATI)	144
RR90-17-02DP Antennas (T-Mobile)	163	OPA-65R-LCUU-H6 w/ Mount Pipe (ATI)	144
Low Profile Platform (T-Mobile)	163	(ATI)	
DB980-F65T4E-M Antennas (Sprint/Nextel)	156	800 10121 (ATI)	144
		OPA-65R-LCUU-H6 w/ Mount Pipe (ATI)	144
APVX86-906513-C Antennas (Sprint/Nextel)	156		
		OPA-65R-LCUU-H8 w/ Mount Pipe (ATI)	144
Low Profile Platform (Sprint/Nextel)	156		
RRUS-12 (ATI)	146	800 10121 (ATI)	144
RRUS A2 Module (ATI)	146	OPA-65R-LCUU-H8 w/ Mount Pipe (ATI)	144
RRUS-11 (ATI)	146		
RRUS-32 (ATI)	146	OPA-65R-LCUU-H8 w/ Mount Pipe (ATI)	144
RRUS-E2 (ATI)	146		
RRUS-12 (ATI)	146	800 10121 (ATI)	144
RRUS A2 Module (ATI)	146	OPA-65R-LCUU-H8 w/ Mount Pipe (ATI)	144
RRUS-11 (ATI)	146	Yagi Antenna	126
RRUS-32 (ATI)	146	Yagi Antenna	126
RRUS-E2 (ATI)	146	Omni Whip Antenna	126
RRUS-12 (ATI)	146	Low Profile Platform	126
RRUS A2 Module (ATI)	146	GPS Antenna and Mount	55
RRUS-11 (ATI)	146		

MATERIAL STRENGTH

GRADE	Fy	Fu	GRADE	Fy	Fu
A572-65	65 ksi	80 ksi			

TOWER DESIGN NOTES

1. Tower is located in Hartford County, Connecticut.
2. Tower designed for a 80 mph basic wind in accordance with the TIA/EIA-222-F Standard.
3. Tower is also designed for a 69 mph basic wind with 0.50 in ice.
4. Deflections are based upon a 50 mph wind.
5. Weld together tower sections have flange connections.
6. Connections use galvanized A325 bolts, nuts and locking devices. Installation per TIA/EIA-222 and AISC Specifications.
7. Tower members are "hot dipped" galvanized in accordance with ASTM A123 and ASTM A153 Standards.
8. Welds are fabricated with ER-70S-6 electrodes.
9. TOWER RATING: 94.7%

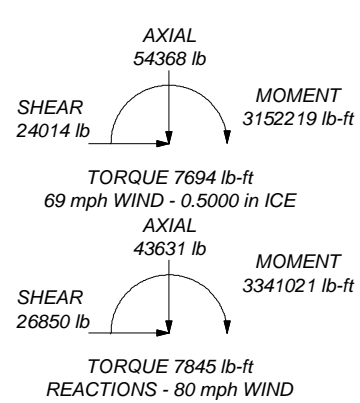
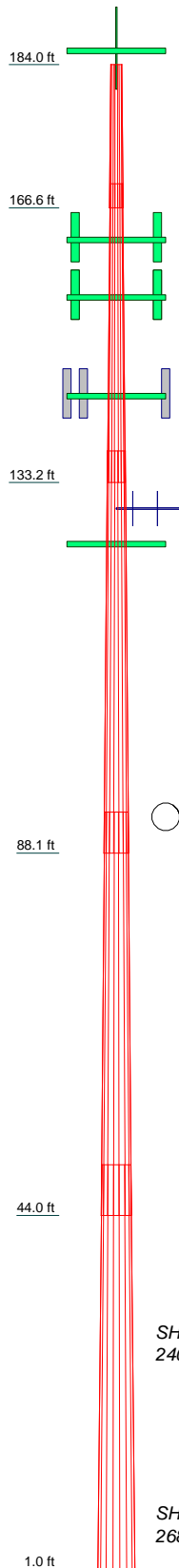

Section	1	2	3	4	5						
Length (ft)	17.38	36.36	48.89	49.05	49.14						
Number of Sides	18	18	18	18	18						
Thickness (in)	0.1875	0.2500	0.3750	0.4375	0.4375						
Lap Splice (ft)	2.92		3.80	4.99	6.11						
Top Dia (in)	15.5000	18.3689	25.0613	34.0369	42.6744						
Bot Dia (in)	19.3990	26.4007	35.8924	44.9030	53.5000						
Grade			A572-65								
Weight (lb)	607.6	2173.1	5960.6	9046.6	11064.1	28851.9					

Destek Engineering		Job: 1429011	
5150 Stilesboro Road, Suite 510		Project: FA100711105 CT5448 Manchester Central - Rev	
Kennesaw, GA 30152		Client: Com-Ex Consultants	Drawn by: AF
Phone: (770) 693-0835		Code: TIA/EIA-222-F	Date: 10/14/14
FAX:		Path:	Scale: NTS
			Dwg No. E-1

RISATower Destek Engineering, LLC 5150 Stilesboro Road, Ste. 510 Kennesaw, GA 30152 Phone: (770) 693-0835 FAX:	Job 1429011	Page 1 of 18
	Project FA100711105 CT5448 Manchester Central	Date 16:55:06 10/09/14
	Client Com-Ex Consultants	Designed by Ahmet C

Tower Input Data

There is a pole section.

This tower is designed using the TIA/EIA-222-F standard.

The following design criteria apply:

Tower is located in Hartford County, Connecticut.

Basic wind speed of 80 mph.

Nominal ice thickness of 0.5000 in.

Ice density of 56 pcf.

A wind speed of 69 mph is used in combination with ice.

Temperature drop of 50 °F.

Deflections calculated using a wind speed of 50 mph.

Weld together tower sections have flange connections..

Connections use galvanized A325 bolts, nuts and locking devices. Installation per TIA/EIA-222 and AISC Specifications..

Tower members are "hot dipped" galvanized in accordance with ASTM A123 and ASTM A153 Standards..

Welds are fabricated with ER-70S-6 electrodes..

A non-linear (P-delta) analysis was used.

Pressures are calculated at each section.

Stress ratio used in pole design is 1.333.

Local bending stresses due to climbing loads, feedline supports, and appurtenance mounts are not considered.

Options

- | | | |
|--|--|--|
| <ul style="list-style-type: none"> Consider Moments - Legs Consider Moments - Horizontals Consider Moments - Diagonals Use Moment Magnification √ Use Code Stress Ratios √ Use Code Safety Factors - Guys Escalate Ice Always Use Max Kz Use Special Wind Profile √ Include Bolts In Member Capacity √ Leg Bolts Are At Top Of Section √ Secondary Horizontal Braces Leg Use Diamond Inner Bracing (4 Sided) Add IBC .6D+W Combination | <ul style="list-style-type: none"> Distribute Leg Loads As Uniform Assume Legs Pinned √ Assume Rigid Index Plate √ Use Clear Spans For Wind Area √ Use Clear Spans For KL/r √ Retension Guys To Initial Tension Bypass Mast Stability Checks √ Use Azimuth Dish Coefficients √ Project Wind Area of Appurt. √ Autocalc Torque Arm Areas √ SR Members Have Cut Ends √ Sort Capacity Reports By Component √ Triangulate Diamond Inner Bracing | <ul style="list-style-type: none"> Treat Feedline Bundles As Cylinder Use ASCE 10 X-Brace Ly Rules √ Calculate Redundant Bracing Forces Ignore Redundant Members in FEA √ SR Leg Bolts Resist Compression √ All Leg Panels Have Same Allowable Offset Girt At Foundation Consider Feedline Torque Include Angle Block Shear Check <li style="text-align: center; background-color: #e0e0e0;">Poles Include Shear-Torsion Interaction Always Use Sub-Critical Flow Use Top Mounted Sockets |
|--|--|--|

Tapered Pole Section Geometry

Section	Elevation	Section Length	Splice Length	Number of Sides	Top Diameter	Bottom Diameter	Wall Thickness	Bend Radius	Pole Grade
	ft	ft	ft		in	in	in	in	
L1	184.00-166.62	17.38	2.92	18	15.5000	19.3990	0.1875	0.7500	A572-65 (65 ksi)
L2	166.62-133.18	36.36	3.80	18	18.3689	26.4007	0.2500	1.0000	A572-65 (65 ksi)
L3	133.18-88.09	48.89	4.99	18	25.0613	35.8924	0.3750	1.5000	A572-65

RISATower Destek Engineering, LLC 5150 Stilesboro Road, Ste. 510 Kennesaw, GA 30152 Phone: (770) 693-0835 FAX:	Job 1429011	Page 2 of 18
	Project FA100711105 CT5448 Manchester Central	Date 16:55:06 10/09/14
	Client Com-Ex Consultants	Designed by Ahmet C

Section	Elevation ft	Section Length ft	Splice Length ft	Number of Sides	Top Diameter in	Bottom Diameter in	Wall Thickness in	Bend Radius in	Pole Grade
L4	88.09-44.03	49.05	6.11	18	34.0369	44.9030	0.4375	1.7500	(65 ksi) A572-65
L5	44.03-1.00	49.14		18	42.6744	53.5000	0.4375	1.7500	(65 ksi) A572-65 (65 ksi)

Tapered Pole Properties

Section	Tip Dia. in	Area in ²	I in ⁴	r in	C in	I/C in ³	J in ⁴	I/Q in ²	w in	w/t
L1	15.7391	9.1129	269.9504	5.4359	7.8740	34.2838	540.2560	4.5573	2.3980	12.789
L2	19.6983	11.4332	533.1255	6.8201	9.8547	54.0986	1066.9525	5.7177	3.0842	16.449
L3	26.3027	29.3829	2262.2648	8.7636	12.7311	177.6954	4527.5063	14.6942	3.7508	10.002
L4	36.4461	42.2746	6737.5056	12.6087	18.2333	369.5157	13483.8766	21.1413	5.6571	15.085
L5	44.6996	58.6513	13219.0421	14.9941	21.6786	609.7733	26455.4782	29.3312	6.7407	15.407
	54.3253	73.6839	26211.1184	18.8372	27.1780	964.4241	52456.7261	36.8490	8.6460	19.762

Tower Elevation	Gusset Area (per face)	Gusset Thickness	Gusset Grade	Adjust. Factor A _f	Adjust. Factor A _r	Weight Mult.	Double Angle Stitch Bolt Spacing Diagonals	Double Angle Stitch Bolt Spacing Horizontals
ft	ft ²	in					in	in
L1				1	1	1		
184.00-166.62				1	1	1		
L2				1	1	1		
166.62-133.18				1	1	1		
L3				1	1	1		
133.18-88.09				1	1	1		
L4				1	1	1		
88.09-44.03				1	1	1		
L5				1	1	1		
44.03-1.00				1	1	1		

Monopole Base Plate Data

Base Plate Data	
Base plate is square	√
Base plate is grouted	√
Anchor bolt grade	A615-75
Anchor bolt size	2.2500 in
Number of bolts	16
Embedment length	84.0000 in
f _c	4 ksi
Grout space	3.0000 in
Base plate grade	A572-60
Base plate thickness	2.0000 in
Bolt circle diameter	62.0000 in
Outer diameter	68.0000 in
Inner diameter	43.0000 in
Base plate type	Stiffened Plate

RISATower Destek Engineering, LLC 5150 Stilesboro Road, Ste. 510 Kennesaw, GA 30152 Phone: (770) 693-0835 FAX:	Job 1429011	Page 3 of 18
	Project FA100711105 CT5448 Manchester Central	Date 16:55:06 10/09/14
	Client Com-Ex Consultants	Designed by Ahmet C

Base Plate Data	
Bolts per stiffener	1
Stiffener thickness	0.5000 in
Stiffener height	6.0000 in

Feed Line/Linear Appurtenances - Entered As Area

Description	Face or Leg	Allow Shield	Component Type	Placement ft	Total Number	C _{AA}		Weight plf
						In Face	Out Face	
7/8"	A	No	Inside Pole	184.00 - 2.00	2	No Ice	0.00	0.54
						1/2" Ice	0.00	0.54
7/8"	A	No	Inside Pole	184.00 - 2.00	2	No Ice	0.00	0.54
						1/2" Ice	0.00	0.54
1-5/8"	A	No	Inside Pole	163.00 - 2.00	12	No Ice	0.00	1.04
(T-Mobile)						1/2" Ice	0.00	1.04
1-5/8"	B	No	Inside Pole	156.00 - 2.00	6	No Ice	0.00	1.04
(Sprint/Nextel)						1/2" Ice	0.00	1.04
1-5/8"	B	No	CaAa (Out Of Face)	156.00 - 2.00	1	No Ice	0.20	1.04
(Sprint/Nextel)						1/2" Ice	0.30	2.55
1-5/8"	B	No	CaAa (Out Of Face)	156.00 - 2.00	6	No Ice	0.00	1.04
(Sprint/Nextel)						1/2" Ice	0.00	2.55
1-5/8"	C	No	Inside Pole	146.00 - 2.00	6	No Ice	0.00	1.04
(AT&T)						1/2" Ice	0.00	1.04
1/2"	C	No	Inside Pole	126.00 - 2.00	3	No Ice	0.00	0.25
						1/2" Ice	0.00	0.25
1/2"	C	No	Inside Pole	55.00 - 2.00	1	No Ice	0.00	0.25
						1/2" Ice	0.00	0.25
RFS HYBRIFLEX 5/8	C	No	Inside Pole	1.00 - 1.00	4	No Ice	0.00	0.70
(AT&T)						1/2" Ice	0.00	0.70

Feed Line/Linear Appurtenances Section Areas

Tower Section	Tower Elevation ft	Face	A _R	A _F	C _{AA} In Face	C _{AA} Out Face	Weight lb
			ft ²	ft ²	ft ²	ft ²	
L1	184.00-166.62	A	0.000	0.000	0.000	0.000	37.54
		B	0.000	0.000	0.000	0.000	0.00
		C	0.000	0.000	0.000	0.000	0.00
		D	0.000	0.000	0.000	0.000	0.00
L2	166.62-133.18	A	0.000	0.000	0.000	0.000	444.38
		B	0.000	0.000	0.000	4.564	308.53
		C	0.000	0.000	0.000	0.000	80.00
		D	0.000	0.000	0.000	0.000	0.00
L3	133.18-88.09	A	0.000	0.000	0.000	0.000	660.12
		B	0.000	0.000	0.000	9.018	609.62
		C	0.000	0.000	0.000	0.000	309.79
		D	0.000	0.000	0.000	0.000	0.00
L4	88.09-44.03	A	0.000	0.000	0.000	0.000	645.04
		B	0.000	0.000	0.000	8.812	595.69
		C	0.000	0.000	0.000	0.000	310.72
		D	0.000	0.000	0.000	0.000	0.00
L5	44.03-1.00	A	0.000	0.000	0.000	0.000	615.32
		B	0.000	0.000	0.000	8.406	568.25
		C	0.000	0.000	0.000	0.000	304.30
		D	0.000	0.000	0.000	0.000	0.00

RISATower Destek Engineering, LLC 5150 Stilesboro Road, Ste. 510 Kennesaw, GA 30152 Phone: (770) 693-0835 FAX:	Job	1429011	Page	4 of 18
	Project	FA100711105 CT5448 Manchester Central	Date	16:55:06 10/09/14
	Client	Com-Ex Consultants	Designed by	Ahmet C

Feed Line/Linear Appurtenances Section Areas - With Ice

Tower Section	Tower Elevation ft	Face or Leg	Ice Thickness in	A _R ft ²	A _F ft ²	C _{AA} In Face ft ²	C _{AA} Out Face ft ²	Weight lb
L1	184.00-166.62	A	0.500	0.000	0.000	0.000	0.000	37.54
		B		0.000	0.000	0.000	0.000	0.00
		C		0.000	0.000	0.000	0.000	0.00
		D		0.000	0.000	0.000	0.000	0.00
L2	166.62-133.18	A	0.500	0.000	0.000	0.000	0.000	444.38
		B		0.000	0.000	0.000	6.846	549.73
		C		0.000	0.000	0.000	0.000	80.00
		D		0.000	0.000	0.000	0.000	0.00
L3	133.18-88.09	A	0.500	0.000	0.000	0.000	0.000	660.12
		B		0.000	0.000	0.000	13.527	1086.22
		C		0.000	0.000	0.000	0.000	309.79
		D		0.000	0.000	0.000	0.000	0.00
L4	88.09-44.03	A	0.500	0.000	0.000	0.000	0.000	645.04
		B		0.000	0.000	0.000	13.218	1061.41
		C		0.000	0.000	0.000	0.000	310.72
		D		0.000	0.000	0.000	0.000	0.00
L5	44.03-1.00	A	0.500	0.000	0.000	0.000	0.000	615.32
		B		0.000	0.000	0.000	12.609	1012.50
		C		0.000	0.000	0.000	0.000	304.30
		D		0.000	0.000	0.000	0.000	0.00

Discrete Tower Loads

Description	Face or Leg	Offset Type	Offsets: Horz Lateral Vert ft ft ft	Azimuth Adjustment °	Placement ft	C _{AA} Front ft ²	C _{AA} Side ft ²	Weight lb	
Lightning Rod	A	None		0.0000	186.00	No Ice 1/2" Ice	1.00 2.00	1.00 2.00	25.00 40.00
Omni Whip Antenna	A	From Face	5.00	0.0000	186.00	No Ice	2.00	2.00	30.00
			0.00			1/2" Ice	3.00	3.00	45.00
4 Element Dipole Antenna	B	From Face	5.00	0.0000	186.00	No Ice	2.70	2.70	25.00
			0.00			1/2" Ice	4.20	4.20	38.00
8 Element Dipole Antenna	C	From Face	5.00	0.0000	186.00	No Ice	3.00	3.00	30.00
			0.00			1/2" Ice	4.50	4.50	45.00
Low Profile Plaform	A	None		0.0000	186.00	No Ice	24.00	24.00	1200.00
						1/2" Ice	36.00	36.00	1800.00
RR90-17-02DP Antennas (T-Mobile)	A	None		0.0000	163.00	No Ice	19.00	19.00	81.00
						1/2" Ice	25.30	25.30	375.00
Low Profile Plaform (T-Mobile)	A	None		0.0000	163.00	No Ice	24.00	24.00	1200.00
						1/2" Ice	36.00	36.00	1800.00
DB980-F65T4E-M Antennas (Sprint/Nextel)	A	None		0.0000	156.00	No Ice	18.60	18.60	51.00
						1/2" Ice	25.40	25.40	328.00
APVX86-906513-C Antennas (Sprint/Nextel)	A	None		0.0000	156.00	No Ice	26.90	26.90	185.00
						1/2" Ice	33.30	33.30	638.00
Low Profile Plaform	A	None		0.0000	156.00	No Ice	24.00	24.00	1200.00

RISATower

Destek Engineering, LLC
 5150 Stilesboro Road, Ste. 510
 Kennesaw, GA 30152
 Phone: (770) 693-0835
 FAX:

Job	1429011	Page	5 of 18
Project	FA100711105 CT5448 Manchester Central	Date	16:55:06 10/09/14
Client	Com-Ex Consultants	Designed by	Ahmet C

Description	Face or Leg	Offset Type	Offsets: Horz Lateral Vert ft ft ft	Azimuth Adjustment °	Placement ft	CAAA Front ft ²	CAAA Side ft ²	Weight lb
(Sprint/Nextel) Yagi Antenna	B	From Face	5.00 0.00 4.00	0.0000	126.00	1/2" Ice 36.00 No Ice 1.71 1/2" Ice 4.00	36.00 1.71 4.00	1800.00 8.00 15.00
Yagi Antenna	B	From Face	5.00 0.00 4.00	0.0000	126.00	No Ice 1.71 1/2" Ice 4.00	1.71 4.00	8.00 15.00
Omni Whip Antenna	A	From Face	5.00 0.00 9.00	0.0000	126.00	No Ice 4.00 1/2" Ice 6.00	4.00 6.00	25.00 38.00
Low Profile Plaform	A	None		0.0000	126.00	No Ice 24.00 1/2" Ice 36.00	24.00 36.00	1200.00 1800.00
GPS Antenna and Mount	A	From Face	4.00 0.00 0.00	0.0000	55.00	No Ice 1.00 1/2" Ice 1.50	1.00 1.50	10.00 15.00

Commscope MTC3607 (AT&T)	A	None		0.0000	144.00	No Ice 51.70 1/2" Ice 62.70	51.70 62.70	2262.00 2935.00
OPA-65R-LCUU-H6 w/ Mount Pipe (AT&T)	A	From Face	5.00 6.00 0.00	0.0000	144.00	No Ice 10.60 1/2" Ice 11.27	7.18 8.36	98.55 172.65
800 10121 (AT&T)	A	From Face	5.00 -6.00 0.00	0.0000	144.00	No Ice 5.45 1/2" Ice 5.87	3.29 3.63	46.30 79.15
OPA-65R-LCUU-H6 w/ Mount Pipe (AT&T)	A	From Face	5.00 -4.00 0.00	0.0000	144.00	No Ice 10.60 1/2" Ice 11.27	7.18 8.36	98.55 172.65
OPA-65R-LCUU-H8 w/ Mount Pipe (AT&T)	B	From Face	5.00 6.00 0.00	0.0000	144.00	ections 13.22 1/2" Ice 14.02	9.32 10.79	119.85 210.61
800 10121 (AT&T)	B	From Face	5.00 -6.00 0.00	0.0000	144.00	No Ice 5.45 1/2" Ice 5.87	3.29 3.63	46.30 79.15
OPA-65R-LCUU-H8 w/ Mount Pipe (AT&T)	B	From Face	5.00 -4.00 0.00	0.0000	144.00	No Ice 13.22 1/2" Ice 14.02	9.32 10.79	119.85 210.61
OPA-65R-LCUU-H8 w/ Mount Pipe (AT&T)	C	From Face	5.00 6.00 0.00	0.0000	144.00	No Ice 13.22 1/2" Ice 14.02	9.32 10.79	119.85 210.61
800 10121 (AT&T)	C	From Face	5.00 -6.00 0.00	0.0000	144.00	No Ice 5.45 1/2" Ice 5.87	3.29 3.63	46.30 79.15
OPA-65R-LCUU-H8 w/ Mount Pipe (AT&T)	C	From Face	5.00 -4.00 0.00	0.0000	144.00	No Ice 13.22 1/2" Ice 14.02	9.32 10.79	119.85 210.61
DC6-48-60-0-8F (AT&T)	A	From Face	2.00 0.00 2.00	0.0000	144.00	No Ice 1.34 1/2" Ice 1.53	1.34 1.53	32.80 49.34
DC6-48-60-0-8F (AT&T)	B	From Face	2.00 0.00 0.00	0.0000	144.00	No Ice 1.34 1/2" Ice 1.53	1.34 1.53	32.80 49.34
RRUS-12 (AT&T)	A	From Face	2.00 6.00 1.00	0.0000	146.00	No Ice 3.67 1/2" Ice 3.93	1.49 1.67	70.00 93.22
RRUS A2 Module (AT&T)	A	From Face	2.00 6.00 1.00	0.0000	146.00	No Ice 0.00 1/2" Ice 0.00	0.56 0.69	22.00 34.83

RISATower Destek Engineering, LLC 5150 Stilesboro Road, Ste. 510 Kennesaw, GA 30152 Phone: (770) 693-0835 FAX:	Job	1429011	Page	6 of 18
	Project	FA100711105 CT5448 Manchester Central	Date	16:55:06 10/09/14
	Client	Com-Ex Consultants	Designed by	Ahmet C

Description	Face or Leg	Offset Type	Offsets:		Azimuth Adjustment	Placement	C _{AA} Front	C _{AA} Side	Weight
			Horz	Lateral					
RRUS-11 (AT&T)	A	From Face	2.00	0.0000	146.00	No Ice	0.00	1.38	50.70
			6.00			1/2" Ice	0.00	1.56	71.48
			3.00						
RRUS-32 (AT&T)	A	From Face	2.00	0.0000	146.00	No Ice	0.00	2.76	77.00
			-4.00			1/2" Ice	0.00	3.02	104.93
			1.00						
RRUS-E2 (AT&T)	A	From Face	2.00	0.0000	146.00	No Ice	0.00	1.49	70.00
			-4.00			1/2" Ice	0.00	1.67	93.22
			3.00						
RRUS-12 (AT&T)	B	From Face	2.00	0.0000	146.00	No Ice	3.67	1.49	70.00
			6.00			1/2" Ice	3.93	1.67	93.22
			1.00						
RRUS A2 Module (AT&T)	B	From Face	2.00	0.0000	146.00	No Ice	0.00	0.56	22.00
			6.00			1/2" Ice	0.00	0.69	34.83
			1.00						
RRUS-11 (AT&T)	B	From Face	2.00	0.0000	146.00	No Ice	0.00	1.38	50.70
			6.00			1/2" Ice	0.00	1.56	71.48
			3.00						
RRUS-32 (AT&T)	B	From Face	2.00	0.0000	146.00	No Ice	0.00	2.76	77.00
			-4.00			1/2" Ice	0.00	3.02	104.93
			1.00						
RRUS-E2 (AT&T)	B	From Face	2.00	0.0000	146.00	No Ice	0.00	1.49	70.00
			-4.00			1/2" Ice	0.00	1.67	93.22
			3.00						
RRUS-12 (AT&T)	C	From Face	2.00	0.0000	146.00	No Ice	3.67	1.49	70.00
			6.00			1/2" Ice	3.93	1.67	93.22
			1.00						
RRUS A2 Module (AT&T)	C	From Face	2.00	0.0000	146.00	No Ice	0.00	0.56	22.00
			6.00			1/2" Ice	0.00	0.69	34.83
			1.00						
RRUS-11 (AT&T)	C	From Face	2.00	0.0000	146.00	No Ice	0.00	1.38	50.70
			6.00			1/2" Ice	0.00	1.56	71.48
			3.00						
RRUS-32 (AT&T)	C	From Face	2.00	0.0000	146.00	No Ice	0.00	2.76	77.00
			-4.00			1/2" Ice	0.00	3.02	104.93
			1.00						
RRUS-E2 (AT&T)	C	From Face	2.00	0.0000	146.00	No Ice	0.00	1.49	70.00
			-4.00			1/2" Ice	0.00	1.67	93.22
			3.00						

Tower Pressures - No Ice

$$G_H = 1.690$$

Section Elevation	z	K _Z	q _z	A _G	F _a	A _F	A _R	A _{leg}	Leg %	C _{AA} In Face	C _{AA} Out Face
ft	ft		psf	ft ²	c	ft ²	ft ²	ft ²	%	ft ²	ft ²
L1	174.99	1.611	26	25.273	A	0.000	25.273	25.273	100.00	0.000	0.000
184.00-166.62					B	0.000	25.273		100.00	0.000	0.000

RISATower Destek Engineering, LLC 5150 Stilesboro Road, Ste. 510 Kennesaw, GA 30152 Phone: (770) 693-0835 FAX:	Job 1429011	Page 7 of 18
	Project FA100711105 CT5448 Manchester Central	Date 16:55:06 10/09/14
	Client Com-Ex Consultants	Designed by Ahmet C

Section Elevation ft	z ft	K_Z	q_z psf	A_G ft ²	F a c e	A_F ft ²	A_R ft ²	A_{leg} ft ²	Leg %	C_{AA} In Face ft ²	C_{AA} Out Face ft ²
L2 166.62-133.18	149.13	1.539	25	63.278	C	0.000	25.273	63.278	100.00	0.000	0.000
					D	0.000	25.273		100.00	0.000	0.000
					A	0.000	63.278		100.00	0.000	0.000
					B	0.000	63.278		100.00	0.000	4.564
					C	0.000	63.278		100.00	0.000	0.000
L3 133.18-88.09	109.75	1.41	23	116.098	D	0.000	63.278	116.098	100.00	0.000	0.000
					A	0.000	116.098		100.00	0.000	0.000
					B	0.000	116.098		100.00	0.000	9.018
					C	0.000	116.098		100.00	0.000	0.000
					D	0.000	116.098		100.00	0.000	0.000
L4 88.09-44.03	65.69	1.217	20	146.950	D	0.000	116.098	146.950	100.00	0.000	0.000
					A	0.000	146.950		100.00	0.000	0.000
					B	0.000	146.950		100.00	0.000	8.812
					C	0.000	146.950		100.00	0.000	0.000
					D	0.000	146.950		100.00	0.000	0.000
L5 44.03-1.00	21.82	1	16	174.846	D	0.000	146.950	174.846	100.00	0.000	0.000
					A	0.000	174.846		100.00	0.000	0.000
					B	0.000	174.846		100.00	0.000	8.406
					C	0.000	174.846		100.00	0.000	0.000
					D	0.000	174.846		100.00	0.000	0.000

Tower Pressure - With Ice

$G_H = 1.690$

Section Elevation ft	z ft	K_Z	q_z psf	t_z in	A_G ft ²	F a c e	A_F ft ²	A_R ft ²	A_{leg} ft ²	Leg %	C_{AA} In Face ft ²	C_{AA} Out Face ft ²
L1 184.00-166.62	174.99	1.611	20	0.5000	26.721	A	0.000	26.721	26.721	100.00	0.000	0.000
						B	0.000	26.721		100.00	0.000	0.000
						C	0.000	26.721		100.00	0.000	0.000
						D	0.000	26.721		100.00	0.000	0.000
L2 166.62-133.18	149.13	1.539	19	0.5000	66.064	A	0.000	66.064	66.064	100.00	0.000	0.000
						B	0.000	66.064		100.00	0.000	6.846
						C	0.000	66.064		100.00	0.000	0.000
						D	0.000	66.064		100.00	0.000	0.000
L3 133.18-88.09	109.75	1.41	17	0.5000	119.856	A	0.000	119.856	119.856	100.00	0.000	0.000
						B	0.000	119.856		100.00	0.000	13.527
						C	0.000	119.856		100.00	0.000	0.000
						D	0.000	119.856		100.00	0.000	0.000
L4 88.09-44.03	65.69	1.217	15	0.5000	150.622	A	0.000	150.622	150.622	100.00	0.000	0.000
						B	0.000	150.622		100.00	0.000	13.218
						C	0.000	150.622		100.00	0.000	0.000
						D	0.000	150.622		100.00	0.000	0.000
L5 44.03-1.00	21.82	1	12	0.5000	178.432	A	0.000	178.432	178.432	100.00	0.000	0.000
						B	0.000	178.432		100.00	0.000	12.609
						C	0.000	178.432		100.00	0.000	0.000
						D	0.000	178.432		100.00	0.000	0.000

Tower Pressure - Service

$G_H = 1.690$

RISATower Destek Engineering, LLC 5150 Stilesboro Road, Ste. 510 Kennesaw, GA 30152 Phone: (770) 693-0835 FAX:	Job 1429011	Page 8 of 18
	Project FA100711105 CT5448 Manchester Central	Date 16:55:06 10/09/14
	Client Com-Ex Consultants	Designed by Ahmet C

Section Elevation ft	z ft	K _Z	q _z psf	A _G ft ²	F _{a c e} ft ²	A _F ft ²	A _R ft ²	A _{leg} ft ²	Leg %	C _{AA} In Face ft ²	C _{AA} Out Face ft ²
L1 184.00-166.62	174.99	1.611	10	25.273	A	0.000	25.273	25.273	100.00	0.000	0.000
					B	0.000	25.273		100.00	0.000	0.000
					C	0.000	25.273		100.00	0.000	0.000
					D	0.000	25.273		100.00	0.000	0.000
L2 166.62-133.18	149.13	1.539	10	63.278	A	0.000	63.278	63.278	100.00	0.000	0.000
					B	0.000	63.278		100.00	0.000	4.564
					C	0.000	63.278		100.00	0.000	0.000
					D	0.000	63.278		100.00	0.000	0.000
L3 133.18-88.09	109.75	1.41	9	116.098	A	0.000	116.098	116.098	100.00	0.000	0.000
					B	0.000	116.098		100.00	0.000	9.018
					C	0.000	116.098		100.00	0.000	0.000
					D	0.000	116.098		100.00	0.000	0.000
L4 88.09-44.03	65.69	1.217	8	146.950	A	0.000	146.950	146.950	100.00	0.000	0.000
					B	0.000	146.950		100.00	0.000	8.812
					C	0.000	146.950		100.00	0.000	0.000
					D	0.000	146.950		100.00	0.000	0.000
L5 44.03-1.00	21.82	1	6	174.846	A	0.000	174.846	174.846	100.00	0.000	0.000
					B	0.000	174.846		100.00	0.000	8.406
					C	0.000	174.846		100.00	0.000	0.000
					D	0.000	174.846		100.00	0.000	0.000

Tower Forces - No Ice - Wind Normal To Face

Section Elevation ft	Add Weight lb	Self Weight lb	F _{a c e}	e	C _F	R _R	D _F	D _R	A _E ft ²	F lb	w plf	Ctrl. Face
L1 184.00-166.62	37.54	607.55	A	1	0.65	1	1	1	25.273	732.60	42.15	D
			B	1	0.65	1	1	25.273				
			C	1	0.65	1	1	25.273				
			D	1	0.65	1	1	25.273				
L2 166.62-133.18	832.91	2173.11	A	1	0.65	1	1	1	63.278	1945.71	58.19	D
			B	1	0.65	1	1	63.278				
			C	1	0.65	1	1	63.278				
			D	1	0.65	1	1	63.278				
L3 133.18-88.09	1579.53	5960.56	A	1	0.65	1	1	1	116.098	3291.14	72.99	D
			B	1	0.65	1	1	116.098				
			C	1	0.65	1	1	116.098				
			D	1	0.65	1	1	116.098				
L4 88.09-44.03	1551.45	9046.60	A	1	0.65	1	1	1	146.950	3498.51	79.40	D
			B	1	0.65	1	1	146.950				
			C	1	0.65	1	1	146.950				
			D	1	0.65	1	1	146.950				
L5 44.03-1.00	1487.86	11064.10	A	1	0.65	1	1	1	174.846	3380.85	78.57	D
			B	1	0.65	1	1	174.846				
			C	1	0.65	1	1	174.846				
			D	1	0.65	1	1	174.846				
Sum Weight:	5489.29	28851.92						OTM	1070304.6 5 lb-ft	12848.81		

Tower Forces - No Ice - Wind 45 To Face

RISATower Destek Engineering, LLC 5150 Stilesboro Road, Ste. 510 Kennesaw, GA 30152 Phone: (770) 693-0835 FAX:	Job	1429011	Page	9 of 18
	Project	FA100711105 CT5448 Manchester Central	Date	16:55:06 10/09/14
	Client	Com-Ex Consultants	Designed by	Ahmet C

Section Elevation	Add Weight	Self Weight	F a c e	e	C _F	R _R	D _F	D _R	A _E	F	w	Ctrl. Face
ft	lb	lb							ft ²	lb	plf	
L1 184.00-166.62	37.54	607.55	A	1	0.65	1	1	1	25.273	732.60	42.15	D
			B	1	0.65	1	1	1	25.273			
			C	1	0.65	1	1	1	25.273			
			D	1	0.65	1	1	1	25.273			
L2 166.62-133.18	832.91	2173.11	A	1	0.65	1	1	1	63.278	1945.71	58.19	D
			B	1	0.65	1	1	1	63.278			
			C	1	0.65	1	1	1	63.278			
			D	1	0.65	1	1	1	63.278			
L3 133.18-88.09	1579.53	5960.56	A	1	0.65	1	1	1	116.098	3291.14	72.99	D
			B	1	0.65	1	1	1	116.098			
			C	1	0.65	1	1	1	116.098			
			D	1	0.65	1	1	1	116.098			
L4 88.09-44.03	1551.45	9046.60	A	1	0.65	1	1	1	146.950	3498.51	79.40	D
			B	1	0.65	1	1	1	146.950			
			C	1	0.65	1	1	1	146.950			
			D	1	0.65	1	1	1	146.950			
L5 44.03-1.00	1487.86	11064.10	A	1	0.65	1	1	1	174.846	3380.85	78.57	D
			B	1	0.65	1	1	1	174.846			
			C	1	0.65	1	1	1	174.846			
			D	1	0.65	1	1	1	174.846			
Sum Weight:	5489.29	28851.92						OTM	1070304.6 5 lb-ft	12848.81		

Tower Forces - With Ice - Wind Normal To Face

Section Elevation	Add Weight	Self Weight	F a c e	e	C _F	R _R	D _F	D _R	A _E	F	w	Ctrl. Face
ft	lb	lb							ft ²	lb	plf	
L1 184.00-166.62	37.54	800.09	A	1	0.65	1	1	1	26.721	580.94	33.43	D
			B	1	0.65	1	1	1	26.721			
			C	1	0.65	1	1	1	26.721			
			D	1	0.65	1	1	1	26.721			
L2 166.62-133.18	1074.11	2652.07	A	1	0.65	1	1	1	66.064	1590.00	47.55	D
			B	1	0.65	1	1	1	66.064			
			C	1	0.65	1	1	1	66.064			
			D	1	0.65	1	1	1	66.064			
L3 133.18-88.09	2056.13	6834.29	A	1	0.65	1	1	1	119.856	2671.45	59.25	D
			B	1	0.65	1	1	1	119.856			
			C	1	0.65	1	1	1	119.856			
			D	1	0.65	1	1	1	119.856			
L4 88.09-44.03	2017.17	10148.51	A	1	0.65	1	1	1	150.622	2794.71	63.43	D
			B	1	0.65	1	1	1	150.622			
			C	1	0.65	1	1	1	150.622			
			D	1	0.65	1	1	1	150.622			
L5 44.03-1.00	1932.12	12372.28	A	1	0.65	1	1	1	178.432	2671.37	62.08	D
			B	1	0.65	1	1	1	178.432			
			C	1	0.65	1	1	1	178.432			
			D	1	0.65	1	1	1	178.432			
Sum Weight:	7117.07	32807.24						OTM	863533.19 lb-ft	10308.47		

RISATower Destek Engineering, LLC 5150 Stilesboro Road, Ste. 510 Kennesaw, GA 30152 Phone: (770) 693-0835 FAX:	Job 1429011	Page 10 of 18
	Project FA100711105 CT5448 Manchester Central	Date 16:55:06 10/09/14
	Client Com-Ex Consultants	Designed by Ahmet C

Tower Forces - With Ice - Wind 45 To Face

Section Elevation	Add Weight	Self Weight	F a c e	e	C _F	R _R	D _F	D _R	A _E	F	w	Ctrl. Face
ft	lb	lb							ft ²	lb	plf	
L1 184.00-166.62	37.54	800.09	A	1	0.65	1	1	1	26.721	580.94	33.43	D
			B	1	0.65	1	1	1				
			C	1	0.65	1	1	1				
			D	1	0.65	1	1	1				
L2 166.62-133.18	1074.11	2652.07	A	1	0.65	1	1	1	66.064	1590.00	47.55	D
			B	1	0.65	1	1	1				
			C	1	0.65	1	1	1				
			D	1	0.65	1	1	1				
L3 133.18-88.09	2056.13	6834.29	A	1	0.65	1	1	1	119.856	2671.45	59.25	D
			B	1	0.65	1	1	1				
			C	1	0.65	1	1	1				
			D	1	0.65	1	1	1				
L4 88.09-44.03	2017.17	10148.51	A	1	0.65	1	1	1	150.622	2794.71	63.43	D
			B	1	0.65	1	1	1				
			C	1	0.65	1	1	1				
			D	1	0.65	1	1	1				
L5 44.03-1.00	1932.12	12372.28	A	1	0.65	1	1	1	178.432	2671.37	62.08	D
			B	1	0.65	1	1	1				
			C	1	0.65	1	1	1				
			D	1	0.65	1	1	1				
Sum Weight:	7117.07	32807.24							OTM 863533.19 lb-ft	10308.47		

Tower Forces - Service - Wind Normal To Face

Section Elevation	Add Weight	Self Weight	F a c e	e	C _F	R _R	D _F	D _R	A _E	F	w	Ctrl. Face
ft	lb	lb							ft ²	lb	plf	
L1 184.00-166.62	37.54	607.55	A	1	0.65	1	1	1	25.273	286.17	16.47	D
			B	1	0.65	1	1	1				
			C	1	0.65	1	1	1				
			D	1	0.65	1	1	1				
L2 166.62-133.18	832.91	2173.11	A	1	0.65	1	1	1	63.278	760.04	22.73	D
			B	1	0.65	1	1	1				
			C	1	0.65	1	1	1				
			D	1	0.65	1	1	1				
L3 133.18-88.09	1579.53	5960.56	A	1	0.65	1	1	1	116.098	1285.60	28.51	D
			B	1	0.65	1	1	1				
			C	1	0.65	1	1	1				
			D	1	0.65	1	1	1				
L4 88.09-44.03	1551.45	9046.60	A	1	0.65	1	1	1	146.950	1366.60	31.02	D
			B	1	0.65	1	1	1				
			C	1	0.65	1	1	1				
			D	1	0.65	1	1	1				
L5 44.03-1.00	1487.86	11064.10	A	1	0.65	1	1	1	174.846	1320.64	30.69	D
			B	1	0.65	1	1	1				
			C	1	0.65	1	1	1				
			D	1	0.65	1	1	1				
Sum Weight:	5489.29	28851.92							OTM 418087.76 lb-ft	5019.07		

RISATower Destek Engineering, LLC 5150 Stilesboro Road, Ste. 510 Kennesaw, GA 30152 Phone: (770) 693-0835 FAX:	Job 1429011	Page 11 of 18
	Project FA100711105 CT5448 Manchester Central	Date 16:55:06 10/09/14
	Client Com-Ex Consultants	Designed by Ahmet C

Tower Forces - Service - Wind 45 To Face

Section Elevation ft	Add Weight lb	Self Weight lb	F a c e	e	C _F	R _R	D _F	D _R	A _E ft ²	F lb	w plf	Ctrl. Face
L1 184.00-166.62	37.54	607.55	A	1	0.65	1	1	1	25.273	286.17	16.47	D
			B	1	0.65	1	1	1	25.273			
			C	1	0.65	1	1	1	25.273			
			D	1	0.65	1	1	1	25.273			
L2 166.62-133.18	832.91	2173.11	A	1	0.65	1	1	1	63.278	760.04	22.73	D
			B	1	0.65	1	1	1	63.278			
			C	1	0.65	1	1	1	63.278			
			D	1	0.65	1	1	1	63.278			
L3 133.18-88.09	1579.53	5960.56	A	1	0.65	1	1	1	116.098	1285.60	28.51	D
			B	1	0.65	1	1	1	116.098			
			C	1	0.65	1	1	1	116.098			
			D	1	0.65	1	1	1	116.098			
L4 88.09-44.03	1551.45	9046.60	A	1	0.65	1	1	1	146.950	1366.60	31.02	D
			B	1	0.65	1	1	1	146.950			
			C	1	0.65	1	1	1	146.950			
			D	1	0.65	1	1	1	146.950			
L5 44.03-1.00	1487.86	11064.10	A	1	0.65	1	1	1	174.846	1320.64	30.69	D
			B	1	0.65	1	1	1	174.846			
			C	1	0.65	1	1	1	174.846			
			D	1	0.65	1	1	1	174.846			
Sum Weight:	5489.29	28851.92						OTM	418087.76 lb-ft	5019.07		

Force Totals

Load Case	Vertical Forces lb	Sum of Forces X lb	Sum of Forces Z lb	Sum of Overturning Moments, M _x lb-ft	Sum of Overturning Moments, M _z lb-ft	Sum of Torques lb-ft
Leg Weight	28851.92					
Bracing Weight	0.00					
Total Member Self-Weight	28851.92					
Total Weight	43631.31			-2875.31	-175.97	
Wind 0 deg - No Ice		0.00	-26642.18	-3160708.81	-175.97	637.84
Wind 45 deg - No Ice		18986.79	-18838.86	-2235800.79	-2253720.76	-5225.99
Wind 90 deg - No Ice		26851.38	0.00	-2875.31	-3187169.58	-8028.51
Wind 135 deg - No Ice		18986.79	18838.86	2230050.17	-2253720.76	-6128.04
Wind 180 deg - No Ice		0.00	26642.18	3154958.19	-175.97	-637.84
Wind 225 deg - No Ice		-18986.79	18838.86	2230050.17	2253368.82	5225.99
Wind 270 deg - No Ice		-26851.38	0.00	-2875.31	3186817.64	8028.51
Wind 315 deg - No Ice		-18986.79	-18838.86	-2235800.79	2253368.82	6128.04
Member Ice	3955.32					
Total Weight Ice	54368.23			-4659.36	-338.28	
Wind 0 deg - Ice		0.00	-23911.03	-2935969.70	-338.28	234.95
Wind 45 deg - Ice		16981.96	-16907.65	-2077408.78	-2083251.26	-5420.12
Wind 90 deg - Ice		24016.12	0.00	-4659.36	-2946022.06	-7900.16
Wind 135 deg - Ice		16981.96	16907.65	2068090.06	-2083251.26	-5752.39
Wind 180 deg - Ice		0.00	23911.03	2926650.98	-338.28	-234.95
Wind 225 deg - Ice		-16981.96	16907.65	2068090.06	2082574.69	5420.12
Wind 270 deg - Ice		-24016.12	0.00	-4659.36	2945345.49	7900.16

RISATower Destek Engineering, LLC 5150 Stilesboro Road, Ste. 510 Kennesaw, GA 30152 Phone: (770) 693-0835 FAX:	Job 1429011	Page 12 of 18
	Project FA100711105 CT5448 Manchester Central	Date 16:55:06 10/09/14
	Client Com-Ex Consultants	Designed by Ahmet C

Load Case	Vertical Forces lb	Sum of Forces X lb	Sum of Forces Z lb	Sum of Overturning Moments, M _x lb-ft	Sum of Overturning Moments, M _z lb-ft	Sum of Torques lb-ft
Wind 315 deg - Ice		-16981.96	-16907.65	-2077408.78	2082574.69	5752.39
Total Weight	43631.31			-2875.31	-175.97	
Wind 0 deg - Service		0.00	-10407.10	-1236404.02	-175.97	249.16
Wind 45 deg - Service		7416.71	-7358.93	-875111.83	-880466.90	-2041.40
Wind 90 deg - Service		10488.82	0.00	-2875.31	-1245095.35	-3136.14
Wind 135 deg - Service		7416.71	7358.93	869361.20	-880466.90	-2393.76
Wind 180 deg - Service		0.00	10407.10	1230653.40	-175.97	-249.16
Wind 225 deg - Service		-7416.71	7358.93	869361.20	880114.97	2041.40
Wind 270 deg - Service		-10488.82	0.00	-2875.31	1244743.41	3136.14
Wind 315 deg - Service		-7416.71	-7358.93	-875111.83	880114.97	2393.76

Load Combinations

Comb. No.	Description
1	Dead Only
2	Dead+Wind 0 deg - No Ice
3	Dead+Wind 45 deg - No Ice
4	Dead+Wind 90 deg - No Ice
5	Dead+Wind 135 deg - No Ice
6	Dead+Wind 180 deg - No Ice
7	Dead+Wind 225 deg - No Ice
8	Dead+Wind 270 deg - No Ice
9	Dead+Wind 315 deg - No Ice
10	Dead+Ice+Temp
11	Dead+Wind 0 deg+Ice+Temp
12	Dead+Wind 45 deg+Ice+Temp
13	Dead+Wind 90 deg+Ice+Temp
14	Dead+Wind 135 deg+Ice+Temp
15	Dead+Wind 180 deg+Ice+Temp
16	Dead+Wind 225 deg+Ice+Temp
17	Dead+Wind 270 deg+Ice+Temp
18	Dead+Wind 315 deg+Ice+Temp
19	Dead+Wind 0 deg - Service
20	Dead+Wind 45 deg - Service
21	Dead+Wind 90 deg - Service
22	Dead+Wind 135 deg - Service
23	Dead+Wind 180 deg - Service
24	Dead+Wind 225 deg - Service
25	Dead+Wind 270 deg - Service
26	Dead+Wind 315 deg - Service

Maximum Member Forces

Section No.	Elevation ft	Component Type	Condition	Gov. Load Comb.	Force lb	Major Axis Moment lb-ft	Minor Axis Moment lb-ft
L1	184 - 166.62	Pole	Max Tension	1	0.00	0.00	0.00
			Max. Compression	10	-2652.38	-2.00	233.77
			Max. Mx	13	-2381.46	-36961.26	181.77
			Max. My	11	-2381.27	23.77	37170.28
			Max. Vy	13	2466.38	-36961.26	181.77
			Max. Vx	11	-2471.06	23.77	37170.28

RISATower Destek Engineering, LLC 5150 Stilesboro Road, Ste. 510 Kennesaw, GA 30152 Phone: (770) 693-0835 FAX:	Job	1429011	Page	13 of 18
	Project	FA100711105 CT5448 Manchester Central	Date	16:55:06 10/09/14
	Client	Com-Ex Consultants	Designed by	Ahmet C

Section No.	Elevation ft	Component Type	Condition	Gov. Load Comb.	Force lb	Major Axis Moment lb-ft	Minor Axis Moment lb-ft	
L2	166.62 - 133.18	Pole	Max. Torque	13			830.93	
			Max Tension	1	0.00	0.00	0.00	
			Max. Compression	10	-16676.55	-676.45	4642.57	
			Max. Mx	13	-15197.11	-311121.31	4241.38	
			Max. My	11	-15208.47	-539.33	314764.78	
			Max. Vy	4	16190.71	-301716.22	2361.98	
			Max. Vx	2	-15972.82	-242.12	303161.86	
L3	133.18 - 88.09	Pole	Max. Torque	8			-7061.61	
			Max Tension	1	0.00	0.00	0.00	
			Max. Compression	10	-26838.58	-465.18	5079.00	
			Max. Mx	4	-18268.47	-1129884.4	2832.98	
						1		
			Max. My	2	-18293.30	-221.95	1121859.24	
			Max. Vy	4	20777.26	-1129884.4	2832.98	
L4	88.09 - 44.03	Pole	Max. Vx	2	-20554.66	-221.95	1121859.24	
			Max. Torque	8			-7906.70	
			Max Tension	1	0.00	0.00	0.00	
			Max. Compression	10	-38351.16	-384.65	5155.41	
			Max. Mx	4	-28824.08	-2090791.9	3017.78	
						6		
			Max. My	2	-28837.56	-184.06	2073248.14	
L5	44.03 - 1	Pole	Max. Vy	4	23929.99	-2090791.9	3017.78	
						6		
			Max. Vx	2	-23708.70	-184.06	2073248.14	
			Max. Torque	8			-7876.20	
			Max Tension	1	0.00	0.00	0.00	
			Max. Compression	10	-54368.23	-382.15	5129.40	
			Max. Mx	4	-43611.80	-3341019.5	3041.08	
						1		
			Max. My	2	-43611.78	-185.36	3312730.62	
			Max. Vy	4	26881.57	-3341019.5	3041.08	
						1		
			Max. Vx	2	-26667.53	-185.36	3312730.62	
			Max. Torque	8			-7853.30	

Maximum Reactions

Location	Condition	Gov. Load Comb.	Vertical lb	Horizontal, X lb	Horizontal, Z lb
Pole	Max. Vert	10	54368.23	0.05	-0.47
	Max. H _x	8	43631.21	26850.06	0.02
	Max. H _z	2	43630.88	-0.01	26636.28
	Max. M _x	2	3312730.62	-0.01	26636.28
	Max. M _z	4	3341019.51	-26850.06	0.02
	Max. Torsion	4	7845.34	-26850.06	0.02
	Min. Vert	2	43630.88	-0.01	26636.28
	Min. H _x	4	43631.21	-26850.06	0.02
	Min. H _z	6	43630.88	-0.01	-26636.30
	Min. M _x	6	-3306500.98	-0.01	-26636.30
	Min. M _z	8	-3340631.57	26850.06	0.02
	Min. Torsion	8	-7845.48	26850.06	0.02

RISATower Destek Engineering, LLC 5150 Stilesboro Road, Ste. 510 Kennesaw, GA 30152 Phone: (770) 693-0835 FAX:	Job 1429011	Page 14 of 18
	Project FA100711105 CT5448 Manchester Central	Date 16:55:06 10/09/14
	Client Com-Ex Consultants	Designed by Ahmet C

Tower Mast Reaction Summary

Load Combination	Vertical	Shear _x	Shear _z	Overturning Moment, M _x	Overturning Moment, M _z	Torque
	lb	lb	lb	lb-ft	lb-ft	lb-ft
Dead Only	43631.30	-0.07	0.81	-2932.72	-180.69	-0.03
Dead+Wind 0 deg - No Ice	43630.88	0.01	-26636.28	-3312730.62	-185.23	607.87
Dead+Wind 45 deg - No Ice	43631.29	18986.60	-18838.67	-2343938.35	-2362707.76	-5106.27
Dead+Wind 90 deg - No Ice	43631.21	26850.06	-0.02	-3039.37	-3341019.51	-7845.34
Dead+Wind 135 deg - No Ice	43631.29	18986.60	18838.67	2337784.56	-2362630.49	-5990.10
Dead+Wind 180 deg - No Ice	43630.88	0.01	26636.30	3306500.98	-185.32	-608.17
Dead+Wind 225 deg - No Ice	43631.29	-18986.60	18838.67	2337774.34	2362252.48	5130.40
Dead+Wind 270 deg - No Ice	43631.21	-26850.06	-0.02	-3039.44	3340631.57	7845.48
Dead+Wind 315 deg - No Ice	43631.29	-18986.59	-18838.67	-2343928.20	2362329.85	5965.82
Dead+Ice+Temp	54368.23	-0.05	0.47	-5129.40	-382.15	-0.08
Dead+Wind 0 deg+Ice+Temp	54367.82	0.00	-23905.80	-3141184.72	-384.42	201.58
Dead+Wind 45 deg+Ice+Temp	54368.21	16981.78	-16907.46	-2223274.28	-2229357.91	-5287.34
Dead+Wind 90 deg+Ice+Temp	54368.07	24014.14	-0.02	-5156.58	-3152215.21	-7693.61
Dead+Wind 135 deg+Ice+Temp	54368.21	16981.78	16907.46	2212862.70	-2229256.24	-5593.70
Dead+Wind 180 deg+Ice+Temp	54367.82	0.00	23905.83	3130675.57	-384.61	-202.00
Dead+Wind 225 deg+Ice+Temp	54368.21	-16981.78	16907.46	2212855.83	2228481.46	5308.30
Dead+Wind 270 deg+Ice+Temp	54368.07	-24014.14	-0.02	-5156.78	3151434.06	7693.78
Dead+Wind 315 deg+Ice+Temp	54368.21	-16981.78	-16907.46	-2223267.66	2228583.37	5572.49
Dead+Wind 0 deg - Service	43631.24	0.00	-10404.67	-1297990.47	-196.73	242.19
Dead+Wind 45 deg - Service	43631.26	7415.66	-7357.89	-918845.19	-924354.29	-2021.97
Dead+Wind 90 deg - Service	43631.24	10486.38	0.00	-3145.22	-1306986.05	-3104.34
Dead+Wind 135 deg - Service	43631.26	7415.67	7357.90	912543.37	-924343.38	-2368.32
Dead+Wind 180 deg - Service	43631.24	0.00	10404.69	1291679.17	-196.76	-242.28
Dead+Wind 225 deg - Service	43631.26	-7415.67	7357.90	912541.91	923948.49	2025.70
Dead+Wind 270 deg - Service	43631.24	-10486.38	0.00	-3145.24	1306589.91	3104.31
Dead+Wind 315 deg - Service	43631.26	-7415.66	-7357.89	-918843.77	923959.45	2364.47

Solution Summary

Load Comb.	Sum of Applied Forces			Sum of Reactions			% Error
	PX lb	PY lb	PZ lb	PX lb	PY lb	PZ lb	
1	0.00	-43631.31	0.00	0.07	43631.30	-0.81	0.002%
2	0.00	-43631.31	-26642.18	-0.01	43630.88	26636.28	0.012%
3	18986.79	-43631.31	-18838.86	-18986.60	43631.29	18838.67	0.001%
4	26851.38	-43631.31	0.00	-26850.06	43631.21	0.02	0.003%
5	18986.79	-43631.31	18838.86	-18986.60	43631.29	-18838.67	0.001%
6	0.00	-43631.31	26642.18	-0.01	43630.88	-26636.30	0.012%
7	-18986.79	-43631.31	18838.86	18986.60	43631.29	-18838.67	0.001%
8	-26851.38	-43631.31	0.00	26850.06	43631.21	0.02	0.003%
9	-18986.79	-43631.31	-18838.86	18986.59	43631.29	18838.67	0.001%
10	0.00	-54368.23	0.00	0.05	54368.23	-0.47	0.001%
11	0.00	-54368.23	-23911.03	-0.00	54367.82	23905.80	0.009%
12	16981.96	-54368.23	-16907.65	-16981.78	54368.21	16907.46	0.000%
13	24016.12	-54368.23	0.00	-24014.14	54368.07	0.02	0.003%
14	16981.96	-54368.23	16907.65	-16981.78	54368.21	-16907.46	0.000%
15	0.00	-54368.23	23911.03	-0.00	54367.82	-23905.83	0.009%
16	-16981.96	-54368.23	16907.65	16981.78	54368.21	-16907.46	0.000%
17	-24016.12	-54368.23	0.00	24014.14	54368.07	0.02	0.003%
18	-16981.96	-54368.23	-16907.65	16981.78	54368.21	16907.46	0.000%
19	0.00	-43631.31	-10407.10	-0.00	43631.24	10404.67	0.005%
20	7416.71	-43631.31	-7358.93	-7415.66	43631.26	7357.89	0.003%
21	10488.82	-43631.31	0.00	-10486.38	43631.24	-0.00	0.005%
22	7416.71	-43631.31	7358.93	-7415.67	43631.26	-7357.90	0.003%

RISATower Destek Engineering, LLC 5150 Stilesboro Road, Ste. 510 Kennesaw, GA 30152 Phone: (770) 693-0835 FAX:	Job	1429011	Page	15 of 18	
	Project	FA100711105 CT5448 Manchester Central		Date	16:55:06 10/09/14
	Client	Com-Ex Consultants		Designed by	Ahmet C

Load Comb.	Sum of Applied Forces			Sum of Reactions			% Error
	PX lb	PY lb	PZ lb	PX lb	PY lb	PZ lb	
23	0.00	-43631.31	10407.10	-0.00	43631.24	-10404.69	0.005%
24	-7416.71	-43631.31	7358.93	7415.67	43631.26	-7357.90	0.003%
25	-10488.82	-43631.31	0.00	10486.38	43631.24	-0.00	0.005%
26	-7416.71	-43631.31	-7358.93	7415.66	43631.26	7357.89	0.003%

Non-Linear Convergence Results

Load Combination	Converged?	Number of Cycles	Displacement Tolerance	Force Tolerance
1	Yes	9	0.00000001	0.00000992
2	Yes	19	0.00012786	0.00012369
3	Yes	25	0.00000001	0.00011988
4	Yes	22	0.00002895	0.00010492
5	Yes	25	0.00000001	0.00011925
6	Yes	19	0.00012797	0.00012327
7	Yes	25	0.00000001	0.00011840
8	Yes	22	0.00002895	0.00010489
9	Yes	25	0.00000001	0.00012060
10	Yes	13	0.00000001	0.00000465
11	Yes	20	0.00013110	0.00012086
12	Yes	26	0.00000001	0.00011116
13	Yes	22	0.00005025	0.00014397
14	Yes	26	0.00000001	0.00010977
15	Yes	20	0.00013126	0.00012010
16	Yes	26	0.00000001	0.00010918
17	Yes	22	0.00005026	0.00014389
18	Yes	26	0.00000001	0.00011144
19	Yes	19	0.00013452	0.00005336
20	Yes	20	0.00008225	0.00009971
21	Yes	19	0.00013451	0.00009739
22	Yes	20	0.00008226	0.00010021
23	Yes	19	0.00013454	0.00005280
24	Yes	20	0.00008227	0.00009609
25	Yes	19	0.00013452	0.00009730
26	Yes	20	0.00008225	0.00010344

Maximum Tower Deflections - Service Wind

Section No.	Elevation ft	Horz. Deflection in	Gov. Load Comb.	Tilt °	Twist °
L1	184 - 166.62	56.233	21	2.7282	0.0315
L2	169.54 - 133.18	48.083	21	2.6518	0.0274
L3	136.98 - 88.09	31.038	21	2.2649	0.0198
L4	93.08 - 44.03	13.697	21	1.4473	0.0075
L5	50.14 - 1	3.831	21	0.7244	0.0028

Critical Deflections and Radius of Curvature - Service Wind

RISATower Destek Engineering, LLC 5150 Stilesboro Road, Ste. 510 Kennesaw, GA 30152 Phone: (770) 693-0835 FAX:	Job 1429011	Page 16 of 18
	Project FA100711105 CT5448 Manchester Central	Date 16:55:06 10/09/14
	Client Com-Ex Consultants	Designed by Ahmet C

Elevation	Appurtenance	Gov. Load Comb.	Deflection in	Tilt °	Twist °	Radius of Curvature ft
186.00	Lightning Rod	21	56.233	2.7282	0.0315	26964
163.00	RR90-17-02DP Antennas	21	44.469	2.5986	0.0258	6755
156.00	DB980-F65T4E-M Antennas	21	40.684	2.5264	0.0242	5217
146.00	RRUS-12	21	35.477	2.3995	0.0219	3936
144.00	Commscope MTC3607	21	34.470	2.3711	0.0215	3752
126.00	Yagi Antenna	21	26.028	2.0817	0.0167	3216
55.00	GPS Antenna and Mount	21	4.581	0.7749	0.0030	2976

Maximum Tower Deflections - Design Wind

Section No.	Elevation ft	Horz. Deflection in	Gov. Load Comb.	Tilt °	Twist °
L1	184 - 166.62	143.342	4	6.9446	0.0799
L2	169.54 - 133.18	122.598	4	6.7528	0.0695
L3	136.98 - 88.09	79.196	4	5.7778	0.0501
L4	93.08 - 44.03	34.979	4	3.6958	0.0189
L5	50.14 - 1	9.788	4	1.8508	0.0070

Critical Deflections and Radius of Curvature - Design Wind

Elevation	Appurtenance	Gov. Load Comb.	Deflection in	Tilt °	Twist °	Radius of Curvature ft
186.00	Lightning Rod	4	143.342	6.9446	0.0799	9336
163.00	RR90-17-02DP Antennas	4	113.397	6.6201	0.0654	2457
156.00	DB980-F65T4E-M Antennas	4	103.762	6.4398	0.0613	1956
146.00	RRUS-12	4	90.504	6.1204	0.0556	1514
144.00	Commscope MTC3607	4	87.938	6.0486	0.0545	1448
126.00	Yagi Antenna	4	66.430	5.3035	0.0422	1262
55.00	GPS Antenna and Mount	4	11.705	2.0188	0.0076	1168

Base Plate Design Data

Plate Thickness	Number of Anchor Bolts	Anchor Bolt Size	Actual Allowable Ratio Bolt Tension lb	Actual Allowable Ratio Concrete Stress ksi	Actual Allowable Ratio Plate Stress ksi	Actual Allowable Ratio Stiffener Stress ksi	Controlling Condition	Critical Ratio
in		in						
2.0000	16	2.2500	119219.00 131210.58 0.91	1.869 2.800 0.67	50.631 45.000 1.13	56.780 45.000 1.26	Stiff	1.26

RISATower Destek Engineering, LLC 5150 Stilesboro Road, Ste. 510 Kennesaw, GA 30152 Phone: (770) 693-0835 FAX:	Job 1429011	Page 17 of 18
	Project FA100711105 CT5448 Manchester Central	Date 16:55:06 10/09/14
	Client Com-Ex Consultants	Designed by Ahmet C

Compression Checks

Pole Design Data

Section No.	Elevation ft	Size	L ft	L _u ft	Kl/r	F _a ksi	A in ²	Actual P lb	Allow. P _a lb	Ratio P P _a
L1	184 - 166.62 (1)	TP19.399x15.5x0.1875	17.38	183.00	333.4	1.344	11.0434	-2381.27	14840.00	0.160
L2	166.62 - 133.18 (2)	TP26.4007x18.3689x0.25	36.36	183.00	244.4	2.500	20.0845	-15208.50	50215.00	0.303
L3	133.18 - 88.09 (3)	TP35.8924x25.0613x0.375	48.89	183.00	179.8	4.621	40.9588	-25641.30	189281.00	0.135
L4	88.09 - 44.03 (4)	TP44.903x34.0369x0.4375	49.05	183.00	143.5	7.253	59.8663	-28824.10	434231.00	0.066
L5	44.03 - 1 (5)	TP53.5x42.6744x0.4375	49.14	183.00	135.7	8.107	63.2917	-33991.10	513113.00	0.066

Pole Bending Design Data

Section No.	Elevation ft	Size	Actual M _x lb-ft	Actual f _{bx} ksi	Allow. F _{bx} ksi	Ratio f _{bx} F _{bx}	Actual M _y lb-ft	Actual f _{by} ksi	Allow. F _{by} ksi	Ratio f _{by} F _{by}
L1	184 - 166.62 (1)	TP19.399x15.5x0.1875	37170.3 3	-8.840	39.000	0.227	0.00	0.000	39.000	0.000
L2	166.62 - 133.18 (2)	TP26.4007x18.3689x0.25	314765. 00	-30.171	39.000	0.774	0.00	0.000	39.000	0.000
L3	133.18 - 88.09 (3)	TP35.8924x25.0613x0.375	1113525. 00	-38.535	39.000	0.988	0.00	0.000	39.000	0.000
L4	88.09 - 44.03 (4)	TP44.903x34.0369x0.4375	2090791. 67	-39.484	39.000	1.012	0.00	0.000	39.000	0.000
L5	44.03 - 1 (5)	TP53.5x42.6744x0.4375	2461991. 67	-41.575	39.000	1.066	0.00	0.000	39.000	0.000

Pole Interaction Design Data

Section No.	Elevation ft	Size	Ratio P P _a	Ratio f _{bx} F _{bx}	Ratio f _{by} F _{by}	Comb. Stress Ratio	Allow. Stress Ratio	Criteria
L1	184 - 166.62 (1)	TP19.399x15.5x0.1875	0.160	0.227	0.000	0.387	1.333	H1-3 ✓
L2	166.62 - 133.18 (2)	TP26.4007x18.3689x0.25	0.303	0.774	0.000	1.076	1.333	H1-3 ✓
L3	133.18 - 88.09 (3)	TP35.8924x25.0613x0.375	0.135	0.988	0.000	1.124	1.333	H1-3 ✓
L4	88.09 - 44.03 (4)	TP44.903x34.0369x0.4375	0.066	1.012	0.000	1.079	1.333	H1-3 ✓
L5	44.03 - 1 (5)	TP53.5x42.6744x0.4375	0.066	1.066	0.000	1.132	1.333	H1-3 ✓

<i>RISATower</i> <i>Destek Engineering, LLC</i> <i>5150 Stilesboro Road, Ste. 510</i> <i>Kennesaw, GA 30152</i> <i>Phone: (770) 693-0835</i> <i>FAX:</i>	Job	1429011	Page	18 of 18
	Project	FA100711105 CT5448 Manchester Central	Date	16:55:06 10/09/14
	Client	Com-Ex Consultants	Designed by	Ahmet C

Section Capacity Table

<i>Section No.</i>	<i>Elevation ft</i>	<i>Component Type</i>	<i>Size</i>	<i>Critical Element</i>	<i>P lb</i>	<i>SF*P_{allow} lb</i>	<i>% Capacity</i>	<i>Pass Fail</i>
L1	184 - 166.62	Pole	TP19.399x15.5x0.1875	1	-2381.27	19781.72	29.0	Pass
L2	166.62 - 133.18	Pole	TP26.4007x18.3689x0.25	2	-15208.50	66936.59	80.8	Pass
L3	133.18 - 88.09	Pole	TP35.8924x25.0613x0.375	3	-25641.30	252311.56	84.3	Pass
L4	88.09 - 44.03	Pole	TP44.903x34.0369x0.4375	4	-28824.10	578829.90	80.9	Pass
L5	44.03 - 1	Pole	TP53.5x42.6744x0.4375	5	-33991.10	683979.60	84.9	Pass
Summary								
Pole (L5)							84.9	Pass
Base Plate							94.7	Pass
RATING =							94.7	Pass

STRUCTURAL ANALYSIS REPORT

For

CT43XC827

MANCHESTER/POLICE TOWER

239 Middle Turnpike
Manchester, CT 06040

Antennas Mounted to the Monopole

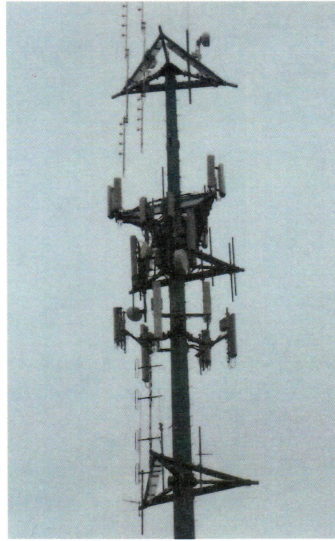

Prepared for:

Sprint[®]
VISION

1 INTERNATIONAL BLVD, SUITE 800
MAHWAH, NJ 07495
TEL: (201) 684-4223

Dated: April 9, 2015

Prepared by:

Hudson
Design Group LLC



1600 Osgood Street Bldg. 20N Suite 3090
North Andover, MA 01845
(P) 978.557.5553 (F) 978.336.5586
www.hudsondesigngroupllc.com

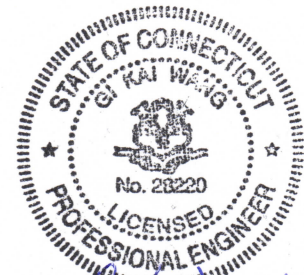

Gi Kai Wang 4/9/2015



SCOPE OF WORK:

Hudson Design Group LLC (HDG) has been authorized by Sprint to conduct a structural evaluation of the 183' monopole supporting the existing and proposed Sprint's antennas located at elevation 153' above the ground level.

This report represents this office's findings, conclusions and recommendations pertaining to the support of Sprint's existing and proposed antennas listed below.

Record drawings of the existing monopole by Engineered Endeavors Inc., dated September 17, 2002, were available for our use. The previous structural analysis report prepared by Ramaker & Associates, Inc., dated November 26, 2012, was available and obtained for our use. The previous structural analysis report prepared by Destek Engineering, LLC, dated October 14, 2014, was also available and obtained for our use.

MONOPOLE ANALYSIS SUMMARY: (FAILING)

Based on our evaluation, we have determined that the existing monopole, base plate and anchor bolts **are NOT in conformance** with the ANSI/TIA-222-F Standard for the loading considered under the criteria listed in this report. The monopole structure is rated at 120.0% - (Base Plate Controlling).

FOUNDATION ANALYSIS SUMMARY: (PASSING)

Based on our evaluation, we have determined that the existing monopole foundation **is in conformance** with the ANSI/TIA-222-F Standard for the loading considered under the criteria listed in this report.



APPURTANENCES CONFIGURATION:

Tenant	Appurtenances	Elev.	Mount
	Lighting Rod	194'	Low Profile Platform
	(2) 20' Dipole	184'	Low Profile Platform
T-MOBILE	(3) AIR 21 B2A B4P Antennas	163'	Low Profile Platform
T-MOBILE	(3) AIR 21 B4A B12P Antennas	163'	Low Profile Platform
T-MOBILE	(3) ATMAP1412D TMA	163'	Low Profile Platform
T-MOBILE	(3) RRUS 11	163'	Low Profile Platform
Sprint	(3) APXVSP18 Antennas	153'	Low Profile Platform
Sprint	(3) RRH-800	153'	Low Profile Platform
Sprint	(6) RRH-1900	153'	Low Profile Platform
Sprint	(3) APXVTM14-C-120 Antennas	153'	Low Profile Platform
Sprint	(3) RRHx20-25	151'	Ring Mount
	(3) 840-10054 Antennas	153'	Low Profile Platform
	(3) 860-10025 RCU	153'	Low Profile Platform
	Panel Antenna	153'	Low Profile Platform
	(2) 2' Dishes	150'	Low Profile Platform
	2.5' Dish	150'	Low Profile Platform
AT&T	(3) 800-10121 Antennas	143'	Low Profile Platform
AT&T	(2) OPA-65R-LCUU-H6 Antennas	143'	Low Profile Platform
AT&T	(4) OPA-65R-LCUU-H8 Antennas	143'	Low Profile Platform
AT&T	(12) RRUs	143'	Low Profile Platform
AT&T	(3) A2 Modules	143'	Low Profile Platform
AT&T	(2) Surge Arrestors	143'	Low Profile Platform
	(2) 20' Omni	129'	Low Profile Platform
	20' Dipole	126'	Low Profile Platform
	(2) 3' Yagi	126'	Low Profile Platform
VERIZON	(6) LNX 6514DS-VTM Antennas	110'	Low Profile Platform
VERIZON	(6) HBX 6517DS-VTM Antennas	110'	Low Profile Platform
VERIZON	(3) RRH 2X40-AWS	110'	Low Profile Platform
VERIZON	(3) RRH 2X40-07U	110'	Low Profile Platform
VERIZON	(3) RRH 2X40-PCS	110'	Low Profile Platform
VERIZON	(2) DB-T1-6Z-8AB-0Z	110'	Low Profile Platform
	GPS	54'	1' Side Mount Standoff
POLICE	(4) VHLPX2-18 Dish	38.9'	1' Side Mount Standoff

***Proposed SPRINT Appurtenances shown in Bold.**



SPRINT EXISTING/PROPOSED COAX CABLES:

Tenant	Coax Cables	Elev.	Mount
Sprint	(3) 1 1/4" Fiber Cables	153'	Inside Monopole

**Proposed SPRINT Coax Cables shown in Bold.*

ANALYSIS RESULTS SUMMARY:

Component	Max. Stress Ratio	Elev. of Component (ft)	Pass/Fail	Comments
Pole Section-L1	14.0 %	166.5 – 184.0	PASS	
Pole Section-L2	66.5 %	133.1 – 166.5	PASS	
Pole Section-L3	96.5 %	88.0 – 133.1	PASS	
Pole Section-L4	102.6 %	43.9 – 88.0	FAIL	
Pole Section-L5	109.6 %	1.0 – 43.9	FAIL	
Base Plate	120.0 %	1.0	FAIL	Controlling



DESIGN CRITERIA:

1. EIA/TIA-222-F Structural Standards for Steel Antenna Towers and Antenna Supporting Structures

County: Hartford
Wind Load: 80 mph (fastest mile)
100 mph (3 second gust)
Nominal Ice Thickness: 1/2 inch

2. Approximate height above grade to proposed antennas: 153'-0"

***Calculations and referenced documents are attached.**

ASSUMPTIONS:

1. The monopole dimensions, member sizes and strength of material are as indicated in the record drawings prepared by Engineered Endeavors Inc., dated September 17, 2002.
2. The appurtenances configuration is as stated in this report. All antennas, coax cables and waveguide cables are assumed to be properly installed and supported as per the manufacturer requirements.
3. The monopole and foundation are properly constructed and maintained. All structural members and their connections are assumed to be in good condition and are free from defects with no deterioration to its member capacities.
4. The support mounts and platforms are not analyzed and are considered adequate to support the loading. The analysis is limited to the primary support structure itself.
5. All prior structural modification, if any, are assumed to be as per the data supplied (if available), and installed properly.



SUPPORT RECOMMENDATIONS:

The 183' monopole requires structural modifications to bring into compliance with the structural requirements as specified in EIA/TIA-222-F.

It is recommended that the existing monopole be modified as follows:

- (1) Strengthen monopole from El.1' to El.88'.**
- (2) Strengthen base plate and anchor bolts.**

ONGOING AND PERIODIC INSPECTION AND MAINTENANCE:

After the Contractor has successfully completed the installation and the work has been accepted, the Owner will be responsible for the ongoing and periodic inspection and maintenance of the tower.

The owner shall refer to TIA/EIA-222-F for recommendations for maintenance and inspection. The frequency of the inspection and maintenance intervals is to be determined by the owner based upon actual site and environmental conditions. It is recommended that a complete and thorough inspection of the entire tower structural system be performed at least yearly and more frequently as conditions warrant. According to TIA/EIA-222-F section 14.1, Note 1: It is recommended that the structure be inspected after severe wind and/or ice storms or other extreme loading conditions.



Photo 1: Photo illustrating the Monopole with Appurtenances shown.



CALCULATIONS

DESIGNED APPURTENANCE LOADING

TYPE	ELEVATION	TYPE	ELEVATION
Lightning Rod 2"x21"	184	Kathrein 800 10121 w/mount pipe	143
PIROD 13' Low Profile Platform	184	Kathrein 800 10121 w/mount pipe	143
20'-4 Bay Dipole	184	Ericsson RRUS-11	143
20'-4 Bay Dipole	184	Ericsson RRUS-11	143
PIROD 13' Low Profile Platform (T-Mobile)	163	Ericsson RRUS-11	143
ERICSSON AIR 21 B2A B4P w/ Mount Pipe	163	DC6-48-60-18-8F	143
ERICSSON AIR 21 B2A B4P w/ Mount Pipe	163	(2) OPA-65R-LCUU-H6 w/mount pipe	143
ERICSSON AIR 21 B2A B4P w/ Mount Pipe	163	(2) OPA-65R-LCUU-H8 w/mount pipe	143
ERICSSON AIR 21 B2A B4P w/ Mount Pipe	163	Ericsson RRUS-12	143
RFS ATMAP1412D-1A20	163	Ericsson RRUS-12	143
RFS ATMAP1412D-1A20	163	Ericsson RRUS-32	143
RFS ATMAP1412D-1A20	163	Ericsson RRUS-32	143
ERICSSON AIR 21 B4A B12P-B8P w/ Mount Pipe	163	Ericsson RRUS-E2	143
ERICSSON AIR 21 B4A B12P-B8P w/ Mount Pipe	163	Ericsson RRUS-E2	143
ERICSSON AIR 21 B4A B12P-B8P w/ Mount Pipe	163	Ericsson RRUS-E2	143
Ericsson RRUS 11	163	Ericsson A2 Module	143
Ericsson RRUS 11	163	Ericsson A2 Module	143
Ericsson RRUS 11	163	Surge Arrestor (DC6-48-60-18-8F)	143
PIROD 13' Low Profile Platform (SPRINT - existing)	153	20'-4 Bay Dipole	123
APXVSP18-C w/mount pipe	153	3' Yagi antenna	123
APXVSP18-C w/mount pipe	153	3' Yagi antenna	123
APXVSP18-C w/mount pipe	153	PIROD 13' Low Profile Platform	123
(2) RRH-1900	153	Omni 2"x10'	123
(2) RRH-1900	153	Omni 2"x10'	123
(2) RRH-1900	153	(2) LNX 6514DS-VTM w/mount pipe	110
RRH-800	153	(2) LNX 6514DS-VTM w/mount pipe	110
RRH-800	153	(2) LNX 6514DS-VTM w/mount pipe	110
RRH-800	153	(2) HBX-6517DS-VTM w/mount pipe	110
RRH-800	153	(2) HBX-6517DS-VTM w/mount pipe	110
RRH-800	153	(2) HBX-6517DS-VTM w/mount pipe	110
APXVTM14-C-120 w/mount pipe (SPRINT - proposed)	153	RRH 2X40-AWS+RDEM	110
APXVTM14-C-120 w/mount pipe	153	RRH 2X40-AWS+RDEM	110
APXVTM14-C-120 w/mount pipe	153	RRH 2X40-07U	110
840-10054 w/mount pipe	153	RRH 2X40-07U	110
840-10054 w/mount pipe	153	RRH 2X40-07U	110
840-10054 w/mount pipe	153	RRH 2X40-07U	110
Kathrein 860 10025 RCU	153	RRH 2X40-PCS	110
Kathrein 860 10025 RCU	153	RRH 2X40-PCS	110
Kathrein 860 10025 RCU	153	RRH 2X40-PCS	110
Panel Antenna 18"x18"	153	RFS DB-T1-6Z-8AB-0Z	110
Ring Mount	151	RFS DB-T1-6Z-8AB-0Z	110
RRH 8x20-25	151	PIROD 13' Low Profile Platform (Verizon - proposed)	110
RRH 8x20-25	151	GPS	54
RRH 8x20-25	151	1' Side Mount Standoff	54
Andrew VHLP2-11	150	1' Side Mount Standoff	38.9
Andrew VHLP2-11	150	1' Side Mount Standoff	38.9
Andrew VHLP2-11	150	1' Side Mount Standoff	38.9
PIROD 13' Low Profile Platform (ATT)	143	Andrew VHLPX2-18-2WH/B	38.9
Kathrein 800 10121 w/mount pipe	143	Andrew VHLPX2-18-2WH/B	38.9
		(2) Andrew VHLPX2-18-2WH/B	38.9

MATERIAL STRENGTH

GRADE	Fy	Fu	GRADE	Fy	Fu
A572-65	65 ksi	80 ksi			

TOWER DESIGN NOTES

1. Tower is located in Hartford County, Connecticut.
2. Tower designed for a 80.0 mph basic wind in accordance with the TIA/EIA-222-F Standard.
3. Tower is also designed for a 69.3 mph basic wind with 0.50 in ice.
4. Deflections are based upon a 50.0 mph wind.

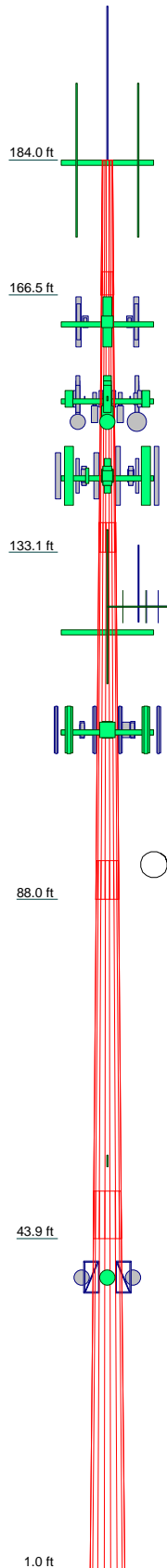

Section	Length (ft)	Number of Sides	Thickness (in)	Socket Length (ft)	Top Dia (in)	Bot Dia (in)	Grade	Weight (lb)
1	17.50	18	0.1875	3.00	15.5000	19.3990		611.7
2	36.42	18	0.2500	3.83	18.3556	26.4010	A572-65	2176.1
3	48.92	18	0.3750	5.00	25.0549	35.8920	A572-65	5963.5
4	49.08	18	0.4375	6.17	34.0344	44.9030	A572-65	9051.8
5	49.08	18	0.4375	42.6617	53.5000		A572-65	11049.1
								28852.3

Hudson Design Group LLC
1600 Osgood Street Bldg. 20N Suite 3090
North Andover, MA 01845
Phone: (978) 557-5553
FAX: (978) 226-5586

Job: **CT43XC827 MANCHESTER POLICE TOWER**

Project: **183 ft Monopole**

Client: SPRINT	Drawn by: kw	App'd:
Code: TIA/EIA-222-F	Date: 04/10/15	Scale: NTS
Path:		Dwg No. E-1



Hudson Design Group LLC
 1600 Osgood Street Bldg. 20N Suite 3090
 North Andover, MA 01845
 Phone: (978) 557-5553
 FAX: (978) 226-5586

Job	CT43XC827 MANCHESTER POLICE TOWER	Page	1 of 11
Project	183 ft Monopole	Date	10:33:39 04/10/15
Client	SPRINT	Designed by	kw

Tower Input Data

There is a pole section.

This tower is designed using the TIA/EIA-222-F standard.

The following design criteria apply:

Tower is located in Hartford County, Connecticut.

Basic wind speed of 80.0 mph.

Nominal ice thickness of 0.5000 in.

Ice density of 56.0 pcf.

A wind speed of 69.3 mph is used in combination with ice.

Temperature drop of 50.0 °F.

Deflections calculated using a wind speed of 50.0 mph.

A non-linear (P-delta) analysis was used.

Pressures are calculated at each section.

Stress ratio used in pole design is 1.333.

Local bending stresses due to climbing loads, feed line supports, and appurtenance mounts are not considered.

Tapered Pole Section Geometry

Section	Elevation ft	Section Length ft	Splice Length ft	Number of Sides	Top Diameter in	Bottom Diameter in	Wall Thickness in	Bend Radius in	Pole Grade
L1	184.00-166.50	17.50	3.00	18	15.5000	19.3990	0.1875	0.7500	A572-65 (65 ksi)
L2	166.50-133.08	36.42	3.83	18	18.3556	26.4010	0.2500	1.0000	A572-65 (65 ksi)
L3	133.08-87.99	48.92	5.00	18	25.0549	35.8920	0.3750	1.5000	A572-65 (65 ksi)
L4	87.99-43.91	49.08	6.17	18	34.0344	44.9030	0.4375	1.7500	A572-65 (65 ksi)
L5	43.91-1.00	49.08		18	42.6617	53.5000	0.4375	1.7500	A572-65 (65 ksi)

Monopole Base Plate Data

Base Plate Data

Base plate is square	
Base plate is grouted	√
Anchor bolt grade	A615-75
Anchor bolt size	2.2500 in
Number of bolts	18
Embedment length	84.0000 in
f_c	4.0 ksi
Grout space	4.0000 in
Base plate grade	A572-60
Base plate thickness	2.0000 in
Bolt circle diameter	62.0000 in
Outer diameter	68.0000 in
Inner diameter	43.0000 in
Base plate type	Stiffened Plate
Bolts per stiffener	1



Hudson Design Group LLC
 1600 Osgood Street Bldg. 20N Suite 3090
 North Andover, MA 01845
 Phone: (978) 557-5553
 FAX: (978) 226-5586

Job	CT43XC827 MANCHESTER POLICE TOWER	Page	2 of 11
Project	183 ft Monopole	Date	10:33:39 04/10/15
Client	SPRINT	Designed by	kw

Base Plate Data

Stiffener thickness	0.5000 in
Stiffener height	6.0000 in

Feed Line/Linear Appurtenances - Entered As Area

Description	Face or Leg	Allow Shield	Component Type	Placement ft	Total Number	C _A A _A		Weight
						No Ice	1/2" Ice	plf
2" Conduit	A	No	CaAa (Out Of Face)	153.00 - 6.00	2	No Ice	0.20	2.80
						1/2" Ice	0.30	4.33
1/2	A	No	CaAa (Out Of Face)	153.00 - 6.00	3	No Ice	0.06	0.25
						1/2" Ice	0.16	0.91
3/8	A	No	Inside Pole	153.00 - 6.00	3	No Ice	0.00	0.25
						1/2" Ice	0.00	0.25
7/8	B	No	Inside Pole	184.00 - 6.00	4	No Ice	0.00	0.54
						1/2" Ice	0.00	0.54
1 5/8 (T-MOBILE)	B	No	Inside Pole	163.00 - 6.00	12	No Ice	0.00	1.04
						1/2" Ice	0.00	1.04
1 5/8 Fiber Cable (T-MOBILE)	B	No	Inside Pole	163.00 - 6.00	9	No Ice	0.00	1.04
						1/2" Ice	0.00	1.04
1 1/4 (SPRINT)	B	No	Inside Pole	153.00 - 6.00	3	No Ice	0.00	0.66
						1/2" Ice	0.00	0.66
1 5/8 (AT&T)	B	No	Inside Pole	143.00 - 6.00	6	No Ice	0.00	1.04
						1/2" Ice	0.00	1.04
FB-L98B-002 (AT&T)	B	No	Inside Pole	143.00 - 6.00	3	No Ice	0.00	0.25
						1/2" Ice	0.00	0.25
WR-VG122ST-BRDA (AT&T)	B	No	Inside Pole	143.00 - 6.00	6	No Ice	0.00	0.25
						1/2" Ice	0.00	0.25
1/2	B	No	Inside Pole	123.00 - 6.00	5	No Ice	0.00	0.25
						1/2" Ice	0.00	0.25
1/2	B	No	Inside Pole	54.00 - 6.00	1	No Ice	0.00	0.25
						1/2" Ice	0.00	0.25
1/2	B	No	Inside Pole	38.90 - 6.00	4	No Ice	0.00	0.25
						1/2" Ice	0.00	0.25

1 5/8 Fiber Cable (VERIZON)	B	No	Inside Pole	110.00 - 6.00	2	No Ice	0.00	1.04
						1/2" Ice	0.00	1.04

Discrete Tower Loads

Description	Face or Leg	Offset Type	Offsets:		Azimuth Adjustment	Placement ft	C _A A _A		Weight lb	
			Horz ft	Vert ft			Front ft ²	Side ft ²		
Lightning Rod 2"x21'	A	From Leg	1.00	0.0000	0.0000	184.00	No Ice	4.20	4.20	80.00
			0.00				1/2" Ice	6.33	6.33	112.30
			10.00							
PiROD 13' Low Profile Platform	A	None		0.0000	0.0000	184.00	No Ice	15.70	15.70	1300.00
20'-4 Bay Dipole	C	From Face	3.50	0.0000	0.0000	184.00	No Ice	4.75	4.75	50.00
			4.00				1/2" Ice	6.25	6.25	80.00
			0.00							
20'-4 Bay Dipole	C	From Face	3.50	0.0000	0.0000	184.00	No Ice	4.75	4.75	50.00



Hudson Design Group LLC
 1600 Osgood Street Bldg. 20N Suite 3090
 North Andover, MA 01845
 Phone: (978) 557-5553
 FAX: (978) 226-5586

Job	CT43XC827 MANCHESTER POLICE TOWER	Page	3 of 11
Project	183 ft Monopole	Date	10:33:39 04/10/15
Client	SPRINT	Designed by	kw

Description	Face or Leg	Offset Type	Offsets: Horz Lateral Vert ft ft ft	Azimuth Adjustment °	Placement ft	C _{AA} Front ft ²	C _{AA} Side ft ²	Weight lb
			-4.00 0.00		1/2" Ice	6.25	6.25	80.00

PiROD 13' Low Profile Platform (T-Mobile)	A	None		0.0000	163.00	No Ice 15.70 1/2" Ice 20.10	15.70 20.10	1300.00 1765.00
ERICSSON AIR 21 B2A B4P w/ Mount Pipe	A	From Face	3.50 0.00 0.00	0.0000	163.00	No Ice 6.83 1/2" Ice 7.35	5.64 6.48	112.18 169.02
ERICSSON AIR 21 B2A B4P w/ Mount Pipe	B	From Face	3.50 0.00 0.00	0.0000	163.00	No Ice 6.83 1/2" Ice 7.35	5.64 6.48	112.18 169.02
ERICSSON AIR 21 B2A B4P w/ Mount Pipe	C	From Face	3.50 0.00 0.00	0.0000	163.00	No Ice 6.83 1/2" Ice 7.35	5.64 6.48	112.18 169.02
RFS ATMAP1412D-1A20	A	From Face	2.50 0.00 0.00	0.0000	163.00	No Ice 1.17 1/2" Ice 1.31	0.47 0.57	13.00 20.62
RFS ATMAP1412D-1A20	B	From Face	2.50 0.00 0.00	0.0000	163.00	No Ice 1.17 1/2" Ice 1.31	0.47 0.57	13.00 20.62
RFS ATMAP1412D-1A20	C	From Face	2.50 0.00 0.00	0.0000	163.00	No Ice 1.17 1/2" Ice 1.31	0.47 0.57	13.00 20.62
ERICSSON AIR 21 B4A B12P-B8P w/ Mount Pipe	A	From Face	3.50 0.00 0.00	0.0000	163.00	No Ice 11.34 1/2" Ice 12.00	9.07 10.30	160.55 248.37
ERICSSON AIR 21 B4A B12P-B8P w/ Mount Pipe	B	From Face	3.50 0.00 0.00	0.0000	163.00	No Ice 11.34 1/2" Ice 12.00	9.07 10.30	160.55 248.37
ERICSSON AIR 21 B4A B12P-B8P w/ Mount Pipe	C	From Face	3.50 0.00 0.00	0.0000	163.00	No Ice 11.34 1/2" Ice 12.00	9.07 10.30	160.55 248.37
Ericsson RRUS 11	A	From Face	2.50 0.00 0.00	0.0000	163.00	No Ice 2.94 1/2" Ice 3.17	1.25 1.41	55.00 74.32
Ericsson RRUS 11	B	From Face	2.50 0.00 0.00	0.0000	163.00	No Ice 2.94 1/2" Ice 3.17	1.25 1.41	55.00 74.32
Ericsson RRUS 11	C	From Face	2.50 0.00 0.00	0.0000	163.00	No Ice 2.94 1/2" Ice 3.17	1.25 1.41	55.00 74.32

PiROD 13' Low Profile Platform (SPRINT - existing)	A	None		0.0000	153.00	No Ice 15.70 1/2" Ice 20.10	15.70 20.10	1300.00 1765.00
APXVSPP18-C w/mount pipe	A	From Face	3.50 0.00 0.00	0.0000	153.00	No Ice 8.50 1/2" Ice 9.15	6.95 8.13	82.55 150.56
APXVSPP18-C w/mount pipe	B	From Face	3.50 0.00 0.00	0.0000	153.00	No Ice 8.50 1/2" Ice 9.15	6.95 8.13	82.55 150.56
APXVSPP18-C w/mount pipe	C	From Face	3.50 0.00 0.00	0.0000	153.00	No Ice 8.50 1/2" Ice 9.15	6.95 8.13	82.55 150.56
(2) RRH-1900	A	From Face	1.00 0.00	0.0000	153.00	No Ice 2.71 1/2" Ice 2.95	3.66 3.92	60.00 88.32



Hudson Design Group LLC
 1600 Osgood Street Bldg. 20N Suite 3090
 North Andover, MA 01845
 Phone: (978) 557-5553
 FAX: (978) 226-5586

Job	CT43XC827 MANCHESTER POLICE TOWER	Page	4 of 11
Project	183 ft Monopole	Date	10:33:39 04/10/15
Client	SPRINT	Designed by	kw

Description	Face or Leg	Offset Type	Offsets:		Azimuth Adjustment	Placement	C _{AA} Front	C _{AA} Side	Weight	
			Horz	Lateral						
			Vert		°	ft	ft ²	ft ²	lb	
			ft	ft						
(2) RRH-1900	B	From Face	0.00	1.00	0.0000	153.00	No Ice	2.71	3.66	60.00
			0.00	0.00			1/2" Ice	2.95	3.92	88.32
			0.00							
(2) RRH-1900	C	From Face	1.00	0.00	0.0000	153.00	No Ice	2.71	3.66	60.00
			0.00	0.00			1/2" Ice	2.95	3.92	88.32
			0.00							
RRH-800	A	From Face	1.00	0.00	0.0000	153.00	No Ice	2.49	3.22	64.00
			0.00	0.00			1/2" Ice	2.71	3.46	91.74
			0.00							
RRH-800	B	From Face	1.00	0.00	0.0000	153.00	No Ice	2.49	3.22	64.00
			0.00	0.00			1/2" Ice	2.71	3.46	91.74
			0.00							
RRH-800	C	From Face	1.00	0.00	0.0000	153.00	No Ice	2.49	3.22	64.00
			0.00	0.00			1/2" Ice	2.71	3.46	91.74
			0.00							

APXVTM14-C-120 w/mount pipe (SPRINT - proposed)	A	From Face	3.50	0.00	0.0000	153.00	No Ice	7.21	5.03	91.90
			0.00	0.00			1/2" Ice	7.77	5.89	147.31
			0.00							
APXVTM14-C-120 w/mount pipe	B	From Face	3.50	0.00	0.0000	153.00	No Ice	7.21	5.03	91.90
			0.00	0.00			1/2" Ice	7.77	5.89	147.31
			0.00							
APXVTM14-C-120 w/mount pipe	C	From Face	3.50	0.00	0.0000	153.00	No Ice	7.21	5.03	91.90
			0.00	0.00			1/2" Ice	7.77	5.89	147.31
			0.00							
RRH 8x20-25	A	From Face	1.00	0.00	0.0000	151.00	No Ice	4.72	1.70	70.00
			0.00	0.00			1/2" Ice	5.01	1.92	97.14
			0.00							
RRH 8x20-25	B	From Face	1.00	0.00	0.0000	151.00	No Ice	4.72	1.70	70.00
			0.00	0.00			1/2" Ice	5.01	1.92	97.14
			0.00							
RRH 8x20-25	C	From Face	1.00	0.00	0.0000	151.00	No Ice	4.72	1.70	70.00
			0.00	0.00			1/2" Ice	5.01	1.92	97.14
			0.00							
Ring Mount	C	None			0.0000	151.00	No Ice	1.40	1.40	90.00
							1/2" Ice	2.40	2.40	130.00

840-10054 w/mount pipe	A	From Face	3.50	0.00	0.0000	153.00	No Ice	5.41	2.39	46.43
			0.00	0.00			1/2" Ice	5.83	2.92	82.55
			0.00							
840-10054 w/mount pipe	B	From Face	3.50	0.00	0.0000	153.00	No Ice	5.41	2.39	46.43
			0.00	0.00			1/2" Ice	5.83	2.92	82.55
			0.00							
840-10054 w/mount pipe	C	From Face	3.50	0.00	0.0000	153.00	No Ice	5.41	2.39	46.43
			0.00	0.00			1/2" Ice	5.83	2.92	82.55
			0.00							
Kathrein 860 10025 RCU	A	From Face	2.50	0.00	0.0000	153.00	No Ice	0.16	0.14	1.20
			0.00	0.00			1/2" Ice	0.23	0.20	2.76
			0.00							
Kathrein 860 10025 RCU	B	From Face	2.50	0.00	0.0000	153.00	No Ice	0.16	0.14	1.20
			0.00	0.00			1/2" Ice	0.23	0.20	2.76
			0.00							
Kathrein 860 10025 RCU	C	From Face	2.50	0.00	0.0000	153.00	No Ice	0.16	0.14	1.20
			0.00	0.00			1/2" Ice	0.23	0.20	2.76
			0.00							
Panel Antenna 18"X18"	B	From Face	3.50	0.0000	153.00	No Ice	3.15	0.53	15.00	



Hudson Design Group LLC
 1600 Osgood Street Bldg. 20N Suite 3090
 North Andover, MA 01845
 Phone: (978) 557-5553
 FAX: (978) 226-5586

Job	CT43XC827 MANCHESTER POLICE TOWER	Page	5 of 11
Project	183 ft Monopole	Date	10:33:39 04/10/15
Client	SPRINT	Designed by	kw

Description	Face or Leg	Offset Type	Offsets: Horz Lateral Vert ft ft ft	Azimuth Adjustment °	Placement ft	C _{AA} Front ft ²	C _{AA} Side ft ²	Weight lb
			0.00		1/2" Ice	3.39	0.67	30.30
			0.00					

PiROD 13' Low Profile Platform	A	None		0.0000	123.00	No Ice 15.70 1/2" Ice 20.10	15.70 20.10	1300.00 1765.00
Omni 2"x10'	B	From Face	3.50 0.00	0.0000	123.00	No Ice 2.00 1/2" Ice 3.02	2.00 3.02	20.00 35.50
Omni 2"x10'	B	From Face	6.00 3.50 0.00	0.0000	123.00	No Ice 2.00 1/2" Ice 3.02	2.00 3.02	20.00 35.50
20'-4 Bay Dipole	C	From Face	6.00 3.50 0.00	0.0000	123.00	No Ice 4.75 1/2" Ice 6.25	4.75 6.25	50.00 80.00
3' Yagi antenna	B	From Face	3.00 3.50 0.00	0.0000	123.00	No Ice 0.70 1/2" Ice 0.95	0.35 0.48	10.00 36.35
3' Yagi antenna	C	From Face	3.00 3.50 0.00	0.0000	123.00	No Ice 0.70 1/2" Ice 0.95	0.35 0.48	10.00 36.35

1' Side Mount Standoff	C	From Face	0.00 1.00 0.00	0.0000	54.00	No Ice 1.00 1/2" Ice 1.50	1.00 1.50	30.00 50.00
GPS	C	From Face	0.00 3.00 0.00	0.0000	54.00	No Ice 0.21 1/2" Ice 0.32	0.21 0.32	5.00 7.52

PiROD 13' Low Profile Platform (AT&T)	A	None		0.0000	143.00	No Ice 15.70 1/2" Ice 20.10	15.70 20.10	1300.00 1765.00
Kathrein 800 10121 w/mount pipe	A	From Face	0.00 3.50 0.00	0.0000	143.00	No Ice 5.72 1/2" Ice 6.21	4.81 5.49	78.15 128.24
Kathrein 800 10121 w/mount pipe	B	From Face	0.00 3.50 0.00	0.0000	143.00	No Ice 5.72 1/2" Ice 6.21	4.81 5.49	78.15 128.24
Kathrein 800 10121 w/mount pipe	C	From Face	0.00 3.50 0.00	0.0000	143.00	No Ice 5.72 1/2" Ice 6.21	4.81 5.49	78.15 128.24
Ericsson RRUS-11	A	From Face	0.00 2.50 0.00	0.0000	143.00	No Ice 3.26 1/2" Ice 3.50	1.38 1.56	50.70 71.57
Ericsson RRUS-11	B	From Face	0.00 2.50 0.00	0.0000	143.00	No Ice 3.26 1/2" Ice 3.50	1.38 1.56	50.70 71.57
Ericsson RRUS-11	C	From Face	0.00 2.50 0.00	0.0000	143.00	No Ice 3.26 1/2" Ice 3.50	1.38 1.56	50.70 71.57
DC6-48-60-18-8F	C	From Leg	0.00 2.00 0.00	0.0000	143.00	No Ice 1.27 1/2" Ice 1.46	1.27 1.46	20.00 35.12

(2) OPA-65R-LCUU-H6 w/mount pipe	A	From Face	0.00 3.50 0.00	0.0000	143.00	No Ice 10.65 1/2" Ice 11.30	7.53 8.56	112.53 192.76
(2) OPA-65R-LCUU-H8	B	From Face	0.00 3.50	0.0000	143.00	No Ice 13.34	9.83	140.11



Hudson Design Group LLC
 1600 Osgood Street Bldg. 20N Suite 3090
 North Andover, MA 01845
 Phone: (978) 557-5553
 FAX: (978) 226-5586

Job	CT43XC827 MANCHESTER POLICE TOWER	Page	6 of 11
Project	183 ft Monopole	Date	10:33:39 04/10/15
Client	SPRINT	Designed by	kw

Description	Face or Leg	Offset Type	Offsets: Horz Lateral Vert ft ft ft	Azimuth Adjustment °	Placement ft	C _{AA} Front ft ²	C _{AA} Side ft ²	Weight lb	
w/mount pipe			0.00		1/2" Ice	14.18	11.34	239.33	
(2) OPA-65R-LCUU-H8 w/mount pipe	C	From Face	3.50 0.00 0.00	0.0000	143.00	No Ice 1/2" Ice	13.34 14.18	9.83 11.34	140.11 239.33
Ericsson RRUS-12	A	From Face	2.50 0.00 0.00	0.0000	143.00	No Ice 1/2" Ice	3.67 3.93	1.49 1.67	58.00 81.22
Ericsson RRUS-12	B	From Face	2.50 0.00 0.00	0.0000	143.00	No Ice 1/2" Ice	3.67 3.93	1.49 1.67	58.00 81.22
Ericsson RRUS-12	C	From Face	2.50 0.00 0.00	0.0000	143.00	No Ice 1/2" Ice	3.67 3.93	1.49 1.67	58.00 81.22
Ericsson RRUS-32	A	From Face	2.50 0.00 0.00	0.0000	143.00	No Ice 1/2" Ice	3.87 4.15	2.76 3.02	77.00 104.93
Ericsson RRUS-32	B	From Face	2.50 0.00 0.00	0.0000	143.00	No Ice 1/2" Ice	3.87 4.15	2.76 3.02	77.00 104.93
Ericsson RRUS-32	C	From Face	2.50 0.00 0.00	0.0000	143.00	No Ice 1/2" Ice	3.87 4.15	2.76 3.02	77.00 104.93
Ericsson RRUS-E2	A	From Face	2.50 0.00 0.00	0.0000	143.00	No Ice 1/2" Ice	3.87 4.15	2.76 3.02	77.00 104.93
Ericsson RRUS-E2	B	From Face	2.50 0.00 0.00	0.0000	143.00	No Ice 1/2" Ice	3.87 4.15	2.76 3.02	77.00 104.93
Ericsson RRUS-E2	C	From Face	2.50 0.00 0.00	0.0000	143.00	No Ice 1/2" Ice	3.87 4.15	2.76 3.02	77.00 104.93
Ericsson A2 Module	A	From Face	2.50 0.00 0.00	0.0000	143.00	No Ice 1/2" Ice	2.42 2.63	0.54 0.67	22.00 34.73
Ericsson A2 Module	B	From Face	2.50 0.00 0.00	0.0000	143.00	No Ice 1/2" Ice	2.42 2.63	0.54 0.67	22.00 34.73
Ericsson A2 Module	C	From Face	2.50 0.00 0.00	0.0000	143.00	No Ice 1/2" Ice	2.42 2.63	0.54 0.67	22.00 34.73
Surge Arrestor (DC6-48-60-18-8F)	A	From Leg	2.00 0.00 0.00	0.0000	143.00	No Ice 1/2" Ice	1.27 1.46	1.27 1.46	20.00 35.12

PiROD 13' Low Profile Platform (Verizon - proposed)	C	None		0.0000	110.00	No Ice 1/2" Ice	15.70 20.10	15.70 20.10	1300.00 1765.00
(2) LNX 6514DS-VTM w/mount pipe	A	From Face	3.50 0.00 0.00	0.0000	110.00	No Ice 1/2" Ice	8.63 9.29	7.07 8.25	64.55 133.55
(2) LNX 6514DS-VTM w/mount pipe	B	From Face	3.50 0.00 0.00	0.0000	110.00	No Ice 1/2" Ice	8.63 9.29	7.07 8.25	64.55 133.55
(2) LNX 6514DS-VTM w/mount pipe	C	From Face	3.50 0.00 0.00	0.0000	110.00	No Ice 1/2" Ice	8.63 9.29	7.07 8.25	64.55 133.55



Hudson Design Group LLC
 1600 Osgood Street Bldg. 20N Suite 3090
 North Andover, MA 01845
 Phone: (978) 557-5553
 FAX: (978) 226-5586

Job	CT43XC827 MANCHESTER POLICE TOWER	Page	7 of 11
Project	183 ft Monopole	Date	10:33:39 04/10/15
Client	SPRINT	Designed by	kw

Description	Face or Leg	Offset Type	Offsets: Horz Lateral Vert ft ft ft	Azimuth Adjustment °	Placement ft	C _{AA} Front ft ²	C _{AA} Side ft ²	Weight lb
(2) HBX-6517DS-VTM w/mount pipe	A	From Face	3.50 0.00 0.00	0.0000	110.00	No Ice 1/2" Ice 5.42 5.97	4.96 6.14	39.25 85.00
(2) HBX-6517DS-VTM w/mount pipe	B	From Face	3.50 0.00 0.00	0.0000	110.00	No Ice 1/2" Ice 5.42 5.97	4.96 6.14	39.25 85.00
(2) HBX-6517DS-VTM w/mount pipe	C	From Face	3.50 0.00 0.00	0.0000	110.00	No Ice 1/2" Ice 5.42 5.97	4.96 6.14	39.25 85.00
RRH 2X40-AWS+RDEM	A	From Face	2.50 0.00 0.00	0.0000	110.00	No Ice 1/2" Ice 3.77 4.04	2.23 2.46	47.60 73.79
RRH 2X40-AWS+RDEM	B	From Face	2.50 0.00 0.00	0.0000	110.00	No Ice 1/2" Ice 3.77 4.04	2.23 2.46	47.60 73.79
RRH 2X40-AWS+RDEM	C	From Face	2.50 0.00 0.00	0.0000	110.00	No Ice 1/2" Ice 3.77 4.04	2.23 2.46	47.60 73.79
RRH 2X40-07U	A	From Face	2.50 0.00 0.00	0.0000	110.00	No Ice 1/2" Ice 2.29 2.49	1.21 1.36	50.00 66.78
RRH 2X40-07U	B	From Face	2.50 0.00 0.00	0.0000	110.00	No Ice 1/2" Ice 2.29 2.49	1.21 1.36	50.00 66.78
RRH 2X40-07U	C	From Face	2.50 0.00 0.00	0.0000	110.00	No Ice 1/2" Ice 2.29 2.49	1.21 1.36	50.00 66.78
RRH 2X40-PCS	A	From Face	2.50 0.00 0.00	0.0000	110.00	No Ice 1/2" Ice 2.57 2.79	2.02 2.23	55.00 75.41
RRH 2X40-PCS	B	From Face	2.50 0.00 0.00	0.0000	110.00	No Ice 1/2" Ice 2.57 2.79	2.02 2.23	55.00 75.41
RRH 2X40-PCS	C	From Face	2.50 0.00 0.00	0.0000	110.00	No Ice 1/2" Ice 2.57 2.79	2.02 2.23	55.00 75.41
RFS DB-T1-6Z-8AB-0Z	B	From Face	1.50 0.00 0.00	0.0000	110.00	No Ice 1/2" Ice 5.60 5.92	2.33 2.56	44.00 80.13
RFS DB-T1-6Z-8AB-0Z	C	From Face	1.50 0.00 0.00	0.0000	110.00	No Ice 1/2" Ice 5.60 5.92	2.33 2.56	44.00 80.13

1' Side Mount Standoff	A	From Face	0.50 0.00 0.00	0.0000	38.90	No Ice 1/2" Ice 1.00 1.50	1.00 1.50	30.00 50.00
1' Side Mount Standoff	B	From Face	0.50 0.00 0.00	0.0000	38.90	No Ice 1/2" Ice 1.00 1.50	1.00 1.50	30.00 50.00
1' Side Mount Standoff	C	From Face	0.50 0.00 0.00	0.0000	38.90	No Ice 1/2" Ice 1.00 1.50	1.00 1.50	30.00 50.00



Hudson Design Group LLC
 1600 Osgood Street Bldg. 20N Suite 3090
 North Andover, MA 01845
 Phone: (978) 557-5553
 FAX: (978) 226-5586

Job	CT43XC827 MANCHESTER POLICE TOWER	Page	8 of 11
Project	183 ft Monopole	Date	10:33:39 04/10/15
Client	SPRINT	Designed by	kw

Dishes

Description	Face or Leg	Dish Type	Offset Type	Offsets: Horz Lateral Vert	Azimuth Adjustment	3 dB Beam Width	Elevation	Outside Diameter	Aperture Area	Weight	
				ft	°	°	ft	ft	ft ²	lb	
Andrew VHL P2-11	A	Paraboloid w/Radome	From Face	3.50 0.00 0.00	0.0000		150.00	2.00	No Ice 1/2" Ice	3.14 3.41	31.00 41.00
Andrew VHL P2-11	B	Paraboloid w/Shroud (HP)	From Face	3.50 0.00 0.00	0.0000		150.00	2.50	No Ice 1/2" Ice	6.00 6.40	49.00 77.00
Andrew VHL P2-11	C	Paraboloid w/Radome	From Face	3.50 0.00 0.00	0.0000		150.00	2.00	No Ice 1/2" Ice	3.14 3.41	31.00 41.00
Andrew VHL P2-18-2WH/B	A	Paraboloid w/Radome	From Face	2.00 0.00 0.00	0.0000		38.90	2.00	No Ice 1/2" Ice	3.14 3.41	25.00 35.00
Andrew VHL P2-18-2WH/B	B	Paraboloid w/Radome	From Face	2.00 0.00 0.00	0.0000		38.90	2.00	No Ice 1/2" Ice	3.14 3.41	25.00 35.00
(2) Andrew VHL P2-18-2WH/B	C	Paraboloid w/Radome	From Face	2.00 0.00 0.00	0.0000		38.90	2.00	No Ice 1/2" Ice	3.14 3.41	25.00 35.00

Load Combinations

Comb. No.	Description
1	Dead Only
2	Dead+Wind 0 deg - No Ice
3	Dead+Wind 30 deg - No Ice
4	Dead+Wind 60 deg - No Ice
5	Dead+Wind 90 deg - No Ice
6	Dead+Wind 120 deg - No Ice
7	Dead+Wind 150 deg - No Ice
8	Dead+Wind 180 deg - No Ice
9	Dead+Wind 210 deg - No Ice
10	Dead+Wind 240 deg - No Ice
11	Dead+Wind 270 deg - No Ice
12	Dead+Wind 300 deg - No Ice
13	Dead+Wind 330 deg - No Ice
14	Dead+Ice+Temp
15	Dead+Wind 0 deg+Ice+Temp
16	Dead+Wind 30 deg+Ice+Temp
17	Dead+Wind 60 deg+Ice+Temp
18	Dead+Wind 90 deg+Ice+Temp
19	Dead+Wind 120 deg+Ice+Temp
20	Dead+Wind 150 deg+Ice+Temp
21	Dead+Wind 180 deg+Ice+Temp
22	Dead+Wind 210 deg+Ice+Temp
23	Dead+Wind 240 deg+Ice+Temp
24	Dead+Wind 270 deg+Ice+Temp
25	Dead+Wind 300 deg+Ice+Temp
26	Dead+Wind 330 deg+Ice+Temp
27	Dead+Wind 0 deg - Service
28	Dead+Wind 30 deg - Service
29	Dead+Wind 60 deg - Service



Hudson Design Group LLC
 1600 Osgood Street Bldg. 20N Suite 3090
 North Andover, MA 01845
 Phone: (978) 557-5553
 FAX: (978) 226-5586

Job	CT43XC827 MANCHESTER POLICE TOWER	Page	9 of 11
Project	183 ft Monopole	Date	10:33:39 04/10/15
Client	SPRINT	Designed by	kw

Comb. No.	Description
30	Dead+Wind 90 deg - Service
31	Dead+Wind 120 deg - Service
32	Dead+Wind 150 deg - Service
33	Dead+Wind 180 deg - Service
34	Dead+Wind 210 deg - Service
35	Dead+Wind 240 deg - Service
36	Dead+Wind 270 deg - Service
37	Dead+Wind 300 deg - Service
38	Dead+Wind 330 deg - Service

Maximum Reactions

Location	Condition	Gov. Load Comb.	Vertical lb	Horizontal, X lb	Horizontal, Z lb
Pole	Max. Vert	24	60909.72	31979.36	-135.40
	Max. H _x	11	49635.09	36362.32	-182.71
	Max. H _z	2	49635.09	-230.38	36337.73
	Max. M _x	2	4492612.05	-230.38	36337.73
	Max. M _z	5	4497984.35	-36335.78	246.35
	Max. Torsion	9	2554.82	18356.28	-31559.96
	Min. Vert	1	49635.09	0.00	0.00
	Min. H _x	5	49635.09	-36335.78	246.35
	Min. H _z	8	49635.09	272.09	-36379.66
	Min. M _x	8	-4495865.87	272.09	-36379.66
	Min. M _z	11	-4500851.61	36362.32	-182.71
	Min. Torsion	3	-2617.56	-18389.62	31539.33

Tower Mast Reaction Summary

Load Combination	Vertical lb	Shear _x lb	Shear _z lb	Overturning Moment, M _x lb-ft	Overturning Moment, M _z lb-ft	Torque lb-ft
Dead Only	49635.09	0.00	0.00	-712.97	-598.82	-0.00
Dead+Wind 0 deg - No Ice	49635.09	230.38	-36337.73	-4492612.05	-34520.04	1900.36
Dead+Wind 30 deg - No Ice	49635.09	18389.62	-31539.33	-3898907.50	-2278622.41	2617.56
Dead+Wind 60 deg - No Ice	49635.09	31576.19	-18329.71	-2268130.09	-3908493.37	2506.95
Dead+Wind 90 deg - No Ice	49635.09	36335.78	-246.35	-34327.22	-4497984.35	1714.33
Dead+Wind 120 deg - No Ice	49635.09	31396.73	17944.97	2214942.19	-3887844.10	577.98
Dead+Wind 150 deg - No Ice	49635.09	18055.53	31395.66	3878672.29	-2234287.03	-707.48
Dead+Wind 180 deg - No Ice	49635.09	-272.09	36379.66	4495865.87	39869.25	-1709.89
Dead+Wind 210 deg - No Ice	49635.09	-18356.28	31559.96	3901869.18	2276059.89	-2554.82
Dead+Wind 240 deg - No Ice	49635.09	-31529.49	18287.63	2264586.74	3904791.20	-2477.32
Dead+Wind 270 deg - No Ice	49635.09	-36362.32	182.71	28450.50	4500851.61	-1752.76
Dead+Wind 300 deg - No Ice	49635.09	-31481.35	-17960.77	-2214271.55	3894947.88	-797.97
Dead+Wind 330 deg - No Ice	49635.09	-18039.39	-31434.23	-3885003.18	2226485.78	683.38
Dead+Ice+Temp	60909.72	0.00	0.00	-1382.25	-1178.49	0.03
Dead+Wind 0 deg+Ice+Temp	60909.72	174.24	-31951.30	-4023470.92	-27452.64	1826.76
Dead+Wind 30 deg+Ice+Temp	60909.72	16148.55	-27721.65	-3490475.39	-2037906.83	2291.89
Dead+Wind 60 deg+Ice+Temp	60909.72	27759.08	-16095.80	-2028683.44	-3499473.31	2037.94
Dead+Wind 90 deg+Ice+Temp	60909.72	31958.67	-187.51	-27401.61	-4029210.48	1229.52
Dead+Wind 120 deg+Ice+Temp	60909.72	27625.02	15804.89	1986147.60	-3484108.25	188.03
Dead+Wind 150 deg+Ice+Temp	60909.72	15898.33	27617.08	3473828.51	-2004337.03	-898.74
Dead+Wind 180 deg+Ice+Temp	60909.72	-207.33	31985.25	4024486.39	30243.01	-1673.60



Hudson Design Group LLC
 1600 Osgood Street Bldg. 20N Suite 3090
 North Andover, MA 01845
 Phone: (978) 557-5553
 FAX: (978) 226-5586

Job	CT43XC827 MANCHESTER POLICE TOWER	Page	10 of 11
Project	183 ft Monopole	Date	10:33:39 04/10/15
Client	SPRINT	Designed by	kw

Load Combination	Vertical	Shear _x	Shear _z	Overturning Moment, M _x	Overturning Moment, M _z	Torque
	lb	lb	lb	lb-ft	lb-ft	lb-ft
Dead+Wind 210 deg+Ice+Temp	60909.72	-16120.69	27737.79	3491176.64	2034164.72	-2241.47
Dead+Wind 240 deg+Ice+Temp	60909.72	-27720.26	16061.07	2023998.81	3494763.67	-2014.15
Dead+Wind 270 deg+Ice+Temp	60909.72	-31979.36	135.40	20806.49	4029919.71	-1260.62
Dead+Wind 300 deg+Ice+Temp	60909.72	-27693.31	-15818.42	-1987347.01	3488363.86	-364.96
Dead+Wind 330 deg+Ice+Temp	60909.72	-15885.89	-27648.10	-3480686.79	1996401.41	879.56
Dead+Wind 0 deg - Service	49635.09	89.99	-14194.43	-1759871.53	-13936.56	757.08
Dead+Wind 30 deg - Service	49635.09	7183.45	-12320.05	-1527394.03	-892815.42	1043.24
Dead+Wind 60 deg - Service	49635.09	12334.45	-7160.05	-888722.27	-1531140.91	1000.24
Dead+Wind 90 deg - Service	49635.09	14193.66	-96.23	-13877.80	-1761967.93	685.49
Dead+Wind 120 deg - Service	49635.09	12264.35	7009.75	866977.27	-1522972.51	232.94
Dead+Wind 150 deg - Service	49635.09	7052.94	12263.93	1518522.32	-875405.47	-279.70
Dead+Wind 180 deg - Service	49635.09	-106.29	14210.83	1760231.55	15201.68	-679.97
Dead+Wind 210 deg - Service	49635.09	-7170.42	12328.11	1527686.55	890980.43	-1018.48
Dead+Wind 240 deg - Service	49635.09	-12316.21	7143.61	886468.39	1528859.08	-989.92
Dead+Wind 270 deg - Service	49635.09	-14204.03	71.37	10711.13	1762282.80	-702.07
Dead+Wind 300 deg - Service	49635.09	-12297.40	-7015.93	-867594.66	1524951.11	-320.36
Dead+Wind 330 deg - Service	49635.09	-7046.64	-12279.00	-1521890.57	871529.16	271.58

Solution Summary

Load Comb.	Sum of Applied Forces			Sum of Reactions			% Error
	PX lb	PY lb	PZ lb	PX lb	PY lb	PZ lb	
1	0.00	-49635.09	0.00	0.00	49635.09	0.00	0.000%
2	230.38	-49635.09	-36337.72	-230.38	49635.09	36337.73	0.000%
3	18389.62	-49635.09	-31539.33	-18389.62	49635.09	31539.33	0.000%
4	31576.19	-49635.09	-18329.71	-31576.19	49635.09	18329.71	0.000%
5	36335.77	-49635.09	-246.35	-36335.78	49635.09	246.35	0.000%
6	31396.73	-49635.09	17944.97	-31396.73	49635.09	-17944.97	0.000%
7	18055.53	-49635.09	31395.66	-18055.53	49635.09	-31395.66	0.000%
8	-272.09	-49635.09	36379.66	272.09	49635.09	-36379.66	0.000%
9	-18356.28	-49635.09	31559.96	18356.28	49635.09	-31559.96	0.000%
10	-31529.49	-49635.09	18287.63	31529.49	49635.09	-18287.63	0.000%
11	-36362.31	-49635.09	182.71	36362.32	49635.09	-182.71	0.000%
12	-31481.35	-49635.09	-17960.77	31481.35	49635.09	17960.77	0.000%
13	-18039.39	-49635.09	-31434.23	18039.39	49635.09	31434.23	0.000%
14	0.00	-60909.72	0.00	-0.00	60909.72	-0.00	0.000%
15	174.24	-60909.72	-31951.28	-174.24	60909.72	31951.30	0.000%
16	16148.55	-60909.72	-27721.64	-16148.55	60909.72	27721.65	0.000%
17	27759.08	-60909.72	-16095.80	-27759.08	60909.72	16095.80	0.000%
18	31958.65	-60909.72	-187.51	-31958.67	60909.72	187.51	0.000%
19	27625.01	-60909.72	15804.88	-27625.02	60909.72	-15804.89	0.000%
20	15898.33	-60909.72	27617.08	-15898.33	60909.72	-27617.08	0.000%
21	-207.33	-60909.72	31985.23	207.33	60909.72	-31985.25	0.000%
22	-16120.68	-60909.72	27737.79	16120.69	60909.72	-27737.79	0.000%
23	-27720.26	-60909.72	16061.07	27720.26	60909.72	-16061.07	0.000%
24	-31979.35	-60909.72	135.40	31979.36	60909.72	-135.40	0.000%
25	-27693.31	-60909.72	-15818.42	27693.31	60909.72	15818.42	0.000%
26	-15885.89	-60909.72	-27648.10	15885.89	60909.72	27648.10	0.000%
27	89.99	-49635.09	-14194.42	-89.99	49635.09	14194.43	0.000%
28	7183.44	-49635.09	-12320.05	-7183.45	49635.09	12320.05	0.000%
29	12334.45	-49635.09	-7160.04	-12334.45	49635.09	7160.05	0.000%
30	14193.66	-49635.09	-96.23	-14193.66	49635.09	96.23	0.000%
31	12264.35	-49635.09	7009.75	-12264.35	49635.09	-7009.75	0.000%
32	7052.94	-49635.09	12263.93	-7052.94	49635.09	-12263.93	0.000%
33	-106.29	-49635.09	14210.80	106.29	49635.09	-14210.83	0.000%
34	-7170.42	-49635.09	12328.11	7170.42	49635.09	-12328.11	0.000%



Hudson Design Group LLC
 1600 Osgood Street Bldg. 20N Suite 3090
 North Andover, MA 01845
 Phone: (978) 557-5553
 FAX: (978) 226-5586

Job	CT43XC827 MANCHESTER POLICE TOWER	Page	11 of 11
Project	183 ft Monopole	Date	10:33:39 04/10/15
Client	SPRINT	Designed by	kw

Load Comb.	Sum of Applied Forces			Sum of Reactions			% Error
	PX lb	PY lb	PZ lb	PX lb	PY lb	PZ lb	
35	-12316.21	-49635.09	7143.61	12316.21	49635.09	-7143.61	0.000%
36	-14204.03	-49635.09	71.37	14204.03	49635.09	-71.37	0.000%
37	-12297.40	-49635.09	-7015.93	12297.40	49635.09	7015.93	0.000%
38	-7046.64	-49635.09	-12279.00	7046.64	49635.09	12279.00	0.000%

Maximum Tower Deflections - Service Wind

Section No.	Elevation ft	Horz. Deflection in	Gov. Load Comb.	Tilt °	Twist °
L1	184 - 166.5	72.9820	29	3.3974	0.0196
L2	169.5 - 133.08	62.7470	29	3.3370	0.0122
L3	136.91 - 87.99	41.0288	29	2.9178	0.0062
L4	92.99 - 43.91	18.3700	29	1.9266	0.0025
L5	50.08 - 1	5.1650	29	0.9759	0.0009

Critical Deflections and Radius of Curvature - Service Wind

Elevation ft	Appurtenance	Gov. Load Comb.	Deflection in	Tilt °	Twist °	Radius of Curvature ft
184.00	Lightning Rod 2"x21'	29	72.9820	3.3974	0.0200	32437
163.00	PiROD 13' Low Profile Platform	29	58.2170	3.2869	0.0101	7010
153.00	PiROD 13' Low Profile Platform	29	51.3959	3.1752	0.0079	4451
151.00	RRH 8x20-25	29	50.0607	3.1481	0.0076	4146
150.00	Andrew VHLP2-11	29	49.3974	3.1340	0.0075	4009
143.00	PiROD 13' Low Profile Platform	29	44.8439	3.0255	0.0068	3252
123.00	PiROD 13' Low Profile Platform	29	32.9119	2.6326	0.0050	2702
110.00	PiROD 13' Low Profile Platform	29	26.1048	2.3333	0.0038	2627
54.00	1' Side Mount Standoff	29	5.9722	1.0579	0.0010	2212
38.90	Andrew VHLPX2-18-2WH/B	29	3.3003	0.7466	0.0007	2827

Section Capacity Table

Section No.	Elevation ft	Component Type	Size	Critical Element	P lb	SF*P _{allow} lb	% Capacity	Pass Fail
L1	184 - 166.5	Pole	TP19.399x15.5x0.1875	1	-2458.14	573700.52	14.0	Pass
L2	166.5 - 133.08	Pole	TP26.401x18.3556x0.25	2	-10908.10	1043870.92	66.5	Pass
L3	133.08 - 87.99	Pole	TP35.892x25.0549x0.375	3	-22141.90	2129160.82	96.5	Pass
L4	87.99 - 43.91	Pole	TP44.903x34.0344x0.4375	4	-33646.00	3111341.84	102.6	Fail X
L5	43.91 - 1	Pole	TP53.5x42.6617x0.4375	5	-46093.80	3650593.64	109.6	Fail X
Summary								
Pole (L5)							109.6	Fail X
Base Plate							120.0	Fail X
RATING =							120.0	Fail X

(Revised)
STRUCTURAL ANALYSIS REPORT

For

CT43XC827
MANCHESTER/POLICE TOWER

239 Middle Turnpike
Manchester, CT 06040

Antennas Mounted to the Monopole

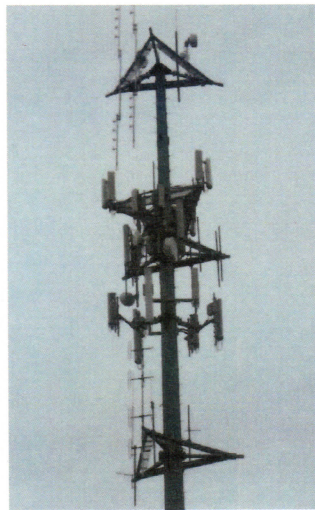

Prepared for:



1 INTERNATIONAL BLVD, SUITE 800
MAHWAH, NJ 07495
TEL: (201) 684-4223

Dated: April 10, 2015

Prepared by:



1600 Osgood Street Bldg. 20N Suite 3090
North Andover, MA 01845
(P) 978.557.5553 (F) 978.336.5586
www.hudsondesigngroupllc.com

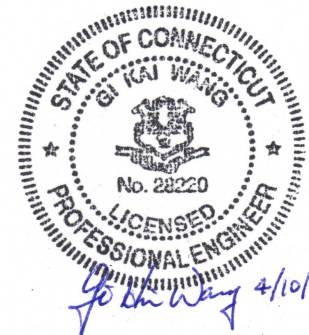

Gi Kai Wang 4/10/2015



SCOPE OF WORK:

Hudson Design Group LLC (HDG) has been authorized by Sprint to conduct a structural evaluation of the 183' monopole supporting the existing and proposed Sprint's antennas located at elevation 153' above the ground level.

This report represents this office's findings, conclusions and recommendations pertaining to the support of Sprint's existing and proposed antennas listed below.

Record drawings of the existing monopole prepared by Engineered Endeavors Inc., dated September 17, 2002, were available for our use. The previous structural analysis report prepared by Ramaker & Associates, Inc., dated November 26, 2012, was available and obtained for our use. The previous structural analysis report prepared by Destek Engineering, LLC, dated October 14, 2014, was also available and obtained for our use.

CONCLUSION SUMMARY:

HDG performed structural analysis of the existing monopole with the following proposed modifications:

- 1. Add steel reinforcing plates to the existing monopole from El.1' to El.88'.**
- 2. Add steel stiffener plates to the base plate of the monopole.**

Estimated costs for materials and labor for the above mentioned tower modifications is estimated between \$70K-\$90K

Based on our evaluation, we have determined that the existing monopole with proposed modifications and foundation are in conformance with the ANSI/TIA-222-F Standard for the loading considered under the criteria listed in this report. The monopole structure is rated at 95.7% - (Pole section L3 from EL.88.0' to EL.133.1' Controlling).



APPURTANENCES CONFIGURATION:

Tenant	Appurtenances	Elev.	Mount
	Lighting Rod	194'	Low Profile Platform
	(2) 20' Dipole	184'	Low Profile Platform
T-MOBILE	(3) AIR 21 B2A B4P Antennas	163'	Low Profile Platform
T-MOBILE	(3) AIR 21 B4A B12P Antennas	163'	Low Profile Platform
T-MOBILE	(3) ATMAP1412D TMA	163'	Low Profile Platform
T-MOBILE	(3) RRUS 11	163'	Low Profile Platform
Sprint	(3) APXVSP18 Antennas	153'	Low Profile Platform
Sprint	(3) RRH-800	153'	Low Profile Platform
Sprint	(6) RRH-1900	153'	Low Profile Platform
Sprint	(3) APXVTM14-C-120 Antennas	153'	Low Profile Platform
Sprint	(3) RRHx20-25	151'	Ring Mount
	(3) 840-10054 Antennas	153'	Low Profile Platform
	(3) 860-10025 RCU	153'	Low Profile Platform
	Panel Antenna	153'	Low Profile Platform
	(2) 2' Dishes	150'	Low Profile Platform
	2.5' Dish	150'	Low Profile Platform
AT&T	(3) 800-10121 Antennas	143'	Low Profile Platform
AT&T	(2) OPA-65R-LCUU-H6 Antennas	143'	Low Profile Platform
AT&T	(4) OPA-65R-LCUU-H8 Antennas	143'	Low Profile Platform
AT&T	(12) RRUs	143'	Low Profile Platform
AT&T	(3) A2 Modules	143'	Low Profile Platform
AT&T	(2) Surge Arrestors	143'	Low Profile Platform
	(2) 20' Omni	129'	Low Profile Platform
	20' Dipole	126'	Low Profile Platform
	(2) 3' Yagi	126'	Low Profile Platform
VERIZON	(6) LNX 6514DS-VTM Antennas	110'	Low Profile Platform
VERIZON	(6) HBX 6517DS-VTM Antennas	110'	Low Profile Platform
VERIZON	(3) RRH 2X40-AWS	110'	Low Profile Platform
VERIZON	(3) RRH 2X40-07U	110'	Low Profile Platform
VERIZON	(3) RRH 2X40-PCS	110'	Low Profile Platform
VERIZON	(2) DB-T1-6Z-8AB-0Z	110'	Low Profile Platform
	GPS	54'	1' Side Mount Standoff
POLICE	(4) VHLPX2-18 Dish	38.9'	1' Side Mount Standoff

***Proposed SPRINT Appurtenances shown in Bold.**



SPRINT EXISTING/PROPOSED COAX CABLES:

Tenant	Coax Cables	Elev.	Mount
Sprint	(3) 1 1/4" Fiber Cables	153'	Inside Monopole

**Proposed SPRINT Coax Cables shown in Bold.*

ANALYSIS RESULTS SUMMARY:

Component	Max. Stress Ratio	Elev. of Component (ft)	Pass/Fail	Comments
Pole Section-L1	13.8 %	166.5 – 184.0	PASS	
Pole Section-L2	66.1 %	133.1 – 166.5	PASS	
Pole Section-L3	95.7 %	88.0 – 133.1	PASS	Controlling
Pole Section-L4	92.2 %	43.9 – 88.0	PASS	
Pole Section-L5	88.9 %	1.0 – 43.9	PASS	
Base Plate	84.3 %	1.0	PASS	



DESIGN CRITERIA:

1. EIA/TIA-222-F Structural Standards for Steel Antenna Towers and Antenna Supporting Structures

County: Hartford
Wind Load: 80 mph (fastest mile)
100 mph (3 second gust)
Nominal Ice Thickness: 1/2 inch

2. Approximate height above grade to proposed antennas: 153'-0"

***Calculations and referenced documents are attached.**

ASSUMPTIONS:

1. The monopole dimensions, member sizes and strength of material are as indicated in the record drawings prepared by Engineered Endeavors Inc., dated September 17, 2002.
2. The appurtenances configuration is as stated in this report. All antennas, coax cables and waveguide cables are assumed to be properly installed and supported as per the manufacturer's requirements.
3. The monopole and foundation are properly constructed and maintained. All structural members and their connections are assumed to be in good condition and are free from defects with no deterioration to its member capacities.
4. The support mounts and platforms are not analyzed and are considered adequate to support the loading. The analysis is limited to the primary support structure itself.
5. All prior structural modification, if any, are assumed to be as per the data supplied (if available), and installed properly.



SUPPORT RECOMMENDATIONS:

HDG recommends that the proposed antennas be mounted on the existing steel platform supported by the monopole; the proposed RRHs be mounted on the proposed mount pipes.

ONGOING AND PERIODIC INSPECTION AND MAINTENANCE:

After the Contractor has successfully completed the installation and the work has been accepted, the Owner will be responsible for the ongoing and periodic inspection and maintenance of the tower.

The owner shall refer to TIA/EIA-222-F for recommendations for maintenance and inspection. The frequency of the inspection and maintenance intervals is to be determined by the owner based upon actual site and environmental conditions. It is recommended that a complete and thorough inspection of the entire tower structural system be performed at least yearly and more frequently as conditions warrant. According to TIA/EIA-222-F section 14.1, Note 1: It is recommended that the structure be inspected after severe wind and/or ice storms or other extreme loading conditions.



Photo 1: Photo illustrating the Monopole with Appurtenances shown.



CALCULATIONS

DESIGNED APPURTENANCE LOADING

TYPE	ELEVATION	TYPE	ELEVATION
Lightning Rod 2"x21"	184	Kathrein 800 10121 w/mount pipe	143
PIROD 13' Low Profile Platform	184	Kathrein 800 10121 w/mount pipe	143
20'-4 Bay Dipole	184	Ericsson RRUS-11	143
20'-4 Bay Dipole	184	Ericsson RRUS-11	143
PIROD 13' Low Profile Platform (T-Mobile)	163	Ericsson RRUS-11	143
ERICSSON AIR 21 B2A B4P w/ Mount Pipe	163	DC6-48-60-18-8F	143
ERICSSON AIR 21 B2A B4P w/ Mount Pipe	163	(2) OPA-65R-LCUU-H6 w/mount pipe	143
ERICSSON AIR 21 B2A B4P w/ Mount Pipe	163	(2) OPA-65R-LCUU-H8 w/mount pipe	143
ERICSSON AIR 21 B2A B4P w/ Mount Pipe	163	Ericsson RRUS-12	143
RFS ATMAP1412D-1A20	163	Ericsson RRUS-12	143
RFS ATMAP1412D-1A20	163	Ericsson RRUS-32	143
RFS ATMAP1412D-1A20	163	Ericsson RRUS-32	143
ERICSSON AIR 21 B4A B12P-B8P w/ Mount Pipe	163	Ericsson RRUS-E2	143
ERICSSON AIR 21 B4A B12P-B8P w/ Mount Pipe	163	Ericsson RRUS-E2	143
ERICSSON AIR 21 B4A B12P-B8P w/ Mount Pipe	163	Ericsson RRUS-E2	143
Ericsson RRUS 11	163	Ericsson A2 Module	143
Ericsson RRUS 11	163	Ericsson A2 Module	143
Ericsson RRUS 11	163	Surge Arrestor (DC6-48-60-18-8F)	143
PIROD 13' Low Profile Platform (SPRINT - existing)	153	20'-4 Bay Dipole	123
APXVSP18-C w/mount pipe	153	3' Yagi antenna	123
APXVSP18-C w/mount pipe	153	3' Yagi antenna	123
APXVSP18-C w/mount pipe	153	PIROD 13' Low Profile Platform	123
(2) RRH-1900	153	Omni 2"x10'	123
(2) RRH-1900	153	Omni 2"x10'	123
(2) RRH-1900	153	(2) LNX 6514DS-VTM w/mount pipe	110
RRH-800	153	(2) LNX 6514DS-VTM w/mount pipe	110
RRH-800	153	(2) LNX 6514DS-VTM w/mount pipe	110
RRH-800	153	(2) HBX-6517DS-VTM w/mount pipe	110
RRH-800	153	(2) HBX-6517DS-VTM w/mount pipe	110
RRH-800	153	(2) HBX-6517DS-VTM w/mount pipe	110
APXVTM14-C-120 w/mount pipe (SPRINT - proposed)	153	RRH 2X40-AWS+RDEM	110
APXVTM14-C-120 w/mount pipe	153	RRH 2X40-AWS+RDEM	110
APXVTM14-C-120 w/mount pipe	153	RRH 2X40-07U	110
840-10054 w/mount pipe	153	RRH 2X40-07U	110
840-10054 w/mount pipe	153	RRH 2X40-07U	110
840-10054 w/mount pipe	153	RRH 2X40-07U	110
Kathrein 860 10025 RCU	153	RRH 2X40-PCS	110
Kathrein 860 10025 RCU	153	RRH 2X40-PCS	110
Kathrein 860 10025 RCU	153	RRH 2X40-PCS	110
Panel Antenna 18"x18"	153	RFS DB-T1-6Z-8AB-0Z	110
Ring Mount	151	RFS DB-T1-6Z-8AB-0Z	110
RRH 8x20-25	151	PIROD 13' Low Profile Platform (Verizon - proposed)	110
RRH 8x20-25	151	GPS	54
RRH 8x20-25	151	1' Side Mount Standoff	54
Andrew VHLP2-11	150	1' Side Mount Standoff	38.9
Andrew VHLP2-11	150	1' Side Mount Standoff	38.9
Andrew VHLP2-11	150	1' Side Mount Standoff	38.9
PIROD 13' Low Profile Platform (ATTI)	143	Andrew VHLPX2-18-2WH/B	38.9
Kathrein 800 10121 w/mount pipe	143	Andrew VHLPX2-18-2WH/B	38.9
		(2) Andrew VHLPX2-18-2WH/B	38.9

MATERIAL STRENGTH

GRADE	Fy	Fu	GRADE	Fy	Fu
A572-65	65 ksi	80 ksi			

TOWER DESIGN NOTES

1. Tower is located in Hartford County, Connecticut.
2. Tower designed for a 80.0 mph basic wind in accordance with the TIA/EIA-222-F Standard.
3. Tower is also designed for a 69.3 mph basic wind with 0.50 in ice.
4. Deflections are based upon a 50.0 mph wind.

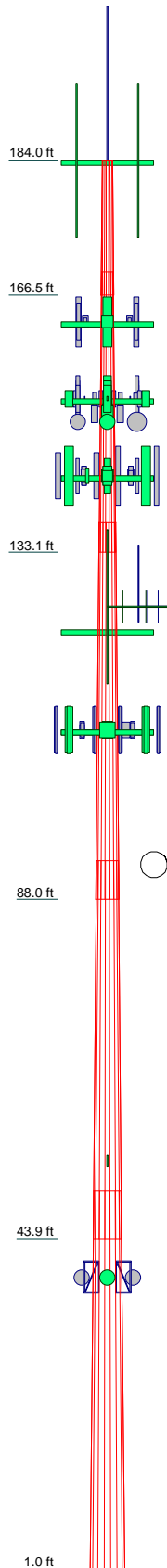

Section	Length (ft)	Number of Sides	Thickness (in)	Socket Length (ft)	Top Dia (in)	Bot Dia (in)	Grade	Weight (lb)
1	17.50	18	0.1875	3.00	15.5000	19.3990		611.7
2	36.42	18	0.2500	3.83	18.3556	26.4010	A572-65	2176.1
3	48.92	18	0.3750	5.00	25.0549	35.8920	A572-65	5963.5
4	49.08	18	0.4850	6.17	34.0344	44.9030		10022.4
5	49.08	18	0.5400	42.5667	53.5000			13594.8
								32368.6

Hudson Design Group LLC

1600 Osgood Street Bldg. 20N Suite 3090

North Andover, MA 01845

Phone: (978) 557-5553

FAX: (978) 226-5586

Job: CT43XC827 MANCHESTER POLICE TOWER		
Project: 183 ft Monopole		
Client: SPRINT	Drawn by: kw	App'd:
Code: TIA/EIA-222-F	Date: 04/10/15	Scale: NTS
Path:		Dwg No. E-1

 Hudson Design Group LLC 1600 Osgood Street Bldg. 20N Suite 3090 North Andover, MA 01845 Phone: (978) 557-5553 FAX: (978) 226-5586	Job CT43XC827 MANCHESTER POLICE TOWER	Page 1 of 11
	Project 183 ft Monopole	Date 10:42:00 04/10/15
	Client SPRINT	Designed by kw

Tower Input Data

There is a pole section.

This tower is designed using the TIA/EIA-222-F standard.

The following design criteria apply:

Tower is located in Hartford County, Connecticut.

Basic wind speed of 80.0 mph.

Nominal ice thickness of 0.5000 in.

Ice density of 56.0 pcf.

A wind speed of 69.3 mph is used in combination with ice.

Temperature drop of 50.0 °F.

Deflections calculated using a wind speed of 50.0 mph.

A non-linear (P-delta) analysis was used.

Pressures are calculated at each section.

Stress ratio used in pole design is 1.333.

Local bending stresses due to climbing loads, feed line supports, and appurtenance mounts are not considered.

Tapered Pole Section Geometry

Section	Elevation ft	Section Length ft	Splice Length ft	Number of Sides	Top Diameter in	Bottom Diameter in	Wall Thickness in	Bend Radius in	Pole Grade
L1	184.00-166.50	17.50	3.00	18	15.5000	19.3990	0.1875	0.7500	A572-65 (65 ksi)
L2	166.50-133.08	36.42	3.83	18	18.3556	26.4010	0.2500	1.0000	A572-65 (65 ksi)
L3	133.08-87.99	48.92	5.00	18	25.0549	35.8920	0.3750	1.5000	A572-65 (65 ksi)
L4	87.99-43.91	49.08	6.17	18	34.0344	44.9030	0.4850	1.9400	A572-65 (65 ksi)
L5	43.91-1.00	49.08		18	42.5667	53.5000	0.5400	2.1600	A572-65 (65 ksi)

Monopole Base Plate Data

Base Plate Data

Base plate is square	
Base plate is grouted	√
Anchor bolt grade	A615-75
Anchor bolt size	2.2500 in
Number of bolts	18
Embedment length	84.0000 in
f_c	4.0 ksi
Grout space	4.0000 in
Base plate grade	A572-60
Base plate thickness	2.0000 in
Bolt circle diameter	62.0000 in
Outer diameter	68.0000 in
Inner diameter	43.0000 in
Base plate type	Stiffened Plate
Bolts per stiffener	1



Hudson Design Group LLC
 1600 Osgood Street Bldg. 20N Suite 3090
 North Andover, MA 01845
 Phone: (978) 557-5553
 FAX: (978) 226-5586

Job	CT43XC827 MANCHESTER POLICE TOWER	Page	2 of 11
Project	183 ft Monopole	Date	10:42:00 04/10/15
Client	SPRINT	Designed by	kw

Base Plate Data

Stiffener thickness	0.5000 in
Stiffener height	9.0000 in

Feed Line/Linear Appurtenances - Entered As Area

Description	Face or Leg	Allow Shield	Component Type	Placement ft	Total Number	C _A A _A		Weight
						No Ice	1/2" Ice	plf
2" Conduit	A	No	CaAa (Out Of Face)	153.00 - 6.00	2	No Ice	0.20	2.80
1/2	A	No	CaAa (Out Of Face)	153.00 - 6.00	3	1/2" Ice	0.30	4.33
3/8	A	No	Inside Pole	153.00 - 6.00	3	No Ice	0.06	0.25
7/8	B	No	Inside Pole	184.00 - 6.00	4	1/2" Ice	0.16	0.91
1 5/8 (T-MOBILE)	B	No	Inside Pole	163.00 - 6.00	12	No Ice	0.00	0.25
1 5/8 Fiber Cable (T-MOBILE)	B	No	Inside Pole	163.00 - 6.00	4	1/2" Ice	0.00	0.54
1 1/4 (SPRINT)	B	No	Inside Pole	153.00 - 6.00	12	No Ice	0.00	1.04
1 5/8 (AT&T)	B	No	Inside Pole	143.00 - 6.00	9	1/2" Ice	0.00	1.04
FB-L98B-002 (AT&T)	B	No	Inside Pole	143.00 - 6.00	3	No Ice	0.00	0.25
WR-VG122ST-BRDA (AT&T)	B	No	Inside Pole	143.00 - 6.00	6	1/2" Ice	0.00	0.25
1/2	B	No	Inside Pole	123.00 - 6.00	5	No Ice	0.00	0.25
1/2	B	No	Inside Pole	54.00 - 6.00	1	1/2" Ice	0.00	0.25
1/2	B	No	Inside Pole	38.90 - 6.00	4	No Ice	0.00	0.25
*****						1/2" Ice	0.00	0.25
1 5/8 Fiber Cable (VERIZON)	B	No	Inside Pole	110.00 - 6.00	2	No Ice	0.00	1.04
						1/2" Ice	0.00	1.04

Discrete Tower Loads

Description	Face or Leg	Offset Type	Offsets:		Azimuth Adjustment	Placement ft	C _A A _A		Weight lb	
			Horz ft	Vert ft			Front ft ²	Side ft ²		
Lightning Rod 2"x21'	A	From Leg	1.00	0.0000	0.0000	184.00	No Ice	4.20	4.20	80.00
			0.00				1/2" Ice	6.33	6.33	112.30
			10.00							
PiROD 13' Low Profile Platform	A	None		0.0000	0.0000	184.00	No Ice	15.70	15.70	1300.00
20'-4 Bay Dipole	C	From Face	3.50	0.0000	0.0000	184.00	No Ice	20.10	20.10	1765.00
			4.00				1/2" Ice	4.75	4.75	50.00
			0.00					6.25	6.25	80.00
20'-4 Bay Dipole	C	From Face	3.50	0.0000	0.0000	184.00	No Ice	4.75	4.75	50.00



Hudson Design Group LLC
 1600 Osgood Street Bldg. 20N Suite 3090
 North Andover, MA 01845
 Phone: (978) 557-5553
 FAX: (978) 226-5586

Job	CT43XC827 MANCHESTER POLICE TOWER	Page	3 of 11
Project	183 ft Monopole	Date	10:42:00 04/10/15
Client	SPRINT	Designed by	kw

Description	Face or Leg	Offset Type	Offsets: Horz Lateral Vert ft ft ft	Azimuth Adjustment °	Placement ft	C _{AA} Front ft ²	C _{AA} Side ft ²	Weight lb
			-4.00 0.00		1/2" Ice	6.25	6.25	80.00

PiROD 13' Low Profile Platform (T-Mobile)	A	None		0.0000	163.00	No Ice 15.70 1/2" Ice 20.10	15.70 20.10	1300.00 1765.00
ERICSSON AIR 21 B2A B4P w/ Mount Pipe	A	From Face	3.50 0.00 0.00	0.0000	163.00	No Ice 6.83 1/2" Ice 7.35	5.64 6.48	112.18 169.02
ERICSSON AIR 21 B2A B4P w/ Mount Pipe	B	From Face	3.50 0.00 0.00	0.0000	163.00	No Ice 6.83 1/2" Ice 7.35	5.64 6.48	112.18 169.02
ERICSSON AIR 21 B2A B4P w/ Mount Pipe	C	From Face	3.50 0.00 0.00	0.0000	163.00	No Ice 6.83 1/2" Ice 7.35	5.64 6.48	112.18 169.02
RFS ATMAP1412D-1A20	A	From Face	2.50 0.00 0.00	0.0000	163.00	No Ice 1.17 1/2" Ice 1.31	0.47 0.57	13.00 20.62
RFS ATMAP1412D-1A20	B	From Face	2.50 0.00 0.00	0.0000	163.00	No Ice 1.17 1/2" Ice 1.31	0.47 0.57	13.00 20.62
RFS ATMAP1412D-1A20	C	From Face	2.50 0.00 0.00	0.0000	163.00	No Ice 1.17 1/2" Ice 1.31	0.47 0.57	13.00 20.62
ERICSSON AIR 21 B4A B12P-B8P w/ Mount Pipe	A	From Face	3.50 0.00 0.00	0.0000	163.00	No Ice 11.34 1/2" Ice 12.00	9.07 10.30	160.55 248.37
ERICSSON AIR 21 B4A B12P-B8P w/ Mount Pipe	B	From Face	3.50 0.00 0.00	0.0000	163.00	No Ice 11.34 1/2" Ice 12.00	9.07 10.30	160.55 248.37
ERICSSON AIR 21 B4A B12P-B8P w/ Mount Pipe	C	From Face	3.50 0.00 0.00	0.0000	163.00	No Ice 11.34 1/2" Ice 12.00	9.07 10.30	160.55 248.37
Ericsson RRUS 11	A	From Face	2.50 0.00 0.00	0.0000	163.00	No Ice 2.94 1/2" Ice 3.17	1.25 1.41	55.00 74.32
Ericsson RRUS 11	B	From Face	2.50 0.00 0.00	0.0000	163.00	No Ice 2.94 1/2" Ice 3.17	1.25 1.41	55.00 74.32
Ericsson RRUS 11	C	From Face	2.50 0.00 0.00	0.0000	163.00	No Ice 2.94 1/2" Ice 3.17	1.25 1.41	55.00 74.32

PiROD 13' Low Profile Platform (SPRINT - existing)	A	None		0.0000	153.00	No Ice 15.70 1/2" Ice 20.10	15.70 20.10	1300.00 1765.00
APXVSPP18-C w/mount pipe	A	From Face	3.50 0.00 0.00	0.0000	153.00	No Ice 8.50 1/2" Ice 9.15	6.95 8.13	82.55 150.56
APXVSPP18-C w/mount pipe	B	From Face	3.50 0.00 0.00	0.0000	153.00	No Ice 8.50 1/2" Ice 9.15	6.95 8.13	82.55 150.56
APXVSPP18-C w/mount pipe	C	From Face	3.50 0.00 0.00	0.0000	153.00	No Ice 8.50 1/2" Ice 9.15	6.95 8.13	82.55 150.56
(2) RRH-1900	A	From Face	1.00 0.00	0.0000	153.00	No Ice 2.71 1/2" Ice 2.95	3.66 3.92	60.00 88.32



Hudson Design Group LLC
 1600 Osgood Street Bldg. 20N Suite 3090
 North Andover, MA 01845
 Phone: (978) 557-5553
 FAX: (978) 226-5586

Job	CT43XC827 MANCHESTER POLICE TOWER	Page	4 of 11
Project	183 ft Monopole	Date	10:42:00 04/10/15
Client	SPRINT	Designed by	kw

Description	Face or Leg	Offset Type	Offsets:		Azimuth Adjustment	Placement	C _{AA} Front	C _{AA} Side	Weight	
			Horz	Lateral						
			Vert		°	ft	ft ²	ft ²	lb	
			ft	ft						
(2) RRH-1900	B	From Face	0.00	1.00	0.0000	153.00	No Ice	2.71	3.66	60.00
			0.00	0.00			1/2" Ice	2.95	3.92	88.32
			0.00							
(2) RRH-1900	C	From Face	1.00	0.00	0.0000	153.00	No Ice	2.71	3.66	60.00
			0.00	0.00			1/2" Ice	2.95	3.92	88.32
			0.00							
RRH-800	A	From Face	1.00	0.00	0.0000	153.00	No Ice	2.49	3.22	64.00
			0.00	0.00			1/2" Ice	2.71	3.46	91.74
			0.00							
RRH-800	B	From Face	1.00	0.00	0.0000	153.00	No Ice	2.49	3.22	64.00
			0.00	0.00			1/2" Ice	2.71	3.46	91.74
			0.00							
RRH-800	C	From Face	1.00	0.00	0.0000	153.00	No Ice	2.49	3.22	64.00
			0.00	0.00			1/2" Ice	2.71	3.46	91.74
			0.00							

APXVTM14-C-120 w/mount pipe (SPRINT - proposed)	A	From Face	3.50	0.00	0.0000	153.00	No Ice	7.21	5.03	91.90
			0.00	0.00			1/2" Ice	7.77	5.89	147.31
			0.00							
APXVTM14-C-120 w/mount pipe	B	From Face	3.50	0.00	0.0000	153.00	No Ice	7.21	5.03	91.90
			0.00	0.00			1/2" Ice	7.77	5.89	147.31
			0.00							
APXVTM14-C-120 w/mount pipe	C	From Face	3.50	0.00	0.0000	153.00	No Ice	7.21	5.03	91.90
			0.00	0.00			1/2" Ice	7.77	5.89	147.31
			0.00							
RRH 8x20-25	A	From Face	1.00	0.00	0.0000	151.00	No Ice	4.72	1.70	70.00
			0.00	0.00			1/2" Ice	5.01	1.92	97.14
			0.00							
RRH 8x20-25	B	From Face	1.00	0.00	0.0000	151.00	No Ice	4.72	1.70	70.00
			0.00	0.00			1/2" Ice	5.01	1.92	97.14
			0.00							
RRH 8x20-25	C	From Face	1.00	0.00	0.0000	151.00	No Ice	4.72	1.70	70.00
			0.00	0.00			1/2" Ice	5.01	1.92	97.14
			0.00							
Ring Mount	C	None			0.0000	151.00	No Ice	1.40	1.40	90.00
							1/2" Ice	2.40	2.40	130.00

840-10054 w/mount pipe	A	From Face	3.50	0.00	0.0000	153.00	No Ice	5.41	2.39	46.43
			0.00	0.00			1/2" Ice	5.83	2.92	82.55
			0.00							
840-10054 w/mount pipe	B	From Face	3.50	0.00	0.0000	153.00	No Ice	5.41	2.39	46.43
			0.00	0.00			1/2" Ice	5.83	2.92	82.55
			0.00							
840-10054 w/mount pipe	C	From Face	3.50	0.00	0.0000	153.00	No Ice	5.41	2.39	46.43
			0.00	0.00			1/2" Ice	5.83	2.92	82.55
			0.00							
Kathrein 860 10025 RCU	A	From Face	2.50	0.00	0.0000	153.00	No Ice	0.16	0.14	1.20
			0.00	0.00			1/2" Ice	0.23	0.20	2.76
			0.00							
Kathrein 860 10025 RCU	B	From Face	2.50	0.00	0.0000	153.00	No Ice	0.16	0.14	1.20
			0.00	0.00			1/2" Ice	0.23	0.20	2.76
			0.00							
Kathrein 860 10025 RCU	C	From Face	2.50	0.00	0.0000	153.00	No Ice	0.16	0.14	1.20
			0.00	0.00			1/2" Ice	0.23	0.20	2.76
			0.00							
Panel Antenna 18"X18"	B	From Face	3.50	0.0000	153.00	No Ice	3.15	0.53	15.00	



Hudson Design Group LLC
 1600 Osgood Street Bldg. 20N Suite 3090
 North Andover, MA 01845
 Phone: (978) 557-5553
 FAX: (978) 226-5586

Job	CT43XC827 MANCHESTER POLICE TOWER	Page	5 of 11
Project	183 ft Monopole	Date	10:42:00 04/10/15
Client	SPRINT	Designed by	kw

Description	Face or Leg	Offset Type	Offsets: Horz Lateral Vert	Azimuth Adjustment	Placement	C _{AA} Front	C _{AA} Side	Weight
			ft ft ft	°	ft	ft ²	ft ²	lb
			0.00		1/2" Ice	3.39	0.67	30.30
			0.00					

PiROD 13' Low Profile Platform	A	None		0.0000	123.00	No Ice 15.70 1/2" Ice 20.10	15.70 20.10	1300.00 1765.00
Omni 2"x10'	B	From Face	3.50 0.00	0.0000	123.00	No Ice 2.00 1/2" Ice 3.02	2.00 3.02	20.00 35.50
Omni 2"x10'	B	From Face	6.00 3.50 0.00	0.0000	123.00	No Ice 2.00 1/2" Ice 3.02	2.00 3.02	20.00 35.50
20'-4 Bay Dipole	C	From Face	6.00 3.50 0.00	0.0000	123.00	No Ice 4.75 1/2" Ice 6.25	4.75 6.25	50.00 80.00
3' Yagi antenna	B	From Face	3.00 3.50 0.00	0.0000	123.00	No Ice 0.70 1/2" Ice 0.95	0.35 0.48	10.00 36.35
3' Yagi antenna	C	From Face	3.00 3.50 0.00	0.0000	123.00	No Ice 0.70 1/2" Ice 0.95	0.35 0.48	10.00 36.35

1' Side Mount Standoff	C	From Face	0.00 1.00 0.00	0.0000	54.00	No Ice 1.00 1/2" Ice 1.50	1.00 1.50	30.00 50.00
GPS	C	From Face	0.00 3.00 0.00	0.0000	54.00	No Ice 0.21 1/2" Ice 0.32	0.21 0.32	5.00 7.52

PiROD 13' Low Profile Platform (AT&T)	A	None		0.0000	143.00	No Ice 15.70 1/2" Ice 20.10	15.70 20.10	1300.00 1765.00
Kathrein 800 10121 w/mount pipe	A	From Face	0.00 3.50 0.00	0.0000	143.00	No Ice 5.72 1/2" Ice 6.21	4.81 5.49	78.15 128.24
Kathrein 800 10121 w/mount pipe	B	From Face	0.00 3.50 0.00	0.0000	143.00	No Ice 5.72 1/2" Ice 6.21	4.81 5.49	78.15 128.24
Kathrein 800 10121 w/mount pipe	C	From Face	0.00 3.50 0.00	0.0000	143.00	No Ice 5.72 1/2" Ice 6.21	4.81 5.49	78.15 128.24
Ericsson RRUS-11	A	From Face	0.00 2.50 0.00	0.0000	143.00	No Ice 3.26 1/2" Ice 3.50	1.38 1.56	50.70 71.57
Ericsson RRUS-11	B	From Face	0.00 2.50 0.00	0.0000	143.00	No Ice 3.26 1/2" Ice 3.50	1.38 1.56	50.70 71.57
Ericsson RRUS-11	C	From Face	0.00 2.50 0.00	0.0000	143.00	No Ice 3.26 1/2" Ice 3.50	1.38 1.56	50.70 71.57
DC6-48-60-18-8F	C	From Leg	0.00 2.00 0.00	0.0000	143.00	No Ice 1.27 1/2" Ice 1.46	1.27 1.46	20.00 35.12

(2) OPA-65R-LCUU-H6 w/mount pipe	A	From Face	0.00 3.50 0.00	0.0000	143.00	No Ice 10.65 1/2" Ice 11.30	7.53 8.56	112.53 192.76
(2) OPA-65R-LCUU-H8	B	From Face	0.00 3.50	0.0000	143.00	No Ice 13.34	9.83	140.11



Hudson Design Group LLC
 1600 Osgood Street Bldg. 20N Suite 3090
 North Andover, MA 01845
 Phone: (978) 557-5553
 FAX: (978) 226-5586

Job	CT43XC827 MANCHESTER POLICE TOWER	Page	6 of 11
Project	183 ft Monopole	Date	10:42:00 04/10/15
Client	SPRINT	Designed by	kw

Description	Face or Leg	Offset Type	Offsets: Horz Lateral Vert ft ft ft	Azimuth Adjustment °	Placement ft	C _{AA} Front ft ²	C _{AA} Side ft ²	Weight lb	
w/mount pipe			0.00 0.00		1/2" Ice	14.18	11.34	239.33	
(2) OPA-65R-LCUU-H8 w/mount pipe	C	From Face	3.50 0.00 0.00	0.0000	143.00	No Ice 1/2" Ice	13.34 14.18	9.83 11.34	140.11 239.33
Ericsson RRUS-12	A	From Face	2.50 0.00 0.00	0.0000	143.00	No Ice 1/2" Ice	3.67 3.93	1.49 1.67	58.00 81.22
Ericsson RRUS-12	B	From Face	2.50 0.00 0.00	0.0000	143.00	No Ice 1/2" Ice	3.67 3.93	1.49 1.67	58.00 81.22
Ericsson RRUS-12	C	From Face	2.50 0.00 0.00	0.0000	143.00	No Ice 1/2" Ice	3.67 3.93	1.49 1.67	58.00 81.22
Ericsson RRUS-32	A	From Face	2.50 0.00 0.00	0.0000	143.00	No Ice 1/2" Ice	3.87 4.15	2.76 3.02	77.00 104.93
Ericsson RRUS-32	B	From Face	2.50 0.00 0.00	0.0000	143.00	No Ice 1/2" Ice	3.87 4.15	2.76 3.02	77.00 104.93
Ericsson RRUS-32	C	From Face	2.50 0.00 0.00	0.0000	143.00	No Ice 1/2" Ice	3.87 4.15	2.76 3.02	77.00 104.93
Ericsson RRUS-E2	A	From Face	2.50 0.00 0.00	0.0000	143.00	No Ice 1/2" Ice	3.87 4.15	2.76 3.02	77.00 104.93
Ericsson RRUS-E2	B	From Face	2.50 0.00 0.00	0.0000	143.00	No Ice 1/2" Ice	3.87 4.15	2.76 3.02	77.00 104.93
Ericsson RRUS-E2	C	From Face	2.50 0.00 0.00	0.0000	143.00	No Ice 1/2" Ice	3.87 4.15	2.76 3.02	77.00 104.93
Ericsson A2 Module	A	From Face	2.50 0.00 0.00	0.0000	143.00	No Ice 1/2" Ice	2.42 2.63	0.54 0.67	22.00 34.73
Ericsson A2 Module	B	From Face	2.50 0.00 0.00	0.0000	143.00	No Ice 1/2" Ice	2.42 2.63	0.54 0.67	22.00 34.73
Ericsson A2 Module	C	From Face	2.50 0.00 0.00	0.0000	143.00	No Ice 1/2" Ice	2.42 2.63	0.54 0.67	22.00 34.73
Surge Arrestor (DC6-48-60-18-8F)	A	From Leg	2.00 0.00 0.00	0.0000	143.00	No Ice 1/2" Ice	1.27 1.46	1.27 1.46	20.00 35.12

PiROD 13' Low Profile Platform (Verizon - proposed)	C	None		0.0000	110.00	No Ice 1/2" Ice	15.70 20.10	15.70 20.10	1300.00 1765.00
(2) LNX 6514DS-VTM w/mount pipe	A	From Face	3.50 0.00 0.00	0.0000	110.00	No Ice 1/2" Ice	8.63 9.29	7.07 8.25	64.55 133.55
(2) LNX 6514DS-VTM w/mount pipe	B	From Face	3.50 0.00 0.00	0.0000	110.00	No Ice 1/2" Ice	8.63 9.29	7.07 8.25	64.55 133.55
(2) LNX 6514DS-VTM w/mount pipe	C	From Face	3.50 0.00 0.00	0.0000	110.00	No Ice 1/2" Ice	8.63 9.29	7.07 8.25	64.55 133.55



Hudson Design Group LLC
 1600 Osgood Street Bldg. 20N Suite 3090
 North Andover, MA 01845
 Phone: (978) 557-5553
 FAX: (978) 226-5586

Job	CT43XC827 MANCHESTER POLICE TOWER	Page	7 of 11
Project	183 ft Monopole	Date	10:42:00 04/10/15
Client	SPRINT	Designed by	kw

Description	Face or Leg	Offset Type	Offsets: Horz Lateral Vert ft ft ft	Azimuth Adjustment °	Placement ft	CAAA Front ft ²	CAAA Side ft ²	Weight lb
(2) HBX-6517DS-VTM w/mount pipe	A	From Face	3.50 0.00 0.00	0.0000	110.00	No Ice 1/2" Ice 5.42 5.97	4.96 6.14	39.25 85.00
(2) HBX-6517DS-VTM w/mount pipe	B	From Face	3.50 0.00 0.00	0.0000	110.00	No Ice 1/2" Ice 5.42 5.97	4.96 6.14	39.25 85.00
(2) HBX-6517DS-VTM w/mount pipe	C	From Face	3.50 0.00 0.00	0.0000	110.00	No Ice 1/2" Ice 5.42 5.97	4.96 6.14	39.25 85.00
RRH 2X40-AWS+RDEM	A	From Face	2.50 0.00 0.00	0.0000	110.00	No Ice 1/2" Ice 3.77 4.04	2.23 2.46	47.60 73.79
RRH 2X40-AWS+RDEM	B	From Face	2.50 0.00 0.00	0.0000	110.00	No Ice 1/2" Ice 3.77 4.04	2.23 2.46	47.60 73.79
RRH 2X40-AWS+RDEM	C	From Face	2.50 0.00 0.00	0.0000	110.00	No Ice 1/2" Ice 3.77 4.04	2.23 2.46	47.60 73.79
RRH 2X40-07U	A	From Face	2.50 0.00 0.00	0.0000	110.00	No Ice 1/2" Ice 2.29 2.49	1.21 1.36	50.00 66.78
RRH 2X40-07U	B	From Face	2.50 0.00 0.00	0.0000	110.00	No Ice 1/2" Ice 2.29 2.49	1.21 1.36	50.00 66.78
RRH 2X40-07U	C	From Face	2.50 0.00 0.00	0.0000	110.00	No Ice 1/2" Ice 2.29 2.49	1.21 1.36	50.00 66.78
RRH 2X40-PCS	A	From Face	2.50 0.00 0.00	0.0000	110.00	No Ice 1/2" Ice 2.57 2.79	2.02 2.23	55.00 75.41
RRH 2X40-PCS	B	From Face	2.50 0.00 0.00	0.0000	110.00	No Ice 1/2" Ice 2.57 2.79	2.02 2.23	55.00 75.41
RRH 2X40-PCS	C	From Face	2.50 0.00 0.00	0.0000	110.00	No Ice 1/2" Ice 2.57 2.79	2.02 2.23	55.00 75.41
RFS DB-T1-6Z-8AB-0Z	B	From Face	1.50 0.00 0.00	0.0000	110.00	No Ice 1/2" Ice 5.60 5.92	2.33 2.56	44.00 80.13
RFS DB-T1-6Z-8AB-0Z	C	From Face	1.50 0.00 0.00	0.0000	110.00	No Ice 1/2" Ice 5.60 5.92	2.33 2.56	44.00 80.13

1' Side Mount Standoff	A	From Face	0.50 0.00 0.00	0.0000	38.90	No Ice 1/2" Ice 1.00 1.50	1.00 1.50	30.00 50.00
1' Side Mount Standoff	B	From Face	0.50 0.00 0.00	0.0000	38.90	No Ice 1/2" Ice 1.00 1.50	1.00 1.50	30.00 50.00
1' Side Mount Standoff	C	From Face	0.50 0.00 0.00	0.0000	38.90	No Ice 1/2" Ice 1.00 1.50	1.00 1.50	30.00 50.00



Hudson Design Group LLC
 1600 Osgood Street Bldg. 20N Suite 3090
 North Andover, MA 01845
 Phone: (978) 557-5553
 FAX: (978) 226-5586

Job	CT43XC827 MANCHESTER POLICE TOWER	Page	8 of 11
Project	183 ft Monopole	Date	10:42:00 04/10/15
Client	SPRINT	Designed by	kw

Dishes

Description	Face or Leg	Dish Type	Offset Type	Offsets: Horz Lateral Vert	Azimuth Adjustment	3 dB Beam Width	Elevation	Outside Diameter	Aperture Area	Weight	
				ft	°	°	ft	ft	ft ²	lb	
Andrew VHLP2-11	A	Paraboloid w/Radome	From Face	3.50 0.00 0.00	0.0000		150.00	2.00	No Ice 1/2" Ice	3.14 3.41	31.00 41.00
Andrew VHLPX2.5-11	B	Paraboloid w/Shroud (HP)	From Face	3.50 0.00 0.00	0.0000		150.00	2.50	No Ice 1/2" Ice	6.00 6.40	49.00 77.00
Andrew VHLP2-11	C	Paraboloid w/Radome	From Face	3.50 0.00 0.00	0.0000		150.00	2.00	No Ice 1/2" Ice	3.14 3.41	31.00 41.00
Andrew VHLPX2-18-2WH/B	A	Paraboloid w/Radome	From Face	2.00 0.00 0.00	0.0000		38.90	2.00	No Ice 1/2" Ice	3.14 3.41	25.00 35.00
Andrew VHLPX2-18-2WH/B	B	Paraboloid w/Radome	From Face	2.00 0.00 0.00	0.0000		38.90	2.00	No Ice 1/2" Ice	3.14 3.41	25.00 35.00
(2) Andrew VHLPX2-18-2WH/B	C	Paraboloid w/Radome	From Face	2.00 0.00 0.00	0.0000		38.90	2.00	No Ice 1/2" Ice	3.14 3.41	25.00 35.00

Load Combinations

Comb. No.	Description
1	Dead Only
2	Dead+Wind 0 deg - No Ice
3	Dead+Wind 30 deg - No Ice
4	Dead+Wind 60 deg - No Ice
5	Dead+Wind 90 deg - No Ice
6	Dead+Wind 120 deg - No Ice
7	Dead+Wind 150 deg - No Ice
8	Dead+Wind 180 deg - No Ice
9	Dead+Wind 210 deg - No Ice
10	Dead+Wind 240 deg - No Ice
11	Dead+Wind 270 deg - No Ice
12	Dead+Wind 300 deg - No Ice
13	Dead+Wind 330 deg - No Ice
14	Dead+Ice+Temp
15	Dead+Wind 0 deg+Ice+Temp
16	Dead+Wind 30 deg+Ice+Temp
17	Dead+Wind 60 deg+Ice+Temp
18	Dead+Wind 90 deg+Ice+Temp
19	Dead+Wind 120 deg+Ice+Temp
20	Dead+Wind 150 deg+Ice+Temp
21	Dead+Wind 180 deg+Ice+Temp
22	Dead+Wind 210 deg+Ice+Temp
23	Dead+Wind 240 deg+Ice+Temp
24	Dead+Wind 270 deg+Ice+Temp
25	Dead+Wind 300 deg+Ice+Temp
26	Dead+Wind 330 deg+Ice+Temp
27	Dead+Wind 0 deg - Service
28	Dead+Wind 30 deg - Service
29	Dead+Wind 60 deg - Service



Hudson Design Group LLC
 1600 Osgood Street Bldg. 20N Suite 3090
 North Andover, MA 01845
 Phone: (978) 557-5553
 FAX: (978) 226-5586

Job	CT43XC827 MANCHESTER POLICE TOWER	Page	9 of 11
Project	183 ft Monopole	Date	10:42:00 04/10/15
Client	SPRINT	Designed by	kw

Comb. No.	Description
30	Dead+Wind 90 deg - Service
31	Dead+Wind 120 deg - Service
32	Dead+Wind 150 deg - Service
33	Dead+Wind 180 deg - Service
34	Dead+Wind 210 deg - Service
35	Dead+Wind 240 deg - Service
36	Dead+Wind 270 deg - Service
37	Dead+Wind 300 deg - Service
38	Dead+Wind 330 deg - Service

Maximum Reactions

Location	Condition	Gov. Load Comb.	Vertical lb	Horizontal, X lb	Horizontal, Z lb
Pole	Max. Vert	24	64424.89	31977.47	-135.40
	Max. H _x	11	53151.36	36359.64	-182.71
	Max. H _z	2	53151.36	-230.38	36335.05
	Max. M _x	2	4462772.09	-230.38	36335.05
	Max. M _z	5	4468109.01	-36333.10	246.35
	Max. Torsion	9	2566.54	18354.94	-31557.65
	Min. Vert	1	53151.36	0.00	0.00
	Min. H _x	5	53151.36	-36333.10	246.35
	Min. H _z	8	53151.36	272.09	-36376.99
	Min. M _x	8	-4466008.94	272.09	-36376.99
	Min. M _z	11	-4470961.07	36359.64	-182.71
	Min. Torsion	3	-2629.11	-18388.28	31537.02

Tower Mast Reaction Summary

Load Combination	Vertical lb	Shear _x lb	Shear _z lb	Overturning Moment, M _x lb-ft	Overturning Moment, M _z lb-ft	Torque lb-ft
Dead Only	53151.36	0.00	0.00	-712.57	-598.81	-0.00
Dead+Wind 0 deg - No Ice	53151.36	230.38	-36335.05	-4462772.09	-34288.58	1910.03
Dead+Wind 30 deg - No Ice	53151.36	18388.28	-31537.02	-3873035.07	-2263502.74	2629.11
Dead+Wind 60 deg - No Ice	53151.36	31573.87	-18328.38	-2253075.22	-3882561.05	2517.37
Dead+Wind 90 deg - No Ice	53151.36	36333.10	-246.35	-34089.33	-4468109.01	1720.90
Dead+Wind 120 deg - No Ice	53151.36	31394.42	17943.63	2200224.36	-3861987.08	579.17
Dead+Wind 150 deg - No Ice	53151.36	18054.19	31393.34	3852890.47	-2219431.32	-711.98
Dead+Wind 180 deg - No Ice	53151.36	-272.09	36376.99	4466008.94	39589.59	-1718.42
Dead+Wind 210 deg - No Ice	53151.36	-18354.94	31557.65	3875984.65	2260940.18	-2566.54
Dead+Wind 240 deg - No Ice	53151.36	-31527.18	18286.29	2249562.04	3878865.56	-2488.36
Dead+Wind 270 deg - No Ice	53151.36	-36359.64	182.71	28258.24	4470961.07	-1759.91
Dead+Wind 300 deg - No Ice	53151.36	-31479.04	-17959.44	-2199563.67	3869056.90	-799.71
Dead+Wind 330 deg - No Ice	53151.36	-18038.05	-31431.92	-3859182.78	2211688.06	688.61
Dead+Ice+Temp	64424.89	0.00	0.00	-1381.36	-1173.21	0.02
Dead+Wind 0 deg+Ice+Temp	64424.89	174.24	-31949.41	-3985611.17	-27189.53	1836.21
Dead+Wind 30 deg+Ice+Temp	64424.89	16147.55	-27719.92	-3457656.51	-2018742.32	2301.66
Dead+Wind 60 deg+Ice+Temp	64424.89	27757.36	-16094.80	-2009604.46	-3466566.76	2045.35
Dead+Wind 90 deg+Ice+Temp	64424.89	31956.78	-187.51	-27134.38	-3991288.24	1232.88
Dead+Wind 120 deg+Ice+Temp	64424.89	27623.29	15803.89	1967460.87	-3451300.84	186.54
Dead+Wind 150 deg+Ice+Temp	64424.89	15897.33	27615.36	3441135.22	-1985466.65	-904.78
Dead+Wind 180 deg+Ice+Temp	64424.89	-207.34	31983.35	3986615.93	29943.10	-1682.08



Hudson Design Group LLC
 1600 Osgood Street Bldg. 20N Suite 3090
 North Andover, MA 01845
 Phone: (978) 557-5553
 FAX: (978) 226-5586

Job	CT43XC827 MANCHESTER POLICE TOWER	Page	10 of 11
Project	183 ft Monopole	Date	10:42:00 04/10/15
Client	SPRINT	Designed by	kw

Load Combination	Vertical lb	Shear _x lb	Shear _z lb	Overturning Moment, M _x lb-ft	Overturning Moment, M _z lb-ft	Torque lb-ft
Dead+Wind 210 deg+Ice+Temp	64424.89	-16119.69	27736.06	3458353.11	2015018.76	-2251.13
Dead+Wind 240 deg+Ice+Temp	64424.89	-27718.53	16060.07	2004967.41	3461885.44	-2022.15
Dead+Wind 270 deg+Ice+Temp	64424.89	-31977.47	135.40	20604.79	3991995.62	-1264.51
Dead+Wind 300 deg+Ice+Temp	64424.89	-27691.59	-15817.42	-1968657.64	3455532.27	-363.81
Dead+Wind 330 deg+Ice+Temp	64424.89	-15884.89	-27646.37	-3447935.92	1977617.07	886.02
Dead+Wind 0 deg - Service	53151.36	89.99	-14193.39	-1747132.40	-13831.51	758.25
Dead+Wind 30 deg - Service	53151.36	7182.92	-12319.15	-1516360.03	-886360.89	1044.07
Dead+Wind 60 deg - Service	53151.36	12333.54	-7159.52	-882300.82	-1520074.01	1000.61
Dead+Wind 90 deg - Service	53151.36	14192.63	-96.23	-13775.53	-1749206.21	685.32
Dead+Wind 120 deg - Service	53151.36	12263.45	7009.23	860712.75	-1511958.70	232.22
Dead+Wind 150 deg - Service	53151.36	7052.42	12263.02	1507548.20	-869075.21	-280.74
Dead+Wind 180 deg - Service	53151.36	-106.29	14209.77	1747524.57	15088.27	-680.98
Dead+Wind 210 deg - Service	53151.36	-7169.90	12327.21	1516648.37	884538.06	-1019.32
Dead+Wind 240 deg - Service	53151.36	-12315.30	7143.08	880061.04	1517807.68	-990.35
Dead+Wind 270 deg - Service	53151.36	-14202.99	71.37	10629.52	1749545.12	-701.97
Dead+Wind 300 deg - Service	53151.36	-12296.50	-7015.41	-861330.02	1513928.68	-319.70
Dead+Wind 330 deg - Service	53151.36	-7046.12	-12278.09	-1510894.32	865233.37	272.72

Solution Summary

Load Comb.	Sum of Applied Forces			Sum of Reactions			% Error
	PX lb	PY lb	PZ lb	PX lb	PY lb	PZ lb	
1	0.00	-53151.36	0.00	0.00	53151.36	0.00	0.000%
2	230.38	-53151.36	-36335.05	-230.38	53151.36	36335.05	0.000%
3	18388.28	-53151.36	-31537.02	-18388.28	53151.36	31537.02	0.000%
4	31573.87	-53151.36	-18328.38	-31573.87	53151.36	18328.38	0.000%
5	36333.10	-53151.36	-246.35	-36333.10	53151.36	246.35	0.000%
6	31394.42	-53151.36	17943.63	-31394.42	53151.36	-17943.63	0.000%
7	18054.19	-53151.36	31393.34	-18054.19	53151.36	-31393.34	0.000%
8	-272.09	-53151.36	36376.98	272.09	53151.36	-36376.99	0.000%
9	-18354.94	-53151.36	31557.65	18354.94	53151.36	-31557.65	0.000%
10	-31527.18	-53151.36	18286.29	31527.18	53151.36	-18286.29	0.000%
11	-36359.64	-53151.36	182.71	36359.64	53151.36	-182.71	0.000%
12	-31479.04	-53151.36	-17959.44	31479.04	53151.36	17959.44	0.000%
13	-18038.05	-53151.36	-31431.92	18038.05	53151.36	31431.92	0.000%
14	0.00	-64424.89	0.00	-0.00	64424.89	-0.00	0.000%
15	174.24	-64424.89	-31949.28	-174.24	64424.89	31949.41	0.000%
16	16147.55	-64424.89	-27719.91	-16147.55	64424.89	27719.92	0.000%
17	27757.35	-64424.89	-16094.80	-27757.36	64424.89	16094.80	0.000%
18	31956.65	-64424.89	-187.51	-31956.78	64424.89	187.51	0.000%
19	27623.28	-64424.89	15803.88	-27623.29	64424.89	-15803.89	0.000%
20	15897.33	-64424.89	27615.35	-15897.33	64424.89	-27615.36	0.000%
21	-207.33	-64424.89	31983.22	207.34	64424.89	-31983.35	0.000%
22	-16119.68	-64424.89	27736.05	16119.69	64424.89	-27736.06	0.000%
23	-27718.52	-64424.89	16060.07	27718.53	64424.89	-16060.07	0.000%
24	-31977.34	-64424.89	135.40	31977.47	64424.89	-135.40	0.000%
25	-27691.58	-64424.89	-15817.42	27691.59	64424.89	15817.42	0.000%
26	-15884.89	-64424.89	-27646.36	15884.89	64424.89	27646.37	0.000%
27	89.99	-53151.36	-14193.38	-89.99	53151.36	14193.39	0.000%
28	7182.92	-53151.36	-12319.15	-7182.92	53151.36	12319.15	0.000%
29	12333.54	-53151.36	-7159.52	-12333.54	53151.36	7159.52	0.000%
30	14192.62	-53151.36	-96.23	-14192.63	53151.36	96.23	0.000%
31	12263.44	-53151.36	7009.23	-12263.45	53151.36	-7009.23	0.000%
32	7052.42	-53151.36	12263.02	-7052.42	53151.36	-12263.02	0.000%
33	-106.29	-53151.36	14209.76	106.29	53151.36	-14209.77	0.000%
34	-7169.90	-53151.36	12327.21	7169.90	53151.36	-12327.21	0.000%



Hudson Design Group LLC
 1600 Osgood Street Bldg. 20N Suite 3090
 North Andover, MA 01845
 Phone: (978) 557-5553
 FAX: (978) 226-5586

Job	CT43XC827 MANCHESTER POLICE TOWER	Page	11 of 11
Project	183 ft Monopole	Date	10:42:00 04/10/15
Client	SPRINT	Designed by	kw

Load Comb.	Sum of Applied Forces			Sum of Reactions			% Error
	PX lb	PY lb	PZ lb	PX lb	PY lb	PZ lb	
35	-12315.30	-53151.36	7143.08	12315.30	53151.36	-7143.08	0.000%
36	-14202.98	-53151.36	71.37	14202.99	53151.36	-71.37	0.000%
37	-12296.50	-53151.36	-7015.41	12296.50	53151.36	7015.41	0.000%
38	-7046.11	-53151.36	-12278.09	7046.12	53151.36	12278.09	0.000%

Maximum Tower Deflections - Service Wind

Section No.	Elevation ft	Horz. Deflection in	Gov. Load Comb.	Tilt °	Twist °
L1	184 - 166.5	64.4825	29	3.1068	0.0194
L2	169.5 - 133.08	55.1277	29	3.0467	0.0119
L3	136.91 - 87.99	35.3750	29	2.6317	0.0059
L4	92.99 - 43.91	15.3054	29	1.6497	0.0022
L5	50.08 - 1	4.1874	29	0.7943	0.0008

Critical Deflections and Radius of Curvature - Service Wind

Elevation ft	Appurtenance	Gov. Load Comb.	Deflection in	Tilt °	Twist °	Radius of Curvature ft
184.00	Lightning Rod 2"x21'	29	64.4825	3.1068	0.0198	33076
163.00	PiROD 13' Low Profile Platform	29	50.9912	2.9974	0.0098	7086
153.00	PiROD 13' Low Profile Platform	29	44.7739	2.8875	0.0076	4474
151.00	RRH 8x20-25	29	43.5593	2.8608	0.0073	4165
150.00	Andrew VHLP2-11	29	42.9562	2.8468	0.0072	4026
143.00	PiROD 13' Low Profile Platform	29	38.8240	2.7392	0.0065	3261
123.00	PiROD 13' Low Profile Platform	29	28.0913	2.3455	0.0047	2730
110.00	PiROD 13' Low Profile Platform	29	22.0546	2.0467	0.0035	2675
54.00	1' Side Mount Standoff	29	4.8516	0.8642	0.0008	2614
38.90	Andrew VHLPX2-18-2WH/B	29	2.6588	0.6023	0.0006	3384

Section Capacity Table

Section No.	Elevation ft	Component Type	Size	Critical Element	P lb	SF*P _{allow} lb	% Capacity	Pass Fail
L1	184 - 166.5	Pole	TP19.399x15.5x0.1875	1	-2483.51	573700.52	13.8	Pass
L2	166.5 - 133.08	Pole	TP26.401x18.3556x0.25	2	-11157.40	1043870.92	66.1	Pass
L3	133.08 - 87.99	Pole	TP35.892x25.0549x0.375	3	-22507.20	2129160.82	95.7	Pass
L4	87.99 - 43.91	Pole	TP44.903x34.0344x0.485	4	-34750.40	3445351.64	92.2	Pass
L5	43.91 - 1	Pole	TP53.5x42.5667x0.54	5	-48220.20	4449967.05	88.9	Pass
Summary								
Pole (L3)							95.7	Pass
Base Plate							84.3	Pass
RATING =							95.7	Pass

BU: CT43XC827
 Site Name:
 App Number: N/A
 Work Order:

Monopole Drilled Pier

Input

Criteria
 TIA Revision: F
 ACI 318 Revision: 2002
 Seismic Category: B

Forces
 Compression: 53 kips
 Shear: 37 kips
 Moment: 4489 k-ft
 Swelling Force: 0 kips

Foundation Dimensions
 Pier Diameter: 7 ft
 Ext. above grade: 1 ft
 Depth below grade: 31 ft

Material Properties
 Number of Rebar: 27
 Rebar Size: 11
 Tie Size: 5
 Rebar tensile strength: 60 ksi
 Concrete Strength: 4000 psi
 Ultimate Concrete Strain: 0.003 in/in
 Clear Cover to Ties: 3 in

Soil Profile: Profile 1

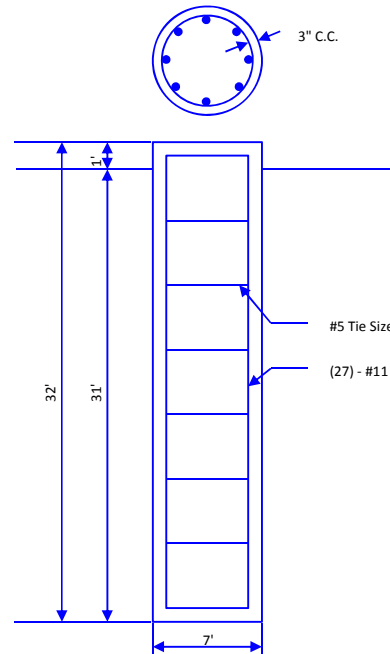

Layer	Thickness (ft)	From (ft)	To (ft)	Unit Weight (pcf)	Cohesion (psf)	Friction Angle (deg)	Ultimate Uplift Friction (ksf)	Ultimate Comp. Friction (ksf)	Ultimate Bearing Capacity (ksf)	SPT 'N' Counts
1	3.5	0	3.5	100	0	0	0	0		
2	2.5	3.5	6	100	0	30				
3	10	6	16	37.6	0	30				
4	15	16	31	37.6	0	30				

Analysis Results

Soil Lateral Capacity
 Depth to Zero Shear: 5.94 ft
 Max Moment, Mu: 4685.58 k-ft
 Soil Safety Factor: 2.22
 Safety Factor Req'd: 2
 RATING: 90.0%

Soil Axial Capacity
 Skin Friction (k): 106.41 kips
 End Bearing (k): 0.00 kips
 Comp. Capacity (k), ϕC_n : 106.41 kips
 Comp. (k), Cu: 68.90 kips
 RATING: 64.7%

Concrete/Steel Check

Mu (from soil analysis) 6091.26 k-ft
 ϕM_n 6753.53 k-ft
 RATING: 90.2%

rho provided 0.76
 rho required 0.33 OK

Rebar Spacing 7.36
 Spacing required 22.56 OK

Dev. Length required 24.81
 Dev. Length provided 53.51 OK

Overall Foundation Rating: 90.2%

TOP OF EXISTING TOWER
ELEV. 184.0'

TOWER SECTION
ELEV. 166.5'

TOWER SECTION
ELEV. 133.1'

TOWER SECTION
ELEV. 88.0'

TOWER SECTION
ELEV. 43.9'

BASE OF EXISTING TOWER
ELEV. 1.0'

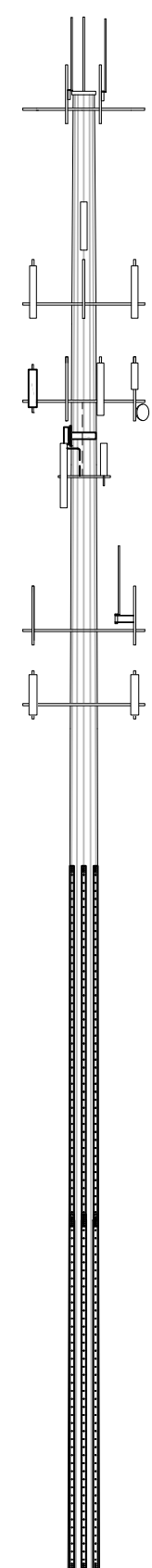

SPECIAL INSPECTIONS (REFERENCE IBC CHAPTER 17):

GENERAL: WHERE APPLICATION IS MADE FOR CONSTRUCTION, THE OWNER OR THE REGISTERED DESIGN PROFESSIONAL IN RESPONSIBLE CHARGE ACTING AS THE OWNER'S AGENT SHALL EMPLOY ONE OR MORE APPROVED AGENCIES TO PERFORM INSPECTIONS DURING CONSTRUCTION ON THE TYPES OF WORK LISTED IN THE INSPECTION CHECKLIST ABOVE.

THE REGISTERED DESIGN PROFESSIONAL IN RESPONSIBLE CHARGE AND ENGINEERS OF RECORD INVOLVED IN THE DESIGN OF THE PROJECT ARE PERMITTED TO ACT AS THE APPROVED AGENCY AND THEIR PERSONNEL ARE PERMITTED TO ACT AS THE SPECIAL INSPECTOR FOR THE WORK DESIGNED BY THEM, PROVIDED THOSE PERSONNEL MEET THE QUALIFICATION REQUIREMENTS.

STATEMENT OF SPECIAL INSPECTIONS: THE APPLICANT SHALL SUBMIT A STATEMENT OF SPECIAL INSPECTIONS PREPARED BY THE REGISTERED DESIGN PROFESSIONAL IN RESPONSIBLE CHARGE IN ACCORDANCE WITH SECTION 107.1 AS A CONDITION FOR ISSUANCE. THIS STATEMENT SHALL BE IN ACCORDANCE WITH SECTION 1705.

REPORT REQUIREMENT: SPECIAL INSPECTORS SHALL KEEP RECORDS OF INSPECTIONS. THE SPECIAL INSPECTOR SHALL FURNISH INSPECTION REPORTS TO THE BUILDING OFFICIAL, AND TO THE REGISTERED DESIGN PROFESSIONAL IN RESPONSIBLE CHARGE. REPORTS SHALL INDICATE THAT WORK INSPECTED WAS OR WAS NOT COMPLETED IN CONFORMANCE TO APPROVED CONSTRUCTION DOCUMENTS. DISCREPANCIES SHALL BE BROUGHT TO THE IMMEDIATE ATTENTION OF THE CONTRACTOR FOR CORRECTION. IF THEY ARE NOT CORRECTED, THE DISCREPANCIES SHALL BE BROUGHT TO THE ATTENTION OF THE BUILDING OFFICIAL AND TO THE REGISTERED DESIGN PROFESSIONAL IN RESPONSIBLE CHARGE. A FINAL REPORT DOCUMENTING REQUIRED SPECIAL INSPECTIONS SHALL BE SUBMITTED.

PROPOSED (6) 1/4"x6" STEEL PLATE REINFORCEMENT
ELEV. 43.9' - 88.0'
(SEE DETAIL 1 ON S-3)

PROPOSED (6) 1/2"x7" STEEL PLATE REINFORCEMENT
ELEV. 1.0' - 43.9'
(SEE DETAIL 1 ON S-2)

1 TOWER ELEVATION
S-1 SCALE: 3/32"=1'-0"

SPECIAL INSPECTION CHECKLIST	
BEFORE CONSTRUCTION	
CONSTRUCTION/INSTALLATION INSPECTIONS AND TESTING REQUIRED (COMPLETED BY ENGINEER OF RECORD)	REPORT ITEM
REQUIRED	ENGINEER OF RECORD APPROVED SHOP DRAWINGS ¹
REQUIRED	MATERIAL SPECIFICATIONS REPORT ²
N/A	FABRICATOR NDE INSPECTION
N/A	NDE REPORT OF MONOPOLE BASE PLATE (AS REQUIRED)
REQUIRED	PACKING SLIPS ³
ADDITIONAL TESTING AND INSPECTIONS:	
DURING CONSTRUCTION	
CONSTRUCTION/INSTALLATION INSPECTIONS AND TESTING REQUIRED (COMPLETED BY ENGINEER OF RECORD)	REPORT ITEM
REQUIRED	STEEL INSPECTIONS
N/A	HIGH STRENGTH BOLT INSPECTIONS
N/A	HIGH WIND ZONE INSPECTIONS
N/A	FOUNDATION INSPECTIONS
N/A	CONCRETE COMP. STRENGTH, SLUMP TESTS AND PLACEMENT
N/A	POST INSTALLED ANCHOR ROD VERIFICATION
N/A	BASE PLATE GROUT VERIFICATION
REQUIRED	CERTIFIED WELD INSPECTION
N/A	EARTHWORK: LIFT AND DENSITY
N/A	ON SITE COLD GALVANIZING VERIFICATION
N/A	GUY WIRE TENSION REPORT
N/A	STEEL & FRP INSPECTION
REQUIRED	FINAL INSPECTION
ADDITIONAL TESTING AND INSPECTIONS:	
AFTER CONSTRUCTION	
CONSTRUCTION/INSTALLATION INSPECTIONS AND TESTING REQUIRED (COMPLETED BY ENGINEER OF RECORD)	REPORT ITEM
REQUIRED	MODIFICATION INSPECTOR REDLINE OR RECORD DRAWINGS ⁵
N/A	POST INSTALLED ANCHOR ROD PULL-OUT TESTING
REQUIRED	PHOTOGRAPHS
ADDITIONAL TESTING AND INSPECTIONS:	

NOTES:

- REQUIRED FOR ANY NEW SHOP FABRICATED FRP OR STEEL.
- PROVIDED BY MANUFACTURER, REQUIRED IF HIGH STRENGTH BOLTS OR STEEL.
- PROVIDED BY GENERAL CONTRACTOR; PROOF OF MATERIALS.
- HIGH WIND ZONE INSPECTION CATB 120MPH OR CAT C,D 110MPH INSPECT FRAMING OF WALLS, ANCHORING, FASTENING SCHEDULE.
- AS REQUIRED; FOR ANY FIELD CHANGES TO THE ITEMS IN THIS TABLE.

GENERAL NOTES:

- ALL WORK SHALL BE DONE IN ACCORDANCE WITH ALL APPLICABLE FEDERAL, STATE, AND LOCAL CODES AND ORDINANCES. IT IS THE CONTRACTOR'S RESPONSIBILITY TO OBTAIN ALL PERMITS NECESSARY TO COMPLETE THE PROJECT AND ABIDE BY ALL CONDITIONS AND REQUIREMENTS OF THE PERMITS.
- THE CONTRACTOR SHALL BE RESPONSIBLE FOR VERIFICATION OF ALL DIMENSIONS, ELEVATIONS, AND EXISTING CONDITIONS AT THE SITE BEFORE ORDERING ANY MATERIALS OR DOING ANY WORK. NO EXTRA CHARGE OR COMPENSATION SHALL BE ALLOWED DUE TO DIFFERENCE BETWEEN ACTUAL DIMENSIONS AND DIMENSIONS INDICATED ON THE CONSTRUCTION DRAWINGS. ANY SUCH DISCREPANCY IN DIMENSION WHICH MAY BE FOUND SHALL BE SUBMITTED TO HUDSON DESIGN GROUP FOR CONSIDERATION BEFORE THE CONTRACTOR PROCEEDS WITH THE WORK IN THE AFFECTED AREA.
- INCORRECTLY FABRICATED, DAMAGED, OTHERWISE MISFITTING, OR NON-CONFORMING MATERIALS AND CONDITIONS SHALL BE REPORTED TO HUDSON DESIGN GROUP PRIOR TO ANY REMEDIAL OR CORRECTIVE ACTION. ALL ACTIONS SHALL REQUIRE HUDSON DESIGN GROUP, LLC APPROVAL.
- IT IS THE CONTRACTOR'S SOLE RESPONSIBILITY TO DETERMINE ERECTION PROCEDURE AND SEQUENCE TO INSURE THE SAFETY OF THE STRUCTURE AND ITS COMPONENT PARTS DURING ERECTION AND/OR FIELD MODIFICATIONS. THIS INCLUDES, BUT IS NOT LIMITED TO, THE ADDITION OF TEMPORARY BRACING, GUYS OR TIE DOWNS THAT MAY BE NECESSARY. SUCH MATERIAL SHALL BE REMOVED AFTER COMPLETION OF THE PROJECT.
- CONTRACTOR SHALL PROMPTLY REMOVE ANY AND ALL DEBRIS FROM SITE AND RESTORE AS BEST AS POSSIBLE TO PRE-CONSTRUCTION CONDITION.

STEEL:

- ALL STRUCTURAL STEEL SHALL BE FABRICATED AND ERECTED IN ACCORDANCE WITH THE LATEST AISC CODE AND ASTM SPECIFICATIONS.
- ALL CONNECTIONS OF STRUCTURAL STEEL MEMBERS SHALL BE MADE USING SPECIFIED WELDS WITH WELDING ELECTRODES E-70XX OR SPECIFIED HIGH STRENGTH BOLTS TO BE ASTM A325N, THREAD INCLUDED WITH SHEAR PLANE UNLESS OTHERWISE NOTED.
- ALL BOLTED CONNECTIONS TO BE INSTALLED TO A SNUG-TIGHTENED CONDITION IN ACCORDANCE WITH AISC 13 PART 16.2. *SPECIFICATION FOR STRUCTURAL JOINTS USING ASTM A325 OR A490 BOLTS*, SECTION 8.1, UNLESS OTHERWISE NOTED.
- ALL STEEL (EXCEPT A490 BOLTS), AFTER FABRICATION, SHALL BE HOT DIPPED GALVANIZED PER ASTM A-123. ALL DAMAGED SURFACES, WELDED AREAS AND AUTHORIZED NON-GALVANIZED MEMBERS OR PARTS (EXISTING OR NEW) SHALL BE PAINTED WITH 2 COATS OF ZRC COLD GALVANIZING COMPOUND.
- ALL SHOP AND FIELD WELDING SHALL BE DONE BY WELDERS QUALIFIED AS DESCRIBED IN THE "AMERICAN WELDING SOCIETY'S STANDARD QUALIFICATION PROCEDURE" TO PERFORM THE TYPE OF WORK REQUIRED.
- STRUCTURAL STEEL MAY NOT BE TORCH CUT FOR FABRICATION. ALL STEEL FABRICATION MUST FOLLOW AISC STANDARDS.
- NEW STEEL MEMBERS AND CONNECTIONS SHALL BE PAINTED TO MATCH EXISTING TOWER.

MISC. NOTES:

- ALL MODIFICATIONS ARE ASSUMED TO BE MADE ON AN EMPTY TOWER. CONTRACTOR IS RESPONSIBLE TO MAKE PROVISIONS TO SUPPORT OR WORK AROUND EXISTING ANTENNAS AND TRANSMISSION LINES. MODIFICATIONS MUST BE CONTINUOUS THROUGH ALL AREAS SHOWN.
- CONTRACTOR SHALL FIELD VERIFY ALL DIMENSIONS PRIOR TO CONSTRUCTION.

FABRICATION NOTES:

- ALL DIMENSIONS ARE PRELIMINARY UNTIL FIELD VERIFIED BY CONTRACTOR. ANY CHANGES MUST BE APPROVED BY ENGINEER OF RECORD IN WRITING PRIOR TO FABRICATION AND INSTALLATION.
- NEW STEEL MEMBERS MUST HAVE SINGLE DRILLED HOLES. SLOTTED AND DOUBLE DRILLED HOLES ARE NOT ACCEPTABLE MEANS OF FABRICATION.

CONTRACTOR QUALIFICATION NOTES:

- ALL REPAIRS SHALL BE PERFORMED BY A TOWER CONTRACTOR WITH A MINIMUM OF 5 YEARS EXPERIENCE IN TOWER ERECTION AND RETROFIT AND WITH WORKING KNOWLEDGE OF THE ANSI/TIA-222-G "STRUCTURAL STANDARD FOR ANTENNA SUPPORTING STRUCTURES AND ANTENNAS".
- CONTRACTOR IS RESPONSIBLE FOR ALL CONSTRUCTION MEANS AND METHODS. SHOULD THE CONTRACTOR REQUIRE DIRECT CONSULTATION, HUDSON DESIGN GROUP, LLC IS WILLING TO OFFER SERVICES BASED UPON AN AGREED FEE FOR THE WORK REQUIRED.
- ALL SUBMITTAL INFORMATION MUST BE SENT TO HUDSON DESIGN GROUP, LLC 1600 OSGOOD ST. BUILDING 20N, SUITE 3090, NORTH ANDOVER, MA 01845 TEL: (978)557-5553, FAX: (978)336-5586. ANY VARIATION OF THESE SPECIFICATIONS OR DRAWINGS WITHOUT CONSENT FROM HUDSON DESIGN GROUP WILL VOID ANY RESPONSIBILITY OR LIABILITY FOR DAMAGE (MATERIAL OR PHYSICAL) TOWARDS HUDSON DESIGN GROUP, LLC.

JOB SITE SAFETY AND NOTES:

NEITHER THE PROFESSIONAL ACTIVITIES OF HUDSON DESIGN GROUP, LLC NOR THE PRESENCE OF HUDSON DESIGN GROUP, LLC OR EMPLOYEES AND SUB-CONSULTANTS AT THE CONSTRUCTION SITE, SHALL RELIEVE THE GENERAL CONTRACTOR AND/OR SUBCONTRACTORS AND ANY OTHER ENTITY OF THEIR OBLIGATIONS, DUTIES AND RESPONSIBILITIES INCLUDING, BUT NOT LIMITED TO, CONSTRUCTION MEANS, METHODS, SEQUENCE, TECHNIQUES, OR PROCEDURES NECESSARY FOR PERFORMING, SUPERINTENDING OR COORDINATING ALL PORTIONS OF THE WORK OF CONSTRUCTION IN ACCORDANCE WITH THE CONTRACT DOCUMENTS AND ANY HEALTH OR SAFETY PRECAUTIONS REQUIRED BY ANY REGULATORY AGENCIES. THE GENERAL CONTRACTOR AND/OR SUBCONTRACTOR IS SOLELY RESPONSIBLE FOR JOB SAFETY, AND WARRANTS THAT THIS INTENT IS EVIDENT BY ACCEPTING THIS WORK.

SUBSTITUTES AND/OR EQUALS:

IF CONTRACTOR WISHES TO FURNISH OR USE A SUBSTITUTE ITEM OF MATERIAL OR EQUIPMENT, CONTRACTOR SHALL MAKE WRITTEN APPLICATION TO ENGINEER FOR ACCEPTANCE THEREOF, CERTIFYING THAT THE PROPOSED SUBSTITUTE WILL ADEQUATELY PERFORM THE FUNCTIONS AND ACHIEVE THE RESULTS CALLED FOR BY THE GENERAL DESIGN, BE SIMILAR IN SUBSTANCE TO THAT SPECIFIED, AND SUITED TO THE SAME USE AS THAT SPECIFIED. ALL VARIATIONS OF THE PROPOSED SUBSTITUTE FROM THAT SPECIFIED WILL BE IDENTIFIED IN THE APPLICATION AND AVAILABLE MAINTENANCE, REPAIR, AND REPLACEMENT SERVICE WILL BE INDICATED. THE APPLICATION WILL ALSO CONTAIN AN ITEMIZED ESTIMATE OF ALL COSTS OR CREDITS THAT WILL RESULT DIRECTLY OR INDIRECTLY FROM ACCEPTANCE OF SUCH SUBSTITUTE INCLUDING COSTS OF REDESIGN AND CLAIMS OF OTHER CONTRACTORS AFFECTED BY THE RESULTING CHANGE, ALL OF WHICH WILL BE CONSIDERED BY ENGINEER IN EVALUATION OF THE PROPOSED SUBSTITUTE. ENGINEER MAY REQUIRE CONTRACTOR TO FURNISH ADDITIONAL DATA ABOUT THE PROPOSED SUBSTITUTE.

NOTE:
REFER TO STRUCTURAL ANALYSIS BY: HUDSON DESIGN GROUP LLC DATED: APRIL 10, 2015 FOR THE CAPACITY OF THE EXISTING STRUCTURES TO SUPPORT THE PROPOSED EQUIPMENT.

1 INTERNATIONAL BLVD, SUITE 800
MAHWAH, NJ 07495
TEL: (800) 357-7641

1600 OSGOOD STREET
BUILDING 20 NORTH, SUITE 3090
N. ANDOVER, MA 01845
TEL: (978) 557-5553
FAX: (978) 336-5586

DANIEL P. HAMM
No. 24178
LICENSED PROFESSIONAL ENGINEER

CHECKED BY: MSC

APPROVED BY: DPH

SUBMITTALS			
REV.	DATE	DESCRIPTION	BY
1	04/10/15	ISSUED FOR CONSTRUCTION	GH

SITE NUMBER:
CT4-3XC827
SITE NAME:
MANCHESTER/POLICE TOWER
SITE ADDRESS:
239 MIDDLE TURNPIKE
MANCHESTER, CT 06040

SHEET TITLE
MODIFICATION ELEVATION & NOTES

SHEET NUMBER
S-1

CHECKED BY: MSC

APPROVED BY: DPH

SUBMITTALS			
REV.	DATE	DESCRIPTION	BY
1	04/10/15	ISSUED FOR CONSTRUCTION	GH

SITE NUMBER:
 CT4-3XC827
 SITE NAME:
 MANCHESTER/POLICE TOWER
 SITE ADDRESS:
 239 MIDDLE TURNPIKE
 MANCHESTER, CT 06040

SHEET TITLE
 MODIFICATION ELEVATION & DETAILS

SHEET NUMBER
 S-3

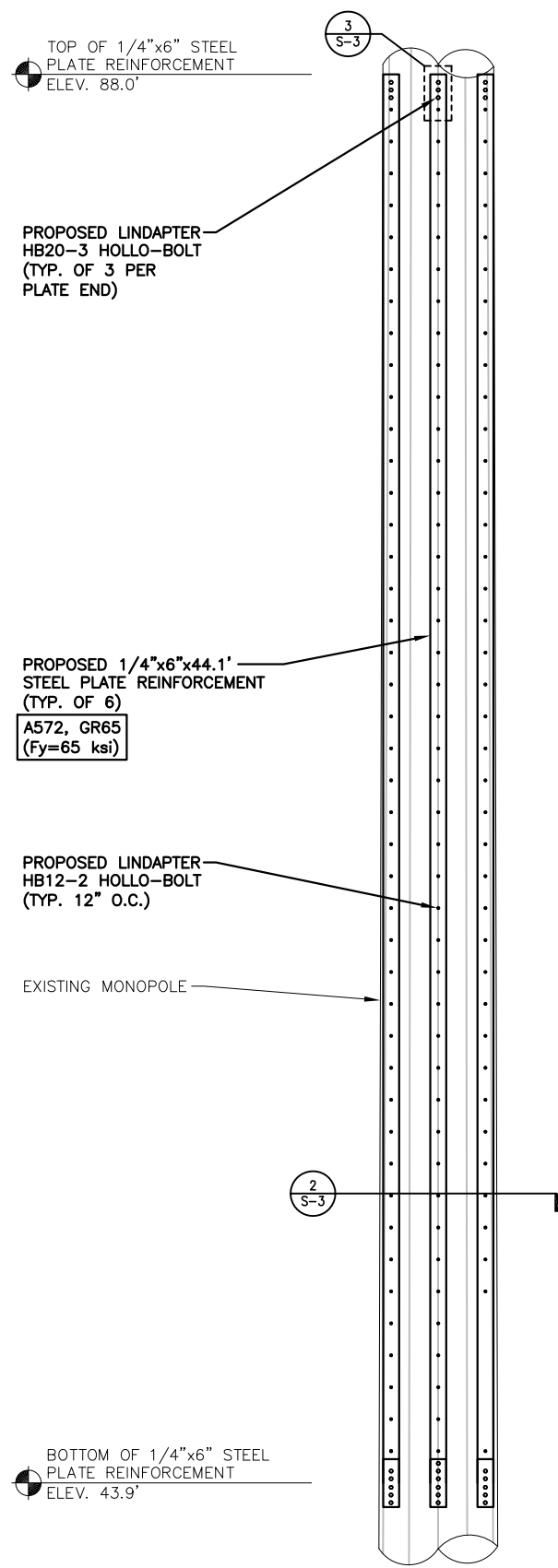

REINFORCEMENT ELEVATION
 ELEV. 43.9' - 88.0'
 SCALE: 3/8"=1'-0"

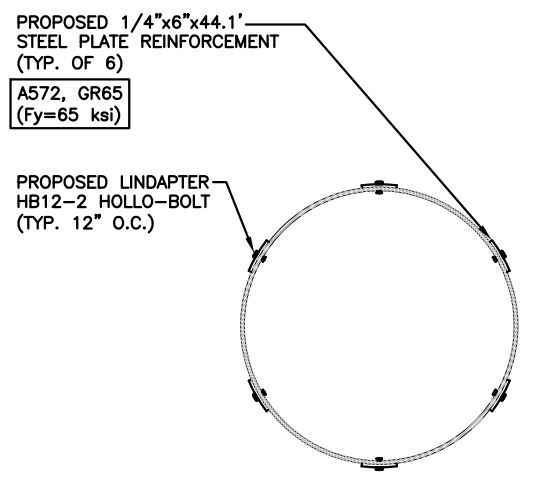

REINFORCEMENT PLAN
 ELEV. 43.9' - 88.0'
 SCALE: 1"=1'-0"

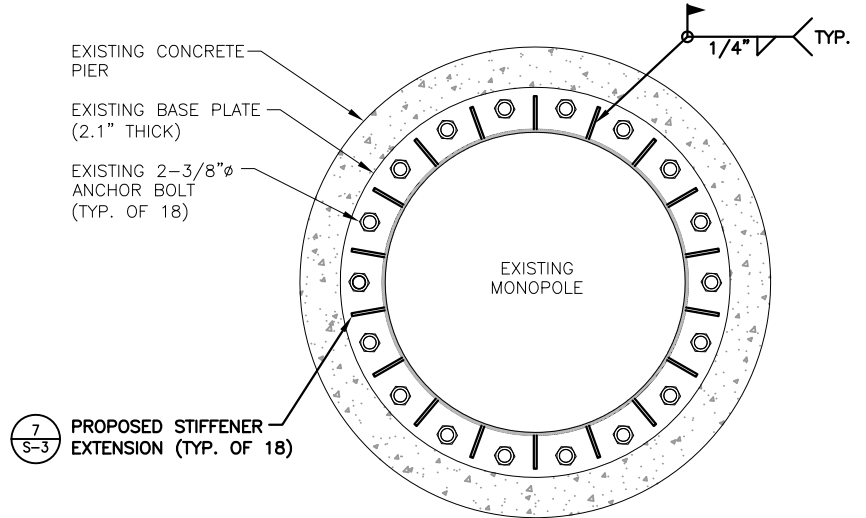

BASE PLATE MODIFICATION PLAN
 SCALE: 3/4"=1'-0"

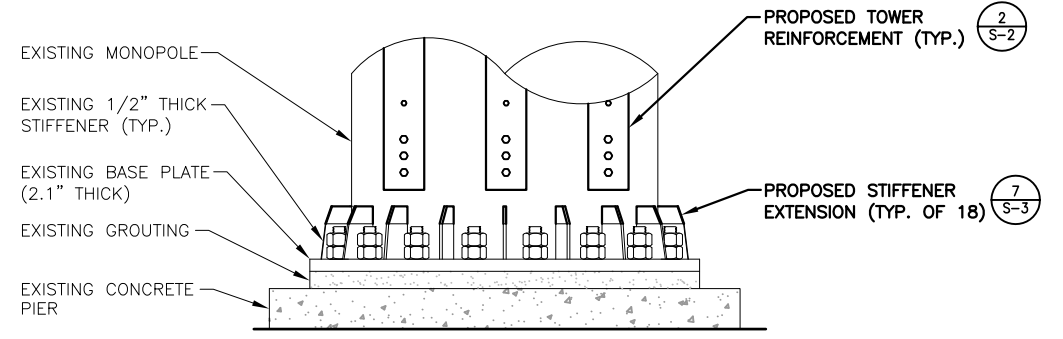

BASE PLATE MODIFICATION ELEVATION
 SCALE: 3/4"=1'-0"

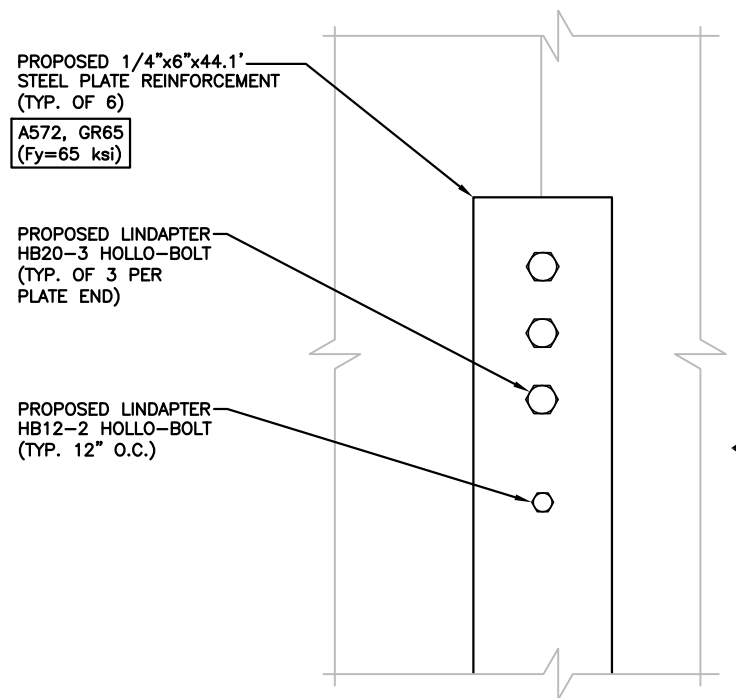

CONNECTION DETAIL
 ELEV. 88.0'
 SCALE: 3"=1'-0"

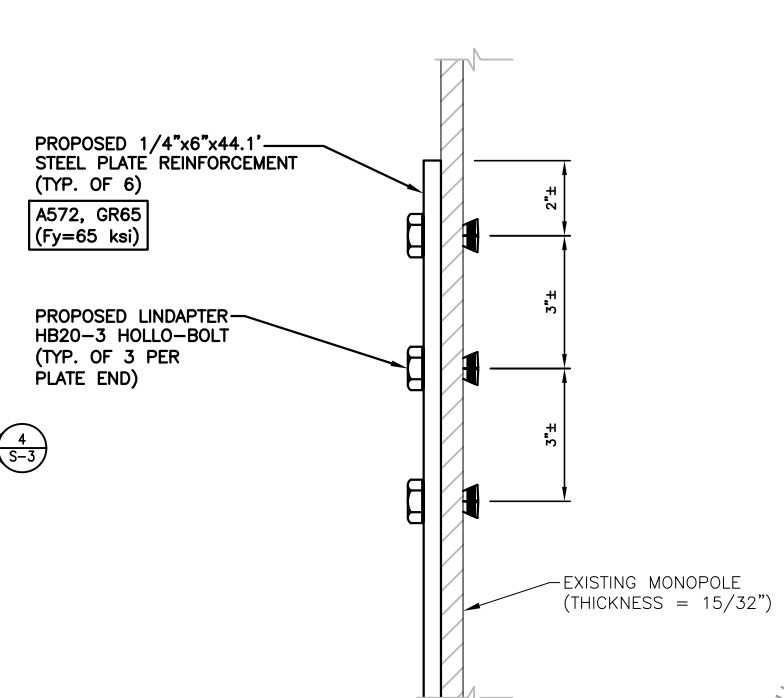

CONNECTION DETAIL
 ELEV. 88.0'
 SCALE: 6"=1'-0"

NOTE:
 REFER TO STRUCTURAL ANALYSIS BY: HUDSON DESIGN GROUP LLC DATED: APRIL 10, 2015 FOR THE CAPACITY OF THE EXISTING STRUCTURES TO SUPPORT THE PROPOSED EQUIPMENT.

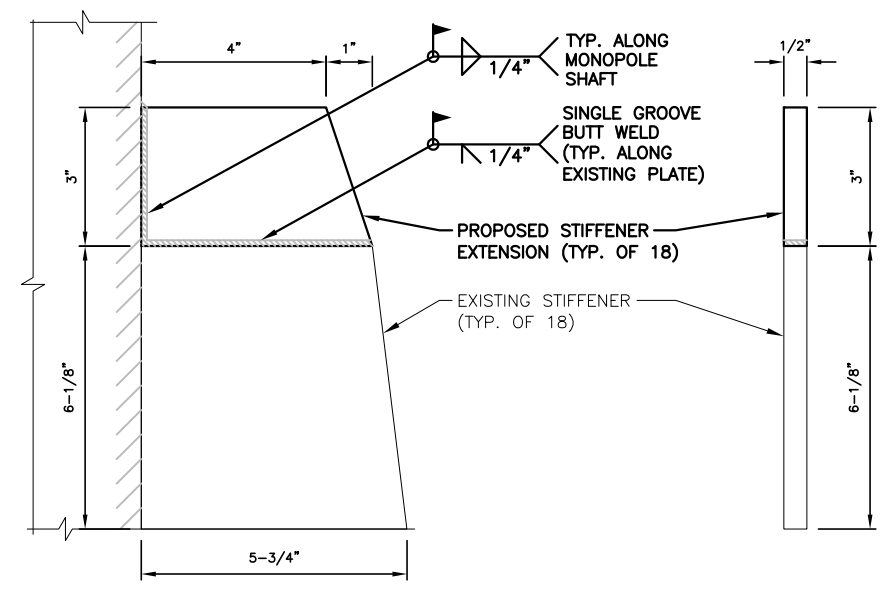

STIFFENER DETAIL (SIDE & FRONT VIEW)
 SCALE: 6"=1'-0"

RADIO FREQUENCY EMISSIONS ANALYSIS REPORT
EVALUATION OF HUMAN EXPOSURE POTENTIAL
TO NON-IONIZING EMISSIONS

AT&T Existing Facility

Site ID: CT5448

Manchester Central
239 Middle Turnpike East
Manchester, CT 06040

October 28, 2014

EBI Project Number: 62145784

Site Compliance Summary	
Compliance Status:	COMPLIANT
Site total MPE% of FCC general public allowable limit:	58.88 %

October 28, 2014

AT&T Mobility – New England
Attn: Cameron Syme, RF Manager
550 Cochituate Road
Suite 550 – 13&14
Framingham, MA 06040

Emissions Analysis for Site: **CT5448 – Manchester Central**

EBI Consulting was directed to analyze the proposed AT&T facility located at **239 Middle Turnpike East, Manchester, CT**, for the purpose of determining whether the emissions from the Proposed AT&T Antenna Installation located on this property are within specified federal limits.

All information used in this report was analyzed as a percentage of current Maximum Permissible Exposure (% MPE) as listed in the FCC OET Bulletin 65 Edition 97-01 and ANSI/IEEE Std C95.1. The FCC regulates Maximum Permissible Exposure in units of microwatts per square centimeter ($\mu\text{W}/\text{cm}^2$). The number of $\mu\text{W}/\text{cm}^2$ calculated at each sample point is called the power density. The exposure limit for power density varies depending upon the frequencies being utilized. Wireless Carriers and Paging Services use different frequency bands each with different exposure limits, therefore it is necessary to report results and limits in terms of percent MPE rather than power density.

All results were compared to the FCC (Federal Communications Commission) radio frequency exposure rules, 47 CFR 1.1307(b)(1) – (b)(3), to determine compliance with the Maximum Permissible Exposure (MPE) limits for General Population/Uncontrolled environments as defined below.

General population/uncontrolled exposure limits apply to situations in which the general public may be exposed or in which persons who are exposed as a consequence of their employment may not be made fully aware of the potential for exposure or cannot exercise control over their exposure. Therefore, members of the general public would always be considered under this category when exposure is not employment related, for example, in the case of a telecommunications tower that exposes persons in a nearby residential area.

Public exposure to radio frequencies is regulated and enforced in units of microwatts per square centimeter ($\mu\text{W}/\text{cm}^2$). The general population exposure limit for the 700 MHz Band is approximately 467 $\mu\text{W}/\text{cm}^2$. The general population exposure limit for the 850 MHz Band is approximately 567 $\mu\text{W}/\text{cm}^2$. The general population exposure limit for the PCS, AWS and WCS bands is 1000 $\mu\text{W}/\text{cm}^2$. Because each carrier will be using different frequency bands, and each frequency band has different exposure limits, it is necessary to report percent of MPE rather than power density.

Occupational/controlled exposure limits apply to situations in which persons are exposed as a consequence of their employment and in which those persons who are exposed have been made fully aware of the potential for exposure and can exercise control over their exposure. Occupational/controlled exposure limits also apply where exposure is of a transient nature as a result of incidental passage through a location where exposure levels may be above general population/uncontrolled limits (see below), as long as the exposed person has been made fully aware of the potential for exposure and can exercise control over his or her exposure by leaving the area or by some other appropriate means.

Additional details can be found in FCC OET 65.

CALCULATIONS

Calculations were done for the proposed AT&T Wireless antenna facility located at **239 Middle Turnpike East, Manchester, CT**, using the equipment information listed below. All calculations were performed per the specifications under FCC OET 65. Since AT&T is proposing highly focused directional panel antennas, which project most of the emitted energy out toward the horizon, all calculations were performed assuming a lobe representing the maximum gain of the antenna per the antenna manufactures supplied specifications, minus 10 dB, was focused at the base of the tower. For this report the sample point is the top of a 6 foot person standing at the base of the tower.

For all calculations, all equipment was calculated using the following assumptions:

- 1) 2 GSM channels (PCS Band - 1900 MHz) were considered for each sector of the proposed installation. These Channels have a transmit power of 30 Watts per Channel.
- 2) 2 GSM channels (850 MHz) were considered for each sector of the proposed installation. These Channels have a transmit power of 30 Watts per Channel.
- 3) 2 UMTS channels (PCS Band - 1900 MHz) were considered for each sector of the proposed installation. These Channels have a transmit power of 30 Watts per Channel.
- 4) 2 UMTS channels (850 MHz) were considered for each sector of the proposed installation. These Channels have a transmit power of 30 Watts per Channel.
- 5) 2 LTE channels (WCS Band – 2300 MHz) were considered for each sector of the proposed installation. These Channels have a transmit power of 30 Watts per Channel.
- 6) 2 LTE channels (PCS Band – 1900 MHz) were considered for each sector of the proposed installation. These Channels have a transmit power of 60 Watts per Channel.

- 7) 4 LTE channel (700 MHz Band) was considered for each sector of the proposed installation. This channel has a transmit power of 60 Watts.
- 8) All radios at the proposed installation were considered to be running at full power and were uncombined in their RF transmissions paths per carrier prescribed configuration. Per FCC OET Bulletin No. 65 - Edition 97-01 recommendations to achieve the maximum anticipated value at each sample point, all power levels emitting from the proposed antenna installation are increased by a factor of 2.56 to account for possible in-phase reflections from the surrounding environment. This is rarely the case, and if so, is never continuous.
- 9) For the following calculations the sample point was the top of a six foot person standing at the base of the tower. The maximum gain of the antenna per the antenna manufactures supplied specifications minus 10 dB was used in this direction. This value is a very conservative estimate as gain reductions for these particular antennas are typically much higher in this direction.
- 10) The antennas used in this modeling are the **Kathrein 800-10121** for 1900 MHz (PCS) and 850MHz GSM and UMTS channels and the **CCI OPA-65R-LCUU-H6 & CCI OPA-65R-LCUU-H8** for 700 MHz, 2300 Mhz and 1900 MHz LTE channels. This is based on feedback from the carrier with regards to anticipated antenna selection. The maximum gain of the antenna per the antenna manufactures supplied specifications, minus 10 dB, was used for all calculations. This value is a very conservative estimate as gain reductions for these particular antennas are typically much higher in this direction. The Manufacturers Gain Values per frequency band are listed in the Site Inventory and Power Data table on the following page.
- 11) The antenna mounting height centerline of the proposed antennas is **143 feet** above ground level (AGL).
- 12) Emissions values for additional carriers were taken from the Connecticut Siting Council active database. Values in this database are provided by the individual carriers themselves.

All calculations were done with respect to uncontrolled / general public threshold limits.

AT&T Site Inventory and Power Data

Sector:	A	Sector:	B	Sector:	C
Antenna #:	1	Antenna #:	1	Antenna #:	1
Make / Model:	Kathrein 800-10121	Make / Model:	Kathrein 800-10121	Make / Model:	Kathrein 800-10121
Gain:	13.3 dBd / 16.2 dBd	Gain:	13.3 dBd / 16.2 dBd	Gain:	13.3 dBd / 16.2 dBd
Height (AGL):	143	Height (AGL):	143	Height (AGL):	143
Frequency Bands	850 MHz / 1900 MHz (PCS)	Frequency Bands	850 MHz / 1900 MHz (PCS)	Frequency Bands	850 MHz / 1900 MHz (PCS)
Channel Count	8	Channel Count	8	# PCS Channels:	8
Total TX Power:	240	Total TX Power:	240	# AWS Channels:	240
ERP (W):	3,483.77	ERP (W):	3,483.77	ERP (W):	3,483.77
Antenna A1 MPE%	1.82	Antenna B1 MPE%	1.82	Antenna C1 MPE%	1.82
Antenna #:	2	Antenna #:	2	Antenna #:	2
Make / Model:	CCI OPA-65R-LCUU-H6	Make / Model:	CCI OPA-65R-LCUU-H8	Make / Model:	CCI OPA-65R-LCUU-H8
Gain:	13.3 dBd / 17.9 dBd	Gain:	13.3 dBd / 17.1 dBd	Gain:	13.3 dBd / 17.1 dBd
Height (AGL):	143	Height (AGL):	143	Height (AGL):	143
Frequency Bands	700 MHz / 2300 MHz (WCS)	Frequency Bands	700 MHz / 2300 MHz (WCS)	Frequency Bands	1900 MHz(PCS) / 2100 MHz (AWS)
Channel Count	4	Channel Count	4	Channel Count	4
Total TX Power:	240	Total TX Power:	240	Total TX Power:	240
ERP (W):	3,522.41	ERP (W):	3,522.41	ERP (W):	3,522.41
Antenna A2 MPE%	2.50	Antenna B2 MPE%	2.50	Antenna C2 MPE%	2.50
Antenna #:	3	Antenna #:	3	Antenna #:	3
Make / Model:	CCI OPA-65R-LCUU-H6	Make / Model:	CCI OPA-65R-LCUU-H8	Make / Model:	CCI OPA-65R-LCUU-H8
Gain:	13.9 dBd / 17.4 dBd	Gain:	13.3 dBd / 17.3 dBd	Gain:	13.3 dBd / 17.3 dBd
Height (AGL):	143	Height (AGL):	143	Height (AGL):	143
Frequency Bands	700 Mhz / 1900 MHz (PCS)	Frequency Bands	700 Mhz / 1900 MHz (PCS)	Frequency Bands	700 Mhz / 1900 MHz (PCS)
Channel Count	4	Channel Count	4	Channel Count	4
Total TX Power:	120	Total TX Power:	120	Total TX Power:	120
ERP (W):	3,534.37	ERP (W):	3,534.37	ERP (W):	3,522.41
Antenna A3 MPE%	2.47	Antenna B3 MPE%	2.47	Antenna C3 MPE%	2.47

Site Composite MPE%	
Carrier	MPE%
AT&T	20.39 %
Town MFRE	0.96 %
Town MPD - ch 1	0.13 %
Town MPD - ch 2	0.15 %
Town MFD	0.26 %
Town services intercity	0.49 %
RAFS I/2	1.65 %
Town public works	0.73 %
Town Services EOC	0.73 %
Town FD	0.73 %
town SP hotline	0.97 %
Town Vol FD	0.56 %
Town Service - School	0.16 %
Htfd City FD	0.73 %
Tolland MUT	0.73 %
Nextel	3.25 %
Sprint	8.51 %
Clearwire	0.81 %
T-Mobile	0.13 %
Verizon Wireless	16.80 %
Site Total MPE %:	58.88 %

AT&T Sector 1 Total:	6.80 %
AT&T Sector 2 Total:	6.80 %
AT&T Sector 3 Total:	6.80 %
Site Total:	58.88 %

Summary

All calculations performed for this analysis yielded results that were **within** the allowable limits for general public exposure to RF Emissions.

The anticipated maximum composite contributions from the AT&T facility as well as the site composite emissions value with regards to compliance with FCC's allowable limits for general public exposure to RF Emissions are shown here:

AT&T Sector	Power Density Value (%)
Sector 1:	6.80 %
Sector 2:	6.80 %
Sector 3 :	6.80 %
AT&T Total:	20.39 %
Site Total:	58.88 %
Site Compliance Status:	COMPLIANT

The anticipated composite MPE value for this site assuming all carriers present is **58.88%** of the allowable FCC established general public limit sampled at the ground level. This is based upon values listed in the Connecticut Siting Council database for existing carrier emissions.

FCC guidelines state that if a site is found to be out of compliance (over allowable thresholds), that carriers over a 5% contribution to the composite value will require measures to bring the site into compliance. For this facility, the composite values calculated were well within the allowable 100% threshold standard per the federal government.



Scott Heffernan
RF Engineering Director

EBI Consulting
21 B Street
Burlington, MA 01803`