



August 29, 2014

David Martin and  
Members of the Siting Council  
Connecticut Siting Council  
Ten Franklin Square  
New Britain, CT 06051

RE: Notice of Exempt Modification  
93 Lake Street  
Manchester CT  
T-Mobile #: CTHA075D  
N 41° 47' 20.7"  
W -72° 28' 55.5"

Dear Mr. Martin and Members of the Siting Council:

On behalf of T-Mobile Northeast LLC, SBA Communications is submitting an exempt modification application to the Connecticut Siting Council for modification of existing equipment at a tower facility located at 93 Lake Street, Manchester CT.

The 93 Lake Street facility consists of a 109' MONOPOLE Tower owned and operated by SBA Infrastructure, LLC. In order to accommodate technological changes and enhance system performance in the State of Connecticut, T-Mobile Northeast LLC plans to modify the equipment configurations at many of its existing cell sites. Please accept this letter and attachments as notification, pursuant to R.C.S.A. Section 16-50j-73, of construction which constitutes an exempt modification pursuant to R.C.S.A. Section 16-50j-72(b)(2). In compliance with R.C.S.A. Section 16-50j-73, a copy of this letter and attachments is being sent to the chief elected official of the municipality in which the affected cell site is located.

T-Mobile Northeast LLC wishes to upgrade their equipment to meet the new standards of 4G technology. The new equipment will allow customers to download files and browse the internet at a high rate of speed while also allowing their phones to be compatible with the latest 4G technology.

Attached is a summary of the planned modifications, including power density calculations reflecting the change in Sprint's operations at the site along with the required fee of \$625.

The changes to the facility do not constitute modifications as defined in Connecticut General Statutes ("C.G.S.") Section 16-50i(d) because the general physical characteristics of the facility will not be



significantly changed or altered. Rather, the planned changes to the facility fall squarely within those activities explicitly provided for in R.C.S.A. Section 16-50j-72(b)(2).

1. The overall height of the structure will be unaffected.
2. The proposed changes will not extend the site boundaries. There will be no effect on the site compound other than the new equipment cabinets.
3. The proposed changes will not increase the noise level at the existing facility by six decibels or more.
4. The changes in radio frequency power density will not increase the calculated "worst case" power density for the combined operations at the site to a level at or above the applicable standard for uncontrolled environments as calculated for a mixed frequency site.

For the foregoing reasons, SBA Communications on behalf of T-Mobile Northeast LLC, respectfully submits that the proposed changes at the referenced site constitute exempt modifications under R.C.S.A. Section 16-50j-72(b)(2).

Please feel free to call me at (508) 251-0720 x 3807 with any questions you may have concerning this matter.

Thank you,

A handwritten signature in blue ink, appearing to read "Peter Nute", is positioned below the "Thank you," text.

Peter Nute  
SBA Communications Corporation  
33 Boston Post Road West Suite 320  
Marlborough, MA 01752  
508-251-0720 x 3807 + T  
508-251-1755 + F  
[Pnute@sbsite.com](mailto:Pnute@sbsite.com)



**T-Mobile Northeast LLC  
Equipment Modification**

93 Lake Street, Manchester CT  
Site number CTHA075D

**Tower Owner:** SBA Infrastructure, LLC

**Equipment Configuration:** MONOPOLE Tower

**Current and/or approved:**

- (6) RFS APX16PV-16PVL-C
- (3) RFS APX18-206513E
- (6) Andrew ETW200VA12UB
- (12) 7/8" Feed Lines

**Planned Modifications:**

- (3) Ericsson Air B2A/B4P
- (3) Ericsson Air B4A/B2P
- (3) RFS APX18-206513E
- (3) Andrew ETW200VA12UB
- (3) Ericsson KRY 112 144/1
- (12) 7/8" Feed Lines
- (1) 1-5/8" Fiber Line

**Structural Information:**

The attached structural analysis demonstrates that the tower and foundation will have adequate structural capacity to accommodate the proposed modifications.

**Power Density:**

The anticipated Maximum Composite contributions from the T-Mobile facility are 9.49% of the allowable FCC established general public limit. The anticipated composite MPE value for this site assuming all carriers present is 11.55% of the allowable FCC established general public limit sampled at the ground level.

Site Composite MPE%	
Carrier	MPE%
T-Mobile	9.49
Clearwire	2.06 %
Site Total MPE %:	11.55 %





August 29, 2014

Mayor Jay Moran  
Town of Manchester  
Town Hall  
41 Center Street  
Manchester, CT 06045

RE: Telecommunications Facility @ 93 Lake Street, Manchester CT

Dear Mayor Moran,

In order to accommodate technological changes and enhance system performance in the State of Connecticut, T-Mobile Northeast LLC will be changing its equipment configuration at certain cell sites.

As required by Regulations of Connecticut State Agencies (R.C.S.A.) Section 16-50j-73, the Connecticut Siting Council has been notified of the changes and will review T-Mobile's proposal. Please accept this letter as notification under Section 16-50j-73 of construction which constitutes an exempt modification pursuant to R.C.S.A. Section 16-50j-72(b)(2).

The accompanying letter to the Siting Council fully describes Sprint's proposal for the referenced cell site. However, if you have any questions or require any further information on our plans or the Siting Council's procedures, please call me at (508) 251-0720 x 3807.

Thank you,

A handwritten signature in blue ink, appearing to read "Peter Nute", is positioned below the "Thank you," text.

Peter Nute  
SBA Communications Corporation  
33 Boston Post Road West Suite 320  
Marlborough, MA 01752  
508-251-0720 x 3807 + T  
508-251-1755 + F  
[Pnute@sbsite.com](mailto:Pnute@sbsite.com)

August 29, 2014

Alan Rossetto  
23 Longview Drive  
Lancaster NH 03584

RE: Telecommunications Facility @ 93 Lake Street, Manchester CT

Dear Mr. Rossetto,

In order to accommodate technological changes and enhance system performance in the State of Connecticut, T-Mobile Northeast LLC will be changing its equipment configuration at certain cell sites.

As required by Regulations of Connecticut State Agencies (R.C.S.A.) Section 16-50j-73, the Connecticut Siting Council has been notified of the changes and will review T-Mobile's proposal. Please accept this letter as notification under Section 16-50j-73 of construction which constitutes an exempt modification pursuant to R.C.S.A. Section 16-50j-72(b)(2).

The accompanying letter to the Siting Council fully describes Sprint's proposal for the referenced cell site. However, if you have any questions or require any further information on our plans or the Siting Council's procedures, please call me at (508) 251-0720 x 3807.

Thank you,



Peter Nute  
SBA Communications Corporation  
33 Boston Post Road West Suite 320  
Marlborough, MA 01752  
508-251-0720 x 3807 + T  
508-251-1755 + F  
[Pnute@sbsite.com](mailto:Pnute@sbsite.com)

RADIO FREQUENCY EMISSIONS ANALYSIS REPORT  
EVALUATION OF HUMAN EXPOSURE POTENTIAL  
TO NON-IONIZING EMISSIONS

T-Mobile Existing Facility

Site ID: CTHA075D

Optasite\_FT MP  
93 Lake Street  
Manchester, CT 06042

**August 25, 2014**

Site Compliance Summary	
Compliance Status:	<b>COMPLIANT</b>
Site total MPE% of FCC general public allowable limit:	<b>11.55 %</b>

August 25, 2014

T-Mobile USA  
Attn: Jason Overbey, RF Manager  
35 Griffin Road South  
Bloomfield, CT 06002

Emissions Analysis for Site: **CTHA075D – Optasite\_FT MP**

EBI Consulting was directed to analyze the proposed T-Mobile facility located at **93 Lake Street, Manchester, CT**, for the purpose of determining whether the emissions from the Proposed T-Mobile Antenna Installation located on this property are within specified federal limits.

All information used in this report was analyzed as a percentage of current Maximum Permissible Exposure (% MPE) as listed in the FCC OET Bulletin 65 Edition 97-01 and ANSI/IEEE Std C95.1. The FCC regulates Maximum Permissible Exposure in units of microwatts per square centimeter ( $\mu\text{W}/\text{cm}^2$ ). The number of  $\mu\text{W}/\text{cm}^2$  calculated at each sample point is called the power density. The exposure limit for power density varies depending upon the frequencies being utilized. Wireless Carriers and Paging Services use different frequency bands each with different exposure limits, therefore it is necessary to report results and limits in terms of percent MPE rather than power density.

All results were compared to the FCC (Federal Communications Commission) radio frequency exposure rules, 47 CFR 1.1307(b)(1) – (b)(3), to determine compliance with the Maximum Permissible Exposure (MPE) limits for General Population/Uncontrolled environments as defined below.

General population/uncontrolled exposure limits apply to situations in which the general public may be exposed or in which persons who are exposed as a consequence of their employment may not be made fully aware of the potential for exposure or cannot exercise control over their exposure. Therefore, members of the general public would always be considered under this category when exposure is not employment related, for example, in the case of a telecommunications tower that exposes persons in a nearby residential area.

Public exposure to radio frequencies is regulated and enforced in units of microwatts per square centimeter ( $\mu\text{W}/\text{cm}^2$ ). The general population exposure limit for the 700 MHz Band is 567  $\mu\text{W}/\text{cm}^2$ , and the general population exposure limit for the PCS and AWS bands is 1000  $\mu\text{W}/\text{cm}^2$ . Because each carrier will be using different frequency bands, and each frequency band has different exposure limits, it is necessary to report percent of MPE rather than power density.

Occupational/controlled exposure limits apply to situations in which persons are exposed as a consequence of their employment and in which those persons who are exposed have been made fully aware of the potential for exposure and can exercise control over their exposure. Occupational/controlled exposure limits also apply where exposure is of a transient nature as a result of incidental passage through a location where exposure levels may be above general population/uncontrolled limits (see below), as long as the exposed person has been made fully aware of the potential for exposure and can exercise control over his or her exposure by leaving the area or by some other appropriate means.

Additional details can be found in FCC OET 65.

## **CALCULATIONS**

Calculations were done for the proposed T-Mobile Wireless antenna facility located at **93 Lake Street, Manchester, CT**, using the equipment information listed below. All calculations were performed per the specifications under FCC OET 65. Since T-Mobile is proposing highly focused directional panel antennas, which project most of the emitted energy out toward the horizon, all calculations were performed assuming a lobe representing the maximum gain of the antenna per the antenna manufactures supplied specifications, minus 10 dB, was focused at the base of the tower. For this report the sample point is the top of a 6 foot person standing at the base of the tower.

For all calculations, all equipment was calculated using the following assumptions:

- 1) 2 GSM channels (PCS Band - 1900 MHz) were considered for each sector of the proposed installation. These Channels have a transmit power of 30 Watts per Channel
- 2) 2 UMTS channels (AWS Band – 2100 MHz) were considered for each sector of the proposed installation. These Channels have a transmit power of 30 Watts per Channel.
- 3) 2 LTE channels (AWS Band – 2100 MHz) were considered for each sector of the proposed installation. These Channels have a transmit power of 60 Watts per Channel.
- 4) All radios at the proposed installation were considered to be running at full power and were uncombined in their RF transmissions paths per carrier prescribed configuration. Per FCC OET Bulletin No. 65 - Edition 97-01 recommendations to achieve the maximum anticipated value at each sample point, all power levels emitting from the proposed antenna installation are increased by a factor of 2.56 to account for possible in-phase reflections from the surrounding environment. This is rarely the case, and if so, is never continuous.



- 5) For the following calculations the sample point was the top of a six foot person standing at the base of the tower. The maximum gain of the antenna per the antenna manufactures supplied specifications minus 10 dB was used in this direction. This value is a very conservative estimate as gain reductions for these particular antennas are typically much higher in this direction.
- 6) The antennas used in this modeling are the **Ericsson AIR21 B4A/B2P** for 1900 MHz (PCS) and 2100 MHz (AWS) channels. This is based on feedback from the carrier with regards to anticipated antenna selection. The **Ericsson AIR21 B4A/B2P** has a maximum gain of **15.6 dBd** at its main lobe. The maximum gain of the antenna per the antenna manufactures supplied specifications, minus 10 dB, was used for all calculations. This value is a very conservative estimate as gain reductions for these particular antennas are typically much higher in this direction.
- 7) The antenna mounting height centerline of the proposed antennas is **105.5 feet** above ground level (AGL).
- 8) Emissions values for additional carriers were taken from the Connecticut Siting Council active database. Values in this database are provided by the individual carriers themselves.

All calculations were done with respect to uncontrolled / general public threshold limits.

**T-Mobile Site Inventory and Power Data**

Sector:	A	Sector:	B	Sector:	C
Antenna #:	1	Antenna #:	1	Antenna #:	1
Make / Model:	Ericsson AIR21 B4A/B2P	Make / Model:	Ericsson AIR21 B4A/B2P	Make / Model:	Ericsson AIR21 B4A/B2P
Gain:	15.6 dBd	Gain:	15.6 dBd	Gain:	15.6 dBd
Height (AGL):	105.5	Height (AGL):	105.5	Height (AGL):	105.5
Frequency Bands	1900 MHz(PCS) / 2100 MHz (AWS)	Frequency Bands	1900 MHz(PCS) / 2100 MHz (AWS)	Frequency Bands	1900 MHz(PCS) / 2100 MHz (AWS)
Channel Count	2	Channel Count	2	# PCS Channels:	2
Total TX Power:	60	Total TX Power:	60	# AWS Channels:	60
ERP (W):	1,888.44	ERP (W):	1,888.44	ERP (W):	1,888.44
Antenna A1 MPE%	1.58	Antenna B1 MPE%	1.58	Antenna C1 MPE%	1.58
Antenna #:	2	Antenna #:	2	Antenna #:	2
Make / Model:	Ericsson AIR21 B4A/B2P	Make / Model:	Ericsson AIR21 B4A/B2P	Make / Model:	Ericsson AIR21 B4A/B2P
Gain:	15.6 dBd	Gain:	15.6 dBd	Gain:	15.6 dBd
Height (AGL):	105.5	Height (AGL):	105.5	Height (AGL):	105.5
Frequency Bands	1900 MHz(PCS) / 2100 MHz (AWS)	Frequency Bands	1900 MHz(PCS) / 2100 MHz (AWS)	Frequency Bands	1900 MHz(PCS) / 2100 MHz (AWS)
Channel Count	4	Channel Count	4	Channel Count	4
Total TX Power:	60	Total TX Power:	60	Total TX Power:	60
ERP (W):	1,888.44	ERP (W):	1,888.44	ERP (W):	1,888.44
Antenna A2 MPE%	1.58	Antenna B2 MPE%	1.58	Antenna C2 MPE%	1.58

Site Composite MPE%	
Carrier	MPE%
T-Mobile	9.49
Clearwire	2.06 %
<b>Site Total MPE %:</b>	<b>11.55 %</b>

T-Mobile Sector 1 Total:	3.16 %
T-Mobile Sector 2 Total:	3.16 %
T-Mobile Sector 3 Total:	3.16 %
<b>Site Total:</b>	<b>11.55 %</b>

## Summary

All calculations performed for this analysis yielded results that were **within** the allowable limits for general public exposure to RF Emissions.

The anticipated maximum composite contributions from the T-Mobile facility as well as the site composite emissions value with regards to compliance with FCC's allowable limits for general public exposure to RF Emissions are shown here:

T-Mobile Sector	Power Density Value (%)
Sector 1:	3.16 %
Sector 2:	3.16 %
Sector 3 :	3.16 %
T-Mobile Total:	9.49 %
Site Total:	11.55 %
Site Compliance Status:	<b>COMPLIANT</b>

The anticipated composite MPE value for this site assuming all carriers present is **11.55%** of the allowable FCC established general public limit sampled at the ground level. This is based upon values listed in the Connecticut Siting Council database for existing carrier emissions.

FCC guidelines state that if a site is found to be out of compliance (over allowable thresholds), that carriers over a 5% contribution to the composite value will require measures to bring the site into compliance. For this facility, the composite values calculated were well within the allowable 100% threshold standard per the federal government.



**Scott Heffernan**  
RF Engineering Director

**EBI Consulting**  
21 B Street  
Burlington, MA 01803`



FDH Engineering, Inc., 6521 Meriden Drive Raleigh, NC 27616, Ph. 919.755.1012

**Structural Analysis for  
SBA Network Services, Inc.**

**109' Monopole Tower**

**SBA Site Name: Manchester 1  
SBA Site ID: CT13529-A-02  
T-Mobile Site ID: CTHA075D**

FDH Project Number 146AMT1400

**Analysis Results**

Tower Components	26.1%	Sufficient
Foundation	31.2%	Sufficient

Prepared By:

Emily Basile, EI  
Project Engineer

Reviewed By:

Bradley R. Newman, PE  
Senior Project Engineer  
CT PE License No. 29630

**FDH Engineering, Inc.**  
6521 Meriden Drive  
Raleigh, NC 27616  
(919) 755-1012  
info@fdh-inc.com

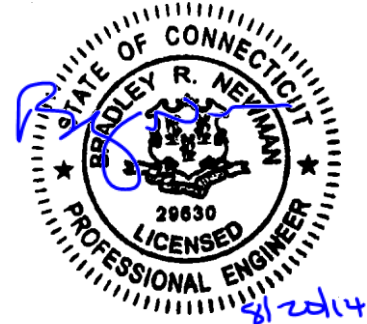

August 20, 2014

*Prepared pursuant to TIA/EIA-222-F Structural Standards for Steel Antenna Towers and Antenna Supporting Structures and 2005 Connecticut State Building Code*

**TABLE OF CONTENTS**

EXECUTIVE SUMMARY .....3

    Conclusions.....3

    Recommendations .....3

APPURTENANCE LISTING .....4

RESULTS .....5

GENERAL COMMENTS .....6

LIMITATIONS .....6

APPENDIX .....7



## EXECUTIVE SUMMARY

At the request of SBA Network Services, Inc., FDH Engineering, Inc. performed a structural analysis of the monopole located in Manchester, CT to determine whether the tower is structurally adequate to support both the existing and proposed loads pursuant to the *Structural Standards for Steel Antenna Towers and Antenna Supporting Structures, TIA/EIA-222-F and 2005 Connecticut Building Code (CBC)*. Information pertaining to the existing/proposed antenna loading, current tower geometry, foundation dimensions, geotechnical data, and member sizes was obtained from:

- Sabre Towers & Poles (Project No. 09-06160) Structural Design Report dated June 17, 2008
- FDH, Inc. (Job No. 08-10008T) TIA Inspection Report dated October 20, 2008
- Terracon Consulting Engineers & Scientists (Project No. J2085152) Geotechnical Engineering Report dated June 6, 2008
- SBA Network Services, Inc.

The *basic design wind speed* per the *TIA/EIA-222-F standards and 2005 CBC* is 80 mph without ice and 69 mph with 1.25" radial ice. Ice is considered to increase in thickness with height.

## Conclusions

With the existing and proposed antennas from T-Mobile in place at 105.5 ft, the tower meets the requirements of the *TIA/EIA-222-F standards and 2005 CBC* provided the **Recommendations** listed below are satisfied. Furthermore, provided the foundation was designed and constructed to support the original design reactions (see Sabre Job No. 09-06160), the foundation should have the necessary capacity to support the existing and proposed loading. For a more detailed description of the analysis of the tower, see the **Results** section of this report.

Our structural analysis has been performed assuming all information provided to FDH Engineering, Inc. is accurate (i.e., the steel data, tower layout, existing antenna loading, and proposed antenna loading) and that the tower has been properly erected and maintained per the original design drawings.

## Recommendations

To ensure the requirements of the *TIA/EIA-222-F standards and 2005 CBC* are met with the existing and proposed loading in place, we have the following recommendations:

1. The proposed feed lines should be installed inside the monopole's shaft.
2. RRU/RRH Stipulation: The equipment may be installed in any arrangement as determined by the client.

**APPURTENANCE LISTING**

The proposed and existing antennas with their corresponding cables/coax lines are shown in **Table 1**. *If the actual layout determined in the field deviates from the layout, FDH Engineering, Inc. should be contacted to perform a revised analysis.*

**Table 1 - Appurtenance Loading**

**Existing Loading:**

Antenna Elevation (ft)	Description	Feed Lines <sup>1</sup>	Carrier	Mount Elevation (ft)	Mount Type
105.5	(6) RFS APX16PV-16PVL-C (3) RFS APX18-206513E (6) Andrew ETW200VA12UB	(12) 7/8"	T-Mobile	105.5	(1) 14.5' Low Profile Platform

1. Feed lines installed inside pole's shaft unless otherwise noted.

**Proposed Carrier Final Loading:**

Antenna Elevation (ft)	Description	Feed Lines	Carrier	Mount Elevation (ft)	Mount Type
105.5	(3) Ericsson Air B2A/B4P (3) Ericsson Air B4A/B2P (3) RFS APX18-206513E (3) Andrew ETW200VA12UB (3) Ericsson KRY 112 144/1	(12) 1-5/8" (1) 1-5/8" Fiber	T-Mobile	105.5	(1) 14.5' Low Profile Platform

## RESULTS

The following yield strength of steel for individual members was used for analysis:

**Table 2 - Material Strength**

Member Type	Yield Strength
Tower Shaft Sections	65 ksi
Base Plate	60 ksi
Anchor Bolts	75 ksi

**Table 3** displays the summary of the ratio (as a percentage) of force in the member to their capacities. Values greater than 100% indicate locations where the maximum force in the member exceeds its capacity. *Note: Capacities up to 100% are considered acceptable.* **Table 4** displays the maximum foundation reactions.

If the assumptions outlined in this report differ from actual field conditions, FDH Engineering, Inc. should be contacted to perform a revised analysis. Furthermore, as no information pertaining to the allowable twist and sway requirements for the existing or proposed appurtenances was provided, deflection and rotation were not taken into consideration when performing this analysis.

See the **Appendix** for detailed modeling information.

**Table 3 - Summary of Working Percentage of Structural Components**

Section No.	Elevation (ft)	Component Type	Size	% Capacity*	Pass Fail
L1	109 - 99	Pole	TP24.21x22.14x0.1875	3.9	Pass
L2	99 - 49	Pole	TP34.18x23.214x0.3125	20.3	Pass
L3	49 - 0	Pole	TP43.7x32.6757x0.375	26.1	Pass
	0	Anchor Bolts	(12) 2.25" $\emptyset$ w/ BC = 50"	23.7	Pass
	0	Base Plate	SQ PL 49" x 2.75" thk.	20.0	Pass

\*Capacities include 1/3 allowable increase for wind per TIA/EIA-222-F standards.

**Table 4 - Maximum Base Reactions**

Base Reactions	Current Analysis* (TIA/EIA-222-F)	Original Design (ANSI/TIA-222-G)
Axial	17 k**	41 k
Shear	9 k***	27 k
Moment	596 k-ft	2,581 k-ft

\*Design analysis reactions are within an allowable factor of 1.35 per the ANSI/TIA-222-G standard when the current reactions are based on an allowable stress design.

\*\*Per our experience with foundations of similar type, the axial loading should not control the foundation analysis.

\*\*\*Per our experience with foundations of similar type, the shear loading should not control the foundation analysis.

## **GENERAL COMMENTS**

This engineering analysis is based upon the theoretical capacity of the structure. It is not a condition assessment of the tower and its foundation. It is the responsibility of SBA Network Services, Inc. to verify that the tower modeled and analyzed is the correct structure (with accurate antenna loading information) modeled. If there are substantial modifications to be made or the assumptions made in this analysis are not accurate, FDH Engineering, Inc. should be notified immediately to perform a revised analysis.

## **LIMITATIONS**

All opinions and conclusions are considered accurate to a reasonable degree of engineering certainty based upon the evidence available at the time of this report. All opinions and conclusions are subject to revision based upon receipt of new or additional/updated information. All services are provided exercising a level of care and diligence equivalent to the standard and care of our profession. No other warranty or guarantee, expressed or implied, is offered. Our services are confidential in nature and we will not release this report to any other party without the client's consent. The use of this engineering work is limited to the express purpose for which it was commissioned and it may not be reused, copied, or distributed for any other purpose without the written consent of FDH Engineering, Inc.

## **APPENDIX**



Section	1	2	3	4
Length (ft)	10.00	53.00	53.25	13.7
Number of Sides	18	18	18	18
Thickness (in)	0.1875	0.3125	0.3750	0.3750
Socket Length (ft)	3.00	4.25	32.6757	4.25
Top Dia (in)	22.1400	23.2140	43.7000	23.2140
Bot Dia (in)	24.2100	34.1800	43.7000	34.1800
Grade		A572-65		
Weight (K)	0.5	5.1	8.2	13.7

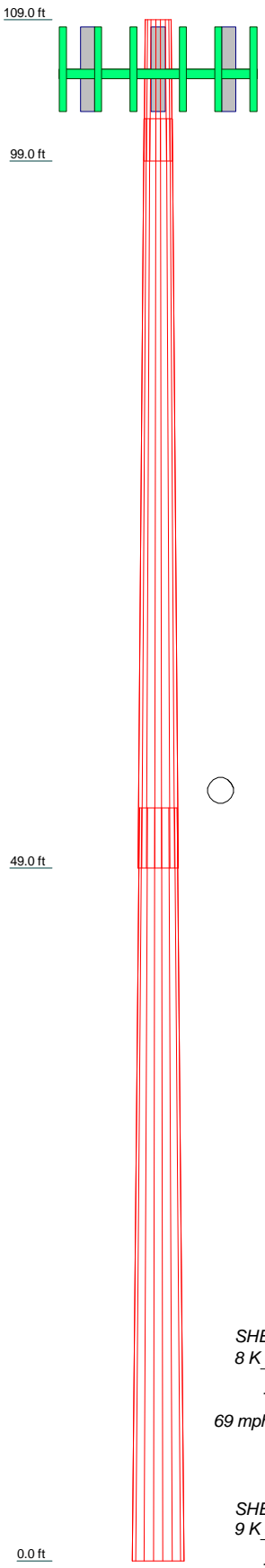

### DESIGNED APPURTENANCE LOADING

TYPE	ELEVATION	TYPE	ELEVATION
AIR 21 B2A/B4P w/Mount Pipe	105.5	APX18-206513E w/ Mount Pipe	105.5
AIR 21 B2A/B4P w/Mount Pipe	105.5	ETW200VA12UB	105.5
AIR 21 B2A/B4P w/Mount Pipe	105.5	ETW200VA12UB	105.5
AIR 21 B4A/B2P w/Mount Pipe	105.5	ETW200VA12UB	105.5
AIR 21 B4A/B2P w/Mount Pipe	105.5	KRY 112 144	105.5
AIR 21 B4A/B2P w/Mount Pipe	105.5	KRY 112 144	105.5
APX18-206513E w/ Mount Pipe	105.5	KRY 112 144	105.5
APX18-206513E w/ Mount Pipe	105.5	14.5' Low Profile Platform	105.5

### MATERIAL STRENGTH

GRADE	Fy	Fu	GRADE	Fy	Fu
A572-65	65 ksi	80 ksi			

### TOWER DESIGN NOTES

1. Tower is located in Hartford County, Connecticut.
2. Tower designed for a 80 mph basic wind in accordance with the TIA/EIA-222-F Standard.
3. Tower is also designed for a 69 mph basic wind with 1.25 in ice.
4. Deflections are based upon a 60 mph wind.
5. TOWER RATING: 26.1%

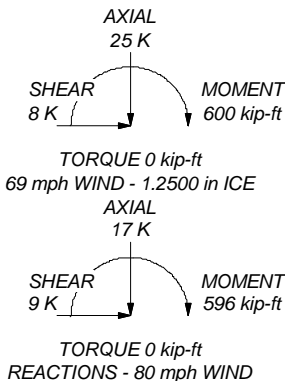

**FDH Engineering, Inc.**  
6521 Meridian Drive, Suite 107  
Raleigh, North Carolina 27616  
Phone: 9197551012  
FAX: 9197551031

Job: **Manchester 1, CT13529-A-02**  
Project: **146AMT1400**  
Client: SBA Network Services, Inc. Drawn by: EBasile App'd:  
Code: TIA/EIA-222-F Date: 08/20/14 Scale: NTS  
Path: Dwg No. E-1

**NOTE:**  
 GENERAL CONTRACTOR TO REFER TO THE  
 STRUCTURAL ANALYSIS BY: FDH ENGINEERING, INC.  
 DATED: AUGUST 20, 2014 AND EQUIPMENT  
 INSTALLATION RECOMMENDATIONS PRIOR TO  
 COMMENCING CONSTRUCTION

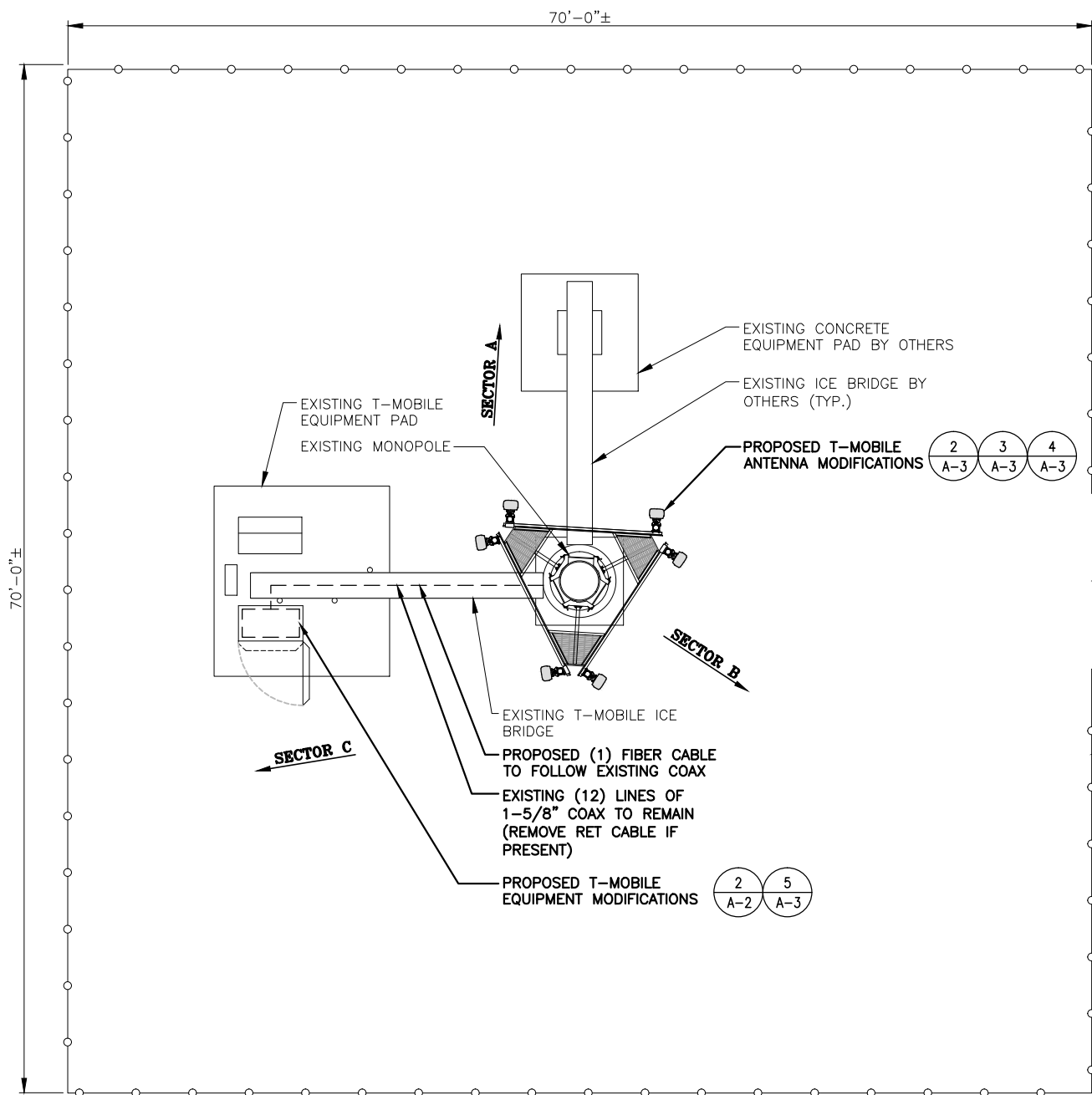

● CENTER OF PROPOSED T-MOBILE ANTENNAS  
 ELEV. 105.5'± (AGL)

1/A-3 EXISTING T-MOBILE ANTENNA TO BE REMOVED  
 (TYP. OF 2 PER SECTOR, TOTAL OF 6) AND  
 REPLACED W/ PROPOSED AIR 21 ANTENNAS  
 (TYP. OF 2 PER SECTOR, TOTAL OF 6)

2/A-3 3/A-3 4/A-3  
 PROPOSED T-MOBILE ANTENNA MODIFICATIONS

2/A-2 5/A-3  
 PROPOSED T-MOBILE EQUIPMENT MODIFICATIONS

PROPOSED (1) FIBER CABLE TO FOLLOW  
 EXISTING COAX INSIDE MONOPOLE  
 (BUNDLED IN ACCORDANCE WITH SBA  
 PROVIDED STRUCTURAL ANALYSIS)

EXISTING (12) LINES OF 1-5/8"  
 COAX TO REMAIN INSIDE MONOPOLE  
 (REMOVE RET CABLE IF PRESENT)



SOURCE: HDG 08-15-2014

2/A-1 PARTIAL ELEVATION PHOTO DETAIL  
 SCALE: N.T.S

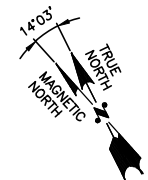

1/A-1 COMPOUND PLAN  
 SCALE: 3/16"=1'-0"

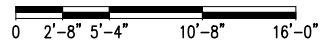

**T-MOBILE NORTHEAST LLC**  
 35 GRIFFIN ROAD SOUTH  
 BLOOMFIELD, CT 06002  
 OFFICE: (860) 648-1116

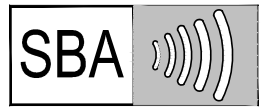

SBA COMMUNICATIONS CORP.  
 33 BOSTON POST ROAD W  
 MARLBOROUGH, MA 01752  
 TEL: (508) 251-1691  
 FAX: (508) 251-1755



1600 OSGOOD STREET  
 BUILDING 20 NORTH, SUITE 3090  
 N. ANDOVER, MA 01854  
 TEL: (978) 557-5553  
 FAX: (978) 336-5586

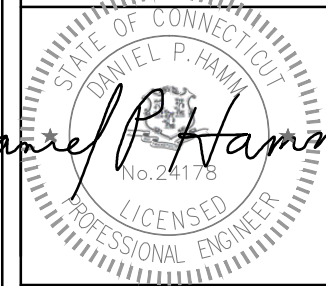

*Daniel P. Hamm*

**APPROVALS**

CONSTRUCTION	DATE
RF ENGINEERING	DATE
ZONING/SITE ACQ.	DATE
OPERATIONS	DATE
TOWER OWNER	DATE

PROJECT NO: CTHA075D  
 DRAWN BY: MAM  
 CHECKED BY: KB

0 08/28/14 ISSUED FOR CONSTRUCTION

**SITE NUMBER: CTHA075D**  
**SITE NAME:**  
**MANCHESTER 1**  
 93 LAKE STREET  
 MANCHESTER, CT 06042  
 HARTFORD COUNTY

**SHEET TITLE**  
 COMPOUND & ELEVATION  
 PLAN

**SHEET NUMBER**  
 A-1

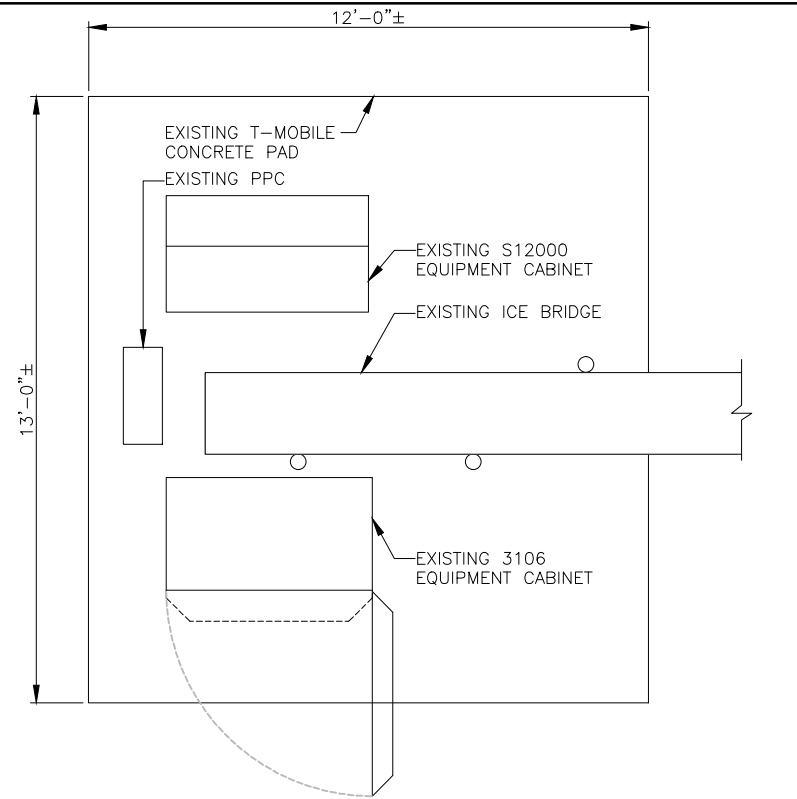

1 EXISTING EQUIPMENT PLAN  
 A-2 SCALE: 1/2"=1'-0" 0 1'-0" 2'-0" 4'-0" 6'-0"

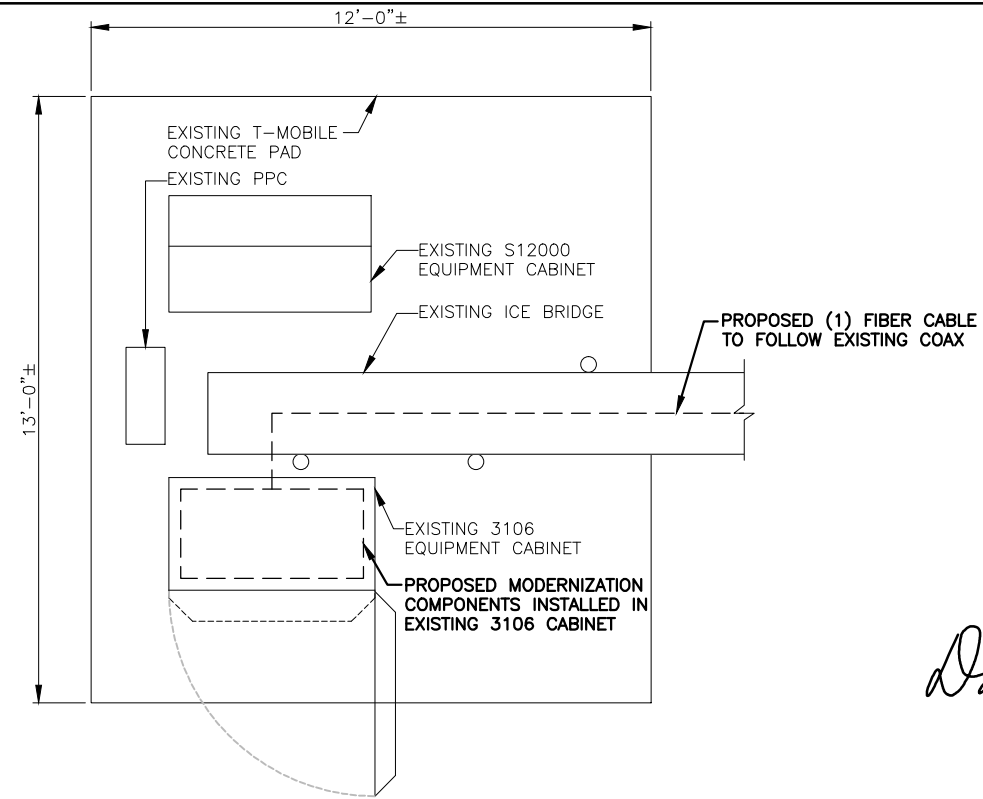
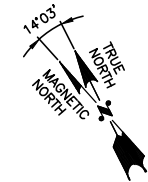

2 PROPOSED EQUIPMENT PLAN  
 A-2 SCALE: 1/2"=1'-0" 0 1'-0" 2'-0" 4'-0" 6'-0"

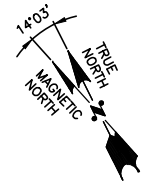

EXISTING S12000 EQUIPMENT CABINET  
 EXISTING PPC



SOURCE: HDG 08-15-2014

3 EXISTING EQUIPMENT PHOTO DETAIL  
 A-2 SCALE: N.T.S

**NOTE:**  
 GENERAL CONTRACTOR TO REFER TO THE STRUCTURAL ANALYSIS BY: FDH ENGINEERING, INC. DATED: AUGUST 20, 2014 AND EQUIPMENT INSTALLATION RECOMMENDATIONS PRIOR TO COMMENCING CONSTRUCTION

**T-MOBILE NORTHEAST LLC**  
 35 GRIFFIN ROAD SOUTH  
 BLOOMFIELD, CT 06002  
 OFFICE: (860) 648-1116

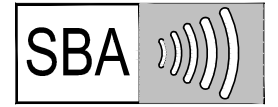

SBA COMMUNICATIONS CORP.  
 33 BOSTON POST ROAD W  
 MARLBOROUGH, MA 01752  
 TEL: (508) 251-1691  
 FAX: (508) 251-1755



1600 OSGOOD STREET  
 BUILDING 20 NORTH, SUITE 3090  
 N. ANDOVER, MA 01845  
 TEL: (978) 557-5553  
 FAX: (978) 336-5586

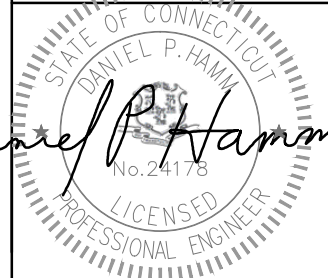

*Daniel P. Hamm*

**APPROVALS**

CONSTRUCTION	DATE
RF ENGINEERING	DATE
ZONING/SITE ACQ.	DATE
OPERATIONS	DATE
TOWER OWNER	DATE

PROJECT NO: CTHA075D  
 DRAWN BY: MAM  
 CHECKED BY: KB

0 08/28/14 ISSUED FOR CONSTRUCTION

**SITE NUMBER: CTHA075D**  
**SITE NAME:**  
**MANCHESTER 1**  
 93 LAKE STREET  
 MANCHESTER, CT 06042  
 HARTFORD COUNTY

**SHEET TITLE**  
 EXISTING & PROPOSED  
 EQUIPMENT PLANS

**SHEET NUMBER**  
 A-2

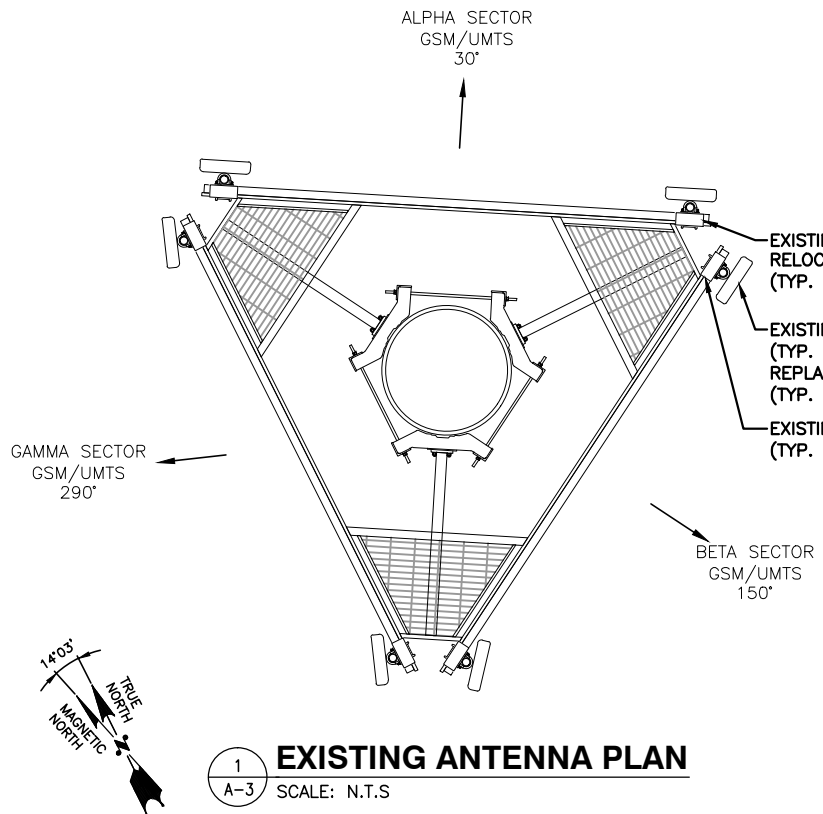

**NOTE:**  
GENERAL CONTRACTOR TO REFER TO THE STRUCTURAL ANALYSIS BY: FDH ENGINEERING, INC. DATED: AUGUST 20, 2014 AND EQUIPMENT INSTALLATION RECOMMENDATIONS PRIOR TO COMMENCING CONSTRUCTION



4  
A-3  
PROPOSED T-MOBILE AIR 21 ANTENNAS TO REPLACE EXISTING ANTENNAS ON EXISTING MOUNTS (TYP. OF 2 PER SECTOR, TOTAL OF 6) (INSTALL NEW AIR 21 ANTENNAS CENTERED ON THE EXISTING MOUNT)

**NOTE:**  
GENERAL CONTRACTOR TO REFER TO THE STRUCTURAL ANALYSIS BY FDH ENGINEERING, INC. AND EQUIPMENT INSTALLATION RECOMMENDATIONS PRIOR TO COMMENCING CONSTRUCTION

**NOTE:**  
REFER TO THE FINAL RF DATA SHEET FOR FINAL ANTENNA SETTINGS.

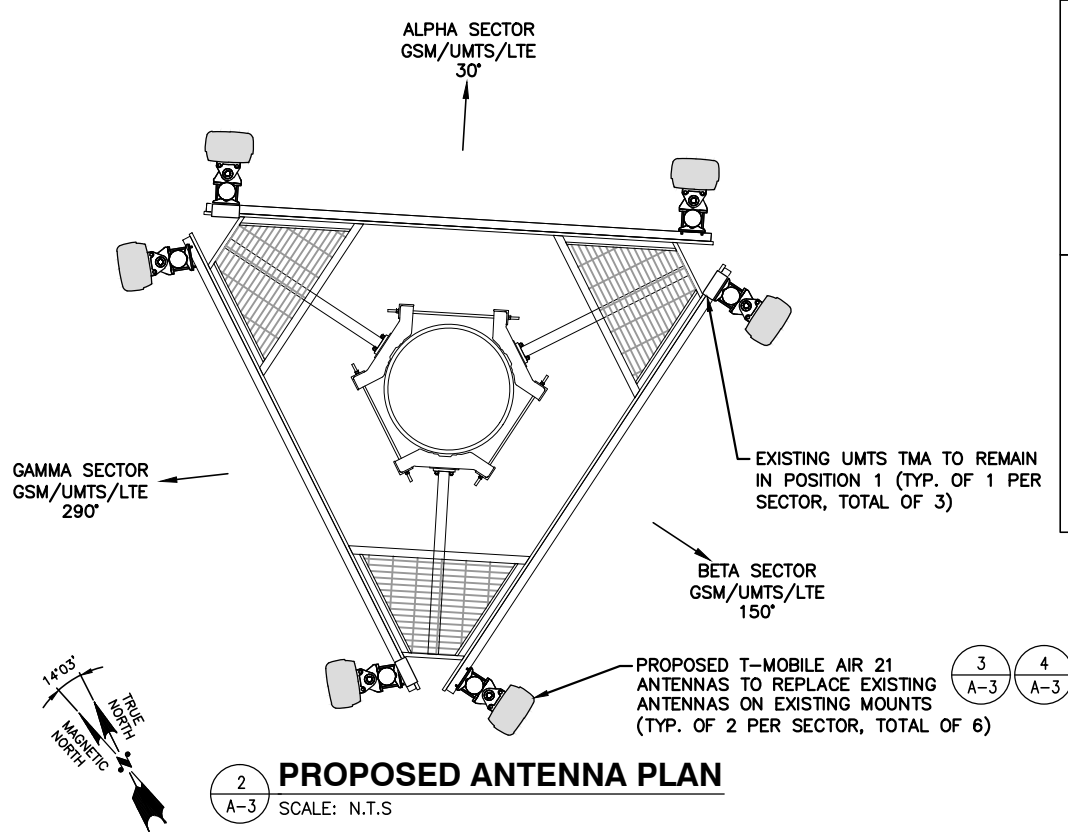

EXISTING ANTENNA SCHEDULE			
SECTOR	MAKE	MODEL#	SIZE (INCHES)
ALPHA:	RFS	APX18DWW_206513-C	27.5x6.65x3.15
	RFS	APX16DWW_16DWVS-A20	55.9x13x3.15
BETA:	RFS	APX18DWW_206513-C	27.5x6.65x3.15
	RFS	APX16DWW_16DWVS-A20	55.9x13x3.15
GAMMA:	RFS	APX18DWW_206513-C	27.5x6.65x3.15
	RFS	APX16DWW_16DWVS-A20	55.9x13x3.15

PROPOSED ANTENNA SCHEDULE			
SECTOR	MAKE	MODEL#	SIZE (INCHES)
ALPHA:	ERICSSON	AIR21 B2A/B4P	56x12x8
	ERICSSON	AIR21 B4A/B2P	56x12x8
BETA:	ERICSSON	AIR21 B2A/B4P	56x12x8
	ERICSSON	AIR21 B4A/B2P	56x12x8
GAMMA:	ERICSSON	AIR21 B2A/B4P	56x12x8
	ERICSSON	AIR21 B4A/B2P	56x12x8

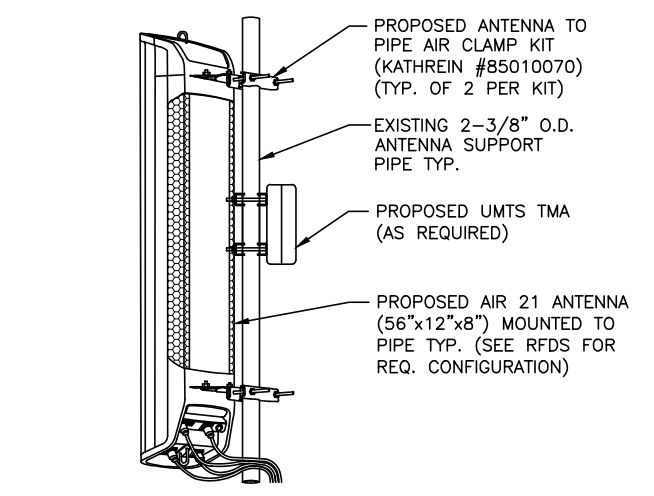

**T-MOBILE NORTHEAST LLC**  
35 GRIFFIN ROAD SOUTH  
BLOOMFIELD, CT 06002  
OFFICE: (860) 648-1116

**SBA**  
SBA COMMUNICATIONS CORP.  
33 BOSTON POST ROAD W  
MARLBOROUGH, MA 01752  
TEL: (508) 251-1691  
FAX: (508) 336-5586

**Hudson Design Group**  
1600 OSGOOD STREET  
BUILDING 20 NORTH, SUITE 3090  
N. ANDOVER, MA 01845  
TEL: (978) 557-5553  
FAX: (978) 336-5586

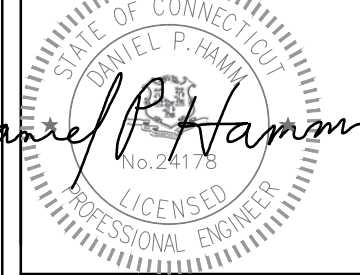

**APPROVALS**

CONSTRUCTION	DATE
RF ENGINEERING	DATE
ZONING/SITE ACQ.	DATE
OPERATIONS	DATE
TOWER OWNER	DATE
PROJECT NO:	CTHA075D
DRAWN BY:	MAM
CHECKED BY:	KB
0 08/28/14	ISSUED FOR CONSTRUCTION

**SITE NUMBER: CTHA075D**  
**SITE NAME: MANCHESTER 1**  
93 LAKE STREET  
MANCHESTER, CT 06042  
HARTFORD COUNTY

**SHEET TITLE**

ANTENNA PLAN & DETAILS

**SHEET NUMBER**

A-3