

HPC Wireless Services
22 Shelter Rock Lane.
Building C
Danbury, CT, 06810
P.: 203.797.1112



June 12, 2014

VIA OVERNIGHT COURIER

Connecticut Siting Council
10 Franklin Square
New Britain, Connecticut 06051
Attn: Ms. Melanie Bachman, Acting Executive Director

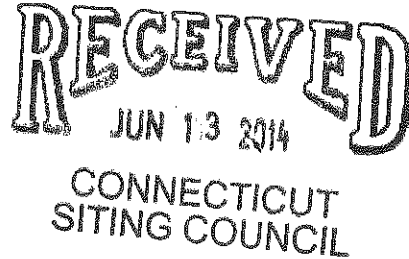

Re: Sprint Spectrum, L.P. – Exempt Modification
60 Adams Street, Manchester, Connecticut

Dear Ms. Bachman:

This letter and attachments are submitted on behalf of Sprint Spectrum, L.P. (“Sprint”). Sprint is undertaking modifications to certain existing sites in its Connecticut system in order to implement updated technology. Please accept this letter and attachments as notification, pursuant to R.C.S.A. Section 16-50j-73, of construction that constitutes an exempt modification pursuant to R.C.S.A. Section 16-50j-72(b)(2). In compliance with R.C.S.A. Section 16-50j-73, a copy of this letter and attachments is being sent to the First Selectman of the Town of Manchester.

Sprint plans to modify the existing wireless communications facility owned by Pom Pom Gali, and located at 60 Adams Street, Manchester (coordinates 41°-47’-38.64” N, 72°-33’-19.24” W). Attached are plan and elevation drawings depicting the planned changes, and documentation of the structural sufficiency of the structure to accommodate the revised antenna configuration, subject to modifications detailed in the attached structural documentation. Also included is a power density report reflecting the modification to Sprint’s operations at the site.

The changes to the facility do not constitute a modification as defined in Connecticut General Statutes (“C.G.S.”) Section 16-50i(d) because the general physical characteristics of the facility will not be significantly changed. Rather, the planned changes to the facility fall squarely within those activities explicitly provided for in R.C.S.A. Section 16-50j-72(b)(2).

1. Sprint will add three (3) more panel antennas for a total of nine (9) antennas, on the existing platform which shall be reinforced, at a centerline height of approximately 115’ AGL. Sprint will also install three (3) more RRHs (remote radio heads) for a total of nine (9) RRHs, also at a centerline height of approximately 115’ AGL. Sprint will also

Ms. Melanie Bachman

June 12, 2013

Page 2

install one (1) hybriflex cable along the existing Ice Bridge for a total of four (4) hybriflex cables. The dimensions of the leased area will not be increased. The proposed modifications will not extend the height of the approximately 140' structure.

2. Sprint will replace related equipment in two (2) of the four (4) existing cabinets including new batteries, all on the existing concrete pad with canopy. These changes will have no effect on the site boundaries.

3. The proposed changes will not increase the noise level at the existing facility by six decibels or more. The incremental effect of the proposed changes will be negligible.

4. The changes to the facility will not increase the calculated "worst case" power density for the combined operations at the site to a level at or above the applicable standard for uncontrolled environments as calculated for a mixed frequency site. As indicated on the attached report prepared by EBI Consulting, Sprint's operations at the site will result in a power density of approximately 2.69%; the combined site operations will result in a total power density of approximately 66.28%.

Please contact me by phone at (203) 610-1071 or by e-mail at mjhowlett@optonline.net with questions concerning this matter. Thank you for your consideration.

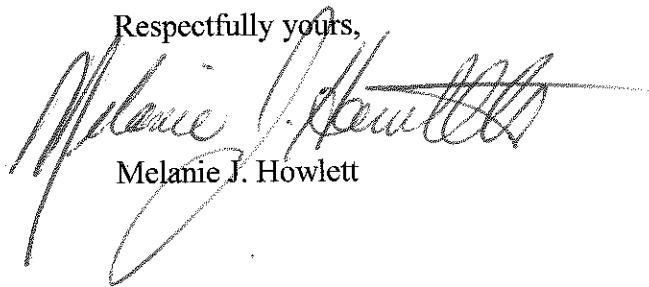

Respectfully yours,

A handwritten signature in black ink, appearing to read "Melanie J. Howlett", with a long horizontal flourish extending to the right.

Melanie J. Howlett

Attachments

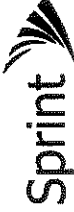
cc: Honorable Leo V. Diana, Mayor, Town of Manchester
Pom Pom Gali (underlying property owner)

 <p>Sprint 6580 SPRINT PARKWAY OVERLAND PARK, KANSAS 66251 (913) 436-7466</p>	 <p>A SAXON DESIGN GROUP TELEPHONE: 860.233.1000 WWW.ASAXON.COM</p>	 <p>MICHAEL L. ROHLINGER ENGINEER'S LICENSE PROFESSIONAL ENGINEER CONNECTICUT LICENSE NO. 23065</p>	<p>PROJECT NO.: ASDGSP22 SUBMIT NO.: CT23XC557 DESIGN TITLE: 2.5 GHz SITE INFORMATION: MANCHESTER / BILL THORNTON 60 ADAMS STREET MANCHESTER, CT 06040</p>	<p>DRAWING TITLE: SITE PLAN</p>	<p>DATE: 2/15/14 PROJECT NO.: ASDGSP22 DRAWING NO.: CT23XC557 SCALE: A-1</p>
--	---	---	--	---------------------------------	--

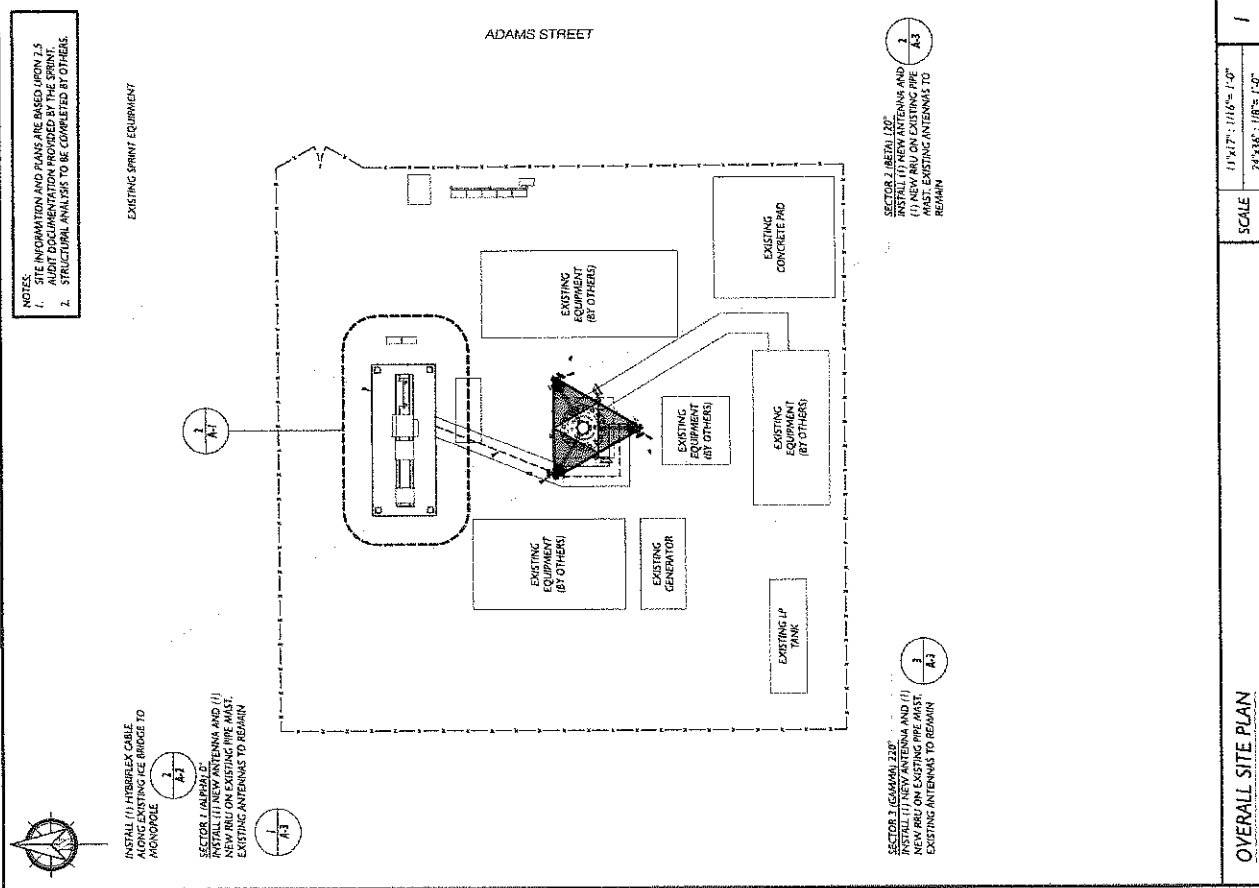
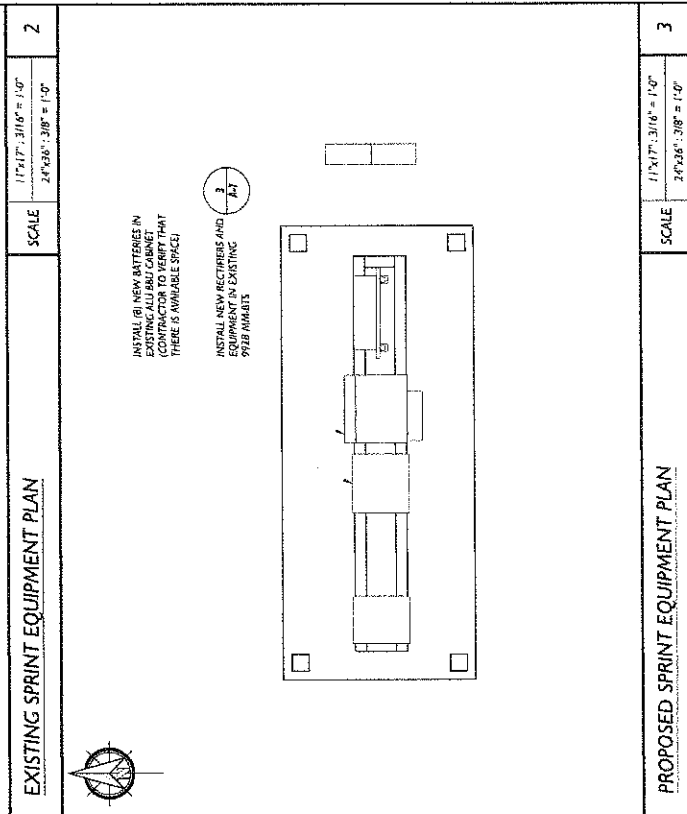
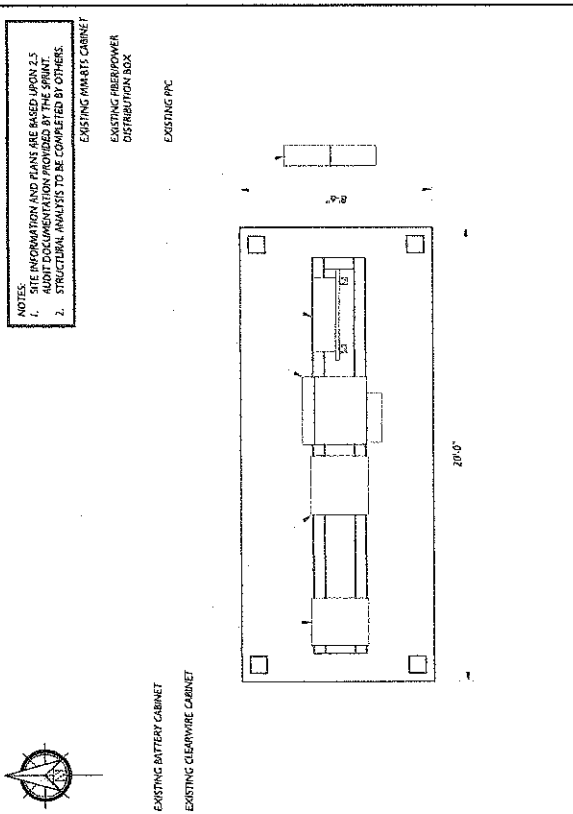

NOTES:
 1. ALL DIMENSIONS AND TOLERANCES ARE AS SHOWN UNLESS OTHERWISE SPECIFIED.
 2. ALL STRUCTURAL ANALYSES TO BE COMPLETED BY OTHERS.

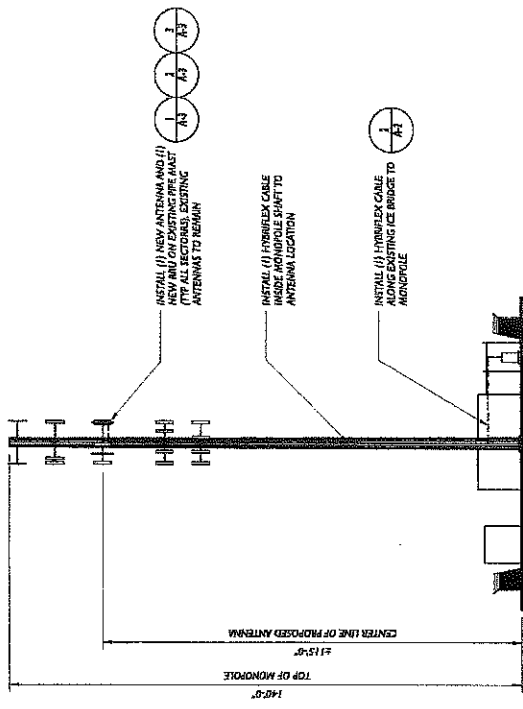

ELEVATION
 SCALE 1/8" = 1'-0"
 2 1/8" = 11'-0"

HYBRID CABLE DC CONDUCTOR SIZE GUIDELINE

CABLE	LENGTH	DC CONDUCTOR	CABLE DIAMETER
FIBER ONLY	VARIABLE	USE NY HYBRIFLEX	3/8"
HYBRIFLEX	OVER 200'	6 AWG	1 1/4"
HYBRIFLEX	225-300'	4 AWG	1 1/4"
HYBRIFLEX	325-375'	4 AWG	1 1/4"

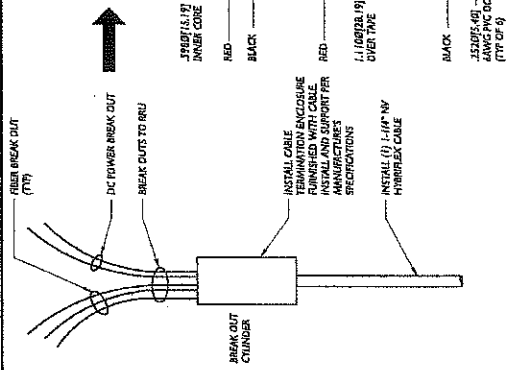

HYBRID BREAK OUT DETAIL
 SCALE 1/4" = 1'-0"
 3/4" = 11'-0"

6600 SPRINT PARKWAY
 OVERLAND PARK, KANSAS 66261
 (817) 435-7486

A BAXON DESIGN GROUP
 COMPANY
 1000 SOUTH MAIN STREET
 OVERLAND PARK, KS 66204

ENGINEER'S LICENSE
MICHAEL BOHLINGER
 STATE OF KANSAS
 PROFESSIONAL ENGINEER
 CONNECTION LICENSE NO. 28405

PROJECT NO.
ASDGSP22

COUNTY NO.
CT23XC557

TELEPHONE
2.5 GHz

DATE PREPARED
**MANCHESTER / BILL THORNTON
 40 ADAMS STREET
 MANCHESTER, CT 06040**

DRAWING TITLE
**BUILDING ELEVATION
 AND CABLE PLAN**

DATE
 2.28.12

PROJECT NO.
 ASDGSP22

DESIGNER
 BT

CHECKER
 BT

DRAWN
 BT

SCALE
 A-2

REV	DATE	DESCRIPTION	BY
1	3/14	PROPOSED ANTENNA LAYOUT	MS
2	4/24	REVISION	MS
3	4/24	REVISION	MS
4	4/24	REVISION	MS
5	4/24	REVISION	MS
6	4/24	REVISION	MS
7	4/24	REVISION	MS
8	4/24	REVISION	MS
9	4/24	REVISION	MS
10	4/24	REVISION	MS
11	4/24	REVISION	MS
12	4/24	REVISION	MS
13	4/24	REVISION	MS
14	4/24	REVISION	MS
15	4/24	REVISION	MS
16	4/24	REVISION	MS
17	4/24	REVISION	MS
18	4/24	REVISION	MS
19	4/24	REVISION	MS
20	4/24	REVISION	MS

Sprint
 5500 SPRINT PARKWAY
 OVERLAND PARK, KANSAS 66261
 (817) 438-7468



A SAXON DESIGN GROUP
 PROFESSIONAL ENGINEERS
 1000 W. 10TH ST. SUITE 100
 OMAHA, NE 68102

ENGINEER'S LICENSE
MICHAEL L. ROHLINGER
 PROFESSIONAL ENGINEER
 CONNECTICUT LICENSE NO. 20405



PROJECT NO.: ASDGSP22
 DRAWING NO.: CT23XC557
 DATE: 2.5 GHz

CLIENT: MANCHESTER / BILL THORNTON
 60 ADAMS STREET
 MANCHESTER, CT 06040

ANTENNA PLAN
 AND MOUNTING DETAILS
 PROJECT NO.: ASDGSP22
 DRAWING NO.: CT23XC557
 DATE: 2.5 GHz
 SCALE: 1/8" = 1'-0"

NOTES:
 1. SITE INFORMATION AND PLANS ARE BASED UPON 2.5 GHz RRU ON EXISTING PIPE MAST MOUNTING ANTENNAS TO REMAIN.
 2. STRUCTURAL ANALYSIS TO BE COMPLETED BY OTHERS.

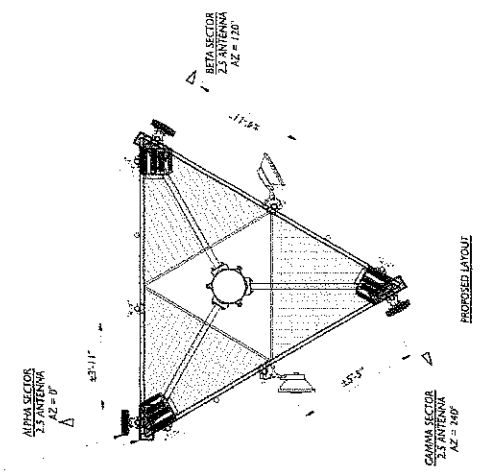

INSTALL (1) NEW ANTENNA AND (1) NEW RRU ON EXISTING PIPE MAST MOUNTING ANTENNAS TO REMAIN.

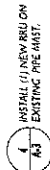

INSTALL (1) NEW RRU ON EXISTING PIPE MAST.

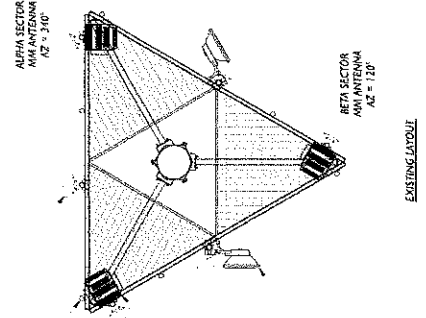

EXISTING ANTENNA PIPE MOUNTED TO EXISTING PIPE MAST (TP)

EXISTING EARLY PIPE MAST (TP)

EXISTING RRU UNITS ON PIPE MAST (TP)

EXISTING MICROWAVE DISH

EXISTING LAYOUT

EXISTING AND PROPOSED LAYOUTS

SCALE: 1/8" = 1'-0"

NOTES:
 1. SITE INFORMATION AND PLANS ARE BASED UPON 2.5 GHz RRU ON EXISTING PIPE MAST MOUNTING ANTENNAS TO REMAIN.
 2. STRUCTURAL ANALYSIS TO BE COMPLETED BY OTHERS.

NOTE:
 1. CUT DC CONDUCTORS TO LENGTH.
 2. CUT CONDUCTORS TO SIDE OF RRU.
 3. DO NOT EXCEED BEND RADIUS.
 4. JUMPERS FROM 2.5 RRU TO 3.5 ANTENNA CAN NOT EXCEED 15'. NOTIFY SPRINT CM OF ANY DISCREPANCY.



SPARE JUMPERS TO BE COILED
 INSTALL RRU MOUNTED TO PIPE MAST WITH RRU MOUNTING KIT AND CABLE IN FRONT OF PIPE BELOW ANTENNA.

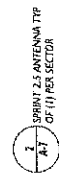
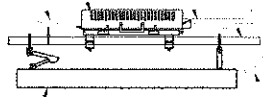

INSTALL RRU ON (1) PER SECTOR

INSTALL CABLE
 EXISTING OR PROPOSED MOUNTING PIPE (CONTRACTOR TO CONFIRM WITH PASSING STRUCTURAL ANALYSIS)

INSTALL RET CABLE
 INSTALL (1) TO JUMPER FROM RRU TO ANTENNA

ANTENNA AND RRU MOUNTING DETAIL

SCALE: 1/8" = 1'-0"
 2 1/4" = 30" - NTS

4



Baseplate Modification Package

Prepared for:

HPC Wireless
 22 Shelter Rock Lane
 Building C
 Danbury, CT 06810

ATTN: Ms. Debra Overbey

Structure : 140 ft EEI Monopole
 Proposed Carrier : Sprint
 Site ID : CT23XC557
 Site Location : Manchester, CT
 County : Hartford
 Date : May 5, 2014
 Shaft Usage : 94.7%
 Stiffeners Plate : 92.5% (with mods)
 Welds

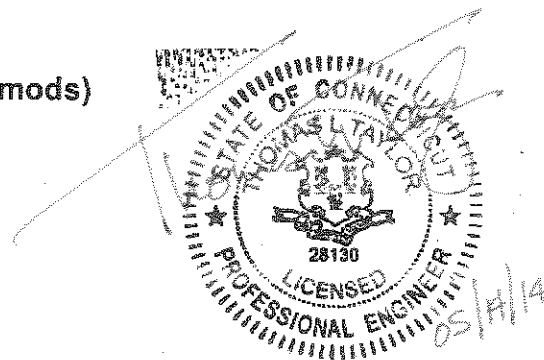

May 5, 2014

Page 1

Introduction

The purpose of this report is to summarize results of the structural analysis performed on the 140 ft EEI Monopole located at Manchester, CT, Hartford County (site # CT23XC557). The tower was originally designed and manufactured by EEI (Drawing # Job No 4795, dated March 23, 1999). Additional information of the monopole from RAMAKER, Inc Job Number 23007 dated June 3, 2013. **The base plate was modified per the Maxton Technology Job # 2906.035 dated March 10, 2010. No drawings were available. This latest modification package assumes that the modifications have been installed and completed.**

Analysis

The tower was analyzed using Semaan Engineering Solutions, Inc., Software. The analysis assumes that the tower is in good, undamaged, and non-corroded condition. The analysis was performed in conformance with **TIA/EIA-222 Rev F and local building codes for a basic wind speed of 80 mph no ice and 69 mph with 1/2" radial ice (fastest mile)**. This is in conformance with the IBC 2006: Section 1609.1.1, Exception (4) and Section 3108.4.

Basic Wind Speed: 80.0 mph
 Radial Ice: 69 mph w/ 0.50" ice
 Code: TIA/EIA-222 Rev F

Antenna Loads

The following antenna loads were used in the tower analysis.

Existing Antennas

Elev. (ft)	Qty	Antennas	Mount	Coax (in)	Carrier
138.0	2	5' x 2" Pipe Mounts	(2) 3 ft Standoff	-	-
132.0	1	5' x 2" Pipe Mount	5 ft Standoff	-	-
125.0	3	800 10121	Platform w/Rail	(12) 1 5/8" (2) Power Cables (1) Fiber Cable	AT&T Wireless
	6	860 10025			
	6	AM-X-WM-17-65-00T			
	1	DC6-48-60-18-8F			
	6	DTMA 1819VG12A			
	6	RRUS11			
115.0	3	APXVSPP18-C-A20	15 ft Low Profile platform	(3) 1-1/4" Fiber/Power	Sprint
	3	RRH-2X50-800			
	3	RRH-4X40-1900			
	3	DAP Heads		(5) 1/2"	Clearwire
	3	LLPX310R			
	1	VHLP1			
	1	VHLP2			
105.0	2	5' x 3" Pipe Mounts	(2) 3 ft Standoff	-	-
102.0	12	DB844H90E-XY	Platform w/Rail	(12) 7/8"	Sprint-Nextel
90.0	3	BXA-70063/6CF	Platform w/Rail	(12) 1 5/8"	Verizon
	6	FD9R6004-1C-3L			
	3	MG D3-900Tx			
	6	SC-E 6014 rev2			

Proposed Antennas

Elev. (ft)	Qty	Antennas	Mount	Coax (in)	Carrier
115.0	3	APXVTM14-C-I20	On existing	(1) Hybriflex Cable	Sprint
	3	TD-RRH-8X20-25	15 ft Low Profile platform		

All transmission lines are assumed running inside of pole shaft. All new access holes shall be reinforced with welded rims that are compatible with the pole and to be sized and supplied by pole manufacturer.

May 5, 2014

Page 2

Results

The existing monopole shaft and anchor bolts are structurally capable of supporting the existing and proposed antennas. The maximum shaft stresses are at 94.7% of allowable. **However the base plate stiffeners plate welds are severely overstressed by as much as 86.0% and will require modifications.** Refer to the attached drawing for additional information.

The maximum structure usage is: 94.7%.

The maximum stiffeners plate welds usage is: 186.0% (without mods) and 92.5% (with mods).

Pole Reactions	Original Design Reactions	Current Analysis Reactions	% Of Design
Moment (ft-kips)	1,939.10	2,163.38	111.6
Shear (kips)	19.73	21.80	110.5

The reactions calculated from the analysis exceed the ones indicated on the original structural design. However, upon reviewing the foundation documents, they were found to be adequate and therefore the foundation will not require modification.

Conclusion

The base plate was modified per the Maxton Technology Job # 2906.035 dated March 10, 2010. This latest modification package assumes that the modifications have been installed and completed.

Based on the analysis results, the existing structure (with the stiffener plate extensions installed and approved per the attached drawings) meets the requirements per the TIA/EIA-222 Rev F standards for a basic wind speed of 80 mph no ice and 69 mph with 1/2" radial ice.

If you have any questions or require additional information, please call 402-289-1888.

Attachment

Drawing S-01, Revision 0, dated 05/05/2014.



Address: 1079 N. 205th Street, Norwalk, CT 06854
 Phone Number: (407)289-1888 Fax Number: (407)289-1881

REV #	DATE	ISSUE FOR CONSTRUCTION	REVISION DESCRIPTION
0	05/05/2014		

HPC WIRELESS SERVICES
 MONOPOLE
 REINFORCEMENT DRAWINGS

DATE: 05/05/2014
 DRAWING NUMBER: CT23XC557
 CLIENT: HPC WIRELESS SERVICES

- GENERAL:**
- THE MODIFICATIONS OUTLINED IN THESE DOCUMENTS WERE DESIGNED IN ACCORDANCE WITH THE TIA/EIA-222 REV. F STANDARD.
 - THE CONTRACTOR SHALL FIELD VERIFY ALL EXISTING DIMENSIONS, ELEVATIONS AND CONDITIONS PRIOR TO FABRICATION. THE CONTRACTOR WILL BE SOLELY RESPONSIBLE FOR THE PROPER FIT AND CLEARANCE IN THE FIELD.
 - CONTACT SEMAM ENGINEERING IF ANY DISCREPANCIES EXIST.
 - REFERENCE THE SEMAM ENGINEERING SOLUTIONS ANALYSIS FOR THIS SITE DATED 08/02/2014 FOR THE PROPOSED AND EXISTING LOADS CONSIDERED. THIS DRAWING IS NOT VALID IF LOADS OTHER THAN THOSE CONSIDERED IN THE ANALYSIS ARE ADDED TO OR REMOVED FROM THE STRUCTURE UNLESS APPROVED IN WRITING BY SES, INC.
 - THE PROPOSED LOADS SHALL NOT BE ADDED TO THE STRUCTURE UNTIL ALL MODIFICATIONS ARE MADE AND APPROVED BY THE ENGINEER.
 - THIS DRAWING DOES NOT INDICATE THE METHOD OF CONSTRUCTION THE CONTRACTOR SHALL SUPERVISE AND DETECT THE WORK AND HE SHALL BE SOLELY RESPONSIBLE FOR ALL THE CONSTRUCTION MEANS, TECHNIQUES, SEQUENCES AND PROCEDURES.
 - THE CONTRACTOR SHALL BE SOLELY RESPONSIBLE FOR THE ON-SITE SAFETY ASSOCIATED WITH THE WORK TO BE PERFORMED. ALL SAFETY REQUIREMENTS AS DICTATED BY OSHA AND THE LOCAL JURISDICTIONS SHALL BE FOLLOWED.
 - THE CONTRACTOR SHALL BE RESPONSIBLE FOR THE SAFETY OF ITS OWN PERSONNEL, AS WELL AS THE PUBLIC AND THE ADJACENT COMMUNITY.
 - THE CONTRACTOR SHALL ALSO BE RESPONSIBLE FOR THE PROTECTION OF THE PROPERTY IN THE VICINITY OF THE JOB SITE. THE CONTRACTOR SHALL USE THE PRECAUTIONARY MEANS NECESSARY FOR ADEQUATE PROTECTION.
 - ALL WORK SHALL BE PERFORMED IN CALM WIND CONDITIONS, WHERE THE WIND SPEED HOES NOT EXCEED 10 MPH.
- STEEL CONSTRUCTION:**
- STRUCTURAL STEEL SHALL CONFORM TO THE AISC MANUAL OF STEEL CONSTRUCTION, NINTH EDITION, FOR THE DESIGN AND FABRICATION OF STEEL COMPONENTS.
 - ALL STEEL SHALL BE GALVANIZED TO A MINIMUM OF 55% ZINC COATING.
 - ALL FABRICATED STEEL ASSEMBLIES INCLUDING MONOPOLE/TOWER EXTENSIONS SHALL INCLUDE ALL FABRICATED STEEL ASSEMBLIES INCLUDING MONOPOLE/TOWER EXTENSIONS SHALL INCLUDE ALL FABRICATED STEEL WORK SHALL BE GALVANIZED IN ACCORDANCE WITH ASTM A112 AND AS FOLLOWS, UNLESS OTHERWISE NOTED:
 - GALVANIZING SHALL BE PERFORMED AFTER SHOP FABRICATION AND WELDING TO THE GREATEST EXTENT POSSIBLE
 - ALL DIMS, SCRAPES, MARKS AND WELDS IN THE GALVANIZED AREA SHALL BE COATED WITH A ZINC-RICH PAINT,
 - IF THE STRUCTURE HAS ORIGINALLY PAINTED AFTER ZINC-RICH PAINT IS DRY, OVERCOAT WITH AN APPROPRIATE PAINT WITH THE SAME COLOR AS THE EXISTING.
 - DO NOT PLACE HOLES THROUGH STRUCTURAL STEEL MEMBERS EXCEPT AS SHOWN AND DETAILED ON DRAWINGS.
- WELDING NOTES:**
- ALL WELDING TO BE PERFORMED BY AWS CERTIFIED WELDERS AND CONDUCTED IN ACCORDANCE WITH THE LATEST EDITION OF THE AWS WELDING CODE D1.1.
 - ALL ELECTRODES TO BE LOW HYDROGEN, MATCHING FILLER METAL, PER AWS D1.1, L14.0.
 - WELDS SHALL BE VISUALLY INSPECTED BY THE APPROVED SPECIAL INSPECTION.
 - PRIOR TO FIELD WELDING GALVANIZED MATERIAL CONTRACTOR SHALL GRIND OFF GALVANIZING 1/2" BEYOND ALL FIELD WELD SURFACES. AFTER WELD AND WELD INSPECTION IS COMPLETE, REPAIR ALL GROUND AND WELDED SURFACES WITH ZRC GALVANITE COLD GALVANIZING COMPOUND PER ASTM A790 AND MANUFACTURERS REQUIREMENTS.
- SPECIAL INSPECTION**
- A QUALIFIED INDEPENDENT TESTING LABORATORY, EMPLOYED BY THE OWNER, SHALL PERFORM INSPECTION AND TESTING IN ACCORDANCE WITH THE IBC 2003, SECTION 704 AS REQUIRED BY PROJECT SPECIFICATIONS FOR THE FOLLOWING:
 - FIELD WELDING: GROOVE WELDS SHALL REQUIRE CONTINUOUS INSPECTION.
 - MULTI PASS FILLET WELDS SHALL REQUIRE CONTINUOUS INSPECTION.
 - SINGLE PASS FILLET WELDS > 5/16".....CONTINUOUS
 - SINGLE PASS FILLET WELDS < 5/16".....PERIODIC INSPECTION
 - ALL WELDS SHALL BE VISUALLY INSPECTED BY THE APPROVED SPECIAL INSPECTION.
 - THE INSPECTION AGENCY SHALL SUBMIT INSPECTION AND TEST REPORTS TO THE BUILDING DEPARTMENT. THE CONTRACTOR SHALL BE RESPONSIBLE FOR OBTAINING APPROVAL FROM THE BUILDING DEPARTMENT. APPROVAL BY THE BUILDING DEPARTMENT IS APPROVED BY THE BUILDING DEPARTMENT OFFICIAL TO PERFORM SUCH WORK WITHOUT THE SPECIAL INSPECTIONS.
- CONTINUOUS STRUCTURE INSPECTION AND MAINTENANCE:**
- CONTINUOUS INSPECTION OF THE STRUCTURE AND THE ADDED REINFORCING CONSISTENT WITH THE CURRENT REQUIREMENTS OF THE LATEST TIA 222 STANDARD SHALL BE IMPLEMENTED BY THE OWNER. ANY FUTURE CORROSION OR OTHER DETERIORATION OF THE STRUCTURE OR ITS REINFORCING WILL REDUCE ITS CAPACITY TO WITHSTAND THE REQUIRED LOADS. ANY DEFECTS SHALL BE REPAIRED TO ENSURE THE STRUCTURAL INTEGRITY FOR THE LIFE OF THE STRUCTURE.

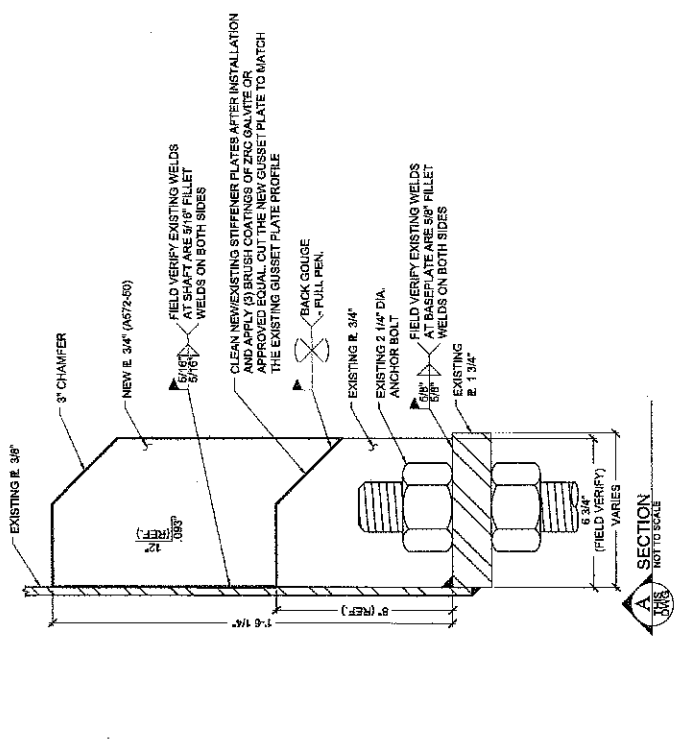
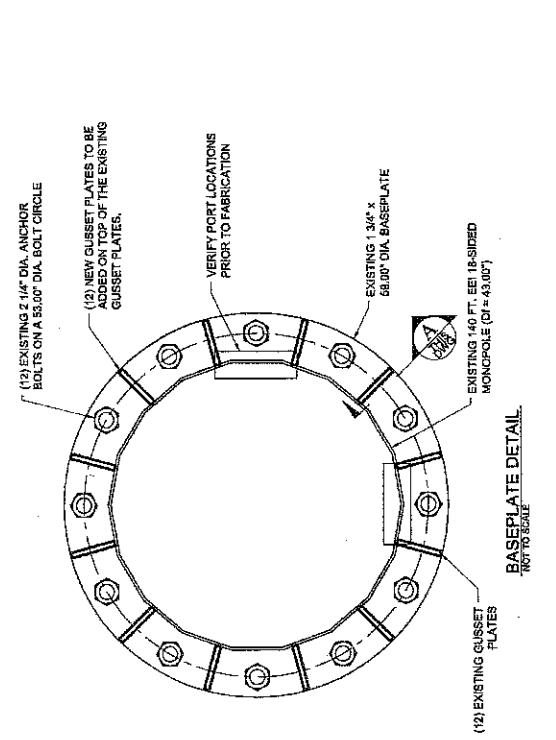
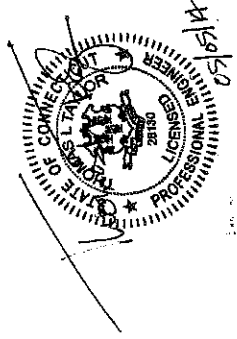

GENERAL:

- THE MODIFICATIONS OUTLINED IN THESE DOCUMENTS WERE DESIGNED IN ACCORDANCE WITH THE TIAEIA-222 REV F. STANDARD.
- THE CONTRACTOR SHALL FIELD VERIFY ALL EXISTING DIMENSIONS, ELEVATIONS, AND CONDITIONS PRIOR TO FABRICATION. THE CONTRACTOR WILL BE SOLELY RESPONSIBLE FOR THE PROPER FIT AND CLEARANCE IN THE FIELD. CONTACT SEMAN ENGINEERING IF ANY DISCREPANCIES EXIST.
- REFERENCE THE SEMAN ENGINEERING SOLUTIONS ANALYSIS FOR THIS SITE DATED 06/09/2014 FOR THE PROPOSED AND EXISTING LOADS CONSIDERED. THIS DRAWING IS NOT VALID IF LOADS OTHER THAN THOSE CONSIDERED IN THE ANALYSIS ARE ADDED TO OR REMOVED FROM THE STRUCTURE UNLESS APPROVED IN WRITING BY SES, INC.
- ALL WELDING SHALL BE PERFORMED IN ACCORDANCE WITH THE WELDING PROCEDURES APPROVED BY THE WELDING INSPECTOR.
- THIS DRAWING DOES NOT INDICATE THE METHOD OF CONSTRUCTION THE CONTRACTOR SHALL SUPERVISE AND DETECT THE WORK AND HE SHALL BE SOLELY RESPONSIBLE FOR ALL THE CONSTRUCTION MEANS, TECHNIQUES, SEQUENCES AND PROCEDURES.
- THE CONTRACTOR SHALL BE SOLELY RESPONSIBLE FOR THE ON-SITE SAFETY ASSOCIATED WITH THE WORK TO BE PERFORMED. ALL SAFETY REQUIREMENTS AS DICTATED BY OSHA AND THE LOCAL JURISDICTIONS SHALL BE FOLLOWED.
- THE CONTRACTOR SHALL BE RESPONSIBLE FOR THE SAFETY OF ITS OWN PERSONNEL AS WELL AS THE PUBLIC AFFECTED BY THE WORK IN THE VICINITY OF THE JOB SITE.
- THE CONTRACTOR SHALL ALSO BE RESPONSIBLE FOR THE PROTECTION OF THE PROPERTY IN THE VICINITY OF THE JOB SITE. THE CONTRACTOR SHALL USE THE PRECAUTIONARY MEANS NECESSARY FOR ADEQUATE PROTECTION.
- ALL WORK SHALL BE PERFORMED IN CALM WIND CONDITIONS, WHERE THE WIND SPEED DOES NOT EXCEED 10 MPH.

STEEL CONSTRUCTION:

- STRUCTURAL STEEL SHALL CONFORM TO THE AISC MANUAL OF STEEL CONSTRUCTION, NINTH EDITION, FOR THE DESIGN AND FABRICATION OF STEEL COMPONENTS.
- ALL PLATE STEEL SHALL CONFORM TO A572-50 UNLESS NOTED OTHERWISE.
- ALL FABRICATION SHALL BE IN ACCORDANCE WITH THE FABRICATOR'S SHOP DRAWINGS SHALL INCLUDE ALL FABRICATED DIMENSIONS INCLUDING MONOPOLE OVER EXTENSIONS.
- ALL EXTERIOR STEEL WORK SHALL BE GALVANIZED IN ACCORDANCE WITH ASTM A123 AND AS FOLLOWS, UNLESS OTHERWISE NOTED.
 - GALVANIZING SHALL BE PERFORMED AFTER SHOP FABRICATION AND WELDING TO THE GREATEST EXTENT POSSIBLE APPLIED IN STRICT ACCORDANCE WITH MANUFACTURER'S RECOMMENDATIONS.
 - IF THE STRUCTURE WAS ORIGINALLY PAINTED, AFTER ZINC-RICH PAINT IS DRY, OVERCOAT WITH AN APPROPRIATE WELDING FILLER AS THE EXISTING.
 - FACE HOLES THROUGH STRUCTURAL STEEL MEMBERS EXCEPT AS SHOWN AND DETAILED ON DRAWINGS.
- ALL WELDING TO BE PERFORMED BY AWS CERTIFIED WELDERS AND CONDUCTED IN ACCORDANCE WITH THE LATEST EDITION OF THE AWS WELDING CODE D1.1.
- ALL ELECTRODES TO BE LOW HYDROGEN, MATCHING FILLER METAL, PER AWS D1.1, UN.D.
- MINIMUM WELD SIZE TO BE 0.1875 INCH FILLET WELDS, UNLESS NOTED OTHERWISE.
- PRIOR TO FIELD WELDING GALVANIZED MATERIAL, CONTRACTOR SHALL CRIMP OFF GALVANIZING 1/2" BEYOND ALL FIELD WELD SURFACES. AFTER WELD AND WELD INSPECTION IS COMPLETE, REPAIR ALL GROUND AND WELDED SURFACES WITH ZRC GALVITE COLD GALVANIZING COMPOUND PER ASTM A780 AND MANUFACTURER'S REQUIREMENTS.

SPECIAL INSPECTION:

- ALL WELDING SHALL BE VISUALLY INSPECTED BY THE APPROVED SPECIAL INSPECTION. THE INSPECTION AGENCY SHALL SUBMIT INSPECTION REPORTS TO THE INSPECTION DEPARTMENT. THE CONTRACTOR SHALL BE RESPONSIBLE FOR THE PROTECTION OF THE PROPERTY IN THE VICINITY OF THE JOB SITE. THE CONTRACTOR SHALL USE THE PRECAUTIONARY MEANS NECESSARY FOR ADEQUATE PROTECTION.
- STRUCTURAL WELDING - GROOVE WELDS SHALL REQUIRE CONTINUOUS INSPECTION.
 - MULTI PASS FILLET WELDS SHALL REQUIRE CONTINUOUS INSPECTION.
 - SINGLE PASS FILLET WELDS < 5/16" PERIODIC INSPECTION
 - SINGLE PASS FILLET WELDS > 5/16" PERIODIC INSPECTION

CONTINUOUS STRUCTURE INSPECTION AND MAINTENANCE:
 CONTINUOUS INSPECTION OF THE STRUCTURE AND THE ADDED REINFORCING CONSISTENT WITH THE CURRENT REQUIREMENTS OF THE LATEST TIA 222 STANDARD SHALL BE IMPLEMENTED BY THE OWNER. ANY FUTURE CORROSION OR OTHER DETERIORATION OF THE STRUCTURE OR ITS REINFORCING WILL REDUCE ITS CAPACITY TO WITHSTAND THE REQUIRED LOADS. ANY DEFECTS SHALL BE REPAIRED TO ENSURE THE STRUCTURAL INTEGRITY FOR THE LIFE OF THE STRUCTURE.

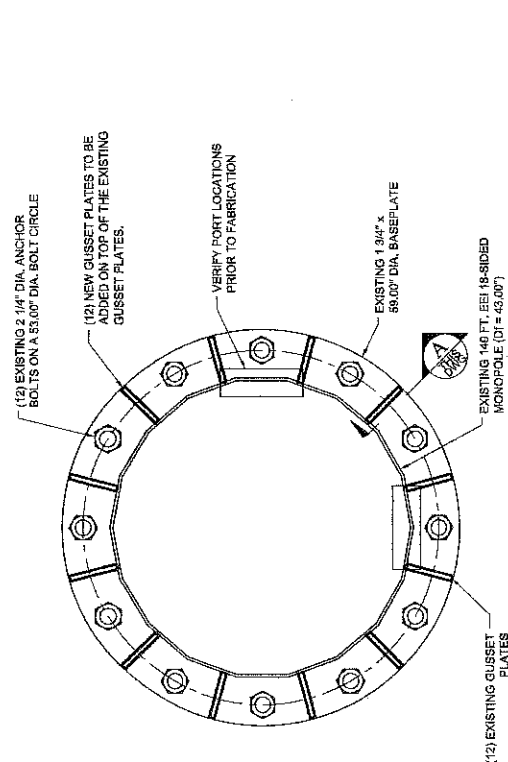

BASEPLATE DETAIL
 NOT TO SCALE

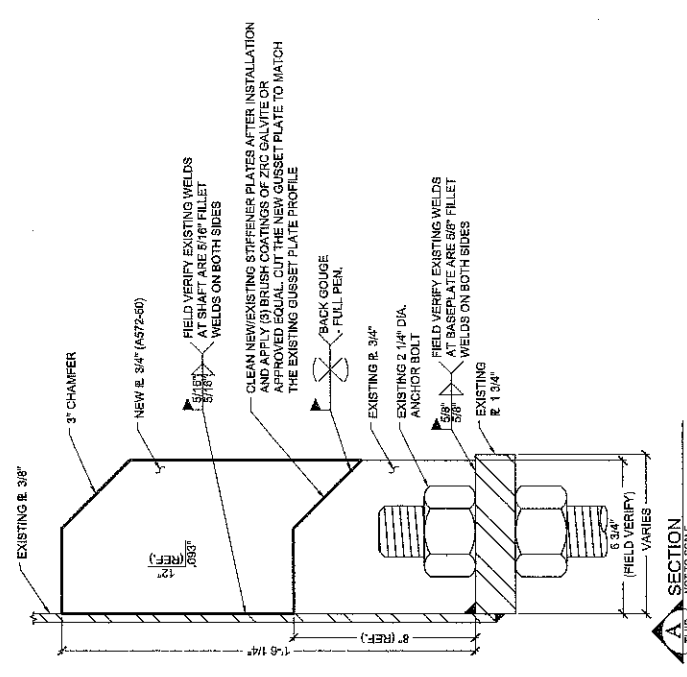

SECTION A-A
 NOT TO SCALE

Standard Conditions

All engineering services are performed on the basis that the information used is current and correct. This information may consist of, but is not necessary limited, to:

- Information supplied by the client regarding the structure itself, the antenna and feed line loading on the structure and its components, or other relevant information.
- Information from drawings in the possession of Semaan Engineering Solutions, or generated by field inspections or measurements of the structure.

It is the responsibility of the client to ensure that the information provided to Semaan Engineering Solutions and used in the performance of our engineering services is correct and complete. In the absence of information to the contrary, we assume that all structures were constructed in accordance with the drawings and specifications and are in an un-corroded condition and have not deteriorated; and we, therefore, assume that their capacity has not significantly changed from the "as new" condition.

All services will be performed to the codes specified by the client, and we do not imply to meet any other codes or requirements unless explicitly agreed in writing. If wind and ice loads or other relevant parameters are to be different from the minimum values recommended by the codes, the client shall specify the exact requirement. In the absence of information to the contrary, all work will be performed in accordance with the latest relevant revision of ANSI/EIA-222.

All services are performed, results obtained, and recommendations made in accordance with generally accepted engineering principles and practices. Semaan Engineering Solutions is not responsible for the conclusions, opinions and recommendations made by others based on the information we supply.

SEMAN ENGINEERING SOLUTIONS, LLC

1079 N 205th Street
 Elkhorn, NE 68022
 Phone: 402-289-1888
 Fax: 402-289-1861

© 2007 - 2014 by ATC IP LLC. All rights reserved.

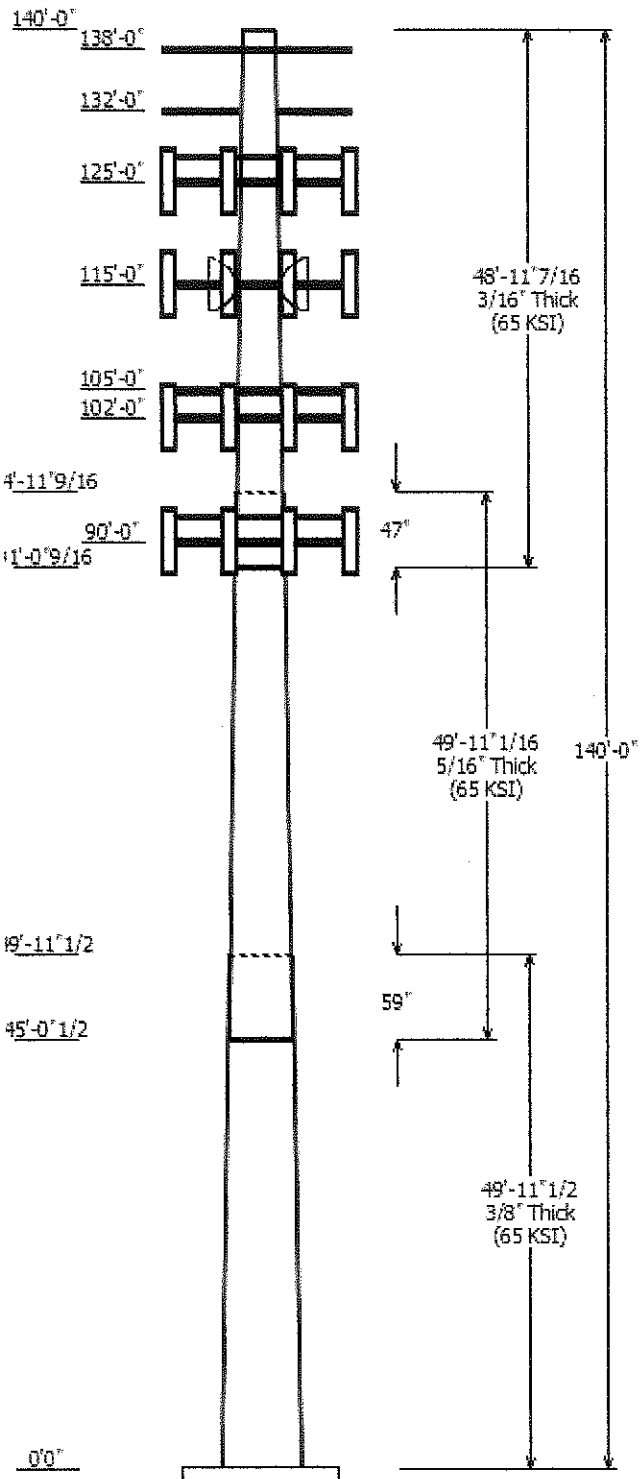

Job Information	
Pole :	CT23XC557_FIX
Code:	TIA/EIA-222 Rev F
Description :	
Client :	WWWWW
Location :	Manchester, CT
Shape :	18 Sides
Height :	140.00 (ft)
Base Elev (ft):	0.00
Taper:	0.18570(in/ft)

Sections Properties						
Shaft Section	Length (ft)	Diameter (in)		Thick Joint (in)	Overlap Length (in)	Steel Taper (in/ft)
		Top	Bottom			
1	49.960	33.72	43.00	0.375	0.000	0.185700
2	49.920	25.99	35.26	0.313 Slip Joint	59.000	0.185700
3	48.953	18.00	27.09	0.188 Slip Joint	47.000	0.185700

Discrete Appurtenance			
Attach Elev (ft)	Force Elev (ft)	Qty	Description
138.000	138.000	2	5' x 2" Pipe Mounts
138.000	138.000	2	3 ft Standoff
132.000	132.000	1	5' x 2" Pipe Mount
132.000	132.000	1	5 ft Standoff
125.000	125.000	1	DC6-48-60-18-8F
125.000	125.000	6	RRUS11
125.000	125.000	6	DTMA 1819VG12A
125.000	125.000	6	860 10025
125.000	125.000	3	800 10121
125.000	125.000	6	AM-X-WM-17-65-00T
125.000	126.500	1	Platform w/Rail
115.000	115.000	3	TD-RRH-8X20-25
115.000	115.000	3	APXVTM14-C-I20
115.000	115.000	1	Collar Mount
115.000	115.000	3	RRH-2X50-800
115.000	115.000	3	RRH-4X40-1900
115.000	115.000	3	APXVSPP18-C-A20
115.000	115.000	1	VHLP2
115.000	115.000	1	VHLP1
115.000	115.000	3	DAP Heads
115.000	115.000	3	LLPX310R
115.000	115.000	1	15 ft Low Profile platform
105.000	105.000	2	5' x 3" Pipe Mounts
105.000	105.000	2	3 ft Standoff
102.000	102.000	12	DB844H90E-XY
102.000	103.500	1	Platform w/Rail
90.000	90.000	6	FD9R6004-1C-3L
90.000	90.000	3	BXA-70063/6CF
90.000	90.000	3	MG D3-900Tx
90.000	90.000	6	SC-E 6014 rev2
90.000	91.500	1	Platform w/Rail

Linear Appurtenance			
From Elev (ft)	To Elev (ft)	Description	Exposed To Wind
0.000	90.000	1 5/8" Coax	No
0.000	102.0	7/8" Coax	No
0.000	115.0	1-1/4" Coax	No
0.000	115.0	1/2" Coax	No
0.000	115.0	Hybriflex Cable	No
0.000	125.0	1 5/8" Coax	No
0.000	125.0	Fiber Cable	No

0.000	125.0	Power Cables	No
-------	-------	--------------	----

Load Cases	
No Ice	80.00 mph Wind with No Ice
Ice	69.28 mph Wind with Ice
Twist/Sway	50.00 mph Wind with No Ice

Reactions			
Load Case	Moment (kip-ft)	Shear (kip)	Axial (kip)
No Ice	2163.40	21.80	26.43
Ice	1925.26	18.65	35.64
Twist/Sway	846.29	8.51	26.47

Dish Deflections			
Load Case	Attach Elev (ft)	Deflection (in)	Rotation (deg)
Twist/Sway	115.00	29.397	2.329
Twist/Sway	115.00	29.397	2.329

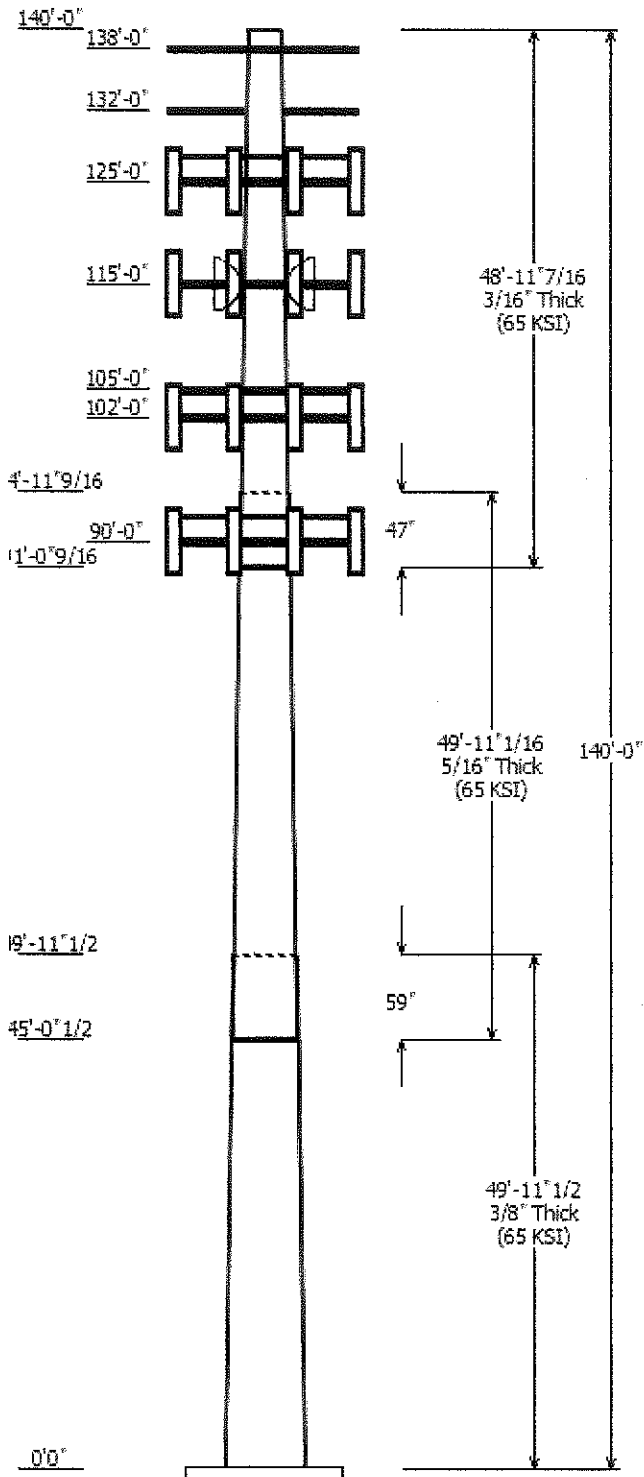

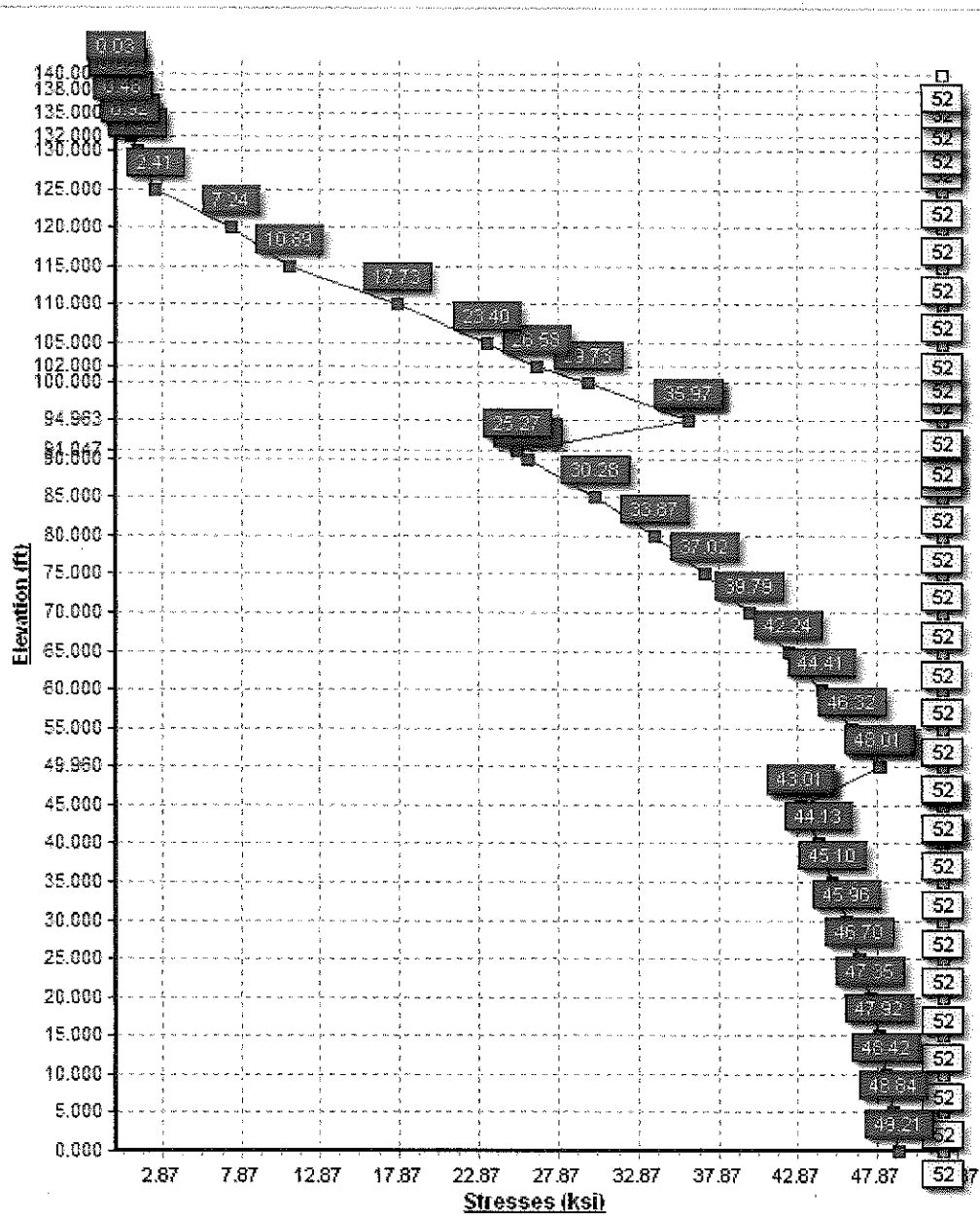

Pole : CT23XC557_FIX
 Location : Manchester, CT
 Height : 140.0 (ft)
 Base Dia : 43.00 (in)
 Top Dia : 18.00 (in)
 Shape : 18 Sides
 Taper : 0.185700 (in/ft)

Code: TIA/EIA-222 Rev F

5/5/2014 4:13:18 PM
 Page: 1

Base Elev : 0.000 (ft)

© 2007 - 2014 by ATC IP LLC. All rights reserved.

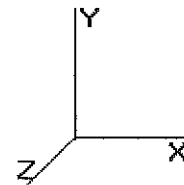

Shaft Section Properties

Sect Info	Length (ft)	Thick (in)	Fy (ksi)	Slip		Weight (lb)	Bottom								Top				Taper (in/ft)	
				Joint Type	Joint Len (in)		Dia (in)	Elev (ft)	Area (sqin)	Ix (in^4)	W/t Ratio	D/t Ratio	Dia (in)	Elev (ft)	Area (sqin)	Ix (in^4)	W/t Ratio	D/t Ratio		
1-18	49.960	0.3750	65		0.00	7,686	43.00	0.00	50.73	11645.8	18.81	114.67	33.72	49.96	39.69	5576.5	14.45	89.93	0.185700	
2-18	49.920	0.3125	65	Slip	59.00	5,107	35.26	45.04	34.66	5348.8	18.48	112.83	25.99	94.96	25.47	2121.6	13.25	83.17	0.185700	
3-18	48.953	0.1875	65	Slip	47.00	2,217	27.09	91.05	16.01	1464.4	24.07	144.49	18.00	140.00	10.60	425.1	15.52	96.01	0.185700	
						Shaft Weight	15,010													

Discrete Appurtenance Properties

Attach Elev (ft)	Description	Qty	Weight (lb)	No Ice CaAa (sf)	CaAa Factor	Weight (lb)	Ice CaAa (sf)	CaAa Factor	Distance From Face (ft)	Vert Ecc (ft)
138.00	3 ft Standoff	2	40.00	2.630	1.00	63.00	4.340	1.00	0.000	0.000
138.00	5' x 2" Pipe Mounts	2	10.00	1.200	1.00	15.00	1.200	1.00	0.000	0.000
132.00	5 ft Standoff	1	53.32	3.500	1.00	84.00	5.790	1.00	0.000	0.000
132.00	5' x 2" Pipe Mount	1	10.00	1.200	1.00	15.00	1.200	1.00	0.000	0.000
125.00	800 10121	3	44.10	5.460	0.79	77.01	6.100	0.79	0.000	0.000
125.00	860 10025	6	1.16	0.177	0.92	2.81	0.285	0.92	0.000	0.000
125.00	AM-X-WM-17-65-00T	6	14.20	3.077	0.70	30.85	3.592	0.70	0.000	0.000
125.00	DC6-48-60-18-8F	1	32.80	2.560	1.00	50.52	2.910	1.00	0.000	0.000
125.00	DTMA 1819VG12A	6	13.30	1.154	0.69	20.36	1.383	0.69	0.000	0.000
125.00	Platform w/Rail	1	2000.00	31.300	1.00	3,500.00	40.460	1.00	0.000	1.500
125.00	RRUS11	6	51.00	3.256	0.73	72.85	3.623	0.73	0.000	0.000
115.00	15 ft Low Profile platform	1	1500.00	17.300	1.00	2,030.00	22.100	1.00	0.000	0.000
115.00	APXVSP18-C-A20	3	57.00	8.260	0.80	99.52	9.080	0.80	0.000	0.000
115.00	APXVTM14-C-I20	3	54.90	6.430	0.76	92.44	7.090	0.76	0.000	0.000
115.00	Collar Mount	1	250.00	5.000	1.00	425.00	7.500	1.00	0.000	0.000
115.00	DAP Heads	3	35.00	2.450	0.89	53.02	2.810	0.89	0.000	0.000
115.00	LLPX310R	3	28.60	4.836	0.69	54.55	5.370	0.69	0.000	0.000
115.00	RRH-2X50-800	3	64.00	2.480	1.00	89.94	2.810	1.00	0.000	0.000
115.00	RRH-4X40-1900	3	91.00	2.890	1.00	122.36	3.240	1.00	0.000	0.000
115.00	TD-RRH-8X20-25	3	70.00	4.800	0.68	70.00	5.250	0.68	0.000	0.000
115.00	VHLP1	1	20.00	1.000	0.75	40.00	1.200	0.75	0.000	0.000
115.00	VHLP2	1	90.00	3.960	0.75	128.00	4.300	0.75	0.000	0.000
105.00	3 ft Standoff	2	40.00	2.630	1.00	63.00	4.340	1.00	0.000	0.000
105.00	5' x 3" Pipe Mounts	2	12.00	1.500	1.00	17.00	1.500	1.00	0.000	0.000
102.00	DB844H90E-XY	12	14.00	3.733	0.91	40.30	4.520	0.91	0.000	0.000
102.00	Platform w/Rail	1	2000.00	31.300	1.00	3,500.00	40.460	1.00	0.000	1.500
90.00	BXA-70063/6CF	3	17.00	7.731	0.70	57.60	8.540	0.70	0.000	0.000
90.00	FD9R6004-1C-3L	6	3.10	0.367	0.61	5.40	0.496	0.61	0.000	0.000
90.00	MG D3-900Tx	3	24.20	4.977	0.78	50.99	5.663	0.78	0.000	0.000
90.00	Platform w/Rail	1	2500.00	35.850	1.00	3,500.00	40.460	1.00	0.000	1.500
90.00	SC-E 6014 rev2	6	15.00	3.553	0.97	42.16	4.064	0.97	0.000	0.000
		Totals	96	10872.06		17,420.99			Number of Loadings :	31

Linear Appurtenance Properties

Elev From (ft)	Elev To (ft)	Description	No Ice Weight (lb/ft)	CaAa (sf/ft)	Ice Weight (lb/ft)	CaAa (sf/ft)	Exposed To Wind
0.00	125.00	(12) 1 5/8" Coax	1.04	0.00	0.00	0.00	N
0.00	125.00	(1) Fiber Cable	0.16	0.00	0.00	0.00	N
0.00	125.00	(2) Power Cables	0.52	0.00	0.00	0.00	N
0.00	115.00	(3) 1-1/4" Fiber/Power	0.95	0.00	0.00	0.00	N
0.00	115.00	(5) 1/2" Coax	0.16	0.00	0.00	0.00	N

Pole : CT23XC557_FX
 Location : Manchester, CT
 Height : 140.0 (ft)
 Base Dia : 43.00 (in)
 Top Dia : 18.00 (in)
 Shape : 18 Sides
 Taper : 0.185700 (in/ft)

Code: TIA/EIA-222 Rev F

Base Elev : 0.000 (ft)

© 2007 - 2014 by ATC IP LLC. All rights reserved.

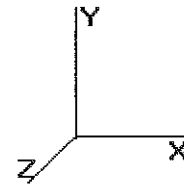

5/5/2014 4:13:18 PM

Page: 2

0.00	115.00	(1) Hybriflex Cable	0.95	0.00	0.00	0.00	N
0.00	102.00	(12) 7/8" Coax	0.52	0.00	0.00	0.00	N
0.00	90.00	(12) 1 5/8" Coax	1.04	0.00	0.00	0.00	N
Total Weight			599.46 (lb)		0.00 (lb)		

Pole : CT23XC557_RX
 Location : Manchester, CT
 Height : 140.0 (ft)
 Base Dia : 43.00 (in)
 Top Dia : 18.00 (in)
 Shape : 18 Sides
 Taper : 0.185700 (in/ft)

Code: TIA/EIA-222 Rev F

Base Elev : 0.000 (ft)

© 2007 - 2014 by ATC IP LLC. All rights reserved.

5/5/2014 4:13:18 PM
 Page: 3

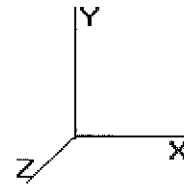

Segment Properties (Max Len : 5 ft)

Seg Top Elev (ft)	Description	Thick (in)	Flat Dia (in)	Area (in^2)	Ix (in^4)	W/t Ratio	D/t Ratio	Fy (ksi)	Fb (ksi)	Weight (lb)
0.00		0.3750	43.000	50.733	11,645.8	18.81	114.67	65	52	0.0
5.00		0.3750	42.071	49.627	10,901.2	18.37	112.19	65	52	853.8
10.00		0.3750	41.143	48.522	10,189.1	17.94	109.71	65	52	835.0
15.00		0.3750	40.215	47.417	9,508.6	17.50	107.24	65	52	816.2
20.00		0.3750	39.286	46.312	8,859.2	17.06	104.76	65	52	797.4
25.00		0.3750	38.358	45.207	8,240.0	16.63	102.29	65	52	778.5
30.00		0.3750	37.429	44.102	7,650.3	16.19	99.81	65	52	759.7
35.00		0.3750	36.500	42.997	7,089.5	15.75	97.33	65	52	740.9
40.00		0.3750	35.572	41.892	6,556.8	15.32	94.86	65	52	722.1
45.00		0.3750	34.644	40.787	6,051.5	14.88	92.38	65	52	703.3
45.04	Bot - Section 2	0.3750	34.635	40.777	6,047.2	14.88	92.36	65	52	6.0
49.96	Top - Section 1	0.3125	34.347	33.757	4,940.5	17.97	109.91	65	52	1,245.5
50.00		0.3125	34.340	33.750	4,937.2	17.97	109.89	65	52	4.6
55.00		0.3125	33.411	32.829	4,544.0	17.44	106.92	65	52	566.4
60.00		0.3125	32.483	31.908	4,172.2	16.92	103.95	65	52	550.7
65.00		0.3125	31.555	30.987	3,821.3	16.39	100.97	65	52	535.0
70.00		0.3125	30.626	30.066	3,490.6	15.87	98.00	65	52	519.4
75.00		0.3125	29.698	29.145	3,179.6	15.35	95.03	65	52	503.7
80.00		0.3125	28.769	28.224	2,887.6	14.82	92.06	65	52	488.0
85.00		0.3125	27.840	27.303	2,614.1	14.30	89.09	65	52	472.4
90.00		0.3125	26.912	26.382	2,358.4	13.77	86.12	65	52	456.7
91.05	Bot - Section 3	0.3125	26.718	26.190	2,307.1	13.66	85.50	65	52	93.6
94.96	Top - Section 2	0.1875	26.365	15.579	1,348.8	23.38	140.61	65	52	554.7
95.00		0.1875	26.359	15.574	1,347.7	23.38	140.58	65	52	1.9
100.0		0.1875	25.430	15.022	1,209.3	22.50	135.63	65	52	260.3
102.0		0.1875	25.059	14.801	1,156.7	22.15	133.65	65	52	101.6
105.0		0.1875	24.502	14.469	1,080.7	21.63	130.67	65	52	149.4
110.0		0.1875	23.573	13.917	961.6	20.76	125.72	65	52	241.5
115.0		0.1875	22.645	13.364	851.5	19.88	120.77	65	52	232.1
120.0		0.1875	21.716	12.812	750.2	19.01	115.82	65	52	222.7
125.0		0.1875	20.788	12.259	657.3	18.14	110.87	65	52	213.3
130.0		0.1875	19.859	11.707	572.3	17.26	105.91	65	52	203.9
132.0		0.1875	19.488	11.486	540.5	16.92	103.93	65	52	78.9
135.0		0.1875	18.931	11.154	495.1	16.39	100.96	65	52	115.6
138.0		0.1875	18.373	10.822	452.2	15.87	97.99	65	52	112.2
140.0		0.1875	18.002	10.601	425.1	15.52	96.01	65	52	72.9
										15,009.7

Pole : CT23XC557_FX
 Location : Manchester, CT
 Height : 140.0 (ft)
 Base Dia : 43.00 (in)
 Top Dia : 18.00 (in)
 Shape : 18 Sides
 Taper : 0.185700 (in/ft)

Code: TIA/EIA-222 Rev F

Base Elev : 0.000 (ft)

© 2007 - 2014 by ATC IP LLC. All rights reserved.

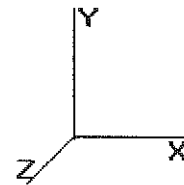

5/5/2014 4:13:18 PM

Page: 4

Load Case: No Ice	80.00 mph Wind with No Ice	26 Iterations
Gust Response Factor : 1.69		
Dead Load Factor : 1.00		
Wind Load Factor : 1.00		

Shaft Segment Forces

Seg Top Elev (ft)	Description	Kz	qz (psf)	qzCh (psf)	C (mph-ft)	Cf	Ice Thick (in)	Tributary (ft)	Aa (sf)	CfAa (sf)	Wind Force X (lb)	Dead Load (lb)	Tot Dead Load (lb)
0.00		0.00	1.00 16.384	27.68	286.66	0.650	0.000	0.00	0.000	0.00	0.0	0.0	0.0
5.00		0.00	1.00 16.384	27.68	280.47	0.650	0.000	5.00	17.723	11.52	319.0	0.0	853.8
10.00		0.00	1.00 16.384	27.68	274.28	0.650	0.000	5.00	17.336	11.27	312.0	0.0	835.0
15.00		0.00	1.00 16.384	27.68	268.09	0.650	0.000	5.00	16.949	11.02	305.1	0.0	816.2
20.00		0.00	1.00 16.384	27.68	261.90	0.650	0.000	5.00	16.563	10.77	298.1	0.0	797.4
25.00		0.00	1.00 16.384	27.68	255.71	0.650	0.000	5.00	16.176	10.51	291.1	0.0	778.5
30.00		0.00	1.00 16.384	27.68	249.52	0.650	0.000	5.00	15.789	10.26	284.2	0.0	759.7
35.00		0.00	1.01 16.662	28.15	245.39	0.650	0.000	5.00	15.402	10.01	281.9	0.0	740.9
40.00		0.00	1.05 17.310	29.25	243.75	0.650	0.000	5.00	15.015	9.76	285.5	0.0	722.1
45.00		0.00	1.09 17.902	30.25	241.42	0.650	0.000	5.00	14.628	9.51	287.7	0.0	703.3
45.04	Bot - Section 2	0.00	1.09 17.907	30.26	241.39	0.650	0.000	0.04	0.125	0.08	2.5	0.0	6.0
49.96	Top - Section 1	0.00	1.12 18.445	31.17	238.53	0.650	0.000	4.92	14.260	9.27	288.9	0.0	1,245.5
50.00		0.00	1.12 18.449	31.17	242.93	0.650	0.000	0.04	0.114	0.07	2.3	0.0	4.6
55.00		0.00	1.15 18.959	32.04	239.60	0.650	0.000	5.00	14.115	9.17	294.0	0.0	566.4
60.00		0.00	1.18 19.436	32.84	235.86	0.650	0.000	5.00	13.728	8.92	293.1	0.0	550.7
65.00		0.00	1.21 19.885	33.60	231.75	0.650	0.000	5.00	13.341	8.67	291.4	0.0	535.0
70.00		0.00	1.24 20.311	34.32	227.32	0.650	0.000	5.00	12.954	8.42	289.0	0.0	519.4
75.00		0.00	1.26 20.715	35.00	222.62	0.650	0.000	5.00	12.567	8.17	286.0	0.0	503.7
80.00		0.00	1.28 21.101	35.66	217.65	0.650	0.000	5.00	12.181	7.92	282.3	0.0	488.0
85.00		0.00	1.31 21.469	36.28	212.46	0.650	0.000	5.00	11.794	7.67	278.1	0.0	472.4
90.00	Appertunance(s)	0.00	1.33 21.823	36.88	207.06	0.650	0.000	5.00	11.407	7.41	273.4	0.0	456.7
91.05	Bot - Section 3	0.00	1.33 21.895	37.00	205.90	0.650	0.000	1.05	2.339	1.52	56.3	0.0	93.6
94.96	Top - Section 2	0.00	1.35 22.160	37.45	201.51	0.650	0.000	3.92	8.724	5.67	212.4	0.0	554.7
95.00		0.00	1.35 22.163	37.45	204.37	0.650	0.000	0.04	0.081	0.05	2.0	0.0	1.9
100.0		0.00	1.37 22.490	38.00	198.62	0.650	0.000	5.00	10.789	7.01	266.6	0.0	260.3
102.0	Appertunance(s)	0.00	1.38 22.617	38.22	196.28	0.650	0.000	2.00	4.207	2.73	104.5	0.0	101.6
105.0	Appertunance(s)	0.00	1.39 22.806	38.54	192.71	0.650	0.000	3.00	6.195	4.03	155.2	0.0	149.4
110.0		0.00	1.41 23.111	39.05	186.64	0.650	0.000	5.00	10.016	6.51	254.3	0.0	241.5
115.0	Appertunance(s)	0.00	1.42 23.406	39.55	180.43	0.650	0.000	5.00	9.629	6.26	247.6	0.0	232.1
120.0		0.00	1.44 23.692	40.04	174.09	0.650	0.000	5.00	9.242	6.01	240.5	0.0	222.7
125.0	Appertunance(s)	0.00	1.46 23.970	40.51	167.62	0.650	0.000	5.00	8.855	5.76	233.2	0.0	213.3
130.0		0.00	1.48 24.241	40.96	161.03	0.650	0.000	5.00	8.468	5.50	225.5	0.0	203.9
132.0	Appertunance(s)	0.00	1.48 24.347	41.14	158.37	0.650	0.000	2.00	3.279	2.13	87.7	0.0	78.9
135.0		0.00	1.49 24.503	41.41	154.33	0.650	0.000	3.00	4.802	3.12	129.3	0.0	115.6
138.0	Appertunance(s)	0.00	1.50 24.658	41.67	150.26	0.650	0.000	3.00	4.663	3.03	126.3	0.0	112.2
140.0		0.00	1.51 24.759	41.84	147.53	0.650	0.000	2.00	3.031	1.97	82.4	0.0	72.9
Totals:								140.00			7,669.2	0.0	15,009.7

Pole : CT23XC557_FX
 Location : Manchester, CT
 Height : 140.0 (ft)
 Base Dia : 43.00 (in)
 Top Dia : 18.00 (in)
 Shape : 18 Sides
 Taper : 0.185700 (in/ft)

Code: TIA/EIA-222 Rev F

Base Elev : 0.000 (ft)

© 2007 - 2014 by ATC IP LLC. All rights reserved.

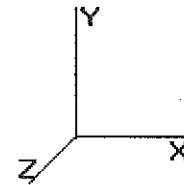

5/5/2014 4:13:18 PM

Page: 5

Load Case: No Ice	80.00 mph Wind with No Ice	26 Iterations
Gust Response Factor : 1.69		
Dead Load Factor : 1.00		
Wind Load Factor : 1.00		

Discrete Appurtenance Segment Forces

Elev (ft)	Description	Qty	qz (psf)	qzGh (psf)	CaAa Factor	Total CaAa (sf)	Horiz Ecc (ft)	Vert Ecc (ft)	Wind FX (lb)	Mom Y (lb-ft)	Mom Z (lb-ft)	Dead Load (lb)
90.00	BXA-70063/6CF	3	21.823	36.881	0.70	16.24	0.000	0.000	598.76	0.00	0.00	51.00
90.00	FD9R6004-1C-3L	6	21.823	36.881	0.61	1.34	0.000	0.000	49.54	0.00	0.00	18.60
90.00	MG D3-900Tx	3	21.823	36.881	0.78	11.65	0.000	0.000	429.52	0.00	0.00	72.60
90.00	Platform w/Rail	1	21.926	37.055	1.00	35.85	0.000	1.500	1,328.44	0.00	1,992.65	2,500.00
90.00	SC-E 6014 rev2	6	21.823	36.881	0.97	20.68	0.000	0.000	762.64	0.00	0.00	90.00
102.0	DB844H90E-XY	12	22.617	38.224	0.91	40.76	0.000	0.000	1,558.16	0.00	0.00	168.00
102.0	Platform w/Rail	1	22.712	38.383	1.00	31.30	0.000	1.500	1,201.40	0.00	1,802.10	2,000.00
105.0	3 ft Standoff	2	22.806	38.541	1.00	5.26	0.000	0.000	202.73	0.00	0.00	80.00
105.0	5' x 3" Pipe Mounts	2	22.806	38.541	1.00	3.00	0.000	0.000	115.62	0.00	0.00	24.00
115.0	15 ft Low Profile pl	1	23.406	39.556	1.00	17.30	0.000	0.000	684.33	0.00	0.00	1,500.00
115.0	APXVSP18-C-A20	3	23.406	39.556	0.80	19.82	0.000	0.000	784.17	0.00	0.00	171.00
115.0	APXVTM14-C-I20	3	23.406	39.556	0.76	14.66	0.000	0.000	579.91	0.00	0.00	164.70
115.0	Collar Mount	1	23.406	39.556	1.00	5.00	0.000	0.000	197.78	0.00	0.00	250.00
115.0	DAP Heads	3	23.406	39.556	0.89	6.54	0.000	0.000	258.76	0.00	0.00	105.00
115.0	LLPX310R	3	23.406	39.556	0.69	10.01	0.000	0.000	395.98	0.00	0.00	85.80
115.0	RRH-2X50-800	3	23.406	39.556	1.00	7.44	0.000	0.000	294.30	0.00	0.00	192.00
115.0	RRH-4X40-1900	3	23.406	39.556	1.00	8.67	0.000	0.000	342.95	0.00	0.00	273.00
115.0	TD-RRH-8X20-25	3	23.406	39.556	0.68	9.79	0.000	0.000	387.34	0.00	0.00	210.00
115.0	VHLP1	1	23.406	39.556	0.75	0.75	0.000	0.000	29.67	0.00	0.00	20.00
115.0	VHLP2	1	23.406	39.556	0.75	2.97	0.000	0.000	117.48	0.00	0.00	90.00
125.0	800 10121	3	23.970	40.510	0.79	12.94	0.000	0.000	524.21	0.00	0.00	132.30
125.0	860 10025	6	23.970	40.510	0.92	0.98	0.000	0.000	39.58	0.00	0.00	6.94
125.0	AM-X-WM-17-65-00T	6	23.970	40.510	0.70	12.92	0.000	0.000	523.53	0.00	0.00	85.20
125.0	DC6-48-60-18-8F	1	23.970	40.510	1.00	2.56	0.000	0.000	103.71	0.00	0.00	32.80
125.0	DTMA 1819VG12A	6	23.970	40.510	0.69	4.78	0.000	0.000	193.54	0.00	0.00	79.80
125.0	Platform w/Rail	1	24.052	40.648	1.00	31.30	0.000	1.500	1,272.29	0.00	1,908.44	2,000.00
125.0	RRUS11	6	23.970	40.510	0.73	14.26	0.000	0.000	577.73	0.00	0.00	306.00
132.0	5 ft Standoff	1	24.347	41.146	1.00	3.50	0.000	0.000	144.01	0.00	0.00	53.32
132.0	5' x 2" Pipe Mount	1	24.347	41.146	1.00	1.20	0.000	0.000	49.37	0.00	0.00	10.00
138.0	3 ft Standoff	2	24.658	41.672	1.00	5.26	0.000	0.000	219.19	0.00	0.00	80.00
138.0	5' x 2" Pipe Mounts	2	24.658	41.672	1.00	2.40	0.000	0.000	100.01	0.00	0.00	20.00
									14,066.64			10,872.06

Pole : CT23XC557_FIX
 Location : Manchester, CT
 Height : 140.0 (ft)
 Base Dia : 43.00 (in)
 Top Dia : 18.00 (in)
 Shape : 18 Sides
 Taper : 0.185700 (in/ft)

Code: TIA/EIA-222 Rev F

Base Elev : 0.000 (ft)

© 2007 - 2014 by ATC IP LLC. All rights reserved.

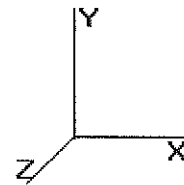

5/5/2014 4:13:18 PM

Page: 6

Load Case: No Ice	80.00 mph Wind with No Ice	26 Iterations
Gust Response Factor : 1.69		
Dead Load Factor : 1.00		
Wind Load Factor : 1.00		

Applied Segment Forces Summary

Seg Elev (ft)	Lateral FX (-) (lb)	Axial FY (-) (lb)	Torsion MY (lb-ft)	Moment MZ (lb-ft)
0.00	0.00	0.00	0.00	0.00
5.00	318.98	880.50	0.00	0.00
10.00	312.02	861.70	0.00	0.00
15.00	305.05	842.89	0.00	0.00
20.00	298.09	824.09	0.00	0.00
25.00	291.13	805.29	0.00	0.00
30.00	284.17	786.49	0.00	0.00
35.00	281.90	767.68	0.00	0.00
40.00	285.51	748.88	0.00	0.00
45.00	287.67	730.08	0.00	0.00
45.04	2.46	6.25	0.00	0.00
49.96	288.93	1,271.76	0.00	0.00
50.00	2.32	4.81	0.00	0.00
55.00	293.96	593.12	0.00	0.00
60.00	293.10	577.45	0.00	0.00
65.00	291.43	561.78	0.00	0.00
70.00	289.03	546.12	0.00	0.00
75.00	285.98	530.45	0.00	0.00
80.00	282.33	514.78	0.00	0.00
85.00	278.14	499.11	0.00	0.00
90.00	3,442.35	3,215.64	0.00	1,992.65
91.05	56.25	98.13	0.00	0.00
94.96	212.37	571.62	0.00	0.00
95.00	1.96	2.10	0.00	0.00
100.0	266.55	281.82	0.00	0.00
102.0	2,864.09	2,278.10	0.00	1,802.10
105.0	473.55	264.76	0.00	0.00
110.0	254.27	260.42	0.00	0.00
115.0	4,320.23	3,312.52	0.00	0.00
120.0	240.53	231.28	0.00	0.00
125.0	3,467.74	2,864.92	0.00	1,908.44
130.0	225.49	203.88	0.00	0.00
132.0	281.08	142.24	0.00	0.00
135.0	129.26	115.56	0.00	0.00
138.0	445.51	212.17	0.00	0.00
140.0	82.45	72.90	0.00	0.00
Totals:	21,735.87	26,481.27	0.00	5,703.19

Pole : CT23XC557_FIX
 Location : Manchester, CT
 Height : 140.0 (ft)
 Base Dia : 43.00 (in)
 Top Dia : 18.00 (in)
 Shape : 18 Sides
 Taper : 0.185700 (in/ft)

Code: TIA/EIA-222 Rev F

Base Elev : 0.000 (ft)

© 2007 - 2014 by ATC IP LLC. All rights reserved.

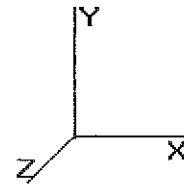

5/5/2014 4:13:18 PM
 Page: 7

Load Case: No Ice	80.00 mph Wind with No Ice	26 Iterations
Gust Response Factor : 1.69		
Dead Load Factor : 1.00		
Wind Load Factor : 1.00		

Calculated Shaft Forces and Deflections

Seg Elev (ft)	Lateral FX (-) (kips)	Axial FY (-) (kips)	Lateral FZ (kips)	Moment MX (ft-kips)	Torsion MY (ft-kips)	Moment MZ (ft-kips)	X Deflect (in)	Z Deflect (in)	Total Deflect (in)	Rotation (deg)
0.00	-21.796	-26.431	0.000	0.000	0.000	-2,163.405	0.000	0.000	0.000	0.000
5.00	-21.590	-25.454	0.000	0.000	0.000	-2,054.428	-0.138	0.000	0.138	-0.258
10.00	-21.385	-24.497	0.000	0.000	0.000	-1,946.480	-0.547	0.000	0.547	-0.519
15.00	-21.180	-23.559	0.000	0.000	0.000	-1,839.558	-1.232	0.000	1.232	-0.783
20.00	-20.975	-22.642	0.000	0.000	0.000	-1,733.661	-2.195	0.000	2.195	-1.050
25.00	-20.770	-21.745	0.000	0.000	0.000	-1,628.789	-3.439	0.000	3.439	-1.320
30.00	-20.566	-20.868	0.000	0.000	0.000	-1,524.940	-4.968	0.000	4.968	-1.592
35.00	-20.357	-20.012	0.000	0.000	0.000	-1,422.112	-6.782	0.000	6.782	-1.866
40.00	-20.138	-19.177	0.000	0.000	0.000	-1,320.328	-8.884	0.000	8.884	-2.142
45.00	-19.866	-18.411	0.000	0.000	0.000	-1,219.640	-11.274	0.000	11.274	-2.417
45.04	-19.907	-18.357	0.000	0.000	0.000	-1,218.780	-11.296	0.000	11.296	-2.420
49.96	-19.602	-17.053	0.000	0.000	0.000	-1,120.904	-13.930	0.000	13.930	-2.690
50.00	-19.646	-16.995	0.000	0.000	0.000	-1,120.120	-13.952	0.000	13.952	-2.692
55.00	-19.411	-16.313	0.000	0.000	0.000	-1,021.889	-16.937	0.000	16.937	-3.001
60.00	-19.169	-15.652	0.000	0.000	0.000	-924.836	-20.242	0.000	20.242	-3.306
65.00	-18.922	-15.011	0.000	0.000	0.000	-828.991	-23.864	0.000	23.864	-3.605
70.00	-18.670	-14.392	0.000	0.000	0.000	-734.383	-27.794	0.000	27.794	-3.896
75.00	-18.413	-13.796	0.000	0.000	0.000	-641.034	-32.022	0.000	32.022	-4.176
80.00	-18.153	-13.222	0.000	0.000	0.000	-548.968	-36.536	0.000	36.536	-4.442
85.00	-17.888	-12.673	0.000	0.000	0.000	-458.206	-41.320	0.000	41.320	-4.690
90.00	-14.211	-9.725	0.000	0.000	0.000	-366.773	-46.350	0.000	46.350	-4.915
91.05	-14.164	-9.606	0.000	0.000	0.000	-351.899	-47.431	0.000	47.431	-4.961
94.96	-13.914	-9.037	0.000	0.000	0.000	-296.426	-51.563	0.000	51.563	-5.117
95.00	-13.935	-9.000	0.000	0.000	0.000	-295.916	-51.602	0.000	51.602	-5.119
100.0	-13.671	-8.700	0.000	0.000	0.000	-226.243	-57.109	0.000	57.109	-5.394
102.0	-10.618	-6.682	0.000	0.000	0.000	-197.098	-59.388	0.000	59.388	-5.494
105.0	-10.139	-6.436	0.000	0.000	0.000	-165.246	-62.880	0.000	62.880	-5.628
110.0	-9.877	-6.175	0.000	0.000	0.000	-114.552	-68.868	0.000	68.868	-5.812
115.0	-5.246	-3.313	0.000	0.000	0.000	-65.166	-75.022	0.000	75.022	-5.945
120.0	-4.987	-3.102	0.000	0.000	0.000	-38.935	-81.288	0.000	81.288	-6.032
125.0	-1.236	-0.619	0.000	0.000	0.000	-12.094	-87.624	0.000	87.624	-6.082
130.0	-0.990	-0.440	0.000	0.000	0.000	-5.913	-93.993	0.000	93.993	-6.102
132.0	-0.696	-0.328	0.000	0.000	0.000	-3.932	-96.545	0.000	96.545	-6.106
135.0	-0.555	-0.227	0.000	0.000	0.000	-1.845	-100.377	0.000	100.377	-6.111
138.0	-0.090	-0.064	0.000	0.000	0.000	-0.179	-104.210	0.000	104.210	-6.113
140.0	-0.082	0.000	0.000	0.000	0.000	0.000	-106.766	0.000	106.766	-6.113

Pole : CT23XC557_FX
 Location : Manchester, CT
 Height : 140.0 (ft)
 Base Dia : 43.00 (in)
 Top Dia : 18.00 (in)
 Shape : 18 Sides
 Taper : 0.185700 (in/ft)

Code: TIA/EIA-222 Rev F

Base Elev : 0.000 (ft)

© 2007 - 2014 by ATC IP LLC. All rights reserved.

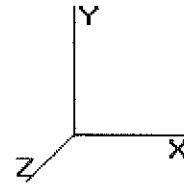

5/5/2014 4:13:18 PM

Page: 8

Load Case: No Ice 80.00 mph Wind with No Ice 26 Iterations

Gust Response Factor : 1.69
 Dead Load Factor : 1.00
 Wind Load Factor : 1.00

Calculated Stresses

Seg Elev (ft)	Applied Stresses							Allowable Stress (Fb) (ksi)	Stress Ratio	
	Axial (Y) (ksi)	Shear (X) (ksi)	Shear (Z) (ksi)	Torsion (ksi)	Bending (X) (ksi)	Bending (Z) (ksi)	Combined (ksi)			
0.00	0.52	0.87	0.00	0.00	0.00	48.67	49.21	52.0	0.0	0.947
5.00	0.51	0.88	0.00	0.00	0.00	48.31	48.84	52.0	0.0	0.940
10.00	0.50	0.89	0.00	0.00	0.00	47.89	48.42	52.0	0.0	0.931
15.00	0.50	0.90	0.00	0.00	0.00	47.40	47.92	52.0	0.0	0.922
20.00	0.49	0.91	0.00	0.00	0.00	46.84	47.35	52.0	0.0	0.911
25.00	0.48	0.93	0.00	0.00	0.00	46.19	46.70	52.0	0.0	0.898
30.00	0.47	0.94	0.00	0.00	0.00	45.45	45.96	52.0	0.0	0.884
35.00	0.47	0.95	0.00	0.00	0.00	44.61	45.10	52.0	0.0	0.868
40.00	0.46	0.97	0.00	0.00	0.00	43.64	44.13	52.0	0.0	0.849
45.00	0.45	0.98	0.00	0.00	0.00	42.54	43.02	52.0	0.0	0.828
45.04	0.45	0.98	0.00	0.00	0.00	42.53	43.01	52.0	0.0	0.827
49.96	0.51	1.17	0.00	0.00	0.00	47.48	48.03	52.0	0.0	0.924
50.00	0.50	1.17	0.00	0.00	0.00	47.47	48.01	52.0	0.0	0.924
55.00	0.50	1.19	0.00	0.00	0.00	45.78	46.32	52.0	0.0	0.891
60.00	0.49	1.21	0.00	0.00	0.00	43.87	44.41	52.0	0.0	0.854
65.00	0.48	1.23	0.00	0.00	0.00	41.71	42.24	52.0	0.0	0.813
70.00	0.48	1.25	0.00	0.00	0.00	39.26	39.79	52.0	0.0	0.766
75.00	0.47	1.27	0.00	0.00	0.00	36.48	37.02	52.0	0.0	0.712
80.00	0.47	1.30	0.00	0.00	0.00	33.32	33.87	52.0	0.0	0.651
85.00	0.46	1.32	0.00	0.00	0.00	29.73	30.28	52.0	0.0	0.583
90.00	0.37	1.09	0.00	0.00	0.00	25.50	25.94	52.0	0.0	0.499
91.05	0.37	1.09	0.00	0.00	0.00	24.83	25.27	52.0	0.0	0.486
94.96	0.58	1.80	0.00	0.00	0.00	35.30	36.02	52.0	0.0	0.693
95.00	0.58	1.80	0.00	0.00	0.00	35.26	35.97	52.0	0.0	0.692
100.00	0.58	1.83	0.00	0.00	0.00	28.99	29.73	52.0	0.0	0.572
102.00	0.45	1.45	0.00	0.00	0.00	26.01	26.58	52.0	0.0	0.511
105.00	0.44	1.41	0.00	0.00	0.00	22.82	23.40	52.0	0.0	0.450
110.00	0.44	1.43	0.00	0.00	0.00	17.11	17.73	52.0	0.0	0.341
115.00	0.25	0.79	0.00	0.00	0.00	10.56	10.89	52.0	0.0	0.210
120.00	0.24	0.78	0.00	0.00	0.00	6.87	7.24	52.0	0.0	0.139
125.00	0.05	0.20	0.00	0.00	0.00	2.33	2.41	52.0	0.0	0.046
130.00	0.04	0.17	0.00	0.00	0.00	1.25	1.32	52.0	0.0	0.025
132.00	0.03	0.12	0.00	0.00	0.00	0.86	0.92	52.0	0.0	0.018
135.00	0.02	0.10	0.00	0.00	0.00	0.43	0.48	52.0	0.0	0.009
138.00	0.01	0.02	0.00	0.00	0.00	0.04	0.06	52.0	0.0	0.001
140.00	0.00	0.02	0.00	0.00	0.00	0.00	0.03	52.0	0.0	0.001

Pole : CT23XC557_FIX
 Location : Manchester, CT
 Height : 140.0 (ft)
 Base Dia : 43.00 (in)
 Top Dia : 18.00 (in)
 Shape : 18 Sides
 Taper : 0.185700 (in/ft)

Code: TIA/EIA-222 Rev F

Base Elev : 0.000 (ft)

© 2007 - 2014 by ATC IP LLC. All rights reserved.

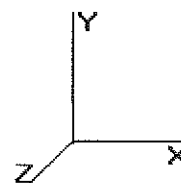

5/5/2014 4:13:18 PM

Page: 9

Load Case: Ice	69.28 mph Wind with Ice	26 Iterations
Gust Response Factor : 1.69		
Dead Load Factor : 1.00		
Wind Load Factor : 1.00		

Shaft Segment Forces

Seg Top Elev (ft)	Description	Kz	qz (psf)	qzGh (psf)	C (mph-ft)	Cf	Ice Thick (in)	Tributary (ft)	Aa (sf)	CfAa (sf)	Wind Force X (lb)	Dead Load (lb)	Tot Dead Load (lb)	
0.00		0.00	1.00	12.287	20.76	248.25	0.650	0.500	0.00	0.000	0.00	0.0	0.0	
5.00		0.00	1.00	12.287	20.76	242.89	0.650	0.500	5.00	18.140	11.79	244.8	131.4	985.1
10.00		0.00	1.00	12.287	20.76	237.53	0.650	0.500	5.00	17.753	11.54	239.6	128.5	963.5
15.00		0.00	1.00	12.287	20.76	232.17	0.650	0.500	5.00	17.366	11.29	234.4	125.6	941.8
20.00		0.00	1.00	12.287	20.76	226.81	0.650	0.500	5.00	16.979	11.04	229.2	122.8	920.1
25.00		0.00	1.00	12.287	20.76	221.45	0.650	0.500	5.00	16.592	10.79	224.0	119.9	898.5
30.00		0.00	1.00	12.287	20.76	216.09	0.650	0.500	5.00	16.206	10.53	218.7	117.0	876.8
35.00		0.00	1.01	12.496	21.11	212.50	0.650	0.500	5.00	15.819	10.28	217.1	114.2	855.1
40.00		0.00	1.05	12.982	21.93	211.09	0.650	0.500	5.00	15.432	10.03	220.1	111.3	833.5
45.00		0.00	1.09	13.426	22.69	209.07	0.650	0.500	5.00	15.045	9.78	221.9	108.4	811.8
45.04	Bot - Section 2	0.00	1.09	13.430	22.69	209.05	0.650	0.500	0.04	0.129	0.08	1.9	0.9	7.0
49.96	Top - Section 1	0.00	1.12	13.833	23.37	206.57	0.650	0.500	4.92	14.670	9.54	222.9	105.7	1,351.2
50.00		0.00	1.12	13.836	23.38	210.38	0.650	0.500	0.04	0.118	0.08	1.8	0.9	5.5
55.00		0.00	1.15	14.218	24.02	207.49	0.650	0.500	5.00	14.532	9.45	227.0	104.6	671.0
60.00		0.00	1.18	14.576	24.63	204.25	0.650	0.500	5.00	14.145	9.19	226.5	101.8	652.5
65.00		0.00	1.21	14.913	25.20	200.69	0.650	0.500	5.00	13.758	8.94	225.4	98.9	634.0
70.00		0.00	1.24	15.232	25.74	196.86	0.650	0.500	5.00	13.371	8.69	223.7	96.0	615.4
75.00		0.00	1.26	15.536	26.25	192.78	0.650	0.500	5.00	12.984	8.44	221.6	93.2	596.9
80.00		0.00	1.28	15.825	26.74	188.49	0.650	0.500	5.00	12.597	8.19	219.0	90.3	578.4
85.00		0.00	1.31	16.101	27.21	183.99	0.650	0.500	5.00	12.210	7.94	216.0	87.5	559.8
90.00	Appertunance(s)	0.00	1.33	16.366	27.65	179.31	0.650	0.500	5.00	11.823	7.69	212.6	84.6	541.3
91.05	Bot - Section 3	0.00	1.33	16.420	27.75	178.31	0.650	0.500	1.05	2.426	1.58	43.8	17.6	111.2
94.96	Top - Section 2	0.00	1.35	16.619	28.08	174.50	0.650	0.500	3.92	9.050	5.88	165.2	64.9	619.7
95.00		0.00	1.35	16.621	28.09	176.99	0.650	0.500	0.04	0.084	0.05	1.5	0.6	2.6
100.0		0.00	1.37	16.866	28.50	172.01	0.650	0.500	5.00	11.206	7.28	207.6	80.0	340.3
102.0	Appertunance(s)	0.00	1.38	16.962	28.66	169.97	0.650	0.500	2.00	4.374	2.84	81.5	31.5	133.0
105.0	Appertunance(s)	0.00	1.39	17.103	28.90	166.89	0.650	0.500	3.00	6.445	4.19	121.1	46.3	195.7
110.0		0.00	1.41	17.332	29.29	161.63	0.650	0.500	5.00	10.432	6.78	198.6	74.3	315.8
115.0	Appertunance(s)	0.00	1.42	17.554	29.66	156.25	0.650	0.500	5.00	10.045	6.53	193.7	71.4	303.5
120.0		0.00	1.44	17.768	30.02	150.76	0.650	0.500	5.00	9.658	6.28	188.5	68.6	291.2
125.0	Appertunance(s)	0.00	1.46	17.977	30.38	145.16	0.650	0.500	5.00	9.272	6.03	183.1	65.7	279.0
130.0		0.00	1.48	18.179	30.72	139.45	0.650	0.500	5.00	8.885	5.78	177.4	62.8	266.7
132.0	Appertunance(s)	0.00	1.48	18.259	30.85	137.14	0.650	0.500	2.00	3.446	2.24	69.1	24.7	103.6
135.0		0.00	1.49	18.376	31.05	133.65	0.650	0.500	3.00	5.052	3.28	102.0	36.0	151.5
138.0	Appertunance(s)	0.00	1.50	18.492	31.25	130.13	0.650	0.500	3.00	4.913	3.19	99.8	34.9	147.1
140.0		0.00	1.51	18.568	31.38	127.76	0.650	0.500	2.00	3.198	2.08	65.2	22.8	95.7
Totals:								140.00			5,946.3	2,645.7	17,655.5	

Pole : CT23XC557_FIX
 Location : Manchester, CT
 Height : 140.0 (ft)
 Base Dia : 43.00 (in)
 Top Dia : 18.00 (in)
 Shape : 18 Sides
 Taper : 0.185700 (in/ft)

Code: TIA/EIA-222 Rev F

5/5/2014 4:13:18 PM
 Page: 10

Base Elev : 0.000 (ft)

© 2007 - 2014 by ATC IP LLC. All rights reserved.

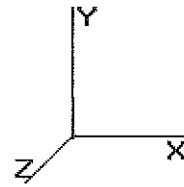

Load Case: Ice	69.28 mph Wind with Ice	26 Iterations
Gust Response Factor : 1.69		
Dead Load Factor : 1.00		
Wind Load Factor : 1.00		

Discrete Appurtenance Segment Forces

Elev (ft)	Description	Qty	qz (psf)	qzGh (psf)	CaAa Factor	Total CaAa (sf)	Horiz Ecc (ft)	Vert Ecc (ft)	Wind FX (lb)	Mom Y (lb-ft)	Mom Z (lb-ft)	Dead Load (lb)
90.00	BXA-70063/6CF	3	16.366	27.659	0.70	17.93	0.000	0.000	496.03	0.00	0.00	172.80
90.00	FD9R6004-1C-3L	6	16.366	27.659	0.61	1.82	0.000	0.000	50.21	0.00	0.00	32.40
90.00	MGD3-900Tx	3	16.366	27.659	0.78	13.25	0.000	0.000	366.52	0.00	0.00	152.97
90.00	Platform w/Rail	1	16.444	27.790	1.00	40.46	0.000	1.500	1,124.38	0.00	1,686.57	3,500.00
90.00	SC-E 6014 rev2	6	16.366	27.659	0.97	23.65	0.000	0.000	654.20	0.00	0.00	252.96
102.0	DB844H90E-XY	12	16.962	28.666	0.91	49.36	0.000	0.000	1,414.91	0.00	0.00	483.60
102.0	Platform w/Rail	1	17.033	28.786	1.00	40.46	0.000	1.500	1,164.67	0.00	1,747.01	3,500.00
105.0	3 ft Standoff	2	17.103	28.904	1.00	8.68	0.000	0.000	250.89	0.00	0.00	126.00
105.0	5' x 3" Pipe Mounts	2	17.103	28.904	1.00	3.00	0.000	0.000	86.71	0.00	0.00	34.00
115.0	15 ft Low Profile pl	1	17.554	29.666	1.00	22.10	0.000	0.000	655.61	0.00	0.00	2,030.00
115.0	APXVSP18-C-A20	3	17.554	29.666	0.80	21.79	0.000	0.000	646.47	0.00	0.00	298.56
115.0	APXVTM14-C-I20	3	17.554	29.666	0.76	16.17	0.000	0.000	479.55	0.00	0.00	277.32
115.0	Collar Mount	1	17.554	29.666	1.00	7.50	0.000	0.000	222.49	0.00	0.00	425.00
115.0	DAP Heads	3	17.554	29.666	0.89	7.50	0.000	0.000	222.57	0.00	0.00	159.06
115.0	LLPX310R	3	17.554	29.666	0.69	11.12	0.000	0.000	329.76	0.00	0.00	163.65
115.0	RRH-2X50-800	3	17.554	29.666	1.00	8.43	0.000	0.000	250.08	0.00	0.00	269.82
115.0	RRH-4X40-1900	3	17.554	29.666	1.00	9.72	0.000	0.000	288.35	0.00	0.00	367.08
115.0	TD-RRH-8X20-25	3	17.554	29.666	0.68	10.71	0.000	0.000	317.72	0.00	0.00	210.00
115.0	VHLP1	1	17.554	29.666	0.75	0.90	0.000	0.000	26.70	0.00	0.00	40.00
115.0	VHLP2	1	17.554	29.666	0.75	3.23	0.000	0.000	95.67	0.00	0.00	128.00
125.0	800 10121	3	17.977	30.381	0.79	14.46	0.000	0.000	439.21	0.00	0.00	231.03
125.0	860 10025	6	17.977	30.381	0.92	1.57	0.000	0.000	47.79	0.00	0.00	16.86
125.0	AM-X-WM-17-65-00T	6	17.977	30.381	0.70	15.09	0.000	0.000	458.34	0.00	0.00	185.10
125.0	DC6-48-60-18-8F	1	17.977	30.381	1.00	2.91	0.000	0.000	88.41	0.00	0.00	50.52
125.0	DTMA 1819VG12A	6	17.977	30.381	0.69	5.73	0.000	0.000	173.95	0.00	0.00	122.16
125.0	Platform w/Rail	1	18.038	30.484	1.00	40.46	0.000	1.500	1,233.40	0.00	1,850.10	3,500.00
125.0	RRUS11	6	17.977	30.381	0.73	15.87	0.000	0.000	482.10	0.00	0.00	437.10
132.0	5 ft Standoff	1	18.259	30.857	1.00	5.79	0.000	0.000	178.66	0.00	0.00	84.00
132.0	5' x 2" Pipe Mount	1	18.259	30.857	1.00	1.20	0.000	0.000	37.03	0.00	0.00	15.00
138.0	3 ft Standoff	2	18.492	31.252	1.00	8.68	0.000	0.000	271.27	0.00	0.00	126.00
138.0	5' x 2" Pipe Mounts	2	18.492	31.252	1.00	2.40	0.000	0.000	75.00	0.00	0.00	30.00
									12,628.67			17,420.99

Pole : CT23XC557_FIX
 Location : Manchester, CT
 Height : 140.0 (ft)
 Base Dia : 43.00 (in)
 Top Dia : 18.00 (in)
 Shape : 18 Sides
 Taper : 0.185700 (in/ft)

Code: TIA/EIA-222 Rev F

Base Elev : 0.000 (ft)

© 2007 - 2014 by ATC IP LLC. All rights reserved.

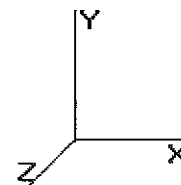

5/5/2014 4:13:18 PM

Page: 11

Load Case: Ice

69.28 mph Wind with Ice

26 iterations

Gust Response Factor : 1.69

Dead Load Factor : 1.00

Wind Load Factor : 1.00

Applied Segment Forces Summary

Seg Elev (ft)	Lateral FX (-) (lb)	Axial FY (-) (lb)	Torsion MY (lb-ft)	Moment MZ (lb-ft)
0.00	0.00	0.00	0.00	0.00
5.00	244.84	1,011.86	0.00	0.00
10.00	239.62	990.19	0.00	0.00
15.00	234.40	968.53	0.00	0.00
20.00	229.18	946.86	0.00	0.00
25.00	223.96	925.19	0.00	0.00
30.00	218.74	903.52	0.00	0.00
35.00	217.13	881.86	0.00	0.00
40.00	220.06	860.19	0.00	0.00
45.00	221.89	838.52	0.00	0.00
45.04	1.90	7.19	0.00	0.00
49.96	222.91	1,377.50	0.00	0.00
50.00	1.79	5.67	0.00	0.00
55.00	226.96	697.76	0.00	0.00
60.00	226.48	679.23	0.00	0.00
65.00	225.38	660.70	0.00	0.00
70.00	223.73	642.16	0.00	0.00
75.00	221.58	623.63	0.00	0.00
80.00	218.98	605.09	0.00	0.00
85.00	215.97	586.56	0.00	0.00
90.00	2,903.91	4,679.16	0.00	1,686.57
91.05	43.76	115.71	0.00	0.00
94.96	165.23	636.55	0.00	0.00
95.00	1.53	2.71	0.00	0.00
100.0	207.62	361.83	0.00	0.00
102.0	2,661.08	4,125.24	0.00	1,747.01
105.0	458.69	367.05	0.00	0.00
110.0	198.62	334.70	0.00	0.00
115.0	3,728.67	4,690.93	0.00	0.00
120.0	188.52	299.83	0.00	0.00
125.0	3,106.30	4,830.33	0.00	1,850.10
130.0	177.43	266.70	0.00	0.00
132.0	284.80	202.59	0.00	0.00
135.0	101.99	151.53	0.00	0.00
138.0	446.07	303.11	0.00	0.00
140.0	65.23	95.74	0.00	0.00
Totals:	18,574.95	35,675.93	0.00	5,283.68

Pole : CT23XC557_FX
 Location : Manchester, CT
 Height : 140.0 (ft)
 Base Dia : 43.00 (in)
 Top Dia : 18.00 (in)
 Shape : 18 Sides
 Taper : 0.185700 (in/ft)

Code: TIA/EIA-222 Rev F

Base Elev : 0.000 (ft)

© 2007 - 2014 by ATC IP LLC. All rights reserved.

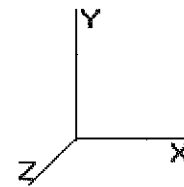

5/5/2014 4:13:18 PM

Page: 12

Load Case: Ice

69.28 mph Wind with Ice

26 Iterations

Gust Response Factor : 1.69
 Dead Load Factor : 1.00
 Wind Load Factor : 1.00

Calculated Shaft Forces and Deflections

Seg Elev (ft)	Lateral FX (-) (kips)	Axial FY (-) (kips)	Lateral FZ (kips)	Moment MX (ft-kips)	Torsion MY (ft-kips)	Moment MZ (ft-kips)	X Deflect (in)	Z Deflect (in)	Total Deflect (in)	Rotation (deg)
0.00	-18.647	-35.638	0.000	0.000	0.000	-1,925.258	0.000	0.000	0.000	0.000
5.00	-18.540	-34.552	0.000	0.000	0.000	-1,832.026	-0.123	0.000	0.123	-0.229
10.00	-18.431	-33.488	0.000	0.000	0.000	-1,739.331	-0.488	0.000	0.488	-0.462
15.00	-18.322	-32.446	0.000	0.000	0.000	-1,647.177	-1.098	0.000	1.098	-0.699
20.00	-18.212	-31.426	0.000	0.000	0.000	-1,555.569	-1.958	0.000	1.958	-0.938
25.00	-18.100	-30.429	0.000	0.000	0.000	-1,464.513	-3.071	0.000	3.071	-1.181
30.00	-17.988	-29.453	0.000	0.000	0.000	-1,374.014	-4.439	0.000	4.439	-1.426
35.00	-17.870	-28.500	0.000	0.000	0.000	-1,284.077	-6.064	0.000	6.064	-1.673
40.00	-17.744	-27.571	0.000	0.000	0.000	-1,194.727	-7.949	0.000	7.949	-1.922
45.00	-17.550	-26.703	0.000	0.000	0.000	-1,106.012	-10.096	0.000	10.096	-2.171
45.04	-17.606	-26.657	0.000	0.000	0.000	-1,105.252	-10.115	0.000	10.115	-2.174
49.96	-17.382	-25.253	0.000	0.000	0.000	-1,018.690	-12.483	0.000	12.483	-2.419
50.00	-17.443	-25.203	0.000	0.000	0.000	-1,017.995	-12.503	0.000	12.503	-2.421
55.00	-17.305	-24.432	0.000	0.000	0.000	-930.781	-15.189	0.000	15.189	-2.702
60.00	-17.159	-23.683	0.000	0.000	0.000	-844.260	-18.167	0.000	18.167	-2.980
65.00	-17.006	-22.955	0.000	0.000	0.000	-758.467	-21.434	0.000	21.434	-3.253
70.00	-16.847	-22.251	0.000	0.000	0.000	-673.438	-24.983	0.000	24.983	-3.520
75.00	-16.681	-21.570	0.000	0.000	0.000	-589.204	-28.806	0.000	28.806	-3.777
80.00	-16.508	-20.913	0.000	0.000	0.000	-505.801	-32.892	0.000	32.892	-4.022
85.00	-16.328	-20.281	0.000	0.000	0.000	-423.263	-37.225	0.000	37.225	-4.251
90.00	-13.110	-15.808	0.000	0.000	0.000	-339.939	-41.788	0.000	41.788	-4.459
91.05	-13.084	-15.675	0.000	0.000	0.000	-326.217	-42.769	0.000	42.769	-4.501
94.96	-12.887	-15.037	0.000	0.000	0.000	-274.974	-46.520	0.000	46.520	-4.646
95.00	-12.921	-15.004	0.000	0.000	0.000	-274.502	-46.556	0.000	46.556	-4.647
100.0	-12.727	-14.623	0.000	0.000	0.000	-209.900	-51.560	0.000	51.560	-4.903
102.0	-9.740	-10.725	0.000	0.000	0.000	-182.700	-53.632	0.000	53.632	-4.996
105.0	-9.278	-10.375	0.000	0.000	0.000	-153.481	-56.808	0.000	56.808	-5.120
110.0	-9.076	-10.037	0.000	0.000	0.000	-107.092	-62.260	0.000	62.260	-5.291
115.0	-4.935	-5.706	0.000	0.000	0.000	-61.712	-67.867	0.000	67.867	-5.416
120.0	-4.725	-5.420	0.000	0.000	0.000	-37.036	-73.578	0.000	73.578	-5.499
125.0	-1.169	-0.911	0.000	0.000	0.000	-11.559	-79.358	0.000	79.358	-5.547
130.0	-0.967	-0.662	0.000	0.000	0.000	-5.715	-85.168	0.000	85.168	-5.565
132.0	-0.664	-0.488	0.000	0.000	0.000	-3.781	-87.497	0.000	87.497	-5.570
135.0	-0.547	-0.347	0.000	0.000	0.000	-1.791	-90.993	0.000	90.993	-5.574
138.0	-0.074	-0.089	0.000	0.000	0.000	-0.148	-94.490	0.000	94.490	-5.576
140.0	-0.065	0.000	0.000	0.000	0.000	0.000	-96.822	0.000	96.822	-5.576

Pole : CT23XC557_FX
 Location : Manchester, CT
 Height : 140.0 (ft)
 Base Dia : 43.00 (in)
 Top Dia : 18.00 (in)
 Shape : 18 Sides
 Taper : 0.185700 (in/ft)

Code: TIA/EIA-222 Rev F

Base Elev : 0.000 (ft)

© 2007 - 2014 by ATC IP LLC. All rights reserved.

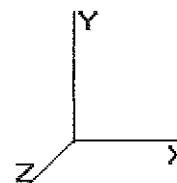

5/5/2014 4:13:18 PM

Page: 13

Load Case: Ice	69.28 mph Wind with Ice	26 Iterations
Gust Response Factor : 1.69		
Dead Load Factor : 1.00		
Wind Load Factor : 1.00		

Calculated Stresses

Seg Elev (ft)	Applied Stresses							Allowable Stress (Fb) (ksi)	Stress Ratio	
	Axial (Y) (ksi)	Shear (X) (ksi)	Shear (Z) (ksi)	Torsion (ksi)	Bending (X) (ksi)	Bending (Z) (ksi)	Combined (ksi)			
0.00	0.70	0.74	0.00	0.00	0.00	43.31	44.03	52.0	0.0	0.847
5.00	0.70	0.75	0.00	0.00	0.00	43.08	43.79	52.0	0.0	0.842
10.00	0.69	0.77	0.00	0.00	0.00	42.79	43.50	52.0	0.0	0.837
15.00	0.68	0.78	0.00	0.00	0.00	42.44	43.15	52.0	0.0	0.830
20.00	0.68	0.79	0.00	0.00	0.00	42.03	42.73	52.0	0.0	0.822
25.00	0.67	0.81	0.00	0.00	0.00	41.54	42.23	52.0	0.0	0.812
30.00	0.67	0.82	0.00	0.00	0.00	40.96	41.65	52.0	0.0	0.801
35.00	0.66	0.84	0.00	0.00	0.00	40.28	40.97	52.0	0.0	0.788
40.00	0.66	0.85	0.00	0.00	0.00	39.49	40.18	52.0	0.0	0.773
45.00	0.65	0.87	0.00	0.00	0.00	38.58	39.26	52.0	0.0	0.755
45.04	0.65	0.87	0.00	0.00	0.00	38.57	39.25	52.0	0.0	0.755
49.96	0.75	1.04	0.00	0.00	0.00	43.15	43.93	52.0	0.0	0.845
50.00	0.75	1.04	0.00	0.00	0.00	43.14	43.92	52.0	0.0	0.845
55.00	0.74	1.06	0.00	0.00	0.00	41.70	42.48	52.0	0.0	0.817
60.00	0.74	1.08	0.00	0.00	0.00	40.05	40.83	52.0	0.0	0.786
65.00	0.74	1.11	0.00	0.00	0.00	38.16	38.95	52.0	0.0	0.749
70.00	0.74	1.13	0.00	0.00	0.00	36.00	36.79	52.0	0.0	0.708
75.00	0.74	1.15	0.00	0.00	0.00	33.53	34.33	52.0	0.0	0.660
80.00	0.74	1.18	0.00	0.00	0.00	30.70	31.51	52.0	0.0	0.606
85.00	0.74	1.21	0.00	0.00	0.00	27.46	28.28	52.0	0.0	0.544
90.00	0.60	1.00	0.00	0.00	0.00	23.63	24.29	52.0	0.0	0.467
91.05	0.60	1.01	0.00	0.00	0.00	23.02	23.68	52.0	0.0	0.456
94.96	0.97	1.67	0.00	0.00	0.00	32.75	33.84	52.0	0.0	0.651
95.00	0.96	1.67	0.00	0.00	0.00	32.71	33.80	52.0	0.0	0.650
100.00	0.97	1.71	0.00	0.00	0.00	26.89	28.02	52.0	0.0	0.539
102.00	0.72	1.33	0.00	0.00	0.00	24.11	24.94	52.0	0.0	0.480
105.00	0.72	1.29	0.00	0.00	0.00	21.20	22.03	52.0	0.0	0.424
110.00	0.72	1.31	0.00	0.00	0.00	15.99	16.87	52.0	0.0	0.325
115.00	0.43	0.74	0.00	0.00	0.00	10.00	10.50	52.0	0.0	0.202
120.00	0.42	0.74	0.00	0.00	0.00	6.53	7.07	52.0	0.0	0.136
125.00	0.07	0.19	0.00	0.00	0.00	2.23	2.33	52.0	0.0	0.045
130.00	0.06	0.17	0.00	0.00	0.00	1.21	1.30	52.0	0.0	0.025
132.00	0.04	0.12	0.00	0.00	0.00	0.83	0.90	52.0	0.0	0.017
135.00	0.03	0.10	0.00	0.00	0.00	0.42	0.48	52.0	0.0	0.009
138.00	0.01	0.01	0.00	0.00	0.00	0.04	0.05	52.0	0.0	0.001
140.00	0.00	0.01	0.00	0.00	0.00	0.00	0.02	52.0	0.0	0.000

Pole : CT23XC557_FIX
 Location : Manchester, CT
 Height : 140.0 (ft)
 Base Dia : 43.00 (in)
 Top Dia : 18.00 (in)
 Shape : 18 Sides
 Taper : 0.185700 (in/ft)

Code: TIA/EIA-222 Rev F

Base Elev : 0.000 (ft)

© 2007 - 2014 by ATC IP LLC. All rights reserved.

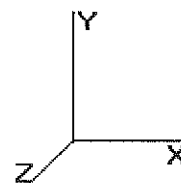

5/5/2014 4:13:18 PM

Page: 14

Load Case: Twist/Sway	50.00 mph Wind with No Ice	25 Iterations
Gust Response Factor : 1.69		
Dead Load Factor : 1.00		
Wind Load Factor : 1.00		

Shaft Segment Forces

Seg Top Elev (ft)	Description	Kz	qz (psf)	qzGh (psf)	C (mph-ft)	Cf	Ice Thick (in)	Tributary (ft)	Aa (sf)	CfAa (sf)	Wind Force X (lb)	Dead Load (lb)	Tot Dead Load (lb)	
0.00		0.00	1.00	6.400	10.81	179.16	0.650	0.000	0.00	0.000	0.00	0.0	0.0	
5.00		0.00	1.00	6.400	10.81	175.29	0.650	0.000	5.00	17.723	11.52	124.6	0.0	853.8
10.00		0.00	1.00	6.400	10.81	171.42	0.650	0.000	5.00	17.336	11.27	121.9	0.0	835.0
15.00		0.00	1.00	6.400	10.81	167.56	0.650	0.000	5.00	16.949	11.02	119.2	0.0	816.2
20.00		0.00	1.00	6.400	10.81	163.69	0.650	0.000	5.00	16.563	10.77	116.4	0.0	797.4
25.00		0.00	1.00	6.400	10.81	159.82	0.650	0.000	5.00	16.176	10.51	113.7	0.0	778.5
30.00		0.00	1.00	6.400	10.81	155.95	0.650	0.000	5.00	15.789	10.26	111.0	0.0	759.7
35.00		0.00	1.01	6.509	10.99	153.36	0.650	0.000	5.00	15.402	10.01	110.1	0.0	740.9
40.00		0.00	1.05	6.762	11.42	152.34	0.650	0.000	5.00	15.015	9.76	111.5	0.0	722.1
45.00		0.00	1.09	6.993	11.81	150.88	0.650	0.000	5.00	14.628	9.51	112.4	0.0	703.3
45.04	Bot - Section 2	0.00	1.09	6.995	11.82	150.87	0.650	0.000	0.04	0.125	0.08	1.0	0.0	6.0
49.96	Top - Section 1	0.00	1.12	7.205	12.17	149.08	0.650	0.000	4.92	14.260	9.27	112.9	0.0	1,245.5
50.00		0.00	1.12	7.207	12.17	151.83	0.650	0.000	0.04	0.114	0.07	0.9	0.0	4.6
55.00		0.00	1.15	7.406	12.51	149.75	0.650	0.000	5.00	14.115	9.17	114.8	0.0	566.4
60.00		0.00	1.18	7.592	12.83	147.41	0.650	0.000	5.00	13.728	8.92	114.5	0.0	550.7
65.00		0.00	1.21	7.768	13.12	144.84	0.650	0.000	5.00	13.341	8.67	113.8	0.0	535.0
70.00		0.00	1.24	7.934	13.40	142.08	0.650	0.000	5.00	12.954	8.42	112.9	0.0	519.4
75.00		0.00	1.26	8.092	13.67	139.13	0.650	0.000	5.00	12.567	8.17	111.7	0.0	503.7
80.00		0.00	1.28	8.242	13.93	136.03	0.650	0.000	5.00	12.181	7.92	110.3	0.0	488.0
85.00		0.00	1.31	8.387	14.17	132.79	0.650	0.000	5.00	11.794	7.67	108.6	0.0	472.4
90.00	Appertunance(s)	0.00	1.33	8.525	14.40	129.41	0.650	0.000	5.00	11.407	7.41	106.8	0.0	456.7
91.05	Bot - Section 3	0.00	1.33	8.553	14.45	128.69	0.650	0.000	1.05	2.339	1.52	22.0	0.0	93.6
94.96	Top - Section 2	0.00	1.35	8.656	14.62	125.94	0.650	0.000	3.92	8.724	5.67	83.0	0.0	554.7
95.00		0.00	1.35	8.657	14.63	127.73	0.650	0.000	0.04	0.081	0.05	0.8	0.0	1.9
100.0		0.00	1.37	8.785	14.84	124.14	0.650	0.000	5.00	10.789	7.01	104.1	0.0	260.3
102.0	Appertunance(s)	0.00	1.38	8.835	14.93	122.67	0.650	0.000	2.00	4.207	2.73	40.8	0.0	101.5
105.0	Appertunance(s)	0.00	1.39	8.908	15.05	120.44	0.650	0.000	3.00	6.195	4.03	60.6	0.0	149.4
110.0		0.00	1.41	9.028	15.25	116.65	0.650	0.000	5.00	10.016	6.51	99.3	0.0	241.5
115.0	Appertunance(s)	0.00	1.42	9.143	15.45	112.77	0.650	0.000	5.00	9.629	6.26	96.7	0.0	232.1
120.0		0.00	1.44	9.255	15.64	108.80	0.650	0.000	5.00	9.242	6.01	94.0	0.0	222.7
125.0	Appertunance(s)	0.00	1.46	9.363	15.82	104.76	0.650	0.000	5.00	8.855	5.76	91.1	0.0	213.3
130.0		0.00	1.48	9.469	16.00	100.64	0.650	0.000	5.00	8.468	5.50	88.1	0.0	203.9
132.0	Appertunance(s)	0.00	1.48	9.510	16.07	98.982	0.650	0.000	2.00	3.279	2.13	34.3	0.0	78.9
135.0		0.00	1.49	9.572	16.17	96.461	0.650	0.000	3.00	4.802	3.12	50.5	0.0	115.6
138.0	Appertunance(s)	0.00	1.50	9.632	16.27	93.917	0.650	0.000	3.00	4.663	3.03	49.3	0.0	112.2
140.0		0.00	1.51	9.672	16.34	92.208	0.650	0.000	2.00	3.031	1.97	32.2	0.0	72.9
Totals:								140.00			2,995.8	0.0	15,009.7	

Pole : CT23XC557_FIX
 Location : Manchester, CT
 Height : 140.0 (ft)
 Base Dia : 43.00 (in)
 Top Dia : 18.00 (in)
 Shape : 18 Sides
 Taper : 0.185700 (in/ft)

Code: TIA/EIA-222 Rev F

Base Elev : 0.000 (ft)

© 2007 - 2014 by ATC IP LLC. All rights reserved.

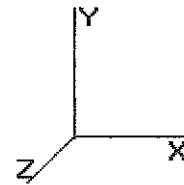

5/5/2014 4:13:18 PM
 Page: 15

Load Case: Twist/Sway 50.00 mph Wind with No Ice 25 Iterations

Gust Response Factor : 1.69
 Dead Load Factor : 1.00
 Wind Load Factor : 1.00

Discrete Appurtenance Segment Forces

Elev (ft)	Description	Qty	qz (psf)	qzGh (psf)	CaAa Factor	Total CaAa (sf)	Horiz Ecc (ft)	Vert Ecc (ft)	Wind FX (lb)	Mom Y (lb-ft)	Mom Z (lb-ft)	Dead Load (lb)
90.00	BXA-70063/6CF	3	8.525	14.407	0.70	16.24	0.000	0.000	233.89	0.00	0.00	51.00
90.00	FD9R6004-1C-3L	6	8.525	14.407	0.61	1.34	0.000	0.000	19.35	0.00	0.00	18.60
90.00	MG D3-900Tx	3	8.525	14.407	0.78	11.65	0.000	0.000	167.78	0.00	0.00	72.60
90.00	Platform w/Rail	1	8.565	14.475	1.00	35.85	0.000	1.500	518.92	0.00	778.38	2,500.00
90.00	SC-E 6014 rev2	6	8.525	14.407	0.97	20.68	0.000	0.000	297.91	0.00	0.00	90.00
102.0	DB844H90E-XY	12	8.835	14.931	0.91	40.76	0.000	0.000	608.66	0.00	0.00	168.00
102.0	Platform w/Rail	1	8.872	14.993	1.00	31.30	0.000	1.500	469.30	0.00	703.94	2,000.00
105.0	3 ft Standoff	2	8.908	15.055	1.00	5.26	0.000	0.000	79.19	0.00	0.00	80.00
105.0	5' x 3" Pipe Mounts	2	8.908	15.055	1.00	3.00	0.000	0.000	45.17	0.00	0.00	24.00
115.0	15 ft Low Profile pl	1	9.143	15.452	1.00	17.30	0.000	0.000	267.31	0.00	0.00	1,500.00
115.0	APXVSP18-C-A20	3	9.143	15.452	0.80	19.82	0.000	0.000	306.31	0.00	0.00	171.00
115.0	APXVTM14-C-I20	3	9.143	15.452	0.76	14.66	0.000	0.000	226.53	0.00	0.00	164.70
115.0	Collar Mount	1	9.143	15.452	1.00	5.00	0.000	0.000	77.26	0.00	0.00	250.00
115.0	DAP Heads	3	9.143	15.452	0.89	6.54	0.000	0.000	101.08	0.00	0.00	105.00
115.0	LLPX310R	3	9.143	15.452	0.69	10.01	0.000	0.000	154.68	0.00	0.00	85.80
115.0	RRH-2X50-800	3	9.143	15.452	1.00	7.44	0.000	0.000	114.96	0.00	0.00	192.00
115.0	RRH-4X40-1900	3	9.143	15.452	1.00	8.67	0.000	0.000	133.97	0.00	0.00	273.00
115.0	TD-RRH-8X20-25	3	9.143	15.452	0.68	9.79	0.000	0.000	151.30	0.00	0.00	210.00
115.0	VHLP1	1	9.143	15.452	0.75	0.75	0.000	0.000	11.59	0.00	0.00	20.00
115.0	VHLP2	1	9.143	15.452	0.75	2.97	0.000	0.000	45.89	0.00	0.00	90.00
125.0	800 10121	3	9.363	15.824	0.79	12.94	0.000	0.000	204.77	0.00	0.00	132.30
125.0	860 10025	6	9.363	15.824	0.92	0.98	0.000	0.000	15.46	0.00	0.00	6.94
125.0	AM-X-WM-17-65-00T	6	9.363	15.824	0.70	12.92	0.000	0.000	204.50	0.00	0.00	85.20
125.0	DC6-48-60-18-8F	1	9.363	15.824	1.00	2.56	0.000	0.000	40.51	0.00	0.00	32.80
125.0	DTMA 1819VG12A	6	9.363	15.824	0.69	4.78	0.000	0.000	75.60	0.00	0.00	79.80
125.0	Platform w/Rail	1	9.395	15.878	1.00	31.30	0.000	1.500	496.99	0.00	745.48	2,000.00
125.0	RRUS11	6	9.363	15.824	0.73	14.26	0.000	0.000	225.67	0.00	0.00	306.00
132.0	5 ft Standoff	1	9.510	16.073	1.00	3.50	0.000	0.000	56.25	0.00	0.00	53.32
132.0	5' x 2" Pipe Mount	1	9.510	16.073	1.00	1.20	0.000	0.000	19.29	0.00	0.00	10.00
138.0	3 ft Standoff	2	9.632	16.278	1.00	5.26	0.000	0.000	85.62	0.00	0.00	80.00
138.0	5' x 2" Pipe Mounts	2	9.632	16.278	1.00	2.40	0.000	0.000	39.07	0.00	0.00	20.00
									5,494.78			10,872.06

Pole : CT23XC557_FX
 Location : Manchester, CT
 Height : 140.0 (ft)
 Base Dia : 43.00 (in)
 Top Dia : 18.00 (in)
 Shape : 18 Sides
 Taper : 0.185700 (in/ft)

Code: TIA/EIA-222 Rev F

Base Elev : 0.000 (ft)

© 2007 - 2014 by ATC IP LLC. All rights reserved.

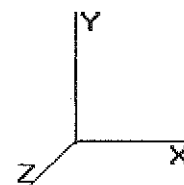

5/5/2014 4:13:18 PM
 Page: 16

Load Case: Twist/Sway 50.00 mph Wind with No Ice 25 Iterations

Gust Response Factor : 1.69
 Dead Load Factor : 1.00
 Wind Load Factor : 1.00

Applied Segment Forces Summary

Seg Elev (ft)	Lateral FX (-) (lb)	Axial FY (-) (lb)	Torsion MY (lb-ft)	Moment MZ (lb-ft)
0.00	0.00	0.00	0.00	0.00
5.00	124.60	880.50	0.00	0.00
10.00	121.88	861.70	0.00	0.00
15.00	119.16	842.89	0.00	0.00
20.00	116.44	824.09	0.00	0.00
25.00	113.72	805.29	0.00	0.00
30.00	111.00	786.49	0.00	0.00
35.00	110.12	767.68	0.00	0.00
40.00	111.53	748.88	0.00	0.00
45.00	112.37	730.08	0.00	0.00
45.04	0.96	6.25	0.00	0.00
49.96	112.86	1,271.76	0.00	0.00
50.00	0.91	4.81	0.00	0.00
55.00	114.83	593.12	0.00	0.00
60.00	114.49	577.45	0.00	0.00
65.00	113.84	561.78	0.00	0.00
70.00	112.90	546.12	0.00	0.00
75.00	111.71	530.45	0.00	0.00
80.00	110.29	514.78	0.00	0.00
85.00	108.65	499.11	0.00	0.00
90.00	1,344.67	3,215.64	0.00	778.38
91.05	21.97	98.13	0.00	0.00
94.96	82.96	571.62	0.00	0.00
95.00	0.77	2.10	0.00	0.00
100.0	104.12	281.82	0.00	0.00
102.0	1,118.79	2,278.10	0.00	703.94
105.0	184.98	264.76	0.00	0.00
110.0	99.32	260.42	0.00	0.00
115.0	1,687.59	3,312.52	0.00	0.00
120.0	93.96	231.28	0.00	0.00
125.0	1,354.59	2,864.92	0.00	745.48
130.0	88.08	203.88	0.00	0.00
132.0	109.80	142.24	0.00	0.00
135.0	50.49	115.56	0.00	0.00
138.0	174.03	212.17	0.00	0.00
140.0	32.21	72.90	0.00	0.00
Totals:	8,490.57	26,481.27	0.00	2,227.81

Pole : CT23XC557_FX
 Location : Manchester, CT
 Height : 140.0 (ft)
 Base Dia : 43.00 (in)
 Top Dia : 18.00 (in)
 Shape : 18 Sides
 Taper : 0.185700 (in/ft)

Code: TIA/EIA-222 Rev F

5/5/2014 4:13:18 PM

Page: 17

Base Elev : 0.000 (ft)

© 2007 - 2014 by ATC IP LLC. All rights reserved.

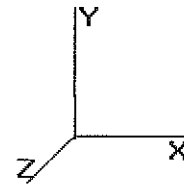
**Load Case:** Twist/Sway

50.00 mph Wind with No Ice

25 Iterations

Gust Response Factor : 1.69

Dead Load Factor : 1.00

Wind Load Factor : 1.00

Calculated Shaft Forces and Deflections

Seg Elev (ft)	Lateral FX (-) (kips)	Axial FY (-) (kips)	Lateral FZ (kips)	Moment MX (ft-kips)	Torsion MY (ft-kips)	Moment MZ (ft-kips)	X Deflect (in)	Z Deflect (in)	Total Deflect (in)	Rotation (deg)
0.00	-8.513	-26.474	0.000	0.000	0.000	-846.293	0.000	0.000	0.000	0.000
5.00	-8.433	-25.578	0.000	0.000	0.000	-803.727	-0.054	0.000	0.054	-0.101
10.00	-8.353	-24.702	0.000	0.000	0.000	-761.562	-0.214	0.000	0.214	-0.203
15.00	-8.274	-23.845	0.000	0.000	0.000	-719.797	-0.482	0.000	0.482	-0.306
20.00	-8.194	-23.006	0.000	0.000	0.000	-678.429	-0.859	0.000	0.859	-0.411
25.00	-8.115	-22.187	0.000	0.000	0.000	-637.458	-1.346	0.000	1.346	-0.517
30.00	-8.036	-21.387	0.000	0.000	0.000	-596.883	-1.944	0.000	1.944	-0.623
35.00	-7.956	-20.605	0.000	0.000	0.000	-556.702	-2.654	0.000	2.654	-0.730
40.00	-7.871	-19.843	0.000	0.000	0.000	-516.924	-3.476	0.000	3.476	-0.838
45.00	-7.766	-19.108	0.000	0.000	0.000	-477.567	-4.412	0.000	4.412	-0.946
45.04	-7.783	-19.094	0.000	0.000	0.000	-477.231	-4.420	0.000	4.420	-0.947
49.96	-7.664	-17.818	0.000	0.000	0.000	-438.967	-5.452	0.000	5.452	-1.053
50.00	-7.682	-17.805	0.000	0.000	0.000	-438.661	-5.460	0.000	5.460	-1.054
55.00	-7.592	-17.198	0.000	0.000	0.000	-400.250	-6.629	0.000	6.629	-1.175
60.00	-7.499	-16.608	0.000	0.000	0.000	-362.292	-7.923	0.000	7.923	-1.294
65.00	-7.405	-16.034	0.000	0.000	0.000	-324.796	-9.342	0.000	9.342	-1.411
70.00	-7.308	-15.477	0.000	0.000	0.000	-287.773	-10.881	0.000	10.881	-1.525
75.00	-7.210	-14.936	0.000	0.000	0.000	-251.233	-12.538	0.000	12.538	-1.635
80.00	-7.110	-14.412	0.000	0.000	0.000	-215.185	-14.307	0.000	14.307	-1.739
85.00	-7.008	-13.905	0.000	0.000	0.000	-179.637	-16.181	0.000	16.181	-1.837
90.00	-5.568	-10.731	0.000	0.000	0.000	-143.819	-18.153	0.000	18.153	-1.925
91.05	-5.550	-10.629	0.000	0.000	0.000	-137.991	-18.577	0.000	18.577	-1.943
94.96	-5.453	-10.058	0.000	0.000	0.000	-116.252	-20.197	0.000	20.197	-2.004
95.00	-5.462	-10.051	0.000	0.000	0.000	-116.052	-20.212	0.000	20.212	-2.005
100.0	-5.361	-9.766	0.000	0.000	0.000	-88.741	-22.371	0.000	22.371	-2.113
102.0	-4.164	-7.528	0.000	0.000	0.000	-77.316	-23.265	0.000	23.265	-2.152
105.0	-3.977	-7.266	0.000	0.000	0.000	-64.825	-24.634	0.000	24.634	-2.204
110.0	-3.875	-7.005	0.000	0.000	0.000	-44.941	-26.983	0.000	26.983	-2.277
115.0	-2.058	-3.762	0.000	0.000	0.000	-25.566	-29.397	0.000	29.397	-2.329
120.0	-1.957	-3.534	0.000	0.000	0.000	-15.274	-31.855	0.000	31.855	-2.363
125.0	-0.485	-0.727	0.000	0.000	0.000	-4.744	-34.341	0.000	34.341	-2.382
130.0	-0.389	-0.527	0.000	0.000	0.000	-2.320	-36.840	0.000	36.840	-2.390
132.0	-0.273	-0.390	0.000	0.000	0.000	-1.543	-37.842	0.000	37.842	-2.392
135.0	-0.218	-0.276	0.000	0.000	0.000	-0.724	-39.345	0.000	39.345	-2.394
138.0	-0.035	-0.071	0.000	0.000	0.000	-0.070	-40.849	0.000	40.849	-2.394
140.0	-0.032	0.000	0.000	0.000	0.000	0.000	-41.851	0.000	41.851	-2.395

Pole : CT23XC557_FX
 Location : Manchester, CT
 Height : 140.0 (ft)
 Base Dia : 43.00 (in)
 Top Dia : 18.00 (in)
 Shape : 18 Sides
 Taper : 0.185700 (in/ft)

Code: TIA/EIA-222 Rev F

Base Elev : 0.000 (ft)

© 2007 - 2014 by ATC IP LLC. All rights reserved.

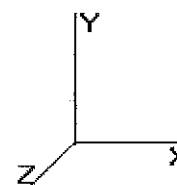

5/5/2014 4:13:18 PM

Page: 18

Load Case: Twist/Sway 50.00 mph Wind with No Ice 25 Iterations

Gust Response Factor : 1.69
 Dead Load Factor : 1.00
 Wind Load Factor : 1.00

Calculated Stresses

Seg Elev (ft)	Applied Stresses							Combined (ksi)	Allowable Stress (Fb) (ksi)	Stress Ratio
	Axial (Y) (ksi)	Shear (X) (ksi)	Shear (Z) (ksi)	Torsion (ksi)	Bending (X) (ksi)	Bending (Z) (ksi)				
0.00	0.52	0.34	0.00	0.00	0.00	19.04	19.57	52.0	0.0	0.376
5.00	0.52	0.34	0.00	0.00	0.00	18.90	19.42	52.0	0.0	0.374
10.00	0.51	0.35	0.00	0.00	0.00	18.74	19.25	52.0	0.0	0.370
15.00	0.50	0.35	0.00	0.00	0.00	18.55	19.06	52.0	0.0	0.367
20.00	0.50	0.36	0.00	0.00	0.00	18.33	18.84	52.0	0.0	0.362
25.00	0.49	0.36	0.00	0.00	0.00	18.08	18.58	52.0	0.0	0.357
30.00	0.48	0.37	0.00	0.00	0.00	17.79	18.29	52.0	0.0	0.352
35.00	0.48	0.37	0.00	0.00	0.00	17.46	17.95	52.0	0.0	0.345
40.00	0.47	0.38	0.00	0.00	0.00	17.09	17.57	52.0	0.0	0.338
45.00	0.47	0.38	0.00	0.00	0.00	16.66	17.14	52.0	0.0	0.330
45.04	0.47	0.38	0.00	0.00	0.00	16.65	17.13	52.0	0.0	0.330
49.96	0.53	0.46	0.00	0.00	0.00	18.59	19.14	52.0	0.0	0.368
50.00	0.53	0.46	0.00	0.00	0.00	18.59	19.13	52.0	0.0	0.368
55.00	0.52	0.47	0.00	0.00	0.00	17.93	18.47	52.0	0.0	0.355
60.00	0.52	0.47	0.00	0.00	0.00	17.18	17.72	52.0	0.0	0.341
65.00	0.52	0.48	0.00	0.00	0.00	16.34	16.88	52.0	0.0	0.325
70.00	0.51	0.49	0.00	0.00	0.00	15.38	15.92	52.0	0.0	0.306
75.00	0.51	0.50	0.00	0.00	0.00	14.30	14.83	52.0	0.0	0.285
80.00	0.51	0.51	0.00	0.00	0.00	13.06	13.60	52.0	0.0	0.262
85.00	0.51	0.52	0.00	0.00	0.00	11.66	12.20	52.0	0.0	0.235
90.00	0.41	0.43	0.00	0.00	0.00	10.00	10.43	52.0	0.0	0.201
91.05	0.41	0.43	0.00	0.00	0.00	9.74	10.17	52.0	0.0	0.196
94.96	0.65	0.71	0.00	0.00	0.00	13.84	14.54	52.0	0.0	0.280
95.00	0.65	0.71	0.00	0.00	0.00	13.83	14.53	52.0	0.0	0.279
100.00	0.65	0.72	0.00	0.00	0.00	11.37	12.08	52.0	0.0	0.232
102.00	0.51	0.57	0.00	0.00	0.00	10.20	10.76	52.0	0.0	0.207
105.00	0.50	0.55	0.00	0.00	0.00	8.95	9.50	52.0	0.0	0.183
110.00	0.50	0.56	0.00	0.00	0.00	6.71	7.28	52.0	0.0	0.140
115.00	0.28	0.31	0.00	0.00	0.00	4.14	4.46	52.0	0.0	0.086
120.00	0.28	0.31	0.00	0.00	0.00	2.69	3.02	52.0	0.0	0.058
125.00	0.06	0.08	0.00	0.00	0.00	0.91	0.98	52.0	0.0	0.019
130.00	0.05	0.07	0.00	0.00	0.00	0.49	0.55	52.0	0.0	0.011
132.00	0.03	0.05	0.00	0.00	0.00	0.34	0.38	52.0	0.0	0.007
135.00	0.02	0.04	0.00	0.00	0.00	0.17	0.21	52.0	0.0	0.004
138.00	0.01	0.01	0.00	0.00	0.00	0.02	0.03	52.0	0.0	0.001
140.00	0.00	0.01	0.00	0.00	0.00	0.00	0.01	52.0	0.0	0.000

Pole : CT23XC557_FIX
 Location : Manchester, CT
 Height : 140.0 (ft)
 Base Dia : 43.00 (in)
 Top Dia : 18.00 (in)
 Shape : 18 Sides
 Taper : 0.185700 (in/ft)

Code: TIA/EIA-222 Rev F

Base Elev : 0.000 (ft)

© 2007 - 2014 by ATC IP LLC. All rights reserved.

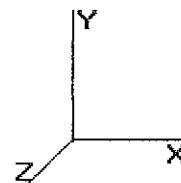

5/5/2014 4:13:18 PM

Page: 19

Analysis Summary

Load Case	Reactions						Max Stresses			
	Shear FX (kips)	Shear FZ (kips)	Axial FY (kips)	Moment MX (ft-kips)	Moment MY (ft-kips)	Moment MZ (ft-kips)	Combined Stress (ksi)	Allowable Stress (ksi)	Elev (ft)	Stress Ratio
No Ice	21.8	0.00	26.43	0.00	0.00	2163.40	49.21	52.0	0.00	0.947
Ice	18.6	0.00	35.64	0.00	0.00	1925.26	44.03	52.0	0.00	0.847
Twist/Sway	8.5	0.00	26.47	0.00	0.00	846.29	19.57	52.0	0.00	0.376



**RADIO FREQUENCY FCC REGULATORY COMPLIANCE
MAXIMUM PERMISSIBLE EXPOSURE (MPE) ASSESSMENT**

Sprint Existing Facility

Site ID: CT23XC557

Manchester / Bill Thornton

**60 Adams Street
Manchester, CT 06040**

June 3, 2014

EBI Project Number: 62143131



June 3, 2014

Sprint
Attn: RF Engineering Manager
1 International Boulevard, Suite 800
Mahwah, NJ 07495

Re: Radio Frequency Maximum Permissible Exposure (MPE) Assessment for Site:
CT23XC557 - Manchester / Bill Thornton

Site Total: 66.28% - MPE% in full compliance

EBI Consulting was directed to analyze the proposed upgrades to the existing Sprint facility located at 60 Adams Street, Manchester, CT, for the purpose of determining whether the radio frequency (RF) exposure levels from the proposed Sprint equipment upgrades on this property are within specified federal limits.

All information used in this report was analyzed as a percentage of current Maximum Permissible Exposure (% MPE) as listed in the FCC OET Bulletin 65 Edition 97-01 and ANSI/IEEE Std C95.1. The FCC regulates Maximum Permissible Exposure in units of microwatts per square centimeter ($\mu\text{W}/\text{cm}^2$). The number of $\mu\text{W}/\text{cm}^2$ calculated at each sample point is called the power density. The exposure limit for power density varies depending upon the frequencies being utilized. Wireless Carriers and Paging Services use different frequency bands each with different exposure limits, therefore it is necessary to report results and limits in terms of percent MPE rather than power density.

All results were compared to the FCC (Federal Communications Commission) radio frequency exposure rules, 47 CFR 1.1307(b)(1) – (b)(3), to determine compliance with the Maximum Permissible Exposure (MPE) limits for General Population/Uncontrolled environments as defined below.

General population/uncontrolled exposure limits apply to situations in which the general public may be exposed or in which persons who are exposed as a consequence of their employment may not be made fully aware of the potential for exposure or cannot exercise control over their exposure. Therefore, members of the general public would always be considered under this category when exposure is not employment related, for example, in the case of a telecommunications tower that exposes persons in a nearby residential area.

Public exposure to radio frequencies is regulated and enforced in units of microwatts per square centimeter ($\mu\text{W}/\text{cm}^2$). The general population exposure limit for the cellular band (850 MHz Band) is approximately $567 \mu\text{W}/\text{cm}^2$, and the general population exposure limit for the 1900 MHz and 2500 MHz bands is $1000 \mu\text{W}/\text{cm}^2$. Because each carrier will be using different frequency bands, and each frequency band has different exposure limits, it is necessary to report percent of MPE rather than power density.



Occupational/controlled exposure limits apply to situations in which persons are exposed as a consequence of their employment and in which those persons who are exposed have been made fully aware of the potential for exposure and can exercise control over their exposure. Occupational/controlled exposure limits also apply where exposure is of a transient nature as a result of incidental passage through a location where exposure levels may be above general population/uncontrolled limits (see below), as long as the exposed person has been made fully aware of the potential for exposure and can exercise control over his or her exposure by leaving the area or by some other appropriate means.

Additional details can be found in FCC OET 65.

CALCULATIONS

Calculations were done for the proposed upgrades to the existing Sprint Wireless antenna facility located at 60 Adams Street, Manchester, CT, using the equipment information listed below. All calculations were performed per the specifications under FCC OET 65. All calculations were performed assuming a lobe representing the maximum gain of the antenna per the antenna manufactures supplied specifications, minus 10 dB, was focused at the base of the tower. For this report the sample point is the top of a 6 foot person standing at the base of the tower.

For all calculations, all emissions were calculated using the following assumptions:

- 1) 4 channels in the 1900 MHz Band were considered for each sector of the proposed installation.
- 2) 1 channel in the 800 MHz Band was considered for each sector of the proposed installation
- 3) 2 channels in the 2500 MHz Band were considered for each sector of the proposed installation.
- 4) All radios at the proposed installation were considered to be running at full power and were uncombined in their RF transmissions paths per carrier prescribed configuration. Per FCC OET Bulletin No. 65 - Edition 97-01 recommendations to achieve the maximum anticipated value at each sample point, all power levels emitting from the proposed antenna installation are increased by a factor of 2.56 to account for possible in-phase reflections from the surrounding environment. This is rarely the case, and if so, is never continuous.
- 5) For the following calculations the sample point was the top of a six foot person standing at the base of the tower. The maximum gain of the antenna per the antenna manufactures supplied specifications minus 10 dB was used in this direction. This value is a very conservative estimate as gain reductions for these particular antennas are typically much higher in this direction.



- 6) The antennas used in this modeling are the RFS APXVSPP18-C-A20 and the RFS APXVTM14-C-I20. This is based on feedback from the carrier with regards to anticipated antenna selection. The RFS APXVSPP18-C-A20 has a 15.9 dBd gain value at its main lobe at 1900 MHz and 13.4 dBd at its main lobe for 850 MHz. The RFS APXVTM14-C-I20 has a 15.9 dBd gain value at its main lobe at 2500 MHz. The maximum gain of the antenna per the antenna manufactures supplied specifications, minus 10 dB, was used for all calculations. This value is a very conservative estimate as gain reductions for these particular antennas are typically much higher in this direction.
- 7) The antenna mounting height centerline for the proposed antennas is **115 feet** above ground level (AGL).
- 8) Emissions values for additional carriers were taken from the Connecticut Siting Council active database. Values in this database are provided by the individual carriers themselves.

All calculation were done with respect to uncontrolled / general public threshold limits

Site ID	CT23XC557 - Manchester / Bill Thornton
Site Address	60 Adams Street, Manchester, CT, 06040
Site Type	Monopole

Sector 1																
Antenna Number	Antenna Make	Antenna Model	Radio Type	Frequency Band	Technology	Power Out Per Channel (Watts)	Number of Channels	Composite Power	Antenna Gain (10 db reduction)	Antenna Height (ft)	Antenna analysis height	Cable Size	Cable Loss (dB)	Additional Loss (dB)	ERP	Power Density Percentage
1a	RFS	APXVSP18-C-A20	RRH	1900 MHz	CDMA / LTE	20	4	80	5.9	115	109	1/2"	0.5	3	139.02	0.42%
1a	RFS	APXVSP18-C-A20	RRH	850 MHz	CDMA / LTE	20	1	20	3.4	115	109	1/2"	0.5	3	19.54	0.10%
1B	RFS	APXVTM14-C-120	RRH	2500 MHz	CDMA / LTE	20	2	40	5.9	115	109	1/2"	0.5	3	69.51	0.37%
											Sector total Power Density Value: 0.90%					

Sector 2																
Antenna Number	Antenna Make	Antenna Model	Radio Type	Frequency Band	Technology	Power Out Per Channel (Watts)	Number of Channels	Composite Power	Antenna Gain (10 db reduction)	Antenna Height (ft)	Antenna analysis height	Cable Size	Cable Loss (dB)	Additional Loss (dB)	ERP	Power Density Percentage
2a	RFS	APXVSP18-C-A20	RRH	1900 MHz	CDMA / LTE	20	4	80	5.9	115	109	1/2"	0.5	3	139.02	0.42%
2a	RFS	APXVSP18-C-A20	RRH	850 MHz	CDMA / LTE	20	1	20	3.4	115	109	1/2"	0.5	3	19.54	0.10%
2B	RFS	APXVTM14-C-120	RRH	2500 MHz	CDMA / LTE	20	2	40	5.9	115	109	1/2"	0.5	3	69.51	0.37%
											Sector total Power Density Value: 0.90%					

Sector 3																
Antenna Number	Antenna Make	Antenna Model	Radio Type	Frequency Band	Technology	Power Out Per Channel (Watts)	Number of Channels	Composite Power	Antenna Gain (10 db reduction)	Antenna Height (ft)	Antenna analysis height	Cable Size	Cable Loss (dB)	Additional Loss (dB)	ERP	Power Density Percentage
3a	RFS	APXVSP18-C-A20	RRH	1900 MHz	CDMA / LTE	20	4	80	5.9	115	109	1/2"	0.5	3	139.02	0.42%
3a	RFS	APXVSP18-C-A20	RRH	850 MHz	CDMA / LTE	20	1	20	3.4	115	109	1/2"	0.5	3	19.54	0.10%
3B	RFS	APXVTM14-C-120	RRH	2500 MHz	CDMA / LTE	20	2	40	5.9	115	109	1/2"	0.5	3	69.51	0.37%
											Sector total Power Density Value: 0.90%					

Site Composite MPE %	
Carrier	MPE %
Sprint	2.69%
AT&T	2.50%
Nextel	5.70%
PageNet	3.99%
Verizon Wireless	49.99%
Clearwire	1.41%
Total Site MPE %	66.28%



Summary

All calculations performed for this analysis yielded results that were well within the allowable limits for general public Maximum Permissible Exposure (MPE) to radio frequency energy.

The anticipated Maximum Composite contributions from the Sprint facility are **2.69% (0.90% from sector 1, 0.90% from sector 2 and 0.90% from sector 3)** of the allowable FCC established general public limit considering all three sectors simultaneously sampled at the ground level.

The anticipated composite MPE value for this site assuming all carriers present is **66.28%** of the allowable FCC established general public limit sampled at 6 feet above ground level. This total composite site value is based upon MPE values listed in the Connecticut Siting Council database for existing carrier emissions.

FCC guidelines state that if a site is found to be out of compliance (over allowable thresholds), that carriers over a 5% contribution to the composite value will require measures to bring the site into compliance. For this facility, the composite values calculated were well within the allowable 100% threshold standard per the federal government.

A handwritten signature in black ink, appearing to read "Scott Heffernan", is written over a horizontal line.

Scott Heffernan
RF Engineering Director

EBI Consulting
21 B Street
Burlington, MA 01803