



Crown Castle
3 Corporate Park Drive, Suite 101
Clifton Park, NY 12065

August 31, 2017

Melanie A. Bachman
Acting Executive Director
Connecticut Siting Council
10 Franklin Square
New Britain, CT 06051

RE: Notice of Exempt Modification for Sprint/ Crown Site BU: 846176
Sprint PCS Site ID: CT33XC540
1749 Durham Road, Madison, CT 06443
Latitude: 41° 23' 22.3"/ Longitude: -72° 38' 56"

Dear Ms. Bachman:

Sprint currently maintains three (3) antennas at the 106-foot level of the existing 119-foot monopole tower at 1749 Durham Road in Madison, Connecticut. The tower is owned by Crown Castle. The property is owned by the South Central Connecticut Regional Water Authority. Sprint intends to install (3) antennas and (3) RRUs with (1) hybrid cable.

This facility was approved by the Council on August 26, 2004, Docket No. 290, subject to the following conditions:

1. The tower shall be constructed as a monopole, no taller than necessary to provide the proposed telecommunications services, sufficient to accommodate the antennas of AT&T Wireless and other entities, both public and private, but such tower shall not exceed a height of 120 feet above ground level. The height at the top of the antennas shall not exceed 123 feet above ground level. The tower and tower foundation shall be of sufficient capacity to support a tower extension to 150 feet above ground level.
2. The Certificate Holder shall prepare a Development and Management (D&M) Plan for this site in compliance with Sections 16-50j-75 through 16-50j-77 of the Regulations of Connecticut State Agencies. The D&M Plan shall be served on the Town of Madison, and all parties and intervenors as listed in the service list, and submitted to and approved by the Council prior to the commencement of facility construction and shall include:
 - a. a final site plan(s) of site development to include specifications for the tower, tower foundation, antennas, equipment building, relocated access road, utility line, and landscaping; and

- b. construction plans for site clearing, water drainage, and erosion and sedimentation control consistent with the 2002 Connecticut Guidelines for Soil Erosion and Sediment Control, as amended.
3. The Certificate Holder shall, prior to the commencement of operation, provide the Council worst-case modeling of electromagnetic radio frequency power density of all proposed entities' antennas at the closest point of uncontrolled access to the tower base, consistent with Federal Communications Commission, Office of Engineering and Technology, Bulletin No. 65, August 1997. The Certificate Holder shall ensure a recalculated report of electromagnetic radio frequency power density is submitted to the Council in the event other carriers locate at this facility or if circumstances in equipment operation cause a change in power density above the levels calculated and provided pursuant to this Decision and Order.
4. Upon the establishment of any new State or federal radio frequency standards applicable to frequencies of this facility, the facility granted herein shall be brought into compliance with such standards.
5. The Certificate Holder shall permit public or private entities to share space on the proposed tower for fair consideration, or shall provide any requesting entity with specific legal, technical, environmental, or economic reasons precluding such tower sharing.
6. The Certificate Holder shall provide reasonable space on the tower for no compensation for any municipal antennas, provided such antennas are compatible with the structural integrity of the tower.
7. If the facility does not initially provide wireless services within one year of completion of construction or ceases to provide wireless services for a period of one year, this Decision and Order shall be void, and the Certificate Holder shall dismantle the tower and remove all associated equipment or reapply for any continued or new use to the Council before any such use is made.
8. Any antenna that becomes obsolete and ceases to function shall be removed within 60 days after such antennas become obsolete and cease to function.
9. Unless otherwise approved by the Council, this Decision and Order shall be void if the facility authorized herein is not operational within one year of the effective date of this Decision and Order or within one year after all appeals to this Decision and Order have been resolved. Any request for extension of this period shall be filed with the Council not

later than sixty days prior to expiration date of this Certificate and shall be served on all parties and intervenors and the Town of Madison, as listed in the service list. Any proposed modifications to this Decision and Order shall likewise be so served.

Please accept this letter as notification pursuant to Regulations of Connecticut State Agencies § 16-50j-73, for construction that constitutes an exempt modification pursuant to R.C.S.A. § 16-50j-72(b)(2). In accordance with R.S.C.A. § 16-50j-73, a copy of this letter is being sent The Honorable Tom Banisch, First Selectman of the Town of Madison, the Town Planner David Anderson, and to the land owner the South Central Connecticut Regional Water Authority. Crown Castle is the tower owner.

1. The proposed modifications will not result in an increase in the height of the existing tower.
2. The proposed modifications will not require the extension of the site boundary.
3. The proposed modification will not increase noise levels at the facility by six decibels or more, or to levels that exceed state and local criteria.
4. The operation of the replacement antennas will not increase radio frequency emissions at the facility to a level at or above the Federal Communication Commission safety standard.
5. The proposed modifications will not cause a change or alteration in the physical or environmental characteristics of the site.
6. The existing structure and its foundation can support the proposed loading.

For the foregoing reasons, Sprint respectfully submits that the proposed modifications to the above-reference telecommunications facility constitutes an exempt modification under R.C.S.A. § 16-50j-72(b)(2). Please send approval/rejection letter to Attn: Jeffrey Barbadora.

Sincerely,

Jeffrey Barbadora
Real Estate Specialist
12 Gill Street, Suite 5800, Woburn, MA 01801
781-729-0053
Jeff.Barbadora@crowncastle.com

Melanie A. Bachman

August 31, 2017

Page 4

Attachments:

Tab 1: Exhibit-1: Compound plan and elevation depicting the planned changes

Tab 2: Exhibit-2: Structural Modification Report

Tab 3: Exhibit-3: General Power Density Table Report (RF Emissions Analysis Report)

cc: Tom Banisch, First Selectman
Town of Madison
8 Campus Drive
Madison, CT 06443

David Anderson, Town Planner
Town of Madison
8 Campus Drive
Madison, CT 06443

South Central Connecticut Regional Water Authority
Attn: Dianne L. Tompkins, Senior Land Use Manager
30 Sargent Drive
New Haven, CT 06511-5966



A
846176

Nathan Pond

Dudley Pond

Legend

Crown Internal Sites Layer

 Tower  DAS NODE  DAS HUB  DAS SYSTEM  Land Under

Alternative Crown Sites

 Alternative Crown Sites

1749 DURHAM RD

Location 1749 DURHAM RD

Mblu 154/ 3/ / /

Acct# 00722900

Owner SOUTH CENTRAL
CONNECTICUT REGIONAL
WATER

Assessment \$136,200

Appraisal \$840,500

PID 7618

Building Count 1

Current Value

Appraisal			
Valuation Year	Improvements	Land	Total
2015	\$0	\$840,500	\$840,500

Assessment			
Valuation Year	Improvements	Land	Total
2015	\$0	\$136,200	\$136,200

Owner of Record

Owner SOUTH CENTRAL CONNECTICUT REGIONAL WATER
Co-Owner AUTHORITY

Sale Price \$0
Certificate
Book & Page 1761/ 176
Sale Date 01/06/2012
Instrument 28

Ownership History

Ownership History					
Owner	Sale Price	Certificate	Book & Page	Instrument	Sale Date
SOUTH CENTRAL CONNECTICUT REGIONAL WATER	\$0		1761/ 176	28	01/06/2012
RUGE ANITA	\$0		1761/ 172	01	01/06/2012
RUGE FRIEDA L/U & ANITA S REMAINDER	\$0		1755/ 158	01	12/02/2011
RUGE FRIEDA L/U& FRED& ANITA S REMAINDER	\$0		1504/ 164	25	04/12/2007
RUGE FRIEDA L/U &FRED& ANITA S REMAINDER	\$0		466/ 239	00	06/20/1991

Building Information

Building 1 : Section 1

Year Built:

Living Area: 0

Building Attributes

Field	Description
Style	Outbuildings
Model	
Stories:	
Heat Fuel	
Heat Type:	
AC Type:	
Total Bedrooms:	
Total Bthrms:	
Total Half Baths:	
Total Xtra Fixtrs:	
Total Rooms:	
Fireplace(s)	
Xtra FPL Open	

Building Photo



(http://images.vgsi.com/photos/MadisonCTPhotos//\01\01\41\63

Building Layout

Building Layout

Building Sub-Areas (sq ft)	Legend
No Data for Building Sub-Areas	

Extra Features

Extra Features	Legend
No Data for Extra Features	

Land

Land Use

Use Code 9300
Description Pilot - Forest
Zone RU-1

Land Line Valuation

Size (Acres) 34.61
Depth 0

Outbuildings

Outbuildings	Legend
No Data for Outbuildings	

Valuation History

Appraisal			
Valuation Year	Improvements	Land	Total
2016	\$0	\$840,500	\$840,500

Assessment

Valuation Year	Improvements	Land	Total
2016	\$0	\$136,200	\$136,200

(c) 2016 Vision Government Solutions, Inc. All rights reserved.

Connecticut Siting Council

Decisions

DOCKET NO. 290 – AT&T Wireless PCS, LLC d/b/a AT&T Wireless application for a Certificate of Environmental Compatibility and Public Need for the construction, maintenance and operation of a wireless telecommunications facility at one of two locations on Durham Road (Route 79), Madison, Connecticut.	}	Connecticut
	}	Siting
	}	Council
		August 26, 2004

Decision and Order

Pursuant to the foregoing Findings of Fact and Opinion, the Connecticut Siting Council (Council) finds that the effects associated with the construction, operation, and maintenance of a telecommunications facility including effects on the natural environment; ecological integrity and balance; public health and safety; scenic, historic, and recreational values; forests and parks; air and water purity; and fish and wildlife are not disproportionate either alone or cumulatively with other effects when compared to need, are not in conflict with the policies of the State concerning such effects, and are not sufficient reason to deny the application and therefore directs that a Certificate of Environmental Compatibility and Public Need, as provided by General Statutes § 16-50k, be issued to AT&T Wireless PCS, LLC d/b/a AT&T Wireless at Site A, located at 1749 Durham Road, Madison, Connecticut. The Council denies certification of Site B, located on the Elka Perez Trust property, Durham Road, Madison, Connecticut.

The facility shall be constructed, operated, and maintained substantially as specified in the Council's record in this matter, and subject to the following conditions:

1. The tower shall be constructed as a monopole, no taller than necessary to provide the proposed telecommunications services, sufficient to accommodate the antennas of AT&T Wireless and other entities, both public and private, but such tower shall not exceed a height of 120 feet above ground level. The height at the top of the antennas shall not exceed 123 feet above ground level. The tower and tower foundation shall be of sufficient capacity to support a tower extension to 150 feet above ground level.
2. The Certificate Holder shall prepare a Development and Management (D&M) Plan for this site in compliance with Sections 16-50j-75 through 16-50j-77 of the Regulations of Connecticut State Agencies. The D&M Plan shall be served on the Town of Madison, and all parties and intervenors as listed in the service list, and submitted to and approved by the Council prior to the commencement of facility construction and shall include:
 - a. a final site plan(s) of site development to include specifications for the tower, tower foundation, antennas, equipment building, relocated access road, utility line, and landscaping; and
 - b. construction plans for site clearing, water drainage, and erosion and sedimentation control consistent with the 2002 Connecticut Guidelines for Soil Erosion and Sediment Control, as amended.
3. The Certificate Holder shall, prior to the commencement of operation, provide the Council

worst-case

modeling of electromagnetic radio frequency power density of all proposed entities' antennas at the closest point of uncontrolled access to the tower base, consistent with Federal Communications Commission, Office of Engineering and Technology, Bulletin No. 65, August 1997. The Certificate Holder shall ensure a recalculated report of electromagnetic radio frequency power density is submitted to the Council in the event other carriers locate at this facility or if circumstances in equipment operation cause a change in power density above the levels calculated and provided pursuant to this Decision and Order.

4. Upon the establishment of any new State or federal radio frequency standards applicable to frequencies of this facility, the facility granted herein shall be brought into compliance with such standards.
5. The Certificate Holder shall permit public or private entities to share space on the proposed tower for fair consideration, or shall provide any requesting entity with specific legal, technical, environmental, or economic reasons precluding such tower sharing.
6. The Certificate Holder shall provide reasonable space on the tower for no compensation for any municipal antennas, provided such antennas are compatible with the structural integrity of the tower.
7. If the facility does not initially provide wireless services within one year of completion of construction or ceases to provide wireless services for a period of one year, this Decision and Order shall be void, and the Certificate Holder shall dismantle the tower and remove all associated equipment or reapply for any continued or new use to the Council before any such use is made.
8. Any antenna that becomes obsolete and ceases to function shall be removed within 60 days after such antennas become obsolete and cease to function.
9. Unless otherwise approved by the Council, this Decision and Order shall be void if the facility authorized herein is not operational within one year of the effective date of this Decision and Order or within one year after all appeals to this Decision and Order have been resolved. Any request for extension of this period shall be filed with the Council not later than sixty days prior to expiration date of this Certificate and shall be served on all parties and intervenors and the Town of Madison, as listed in the service list. Any proposed modifications to this Decision and Order shall likewise be so served.

Pursuant to General Statutes § 16-50p, we hereby direct that a copy of the Findings of Fact, Opinion, and Decision and Order be served on each person listed below, and notice of issuance shall be published in the The Shoreline Times and The Source.

By this Decision and Order, the Council disposes of the legal rights, duties, and privileges of each party named or admitted to the proceeding in accordance with Section 16-50j-17 of the Regulations of Connecticut State Agencies.

The parties and intervenors to this proceeding are:

<u>Applicant</u>	<u>Its Representative</u>
AT&T Wireless PCS, LLC d/b/a AT&T Wireless	Christopher B. Fisher, Esq.

	90 Maple Avenue White Plains, New York 10601
<u>Intervenor</u> Sprint Spectrum L. P. d/b/a Sprint PCS	<u>Its Representative</u> Thomas J. Regan, Esq. Brown Rudnick Berlack Israels LLP CityPlace I, 38 th Floor 185 Asylum Street Hartford, CT 06103-3402

Content Last Modified on 8/27/2004 4:39:20 PM

Connecticut Siting Council

Decisions

DOCKET NO. 290 – AT&T Wireless PCS, LLC d/b/a AT&T Wireless application for a Certificate of Environmental Compatibility and Public Need for the construction, maintenance and operation of a wireless telecommunications facility at one of two locations on Durham Road (Route 79), Madison, Connecticut.	}	Connecticut
	}	Siting
	}	Council
		August 26, 2004

Decision and Order

Pursuant to the foregoing Findings of Fact and Opinion, the Connecticut Siting Council (Council) finds that the effects associated with the construction, operation, and maintenance of a telecommunications facility including effects on the natural environment; ecological integrity and balance; public health and safety; scenic, historic, and recreational values; forests and parks; air and water purity; and fish and wildlife are not disproportionate either alone or cumulatively with other effects when compared to need, are not in conflict with the policies of the State concerning such effects, and are not sufficient reason to deny the application and therefore directs that a Certificate of Environmental Compatibility and Public Need, as provided by General Statutes § 16-50k, be issued to AT&T Wireless PCS, LLC d/b/a AT&T Wireless at Site A, located at 1749 Durham Road, Madison, Connecticut. The Council denies certification of Site B, located on the Elka Perez Trust property, Durham Road, Madison, Connecticut.

The facility shall be constructed, operated, and maintained substantially as specified in the Council's record in this matter, and subject to the following conditions:

1. The tower shall be constructed as a monopole, no taller than necessary to provide the proposed telecommunications services, sufficient to accommodate the antennas of AT&T Wireless and other entities, both public and private, but such tower shall not exceed a height of 120 feet above ground level. The height at the top of the antennas shall not exceed 123 feet above ground level. The tower and tower foundation shall be of sufficient capacity to support a tower extension to 150 feet above ground level.
2. The Certificate Holder shall prepare a Development and Management (D&M) Plan for this site in compliance with Sections 16-50j-75 through 16-50j-77 of the Regulations of Connecticut State Agencies. The D&M Plan shall be served on the Town of Madison, and all parties and intervenors as listed in the service list, and submitted to and approved by the Council prior to the commencement of facility construction and shall include:
 - a. a final site plan(s) of site development to include specifications for the tower, tower foundation, antennas, equipment building, relocated access road, utility line, and landscaping; and
 - b. construction plans for site clearing, water drainage, and erosion and sedimentation control consistent with the 2002 Connecticut Guidelines for Soil Erosion and Sediment Control, as amended.
3. The Certificate Holder shall, prior to the commencement of operation, provide the Council

worst-case

modeling of electromagnetic radio frequency power density of all proposed entities' antennas at the closest point of uncontrolled access to the tower base, consistent with Federal Communications Commission, Office of Engineering and Technology, Bulletin No. 65, August 1997. The Certificate Holder shall ensure a recalculated report of electromagnetic radio frequency power density is submitted to the Council in the event other carriers locate at this facility or if circumstances in equipment operation cause a change in power density above the levels calculated and provided pursuant to this Decision and Order.

4. Upon the establishment of any new State or federal radio frequency standards applicable to frequencies of this facility, the facility granted herein shall be brought into compliance with such standards.
5. The Certificate Holder shall permit public or private entities to share space on the proposed tower for fair consideration, or shall provide any requesting entity with specific legal, technical, environmental, or economic reasons precluding such tower sharing.
6. The Certificate Holder shall provide reasonable space on the tower for no compensation for any municipal antennas, provided such antennas are compatible with the structural integrity of the tower.
7. If the facility does not initially provide wireless services within one year of completion of construction or ceases to provide wireless services for a period of one year, this Decision and Order shall be void, and the Certificate Holder shall dismantle the tower and remove all associated equipment or reapply for any continued or new use to the Council before any such use is made.
8. Any antenna that becomes obsolete and ceases to function shall be removed within 60 days after such antennas become obsolete and cease to function.
9. Unless otherwise approved by the Council, this Decision and Order shall be void if the facility authorized herein is not operational within one year of the effective date of this Decision and Order or within one year after all appeals to this Decision and Order have been resolved. Any request for extension of this period shall be filed with the Council not later than sixty days prior to expiration date of this Certificate and shall be served on all parties and intervenors and the Town of Madison, as listed in the service list. Any proposed modifications to this Decision and Order shall likewise be so served.

Pursuant to General Statutes § 16-50p, we hereby direct that a copy of the Findings of Fact, Opinion, and Decision and Order be served on each person listed below, and notice of issuance shall be published in the The Shoreline Times and The Source.

By this Decision and Order, the Council disposes of the legal rights, duties, and privileges of each party named or admitted to the proceeding in accordance with Section 16-50j-17 of the Regulations of Connecticut State Agencies.

The parties and intervenors to this proceeding are:

<u>Applicant</u>	<u>Its Representative</u>
AT&T Wireless PCS, LLC d/b/a AT&T Wireless	Christopher B. Fisher, Esq.

	90 Maple Avenue White Plains, New York 10601
<u>Intervenor</u> Sprint Spectrum L. P. d/b/a Sprint PCS	<u>Its Representative</u> Thomas J. Regan, Esq. Brown Rudnick Berlack Israels LLP CityPlace I, 38 th Floor 185 Asylum Street Hartford, CT 06103-3402

Content Last Modified on 8/27/2004 4:39:20 PM

Connecticut Siting Council

Decisions

DOCKET NO. 290 – AT&T Wireless PCS, LLC d/b/a AT&T Wireless application for a Certificate of Environmental Compatibility and Public Need for the construction, maintenance and operation of a wireless telecommunications facility at one of two locations on Durham Road (Route 79), Madison, Connecticut.	}	Connecticut
	}	Siting
	}	Council
		August 26, 2004

Decision and Order

Pursuant to the foregoing Findings of Fact and Opinion, the Connecticut Siting Council (Council) finds that the effects associated with the construction, operation, and maintenance of a telecommunications facility including effects on the natural environment; ecological integrity and balance; public health and safety; scenic, historic, and recreational values; forests and parks; air and water purity; and fish and wildlife are not disproportionate either alone or cumulatively with other effects when compared to need, are not in conflict with the policies of the State concerning such effects, and are not sufficient reason to deny the application and therefore directs that a Certificate of Environmental Compatibility and Public Need, as provided by General Statutes § 16-50k, be issued to AT&T Wireless PCS, LLC d/b/a AT&T Wireless at Site A, located at 1749 Durham Road, Madison, Connecticut. The Council denies certification of Site B, located on the Elka Perez Trust property, Durham Road, Madison, Connecticut.

The facility shall be constructed, operated, and maintained substantially as specified in the Council's record in this matter, and subject to the following conditions:

1. The tower shall be constructed as a monopole, no taller than necessary to provide the proposed telecommunications services, sufficient to accommodate the antennas of AT&T Wireless and other entities, both public and private, but such tower shall not exceed a height of 120 feet above ground level. The height at the top of the antennas shall not exceed 123 feet above ground level. The tower and tower foundation shall be of sufficient capacity to support a tower extension to 150 feet above ground level.
2. The Certificate Holder shall prepare a Development and Management (D&M) Plan for this site in compliance with Sections 16-50j-75 through 16-50j-77 of the Regulations of Connecticut State Agencies. The D&M Plan shall be served on the Town of Madison, and all parties and intervenors as listed in the service list, and submitted to and approved by the Council prior to the commencement of facility construction and shall include:
 - a. a final site plan(s) of site development to include specifications for the tower, tower foundation, antennas, equipment building, relocated access road, utility line, and landscaping; and
 - b. construction plans for site clearing, water drainage, and erosion and sedimentation control consistent with the 2002 Connecticut Guidelines for Soil Erosion and Sediment Control, as amended.
3. The Certificate Holder shall, prior to the commencement of operation, provide the Council

worst-case

modeling of electromagnetic radio frequency power density of all proposed entities' antennas at the closest point of uncontrolled access to the tower base, consistent with Federal Communications Commission, Office of Engineering and Technology, Bulletin No. 65, August 1997. The Certificate Holder shall ensure a recalculated report of electromagnetic radio frequency power density is submitted to the Council in the event other carriers locate at this facility or if circumstances in equipment operation cause a change in power density above the levels calculated and provided pursuant to this Decision and Order.

4. Upon the establishment of any new State or federal radio frequency standards applicable to frequencies of this facility, the facility granted herein shall be brought into compliance with such standards.
5. The Certificate Holder shall permit public or private entities to share space on the proposed tower for fair consideration, or shall provide any requesting entity with specific legal, technical, environmental, or economic reasons precluding such tower sharing.
6. The Certificate Holder shall provide reasonable space on the tower for no compensation for any municipal antennas, provided such antennas are compatible with the structural integrity of the tower.
7. If the facility does not initially provide wireless services within one year of completion of construction or ceases to provide wireless services for a period of one year, this Decision and Order shall be void, and the Certificate Holder shall dismantle the tower and remove all associated equipment or reapply for any continued or new use to the Council before any such use is made.
8. Any antenna that becomes obsolete and ceases to function shall be removed within 60 days after such antennas become obsolete and cease to function.
9. Unless otherwise approved by the Council, this Decision and Order shall be void if the facility authorized herein is not operational within one year of the effective date of this Decision and Order or within one year after all appeals to this Decision and Order have been resolved. Any request for extension of this period shall be filed with the Council not later than sixty days prior to expiration date of this Certificate and shall be served on all parties and intervenors and the Town of Madison, as listed in the service list. Any proposed modifications to this Decision and Order shall likewise be so served.

Pursuant to General Statutes § 16-50p, we hereby direct that a copy of the Findings of Fact, Opinion, and Decision and Order be served on each person listed below, and notice of issuance shall be published in the The Shoreline Times and The Source.

By this Decision and Order, the Council disposes of the legal rights, duties, and privileges of each party named or admitted to the proceeding in accordance with Section 16-50j-17 of the Regulations of Connecticut State Agencies.

The parties and intervenors to this proceeding are:

<u>Applicant</u>	<u>Its Representative</u>
AT&T Wireless PCS, LLC d/b/a AT&T Wireless	Christopher B. Fisher, Esq.

	90 Maple Avenue White Plains, New York 10601
<u>Intervenor</u> Sprint Spectrum L. P. d/b/a Sprint PCS	<u>Its Representative</u> Thomas J. Regan, Esq. Brown Rudnick Berlack Israels LLP CityPlace I, 38 th Floor 185 Asylum Street Hartford, CT 06103-3402

Content Last Modified on 8/27/2004 4:39:20 PM



2.5 EQUIPMENT DEPLOYMENT

SITE NUMBER:
CT33XC540

SITE NAME:
MADISON-ATT

SITE ADDRESS:
1749 DURHAM ROAD
MADISON, CT 06443

CROWN ID#: 846176

CROWN SITE NAME: MADISON DURHAM ROAD

Sprint
2.5 EQUIPMENT DEPLOYMENT
6850 SPRINT PARKWAY
OVERLAND PARK, KANSAS 66251



TECTONIC
ENGINEERING & SURVEYING CONSULTANTS P.C.
1279 Route 300
Newburgh, NY 12550
Phone: (845) 567-6656
Fax: (845) 567-8703
www.tectonicengineering.com

SHEET INFORMATION

SITE NUMBER:	CT33XC540	LANDLORD:	CROWN CASTLE USA 2000 CORPORATE DRIVE CANONSBURG, PA
SITE NAME:	MADISON-ATT	LOCAL POWER COMPANY:	CONNECTICUT LIGHT AND POWER CONTACT CUSTOMER SERVICE (800) 288-2000
SITE ADDRESS:	1749 DURHAM ROAD MADISON, CT 06443	APPLICANT:	SPRINT 6580 SPRINT PARKWAY OVERLAND PARK, KANSAS 66251
COUNTY:	NEW HAVEN	ENGINEER:	JAMES QUICKSELL (845) 567-6656 EXT. 2835 jquicksell@tectonicengineering.com
COORDINATES: (NAD 83)	41° 23' 22.3" N 72° 38' 56.0" W	SPRINT CM:	PETER CULBERT (803) 203-6646 Peter.Culbert@sprint.com
GROUND ELEV:	337'± AMSL	CROWN CM:	JASON D'AMICO (860) 209-0104 jason.d'amico@crowncastle.com
STRUCTURE TYPE:	MONOPOLE	AAV:	AT&T
STRUCTURE HEIGHT:	119'-0"± AGL		
STRUCTURE RAD CENTER:	106'-0"± AGL		
ZONING CLASSIFICATION:	4310 TEL REL TW		
MAP-BLOCK-LOT:	154/3/CELL//		

VICINITY MAP (NOT TO SCALE)



SHEET INDEX

SHT. NO.	SHEET DESCRIPTION
T-1	TITLE SHEET
SP-1	GENERAL NOTES
SP-2	GENERAL NOTES
A-1	SITE PLAN
A-2	ELEVATION
A-3	ENLARGED EQUIPMENT LAYOUT PLANS
A-4	ANTENNA LAYOUT PLANS
A-5	RAN WIRING DIAGRAM
A-6	CABLE DETAILS
S-1	EQUIPMENT DETAILS
S-2	EQUIPMENT SCHEMATIC DETAILS
E-1	ELECTRICAL & GROUNDING PLANS
E-2	GROUNDING DETAILS & NOTES

THIS DOCUMENT IS THE CREATION, DESIGN, PROPERTY AND COPYRIGHTED WORK OF SPRINT COMMUNICATIONS, INC. ANY DUPLICATION OR USE WITHOUT EXPRESS WRITTEN CONSENT IS STRICTLY PROHIBITED. DULCATION AND USE BY GOVERNMENT AGENCIES FOR THE PURPOSES OF CONDUCTING THEIR LAWFULLY AUTHORIZED REGULATORY AND ADMINISTRATIVE FUNCTIONS IS SPECIFICALLY ALLOWED.

SUBMITTALS

PROJECT NO: 7225.CT33XC540

NO	DATE	DESCRIPTION	BY
0	07/08/14	FOR COMMENT	DC
1	01/05/15	FOR CONSTRUCTION	DC

DATE	REVIEWED BY
1/5/15	JMQ

GENERAL NOTES

- THIS IS AN UNMANNED TELECOMMUNICATION FACILITY AND NOT FOR HUMAN HABITATION. HANDICAP ACCESS REQUIREMENTS ARE NOT REQUIRED. FACILITY HAS NO PLUMBING OR REFRIGERANTS. THIS FACILITY SHALL MEET OR EXCEED ALL FAA AND FCC REGULATOR REQUIREMENTS.
- CONTRACTOR SHALL VERIFY ALL PLANS AND EXISTING DIMENSIONS AND CONDITIONS ON THE JOB SITE AND SHALL IMMEDIATELY NOTIFY THE PROJECT OWNER'S REPRESENTATIVE IN WRITING OF DISCREPANCIES BEFORE PROCEEDING WITH THE WORK OR BE RESPONSIBLE FOR SAME.
- DEVELOPMENT AND USE OF THIS SITE WILL CONFORM TO ALL APPLICABLE CODES AND ORDINANCES.
 - 2005 STATE OF CONNECTICUT BUILDING CODE..
 - ANSI/TIA/EIA-222-F-1996.
 - NATIONAL ELECTRICAL CODE, LATEST EDITION.

AERIAL VIEW (NOT TO SCALE)



APPROVALS

THE FOLLOWING PARTIES HEREBY APPROVE AND ACCEPT THESE DOCUMENTS AND AUTHORIZE THE CONTRACTOR TO PROCEED WITH THE CONSTRUCTION DESCRIBED HEREIN. ALL DOCUMENTS ARE SUBJECT TO REVIEW BY THE LOCAL BUILDING DEPARTMENT AND MAY IMPOSE CHANGES OR MODIFICATIONS.

CONSTRUCTION: _____ DATE: _____

LEASING/
SITE ACQUISITION: _____ DATE: _____

LANDLORD/
PROPERTY OWNER: _____ DATE: _____

R.F. ENGINEER: _____ DATE: _____



PROJECT DESCRIPTION

- (1) NEW ALU 9929 EXPANSION CABINET.
- (3) NEW RFS APXVTM14-C-120 ANTENNAS.
- (3) NEW TD-RRH8x20-25 RRH.
- (1) NEW 5/8" FIBER CABLE.

SITE NUMBER:
CT33XC540

SITE NAME:
MADISON-ATT

SITE ADDRESS:
1749 DURHAM ROAD
MADISON, CT 06443

SHEET TITLE:
TITLE SHEET

SHEET NO:
T-1



DIVISION 01000—GENERAL NOTES

1. THE CONTRACTOR SHALL GIVE ALL NOTICES AND COMPLY WITH ALL LAWS, ORDINANCES, RULES, REGULATIONS AND LAWFUL ORDERS OF ANY PUBLIC AUTHORITY, MUNICIPAL AND UTILITY COMPANY SPECIFICATIONS, AND LOCAL AND STATE JURISDICTIONAL CODES BEARING ON THE PERFORMANCE OF THE WORK. THE WORK PERFORMED ON THE PROJECT AND THE MATERIALS INSTALLED SHALL BE IN STRICT ACCORDANCE WITH ALL APPLICABLE CODES, REGULATIONS, AND ORDINANCES.
2. THE ARCHITECT/ENGINEER HAVE MADE EVERY EFFORT TO SET FORTH IN THE CONSTRUCTION AND CONTRACT DOCUMENTS THE COMPLETE SCOPE OF WORK. THE CONTRACTOR BIDDING THE JOB IS NEVERTHELESS CAUTIONED THAT MINOR OMISSIONS OR ERRORS IN THE DRAWINGS AND OR SPECIFICATIONS SHALL NOT EXCUSE SAID CONTRACTOR FROM COMPLETING THE PROJECT AND IMPROVEMENTS IN ACCORDANCE WITH THE INTENT OF THESE DOCUMENTS.
3. THE CONTRACTOR OR BIDDER SHALL BEAR THE RESPONSIBILITY OF NOTIFYING (IN WRITING) THE PROJECT OWNER'S REPRESENTATIVE OF ANY CONFLICTS, ERRORS, OR OMISSIONS PRIOR TO THE SUBMISSION OF CONTRACTOR'S PROPOSAL OR PERFORMANCE OF WORK.
4. THE SCOPE OF WORK SHALL INCLUDE FURNISHING ALL MATERIALS, EQUIPMENT, LABOR AND ALL OTHER MATERIALS AND LABOR DEEMED NECESSARY TO COMPLETE THE WORK/PROJECT AS DESCRIBED HEREIN.
5. THE CONTRACTOR SHALL VISIT THE JOB SITE PRIOR TO THE SUBMISSION OF BIDS OR PERFORMING WORK TO FAMILIARIZE HIMSELF WITH THE FIELD CONDITIONS AND TO VERIFY THAT THE PROJECT CAN BE CONSTRUCTED IN ACCORDANCE WITH THE CONTRACT DOCUMENTS.
6. ONCE THE CONTRACTOR HAS RECEIVED AND ACCEPTED THE NOTICE TO PROCEED, CONTRACTOR WILL CONTACT THE CROWN CASTLE CONSTRUCTION MANAGER OF RECORD (NOTED ON THE FIRST PAGE ON THIS CONSTRUCTION DRAWING) A MINIMUM OF 48 HOURS PRIOR TO WORK START. UPON ARRIVAL TO THE JOB SITE, CONTRACTOR CREW IS REQUIRED CALL 1-800-788-7011 TO NOTIFY THE CROWN CASTLE NOC WORK HAS BEGUN.
7. THE CONTRACTOR SHALL INSTALL ALL EQUIPMENT AND MATERIALS ACCORDING TO THE MANUFACTURER'S/VENDOR'S SPECIFICATIONS UNLESS NOTED OTHERWISE OR WHERE LOCAL CODES OR ORDINANCES TAKE PRECEDENCE.
8. THE CONTRACTOR SHALL PROVIDE A FULL SET OF CONSTRUCTION DOCUMENTS AT THE SITE UPDATED WITH THE LATEST REVISIONS AND ADDENDUMS OR CLARIFICATIONS AVAILABLE FOR THE USE BY ALL PERSONNEL INVOLVED WITH THE PROJECT.
9. THE CONTRACTOR SHALL SUPERVISE AND DIRECT THE PROJECT DESCRIBED HEREIN. THE CONTRACTOR SHALL BE SOLELY RESPONSIBLE FOR ALL CONSTRUCTION MEANS, METHODS, TECHNIQUES, SEQUENCES AND PROCEDURES AND FOR COORDINATING ALL PORTIONS OF THE WORK UNDER THE CONTRACT.
10. THE CONTRACTOR SHALL BE RESPONSIBLE FOR OBTAINING ALL PERMITS AND INSPECTIONS WHICH MAY BE REQUIRED FOR THE WORK BY THE ARCHITECT/ENGINEER, THE STATE, COUNTY OR LOCAL GOVERNMENT AUTHORITY.
11. THE CONTRACTOR SHALL MAKE NECESSARY PROVISIONS TO PROTECT EXISTING IMPROVEMENTS, EASEMENTS, PAVING, CURBING, ETC. DURING CONSTRUCTION. UPON COMPLETION OF WORK, THE CONTRACTOR SHALL REPAIR ANY DAMAGE THAT MAY HAVE OCCURRED DUE TO CONSTRUCTION ON OR ABOUT THE PROPERTY.
12. THE CONTRACTOR SHALL KEEP THE GENERAL WORK AREA CLEAN AND HAZARD FREE DURING CONSTRUCTION AND DISPOSE OF ALL DIRT, DEBRIS, RUBBISH AND REMOVE EQUIPMENT NOT SPECIFIED AS REMAINING ON THE PROPERTY. PREMISES SHALL BE LEFT IN CLEAN CONDITION AND FREE FROM PAINT SPOTS, DUST, OR SMUDGES OF ANY NATURE.
13. THE CONTRACTOR SHALL COMPLY WITH ALL PERTINENT SECTIONS OF THE BASIC STATE BUILDING CODE, LATEST EDITION, AND ALL OSHA REQUIREMENTS AS THEY APPLY TO THIS PROJECT. ALL EXISTING ACTIVE SEWER, WATER, GAS, ELECTRIC, AND OTHER UTILITIES WHERE ENCOUNTERED IN THE WORK SHALL BE PROTECTED AT ALL TIMES, AND WHERE REQUIRED FOR THE PROPER EXECUTION OF THE WORK SHALL BE RELOCATED AS DIRECTED BY THE ARCHITECT/ENGINEER. EXTREME CAUTION SHOULD BE USED BY THE CONTRACTOR WHEN EXCAVATING OR PIER DRILLING AROUND OR NEAR UTILITIES. THE CONTRACTOR SHALL PROVIDE SAFETY TRAINING FOR THE WORKING CREW. THIS WILL INCLUDE BUT NOT LIMITED TO A) FALL PROTECTION, B) CONFINED SPACE, C) ELECTRICAL SAFETY, D) TRENCHING AND EXCAVATION OF ALL EXISTING INACTIVE SEWER, WATER, GAS, ELECTRIC AND OTHER UTILITIES WHICH INTERFERE WITH THE EXECUTION OF THE WORK SHALL BE REMOVED AND OR CAPPED, PLUGGED OR OTHERWISE DISCONTINUED AT THE POINTS WHICH WILL NOT INTERFERE WITH THE EXECUTION OF THE WORK SUBJECT TO THE APPROVAL OF THE ARCHITECT/ENGINEER.
14. THE CONTRACTOR SHALL NOTIFY THE PROJECT OWNER'S REPRESENTATIVE IN WRITING WHERE A CONFLICT OCCURS ON ANY OF THE CONTRACT DOCUMENTS. THE CONTRACTOR IS NOT TO ORDER MATERIAL OR CONSTRUCT ANY PORTION OF THE WORK THAT IS IN CONFLICT UNTIL CONFLICT IS RESOLVED BY THE LESSEE/LICENSEE REPRESENTATIVE.
15. THE CONTRACTOR SHALL VERIFY ALL DIMENSIONS, ELEVATIONS, PROPERTY LINES, ETC. ON THE JOB.
16. THE CONTRACTOR SHALL NOTIFY THE THE RF ENGINEER FOR ANTENNA AZIMUTH VERIFICATION (DURING ANTENNA INSTALLATION) PRIOR TO CONDUCTING SWEEP TESTS.
17. THE CONTRACTOR SHALL SUBMIT AT THE END OF THE PROJECT A COMPLETE SET OF AS-BUILT DRAWINGS TO THE CLIENT REPRESENTATIVE.

18. REFER TO: CONSTRUCTION STANDARDS—SPRINT DOCUMENT EXHIBIT A—STANDARD CONSTRUCTION SPECIFICATIONS FOR WIRELESS SITES REV. 4.0— 02.15.2011.DOCM.
19. REFER TO: WEATHER PROOFING SPECS: EXCERPT EXH A—WIHRPRF—STD CONSTR SPECS...157201110421855492.DOCM.
20. REFER TO: COLOR CODING—SPRINT NEXTEL ANT AND LINE COLOR CODING (DRAFT) V3 09-08-11.PDF
21. REFER TO LATEST DOCUMENTATION REVISION.

DIVISION 03000—CONCRETE

- 1.03 APPLICABLE STANDARDS (USE LATEST EDITIONS)
 - A. ACI-301 — SPECIFICATIONS FOR STRUCTURAL CONCRETE FOR BUILDINGS.
 - B. ACI-347 GUIDE TO FORM WORK FOR CONCRETE.
 - C. ASTM C33— CONCRETE AGGREGATE
 - D. ASTM C94 — READY MIXED CONCRETE e. ASTM C150 — PORTLAND CEMENT.
 - E. ASTM C260 — AIR-ENTRAINING ADMIXTURES FOR CONCRETE
 - F. ASTM C309— LIQUID MEMBRANE FORMING COMPOUNDS FOR CURING CONCRETE.
 - H. ASTM C494 — CHEMICAL ADMIXTURES FOR CONCRETE
 - I. ASTM A615— DEFORMED AND PLAIN BILLET—STEEL BARS FOR CONCRETE REINFORCEMENT
 - J. ASTM A185— STEEL WELDED WIRE FABRIC (PLAIN) FOR CONCRETE REINFORCEMENT
- 1.04 QUALITY ASSURANCE

CONCRETE MATERIALS AND OPERATIONS SHALL BE TESTED AND INSPECTED BY THE ARCHITECT/ENGINEER AS DIRECTED BY THE CLIENT'S REPRESENTATIVE.

3.04 SURFACE FINISHES

- A. SURFACES AGAINST WHICH BACKFILL OR CONCRETE SHALL BE PLACED REQUIRE NO TREATMENT EXCEPT REPAIR OF DEFECTIVE AREAS.
- B. SURFACES THAT WILL BE PERMANENTLY EXPOSED SHALL PRESENT A UNIFORM FINISH PROVIDED BY THE REMOVAL OF FINS AND THE FILLING HOLES AND OTHER IRREGULARITIES WITH DRY PACK GROUT, OR BY SACKING WITH UTILITY OR ORDINARY GROUT.
- C. SURFACES THAT WOULD NORMALLY BE LEVEL AND WHICH WILL BE PERMANENTLY EXPOSED TO THE WEATHER SHALL BE SLOPED FOR DRAINAGE. UNLESS ENGINEER'S DESIGN DRAWING SPECIFIES A HORIZONTAL SURFACE OR SURFACES SUCH AS STAIR TREADS, WALLS, CURBS, AND PARAPETS SHALL BE SLOPED APPROXIMATELY 1/4" PER FOOT.
- D. SURFACES THAT WILL BE COVERED BY BACKFILL OR CONCRETE SHALL BE SMOOTH SCREENED.
- E. EXPOSED SLAB SURFACES SHALL BE CONSOLIDATED, SCREENED, FLOATED, AND STEEL TROWELED. HAND OR POWER-DRIVEN EQUIPMENT MAY BE USED FOR FLOATING. FLOATING SHALL BE STARTED AS SOON AS THE SCREENED SURFACE HAS ATTAINED A STIFFNESS TO PERMIT FINISHING OPERATIONS. OPERATIONS. ALL EDGES MUST HAVE A 3/4" CHAMFER.

1.04 QUALITY ASSURANCE CONCRETE MATERIALS AND OPERATIONS SHALL BE TESTED AND INSPECTED BY THE ENGINEER.

3.05 PATCHING

THE CONTRACTOR SHALL NOTIFY THE ENGINEER IMMEDIATELY UPON REMOVAL OF THE FORMS TO OBSERVE CONCRETE SURFACE CONDITIONS. IMPERFECTIONS SHALL BE PATCHED ACCORDING TO THE ENGINEER'S DIRECTION.

3.06 DEFECTIVE CONCRETE

THE CONTRACTOR SHALL NOTIFY OR REPLACE CONCRETE NOT CONFORMING TO REQUIRED LEVELS AND LINES, DETAILS, AND ELEVATIONS AS SPECIFIED IN ACI 301.

3.07 PROTECTION

- A. IMMEDIATELY AFTER PLACEMENT. THE CONTRACTOR SHALL PROTECT THE CONCRETE FROM PREMATURE DRYING, EXCESSIVELY HOT OR COLD TEMPERATURES, AND MECHANICAL INJURY. FINISHED WORK SHALL BE PROTECTED.
- B. CONCRETE SHALL BE MAINTAINED WITH MINIMAL MOISTURE LOSS AT RELATIVELY CONSTANT TEMPERATURE FOR PERIOD NECESSARY FOR HYDRATION OF CEMENT AND HARDENING OF CONCRETE.
- C. ALL CONCRETE SHALL BE WATER CURED PER ACCEPTABLE PRACTICES SPECIFIED BY ACI CODE (LATEST EDITION)

DIVISION 05000 — METALS

PART 1 — GENERAL

- 1.01 WORK INCLUDED
 - A. THE WORK CONSISTS OF THE FABRICATION AND INSTALLATION OF ALL MATERIALS TO BE FURNISHED. AND WITHOUT LIMITING THE GENERALITY THEREOF, INCLUDING ALL EQUIPMENT, LABOR AND SERVICES REQUIRED FOR ALL STRUCTURAL STEEL WORK AND ALL ITEMS INCIDENTAL AS SPECIFIED AND AS SHOWN ON THE DRAWINGS:
 1. STEEL FRAMING INCLUDING BEAMS, ANGLES, CHANNELS AND PLATES.
 2. WELDING AND BOLTING OF ATTACHMENTS.

1.02 REFERENCE STANDARDS

- A. THE WORK SHALL CONFORM TO THE CODES AND STANDARDS OF THE FOLLOWING AGENCIES AS FURTHER CITED HEREIN:
 1. ASTM: AMERICAN SOCIETY FOR TESTING AND MATERIALS AS PUBLISHED IN "COMPILATION OF ASTM STANDARDS IN BUILDING CODES" OR LATEST EDITION.
 2. AWS: AMERICAN WELDING SOCIETY CODE OR LATEST EDITION.
 3. AISC: AMERICAN INSTITUTE OF STEEL CONSTRUCTION, "SPECIFICATION FOR THE DESIGN, FABRICATION AND ERECTION OF STRUCTURAL STEEL FOR BUILDINGS" (LATEST EDITION).

PART 2 — PRODUCTS

- 2.01 MATERIALS
 - A. STRUCTURAL STEEL: SHALL COMPLY WITH THE REQUIREMENTS OF ASTM A36 AND A992 FOR STRUCTURAL STEEL.

ALL PROPOSED STRUCTURAL STEEL SHALL BE FABRICATED AND ERECTED IN ACCORDANCE WITH AISC CODE AND ASTM SPECIFICATIONS (LATEST EDITION) ALL NEW STEEL SHALL CONFORM TO THE FOLLOWING.

1. STRUCTURAL WIDE FLANGE: ASTM A992 Fy=50KSI.
2. MISCELLANEOUS STEEL (PLATES), CHANNELS, ANGLES, ETC): ASTM A36 (Fy=36KSI).
3. STRUCTURAL TUBING: ASTM A500 Gr. B (Fy=46KSI).
4. STEEL PIPE: ASTM A53 Gr B (Fy=35KSI).

2.02 WELDING

- A. ALL WELDING SHALL BE DONE BY CERTIFIED WELDERS. CERTIFICATION DOCUMENTS SHALL BE MADE AVAILABLE FOR ENGINEER'S AND/OR OWNER'S REVIEW IF REQUESTED.
- B. WELDING ELECTRODES FOR MANUAL SHIELDED METAL ARC WELDING SHALL CONFORM TO ASTM 1-233, E70 SERIES. BARE ELECTRODES AND GRANULAR FLUX USED IN THE SUBMERGED ARC PROCESS SHALL CONFORM TO AISC SPECIFICATIONS.
- C. FIELD WELDING SHALL BE DONE AS PER AWS D1.1 REQUIREMENTS VISUAL INSPECTION IS ACCEPTABLE.
- D. STUD WELDING SHALL BE ACCOMPLISHED BY CAPACITOR DISCHARGE (CD) WELDING TECHNIQUE USING CAPACITOR DISCHARGE STUD WELDER.
- E. PROVIDE STUD FASTENERS OF MATERIALS AND SIZES SHOWN ON DRAWINGS OR AS RECOMMENDED BY THE MANUFACTURER FOR STRUCTURAL LOADINGS REQUIRED.
- F. FOLLOW MANUFACTURERS SPECIFICATIONS AND INSTRUCTIONS TO PROPERLY SELECT AND INSTALL STUD WELDS.

2.03 BOLTING

- A. BOLTS SHALL BE CONFORMING TO ASTM A35 HIGH STRENGTH HOT DIP GALVANIZED WITH ASTM A153 HEAVY HEX TYPE NUTS.
- B. BOLTS SHALL BE 3/4" (MINIMUM) CONFORMING TO ASTM A325, HOT DIP GALVANIZED, ASTM A153 NUTS SHALL BE HEAVY HEX TYPE.
- C. ALL CONNECTIONS SHALL BE 2 BOLTS MINIMUM.
- D. EXCEPT WHERE SHOWN, ALL BEAM TO BEAM AND BEAM TO COLUMN CONNECTIONS TO BE DOUBLE ANGLED CONNECTIONS WITH HIGH STRENGTH BOLTS (THREADS EXCLUDED FROM SHEAR PLANE) AND HARDENED WASHERS.
- E. STANDARD, OVERSIZED OR HORIZONTAL SHORT SLOTTED HOLES.
- F. SNUG-TIGHT STRENGTH BEARING BOLTS MAY BE USED IN STANDARD HOLES CONFORMING TO ACIS, USING THE TURN OF THE NUT METHOD.
- H. FULLY-TENSIONED HIGH STRENGTH (SLIP CRITICAL) SHALL BE USED IN OVERSIZED SLOT HOLES (RESPECTIVE OF SLOT ORIENTATION).
- I. ALL BRACED CONNECTION, MOMENT CONNECTION AND CONNECTIONS NOTED AS "SLIP CRITICAL" SHALL BE BE SLIP CRITICAL JOINTS WITH CLASS A SURFACE CONDITIONS, UNLESS OTHERWISE NOTED.
- J. EPOXY ANCHOR ASSEMBLIES SHALL BE AS MANUFACTURED BY HILTI OR ENGINEER APPROVED EQUAL, AS FOLLOWS:

<u>BASE MATERIAL</u>	<u>ANCHOR SYSTEM</u>
CONCRETE	HILTI HIT-HY 200
HOLLOW & GROUTED CMU OR BRICK	HILTI HIT-HY 70

2.04 FABRICATION

- A. FABRICATION OF STEEL SHALL CONFORM TO THE AISC AND AWS

2.05 FINISH

- A. STRUCTURAL STEEL EXPOSED TO WEATHER SHALL BE HOT-DIP GALVANIZED AFTER FABRICATION IN ACCORDANCE WITH ASTM A123. (LATEST EDITION) UNLESS OTHERWISE NOTED.

2.06 PROTECTION

- A. UPON COMPLETION OF ERECTION, INSPECT ALL GALVANIZED STEEL AND PAINT ANY FIELD CUTS, WELDS OR GALVANIZED BREAKS WITH (2) COATS OF ZINC-RICH COLD GALVANIZING PAINT.

PART 3 — ERECTION

- A. PROVIDE ALL ERECTION, EQUIPMENT, BRACING, PLANKING, FIELD BOLTS, NUTS, WASHERS, DRIFT PINS, AND SIMILAR MATERIALS WHICH DO NOT FORM A PART OF THE COMPLETED CONSTRUCTION, BUT ARE NECESSARY FOR ITS PROPER ERECTION.
- B. ERECT AND ANCHOR ALL STRUCTURAL STEEL IN ACCORDANCE WITH AISC REFERENCE STANDARDS. ALL WORK SHALL BE ACCURATELY SET TO ESTABLISHED SUITABLE ATTACHMENTS TO THE CONSTRUCTION OF THE BUILDING
- C. TEMPORARY BRACING, GUYING, AND SUPPORT SHALL BE PROVIDED TO KEEP THE STRUCTURE SET AND ALIGNED AT ALL TIMES DURING CONSTRUCTION, AND TO PREVENT DANGER TO PERSONS AND PROPERTY. CHECK ALL TEMPORARY LOADS AND STAY WITHIN SAFE CAPACITY OF ALL BUILDING COMPONENTS.



2.5 EQUIPMENT DEPLOYMENT
6850 SPRINT PARKWAY
OVERLAND PARK, KANSAS 66251





TECTONIC Engineering & Surveying Consultants P.C.
1279 Route 300
Newburgh, NY 12550
Phone: (845) 567-6656
Fax: (845) 567-8703
www.tectonicengineering.com

THIS DOCUMENT IS THE CREATION, DESIGN, PROPERTY AND COPYRIGHTED WORK OF SPRINT COMMUNICATIONS, INC. ANY DUPLICATION OR USE WITHOUT EXPRESS WRITTEN CONSENT IS STRICTLY PROHIBITED. DUPLICATION AND USE BY GOVERNMENT AGENCIES FOR THE PURPOSES OF CONDUCTING THEIR LAWFULLY AUTHORIZED REGULATORY AND ADMINISTRATIVE FUNCTIONS IS SPECIFICALLY ALLOWED.

SUBMITTALS

PROJECT NO: 7225.CT33XC540			
NO	DATE	DESCRIPTION	BY
0	07/08/14	FOR COMMENT	DC
1	01/05/15	FOR CONSTRUCTION	DC

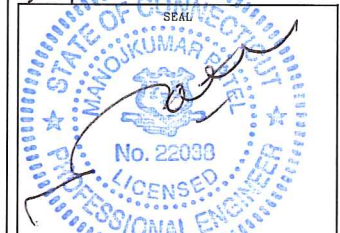
DATE	REVIEWED BY
1/5/15	JMG



MANOJ KUMAR BHAT
No. 22038
LICENSED PROFESSIONAL ENGINEER

SITE NUMBER:
CT33XC540

SITE NAME:
MADISON- ATT

SITE ADDRESS:
1749 DURHAM ROAD
MADISON, CT 06443

SHEET TITLE:
GENERAL NOTES

SHEET NO:
SP-1

DIVISION 13000—SPECIAL CONSTRUCTION ANTENNA INSTALLATION

PART 1 — GENERAL

1.01 WORK INCLUDED

A. ANTENNAS AND HYBRIFLEX CABLES ARE FURNISHED BY CLIENT'S REPRESENTATIVE UNDER SEPARATE CONTRACT. THE CONTRACTOR SHALL ASSIST ANTENNA INSTALLATION CONTRACTOR IN TERMS OF COORDINATION AND SITE ACCESS. ERECTION SUBCONTRACTOR SHALL BE RESPONSIBLE FOR THE PROPERTY.

B. INSTALL ANTENNAS AS INDICATED ON DRAWINGS AND CLIENT'S REPRESENTATIVE SPECIFICATIONS.

C. INSTALL GALVANIZED STEEL ANTENNA MOUNTS AS INDICATED ON DRAWINGS.

D. INSTALL FURNISHED GALVANIZED STEEL OR ALUMINUM WAVEGUIDE AND PROVIDE PRINTOUT OF THAT RESULT

F. INSTALL HYBRIFLEX CABLES AND TERMINATIONS BETWEEN ANTENNAS AND EQUIPMENT PER MANUFACTURER'S RECOMMENDATIONS. WEATHERPROOF ALL CONNECTORS BETWEEN THE ANTENNA AND EQUIPMENT PER MANUFACTURER'S REQUIREMENTS.

G. ANTENNA AND HYBRIFLEX CABLE GROUNDING:

1. ALL EXTERIOR #6 GREEN GROUND WIRE DAISY CHAIN CONNECTIONS ARE TO BE WEATHER SEALED WITH ANDREWS CONNECTOR/SPLICE WEATHERPROOFING KIT TYPE 3221213 OR EQUIVALENT.

2. ALL HYBRIFLEX CABLE GROUNDING KITS ARE TO BE INSTALLED ON STRAIGHT RUNS OF HYBRIFLEX CABLE (NOT WITHIN BENDS). 1.02 RELATED WORK FURNISH THE FOLLOWING WORK AS SPECIFIED UNDER CONSTRUCTION DOCUMENTS, BUT COORDINATE WITH OTHER TRADES PRIOR TO BID:

1. FLASHING OF OPENING INTO OUTSIDE WALLS.
2. SEALING AND CAULKING ALL OPENINGS.
3. PAINTING.
4. CUTTING AND PATCHING.

1.03 REQUIREMENTS OF REGULATOR AGENCIES

A. FURNISH U.L. LISTED EQUIPMENT WHERE SUCH LABEL IS AVAILABLE. INSTALL IN CONFORMANCE WITH U.L. STANDARDS WHERE APPLICABLE.

B. INSTALL ANTENNA, ANTENNA CABLES, GROUNDING SYSTEM IN ACCORDANCE WITH DRAWINGS AND SPECIFICATIONS IN EFFECT AT PROJECT LOCATION AND RECOMMENDATIONS OF STATE AND LOCAL BUILDING CODES HAVING JURISDICTION OVER SPECIFIC PORTIONS OF WORK. THIS WORK INCLUDES, BUT IS NOT LIMITED TO THE FOLLOWING:

1. EIA — ELECTRONIC INDUSTRIES ASSOCIATION RS-22. STRUCTURAL STANDARDS FOR STEEL ANTENNA TOWERS AND ANTENNA SUPPORTING STRUCTURES.
2. FAA — FEDERAL AVIATION ADMINISTRATION ADVISORY CIRCULAR AC 70/7480-IH, CONSTRUCTION MARKING AND LIGHTING.
3. FCC — FEDERAL COMMUNICATION COMMISSION RULES AND REGULATIONS FORM 715, OBSTRUCTION MARKING AND LIGHTING SPECIFICATION FOR ANTENNA STRUCTURES
4. AISC — AMERICAN INSTITUTE OF STEEL CONSTRUCTION FOR STRUCTURAL JOINTS USING ASTM 1325 OR A490 BOLTS.
5. NEC — NATIONAL ELECTRIC CODE — ON TOWER LIGHTING KITS.
6. UL — UNDERWRITER'S LABORATORIES APPROVED ELECTRICAL PRODUCTS.
7. IN ALL CASES, PART 77 OF THE FAA RULES AND PARTS 17 AND 22 OF THE FCC RULES ARE APPLICABLE AND IN THE EVENT OF CONFLICT, SUPERSEDE ANY OTHER STANDARDS OR SPECIFICATIONS.
8. LIFE SAFETY CODE NFPA, LATEST EDITION.

DIVISION 13000—EARTHWORK

PART 1 GENERAL

1.01 WORK INCLUDED: REFER TO SURVEY AND SITE PLAN FOR WORK INCLUDED.

1.02 RELATED WORK

A. CONSTRUCTION OF EQUIPMENT FOUNDATIONS
B. INSTALLATION OF ANTENNA SYSTEM

PART 2 PRODUCTS

2.01 MATERIALS

A. ROAD AND SITE MATERIALS; FILL MATERIAL SHALL BE ACCEPTABLE, SELECT FILL SHALL BE IN ACCORDANCE WITH LOCAL DEPARTMENT OF HIGHWAY AND PUBLIC TRANSPORTATION STANDARD SPECIFICATIONS.

B. SOIL STERILIZER SHALL BE EPA REGISTERED OF LIQUID COMPOSITION AND OF PRE-EMERGENCE DESIGN.

C. SOIL STABILIZER FABRIC SHALL BE MIRAFI OR EQUAL — 600X AT ACCESS ROAD AND COMPOUND.

D. GRAVEL FILL; WELL GRADED, HARD, DURABLE, NATURAL SAND AND GRAVEL, FREE FROM ICE AND SNOW, ROOTS, SOD RUBBISH, AND OTHER DELETERIOUS OR ORGANIC MATTER.

MATERIAL SHALL CONFORM TO THE FOLLOWING GRADATION REQUIREMENTS.

GRAVEL FILL TO BE PLACED IN LIFTS OF 9" MAXIMUM THICKNESS AND 90 % DENSITY. COMPACTED TO 95

E. NO FILL OR EMBANKMENT MATERIALS SHALL BE PLACED ON FROZEN GROUND. FROZEN MATERIALS SNOW OR ICE SHALL NOT BE PLACED IN ANY FILL OF EMBANKMENT

2.02 EQUIPMENT

A. COMPACTION SHALL BE ACCOMPLISHED BY MECHANICAL MEANS. LARGER AREAS SHALL BE COMPACTED BY SHEEPS FOOT, VIBRATORY OR RUBBER TIED ROLLERS WEIGHING AT LEAST FIVE TONS. SMALLER AREAS SHALL BE COMPACTED BY POWER-DRIVER, HAND HELD TAMPER.

B. PRIOR TO OTHER EXCAVATION AND CONSTRUCTION EFFORTS GRUB ORGANIC MATERIAL TO A MINIMUM OF 6" BELOW ORIGINAL GROUND LEVEL.

C. UNLESS OTHERWISE INSTRUCTED BY CLIENT'S REPRESENTATIVE. REMOVE TREES, BRUSH AND DEBRIS FROM THE PROPERTY TO AN AUTHORIZED DISPOSAL LOCATION.

D. PRIOR TO PLACEMENT OF FILL OR BASE MATERIALS, ROLL THE SOIL.

E. WHERE UNSTABLE SOIL CONDITIONS ARE ENCOUNTERED, LINE THE GRUBBED AREAS WITH STABILIZER MAT PRIOR TO PLACEMENT OF FILL OR BASE MATERIAL.

3.03 INSTALLATION

A. THE SITE AND TURNAROUND AREAS SHALL BE AT THE SUB-BASE COURSE ELEVATION PRIOR TO FORMING FOUNDATIONS. GRADE OR FILL THE SITE AND ACCESS ROAD AS REQUIRED TO PRODUCE EVEN DISTRIBUTION OF SPOILS RESULTING FROM FOUNDATION EXCAVATIONS. THE RESULTING GRADE SHALL CORRESPOND WITH SAID SUB-BASE COURSE, ELEVATIONS ARE TO BE CALCULATED FROM FINISHED GRADES OR SLOPES INDICATED.

B. THE ACCESS ROAD SHALL BE BROUGHT TO BASE COURSE ELEVATION PRIOR TO FOUNDATION CONSTRUCTION.

C. DO NOT CREATE DEPRESSIONS WHERE WATER MAY POND.

D. THE CONTRACT INCLUDES ALL NECESSARY GRADING, BANKING, DITCHING AND COMPLETE SURFACE COURSE FOR ACCESS ROAD. ALL ROADS OR ROUTES UTILIZED FOR ACCESS TO PUBLIC THOROUGHFARE IS INCLUDED IN SCOPE OF WORK UNLESS OTHERWISE INDICATED.

E. WHEN IMPROVING AN EXISTING ACCESS ROAD, GRADE THE EXISTING ROAD TO REMOVE ANY ORGANIC MATTER AND SMOOTH THE SURFACE BEFORE PLACING FILL OR STONE.

F. PLACE FILL OR STONE IN 3" MAXIMUM LIFTS AND COMPACT BEFORE PLACING NEXT LIFT.

G. THE FINISH GRADE, INCLUDING TOP SURFACE COURSE, SHALL EXTEND A MINIMUM OF 12" BEYOND THE SITE FENCE AND SHALL COVER THE AREA AS INDICATED.

H. RIPRAP SHALL BE APPLIED TO THE SIDE SLOPES OF ALL FENCED AREAS, PARKING AREAS AND TO ALL OTHER SLOPES GREATER THAN

I. RIPRAP SHALL BE APPLIED TO THE SIDES OF DITCHES OR DRAINAGE SWALES AS INDICATED ON PLANS.

J. RIPRAP ENTIRE DITCH FOR 6'-0" IN ALL DIRECTIONS AT CULVERT OPENINGS.

K. SEED, FERTILIZER AND STRAW COVER SHALL BE APPLIED TO ALL OTHER DISTURBED AREAS AND DITCHES, DRAINAGE, SWALES, NOT OTHERWISE RIP-RAPPED.

L. UNDER NO CIRCUMSTANCES SHALL DITCHES, SWALES OR CULVERTS BE PLACED SO THEY DIRECT WATER TOWARDS, OR PERMIT STANDING WATER IMMEDIATELY ADJACENT TO SITE. IF OWNER DESIGNS OR IF DESIGN ELEVATIONS CONFLICT WITH THIS GUIDANCE ADVISE THE OWNER IMMEDIATELY.

M. IF A DITCH LIES WITH SLOPE GREATER THAN TEN PERCENT, MOUND DIVERSIONARY HEADWALL IN THE DITCH AT CULVERT ENTRANCES. RIP-RAP THE UPSTREAM SIDE OF THE HEADWALL AS WELL AS THE DITCH FOR 6'-0" ABOVE THE CULVERT.

N. IF A DITCH LIES WITH SLOPES GREATER THAN TEN PERCENT, MOUND DIVERSIONARY HEADWALLS IN THE DITCH FOR 6'-0" ABOVE THE CULVERT ENTRANCE.

O. SEED AND FERTILIZER SHALL BE APPLIED TO SURFACE CONDITIONS WHICH WILL ENCOURAGE ROOTING. RAKE AREAS TO BE SEEDED TO EVEN THE SURFACE AND TO LOOSEN THE SOIL.

P. SOW SEED IN TWO DIRECTIONS IN TWICE THE QUANTITY RECOMMENDED BY THE SEED PRODUCER.

Q. IT IS THE CONTRACTOR'S RESPONSIBILITY TO ENSURE GROWTH OF SEEDED AND LANDSCAPED AREAS BY WATERING UP TO THE POINT OF RELEASE FROM THE CONTRACT. CONTINUE TO REWORK BARE AREAS UNTIL COMPLETE COVERAGE IS OBTAINED.

3.04 FIELD QUALITY CONTROL

A. COMPACTION SHALL BE D-1557 FOR SITE WORK AND 95 % MAXIMUM DENSITY UNDER SLAB AREAS. AREAS OF SETTLEMENT WILL BE EXCAVATED AND REFILLED AT CONTRACTOR'S EXPENSE. REQUIRED. USE OF EROSION CONTROL MESH OR MULCH NET SHALL BE AN ACCEPTABLE ALTERNATIVE.

B. THE COMPACTION TEST RESULTS SHALL BE AVAILABLE PRIOR TO THE CONCRETE POUR.

3.05 PROTECTION

A. PROTECT SEEDED AREAS FORM EROSION BY SPREADING STRAW TO A UNIFORM LOOSE DEPTH OF 1"-2". STAKE AND TIE DOWN AS REQUIRED. USE OF EROSION CONTROL MESH OR MULCH NET SHALL BE AN ACCEPTABLE ALTERNATIVE.

B. ALL TREES PLACED IN CONJUNCTION WITH A LANDSCAPE CONTRACT SHALL BE WRAPPED, TIED WITH HOSE PROTECTED WIRE AND SECURED TO STAKES EXTENDING 2'-0" INTO THE GROUND ON FOUR SIDES OF THE TREE.

C. ALL EXPOSED AREAS SHALL BE PROTECTED AGAINST WASHOUTS AND SOIL EROSION. STRAW BALES SHALL BE PLACED AT THE INLET APPROACH TO ALL NEW OR EXISTING CULVERTS. REFER TO DETAILS ON DRAWINGS

SYMBOLS	ABBREVIATIONS
— — — — G — — — — G — —	GROUND WIRE
— — — — E — — — — E — —	ELECTRIC
— — — — T — — — — T — —	TELEPHONE
— — — — O — — — — O — —	OVERHEAD WIRE
— — — — — — — — — —	PROPERTY LINE
— X — — — X — — — — X — —	CHAIN LINK FENCE
A-1	ANTENNA MARK
(E)	EXISTING
(P)	PROPOSED DETAIL
	REFERENCE
	SURFACE ELEVATION

2.5 EQUIPMENT DEPLOYMENT
6850 SPRINT PARKWAY
OVERLAND PARK, KANSAS 66251

TECTONIC Engineering & Surveying Consultants P.C.
1279 Route 300
Newburgh, NY 12550
Phone: (845) 567-6656
Fax: (845) 567-8703
www.tectonicengineering.com

THIS DOCUMENT IS THE CREATION, DESIGN, PROPERTY AND COPYRIGHTED WORK OF SPRINT COMMUNICATIONS, INC. ANY DUPLICATION OR USE WITHOUT EXPRESS WRITTEN CONSENT IS STRICTLY PROHIBITED. DUPLICATION AND USE BY GOVERNMENT AGENCIES FOR THE PURPOSES OF CONDUCTING THEIR LAWFULLY AUTHORIZED REGULATORY AND ADMINISTRATIVE FUNCTIONS IS SPECIFICALLY ALLOWED.

SUBMITTALS

PROJECT NO: 7225.CT33XC540

NO	DATE	DESCRIPTION	BY
0	07/08/14	FOR COMMENT	DC
1	01/05/15	FOR CONSTRUCTION	DC

DATE	REVIEWED BY
1/5/15	JMQ

STATE OF CONNECTICUT
MANOJ KUMAR
No. 22038
LICENSED PROFESSIONAL ENGINEER

SITE NUMBER:
CT33XC540
SITE NAME:
MADISON-ATT
SITE ADDRESS:
1749 DURHAM ROAD
MADISON, CT 06443

SHEET TITLE:
GENERAL NOTES

SHEET NO:
SP-2

NORTH NOTE:

NORTH SHOWN HAS BEEN ESTABLISHED USING THE USGS QUADRANGLE 7.5 MINUTE MAPS AND IS APPROXIMATE. VERIFY TRUE NORTH PRIOR TO INSTALLATION OF ANTENNAS.

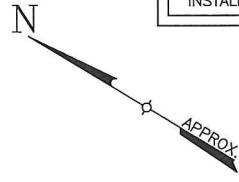

1
A-2

EXIST TRANSFORMER

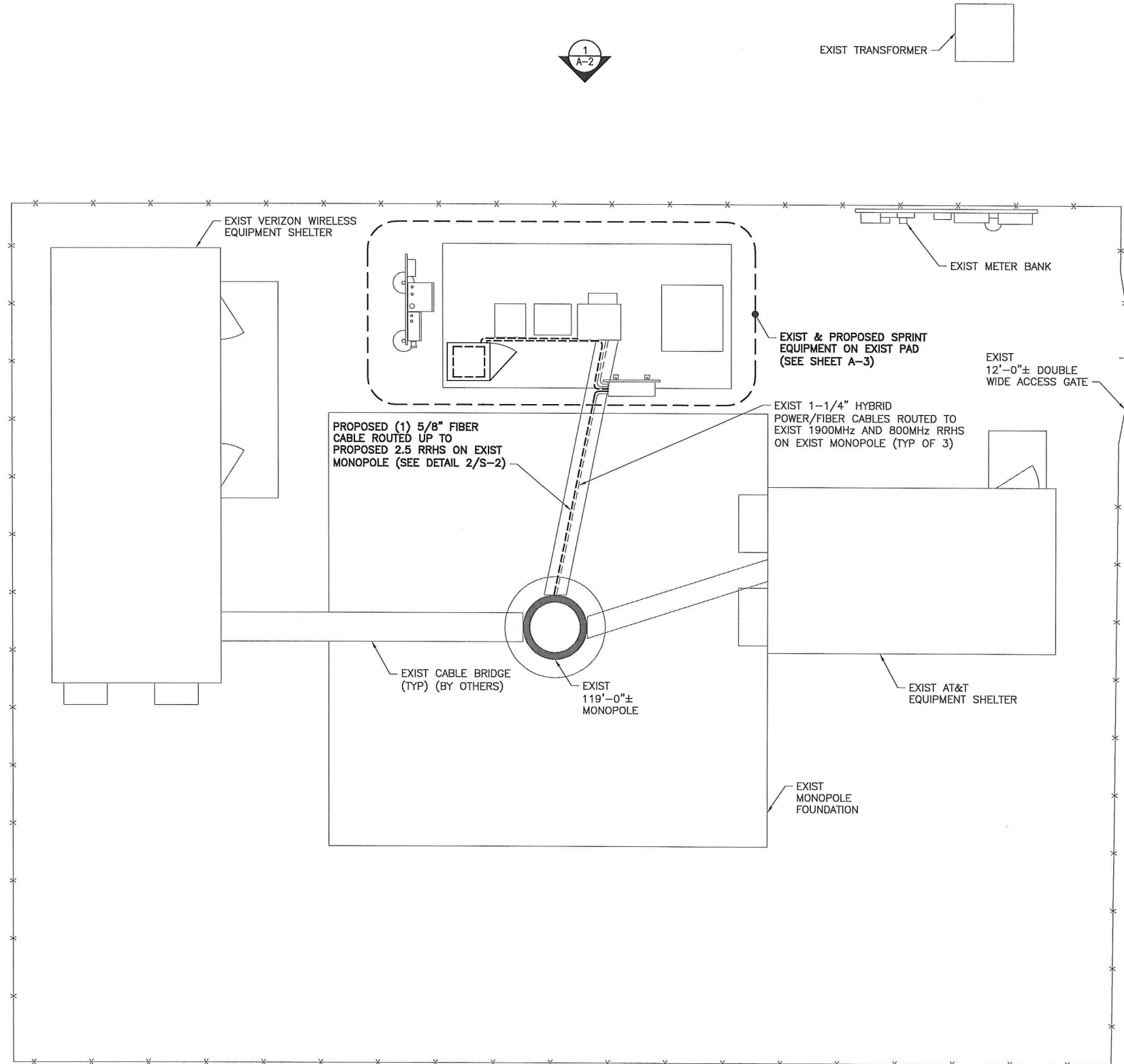

1
A-1 **SITE PLAN**
SCALE: 3/16" = 1'-0"

Sprint

2.5 EQUIPMENT DEPLOYMENT
6850 SPRINT PARKWAY
OVERLAND PARK, KANSAS 66251

CROWN CASTLE

TECTONIC
• PLANNING
• ENGINEERING
• SURVEYING
• CONSTRUCTION MANAGEMENT

TECTONIC Engineering & Surveying
Consultants P.C.

1279 Route 300
Newburgh, NY 12550

Phone: (845) 567-6656
Fax: (845) 567-8703

www.tectoniceengineering.com

THIS DOCUMENT IS THE CREATION, DESIGN, PROPERTY AND COPYRIGHTED WORK OF SPRINT COMMUNICATIONS, INC. ANY DUPLICATION OR USE WITHOUT EXPRESS WRITTEN CONSENT IS STRICTLY PROHIBITED. DUPLICATION AND USE BY GOVERNMENT AGENCIES FOR THE PURPOSES OF CONDUCTING THEIR LAWFULLY AUTHORIZED REGULATORY AND ADMINISTRATIVE FUNCTIONS IS SPECIFICALLY ALLOWED.

SUBMITTALS

PROJECT NO: 7225.CT33XC540

NO	DATE	DESCRIPTION	BY
0	07/08/14	FOR COMMENT	DC
1	01/05/15	FOR CONSTRUCTION	DC

DATE	REVIEWED BY
1/5/15	JMG

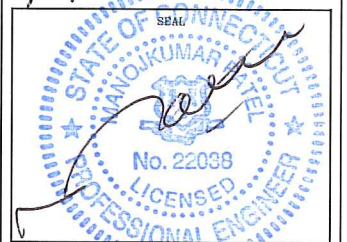

SITE NUMBER:
CT33XC540

SITE NAME:
MADISON-ATT

SITE ADDRESS:
1749 DURHAM ROAD
MADISON, CT 06448

SHEET TITLE:
SITE PLAN

SHEET NO:
A-1

THE EXISTING MONOPOLE SHALL BE ANALYZED BY A PROFESSIONAL ENGINEER LICENSED IN THE STATE OF CONNECTICUT (TO BE COORDINATED BY OTHERS).

THE EXISTING MOUNT HAS BEEN ANALYZED BY TECTONIC ENGINEERING AND FOUND TO BE ADEQUATE TO SUPPORT THE PROPOSED SPRINT UPGRADE AS DETAILED IN THE STRUCTURAL ANALYSIS EVALUATION LETTER DATED 01/05/15.

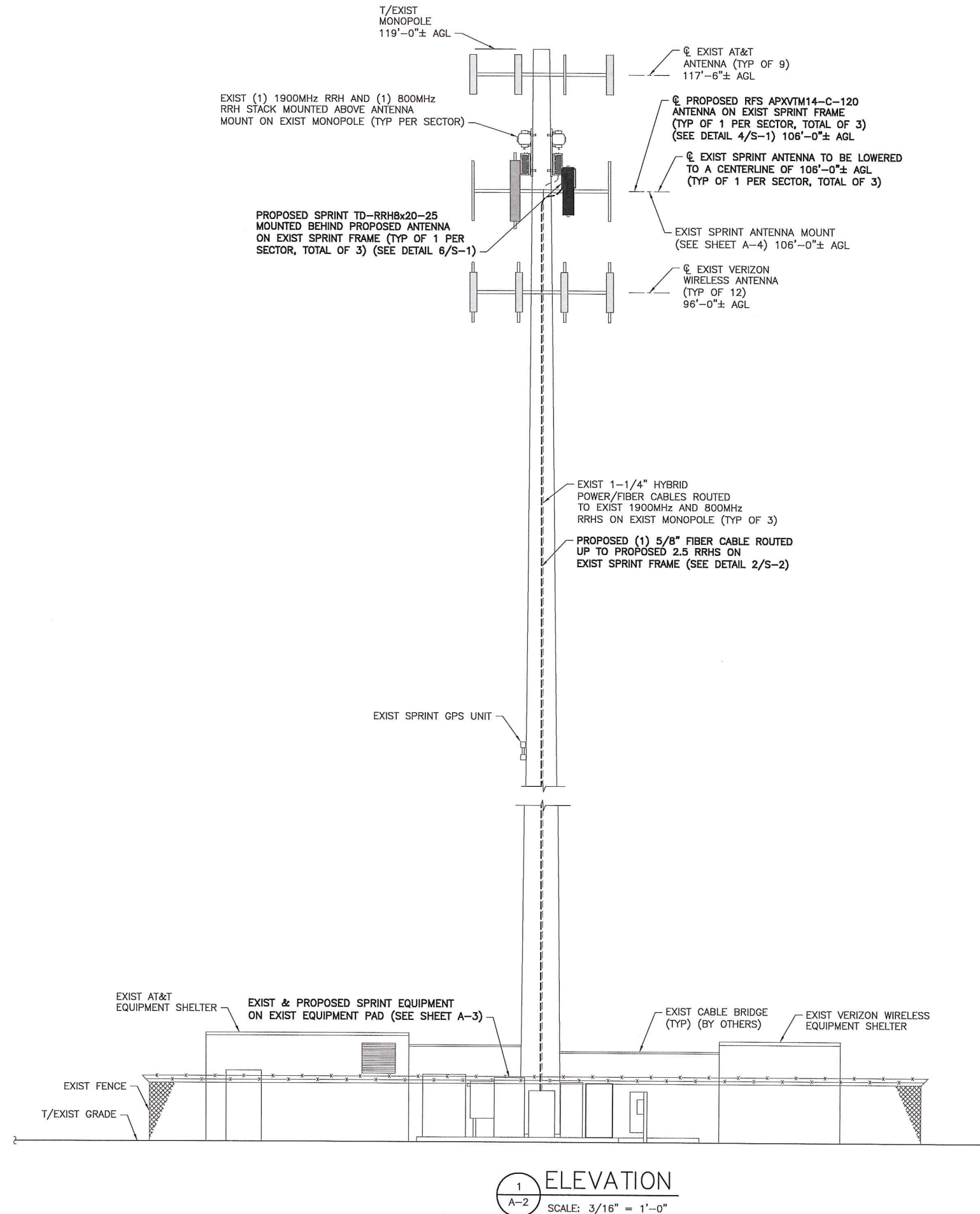
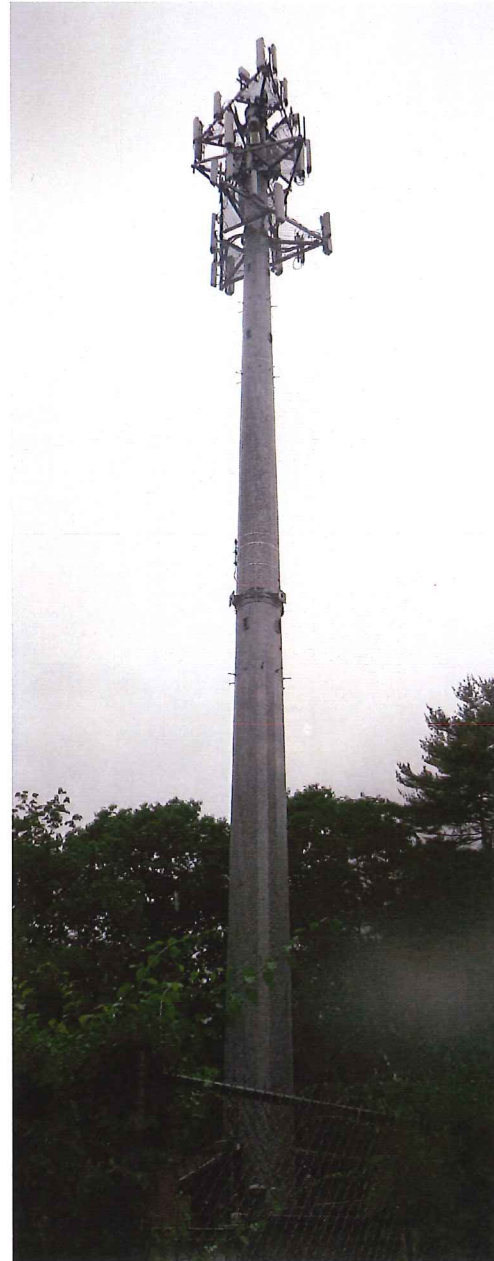

Sprint
 2.5 EQUIPMENT DEPLOYMENT
 6850 SPRINT PARKWAY
 OVERLAND PARK, KANSAS 66251

CROWN CASTLE

TECTONIC
 • PLANNING
 • ENGINEERING
 • SURVEYING
 • CONSTRUCTION MANAGEMENT
TECTONIC Engineering & Surveying
 Consultants P.C.
 1279 Route 300
 Newburgh, NY 12550
 Phone: (845) 567-6656
 Fax: (845) 567-8703
 www.tectonicengineering.com

THIS DOCUMENT IS THE CREATION, DESIGN, PROPERTY AND COPYRIGHTED WORK OF SPRINT COMMUNICATIONS, INC. ANY DUPLICATION OR USE WITHOUT EXPRESS WRITTEN CONSENT IS STRICTLY PROHIBITED. DUPLICATION AND USE BY GOVERNMENT AGENCIES FOR THE PURPOSES OF CONDUCTING THEIR LAWFULLY AUTHORIZED REGULATORY AND ADMINISTRATIVE FUNCTIONS IS SPECIFICALLY ALLOWED.

SUBMITTALS			
NO	DATE	DESCRIPTION	BY
0	07/08/14	FOR COMMENT	DC
1	01/05/15	FOR CONSTRUCTION	DC

DATE	REVIEWED BY
1/5/15	JMA



SITE NUMBER:
 CT33XC540
 SITE NAME:
 MADISON-ATT
 SITE ADDRESS:
 1749 DURHAM ROAD
 MADISON, CT 06443

SHEET TITLE:
 ELEVATION

SHEET NO:
 A-2

NORTH NOTE:
 NORTH SHOWN HAS BEEN ESTABLISHED USING THE USGS QUADRANGLE 7.5 MINUTE MAPS AND IS APPROXIMATE. VERIFY TRUE NORTH PRIOR TO INSTALLATION OF ANTENNAS.

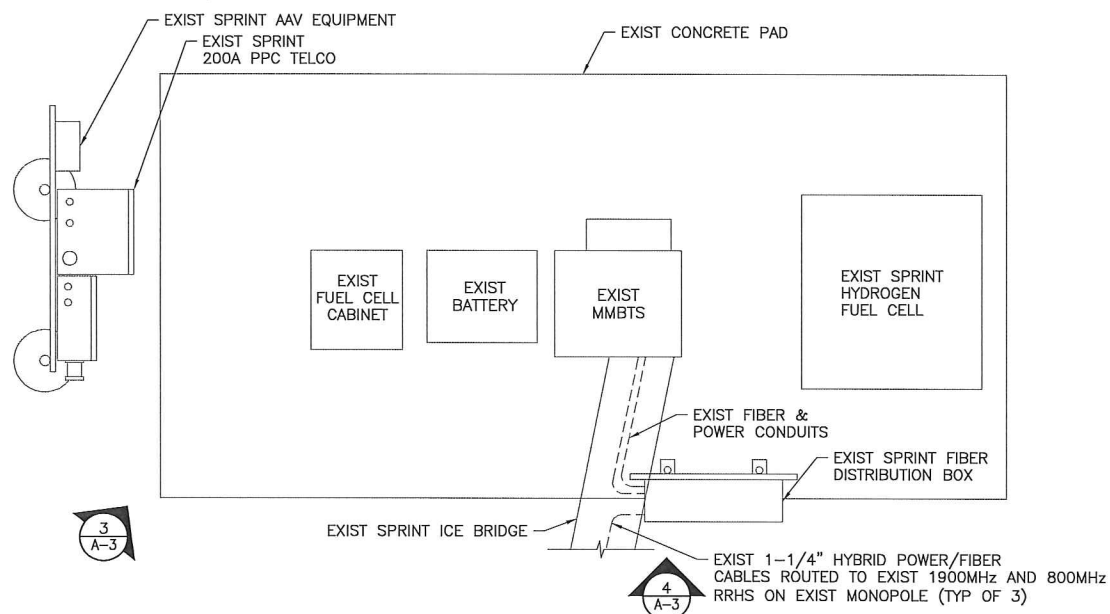
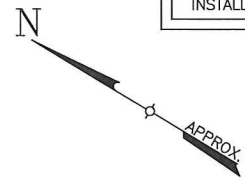

1 ENLARGED EQUIP. LAYOUT PLAN (EXIST)

SCALE: 1/2" = 1'-0"

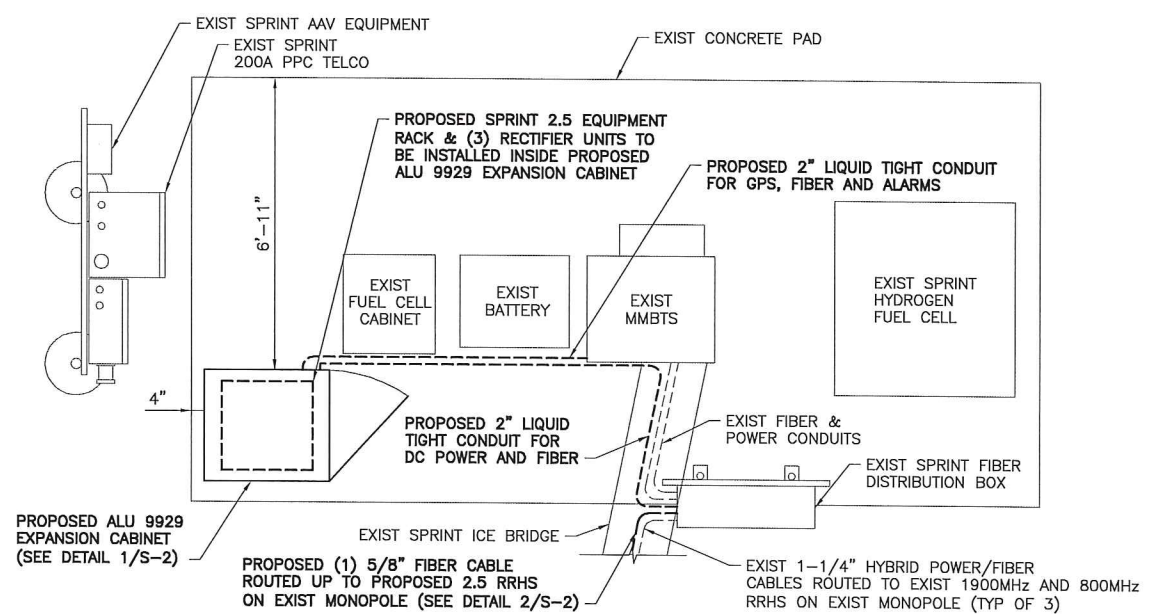

2 ENLARGED EQUIP. LAYOUT PLAN (FINAL)

SCALE: 1/2" = 1'-0"



3 EXIST EQUIPMENT PAD

SCALE: NTS



4 EXIST FIBER DISTRIBUTION BOX

SCALE: NTS

Sprint
 2.5 EQUIPMENT DEPLOYMENT
 6850 SPRINT PARKWAY
 OVERLAND PARK, KANSAS 66251

CROWN CASTLE

TECTONIC
 • PLANNING
 • ENGINEERING
 • SURVEYING
 • CONSTRUCTION MANAGEMENT
TECTONIC Engineering & Surveying Consultants P.C.
 1279 Route 300
 Newburgh, NY 12550
 Phone: (845) 567-6656
 Fax: (845) 567-8703
 www.tectonicengineering.com

THIS DOCUMENT IS THE CREATION, DESIGN, PROPERTY AND COPYRIGHTED WORK OF SPRINT COMMUNICATIONS, INC. ANY DUPLICATION OR USE WITHOUT EXPRESS WRITTEN CONSENT IS STRICTLY PROHIBITED. DUPLICATION AND USE BY GOVERNMENT AGENCIES FOR THE PURPOSES OF CONDUCTING THEIR LAWFULLY AUTHORIZED REGULATORY AND ADMINISTRATIVE FUNCTIONS IS SPECIFICALLY ALLOWED.

SUBMITTALS

PROJECT NO: 7225.CT33XC540

NO	DATE	DESCRIPTION	BY
0	07/08/14	FOR COMMENT	DC
1	01/05/15	FOR CONSTRUCTION	DC

DATE	REVIEWED BY
1/5/15	JMC

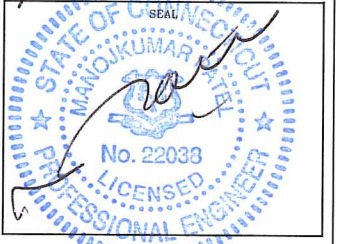

SITE NUMBER:
 CT33XC540
 SITE NAME:
 MADISON-ATT
 SITE ADDRESS:
 1749 DURHAM ROAD
 MADISON, CT 06443

SHEET TITLE:
 ENLARGED EQUIPMENT LAYOUT PLANS

SHEET NO:
 A-3

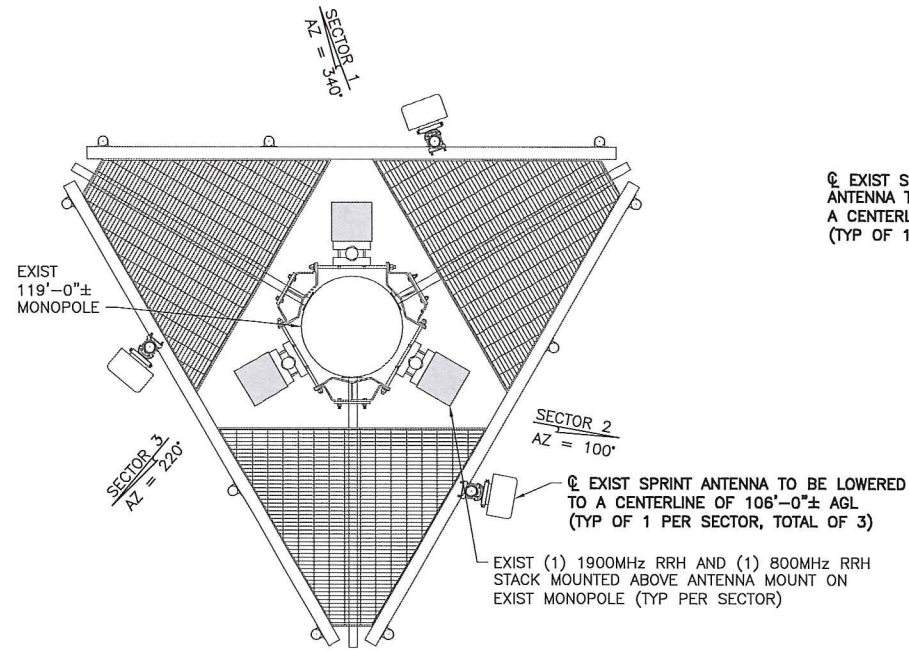

1 ANTENNA LAYOUT PLAN (EXIST)
A-4 SCALE: 3/8" = 1'-0"

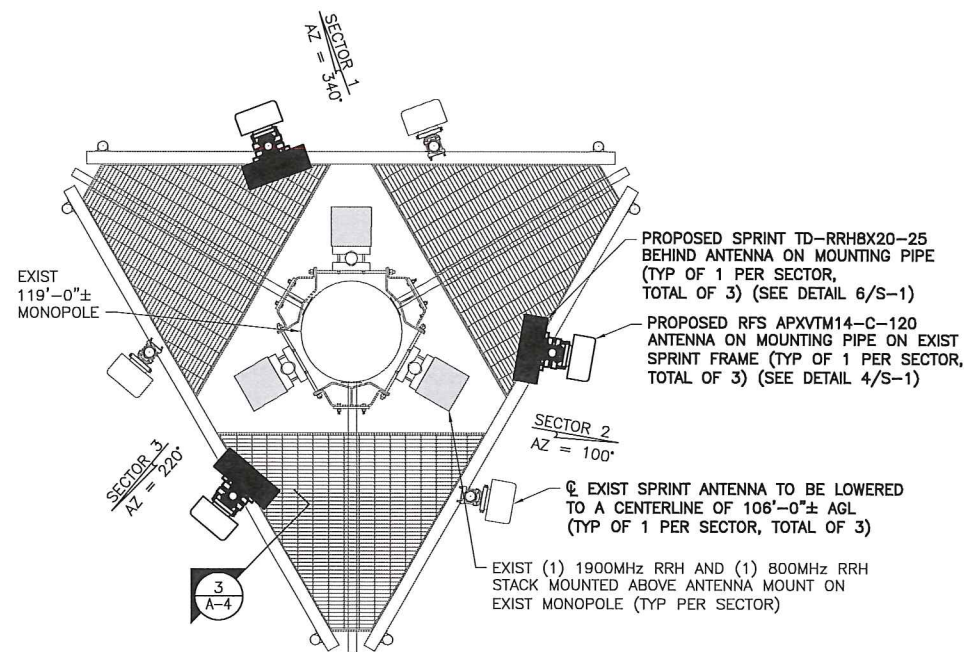

2 ANTENNA LAYOUT PLAN (FINAL)
A-4 SCALE: 3/8" = 1'-0"

EXIST SPRINT ANTENNA TO BE LOWERED TO A CENTERLINE OF 106'-0"± AGL (TYP OF 1 PER SECTOR, TOTAL OF 3)

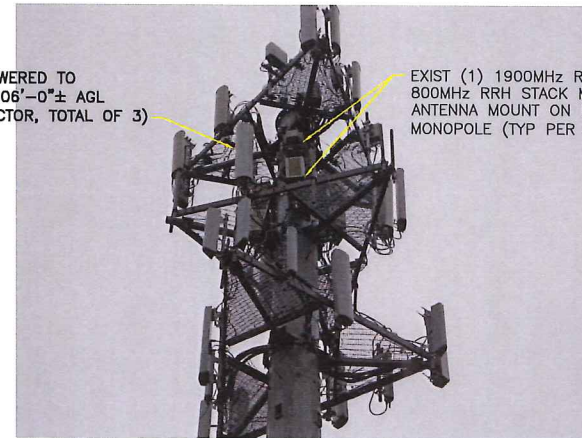

EXIST (1) 1900MHz RRH AND (1) 800MHz RRH STACK MOUNTED ABOVE ANTENNA MOUNT ON EXIST MONOPOLE (TYP PER SECTOR)

THE EXISTING MONOPOLE SHALL BE ANALYZED BY A PROFESSIONAL ENGINEER LICENSED IN THE STATE OF CONNECTICUT (TO BE COORDINATED BY OTHERS).

THE EXISTING MOUNT HAS BEEN ANALYZED BY TECTONIC ENGINEERING AND FOUND TO BE ADEQUATE TO SUPPORT THE PROPOSED SPRINT UPGRADE AS DETAILED IN THE STRUCTURAL ANALYSIS EVALUATION LETTER DATED 01/05/15.

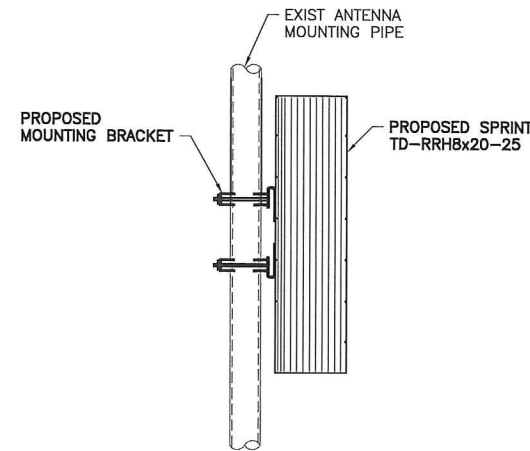

3 RRH MOUNTING DETAIL
A-4 SCALE: 1 1/2" = 1'-0"

ANTENNA DATA

Status	Exist	Proposed
Antenna Manufacturer	RFS-CEL WAVE	RFS-CEL WAVE
Antenna Model Number	APXVSP18C-A20	APXVTM14-C-120
Number of Antennas	3	3
Antenna RAD Center	106'	106'
Antenna Azimuth	340/100/220	340/100/220
Antenna RRH Model Number	1900MHz/800MHz RRHS	TD-RRHx20-25
Number of RRH	6	3

Sprint
2.5 EQUIPMENT DEPLOYMENT
6850 SPRINT PARKWAY
OVERLAND PARK, KANSAS 66251

CROWN CASTLE

TECTONIC
PLANNING
ENGINEERING
SURVEYING
CONSTRUCTION MANAGEMENT

TECTONIC Engineering & Surveying Consultants P.C.
1279 Route 300
Newburgh, NY 12550
Phone: (845) 567-6656
Fax: (845) 567-8703
www.tectonicengineering.com

THIS DOCUMENT IS THE CREATION, DESIGN, PROPERTY AND COPYRIGHTED WORK OF SPRINT COMMUNICATIONS, INC. ANY DUPLICATION OR USE WITHOUT EXPRESS WRITTEN CONSENT IS STRICTLY PROHIBITED. DUPLICATION AND USE BY GOVERNMENT AGENCIES FOR THE PURPOSES OF CONDUCTING THEIR LAWFULLY AUTHORIZED REGULATORY AND ADMINISTRATIVE FUNCTIONS IS SPECIFICALLY ALLOWED.

SUBMITTALS

PROJECT NO: 7225.CT33XC540

NO	DATE	DESCRIPTION	BY
0	07/08/14	FOR COMMENT	DC
1	01/05/15	FOR CONSTRUCTION	DC

DATE: 1/5/15
REVIEWED BY: JMQ



SITE NUMBER:
CT33XC540

SITE NAME:
MADISON-ATT

SITE ADDRESS:
1749 DURHAM ROAD
MADISON, CT 06443

SHEET TITLE:
ANTENNA LAYOUT PLANS

SHEET NO:
A-4

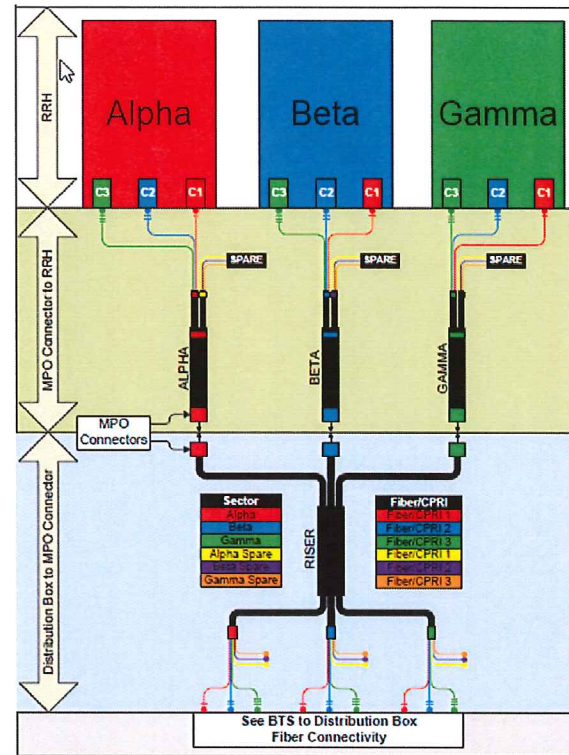

1 2.5 CABLE COLOR CODING
A-5 SCALE: N.T.S.

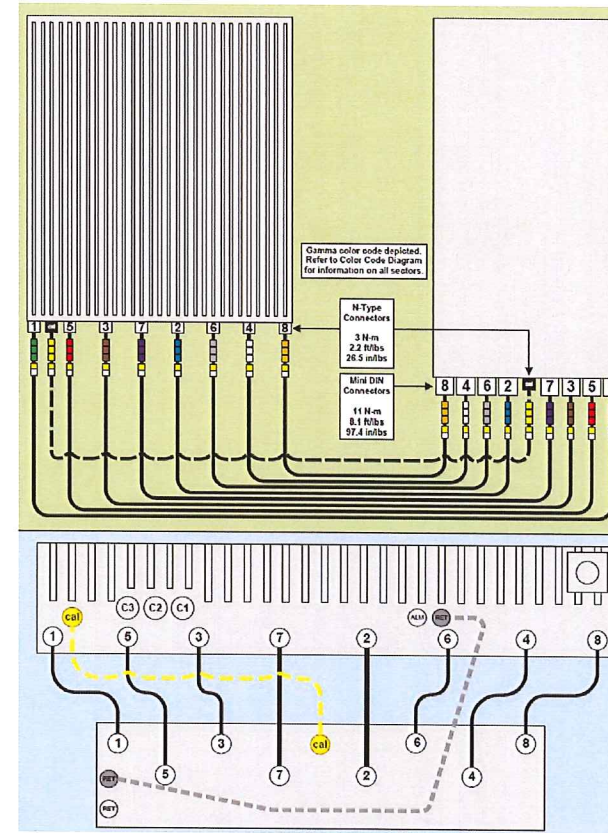

2 RRH CONNECTIVITY
A-5 SCALE: N.T.S.

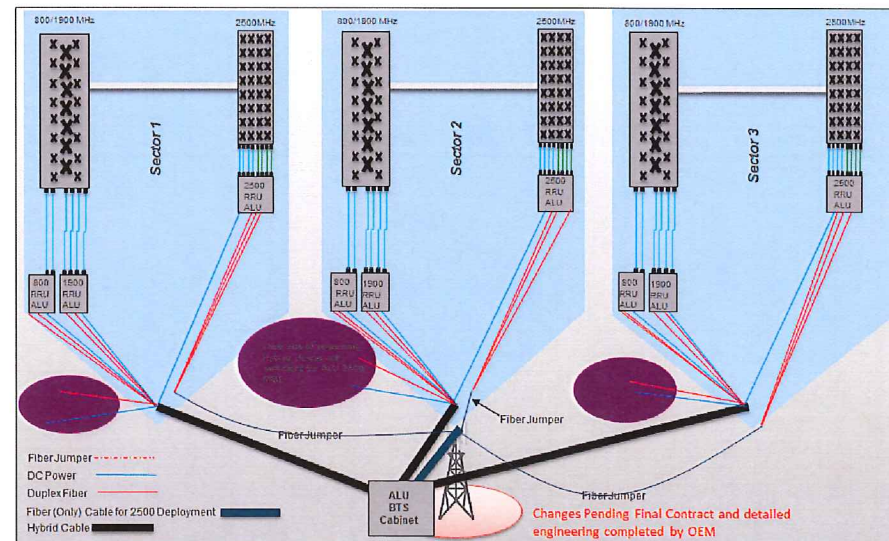

3 RAN WIRING
A-5 SCALE: N.T.S.

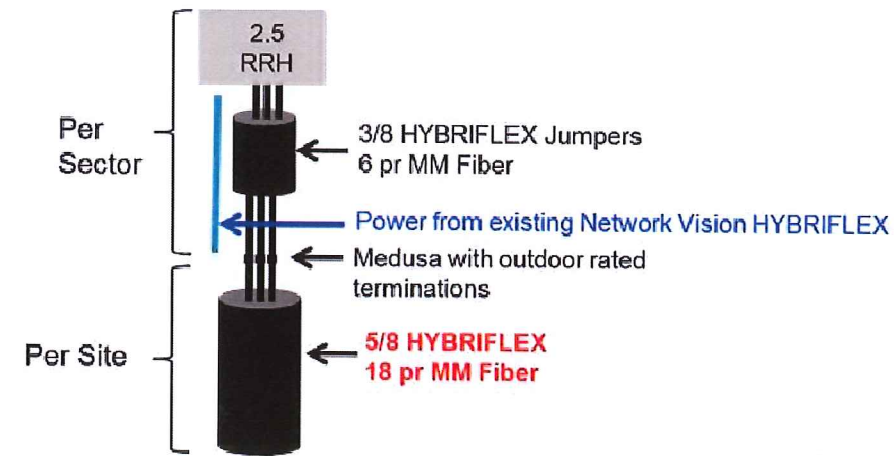

4 CABLE SCENARIO
A-5 SCALE: N.T.S.

Sprint
2.5 EQUIPMENT DEPLOYMENT
6850 SPRINT PARKWAY
OVERLAND PARK, KANSAS 66251

CROWN CASTLE

TECTONIC

TECTONIC Engineering & Surveying Consultants P.C.
1279 Route 300
Newburgh, NY 12550
Phone: (845) 567-6656
Fax: (845) 567-8703
www.tectonicengineering.com

THIS DOCUMENT IS THE CREATION, DESIGN, PROPERTY AND COPYRIGHTED WORK OF SPRINT COMMUNICATIONS, INC. ANY DUPLICATION OR USE WITHOUT EXPRESS WRITTEN CONSENT IS STRICTLY PROHIBITED. DUPLICATION AND USE BY GOVERNMENT AGENCIES FOR THE PURPOSES OF CONDUCTING THEIR LAWFULLY AUTHORIZED REGULATORY AND ADMINISTRATIVE FUNCTIONS IS SPECIFICALLY ALLOWED.

SUBMITTALS

NO	DATE	DESCRIPTION	BY
0	07/08/14	FOR COMMENT	DC
1	01/05/15	FOR CONSTRUCTION	DC

DATE	REVIEWED BY
1/5/15	JMG

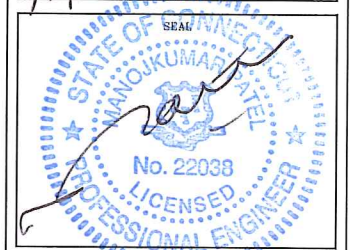

SITE NUMBER:
CT33XC540
SITE NAME:
MADISON-ATT
SITE ADDRESS:
1749 DURHAM ROAD
MADISON, CT 06443

SHEET TITLE:
RAN WIRING DIAGRAM

SHEET NO:
A-5

THIS DOCUMENT IS THE CREATION, DESIGN, PROPERTY AND COPYRIGHTED WORK OF SPRINT COMMUNICATIONS, INC. ANY DUPLICATION OR USE WITHOUT EXPRESS WRITTEN CONSENT IS STRICTLY PROHIBITED. DUPLICATION AND USE BY GOVERNMENT AGENCIES FOR THE PURPOSES OF CONDUCTING THEIR LAWFULLY AUTHORIZED REGULATORY AND ADMINISTRATIVE FUNCTIONS IS SPECIFICALLY ALLOWED.

SUBMITTALS

PROJECT NO: 7225.CT33XC540

NO	DATE	DESCRIPTION	BY
0	07/08/14	FOR COMMENT	DC
1	01/05/15	FOR CONSTRUCTION	DC

DATE	REVIEWED BY
1/5/15	JMA

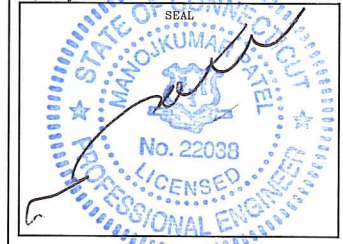

SITE NUMBER:
CT33XC540

SITE NAME:
MADISON-ATT

SITE ADDRESS:
**1749 DURHAM ROAD
 MADISON, CT 06443**

SHEET TITLE:
CABLE DETAILS

SHEET NO:
A-6

IMPORTANT!! LINE UP WHITE MARKINGS ON JUMPER AND RISER IP-MPO CONNECTOR. PUSH THE WHITE MARK ON THE JUMPER CONNECTOR FLUSH AGAINST THE RED SEAL ON THE RISER CONNECTION



IMPORTANT!! ROTATE THE BAYONET HOUSING CLOCKWISE UNTIL A CLICK SOUND IS HEARD TO ENSURE A GOOD CONNECTION

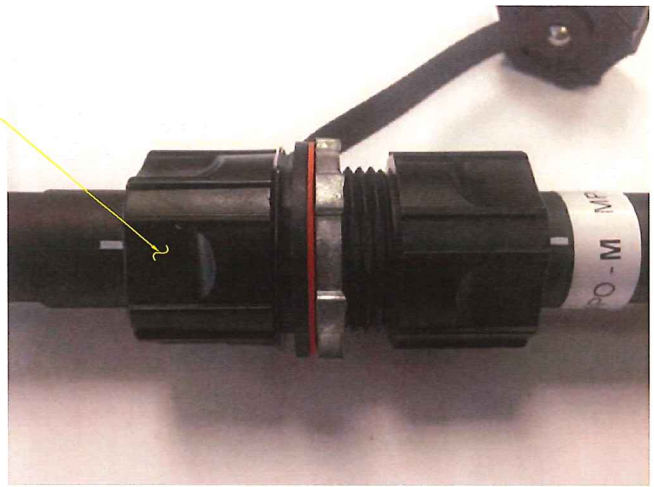

1 HYBRIFLEX RISER/JUMPER CONNECTION DETAILS
 A-6 SCALE: N.T.S.

TRUNK-LINE TO JUMPER CONNECTION (MPO) TO BE INSTALLED PER MANUFACTURER REQUIREMENTS. SEE DETAIL.

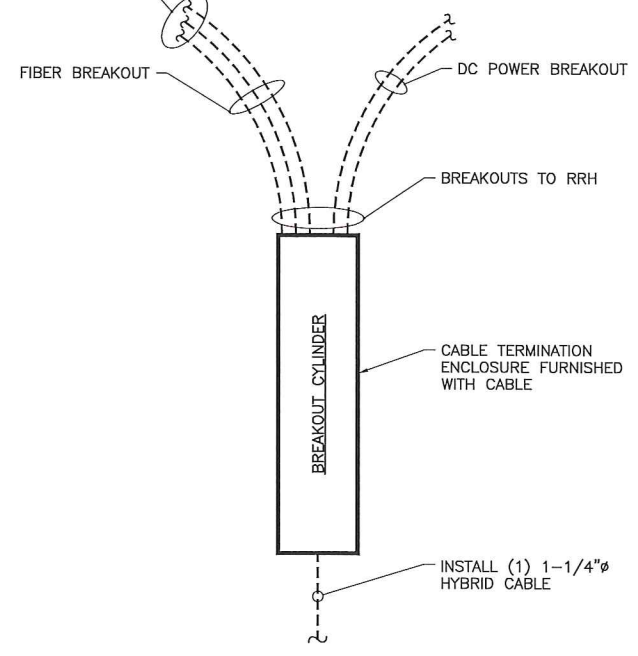

2 2.5 HYBRID CABLE W/FIBER & DC FEEDERS
 A-6 SCALE: N.T.S.

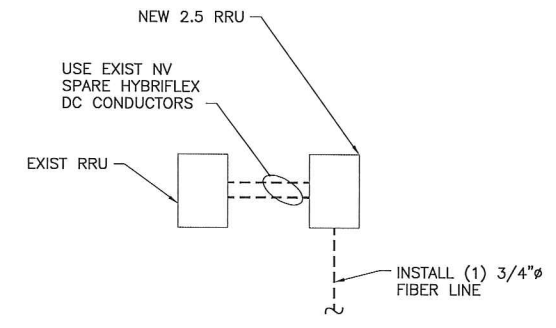

2 FIBER ONLY TRUNK LINES
 A-6 SCALE: N.T.S.

SPECIAL NOTES: CABLE MARKINGS AT RAD CENTER AND ALL WALL/BLDG. PENETRATIONS

- ALL COLOR CODE TAPE SHALL BE 3M-35 AND SHALL BE INSTALLED USING A MINIMUM OF (3) WRAPS OF TAPE.
- ALL COLOR BANDS INSTALLED AT THE TOWER TOP SHALL BE A MINIMUM OF 3" WIDE AND SHALL HAVE A MINIMUM OF 3/4" OF SPACING BETWEEN EACH COLOR.
- ALL COLOR BANDS INSTALLED AT OR NEAR THE GROUND MAY BE ONLY 3/4" WIDE. EACH TOP-JUMPER SHALL BE COLOR CODED WITH (1) SET OF 3" WIDE BANDS.
- EACH MAIN COAX SHALL BE COLOR CODED WITH (1) SET OF 3" BANDS NEAR THE TOP-JUMPER CONNECTION AND WITH 3/4" COLOR BANDS JUST PRIOR TO ENTERING THE BTS OR TRANSMITTER BUILDING.
- ALL BOTTOM JUMPERS SHALL BE COLOR CODED WITH (1) SET OF 3/4" BANDS ON EACH END OF THE BOTTOM JUMPER.
- ALL COLOR CODES SHALL BE INSTALLED SO AS TO ALIGN NEATLY WITH ONE ANOTHER FROM SIDE-TO-SIDE.
- EACH COLOR BAND SHALL HAVE A MINIMUM OF (3) WRAPS AND SHALL BE NEATLY TRIMMED AND SMOOTHED OUT AS TO AVOID UNRAVELING.
- X-POLE ANTENNAS SHOULD USE "XX-1" FOR THE "+45" PORT, "XX-2" FOR THE "-45" PORT.
- COLOR BAND #4 REFERS TO THE FREQUENCY BAND: ORANGE=850, VIOLET=1900. USED ON JUMPERS ONLY.
- RF FEEDLINE SHALL BE IDENTIFIED WITH A METAL TAG (STAINLESS OR BRASS) AND STAMPED WITH THE SECTOR, ANTENNA POSITION, AND CABLE NUMBER.
- ANTENNAS MUST BE IDENTIFIED, USING THE SECTOR LETTER AND ANTENNA NUMBER, WITH A BLACK MARKER PRIOR TO INSTALLATION.

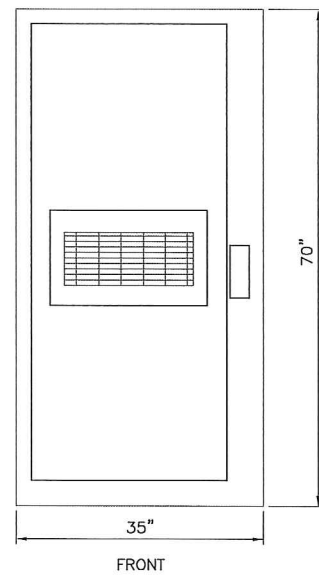

CABINET FRONT
9928 MMBTS MODULAR CELL

SPECIFICATIONS:

HEIGHT: 70"
WIDTH: 35"
DEPTH: 37.8"
WEIGHT: 1090 LBS.

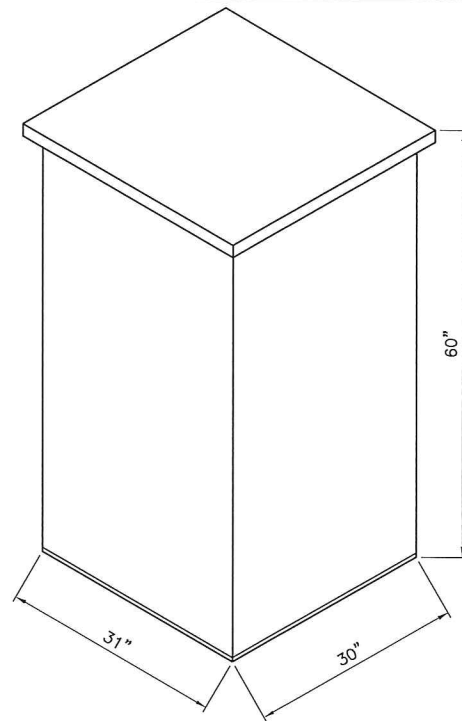

ANDREW 60ECv2

SPECIFICATIONS:

HEIGHT: 60"
WIDTH: 31"
DEPTH: 30"
WEIGHT: 2430 LBS.

1 (EXIST) MMBTS CABINET
S-1 SCALE: 1" = 1'-0"

2 (EXIST) BATTERY CABINET
S-1 SCALE: 1" = 1'-0"

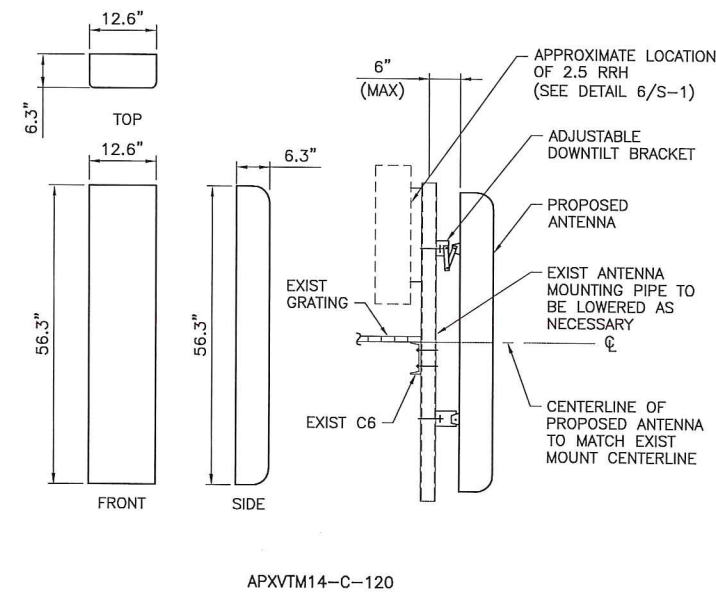
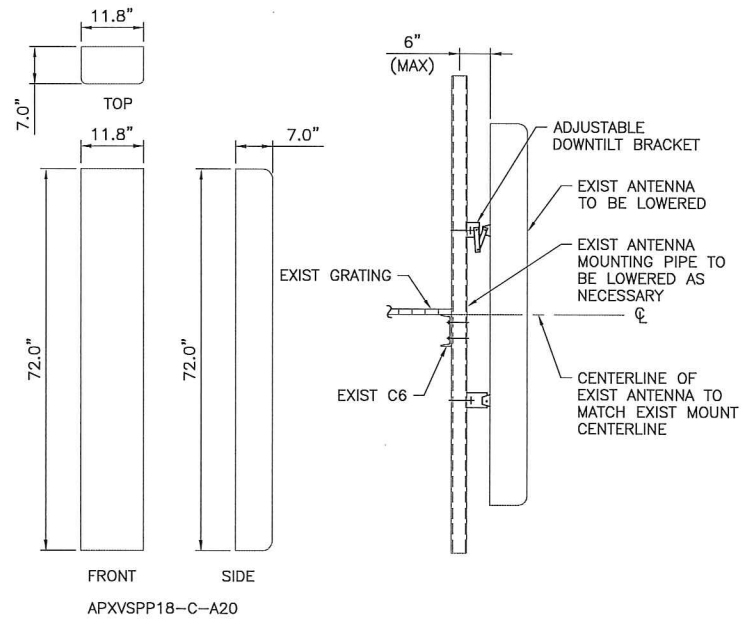

3 (EXIST) ANTENNA DETAILS
S-1 SCALE: 3/4" = 1'-0"

4 (PROPOSED) ANTENNA DETAIL
S-1 SCALE: 3/4" = 1'-0"

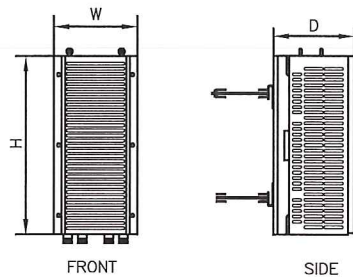

TYPE: 1900 MHz 4x45W
MODEL #: RRH 1900 4X45 65MHz
HEIGHT: 25.0"
WIDTH: 11.1"
DEPTH: 11.4"
WEIGHT: ±60 LBS.

5 (EXIST) RRH DETAILS
S-1 SCALE: 1 1/2" = 1'-0"

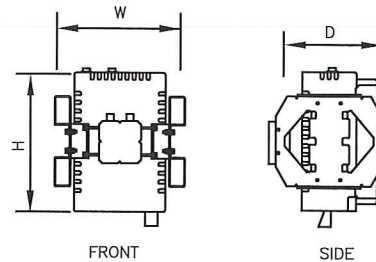

TYPE: 800 MHz 2x50W
MODEL #: FD-RRH-2x50-800
HEIGHT: 19.7"
WIDTH: 13"
DEPTH: 10.8"
WEIGHT: ±53 LBS.

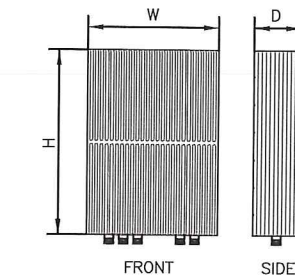

TYPE: 2.5 RRH
MODEL #: TD-RRH8x20-25
HEIGHT: 26.1"
WIDTH: 18.6"
DEPTH: 6.7"
WEIGHT: ±70 LBS.

6 (PROPOSED) RRH DETAIL
S-1 SCALE: 1" = 1'-0"

Sprint

2.5 EQUIPMENT DEPLOYMENT
6850 SPRINT PARKWAY
OVERLAND PARK, KANSAS 66251

CROWN CASTLE

TECTONIC

• PLANNING
• ENGINEERING
• SURVEYING
• CONSTRUCTION MANAGEMENT

TECTONIC Engineering & Surveying
Consultants P.C.

1279 Route 300
Newburgh, NY 12550

Phone: (845) 567-6656
Fax: (845) 567-8703
www.tectonicengineering.com

THIS DOCUMENT IS THE CREATION, DESIGN, PROPERTY AND COPYRIGHTED WORK OF SPRINT COMMUNICATIONS, INC. ANY DUPLICATION OR USE WITHOUT EXPRESS WRITTEN CONSENT IS STRICTLY PROHIBITED. DUPLICATION AND USE BY GOVERNMENT AGENCIES FOR THE PURPOSES OF CONDUCTING THEIR LAWFULLY AUTHORIZED REGULATORY AND ADMINISTRATIVE FUNCTIONS IS SPECIFICALLY ALLOWED.

SUBMITTALS

PROJECT NO: 7225.CT33XC540

NO	DATE	DESCRIPTION	BY
0	07/08/14	FOR COMMENT	DC
1	01/05/15	FOR CONSTRUCTION	DC

DATE	REVIEWED BY
1/5/15	JMG



SITE NUMBER:
CT33XC540

SITE NAME:
MADISON- ATT

SITE ADDRESS:
1749 DURHAM ROAD
MADISON, CT 06443

SHEET TITLE:
EQUIPMENT DETAILS

SHEET NO:
S-1

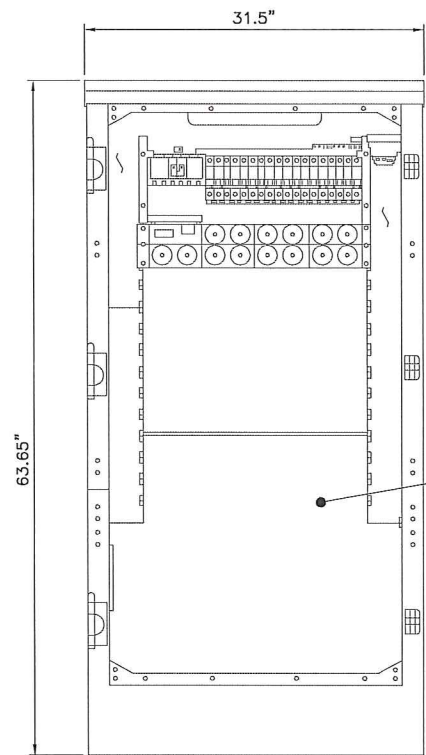

9929 EXPANSION CABINET	
CABINET SPECIFICATIONS	
EXPANSION CABINET:	
- HEIGHT -	63.65"
- WIDTH -	31.5"
- DEPTH -	35.5"
WEIGHT: 1,600 LBS.	

INSTALL NEW 2.5 EQUIPMENT IN PROPOSED 9929 EXPANSION CABINET INCLUDING BUT NOT LIMITED TO BASE BAND UNIT, CELL SITE ROUTER AND SURGE ARRESTORS. GROUND EQUIPMENT TO PROPOSED INTERIOR CABINET GROUND BAR

FRONT ELEVATION (CABINET INTERIOR)

1 9929 INTERIOR DETAIL
SCALE: N.T.S.

- LEGEND:**
- P1000T-HG UNISTRUT, 12" LONG.
 - 6" PIPE HANGER.
 - EXISTING SUPPORT PIPE.
 - NEW STANDOFF BRACKET, ANDREW PART# 30848-4.
 - NEW ROUND MEMBER ADAPTER SIZED FOR EXISTING PIPE SUPPORT.
 - BREAKOUT UNIT.
 - CABLE.

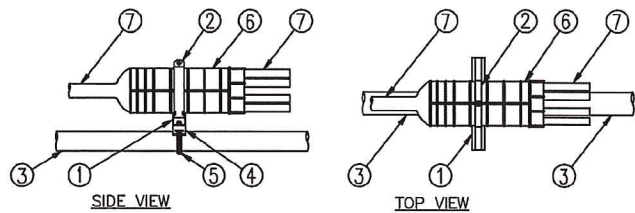

3 MEDUSA HEAD DETAIL
SCALE: NTS

RFS HYBRIFLEX RISER CABLES SCHEDULE

Fiber Only (Existing DC Power)	Hybrid cable MN: HB058-M12-050F 12x multi-mode fiber pairs, Top: Outdoor protected connectors, Bottom: LC Connectors, 5/8 cable, 50ft	50 ft	
	MN: HB058-M12-075F	75 ft	
	MN: HB058-M12-100F	100 ft	
	MN: HB058-M12-125F	125 ft	
	MN: HB058-M12-150F	150 ft	
	MN: HB058-M12-175F	175 ft	
8 AWG Power	Hybrid cable MN: HB114-08U3M12-050F 3x 8 AWG power pairs, 12x multi-mode fiber pairs, Outdoor rated connectors & LC Connectors, 1 1/4 cable, 50ft	50 ft	
	MN: HB114-08U3M12-075F	75 ft	
	MN: HB114-08U3M12-100F	100 ft	
	MN: HB114-08U3M12-125F	125 ft	
	MN: HB114-08U3M12-150F	150 ft	
	MN: HB114-08U3M12-175F	175 ft	
6 AWG Power	Hybrid cable MN: HB114-13U3M12-225F 3x 6 AWG power pairs, 12x multi-mode fiber pairs, Outdoor rated connectors & LC Connectors, 1 1/4 cable, 225ft	225 ft	
	MN: HB114-13U3M12-250F	250 ft	
	MN: HB114-13U3M12-275F	275 ft	
	MN: HB114-13U3M12-300F	300 ft	
	4 AWG Power	Hybrid cable MN: HB114-21U3M12-225F 3x 4 AWG power pairs, 12x multi-mode fiber pairs, Outdoor rated connectors & LC Connectors, 1 1/4 cable, 225ft	325 ft
		MN: HB114-21U3M12-250F	350 ft
MN: HB114-21U3M12-275F		375 ft	

RFS HYBRIFLEX JUMPER CABLE SCHEDULE

Fiber Only	Hybrid Jumper cable MN: HBF012-M3-5F1 5 ft, 3x multi-mode fiber pairs, Outdoor & LC connectors, 1/2 cable	5 ft
	MN: HBF012-M3-10F1	10 ft
	MN: HBF012-M3-15F1	15 ft
	MN: HBF012-M3-20F1	20 ft
	MN: HBF012-M3-25F1	25 ft
	MN: HBF012-M3-30F1	30 ft
8 AWG Power	Hybrid Jumper cable MN: HBF058-08U1M3-5F1 5 ft, 1x 8 AWG power pair, 3x multi-mode fiber pairs, Outdoor & LC Connectors, 5/8 cable	5 ft
	MN: HBF058-08U1M3-10F1	10 ft
	MN: HBF058-08U1M3-15F1	15 ft
	MN: HBF058-08U1M3-20F1	20 ft
	MN: HBF058-08U1M3-25F1	25 ft
	MN: HBF058-08U1M3-30F1	30 ft
6 AWG Power	Hybrid Jumper cable MN: HBF058-13U1M3-5F1 5 ft, 1x 6 AWG power pair, 3x multi-mode fiber pairs, Outdoor & LC Connectors, 5/8 cable	5 ft
	MN: HBF058-13U1M3-10F1	10 ft
	MN: HBF058-13U1M3-15F1	15 ft
	MN: HBF058-13U1M3-20F1	20 ft
	MN: HBF058-13U1M3-25F1	25 ft
	MN: HBF058-13U1M3-30F1	30 ft
4 AWG Power	Hybrid Jumper cable MN: HBF078-21U1M3-5F1 5 ft, 1x 4 AWG power pair, 3x multi-mode fiber pairs, Outdoor & LC Connectors, 7/8 cable	5 ft
	MN: HBF078-21U1M3-10F1	10 ft
	MN: HBF078-21U1M3-15F1	15 ft
	MN: HBF078-21U1M3-20F1	20 ft
	MN: HBF078-21U1M3-25F1	25 ft
	MN: HBF078-21U1M3-30F1	30 ft

HYBRID CABLE DC CONDUCTOR SIZE GUIDELINE

MANUF:	RFS		
CABLE	LENGTH	DC CONDUCTOR	CABLE DIAMETER
FIBER ONLY	VARIES	USE NV HYBRIFLEX	7/8"
HYBRIFLEX	<200'	8 AWG	1-1/4"
HYBRIFLEX	225-300'	6 AWG	1-1/4"
HYBRIFLEX	325-375'	4 AWG	1-1/4"

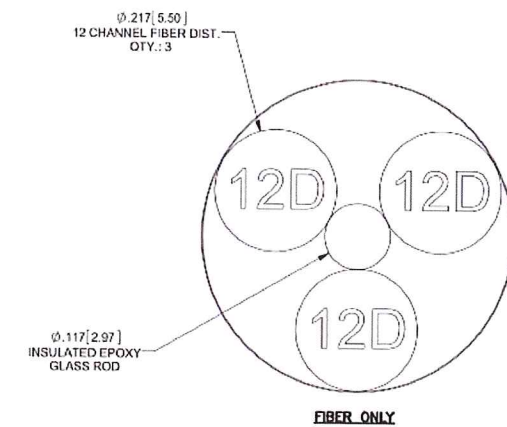
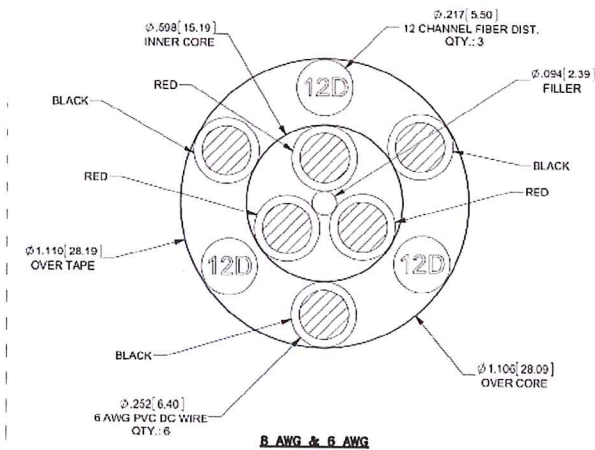
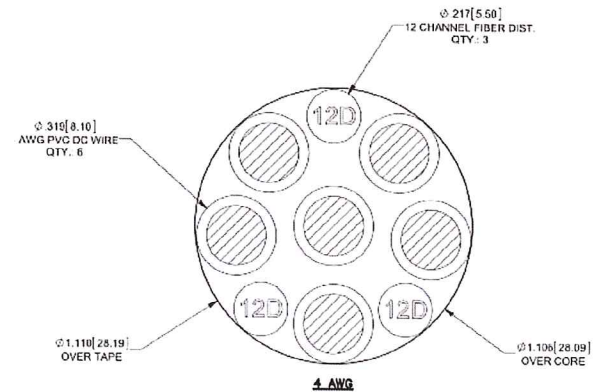

2 2.5 HYBRID CABLE X-SECTION AND DATA
SCALE: NTS

Sprint

2.5 EQUIPMENT DEPLOYMENT
6850 SPRINT PARKWAY
OVERLAND PARK, KANSAS 66251

CROWN CASTLE

TECTONIC

TECTONIC Engineering & Surveying Consultants P.C.

1279 Route 300

Newburgh, NY 12550

Phone: (845) 567-6656

Fax: (845) 567-8703

www.tectonicengineering.com

THIS DOCUMENT IS THE CREATION, DESIGN, PROPERTY AND COPYRIGHTED WORK OF SPRINT COMMUNICATIONS, INC. ANY DUPLICATION OR USE WITHOUT EXPRESS WRITTEN CONSENT IS STRICTLY PROHIBITED. DUPLICATION AND USE BY GOVERNMENT AGENCIES FOR THE PURPOSES OF CONDUCTING THEIR LAWFULLY AUTHORIZED REGULATORY AND ADMINISTRATIVE FUNCTIONS IS SPECIFICALLY ALLOWED.

SUBMITTALS

PROJECT NO: 7225.CT33XC540

NO	DATE	DESCRIPTION	BY
0	07/08/14	FOR COMMENT	DC
1	01/05/15	FOR CONSTRUCTION	DC

DATE	REVIEWED BY
1/5/15	SMG



SITE NUMBER:
CT33XC540

SITE NAME:
MADISON-ATT

SITE ADDRESS:

1749 DURHAM ROAD
MADISON, CT 06443

SHEET TITLE:
EQUIPMENT
SCHEMATIC DETAILS

SHEET NO:

S-2

THIS DOCUMENT IS THE CREATION, DESIGN, PROPERTY AND COPYRIGHTED WORK OF SPRINT COMMUNICATIONS, INC. ANY DUPLICATION OR USE WITHOUT EXPRESS WRITTEN CONSENT IS STRICTLY PROHIBITED. DUPLICATION AND USE BY GOVERNMENT AGENCIES FOR THE PURPOSES OF CONDUCTING THEIR LAWFULLY AUTHORIZED REGULATORY AND ADMINISTRATIVE FUNCTIONS IS SPECIFICALLY ALLOWED.

SUBMITTALS

NO	DATE	DESCRIPTION	BY
0	07/08/14	FOR COMMENT	DC
1	01/05/15	FOR CONSTRUCTION	DC

DATE	REVIEWED BY
1/5/15	JMQ

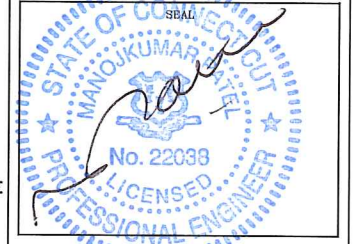

SITE NUMBER:
CT33XC540

SITE NAME:
MADISON-ATT

SITE ADDRESS:
**1749 DURHAM ROAD
 MADISON, CT 06443**

SHEET TITLE:
ELECTRICAL & GROUNDING PLANS

SHEET NO:
E-1

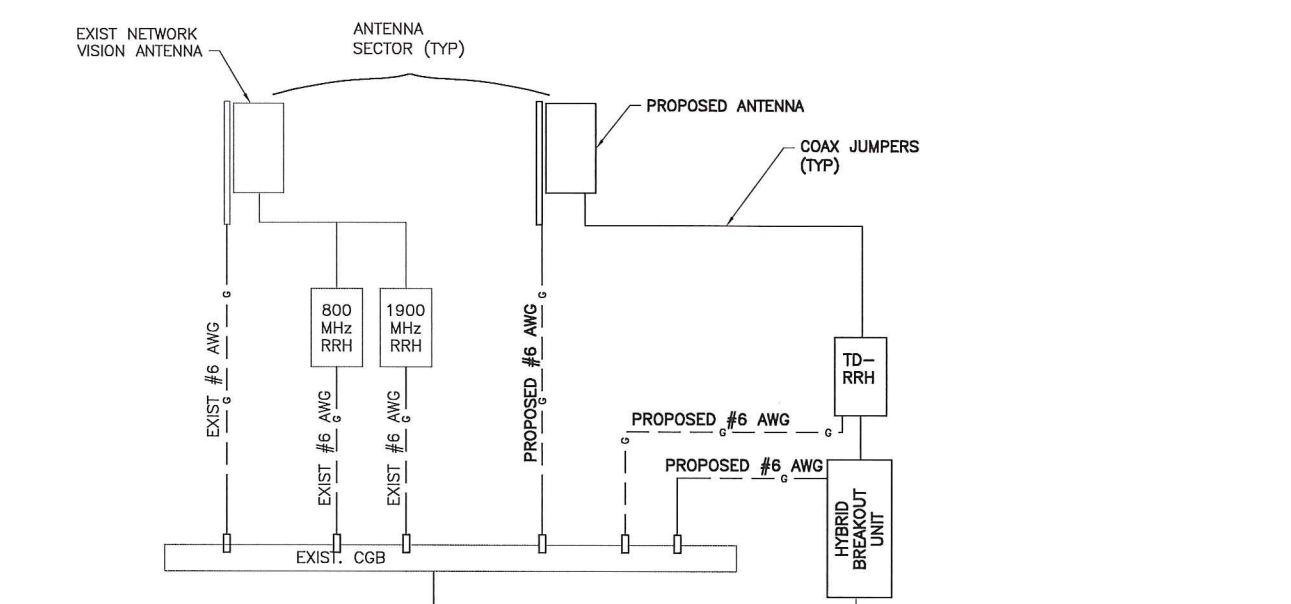

NOTE:
 ALL CONDUCTORS SHALL BE #6 AWG SOLID TINNED UNLESS OTHERWISE NOTED.

EXIST (1) 1900MHz RRH AND (1) 800MHz RRH STACK MOUNTED ABOVE ANTENNA MOUNT ON EXIST MONOPOLE (TYP PER SECTOR)

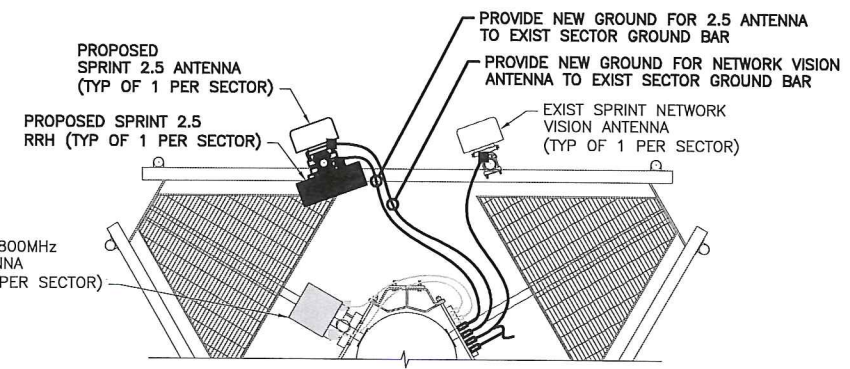

2 TYPICAL ANTENNA GROUNDING PLAN
 SCALE: NTS

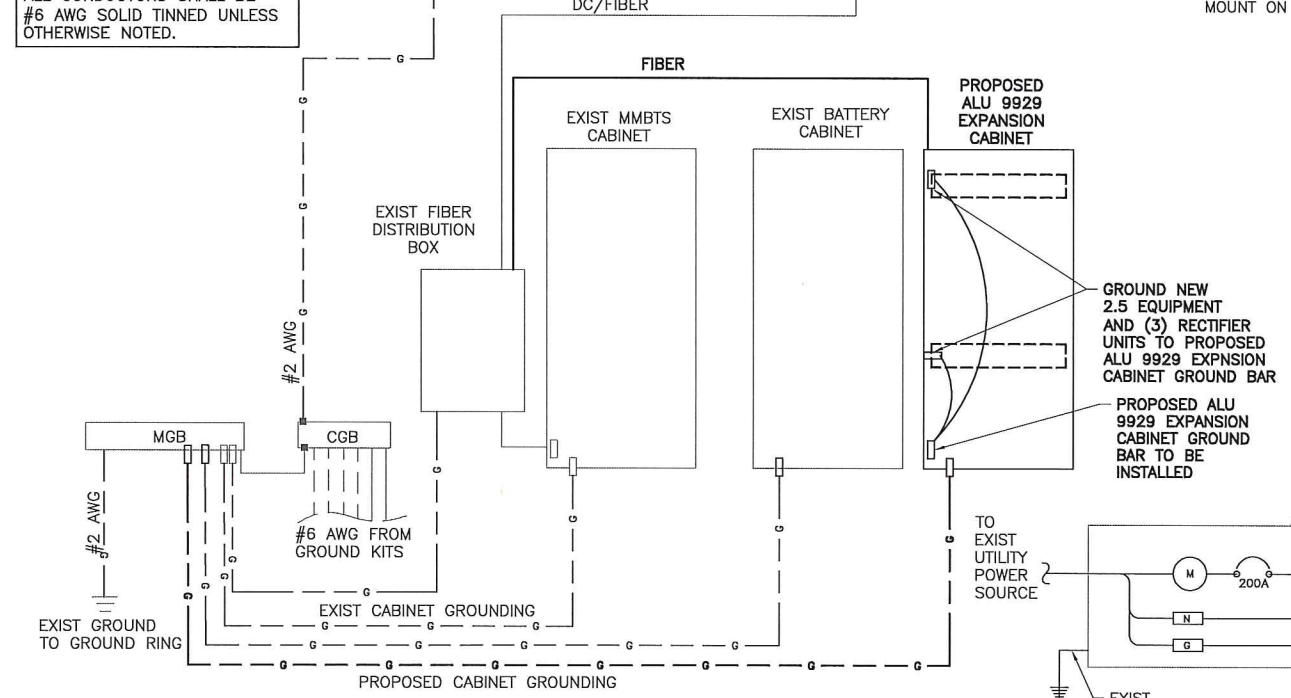

LEGEND
 ■ CADWELD CONNECTION
 □ MECHANICAL CONNECTION
 ● COMPRESSION CONNECTION

1 TYPICAL GROUNDING ONE LINE DIAGRAM
 SCALE: NTS

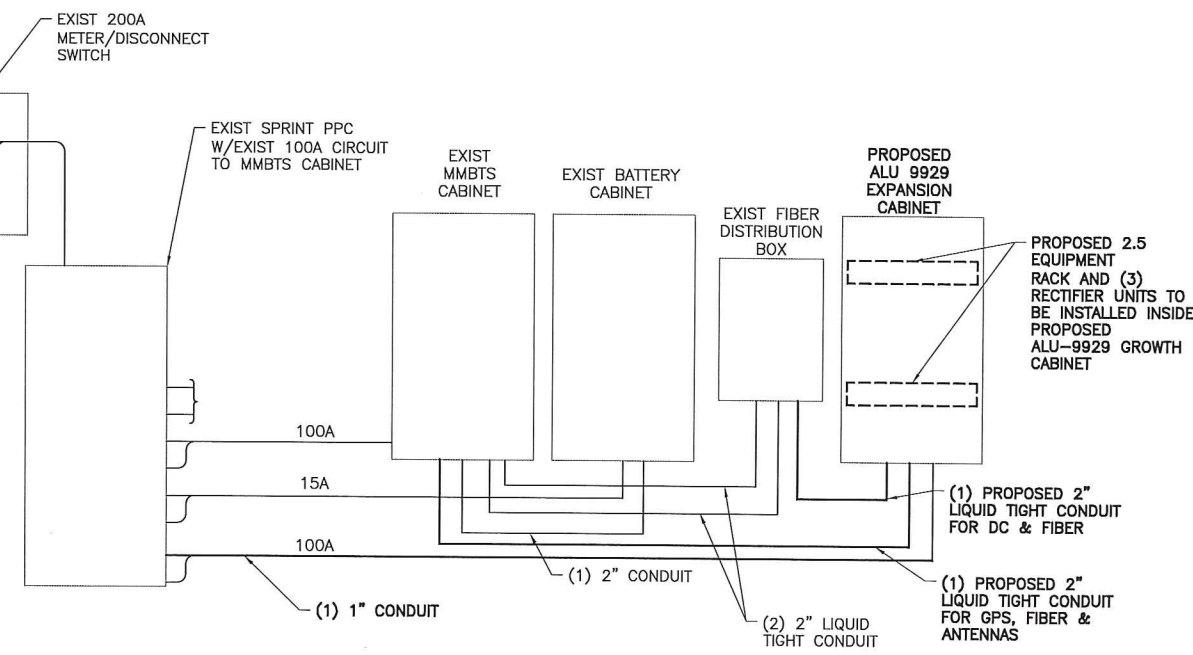

NOTE: FINAL ELECTRICAL DESIGN TO BE DETERMINED BY OTHER.
3 TYPICAL ELECTRICAL & TELCO PLAN
 SCALE: NTS

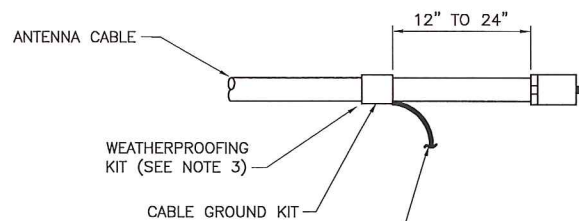

6 AWG STRANDED Cu WIRE WITH GREEN, 600V, THWN INSULATION OR BLACK, MARKED AS REQUIRED BY THE NEC (GROUNDED TO GROUND BAR) (SEE NOTES 1 & 2)

CONNECTION OF CABLE GROUND KIT TO ANTENNA CABLE

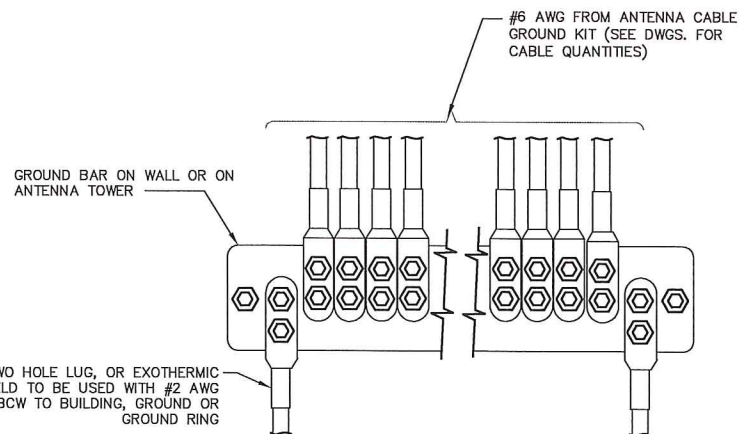

*TWO HOLE LUG, OR EXOTHERMIC WELD TO BE USED WITH #2 AWG BCW TO BUILDING, GROUND OR GROUND RING

* - GROUND BARS AT THE BOTTOM OF TOWERS/MONOPOLES SHALL ONLY USE EXOTHERMIC WELDS.

- ATTACH "DO NOT DISCONNECT" LABELS TO GROUND BARS. CAN USE BRASS TAG "DO NOT DISCONNECT" AT EACH HYBRID GROUND POINT OR BACK-A-LITE PLATE LABEL ON GROUND BAR.

- CONNECT SEQUENCE- BOLT/WASHER/NO-OX/GROUND BAR/NO-OX/WASHER/LOCK-WASHER/NUT. THIS IS REPEATED FOR EACH LUG CONNECTION POINT.

4 ANTENNA GROUND BAR DETAIL

SCALE: NTS

NOTES:

DO NOT INSTALL CABLE GROUND KIT AT A BEND AND ALWAYS DIRECT GROUND WIRE DOWN TO GROUND BAR.

GROUNTING KIT SHALL BE TYPE AND PART NUMBER AS SUPPLIED OR RECOMMENDED BY CABLE MANUFACTURER.

WEATHER PROOFING SHALL BE (TYPE AND PART NUMBER) AS SUPPLIED OR RECOMMENDED BY CABLE MANUFACTURER AND APPROVED BY CONTRACTOR.

1 CABLE GROUNDING KIT DETAIL

SCALE: N.T.S.

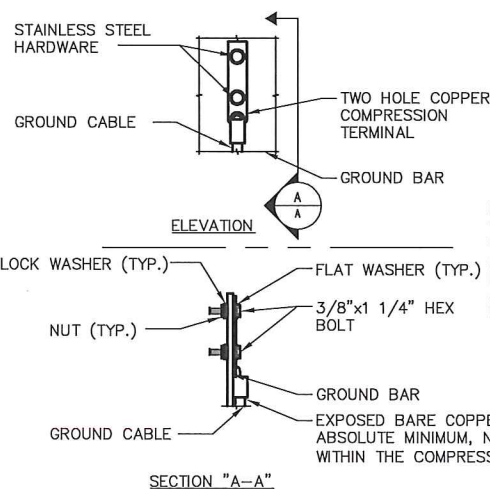

NOTE:
1. "DOUBLING UP" OR "STACKING" OF CONNECTION IS NOT PERMITTED.
2. OXIDE INHIBITING COMPOUND TO BE USED AT ALL LOCATIONS.
3. CADWELD DOWNLEADS FROM UPPER EGB, LOWER EGB AND MGB.

SECTION "A-A"

2 GROUNDING BAR CONN. DETAIL

SCALE: NTS

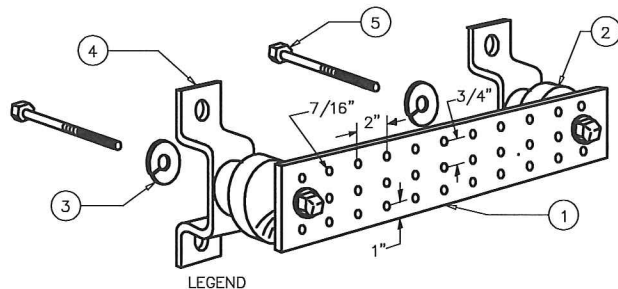

- LEGEND
- 1- COPPER TINNED GROUND BAR, 1/4" X 4" X 20", OR OTHER LENGTH AS REQUIRED, HOLE CENTERS TO MATCH NEMA DOUBLE LUG CONFIGURATION
 - 2- INSULATORS, NEWTON INSTRUMENT CAT. NO. 3061-4 OR EQUAL
 - 3- 5/8" LOCKWASHERS OR EQUAL
 - 4- WALL MOUNTING BRACKET, NEWTON INSTRUMENT CO. CAT. NO. A-6056 OR EQUAL
 - 5- 5/8-11 X 1" H.H.C.S.BOLTS

NOTE:
ALL BOLTS, NUTS, WASHERS AND LOCK WASHERS SHALL BE 18-8 STAINLESS STEEL.

3 GROUNDING BAR DETAIL

SCALE: NTS

ELECTRICAL AND GROUNDING NOTES

1. ALL ELECTRICAL WORK SHALL CONFORM TO THE REQUIREMENTS OF THE NATIONAL ELECTRICAL CODE (NEC) AS WELL AS APPLICABLE STATE AND LOCAL CODES.
2. ALL ELECTRICAL ITEMS SHALL BE U.L. APPROVED OR LISTED AND PROCURED PER SPECIFICATION REQUIREMENTS.
3. ELECTRICAL AND TELCO WIRING OUTSIDE A BUILDING AND EXPOSED TO WEATHER SHALL BE IN WATER TIGHT GALVANIZED RIGID STEEL CONDUITS OR SCHEDULE 80 PVC (AS PERMITTED BY CODE) AND WHERE REQUIRED IN LIQUID TIGHT FLEXIBLE METAL OR NONMETALLIC CONDUITS.
4. BURIED CONDUIT SHALL BE SCHEDULE 40 PVC.
5. ELECTRICAL WIRING SHALL BE COPPER WITH TYPE XHHW, THWN, OR THNN INSULATION.
6. RUN TELCO CONDUIT OR CABLE BETWEEN TELEPHONE UTILITY DEMARCATION POINT AND PROJECT OWNER CELL SITE TELCO CABINET AND BTS CABINET AS INDICATED ON THIS DRAWING PROVIDE FULL LENGTH PULL ROPE IN INSTALLED TELCO CONDUIT. PROVIDE GREENLEE CONDUIT MEASURING TAPE AT EACH END.
7. WHERE CONDUIT BETWEEN BTS AND PROJECT OWNER CELL SITE PPC AND BETWEEN BTS AND PROJECT OWNER CELL SITE TELCO SERVICE CABINET ARE UNDERGROUND USE PVC, SCHEDULE 40 CONDUIT. ABOVE THE GROUND PORTION OF THESE CONDUITS SHALL BE PVC CONDUIT.
8. ALL EQUIPMENT LOCATED OUTSIDE SHALL HAVE NEMA 3R ENCLOSURE.
9. GROUNTING SHALL COMPLY WITH NEC ART. 250.
10. GROUND HYBRID CABLE SHIELDS AT 3 LOCATIONS USING MANUFACTURER'S HYBRID CABLE GROUNTING KITS SUPPLIED BY PROJECT OWNER.
11. USE #2 COPPER STRANDED WIRE WITH GREEN COLOR INSULATION FOR ABOVE GRADE GROUNTING (UNLESS OTHERWISE SPECIFIED) AND #2 SOLID TINNED BARE COPPER WIRE FOR BELOW GRADE GROUNTING AS INDICATED ON THE DRAWING.
12. ALL GROUND CONNECTIONS TO BE BURNDY HYGROUND COMPRESSION TYPE CONNECTORS OR CADWELD EXOTHERMIC WELD. DO NOT ALLOW BARE COPPER WIRE TO BE IN CONTACT WITH GALVANIZED STEEL.
13. ROUTE GROUNTING CONDUCTORS ALONG THE SHORTEST AND STRAIGHTEST PATH POSSIBLE, EXCEPT AS OTHERWISE INDICATED. GROUNTING LEADS SHOULD NEVER BE BENT AT RIGHT ANGLE. ALWAYS MAKE AT LEAST 12" RADIUS BENDS. #2 WIRE CAN BE BENT AT 6" RADIUS WHEN NECESSARY. BOND ANY METAL OBJECTS WITHIN 6 FEET OF PROJECT OWNER EQUIPMENT OR CABINET TO MASTER GROUND BAR OR GROUNTING RING.
14. CONNECTIONS TO GROUND BARS SHALL BE MADE WITH TWO HOLE COMPRESSION TYPE COPPER LUGS. APPLY OXIDE INHIBITING COMPOUND TO ALL LOCATIONS.
15. APPLY OXIDE INHIBITING COMPOUND TO ALL COMPRESSION TYPE GROUND CONNECTIONS.
16. BOND ANTENNA MOUNTING BRACKETS, HYBRID CABLE GROUND KITS, AND RRHs TO EGB PLACED NEAR THE ANTENNA LOCATION.
17. BOND ANTENNA EGB'S AND MGB TO GROUND RING.
18. CONTRACTOR SHALL TEST COMPLETED GROUND SYSTEM AND RECORD RESULT FOR PROJECT CLOSE-OUT DOCUMENTATION. 5 OHMS MINIMUM RESISTANCE REQUIRED.
19. CONTRACTOR SHALL CONDUCT ANTENNA, HYBRID CABLES, GPS COAX AND RRH RETURN-LOSS AND DISTANCE- TO-FAULT MEASUREMENTS (SWEEP TESTS) AND RECORD RESULTS FOR PROJECT CLOSE OUT.
20. CONTRACTOR SHALL CHECK CAPACITY OF EXISTING SERVICE & PANEL ON SITE TO DETERMINE IF CAPACITY EXISTS TO ACCOMMODATE THE ADDED LOAD OF THIS PROJECT. ADVISE ENGINEER OF ANY DISCREPANCY.
21. LOCATION OF ALL OUTLET, BOXES, ETC, AND THE TYPE OF CONNECTION (PLUG OR DIRECT) SHALL BE CONFIRMED WITH THE OWNER'S REPRESENTATIVE PRIOR TO ROUGH-IN.
22. ELECTRICAL CHARACTERISTICS OF ALL EQUIPMENT (NEW AND EXISTING) SHALL BE FIELD VERIFIED WITH THE OWNERS REPRESENTATIVE AND EQUIPMENT SUPPLIER PRIOR TO ROUGH-IN OF CONDUIT AND WIRE. ALL EQUIPMENT SHALL BE PROPERLY CONNECTED ACCORDING TO THE NAMEPLATE DATA FURNISHED ON THE EQUIPMENT.

GROUNTING NOTES:

1. GROUNTING SHALL BE IN ACCORDANCE WITH NEC ARTICLE 250-GROUNTING AND BONDING.
2. ALL GROUND WIRES SHALL BE #2 AWG UNLESS NOTED OTHERWISE.
3. ALL GROUNTING WIRES SHALL PROVIDE A STRAIGHT, DOWNWARD PATH TO GROUND WITH GRADUAL BENDS AS REQUIRED. GROUND WIRES SHALL NOT BE LOOPED OR SHARPLY BENT.
4. EACH EQUIPMENT CABINET SHALL BE CONNECTED TO THE MASTER ISOLATION GROUND BAR (MGB) WITH #2 AWG INSULATED STRANDED COPPER WIRE. EQUIPMENT CABINETS WALL HAVE (2) CONNECTIONS.
5. PROVIDE DEDICATED #2 AWG COPPER GROUND WIRE FROM EACH ANTENNA MOUNTING PIPE TO ASSOCIATED CIGBE.
6. THE CONTRACTOR SHALL VERIFY THAT THE EXISTING GROUND BARS HAVE ENOUGH SPACE/HOLES FOR ADDITIONAL TWO HOLE LUGS.
7. ALL CONDUITS SHALL BE RIGID GALVANIZED STEEL AND SHALL BE PROVIDED WITH GROUNTING BUSHINGS.
8. PROVIDE GROUND CONNECTIONS FOR ALL METALLIC STRUCTURES, ENCLOSURES, RACEWAYS AND OTHER CONDUCTIVE ITEMS ASSOCIATED WITH THE INSTALLATION OF CARRIER'S EQUIPMENT.
9. WHEN CABLE LENGTH IS OVER 20' THE MANUFACTURERS GROUND KIT MUST BE INSTALLED PER THE MANUFACTURERS SPECIFICATIONS.
10. REFER TO "ANTI-THEFT UPDATE TO SPRINT GROUNTING 082412.PDF" FOR GUIDELINE TO SUSPECTED OR ACTUAL THEFT OF GROUNTING.
11. HOME RUN GROUNDS ARE NOT APPROVED BY CROWN CASTLE CONSTRUCTION STANDARDS AND THAT ANTENNA BUSS BARS SHOULD BE INSTALLED DIRECTLY TO TOWER STEEL WITHOUT INSULATORS OR DOWN CONDUCTORS.

PROTECTIVE GROUNTING SYSTEM GENERAL NOTES:

1. AT ALL TERMINATIONS AT EQUIPMENT ENCLOSURES, PANEL, AND FRAMES OF EQUIPMENT AND WHERE EXPOSED FOR GROUNTING. CONDUCTOR TERMINATION SHALL BE PERFORMED UTILIZING TWO HOLE BOLTED TONGUE COMPRESSION TYPE LUGS WITH STAINLESS STEEL SELF-TAPPING SCREWS.
2. ALL CLAMPS AND SUPPORTS USED TO SUPPORT THE GROUNTING SYSTEM CONDUCTORS AND PVC CONDUITS SHALL BE PVC TYPE (NON CONDUCTIVE). DO NOT USE METAL BRACKETS OR SUPPORTS WHICH WOULD FORM A COMPLETE RING AROUND ANY GROUNTING CONDUCTOR.
3. ALL GROUNDING CONNECTIONS SHALL BE COATED WITH A COPPER SHIELD ANTI-CORROSIVE AGENT SUCH AS T&B KOPR SHIELD. VERIFY PRODUCT WITH PROJECT MANAGER.
4. ALL BOLTS, WASHERS, AND NUTS USED ON GROUNTING CONNECTIONS SHALL BE STAINLESS STEEL.
5. INSTALL GROUND BUSHING ON ALL METALLIC CONDUITS AND BOND TO THE EQUIPMENT GROUND BUS IN THE PANEL BOARD.
6. GROUND ANTENNA BASES, FRAMES, CABLE RACKS, AND OTHER METALLIC COMPONENTS WITH #2 INSULATED TINNED STRANDED COPPER GROUNTING CONDUCTORS AND CONNECT TO INSULATED SURFACE MOUNTED GROUND BARS. CONNECTION DETAILS SHALL FOLLOW MANUFACTURER'S SPECIFICATIONS FOR GROUNTING.
7. GROUND HYBRID CABLE SHIELD AT BOTH ENDS USING MANUFACTURER'S GUIDELINES.

Sprint
2.5 EQUIPMENT DEPLOYMENT
6850 SPRINT PARKWAY
OVERLAND PARK, KANSAS 66251

CROWN CASTLE

TECTONIC
PLANNING
ENGINEERING
SURVEYING
CONSTRUCTION MANAGEMENT

TECTONIC Engineering & Surveying Consultants P.C.
1279 Route 300
Newburgh, NY 12550
Phone: (845) 567-6656
Fax: (845) 567-8703
www.tectonicengineering.com

THIS DOCUMENT IS THE CREATION, DESIGN, PROPERTY AND COPYRIGHTED WORK OF SPRINT COMMUNICATIONS, INC. ANY DUPLICATION OR USE WITHOUT EXPRESS WRITTEN CONSENT IS STRICTLY PROHIBITED. DUPLICATION AND USE BY GOVERNMENT AGENCIES FOR THE PURPOSES OF CONDUCTING THEIR LAWFULLY AUTHORIZED REGULATORY AND ADMINISTRATIVE FUNCTIONS IS SPECIFICALLY ALLOWED.

SUBMITTALS

PROJECT NO: 7225.CT33XC540

NO	DATE	DESCRIPTION	BY
0	07/08/14	FOR COMMENT	DC
1	01/05/15	FOR CONSTRUCTION	DC

DATE	REVIEWED BY
1/5/15	JMG

STATE OF CONNECTICUT
MANOJKUMAR PATEL
No. 22038
LICENSED PROFESSIONAL ENGINEER

SITE NUMBER:
CT33XC540
SITE NAME:
MADISON-ATT
SITE ADDRESS:
1749 DURHAM ROAD
MADISON, CT 06443

SHEET TITLE:
GROUNTING DETAILS & NOTES

SHEET NO:
E-2



July 21, 2017

Marianne Dunst
Crown Castle
3530 Toringdon Way Suite 300
Charlotte, NC 28277
(704) 405-6580

B+T Group
1717 S. Boulder, Suite 300
Tulsa, OK 74119
(918) 587-4630
btwo@btgrp.com

Subject: Structural Analysis Report

Carrier Designation: **Sprint PCS Co-Locate**
Carrier Site Number: CT33XC540
Carrier Site Name: CT33XC540

Crown Castle Designation: **Crown Castle BU Number:** 846176
Crown Castle Site Name: Madison Durham Road
Crown Castle JDE Job Number: 444143
Crown Castle Work Order Number: 1431633
Crown Castle Application Number: 395034 Rev. 0

Engineering Firm Designation: **B+T Group Project Number:** 115218.001.01

Site Data: **1749 Durham Road, Madison, New Haven County, CT**
Latitude 41° 23' 22.33", Longitude -72° 38' 55.97"
119 Foot - Monopole Tower

Dear Marianne Dunst,

B+T Group is pleased to submit this "Structural Analysis Report" to determine the structural integrity of the above mentioned tower. This analysis has been performed in accordance with the Crown Castle Structural 'Statement of Work' and the terms of Crown Castle Purchase Order Number 1059655, in accordance with application 395034, revision 0.

The purpose of the analysis is to determine acceptability of the tower stress level. Based on our analysis we have determined the tower stress level for the structure and foundation, under the following load case, to be:

LC7: Existing + Reserved + Proposed Equipment **Sufficient Capacity**
Note: See Table 1 and Table 2 for the proposed and existing/reserved loading, respectively.

This analysis has been performed in accordance with the 2016 Connecticut State Building Code based upon an ultimate 3-second gust wind speed of 130 mph converted to a nominal 3-second gust wind speed of 101 mph per Section 1609.3 and Appendix N as required for use in the TIA-222-G Standard per Exception #5 of Section 1609.1.1. Exposure Category B with a maximum topographic factor 1 and Risk Category II were used in this analysis.

All equipment proposed in this report shall be installed in accordance with the attached drawings for the determined available structural capacity to be effective.

We at B+T Group appreciate the opportunity of providing our continuing professional services to you and Crown Castle. If you have any questions or need further assistance on this or any other projects please give us a call.

Structural analysis prepared by: Xavier Jones, E.I.T

Respectfully submitted by: B&T Engineering, Inc.
COA: PEC.0001564 Expires: 02-10-2018

Scott S. Vance, P.E.

tnxTower Report - version 7.0.5.1



7/21/17

TABLE OF CONTENTS

1) INTRODUCTION

2) ANALYSIS CRITERIA

Table 1 - Proposed Antenna and Cable Information

Table 2 - Existing and Reserved Antenna and Cable Information

Table 3 - Design Antenna and Cable Information

3) ANALYSIS PROCEDURE

Table 4 - Documents Provided

3.1) Analysis Method

3.2) Assumptions

4) ANALYSIS RESULTS

Table 5 - Section Capacity (Summary)

Table 6 – Tower Components vs. Capacity

4.1) Recommendations

5) APPENDIX A

tnxTower Output

6) APPENDIX B

Base Level Drawing

7) APPENDIX C

Additional Calculations

1) INTRODUCTION

This tower is a 119 ft. Monopole tower designed by Sabre Communications in December of 2005. The tower was originally designed for a wind speed of 85 mph per TIA/EIA-222-F.

2) ANALYSIS CRITERIA

The structural analysis was performed for this tower in accordance with the requirements of TIA-222-G Structural Standards for Steel Antenna Towers and Antenna Supporting Structures using a 3-second gust wind speed of 101 mph with no ice, 50 mph with 0.75 inch ice thickness and 60 mph under service loads, exposure category B with topographic category 1 and crest height of 0 feet.

Table 1 - Proposed Antenna and Cable Information

Mounting Level (ft)	Center Line Elevation (ft)	Number of Antennas	Antenna Manufacturer	Antenna Model	Number of Feed Lines	Feed Line Size (in)	Note
106.0	110.0	3	Alcatel Lucent	TD-RRH8x20-25	--	--	--
		3	Rfs Celwave	APXVTM14-ALU-I20			

Table 2 - Existing and Reserved Antenna and Cable Information

Mounting Level (ft)	Center Line Elevation (ft)	Number of Antennas	Antenna Manufacturer	Antenna Model	Number of Feed Lines	Feed Line Size (in)	Note				
116.0	118.0	6	Ericsson	RBS 6601	12	1-5/8	1				
		3	Kmw Comm.	AM-X-CD-16-65-00T-RET							
		6	Powerwave Tech.	7770.00							
		3	Powerwave Tech.	LGP13519							
		6	Powerwave Tech.	LGP21401							
	1	Raycap	DC6-48-60-18-8F								
	116.0	1	--	Platform Mount [LP 601-1]							
108.0	110.0	3	Alcatel Lucent	1900MHz RRH	--	--	1				
		3	Alcatel Lucent	800MHZ 2X50W RRH W/FILTER							
	108.0	1	--	Side Arm Mount [SO 104-3]							
106.0	108.0	3	Rfs Celwave	APXVSP18-C-A20	4	1-1/4	1				
	106.0	1	--	Platform Mount [LP 601-1]							
94.0	96.0	1	Antel	BXA-171063-12BF	12	1-5/8	1				
		2	Antel	BXA-171063-8BF-EDIN-0							
		3	Antel	BXA-70063-6CF-EDIN-0							
		2	Decibel	DB846F65E-SX							
		4	Rfs Celwave	APL868013							
		6	Rfs Celwave	FD9R6004/2C-3L							
		3	Kathrein	742 213							
	94.0	94.0	3	Alcatel Lucent				RRH2X40-AWS	1	1-5/8	2
			1	Rfs Celwave				TMA-DB-T1-6Z-8AB-0Z	--	--	1
1	--	Platform Mount [LP 601-1]									
55.0	55.0	1	Pctel	GPS-TMG-HR-26NCM	1	1/2	1				
		1	--	Side Arm Mount [SO 701-1]							

Mounting Level (ft)	Center Line Elevation (ft)	Number of Antennas	Antenna Manufacturer	Antenna Model	Number of Feed Lines	Feed Line Size (in)	Note
50.0	50.0	1	--	Side Arm Mount [SO 102-3]	--	--	3

Notes:

- 1) Existing Equipment
- 2) Reserved Equipment
- 3) Empty Mount; Considered in this analysis.

Table 3 - Design Antenna and Cable Information

Mounting Level (ft)	Center Line Elevation (ft)	Number of Antennas	Antenna Manufacturer	Antenna Model	Number of Feed Lines	Feed Line Size (in)
117	119	12	Allgon	7120.16	--	--
	117	1	Generic	12' Low Profile Platform		
109	109	12	Allgon	7120.16	--	--
		1	Generic	12' Low Profile Platform		
99	99	12	Allgon	7120.16	--	--
		1	Generic	12' Low Profile Platform		
49	49	1	Generic	GPS	--	--
		1	Generic	Tri Collor Mount 42"-48"		

3) ANALYSIS PROCEDURE

Table 4 - Documents Provided

Document	Remarks	Reference	Source
Online Order Information	Sprint Co-Locate, Rev# 0	395034	CCI Sites
Tower Manufacturer Drawings	Sabre, Job No: 06-11290	4516773	CCI Sites
Foundation Drawings	Sabre, Job No: 06-11290	4552185	CCI Sites
Geotech Report	TEP, Project No: 113408.10	4301706	CCI Sites
Antenna Configuration	Crown CAD Package	Date:07/18/2017	CCI Sites

3.1) Analysis Method

tnxTower (version 7.0.5.1), a commercially available analysis software package, was used to create a three-dimensional model of the tower and calculate member stresses for various loading cases. Selected output from the analysis is included in Appendix A.

3.2) Assumptions

- 1) Tower and structures were built in accordance with the manufacturer's specifications.
- 2) The tower and structures have been maintained in accordance with the manufacturer's specification.
- 3) The configuration of antennas, transmission cables, mounts and other appurtenances are as specified in Tables 1 and 2 and the referenced drawings.
- 4) Mount areas and weights are assumed based on photographs provided.

This analysis may be affected if any assumptions are not valid or have been made in error. B+T Group should be notified to determine the effect on the structural integrity of the tower.

4) ANALYSIS RESULTS

Table 5 - Section Capacity (Summary)

Section No.	Elevation (ft)	Component Type	Size	Critical Element	P (K)	SF*P_allow (K)	% Capacity	Pass / Fail
L1	119 - 97.25	Pole	TP30.86x25.5x0.25	1	-6.756	1665.710	10.4	Pass
L2	97.25 - 48	Pole	TP42.47x29.374x0.313	2	-17.959	2779.580	36.6	Pass
L3	48 - 0	Pole	TP53.65x40.554x0.375	3	-33.512	4214.870	42.0	Pass
							Summary	
						Pole (L3)	42.0	Pass
						Rating =	42.0	Pass

Table 6 - Tower Component Stresses vs. Capacity – LC7

Notes	Component	Elevation (ft.)	% Capacity	Pass / Fail
1	Anchor Rods	Base	38.5	Pass
1	Base Plate	Base	35.2	Pass
1	Base Foundation (Structural)	Base	57.0	Pass
1	Base Foundation (Soil Interaction)	Base	71.5	Pass

Structure Rating (max from all components) =	71.5%
---	--------------

Notes:

- 1) See additional documentation in "Appendix C – Additional Calculations" for calculations supporting the % capacity consumed.

4.1) Recommendations

The tower and its foundation have sufficient capacity to carry the final load configuration. No modifications are required at this time.



RADIO FREQUENCY EMISSIONS ANALYSIS REPORT EVALUATION OF HUMAN EXPOSURE POTENTIAL TO NON-IONIZING EMISSIONS

SPRINT Existing Facility

Site ID: CT33XC540

Madison-ATT
1749 Durham Road
Madison, CT 06443

August 19, 2017

EBI Project Number: 6217003658

Site Compliance Summary	
Compliance Status:	COMPLIANT
Site total MPE% of FCC general population allowable limit:	13.93 %



August 19, 2017

SPRINT

Attn: RF Engineering Manager
1 International Boulevard, Suite 800
Mahwah, NJ 07495

Emissions Analysis for Site: **CT33XC540 – Madison-ATT**

EBI Consulting was directed to analyze the proposed SPRINT facility located at **1749 Durham Road, Madison, CT**, for the purpose of determining whether the emissions from the Proposed SPRINT Antenna Installation located on this property are within specified federal limits.

All information used in this report was analyzed as a percentage of current Maximum Permissible Exposure (% MPE) as listed in the FCC OET Bulletin 65 Edition 97-01 and ANSI/IEEE Std C95.1. The FCC regulates Maximum Permissible Exposure in units of microwatts per square centimeter ($\mu\text{W}/\text{cm}^2$). The number of $\mu\text{W}/\text{cm}^2$ calculated at each sample point is called the power density. The exposure limit for power density varies depending upon the frequencies being utilized. Wireless Carriers and Paging Services use different frequency bands each with different exposure limits, therefore it is necessary to report results and limits in terms of percent MPE rather than power density.

All results were compared to the FCC (Federal Communications Commission) radio frequency exposure rules, 47 CFR 1.1307(b)(1) – (b)(3), to determine compliance with the Maximum Permissible Exposure (MPE) limits for General Population/Uncontrolled environments as defined below.

General population/uncontrolled exposure limits apply to situations in which the general population may be exposed or in which persons who are exposed as a consequence of their employment may not be made fully aware of the potential for exposure or cannot exercise control over their exposure. Therefore, members of the general population would always be considered under this category when exposure is not employment related, for example, in the case of a telecommunications tower that exposes persons in a nearby residential area.

Population exposure to radio frequencies is regulated and enforced in units of microwatts per square centimeter ($\mu\text{W}/\text{cm}^2$). The general population exposure limits for the 850 MHz Band is approximately $567 \mu\text{W}/\text{cm}^2$. The general population exposure limit for the 1900 MHz (PCS) and 2500 MHz (BRS) bands is $1000 \mu\text{W}/\text{cm}^2$. Because each carrier will be using different frequency bands, and each frequency band has different exposure limits, it is necessary to report percent of MPE rather than power density.



Occupational/controlled exposure limits apply to situations in which persons are exposed as a consequence of their employment and in which those persons who are exposed have been made fully aware of the potential for exposure and can exercise control over their exposure. Occupational/controlled exposure limits also apply where exposure is of a transient nature as a result of incidental passage through a location where exposure levels may be above general population/uncontrolled limits (see below), as long as the exposed person has been made fully aware of the potential for exposure and can exercise control over his or her exposure by leaving the area or by some other appropriate means.

Additional details can be found in FCC OET 65.

CALCULATIONS

Calculations were done for the proposed SPRINT Wireless antenna facility located at **1749 Durham Road, Madison, CT**, using the equipment information listed below. All calculations were performed per the specifications under FCC OET 65. Since SPRINT is proposing highly focused directional panel antennas, which project most of the emitted energy out toward the horizon, all calculations were performed assuming a lobe representing the maximum gain of the antenna per the antenna manufactures supplied specifications, minus 10 dB, was focused at the base of the tower. For this report the sample point is the top of a 6-foot person standing at the base of the tower.

For all calculations, all equipment was calculated using the following assumptions:

- 1) 1 CDMA channels (850 MHz) were considered for each sector of the proposed installation. These Channels have a transmit power of 20 Watts per Channel.
- 2) 2 LTE channels (850 MHz) were considered for each sector of the proposed installation. These Channels have a transmit power of 20 Watts per Channel.
- 3) 5 CDMA channels (1900 MHz (PCS)) were considered for each sector of the proposed installation. These Channels have a transmit power of 16 Watts per Channel.
- 4) 2 LTE channels (1900 MHz (PCS)) were considered for each sector of the proposed installation. These Channels have a transmit power of 40 Watts per Channel.
- 5) 8 LTE channels (2500 MHz (BRS)) were considered for each sector of the proposed installation. These Channels have a transmit power of 20 Watts per Channel.



- 6) All radios at the proposed installation were considered to be running at full power and were uncombined in their RF transmissions paths per carrier prescribed configuration. Per FCC OET Bulletin No. 65 - Edition 97-01 recommendations to achieve the maximum anticipated value at each sample point, all power levels emitting from the proposed antenna installation are increased by a factor of 2.56 to account for possible in-phase reflections from the surrounding environment. This is rarely the case, and if so, is never continuous.
- 7) For the following calculations, the sample point was the top of a 6-foot person standing at the base of the tower. The maximum gain of the antenna per the antenna manufactures supplied specifications minus 10 dB was used in this direction. This value is a very conservative estimate as gain reductions for these particular antennas are typically much higher in this direction.
- 8) The antennas used in this modeling are the **RFS APXVSP18-C-A20** and the **RFS APXVTM14-C-I20** for transmission in the 850 MHz, 1900 MHz (PCS) and 2500 MHz (BRS) frequency bands. This is based on feedback from the carrier with regards to anticipated antenna selection. Maximum gain values for all antennas are listed in the Inventory and Power Data table below. The maximum gain of the antenna per the antenna manufactures supplied specifications, minus 10 dB, was used for all calculations. This value is a very conservative estimate as gain reductions for these particular antennas are typically much higher in this direction.
- 9) The antenna mounting height centerlines of the proposed antennas are **106 feet** above ground level (AGL) for **Sector A**, **106 feet** above ground level (AGL) for **Sector B** and **106 feet** above ground level (AGL) for Sector C.
- 10) Emissions values for additional carriers were taken from the Connecticut Siting Council active database. Values in this database are provided by the individual carriers themselves.

All calculations were done with respect to uncontrolled / general population threshold limits.



SPRINT Site Inventory and Power Data by Antenna

Sector:	A	Sector:	B	Sector:	C
Antenna #:	1	Antenna #:	1	Antenna #:	1
Make / Model:	RFS APXVSPPI8-C-A20	Make / Model:	RFS APXVSPPI8-C-A20	Make / Model:	RFS APXVSPPI8-C-A20
Gain:	13.4 / 15.9 dBd	Gain:	13.4 / 15.9 dBd	Gain:	13.4 / 15.9 dBd
Height (AGL):	106 feet	Height (AGL):	106 feet	Height (AGL):	106 feet
Frequency Bands	850 MHz / 1900 MHz (PCS)	Frequency Bands	850 MHz / 1900 MHz (PCS)	Frequency Bands	850 MHz / 1900 MHz (PCS)
Channel Count	10	Channel Count	10	Channel Count	10
Total TX Power(W):	220 Watts	Total TX Power(W):	220 Watts	Total TX Power(W):	220 Watts
ERP (W):	7,537.38	ERP (W):	7,537.38	ERP (W):	7,537.38
Antenna A1 MPE%	3.07 %	Antenna B1 MPE%	3.07 %	Antenna C1 MPE%	3.07 %
Antenna #:	2	Antenna #:	2	Antenna #:	2
Make / Model:	RFS APXVTM14-C-I20	Make / Model:	RFS APXVTM14-C-I20	Make / Model:	RFS APXVTM14-C-I20
Gain:	15.9 dBd	Gain:	15.9 dBd	Gain:	15.9 dBd
Height (AGL):	106 feet	Height (AGL):	106 feet	Height (AGL):	106 feet
Frequency Bands	2500 MHz (BRS)	Frequency Bands	2500 MHz (BRS)	Frequency Bands	2500 MHz (BRS)
Channel Count	8	Channel Count	8	Channel Count	8
Total TX Power(W):	160 Watts	Total TX Power(W):	160 Watts	Total TX Power(W):	160 Watts
ERP (W):	6,224.72	ERP (W):	6,224.72	ERP (W):	6,224.72
Antenna A2 MPE%	2.24 %	Antenna B2 MPE%	2.24 %	Antenna C2 MPE%	2.24 %

Site Composite MPE%	
Carrier	MPE%
SPRINT – Max per sector	5.31 %
AT&T	2.59 %
Verizon Wireless	6.03 %
Site Total MPE %:	13.93 %

SPRINT Sector A Total:	5.31 %
SPRINT Sector B Total:	5.31 %
SPRINT Sector C Total:	5.31 %
Site Total:	13.93 %

SPRINT _ Max Values per Frequency Band / Technology Per Sector	# Channels	Watts ERP (Per Channel)	Height (feet)	Total Power Density ($\mu\text{W}/\text{cm}^2$)	Frequency (MHz)	Allowable MPE ($\mu\text{W}/\text{cm}^2$)	Calculated % MPE
Sprint 850 MHz CDMA	1	437.55	106	1.57	850 MHz	567	0.28%
Sprint 850 MHz LTE	2	437.55	106	3.15	850 MHz	567	0.55%
Sprint 1900 MHz (PCS) CDMA	5	622.47	106	11.19	1900 MHz (PCS)	1000	1.12%
Sprint 1900 MHz (PCS) LTE	2	1,556.18	106	11.19	1900 MHz (PCS)	1000	1.12%
Sprint 2500 MHz (BRS) LTE	8	778.09	106	22.38	2500 MHz (BRS)	1000	2.24%
Total:						5.31%	



Summary

All calculations performed for this analysis yielded results that were **within** the allowable limits for general population exposure to RF Emissions.

The anticipated maximum composite contributions from the SPRINT facility as well as the site composite emissions value with regards to compliance with FCC's allowable limits for general population exposure to RF Emissions are shown here:

SPRINT Sector	Power Density Value (%)
Sector A:	5.31 %
Sector B:	5.31 %
Sector C:	5.31 %
SPRINT Maximum Total (per sector):	5.31 %
Site Total:	13.93 %
Site Compliance Status:	COMPLIANT

The anticipated composite MPE value for this site assuming all carriers present is **13.93 %** of the allowable FCC established general population limit sampled at the ground level. This is based upon values listed in the Connecticut Siting Council database for existing carrier emissions.

FCC guidelines state that if a site is found to be out of compliance (over allowable thresholds), that carriers over a 5% contribution to the composite value will require measures to bring the site into compliance. For this facility, the composite values calculated were well within the allowable 100% threshold standard per the federal government.