

January 7, 2015

Melanie A. Bachman
Connecticut Siting Council
10 Franklin Square
New Britain, CT 06051

RE: Sprint PCS-Exempt Modification – Crown Site BU: 846176
Sprint PCS Site ID: CT33XC540
Located at: 1749 Durham Road, Madison, CT 06443

Dear Ms. Bachman:

This letter and exhibits are submitted on behalf of Sprint PCS (Sprint). Sprint is making modifications to certain existing sites in its Connecticut system in order to implement their 2.5GHz LTE technology. Please accept this letter and exhibits as notification, pursuant to § 16-50j-73 of the Regulations of Connecticut State Agencies (“R.C.S.A.”), of construction that constitutes an exempt modification pursuant to R.C.S.A. § 16-50j-72(b)(2). In compliance with R.C.S.A. § 16-50j-73, a copy of this letter is being sent to Mr. Fillmore McPherson, First Selectman for the Town of Madison, and South Central Connecticut Regional Water Authority, Property Owner.

Sprint plans to modify the existing wireless communications facility owned by Crown Castle and located at **1749 Durham Road, Madison, CT 06443**. Attached are a compound plan and elevation depicting the planned changes (Exhibit-1), and documentation of the structural sufficiency of the structure to accommodate the revised antenna configuration (Exhibit-2). Also included is a power density table report reflecting the modification to Sprint’s operations at the site (Exhibit-3).

The changes to the facility do not constitute a modification as defined in Connecticut General Statutes (“C.G.S.”) § 16-50i(d) because the general physical characteristics of the facility will not be significantly changed. Rather, the planned changes to the facility fall squarely within those activities explicitly provided for in the R.C.S.A. § 16-50j-72(b)(2).

1. The proposed modifications will not result in an increase in the height of the existing tower. Sprint’s additional antennas will be located at the same elevation on the existing tower.
2. There will be no proposed modifications to the ground and no extension of boundaries.
3. The proposed modifications will not increase noise levels at the facility by six decibels or more.

Melanie A. Bachman

January 7, 2015

Page 2

4. A Structural Modification Report confirming that the tower and foundation can support Sprint's proposed modifications is included as Exhibit-2.
5. The operation of the additional antennas will not increase radio frequency (RF) emissions at the facility to a level at or above the Federal Communications Commission (FCC) adopted safety standard. A cumulative General Power Density table report for Sprint's modified facility is included as Exhibit-3.

For the foregoing reasons, Sprint respectfully submits the proposed modifications to the above-reference telecommunications facility constitutes an exempt modification under R.C.S.A. § 16-50j-72(b)(2). Please send approval/rejection letter to Attn: Donna Neal.

Sincerely,



Susan Vale
Real Estate Specialist

Enclosures

Tab 1: Exhibit-1: Compound plan and elevation depicting the planned changes

Tab 2: Exhibit-2: Structural Modification Report

Tab 3: Exhibit-3: General Power Density Table Report (RF Emissions Analysis Report)

cc: Mr. Fillmore McPherson, First Selectman
Town of Madison
8 Campus Drive
Madison, CT 06443

South Central Connecticut
Regional Water Authority
Attn: Real Estate Manager
90 Sargent Drive
New Haven, CT 06511



2.5 EQUIPMENT DEPLOYMENT

SITE NUMBER:
CT33XC540

SITE NAME:
MADISON-ATT

SITE ADDRESS:
1749 DURHAM ROAD
MADISON, CT 06443

CROWN ID#: 846176

CROWN SITE NAME: MADISON DURHAM ROAD



2.5 EQUIPMENT DEPLOYMENT
6850 SPRINT PARKWAY
OVERLAND PARK, KANSAS 66251



TECTONIC Engineering & Surveying
Consultants P.C.
1279 Route 300
Newburgh, NY 12550
Phone: (845) 567-6656
Fax: (845) 567-8703
www.tectonicengineering.com

THIS DOCUMENT IS THE CREATION, DESIGN, PROPERTY AND COPYRIGHTED WORK OF SPRINT COMMUNICATIONS, INC. ANY DUPLICATION OR USE WITHOUT EXPRESS WRITTEN CONSENT IS STRICTLY PROHIBITED. DUPLICATION AND USE BY GOVERNMENT AGENCIES FOR THE PURPOSES OF CONDUCTING THEIR LAWFULLY AUTHORIZED REGULATORY AND ADMINISTRATIVE FUNCTIONS IS SPECIFICALLY ALLOWED.

SUBMITTALS

PROJECT NO: 7225.CT33XC540			
NO	DATE	DESCRIPTION	BY
0	07/08/14	FOR COMMENT	DC
1	01/05/15	FOR CONSTRUCTION	DC

DATE	REVIEWED BY
1/5/15	JMQ

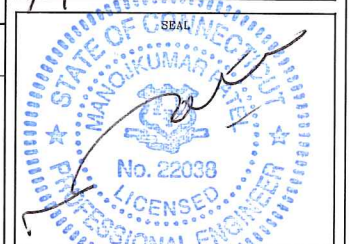

SITE NUMBER:
CT33XC540
SITE NAME:
MADISON-ATT
SITE ADDRESS:
1749 DURHAM ROAD
MADISON, CT 06443

SHEET TITLE:
TITLE SHEET

SHEET NO:
T-1

SHEET INFORMATION

SITE NUMBER:	CT33XC540	LANDLORD:	CROWN CASTLE USA 2000 CORPORATE DRIVE CANONSBURG, PA
SITE NAME:	MADISON-ATT	LOCAL POWER COMPANY:	CONNECTICUT LIGHT AND POWER CONTACT CUSTOMER SERVICE (800) 288-2000
SITE ADDRESS:	1749 DURHAM ROAD MADISON, CT 06443	APPLICANT:	SPRINT 6580 SPRINT PARKWAY OVERLAND PARK, KANSAS 66251
COUNTY:	NEW HAVEN	ENGINEER:	JAMES QUICKSELL (845) 567-6656 EXT. 2835 jquicksell@tectonicengineering.com
COORDINATES: (NAD 83)	41° 23' 22.3" N 72° 38' 56.0" W	SPRINT CM:	PETER CULBERT (803) 203-6646 Peter.Culbert@sprint.com
GROUND ELEV:	337'± AMSL	CROWN CM:	JASON D'AMICO (860) 209-0104 jason.d'amico@crowncastle.com
STRUCTURE TYPE:	MONOPOLE	AAV:	AT&T
STRUCTURE HEIGHT:	119'-0"± AGL		
STRUCTURE RAD CENTER:	106'-0"± AGL		
ZONING CLASSIFICATION:	4310 TEL REL TW		
MAP-BLOCK-LOT:	154/3/CELL//		

VICINITY MAP (NOT TO SCALE)

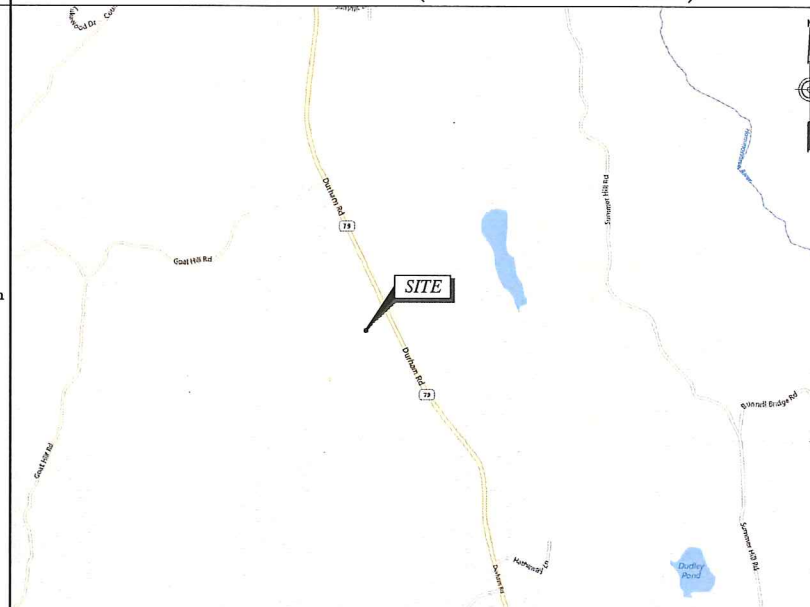

SHEET INDEX

SHT. NO.	SHEET DESCRIPTION
T-1	TITLE SHEET
SP-1	GENERAL NOTES
SP-2	GENERAL NOTES
A-1	SITE PLAN
A-2	ELEVATION
A-3	ENLARGED EQUIPMENT LAYOUT PLANS
A-4	ANTENNA LAYOUT PLANS
A-5	RAN WIRING DIAGRAM
A-6	CABLE DETAILS
S-1	EQUIPMENT DETAILS
S-2	EQUIPMENT SCHEMATIC DETAILS
E-1	ELECTRICAL & GROUNDING PLANS
E-2	GROUNDING DETAILS & NOTES

GENERAL NOTES

- THIS IS AN UNMANNED TELECOMMUNICATION FACILITY AND NOT FOR HUMAN HABITATION. HANDICAP ACCESS REQUIREMENTS ARE NOT REQUIRED. FACILITY HAS NO PLUMBING OR REFRIGERANTS. THIS FACILITY SHALL MEET OR EXCEED ALL FAA AND FCC REGULATOR REQUIREMENTS.
- CONTRACTOR SHALL VERIFY ALL PLANS AND EXISTING DIMENSIONS AND CONDITIONS ON THE JOB SITE AND SHALL IMMEDIATELY NOTIFY THE PROJECT OWNER'S REPRESENTATIVE IN WRITING OF DISCREPANCIES BEFORE PROCEEDING WITH THE WORK OR BE RESPONSIBLE FOR SAME.
- DEVELOPMENT AND USE OF THIS SITE WILL CONFORM TO ALL APPLICABLE CODES AND ORDINANCES.
 - 2005 STATE OF CONNECTICUT BUILDING CODE..
 - ANSI/TIA/EIA-222-F-1996.
 - NATIONAL ELECTRICAL CODE, LATEST EDITION.

AERIAL VIEW (NOT TO SCALE)



APPROVALS

THE FOLLOWING PARTIES HEREBY APPROVE AND ACCEPT THESE DOCUMENTS AND AUTHORIZE THE CONTRACTOR TO PROCEED WITH THE CONSTRUCTION DESCRIBED HEREIN. ALL DOCUMENTS ARE SUBJECT TO REVIEW BY THE LOCAL BUILDING DEPARTMENT AND MAY IMPOSE CHANGES OR MODIFICATIONS.

CONSTRUCTION: _____ DATE: _____

LEASING/
SITE ACQUISITION: _____ DATE: _____

LANDLORD/
PROPERTY OWNER: _____ DATE: _____

R.F. ENGINEER: _____ DATE: _____

PROJECT DESCRIPTION

- (1) NEW ALU 9929 EXPANSION CABINET.
- (3) NEW RFS APXVTM14-C-120 ANTENNAS.
- (3) NEW TD-RRH8x20-25 RRH.
- (1) NEW 5/8" FIBER CABLE.



DIVISION 01000—GENERAL NOTES

1. THE CONTRACTOR SHALL GIVE ALL NOTICES AND COMPLY WITH ALL LAWS, ORDINANCES, RULES, REGULATIONS AND LAWFUL ORDERS OF ANY PUBLIC AUTHORITY, MUNICIPAL AND UTILITY COMPANY SPECIFICATIONS, AND LOCAL AND STATE JURISDICTIONAL CODES BEARING ON THE PERFORMANCE OF THE WORK. THE WORK PERFORMED ON THE PROJECT AND THE MATERIALS INSTALLED SHALL BE IN STRICT ACCORDANCE WITH ALL APPLICABLE CODES, REGULATIONS, AND ORDINANCES.
2. THE ARCHITECT/ENGINEER HAVE MADE EVERY EFFORT TO SET FORTH IN THE CONSTRUCTION AND CONTRACT DOCUMENTS THE COMPLETE SCOPE OF WORK. THE CONTRACTOR BIDDING THE JOB IS NEVERTHELESS CAUTIONED THAT MINOR OMISSIONS OR ERRORS IN THE DRAWINGS AND OR SPECIFICATIONS SHALL NOT EXCUSE SAID CONTRACTOR FROM COMPLETING THE PROJECT AND IMPROVEMENTS IN ACCORDANCE WITH THE INTENT OF THESE DOCUMENTS.
3. THE CONTRACTOR OR BIDDER SHALL BEAR THE RESPONSIBILITY OF NOTIFYING (IN WRITING) THE PROJECT OWNER'S REPRESENTATIVE OF ANY CONFLICTS, ERRORS, OR OMISSIONS PRIOR TO THE SUBMISSION OF CONTRACTOR'S PROPOSAL OR PERFORMANCE OF WORK.
4. THE SCOPE OF WORK SHALL INCLUDE FURNISHING ALL MATERIALS, EQUIPMENT, LABOR AND ALL OTHER MATERIALS AND LABOR DEEMED NECESSARY TO COMPLETE THE WORK/PROJECT AS DESCRIBED HEREIN.
5. THE CONTRACTOR SHALL VISIT THE JOB SITE PRIOR TO THE SUBMISSION OF BIDS OR PERFORMING WORK TO FAMILIARIZE HIMSELF WITH THE FIELD CONDITIONS AND TO VERIFY THAT THE PROJECT CAN BE CONSTRUCTED IN ACCORDANCE WITH THE CONTRACT DOCUMENTS.
6. ONCE THE CONTRACTOR HAS RECEIVED AND ACCEPTED THE NOTICE TO PROCEED, CONTRACTOR WILL CONTACT THE CROWN CASTLE CONSTRUCTION MANAGER OF RECORD (NOTED ON THE FIRST PAGE ON THIS CONSTRUCTION DRAWING) A MINIMUM OF 48 HOURS PRIOR TO WORK START. UPON ARRIVAL TO THE JOB SITE, CONTRACTOR CREW IS REQUIRED CALL 1-800-788-7011 TO NOTIFY THE CROWN CASTLE NOC WORK HAS BEGUN.
7. THE CONTRACTOR SHALL INSTALL ALL EQUIPMENT AND MATERIALS ACCORDING TO THE MANUFACTURER'S/VENDOR'S SPECIFICATIONS UNLESS NOTED OTHERWISE OR WHERE LOCAL CODES OR ORDINANCES TAKE PRECEDENCE.
8. THE CONTRACTOR SHALL PROVIDE A FULL SET OF CONSTRUCTION DOCUMENTS AT THE SITE UPDATED WITH THE LATEST REVISIONS AND ADDENDUMS OR CLARIFICATIONS AVAILABLE FOR THE USE BY ALL PERSONNEL INVOLVED WITH THE PROJECT.
9. THE CONTRACTOR SHALL SUPERVISE AND DIRECT THE PROJECT DESCRIBED HEREIN. THE CONTRACTOR SHALL BE SOLELY RESPONSIBLE FOR ALL CONSTRUCTION MEANS, METHODS, TECHNIQUES, SEQUENCES AND PROCEDURES AND FOR COORDINATING ALL PORTIONS OF THE WORK UNDER THE CONTRACT.
10. THE CONTRACTOR SHALL BE RESPONSIBLE FOR OBTAINING ALL PERMITS AND INSPECTIONS WHICH MAY BE REQUIRED FOR THE WORK BY THE ARCHITECT/ENGINEER, THE STATE, COUNTY OR LOCAL GOVERNMENT AUTHORITY.
11. THE CONTRACTOR SHALL MAKE NECESSARY PROVISIONS TO PROTECT EXISTING IMPROVEMENTS, EASEMENTS, PAVING, CURBING, ETC. DURING CONSTRUCTION. UPON COMPLETION OF WORK, THE CONTRACTOR SHALL REPAIR ANY DAMAGE THAT MAY HAVE OCCURRED DUE TO CONSTRUCTION ON OR ABOUT THE PROPERTY.
12. THE CONTRACTOR SHALL KEEP THE GENERAL WORK AREA CLEAN AND HAZARD FREE DURING CONSTRUCTION AND DISPOSE OF ALL DIRT, DEBRIS, RUBBISH AND REMOVE EQUIPMENT NOT SPECIFIED AS REMAINING ON THE PROPERTY. PREMISES SHALL BE LEFT IN CLEAN CONDITION AND FREE FROM PAINT SPOTS, DUST, OR SMUDGES OF ANY NATURE.
13. THE CONTRACTOR SHALL COMPLY WITH ALL PERTINENT SECTIONS OF THE BASIC STATE BUILDING CODE, LATEST EDITION, AND ALL OSHA REQUIREMENTS AS THEY APPLY TO THIS PROJECT. ALL EXISTING ACTIVE SEWER, WATER, GAS, ELECTRIC, AND OTHER UTILITIES WHERE ENCOUNTERED IN THE WORK SHALL BE PROTECTED AT ALL TIMES, AND WHERE REQUIRED FOR THE PROPER EXECUTION OF THE WORK SHALL BE RELOCATED AS DIRECTED BY THE ARCHITECT/ENGINEER. EXTREME CAUTION SHOULD BE USED BY THE CONTRACTOR WHEN EXCAVATING OR PIER DRILLING AROUND OR NEAR UTILITIES. THE CONTRACTOR SHALL PROVIDE SAFETY TRAINING FOR THE WORKING CREW. THIS WILL INCLUDE BUT NOT LIMITED TO A) FALL PROTECTION, B) CONFINED SPACE, C) ELECTRICAL SAFETY, D) TRENCHING AND EXCAVATION OF ALL EXISTING INACTIVE SEWER, WATER, GAS, ELECTRIC AND OTHER UTILITIES WHICH INTERFERE WITH THE EXECUTION OF THE WORK SHALL BE REMOVED AND OR CAPPED, PLUGGED OR OTHERWISE DISCONTINUED AT THE POINTS WHICH WILL NOT INTERFERE WITH THE EXECUTION OF THE WORK SUBJECT TO THE APPROVAL OF THE ARCHITECT/ENGINEER.
14. THE CONTRACTOR SHALL NOTIFY THE PROJECT OWNER'S REPRESENTATIVE IN WRITING WHERE A CONFLICT OCCURS ON ANY OF THE CONTRACT DOCUMENTS. THE CONTRACTOR IS NOT TO ORDER MATERIAL OR CONSTRUCT ANY PORTION OF THE WORK THAT IS IN CONFLICT UNTIL CONFLICT IS RESOLVED BY THE LESSEE/LICENSEE REPRESENTATIVE.
15. THE CONTRACTOR SHALL VERIFY ALL DIMENSIONS, ELEVATIONS, PROPERTY LINES, ETC. ON THE JOB.
16. THE CONTRACTOR SHALL NOTIFY THE THE RF ENGINEER FOR ANTENNA AZIMUTH VERIFICATION (DURING ANTENNA INSTALLATION) PRIOR TO CONDUCTING SWEEP TESTS.
17. THE CONTRACTOR SHALL SUBMIT AT THE END OF THE PROJECT A COMPLETE SET OF AS-BUILT DRAWINGS TO THE CLIENT REPRESENTATIVE.

18. REFER TO: CONSTRUCTION STANDARDS—SPRINT DOCUMENT EXHIBIT A—STANDARD CONSTRUCTION SPECIFICATIONS FOR WIRELESS SITES REV. 4.0— 02.15.2011.DOCM.
19. REFER TO: WEATHER PROOFING SPECS: EXCERPT EXH A—WIHRPRF—STD CONSTR SPECS...157201110421855492.DOCM.
20. REFER TO: COLOR CODING—SPRINT NEXTEL ANT AND LINE COLOR CODING (DRAFT) V3 09-08-11.PDF
21. REFER TO LATEST DOCUMENTATION REVISION.

DIVISION 03000—CONCRETE

- 1.03 APPLICABLE STANDARDS (USE LATEST EDITIONS)
- A. ACI-301 — SPECIFICATIONS FOR STRUCTURAL CONCRETE FOR BUILDINGS.
 - B. ACI-347 GUIDE TO FORM WORK FOR CONCRETE.
 - C. ASTM C33— CONCRETE AGGREGATE
 - D. ASTM C94 — READY MIXED CONCRETE e. ASTM C150 — PORTLAND CEMENT.
 - E. ASTM C260 — AIR-ENTRAINING ADMIXTURES FOR CONCRETE
 - F. ASTM C309— LIQUID MEMBRANE FORMING COMPOUNDS FOR CURING CONCRETE.
 - H. ASTM C494 — CHEMICAL ADMIXTURES FOR CONCRETE
 - I. ASTM A615— DEFORMED AND PLAIN BILLET—STEEL BARS FOR CONCRETE REINFORCEMENT
 - J. ASTM A185— STEEL WELDED WIRE FABRIC (PLAIN) FOR CONCRETE REINFORCEMENT
- 1.04 QUALITY ASSURANCE

CONCRETE MATERIALS AND OPERATIONS SHALL BE TESTED AND INSPECTED BY THE ARCHITECT/ENGINEER AS DIRECTED BY THE CLIENT'S REPRESENTATIVE.

- 3.04 SURFACE FINISHES
- A. SURFACES AGAINST WHICH BACKFILL OR CONCRETE SHALL BE PLACED REQUIRE NO TREATMENT EXCEPT REPAIR OF DEFECTIVE AREAS.
 - B. SURFACES THAT WILL BE PERMANENTLY EXPOSED SHALL PRESENT A UNIFORM FINISH PROVIDED BY THE REMOVAL OF FINS AND THE FILLING HOLES AND OTHER IRREGULARITIES WITH DRY PACK GROUT, OR BY SACKING WITH UTILITY OR ORDINARY GROUT.

- C. SURFACES THAT WOULD NORMALLY BE LEVEL AND WHICH WILL BE PERMANENTLY EXPOSED TO THE WEATHER SHALL BE SLOPED FOR DRAINAGE. UNLESS ENGINEER'S DESIGN DRAWING SPECIFIES A HORIZONTAL SURFACE OR SURFACES SUCH AS STAIR TREADS, WALLS, CURBS, AND PARAPETS SHALL BE SLOPED APPROXIMATELY 1/4" PER FOOT.
- D. SURFACES THAT WILL BE COVERED BY BACKFILL OR CONCRETE SHALL BE SMOOTH SCREENED.
- E. EXPOSED SLAB SURFACES SHALL BE CONSOLIDATED, SCREENED, FLOATED, AND STEEL TROWELED. HAND OR POWER-DRIVEN EQUIPMENT MAY BE USED FOR FLOATING. FLOATING SHALL BE STARTED AS SOON AS THE SCREENED SURFACE HAS ATTAINED A STIFFNESS TO PERMIT FINISHING OPERATIONS. OPERATIONS. ALL EDGES MUST HAVE A 3/4" CHAMFER.

1.04 QUALITY ASSURANCE CONCRETE MATERIALS AND OPERATIONS SHALL BE TESTED AND INSPECTED BY THE ENGINEER.

- 3.05 PATCHING
- THE CONTRACTOR SHALL NOTIFY THE ENGINEER IMMEDIATELY UPON REMOVAL OF THE FORMS TO OBSERVE CONCRETE SURFACE CONDITIONS. IMPERFECTIONS SHALL BE PATCHED ACCORDING TO THE ENGINEER'S DIRECTION.

- 3.06 DEFECTIVE CONCRETE
- THE CONTRACTOR SHALL NOTIFY OR REPLACE CONCRETE NOT CONFORMING TO REQUIRED LEVELS AND LINES, DETAILS, AND ELEVATIONS AS SPECIFIED IN ACI 301.

- 3.07 PROTECTION
- A. IMMEDIATELY AFTER PLACEMENT. THE CONTRACTOR SHALL PROTECT THE CONCRETE FROM PREMATURE DRYING, EXCESSIVELY HOT OR COLD TEMPERATURES, AND MECHANICAL INJURY. FINISHED WORK SHALL BE PROTECTED.
 - B. CONCRETE SHALL BE MAINTAINED WITH MINIMAL MOISTURE LOSS AT RELATIVELY CONSTANT TEMPERATURE FOR PERIOD NECESSARY FOR HYDRATION OF CEMENT AND HARDENING OF CONCRETE.

C. ALL CONCRETE SHALL BE WATER CURED PER ACCEPTABLE PRACTICES SPECIFIED BY ACI CODE (LATEST EDITION)

DIVISION 05000 — METALS

- PART 1 — GENERAL
- 1.01 WORK INCLUDED
- A. THE WORK CONSISTS OF THE FABRICATION AND INSTALLATION OF ALL MATERIALS TO BE FURNISHED. AND WITHOUT LIMITING THE GENERALITY THEREOF, INCLUDING ALL EQUIPMENT, LABOR AND SERVICES REQUIRED FOR ALL STRUCTURAL STEEL WORK AND ALL ITEMS INCIDENTAL AS SPECIFIED AND AS SHOWN ON THE DRAWINGS:
1. STEEL FRAMING INCLUDING BEAMS, ANGLES, CHANNELS AND PLATES.
 2. WELDING AND BOLTING OF ATTACHMENTS.
- 1.02 REFERENCE STANDARDS
- A. THE WORK SHALL CONFORM TO THE CODES AND STANDARDS OF THE FOLLOWING AGENCIES AS FURTHER CITED HEREIN:
1. ASTM: AMERICAN SOCIETY FOR TESTING AND MATERIALS AS PUBLISHED IN "COMPILATION OF ASTM STANDARDS IN BUILDING CODES" OR LATEST EDITION.
 2. AWS: AMERICAN WELDING SOCIETY CODE OR LATEST EDITION.
 3. AISC: AMERICAN INSTITUTE OF STEEL CONSTRUCTION, "SPECIFICATION FOR THE DESIGN, FABRICATION AND ERECTION OF STRUCTURAL STEEL FOR BUILDINGS" (LATEST EDITION).
- PART 2 — PRODUCTS
- 2.01 MATERIALS
- A. STRUCTURAL STEEL: SHALL COMPLY WITH THE REQUIREMENTS OF ASTM A36 AND A992 FOR STRUCTURAL STEEL.
- ALL PROPOSED STRUCTURAL STEEL SHALL BE FABRICATED AND ERECTED IN ACCORDANCE WITH AISC CODE AND ASTM SPECIFICATIONS (LATEST EDITION) ALL NEW STEEL SHALL CONFORM TO THE FOLLOWING.
1. STRUCTURAL WIDE FLANGE: ASTM A992 Fy=50KSI.
 2. MISCELLANEOUS STEEL (PLATES), CHANNELS, ANGLES, ETC): ASTM A36 (Fy=36KSI).
 3. STRUCTURAL TUBING: ASTM A500 Gr. B (Fy=46KSI).
 4. STEEL PIPE: ASTM A53 Gr B (Fy=35KSI).

- 2.02 WELDING
- A. ALL WELDING SHALL BE DONE BY CERTIFIED WELDERS. CERTIFICATION DOCUMENTS SHALL BE MADE AVAILABLE FOR ENGINEER'S AND/OR OWNER'S REVIEW IF REQUESTED.
 - B. WELDING ELECTRODES FOR MANUAL SHIELDED METAL ARC WELDING SHALL CONFORM TO ASTM 1-233, E70 SERIES. BARE ELECTRODES AND GRANULAR FLUX USED IN THE SUBMERGED ARC PROCESS SHALL CONFORM TO AISC SPECIFICATIONS.
 - C. FIELD WELDING SHALL BE DONE AS PER AWS D1.1 REQUIREMENTS VISUAL INSPECTION IS ACCEPTABLE.
 - D. STUD WELDING SHALL BE ACCOMPLISHED BY CAPACITOR DISCHARGE (CD) WELDING TECHNIQUE USING CAPACITOR DISCHARGE STUD WELDER.
 - E. PROVIDE STUD FASTENERS OF MATERIALS AND SIZES SHOWN ON DRAWINGS OR AS RECOMMENDED BY THE MANUFACTURER FOR STRUCTURAL LOADINGS REQUIRED.
 - F. FOLLOW MANUFACTURERS SPECIFICATIONS AND INSTRUCTIONS TO PROPERLY SELECT AND INSTALL STUD WELDS.

- 2.03 BOLTING
- A. BOLTS SHALL BE CONFORMING TO ASTM A35 HIGH STRENGTH HOT DIP GALVANIZED WITH ASTM A153 HEAVY HEX TYPE NUTS.
 - B. BOLTS SHALL BE 3/4" (MINIMUM) CONFORMING TO ASTM A325, HOT DIP GALVANIZED, ASTM A153 NUTS SHALL BE HEAVY HEX TYPE.
 - C. ALL CONNECTIONS SHALL BE 2 BOLTS MINIMUM.
 - D. EXCEPT WHERE SHOWN, ALL BEAM TO BEAM AND BEAM TO COLUMN CONNECTIONS TO BE DOUBLE ANGLED CONNECTIONS WITH HIGH STRENGTH BOLTS (THREADS EXCLUDED FROM SHEAR PLANE) AND HARDENED WASHERS.
 - E. STANDARD, OVERSIZED OR HORIZONTAL SHORT SLOTTED HOLES.
 - F. SNUG-TIGHT STRENGTH BEARING BOLTS MAY BE USED IN STANDARD HOLES CONFORMING TO ACIS, USING THE TURN OF THE NUT METHOD.
 - H. FULLY-TENSIONED HIGH STRENGTH (SLIP CRITICAL) SHALL BE USED IN OVERSIZED SLOT HOLES (RESPECTIVE OF SLOT ORIENTATION).
 - I. ALL BRACED CONNECTION, MOMENT CONNECTION AND CONNECTIONS NOTED AS "SLIP CRITICAL" SHALL BE BE SLIP CRITICAL JOINTS WITH CLASS A SURFACE CONDITIONS, UNLESS OTHERWISE NOTED.
 - J. EPOXY ANCHOR ASSEMBLIES SHALL BE AS MANUFACTURED BY HILTI OR ENGINEER APPROVED EQUAL, AS FOLLOWS:

<u>BASE MATERIAL</u>	<u>ANCHOR SYSTEM</u>
CONCRETE	HILTI HIT-HY 200
HOLLOW & GROUTED CMU OR BRICK	HILTI HIT-HY 70

- 2.04 FABRICATION
- A. FABRICATION OF STEEL SHALL CONFORM TO THE AISC AND AWS

- 2.05 FINISH
- A. STRUCTURAL STEEL EXPOSED TO WEATHER SHALL BE HOT-DIP GALVANIZED AFTER FABRICATION IN ACCORDANCE WITH ASTM A123. (LATEST EDITION) UNLESS OTHERWISE NOTED.
- 2.06 PROTECTION
- A. UPON COMPLETION OF ERECTION, INSPECT ALL GALVANIZED STEEL AND PAINT ANY FIELD CUTS, WELDS OR GALVANIZED BREAKS WITH (2) COATS OF ZINC-RICH COLD GALVANIZING PAINT.

- PART 3 — ERECTION
- A. PROVIDE ALL ERECTION, EQUIPMENT, BRACING, PLANKING, FIELD BOLTS, NUTS, WASHERS, DRIFT PINS, AND SIMILAR MATERIALS WHICH DO NOT FORM A PART OF THE COMPLETED CONSTRUCTION, BUT ARE NECESSARY FOR ITS PROPER ERECTION.
 - B. ERECT AND ANCHOR ALL STRUCTURAL STEEL IN ACCORDANCE WITH AISC REFERENCE STANDARDS. ALL WORK SHALL BE ACCURATELY SET TO ESTABLISHED SUITABLE ATTACHMENTS TO THE CONSTRUCTION OF THE BUILDING
 - C. TEMPORARY BRACING, GUYING, AND SUPPORT SHALL BE PROVIDED TO KEEP THE STRUCTURE SET AND ALIGNED AT ALL TIMES DURING CONSTRUCTION, AND TO PREVENT DANGER TO PERSONS AND PROPERTY. CHECK ALL TEMPORARY LOADS AND STAY WITHIN SAFE CAPACITY OF ALL BUILDING COMPONENTS.



TECTONIC ENGINEERING & SURVEYING CONSULTANTS P.C.

1279 Route 300
Newburgh, NY 12550
Phone: (845) 567-6656
Fax: (845) 567-8703
www.tectonicengineering.com

PLANNING
ENGINEERING
SURVEYING
CONSTRUCTION MANAGEMENT

THIS DOCUMENT IS THE CREATION, DESIGN, PROPERTY AND COPYRIGHTED WORK OF SPRINT COMMUNICATIONS, INC. ANY DUPLICATION OR USE WITHOUT EXPRESS WRITTEN CONSENT IS STRICTLY PROHIBITED. REPRODUCTION AND USE BY GOVERNMENT AGENCIES FOR THE PURPOSES OF CONDUCTING THEIR LAWFULLY AUTHORIZED REGULATORY AND ADMINISTRATIVE FUNCTIONS IS SPECIFICALLY ALLOWED.

SUBMITTALS

PROJECT NO: 7225.CT33XC540

NO	DATE	DESCRIPTION	BY
0	07/08/14	FOR COMMENT	DC
1	01/05/15	FOR CONSTRUCTION	DC

DATE	REVIEWED BY
1/5/15	JMG

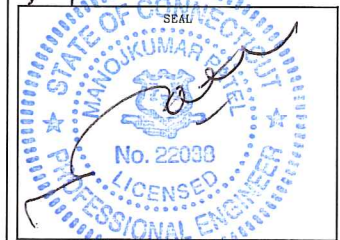

SITE NUMBER:
CT33XC540

SITE NAME:
MADISON- ATT

SITE ADDRESS:
**1749 DURHAM ROAD
MADISON, CT 06443**

SHEET TITLE:
GENERAL NOTES

SHEET NO:
SP-1

DIVISION 13000—SPECIAL CONSTRUCTION ANTENNA INSTALLATION

PART 1 — GENERAL

1.01 WORK INCLUDED

A. ANTENNAS AND HYBRIFLEX CABLES ARE FURNISHED BY CLIENT'S REPRESENTATIVE UNDER SEPARATE CONTRACT. THE CONTRACTOR SHALL ASSIST ANTENNA INSTALLATION CONTRACTOR IN TERMS OF COORDINATION AND SITE ACCESS. ERECTION SUBCONTRACTOR SHALL BE RESPONSIBLE FOR THE PROPERTY.

B. INSTALL ANTENNAS AS INDICATED ON DRAWINGS AND CLIENT'S REPRESENTATIVE SPECIFICATIONS.

C. INSTALL GALVANIZED STEEL ANTENNA MOUNTS AS INDICATED ON DRAWINGS.

D. INSTALL FURNISHED GALVANIZED STEEL OR ALUMINUM WAVEGUIDE AND PROVIDE PRINTOUT OF THAT RESULT

F. INSTALL HYBRIFLEX CABLES AND TERMINATIONS BETWEEN ANTENNAS AND EQUIPMENT PER MANUFACTURER'S RECOMMENDATIONS. WEATHERPROOF ALL CONNECTORS BETWEEN THE ANTENNA AND EQUIPMENT PER MANUFACTURER'S REQUIREMENTS.

G. ANTENNA AND HYBRIFLEX CABLE GROUNDING:

1. ALL EXTERIOR #6 GREEN GROUND WIRE DAISY CHAIN CONNECTIONS ARE TO BE WEATHER SEALED WITH ANDREWS CONNECTOR/SPLICE WEATHERPROOFING KIT TYPE 3221213 OR EQUIVALENT.

2. ALL HYBRIFLEX CABLE GROUNDING KITS ARE TO BE INSTALLED ON STRAIGHT RUNS OF HYBRIFLEX CABLE (NOT WITHIN BENDS). 1.02 RELATED WORK FURNISH THE FOLLOWING WORK AS SPECIFIED UNDER CONSTRUCTION DOCUMENTS, BUT COORDINATE WITH OTHER TRADES PRIOR TO BID:

1. FLASHING OF OPENING INTO OUTSIDE WALLS.
2. SEALING AND CAULKING ALL OPENINGS.
3. PAINTING.
4. CUTTING AND PATCHING.

1.03 REQUIREMENTS OF REGULATOR AGENCIES

A. FURNISH U.L. LISTED EQUIPMENT WHERE SUCH LABEL IS AVAILABLE. INSTALL IN CONFORMANCE WITH U.L. STANDARDS WHERE APPLICABLE.

B. INSTALL ANTENNA, ANTENNA CABLES, GROUNDING SYSTEM IN ACCORDANCE WITH DRAWINGS AND SPECIFICATIONS IN EFFECT AT PROJECT LOCATION AND RECOMMENDATIONS OF STATE AND LOCAL BUILDING CODES HAVING JURISDICTION OVER SPECIFIC PORTIONS OF WORK. THIS WORK INCLUDES, BUT IS NOT LIMITED TO THE FOLLOWING:

1. EIA — ELECTRONIC INDUSTRIES ASSOCIATION RS-22. STRUCTURAL STANDARDS FOR STEEL ANTENNA TOWERS AND ANTENNA SUPPORTING STRUCTURES.
2. FAA — FEDERAL AVIATION ADMINISTRATION ADVISORY CIRCULAR AC 70/7480-IH, CONSTRUCTION MARKING AND LIGHTING.
3. FCC — FEDERAL COMMUNICATION COMMISSION RULES AND REGULATIONS FORM 715, OBSTRUCTION MARKING AND LIGHTING SPECIFICATION FOR ANTENNA STRUCTURES
4. AISC — AMERICAN INSTITUTE OF STEEL CONSTRUCTION FOR STRUCTURAL JOINTS USING ASTM 1325 OR A490 BOLTS.
5. NEC — NATIONAL ELECTRIC CODE — ON TOWER LIGHTING KITS.
6. UL — UNDERWRITER'S LABORATORIES APPROVED ELECTRICAL PRODUCTS.
7. IN ALL CASES, PART 77 OF THE FAA RULES AND PARTS 17 AND 22 OF THE FCC RULES ARE APPLICABLE AND IN THE EVENT OF CONFLICT, SUPERSEDE ANY OTHER STANDARDS OR SPECIFICATIONS.
8. LIFE SAFETY CODE NFPA, LATEST EDITION.

DIVISION 13000—EARTHWORK

PART 1 GENERAL

1.01 WORK INCLUDED: REFER TO SURVEY AND SITE PLAN FOR WORK INCLUDED.

1.02 RELATED WORK

A. CONSTRUCTION OF EQUIPMENT FOUNDATIONS
B. INSTALLATION OF ANTENNA SYSTEM

PART 2 PRODUCTS

2.01 MATERIALS

A. ROAD AND SITE MATERIALS; FILL MATERIAL SHALL BE ACCEPTABLE, SELECT FILL SHALL BE IN ACCORDANCE WITH LOCAL DEPARTMENT OF HIGHWAY AND PUBLIC TRANSPORTATION STANDARD SPECIFICATIONS.

B. SOIL STERILIZER SHALL BE EPA REGISTERED OF LIQUID COMPOSITION AND OF PRE-EMERGENCE DESIGN.

C. SOIL STABILIZER FABRIC SHALL BE MIRAFI OR EQUAL — 600X AT ACCESS ROAD AND COMPOUND.

D. GRAVEL FILL; WELL GRADED, HARD, DURABLE, NATURAL SAND AND GRAVEL, FREE FROM ICE AND SNOW, ROOTS, SOD RUBBISH, AND OTHER DELETERIOUS OR ORGANIC MATTER.

MATERIAL SHALL CONFORM TO THE FOLLOWING GRADATION REQUIREMENTS.

GRAVEL FILL TO BE PLACED IN LIFTS OF 9" MAXIMUM THICKNESS AND 90 % DENSITY. COMPACTED TO 95

E. NO FILL OR EMBANKMENT MATERIALS SHALL BE PLACED ON FROZEN GROUND. FROZEN MATERIALS SNOW OR ICE SHALL NOT BE PLACED IN ANY FILL OF EMBANKMENT

2.02 EQUIPMENT

A. COMPACTION SHALL BE ACCOMPLISHED BY MECHANICAL MEANS. LARGER AREAS SHALL BE COMPACTED BY SHEEPS FOOT, VIBRATORY OR RUBBER TIED ROLLERS WEIGHING AT LEAST FIVE TONS. SMALLER AREAS SHALL BE COMPACTED BY POWER-DRIVER, HAND HELD TAMPERS.

B. PRIOR TO OTHER EXCAVATION AND CONSTRUCTION EFFORTS GRUB ORGANIC MATERIAL TO A MINIMUM OF 6" BELOW ORIGINAL GROUND LEVEL.

C. UNLESS OTHERWISE INSTRUCTED BY CLIENT'S REPRESENTATIVE. REMOVE TREES, BRUSH AND DEBRIS FROM THE PROPERTY TO AN AUTHORIZED DISPOSAL LOCATION.

D. PRIOR TO PLACEMENT OF FILL OR BASE MATERIALS, ROLL THE SOIL.

E. WHERE UNSTABLE SOIL CONDITIONS ARE ENCOUNTERED, LINE THE GRUBBED AREAS WITH STABILIZER MAT PRIOR TO PLACEMENT OF FILL OR BASE MATERIAL.

3.03 INSTALLATION

A. THE SITE AND TURNAROUND AREAS SHALL BE AT THE SUB-BASE COURSE ELEVATION PRIOR TO FORMING FOUNDATIONS. GRADE OR FILL THE SITE AND ACCESS ROAD AS REQUIRED TO PRODUCE EVEN DISTRIBUTION OF SPOILS RESULTING FROM FOUNDATION EXCAVATIONS. THE RESULTING GRADE SHALL CORRESPOND WITH SAID SUB-BASE COURSE, ELEVATIONS ARE TO BE CALCULATED FROM FINISHED GRADES OR SLOPES INDICATED.

B. THE ACCESS ROAD SHALL BE BROUGHT TO BASE COURSE ELEVATION PRIOR TO FOUNDATION CONSTRUCTION.

C. DO NOT CREATE DEPRESSIONS WHERE WATER MAY POND.

D. THE CONTRACT INCLUDES ALL NECESSARY GRADING, BANKING, DITCHING AND COMPLETE SURFACE COURSE FOR ACCESS ROAD. ALL ROADS OR ROUTES UTILIZED FOR ACCESS TO PUBLIC THOROUGHFARE IS INCLUDED IN SCOPE OF WORK UNLESS OTHERWISE INDICATED.

E. WHEN IMPROVING AN EXISTING ACCESS ROAD, GRADE THE EXISTING ROAD TO REMOVE ANY ORGANIC MATTER AND SMOOTH THE SURFACE BEFORE PLACING FILL OR STONE.

F. PLACE FILL OR STONE IN 3" MAXIMUM LIFTS AND COMPACT BEFORE PLACING NEXT LIFT.

G. THE FINISH GRADE, INCLUDING TOP SURFACE COURSE, SHALL EXTEND A MINIMUM OF 12" BEYOND THE SITE FENCE AND SHALL COVER THE AREA AS INDICATED.

H. RIPRAP SHALL BE APPLIED TO THE SIDE SLOPES OF ALL FENCED AREAS, PARKING AREAS AND TO ALL OTHER SLOPES GREATER THAN

I. RIPRAP SHALL BE APPLIED TO THE SIDES OF DITCHES OR DRAINAGE SWALES AS INDICATED ON PLANS.

J. RIPRAP ENTIRE DITCH FOR 6'-0" IN ALL DIRECTIONS AT CULVERT OPENINGS.

K. SEED, FERTILIZER AND STRAW COVER SHALL BE APPLIED TO ALL OTHER DISTURBED AREAS AND DITCHES, DRAINAGE, SWALES, NOT OTHERWISE RIP-RAPPED.

L. UNDER NO CIRCUMSTANCES SHALL DITCHES, SWALES OR CULVERTS BE PLACED SO THEY DIRECT WATER TOWARDS, OR PERMIT STANDING WATER IMMEDIATELY ADJACENT TO SITE. IF OWNER DESIGNS OR IF DESIGN ELEVATIONS CONFLICT WITH THIS GUIDANCE ADVISE THE OWNER IMMEDIATELY.

M. IF A DITCH LIES WITH SLOPE GREATER THAN TEN PERCENT, MOUND DIVERSIONARY HEADWALL IN THE DITCH AT CULVERT ENTRANCES. RIP-RAP THE UPSTREAM SIDE OF THE HEADWALL AS WELL AS THE DITCH FOR 6'-0" ABOVE THE CULVERT.

N. IF A DITCH LIES WITH SLOPES GREATER THAN TEN PERCENT, MOUND DIVERSIONARY HEADWALLS IN THE DITCH FOR 6'-0" ABOVE THE CULVERT ENTRANCE.

O. SEED AND FERTILIZER SHALL BE APPLIED TO SURFACE CONDITIONS WHICH WILL ENCOURAGE ROOTING. RAKE AREAS TO BE SEEDED TO EVEN THE SURFACE AND TO LOOSEN THE SOIL.

P. SOW SEED IN TWO DIRECTIONS IN TWICE THE QUANTITY RECOMMENDED BY THE SEED PRODUCER.

Q. IT IS THE CONTRACTOR'S RESPONSIBILITY TO ENSURE GROWTH OF SEEDED AND LANDSCAPED AREAS BY WATERING UP TO THE POINT OF RELEASE FROM THE CONTRACT. CONTINUE TO REWORK BARE AREAS UNTIL COMPLETE COVERAGE IS OBTAINED.

3.04 FIELD QUALITY CONTROL

A. COMPACTION SHALL BE D-1557 FOR SITE WORK AND 95 % MAXIMUM DENSITY UNDER SLAB AREAS. AREAS OF SETTLEMENT WILL BE EXCAVATED AND REFILLED AT CONTRACTOR'S EXPENSE. REQUIRED. USE OF EROSION CONTROL MESH OR MULCH NET SHALL BE AN ACCEPTABLE ALTERNATIVE.

B. THE COMPACTION TEST RESULTS SHALL BE AVAILABLE PRIOR TO THE CONCRETE POUR.

3.05 PROTECTION

A. PROTECT SEEDED AREAS FORM EROSION BY SPREADING STRAW TO A UNIFORM LOOSE DEPTH OF 1"-2". STAKE AND TIE DOWN AS REQUIRED. USE OF EROSION CONTROL MESH OR MULCH NET SHALL BE AN ACCEPTABLE ALTERNATIVE.

B. ALL TREES PLACED IN CONJUNCTION WITH A LANDSCAPE CONTRACT SHALL BE WRAPPED, TIED WITH HOSE PROTECTED WIRE AND SECURED TO STAKES EXTENDING 2'-0" INTO THE GROUND ON FOUR SIDES OF THE TREE.

C. ALL EXPOSED AREAS SHALL BE PROTECTED AGAINST WASHOUTS AND SOIL EROSION. STRAW BALES SHALL BE PLACED AT THE INLET APPROACH TO ALL NEW OR EXISTING CULVERTS. REFER TO DETAILS ON DRAWINGS

SYMBOLS	ABBREVIATIONS
— — — — G — — — — G — —	GROUND WIRE
— — — — E — — — — E — —	ELECTRIC
— — — — T — — — — T — —	TELEPHONE
— — — — O — — — — O — —	OVERHEAD WIRE
— — — — — — — — — —	PROPERTY LINE
— X — — — X — — — — X — —	CHAIN LINK FENCE
A-1	ANTENNA MARK
(E)	EXISTING
(P)	PROPOSED DETAIL
	REFERENCE
	SURFACE ELEVATION

2.5 EQUIPMENT DEPLOYMENT
6850 SPRINT PARKWAY
OVERLAND PARK, KANSAS 66251

TECTONIC Engineering & Surveying Consultants P.C.
1279 Route 300
Newburgh, NY 12550
Phone: (845) 567-6656
Fax: (845) 567-8703
www.tectonicengineering.com

THIS DOCUMENT IS THE CREATION, DESIGN, PROPERTY AND COPYRIGHTED WORK OF SPRINT COMMUNICATIONS, INC. ANY DUPLICATION OR USE WITHOUT EXPRESS WRITTEN CONSENT IS STRICTLY PROHIBITED. DUPLICATION AND USE BY GOVERNMENT AGENCIES FOR THE PURPOSES OF CONDUCTING THEIR LAWFULLY AUTHORIZED REGULATORY AND ADMINISTRATIVE FUNCTIONS IS SPECIFICALLY ALLOWED.

SUBMITTALS			
PROJECT NO: 7225.CT33XC540			
NO	DATE	DESCRIPTION	BY
0	07/08/14	FOR COMMENT	DC
1	01/05/15	FOR CONSTRUCTION	DC

DATE	REVIEWED BY
1/5/15	JMG

SITE NUMBER:
CT33XC540
SITE NAME:
MADISON-ATT
SITE ADDRESS:
1749 DURHAM ROAD
MADISON, CT 06443

SHEET TITLE:
GENERAL NOTES

SHEET NO:
SP-2

NORTH NOTE:

NORTH SHOWN HAS BEEN ESTABLISHED USING THE USGS QUADRANGLE 7.5 MINUTE MAPS AND IS APPROXIMATE. VERIFY TRUE NORTH PRIOR TO INSTALLATION OF ANTENNAS.

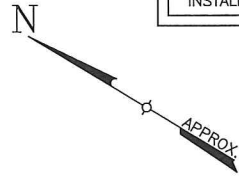

1
A-2

EXIST TRANSFORMER

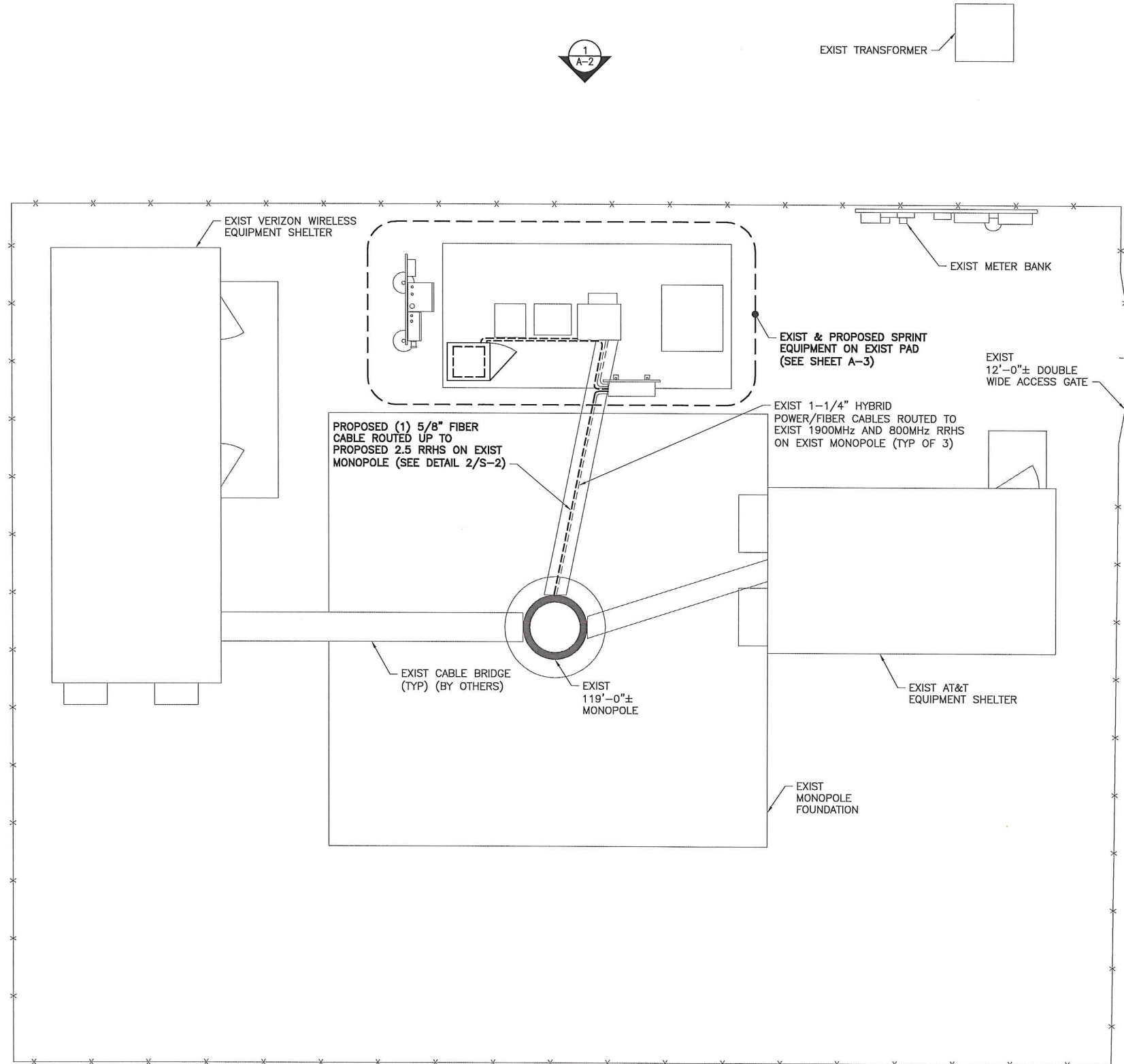

1
A-1 **SITE PLAN**
SCALE: 3/16" = 1'-0"

Sprint

2.5 EQUIPMENT DEPLOYMENT
6850 SPRINT PARKWAY
OVERLAND PARK, KANSAS 66251

CROWN CASTLE

TECTONIC
• PLANNING
• ENGINEERING
• SURVEYING
• CONSTRUCTION MANAGEMENT

TECTONIC Engineering & Surveying
Consultants P.C.

1279 Route 300
Newburgh, NY 12550

Phone: (845) 567-6656
Fax: (845) 567-8703

www.tectoniceengineering.com

THIS DOCUMENT IS THE CREATION, DESIGN, PROPERTY AND COPYRIGHTED WORK OF SPRINT COMMUNICATIONS, INC. ANY DUPLICATION OR USE WITHOUT EXPRESS WRITTEN CONSENT IS STRICTLY PROHIBITED. DUPLICATION AND USE BY GOVERNMENT AGENCIES FOR THE PURPOSES OF CONDUCTING THEIR LAWFULLY AUTHORIZED REGULATORY AND ADMINISTRATIVE FUNCTIONS IS SPECIFICALLY ALLOWED.

SUBMITTALS

PROJECT NO: 7225.CT33XC540

NO	DATE	DESCRIPTION	BY
0	07/08/14	FOR COMMENT	DC
1	01/05/15	FOR CONSTRUCTION	DC

DATE	REVIEWED BY
1/5/15	JMG

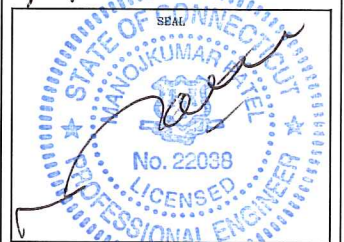

SITE NUMBER:
CT33XC540

SITE NAME:
MADISON-ATT

SITE ADDRESS:
1749 DURHAM ROAD
MADISON, CT 06448

SHEET TITLE:
SITE PLAN

SHEET NO:
A-1

THE EXISTING MONOPOLE SHALL BE ANALYZED BY A PROFESSIONAL ENGINEER LICENSED IN THE STATE OF CONNECTICUT (TO BE COORDINATED BY OTHERS).

THE EXISTING MOUNT HAS BEEN ANALYZED BY TECTONIC ENGINEERING AND FOUND TO BE ADEQUATE TO SUPPORT THE PROPOSED SPRINT UPGRADE AS DETAILED IN THE STRUCTURAL ANALYSIS EVALUATION LETTER DATED 01/05/15.

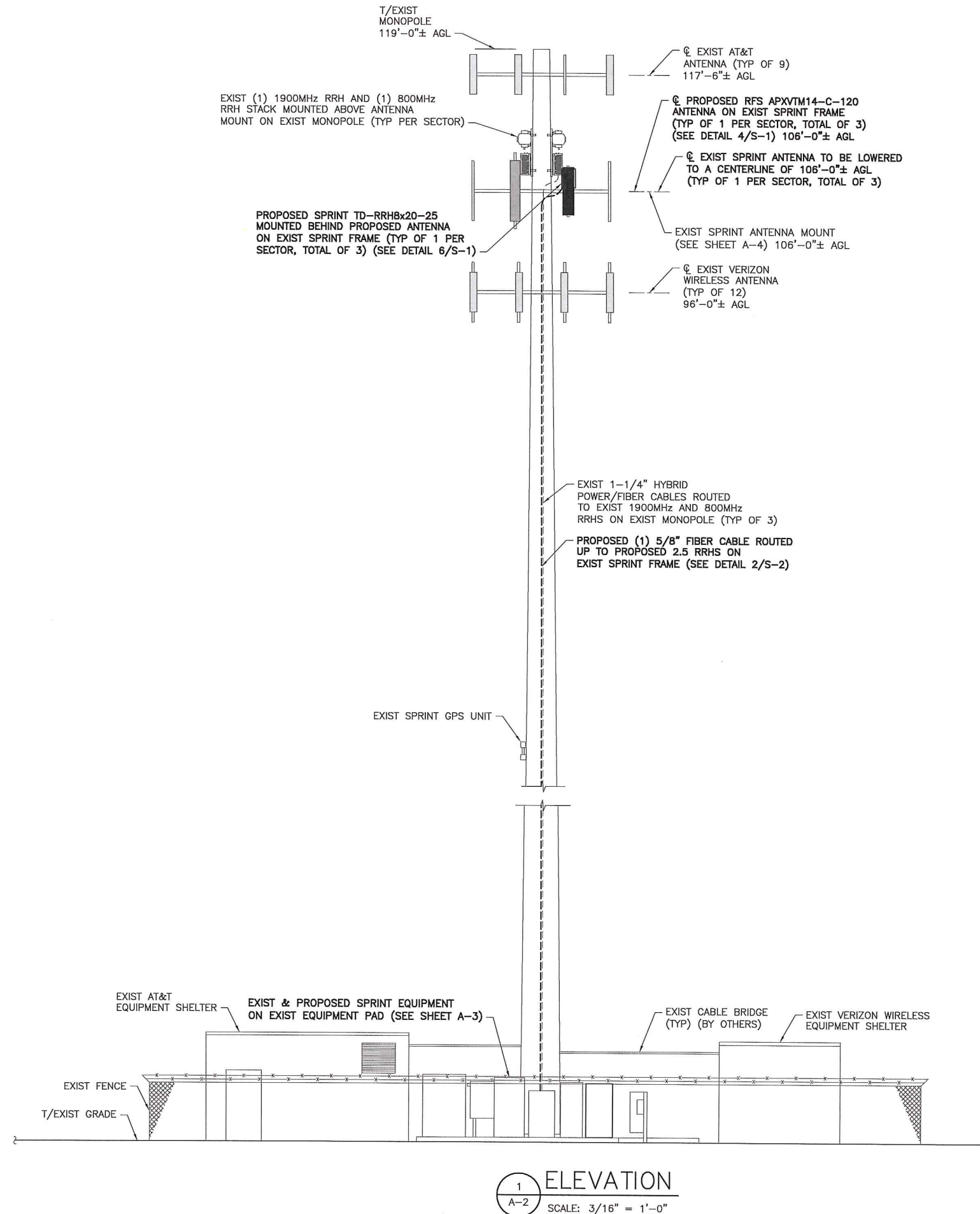
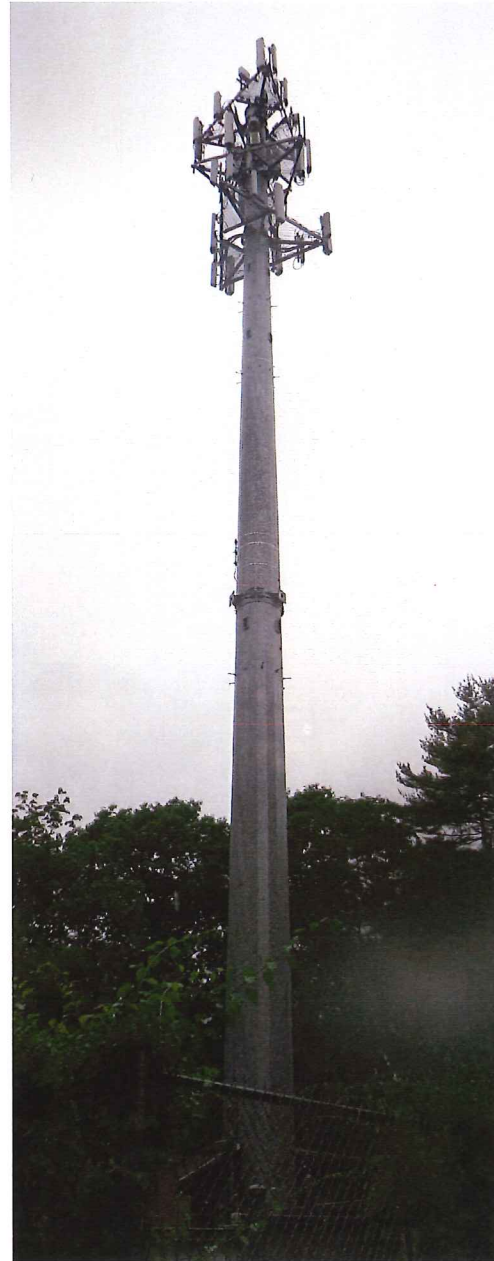

1
A-2 ELEVATION
SCALE: 3/16" = 1'-0"

Sprint
2.5 EQUIPMENT DEPLOYMENT
6850 SPRINT PARKWAY
OVERLAND PARK, KANSAS 66251

CROWN CASTLE

TECTONIC
• PLANNING
• ENGINEERING
• SURVEYING
• CONSTRUCTION MANAGEMENT
TECTONIC Engineering & Surveying
Consultants P.C.
1279 Route 300
Newburgh, NY 12550
Phone: (845) 567-6656
Fax: (845) 567-8703
www.tectonicengineering.com

THIS DOCUMENT IS THE CREATION, DESIGN, PROPERTY AND COPYRIGHTED WORK OF SPRINT COMMUNICATIONS, INC. ANY DUPLICATION OR USE WITHOUT EXPRESS WRITTEN CONSENT IS STRICTLY PROHIBITED. DUPLICATION AND USE BY GOVERNMENT AGENCIES FOR THE PURPOSES OF CONDUCTING THEIR LAWFULLY AUTHORIZED REGULATORY AND ADMINISTRATIVE FUNCTIONS IS SPECIFICALLY ALLOWED.

SUBMITTALS			
NO	DATE	DESCRIPTION	BY
0	07/08/14	FOR COMMENT	DC
1	01/05/15	FOR CONSTRUCTION	DC

DATE	REVIEWED BY
1/5/15	JMA

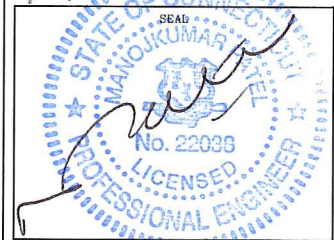

SITE NUMBER:
CT33XC540
SITE NAME:
MADISON-ATT
SITE ADDRESS:
1749 DURHAM ROAD
MADISON, CT 06443

SHEET TITLE:
ELEVATION

SHEET NO:
A-2

NORTH NOTE:

NORTH SHOWN HAS BEEN ESTABLISHED USING THE USGS QUADRANGLE 7.5 MINUTE MAPS AND IS APPROXIMATE. VERIFY TRUE NORTH PRIOR TO INSTALLATION OF ANTENNAS.

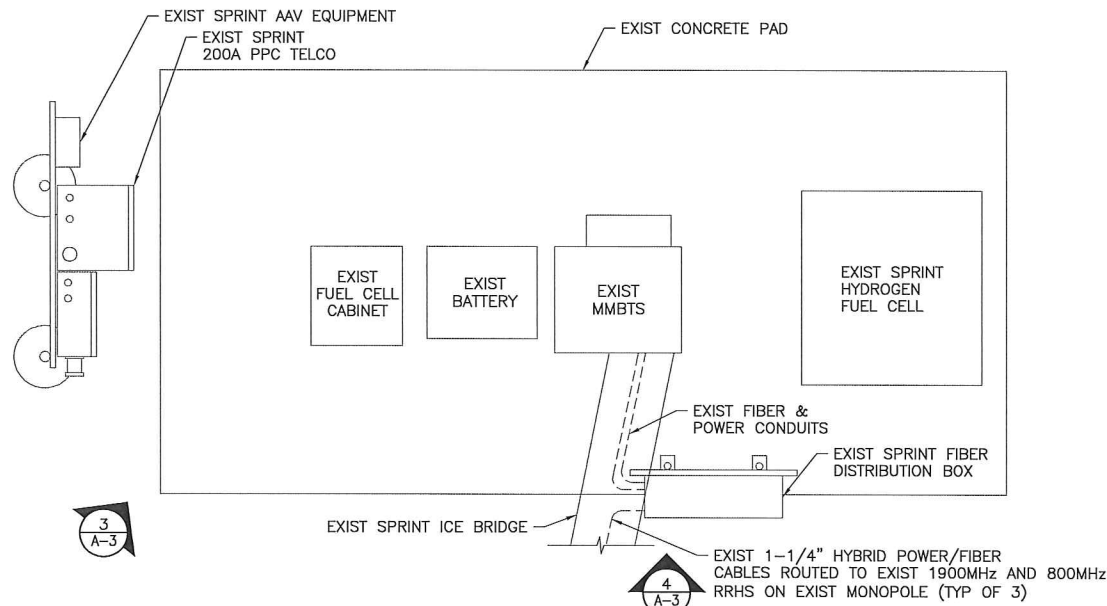
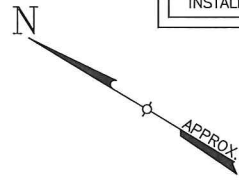

1 ENLARGED EQUIP. LAYOUT PLAN (EXIST)

SCALE: 1/2" = 1'-0"

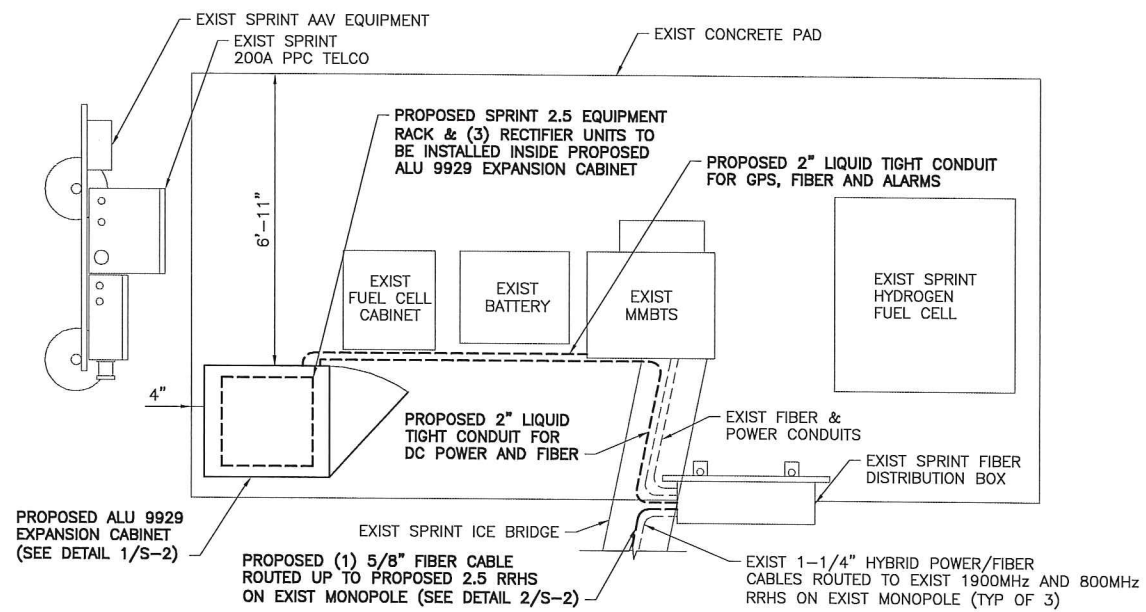

2 ENLARGED EQUIP. LAYOUT PLAN (FINAL)

SCALE: 1/2" = 1'-0"



3 EXIST EQUIPMENT PAD

SCALE: NTS



4 EXIST FIBER DISTRIBUTION BOX

SCALE: NTS

Sprint

2.5 EQUIPMENT DEPLOYMENT
6850 SPRINT PARKWAY
OVERLAND PARK, KANSAS 66251

CROWN CASTLE

TECTONIC

TECTONIC Engineering & Surveying Consultants P.C.
1279 Route 300
Newburgh, NY 12550
Phone: (845) 567-6656
Fax: (845) 567-8703
www.tectonicengineering.com

THIS DOCUMENT IS THE CREATION, DESIGN, PROPERTY AND COPYRIGHTED WORK OF SPRINT COMMUNICATIONS, INC. ANY DUPLICATION OR USE WITHOUT EXPRESS WRITTEN CONSENT IS STRICTLY PROHIBITED. DUPLICATION AND USE BY GOVERNMENT AGENCIES FOR THE PURPOSES OF CONDUCTING THEIR LAWFULLY AUTHORIZED REGULATORY AND ADMINISTRATIVE FUNCTIONS IS SPECIFICALLY ALLOWED.

SUBMITTALS

NO	DATE	DESCRIPTION	BY
0	07/08/14	FOR COMMENT	DC
1	01/05/15	FOR CONSTRUCTION	DC

DATE	REVIEWED BY
1/5/15	JMC



SITE NUMBER:
CT33XC540
SITE NAME:
MADISON-ATT
SITE ADDRESS:
1749 DURHAM ROAD
MADISON, CT 06443

SHEET TITLE:
ENLARGED EQUIPMENT
LAYOUT PLANS

SHEET NO:
A-3

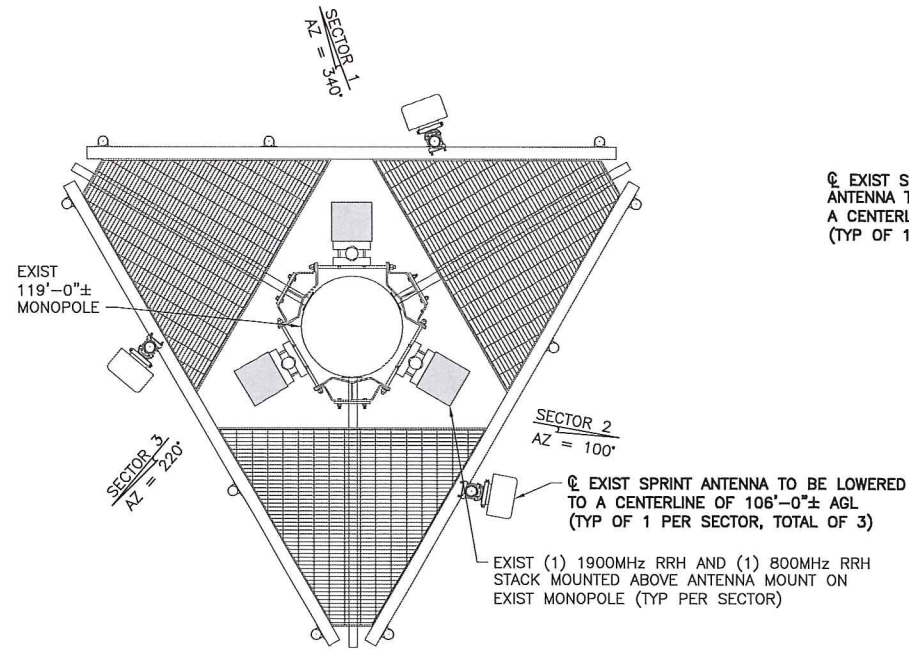

1 ANTENNA LAYOUT PLAN (EXIST)
A-4 SCALE: 3/8" = 1'-0"

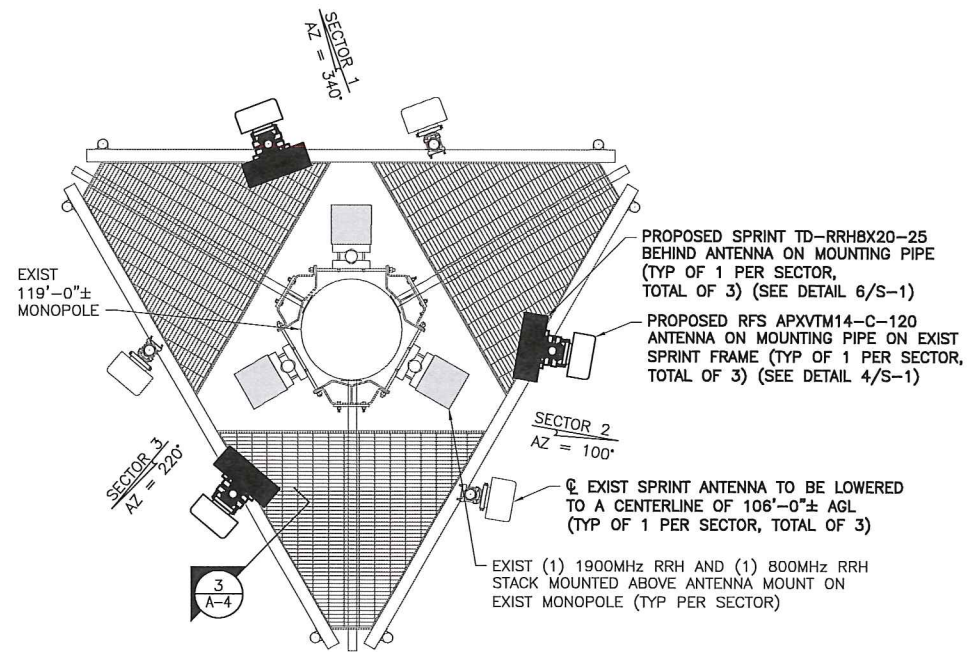

2 ANTENNA LAYOUT PLAN (FINAL)
A-4 SCALE: 3/8" = 1'-0"

EXIST SPRINT ANTENNA TO BE LOWERED TO A CENTERLINE OF 106'-0"± AGL (TYP OF 1 PER SECTOR, TOTAL OF 3)

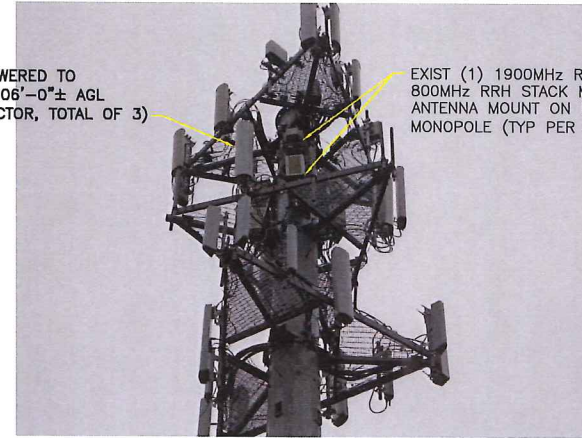

EXIST (1) 1900MHz RRH AND (1) 800MHz RRH STACK MOUNTED ABOVE ANTENNA MOUNT ON EXIST MONOPOLE (TYP PER SECTOR)

THE EXISTING MONOPOLE SHALL BE ANALYZED BY A PROFESSIONAL ENGINEER LICENSED IN THE STATE OF CONNECTICUT (TO BE COORDINATED BY OTHERS).

THE EXISTING MOUNT HAS BEEN ANALYZED BY TECTONIC ENGINEERING AND FOUND TO BE ADEQUATE TO SUPPORT THE PROPOSED SPRINT UPGRADE AS DETAILED IN THE STRUCTURAL ANALYSIS EVALUATION LETTER DATED 01/05/15.

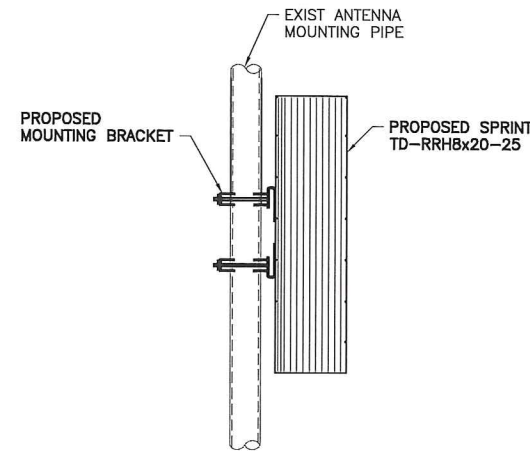

3 RRH MOUNTING DETAIL
A-4 SCALE: 1 1/2" = 1'-0"

ANTENNA DATA

Status	Exist	Proposed
Antenna Manufacturer	RFS-CEL WAVE	RFS-CEL WAVE
Antenna Model Number	APXVSP18C-A20	APXVTM14-C-120
Number of Antennas	3	3
Antenna RAD Center	106'	106'
Antenna Azimuth	340/100/220	340/100/220
Antenna RRH Model Number	1900MHz/800MHz RRHS	TD-RRHx20-25
Number of RRH	6	3

Sprint
2.5 EQUIPMENT DEPLOYMENT
6850 SPRINT PARKWAY
OVERLAND PARK, KANSAS 66251

CROWN CASTLE

TECTONIC
• PLANNING
• ENGINEERING
• SURVEYING
• CONSTRUCTION MANAGEMENT

TECTONIC Engineering & Surveying Consultants P.C.
1279 Route 300
Newburgh, NY 12550
Phone: (845) 567-6656
Fax: (845) 567-8703
www.tectonicengineering.com

THIS DOCUMENT IS THE CREATION, DESIGN, PROPERTY AND COPYRIGHTED WORK OF SPRINT COMMUNICATIONS, INC. ANY DUPLICATION OR USE WITHOUT EXPRESS WRITTEN CONSENT IS STRICTLY PROHIBITED. DUPLICATION AND USE BY GOVERNMENT AGENCIES FOR THE PURPOSES OF CONDUCTING THEIR LAWFULLY AUTHORIZED REGULATORY AND ADMINISTRATIVE FUNCTIONS IS SPECIFICALLY ALLOWED.

SUBMITTALS

PROJECT NO: 7225.CT33XC540

NO	DATE	DESCRIPTION	BY
0	07/08/14	FOR COMMENT	DC
1	01/05/15	FOR CONSTRUCTION	DC

DATE: 1/5/15
REVIEWED BY: JMQ

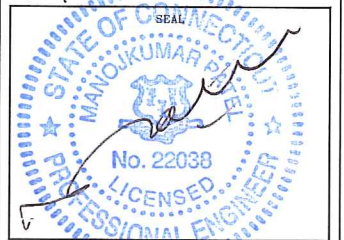

SITE NUMBER: CT33XC540
SITE NAME: MADISON-ATT
SITE ADDRESS: 1749 DURHAM ROAD MADISON, CT 06443

SHEET TITLE: ANTENNA LAYOUT PLANS

SHEET NO: A-4

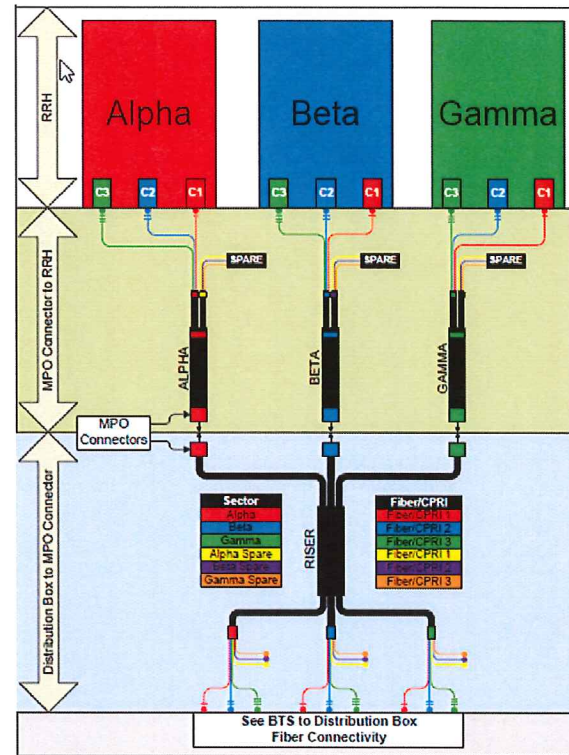

1 2.5 CABLE COLOR CODING
A-5 SCALE: N.T.S.

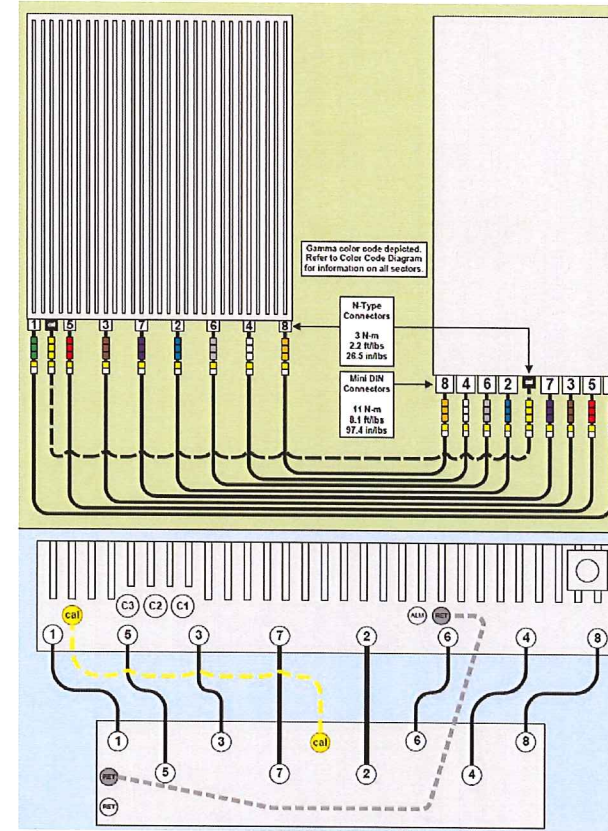

2 RRH CONNECTIVITY
A-5 SCALE: N.T.S.

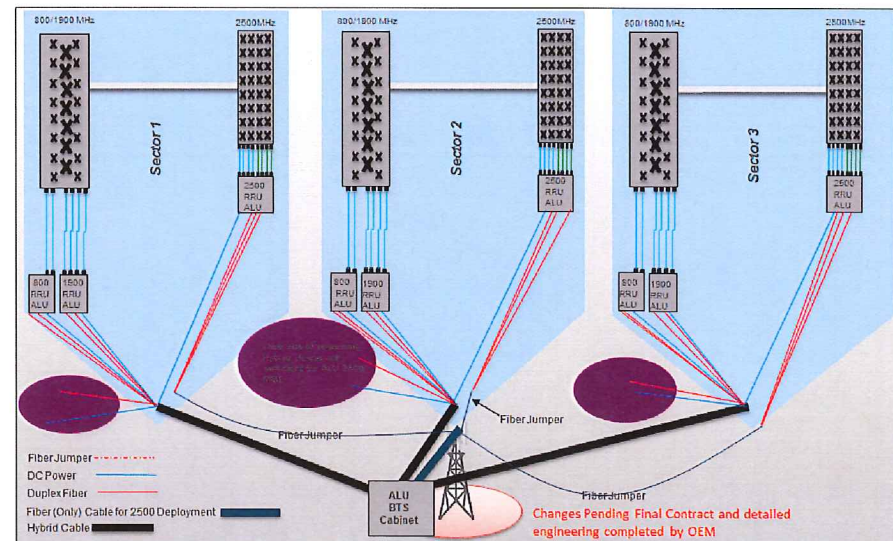

3 RAN WIRING
A-5 SCALE: N.T.S.

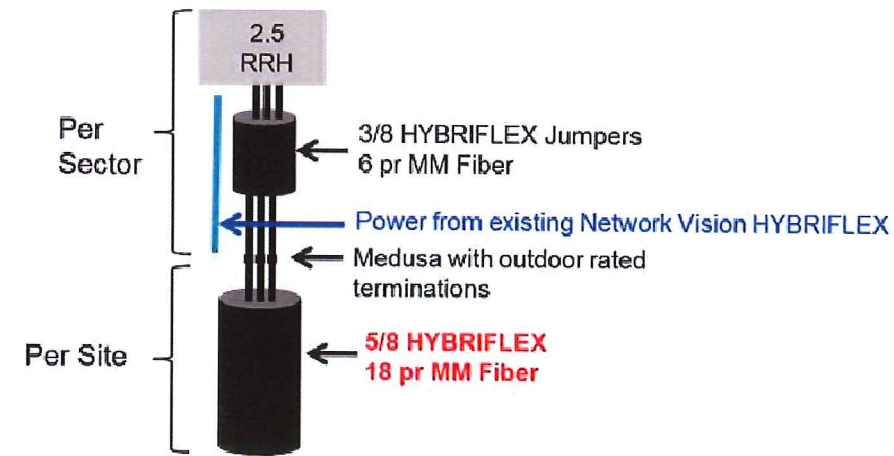

4 CABLE SCENARIO
A-5 SCALE: N.T.S.

Sprint
2.5 EQUIPMENT DEPLOYMENT
6850 SPRINT PARKWAY
OVERLAND PARK, KANSAS 66251

CROWN CASTLE

TECTONIC
• PLANNING
• ENGINEERING
• SURVEYING
• CONSTRUCTION MANAGEMENT

TECTONIC Engineering & Surveying Consultants P.C.
1279 Route 300
Newburgh, NY 12550
Phone: (845) 567-6656
Fax: (845) 567-8703
www.tectonicengineering.com

THIS DOCUMENT IS THE CREATION, DESIGN, PROPERTY AND COPYRIGHTED WORK OF SPRINT COMMUNICATIONS, INC. ANY DUPLICATION OR USE WITHOUT EXPRESS WRITTEN CONSENT IS STRICTLY PROHIBITED. DUPLICATION AND USE BY GOVERNMENT AGENCIES FOR THE PURPOSES OF CONDUCTING THEIR LAWFULLY AUTHORIZED REGULATORY AND ADMINISTRATIVE FUNCTIONS IS SPECIFICALLY ALLOWED.

SUBMITTALS			
NO	DATE	DESCRIPTION	BY
0	07/08/14	FOR COMMENT	DC
1	01/05/15	FOR CONSTRUCTION	DC

DATE	REVIEWED BY
1/5/15	JMG

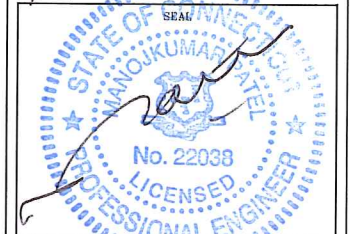

SITE NUMBER:
CT33XC540
SITE NAME:
MADISON-ATT
SITE ADDRESS:
1749 DURHAM ROAD
MADISON, CT 06443

SHEET TITLE:
RAN WIRING DIAGRAM

SHEET NO:
A-5

THIS DOCUMENT IS THE CREATION, DESIGN, PROPERTY AND COPYRIGHTED WORK OF SPRINT COMMUNICATIONS, INC. ANY DUPLICATION OR USE WITHOUT EXPRESS WRITTEN CONSENT IS STRICTLY PROHIBITED. DUPLICATION AND USE BY GOVERNMENT AGENCIES FOR THE PURPOSES OF CONDUCTING THEIR LAWFULLY AUTHORIZED REGULATORY AND ADMINISTRATIVE FUNCTIONS IS SPECIFICALLY ALLOWED.

SUBMITTALS			
NO	DATE	DESCRIPTION	BY
0	07/08/14	FOR COMMENT	DC
1	01/05/15	FOR CONSTRUCTION	DC

DATE	REVIEWED BY
1/5/15	JMA

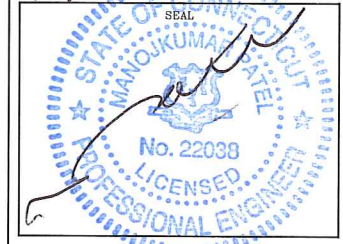

SITE NUMBER:
CT33XC540

SITE NAME:
MADISON-ATT

SITE ADDRESS:
**1749 DURHAM ROAD
 MADISON, CT 06443**

SHEET TITLE:
CABLE DETAILS

SHEET NO:
A-6

IMPORTANT!! LINE UP WHITE MARKINGS ON JUMPER AND RISER IP-MPO CONNECTOR. PUSH THE WHITE MARK ON THE JUMPER CONNECTOR FLUSH AGAINST THE RED SEAL ON THE RISER CONNECTION



IMPORTANT!! ROTATE THE BAYONET HOUSING CLOCKWISE UNTIL A CLICK SOUND IS HEARD TO ENSURE A GOOD CONNECTION

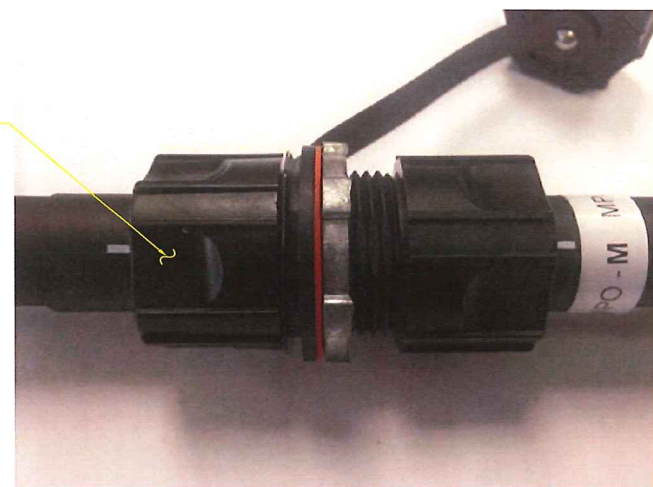

1 HYBRIFLEX RISER/JUMPER CONNECTION DETAILS
 A-6 SCALE: N.T.S.

TRUNK-LINE TO JUMPER CONNECTION (MPO) TO BE INSTALLED PER MANUFACTURER REQUIREMENTS. SEE DETAIL.

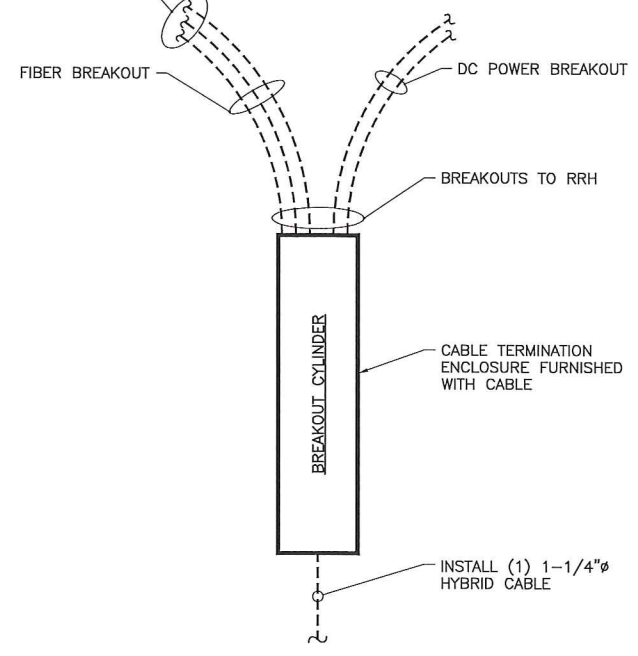

2 2.5 HYBRID CABLE W/FIBER & DC FEEDERS
 A-6 SCALE: N.T.S.

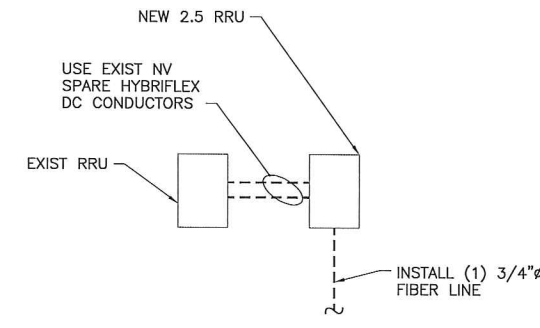

FIBER ONLY TRUNK LINES

SPECIAL NOTES: CABLE MARKINGS AT RAD CENTER AND ALL WALL/BLDG. PENETRATIONS

- ALL COLOR CODE TAPE SHALL BE 3M-35 AND SHALL BE INSTALLED USING A MINIMUM OF (3) WRAPS OF TAPE.
- ALL COLOR BANDS INSTALLED AT THE TOWER TOP SHALL BE A MINIMUM OF 3" WIDE AND SHALL HAVE A MINIMUM OF 3/4" OF SPACING BETWEEN EACH COLOR.
- ALL COLOR BANDS INSTALLED AT OR NEAR THE GROUND MAY BE ONLY 3/4" WIDE. EACH TOP-JUMPER SHALL BE COLOR CODED WITH (1) SET OF 3" WIDE BANDS.
- EACH MAIN COAX SHALL BE COLOR CODED WITH (1) SET OF 3" BANDS NEAR THE TOP-JUMPER CONNECTION AND WITH 3/4" COLOR BANDS JUST PRIOR TO ENTERING THE BTS OR TRANSMITTER BUILDING.
- ALL BOTTOM JUMPERS SHALL BE COLOR CODED WITH (1) SET OF 3/4" BANDS ON EACH END OF THE BOTTOM JUMPER.
- ALL COLOR CODES SHALL BE INSTALLED SO AS TO ALIGN NEATLY WITH ONE ANOTHER FROM SIDE-TO-SIDE.
- EACH COLOR BAND SHALL HAVE A MINIMUM OF (3) WRAPS AND SHALL BE NEATLY TRIMMED AND SMOOTHED OUT AS TO AVOID UNRAVELING.
- X-POLE ANTENNAS SHOULD USE "XX-1" FOR THE "+45" PORT, "XX-2" FOR THE "-45" PORT.
- COLOR BAND #4 REFERS TO THE FREQUENCY BAND: ORANGE=850, VIOLET=1900. USED ON JUMPERS ONLY.
- RF FEEDLINE SHALL BE IDENTIFIED WITH A METAL TAG (STAINLESS OR BRASS) AND STAMPED WITH THE SECTOR, ANTENNA POSITION, AND CABLE NUMBER.
- ANTENNAS MUST BE IDENTIFIED, USING THE SECTOR LETTER AND ANTENNA NUMBER, WITH A BLACK MARKER PRIOR TO INSTALLATION.

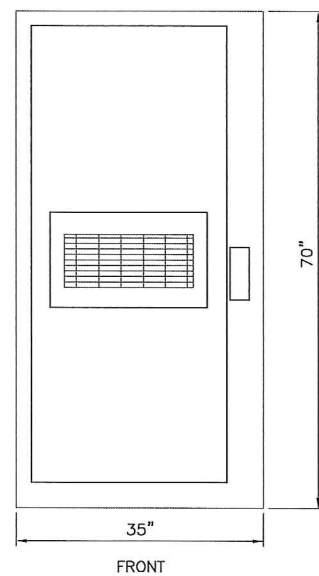

CABINET FRONT
9928 MMBTS MODULAR CELL

SPECIFICATIONS:

HEIGHT: 70"
WIDTH: 35"
DEPTH: 37.8"
WEIGHT: 1090 LBS.

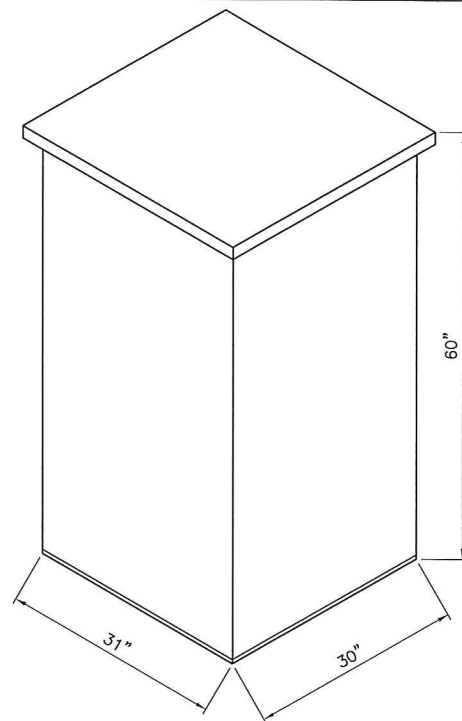

ANDREW 60ECv2

SPECIFICATIONS:

HEIGHT: 60"
WIDTH: 31"
DEPTH: 30"
WEIGHT: 2430 LBS.

1 (EXIST) MMBTS CABINET
S-1 SCALE: 1" = 1'-0"

2 (EXIST) BATTERY CABINET
S-1 SCALE: 1" = 1'-0"

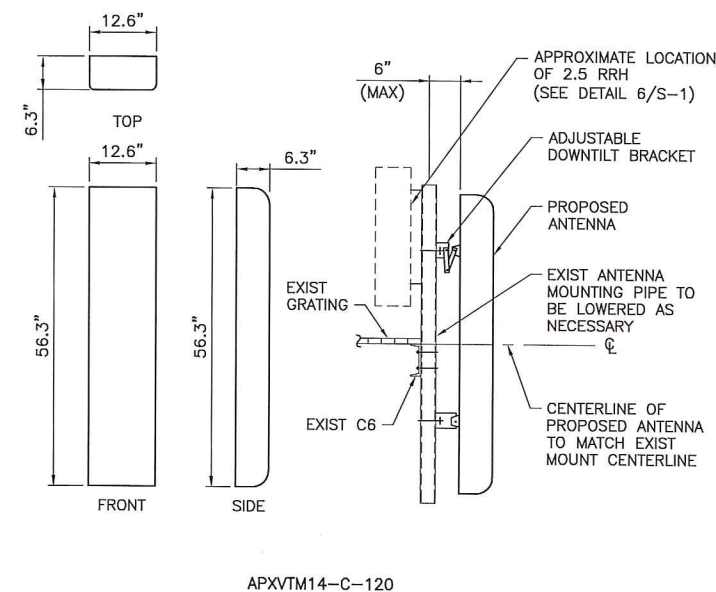
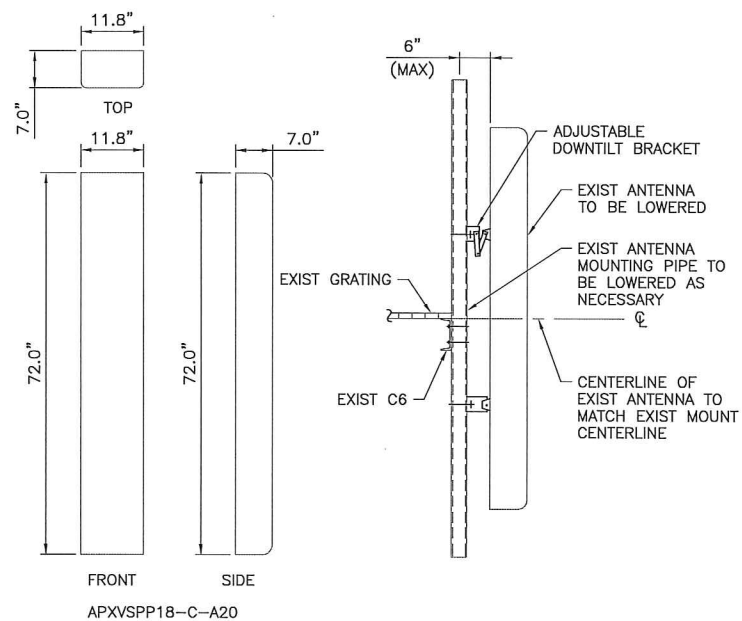

3 (EXIST) ANTENNA DETAILS
S-1 SCALE: 3/4" = 1'-0"

4 (PROPOSED) ANTENNA DETAIL
S-1 SCALE: 3/4" = 1'-0"

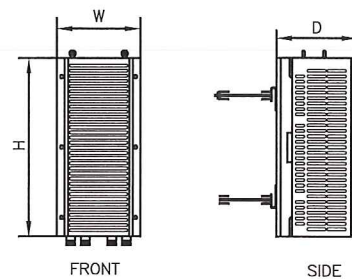

TYPE: 1900 MHz 4x45W
MODEL #: RRH 1900 4X45 65MHz
HEIGHT: 25.0"
WIDTH: 11.1"
DEPTH: 11.4"
WEIGHT: ±60 LBS.

5 (EXIST) RRH DETAILS
S-1 SCALE: 1 1/2" = 1'-0"

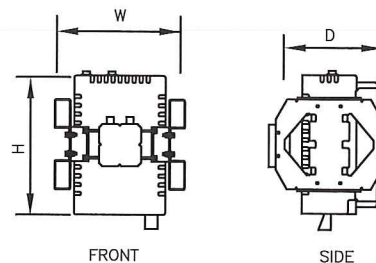

TYPE: 800 MHz 2x50W
MODEL #: FD-RRH-2x50-800
HEIGHT: 19.7"
WIDTH: 13"
DEPTH: 10.8"
WEIGHT: ±53 LBS.

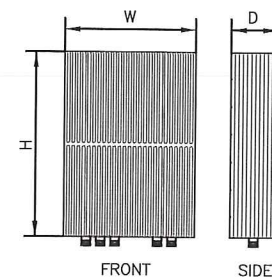

TYPE: 2.5 RRH
MODEL #: TD-RRH8x20-25
HEIGHT: 26.1"
WIDTH: 18.6"
DEPTH: 6.7"
WEIGHT: ±70 LBS.

6 (PROPOSED) RRH DETAIL
S-1 SCALE: 1" = 1'-0"

Sprint

2.5 EQUIPMENT DEPLOYMENT
6850 SPRINT PARKWAY
OVERLAND PARK, KANSAS 66251

CROWN CASTLE

TECTONIC

• PLANNING
• ENGINEERING
• SURVEYING
• CONSTRUCTION MANAGEMENT

TECTONIC Engineering & Surveying
Consultants P.C.

1279 Route 300
Newburgh, NY 12550
Phone: (845) 567-6656
Fax: (845) 567-8703
www.tectonicengineering.com

THIS DOCUMENT IS THE CREATION, DESIGN, PROPERTY AND COPYRIGHTED WORK OF SPRINT COMMUNICATIONS, INC. ANY DUPLICATION OR USE WITHOUT EXPRESS WRITTEN CONSENT IS STRICTLY PROHIBITED. DUPLICATION AND USE BY GOVERNMENT AGENCIES FOR THE PURPOSES OF CONDUCTING THEIR LAWFULLY AUTHORIZED REGULATORY AND ADMINISTRATIVE FUNCTIONS IS SPECIFICALLY ALLOWED.

SUBMITTALS

PROJECT NO: 7225.CT33XC540

NO	DATE	DESCRIPTION	BY
0	07/08/14	FOR COMMENT	DC
1	01/05/15	FOR CONSTRUCTION	DC

DATE	REVIEWED BY
1/5/15	JMG

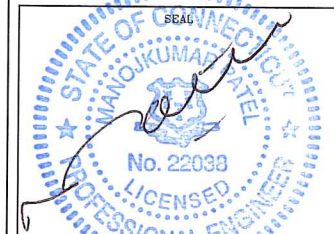

SITE NUMBER:
CT33XC540

SITE NAME:
MADISON- ATT

SITE ADDRESS:
1749 DURHAM ROAD
MADISON, CT 06443

SHEET TITLE:
EQUIPMENT DETAILS

SHEET NO:
S-1

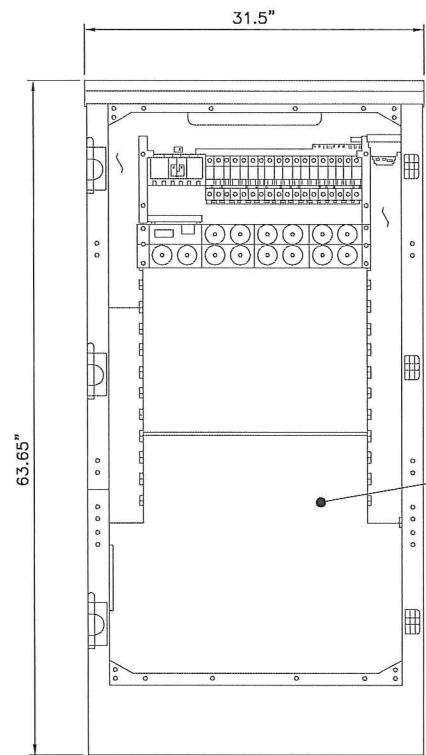

9929 EXPANSION CABINET	
CABINET SPECIFICATIONS	
EXPANSION CABINET:	
- HEIGHT -	63.65"
- WIDTH -	31.5"
- DEPTH -	35.5"
WEIGHT: 1,600 LBS.	

INSTALL NEW 2.5 EQUIPMENT IN PROPOSED 9929 EXPANSION CABINET INCLUDING BUT NOT LIMITED TO BASE BAND UNIT, CELL SITE ROUTER AND SURGE ARRESTORS. GROUND EQUIPMENT TO PROPOSED INTERIOR CABINET GROUND BAR

FRONT ELEVATION (CABINET INTERIOR)

1 9929 INTERIOR DETAIL
S-2 SCALE: N.T.S.

- LEGEND:
- P1000T-HG UNISTRUT, 12" LONG.
 - 6" PIPE HANGER.
 - EXISTING SUPPORT PIPE.
 - NEW STANDOFF BRACKET, ANDREW PART# 30848-4.
 - NEW ROUND MEMBER ADAPTER SIZED FOR EXISTING PIPE SUPPORT.
 - BREAKOUT UNIT.
 - CABLE.

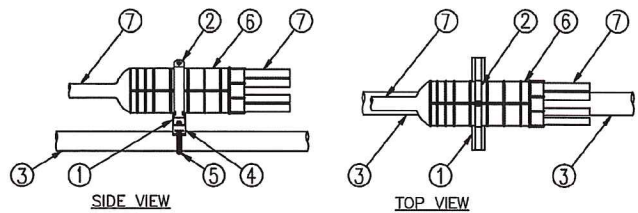

3 MEDUSA HEAD DETAIL
S-2 SCALE: NTS

RFS HYBRIFLEX RISER CABLES SCHEDULE

Fiber Only (Existing DC Power)	Hybrid cable MN: HB058-M12-050F 12x multi-mode fiber pairs, Top: Outdoor protected connectors, Bottom: LC Connectors, 5/8 cable, 50ft	50 ft
	MN: HB058-M12-075F	75 ft
	MN: HB058-M12-100F	100 ft
	MN: HB058-M12-125F	125 ft
	MN: HB058-M12-150F	150 ft
	MN: HB058-M12-175F	175 ft
MN: HB058-M12-200F	200 ft	
8 AWG Power	Hybrid cable MN: HB114-08U3M12-050F 3x 8 AWG power pairs, 12x multi-mode fiber pairs, Outdoor rated connectors & LC Connectors, 1 1/4 cable, 50ft	50 ft
	MN: HB114-08U3M12-075F	75 ft
	MN: HB114-08U3M12-100F	100 ft
	MN: HB114-08U3M12-125F	125 ft
	MN: HB114-08U3M12-150F	150 ft
	MN: HB114-08U3M12-175F	175 ft
MN: HB114-08U3M12-200F	200 ft	
6 AWG Power	Hybrid cable MN: HB114-13U3M12-225F 3x 6 AWG power pairs, 12x multi-mode fiber pairs, Outdoor rated connectors & LC Connectors, 1 1/4 cable, 225ft	225 ft
	MN: HB114-13U3M12-250F	250 ft
	MN: HB114-13U3M12-275F	275 ft
	MN: HB114-13U3M12-300F	300 ft
4 AWG Power	Hybrid cable MN: HB114-21U3M12-225F 3x 4 AWG power pairs, 12x multi-mode fiber pairs, Outdoor rated connectors & LC Connectors, 1 1/4 cable, 225ft	325 ft
	MN: HB114-21U3M12-350F	350 ft
	MN: HB114-21U3M12-375F	375 ft

RFS HYBRIFLEX JUMPER CABLE SCHEDULE

Fiber Only	Hybrid Jumper cable MN: HBF012-M3-5F1 5 ft, 3x multi-mode fiber pairs, Outdoor & LC connectors, 1/2 cable	5 ft
	MN: HBF012-M3-10F1	10 ft
	MN: HBF012-M3-15F1	15 ft
	MN: HBF012-M3-20F1	20 ft
	MN: HBF012-M3-25F1	25 ft
	MN: HBF012-M3-30F1	30 ft
8 AWG Power	Hybrid Jumper cable MN: HBF058-08U1M3-5F1 5 ft, 1x 8 AWG power pair, 3x multi-mode fiber pairs, Outdoor & LC Connectors, 5/8 cable	5 ft
	MN: HBF058-08U1M3-10F1	10 ft
	MN: HBF058-08U1M3-15F1	15 ft
	MN: HBF058-08U1M3-20F1	20 ft
	MN: HBF058-08U1M3-25F1	25 ft
	MN: HBF058-08U1M3-30F1	30 ft
6 AWG Power	Hybrid Jumper cable MN: HBF058-13U1M3-5F1 5 ft, 1x 6 AWG power pair, 3x multi-mode fiber pairs, Outdoor & LC Connectors, 5/8 cable	5 ft
	MN: HBF058-13U1M3-10F1	10 ft
	MN: HBF058-13U1M3-15F1	15 ft
	MN: HBF058-13U1M3-20F1	20 ft
	MN: HBF058-13U1M3-25F1	25 ft
	MN: HBF058-13U1M3-30F1	30 ft
4 AWG Power	Hybrid Jumper cable MN: HBF078-21U1M3-5F1 5 ft, 1x 4 AWG power pair, 3x multi-mode fiber pairs, Outdoor & LC Connectors, 7/8 cable	5 ft
	MN: HBF078-21U1M3-10F1	10 ft
	MN: HBF078-21U1M3-15F1	15 ft
	MN: HBF078-21U1M3-20F1	20 ft
	MN: HBF078-21U1M3-25F1	25 ft
	MN: HBF078-21U1M3-30F1	30 ft

HYBRID CABLE DC CONDUCTOR SIZE GUIDELINE

MANUF:	RFS		
CABLE	LENGTH	DC CONDUCTOR	CABLE DIAMETER
FIBER ONLY	VARIABLES	USE NV HYBRIFLEX	7/8"
HYBRIFLEX	<200'	8 AWG	1-1/4"
HYBRIFLEX	225-300'	6 AWG	1-1/4"
HYBRIFLEX	325-375'	4 AWG	1-1/4"

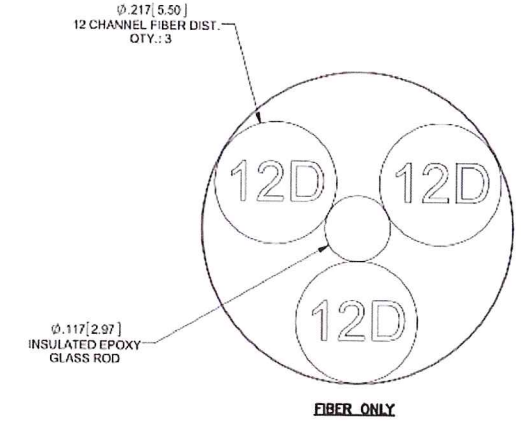
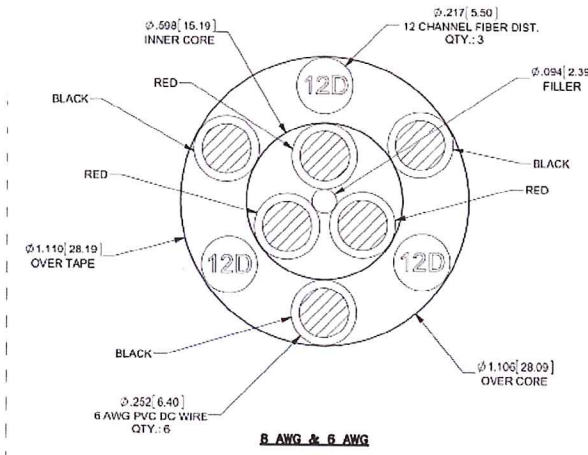
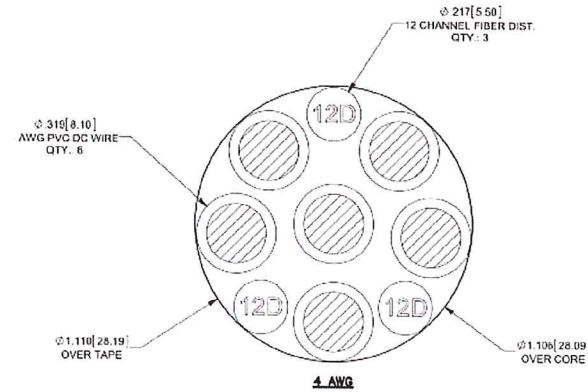

2 2.5 HYBRID CABLE X-SECTION AND DATA
S-2 SCALE: NTS

Sprint
2.5 EQUIPMENT DEPLOYMENT
6850 SPRINT PARKWAY
OVERLAND PARK, KANSAS 66251

CROWN CASTLE

TECTONIC
TECTONIC Engineering & Surveying Consultants P.C.
1279 Route 300
Newburgh, NY 12550
Phone: (845) 567-6656
Fax: (845) 567-8703
www.tectonicengineering.com

THIS DOCUMENT IS THE CREATION, DESIGN, PROPERTY AND COPYRIGHTED WORK OF SPRINT COMMUNICATIONS, INC. ANY DUPLICATION OR USE WITHOUT EXPRESS WRITTEN CONSENT IS STRICTLY PROHIBITED. DUPLICATION AND USE BY GOVERNMENT AGENCIES FOR THE PURPOSES OF CONDUCTING THEIR LAWFULLY AUTHORIZED REGULATORY AND ADMINISTRATIVE FUNCTIONS IS SPECIFICALLY ALLOWED.

SUBMITTALS

PROJECT NO: 7225.CT33XC540

NO	DATE	DESCRIPTION	BY
0	07/08/14	FOR COMMENT	DC
1	01/05/15	FOR CONSTRUCTION	DC

DATE: 1/5/15
REVIEWED BY: SMG



SITE NUMBER:
CT33XC540

SITE NAME:
MADISON-ATT

SITE ADDRESS:
1749 DURHAM ROAD
MADISON, CT 06443

SHEET TITLE:
EQUIPMENT SCHEMATIC DETAILS

SHEET NO:
S-2

THIS DOCUMENT IS THE CREATION, DESIGN, PROPERTY AND COPYRIGHTED WORK OF SPRINT COMMUNICATIONS, INC. ANY DUPLICATION OR USE WITHOUT EXPRESS WRITTEN CONSENT IS STRICTLY PROHIBITED. DUPLICATION AND USE BY GOVERNMENT AGENCIES FOR THE PURPOSES OF CONDUCTING THEIR LAWFULLY AUTHORIZED REGULATORY AND ADMINISTRATIVE FUNCTIONS IS SPECIFICALLY ALLOWED.

SUBMITTALS

NO	DATE	DESCRIPTION	BY
0	07/08/14	FOR COMMENT	DC
1	01/05/15	FOR CONSTRUCTION	DC

DATE	REVIEWED BY
1/5/15	JMQ

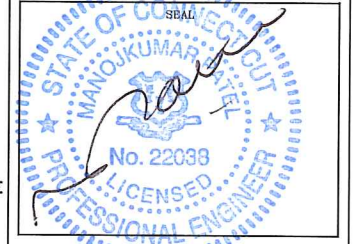

SITE NUMBER:
CT33XC540

SITE NAME:
MADISON-ATT

SITE ADDRESS:
**1749 DURHAM ROAD
 MADISON, CT 06443**

SHEET TITLE:
ELECTRICAL & GROUNDING PLANS

SHEET NO:
E-1

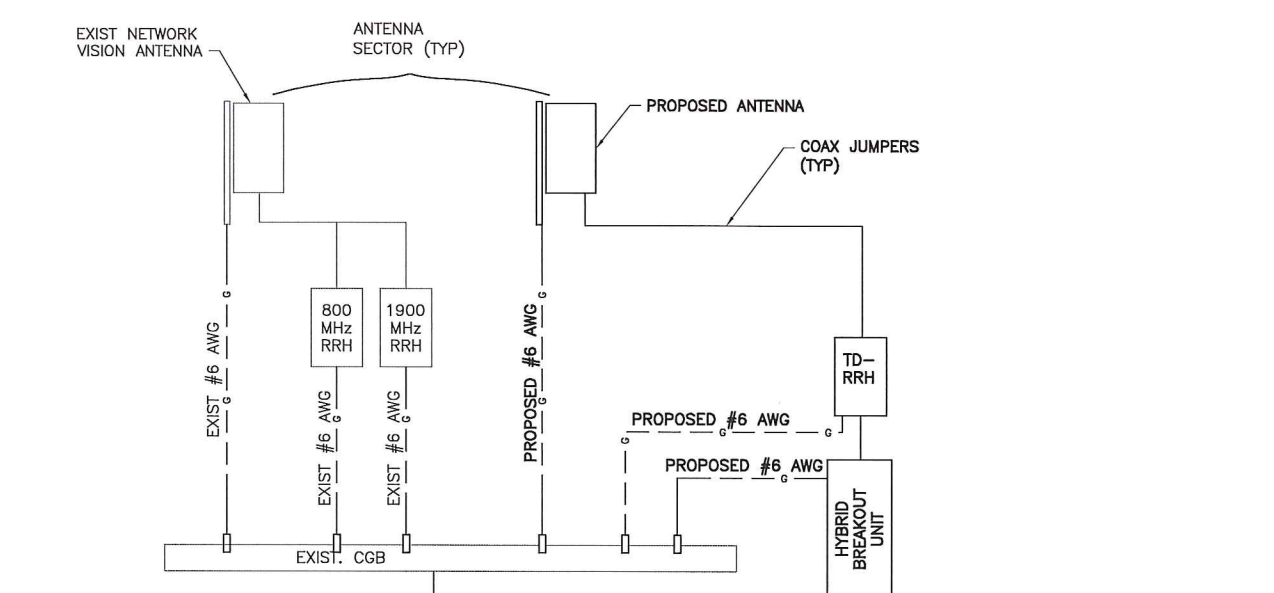

NOTE:
 ALL CONDUCTORS SHALL BE #6 AWG SOLID TINNED UNLESS OTHERWISE NOTED.

EXIST (1) 1900MHz RRH AND (1) 800MHz RRH STACK MOUNTED ABOVE ANTENNA MOUNT ON EXIST MONOPOLE (TYP PER SECTOR)

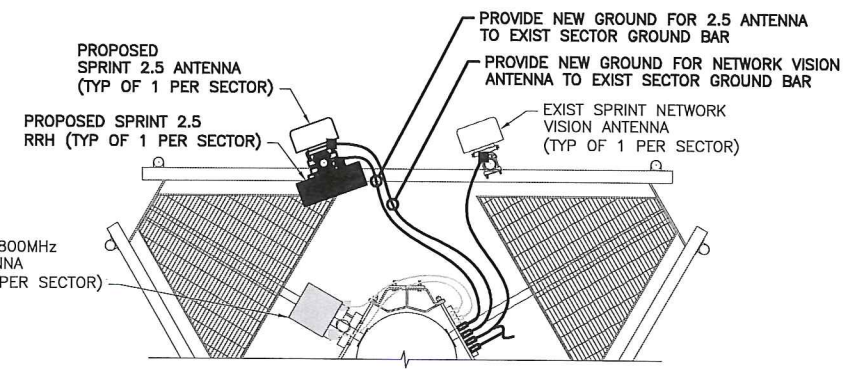

2 TYPICAL ANTENNA GROUNDING PLAN
 SCALE: NTS

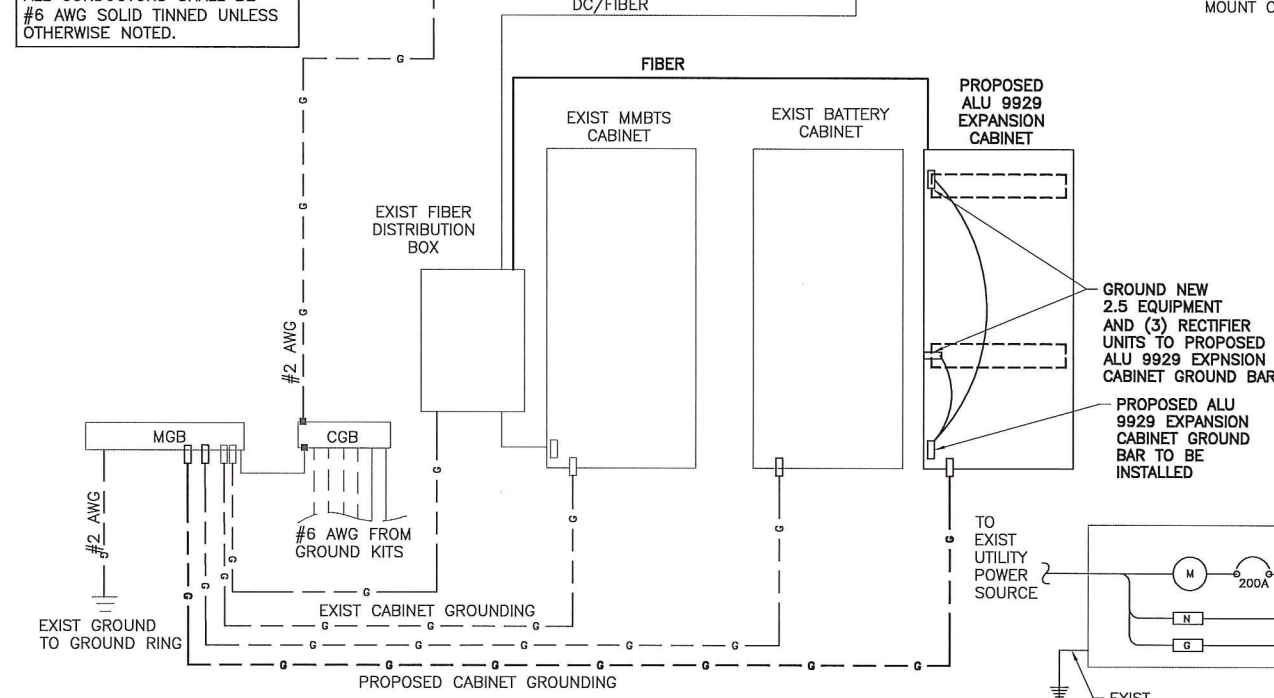

LEGEND

- CADWELD CONNECTION
- MECHANICAL CONNECTION
- COMPRESSION CONNECTION

1 TYPICAL GROUNDING ONE LINE DIAGRAM
 SCALE: NTS

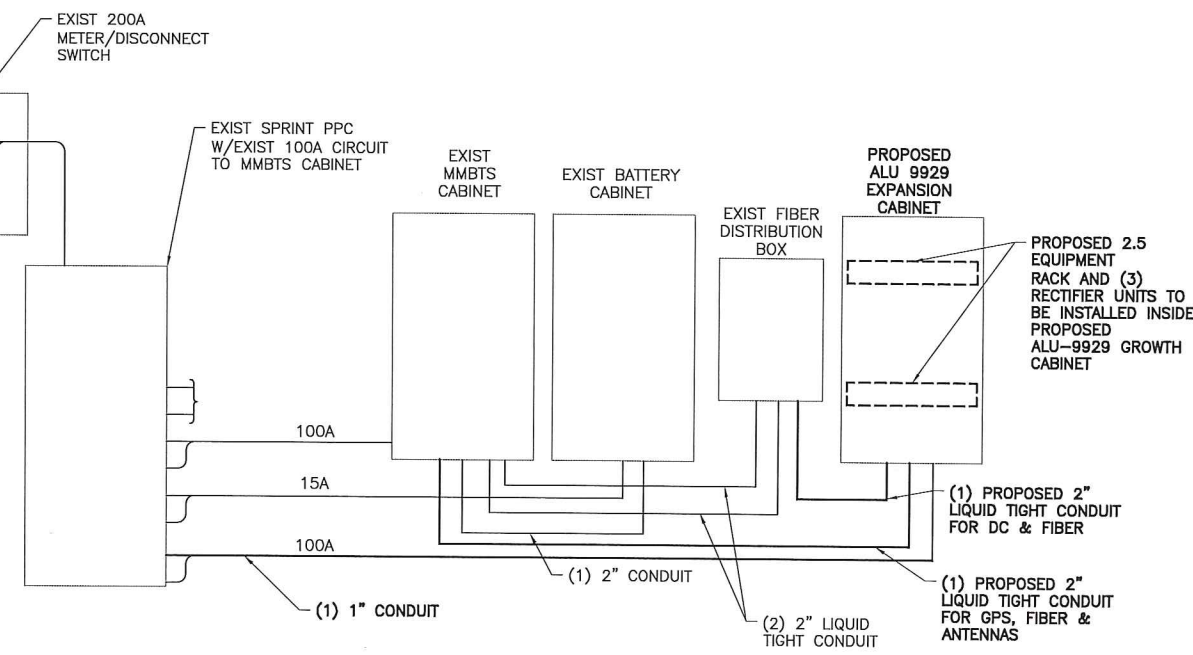

NOTE: FINAL ELECTRICAL DESIGN TO BE DETERMINED BY OTHER.
3 TYPICAL ELECTRICAL & TELCO PLAN
 SCALE: NTS

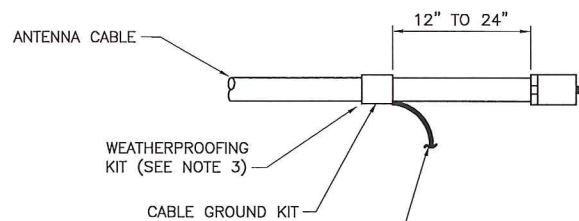

6 AWG STRANDED Cu WIRE WITH GREEN, 600V, THWN INSULATION OR BLACK, MARKED AS REQUIRED BY THE NEC (GROUNDED TO GROUND BAR) (SEE NOTES 1 & 2)

CONNECTION OF CABLE GROUND KIT TO ANTENNA CABLE

NOTES:

DO NOT INSTALL CABLE GROUND KIT AT A BEND AND ALWAYS DIRECT GROUND WIRE DOWN TO GROUND BAR.

GROUNTING KIT SHALL BE TYPE AND PART NUMBER AS SUPPLIED OR RECOMMENDED BY CABLE MANUFACTURER.

WEATHER PROOFING SHALL BE (TYPE AND PART NUMBER) AS SUPPLIED OR RECOMMENDED BY CABLE MANUFACTURER AND APPROVED BY CONTRACTOR.

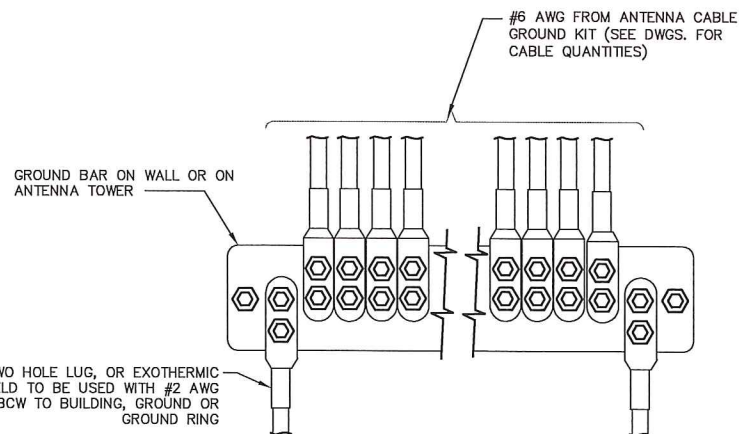

*TWO HOLE LUG, OR EXOTHERMIC WELD TO BE USED WITH #2 AWG BCW TO BUILDING, GROUND OR GROUND RING

* - GROUND BARS AT THE BOTTOM OF TOWERS/MONOPOLES SHALL ONLY USE EXOTHERMIC WELDS.

- ATTACH "DO NOT DISCONNECT" LABELS TO GROUND BARS. CAN USE BRASS TAG "DO NOT DISCONNECT" AT EACH HYBRID GROUND POINT OR BACK-A-LITE PLATE LABEL ON GROUND BAR.

- CONNECT SEQUENCE- BOLT/WASHER/NO-OX/GROUND BAR/NO-OX/WASHER/LOCK-WASHER/NUT. THIS IS REPEATED FOR EACH LUG CONNECTION POINT.

4 ANTENNA GROUND BAR DETAIL

SCALE: NTS

GROUNTING NOTES:

- GROUNTING SHALL BE IN ACCORDANCE WITH NEC ARTICLE 250-GROUNTING AND BONDING.
- ALL GROUND WIRES SHALL BE #2 AWG UNLESS NOTED OTHERWISE.
- ALL GROUNTING WIRES SHALL PROVIDE A STRAIGHT, DOWNWARD PATH TO GROUND WITH GRADUAL BENDS AS REQUIRED. GROUND WIRES SHALL NOT BE LOOPED OR SHARPLY BENT.
- EACH EQUIPMENT CABINET SHALL BE CONNECTED TO THE MASTER ISOLATION GROUND BAR (MGB) WITH #2 AWG INSULATED STRANDED COPPER WIRE. EQUIPMENT CABINETS WILL HAVE (2) CONNECTIONS.
- PROVIDE DEDICATED #2 AWG COPPER GROUND WIRE FROM EACH ANTENNA MOUNTING PIPE TO ASSOCIATED CIGBE.
- THE CONTRACTOR SHALL VERIFY THAT THE EXISTING GROUND BARS HAVE ENOUGH SPACE/HOLES FOR ADDITIONAL TWO HOLE LUGS.
- ALL CONDUITS SHALL BE RIGID GALVANIZED STEEL AND SHALL BE PROVIDED WITH GROUNTING BUSHINGS.
- PROVIDE GROUND CONNECTIONS FOR ALL METALLIC STRUCTURES, ENCLOSURES, RACEWAYS AND OTHER CONDUCTIVE ITEMS ASSOCIATED WITH THE INSTALLATION OF CARRIER'S EQUIPMENT.
- WHEN CABLE LENGTH IS OVER 20' THE MANUFACTURERS GROUND KIT MUST BE INSTALLED PER THE MANUFACTURERS SPECIFICATIONS.
- REFER TO "ANTI-THEFT UPDATE TO SPRINT GROUNTING 082412.PDF" FOR GUIDELINE TO SUSPECTED OR ACTUAL THEFT OF GROUNTING.
- HOME RUN GROUNDS ARE NOT APPROVED BY CROWN CASTLE CONSTRUCTION STANDARDS AND THAT ANTENNA BUSS BARS SHOULD BE INSTALLED DIRECTLY TO TOWER STEEL WITHOUT INSULATORS OR DOWN CONDUCTORS.

PROTECTIVE GROUNTING SYSTEM GENERAL NOTES:

- AT ALL TERMINATIONS AT EQUIPMENT ENCLOSURES, PANEL, AND FRAMES OF EQUIPMENT AND WHERE EXPOSED FOR GROUNTING. CONDUCTOR TERMINATION SHALL BE PERFORMED UTILIZING TWO HOLE BOLTED TONGUE COMPRESSION TYPE LUGS WITH STAINLESS STEEL SELF-TAPPING SCREWS.
- ALL CLAMPS AND SUPPORTS USED TO SUPPORT THE GROUNTING SYSTEM CONDUCTORS AND PVC CONDUITS SHALL BE PVC TYPE (NON CONDUCTIVE). DO NOT USE METAL BRACKETS OR SUPPORTS WHICH WOULD FORM A COMPLETE RING AROUND ANY GROUNTING CONDUCTOR.
- ALL GROUNTING CONNECTIONS SHALL BE COATED WITH A COPPER SHIELD ANTI-CORROSIVE AGENT SUCH AS T&B KOPR SHIELD. VERIFY PRODUCT WITH PROJECT MANAGER.
- ALL BOLTS, WASHERS, AND NUTS USED ON GROUNTING CONNECTIONS SHALL BE STAINLESS STEEL.
- INSTALL GROUND BUSHING ON ALL METALLIC CONDUITS AND BOND TO THE EQUIPMENT GROUND BUS IN THE PANEL BOARD.
- GROUND ANTENNA BASES, FRAMES, CABLE RACKS, AND OTHER METALLIC COMPONENTS WITH #2 INSULATED TINNED STRANDED COPPER GROUNTING CONDUCTORS AND CONNECT TO INSULATED SURFACE MOUNTED GROUND BARS. CONNECTION DETAILS SHALL FOLLOW MANUFACTURER'S SPECIFICATIONS FOR GROUNTING.
- GROUND HYBRID CABLE SHIELD AT BOTH ENDS USING MANUFACTURER'S GUIDELINES.

ELECTRICAL AND GROUNTING NOTES

- ALL ELECTRICAL WORK SHALL CONFORM TO THE REQUIREMENTS OF THE NATIONAL ELECTRICAL CODE (NEC) AS WELL AS APPLICABLE STATE AND LOCAL CODES.
- ALL ELECTRICAL ITEMS SHALL BE U.L. APPROVED OR LISTED AND PROCURED PER SPECIFICATION REQUIREMENTS.
- ELECTRICAL AND TELCO WIRING OUTSIDE A BUILDING AND EXPOSED TO WEATHER SHALL BE IN WATER TIGHT GALVANIZED RIGID STEEL CONDUITS OR SCHEDULE 80 PVC (AS PERMITTED BY CODE) AND WHERE REQUIRED IN LIQUID TIGHT FLEXIBLE METAL OR NONMETALLIC CONDUITS.
- BURIED CONDUIT SHALL BE SCHEDULE 40 PVC.
- ELECTRICAL WIRING SHALL BE COPPER WITH TYPE XHHW, THWN, OR THNN INSULATION.
- RUN TELCO CONDUIT OR CABLE BETWEEN TELEPHONE UTILITY DEMARCATION POINT AND PROJECT OWNER CELL SITE TELCO CABINET AND BTS CABINET AS INDICATED ON THIS DRAWING PROVIDE FULL LENGTH PULL ROPE IN INSTALLED TELCO CONDUIT. PROVIDE GREENLEE CONDUIT MEASURING TAPE AT EACH END.
- WHERE CONDUIT BETWEEN BTS AND PROJECT OWNER CELL SITE PPC AND BETWEEN BTS AND PROJECT OWNER CELL SITE TELCO SERVICE CABINET ARE UNDERGROUND USE PVC, SCHEDULE 40 CONDUIT. ABOVE THE GROUND PORTION OF THESE CONDUITS SHALL BE PVC CONDUIT.
- ALL EQUIPMENT LOCATED OUTSIDE SHALL HAVE NEMA 3R ENCLOSURE.
- GROUNTING SHALL COMPLY WITH NEC ART. 250.
- GROUND HYBRID CABLE SHIELDS AT 3 LOCATIONS USING MANUFACTURER'S HYBRID CABLE GROUNTING KITS SUPPLIED BY PROJECT OWNER.
- USE #2 COPPER STRANDED WIRE WITH GREEN COLOR INSULATION FOR ABOVE GRADE GROUNTING (UNLESS OTHERWISE SPECIFIED) AND #2 SOLID TINNED BARE COPPER WIRE FOR BELOW GRADE GROUNTING AS INDICATED ON THE DRAWING.
- ALL GROUND CONNECTIONS TO BE BURNDY HYGROUND COMPRESSION TYPE CONNECTORS OR CADWELD EXOTHERMIC WELD. DO NOT ALLOW BARE COPPER WIRE TO BE IN CONTACT WITH GALVANIZED STEEL.
- ROUTE GROUNTING CONDUCTORS ALONG THE SHORTEST AND STRAIGHTEST PATH POSSIBLE, EXCEPT AS OTHERWISE INDICATED. GROUNTING LEADS SHOULD NEVER BE BENT AT RIGHT ANGLE. ALWAYS MAKE AT LEAST 12" RADIUS BENDS. #2 WIRE CAN BE BENT AT 6" RADIUS WHEN NECESSARY. BOND ANY METAL OBJECTS WITHIN 6 FEET OF PROJECT OWNER EQUIPMENT OR CABINET TO MASTER GROUND BAR OR GROUNTING RING.
- CONNECTIONS TO GROUND BARS SHALL BE MADE WITH TWO HOLE COMPRESSION TYPE COPPER LUGS. APPLY OXIDE INHIBITING COMPOUND TO ALL LOCATIONS.
- APPLY OXIDE INHIBITING COMPOUND TO ALL COMPRESSION TYPE GROUND CONNECTIONS.
- BOND ANTENNA MOUNTING BRACKETS, HYBRID CABLE GROUND KITS, AND RRHs TO EGB PLACED NEAR THE ANTENNA LOCATION.
- BOND ANTENNA EGB'S AND MGB TO GROUND RING.
- CONTRACTOR SHALL TEST COMPLETED GROUND SYSTEM AND RECORD RESULT FOR PROJECT CLOSE-OUT DOCUMENTATION. 5 OHMS MINIMUM RESISTANCE REQUIRED.
- CONTRACTOR SHALL CONDUCT ANTENNA, HYBRID CABLES, GPS COAX AND RRH RETURN-LOSS AND DISTANCE- TO-FAULT MEASUREMENTS (SWEEP TESTS) AND RECORD RESULTS FOR PROJECT CLOSE OUT.
- CONTRACTOR SHALL CHECK CAPACITY OF EXISTING SERVICE & PANEL ON SITE TO DETERMINE IF CAPACITY EXISTS TO ACCOMMODATE THE ADDED LOAD OF THIS PROJECT. ADVISE ENGINEER OF ANY DISCREPANCY.
- LOCATION OF ALL OUTLET, BOXES, ETC, AND THE TYPE OF CONNECTION (PLUG OR DIRECT) SHALL BE CONFIRMED WITH THE OWNER'S REPRESENTATIVE PRIOR TO ROUGH-IN.
- ELECTRICAL CHARACTERISTICS OF ALL EQUIPMENT (NEW AND EXISTING) SHALL BE FIELD VERIFIED WITH THE OWNERS REPRESENTATIVE AND EQUIPMENT SUPPLIER PRIOR TO ROUGH-IN OF CONDUIT AND WIRE. ALL EQUIPMENT SHALL BE PROPERLY CONNECTED ACCORDING TO THE NAMEPLATE DATA FURNISHED ON THE EQUIPMENT.

1 CABLE GROUNTING KIT DETAIL

SCALE: N.T.S.

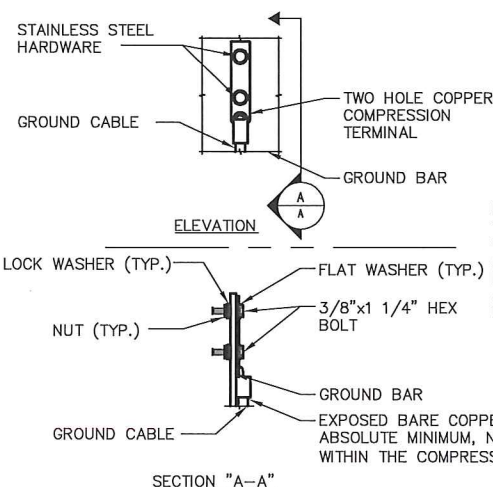

NOTE:
1. "DOUBLING UP" OR "STACKING" OF CONNECTION IS NOT PERMITTED.
2. OXIDE INHIBITING COMPOUND TO BE USED AT ALL LOCATIONS.
3. CADWELD DOWNLEADS FROM UPPER EGB, LOWER EGB AND MGB.

SECTION "A-A"

2 GROUNTING BAR CONN. DETAIL

SCALE: NTS

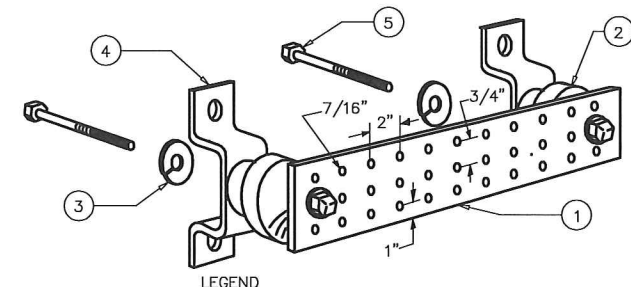

- LEGEND
- COPPER TINNED GROUND BAR, 1/4" X 4" X 20", OR OTHER LENGTH AS REQUIRED, HOLE CENTERS TO MATCH NEMA DOUBLE LUG CONFIGURATION
 - INSULATORS, NEWTON INSTRUMENT CAT. NO. 3061-4 OR EQUAL
 - 5/8" LOCKWASHERS OR EQUAL
 - WALL MOUNTING BRACKET, NEWTON INSTRUMENT CO. CAT NO. A-6056 OR EQUAL
 - 5/8-11 X 1" H.H.C.S.BOLTS

NOTE:
ALL BOLTS, NUTS, WASHERS AND LOCK WASHERS SHALL BE 18-8 STAINLESS STEEL.

3 GROUNTING BAR DETAIL

SCALE: NTS

Sprint
2.5 EQUIPMENT DEPLOYMENT
6850 SPRINT PARKWAY
OVERLAND PARK, KANSAS 66251

CROWN CASTLE

TECTONIC
• PLANNING
• ENGINEERING
• SURVEYING
• CONSTRUCTION MANAGEMENT

TECTONIC Engineering & Surveying Consultants P.C.
1279 Route 300
Newburgh, NY 12550
Phone: (845) 567-6656
Fax: (845) 567-8703
www.tectonicengineering.com

THIS DOCUMENT IS THE CREATION, DESIGN, PROPERTY AND COPYRIGHTED WORK OF SPRINT COMMUNICATIONS, INC. ANY DUPLICATION OR USE WITHOUT EXPRESS WRITTEN CONSENT IS STRICTLY PROHIBITED. DUPLICATION AND USE BY GOVERNMENT AGENCIES FOR THE PURPOSES OF CONDUCTING THEIR LAWFULLY AUTHORIZED REGULATORY AND ADMINISTRATIVE FUNCTIONS IS SPECIFICALLY ALLOWED.

SUBMITTALS

NO	DATE	DESCRIPTION	BY
0	07/08/14	FOR COMMENT	DC
1	01/05/15	FOR CONSTRUCTION	DC

DATE	REVIEWED BY
1/5/15	JMG

STATE OF CONNECTICUT
MANOJKUMAR PATEL
No. 22038
LICENSED PROFESSIONAL ENGINEER

SITE NUMBER:
CT33XC540
SITE NAME:
MADISON-ATT
SITE ADDRESS:
1749 DURHAM ROAD
MADISON, CT 06443

SHEET TITLE:
GROUNTING DETAILS & NOTES

SHEET NO:
E-2



Date: **June 24, 2014**

Darcy Tarr
Crown Castle
3530 Toringdon Way, Suite 300
Charlotte, NC 28277

Aero Solutions LLC
5500 Flatiron Pkwy, Suite 100
Boulder, CO 80301
720-279-8975

Subject: Structural Analysis Report

Carrier Designation:	Sprint PCS Co-Locate Carrier Site Number:	Scenario 2.5B CT33XC540
Crown Castle Designation:	Crown Castle BU Number: Crown Castle Site Name: Crown Castle JDE Job Number: Crown Castle Work Order Number: Crown Castle Application Number:	846176 MADISON DURHAM ROAD 292804 780645 248843 Rev. 1
Engineering Firm Designation:	Aero Solutions LLC Project Number:	003-14-0650
Site Data:	1749 DURHAM ROAD, MADISON, New Haven County, CT Latitude 41° 23' 22.3", Longitude -72° 38' 56" 119 Foot - Monopole Tower	

Dear Darcy Tarr,

Aero Solutions LLC is pleased to submit this “**Structural Analysis Report**” to determine the structural integrity of the above mentioned tower. This analysis has been performed in accordance with the Crown Castle Structural ‘Statement of Work’ and the terms of Crown Castle Purchase Order Number 659389, in accordance with application 248843, revision 1.

The purpose of the analysis is to determine acceptability of the tower stress level. Based on our analysis we have determined the tower stress level for the structure and foundation, under the following load case, to be:

LC5: Existing + Proposed Equipment **Sufficient Capacity**
Note: See Table I and Table II for the proposed and existing loading, respectively.

This analysis has been performed in accordance with the TIA/EIA-222-F standard and 2005 CT State Building Code with 2009 amendment based upon a wind speed of 85 mph fastest mile.

All modifications and equipment proposed in this report shall be installed in accordance with the attached drawings for the determined available structural capacity to be effective.

We at Aero Solutions LLC appreciate the opportunity of providing our continuing professional services to you and Crown Castle. If you have any questions or need further assistance on this or any other projects please give us a call.

Structural analysis prepared by: Zach Gremillion

Respectfully submitted by:

Shraddha Dharia, P.E.
Structural Engineer
CT PE#: PEN0028187
Expires: 1/31/2015

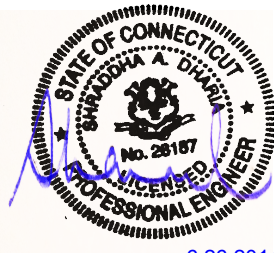

6.26.2014

TABLE OF CONTENTS

1) INTRODUCTION

2) ANALYSIS CRITERIA

Table 1 - Proposed Antenna and Cable Information

Table 2 - Existing and Reserved Antenna and Cable Information

Table 3 - Design Antenna and Cable Information

3) ANALYSIS PROCEDURE

Table 4 - Documents Provided

3.1) Analysis Method

3.2) Assumptions

4) ANALYSIS RESULTS

Table 5 - Section Capacity (Summary)

Table 6 – Tower Components vs. Capacity

4.1) Recommendations

5) APPENDIX A

tnxTower Output

6) APPENDIX B

Base Level Drawing

7) APPENDIX C

Additional Calculations

1) INTRODUCTION

This tower is a 119 ft Monopole tower designed by SABRE COMMUNICATIONS in April of 2000. The tower was originally designed for a wind speed of 80 mph per TIA/EIA-222-F.

2) ANALYSIS CRITERIA

The structural analysis was performed for this tower in accordance with the requirements of TIA/EIA-222-F Structural Standards for Steel Antenna Towers and Antenna Supporting Structures using a fastest mile wind speed of 85 mph with no ice, 38 mph with 0.75 inch ice thickness and 50 mph under service loads.

Table 1 - Proposed Antenna and Cable Information

Mounting Level (ft)	Center Line Elevation (ft)	Number of Antennas	Antenna Manufacturer	Antenna Model	Number of Feed Lines	Feed Line Size (in)	Note
106.0	108.0	3	alcatel lucent	TD-RRH8x20-25	1	1-1/4"	
		3	rfs celwave	APXVTM14-C-120 w/ Mount Pipe			

Table 2 - Existing Antenna and Cable Information

Mounting Level (ft)	Center Line Elevation (ft)	Number of Antennas	Antenna Manufacturer	Antenna Model	Number of Feed Lines	Feed Line Size (in)	Note
116.0	118.0	6	ericsson	RBS6601	18	1-5/8"	1
		3	kmw communications	AM-X-CD-16-65-00T-RET w/ Mount Pipe			
		6	powerwave	7770.00 w/Mount Pipe			
		6	powerwave	LGP13519 TMA			
		6	powerwave	LGP21401 TMA			
	1	raycap	DC6-48-60-18-8F				
	116.0	1	crown mounts	Platform Mount [LP 601-1]			
109.0	110.0	3	alcatel lucent	800 EXTERNAL NOTCH FILTER	3	1-1/4"	1
		3	alcatel lucent	800MHZ RRH			
	109.0	1	tower mounts	Side Arm Mount [SO 104-3]			
	108.0	3	alcatel lucent	1900MHz RRH			
106.0	108.0	3	rfs celwave	APXVSP18-C-A20 w/Mount Pipe	3	1-1/4"	1
	106.0	1	crown mounts	Platform Mount [LP 601-1]			
94.0	96.0	1	antel	BXA-171063-12BF w/ Mount Pipe	12	1-5/8"	1
		2	antel	BXA-171063-8BF-EDIN-0 w/ Mount Pipe			
		3	antel	BXA-70063-6CF-EDIN-0 w/ Mount Pipe			
		2	decibel	DB846F65E-SX w/ Mount Pipe			

Mounting Level (ft)	Center Line Elevation (ft)	Number of Antennas	Antenna Manufacturer	Antenna Model	Number of Feed Lines	Feed Line Size (in)	Note
		4	rfs celwave	APL868013 w/ Mount Pipe			
		6	rfs celwave	FD9R6004/2C-3L			
	94.0	1	crown mounts	Platform Mount [LP 601-1]			
55.0	55.0	1	pctel	GPS-TMG-HR-26NCM GPS	1	1/2"	1
50.0	50.0	1	tower mounts	Side Arm Mount [SO 104-3]			1

Notes:
 1) Existing Equipment

Table 3 - Design Antenna and Cable Information

Mounting Level (ft)	Center Line Elevation (ft)	Number of Antennas	Antenna Manufacturer	Antenna Model	Number of Feed Lines	Feed Line Size (in)
120	120	12	decibel	DB950F65		-
110	110	12	decibel	DB950F65		-
100	100	12	decibel	DB950F65		-

3) ANALYSIS PROCEDURE

Table 4 - Documents Provided

Document	Remarks	Reference	Source
4-GEOTECHNICAL REPORTS	TEP	4301706	CCISITES
4-TOWER FOUNDATION DRAWINGS/DESIGN/SPECS	Sabre	4552185	CCISITES
4-TOWER MANUFACTURER DRAWINGS	Sabre	4516773	CCISITES

3.1) Analysis Method

tnxTower (version 6.1.4.1), a commercially available analysis software package, was used to create a three-dimensional model of the tower and calculate member stresses for various loading cases. Selected output from the analysis is included in Appendix A.

3.2) Assumptions

- 1) Tower and structures were built in accordance with the manufacturer's specifications.
- 2) The tower and structures have been maintained in accordance with the manufacturer's specification.
- 3) The configuration of antennas, transmission cables, mounts and other appurtenances are as specified in Tables 1 and 2 and the referenced drawings.
- 4) When applicable, transmission cables are considered as structural components for calculating wind loads as allowed by TIA/EIA-222-F.

This analysis may be affected if any assumptions are not valid or have been made in error. Aero Solutions LLC should be notified to determine the effect on the structural integrity of the tower.

4) ANALYSIS RESULTS

Table 5 - Section Capacity (Summary)

Section No.	Elevation (ft)	Component Type	Size	Critical Element	P (K)	SF*P_allow (K)	% Capacity	Pass / Fail
L1	119 - 97.25	Pole	TP30.86x25.5x0.25	1	-6.10	1222.05	17.3	Pass
L2	97.25 - 48	Pole	TP42.47x29.3743x0.3125	2	-15.14	2107.26	54.5	Pass
L3	48 - 0	Pole	TP53.65x40.5539x0.375	3	-28.30	3296.52	59.3	Pass
							Summary	
						Pole (L3)	59.3	Pass
						Rating =	59.3	Pass

Table 6 - Tower Component Stresses vs. Capacity – LC5

Notes	Component	Elevation (ft)	% Capacity	Pass / Fail
1	Anchor Rods	0	53.2	Pass
1	Base Plate	0	52.4	Pass
1	Base Foundation Soil Interaction	0	70.4	Pass

Structure Rating (max from all components) =	70.5%
---	--------------

Notes:

- 1) See additional documentation in "Appendix C – Additional Calculations" for calculations supporting the % capacity consumed.

4.1) Recommendations

The tower and its foundation have sufficient capacity to carry the existing and proposed loads. No modifications are required at this time.

APPENDIX A
TNXTOWER OUTPUT

Section	1	2	3
Length (ft)	21.75	53.25	53.25
Number of Sides	18	18	18
Thickness (in)	0.2500	0.3125	0.3750
Socket Length (ft)	4.00	5.25	
Top Dia (in)	25.5000	29.3743	40.5539
Bot Dia (in)	30.8600	42.4700	53.6500
Grade		A572-65	
Weight (K)	1.6	6.4	10.1

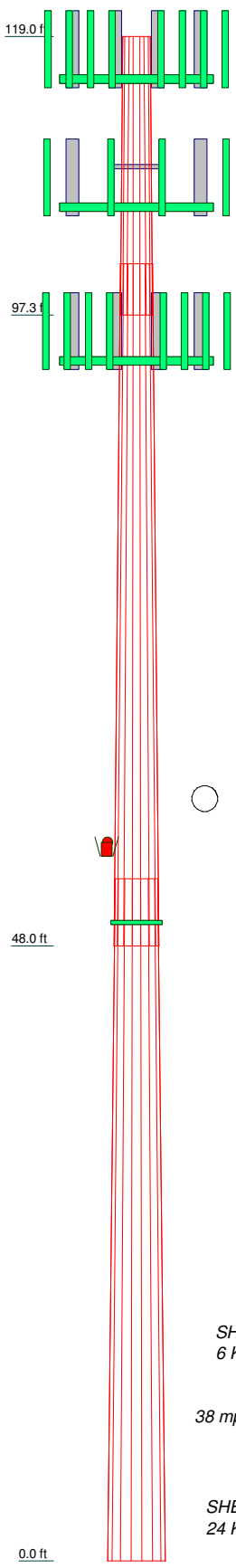

DESIGNED APPURTENANCE LOADING

TYPE	ELEVATION	TYPE	ELEVATION
(2) 7770.00 w/Mount Pipe	116	800 EXTERNAL NOTCH FILTER	109
(2) 7770.00 w/Mount Pipe	116	APXVSP18-C-A20 w/Mount Pipe	106
(2) 7770.00 w/Mount Pipe	116	APXVSP18-C-A20 w/Mount Pipe	106
AM-X-CD-16-65-00T-RET w/ Mount Pipe	116	APXVSP18-C-A20 w/Mount Pipe	106
AM-X-CD-16-65-00T-RET w/ Mount Pipe	116	APXVTM14-C-120 w/ Mount Pipe	106
AM-X-CD-16-65-00T-RET w/ Mount Pipe	116	TD-RRH8x20-25	106
(2) LGP21401 TMA	116	APXVTM14-C-120 w/ Mount Pipe	106
(2) LGP21401 TMA	116	TD-RRH8x20-25	106
(2) LGP13519 TMA	116	Platform Mount [LP 601-1]	106
(2) LGP13519 TMA	116	(2) 6' x 2 3/8" Pipe Mount	106
(2) LGP13519 TMA	116	(2) 6' x 2 3/8" Pipe Mount	106
(2) RBS6601	116	(2) 6' x 2 3/8" Pipe Mount	106
(2) RBS6601	116	BXA-171063-8BF-EDIN-0 w/ Mount Pipe	94
(2) RBS6601	116	BXA-171063-8BF-EDIN-0 w/ Mount Pipe	94
DC6-48-60-18-8F	116	BXA-171063-12BF w/ Mount Pipe	94
Platform Mount [LP 601-1]	116	BXA-70063-6CF-EDIN-0 w/ Mount Pipe	94
6' x 2 3/8" Pipe Mount	116	BXA-70063-6CF-EDIN-0 w/ Mount Pipe	94
6' x 2 3/8" Pipe Mount	116	BXA-70063-6CF-EDIN-0 w/ Mount Pipe	94
6' x 2 3/8" Pipe Mount	116	BXA-70063-6CF-EDIN-0 w/ Mount Pipe	94
Side Arm Mount [SO 104-3]	109	(2) APL868013 w/ Mount Pipe	94
6' x 2 3/8" Pipe Mount	109	(2) APL868013 w/ Mount Pipe	94
6' x 2 3/8" Pipe Mount	109	(2) DB846F65E-SX w/ Mount Pipe	94
1900MHz RRH	109	(2) FD9R6004/2C-3L	94
1900MHz RRH	109	(2) FD9R6004/2C-3L	94
1900MHz RRH	109	(2) FD9R6004/2C-3L	94
800MHZ RRH	109	Platform Mount [LP 601-1]	94
800MHZ RRH	109	GPS-TMG-HR-26NCM GPS	55
800MHZ RRH	109	Side Arm Mount [SO 104-3]	50
800 EXTERNAL NOTCH FILTER	109		
800 EXTERNAL NOTCH FILTER	109		

MATERIAL STRENGTH

GRADE	Fy	Fu	GRADE	Fy	Fu
A572-65	65 ksi	80 ksi			

TOWER DESIGN NOTES

1. Tower is located in New Haven County, Connecticut.
2. Tower designed for a 85 mph basic wind in accordance with the TIA/EIA-222-F Standard.
3. Tower is also designed for a 38 mph basic wind with 0.75 in ice. Ice is considered to increase in thickness with height.
4. Deflections are based upon a 50 mph wind.
5. TOWER RATING: 59.3%

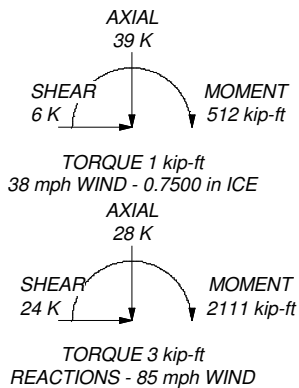

Aero Solutions LLC		Job: BU#846176 MADISON DURHAM ROAD	
5500 Flatiron Pkwy, Suite 100		Project: Existing 119 ft. Monopole	
Boulder, CO 80301		Client: Crown Castle	Drawn by: Zach Gremillion
Phone: 720-279-8975		Code: TIA/EIA-222-F	Date: 06/24/14
FAX:		Path:	Scale: NTS
		Dwg No. E-1	

Tower Input Data

There is a pole section.
 This tower is designed using the TIA/EIA-222-F standard.
 The following design criteria apply:

- 2) Tower is located in New Haven County, Connecticut.
- 3) Basic wind speed of 85 mph.
- 4) Nominal ice thickness of 0.7500 in.
- 5) Ice thickness is considered to increase with height.
- 6) Ice density of 56 pcf.
- 7) A wind speed of 38 mph is used in combination with ice.
- 8) Temperature drop of 50 °F.
- 9) Deflections calculated using a wind speed of 50 mph.
- 10) A non-linear (P-delta) analysis was used.
- 11) Pressures are calculated at each section.
- 12) Stress ratio used in pole design is 1.333.
- 13) Local bending stresses due to climbing loads, feed line supports, and appurtenance mounts are not considered.

Options

Consider Moments - Legs Consider Moments - Horizontals Consider Moments - Diagonals Use Moment Magnification ✓ Use Code Stress Ratios ✓ Use Code Safety Factors - Guys ✓ Escalate Ice Always Use Max Kz Use Special Wind Profile Include Bolts In Member Capacity Leg Bolts Are At Top Of Section Secondary Horizontal Braces Leg Use Diamond Inner Bracing (4 Sided) Add IBC .6D+W Combination	Distribute Leg Loads As Uniform Assume Legs Pinned ✓ Assume Rigid Index Plate ✓ Use Clear Spans For Wind Area Use Clear Spans For KL/r Retension Guys To Initial Tension ✓ Bypass Mast Stability Checks ✓ Use Azimuth Dish Coefficients ✓ Project Wind Area of Appurt. Autocalc Torque Arm Areas SR Members Have Cut Ends Sort Capacity Reports By Component Triangulate Diamond Inner Bracing Use TIA-222-G Tension Splice Capacity Exemption	Treat Feedline Bundles As Cylinder Use ASCE 10 X-Brace Ly Rules Calculate Redundant Bracing Forces Ignore Redundant Members in FEA SR Leg Bolts Resist Compression All Leg Panels Have Same Allowable Offset Girt At Foundation ✓ Consider Feedline Torque Include Angle Block Shear Check <div style="text-align: center; background-color: #e0e0e0; padding: 2px;">Poles</div> ✓ Include Shear-Torsion Interaction Always Use Sub-Critical Flow Use Top Mounted Sockets
--	--	---

Tapered Pole Section Geometry

Section	Elevation ft	Section Length ft	Splice Length ft	Number of Sides	Top Diameter in	Bottom Diameter in	Wall Thickness in	Bend Radius in	Pole Grade
L1	119.00-97.25	21.75	4.00	18	25.5000	30.8600	0.2500	1.0000	A572-65 (65 ksi)
L2	97.25-48.00	53.25	5.25	18	29.3743	42.4700	0.3125	1.2500	A572-65 (65 ksi)
L3	48.00-0.00	53.25		18	40.5539	53.6500	0.3750	1.5000	A572-65 (65 ksi)

Tapered Pole Properties

Section	Tip Dia. in	Area in ²	I in ⁴	r in	C in	I/C in ³	J in ⁴	It/Q in ²	w in	w/t
L1	25.8934 31.3361	20.0359 24.2890	1613.8699 2875.2418	8.9637 10.8666	12.9540 15.6769	124.5847 183.4065	3229.8634 5754.2669	10.0198 12.1468	4.0480 4.9914	16.192 19.965

Section	Tip Dia. in	Area in ²	I in ⁴	r in	C in	I/C in ³	J in ⁴	I/Q in ²	w in	w/t
L2	30.8263	28.8256	3075.8122	10.3169	14.9221	206.1243	6155.6716	14.4156	4.6199	14.784
	43.1252	41.8150	9388.9914	14.9659	21.5748	435.1840	18790.3370	20.9115	6.9247	22.159
L3	42.4906	47.8229	9753.6866	14.2635	20.6014	473.4485	19520.2073	23.9160	6.4775	17.273
	54.4776	63.4106	22737.6730	18.9126	27.2542	834.2814	45505.2647	31.7113	8.7824	23.42

Tower Elevation	Gusset Area (per face)	Gusset Thickness	Gusset Grade	Adjust. Factor A _r	Adjust. Factor A _r	Weight Mult.	Double Angle Stitch Bolt Spacing Diagonals	Double Angle Stitch Bolt Spacing Horizontals
ft	ft ²	in					in	in
L1 119.00-97.25				1	1	1		
L2 97.25-48.00				1	1	1		
L3 48.00-0.00				1	1	1		

Feed Line/Linear Appurtenances - Entered As Round Or Flat

Description	Face or Leg	Allow Shield	Component Type	Placement	Total Number	Number Per Row	Clear Spacing	Width or Diameter	Perimeter	Weight
				ft			in	r in	r in	plf

Feed Line/Linear Appurtenances - Entered As Area

Description	Face or Leg	Allow Shield	Component Type	Placement	Total Number		C _A A _A	Weight
				ft			ft ² /ft	plf
**								
LDF7-50A(1-5/8")	B	No	Inside Pole	116.00 - 7.00	18	No Ice	0.00	0.82
						1/2" Ice	0.00	0.82
						1" Ice	0.00	0.82
						2" Ice	0.00	0.82
						4" Ice	0.00	0.82
**								
LDF6-50A(1-1/4")	B	No	Inside Pole	106.00 - 7.00	3	No Ice	0.00	0.66
						1/2" Ice	0.00	0.66
						1" Ice	0.00	0.66
						2" Ice	0.00	0.66
						4" Ice	0.00	0.66
HB114-21U3M12-XXXF(1-1/4")	B	No	Inside Pole	106.00 - 7.00	1	No Ice	0.00	1.22
						1/2" Ice	0.00	1.22
						1" Ice	0.00	1.22
						2" Ice	0.00	1.22
						4" Ice	0.00	1.22
**								
561(1-5/8")	A	No	Inside Pole	94.00 - 7.00	12	No Ice	0.00	1.35
						1/2" Ice	0.00	1.35
						1" Ice	0.00	1.35
						2" Ice	0.00	1.35
						4" Ice	0.00	1.35
**								
LDF4-50A(1/2")	B	No	Inside Pole	55.00 - 7.00	1	No Ice	0.00	0.15
						1/2" Ice	0.00	0.15
						1" Ice	0.00	0.15
						2" Ice	0.00	0.15
						4" Ice	0.00	0.15

Feed Line/Linear Appurtenances Section Areas

Tower Section n	Tower Elevation ft	Face	A_R ft ²	A_F ft ²	C_{AA} In Face ft ²	C_{AA} Out Face ft ²	Weight K
L1	119.00-97.25	A	0.000	0.000	0.000	0.000	0.00
		B	0.000	0.000	0.000	0.000	0.30
		C	0.000	0.000	0.000	0.000	0.00
L2	97.25-48.00	A	0.000	0.000	0.000	0.000	0.75
		B	0.000	0.000	0.000	0.000	0.89
		C	0.000	0.000	0.000	0.000	0.00
L3	48.00-0.00	A	0.000	0.000	0.000	0.000	0.66
		B	0.000	0.000	0.000	0.000	0.74
		C	0.000	0.000	0.000	0.000	0.00

Feed Line/Linear Appurtenances Section Areas - With Ice

Tower Section n	Tower Elevation ft	Face or Leg	Ice Thickness in	A_R ft ²	A_F ft ²	C_{AA} In Face ft ²	C_{AA} Out Face ft ²	Weight K
L1	119.00-97.25	A	0.864	0.000	0.000	0.000	0.000	0.00
		B		0.000	0.000	0.000	0.000	0.30
		C		0.000	0.000	0.000	0.000	0.00
L2	97.25-48.00	A	0.823	0.000	0.000	0.000	0.000	0.75
		B		0.000	0.000	0.000	0.000	0.89
		C		0.000	0.000	0.000	0.000	0.00
L3	48.00-0.00	A	0.750	0.000	0.000	0.000	0.000	0.66
		B		0.000	0.000	0.000	0.000	0.74
		C		0.000	0.000	0.000	0.000	0.00

Feed Line Center of Pressure

Section	Elevation ft	CP_x in	CP_z in	CP_x Ice in	CP_z Ice in
L1	119.00-97.25	0.0000	0.0000	0.0000	0.0000
L2	97.25-48.00	0.0000	0.0000	0.0000	0.0000
L3	48.00-0.00	0.0000	0.0000	0.0000	0.0000

Discrete Tower Loads

Description	Face or Leg	Offset Type	Offsets: Horz Lateral Vert ft ft ft	Azimuth Adjustmen t °	Placement ft	C_{AA} Front ft ²	C_{AA} Side ft ²	Weight K	
**									
(2) 7770.00 w/Mount Pipe	A	From Leg	4.00	0.0000	116.00	No Ice	6.46	4.59	0.05
			0.00			1/2"	7.14	5.66	0.10
			2.00			Ice	7.73	6.45	0.16
						1" Ice	8.94	8.06	0.30
						2" Ice	11.51	11.64	0.71
(2) 7770.00 w/Mount Pipe	B	From Leg	4.00	0.0000	116.00	No Ice	6.46	4.59	0.05
			0.00			1/2"	7.14	5.66	0.10

Description	Face or Leg	Offset Type	Offsets: Horz Lateral Vert ft ft ft	Azimuth Adjustment t °	Placement ft	C _{AA} Front ft ²	C _{AA} Side ft ²	Weight K
			2.00			Ice 7.73	6.45	0.16
						1" Ice 8.94	8.06	0.30
						2" Ice 11.51	11.64	0.71
						4" Ice		
(2) 7770.00 w/Mount Pipe	C	From Leg	4.00	0.0000	116.00	No Ice 6.46	4.59	0.05
			0.00			1/2" 7.14	5.66	0.10
			2.00			Ice 7.73	6.45	0.16
						1" Ice 8.94	8.06	0.30
						2" Ice 11.51	11.64	0.71
						4" Ice		
AM-X-CD-16-65-00T-RET w/ Mount Pipe	A	From Leg	4.00	0.0000	116.00	No Ice 8.50	6.30	0.07
			0.00			1/2" 9.15	7.48	0.14
			2.00			Ice 9.77	8.37	0.21
						1" Ice 11.03	10.18	0.38
						2" Ice 13.68	14.02	0.87
						4" Ice		
AM-X-CD-16-65-00T-RET w/ Mount Pipe	B	From Leg	4.00	0.0000	116.00	No Ice 8.50	6.30	0.07
			0.00			1/2" 9.15	7.48	0.14
			2.00			Ice 9.77	8.37	0.21
						1" Ice 11.03	10.18	0.38
						2" Ice 13.68	14.02	0.87
						4" Ice		
AM-X-CD-16-65-00T-RET w/ Mount Pipe	C	From Leg	4.00	0.0000	116.00	No Ice 8.50	6.30	0.07
			0.00			1/2" 9.15	7.48	0.14
			2.00			Ice 9.77	8.37	0.21
						1" Ice 11.03	10.18	0.38
						2" Ice 13.68	14.02	0.87
						4" Ice		
(2) LGP21401 TMA	A	From Leg	4.00	0.0000	116.00	No Ice 0.95	0.37	0.02
			0.00			1/2" 1.09	0.48	0.02
			2.00			Ice 1.24	0.60	0.03
						1" Ice 1.57	0.87	0.05
						2" Ice 2.32	1.51	0.12
						4" Ice		
(2) LGP21401 TMA	B	From Leg	4.00	0.0000	116.00	No Ice 0.95	0.37	0.02
			0.00			1/2" 1.09	0.48	0.02
			2.00			Ice 1.24	0.60	0.03
						1" Ice 1.57	0.87	0.05
						2" Ice 2.32	1.51	0.12
						4" Ice		
(2) LGP21401 TMA	C	From Leg	4.00	0.0000	116.00	No Ice 0.95	0.37	0.02
			0.00			1/2" 1.09	0.48	0.02
			2.00			Ice 1.24	0.60	0.03
						1" Ice 1.57	0.87	0.05
						2" Ice 2.32	1.51	0.12
						4" Ice		
(2) LGP13519 TMA	A	From Leg	4.00	0.0000	116.00	No Ice 0.34	0.21	0.01
			0.00			1/2" 0.42	0.28	0.01
			2.00			Ice 0.51	0.36	0.01
						1" Ice 0.73	0.55	0.02
						2" Ice 1.25	1.03	0.07
						4" Ice		
(2) LGP13519 TMA	B	From Leg	4.00	0.0000	116.00	No Ice 0.34	0.21	0.01
			0.00			1/2" 0.42	0.28	0.01
			2.00			Ice 0.51	0.36	0.01
						1" Ice 0.73	0.55	0.02
						2" Ice 1.25	1.03	0.07
						4" Ice		
(2) LGP13519 TMA	C	From Leg	4.00	0.0000	116.00	No Ice 0.34	0.21	0.01
			0.00			1/2" 0.42	0.28	0.01
			2.00			Ice 0.51	0.36	0.01
						1" Ice 0.73	0.55	0.02
						2" Ice 1.25	1.03	0.07
						4" Ice		
(2) RBS6601	A	From Leg	4.00	0.0000	116.00	No Ice 2.94	1.25	0.06

Description	Face or Leg	Offset Type	Offsets:		Azimuth Adjustment °	Placement ft	C _{AA} _{Front}	C _{AA} _{Side}	Weight K	
			Horz ft	Lateral ft			ft ²	ft ²		
				0.00			1/2"	3.17	1.41	0.07
				2.00			Ice	3.41	1.59	0.10
							1" Ice	3.91	1.96	0.15
							2" Ice	5.02	2.82	0.30
							4" Ice			
(2) RBS6601	B	From Leg	4.00	0.0000	116.00	No Ice	2.94	1.25	0.06	
			0.00			1/2"	3.17	1.41	0.07	
			2.00			Ice	3.41	1.59	0.10	
						1" Ice	3.91	1.96	0.15	
						2" Ice	5.02	2.82	0.30	
						4" Ice				
(2) RBS6601	C	From Leg	4.00	0.0000	116.00	No Ice	2.94	1.25	0.06	
			0.00			1/2"	3.17	1.41	0.07	
			2.00			Ice	3.41	1.59	0.10	
						1" Ice	3.91	1.96	0.15	
						2" Ice	5.02	2.82	0.30	
						4" Ice				
DC6-48-60-18-8F	C	From Leg	2.00	0.0000	116.00	No Ice	2.57	2.57	0.02	
			0.00			1/2"	2.80	2.80	0.04	
			2.00			Ice	3.04	3.04	0.07	
						1" Ice	3.54	3.54	0.13	
						2" Ice	4.66	4.66	0.30	
						4" Ice				
Platform Mount [LP 601-1]	C	None		0.0000	116.00	No Ice	28.47	28.47	1.12	
						1/2"	33.59	33.59	1.51	
						Ice	38.71	38.71	1.91	
						1" Ice	48.95	48.95	2.69	
						2" Ice	69.43	69.43	4.26	
						4" Ice				
6' x 2 3/8" Pipe Mount	A	From Leg	4.00	0.0000	116.00	No Ice	1.43	1.43	0.04	
			0.00			1/2"	1.92	1.92	0.05	
			0.00			Ice	2.29	2.29	0.07	
						1" Ice	3.06	3.06	0.11	
						2" Ice	4.70	4.70	0.25	
						4" Ice				
6' x 2 3/8" Pipe Mount	B	From Leg	4.00	0.0000	116.00	No Ice	1.43	1.43	0.04	
			0.00			1/2"	1.92	1.92	0.05	
			0.00			Ice	2.29	2.29	0.07	
						1" Ice	3.06	3.06	0.11	
						2" Ice	4.70	4.70	0.25	
						4" Ice				
6' x 2 3/8" Pipe Mount	C	From Leg	4.00	0.0000	116.00	No Ice	1.43	1.43	0.04	
			0.00			1/2"	1.92	1.92	0.05	
			0.00			Ice	2.29	2.29	0.07	
						1" Ice	3.06	3.06	0.11	
						2" Ice	4.70	4.70	0.25	
						4" Ice				
**										
Side Arm Mount [SO 104-3]	A	From Leg	0.00	0.0000	109.00	No Ice	3.30	3.30	0.29	
			0.00			1/2"	4.13	4.13	0.32	
			0.00			Ice	4.96	4.96	0.35	
						1" Ice	6.62	6.62	0.41	
						2" Ice	9.94	9.94	0.53	
						4" Ice				
6' x 2 3/8" Pipe Mount	A	From Leg	0.00	0.0000	109.00	No Ice	1.43	1.43	0.04	
			0.00			1/2"	1.92	1.92	0.05	
			0.00			Ice	2.29	2.29	0.07	
						1" Ice	3.06	3.06	0.11	
						2" Ice	4.70	4.70	0.25	
						4" Ice				
6' x 2 3/8" Pipe Mount	A	From Leg	0.00	0.0000	109.00	No Ice	1.43	1.43	0.04	
			0.00			1/2"	1.92	1.92	0.05	
			0.00			Ice	2.29	2.29	0.07	
						1" Ice	3.06	3.06	0.11	
						2" Ice	4.70	4.70	0.25	

Description	Face or Leg	Offset Type	Offsets:		Azimuth Adjustment °	Placement ft	C _{AA} Front ft ²	C _{AA} Side ft ²	Weight K
			Horz ft	Lateral ft					
6' x 2 3/8" Pipe Mount	A	From Leg	0.00	0.0000	109.00	4" Ice			
						No Ice	1.43	1.43	0.04
						1/2"	1.92	1.92	0.05
						Ice	2.29	2.29	0.07
						1" Ice	3.06	3.06	0.11
1900MHz RRH	A	From Leg	0.00	0.0000	109.00	2" Ice	4.70	4.70	0.25
						4" Ice			
						No Ice	2.91	3.80	0.04
						1/2"	3.14	4.06	0.08
						Ice	3.39	4.34	0.11
1900MHz RRH	B	From Leg	0.00	0.0000	109.00	1" Ice	3.91	4.91	0.19
						2" Ice	5.05	6.15	0.41
						4" Ice			
						No Ice	2.91	3.80	0.04
						1/2"	3.14	4.06	0.08
1900MHz RRH	C	From Leg	0.00	0.0000	109.00	Ice	3.39	4.34	0.11
						1" Ice	3.91	4.91	0.19
						2" Ice	5.05	6.15	0.41
						4" Ice			
						No Ice	2.91	3.80	0.04
800MHZ RRH	A	From Leg	0.00	0.0000	109.00	1/2"	3.14	4.06	0.08
						Ice	3.39	4.34	0.11
						1" Ice	3.91	4.91	0.19
						2" Ice	5.05	6.15	0.41
						4" Ice			
800MHZ RRH	B	From Leg	0.00	0.0000	109.00	No Ice	2.49	2.07	0.05
						1/2"	2.71	2.27	0.07
						Ice	2.93	2.48	0.10
						1" Ice	3.41	2.93	0.16
						2" Ice	4.46	3.93	0.32
800MHZ RRH	C	From Leg	0.00	0.0000	109.00	4" Ice			
						No Ice	2.49	2.07	0.05
						1/2"	2.71	2.27	0.07
						Ice	2.93	2.48	0.10
						1" Ice	3.41	2.93	0.16
800 EXTERNAL NOTCH FILTER	A	From Leg	0.00	0.0000	109.00	2" Ice	4.46	3.93	0.32
						4" Ice			
						No Ice	0.77	0.37	0.01
						1/2"	0.89	0.46	0.02
						Ice	1.02	0.56	0.02
800 EXTERNAL NOTCH FILTER	B	From Leg	0.00	0.0000	109.00	1" Ice	1.30	0.79	0.04
						2" Ice	1.97	1.34	0.11
						4" Ice			
						No Ice	0.77	0.37	0.01
						1/2"	0.89	0.46	0.02
800 EXTERNAL NOTCH FILTER	C	From Leg	0.00	0.0000	109.00	Ice	1.02	0.56	0.02
						1" Ice	1.30	0.79	0.04
						2" Ice	1.97	1.34	0.11
						4" Ice			
						No Ice	0.77	0.37	0.01
** APXVSP18-C-A20 w/Mount Pipe	A	From Leg	4.00	-20.0000	106.00	1/2"	0.89	0.46	0.02
						Ice	1.02	0.56	0.02
						1" Ice	1.30	0.79	0.04
						2" Ice	1.97	1.34	0.11
			2.00			Ice	9.77	9.02	0.22

Description	Face or Leg	Offset Type	Offsets:			Azimuth Adjustment	Placement	C _{AA} _{Front}	C _{AA} _{Side}	Weight
			Horz	Lateral	Vert					
			ft	ft	ft	°	ft	ft ²	ft ²	K
							1" Ice	11.03	10.84	0.41
							2" Ice	13.68	14.85	0.91
							4" Ice			
APXVSP18-C-A20 w/ Mount Pipe	B	From Leg	4.00	-20.0000	106.00		No Ice	8.50	6.95	0.08
			0.00				1/2" Ice	9.15	8.13	0.15
			2.00				Ice	9.77	9.02	0.22
							1" Ice	11.03	10.84	0.41
							2" Ice	13.68	14.85	0.91
							4" Ice			
APXVSP18-C-A20 w/ Mount Pipe	C	From Leg	4.00	-20.0000	106.00		No Ice	8.50	6.95	0.08
			0.00				1/2" Ice	9.15	8.13	0.15
			2.00				Ice	9.77	9.02	0.22
							1" Ice	11.03	10.84	0.41
							2" Ice	13.68	14.85	0.91
							4" Ice			
APXVTM14-C-120 w/ Mount Pipe	A	From Leg	4.00	-20.0000	106.00		No Ice	7.13	4.96	0.08
			0.00				1/2" Ice	7.66	5.75	0.13
			2.00				Ice	8.18	6.47	0.19
							1" Ice	9.26	8.01	0.34
							2" Ice	11.53	11.41	0.75
							4" Ice			
TD-RRH8x20-25	A	From Leg	4.00	-20.0000	106.00		No Ice	4.72	1.70	0.07
			0.00				1/2" Ice	5.01	1.92	0.10
			2.00				Ice	5.32	2.15	0.13
							1" Ice	5.95	2.62	0.20
							2" Ice	7.31	3.68	0.40
							4" Ice			
APXVTM14-C-120 w/ Mount Pipe	B	From Leg	4.00	-20.0000	106.00		No Ice	7.13	4.96	0.08
			0.00				1/2" Ice	7.66	5.75	0.13
			2.00				Ice	8.18	6.47	0.19
							1" Ice	9.26	8.01	0.34
							2" Ice	11.53	11.41	0.75
							4" Ice			
TD-RRH8x20-25	B	From Leg	4.00	-20.0000	106.00		No Ice	4.72	1.70	0.07
			0.00				1/2" Ice	5.01	1.92	0.10
			2.00				Ice	5.32	2.15	0.13
							1" Ice	5.95	2.62	0.20
							2" Ice	7.31	3.68	0.40
							4" Ice			
APXVTM14-C-120 w/ Mount Pipe	C	From Leg	4.00	-20.0000	106.00		No Ice	7.13	4.96	0.08
			0.00				1/2" Ice	7.66	5.75	0.13
			2.00				Ice	8.18	6.47	0.19
							1" Ice	9.26	8.01	0.34
							2" Ice	11.53	11.41	0.75
							4" Ice			
TD-RRH8x20-25	C	From Leg	4.00	-20.0000	106.00		No Ice	4.72	1.70	0.07
			0.00				1/2" Ice	5.01	1.92	0.10
			2.00				Ice	5.32	2.15	0.13
							1" Ice	5.95	2.62	0.20
							2" Ice	7.31	3.68	0.40
							4" Ice			
Platform Mount [LP 601-1]	C	None		0.0000	106.00		No Ice	28.47	28.47	1.12
							1/2" Ice	33.59	33.59	1.51
							Ice	38.71	38.71	1.91
							1" Ice	48.95	48.95	2.69
							2" Ice	69.43	69.43	4.26
							4" Ice			
(2) 6' x 2 3/8" Pipe Mount	A	From Leg	4.00	0.0000	106.00		No Ice	1.43	1.43	0.04
			0.00				1/2" Ice	1.92	1.92	0.05
			2.00				Ice	2.29	2.29	0.07
							1" Ice	3.06	3.06	0.11
							2" Ice	4.70	4.70	0.25
							4" Ice			
(2) 6' x 2 3/8" Pipe Mount	B	From Leg	4.00	0.0000	106.00		No Ice	1.43	1.43	0.04
			0.00				1/2" Ice	1.92	1.92	0.05

Description	Face or Leg	Offset Type	Offsets: Horz Lateral Vert ft ft ft	Azimuth Adjustment t °	Placement ft	C _{AA} Front ft ²	C _{AA} Side ft ²	Weight K	
			2.00			Ice	2.29	2.29	0.07
						1" Ice	3.06	3.06	0.11
						2" Ice	4.70	4.70	0.25
						4" Ice			
(2) 6' x 2 3/8" Pipe Mount	C	From Leg	4.00 0.00 2.00	0.0000	106.00	No Ice	1.43	1.43	0.04
						1/2"	1.92	1.92	0.05
						Ice	2.29	2.29	0.07
						1" Ice	3.06	3.06	0.11
						2" Ice	4.70	4.70	0.25
						4" Ice			
**									
BXA-171063-8BF-EDIN-0 w/ Mount Pipe	C	From Leg	4.00 0.00 2.00	-80.0000	94.00	No Ice	3.18	3.35	0.03
						1/2"	3.56	3.97	0.06
						Ice	3.96	4.60	0.10
						1" Ice	4.85	5.89	0.19
						2" Ice	6.77	8.89	0.49
						4" Ice			
BXA-171063-8BF-EDIN-0 w/ Mount Pipe	B	From Leg	4.00 0.00 2.00	-60.0000	94.00	No Ice	3.18	3.35	0.03
						1/2"	3.56	3.97	0.06
						Ice	3.96	4.60	0.10
						1" Ice	4.85	5.89	0.19
						2" Ice	6.77	8.89	0.49
						4" Ice			
BXA-171063-12BF w/ Mount Pipe	A	From Leg	4.00 0.00 2.00	-20.0000	94.00	No Ice	4.97	5.23	0.04
						1/2"	5.52	6.39	0.09
						Ice	6.04	7.26	0.14
						1" Ice	7.09	9.05	0.27
						2" Ice	9.36	12.82	0.67
						4" Ice			
BXA-70063-6CF-EDIN-0 w/ Mount Pipe	A	From Leg	4.00 0.00 2.00	-20.0000	94.00	No Ice	7.97	5.80	0.04
						1/2"	8.61	6.95	0.10
						Ice	9.22	7.82	0.17
						1" Ice	10.46	9.60	0.34
						2" Ice	13.07	13.37	0.80
						4" Ice			
BXA-70063-6CF-EDIN-0 w/ Mount Pipe	B	From Leg	4.00 0.00 2.00	-60.0000	94.00	No Ice	7.97	5.80	0.04
						1/2"	8.61	6.95	0.10
						Ice	9.22	7.82	0.17
						1" Ice	10.46	9.60	0.34
						2" Ice	13.07	13.37	0.80
						4" Ice			
BXA-70063-6CF-EDIN-0 w/ Mount Pipe	C	From Leg	4.00 0.00 2.00	-80.0000	94.00	No Ice	7.97	5.80	0.04
						1/2"	8.61	6.95	0.10
						Ice	9.22	7.82	0.17
						1" Ice	10.46	9.60	0.34
						2" Ice	13.07	13.37	0.80
						4" Ice			
(2) APL868013 w/ Mount Pipe	C	From Leg	4.00 0.00 2.00	-80.0000	94.00	No Ice	3.10	4.92	0.02
						1/2"	3.48	5.60	0.06
						Ice	3.88	6.28	0.11
						1" Ice	4.76	7.71	0.22
						2" Ice	6.66	10.83	0.54
						4" Ice			
(2) APL868013 w/ Mount Pipe	B	From Leg	4.00 0.00 2.00	-60.0000	94.00	No Ice	3.10	4.92	0.02
						1/2"	3.48	5.60	0.06
						Ice	3.88	6.28	0.11
						1" Ice	4.76	7.71	0.22
						2" Ice	6.66	10.83	0.54
						4" Ice			
(2) DB846F65E-SX w/ Mount Pipe	A	From Leg	4.00 0.00 2.00	-20.0000	94.00	No Ice	14.59	8.11	0.04
						1/2"	15.30	9.30	0.14
						Ice	15.97	10.21	0.24
						1" Ice	17.35	12.17	0.48
						2" Ice	20.22	16.35	1.11
						4" Ice			

Description	Face or Leg	Offset Type	Offsets: Horz Lateral Vert ft ft ft	Azimuth Adjustment t °	Placement ft	C _{AA} Front ft ²	C _{AA} Side ft ²	Weight K	
(2) FD9R6004/2C-3L	A	From Leg	4.00 0.00 2.00	-20.0000	94.00	No Ice	0.37	0.08	0.00
						1/2" Ice	0.45	0.14	0.01
						Ice	0.54	0.20	0.01
						1" Ice	0.75	0.34	0.02
						2" Ice	1.28	0.74	0.06
(2) FD9R6004/2C-3L	B	From Leg	4.00 0.00 2.00	-60.0000	94.00	No Ice	0.37	0.08	0.00
						1/2" Ice	0.45	0.14	0.01
						Ice	0.54	0.20	0.01
						1" Ice	0.75	0.34	0.02
						2" Ice	1.28	0.74	0.06
(2) FD9R6004/2C-3L	C	From Leg	4.00 0.00 2.00	-80.0000	94.00	No Ice	0.37	0.08	0.00
						1/2" Ice	0.45	0.14	0.01
						Ice	0.54	0.20	0.01
						1" Ice	0.75	0.34	0.02
						2" Ice	1.28	0.74	0.06
Platform Mount [LP 601-1]	C	None		0.0000	94.00	No Ice	28.47	28.47	1.12
						1/2" Ice	33.59	33.59	1.51
						Ice	38.71	38.71	1.91
						1" Ice	48.95	48.95	2.69
						2" Ice	69.43	69.43	4.26
** GPS-TMG-HR-26NCM GPS	C	From Leg	1.00 0.00 0.00	0.0000	55.00	No Ice	0.09	0.09	0.00
						1/2" Ice	0.14	0.14	0.00
						Ice	0.20	0.20	0.00
						1" Ice	0.36	0.36	0.01
						2" Ice	0.81	0.81	0.04
** Side Arm Mount [SO 104-3]	C	None		0.0000	50.00	No Ice	3.30	3.30	0.29
						1/2" Ice	4.13	4.13	0.32
						Ice	4.96	4.96	0.35
						1" Ice	6.62	6.62	0.41
						2" Ice	9.94	9.94	0.53
						4" Ice			

Load Combinations

Comb. No.	Description
1	Dead Only
2	Dead+Wind 0 deg - No Ice
3	Dead+Wind 30 deg - No Ice
4	Dead+Wind 60 deg - No Ice
5	Dead+Wind 90 deg - No Ice
6	Dead+Wind 120 deg - No Ice
7	Dead+Wind 150 deg - No Ice
8	Dead+Wind 180 deg - No Ice
9	Dead+Wind 210 deg - No Ice
10	Dead+Wind 240 deg - No Ice
11	Dead+Wind 270 deg - No Ice
12	Dead+Wind 300 deg - No Ice
13	Dead+Wind 330 deg - No Ice
14	Dead+Ice+Temp
15	Dead+Wind 0 deg+Ice+Temp
16	Dead+Wind 30 deg+Ice+Temp

Comb. No.	Description
17	Dead+Wind 60 deg+Ice+Temp
18	Dead+Wind 90 deg+Ice+Temp
19	Dead+Wind 120 deg+Ice+Temp
20	Dead+Wind 150 deg+Ice+Temp
21	Dead+Wind 180 deg+Ice+Temp
22	Dead+Wind 210 deg+Ice+Temp
23	Dead+Wind 240 deg+Ice+Temp
24	Dead+Wind 270 deg+Ice+Temp
25	Dead+Wind 300 deg+Ice+Temp
26	Dead+Wind 330 deg+Ice+Temp
27	Dead+Wind 0 deg - Service
28	Dead+Wind 30 deg - Service
29	Dead+Wind 60 deg - Service
30	Dead+Wind 90 deg - Service
31	Dead+Wind 120 deg - Service
32	Dead+Wind 150 deg - Service
33	Dead+Wind 180 deg - Service
34	Dead+Wind 210 deg - Service
35	Dead+Wind 240 deg - Service
36	Dead+Wind 270 deg - Service
37	Dead+Wind 300 deg - Service
38	Dead+Wind 330 deg - Service

Maximum Member Forces

Section No.	Elevation ft	Component Type	Condition	Gov. Load Comb.	Force K	Major Axis Moment kip-ft	Minor Axis Moment kip-ft
L1	119 - 97.25	Pole	Max Tension	15	0.00	0.00	-0.00
			Max. Compression	14	-11.25	0.16	0.53
			Max. Mx	11	-6.11	124.13	0.48
			Max. My	2	-6.10	0.06	124.57
			Max. Vy	11	-11.34	124.13	0.48
			Max. Vx	2	-11.34	0.06	124.57
			Max. Torque	9			-0.37
L2	97.25 - 48	Pole	Max Tension	1	0.00	0.00	0.00
			Max. Compression	14	-24.08	0.17	1.95
			Max. Mx	11	-15.17	927.73	10.12
			Max. My	2	-15.14	9.48	949.74
			Max. Vy	11	-19.09	927.73	10.12
			Max. Vx	2	-19.59	9.48	949.74
			Max. Torque	6			2.82
L3	48 - 0	Pole	Max Tension	1	0.00	0.00	0.00
			Max. Compression	14	-39.40	0.17	1.95
			Max. Mx	11	-28.30	2055.94	21.74
			Max. My	2	-28.30	21.07	2104.30
			Max. Vy	11	-23.20	2055.94	21.74
			Max. Vx	2	-23.69	21.07	2104.30
			Max. Torque	6			2.81

Maximum Reactions

Location	Condition	Gov. Load Comb.	Vertical K	Horizontal, X K	Horizontal, Z K
Pole	Max. Vert	26	39.40	2.76	4.80
	Max. H _x	11	28.31	23.19	0.22
	Max. H _z	2	28.31	0.22	23.67
	Max. M _x	2	2104.30	0.22	23.67
	Max. M _z	5	2055.82	-23.19	-0.22
	Max. Torsion	6	2.81	-20.19	-12.02
	Min. Vert	1	28.31	0.00	0.00
	Min. H _x	5	28.31	-23.19	-0.22

Location	Condition	Gov. Load Comb.	Vertical K	Horizontal, X K	Horizontal, Z K
	Min. H _z	8	28.31	-0.22	-23.67
	Min. M _x	8	-2102.84	-0.22	-23.67
	Min. M _z	11	-2055.94	23.19	0.22
	Min. Torsion	12	-2.79	20.19	12.02

Tower Mast Reaction Summary

Load Combination	Vertical K	Shear _x K	Shear _z K	Overturning Moment, M _x kip-ft	Overturning Moment, M _z kip-ft	Torque kip-ft
Dead Only	28.31	0.00	0.00	-0.71	0.05	0.00
Dead+Wind 0 deg - No Ice	28.31	-0.22	-23.67	-2104.30	21.07	0.92
Dead+Wind 30 deg - No Ice	28.31	11.41	-20.40	-1811.98	-1009.68	-0.55
Dead+Wind 60 deg - No Ice	28.31	19.97	-11.65	-1034.33	-1769.88	-1.89
Dead+Wind 90 deg - No Ice	28.31	23.19	0.22	20.29	-2055.82	-2.71
Dead+Wind 120 deg - No Ice	28.31	20.19	12.02	1069.27	-1790.88	-2.81
Dead+Wind 150 deg - No Ice	28.31	11.78	20.61	1831.52	-1046.06	-2.15
Dead+Wind 180 deg - No Ice	28.31	0.22	23.67	2102.84	-20.96	-0.91
Dead+Wind 210 deg - No Ice	28.31	-11.41	20.40	1810.53	1009.79	0.57
Dead+Wind 240 deg - No Ice	28.31	-19.97	11.65	1032.88	1770.00	1.89
Dead+Wind 270 deg - No Ice	28.31	-23.19	-0.22	-21.74	2055.94	2.70
Dead+Wind 300 deg - No Ice	28.31	-20.19	-12.02	-1070.72	1790.99	2.79
Dead+Wind 330 deg - No Ice	28.31	-11.78	-20.61	-1832.98	1046.18	2.14
Dead+Ice+Temp	39.40	0.00	0.00	-1.95	0.17	-0.00
Dead+Wind 0 deg+Ice+Temp	39.40	-0.04	-5.52	-510.49	3.87	0.18
Dead+Wind 30 deg+Ice+Temp	39.40	2.69	-4.76	-440.52	-247.13	-0.22
Dead+Wind 60 deg+Ice+Temp	39.40	4.70	-2.73	-253.06	-431.87	-0.56
Dead+Wind 90 deg+Ice+Temp	39.40	5.45	0.04	1.67	-500.84	-0.74
Dead+Wind 120 deg+Ice+Temp	39.40	4.74	2.79	255.40	-435.56	-0.73
Dead+Wind 150 deg+Ice+Temp	39.40	2.76	4.80	440.16	-253.53	-0.52
Dead+Wind 180 deg+Ice+Temp	39.40	0.04	5.52	506.44	-3.52	-0.18
Dead+Wind 210 deg+Ice+Temp	39.40	-2.69	4.76	436.47	247.49	0.22
Dead+Wind 240 deg+Ice+Temp	39.40	-4.70	2.73	249.01	432.23	0.56
Dead+Wind 270 deg+Ice+Temp	39.40	-5.45	-0.04	-5.72	501.20	0.74
Dead+Wind 300 deg+Ice+Temp	39.40	-4.74	-2.79	-259.46	435.92	0.73
Dead+Wind 330 deg+Ice+Temp	39.40	-2.76	-4.80	-444.21	253.89	0.52
Dead+Wind 0 deg - Service	28.31	-0.07	-8.19	-728.85	7.33	0.32
Dead+Wind 30 deg - Service	28.31	3.95	-7.06	-627.66	-349.45	-0.19
Dead+Wind 60 deg - Service	28.31	6.91	-4.03	-358.49	-612.57	-0.65
Dead+Wind 90 deg - Service	28.31	8.02	0.07	6.55	-711.55	-0.94
Dead+Wind 120 deg - Service	28.31	6.99	4.16	369.63	-619.85	-0.97
Dead+Wind 150 deg - Service	28.31	4.08	7.13	633.48	-362.04	-0.74
Dead+Wind 180 deg - Service	28.31	0.07	8.19	727.39	-7.22	-0.32
Dead+Wind 210 deg - Service	28.31	-3.95	7.06	626.21	349.56	0.20
Dead+Wind 240 deg - Service	28.31	-6.91	4.03	357.03	612.69	0.66
Dead+Wind 270 deg - Service	28.31	-8.02	-0.07	-8.00	711.66	0.94
Dead+Wind 300 deg - Service	28.31	-6.99	-4.16	-371.09	619.96	0.97

Load Combination	Vertical K	Shear _x K	Shear _z K	Overturning Moment, M _x kip-ft	Overturning Moment, M _z kip-ft	Torque kip-ft
Service Dead+Wind 330 deg - Service	28.31	-4.08	-7.13	-634.94	362.16	0.74

Solution Summary

Load Comb.	Sum of Applied Forces			Sum of Reactions			% Error
	PX K	PY K	PZ K	PX K	PY K	PZ K	
1	0.00	-28.31	0.00	0.00	28.31	0.00	0.000%
2	-0.22	-28.31	-23.67	0.22	28.31	23.67	0.000%
3	11.41	-28.31	-20.40	-11.41	28.31	20.40	0.000%
4	19.97	-28.31	-11.65	-19.97	28.31	11.65	0.000%
5	23.19	-28.31	0.22	-23.19	28.31	-0.22	0.000%
6	20.19	-28.31	12.02	-20.19	28.31	-12.02	0.000%
7	11.78	-28.31	20.61	-11.78	28.31	-20.61	0.000%
8	0.22	-28.31	23.67	-0.22	28.31	-23.67	0.000%
9	-11.41	-28.31	20.40	11.41	28.31	-20.40	0.000%
10	-19.97	-28.31	11.65	19.97	28.31	-11.65	0.000%
11	-23.19	-28.31	-0.22	23.19	28.31	0.22	0.000%
12	-20.19	-28.31	-12.02	20.19	28.31	12.02	0.000%
13	-11.78	-28.31	-20.61	11.78	28.31	20.61	0.000%
14	0.00	-39.40	0.00	0.00	39.40	0.00	0.000%
15	-0.04	-39.40	-5.52	0.04	39.40	5.52	0.000%
16	2.69	-39.40	-4.76	-2.69	39.40	4.76	0.000%
17	4.70	-39.40	-2.73	-4.70	39.40	2.73	0.000%
18	5.45	-39.40	0.04	-5.45	39.40	-0.04	0.000%
19	4.74	-39.40	2.79	-4.74	39.40	-2.79	0.000%
20	2.76	-39.40	4.80	-2.76	39.40	-4.80	0.000%
21	0.04	-39.40	5.52	-0.04	39.40	-5.52	0.000%
22	-2.69	-39.40	4.76	2.69	39.40	-4.76	0.000%
23	-4.70	-39.40	2.73	4.70	39.40	-2.73	0.000%
24	-5.45	-39.40	-0.04	5.45	39.40	0.04	0.000%
25	-4.74	-39.40	-2.79	4.74	39.40	2.79	0.000%
26	-2.76	-39.40	-4.80	2.76	39.40	4.80	0.000%
27	-0.07	-28.31	-8.19	0.07	28.31	8.19	0.000%
28	3.95	-28.31	-7.06	-3.95	28.31	7.06	0.000%
29	6.91	-28.31	-4.03	-6.91	28.31	4.03	0.000%
30	8.02	-28.31	0.07	-8.02	28.31	-0.07	0.000%
31	6.99	-28.31	4.16	-6.99	28.31	-4.16	0.000%
32	4.08	-28.31	7.13	-4.08	28.31	-7.13	0.000%
33	0.07	-28.31	8.19	-0.07	28.31	-8.19	0.000%
34	-3.95	-28.31	7.06	3.95	28.31	-7.06	0.000%
35	-6.91	-28.31	4.03	6.91	28.31	-4.03	0.000%
36	-8.02	-28.31	-0.07	8.02	28.31	0.07	0.000%
37	-6.99	-28.31	-4.16	6.99	28.31	4.16	0.000%
38	-4.08	-28.31	-7.13	4.08	28.31	7.13	0.000%

Non-Linear Convergence Results

Load Combination	Converged?	Number of Cycles	Displacement Tolerance	Force Tolerance
1	Yes	4	0.00000001	0.00000001
2	Yes	4	0.00000001	0.00008147
3	Yes	5	0.00000001	0.00003777
4	Yes	5	0.00000001	0.00004277
5	Yes	4	0.00000001	0.00039883
6	Yes	5	0.00000001	0.00003682
7	Yes	5	0.00000001	0.00004465
8	Yes	4	0.00000001	0.00017399
9	Yes	5	0.00000001	0.00004020
10	Yes	5	0.00000001	0.00003589

11	Yes	4	0.00000001	0.00049056
12	Yes	5	0.00000001	0.00004606
13	Yes	5	0.00000001	0.00003755
14	Yes	4	0.00000001	0.00000001
15	Yes	4	0.00000001	0.00055382
16	Yes	4	0.00000001	0.00061557
17	Yes	4	0.00000001	0.00061996
18	Yes	4	0.00000001	0.00054734
19	Yes	4	0.00000001	0.00061398
20	Yes	4	0.00000001	0.00062283
21	Yes	4	0.00000001	0.00054525
22	Yes	4	0.00000001	0.00061043
23	Yes	4	0.00000001	0.00060441
24	Yes	4	0.00000001	0.00054867
25	Yes	4	0.00000001	0.00063356
26	Yes	4	0.00000001	0.00062614
27	Yes	4	0.00000001	0.00002099
28	Yes	4	0.00000001	0.00011884
29	Yes	4	0.00000001	0.00016035
30	Yes	4	0.00000001	0.00007474
31	Yes	4	0.00000001	0.00011897
32	Yes	4	0.00000001	0.00016959
33	Yes	4	0.00000001	0.00002624
34	Yes	4	0.00000001	0.00013711
35	Yes	4	0.00000001	0.00011046
36	Yes	4	0.00000001	0.00008025
37	Yes	4	0.00000001	0.00018349
38	Yes	4	0.00000001	0.00011811

Maximum Tower Deflections - Service Wind

Section No.	Elevation ft	Horz. Deflection in	Gov. Load Comb.	Tilt °	Twist °
L1	119 - 97.25	13.458	38	0.9272	0.0037
L2	101.25 - 48	10.050	38	0.8919	0.0038
L3	53.25 - 0	2.804	38	0.4864	0.0012

Critical Deflections and Radius of Curvature - Service Wind

Elevation ft	Appurtenance	Gov. Load Comb.	Deflection in	Tilt °	Twist °	Radius of Curvature ft
116.00	(2) 7770.00 w/Mount Pipe	38	12.874	0.9239	0.0038	47972
109.00	Side Arm Mount [SO 104-3]	38	11.520	0.9137	0.0039	23986
106.00	APXVSP18-C-A20 w/Mount Pipe	38	10.946	0.9070	0.0039	18450
94.00	BXA-171063-8BF-EDIN-0 w/ Mount Pipe	38	8.721	0.8562	0.0037	10333
55.00	GPS-TMG-HR-26NCM GPS	38	2.984	0.5041	0.0013	4589
50.00	Side Arm Mount [SO 104-3]	38	2.491	0.4538	0.0010	4736

Maximum Tower Deflections - Design Wind

Section No.	Elevation ft	Horz. Deflection in	Gov. Load Comb.	Tilt °	Twist °
L1	119 - 97.25	38.810	13	2.6730	0.0109
L2	101.25 - 48	28.989	13	2.5720	0.0112
L3	53.25 - 0	8.094	13	1.4038	0.0035

Section No.	Elevation ft	Horz. Deflection in	Gov. Load Comb.	Tilt °	Twist °
-------------	-----------------	------------------------	-----------------	-----------	------------

Critical Deflections and Radius of Curvature - Design Wind

Elevation ft	Appurtenance	Gov. Load Comb.	Deflection in	Tilt °	Twist °	Radius of Curvature ft
116.00	(2) 7770.00 w/Mount Pipe	13	37.129	2.6638	0.0110	16807
109.00	Side Arm Mount [SO 104-3]	13	33.226	2.6344	0.0112	8403
106.00	APXVSP18-C-A20 w/Mount Pipe	13	31.572	2.6152	0.0112	6464
94.00	BXA-171063-8BF-EDIN-0 w/Mount Pipe	13	25.160	2.4694	0.0106	3610
55.00	GPS-TMG-HR-26NCM GPS	13	8.614	1.4550	0.0038	1593
50.00	Side Arm Mount [SO 104-3]	13	7.191	1.3100	0.0030	1643

Compression Checks

Pole Design Data

Section No.	Elevation ft	Size	L ft	L _u ft	KI/r	F _a ksi	A in ²	Actual P K	Allow. P _a K	Ratio P/P _a
L1	119 - 97.25 (1)	TP30.86x25.5x0.25	21.75	0.00	0.0	39.000	23.5068	-6.10	916.77	0.007
L2	97.25 - 48 (2)	TP42.47x29.3743x0.3125	53.25	0.00	0.0	39.000	40.5343	-15.14	1580.84	0.010
L3	48 - 0 (3)	TP53.65x40.5539x0.375	53.25	0.00	0.0	39.000	63.4106	-28.30	2473.01	0.011

Pole Bending Design Data

Section No.	Elevation ft	Size	Actual M _x kip-ft	Actual f _{bx} ksi	Allow. F _{bx} ksi	Ratio f _{bx} /F _{bx}	Actual M _y kip-ft	Actual f _{by} ksi	Allow. F _{by} ksi	Ratio f _{by} /F _{by}
L1	119 - 97.25 (1)	TP30.86x25.5x0.25	124.57	8.704	39.000	0.223	0.00	0.000	39.000	0.000
L2	97.25 - 48 (2)	TP42.47x29.3743x0.3125	952.49	27.957	39.000	0.717	0.00	0.000	39.000	0.000
L3	48 - 0 (3)	TP53.65x40.5539x0.375	2110.5	30.357	39.000	0.778	0.00	0.000	39.000	0.000

Pole Shear Design Data

Section No.	Elevation ft	Size	Actual V K	Actual f _v ksi	Allow. F _v ksi	Ratio f _v /F _v	Actual T kip-ft	Actual f _{vt} ksi	Allow. F _{vt} ksi	Ratio f _{vt} /F _{vt}
L1	119 - 97.25 (1)	TP30.86x25.5x0.25	11.34	0.483	26.000	0.037	0.31	0.011	26.000	0.000
L2	97.25 - 48 (2)	TP42.47x29.3743x0.3125	19.65	0.485	26.000	0.037	2.15	0.031	26.000	0.001
L3	48 - 0 (3)	TP53.65x40.5539x0.375	23.76	0.375	26.000	0.029	2.14	0.015	26.000	0.001

Pole Interaction Design Data

Section No.	Elevation ft	Ratio $\frac{P}{P_a}$	Ratio $\frac{f_{bx}}{F_{bx}}$	Ratio $\frac{f_{by}}{F_{by}}$	Ratio $\frac{f_v}{F_v}$	Ratio $\frac{f_{vt}}{F_{vt}}$	Comb. Stress Ratio	Allow. Stress Ratio	Criteria
L1	119 - 97.25 (1)	0.007	0.223	0.000	0.037	0.000	0.230 ✓	1.333	H1-3+VT ✓
L2	97.25 - 48 (2)	0.010	0.717	0.000	0.037	0.001	0.727 ✓	1.333	H1-3+VT ✓
L3	48 - 0 (3)	0.011	0.778	0.000	0.029	0.001	0.790 ✓	1.333	H1-3+VT ✓

Section Capacity Table

Section No.	Elevation ft	Component Type	Size	Critical Element	P K	$SF \cdot P_{allow}$ K	% Capacity	Pass Fail	
L1	119 - 97.25	Pole	TP30.86x25.5x0.25	1	-6.10	1222.05	17.3	Pass	
L2	97.25 - 48	Pole	TP42.47x29.3743x0.3125	2	-15.14	2107.26	54.5	Pass	
L3	48 - 0	Pole	TP53.65x40.5539x0.375	3	-28.30	3296.52	59.3	Pass	
							Summary		
							Pole (L3)	59.3	Pass
							RATING =	59.3	Pass

APPENDIX B
BASE LEVEL DRAWING

(INSTALLED)
(12) 1-5/8" TO 94 FT LEVEL

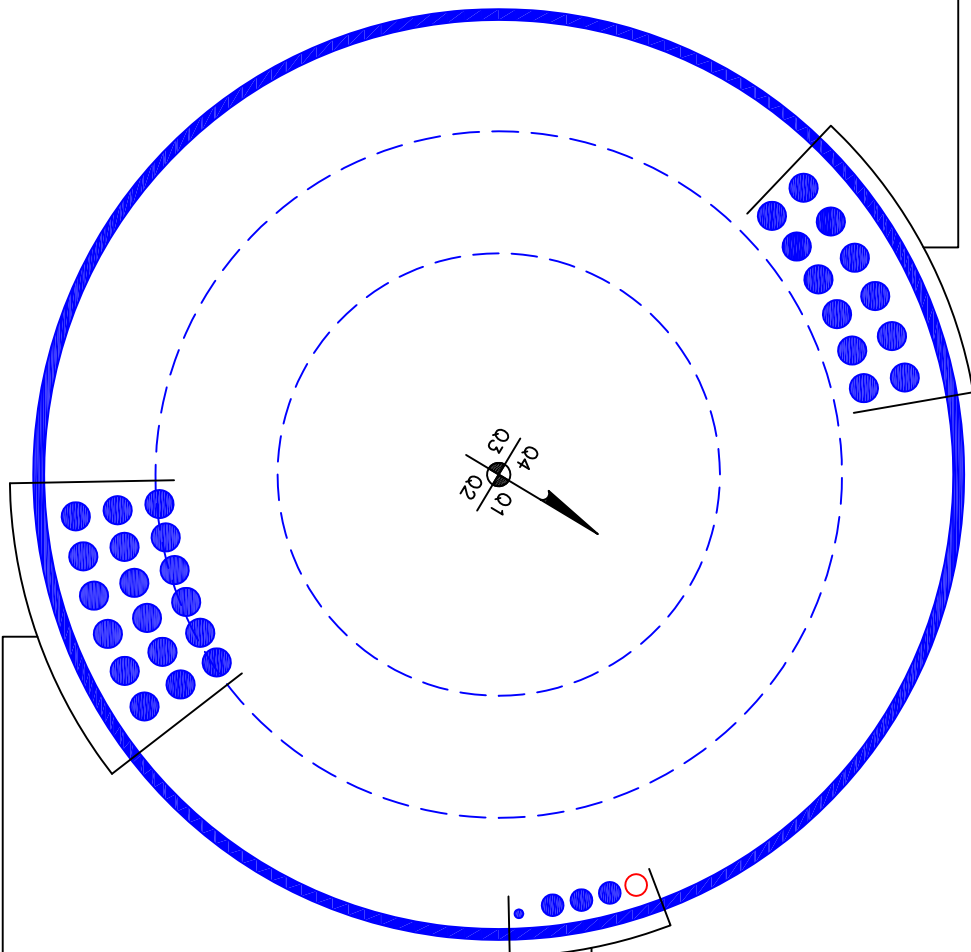

Q4
Q3
Q1
Q2

(PROPOSED)
(1) 1-1/4" TO 106 FT LEVEL
(INSTALLED)
(1) 1/2" TO 55 FT LEVEL
(3) 1-1/4" TO 106 FT LEVEL

(INSTALLED)
(18) 1-5/8" TO 116 FT LEVEL

APPENDIX C
ADDITIONAL CALCULATIONS

Square, Stiffened / Unstiffened Base Plate, Any Rod Material - Rev. F /C

- Assumptions:**
- 1) Rod groups at corners. Total # rods divisible by 4. Maximum total # of rods = 48 (12 per Corner).
 - 2) Rod Spacing = Straight Center-to-Center distance between any (2) adjacent rods (same corner)
 - 3) Clear space between bottom of leveling nut and top of concrete **not** exceeding (1)*(Rod Diameter)

Site Data

BU#:	846176
Site Name:	MADISON DURHAM ROAD
App #:	248843 R1

Anchor Rod Data

Qty:	16	
Diam:	2.25	in
Rod Material:	A615-J	
Yield, Fy:	75	ksi
Strength, Fu:	100	ksi
Bolt Circle:	60	in
Anchor Spacing:	6	in

Plate Data

W=Side:	60	in
Thick:	2.5	in
Grade:	60	ksi
Clip Distance:	16.875	in

Stiffener Data (Welding at both sides)

Configuration:	Unstiffened	
Weld Type:		**
Groove Depth:		in **
Groove Angle:		degrees
Fillet H. Weld:		<-- Disregard
Fillet V. Weld:		in
Width:		in
Height:		in
Thick:		in
Notch:		in
Grade:		ksi
Weld str.:		ksi

Pole Data

Diam:	53.65	in
Thick:	0.375	in
Grade:	65	ksi
# of Sides:	18	"0" IF Round

Stress Increase Factor

ASD ASIF:	1.333
-----------	-------

** Note: for complete joint penetration groove welds the groove depth must be exactly 1/2 the stiffener thickness for calculation purposes

Base Reactions

TIA Revision:	F	
Unfactored Moment, M:	2110.52074	ft-kips
Unfactored Axial, P:	28.2972	kips
Unfactored Shear, V:	23.755889	kips

Anchor Rod Results

TIA F --> Maximum Rod Tension	103.8 Kips
Allowable Tension:	195.0 Kips
Anchor Rod Stress Ratio:	53.2% Pass

Base Plate Results

Base Plate Stress:	31.4 ksi
Allowable PL Bending Stress:	60.0 ksi
Base Plate Stress Ratio:	52.4% Pass

Flexural Check

N/A - Unstiffened

Stiffener Results

Horizontal Weld :	N/A
Vertical Weld:	N/A
Plate Flex+Shear, $f_b/F_b + (f_v/F_v)^2$:	N/A
Plate Tension+Shear, $f_t/F_t + (f_v/F_v)^2$:	N/A
Plate Comp. (AISC Bracket):	N/A

Pole Results

Pole Punching Shear Check:	N/A
----------------------------	-----

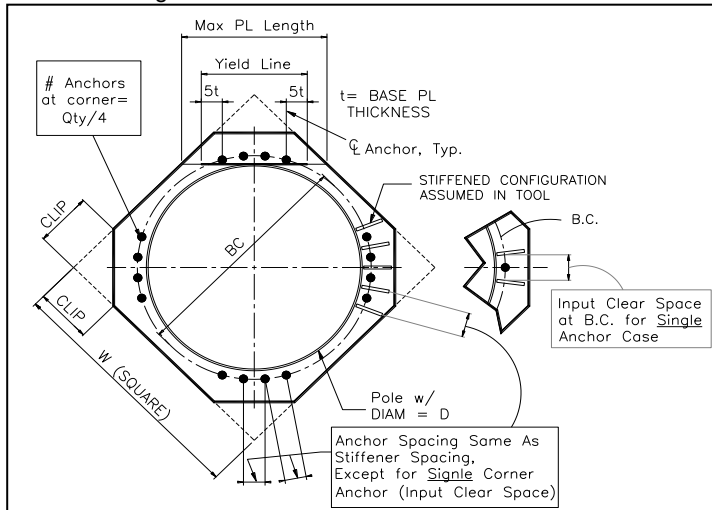

(Bearing and Stability Checks) Tool for TIA Rev F or G - Application (MP, SST with unitbase)

Site Data

BU#: 846176
Site Name: MADISON DURHAM ROAD
App #: ????

Monopole Base Reaction Forces		
TIA Revision:	F	<--Pull Down
Unfactored DL Axial, PD:	28.2972	kips
Unfactored WL Axial, PW:	0	kips
Unfactored WL Shear, V:	23.75589	kips
Unfactored WL Moment, M:	2110.521	ft-kips

Load Factor	Shaft Factored Loads	
1.20	1.2D+1.6W, Pu:	33.95664 kips
0.90	0.9D+1.6W, Pu:	25.46748 kips
1.35	Vu:	32.07045 kips
	Mu:	2849.203 ft-kips

1.2D+1.6W Load Combination, Bearing Results:

(No Soil Wedges) [Reaction+Conc+Soil]	368.85	P1="1.2D+1.6W" (Kips)
Factored "1.6W" Overturning Moment (MW-Msoil), M1	2911.33	ft-kips

Orthogonal Direction:

ecc1 = M1/P1 = 7.89 ft
 Orthogonal qu= 0.82 ksf
 qu/φ*qn Ratio= **7.19% Pass**

Diagonal Direction:

ecc2 = (0.707M1)/P1 = 5.58 ft
 Diagonal qu= 0.99 ksf
 qu/φ*qn Ratio= **8.62% Pass**

<-- Press Upon Completing All Input

Overturning Stability Check

0.9D+1.6W Load Combination, Bearing Results:

(w/ Soil Wedges) [Reaction+Conc+Soil]	276.63	P2="0.9D+1.6W" (Kips)
Factored "1.6W" Overturning Moment (MW-Msoil) - 0.9(M of Wedge + M of Cohesion), M2	2911.33	ft-kips

Orthogonal ecc3 = M2/P2 = 10.52 ft
 Ortho Non Bearing Length,NBL= **21.05 ft**
 Orthogonal qu= 0.96 ksf
 Diagonal qu= 1.13 ksf

Max Reaction Moment (ft-kips) so that qu=φ*qn = 100% Capacity Rating

Actual M:	2110.52		
M Orthogonal:	2997.68	70.41%	Pass
M Diagonal:	2997.68	70.41%	Pass

Enter Load Factors Below:		
For P (DL)	1.2	<---- Enter Factor
For P,V, and M (WL)	1.35	<---- Enter Factor

Pad & Pier Data		
Base PL Dist. Above Pier:	0	in
Pier Dist. Above Grade:	12	in
Pad Bearing Depth, D:	1	ft
Pad Thickness, T:	1	ft
Pad Width=Length, L:	30.5	ft
Pier Cross Section Shape:	Square	<--Pull Down
Enter Pier Side Width:	30.5	ft
Concrete Density:	150.0	pcf
Pier Cross Section Area:	930.25	ft^2
Pier Height:	1.00	ft
Soil (above pad) Height:	0.00	ft

Soil Parameters		
Unit Weight, γ:	120.0	pcf
Ultimate Bearing Capacity, qn:	15.25	ksf
Strength Reduct. factor, φ:	0.75	
Angle of Friction, Φ:	39.0	degrees
Undrained Shear Strength, Cu:	0.00	ksf
Allowable Bearing: φ*qn:	11.44	ksf
Passive Pres. Coeff., Kp	4.40	

Forces/Moments due to Wind and Lateral Soil		
Minimum of (φ*Ultimate Pad Passive Force, Vu):	6.0	kips
Pad Force Location Above D:	0.33	ft
φ(Passive Pressure Moment):	2.01	ft-kips
Factored O.T. M(WL), "1.6W":	2913.3	ft-kips
Factored OT (MW-Msoil), M1	2911.33	ft-kips

Resistance due to Foundation Gravity		
Soil Wedge Projection grade, a:	0.00	ft
Sum of Soil Wedges Wt:	0.00	kips
Soil Wedges ecc, K1:	0.00	ft
Ftg+Soil above Pad wt:	279.1	kips
Unfactored (Total ftg-soil Wt):	279.08	kips
1.2D. No Soil Wedges.	368.85	kips
0.9D. With Soil Wedges	276.63	kips

Resistance due to Cohesion (Vertical)		
φ*(1/2*Cu)(Total Vert. Planes)	0.00	kips
Cohesion Force Eccentricity, K2	0.00	ft

RADIO FREQUENCY FCC REGULATORY COMPLIANCE
MAXIMUM PERMISSIBLE EXPOSURE (MPE) ASSESSMENT

Sprint Existing Facility

Site ID: CT33XC540

Madison ATT

1749 Durham Road (Rt 79)
Madison, CT 06443

September 6, 2014

EBI Project Number: 62144513

September 6, 2014

Sprint
Attn: RF Engineering Manager
1 International Boulevard, Suite 800
Mahwah, NJ 07495

Re: Radio Frequency Maximum Permissible Exposure (MPE) Assessment for Site:
CT33XC540 - Madison ATT

Site Total: 80.99% - MPE% in full compliance

EBI Consulting was directed to analyze the proposed upgrades to the existing Sprint facility located at **1749 Durham Road (Rt 79), Madison, CT**, for the purpose of determining whether the radio frequency (RF) exposure levels from the proposed Sprint equipment upgrades on this property are within specified federal limits.

All information used in this report was analyzed as a percentage of current Maximum Permissible Exposure (% MPE) as listed in the FCC OET Bulletin 65 Edition 97-01 and ANSI/IEEE Std C95.1. The FCC regulates Maximum Permissible Exposure in units of microwatts per square centimeter ($\mu\text{W}/\text{cm}^2$). The number of $\mu\text{W}/\text{cm}^2$ calculated at each sample point is called the power density. The exposure limit for power density varies depending upon the frequencies being utilized. Wireless Carriers and Paging Services use different frequency bands each with different exposure limits, therefore it is necessary to report results and limits in terms of percent MPE rather than power density.

All results were compared to the FCC (Federal Communications Commission) radio frequency exposure rules, 47 CFR 1.1307(b)(1) – (b)(3), to determine compliance with the Maximum Permissible Exposure (MPE) limits for General Population/Uncontrolled environments as defined below.

General population/uncontrolled exposure limits apply to situations in which the general public may be exposed or in which persons who are exposed as a consequence of their employment may not be made fully aware of the potential for exposure or cannot exercise control over their exposure. Therefore, members of the general public would always be considered under this category when exposure is not employment related, for example, in the case of a telecommunications tower that exposes persons in a nearby residential area.

Public exposure to radio frequencies is regulated and enforced in units of microwatts per square centimeter ($\mu\text{W}/\text{cm}^2$). The general population exposure limit for the cellular band (850 MHz Band) is approximately $567 \mu\text{W}/\text{cm}^2$, and the general population exposure limit for the 1900 MHz and 2500 MHz bands is $1000 \mu\text{W}/\text{cm}^2$. Because each carrier will be using different frequency bands, and each frequency band has different exposure limits, it is necessary to report percent of MPE rather than power density.

Occupational/controlled exposure limits apply to situations in which persons are exposed as a consequence of their employment and in which those persons who are exposed have been made fully aware of the potential for exposure and can exercise control over their exposure. Occupational/controlled exposure limits also apply where exposure is of a transient nature as a result of incidental passage through a location where exposure levels may be above general population/uncontrolled limits (see below), as long as the exposed person has been made fully aware of the potential for exposure and can exercise control over his or her exposure by leaving the area or by some other appropriate means.

Additional details can be found in FCC OET 65.

CALCULATIONS

Calculations were done for the proposed upgrades to the existing Sprint Wireless antenna facility located at **1749 Durham Road (Rt 79), Madison, CT**, using the equipment information listed below. All calculations were performed per the specifications under FCC OET 65. All calculations were performed assuming a lobe representing the maximum gain of the antenna per the antenna manufactures supplied specifications, minus 10 dB, was focused at the base of the tower. For this report the sample point is the top of a 6 foot person standing at the base of the tower.

For all calculations, all emissions were calculated using the following assumptions:

- 1) 2 channels in the 1900 MHz Band were considered for each sector of the proposed installation.
- 2) 1 channel in the 800 MHz Band was considered for each sector of the proposed installation.
- 3) 2 channels in the 2500 MHz Band were considered for each sector of the proposed installation.
- 4) All radios at the proposed installation were considered to be running at full power and were uncombined in their RF transmissions paths per carrier prescribed configuration. Per FCC OET Bulletin No. 65 - Edition 97-01 recommendations to achieve the maximum anticipated value at each sample point, all power levels emitting from the proposed antenna installation are increased by a factor of 2.56 to account for possible in-phase reflections from the surrounding environment. This is rarely the case, and if so, is never continuous.

- 5) For the following calculations the sample point was the top of a six foot person standing at the base of the tower. The maximum gain of the antenna per the antenna manufactures supplied specifications minus 10 dB was used in this direction. This value is a very conservative estimate as gain reductions for these particular antennas are typically much higher in this direction.
- 6) The antennas used in this modeling are the RFS APXVSPP18-C-A20 and the RFS APXVTM14-C-I20. This is based on feedback from the carrier with regards to anticipated antenna selection. The RFS APXVSPP18-C-A20 has a 15.9 dBd gain value at its main lobe at 1900 MHz and 13.4 dBd at its main lobe for 850 MHz. The RFS APXVTM14-C-I20 has a 15.9 dBd gain value at its main lobe at 2500 MHz. The maximum gain of the antenna per the antenna manufactures supplied specifications, minus 10 dB, was used for all calculations. This value is a very conservative estimate as gain reductions for these particular antennas are typically much higher in this direction.
- 7) The antenna mounting height centerline for the proposed antennas is **108 feet** above ground level (AGL).
- 8) Emissions values for additional carriers were taken from the Connecticut Siting Council active database. Values in this database are provided by the individual carriers themselves.

All calculation were done with respect to uncontrolled / general public threshold limits

Site ID	CT33XC540 - Madison ATT
Site Address	1749 Durham Road (Rt 79), Madison, CT, 06443
Site Type	Monopole

Sector 1

Antenna Number	Antenna Make	Antenna Model	Radio Type	Frequency Band	Technology	Power Out Per Channel (Watts)	Number of Channels	Composite Power	Antenna Gain (10 db reduction)	Antenna Height (ft)	analysis height	Cable Size	Cable Loss (dB)	Additional Loss (dB)	ERP	Power Density Percentage
1a	RFS	APXVSP18-C-A20	RRH	1900 MHz	CDMA / LTE	20	2	40	5.9	108	102	1/2 "	0.5	0	138.69	0.48%
1a	RFS	APXVSP18-C-A20	RRH	850 MHz	CDMA / LTE	20	1	20	3.4	108	102	1/2 "	0.5	0	39.00	0.24%
1B	RFS	APXVTMM14-C-120	RRH	2500 MHz	CDMA / LTE	20	2	40	5.9	108	102	1/2 "	0.5	0	138.69	0.85%
Sector total Power Density Value:																1.56%

Sector 2

Antenna Number	Antenna Make	Antenna Model	Radio Type	Frequency Band	Technology	Power Out Per Channel (Watts)	Number of Channels	Composite Power	Antenna Gain (10 db reduction)	Antenna Height (ft)	analysis height	Cable Size	Cable Loss (dB)	Additional Loss (dB)	ERP	Power Density Percentage
2a	RFS	APXVSP18-C-A20	RRH	1900 MHz	CDMA / LTE	20	2	40	5.9	108	102	1/2 "	0.5	0	138.69	0.48%
2a	RFS	APXVSP18-C-A20	RRH	850 MHz	CDMA / LTE	20	1	20	3.4	108	102	1/2 "	0.5	0	39.00	0.24%
2B	RFS	APXVTMM14-C-120	RRH	2500 MHz	CDMA / LTE	20	2	40	5.9	108	102	1/2 "	0.5	0	138.69	0.85%
Sector total Power Density Value:																1.56%

Sector 3

Antenna Number	Antenna Make	Antenna Model	Radio Type	Frequency Band	Technology	Power Out Per Channel (Watts)	Number of Channels	Composite Power	Antenna Gain (10 db reduction)	Antenna Height (ft)	analysis height	Cable Size	Cable Loss (dB)	Additional Loss (dB)	ERP	Power Density Percentage
3a	RFS	APXVSP18-C-A20	RRH	1900 MHz	CDMA / LTE	20	2	40	5.9	108	102	1/2 "	0.5	0	138.69	0.48%
3a	RFS	APXVSP18-C-A20	RRH	850 MHz	CDMA / LTE	20	1	20	3.4	108	102	1/2 "	0.5	0	39.00	0.24%
3B	RFS	APXVTMM14-C-120	RRH	2500 MHz	CDMA / LTE	20	2	40	5.9	108	102	1/2 "	0.5	0	138.69	0.85%
Sector total Power Density Value:																1.56%

Site Composite MPE %	
Carrier	MPE %
Sprint	4.69%
AT&T	23.29%
Verizon Wireless	53.01%
Total Site MPE %	80.99%

Summary

All calculations performed for this analysis yielded results that were well within the allowable limits for general public Maximum Permissible Exposure (MPE) to radio frequency energy.

The anticipated Maximum Composite contributions from the Sprint facility are **4.69% (1.56% from sector 1, 1.56% from sector 2 and 1.56% from sector 3)** of the allowable FCC established general public limit considering all three sectors simultaneously sampled at the ground level.

The anticipated composite MPE value for this site assuming all carriers present is **80.99%** of the allowable FCC established general public limit sampled at 6 feet above ground level. This total composite site value is based upon MPE values listed in the Connecticut Siting Council database for existing carrier emissions.

FCC guidelines state that if a site is found to be out of compliance (over allowable thresholds), that carriers over a 5% contribution to the composite value will require measures to bring the site into compliance. For this facility, the composite values calculated were well within the allowable 100% threshold standard per the federal government.



Scott Heffernan
RF Engineering Director

EBI Consulting
21 B Street
Burlington, MA 01803