

February 28, 2014

David Martin and  
Members of the Siting Council  
Connecticut Siting Council  
Ten Franklin Square  
New Britain, CT 06051

RE: Notice of Exempt Modification  
17 Cottage Road  
Madison CT 06443  
N 41.275913  
W 72.561422

Dear Mr. Martin and Members of the Siting Council:

On behalf of T-Mobile, SBA Communications is submitting an exempt modification application to the Connecticut Siting council for modification of existing equipment at a tower facility located at 17 Cottage Road, Madison, CT.

The 17 Cottage Road facility consists of a 130' Monopole Tower owned and operated by SBA Towers II LLC. In order to accommodate technological changes and enhance system performance in the State of Connecticut, T-Mobile plans to modify the equipment configurations at many of its existing cell sites. Please accept this letter and attachments as notification, pursuant to R.C.S.A. Section 16-50j-73, of construction which constitutes an exempt modification pursuant to R.C.S.A. Section 16-50j-72(b)(2). In compliance with R.C.S.A. Section 16-50j-73, a copy of this letter and attachments is being sent to the chief elected official of the municipality in which the affected cell site is located.

As part of T-Mobile's modernization project, T-Mobile desires to upgrade their equipment to meet the new standards of 4G technology. The new equipment will allow customers to download files and browse the internet at a high rate of speed while also allowing their phones to be compatible with the latest 4G technology.

Attached is a summary of the planned modifications, including power density calculations reflecting the change in T-Mobile's operations at the site along with the required fee of \$625.

The changes to the facility do not constitute modifications as defined in Connecticut General Statutes ("C.G.S.") Section 16-50i(d) because the general physical characteristics of the facility will not be

significantly changed or altered. Rather, the planned changes to the facility fall squarely within those activities explicitly provided for in R.C.S.A. Section 16-50j-72(b)(2).

1. The overall height of the structure will be unaffected.
2. The proposed changes will not extend the site boundaries. There will be no effect on the site compound other than the new equipment cabinets.
3. The proposed changes will not increase the noise level at the existing facility by six decibels or more.
4. The changes in radio frequency power density will not increase the calculated "worst case" power density for the combined operations at the site to a level at or above the applicable standard for uncontrolled environments as calculated for a mixed frequency site.

For the foregoing reasons, SBA Communications on behalf of T-Mobile, respectfully submits that he proposed changes at the referenced site constitute exempt modifications under R.C.S.A. Section 16-50j-72(b)(2).

Please feel free to call me at 508.251.0720 x 3804 with any questions you may have concerning this matter.

Thank you,



Kri Pelletier  
SBA Communications Corporation  
33 Boston Post Road West Suite 320  
Marlborough, MA 01752  
508-251-0720 x 3804 + T  
508-251-1755 + F  
203-446-7700 + C  
[kpelletier@sbsite.com](mailto:kpelletier@sbsite.com)



**T-Mobile  
Equipment Modification**

17 Cottage Road, Madison, CT  
Site number CT11443E

**Tower Owner:** SBA Towers II LLC

**Equipment Configuration:** Monopole

**Current and/or approved:**

- (9) RFS APXV18-209014
- (3) RFS ATMAA1412D-1A20 TMAs
- (3) RFS ATMPP1412D-1CWA TMAs
- (18) 1-5/8" Feedlines

**Planned Modifications:**

- (3) Ericsson AIR 21 B2A B4P
- (3) Ericsson AIR 21 B4A B2P
- (3) Ericsson KRY 112 144 TMAs
- (12) 1 5/8" Feedlines
- (1) 1 5/8" Fiber

**Structural Information:**

The attached structural analysis demonstrates that the tower and foundation will have adequate structural capacity to accommodate the proposed modifications.

**Power Density:**

The anticipated Maximum Composite contributions from the T-Mobile facility are .846% of the allowable FCC established general public limit. The anticipated composite MPE value for this site assuming all carriers present is 11.576% of the allowable FCC established general public limit sampled at the ground level.

Site Composite MPE %	
Carrier	MPE %
T-Mobile	0.846%
AT&T	10.730%
Total Site MPE %	11.576%



February 28, 2014

Fillmore McPherson  
First Selectman  
Town of Madison  
8 Campus Drive  
Madison, CT 06443

RE: Telecommunications Facility @ 17 Cottage Road, Madison, CT

Dear Mr. McPherson,

In order to accommodate technological changes and enhance system performance in the State of Connecticut, T-Mobile will be changing its equipment configuration at certain cell sites.

As required by Regulations of Connecticut State Agencies (R.C.S.A.) Section 16-50j-73, the Connecticut Siting Council has been notified of the changes and will review T-Mobile's proposal. Please accept this letter as notification under Section 16-50j-73 of construction which constitutes an exempt modification pursuant to R.C.S.A. Section 16-50j-72(b)(2).

The accompanying letter to the Siting Council fully describes T-Mobile's proposal for the referenced cell site. However, if you have any questions or require any further information on our plans or the Siting Council's procedures, please call me at 508.251.0720 x 3804.

Thank you,

A handwritten signature in black ink, appearing to read "Kri Pelletier", is positioned above the typed name.

Kri Pelletier  
SBA Communications Company  
33 Boston Post Road West Suite 320  
Marlborough, MA 01752  
508-251-0720 x 3804 + T  
508-251-1755 + F  
203-446-7700 + C  
[kpelletier@sbsite.com](mailto:kpelletier@sbsite.com)



FDH Engineering, Inc., 6521 Meriden Drive Raleigh, NC 27616, Ph. 919.755.1012

**Structural Analysis for  
SBA Network Services, Inc.**

**130' Monopole Tower**

**SBA Site Name: Madison 7  
SBA Site ID: CT13615-A-00  
T-Mobile Site ID: CT11443E**

FDH Project Number 1422QY1400

**Analysis Results**

Tower Components	57.2%	Sufficient
Foundation	42.2%	Sufficient

Prepared By:

Jeffrey B. Ray, EI  
Project Engineer

Reviewed By:

Bradley R. Newman, PE  
Senior Project Engineer  
CT PE License No. 29630

**FDH Engineering, Inc.**  
6521 Meriden Drive  
Raleigh, NC 27616  
(919) 755-1012  
info@fdh-inc.com

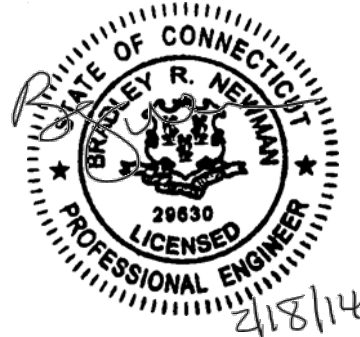

February 18, 2014

*Prepared pursuant to TIA/EIA-222-F Structural Standards for Steel Antenna Towers and Antenna Supporting Structures and the 2005 Connecticut State Building Code*

**TABLE OF CONTENTS**

EXECUTIVE SUMMARY .....3  
    Conclusions.....3  
    Recommendation .....3  
APPURTENANCE LISTING .....4  
RESULTS .....5  
GENERAL COMMENTS .....6  
LIMITATIONS .....6  
APPENDIX .....7

## EXECUTIVE SUMMARY

At the request of SBA Network Services, Inc., FDH Engineering, Inc. performed a structural analysis of the monopole located in Madison, CT to determine whether the tower is structurally adequate to support both the existing and proposed loads pursuant to the *Structural Standards for Steel Antenna Towers and Antenna Supporting Structures, TIA/EIA-222-F* and *2005 Connecticut Building Code (CBC)*. Information pertaining to the existing/proposed antenna loading, current tower geometry, geotechnical data, foundation dimensions, and member sizes was obtained from:

- Radian Communication Services (Eng. File No. 060-4236) original design drawings dated October 1, 2007
- FDH, Inc. (Job No. 08-07611T) TIA Inspection Report dated September 4, 2008
- JGI Eastern, Inc (Project No. J2075395) Geotechnical Evaluation dated September 10, 2007
- SBA Network Services, Inc.

The *basic design wind speed* per the *TIA/EIA-222-F* standard and *2005 CBC* is 85 mph without ice and 38 mph with 3/4" radial ice. Ice is considered to increase in thickness with height.

## Conclusions

With the existing and proposed antennas from T-Mobile in place at 117 ft, the tower meets the requirements of the *TIA/EIA-222-F* standard and *2005 CBC* provided the **Recommendations** listed below are satisfied. Furthermore, provided the foundation was designed and constructed to support the original design reactions (see Radian Communication Services Eng. File No. 060-4236), the foundations should have the necessary capacity to support the existing and proposed loading. For a more detailed description of the analysis of the tower, see the **Results** section of this report.

Our structural analysis has been performed assuming all information provided to FDH Engineering, Inc. is accurate (i.e., the steel data, tower layout, existing antenna loading, and proposed antenna loading) and that the tower has been properly erected and maintained per the original design drawings.

## Recommendations

To ensure the requirements of the *TIA/EIA-222-F* standard and *2005 CBC* are met with the existing and proposed loading in place, we have the following recommendations:

1. The proposed coax should be installed inside the pole's shaft.
2. The proposed TMAs should be installed behind the proposed panels.

## APPURTENANCE LISTING

The proposed and existing antennas with their corresponding cables/coax lines are shown in **Table 1**. *If the actual layout determined in the field deviates from the layout, FDH Engineering, Inc. should be contacted to perform a revised analysis.*

**Table 1 - Appurtenance Loading**

### Existing Loading:

Antenna Elevation (ft)	Description	Feedlines	Carrier	Mount Elevation (ft)	Mount Type
128	(6) Ericsson RRUS-11 RRUs	(12) 1-5/8"	AT&T	128	(1) Collar Mount
127	(6) Powerwave P90-15-XLH-RR (3) KMW AM-X-CD-14-65-00T-RET (6) Powerwave TT19-08BP111-001 TMAs (1) Raycap DC6-48-60-18-8F Surge Arrestor	(1) 1/2" Fiber (2) 3/4" DC (1) 3" Flex Conduit		127	(1) Low Profile Platform (Assumed CaAa = 18.01 ft <sup>2</sup> )
117	(9) RFS APXV18-209014 (3) RFS ATMAA1412D-1A20 TMAs (3) RFS ATMPP1412D-1CWA TMAs	(18) 1-5/8"	T-Mobile	117	(1) 12.5' Low Profile Platform
107	(6) Amphenol BXA-70063-6CF_2 (6) Amphenol BXA-171063-12CF_2 (3) ALU RRH2x40-AWS RRHs (3) ALU RRH2x40-07 RRHs (1) RFS DB-B1-6C-8AB-OZ Surge Suppressor	(2) 1-5/8" Fiber	Verizon	107	(1) Low Profile Platform (Assumed CaAa = 18.01 ft <sup>2</sup> )

### Proposed Loading:

Antenna Elevation (ft)	Description	Feedlines	Carrier	Mount Elevation (ft)	Mount Type
117	(3) Ericsson Air 21 B2A B4P (3) Ericsson Air 21 B4A B2P (3) Ericsson KRY 112 144 TMAs	(12) 1-5/8" (1) 1-5/8" Fiber	T-Mobile	117	(1) 12.5' Low Profile Platform



## RESULTS

The following yield strength of steel for individual members was used for analysis:

**Table 2 - Material Strength**

Member Type	Yield Strength
Tower Shaft Sections	65 ksi
Base Plate	50 ksi
Anchor Bolts	105 ksi

**Table 3** displays the summary of the ratio (as a percentage) of force in the member to their capacities. Values greater than 100% indicate locations where the maximum force in the member exceeds its capacity. *Note: Capacities up to 100% are considered acceptable.* **Table 4** displays the maximum foundation reactions.

If the assumptions outlined in this report differ from actual field conditions, FDH Engineering, Inc. should be contacted to perform a revised analysis. Furthermore, as no information pertaining to the allowable twist and sway requirements for the existing or proposed appurtenances was provided, deflection and rotation were not taken into consideration when performing this analysis.

See the **Appendix** for detailed modeling information

**Table 3 - Summary of Working Percentage of Structural Components**

Section No.	Elevation ft	Component Type	Size	% Capacity	Pass Fail
L1	130 - 85.25	Pole	TP38.218x27.01x0.25	35.6	Pass
L2	85.25 - 42	Pole	TP48.39x36.5283x0.375	41.7	Pass
L3	42 - 0	Pole	TP58x46.1573x0.4375	44.5	Pass
		Anchor Bolts	(26) 1.5" on a 63" BC	52.1	Pass
		Base Plate	67" x 1.75" thick PL	57.2	Pass

**Table 4 - Maximum Base Reactions**

Base Reactions	Current Analysis (TIA/EIA-222-F)	Original Design (TIA/EIA-222-F)
Axial	34 k	101 k
Shear	23 k	46 k
Moment	2,151 k-ft	5,098 k-ft

## **GENERAL COMMENTS**

This engineering analysis is based upon the theoretical capacity of the structure. It is not a condition assessment of the tower and its foundation. It is the responsibility of SBA Network Services, Inc. to verify that the tower modeled and analyzed is the correct structure (with accurate antenna loading information) modeled. If there are substantial modifications to be made or the assumptions made in this analysis are not accurate, FDH Engineering, Inc. should be notified immediately to perform a revised analysis.

## **LIMITATIONS**

All opinions and conclusions are considered accurate to a reasonable degree of engineering certainty based upon the evidence available at the time of this report. All opinions and conclusions are subject to revision based upon receipt of new or additional/updated information. All services are provided exercising a level of care and diligence equivalent to the standard and care of our profession. No other warranty or guarantee, expressed or implied, is offered. Our services are confidential in nature and we will not release this report to any other party without the client's consent. The use of this engineering work is limited to the express purpose for which it was commissioned and it may not be reused, copied, or distributed for any other purpose without the written consent of FDH Engineering, Inc.

## **APPENDIX**

Section	1	2	3
Length (ft)	44.75	48.00	48.00
Number of Slides	18	18	18
Thickness (in)	0.2500	0.3750	0.4375
Socket Length (ft)	4.75	6.00	6.00
Top Dia (in)	27.0100	36.5283	46.1573
Bot Dia (in)	36.2180	46.3900	56.0000
Grade	A572-65	A572-65	A572-65
Weight (K)	3.9	8.2	11.7

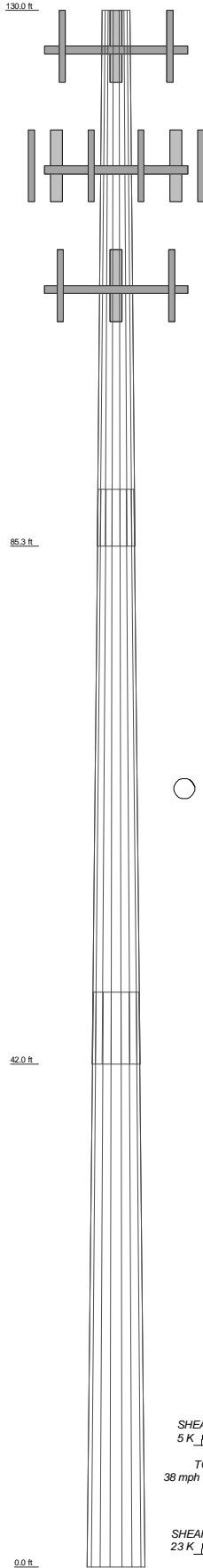

### DESIGNED APPURTENANCE LOADING

TYPE	ELEVATION	TYPE	ELEVATION
Lightning Rod	150	AIR 21 B4A/B2P w/Mount Pipe	117
(2) RRUS-11	128	AIR 21 B4A/B2P w/Mount Pipe	117
(2) RRUS-11	128	KRY 112 144/1	117
(2) RRUS-11	128	KRY 112 144/1	117
Collar Mount	128	KRY 112 144/1	117
(2) P90-15-XLH-RR w/Mount Pipe	127	LP Platform	117
(2) P90-15-XLH-RR w/Mount Pipe	127	(2) BXA-70063-6CF-EDIN-X w/ Mount Pipe	107
(2) P90-15-XLH-RR w/Mount Pipe	127	(2) BXA-70063-6CF-EDIN-X w/ Mount Pipe	107
AM-X-CD-14-65-00T-RET w/mount pipe	127	(2) BXA-70063-6CF-EDIN-X w/ Mount Pipe	107
AM-X-CD-14-65-00T-RET w/mount pipe	127	(2) BXA-171063-12CF-EDIN-X w/ Mount Pipe	107
AM-X-CD-14-65-00T-RET w/mount pipe	127	(2) BXA-171063-12CF-EDIN-X w/ Mount Pipe	107
(2) TT19-08BP111-001 TMA	127	(2) BXA-171063-12CF-EDIN-X w/ Mount Pipe	107
(2) TT19-08BP111-001 TMA	127	9442 RRH2x40-AWS	107
(2) TT19-08BP111-001 TMA	127	9442 RRH2x40-AWS	107
DC6-48-60-18-8F Surge Arrestor	127	9442 RRH2x40-AWS	107
12.5 Low Profile Platform	127	9442 RRH2x40-07	107
AIR 21 B2A/B4P w/Mount Pipe	117	9442 RRH2x40-07	107
AIR 21 B2A/B4P w/Mount Pipe	117	9442 RRH2x40-07	107
AIR 21 B2A/B4P w/Mount Pipe	117	DB-B1-6C-SAB-02 Diplexer	107
AIR 21 B4A/B2P w/Mount Pipe	117	LP Platform	107

### MATERIAL STRENGTH

GRADE	Fy	Fu	GRADE	Fy	Fu
A572-65	65 ksi	80 ksi			

### TOWER DESIGN NOTES

1. Tower is located in New Haven County, Connecticut.
2. Tower designed for a 85 mph basic wind in accordance with the TIA/EIA-222-F Standard.
3. Tower is also designed for a 38 mph basic wind with 0.75 in ice. Ice is considered to increase in thickness with height.
4. Deflections are based upon a 50 mph wind.
5. TOWER RATING: 44.5%

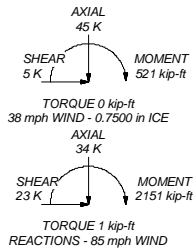

RADIO FREQUENCY EMISSIONS ANALYSIS REPORT  
EVALUATION OF HUMAN EXPOSURE POTENTIAL  
TO NON-IONIZING EMISSIONS

T-Mobile Existing Facility

Site ID: CT11443E

Gridcom Stonehart  
17 Cottage Street  
Madison, CT 06443

**February 25, 2014**

February 25, 2014

T-Mobile USA  
Attn: Jason Overbey, RF Manager  
35 Griffin Road South  
Bloomfield, CT 06002

Re: Emissions Values for Site: **CT11443E - Gridcom Stonehart**

EBI Consulting was directed to analyze the proposed T-Mobile facility located at 17 Cottage Street, Madison, CT, for the purpose of determining whether the emissions from the Proposed T-Mobile Antenna Installation located on this property are within specified federal limits.

All information used in this report was analyzed as a percentage of current Maximum Permissible Exposure (% MPE) as listed in the FCC OET Bulletin 65 Edition 97-01 and ANSI/IEEE Std C95.1. The FCC regulates Maximum Permissible Exposure in units of microwatts per square centimeter ( $\mu\text{W}/\text{cm}^2$ ). The number of  $\mu\text{W}/\text{cm}^2$  calculated at each sample point is called the power density. The exposure limit for power density varies depending upon the frequencies being utilized. Wireless Carriers and Paging Services use different frequency bands each with different exposure limits, therefore it is necessary to report results and limits in terms of percent MPE rather than power density.

All results were compared to the FCC (Federal Communications Commission) radio frequency exposure rules, 47 CFR 1.1307(b)(1) – (b)(3), to determine compliance with the Maximum Permissible Exposure (MPE) limits for General Population/Uncontrolled environments as defined below.

General population/uncontrolled exposure limits apply to situations in which the general public may be exposed or in which persons who are exposed as a consequence of their employment may not be made fully aware of the potential for exposure or cannot exercise control over their exposure. Therefore, members of the general public would always be considered under this category when exposure is not employment related, for example, in the case of a telecommunications tower that exposes persons in a nearby residential area.

Public exposure to radio frequencies is regulated and enforced in units of microwatts per square centimeter ( $\mu\text{W}/\text{cm}^2$ ). The general population exposure limit for the cellular band is  $567 \mu\text{W}/\text{cm}^2$ , and the general population exposure limit for the PCS and AWS bands is  $1000 \mu\text{W}/\text{cm}^2$ . Because each carrier will be using different frequency bands, and each frequency band has different exposure limits, it is necessary to report percent of MPE rather than power density.

Occupational/controlled exposure limits apply to situations in which persons are exposed as a consequence of their employment and in which those persons who are exposed have been made fully aware of the potential for exposure and can exercise control over their exposure. Occupational/controlled exposure limits also apply where exposure is of a transient nature as a result of incidental passage through a location where exposure levels may be above general population/uncontrolled limits (see below), as long as the exposed person has been made fully aware of the potential for exposure and can exercise control over his or her exposure by leaving the area or by some other appropriate means.

Additional details can be found in FCC OET 65.

## **CALCULATIONS**

Calculations were done for the proposed T-Mobile Wireless antenna facility located at 17 Cottage Street, Madison, CT, using the equipment information listed below. All calculations were performed per the specifications under FCC OET 65. Since T-Mobile is proposing highly focused directional panel antennas, which project most of the emitted energy out toward the horizon, the actual antenna pattern gain value in the direction of the sample area was used. For this report the sample point is a 6 foot person standing at the base of the tower

For all calculations, all equipment was calculated using the following assumptions:

- 1) 2 GSM channels (1935.000 MHz—to 1945.000 MHz / 1980.000 MHz—to 1985.000 MHz) were considered for each sector of the proposed installation.
- 2) 2 UMTS channels (2110.000 to 2120.000 MHz / 2140.000 MHz to 2145.000 MHz) were considered for each sector of the proposed installation.
- 3) 2 LTE channels (2110.000 to 2120.000 MHz / 2140.000 MHz to 2145.000 MHz) were considered for each sector of the proposed installation.
- 4) All radios at the proposed installation were considered to be running at full power and were uncombined in their RF transmissions paths per carrier prescribed configuration. Per FCC OET Bulletin No. 65 - Edition 97-01 recommendations to achieve the maximum anticipated value at each sample point, all power levels emitting from the proposed antenna installation are increased by a factor of 2.56 to account for possible in-phase reflections from the surrounding environment. This is rarely the case, and if so, is never continuous.
- 5) For the following calculations the sample point was the top of a six foot person standing at the base of the tower. The actual gain in this direction was used per the manufactures supplied specifications.
- 6) The antenna used in this modeling is the Ericsson AIR21 for LTE, UMTS and GSM. This is based on feedback from the carrier with regards to anticipated antenna selection. This antenna has a 15.6 dBd gain value at its main lobe. Actual antenna gain values were used for all calculations as per the manufacturers specifications

- 7) The antenna mounting height centerline of the proposed antennas is **117 feet** above ground level (AGL)
- 8) Emissions values for additional carriers were taken from the Connecticut Siting Council active database. Values in this database are provided by the individual carriers themselves.

All calculation were done with respect to uncontrolled / general public threshold limits



Site ID	CT11443E - Gridcom Stonehart
Site Address	17 Cottage Street, Madison, CT 06443
Site Type	Monopole

**Sector 1**

Antenna Number	Antenna Make	Antenna Model	Status	Frequency Band	Technology	Power Out Per Channel (Watts)	Number of Channels	Composite Power	Antenna Gain in direction of sample point (dBD)	Antenna Height (ft)	analysis height	Cable Size	Cable Loss (dB)	Additional Loss	ERP	Power Density Value	Power Density Percentage
1a	Ericsson	AIR21 B4A/B2P	Active	AWS - 2100 MHz	LTE	60	2	120	-3.95	117	111	None	0	0	48.326044	1.410072	0.14101%
1b	Ericsson	AIR21 B4A/B2P	Not Used	-	-			0	-3.95	117	111	None	0	0	0	0	0.00000%
2a	Ericsson	AIR21 B2A / B4P	Active	PCS - 1950 MHz	GSM / UMTS	30	2	60	-3.95	117	111	1-5/8"	0	0	24.163022	0.705036	0.07050%
2B	Ericsson	AIR21 B2A / B4P	Passive	AWS - 2100 MHz	UMTS	30	2	60	-3.95	117	111	1-5/8"	0	0	24.163022	0.705036	0.07050%

Sector total Power Density Value: 0.282%

**Sector 2**

Antenna Number	Antenna Make	Antenna Model	Status	Frequency Band	Technology	Power Out Per Channel (Watts)	Number of Channels	Composite Power	Antenna Gain in direction of sample point (dBD)	Antenna Height (ft)	analysis height	Cable Size	Cable Loss (dB)	Additional Loss	ERP	Power Density Value	Power Density Percentage
1a	Ericsson	AIR21 B4A/B2P	Active	AWS - 2100 MHz	LTE	60	2	120	-3.95	117	111	None	0	0	48.326044	1.410072	0.14101%
1b	Ericsson	AIR21 B4A/B2P	Not Used	-	-			0	-3.95	117	111	None	0	0	0	0	0.00000%
2a	Ericsson	AIR21 B2A / B4P	Active	PCS - 1950 MHz	GSM / UMTS	30	2	60	-3.95	117	111	1-5/8"	0	0	24.163022	0.705036	0.07050%
2B	Ericsson	AIR21 B2A / B4P	Passive	AWS - 2100 MHz	UMTS	30	2	60	-3.95	117	111	1-5/8"	0	0	24.163022	0.705036	0.07050%

Sector total Power Density Value: 0.282%

**Sector 3**

Antenna Number	Antenna Make	Antenna Model	Status	Frequency Band	Technology	Power Out Per Channel (Watts)	Number of Channels	Composite Power	Antenna Gain in direction of sample point (dBD)	Antenna Height (ft)	analysis height	Cable Size	Cable Loss (dB)	Additional Loss	ERP	Power Density Value	Power Density Percentage
1a	Ericsson	AIR21 B4A/B2P	Active	AWS - 2100 MHz	LTE	60	2	120	-3.95	117	111	None	0	0	48.326044	1.410072	0.14101%
1b	Ericsson	AIR21 B4A/B2P	Not Used	-	-			0	-3.95	117	111	None	0	0	0	0	0.00000%
2a	Ericsson	AIR21 B2A / B4P	Active	PCS - 1950 MHz	GSM / UMTS	30	2	60	-3.95	117	111	1-5/8"	0	0	24.163022	0.705036	0.07050%
2B	Ericsson	AIR21 B2A / B4P	Passive	AWS - 2100 MHz	UMTS	30	2	60	-3.95	117	111	1-5/8"	0	0	24.163022	0.705036	0.07050%

Sector total Power Density Value: 0.282%

Site Composite MPE %	
Carrier	MPE %
T-Mobile	0.846%
AT&T	10.730%
<b>Total Site MPE %</b>	<b>11.576%</b>

## Summary

All calculations performed for this analysis yielded results that were well within the allowable limits for general public exposure to RF Emissions.

The anticipated Maximum Composite contributions from the T-Mobile facility are **0.846% (0.282% from each sector)** of the allowable FCC established general public limit considering all three sectors simultaneously sampled at the ground level.

The anticipated composite MPE value for this site assuming all carriers present is **11.576%** of the allowable FCC established general public limit sampled at the ground level. This is based upon values listed in the Connecticut Siting Council database for existing carrier emissions.

FCC guidelines state that if a site is found to be out of compliance (over allowable thresholds), that carriers over a 5% contribution to the composite value will require measures to bring the site into compliance. For this facility, the composite values calculated were within the allowable 100% threshold standard per the federal government.



Scott Heffernan  
RF Engineering Director

**EBI Consulting**  
21 B Street  
Burlington, MA 01803

(E) T-MOBILE PANEL ANTENNAS  
TYP. OF (2) PER SECTOR, (6)  
TOTAL TO BE REMOVED

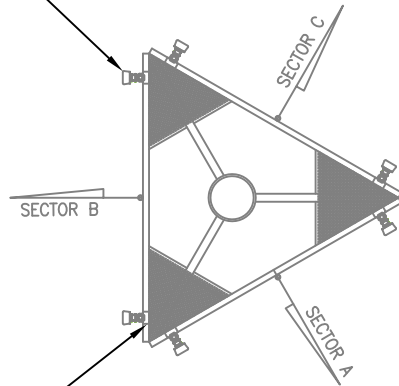

(E) TMA'S TO BE  
REMOVED, TYP. OF (2)  
PER SECTOR, (6) TOTAL

**1 EXISTING ANTENNA PLAN**  
SCALE: 1/8"=1'-0"

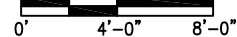

EXISTING ANTENNA SCHEDULE				
SECTOR	MAKE	MODEL#	SIZE (INCHES)	
SECTOR A:	RFS	APXV18_209014	6.65x3.15x53.0	
	RFS	APXV18_209014	6.65x3.15x53.0	
SECTOR B:	RFS	APXV18_209014	6.65x3.15x53.0	
	RFS	APXV18_209014	6.65x3.15x53.0	
SECTOR C:	RFS	APXV18_209014	6.65x3.15x53.0	
	RFS	APXV18_209014	6.65x3.15x53.0	

  

PROPOSED ANTENNA SCHEDULE				
SECTOR	MAKE	MODEL#	SIZE (INCHES)	
SECTOR A:	ERICSSON	AIR21 B2A/B4P	12x8x56	
	ERICSSON	AIR21 B4A/B2P	12x8x56	
SECTOR B:	ERICSSON	AIR21 B2A/B4P	12x8x56	
	ERICSSON	AIR21 B4A/B2P	12x8x56	
SECTOR C:	ERICSSON	AIR21 B2A/B4P	12x8x56	
	ERICSSON	AIR21 B4A/B2P	12x8x56	

**NOTE:**  
1. REFER TO FINAL RF DATA SHEET FOR FINAL  
ANTENNA SETTINGS.

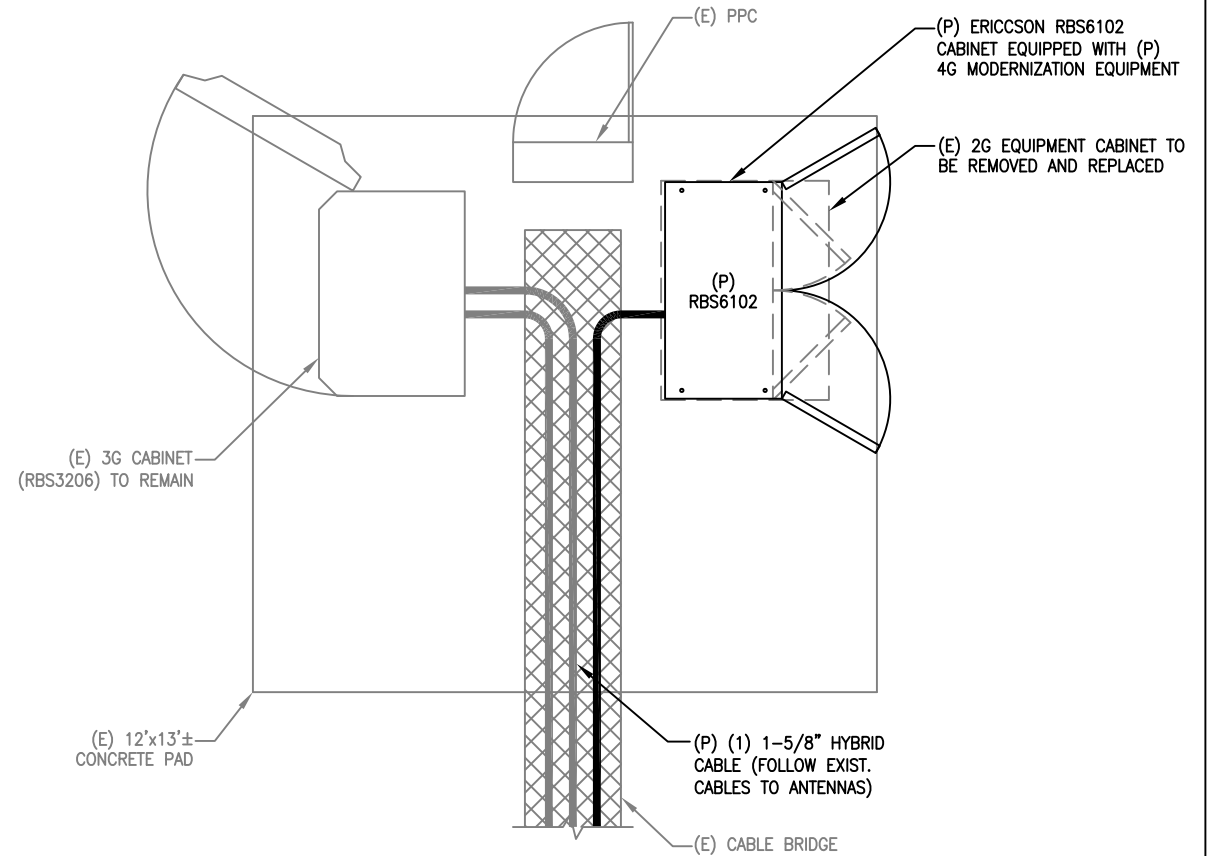

**3 PROPOSED EQUIPMENT PLAN**  
SCALE: 1/4"=1'-0"

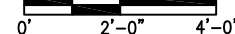

\*(P) T-MOBILE PANEL  
ANTENNAS TO BE  
MOUNTED TO (E) PIPES  
TYP. OF (2) PER  
SECTOR, (6) TOTAL

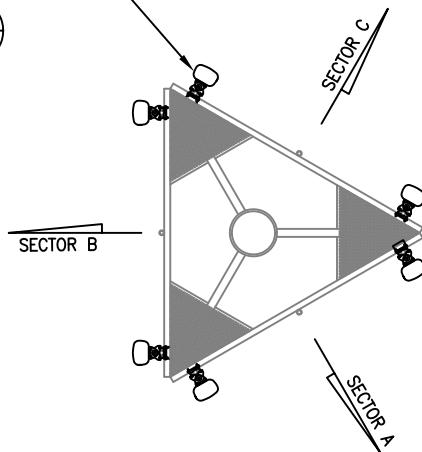

**\* SPECIAL INSTALLATION NOTE:**  
PROPOSED ANTENNAS SHALL BE  
VERTICALLY CENTERED ON EXISTING  
PLATFORM RAIL. ADJUST ANTENNA  
MOUNTING PIPE AS REQUIRED.

**2 PROPOSED ANTENNA PLAN**  
SCALE: 1/8"=1'-0"

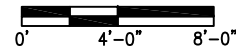

**4 EXISTING EQUIPMENT AREA.**  
N.T.S.

(E) 2G EQUIPMENT CABINET TO BE  
REMOVED AND REPLACED W/ (P) ERICSSON  
RBS6102 CABINET EQUIPPED WITH (P) 4G  
MODERNIZATION EQUIPMENT



*Marc R. Chretien*

