

Mount Analysis Report

Site Address	244 Gates Rd Lebanon, CT 06249
Site Name	CTNL125A
Site ID	CTNL125A
Project Name	Coverage Strategy
Design Codes	2015 International Building Code ASCE 7-10 TIA-222-G Standards 2018 CT State Building Code

	Stress Ratio	Overall Result
Proposed Mount	55%	PASS

Client:

T - Mobile
NORTHEAST, LLC
35 Griffin Rd S
Bloomfield, CT 06002

Date: 9/28/2021

Scope of Work:

Centerline Communications was authorized by T-Mobile Northeast LLC to perform an analysis of the proposed antenna mounts to determine their capacity to support the proposed T-Mobile equipment listed in this report. These mounts were analyzed using RISA 3D v17.0.4.

Final Appurtenances Configuration:

Elevation (ft)	Position ¹	Azimuth (degrees)	Quantity	Appurtenance	Sector
109	MP1	30	1	APX16DWV-16DWV-S-E-A20 Antenna	Sector 1
109	MP2	30	1	APXVAALL24_43-U-NA20 Antenna	
109	MP3	30	1	AIR6449 B41 Antenna	
109	MP1	30	1	4460 B25+B66 RRH	
109	MP2	30	1	4480 B71+B85 RRH	
109	-	160	1	APX16DWV-16DWV-S-E-A20 Antenna	Sector 2
109	-	160	1	APXVAALL24_43-U-NA20 Antenna	
109	-	160	1	AIR6449 B41 Antenna	
109	-	160	1	4460 B25+B66 RRH	
109	-	160	1	4480 B71+B85 RRH	
109	-	270	1	APX16DWV-16DWV-S-E-A20 Antenna	Sector 3
109	-	270	1	APXVAALL24_43-U-NA20 Antenna	
109	-	270	1	AIR6449 B41 Antenna	
109	-	270	1	4460 B25+B66 RRH	
109	-	270	1	4480 B71+B85 RRH	

Notes:

1. MP represent Mount Pipe.
2. Existing Appurtenance
3. **Proposed Appurtenance**

Design Criteria:

Design Codes:

2015 International Building Code
 ASCE 7-10
 TIA-222-G Standards
 2018 CT State Building Code

Ultimate Wind Speed	130 mph
Nominal Wind Speed	101 mph
Wind Speed with Ice	50 mph
Ice Thickness	0.75 in.
Exposure Category	B
Topographic Category	1
Structure Class	II
Site Soil Class (Assumed)	D-Stiff Soil
Seismic Design Category	B
Spectral Response Acceleration Parameter at a Short Periods, S_s	0.173 g
Spectral Response Acceleration Parameter at a Period of 1 Second, S_1	0.062 g
Short Period Site Coefficient, F_a	1.6
Long Period Site Coefficient, F_v	2.4

*Refer to calculations for additional design criteria.

Conclusion:

Based on the results of the analysis, we have determined that the proposed T-Mobile mounts are adequate to support the proposed T-Mobile equipment loading.

- Install (3) Site Pro 1 VFA12-HD mount.

	Stress Ratio	Overall Result
Proposed Mount	55%	PASS

Reference Documents:

- T-Mobile RFDS CTNL125A_Coverage Strategy_1_draft, dated 07/12/2021
- Construction Drawings by Centerline Communications, LLC, dated 07/22/2021
- Structural Analysis by Fullerton Engineering Consultants, Inc, dated 12/07/2017

Assumptions and Limitations:

- The calculations performed by Centerline Communications are limited to the structural members in these calculations only.
- Structural calculations in this report do not check the adequacy of the supporting structure, other mounts, or coax mounting attachments.
- The calculation assumes all structural members to be in good condition i.e. no damage, rust, or other defects.

Site Photos:



Overall Tower

Design Calculations



Site Details	
Site Name	CTNL125A
Carrier	T-Mobile
City, State	Lebanon, CT
Project	Coverage Strategy

Mount Details	
Mount Type	Sector Frame
Mount Height, z	109 ft
Number of Sectors	3
Tower Type	SST
Tower Height, h	121 ft

Topographic Factors	
Topographic Category	1
Feature	Flat
Crest Height, H	N/A ft
Distance from Crest, x	N/A ft
Slope (H/L)	N/A
Topographic Factor, K_{zt}	1.00

Seismic Factors	
Importance Factor, I_E	1
Short Period Spectral Acceleration, S_s	0.173 g
1 Second Period Spectral Acceleration, S_1	0.062 g
Long-Period Transition Period, T_L	6
Design Category	B
Short Period Site Coefficient, F_a	1.60
Long-Period Site Coefficient, F_v	2.4

Site Parameters	
Ultimate Wind Speed, V_{ULT}	130 mph
Nominal Wind Speed, V	101 mph
Wind Speed with Ice, V_i	50 mph
Design Ice Thickness, t_i	0.75 in
Structural Class	II
Exposure Category	B
Site Soil Class	D-Stiff Soil (Assumed)

Code	
Building Code	2015 IBC
TIA Code	TIA-222-G
ASCE Code	7-10

Site Constants	
Importance Factor, I (Wind no Ice)	1.00
Importance Factor, I (Ice Thickness)	1.00
Importance Factor, I (wind with Ice)	1.00
Wind Direction Prob. Factor, K_d	0.95
Velocity Pressure Coefficient, K_z	1.01
Gust Effect Factor, G_h	1.00
Design Ice Thickness, t_{iz}	1.69 in
Velocity Pressure, q_z	25.13 psf
Velocity Pressure with Ice, q_{zi}	6.16 psf
Shielding Factor, K_a	1.00
Flat Velocity Pressure (Ca = 2.0)	50.26 psf
Round Velocity Pressure (Ca = 1.2)	30.15 psf
Round Velocity Pressure with Ice (Ca = 1.2)	7.39 psf
Engineer Initials	AP

Proposed Mount Results



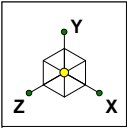

Install (3) Site Pro 1
VFA12-HD mount

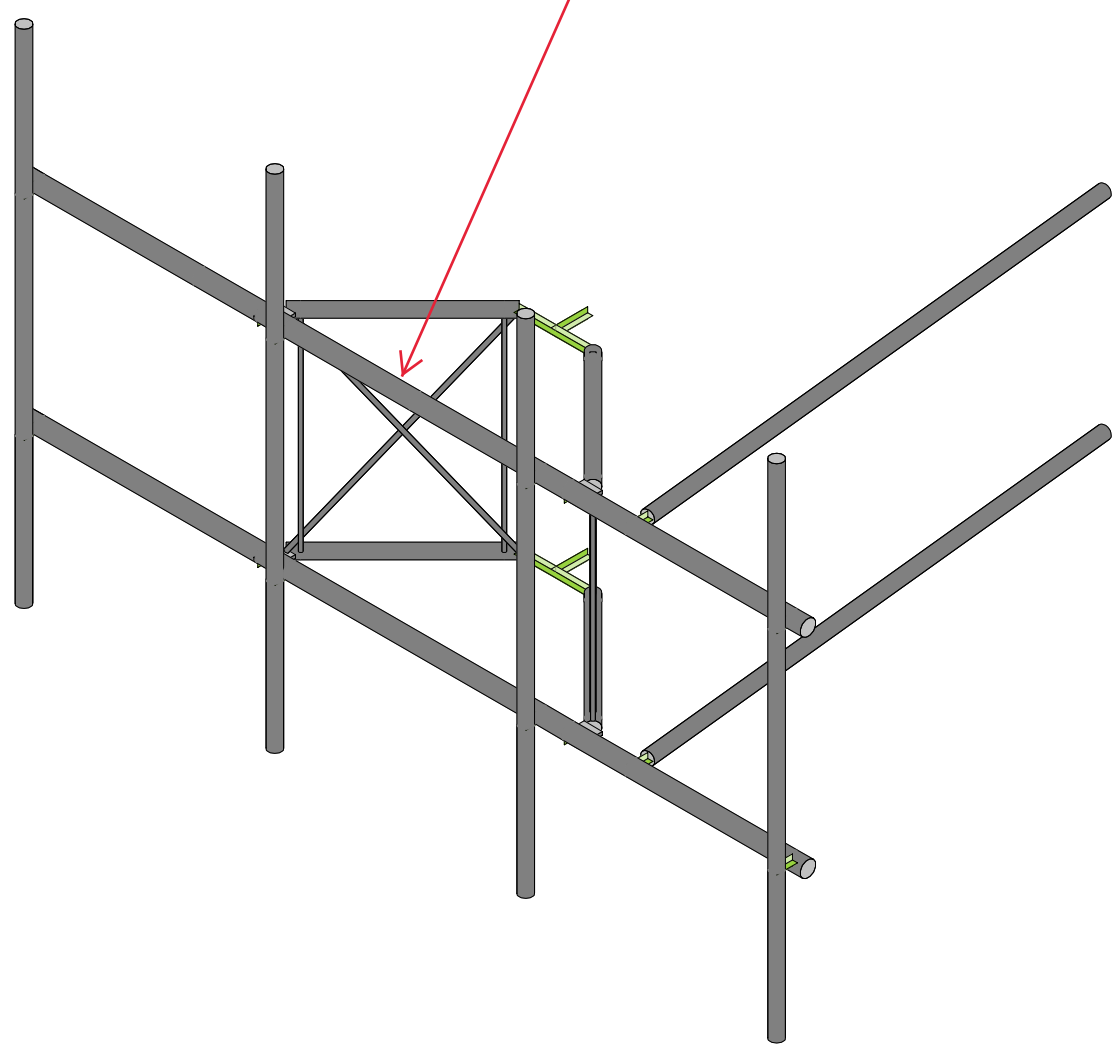

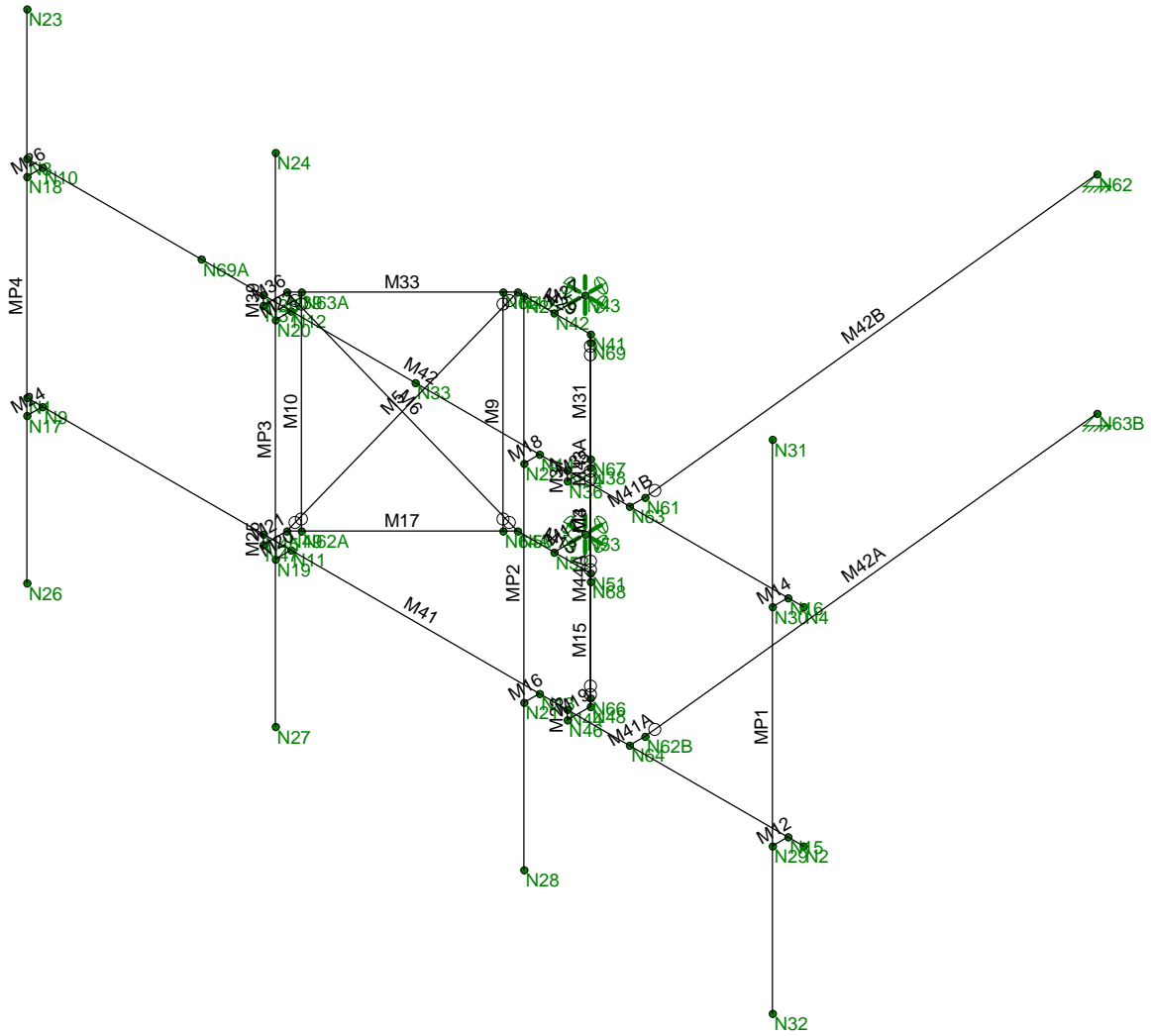
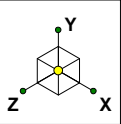

Centerline Communication...	CTNL125A_MA	Wireframe
AP		Sept 27, 2021 at 12:01 PM
		CTNL125A_MA.r3d

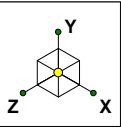

Section Sets	
█	Face Horizontal
█	Standoff
█	Bracing (Vert)
█	Connection Plate
█	Tieback
█	Bracing (Diag)
█	RIGID

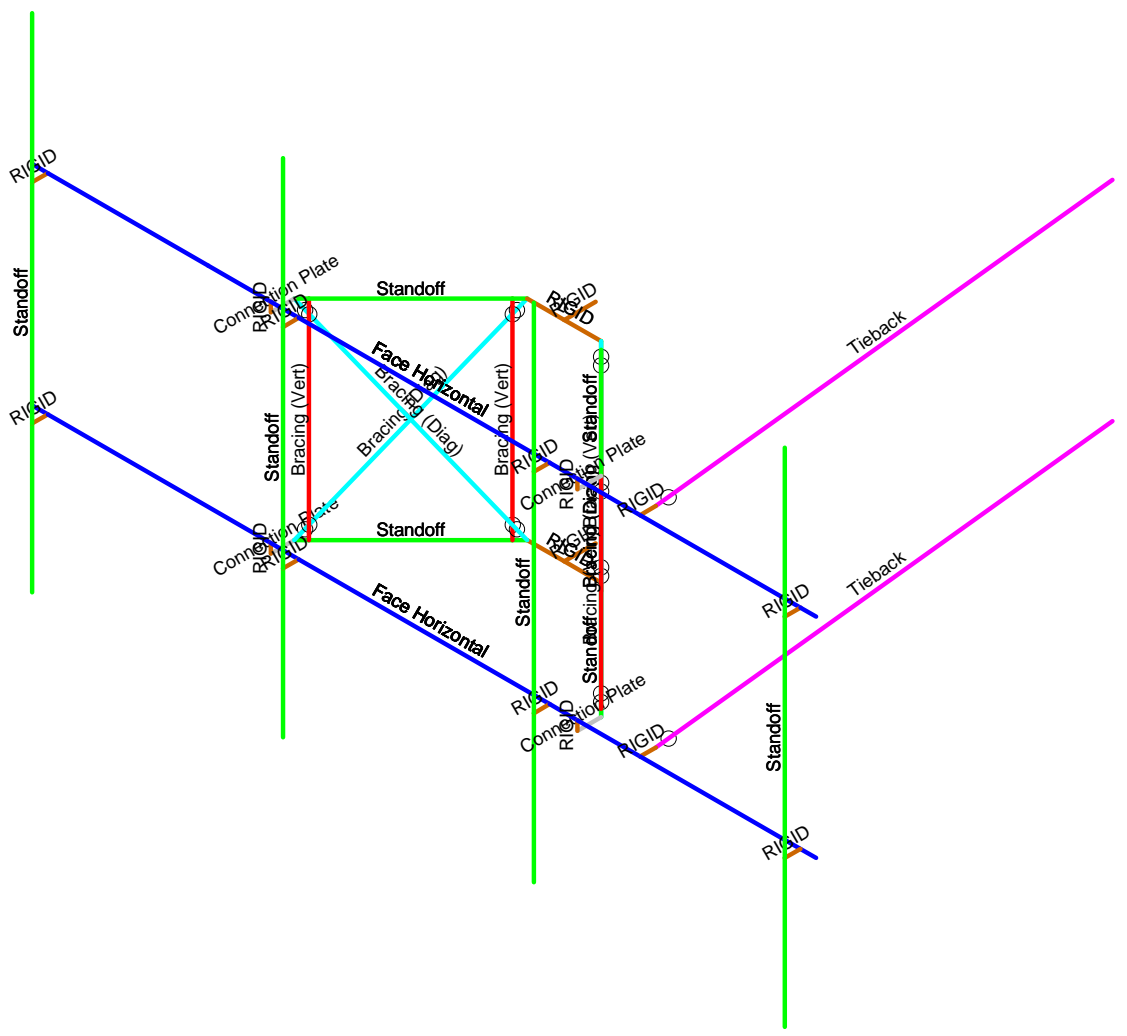

Centerline Communication...
AP

CTNL125A_MA

Section Sets
Sept 27, 2021 at 12:01 PM
CTNL125A_MA.r3d

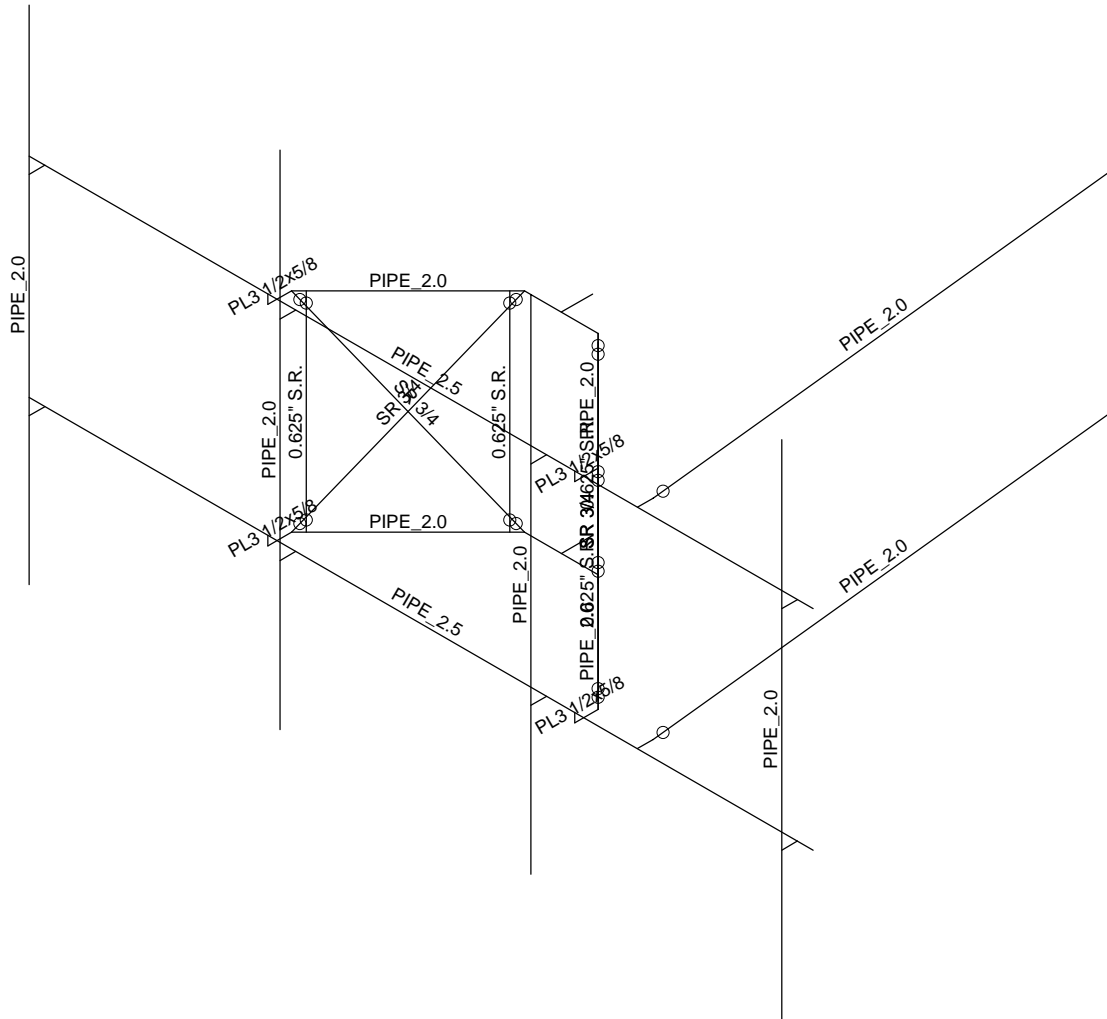
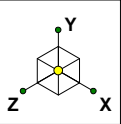

Centerline Communication...

AP

CTNL125A_MA

Member Shape

Sept 27, 2021 at 12:02 PM

CTNL125A_MA.r3d

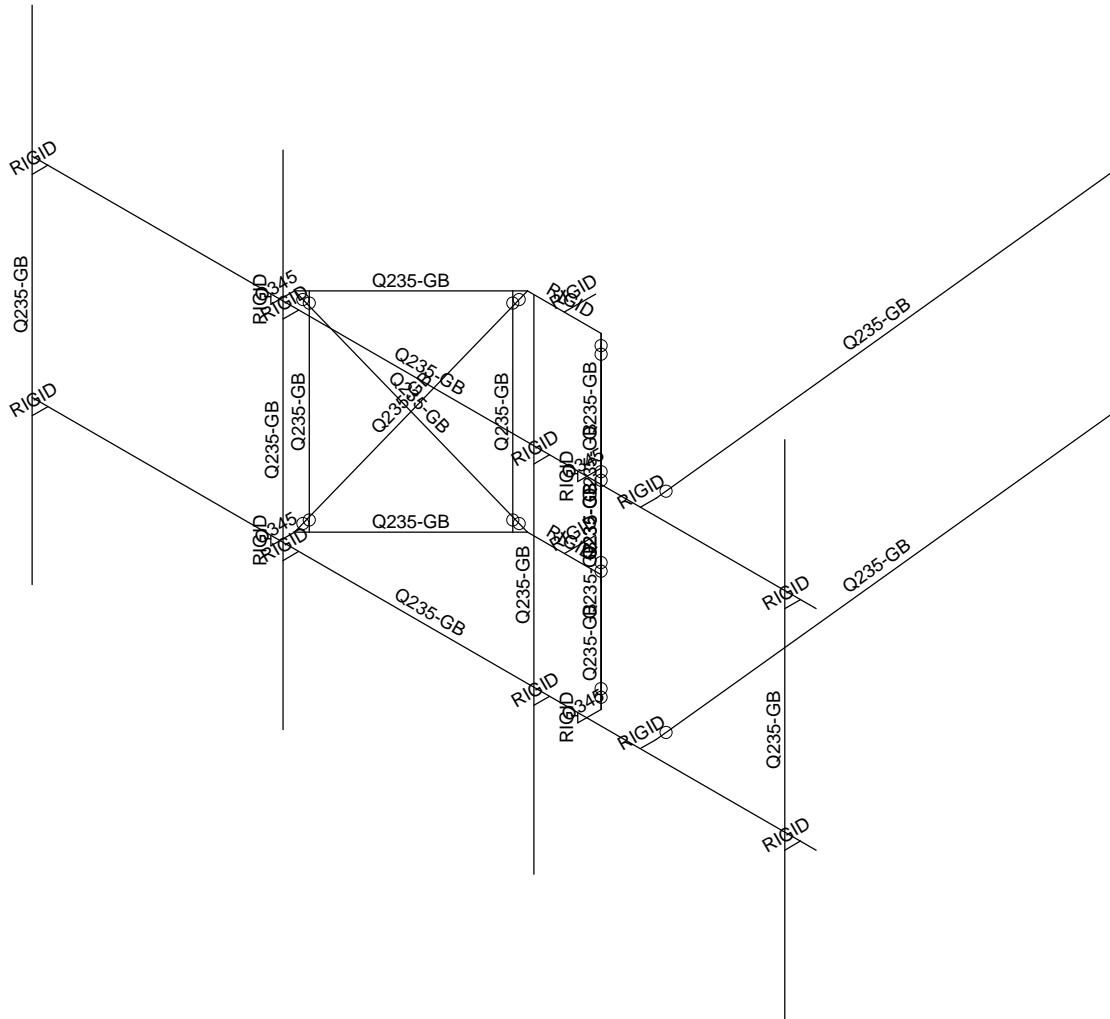
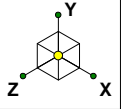

Centerline Communication...

AP

CTNL125A_MA

Material Sets

Sept 27, 2021 at 12:02 PM

CTNL125A_MA.r3d

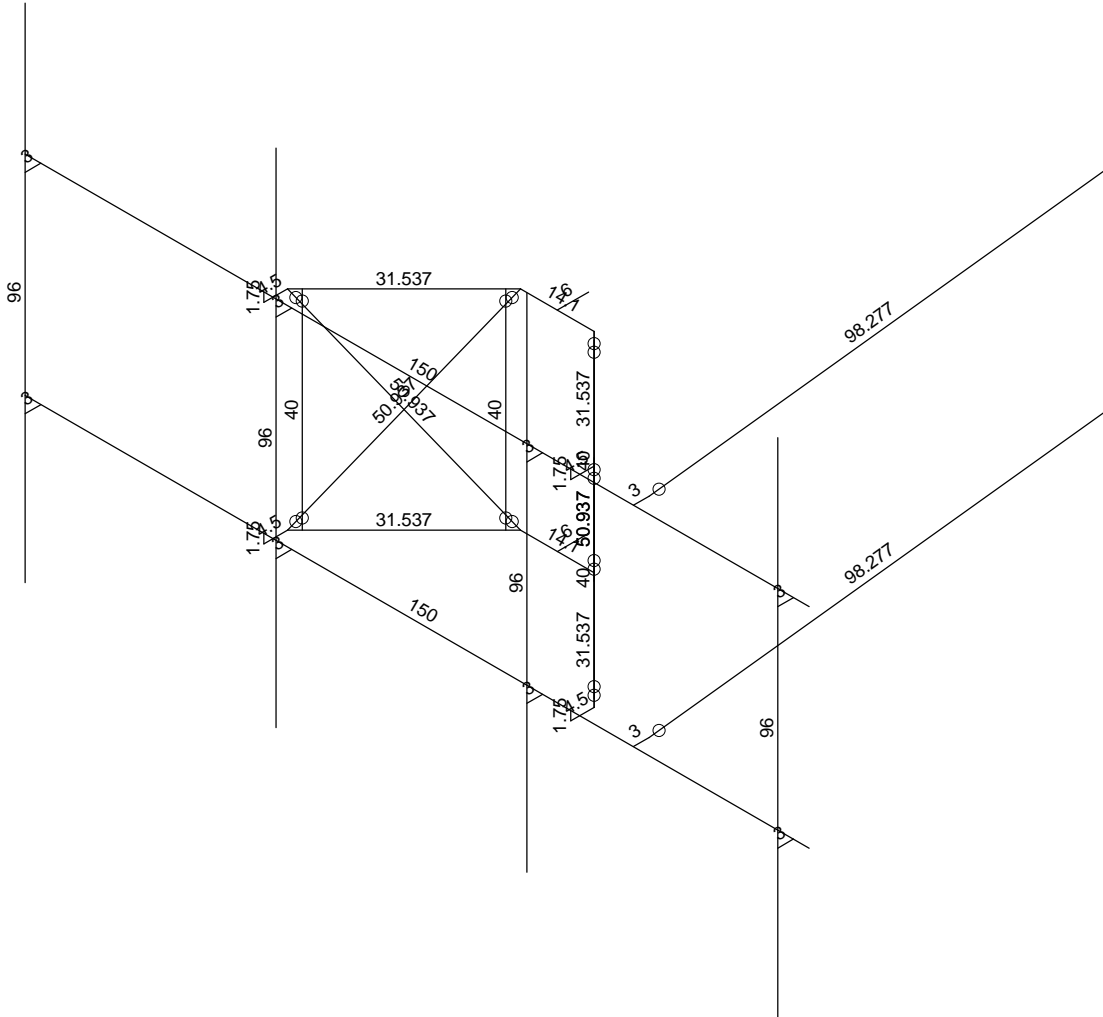
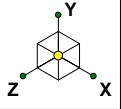

Member Length (in) Displayed

Centerline Communication...	CTNL125A_MA	Member Length
AP		Sept 27, 2021 at 12:02 PM
		CTNL125A_MA.r3d

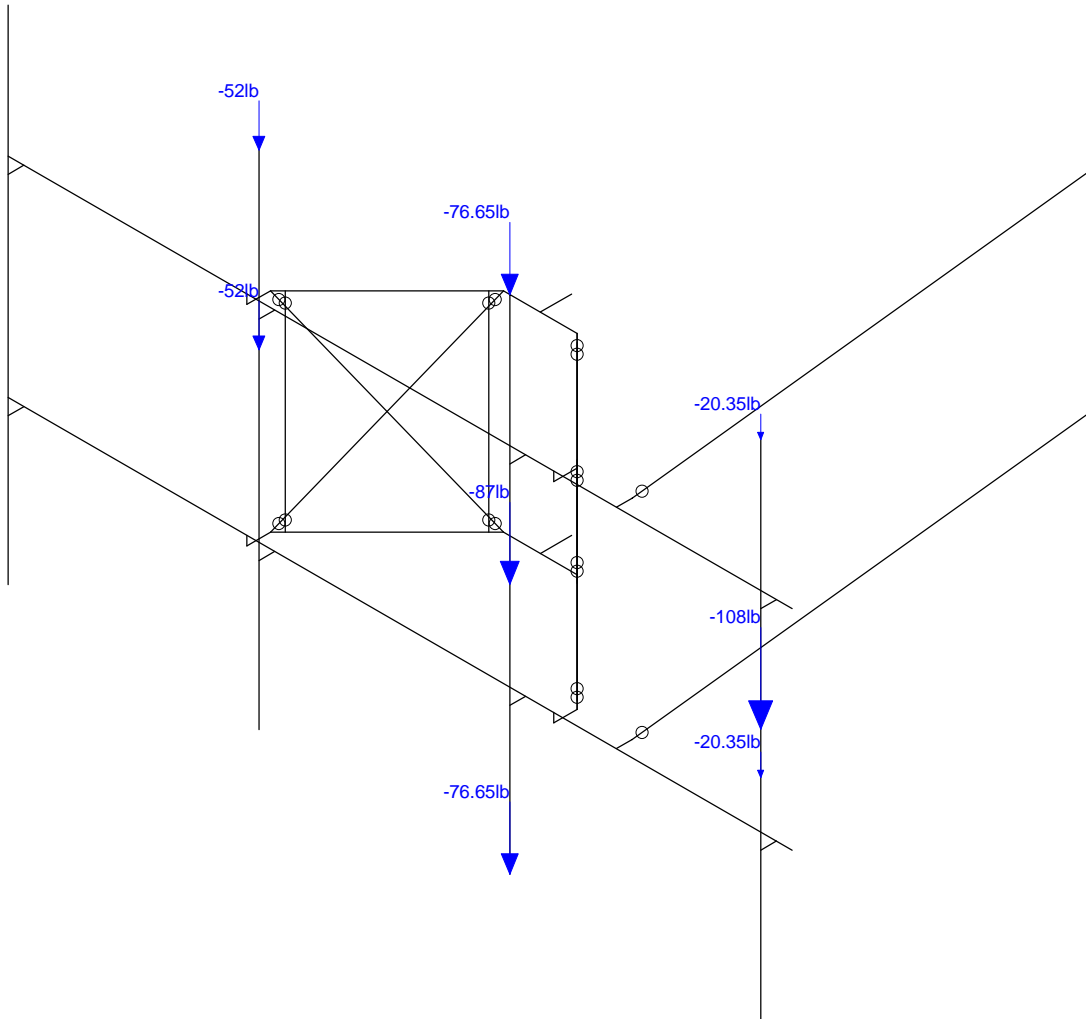
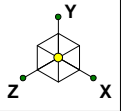

Loads: BLC 1, Dead Load

Centerline Communication...	CTNL125A_MA	Dead Load
AP		Sept 27, 2021 at 12:02 PM
		CTNL125A_MA.r3d

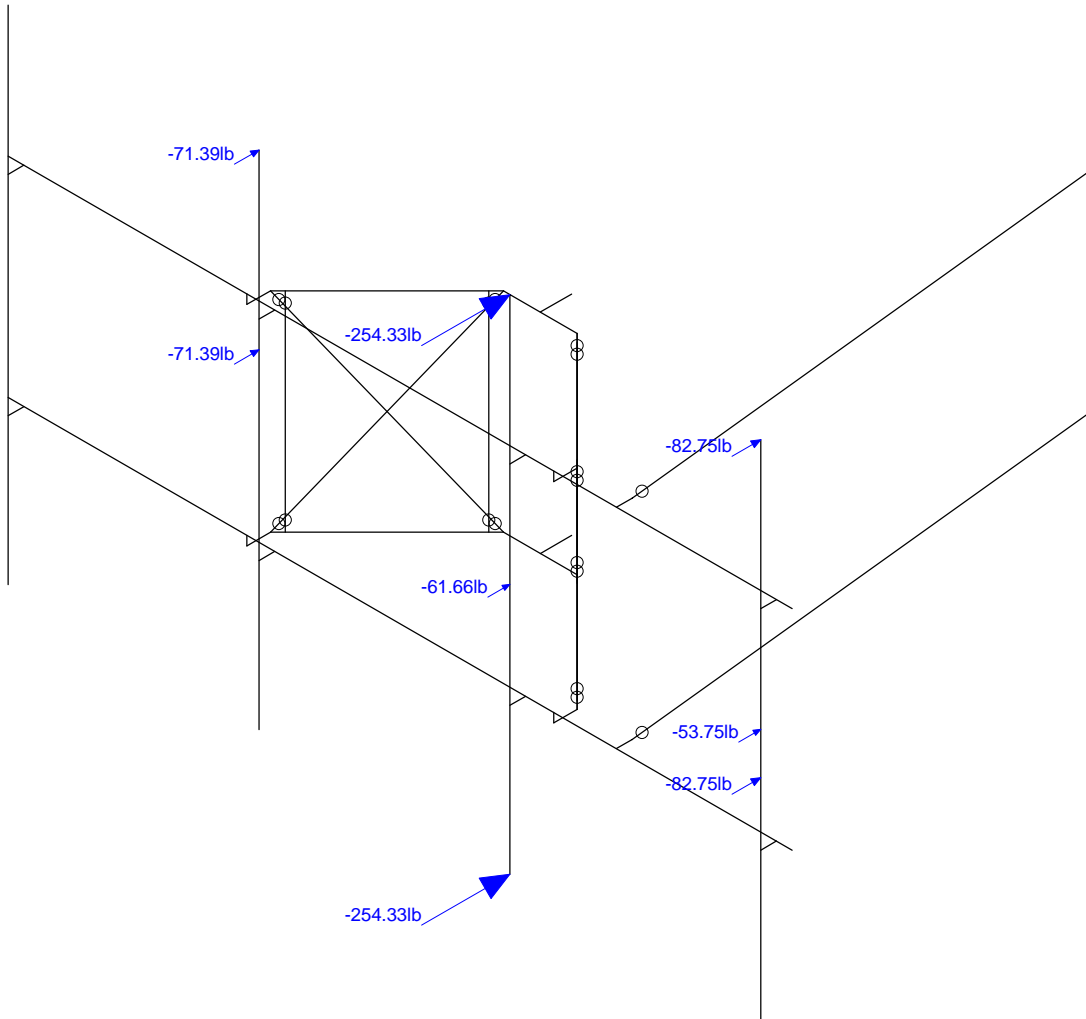
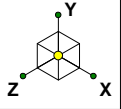

Loads: BLC 2, Wind 0

Centerline Communication...		Wind 0
AP	CTNL125A_MA	Sept 27, 2021 at 12:03 PM
		CTNL125A_MA.r3d

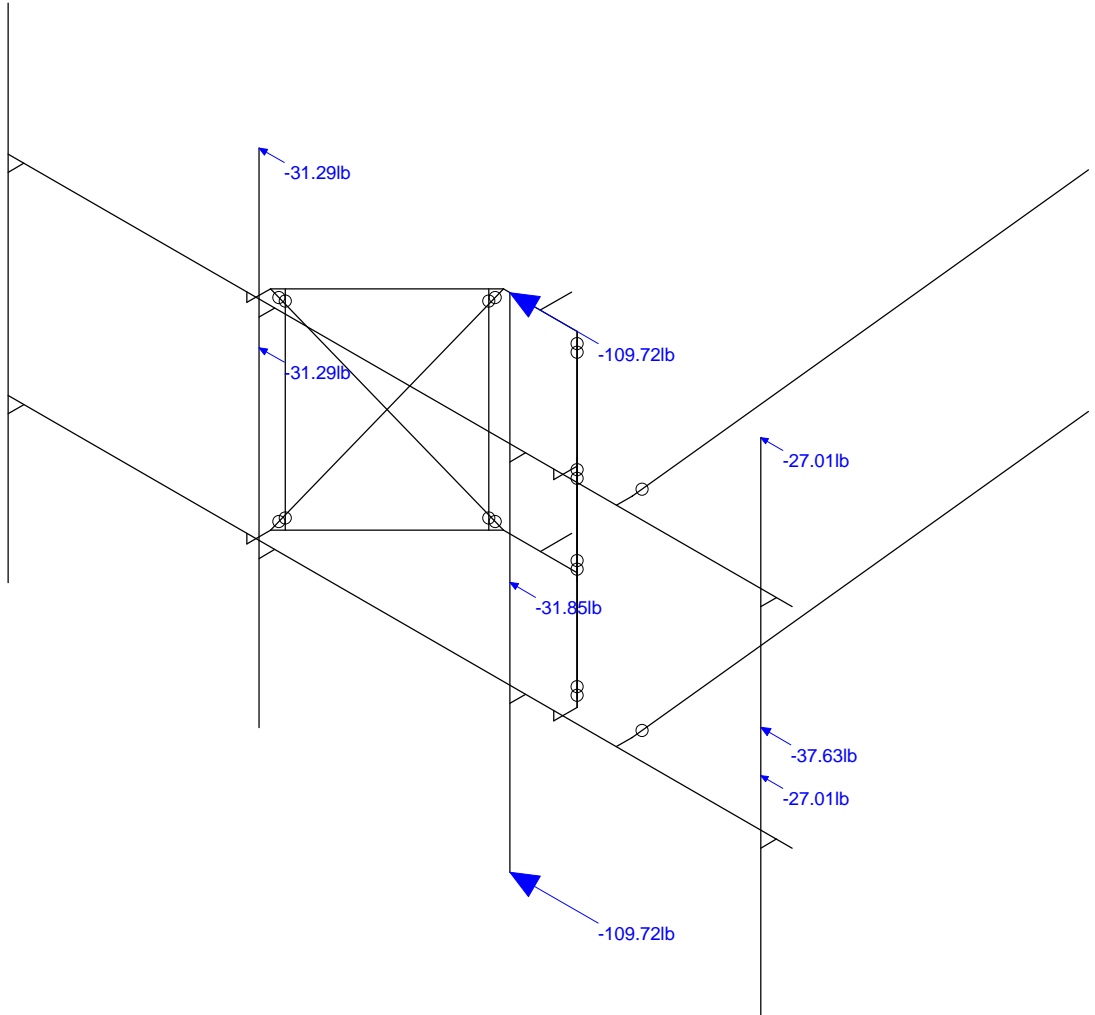
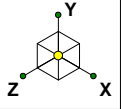

Loads: BLC 5, Wind 90

Centerline Communication...

AP

CTNL125A_MA

Wind 90

Sept 27, 2021 at 12:03 PM

CTNL125A_MA.r3d

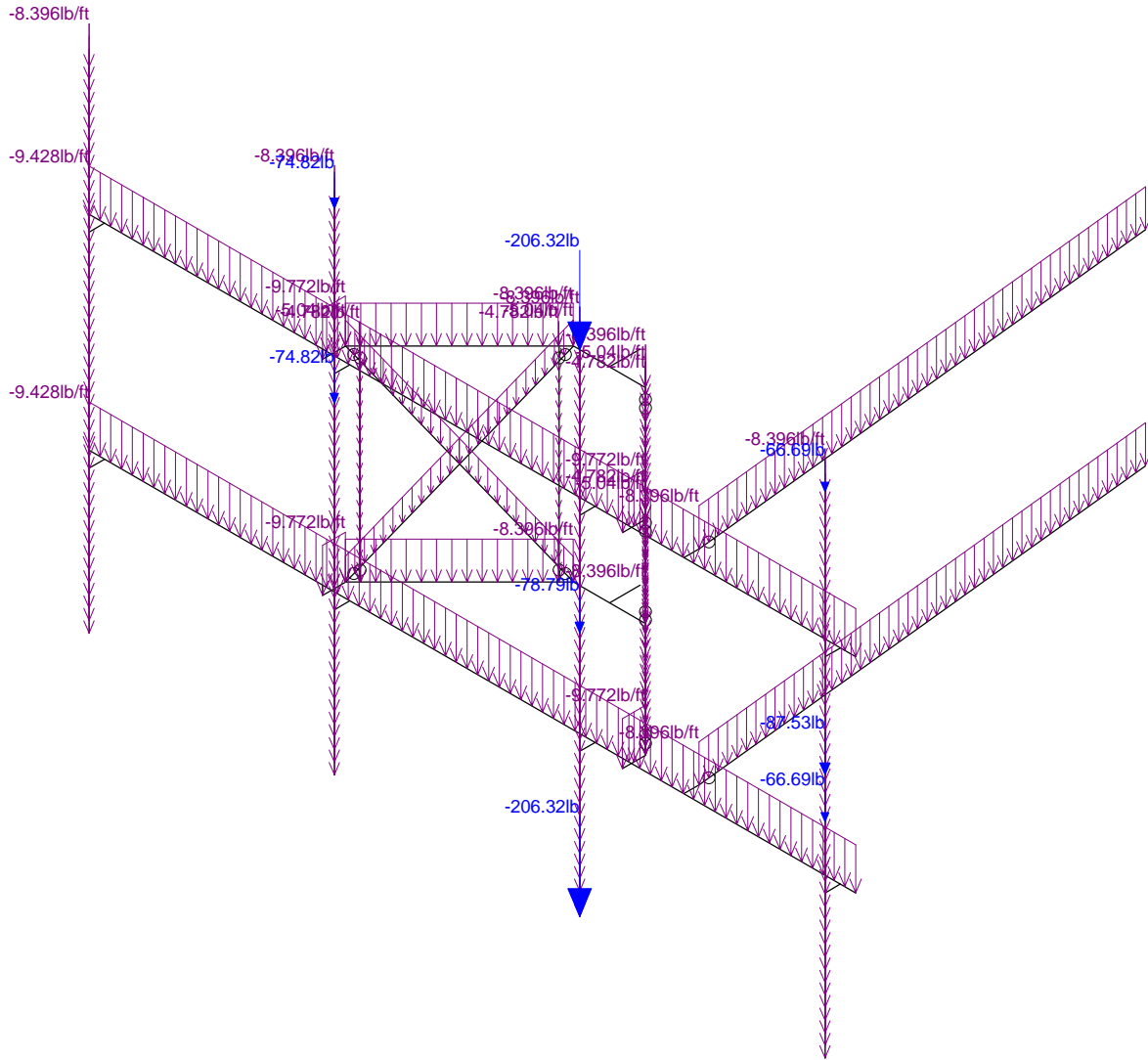
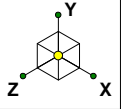

Loads: BLC 9, Ice Weight

Centerline Communication...

AP

CTNL125A_MA

Ice Weight

Sept 27, 2021 at 12:03 PM

CTNL125A_MA.r3d

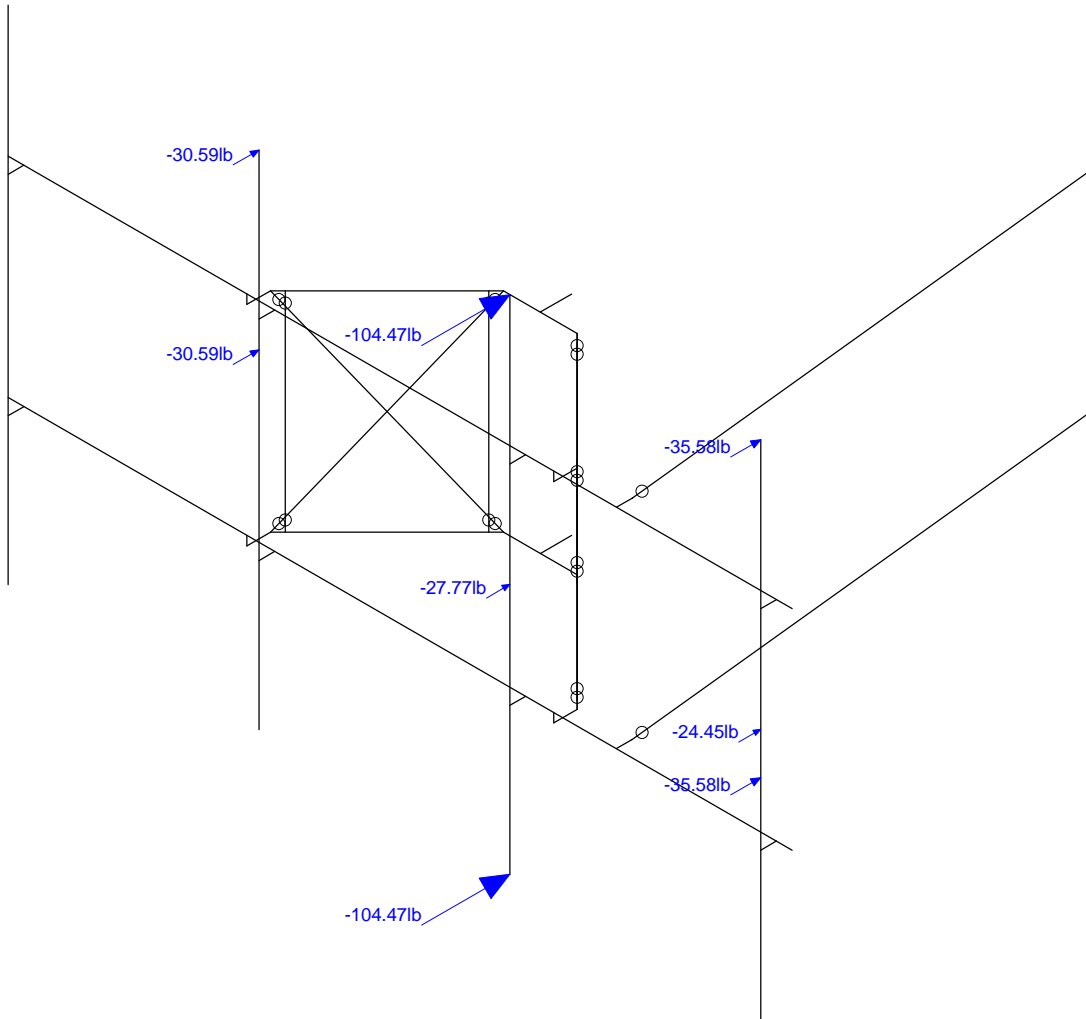
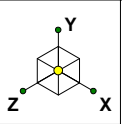

Loads: BLC 10, Ice + Wind 0

Centerline Communication...

AP

CTNL125A_MA

Ice + Wind 0

Sept 27, 2021 at 12:03 PM

CTNL125A_MA.r3d

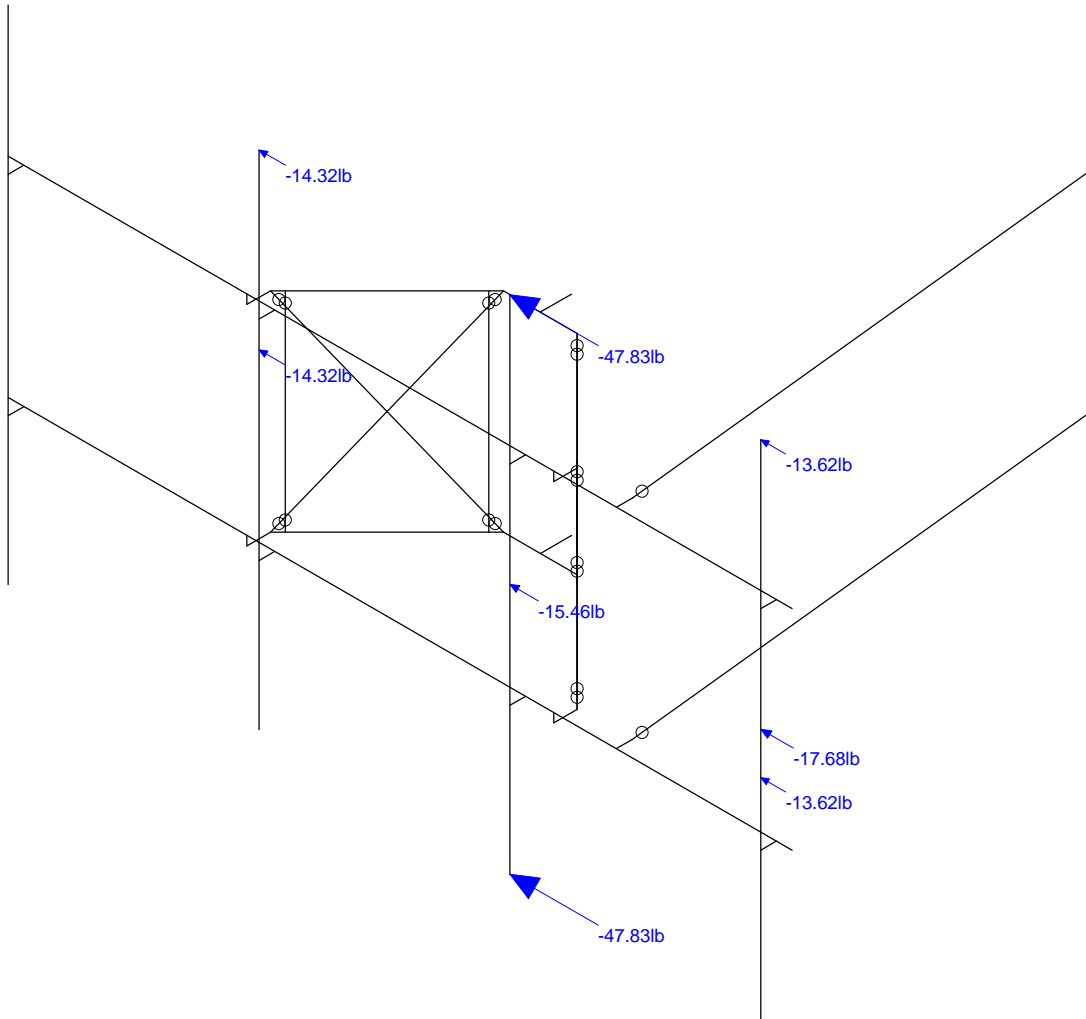
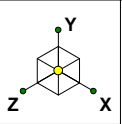

Loads: BLC 13, Ice + Wind 90

Centerline Communication...
AP

CTNL125A_MA

Ice + Wind 90
Sept 27, 2021 at 12:03 PM
CTNL125A_MA.r3d

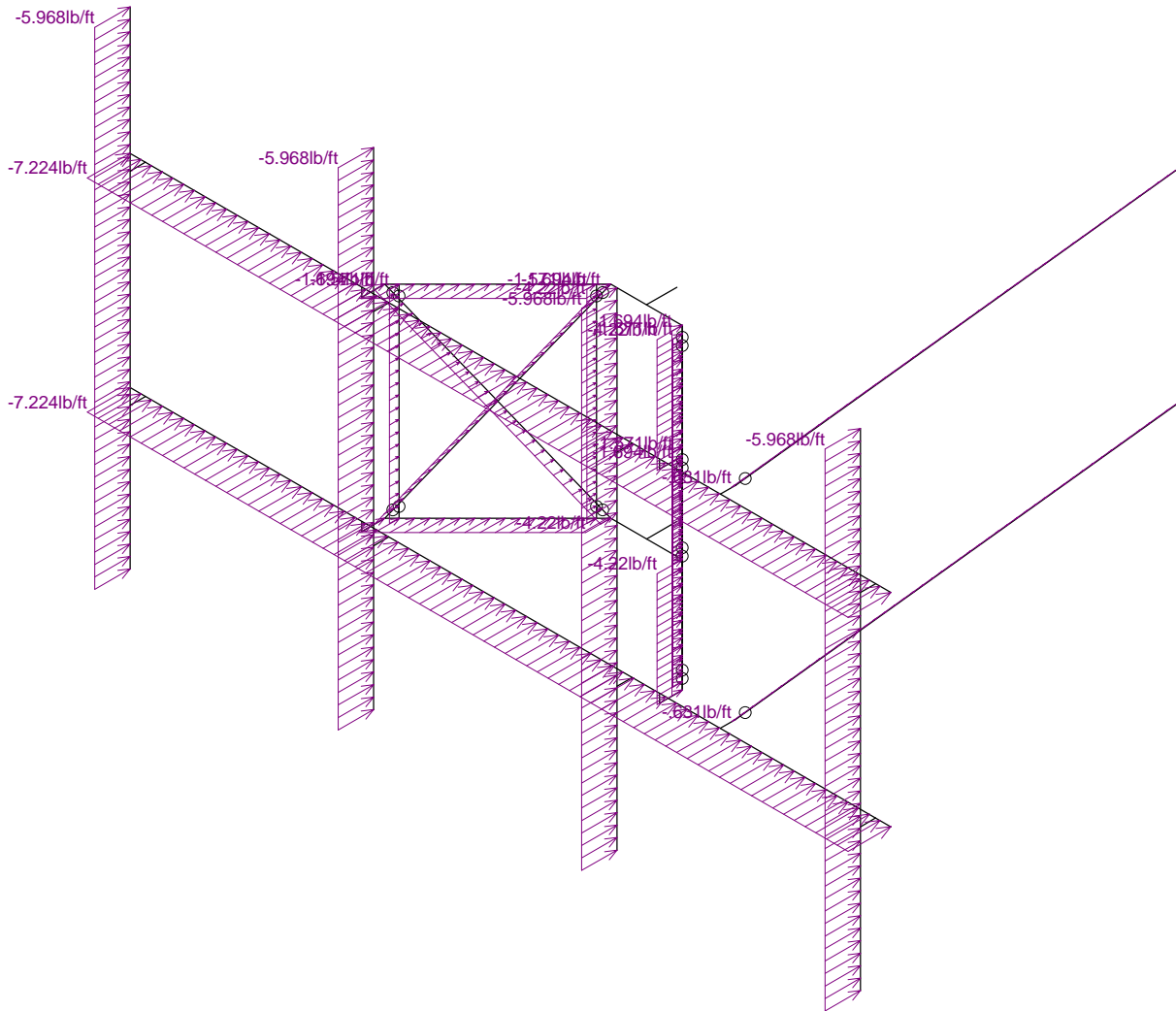
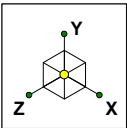

Loads: BLC 17, Distri. Wind Z

Centerline Communication...		Distr. Wind 0
AP	CTNL125A_MA	Sept 27, 2021 at 12:04 PM
		CTNL125A_MA.r3d

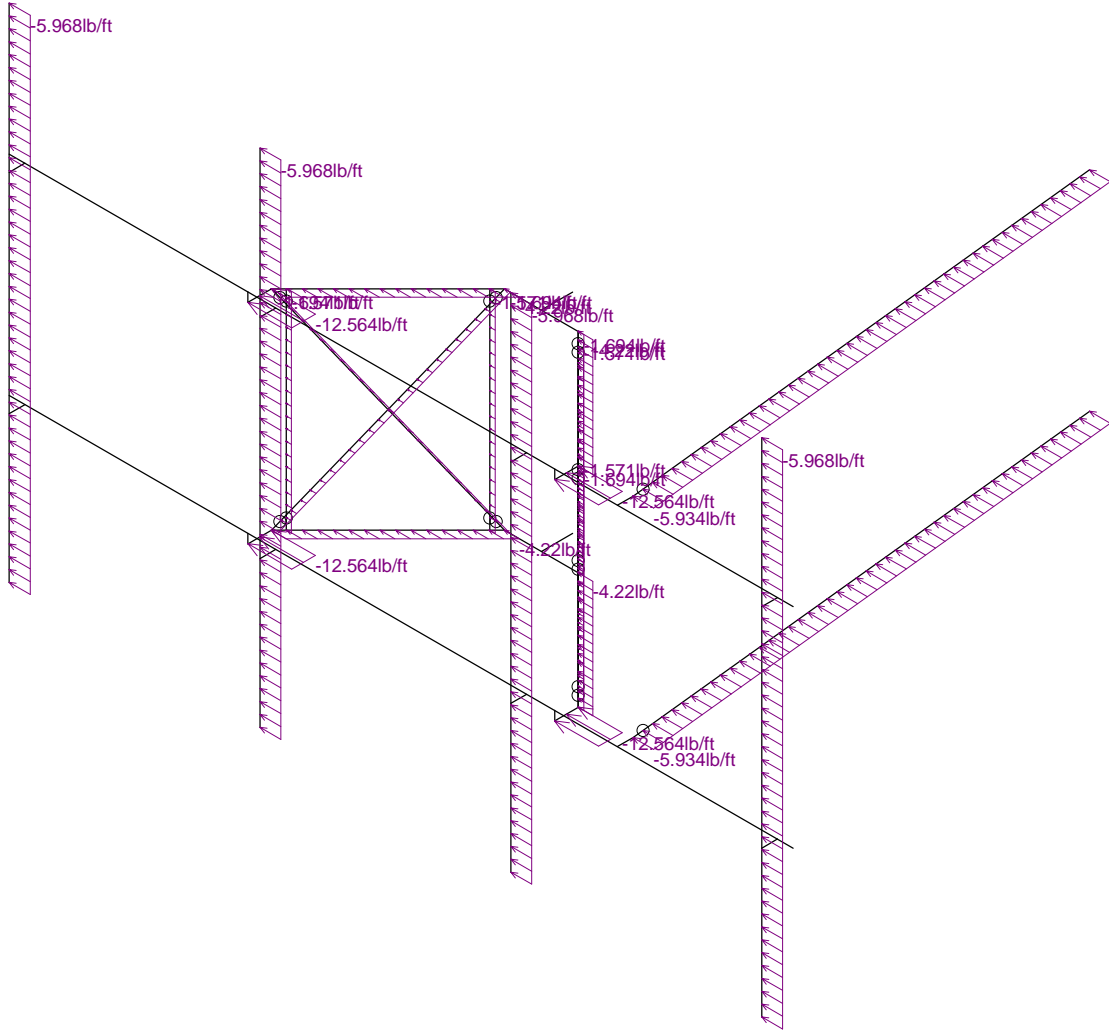
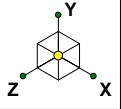

Loads: BLC 18, Distri. Wind X

Centerline Communication...

AP

CTNL125A_MA

Distr. Wind 90

Sept 27, 2021 at 12:04 PM

CTNL125A_MA.r3d

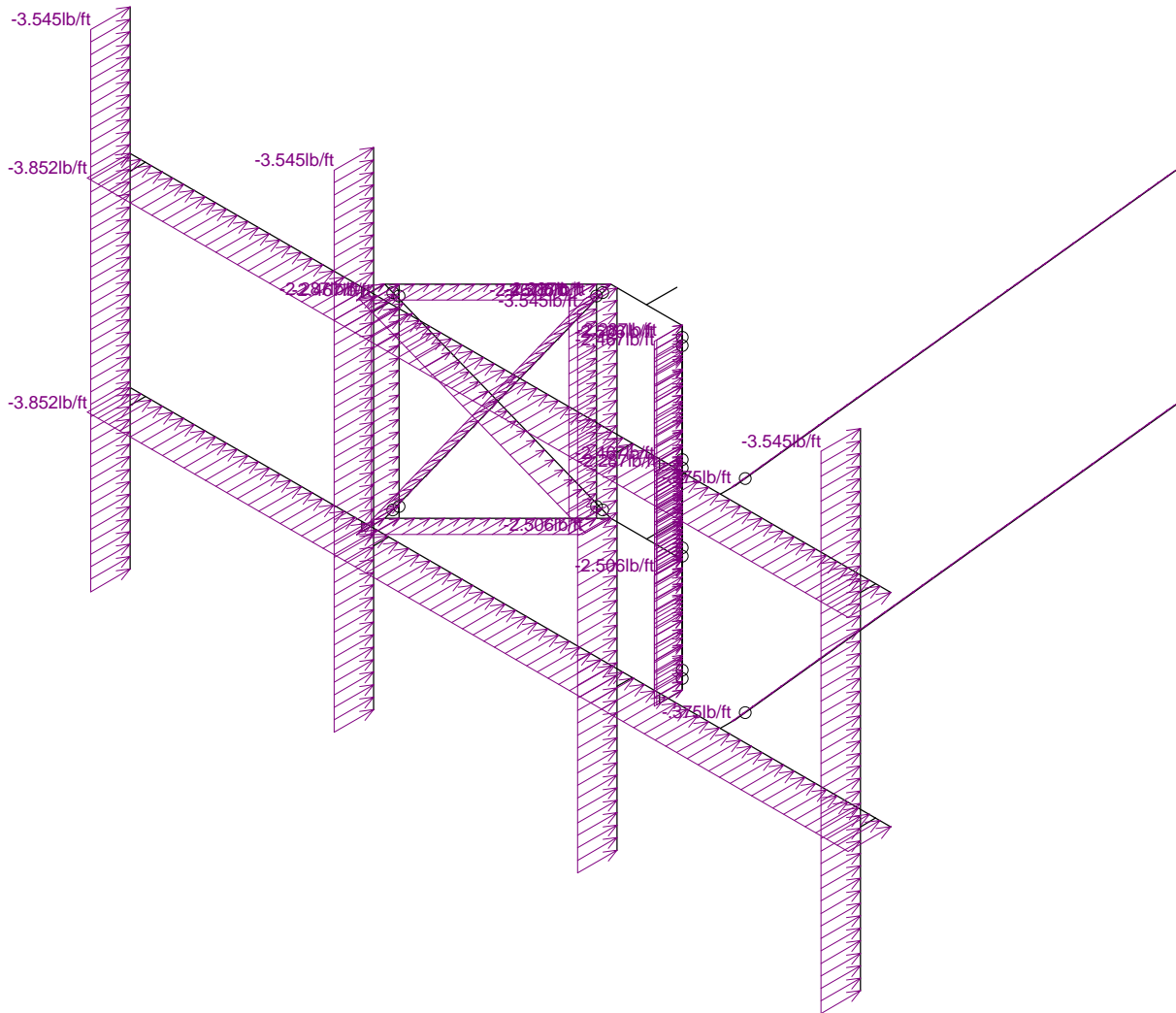
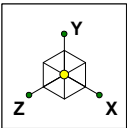

Loads: BLC 19, Distri. Ice + Wind Z

Centerline Communication...		Distr. Ice + Wind 0
AP	CTNL125A_MA	Sept 27, 2021 at 12:04 PM
		CTNL125A_MA.r3d

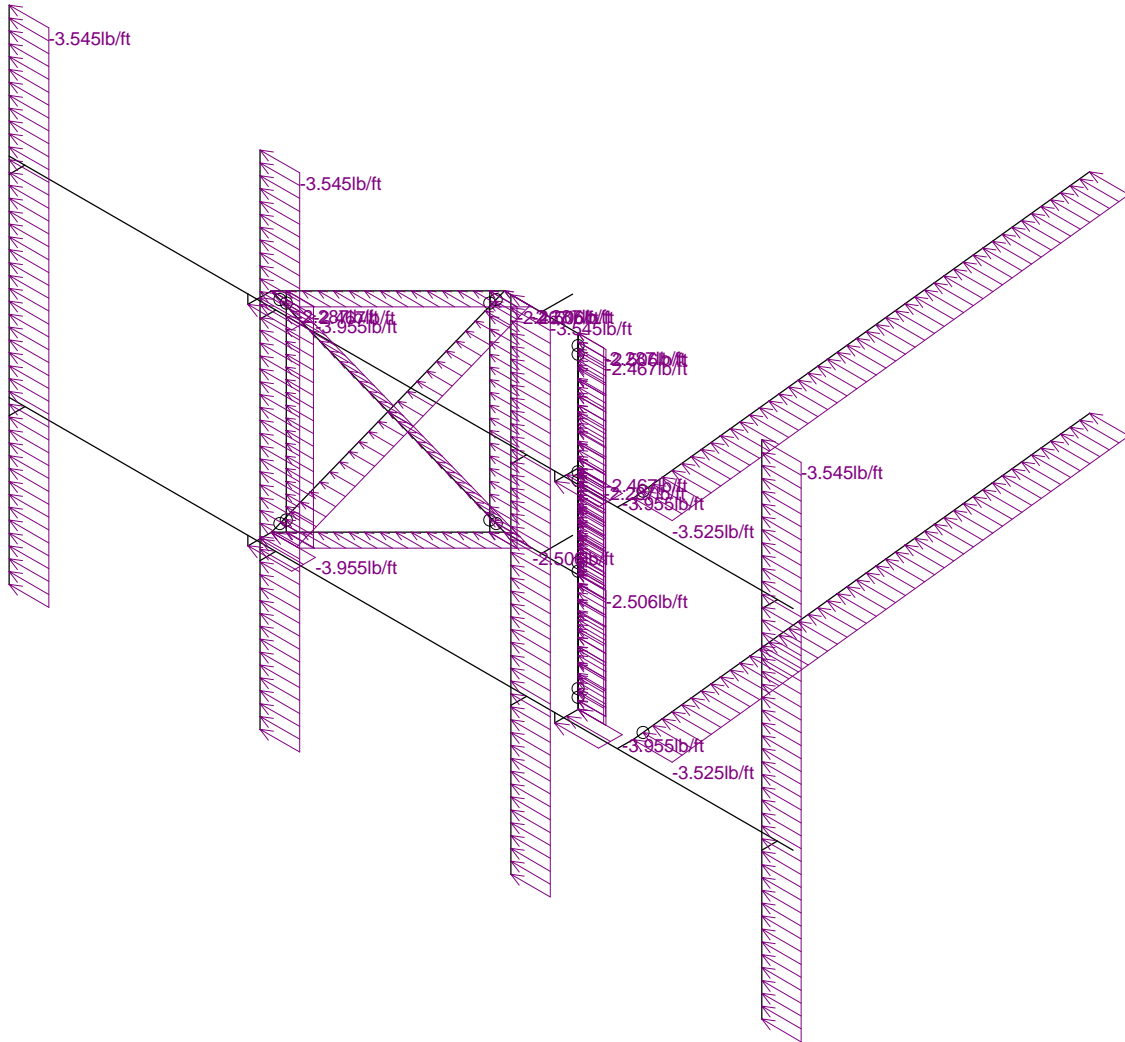
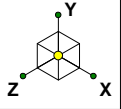

Loads: BLC 20, Distr. Ice + Wind X

Centerline Communication...
AP

CTNL125A_MA

Distr. Ice + Wind 90
Sept 27, 2021 at 12:04 PM
CTNL125A_MA.r3d

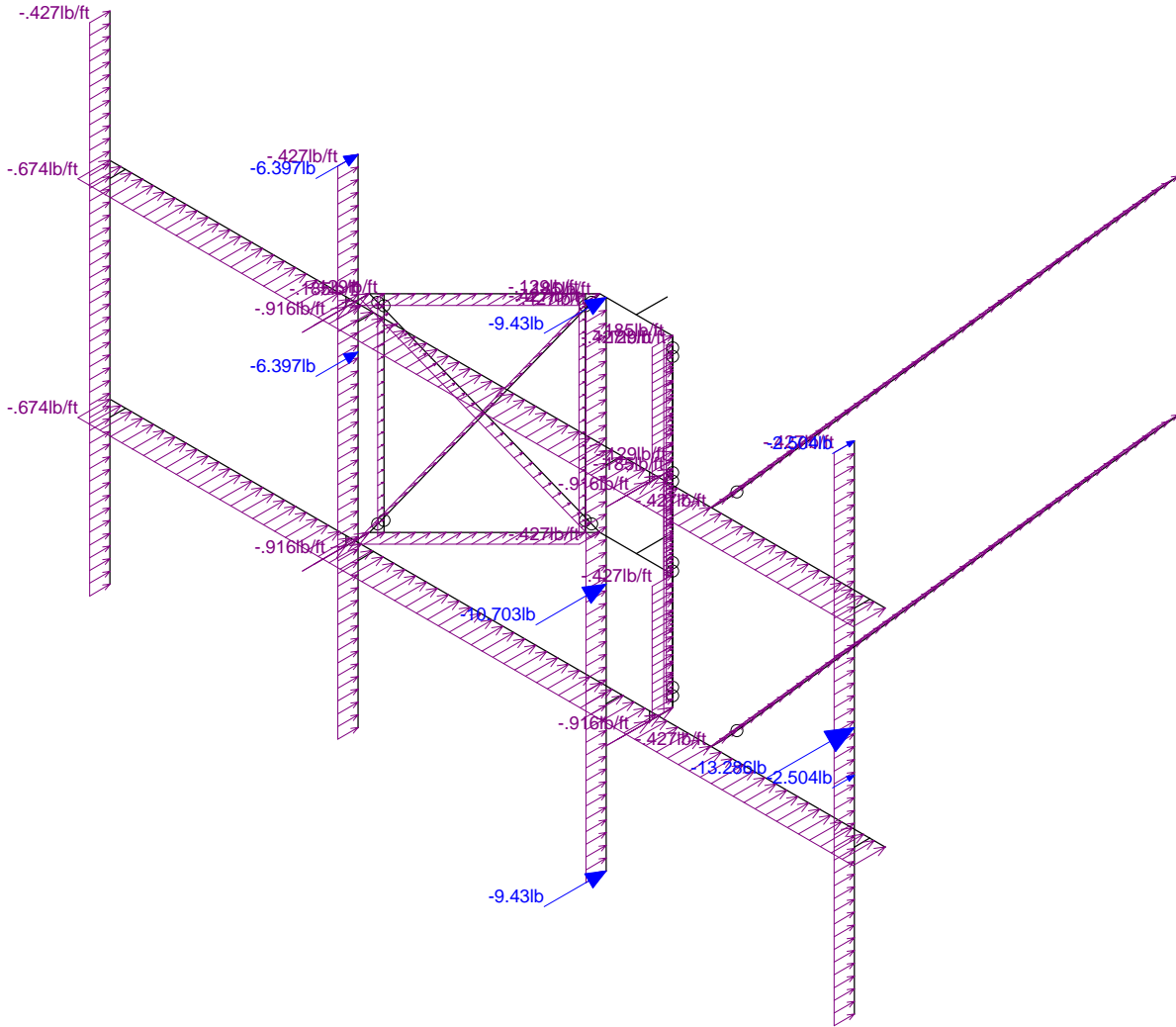
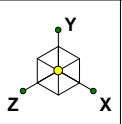

Loads: BLC 21, Seismic Load Z

Centerline Communication...

AP

CTNL125A_MA

Seismic Z

Sept 27, 2021 at 12:04 PM

CTNL125A_MA.r3d

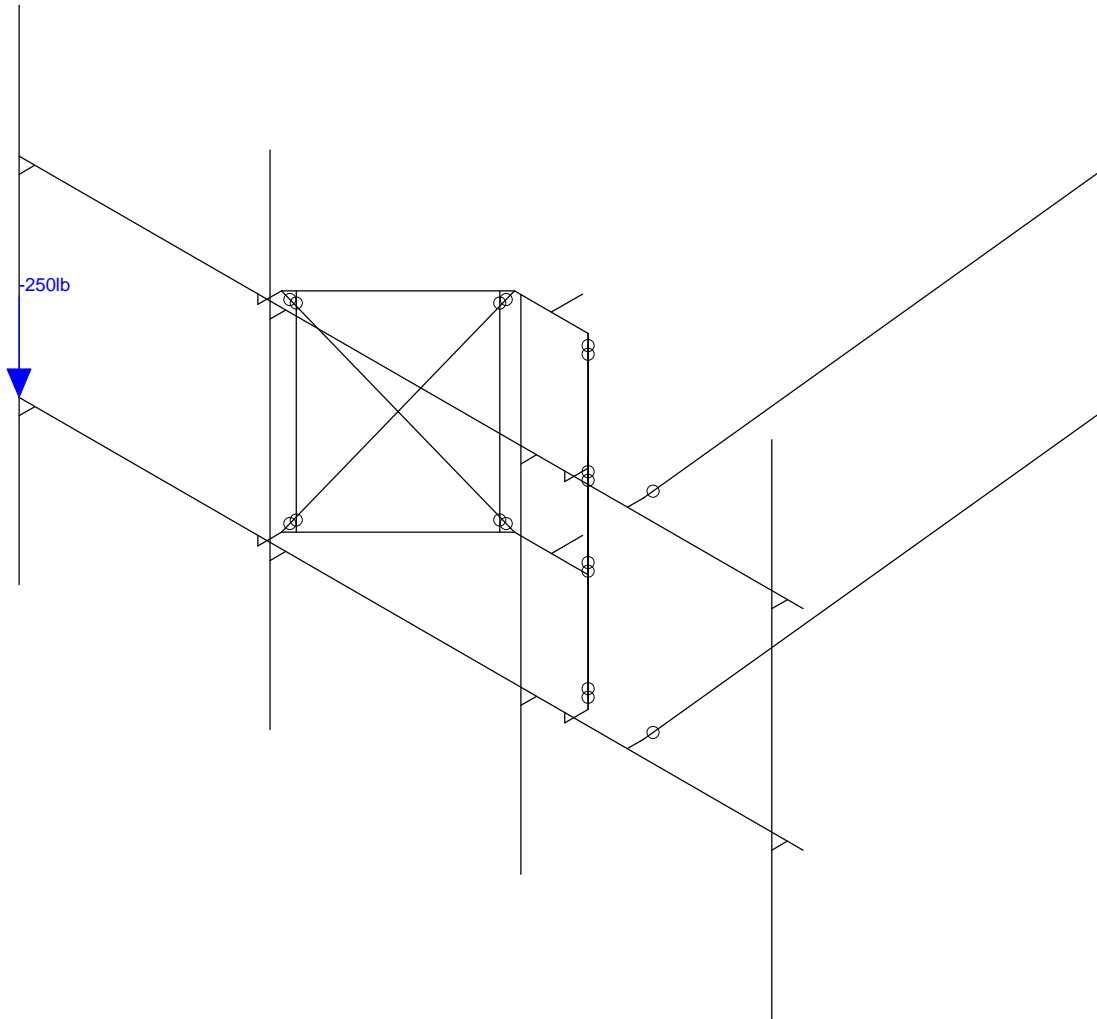
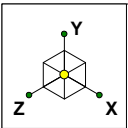

Loads: BLC 23, Live Load 1

Centerline Communication...	CTNL125A_MA	Live Load
AP		Sept 27, 2021 at 12:04 PM
		CTNL125A_MA.r3d

Hot Rolled Steel Properties

	Label	E [ksi]	G [ksi]	Nu	Therm (/...	Density[lb/ft^3]	Yield[ksi]	Ry	Fu[ksi]	Rt
1	A992	29000	11154	.3	.65	490	50	1.1	65	1.1
2	Q345	29000	11154	.3	.65	490	36	1.5	58	1.2
3	A572 Gr.50	29000	11154	.3	.65	490	50	1.1	65	1.1
4	A500 Gr.B RND	29000	11154	.3	.65	527	42	1.4	58	1.3
5	A500 Gr.B Rect	29000	11154	.3	.65	527	46	1.4	58	1.3
6	Q235-GB	29000	11154	.3	.65	490	35	1.6	60	1.2
7	A1085	29000	11154	.3	.65	490	50	1.4	65	1.3

Hot Rolled Steel Section Sets

	Label	Shape	Type	Design List	Material	Design ...	A [in2]	Iyy [in4]	Izz [in4]	J [in4]
1	Face Horizontal	PIPE 2.5	Beam	None	Q235-GB	Typical	1.61	1.45	1.45	2.89
2	Standoff	PIPE 2.0	Beam	None	Q235-GB	Typical	1.02	.627	.627	1.25
3	Bracing (Vert)	0.625" S.R.	Beam	None	Q235-GB	Typical	.307	.007	.007	.015
4	Mount Pipe	PIPE 2.0	Beam	None	Q235-GB	Typical	1.02	.627	.627	1.25
5	Conn. Plate	PL0.625x3.5	Beam	None	Q345	Typical	2.188	.071	2.233	.253
6	Pivot Plate	PL0.625x9.25	Beam	None	Q345	Typical	5.781	.188	41.222	.721
7	Connection Plate	PL3 1/2x5/8	Beam	None	Q345	Typical	2.188	.071	2.233	.253
8	Tieback	PIPE 2.0	Beam	None	Q235-GB	Typical	1.02	.627	.627	1.25
9	Bracing (Diag)	SR 3/4	Beam	None	Q235-GB	Typical	.442	.016	.016	.031

Joint Coordinates and Temperatures

	Label	X [in]	Y [in]	Z [in]	Temp [F]	Detach From Diap...
1	N1	-75	0	31.3	0	
2	N2	75	0	31.3	0	
3	N3	-75	40	31.3	0	
4	N4	75	40	31.3	0	
5	N9	-72	0	31.3	0	
6	N10	-72	40	31.3	0	
7	N11	-24	0	31.3	0	
8	N12	-24	40	31.3	0	
9	N13	24	0	31.3	0	
10	N14	24	40	31.3	0	
11	N15	72	0	31.3	0	
12	N16	72	40	31.3	0	
13	N17	-72	0	34.3	0	
14	N18	-72	40	34.3	0	



Company : Centerline Communications, LLC
 Designer : AP
 Job Number :
 Model Name : CTNL125A_MA

Sept 27, 2021
 12:05 PM
 Checked By: JG

Joint Coordinates and Temperatures (Continued)

	Label	X [in]	Y [in]	Z [in]	Temp [F]	Detach From Diap...
15	N19	-24	0	34.3	0	
16	N20	-24	40	34.3	0	
17	N21	24	0	34.3	0	
18	N22	24	40	34.3	0	
19	N23	-72	68	34.3	0	
20	N24	-24	68	34.3	0	
21	N25	24	68	34.3	0	
22	N26	-72	-28	34.3	0	
23	N27	-24	-28	34.3	0	
24	N28	24	-28	34.3	0	
25	N29	72	0	34.3	0	
26	N30	72	40	34.3	0	
27	N31	72	68	34.3	0	
28	N32	72	-28	34.3	0	
29	N33	0	40	31.3	0	
30	N34	29.35	40	31.3	0	
31	N35	-29.35	40	31.3	0	
32	N36	29.35	38.25	31.3	0	
33	N37	-29.35	38.25	31.3	0	
34	N38	29.35	38.25	26.8	0	
35	N39	-29.35	38.25	26.8	0	
36	N40	-7.05	38.25	4.5	0	
37	N41	7.05	38.25	4.5	0	
38	N42	0	38.25	4.5	0	
39	N43	0	38.25	-1.5	0	
40	N44	29.35	0	31.3	0	
41	N45	-29.35	0	31.3	0	
42	N46	29.35	-1.75	31.3	0	
43	N47	-29.35	-1.75	31.3	0	
44	N48	29.35	-1.75	26.8	0	
45	N49	-29.35	-1.75	26.8	0	
46	N50	-7.05	-1.75	4.5	0	
47	N51	7.05	-1.75	4.5	0	
48	N52	0	-1.75	4.5	0	
49	N53	0	-1.75	-1.5	0	
50	N62A	-27.935813	-1.75	25.385813	0	
51	N63A	-27.935813	38.25	25.385813	0	
52	N64A	-8.464214	-1.75	5.914214	0	
53	N65	-8.464214	38.25	5.914214	0	
54	N66	27.935813	-1.75	25.385813	0	

Joint Coordinates and Temperatures (Continued)

	Label	X [in]	Y [in]	Z [in]	Temp [F]	Detach From Diap...
55	N67	27.935813	38.25	25.385813	0	
56	N68	8.464214	-1.75	5.914214	0	
57	N69	8.464214	38.25	5.914214	0	
58	N69A	-41.35	40	31.3	0	
59	N61	41.35	40	28.3	0	
60	N62	30.965133	40	-69.426852	0	
61	N63	41.35	40	31.3	0	
62	N62B	41.35	0	28.3	0	
63	N63B	30.965133	0	-69.426852	0	
64	N64	41.35	0	31.3	0	

Envelope Joint Reactions

	Joint		X [lb]	LC	Y [lb]	LC	Z [lb]	LC	MX [lb-ft]	LC	MY [lb-ft]	LC	MZ [lb-ft]	LC
1	N43	max	535.734	12	2378.277	22	420.313	10	92.982	9	0	78	1198.097	16
2		min	-956.506	51	-220.555	9	-2122.141	22	-1296.591	16	0	1	-152.188	9
3	N53	max	1161.331	20	991.65	9	2116.504	18	97.139	15	0	78	301.726	51
4		min	-302.045	37	-225.904	15	164.581	15	-491.344	9	0	1	-432.862	16
5	N62	max	92.364	2	51.608	20	874.688	2	0	78	0	78	0	78
6		min	-74.112	15	12.626	9	-882.622	14	0	1	0	1	0	1
7	N63B	max	38.657	9	51.658	20	368.043	9	0	78	0	78	0	78
8		min	-44.733	7	12.765	9	-644.542	6	0	1	0	1	0	1
9	Totals:	max	1290.579	5	2818.09	20	2253.341	9						
10		min	0	9	796.484	15	-2253.341	8						

Joint Boundary Conditions

	Joint Label	X [k/in]	Y [k/in]	Z [k/in]	X Rot.[k-ft/rad]	Y Rot.[k-ft/rad]	Z Rot.[k-ft/rad]
1	N43	Reaction	Reaction	Reaction	Reaction		Reaction
2	N53	Reaction	Reaction	Reaction	Reaction		Reaction
3	N62	Reaction	Reaction	Reaction			
4	N63B	Reaction	Reaction	Reaction			

Hot Rolled Steel Design Parameters

	Label	Shape	Length[in]	Lbyy[in]	Lbzz[in]	Lcomp top[in]	Lcomp bot[in]	L-torq...	Kyy	Kzz	Cb	Function
1	M3	Bracing (Di...	50.937			Lbyy						Lateral
2	M4	Bracing (Di...	50.937			Lbyy						Lateral
3	M5	Bracing (Di...	50.937			Lbyy						Lateral

Hot Rolled Steel Design Parameters (Continued)

	Label	Shape	Length[in]	Lbyy[in]	Lbzz[in]	Lcomp top[in]	Lcomp bot[in]	L-torq...	Kyy	Kzz	Cb	Function
4	M6	Bracing (Di...	50.937			Lbyy						Lateral
5	M9	Bracing (Ve...	40			Lbyy						Lateral
6	M10	Bracing (Ve...	40			Lbyy						Lateral
7	M15	Standoff	31.537			Lbyy						Lateral
8	M17	Standoff	31.537			Lbyy						Lateral
9	M19	Connection ...	4.5			Lbyy						Lateral
10	M21	Connection ...	4.5			Lbyy						Lateral
11	MP1	Standoff	96			Lbyy						Lateral
12	MP2	Standoff	96			Lbyy						Lateral
13	M31	Standoff	31.537			Lbyy						Lateral
14	MP3	Standoff	96			Lbyy						Lateral
15	M33	Standoff	31.537			Lbyy						Lateral
16	MP4	Standoff	96			Lbyy						Lateral
17	M35	Connection ...	4.5			Lbyy						Lateral
18	M36	Connection ...	4.5			Lbyy						Lateral
19	M41	Face Horizo...	150			Lbyy						Lateral
20	M42	Face Horizo...	150			Lbyy						Lateral
21	M43A	Bracing (Ve...	40			Lbyy						Lateral
22	M44A	Bracing (Ve...	40			Lbyy						Lateral
23	M42B	Tieback	98.277			Lbyy						Lateral
24	M42A	Tieback	98.277			Lbyy						Lateral

Member Primary Data

	Label	I Joint	J Joint	K Joint	Rotate(deg)	Section/Shape	Type	Design List	Material	Design Rules
1	M3	N38	N51			Bracing (Diag)	Beam	None	Q235-GB	Typical
2	M4	N41	N48			Bracing (Diag)	Beam	None	Q235-GB	Typical
3	M5	N40	N49			Bracing (Diag)	Beam	None	Q235-GB	Typical
4	M6	N39	N50			Bracing (Diag)	Beam	None	Q235-GB	Typical
5	M9	N65	N64A			Bracing (Vert)	Beam	None	Q235-GB	Typical
6	M10	N63A	N62A			Bracing (Vert)	Beam	None	Q235-GB	Typical
7	M11	N53	N52		90	RIGID	None	None	RIGID	Typical
8	M12	N15	N29			RIGID	None	None	RIGID	Typical
9	M13	N50	N51			RIGID	None	None	RIGID	Typical
10	M14	N16	N30			RIGID	None	None	RIGID	Typical
11	M15	N51	N48			Standoff	Beam	None	Q235-GB	Typical
12	M16	N13	N21			RIGID	None	None	RIGID	Typical
13	M17	N50	N49			Standoff	Beam	None	Q235-GB	Typical
14	M18	N14	N22			RIGID	None	None	RIGID	Typical
15	M19	N48	N46		90	Connection Pl...	Beam	None	Q345	Typical

Member Primary Data (Continued)

	Label	I Joint	J Joint	K Joint	Rotate(deg)	Section/Shape	Type	Design List	Material	Design Rules
16	M20	N11	N19			RIGID	None	None	RIGID	Typical
17	M21	N49	N47		90	Connection Pl...	Beam	None	Q345	Typical
18	M22	N12	N20			RIGID	None	None	RIGID	Typical
19	M23	N44	N46			RIGID	None	None	RIGID	Typical
20	M24	N9	N17			RIGID	None	None	RIGID	Typical
21	M25	N45	N47			RIGID	None	None	RIGID	Typical
22	M26	N10	N18			RIGID	None	None	RIGID	Typical
23	M27	N43	N42		90	RIGID	None	None	RIGID	Typical
24	MP1	N31	N32			Standoff	Beam	None	Q235-GB	Typical
25	M29	N40	N41			RIGID	None	None	RIGID	Typical
26	MP2	N25	N28			Standoff	Beam	None	Q235-GB	Typical
27	M31	N41	N38			Standoff	Beam	None	Q235-GB	Typical
28	MP3	N24	N27			Standoff	Beam	None	Q235-GB	Typical
29	M33	N40	N39			Standoff	Beam	None	Q235-GB	Typical
30	MP4	N23	N26			Standoff	Beam	None	Q235-GB	Typical
31	M35	N38	N36		90	Connection Pl...	Beam	None	Q345	Typical
32	M36	N39	N37		90	Connection Pl...	Beam	None	Q345	Typical
33	M37	N34	N36			RIGID	None	None	RIGID	Typical
34	M39	N35	N37			RIGID	None	None	RIGID	Typical
35	M41	N1	N2			Face Horizontal	Beam	None	Q235-GB	Typical
36	M42	N3	N4			Face Horizontal	Beam	None	Q235-GB	Typical
37	M43A	N69	N68			Bracing (Vert)	Beam	None	Q235-GB	Typical
38	M44A	N67	N66			Bracing (Vert)	Beam	None	Q235-GB	Typical
39	M41B	N61	N63			RIGID	None	None	RIGID	Typical
40	M42B	N61	N62			Tieback	Beam	None	Q235-GB	Typical
41	M41A	N62B	N64			RIGID	None	None	RIGID	Typical
42	M42A	N62B	N63B			Tieback	Beam	None	Q235-GB	Typical

Member Advanced Data

	Label	I Release	J Release	I Offset[in]	J Offset[in]	T/C Only	Physical	Defl Rat...	Analysis ...	Inactive	Seismic...
1	M3	BenPIN	BenPIN			Euler Buc...	Yes				None
2	M4	BenPIN	BenPIN			Euler Buc...	Yes				None
3	M5	BenPIN	BenPIN			Euler Buc...	Yes				None
4	M6	BenPIN	BenPIN			Euler Buc...	Yes				None
5	M9	BenPIN	BenPIN			Euler Buc...	Yes				None
6	M10	BenPIN	BenPIN			Euler Buc...	Yes				None
7	M11						Yes	** NA **			None
8	M12						Yes	** NA **			None
9	M13						Yes	** NA **			None

Member Advanced Data (Continued)

	Label	I Release	J Release	I Offset[in]	J Offset[in]	T/C Only	Physical	Defl Rat...	Analysis ...	Inactive	Seismic...
10	M14						Yes	** NA **			None
11	M15						Yes				None
12	M16						Yes	** NA **			None
13	M17						Yes				None
14	M18						Yes	** NA **			None
15	M19						Yes				None
16	M20						Yes	** NA **			None
17	M21						Yes				None
18	M22						Yes	** NA **			None
19	M23						Yes	** NA **			None
20	M24						Yes	** NA **			None
21	M25						Yes	** NA **			None
22	M26						Yes	** NA **			None
23	M27						Yes	** NA **			None
24	MP1						Yes				None
25	M29						Yes	** NA **			None
26	MP2						Yes				None
27	M31						Yes				None
28	MP3						Yes				None
29	M33						Yes	Default			None
30	MP4						Yes	Default			None
31	M35						Yes				None
32	M36						Yes				None
33	M37						Yes	** NA **			None
34	M39						Yes	** NA **			None
35	M41						Yes				None
36	M42						Yes				None
37	M43A	BenPIN	BenPIN			Euler Buc...	Yes				None
38	M44A	BenPIN	BenPIN			Euler Buc...	Yes				None
39	M41B						Yes	** NA **			None
40	M42B	BenPIN					Yes				None
41	M41A						Yes	** NA **			None
42	M42A	BenPIN					Yes				None

Basic Load Cases

	BLC Description	Category	X Gravity	Y Gravity	Z Gravity	Joint	Point	Distributed Area(Me...	Surface(P...
1	Dead Load	DL		-1			8		
2	Wind 0	WLZ					16		
3	Wind 30	None					16		



Company : Centerline Communications, LLC
 Designer : AP
 Job Number :
 Model Name : CTNL125A_MA

Sept 27, 2021
 12:05 PM
 Checked By: JG

Basic Load Cases (Continued)

	BLC Description	Category	X Gravity	Y Gravity	Z Gravity	Joint	Point	Distributed Area(Me...	Surface(P...
4	Wind 60	None					16		
5	Wind 90	WLX					16		
6	Wind 120	None					16		
7	Wind 150	None					16		
8	Wind 180	WLZ					16		
9	Ice Weight	DL					8	42	
10	Ice + Wind 0	WLZ					16		
11	Ice + Wind 30	None					16		
12	Ice + Wind 60	None					16		
13	Ice + Wind 90	WLX					16		
14	Ice + Wind 120	None					16		
15	Ice + Wind 150	None					16		
16	Ice + Wind 180	WLZ					16		
17	Distri. Wind Z	WLZ						42	
18	Distri. Wind X	WLX						42	
19	Distri. Ice + Wind Z	WLZ						42	
20	Distrr. Ice + Wind X	WLX						42	
21	Seismic Load Z	ELZ					8	42	
22	Seismic Load X	ELX					8	42	
23	Live Load 1	LL					1		
24	Live Load 2	LL					1		
25	Live Load 3	LL					1		

Load Combinations

	Description	Solve	P...	S...	B...	Fa...	B...	Fa...	B...	Fa...	B...	Fa...	B...	Fa...	B...	Fa...	B...	Fa...	B...	Fa...	B...	Fa...	
1	1.4D	Yes	Y		1	1.4																	
2	1.2D + 1.6W 0°	Yes	Y		1	1.2	2	1.6	17	1.6	18												
3	1.2D + 1.6W 30°	Yes	Y		1	1.2	3	1.6	17	1.3...	18	.8											
4	1.2D + 1.6W 60°	Yes	Y		1	1.2	4	1.6	17	.8	18	1.3...											
5	1.2D + 1.6W 90°	Yes	Y		1	1.2	5	1.6	17		18	1.6											
6	1.2D + 1.6W 120°	Yes	Y		1	1.2	6	1.6	17	-.8	18	1.3...											
7	1.2D + 1.6W 150°	Yes	Y		1	1.2	7	1.6	17	-1....	18	.8											
8	1.2D + 1.6W 180°	Yes	Y		1	1.2	8	1.6	17	-1.6	18												
9	0.9D + 1.6W 0°	Yes	Y		1	.9	2	1.6	17	1.6	18												
10	0.9D + 1.6W 30°	Yes	Y		1	.9	3	1.6	17	1.3...	18	.8											
11	0.9D + 1.6W 60°	Yes	Y		1	.9	4	1.6	17	.8	18	1.3...											
12	0.9D + 1.6W 90°	Yes	Y		1	.9	5	1.6	17		18	1.6											
13	0.9D + 1.6W 120°	Yes	Y		1	.9	6	1.6	17	-.8	18	1.3...											
14	0.9D + 1.6W 150°	Yes	Y		1	.9	7	1.6	17	-1....	18	.8											



Company : Centerline Communications, LLC
 Designer : AP
 Job Number :
 Model Name : CTNL125A_MA

Sept 27, 2021
 12:05 PM
 Checked By: JG

Load Combinations (Continued)

	Description	Solve	P...	S...	B...	Fa...	B...	Fa...	B...	Fa...	B...	Fa...	B...	Fa...	B...	Fa...	B...	Fa...	B...	Fa...	B...	Fa...	
15	0.9D + 1.6W 180°	Yes	Y		1	.9	8	1.6	17	-1.6	18												
16	1.2D + 1.0Di + 1.0Wi 0°	Yes	Y		1	1.2	9	1	10	1	19	1	20										
17	1.2D + 1.0Di + 1.0Wi 30°	Yes	Y		1	1.2	9	1	11	1	19	.866	20	.5									
18	1.2D + 1.0Di + 1.0Wi 60°	Yes	Y		1	1.2	9	1	12	1	19	.5	20	.866									
19	1.2D + 1.0Di + 1.0Wi 90°	Yes	Y		1	1.2	9	1	13	1	19		20	1									
20	1.2D + 1.0Di + 1.0Wi 120°	Yes	Y		1	1.2	9	1	14	1	19	-.5	20	.866									
21	1.2D + 1.0Di + 1.0Wi 150°	Yes	Y		1	1.2	9	1	15	1	19	-.866	20	.5									
22	1.2D + 1.0Di + 1.0Wi 180°	Yes	Y		1	1.2	9	1	16	1	19	-1	20										
23	1.2D + 1.0Eh 0°	Yes	Y		1	1.2	21	1	22														
24	1.2D + 1.0Eh 30°	Yes	Y		1	1.2	21	.866	22	.5													
25	1.2D + 1.0Eh 60°	Yes	Y		1	1.2	21	.5	22	.866													
26	1.2D + 1.0Eh 90°	Yes	Y		1	1.2	21		22	1													
27	1.2D + 1.0Eh 120°	Yes	Y		1	1.2	21	-.5	22	.866													
28	1.2D + 1.0Eh 150°	Yes	Y		1	1.2	21	-.866	22	.5													
29	1.2D + 1.0Eh 180°	Yes	Y		1	1.2	21	-1	22														
30	0.9D + 1.0Eh 0°	Yes	Y		1	.9	21	1	22														
31	0.9D + 1.0Eh 30°	Yes	Y		1	.9	21	.866	22	.5													
32	0.9D + 1.0Eh 60°	Yes	Y		1	.9	21	.5	22	.866													
33	0.9D + 1.0Eh 90°	Yes	Y		1	.9	21		22	1													
34	0.9D + 1.0Eh 120°	Yes	Y		1	.9	21	-.5	22	.866													
35	0.9D + 1.0Eh 150°	Yes	Y		1	.9	21	-.866	22	.5													
36	0.9D + 1.0Eh 180°	Yes	Y		1	.9	21	-1	22														
37	1.0D + 1.5Lv + 1.0W (6...)	Yes	Y		1	1	23	1.5	2	.316	17	.316	18										
38	1.0D + 1.5Lv + 1.0W (6...)	Yes	Y		1	1	23	1.5	3	.316	17	.273	18	.158									
39	1.0D + 1.5Lv + 1.0W (6...)	Yes	Y		1	1	23	1.5	4	.316	17	.158	18	.273									
40	1.0D + 1.5Lv + 1.0W (6...)	Yes	Y		1	1	23	1.5	5	.316	17		18	.316									
41	1.0D + 1.5Lv + 1.0W (6...)	Yes	Y		1	1	23	1.5	6	.316	17	-.158	18	.273									
42	1.0D + 1.5Lv + 1.0W (6...)	Yes	Y		1	1	23	1.5	7	.316	17	-.273	18	.158									
43	1.0D + 1.5Lv + 1.0W (6...)	Yes	Y		1	1	23	1.5	8	.316	17	-.316	18										
44	1.0D + 1.5Lv + 1.0W (6...)	Yes	Y		1	1	24	1.5	2	.316	17	.316	18										
45	1.0D + 1.5Lv + 1.0W (6...)	Yes	Y		1	1	24	1.5	3	.316	17	.273	18	.158									
46	1.0D + 1.5Lv + 1.0W (6...)	Yes	Y		1	1	24	1.5	4	.316	17	.158	18	.273									
47	1.0D + 1.5Lv + 1.0W (6...)	Yes	Y		1	1	24	1.5	5	.316	17		18	.316									
48	1.0D + 1.5Lv + 1.0W (6...)	Yes	Y		1	1	24	1.5	6	.316	17	-.158	18	.273									
49	1.0D + 1.5Lv + 1.0W (6...)	Yes	Y		1	1	24	1.5	7	.316	17	-.273	18	.158									
50	1.0D + 1.5Lv + 1.0W (6...)	Yes	Y		1	1	24	1.5	8	.316	17	-.316	18										
51	1.0D + 1.5Lv + 1.0W (6...)	Yes	Y		1	1	25	1.5	2	.316	17	.316	18										
52	1.0D + 1.5Lv + 1.0W (6...)	Yes	Y		1	1	25	1.5	3	.316	17	.273	18	.158									
53	1.0D + 1.5Lv + 1.0W (6...)	Yes	Y		1	1	25	1.5	4	.316	17	.158	18	.273									
54	1.0D + 1.5Lv + 1.0W (6...)	Yes	Y		1	1	25	1.5	5	.316	17		18	.316									



Company : Centerline Communications, LLC
 Designer : AP
 Job Number :
 Model Name : CTNL125A_MA

Sept 27, 2021
 12:05 PM
 Checked By: JG

Envelope AISC 14th(360-10): LRFD Steel Code Checks (Continued)

Member	Shape	Code Check	Loc[in]	LC	Shear Check	Loc[in]	Dir	LC	phi*P...	phi*P...	phi*M...	phi*M.....	Eqn	
13	M21	PL3 1/2x...	.127	4.5	8	.092	4.5	y	38	68591...	70875	922.8...	5167....	H1-1b
14	M42B	PIPE_2.0	.069	49.139	16	.006	98.2...		19	14376...	32130	1871....	1871....	H1-1b
15	M42A	PIPE_2.0	.063	49.139	20	.006	98.2...		19	14376...	32130	1871....	1871....	H1-1b
16	M44A	0.625" S...	.061	0	8	.003	0		22	988.3...	9670.5	94.08	94.08	1 H1-1...
17	M33	PIPE_2.0	.058	31.537	42	.044	29.5...		2	29576...	32130	1871....	1871....	H1-1b
18	M17	PIPE_2.0	.053	31.537	43	.037	29.5...		8	29576...	32130	1871....	1871....	H1-1b
19	M5	SR 3/4	.040	0	43	.003	50.9...		16	1352....	13916...	173.9...	173.9...	H1-1...
20	M10	0.625" S...	.018	0	8	.003	0		22	988.3...	9670.5	94.08	94.08	1 H1-1...
21	M3	SR 3/4	.008	50.937	15	.004	50.9...		4	1352....	13916...	173.9...	173.9...	H1-1...
22	M6	SR 3/4	.006	50.937	15	.004	0		3	1352....	13916...	173.9...	173.9...	H1-1...
23	M43A	0.625" S...	.003	0	9	.005	0		8	988.3...	9670.5	94.08	94.08	1 H1-1...
24	M9	0.625" S...	.002	0	16	.005	0		8	988.3...	9670.5	94.08	94.08	1 H1-1...