



1280 Route 46 West, Suite 9, Parsippany NJ, 07054

Connecticut Siting Council  
Ten Franklin Square  
New Britain, CT 06051  
Attn: Ms. Melanie Bachman, Executive Director

Re: Notice of Exempt Modification Application  
Hamden Fish & Game Protective Assoc. Tower  
150 Willow Avenue  
Hamden, CT 06010

September 12, 2017

Dear Ms. Bachman:

On behalf of Sprint Spectrum Realty Company, L.P. ("Sprint"), enclosed for filing are an original and two (2) copies of Sprint's Notice of Exempt Modification for Proposed Modifications to an Existing Telecommunications Facility located at the above-referenced site. A soft copy will also be forwarded.

I also enclose herewith a check in the amount of \$625.00 representing the fee for the Notice of Exempt Modification.

If you have any questions, please feel free to contact me.

Thank you,

By: *Paul F. Sagristano*

Paul F. Sagristano  
Cherundolo Consulting  
4 Davis Road West, Suite 5  
Old Lyme, CT 06371  
917.841.0247  
[psagristano@lrvassoc.com](mailto:psagristano@lrvassoc.com)



1280 Route 46 West, Suite 9, Parsippany NJ, 07054

Ms. Melanie Bachman  
Executive Director  
CT Siting Council  
10 Franklin Square  
New Britain, CT 06051

September 6, 2017

Re: Notice of Exempt Modification –  
Existing Sprint Telecommunication Facility  
150 Willow Street, Hamden, CT 06518  
Latitude: N41.44944  
Longitude: W72.9047

Dear Ms. Bachman:

Sprint currently maintains three (3) existing telecommunications antennas, 3 tower mounted amplifiers and associated equipment at the 157.5' level of an existing 157.5' multicarrier telecommunications tower at 150 Willow Street in Hamden, Connecticut. Sprint intends to add three (3) new antennas to a new pipe mounts as well as (3) new tower mounted amplifiers. Sprint is performing a new high-performance air interface upgrade for cellular mobile communications. It is designed to increase the capacity and speed of mobile telephone networks.

The facility noted above was approved by CT Siting Council on May 1, 2007 and via building permit issuance by the Town of Hamden on August 21, 2007. A copy of this approval is attached.

Please accept this letter as notification to the Council, pursuant to R.C.S.A. Section 16-50j-73, for construction which constitutes an exempt modification pursuant to R.C.S.A. Section 16-50j-72(b)(2). In compliance with R.C.S.A. Section 16-50j-73, a copy of this letter is also being sent to Mr. Kurt Leng, Mayor of the Town of Hamden and to Mr. Lew Lagervall, Treasurer of the Hamden Fish & Game Protective Association, the property owner

Attached is a summary of the planned modifications, including power density calculations reflecting the change in Sprint's operations at the site. Also included is documentation of the structural sufficiency of the tower with proposed modifications to accommodate the revised antenna configuration.

#### **Existing Facility**

The Hamden facility is located at 150 Willow Street, the Site coordinates are: 41. 44944 N, - 72. 9047 W. The facility is owned by The Hamden Fish & Game Protective Association, Hamden, CT 06518.

The existing facility consists of a 157.5' Monopole tower. Sprint currently operates wireless communications equipment on a steel platform at the facility and has three antennas mounted on the tower at a centerline of 157.5' feet.

### **Statutory Considerations**

The planned modifications to the facility fall within the activities explicitly provided for in R.C.S.A. 16-50j-72(b)(2)

1. The height of the overall structure will be unaffected.
2. The proposed changes will not require an extension of the property boundaries.
3. The proposed additions will not increase the noise level at the existing facility by six decibels or more, or to levels that exceed state and/or local criteria
4. The changes will not increase the calculated "worst case" power density for the combined operations at the site to a level at or above the Federal Communications Commission safety standard.
5. The proposed modifications will not cause a change or alteration in the physical or environmental characteristics of the site.
6. The existing structure and its foundation can support the proposed loading.

For the foregoing reasons, Sprint respectfully submits that the proposed changes at the referenced site constitute exempt modifications under R.C.S.A Section §16-50j-72(b)(2).

Respectfully submitted,

Paul F. Sagristano  
Charles Cherundolo Consulting  
917-841-0247  
psagristano@lrvassoc.com

Additional Recipients:

Town of Hamden Mayor, Mr. Kurt Leng  
Property Owner, Mr. Lew Lagervall, Treasurer of the Hamden Fish & Game Protective Association

Google Maps 150 Willow St



Imagery ©2017 Google, Map data ©2017 Google United States 200 ft



# TOWN OF HAMDEN, CONNECTICUT

## GEOGRAPHIC & PROPERTY INFORMATION NETWORK



2750 DIXWELL AVENUE  
HAMDEN, CT 06518  
203-287-2500  
E-MAIL: GENERAL INFORMATION

### ❖ MAIN MENU

- [GIS HOME](#)
- [➤ GIS PROPERTY MAP SEARCH](#)
- [TOWN WIDE MAP GALLERY](#)
- [TOWN GRID MAPS](#)
- [INTERACTIVE MAPPING](#)
- [HELP](#)

### PROPERTY INFO DATA UPDATED

Nightly

### CURRENT PARCEL COUNT

16,800 +/-

### ❖ SUMMARY PARCEL INFORMATION & MAP DOCUMENTS

## Detailed Parcel Information

**Parcel No**  
3430-001-00-0000

**Unique ID**  
18077

**Account**

**Owner**  
HAMDEN FISH & GAME  
PROTECTIVE AS

**Location**  
150 WILLOW ST

**MAILING ADDRESS**  
P O BOX 5619  
HAMDEN CT 06518-0619



3430-001-00-0000 04/23/2015

Scroll Down For Complete Property Detail

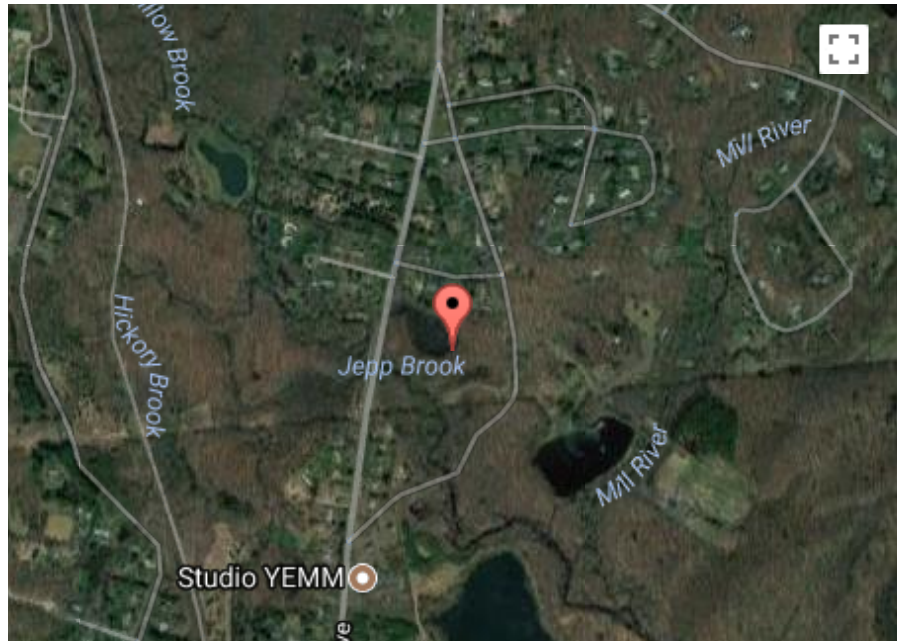

Map data ©2017 Google Imagery ©2017, CNES / Airbus, DigitalGlobe, U.S. Geological Survey, USDA Farm Report a map error

Click on the Google logo to go to Google Maps

## Parcel Documents

[Create Parcel Map](#)

[Property Summary Card](#)

---

## Full Size Assessor Maps

[Full Assessor Map](#)

---

## Interactive GIS Maps of Property

[GO TO VIRTUAL EARTH BIRDS EYE!](#)

[GO TO INTERACTIVE MAP!](#)

Once in Interactive Map, Select Parcel and enter Abutters distance.

---

## PARCEL VALUATIONS

	Appraised Value	Assessed Value
Buildings	164900	115430
Outbuildings	17000	11900
Improvements	187200	131040
Extra Features	5300	3710
Land	1172000	288530
TOTAL:	1359200	419570

---

## PROPERTY INFORMATION

Land Acres	85.58
Land Use	FISH&GAME
Land Class	C
Zoning	T1
Neighborhood	130
Lot Description	Level
Lot Setting	Suburban
Lot Utilities	Public Water,Public Sewer,Gas/Electric
Street Description	Paved

---

## SALE INFORMATION

Sale Date	10/10/1945
Sale Price	0
Book / Page	232/ 49

---

## BUILDING AREA

Gross Building Area	5759
Total Living Area	3081

---

## CONSTRUCTION DETAILS

Building Style	Clubs/Lodges
----------------	--------------

Building Use	Comm/Ind
Number of Rooms	
Number of Bedrooms	
Number of Bathrooms	
Number of Half Bathrooms	
Kitchen Style	
Stories	2
Roof Style	Gable/Hip
Roof Cover	Asphalt
Primary Exterior Wall Type	Vinyl Siding
Secondary Exterior Wall Type	
Primary Interior Wall Type	K PINE/A WD
Secondary Interior Wall Type	
Primary Floor Type	Vinyl/Asphalt
Secondary Floor Type	
Heating Type	Forced Air-Duc
Heating Fuel	Oil
Air Conditioning Type	

---

[Back](#) | [New Search](#) | [Town of Hamden](#)

---

Copyright© 2007 Town of Hamden, Connecticut, U.S.A. All rights reserved.  
All information is intended for your general knowledge only and is not a substitute for contacting the Town Hall or other departments listed at this web site.

You should promptly consult the specific office or department with any questions.  
Use of this web site and any information you find through it is subject to the [Disclaimer](#).



September 12, 2017

Dear Customer:

The following is the proof-of-delivery for tracking number **770193508695**.

---

**Delivery Information:**

---

<b>Status:</b>	Delivered	<b>Delivered to:</b>	Receptionist/Front Desk
<b>Signed for by:</b>	M.RAMPERSAUD	<b>Delivery location:</b>	2750 DIXWELL AVENUE HAMDEN, CT 06518
<b>Service type:</b>	FedEx Express Saver	<b>Delivery date:</b>	Sep 11, 2017 13:01
<b>Special Handling:</b>	Deliver Weekday		
	Direct Signature Required		



---

**Shipping Information:**

---

<b>Tracking number:</b>	770193508695	<b>Ship date:</b>	Sep 6, 2017
		<b>Weight:</b>	0.5 lbs/0.2 kg

**Recipient:**

Kurt Leng, Mayor  
Town of Hamden  
2750 Dixwell Avenue  
HAMDEN, CT 06518 US

**Shipper:**

Paul Sagristano  
Charles Cherundolo Consulting  
4 Davis Road West  
Suite 5  
OLD LYME, CT 06371 US  
CT54XC773 - Notice to Mayor

**Reference**

Thank you for choosing FedEx.





September 11, 2017

Dear Customer:

The following is the proof-of-delivery for tracking number **770193748179**.

---

**Delivery Information:**

---

<b>Status:</b>	Delivered	<b>Delivered to:</b>	Residence
<b>Signed for by:</b>	J.RUGGIERO	<b>Delivery location:</b>	150 WILLOW STRET HAMDEN, CT 06518
<b>Service type:</b>	FedEx Express Saver	<b>Delivery date:</b>	Sep 8, 2017 17:53
<b>Special Handling:</b>	Deliver Weekday  Residential Delivery  Direct Signature Required		



---

**Shipping Information:**

---

<b>Tracking number:</b>	770193748179	<b>Ship date:</b>	Sep 6, 2017
		<b>Weight:</b>	0.5 lbs/0.2 kg

**Recipient:**  
Mr. Lew Lagervall, Treasurer  
Hamden Fish and Game Association  
150 Willow Stret  
HAMDEN, CT 06518 US

**Shipper:**  
Paul Sagristano  
Charles Cherundolo Consulting  
4 Davis Road West  
Suite 5  
OLD LYME, CT 06371 US  
CT54XC773 CSC Notice to Owner

**Reference**

Thank you for choosing FedEx.



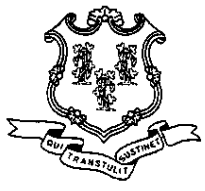

STATE OF CONNECTICUT

CONNECTICUT SITING COUNCIL

Ten Franklin Square, New Britain, CT 06051

Phone: (860) 827-2935 Fax: (860) 827-2950

E-Mail: [siting.council@ct.gov](mailto:siting.council@ct.gov)

Internet: [ct.gov/csc](http://ct.gov/csc)

Daniel F. Caruso  
Chairman

May 10, 2007

Thomas J. Regan, Esq.  
Brown Rudnick Berlack Israels LLP  
CityPlace I, 185 Asylum Street  
Hartford, CT 06103

RE: **DOCKET NO. 324** – Sprint Nextel Corporation application for a Certificate of Environmental Compatibility and Public Need for the construction, maintenance and operation of a wireless telecommunications facility at 150 Willow Street, Hamden, Connecticut.

Dear Attorney Regan:

By its Decision and Order dated May 1, 2007, the Connecticut Siting Council (Council) granted a Certificate of Environmental Compatibility and Public Need (Certificate) for the construction, maintenance and operation of a wireless telecommunications facility at 150 Willow Street, Hamden, Connecticut.

Enclosed are the Council's Certificate, Findings of Fact, Opinion, and Decision and Order.

Very truly yours,

S. Derek Phelps  
Executive Director

SDP/MP/laf

Enclosures (4)

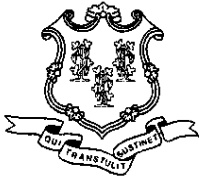

Daniel F. Caruso  
Chairman

# STATE OF CONNECTICUT

## CONNECTICUT SITING COUNCIL

Ten Franklin Square, New Britain, CT 06051

Phone: (860) 827-2935 Fax: (860) 827-2950

E-Mail: [siting.council@ct.gov](mailto:siting.council@ct.gov)

Internet: [ct.gov/csc](http://ct.gov/csc)

**CERTIFICATE  
OF  
ENVIRONMENTAL COMPATIBILITY AND PUBLIC NEED  
DOCKET NO. 324**

Pursuant to General Statutes § 16-50k, as amended, the Connecticut Siting Council hereby issues a Certificate of Environmental Compatibility and Public Need to Sprint Nextel Corporation application for the construction, maintenance and operation of a wireless telecommunications facility at 150 Willow Street, Hamden, Connecticut. This Certificate is issued in accordance with and subject to the terms and conditions set forth in the Decision and Order of the Council on May 1, 2007

By order of the Council,

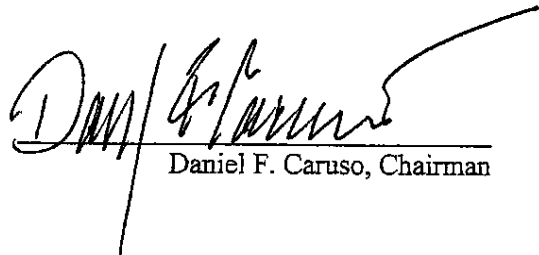

\_\_\_\_\_  
Daniel F. Caruso, Chairman

May 1, 2007



Daniel F. Caruso  
Chairman

# STATE OF CONNECTICUT

## CONNECTICUT SITING COUNCIL

Ten Franklin Square, New Britain, CT 06051

Phone: (860) 827-2935 Fax: (860) 827-2950

E-Mail: [siting.council@ct.gov](mailto:siting.council@ct.gov)

Internet: [ct.gov/csc](http://ct.gov/csc)

May 10, 2007

TO: Parties and Intervenors

FROM: S. Derek Phelps, Executive Director

RE: **DOCKET NO. 324** – Sprint Nextel Corporation application for a Certificate of Environmental Compatibility and Public Need for the construction, maintenance and operation of a wireless telecommunications facility at 150 Willow Street, Hamden, Connecticut.

---

By its Decision and Order dated May 1, 2007, the Connecticut Siting Council granted a Certificate of Environmental Compatibility and Public Need (Certificate) for the construction, maintenance and operation of a wireless telecommunications facility at 150 Willow Street, Hamden, Connecticut.

Enclosed are the Council's Findings of Fact, Opinion, and Decision and Order.

SDP/MP/laf

Enclosures (3)

c: State Documents Librarian

STATE OF CONNECTICUT )

ss. New Britain, Connecticut :

COUNTY OF HARTFORD )

I hereby certify that the foregoing is a true and correct copy of the Findings of Fact, Opinion, and Decision and Order issued by the Connecticut Siting Council, State of Connecticut.

ATTEST:

  
\_\_\_\_\_  
Fred O. Cunliffe  
Supervising Siting Analyst  
Connecticut Siting Council

I certify that a copy of the Findings of Fact, Opinion, and Decision and Order in Docket No. 324 has been forwarded by Certified First Class Return Receipt Requested mail on May 10, 2007, to all parties and intervenors of record as listed on the attached service list, dated November 3, 2006.

ATTEST:

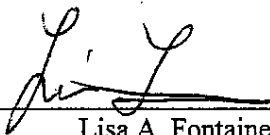
  
\_\_\_\_\_  
Lisa A. Fontaine  
Administrative Assistant  
Connecticut Siting Council

**LIST OF PARTIES AND INTERVENORS**  
**SERVICE LIST**

<b>Status Granted</b>	<b>Status Holder (name, address &amp; phone number)</b>	<b>Representative (name, address &amp; phone number)</b>
<b>Applicant</b>	Sprint Nextel Corporation	Thomas J. Regan, Esq. Brown Rudnick Berlack Israels LLP CityPlace I, 185 Asylum Street Hartford, CT 06103 (860) 509-6522 (860) 509-6501 fax <a href="mailto:tregan@brownrudnick.com">tregan@brownrudnick.com</a>

<b>DOCKET NO. 324</b> – Sprint Nextel Corporation application for a Certificate of Environmental Compatibility and Public Need for the construction, maintenance and operation of a wireless telecommunications facility at 150 Willow Street, Hamden, Connecticut.	} Connecticut } Siting } Council } May 1, 2007
---	---

**Findings of Fact**

**Introduction**

1. Sprint Nextel Corporation (Sprint) in accordance with provisions of Connecticut General Statutes (CGS) § 16-50g through 16-50aa, applied to the Connecticut Siting Council (Council) on October 27, 2006 for the construction, operation, and maintenance of a wireless telecommunications facility at 150 Willow Street, Hamden, Connecticut. (Sprint 1, p.4)
2. Sprint Nextel Corporation is a Delaware corporation. Sprint's principal business offices are located in Mahwah, New Jersey. Sprint is licensed by the Federal Communications Commission (FCC) in many major trading areas in the United States, including Connecticut. (Sprint 1, p. 4)
3. The party in this proceeding is the applicant. (Transcript 1, March 8, 2007, 3:00 p.m. [Tr. 1], p. 4)
4. The purpose of the proposed facility is to provide service to coverage gaps identified by Sprint on Route 10 and surrounding areas in Cheshire and Hamden. (Sprint 1, pp. 3, 6)
5. Pursuant to General Statutes § 16-50m, the Council, after giving due notice thereof, held a public hearing on March 8, 2007, beginning at 3:00 p.m. and continuing at 7:00 p.m. at the Miller Library Complex, Thornton Wilder Hall, 2901 Dixwell Avenue, Hamden, Connecticut. (Council's Hearing Notice dated January 25, 2007; Tr. 1, p. 2; Transcript 2, March 8, 2007, 7:00 p.m. [Tr. 2], p. 2)
6. The Council and its staff conducted an inspection of the proposed site on March 8, 2007, beginning at 2:00 p.m. During the field inspection, the applicant flew a red balloon at the proposed site to simulate the height of the proposed tower. Weather conditions included winds of 15 to 20 miles per hour and were not conducive to a proper balloon flight. Sprint lost three balloons between approximately 12:30 pm and 2:10 pm. The balloon reached its proposed height of 160 feet above ground level for approximately two minutes during the Council's inspection. (Council's Hearing Notice dated January 25, 2007; Tr. 1, pp. 12-13)
7. Pursuant to CGS § 16-501 (b), public notice of the application was published in The New Haven Register on October 17 and 19, 2006. (Sprint 1, p. 5)



8. Pursuant to General Statute § 16-501(b), notice of the application was provided to all abutting property owners by certified mail. Notice was unclaimed by four abutters: George L. Parente, Linus L. Darley, John Candella and Salvatore Hoo, and the State of Connecticut Nature Preserve. Sprint re-sent letters to these four abutters by first class mail. The first class letter to the State of Connecticut Nature Preserve was returned and then re-sent a final time to a different address. (Sprint 1, p. 5; Tr. 1, pp. 13-14)
9. Pursuant to CGS § 16-501 (b), Sprint provided notice to all federal, state and local officials and agencies listed therein. (Sprint 1, Tab 5)

#### State Agency Comment

10. Pursuant to General Statutes § 16-50j (h), on January 25, 2007 and March 9, 2007, the following State agencies were solicited by the Council to submit written comments regarding the proposed facility; Department of Environmental Protection (DEP), Department of Public Health (DPH), Council on Environmental Quality (CEQ), Department of Public Utility Control (DPUC), Office of Policy and Management (OPM), Department of Economic and Community Development (DECD), and the Department of Transportation (DOT). (Record)
11. The Council received a response from the DOT's Bureau of Engineering and Highway Operations on March 1, 2007 with no comments on this proposal. (DOT Comments dated March 1, 2007)
12. DPH responded with comments that are reflected in Finding of Fact #61. (DPH Comments dated March 26, 2007 and March 29, 2007)
13. The following agencies did not respond with comment on the application: DEP, CEQ, DPUC, OPM, and the DECD. (Record)

#### Municipal Consultation

14. Sprint notified the Town of Hamden (Town) of the proposal on July 27, 2006 by sending a technical report to the Mayor, Craig Henrici. Sprint contacted the Town by telephone on several occasions to discuss the proposal and to inquire as to whether the Town wanted to set up a meeting or provide comments on the proposal. The Town did not respond to Sprint's offer and did not provide Sprint with any comments. (Sprint 1, p. 10)
15. Due to the proposed tower site's close proximity to the Cheshire town line, Sprint also notified the Town of Cheshire of the proposal on July 27, 2006 by sending a technical report to the Chairman of the Cheshire Town Council, Matt Hall. The Cheshire Town Planner, William S. Voelker, contacted Sprint to indicate that the Town of Cheshire did not have any comments on Sprint's notice. (Sprint 1, p. 10)
16. By letter dated August 2, 2007, the Hamden Town Planner submitted a letter to the Council recommending that the tower be disguised as a silo. (Administrative Notice Item No. 16)

17. Sprint would provide space on the tower for the Town and any emergency response system for no compensation. The Hamden Police Department expressed an interest in co-locating at the top of the tower in the future. (Sprint 1, p. 7; Tr. 1, p. 65)

#### Public Need for Service

18. In 1996, the United States Congress recognized a nationwide need for high quality wireless telecommunications services, including cellular telephone service. Through the Federal Telecommunications Act of 1996, Congress seeks to promote competition, encourage technical innovations, and foster lower prices for telecommunications services. (Council Administrative Notice Item No. 7)
19. In issuing cellular licenses, the Federal government has preempted the determination of public need for cellular service by the states, and has established design standards to ensure technical integrity and nationwide compatibility among all systems. Sprint is licensed by the Federal Communications Commission (FCC) to provide personal wireless communication service to New Haven County, Connecticut. (Council Administrative Notice Item No. 7; Sprint 1, p. 4)
20. The Telecommunications Act of 1996 prohibits local and state entities from discriminating among providers of functionally equivalent services. (Council Administrative Notice Item No. 7)
21. The Telecommunications Act of 1996, a Federal law passed by the United States Congress, prohibits any state or local entity from regulating telecommunications towers on the basis of the environmental effects of radio frequency emissions to the extent that such towers and equipment comply with FCC's regulations concerning such emissions. This Act also blocks the Council from prohibiting or acting with the effect of prohibiting the provision of personal wireless service. (Council Administrative Notice Item No. 7)
22. In an effort to ensure the benefits of wireless technologies to all Americans, Congress enacted the Wireless Communications and Public Safety Act of 1999 (the 911 Act). The purpose of this legislation was to promote public safety through the deployment of a seamless, nationwide emergency communications infrastructure that includes wireless communications services. (Sprint 1, p. 7)
23. Sprint's facility would be in compliance with the requirements of the 911 Act. (Sprint 1, p. 7)

#### Site Selection

24. Sprint established a search ring in northern Hamden roughly centered on CL&P's easement and located to the east of Route 10. The search ring consisted of a six-sided area, approximately 0.5 miles wide at the widest point. The area is mostly residential with rolling hills that range in elevation from approximately 150 feet above mean sea level (amsl) to over 700 feet amsl. (Sprint 1, Tab 7; Sprint 1, p. 11)

25. Prior to selecting the proposed site, Sprint considered 15 existing structures in the Hamden, Cheshire, and Wallingford area. The sites consisted of electric transmission structures, a silo, a building, a flagpole tower, and one existing tower. All of the sites were rejected due to inadequate coverage to the target service area. (Sprint 1, p. 9)
26. Twelve existing towers are located within two miles of the search area. Sprint is not located on any of these twelve existing towers. None of these sites met Sprint's coverage objectives. The locations of the twelve existing towers are as follows:
- a) NU Power Mount at 150 Willow Street, Hamden
  - b) NU Power Mount #2466 at 450 Tuttle Avenue, Hamden
  - c) NU Power Mount #2465 at 450 Tuttle Avenue, Hamden
  - d) NU Pole at Old Lane Road, Cheshire
  - e) Fire Department Whip at King Road, Cheshire
  - f) NU Pole #1 at Brooksvale Avenue, Hamden
  - g) NU Pole #3 at Cook Hill Road, Cheshire
  - h) NU Pole #4 at Mansion Road, Wallingford
  - i) Golf Range Pole at Brooksvale Avenue, Hamden
  - j) NU Pole #5 at Turte Avenue, Wallingford
  - k) Quinnipiac University Building at Hogan Road, Hamden
  - l) Cingular Flagpole at Quinnipiac University at New Road, Hamden
- (Sprint 1, pp. 9-10; Sprint 1, Tab 6)
27. The 120-foot CL&P transmission structure #5215 was also considered by Sprint, but structurally, it can only support two carriers. New Cingular Wireless and T-Mobile already plan to locate on the pole. (Sprint 2, response 16)
28. Sprint also considered utilizing the existing CL&P structures on the subject property with height extensions in order to meet its coverage objectives. However, CL&P's right of way in this area does not permit the installation of telephone and telecommunications equipment within the easement area. (Tr. 1, pp. 24-25)
29. Microcells and repeaters are not viable technological alternatives for providing coverage to the identified coverage gap. Microcells and repeaters are low power sites that are limited in coverage and capacity. The coverage gap in the Hamden area is significant. Therefore, technologies such as repeaters and microcells are not viable options to cover the portions of Route 10 and the surrounding areas of Hamden and Cheshire that Sprint seeks to cover. (Sprint 1, pp. 8-9)

#### Site Description

30. The proposed site is located on an 87-acre parcel at 150 Willow Street in Hamden. The parcel, owned by Hamden Fish and Game Protective Association, Inc., contains mainly undeveloped, forested land with a firing range. The proposed site is depicted on Figure 1. (Sprint 1, p. 11; Tr. 1, p. 14)
31. The property is zoned residential, R-1. The Town's zoning regulations permit telecommunication towers in R-1 Zone districts, subject to issuance of a Special Permit and Site Plan Approval. (Sprint 1a, Town of Hamden Zoning Regulations)

32. Land use in the surrounding area is medium-density residential development, undeveloped forested lands, and overhead electric utility infrastructure and associated rights of way. (Sprint 1, p. 11)
33. The tower site is located in the western half of the property just north of CL&P's easement, at an elevation of approximately 126 feet amsl. The wooded site is dominated by sugar maple, Norway maple, black oak, and red cedar. (Sprint 1, p. 19; Sprint 3, drawings Z2 and Z3A)
34. The proposed facility would consist of a 160-foot monopole within a 100-foot by 100-foot leased area. The tower would be designed to support a total of five levels of antennas with a 10-foot vertical separation between antenna centers. The tower would be constructed of galvanized steel that would weather to a non-reflective gray finish. (Sprint 1, pp. 3, 12, 18-19; Sprint 1, Tab 9, drawing Z5)
35. Sprint would install twelve antennas on a triangular platform at a centerline height of 157 feet agl. The total height of the facility with antennas would be 160 feet agl. (Sprint 1, p. 12; Sprint 1, Tab 9, drawing Z5)
36. The tower would be designed and constructed in accordance with the American National Standards Institute TIA/EIA-222-F "Structural Standards for Steel Antenna Towers and Antenna Support Structures". (Sprint 1, p. 12)
37. A silo tower design is feasible from both a structural and RF standpoint, but visually may be a large, cumbersome structure. (Tr. 1, pp. 17-19)
38. A monopine design is possible, but visually may not blend in effectively due to the existing utility corridor. (Tr. 1, pp. 21-22)
39. A narrow "stick" tower design is possible, but the sector orientation would have to be changed in order for the antennas to fit, thereby resulting in more dropped calls. (Tr. 1, p. 37)
40. A "one-antenna-per-sector" configuration would degrade coverage similar to a decrease in height. (Tr. 1, p. 66)
41. It would be difficult for Sprint to flush-mount its antennas because the cluster of antennas is already very close together due to the sector orientation. (Tr. 1, pp. 16, 39-41)
42. T-bars could be used to mount the antennas. (Tr. 1, pp. 38-39)
43. Cellco Partnership d/b/a Verizon Wireless did not participate in this proceeding, but informed the Council of its interest in co-locating at this facility in the future by letter dated March 16, 2007. No other carriers have expressed an interest in co-locating at this facility at this time. (Cellco Letter dated March 20, 2007; Tr. 1, p. 14)
44. A 50-foot by 50-foot equipment compound enclosed by a six-foot high chain link fence would be established at the base of the tower. Sprint would install an equipment cabinet and a battery backup cabinet on a concrete pad within the compound. (Sprint 1, pp. 12-13; Sprint 1, Tab 9, drawing Z3)

45. Development of the site would require approximately 500 cubic yards of cut and 400 cubic yards of fill. (Sprint 2, response 12)
46. Access to the tower site begins at Willow Street and follows the existing access for approximately 180 feet. The access would turn to the northeast and continue along an abandoned access way for approximately 500 feet to the compound. This access way would be improved to a width of 12 feet and covered with gravel. (Sprint 3, drawings Z2 and Z3A; Tr. 1, pp. 19-20)
47. The new access could be shifted an additional 20 feet to save several large white pines. (Tr. 1, p 20)
48. Utilities would be installed underground and leave the compound in a southeasterly direction to reach an existing pole on the property. (Sprint 3, drawing Z2)
49. Development of the site would not require blasting. (Sprint 2, response 13)
50. The tower setback radius would not extend beyond the boundaries of the Hamden Fish and Game Protective Association, Inc. property but would overlap CL&P's easement by 27.5 feet. (Sprint 2, response 15; Sprint 3, drawing Z2)
51. Sprint is willing to engineer a break point on the monopole so that the tower setback radius would stay outside of the CL&P easement. Alternatively, Sprint could shift the monopole and lease area slightly north to keep the tower setback radius off of the CL&P easement. However, Sprint would prefer the break point method rather than shifting the monopole and lease area. (Sprint 2, response 15)
52. The nearest property boundary from the proposed tower is approximately 340 feet to the north (Rubin/Corrine property). The tower setback radius would not extend onto the Rubin/Corrine property. (Sprint 3, drawing Z2)
53. There are 27 residences within 1,000 feet of the proposed tower site. The nearest residence is approximately 406 feet north of the tower site (Rubin/Corrine residence). (Sprint 2, responses 10 and 11)

54. The estimated construction cost of the proposed facility is:

Site Work	\$ 30,500
Monopole	\$ 30,000
Electrical & Telephone	\$ 17,500
Foundation	\$ 31,800
Landscaping	\$ 3,000
<u>Road</u>	<u>\$ 4,000</u>
<b>Total</b>	<b>\$116,800 (Sprint 1, Tab 10)</b>

### Environmental Considerations

55. The proposed facility would have no effect upon historic, architectural, or archaeological resources listed on or eligible for the National Register of Historic Places or upon properties of traditional cultural importance to Connecticut's Native American community. (Sprint 1, Tab 14)
56. There are no known existing populations of federal or state endangered or threatened species or state special concern species occurring at the proposed site, based on a review of the Connecticut Department of Environmental Protection Natural Diversity Database. (Sprint 1, Tab 14)
57. Vegetation at the site consists of sugar maple, Norway maple, black oak, and red cedar ranging in size from 6 to 12 inches diameter at breast height (dbh). Approximately 15 trees six inches dbh or greater would be removed to develop the site. (Sprint 1, p. 19; Sprint 2, response 9; Tr. 1, p. 20)
58. Wetlands are located to the east of the pavilion, approximately 200 feet from the proposed compound. Wetland vegetation consists of red maple, green ash, spicebush, skunk cabbage, and sensitive fern. Wetland vegetation inside the CL&P right of way consists of multiflora rose, brambles, grape, silky dogwood, and goldenrod. (Sprint 1, Tab 14)
59. No work would be conducted within wetland resource areas. Some construction activities associated with the underground utility trench would be located within the Town's 200-foot upland review area. These activities would be located within existing disturbed areas and are not expected to adversely impact the nearby wetlands. (Tr. 1, p. 15)
60. There are no airports within two nautical miles of the site. Lighting of the tower would not be required. (Sprint 1, Tabs 12 and 14)
61. The proposed construction is located within the Watershed Area for the Mill River System and the Level A Aquifer Protection Area of the North Sleeping Giant Well Field, sources of drinking water for the South Central Connecticut Regional Water Authority (RWA). The DPH Drinking Water Section recommends that the RWA be contacted prior to any construction and that the following Best Management Practices be followed to ensure the safety of the drinking water supply:
  - a) Coordinate any construction activities with the RWA.
  - b) Write an emergency response plan for actions to be taken in the event of an accidental fuel or chemical spill that may occur during construction.
  - c) Have spill response equipment available on-site at all times along with personnel trained in the proper use of such equipment.
  - d) Designate a person or persons for emergency response coordination on a 24/7 basis.
  - e) Contact the RWA immediately in the event of an accidental spill.

- f) Avoid the cleaning of equipment on the locations of construction due to possible contamination from equipment chemicals.
- g) Avoid any storage of fuel or refueling within the watershed and aquifer protection areas.
- h) Designate one area (off of the source areas) for auto parking, vehicle refueling and routine equipment maintenance. This area should be well away from exposed surfaces or storm drains.
- i) Perform all major equipment repairs off site.
- j) Keep pollutants off of exposed surfaces.
- k) Do not bury stumps or construction debris on the job site.
- l) Place sediment fences and hay bales strategically and inspect and maintain them to prevent sedimentation and erosion.
- m) Inspect and maintain temporary storm water ponds and basins routinely.
- n) Have additional sediment fences and hay bales available for use as needed to prevent runoff in the event that unexpected conditions occur.
- o) Protect exposed stockpiles of soil to prevent runoff.
- p) Use as little water as possible for dust control.
- q) Clean up leaks, drips and other spills immediately to prevent or minimize soil contamination.
- r) Never hose down "dirty" pavement or surfaces where materials have spilled. Use dry cleanup methods whenever possible.
- s) Perform any blasting only with careful consideration to impacts to the area, including possible effects to ground water which could affect drinking water quality and quantity.
- t) Remove paints, paint products and other hazardous materials from the site during non-work hours or otherwise store these materials in a secure area to prevent vandalism.
- u) Place covered trashcans and recycling receptacles around the site. Cover and maintain dumpsters, check frequently for leaks, and never clean a dumpster by hosing it down on site.
- v) Avoid development of slopes at 15 percent or greater. If they cannot be avoided in this project, a separate environmental consultant should be on site to ensure proper erosion and sedimentation controls are in place. This consultant would be

responsible to report to the RWA so water quality issues are avoided. (DPH Comments dated March 23 and 26, 2007)

62. The maximum power density from the radio frequency emissions of Sprint's proposed antennas would be 0.0482 mW/cm<sup>2</sup>, or 4.82% of the standard for Maximum Permissible Exposure, as adopted by the FCC, at the base of the proposed tower. This calculation was based on methodology prescribed by the FCC Office of Engineering and Technology Bulletin No. 65E, Edition 97-01 (August 1997) that assumes all antennas would be pointed at the base of the tower and all channels would be operating simultaneously. (Sprint 1, p. 23)

**Visibility**

63. The proposed tower would be visible year-round from approximately 59 acres within a two-mile radius of the site (refer to Figure 6). The tower would be seasonally visible from approximately 97 acres within a two-mile radius of the site. (Sprint 1, Tab 12, pp. 4-5; Tr. 1, pp. 45-46)
64. Visibility of the proposed tower from roads within a two-mile radius of the site is presented in the table below:

Road	Length of Road Visibility (Seasonal)	Length of Road Visibility (Year-round)	Nearest Distance with Visibility to Site A
Route 10	0.1 miles	0.2 miles	0.3 miles west
Bittersweet Lane	0.1 miles	-	0.3 miles northwest
Still Hill Road	0.3 miles	-	0.6 miles southwest
Brooksvale Avenue	0.1 miles	0.1 miles	0.6 miles southwest
Knoll Drive	0.1 miles	-	0.1 miles north
Willow Street	0.1 miles	0.03 miles	0.1 miles southwest

(Sprint 1, Tab 12)



65. Visibility of the proposed tower from specific locations within a two-mile radius of the site is presented in the table below:

Location	Visible	Approx. Portion of Tower Visible	Approx. Distance to Tower
Route 10 – north of Brooksville Avenue	Yes	20 feet – above trees	0.6 miles northeast
Knoll Drive – Adjacent to house #162	Yes	15 feet – above trees	0.3 miles south
Brooksville Avenue – at existing utility right of way	Yes	20 feet – above trees	0.6 miles northeast
Route 10 – at existing utility right of way	Yes	25 feet – above trees	0.3 miles northeast
Willow Street – at existing utility right of way	Yes	30 feet – obstructed through trees	0.1 miles northeast

(Sprint, Tab 12)

66. A significant amount of the total visibility of the proposed facility falls on the host property and the existing utility right of way that traverses the study area. Other areas of visibility include a roadside commercial development along Route 10 located within the general vicinity, an adjacent open field located to the southwest of the site, and portions of Knoll Drive approximately 1,000 feet to the northeast. (Sprint 1, p. 21)
67. The proposed site would be visible year-round from four residences along Knoll Drive and two residences along Route 10. There are also several small areas of potential visibility located over one mile to the northwest and approximately 900 feet northeast of the proposed facility. These areas are private property and the views could not be verified by Sprint's visual resource consultant. However, views from these areas are expected to be limited to tree-line views and/or views of the upper 25 percent of the proposed facility. (Sprint 1, p. 22)
68. The proposed site would be seasonally visible from five properties along Knoll Drive and three properties along Willow Street. (Sprint 1, p. 22)
69. The nearest state or local recreational area is the Sleeping Giant State Park, which is approximately 0.3 miles east of the tower site at its closest point. The proposed tower may be visible from the Naugatuck Trail in Sleeping Giant State Park, but the viewer would have to pick it out from the existing trees and utility infrastructure. The proposed tower may be visible from other trails in the Sleeping Giant State Park, but the viewer would be looking down on the tower and the view would be largely lost because it would blend in with the valley. (Sprint 1, Tab 12; Tr. 1, pp. 30-32)
70. The proposed tower is not expected to be visible from the Quinnipiac Trail. (Sprint 1, Tab 12)
71. The proposed tower would be seasonally visible from a 0.2 mile long section of the Farmington Canal Linear State Park Trail, which is located approximately 0.5 miles to the west of the proposed site at its nearest point. (Sprint 1, Tab 12)

72. The proposed tower may be visible from the Naugatuck State Forest but the view would be limited to a tree-top view and would also be mitigated by the distance of roughly two miles. (Tr. 1, pp. 33-34)
73. The proposed tower is not expected to be visible from Brooksvale Recreation Park. (Tr. 2, pp. 13-14; Sprint 1, Tab 12)
74. There are no state or local scenic roads within two miles of the proposed tower site. (Tr. 1, p. 15)
75. There are no historic districts within a two-mile radius of the proposed site. (Sprint 1, Tab 12)

#### Existing and Proposed Wireless Coverage

76. Sprint transmits in the 1950 - 1965 MHz frequency bands and has a signal-level service design of -92 dBm for this area, sufficient for in-vehicle coverage. The signal-level threshold for in-building coverage is -87 dBm. (Sprint 2, response 4; Sprint 1, Tab 7)
77. Sprint's existing signal strength in the majority of the area to be covered by this proposed facility is below -92 dBm. (Sprint 2, response 3)
78. Sprint's customers are currently experiencing a high number of dropped calls (over 2 percent) in the area to be covered by the proposed facility. (Sprint 1, p. 6)
79. Sprint's existing coverage gap along Route 10 is approximately 2.8 miles. The proposed site would fill this gap. Refer to Figure 2. (Sprint 2, response 8)
80. Sprint's minimum height to meet coverage design objectives is 157 feet. Refer to Figure 3. (Sprint 1, response 2)
81. Installing the antennas at lower heights, such as 147 feet or 137 feet, would cause the coverage gap on Route 10 north of Cook Hill Road to increase in size. Refer to Figures 4 and 5. (Tr. 1, pp. 50-51)
82. The proposed tower would provide approximately 4.5 square miles of improved coverage. (Sprint 2, response 7)

Figure 1: Location Map

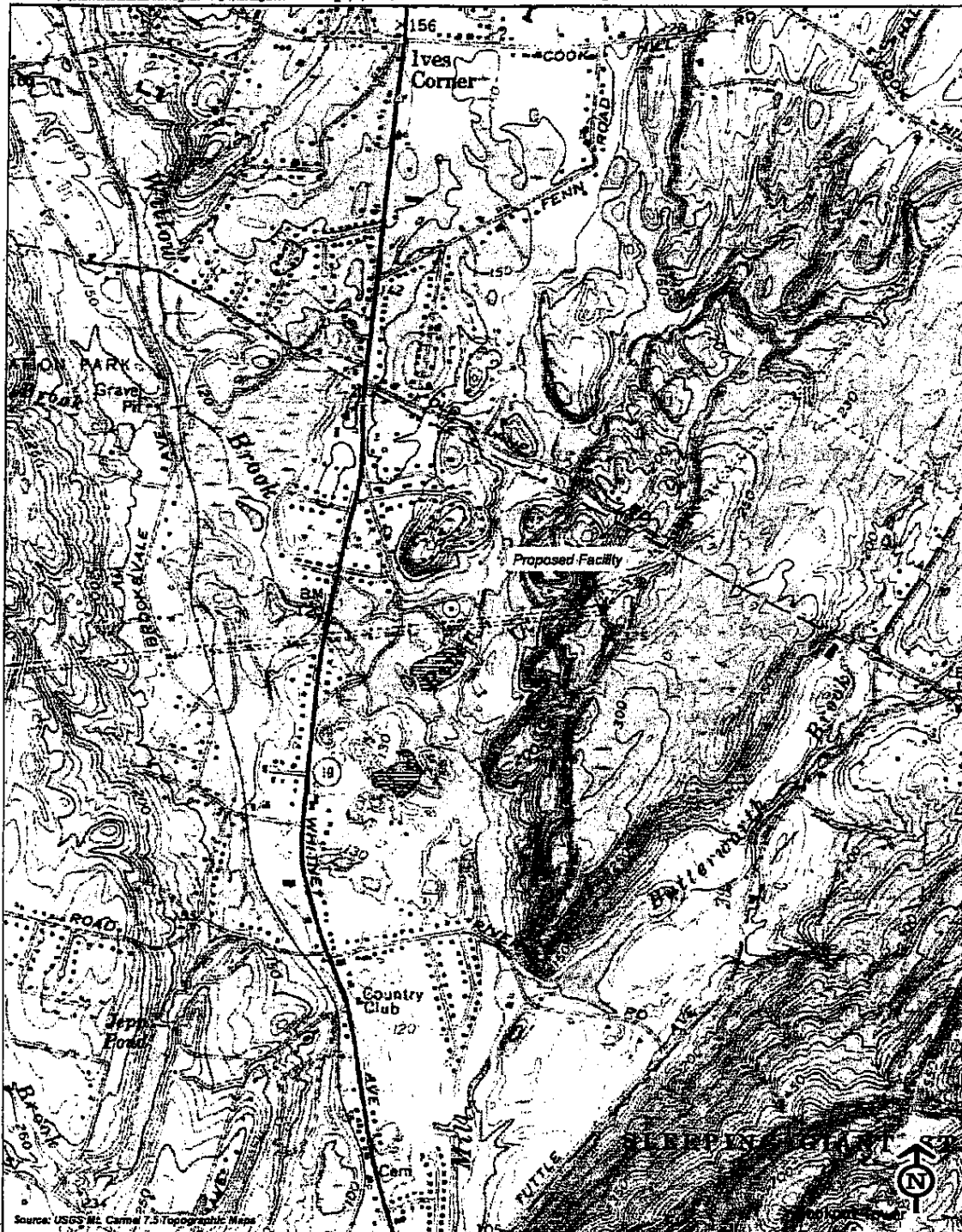

(Sprint 1, p. Tab 1)

Figure 2: Existing Coverage

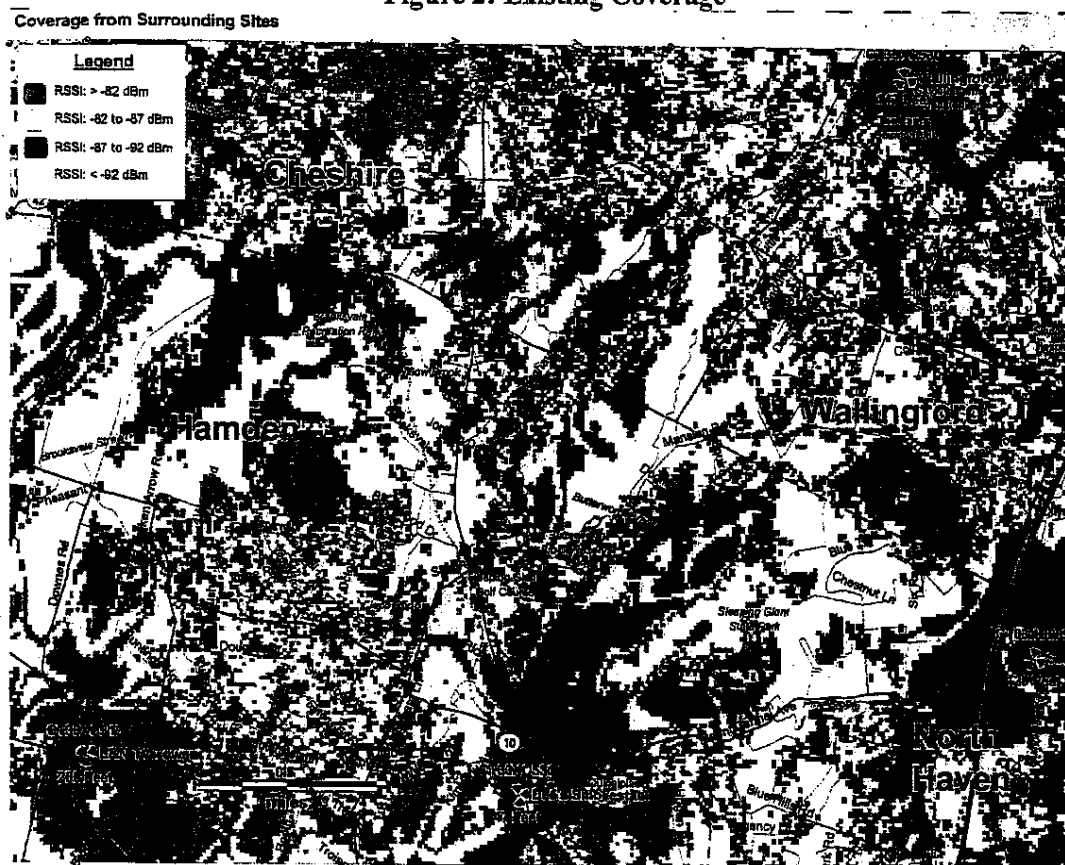

(Sprint 1, Tab 11)

Figure 3: Coverage with Proposed Antennas at 157 feet

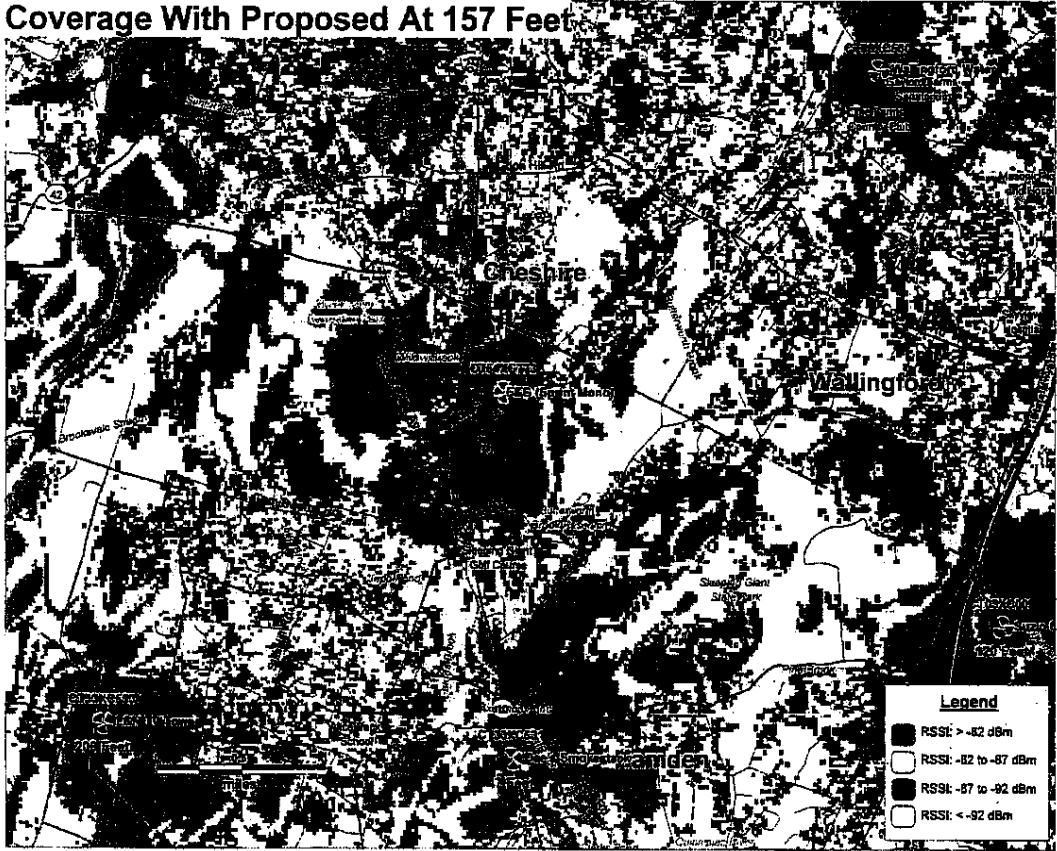

(Sprint 2, response 1)

Figure 4: Coverage with Proposed Antennas at 147 feet

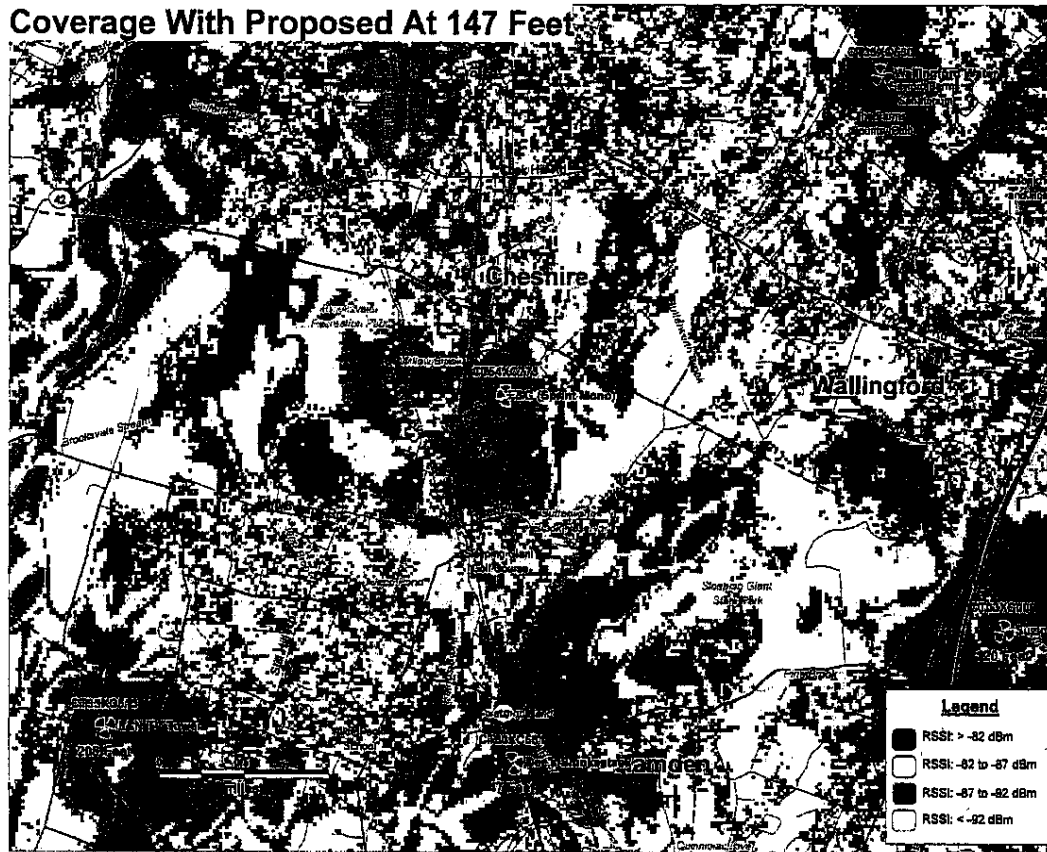

(Sprint 2, response 1)

Figure 5: Coverage with Proposed Antennas at 137 feet

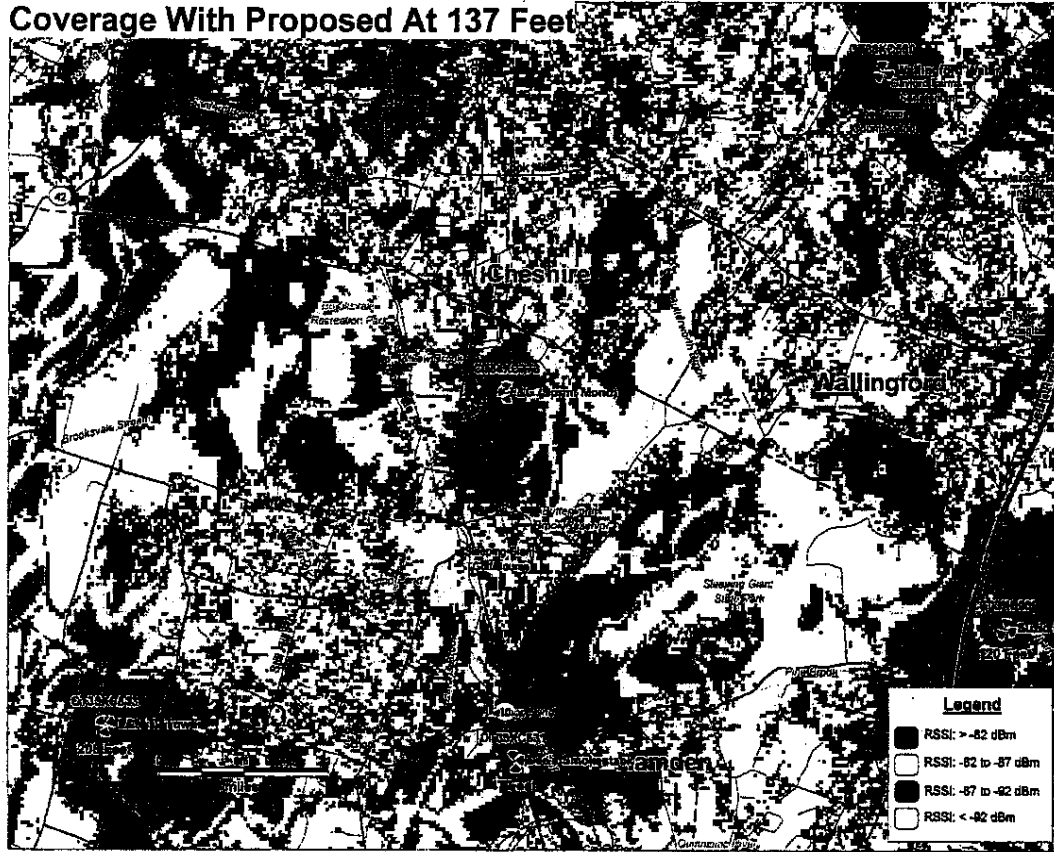

(Sprint 2, response 1)

**Figure 6: Viewshed Map**



(Sprint 1, Tab 12)



Figure 6: Viewshed Map Legend

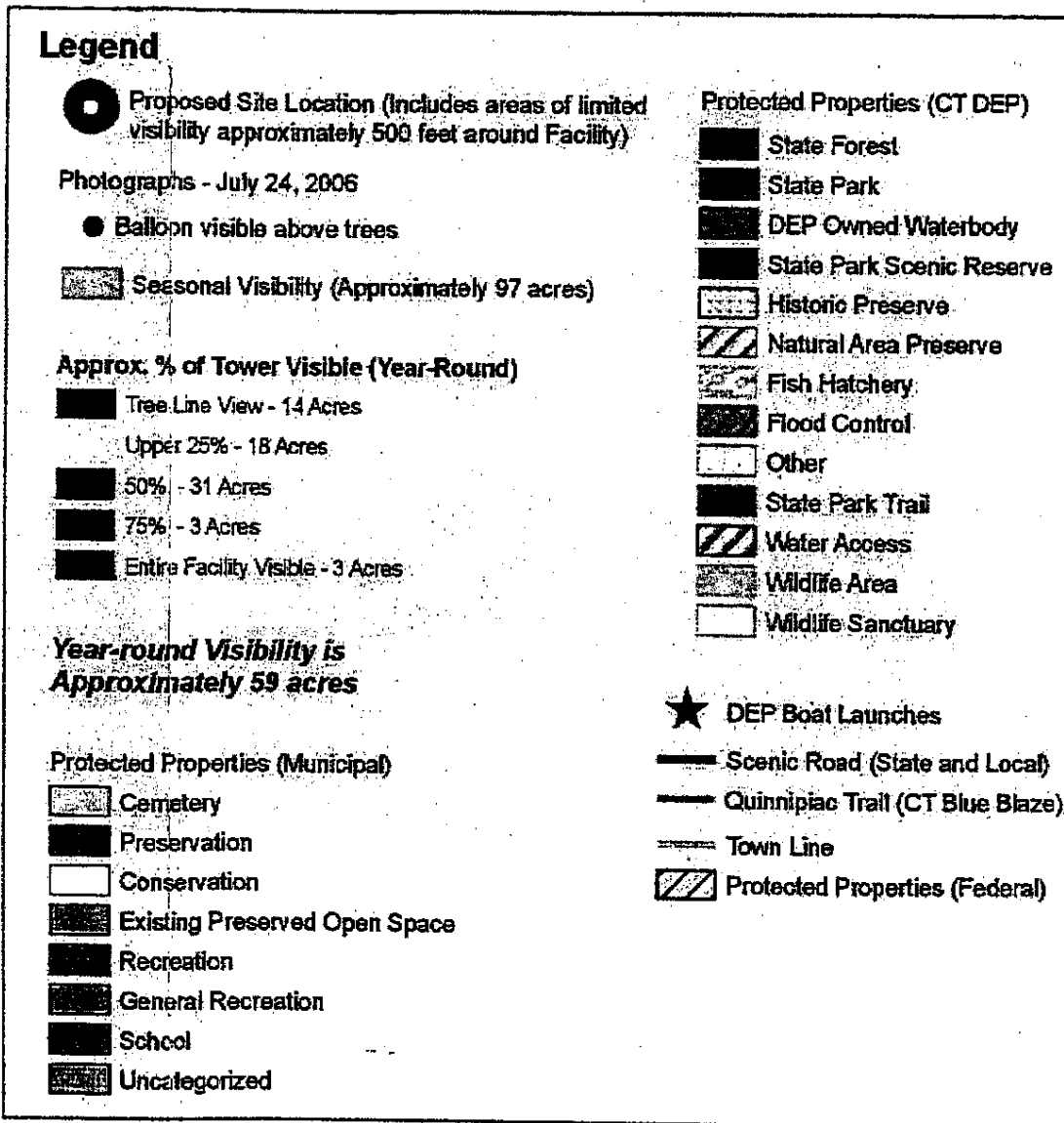

(Sprint 1, Tab 12)

DOCKET NO. 324 – Sprint Nextel Corporation application for a } Connecticut  
Certificate of Environmental Compatibility and Public Need for }  
the construction, maintenance and operation of a wireless } Siting  
telecommunications facility at 150 Willow Street, Hamden, }  
Connecticut. } Council

May 1, 2007

### Opinion

On October 27, 2006, Sprint Nextel Corporation (Sprint) applied to the Connecticut Siting Council (Council) for a Certificate of Environmental Compatibility and Public Need (Certificate) for the construction, maintenance and operation of a wireless telecommunications facility to be located at 150 Willow Street, Hamden, Connecticut. Sprint is seeking to develop a facility on property owned by the Hamden Fish and Game Protective Association, Inc. (Hamden Fish and Game). Sprint's objective in locating a facility at this location is to provide service on Route 10 and surrounding areas in Cheshire and Hamden.

Sprint proposes to construct a 160-foot monopole and associated compound on an 87-acre parcel owned by Hamden Fish and Game and consisting of mainly undeveloped, forested land with a firing range. The tower and the 50-foot by 50-foot compound area will be located in the western half of the property just north of The Connecticut Light and Power Company's (CL&P) easement. The tower would be designed to support the antennas of four additional carriers.

Utilities will be installed underground to reach an existing pole on the subject property. Access to the tower site begins at Willow Street and follows the existing access for approximately 180 feet. The access would turn to the northeast and continue along an abandoned access way for approximately 500 feet to the compound. This access way would be improved to a width of 12 feet and covered with gravel.

The tower setback radius would not extend beyond the boundaries of Hamden Fish and Game property, but would overlap The Connecticut Light and Power Company's (CL&P) easement by 27.5 feet. Sprint is willing to engineer a break point on the monopole so that the tower setback radius would stay outside of the CL&P easement. Accordingly, the Council will order the design of the monopole to include a break point to prevent the tower from extending onto CL&P's transmission line easement in the event of a tower failure.

The tower will be visible year-round from approximately 59 acres within a two-mile radius of the site. The tower will be seasonally visible from approximately 97 acres within a two-mile radius of the site. The proposed site would be visible year-round from four residences along Knoll Drive and two residences along Route 10. There are also several small areas of potential visibility located over one mile to the northwest and approximately 900 feet northeast of the proposed facility. However, views from these areas are expected to be limited to tree-line views and/or views of the upper 25 percent of the proposed facility. The proposed site would be seasonally visible from five properties along Knoll Drive and three properties along Willow Street.

The nearest state or local recreational area is the Sleeping Giant State Park, which is approximately 0.3 miles east from the tower site at its closest point. The proposed tower may be visible from the Naugutuck Trail in Sleeping Giant State Park, but the viewer would have to pick

it out from the existing trees and utility infrastructure. The proposed tower may be visible from other trails in the Sleeping Giant State Park, but the viewer would be looking down on the tower, and the view would be largely lost because it would blend in with the valley. The proposed tower is not expected to be visible from the Quinnipiac Trail.

Sprint transmits in the 1950 - 1965 MHz frequency bands and has a signal-level service design of -92 dBm for this area, sufficient for in-vehicle coverage. The signal-level threshold for in-building coverage is -87 dBm. Sprint's existing signal strength in the majority of the area to be covered by this proposed facility is below -92 dBm. Sprint's customers are currently experiencing a high number of dropped calls (over 2 percent), which decreases Sprint's reliability. Sprint's existing coverage gap along Route 10 is approximately 2.8 miles. The proposed site would fill this gap. Sprint's minimum height to meet coverage design objectives is 157 feet. Installing the antennas at lower heights, such as 147 feet or 137 feet, would cause the coverage gap on Route 10 north of Cook Hill Road to increase in size. The proposed tower would provide approximately 4.5 square miles of improved coverage.

The site is wooded and is dominated by sugar maple, Norway maple, black oak, and red cedar. Development of the proposed site will require clearing of approximately 15 trees of six inches in diameter or greater at breast height (dbh). No work will be conducted within wetland resource areas. Some construction activities associated with the underground utility trench will be located within the Town's 200-foot upland review area. These activities will be located within existing disturbed areas and are not expected to adversely impact the nearby wetlands. Therefore, the Council will order erosion and sedimentation controls consistent with the Connecticut Guidelines for Soil Erosion and Sediment Control, May 2002, as amended.

There are no known existing populations of federal or state endangered or threatened species or state special concern species occurring at the proposed site, based on a review of the Connecticut Department of Environmental Protection Natural Diversity Database. The proposed facility will have no effect on archaeological or historic resources.

The Council is concerned, however, that the proposed tower is located within the Watershed Area for the Mill River System and the Level A Aquifer Protection Area of the North Sleeping Giant Well Field, sources of drinking water for the South Central Connecticut Regional Water Authority. To minimize the risk of contamination of drinking water during construction, the Council will order Sprint to comply with the Connecticut Department of Public Health's Best Management Practices to the extent applicable.

According to a methodology prescribed by the FCC Office of Engineering and Technology Bulletin No. 65E, Edition 97-01 (August 1997), the combined radio frequency power density levels of the antennas proposed to be installed on the tower have been calculated by Council staff to amount to 4.82% of the FCC's Maximum Permissible Exposure, as measured at the base of the tower. This percentage is well below federal and state standards established for the frequencies used by wireless companies. If federal or state standards change, the Council will require that the tower be brought into compliance with such standards. The Council will require that the power densities be recalculated in the event other carriers add antennas to the tower. The Telecommunications Act of 1996 prohibits any state or local agency from regulating telecommunications towers on the basis of the environmental effects of radio frequency emissions to the extent that such towers and equipment comply with FCC's regulations concerning such emissions.

Based on the record in this proceeding, the Council finds that the effects associated with the construction, operation, and maintenance of the telecommunications facility at the proposed site, including effects on the natural environment; ecological integrity and balance; public health and safety; scenic, historic, and recreational values; forests and parks; air and water purity; and fish and wildlife are not disproportionate either alone or cumulatively with other effects when compared to need, are not in conflict with policies of the State concerning such effects, and are not sufficient reason to deny this application. Therefore, the Council will issue a Certificate for the construction, operation, and maintenance of a 160-foot monopole telecommunications facility at the proposed site at 150 Willow Street, Hamden, Connecticut.

DOCKET NO. 324 – Sprint Nextel Corporation application for a Certificate of Environmental Compatibility and Public Need for the construction, maintenance and operation of a wireless telecommunications facility at 150 Willow Street, Hamden, Connecticut.	} } }	Connecticut  Siting  Council  May 1, 2007
--	-------------	---

**Decision and Order**

Pursuant to the foregoing Findings of Fact and Opinion, the Connecticut Siting Council (Council) finds that the effects associated with the construction, operation, and maintenance of a telecommunications facility, including effects on the natural environment; ecological integrity and balance; public health and safety; scenic, historic, and recreational values; forests and parks; air and water purity; and fish and wildlife are not disproportionate, either alone or cumulatively with other effects, when compared to need, are not in conflict with the policies of the State concerning such effects, and are not sufficient reason to deny the application, and therefore directs that a Certificate of Environmental Compatibility and Public Need, as provided by General Statutes § 16-50k, be issued to Sprint Nextel Corporation, hereinafter referred to as the Certificate Holder, for a telecommunications facility at 150 Willow Street, Hamden, Connecticut.

The facility shall be constructed, operated, and maintained substantially as specified in the Council's record in this matter, and subject to the following conditions:

1. The tower shall be constructed as a monopole, no taller than necessary to provide the proposed telecommunications services, sufficient to accommodate the antennas of Sprint Nextel Corporation and other entities, both public and private, but such tower shall not exceed a height of 160 feet above ground level. The height at the top of the antennas shall not exceed 160 feet above ground level.
2. The Certificate Holder shall prepare a Development and Management (D&M) Plan for this site in compliance with Sections 16-50j-75 through 16-50j-77 of the Regulations of Connecticut State Agencies. The D&M Plan shall be served on the Town of Hamden for comment, and all parties and intervenors as listed in the service list, and submitted to and approved by the Council prior to the commencement of facility construction and shall include:
  - a) a final site plan(s) of site development to include specifications for the tower, tower foundation, antennas, equipment compound, radio equipment, access road, utility line, and landscaping; and
  - b) construction plans for site clearing, water drainage, and erosion and sedimentation control consistent with the 2002 Connecticut Guidelines for Soil Erosion and Sediment Control, as amended.
3. The Certificate Holder shall, prior to the commencement of operation, provide the Council worst-case modeling of electromagnetic radio frequency power density of all proposed entities' antennas at the closest point of uncontrolled access to the tower base, consistent with Federal Communications Commission, Office of Engineering and Technology, Bulletin No. 65, August 1997. The Certificate Holder shall ensure a recalculated report of electromagnetic radio frequency power density is submitted to the Council if and when circumstances in operation cause a change in power density above the levels calculated and provided pursuant to this Decision and Order.

4. Upon the establishment of any new State or federal radio frequency standards applicable to frequencies of this facility, the facility granted herein shall be brought into compliance with such standards.
5. The Certificate Holder shall permit public or private entities to share space on the proposed tower for fair consideration, or shall provide any requesting entity with specific legal, technical, environmental, or economic reasons precluding such tower sharing.
6. The Certificate Holder shall provide reasonable space on the tower for no compensation for any Town of public safety services (police, fire and medical services), provided such use can be accommodated and is compatible with the structural integrity of the tower.
7. The Certificate Holder shall engineer a break point on the monopole to ensure that the tower setback radius remains outside of The Connecticut Light and Power Company easement.
8. The Certificate Holder shall comply with the Connecticut Department of Public Health's Best Management Practices to the extent applicable, to protect the drinking water supply.
9. Unless otherwise approved by the Council, if the facility authorized herein is not fully constructed and providing wireless services within eighteen months from the date of the mailing of the Council's Findings of Fact, Opinion, and Decision and Order (collectively called "Final Decision"), this Decision and Order shall be void, and the Certificate Holder shall dismantle the tower and remove all associated equipment or reapply for any continued or new use to the Council before any such use is made. The time between the filing and resolution of any appeals of the Council's Final Decision shall not be counted in calculating this deadline.
10. Any request for extension of the time period referred to in Condition 9 shall be filed with the Council not later than 60 days prior to the expiration date of this Certificate and shall be served on all parties and intervenors, as listed in the service list, and the Town of Hamden. Any proposed modifications to this Decision and Order shall likewise be so served.
11. If the facility ceases to provide wireless services for a period of one year, this Decision and Order shall be void, and the Certificate Holder shall dismantle the tower and remove all associated equipment or reapply for any continued or new use to the Council before any such use is made.
12. The Certificate Holder shall remove any nonfunctioning antenna, and associated antenna mounting equipment, within 60 days of the date the antenna ceased to function.
13. In accordance with Section 16-50j-77 of the Regulations of Connecticut State Agencies, the Certificate Holder shall provide the Council with written notice two weeks prior to the commencement of site construction activities. In addition, the Certificate Holder shall provide the Council with written notice of the completion of site construction and the commencement of site operation.

Pursuant to General Statutes § 16-50p, the Council hereby directs that a copy of the Findings of Fact, Opinion, and Decision and Order be served on each person listed below, and notice of issuance shall be published in The New Haven Register.

By this Decision and Order, the Council disposes of the legal rights, duties, and privileges of each party named or admitted to the proceeding in accordance with Section 16-50j-17 of the Regulations of Connecticut State Agencies.

The parties and intervenors to this proceeding are:

**Applicant**

Sprint Nextel Corporation





**Its Representative**

Thomas J. Regan, Esq.  
Brown Rudnick Berlack Israels LLP  
CityPlace I, 38<sup>th</sup> Floor  
185 Asylum Street  
Hartford, CT 06103-3402  
Phone: 860-509-6522  
Fax: 860-509-6501  
Email: [tregan@brownrudnick.com](mailto:tregan@brownrudnick.com)

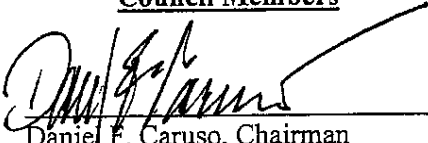
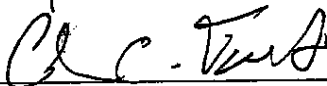
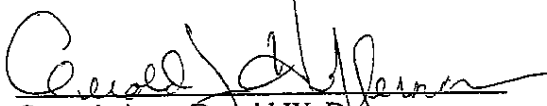

**CERTIFICATION**

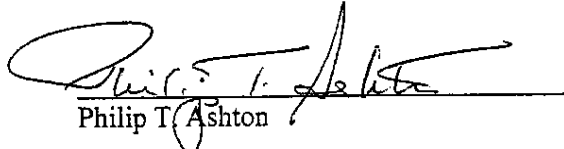
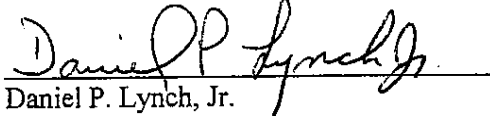
The undersigned members of the Connecticut Siting Council (Council) hereby certify that they have heard this case, or read the record thereof, in **DOCKET NO. 324** – Sprint Nextel Corporation application for a Certificate of Environmental Compatibility and Public Need for the construction, maintenance and operation of a wireless telecommunications facility at 150 Willow Street, Hamden, Connecticut, and voted as follows to approve the proposed site, located at 150 Willow Street, Hamden, Connecticut:

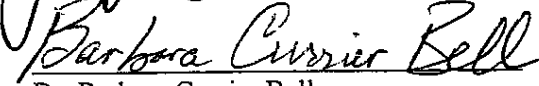
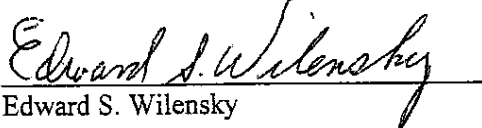
<u>Council Members</u>	<u>Vote Cast</u>
 Daniel F. Caruso, Chairman	Yes
 Colin C. Tait, Vice Chairman	Yes
 Commissioner Donald W. Downes Designee: Gerald J. Heffernan	Yes
 Commissioner Gina McCarthy Designee: Brian J. Emerick	Yes
 Philip T. Ashton	Abstain
 Daniel P. Lynch, Jr.	Yes
 James J. Murphy, Jr.	Yes
 Dr. Barbara Currier Bell	Yes
 Edward S. Wilensky	Yes

Dated at New Britain, Connecticut, May 1, 2007.



## RADIO FREQUENCY EMISSIONS ANALYSIS REPORT EVALUATION OF HUMAN EXPOSURE POTENTIAL TO NON-IONIZING EMISSIONS

SPRINT Existing Facility

Site ID: CT54XC773

Hamden Fish & Game Club  
150 Willow Street  
Hamden, CT 06518

**September 5, 2017**

**EBI Project Number: 6217003654**

Site Compliance Summary	
Compliance Status:	<b>COMPLIANT</b>
Site total MPE% of FCC general population allowable limit:	<b>7.91 %</b>



September 5, 2017

SPRINT

Attn: RF Engineering Manager  
1 International Boulevard, Suite 800  
Mahwah, NJ 07495

Emissions Analysis for Site: **CT54XC773 – Hamden Fish & Game Club**

EBI Consulting was directed to analyze the proposed SPRINT facility located at **150 Willow Street, Hamden, CT**, for the purpose of determining whether the emissions from the Proposed SPRINT Antenna Installation located on this property are within specified federal limits.

All information used in this report was analyzed as a percentage of current Maximum Permissible Exposure (% MPE) as listed in the FCC OET Bulletin 65 Edition 97-01 and ANSI/IEEE Std C95.1. The FCC regulates Maximum Permissible Exposure in units of microwatts per square centimeter ( $\mu\text{W}/\text{cm}^2$ ). The number of  $\mu\text{W}/\text{cm}^2$  calculated at each sample point is called the power density. The exposure limit for power density varies depending upon the frequencies being utilized. Wireless Carriers and Paging Services use different frequency bands each with different exposure limits, therefore it is necessary to report results and limits in terms of percent MPE rather than power density.

All results were compared to the FCC (Federal Communications Commission) radio frequency exposure rules, 47 CFR 1.1307(b)(1) – (b)(3), to determine compliance with the Maximum Permissible Exposure (MPE) limits for General Population/Uncontrolled environments as defined below.

General population/uncontrolled exposure limits apply to situations in which the general population may be exposed or in which persons who are exposed as a consequence of their employment may not be made fully aware of the potential for exposure or cannot exercise control over their exposure. Therefore, members of the general population would always be considered under this category when exposure is not employment related, for example, in the case of a telecommunications tower that exposes persons in a nearby residential area.

Population exposure to radio frequencies is regulated and enforced in units of microwatts per square centimeter ( $\mu\text{W}/\text{cm}^2$ ). The general population exposure limits for the 850 MHz Band is approximately  $567 \mu\text{W}/\text{cm}^2$ . The general population exposure limit for the 1900 MHz (PCS) and 2500 MHz (BRS) bands is  $1000 \mu\text{W}/\text{cm}^2$ . Because each carrier will be using different frequency bands, and each frequency band has different exposure limits, it is necessary to report percent of MPE rather than power density.



Occupational/controlled exposure limits apply to situations in which persons are exposed as a consequence of their employment and in which those persons who are exposed have been made fully aware of the potential for exposure and can exercise control over their exposure. Occupational/controlled exposure limits also apply where exposure is of a transient nature as a result of incidental passage through a location where exposure levels may be above general population/uncontrolled limits (see below), as long as the exposed person has been made fully aware of the potential for exposure and can exercise control over his or her exposure by leaving the area or by some other appropriate means.

Additional details can be found in FCC OET 65.

## CALCULATIONS

Calculations were done for the proposed SPRINT Wireless antenna facility located at **150 Willow Street, Hamden, CT**, using the equipment information listed below. All calculations were performed per the specifications under FCC OET 65. Since SPRINT is proposing highly focused directional panel antennas, which project most of the emitted energy out toward the horizon, all calculations were performed assuming a lobe representing the maximum gain of the antenna per the antenna manufactures supplied specifications, minus 10 dB, was focused at the base of the tower. For this report the sample point is the top of a 6-foot person standing at the base of the tower.

For all calculations, all equipment was calculated using the following assumptions:

- 1) 1 CDMA channels (850 MHz) were considered for each sector of the proposed installation. These Channels have a transmit power of 20 Watts per Channel.
- 2) 2 LTE channels (850 MHz) were considered for each sector of the proposed installation. These Channels have a transmit power of 20 Watts per Channel.
- 3) 5 CDMA channels (1900 MHz (PCS)) were considered for each sector of the proposed installation. These Channels have a transmit power of 16 Watts per Channel.
- 4) 2 LTE channels (1900 MHz (PCS)) were considered for each sector of the proposed installation. These Channels have a transmit power of 40 Watts per Channel.
- 5) 8 LTE channels (2500 MHz (BRS)) were considered for each sector of the proposed installation. These Channels have a transmit power of 20 Watts per Channel.



- 6) All radios at the proposed installation were considered to be running at full power and were uncombined in their RF transmissions paths per carrier prescribed configuration. Per FCC OET Bulletin No. 65 - Edition 97-01 recommendations to achieve the maximum anticipated value at each sample point, all power levels emitting from the proposed antenna installation are increased by a factor of 2.56 to account for possible in-phase reflections from the surrounding environment. This is rarely the case, and if so, is never continuous.
- 7) For the following calculations, the sample point was the top of a 6-foot person standing at the base of the tower. The maximum gain of the antenna per the antenna manufactures supplied specifications minus 10 dB was used in this direction. This value is a very conservative estimate as gain reductions for these particular antennas are typically much higher in this direction.
- 8) The antennas used in this modeling are the **RFS APXV9ERR18-C-A20** and **RFS APXVTM14-C-I20** for transmission in the 850 MHz, 1900 MHz (PCS) and 2500 MHz (BRS) frequency bands. This is based on feedback from the carrier with regards to anticipated antenna selection. Maximum gain values for all antennas are listed in the Inventory and Power Data table below. The maximum gain of the antenna per the antenna manufactures supplied specifications, minus 10 dB, was used for all calculations. This value is a very conservative estimate as gain reductions for these particular antennas are typically much higher in this direction.
- 9) The antenna mounting height centerlines of the proposed antennas are **136.5 feet** above ground level (AGL) for **Sector A**, **136.5 feet** above ground level (AGL) for **Sector B** and **136.5 feet** above ground level (AGL) for Sector C.
- 10) Emissions values for additional carriers were taken from the Connecticut Siting Council active database. Values in this database are provided by the individual carriers themselves.

All calculations were done with respect to uncontrolled / general population threshold limits.



## SPRINT Site Inventory and Power Data by Antenna

Sector:	A	Sector:	B	Sector:	C
Antenna #:	<b>1</b>	Antenna #:	<b>1</b>	Antenna #:	<b>1</b>
Make / Model:	RFS APXV9ERR18-C-A20	Make / Model:	RFS APXV9ERR18-C-A20	Make / Model:	RFS APXV9ERR18-C-A20
Gain:	11.9 / 14.9 dBd	Gain:	11.9 / 14.9 dBd	Gain:	11.9 / 14.9 dBd
Height (AGL):	<b>136.5 feet</b>	Height (AGL):	<b>136.5 feet</b>	Height (AGL):	<b>136.5 feet</b>
Frequency Bands	850 MHz / 1900 MHz (PCS)	Frequency Bands	850 MHz / 1900 MHz (PCS)	Frequency Bands	850 MHz / 1900 MHz (PCS)
Channel Count	10	Channel Count	10	Channel Count	10
Total TX Power(W):	220 Watts	Total TX Power(W):	220 Watts	Total TX Power(W):	220 Watts
ERP (W):	5,873.76	ERP (W):	5,873.76	ERP (W):	5,873.76
Antenna A1 MPE%	<b>1.39 %</b>	Antenna B1 MPE%	<b>1.39 %</b>	Antenna C1 MPE%	<b>1.39 %</b>
Antenna #:	<b>2</b>	Antenna #:	<b>2</b>	Antenna #:	<b>2</b>
Make / Model:	RFS APXVTM14-C-I20	Make / Model:	RFS APXVTM14-C-I20	Make / Model:	RFS APXVTM14-C-I20
Gain:	15.9 dBd	Gain:	15.9 dBd	Gain:	15.9 dBd
Height (AGL):	<b>136.5 feet</b>	Height (AGL):	<b>136.5 feet</b>	Height (AGL):	<b>136.5 feet</b>
Frequency Bands	2500 MHz (BRS)	Frequency Bands	2500 MHz (BRS)	Frequency Bands	2500 MHz (BRS)
Channel Count	8	Channel Count	8	Channel Count	8
Total TX Power(W):	160 Watts	Total TX Power(W):	160 Watts	Total TX Power(W):	160 Watts
ERP (W):	6,224.72	ERP (W):	6,224.72	ERP (W):	6,224.72
Antenna A2 MPE%	<b>1.31 %</b>	Antenna B2 MPE%	<b>1.31 %</b>	Antenna C2 MPE%	<b>1.31 %</b>

Site Composite MPE%	
Carrier	MPE%
SPRINT – Max per sector	<b>2.70 %</b>
T-Mobile	2.68 %
MetroPCS	0.40 %
Verizon Wireless	2.13 %
<b>Site Total MPE %:</b>	<b>7.91 %</b>

SPRINT Sector A Total:	2.70 %
SPRINT Sector B Total:	2.70 %
SPRINT Sector C Total:	2.70 %
<b>Site Total:</b>	<b>7.91 %</b>

SPRINT _ Max Values per Frequency Band / Technology Per Sector	# Channels	Watts ERP (Per Channel)	Height (feet)	Total Power Density ( $\mu\text{W}/\text{cm}^2$ )	Frequency (MHz)	Allowable MPE ( $\mu\text{W}/\text{cm}^2$ )	Calculated % MPE
Sprint 850 MHz CDMA	1	309.76	136.5	0.65	850 MHz	567	0.12%
Sprint 850 MHz LTE	2	309.76	136.5	1.31	850 MHz	567	0.23%
Sprint 1900 MHz (PCS) CDMA	5	494.45	136.5	5.22	1900 MHz (PCS)	1000	0.52%
Sprint 1900 MHz (PCS) LTE	2	1,236.12	136.5	5.22	1900 MHz (PCS)	1000	0.52%
Sprint 2500 MHz (BRS) LTE	8	778.09	136.5	13.14	2500 MHz (BRS)	1000	1.31%
						<b>Total:</b>	<b>2.70%</b>



## Summary

All calculations performed for this analysis yielded results that were **within** the allowable limits for general population exposure to RF Emissions.

The anticipated maximum composite contributions from the SPRINT facility as well as the site composite emissions value with regards to compliance with FCC's allowable limits for general population exposure to RF Emissions are shown here:

SPRINT Sector	Power Density Value (%)
Sector A:	2.70 %
Sector B:	2.70 %
Sector C:	2.70 %
SPRINT Maximum Total (per sector):	2.70 %
Site Total:	7.91 %
Site Compliance Status:	<b>COMPLIANT</b>

The anticipated composite MPE value for this site assuming all carriers present is **7.91 %** of the allowable FCC established general population limit sampled at the ground level. This is based upon values listed in the Connecticut Siting Council database for existing carrier emissions.

FCC guidelines state that if a site is found to be out of compliance (over allowable thresholds), that carriers over a 5% contribution to the composite value will require measures to bring the site into compliance. For this facility, the composite values calculated were well within the allowable 100% threshold standard per the federal government.

# INFINIGY

FROM ZERO TO INFINIGY  
the solutions are endless

1033 WATERVLIET SHAKER RD, ALBANY, NY 12205

## Structural Analysis Report

August 1, 2017

Sprint Site Name	Hamden Fish & Game Club
Sprint Site Number	CT54XC773
Infinigy Job Number	526-102
Client	Sprint
Proposed Carrier	Sprint
Site Location	150 Willow St, Hamden, CT 06518 New Haven County 41° 26' 57.81" N 72° 54' 16.46" W
Structure Type	158' EEI Monopole
Structural Usage Ratio	<b>73.0%</b>
Overall Result	<b>Pass</b>

Upon reviewing the results of this analysis, it is our opinion that the structure meets the specified TIA code requirements. The tower and foundation are therefore deemed adequate to support the existing and proposed loading as listed in this report.



Matt A. Nichols, P.E.  
Senior Structural Engineer

AZ CA CO FL GA IL MD NC NH NJ NY TN TX WA

# INFINIGY



**Contents**

Introduction.....	3
Supporting Documentation.....	3
Analysis Code Requirements.....	3
Conclusion.....	3
Existing and Reserved Loading.....	4
To Be Removed Loading.....	4
Proposed Loading.....	4
Final Configuration.....	4
Structure Usages.....	5
Foundation Reactions.....	5
Deflection, Twist, and Sway.....	5
Assumptions and Limitations.....	5
Calculations.....	Appended

## **Introduction**

Infinigy Engineering has been requested to perform a structural analysis on the existing 158' EEI Monopole Tower. All supporting documents have been obtained from the client and are assumed to be accurate and applicable to this site. The tower was analyzed using tnxTower version 7.0.7.0 tower analysis software.

## **Supporting Documentation**

<b>Tower Drawings</b>	EEI Project No. 14977, dated July 17, 2007
<b>Construction Drawings</b>	Infinigy Engineering Job # 526-102, dated May 19, 2017
<b>Previous Analysis</b>	Infinigy Engineering Job # 333-000, dated June 27, 2014
<b>Geotechnical Report</b>	JGI Geotechnical Evaluation #J2075344, dated June 29, 2007

## **Analysis Code Requirements**

Wind Speed	97 mph (3-Second Gust, $V_{ASD}$ ) / 125 mph (3-Second Gust, $V_{ULT}$ )
Wind Speed w/ ice	50 mph (3-Second Gust) w/ 0.75" ice
TIA Revision	ANSI/TIA-222-G
Adopted IBC	2012 IBC/2016 Connecticut State Building Code
Structure Class	II
Exposure Category	B
Topographic Category	1
Calculated Crest Height	0

## **Conclusion**

Upon reviewing the results of this analysis, it is our opinion that the structure meets the specified TIA code requirements. The tower and foundation are therefore deemed adequate to support the existing and proposed loading as listed in this report.

If you have any questions, require additional information, or actual conditions differ from those as detailed in this report please contact me via the information below:

Matt A. Nichols, P.E.  
 Senior Structural Engineer | Infinigy  
 1033 Watervliet Shaker Road, Albany, NY 12205  
 (O) (518) 690-0790  
[mnichols@infinigy.com](mailto:mnichols@infinigy.com) | [www.infinigy.com](http://www.infinigy.com)

Structural Analysis Report

August 1, 2017

**Existing and Reserved Loading**

Mount Height (ft)	Qty.	Appurtenance	Mount Type	Coax& Lines	Carrier
157.5	3	RFS APXV9ERR18-C-A20	Platform w/ Handrails	(3) 1-5/8" Hyrbriflex	Sprint
	3	Sprint Legacy Antennas			
	3	Alcatel Lucent 800 MHz RRH			
	3	Alcatel Lucent 1900 MHz RRH			
147.0	12	Panel Antennas	Platform	*(12) 1-5/8"	Verizon
137.0	3	Panel Antennas	Pipe	*(12) 1-5/8"	-

\*Assumed (12) 1-5/8" Coax at 137' and 147' for analysis

**To Be Removed Loading**

Mount Height (ft)	Qty.	Appurtenance	Mount Type	Coax& Lines	Carrier
157.5	3	Sprint Legacy Antennas	-	-	Sprint

**Proposed Loading**

Mount Height (ft)	Qty.	Appurtenance	Mount Type	Coax& Lines	Carrier
157.5	3	RFS APXVTM14-C-120	-	(1) 1-1/4" Fiber	Sprint
	3	Alcatel Lucent TD-RRH8x20			

**Final Configuration**

Mount Height (ft)	Qty.	Appurtenance	Mount Type	Coax& Lines	Carrier
157.5	3	RFS APXV9ERR18-C-A20	Platform w/ Handrails	(3) 1-5/8" Hyrbriflex (1) 1-1/4" Fiber	Sprint
	3	RFS APXVTM14-C-120			
	3	Alcatel Lucent 800 MHz RRH			
	3	Alcatel Lucent 1900 MHz RRH			
	3	Alcatel Lucent TD-RRH8x20			
147.0	12	Panel Antennas	Platform	*(12) 1-5/8"	Verizon
137.0	3	Panel Antennas	Pipe	*(12) 1-5/8"	-

\*Assumed (12) 1-5/8" Coax at 137' and 147' for analysis

**Structure Usages**

Pole (L1)	38.0	Pass
Pole (L2)	26.5	Pass
Pole (L3)	26.1	Pass
Pole (L4)	29.4	Pass
Base Plate	17.6	Pass
Anchor Bolts	16.3	Pass
<b>RATING</b>	<b>38.0</b>	<b>Pass</b>

**Foundation Reactions**

Reaction Data	Design Reactions	Analysis Reactions	Result
Moment (kip-ft)	7,151.4	2,332.5	32.6%
Shear (kip)	61.2	22.3	36.4%
Axial (kip)	68.8	50.2	73.0%

Tower base reactions are acceptable when compared to the original design reactions.

**Deflection, Twist, and Sway**

Antenna Elevation (ft)	Deflection (in)	Twist (°)	Sway (°)
157.5	8.424	0.000	0.558

\*Per ANSI/TIA-222-G Section 2.8.2 maximum serviceability structural deflection limit is 3% of structure height.

\*Per ANSI/TIA-222-G Section 2.8.2 maximum serviceability structural twist and sway limit is 4 degrees.

\*Per ANSI/TIA-222-G Section 2.8.3 deflection, Twist, and sway values were calculated using a basic 3-second gust wind speed of 60 mph.

\*It is the responsibility of the client to ensure their proposed and/or existing equipment will meet ANSI/TIA-222-G Annex D or other appropriate microwave signal degradation limits based on the provided values above.

**Assumptions and Limitations**

Our structural calculations are completed assuming all information provided to Infinigy Engineering is accurate and applicable to this site. For the purposes of calculations, we assume an overall structure condition of “like new” and all members and connections to be free of corrosion and/or structural defects. The structure owner and/or contractor shall verify the structure’s condition prior to installation of any proposed equipment. If actual conditions differ from those described in this report Infinigy Engineering should be notified immediately to complete a revised evaluation.

Our evaluation is completed using standard TIA, AISC, ACI, and ASCE methods and procedures. Our structural results are proprietary and should not be used by others as their own. Infinigy Engineering is not responsible for decisions made by others that are or are not based on our supplied assumptions and conclusions.

This report is an evaluation of the tower structure only and does not reflect adequacy of any existing antenna mounts, mount connections, or cable mounting attachments. These elements are assumed to be adequate for the purposes of this analysis and are assumed to have been installed per their manufacturer requirements.

Section	1	2	3	4	
Length (ft)	27.00	41.75	52.42	52.66	
Number of Sides	18	18	18	18	
Thickness (in)	0.188	0.375	0.438	0.438	
Socket Length (ft)	4.00	5.50	7.33	50.742	
Top Dia (in)	18.500	25.724	36.840	68.000	
Bot Dia (in)	27.420	39.390	54.020	14665.2	
Grade		A572-65			
Weight (lb)	1245.1	5441.8	11144.4		32496.5

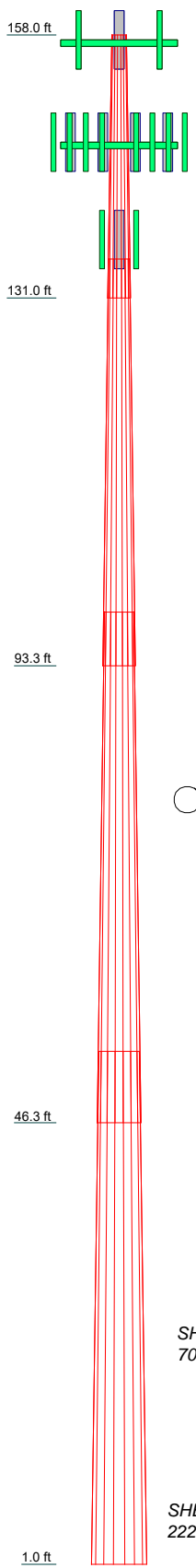

### DESIGNED APPURTENANCE LOADING

TYPE	ELEVATION	TYPE	ELEVATION
Angle Platform w/ Handrails (Sprint)	157.5	TD-RRH8X20 (Sprint)	157.5
APXV9ERR18-C-A20 (Sprint)	157.5	TD-RRH8X20 (Sprint)	157.5
APXV9ERR18-C-A20 (Sprint)	157.5	TD-RRH8X20 (Sprint)	157.5
APXV9ERR18-C-A20 (Sprint)	157.5	Angle Low Profile Platform (Verizon)	147
APXVTM14-C-120 (Sprint)	157.5	(4) 72" x 12" Panel (Verizon)	147
APXVTM14-C-120 (Sprint)	157.5	(4) 72" x 12" Panel (Verizon)	147
APXVTM14-C-120 (Sprint)	157.5	(4) 72" x 12" Panel (Verizon)	147
800 MHz RRH (Sprint)	157.5	Antenna Pipe Mount	137
800 MHz RRH (Sprint)	157.5	Antenna Pipe Mount	137
800 MHz RRH (Sprint)	157.5	Antenna Pipe Mount	137
1900 MHz RRH (Sprint)	157.5	72" x 12" Panel	137
1900 MHz RRH (Sprint)	157.5	72" x 12" Panel	137
1900 MHz RRH (Sprint)	157.5	72" x 12" Panel	137

### MATERIAL STRENGTH

GRADE	Fy	Fu	GRADE	Fy	Fu
A572-65	65 ksi	80 ksi			

### TOWER DESIGN NOTES

1. Tower is located in New Haven County, Connecticut.
2. Tower designed for Exposure B to the TIA-222-G Standard.
3. Tower designed for a 97 mph basic wind in accordance with the TIA-222-G Standard.
4. Tower is also designed for a 50 mph basic wind with 0.75 in ice. Ice is considered to increase in thickness with height.
5. Deflections are based upon a 60 mph wind.
6. Tower Structure Class II.
7. Topographic Category 1 with Crest Height of 0.00 ft
8. TOWER RATING: 38%

ALL REACTIONS ARE FACTORED

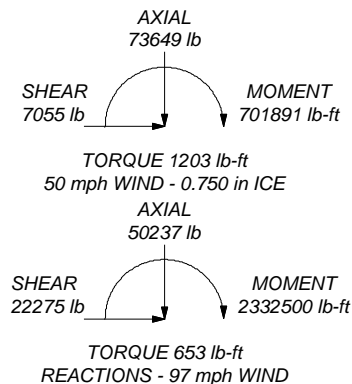

<b>INFINIGY</b> Infingy 1033 Watervliet Shaker Road Albany, NY 12205 Phone: (518) 690-0790 FAX: (518) 690-0793	<b>Job: 526-102</b> Project: <b>CT54XC773</b>	
	Client: Sprint Code: TIA-222-G Path:	Drawn by: Matt Nichols, P.E. Date: 08/01/17 Scale: NTS Dwg No. E-1
	<small>C:\Users\MNichols\Desktop\Current Jobs\Subs Work\Hamden\Structural Calculations\CT54XC773\Inf</small>	

<b>tnxTower</b>  <b>Infinigy Engineering PLLC</b> 1033 Watervliet Shaker Road Albany, NY 12205 Phone: (518) 690-0790 FAX: (518) 690-0793	<b>Job</b>	526-102	<b>Page</b>	1 of 9
	<b>Project</b>	CT54XC773	<b>Date</b>	12:33:00 08/01/17
	<b>Client</b>	Sprint	<b>Designed by</b>	Matt Nichols, P.E.

## Tower Input Data

There is a pole section.

This tower is designed using the TIA-222-G standard.

The following design criteria apply:

- Tower is located in New Haven County, Connecticut.
- Basic wind speed of 97 mph.
- Structure Class II.
- Exposure Category B.
- Topographic Category 1.
- Crest Height 0.00 ft.
- Nominal ice thickness of 0.750 in.
- Ice thickness is considered to increase with height.
- Ice density of 56 pcf.
- A wind speed of 50 mph is used in combination with ice.
- Temperature drop of 50 °F.
- Deflections calculated using a wind speed of 60 mph.
- A non-linear (P-delta) analysis was used.
- Pressures are calculated at each section.
- Stress ratio used in pole design is 1.
- Local bending stresses due to climbing loads, feed line supports, and appurtenance mounts are not considered.

## Options

- |  |  |   |
|--|--|---|
| <ul style="list-style-type: none"> <li>Consider Moments - Legs</li> <li>Consider Moments - Horizontals</li> <li>Consider Moments - Diagonals</li> <li>Use Moment Magnification</li> <li>√ Use Code Stress Ratios</li> <li>√ Use Code Safety Factors - Guys</li> <li>Escalate Ice</li> <li>Always Use Max Kz</li> <li>Use Special Wind Profile</li> <li>√ Include Bolts In Member Capacity</li> <li>Leg Bolts Are At Top Of Section</li> <li>Secondary Horizontal Braces Leg</li> <li>Use Diamond Inner Bracing (4 Sided)</li> <li>SR Members Have Cut Ends</li> <li>SR Members Are Concentric</li> </ul> | <ul style="list-style-type: none"> <li>Distribute Leg Loads As Uniform</li> <li>Assume Legs Pinned</li> <li>Assume Rigid Index Plate</li> <li>Use Clear Spans For Wind Area</li> <li>Use Clear Spans For KL/r</li> <li>Retention Guys To Initial Tension</li> <li>Bypass Mast Stability Checks</li> <li>√ Use Azimuth Dish Coefficients</li> <li>√ Project Wind Area of Appurt.</li> <li>Autocalc Torque Arm Areas</li> <li>Add IBC .6D+W Combination</li> <li>Sort Capacity Reports By Component</li> <li>Triangulate Diamond Inner Bracing</li> <li>Treat Feed Line Bundles As Cylinder</li> </ul> | <ul style="list-style-type: none"> <li>Use ASCE 10 X-Brace Ly Rules</li> <li>Calculate Redundant Bracing Forces</li> <li>Ignore Redundant Members in FEA</li> <li>SR Leg Bolts Resist Compression</li> <li>√ All Leg Panels Have Same Allowable</li> <li>Offset Girt At Foundation</li> <li>√ Consider Feed Line Torque</li> <li>Include Angle Block Shear Check</li> <li>Use TIA-222-G Bracing Resist. Exemption</li> <li>Use TIA-222-G Tension Splice Exemption</li> <li style="text-align: center;">Poles</li> <li>√ Include Shear-Torsion Interaction</li> <li>Always Use Sub-Critical Flow</li> <li>Use Top Mounted Sockets</li> </ul> |
|--|--|---|

## Tapered Pole Section Geometry

Section	Elevation ft	Section Length ft	Splice Length ft	Number of Sides	Top Diameter in	Bottom Diameter in	Wall Thickness in	Bend Radius in	Pole Grade
L1	158.00-131.00	27.00	4.00	18	18.500	27.420	0.188	0.750	A572-65 (65 ksi)
L2	131.00-93.25	41.75	5.50	18	25.724	39.390	0.375	1.500	A572-65 (65 ksi)

<b>tnxTower</b>  <b>Infinigy Engineering PLLC</b> 1033 Watervliet Shaker Road Albany, NY 12205 Phone: (518) 690-0790 FAX: (518) 690-0793	<b>Job</b>	526-102	<b>Page</b>	2 of 9
	<b>Project</b>	CT54XC773	<b>Date</b>	12:33:00 08/01/17
	<b>Client</b>	Sprint	<b>Designed by</b>	Matt Nichols, P.E.

Section	Elevation ft	Section Length ft	Splice Length ft	Number of Sides	Top Diameter in	Bottom Diameter in	Wall Thickness in	Bend Radius in	Pole Grade
L3	93.25-46.33	52.42	7.33	18	36.840	54.020	0.438	1.750	A572-65 (65 ksi)
L4	46.33-1.00	52.66		18	50.742	68.000	0.438	1.750	A572-65 (65 ksi)

### Tapered Pole Properties

Section	Tip Dia. in	Area in <sup>2</sup>	I in <sup>4</sup>	r in	C in	I/C in <sup>3</sup>	J in <sup>4</sup>	I/Q in <sup>2</sup>	w in	w/t
L1	18.785	10.898	461.730	6.501	9.398	49.131	924.069	5.450	2.926	15.605
L2	27.843	16.207	1518.477	9.668	13.929	109.013	3038.952	8.105	4.496	23.978
L3	39.998	46.438	8930.391	13.850	20.010	446.294	17872.533	23.223	6.273	16.727
L4	54.853	74.406	26989.283	19.022	27.442	983.497	54014.079	37.210	8.738	19.971
	53.965	69.853	22332.174	17.858	25.777	866.371	44693.734	34.933	8.161	18.653
	69.049	93.819	54105.269	23.985	34.544	1566.271	108281.732	46.918	11.198	25.595

Tower Elevation ft	Gusset Area (per face) ft <sup>2</sup>	Gusset Thickness in	Gusset Grade	Adjust. Factor A <sub>f</sub>	Adjust. Factor A <sub>r</sub>	Weight Mult.	Double Angle Stitch Bolt Spacing Diagonals in	Double Angle Stitch Bolt Spacing Horizontals in	Double Angle Stitch Bolt Spacing Redundants in
L1 158.00-131.00				1	1	1			
L2 131.00-93.25				1	1	1			
L3 93.25-46.33				1	1	1			
L4 46.33-1.00				1	1	1			

### Feed Line/Linear Appurtenances - Entered As Area

Description	Face or Leg	Allow Shield	Component Type	Placement ft	Total Number	C <sub>A</sub> A <sub>A</sub> ft <sup>2</sup> /ft	Weight plf
Step Pegs 5/8" SR, 7"w, 15"s (Ladder)	A	No	CaAa (Out Of Face)	158.00 - 1.00	1	No Ice	0.03
						1/2" Ice	0.13
						1" Ice	0.23
Safety Line 3/8 (Ladder)	A	No	CaAa (Out Of Face)	158.00 - 1.00	1	No Ice	0.04
						1/2" Ice	0.14
						1" Ice	0.24
1 5/8 (Sprint)	A	No	Inside Pole	157.50 - 1.00	3	No Ice	0.00
						1/2" Ice	0.00
						1" Ice	0.00
1 1/4 (Sprint)	A	No	Inside Pole	157.50 - 1.00	1	No Ice	0.00
						1/2" Ice	0.00
						1" Ice	0.00
1 5/8 (Verizon)	A	No	Inside Pole	147.00 - 1.00	12	No Ice	0.00
						1/2" Ice	0.00
						1" Ice	0.00
1 5/8	A	No	Inside Pole	137.00 - 1.00	12	No Ice	0.00
						1/2" Ice	0.00
						1" Ice	0.00

<b>tnxTower</b>  <b>Infinigy Engineering PLLC</b> 1033 Watervliet Shaker Road Albany, NY 12205 Phone: (518) 690-0790 FAX: (518) 690-0793	<b>Job</b>	526-102	<b>Page</b>	3 of 9
	<b>Project</b>	CT54XC773	<b>Date</b>	12:33:00 08/01/17
	<b>Client</b>	Sprint	<b>Designed by</b>	Matt Nichols, P.E.

Description	Face or Leg	Allow Shield	Component Type	Placement ft	Total Number	C <sub>AA</sub> ft <sup>2</sup> /ft	Weight plf
						1" Ice	1.04

### Feed Line/Linear Appurtenances Section Areas

Tower Section	Tower Elevation ft	Face	A <sub>R</sub> ft <sup>2</sup>	A <sub>F</sub> ft <sup>2</sup>	C <sub>AA</sub> In Face ft <sup>2</sup>	C <sub>AA</sub> Out Face ft <sup>2</sup>	Weight lb
L1	158.00-131.00	A	0.000	0.000	0.000	1.800	393.82
		B	0.000	0.000	0.000	0.000	0.00
		C	0.000	0.000	0.000	0.000	0.00
L2	131.00-93.25	A	0.000	0.000	0.000	2.517	1111.63
		B	0.000	0.000	0.000	0.000	0.00
		C	0.000	0.000	0.000	0.000	0.00
L3	93.25-46.33	A	0.000	0.000	0.000	3.128	1381.66
		B	0.000	0.000	0.000	0.000	0.00
		C	0.000	0.000	0.000	0.000	0.00
L4	46.33-1.00	A	0.000	0.000	0.000	3.022	1334.84
		B	0.000	0.000	0.000	0.000	0.00
		C	0.000	0.000	0.000	0.000	0.00

### Feed Line/Linear Appurtenances Section Areas - With Ice

Tower Section	Tower Elevation ft	Face or Leg	Ice Thickness in	A <sub>R</sub> ft <sup>2</sup>	A <sub>F</sub> ft <sup>2</sup>	C <sub>AA</sub> In Face ft <sup>2</sup>	C <sub>AA</sub> Out Face ft <sup>2</sup>	Weight lb
L1	158.00-131.00	A	1.738	0.000	0.000	0.000	20.567	566.26
		B		0.000	0.000	0.000	0.000	0.00
		C		0.000	0.000	0.000	0.000	0.00
L2	131.00-93.25	A	1.694	0.000	0.000	0.000	28.755	1352.72
		B		0.000	0.000	0.000	0.000	0.00
		C		0.000	0.000	0.000	0.000	0.00
L3	93.25-46.33	A	1.615	0.000	0.000	0.000	34.916	1670.84
		B		0.000	0.000	0.000	0.000	0.00
		C		0.000	0.000	0.000	0.000	0.00
L4	46.33-1.00	A	1.447	0.000	0.000	0.000	32.304	1596.08
		B		0.000	0.000	0.000	0.000	0.00
		C		0.000	0.000	0.000	0.000	0.00

### Feed Line Center of Pressure

Section	Elevation ft	CP <sub>X</sub> in	CP <sub>Z</sub> in	CP <sub>X</sub> Ice in	CP <sub>Z</sub> Ice in
L1	158.00-131.00	0.000	-0.095	0.000	-0.730
L2	131.00-93.25	0.000	-0.096	0.000	-0.819
L3	93.25-46.33	0.000	-0.097	0.000	-0.871
L4	46.33-1.00	0.000	-0.097	0.000	-0.883



<b>tnxTower</b>  <b>Infinigy Engineering PLLC</b> 1033 Watervliet Shaker Road Albany, NY 12205 Phone: (518) 690-0790 FAX: (518) 690-0793	<b>Job</b>	526-102	<b>Page</b>	4 of 9
	<b>Project</b>	CT54XC773	<b>Date</b>	12:33:00 08/01/17
	<b>Client</b>	Sprint	<b>Designed by</b>	Matt Nichols, P.E.

## Shielding Factor Ka

Tower Section	Feed Line Record No.	Description	Feed Line Segment Elev.	K <sub>a</sub> No Ice	K <sub>a</sub> Ice
---------------	----------------------	-------------	-------------------------	-----------------------	--------------------

## Discrete Tower Loads

Description	Face or Leg	Offset Type	Offsets:		Azimuth Adjustment	Placement	C <sub>A</sub> A <sub>A</sub> Front	C <sub>A</sub> A <sub>A</sub> Side	Weight
			Horz	Vert					
			ft	ft	°	ft	ft <sup>2</sup>	ft <sup>2</sup>	lb
Angle Platform w/ Handrails (Sprint)	C	None			0.000	157.50	No Ice 42.40 1/2" Ice 48.40 1" Ice 54.40	42.40 48.40 54.40	2000.00 2450.00 2900.00
APXV9ERR18-C-A20 (Sprint)	A	From Leg	4.00 0.00 0.00		0.000	157.50	No Ice 5.28 1/2" Ice 5.74 1" Ice 6.20	8.02 8.48 8.94	60.00 106.52 162.12
APXV9ERR18-C-A20 (Sprint)	B	From Leg	4.00 0.00 0.00		0.000	157.50	No Ice 5.28 1/2" Ice 5.74 1" Ice 6.20	8.02 8.48 8.94	60.00 106.52 162.12
APXV9ERR18-C-A20 (Sprint)	C	From Leg	4.00 0.00 0.00		0.000	157.50	No Ice 5.28 1/2" Ice 5.74 1" Ice 6.20	8.02 8.48 8.94	60.00 106.52 162.12
APXVTM14-C-120 (Sprint)	A	From Leg	4.00 0.00 0.00		0.000	157.50	No Ice 5.96 1/2" Ice 6.31 1" Ice 6.68	3.38 3.72 4.07	50.00 90.49 132.96
APXVTM14-C-120 (Sprint)	B	From Leg	4.00 0.00 0.00		0.000	157.50	No Ice 5.96 1/2" Ice 6.31 1" Ice 6.68	3.38 3.72 4.07	50.00 90.49 132.96
APXVTM14-C-120 (Sprint)	C	From Leg	4.00 0.00 0.00		0.000	157.50	No Ice 5.96 1/2" Ice 6.31 1" Ice 6.68	3.38 3.72 4.07	50.00 90.49 132.96
800 MHz RRH (Sprint)	A	From Leg	4.00 0.00 0.00		0.000	157.50	No Ice 1.93 1/2" Ice 2.11 1" Ice 2.29	2.06 2.24 2.43	60.00 86.12 111.30
800 MHz RRH (Sprint)	B	From Leg	4.00 0.00 0.00		0.000	157.50	No Ice 1.93 1/2" Ice 2.11 1" Ice 2.29	2.06 2.24 2.43	60.00 86.12 111.30
800 MHz RRH (Sprint)	C	From Leg	4.00 0.00 0.00		0.000	157.50	No Ice 1.93 1/2" Ice 2.11 1" Ice 2.29	2.06 2.24 2.43	60.00 86.12 111.30
1900 MHz RRH (Sprint)	A	From Leg	4.00 0.00 0.00		0.000	157.50	No Ice 2.73 1/2" Ice 2.96 1" Ice 3.20	1.45 1.64 1.84	44.09 62.32 83.43
1900 MHz RRH (Sprint)	B	From Leg	4.00 0.00 0.00		0.000	157.50	No Ice 2.73 1/2" Ice 2.96 1" Ice 3.20	1.45 1.64 1.84	44.09 62.32 83.43
1900 MHz RRH (Sprint)	C	From Leg	4.00 0.00 0.00		0.000	157.50	No Ice 2.73 1/2" Ice 2.96 1" Ice 3.20	1.45 1.64 1.84	44.09 62.32 83.43
TD-RRH8X20 (Sprint)	A	From Leg	4.00 0.00 0.00		0.000	157.50	No Ice 3.70 1/2" Ice 3.95 1" Ice 4.20	1.29 1.46 1.64	70.00 90.08 117.36
TD-RRH8X20 (Sprint)	B	From Leg	4.00 0.00 0.00		0.000	157.50	No Ice 3.70 1/2" Ice 3.95 1" Ice 4.20	1.29 1.46 1.64	70.00 90.08 117.36
TD-RRH8X20	C	From Leg	4.00		0.000	157.50	No Ice 3.70	1.29	70.00

<b>tnxTower</b>  <b>Infinigy Engineering PLLC</b> 1033 Watervliet Shaker Road Albany, NY 12205 Phone: (518) 690-0790 FAX: (518) 690-0793	<b>Job</b>	526-102	<b>Page</b>	5 of 9
	<b>Project</b>	CT54XC773	<b>Date</b>	12:33:00 08/01/17
	<b>Client</b>	Sprint	<b>Designed by</b>	Matt Nichols, P.E.

Description	Face or Leg	Offset Type	Offsets:		Azimuth Adjustment	Placement	C <sub>AA</sub> Front	C <sub>AA</sub> Side	Weight	
			Horz	Vert						
			ft	ft	°	ft	ft <sup>2</sup>	ft <sup>2</sup>	lb	
(Sprint)			0.00			1/2" Ice	3.95	1.46	90.08	
***			0.00			1" Ice	4.20	1.64	117.36	
Angle Low Profile Platform (Verizon)	C	None			0.000	147.00	No Ice	26.10	26.10	1500.00
							1/2" Ice	31.60	31.60	1700.00
							1" Ice	37.10	37.10	1900.00
(4) 72" x 12" Panel (Verizon)	A	From Leg	4.00		0.000	147.00	No Ice	8.13	4.70	50.00
			0.00				1/2" Ice	8.59	5.15	92.28
			0.00				1" Ice	9.05	5.60	145.59
(4) 72" x 12" Panel (Verizon)	B	From Leg	4.00		0.000	147.00	No Ice	8.13	4.70	50.00
			0.00				1/2" Ice	8.59	5.15	92.28
			0.00				1" Ice	9.05	5.60	145.59
(4) 72" x 12" Panel (Verizon)	C	From Leg	4.00		0.000	147.00	No Ice	8.13	4.70	50.00
			0.00				1/2" Ice	8.59	5.15	92.28
			0.00				1" Ice	9.05	5.60	145.59
***										
Antenna Pipe Mount	A	From Leg	1.00		0.000	137.00	No Ice	0.87	0.87	14.60
			0.00				1/2" Ice	1.12	1.12	25.30
			0.00				1" Ice	1.39	1.39	37.43
Antenna Pipe Mount	B	From Leg	1.00		0.000	137.00	No Ice	0.87	0.87	14.60
			0.00				1/2" Ice	1.12	1.12	25.30
			0.00				1" Ice	1.39	1.39	37.43
Antenna Pipe Mount	C	From Leg	1.00		0.000	137.00	No Ice	0.87	0.87	14.60
			0.00				1/2" Ice	1.12	1.12	25.30
			0.00				1" Ice	1.39	1.39	37.43
72" x 12" Panel	A	From Leg	1.00		0.000	137.00	No Ice	8.13	4.70	50.00
			0.00				1/2" Ice	8.59	5.15	92.28
			0.00				1" Ice	9.05	5.60	145.59
72" x 12" Panel	B	From Leg	1.00		0.000	137.00	No Ice	8.13	4.70	50.00
			0.00				1/2" Ice	8.59	5.15	92.28
			0.00				1" Ice	9.05	5.60	145.59
72" x 12" Panel	C	From Leg	1.00		0.000	137.00	No Ice	8.13	4.70	50.00
			0.00				1/2" Ice	8.59	5.15	92.28
			0.00				1" Ice	9.05	5.60	145.59

## Load Combinations

Comb. No.	Description
1	Dead Only
2	1.2 Dead+1.6 Wind 0 deg - No Ice
3	0.9 Dead+1.6 Wind 0 deg - No Ice
4	1.2 Dead+1.6 Wind 30 deg - No Ice
5	0.9 Dead+1.6 Wind 30 deg - No Ice
6	1.2 Dead+1.6 Wind 60 deg - No Ice
7	0.9 Dead+1.6 Wind 60 deg - No Ice
8	1.2 Dead+1.6 Wind 90 deg - No Ice
9	0.9 Dead+1.6 Wind 90 deg - No Ice
10	1.2 Dead+1.6 Wind 120 deg - No Ice
11	0.9 Dead+1.6 Wind 120 deg - No Ice
12	1.2 Dead+1.6 Wind 150 deg - No Ice

<b>tnxTower</b>  <b>Infinigy Engineering PLLC</b> 1033 Watervliet Shaker Road Albany, NY 12205 Phone: (518) 690-0790 FAX: (518) 690-0793	<b>Job</b>	526-102	<b>Page</b>	6 of 9
	<b>Project</b>	CT54XC773	<b>Date</b>	12:33:00 08/01/17
	<b>Client</b>	Sprint	<b>Designed by</b>	Matt Nichols, P.E.

<i>Comb. No.</i>	<i>Description</i>
13	0.9 Dead+1.6 Wind 150 deg - No Ice
14	1.2 Dead+1.6 Wind 180 deg - No Ice
15	0.9 Dead+1.6 Wind 180 deg - No Ice
16	1.2 Dead+1.6 Wind 210 deg - No Ice
17	0.9 Dead+1.6 Wind 210 deg - No Ice
18	1.2 Dead+1.6 Wind 240 deg - No Ice
19	0.9 Dead+1.6 Wind 240 deg - No Ice
20	1.2 Dead+1.6 Wind 270 deg - No Ice
21	0.9 Dead+1.6 Wind 270 deg - No Ice
22	1.2 Dead+1.6 Wind 300 deg - No Ice
23	0.9 Dead+1.6 Wind 300 deg - No Ice
24	1.2 Dead+1.6 Wind 330 deg - No Ice
25	0.9 Dead+1.6 Wind 330 deg - No Ice
26	1.2 Dead+1.0 Ice+1.0 Temp
27	1.2 Dead+1.0 Wind 0 deg+1.0 Ice+1.0 Temp
28	1.2 Dead+1.0 Wind 30 deg+1.0 Ice+1.0 Temp
29	1.2 Dead+1.0 Wind 60 deg+1.0 Ice+1.0 Temp
30	1.2 Dead+1.0 Wind 90 deg+1.0 Ice+1.0 Temp
31	1.2 Dead+1.0 Wind 120 deg+1.0 Ice+1.0 Temp
32	1.2 Dead+1.0 Wind 150 deg+1.0 Ice+1.0 Temp
33	1.2 Dead+1.0 Wind 180 deg+1.0 Ice+1.0 Temp
34	1.2 Dead+1.0 Wind 210 deg+1.0 Ice+1.0 Temp
35	1.2 Dead+1.0 Wind 240 deg+1.0 Ice+1.0 Temp
36	1.2 Dead+1.0 Wind 270 deg+1.0 Ice+1.0 Temp
37	1.2 Dead+1.0 Wind 300 deg+1.0 Ice+1.0 Temp
38	1.2 Dead+1.0 Wind 330 deg+1.0 Ice+1.0 Temp
39	Dead+Wind 0 deg - Service
40	Dead+Wind 30 deg - Service
41	Dead+Wind 60 deg - Service
42	Dead+Wind 90 deg - Service
43	Dead+Wind 120 deg - Service
44	Dead+Wind 150 deg - Service
45	Dead+Wind 180 deg - Service
46	Dead+Wind 210 deg - Service
47	Dead+Wind 240 deg - Service
48	Dead+Wind 270 deg - Service
49	Dead+Wind 300 deg - Service
50	Dead+Wind 330 deg - Service

### Maximum Tower Deflections - Service Wind

<i>Section No.</i>	<i>Elevation ft</i>	<i>Horz. Deflection in</i>	<i>Gov. Load Comb.</i>	<i>Tilt °</i>	<i>Twist °</i>
L1	158 - 131	8.482	39	0.560	0.000
L2	135 - 93.25	5.936	39	0.468	0.000
L3	98.75 - 46.33	2.970	39	0.305	0.000
L4	53.6633 - 1	0.825	39	0.146	0.000

### Critical Deflections and Radius of Curvature - Service Wind

<i>Elevation ft</i>	<i>Appurtenance</i>	<i>Gov. Load Comb.</i>	<i>Deflection in</i>	<i>Tilt °</i>	<i>Twist °</i>	<i>Radius of Curvature ft</i>
157.50	Angle Platform w/ Handrails	39	8.424	0.558	0.000	44924

<b>tnxTower</b>  <b>Infinigy Engineering PLLC</b> 1033 Watervliet Shaker Road Albany, NY 12205 Phone: (518) 690-0790 FAX: (518) 690-0793	<b>Job</b> 526-102	<b>Page</b> 7 of 9
	<b>Project</b> CT54XC773	<b>Date</b> 12:33:00 08/01/17
	<b>Client</b> Sprint	<b>Designed by</b> Matt Nichols, P.E.

Elevation	Appurtenance	Gov. Load Comb.	Deflection in	Tilt °	Twist °	Radius of Curvature ft
147.00	Angle Low Profile Platform	39	7.224	0.517	0.000	20420
137.00	Antenna Pipe Mount	39	6.141	0.476	0.000	10811

### Maximum Tower Deflections - Design Wind

Section No.	Elevation ft	Horz. Deflection in	Gov. Load Comb.	Tilt °	Twist °
L1	158 - 131	39.793	2	2.630	0.002
L2	135 - 93.25	27.846	2	2.195	0.002
L3	98.75 - 46.33	13.932	2	1.433	0.001
L4	53.6633 - 1	3.871	2	0.686	0.000

### Critical Deflections and Radius of Curvature - Design Wind

Elevation	Appurtenance	Gov. Load Comb.	Deflection in	Tilt °	Twist °	Radius of Curvature ft
157.50	Angle Platform w/ Handrails	2	39.522	2.621	0.002	9603
147.00	Angle Low Profile Platform	2	33.892	2.427	0.002	4365
137.00	Antenna Pipe Mount	2	28.807	2.235	0.002	2310

### Compression Checks

### Pole Design Data

Section No.	Elevation ft	Size	L ft	L <sub>u</sub> ft	Kl/r	A in <sup>2</sup>	P <sub>u</sub> lb	φP <sub>n</sub> lb	Ratio $\frac{P_u}{\phi P_n}$
L1	158 - 131 (1)	TP27.42x18.5x0.188	27.00	157.00	204.8	15.420	-7410.72	83041.70	0.089
L2	131 - 93.25 (2)	TP39.39x25.724x0.375	41.75	157.00	142.6	44.295	-14458.90	492055.00	0.029
L3	93.25 - 46.33 (3)	TP54.02x36.84x0.438	52.42	157.00	103.7	71.068	-28388.10	1493120.00	0.019
L4	46.33 - 1 (4)	TP68x50.742x0.438	52.66	157.00	78.6	93.819	-50231.70	3163880.00	0.016

### Pole Bending Design Data

Section No.	Elevation ft	Size	M <sub>ux</sub> lb-ft	φM <sub>ux</sub> lb-ft	Ratio $\frac{M_{ux}}{\phi M_{ux}}$	M <sub>uy</sub> lb-ft	φM <sub>uy</sub> lb-ft	Ratio $\frac{M_{uy}}{\phi M_{uy}}$
L1	158 - 131 (1)	TP27.42x18.5x0.188	160640.83	552396.67	0.291	0.00	552396.67	0.000

<b>tnxTower</b>  <b>Infinigy Engineering PLLC</b> 1033 Watervliet Shaker Road Albany, NY 12205 Phone: (518) 690-0790 FAX: (518) 690-0793	<b>Job</b> 526-102	<b>Page</b> 8 of 9
	<b>Project</b> CT54XC773	<b>Date</b> 12:33:00 08/01/17
	<b>Client</b> Sprint	<b>Designed by</b> Matt Nichols, P.E.

Section No.	Elevation ft	Size	$M_{ux}$ lb-ft	$\phi M_{rx}$ lb-ft	Ratio $\frac{M_{ux}}{\phi M_{rx}}$	$M_{uy}$ lb-ft	$\phi M_{ry}$ lb-ft	Ratio $\frac{M_{uy}}{\phi M_{ry}}$
L2	131 - 93.25 (2)	TP39.39x25.724x0.375	592602.50	2512833.33	0.236	0.00	2512833.33	0.000
L3	93.25 - 46.33 (3)	TP54.02x36.84x0.438	1286291.67	5317375.00	0.242	0.00	5317375.00	0.000
L4	46.33 - 1 (4)	TP68x50.742x0.438	2332500.00	8375166.67	0.279	0.00	8375166.67	0.000

### Pole Shear Design Data

Section No.	Elevation ft	Size	Actual $V_u$ lb	$\phi V_n$ lb	Ratio $\frac{V_u}{\phi V_n}$	Actual $T_u$ lb-ft	$\phi T_n$ lb-ft	Ratio $\frac{T_u}{\phi T_n}$
L1	158 - 131 (1)	TP27.42x18.5x0.188	10565.50	518055.00	0.020	0.00	1106141.67	0.000
L2	131 - 93.25 (2)	TP39.39x25.724x0.375	13362.30	1645440.00	0.008	0.00	5031808.33	0.000
L3	93.25 - 46.33 (3)	TP54.02x36.84x0.438	17455.50	2528010.00	0.007	0.00	10647750.00	0.000
L4	46.33 - 1 (4)	TP68x50.742x0.438	22287.60	3010010.00	0.007	0.00	16770833.33	0.000

### Pole Interaction Design Data

Section No.	Elevation ft	Ratio $\frac{P_u}{\phi P_n}$	Ratio $\frac{M_{ux}}{\phi M_{rx}}$	Ratio $\frac{M_{uy}}{\phi M_{ry}}$	Ratio $\frac{V_u}{\phi V_n}$	Ratio $\frac{T_u}{\phi T_n}$	Comb. Stress Ratio	Allow. Stress Ratio	Criteria
L1	158 - 131 (1)	0.089	0.291	0.000	0.020	0.000	0.380	1.000	4.8.2 ✓
L2	131 - 93.25 (2)	0.029	0.236	0.000	0.008	0.000	0.265	1.000	4.8.2 ✓
L3	93.25 - 46.33 (3)	0.019	0.242	0.000	0.007	0.000	0.261	1.000	4.8.2 ✓
L4	46.33 - 1 (4)	0.016	0.279	0.000	0.007	0.000	0.294	1.000	4.8.2 ✓

### Section Capacity Table

Section No.	Elevation ft	Component Type	Size	Critical Element	P lb	$\phi P_{allow}$ lb	% Capacity	Pass Fail
L1	158 - 131	Pole	TP27.42x18.5x0.188	1	-7410.72	83041.70	38.0	Pass
L2	131 - 93.25	Pole	TP39.39x25.724x0.375	2	-14458.90	492055.00	26.5	Pass
L3	93.25 - 46.33	Pole	TP54.02x36.84x0.438	3	-28388.10	1493120.00	26.1	Pass
L4	46.33 - 1	Pole	TP68x50.742x0.438	4	-50231.70	3163880.00	29.4	Pass
Summary								
Pole (L1)							38.0	Pass
<b>RATING =</b>							<b>38.0</b>	<b>Pass</b>

<b><i>tnxTower</i></b>  <b><i>Infinigy Engineering PLLC</i></b> <i>1033 Watervliet Shaker Road</i> <i>Albany, NY 12205</i> <i>Phone: (518) 690-0790</i> <i>FAX: (518) 690-0793</i>	<b>Job</b>  526-102	<b>Page</b>  9 of 9
	<b>Project</b>  CT54XC773	<b>Date</b>  12:33:00 08/01/17
	<b>Client</b>  Sprint	<b>Designed by</b>  Matt Nichols, P.E.

Date: 8/1/2017  
 Customer: Sprint  
 Engineer: MAN  
 Job #: 526-102  
 Baseplate/Flange: Base Plate  
 Plate Shape: Circle

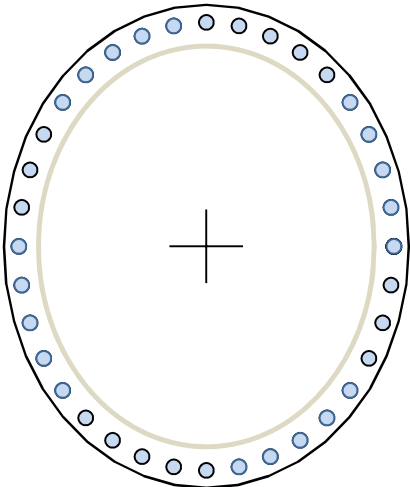

**Loading Data**

TIA Code Revision: Rev-G  
 Axial: 50.237 kips  
 Moment: 2332.5 k-ft

**Plate Data**

Pole Base Diameter: 68 in  
 Pole Base Shape: 18 Sided  
 Pole thickness: 0.4375 in  
 Base Weld Size: 0.25 in  
 Plate Diameter: 82 in  
 Plate Thickness: 3 in  
 Plate Steel Grade: A572 Gr. 50 ksi

**Bolt Data**

Bolt Diameter: 2.25 in  
 Bolt Hole Diameter: 2.75 in  
 Bolt Quantity: 36  
 Bolt Grade: A615 Gr. 75 psi  
 Bolt Circle: 76 in  
 Bolt Spacing: 6 in

**Stiffener Data**

Stiffener Quantity:  
 Stiffener Height: in  
 Stiffener Width: in  
 Stiffener Thickness: in  
 Stiffener Steel Grade:  
 Vertical Weld Size: in  
 Horizontal Weld Size: in  
 Stiffener Notch width: in

Plate Ratio:	17.61
Bolt Ratio:	16.28
Vertical Weld Ratio:	-
Horizontal Weld Ratio:	-
Stiffener Ratio:	-

**PROJECT DESCRIPTION:**  
CONSTRUCTION OF PERSONAL COMMUNICATION SYSTEM (PCS) CONSISTING OF A MONOPOLE TOWER, EQUIPMENT CABINETS AND A UTILITY BACKBOARD WITHIN A FENCED COMPOUND. NO WATER OR SEWER IS REQUIRED.

**CODE COMPLIANCE:**

ALL WORK AND MATERIALS SHALL BE PERFORMED AND INSTALLED IN ACCORDANCE WITH THE CURRENT EDITIONS OF THE FOLLOWING CODES AS ADOPTED BY THE LOCAL GOVERNING AUTHORITIES. NOTHING IN THESE PLANS IS TO BE CONSTRUED TO PERMIT WORK NOT CONFORMING TO THE LATEST EDITIONS OF THE FOLLOWING:

1. CT BUILDING CODE
2. UNIFORM BUILDING CODE
3. BUILDING OFFICIALS AND ADMINISTRATORS (BOCA)
4. UNIFORM MECHANICAL CODE
5. ANSI/TIA/EIA-222-F
6. UNIFORM PLUMBING CODE
7. NATIONAL ELECTRIC CODE
8. LOCAL BUILDING CODE
9. CITY/COUNTY ORDINANCES



**Sprint PCS**

**DIRECTIONS:**  
RTE 84 EAST TO RTE 691 EAST TO EXIT 3 (RTE 10). TAKE A RIGHT (SOUTH) ON RTE 10. TAKE LEFT ONTO WILLOW STREET - ACCESS TO CLUB IS ON LEFT.

**HAMDEN**

PROPOSED UNMANNED WIRELESS TELECOMMUNICATION SITE

**SITE NUMBER: CT54XC773**

**150 WILLOW STREET  
HAMDEN, CT 06518**

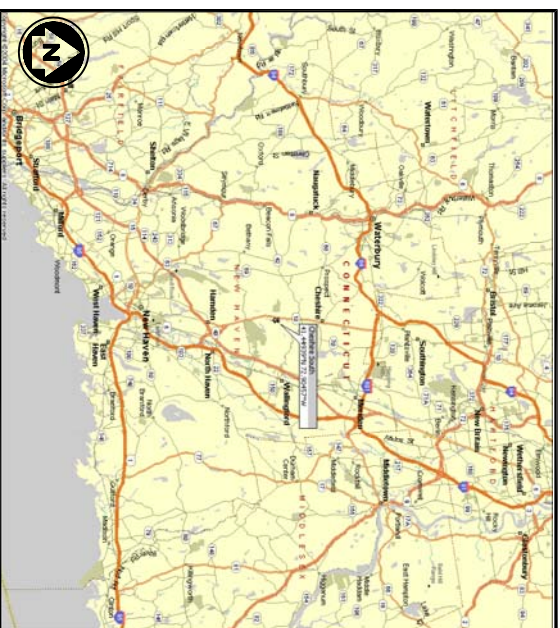

VICINITY MAP  
M.T.S.



LOCATION MAP  
M.T.S.

**infinigy**  
ENGINEERING

810 MARIETTA HIGHWAY  
ROSWELL, GA 30075  
OFFICE #: (770) 640-9969  
FAX #: (770) 640-7363  
158-06

**CONSTRUCTION  
DRAWINGS**

NAD 83/NAVD 88  
SURVEYOR CERTIFIES THAT THE COORDINATES ARE ACCURATE TO WITHIN 50' +/- HORIZONTAL AND 20' +/- VERTICAL.

RAD CENTER: ±157' AGL  
LATITUDE: 41° 26' 57.81"  
LONGITUDE: 72° 54' 16.46"  
GROUND ELEVATION: 126' AMSL

**HAMDEN, CONNECTICUT**

**DIG ALERT:**  
CALL FOR UNDERGROUND UTILITIES PRIOR TO DIGGING:  
1-800-922-4455  
**EMERGENCY:**  
CALL 911



**PROJECT INFORMATION**

SITE NAME: HAMDEN  
SITE ADDRESS: 150 WILLOW STREET  
HAMDEN, CT 06518  
ZONING DISTRICT: R-1  
PROPERTY: MAP: 3430  
LOT: 001

CONSTRUCTION AREA: ±2500 SQ. FT.  
LATITUDE: 41° 26' 57.81"  
LONGITUDE: 72° 54' 16.46"

**PROJECT DIRECTORY**

LAND OWNER: HAMDEN FISH & GAME PROTECTIVE  
CONTACT: JOHN KNOTT  
(203) 271-3031

**APPLICANT**

SPRINT  
GROSSROADS CORPORATE CENTER  
INTERNATIONAL BOULEVARD  
SUITE 800  
MAHWAH, NJ 07495  
CONTACT: MAUREEN MUTI  
PHONE: (201) 684-4313

POWER COMPANY: NORTHEAST UTILITIES  
TELCO COMPANY: SNET

**DRAWING INDEX**

DRWG. #	TITLE	REV.#	DATE
T1	TITLE SHEET	1	7/17/07
C1	GENERAL NOTES & LEGEND	1	7/17/07
C2	OVERALL SITE LAYOUT	1	7/17/07
C3	ENLARGED SITE LAYOUT & STAKING PLAN	1	7/17/07
C3A	GRADING PLAN	1	7/17/07
C4	GRADING & EROSION CONTROL NOTES	1	7/17/07
C5	TOWER ELEVATION	1	7/17/07
C6	DETAILS	1	7/17/07
C7	DETAILS	1	7/17/07
C8	DETAILS	1	7/17/07
C9	DETAILS	1	7/17/07
C10	CELL SITE INSTALLATION NOTES	1	7/17/07
C11	PPC DETAILS	1	7/17/07
E1	ELECTRICAL ONE-LINE DIAGRAM	1	7/17/07
E2	ELECTRICAL SITE PLAN	1	7/17/07
E3	GROUNDING SITE PLAN	1	7/17/07
E4	ELECTRICAL DETAILS	1	7/17/07
E5	GROUNDING DETAILS	1	7/17/07
E6	GROUNDING DETAILS	1	7/17/07



**GENERAL NOTES**

1. ALL DIMENSIONS TO, OF, AND ON EXISTING BUILDINGS, DRAINAGE STRUCTURES, AND SITE IMPROVEMENTS SHALL BE VERIFIED IN FIELD BY CONTRACTOR WITH ALL DISCREPANCIES REPORTED TO THE ENGINEER.
2. DO NOT CHANGE SIZE NOR SPACING OF STRUCTURAL ELEMENTS.
3. DETAILS SHOWN ARE TYPICAL; SIMILAR DETAILS APPLY TO SIMILAR CONDITIONS UNLESS OTHERWISE NOTED.
4. THESE DRAWINGS DO NOT INCLUDE NECESSARY COMPONENTS FOR CONSTRUCTION SAFETY.
5. BRACE STRUCTURES UNTIL ALL STRUCTURAL ELEMENTS NEEDED FOR STABILITY ARE INSTALLED. THESE ELEMENTS ARE AS FOLLOWS: LATERAL BRACING, ANCHOR BOLTS, ETC.
6. DETERMINE EXACT LOCATION OF EXISTING UTILITIES, GROUNDS DRAINS, DRAIN PIPES, VENTS, ETC. BEFORE COMMENCING WORK.
7. INCORRECTLY FABRICATED, DAMAGED, OR OTHERWISE MISFITTING OR NONCONFORMING MATERIALS OR CONDITIONS SHALL BE REPORTED TO THE OWNER PRIOR TO REMEDIAL OR CORRECTIVE ACTION. ANY SUCH ACTION SHALL REQUIRE APPROVAL.
8. EACH CONTRACTOR SHALL COOPERATE WITH THE OWNER'S REPRESENTATIVE, AND COORDINATE HIS WORK WITH THE WORK OF OTHERS.
9. IT IS THE CONTRACTOR'S RESPONSIBILITY TO EXAMINE ALL PLAN SHEETS AND SPECIFICATIONS AND COORDINATE HIS WORK WITH THE WORK OF ALL OTHER CONTRACTORS TO ENSURE THAT WORK PROGRESSION IS NOT INTERRUPTED.
10. THE CONTRACTOR IS RESPONSIBLE FOR MAINTAINING A NEAT AND ORDERLY SITE, YARD AND GROUNDS. REMOVE AND DISPOSE OFF SITE ALL RUBBISH, WASTE MATERIALS, LITTER, AND ALL FOREIGN SUBSTANCES. REMOVE PETRO-CHEMICAL SPILLS, STAINS AND OTHER FOREIGN DEPOSITS. RAKE GROUNDS TO A SMOOTH EVEN-TEXTURED SURFACE.
11. THE PLANS SHOW SOME KNOWN SUBSURFACE STRUCTURES, ABOVE-GROUND STRUCTURES AND/OR UTILITIES BELIEVED TO EXIST IN THE WORKING AREA. EXACT LOCATION OF WHICH MAY VARY FROM THE LOCATIONS INDICATED. IN PARTICULAR, THE CONTRACTOR IS WARNED THAT THE EXACT OR EVEN APPROXIMATE LOCATION OF SUCH PIPELINES, SUBSURFACE STRUCTURES AND/OR UTILITIES IN THE AREA MAY BE SHOWN OR MAY NOT BE SHOWN; AND IT SHALL BE HIS RESPONSIBILITY TO PROCEED WITH GREAT CARE IN EXECUTING ANY WORK. 48 HOURS BEFORE YOU DIG, DRILL OR BLAST, CALL 1-800-922-4455
12. THE OWNER OR OWNER'S REPRESENTATIVE SHALL BE NOTIFIED IN WRITING OF ANY CONDITIONS THAT VARY FROM THOSE SHOWN ON THE PLANS. THE CONTRACTOR'S WORK SHALL NOT VARY FROM THE PLANS WITHOUT THE EXPRESSED APPROVAL OF THE OWNER OR OWNER'S REPRESENTATIVE.
13. THE CONTRACTOR IS INSTRUCTED TO COOPERATE WITH ANY AND ALL OTHER CONTRACTORS PERFORMING WORK ON THIS JOB SITE DURING THE PERFORMANCE OF THIS CONTRACT.
14. THE CONTRACTOR SHALL RESTORE ALL PUBLIC OR PRIVATE PROPERTY DAMAGED OR REMOVED TO AT LEAST AS GOOD OF CONDITION AS BEFORE DISTURBED AS DETERMINED BY THE OWNER OR OWNER'S REPRESENTATIVE.
15. THE CONTRACTOR SHALL COMPLY WITH ALL REQUIRED PERMITS.
16. THE CONTRACTOR SHALL BE RESPONSIBLE FOR OBTAINING, AND INCURRING THE COST OF ALL REQUIRED PERMITS, INCLUDING, BUT NOT LIMITED TO, THE BUILDING PERMIT, INSPECTIONS, CERTIFICATES, ETC.
17. THE CONTRACTOR SHALL PROTECT EXISTING PROPERTY LINE MONUMENTATION. ANY MONUMENTATION DISTURBED OR DESTROYED, AS JUDGED BY THE OWNER OR OWNER'S REPRESENTATIVE SHALL BE REPLACED AT THE CONTRACTOR'S EXPENSE UNDER THE SUPERVISION OF A LICENSED LAND SURVEYOR.
18. ALL TRENCH EXCAVATION AND ANY REQUIRED SHEETING AND SHORING SHALL BE DONE IN ACCORDANCE OSHA REGULATIONS FOR CONSTRUCTION.
19. CONTRACTOR SHALL BE RESPONSIBLE FOR DEWATERING AND THE MAINTENANCE OF SURFACE DRAINAGE DURING THE COURSE OF WORK.
20. ALL UTILITY WORK INVOLVING CONNECTIONS TO EXISTING SYSTEMS SHALL BE COORDINATED WITH THE OWNER OR OWNER'S REPRESENTATIVE AND THE UTILITY OWNER. NOTIFY THE OWNER OR OWNER'S REPRESENTATIVE AND THE UTILITY OWNER BEFORE EACH AND EVERY CONNECTION TO EXISTING SYSTEMS IS MADE.
21. MAINTAIN FLOW FOR ALL EXISTING UTILITIES.
22. ALL SITE FILL SHALL MEET SELECTED FILL STANDARDS AS DEFINED BY THE OWNER OR OWNER'S REPRESENTATIVE ON THE DRAWINGS.
23. CONTRACTOR SHALL GRADE ALL AREAS ON THE SITE TO PROVIDE POSITIVE DRAINAGE AWAY FROM THE EQUIPMENT PAD AND THE TOWER.
24. ALL IMPROVEMENTS TO CONFORM WITH LOCAL JURISDICTION CONSTRUCTION STANDARDS AND SPECIFICATIONS, LATEST EDITION.

**STRUCTURAL STEEL NOTES**

1. STRUCTURAL STEEL SHALL CONFORM TO THE LATEST EDITION OF THE AISC "SPECIFICATION FOR THE DESIGN, FABRICATION AND ERECTION OF STRUCTURAL STEEL FOR BUILDINGS".
2. ALL INTERIOR STRUCTURAL STEEL USED SHALL BE, WHEN DELIVERED, FINISHED WITH ONE COAT FABRICATOR'S NON-LEAD, RED OXIDE PRIMER. PRIMING SHALL BE PERFORMED AFTER SHOP FABRICATION TO THE GREATEST EXTENT POSSIBLE. ALL DINGS, SCRAPES, MARS, AND WELDS IN THE PRIMED AREAS SHALL BE REPAIRED BY FIELD TOUCH-UP PRIOR TO COMPLETION OF THE WORK.
3. ALL EXTERIOR STEEL WORK SHALL BE GALVANIZED IN ACCORDANCE WITH SPECIFICATION ASTM A36 UNLESS OTHERWISE NOTED. GALVANIZING SHALL BE PERFORMED AFTER SHOP FABRICATION TO THE GREATEST EXTENT POSSIBLE. ALL DINGS, SCRAPES, MARS, AND WELDS IN THE GALVANIZED AREAS SHALL BE REPAIRED BY FIELD TOUCH-UP PRIOR TO COMPLETION OF THE WORK.
4. DO NOT PLACE HOLES THROUGH STRUCTURAL STEEL MEMBERS EXCEPT AS SHOWN AND DETAILED ON STRUCTURAL DRAWINGS.
5. CONNECTIONS:
  - A. ALL WELDING SHALL BE DONE USING E70XX ELECTRODES AND WELDING SHALL CONFORM TO AISC AND AWS D1.1, WHERE FILLET WELD SIZES ARE NOT SHOWN, PROVIDE THE MINIMUM SIZE PER TABLE J2.4 IN THE AISC "MANUAL OF STEEL CONSTRUCTION", 9TH EDITION. AT THE COMPLETION OF WELDING, ALL DAMAGE TO GALVANIZED COATING SHALL BE REPAIRED.
  - B. BOLTED CONNECTIONS SHALL USE BEARING TYPE GALVANIZED ASTM A325 BOLTS (3/4" DIA) AND SHALL HAVE MINIMUM OF TWO BOLTS UNLESS NOTED OTHERWISE.
  - C. NON-STRUCTURAL CONNECTIONS FOR STEEL GRATING MAY USE 5/8" DIA. GALVANIZED ASTM A 307 BOLTS UNLESS NOTED OTHERWISE.
  - D. CONNECTION DESIGN BY FABRICATOR WILL BE SUBJECT TO REVIEW AND APPROVAL BY ENGINEER.

**DESIGN DATA**

1. WIND LOADS: PER EIA/TIA F--222  
ICE LOADS: 1/2" RADIAL ON ALL COMPONENTS & CABLE  
SNOW LOAD: PER CT STATE BLDG. CODE.  
SEISMIC LOADS: PER CT STATE BLDG CODE.
2. DEAD LOADS  
BATTERY CABINET 2825#  
FUTURE BATTERY CABINET 2825#  
MODCELL 4.0 PRIMARY CABINET 1210#  
MODCELL 4.0 GROWTH CABINET 1210#  
PPG FRAME 270#  
WIREWAY 40#

**CONCRETE NOTES**

1. DESIGN AND CONSTRUCTION OF ALL CONCRETE ELEMENTS SHALL CONFORM TO THE LATEST EDITIONS OF THE FOLLOWING APPLICABLE CODES: ACI 301 "SPECIFICATIONS FOR STRUCTURAL CONCRETE FOR BUILDINGS"; ACI 318, "BUILDING CODE REQUIREMENTS FOR REINFORCED CONCRETE";
2. MIX DESIGN SHALL BE APPROVED BY OWNER'S REPRESENTATIVE PRIOR TO PLACING CONCRETE.
3. CONCRETE SHALL BE NORMAL WEIGHT, 6% AIR ENTRAINED (±1.5%) WITH A MAXIMUM 4" SLUMP, AND HAVE A MINIMUM 28-DAY COMPRESSIVE STRENGTH OF 3000 PSI UNLESS OTHERWISE NOTED.
4. MAXIMUM AGGREGATE SIZE SHALL BE 1".
5. THE FOLLOWING MATERIALS SHALL BE USED:  
PORTLAND CEMENT: ASTM C 150, TYPE I  
REINFORCEMENT: ASTM A 185  
NORMAL WEIGHT AGGREGATE: ASTM C 33  
WATER: DRINKABLE  
ADMIXTURES: NON-CHLORIDE CONTAINING
6. REINFORCING DETAILS SHALL BE IN ACCORDANCE WITH THE LATEST EDITION OF ACI 315.
7. REINFORCING STEEL SHALL CONFORM TO ASTM A 615, GRADE 60, DEFORMED UNLESS NOTED OTHERWISE. WELDED WIRE FABRIC SHALL CONFORM TO ASTM A 185 WELDED STEEL WIRE FABRIC UNLESS NOTED OTHERWISE. SPLICES SHALL BE CLASS "B" AND ALL HOOKS SHALL BE STANDARD, UNO.
8. THE FOLLOWING MINIMUM CONCRETE COVER SHALL BE PROVIDED FOR REINFORCING STEEL UNLESS SHOWN OTHERWISE ON DRAWINGS:  
CONCRETE CAST AGAINST EARTH.....3 IN.  
CONCRETE EXPOSED TO EARTH OR WEATHER:  
#6 AND LARGER .....2 IN.  
#5 AND SMALLER & WWF .....1 1/2 IN.  
CONCRETE NOT EXPOSED TO EARTH OR WEATHER OR NOT CAST AGAINST THE GROUND: SLAB AND WALL .....3/4 IN.  
BEAMS AND COLUMNS .....1 1/2 IN.

9. A CHAMFER 3/4" SHALL BE PROVIDED AT ALL EXPOSED EDGES OF CONCRETE, UNO, IN ACCORDANCE WITH ACI 301 SECTION 4.2.4.
10. INSTALLATION OF CONCRETE EXPANSION/WEDGE ANCHOR, SHALL BE PER MANUFACTURER'S WRITTEN RECOMMENDED PROCEDURE. THE ANCHOR BOLT, DOWEL OR ROD SHALL CONFORM TO MANUFACTURER'S RECOMMENDATION FOR EMBEDMENT DEPTH OR AS SHOWN ON THE DRAWINGS. NO REBAR SHALL BE CUT WITHOUT PRIOR ENGINEERING APPROVAL WHEN DRILLING HOLES IN CONCRETE.
11. CURING COMPOUNDS SHALL CONFORM TO ASTM C-309.
12. ADMIXTURES SHALL CONFORM TO THE APPROPRIATE ASTM STANDARD AS REFERENCED IN ACI-301.
13. DO NOT WELD OR TACKWELD REINFORCING STEEL.
14. ALL DOWELS, ANCHOR BOLTS, EMBEDDED STEEL, ELECTRICAL CONDUITS, PIPE SLEEVES, GROUNDS AND ALL OTHER EMBEDDED ITEMS AND FORMED DETAILS SHALL BE IN PLACE BEFORE START OF CONCRETE PLACEMENT.
15. LOCATE ADDITIONAL CONSTRUCTION JOINTS REQUIRED TO FACILITATE CONSTRUCTION AS ACCEPTABLE TO ENGINEER. PLACE REINFORCEMENT CONTINUOUSLY THROUGH JOINT.
16. REINFORCEMENT SHALL BE COLD BENT WHENEVER BENDING IS REQUIRED.
17. PLACE CONCRETE IN A UNIFORM MANNER TO PREVENT THE FORMATION OF COLD JOINTS AND OTHER PLANES OF WEAKNESS. VIBRATE THE CONCRETE TO FULLY EMBED REINFORCING. DO NOT USE VIBRATORS TO TRANSPORT CONCRETE THROUGH CHUTES OR FORMWORK.
18. DO NOT PLACE CONCRETE IN WATER, ICE, OR ON FROZEN GROUND.
19. DO NOT ALLOW CONCRETE SUBBASE TO FREEZE DURING CONCRETE CURING AND SETTING PERIOD, OR FOR A MINIMUM OF 14 DAYS AFTER PLACEMENT.
20. FOR COLD-WEATHER AND HOT-WEATHER CONCRETE PLACEMENT, CONFORM TO APPLICABLE ACI CODES AND RECOMMENDATIONS. IN EITHER CASE, MATERIALS CONTAINING CHLORIDE, CALCIUM, SALTS, ETC. SHALL NOT BE USED. PROTECT FRESH CONCRETE FROM WEATHER FOR 7 DAYS MINIMUM.

**CIVIL LEGEND**

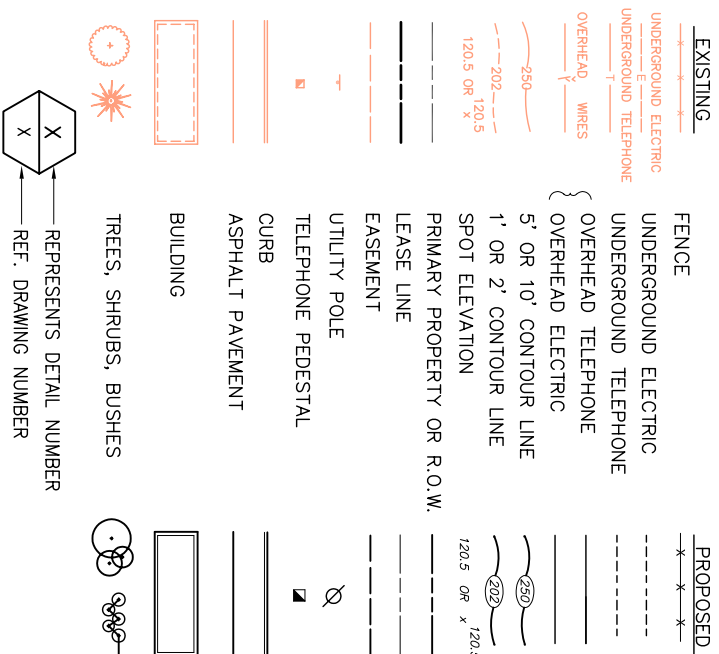

**GENERAL NOTES & LEGEND**

CT54XC773	C1
DATE: 03/29/07	REV 1

IT IS A VIOLATION OF LAW FOR ANY PERSON, UNLESS THEY ARE ACTING UNDER THE DIRECTION OF A LICENSED PROFESSIONAL ENGINEER, TO ALTER THIS DOCUMENT.

NO.	DATE	REVISIONS	BY	CHK	APPRD.
0	03/29/07	ISSUED FOR REVIEW	DJW	SJB	CMW
0	07/17/07	REVISED PER CLIENT COMMENT	EAM	SJB	CMW

**infinigy**  
engineering  
810 MARBETTA HIGHWAY  
ROSWELL, GA 30075  
158-06

**Sprint**  
CROSSROADS CORPORATE CENTER  
INTERNATIONAL BOULEVARD  
SUITE 800  
MAHWAH, NJ 07495

HAMDEN  
150 WILLOW STREET  
HAMDEN, CT 06518

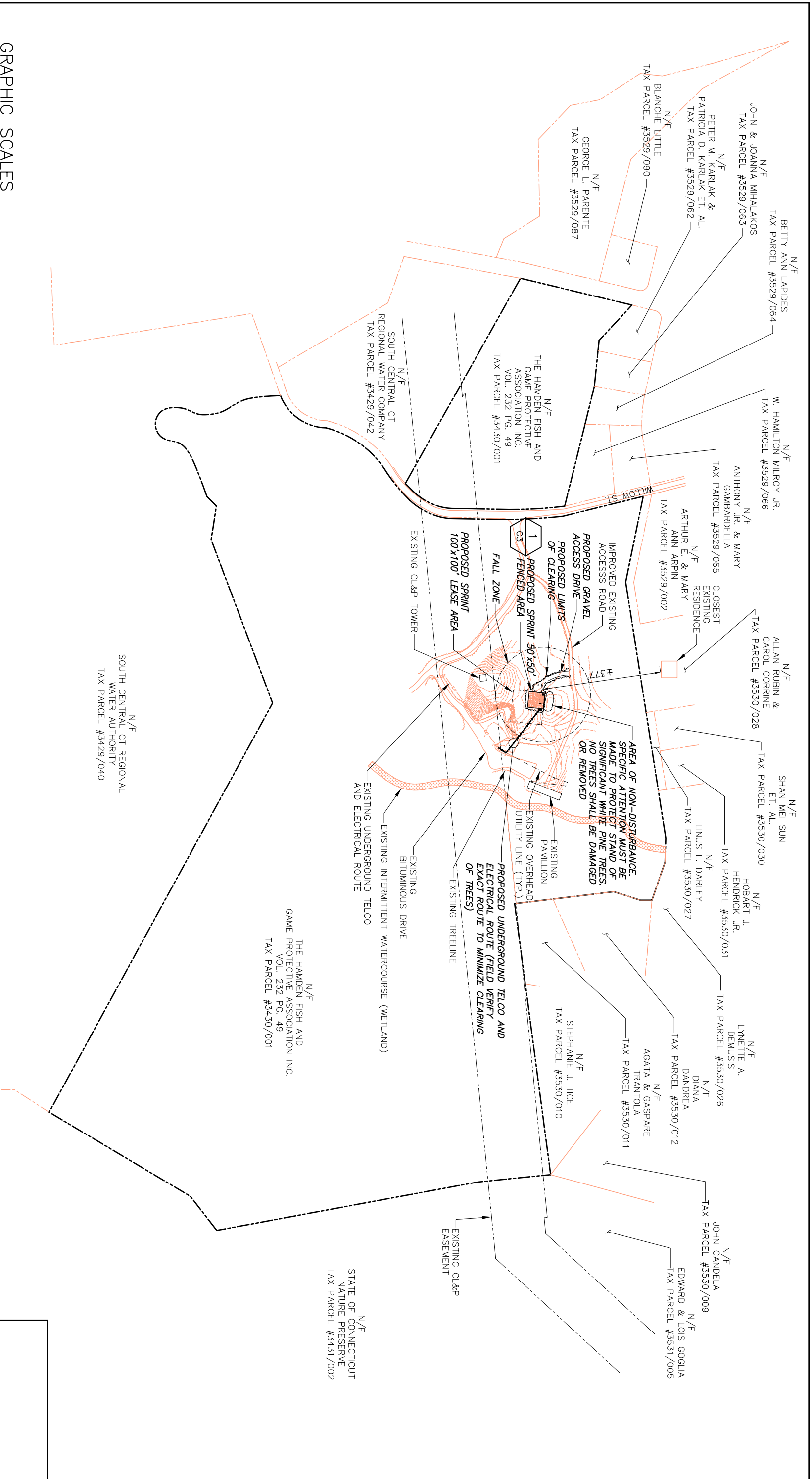

GRAPHIC SCALES

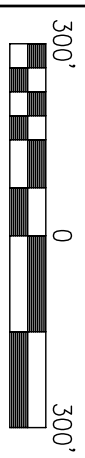

NOTE:  
AVERAGE TIMBER DIAMETER  
TO BE CLEARED = ± 1'



1 OVERALL SITE LAYOUT  
TYP

BASEMAPMING PREPARED FROM A  
SURVEY COMPLETED BY BL COMPANIES,  
DATED 10/13/05, AND A SITE VISIT BY  
INFINIGY ENGINEERING.

NO.	DATE	REVISIONS	BY	CHK	APP'D
0	07/17/07	REVISED PER CLIENT COMMENT	EAM	SJB	CAW
0	03/29/07	ISSUED FOR REVIEW	DJW	SJB	CAW

**infinigy**  
engineering  
810 MARBETA HIGHWAY  
ROSWELL, GA 30075  
158-06

**Sprint**  
CROSSROADS CORPORATE CENTER  
INTERNATIONAL BOULEVARD  
SUITE 800  
MAHWAH, NJ 07495

HAMDEN  
150 WILLOW STREET  
HAMDEN, CT 06518

OVERALL SITE LAYOUT		CT54XC773	C2
DATE:	03/29/07		REV 1

IT IS A VIOLATION OF LAW FOR ANY PERSON,  
UNLESS THEY ARE ACTING UNDER THE DIRECTION  
OF A LICENSED PROFESSIONAL ENGINEER, TO ALTER  
THIS DOCUMENT.

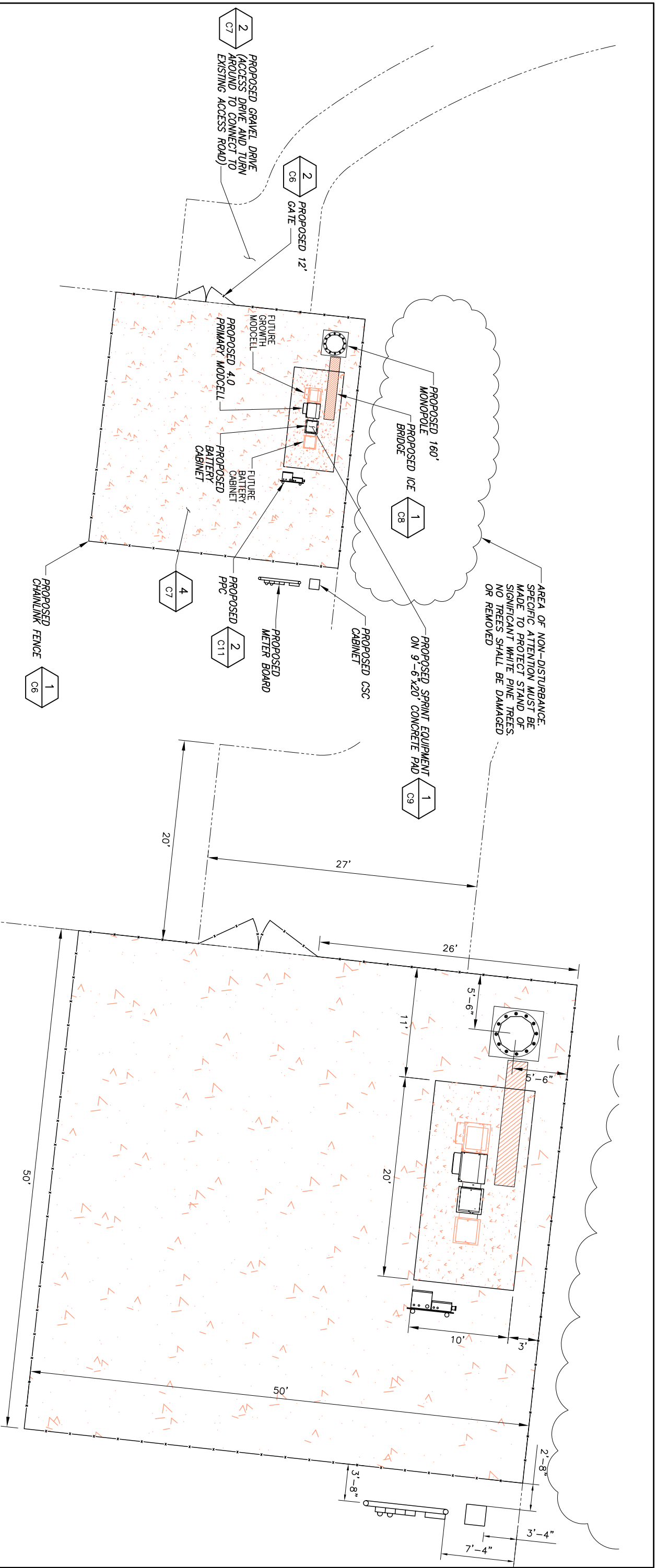

1 SITE LAYOUT

GENERAL SITE NOTES:

1. THE SUBGRADE SHALL BE COMPACTED AND BROUGHT TO A SMOOTH UNIFORM GRADE PRIOR TO FINISHED SURFACE APPLICATION.
2. ALL EXISTING ACTIVE SEWER, WATER, GAS, ELECTRIC, AND OTHER UTILITIES WHERE ENCOUNTERED IN THE WORK, SHALL BE PROTECTED AT ALL TIMES, AND WHERE REQUIRED FOR THE PROPER EXECUTION OF THE WORK, SHALL BE RELOCATED AS DIRECTED BY ENGINEERS. EXTREME CAUTION SHOULD BE USED BY THE CONTRACTOR WHEN EXCAVATING OR PIER DRILLING AROUND OR NEAR UTILITIES. CONTRACTOR SHALL PROVIDE SAFETY TRAINING FOR THE WORKING ENGINEER.
3. ALL EXISTING, INACTIVE SEWER, WATER, GAS, ELECTRIC, AND OTHER UTILITIES WHICH INTERFERE WITH THE EXECUTION OF THE WORK, SHALL BE REMOVED AND/OR CAPPED, PLUGGED OR OTHERWISE DISCONTINUED AT POINTS WHICH WILL NOT INTERFERE WITH THE EXECUTION OF THE WORK, SUBJECT TO THE APPROVAL OF AN ENGINEER.
4. THE SITE SHALL BE GRADED TO CAUSE SURFACE WATER TO FLOW
5. GARBAGE, STUMPS, DEBRIS, STICKS, STONES AND OTHER REFUSE SHALL BE REMOVED FROM THE SITE AND DISPOSED OF IN A LEGAL MANNER.
6. THE AREAS OF THE OWNERS PROPERTY DISTURBED BY THE WORK AND NOT COVERED BY THE BUILDING OR DRIVEWAY, SHALL BE GRADED TO A UNIFORM SLOPE, FERTILIZED, AND SEEDED.
7. ALL SITE WORK SHALL BE AS INDICATED ON THE DRAWINGS AND STIPULATED IN THE SPECIFICATION SUMMARY.
8. NO FILL OR EMBANKMENT MATERIAL SHALL BE PLACED ON FROZEN GROUND. FROZEN MATERIALS, SNOW OR ICE SHALL NOT BE PLACED IN ANY FILL OR EMBANKMENT.
9. CONTRACTOR IS TO SUPPLY 8-COMBINATION LOCKS (MASTER LOCK 175LH, PART NUMBER 71649 39565).
10. TREE CLEARING WILL BE LIMITED TO TOWER COMPOUND AND ACCESS DRIVE.

BASEMAPPING PREPARED FROM A SURVEY COMPLETED BY BL COMPANIES, DATED 10/13/05, AND A SITE VISIT BY INFINIGY ENGINEERING.

GRAPHIC SCALES

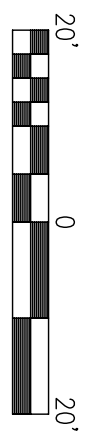

2 STAKING PLAN

GRAPHIC SCALES

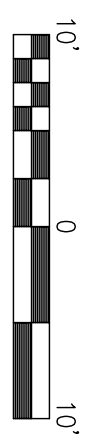

NO.	DATE	REVISIONS	BY	CHK	APP'D
0	07/17/07	REVISED PER CLIENT COMMENT	EJM	SJB	CAW
0	03/29/07	ISSUED FOR REVIEW	DJM	SJB	CAW

**infinigy**  
engineering  
810 MARBETH HIGHWAY  
ROSWELL, GA 30075  
158-06

**Sprint**  
CROSSROADS CORPORATE CENTER  
INTERNATIONAL BOULEVARD  
SUITE 800  
MAHWAH, NJ 07495

HAMDEN  
150 WILLOW STREET  
HAMDEN, CT 06518

ENLARGED SITE LAYOUT & STAKING PLAN  
CT54XC773

C3  
REV 1  
DATE: 03/29/07  
IT IS A VIOLATION OF LAW FOR ANY PERSON, UNLESS THEY ARE ACTING UNDER THE DIRECTION OF A LICENSED PROFESSIONAL ENGINEER, TO ALTER THIS DOCUMENT.

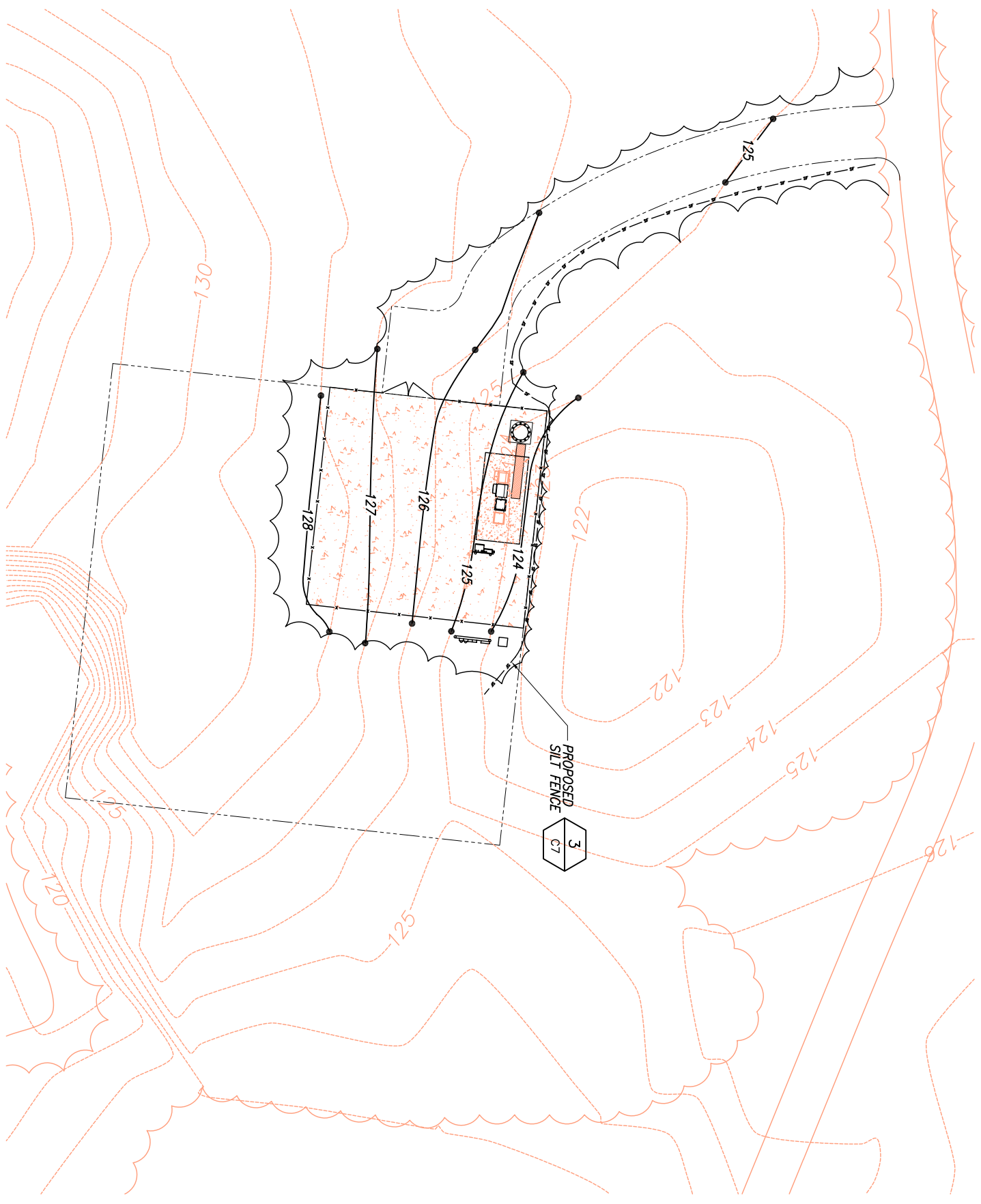

1 GRADING PLAN  
TYP

BASEMAPPING PREPARED FROM A SURVEY COMPLETED BY BL COMPANIES, DATED 10/13/05, AND A SITE VISIT BY INFINGY ENGINEERING.

NO.	DATE	REVISIONS	BY	CHK	APP'D
0	07/17/07	REVISED PER CLIENT COMMENT	EMJ	SJB	CAW
0	03/29/07	ISSUED FOR REVIEW	DJM	SJB	CAW

**infingy**  
engineering  
810 MARBETA HIGHWAY  
ROSWELL, GA 30075  
158-06

**Sprint**  
CROSSROADS CORPORATE CENTER  
INTERNATIONAL BOULEVARD  
SUITE 800  
MAHWAH, NJ 07495

HAMDEN  
150 WILLOW STREET  
HAMDEN, CT 06518

GRADING PLAN	CT54XC773	C3A
DATE: 03/29/07		REV 1

IT IS A VIOLATION OF LAW FOR ANY PERSON, UNLESS THEY ARE ACTING UNDER THE DIRECTION OF A LICENSED PROFESSIONAL ENGINEER, TO ALTER THIS DOCUMENT.

**GRADING & EXCAVATING NOTES:**

- ALL EXCAVATIONS ON WHICH CONCRETE IS TO BE PLACED SHALL BE SUBSTANTIALLY HORIZONTAL ON UNDISTURBED AND UNFROZEN SOIL AND BE FREE FROM LOOSE MATERIAL AND EXCESS GROUNDWATER. DEWATERING FOR EXCESS GROUNDWATER SHALL BE PROVIDED IF REQUIRED.
- CONCRETE FOUNDATIONS SHALL NOT BE PLACED ON ORGANIC MATERIAL. IF SOUND SOIL IS NOT REACHED AT THE DESIGNATED EXCAVATION DEPTH, THE UNSATISFACTORY SOIL SHALL BE EXCAVATED TO ITS FULL DEPTH AND EITHER BE REPLACED WITH MECHANICALLY COMPACTED GRANULAR MATERIAL OR THE EXCAVATION BE FILLED WITH CONCRETE OF THE SAME QUALITY SPECIFIED FOR THE FOUNDATION.
- ANY EXCAVATION OVER THE REQUIRED DEPTH SHALL BE FILLED WITH EITHER MECHANICALLY COMPACTED GRANULAR MATERIAL OR CONCRETE OF THE SAME QUALITY SPECIFIED FOR THE FOUNDATION. CRUSHED STONE MAY BE USED TO STABILIZE THE BOTTOM OF THE EXCAVATION. STONE, IF USED, SHALL NOT BE USED AS COMPILING CONCRETE THICKNESS.
- AFTER COMPLETION OF THE FOUNDATION AND OTHER CONSTRUCTION BELOW GRADE, AND BEFORE BACKFILLING, ALL EXCAVATIONS SHALL BE CLEAN OF UNSUITABLE MATERIAL SUCH AS VEGETATION, TRASH, DEBRIS, AND SO FORTH.
- USE APPROVED MATERIALS CONSISTING OF EARTH, LOAM, SANDY CLAY, SAND -BE FREE FROM CLODS OR STONES OVER 2-1/2" MAXIMUM DIMENSIONS -BE PLACED IN 6" LAYERS AND COMPACTED TO 95% STANDARD PROCTOR EXCEPT IN GRASSED/LANDSCAPED AREAS, WHERE 90% STANDARD PROCTOR
- REMOVE ALL VEGETATION, TOPSOIL, DEBRIS, WET AND UNSATISFACTORY SOIL MATERIALS, OBSTRUCTIONS, AND DELETERIOUS MATERIALS FROM GROUND SURFACE PRIOR TO PLACING FILLS, PLOW, STRIP, OR BREAK UP SLOPED SURFACES STEEPER THAN THAN 1 VERTICAL TO 4 HORIZONTAL SO FILL MATERIAL WILL BOND WITH EXISTING SURFACE. WHEN SUBGRADE OR EXISTING GROUND SURFACE TO RECEIVE FILL HAS A DENSITY LESS THAN THAT REQUIRED FOR FILL, BREAK UP GROUND SURFACE TO DEPTH REQUIRED, PULVERIZE, MOISTURE-CONDITION OR AERATE SOIL AND RECOMPACT TO REQUIRED DENSITY.
- PROTECT EXISTING GRAVEL SURFACING AND SUBGRADE IN AREAS WHERE EQUIPMENT LOADS WILL OPERATE. USE PLANKING OR OTHER SUITABLE MATERIALS DESIGNED TO SPREAD EQUIPMENT LOADS. REPAIR DAMAGE TO EXISTING GRAVEL SURFACING OR SUBGRADE WHERE SUCH DAMAGE IS DUE TO THE CONTRACTOR'S OPERATIONS. DAMAGED GRAVEL SURFACING SHALL BE RESTORED TO MATCH THE ADJACENT UNDAIMAGED GRAVEL SURFACING AND SHALL BE OF THE SAME THICKNESS.
- REPLACE EXISTING GRAVEL SURFACING ON AREAS FROM WHICH GRAVEL SURFACING IS REMOVED DURING CONSTRUCTION OPERATIONS. GRAVEL SURFACING SHALL BE REPLACED TO MATCH EXISTING ADJACENT GRAVEL SURFACING AND SHALL BE OF THE SAME THICKNESS. SURFACES OF GRAVEL SURFACING SHALL BE FREE FROM CORRUGATIONS AND WAVES. EXISTING GRAVEL SURFACING MAY BE EXCAVATED SEPARATELY AND REUSED IF INJURIOUS AMOUNTS OF EARTH, ORGANIC MATTER, OR OTHER DELETERIOUS MATERIALS ARE REMOVED PRIOR TO REUSE. FURNISH ALL ADDITIONAL GRAVEL RESURFACING MATERIAL AS REQUIRED. BEFORE GRAVEL SURFACING IS REPLACED, SUBGRADE SHALL BE GRADED TO CONFORM TO REQUIRED SUBGRADE ELEVATIONS, AND LOOSE OR DISTURBED MATERIALS SHALL BE THOROUGHLY COMPACTED. DEPRESSIONS IN THE SUBGRADE SHALL BE FILLED AND COMPACTED WITH APPROVED SELECTED MATERIAL. GRAVEL SURFACING MATERIAL MAY BE USED FOR FILLING DEPRESSIONS IN THE SUBGRADE, SUBJECT TO ENGINEER'S APPROVAL.
- DAMAGE TO EXISTING STRUCTURES AND UTILITIES RESULTING FROM CONTRACTOR'S NEGLIGENCE SHALL BE REPAIRED/REPLACED TO OWNER'S SATISFACTION AT CONTRACTOR'S EXPENSE.
- CONTRACTOR SHALL COORDINATE THE CONSTRUCTION SCHEDULE WITH PROPERTY OWNER SO AS TO AVOID INTERRUPTIONS TO PROPERTY OWNER'S OPERATIONS.
- ENSURE POSITIVE DRAINAGE DURING AND AFTER COMPLETION OF CONSTRUCTION.
- ALL CUT AND FILL SLOPES SHALL BE MAXIMUM 2 HORIZONTAL TO 1 VERTICAL.
- CONTRACTOR SHALL BE RESPONSIBLE FOR MONITORING SITE VEHICLE TRAFFIC AS TO NOT ALLOW VEHICLES LEAVING THE SITE TO TRACK MUD ONTO PUBLIC STREETS. THE CONTRACTOR IS RESPONSIBLE FOR CLEANING PUBLIC STREETS DUE TO MUDDY VEHICLES LEAVING THE SITE.

**GENERAL EROSION & SEDIMENT CONTROL NOTES:**

- THE SOIL EROSION AND SEDIMENT CONTROL MEASURES AND DETAILS AS SHOWN HEREIN AND STIPULATED WITHIN STATE STANDARDS SHALL BE FOLLOWED AND INSTALLED IN A MANNER SO AS TO MINIMIZE SEDIMENT LEAVING THE SITE.
- PRIOR TO COMMENCING LAND DISTURBANCE ACTIVITY, THE LIMITS OF LAND DISTURBANCE SHALL BE CLEARLY AND ACCURATELY DEMARCATED WITH STAKES, RIBBONS, OR OTHER APPROPRIATE MEANS.
- EROSION CONTROL DEVICES SHALL BE INSTALLED BEFORE GROUND DISTURBANCE OCCURS. THE LOCATION OF SOME OF THE EROSION CONTROL DEVICES MAY HAVE TO BE ALTERED FROM THOSE SHOWN ON THE APPROVED PLANS IF DRAINAGE PATTERNS DURING CONSTRUCTION ARE DIFFERENT FROM THE FINAL PROPOSED DRAINAGE PATTERNS. IT IS THE CONTRACTOR'S RESPONSIBILITY TO ACCOMPLISH EROSION CONTROL FOR ALL DRAINAGE PATTERNS CREATED AT VARIOUS STAGES DURING CONSTRUCTION. ANY DIFFICULTY IN CONTROLLING EROSION DURING ANY PHASE OF CONSTRUCTION SHALL BE REPORTED TO THE ENGINEER IMMEDIATELY.
- THE LOCATION OF SOME OF THE EROSION CONTROL DEVICES MAY HAVE TO BE ALTERED FROM THAT SHOWN ON THE PLANS IF DRAINAGE PATTERNS DURING CONSTRUCTION ARE DIFFERENT FROM THE FINAL PROPOSED DRAINAGE PATTERNS. ANY DIFFICULTY IN CONTROLLING EROSION DURING ANY PHASE OF CONSTRUCTION SHALL BE REPORTED TO THE ENGINEER IMMEDIATELY.
- CONTRACTOR SHALL MAINTAIN ALL EROSION CONTROL MEASURES UNTIL PERMANENT VEGETATION HAS BEEN ESTABLISHED. CONTRACTOR SHALL CLEAN OUT ALL SEDIMENT PONDS WHEN REQUIRED BY THE ENGINEER OR THE LOCAL JURISDICTION INSPECTOR. CONTRACTOR SHALL INSPECT EROSION CONTROL MEASURES AT THE END OF EACH WORKING DAY TO ENSURE MEASURES ARE FUNCTIONING PROPERLY.
- THE CONTRACTOR SHALL REMOVE ACCUMULATED SILT WHEN THE SILT IS WITHIN 12" OF THE TOP OF THE SILT FENCE.
- FAILURE TO INSTALL, OPERATE OR MAINTAIN ALL EROSION CONTROL MEASURES WILL RESULT IN ALL CONSTRUCTION BEING STOPPED ON THE JOB SITE UNTIL SUCH MEASURES ARE CORRECTED.
- SILT BARRIERS TO BE PLACED AT DOWNSTREAM TOE OF ALL CUT AND FILL SLOPES.
- ALL CUT AND FILL SLOPES MUST BE SURFACED ROUGHENED AND VEGETATED WITHIN SEVEN (7) DAYS OF THEIR CONSTRUCTION.
- CONTRACTOR SHALL REMOVE ALL EROSION & SEDIMENT CONTROL MEASURES AFTER COMPLETION OF CONSTRUCTION AND ESTABLISHMENT OF PERMANENT GROUND COVER.
- THE ESCAPE OF SEDIMENT FROM THE SITE SHALL BE PREVENTED BY THE INSTALLATION OF EROSION CONTROL MEASURES AND PRACTICES PRIOR TO, OR CONCURRENT WITH, LAND-DISTURBING ACTIVITIES.

VEGETATIVE SPECIES	SCHEDULE		DATE
	RATE/1000 S.F.		
TALL FESCUE GRASS	1.0#		APRIL 1 - OCTOBER 15
SERICEA LESPEDEZA SEED BEARING HAY WITH OVERSEEDING WEEPING LOVEGRASS	140# 0.2#		OCTOBER 1 - MARCH 15 MARCH 15 - MAY 1
<b>FERTILIZER MIX</b>			
APPLICATION	N, #/ACRE	P <sub>2</sub> O <sub>5</sub> , #/ACRE	K <sub>2</sub> O, #/ACRE
1st	60 - 90	120 - 180	120 - 180
2nd	60	120	120

NOTE:  
- GRASS AND MULCH ALL DISTURBED AREAS

**HYDRAULIC SEEDING EQUIPMENT**

WHEN HYDRAULIC SEEDING AND FERTILIZING EQUIPMENT IS USED, NO GRADING AND SHAPING OR SEEDBED PREPARATION WILL BE REQUIRED. THE FERTILIZER, SEED AND WOOD CELLULOSE FIBER MULCH WILL BE MIXED WITH WATER AND APPLIED IN A SLURRY. ALL SLURRY INGREDIENTS MUST BE COMBINED TO FORM A HOMOGENEOUS MIXTURE, AND SPREAD UNIFORMLY OVER THE AREA WITHIN ONE HOUR AFTER MIXTURE IS MADE. STRAW OR HAY MULCH AND ASPHALT EMULSION WILL BE APPLIED WITH BLOWER-TYPE MULCH SPREADING EQUIPMENT WITHIN 24 HOURS AFTER SEEDING. THE MULCH WILL BE SPREAD UNIFORMLY OVER THE AREA, LEAVING ABOUT 25 PERCENT OF THE GROUND SURFACE EXPOSED.

**CONVENTIONAL SEEDING EQUIPMENT**

GRADE, SHAPE AND SMOOTH WHERE NEEDED TO PROVIDE FOR SAFE EQUIPMENT OPERATION AT SEEDING TIME AND FOR MAINTENANCE PURPOSES. THE LIME AND FERTILIZER IN DRY FORM WILL BE SPREAD UNIFORMLY OVER THE AREA IMMEDIATELY BEFORE SEEDBED PREPARATION. A SEEDBED WILL BE PREPARED BY SCARIFYING TO A DEPTH OF 1 TO 4 INCHES AS DETERMINED ON SITE. THE SEEDBED MUST BE WELL PULVERIZED, SMOOTHED AND FIRMED. SEEDING WILL BE DONE WITH CULTIPACKER-SEEDER, DRILL, ROTARY SEEDER OR OTHER MECHANICAL OR HAND SEEDER. SEED WILL BE DISTRIBUTED UNIFORMLY OVER A FRESHLY PREPARED SEEDBED AND COVERED LIGHTLY. WITHIN 24 HOURS AFTER SEEDING, STRAW OR HAY MULCH WILL BE SPREAD UNIFORMLY OVER THE AREA, LEAVING ABOUT 25 PERCENT OF THE GROUND SURFACE EXPOSED. MULCH WILL BE SPREAD WITH BLOWER-TYPE MULCH EQUIPMENT OR BY HAND AND ANCHORED IMMEDIATELY AFTER IT IS SPREAD. A DISK HARROW WITH THE DISK SET STRAIGHT OR A SPECIAL PACKER DISK MAY BE USED TO PRESS THE MULCH INTO THE SOIL.

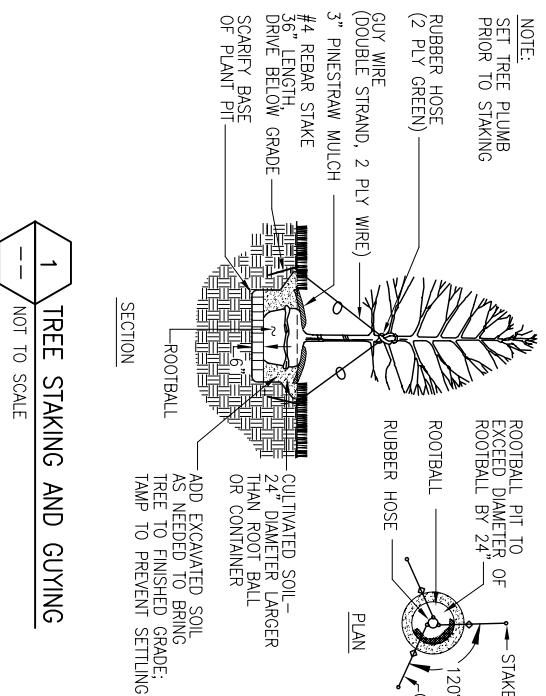

**1 TREE STAKING AND GUYING**  
NOT TO SCALE

NO.	DATE	REVISIONS	BY	CHK	APPRD
0	07/17/07	REVISED PER CLIENT COMMENT	EMM	SJB	CMW
0	03/29/07	ISSUED FOR REVIEW	DAW	SJB	CMW

**infinigy**  
engineering  
810 MARBETH HIGHWAY  
ROSWELL, GA 30075  
158-06

**Sprint**  
CROSSROADS CORPORATE CENTER  
INTERNATIONAL BOULEVARD  
SUITE 800  
MAHWAH, NJ 07495

HAMDEN  
150 WILLOW STREET  
HAMDEN, CT 06518

GRADING & EROSION CONTROL NOTES		C4
CT54XC773		
DATE: 03/29/07		REV 1

IT IS A VIOLATION OF LAW FOR ANY PERSON, UNLESS THEY ARE ACTING UNDER THE DIRECTION OF A LICENSED PROFESSIONAL ENGINEER, TO ALTER THIS DOCUMENT.

ANTENNA CABLE CONFIGURATION

ITEM NO.	DESCRIPTION	QUANTITY (EACH)	LENGTH (FT. EACH)	TOTAL LENGTH
1	ANTENNAS: * DB9321G685R2E-B * DB9321G685R2E-B * GPS - LUCENT # 407517689	1 1 1	N/A N/A N/A	N/A N/A N/A
2	TILT BRACKET MODEL #DBS098	N/A	N/A	N/A
3	JUMPER CABLES: DIN MALE - DIN MALE 6' SUPERFLEX DIN MALE - DIN MALE 3' SUPERFLEX	3 3	6' 3'	N/A N/A
4	MAIN CABLES: * 1/2" DIA. FLEXWELL COAXIAL (CABLEWAVE 810918-001) * 7/8" DIA. FLEXWELL COAXIAL (CABLEWAVE 810921-001) * 1-5/8" DIA. FLEXWELL COAXIAL (CABLEWAVE 810920-001)	1 N/A 3	N/A N/A LENGTH	80' N/A 600'
5	GROUNDING KITS WITH 60" GROUND CABLE AND 2-HOLE LUGS FOR THE FOLLOWING: * 1/2" CABLE (CABLEWAVE 916382) * 7/8" CABLE (CABLEWAVE 916385) * 1-5/8" CABLE (CABLEWAVE 916391)	2 N/A 6	N/A N/A N/A	N/A N/A N/A
6	CONNECTORS - UNATTACHED FOR GPS AND MAIN CABLES: * MALE "N" 1/2" (CABLEWAVE 734803) * FEMALE "N" 1/2" (CABLEWAVE 734806) * MALE "DN" 7/8" (CABLEWAVE 734737) * FEMALE "N" 7/8" (CABLEWAVE 734837) * FEMALE "DN" 1-5/8" (CABLEWAVE 734756)	2 N/A N/A N/A 6	N/A N/A N/A N/A N/A	N/A N/A N/A N/A N/A
7	PPC MINI (200 AMP), IN LINE TYPE AS MANUFACTURED BY NORTHERN TECHNOLOGIES, MODEL # N2101-W01	1	N/A	N/A
8	ACCA. PROVIDED BY LUCENT W/O JUMPERS	N/A	N/A	N/A
9	HOISTING GRIPS * 1/2" CABLE (CABLEWAVE 910303) * 7/8" CABLE (CABLEWAVE 910307) * 1-5/8" CABLE (CABLEWAVE 910311)	1 N/A 3	N/A N/A N/A	N/A N/A N/A
10	WEATHERPROOFING KITS (CABLEWAVE 916132)	12	N/A	N/A

NOTES: 1. ITEMS LISTED TO BE SUPPLIED BY OWNER.  
2. ITEM 4 IS TO BE FIELD FABRICATED BY CONTRACTOR.

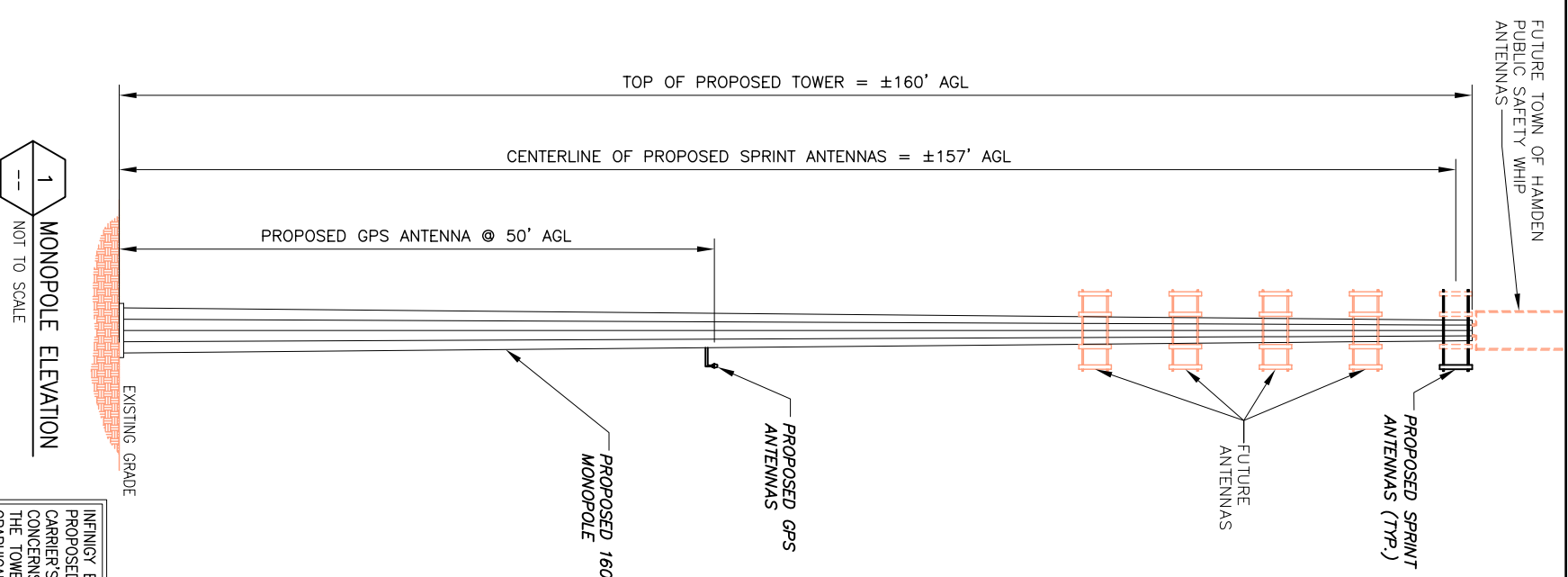

INFINIGY ENGINEERING HAS NOT EVALUATED THE PROPOSED TOWER FOR THIS SITE. IT IS THE CARRIER'S RESPONSIBILITY TO INVESTIGATE ANY LOADING CONCERNS WHEN ADDING ADDITIONAL EQUIPMENT TO THE TOWER. ANY FUTURE ANTENNAS SHOWN ARE FOR GRAPHICAL PURPOSES ONLY.

ANTENNA CABLE CONFIGURATION

FROM/TO	AZIMUTH: 0°	ELEC. DOWNTILT = 0°		AZIMUTH: 200°	ELEC. DOWNTILT = 2°		AZIMUTH: 290°	ELEC. DOWNTILT = 0°		GPS ANTENNA
		MECH. LENGTH (FT)*	GROWTH		MECH. LENGTH (FT)*	GROWTH		MECH. LENGTH (FT)*	GROWTH	
TOP JUMPER CABLE	DIN MALE 6' SUPERFLEX	6'	N/A	DIN MALE 6' SUPERFLEX	6'	N/A	DIN MALE 6' SUPERFLEX	6'	N/A	N/A
FROM TOP JUMPER TO ANTENNA CABLE COVER ASSEMBLY	810920-001 1 5/8"	200'	N/A	810920-001 1 5/8"	200'	N/A	810920-001 1 5/8"	200'	1/2"	80'
ANTENNA CABLE COVER ASSEMBLY TO PRIMARY RADIO CABINET	DIN MALE 3' SUPERFLEX	3'	N/A	DIN MALE 3' SUPERFLEX	3'	N/A	DIN MALE 3' SUPERFLEX	3'	N/A	TBD

NOTE: CONTRACTOR TO CERTIFY ANTENNA AZIMUTHS ARE WITHIN ± 2° OF INFORMATION SHOWN WITH REGISTERED LAND SURVEYOR.

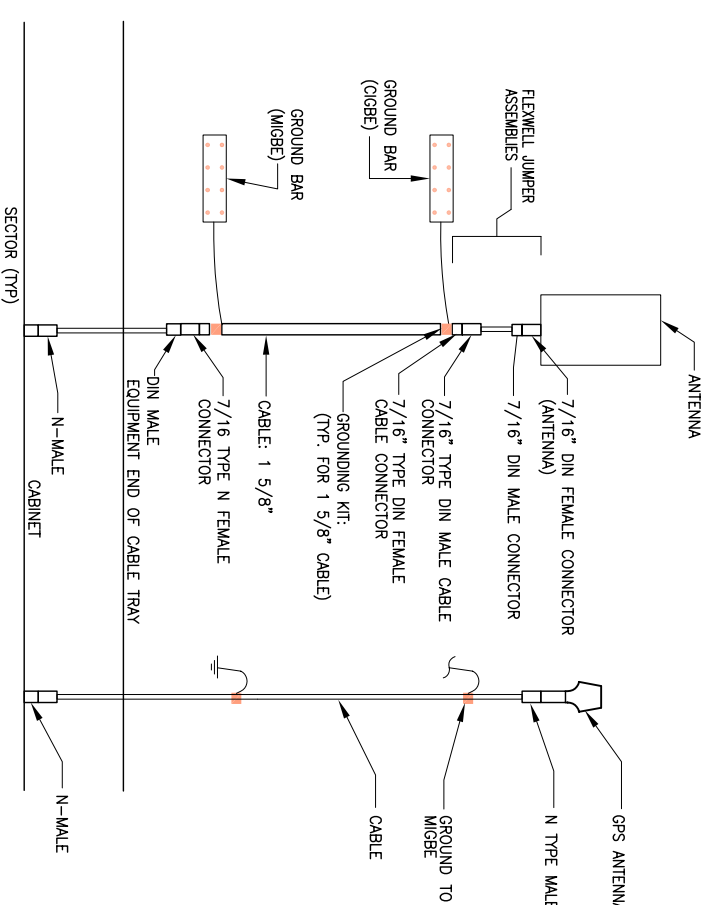

NO.	DATE	REVISIONS	BY	CHK	APP'D
0	07/17/07	REVISED PER CLIENT COMMENT	EAM	SJB	CAW
0	03/29/07	ISSUED FOR REVIEW	DJW	SJB	CAW

**infinigy** engineering  
810 MARBETH HIGHWAY  
ROSWELL, GA 30075  
158-06

**Sprint**  
CROSSROADS CORPORATE CENTER  
INTERNATIONAL BOULEVARD  
SUITE 800  
MAHWAH, NJ 07495

HAMDEN  
150 WILLOW STREET  
HAMDEN, CT 06518

TOWER ELEVATION  
CT54XC773  
DATE: 03/29/07

C5  
REV 1  
IT IS A VIOLATION OF LAW FOR ANY PERSON, UNLESS THEY ARE ACTING UNDER THE DIRECTION OF A LICENSED PROFESSIONAL ENGINEER, TO ALTER THIS DOCUMENT.

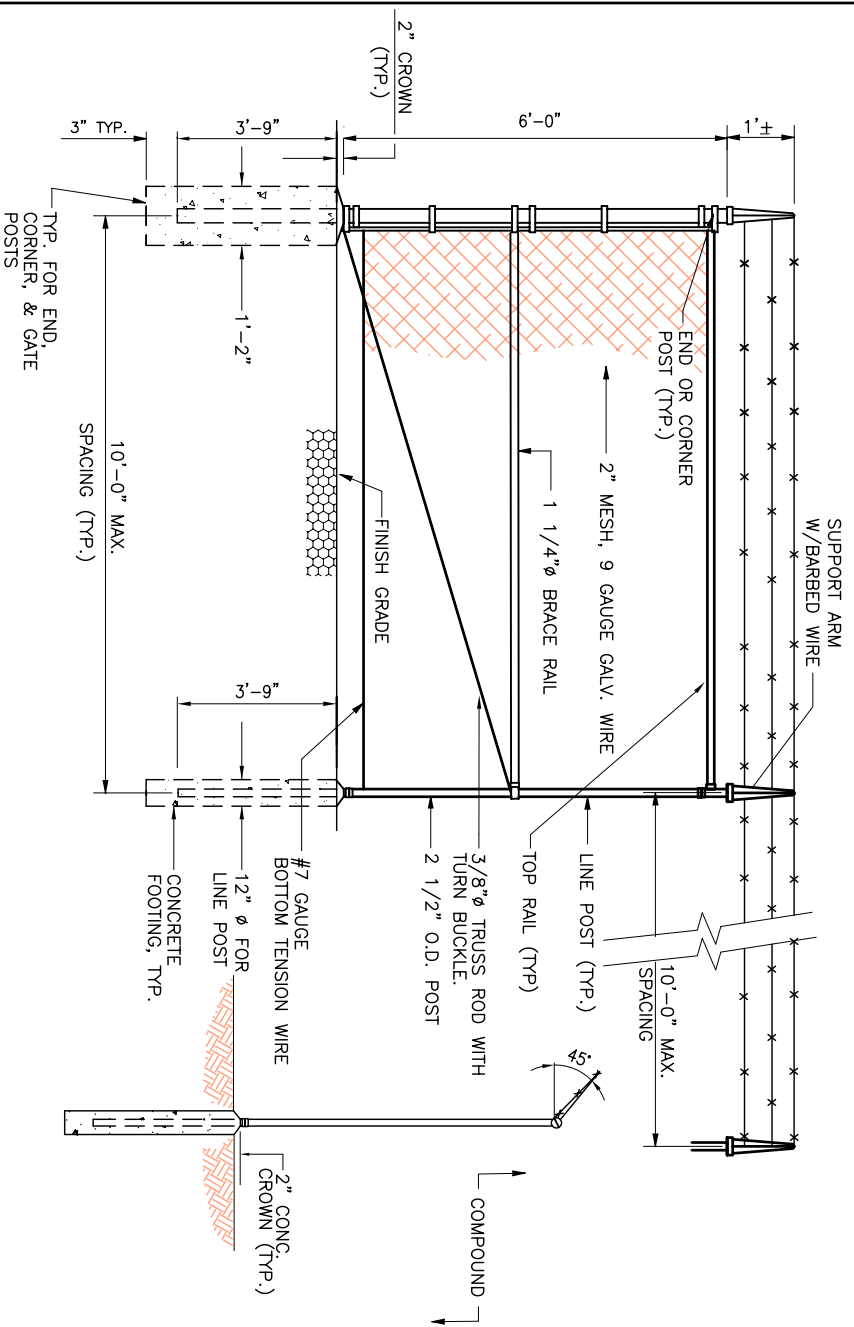

1 CHAIN LINK FENCE DETAIL (ELEVATION)  
NOT TO SCALE

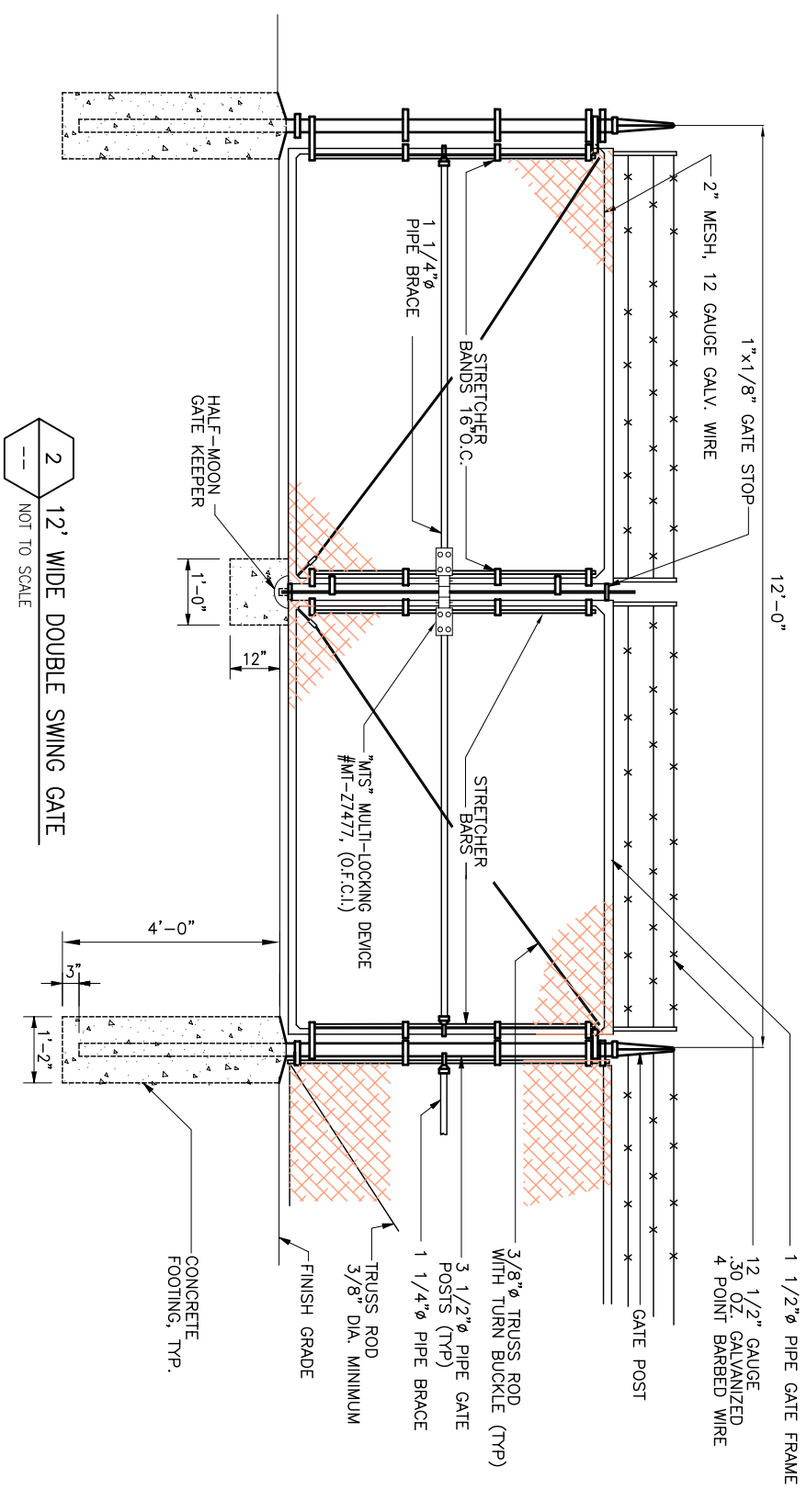

2 12' WIDE DOUBLE SWING GATE  
NOT TO SCALE

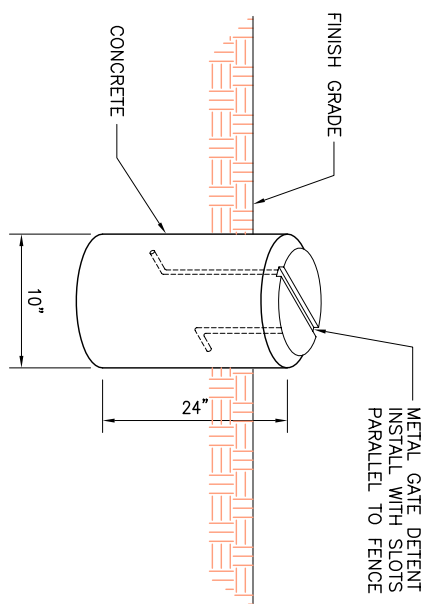

3 GATE DETENT DETAIL  
NOT TO SCALE

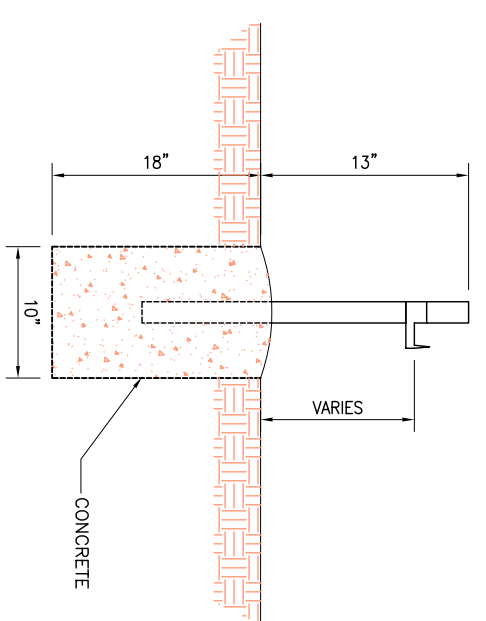

4 GATE/STOPPER DETAIL  
NOT TO SCALE

**FENCE NOTES:**

1. FENCING MATERIALS SHALL BE OF GALVANIZED STEEL.
2. POST, BRACES AND GATE FRAMES SHALL BE SCHEDULE 40 (STANDARD WEIGHT) PIPE. SIZES SPECIFIED ARE NOMINAL DIAMETER.
3. DOUBLE SWING GATE SHALL BE PROVIDED WITH TUBULAR PLUNGER BAR, 1 LOCK KEEPER, 1 LOCK KEEPER GUIDE, 2 LATCH FORKS, 2 FORK CATCHES, 1 CATCH FOR PLUNGER BAR, AND 2 GATE STOPS LOCATED AS DIRECTED BY THE OWNER.
4. POSTS, CAPS AND OTHER NECESSARY FENCE FITTINGS SHALL BE AS MANUFACTURED BY THE FENCE MANUFACTURER OR EQUAL.
5. POSTS SHALL BE SPACED EQUIDISTANT BUT NOT MORE THAN 10' O.C.
6. BOTTOM OF FENCE SHALL BE NO MORE THAN 3" ABOVE GRADE AT ANY SECTION.

NO.	DATE	REVISIONS	BY	CHK	APP'D
0	07/17/07	REVISED PER CLIENT COMMENT	EMJ	SJB	CAW
0	03/29/07	ISSUED FOR REVIEW	DAW	SJB	CAW

**infinigy**  
engineering  
810 MARBETH HIGHWAY  
ROSWELL, GA 30075  
158-06

**Sprint**  
CROSSROADS CORPORATE CENTER  
SUITE 800  
MAHWAH, NJ 07495

HAMDEN  
150 WILLOW STREET  
HAMDEN, CT 06518

DETAILS	REV
CT54XC773	1
C6	1

DATE: 03/29/07

IF IS A VIOLATION OF LAW FOR ANY PERSON, UNLESS THEY ARE ACTING UNDER THE DIRECTION OF A LICENSED PROFESSIONAL ENGINEER, TO ALTER THIS DOCUMENT.

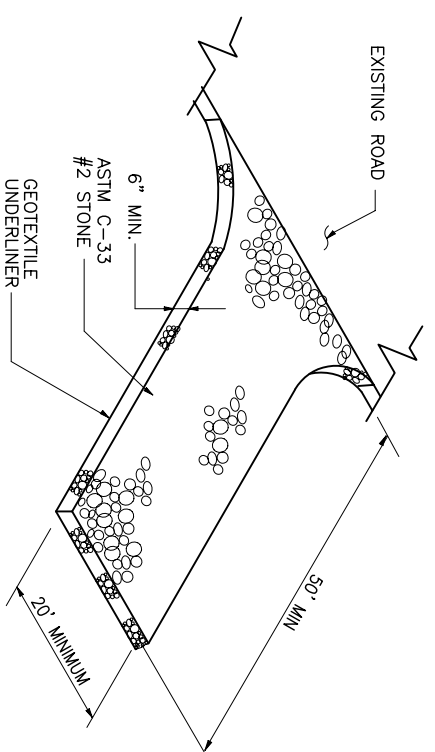

1 CONSTRUCTION EXIT DETAIL  
NOT TO SCALE

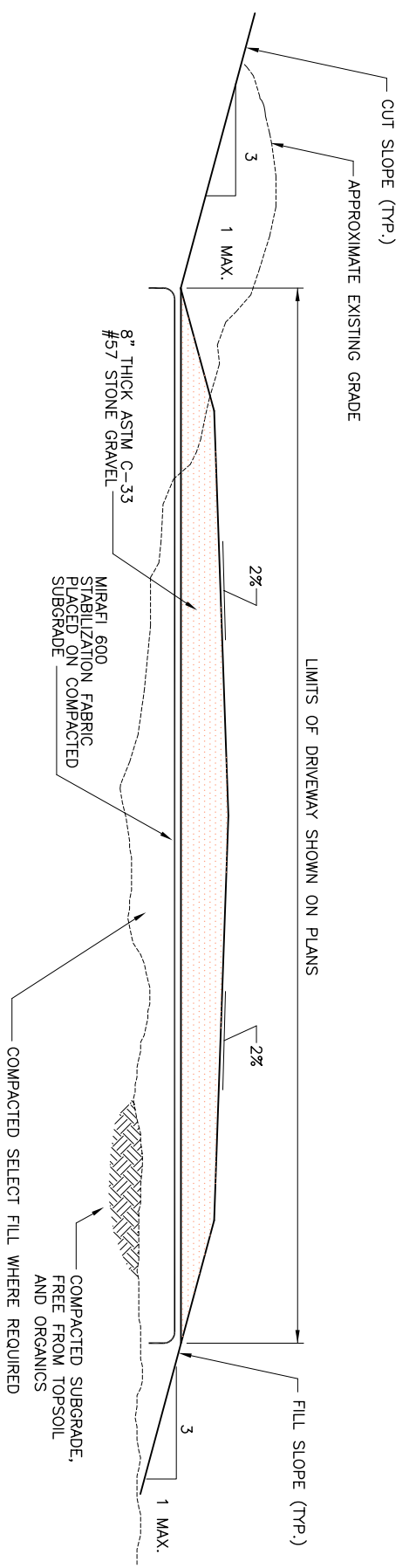

2 DRIVEWAY SECTION - CROWNED  
NOT TO SCALE

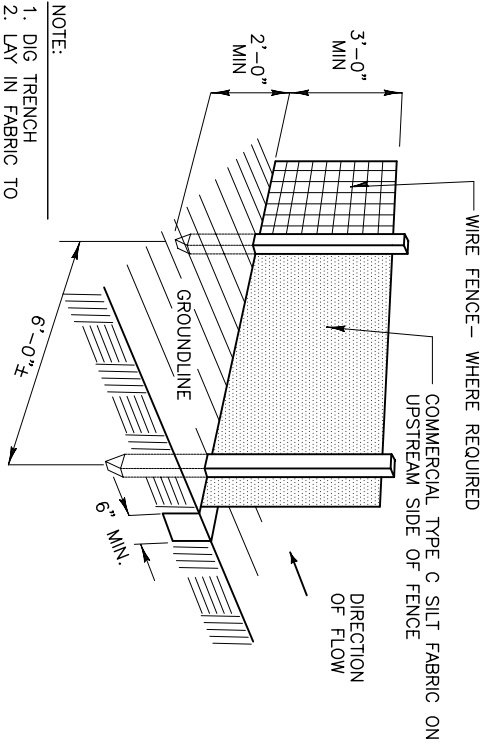

3 SILT FENCE DETAIL  
NOT TO SCALE

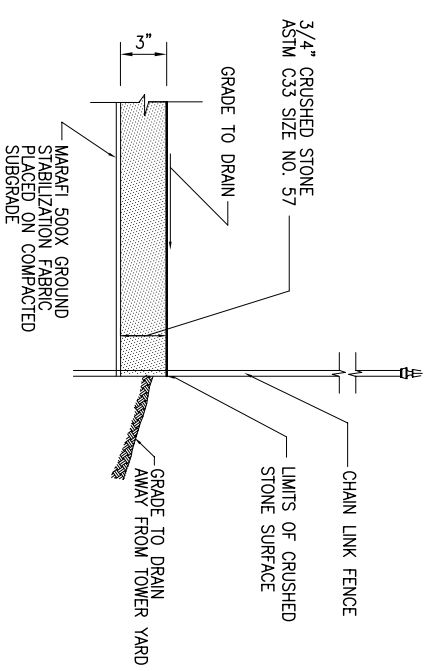

4 SECTION THROUGH COMPOUND  
NOT TO SCALE

CONSTRUCTION NOTES FOR FABRICATED SILT FENCE

1. WOVEN WIRE FENCE TO BE FASTENED SECURELY TO FENCE POSTS WITH WIRE TIES OR STAPLES.
2. FILTER CLOTH TO BE FASTENED SECURELY TO WOVEN WIRE FENCE WITH TIES SPACED EVERY 24" AT TOP AND MID SECTION.
3. WHEN TWO SECTIONS OF FILTER CLOTH ADJOIN EACH OTHER THEY SHALL BE OVERLAPPED BY SIX INCHES AND FOLDED.
4. MAINTENANCE SHALL BE PERFORMED AS NEEDED AND MATERIAL REMOVED WHEN "BUDGES" DEVELOP IN THE SILT FENCE.
5. ALL SILT FENCE MATERIALS MUST BE LISTED ON THE CURRENT STATES. D.O.T. QUALIFIED PRODUCTS LIST.

POSTS: STEEL EITHER T OR U TYPE.

FENCE: WOVEN WIRE, 14 GA. 6" MAX. MESH OPENING.

FILTER CLOTH: FILTER X, MIRAFI 100X STABILINKA T140N OR APPROVED EQUAL.

PREFABRICATED UNIT: GEOFAB, ENVIROFENCE OR APPROVED EQUAL.

NO.	DATE	REVISIONS	BY	CHK	APP'D
0	07/17/07	REVISED PER CLIENT COMMENT	EMJ	SJB	CMW
0	03/29/07	ISSUED FOR REVIEW	DJM	SJB	CMW

**infinigy**  
engineering  
810 MARIETTA HIGHWAY  
ROSWELL, GA 30075  
158-06

**Sprint**  
CROSSROADS CORPORATE CENTER  
INTERNATIONAL BOULEVARD  
SUITE 800  
MAHWAH, NJ 07495

HAMDEN  
150 WILLOW STREET  
HAMDEN, CT 06518

DETAILS	REV
CT54XC773	1

IT IS A VIOLATION OF LAW FOR ANY PERSON, UNLESS THEY ARE ACTING UNDER THE DIRECTION OF A LICENSED PROFESSIONAL ENGINEER, TO ALTER THIS DOCUMENT.



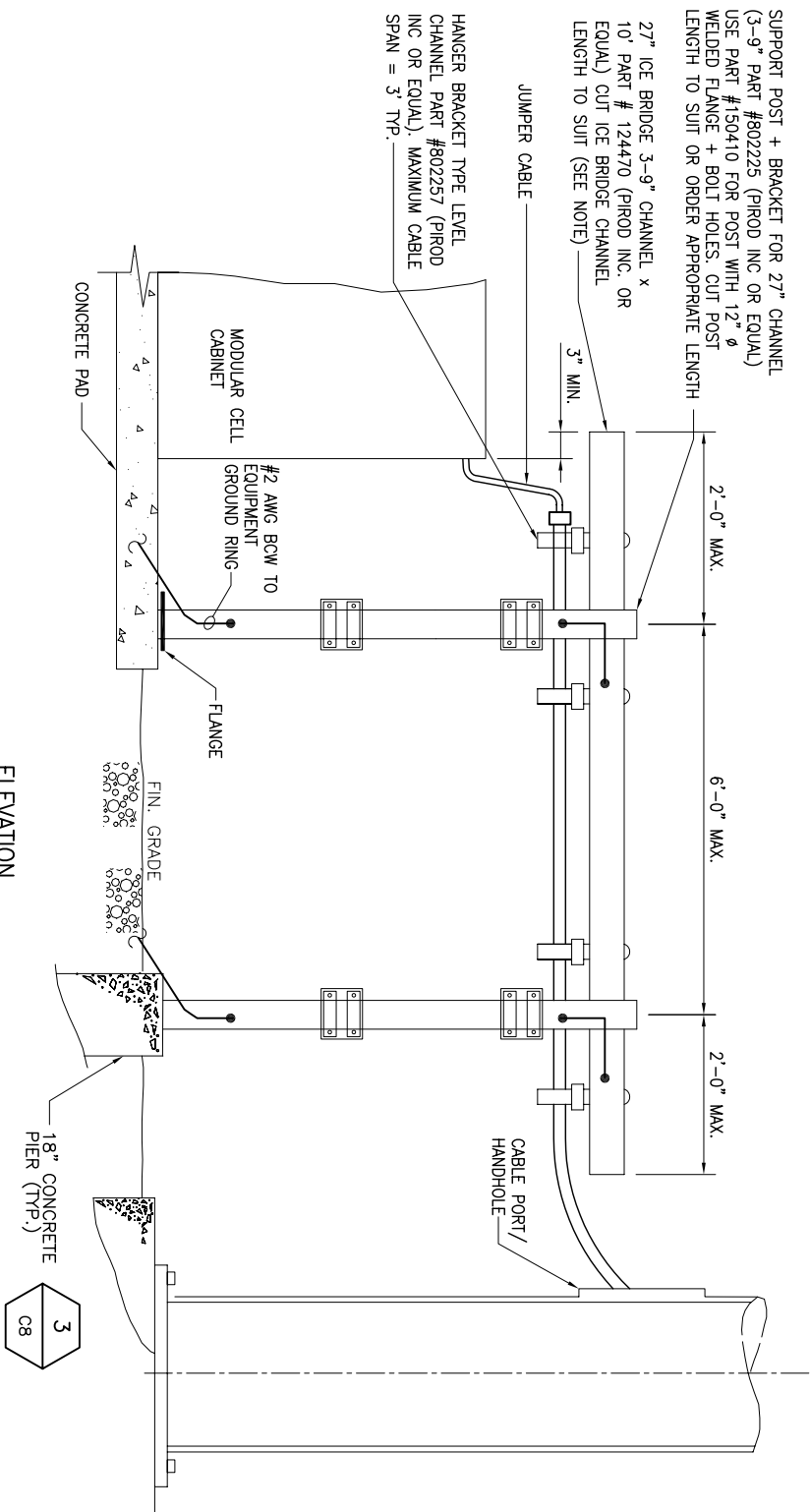

SUPPORT POST + BRACKET FOR 27" CHANNEL  
(3-9" PART #802225 (PIROD INC. OR EQUAL)  
USE PART #150410 FOR POST WITH 12" Ø  
WELDED FLANGE + BOLT HOLES. CUT POST  
LENGTH TO SUIT OR ORDER APPROPRIATE LENGTH

27" ICE BRIDGE 3-9" CHANNEL x  
10" PART # 124470 (PIROD INC. OR  
EQUAL) CUT ICE BRIDGE CHANNEL  
LENGTH TO SUIT (SEE NOTE)

JUMPER CABLE

HANGER BRACKET TYPE LEVEL  
CHANNEL PART #802257 (PIROD  
INC. OR EQUAL). MAXIMUM CABLE  
SPAN = 3' TYP.

2'-0" MAX.

6'-0" MAX.

2'-0" MAX.

3" MIN.

CONCRETE PAD

MODULAR CELL  
EQUIPMENT  
GROUND RING

#2 AWG BCW TO  
EQUIPMENT  
GROUND RING

FLANGE

FIN. GRADE

18" CONCRETE  
PIER (TYP.)

CABLE PORT/  
HANDHOLE

ELEVATION

NOMINAL CABLE SIZE	NOMINAL CABLE SIZE	CABLE PART NO.	MINIMUM BEND RADIUS	STANDARD NON-INSULATED HANGER KIT	SNAP-IN HANGER KIT
1/2"	810918-001	LCF12-50	5"	920981-010	915659
7/8"	810921-001	LCF78-50	10"	920981-007	915660
1 1/4"	810916-001	LCF14-50	15"	920981-004	915594
1 5/8"	810920-001	LCF158-50	20"	920981-012	915661
1/2" JUMPER	826052-003 3' 826052-006 6' 826052-008 8' 826052-010 10'	SCF12-50	5"	920981-010	915659

NOTES:

1. WHEN USING PIROD COMPONENTS AS SHOWN IN STANDARD DETAILS, MAXIMUM ALLOWABLE SPAN BETWEEN SUPPORTS ON A CONTINUOUS, SINGLE SECTION OF BRIDGE CHANNEL SHALL BE 19 FEET FOR 20 FEET BRIDGE CHANNEL, OR 9 FEET FOR 10 FEET BRIDGE CHANNEL.
2. WHEN USING PIROD COMPONENTS, FOR SPLICING BRIDGE CHANNEL SECTIONS, THE SPLICE SHOULD BE PROVIDED AT THE SUPPORT, IF POSSIBLE, OR AT A MAXIMUM OF 2 FEET FROM THE SUPPORT.
3. WHEN USING PIROD COMPONENTS, SUPPORT SHOULD BE PROVIDED AS CLOSE AS POSSIBLE TO THE ENDS OF ICE BRIDGES, WITH A MAXIMUM CANTILEVER DISTANCE OF 2 FEET FROM THE SUPPORT TO THE FREE END OF THE ICE BRIDGE.
4. CUT BRIDGE CHANNEL SECTIONS SHOULD HAVE RAW EDGES TREATED WITH A MATERIAL TO RESTORE THE EDGES TO THE ORIGINAL CHANNEL, OR EQUIVALENT, FINISH.
5. ICE BRIDGES MAY BE CONSTRUCTED WITH COMPONENTS FROM MANUFACTURERS OTHER THAN PIROD, PROVIDED THE MANUFACTURER'S INSTALLATION GUIDELINES ARE FOLLOWED.
6. DEVIATIONS FROM STANDARDS FOR COMPONENT INSTALLATIONS ARE PERMITTED WITH THE RESPECTIVE MANUFACTURER'S APPROVAL.
7. ATTACH FLANGED END OF SUPPORT POST TO CONCRETE PAD USING 4 - 3/8" DIA. HILT-HY 150 ADHESIVE ANCHORS. PROVIDE MINIMUM OF 1/2" EMBEDMENT.
8. DEVIATIONS FROM ICE BRIDGE FOUNDATIONS SHOWN ON SITE SPECIFIC DRAWINGS OR STANDARD DETAILS REQUIRE ENGINEERING APPROVAL.

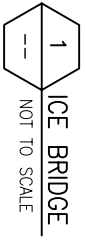

1 ICE BRIDGE  
NOT TO SCALE

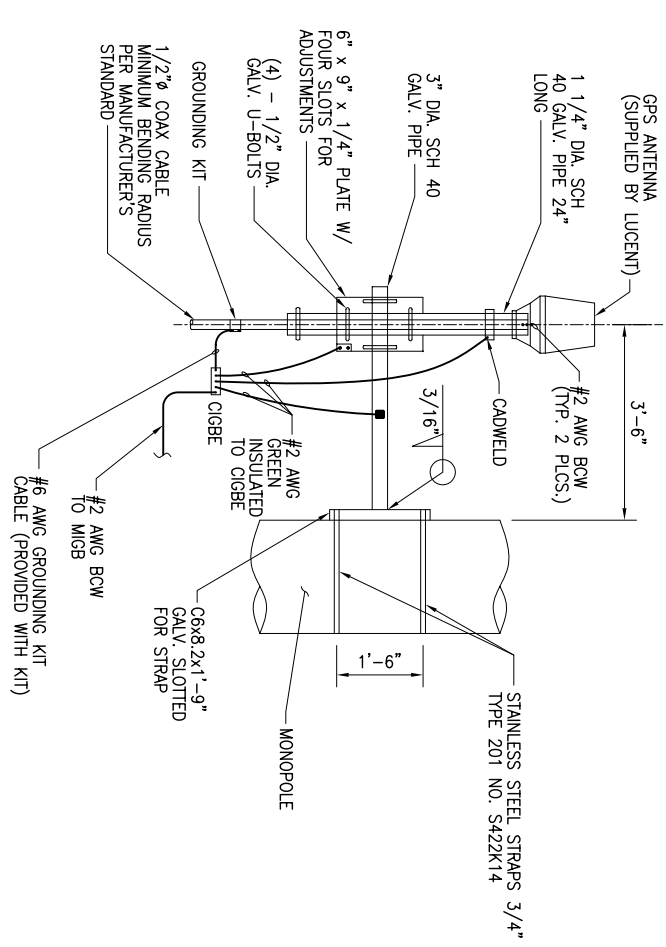

NOTES:

1. THE ELEVATION AND LOCATION OF THE GPS ANTENNA SHALL BE IN ACCORDANCE WITH THE FINAL RF REPORTS.
2. THE GPS ANTENNA MOUNT IS DESIGNED TO FASTEN TO A STANDARD 1-1/4" DIAMETER, SCHEDULE 40 GALVANIZED STEEL OR STAINLESS STEEL PIPE. THE PIPE MUST NOT BE THREADED AT THE ANTENNA MOUNT END. THE PIPE SHALL BE CUT TO THE REQUIRED LENGTH (MINIMUM OF 18 INCHES) USING A HAND OR ROTARY PIPE CUTTER TO ASSURE A SMOOTH AND PERPENDICULAR CUT. A HACK SAW SHALL NOT BE USED. THE CUT PIPE END SHALL BE DEBURRED AND SMOOTH IN ORDER TO SEAL AGAINST THE NEOPRENE GASKET ATTACHED TO THE ANTENNA MOUNT.

GPS ANTENNA MOUNTING BRACKET



2 GPS ANTENNA  
NOT TO SCALE

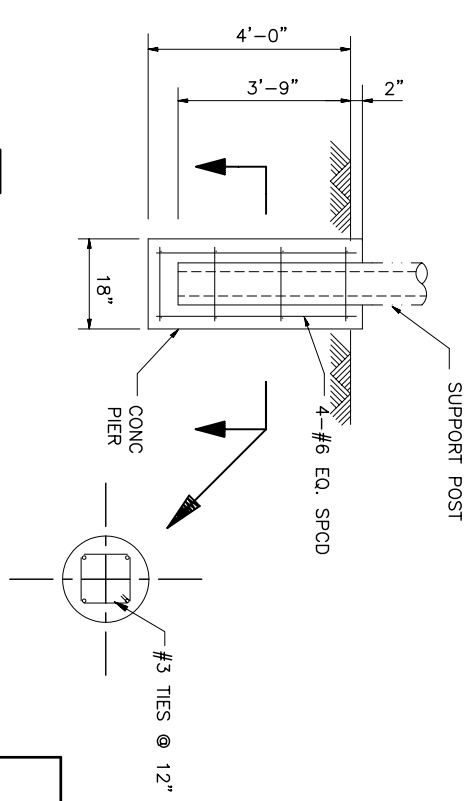

3 SUPPORT POST FOOTING  
NOT TO SCALE

NO.	DATE	REVISIONS	BY	CHK	APP'D
0	07/17/07	REVISED PER CLIENT COMMENT	EM	SJB	CM
0	03/29/07	ISSUED FOR REVIEW	DJM	SJB	CM

**infinigy**  
engineering  
810 MARBETH HIGHWAY  
ROSWELL, GA 30075  
158-06

**Sprint**  
CROSSROADS CORPORATE CENTER  
INTERNATIONAL BOULEVARD  
SUITE 800  
MAHWAH, NJ 07495

HAMDEN  
150 WILLOW STREET  
HAMDEN, CT 06518

DETAILS	REV
CT54XC773	1
DATE: 03/29/07	

IT IS A VIOLATION OF LAW FOR ANY PERSON, UNLESS THEY ARE ACTING UNDER THE DIRECTION OF A LICENSED PROFESSIONAL ENGINEER, TO ALTER THIS DOCUMENT.

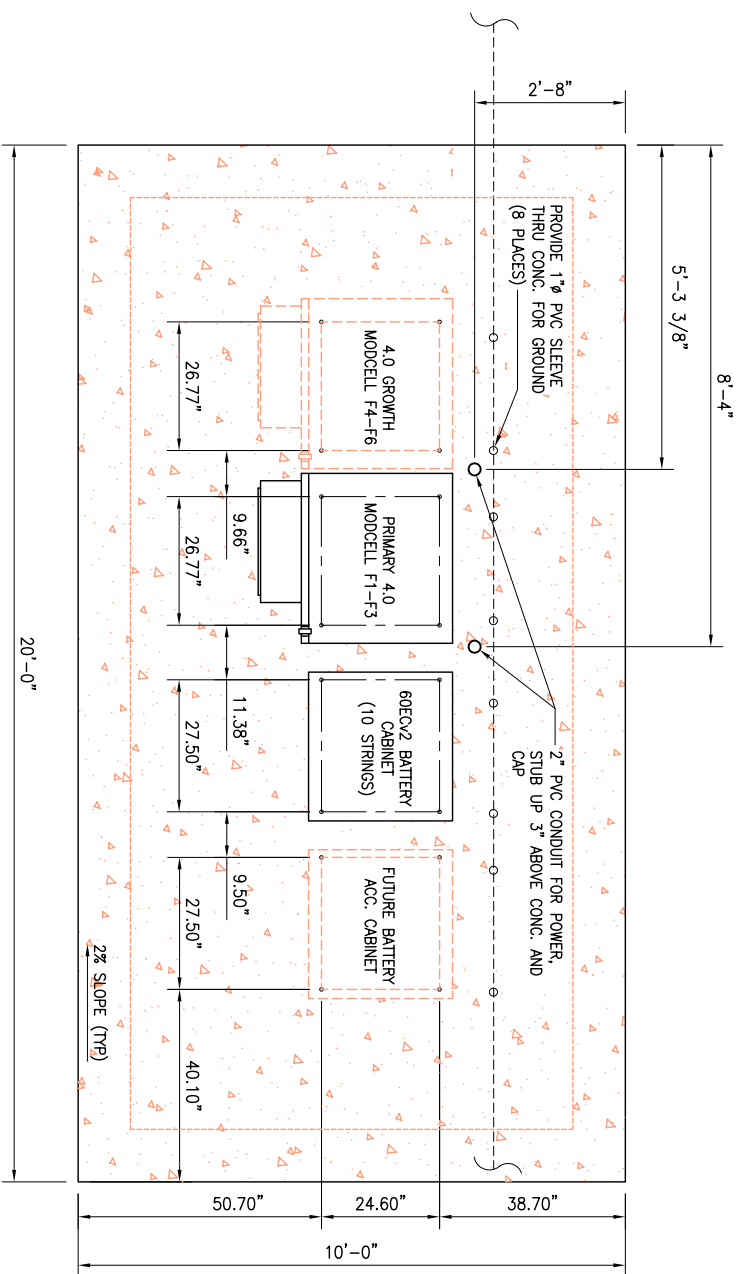

**1** EQUIPMENT CABINET LAYOUT AND ANCHORING  
NOT TO SCALE

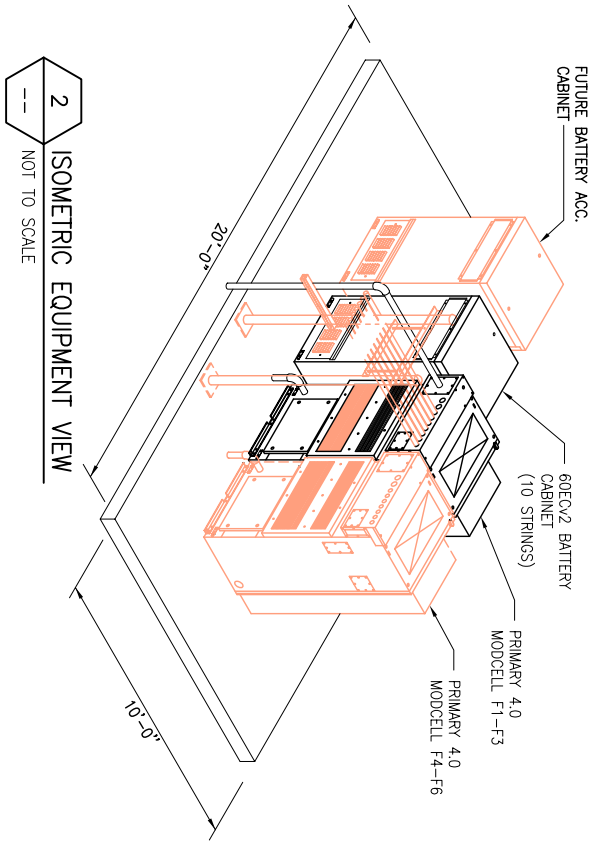

**2** ISOMETRIC EQUIPMENT VIEW  
NOT TO SCALE

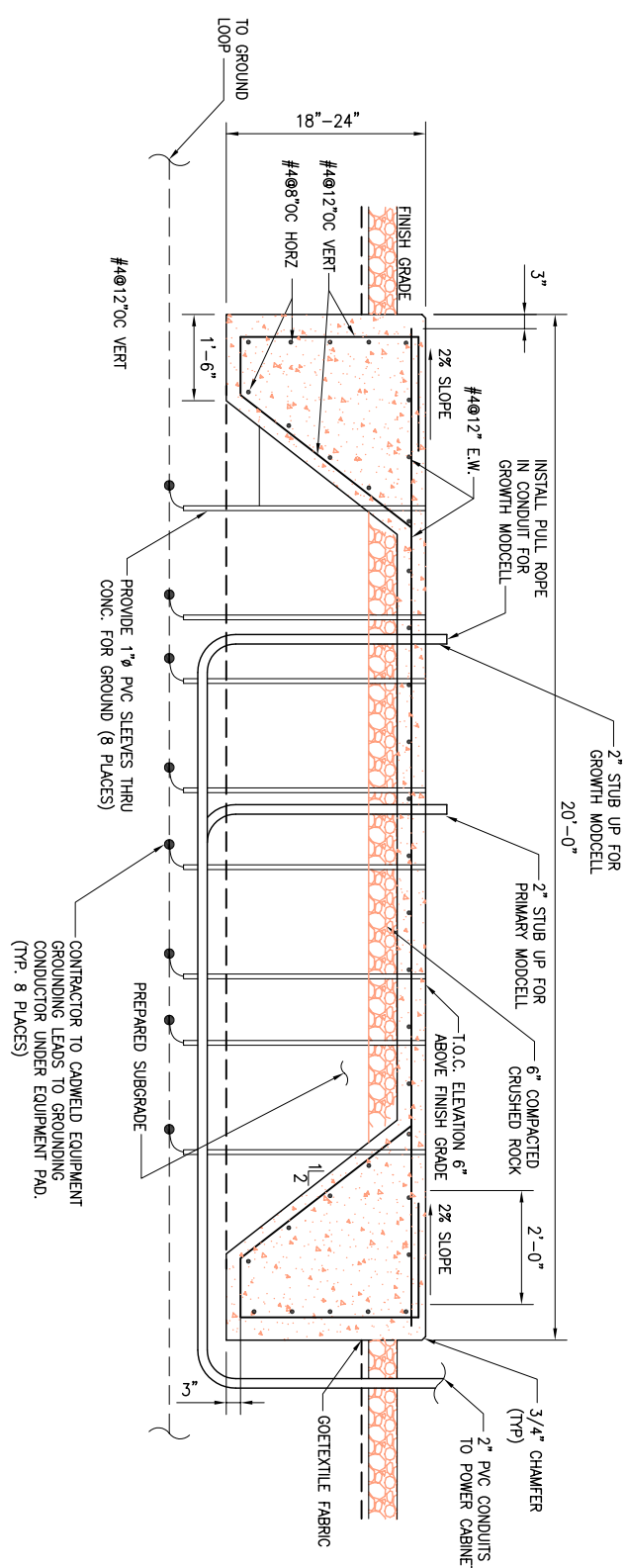

**3** EQUIPMENT CABINET FOUNDATION  
NOT TO SCALE

NO.	DATE	REVISIONS	BY	CHK	APP'D
0	07/17/07	REVISED PER CLIENT COMMENT	EMM	SJB	CAW
0	03/29/07	ISSUED FOR REVIEW	DJW	SJB	CAW

**infinigy**  
engineering  
810 MARBETH HIGHWAY  
ROSWELL, GA 30075  
158-06

**Sprint**  
CROSSROADS CORPORATE CENTER  
INTERNATIONAL BOULEVARD  
SUITE 800  
MAHWAH, NJ 07495

HAMDEN  
150 WILLOW STREET  
HAMDEN, CT 06518

DETAILS	REV
CT54XC773	1

DATE: 03/29/07

IT IS A VIOLATION OF LAW FOR ANY PERSON, UNLESS THEY ARE ACTING UNDER THE DIRECTION OF A LICENSED PROFESSIONAL ENGINEER, TO ALTER THIS DOCUMENT.

**CELL SITE INSTALLATION NOTES:**

THE FOLLOWING INSTALLATION NOTES HAVE BEEN COMPILED FROM EXISTING PROJECT DOCUMENTS (I.E. PROJECT SPECIFICATIONS, SPRINT STANDARD PRACTICE, LUCENT DOCUMENTS, ETC.) FOR USE. THESE NOTES SHALL BE UTILIZED FOR THE CONSTRUCTION OF THE CELL SITES TO ENSURE COMPLIANCE WITH THE PROJECT DESIGN AND SPECIFICATION REQUIREMENTS.

**A. GROUNDING:**

1. ALL METAL CONDUIT FOR GROUNDING DOWN CONDUCTORS SHALL BE BONDED TO THE GROUND SYSTEM AT BOTH ENDS.
2. KOPR-SHIELD ANTI-OXIDATION COMPOUND SHALL BE USED ON ALL GROUNDING CONNECTIONS.
3. ALL UNDERGROUND GROUNDING CONNECTIONS SHALL BE MADE BY THE CADWELD PROCESS.
4. ALL CADWELDS SHALL BE INSTALLED USING THE PROPER CONNECTION/MOLD AND MATERIALS FOR THE PARTICULAR CONNECTION AND/OR APPLICATION.

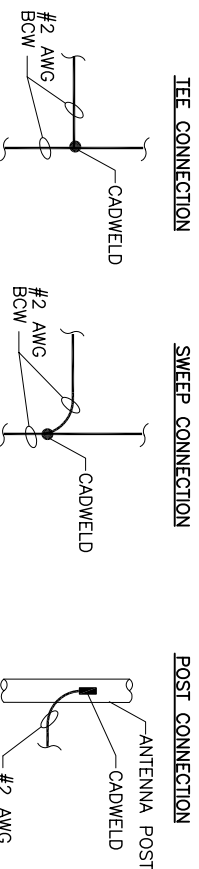

5. ALL BOLTED GROUNDING CONNECTIONS SHALL BE INSTALLED WITH A LOCK WASHER UNDER THE NUT. HARDWARE FOR BOLTED CONNECTIONS SHALL BE MINIMUM OF 3/8" DIAMETER AND SHALL BE STAINLESS STEEL.
6. GROUNDING WIRE SHALL NOT BE INSTALLED OR ROUTED THROUGH HOLES IN ANY METAL OBJECTS OR SUPPORTS TO PRECLUDE ESTABLISHING A "CHOKE" POINT.

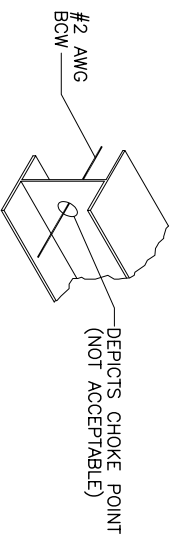

7. FERROUS METAL CLIPS WHICH COMPLETELY SURROUND THE GROUNDING CONDUCTOR SHALL NOT BE USED, THE FOLLOWING CLIPS MAY BE USED TO FASTEN AND SUPPORT GROUNDING CONDUCTORS.

\* METAL CLIPS WHICH DO NOT COMPLETELY SURROUND THE GROUND CONDUCTOR

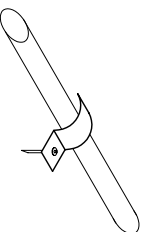

8. STANDARD BUSS BARS (CIGBES AND MGBS) SHALL BE FURNISHED AND INSTALLED. THEY SHALL NOT BE FABRICATED OR MODIFIED IN THE FIELD.
9. THE GROUNDING CONNECTION TO THE POWER AND TELCO CABINETS OF THE PRC SHALL BE MADE BY CONNECTING THE CONDUCTOR FROM THE GROUND RING TO THE FACTORY FURNISHED BUSS BAR IN EACH COMPARTMENT.
10. ALL GROUNDING WIRES SHALL BE INSTALLED WITHOUT LOOPS (PIGTALS) AND SHARP BEND RADIIUS.

**B. ANTENNA COAXIAL CABLES (WAVEGUIDE)**

NOTE: THE RF TRANSMISSION LINE INSTALLED BETWEEN THE PRIMARY RADIO CABINET (PRC), FURNISHED BY LUCENT, AND THE ANTENNA CONSISTS OF A COAXIAL CABLE, SOMETIMES REFERRED TO AS A WAVEGUIDE.

1. ALL ANTENNA COAXIAL CABLES AND JUMPERS SHALL BE INSTALLED WITHOUT LOOPS AND/OR PIGTAILS.
2. ANTENNA COAXIAL CABLE GROUND KITS SHALL NO BE INSTALLED ON THE JUMPER BETWEEN THE ANTENNA AND MAIN LINE CABLE.
3. ANTENNA COAXIAL CABLE GROUND KITS SHALL BE INSTALLED AS CLOSE TO THE CONNECTOR AS POSSIBLE AT EACH ANTENNA. IF THIS IS NOT FEASIBLE THE GROUND KIT SHALL BE INSTALLED IMMEDIATELY AFTER THE BEND ON THE FIRST STRAIGHT RUN OF CABLE. THE GROUNDKIT SHALL BE INSTALLED ON STRAIGHT SECTION OF CABLE ONLY AND NOT ON BENDS
4. ANTENNA COAXIAL CABLE SHALL BE INSTALLED TO COMPLY WITH THE MANUFACTURER'S MINIMUM BEND RADIUS SPECIFIED BELOW. THE CONTRACTOR SHALL INSTALL RACEWAY FOR COAXIAL CABLE USING THE PROPER FITTINGS NECESSARY TO ENSURE THAT THE MINIMUM BEND RADIUS REQUIREMENTS ARE MET. (REFERENCE: TECHNICAL INFORMATION BULLETIN NO. 96-026)
5. THE GPS ANTENNA COAXIAL CABLE SHALL BE A CONTINUOUS CABLE RUN, FROM THE CONNECTOR AT THE ANTENNA HEAD TO THE CONNECTION AT THE BTS CABINETS, WITHOUT JUMPERS.
6. THE ANTENNA COAXIAL CABLE AT THE BTS SHALL BE INSTALLED IN THE ACCA. THE FINISHED ANTENNA CABLES (WITH CONNECTOR AND GROUND KIT INSTALLED) SHALL BE INSTALLED SO THAT THE END OF THE CONNECTOR PROTRUDES NO FARTHER THAN 12 INCHES INTO THE ACCA.
7. THE COAXIAL CABLE ENTRY HATCHPLATE ON THE REAR OF THE ACCA SHALL BE INSTALLED WITH THE SMALL 1/2" DIAMETER HOLE (FOR THE GPS ANTENNA AND GROUND WIRES) TO THE RIGHT (WHEN FACING THE ACCA FROM THE REAR OF THE PRC).
8. ALL ANTENNA COAXIAL CABLES SHALL BE MARKED AND TAGGED IN ACCORDANCE WITH THE REQUIREMENTS IN PROJECT SPECIFICATION G-002, SECTION 16000, PARAGRAPHS 36 AND 37. THE FIGURE TO THE RIGHT INDICATES AN EXAMPLE OF THE COLOR CODE MARKED ON THE COAXIAL CABLES.
9. SINCE THERE ARE A NUMBER OF DIFFERENT COAXIAL CABLE ENTRY HATCHPLATES THAT MAY BE SUPPLIED WITH THE ACCA, THE CONTRACTOR SHALL ORIENT THE COAXIAL CABLE ENTRANCE IN TO THE ACCA IN ACCORDANCE WITH THE DIRECTION ISSUED BY EACH MTA. THE FIGURE SHOWN BELOW INDICATES THE PROPER ORIENTATION FOR THE COAXIAL CABLE ENTRANCE INTO THE ACCA.

**C. ELECTRICAL**

1. THE ELECTRICAL RACEWAY INSTALLED FROM THE MINI-PRC TO THE PRIMARY RADIO CABINET, FURNISHED BY LUCENT, SHALL HAVE AN 1 1/4" MALE CONNECTOR/REDUCER FOR THE TIE TO THE ELECTRICAL FITTING ON THE CABINET. THIS MAY BE ACCOMPLISHED USING EITHER A 1 1/4" CONDUIT, 1 1/4" FLEXIBLE CONDUIT OR A 1 1/4" BUSHING.

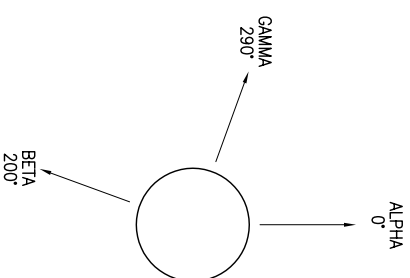

	ALPHA FACE	BETA FACE	GAMMA FACE
COAX 1	Y B W	R B W	G B W
COAX 2	Y O W	R O W	G O W
COAX 3	Y O O	R O O	G O O
COAX 4	Y B O	R B O	G B O

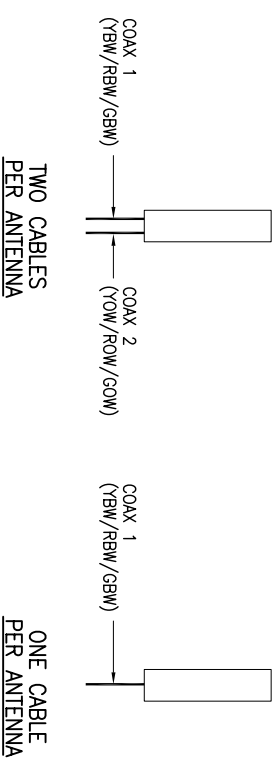

NO.	DATE	REVISIONS	BY	CHK	APP'D
0	07/17/07	REVISED PER CLIENT COMMENT	EMM	SJB	CMW
0	03/29/07	ISSUED FOR REVIEW	DAW	SJB	CMW

**infinigy**  
engineering  
810 MARBETH HIGHWAY  
ROSWELL, GA 30075  
158-06

**Sprint**  
CROSSROADS CORPORATE CENTER  
INTERNATIONAL BOULEVARD  
SUITE 800  
MAHWAH, NJ 07495

HAMDEN  
150 WILLOW STREET  
HAMDEN, CT 06518

CELL SITE INSTALLATION NOTES  
CT54XC773  
DATE: 03/29/07  
REV 1

C10  
IT IS A VIOLATION OF LAW FOR ANY PERSON, UNLESS THEY ARE ACTING UNDER THE DIRECTION OF A LICENSED PROFESSIONAL ENGINEER, TO ALTER THIS DOCUMENT.

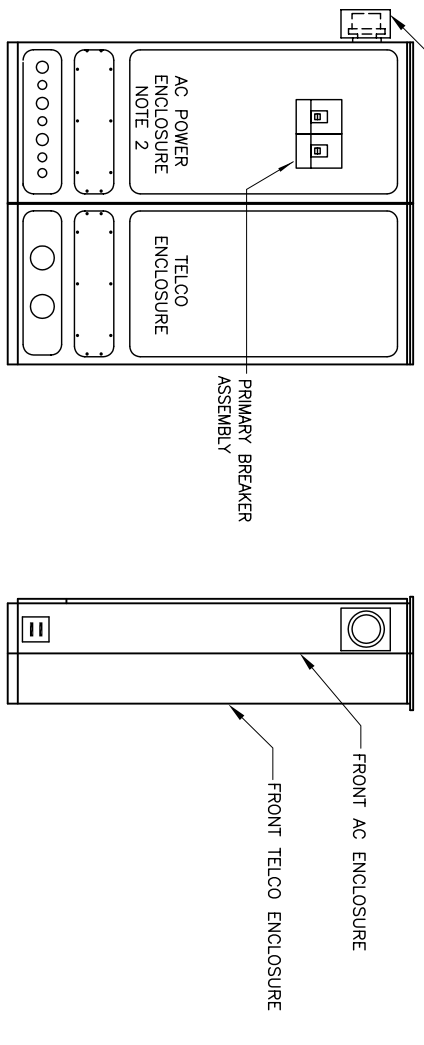
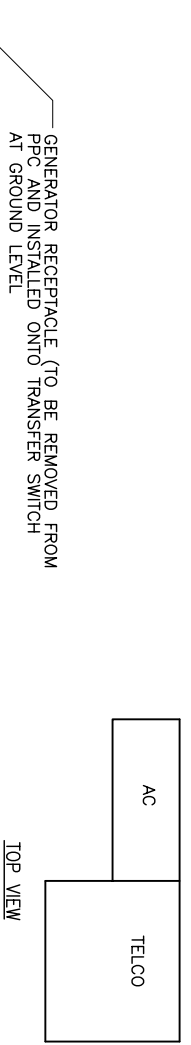

- NOTES**
1. METER SOCKET BY THIS CONTRACT. METER TO BE SUPPLIED BY LOCAL UTILITY COMPANY.
  2. AC POWER ENCLOSURE. 200 AMP, 240/120V, 1Ø, 3W W/ GROUND. 2000A/2P MAIN CIRCUIT BREAKER.
  3. ALL EQUIPMENT SHALL BE GROUNDED PER LATEST EDITION OF NEC AND AS INDICATED.
  4. ELECTRICAL EQUIPMENT SHALL BE MIN. 3'-0" FROM ANY STRUCTURE AND AS REQUIRED BY LOCAL UTILITY COMPANIES AND AHJ.
  5. CONTRACTOR MUST LABEL ALIKE BREAKERS IN POWER CABINET.
  6. REFER TO ACTUAL EQUIPMENT DRAWINGS

**1** PPC DETAIL  
NOT TO SCALE

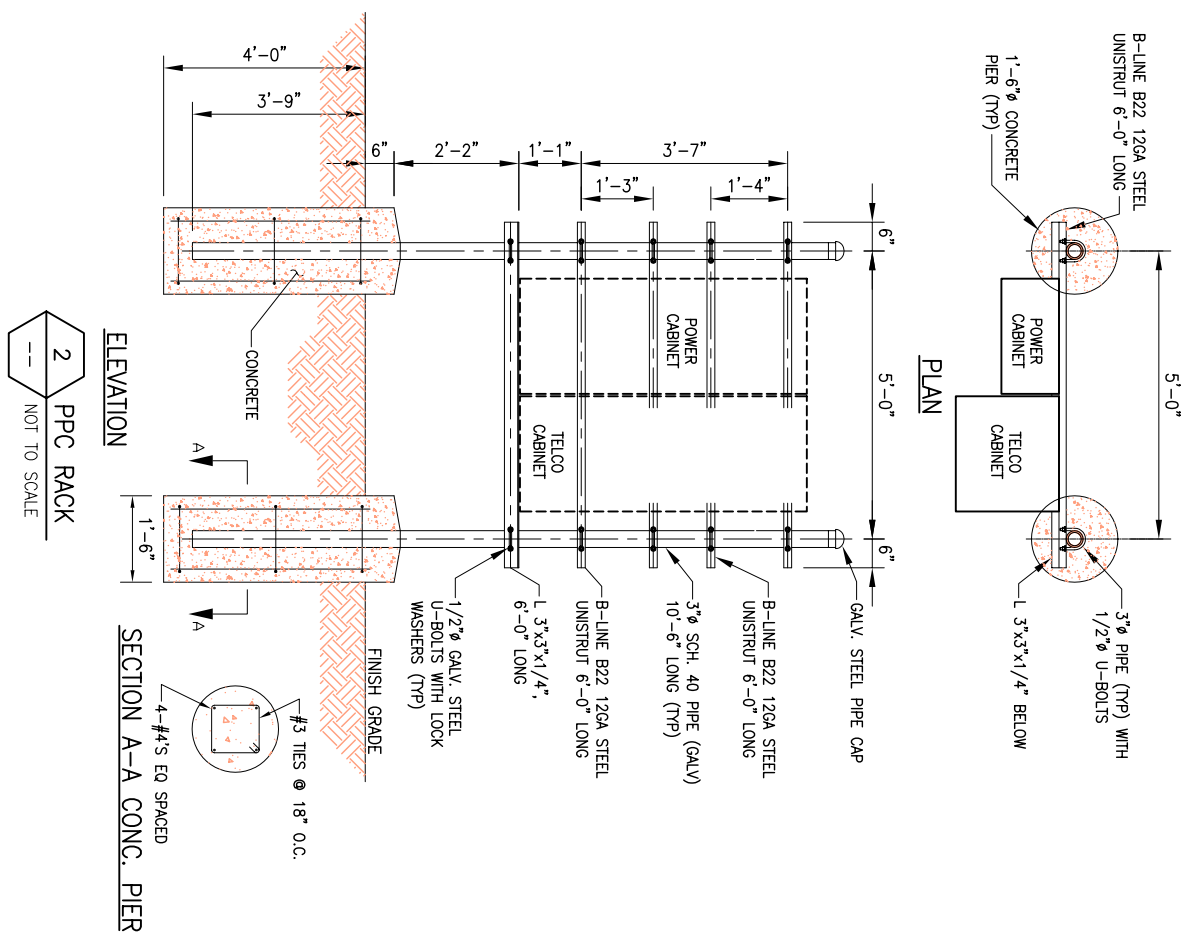

**2** PPC RACK  
NOT TO SCALE

SECTION A-A CONC. PIER

NO.	DATE	REVISIONS	BY	CHK	APP'D
0	07/17/07	REVISED PER CLIENT COMMENT	EMM	SJB	CAW
0	03/29/07	ISSUED FOR REVIEW	DJM	SJB	CAW

**infinigy**  
engineering  
810 MARBETA HIGHWAY  
ROSWELL, GA 30075  
158-06

**Sprint**  
CROSSROADS CORPORATE CENTER  
INTERNATIONAL BOULEVARD  
SUITE 800  
MAHWAH, NJ 07495

HAMDEN  
150 WILLOW STREET  
HAMDEN, CT 06518

PPC DETAILS		REV
CT54XC773	C11	1
DATE: 03/29/07		

IT IS A VIOLATION OF LAW FOR ANY PERSON, UNLESS THEY ARE ACTING UNDER THE DIRECTION OF A LICENSED PROFESSIONAL ENGINEER, TO ALTER THIS DOCUMENT.

**INCOMING POWER AND TELEPHONE SERVICE NOTES:**

1. WHEN THE LOCATION IS SHOWN FOR THE UTILITY POLE. CONNECTION TO EXISTING UTILITIES AND INCOMING POWER AND TELEPHONE SERVICES IS FOR CONCEPT ONLY. THE CONTRACTOR SHALL COORDINATE THE ACTUAL LOCATION WITH THE ELECTRIC AND TELEPHONE UTILITIES AND SPRINT.
  2. THE CONTRACTOR IS RESPONSIBLE FOR MAKING ARRANGEMENTS WITH THE ELECTRIC AND TELEPHONE UTILITIES TO ENSURE A TIMELY INSTALLATION OF THE INCOMING POWER AND TELEPHONE SERVICES AND IS RESPONSIBLE FOR ALL NON-RECURRING UTILITY FEES AND INSTALLATION.
  3. THE INCOMING ELECTRIC SERVICE SHALL BE INSPECTED BY THE AUTHORITY HAVING JURISDICTION AND A CERTIFICATE OF SUCH INSPECTION SHALL BE FURNISHED TO SPRINT WITH A COPY FORWARDED TO THAT UTILITY.
  4. ANY RECURRING UTILITY CHARGES ASSOCIATED WITH THIS SITE SHALL BE PAID BY SPRINT.
  5. FOR INCOMING UNDERGROUND TELEPHONE SERVICE, THE CONTRACTOR SHALL INSTALL THE CONDUIT INCLUDING A PULLWIRE BETWEEN THE POWER/TELCO FRAME TO POWER PROTECTION CABINET (PPC).
  6. COORDINATE METER SOCKET REQUIREMENTS AND UTILITY METER ENCLOSURE WITH SPRINT, INC. AND ELECTRIC UTILITY.
  7. INCOMING ELECTRIC SERVICES SHALL BE IN CONFORMANCE WITH THE UTILITIES STANDARDS (LATEST EDITION).
  8. THIS SITE INCLUDES EXISTING CRITICAL UNDERGROUND ELECTRIC, TELEPHONE AND OTHER SERVICES IN THE VICINITY OF THE NEW UNDERGROUND SERVICES AND EQUIPMENT SUPPORTS. THE CONTRACTOR SHALL TAKE ALL NECESSARY PRECAUTIONS TO AVOID SERVICE DISRUPTION TO THESE FACILITIES. THE CONTRACTOR SHALL ALSO CONTACT ELECTRIC AND TELEPHONE, AND ALL OTHER APPROPRIATE AGENCIES PRIOR TO EXCAVATION AT THIS SITE. ALL EXCAVATION IN THE IMMEDIATE VICINITY OF ANY EXISTING UTILITY POLES SHALL BE PERFORMED BY HAND.
  9. TELCO CONDUIT SHALL BE INSTALLED TO ACCOMMODATE THE FUTURE USE OF FIBER OPTIC.
  10. T1 CABLING SHALL BE SUPERIOR ESSEX TYPE SEALPGC - FSF (RUS PE-89) 22AWG 25 PAIR CABLE OR EQUAL BY COMPOSITE. CABLE SHALL BE NON-TINNED WITH SOLID ANNEALED COPPER AND INSULATING INNER LAYER OF FOAMED, POLYOLEFIN FOAM COVERED BY AN OUTER LAYER OF SOLID, COLORED POLYOLEFIN. CONDUCTOR SHALL BE COLOR CODED TO INDUSTRY STANDARDS WITH A WRAP OF DIELECTRIC TAPE APPLIED OVER THE CORE ASSEMBLY. SHIELDING SHALL BE COPOLYMER COATED 8-MIL ALUMINUM TAPE. OVERALL JACKET SHALL BE BLACK POLYETHYLENE MARKED WITH MANUFACTURER'S IDENTIFICATION, PAIR COUNT, AWG, AND PRODUCT IDENTIFICATION AT REGULAR INTERVALS. MAXIMUM CONDUCTOR RESISTANCE AT 68 °F SHALL BE LESS THAN 92.0 OHMS/MILE. T1 CABLES SHALL MEET OR EXCEED THE REQUIREMENTS OF ANSI/ICEA S-84-608-2002 TELECOMMUNICATIONS CABLE-- FILLED POLYOLEFIN INSULATED COPPER CONDUCTOR, AND RURAL UTILITIES SERVICE 7 CFR 1755.890 SPECIFICATION FOR FILLED TELECOMMUNICATIONS CABLES WITH EXPANDED INSULATION.
- THE CONTRACTOR SHALL PROVIDE AND INSTALL CABLE IN THE T1 CONDUIT FROM THE NETWORK INTERFACE UNIT (NIU) AT THE POWER PROTECTION CABINET (PPC) TO THE BASE TRANSCIVER STATION (BTS). IN THE EVENT THAT THE NIU IS REMOTE FROM THE PPC, THE CABLE SHALL BE ROUTED FROM THE NIU, THROUGH THE PPC WITHOUT TERMINATION EXCEPT AS OTHERWISE INDICATED, AND THEN TO THE BTS. WHEN THE NIU IS REMOTE FROM THE PPC, 48" OF SLACK CABLE SHALL BE COILED IN THE PPC TO ENABLE TERMINATION ON A PUNCH-DOWN BLOCK AT A FUTURE TIME AND UNDER A SEPARATE CONTRACT.
- AT THE NIU AND AT THE BTS, CONTRACTOR SHALL TERMINATE SUITABLE Pairs TO PROVIDE THE T1 CIRCUITS REQUIRED. ADDITIONAL CARE SHALL BE TAKEN BY THE CONTRACTOR TO ENSURE THAT SUITABLE LENGTHS OF THE REMAINING SPARE CONDUCTOR Pairs ARE PIG-TAILED FOR TERMINATION AT FUTURE EQUIPMENT. THESE SPARE CONDUCTORS WILL BE UTILIZED AS NEW T1'S ARE ADDED DURING FUTURE PROJECTS REQUIRING ADDITIONAL T1'S. THE LENGTHS OF SPARE Pairs SHALL BE COILED AND TAPED-OFF BOTH AT THE BTS AND THE END-POINT OF SPRINT'S RESPONSIBILITY WITH THE LEC (TELCO BOX, NIU, MUX ETC.) PROVIDE MINIMUM 36" COILED CONDUCTOR AT EACH LOCATION.
11. PROVIDE 4" DIAMETER, SCHEDULE 40 PVC CONDUIT WITH MINIMUM 3'-0" RADIUS SWEEPS AND ELBOWS FOR UNDERGROUND TELEPHONE CONDUIT UNLESS NOTED OTHERWISE.
  12. INSTALL PULL ROPES IN ALL CONDUITS UNLESS NOTED OTHERWISE.
  13. CONDUIT RUNS SHALL HAVE ONE 18"x18"x8" PULLBOX AFTER 270 DEGREES OF BEND.
  14. STRAIGHT RUNS SHALL HAVE A PULLBOX AFTER EACH 75'-0" OF STRAIGHT RUN.
  15. CONTRACTOR WILL CONDUCT ALL ACTIVITIES ASSOCIATED WITH ORDERING, DESIGN, AND INSTALLATION OF INCOMING ELECTRICAL SERVICES.
  16. CONTRACTOR WILL BE RESPONSIBLE FOR ALL COORDINATION WITH THE LOCAL SERVICE PROVIDER (LSP) TO PLACE ORDERS, AND SCHEDULE DELIVERY DATE FOR SERVICE TO THE SITE. CONTRACTOR WILL ATTEND ALL COORDINATION MEETINGS AS REQUESTED BY THE LSP.
  17. CONTRACTOR WILL BE RESPONSIBLE FOR PROVIDING ANY AND ALL ANCILLARY EQUIPMENT SUCH AS TRANSFORMERS, CONDUIT, CONNECTORS, AND CONNECTORS AS REQUIRED BY THE LSP.
  18. ALL NON-RECURRING UTILITY FEES ARE THE RESPONSIBILITY OF THE CONTRACTOR.
  19. CONTRACTOR WILL COMPLETE THE SPRINT CELL SITE UTILITY SET-UP FORM.

**infinigy**  
engineering  
810 MARBETH HIGHWAY  
ROSWELL, GA 30075  
158-06

**Sprint**  
CROSSROADS CORPORATE CENTER  
INTERNATIONAL BOULEVARD  
SUITE 800  
MAHWAH, NJ 07495

HAMDEN  
150 WILLOW STREET  
HAMDEN, CT 06518

DATE: 03/29/07	REV 1
CT54XC773	E1
ONE-LINE DIAGRAM	

IT IS A VIOLATION OF LAW FOR ANY PERSON, UNLESS THEY ARE ACTING UNDER THE DIRECTION OF A LICENSED PROFESSIONAL ENGINEER, TO ALTER THIS DOCUMENT.

**GROUNDING SYMBOLS**

- ⊗ GROUND ROD
- ACCESS WELL
- ⊠ GROUND ROD WITH ACCESS
- G— #2 BCW GROUNDING WIRE U.N.O
- # INDICATES CODED NOTE

**ELECTRICAL SYMBOLS**

- ⚡ RECEPTACLE
- BURIED RACEWAY
- ⌈ TOWER LIGHT SYSTEM
- # INDICATES CODED NUMBER
- ⌋ INDICATES DISCONNECT SWITCH
- ⏏ AUTOMATIC TRANSFER SWITCH

**ABBREVIATIONS**

- CIGBE COAX ISOLATED GROUND BAR EXTERNAL
- MIGB MASTER ISOLATED GROUND BAR
- SST SELF SUPPORTING TOWER
- GPS GLOBAL POSITIONING SYSTEM
- TYP. TYPICAL
- DWG DRAWING
- BCW BARE COPPER WIRE
- BFG BELOW FINISH GRADE
- W/ WITH
- PVC POLYVINYL CHLORIDE
- CAB CABINET
- C CONDUIT
- SS STAINLESS STEEL
- G GROUND
- AWG AMERICAN WIRE GAUGE
- RGS RIGID GALVANIZED STEEL

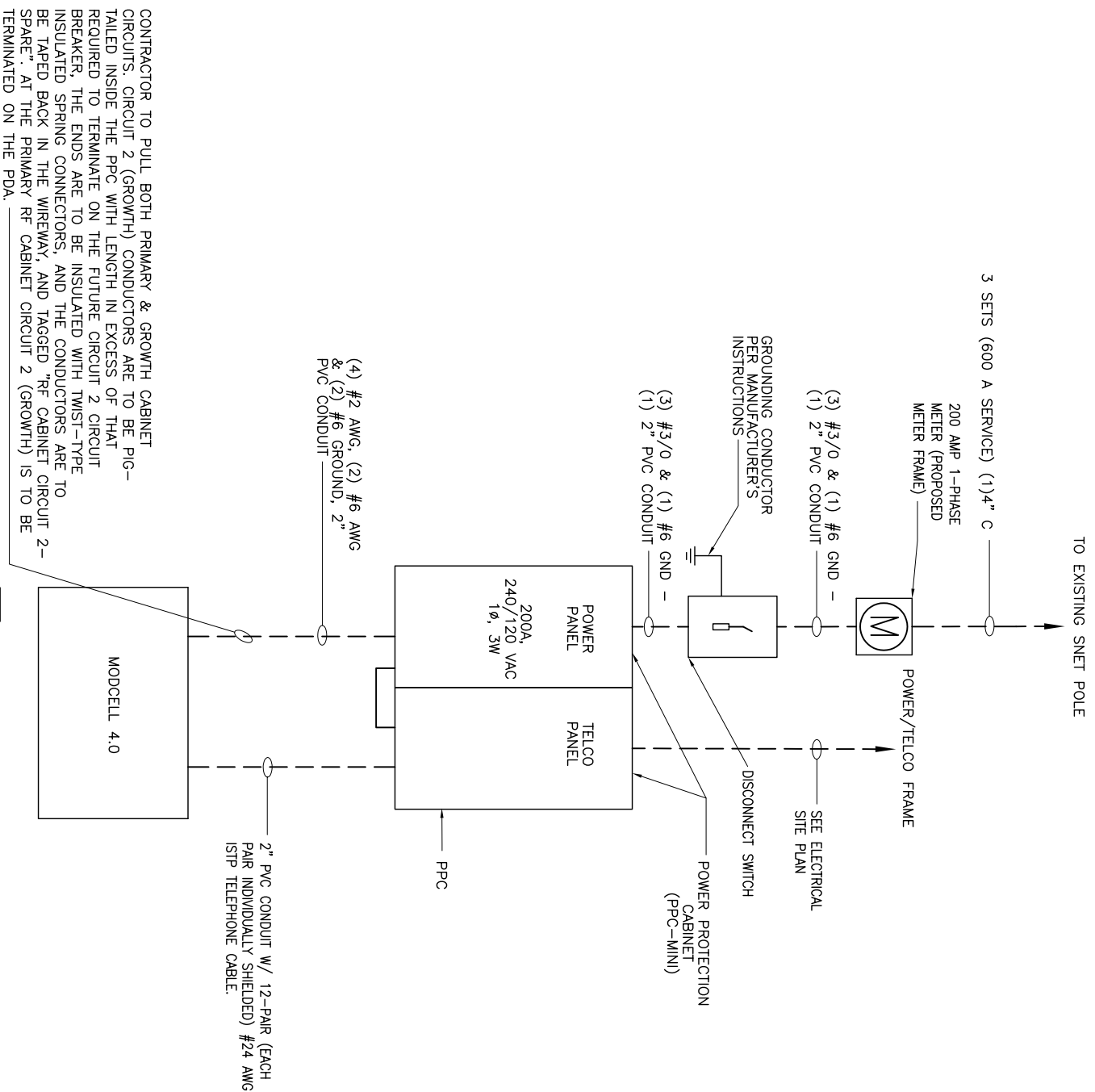

**ONE-LINE DIAGRAM**  
NOT TO SCALE

- NOTE:
1. FOR COMPLETE INTERNAL WIRING AND ARRANGEMENT FOR PPC, REFER TO VENDOR WIRING DIAGRAM PROVIDED BY MANUFACTURER & REFERENCED INSIDE PPC CABINET.
  2. EACH ELECTRICAL SERVICE SHALL BE RATED 200A, 240/120, 1Ø 3W.
  3. PROVIDE (2) 80 AMP, SINGLE PHASE BREAKERS IN LOAD CENTER FOR MOD CELL 4.0.

**CODED DRAWING NOTES:**

- 1 2" PVC W/(3) #3/0 + #6G TO POWER/TELCO FRAME.
- 2 (1) 27C WITH (2) PULL STRINGS AND 12-PAIR (EACH PAIR INDIVIDUALLY SHIELDED) #24 AWG ISTP TELEPHONE CABLE. INSTALL CABLE WITHOUT SPLICE (FROM DEMARCATION TO PPC). LEAVE 15'-0" OF SLACK CABLE AT EACH END. LABEL AS "1-1" AT EACH END AND AT ALL PULL BOXES.
- 3 PPC FURNISHED BY SPRINT. COORDINATE STUB-UP LOCATIONS WITH EQUIPMENT LAYOUT.
- 4 T1 CABLING SHALL BE SUPERIOR ESSEX TYPE SEALPIC - FSF (RUS PE-89) 22AWG 25 PAIR CABLE OR EQUAL BY COMMSCOPE. CABLE SHALL BE NON-TINNED WITH SOLID ANNEALED COPPER AND INSULATING INNER LAYER OF FOAMED, POLYOLEFIN FOAM COVERED BY AN OUTER LAYER OF SOLID, COLORED POLYOLEFIN. CONDUCTOR SHALL BE COLOR CODED TO INDUSTRY STANDARDS WITH A WRAP OF DIELECTRIC TAPE APPLIED OVER THE CORE ASSEMBLY. SHIELDING SHALL BE COPOLYMER COATED 8-MIL ALUMINUM TAPE. OVERALL JACKET SHALL BE BLACK POLYETHYLENE MARKED WITH MANUFACTURER'S IDENTIFICATION, PAIR COUNT, AWG, AND PRODUCT IDENTIFICATION AT REGULAR INTERVALS. MAXIMUM CONDUCTOR RESISTANCE AT 68 °F SHALL BE LESS THAN 92.0 OHMS/MILE. T1 CABLES SHALL MEET OR EXCEED THE REQUIREMENTS OF ANSI/CEA S-84-608-2002 TELECOMMUNICATIONS CABLE-FILLED POLYOLEFIN INSULATED COPPER CONDUCTOR, AND RURAL UTILITIES SERVICE 7 CFR 1753.890 SPECIFICATION FOR FILLED TELECOMMUNICATIONS CABLES WITH EXPANDED INSULATION.

THE CONTRACTOR SHALL PROVIDE AND INSTALL CABLE IN THE T1 CONDUIT FROM THE NETWORK INTERFACE UNIT (NIU) AT THE POWER PROTECTION CABINET (PPC) TO THE BASE TRANSCIVER STATION (BTS). IN THE EVENT THAT THE NIU IS REMOVE FROM THE PPC, THE CABLE SHALL BE ROUTED FROM THE NIU, THROUGH THE PPC, WITHOUT TERMINATION EXCEPT AS OTHERWISE INDICATED, AND THEN TO THE BTS. WHEN THE NIU IS REMOVE FROM THE PPC, 48" OF SLACK CABLE SHALL BE COILED IN THE PPC TO ENABLE TERMINATION ON A PUNCH-DOWN BLOCK AT A FUTURE TIME AND UNDER A SEPARATE CONTRACT.

AT THE NIU AND AT THE BTS, CONTRACTOR SHALL TERMINATE SUITABLE PARS TO PROVIDE THE T1 CIRCUITS REQUIRED. ADDITIONAL CARE SHALL BE TAKEN BY THE CONTRACTOR TO ENSURE THAT SUITABLE LENGTHS OF THE REMAINING SPARE CONDUCTOR PARS ARE PIG-TAILED FOR TERMINATION AT FUTURE EQUIPMENT. THESE SPARE CONDUCTORS WILL BE UTILIZED AS NEW T1'S ARE ADDED DURING FUTURE PROJECTS REQUIRING ADDITIONAL T1'S. THE LENGTHS OF SPARE PARS SHALL BE COILED AND TAPED-OFF BOTH AT THE BTS AND THE END-POINT OF SPRINT'S RESPONSIBILITY WITH THE LEC (TELCO BOX, NIU, MUX ETC.) PROVIDE MINIMUM 36" COILED CONDUCTOR AT EACH LOCATION.

- 5 200A COMBINATION METER/CIRCUIT BREAKER FOR SPRINT. METER BY UTILITIES.
- 6 (1) 1/4" CONDUIT W/PULLSTRING FOR POWER FROM EXISTING UTILITY POLE TO POWER/TELCO FRAME. (600 AMP SERVICE)
- 7 (2) 1/4" CONDUITS W/PULLSTRINGS FROM EXISTING UTILITY POLE TO CSC CABINET FOR TELCO.
- 8 STRAIGHT RUNS SHALL HAVE 18"x18"x18" PULLBOX EVERY 75'
- 9 (1) 1/2" MC (INTERMEDIATE METAL CONDUIT) W/2 #12 THHN WIRES & (1) #12G FOR CELL SITE LIGHT
- 10 2" PVC CONDUIT W/(4) #2 AWG, (1) #6 AWG & (1) #6 GND.
- 11 2" PVC CONDUIT W/12-PAIR (EACH PAIR INDIVIDUALLY SHIELDED) #24 AWG ISTP TELEPHONE CABLE.

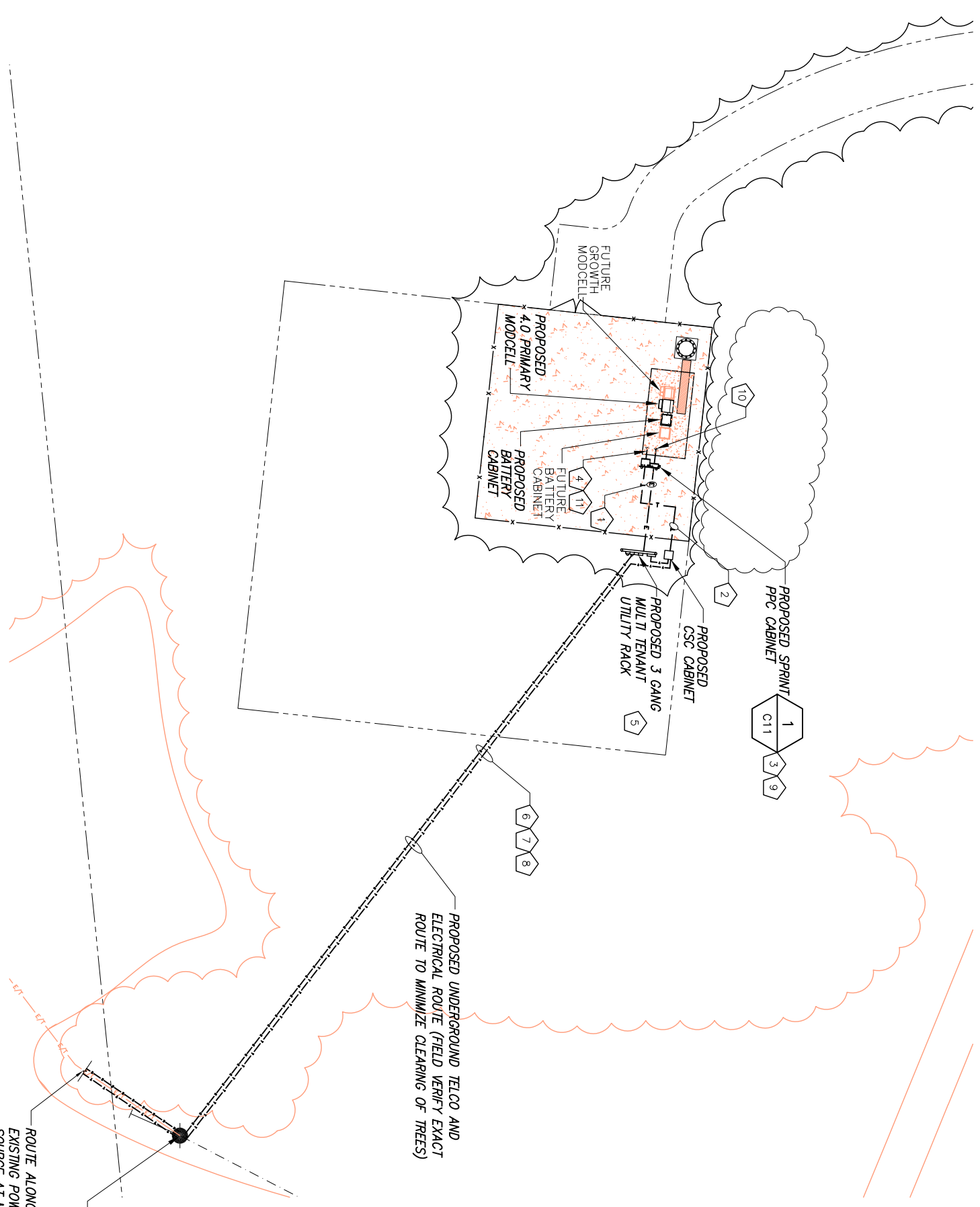

**ELECTRICAL SYMBOLS**

- BURIED RAGEWAY
- # INDICATES CODED NUMBER

**ABBREVIATIONS**

CIGBE	COAX ISOLATED GROUND BAR EXTERNAL
SST	SELF SUPPORTING TOWER
GPS	GLOBAL POSITIONING SYSTEM
TYP.	TYPICAL
DWG	DRAWING
BCW	BARE COPPER WIRE
BFG	BELOW FINISH GRADE
W/	WITH
PVC	POLYVINYL CHLORIDE
CAB	CABINET
C	CONDUIT
SS	STAINLESS STEEL
G	GROUND
AWG	AMERICAN WIRE GAUGE
RGS	RIGID GALVANIZED STEEL

**GENERAL ELECTRICAL NOTES:**

1. ALL MATERIALS SHALL BE FURNISHED AND WORK SHALL BE PERFORMED IN ACCORDANCE WITH THE APPLICABLE SECTIONS OF THE ATTACHED SPRINT SPECIFICATIONS NO G-001, "TECHNICAL SPECIFICATION FOR CONSTRUCTION" AND NO. G-002, "TECHNICAL SPECIFICATION FOR CONSTRUCTION OF ELECTRICAL AND GROUNDING SYSTEM". IN CASE OF A CONFLICT BETWEEN THE CONSTRUCTION SPECIFICATIONS AND THE DRAWINGS, THE DRAWINGS SHALL GOVERN. IN CASE OF A CONFLICT BETWEEN SSPJ STANDARD PRACTICES AND EITHER THE CONSTRUCTION SPECIFICATIONS OR THE DRAWINGS, THE SPRINT PCS STANDARD PRACTICES SHALL GOVERN.
2. COORDINATE ALL CONDUIT STUB-UP LOCATIONS WITH UTILITY COMPANY.
3. PROVIDE WEATHERPROOF SEALS FOR ALL CONDUIT STUB-UPS.
4. ALL ABOVE GROUND CONDUITS TO BE RGS.
5. ALL CONDUCTORS SHALL BE COPPER. ALUMINUM CONDUCTORS SHALL NOT BE USED.
6. ALL CONDUCTORS SHALL BE PREPARED FOR TERMINATION, COILED BAGGED AND SECURED FOR FUTURE CONNECTION OF OTHERS.
7. ALL CONDUCTORS TERMINATION IN THE COMMUNICATION EQUIPMENT SHALL HAVE A MINIMUM OF 8'-0" OF SLACK FOR INSTALLATION INTO EQUIPMENT.

1 ELECTRICAL SITE PLAN  
SCALE:

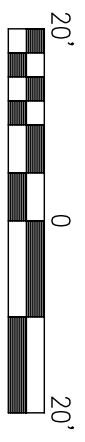

NO.	DATE	REVISIONS	BY	CHK	APP'D
0	07/17/07	REVISED PER CLIENT COMMENT	EMJ	SJB	CMW
0	03/29/07	ISSUED FOR REVIEW	DAW	SJB	CMW

**infinigy**  
engineering  
810 MARETTA HIGHWAY  
ROSWELL, GA 30075  
158-06

**Sprint**  
CROSSROADS CORPORATE CENTER  
INTERNATIONAL BOULEVARD  
SUITE 800  
MAHWAH, NJ 07495

HAMDEN  
150 WILLOW STREET  
HAMDEN, CT 06518

ELECTRICAL SITE PLAN	E2
CT54XC773	REV 1
DATE: 03/29/07	

IF IT IS A VIOLATION OF LAW FOR ANY PERSON, UNLESS THEY ARE ACTING UNDER THE DIRECTION OF A LICENSED PROFESSIONAL ENGINEER, TO ALTER THIS DOCUMENT.

**CODED DRAWING NOTES**

- ① FUTURE MODELL. FURNISHED BY S.S.L.P.
- ② PRIMARY MODELL. FURNISHED BY S.S.L.P.
- ③ BATTERY CABINET. FURNISHED BY S.S.L.P.
- ④ FUTURE BATTERY CABINET. FURNISHED BY S.S.L.P.
- ⑤ M.I.G.B.
- ⑥ ICE BRIDGE. BOND EACH SECTION TO GROUND RING WITH #2 AWG CONDUCTORS.
- ⑦ #2 AWG SOLID ANNEALED TINNED BOW BURIED GROUND RING.
- ⑧ CIGBE.
- ⑨ BOND PROPOSED METER WITH #2 SOLID TINNED BOW. TERMINATE AT METER PER UTILITY COMPANY SPECIFICATIONS AND PER NEC REQUIREMENTS.
- ⑩ BOND PPC TO NEW GROUND RING (TYP. OF 2 PLACES).
- ⑪ BOND EQUIPMENT TO GROUND RING (TYP. 8 PLACES)
- ⑫ BOND FENCE POST AND GATE TO GROUND RING.
- ⑬ BOND TO PROPOSED TOWER GROUND RING.

**GROUNDING SYSTEM NOTES:**

1. THE CONTRACTOR SHALL VERIFY THAT THE SYSTEM IS EFFECTIVELY GROUNDED, MEETS NEC ARTICLE 250 REQUIREMENTS, IS ACCEPTABLE TO THE LOCAL UTILITY AND THE LOCAL AUTHORITY HAVING JURISDICTION, AND MEETS SPRINT PCS ELECTRICAL AND GROUNDING SPECIFICATIONS.
2. ALL EXTERIOR AND UNDERGROUND CONNECTIONS SHALL BE IN ACCORDANCE WITH SPRINT PCS ELECTRICAL AND GROUNDING SPECIFICATIONS.
3. ALL INTERIOR GROUNDING AND BONDING CONNECTIONS WITHIN BUILDINGS SHALL BE IN ACCORDANCE WITH SPRINT PCS ELECTRICAL AND GROUNDING SPECIFICATIONS.
4. REFER TO DRAWINGS FOR GROUND SYSTEM REQUIREMENTS. WHERE SHOWN ON DRAWINGS, CABLE SHALL BE AS FOLLOWS:
  - A. LIGHTNING PROTECTION CONNECTION, WATER \_\_\_\_\_ #4/0 AWG (INSULATED GREEN) SERVICE CONNECTION, BUILDING STEEL CONNECTION. (ABOVE GROUND APPLICATIONS)
  - B. ANTENNA CABLE GROUND CONNECTIONS \_\_\_\_\_ #2 AWG BTGW
  - C. SOLID OUTDOOR GROUND RING, ALL \_\_\_\_\_ #2 AWG SOLID TINNED COPPER EQUIPMENT ON POLES AND TOWERS, CABLE TRAY GROUNDING
  - D. ROOFTOP GROUND RING \_\_\_\_\_ #2 AWG SOLID TINNED COPPER
  - E. INDOOR HALO RING \_\_\_\_\_ #2 STRANDED (INSULATED GREEN)
  - F. FENCE GROUNDING CONNECTIONS \_\_\_\_\_ #2 AWG BARE TINNED COPPER WIRE
  - G. FENCE GATE JUMPER \_\_\_\_\_ #2 AWG WELDING CABLE
5. ROOFTOP GROUND RING (IF APPLICABLE) SHALL ENGIRCLE STRUCTURAL MEMBERS WITH A MINIMUM RADIUS OF 24" AND ONE SINGLE PATH TO THE MAIN ISOLATED GROUND BAR (MIGB).
6. CABLE TRAY GROUNDING SHALL BE AS INDICATED ON DRAWINGS.

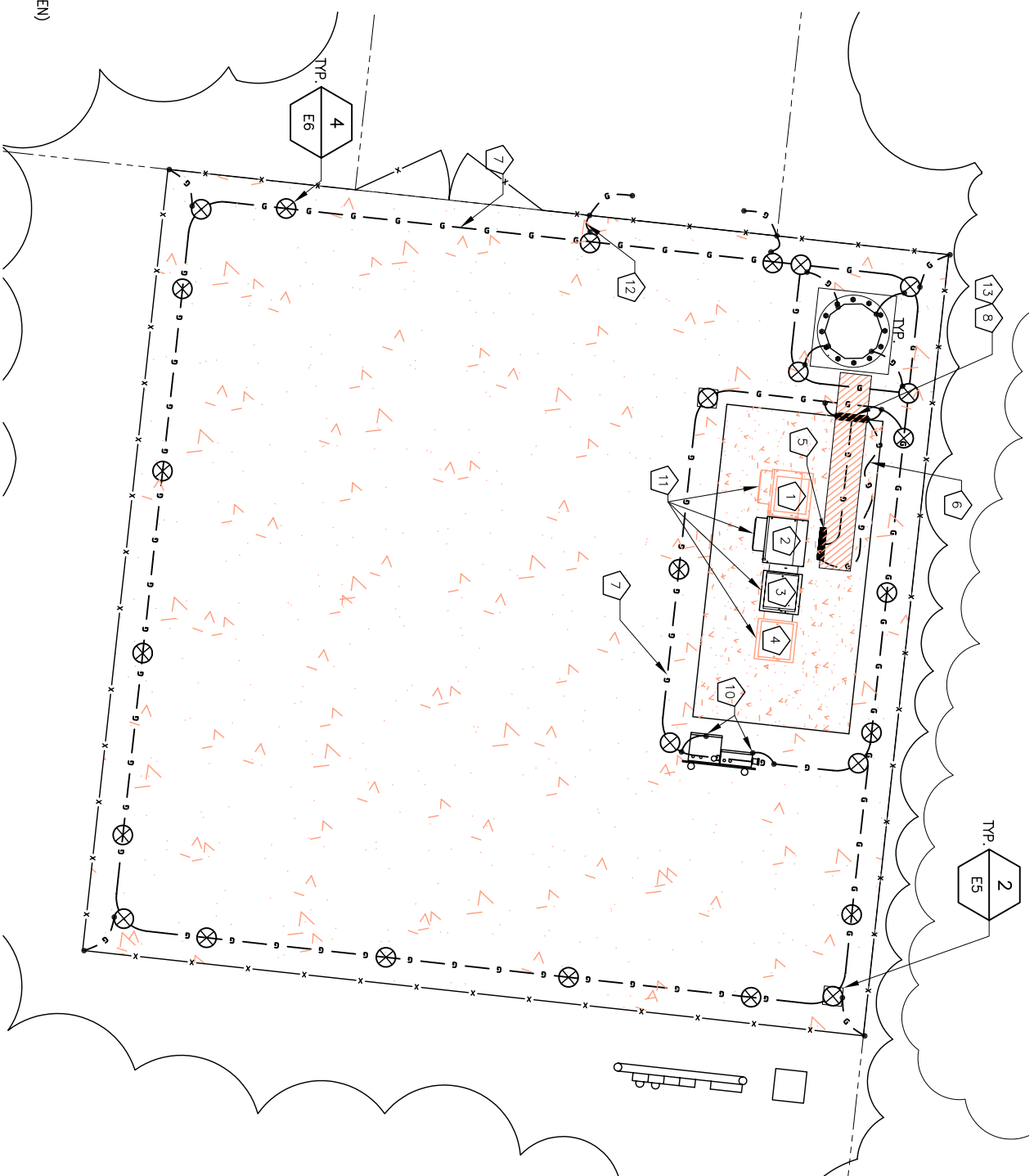

**GENERAL GROUNDING NOTES:**

1. PROVIDE A GROUND RING BURIED A MINIMUM OF 30" BELOW GRADE OR 6" BELOW FROST LINE. THE GROUND RING SHALL BE INSTALLED 2'-0" AWAY FROM PLATFORM/FOUNDATION (MINIMUM UNLESS SHOWN OTHERWISE ON DRAWING).
2. BOND FENCE POST TO GROUND RING AS SHOWN USING AN EXOTHERMIC WELD. BOND FENCE GATE TO POST WITH A #2 AWG WELDING CABLE. ERICO #FJ1024 OR BURNDY FLEXIBLE COPPER BRAIDED JUMPER TPE "B", OR APPROVED EQUAL. PROVIDE EXOTHERMIC WELDS AND ANY NECESSARY ACCESSORIES TO BOND STRAP TO GATE AND FENCE POST. PROVIDE LENGTH AS REQUIRED TO MAKE CONNECTION.
3. BOND PPC AND EQUIPMENT ENCLOSURES TO BURIED GROUNDING CONDUCTOR. USE A NEMA DRILLED, TWO-HOLE CONNECTOR FOR BONDS TO EQUIPMENT ENCLOSURES. USE AN APPROVED CONDUIT CLAMP FOR CONNECTIONS TO SERVICE CONDUITS. EXOTHERMICALLY WELD CONNECTIONS TO GROUNDING CONDUCTOR.
4. EXOTHERMICALLY WELD GROUNDING CONDUCTOR TO COMMUNICATION STRUCTURE 1'-0" ABOVE FOUNDATION AND BOND TO BURIED GROUND RING. PROVIDE A 3/4" PVC SLEEVE WITH A GRADUAL BEND IN THE CONCRETE FOUNDATION.
5. 5/8"x8'-0" LONG COPPER CLAD GROUND ROD. SPACING BETWEEN RODS, AS SHOWN (NON-LINEAR). PROVIDE TEE TPE EXOTHERMIC WELD TO BOND GROUND ROD TO BURIED GROUND RING. TYPICAL FOR ALL GROUND RODS SHOWN AROUND TOWER. SEE GROUND ROD INSPECTION SLEEVE DETAIL.
6. BOND ALL EXTERIOR CONDUITS, PIPES AND CYLINDRICAL METALLIC OBJECTS WITH A PENN-UNION GT SERIES CLAMP, BLACKBURN GUY SERIES CLAMP OR A BURNDY GAR 3900BU SERIES CLAMP ONLY. NO SUBSTITUTES ACCEPTED.
7. AFTER INSTALLATION IS COMPLETED IN CONFORMANCE WITH THESE DRAWINGS AND THE STANDARD SPECIFICATIONS. THE CONTRACTOR SHALL CONFIRM THE IMPEDANCE (GROUND RESISTANCE) TO EARTH AND BETWEEN GROUNDING CIRCUITS. THE GROUNDING SYSTEM IS EXPECTED TO PROVIDE FOR A MAXIMUM EARTH RESISTANCE OF 10 OHMS. THE CONTRACTOR SHALL NOTIFY SPRINT PRIOR TO ALL TESTING AND SHALL FURTHER NOTIFY SPRINT IN THE EVENT THE EARTH RESISTANCE IS GREATER THAN 10 OHMS.
8. GROUNDING SHALL BE IN ACCORDANCE WITH SPRINT SPECIFICATIONS.
9. ALL BENDS ON THE GROUND CONDUCTOR TO BE MADE WITH A MINIMUM 24" RADIUS.
10. GROUNDING DESIGN PENDING RESISTIVITY TEST RESULTS.



1" GROUNDING SITE PLAN SCALE

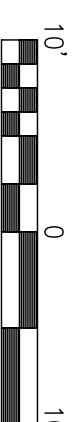

GRAPHIC SCALE

NO.	DATE	REVISIONS	BY	CHK	APP'D
0	07/17/07	REVISED PER CLIENT COMMENT	EMJ	SJB	CMW
0	03/29/07	ISSUED FOR REVIEW	DJW	SJB	CMW

**infinigy**  
engineering  
810 MARBETH HIGHWAY  
ROSWELL, GA 30075  
158-06

**Sprint**  
CROSSROADS CORPORATE CENTER  
INTERNATIONAL BOULEVARD  
SUITE 800  
MAHWAH, NJ 07495

HAMDEN  
150 WILLOW STREET  
HAMDEN, CT 06518

GROUNDING SITE PLAN  
CT54XC773

DATE: 03/29/07

REV 1

IT IS A VIOLATION OF LAW FOR ANY PERSON, UNLESS THEY ARE ACTING UNDER THE DIRECTION OF A LICENSED PROFESSIONAL ENGINEER, TO ALTER THIS DOCUMENT.

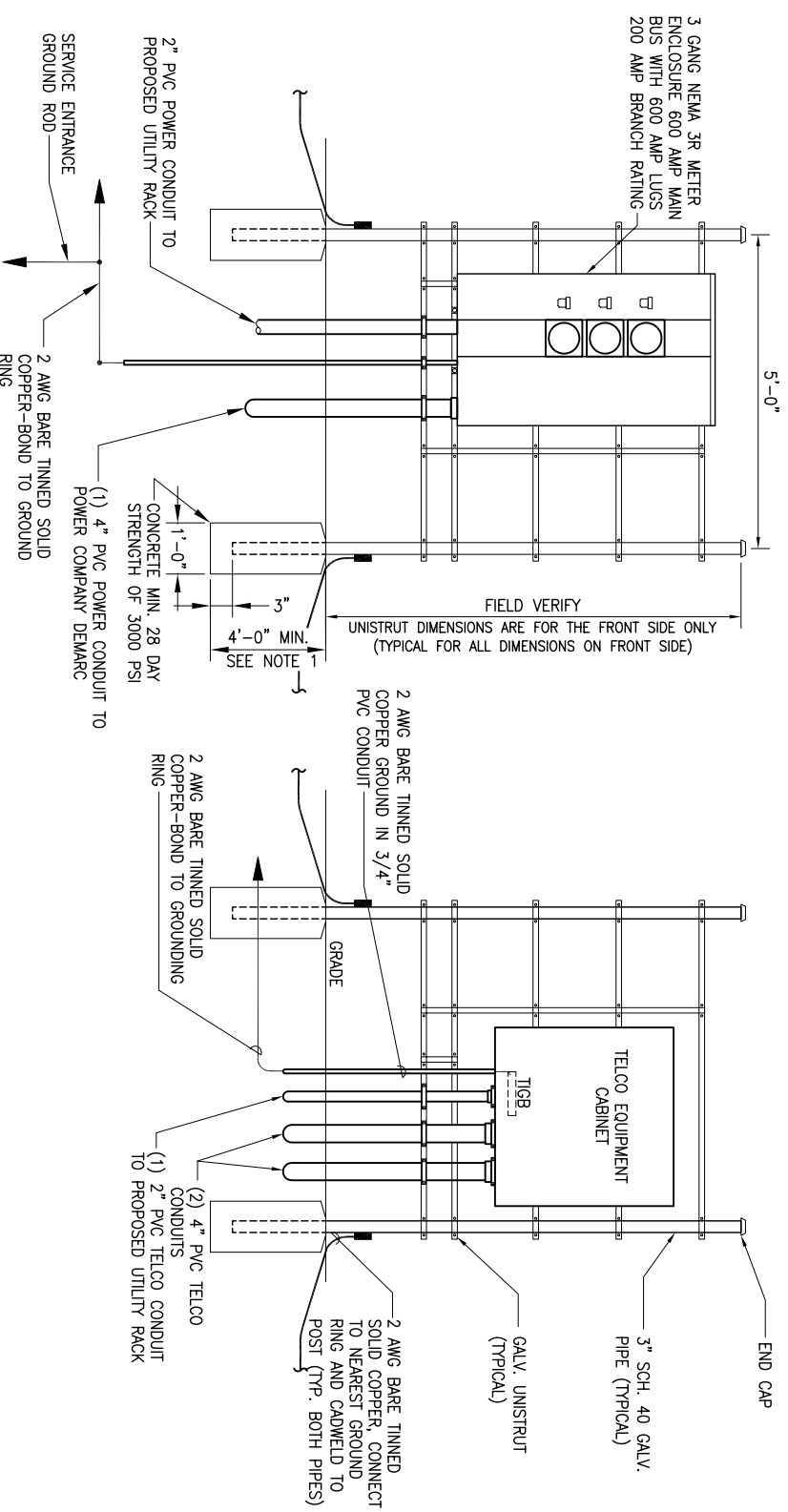
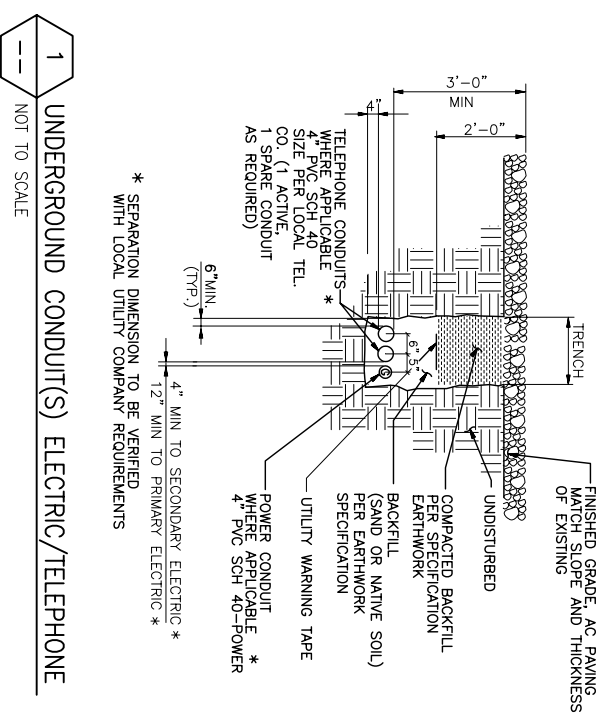

**NOTES**

1. CONSTRUCT SO CONCRETE FOOTING EXTENDS 6" BELOW FROST LINE AND IN COMPLIANCE WITH ALL LOCAL AND STATE CODES.

**2** POWER / TELCO FRAME  
NOT TO SCALE

NO.	DATE	REVISIONS	BY	CHK	APP'D
0	07/17/07	REVISED PER CLIENT COMMENT	EMM	SJB	CAW
0	03/29/07	ISSUED FOR REVIEW	DJW	SJB	CAW

**infinity**  
engineering  
810 MARBETA HIGHWAY  
ROSWELL, GA 30075  
158-06

**Sprint**  
CROSSROADS CORPORATE CENTER  
SUITE 800  
MAHWAH, NJ 07495

HAMDEN  
150 WILLOW STREET  
HAMDEN, CT 06518

ELECTRICAL DETAILS	
CT54XC773	E4
DATE: 03/29/07	REV 1

IT IS A VIOLATION OF LAW FOR ANY PERSON, UNLESS THEY ARE ACTING UNDER THE DIRECTION OF A LICENSED PROFESSIONAL ENGINEER, TO ALTER THIS DOCUMENT.



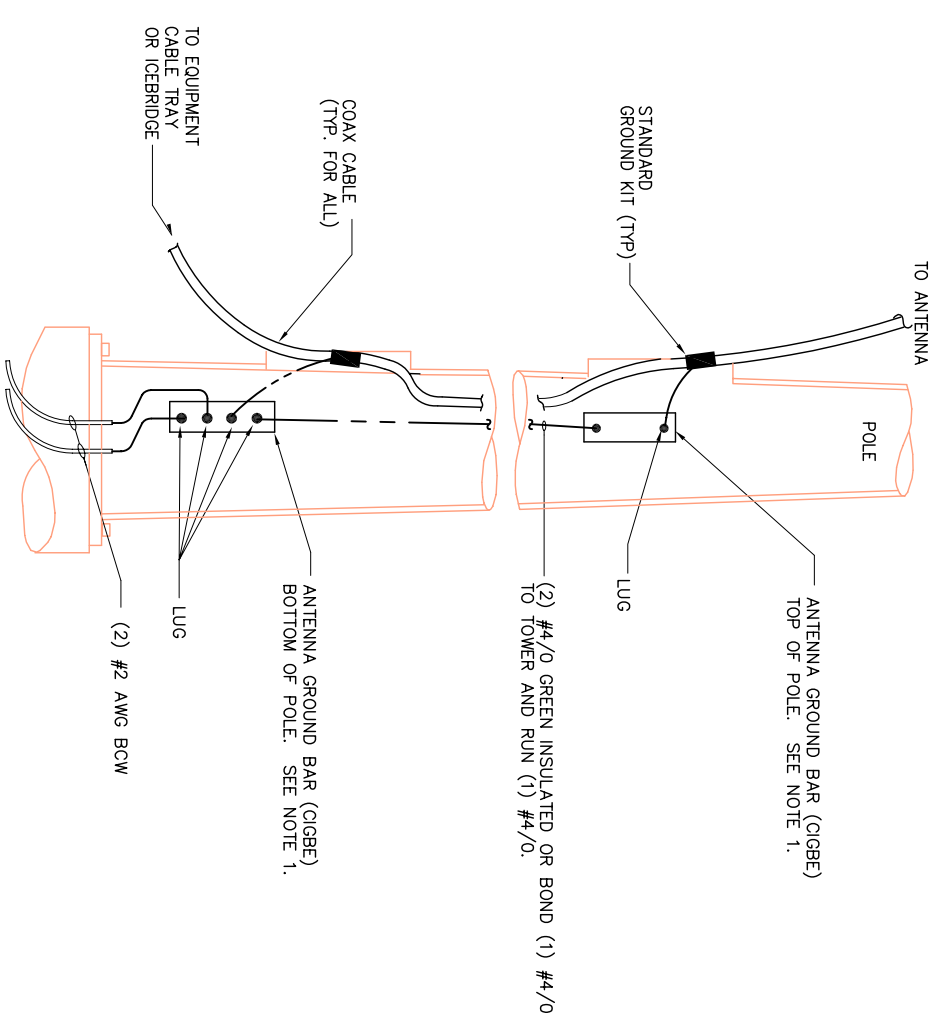

**NOTES**

1. NUMBER OF GROUND BARS MAY VARY DEPENDING ON THE TYPE OF TOWER, ANTENNA LOCATION AND CONNECTION ORIENTATION. PROVIDE AS REQUIRED.
2. PROVIDE A SEPARATE GROUND BAR FOR GPS ANTENNA.
3. CADWELD TO GROUND RING.
4. INTERMEDIATE CIGBE IS ONLY REQUIRED WHEN RAD CENTER IS GREATER THAN 200 FEET ABOVE BOTTOM CIGBE.

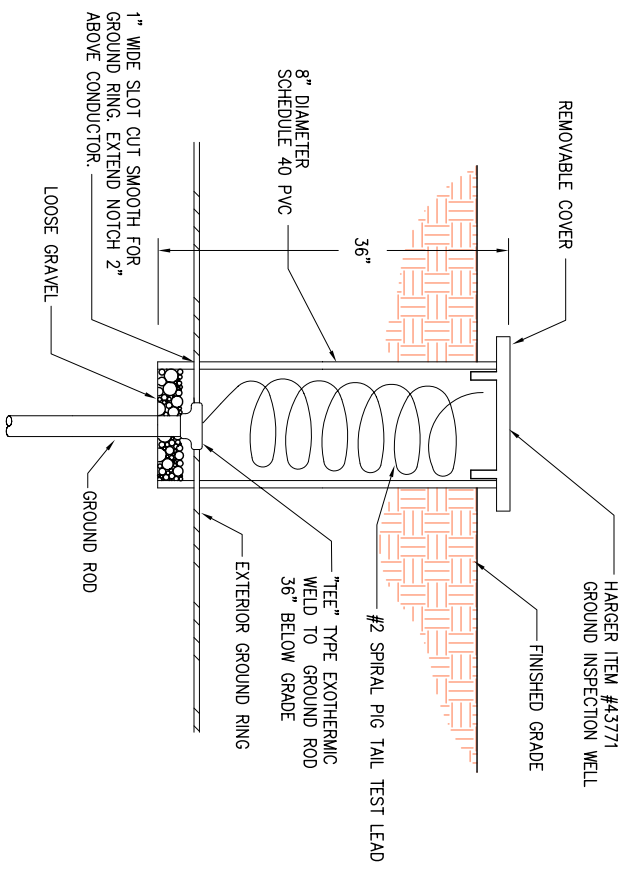

NO.	DATE	BY	CHK	APP'D
0	07/17/07	EKM	SJB	CAW
0	03/29/07	DJW	SJB	CAW

**infinigy**  
engineering  
810 MARBETA HIGHWAY  
ROSWELL, GA 30075  
158-06

**Sprint**  
CROSSROADS CORPORATE CENTER  
INTERNATIONAL BOULEVARD  
SUITE 800  
MAHWAH, NJ 07495

HAMDEN  
150 WILLOW STREET  
HAMDEN, CT 06518

GROUNDING DETAILS	CT54XC773	E5
DATE: 03/29/07		REV 1

IT IS A VIOLATION OF LAW FOR ANY PERSON, UNLESS THEY ARE ACTING UNDER THE DIRECTION OF A LICENSED PROFESSIONAL ENGINEER, TO ALTER THIS DOCUMENT.

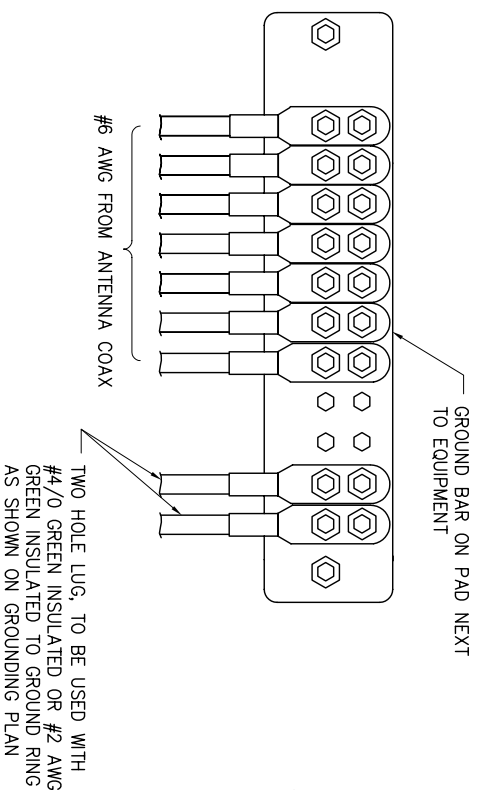

**1 MASTER ISOLATED GROUND BAR**  
NOT TO SCALE

CONTRACTOR TO USE KOPR-SHIELD (THOMAS & BETTS) ON ALL LUG CONNECTIONS.

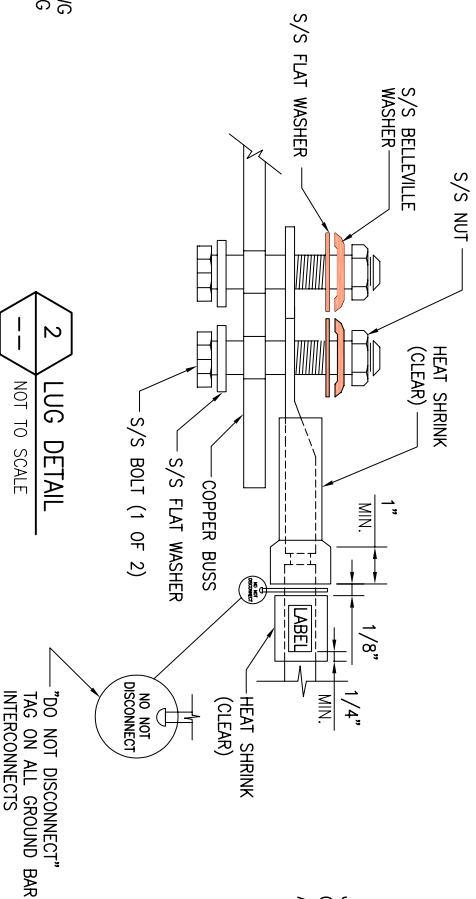

**2 LUG DETAIL**  
NOT TO SCALE

1. ALL HARDWARE 18-8 STAINLESS STEEL INCLUDING BELLEVILLES. COAT ALL SURFACES WITH KOPR-SHIELD BEFORE MATTING.
2. FOR GROUND, BOND TO STEEL ONLY. INSERT A DRAGON TOOTH WASHER BETWEEN LUG AND STEEL. COAT ALL SURFACES WITH KOPR-SHIELD.
3. COAT ALL BARRELS WITH ANTI-OXIDATION COMPOUND BEFORE CRIMPING.

"DO NOT DISCONNECT" TAG ON ALL GROUND BAR INTERCONNECTS

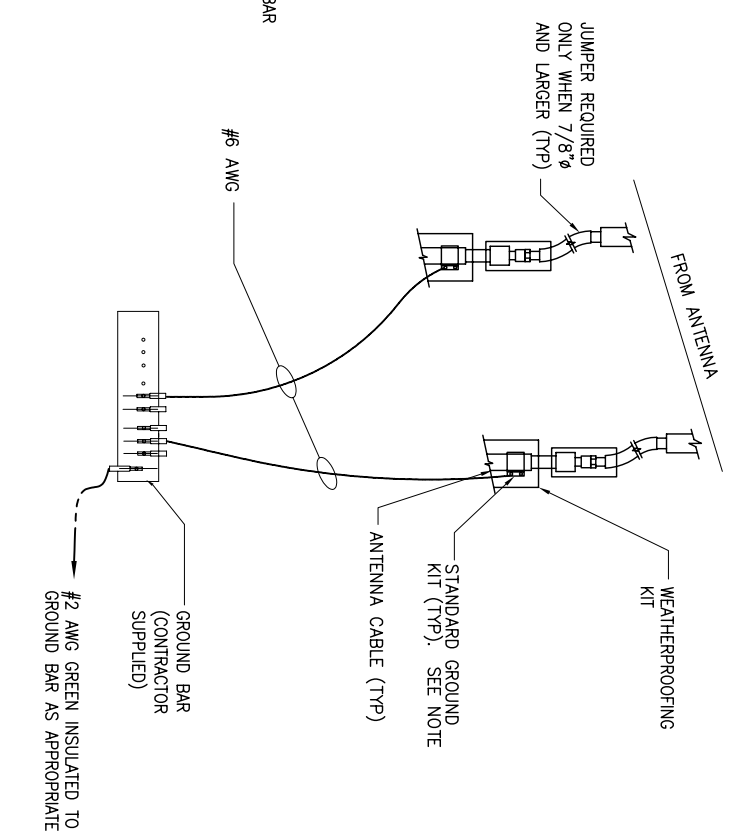

**3 CONNECTION OF GROUND WIRES TO GROUNDING BARS @ ANTENNAS**

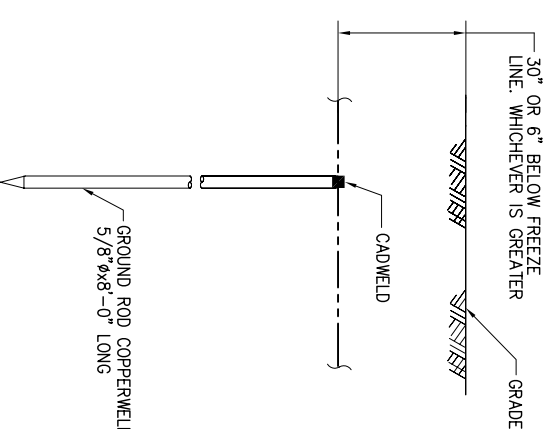

**4 COPPER-CLAD STEEL GROUND ROD**  
NOT TO SCALE

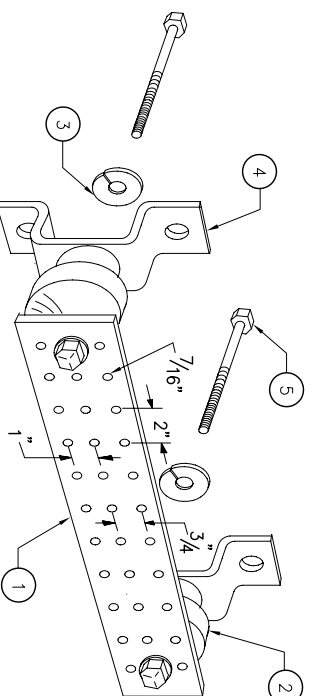

**LEGEND**

- 1 - SOLID TINNED COPPER GROUND BAR, 1/4" x 4" x 20" MIN., NEWTON INSTRUMENT CO. CAT. NO. B-6142. HOLE CENTERS TO MATCH NEMA DOUBLE LUG CONFIGURATION
- 2 - INSULATORS, NEWTON INSTRUMENT CAT. NO. 3061-4
- 3 - 5/8" LOCKWASHERS, NEWTON INSTRUMENT CO. CAT. NO. 3015-8
- 4 - WALL MOUNTING BRACKET, NEWTON INSTRUMENT CO. CAT NO. A-6056
- 5 - 5/8-11 X 1" H.H.C.S. BOLTS, NEWTON INSTRUMENT CO. CAT NO. 3012-1
- 6 - GROUND BAR SHALL BE SIZED TO ACCOMMODATE ALL GROUNDING CONNECTIONS REQUIRED PLUS PROVIDE 50% SPARE CAPACITY
- 7 - GROUND BARS SHALL NEITHER BE FIELD FABRICATED NOR NEW HOLES DRILLED
- 8 - GROUND LUGS SHALL MATCH THE HOLE SPACING ON THE BAR
- 9 - HARDWARE DIAMETER SHALL BE MINIMUM 3/8"
- 10 - APPLY COPPER NO-OX TO EXPOSED AREA OF GROUND BAR.

**5 STANDARD GROUND BAR**  
NOT TO SCALE

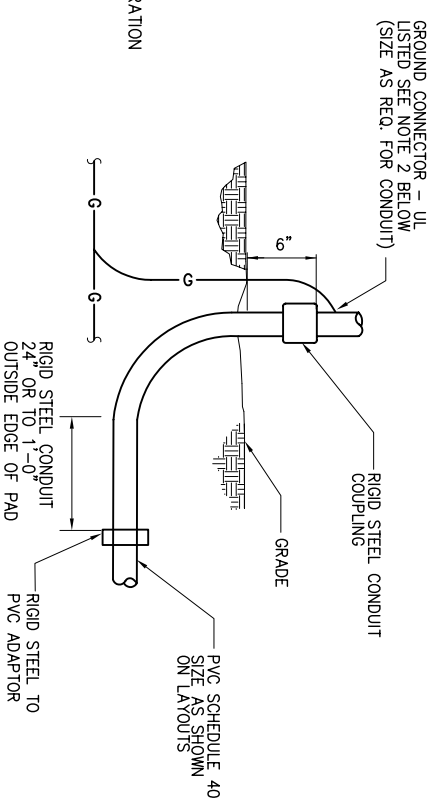

**6 UNDERGROUND CONDUIT STUB-UP**  
NOT TO SCALE

NOTE:  
ALL CONDUIT ABOVE GRADE MUST BE RIGID STEEL.  
ALL PVC SCH. 40 CONDUIT MUST HAVE MIN. BURIAL DEPTH.

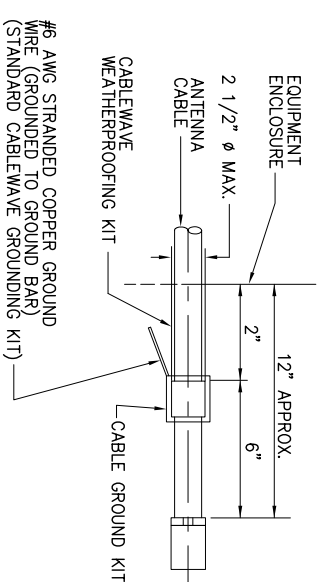

**7 CABLE GROUND KIT CONNECTION TO ANTENNA CABLE**  
NOT TO SCALE

NOTE:  
DO NOT INSTALL CABLE GROUND KIT AT A BEND AND ALWAYS DIRECT GROUND WIRE DOWN TO GROUND BAR.

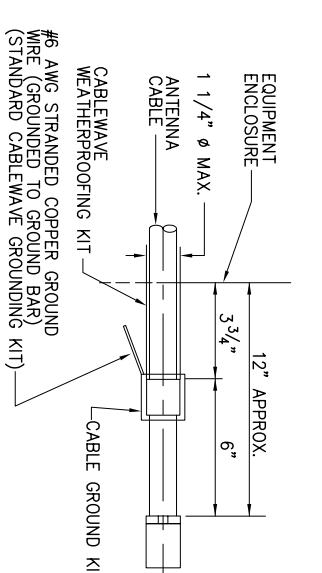

**TO ANTENNA GPS CABLE**

NO.	DATE	REVISIONS	BY	CHK	APP'D
0	07/17/07	REVISED PER CLIENT COMMENT	EMM	SJB	CMW
0	03/29/07	ISSUED FOR REVIEW	DJW	SJB	CMW

**infinigy**  
engineering  
810 MARBETH HIGHWAY  
ROSWELL, GA 30075  
158-06

**Sprint**  
CROSSROADS CORPORATE CENTER  
INTERNATIONAL BOULEVARD  
SUITE 800  
MAHWAH, NJ 07495

HAMDEN  
150 WILLOW STREET  
HAMDEN, CT 06518

GROUNDING DETAILS	
CT54XC773	E6
DATE: 03/29/07	REV 1

IT IS A VIOLATION OF LAW FOR ANY PERSON, UNLESS THEY ARE ACTING UNDER THE DIRECTION OF A LICENSED PROFESSIONAL ENGINEER, TO ALTER THIS DOCUMENT.