



STATE OF CONNECTICUT

CONNECTICUT SITING COUNCIL

Ten Franklin Square, New Britain, CT 06051

Phone: (860) 827-2935 Fax: (860) 827-2950

E-Mail: siting.council@ct.gov

www.ct.gov/csc

VIA ELECTRONIC MAIL

November 4, 2019

Jake Shappy
Transcend Wireless
10 Industrial Avenue, Suite 3
Mahwah, NJ 07430

RE: **EM-SPRINT-061-191007** – Sprint notice of intent to modify an existing telecommunications facility located at 330 Pokorny Road, Haddam, Connecticut.

Dear Mr. Shappy:

The Connecticut Siting Council (Council) is in receipt of your correspondence of October 29, 2019 submitted in response to the Council's October 9, 2019 notification of an incomplete request for exempt modification with regard to the above-referenced matter.

The submission renders the request for exempt modification complete and the Council will process the request in accordance with the Federal Communications Commission 60-day timeframe.

Thank you for your attention and cooperation.

Sincerely,

Melanie A. Bachman
Executive Director

MAB/IN/emr



Robidoux, Evan

From: jshappy@transcendwireless.com
Sent: Tuesday, October 29, 2019 10:03 AM
To: Robidoux, Evan
Cc: CSC-DL Siting Council; 'Shappy, Gregg'
Subject: RE: Council Incomplete Letter for EM-SPRINT-061-191007 (330 Pokorny Road, Haddam)
Attachments: 17159.10 - CT33XC089 - Structural Analysis Rev2 19.10.11.pdf; 17159.10 - CT33XC089 Mount Analysis Rev 0_19.10.28.pdf; em-sprint-061-191007_incompleteltr_PokornyRd.pdf

Evan,

Please see attached soft copies of the mount analysis and revised structural analysis for your review for this exempt mod. The hard copies will be sent to you as soon as they are received from the A&E.

Jake Shappy
10 Industrial Ave, Suite 3
Mahwah, NJ 07430
Cell: 845-553-3330
jshappy@transcendwireless.com

From: Robidoux, Evan <Evan.Robidoux@ct.gov>
Sent: Thursday, October 10, 2019 3:10 PM
To: 'jshappy@transcendwireless.com' <jshappy@transcendwireless.com>
Cc: CSC-DL Siting Council <Siting.Council@ct.gov>
Subject: Council Incomplete Letter for EM-SPRINT-061-191007 (330 Pokorny Road, Haddam)

Please see the attached correspondence.

Evan Robidoux
Clerk Typist
Connecticut Siting Council
10 Franklin Square
New Britain, CT 06051

Structural Analysis Report

280' Existing Valmont Lattice Tower

Proposed Sprint Antenna Upgrade

Sprint Site Ref: CT33XC089

*330 Pokorny Road
Haddam, CT*

CEN TEK Project No. 17159.10

~~*Date: August 21, 2018*~~

Rev 2: October 11, 2019

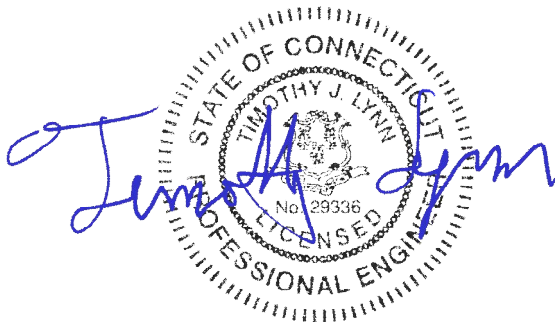

Prepared for:
*Transcend Wireless
10 Industrial Ave, Suite 3
Mahwah, NJ 07430*

Table of Contents

SECTION 1 - REPORT

- INTRODUCTION
- ANTENNA AND APPURTENANCE SUMMARY
- PRIMARY ASSUMPTIONS USED IN THE ANALYSIS
- ANALYSIS
- TOWER LOADING
- TOWER CAPACITY
- FOUNDATION AND ANCHORS
- CONCLUSION AND RECOMMENDATIONS

SECTION 2 – CONDITIONS & SOFTWARE

- STANDARD ENGINEERING CONDITIONS
- GENERAL DESCRIPTION OF STRUCTURAL ANALYSIS PROGRAM

SECTION 3 – CALCULATIONS

- tnxTower INPUT/OUTPUT SUMMARY
- tnxTower FEED LINE PLAN
- tnxTower FEED LINE DISTRIBUTION
- tnxTower DETAILED OUTPUT
- FOUNDATION ANALYSIS

SECTION 4 – REFERENCE MATERIALS

- EQUIPMENT CUT SHEETS.

I n t r o d u c t i o n

The purpose of this report is to summarize the results of the non-linear, P- Δ structural analysis of the antenna upgrade proposed by Sprint on the existing lattice tower located in Haddam, Connecticut.

The host tower is a 280-ft, three legged, lattice tower originally manufactured by Valmont eng. file no. A-175068 dated 5/14/2012. The tower geometry, structure member sizes and foundation information were taken from the original design documents.

Antenna and appurtenance inventory were taken from a previous structural analysis report prepared by Centek job no. 16095.000 dated June 7, 2016, a previous structural analysis report prepared by Paul J. Ford job no.24317-0014.001.8700_R1 dated August 22, 2017 and a Sprint RF data sheet.

The tower consists of fourteen (14) vertical sections consisting of steel truss legs conforming to ASTM A572 Gr. 50 and lateral bracing conforming to ASTM A36. The vertical tower sections are connected by bolted flange plates with the diagonal and horizontal bracing to pipe legs consisting of bolted connections. The width of the tower face is 12-ft at the top and 40-ft at the bottom.

S u m m a r y

The existing and proposed loads considered in the analysis consist of the following:

- UNKNOWN (Existing):
Antenna: Lighting mounted to the top of the tower.
Cable: One (1) 3/8" \varnothing cable running on a leg/face of the existing tower as specified in Section 3 of this report.
- VSC (Existing):
Antenna: One (1) Celwave PD1142-2C Omni-directional whip antenna leg mounted with an elevation of ± 279 -ft above grade level.
Coax Cable: One (1) 1-5/8" \varnothing coax cable running on a leg/face of the existing tower as specified in Section 3 of this report.
- Eversource (Existing):
Antenna: One (1) Decibel DB538 Omni-directional whip antenna leg mounted with an elevation of ± 279 -ft above grade level.
Coax Cable: One (1) 7/8" \varnothing coax cable running on a leg/face of the existing tower as specified in Section 3 of this report.
- Eversource (Existing):
Antenna: One (1) Telewave ANT150F6 Omni-directional whip antenna leg mounted with an elevation of ± 279 -ft above grade level.
Coax Cable: One (1) 7/8" \varnothing coax cable running on a leg/face of the existing tower as specified in Section 3 of this report.

- EVERSOURCE (Existing):
Antenna: Two (2) 8-ft microwave dishes pipe mounted with an elevation of ± 276 -ft above grade level.
Cables: Two (2) EW63 cables running on a leg/face of the existing tower as specified in Section 3 of this report.
- EVERSOURCE (Reserved):
Antenna: One (1) 8-ft microwave dish pipe mounted with an elevation of ± 276 -ft above grade level.
Cables: One (1) EW63 cable running on a leg/face of the existing tower as specified in Section 3 of this report.
- EVERSOURCE (Existing):
Antenna: One (1) 8-ft microwave dish pipe mounted with an elevation of ± 266 -ft above grade level.
Cables: One (1) EW63 cables running on a leg/face of the existing tower as specified in Section 3 of this report.
- EVERSOURCE (Existing):
Antenna: One (1) 8-ft microwave dish pipe mounted with an elevation of ± 266 -ft above grade level.
Cables: One (1) EW63 cables running on a leg/face of the existing tower as specified in Section 3 of this report.
- VSC (Existing):
Antenna: One (1) 10-ft dipole mounted on one (1) 6-ft side arm with an elevation of ± 161 -ft above grade level.
Coax Cable: Two (2) 7/8" \varnothing coax cables running on a leg/face of the existing tower as specified in Section 3 of this report.
- EVERSOURCE (Existing):
Antenna: Two (2) Decibel DB589-Y Omni-directional whip antennas (one upright and one inverted) and one (1) 12"x16"x6" TMA mounted on one (1) 6-ft side arm with an elevation of ± 260 -ft above grade level.
Coax Cable: Two (2) 1-5/8" \varnothing and one (1) 1/2" \varnothing coax cables running on a leg/face of the existing tower as specified in Section 3 of this report.
- EVERSOURCE (Existing):
Antenna: One (1) Decibel DB212-C dipole antenna mounted on one (1) 6-ft side arm with an elevation of ± 255 -ft above grade level.
Coax Cable: One (1) 7/8" \varnothing coax cable running on a leg/face of the existing tower as specified in Section 3 of this report.
- EVERSOURCE (Existing):
Antenna: One (1) Sinclair SD110-SFXPASNM dipole antenna mounted on one (1) 6-ft side arm with an elevation of ± 241 -ft above grade level.
Coax Cable: One (1) 7/8" \varnothing coax cable running on a leg/face of the existing tower as specified in Section 3 of this report.

- EVERSOURCE (Existing):
Antenna: One (1) Kreco CO-36A Omni-directional whip antenna mounted on one (1) 6-ft side arm with an elevation of ± 240 -ft above grade level.
Coax Cable: One (1) 7/8" \varnothing coax cable running on a leg/face of the existing tower as specified in Section 3 of this report.
- EVERSOURCE (Existing):
Antenna: One (1) 6-ft microwave dish pipe mounted with an elevation of ± 240 -ft above grade level.
Cables: Two (2) E65 cables running on a leg/face of the existing tower as specified in Section 3 of this report.
- CSP (Existing):
Antenna: Two (2) Sinclair SE419-SF3P4LDF panel antennas (one upright and one inverted) and one (1) 12"x16"x6" TMA mounted on one (1) 6-ft side arm with an elevation of ± 235 -ft above grade level.
Coax Cable: Two (2) 1-5/8" \varnothing and two (2) 1/2" \varnothing coax cables running on a leg/face of the existing tower as specified in Section 3 of this report.
- EVERSOURCE (Reserved):
Antenna: One (1) 8-ft microwave dish pipe mounted with an elevation of ± 230 -ft above grade level.
Cables: One (1) EW63 cable running on a leg/face of the existing tower as specified in Section 3 of this report.
- EVERSOURCE (Existing):
Antenna: One (1) Comprod 531-70HD dipole antenna mounted on one (1) 3-ft side arm with an elevation of ± 230 -ft above grade level.
Coax Cable: One (1) 7/8" \varnothing coax cable running on a leg/face of the existing tower as specified in Section 3 of this report.
- EVERSOURCE (Existing):
Antenna: One (1) 8-ft microwave dish pipe mounted with an elevation of ± 220 -ft above grade level.
Cables: One (1) EW63 cables running on a leg/face of the existing tower as specified in Section 3 of this report.
- EVERSOURCE (Existing):
Antenna: One (1) Sinclair SD110-SFXPASNM dipole antenna mounted on one (1) 6-ft side arm with an elevation of ± 216 -ft above grade level.
Coax Cable: One (1) 7/8" \varnothing coax cable running on a leg/face of the existing tower as specified in Section 3 of this report.
- VSC (Existing):
Antenna: One (1) Telewave ANT450F10 Omni-directional whip antenna mounted on one (1) 6-ft side arm with an elevation of ± 216 -ft above grade level.
Coax Cable: One (1) 7/8" \varnothing coax cable running on a leg/face of the existing tower as specified in Section 3 of this report.

- EVERSOURCE (Reserved):
Antenna: One (1) 10-ft microwave dish pipe mounted with an elevation of ±205.5-ft above grade level.
Cables: One (1) EW63 cable running on a leg/face of the existing tower as specified in Section 3 of this report.
- CSP (Existing):
Antenna: Two (2) Sinclair SC479 Omni-directional whip antennas (one upright and one inverted) and one (1) 12"x16"x6" TMA mounted on one (1) 6-ft side arm with an elevation of ±200-ft above grade level.
Coax Cable: Two (2) 1-5/8" Ø and one (1) 1/2" Ø coax cables running on a leg/face of the existing tower as specified in Section 3 of this report.
- CSP (Existing):
Antenna: One (1) Sinclair SC479 Omni-directional whip antenna (inverted) mounted on one (1) 3-ft side arm with an elevation of ±200-ft above grade level.
Coax Cable: One (1) 1-5/8" Ø cable running on a leg/face of the existing tower as specified in Section 3 of this report.
- CSP (Existing):
Antenna: One (1) 6-ft microwave dish pipe mounted with an elevation of ±197-ft above grade level.
Cables: One (1) EW63 cable running on a leg/face of the existing tower as specified in Section 3 of this report.
- CSP (Existing):
Antenna: One (1) 10-ft microwave dish pipe mounted with an elevation of ±195-ft above grade level.
Cables: One (1) EW63 cable running on a leg/face of the existing tower as specified in Section 3 of this report.
- CSP (Existing):
Antenna: Two (2) Sinclair SC479 Omni-directional whip antennas (one upright and one inverted) mounted on one (1) 6-ft side arm with an elevation of ±175-ft above grade level.
Coax Cable: Two (2) 1-5/8" Ø coax cables running on a leg/face of the existing tower as specified in Section 3 of this report.
- CSP (Existing):
Antenna: One (1) Antel BCR-80010-90 Omni-directional whip antenna with reflector (upright), one (1) Antel BCD-80609 Omni-directional whip antenna (inverted) and one (1) 12"x16"x6" TMA mounted on one (1) 3-ft side arm with an elevation of ±175-ft above grade level.
Coax Cable: Two (2) 1-5/8" Ø and two (2) 1/2" Ø coax cables running on a leg/face of the existing tower as specified in Section 3 of this report.
- Town of Haddam (Existing):
Antenna: One (1) Telewave ANT450F6 Omni-directional whip antenna mounted on one (1) 3-ft side arm with an elevation of ±168-ft above grade level.
Coax Cable: One (1) 7/8" Ø coax cable running on a leg/face of the existing tower as specified in Section 3 of this report.

- CSP (Existing):
Antenna: One (1) 6-ft microwave dish pipe mounted with an elevation of ±163-ft above grade level.
Cables: One (1) EW63 cable running on a leg/face of the existing tower as specified in Section 3 of this report.
- VERIZON (Existing):
Antennas: Six (6) Andrew HBXX-6517DS panel antennas, six (6) Andrew LNX-6515DS panel antennas, three (3) Alcatel-Lucent B25 RRH4x30 remote radio heads, three (3) Alcatel-Lucent B13 RRH4x30 remote radio heads, three (3) Alcatel-Lucent RRH4x45 remote radio heads and two (2) RFS DB-T1-6Z-8AB main distribution boxes mounted on three (3) 12-ft frames with a RAD center elevation of ±145-ft above grade level.
Coax Cables: Three (3) 1-5/8" ∅ fiber cables running on a leg/face of the existing tower as specified in Section 3 of this report.
- VSC (Existing):
Antenna: One (1) Kreco CO-36A Omni-directional whip antenna mounted on one (1) 6-ft side arm with an elevation of ±130-ft above grade level.
Coax Cable: One (1) 7/8" ∅ coax cable running on a leg/face of the existing tower as specified in Section 3 of this report.
- VSC (Existing):
Antenna: One (1) Kathrein PR-950 paraflector mounted on one (1) 6-ft side arm with an elevation of ±126-ft above grade level.
Coax Cable: One (1) 7/8" ∅ coax cable running on a leg/face of the existing tower as specified in Section 3 of this report.
- VSC (Existing):
Antenna: One (1) Telewave ANT450F6 Omni-directional whip antenna mounted on one (1) 6-ft side arm with an elevation of ±124-ft above grade level.
Coax Cable: One (1) 7/8" ∅ coax cable running on a leg/face of the existing tower as specified in Section 3 of this report.
- EVERSOURCE (Existing):
Antenna: One (1) RFS SBX4-W60 microwave dish pipe mounted with an elevation of ±123-ft above grade level on leg "C".
Cables: One (1) E60 cable running on a leg/face of the existing tower as specified in Section 3 of this report.
- VSC (Existing):
Antenna: One (1) grid dish mounted on one (1) 3-ft side arm with an elevation of ±117-ft above grade level.
Coax Cable: One (1) 7/8" ∅ coax cable running on a leg/face of the existing tower as specified in Section 3 of this report.
- VSC (Existing):
Antenna: One (1) Browning BR6155 Omni-directional whip antenna mounted on one (1) 3-ft side arm with an elevation of ±116-ft above grade level.
Coax Cable: One (1) 7/8" ∅ coax cable running on a leg/face of the existing tower as specified in Section 3 of this report.

- **CSP (Existing):**
Antenna: One (1) Telewave ANT400D dipole antenna mounted on the 3-ft side arm (above) with an elevation of ±116-ft above grade level.
Coax Cable: One (1) 7/8" Ø coax cable running on a leg/face of the existing tower as specified in Section 3 of this report.
- **CSP (Existing):**
Antenna: One (1) 6-ft microwave dish pipe mounted with an elevation of ±104-ft above grade level.
Cables: One (1) EW63 cable running on a leg/face of the existing tower as specified in Section 3 of this report.
- **VSC (Existing):**
Antenna: One (1) Browning BR6155 Omni-directional whip antenna mounted on one (1) 3-ft side arm with an elevation of ±97-ft above grade level.
Coax Cable: One (1) 7/8" Ø coax cable running on a leg/face of the existing tower as specified in Section 3 of this report.
- **CSP (Existing):**
Antenna: One (1) 5-ft dipole antenna mounted on one (1) 3-ft side arm with an elevation of ±55-ft above grade level.
Coax Cable: One (1) 7/8" Ø coax cable running on a leg/face of the existing tower as specified in Section 3 of this report.
- **SPRINT (Existing to Remain):**
Coax Cable: Six (6) 1-5/8" Ø coax cables running on a leg/face of the existing tower as specified in Section 3 of this report.
- **SPRINT (Existing to Relocate):**
Appurtenances: **Three (3) 1900MHz 4X45W RRHs to be relocated from grade to tower.**
- **SPRINT (Existing to Remove):**
Antennas: **Three (3) RFS APXVSP18C panel antennas mounted on three (3) 12-ft frames with a RAD center elevation of ±155-ft above grade level.**
- **SPRINT (Proposed):**
Antennas: **Three (3) Commscope NNVV-65B-R4 panel antennas, three (3) RFS APXVTM14 panel antennas, three (3) TD-RRH8x20-25 radio heads and six (6) RRH2x50-800 radio heads mounted on three (3) 12-ft frames with a RAD center elevation of ±155-ft above grade level..**
Coax Cables: **Four (4) 1-1/4"Ø Hybriflex cable running on a face of the existing tower as specified in Section 3 of this report.**

Primary Assumptions Used in the Analysis

- The tower structure's theoretical capacity not including any assessment of the condition of the tower.
- The tower carries the horizontal and vertical loads due to the weight of antennas, ice load and wind.
- Tower is properly installed and maintained.
- Tower is in plumb condition.
- Tower loading for antennas and mounts as listed in this report.
- All bolts are appropriately tightened providing the necessary connection continuity.
- All welds are fabricated with ER-70S-6 electrodes.
- All members are assumed to be as specified in the original tower design documents.
- All members are "hot dipped" galvanized in accordance with ASTM A123 and ASTM A153 Standards.
- All member protective coatings are in good condition.
- All tower members were properly designed, detailed, fabricated, installed and have been properly maintained since erection.
- Any deviation from the analyzed antenna loading will require a new analysis for verification of structural adequacy.
- All coax cables should be routed as specified in section 3 of this report.

Analysis

The existing tower was analyzed using a comprehensive computer program entitled tnxTower. The program analyzes the tower, considering the worst case loading condition. The tower is considered as loaded by concentric forces along the tower, and the model assumes that the tower members are subjected to bending, axial, and shear forces.

The existing tower was analyzed for the controlling basic wind speed (3-second gust) with no ice and the applicable wind and ice combination to determine stresses in members as per guidelines of TIA-222-G-2005 entitled “Structural Standard for Antenna Support Structures and Antennas”, the American Institute of Steel Construction (AISC) and the Manual of Steel Construction; Load and Resistance Factor Design (LRFD).

The controlling wind speed is determined by evaluating the local available wind speed data as provided in Appendix N of the CSBC¹ and the wind speed data available in the TIA-222-G-2005 Standard.

Tower Loading

Tower loading was determined by the basic wind speed as applied to projected surface areas with modification factors per TIA-222-G-2005, gravity loads of the tower structure and its components, and the application of 0.75” radial ice on the tower structure and its components.

Basic Wind Speed:	Middlesex County; $v = 100-120$ mph (3-second gust) [Annex B of TIA-222-G-2005]
	Haddam; $v = 101$ mph (Nominal – Structure Class III) [Appendix N of the 2018 CT Building Code]
Load Cases:	<u>Load Case 1</u> ; 101 mph wind speed w/ no ice plus gravity load – used in calculation of tower stresses and rotation. [Appendix N of the 2018 CT Building Code]
	<u>Load Case 2</u> ; 50 mph wind speed w/ 0.75” radial ice plus gravity load – used in calculation of tower stresses. [Annex B of TIA-222-G-2005]

¹ The 2015 International Building Code as amended by the 2018 Connecticut State Building Code (CSBC).

Tower Capacity

- Calculated stresses were found to be within allowable limits. This tower was found to be at **80.0%** of its total capacity.

Tower Section	Elevation	Stress Ratio (percentage of capacity)	Result
Diagonal (T9)	120'-0"-140'-0"	80.0%	PASS
Leg (T15)	0'-0"-20'-0"	76.4%	PASS
Mid Girt (T3)	220'-0"-240'-0"	61.0%	PASS

- The tower combined deflection is **0.4876 degrees**.

Deflection Criteria	Proposed (degrees)
Sway (Tilt)	0.5855
Twist	0.0496
Combined	0.5876

| Note 1: Tower deflection subject to approval by Eversource.

Foundation and Anchors

The existing foundation consists of three (3) 5.5-ft \varnothing x 4.25-ft long piers on a 49.5-ft square x 2.25-ft thick reinforced concrete mat. The base of the tower is connected to the foundation by means of (12) 1.25" \varnothing , ASTM F1554-105 anchor bolts per leg embedded approximately 5-ft into the concrete foundation structure.

- The tower reactions developed from the governing Load Case were used in the verification of the foundation:

Reactions	Vector	Proposed Base Reactions
Base	Shear	165 kips
	Compression	149 kips
	Moment	24424 kip-ft
Leg	Shear	100 kips
	Uplift	633 kips
	Compression	755 kips

- The anchor bolts were found to be within allowable limits.

Tower Component	Design Limit	Stress Ratio (percentage of capacity)	Result
Anchor Bolts	Tension	58.5%	PASS

- The foundation was found to be within allowable limits.

Foundation	Design Limit	TIA-222-G Section 9.4 FS ⁽¹⁾	Proposed Loading (FS) ⁽¹⁾	Result
Reinforced Concrete Piers (3) and Mat	OM ⁽²⁾	1.0	1.77	PASS

Note 1: FS denotes Factor of Safety

Note 2: OM denotes Overturning Moment.

Conclusion

This analysis shows that the subject tower **is adequate** to support the proposed modified antenna configuration with the below recommendations.

The analysis is based, in part, on the information provided to this office by Eversource. If the existing conditions are different than the information in this report, Centek Engineering, Inc. must be contacted for resolution of any potential issues.

Please feel free to call with any questions or comments.

Respectfully Submitted by:

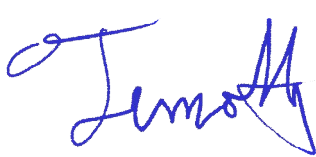

Timothy J. Lynn, PE
Structural Engineer

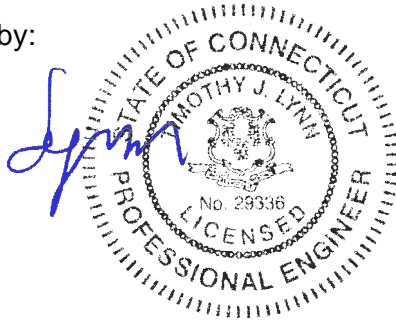

*Standard Conditions for Furnishing of
Professional Engineering Services on
Existing Structures*

All engineering services are performed on the basis that the information used is current and correct. This information may consist of, but is not necessarily limited to:

- Information supplied by the client regarding the structure itself, its foundations, the soil conditions, the antenna and feed line loading on the structure and its components, or other relevant information.
- Information from the field and/or drawings in the possession of Centek Engineering, Inc. or generated by field inspections or measurements of the structure.
- It is the responsibility of the client to ensure that the information provided to Centek Engineering, Inc. and used in the performance of our engineering services is correct and complete. In the absence of information to the contrary, we assume that all structures were constructed in accordance with the drawings and specifications and are in an un-corroded condition and have not deteriorated. It is therefore assumed that its capacity has not significantly changed from the “as new” condition.
- All services will be performed to the codes specified by the client, and we do not imply to meet any other codes or requirements unless explicitly agreed in writing. If wind and ice loads or other relevant parameters are to be different from the minimum values recommended by the codes, the client shall specify the exact requirement. In the absence of information to the contrary, all work will be performed in accordance with the latest revision of ANSI/ASCE10 & ANSI/EIA-222
- All services performed, results obtained, and recommendations made are in accordance with generally accepted engineering principles and practices. Centek Engineering, Inc. is not responsible for the conclusions, opinions and recommendations made by others based on the information we supply.

GENERAL DESCRIPTION OF STRUCTURAL ANALYSIS PROGRAM

tnxTower, is an integrated structural analysis and design software package for Designed specifically for the telecommunications industry, tnxTower, formerly RISATower, automates much of the tower analysis and design required by the TIA/EIA 222 Standard.

tnxTower Features:

- tnxTower can analyze and design 3- and 4-sided guyed towers, 3- and 4-sided self-supporting towers and either round or tapered ground mounted poles with or without guys.
- The program analyzes towers using the TIA-222-G (2005) standard or any of the previous TIA/EIA standards back to RS-222 (1959). Steel design is checked using the AISC ASD 9th Edition or the AISC LRFD specifications.
- Linear and non-linear (P-delta) analyses can be used in determining displacements and forces in the structure. Wind pressures and forces are automatically calculated.
- Extensive graphics plots include material take-off, shear-moment, leg compression, displacement, twist, feed line, guy anchor and stress plots.
- tnxTower contains unique features such as True Cable behavior, hog rod take-up, foundation stiffness and much more.

Section	T1	T2	T3	T4	T5	T6	T7	T8	T9	T10	T11	T12	T13	T14	T15
Legs	#12ZG - 1.25" - 1.00" conn. (Pirod 207628)														
Leg Grade	A572-50														
Diagonals	L3x3x5/16														
Diagonal Grade	A36														
Top Girts	N.A.														
Mid Girts	N.A.														
Sec. Horizontals	N.A.														
Face Width (ft)	40	40	40	40	40	40	40	40	40	40	40	40	40	40	40
# Panels @ (ft)	12	14	16	18	19	20	22	24	26	28	30	32	34	36	38
Weight (K)	3.2	2.8	3.7	1.9	2.1	5.1	5.7	6.2	8.1	9.1	10.1	10.5	11.5	11.8	12.0

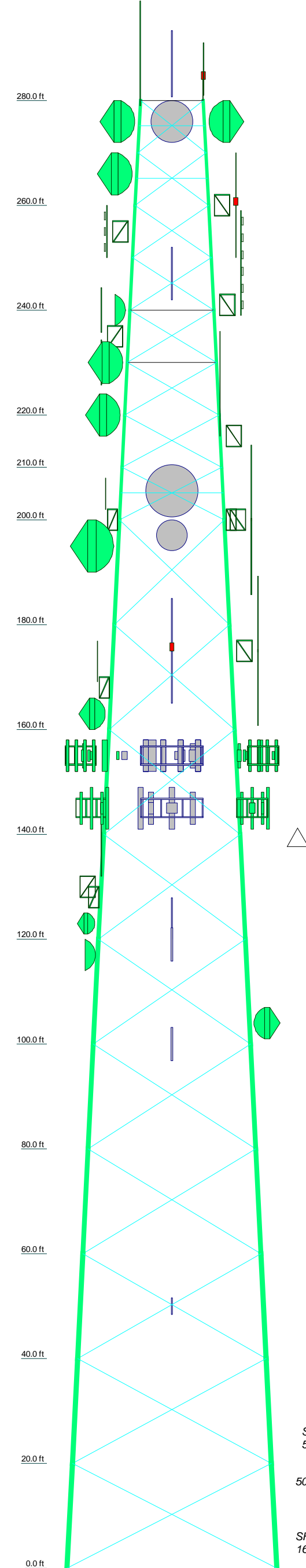

DESIGNED APPURTENANCE LOADING

TYPE	ELEVATION	TYPE	ELEVATION
Beacon Extender (4) 803062	280	12' V Frame (Sprint)	155
Beacon	280	FD-RRH 4x45 1900 (Sprint - Proposed)	155
DB538 (Eversource)	279	FD-RRH 4x45 1900 (Sprint - Proposed)	155
ANT150F6 -138-151 MHZ (Eversource)	279	(2) FD-RRH 2x50 800 (Sprint - Proposed)	155
1142-2C (VSC)	279	(2) FD-RRH 2x50 800 (Sprint - Proposed)	155
8' Solid w/ Radome (Eversource)	276	NNVV-65B-R4 (Sprint - Proposed)	155
8' Solid w/ Radome (Eversource)	276	APXVTM14 (Sprint - Proposed)	155
8' Solid w/ Radome (Eversource)	276	(2) FD-RRH 2x50 800 (Sprint - Proposed)	155
8' Solid w/ Radome (Eversource)	266	12' V Frame (Sprint)	155
10' Dipole (VSC)	261	NNVV-65B-R4 (Sprint - Proposed)	155
6' Pivot Side Arm (50" pipe) (VSC)	261	TD-RRH8x20-25 (Sprint - Proposed)	155
DB589-Y (Eversource)	260	TD-RRH8x20-25 (Sprint - Proposed)	155
DB589-Y (Eversource)	260	TD-RRH8x20-25 (Sprint - Proposed)	155
TMA (12"x16"x6") (Eversource)	260	RRH4x45/2x90-AWS (Verizon)	145
6' Pivot Side Arm (50" pipe) (Eversource)	260	RRH4x45/2x90-AWS (Verizon)	145
DB212-1-C (Eversource)	255	DB-T1-6Z-8AB-0Z (Verizon)	145
6' Pivot Side Arm (50" pipe) (Eversource)	255	DB-T1-6Z-8AB-0Z (Verizon)	145
SD110-SFXPASNM (Eversource)	241	DB-T1-6Z-8AB-0Z (Verizon)	145
6' Pivot Side Arm (50" pipe) (Eversource)	241	12' V Frame (Verizon)	145
KRECO CO-36A (Eversource)	240	12' V Frame (Verizon)	145
6' Pivot Side Arm (50" pipe) (Eversource)	240	12' V Frame (Verizon)	145
6' Dish (Eversource - Proposed)	240	HBXX-6517DS (Verizon)	145
TMA (12"x16"x6") (CSP)	235	LNX-6515DS (Verizon)	145
SE419-SF3P4LDF (CSP)	235	HBXX-6517DS (Verizon)	145
SE419-SF3P4LDF (CSP)	235	LNX-6515DS (Verizon)	145
6' Pivot Side Arm (50" pipe) (CSP)	235	HBXX-6517DS (Verizon)	145
531-70HD (Eversource)	230	LNX-6515DS (Verizon)	145
3' Pivot Side Arm (50" pipe) (Eversource)	230	HBXX-6517DS (Verizon)	145
8' Solid w/ Radome (Eversource)	230	LNX-6515DS (Verizon)	145
8' Solid w/ Radome (Eversource)	220	HBXX-6517DS (Verizon)	145
ANT450F10 (VSC)	216	LNX-6515DS (Verizon)	145
6' Pivot Side Arm (50" pipe) (VSC)	216	HBXX-6517DS (Verizon)	145
SD110-SFXPASNM (Eversource)	216	B25 RRH4x30 (Verizon)	145
6' Pivot Side Arm (50" pipe) (Eversource)	216	B25 RRH4x30 (Verizon)	145
10' Solid w/ Radome (Eversource)	205.5	B25 RRH4x30 (Verizon)	145
SC479 (CSP)	200	RRH4x30-B13 (Verizon)	145
3' Pivot Side Arm (50" pipe) (CSP)	200	RRH4x30-B13 (Verizon)	145
SC479 (CSP)	200	RRH4x30-B13 (Verizon)	145
3' Pivot Side Arm (50" pipe) (CSP)	200	RRH4x45/2x90-AWS (Verizon)	145
SC479 (CSP)	200	LNX-6515DS (Verizon)	145
6' Pivot Side Arm (50" pipe) (CSP)	200	KRECO CO-36A (VSC)	130
TMA (12"x16"x6") (CSP)	200	6' Pivot Side Arm (50" pipe) (VSC)	130
ANT900D6-9 (CSP)	200	3' Pivot Side Arm (50" pipe) (VSC)	128
6' Solid w/ Radome (CSP)	197	PR-950 (VSC)	126
10' Solid w/ Radome (CSP)	195	6' Pivot Side Arm (50" pipe) (VSC)	126
6' Pivot Side Arm (50" pipe) (CSP)	175	ANT450F6 (VSC)	124
BCR-80010-90 (CSP)	175	6' Pivot Side Arm (50" pipe) (VSC)	124
BCD-80609 (CSP)	175	SBX4-W60 (Eversource)	123
TMA (12"x16"x6") (CSP)	175	6' Grid Dish (VSC)	117
3' Pivot Side Arm (50" pipe) (CSP)	175	BR-6155 (VSC)	116
SC479 (CSP)	175	ANT400D (CSP)	116
SC479 (CSP)	175	3' Pivot Side Arm (50" pipe) (VSC/CSP)	116
ANT450F6 (Town of Haddam)	168	6' Solid w/ Radome (Eversource)	104
3' Pivot Side Arm (50" pipe) (Town of Haddam)	168	3' Pivot Side Arm (50" pipe) (VSC)	97
6' Solid w/ Radome (CSP)	163	BR-6155 (VSC)	97
APXVTM14 (Sprint - Proposed)	155	5-ft dipole (CSP)	55
12' V Frame (Sprint)	155	3' Pivot Side Arm (50" pipe) (CSP)	55
FD-RRH 4x45 1900 (Sprint - Proposed)	155	3' Pivot Side Arm (50" pipe)	50
NNVV-65B-R4 (Sprint - Proposed)	155	ANT790F2	50
APXVTM14 (Sprint - Proposed)	155		

SYMBOL LIST

MARK	SIZE	MARK	SIZE
A	#12ZG - 1.75" - 1.00" conn. (Pirod 195557)	E	#12ZG - 3.00" - 0.875 - DB-0.625" - HP-Trans - (Pirod 238707)
B	#12ZG - 2.00" - 0.875" conn.-Trans (Pirod 211843)	F	#12ZG - 3.00" - 0.875 - DB-0.625" - HP- (Pirod 238708)
C	#12ZG - 2.50" - 0.875" conn. (Pirod 208335)	G	L2 1/2x2 1/2x3/16
D	#12ZG - 2.75" - 0.875 - DB-0.625" - HP- (Pirod 238706)		

MATERIAL STRENGTH

GRADE	Fy	Fu	GRADE	Fy	Fu
A572-50	50 ksi	65 ksi	A36	36 ksi	58 ksi

TOWER DESIGN NOTES

1. Tower designed for Exposure C to the TIA-222-G Standard.
2. Tower designed for a 101 mph basic wind in accordance with the TIA-222-G Standard.
3. Tower is also designed for a 50 mph basic wind with 0.75 in ice. Ice is considered to increase in thickness with height.
4. Deflections are based upon a 60 mph wind.
5. Tower Structure Class III.
6. Topographic Category 1 with Crest Height of 0.00 ft
7. TOWER RATING: 80%

ALL REACTIONS ARE FACTORED

MAX. CORNER REACTIONS AT BASE:
 DOWN: 755 K
 SHEAR: 100 K

UPLIFT: -633 K
 SHEAR: 88 K

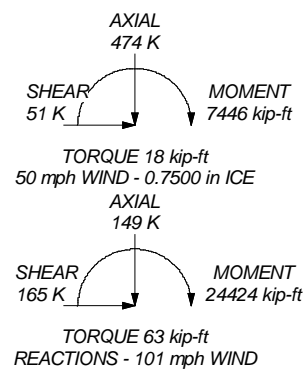

Centek Engineering Inc. 63-2 North Branford Rd. Branford, CT 06405 Phone: (203) 488-0580 FAX: (203) 488-8587	Job: 17159.10 - CT33XC089
	Project: U-40 x 280' - Haddam - Goose Hill, CT
	Client: Sprint
	Code: TIA-222-G
Drawn by: TJL	App'd:
Date: 08/21/18	Scale: NTS
Path: <small>J:\2018\1715901\W10_C133XC089\W10_Haddam\04_Structural\Backup Documentation\Digital\Tower\280_Lattice Tower Goose Hill.dwg</small>	Dwg No. E-1

Feed Line Distribution Chart 0' - 280'

— Round
 — Flat
 — App In Face
 — App Out Face
 — Truss Leg

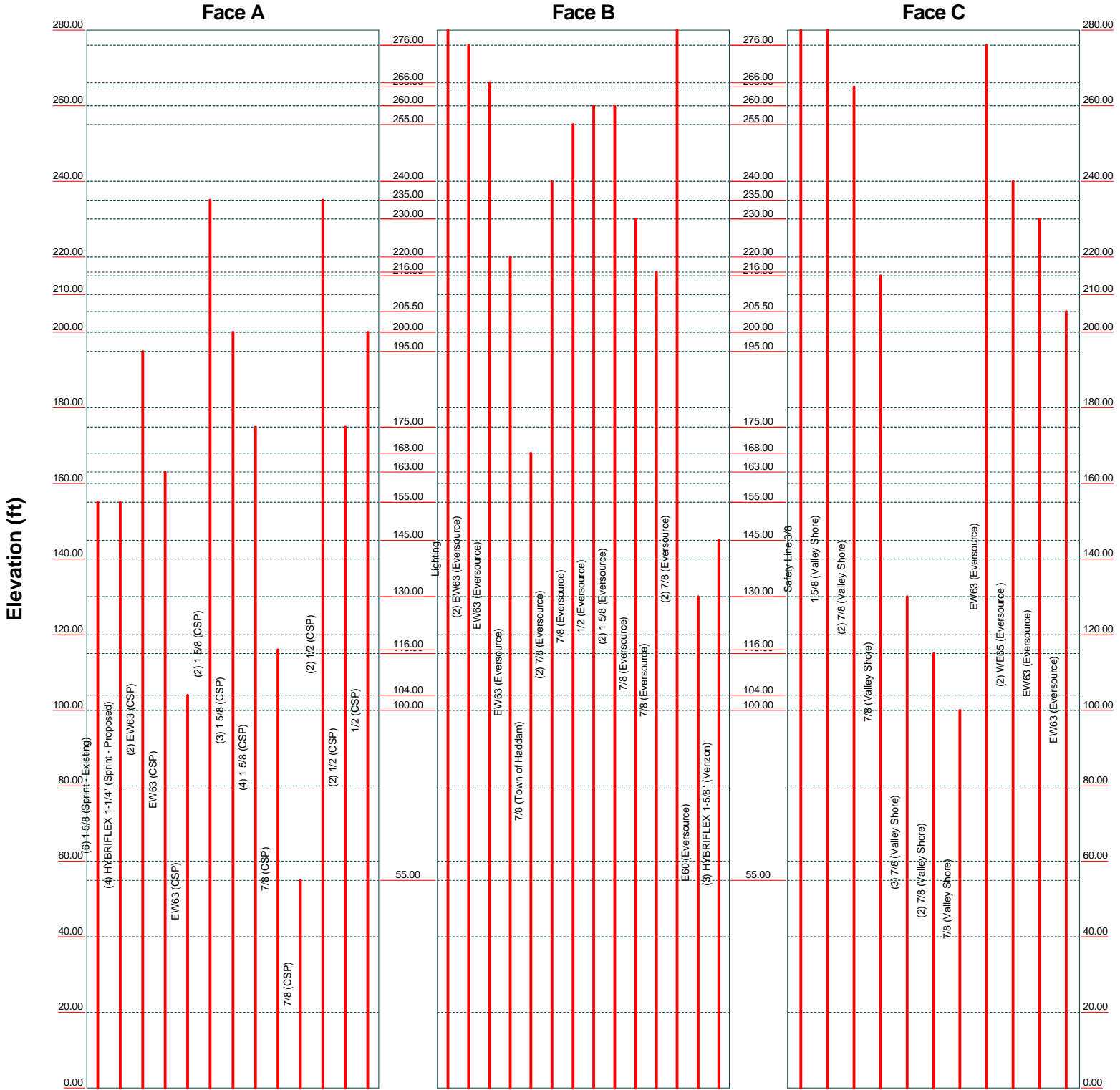

Centek Engineering Inc.		
63-2 North Branford Rd. Branford, CT 06405 Phone: (203) 488-0580 FAX: (203) 488-8587		
Job: 17159.10 - CT33XC089		
Project: U-40 x 280' - Haddam - Goose Hill, CT		
Client: Sprint	Drawn by: TJL	App'd:
Code: TIA-222-G	Date: 08/21/18	Scale: NTS
Path:		Dwg No. E-7

tnxTower Centek Engineering Inc. 63-2 North Branford Rd. Branford, CT 06405 Phone: (203) 488-0580 FAX: (203) 488-8587	Job 17159.10 - CT33XC089	Page 1 of 63
	Project U-40 x 280' - Haddam - Goose Hill, CT	Date 09:04:47 08/21/18
	Client Sprint	Designed by TJL

Tower Input Data

The main tower is a 3x free standing tower with an overall height of 280.00 ft above the ground line.

The base of the tower is set at an elevation of 0.00 ft above the ground line.

The face width of the tower is 12.00 ft at the top and 40.00 ft at the base.

This tower is designed using the TIA-222-G standard.

The following design criteria apply:

Basic wind speed of 101 mph.

Structure Class III.

Exposure Category C.

Topographic Category 1.

Crest Height 0.00 ft.

Nominal ice thickness of 0.7500 in.

Ice thickness is considered to increase with height.

Ice density of 56 pcf.

A wind speed of 50 mph is used in combination with ice.

Temperature drop of 50 °F.

Deflections calculated using a wind speed of 60 mph.

A non-linear (P-delta) analysis was used.

Pressures are calculated at each section.

Stress ratio used in tower member design is 1.

Local bending stresses due to climbing loads, feed line supports, and appurtenance mounts are not considered.

Options

Consider Moments - Legs	Distribute Leg Loads As Uniform	Use ASCE 10 X-Brace Ly Rules
Consider Moments - Horizontals	Assume Legs Pinned	√ Calculate Redundant Bracing Forces
Consider Moments - Diagonals	√ Assume Rigid Index Plate	Ignore Redundant Members in FEA
Use Moment Magnification	√ Use Clear Spans For Wind Area	√ SR Leg Bolts Resist Compression
√ Use Code Stress Ratios	√ Use Clear Spans For KL/r	√ All Leg Panels Have Same Allowable
√ Use Code Safety Factors - Guys	√ Retension Guys To Initial Tension	Offset Girt At Foundation
Escalate Ice	Bypass Mast Stability Checks	√ Consider Feed Line Torque
Always Use Max Kz	√ Use Azimuth Dish Coefficients	Include Angle Block Shear Check
Use Special Wind Profile	√ Project Wind Area of Appurt.	Use TIA-222-G Bracing Resist. Exemption
√ Include Bolts In Member Capacity	Autocalc Torque Arm Areas	Use TIA-222-G Tension Splice Exemption
Leg Bolts Are At Top Of Section	Add IBC .6D+W Combination	Poles
Secondary Horizontal Braces Leg	√ Sort Capacity Reports By Component	Include Shear-Torsion Interaction
Use Diamond Inner Bracing (4 Sided)	Triangulate Diamond Inner Bracing	Always Use Sub-Critical Flow
SR Members Have Cut Ends	√ Treat Feed Line Bundles As Cylinder	Use Top Mounted Sockets
SR Members Are Concentric		

tnxTower Centek Engineering Inc. 63-2 North Branford Rd. Branford, CT 06405 Phone: (203) 488-0580 FAX: (203) 488-8587	Job 17159.10 - CT33XC089	Page 3 of 63
	Project U-40 x 280' - Haddam - Goose Hill, CT	Date 09:04:47 08/21/18
	Client Sprint	Designed by TJL

Tower Section	Tower Elevation ft	Diagonal Spacing ft	Bracing Type	Has K Brace End Panels	Has Horizontals	Top Girt Offset in	Bottom Girt Offset in
T1	280.00-260.00	10.00	X Brace	No	Yes	0.0000	0.0000
T2	260.00-240.00	10.00	X Brace	No	No	0.0000	0.0000
T3	240.00-220.00	10.00	X Brace	No	No	0.0000	0.0000
T4	220.00-210.00	10.00	X Brace	No	Yes	0.0000	0.0000
T5	210.00-200.00	10.00	X Brace	No	Yes	0.0000	0.0000
T6	200.00-180.00	20.00	X Brace	No	No	0.0000	0.0000
T7	180.00-160.00	20.00	X Brace	No	No	0.0000	0.0000
T8	160.00-140.00	20.00	X Brace	No	No	0.0000	0.0000
T9	140.00-120.00	20.00	X Brace	No	No	0.0000	0.0000
T10	120.00-100.00	20.00	X Brace	No	No	0.0000	0.0000
T11	100.00-80.00	20.00	X Brace	No	No	0.0000	0.0000
T12	80.00-60.00	20.00	X Brace	No	No	0.0000	0.0000
T13	60.00-40.00	20.00	X Brace	No	No	0.0000	0.0000
T14	40.00-20.00	20.00	X Brace	No	No	0.0000	0.0000
T15	20.00-0.00	20.00	X Brace	No	No	0.0000	0.0000

Tower Section Geometry (cont'd)

Tower Elevation ft	Leg Type	Leg Size	Leg Grade	Diagonal Type	Diagonal Size	Diagonal Grade
T1 280.00-260.00	Truss Leg	#12ZG - 1.25" - 1.00" conn. (Pirod 207628)	A572-50 (50 ksi)	Equal Angle	L3x3x5/16	A36 (36 ksi)
T2 260.00-240.00	Truss Leg	#12ZG - 1.25" - 1.00" conn. (Pirod 207628)	A572-50 (50 ksi)	Equal Angle	L3x3x5/16	A36 (36 ksi)
T3 240.00-220.00	Truss Leg	#12ZG - 1.25" - 1.00" conn. (Pirod 207628)	A572-50 (50 ksi)	Equal Angle	L4x4x1/4	A36 (36 ksi)
T4 220.00-210.00	Truss Leg	#12ZG - 1.75" - 1.00" conn. (Pirod 195557)	A572-50 (50 ksi)	Equal Angle	L4x4x1/4	A36 (36 ksi)
T5 210.00-200.00	Truss Leg	#12ZG - 1.75" - 1.00" conn. (Pirod 195557)	A572-50 (50 ksi)	Equal Angle	L4x4x1/4	A36 (36 ksi)
T6 200.00-180.00	Truss Leg	#12ZG -2.00" - 0.875" conn.-Trans (Pirod 211843)	A572-50 (50 ksi)	Double Equal Angle	2L3 1/2x3 1/2x1/4	A36 (36 ksi)
T7 180.00-160.00	Truss Leg	#12ZG -2.25" - 0.875" conn. (Pirod 208334)	A572-50 (50 ksi)	Double Equal Angle	2L3 1/2x3 1/2x1/4	A36 (36 ksi)
T8 160.00-140.00	Truss Leg	#12ZG -2.25" - 0.875" conn. (Pirod 208334)	A572-50 (50 ksi)	Double Equal Angle	2L4x4x1/4	A36 (36 ksi)
T9 140.00-120.00	Truss Leg	#12ZG - 2.50" - 0.875" conn. (Pirod 208335)	A572-50 (50 ksi)	Double Equal Angle	2L4x4x3/8	A36 (36 ksi)
T10 120.00-100.00	Truss Leg	#12ZG -2.75"-0.875 -DB-0.625"-HP- (Pirod 238706)	A572-50 (50 ksi)	Double Equal Angle	2L4x4x3/8	A36 (36 ksi)
T11 100.00-80.00	Truss Leg	#12ZG -3.00"-0.875 -DB-0.625"-HP-Trans- (Pirod 238707)	A572-50 (50 ksi)	Double Equal Angle	2L4x4x3/8	A36 (36 ksi)
T12 80.00-60.00	Truss Leg	#12ZG -3.00"-0.875 -DB-0.625"-HP- (Pirod 238708)	A572-50 (50 ksi)	Double Equal Angle	2L5x5x5/16	A36 (36 ksi)
T13 60.00-40.00	Truss Leg	#12ZG -3.25"-0.875 -DB-0.625"-HP- (Pirod 238709)	A572-50 (50 ksi)	Double Equal Angle	2L5x5x5/16	A36 (36 ksi)
T14 40.00-20.00	Truss Leg	#12ZG -3.25"-0.875 -DB-0.625"-HP- (Pirod 238709)	A572-50 (50 ksi)	Double Equal Angle	2L5x5x5/16	A36 (36 ksi)
T15 20.00-0.00	Truss Leg	#12ZG -3.25"-0.875 -DB-0.625"-HP- (Pirod 238709)	A572-50 (50 ksi)	Double Equal Angle	2L5x5x5/16	A36 (36 ksi)

tnxTower Centek Engineering Inc. 63-2 North Branford Rd. Branford, CT 06405 Phone: (203) 488-0580 FAX: (203) 488-8587	Job 17159.10 - CT33XC089	Page 4 of 63
	Project U-40 x 280' - Haddam - Goose Hill, CT	Date 09:04:47 08/21/18
	Client Sprint	Designed by TJL

Tower Elevation ft	Leg Type	Leg Size	Leg Grade	Diagonal Type	Diagonal Size	Diagonal Grade
		238709)				

Tower Section Geometry (cont'd)

Tower Elevation ft	Top Girt Type	Top Girt Size	Top Girt Grade	Bottom Girt Type	Bottom Girt Size	Bottom Girt Grade
T1 280.00-260.00	Equal Angle	L3 1/2x3 1/2x5/16	A36 (36 ksi)	Solid Round		A36 (36 ksi)
T3 240.00-220.00	Equal Angle	L5x5x3/8	A36 (36 ksi)	Solid Round		A36 (36 ksi)

Tower Section Geometry (cont'd)

Tower Elevation ft	No. of Mid Girts	Mid Girt Type	Mid Girt Size	Mid Girt Grade	Horizontal Type	Horizontal Size	Horizontal Grade
T3 240.00-220.00	1	Equal Angle	L3x3x3/16	A36 (36 ksi)	Solid Round		A572-50 (50 ksi)

Tower Section Geometry (cont'd)

Tower Elevation ft	Secondary Horizontal Type	Secondary Horizontal Size	Secondary Horizontal Grade	Inner Bracing Type	Inner Bracing Size	Inner Bracing Grade
T1 280.00-260.00	Equal Angle	L2 1/2x2 1/2x5/16	A36 (36 ksi)	Solid Round		A36 (36 ksi)
T5 210.00-200.00	Single Angle	L2 1/2x2 1/2x3/16	A36 (36 ksi)	Solid Round		A36 (36 ksi)

Tower Section Geometry (cont'd)

Tower Elevation ft	Gusset Area (per face) ft ²	Gusset Thickness in	Gusset Grade	Adjust. Factor A _f	Adjust. Factor A _r	Weight Mult.	Double Angle Stitch Bolt Spacing Diagonals in	Double Angle Stitch Bolt Spacing Horizontals in	Double Angle Stitch Bolt Spacing Redundants in
T1 280.00-260.00	0.00	0.5000	A36 (36 ksi)	1	1	1.05	36.0000	36.0000	36.0000
T2	0.00	0.5000	A36	1	1	1.05	36.0000	36.0000	36.0000

tnxTower Centek Engineering Inc. 63-2 North Branford Rd. Branford, CT 06405 Phone: (203) 488-0580 FAX: (203) 488-8587	Job 17159.10 - CT33XC089	Page 6 of 63
	Project U-40 x 280' - Haddam - Goose Hill, CT	Date 09:04:47 08/21/18
	Client Sprint	Designed by TJL

Tower Elevation ft	Calc K Single Angles	Calc K Solid Rounds	K Factors ¹							
			Legs	X Brace Diags	K Brace Diags	Single Diags	Girts	Horiz.	Sec. Horiz.	Inner Brace
				X Y	X Y	X Y	X Y	X Y	X Y	X Y
120.00-100.00				1	1	1	1	1	1	1
T11	Yes	Yes	1	1	1	1	1	1	1	1
100.00-80.00				1	1	1	1	1	1	1
T12	Yes	Yes	1	1	1	1	1	1	1	1
80.00-60.00				1	1	1	1	1	1	1
T13	Yes	Yes	1	1	1	1	1	1	1	1
60.00-40.00				1	1	1	1	1	1	1
T14	Yes	Yes	1	1	1	1	1	1	1	1
40.00-20.00				1	1	1	1	1	1	1
T15	Yes	Yes	1	1	1	1	1	1	1	1
20.00-0.00				1	1	1	1	1	1	1

¹Note: K factors are applied to member segment lengths. K-braces without inner supporting members will have the K factor in the out-of-plane direction applied to the overall length.

Tower Section Geometry (cont'd)

Tower Elevation ft	Truss-Leg K Factors					
	Truss-Legs Used As Leg Members			Truss-Legs Used As Inner Members		
	Leg Panels	X Brace Diagonals	Z Brace Diagonals	Leg Panels	X Brace Diagonals	Z Brace Diagonals
T1	1	0.5	0.7	1	0.5	0.7
280.00-260.00						
T2	1	0.5	0.7	1	0.5	0.7
260.00-240.00						
T3	1	0.5	0.7	1	0.5	0.7
240.00-220.00						
T4	1	0.5	0.7	1	0.5	0.7
220.00-210.00						
T5	1	0.5	0.7	1	0.5	0.7
210.00-200.00						
T6	1	0.5	0.7	1	0.5	0.7
200.00-180.00						
T7	1	0.5	0.7	1	0.5	0.7
180.00-160.00						
T8	1	0.5	0.7	1	0.5	0.7
160.00-140.00						
T9	1	0.5	0.7	1	0.5	0.7
140.00-120.00						
T10	1	0.5	0.7	1	0.5	0.7
120.00-100.00						
T11	1	0.5	0.7	1	0.5	0.7
100.00-80.00						
T12	1	0.5	0.7	1	0.5	0.7
80.00-60.00						
T13	1	0.5	0.7	1	0.5	0.7
60.00-40.00						
T14	1	0.5	0.7	1	0.5	1
40.00-20.00						
T15	1	0.5	0.7	1	0.5	1
20.00-0.00						

tnxTower Centek Engineering Inc. 63-2 North Branford Rd. Branford, CT 06405 Phone: (203) 488-0580 FAX: (203) 488-8587	Job 17159.10 - CT33XC089	Page 7 of 63
	Project U-40 x 280' - Haddam - Goose Hill, CT	Date 09:04:47 08/21/18
	Client Sprint	Designed by TJL

Tower Section Geometry (cont'd)

Tower Elevation ft	Leg		Diagonal		Top Girt		Bottom Girt		Mid Girt		Long Horizontal		Short Horizontal	
	Net Width Deduct in	U	Net Width Deduct in	U	Net Width Deduct in	U	Net Width Deduct in	U	Net Width Deduct in	U	Net Width Deduct in	U	Net Width Deduct in	U
T1 280.00-260.00	0.0000	1	0.0000	0.75	0.0000	0.75	0.0000	0.75	0.0000	0.75	0.0000	0.75	0.0000	0.75
T2 260.00-240.00	0.0000	1	0.0000	0.75	0.0000	0.75	0.0000	0.75	0.0000	0.75	0.0000	0.75	0.0000	0.75
T3 240.00-220.00	0.0000	1	0.0000	0.75	0.0000	0.75	0.0000	0.75	0.0000	0.75	0.0000	0.75	0.0000	0.75
T4 220.00-210.00	0.0000	1	0.0000	0.75	0.0000	0.75	0.0000	0.75	0.0000	0.75	0.0000	0.75	0.0000	0.75
T5 210.00-200.00	0.0000	1	0.0000	0.75	0.0000	0.75	0.0000	0.75	0.0000	0.75	0.0000	0.75	0.0000	0.75
T6 200.00-180.00	0.0000	1	0.0000	0.75	0.0000	0.75	0.0000	0.75	0.0000	0.75	0.0000	0.75	0.0000	0.75
T7 180.00-160.00	0.0000	1	0.0000	0.75	0.0000	0.75	0.0000	0.75	0.0000	0.75	0.0000	0.75	0.0000	0.75
T8 160.00-140.00	0.0000	1	0.0000	0.75	0.0000	0.75	0.0000	0.75	0.0000	0.75	0.0000	0.75	0.0000	0.75
T9 140.00-120.00	0.0000	1	0.0000	0.75	0.0000	0.75	0.0000	0.75	0.0000	0.75	0.0000	0.75	0.0000	0.75
T10 120.00-100.00	0.0000	1	0.0000	0.75	0.0000	0.75	0.0000	0.75	0.0000	0.75	0.0000	0.75	0.0000	0.75
T11 100.00-80.00	0.0000	1	0.0000	0.75	0.0000	0.75	0.0000	0.75	0.0000	0.75	0.0000	0.75	0.0000	0.75
T12 80.00-60.00	0.0000	1	0.0000	0.75	0.0000	0.75	0.0000	0.75	0.0000	0.75	0.0000	0.75	0.0000	0.75
T13 60.00-40.00	0.0000	1	0.0000	0.75	0.0000	0.75	0.0000	0.75	0.0000	0.75	0.0000	0.75	0.0000	0.75
T14 40.00-20.00	0.0000	1	0.0000	0.75	0.0000	0.75	0.0000	0.75	0.0000	0.75	0.0000	0.75	0.0000	0.75
T15 20.00-0.00	0.0000	1	0.0000	0.75	0.0000	0.75	0.0000	0.75	0.0000	0.75	0.0000	0.75	0.0000	0.75

Tower Section Geometry (cont'd)

Tower Elevation ft	Connection Offsets							
	Diagonal				K-Bracing			
	Vert. Top	Horiz. Top	Vert. Bot.	Horiz. Bot.	Vert. Top	Horiz. Top	Vert. Bot.	Horiz. Bot.
in	in	in	in	in	in	in	in	
T1 280.00-260.00	5.0000	10.7500	5.0000	10.7500	0.0000	0.0000	0.0000	0.0000
T2 260.00-240.00	5.0000	10.7500	5.0000	10.7500	0.0000	0.0000	0.0000	0.0000
T3 240.00-220.00	5.0000	10.7500	5.0000	10.7500	0.0000	0.0000	0.0000	0.0000
T4 220.00-210.00	5.0000	10.7500	5.0000	10.7500	0.0000	0.0000	0.0000	0.0000

tnxTower Centek Engineering Inc. 63-2 North Branford Rd. Branford, CT 06405 Phone: (203) 488-0580 FAX: (203) 488-8587	Job 17159.10 - CT33XC089	Page 9 of 63
	Project U-40 x 280' - Haddam - Goose Hill, CT	Date 09:04:47 08/21/18
	Client Sprint	Designed by TJL

Tower Elevation ft	Leg Connection Type	Leg		Diagonal		Top Girt		Bottom Girt		Mid Girt		Long Horizontal		Short Horizontal	
		Bolt Size in	No.	Bolt Size in	No.	Bolt Size in	No.	Bolt Size in	No.	Bolt Size in	No.	Bolt Size in	No.	Bolt Size in	No.
T12 80.00-60.00	Flange	1.2500	12	0.8750	2	0.0000	0	1.0000	0	1.0000	0	1.0000	0	1.0000	0
		A325N		A325N		A325N		A325N		A325N		A325N		A325N	
T13 60.00-40.00	Flange	1.2500	12	0.8750	2	0.0000	0	1.0000	0	1.0000	0	1.0000	0	1.0000	0
		A325N		A325N		A325N		A325N		A325N		A325N		A325N	
T14 40.00-20.00	Flange	1.2500	12	0.8750	2	0.0000	0	1.0000	0	1.0000	0	1.0000	0	1.0000	0
		A325N		A325N		A325N		A325N		A325N		A325N		A325N	
T15 20.00-0.00	Flange	1.2500	12	0.8750	2	0.0000	0	1.0000	0	1.0000	0	1.0000	0	1.0000	0
		F1554-105		A325N		A325N		A325N		A325N		A325N		A325N	

Feed Line/Linear Appurtenances - Entered As Round Or Flat

Description	Face or Leg	Allow Shield	Component Type	Placement ft	Face Offset in	Lateral Offset (Frac FW)	#	# Per Row	Clear Spacing in	Width or Diameter in	Perimeter in	Weight plf
Safety Line 3/8	C	No	Ar (CaAa)	280.00 - 0.00	3.0000	0	1	1	0.3750	0.3750		0.22
Lighting 1 5/8	B	No	Ar (CaAa)	280.00 - 0.00	1.0000	0.5	1	1	0.8700	0.8700		0.15
(Sprint - Existing)	A	No	Ar (CaAa)	155.00 - 0.00	3.0000	0.4	6	6	1.9800	1.9800		1.04
HYBRIFLEX 1-1/4" (Sprint - Proposed)	A	No	Ar (CaAa)	155.00 - 0.00	3.0000	0.45	4	4	1.5400	1.5400		1.30
EW63 (CSP)	A	No	Ar (CaAa)	195.00 - 0.00	3.0000	-0.45	2	2	1.5742	1.5742		0.51
EW63 (CSP)	A	No	Ar (CaAa)	163.00 - 0.00	3.0000	-0.43	1	1	1.5742	1.5742		0.51
EW63 (CSP)	A	No	Ar (CaAa)	104.00 - 0.00	3.0000	-0.42	1	1	1.5742	1.5742		0.51
1 5/8 (CSP)	A	No	Ar (CaAa)	235.00 - 0.00	3.0000	-0.38	2	1	1.9800	1.9800		1.04
1 5/8 (CSP)	A	No	Ar (CaAa)	200.00 - 0.00	3.0000	-0.36	3	2	1.9800	1.9800		1.04
1 5/8 (CSP)	A	No	Ar (CaAa)	175.00 - 0.00	3.0000	-0.34	4	2	1.9800	1.9800		1.04
1 5/8 (CSP)	C	No	Ar (CaAa)	280.00 - 0.00	3.0000	0.46	1	1	1.9800	1.9800		1.04
(Valley Shore) 7/8	C	No	Ar (CaAa)	265.00 - 0.00	3.0000	0.45	2	2	1.1100	1.1100		0.54
(Valley Shore) 7/8	C	No	Ar (CaAa)	215.00 - 0.00	3.0000	0.44	1	1	1.1100	1.1100		0.54
(Valley Shore) 7/8	C	No	Ar (CaAa)	130.00 - 0.00	3.0000	0.42	3	3	1.1100	1.1100		0.54
(Valley Shore) 7/8	C	No	Ar (CaAa)	115.00 - 0.00	3.0000	0.4	2	2	1.1100	1.1100		0.54
(Valley Shore) 7/8	C	No	Ar (CaAa)	100.00 - 0.00	3.0000	0.38	1	1	1.1100	1.1100		0.54
(Valley Shore) EW63 (Eversource)	B	No	Ar (CaAa)	276.00 - 0.00	3.0000	0.47	2	2	1.5742	1.5742		0.51
EW63 (Eversource)	B	No	Ar (CaAa)	266.00 - 0.00	3.0000	0.46	1	1	1.5742	1.5742		0.51
EW63 (Eversource)	B	No	Ar (CaAa)	220.00 - 0.00	3.0000	0.45	1	1	1.5742	1.5742		0.51

tnxTower Centek Engineering Inc. 63-2 North Branford Rd. Branford, CT 06405 Phone: (203) 488-0580 FAX: (203) 488-8587	Job	17159.10 - CT33XC089	Page	10 of 63
	Project	U-40 x 280' - Haddam - Goose Hill, CT	Date	09:04:47 08/21/18
	Client	Sprint	Designed by	TJL

Description	Face or Leg	Allow Shield	Component Type	Placement ft	Face Offset in	Lateral Offset (Frac FW)	#	# Per Row	Clear Spacing in	Width or Diameter in	Perimeter in	Weight plf
7/8 (Town of Haddam)	B	No	Ar (CaAa)	168.00 - 0.00	3.0000	0.43	1	1	1.1100	1.1100		0.54
7/8 (Eversource)	B	No	Ar (CaAa)	240.00 - 0.00	3.0000	0.42	2	1	1.1100	1.1100		0.54
7/8 (Eversource)	B	No	Ar (CaAa)	255.00 - 0.00	3.0000	0.41	1	1	1.1100	1.1100		0.54
1/2 (Eversource)	B	No	Ar (CaAa)	260.00 - 0.00	5.0000	0.41	1	1	0.5800	0.5800		0.25
1 5/8 (Eversource)	B	No	Ar (CaAa)	260.00 - 0.00	3.0000	0.39	2	2	1.9800	1.9800		1.04
7/8 (Eversource)	B	No	Ar (CaAa)	230.00 - 0.00	3.0000	0.38	1	1	1.1100	1.1100		0.54
7/8 (Eversource)	B	No	Ar (CaAa)	216.00 - 0.00	5.0000	0.38	1	1	1.1100	1.1100		0.54
7/8 (Eversource)	B	No	Ar (CaAa)	280.00 - 0.00	3.0000	0.37	2	1	1.1100	1.1100		0.54
7/8 (CSP)	A	No	Ar (CaAa)	116.00 - 0.00	3.0000	-0.32	1	1	1.1100	1.1100		0.54
7/8 (CSP)	A	No	Ar (CaAa)	55.00 - 0.00	3.0000	-0.32	1	1	1.1100	1.1100		0.54
1/2 (CSP)	A	No	Ar (CaAa)	235.00 - 0.00	3.0000	-0.41	2	1	0.5800	0.5800		0.25
1/2 (CSP)	A	No	Ar (CaAa)	175.00 - 0.00	3.0000	-0.4	2	1	0.5800	0.5800		0.25
1/2 (CSP)	A	No	Ar (CaAa)	200.00 - 0.00	5.0000	-0.36	1	1	0.5800	0.5800		0.25
E60 (Eversource)	B	No	Ar (CaAa)	130.00 - 0.00	3.0000	0.44	1	1	2.2000	2.2000		0.68
EW63 (Eversource)	C	No	Ar (CaAa)	276.00 - 0.00	3.0000	-0.47	1	1	1.5742	1.5742		0.51
WE65 (Eversource)	C	No	Ar (CaAa)	240.00 - 0.00	3.0000	-0.46	2	2	1.5836	1.5836		0.53
EW63 (Eversource)	C	No	Ar (CaAa)	230.00 - 0.00	3.0000	-0.45	1	1	1.5742	1.5742		0.51
EW63 (Eversource)	C	No	Ar (CaAa)	205.50 - 0.00	3.0000	-0.44	1	1	1.5742	1.5742		0.51
HYBRIFLEX 1-5/8" (Verizon)	B	No	Ar (CaAa)	145.00 - 0.00	3.0000	-0.44	3	3	1.9800	1.9800		1.90

Feed Line/Linear Appurtenances Section Areas

Tower Section	Tower Elevation ft	Face	A _R ft ²	A _F ft ²	C _{AA} In Face ft ²	C _{AA} Out Face ft ²	Weight K
T1	280.00-260.00	A	0.000	0.000	0.000	0.000	0.00
		B	0.000	0.000	12.162	0.000	0.04
		C	0.000	0.000	8.339	0.000	0.04
T2	260.00-240.00	A	0.000	0.000	0.000	0.000	0.00
		B	0.000	0.000	26.370	0.000	0.11
		C	0.000	0.000	12.298	0.000	0.06
T3	240.00-220.00	A	0.000	0.000	7.680	0.000	0.04
		B	0.000	0.000	32.475	0.000	0.14
		C	0.000	0.000	20.207	0.000	0.08
T4	220.00-210.00	A	0.000	0.000	5.120	0.000	0.03
		B	0.000	0.000	19.033	0.000	0.08

tnxTower Centek Engineering Inc. 63-2 North Branford Rd. Branford, CT 06405 Phone: (203) 488-0580 FAX: (203) 488-8587	Job	17159.10 - CT33XC089	Page	11 of 63
	Project	U-40 x 280' - Haddam - Goose Hill, CT	Date	09:04:47 08/21/18
	Client	Sprint	Designed by	TJL

Tower Section	Tower Elevation ft	Face	A _R ft ²	A _F ft ²	C _{AA} In Face ft ²	C _{AA} Out Face ft ²	Weight K
T5	210.00-200.00	C	0.000	0.000	11.446	0.000	0.05
		A	0.000	0.000	5.120	0.000	0.03
		B	0.000	0.000	19.477	0.000	0.08
T6	200.00-180.00	C	0.000	0.000	12.866	0.000	0.05
		A	0.000	0.000	28.003	0.000	0.13
		B	0.000	0.000	38.954	0.000	0.17
T7	180.00-160.00	C	0.000	0.000	27.150	0.000	0.11
		A	0.000	0.000	43.669	0.000	0.21
		B	0.000	0.000	39.842	0.000	0.17
T8	160.00-140.00	C	0.000	0.000	27.150	0.000	0.11
		A	0.000	0.000	77.945	0.000	0.41
		B	0.000	0.000	44.144	0.000	0.21
T9	140.00-120.00	C	0.000	0.000	27.150	0.000	0.11
		A	0.000	0.000	86.965	0.000	0.47
		B	0.000	0.000	55.254	0.000	0.30
T10	120.00-100.00	C	0.000	0.000	30.480	0.000	0.13
		A	0.000	0.000	89.371	0.000	0.48
		B	0.000	0.000	57.454	0.000	0.30
T11	100.00-80.00	C	0.000	0.000	37.140	0.000	0.16
		A	0.000	0.000	92.334	0.000	0.49
		B	0.000	0.000	57.454	0.000	0.30
T12	80.00-60.00	C	0.000	0.000	40.470	0.000	0.17
		A	0.000	0.000	92.334	0.000	0.49
		B	0.000	0.000	57.454	0.000	0.30
T13	60.00-40.00	C	0.000	0.000	40.470	0.000	0.17
		A	0.000	0.000	93.999	0.000	0.50
		B	0.000	0.000	57.454	0.000	0.30
T14	40.00-20.00	C	0.000	0.000	40.470	0.000	0.17
		A	0.000	0.000	94.554	0.000	0.50
		B	0.000	0.000	57.454	0.000	0.30
T15	20.00-0.00	C	0.000	0.000	40.470	0.000	0.17
		A	0.000	0.000	94.554	0.000	0.50
		B	0.000	0.000	57.454	0.000	0.30

Feed Line/Linear Appurtenances Section Areas - With Ice

Tower Section	Tower Elevation ft	Face or Leg	Ice Thickness in	A _R ft ²	A _F ft ²	C _{AA} In Face ft ²	C _{AA} Out Face ft ²	Weight K
T1	280.00-260.00	A	2.314	0.000	0.000	0.000	0.000	0.00
		B		0.000	0.000	61.679	0.000	0.96
		C		0.000	0.000	39.272	0.000	0.68
T2	260.00-240.00	A	2.296	0.000	0.000	0.000	0.000	0.00
		B		0.000	0.000	125.512	0.000	1.96
		C		0.000	0.000	59.809	0.000	0.95
T3	240.00-220.00	A	2.277	0.000	0.000	38.406	0.000	0.63
		B		0.000	0.000	157.593	0.000	2.49
		C		0.000	0.000	93.440	0.000	1.42
T4	220.00-210.00	A	2.261	0.000	0.000	25.497	0.000	0.42
		B		0.000	0.000	90.740	0.000	1.45
		C		0.000	0.000	52.372	0.000	0.81
T5	210.00-200.00	A	2.251	0.000	0.000	25.423	0.000	0.41
		B		0.000	0.000	92.693	0.000	1.48
		C		0.000	0.000	58.348	0.000	0.91
T6	200.00-180.00	A	2.234	0.000	0.000	118.120	0.000	1.87
		B		0.000	0.000	184.436	0.000	2.93
		C		0.000	0.000	121.518	0.000	1.90

tnxTower Centek Engineering Inc. 63-2 North Branford Rd. Branford, CT 06405 Phone: (203) 488-0580 FAX: (203) 488-8587	Job 17159.10 - CT33XC089	Page 12 of 63
	Project U-40 x 280' - Haddam - Goose Hill, CT	Date 09:04:47 08/21/18
	Client Sprint	Designed by TJL

Tower Section	Tower Elevation ft	Face or Leg	Ice Thickness in	A _R ft ²	A _F ft ²	C _{AA} In Face ft ²	C _{AA} Out Face ft ²	Weight K
T7	180.00-160.00	A	2.209	0.000	0.000	168.339	0.000	2.76
		B		0.000	0.000	187.481	0.000	2.96
		C		0.000	0.000	120.582	0.000	1.87
T8	160.00-140.00	A	2.182	0.000	0.000	272.179	0.000	4.58
		B		0.000	0.000	202.229	0.000	3.18
		C		0.000	0.000	119.540	0.000	1.84
T9	140.00-120.00	A	2.151	0.000	0.000	297.213	0.000	4.97
		B		0.000	0.000	235.943	0.000	3.74
		C		0.000	0.000	132.415	0.000	1.99
T10	120.00-100.00	A	2.115	0.000	0.000	305.852	0.000	5.06
		B		0.000	0.000	239.938	0.000	3.78
		C		0.000	0.000	162.227	0.000	2.33
T11	100.00-80.00	A	2.073	0.000	0.000	314.313	0.000	5.14
		B		0.000	0.000	236.984	0.000	3.68
		C		0.000	0.000	176.354	0.000	2.51
T12	80.00-60.00	A	2.021	0.000	0.000	310.690	0.000	5.00
		B		0.000	0.000	233.369	0.000	3.56
		C		0.000	0.000	173.493	0.000	2.42
T13	60.00-40.00	A	1.955	0.000	0.000	313.511	0.000	4.94
		B		0.000	0.000	228.670	0.000	3.40
		C		0.000	0.000	169.775	0.000	2.32
T14	40.00-20.00	A	1.857	0.000	0.000	308.785	0.000	4.71
		B		0.000	0.000	221.836	0.000	3.18
		C		0.000	0.000	164.367	0.000	2.16
T15	20.00-0.00	A	1.664	0.000	0.000	294.443	0.000	4.20
		B		0.000	0.000	208.286	0.000	2.77
		C		0.000	0.000	153.644	0.000	1.88

Feed Line Center of Pressure

Section	Elevation ft	CP _X in	CP _Z in	CP _X Ice in	CP _Z Ice in
T1	280.00-260.00	2.3610	2.6069	2.5024	2.7519
T2	260.00-240.00	5.1540	4.6798	5.1301	4.2584
T3	240.00-220.00	5.0091	5.4875	4.6553	5.2370
T4	220.00-210.00	5.9769	6.7815	5.6245	6.6282
T5	210.00-200.00	5.9461	6.8457	5.6710	6.8622
T6	200.00-180.00	3.3103	8.9761	4.5783	8.0494
T7	180.00-160.00	0.5278	9.7981	3.3799	8.7338
T8	160.00-140.00	-0.9042	3.5628	2.1780	4.9719
T9	140.00-120.00	-1.0031	0.8558	2.1566	3.3462
T10	120.00-100.00	-1.9282	1.8456	1.5368	3.9847
T11	100.00-80.00	-2.8941	2.4634	0.4536	4.6974
T12	80.00-60.00	-2.9694	2.5470	0.4459	4.8521
T13	60.00-40.00	-3.3368	2.7361	0.0139	5.0749
T14	40.00-20.00	-3.5776	2.9051	-0.1877	5.1686
T15	20.00-0.00	-3.7380	3.0512	-0.3447	4.9652

Shielding Factor Ka

Job	17159.10 - CT33XC089	Page	13 of 63
Project	U-40 x 280' - Haddam - Goose Hill, CT	Date	09:04:47 08/21/18
Client	Sprint	Designed by	TJL

Tower Section	Feed Line Record No.	Description	Feed Line Segment Elev.	K _a No Ice	K _a Ice
T1	1	Safety Line 3/8	260.00 - 280.00	0.6000	0.5359
T1	2	Lighting	260.00 - 280.00	0.6000	0.5359
T1	11	1 5/8	260.00 - 280.00	0.6000	0.5359
T1	12	7/8	260.00 - 265.00	0.6000	0.5359
T1	17	EW63	260.00 - 276.00	0.6000	0.5359
T1	18	EW63	260.00 - 266.00	0.6000	0.5359
T1	27	7/8	260.00 - 280.00	0.6000	0.5359
T1	34	EW63	260.00 - 276.00	0.6000	0.5359
T2	1	Safety Line 3/8	240.00 - 260.00	0.6000	0.6000
T2	2	Lighting	240.00 - 260.00	0.6000	0.6000
T2	11	1 5/8	240.00 - 260.00	0.6000	0.6000
T2	12	7/8	240.00 - 260.00	0.6000	0.6000
T2	17	EW63	240.00 - 260.00	0.6000	0.6000
T2	18	EW63	240.00 - 260.00	0.6000	0.6000
T2	22	7/8	240.00 - 255.00	0.6000	0.6000
T2	23	1/2	240.00 - 260.00	0.6000	0.6000
T2	24	1 5/8	240.00 - 260.00	0.6000	0.6000
T2	27	7/8	240.00 - 260.00	0.6000	0.6000
T2	34	EW63	240.00 - 260.00	0.6000	0.6000
T3	1	Safety Line 3/8	220.00 - 240.00	0.6000	0.5988
T3	2	Lighting	220.00 - 240.00	0.6000	0.5988
T3	8	1 5/8	220.00 - 235.00	0.6000	0.5988
T3	11	1 5/8	220.00 - 240.00	0.6000	0.5988
T3	12	7/8	220.00 - 240.00	0.6000	0.5988
T3	17	EW63	220.00 - 240.00	0.6000	0.5988
T3	18	EW63	220.00 - 240.00	0.6000	0.5988
T3	21	7/8	220.00 - 240.00	0.6000	0.5988
T3	22	7/8	220.00 - 240.00	0.6000	0.5988
T3	23	1/2	220.00 - 240.00	0.6000	0.5988
T3	24	1 5/8	220.00 - 240.00	0.6000	0.5988
T3	25	7/8	220.00 - 230.00	0.6000	0.5988

Job	17159.10 - CT33XC089	Page	14 of 63
Project	U-40 x 280' - Haddam - Goose Hill, CT	Date	09:04:47 08/21/18
Client	Sprint	Designed by	TJL

Tower Section	Feed Line Record No.	Description	Feed Line Segment Elev.	K _a No Ice	K _a Ice
T3	27	7/8	220.00 - 240.00	0.6000	0.5988
T3	30	1/2	220.00 - 235.00	0.6000	0.5988
T3	34	EW63	220.00 - 240.00	0.6000	0.5988
T3	35	WE65	220.00 - 240.00	0.6000	0.5988
T3	36	EW63	220.00 - 230.00	0.6000	0.5988
T4	1	Safety Line 3/8	210.00 - 220.00	0.6000	0.6000
T4	2	Lighting	210.00 - 220.00	0.6000	0.6000
T4	8	1 5/8	210.00 - 220.00	0.6000	0.6000
T4	11	1 5/8	210.00 - 220.00	0.6000	0.6000
T4	12	7/8	210.00 - 220.00	0.6000	0.6000
T4	13	7/8	210.00 - 215.00	0.6000	0.6000
T4	17	EW63	210.00 - 220.00	0.6000	0.6000
T4	18	EW63	210.00 - 220.00	0.6000	0.6000
T4	19	EW63	210.00 - 220.00	0.6000	0.6000
T4	21	7/8	210.00 - 220.00	0.6000	0.6000
T4	22	7/8	210.00 - 220.00	0.6000	0.6000
T4	23	1/2	210.00 - 220.00	0.6000	0.6000
T4	24	1 5/8	210.00 - 220.00	0.6000	0.6000
T4	25	7/8	210.00 - 220.00	0.6000	0.6000
T4	26	7/8	210.00 - 216.00	0.6000	0.6000
T4	27	7/8	210.00 - 220.00	0.6000	0.6000
T4	30	1/2	210.00 - 220.00	0.6000	0.6000
T4	34	EW63	210.00 - 220.00	0.6000	0.6000
T4	35	WE65	210.00 - 220.00	0.6000	0.6000
T4	36	EW63	210.00 - 220.00	0.6000	0.6000
T5	1	Safety Line 3/8	200.00 - 210.00	0.6000	0.6000
T5	2	Lighting	200.00 - 210.00	0.6000	0.6000
T5	8	1 5/8	200.00 - 210.00	0.6000	0.6000
T5	11	1 5/8	200.00 - 210.00	0.6000	0.6000
T5	12	7/8	200.00 - 210.00	0.6000	0.6000
T5	13	7/8	200.00 - 210.00	0.6000	0.6000

Job	17159.10 - CT33XC089	Page	15 of 63
Project	U-40 x 280' - Haddam - Goose Hill, CT	Date	09:04:47 08/21/18
Client	Sprint	Designed by	TJL

Tower Section	Feed Line Record No.	Description	Feed Line Segment Elev.	K _a No Ice	K _a Ice
T5	17	EW63	200.00 - 210.00	0.6000	0.6000
T5	18	EW63	200.00 - 210.00	0.6000	0.6000
T5	19	EW63	200.00 - 210.00	0.6000	0.6000
T5	21	7/8	200.00 - 210.00	0.6000	0.6000
T5	22	7/8	200.00 - 210.00	0.6000	0.6000
T5	23	1/2	200.00 - 210.00	0.6000	0.6000
T5	24	1 5/8	200.00 - 210.00	0.6000	0.6000
T5	25	7/8	200.00 - 210.00	0.6000	0.6000
T5	26	7/8	200.00 - 210.00	0.6000	0.6000
T5	27	7/8	200.00 - 210.00	0.6000	0.6000
T5	30	1/2	200.00 - 210.00	0.6000	0.6000
T5	34	EW63	200.00 - 210.00	0.6000	0.6000
T5	35	WE65	200.00 - 210.00	0.6000	0.6000
T5	36	EW63	200.00 - 210.00	0.6000	0.6000
T5	37	EW63	200.00 - 205.50	0.6000	0.6000
T6	1	Safety Line 3/8	180.00 - 200.00	0.6000	0.6000
T6	2	Lighting	180.00 - 200.00	0.6000	0.6000
T6	5	EW63	180.00 - 195.00	0.6000	0.6000
T6	8	1 5/8	180.00 - 200.00	0.6000	0.6000
T6	9	1 5/8	180.00 - 200.00	0.6000	0.6000
T6	11	1 5/8	180.00 - 200.00	0.6000	0.6000
T6	12	7/8	180.00 - 200.00	0.6000	0.6000
T6	13	7/8	180.00 - 200.00	0.6000	0.6000
T6	17	EW63	180.00 - 200.00	0.6000	0.6000
T6	18	EW63	180.00 - 200.00	0.6000	0.6000
T6	19	EW63	180.00 - 200.00	0.6000	0.6000
T6	21	7/8	180.00 - 200.00	0.6000	0.6000
T6	22	7/8	180.00 - 200.00	0.6000	0.6000
T6	23	1/2	180.00 - 200.00	0.6000	0.6000
T6	24	1 5/8	180.00 - 200.00	0.6000	0.6000
T6	25	7/8	180.00 - 200.00	0.6000	0.6000

Job	17159.10 - CT33XC089	Page	16 of 63
Project	U-40 x 280' - Haddam - Goose Hill, CT	Date	09:04:47 08/21/18
Client	Sprint	Designed by	TJL

Tower Section	Feed Line Record No.	Description	Feed Line Segment Elev.	K _a No Ice	K _a Ice
T6	26	7/8	180.00 - 200.00	0.6000	0.6000
T6	27	7/8	180.00 - 200.00	0.6000	0.6000
T6	30	1/2	180.00 - 200.00	0.6000	0.6000
T6	32	1/2	180.00 - 200.00	0.6000	0.6000
T6	34	EW63	180.00 - 200.00	0.6000	0.6000
T6	35	WE65	180.00 - 200.00	0.6000	0.6000
T6	36	EW63	180.00 - 200.00	0.6000	0.6000
T6	37	EW63	180.00 - 200.00	0.6000	0.6000
T7	1	Safety Line 3/8	160.00 - 180.00	0.6000	0.6000
T7	2	Lighting	160.00 - 180.00	0.6000	0.6000
T7	5	EW63	160.00 - 180.00	0.6000	0.6000
T7	6	EW63	160.00 - 163.00	0.6000	0.6000
T7	8	1 5/8	160.00 - 180.00	0.6000	0.6000
T7	9	1 5/8	160.00 - 180.00	0.6000	0.6000
T7	10	1 5/8	160.00 - 175.00	0.6000	0.6000
T7	11	1 5/8	160.00 - 180.00	0.6000	0.6000
T7	12	7/8	160.00 - 180.00	0.6000	0.6000
T7	13	7/8	160.00 - 180.00	0.6000	0.6000
T7	17	EW63	160.00 - 180.00	0.6000	0.6000
T7	18	EW63	160.00 - 180.00	0.6000	0.6000
T7	19	EW63	160.00 - 180.00	0.6000	0.6000
T7	20	7/8	160.00 - 168.00	0.6000	0.6000
T7	21	7/8	160.00 - 180.00	0.6000	0.6000
T7	22	7/8	160.00 - 180.00	0.6000	0.6000
T7	23	1/2	160.00 - 180.00	0.6000	0.6000
T7	24	1 5/8	160.00 - 180.00	0.6000	0.6000
T7	25	7/8	160.00 - 180.00	0.6000	0.6000
T7	26	7/8	160.00 - 180.00	0.6000	0.6000
T7	27	7/8	160.00 - 180.00	0.6000	0.6000
T7	30	1/2	160.00 - 180.00	0.6000	0.6000
T7	31	1/2	160.00 - 175.00	0.6000	0.6000

<i>Tower Section</i>	<i>Feed Line Record No.</i>	<i>Description</i>	<i>Feed Line Segment Elev.</i>	<i>K_a No Ice</i>	<i>K_a Ice</i>
T7	32	1/2	160.00 - 180.00	0.6000	0.6000
T7	34	EW63	160.00 - 180.00	0.6000	0.6000
T7	35	WE65	160.00 - 180.00	0.6000	0.6000
T7	36	EW63	160.00 - 180.00	0.6000	0.6000
T7	37	EW63	160.00 - 180.00	0.6000	0.6000
T8	1	Safety Line 3/8	140.00 - 160.00	0.6000	0.6000
T8	2	Lighting	140.00 - 160.00	0.6000	0.6000
T8	3	1 5/8	140.00 - 155.00	0.6000	0.6000
T8	4	HYBRIFLEX 1-1/4"	140.00 - 155.00	0.6000	0.6000
T8	5	EW63	140.00 - 160.00	0.6000	0.6000
T8	6	EW63	140.00 - 160.00	0.6000	0.6000
T8	8	1 5/8	140.00 - 160.00	0.6000	0.6000
T8	9	1 5/8	140.00 - 160.00	0.6000	0.6000
T8	10	1 5/8	140.00 - 160.00	0.6000	0.6000
T8	11	1 5/8	140.00 - 160.00	0.6000	0.6000
T8	12	7/8	140.00 - 160.00	0.6000	0.6000
T8	13	7/8	140.00 - 160.00	0.6000	0.6000
T8	17	EW63	140.00 - 160.00	0.6000	0.6000
T8	18	EW63	140.00 - 160.00	0.6000	0.6000
T8	19	EW63	140.00 - 160.00	0.6000	0.6000
T8	20	7/8	140.00 - 160.00	0.6000	0.6000
T8	21	7/8	140.00 - 160.00	0.6000	0.6000
T8	22	7/8	140.00 - 160.00	0.6000	0.6000
T8	23	1/2	140.00 - 160.00	0.6000	0.6000
T8	24	1 5/8	140.00 - 160.00	0.6000	0.6000
T8	25	7/8	140.00 - 160.00	0.6000	0.6000
T8	26	7/8	140.00 - 160.00	0.6000	0.6000
T8	27	7/8	140.00 - 160.00	0.6000	0.6000
T8	30	1/2	140.00 - 160.00	0.6000	0.6000
T8	31	1/2	140.00 - 160.00	0.6000	0.6000
T8	32	1/2	140.00 - 160.00	0.6000	0.6000

Job	17159.10 - CT33XC089	Page	18 of 63
Project	U-40 x 280' - Haddam - Goose Hill, CT	Date	09:04:47 08/21/18
Client	Sprint	Designed by	TJL

Tower Section	Feed Line Record No.	Description	Feed Line Segment Elev.	K _a No Ice	K _a Ice
T8	34	EW63	140.00 - 160.00	0.6000	0.6000
T8	35	WE65	140.00 - 160.00	0.6000	0.6000
T8	36	EW63	140.00 - 160.00	0.6000	0.6000
T8	37	EW63	140.00 - 160.00	0.6000	0.6000
T8	38	HYBRIFLEX 1-5/8"	140.00 - 145.00	0.6000	0.6000
T9	1	Safety Line 3/8	120.00 - 140.00	0.6000	0.6000
T9	2	Lighting	120.00 - 140.00	0.6000	0.6000
T9	3	1 5/8	120.00 - 140.00	0.6000	0.6000
T9	4	HYBRIFLEX 1-1/4"	120.00 - 140.00	0.6000	0.6000
T9	5	EW63	120.00 - 140.00	0.6000	0.6000
T9	6	EW63	120.00 - 140.00	0.6000	0.6000
T9	8	1 5/8	120.00 - 140.00	0.6000	0.6000
T9	9	1 5/8	120.00 - 140.00	0.6000	0.6000
T9	10	1 5/8	120.00 - 140.00	0.6000	0.6000
T9	11	1 5/8	120.00 - 140.00	0.6000	0.6000
T9	12	7/8	120.00 - 140.00	0.6000	0.6000
T9	13	7/8	120.00 - 140.00	0.6000	0.6000
T9	14	7/8	120.00 - 130.00	0.6000	0.6000
T9	17	EW63	120.00 - 140.00	0.6000	0.6000
T9	18	EW63	120.00 - 140.00	0.6000	0.6000
T9	19	EW63	120.00 - 140.00	0.6000	0.6000
T9	20	7/8	120.00 - 140.00	0.6000	0.6000
T9	21	7/8	120.00 - 140.00	0.6000	0.6000
T9	22	7/8	120.00 - 140.00	0.6000	0.6000
T9	23	1/2	120.00 - 140.00	0.6000	0.6000
T9	24	1 5/8	120.00 - 140.00	0.6000	0.6000
T9	25	7/8	120.00 - 140.00	0.6000	0.6000
T9	26	7/8	120.00 - 140.00	0.6000	0.6000
T9	27	7/8	120.00 - 140.00	0.6000	0.6000
T9	30	1/2	120.00 - 140.00	0.6000	0.6000
T9	31	1/2	120.00 - 140.00	0.6000	0.6000

Job	17159.10 - CT33XC089	Page	19 of 63
Project	U-40 x 280' - Haddam - Goose Hill, CT	Date	09:04:47 08/21/18
Client	Sprint	Designed by	TJL

Tower Section	Feed Line Record No.	Description	Feed Line Segment Elev.	K _a No Ice	K _a Ice
T9	32	1/2	120.00 - 140.00	0.6000	0.6000
T9	33	E60	120.00 - 130.00	0.6000	0.6000
T9	34	EW63	120.00 - 140.00	0.6000	0.6000
T9	35	WE65	120.00 - 140.00	0.6000	0.6000
T9	36	EW63	120.00 - 140.00	0.6000	0.6000
T9	37	EW63	120.00 - 140.00	0.6000	0.6000
T9	38	HYBRIFLEX 1-5/8"	120.00 - 140.00	0.6000	0.6000
T10	1	Safety Line 3/8	100.00 - 120.00	0.6000	0.6000
T10	2	Lighting	100.00 - 120.00	0.6000	0.6000
T10	3	1 5/8	100.00 - 120.00	0.6000	0.6000
T10	4	HYBRIFLEX 1-1/4"	100.00 - 120.00	0.6000	0.6000
T10	5	EW63	100.00 - 120.00	0.6000	0.6000
T10	6	EW63	100.00 - 120.00	0.6000	0.6000
T10	7	EW63	100.00 - 104.00	0.6000	0.6000
T10	8	1 5/8	100.00 - 120.00	0.6000	0.6000
T10	9	1 5/8	100.00 - 120.00	0.6000	0.6000
T10	10	1 5/8	100.00 - 120.00	0.6000	0.6000
T10	11	1 5/8	100.00 - 120.00	0.6000	0.6000
T10	12	7/8	100.00 - 120.00	0.6000	0.6000
T10	13	7/8	100.00 - 120.00	0.6000	0.6000
T10	14	7/8	100.00 - 120.00	0.6000	0.6000
T10	15	7/8	100.00 - 115.00	0.6000	0.6000
T10	17	EW63	100.00 - 120.00	0.6000	0.6000
T10	18	EW63	100.00 - 120.00	0.6000	0.6000
T10	19	EW63	100.00 - 120.00	0.6000	0.6000
T10	20	7/8	100.00 - 120.00	0.6000	0.6000
T10	21	7/8	100.00 - 120.00	0.6000	0.6000
T10	22	7/8	100.00 - 120.00	0.6000	0.6000
T10	23	1/2	100.00 - 120.00	0.6000	0.6000
T10	24	1 5/8	100.00 - 120.00	0.6000	0.6000
T10	25	7/8	100.00 - 120.00	0.6000	0.6000

Job	17159.10 - CT33XC089	Page	20 of 63
Project	U-40 x 280' - Haddam - Goose Hill, CT	Date	09:04:47 08/21/18
Client	Sprint	Designed by	TJL

Tower Section	Feed Line Record No.	Description	Feed Line Segment Elev.	K _a No Ice	K _a Ice
T10	26	7/8	100.00 - 120.00	0.6000	0.6000
T10	27	7/8	100.00 - 120.00	0.6000	0.6000
T10	28	7/8	100.00 - 116.00	0.6000	0.6000
T10	30	1/2	100.00 - 120.00	0.6000	0.6000
T10	31	1/2	100.00 - 120.00	0.6000	0.6000
T10	32	1/2	100.00 - 120.00	0.6000	0.6000
T10	33	E60	100.00 - 120.00	0.6000	0.6000
T10	34	EW63	100.00 - 120.00	0.6000	0.6000
T10	35	WE65	100.00 - 120.00	0.6000	0.6000
T10	36	EW63	100.00 - 120.00	0.6000	0.6000
T10	37	EW63	100.00 - 120.00	0.6000	0.6000
T10	38	HYBRIFLEX 1-5/8"	100.00 - 120.00	0.6000	0.6000
T11	1	Safety Line 3/8	80.00 - 100.00	0.6000	0.6000
T11	2	Lighting	80.00 - 100.00	0.6000	0.6000
T11	3	1 5/8	80.00 - 100.00	0.6000	0.6000
T11	4	HYBRIFLEX 1-1/4"	80.00 - 100.00	0.6000	0.6000
T11	5	EW63	80.00 - 100.00	0.6000	0.6000
T11	6	EW63	80.00 - 100.00	0.6000	0.6000
T11	7	EW63	80.00 - 100.00	0.6000	0.6000
T11	8	1 5/8	80.00 - 100.00	0.6000	0.6000
T11	9	1 5/8	80.00 - 100.00	0.6000	0.6000
T11	10	1 5/8	80.00 - 100.00	0.6000	0.6000
T11	11	1 5/8	80.00 - 100.00	0.6000	0.6000
T11	12	7/8	80.00 - 100.00	0.6000	0.6000
T11	13	7/8	80.00 - 100.00	0.6000	0.6000
T11	14	7/8	80.00 - 100.00	0.6000	0.6000
T11	15	7/8	80.00 - 100.00	0.6000	0.6000
T11	16	7/8	80.00 - 100.00	0.6000	0.6000
T11	17	EW63	80.00 - 100.00	0.6000	0.6000
T11	18	EW63	80.00 - 100.00	0.6000	0.6000
T11	19	EW63	80.00 - 100.00	0.6000	0.6000
T11	20	7/8	80.00 - 100.00	0.6000	0.6000
T11	21	7/8	80.00 - 100.00	0.6000	0.6000
T11	22	7/8	80.00 - 100.00	0.6000	0.6000
T11	23	1/2	80.00 - 100.00	0.6000	0.6000
T11	24	1 5/8	80.00 - 100.00	0.6000	0.6000
T11	25	7/8	80.00 - 100.00	0.6000	0.6000
T11	26	7/8	80.00 - 100.00	0.6000	0.6000
T11	27	7/8	80.00 - 100.00	0.6000	0.6000
T11	28	7/8	80.00 - 100.00	0.6000	0.6000
T11	30	1/2	80.00 - 100.00	0.6000	0.6000
T11	31	1/2	80.00 - 100.00	0.6000	0.6000
T11	32	1/2	80.00 - 100.00	0.6000	0.6000
T11	33	E60	80.00 - 100.00	0.6000	0.6000
T11	34	EW63	80.00 - 100.00	0.6000	0.6000
T11	35	WE65	80.00 - 100.00	0.6000	0.6000
T11	36	EW63	80.00 - 100.00	0.6000	0.6000
T11	37	EW63	80.00 - 100.00	0.6000	0.6000
T11	38	HYBRIFLEX 1-5/8"	80.00 - 100.00	0.6000	0.6000
T12	1	Safety Line 3/8	60.00 - 80.00	0.6000	0.6000

Job	17159.10 - CT33XC089	Page	21 of 63
Project	U-40 x 280' - Haddam - Goose Hill, CT	Date	09:04:47 08/21/18
Client	Sprint	Designed by	TJL

Tower Section	Feed Line Record No.	Description	Feed Line Segment Elev.	K _a No Ice	K _a Ice
T12	2	Lighting	60.00 - 80.00	0.6000	0.6000
T12	3	1 5/8	60.00 - 80.00	0.6000	0.6000
T12	4	HYBRIFLEX 1-1/4"	60.00 - 80.00	0.6000	0.6000
T12	5	EW63	60.00 - 80.00	0.6000	0.6000
T12	6	EW63	60.00 - 80.00	0.6000	0.6000
T12	7	EW63	60.00 - 80.00	0.6000	0.6000
T12	8	1 5/8	60.00 - 80.00	0.6000	0.6000
T12	9	1 5/8	60.00 - 80.00	0.6000	0.6000
T12	10	1 5/8	60.00 - 80.00	0.6000	0.6000
T12	11	1 5/8	60.00 - 80.00	0.6000	0.6000
T12	12	7/8	60.00 - 80.00	0.6000	0.6000
T12	13	7/8	60.00 - 80.00	0.6000	0.6000
T12	14	7/8	60.00 - 80.00	0.6000	0.6000
T12	15	7/8	60.00 - 80.00	0.6000	0.6000
T12	16	7/8	60.00 - 80.00	0.6000	0.6000
T12	17	EW63	60.00 - 80.00	0.6000	0.6000
T12	18	EW63	60.00 - 80.00	0.6000	0.6000
T12	19	EW63	60.00 - 80.00	0.6000	0.6000
T12	20	7/8	60.00 - 80.00	0.6000	0.6000
T12	21	7/8	60.00 - 80.00	0.6000	0.6000
T12	22	7/8	60.00 - 80.00	0.6000	0.6000
T12	23	1/2	60.00 - 80.00	0.6000	0.6000
T12	24	1 5/8	60.00 - 80.00	0.6000	0.6000
T12	25	7/8	60.00 - 80.00	0.6000	0.6000
T12	26	7/8	60.00 - 80.00	0.6000	0.6000
T12	27	7/8	60.00 - 80.00	0.6000	0.6000
T12	28	7/8	60.00 - 80.00	0.6000	0.6000
T12	30	1/2	60.00 - 80.00	0.6000	0.6000
T12	31	1/2	60.00 - 80.00	0.6000	0.6000
T12	32	1/2	60.00 - 80.00	0.6000	0.6000
T12	33	E60	60.00 - 80.00	0.6000	0.6000
T12	34	EW63	60.00 - 80.00	0.6000	0.6000
T12	35	WE65	60.00 - 80.00	0.6000	0.6000
T12	36	EW63	60.00 - 80.00	0.6000	0.6000
T12	37	EW63	60.00 - 80.00	0.6000	0.6000
T12	38	HYBRIFLEX 1-5/8"	60.00 - 80.00	0.6000	0.6000
T13	1	Safety Line 3/8	40.00 - 60.00	0.6000	0.6000
T13	2	Lighting	40.00 - 60.00	0.6000	0.6000
T13	3	1 5/8	40.00 - 60.00	0.6000	0.6000
T13	4	HYBRIFLEX 1-1/4"	40.00 - 60.00	0.6000	0.6000
T13	5	EW63	40.00 - 60.00	0.6000	0.6000
T13	6	EW63	40.00 - 60.00	0.6000	0.6000
T13	7	EW63	40.00 - 60.00	0.6000	0.6000
T13	8	1 5/8	40.00 - 60.00	0.6000	0.6000
T13	9	1 5/8	40.00 - 60.00	0.6000	0.6000
T13	10	1 5/8	40.00 - 60.00	0.6000	0.6000
T13	11	1 5/8	40.00 - 60.00	0.6000	0.6000
T13	12	7/8	40.00 - 60.00	0.6000	0.6000
T13	13	7/8	40.00 - 60.00	0.6000	0.6000
T13	14	7/8	40.00 - 60.00	0.6000	0.6000
T13	15	7/8	40.00 - 60.00	0.6000	0.6000
T13	16	7/8	40.00 - 60.00	0.6000	0.6000
T13	17	EW63	40.00 - 60.00	0.6000	0.6000
T13	18	EW63	40.00 - 60.00	0.6000	0.6000
T13	19	EW63	40.00 - 60.00	0.6000	0.6000
T13	20	7/8	40.00 - 60.00	0.6000	0.6000
T13	21	7/8	40.00 - 60.00	0.6000	0.6000
T13	22	7/8	40.00 - 60.00	0.6000	0.6000
T13	23	1/2	40.00 - 60.00	0.6000	0.6000
T13	24	1 5/8	40.00 - 60.00	0.6000	0.6000
T13	25	7/8	40.00 - 60.00	0.6000	0.6000
T13	26	7/8	40.00 - 60.00	0.6000	0.6000

Job	17159.10 - CT33XC089	Page	22 of 63
Project	U-40 x 280' - Haddam - Goose Hill, CT	Date	09:04:47 08/21/18
Client	Sprint	Designed by	TJL

Tower Section	Feed Line Record No.	Description	Feed Line Segment Elev.	K _a No Ice	K _a Ice
T13	27	7/8	40.00 - 60.00	0.6000	0.6000
T13	28	7/8	40.00 - 60.00	0.6000	0.6000
T13	29	7/8	40.00 - 55.00	0.6000	0.6000
T13	30	1/2	40.00 - 60.00	0.6000	0.6000
T13	31	1/2	40.00 - 60.00	0.6000	0.6000
T13	32	1/2	40.00 - 60.00	0.6000	0.6000
T13	33	E60	40.00 - 60.00	0.6000	0.6000
T13	34	EW63	40.00 - 60.00	0.6000	0.6000
T13	35	WE65	40.00 - 60.00	0.6000	0.6000
T13	36	EW63	40.00 - 60.00	0.6000	0.6000
T13	37	EW63	40.00 - 60.00	0.6000	0.6000
T13	38	HYBRIFLEX 1-5/8"	40.00 - 60.00	0.6000	0.6000
T14	1	Safety Line 3/8	20.00 - 40.00	0.6000	0.6000
T14	2	Lighting	20.00 - 40.00	0.6000	0.6000
T14	3	1 5/8	20.00 - 40.00	0.6000	0.6000
T14	4	HYBRIFLEX 1-1/4"	20.00 - 40.00	0.6000	0.6000
T14	5	EW63	20.00 - 40.00	0.6000	0.6000
T14	6	EW63	20.00 - 40.00	0.6000	0.6000
T14	7	EW63	20.00 - 40.00	0.6000	0.6000
T14	8	1 5/8	20.00 - 40.00	0.6000	0.6000
T14	9	1 5/8	20.00 - 40.00	0.6000	0.6000
T14	10	1 5/8	20.00 - 40.00	0.6000	0.6000
T14	11	1 5/8	20.00 - 40.00	0.6000	0.6000
T14	12	7/8	20.00 - 40.00	0.6000	0.6000
T14	13	7/8	20.00 - 40.00	0.6000	0.6000
T14	14	7/8	20.00 - 40.00	0.6000	0.6000
T14	15	7/8	20.00 - 40.00	0.6000	0.6000
T14	16	7/8	20.00 - 40.00	0.6000	0.6000
T14	17	EW63	20.00 - 40.00	0.6000	0.6000
T14	18	EW63	20.00 - 40.00	0.6000	0.6000
T14	19	EW63	20.00 - 40.00	0.6000	0.6000
T14	20	7/8	20.00 - 40.00	0.6000	0.6000
T14	21	7/8	20.00 - 40.00	0.6000	0.6000
T14	22	7/8	20.00 - 40.00	0.6000	0.6000
T14	23	1/2	20.00 - 40.00	0.6000	0.6000
T14	24	1 5/8	20.00 - 40.00	0.6000	0.6000
T14	25	7/8	20.00 - 40.00	0.6000	0.6000
T14	26	7/8	20.00 - 40.00	0.6000	0.6000
T14	27	7/8	20.00 - 40.00	0.6000	0.6000
T14	28	7/8	20.00 - 40.00	0.6000	0.6000
T14	29	7/8	20.00 - 40.00	0.6000	0.6000
T14	30	1/2	20.00 - 40.00	0.6000	0.6000
T14	31	1/2	20.00 - 40.00	0.6000	0.6000
T14	32	1/2	20.00 - 40.00	0.6000	0.6000
T14	33	E60	20.00 - 40.00	0.6000	0.6000
T14	34	EW63	20.00 - 40.00	0.6000	0.6000
T14	35	WE65	20.00 - 40.00	0.6000	0.6000
T14	36	EW63	20.00 - 40.00	0.6000	0.6000
T14	37	EW63	20.00 - 40.00	0.6000	0.6000
T14	38	HYBRIFLEX 1-5/8"	20.00 - 40.00	0.6000	0.6000
T15	1	Safety Line 3/8	0.00 - 20.00	0.6000	0.6000
T15	2	Lighting	0.00 - 20.00	0.6000	0.6000
T15	3	1 5/8	0.00 - 20.00	0.6000	0.6000
T15	4	HYBRIFLEX 1-1/4"	0.00 - 20.00	0.6000	0.6000
T15	5	EW63	0.00 - 20.00	0.6000	0.6000
T15	6	EW63	0.00 - 20.00	0.6000	0.6000
T15	7	EW63	0.00 - 20.00	0.6000	0.6000
T15	8	1 5/8	0.00 - 20.00	0.6000	0.6000
T15	9	1 5/8	0.00 - 20.00	0.6000	0.6000
T15	10	1 5/8	0.00 - 20.00	0.6000	0.6000
T15	11	1 5/8	0.00 - 20.00	0.6000	0.6000
T15	12	7/8	0.00 - 20.00	0.6000	0.6000

tnxTower Centek Engineering Inc. 63-2 North Branford Rd. Branford, CT 06405 Phone: (203) 488-0580 FAX: (203) 488-8587	Job 17159.10 - CT33XC089	Page 23 of 63
	Project U-40 x 280' - Haddam - Goose Hill, CT	Date 09:04:47 08/21/18
	Client Sprint	Designed by TJL

Tower Section	Feed Line Record No.	Description	Feed Line Segment Elev.	K _a No Ice	K _a Ice
T15	13	7/8	0.00 - 20.00	0.6000	0.6000
T15	14	7/8	0.00 - 20.00	0.6000	0.6000
T15	15	7/8	0.00 - 20.00	0.6000	0.6000
T15	16	7/8	0.00 - 20.00	0.6000	0.6000
T15	17	EW63	0.00 - 20.00	0.6000	0.6000
T15	18	EW63	0.00 - 20.00	0.6000	0.6000
T15	19	EW63	0.00 - 20.00	0.6000	0.6000
T15	20	7/8	0.00 - 20.00	0.6000	0.6000
T15	21	7/8	0.00 - 20.00	0.6000	0.6000
T15	22	7/8	0.00 - 20.00	0.6000	0.6000
T15	23	1/2	0.00 - 20.00	0.6000	0.6000
T15	24	1 5/8	0.00 - 20.00	0.6000	0.6000
T15	25	7/8	0.00 - 20.00	0.6000	0.6000
T15	26	7/8	0.00 - 20.00	0.6000	0.6000
T15	27	7/8	0.00 - 20.00	0.6000	0.6000
T15	28	7/8	0.00 - 20.00	0.6000	0.6000
T15	29	7/8	0.00 - 20.00	0.6000	0.6000
T15	30	1/2	0.00 - 20.00	0.6000	0.6000
T15	31	1/2	0.00 - 20.00	0.6000	0.6000
T15	32	1/2	0.00 - 20.00	0.6000	0.6000
T15	33	E60	0.00 - 20.00	0.6000	0.6000
T15	34	EW63	0.00 - 20.00	0.6000	0.6000
T15	35	WE65	0.00 - 20.00	0.6000	0.6000
T15	36	EW63	0.00 - 20.00	0.6000	0.6000
T15	37	EW63	0.00 - 20.00	0.6000	0.6000
T15	38	HYBRIFLEX 1-5/8"	0.00 - 20.00	0.6000	0.6000

Discrete Tower Loads

Description	Face or Leg	Offset Type	Offsets: Horz Lateral Vert	Azimuth Adjustment	Placement	C _{AA} Front	C _{AA} Side	Weight	
			ft	°	ft	ft ²	ft ²	K	
Beacon Extender (4') 803062	B	From Leg	0.00	0.0000	280.00	No Ice	1.11	1.11	0.03
			0.00			1/2" Ice	1.32	1.32	0.04
			2.00			1" Ice	1.54	1.53	0.05
Beacon	B	From Leg	0.00	0.0000	280.00	No Ice	2.40	2.40	0.07
			0.00			1/2" Ice	2.67	2.67	0.10
			4.00			1" Ice	2.96	2.96	0.12
DB538 (Eversource)	B	From Leg	0.00	0.0000	279.00	No Ice	2.25	2.25	0.01
			0.00			1/2" Ice	4.46	4.46	0.02
			7.00			1" Ice	6.69	6.69	0.03
DB589-Y (Eversource)	B	From Leg	6.00	0.0000	260.00	No Ice	1.83	1.83	0.01
			0.00			1/2" Ice	2.75	2.75	0.03
			5.00			1" Ice	3.67	3.67	0.05
DB589-Y (Eversource)	B	From Leg	6.00	0.0000	260.00	No Ice	1.83	1.83	0.01
			0.00			1/2" Ice	2.75	2.75	0.03
			-5.00			1" Ice	3.67	3.67	0.05
TMA (12"x16"x6") (Eversource)	B	From Leg	6.00	0.0000	260.00	No Ice	2.53	1.20	0.02
			0.00			1/2" Ice	2.71	1.33	0.04
			0.00			1" Ice	2.89	1.46	0.06
6' Pivot Side Arm (50" pipe)	B	From Leg	3.00	0.0000	260.00	No Ice	1.91	3.93	0.13

tnxTower Centek Engineering Inc. 63-2 North Branford Rd. Branford, CT 06405 Phone: (203) 488-0580 FAX: (203) 488-8587	Job	17159.10 - CT33XC089	Page	24 of 63
	Project	U-40 x 280' - Haddam - Goose Hill, CT	Date	09:04:47 08/21/18
	Client	Sprint	Designed by	TJL

Description	Face or Leg	Offset Type	Offsets:		Azimuth Adjustment	Placement	C _{AA} Front	C _{AA} Side	Weight	
			Horz	Vert						
			ft	ft	°	ft	ft ²	ft ²	K	
(Eversource)			0.00				1/2" Ice	2.67	4.99	0.17
			0.00				1" Ice	3.20	5.86	0.22
SD110-SFXPASNM	B	From Leg	6.00		0.0000	241.00	No Ice	2.43	2.43	0.03
(Eversource)			0.00				1/2" Ice	4.46	4.46	0.04
			8.00				1" Ice	6.51	6.51	0.05
6' Pivot Side Arm (50" pipe)	B	From Leg	3.00		0.0000	241.00	No Ice	1.91	3.93	0.13
(Eversource)			0.00				1/2" Ice	2.67	4.99	0.17
			0.00				1" Ice	3.20	5.86	0.22
ANT450F10	B	From Leg	0.00		0.0000	216.00	No Ice	5.59	5.59	0.04
(VSC)			0.00				1/2" Ice	7.63	7.63	0.08
			10.00				1" Ice	9.66	9.66	0.13
6' Pivot Side Arm (50" pipe)	B	From Leg	3.00		0.0000	216.00	No Ice	1.91	3.93	0.13
(VSC)			0.00				1/2" Ice	2.67	4.99	0.17
			0.00				1" Ice	3.20	5.86	0.22
TMA (12"x16"x6")	B	From Leg	6.00		0.0000	200.00	No Ice	2.53	1.20	0.02
(CSP)			0.00				1/2" Ice	2.71	1.33	0.04
			0.00				1" Ice	2.89	1.46	0.06
SC479	B	From Leg	6.00		0.0000	200.00	No Ice	4.23	4.23	0.03
(CSP)			0.00				1/2" Ice	6.54	6.54	0.07
			7.00				1" Ice	8.04	8.04	0.11
SC479	B	From Leg	6.00		0.0000	200.00	No Ice	4.23	4.23	0.03
(CSP)			0.00				1/2" Ice	6.54	6.54	0.07
			-7.00				1" Ice	8.04	8.04	0.11
6' Pivot Side Arm (50" pipe)	B	From Leg	3.00		0.0000	200.00	No Ice	1.91	3.93	0.13
(CSP)			0.00				1/2" Ice	2.67	4.99	0.17
			0.00				1" Ice	3.20	5.86	0.22
SC479	B	From Leg	6.00		0.0000	200.00	No Ice	4.23	4.23	0.03
(CSP)			0.00				1/2" Ice	6.54	6.54	0.07
			-7.00				1" Ice	8.04	8.04	0.11
3' Pivot Side Arm (50" pipe)	B	From Leg	1.50		0.0000	200.00	No Ice	1.91	2.49	0.11
(CSP)			0.00				1/2" Ice	2.70	3.30	0.13
			0.00				1" Ice	3.27	3.97	0.17
SC479	B	From Leg	6.00		0.0000	175.00	No Ice	4.29	4.29	0.03
(CSP)			0.00				1/2" Ice	6.54	6.54	0.07
			7.00				1" Ice	8.04	8.04	0.11
SC479	B	From Leg	6.00		0.0000	175.00	No Ice	4.29	4.29	0.03
(CSP)			0.00				1/2" Ice	6.54	6.54	0.07
			-7.00				1" Ice	8.04	8.04	0.11
6' Pivot Side Arm (50" pipe)	B	From Leg	3.00		0.0000	175.00	No Ice	1.91	3.93	0.13
(CSP)			0.00				1/2" Ice	2.67	4.99	0.17
			0.00				1" Ice	3.20	5.86	0.22
PR-950	A	From Leg	3.00		0.0000	126.00	No Ice	6.35	6.35	0.04
(VSC)			0.00				1/2" Ice	11.43	11.43	0.05
			0.00				1" Ice	16.51	16.51	0.06
6' Pivot Side Arm (50" pipe)	A	From Leg	3.00		0.0000	126.00	No Ice	1.91	3.93	0.13
(VSC)			0.00				1/2" Ice	2.67	4.99	0.17
			0.00				1" Ice	3.20	5.86	0.22
ANT150F6 -138-151 MHZ	C	From Leg	0.00		0.0000	279.00	No Ice	5.87	5.87	0.03
(Eversource)			0.00				1/2" Ice	8.00	8.00	0.07
			10.00				1" Ice	10.13	10.13	0.13
DB212-1-C	C	From Leg	6.00		0.0000	255.00	No Ice	2.61	2.61	0.01
(Eversource)			0.00				1/2" Ice	5.38	5.38	0.03
			0.00				1" Ice	8.18	8.18	0.05
6' Pivot Side Arm (50" pipe)	C	From Leg	3.00		0.0000	255.00	No Ice	1.91	3.93	0.13
(Eversource)			0.00				1/2" Ice	2.67	4.99	0.17
			0.00				1" Ice	3.20	5.86	0.22
TMA (12"x16"x6")	C	From Leg	6.00		0.0000	235.00	No Ice	2.53	1.20	0.02

tnxTower Centek Engineering Inc. 63-2 North Branford Rd. Branford, CT 06405 Phone: (203) 488-0580 FAX: (203) 488-8587	Job	17159.10 - CT33XC089	Page	25 of 63
	Project	U-40 x 280' - Haddam - Goose Hill, CT	Date	09:04:47 08/21/18
	Client	Sprint	Designed by	TJL

Description	Face or Leg	Offset Type	Offsets:		Azimuth Adjustment	Placement	C _{AA} Front	C _{AA} Side	Weight
			Horz	Vert					
			ft	ft	°	ft	ft ²	ft ²	K
(CSP)			0.00			1/2" Ice	2.71	1.33	0.04
			0.00			1" Ice	2.89	1.46	0.06
SE419-SF3P4LDF	C	From Leg	6.00		0.0000	No Ice	4.12	0.04	0.04
(CSP)			0.00			1/2" Ice	5.11	1.00	0.05
			5.00			1" Ice	6.08	1.97	0.07
SE419-SF3P4LDF	C	From Leg	6.00		0.0000	No Ice	4.12	0.04	0.04
(CSP)			0.00			1/2" Ice	5.11	1.00	0.05
			-5.00			1" Ice	6.08	1.97	0.07
6' Pivot Side Arm (50" pipe)	C	From Leg	3.00		0.0000	No Ice	1.91	3.93	0.13
(CSP)			0.00			1/2" Ice	2.67	4.99	0.17
			0.00			1" Ice	3.20	5.86	0.22
ANT900D6-9	C	From Leg	3.00		0.0000	No Ice	1.39	1.39	0.01
(CSP)			0.00			1/2" Ice	2.03	2.03	0.03
			5.00			1" Ice	2.69	2.69	0.05
3' Pivot Side Arm (50" pipe)	C	From Leg	1.50		0.0000	No Ice	1.91	2.49	0.11
(CSP)			0.00			1/2" Ice	2.70	3.30	0.13
			0.00			1" Ice	3.27	3.97	0.17
ANT450F6	C	From Leg	3.00		0.0000	No Ice	1.86	1.86	0.02
(Town of Haddam)			0.00			1/2" Ice	2.67	2.67	0.04
			5.00			1" Ice	3.30	3.30	0.05
3' Pivot Side Arm (50" pipe)	C	From Leg	1.50		0.0000	No Ice	1.91	2.49	0.11
(Town of Haddam)			0.00			1/2" Ice	2.70	3.30	0.13
			0.00			1" Ice	3.27	3.97	0.17
KRECO CO-36A	C	From Leg	0.00		0.0000	No Ice	5.87	5.87	0.03
(VSC)			0.00			1/2" Ice	8.00	8.00	0.07
			7.00			1" Ice	10.13	10.13	0.13
6' Pivot Side Arm (50" pipe)	C	From Leg	3.00		0.0000	No Ice	1.91	3.93	0.13
(VSC)			0.00			1/2" Ice	2.67	4.99	0.17
			0.00			1" Ice	3.20	5.86	0.22
3' Pivot Side Arm (50" pipe)	C	From Leg	1.50		0.0000	No Ice	1.91	2.49	0.11
(VSC)			0.00			1/2" Ice	2.70	3.30	0.13
			0.00			1" Ice	3.27	3.97	0.17
APXVTM14	A	From Leg	3.00		0.0000	No Ice	6.34	3.61	0.06
(Sprint - Proposed)			4.00			1/2" Ice	6.72	3.97	0.10
			0.00			1" Ice	7.10	4.33	0.14
NNVV-65B-R4	A	From Leg	3.00		0.0000	No Ice	14.61	9.17	0.11
(Sprint - Proposed)			-4.00			1/2" Ice	15.13	9.63	0.21
			0.00			1" Ice	15.65	10.11	0.32
APXVTM14	B	From Leg	3.00		0.0000	No Ice	6.34	3.61	0.06
(Sprint - Proposed)			4.00			1/2" Ice	6.72	3.97	0.10
			0.00			1" Ice	7.10	4.33	0.14
NNVV-65B-R4	B	From Leg	3.00		0.0000	No Ice	14.61	9.17	0.11
(Sprint - Proposed)			-4.00			1/2" Ice	15.13	9.63	0.21
			0.00			1" Ice	15.65	10.11	0.32
APXVTM14	C	From Leg	3.00		0.0000	No Ice	6.34	3.61	0.06
(Sprint - Proposed)			4.00			1/2" Ice	6.72	3.97	0.10
			0.00			1" Ice	7.10	4.33	0.14
NNVV-65B-R4	C	From Leg	3.00		0.0000	No Ice	14.61	9.17	0.11
(Sprint - Proposed)			-4.00			1/2" Ice	15.13	9.63	0.21
			0.00			1" Ice	15.65	10.11	0.32
TD-RRH8x20-25	A	From Leg	3.00		0.0000	No Ice	4.05	1.53	0.07
(Sprint - Proposed)			4.00			1/2" Ice	4.30	1.71	0.10
			0.00			1" Ice	4.56	1.90	0.13
TD-RRH8x20-25	B	From Leg	3.00		0.0000	No Ice	4.05	1.53	0.07
(Sprint - Proposed)			4.00			1/2" Ice	4.30	1.71	0.10
			0.00			1" Ice	4.56	1.90	0.13
TD-RRH8x20-25	C	From Leg	3.00		0.0000	No Ice	4.05	1.53	0.07

tnxTower Centek Engineering Inc. 63-2 North Branford Rd. Branford, CT 06405 Phone: (203) 488-0580 FAX: (203) 488-8587	Job	17159.10 - CT33XC089	Page	26 of 63
	Project	U-40 x 280' - Haddam - Goose Hill, CT	Date	09:04:47 08/21/18
	Client	Sprint	Designed by	TJL

Description	Face or Leg	Offset Type	Offsets:		Azimuth Adjustment	Placement	C _{AA} Front	C _{AA} Side	Weight
			Horz	Vert					
			ft	ft	°	ft	ft ²	ft ²	K
(Sprint - Proposed)			4.00			1/2" Ice	4.30	1.71	0.10
			0.00			1" Ice	4.56	1.90	0.13
FD-RRH 4x45 1900	A	From Leg	3.00		0.0000	No Ice	2.32	2.38	0.06
(Sprint - Proposed)			2.00			1/2" Ice	2.52	2.59	0.08
			0.00			1" Ice	2.74	2.80	0.11
FD-RRH 4x45 1900	B	From Leg	3.00		0.0000	No Ice	2.32	2.38	0.06
(Sprint - Proposed)			2.00			1/2" Ice	2.52	2.59	0.08
			0.00			1" Ice	2.74	2.80	0.11
FD-RRH 4x45 1900	C	From Leg	3.00		0.0000	No Ice	2.32	2.38	0.06
(Sprint - Proposed)			2.00			1/2" Ice	2.52	2.59	0.08
			0.00			1" Ice	2.74	2.80	0.11
(2) FD-RRH 2x50 800	A	From Leg	3.00		0.0000	No Ice	2.06	1.93	0.06
(Sprint - Proposed)			-4.00			1/2" Ice	2.24	2.11	0.09
			0.00			1" Ice	2.43	2.29	0.11
(2) FD-RRH 2x50 800	B	From Leg	3.00		0.0000	No Ice	2.06	1.93	0.06
(Sprint - Proposed)			-4.00			1/2" Ice	2.24	2.11	0.09
			0.00			1" Ice	2.43	2.29	0.11
(2) FD-RRH 2x50 800	C	From Leg	3.00		0.0000	No Ice	2.06	1.93	0.06
(Sprint - Proposed)			-4.00			1/2" Ice	2.24	2.11	0.09
			0.00			1" Ice	2.43	2.29	0.11
12' V Frame	A	From Leg	3.00		0.0000	No Ice	9.22	3.08	0.30
(Sprint)			0.00			1/2" Ice	12.97	6.17	0.39
			0.00			1" Ice	16.66	8.88	0.52
12' V Frame	C	From Leg	3.00		0.0000	No Ice	9.22	3.08	0.30
(Sprint)			0.00			1/2" Ice	12.97	6.17	0.39
			0.00			1" Ice	16.66	8.88	0.52
12' V Frame	B	From Leg	3.00		0.0000	No Ice	9.22	3.08	0.30
(Sprint)			0.00			1/2" Ice	12.97	6.17	0.39
			0.00			1" Ice	16.66	8.88	0.52
LNx-6515DS	A	From Leg	3.00		0.0000	No Ice	11.45	7.70	0.06
(Verizon)			-6.00			1/2" Ice	12.06	8.29	0.12
			0.00			1" Ice	12.69	8.89	0.19
HBXX-6517DS	A	From Leg	3.00		0.0000	No Ice	8.53	5.24	0.05
(Verizon)			-4.00			1/2" Ice	9.00	5.71	0.10
			0.00			1" Ice	9.48	6.18	0.16
LNx-6515DS	A	From Leg	3.00		0.0000	No Ice	11.45	7.70	0.06
(Verizon)			0.00			1/2" Ice	12.06	8.29	0.12
			0.00			1" Ice	12.69	8.89	0.19
HBXX-6517DS	A	From Leg	3.00		0.0000	No Ice	8.53	5.24	0.05
(Verizon)			4.00			1/2" Ice	9.00	5.71	0.10
			0.00			1" Ice	9.48	6.18	0.16
LNx-6515DS	B	From Leg	3.00		0.0000	No Ice	11.45	7.70	0.06
(Verizon)			-6.00			1/2" Ice	12.06	8.29	0.12
			0.00			1" Ice	12.69	8.89	0.19
HBXX-6517DS	B	From Leg	3.00		0.0000	No Ice	8.53	5.24	0.05
(Verizon)			-4.00			1/2" Ice	9.00	5.71	0.10
			0.00			1" Ice	9.48	6.18	0.16
LNx-6515DS	B	From Leg	3.00		0.0000	No Ice	11.45	7.70	0.06
(Verizon)			0.00			1/2" Ice	12.06	8.29	0.12
			0.00			1" Ice	12.69	8.89	0.19
HBXX-6517DS	B	From Leg	3.00		0.0000	No Ice	8.53	5.24	0.05
(Verizon)			4.00			1/2" Ice	9.00	5.71	0.10
			0.00			1" Ice	9.48	6.18	0.16
LNx-6515DS	C	From Leg	3.00		0.0000	No Ice	11.45	7.70	0.06
(Verizon)			-6.00			1/2" Ice	12.06	8.29	0.12
			0.00			1" Ice	12.69	8.89	0.19
HBXX-6517DS	C	From Leg	3.00		0.0000	No Ice	8.53	5.24	0.05

tnxTower Centek Engineering Inc. 63-2 North Branford Rd. Branford, CT 06405 Phone: (203) 488-0580 FAX: (203) 488-8587	Job		17159.10 - CT33XC089					Page		
	Project		U-40 x 280' - Haddam - Goose Hill, CT					Date		
	Client		Sprint					Designed by		
									TJL	

Description	Face or Leg	Offset Type	Offsets:		Azimuth Adjustment	Placement	C _{AA} Front	C _{AA} Side	Weight
			Horz	Lateral					
(Verizon)			-4.00						0.10
			0.00			1/2" Ice	9.00	5.71	0.16
			0.00			1" Ice	9.48	6.18	0.16
LNx-6515DS	C	From Leg	3.00	0.0000	145.00	No Ice	11.45	7.70	0.06
(Verizon)			0.00			1/2" Ice	12.06	8.29	0.12
			0.00			1" Ice	12.69	8.89	0.19
HBXX-6517DS	C	From Leg	3.00	0.0000	145.00	No Ice	8.53	5.24	0.05
(Verizon)			4.00			1/2" Ice	9.00	5.71	0.10
			0.00			1" Ice	9.48	6.18	0.16
B25 RRH4x30	A	From Leg	3.00	0.0000	145.00	No Ice	2.11	1.29	0.06
(Verizon)			-4.00			1/2" Ice	2.30	1.45	0.07
			0.00			1" Ice	2.50	1.61	0.09
B25 RRH4x30	B	From Leg	3.00	0.0000	145.00	No Ice	2.11	1.29	0.06
(Verizon)			-4.00			1/2" Ice	2.30	1.45	0.07
			0.00			1" Ice	2.50	1.61	0.09
B25 RRH4x30	C	From Leg	3.00	0.0000	145.00	No Ice	2.11	1.29	0.06
(Verizon)			-4.00			1/2" Ice	2.30	1.45	0.07
			0.00			1" Ice	2.50	1.61	0.09
RRH4x30-B13	A	From Leg	3.00	0.0000	145.00	No Ice	2.16	1.62	0.06
(Verizon)			-4.00			1/2" Ice	2.35	1.79	0.08
			0.00			1" Ice	2.55	1.97	0.10
RRH4x30-B13	B	From Leg	3.00	0.0000	145.00	No Ice	2.16	1.62	0.06
(Verizon)			-4.00			1/2" Ice	2.35	1.79	0.08
			0.00			1" Ice	2.55	1.97	0.10
RRH4x30-B13	C	From Leg	3.00	0.0000	145.00	No Ice	2.16	1.62	0.06
(Verizon)			-4.00			1/2" Ice	2.35	1.79	0.08
			0.00			1" Ice	2.55	1.97	0.10
RRH4x45/2x90-AWS	A	From Leg	3.00	0.0000	145.00	No Ice	2.58	1.69	0.08
(Verizon)			-4.00			1/2" Ice	2.79	1.87	0.10
			0.00			1" Ice	3.01	2.06	0.12
RRH4x45/2x90-AWS	B	From Leg	3.00	0.0000	145.00	No Ice	2.58	1.69	0.08
(Verizon)			-4.00			1/2" Ice	2.79	1.87	0.10
			0.00			1" Ice	3.01	2.06	0.12
RRH4x45/2x90-AWS	C	From Leg	3.00	0.0000	145.00	No Ice	2.58	1.69	0.08
(Verizon)			-4.00			1/2" Ice	2.79	1.87	0.10
			0.00			1" Ice	3.01	2.06	0.12
DB-T1-6Z-8AB-0Z	A	From Leg	3.00	0.0000	145.00	No Ice	4.80	2.00	0.04
(Verizon)			0.00			1/2" Ice	5.07	2.19	0.08
			0.00			1" Ice	5.35	2.39	0.12
DB-T1-6Z-8AB-0Z	B	From Leg	3.00	0.0000	145.00	No Ice	4.80	2.00	0.04
(Verizon)			0.00			1/2" Ice	5.07	2.19	0.08
			0.00			1" Ice	5.35	2.39	0.12
DB-T1-6Z-8AB-0Z	B	From Leg	3.00	0.0000	145.00	No Ice	4.80	2.00	0.04
(Verizon)			0.00			1/2" Ice	5.07	2.19	0.08
			0.00			1" Ice	5.35	2.39	0.12
12' V Frame	A	From Leg	3.00	0.0000	145.00	No Ice	9.22	3.08	0.30
(Verizon)			0.00			1/2" Ice	12.97	6.17	0.39
			0.00			1" Ice	16.66	8.88	0.52
12' V Frame	B	From Leg	3.00	0.0000	145.00	No Ice	9.22	3.08	0.30
(Verizon)			0.00			1/2" Ice	12.97	6.17	0.39
			0.00			1" Ice	16.66	8.88	0.52
12' V Frame	C	From Leg	3.00	0.0000	145.00	No Ice	9.22	3.08	0.30
(Verizon)			0.00			1/2" Ice	12.97	6.17	0.39
			0.00			1" Ice	16.66	8.88	0.52
1142-2C	A	From Leg	0.00	0.0000	279.00	No Ice	2.09	2.09	0.02
(VSC)			0.00			1/2" Ice	3.37	3.37	0.04
			8.00			1" Ice	4.67	4.67	0.07
10' Dipole	A	From Leg	3.00	0.0000	261.00	No Ice	4.00	4.00	0.05

tnxTower Centek Engineering Inc. 63-2 North Branford Rd. Branford, CT 06405 Phone: (203) 488-0580 FAX: (203) 488-8587	Job		17159.10 - CT33XC089				Page		28 of 63
	Project		U-40 x 280' - Haddam - Goose Hill, CT				Date		09:04:47 08/21/18
	Client		Sprint				Designed by		TJL

Description	Face or Leg	Offset Type	Offsets:		Azimuth Adjustment	Placement	C _{AA} Front	C _{AA} Side	Weight
			Horz	Vert					
			ft	ft	°	ft	ft ²	ft ²	K
(VSC)			0.00			1/2" Ice	6.00	6.00	0.07
			5.00			1" Ice	8.00	8.00	0.10
6' Pivot Side Arm (50" pipe)	A	From Leg	3.00		0.0000	No Ice	1.91	3.93	0.13
(VSC)			0.00			1/2" Ice	2.67	4.99	0.17
			0.00			1" Ice	3.20	5.86	0.22
KRECO CO-36A	A	From Leg	0.00		0.0000	No Ice	5.87	5.87	0.03
(Eversource)			0.00			1/2" Ice	8.00	8.00	0.07
			7.00			1" Ice	10.13	10.13	0.13
6' Pivot Side Arm (50" pipe)	A	From Leg	3.00		0.0000	No Ice	1.91	3.93	0.13
(Eversource)			0.00			1/2" Ice	2.67	4.99	0.17
			0.00			1" Ice	3.20	5.86	0.22
531-70HD	A	From Leg	6.00		0.0000	No Ice	6.00	6.00	0.04
(Eversource)			0.00			1/2" Ice	6.90	6.90	0.05
			0.00			1" Ice	7.80	7.80	0.06
3' Pivot Side Arm (50" pipe)	A	From Leg	1.50		0.0000	No Ice	1.91	2.49	0.11
(Eversource)			0.00			1/2" Ice	2.70	3.30	0.13
			0.00			1" Ice	3.27	3.97	0.17
SD110-SFXPASNM	A	From Leg	6.00		0.0000	No Ice	2.43	2.43	0.03
(Eversource)			0.00			1/2" Ice	4.46	4.46	0.04
			0.00			1" Ice	6.51	6.51	0.05
6' Pivot Side Arm (50" pipe)	A	From Leg	3.00		0.0000	No Ice	1.91	3.93	0.13
(Eversource)			0.00			1/2" Ice	2.67	4.99	0.17
			0.00			1" Ice	3.20	5.86	0.22
BCR-80010-90	A	From Leg	6.00		0.0000	No Ice	4.86	4.86	0.04
(CSP)			0.00			1/2" Ice	5.99	5.99	0.07
			5.00			1" Ice	6.66	6.66	0.11
BCD-80609	A	From Leg	6.00		0.0000	No Ice	2.95	2.95	0.03
(CSP)			0.00			1/2" Ice	4.08	4.08	0.05
			-5.00			1" Ice	5.21	5.21	0.08
TMA (12"x16"x6")	A	From Leg	6.00		0.0000	No Ice	2.53	1.20	0.02
(CSP)			0.00			1/2" Ice	2.71	1.33	0.04
			0.00			1" Ice	2.89	1.46	0.06
3' Pivot Side Arm (50" pipe)	A	From Leg	1.50		0.0000	No Ice	1.91	2.49	0.11
(CSP)			0.00			1/2" Ice	2.70	3.30	0.13
			0.00			1" Ice	3.27	3.97	0.17
ANT450F6	A	From Leg	6.00		0.0000	No Ice	1.86	1.86	0.02
(VSC)			0.00			1/2" Ice	2.67	2.67	0.04
			0.00			1" Ice	3.30	3.30	0.05
6' Pivot Side Arm (50" pipe)	A	From Leg	3.00		0.0000	No Ice	1.91	3.93	0.13
(VSC)			0.00			1/2" Ice	2.67	4.99	0.17
			0.00			1" Ice	3.20	5.86	0.22
BR-6155	A	From Leg	1.50		0.0000	No Ice	1.90	1.90	0.01
(VSC)			0.00			1/2" Ice	2.29	2.29	0.02
			3.00			1" Ice	2.68	2.68	0.04
ANT400D	A	From Leg	3.00		0.0000	No Ice	0.34	0.34	0.01
(CSP)			0.00			1/2" Ice	0.40	0.40	0.18
			-1.00			1" Ice	0.46	0.46	0.34
3' Pivot Side Arm (50" pipe)	A	From Leg	1.50		0.0000	No Ice	1.91	2.49	0.11
(VSC/CSP)			0.00			1/2" Ice	2.70	3.30	0.13
			0.00			1" Ice	3.27	3.97	0.17
BR-6155	A	From Leg	1.50		0.0000	No Ice	1.90	1.90	0.01
(VSC)			0.00			1/2" Ice	2.29	2.29	0.02
			3.00			1" Ice	2.68	2.68	0.04
3' Pivot Side Arm (50" pipe)	A	From Leg	1.50		0.0000	No Ice	1.91	2.49	0.11
(VSC)			0.00			1/2" Ice	2.70	3.30	0.13
			0.00			1" Ice	3.27	3.97	0.17
5-ft dipole	A	From Leg	3.00		0.0000	No Ice	2.70	2.70	0.01

tnxTower Centek Engineering Inc. 63-2 North Branford Rd. Branford, CT 06405 Phone: (203) 488-0580 FAX: (203) 488-8587	Job 17159.10 - CT33XC089	Page 29 of 63
	Project U-40 x 280' - Haddam - Goose Hill, CT	Date 09:04:47 08/21/18
	Client Sprint	Designed by TJL

Description	Face or Leg	Offset Type	Offsets:		Azimuth Adjustment	Placement	C _{AA} Front	C _{AA} Side	Weight
			Horz	Lateral					
			ft	ft	°	ft	ft ²	ft ²	K
(CSP)			0.00			1/2" Ice	4.50	4.50	0.03
			0.00			1" Ice	6.30	6.30	0.04
3' Pivot Side Arm (50" pipe)	A	From Leg	1.50		0.0000	No Ice	1.91	2.49	0.11
(CSP)			0.00			1/2" Ice	2.70	3.30	0.13
			0.00			1" Ice	3.27	3.97	0.17
ANT790F2	A	From Leg	6.00		0.0000	No Ice	0.69	0.69	0.01
			0.00			1/2" Ice	0.89	0.89	0.01
			0.00			1" Ice	1.10	1.10	0.02
3' Pivot Side Arm (50" pipe)	A	From Leg	1.50		0.0000	No Ice	1.91	2.49	0.11
			0.00			1/2" Ice	2.70	3.30	0.13
			0.00			1" Ice	3.27	3.97	0.17

Dishes

Description	Face or Leg	Dish Type	Offset Type	Offsets:		Azimuth Adjustment	3 dB Beam Width	Elevation	Outside Diameter	Aperture Area	Weight	
				Horz	Lateral							
				ft	ft	°	°	ft	ft	ft ²	K	
8' Solid w/ Radome (Eversource)	C	Paraboloid w/Radome	From Leg	1.00		0.0000		276.00	8.00	No Ice	50.27	0.30
				0.00						1/2" Ice	51.32	0.62
				0.00						1" Ice	52.37	0.94
8' Solid w/ Radome (Eversource)	B	Paraboloid w/Radome	From Leg	1.00		0.0000		276.00	8.00	No Ice	50.27	0.30
				0.00						1/2" Ice	51.32	0.62
				0.00						1" Ice	52.37	0.94
8' Solid w/ Radome (Eversource)	A	Paraboloid w/Radome	From Leg	1.00		0.0000		276.00	8.00	No Ice	50.27	0.30
				0.00						1/2" Ice	51.32	0.62
				0.00						1" Ice	52.37	0.94
8' Solid w/ Radome (Eversource)	C	Paraboloid w/Radome	From Leg	1.00		0.0000		266.00	8.00	No Ice	50.27	0.30
				0.00						1/2" Ice	51.32	0.62
				0.00						1" Ice	52.37	0.94
6' Dish (Eversource - Proposed)	C	Paraboloid w/o Radome	From Leg	1.00		0.0000		240.00	6.00	No Ice	28.27	0.08
				0.00						1/2" Ice	29.07	0.10
				0.00						1" Ice	29.87	0.12
8' Solid w/ Radome (Eversource)	C	Paraboloid w/Radome	From Leg	1.00		0.0000		230.00	8.00	No Ice	50.27	0.30
				0.00						1/2" Ice	51.32	0.62
				0.00						1" Ice	52.37	0.94
8' Solid w/ Radome (Eversource)	C	Paraboloid w/Radome	From Leg	1.00		0.0000		220.00	8.00	No Ice	50.27	0.30
				0.00						1/2" Ice	51.32	0.62
				0.00						1" Ice	52.37	0.94
10' Solid w/ Radome (Eversource)	A	Paraboloid w/Radome	From Leg	1.00		0.0000		205.50	10.00	No Ice	78.54	0.40
				0.00						1/2" Ice	79.85	0.81
				0.00						1" Ice	81.17	1.22
6' Solid w/ Radome (CSP)	A	Paraboloid w/Radome	From Leg	1.00		0.0000		197.00	6.00	No Ice	28.27	0.16
				0.00						1/2" Ice	29.07	0.32
				0.00						1" Ice	32.82	0.49
10' Solid w/ Radome (CSP)	C	Paraboloid w/Radome	From Leg	1.00		0.0000		195.00	10.00	No Ice	78.54	0.40
				0.00						1/2" Ice	79.85	0.81
				0.00						1" Ice	81.17	1.22
6' Solid w/ Radome (CSP)	C	Paraboloid w/Radome	From Leg	1.00		0.0000		163.00	6.00	No Ice	28.27	0.16
				0.00						1/2" Ice	29.07	0.32

tnxTower Centek Engineering Inc. 63-2 North Branford Rd. Branford, CT 06405 Phone: (203) 488-0580 FAX: (203) 488-8587	Job	17159.10 - CT33XC089	Page	30 of 63
	Project	U-40 x 280' - Haddam - Goose Hill, CT	Date	09:04:47 08/21/18
	Client	Sprint	Designed by	TJL

Description	Face or Leg	Dish Type	Offset Type	Offsets: Horz Lateral Vert ft	Azimuth Adjustment °	3 dB Beam Width °	Elevation ft	Outside Diameter ft	Aperture Area ft ²	Weight K
SBX4-W60 (Eversource)	C	Paraboloid w/Radome	From Leg	0.00 1.00 0.00	0.0000		123.00	4.00	1" Ice 32.82 No Ice 12.57 1/2" Ice 13.10	0.49 0.08 0.14
6' Solid w/ Radome (Eversource)	B	Paraboloid w/Radome	From Leg	0.00 1.00 0.00	0.0000		104.00	6.00	1" Ice 13.62 No Ice 28.27 1/2" Ice 29.07	0.21 0.16 0.32
6' Grid Dish (VSC)	C	Grid	From Leg	0.00 0.50 0.00 0.00	0.0000		117.00	6.00	1" Ice 32.82 No Ice 28.27 1/2" Ice 29.07 1" Ice 29.86	0.49 0.08 0.23 0.38

Truss-Leg Properties

Section Designation	Area in ²	Area Ice in ²	Self Weight K	Ice Weight K	Equiv. Diameter in	Equiv. Diameter Ice in	Leg Area in ²
#12ZG - 1.25" - 1.00" conn. (Pirod 207628)	2175.9279	6554.9782	0.47	2.50	7.5553	22.7603	3.6816
#12ZG - 1.25" - 1.00" conn. (Pirod 207628)	2175.9279	6542.3611	0.47	2.49	7.5553	22.7165	3.6816
#12ZG - 1.25" - 1.00" conn. (Pirod 207628)	2175.9279	6528.8005	0.47	2.48	7.5553	22.6694	3.6816
#12ZG - 1.75" - 1.00" conn. (Pirod 195557)	2421.2670	6661.9148	0.71	2.56	8.4072	23.1316	7.2158
#12ZG - 1.75" - 1.00" conn. (Pirod 195557)	2421.2670	6654.2712	0.71	2.56	8.4072	23.1051	7.2158
#12ZG -2.00" - 0.875" conn.-Trans (Pirod 211843)	2550.9192	6714.1518	1.05	2.59	8.8574	23.3130	9.4248
#12ZG -2.25" - 0.875" conn. (Pirod 208334)	2686.5516	6768.5770	1.22	2.62	9.3283	23.5020	11.9282
#12ZG -2.25" - 0.875" conn. (Pirod 208334)	2686.5516	6749.0323	1.22	2.61	9.3283	23.4341	11.9282
#12ZG - 2.50" - 0.875" conn. (Pirod 208335)	2826.7749	6798.9842	1.42	2.63	9.8152	23.6076	14.7262
#12ZG -2.75"-0.875 -DB-0.625"-HP- (Pirod 238706)	3044.1575	6845.6415	1.69	2.65	10.5700	23.7696	17.8187
#12ZG -3.00"-0.875 -DB-0.625"-HP-Trans- (Pirod 238707)	3198.8474	6887.7536	1.93	2.66	11.1071	23.9158	21.2058
#12ZG -3.00"-0.875 -DB-0.625"-HP- (Pirod 238708)	3198.8474	6851.1588	1.93	2.63	11.1071	23.7887	21.2058
#12ZG -3.25"-0.875 -DB-0.625"-HP- (Pirod 238709)	3360.5698	6875.5819	2.19	2.62	11.6686	23.8735	24.8873

tnxTower Centek Engineering Inc. 63-2 North Branford Rd. Branford, CT 06405 Phone: (203) 488-0580 FAX: (203) 488-8587	Job 17159.10 - CT33XC089	Page 31 of 63
	Project U-40 x 280' - Haddam - Goose Hill, CT	Date 09:04:47 08/21/18
	Client Sprint	Designed by TJL

Section Designation	Area in ²	Area Ice in ²	Self Weight K	Ice Weight K	Equiv. Diameter in	Equiv. Diameter Ice in	Leg Area in ²
#12ZG -3.25"-0.875 -DB-0.625"-HP- (Pirod 238709)	3360.5698	6806.3435	2.19	2.53	11.6686	23.6331	24.8873
#12ZG -3.25"-0.875 -DB-0.625"-HP- (Pirod 238709)	3360.5698	6668.8943	2.19	2.37	11.6686	23.1559	24.8873

Tower Pressures - No Ice

$$G_H = 0.850$$

Section Elevation ft	z ft	K _Z	q _z psf	A _G ft ²	F a c e	A _F ft ²	A _R ft ²	A _{leg} ft ²	Leg %	C _A A _A In Face ft ²	C _A A _A Out Face ft ²
T1 280.00-260.00	270.00	1.56	40	282.111	A	22.686	25.226	25.226	52.65	0.000	0.000
					B	22.686	25.226	52.65	12.162	0.000	
					C	22.686	25.226	52.65	8.339	0.000	
T2 260.00-240.00	250.00	1.535	39	322.111	A	16.082	25.226	25.226	61.07	0.000	0.000
					B	16.082	25.226	61.07	26.370	0.000	
					C	16.082	25.226	61.07	12.298	0.000	
T3 240.00-220.00	230.00	1.508	38	362.111	A	33.932	25.226	25.226	42.64	7.680	0.000
					B	33.932	25.226	42.64	32.475	0.000	
					C	33.932	25.226	42.64	20.207	0.000	
T4 220.00-210.00	215.00	1.487	38	196.473	A	12.706	14.035	14.035	52.48	5.120	0.000
					B	12.706	14.035	52.48	19.033	0.000	
					C	12.706	14.035	52.48	11.446	0.000	
T5 210.00-200.00	205.00	1.472	38	206.473	A	17.146	14.035	14.035	45.01	5.120	0.000
					B	17.146	14.035	45.01	19.477	0.000	
					C	17.146	14.035	45.01	12.866	0.000	
T6 200.00-180.00	190.00	1.449	37	443.362	A	15.781	29.574	29.574	65.21	28.003	0.000
					B	15.781	29.574	65.21	38.954	0.000	
					C	15.781	29.574	65.21	27.150	0.000	
T7 180.00-160.00	170.00	1.415	36	483.780	A	16.624	31.146	31.146	65.20	43.669	0.000
					B	16.624	31.146	65.20	39.842	0.000	
					C	16.624	31.146	65.20	27.150	0.000	
T8 160.00-140.00	150.00	1.378	35	523.780	A	20.006	31.146	31.146	60.89	77.945	0.000
					B	20.006	31.146	60.89	44.144	0.000	
					C	20.006	31.146	60.89	27.150	0.000	
T9 140.00-120.00	130.00	1.337	34	564.197	A	21.049	32.772	32.772	60.89	86.965	0.000
					B	21.049	32.772	60.89	55.254	0.000	
					C	21.049	32.772	60.89	30.480	0.000	
T10 120.00-100.00	110.00	1.291	33	604.614	A	22.123	35.292	35.292	61.47	89.371	0.000
					B	22.123	35.292	61.47	57.454	0.000	
					C	22.123	35.292	61.47	37.140	0.000	
T11 100.00-80.00	90.00	1.238	32	645.031	A	23.224	37.085	37.085	61.49	92.334	0.000
					B	23.224	37.085	61.49	57.454	0.000	
					C	23.224	37.085	61.49	40.470	0.000	
T12 80.00-60.00	70.00	1.174	30	685.031	A	30.435	37.085	37.085	54.92	92.334	0.000
					B	30.435	37.085	54.92	57.454	0.000	
					C	30.435	37.085	54.92	40.470	0.000	
T13 60.00-40.00	50.00	1.094	28	725.448	A	31.865	38.960	38.960	55.01	93.999	0.000
					B	31.865	38.960	55.01	57.454	0.000	
					C	31.865	38.960	55.01	40.470	0.000	
T14 40.00-20.00	30.00	0.982	25	765.448	A	33.318	38.960	38.960	53.90	94.554	0.000
					B	33.318	38.960	53.90	57.454	0.000	

tnxTower Centek Engineering Inc. 63-2 North Branford Rd. Branford, CT 06405 Phone: (203) 488-0580 FAX: (203) 488-8587	Job	17159.10 - CT33XC089	Page	32 of 63
	Project	U-40 x 280' - Haddam - Goose Hill, CT	Date	09:04:47 08/21/18
	Client	Sprint	Designed by	TJL

Section Elevation ft	z ft	K _Z	q _z psf	A _G ft ²	F a c e	A _F ft ²	A _R ft ²	A _{leg} ft ²	Leg %	C _{AA} In Face ft ²	C _{AA} Out Face ft ²
T15 20.00-0.00	10.00	0.85	22	805.448	C	33.318	38.960	38.960	53.90	40.470	0.000
					A	34.790	38.960	38.960	52.83	94.554	0.000
					B	34.790	38.960	38.960	52.83	57.454	0.000
					C	34.790	38.960	38.960	52.83	40.470	0.000

Tower Pressure - With Ice

$G_H = 0.850$

Section Elevation ft	z ft	K _Z	q _z psf	t _z in	A _G ft ²	F a c e	A _F ft ²	A _R ft ²	A _{leg} ft ²	Leg %	C _{AA} In Face ft ²	C _{AA} Out Face ft ²
T1 280.00-260.00	270.00	1.56	8	2.3136	289.833	A	22.686	111.818	75.994	56.50	0.000	0.000
						B	22.686	111.818	75.994	56.50	61.679	0.000
						C	22.686	111.818	75.994	56.50	39.272	0.000
T2 260.00-240.00	250.00	1.535	8	2.2959	329.773	A	16.082	100.463	75.848	65.08	0.000	0.000
						B	16.082	100.463	75.848	65.08	125.512	0.000
						C	16.082	100.463	75.848	65.08	59.809	0.000
T3 240.00-220.00	230.00	1.508	8	2.2768	369.710	A	33.932	114.413	75.691	51.02	38.406	0.000
						B	33.932	114.413	75.691	51.02	157.593	0.000
						C	33.932	114.413	75.691	51.02	93.440	0.000
T4 220.00-210.00	215.00	1.487	8	2.2615	200.246	A	12.706	52.985	38.617	58.79	25.497	0.000
						B	12.706	52.985	38.617	58.79	90.740	0.000
						C	12.706	52.985	38.617	58.79	52.372	0.000
T5 210.00-200.00	205.00	1.472	8	2.2507	210.229	A	17.146	60.469	38.573	49.70	25.423	0.000
						B	17.146	60.469	38.573	49.70	92.693	0.000
						C	17.146	60.469	38.573	49.70	58.348	0.000
T6 200.00-180.00	190.00	1.449	8	2.2337	450.817	A	15.781	97.982	77.839	68.42	118.120	0.000
						B	15.781	97.982	77.839	68.42	184.436	0.000
						C	15.781	97.982	77.839	68.42	121.518	0.000
T7 180.00-160.00	170.00	1.415	8	2.2090	491.152	A	16.624	99.455	78.470	67.60	168.339	0.000
						B	16.624	99.455	78.470	67.60	187.481	0.000
						C	16.624	99.455	78.470	67.60	120.582	0.000
T8 160.00-140.00	150.00	1.378	7	2.1815	531.060	A	20.006	100.065	78.244	65.16	272.179	0.000
						B	20.006	100.065	78.244	65.16	202.229	0.000
						C	20.006	100.065	78.244	65.16	119.540	0.000
T9 140.00-120.00	130.00	1.337	7	2.1505	571.374	A	21.049	101.456	78.823	64.34	297.213	0.000
						B	21.049	101.456	78.823	64.34	235.943	0.000
						C	21.049	101.456	78.823	64.34	132.415	0.000
T10 120.00-100.00	110.00	1.291	7	2.1149	611.673	A	22.123	102.758	79.364	63.55	305.852	0.000
						B	22.123	102.758	79.364	63.55	239.938	0.000
						C	22.123	102.758	79.364	63.55	162.227	0.000
T11 100.00-80.00	90.00	1.238	7	2.0729	651.949	A	23.224	103.922	79.852	62.80	314.313	0.000
						B	23.224	103.922	79.852	62.80	236.984	0.000
						C	23.224	103.922	79.852	62.80	176.354	0.000
T12 80.00-60.00	70.00	1.174	6	2.0214	691.778	A	30.435	104.037	79.428	59.07	310.690	0.000
						B	30.435	104.037	79.428	59.07	233.369	0.000
						C	30.435	104.037	79.428	59.07	173.493	0.000
T13 60.00-40.00	50.00	1.094	6	1.9546	731.972	A	31.865	104.624	79.711	58.40	313.511	0.000
						B	31.865	104.624	79.711	58.40	228.670	0.000
						C	31.865	104.624	79.711	58.40	169.775	0.000
T14 40.00-20.00	30.00	0.982	5	1.8572	771.647	A	33.318	103.660	78.908	57.61	308.785	0.000
						B	33.318	103.660	78.908	57.61	221.836	0.000
						C	33.318	103.660	78.908	57.61	164.367	0.000
T15 20.00-0.00	10.00	0.85	5	1.6640	811.002	A	34.790	100.471	77.315	57.16	294.443	0.000

tnxTower Centek Engineering Inc. 63-2 North Branford Rd. Branford, CT 06405 Phone: (203) 488-0580 FAX: (203) 488-8587	Job 17159.10 - CT33XC089	Page 33 of 63
	Project U-40 x 280' - Haddam - Goose Hill, CT	Date 09:04:47 08/21/18
	Client Sprint	Designed by TJL

Section Elevation	z	K _Z	q _z	t _z	A _G	F a c e	A _F	A _R	A _{leg}	Leg %	C _A A _A In Face ft ²	C _A A _A Out Face ft ²
ft	ft		psf	in	ft ²		ft ²	ft ²	ft ²			
						B	34.790	100.471		57.16	208.286	0.000
						C	34.790	100.471		57.16	153.644	0.000

Tower Pressure - Service

$G_H = 0.850$

Section Elevation	z	K _Z	q _z	A _G	F a c e	A _F	A _R	A _{leg}	Leg %	C _A A _A In Face ft ²	C _A A _A Out Face ft ²
ft	ft		psf	ft ²		ft ²	ft ²	ft ²			
T1 280.00-260.00	270.00	1.56	12	282.111	A	22.686	25.226	25.226	52.65	0.000	0.000
					B	22.686	25.226		52.65	12.162	0.000
					C	22.686	25.226		52.65	8.339	0.000
T2 260.00-240.00	250.00	1.535	12	322.111	A	16.082	25.226	25.226	61.07	0.000	0.000
					B	16.082	25.226		61.07	26.370	0.000
					C	16.082	25.226		61.07	12.298	0.000
T3 240.00-220.00	230.00	1.508	12	362.111	A	33.932	25.226	25.226	42.64	7.680	0.000
					B	33.932	25.226		42.64	32.475	0.000
					C	33.932	25.226		42.64	20.207	0.000
T4 220.00-210.00	215.00	1.487	12	196.473	A	12.706	14.035	14.035	52.48	5.120	0.000
					B	12.706	14.035		52.48	19.033	0.000
					C	12.706	14.035		52.48	11.446	0.000
T5 210.00-200.00	205.00	1.472	12	206.473	A	17.146	14.035	14.035	45.01	5.120	0.000
					B	17.146	14.035		45.01	19.477	0.000
					C	17.146	14.035		45.01	12.866	0.000
T6 200.00-180.00	190.00	1.449	11	443.362	A	15.781	29.574	29.574	65.21	28.003	0.000
					B	15.781	29.574		65.21	38.954	0.000
					C	15.781	29.574		65.21	27.150	0.000
T7 180.00-160.00	170.00	1.415	11	483.780	A	16.624	31.146	31.146	65.20	43.669	0.000
					B	16.624	31.146		65.20	39.842	0.000
					C	16.624	31.146		65.20	27.150	0.000
T8 160.00-140.00	150.00	1.378	11	523.780	A	20.006	31.146	31.146	60.89	77.945	0.000
					B	20.006	31.146		60.89	44.144	0.000
					C	20.006	31.146		60.89	27.150	0.000
T9 140.00-120.00	130.00	1.337	10	564.197	A	21.049	32.772	32.772	60.89	86.965	0.000
					B	21.049	32.772		60.89	55.254	0.000
					C	21.049	32.772		60.89	30.480	0.000
T10 120.00-100.00	110.00	1.291	10	604.614	A	22.123	35.292	35.292	61.47	89.371	0.000
					B	22.123	35.292		61.47	57.454	0.000
					C	22.123	35.292		61.47	37.140	0.000
T11 100.00-80.00	90.00	1.238	10	645.031	A	23.224	37.085	37.085	61.49	92.334	0.000
					B	23.224	37.085		61.49	57.454	0.000
					C	23.224	37.085		61.49	40.470	0.000
T12 80.00-60.00	70.00	1.174	9	685.031	A	30.435	37.085	37.085	54.92	92.334	0.000
					B	30.435	37.085		54.92	57.454	0.000
					C	30.435	37.085		54.92	40.470	0.000
T13 60.00-40.00	50.00	1.094	9	725.448	A	31.865	38.960	38.960	55.01	93.999	0.000
					B	31.865	38.960		55.01	57.454	0.000
					C	31.865	38.960		55.01	40.470	0.000
T14 40.00-20.00	30.00	0.982	8	765.448	A	33.318	38.960	38.960	53.90	94.554	0.000
					B	33.318	38.960		53.90	57.454	0.000
					C	33.318	38.960		53.90	40.470	0.000
T15 20.00-0.00	10.00	0.85	7	805.448	A	34.790	38.960	38.960	52.83	94.554	0.000
					B	34.790	38.960		52.83	57.454	0.000

tnxTower Centek Engineering Inc. 63-2 North Branford Rd. Branford, CT 06405 Phone: (203) 488-0580 FAX: (203) 488-8587	Job 17159.10 - CT33XC089	Page 34 of 63
	Project U-40 x 280' - Haddam - Goose Hill, CT	Date 09:04:47 08/21/18
	Client Sprint	Designed by TJJ

Section Elevation	z	K _Z	q _z	A _G	F _a	A _F	A _R	A _{leg}	Leg %	C _{AA} In Face	C _{AA} Out Face
ft	ft		psf	ft ²	c	ft ²	ft ²	ft ²		ft ²	ft ²
					C	34.790	38.960		52.83	40.470	0.000

Tower Forces - No Ice - Wind Normal To Face

Section Elevation	Add Weight	Self Weight	F _a	e	C _F	q _z	D _F	D _R	A _E	F	w	Ctrl. Face
ft	K	K	c			psf			ft ²	K	plf	
T1 280.00-260.00	0.08	3.18	A	0.17	2.7	40	1	1	37.061	3.80	190.16	C
			B	0.17	2.7		1	1	37.061			
			C	0.17	2.7		1	1	37.061			
T2 260.00-240.00	0.17	2.63	A	0.128	2.853	39	1	1	30.353	3.66	182.84	C
			B	0.128	2.853		1	1	30.353			
			C	0.128	2.853		1	1	30.353			
T3 240.00-220.00	0.26	3.70	A	0.163	2.723	38	1	1	48.286	5.49	274.39	C
			B	0.163	2.723		1	1	48.286			
			C	0.163	2.723		1	1	48.286			
T4 220.00-210.00	0.15	1.86	A	0.136	2.823	38	1	1	20.654	2.57	257.05	C
			B	0.136	2.823		1	1	20.654			
			C	0.136	2.823		1	1	20.654			
T5 210.00-200.00	0.16	2.09	A	0.151	2.768	38	1	1	25.113	2.94	293.81	C
			B	0.151	2.768		1	1	25.113			
			C	0.151	2.768		1	1	25.113			
T6 200.00-180.00	0.41	5.10	A	0.102	2.955	37	1	1	32.473	4.79	239.55	C
			B	0.102	2.955		1	1	32.473			
			C	0.102	2.955		1	1	32.473			
T7 180.00-160.00	0.49	5.74	A	0.099	2.969	36	1	1	34.201	5.16	257.85	C
			B	0.099	2.969		1	1	34.201			
			C	0.099	2.969		1	1	34.201			
T8 160.00-140.00	0.73	6.17	A	0.098	2.973	35	1	1	37.582	6.02	301.01	C
			B	0.098	2.973		1	1	37.582			
			C	0.098	2.973		1	1	37.582			
T9 140.00-120.00	0.89	8.15	A	0.095	2.983	34	1	1	39.541	6.43	321.48	C
			B	0.095	2.983		1	1	39.541			
			C	0.095	2.983		1	1	39.541			
T10 120.00-100.00	0.94	9.14	A	0.095	2.984	33	1	1	42.036	6.61	330.37	C
			B	0.095	2.984		1	1	42.036			
			C	0.095	2.984		1	1	42.036			
T11 100.00-80.00	0.97	10.06	A	0.093	2.99	32	1	1	44.148	6.61	330.59	C
			B	0.093	2.99		1	1	44.148			
			C	0.093	2.99		1	1	44.148			
T12 80.00-60.00	0.97	10.53	A	0.099	2.97	30	1	1	51.363	6.79	339.70	C
			B	0.099	2.97		1	1	51.363			
			C	0.099	2.97		1	1	51.363			
T13 60.00-40.00	0.98	11.54	A	0.098	2.974	28	1	1	53.851	6.53	326.66	C
			B	0.098	2.974		1	1	53.851			
			C	0.098	2.974		1	1	53.851			
T14 40.00-20.00	0.98	11.76	A	0.094	2.987	25	1	1	55.301	5.98	299.07	C
			B	0.094	2.987		1	1	55.301			
			C	0.094	2.987		1	1	55.301			
T15 20.00-0.00	0.98	11.99	A	0.092	2.998	22	1	1	56.771	5.27	263.46	C
			B	0.092	2.998		1	1	56.771			
			C	0.092	2.998		1	1	56.771			
Sum Weight:	9.18	103.64						OTM	10240.36 kip-ft	78.65		

tnxTower Centek Engineering Inc. 63-2 North Branford Rd. Branford, CT 06405 Phone: (203) 488-0580 FAX: (203) 488-8587	Job 17159.10 - CT33XC089	Page 35 of 63
	Project U-40 x 280' - Haddam - Goose Hill, CT	Date 09:04:47 08/21/18
	Client Sprint	Designed by TJL

Tower Forces - No Ice - Wind 60 To Face

Section Elevation	Add Weight	Self Weight	F a c e	e	C _F	q _z	D _F	D _R	A _E	F	w	Ctrl. Face
ft	K	K				psf			ft ²	K	plf	
T1 280.00-260.00	0.08	3.18	A	0.17	2.7	40	0.8	1	32.524	3.39	169.43	C
			B	0.17	2.7		0.8	1	32.524			
			C	0.17	2.7		0.8	1	32.524			
T2 260.00-240.00	0.17	2.63	A	0.128	2.853	39	0.8	1	27.136	3.35	167.56	C
			B	0.128	2.853		0.8	1	27.136			
			C	0.128	2.853		0.8	1	27.136			
T3 240.00-220.00	0.26	3.70	A	0.163	2.723	38	0.8	1	41.500	4.88	244.16	C
			B	0.163	2.723		0.8	1	41.500			
			C	0.163	2.723		0.8	1	41.500			
T4 220.00-210.00	0.15	1.86	A	0.136	2.823	38	0.8	1	18.113	2.34	233.90	C
			B	0.136	2.823		0.8	1	18.113			
			C	0.136	2.823		0.8	1	18.113			
T5 210.00-200.00	0.16	2.09	A	0.151	2.768	38	0.8	1	21.684	2.63	263.50	C
			B	0.151	2.768		0.8	1	21.684			
			C	0.151	2.768		0.8	1	21.684			
T6 200.00-180.00	0.41	5.10	A	0.102	2.955	37	0.8	1	29.317	4.50	224.89	C
			B	0.102	2.955		0.8	1	29.317			
			C	0.102	2.955		0.8	1	29.317			
T7 180.00-160.00	0.49	5.74	A	0.099	2.969	36	0.8	1	30.876	4.85	242.69	C
			B	0.099	2.969		0.8	1	30.876			
			C	0.099	2.969		0.8	1	30.876			
T8 160.00-140.00	0.73	6.17	A	0.098	2.973	35	0.8	1	33.581	5.66	283.22	C
			B	0.098	2.973		0.8	1	33.581			
			C	0.098	2.973		0.8	1	33.581			
T9 140.00-120.00	0.89	8.15	A	0.095	2.983	34	0.8	1	35.331	6.07	303.26	C
			B	0.095	2.983		0.8	1	35.331			
			C	0.095	2.983		0.8	1	35.331			
T10 120.00-100.00	0.94	9.14	A	0.095	2.984	33	0.8	1	37.612	6.24	311.87	C
			B	0.095	2.984		0.8	1	37.612			
			C	0.095	2.984		0.8	1	37.612			
T11 100.00-80.00	0.97	10.06	A	0.093	2.99	32	0.8	1	39.504	6.24	311.94	C
			B	0.093	2.99		0.8	1	39.504			
			C	0.093	2.99		0.8	1	39.504			
T12 80.00-60.00	0.97	10.53	A	0.099	2.97	30	0.8	1	45.276	6.33	316.67	C
			B	0.099	2.97		0.8	1	45.276			
			C	0.099	2.97		0.8	1	45.276			
T13 60.00-40.00	0.98	11.54	A	0.098	2.974	28	0.8	1	47.478	6.08	304.17	C
			B	0.098	2.974		0.8	1	47.478			
			C	0.098	2.974		0.8	1	47.478			
T14 40.00-20.00	0.98	11.76	A	0.094	2.987	25	0.8	1	48.638	5.56	277.86	C
			B	0.094	2.987		0.8	1	48.638			
			C	0.094	2.987		0.8	1	48.638			
T15 20.00-0.00	0.98	11.99	A	0.092	2.998	22	0.8	1	49.813	4.88	244.22	C
			B	0.092	2.998		0.8	1	49.813			
			C	0.092	2.998		0.8	1	49.813			
Sum Weight:	9.18	103.64						OTM	9447.46 kip-ft	73.01		

tnxTower Centek Engineering Inc. 63-2 North Branford Rd. Branford, CT 06405 Phone: (203) 488-0580 FAX: (203) 488-8587	Job 17159.10 - CT33XC089	Page 36 of 63
	Project U-40 x 280' - Haddam - Goose Hill, CT	Date 09:04:47 08/21/18
	Client Sprint	Designed by TJJ

Tower Forces - No Ice - Wind 90 To Face

Section Elevation	Add Weight	Self Weight	F a c e	e	C _F	q _z	D _F	D _R	A _E	F	w	Ctrl. Face
ft	K	K				psf			ft ²	K	plf	
T1 280.00-260.00	0.08	3.18	A	0.17	2.7	40	0.85	1	33.658	3.49	174.61	C
			B	0.17	2.7		0.85	1	33.658			
			C	0.17	2.7		0.85	1	33.658			
T2 260.00-240.00	0.17	2.63	A	0.128	2.853	39	0.85	1	27.940	3.43	171.38	C
			B	0.128	2.853		0.85	1	27.940			
			C	0.128	2.853		0.85	1	27.940			
T3 240.00-220.00	0.26	3.70	A	0.163	2.723	38	0.85	1	43.197	5.03	251.71	C
			B	0.163	2.723		0.85	1	43.197			
			C	0.163	2.723		0.85	1	43.197			
T4 220.00-210.00	0.15	1.86	A	0.136	2.823	38	0.85	1	18.748	2.40	239.69	C
			B	0.136	2.823		0.85	1	18.748			
			C	0.136	2.823		0.85	1	18.748			
T5 210.00-200.00	0.16	2.09	A	0.151	2.768	38	0.85	1	22.541	2.71	271.08	C
			B	0.151	2.768		0.85	1	22.541			
			C	0.151	2.768		0.85	1	22.541			
T6 200.00-180.00	0.41	5.10	A	0.102	2.955	37	0.85	1	30.106	4.57	228.56	C
			B	0.102	2.955		0.85	1	30.106			
			C	0.102	2.955		0.85	1	30.106			
T7 180.00-160.00	0.49	5.74	A	0.099	2.969	36	0.85	1	31.707	4.93	246.48	C
			B	0.099	2.969		0.85	1	31.707			
			C	0.099	2.969		0.85	1	31.707			
T8 160.00-140.00	0.73	6.17	A	0.098	2.973	35	0.85	1	34.581	5.75	287.67	C
			B	0.098	2.973		0.85	1	34.581			
			C	0.098	2.973		0.85	1	34.581			
T9 140.00-120.00	0.89	8.15	A	0.095	2.983	34	0.85	1	36.383	6.16	307.82	C
			B	0.095	2.983		0.85	1	36.383			
			C	0.095	2.983		0.85	1	36.383			
T10 120.00-100.00	0.94	9.14	A	0.095	2.984	33	0.85	1	38.718	6.33	316.50	C
			B	0.095	2.984		0.85	1	38.718			
			C	0.095	2.984		0.85	1	38.718			
T11 100.00-80.00	0.97	10.06	A	0.093	2.99	32	0.85	1	40.665	6.33	316.60	C
			B	0.093	2.99		0.85	1	40.665			
			C	0.093	2.99		0.85	1	40.665			
T12 80.00-60.00	0.97	10.53	A	0.099	2.97	30	0.85	1	46.798	6.45	322.43	C
			B	0.099	2.97		0.85	1	46.798			
			C	0.099	2.97		0.85	1	46.798			
T13 60.00-40.00	0.98	11.54	A	0.098	2.974	28	0.85	1	49.071	6.20	309.79	C
			B	0.098	2.974		0.85	1	49.071			
			C	0.098	2.974		0.85	1	49.071			
T14 40.00-20.00	0.98	11.76	A	0.094	2.987	25	0.85	1	50.303	5.66	283.16	C
			B	0.094	2.987		0.85	1	50.303			
			C	0.094	2.987		0.85	1	50.303			
T15 20.00-0.00	0.98	11.99	A	0.092	2.998	22	0.85	1	51.553	4.98	249.03	C
			B	0.092	2.998		0.85	1	51.553			
			C	0.092	2.998		0.85	1	51.553			
Sum Weight:	9.18	103.64						OTM	9645.69 kip-ft	74.42		

Tower Forces - With Ice - Wind Normal To Face

tnxTower Centek Engineering Inc. 63-2 North Branford Rd. Branford, CT 06405 Phone: (203) 488-0580 FAX: (203) 488-8587	Job 17159.10 - CT33XC089	Page 37 of 63
	Project U-40 x 280' - Haddam - Goose Hill, CT	Date 09:04:47 08/21/18
	Client Sprint	Designed by TJJ

Section Elevation	Add Weight	Self Weight	F a c e	e	C _F	q _z	D _F	D _R	A _E	F	w	Ctrl. Face
ft	K	K				psf			ft ²	K	plf	
T1 280.00-260.00	1.64	15.94	A	0.464	1.951	8	1	1	97.185	1.76	87.90	C
			B	0.464	1.951		1	1	97.185			
			C	0.464	1.951		1	1	97.185			
T2 260.00-240.00	2.91	13.65	A	0.353	2.164	8	1	1	78.103	1.99	99.43	C
			B	0.353	2.164		1	1	78.103			
			C	0.353	2.164		1	1	78.103			
T3 240.00-220.00	4.54	18.02	A	0.401	2.062	8	1	1	106.788	2.74	137.19	C
			B	0.401	2.062		1	1	106.788			
			C	0.401	2.062		1	1	106.788			
T4 220.00-210.00	2.68	8.22	A	0.328	2.224	8	1	1	44.929	1.38	138.26	C
			B	0.328	2.224		1	1	44.929			
			C	0.328	2.224		1	1	44.929			
T5 210.00-200.00	2.81	9.46	A	0.369	2.128	8	1	1	54.846	1.52	151.52	C
			B	0.369	2.128		1	1	54.846			
			C	0.369	2.128		1	1	54.846			
T6 200.00-180.00	6.70	16.99	A	0.252	2.43	8	1	1	73.157	2.90	144.78	C
			B	0.252	2.43		1	1	73.157			
			C	0.252	2.43		1	1	73.157			
T7 180.00-160.00	7.59	17.87	A	0.236	2.479	8	1	1	74.485	3.08	153.94	C
			B	0.236	2.479		1	1	74.485			
			C	0.236	2.479		1	1	74.485			
T8 160.00-140.00	9.60	18.89	A	0.226	2.511	7	1	1	77.997	3.52	175.99	C
			B	0.226	2.511		1	1	77.997			
			C	0.226	2.511		1	1	77.997			
T9 140.00-120.00	10.70	21.10	A	0.214	2.549	7	1	1	79.604	3.72	186.22	C
			B	0.214	2.549		1	1	79.604			
			C	0.214	2.549		1	1	79.604			
T10 120.00-100.00	11.17	22.30	A	0.204	2.582	7	1	1	81.231	3.79	189.44	C
			B	0.204	2.582		1	1	81.231			
			C	0.204	2.582		1	1	81.231			
T11 100.00-80.00	11.33	23.39	A	0.195	2.613	7	1	1	82.836	3.74	186.89	C
			B	0.195	2.613		1	1	82.836			
			C	0.195	2.613		1	1	82.836			
T12 80.00-60.00	10.98	24.94	A	0.194	2.615	6	1	1	90.102	3.62	180.82	C
			B	0.194	2.615		1	1	90.102			
			C	0.194	2.615		1	1	90.102			
T13 60.00-40.00	10.66	25.95	A	0.186	2.642	6	1	1	91.736	3.39	169.31	C
			B	0.186	2.642		1	1	91.736			
			C	0.186	2.642		1	1	91.736			
T14 40.00-20.00	10.06	25.83	A	0.178	2.673	5	1	1	92.498	3.02	150.84	C
			B	0.178	2.673		1	1	92.498			
			C	0.178	2.673		1	1	92.498			
T15 20.00-0.00	8.86	25.05	A	0.167	2.711	5	1	1	92.003	2.53	126.41	C
			B	0.167	2.711		1	1	92.003			
			C	0.167	2.711		1	1	92.003			
Sum Weight:	112.23	287.61						OTM	5587.92 kip-ft	42.68		

Tower Forces - With Ice - Wind 60 To Face

Section Elevation	Add Weight	Self Weight	F a c e	e	C _F	q _z	D _F	D _R	A _E	F	w	Ctrl. Face
ft	K	K				psf			ft ²	K	plf	

tnxTower Centek Engineering Inc. 63-2 North Branford Rd. Branford, CT 06405 Phone: (203) 488-0580 FAX: (203) 488-8587	Job 17159.10 - CT33XC089	Page 38 of 63
	Project U-40 x 280' - Haddam - Goose Hill, CT	Date 09:04:47 08/21/18
	Client Sprint	Designed by TJJ

Section Elevation	Add Weight	Self Weight	F a c e	e	C _F	q _z	D _F	D _R	A _E	F	w	Ctrl. Face
ft	K	K				psf			ft ²	K	plf	
T1 280.00-260.00	1.64	15.94	A	0.464	1.951	8	0.8	1	92.648	1.69	84.71	C
			B	0.464	1.951		0.8	1	92.648			
			C	0.464	1.951		0.8	1	92.648			
T2 260.00-240.00	2.91	13.65	A	0.353	2.164	8	0.8	1	74.886	1.94	96.96	C
			B	0.353	2.164		0.8	1	74.886			
			C	0.353	2.164		0.8	1	74.886			
T3 240.00-220.00	4.54	18.02	A	0.401	2.062	8	0.8	1	100.002	2.65	132.31	C
			B	0.401	2.062		0.8	1	100.002			
			C	0.401	2.062		0.8	1	100.002			
T4 220.00-210.00	2.68	8.22	A	0.328	2.224	8	0.8	1	42.388	1.34	134.37	C
			B	0.328	2.224		0.8	1	42.388			
			C	0.328	2.224		0.8	1	42.388			
T5 210.00-200.00	2.81	9.46	A	0.369	2.128	8	0.8	1	51.417	1.47	146.56	C
			B	0.369	2.128		0.8	1	51.417			
			C	0.369	2.128		0.8	1	51.417			
T6 200.00-180.00	6.70	16.99	A	0.252	2.43	8	0.8	1	70.001	2.84	142.21	C
			B	0.252	2.43		0.8	1	70.001			
			C	0.252	2.43		0.8	1	70.001			
T7 180.00-160.00	7.59	17.87	A	0.236	2.479	8	0.8	1	71.161	3.02	151.25	C
			B	0.236	2.479		0.8	1	71.161			
			C	0.236	2.479		0.8	1	71.161			
T8 160.00-140.00	9.60	18.89	A	0.226	2.511	7	0.8	1	73.996	3.46	172.79	C
			B	0.226	2.511		0.8	1	73.996			
			C	0.226	2.511		0.8	1	73.996			
T9 140.00-120.00	10.70	21.10	A	0.214	2.549	7	0.8	1	75.394	3.66	182.91	C
			B	0.214	2.549		0.8	1	75.394			
			C	0.214	2.549		0.8	1	75.394			
T10 120.00-100.00	11.17	22.30	A	0.204	2.582	7	0.8	1	76.807	3.72	186.03	C
			B	0.204	2.582		0.8	1	76.807			
			C	0.204	2.582		0.8	1	76.807			
T11 100.00-80.00	11.33	23.39	A	0.195	2.613	7	0.8	1	78.191	3.67	183.42	C
			B	0.195	2.613		0.8	1	78.191			
			C	0.195	2.613		0.8	1	78.191			
T12 80.00-60.00	10.98	24.94	A	0.194	2.615	6	0.8	1	84.015	3.53	176.50	C
			B	0.194	2.615		0.8	1	84.015			
			C	0.194	2.615		0.8	1	84.015			
T13 60.00-40.00	10.66	25.95	A	0.186	2.642	6	0.8	1	85.363	3.30	165.05	C
			B	0.186	2.642		0.8	1	85.363			
			C	0.186	2.642		0.8	1	85.363			
T14 40.00-20.00	10.06	25.83	A	0.178	2.673	5	0.8	1	85.834	2.94	146.80	C
			B	0.178	2.673		0.8	1	85.834			
			C	0.178	2.673		0.8	1	85.834			
T15 20.00-0.00	8.86	25.05	A	0.167	2.711	5	0.8	1	85.046	2.45	122.70	C
			B	0.167	2.711		0.8	1	85.046			
			C	0.167	2.711		0.8	1	85.046			
Sum Weight:	112.23	287.61						OTM	5452.95 kip-ft	41.68		

Tower Forces - With Ice - Wind 90 To Face

Section Elevation	Add Weight	Self Weight	F a c e	e	C _F	q _z	D _F	D _R	A _E	F	w	Ctrl. Face
ft	K	K				psf			ft ²	K	plf	

tnxTower Centek Engineering Inc. 63-2 North Branford Rd. Branford, CT 06405 Phone: (203) 488-0580 FAX: (203) 488-8587	Job 17159.10 - CT33XC089	Page 39 of 63
	Project U-40 x 280' - Haddam - Goose Hill, CT	Date 09:04:47 08/21/18
	Client Sprint	Designed by TJL

Section Elevation	Add Weight	Self Weight	F a c e	e	C _F	q _z	D _F	D _R	A _E	F	w	Ctrl. Face
ft	K	K				psf			ft ²	K	plf	
T1 280.00-260.00	1.64	15.94	A	0.464	1.951	8	0.85	1	93.782	1.71	85.51	C
			B	0.464	1.951		0.85	1	93.782			
			C	0.464	1.951		0.85	1	93.782			
T2 260.00-240.00	2.91	13.65	A	0.353	2.164	8	0.85	1	75.690	1.95	97.57	C
			B	0.353	2.164		0.85	1	75.690			
			C	0.353	2.164		0.85	1	75.690			
T3 240.00-220.00	4.54	18.02	A	0.401	2.062	8	0.85	1	101.698	2.67	133.53	C
			B	0.401	2.062		0.85	1	101.698			
			C	0.401	2.062		0.85	1	101.698			
T4 220.00-210.00	2.68	8.22	A	0.328	2.224	8	0.85	1	43.023	1.35	135.35	C
			B	0.328	2.224		0.85	1	43.023			
			C	0.328	2.224		0.85	1	43.023			
T5 210.00-200.00	2.81	9.46	A	0.369	2.128	8	0.85	1	52.274	1.48	147.80	C
			B	0.369	2.128		0.85	1	52.274			
			C	0.369	2.128		0.85	1	52.274			
T6 200.00-180.00	6.70	16.99	A	0.252	2.43	8	0.85	1	70.790	2.86	142.85	C
			B	0.252	2.43		0.85	1	70.790			
			C	0.252	2.43		0.85	1	70.790			
T7 180.00-160.00	7.59	17.87	A	0.236	2.479	8	0.85	1	71.992	3.04	151.92	C
			B	0.236	2.479		0.85	1	71.992			
			C	0.236	2.479		0.85	1	71.992			
T8 160.00-140.00	9.60	18.89	A	0.226	2.511	7	0.85	1	74.996	3.47	173.59	C
			B	0.226	2.511		0.85	1	74.996			
			C	0.226	2.511		0.85	1	74.996			
T9 140.00-120.00	10.70	21.10	A	0.214	2.549	7	0.85	1	76.447	3.67	183.74	C
			B	0.214	2.549		0.85	1	76.447			
			C	0.214	2.549		0.85	1	76.447			
T10 120.00-100.00	11.17	22.30	A	0.204	2.582	7	0.85	1	77.913	3.74	186.89	C
			B	0.204	2.582		0.85	1	77.913			
			C	0.204	2.582		0.85	1	77.913			
T11 100.00-80.00	11.33	23.39	A	0.195	2.613	7	0.85	1	79.353	3.69	184.28	C
			B	0.195	2.613		0.85	1	79.353			
			C	0.195	2.613		0.85	1	79.353			
T12 80.00-60.00	10.98	24.94	A	0.194	2.615	6	0.85	1	85.537	3.55	177.58	C
			B	0.194	2.615		0.85	1	85.537			
			C	0.194	2.615		0.85	1	85.537			
T13 60.00-40.00	10.66	25.95	A	0.186	2.642	6	0.85	1	86.956	3.32	166.12	C
			B	0.186	2.642		0.85	1	86.956			
			C	0.186	2.642		0.85	1	86.956			
T14 40.00-20.00	10.06	25.83	A	0.178	2.673	5	0.85	1	87.500	2.96	147.81	C
			B	0.178	2.673		0.85	1	87.500			
			C	0.178	2.673		0.85	1	87.500			
T15 20.00-0.00	8.86	25.05	A	0.167	2.711	5	0.85	1	86.785	2.47	123.63	C
			B	0.167	2.711		0.85	1	86.785			
			C	0.167	2.711		0.85	1	86.785			
Sum Weight:	112.23	287.61						OTM	5486.69 kip-ft	41.93		

Tower Forces - Service - Wind Normal To Face

Section Elevation	Add Weight	Self Weight	F a c e	e	C _F	q _z	D _F	D _R	A _E	F	w	Ctrl. Face
ft	K	K				psf			ft ²	K	plf	

tnxTower Centek Engineering Inc. 63-2 North Branford Rd. Branford, CT 06405 Phone: (203) 488-0580 FAX: (203) 488-8587	Job 17159.10 - CT33XC089	Page 40 of 63
	Project U-40 x 280' - Haddam - Goose Hill, CT	Date 09:04:47 08/21/18
	Client Sprint	Designed by TJJ

Section Elevation	Add Weight	Self Weight	F a c e	e	C _F	q _z	D _F	D _R	A _E	F	w	Ctrl. Face
ft	K	K				psf			ft ²	K	plf	
T1 280.00-260.00	0.08	3.18	A	0.17	2.7	12	1	1	37.061	1.17	58.35	C
			B	0.17	2.7		1	1	37.061			
			C	0.17	2.7		1	1	37.061			
T2 260.00-240.00	0.17	2.63	A	0.128	2.853	12	1	1	30.353	1.12	56.11	C
			B	0.128	2.853		1	1	30.353			
			C	0.128	2.853		1	1	30.353			
T3 240.00-220.00	0.26	3.70	A	0.163	2.723	12	1	1	48.286	1.68	84.20	C
			B	0.163	2.723		1	1	48.286			
			C	0.163	2.723		1	1	48.286			
T4 220.00-210.00	0.15	1.86	A	0.136	2.823	12	1	1	20.654	0.79	78.88	C
			B	0.136	2.823		1	1	20.654			
			C	0.136	2.823		1	1	20.654			
T5 210.00-200.00	0.16	2.09	A	0.151	2.768	12	1	1	25.113	0.90	90.16	C
			B	0.151	2.768		1	1	25.113			
			C	0.151	2.768		1	1	25.113			
T6 200.00-180.00	0.41	5.10	A	0.102	2.955	11	1	1	32.473	1.47	73.51	C
			B	0.102	2.955		1	1	32.473			
			C	0.102	2.955		1	1	32.473			
T7 180.00-160.00	0.49	5.74	A	0.099	2.969	11	1	1	34.201	1.58	79.13	C
			B	0.099	2.969		1	1	34.201			
			C	0.099	2.969		1	1	34.201			
T8 160.00-140.00	0.73	6.17	A	0.098	2.973	11	1	1	37.582	1.85	92.37	C
			B	0.098	2.973		1	1	37.582			
			C	0.098	2.973		1	1	37.582			
T9 140.00-120.00	0.89	8.15	A	0.095	2.983	10	1	1	39.541	1.97	98.65	C
			B	0.095	2.983		1	1	39.541			
			C	0.095	2.983		1	1	39.541			
T10 120.00-100.00	0.94	9.14	A	0.095	2.984	10	1	1	42.036	2.03	101.38	C
			B	0.095	2.984		1	1	42.036			
			C	0.095	2.984		1	1	42.036			
T11 100.00-80.00	0.97	10.06	A	0.093	2.99	10	1	1	44.148	2.03	101.45	C
			B	0.093	2.99		1	1	44.148			
			C	0.093	2.99		1	1	44.148			
T12 80.00-60.00	0.97	10.53	A	0.099	2.97	9	1	1	51.363	2.08	104.24	C
			B	0.099	2.97		1	1	51.363			
			C	0.099	2.97		1	1	51.363			
T13 60.00-40.00	0.98	11.54	A	0.098	2.974	9	1	1	53.851	2.00	100.24	C
			B	0.098	2.974		1	1	53.851			
			C	0.098	2.974		1	1	53.851			
T14 40.00-20.00	0.98	11.76	A	0.094	2.987	8	1	1	55.301	1.84	91.78	C
			B	0.094	2.987		1	1	55.301			
			C	0.094	2.987		1	1	55.301			
T15 20.00-0.00	0.98	11.99	A	0.092	2.998	7	1	1	56.771	1.62	80.85	C
			B	0.092	2.998		1	1	56.771			
			C	0.092	2.998		1	1	56.771			
Sum Weight:	9.18	103.64						OTM	3142.51 kip-ft	24.14		

Tower Forces - Service - Wind 60 To Face

Section Elevation	Add Weight	Self Weight	F a c e	e	C _F	q _z	D _F	D _R	A _E	F	w	Ctrl. Face
ft	K	K				psf			ft ²	K	plf	

tnxTower Centek Engineering Inc. 63-2 North Branford Rd. Branford, CT 06405 Phone: (203) 488-0580 FAX: (203) 488-8587	Job 17159.10 - CT33XC089	Page 41 of 63
	Project U-40 x 280' - Haddam - Goose Hill, CT	Date 09:04:47 08/21/18
	Client Sprint	Designed by TJJ

Section Elevation	Add Weight	Self Weight	F a c e	e	C _F	q _z	D _F	D _R	A _E	F	w	Ctrl. Face
ft	K	K				psf			ft ²	K	plf	
T1 280.00-260.00	0.08	3.18	A	0.17	2.7	12	0.8	1	32.524	1.04	51.99	C
			B	0.17	2.7		0.8	1	32.524			
			C	0.17	2.7		0.8	1	32.524			
T2 260.00-240.00	0.17	2.63	A	0.128	2.853	12	0.8	1	27.136	1.03	51.42	C
			B	0.128	2.853		0.8	1	27.136			
			C	0.128	2.853		0.8	1	27.136			
T3 240.00-220.00	0.26	3.70	A	0.163	2.723	12	0.8	1	41.500	1.50	74.93	C
			B	0.163	2.723		0.8	1	41.500			
			C	0.163	2.723		0.8	1	41.500			
T4 220.00-210.00	0.15	1.86	A	0.136	2.823	12	0.8	1	18.113	0.72	71.78	C
			B	0.136	2.823		0.8	1	18.113			
			C	0.136	2.823		0.8	1	18.113			
T5 210.00-200.00	0.16	2.09	A	0.151	2.768	12	0.8	1	21.684	0.81	80.86	C
			B	0.151	2.768		0.8	1	21.684			
			C	0.151	2.768		0.8	1	21.684			
T6 200.00-180.00	0.41	5.10	A	0.102	2.955	11	0.8	1	29.317	1.38	69.01	C
			B	0.102	2.955		0.8	1	29.317			
			C	0.102	2.955		0.8	1	29.317			
T7 180.00-160.00	0.49	5.74	A	0.099	2.969	11	0.8	1	30.876	1.49	74.48	C
			B	0.099	2.969		0.8	1	30.876			
			C	0.099	2.969		0.8	1	30.876			
T8 160.00-140.00	0.73	6.17	A	0.098	2.973	11	0.8	1	33.581	1.74	86.91	C
			B	0.098	2.973		0.8	1	33.581			
			C	0.098	2.973		0.8	1	33.581			
T9 140.00-120.00	0.89	8.15	A	0.095	2.983	10	0.8	1	35.331	1.86	93.06	C
			B	0.095	2.983		0.8	1	35.331			
			C	0.095	2.983		0.8	1	35.331			
T10 120.00-100.00	0.94	9.14	A	0.095	2.984	10	0.8	1	37.612	1.91	95.71	C
			B	0.095	2.984		0.8	1	37.612			
			C	0.095	2.984		0.8	1	37.612			
T11 100.00-80.00	0.97	10.06	A	0.093	2.99	10	0.8	1	39.504	1.91	95.73	C
			B	0.093	2.99		0.8	1	39.504			
			C	0.093	2.99		0.8	1	39.504			
T12 80.00-60.00	0.97	10.53	A	0.099	2.97	9	0.8	1	45.276	1.94	97.18	C
			B	0.099	2.97		0.8	1	45.276			
			C	0.099	2.97		0.8	1	45.276			
T13 60.00-40.00	0.98	11.54	A	0.098	2.974	9	0.8	1	47.478	1.87	93.34	C
			B	0.098	2.974		0.8	1	47.478			
			C	0.098	2.974		0.8	1	47.478			
T14 40.00-20.00	0.98	11.76	A	0.094	2.987	8	0.8	1	48.638	1.71	85.27	C
			B	0.094	2.987		0.8	1	48.638			
			C	0.094	2.987		0.8	1	48.638			
T15 20.00-0.00	0.98	11.99	A	0.092	2.998	7	0.8	1	49.813	1.50	74.95	C
			B	0.092	2.998		0.8	1	49.813			
			C	0.092	2.998		0.8	1	49.813			
Sum Weight:	9.18	103.64						OTM	2899.19 kip-ft	22.41		

Tower Forces - Service - Wind 90 To Face

Section Elevation	Add Weight	Self Weight	F a c e	e	C _F	q _z	D _F	D _R	A _E	F	w	Ctrl. Face
ft	K	K				psf			ft ²	K	plf	

tnxTower Centek Engineering Inc. 63-2 North Branford Rd. Branford, CT 06405 Phone: (203) 488-0580 FAX: (203) 488-8587	Job 17159.10 - CT33XC089	Page 42 of 63
	Project U-40 x 280' - Haddam - Goose Hill, CT	Date 09:04:47 08/21/18
	Client Sprint	Designed by TJL

Section Elevation	Add Weight	Self Weight	F a c e	e	C _F	q _z	D _F	D _R	A _E	F	w	Ctrl. Face
ft	K	K				psf			ft ²	K	plf	
T1 280.00-260.00	0.08	3.18	A	0.17	2.7	12	0.85	1	33.658	1.07	53.58	C
			B	0.17	2.7		0.85	1	33.658			
			C	0.17	2.7		0.85	1	33.658			
T2 260.00-240.00	0.17	2.63	A	0.128	2.853	12	0.85	1	27.940	1.05	52.59	C
			B	0.128	2.853		0.85	1	27.940			
			C	0.128	2.853		0.85	1	27.940			
T3 240.00-220.00	0.26	3.70	A	0.163	2.723	12	0.85	1	43.197	1.54	77.24	C
			B	0.163	2.723		0.85	1	43.197			
			C	0.163	2.723		0.85	1	43.197			
T4 220.00-210.00	0.15	1.86	A	0.136	2.823	12	0.85	1	18.748	0.74	73.55	C
			B	0.136	2.823		0.85	1	18.748			
			C	0.136	2.823		0.85	1	18.748			
T5 210.00-200.00	0.16	2.09	A	0.151	2.768	12	0.85	1	22.541	0.83	83.19	C
			B	0.151	2.768		0.85	1	22.541			
			C	0.151	2.768		0.85	1	22.541			
T6 200.00-180.00	0.41	5.10	A	0.102	2.955	11	0.85	1	30.106	1.40	70.14	C
			B	0.102	2.955		0.85	1	30.106			
			C	0.102	2.955		0.85	1	30.106			
T7 180.00-160.00	0.49	5.74	A	0.099	2.969	11	0.85	1	31.707	1.51	75.64	C
			B	0.099	2.969		0.85	1	31.707			
			C	0.099	2.969		0.85	1	31.707			
T8 160.00-140.00	0.73	6.17	A	0.098	2.973	11	0.85	1	34.581	1.77	88.28	C
			B	0.098	2.973		0.85	1	34.581			
			C	0.098	2.973		0.85	1	34.581			
T9 140.00-120.00	0.89	8.15	A	0.095	2.983	10	0.85	1	36.383	1.89	94.46	C
			B	0.095	2.983		0.85	1	36.383			
			C	0.095	2.983		0.85	1	36.383			
T10 120.00-100.00	0.94	9.14	A	0.095	2.984	10	0.85	1	38.718	1.94	97.13	C
			B	0.095	2.984		0.85	1	38.718			
			C	0.095	2.984		0.85	1	38.718			
T11 100.00-80.00	0.97	10.06	A	0.093	2.99	10	0.85	1	40.665	1.94	97.16	C
			B	0.093	2.99		0.85	1	40.665			
			C	0.093	2.99		0.85	1	40.665			
T12 80.00-60.00	0.97	10.53	A	0.099	2.97	9	0.85	1	46.798	1.98	98.94	C
			B	0.099	2.97		0.85	1	46.798			
			C	0.099	2.97		0.85	1	46.798			
T13 60.00-40.00	0.98	11.54	A	0.098	2.974	9	0.85	1	49.071	1.90	95.07	C
			B	0.098	2.974		0.85	1	49.071			
			C	0.098	2.974		0.85	1	49.071			
T14 40.00-20.00	0.98	11.76	A	0.094	2.987	8	0.85	1	50.303	1.74	86.89	C
			B	0.094	2.987		0.85	1	50.303			
			C	0.094	2.987		0.85	1	50.303			
T15 20.00-0.00	0.98	11.99	A	0.092	2.998	7	0.85	1	51.553	1.53	76.42	C
			B	0.092	2.998		0.85	1	51.553			
			C	0.092	2.998		0.85	1	51.553			
Sum Weight:	9.18	103.64						OTM	2960.02 kip-ft	22.84		

Force Totals

Load Case	Vertical Forces	Sum of Forces X	Sum of Forces Z	Sum of Overturning Moments, M _x	Sum of Overturning Moments, M _z	Sum of Torques
	K	K	K	kip-ft	kip-ft	kip-ft

tnxTower Centek Engineering Inc. 63-2 North Branford Rd. Branford, CT 06405 Phone: (203) 488-0580 FAX: (203) 488-8587	Job 17159.10 - CT33XC089	Page 43 of 63
	Project U-40 x 280' - Haddam - Goose Hill, CT	Date 09:04:47 08/21/18
	Client Sprint	Designed by TJL

Load Case	Vertical Forces K	Sum of Forces X K	Sum of Forces Z K	Sum of Overturning Moments, M _x kip-ft	Sum of Overturning Moments, M _z kip-ft	Sum of Torques kip-ft
Leg Weight	57.49					
Bracing Weight	46.14					
Total Member Self-Weight	103.64			-10.48	24.16	
Total Weight	124.28			-10.48	24.16	
Wind 0 deg - No Ice		2.24	-102.66	-15080.92	-499.13	-38.65
Wind 30 deg - No Ice		50.74	-86.37	-12789.24	-7559.34	-30.55
Wind 60 deg - No Ice		84.95	-48.86	-7227.61	-12534.12	-1.06
Wind 90 deg - No Ice		99.83	-0.39	-111.98	-14740.64	29.10
Wind 120 deg - No Ice		89.92	49.58	7115.70	-13247.59	39.16
Wind 150 deg - No Ice		49.15	82.47	11899.83	-7192.02	35.63
Wind 180 deg - No Ice		-0.06	94.20	13630.45	39.81	39.26
Wind 210 deg - No Ice		-49.73	84.75	12411.89	7368.57	33.39
Wind 240 deg - No Ice		-89.45	51.89	7648.48	13172.13	-0.51
Wind 270 deg - No Ice		-97.20	1.03	226.05	14190.90	-32.24
Wind 300 deg - No Ice		-80.71	-46.34	-6653.96	11620.13	-38.21
Wind 330 deg - No Ice		-46.50	-83.15	-12073.24	6636.56	-35.33
Member Ice	183.97					
Total Weight Ice	448.67			271.06	43.33	
Wind 0 deg - Ice		0.75	-50.74	-6899.40	-105.85	2.03
Wind 30 deg - Ice		25.48	-43.50	-5900.67	-3586.83	7.37
Wind 60 deg - Ice		43.34	-24.98	-3267.29	-6098.62	12.80
Wind 90 deg - Ice		50.34	-0.23	231.10	-7094.10	14.93
Wind 120 deg - Ice		44.30	24.76	3737.55	-6230.91	11.22
Wind 150 deg - Ice		24.94	42.55	6236.77	-3480.76	3.89
Wind 180 deg - Ice		-0.03	49.00	7149.16	48.58	-0.76
Wind 210 deg - Ice		-25.09	43.12	6360.61	3598.76	-5.12
Wind 240 deg - Ice		-44.04	25.48	3882.67	6270.56	-13.25
Wind 270 deg - Ice		-49.65	0.24	326.24	7031.95	-17.27
Wind 300 deg - Ice		-42.25	-24.31	-3124.69	5948.80	-12.04
Wind 330 deg - Ice		-24.31	-42.72	-5730.31	3425.11	-3.80
Total Weight	124.28			-10.48	24.16	
Wind 0 deg - Service		0.69	-31.50	-4632.69	-148.69	-11.86
Wind 30 deg - Service		15.57	-26.50	-3929.43	-2315.30	-9.37
Wind 60 deg - Service		26.07	-14.99	-2222.71	-3841.93	-0.32
Wind 90 deg - Service		30.63	-0.12	-39.10	-4519.06	8.93
Wind 120 deg - Service		27.60	15.22	2178.90	-4060.88	12.02
Wind 150 deg - Service		15.08	25.31	3647.03	-2202.57	10.93
Wind 180 deg - Service		-0.02	28.91	4178.12	16.70	12.05
Wind 210 deg - Service		-15.26	26.01	3804.17	2265.71	10.25
Wind 240 deg - Service		-27.45	15.92	2342.40	4046.68	-0.16
Wind 270 deg - Service		-29.83	0.32	64.64	4359.32	-9.89
Wind 300 deg - Service		-24.77	-14.22	-2046.67	3570.41	-11.72
Wind 330 deg - Service		-14.27	-25.52	-3709.71	2041.08	-10.84

Load Combinations

Comb. No.	Description
1	Dead Only
2	1.2 Dead+1.6 Wind 0 deg - No Ice
3	0.9 Dead+1.6 Wind 0 deg - No Ice
4	1.2 Dead+1.6 Wind 30 deg - No Ice
5	0.9 Dead+1.6 Wind 30 deg - No Ice
6	1.2 Dead+1.6 Wind 60 deg - No Ice
7	0.9 Dead+1.6 Wind 60 deg - No Ice
8	1.2 Dead+1.6 Wind 90 deg - No Ice

tnxTower Centek Engineering Inc. 63-2 North Branford Rd. Branford, CT 06405 Phone: (203) 488-0580 FAX: (203) 488-8587	Job 17159.10 - CT33XC089	Page 44 of 63
	Project U-40 x 280' - Haddam - Goose Hill, CT	Date 09:04:47 08/21/18
	Client Sprint	Designed by TJL

Comb. No.	Description
9	0.9 Dead+1.6 Wind 90 deg - No Ice
10	1.2 Dead+1.6 Wind 120 deg - No Ice
11	0.9 Dead+1.6 Wind 120 deg - No Ice
12	1.2 Dead+1.6 Wind 150 deg - No Ice
13	0.9 Dead+1.6 Wind 150 deg - No Ice
14	1.2 Dead+1.6 Wind 180 deg - No Ice
15	0.9 Dead+1.6 Wind 180 deg - No Ice
16	1.2 Dead+1.6 Wind 210 deg - No Ice
17	0.9 Dead+1.6 Wind 210 deg - No Ice
18	1.2 Dead+1.6 Wind 240 deg - No Ice
19	0.9 Dead+1.6 Wind 240 deg - No Ice
20	1.2 Dead+1.6 Wind 270 deg - No Ice
21	0.9 Dead+1.6 Wind 270 deg - No Ice
22	1.2 Dead+1.6 Wind 300 deg - No Ice
23	0.9 Dead+1.6 Wind 300 deg - No Ice
24	1.2 Dead+1.6 Wind 330 deg - No Ice
25	0.9 Dead+1.6 Wind 330 deg - No Ice
26	1.2 Dead+1.0 Ice+1.0 Temp
27	1.2 Dead+1.0 Wind 0 deg+1.0 Ice+1.0 Temp
28	1.2 Dead+1.0 Wind 30 deg+1.0 Ice+1.0 Temp
29	1.2 Dead+1.0 Wind 60 deg+1.0 Ice+1.0 Temp
30	1.2 Dead+1.0 Wind 90 deg+1.0 Ice+1.0 Temp
31	1.2 Dead+1.0 Wind 120 deg+1.0 Ice+1.0 Temp
32	1.2 Dead+1.0 Wind 150 deg+1.0 Ice+1.0 Temp
33	1.2 Dead+1.0 Wind 180 deg+1.0 Ice+1.0 Temp
34	1.2 Dead+1.0 Wind 210 deg+1.0 Ice+1.0 Temp
35	1.2 Dead+1.0 Wind 240 deg+1.0 Ice+1.0 Temp
36	1.2 Dead+1.0 Wind 270 deg+1.0 Ice+1.0 Temp
37	1.2 Dead+1.0 Wind 300 deg+1.0 Ice+1.0 Temp
38	1.2 Dead+1.0 Wind 330 deg+1.0 Ice+1.0 Temp
39	Dead+Wind 0 deg - Service
40	Dead+Wind 30 deg - Service
41	Dead+Wind 60 deg - Service
42	Dead+Wind 90 deg - Service
43	Dead+Wind 120 deg - Service
44	Dead+Wind 150 deg - Service
45	Dead+Wind 180 deg - Service
46	Dead+Wind 210 deg - Service
47	Dead+Wind 240 deg - Service
48	Dead+Wind 270 deg - Service
49	Dead+Wind 300 deg - Service
50	Dead+Wind 330 deg - Service

Maximum Member Forces

Section No.	Elevation ft	Component Type	Condition	Gov. Load Comb.	Axial K	Major Axis Moment kip-ft	Minor Axis Moment kip-ft
T1	280 - 260	Leg	Max Tension	7	7.12	0.13	0.01
			Max. Compression	18	-11.13	2.74	-0.02
			Max. Mx	10	-10.84	2.75	-0.32
			Max. My	4	-1.02	0.01	1.82
			Max. Vy	29	-0.96	-2.53	-0.03
			Max. Vx	16	0.73	-0.04	-0.24
			Max Tension	9	5.02	-0.01	0.01
		Diagonal	Max. Compression	8	-5.20	0.00	0.00
			Max. Mx	32	-1.49	0.16	0.02
			Max. My	31	-0.07	0.14	-0.03
			Max. Vy	32	0.10	0.16	0.02

tnxTower Centek Engineering Inc. 63-2 North Branford Rd. Branford, CT 06405 Phone: (203) 488-0580 FAX: (203) 488-8587	Job 17159.10 - CT33XC089	Page 45 of 63
	Project U-40 x 280' - Haddam - Goose Hill, CT	Date 09:04:47 08/21/18
	Client Sprint	Designed by TJJ

Section No.	Elevation ft	Component Type	Condition	Gov. Load Comb.	Axial K	Major Axis Moment kip-ft	Minor Axis Moment kip-ft
T2	260 - 240	Secondary Horizontal	Max. Vx	31	0.01	0.00	0.00
			Max Tension	14	1.14	-0.05	-0.00
			Max. Compression	3	-1.47	0.11	0.01
			Max. Mx	34	0.54	0.16	0.01
			Max. My	35	0.63	0.13	0.02
			Max. Vy	34	0.10	0.16	0.01
			Max. Vx	31	-0.00	0.00	0.00
			Max Tension	35	0.35	0.00	0.00
			Max. Compression	22	-0.34	0.00	0.00
			Max. Mx	26	0.27	-0.53	0.00
		Top Girt	Max. My	36	0.18	0.00	0.02
			Max. Vy	26	0.18	0.00	0.00
			Max. Vx	36	-0.01	0.00	0.00
			Max Tension	7	27.38	0.60	-0.03
			Max. Compression	18	-35.48	2.93	0.15
			Max. Mx	18	-35.48	2.93	0.15
			Max. My	4	-1.94	-0.07	-2.10
			Max. Vy	18	-0.69	2.93	0.15
			Max. Vx	12	0.53	-0.09	-2.09
			Max Tension	8	6.97	0.00	0.00
T3	240 - 220	Diagonal	Max. Compression	8	-7.08	0.00	0.00
			Max. Mx	31	1.23	0.20	0.02
			Max. My	31	-0.08	0.19	-0.03
			Max. Vy	32	0.12	0.20	-0.03
			Max. Vx	31	-0.01	0.00	0.00
			Max Tension	7	55.33	0.11	-0.06
			Max. Compression	18	-68.46	2.39	0.11
			Max. Mx	18	-50.06	3.13	0.12
			Max. My	5	-3.87	-0.07	-2.72
			Max. Vy	6	-1.00	-0.02	-0.06
		Leg	Max. Vx	8	1.17	-0.07	0.12
			Max Tension	8	11.01	0.00	0.00
			Max. Compression	8	-11.13	0.00	0.00
			Max. Mx	31	1.91	0.29	-0.04
			Max. My	35	-1.75	0.23	0.04
			Max. Vy	33	0.15	0.26	-0.04
			Max. Vx	35	-0.01	0.00	0.00
			Max Tension	33	2.76	0.00	0.00
			Max. Compression	11	-1.30	0.00	0.00
			Max. Mx	26	2.45	-1.33	0.00
Top Girt	Max. My	36	2.55	0.00	0.04		
	Max. Vy	26	0.33	0.00	0.00		
	Max. Vx	36	-0.01	0.00	0.00		
	Max Tension	33	2.60	0.00	0.00		
	Max. Compression	19	-1.51	0.00	0.00		
	Max. Mx	26	2.22	-0.82	0.00		
	Max. My	36	2.41	0.00	0.02		
	Max. Vy	26	0.19	0.00	0.00		
	Max. Vx	36	-0.01	0.00	0.00		
	Max Tension	33	2.60	0.00	0.00		
Mid Girt	Max. Compression	19	-1.51	0.00	0.00		
	Max. Mx	26	2.22	-0.82	0.00		
	Max. My	36	2.41	0.00	0.02		
	Max. Vy	26	0.19	0.00	0.00		
	Max. Vx	36	-0.01	0.00	0.00		
	Max Tension	7	73.87	0.07	-0.07		
	Max. Compression	18	-89.52	3.03	-0.20		
	Max. Mx	18	-89.52	3.03	-0.20		
	Max. My	16	-3.04	-0.25	2.09		
	Max. Vy	6	-0.96	0.00	-0.07		
Leg	Max. Vx	10	-1.31	-0.09	-1.41		
	Max Tension	8	13.28	0.00	0.00		
	Max. Compression	8	-13.40	0.00	0.00		
	Max. Mx	35	2.98	0.34	-0.04		
	Max. My	36	1.63	0.32	0.05		
	Max. Vy	34	0.16	0.34	0.04		
	Diagonal	Max. Mx	35	2.98	0.34	-0.04	
		Max. My	36	1.63	0.32	0.05	
		Max. Vy	34	0.16	0.34	0.04	

tnxTower Centek Engineering Inc. 63-2 North Branford Rd. Branford, CT 06405 Phone: (203) 488-0580 FAX: (203) 488-8587	Job 17159.10 - CT33XC089	Page 46 of 63
	Project U-40 x 280' - Haddam - Goose Hill, CT	Date 09:04:47 08/21/18
	Client Sprint	Designed by TJJ

Section No.	Elevation ft	Component Type	Condition	Gov. Load Comb.	Axial K	Major Axis Moment kip-ft	Minor Axis Moment kip-ft		
T5	210 - 200	Leg	Max. Vx	31	-0.01	0.00	0.00		
			Max Tension	7	93.09	-0.26	0.14		
			Max. Compression	18	-110.94	7.85	-0.62		
			Max. Mx	6	91.07	-8.51	0.42		
			Max. My	12	-3.65	-0.82	-7.24		
			Max. Vy	29	1.27	-4.53	-0.06		
		Diagonal	Max. Vx	18	1.50	-4.60	-6.45		
			Max Tension	4	13.39	0.00	0.00		
			Max. Compression	4	-13.40	0.00	0.00		
			Max. Mx	34	3.74	0.32	0.05		
			Max. My	32	-1.14	0.29	-0.06		
			Max. Vy	32	0.17	0.31	0.06		
		Secondary Horizontal	Max. Vx	32	0.01	0.00	0.00		
			Max Tension	18	1.92	0.00	0.00		
			Max. Compression	18	-1.92	0.02	0.00		
			Max. Mx	34	0.58	0.24	0.00		
			Max. My	31	-0.33	0.23	0.01		
			Max. Vy	34	0.12	0.24	0.00		
T6	200 - 180	Leg	Max. Vx	31	-0.00	0.00	0.00		
			Max Tension	7	124.22	2.56	0.41		
			Max. Compression	18	-146.64	15.08	0.15		
			Max. Mx	18	-146.64	15.08	0.15		
			Max. My	4	-11.67	0.41	-8.74		
			Max. Vy	19	-1.70	15.03	0.15		
		Diagonal	Max. Vx	10	-1.65	1.30	-1.92		
			Max Tension	4	21.15	0.00	0.00		
			Max. Compression	4	-21.64	0.00	0.00		
			Max. Mx	33	3.75	-0.70	-0.11		
			Max. My	29	-5.81	-0.66	0.12		
			Max. Vy	33	-0.25	-0.70	-0.11		
		T7	180 - 160	Leg	Max. Vx	34	-0.02	0.00	0.00
					Max Tension	7	171.85	7.90	-0.22
					Max. Compression	18	-202.38	19.66	0.25
					Max. Mx	18	-202.38	19.66	0.25
					Max. My	12	-6.77	-0.45	-10.90
					Max. Vy	6	2.36	-18.96	-0.29
Diagonal	Max. Vx			12	1.46	-0.45	-10.90		
	Max Tension			4	22.24	0.00	0.00		
	Max. Compression			4	-22.43	0.00	0.00		
	Max. Mx			33	5.28	-0.80	0.12		
	Max. My			35	0.27	-0.79	-0.12		
	Max. Vy			33	-0.27	-0.80	0.12		
T8	160 - 140			Leg	Max. Vx	35	-0.02	0.00	0.00
					Max Tension	7	218.47	0.89	-0.14
					Max. Compression	18	-257.28	19.93	-0.09
					Max. Mx	10	-252.88	19.94	-0.84
					Max. My	12	-9.53	-0.43	-13.40
					Max. Vy	11	-3.24	19.94	-0.85
		Diagonal	Max. Vx	12	2.71	-0.43	-13.40		
			Max Tension	8	25.60	0.00	0.00		
			Max. Compression	8	-26.35	0.00	0.00		
			Max. Mx	33	4.81	-1.03	0.15		
			Max. My	29	-7.82	-0.97	0.16		
			Max. Vy	33	-0.33	-1.03	0.15		
		T9	140 - 120	Leg	Max. Vx	35	-0.02	0.00	0.00
					Max Tension	7	272.28	1.81	0.13
					Max. Compression	18	-320.94	16.15	-0.26
					Max. Mx	18	-320.94	16.15	-0.26
					Max. My	12	-12.21	-0.05	-8.34
					Max. Vy	10	-1.83	15.98	-0.65

tnxTower Centek Engineering Inc. 63-2 North Branford Rd. Branford, CT 06405 Phone: (203) 488-0580 FAX: (203) 488-8587	Job 17159.10 - CT33XC089	Page 47 of 63
	Project U-40 x 280' - Haddam - Goose Hill, CT	Date 09:04:47 08/21/18
	Client Sprint	Designed by TJJ

Section No.	Elevation ft	Component Type	Condition	Gov. Load Comb.	Axial K	Major Axis Moment kip-ft	Minor Axis Moment kip-ft		
T10	120 - 100	Diagonal	Max. Vx	18	1.07	-7.68	-7.80		
			Max Tension	8	29.57	0.00	0.00		
			Max. Compression	8	-30.26	0.00	0.00		
			Max. Mx	33	7.04	-1.35	-0.19		
			Max. My	31	0.35	-1.32	0.19		
			Max. Vy	33	-0.42	-1.35	-0.19		
		Leg	Max. Vx	31	0.02	0.00	0.00		
			Max Tension	7	328.07	4.44	0.35		
			Max. Compression	18	-386.54	15.82	0.32		
			Max. Mx	18	-386.54	15.82	0.32		
			Max. My	4	-29.70	0.07	-9.16		
			Max. Vy	19	-1.86	15.80	0.32		
		Diagonal	Max. Vx	4	1.25	0.07	-9.16		
			Max Tension	4	31.76	0.00	0.00		
Max. Compression	4		-32.19	0.00	0.00				
Max. Mx	33		6.16	-1.55	0.21				
Max. My	35		0.01	-1.37	-0.22				
Max. Vy	33		-0.45	-1.55	0.21				
T11	100 - 80	Leg	Max. Vx	35	-0.03	0.00	0.00		
			Max Tension	7	384.82	2.70	-0.24		
			Max. Compression	18	-453.39	15.72	-0.07		
			Max. Mx	18	-453.39	15.72	-0.07		
			Max. My	13	-11.33	0.16	-7.72		
			Max. Vy	18	-1.50	15.72	-0.07		
		Diagonal	Max. Vx	12	0.84	0.28	-7.72		
			Max Tension	8	33.16	0.00	0.00		
			Max. Compression	8	-33.85	0.00	0.00		
			Max. Mx	33	8.74	-1.66	-0.21		
			Max. My	35	0.62	-1.64	-0.22		
			Max. Vy	33	-0.47	-1.66	-0.21		
		T12	80 - 60	Leg	Max. Vx	35	-0.03	0.00	0.00
					Max Tension	7	441.17	0.99	0.07
Max. Compression	18				-520.87	12.17	-0.10		
Max. Mx	19				-512.03	12.24	-0.11		
Max. My	8				-37.31	-0.34	10.96		
Max. Vy	6				1.21	-11.96	0.06		
Diagonal	Max. Vx			12	0.96	-0.53	-10.51		
	Max Tension			8	34.61	0.00	0.00		
	Max. Compression			8	-35.18	0.00	0.00		
	Max. Mx			33	5.93	-2.18	0.28		
	Max. My			29	-12.40	-2.07	0.29		
	Max. Vy			33	-0.56	-2.18	0.28		
T13	60 - 40			Leg	Max. Vx	35	-0.03	0.00	0.00
					Max Tension	7	496.76	0.83	0.07
		Max. Compression	18		-587.84	15.29	-0.09		
		Max. Mx	18		-587.84	15.29	-0.09		
		Max. My	8		-39.62	-1.22	6.51		
		Max. Vy	18		-1.42	15.29	-0.09		
		Diagonal	Max. Vx	8	0.83	-1.22	6.51		
			Max Tension	4	36.20	0.00	0.00		
			Max. Compression	4	-37.01	0.00	0.00		
			Max. Mx	33	11.01	-2.18	-0.28		
			Max. My	36	7.41	-2.16	-0.28		
			Max. Vy	33	-0.57	-2.18	-0.28		
		Leg	Max. Vx	36	-0.03	0.00	0.00		
			Max Tension	7	553.27	-2.25	0.10		
Max. Compression	18		-656.98	10.02	-0.01				
Max. Mx	27		-310.65	14.30	0.06				
Max. My	4		-50.32	-0.56	-15.26				
Max. Vy	35		-1.27	-10.13	-0.05				
T14	40 - 20	Leg	Max. Vx	4	1.26	-0.56	-15.26		

tnxTower Centek Engineering Inc. 63-2 North Branford Rd. Branford, CT 06405 Phone: (203) 488-0580 FAX: (203) 488-8587	Job 17159.10 - CT33XC089	Page 48 of 63
	Project U-40 x 280' - Haddam - Goose Hill, CT	Date 09:04:47 08/21/18
	Client Sprint	Designed by TJJ

Section No.	Elevation ft	Component Type	Condition	Gov. Load Comb.	Axial K	Major Axis Moment kip-ft	Minor Axis Moment kip-ft
T15	20 - 0	Diagonal	Max Tension	4	37.27	0.00	0.00
			Max. Compression	4	-37.67	0.00	0.00
			Max. Mx	33	4.53	-2.60	0.34
			Max. My	29	-15.37	-2.51	0.37
			Max. Vy	33	-0.60	-2.60	0.34
			Max. Vx	29	0.03	0.00	0.00
		Leg	Max Tension	7	605.99	-2.48	-0.06
			Max. Compression	18	-721.31	4.86	0.00
			Max. Mx	31	-355.03	8.61	0.06
			Max. My	4	-52.91	-1.44	-12.08
			Max. Vy	29	0.70	-0.95	-0.01
			Max. Vx	4	-0.95	-1.44	-12.08
		Diagonal	Max Tension	4	38.54	0.00	0.00
			Max. Compression	4	-39.86	0.00	0.00
			Max. Mx	34	14.55	-2.33	-0.29
			Max. My	35	12.43	-2.32	-0.29
			Max. Vy	34	-0.58	-2.33	-0.29
			Max. Vx	35	-0.03	0.00	0.00

Maximum Reactions

Location	Condition	Gov. Load Comb.	Vertical K	Horizontal, X K	Horizontal, Z K
Leg C	Max. Vert	18	754.78	86.52	-49.96
	Max. H _x	18	754.78	86.52	-49.96
	Max. H _z	5	-561.86	-63.29	45.47
	Min. Vert	7	-632.54	-75.82	43.77
	Min. H _x	7	-632.54	-75.82	43.77
	Min. H _z	18	754.78	86.52	-49.96
Leg B	Max. Vert	10	745.95	-86.40	-48.68
	Max. H _x	23	-581.78	72.03	40.53
	Max. H _z	25	-507.46	59.54	41.47
	Min. Vert	23	-581.78	72.03	40.53
	Min. H _x	10	745.95	-86.40	-48.68
	Min. H _z	10	745.95	-86.40	-48.68
Leg A	Max. Vert	2	747.85	-1.05	99.19
	Max. H _x	21	26.60	13.13	2.20
	Max. H _z	2	747.85	-1.05	99.19
	Min. Vert	15	-593.64	0.91	-83.77
	Min. H _x	8	54.78	-13.43	4.74
	Min. H _z	15	-593.64	0.91	-83.77

Tower Mast Reaction Summary

Load Combination	Vertical K	Shear _x K	Shear _z K	Overturning Moment, M _x kip-ft	Overturning Moment, M _z kip-ft	Torque kip-ft
Dead Only	124.28	0.00	-0.00	-10.49	24.13	-0.00
1.2 Dead+1.6 Wind 0 deg - No Ice	149.13	3.58	-164.26	-24184.37	-810.45	-61.98
0.9 Dead+1.6 Wind 0 deg - No Ice	111.85	3.58	-164.26	-24166.29	-817.11	-61.95

tnxTower Centek Engineering Inc. 63-2 North Branford Rd. Branford, CT 06405 Phone: (203) 488-0580 FAX: (203) 488-8587	Job	17159.10 - CT33XC089	Page	49 of 63
	Project	U-40 x 280' - Haddam - Goose Hill, CT	Date	09:04:47 08/21/18
	Client	Sprint	Designed by	TJL

Load Combination	Vertical K	Shear _x K	Shear _z K	Overturning Moment, M _x kip-ft	Overturning Moment, M _z kip-ft	Torque kip-ft
1.2 Dead+1.6 Wind 30 deg - No Ice	149.13	81.18	-138.19	-20508.84	-12134.49	-48.94
0.9 Dead+1.6 Wind 30 deg - No Ice	111.85	81.18	-138.19	-20493.01	-12134.19	-48.94
1.2 Dead+1.6 Wind 60 deg - No Ice	149.13	135.92	-78.18	-11588.30	-20113.50	-1.72
0.9 Dead+1.6 Wind 60 deg - No Ice	111.85	135.92	-78.18	-11578.01	-20108.32	-1.72
1.2 Dead+1.6 Wind 90 deg - No Ice	149.13	159.72	-0.62	-175.42	-23652.69	46.54
0.9 Dead+1.6 Wind 90 deg - No Ice	111.85	159.72	-0.62	-172.14	-23645.30	46.56
1.2 Dead+1.6 Wind 120 deg - No Ice	149.13	143.88	79.33	11417.14	-21257.82	62.75
0.9 Dead+1.6 Wind 120 deg - No Ice	111.85	143.88	79.33	11413.29	-21251.91	62.72
1.2 Dead+1.6 Wind 150 deg - No Ice	149.13	78.64	131.94	19090.38	-11544.88	57.15
0.9 Dead+1.6 Wind 150 deg - No Ice	111.85	78.64	131.94	19081.82	-11545.03	57.09
1.2 Dead+1.6 Wind 180 deg - No Ice	149.13	-0.10	150.71	21865.95	54.37	62.93
0.9 Dead+1.6 Wind 180 deg - No Ice	111.85	-0.10	150.71	21855.71	47.07	62.90
1.2 Dead+1.6 Wind 210 deg - No Ice	149.13	-79.57	135.60	19911.80	11809.05	53.49
0.9 Dead+1.6 Wind 210 deg - No Ice	111.85	-79.57	135.60	19902.66	11794.49	53.49
1.2 Dead+1.6 Wind 240 deg - No Ice	149.13	-143.11	83.02	12271.87	21117.38	-0.76
0.9 Dead+1.6 Wind 240 deg - No Ice	111.85	-143.11	83.02	12267.40	21097.06	-0.77
1.2 Dead+1.6 Wind 270 deg - No Ice	149.13	-155.51	1.65	367.09	22751.22	-51.58
0.9 Dead+1.6 Wind 270 deg - No Ice	111.85	-155.51	1.65	369.94	22729.96	-51.58
1.2 Dead+1.6 Wind 300 deg - No Ice	149.13	-129.14	-74.15	-10667.69	18627.67	-61.20
0.9 Dead+1.6 Wind 300 deg - No Ice	111.85	-129.14	-74.15	-10658.06	18609.05	-61.18
1.2 Dead+1.6 Wind 330 deg - No Ice	149.13	-74.40	-133.04	-19359.91	10634.65	-56.67
0.9 Dead+1.6 Wind 330 deg - No Ice	111.85	-74.40	-133.04	-19344.90	10620.92	-56.62
1.2 Dead+1.0 Ice+1.0 Temp	473.52	-0.00	-0.00	272.14	47.99	-0.00
1.2 Dead+1.0 Wind 0 deg+1.0 Ice+1.0 Temp	473.52	0.75	-50.74	-6963.60	-102.81	2.07
1.2 Dead+1.0 Wind 30 deg+1.0 Ice+1.0 Temp	473.52	25.48	-43.50	-5955.82	-3615.62	7.62
1.2 Dead+1.0 Wind 60 deg+1.0 Ice+1.0 Temp	473.52	43.34	-24.98	-3298.21	-6150.36	13.20
1.2 Dead+1.0 Wind 90 deg+1.0 Ice+1.0 Temp	473.52	50.34	-0.23	232.24	-7155.02	15.38
1.2 Dead+1.0 Wind 120 deg+1.0 Ice+1.0 Temp	473.52	44.30	24.76	3770.70	-6283.89	11.61
1.2 Dead+1.0 Wind 150 deg+1.0 Ice+1.0 Temp	473.52	24.94	42.55	6292.68	-3508.43	4.09
1.2 Dead+1.0 Wind 180 deg+1.0 Ice+1.0 Temp	473.52	-0.03	49.00	7213.40	53.26	-0.78
1.2 Dead+1.0 Wind 210 deg+1.0 Ice+1.0 Temp	473.52	-25.09	43.12	6417.88	3636.03	-5.37

tnxTower Centek Engineering Inc. 63-2 North Branford Rd. Branford, CT 06405 Phone: (203) 488-0580 FAX: (203) 488-8587	Job 17159.10 - CT33XC089	Page 50 of 63
	Project U-40 x 280' - Haddam - Goose Hill, CT	Date 09:04:47 08/21/18
	Client Sprint	Designed by TJL

Load Combination	Vertical K	Shear _x K	Shear _z K	Overturning Moment, M _x kip-ft	Overturning Moment, M _z kip-ft	Torque kip-ft
1.2 Dead+1.0 Wind 240 deg+1.0 Ice+1.0 Temp	473.52	-44.04	25.48	3917.38	6332.33	-13.66
1.2 Dead+1.0 Wind 270 deg+1.0 Ice+1.0 Temp	473.52	-49.65	0.24	328.42	7100.51	-17.71
1.2 Dead+1.0 Wind 300 deg+1.0 Ice+1.0 Temp	473.52	-42.25	-24.31	-3154.04	6007.20	-12.40
1.2 Dead+1.0 Wind 330 deg+1.0 Ice+1.0 Temp	473.52	-24.31	-42.72	-5783.58	3460.44	-3.99
Dead+Wind 0 deg - Service	124.28	0.69	-31.50	-4644.70	-136.76	-11.88
Dead+Wind 30 deg - Service	124.28	15.57	-26.50	-3940.03	-2307.78	-9.39
Dead+Wind 60 deg - Service	124.28	26.07	-14.99	-2229.78	-3837.52	-0.33
Dead+Wind 90 deg - Service	124.28	30.63	-0.12	-41.69	-4516.06	8.93
Dead+Wind 120 deg - Service	124.28	27.59	15.22	2180.82	-4056.94	12.03
Dead+Wind 150 deg - Service	124.28	15.08	25.31	3651.94	-2194.79	10.96
Dead+Wind 180 deg - Service	124.28	-0.02	28.91	4184.10	29.03	12.07
Dead+Wind 210 deg - Service	124.28	-15.26	26.01	3809.44	2282.67	10.26
Dead+Wind 240 deg - Service	124.28	-27.45	15.92	2344.70	4067.28	-0.15
Dead+Wind 270 deg - Service	124.28	-29.83	0.32	62.30	4380.52	-9.89
Dead+Wind 300 deg - Service	124.28	-24.77	-14.22	-2053.31	3589.94	-11.74
Dead+Wind 330 deg - Service	124.28	-14.27	-25.52	-3719.78	2057.49	-10.86

Solution Summary

Load Comb.	Sum of Applied Forces			Sum of Reactions			% Error
	PX K	PY K	PZ K	PX K	PY K	PZ K	
1	0.00	-124.28	0.00	-0.00	124.28	0.00	0.000%
2	3.58	-149.13	-164.26	-3.58	149.13	164.26	0.000%
3	3.58	-111.85	-164.26	-3.58	111.85	164.26	0.000%
4	81.18	-149.13	-138.19	-81.18	149.13	138.19	0.000%
5	81.18	-111.85	-138.19	-81.18	111.85	138.19	0.000%
6	135.92	-149.13	-78.18	-135.92	149.13	78.18	0.000%
7	135.92	-111.85	-78.18	-135.92	111.85	78.18	0.000%
8	159.72	-149.13	-0.62	-159.72	149.13	0.62	0.000%
9	159.72	-111.85	-0.62	-159.72	111.85	0.62	0.000%
10	143.88	-149.13	79.33	-143.88	149.13	-79.33	0.000%
11	143.88	-111.85	79.33	-143.88	111.85	-79.33	0.000%
12	78.64	-149.13	131.94	-78.64	149.13	-131.94	0.000%
13	78.64	-111.85	131.94	-78.64	111.85	-131.94	0.000%
14	-0.10	-149.13	150.71	0.10	149.13	-150.71	0.000%
15	-0.10	-111.85	150.71	0.10	111.85	-150.71	0.000%
16	-79.57	-149.13	135.60	79.57	149.13	-135.60	0.000%
17	-79.57	-111.85	135.60	79.57	111.85	-135.60	0.000%
18	-143.11	-149.13	83.02	143.11	149.13	-83.02	0.000%
19	-143.11	-111.85	83.02	143.11	111.85	-83.02	0.000%
20	-155.51	-149.13	1.65	155.51	149.13	-1.65	0.001%
21	-155.51	-111.85	1.65	155.51	111.85	-1.65	0.000%
22	-129.14	-149.13	-74.15	129.14	149.13	74.15	0.000%
23	-129.14	-111.85	-74.15	129.14	111.85	74.15	0.000%
24	-74.40	-149.13	-133.04	74.40	149.13	133.04	0.000%
25	-74.40	-111.85	-133.04	74.40	111.85	133.04	0.000%
26	0.00	-473.52	0.00	0.00	473.52	0.00	0.000%
27	0.75	-473.52	-50.74	-0.75	473.52	50.74	0.000%
28	25.48	-473.52	-43.50	-25.48	473.52	43.50	0.000%
29	43.34	-473.52	-24.98	-43.34	473.52	24.98	0.000%
30	50.34	-473.52	-0.23	-50.34	473.52	0.23	0.000%
31	44.30	-473.52	24.76	-44.30	473.52	-24.76	0.000%
32	24.94	-473.52	42.55	-24.94	473.52	-42.55	0.000%

tnxTower Centek Engineering Inc. 63-2 North Branford Rd. Branford, CT 06405 Phone: (203) 488-0580 FAX: (203) 488-8587	Job 17159.10 - CT33XC089	Page 51 of 63
	Project U-40 x 280' - Haddam - Goose Hill, CT	Date 09:04:47 08/21/18
	Client Sprint	Designed by TJL

Load Comb.	Sum of Applied Forces			Sum of Reactions			% Error
	PX K	PY K	PZ K	PX K	PY K	PZ K	
33	-0.03	-473.52	49.00	0.03	473.52	-49.00	0.000%
34	-25.09	-473.52	43.12	25.09	473.52	-43.12	0.000%
35	-44.04	-473.52	25.48	44.04	473.52	-25.48	0.000%
36	-49.65	-473.52	0.24	49.65	473.52	-0.24	0.000%
37	-42.25	-473.52	-24.31	42.25	473.52	24.31	0.000%
38	-24.31	-473.52	-42.72	24.31	473.52	42.72	0.000%
39	0.69	-124.28	-31.50	-0.69	124.28	31.50	0.000%
40	15.57	-124.28	-26.50	-15.57	124.28	26.50	0.000%
41	26.07	-124.28	-14.99	-26.07	124.28	14.99	0.000%
42	30.63	-124.28	-0.12	-30.63	124.28	0.12	0.000%
43	27.60	-124.28	15.22	-27.59	124.28	-15.22	0.000%
44	15.08	-124.28	25.31	-15.08	124.28	-25.31	0.000%
45	-0.02	-124.28	28.91	0.02	124.28	-28.91	0.000%
46	-15.26	-124.28	26.01	15.26	124.28	-26.01	0.000%
47	-27.45	-124.28	15.92	27.45	124.28	-15.92	0.000%
48	-29.83	-124.28	0.32	29.83	124.28	-0.32	0.000%
49	-24.77	-124.28	-14.22	24.77	124.28	14.22	0.000%
50	-14.27	-124.28	-25.52	14.27	124.28	25.52	0.000%

Non-Linear Convergence Results

Load Combination	Converged?	Number of Cycles	Displacement Tolerance	Force Tolerance
1	Yes	6	0.0000001	0.00005779
2	Yes	9	0.0000001	0.00005197
3	Yes	9	0.0000001	0.00004982
4	Yes	9	0.0000001	0.00005376
5	Yes	9	0.0000001	0.00005157
6	Yes	9	0.0000001	0.00005512
7	Yes	9	0.0000001	0.00005291
8	Yes	9	0.0000001	0.00005377
9	Yes	9	0.0000001	0.00005158
10	Yes	9	0.0000001	0.00005202
11	Yes	9	0.0000001	0.00004985
12	Yes	9	0.0000001	0.00005317
13	Yes	9	0.0000001	0.00005099
14	Yes	9	0.0000001	0.00005456
15	Yes	9	0.0000001	0.00005235
16	Yes	9	0.0000001	0.00005346
17	Yes	9	0.0000001	0.00005126
18	Yes	9	0.0000001	0.00005205
19	Yes	9	0.0000001	0.00004987
20	Yes	9	0.0000001	0.00005341
21	Yes	9	0.0000001	0.00005122
22	Yes	9	0.0000001	0.00005446
23	Yes	9	0.0000001	0.00005228
24	Yes	9	0.0000001	0.00005310
25	Yes	9	0.0000001	0.00005094
26	Yes	7	0.0000001	0.00010574
27	Yes	9	0.0000001	0.00005244
28	Yes	9	0.0000001	0.00005359
29	Yes	9	0.0000001	0.00005475
30	Yes	9	0.0000001	0.00005614
31	Yes	9	0.0000001	0.00005709
32	Yes	9	0.0000001	0.00005706
33	Yes	9	0.0000001	0.00005728

tnxTower Centek Engineering Inc. 63-2 North Branford Rd. Branford, CT 06405 Phone: (203) 488-0580 FAX: (203) 488-8587	Job	17159.10 - CT33XC089	Page	52 of 63
	Project	U-40 x 280' - Haddam - Goose Hill, CT	Date	09:04:47 08/21/18
	Client	Sprint	Designed by	TJL

34	Yes	9	0.00000001	0.00005741
35	Yes	9	0.00000001	0.00005665
36	Yes	9	0.00000001	0.00005440
37	Yes	9	0.00000001	0.00005210
38	Yes	9	0.00000001	0.00005124
39	Yes	9	0.00000001	0.00004795
40	Yes	9	0.00000001	0.00004820
41	Yes	9	0.00000001	0.00004817
42	Yes	9	0.00000001	0.00004824
43	Yes	9	0.00000001	0.00004809
44	Yes	9	0.00000001	0.00004750
45	Yes	9	0.00000001	0.00004753
46	Yes	9	0.00000001	0.00004811
47	Yes	9	0.00000001	0.00004837
48	Yes	9	0.00000001	0.00004788
49	Yes	9	0.00000001	0.00004717
50	Yes	9	0.00000001	0.00004720

Maximum Tower Deflections - Service Wind

Section No.	Elevation ft	Horz. Deflection in	Gov. Load Comb.	Tilt °	Twist °
T1	280 - 260	3.958	47	0.1133	0.0095
T2	260 - 240	3.447	47	0.1131	0.0091
T3	240 - 220	2.953	47	0.1077	0.0081
T4	220 - 210	2.496	47	0.0967	0.0065
T5	210 - 200	2.285	47	0.0928	0.0054
T6	200 - 180	2.081	47	0.0882	0.0048
T7	180 - 160	1.689	47	0.0797	0.0039
T8	160 - 140	1.341	47	0.0712	0.0031
T9	140 - 120	1.033	47	0.0611	0.0024
T10	120 - 100	0.775	47	0.0514	0.0019
T11	100 - 80	0.557	47	0.0425	0.0015
T12	80 - 60	0.374	47	0.0343	0.0012
T13	60 - 40	0.227	47	0.0254	0.0008
T14	40 - 20	0.118	47	0.0174	0.0005
T15	20 - 0	0.037	47	0.0088	0.0003

Critical Deflections and Radius of Curvature - Service Wind

Elevation ft	Appurtenance	Gov. Load Comb.	Deflection in	Tilt °	Twist °	Radius of Curvature ft
280.00	Beacon Extender (4') 803062	47	3.958	0.1133	0.0095	Inf
279.00	DB538	47	3.932	0.1134	0.0095	Inf
276.00	8' Solid w/ Radome	47	3.855	0.1135	0.0095	Inf
266.00	8' Solid w/ Radome	47	3.599	0.1135	0.0093	393303
261.00	10' Dipole	47	3.472	0.1132	0.0092	288810
260.00	DB589-Y	47	3.447	0.1131	0.0091	273570
255.00	DB212-1-C	47	3.321	0.1125	0.0089	213718
241.00	SD110-SFXPASNM	47	2.977	0.1081	0.0081	131819
240.00	6' Dish	47	2.953	0.1077	0.0081	128655
235.00	TMA (12"x16"x6")	47	2.835	0.1050	0.0078	116470
230.00	8' Solid w/ Radome	47	2.719	0.1021	0.0074	106926
220.00	8' Solid w/ Radome	47	2.496	0.0967	0.0065	97269

tnxTower Centek Engineering Inc. 63-2 North Branford Rd. Branford, CT 06405 Phone: (203) 488-0580 FAX: (203) 488-8587	Job 17159.10 - CT33XC089	Page 53 of 63
	Project U-40 x 280' - Haddam - Goose Hill, CT	Date 09:04:47 08/21/18
	Client Sprint	Designed by TJJ

Elevation ft	Appurtenance	Gov. Load Comb.	Deflection in	Tilt °	Twist °	Radius of Curvature ft
216.00	ANT450F10	47	2.410	0.0951	0.0060	116379
205.50	10' Solid w/ Radome	47	2.192	0.0908	0.0050	239270
200.00	TMA (12"x16"x6")	47	2.081	0.0882	0.0048	301146
197.00	6' Solid w/ Radome	47	2.020	0.0868	0.0046	247361
195.00	10' Solid w/ Radome	47	1.980	0.0859	0.0046	207202
175.00	SC479	47	1.598	0.0777	0.0037	100325
168.00	ANT450F6	47	1.475	0.0748	0.0034	116606
163.00	6' Solid w/ Radome	47	1.391	0.0726	0.0032	131490
155.00	APXVTM14	47	1.260	0.0688	0.0029	122142
145.00	LNX-6515DS	47	1.106	0.0636	0.0025	94420
130.00	KRECO CO-36A	47	0.898	0.0561	0.0021	102552
128.00	3' Pivot Side Arm (50" pipe)	47	0.873	0.0552	0.0021	107034
126.00	PR-950	47	0.848	0.0542	0.0020	111926
124.00	ANT450F6	47	0.823	0.0533	0.0020	117270
123.00	SBX4-W60	47	0.811	0.0528	0.0020	120024
117.00	6' Grid Dish	47	0.740	0.0500	0.0019	130638
116.00	BR-6155	47	0.729	0.0496	0.0019	131152
104.00	6' Solid w/ Radome	47	0.598	0.0442	0.0016	135755
97.00	BR-6155	47	0.527	0.0413	0.0015	137075
55.00	5-ft dipole	47	0.197	0.0233	0.0008	133180
50.00	ANT790F2	47	0.169	0.0213	0.0007	158820

Maximum Tower Deflections - Design Wind

Section No.	Elevation ft	Horz. Deflection in	Gov. Load Comb.	Tilt °	Twist °
T1	280 - 260	20.517	18	0.5855	0.0496
T2	260 - 240	17.875	18	0.5846	0.0476
T3	240 - 220	15.324	18	0.5566	0.0421
T4	220 - 210	12.961	18	0.5004	0.0341
T5	210 - 200	11.866	18	0.4809	0.0280
T6	200 - 180	10.807	18	0.4571	0.0249
T7	180 - 160	8.778	18	0.4134	0.0204
T8	160 - 140	6.971	18	0.3696	0.0161
T9	140 - 120	5.373	18	0.3170	0.0124
T10	120 - 100	4.032	18	0.2671	0.0101
T11	100 - 80	2.897	18	0.2209	0.0079
T12	80 - 60	1.946	18	0.1782	0.0060
T13	60 - 40	1.184	18	0.1319	0.0044
T14	40 - 20	0.613	18	0.0903	0.0029
T15	20 - 0	0.195	18	0.0458	0.0014

Critical Deflections and Radius of Curvature - Design Wind

Elevation ft	Appurtenance	Gov. Load Comb.	Deflection in	Tilt °	Twist °	Radius of Curvature ft
280.00	Beacon Extender (4') 803062	18	20.517	0.5855	0.0496	219815
279.00	DB538	18	20.384	0.5856	0.0495	219815
276.00	8' Solid w/ Radome	18	19.986	0.5862	0.0494	219815
266.00	8' Solid w/ Radome	18	18.663	0.5865	0.0485	78505

tnxTower Centek Engineering Inc. 63-2 North Branford Rd. Branford, CT 06405 Phone: (203) 488-0580 FAX: (203) 488-8587	Job	17159.10 - CT33XC089	Page	54 of 63
	Project	U-40 x 280' - Haddam - Goose Hill, CT	Date	09:04:47 08/21/18
	Client	Sprint	Designed by	TJL

Elevation	Appurtenance	Gov. Load Comb.	Deflection in	Tilt °	Twist °	Radius of Curvature ft
261.00	10' Dipole	18	18.006	0.5851	0.0477	57559
260.00	DB589-Y	18	17.875	0.5846	0.0476	54450
255.00	DB212-1-C	18	17.225	0.5811	0.0465	42096
241.00	SD110-SFXPASNM	18	15.448	0.5590	0.0424	25543
240.00	6' Dish	18	15.324	0.5566	0.0421	24939
235.00	TMA (12"x16"x6")	18	14.712	0.5430	0.0405	22729
230.00	8' Solid w/ Radome	18	14.114	0.5280	0.0388	21025
220.00	8' Solid w/ Radome	18	12.961	0.5004	0.0341	19314
216.00	ANT450F10	18	12.517	0.4923	0.0315	22982
205.50	10' Solid w/ Radome	18	11.386	0.4706	0.0263	45428
200.00	TMA (12"x16"x6")	18	10.807	0.4571	0.0249	58304
197.00	6' Solid w/ Radome	18	10.493	0.4499	0.0242	47979
195.00	10' Solid w/ Radome	18	10.285	0.4453	0.0238	40220
175.00	SC479	18	8.305	0.4031	0.0193	19475
168.00	ANT450F6	18	7.668	0.3881	0.0178	22554
163.00	6' Solid w/ Radome	18	7.228	0.3768	0.0168	25348
155.00	APXVTM14	18	6.551	0.3569	0.0151	23556
145.00	LNx-6515DS	18	5.750	0.3303	0.0132	18281
130.00	KRECO CO-36A	18	4.672	0.2915	0.0111	19811
128.00	3' Pivot Side Arm (50" pipe)	18	4.540	0.2865	0.0109	20659
126.00	PR-950	18	4.409	0.2816	0.0107	21582
124.00	ANT450F6	18	4.281	0.2768	0.0105	22588
123.00	SBX4-W60	18	4.218	0.2743	0.0104	23106
117.00	6' Grid Dish	18	3.850	0.2599	0.0098	25135
116.00	BR-6155	18	3.790	0.2575	0.0096	25244
104.00	6' Solid w/ Radome	18	3.109	0.2297	0.0083	26279
97.00	BR-6155	18	2.743	0.2144	0.0076	26526
55.00	5-ft dipole	18	1.025	0.1212	0.0040	25747
50.00	ANT790F2	18	0.878	0.1108	0.0036	30508

Bolt Design Data

Section No.	Elevation ft	Component Type	Bolt Grade	Bolt Size in	Number Of Bolts	Maximum Load per Bolt K	Allowable Load K	Ratio Load Allowable	Allowable Ratio	Criteria	
T1	280	Leg	A325N	1.0000	6	1.19	53.01	0.022	✓	1	Bolt Tension
		Diagonal	A325N	1.0000	1	5.02	26.38	0.190	✓	1	Member Bearing
		Top Girt	A325N	1.0000	1	0.35	26.38	0.013	✓	1	Member Bearing
T2	260	Leg	A325N	1.0000	6	4.56	53.01	0.086	✓	1	Bolt Tension
		Diagonal	A325N	1.0000	1	6.97	26.38	0.264	✓	1	Member Bearing
T3	240	Leg	A325N	1.0000	6	9.19	53.01	0.173	✓	1	Bolt Tension
		Diagonal	A325N	1.0000	1	11.01	21.11	0.522	✓	1	Member Bearing
		Top Girt	A325N	1.0000	1	2.76	31.66	0.087	✓	1	Member Bearing
		Mid Girt	A325N	1.0000	1	2.60	12.72	0.205	✓	1	Member Bearing
T4	220	Diagonal	A325N	1.0000	1	13.28	21.11	0.629	✓	1	Member Bearing
T5	210	Leg	A325N	1.0000	6	15.52	53.01	0.293	✓	1	Bolt Tension
		Diagonal	A325N	1.0000	1	13.39	21.11	0.634	✓	1	Member Bearing
T6	200	Leg	A325N	1.0000	12	10.35	53.01	0.195	✓	1	Bolt Tension

tnxTower Centek Engineering Inc. 63-2 North Branford Rd. Branford, CT 06405 Phone: (203) 488-0580 FAX: (203) 488-8587	Job 17159.10 - CT33XC089	Page 55 of 63
	Project U-40 x 280' - Haddam - Goose Hill, CT	Date 09:04:47 08/21/18
	Client Sprint	Designed by TJL

Section No.	Elevation ft	Component Type	Bolt Grade	Bolt Size in	Number Of Bolts	Maximum Load per Bolt K	Allowable Load K	Ratio Load Allowable	Allowable Ratio	Criteria	
T7	180	Diagonal	A325N	0.8750	1	21.15	36.98	0.572	✓	1	Gusset Bearing
		Leg	A325N	1.0000	12	14.32	53.01	0.270	✓	1	Bolt Tension
T8	160	Diagonal	A325N	0.8750	1	22.24	36.98	0.602	✓	1	Gusset Bearing
		Leg	A325N	1.0000	12	18.21	53.01	0.343	✓	1	Bolt Tension
T9	140	Diagonal	A325N	0.8750	1	25.60	36.98	0.692	✓	1	Gusset Bearing
		Leg	A325N	1.0000	12	22.69	53.01	0.428	✓	1	Bolt Tension
T10	120	Diagonal	A325N	0.8750	1	29.57	36.98	0.800	✓	1	Gusset Bearing
		Leg	A325N	1.0000	12	27.34	53.01	0.516	✓	1	Bolt Tension
T11	100	Diagonal	A325N	0.8750	2	16.09	48.71	0.330	✓	1	Bolt Shear
		Leg	A325N	1.2500	12	32.07	82.83	0.387	✓	1	Bolt Tension
T12	80	Diagonal	A325N	0.8750	2	16.92	48.71	0.347	✓	1	Bolt Shear
		Leg	A325N	1.2500	12	36.76	82.83	0.444	✓	1	Bolt Tension
T13	60	Diagonal	A325N	0.8750	2	17.59	48.71	0.361	✓	1	Bolt Shear
		Leg	A325N	1.2500	12	41.40	82.83	0.500	✓	1	Bolt Tension
T14	40	Diagonal	A325N	0.8750	2	18.50	48.71	0.380	✓	1	Bolt Shear
		Leg	A325N	1.2500	12	46.11	82.83	0.557	✓	1	Bolt Tension
T15	20	Diagonal	A325N	0.8750	2	18.83	48.71	0.387	✓	1	Bolt Shear
		Leg	F1554-10 5	1.2500	12	50.50	86.29	0.585	✓	1	Bolt Tension
		Diagonal	A325N	0.8750	2	19.93	48.71	0.409	✓	1	Bolt Shear

Compression Checks

Leg Design Data (Compression)

Section No.	Elevation ft	Size	L ft	L _u ft	Kl/r	A in ²	P _u K	φP _n K	Ratio P _u / φP _n
T1	280 - 260	#12ZG - 1.25" - 1.00" conn. (Pirod 207628)	20.03	10.02	45.0 K=1.00	3.6816	-11.13	142.87	0.078 ¹ ✓
T2	260 - 240	#12ZG - 1.25" - 1.00" conn. (Pirod 207628)	20.03	10.02	45.0 K=1.00	3.6816	-35.48	142.87	0.248 ¹ ✓
T3	240 - 220	#12ZG - 1.25" - 1.00" conn. (Pirod 207628)	20.03	10.02	45.0 K=1.00	3.6816	-68.46	142.87	0.479 ¹ ✓
T4	220 - 210	#12ZG - 1.75" - 1.00" conn. (Pirod 195557)	10.02	10.02	31.9 K=1.00	7.2158	-89.52	301.49	0.297 ¹ ✓
T5	210 - 200	#12ZG - 1.75" - 1.00" conn. (Pirod 195557)	10.02	10.02	31.9 K=1.00	7.2158	-110.94	301.49	0.368 ¹ ✓
T6	200 - 180	#12ZG - 2.00" - 0.875" conn.-Trans (Pirod 211843)	20.03	20.03	48.8 K=1.00	9.4248	-146.63	356.29	0.412 ¹ ✓
T7	180 - 160	#12ZG - 2.25" - 0.875" conn.	20.03	20.03	48.8	11.9282	-202.38	451.15	0.449 ¹ ✓

tnxTower Centek Engineering Inc. 63-2 North Branford Rd. Branford, CT 06405 Phone: (203) 488-0580 FAX: (203) 488-8587	Job	17159.10 - CT33XC089	Page	56 of 63
	Project	U-40 x 280' - Haddam - Goose Hill, CT	Date	09:04:47 08/21/18
	Client	Sprint	Designed by	TJL

Section No.	Elevation ft	Size	L ft	L _u ft	Kl/r	A in ²	P _u K	φP _n K	Ratio P _u / φP _n
		(Pirod 208334)			K=1.00				✓
T8	160 - 140	#12ZG -2.25" - 0.875" conn. (Pirod 208334)	20.03	20.03	48.8	11.9282	-257.28	451.15	0.570 ¹ ✓
T9	140 - 120	#12ZG - 2.50" - 0.875" conn. (Pirod 208335)	20.03	20.03	48.7	14.7262	-320.94	557.27	0.576 ¹ ✓
T10	120 - 100	#12ZG -2.75"-0.875 -DB-0.625"-HP- (Pirod 238706)	20.03	20.03	48.6	17.8187	-386.54	674.68	0.573 ¹ ✓
T11	100 - 80	#12ZG -3.00"-0.875 -DB-0.625"-HP-Trans- (Pirod 238707)	20.03	20.03	48.5	21.2057	-453.39	803.44	0.564 ¹ ✓
T12	80 - 60	#12ZG -3.00"-0.875 -DB-0.625"-HP- (Pirod 238708)	20.03	20.03	48.5	21.2057	-520.87	803.44	0.648 ¹ ✓
T13	60 - 40	#12ZG -3.25"-0.875 -DB-0.625"-HP- (Pirod 238709)	20.03	20.03	48.4	24.8873	-587.84	943.57	0.623 ¹ ✓
T14	40 - 20	#12ZG -3.25"-0.875 -DB-0.625"-HP- (Pirod 238709)	20.03	20.03	48.4	24.8873	-656.98	943.57	0.696 ¹ ✓
T15	20 - 0	#12ZG -3.25"-0.875 -DB-0.625"-HP- (Pirod 238709)	20.03	20.03	48.4	24.8873	-721.31	943.57	0.764 ¹ ✓

¹ P_u / φP_n controls

Truss-Leg Diagonal Data

Section No.	Elevation ft	Diagonal Size	L _d ft	Kl/r	φP _n K	A in ²	V _u K	φV _n K	Stress Ratio
T1	280 - 260	0.5	1.48	99.1	165.67	0.1963	0.96	4.85	0.198
T2	260 - 240	0.5	1.48	99.1	165.67	0.1963	0.70	4.85	0.145 ✓
T3	240 - 220	0.5	1.48	99.1	165.67	0.1963	1.23	4.85	0.254 ✓
T4	220 - 210	0.5	1.44	96.9	324.71	0.1963	1.40	5.03	0.281 ✓
T5	210 - 200	0.5	1.44	96.9	324.71	0.1963	1.67	5.03	0.334 ✓
T6	200 - 180	0.5	1.39	93.2	424.12	0.1963	1.94	4.67	0.419 ✓
T7	180 - 160	0.5	1.38	92.4	536.77	0.1963	2.36	4.71	0.502 ✓
T8	160 - 140	0.5	1.38	92.4	536.77	0.1963	3.24	4.71	0.688 ✓
T9	140 - 120	0.5	1.36	91.6	662.68	0.1963	1.83	4.75	0.387 ✓
T10	120 - 100	0.625	1.35	72.6	801.84	0.3068	1.87	8.74	0.214 ✓
T11	100 - 80	0.625	1.34	72.0	954.26	0.3068	1.50	8.78	0.171 ✓

tnxTower Centek Engineering Inc. 63-2 North Branford Rd. Branford, CT 06405 Phone: (203) 488-0580 FAX: (203) 488-8587	Job 17159.10 - CT33XC089	Page 57 of 63
	Project U-40 x 280' - Haddam - Goose Hill, CT	Date 09:04:47 08/21/18
	Client Sprint	Designed by TJL

Section No.	Elevation ft	Diagonal Size	L_d ft	Kl/r	ϕP_n K	A in ²	V_u K	ϕV_n K	Stress Ratio
T12	80 - 60	0.625	1.34	72.0	954.26	0.3068	1.19	8.78	0.141
T13	60 - 40	0.625	1.33	71.4	1119.93	0.3068	1.42	8.82	0.161
T14	40 - 20	0.625	1.33	71.4	1119.93	0.3068	1.29	8.82	0.153
T15	20 - 0	0.625	1.33	71.4	1119.93	0.3068	0.93	8.82	0.112

Diagonal Design Data (Compression)

Section No.	Elevation ft	Size	L ft	L_u ft	Kl/r	A in ²	P_u K	ϕP_n K	Ratio $\frac{P_u}{\phi P_n}$
T1	280 - 260	L3x3x5/16	14.87	7.52	153.2 K=1.00	1.7800	-5.20	17.13	0.304 ¹
T2	260 - 240	L3x3x5/16	16.49	8.32	169.5 K=1.00	1.7800	-7.08	13.99	0.506 ¹
T3	240 - 220	L4x4x1/4	18.19	9.16	138.3 K=1.00	1.9400	-11.13	22.91	0.486 ¹
T4	220 - 210	L4x4x1/4	19.06	9.60	144.8 K=1.00	1.9400	-13.40	20.89	0.641 ¹
T5	210 - 200	L4x4x1/4	19.94	10.04	151.5 K=1.00	1.9400	-13.40	19.10	0.701 ¹
T6	200 - 180	2L3 1/2x3 1/2x1/4	27.05	13.98	153.9 K=1.00	3.3800	-21.64	32.22	0.672 ¹
T7	180 - 160	2L3 1/2x3 1/2x1/4	28.50	14.68	161.6 K=1.00	3.3800	-22.43	29.23	0.768 ¹
T8	160 - 140	2L4x4x1/4	30.01	15.42	148.0 K=1.00	3.8800	-26.35	40.02	0.659 ¹
T9	140 - 120	2L4x4x3/8	31.57	16.18	157.9 K=1.00	5.7200	-30.26	51.84	0.584 ¹
T10	120 - 100	2L4x4x3/8	33.18	16.87	154.0 K=0.94	5.7200	-32.19	54.49	0.591 ¹
T11	100 - 80	2L4x4x3/8	34.84	17.68	160.1 K=0.93	5.7200	-33.85	50.44	0.671 ¹
T12	80 - 60	2L5x5x5/16	36.52	18.52	136.4 K=0.96	6.0500	-35.18	73.41	0.479 ¹
T13	60 - 40	2L5x5x5/16	38.24	19.37	141.4 K=0.96	6.0500	-37.01	68.35	0.541 ¹
T14	40 - 20	2L5x5x5/16	39.98	20.23	146.4 K=0.95	6.0500	-37.67	63.73	0.591 ¹
T15	20 - 0	2L5x5x5/16	41.75	21.11	151.6 K=0.94	6.0500	-39.86	59.50	0.670 ¹

¹ $P_u / \phi P_n$ controls

Secondary Horizontal Design Data (Compression)

tnxTower Centek Engineering Inc. 63-2 North Branford Rd. Branford, CT 06405 Phone: (203) 488-0580 FAX: (203) 488-8587	Job 17159.10 - CT33XC089	Page 58 of 63
	Project U-40 x 280' - Haddam - Goose Hill, CT	Date 09:04:47 08/21/18
	Client Sprint	Designed by TJL

Section No.	Elevation ft	Size	L ft	L _u ft	Kl/r	A in ²	P _u K	φP _n K	Ratio $\frac{P_u}{\phi P_n}$
T1	280 - 260	L2 1/2x2 1/2x5/16	12.48	11.48	157.5 K=0.87	1.4600	-1.47	13.29	0.111 ¹ ✓
T5	210 - 200	L2 1/2x2 1/2x3/16	19.49	18.49	221.6 K=0.78	0.9020	-1.92	4.15	0.464 ¹ ✓

¹ P_u / φP_n controls

Top Girt Design Data (Compression)

Section No.	Elevation ft	Size	L ft	L _u ft	Kl/r	A in ²	P _u K	φP _n K	Ratio $\frac{P_u}{\phi P_n}$
T1	280 - 260	L3 1/2x3 1/2x5/16	12.00	10.62	184.6 K=1.00	2.0900	-0.34	13.85	0.024 ¹ ✓
T3	240 - 220	L5x5x3/8	16.00	14.62	177.2 K=1.00	3.6100	-1.30	25.98	0.050 ¹ ✓

¹ P_u / φP_n controls

Mid Girt Design Data (Compression)

Section No.	Elevation ft	Size	L ft	L _u ft	Kl/r	A in ²	P _u K	φP _n K	Ratio $\frac{P_u}{\phi P_n}$
T3	240 - 220	L3x3x3/16	17.00	15.67	315.4 K=1.00	1.0900	-1.51	2.47	0.610 ¹ ✓

KL/R > 200 (C) - 47

¹ P_u / φP_n controls

Tension Checks

Leg Design Data (Tension)

Section No.	Elevation ft	Size	L ft	L _u ft	Kl/r	A in ²	P _u K	φP _n K	Ratio $\frac{P_u}{\phi P_n}$
T1	280 - 260	#12ZG - 1.25" - 1.00" conn. (Pirod 207628)	20.03	10.02	45.0	3.6816	7.12	165.67	0.043 ¹ ✓
T2	260 - 240	#12ZG - 1.25" - 1.00" conn. (Pirod 207628)	20.03	10.02	45.0	3.6816	27.38	165.67	0.165 ¹ ✓

tnxTower Centek Engineering Inc. 63-2 North Branford Rd. Branford, CT 06405 Phone: (203) 488-0580 FAX: (203) 488-8587	Job 17159.10 - CT33XC089	Page 59 of 63
	Project U-40 x 280' - Haddam - Goose Hill, CT	Date 09:04:47 08/21/18
	Client Sprint	Designed by TJL

Section No.	Elevation ft	Size	L ft	L _u ft	Kl/r	A in ²	P _u K	φP _n K	Ratio P _u / φP _n
T3	240 - 220	#12ZG - 1.25" - 1.00" conn. (Pirod 207628)	20.03	10.02	45.0	3.6816	55.11	165.67	0.333 ¹
T4	220 - 210	#12ZG - 1.75" - 1.00" conn. (Pirod 195557)	10.02	10.02	31.9	7.2158	73.87	324.71	0.227 ¹
T5	210 - 200	#12ZG - 1.75" - 1.00" conn. (Pirod 195557)	10.02	10.02	31.9	7.2158	93.09	324.71	0.287 ¹
T6	200 - 180	#12ZG -2.00" - 0.875" conn.-Trans (Pirod 211843)	20.03	20.03	48.8	9.4248	124.22	424.12	0.293 ¹
T7	180 - 160	#12ZG -2.25" - 0.875" conn. (Pirod 208334)	20.03	20.03	48.8	11.9282	171.85	536.77	0.320 ¹
T8	160 - 140	#12ZG -2.25" - 0.875" conn. (Pirod 208334)	20.03	20.03	48.8	11.9282	218.47	536.77	0.407 ¹
T9	140 - 120	#12ZG - 2.50" - 0.875" conn. (Pirod 208335)	20.03	20.03	48.7	14.7262	272.28	662.68	0.411 ¹
T10	120 - 100	#12ZG -2.75"-0.875 -DB-0.625"-HP- (Pirod 238706)	20.03	20.03	48.6	17.8187	328.07	801.84	0.409 ¹
T11	100 - 80	#12ZG -3.00"-0.875 -DB-0.625"-HP-Trans- (Pirod 238707)	20.03	20.03	48.5	21.2057	384.82	954.26	0.403 ¹
T12	80 - 60	#12ZG -3.00"-0.875 -DB-0.625"-HP- (Pirod 238708)	20.03	20.03	48.5	21.2057	441.17	954.26	0.462 ¹
T13	60 - 40	#12ZG -3.25"-0.875 -DB-0.625"-HP- (Pirod 238709)	20.03	20.03	48.4	24.8873	496.76	1119.93	0.444 ¹
T14	40 - 20	#12ZG -3.25"-0.875 -DB-0.625"-HP- (Pirod 238709)	20.03	20.03	48.4	24.8873	553.27	1119.93	0.494 ¹
T15	20 - 0	#12ZG -3.25"-0.875 -DB-0.625"-HP- (Pirod 238709)	20.03	20.03	48.4	24.8873	605.99	1119.93	0.541 ¹

¹ P_u / φP_n controls

Truss-Leg Diagonal Data

Section No.	Elevation ft	Diagonal Size	L _d ft	Kl/r	φP _n K	A in ²	V _u K	φV _n K	Stress Ratio
T1	280 - 260	0.5	1.48	99.1	165.67	0.1963	0.96	4.85	0.198
T2	260 - 240	0.5	1.48	99.1	165.67	0.1963	0.70	4.85	0.145
T3	240 - 220	0.5	1.48	99.1	165.67	0.1963	1.23	4.85	0.254
T4	220 - 210	0.5	1.44	96.9	324.71	0.1963	1.40	5.03	0.281
T5	210 - 200	0.5	1.44	96.9	324.71	0.1963	1.67	5.03	0.334
T6	200 - 180	0.5	1.39	93.2	424.12	0.1963	1.94	4.67	0.419
T7	180 - 160	0.5	1.38	92.4	536.77	0.1963	2.36	4.71	0.502

tnxTower Centek Engineering Inc. 63-2 North Branford Rd. Branford, CT 06405 Phone: (203) 488-0580 FAX: (203) 488-8587	Job 17159.10 - CT33XC089	Page 60 of 63
	Project U-40 x 280' - Haddam - Goose Hill, CT	Date 09:04:47 08/21/18
	Client Sprint	Designed by TJL

Section No.	Elevation ft	Diagonal Size	L_d ft	Kl/r	ϕP_n K	A in ²	V_u K	ϕV_n K	Stress Ratio
T8	160 - 140	0.5	1.38	92.4	536.77	0.1963	3.24	4.71	0.688
T9	140 - 120	0.5	1.36	91.6	662.68	0.1963	1.83	4.75	0.387
T10	120 - 100	0.625	1.35	72.6	801.84	0.3068	1.87	8.74	0.214
T11	100 - 80	0.625	1.34	72.0	954.26	0.3068	1.50	8.78	0.171
T12	80 - 60	0.625	1.34	72.0	954.26	0.3068	1.19	8.78	0.141
T13	60 - 40	0.625	1.33	71.4	1119.93	0.3068	1.42	8.82	0.161
T14	40 - 20	0.625	1.33	71.4	1119.93	0.3068	1.29	8.82	0.153
T15	20 - 0	0.625	1.33	71.4	1119.93	0.3068	0.93	8.82	0.112

Diagonal Design Data (Tension)

Section No.	Elevation ft	Size	L ft	L_u ft	Kl/r	A in ²	P_u K	ϕP_n K	Ratio $\frac{P_u}{\phi P_n}$
T1	280 - 260	L3x3x5/16	14.87	7.52	100.4	1.0713	5.02	46.60	0.108 ¹
T2	260 - 240	L3x3x5/16	16.49	8.32	110.8	1.0713	6.97	46.60	0.150 ¹
T3	240 - 220	L4x4x1/4	18.19	9.16	89.8	1.2441	11.01	54.12	0.204 ¹
T4	220 - 210	L4x4x1/4	19.06	9.60	94.0	1.2441	13.28	54.12	0.245 ¹
T5	210 - 200	L4x4x1/4	19.94	10.04	98.2	1.2441	13.39	54.12	0.247 ¹
T6	200 - 180	2L3 1/2x3 1/2x1/4	27.05	13.98	156.0	2.1600	21.15	93.96	0.225 ¹
T7	180 - 160	2L3 1/2x3 1/2x1/4	28.50	14.68	163.7	2.1600	22.24	93.96	0.237 ¹
T8	160 - 140	2L4x4x1/4	30.01	15.42	149.8	2.5350	25.60	110.27	0.232 ¹
T9	140 - 120	2L4x4x3/8	31.57	16.18	159.7	3.7275	29.57	162.15	0.182 ¹
T10	120 - 100	2L4x4x3/8	33.18	16.87	167.5	3.7275	31.76	162.15	0.196 ¹
T11	100 - 80	2L4x4x3/8	34.84	17.68	175.4	3.7275	33.16	162.15	0.204 ¹
T12	80 - 60	2L5x5x5/16	36.52	18.52	143.8	4.0687	34.61	176.99	0.196 ¹
T13	60 - 40	2L5x5x5/16	38.24	19.37	150.3	4.0687	36.20	176.99	0.205 ¹
T14	40 - 20	2L5x5x5/16	39.98	20.23	156.9	4.0687	37.27	176.99	0.211 ¹

tnxTower Centek Engineering Inc. 63-2 North Branford Rd. Branford, CT 06405 Phone: (203) 488-0580 FAX: (203) 488-8587	Job 17159.10 - CT33XC089	Page 61 of 63
	Project U-40 x 280' - Haddam - Goose Hill, CT	Date 09:04:47 08/21/18
	Client Sprint	Designed by TJL

Section No.	Elevation ft	Size	L ft	L _u ft	Kl/r	A in ²	P _u K	φP _n K	Ratio $\frac{P_u}{\phi P_n}$
T15	20 - 0	2L5x5x5/16	41.75	21.11	163.6	4.0687	38.54	176.99	0.218 ¹ ✓ ✓

¹ P_u / φP_n controls

Secondary Horizontal Design Data (Tension)

Section No.	Elevation ft	Size	L ft	L _u ft	Kl/r	A in ²	P _u K	φP _n K	Ratio $\frac{P_u}{\phi P_n}$
T1	280 - 260	L2 1/2x2 1/2x5/16	12.48	11.48	181.0	1.4600	1.14	47.30	0.024 ¹ ✓
T5	210 - 200	L2 1/2x2 1/2x3/16	19.49	18.49	285.1	0.9020	1.92	29.22	0.066 ¹ ✓ ✓

¹ P_u / φP_n controls

Top Girt Design Data (Tension)

Section No.	Elevation ft	Size	L ft	L _u ft	Kl/r	A in ²	P _u K	φP _n K	Ratio $\frac{P_u}{\phi P_n}$
T1	280 - 260	L3 1/2x3 1/2x5/16	12.00	10.62	122.2	1.3038	0.35	56.72	0.006 ¹ ✓
T3	240 - 220	L5x5x3/8	16.00	14.62	115.4	2.3911	2.76	104.01	0.027 ¹ ✓ ✓

¹ P_u / φP_n controls

Mid Girt Design Data (Tension)

Section No.	Elevation ft	Size	L ft	L _u ft	Kl/r	A in ²	P _u K	φP _n K	Ratio $\frac{P_u}{\phi P_n}$
T3	240 - 220	L3x3x3/16	17.00	15.67	204.5	0.6593	2.60	28.68	0.091 ¹ ✓

¹ P_u / φP_n controls

tnxTower Centek Engineering Inc. 63-2 North Branford Rd. Branford, CT 06405 Phone: (203) 488-0580 FAX: (203) 488-8587	Job 17159.10 - CT33XC089	Page 62 of 63
	Project U-40 x 280' - Haddam - Goose Hill, CT	Date 09:04:47 08/21/18
	Client Sprint	Designed by TJL

Section Capacity Table

Section No.	Elevation ft	Component Type	Size	Critical Element	P K	ϕP_{allow} K	% Capacity	Pass Fail
T1	280 - 260	Leg	#12ZG - 1.25" - 1.00" conn. (Pirod 207628)	1	-11.13	142.87	19.8	Pass
T2	260 - 240	Leg	#12ZG - 1.25" - 1.00" conn. (Pirod 207628)	25	-35.48	142.87	24.8	Pass
T3	240 - 220	Leg	#12ZG - 1.25" - 1.00" conn. (Pirod 207628)	40	-68.46	142.87	47.9	Pass
T4	220 - 210	Leg	#12ZG - 1.75" - 1.00" conn. (Pirod 195557)	61	-89.52	301.49	29.7	Pass
T5	210 - 200	Leg	#12ZG - 1.75" - 1.00" conn. (Pirod 195557)	70	-110.94	301.49	36.8	Pass
T6	200 - 180	Leg	#12ZG -2.00" - 0.875" conn.-Trans (Pirod 211843)	82	-146.63	356.29	41.9	Pass
T7	180 - 160	Leg	#12ZG -2.25" - 0.875" conn. (Pirod 208334)	91	-202.38	451.15	50.2	Pass
T8	160 - 140	Leg	#12ZG -2.25" - 0.875" conn. (Pirod 208334)	101	-252.88	451.15	68.8	Pass
T9	140 - 120	Leg	#12ZG - 2.50" - 0.875" conn. (Pirod 208335)	109	-320.94	557.27	57.6	Pass
T10	120 - 100	Leg	#12ZG -2.75"-0.875	118	-386.54	674.68	57.3	Pass
T11	100 - 80	Leg	-DB-0.625"-HP- (Pirod 238706) #12ZG -3.00"-0.875	127	-453.39	803.44	56.4	Pass
T12	80 - 60	Leg	-DB-0.625"-HP-Trans- (Pirod 238707) #12ZG -3.00"-0.875	136	-520.87	803.44	64.8	Pass
T13	60 - 40	Leg	-DB-0.625"-HP- (Pirod 238708) #12ZG -3.25"-0.875	145	-587.84	943.57	62.3	Pass
T14	40 - 20	Leg	-DB-0.625"-HP- (Pirod 238709) #12ZG -3.25"-0.875	154	-656.98	943.57	69.6	Pass
T15	20 - 0	Leg	-DB-0.625"-HP- (Pirod 238709) #12ZG -3.25"-0.875	163	-721.31	943.57	76.4	Pass
T1	280 - 260	Diagonal	L3x3x5/16	8	-5.20	17.13	30.4	Pass
T2	260 - 240	Diagonal	L3x3x5/16	29	-7.08	13.99	50.6	Pass
T3	240 - 220	Diagonal	L4x4x1/4	50	-11.13	22.91	48.6	Pass
							52.2 (b)	
T4	220 - 210	Diagonal	L4x4x1/4	65	-13.40	20.89	64.1	Pass
T5	210 - 200	Diagonal	L4x4x1/4	77	-13.40	19.10	70.1	Pass
T6	200 - 180	Diagonal	2L3 1/2x3 1/2x1/4	89	-21.64	32.22	67.2	Pass
T7	180 - 160	Diagonal	2L3 1/2x3 1/2x1/4	98	-22.43	29.23	76.8	Pass
T8	160 - 140	Diagonal	2L4x4x1/4	104	-26.35	40.02	65.9	Pass
							69.2 (b)	
T9	140 - 120	Diagonal	2L4x4x3/8	113	-30.26	51.84	58.4	Pass
							80.0 (b)	
T10	120 - 100	Diagonal	2L4x4x3/8	125	-32.19	54.49	59.1	Pass
T11	100 - 80	Diagonal	2L4x4x3/8	131	-33.85	50.44	67.1	Pass
T12	80 - 60	Diagonal	2L5x5x5/16	140	-35.18	73.41	47.9	Pass
T13	60 - 40	Diagonal	2L5x5x5/16	152	-37.01	68.35	54.1	Pass
T14	40 - 20	Diagonal	2L5x5x5/16	161	-37.67	63.73	59.1	Pass
T15	20 - 0	Diagonal	2L5x5x5/16	170	-39.86	59.50	67.0	Pass
T1	280 - 260	Secondary Horizontal	L2 1/2x2 1/2x5/16	23	-1.47	13.29	11.1	Pass
T5	210 - 200	Secondary Horizontal	L2 1/2x2 1/2x3/16	81	-1.92	4.15	46.4	Pass
T1	280 - 260	Top Girt	L3 1/2x3 1/2x5/16	6	-0.34	13.85	2.4	Pass
T3	240 - 220	Top Girt	L5x5x3/8	45	-1.30	25.98	5.0	Pass
							8.7 (b)	
T3	240 - 220	Mid Girt	L3x3x3/16	47	-1.51	2.47	61.0	Pass
							Summary	
						Leg (T15)	76.4	Pass
						Diagonal	80.0	Pass

tnxTower Centek Engineering Inc. 63-2 North Branford Rd. Branford, CT 06405 Phone: (203) 488-0580 FAX: (203) 488-8587	Job 17159.10 - CT33XC089	Page 63 of 63
	Project U-40 x 280' - Haddam - Goose Hill, CT	Date 09:04:47 08/21/18
	Client Sprint	Designed by TJL

Section No.	Elevation ft	Component Type	Size	Critical Element	P K	ϕP_{allow} K	% Capacity	Pass Fail
						(T9)		
						Secondary Horizontal	46.4	Pass
						(T5)		
						Top Girt	8.7	Pass
						(T3)		
						Mid Girt	61.0	Pass
						(T3)		
						Bolt Checks	80.0	Pass
						RATING =	80.0	Pass

Program Version 7.0.5.1 - 2/1/2016 File:J:/Jobs/1715900.WI/10_CT33XC089 West Haddam/04_Structural/Backup Documentation/Calcs/tnxTower/280' Lattice Tower Goose Hill.eri

Pier and Mat Foundation Analysis:

Input Data:

Tower Data

Overturing Moment =	OM := 24424-ft-kips	(User Input from tnxTower)
Shear Force =	S _t := 165-kip	(User Input from tnxTower)
Axial Force =	WT _t := 149-kip	(User Input from tnxTower)
Max Compression Force =	C _t := 755-kip	(User Input from tnxTower)
Max Uplift Force =	U _t := 633-kip	(User Input from tnxTower)
Tower Height =	H _t := 280-ft	(User Input)
Tower Width =	W _t := 40-ft	(User Input)
Tower Position on Foundation (1=offset, 2=centered) =	Pos _t := 1	(User Input)

Footing Data:

Overall Depth of Footing =	D _f := 6.0-ft	(User Input)
Length of Pier =	L _p := 4.25-ft	(User Input)
Extension of Pier Above Grade =	L _{pag} := 0.5-ft	(User Input)
Diameter of Pier =	d _p := 5.5-ft	(User Input)
Thickness of Footing =	T _f := 2.25-ft	(User Input)
Width of Footing =	W _f := 49.5-ft	(User Input)

Material Properties:

Concrete Compressive Strength =	f _c := 4000-psi	(User Input)
Steel Reinforcement Yield Strength =	f _y := 60000-psi	(User Input)
Internal Friction Angle of Soil =	Φ _s := 30-deg	(User Input)
Allowable Soil Bearing Capacity =	q _s := 6000-psf	(User Input)
Unit Weight of Soil =	γ _{soil} := 125-pcf	(User Input)
Unit Weight of Concrete =	γ _{conc} := 150-pcf	(User Input)
Foundation Bouyancy =	Bouyancy := 0	(User Input) (Yes=1 / No=0)
Depth to Neglect =	n := 0-ft	(User Input)
Cohesion of Clay Type Soil =	c := 0-ksf	(User Input) (Use 0 for Sandy Soil)
Seismic Zone Factor =	Z := 2	(User Input) (UBC-1997 Fig 23-2)
Coefficient of Friction Between Concrete =	μ := 0.45	(User Input)

Pier Reinforcement:

Bar Size =	$BS_{\text{pier}} := 9$	(User Input)	
Bar Diameter =	$d_{\text{bpier}} := 1.128 \cdot \text{in}$	(User Input)	
Number of Bars =	$NB_{\text{pier}} := 26$	(User Input)	
Clear Cover of Reinforcement =	$Cvr_{\text{pier}} := 3 \cdot \text{in}$	(User Input)	
Reinforcement Location Factor =	$\alpha_{\text{pier}} := 1.0$	(User Input)	(ACI-2008 12.2.4)
Coating Factor =	$\beta_{\text{pier}} := 1.0$	(User Input)	(ACI-2008 12.2.4)
Concrete Strength Factor =	$\lambda_{\text{pier}} := 1.0$	(User Input)	(ACI-2008 12.2.4)
Reinforcement Size Factor =	$\gamma_{\text{pier}} := 1.0$	(User Input)	(ACI-2008 12.2.4)
Diameter of Tie =	$d_{\text{Tie}} := 4 \cdot \text{in}$	(User Input)	

Pad Reinforcement:

Bar Size =	$BS_{\text{top}} := 11$	(User Input)	(Top of Pad)
Bar Diameter =	$d_{\text{btop}} := 1.41 \cdot \text{in}$	(User Input)	(Top of Pad)
Number of Bars =	$NB_{\text{top}} := 91$	(User Input)	(Top of Pad)
Bar Size =	$BS_{\text{bot}} := 11$	(User Input)	(Bottom of Pad)
Bar Diameter =	$d_{\text{bbot}} := 1.41 \cdot \text{in}$	(User Input)	(Bottom of Pad)
Number of Bars =	$NB_{\text{bot}} := 91$	(User Input)	(Bottom of Pad)
Clear Cover of Reinforcement =	$Cvr_{\text{pad}} := 3.0 \cdot \text{in}$	(User Input)	
Reinforcement Location Factor =	$\alpha_{\text{pad}} := 1.0$	(User Input)	(ACI-2008 12.2.4)
Coating Factor =	$\beta_{\text{pad}} := 1.0$	(User Input)	(ACI-2008 12.2.4)
Concrete Strength Factor =	$\lambda_{\text{pad}} := 1.0$	(User Input)	(ACI-2008 12.2.4)
Reinforcement Size Factor =	$\gamma_{\text{pad}} := 1.0$	(User Input)	(ACI-2008 12.2.4)

Calculated Factors:

Pier Reinforcement Bar Area =	$A_{\text{bpier}} := \frac{\pi \cdot d_{\text{bpier}}^2}{4} = 0.999 \cdot \text{in}^2$
Pad Top Reinforcement Bar Area =	$A_{\text{btop}} := \frac{\pi \cdot d_{\text{btop}}^2}{4} = 1.561 \cdot \text{in}^2$
Pad Bottom Reinforcement Bar Area =	$A_{\text{bbot}} := \frac{\pi \cdot d_{\text{bbot}}^2}{4} = 1.561 \cdot \text{in}^2$
Coefficient of Lateral Soil Pressure =	$K_p := \frac{1 + \sin(\Phi_s)}{1 - \sin(\Phi_s)} = 3$
Load Factor =	$LF := 1$

Stability of Footing:

Adjusted Concrete Unit Weight =

$$\gamma_c := \text{if}(\text{Bouyancy} = 1, \gamma_{\text{conc}} - 62.4\text{pcf}, \gamma_{\text{conc}}) = 150\text{-pcf}$$

Adjusted Soil Unit Weight =

$$\gamma_s := \text{if}(\text{Bouyancy} = 1, \gamma_{\text{soil}} - 62.4\text{pcf}, \gamma_{\text{soil}}) = 125\text{-pcf}$$

Passive Pressure =

$$P_{pn} := K_p \cdot \gamma_s \cdot n + c \cdot 2 \cdot \sqrt{K_p} = 0\text{-ksf}$$

$$P_{pt} := K_p \cdot \gamma_s \cdot (D_f - T_f) + c \cdot 2 \cdot \sqrt{K_p} = 1.406\text{-ksf}$$

$$P_{top} := \text{if}[n < (D_f - T_f), P_{pt}, P_{pn}] = 1.406\text{-ksf}$$

$$P_{bot} := K_p \cdot \gamma_s \cdot D_f + c \cdot 2 \cdot \sqrt{K_p} = 2.25\text{-ksf}$$

$$P_{ave} := \frac{P_{top} + P_{bot}}{2} = 1.828\text{-ksf}$$

$$T_p := \text{if}[n < (D_f - T_f), T_f, (D_f - n)] = 2.25\text{-ft}$$

$$A_p := W_f \cdot T_p = 111.375\text{-ft}^2$$

Ultimate Shear =

$$S_u := P_{ave} \cdot A_p = 203.607\text{-kip}$$

Weight of Concrete =

$$WT_c := \left[(W_f^2 \cdot T_f) + (3) \cdot \left(\frac{d_p^2 \cdot \pi}{4} \cdot L_p \right) \right] \cdot \gamma_c = 872.397\text{-kip}$$

Weight of Soil Above Footing =

$$WT_{s1} := \left[W_f^2 - (3) \cdot \left(\frac{d_p^2 \cdot \pi}{4} \right) \right] \cdot (L_p - L_{pag} - n) \cdot \gamma_s = 1115\text{-kip}$$

Weight of Soil Wedge at Back Face =

$$WT_{s2} := \left[\frac{(D_f - n)^2 \cdot \tan(\Phi_s)}{2} \cdot W_f \right] \cdot \gamma_s = 64.302\text{-kip}$$

Foundation has undercut toe per Fred A. Nudd dwg 96-4992-1

Tower Offset =

$$X_{t1} := \left[\frac{W_f}{2} - \frac{(W_t \cdot \cos(30\text{-deg}))}{2} \right] \quad X_{t2} := \frac{W_f}{2} - \frac{(W_t \cdot \cos(30\text{-deg}))}{3}$$

$$X_t := \text{if}(\text{Pos}_t = 1, X_{t1}, X_{t2}) = 7.429$$

$$X_{off1} := \frac{W_f}{2} - \left[\frac{(W_t \cdot \cos(30\text{-deg}))}{3} + X_t \right] = 5.774 \quad X_{off2} := 0$$

$$X_{off} := \text{if}(\text{Pos}_t = 1, X_{off1}, X_{off2}) \quad X_{off} = 5.774\text{-ft}$$

$$\text{Total Weight} = WT_{tot} = 0.9WT_c + 0.75WT_{s1} = 1621.5\text{-kip}$$

$$\text{Resisting Moment} = M_r := (WT_{tot}) \cdot \frac{W_f}{2} + 0.9WT_t \cdot \left(\frac{W_f}{2} - X_{off} \right) + 0.75 \left(S_u \cdot \frac{T_p}{3} \right) + 0.75WT_{s2} \cdot \left[W_f + \frac{(D_f - n) \cdot \tan(\Phi_s)}{3} \right] = 45235\text{-kip-ft}$$

$$\text{Overturning Moment} = M_{ot} := OM + S_t \cdot (L_p + T_f) = 25496.5\text{-kip-ft}$$

Foundation has undercut toe per Fred A. Nudd dwg 96-4992-1

$$\text{Factor of Safety Actual} = FS := \frac{M_r}{M_{ot}} = 1.77$$

$$\text{Factor of Safety Required} = FS_{req} := 1 \quad \text{OverTurning_Moment_Check} := \text{if}(FS \geq FS_{req}, \text{"Okay"}, \text{"No Good"})$$

OverTurning_Moment_Check = "Okay"

Shear Capacity in Pier:

Shear Resistance of Pier =

$$S_p := \frac{P_{ave} \cdot A_p + \mu \cdot W_{T_{tot}}}{FS_{req}} = 933.29 \text{ kips}$$

$$\text{Shear_Check} := \text{if}(S_p > S_t, \text{"Okay"}, \text{"No Good"})$$

Shear_Check = "Okay"

Bearing Pressure Caused by Footing:

Total Load =

$$\text{Load}_{tot} := W_{T_c} + W_{T_{s1}} + W_{T_t} = 2137 \text{ kip}$$

Area of the Mat =

$$A_{mat} := W_f^2 = 2.45 \times 10^3$$

Section Modulus of Mat =

$$S := \frac{W_f^3}{6} = 2.02 \times 10^4 \text{ ft}^3$$

Maximum Pressure in Mat =

$$P_{max} := \frac{\text{Load}_{tot}}{A_{mat}} + \frac{M_{ot}}{S} = 2.133 \text{ ksf}$$

$$\text{Max_Pressure_Check} := \text{if}(P_{max} < 0.75q_s, \text{"Okay"}, \text{"No Good"})$$

Max_Pressure_Check = "Okay"

Minimum Pressure in Mat =

$$P_{min} := \frac{\text{Load}_{tot}}{A_{mat}} - \frac{M_{ot}}{S} = -0.389 \text{ ksf}$$

$$\text{Min_Pressure_Check} := \text{if}((P_{min} \geq 0) \cdot (P_{min} < 0.75q_s), \text{"Okay"}, \text{"No Good"})$$

Min_Pressure_Check = "No Good"

Distance to Resultant of Pressure Distribution =

$$X_p := \frac{P_{max}}{P_{max} - P_{min}} \cdot \frac{1}{3} = 13.953$$

Distance to Kern =

$$X_k := \frac{W_f}{6} = 8.25$$

Since Resultant Force is Not in Kern, Area to which Pressure is Applied Must be Reduced.

Eccentricity =

$$e := \frac{M_{ot}}{\text{Load}_{tot}} = 11.934$$

Adjusted Soil Pressure =

$$P_a := \frac{2 \cdot \text{Load}_{tot}}{3 \cdot W_f \left(\frac{W_f}{2} - e \right)} = 2.245 \text{ ksf}$$

$$q_{adj} := \text{if}(P_{min} < 0, P_a \cdot P_{max}) = 2.245 \text{ ksf}$$

$$\text{Pressure_Check} := \text{if}(q_{adj} < 0.75q_s, \text{"Okay"}, \text{"No Good"})$$

Pressure_Check = "Okay"

Concrete Bearing Capacity:

Strength Reduction Factor =

$$\Phi_c := 0.65 \quad (\text{ACI-2008 9.3.2.2})$$

Bearing Strength Between Pier and Pad =

$$P_b := \Phi_c \cdot 0.85 \cdot f_c \cdot \frac{\pi \cdot d_p^2}{4} = 7.561 \times 10^3 \text{ kips} \quad (\text{ACI-2008 10.14})$$

$$\text{Bearing_Check} := \text{if}(P_b > LF \cdot C_t, \text{"Okay"}, \text{"No Good"})$$

Bearing_Check = "Okay"

Shear Strength of Concrete:

Beam Shear:

(Critical section located at a distance d from the face of Pier) (ACI 11.3.1.1)

$$\Phi_c := 0.85 \quad (\text{ACI 9.3.2.5})$$

$$d := T_f - C_{vr_pad} - d_{bot} = 22.59 \text{ in}$$

$$FL := LF \cdot \frac{C_t}{W_f^2} = 0.308 \text{ ksf}$$

$$V_{req} := FL \cdot (X_t - .5 \cdot d_p - d) \cdot W_f = 42.661 \text{ kips}$$

$$V_{Avail} := \Phi_c \cdot 2 \cdot \sqrt{f_c \cdot \text{psi}} \cdot W_f \cdot d = 1443 \text{ kip} \quad (\text{ACI-2008 11.2.1.1})$$

$$\text{Beam_Shear_Check} := \text{if}(V_{req} < V_{Avail}, \text{"Okay"}, \text{"No Good"})$$

Beam_Shear_Check = "Okay"

Punching Shear:

(Critical Section Located at a distance of d/2 from the face of pier) (ACI 11.11.1.2)

Critical Perimeter of Punching Shear =

$$b_o := (d_p + d) \cdot \pi = 23.2$$

Area Included Inside Perimeter =

$$A_{bo} := \frac{\pi \cdot (d_p + d)^2}{4} = 42.8$$

Required Shear Strength =

$$V_{req} := FL \cdot (W_f^2 - A_{bo}) = 742 \text{ kips}$$

Available Shear Strength =

$$V_{Avail} := \Phi_c \cdot 4 \cdot \sqrt{f_c \cdot \text{psi}} \cdot b_o \cdot d = 1351.9 \text{ kip} \quad (\text{ACI-2008 11.11.2.1})$$

$$\text{Punching_Shear_Check} := \text{if}(V_{req} < V_{Avail}, \text{"Okay"}, \text{"No Good"})$$

Punching_Shear_Check = "Okay"

Steel Reinforcement in Pad:

Required Reinforcement for Bending:

Strength Reduction Factor = $\phi_m := .90$ (ACI-2008 9.3.2.1)

Maximum Moment in Pad = $M_{max} := 12040 \text{ kip-ft}$ (User Input)

Design Moment = $M_n := \frac{LF \cdot M_{max}}{\phi_m} = 1.338 \times 10^4 \text{ kips-ft}$

$$\beta := \begin{cases} 0.85 & \text{if } 2500 \text{ psi} \leq f_c \leq 4000 \text{ psi} \\ 0.65 & \text{if } f_c > 8000 \text{ psi} \\ \left[0.85 - \left[\frac{\left(\frac{f_c}{\text{psi}} - 4000 \right)}{1000} \right] \cdot 0.5 \right] & \text{otherwise} \end{cases} = 0.85$$

(ACI-2008 10.2.7.3)

$b_{eff} := W_t \cdot \cos(30 \text{ deg}) + d_p = 481.692 \text{ in}$

$A_s := \frac{M_n}{(f_y \cdot d)} = 118.44 \text{ in}^2$

$a := \frac{A_s \cdot f_y}{\beta \cdot f_c \cdot b_{eff}} = 4.339 \text{ in}$

$A_s := \frac{M_n}{f_y \cdot \left(d - \frac{a}{2} \right)} = 131.023 \text{ in}^2$

$\rho := \frac{A_s}{b_{eff} \cdot d} = 0.14449 \text{ in}$

Required Reinforcement for Temperature and Shrinkage:

$$\rho_{sh} := \begin{cases} .0018 & \text{if } f_y \geq 60000 \text{ psi} \\ .0020 & \text{otherwise} \end{cases} = 0.0018 \quad (\text{ACI-2008 7.12.2.1})$$

Check Bottom Bars:

$$A_s := \text{if} \left(\rho \geq \rho_{sh}, A_s, \rho_{sh} \cdot \frac{b_{eff}}{2} \cdot d \right) = 131 \cdot \text{in}^2$$

$$A_{s_{prov}} := A_{bbot} \cdot NB_{bot} = 142.1 \cdot \text{in}^2$$

$$\text{Pad_Reinforcement_Bot} := \text{if} (A_{s_{prov}} > A_s, \text{"Okay"}, \text{"No Good"})$$

Pad_Reinforcement_Bot = "Okay"

Check top Bars:

$$A_s := \text{if} \left(\rho \geq \rho_{sh}, A_s, \rho_{sh} \cdot \frac{b_{eff}}{2} \cdot d \right) = 131 \cdot \text{in}^2$$

$$A_{s_{prov}} := A_{btop} \cdot NB_{top} = 142.1 \cdot \text{in}^2$$

$$\text{Pad_Reinforcement_Top} := \text{if} (A_{s_{prov}} > A_s, \text{"Okay"}, \text{"No Good"})$$

Pad_Reinforcement_Top = "Okay"

Steel Reinforcement in Pier:

Area of Pier = $A_p := \frac{\pi \cdot d_p^2}{4} = 3421.19 \cdot \text{in}^2$

$A_{smin} := 0.01 \cdot 0.5 \cdot A_p = 17.11 \cdot \text{in}^2$ (ACI-2008 10.8.4 & 10.9.1)

$A_{sprov} := N_{B_{pier}} \cdot A_{b_{pier}} = 25.98 \cdot \text{in}^2$

Steel_Area_Check := if($A_{sprov} > A_{smin}$, "Okay", "No Good")

Steel_Area_Check = "Okay"

Bar Spacing In Pier = $B_{sPier} := \frac{d_p \cdot \pi}{N_{B_{pier}}} - d_{b_{pier}} = 6.847 \cdot \text{in}$

Diameter of Reinforcement Cage = $Diam_{cage} := d_p - 2 \cdot C_{vr_{pier}} = 60 \cdot \text{in}$

Maximum Moment in Pier = $M_p := S_t(L_p) \cdot LF = 8415 \cdot \text{in} \cdot \text{kips}$

Pier Check evaluated from outside program and results are listed below;

$(D \ N \ n \ P_u \ M_{xu}) := \left(d_p^{12} \ N_{B_{pier}} \ B_{S_{pier}} \ \frac{C_t \cdot 1.333}{\text{kips}} \ \frac{M_p}{\text{in} \cdot \text{kips}} \right)$

$(D \ N \ n \ P_u \ M_{xu}) = (66 \ 26 \ 9 \ 1.006 \times 10^3 \ 8.415 \times 10^3)$

$(\phi P_n \ \phi M_{xn} \ f_{sp} \ \rho) := (0 \ 0 \ 0 \ 0)$

$(\phi P_n \ \phi M_{xn} \ f_{sp} \ \rho) := \phi P'_n (D, N, n, P_u, M_{xu})^T$

$(\phi P_n \ \phi M_{xn} \ f_{sp} \ \rho) = (5.114 \times 10^3 \ 4.276 \times 10^4 \ -26.502 \ 7.6 \times 10^{-3})$

Axial_Load_Check := if($\phi P_n \geq P_u$, "Okay", "No Good")

Axial_Load_Check = "Okay"

Bending_Check := if($\phi M_{xn} \geq M_{xu}$, "Okay", "No Good")

Bending_Check = "Okay"



Site Identification	
Cascade	CT33XC089
SMS Schedule ID	12322228
SMS Schedule Name	DO Macro Upgrade
PID	DOKU_CT33XC089
RRU OEM	ALU
Switch OEM	Alcatel-Lucent
RFDS Issue Date	2017-10-18 03:20:53.0
RFDS Revision Date	3

Filter Analysis Complete	YES
RFDS - Issue Date	
Design Status	Complete
Project Description	DO Macro Upgrade - Add 800MHz (2G + 4G) and 2500 MHz

Battery Backup Cabinet Model	
Model Number	
Weight (Lbs.)	
Dimensions (In.)	
Manufacturer	

Junction Box Model	
Model Number	
Weight (Lbs.)	
Dimensions (In.)	
Manufacturer	
Junction Boxes needed at site	

BTS #2 Model	
Model Number	
Weight (Lbs.)	
Dimensions (In.)	
Manufacturer	
Needed at site	

Contact Information	
Engineer Email	Bill.M.Hastings@sprint.com
Sprint Badged RF Engineer	Bill Hastings
RF Engineer Email	Bill.M.Hastings@sprint.com
RF Engineer Phone	978-590-9700
RF Manager	Jonathan Hull
RF Manager Email	Jonathan.B.Hull@sprint.com
RF Manager Phone	617-233-2920

Carrier Count	
2500 LTE	3
1900 LTE	1
1900 EVDO	
1900 Voice	1
800 LTE	1
800 Voice	1

UE Relay Model	
Model Number	
Weight (Lbs.)	
Dimensions (In.)	
UE Relay Azimuth	
Manufacturer	
UE Relay CL Height (meters)	

ALU Top Hat Model	
Model Number	
Weight (Lbs.)	
Dimensions (In.)	
Manufacturer	
Top Hat Quantity	

Power Protection Cabinet Model	
Model Number	
Weight (Lbs.)	
Dimensions (In.)	
Manufacturer	
Power Protection Cabinet	

Location Details	
Latitude	41.44360277
Longitude	-72.59639811
Market	Northern Connecticut
Region	Northeast
City	West Haddam
State	CT
Zip Code	CT06438
County	Middlesex

2500MHz	3
1900MHz	3
800MHz	3

GPS Antenna Model	
Model Number	
Weight (Lbs.)	
Dimensions (In.)	
Manufacturer	
GPS Antenna needed at site	

Repeater Model	
Model Number	
Weight (Lbs.)	
Dimensions (In.)	
Manufacturer	

Growth Cabinet Model	
Model Number	
Weight (Lbs.)	
Dimensions (In.)	
Manufacturer	

BTS #1 Model	
Model Number	
Weight (Lbs.)	
Dimensions (In.)	
Manufacturer	
Number of BTS #1	

A&E Drawing Requirements	
10/10/2017 (WR): RFDS revised to modify RRU location to "GM to Standard".	

Additional RF Notes Special Construction Requirements	
10/10/2017 (WR): RFDS revised to modify RRU location to "GM to Standard".	

Band: 2500	Alpha	Beta	Gamma	Delta	Epsilon	Zeta
Radio Model						
Model Number	TD-RRH8x20-25	TD-RRH8x20-25	TD-RRH8x20-25	N/A	N/A	N/A
Weight (lbs)	76.2	76.2	76.2	N/A	N/A	N/A
Dimensions	26 x 18.6 x 6.7	26 x 18.6 x 6.7	26 x 18.6 x 6.7	N/A	N/A	N/A
Manufacturer	ALU	ALU	ALU	N/A	N/A	N/A
Number of RRUs needed	1	1	1	0	0	0
Filter Model						
Model Number	N/A	N/A	N/A	N/A	N/A	N/A
Weight (lbs)	N/A	N/A	N/A	N/A	N/A	N/A
Dimensions	N/A	N/A	N/A	N/A	N/A	N/A
Manufacturer	N/A	N/A	N/A	N/A	N/A	N/A
Filter Model 2						
Model Number	N/A	N/A	N/A	N/A	N/A	N/A
Weight (lbs)	N/A	N/A	N/A	N/A	N/A	N/A
Dimensions	N/A	N/A	N/A	N/A	N/A	N/A
Manufacturer	N/A	N/A	N/A	N/A	N/A	N/A
Filter Model 3						
Model Number	N/A	N/A	N/A	N/A	N/A	N/A
Weight (lbs)	N/A	N/A	N/A	N/A	N/A	N/A
Dimensions	N/A	N/A	N/A	N/A	N/A	N/A
Manufacturer	N/A	N/A	N/A	N/A	N/A	N/A
Trunk Cable 1						
Model Number	Hybriflex	N/A	N/A	N/A	N/A	N/A
Weight (lbs.)	1	N/A	N/A	N/A	N/A	N/A
Dimensions (in.)	1.54	N/A	N/A	N/A	N/A	N/A
Manufacturer	ALU	N/A	N/A	N/A	N/A	N/A
Trunk Cable 1 Qty						
Power Junction Cylinder Model						
Model Number	N/A	N/A	N/A	N/A	N/A	N/A
Weight (lbs.)	N/A	N/A	N/A	N/A	N/A	N/A
Dimensions (in.)	N/A	N/A	N/A	N/A	N/A	N/A
Manufacturer	N/A	N/A	N/A	N/A	N/A	N/A
Power Junction Cylinder Qty	0	0	0	0	0	0
Optical Junction Cylinder Qty needed						
Model Number	N/A	N/A	N/A	N/A	N/A	N/A
Weight (lbs.)	N/A	N/A	N/A	N/A	N/A	N/A
Dimensions (in.)	N/A	N/A	N/A	N/A	N/A	N/A
Manufacturer	N/A	N/A	N/A	N/A	N/A	N/A
Optical Junction Cylinder Qty needed	0	0	0	0	0	0

Band: 1900	Alpha	Beta	Gamma	Delta	Epsilon	Zeta
Radio Model						
Model Number	RRH-4x45-1900	RRH-4x45-1900	RRH-4x45-1900	N/A	N/A	N/A
Weight (lbs)	69.5	69.5	69.5	N/A	N/A	N/A
Dimensions	25 x 12 x 12	25 x 12 x 12	25 x 12 x 12	N/A	N/A	N/A
Manufacturer	ALU	ALU	ALU	N/A	N/A	N/A
Number of RRUs needed	1	1	1	0	0	0
Filter Model						
Model Number	N/A	N/A	N/A	N/A	N/A	N/A
Weight (lbs)	N/A	N/A	N/A	N/A	N/A	N/A
Dimensions	N/A	N/A	N/A	N/A	N/A	N/A
Manufacturer	N/A	N/A	N/A	N/A	N/A	N/A
Filter Model 2						
Model Number	N/A	N/A	N/A	N/A	N/A	N/A
Weight (lbs)	N/A	N/A	N/A	N/A	N/A	N/A
Dimensions	N/A	N/A	N/A	N/A	N/A	N/A
Manufacturer	N/A	N/A	N/A	N/A	N/A	N/A
Filter Model 3						
Model Number	N/A	N/A	N/A	N/A	N/A	N/A
Weight (lbs)	N/A	N/A	N/A	N/A	N/A	N/A
Dimensions	N/A	N/A	N/A	N/A	N/A	N/A
Manufacturer	N/A	N/A	N/A	N/A	N/A	N/A
Trunk Cable 1						
Model Number	1900 Hybrid_ALU	1900 Hybrid_ALU	1900 Hybrid_ALU	N/A	N/A	N/A
Weight (lbs.)	1.1	1.1	1.1	N/A	N/A	N/A
Dimensions (in.)	1.25	1.25	1.25	N/A	N/A	N/A
Manufacturer	ALU	ALU	ALU	N/A	N/A	N/A
Trunk Cable 1 Qty						
Power Junction Cylinder Model						
Model Number	N/A	N/A	N/A	N/A	N/A	N/A
Weight (lbs.)	N/A	N/A	N/A	N/A	N/A	N/A
Dimensions (in.)	N/A	N/A	N/A	N/A	N/A	N/A
Manufacturer	N/A	N/A	N/A	N/A	N/A	N/A
Power Junction Cylinder Qty 0	0	0	0	0	0	0
Optical Junction Cylinder Qty needed						
Model Number	N/A	N/A	N/A	N/A	N/A	N/A
Weight (lbs.)	N/A	N/A	N/A	N/A	N/A	N/A
Dimensions (in.)	N/A	N/A	N/A	N/A	N/A	N/A
Manufacturer	N/A	N/A	N/A	N/A	N/A	N/A
Optical Junction Cylinder Qty needed	0	0	0	0	0	0

Band: 800	Alpha	Beta	Gamma	Delta	Epsilon	Zeta
Radio Model						
Model Number	RRH-2x50-800	RRH-2x50-800	RRH-2x50-800	N/A	N/A	N/A
Weight (lbs)	69.1	69.1	69.1	N/A	N/A	N/A
Dimensions	16 x 13 x 10	16 x 13 x 10	16 x 13 x 10	N/A	N/A	N/A
Manufacturer	ALU	ALU	ALU	N/A	N/A	N/A
Number of RRUs needed	2	2	2	0	0	0
Filter Model						
Model Number	N/A	N/A	N/A	N/A	N/A	N/A
Weight (lbs)	N/A	N/A	N/A	N/A	N/A	N/A
Dimensions	N/A	N/A	N/A	N/A	N/A	N/A
Manufacturer	N/A	N/A	N/A	N/A	N/A	N/A
Filter Model 2						
Model Number	N/A	N/A	N/A	N/A	N/A	N/A
Weight (lbs)	N/A	N/A	N/A	N/A	N/A	N/A
Dimensions	N/A	N/A	N/A	N/A	N/A	N/A
Manufacturer	N/A	N/A	N/A	N/A	N/A	N/A
Filter Model 3						
Model Number	N/A	N/A	N/A	N/A	N/A	N/A
Weight (lbs)	N/A	N/A	N/A	N/A	N/A	N/A
Dimensions	N/A	N/A	N/A	N/A	N/A	N/A
Manufacturer	N/A	N/A	N/A	N/A	N/A	N/A
Trunk Cable 1						
Model Number	N/A	N/A	N/A	N/A	N/A	N/A
Weight (lbs.)	N/A	N/A	N/A	N/A	N/A	N/A
Dimensions (in.)	N/A	N/A	N/A	N/A	N/A	N/A
Manufacturer	N/A	N/A	N/A	N/A	N/A	N/A
Trunk Cable 1 Qty						
Power Junction Cylinder Model						
Model Number	N/A	N/A	N/A	N/A	N/A	N/A
Weight (lbs.)	N/A	N/A	N/A	N/A	N/A	N/A
Dimensions (in.)	N/A	N/A	N/A	N/A	N/A	N/A
Manufacturer	N/A	N/A	N/A	N/A	N/A	N/A
Power Junction Cylinder Qty	0	0	0	0	0	0
Optical Junction Cylinder Qty needed						
Model Number	N/A	N/A	N/A	N/A	N/A	N/A
Weight (lbs.)	N/A	N/A	N/A	N/A	N/A	N/A
Dimensions (in.)	N/A	N/A	N/A	N/A	N/A	N/A
Manufacturer	N/A	N/A	N/A	N/A	N/A	N/A
Optical Junction Cylinder Qty needed	0	0	0	0	0	0

Band: 2500	Alpha	Beta	Gamma	Delta	Epsilon	Zeta
Antenna1						
Model Number	APXVTM14-ALU-I20	APXVTM14-ALU-I20	APXVTM14-ALU-I20			
Weight (lbs)	56.2	56.2	56.2	N/A	N/A	N/A
Dimensions	56.3 x 12.6 x 6.3	56.3 x 12.6 x 6.3	56.3 x 12.6 x 6.3	N/A	N/A	N/A
Manufacturer	RFS	RFS	RFS	N/A	N/A	N/A
Ant1 Top Jumper Make/Mode/Qty	2.5 Jumper	2.5 Jumper	2.5 Jumper	0	0	0
Ant 1 RF requested Diameter	1/2"	1/2"	1/2"	N/A	N/A	N/A
Ant 1 RF requested Top Jumper Length(ft)	8	8	8	N/A	N/A	N/A
Antenna 1 Azimuth	30	150	270	N/A	N/A	N/A
Antenna 1 Mechanical DT	N/A	N/A	N/A	N/A	N/A	N/A
Antenna 1 Center Line (ft)	149.9671964	149.9671964	149.9671964	N/A	N/A	N/A
Antenna 1 Electrical DT	2	2	2	N/A	N/A	N/A
Antenna 1 Electrical DT 2	N/A	N/A	N/A	N/A	N/A	N/A
Antenna 1 Electrical DT 3	N/A	N/A	N/A	N/A	N/A	N/A
Antenna 1 Twist	N/A	N/A	N/A	N/A	N/A	N/A
Antenna2						
Model Number						
Weight (lbs)	N/A	N/A	N/A	N/A	N/A	N/A
Dimensions	N/A	N/A	N/A	N/A	N/A	N/A
Manufacturer	N/A	N/A	N/A	N/A	N/A	N/A
Ant2 Top Jumper Make/Mode/Qty	N/A	N/A	N/A	0	0	0
Ant 2 RF Top Jumper Diameter	N/A	N/A	N/A	N/A	N/A	N/A
Ant 2 RF Top Jumper Length(ft)	N/A	N/A	N/A	N/A	N/A	N/A
Antenna 2 Azimuth	0	N/A	N/A	N/A	N/A	N/A
Antenna 2 Mechanical DT	N/A	N/A	N/A	N/A	N/A	N/A
Antenna 2 Center Line (ft)	N/A	N/A	N/A	N/A	N/A	N/A
Antenna 2 Electrical DT	N/A	N/A	N/A	N/A	N/A	N/A
Antenna 2 Electrical DT 2	N/A	N/A	N/A	N/A	N/A	N/A
Antenna 2 Electrical DT 3	N/A	N/A	N/A	N/A	N/A	N/A
Antenna 2 Twist	N/A	N/A	N/A	N/A	N/A	N/A

Band: 1900	Alpha	Beta	Gamma	Delta	Epsilon	Zeta
Antenna1						
Model Number	NNVV-65B-R4	NNVV-65B-R4	NNVV-65B-R4			
Weight (lbs)	84.7	84.7	84.7	N/A	N/A	N/A
Dimensions	72 x 19.6 x 7.8	72 x 19.6 x 7.8	72 x 19.6 x 7.8	N/A	N/A	N/A
Manufacturer	CommScope	CommScope	CommScope	N/A	N/A	N/A
Ant1 Top Jumper Make/Mode/Qty	800/1900 Jumper	800/1900 Jumper	800/1900 Jumper	0	0	0
Ant 1 RF requested Diameter Length(ft)	1/2"	1/2"	1/2"	N/A	N/A	N/A
Ant 1 RF requested Top Jumper Length(ft)	8	8	8	N/A	N/A	N/A
Antenna 1 Azimuth	30	150	270	N/A	N/A	N/A
Antenna 1 Mechanical DT	N/A	N/A	N/A	N/A	N/A	N/A
Antenna 1 Center Line (ft)	149.9671964	149.9671964	149.9671964	N/A	N/A	N/A
Antenna 1 Electrical DT	3	3	3	N/A	N/A	N/A
Antenna 1 Electrical DT 2	N/A	N/A	N/A	N/A	N/A	N/A
Antenna 1 Electrical DT 3	N/A	N/A	N/A	N/A	N/A	N/A
Antenna 1 Twist	N/A	N/A	N/A	N/A	N/A	N/A
Antenna2						
Model Number						
Weight (lbs)	N/A	N/A	N/A	N/A	N/A	N/A
Dimensions	N/A	N/A	N/A	N/A	N/A	N/A
Manufacturer	N/A	N/A	N/A	N/A	N/A	N/A
Ant2 Top Jumper Make/Mode/Qty	N/A	N/A	N/A	0	0	0
Ant 2 RF Top Jumper Diameter	N/A	N/A	N/A	N/A	N/A	N/A
Ant 2 RF Top Jumper Length(ft)	N/A	N/A	N/A	N/A	N/A	N/A
Antenna 2 Azimuth	N/A	N/A	N/A	N/A	N/A	N/A
Antenna 2 Mechanical DT	N/A	N/A	N/A	N/A	N/A	N/A
Antenna 2 Center Line (ft)	N/A	N/A	N/A	N/A	N/A	N/A
Antenna 2 Electrical DT	N/A	N/A	N/A	N/A	N/A	N/A
Antenna 2 Electrical DT 2	N/A	N/A	N/A	N/A	N/A	N/A
Antenna 2 Electrical DT 3	N/A	N/A	N/A	N/A	N/A	N/A
Antenna 2 Twist	N/A	N/A	N/A	N/A	N/A	N/A

Band: 800	Alpha	Beta	Gamma	Delta	Epsilon	Zeta
Antenna1						
Model Number	Antenna assigned on a different band	Antenna assigned on a different band	Antenna assigned on a different band			
Weight (lbs)	0	0	0	N/A	N/A	N/A
Dimensions	0 x 0 x 0	0 x 0 x 0	0 x 0 x 0	N/A	N/A	N/A
Manufacturer	-	-	-	N/A	N/A	N/A
Ant1 Top Jumper Make/Mode/Qty	800/1900 Jumper 4	800/1900 Jumper 4	800/1900 Jumper 4	N/A 0	N/A 0	N/A 0
Ant 1 RF requested Diameter Length(ft)	1/2"	1/2"	1/2"	N/A	N/A	N/A
Ant 1 RF requested Top Jumper Length(ft)	8	8	8	N/A	N/A	N/A
Antenna 1 Azimuth	30	150	270	N/A	N/A	N/A
Antenna 1 Mechanical DT	N/A	N/A	N/A	N/A	N/A	N/A
Antenna 1 Center Line (ft)	149.9671964	149.9671964	149.9671964	N/A	N/A	N/A
Antenna 1 Electrical DT	5	5	5	N/A	N/A	N/A
Antenna 1 Electrical DT 2	N/A	N/A	N/A	N/A	N/A	N/A
Antenna 1 Electrical DT 3	N/A	N/A	N/A	N/A	N/A	N/A
Antenna 1 Twist	N/A	N/A	N/A	N/A	N/A	N/A
Antenna2						
Model Number						
Weight (lbs)	N/A	N/A	N/A	N/A	N/A	N/A
Dimensions	N/A	N/A	N/A	N/A	N/A	N/A
Manufacturer	N/A	N/A	N/A	N/A	N/A	N/A
Ant2 Top Jumper Make/Mode/Qty	N/A 0	N/A 0	N/A 0	N/A 0	N/A 0	N/A 0
Ant 2 RF Top Jumper Diameter	N/A	N/A	N/A	N/A	N/A	N/A
Ant 2 RF Top Jumper Length(ft)	N/A	N/A	N/A	N/A	N/A	N/A
Antenna 2 Azimuth	N/A	N/A	N/A	N/A	N/A	N/A
Antenna 2 Mechanical DT	N/A	N/A	N/A	N/A	N/A	N/A
Antenna 2 Center Line (ft)	N/A	N/A	N/A	N/A	N/A	N/A
Antenna 2 Electrical DT	N/A	N/A	N/A	N/A	N/A	N/A
Antenna 2 Electrical DT 2	N/A	N/A	N/A	N/A	N/A	N/A
Antenna 2 Electrical DT 3	N/A	N/A	N/A	N/A	N/A	N/A
Antenna 2 Twist	N/A	N/A	N/A	N/A	N/A	N/A

Band: 2500	Alpha	Beta	Gamma	Delta	Epsilon	Zeta
Antenna 1 Split						
Model Number						
Weight (lbs)	N/A		N/A	N/A	N/A	N/A
Dimensions	N/A		N/A	N/A	N/A	N/A
Manufacturer	N/A		N/A	N/A	N/A	N/A
Accept Proposed Ant1 Model Change?	N/A		N/A	N/A	N/A	N/A
Antenna 1 band combined with	N/A		N/A	N/A	N/A	N/A
Antenna 1 Upper Passive Component Model						
Model Number						
Weight (lbs)	N/A		N/A	N/A	N/A	N/A
Dimensions	N/A		N/A	N/A	N/A	N/A
Manufacturer	N/A		N/A	N/A	N/A	N/A
Ant1 Upper Passive Comp Qty needed	0		0	0	0	0
Ant1 Upper Pass Comp band combi with						
Antenna 1 Lower Passive Component Model						
Model Number						
Weight (lbs)	N/A		N/A	N/A	N/A	N/A
Dimensions	N/A		N/A	N/A	N/A	N/A
Manufacturer	N/A		N/A	N/A	N/A	N/A
Ant1 Lower Passive Comp Qty needed	0		0	0	0	0
Ant1 Low Pass Comp band comb with						
Position Ant 1						
Antenna 2 Split						
Model Number						
Weight (lbs)	N/A		N/A	N/A	N/A	N/A
Dimensions	N/A		N/A	N/A	N/A	N/A
Manufacturer	N/A		N/A	N/A	N/A	N/A
Accept Proposed Ant2 Model Change?	N/A		N/A	N/A	N/A	N/A
Antenna 2 band combined with						
Antenna 2 Upper Passive Component Model						
Model Number						
Weight (lbs)	N/A		N/A	N/A	N/A	N/A
Dimensions	N/A		N/A	N/A	N/A	N/A
Manufacturer	N/A		N/A	N/A	N/A	N/A
Ant2 Upper Passive Comp Qty needed	0		0	0	0	0
Antenna 2 Lower Passive Component Model						
Model Number						
Weight (lbs)	N/A		N/A	N/A	N/A	N/A
Dimensions	N/A		N/A	N/A	N/A	N/A
Manufacturer	N/A		N/A	N/A	N/A	N/A
Ant1 Lower Passive Comp Qty needed	0		0	0	0	0
Ant1 Lower Passive Component band combined with						
Position Ant 2						

Band: 1900	Alpha	Beta	Gamma	Delta	Epsilon	Zeta
Antenna 1 Split						
Model Number	N/A					
Weight (lbs)	N/A		N/A	N/A	N/A	N/A
Dimensions	N/A		N/A	N/A	N/A	N/A
Manufacturer	N/A		N/A	N/A	N/A	N/A
Accept Proposed Ant1 Model Change?	N/A		N/A	N/A	N/A	N/A
Antenna 1 band combined with	800MHz		800MHz	N/A	N/A	N/A
Antenna 1 Upper Passive Component Model						
Model Number						
Weight (lbs)	N/A		N/A	N/A	N/A	N/A
Dimensions	N/A		N/A	N/A	N/A	N/A
Manufacturer	N/A		N/A	N/A	N/A	N/A
Ant1 Upper Passive Comp Qty needed	0		0	0	0	0
Ant1 Upper Pass Comp band combi with						
Antenna 1 Lower Passive Component Model						
Model Number						
Weight (lbs)	N/A		N/A	N/A	N/A	N/A
Dimensions	N/A		N/A	N/A	N/A	N/A
Manufacturer	N/A		N/A	N/A	N/A	N/A
Ant1 Lower Passive Comp Qty needed	0		0	0	0	0
Ant1 Low Pass Comp band comb with						
Position Ant 1						
Antenna 2 Split						
Model Number						
Weight (lbs)	N/A		N/A	N/A	N/A	N/A
Dimensions	N/A		N/A	N/A	N/A	N/A
Manufacturer	N/A		N/A	N/A	N/A	N/A
Accept Proposed Ant2 Model Change?	N/A		N/A	N/A	N/A	N/A
Antenna 2 band combined with						
Antenna 2 Upper Passive Component Model						
Model Number						
Weight (lbs)	N/A		N/A	N/A	N/A	N/A
Dimensions	N/A		N/A	N/A	N/A	N/A
Manufacturer	N/A		N/A	N/A	N/A	N/A
Ant2 Upper Passive Comp Qty needed	0		0	0	0	0
Antenna 2 Lower Passive Component Model						
Model Number						
Weight (lbs)	N/A		N/A	N/A	N/A	N/A
Dimensions	N/A		N/A	N/A	N/A	N/A
Manufacturer	N/A		N/A	N/A	N/A	N/A
Ant1 Lower Passive Comp Qty needed	0		0	0	0	0
Ant1 Lower Passive Component band combined with						
Position Ant 2						

Band: 800	Alpha	Beta	Gamma	Delta	Epsilon	Zeta
Antenna1 Split						
Model Number						
Weight (lbs)	N/A		N/A	N/A	N/A	N/A
Dimensions	N/A		N/A	N/A	N/A	N/A
Manufacturer	N/A		N/A	N/A	N/A	N/A
Accept Proposed Ant1 Model Change?	N/A		N/A	N/A	N/A	N/A
Antenna 1 band combined with	1900MHz		1900MHz	N/A	N/A	N/A
Antenna 1 Upper Passive Component Model						
Model Number						
Weight (lbs)	N/A		N/A	N/A	N/A	N/A
Dimensions	N/A		N/A	N/A	N/A	N/A
Manufacturer	N/A		N/A	N/A	N/A	N/A
Ant1 Upper Passive Comp Qty needed	0		0	0	0	0
Ant1 Upper Pass Comp band combi with						
Antenna 1 Lower Passive Component Model						
Model Number						
Weight (lbs)	N/A		N/A	N/A	N/A	N/A
Dimensions	N/A		N/A	N/A	N/A	N/A
Manufacturer	N/A		N/A	N/A	N/A	N/A
Ant1 Lower Passive Comp Qty needed	0		0	0	0	0
Ant1 Low Pass Comp band comb with						
Position Ant 1						
Antenna2 Split						
Model Number						
Weight (lbs)	N/A		N/A	N/A	N/A	N/A
Dimensions	N/A		N/A	N/A	N/A	N/A
Manufacturer	N/A		N/A	N/A	N/A	N/A
Accept Proposed Ant2 Model Change?	N/A		N/A	N/A	N/A	N/A
Antenna 2 band combined with						
Antenna 2 Upper Passive Component Model						
Model Number						
Weight (lbs)	N/A		N/A	N/A	N/A	N/A
Dimensions	N/A		N/A	N/A	N/A	N/A
Manufacturer	N/A		N/A	N/A	N/A	N/A
Ant2 Upper Passive Comp Qty needed	0		0	0	0	0
Antenna 2 Lower Passive Component Model						
Model Number						
Weight (lbs)	N/A		N/A	N/A	N/A	N/A
Dimensions	N/A		N/A	N/A	N/A	N/A
Manufacturer	N/A		N/A	N/A	N/A	N/A
Ant1 Lower Passive Comp Qty needed	0		0	0	0	0
Ant1 Lower Passive Component band combined with						
Position Ant 2						

Structural Analysis Report

Antenna Mount Analysis

Sprint Site Ref: CT33XC089

*330 Pokorny Road
Haddam, CT*

Centek Project No. 17159.10

Date: October 28, 2019

Max Stress Ratio = 93.2%

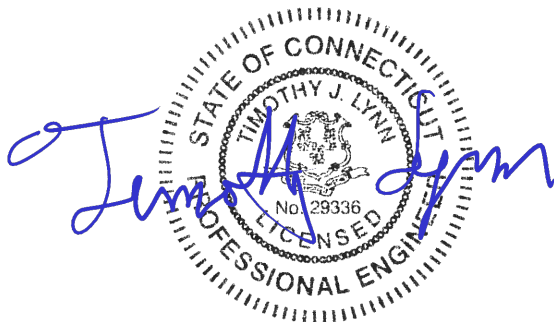

Prepared for:

*Transcend Wireless
10 Industrial Ave, Suite 3
Mahwah, NJ 07430*

Table of Contents

SECTION 1 – REPORT

- ANTENNA AND APPURTENANCE SUMMARY
- STRUCTURE LOADING
- CONCLUSION

SECTION 2 – CALCULATIONS

- WIND LOAD ON APPURTENANCES
- RISA3D OUTPUT REPORT

SECTION 3 – REFERENCE MATERIALS

- RF DATA SHEET, DATED 10/18/2017
- EQUIPMENT CUT SHEETS

October 28, 2019

Mr. Jake Shappy
Transcend Wireless
10 Industrial Ave
Mahwah, NJ 07430

Re: *Structural Letter ~ Antenna Mount*
Sprint – Site Ref: CT33XC089
330 Pokorny Road
Haddam, CT 06441

Centek Project No. 17159.10

Dear Mr. Shappy,

Centek Engineering, Inc. has reviewed the Sprint antenna installation at the above referenced site. The purpose of the review is to determine the structural adequacy of the existing mount, consisting of three (3) 12-ft V-Frames to support the equipment configuration. The review considered the effects of wind load, dead load and ice load in accordance with the 2018 Connecticut State Building Code (CTBC) including ASCE 7-10 and ANSI/TIA-222-G *Structural Standards for Steel Antenna Towers and Supporting Structures*.

The loads considered in this analysis consist of the following:

- Sprint:
V-Frames: Three (3) Commscope NNVV-65B-R4 panel antennas, three (3) RFS APXVTM14 panel antennas, three (3) TD-RRH8x20-25 radio heads, three (3) 1900MHz 4X45W RRHs and six (6) RRH2x50-800 radio heads mounted on three (3) 12-ft frames with a RAD center elevation of +/-155-ft AGL.

The antenna mount was analyzed per the requirements of the 2015 International Building Code as modified by the 2018 Connecticut State Building Code considering a nominal design wind speed of 101 mph for Haddam as required in Appendix N of the 2018 Connecticut State Building Code.

Based on our review of the installation, it is our opinion that the subject antenna mount has sufficient capacity to support the aforementioned antenna configuration. If there are any questions regarding this matter, please feel free to call.

Respectfully Submitted by:

Prepared by:



Timothy J. Lynn, PE
Structural Engineer



Fernando J. Palacios
Engineer

CEN TEK Engineering, Inc.
Structural Analysis – Mount Analysis
T-Mobile Site Ref. ~ CT33XC089
Haddam, CT
October 28, 2019

Section 2 - Calculations

Development of Design Heights, Exposure Coefficients, and Velocity Pressures Per TIA-222-G

Wind Speeds

Basic Wind Speed V := 101 mph (User Input - 2018 CSBC Appendix N)
 Basic Wind Speed with Ice V_i := 50 mph (User Input per Annex B of TIA-222-G)

Input

Structure Type = Structure_Type := Lattice (User Input)
 Structure Category = SC := 11 (User Input)
 Exposure Category = Exp := C (User Input)
 Structure Height = h := 280 ft (User Input)
 Height to Center of Antennas = z_{Sprint} := 155 ft (User Input)
 Radial Ice Thickness = t_i := 0.75 in (User Input per Annex B of TIA-222-G)
 Radial Ice Density = I_d := 56.00 pcf (User Input)
 Topographic Factor = K_{zt} := 1.0 (User Input)
 K_a := 1.0 (User Input)
 Gust Response Factor = G_H = 0.85 (User Input)

Output

Wind Direction Probability Factor =
$$K_d := \begin{cases} \text{if Structure_Type = Pole} \\ 0.95 \\ \text{if Structure_Type = Lattice} \\ 0.85 \end{cases} = 0.85$$
 (Per Table 2-2 of TIA-222-G)
 (Per Table 2-3 of TIA-222-G)

Importance Factors =
$$I_{Wind} := \begin{cases} \text{if SC = 1} \\ 0.87 \\ \text{if SC = 2} \\ 1.00 \\ \text{if SC = 3} \\ 1.15 \end{cases} = 1$$

$$I_{Wind_w_Ice} := \begin{cases} \text{if SC = 1} \\ 0 \\ \text{if SC = 2} \\ 1.00 \\ \text{if SC = 3} \\ 1.00 \end{cases} = 1$$

$$K_{iz} := \left(\frac{z_{Sprint}}{33} \right)^{0.1} = 1.167$$

$$I_{ice} := \begin{cases} \text{if SC = 1} \\ 0 \\ \text{if SC = 2} \\ 1.00 \\ \text{if SC = 3} \\ 1.25 \end{cases} = 1$$

Velocity Pressure Coefficient Antennas = $t_{iz} := 2.0 \cdot t_i \cdot I_{ice} \cdot K_{iz} \cdot K_{zt}^{0.35} = 1.751$

$$Kz_{Sprint} := 2.01 \cdot \left(\frac{z_{Sprint}}{zg} \right)^\alpha = 1.388$$

Velocity Pressure w/o Ice Antennas = $qz_{Sprint} := 0.00256 \cdot K_d \cdot Kz_{Sprint} \cdot V^2 \cdot I_{Wind} = 30 \text{ psf}$

Velocity Pressure with Ice Antennas = $qz_{Ice.Sprint} := 0.00256 \cdot K_d \cdot Kz_{Sprint} \cdot V_i^2 \cdot I_{Wind} = 8 \text{ psf}$

Development of Wind & Ice Load on Antennas

Antenna Data:

Antenna Model =	Commscope NNVV-65B-R4	
Antenna Shape =	Flat	(User Input)
Antenna Height =	$L_{ant} := 72$	in (User Input)
Antenna Width =	$W_{ant} := 19.6$	in (User Input)
Antenna Thickness =	$T_{ant} := 7.8$	in (User Input)
Antenna Weight =	$WT_{ant} := 77.4$	lbs (User Input)
Number of Antennas =	$N_{ant} := 1$	(User Input)
Antenna Aspect Ratio =	$Ar_{ant} := \frac{L_{ant}}{W_{ant}} = 3.7$	
Antenna Force Coefficient =	$Ca_{ant} = 1.25$	

Wind Load (without ice)

Surface Area for One Antenna = $SA_{antF} := \frac{L_{ant} \cdot W_{ant}}{144} = 9.8$ sf

Total Antenna Wind Force Front = $F_{ant} := q_{z_{sprint}} \cdot G_H \cdot Ca_{ant} \cdot K_a \cdot SA_{antF} = 321$ lbs

Surface Area for One Antenna = $SA_{antS} := \frac{L_{ant} \cdot T_{ant}}{144} = 3.9$ sf

Total Antenna Wind Force Side = $F_{ant} := q_{z_{sprint}} \cdot G_H \cdot Ca_{ant} \cdot K_a \cdot SA_{antS} = 128$ lbs

Wind Load (with ice)

Surface Area for One Antenna w/ Ice = $SA_{ICEantF} := \frac{(L_{ant} + 2 \cdot t_{iz}) \cdot (W_{ant} + 2 \cdot t_{iz})}{144} = 12.1$ sf

Total Antenna Wind Force w/ Ice Front = $F_{ant} := q_{z_{ice, sprint}} \cdot G_H \cdot Ca_{ant} \cdot K_a \cdot SA_{ICEantF} = 97$ lbs

Surface Area for One Antenna w/ Ice = $SA_{ICEantS} := \frac{(L_{ant} + 2 \cdot t_{iz}) \cdot (T_{ant} + 2 \cdot t_{iz})}{144} = 5.9$ sf

Total Antenna Wind Force w/ Ice Side = $F_{ant} := q_{z_{ice, sprint}} \cdot G_H \cdot Ca_{ant} \cdot K_a \cdot SA_{ICEantS} = 48$ lbs

Gravity Load (without ice)

Weight of All Antennas = $WT_{ant} \cdot N_{ant} = 77$ lbs

Gravity Loads (ice only)

Volume of Each Antenna = $V_{ant} := L_{ant} \cdot W_{ant} \cdot T_{ant} = 1 \cdot 10^4$ cu in

Volume of Ice on Each Antenna = $V_{ice} := (L_{ant} + 2 \cdot t_{iz}) \cdot (W_{ant} + 2 \cdot t_{iz}) \cdot (T_{ant} + 2 \cdot t_{iz}) - V_{ant} = 8706$

Weight of Ice on Each Antenna = $W_{ICEant} := \frac{V_{ice}}{1728} \cdot \rho = 282$ lbs

Weight of Ice on All Antennas = $W_{ICEant} \cdot N_{ant} = 282$ lbs

Development of Wind & Ice Load on Antennas

Antenna Data:

Antenna Model =	RFS APXVTM14-ALU-I20	
Antenna Shape =	Flat	(User Input)
Antenna Height =	$L_{ant} := 56.3$	in (User Input)
Antenna Width =	$W_{ant} := 12.6$	in (User Input)
Antenna Thickness =	$T_{ant} := 6.3$	in (User Input)
Antenna Weight =	$WT_{ant} := 67.7$	lbs (User Input)
Number of Antennas =	$N_{ant} := 1$	(User Input)
Antenna Aspect Ratio =	$AR_{ant} := \frac{L_{ant}}{W_{ant}} = 4.5$	(User Input)
Antenna Force Coefficient =	$Ca_{ant} = 1.29$	

Wind Load (without ice)

Surface Area for One Antenna = $SA_{antF} := \frac{L_{ant} \cdot W_{ant}}{144} = 4.9$ sf

Total Antenna Wind Force Front = $F_{ant} := q_{Z_{Sprint}} \cdot G_H \cdot Ca_{ant} \cdot K_a \cdot SA_{antF} = 166$ lbs

Surface Area for One Antenna = $SA_{antS} := \frac{L_{ant} \cdot T_{ant}}{144} = 2.5$ sf

Total Antenna Wind Force Side = $F_{ant} := q_{Z_{Sprint}} \cdot G_H \cdot Ca_{ant} \cdot K_a \cdot SA_{antS} = 83$ lbs

Wind Load (with ice)

Surface Area for One Antenna w/ Ice = $SA_{ICEantF} := \frac{(L_{ant} + 2 \cdot t_{iz}) \cdot (W_{ant} + 2 \cdot t_{iz})}{144} = 6.7$ sf

Total Antenna Wind Force w/ Ice Front = $F_{ant} := q_{Z_{ice.Sprint}} \cdot G_H \cdot Ca_{ant} \cdot K_a \cdot SA_{ICEantF} = 55$ lbs

Surface Area for One Antenna w/ Ice = $SA_{ICEantS} := \frac{(L_{ant} + 2 \cdot t_{iz}) \cdot (T_{ant} + 2 \cdot t_{iz})}{144} = 4.1$ sf

Total Antenna Wind Force w/ Ice Side = $F_{ant} := q_{Z_{ice.Sprint}} \cdot G_H \cdot Ca_{ant} \cdot K_a \cdot SA_{ICEantS} = 34$ lbs

Gravity Load (without ice)

Weight of All Antennas = $WT_{ant} \cdot N_{ant} = 68$ lbs

Gravity Loads (ice only)

Volume of Each Antenna = $V_{ant} := L_{ant} \cdot W_{ant} \cdot T_{ant} = 4469$ cu in

Volume of Ice on Each Antenna = $V_{ice} := (L_{ant} + 2 \cdot t_{iz}) \cdot (W_{ant} + 2 \cdot t_{iz}) \cdot (T_{ant} + 2 \cdot t_{iz}) - V_{ant} = 4969$

Weight of Ice on Each Antenna = $W_{ICEant} := \frac{V_{ice}}{1728} \cdot 1d = 161$ lbs

Weight of Ice on All Antennas = $W_{ICEant} \cdot N_{ant} = 161$ lbs

Development of Wind & Ice Load on RRUS's

RRUS Data:

RRUS Model =	RRUS-2x50-800	
RRUS Shape =	Flat	(User Input)
RRUS Height =	$L_{RRUS} := 16$	in (User Input)
RRUS Width =	$W_{RRUS} := 13$	in (User Input)
RRUS Thickness =	$T_{RRUS} := 10$	in (User Input)
RRUS Weight =	$WT_{RRUS} := 69.1$	lbs (User Input)
Number of RRUS's =	$N_{RRUS} := 1$	
RRUS Aspect Ratio =	$A_{RRUS} := \frac{L_{RRUS}}{W_{RRUS}} = 1.2$	
RRUS Force Coefficient =	$C_{aRRUS} = 1.2$	

Wind Load (without ice)

Surface Area for One RRUS = $SA_{RRUSF} := \frac{L_{RRUS} \cdot W_{RRUS}}{144} = 1.4$ sf

Total RRUS Wind Force = $F_{RRUS} := q_{Z_{Sprint}} \cdot G_H \cdot C_{aRRUS} \cdot K_a \cdot SA_{RRUSF} = 45$ lbs

Surface Area for One RRUS = $SA_{RRUSU} := \frac{L_{RRUS} \cdot T_{RRUS}}{144} = 1.1$ sf

Total RRUS Wind Force = $F_{RRUS} := q_{Z_{Sprint}} \cdot G_H \cdot C_{aRRUS} \cdot K_a \cdot SA_{RRUSU} = 35$ lbs

Wind Load (with ice)

Surface Area for One RRUS w/ Ice = $SA_{ICERRUSF} := \frac{(L_{RRUS} + 2 \cdot t_{iz}) \cdot (W_{RRUS} + 2 \cdot t_{iz})}{144} = 2.2$ sf

Total RRUS Wind Force w/ Ice = $F_{IRRUS} := q_{Z_{Ice.Sprint}} \cdot G_H \cdot C_{aRRUS} \cdot K_a \cdot SA_{ICERRUSF} = 17$ lbs

Surface Area for One RRUS w/ Ice = $SA_{ICERRUSU} := \frac{(L_{RRUS} + 2 \cdot t_{iz}) \cdot (T_{RRUS} + 2 \cdot t_{iz})}{144} = 1.8$ sf

Total RRUS Wind Force w/ Ice = $F_{IRRUS} := q_{Z_{Ice.Sprint}} \cdot G_H \cdot C_{aRRUS} \cdot K_a \cdot SA_{ICERRUSU} = 14$ lbs

Gravity Load (without ice)

Weight of All RRUSs = $WT_{RRUS} \cdot N_{RRUS} = 69$ lbs

Gravity Loads (ice only)

Volume of Each RRUS = $V_{RRUS} := L_{RRUS} \cdot W_{RRUS} \cdot T_{RRUS} = 2080$ cu in

Volume of Ice on Each RRUS = $V_{Ice} := (L_{RRUS} + 2 \cdot t_{iz}) \cdot (W_{RRUS} + 2 \cdot t_{iz}) \cdot (T_{RRUS} + 2 \cdot t_{iz}) - V_{RRUS} = 2265$ cu in

Weight of Ice on Each RRUS = $W_{ICERRUS} := \frac{V_{Ice}}{1728} \cdot \rho_d = 73$ lbs

Weight of Ice on All RRUSs = $W_{ICERRUS} \cdot N_{RRUS} = 73$ lbs

Development of Wind & Ice Load on RRUS's

RRUS Data:

RRUS Model =	RRUS-8X20-25	
RRUS Shape =	Flat	(User Input)
RRUS Height =	$L_{RRUS} := 26$	in (User Input)
RRUS Width =	$W_{RRUS} := 18.6$	in (User Input)
RRUS Thickness =	$T_{RRUS} := 6.7$	in (User Input)
RRUS Weight =	$WT_{RRUS} := 76.2$	lbs (User Input)
Number of RRUS's =	$N_{RRUS} := 1$	
RRUS Aspect Ratio =	$A_{RRUS} := \frac{L_{RRUS}}{W_{RRUS}} = 1.4$	
RRUS Force Coefficient =	$Ca_{RRUS} = 1.2$	

Wind Load (without ice)

Surface Area for One RRUS = $SA_{RRUSF} := \frac{L_{RRUS} \cdot W_{RRUS}}{144} = 3.4$ sf

Total RRUS Wind Force = $F_{RRUS} := q_{z_{Sprint}} \cdot G_H \cdot Ca_{RRUS} \cdot K_a \cdot SA_{RRUSF} = 106$ lbs

Surface Area for One RRUS = $SA_{RRUSU} := \frac{L_{RRUS} \cdot T_{RRUS}}{144} = 1.2$ sf

Total RRUS Wind Force = $F_{RRUS} := q_{z_{Sprint}} \cdot G_H \cdot Ca_{RRUS} \cdot K_a \cdot SA_{RRUSU} = 38$ lbs

Wind Load (with ice)

Surface Area for One RRUS w/ Ice = $SA_{ICERRUSF} := \frac{(L_{RRUS} + 2 \cdot t_{iz}) \cdot (W_{RRUS} + 2 \cdot t_{iz})}{144} = 4.5$ sf

Total RRUS Wind Force w/ Ice = $F_{IRRUS} := q_{z_{ice.Sprint}} \cdot G_H \cdot Ca_{RRUS} \cdot K_a \cdot SA_{ICERRUSF} = 35$ lbs

Surface Area for One RRUS w/ Ice = $SA_{ICERRUSU} := \frac{(L_{RRUS} + 2 \cdot t_{iz}) \cdot (T_{RRUS} + 2 \cdot t_{iz})}{144} = 2.1$ sf

Total RRUS Wind Force w/ Ice = $F_{IRRUS} := q_{z_{ice.Sprint}} \cdot G_H \cdot Ca_{RRUS} \cdot K_a \cdot SA_{ICERRUSU} = 16$ lbs

Gravity Load (without ice)

Weight of All RRUSs = $WT_{RRUS} \cdot N_{RRUS} = 76$ lbs

Gravity Loads (ice only)

Volume of Each RRUS = $V_{RRUS} := L_{RRUS} \cdot W_{RRUS} \cdot T_{RRUS} = 3240$ cu in

Volume of Ice on Each RRUS = $V_{ice} := (L_{RRUS} + 2 \cdot t_{iz}) \cdot (W_{RRUS} + 2 \cdot t_{iz}) \cdot (T_{RRUS} + 2 \cdot t_{iz}) - V_{RRUS} = 3412$ cu in

Weight of Ice on Each RRUS = $W_{ICERRUS} := \frac{V_{ice}}{1728} \cdot Id = 111$ lbs

Weight of Ice on All RRUSs = $W_{ICERRUS} \cdot N_{RRUS} = 111$ lbs

Development of Wind & Ice Load on RRUS's

RRUS Data:

RRUS Model =	RRUS-4X45-1900	
RRUS Shape =	Flat	(User Input)
RRUS Height =	$L_{RRUS} := 25$	in (User Input)
RRUS Width =	$W_{RRUS} := 12$	in (User Input)
RRUS Thickness =	$T_{RRUS} := 12$	in (User Input)
RRUS Weight =	$WT_{RRUS} := 69.5$	lbs (User Input)
Number of RRUS's =	$N_{RRUS} := 1$	
RRUS Aspect Ratio =	$A_{RRUS} := \frac{L_{RRUS}}{W_{RRUS}} = 2.1$	
RRUS Force Coefficient =	$C_{aRRUS} = 1.2$	

Wind Load (without ice)

Surface Area for One RRUS = $SA_{RRUSF} := \frac{L_{RRUS} \cdot W_{RRUS}}{144} = 2.1$ sf

Total RRUS Wind Force = $F_{RRUS} := q_{Z_{Sprint}} \cdot G_H \cdot C_{aRRUS} \cdot K_a \cdot SA_{RRUSF} = 65$ lbs

Surface Area for One RRUS = $SA_{RRUS} := \frac{L_{RRUS} \cdot T_{RRUS}}{144} = 2.1$ sf

Total RRUS Wind Force = $F_{RRUS} := q_{Z_{Sprint}} \cdot G_H \cdot C_{aRRUS} \cdot K_a \cdot SA_{RRUS} = 65$ lbs

Wind Load (with ice)

Surface Area for One RRUS w/ Ice = $SA_{ICERRUSF} := \frac{(L_{RRUS} + 2 \cdot t_{iz}) \cdot (W_{RRUS} + 2 \cdot t_{iz})}{144} = 3.1$ sf

Total RRUS Wind Force w/ Ice = $F_{IRRUS} := q_{Z_{ice.Sprint}} \cdot G_H \cdot C_{aRRUS} \cdot K_a \cdot SA_{ICERRUSF} = 24$ lbs

Surface Area for One RRUS w/ Ice = $SA_{ICERRUS} := \frac{(L_{RRUS} + 2 \cdot t_{iz}) \cdot (T_{RRUS} + 2 \cdot t_{iz})}{144} = 3.1$ sf

Total RRUS Wind Force w/ Ice = $F_{IRRUS} := q_{Z_{ice.Sprint}} \cdot G_H \cdot C_{aRRUS} \cdot K_a \cdot SA_{ICERRUS} = 24$ lbs

Gravity Load (without ice)

Weight of All RRUSs = $WT_{RRUS} \cdot N_{RRUS} = 70$ lbs

Gravity Loads (ice only)

Volume of Each RRUS = $V_{RRUS} := L_{RRUS} \cdot W_{RRUS} \cdot T_{RRUS} = 3600$ cu in

Volume of Ice on Each RRUS = $V_{ice} := (L_{RRUS} + 2 \cdot t_{iz}) \cdot (W_{RRUS} + 2 \cdot t_{iz}) \cdot (T_{RRUS} + 2 \cdot t_{iz}) - V_{RRUS} = 3249$ cu in

Weight of Ice on Each RRUS = $W_{ICERRUS} := \frac{V_{ice}}{1728} \cdot \rho_d = 105$ lbs

$W_{ICERRUS} \cdot N_{RRUS} = 105$

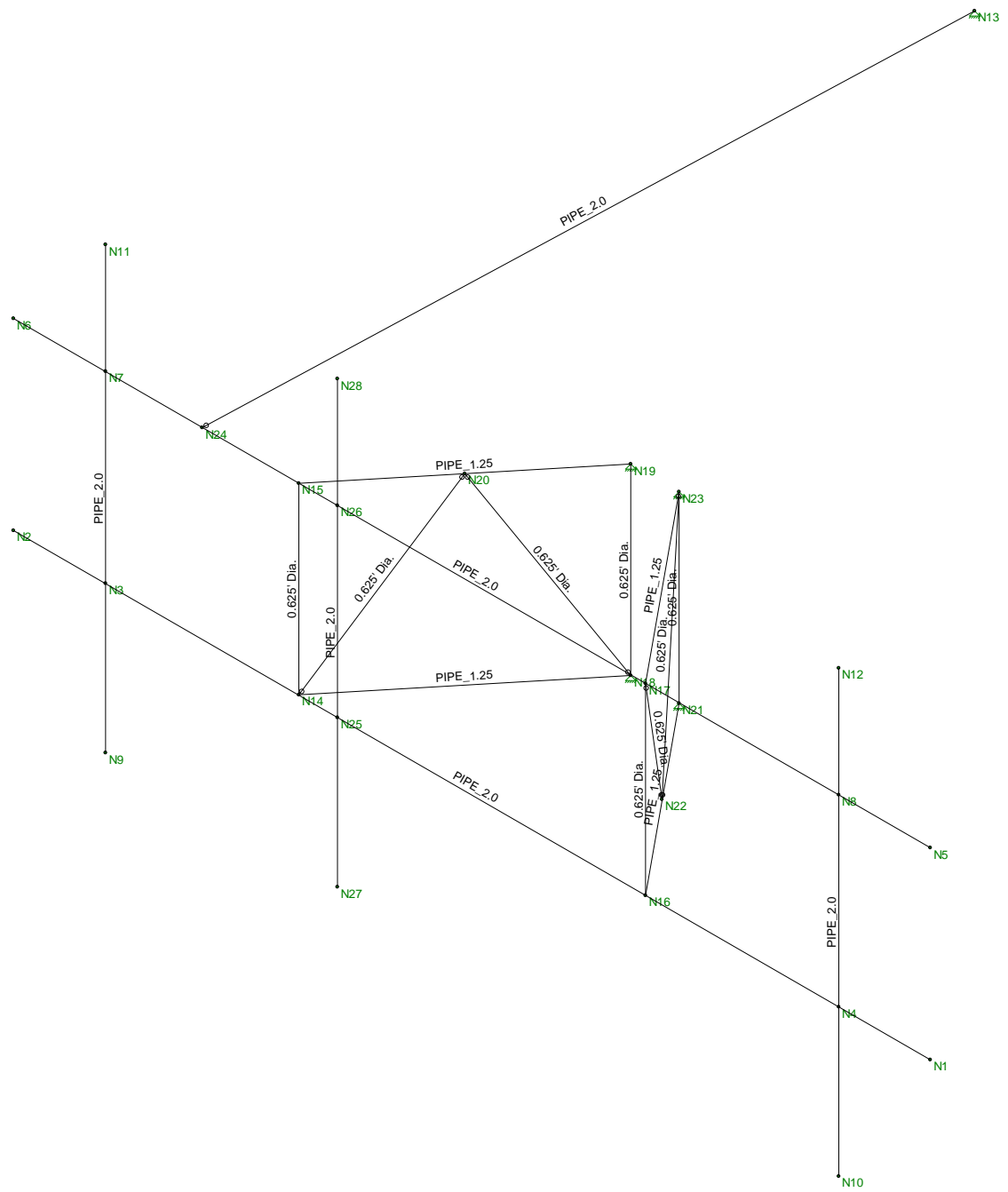

Centek
FJP
17159.10

CT33XC089 - Mount
Member Framing

Oct 28, 2019 at 1:11 PM
Antenna Mount.r3d

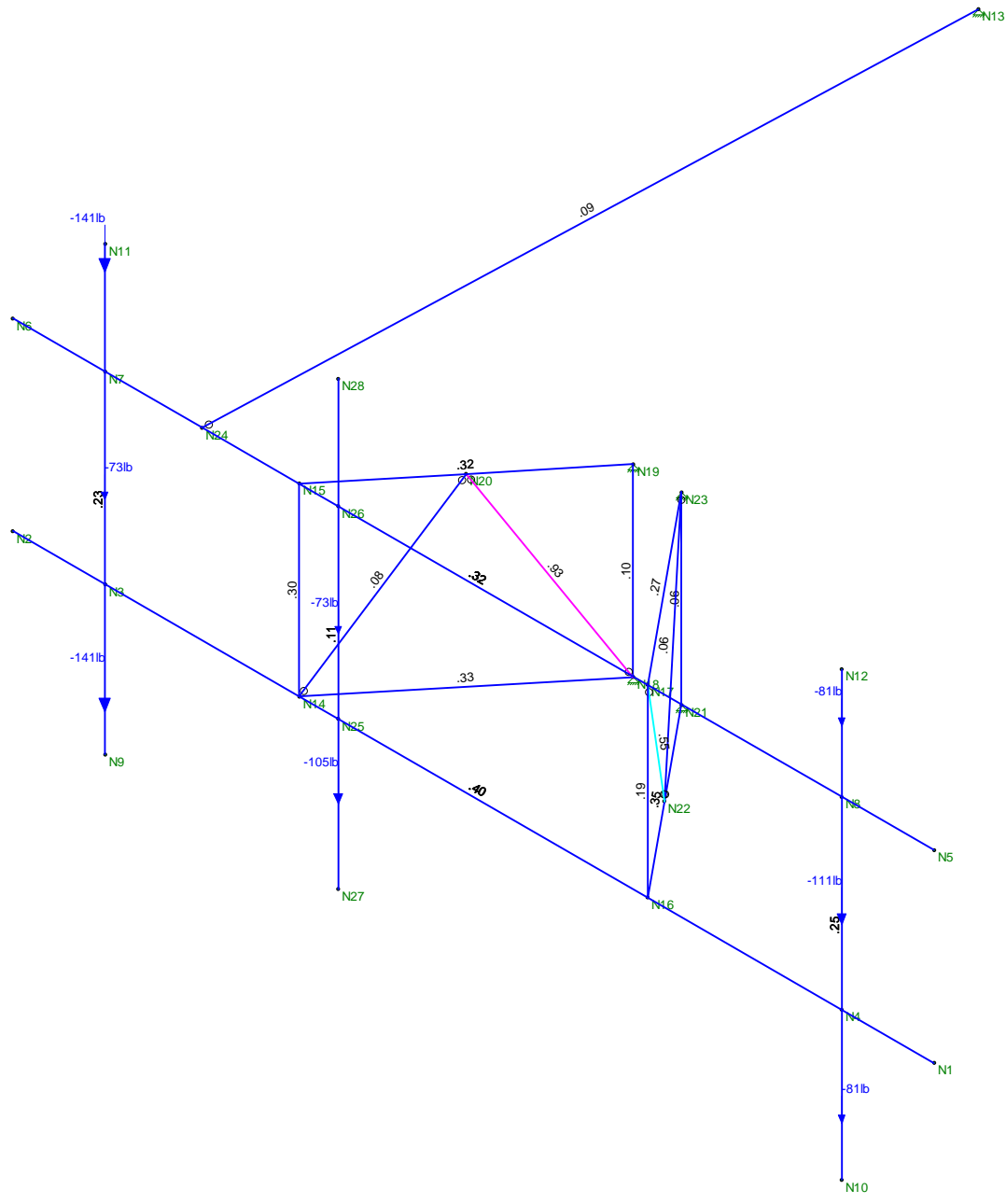

Member Code Checks Displayed (Enveloped)
 Loads: BLC 3, Ice Load
 Envelope Only Solution

Centek
FJP
17159.10

CT33XC089 - Mount Member Unity Check

Oct 28, 2019 at 4:14 PM
Antenna Mount.r3d



Site Identification	
Cascade	CT33XC089
SMS Schedule ID	12322228
SMS Schedule Name	DO Macro Upgrade
PID	DOKU_CT33XC089
RRU OEM	ALU
Switch OEM	Alcatel-Lucent
RFDS Issue Date	2017-10-18 03:20:53.0
RFDS Revision Date	3

Filter Analysis Complete	YES
RFDS - Issue Date	
Design Status	Complete
Project Description	DO Macro Upgrade - Add 800MHz (2G + 4G) and 2500 MHz

Battery Backup Cabinet Model	
Model Number	
Weight (Lbs.)	
Dimensions (In.)	
Manufacturer	

Junction Box Model	
Model Number	
Weight (Lbs.)	
Dimensions (In.)	
Manufacturer	
Junction Boxes needed at site	

BTS #2 Model	
Model Number	
Weight (Lbs.)	
Dimensions (In.)	
Manufacturer	
Needed at site	

Contact Information	
Engineer Email	Bill.M.Hastings@sprint.com
Sprint Badged RF Engineer	Bill Hastings
RF Engineer Email	Bill.M.Hastings@sprint.com
RF Engineer Phone	978-590-9700
RF Manager	Jonathan Hull
RF Manager Email	Jonathan.B.Hull@sprint.com
RF Manager Phone	617-233-2920

Carrier Count	
2500 LTE	3
1900 LTE	1
1900 EVDO	
1900 Voice	1
800 LTE	1
800 Voice	1

UE Relay Model	
Model Number	
Weight (Lbs.)	
Dimensions (In.)	
UE Relay Azimuth	
Manufacturer	
UE Relay CL Height (meters)	

ALU Top Hat Model	
Model Number	
Weight (Lbs.)	
Dimensions (In.)	
Manufacturer	
Top Hat Quantity	

Power Protection Cabinet Model	
Model Number	
Weight (Lbs.)	
Dimensions (In.)	
Manufacturer	
Power Protection Cabinet	

Location Details	
Latitude	41.44360277
Longitude	-72.59639811
Market	Northern Connecticut
Region	Northeast
City	West Haddam
State	CT
Zip Code	CT06438
County	Middlesex

2500MHz	3
1900MHz	3
800MHz	3

GPS Antenna Model	
Model Number	
Weight (Lbs.)	
Dimensions (In.)	
Manufacturer	
GPS Antenna needed at site	

Repeater Model	
Model Number	
Weight (Lbs.)	
Dimensions (In.)	
Manufacturer	

Growth Cabinet Model	
Model Number	
Weight (Lbs.)	
Dimensions (In.)	
Manufacturer	

BTS #1 Model	
Model Number	
Weight (Lbs.)	
Dimensions (In.)	
Manufacturer	
Number of BTS #1	

A&E Drawing Requirements

10/10/2017 (WR): RFDS revised to modify RRU location to "GM to Standard".

Additional RF Notes Special Construction Requirements

10/10/2017 (WR): RFDS revised to modify RRU location to "GM to Standard".

Band: 2500	Alpha	Beta	Gamma	Delta	Epsilon	Zeta
Radio Model						
Model Number	TD-RRH8x20-25	TD-RRH8x20-25	TD-RRH8x20-25	N/A	N/A	N/A
Weight (lbs)	76.2	76.2	76.2	N/A	N/A	N/A
Dimensions	26 x 18.6 x 6.7	26 x 18.6 x 6.7	26 x 18.6 x 6.7	N/A	N/A	N/A
Manufacturer	ALU	ALU	ALU	N/A	N/A	N/A
Number of RRUs needed	1	1	1	0	0	0
Filter Model						
Model Number	N/A	N/A	N/A	N/A	N/A	N/A
Weight (lbs)	N/A	N/A	N/A	N/A	N/A	N/A
Dimensions	N/A	N/A	N/A	N/A	N/A	N/A
Manufacturer	N/A	N/A	N/A	N/A	N/A	N/A
Filter Model 2						
Model Number	N/A	N/A	N/A	N/A	N/A	N/A
Weight (lbs)	N/A	N/A	N/A	N/A	N/A	N/A
Dimensions	N/A	N/A	N/A	N/A	N/A	N/A
Manufacturer	N/A	N/A	N/A	N/A	N/A	N/A
Filter Model 3						
Model Number	N/A	N/A	N/A	N/A	N/A	N/A
Weight (lbs)	N/A	N/A	N/A	N/A	N/A	N/A
Dimensions	N/A	N/A	N/A	N/A	N/A	N/A
Manufacturer	N/A	N/A	N/A	N/A	N/A	N/A
Trunk Cable 1						
Model Number	Hybriflex	N/A	N/A	N/A	N/A	N/A
Weight (lbs.)	1	N/A	N/A	N/A	N/A	N/A
Dimensions (in.)	1.54	N/A	N/A	N/A	N/A	N/A
Manufacturer	ALU	N/A	N/A	N/A	N/A	N/A
Trunk Cable 1 Qty						
Power Junction Cylinder Model						
Model Number	N/A	N/A	N/A	N/A	N/A	N/A
Weight (lbs.)	N/A	N/A	N/A	N/A	N/A	N/A
Dimensions (in.)	N/A	N/A	N/A	N/A	N/A	N/A
Manufacturer	N/A	N/A	N/A	N/A	N/A	N/A
Power Junction Cylinder Qty	0	0	0	0	0	0
Optical Junction Cylinder Qty needed						
Model Number	N/A	N/A	N/A	N/A	N/A	N/A
Weight (lbs.)	N/A	N/A	N/A	N/A	N/A	N/A
Dimensions (in.)	N/A	N/A	N/A	N/A	N/A	N/A
Manufacturer	N/A	N/A	N/A	N/A	N/A	N/A
Optical Junction Cylinder Qty needed	0	0	0	0	0	0

Band: 1900	Alpha	Beta	Gamma	Delta	Epsilon	Zeta
Radio Model						
Model Number	RRH-4x45-1900	RRH-4x45-1900	RRH-4x45-1900	N/A	N/A	N/A
Weight (lbs)	69.5	69.5	69.5	N/A	N/A	N/A
Dimensions	25 x 12 x 12	25 x 12 x 12	25 x 12 x 12	N/A	N/A	N/A
Manufacturer	ALU	ALU	ALU	N/A	N/A	N/A
Number of RRUs needed	1	1	1	0	0	0
Filter Model						
Model Number	N/A	N/A	N/A	N/A	N/A	N/A
Weight (lbs)	N/A	N/A	N/A	N/A	N/A	N/A
Dimensions	N/A	N/A	N/A	N/A	N/A	N/A
Manufacturer	N/A	N/A	N/A	N/A	N/A	N/A
Filter Model 2						
Model Number	N/A	N/A	N/A	N/A	N/A	N/A
Weight (lbs)	N/A	N/A	N/A	N/A	N/A	N/A
Dimensions	N/A	N/A	N/A	N/A	N/A	N/A
Manufacturer	N/A	N/A	N/A	N/A	N/A	N/A
Filter Model 3						
Model Number	N/A	N/A	N/A	N/A	N/A	N/A
Weight (lbs)	N/A	N/A	N/A	N/A	N/A	N/A
Dimensions	N/A	N/A	N/A	N/A	N/A	N/A
Manufacturer	N/A	N/A	N/A	N/A	N/A	N/A
Trunk Cable 1						
Model Number	1900 Hybrid_ALU	1900 Hybrid_ALU	1900 Hybrid_ALU	N/A	N/A	N/A
Weight (lbs.)	1.1	1.1	1.1	N/A	N/A	N/A
Dimensions (in.)	1.25	1.25	1.25	N/A	N/A	N/A
Manufacturer	ALU	ALU	ALU	N/A	N/A	N/A
Trunk Cable 1 Qty						
Power Junction Cylinder Model						
Model Number	N/A	N/A	N/A	N/A	N/A	N/A
Weight (lbs.)	N/A	N/A	N/A	N/A	N/A	N/A
Dimensions (in.)	N/A	N/A	N/A	N/A	N/A	N/A
Manufacturer	N/A	N/A	N/A	N/A	N/A	N/A
Power Junction Cylinder Qty 0	0	0	0	0	0	0
Optical Junction Cylinder Qty needed						
Model Number	N/A	N/A	N/A	N/A	N/A	N/A
Weight (lbs.)	N/A	N/A	N/A	N/A	N/A	N/A
Dimensions (in.)	N/A	N/A	N/A	N/A	N/A	N/A
Manufacturer	N/A	N/A	N/A	N/A	N/A	N/A
Optical Junction Cylinder Qty needed	0	0	0	0	0	0

Band: 800	Alpha	Beta	Gamma	Delta	Epsilon	Zeta
Radio Model						
Model Number	RRH-2x50-800	RRH-2x50-800	RRH-2x50-800	N/A	N/A	N/A
Weight (lbs)	69.1	69.1	69.1	N/A	N/A	N/A
Dimensions	16 x 13 x 10	16 x 13 x 10	16 x 13 x 10	N/A	N/A	N/A
Manufacturer	ALU	ALU	ALU	N/A	N/A	N/A
Number of RRUs needed	2	2	2	0	0	0
Filter Model						
Model Number	N/A	N/A	N/A	N/A	N/A	N/A
Weight (lbs)	N/A	N/A	N/A	N/A	N/A	N/A
Dimensions	N/A	N/A	N/A	N/A	N/A	N/A
Manufacturer	N/A	N/A	N/A	N/A	N/A	N/A
Filter Model 2						
Model Number	N/A	N/A	N/A	N/A	N/A	N/A
Weight (lbs)	N/A	N/A	N/A	N/A	N/A	N/A
Dimensions	N/A	N/A	N/A	N/A	N/A	N/A
Manufacturer	N/A	N/A	N/A	N/A	N/A	N/A
Filter Model 3						
Model Number	N/A	N/A	N/A	N/A	N/A	N/A
Weight (lbs)	N/A	N/A	N/A	N/A	N/A	N/A
Dimensions	N/A	N/A	N/A	N/A	N/A	N/A
Manufacturer	N/A	N/A	N/A	N/A	N/A	N/A
Trunk Cable 1						
Model Number	N/A	N/A	N/A	N/A	N/A	N/A
Weight (lbs.)	N/A	N/A	N/A	N/A	N/A	N/A
Dimensions (in.)	N/A	N/A	N/A	N/A	N/A	N/A
Manufacturer	N/A	N/A	N/A	N/A	N/A	N/A
Trunk Cable 1 Qty						
Power Junction Cylinder Model						
Model Number	N/A	N/A	N/A	N/A	N/A	N/A
Weight (lbs.)	N/A	N/A	N/A	N/A	N/A	N/A
Dimensions (in.)	N/A	N/A	N/A	N/A	N/A	N/A
Manufacturer	N/A	N/A	N/A	N/A	N/A	N/A
Power Junction Cylinder Qty	0	0	0	0	0	0
Optical Junction Cylinder Qty needed						
Model Number	N/A	N/A	N/A	N/A	N/A	N/A
Weight (lbs.)	N/A	N/A	N/A	N/A	N/A	N/A
Dimensions (in.)	N/A	N/A	N/A	N/A	N/A	N/A
Manufacturer	N/A	N/A	N/A	N/A	N/A	N/A
Optical Junction Cylinder Qty needed	0	0	0	0	0	0

Band: 2500	Alpha	Beta	Gamma	Delta	Epsilon	Zeta
Antenna1						
Model Number	APXVTM14-ALU-I20	APXVTM14-ALU-I20	APXVTM14-ALU-I20			
Weight (lbs)	56.2	56.2	56.2	N/A	N/A	N/A
Dimensions	56.3 x 12.6 x 6.3	56.3 x 12.6 x 6.3	56.3 x 12.6 x 6.3	N/A	N/A	N/A
Manufacturer	RFS	RFS	RFS	N/A	N/A	N/A
Ant1 Top Jumper Make/Mode/Qty	2.5 Jumper	2.5 Jumper	2.5 Jumper	0	0	0
Ant 1 RF requested Diameter	1/2"	1/2"	1/2"	N/A	N/A	N/A
Ant 1 RF requested Top Jumper Length(ft)	8	8	8	N/A	N/A	N/A
Antenna 1 Azimuth	30	150	270	N/A	N/A	N/A
Antenna 1 Mechanical DT	N/A	N/A	N/A	N/A	N/A	N/A
Antenna 1 Center Line (ft)	149.9671964	149.9671964	149.9671964	N/A	N/A	N/A
Antenna 1 Electrical DT	2	2	2	N/A	N/A	N/A
Antenna 1 Electrical DT 2	N/A	N/A	N/A	N/A	N/A	N/A
Antenna 1 Electrical DT 3	N/A	N/A	N/A	N/A	N/A	N/A
Antenna 1 Twist	N/A	N/A	N/A	N/A	N/A	N/A
Antenna2						
Model Number						
Weight (lbs)	N/A	N/A	N/A	N/A	N/A	N/A
Dimensions	N/A	N/A	N/A	N/A	N/A	N/A
Manufacturer	N/A	N/A	N/A	N/A	N/A	N/A
Ant2 Top Jumper Make/Mode/Qty	N/A	N/A	N/A	0	0	0
Ant 2 RF Top Jumper Diameter	N/A	N/A	N/A	N/A	N/A	N/A
Ant 2 RF Top Jumper Length(ft)	N/A	N/A	N/A	N/A	N/A	N/A
Antenna 2 Azimuth	0	N/A	N/A	N/A	N/A	N/A
Antenna 2 Mechanical DT	N/A	N/A	N/A	N/A	N/A	N/A
Antenna 2 Center Line (ft)	N/A	N/A	N/A	N/A	N/A	N/A
Antenna 2 Electrical DT	N/A	N/A	N/A	N/A	N/A	N/A
Antenna 2 Electrical DT 2	N/A	N/A	N/A	N/A	N/A	N/A
Antenna 2 Electrical DT 3	N/A	N/A	N/A	N/A	N/A	N/A
Antenna 2 Twist	N/A	N/A	N/A	N/A	N/A	N/A

Band: 1900	Alpha	Beta	Gamma	Delta	Epsilon	Zeta
Antenna1						
Model Number	NNVV-65B-R4	NNVV-65B-R4	NNVV-65B-R4			
Weight (lbs)	84.7	84.7	84.7	N/A	N/A	N/A
Dimensions	72 x 19.6 x 7.8	72 x 19.6 x 7.8	72 x 19.6 x 7.8	N/A	N/A	N/A
Manufacturer	CommScope	CommScope	CommScope	N/A	N/A	N/A
Ant1 Top Jumper Make/Mode/Qty	800/1900 Jumper	800/1900 Jumper	800/1900 Jumper	0	0	0
Ant 1 RF requested Diameter Length(ft)	1/2"	1/2"	1/2"	N/A	N/A	N/A
Ant 1 RF requested Top Jumper Length(ft)	8	8	8	N/A	N/A	N/A
Antenna 1 Azimuth	30	150	270	N/A	N/A	N/A
Antenna 1 Mechanical DT	N/A	N/A	N/A	N/A	N/A	N/A
Antenna 1 Center Line (ft)	149.9671964	149.9671964	149.9671964	N/A	N/A	N/A
Antenna 1 Electrical DT	3	3	3	N/A	N/A	N/A
Antenna 1 Electrical DT 2	N/A	N/A	N/A	N/A	N/A	N/A
Antenna 1 Electrical DT 3	N/A	N/A	N/A	N/A	N/A	N/A
Antenna 1 Twist	N/A	N/A	N/A	N/A	N/A	N/A
Antenna2						
Model Number						
Weight (lbs)	N/A	N/A	N/A	N/A	N/A	N/A
Dimensions	N/A	N/A	N/A	N/A	N/A	N/A
Manufacturer	N/A	N/A	N/A	N/A	N/A	N/A
Ant2 Top Jumper Make/Mode/Qty	N/A	N/A	N/A	0	0	0
Ant 2 RF Top Jumper Diameter	N/A	N/A	N/A	N/A	N/A	N/A
Ant 2 RF Top Jumper Length(ft)	N/A	N/A	N/A	N/A	N/A	N/A
Antenna 2 Azimuth	N/A	N/A	N/A	N/A	N/A	N/A
Antenna 2 Mechanical DT	N/A	N/A	N/A	N/A	N/A	N/A
Antenna 2 Center Line (ft)	N/A	N/A	N/A	N/A	N/A	N/A
Antenna 2 Electrical DT	N/A	N/A	N/A	N/A	N/A	N/A
Antenna 2 Electrical DT 2	N/A	N/A	N/A	N/A	N/A	N/A
Antenna 2 Electrical DT 3	N/A	N/A	N/A	N/A	N/A	N/A
Antenna 2 Twist	N/A	N/A	N/A	N/A	N/A	N/A

Band: 800	Alpha	Beta	Gamma	Delta	Epsilon	Zeta
Antenna1						
Model Number	Antenna assigned on a different band	Antenna assigned on a different band	Antenna assigned on a different band			
Weight (lbs)	0	0	0	N/A	N/A	N/A
Dimensions	0 x 0 x 0	0 x 0 x 0	0 x 0 x 0	N/A	N/A	N/A
Manufacturer	-	-	-	N/A	N/A	N/A
Ant1 Top Jumper Make/Mode/Qty	800/1900 Jumper	800/1900 Jumper	800/1900 Jumper	0	0	0
Ant 1 RF requested Diameter Length(ft)	1/2"	1/2"	1/2"	N/A	N/A	N/A
Antenna 1 Azimuth	8	8	8	N/A	N/A	N/A
Antenna 1 Mechanical DT	30	150	270	N/A	N/A	N/A
Antenna 1 Center Line (ft)	N/A	N/A	N/A	N/A	N/A	N/A
Antenna 1 Electrical DT	149.9671964	149.9671964	149.9671964	N/A	N/A	N/A
Antenna 1 Electrical DT 2	5	5	5	N/A	N/A	N/A
Antenna 1 Electrical DT 3	N/A	N/A	N/A	N/A	N/A	N/A
Antenna 1 Twist	N/A	N/A	N/A	N/A	N/A	N/A
Antenna2						
Model Number						
Weight (lbs)	N/A	N/A	N/A	N/A	N/A	N/A
Dimensions	N/A	N/A	N/A	N/A	N/A	N/A
Manufacturer	N/A	N/A	N/A	N/A	N/A	N/A
Ant2 Top Jumper Make/Mode/Qty	N/A	N/A	N/A	0	0	0
Ant 2 RF Top Jumper Diameter	N/A	N/A	N/A	N/A	N/A	N/A
Ant 2 RF Top Jumper Length(ft)	N/A	N/A	N/A	N/A	N/A	N/A
Antenna 2 Azimuth	N/A	N/A	N/A	N/A	N/A	N/A
Antenna 2 Mechanical DT	N/A	N/A	N/A	N/A	N/A	N/A
Antenna 2 Center Line (ft)	N/A	N/A	N/A	N/A	N/A	N/A
Antenna 2 Electrical DT	N/A	N/A	N/A	N/A	N/A	N/A
Antenna 2 Electrical DT 2	N/A	N/A	N/A	N/A	N/A	N/A
Antenna 2 Electrical DT 3	N/A	N/A	N/A	N/A	N/A	N/A
Antenna 2 Twist	N/A	N/A	N/A	N/A	N/A	N/A

Band: 2500	Alpha	Beta	Gamma	Delta	Epsilon	Zeta
Antenna 1 Split						
Model Number						
Weight (lbs)	N/A		N/A	N/A	N/A	N/A
Dimensions	N/A		N/A	N/A	N/A	N/A
Manufacturer	N/A		N/A	N/A	N/A	N/A
Accept Proposed Ant1 Model Change?	N/A		N/A	N/A	N/A	N/A
Antenna 1 band combined with	N/A		N/A	N/A	N/A	N/A
Antenna 1 Upper Passive Component Model						
Model Number						
Weight (lbs)	N/A		N/A	N/A	N/A	N/A
Dimensions	N/A		N/A	N/A	N/A	N/A
Manufacturer	N/A		N/A	N/A	N/A	N/A
Ant1 Upper Passive Comp Qty needed	0		0	0	0	0
Ant1 Upper Pass Comp band combi with						
Antenna 1 Lower Passive Component Model						
Model Number						
Weight (lbs)	N/A		N/A	N/A	N/A	N/A
Dimensions	N/A		N/A	N/A	N/A	N/A
Manufacturer	N/A		N/A	N/A	N/A	N/A
Ant1 Lower Passive Comp Qty needed	0		0	0	0	0
Ant1 Low Pass Comp band comb with						
Position Ant 1						
Antenna 2 Split						
Model Number						
Weight (lbs)	N/A		N/A	N/A	N/A	N/A
Dimensions	N/A		N/A	N/A	N/A	N/A
Manufacturer	N/A		N/A	N/A	N/A	N/A
Accept Proposed Ant2 Model Change?	N/A		N/A	N/A	N/A	N/A
Antenna 2 band combined with						
Antenna 2 Upper Passive Component Model						
Model Number						
Weight (lbs)	N/A		N/A	N/A	N/A	N/A
Dimensions	N/A		N/A	N/A	N/A	N/A
Manufacturer	N/A		N/A	N/A	N/A	N/A
Ant2 Upper Passive Comp Qty needed	0		0	0	0	0
Antenna 2 Lower Passive Component Model						
Model Number						
Weight (lbs)	N/A		N/A	N/A	N/A	N/A
Dimensions	N/A		N/A	N/A	N/A	N/A
Manufacturer	N/A		N/A	N/A	N/A	N/A
Ant1 Lower Passive Comp Qty needed	0		0	0	0	0
Ant1 Lower Passive Component band combined with						
Position Ant 2						

Band: 1900	Alpha	Beta	Gamma	Delta	Epsilon	Zeta
Antenna 1 Split						
Model Number	N/A					
Weight (lbs)	N/A		N/A	N/A	N/A	N/A
Dimensions	N/A		N/A	N/A	N/A	N/A
Manufacturer	N/A		N/A	N/A	N/A	N/A
Accept Proposed Ant1 Model Change?	N/A		N/A	N/A	N/A	N/A
Antenna 1 band combined with	800MHz		800MHz	N/A	N/A	N/A
Antenna 1 Upper Passive Component Model						
Model Number						
Weight (lbs)	N/A		N/A	N/A	N/A	N/A
Dimensions	N/A		N/A	N/A	N/A	N/A
Manufacturer	N/A		N/A	N/A	N/A	N/A
Ant1 Upper Passive Comp Qty needed	0		0	0	0	0
Ant1 Upper Pass Comp band combi with						
Antenna 1 Lower Passive Component Model						
Model Number						
Weight (lbs)	N/A		N/A	N/A	N/A	N/A
Dimensions	N/A		N/A	N/A	N/A	N/A
Manufacturer	N/A		N/A	N/A	N/A	N/A
Ant1 Lower Passive Comp Qty needed	0		0	0	0	0
Ant1 Low Pass Comp band comb with						
Position Ant 1						
Antenna 2 Split						
Model Number						
Weight (lbs)	N/A		N/A	N/A	N/A	N/A
Dimensions	N/A		N/A	N/A	N/A	N/A
Manufacturer	N/A		N/A	N/A	N/A	N/A
Accept Proposed Ant2 Model Change?	N/A		N/A	N/A	N/A	N/A
Antenna 2 band combined with						
Antenna 2 Upper Passive Component Model						
Model Number						
Weight (lbs)	N/A		N/A	N/A	N/A	N/A
Dimensions	N/A		N/A	N/A	N/A	N/A
Manufacturer	N/A		N/A	N/A	N/A	N/A
Ant2 Upper Passive Comp Qty needed	0		0	0	0	0
Antenna 2 Lower Passive Component Model						
Model Number						
Weight (lbs)	N/A		N/A	N/A	N/A	N/A
Dimensions	N/A		N/A	N/A	N/A	N/A
Manufacturer	N/A		N/A	N/A	N/A	N/A
Ant1 Lower Passive Comp Qty needed	0		0	0	0	0
Ant1 Lower Passive Component band combined with						
Position Ant 2						

Band: 800	Alpha	Beta	Gamma	Delta	Epsilon	Zeta
Antenna1 Split						
Model Number						
Weight (lbs)	N/A		N/A	N/A	N/A	N/A
Dimensions	N/A		N/A	N/A	N/A	N/A
Manufacturer	N/A		N/A	N/A	N/A	N/A
Accept Proposed Ant1 Model Change?	N/A		N/A	N/A	N/A	N/A
Antenna 1 band combined with	1900MHz		1900MHz	N/A	N/A	N/A
Antenna 1 Upper Passive Component Model						
Model Number						
Weight (lbs)	N/A		N/A	N/A	N/A	N/A
Dimensions	N/A		N/A	N/A	N/A	N/A
Manufacturer	N/A		N/A	N/A	N/A	N/A
Ant1 Upper Passive Comp Qty needed	0		0	0	0	0
Ant1 Upper Pass Comp band combi with						
Antenna 1 Lower Passive Component Model						
Model Number						
Weight (lbs)	N/A		N/A	N/A	N/A	N/A
Dimensions	N/A		N/A	N/A	N/A	N/A
Manufacturer	N/A		N/A	N/A	N/A	N/A
Ant1 Lower Passive Comp Qty needed	0		0	0	0	0
Ant1 Low Pass Comp band comb with						
Position Ant 1						
Antenna2 Split						
Model Number						
Weight (lbs)	N/A		N/A	N/A	N/A	N/A
Dimensions	N/A		N/A	N/A	N/A	N/A
Manufacturer	N/A		N/A	N/A	N/A	N/A
Accept Proposed Ant2 Model Change?	N/A		N/A	N/A	N/A	N/A
Antenna 2 band combined with						
Antenna 2 Upper Passive Component Model						
Model Number						
Weight (lbs)	N/A		N/A	N/A	N/A	N/A
Dimensions	N/A		N/A	N/A	N/A	N/A
Manufacturer	N/A		N/A	N/A	N/A	N/A
Ant2 Upper Passive Comp Qty needed	0		0	0	0	0
Antenna 2 Lower Passive Component Model						
Model Number						
Weight (lbs)	N/A		N/A	N/A	N/A	N/A
Dimensions	N/A		N/A	N/A	N/A	N/A
Manufacturer	N/A		N/A	N/A	N/A	N/A
Ant1 Lower Passive Comp Qty needed	0		0	0	0	0
Ant1 Lower Passive Component band combined with						
Position Ant 2						