



Northeast Site Solutions
Denise Sabo
4 Angela's Way, Burlington CT 06013
203-435-3640
denise@northeastsitesolutions.com

June 16, 2022

Members of the Siting Council
Connecticut Siting Council
Ten Franklin Square
New Britain, CT 06051

RE: Tower Share Application
75 Roberts Road, Groton, CT 06340
Latitude: 41.360280
Longitude: -72.048425
Site #: 881533_Crown_Dish

Dear Ms. Bachman:

This letter and attachments are submitted on behalf of Dish Wireless LLC. Dish Wireless LLC plans to install antennas and related equipment to the tower site located at 75 Roberts Road, Groton, Connecticut.

Dish Wireless LLC proposes to install three (3) 600/1900 MHz 5G antennas and six (6) RRUs, at the 98-foot level of the existing 145-foot monopole tower, one (1) Fiber cable will also be installed. Dish Wireless LLC equipment cabinets will be placed within a 7' x 5' lease area within the existing fenced compound. Included are plans by Hudson Design Group, dated June 9, 2022, Exhibit C. Also included is a structural analysis prepared by B+T, dated October 27, 2021, confirming that the existing tower is structurally capable of supporting the proposed equipment. Attached as Exhibit D. The facility was approved by the Town of Groton Planning Commission on February 22, 2000. Please see attached Exhibit A.

Please accept this letter as notification pursuant to Regulations of Connecticut State Agencies 16-50aa, of Dish Wireless LLC intent to share a telecommunications facility pursuant to R.C.S.A. 16-50j-88. In accordance with R.C.S.A., a copy of this letter is being sent to Mayor Patrice Granatosky, John Burt, Town Manager and Jonathan Reiner, Director of Planning for the Town of Groton, as well as the tower owner (Crown Castle) and property owner (Daniel & Stacey Perrotta).

The planned modifications of the facility fall squarely within those activities explicitly provided for in R.C.S.A. 16-50j-89.

1. The proposed modification will not result in an increase in the height of the existing structure. The top of the existing tower is 145-feet and the Dish Wireless LLC antennas will be located at a centerline height of 98-feet.
2. The proposed modifications will not result in an increase of the site boundary as depicted on the attached site plan.



NSS **NORTHEAST**
SITE SOLUTIONS

Turnkey Wireless Development

3. The proposed modifications will not increase noise levels at the facility by six decibels or more, or to levels that exceed local and state criteria. The incremental effect of the proposed changes will be negligent.

4. The operation of the proposed antennas will not increase radio frequency emissions at the facility to a level at or above the Federal Communications Commission safety standard. The combined site operations will result in a total power density of 30.52% as evidenced by Exhibit F.

Connecticut General Statutes 16-50aa indicates that the Council must approve the shared use of a telecommunications facility provided it finds the shared use is technically, legally, environmentally, and economically feasible and meets public safety concerns. As demonstrated in this letter, Dish Wireless LLC respectfully submits that the shared use of this facility satisfies these criteria.

A. Technical Feasibility. The existing tower has been deemed structurally capable of supporting Dish Wireless LLC proposed loading. The structural analysis is included as Exhibit D.

B. Legal Feasibility. As referenced above, C.G.S. 16-50aa has been authorized to issue orders approving the shared use of an existing tower such as this tower in Groton. Under the authority granted to the Council, an order of the Council approving the requested shared use would permit Dish Wireless LLC to obtain a building permit for the proposed installation. Further, a Letter of Authorization is included as Exhibit G, authorizing Dish Wireless LLC to file this application for shared use.

C. Environmental Feasibility. The proposed shared use of this facility would have a minimal environmental impact. The installation of Dish Wireless LLC equipment at the 98-foot level of the existing 145-foot tower would have an insignificant visual impact on the area around the tower. Dish Wireless LLC ground equipment would be installed within the existing facility compound. Dish Wireless LLC shared use would therefore not cause any significant alteration in the physical or environmental characteristics of the existing site. Additionally, as evidenced by Exhibit F, the proposed antennas would not increase radio frequency emissions to a level at or above the Federal Communications Commission safety standard.

D. Economic Feasibility. Dish Wireless LLC will be entering into an agreement with the owner of this facility to mutually agreeable terms. As previously mentioned, the Letter of Authorization has been provided by the owner to assist Dish Wireless LLC with this tower sharing application.

E. Public Safety Concerns. As discussed above, the tower is structurally capable of supporting Dish Wireless LLC proposed loading. Dish Wireless LLC is not aware of any public safety concerns relative to the proposed sharing of the existing tower. Dish Wireless LLC intentions of providing new and improved wireless service through the shared use of this facility is expected to enhance the safety and welfare of local residents and individuals traveling through Groton.

Sincerely,

Denise Sabo

Denise Sabo

Mobile: 203-435-3640

Fax: 413-521-0558

Office: 4 Angela's Way, Burlington CT 06013

Email: denise@northeastsitesolutions.com



NSS

NORTHEAST
SITE SOLUTIONS

Turnkey Wireless Development

Attachments

Cc: Mayor Patrice Granatosky
Town of Groton
45 Fort Hill Rd.
Groton, CT 06340

John Burt - Town Manager
Town of Groton
45 Fort Hill Rd.
Groton, CT 06340

Jonathan Reiner - Director of Planning
Town of Groton
45 Fort Hill Rd.
Groton, CT 06340

Daniel & Stacey Perrotta - Property Owners
75 Roberts Road
Groton, CT 06340

Crown Castle, Tower Owner

Exhibit A

Original Facility Approval



TOWN OF GROTON

PLANNING AND DEVELOPMENT SERVICES

Planning Department

134 Groton Long Point Road
Groton, Connecticut 06340-4873

March 1, 2000

Gerald Longobardi
Candid Communications of Groton, LLC
110 Washington Avenue
North Haven, Connecticut 06473

Dear Mr. Longobardi:

The Town of Groton Planning Commission, at its meeting on February 22, 2000, approved with modifications your site plan entitled Candid Communications Telecommunications Tower and Facilities, Roberts Road (see attachment).

If your plan was approved with modifications, you should submit two paper check prints of the revised plan for final review to insure compliance with the Commission's approval. Following this review, two mylars and eight paper prints of the entire plan must be submitted for the Chairman's signature.

Please note that this plan, after being signed by the Chairman of the Commission, must be filed by you or your representative in the Land Records Office at Town Hall, and until such filing has been done, no building permit can be issued and no construction shall commence. Please note as per the Zoning Regulations, "any approved site plan for which construction has not commenced or which is not otherwise put into effect within a period of one year shall become null and void, unless an extension of time is applied for by the applicant and granted by the Planning Commission."

If a building permit is involved, "Post Site Plan Approval Requirements and Procedures" and "Contractor's Punch List for Site Work" have been enclosed to assist you in the construction phase of your project.

Please note that any modification to this plan subsequent to Planning Commission approval requires resubmission of an application for site plan modification approval in the same manner as the original application. Failure to submit requisite modification applications could result in delays in issuance of Certificates of Site Plan Compliance and Certificates of Occupancy.

If you have any questions, please do not hesitate to contact me.

Sincerely,

Michael J. Murphy, AICP
Assistant Director of
Planning and Development

MJM:nb

Certified # Z 414 682 282

Exhibit B

Property Card

6/11/2019

Residential Property Card

Residential Property Card

Print Date: 6/11/2019

Card 1 Of 1

Account	Location	Grand List Code	Zoning	Acres
169914226707	75 ROBERTS RD	RESIDENTIAL	RU-20	3.18
District	Neighborhood	Deed Book/Page	Use Code	
POQUONNOCK BRIDGE	1031	1206/918	SINGLE FAMILY	

Current Owner

PERROTTA DANIEL J & STACEY A
75 ROBERTS RD
GROTON CT 06340

Property Picture



Building Information

Style:	RAISED RANCH
Exterior:	ALUM/VINYL
Attic:	NONE
Stories:	1
Basement:	FULL
Year Built:	1977
Tot Living Area:	2120 SqFt.
Fuel:	ELECTRIC
Heating:	BASIC
System:	ELECTRIC
Bedrooms:	4
Full Baths:	2
Half Baths:	

Building Sketch

Valuation

Land:	\$94,000
Building:	\$200,500
Total:	\$294,500
Assessed Value:	\$206,150

Recent Sales

Book/Page	Date	Price
1206/918	10/15/2018	\$0
1091/1053	5/4/2012	\$300,000
1091/1050	5/3/2012	\$0

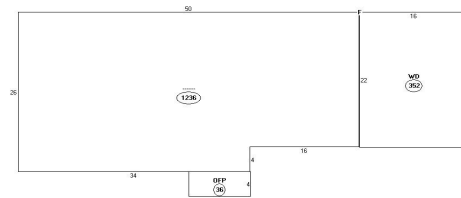

Decade
 A-1200
 B-1200
 C-1200
 D-1200
 E-1200
 F-1200
 G-1200

Sketch Legend



Town of Groton



GIS Map



1 inch = 104 feet

Date: June 11, 2019

Disclaimer:
The planning and topographic information depicted on this map was compiled by the Barber Map Company based on an aerial flight performed in April 2010. The accuracy of data has not been independently verified and may be derived from various sources, including aerial photography, GIS data, and other sources of information. The Town of Groton is not responsible for any errors or omissions in this map. The user of this map is advised to verify the accuracy of any information used in this map. The Town of Groton and the planning commission assume no legal responsibility for the information contained in this map.
THIS MAP SHOULD BE USED FOR THE PURPOSES OF PROPERTY.

Horizontal Datum:
Connecticut State Plane Coordinate, North American Datum of 1983 (NAD83)
Foot
Vertical Datum:
North American Vertical Datum of 1988 (NAVD88)

Exhibit C

Construction Drawings



DISH Wireless L.L.C. SITE ID:
BOBOS01000A

DISH Wireless L.L.C. SITE ADDRESS:
**75 ROBERTS ROAD
GROTON, CT 06340**

SCOPE OF WORK

THIS IS NOT AN ALL INCLUSIVE LIST. CONTRACTOR SHALL UTILIZE SPECIFIED EQUIPMENT PART OR ENGINEER APPROVED EQUIVALENT. CONTRACTOR SHALL VERIFY ALL NEEDED EQUIPMENT TO PROVIDE A FUNCTIONAL SITE. THE PROJECT GENERALLY CONSISTS OF THE FOLLOWING:

- TOWER SCOPE OF WORK:**
- INSTALL (3) PROPOSED PANEL ANTENNAS (1 PER SECTOR)
 - INSTALL (1) PROPOSED ANTENNA PLATFORM MOUNT
 - INSTALL PROPOSED JUMPERS
 - INSTALL (6) PROPOSED RRUs (2 PER SECTOR)
 - INSTALL (1) PROPOSED OVER VOLTAGE PROTECTION DEVICE (OVP)
 - INSTALL (1) PROPOSED HYBRID CABLE
 - INSTALL (1) PROPOSED CABLE ENTRY PORT

- GROUND SCOPE OF WORK:**
- INSTALL (1) PROPOSED METAL PLATFORM
 - INSTALL (1) PROPOSED PPC CABINET
 - INSTALL (1) PROPOSED EQUIPMENT CABINET
 - INSTALL (1) PROPOSED POWER CONDUIT
 - INSTALL (1) PROPOSED TELCO CONDUIT
 - INSTALL (1) PROPOSED TELCO-FIBER BOX
 - INSTALL (1) PROPOSED GPS UNIT
 - INSTALL (1) PROPOSED SAFETY SWITCH (IF REQUIRED)
 - INSTALL (1) PROPOSED FIBER NID (IF REQUIRED)
 - INSTALL (1) PROPOSED NEW 200A METER IN EXISTING SOCKET

SITE INFORMATION

PROPERTY OWNER: GLOBAL SIGNAL ACQUISITIONS IV LLC (1)

PROPERTY OWNER ADDRESS: 75 ROBERTS ROAD GROTON, CT 06340

TOWER TYPE: MONOPOLE
TOWER CO SITE ID: 881533
TOWER APP NUMBER: 576662

COUNTY: NEW LONDON

LATITUDE (NAD 83): 41° 21' 36.80" N 41.36022222
LONGITUDE (NAD 83): 72° 02' 55.10" W -72.04863889

ZONING JURISDICTION: CONNECTICUT SITING COUNCIL, CT
ZONING DISTRICT: CONNECTICUT SITING COUNCIL, CT

PARCEL NUMBER: GROT-001699-001422-006707

OCCUPANCY GROUP: U

CONSTRUCTION TYPE: II-B

POWER COMPANY: GROTON UTILITIES

TELEPHONE COMPANY: CROWN CASTLE

PROJECT DIRECTORY

APPLICANT: DISH Wireless L.L.C.
5701 SOUTH SANTA FE DRIVE
LITTLETON, CO 80120

TOWER OWNER: CROWN CASTLE
2000 CORPORATE DRIVE
CANONSBURG, PA 15317
(877) 486-9377

SITE DESIGNER: HUDSON DESIGN GROUP, LLC.
45 BEECHWOOD DRIVE
NORTH ANDOVER, MA 01845
(978) 557-5553

SITE ACQUISITION: COURTNEY PRESTON
COURTNEY.PRESTON.CONTRACTOR
@CROWNCastle.COM

CONSTRUCTION MANAGER: JAVIER SOTO
JAVIER.SOTO@DISH.COM

RF ENGINEER: ARVIN SEBASTIAN
ARVIN.SEBASTIAN@DISH.COM



5701 SOUTH SANTA FE DRIVE
LITTLETON, CO 80120



45 BEECHWOOD DRIVE N. ANDOVER, MA 01845 TEL: (978) 557-5553 FAX: (978) 336-5586

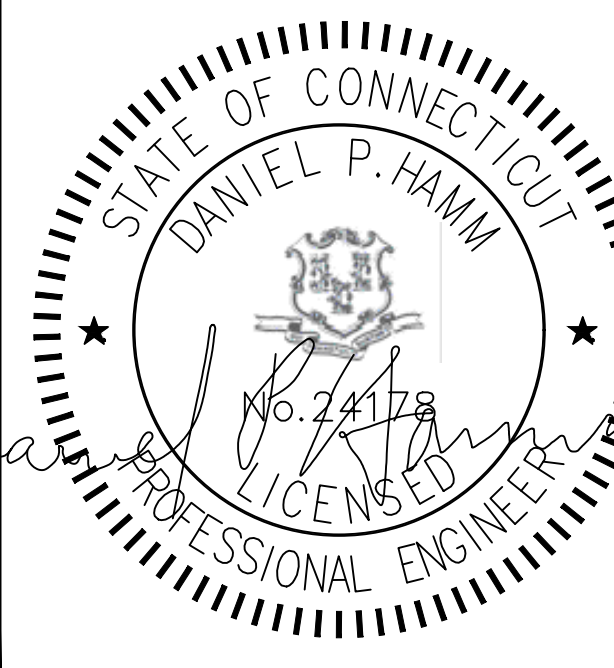

IT IS A VIOLATION OF LAW FOR ANY PERSON, UNLESS THEY ARE ACTING UNDER THE DIRECTION OF A LICENSED PROFESSIONAL ENGINEER, TO ALTER THIS DOCUMENT.

DRAWN BY: MRK CHECKED BY: SMA APPROVED BY: DPH

RFDS REV #: 4

PRELIMINARY DOCUMENT

SUBMITTALS		
REV	DATE	DESCRIPTION
A	11/16/2021	ISSUED FOR REVIEW
B	04/04/2022	ISSUED FOR REVIEW
C	06/06/2022	ISSUED FOR REVIEW

A&E PROJECT NUMBER
BOBOS01000A

DISH Wireless L.L.C.
PROJECT INFORMATION
BOBOS01000A
CROWN CASTLE BU#881533
75 ROBERTS ROAD
GROTON, CT 06340

SHEET TITLE
TITLE SHEET

SHEET NUMBER
T-1

CONNECTICUT CODE OF COMPLIANCE

ALL WORK SHALL BE PERFORMED AND MATERIALS INSTALLED IN ACCORDANCE WITH THE CURRENT EDITIONS OF THE FOLLOWING CODES AS ADOPTED BY THE LOCAL GOVERNING AUTHORITIES. NOTHING IN THESE PLANS IS TO BE CONSTRUED TO PERMIT WORK NOT CONFORMING TO THESE CODES

CODE TYPE	CODE
BUILDING	2018 CT STATE BUILDING CODE/2015 IBC W/ CT AMENDMENTS
MECHANICAL	2018 CT STATE BUILDING CODE/2015 IMC W/ CT AMENDMENTS
ELECTRICAL	2018 CT STATE BUILDING CODE/2017 NEC W/ CT AMENDMENTS

SHEET INDEX

SHEET NO.	SHEET TITLE
T-1	TITLE SHEET
A-1	COMPOUND AND EQUIPMENT PLANS
A-2	ELEVATION, ANTENNA LAYOUT AND SCHEDULE
A-3	EQUIPMENT PLATFORM AND H-FRAME DETAILS
A-4	EQUIPMENT DETAILS
A-5	EQUIPMENT DETAILS
A-6	EQUIPMENT DETAILS
E-1	ELECTRICAL/FIBER ROUTE PLAN AND NOTES
E-2	ELECTRICAL DETAILS
E-3	ELECTRICAL ONE-LINE, FAULT CALCS & PANEL SCHEDULE
G-1	GROUNDING PLANS AND NOTES
G-2	GROUNDING DETAILS
G-3	GROUNDING DETAILS
RF-1	RF CABLE COLOR CODE
GN-1	LEGEND AND ABBREVIATIONS
GN-2	GENERAL NOTES
GN-3	GENERAL NOTES
GN-4	GENERAL NOTES

SITE PHOTO



UNDERGROUND SERVICE ALERT CBYD 811
UTILITY NOTIFICATION CENTER OF CONNECTICUT
(800) 922-4455
WWW.CBYD.COM
CALL 2 WORKING DAYS UTILITY NOTIFICATION PRIOR TO CONSTRUCTION



GENERAL NOTES

THE FACILITY IS UNMANNED AND NOT FOR HUMAN HABITATION. A TECHNICIAN WILL VISIT THE SITE AS REQUIRED FOR ROUTINE MAINTENANCE. THE PROJECT WILL NOT RESULT IN ANY SIGNIFICANT DISTURBANCE OR EFFECT ON DRAINAGE. NO SANITARY SEWER SERVICE, POTABLE WATER, OR TRASH DISPOSAL IS REQUIRED AND NO COMMERCIAL SIGNAGE IS PROPOSED.

11"x17" PLOT WILL BE HALF SCALE UNLESS OTHERWISE NOTED

CONTRACTOR SHALL VERIFY ALL PLANS, EXISTING DIMENSIONS, AND CONDITIONS ON THE JOB SITE, AND SHALL IMMEDIATELY NOTIFY THE ENGINEER IN WRITING OF ANY DISCREPANCIES BEFORE PROCEEDING WITH THE WORK.

DIRECTIONS

DIRECTIONS FROM GROTON-NEW LONDON AIRPORT:
START OUT GOING EAST ON TOWER AVE TOWARD SOUTH RD. TOWER AVE BECOMES SOUTH RD. TURN LEFT ONTO POQUONNOCK RD/US-1 S. TAKE THE 2ND RIGHT ONTO BUDDINGTON RD. TURN LEFT ONTO ROBERTS RD (PORTIONS UNPAVED). 75 ROBERTS RD, GROTON, CT 06340-3218, 75 ROBERTS RD IS ON THE LEFT.

VICINITY MAP

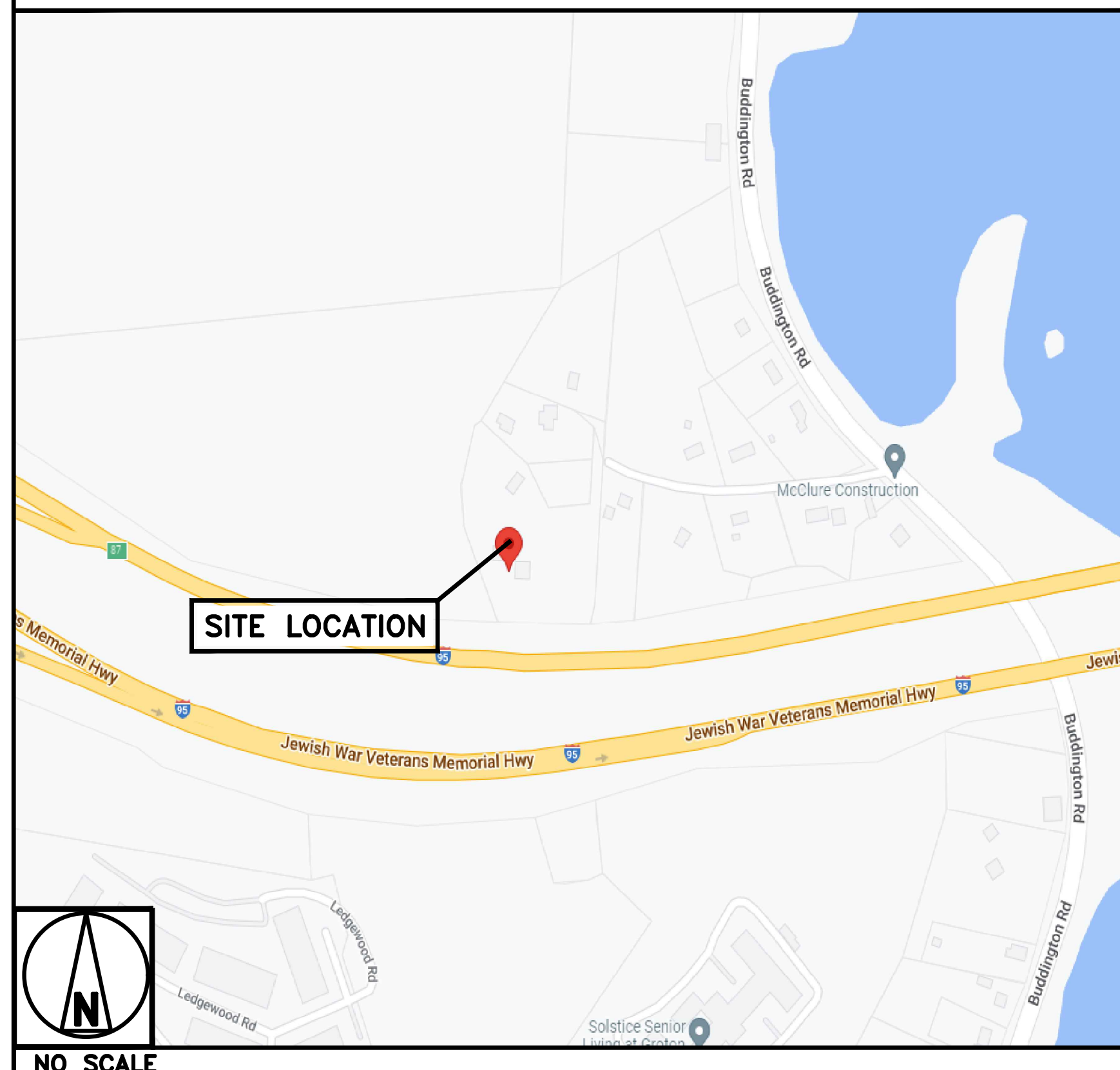

NOTES

1. CONTRACTOR SHALL FIELD VERIFY ALL DIMENSIONS.
2. ANTENNAS AND MOUNTS OMITTED FOR CLARITY.

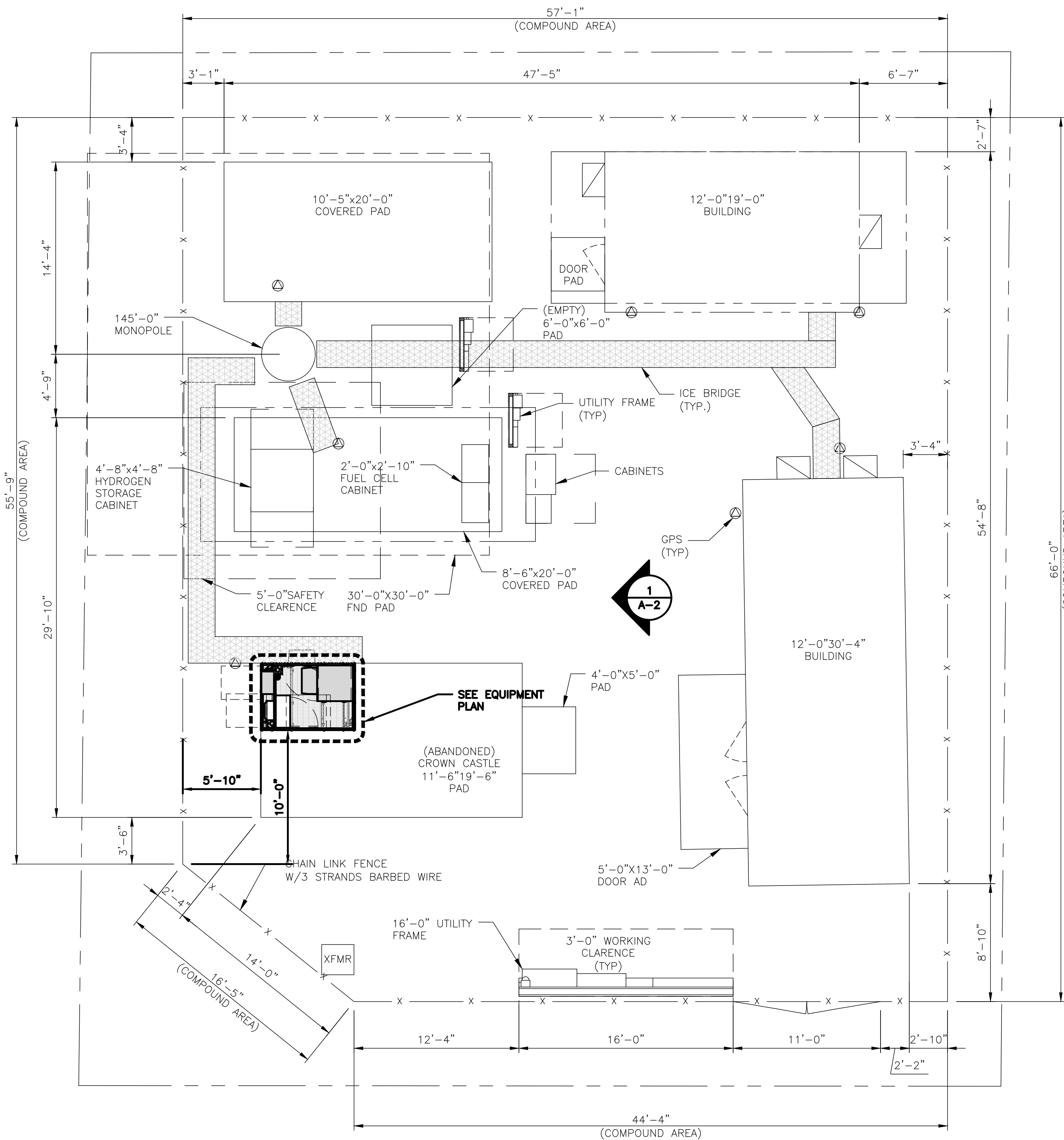

COMPOUND PLAN

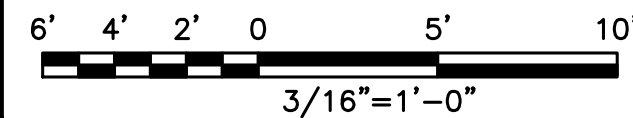

1

NOTES

1. CONTRACTOR SHALL FIELD VERIFY ALL DIMENSIONS.
2. CONTRACTOR SHALL MAINTAIN A 10'-0" MINIMUM SEPARATION BETWEEN THE PROPOSED GPS UNIT, TRANSMITTING ANTENNAS AND EXISTING GPS UNITS.
3. ANTENNAS AND MOUNTS OMITTED FOR CLARITY.

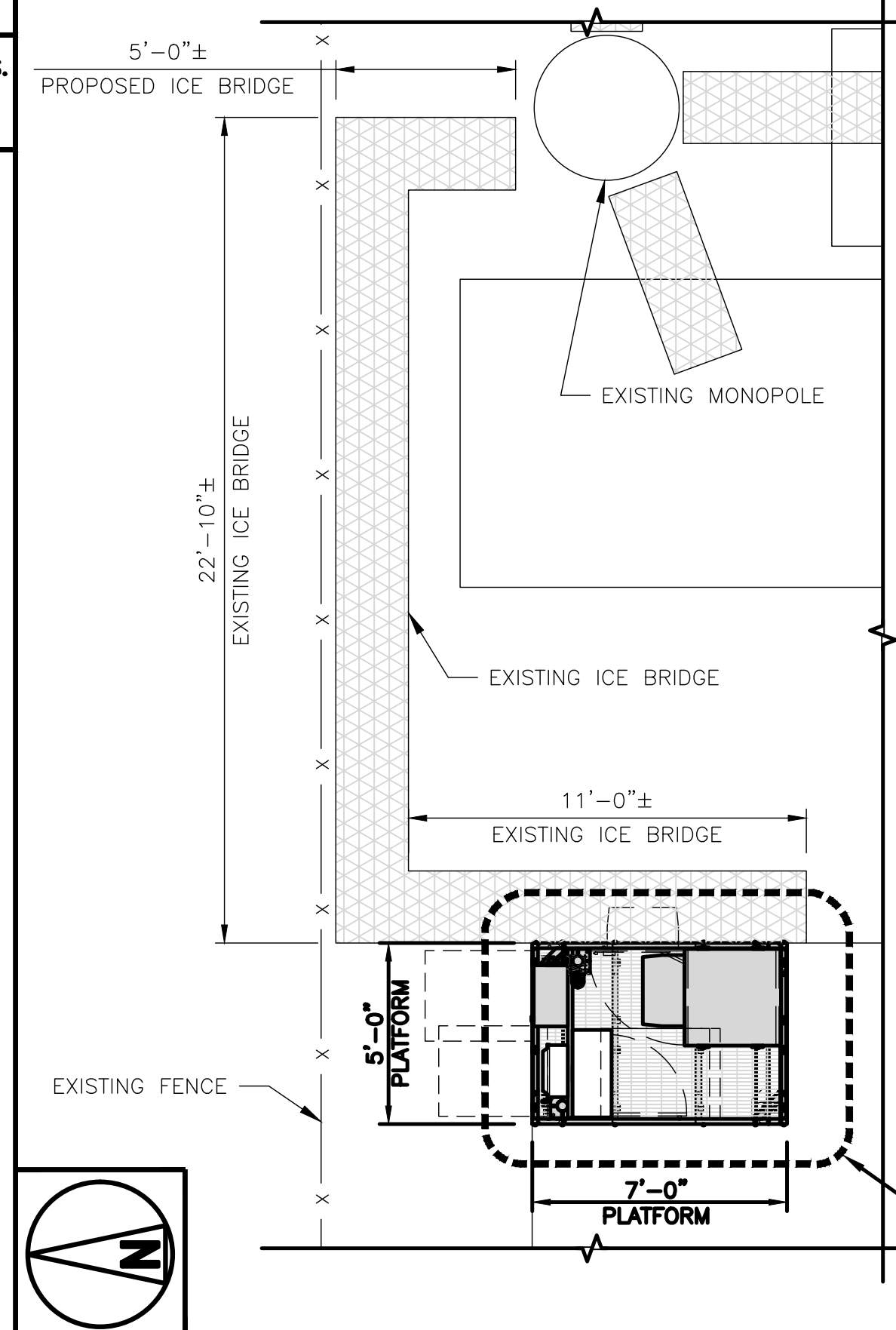

EQUIPMENT PLAN

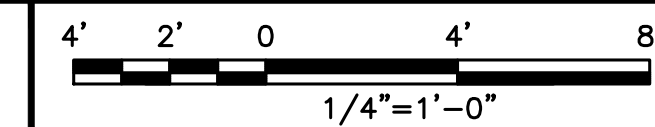

2



POWER & TELCO RUN

NO SCALE

3



5701 SOUTH SANTA FE DRIVE
LITTLETON, CO 80120



45 BEECHWOOD DRIVE TEL: (978) 557-5553
N. ANDOVER, MA 01845 FAX: (978) 336-5586

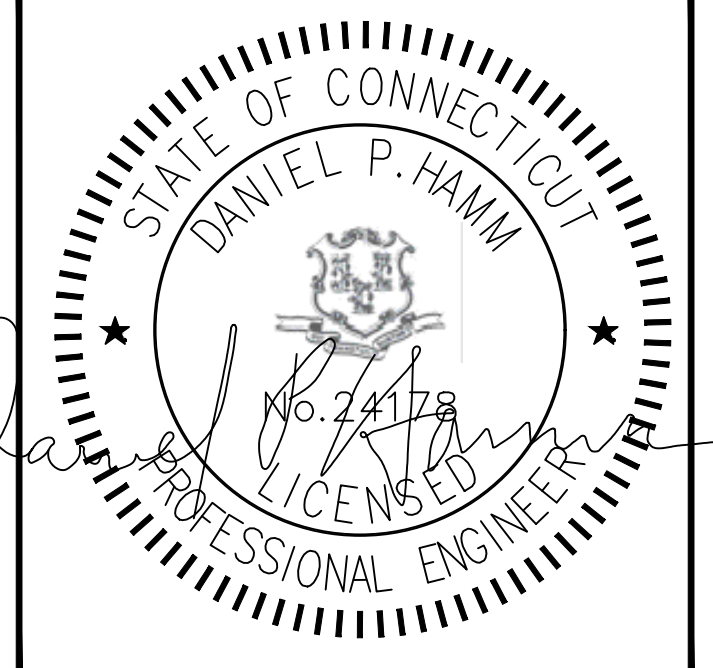

IT IS A VIOLATION OF LAW FOR ANY PERSON, UNLESS THEY ARE ACTING UNDER THE DIRECTION OF A LICENSED PROFESSIONAL ENGINEER, TO ALTER THIS DOCUMENT.

DRAWN BY: MRK CHECKED BY: SMA APPROVED BY: DPH

RFDS REV #: 4

PRELIMINARY DOCUMENT

SUBMITTALS		
REV	DATE	DESCRIPTION
A	11/16/2021	ISSUED FOR REVIEW
B	04/04/2022	ISSUED FOR REVIEW
C	06/06/2022	ISSUED FOR REVIEW

A&E PROJECT NUMBER
BOBOS01000A

DISH Wireless L.L.C.
PROJECT INFORMATION
BOBOS01000A
CROWN CASTLE BU#881533
75 ROBERTS ROAD
GROTON, CT 06340

SHEET TITLE
COMPOUND AND EQUIPMENT PLANS

SHEET NUMBER
A-1

NOTES

1. CONTRACTOR SHALL FIELD VERIFY ALL DIMENSIONS.
2. ANTENNA AND MW DISH SPECIFICATIONS REFER TO ANTENNA SCHEDULE AND TO FINAL CONSTRUCTION RFDS FOR ALL RF DETAILS
3. EXISTING EQUIPMENT AND FENCE OMITTED FOR CLARITY.

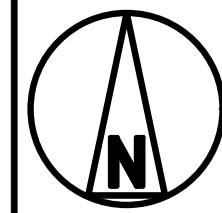
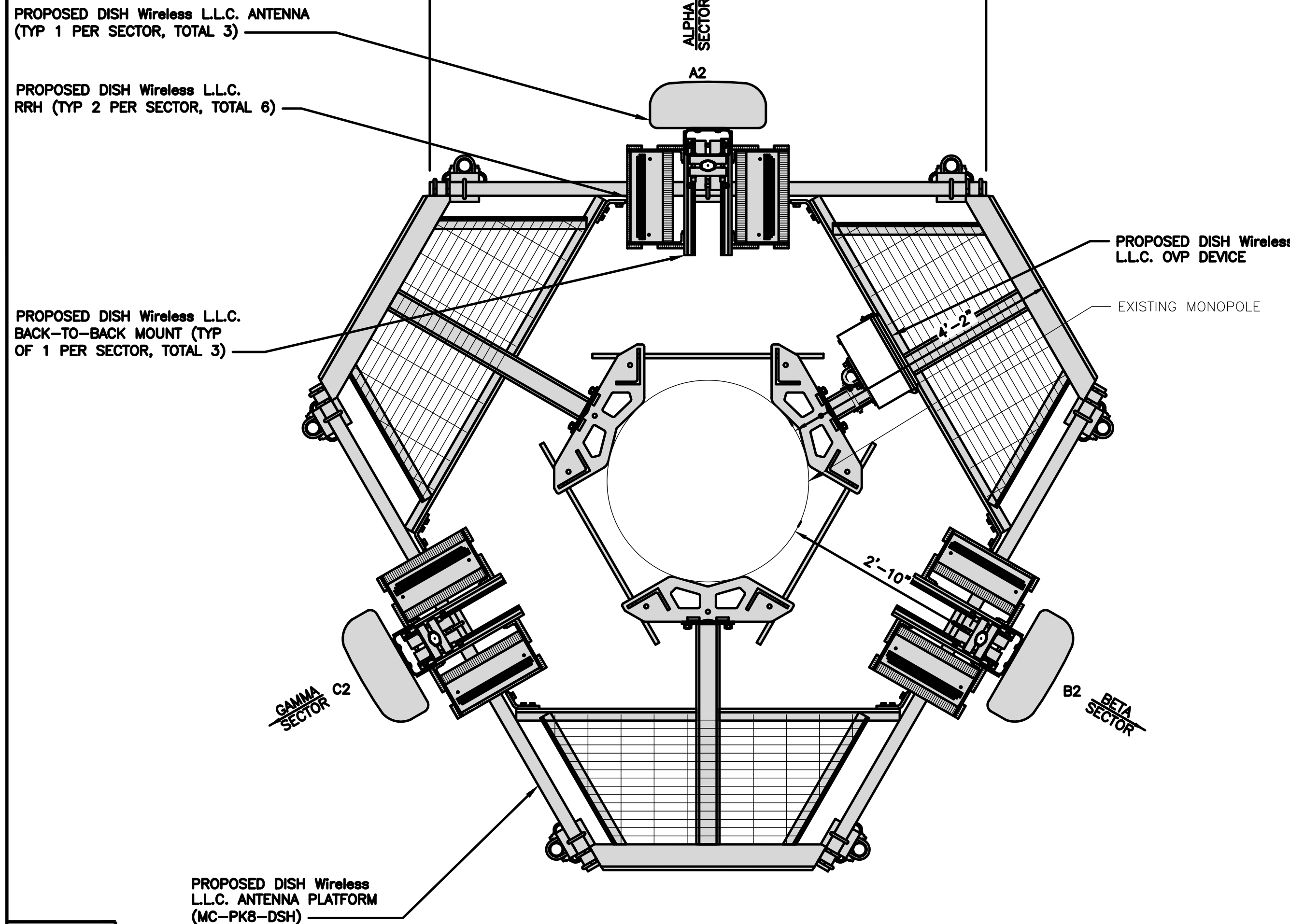
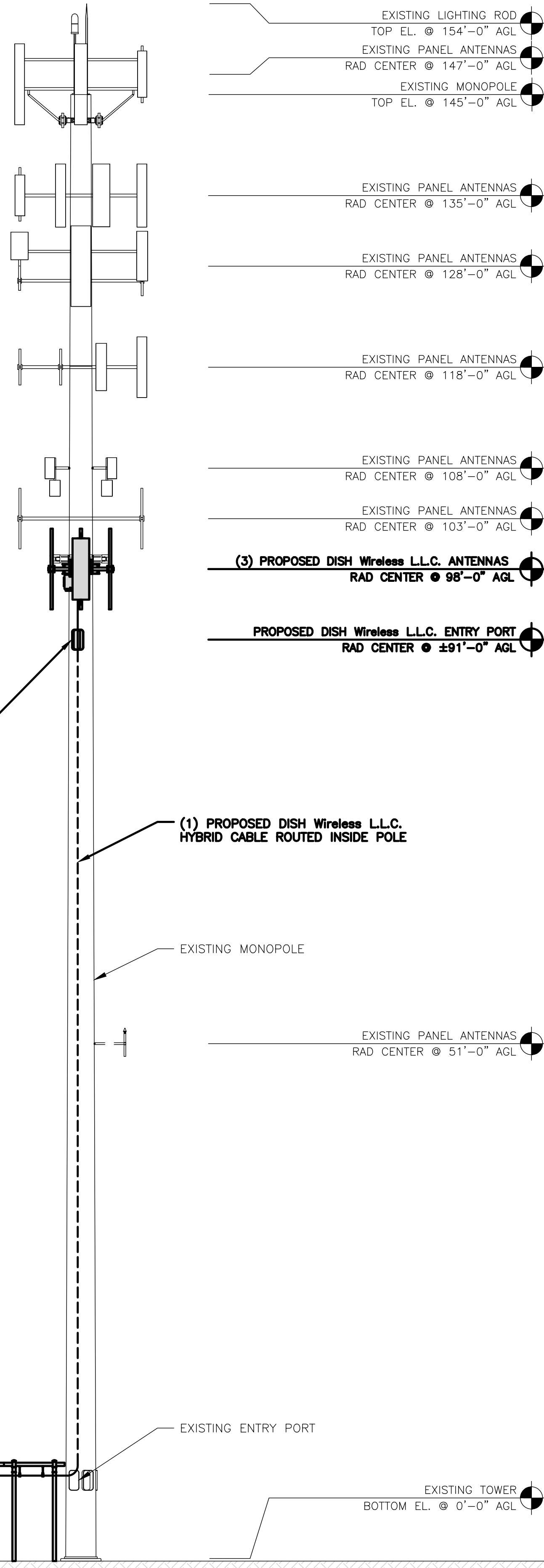

ANTENNA LAYOUT

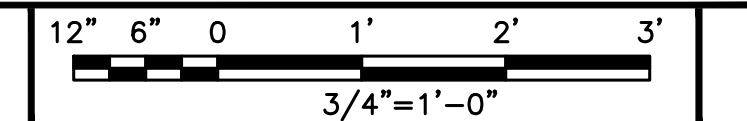

2

SECTOR POS.	ANTENNA					TRANSMISSION CABLE	RRH			OVP
	EXISTING OR PROPOSED	MANUFACTURER -- MODEL NUMBER	TECH	AZIMUTH	RAD CENTER		FEED LINE TYPE AND LENGTH	MANUFACTURER -- MODEL NUMBER	TECH	
A1	---	---	---	---	---	(1) HIGH-CAPACITY HYBRID CABLE (160' LONG)	FUJITSU / TA08025-B604	5G	A2	RAYCAP / RDIC-9181-PF-48
A2	PROPOSED	JMA WIRELESS/MX08FR0665-21	5G	0°	98'-0"		FUJITSU / TA08025-B605	5G	A2	
A3	---	---	---	---	---		---	---	---	
B1	---	---	---	---	---	SHARED W/ALPHA	FUJITSU / TA08025-B604	5G	B2	SHARED W/ALPHA
B2	PROPOSED	JMA WIRELESS/MX08FR0665-21	5G	120°	98'-0"		FUJITSU / TA08025-B605	5G	B2	
B3	---	---	---	---	---		---	---	---	
C1	---	---	---	---	---	SHARED W/ALPHA	FUJITSU / TA08025-B604	5G	C2	SHARED W/ALPHA
C2	PROPOSED	JMA WIRELESS/MX08FR0665-21	5G	240°	98'-0"		FUJITSU / TA08025-B605	5G	C2	
C3	---	---	---	---	---		---	---	---	

- NOTES**
1. CONTRACTOR TO REFER TO FINAL CONSTRUCTION RFDS FOR ALL RF DETAILS.
 2. ANTENNA AND RRH MODELS MAY CHANGE DUE TO EQUIPMENT AVAILABILITY. ALL EQUIPMENT CHANGES MUST BE APPROVED AND REMAIN IN COMPLIANCE WITH THE PROPOSED DESIGN AND STRUCTURAL ANALYSES.

PROPOSED ELEVATION

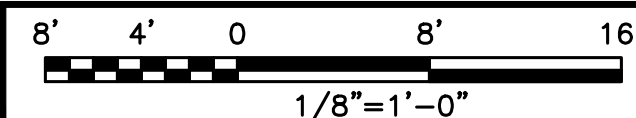

1

ANTENNA SCHEDULE

NO SCALE

3



5701 SOUTH SANTA FE DRIVE
LITTLETON, CO 80120



45 BEECHWOOD DRIVE TEL: (978) 557-5553
N. ANDOVER, MA 01845 FAX: (978) 336-5586

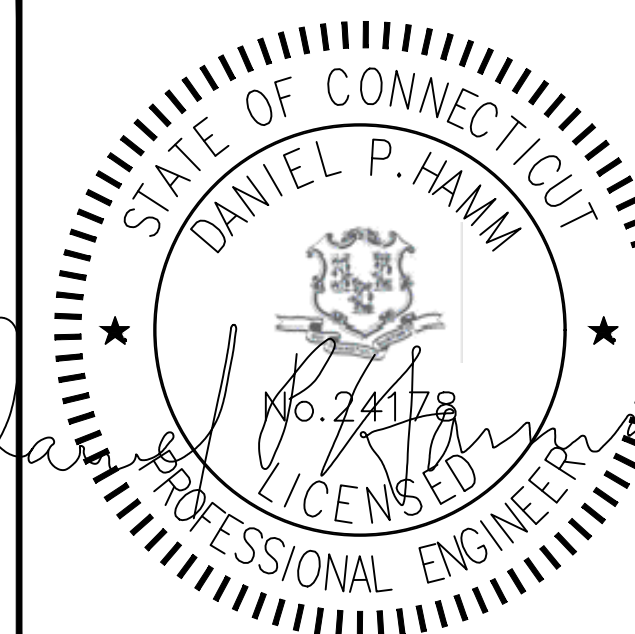

IT IS A VIOLATION OF LAW FOR ANY PERSON, UNLESS THEY ARE ACTING UNDER THE DIRECTION OF A LICENSED PROFESSIONAL ENGINEER, TO ALTER THIS DOCUMENT.

DRAWN BY: CHECKED BY: APPROVED BY:
MRK SMA DPH

RFDS REV #: 4

PRELIMINARY DOCUMENT

SUBMITTALS		
REV	DATE	DESCRIPTION
A	11/16/2021	ISSUED FOR REVIEW
B	04/04/2022	ISSUED FOR REVIEW
C	06/06/2022	ISSUED FOR REVIEW

A&E PROJECT NUMBER
BOBOS01000A

DISH Wireless L.L.C.
PROJECT INFORMATION
BOBOS01000A
CROWN CASTLE BU#881533
75 ROBERTS ROAD
GROTON, CT 06340

SHEET TITLE
ELEVATION, ANTENNA
LAYOUT AND SCHEDULE

SHEET NUMBER
A-2



5701 SOUTH SANTA FE DRIVE
LITTLETON, CO 80120



45 BEECHWOOD DRIVE TEL: (978) 557-5553
N. ANDOVER, MA 01845 FAX: (978) 336-5586



IT IS A VIOLATION OF LAW FOR ANY PERSON, UNLESS THEY ARE ACTING UNDER THE DIRECTION OF A LICENSED PROFESSIONAL ENGINEER, TO ALTER THIS DOCUMENT.

DRAWN BY: MRK CHECKED BY: SMA APPROVED BY: DPH

RFDS REV #: 4

PRELIMINARY DOCUMENT

SUBMITTALS		
REV	DATE	DESCRIPTION
A	11/16/2021	ISSUED FOR REVIEW
B	04/04/2022	ISSUED FOR REVIEW
C	06/06/2022	ISSUED FOR REVIEW

A&E PROJECT NUMBER
BOBOS01000A

DISH Wireless L.L.C.
PROJECT INFORMATION
BOBOS01000A
CROWN CASTLE BU#881533
75 ROBERTS ROAD
GROTON, CT 06340

SHEET TITLE
EQUIPMENT PLATFORM AND
H-FRAME DETAILS

SHEET NUMBER
A-3

NOTES

1. CONTRACTOR TO BURY PLATFORM FEET WITH A MINIMUM OF 2" OF FILL PER EXISTING SITE SURFACE
2. WEED BARRIER FABRIC TO BE ADDED AT DISCRETION OF DISH Wireless L.L.C. CONSTRUCTION MANAGER AT TIME OF CONSTRUCTION. ONE SHEET 8'x8' INSTALLED UNDER ALL FOUR FEET OF THE PLATFORM (4 MIL BLACK PLASTIC)
3. EQUIPMENT CABINET OMITTED FOR CLARITY

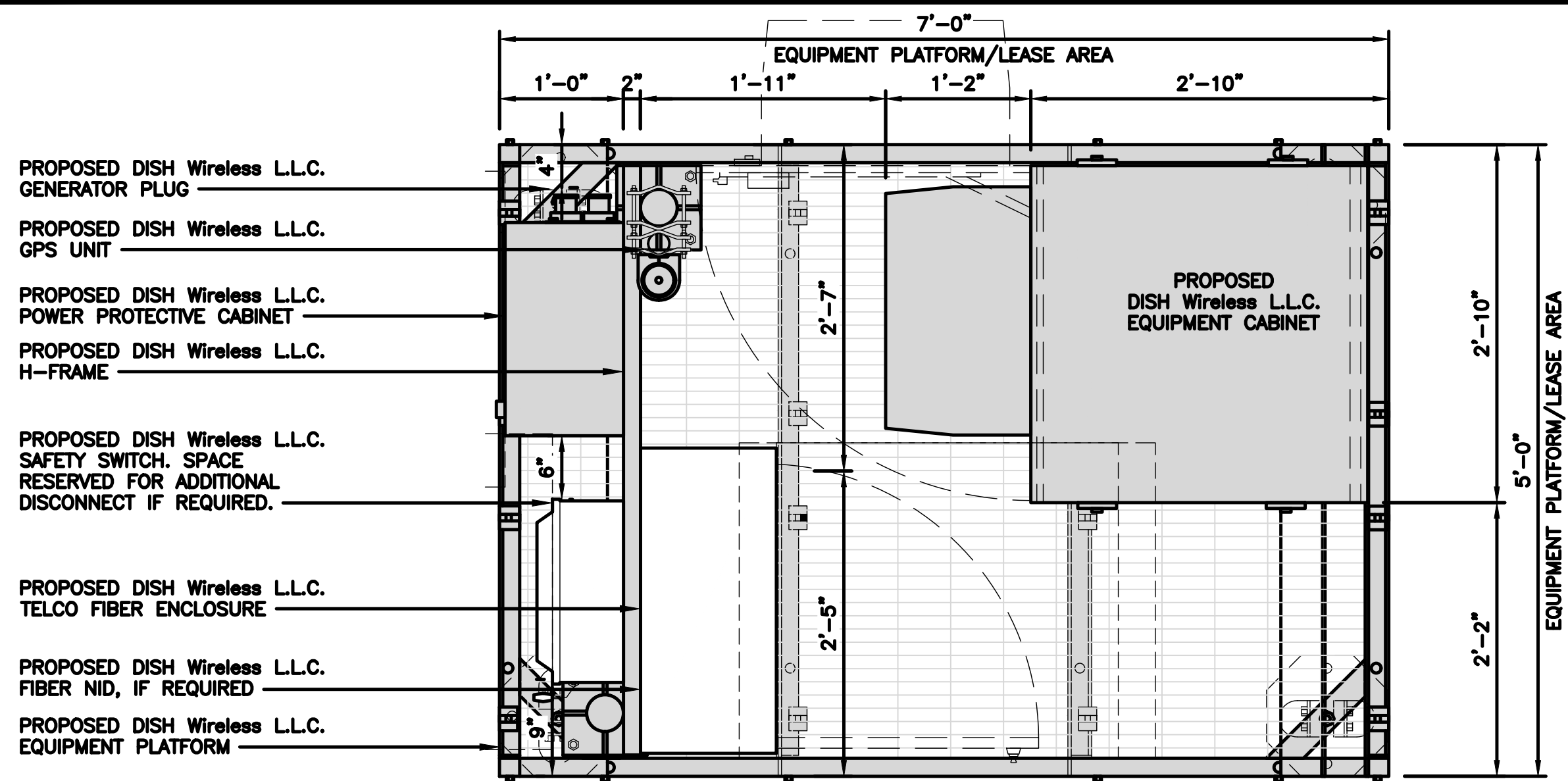

PLATFORM EQUIPMENT PLAN

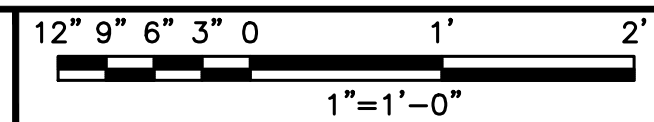

1

COMMSCOPE MTC4045LP 5X7 PLATFORM	
DIMENSIONS (HxWxD)	16"x84"x60"
TOTAL WEIGHT	423 LBS

NOTE:
GC TO PROVIDE EXTENDED
THREAD FOR PLATFORM IF
REQUIRED HEIGHT EXCEEDS 17"

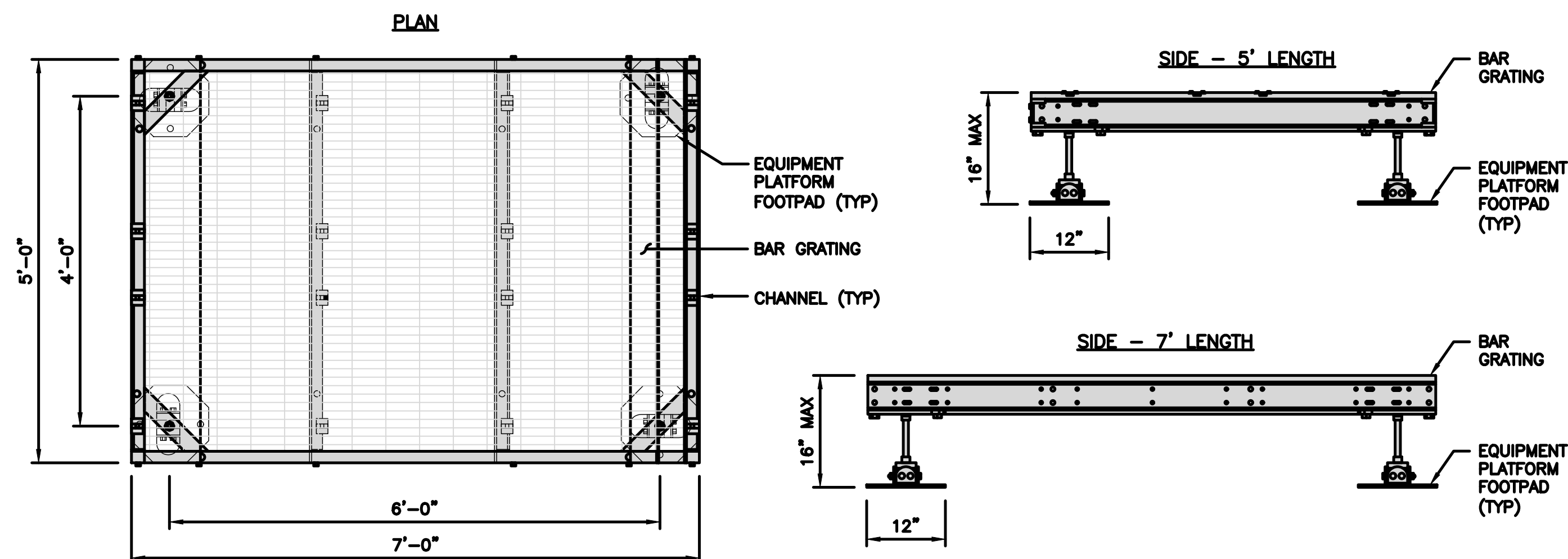

PLATFORM DETAIL

NO SCALE 2

COMMSCOPE MTC4045HFLD H-FRAME	
UNISTRUT/SUPPORT RAILS QTY	5
WEIGHT	59.74 lbs

NOTE:
OR DISH Wireless L.L.C.
APPROVED EQUIVALENT

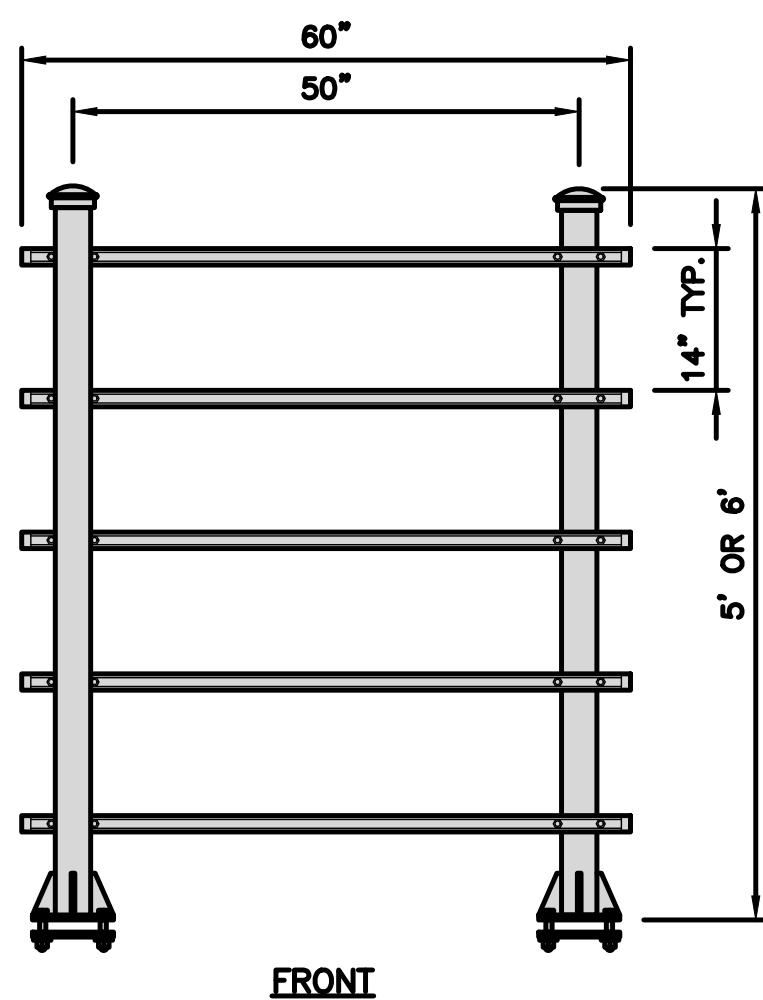
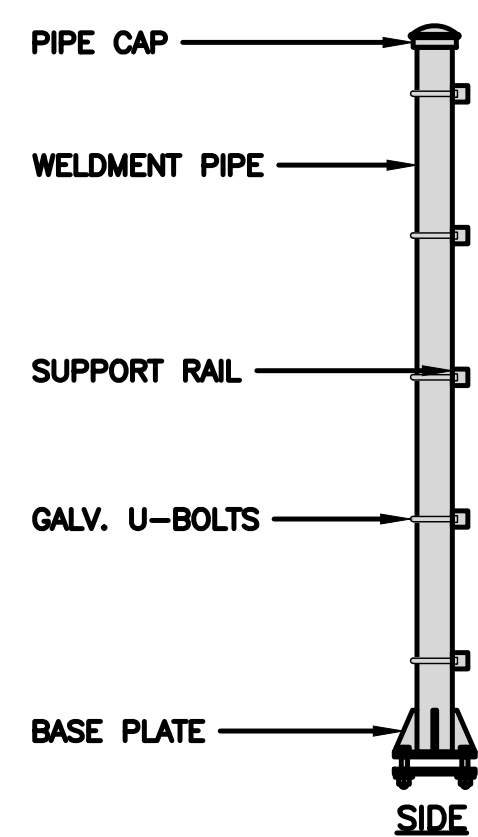

H-FRAME DETAIL

NO SCALE 3

NOT USED

NO SCALE 4

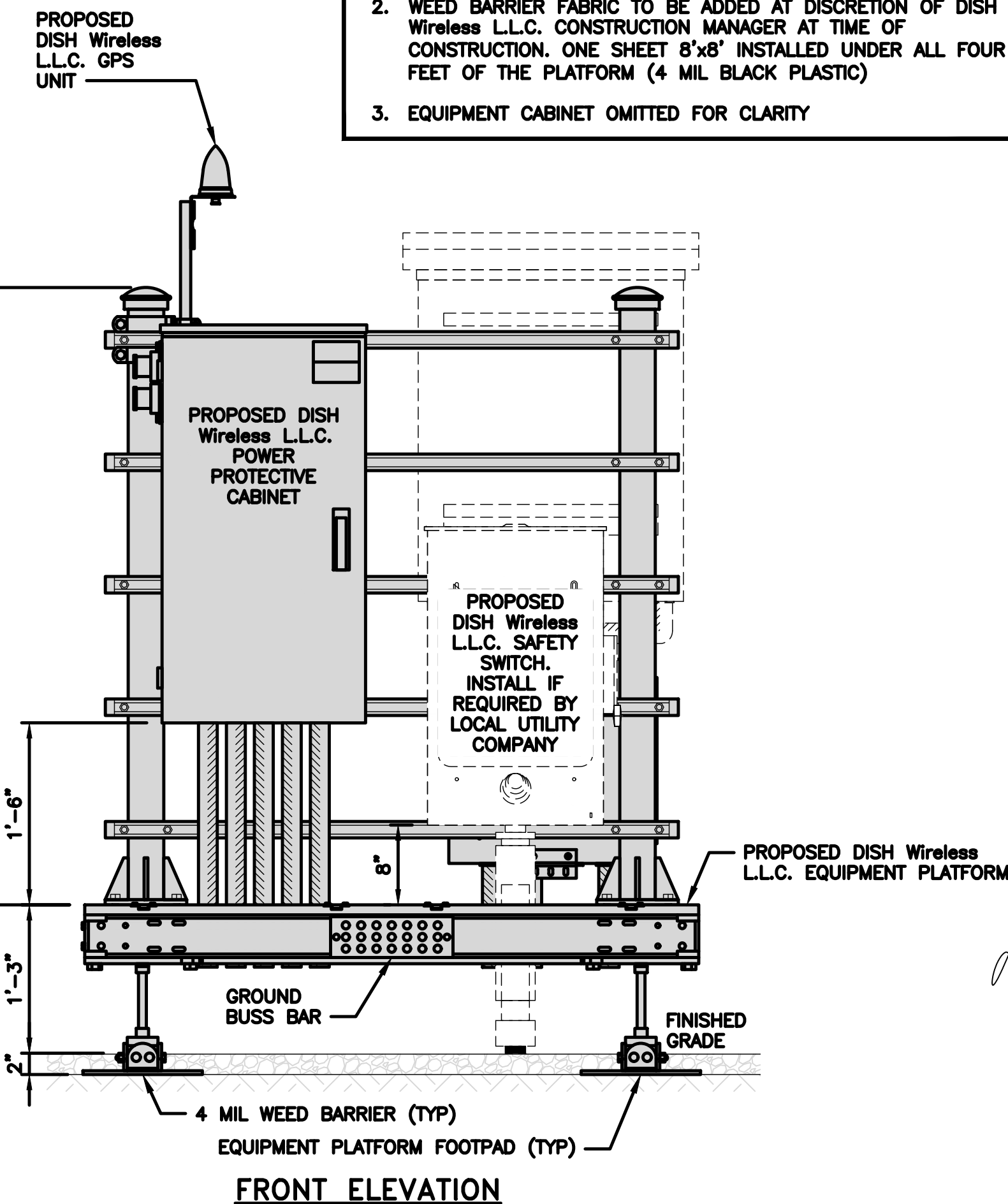

FRONT ELEVATION

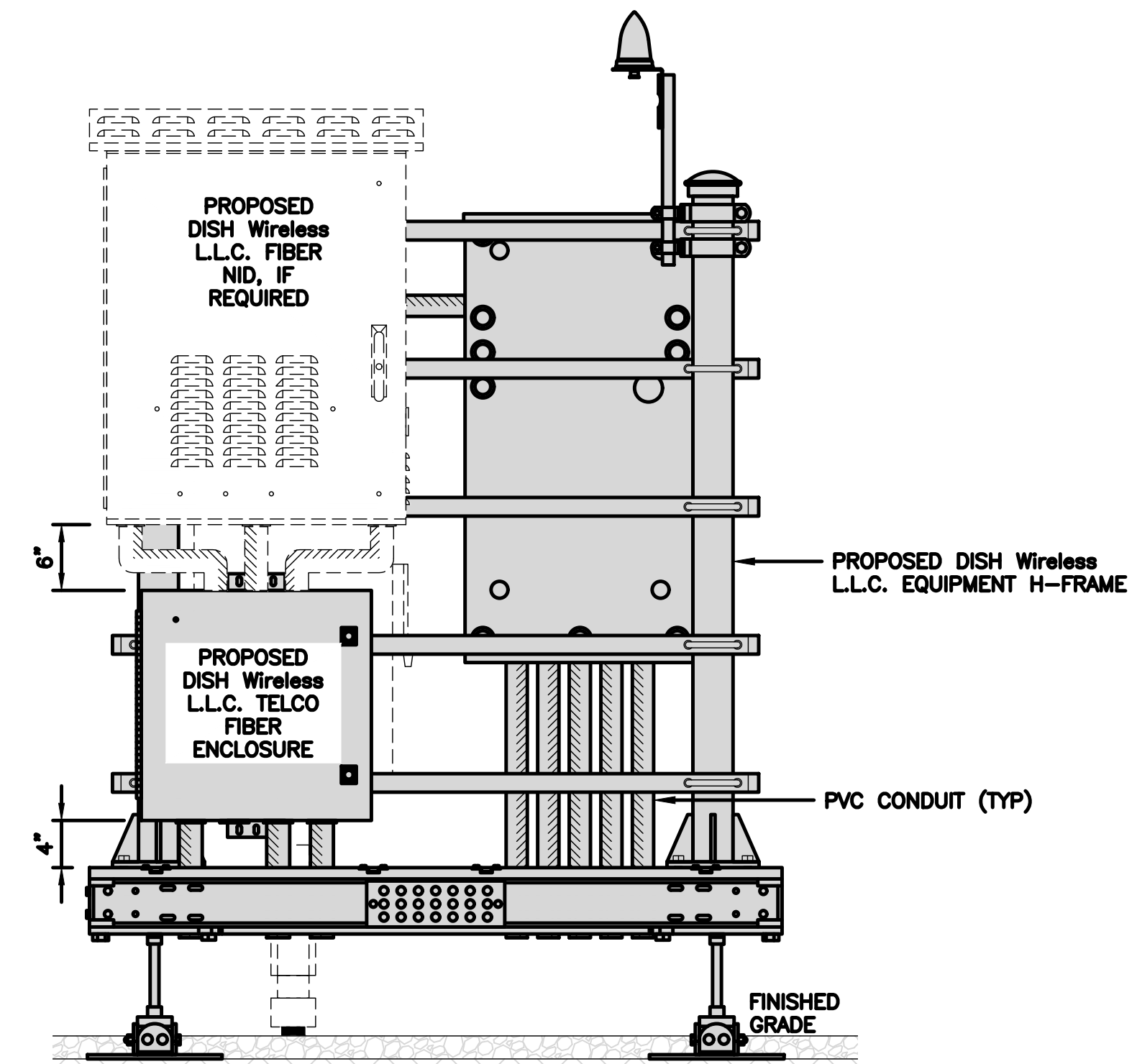

BACK ELEVATION

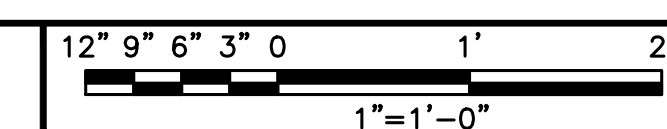

5

ENERSYS HEX 20000059996	
DIMENSIONS (HxWxD)	73"x30"x32"
POWER SYSTEM	-48V ALPHA/600A
HEATER	800W
TOTAL WEIGHT (EMPTY)	376 lbs

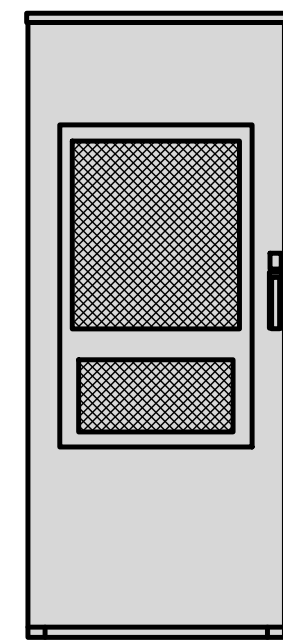
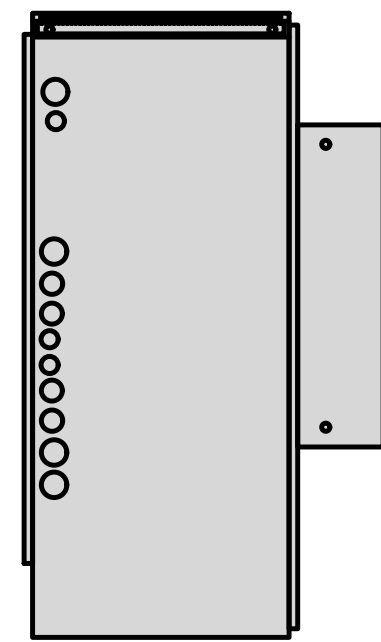
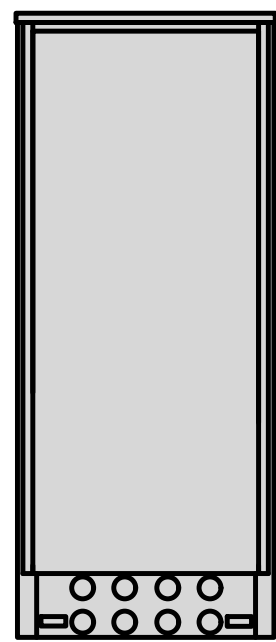
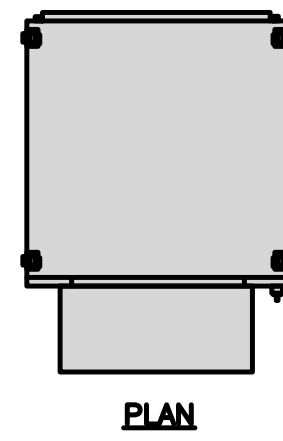

CABINET DETAIL

NO SCALE

1

RAYCAP PPC RDIAC-2465-P-240-MTS	
ENCLOSURE DIMENSIONS (HxWxD):	39"x22.855"x12.593
WEIGHT:	80 lbs
OPERATING AC VOLTAGE	240/120 1 PHASE 3W+G

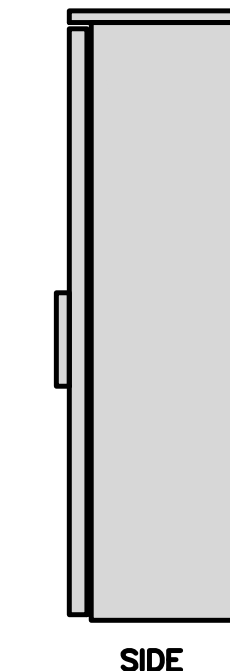
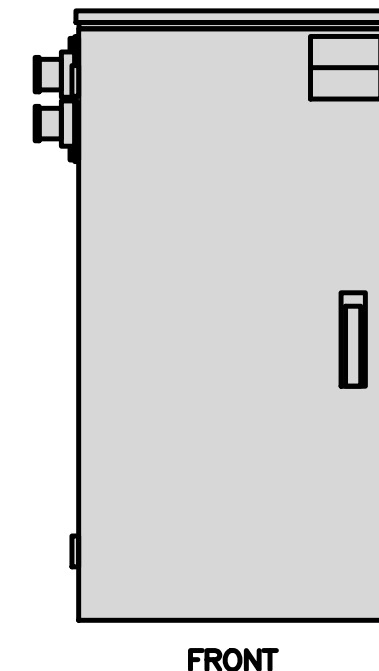
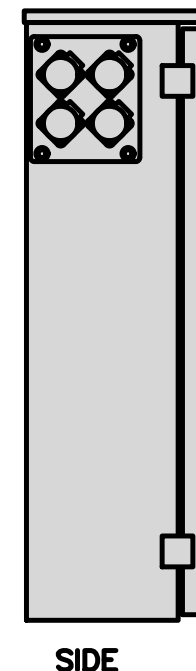
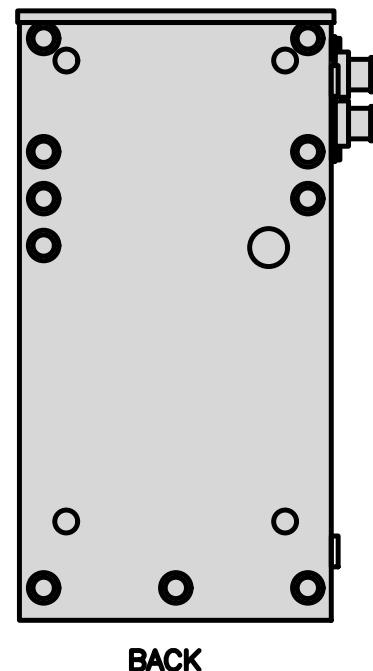
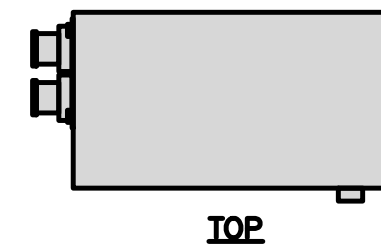

POWER PROTECTION CABINET (PPC) DETAIL

NO SCALE

2

SQUARE D SAFETY SWITCHES D224NRB	
ENCLOSURE DIM (HxWxD)	29.25"x19.00"x8.50"
ENCLOSURE TYPE	NEMA 3R RAINPROOF
UL LISTED	FILE E-2875

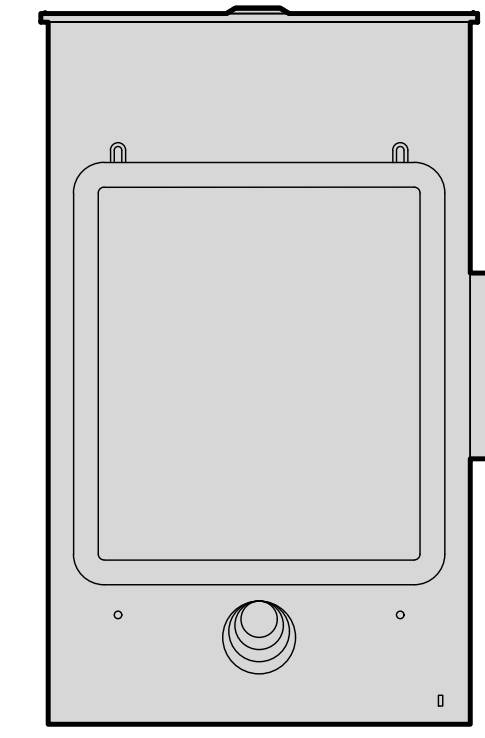
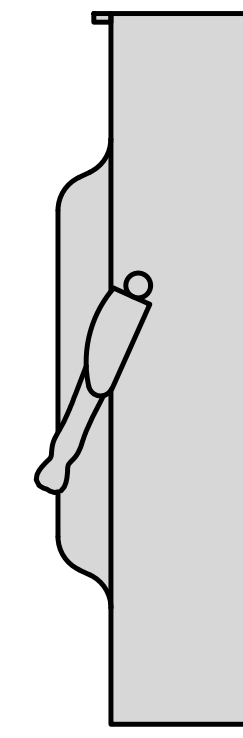
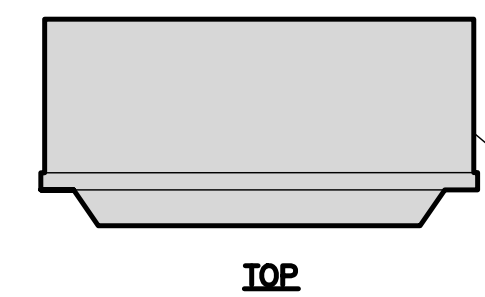

SAFETY SWITCH DETAIL

NO SCALE

3

ZAYO 5RU (LEFT SWING DOOR) FIBER NID ENCLOSURE	
DIMENSIONS (HxWxD)	36.1"x29"x12.9"
WEIGHT	85 lbs

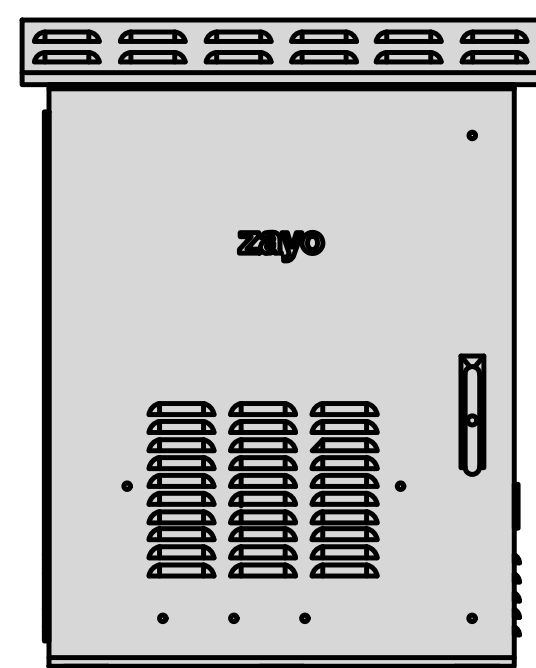
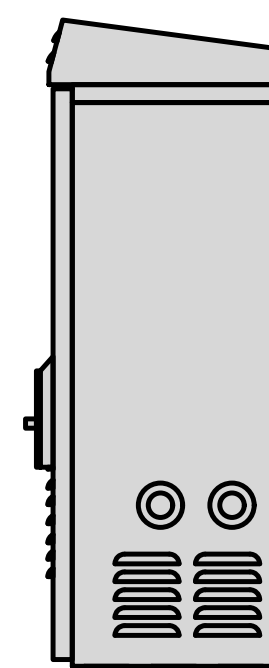
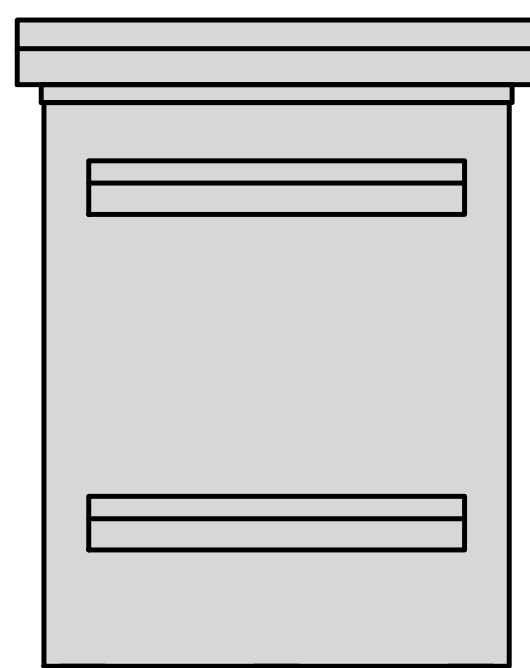
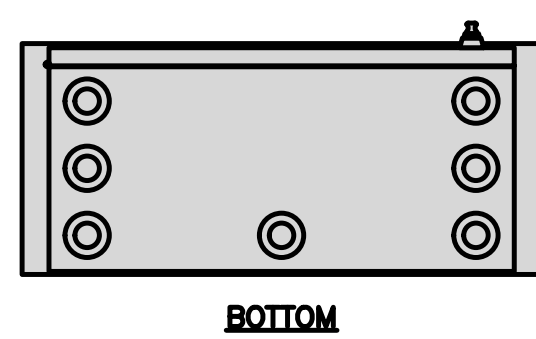

FIBER NID ENCLOSURE DETAIL

NO SCALE

4

CHARLES CFIT-PF2020DSH1 FIBER TELCO ENCLOSURE	
ENCLOSURE DIMS (HxWxD)	20"x20"x9"
ENCLOSURE WEIGHT	20 lbs
MOUNTING	WALL
COMPLIANCE	TYPE 4

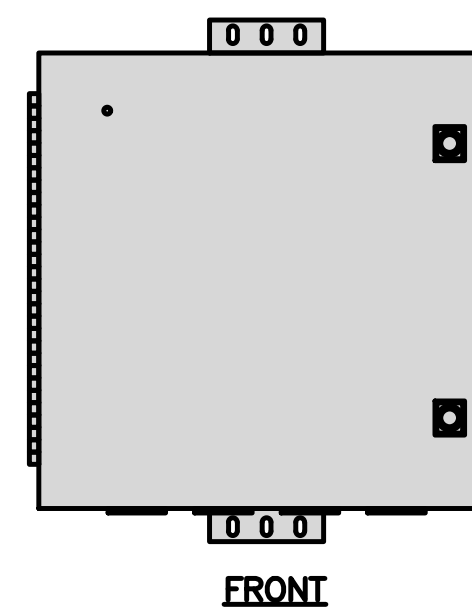
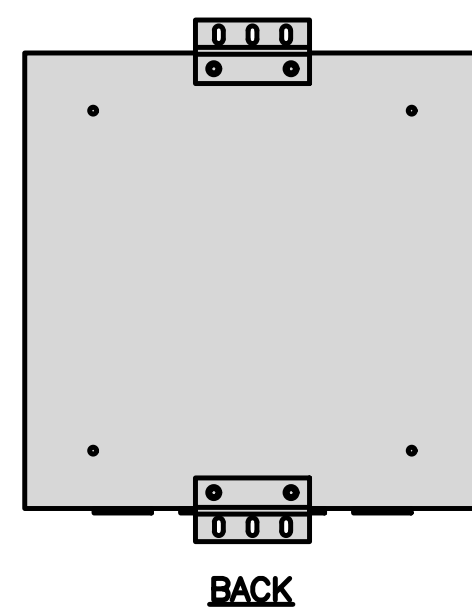
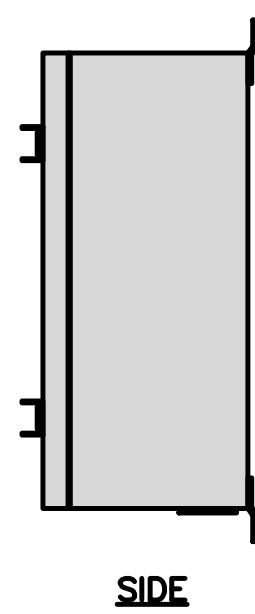
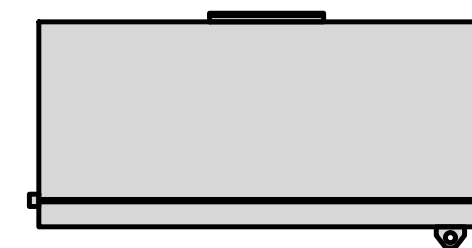

FIBER TELCO ENCLOSURE DETAIL

NO SCALE

5

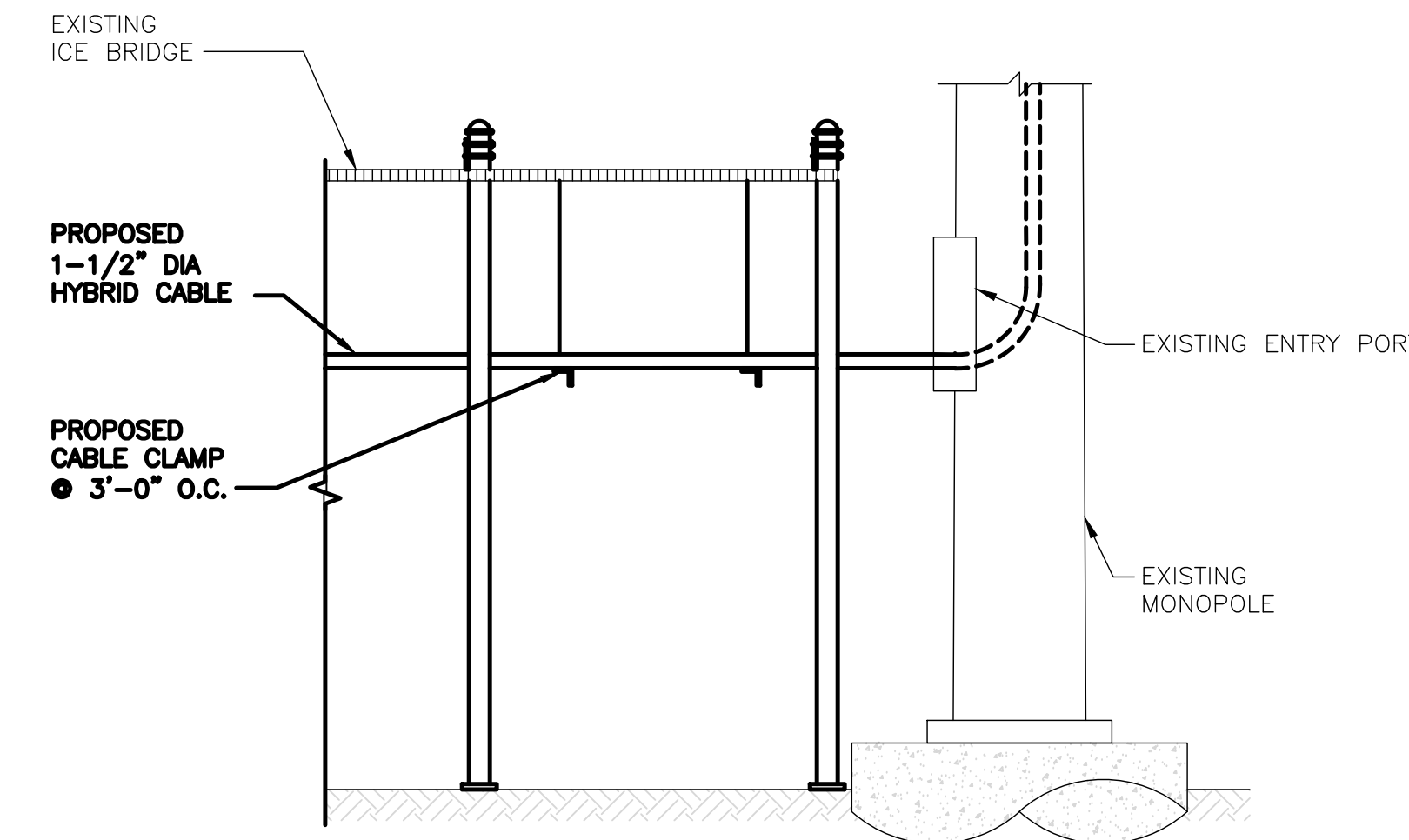

HYBRID CABLE RUN

NO SCALE

6



NOT USED

NO SCALE

7



NOT USED

NO SCALE

8



NOT USED

NO SCALE

9

dish
wireless.

5701 SOUTH SANTA FE DRIVE
LITTLETON, CO 80120

HG
HUDSON
Design Group LLC

45 BEECHWOOD DRIVE TEL: (978) 557-5553
N. ANDOVER, MA 01845 FAX: (978) 336-5586

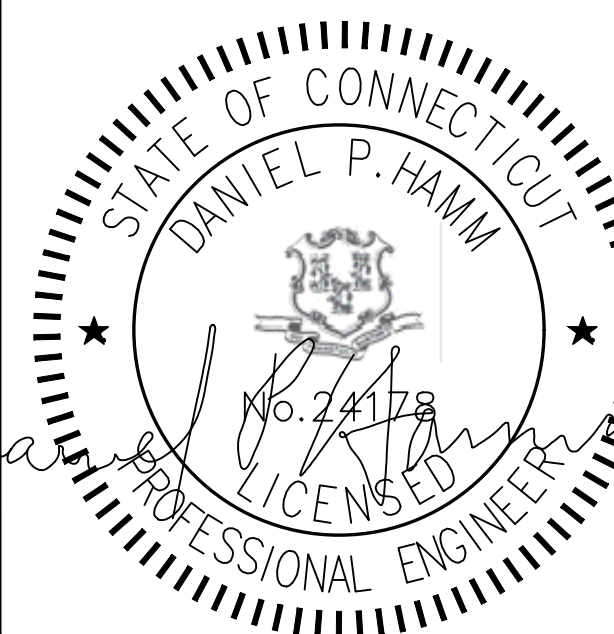

IT IS A VIOLATION OF LAW FOR ANY PERSON,
UNLESS THEY ARE ACTING UNDER THE DIRECTION
OF A LICENSED PROFESSIONAL ENGINEER,
TO ALTER THIS DOCUMENT.

DRAWN BY: CHECKED BY: APPROVED BY:

MRK SMA DPH

RFDS REV #: 4

**PRELIMINARY
DOCUMENT**

SUBMITTALS		
REV	DATE	DESCRIPTION
A	11/16/2021	ISSUED FOR REVIEW
B	04/04/2022	ISSUED FOR REVIEW
C	06/06/2022	ISSUED FOR REVIEW

A&E PROJECT NUMBER
BOBOS01000A

DISH Wireless L.L.C.
PROJECT INFORMATION
BOBOS01000A
CROWN CASTLE BU#881533
75 ROBERTS ROAD
GROTON, CT 06340

SHEET TITLE
EQUIPMENT DETAILS

SHEET NUMBER

A-4

PCTEL GPSGL-TMG-SPI-40NCB	
DIMENSIONS (DIAxH) MM/INCH	81x184mm 3.2"x7.25"
WEIGHT W/ACCESSORIES	075 lbs
CONNECTOR	N-FEMALE
FREQUENCY RANGE	1590 ± 30MHz

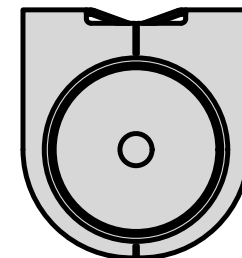

TOP

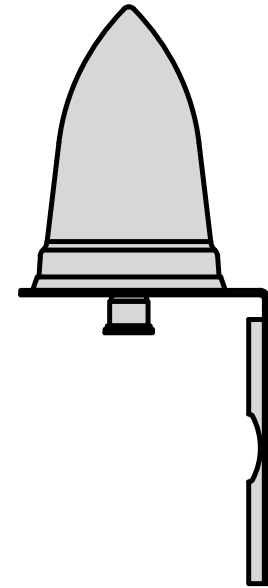

BACK

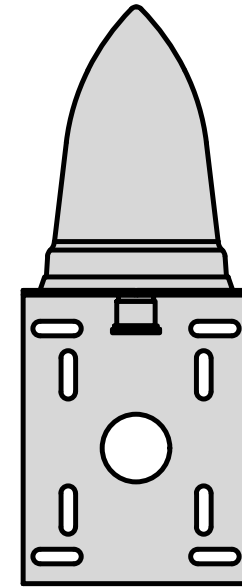

SIDE

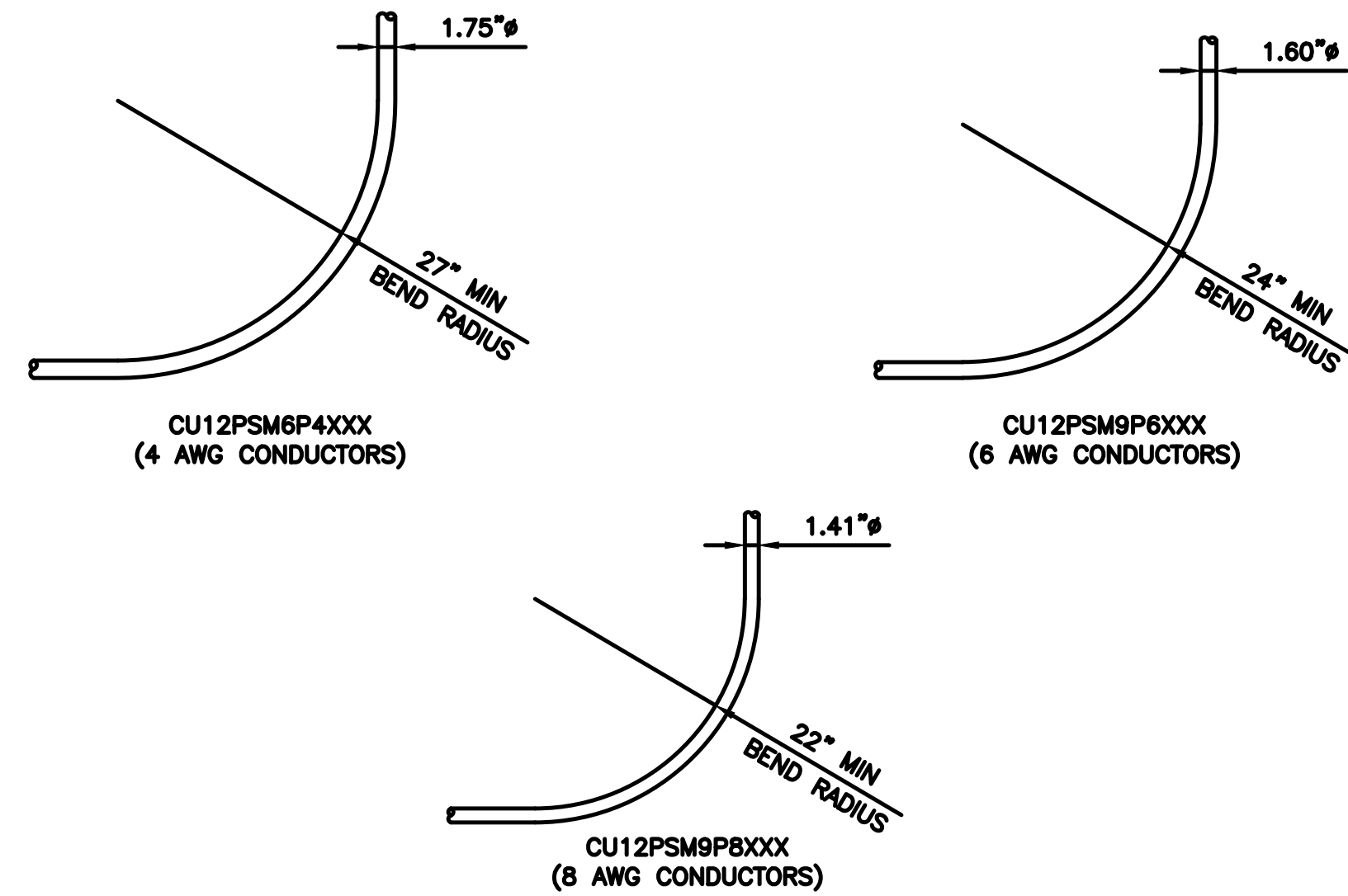
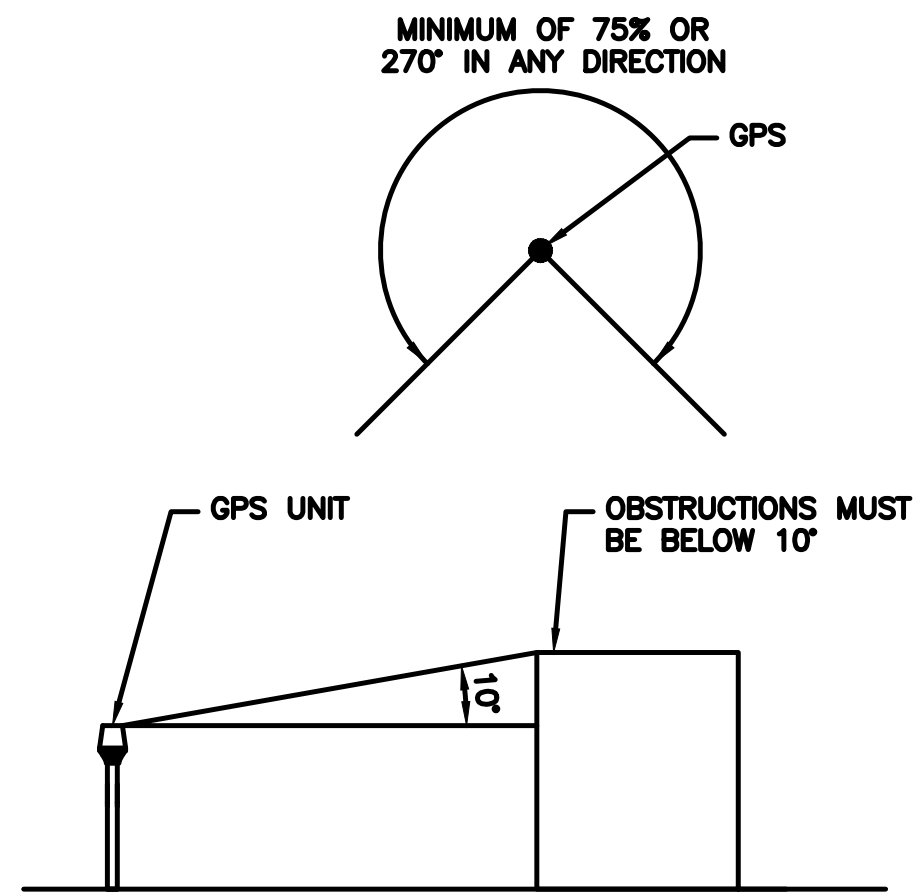

dish
wireless.

5701 SOUTH SANTA FE DRIVE
LITTLETON, CO 80120

HG
HUDSON
Design Group LLC

45 BEECHWOOD DRIVE TEL: (978) 557-5553
N. ANDOVER, MA 01845 FAX: (978) 336-5586

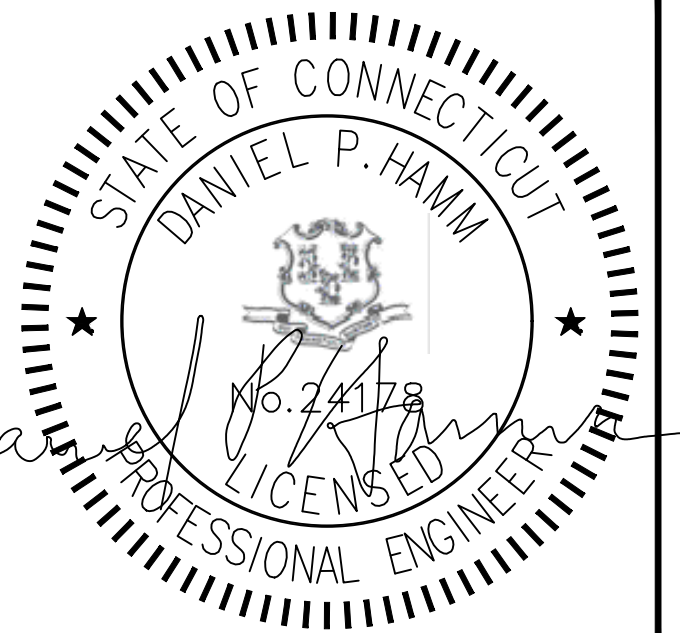

IT IS A VIOLATION OF LAW FOR ANY PERSON, UNLESS THEY ARE ACTING UNDER THE DIRECTION OF A LICENSED PROFESSIONAL ENGINEER, TO ALTER THIS DOCUMENT.

DRAWN BY: CHECKED BY: APPROVED BY:
MRK SMA DPH

RFDS REV #: 4

**PRELIMINARY
DOCUMENT**

SUBMITTALS		
REV	DATE	DESCRIPTION
A	11/16/2021	ISSUED FOR REVIEW
B	04/04/2022	ISSUED FOR REVIEW
C	06/08/2022	ISSUED FOR REVIEW

A&E PROJECT NUMBER
BOBOS01000A

DISH Wireless L.L.C.
PROJECT INFORMATION
BOBOS01000A
CROWN CASTLE BU#881533
75 ROBERTS ROAD
GROTON, CT 06340

SHEET TITLE
EQUIPMENT DETAILS

SHEET NUMBER
A-5

GPS DETAIL

NO SCALE

1

GPS MINIMUM SKY VIEW REQUIREMENTS

NO SCALE

2

CABLES UNLIMITED HYBRID CABLE
MINIMUM BEND RADIUSES

NO SCALE

3

NOT USED

NO SCALE

4

NOT USED

NO SCALE

5

NOT USED

NO SCALE

6

NOT USED

NO SCALE

7

NOT USED

NO SCALE

8

NOT USED

NO SCALE

9

FUJITSU TRIPLE BAND TA08025-B605	
DIMENSIONS (HxWxD)	14.9"x15.7"x9"
WEIGHT	74.95 lbs
CONNECTOR TYPE	4.3-10 RF CONNECTOR
POWER SUPPLY	DC -58~-36V

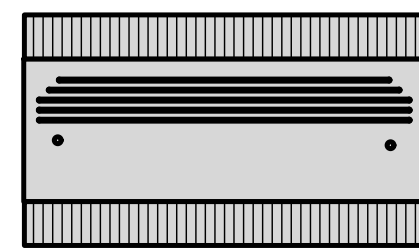

PLAN

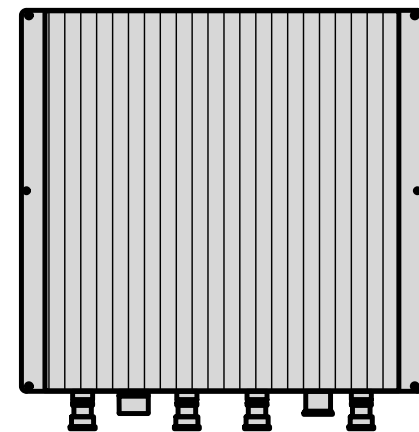

BACK

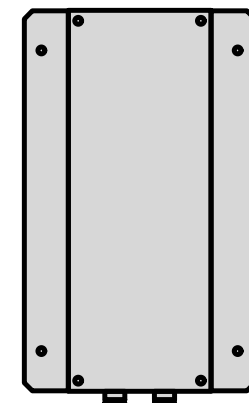

SIDE

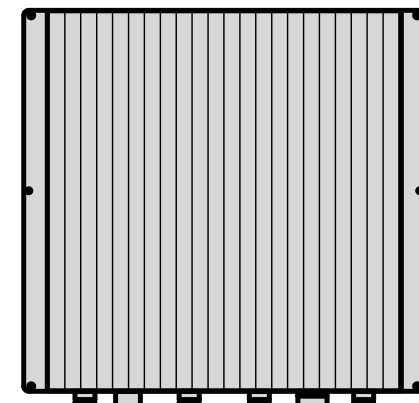

FRONT

RRH DETAIL

NO SCALE

1

FUJITSU DUAL BAND TA08025-B604	
DIMENSIONS (HxWxD)	14.9"x15.7"x7.8"
WEIGHT	63.9 lbs
CONNECTOR TYPE	4.3-10 RF CONNECTOR
POWER SUPPLY	DC -58~-36V

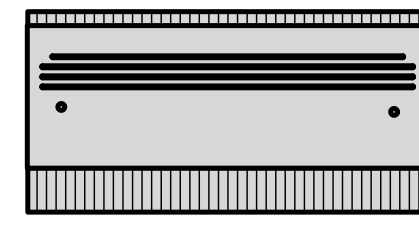

PLAN

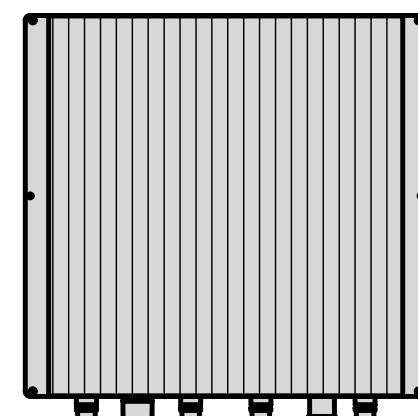

BACK

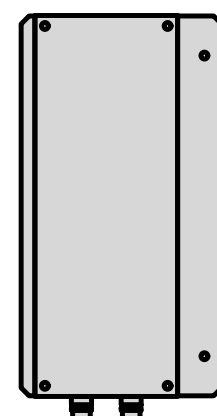

SIDE

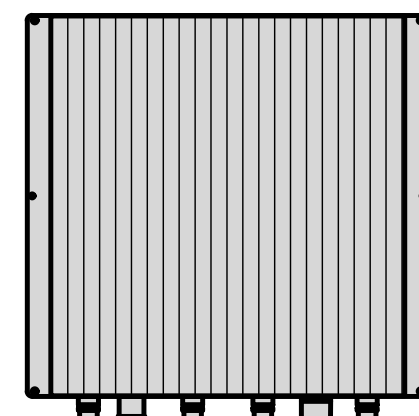

FRONT

RRH DETAIL

NO SCALE

2

SABRE DOUBLE Z-BRACKET C10123155	
DIMENSIONS (HxWxD) (1 BRACKET)	5"x20"x1-13/16"
WEIGHT (FULL ASSEMBLY)	35.79 lbs
PACKAGE QUANTITY	4

#	DESCRIPTION
1	PLATE, CHANNEL BRACKET
2	RRH Z BRACKET, 3/16"
3	THREADED ROD ASSEMBLY 1/2"x12"

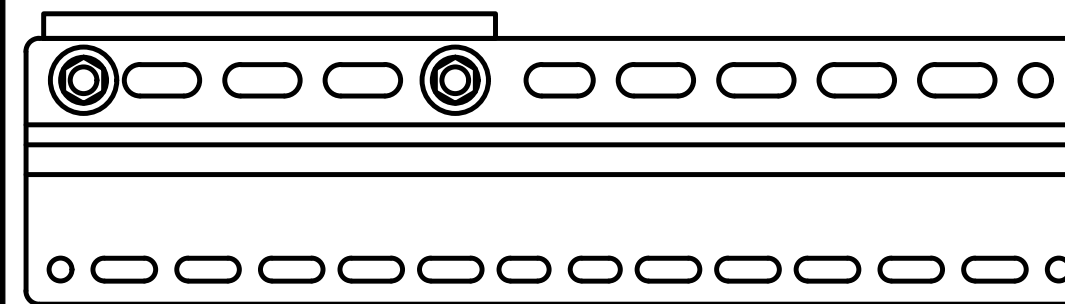

NOTE:
OR DISH Wireless L.L.C.
APPROVED EQUIVALENT

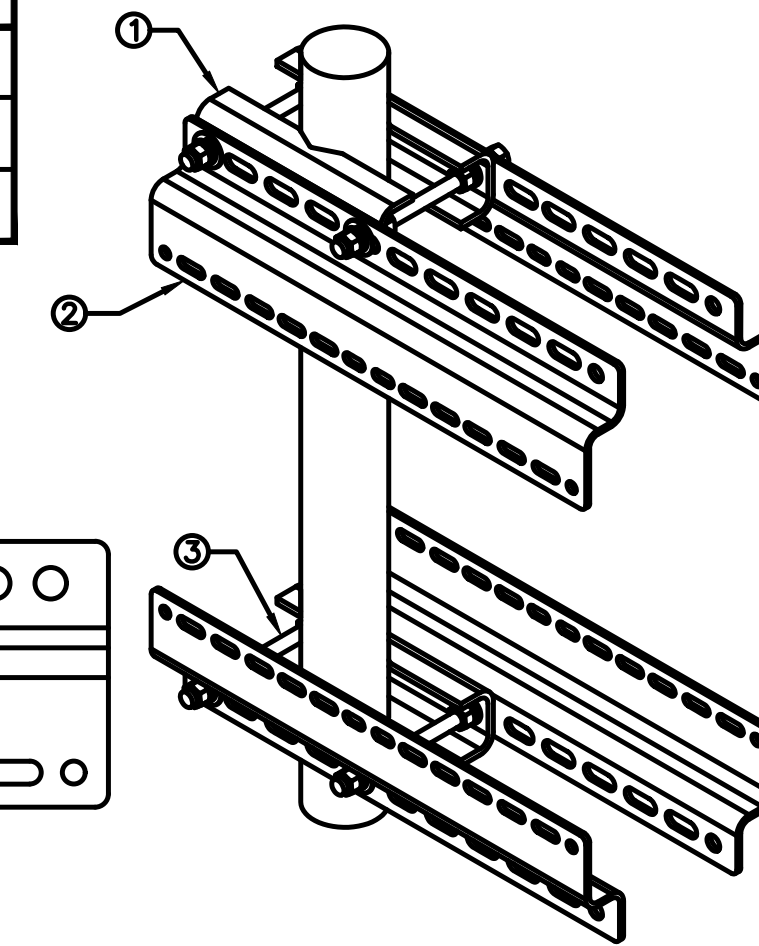

RRH MOUNT DETAIL

NO SCALE

3

JMA MX08FRO665-21	
DIMENSIONS (HxWxD)	72"x20.0"x8.0"
RF PORTS, CONNECTOR TYPE	8 x 4.3-10 FEMALE
WEIGHT	64.5 lbs
WEIGHT WITH BRACKETS	82.5 lbs

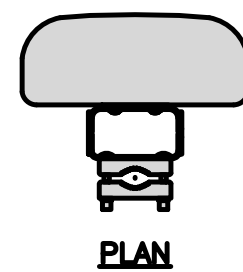

PLAN

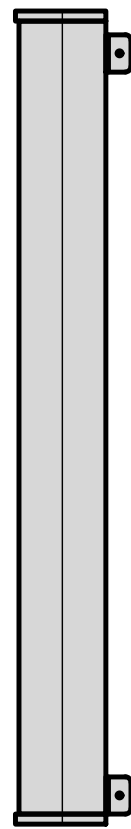

SIDE

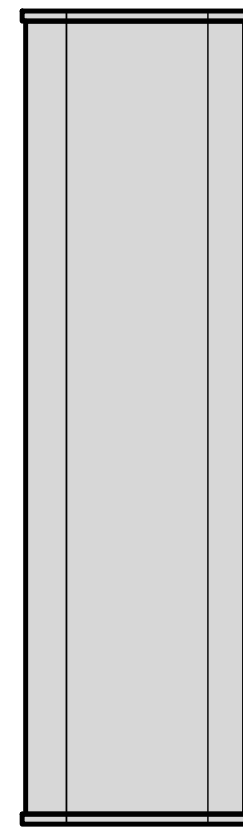

FRONT

ANTENNA DETAIL

NO SCALE

4

RAYCAP RDIC-9181-PF-48 DC SURGE PROTECTION (OVP)	
DIMENSIONS (HxWxD)	18.98"x14.39"x8.15"
WEIGHT	21.82 LBS

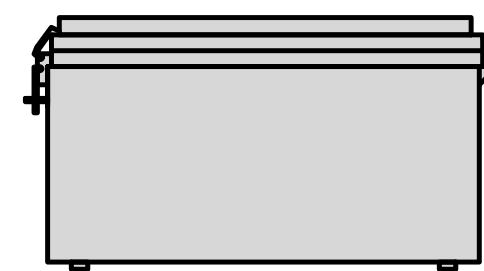

PLAN

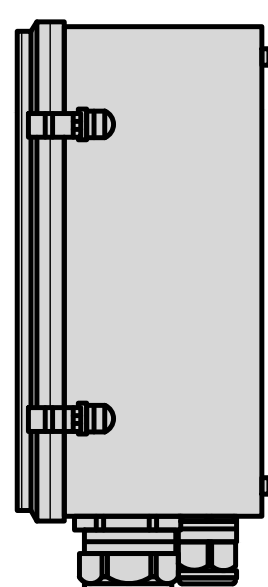

SIDE

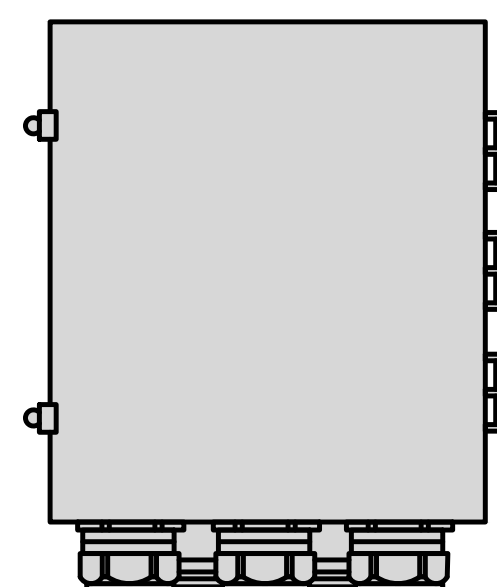

BACK

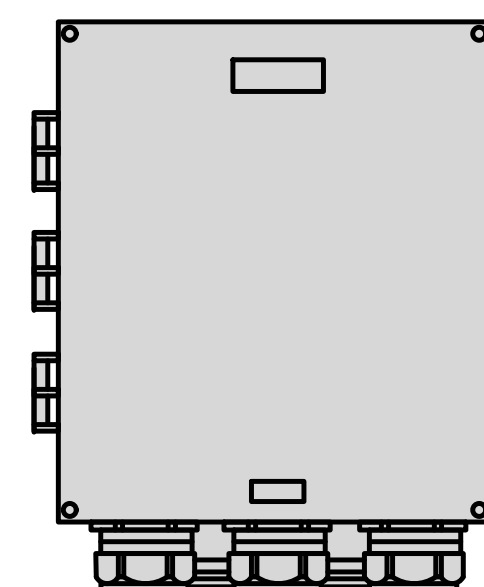

FRONT

SURGE SUPPRESSION DETAIL (OVP)

NO SCALE

7

COMMSCOPE XP-2040 CROSSOVER PLATE	
DIMENSIONS (HxW)	10"x12"
WEIGHT	11 lbs

NOTE:
OR DISH Wireless L.L.C.
APPROVED EQUIVALENT

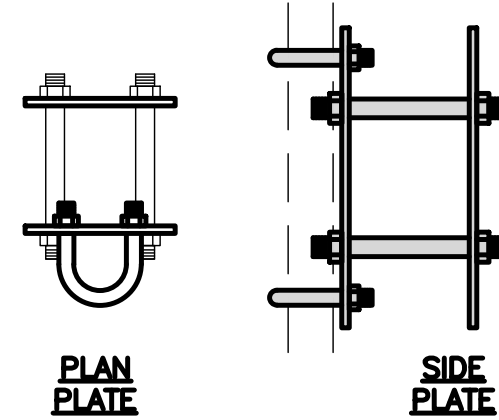

PLAN
U-BOLT

SIDE
U-BOLT

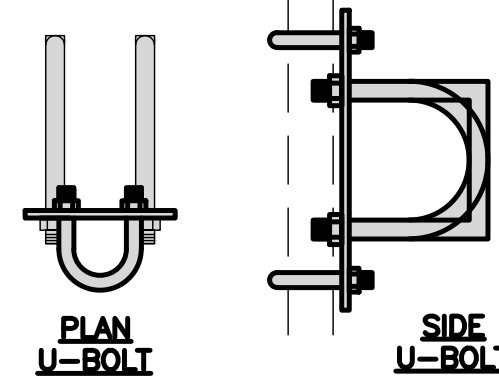

PLAN
U-BOLT

SIDE
U-BOLT

RRH/OVP MOUNT DETAIL

NO SCALE

8

COMMSCOPE MC-PK8-DSH	
FACE WIDTH	96"
WEIGHT	1373.08 lbs
NOTE: 15" TO 38" O.D.	

NOTE:
OR DISH Wireless L.L.C.
APPROVED EQUIVALENT

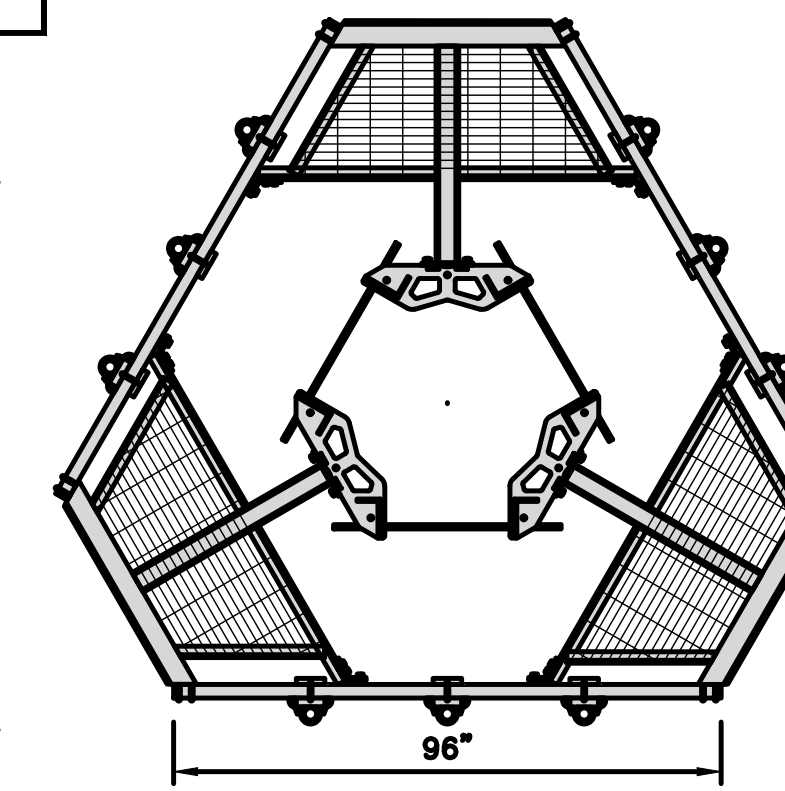
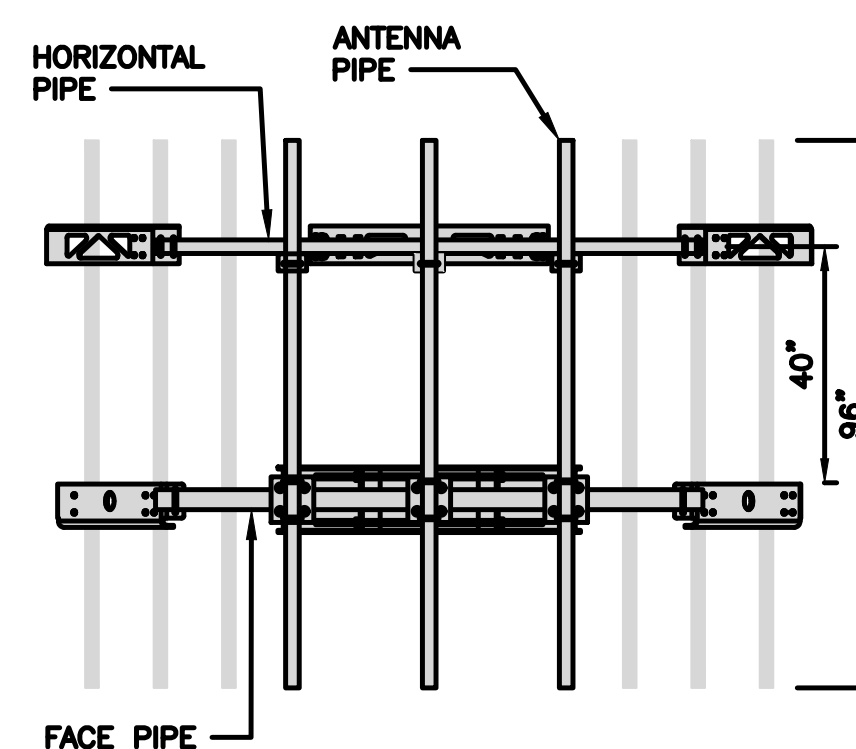

ANTENNA PLATFORM DETAIL

NO SCALE

9

dish
wireless.

5701 SOUTH SANTA FE DRIVE
LITTLETON, CO 80120

HG
HUDSON
Design Group LLC

45 BEECHWOOD DRIVE TEL: (978) 557-5553
N. ANDOVER, MA 01845 FAX: (978) 336-5586

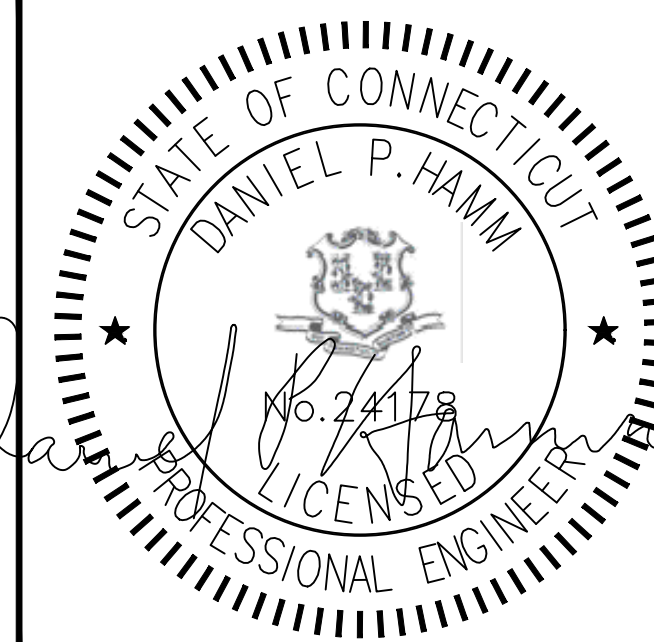

IT IS A VIOLATION OF LAW FOR ANY PERSON,
UNLESS THEY ARE ACTING UNDER THE DIRECTION
OF A LICENSED PROFESSIONAL ENGINEER,
TO ALTER THIS DOCUMENT.

DRAWN BY: CHECKED BY: APPROVED BY:

MRK SMA DPH

RFDS REV #: 4

**PRELIMINARY
DOCUMENT**

SUBMITTALS		
REV	DATE	DESCRIPTION
A	11/16/2021	ISSUED FOR REVIEW
B	04/04/2022	ISSUED FOR REVIEW
C	06/06/2022	ISSUED FOR REVIEW

A&E PROJECT NUMBER
BOBOS01000A

DISH Wireless L.L.C.
PROJECT INFORMATION
BOBOS01000A
CROWN CASTLE BU#881533
75 ROBERTS ROAD
GROTON, CT 06340

SHEET TITLE
EQUIPMENT DETAILS

SHEET NUMBER

A-6

NOTES

1. CONTRACTOR SHALL FIELD VERIFY ALL PROPOSED UNDERGROUND UTILITY CONDUIT ROUTE.
2. ANTENNAS AND MOUNTS OMITTED FOR CLARITY.
3. DUE TO UTILITY EASEMENT RIGHTS SPECIFIED IN THE GROUND LEASE, CUSTOMER MAY INSTALL EQUIPMENT WITHIN SPECIFIED UTILITY EASEMENT AREA. "PWR" AND "FBR" PATH DEPICTED ON A-1 AND E-1 REPRESENT PLANNED ROUTING BASED ON BEST AVAILABLE INFORMATION INCLUDING BUT NOT LIMITED TO A SURVEY, EXHIBITS, METES AND BOUNDS OF THE UTILITY EASEMENT, FIELD VERIFICATION, PRIOR PROJECT DOCUMENTATION AND OTHER REAL PROPERTY DOCUMENTS. WHEN INSTALLING THE UTILITIES PLEASE LOCATE AND FOLLOW EXISTING PATH, IF EXISTING PATH IS MATERIALLY INCONSISTENT WITH "PWR" AND "FBR" PATH DEPICTED ON A-1 AND E-1 AND SAID VARIANCE IS NOT NOTED ON CDs, PLEASE NOTIFY TOWER OWNER AS FURTHER COORDINATION MAY BE NEEDED.

DC POWER WIRING SHALL BE COLOR CODED AT EACH END FOR IDENTIFYING +24V AND -48V CONDUCTORS. RED MARKINGS SHALL IDENTIFY +24V AND BLUE MARKINGS SHALL IDENTIFY -48V.

1. CONTRACTOR SHALL INSPECT THE EXISTING CONDITIONS PRIOR TO SUBMITTING A BID. ANY QUESTIONS ARISING DURING THE BID PERIOD IN REGARDS TO THE CONTRACTOR'S FUNCTIONS, THE SCOPE OF WORK, OR ANY OTHER ISSUE RELATED TO THIS PROJECT SHALL BE BROUGHT UP DURING THE BID PERIOD WITH THE PROJECT MANAGER FOR CLARIFICATION, NOT AFTER THE CONTRACT HAS BEEN AWARDED.
2. ALL ELECTRICAL WORK SHALL BE DONE IN ACCORDANCE WITH CURRENT NATIONAL ELECTRICAL CODES AND ALL STATE AND LOCAL CODES, LAWS, AND ORDINANCES. PROVIDE ALL COMPONENTS AND WIRING SIZES AS REQUIRED TO MEET NEC STANDARDS.
3. LOCATION OF EQUIPMENT, CONDUIT AND DEVICES SHOWN ON THE DRAWINGS ARE APPROXIMATE AND SHALL BE COORDINATED WITH FIELD CONDITIONS PRIOR TO CONSTRUCTION.
4. CONDUIT ROUGH-IN SHALL BE COORDINATED WITH THE MECHANICAL EQUIPMENT TO AVOID LOCATION CONFLICTS. VERIFY WITH THE MECHANICAL EQUIPMENT CONTRACTOR AND COMPLY AS REQUIRED.
5. CONTRACTOR SHALL PROVIDE ALL BREAKERS, CONDUITS AND CIRCUITS AS REQUIRED FOR A COMPLETE SYSTEM.
6. CONTRACTOR SHALL PROVIDE PULL BOXES AND JUNCTION BOXES AS REQUIRED BY THE NEC ARTICLE 314.
7. CONTRACTOR SHALL PROVIDE ALL STRAIN RELIEF AND CABLE SUPPORTS FOR ALL CABLE ASSEMBLIES. INSTALLATION SHALL BE IN ACCORDANCE WITH MANUFACTURER'S SPECIFICATIONS AND RECOMMENDATIONS.
8. ALL DISCONNECTS AND CONTROLLING DEVICES SHALL BE PROVIDED WITH ENGRAVED PHENOLIC NAMEPLATES INDICATING EQUIPMENT CONTROLLED, BRANCH CIRCUITS INSTALLED ON, AND PANEL FIELD LOCATIONS FED FROM.
9. INSTALL AN EQUIPMENT GROUNDING CONDUCTOR IN ALL CONDUITS PER THE SPECIFICATIONS AND NEC 250. THE EQUIPMENT GROUNDING CONDUCTORS SHALL BE BONDED AT ALL JUNCTION BOXES, PULL BOXES, AND ALL DISCONNECT SWITCHES, AND EQUIPMENT CABINETS.
10. ALL NEW MATERIAL SHALL HAVE A U.L. LABEL.
11. PANEL SCHEDULE LOADING AND CIRCUIT ARRANGEMENTS REFLECT POST-CONSTRUCTION EQUIPMENT.
12. CONTRACTOR SHALL BE RESPONSIBLE FOR AS-BUILT PANEL SCHEDULE AND SITE DRAWINGS.
13. ALL TRENCHES IN COMPOUND TO BE HAND DUG



5701 SOUTH SANTA FE DRIVE
LITTLETON, CO 80120



45 BEECHWOOD DRIVE TEL: (978) 557-5553
N. ANDOVER, MA 01845 FAX: (978) 336-5586

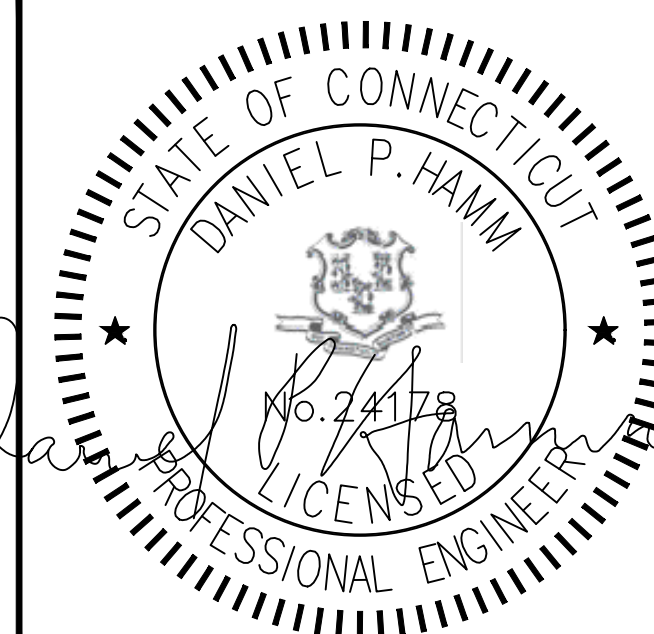

IT IS A VIOLATION OF LAW FOR ANY PERSON, UNLESS THEY ARE ACTING UNDER THE DIRECTION OF A LICENSED PROFESSIONAL ENGINEER, TO ALTER THIS DOCUMENT.

DRAWN BY: MRK CHECKED BY: SMA APPROVED BY: DPH

RFDS REV #: 4

PRELIMINARY DOCUMENT

SUBMITTALS		
REV	DATE	DESCRIPTION
A	11/16/2021	ISSUED FOR REVIEW
B	04/04/2022	ISSUED FOR REVIEW
C	06/06/2022	ISSUED FOR REVIEW

A&E PROJECT NUMBER
BOBOS01000A

DISH Wireless L.L.C.
PROJECT INFORMATION
BOBOS01000A
CROWN CASTLE BU#881533
75 ROBERTS ROAD
GROTON, CT 06340

SHEET TITLE
ELECTRICAL/FIBER ROUTE
PLAN AND NOTES

SHEET NUMBER

E-1

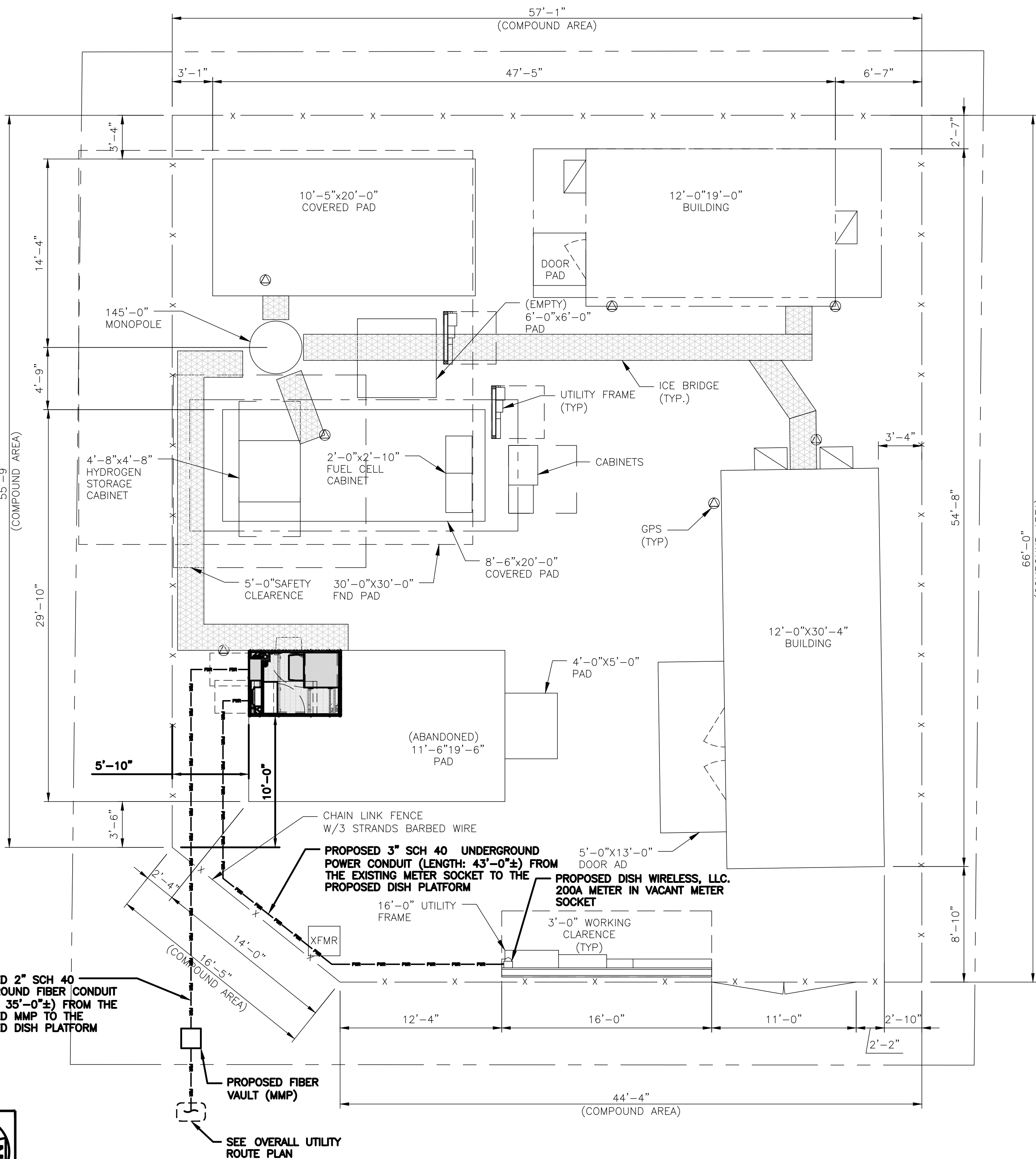

UTILITY ROUTE PLAN

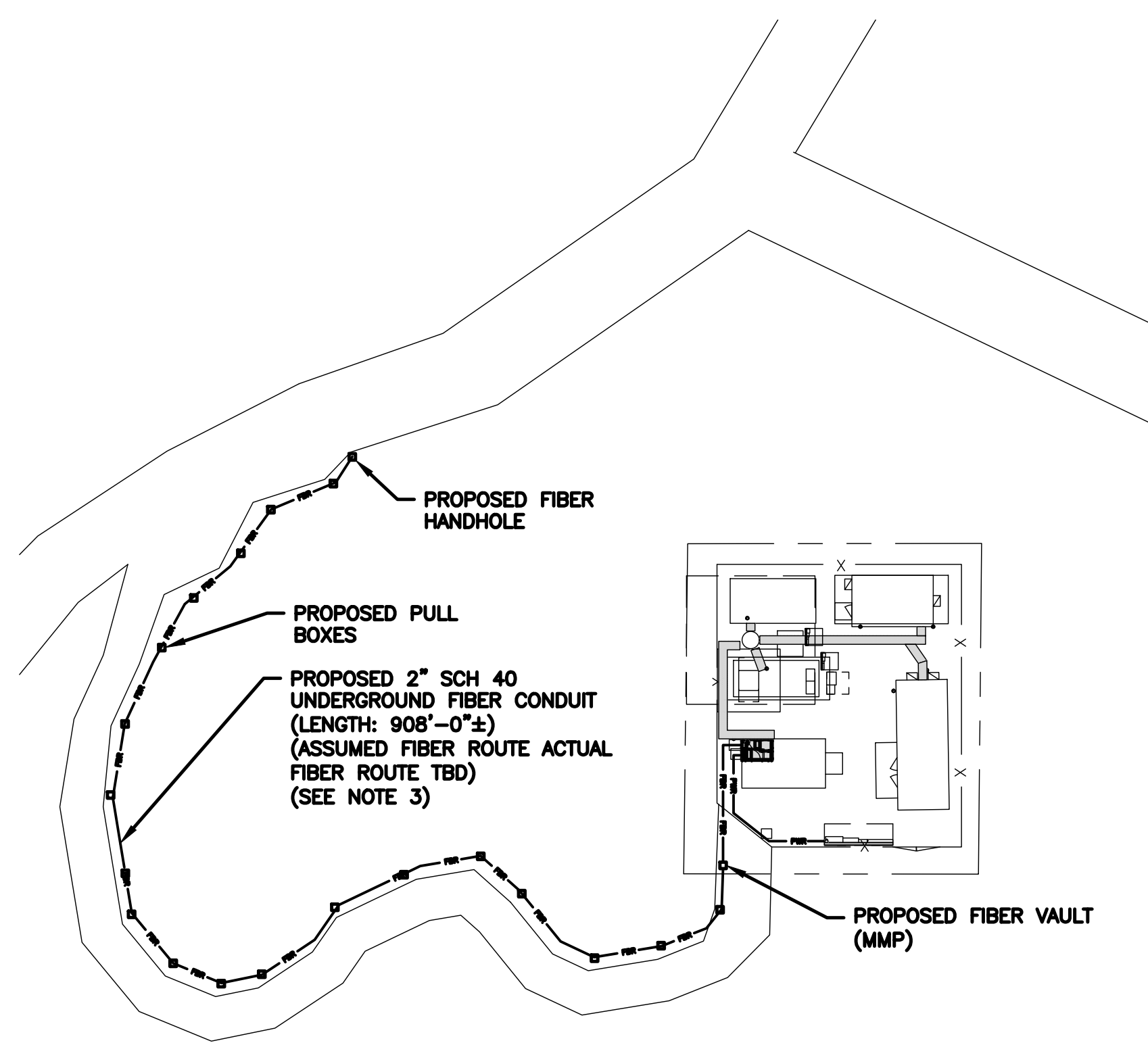
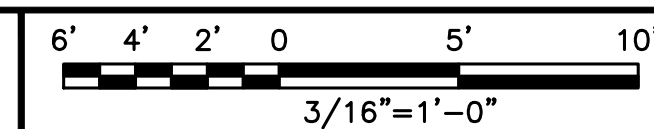

OVERALL UTILITY ROUTE PLAN

NO SCALE

CARLON EXPANSION FITTINGS

COUPLING END PART#	MALE TERMINAL ADAPTER END PART#	SIZE	STD CTN QTY.	TRAVEL LENGTH
E945D	E945DX	1/2"	20	4"
E945E	E945EX	3/4"	15	4"
E945F	E945FX	1"	10	4"
E945G	E945GX	1 1/4"	5	4"
E945H	E945HX	1 1/2"	5	4"
E945J	E945JX	2"	15	8"
E945K	E945KX	2 1/2"	10	8"
E945L	E945LX	3"	10	8"
E945M	E945MX	3 1/2"	5	8"
E945N	E945NX	4"	5	8"
E945P	E945PX	5"	1	8"
E945R	E945RX	6"	1	8"

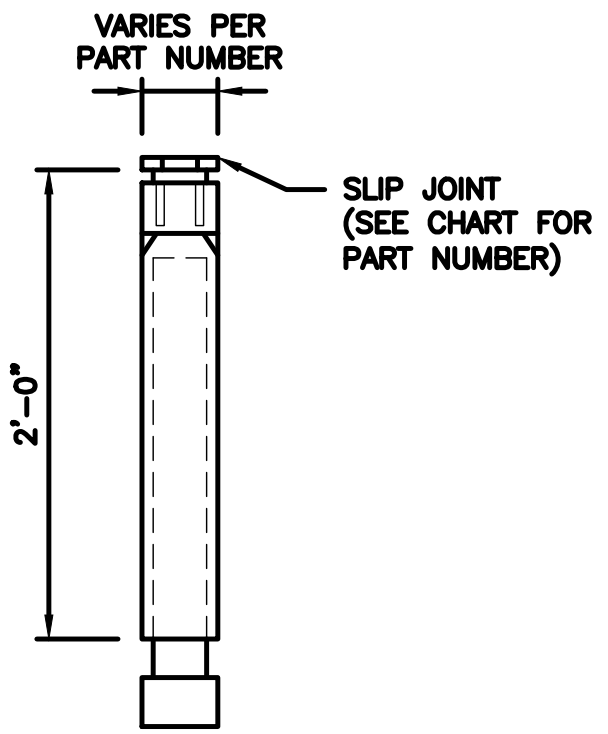

NOTE: CONTRACTOR TO INSTALL EXPANSION FITTING SLIP JOINT AT METER CENTER CONDUIT TERMINATION, AS PER LOCAL UTILITY POLICY, ORDINANCE AND/OR SPECIFIED REQUIREMENT.

TRENCHING NOTES

- CONTRACTOR SHALL RESTORE THE TRENCH TO ITS ORIGINAL CONDITIONS BY EITHER SEEDING OR SODDING GRASS AREAS, OR REPLACING ASPHALT OR CONCRETE AREAS TO ITS ORIGINAL CROSS SECTION.
- TRENCHING SAFETY; INCLUDING, BUT NOT LIMITED TO SOIL CLASSIFICATION, SLOPING, AND SHORING, SHALL BE GOVERNED BY THE CURRENT OSHA TRENCHING AND EXCAVATION SAFETY STANDARDS.
- ALL CONDUITS SHALL BE INSTALLED IN COMPLIANCE WITH THE CURRENT NATIONAL ELECTRIC CODE (NEC) OR AS REQUIRED BY THE LOCAL JURISDICTION, WHICHEVER IS THE MOST STRINGENT.

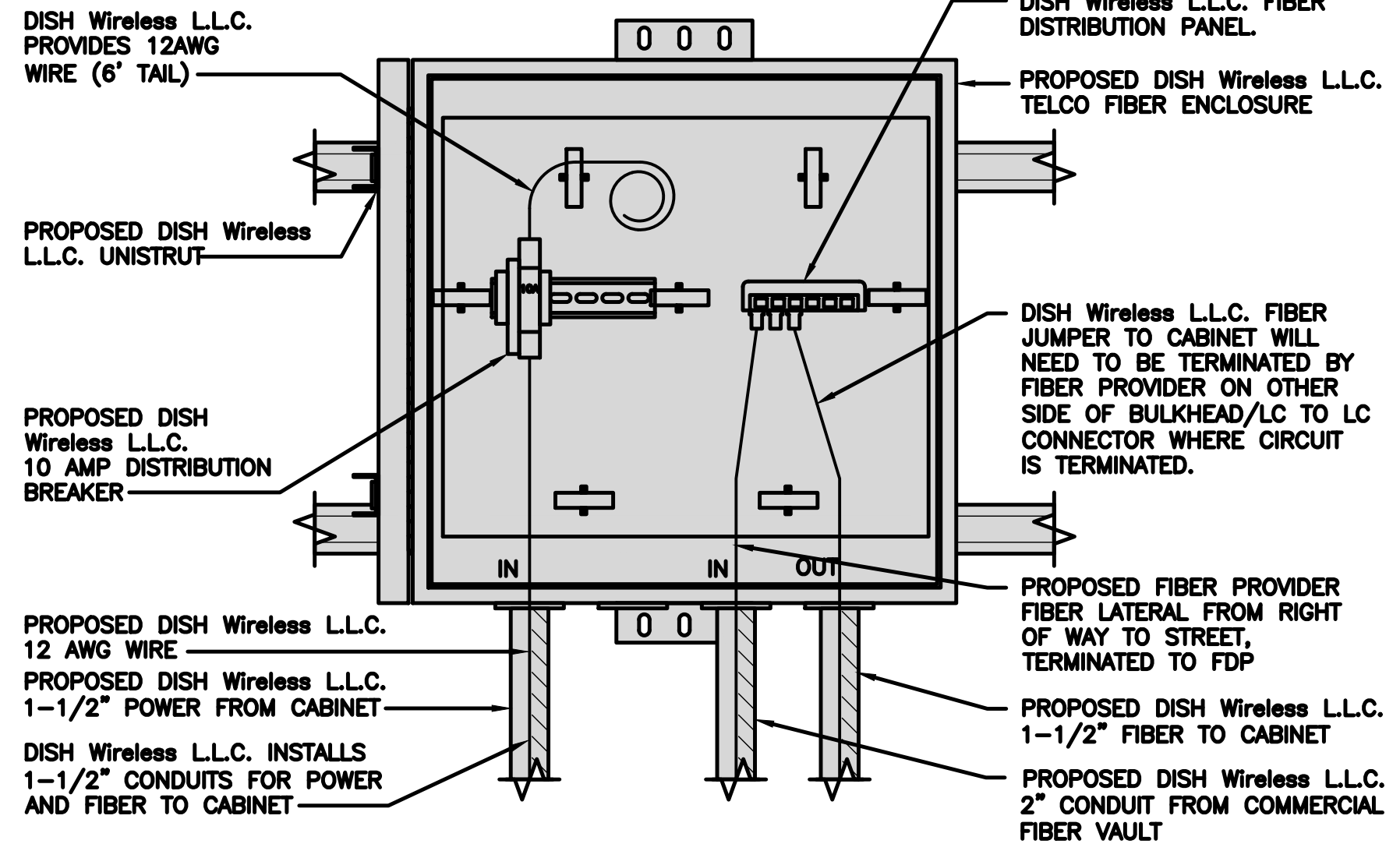
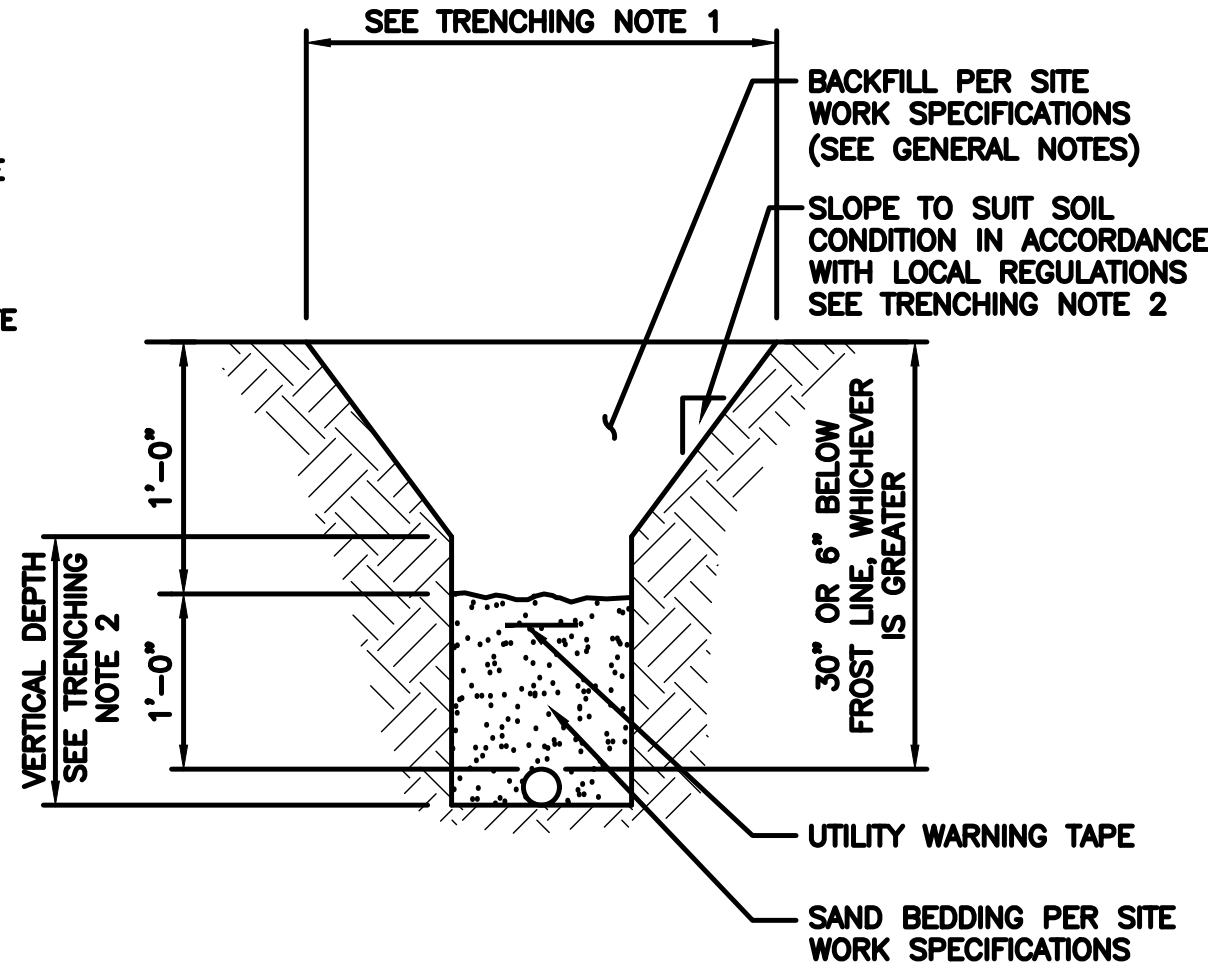

5701 SOUTH SANTA FE DRIVE
LITTLETON, CO 80120



45 BEECHWOOD DRIVE
N. ANDOVER, MA 01845
TEL: (978) 557-5553
FAX: (978) 336-5586

EXPANSION JOINT DETAIL NO SCALE 1

TYPICAL UNDERGROUND TRENCH DETAIL NO SCALE 2

DARK TELCO BOX - INTERIOR WIRING LAYOUT NO SCALE 3

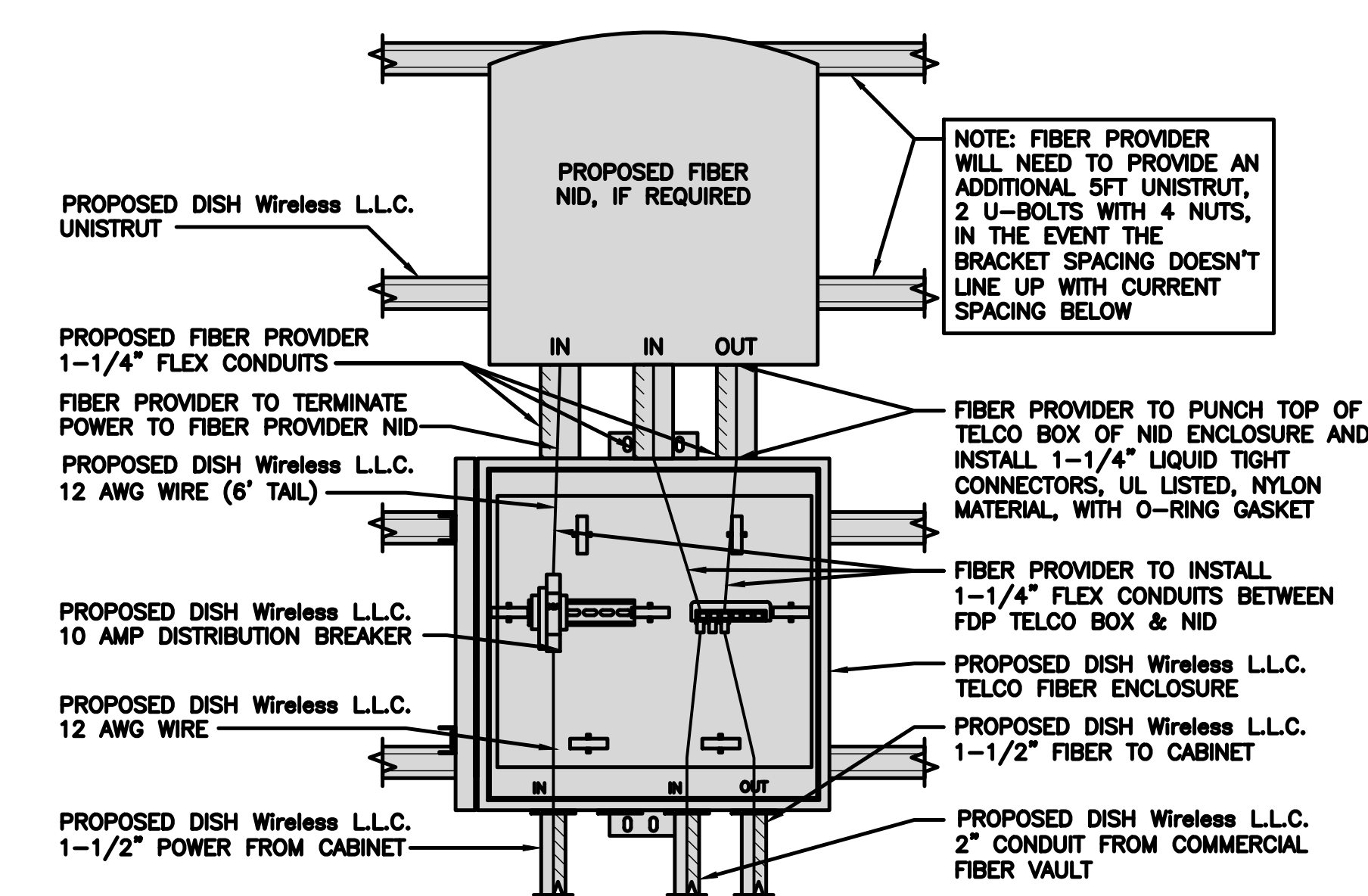

LIT TELCO BOX - INTERIOR WIRING LAYOUT (OPTIONAL) NO SCALE 4

NOT USED NO SCALE 5

NOT USED NO SCALE 6

NOT USED NO SCALE 7

NOT USED NO SCALE 8

NOT USED NO SCALE 9

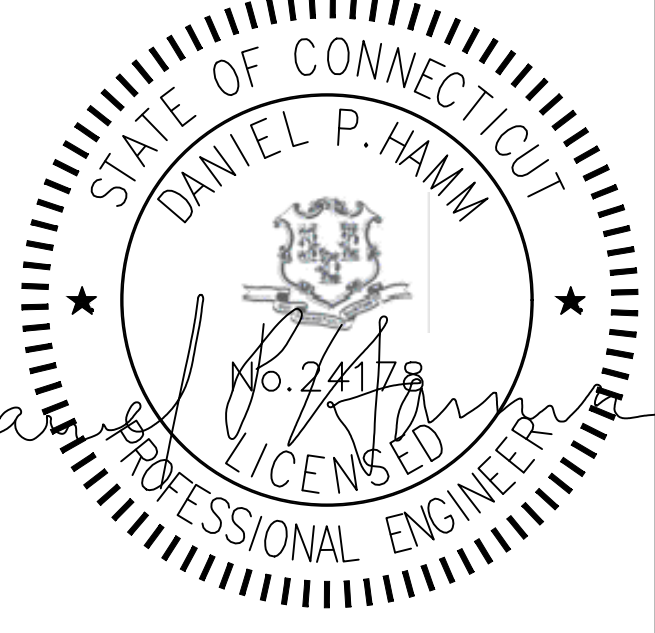

IT IS A VIOLATION OF LAW FOR ANY PERSON, UNLESS THEY ARE ACTING UNDER THE DIRECTION OF A LICENSED PROFESSIONAL ENGINEER, TO ALTER THIS DOCUMENT.

DRAWN BY: MRK	CHECKED BY: SMA	APPROVED BY: DPH
RFDS REV #:		4

PRELIMINARY DOCUMENT

SUBMITTALS		
REV	DATE	DESCRIPTION
A	11/16/2021	ISSUED FOR REVIEW
B	04/04/2022	ISSUED FOR REVIEW
C	06/06/2022	ISSUED FOR REVIEW

A&E PROJECT NUMBER
BOBOS01000A

DISH Wireless L.L.C. PROJECT INFORMATION
BOBOS01000A
CROWN CASTLE BU#881533
75 ROBERTS ROAD
GROTON, CT 06340

SHEET TITLE
ELECTRICAL DETAILS

SHEET NUMBER
E-2

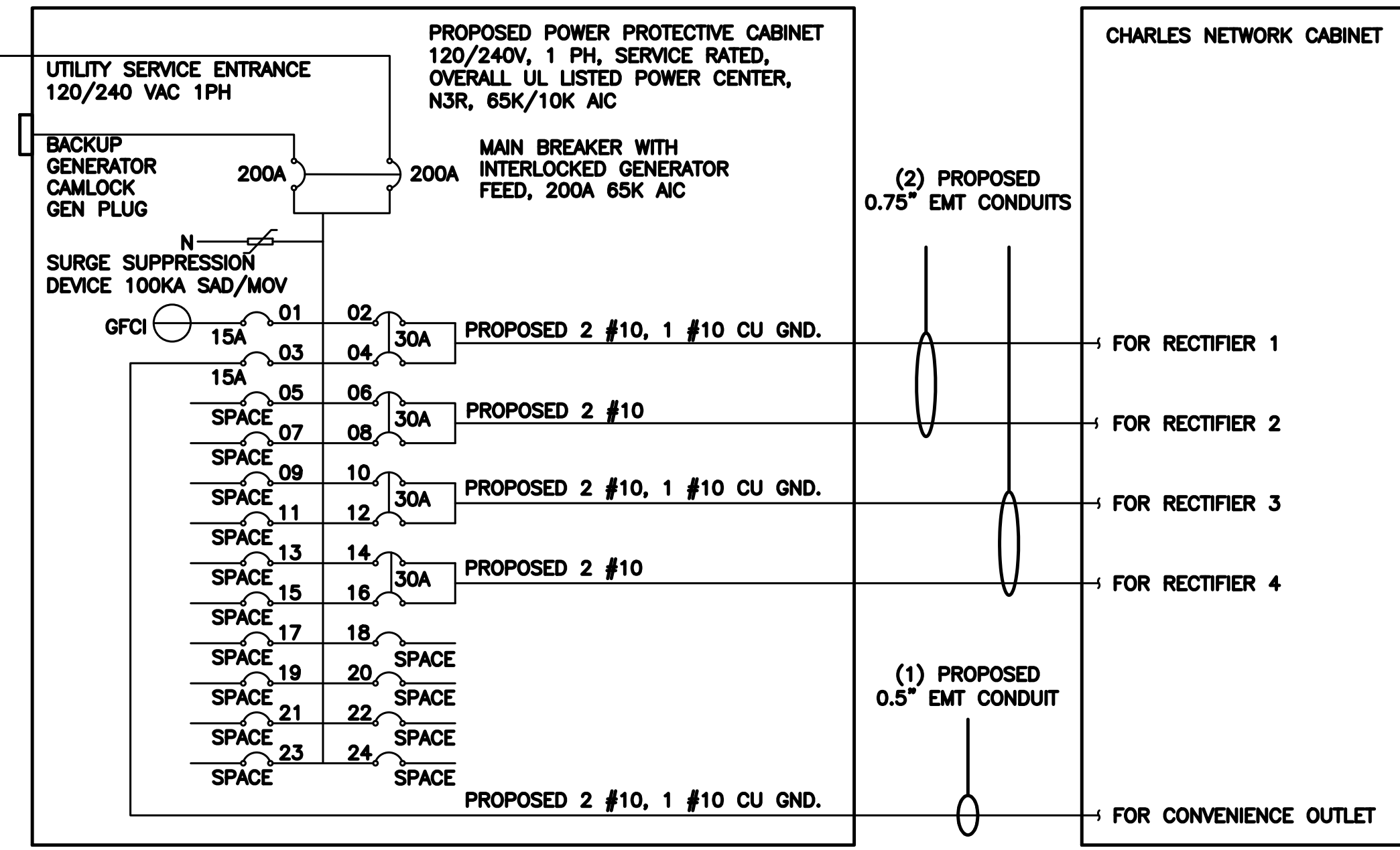
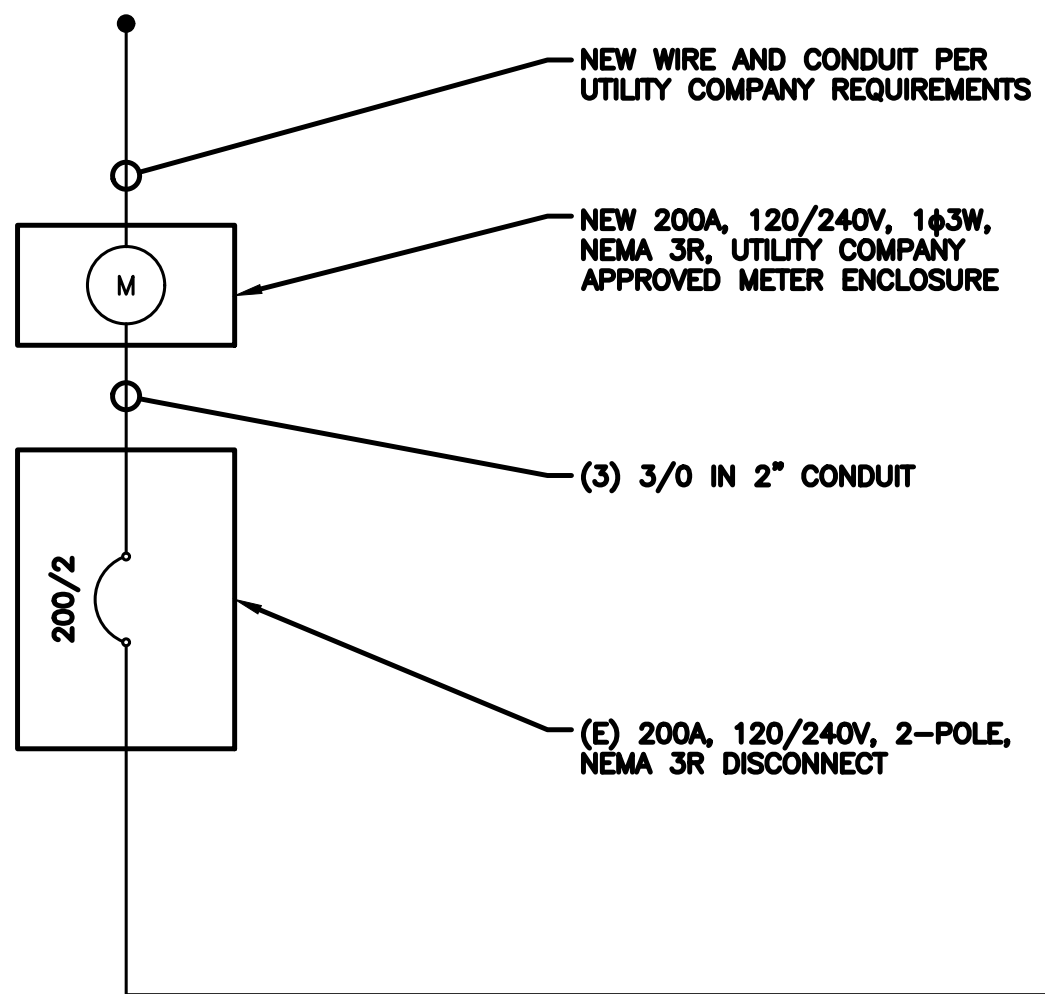

NOTE: BRANCH CIRCUIT WIRING SUPPLYING RECTIFIERS ARE TO BE RATED UL1015, 105°C, 600V, AND PVC INSULATED, IN THE SIZES SHOWN IN THE ONE-LINE DIAGRAM. CONTRACTOR MAY SUBSTITUTE UL1015 WIRE FOR THWN-2 FOR CONVENIENCE OUTLET BRANCH CIRCUIT.

BREAKERS REQUIRED:
 (4) 30A, 2P BREAKER - SQUARE D P/N:Q0230
 (1) 15A, 1P BREAKER - SQUARE D P/N:Q0115

NOTES

THE ENGINEER OF RECORD HAS PERFORMED ALL REQUIRED SHORT CIRCUIT CALCULATIONS AND THE AIC RATINGS FOR EACH DEVICE IS ADEQUATE TO PROTECT THE EQUIPMENT AND THE ELECTRICAL SYSTEM.

THE ENGINEER OF RECORD HAS PERFORMED ALL REQUIRED VOLTAGE DROP CALCULATIONS AND ALL BRANCH CIRCUIT AND FEEDERS COMPLY WITH THE NEC (LISTED ON T-1) ARTICLE 210.19(A)(1) FPN NO. 4.

THE (2) CONDUITS WITH (4) CURRENT CARRYING CONDUCTORS EACH, SHALL APPLY THE ADJUSTMENT FACTOR OF 80% PER 2014/17 NEC TABLE 310.15(B)(3)(a) OR 2020 NEC TABLE 310.15(C)(1) FOR UL1015 WIRE.

#12 FOR 15A-20A/1P BREAKER: 0.8 x 30A = 24.0A
 #10 FOR 25A-30A/2P BREAKER: 0.8 x 40A = 32.0A
 #8 FOR 35A-40A/2P BREAKER: 0.8 x 55A = 44.0A
 #6 FOR 45A-60A/2P BREAKER: 0.8 x 75A = 60.0A

CONDUIT SIZING: AT 40% FILL PER NEC CHAPTER 9, TABLE 4, ARTICLE 358.
 0.5" CONDUIT - 0.122 SQ. IN AREA
 0.75" CONDUIT - 0.213 SQ. IN AREA
 2.0" CONDUIT - 1.316 SQ. IN AREA
 3.0" CONDUIT - 2.907 SQ. IN AREA

CABINET CONVENIENCE OUTLET CONDUCTORS (1 CONDUIT): USING THWN-2, CU.
 #10 - 0.0211 SQ. IN X 2 = 0.0422 SQ. IN
 #10 - 0.0211 SQ. IN X 1 = 0.0211 SQ. IN <GROUND
TOTAL = 0.0633 SQ. IN

0.5" EMT CONDUIT IS ADEQUATE TO HANDLE THE TOTAL OF (3) WIRES, INCLUDING GROUND WIRE, AS INDICATED ABOVE.

RECTIFIER CONDUCTORS (2 CONDUITS): USING UL1015, CU.
 #10 - 0.0266 SQ. IN X 4 = 0.1064 SQ. IN
 #10 - 0.0082 SQ. IN X 1 = 0.0082 SQ. IN <BARE GROUND
TOTAL = 0.1146 SQ. IN

0.75" EMT CONDUIT IS ADEQUATE TO HANDLE THE TOTAL OF (5) WIRES, INCLUDING GROUND WIRE, AS INDICATED ABOVE.

PPC FEED CONDUCTORS (1 CONDUIT): USING THWN, CU.
 3/0 - 0.2679 SQ. IN X 3 = 0.8037 SQ. IN
 #6 - 0.0507 SQ. IN X 1 = 0.0507 SQ. IN <GROUND
TOTAL = 0.8544 SQ. IN

3.0" SCH 40 PVC CONDUIT IS ADEQUATE TO HANDLE THE TOTAL OF (4) WIRES, INCLUDING GROUND WIRE, AS INDICATED ABOVE.



5701 SOUTH SANTA FE DRIVE
LITTLETON, CO 80120



45 BEECHWOOD DRIVE N. ANDOVER, MA 01845 TEL: (978) 557-5553 FAX: (978) 336-5586



IT IS A VIOLATION OF LAW FOR ANY PERSON, UNLESS THEY ARE ACTING UNDER THE DIRECTION OF A LICENSED PROFESSIONAL ENGINEER, TO ALTER THIS DOCUMENT.

DRAWN BY: MRK CHECKED BY: SMA APPROVED BY: DPH

RFDS REV #: 4

PRELIMINARY DOCUMENT

SUBMITTALS		
REV	DATE	DESCRIPTION
A	11/16/2021	ISSUED FOR REVIEW
B	04/04/2022	ISSUED FOR REVIEW
C	06/06/2022	ISSUED FOR REVIEW

A&E PROJECT NUMBER
BOBOS01000A

DISH Wireless L.L.C.
PROJECT INFORMATION
BOBOS01000A
CROWN CASTLE BU#881533
75 ROBERTS ROAD
GROTON, CT 06340

SHEET TITLE
ELECTRICAL ONE-LINE, FAULT
CALCS & PANEL SCHEDULE

SHEET NUMBER

E-3

PPC ONE-LINE DIAGRAM

NO SCALE 1

PROPOSED CHARLES PANEL SCHEDULE

LOAD SERVED	VOLT AMPS (WATTS)		TRIP	CKT #	PHASE	CKT #	TRIP	VOLT AMPS (WATTS)		LOAD SERVED
	L1	L2						L1	L2	
PPC GFCI OUTLET	180	180	15A	1	A	2	30A	2880	2880	ABB/GE INFINITY RECTIFIER 1
CHARLES GFCI OUTLET			15A	3	B	4				
-SPACE-				5	A	6	30A	2880	2880	ABB/GE INFINITY RECTIFIER 2
-SPACE-				7	B	8				
-SPACE-				9	A	10	30A	2880	2880	ABB/GE INFINITY RECTIFIER 3
-SPACE-				11	B	12				
-SPACE-				13	A	14	30A	2880	2880	ABB/GE INFINITY RECTIFIER 4
-SPACE-				15	B	16				
-SPACE-				17	A	18				-SPACE-
-SPACE-				19	B	20				-SPACE-
-SPACE-				21	A	22				-SPACE-
-SPACE-				23	B	24				-SPACE-
VOLTAGE AMPS		180	180					11520	11520	
200A MCB, 1 ϕ , 24 SPACE, 120/240V				L1	L2					
MB RATING: 65,000 AIC				11700	11700					
				98	98					
				98						
				123						

PANEL SCHEDULE

NO SCALE 2

NOT USED

NO SCALE 3

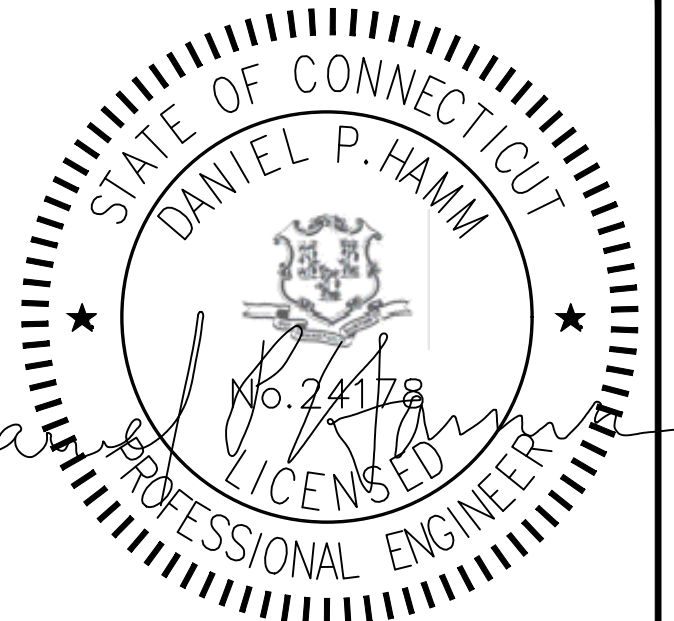

IT IS A VIOLATION OF LAW FOR ANY PERSON, UNLESS THEY ARE ACTING UNDER THE DIRECTION OF A LICENSED PROFESSIONAL ENGINEER, TO ALTER THIS DOCUMENT.

DRAWN BY: MRK CHECKED BY: SMA APPROVED BY: DPH

RFDS REV #: 4

PRELIMINARY DOCUMENT

SUBMITTALS		
REV	DATE	DESCRIPTION
A	11/16/2021	ISSUED FOR REVIEW
B	04/04/2022	ISSUED FOR REVIEW
C	06/06/2022	ISSUED FOR REVIEW

A&E PROJECT NUMBER
BOBOS01000A

DISH Wireless L.L.C.
PROJECT INFORMATION
BOBOS01000A
CROWN CASTLE BU#881533
75 ROBERTS ROAD
GROTON, CT 06340

SHEET TITLE
GROUNDING PLANS AND NOTES

SHEET NUMBER

G-1

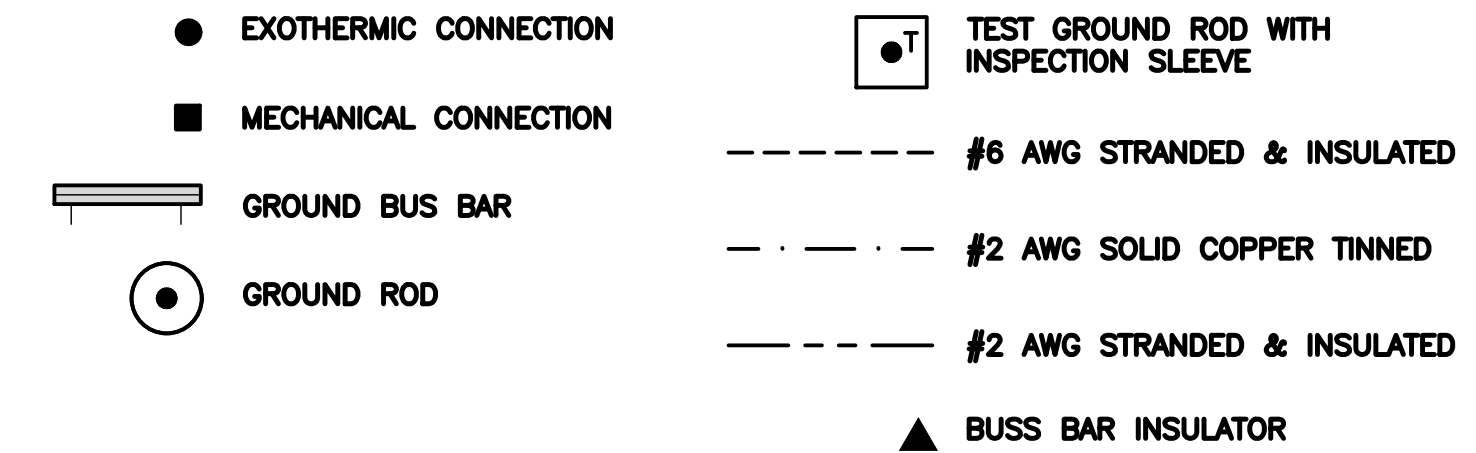

GROUNDING LEGEND

- GROUNDING IS SHOWN DIAGRAMMATICALLY ONLY.
- CONTRACTOR SHALL GROUND ALL EQUIPMENT AS A COMPLETE SYSTEM. GROUNDING SHALL BE IN COMPLIANCE WITH NEC SECTION 250 AND DISH Wireless L.L.C. GROUNDING AND BONDING REQUIREMENTS AND MANUFACTURER'S SPECIFICATIONS.
- ALL GROUND CONDUCTORS SHALL BE COPPER; NO ALUMINUM CONDUCTORS SHALL BE USED.

GROUNDING KEY NOTES

- EXTERIOR GROUND RING:** #2 AWG SOLID COPPER, BURIED AT A DEPTH OF AT LEAST 30 INCHES BELOW GRADE, OR 6 INCHES BELOW THE FROST LINE AND APPROXIMATELY 24 INCHES FROM THE EXTERIOR WALL OR FOOTING.
- TOWER GROUND RING:** THE GROUND RING SYSTEM SHALL BE INSTALLED AROUND AN ANTENNA TOWER'S LEGS, AND/OR GUY ANCHORS. WHERE SEPARATE SYSTEMS HAVE BEEN PROVIDED FOR THE TOWER AND THE BUILDING, AT LEAST TWO BONDS SHALL BE MADE BETWEEN THE TOWER RING GROUND SYSTEM AND THE BUILDING RING GROUND SYSTEM USING MINIMUM #2 AWG SOLID COPPER CONDUCTORS.
- INTERIOR GROUND RING:** #2 AWG STRANDED GREEN INSULATED COPPER CONDUCTOR EXTENDED AROUND THE PERIMETER OF THE EQUIPMENT AREA. ALL NON-TELECOMMUNICATIONS RELATED METALLIC OBJECTS FOUND WITHIN A SITE SHALL BE GROUNDED TO THE INTERIOR GROUND RING WITH #6 AWG STRANDED GREEN INSULATED CONDUCTOR.
- BOND TO INTERIOR GROUND RING:** #2 AWG SOLID TINNED COPPER WIRE PRIMARY BONDS SHALL BE PROVIDED AT LEAST AT FOUR POINTS ON THE INTERIOR GROUND RING, LOCATED AT THE CORNERS OF THE BUILDING.
- GROUND ROD:** UL LISTED COPPER CLAD STEEL, MINIMUM 1/2" DIAMETER BY EIGHT FEET LONG. GROUND RODS SHALL BE INSTALLED WITH INSPECTION SLEEVES. GROUND RODS SHALL BE DRIVEN TO THE DEPTH OF GROUND RING CONDUCTOR.
- CELL REFERENCE GROUND BAR:** POINT OF GROUND REFERENCE FOR ALL COMMUNICATIONS EQUIPMENT FRAMES. ALL BONDS ARE MADE WITH #2 AWG UNLESS NOTED OTHERWISE. STRANDED GREEN INSULATED COPPER CONDUCTORS. BOND TO GROUND RING WITH (2) #2 SOLID TINNED COPPER CONDUCTORS.
- HATCH PLATE GROUND BAR:** BOND TO THE INTERIOR GROUND RING WITH TWO #2 AWG STRANDED GREEN INSULATED COPPER CONDUCTORS. WHEN A HATCH-PLATE AND A CELL REFERENCE GROUND BAR ARE BOTH PRESENT, THE CRGB MUST BE CONNECTED TO THE HATCH-PLATE AND TO THE INTERIOR GROUND RING USING (2) TWO #2 AWG STRANDED GREEN INSULATED COPPER CONDUCTORS EACH.
- EXTERIOR CABLE ENTRY PORT GROUND BARS:** LOCATED AT THE ENTRANCE TO THE CELL SITE BUILDING. BOND TO GROUND RING WITH A #2 AWG SOLID TINNED COPPER CONDUCTORS WITH AN EXOTHERMIC WELD AND INSPECTION SLEEVE.
- TELCO GROUND BAR:** BOND TO BOTH CELL REFERENCE GROUND BAR OR EXTERIOR GROUND RING.
- FRAME BONDING:** THE BONDING POINT FOR TELECOM EQUIPMENT FRAMES SHALL BE THE GROUND BUS THAT IS NOT ISOLATED FROM THE EQUIPMENTS METAL FRAMEWORK.
- INTERIOR UNIT BONDS:** METAL FRAMES, CABINETS AND INDIVIDUAL METALLIC UNITS LOCATED WITH THE AREA OF THE INTERIOR GROUND RING REQUIRE A #6 AWG STRANDED GREEN INSULATED COPPER BOND TO THE INTERIOR GROUND RING.
- FENCE AND GATE GROUNDING:** METAL FENCES WITHIN 7 FEET OF THE EXTERIOR GROUND RING OR OBJECTS BONDED TO THE EXTERIOR GROUND RING SHALL BE BONDED TO THE GROUND RING WITH A #2 AWG SOLID TINNED COPPER CONDUCTOR AT AN INTERVAL NOT EXCEEDING 25 FEET. BONDS SHALL BE MADE AT EACH GATE POST AND ACROSS GATE OPENINGS.
- EXTERIOR UNIT BONDS:** METALLIC OBJECTS, EXTERNAL TO OR MOUNTED TO THE BUILDING, SHALL BE BONDED TO THE EXTERIOR GROUND RING. USING #2 TINNED SOLID COPPER WIRE
- ICE BRIDGE SUPPORTS:** EACH ICE BRIDGE LEG SHALL BE BONDED TO THE GROUND RING WITH #2 AWG BARE TINNED COPPER CONDUCTOR. PROVIDE EXOTHERMIC WELDS AT BOTH THE ICE BRIDGE LEG AND BURIED GROUND RING.
- DURING ALL DC POWER SYSTEM CHANGES INCLUDING DC SYSTEM CHANGE OUTS, RECTIFIER REPLACEMENTS OR ADDITIONS, BREAKER DISTRIBUTION CHANGES, BATTERY ADDITIONS, BATTERY REPLACEMENTS AND INSTALLATIONS OR CHANGES TO DC CONVERTER SYSTEMS IT SHALL BE REQUIRED THAT SERVICE CONTRACTORS VERIFY ALL DC POWER SYSTEMS ARE EQUIPPED WITH A MASTER DC SYSTEM RETURN GROUND CONDUCTOR FROM THE DC POWER SYSTEM COMMON RETURN BUS DIRECTLY CONNECTED TO THE CELL SITE REFERENCE GROUND BAR**
- TOWER TOP COLLECTOR BUSS BAR IS TO BE MECHANICALLY BONDED TO PROPOSED ANTENNA MOUNT COLLAR. REFER TO DISH Wireless L.L.C. GROUNDING NOTES.**

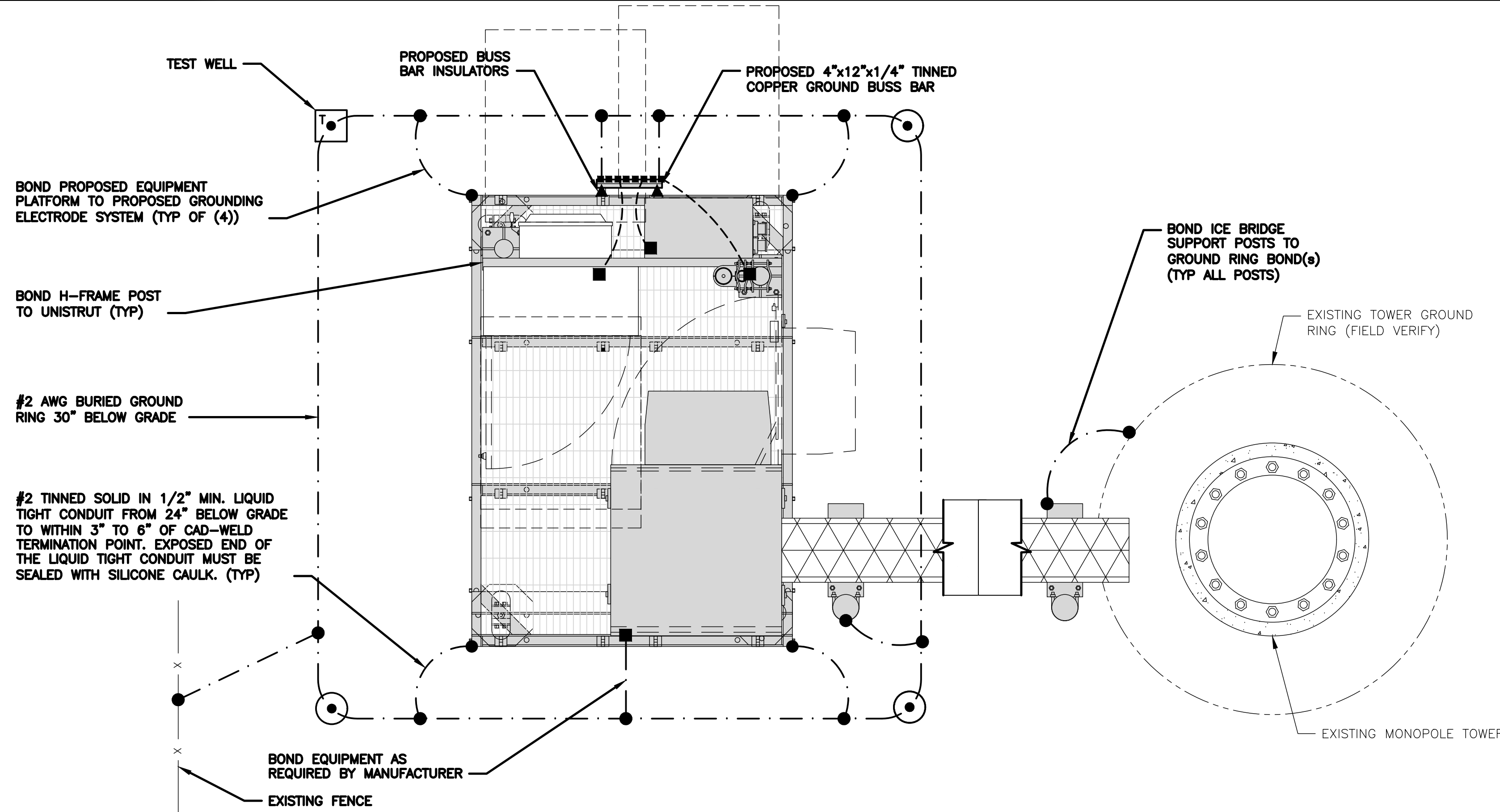

TYPICAL EQUIPMENT GROUNDING PLAN

NO SCALE 1

NOTES

ANTENNAS AND OVP SHOWN ARE GENERIC AND NOT REFERENCING TO A SPECIFIC MANUFACTURER. THIS LAYOUT IS FOR REFERENCE PURPOSES ONLY

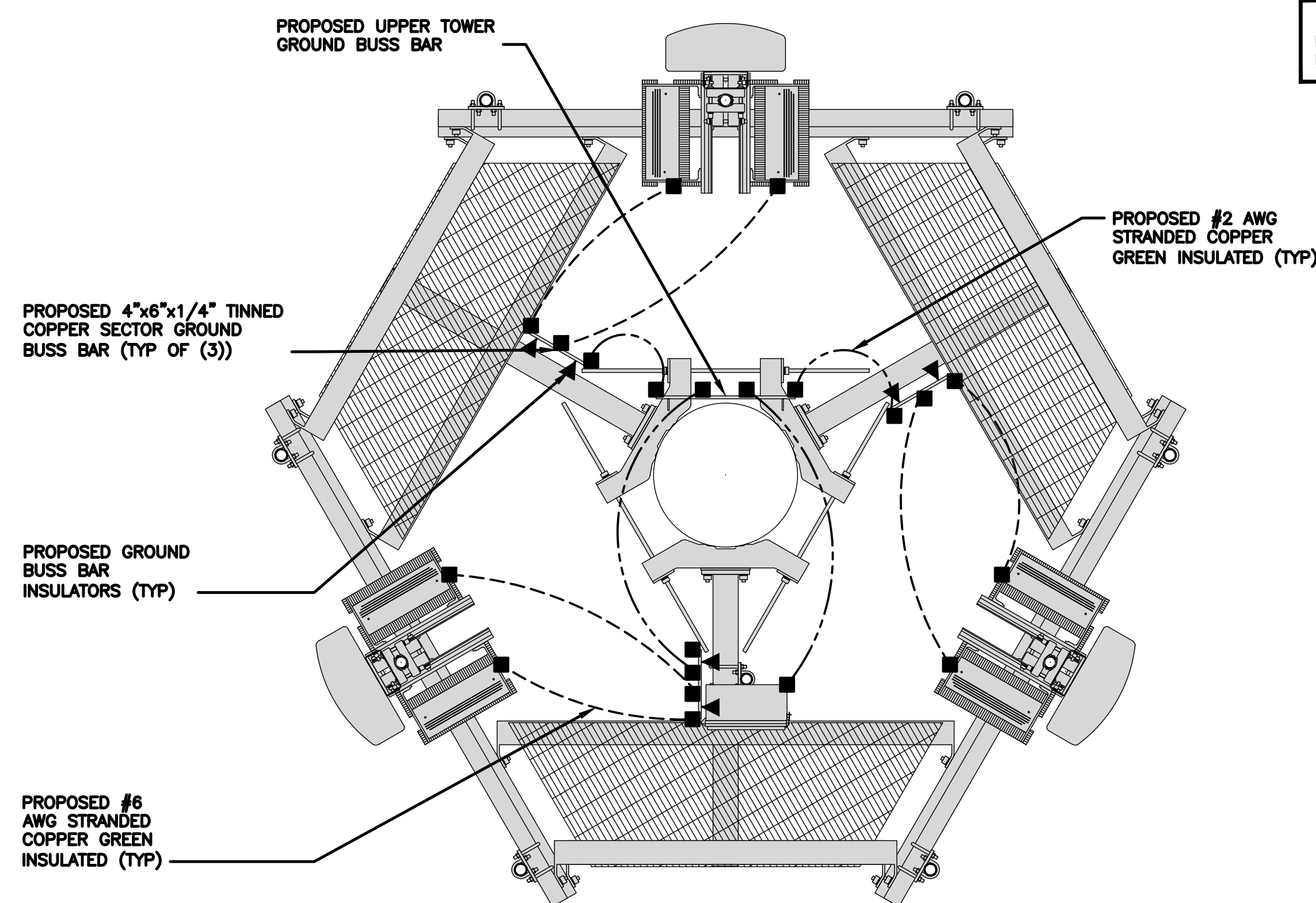

TYPICAL ANTENNA GROUNDING PLAN

NO SCALE 2

GROUNDING KEY NOTES

NO SCALE 3

NOTES
EQUIPMENT CABINET OMITTED FOR CLARITY

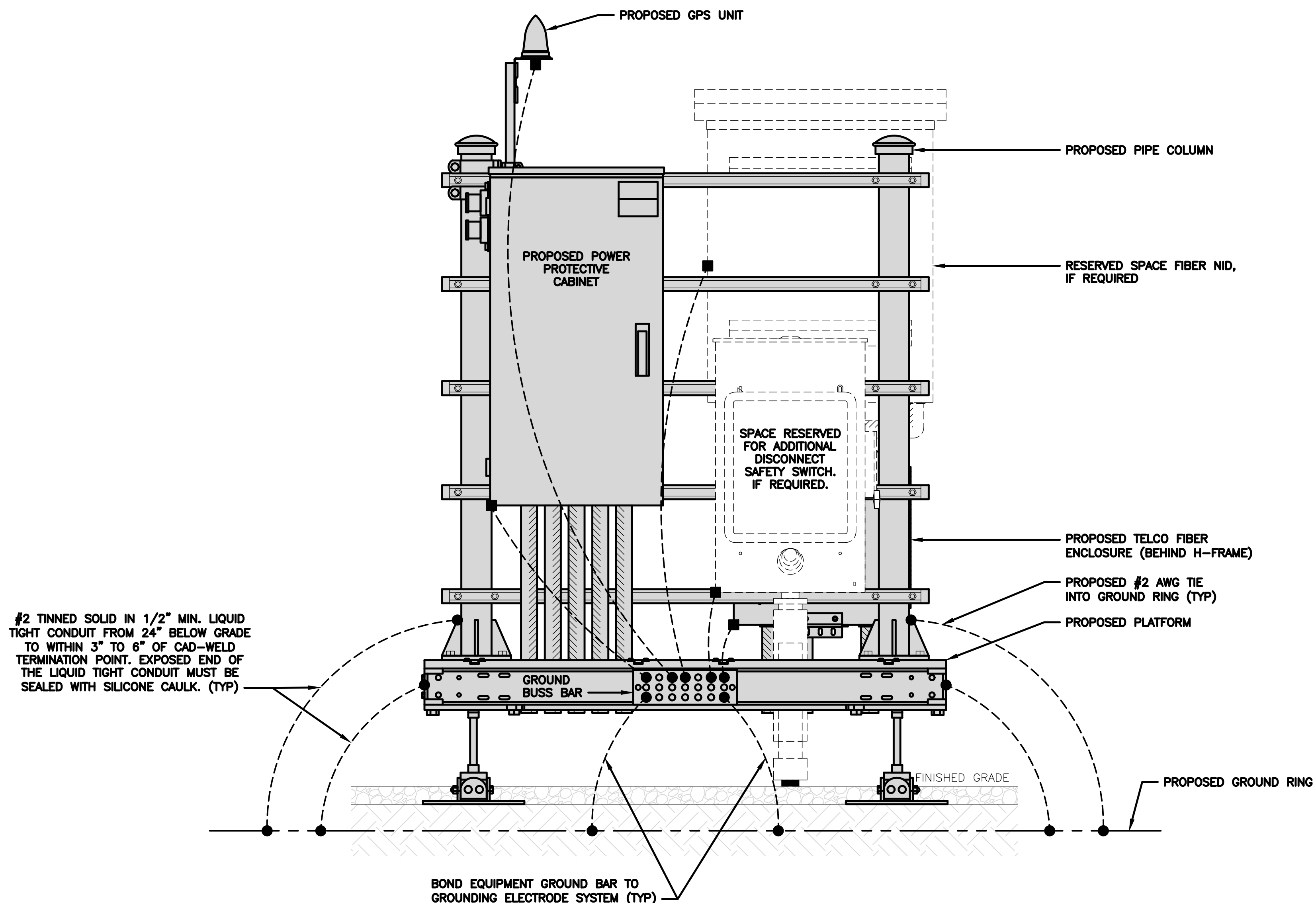

H-FRAME GROUNDING DETAIL

NO SCALE 1

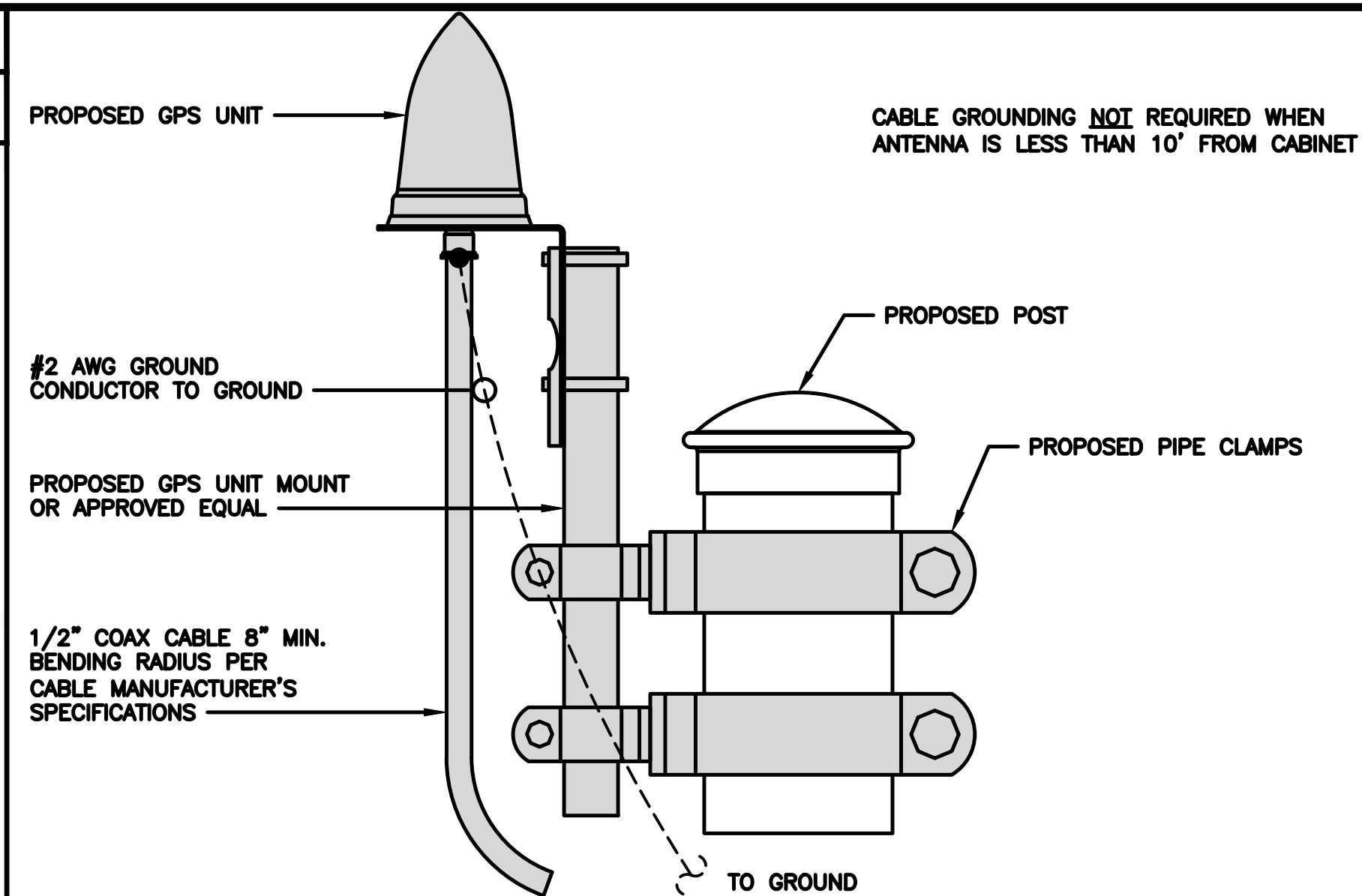

TYPICAL GPS UNIT GROUNDING

NO SCALE 2

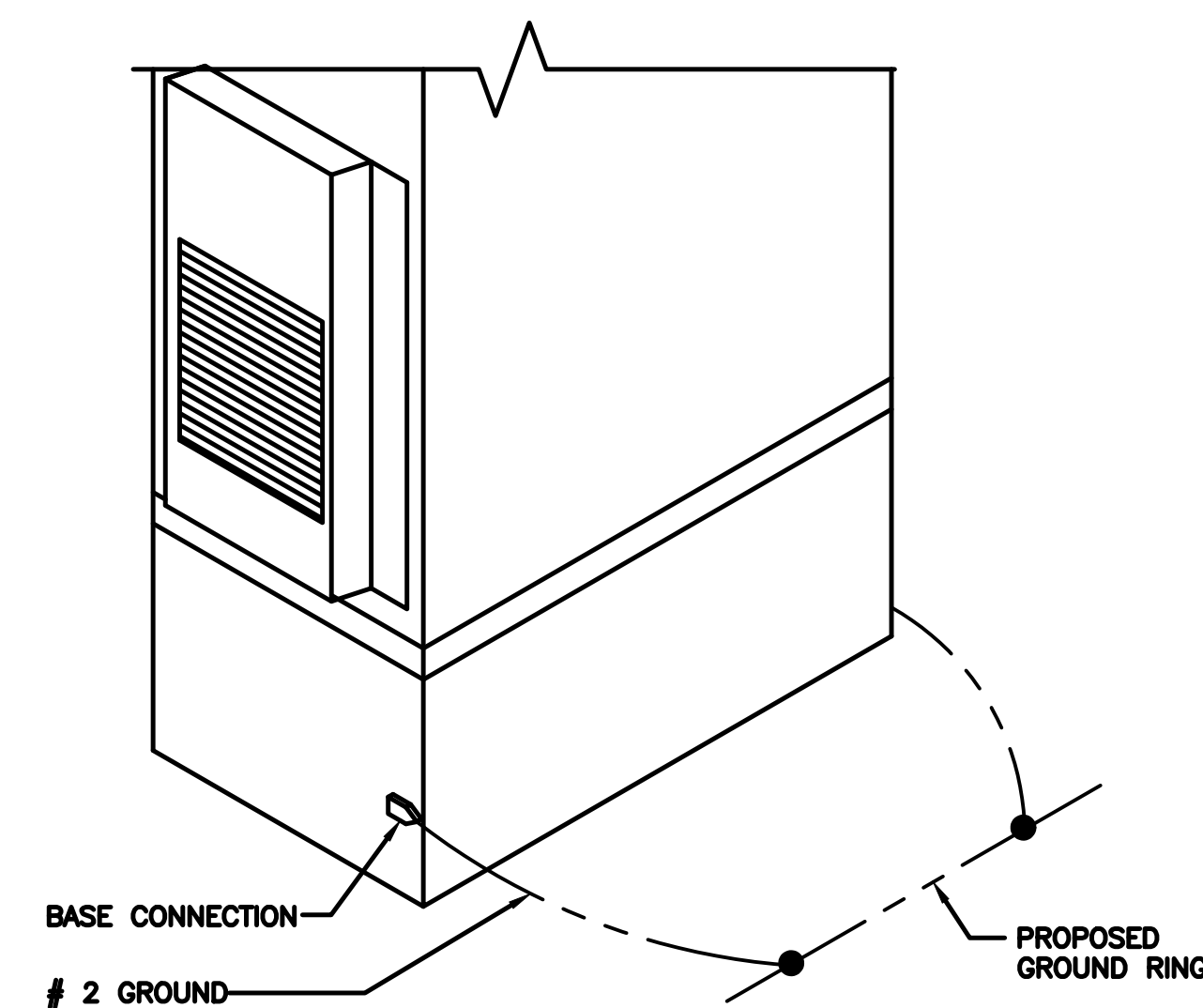

OUTDOOR CABINET GROUNDING

NO SCALE 3

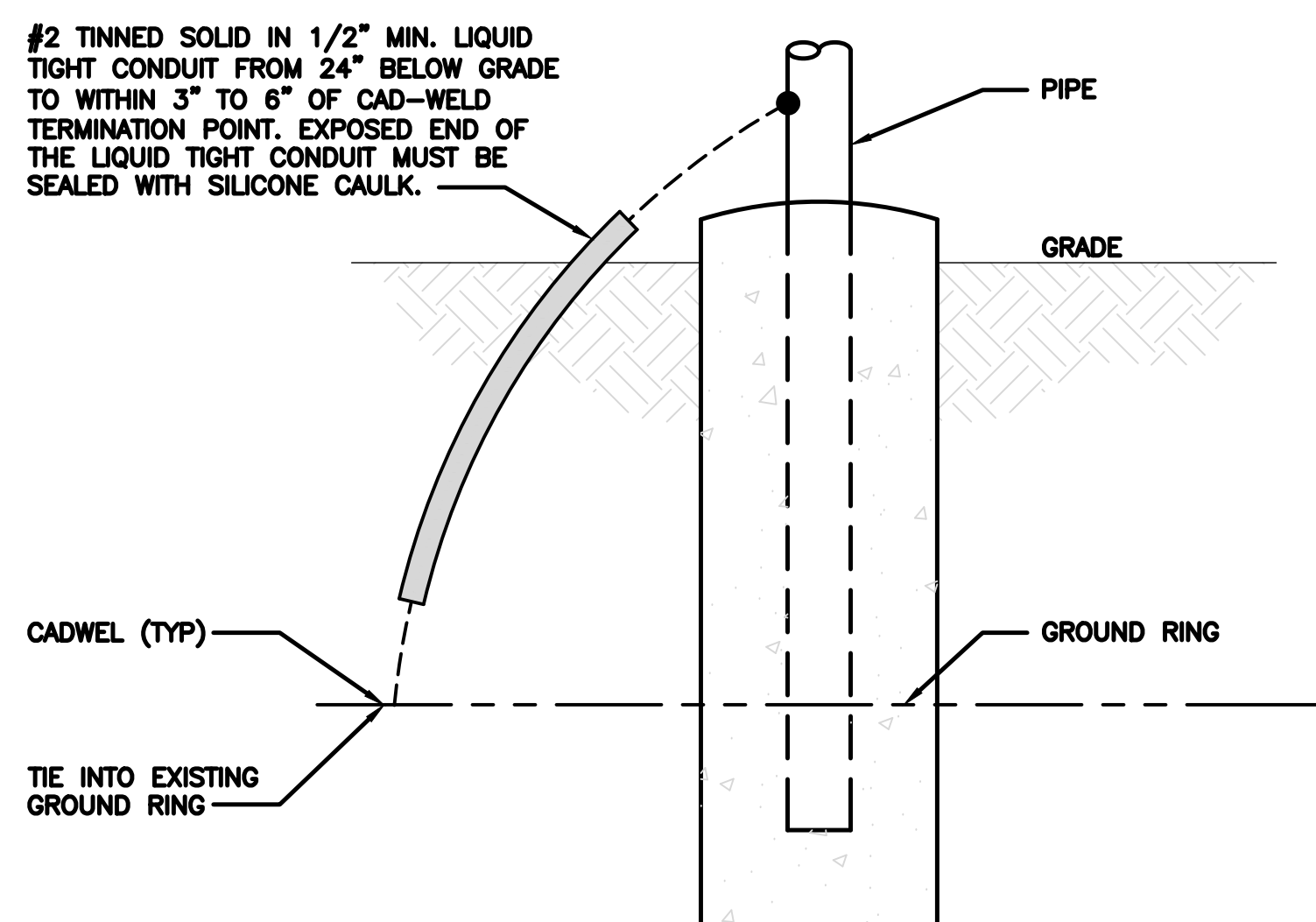

TRANSITIONING GROUND DETAIL

NO SCALE 4

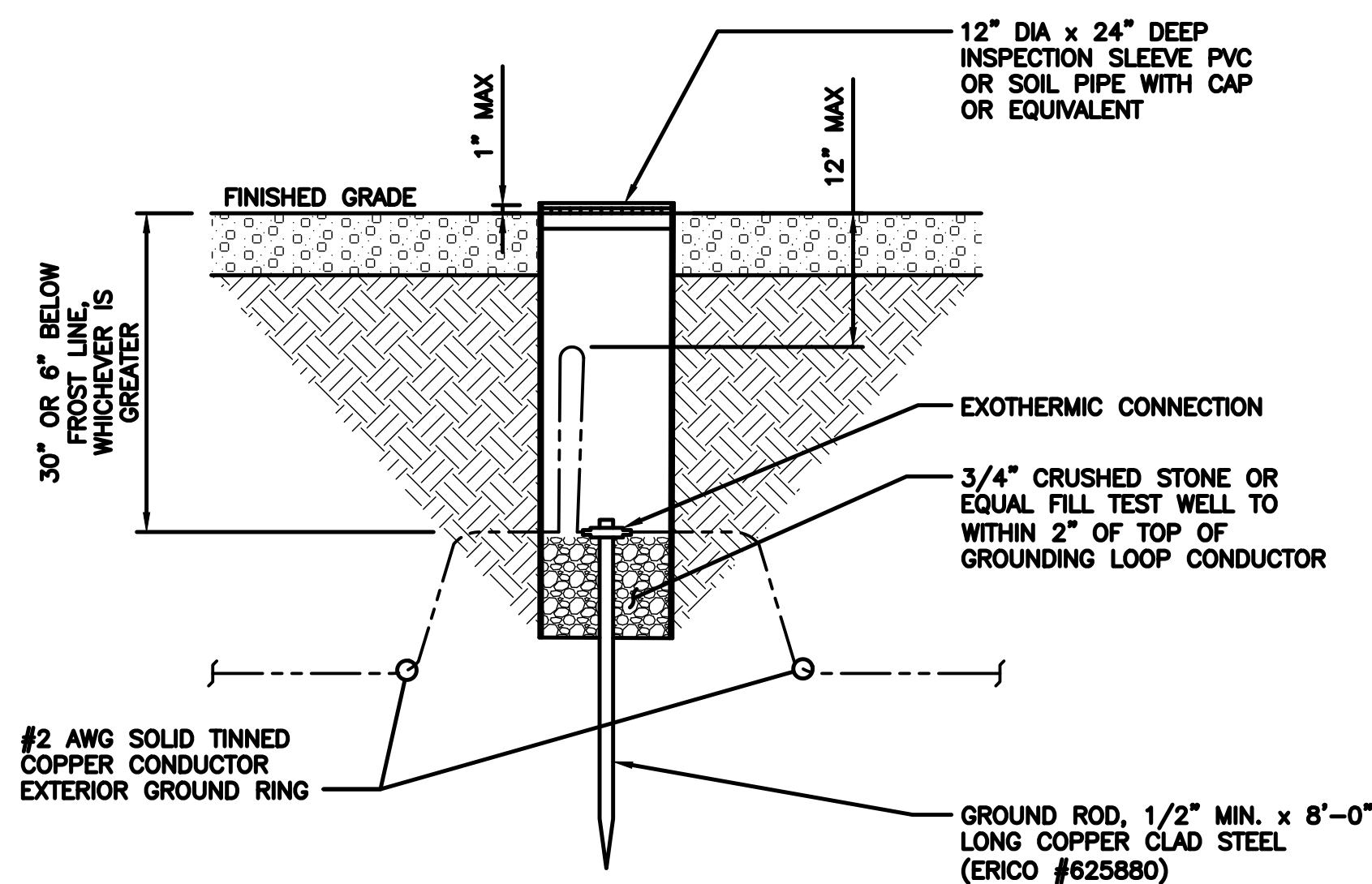

TYPICAL TEST GROUND ROD WITH INSPECTION SLEEVE

NO SCALE 5

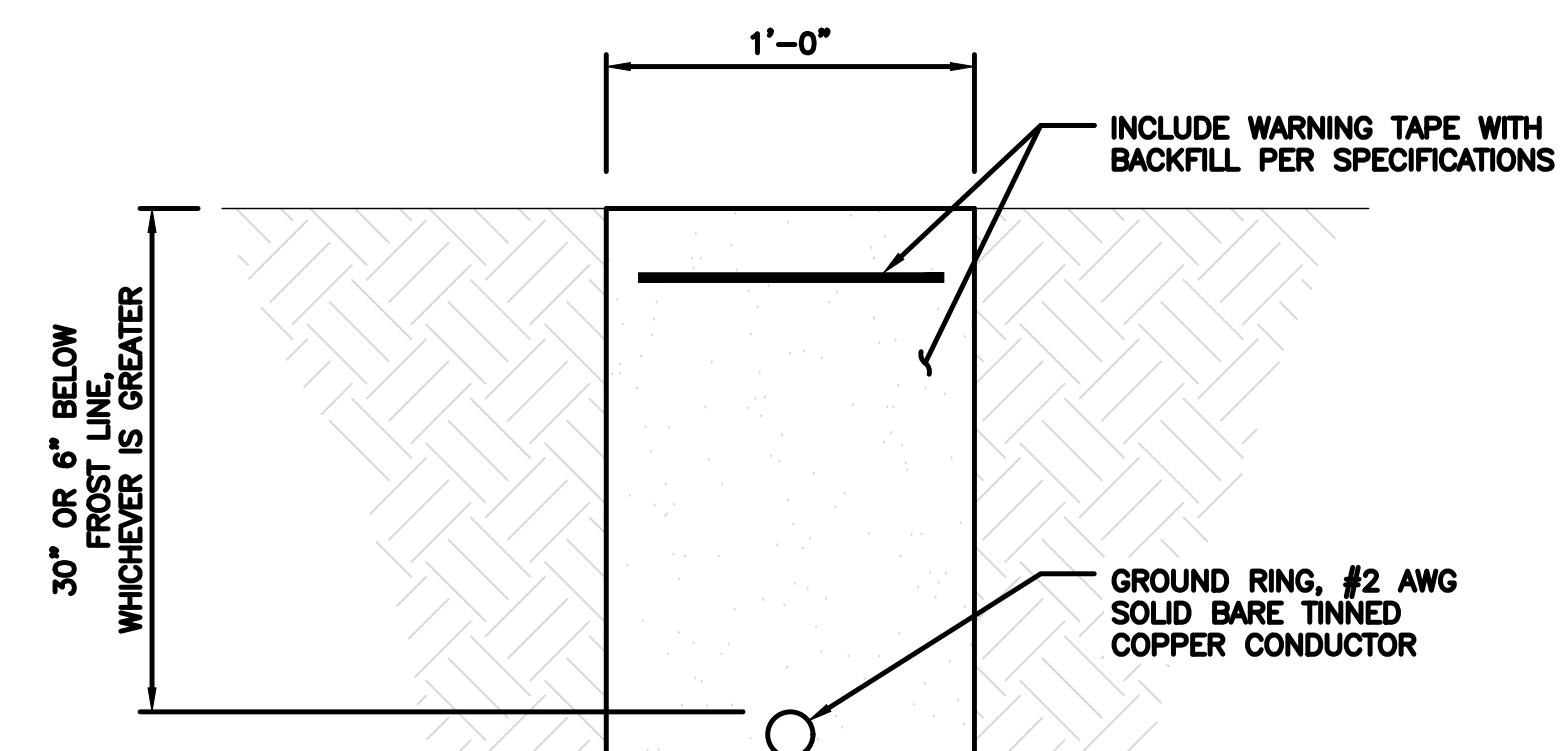

TYPICAL GROUND RING TRENCH

NO SCALE 6

dish wireless.

5701 SOUTH SANTA FE DRIVE
LITTLETON, CO 80120

HG HUDSON Design Group LLC

45 BEECHWOOD DRIVE N. ANDOVER, MA 01845 TEL: (978) 557-5553 FAX: (978) 336-5586

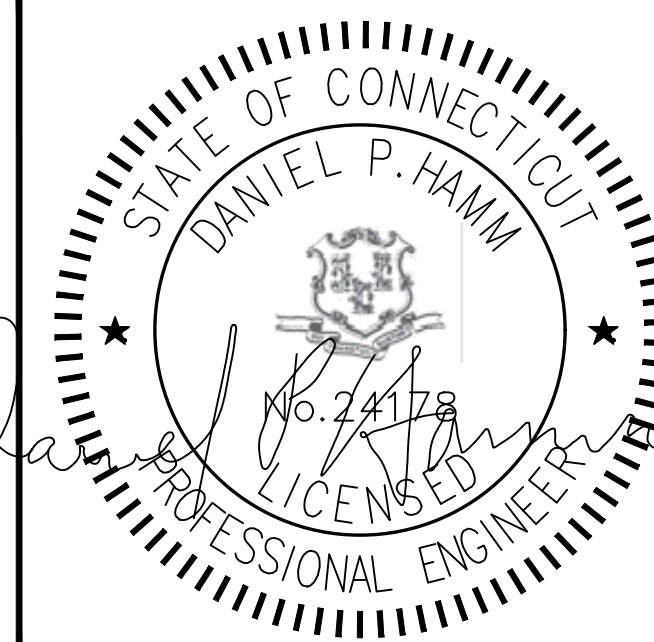

IT IS A VIOLATION OF LAW FOR ANY PERSON, UNLESS THEY ARE ACTING UNDER THE DIRECTION OF A LICENSED PROFESSIONAL ENGINEER, TO ALTER THIS DOCUMENT.

DRAWN BY: MRK CHECKED BY: SMA APPROVED BY: DPH

RFDS REV #: 4

PRELIMINARY DOCUMENT

SUBMITTALS		
REV	DATE	DESCRIPTION
A	11/16/2021	ISSUED FOR REVIEW
B	04/04/2022	ISSUED FOR REVIEW
C	06/06/2022	ISSUED FOR REVIEW

A&E PROJECT NUMBER
BOBOS01000A

DISH Wireless L.L.C.
PROJECT INFORMATION
BOBOS01000A
CROWN CASTLE BU#881533
75 ROBERTS ROAD
GROTON, CT 06340

SHEET TITLE
GROUNDING DETAILS

SHEET NUMBER

G-2

- EXOTHERMIC WELD (2) TWO, #2 AWG BARE TINNED SOLID COPPER CONDUCTORS TO GROUND BAR. ROUTE CONDUCTORS TO BURIED GROUND RING AND PROVIDE PARALLEL EXOTHERMIC WELD.
- ALL EXTERIOR GROUNDING HARDWARE SHALL BE STAINLESS STEEL 3/8" DIAMETER OR LARGER. ALL HARDWARE 18-8 STAINLESS STEEL INCLUDING LOCK WASHERS, COAT ALL SURFACES WITH AN ANTI-OXIDANT COMPOUND BEFORE MATING.
- FOR GROUND BOND TO STEEL ONLY: COAT ALL SURFACES WITH AN ANTI-OXIDANT COMPOUND BEFORE MATING.
- DO NOT INSTALL CABLE GROUNDING KIT AT A BEND AND ALWAYS DIRECT GROUND CONDUCTOR DOWN TO GROUNDING BUS.
- NUT & WASHER SHALL BE PLACED ON THE FRONT SIDE OF THE GROUND BAR AND BOLTED ON THE BACK SIDE.
- ALL GROUNDING PARTS AND EQUIPMENT TO BE SUPPLIED AND INSTALLED BY CONTRACTOR.
- THE CONTRACTOR SHALL BE RESPONSIBLE FOR INSTALLING ADDITIONAL GROUND BAR AS REQUIRED.
- ENSURE THE WIRE INSULATION TERMINATION IS WITHIN 1/8" OF THE BARREL (NO SHINERS).

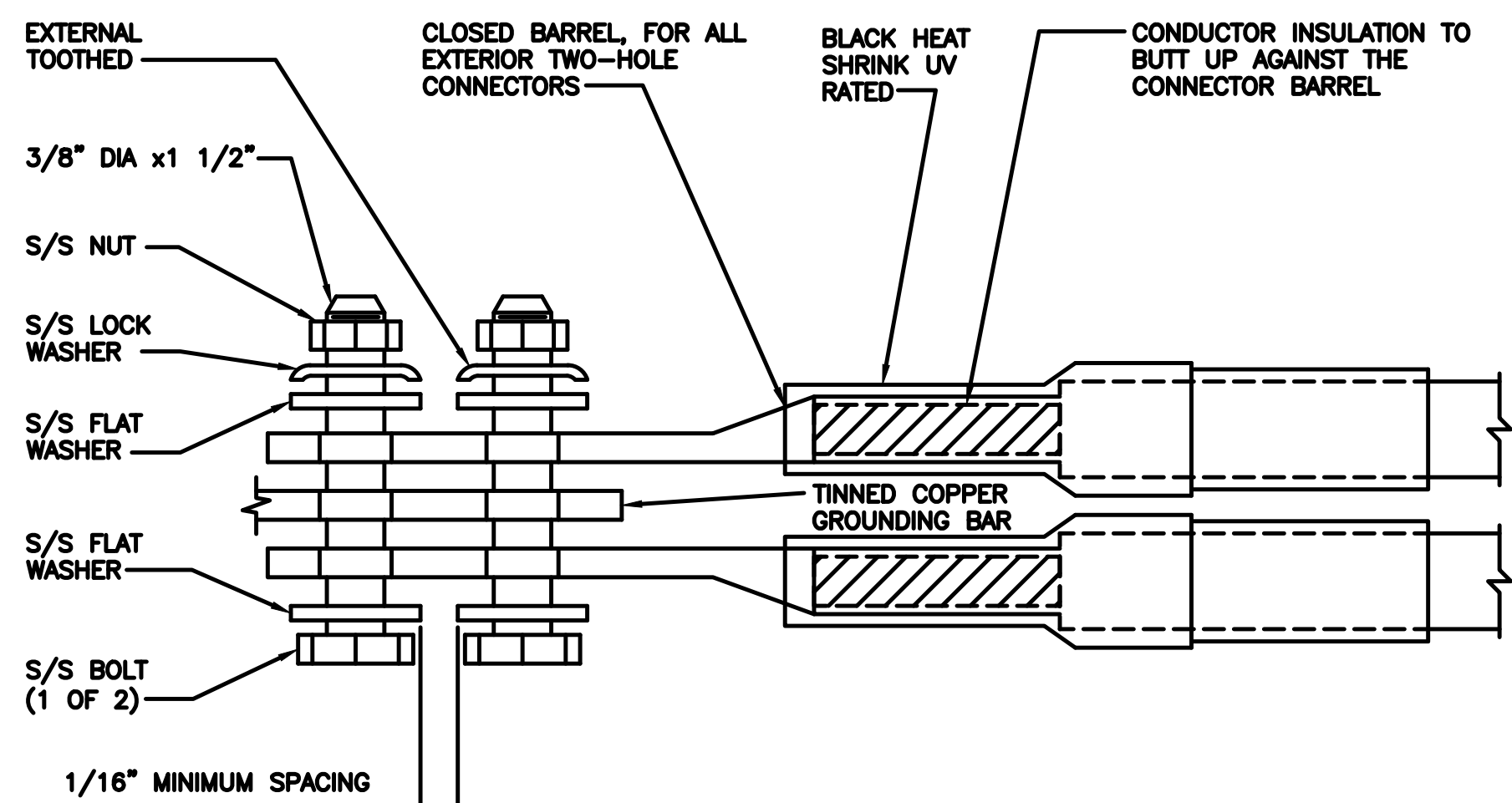

TYPICAL GROUNDING NOTES

NO SCALE 1

TYPICAL EXTERIOR TWO HOLE LUG

NO SCALE 2

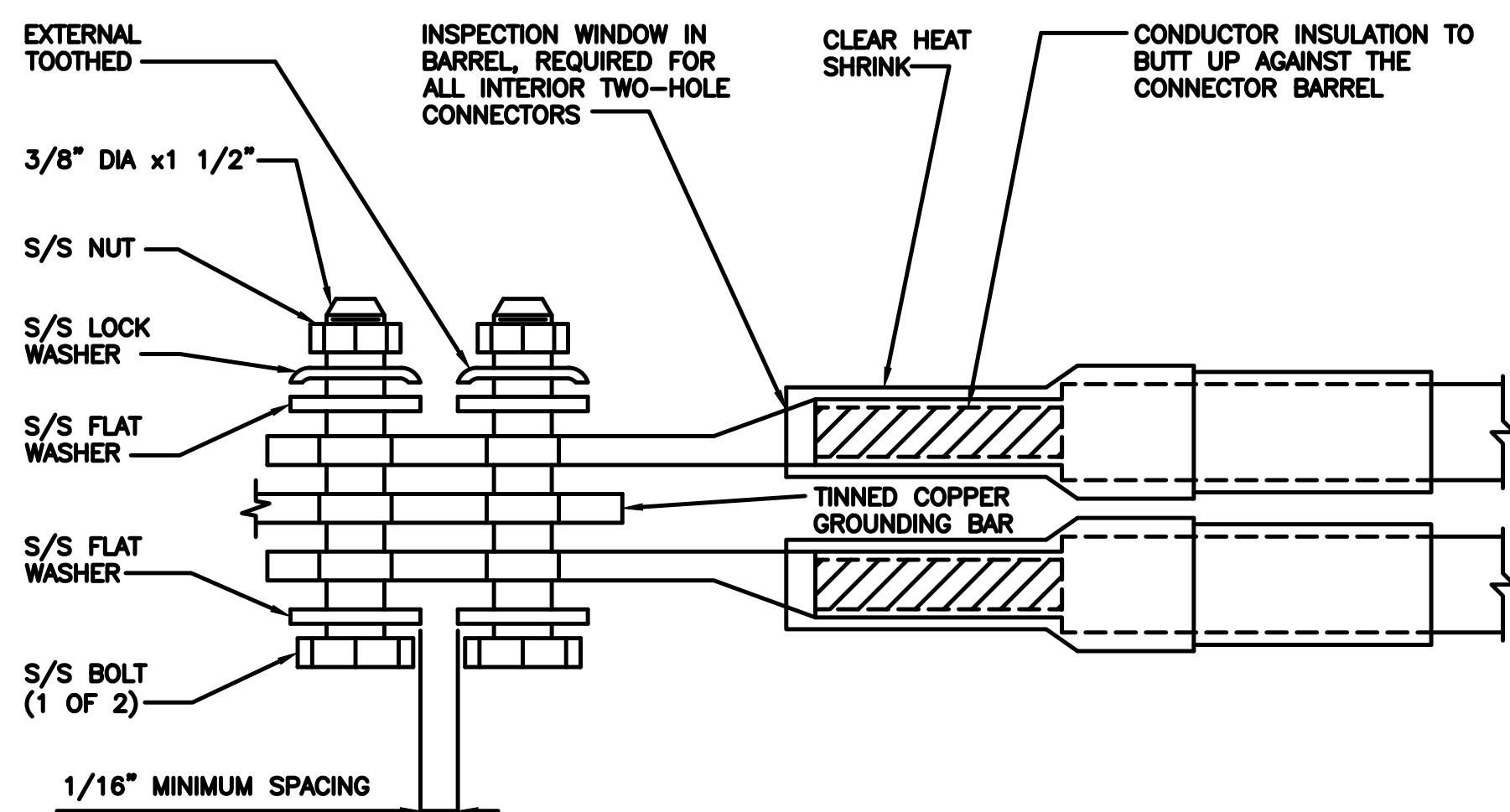

TYPICAL INTERIOR TWO HOLE LUG

NO SCALE 3

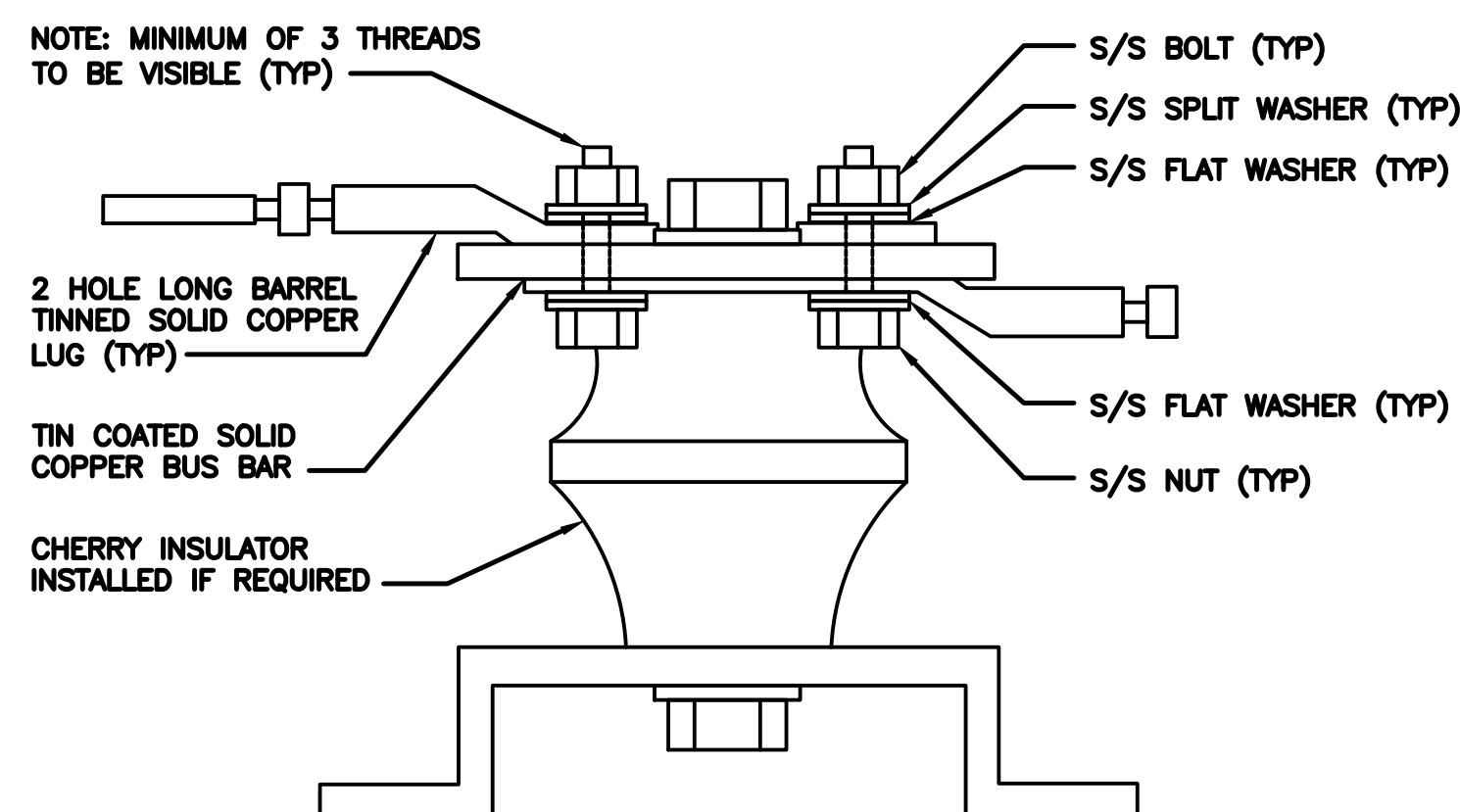

LUG DETAIL

NO SCALE 4

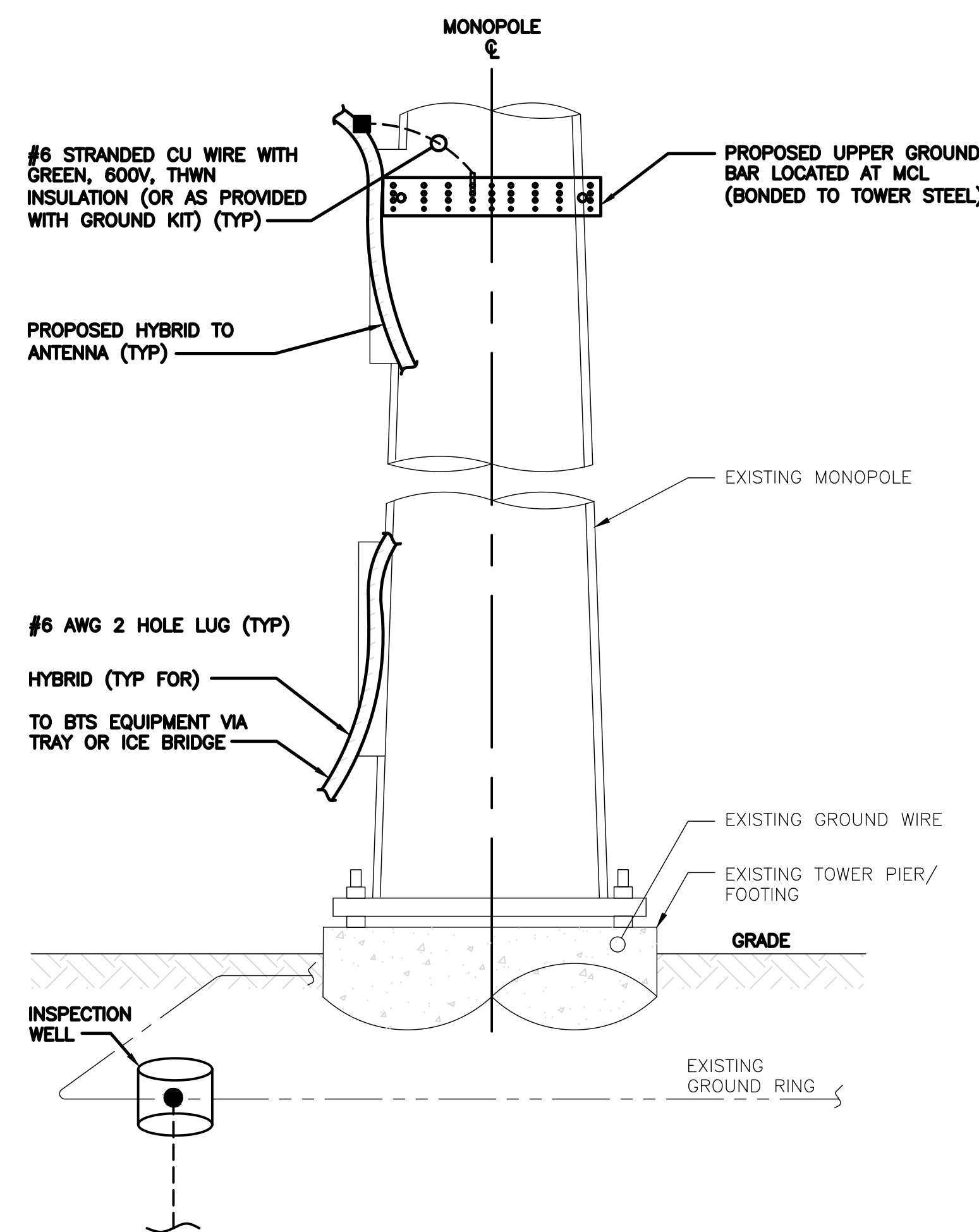

NOTES:

- ONLY MECHANICAL CONNECTIONS ARE ALLOWED TO BE MADE TO TOWERS. ALL MECHANICAL CONNECTIONS SHALL BE TREATED WITH AN ANTI-OXIDANT COATING.
- ALL TOWER GROUNDING SYSTEMS SHALL COMPLY WITH THE REQUIREMENTS OF THE RECOGNIZED EDITION OF ANSI/TIA 222 AND NFPA 780.

TYPICAL ANTENNA CABLE GROUNDING

NO SCALE 5

dish
wireless.

5701 SOUTH SANTA FE DRIVE
LITTLETON, CO 80120

HG
HUDSON
Design Group LLC

45 BEECHWOOD DRIVE TEL: (978) 557-5553
N. ANDOVER, MA 01845 FAX: (978) 336-5586

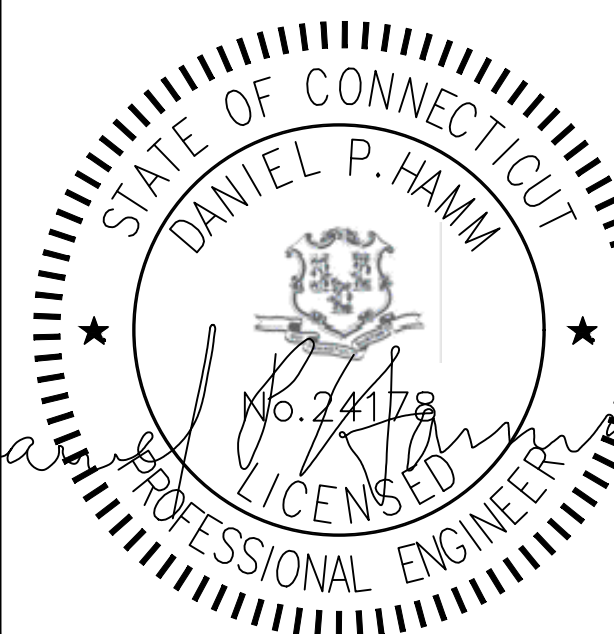

IT IS A VIOLATION OF LAW FOR ANY PERSON, UNLESS THEY ARE ACTING UNDER THE DIRECTION OF A LICENSED PROFESSIONAL ENGINEER, TO ALTER THIS DOCUMENT.

DRAWN BY: CHECKED BY: APPROVED BY:
MRK SMA DPH

RFDS REV #: 4

PRELIMINARY DOCUMENT

SUBMITTALS		
REV	DATE	DESCRIPTION
A	11/16/2021	ISSUED FOR REVIEW
B	04/04/2022	ISSUED FOR REVIEW
C	06/06/2022	ISSUED FOR REVIEW

A&E PROJECT NUMBER
BOBOS01000A

DISH Wireless L.L.C.
PROJECT INFORMATION
BOBOS01000A
CROWN CASTLE BU#881533
75 ROBERTS ROAD
GROTON, CT 06340

SHEET TITLE
GROUNDING DETAILS

SHEET NUMBER

G-3

HYBRID/DISCREET CABLES

3/4" TAPE WIDTHS WITH 3/4" SPACING

LOW-BAND RRH
(600 MHz N71 BASEBAND) +
(850 MHz N26 BAND) +
(700 MHz N29 BAND) - OPTIONAL PER MARKET
ADD FREQUENCY COLOR TO SECTOR BAND
(CBRS WILL USE YELLOW BAND)

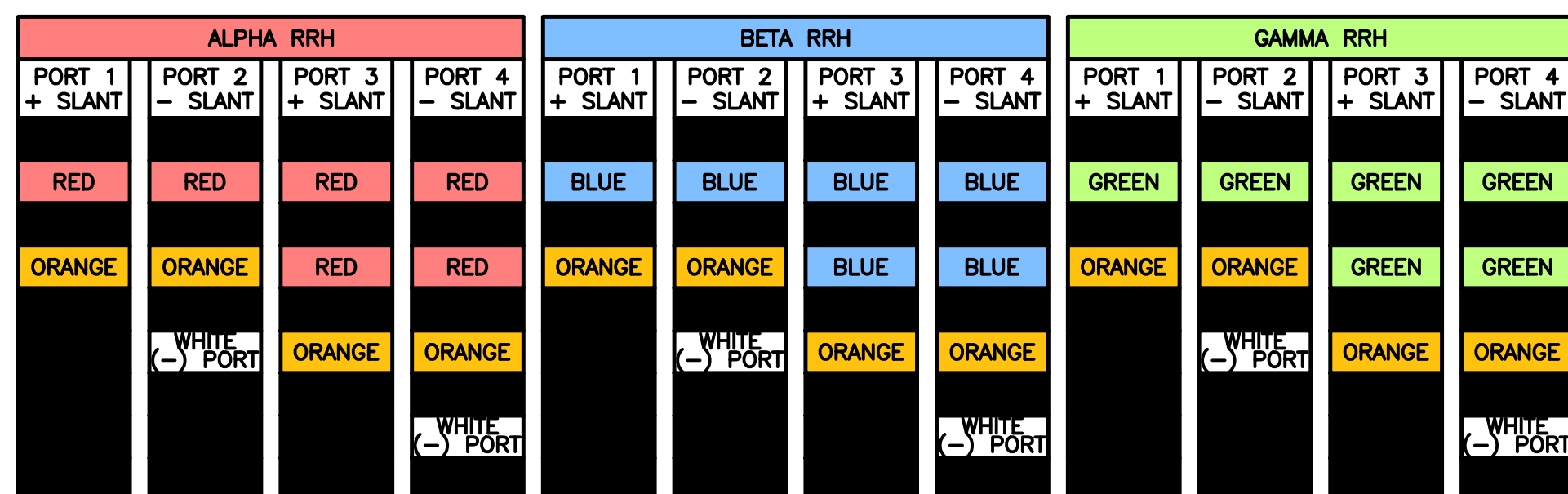

MID-BAND RRH
(AWS BANDS N66+N70)
ADD FREQUENCY COLOR TO SECTOR BAND
(CBRS WILL USE YELLOW BANDS)

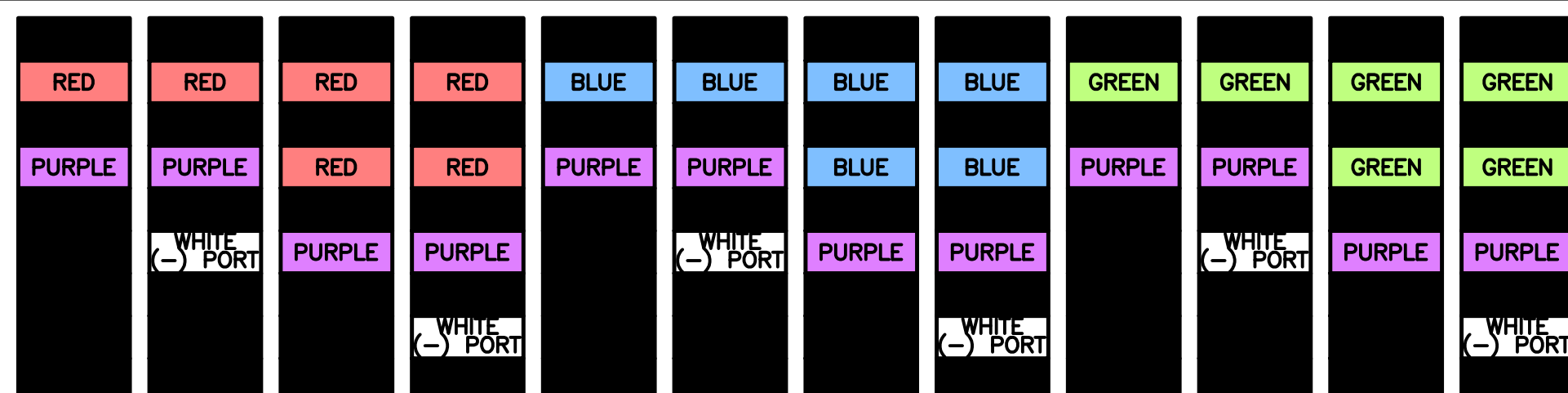

HYBRID/DISCREET CABLES

INCLUDE SECTOR BANDS BEING SUPPORTED
ALONG WITH FREQUENCY BANDS.
EXAMPLE 1 - HYBRID, OR DISCREET, SUPPORTS
ALL SECTORS, BOTH LOW-BANDS AND
MID-BANDS.
EXAMPLE 2 - HYBRID, OR DISCREET, SUPPORTS
CBRS ONLY, ALL SECTORS.
EXAMPLE 3 - MAIN COAX WITH GROUND
MOUNTED RRHS.

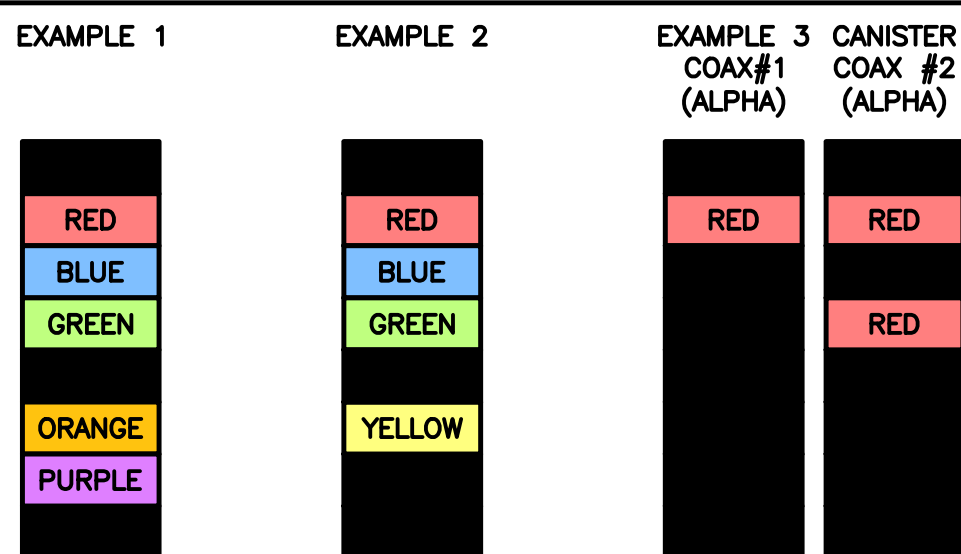

FIBER JUMPERS TO RRHS

LOW-BAND HHR FIBER CABLES HAVE SECTOR
STRIPE ONLY.

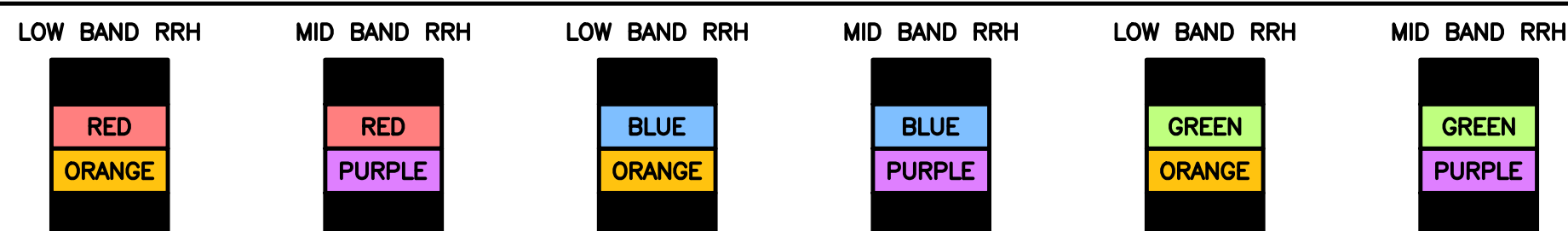

POWER CABLES TO RRHS

LOW-BAND RRH POWER CABLES HAVE SECTOR
STRIPE ONLY.

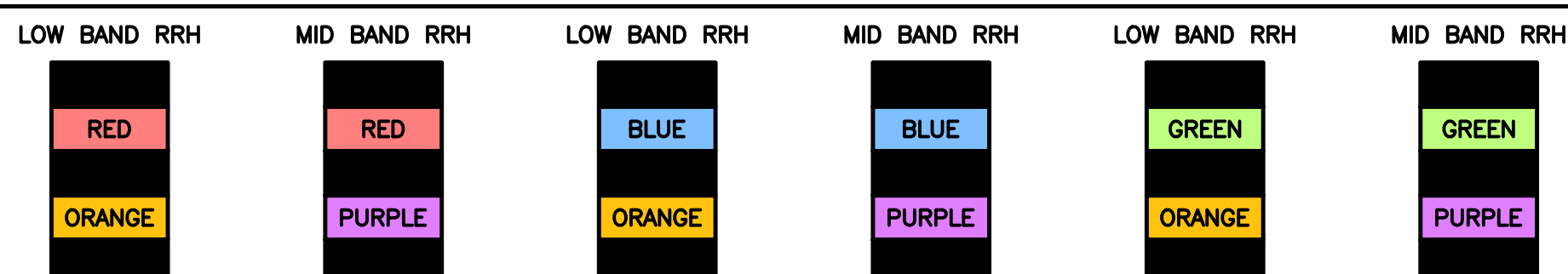

RET MOTORS AT ANTENNAS

RET CONTROL IS HANDLED BY THE MID-BAND
RRH WHEN ONE SET OF RET PORTS EXIST ON
ANTENNA.
SEPARATE RET CABLES ARE USED WHEN
ANTENNA PORTS PROVIDE INPUTS FOR BOTH
LOW AND MID BANDS.

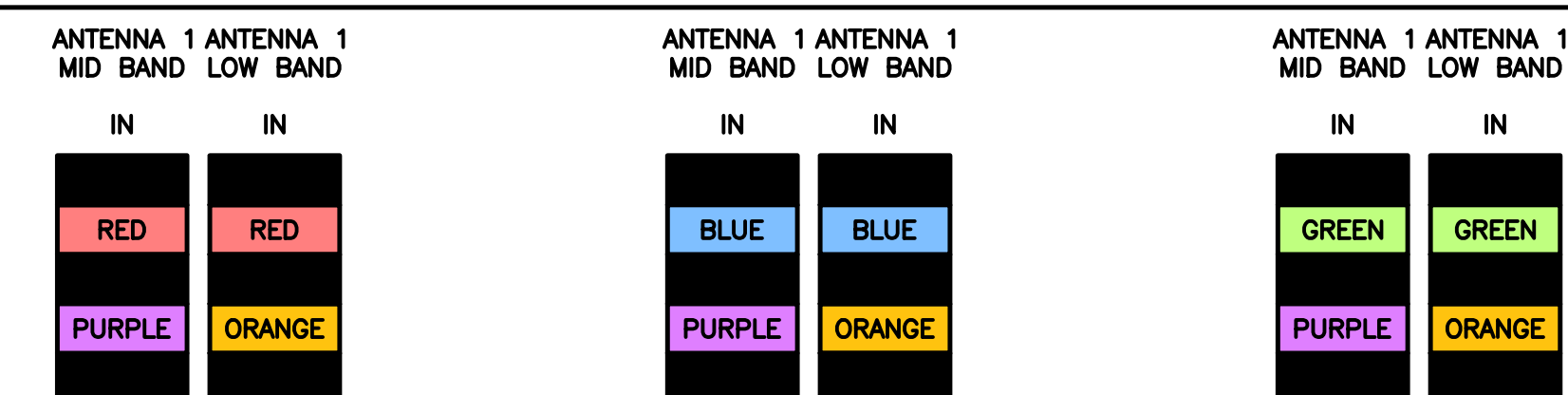

MICROWAVE RADIO LINKS

LINKS WILL HAVE A 1.5-2 INCH WHITE WRAP
WITH THE AZIMUTH COLOR OVERLAPPING IN THE
MIDDLE.
ADD ADDITIONAL SECTOR COLOR BANDS FOR
EACH ADDITIONAL MW RADIO.
MICROWAVE CABLES WILL REQUIRE P-TOUCH
LABELS INSIDE THE CABINET TO IDENTIFY THE
LOCAL AND REMOTE SITE ID'S.

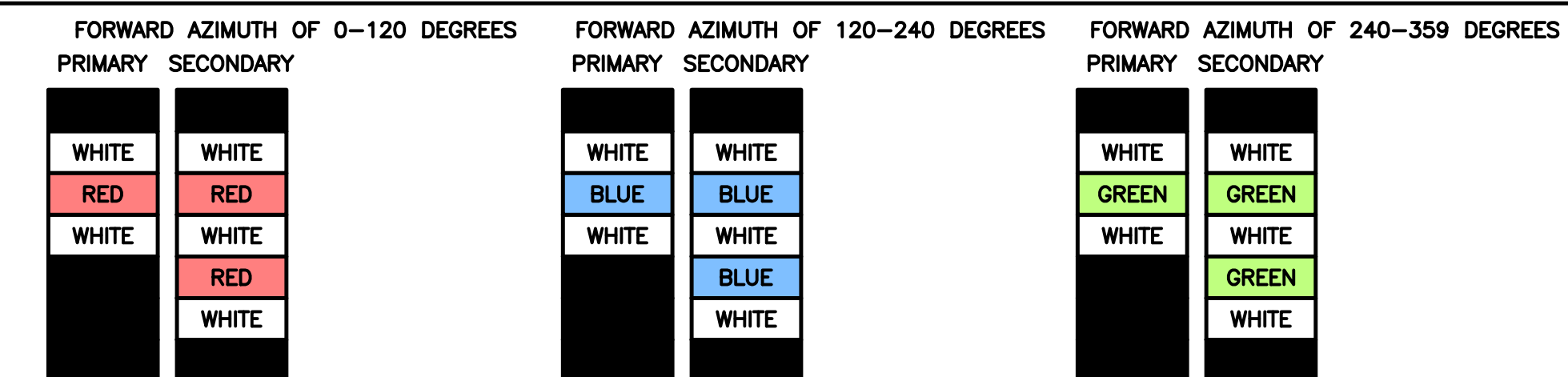

RF CABLE COLOR CODES

NO SCALE

1

NOT USED

NO SCALE

4

LOW BANDS (N71+N26)
OPTIONAL - (N29)



AWS
(N66+N70+H-BLOCK)



CBRS TECH
(3 GHz)

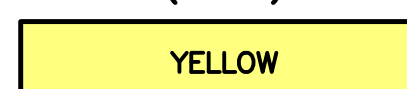

NEGATIVE SLANT PORT
ON ANT/RRH



ALPHA SECTOR



BETA SECTOR



GAMMA SECTOR



COLOR IDENTIFIER

NO SCALE

2

NOT USED

NO SCALE

3

dish
wireless.

5701 SOUTH SANTA FE DRIVE
LITTLETON, CO 80120

HG
HUDSON
Design Group LLC

45 BEECHWOOD DRIVE TEL: (978) 557-5553
N. ANDOVER, MA 01845 FAX: (978) 336-5586

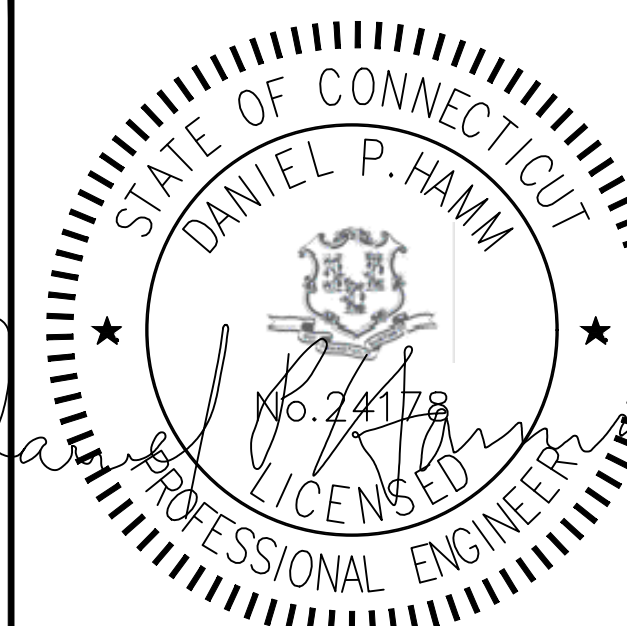

IT IS A VIOLATION OF LAW FOR ANY PERSON,
UNLESS THEY ARE ACTING UNDER THE DIRECTION
OF A LICENSED PROFESSIONAL ENGINEER,
TO ALTER THIS DOCUMENT.

DRAWN BY: CHECKED BY: APPROVED BY:
MRK SMA DPH

RFDS REV #: 4

**PRELIMINARY
DOCUMENT**

SUBMITTALS		
REV	DATE	DESCRIPTION
A	11/16/2021	ISSUED FOR REVIEW
B	04/04/2022	ISSUED FOR REVIEW
C	06/06/2022	ISSUED FOR REVIEW

A&E PROJECT NUMBER
BOBOS01000A

DISH Wireless L.L.C.
PROJECT INFORMATION
BOBOS01000A
CROWN CASTLE BU#881533
75 ROBERTS ROAD
GROTON, CT 06340

SHEET TITLE
RF
CABLE COLOR CODES

SHEET NUMBER
RF-1

EXOTHERMIC CONNECTION
 MECHANICAL CONNECTION
 BUSS BAR INSULATOR
 CHEMICAL ELECTROLYTIC GROUNDING SYSTEM
 TEST CHEMICAL ELECTROLYTIC GROUNDING SYSTEM
 EXOTHERMIC WITH INSPECTION SLEEVE
 GROUNDING BAR
 GROUND ROD
 TEST GROUND ROD WITH INSPECTION SLEEVE
 SINGLE POLE SWITCH
 DUPLEX RECEPTACLE
 DUPLEX GFCI RECEPTACLE
 FLUORESCENT LIGHTING FIXTURE (2) TWO LAMPS 48-T8
 SMOKE DETECTION (DC)
 EMERGENCY LIGHTING (DC)
 SECURITY LIGHT W/PHOTOCELL LITHONIA ALXW
 LED-1-25A400/51K-SR4-120-PE-DBBTXD
 CHAIN LINK FENCE
 WOOD/WROUGHT IRON FENCE
 WALL STRUCTURE
 LEASE AREA
 PROPERTY LINE (PL)
 SETBACKS
 ICE BRIDGE
 CABLE TRAY
 WATER LINE
 UNDERGROUND POWER
 UNDERGROUND TELCO
 OVERHEAD POWER
 OVERHEAD TELCO
 UNDERGROUND TELCO/POWER
 ABOVE GROUND POWER
 ABOVE GROUND TELCO
 ABOVE GROUND TELCO/POWER
 WORKPOINT

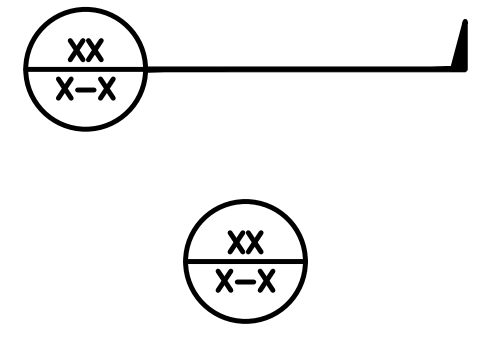
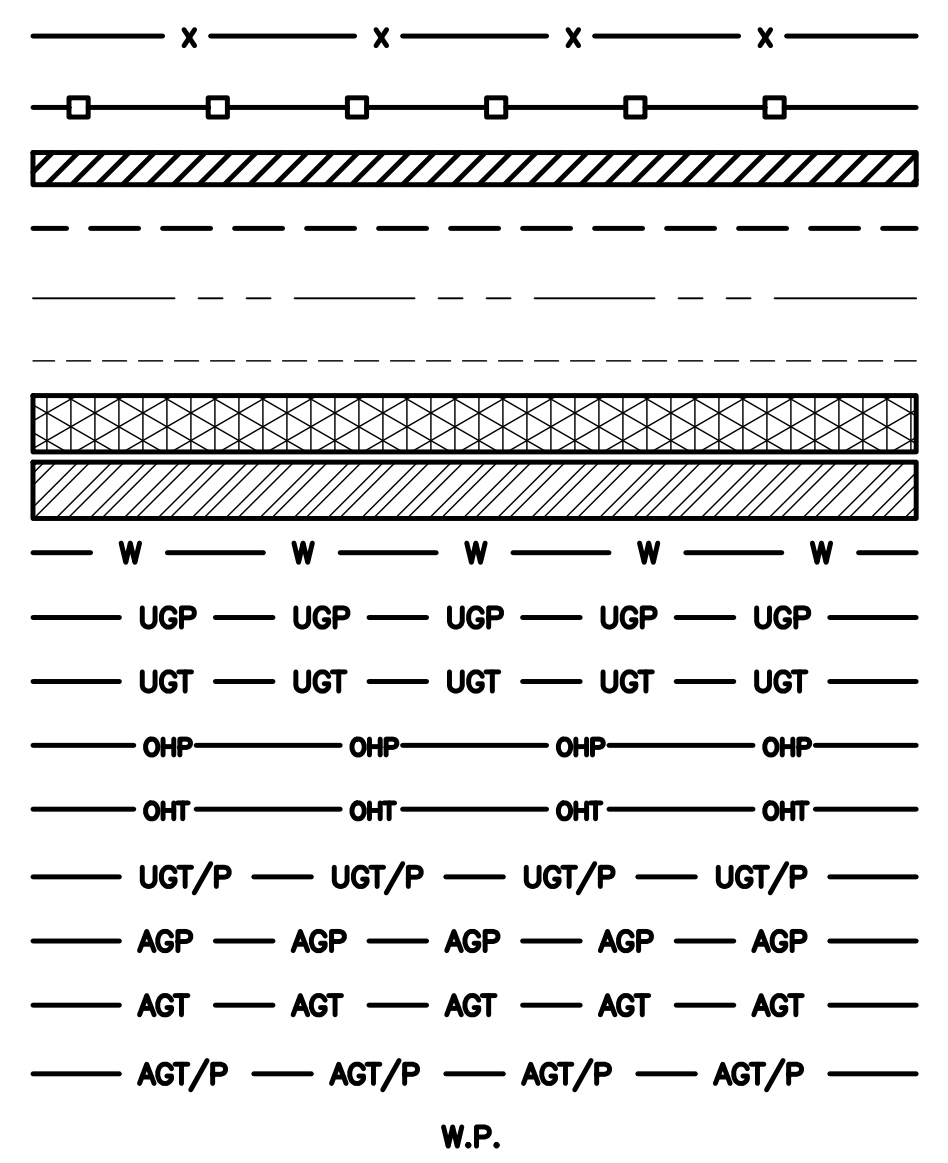
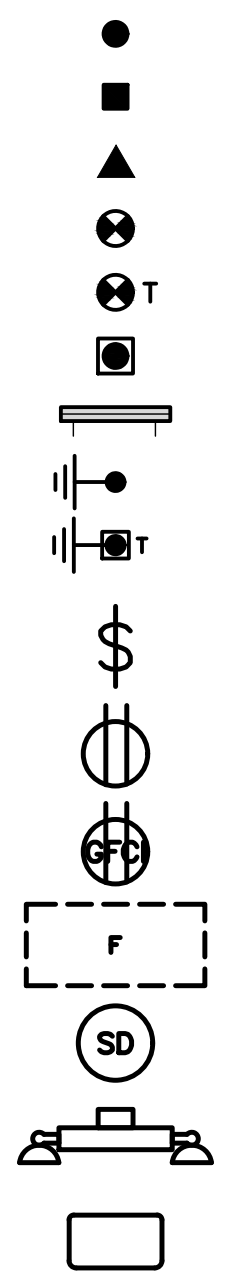

SECTION REFERENCE
 DETAIL REFERENCE

LEGEND

AB	ANCHOR BOLT	IN	INCH
ABV	ABOVE	INT	INTERIOR
AC	ALTERNATING CURRENT	LB(S)	POUND(S)
ADDL	ADDITIONAL	LF	LINEAR FEET
AFF	ABOVE FINISHED FLOOR	LTE	LONG TERM EVOLUTION
AFG	ABOVE FINISHED GRADE	MAS	MASONRY
AGL	ABOVE GROUND LEVEL	MAX	MAXIMUM
AIC	AMPERAGE INTERRUPTION CAPACITY	MB	MACHINE BOLT
ALUM	ALUMINUM	MECH	MECHANICAL
ALT	ALTERNATE	MFR	MANUFACTURER
ANT	ANTENNA	MGB	MASTER GROUND BAR
APPROX	APPROXIMATE	MIN	MINIMUM
ARCH	ARCHITECTURAL	MISC	MISCELLANEOUS
ATS	AUTOMATIC TRANSFER SWITCH	MTL	METAL
AWG	AMERICAN WIRE GAUGE	MTS	MANUAL TRANSFER SWITCH
BATT	BATTERY	MW	MICROWAVE
BLDG	BUILDING	NEC	NATIONAL ELECTRIC CODE
BLK	BLOCK	NM	NEWTON METERS
BLKG	BLOCKING	NO.	NUMBER
BM	BEAM	#	NUMBER
BTC	BARE TINNED COPPER CONDUCTOR	NTS	NOT TO SCALE
BOF	BOTTOM OF FOOTING	OC	ON-CENTER
CAB	CABINET	OSHA	OCCUPATIONAL SAFETY AND HEALTH ADMINISTRATION
CANT	CANTILEVERED	OPNG	OPENING
CHG	CHARGING	P/C	PRECAST CONCRETE
CLG	CEILING	PCS	PERSONAL COMMUNICATION SERVICES
CLR	CLEAR	PCU	PRIMARY CONTROL UNIT
COL	COLUMN	PRC	PRIMARY RADIO CABINET
COMM	COMMON	PP	POLARIZING PRESERVING
CONC	CONCRETE	PSF	POUNDS PER SQUARE FOOT
CONSTR	CONSTRUCTION	PSI	POUNDS PER SQUARE INCH
DBL	DOUBLE	PT	PRESSURE TREATED
DC	DIRECT CURRENT	PWR	POWER CABINET
DEPT	DEPARTMENT	QTY	QUANTITY
DF	DOUGLAS FIR	RAD	RADIUS
DIA	DIAMETER	RECT	RECTIFIER
DIAG	DIAGONAL	REF	REFERENCE
DIM	DIMENSION	REINF	REINFORCEMENT
DWG	DRAWING	REQ'D	REQUIRED
DWL	DOWEL	RET	REMOTE ELECTRIC TILT
EA	EACH	RF	RADIO FREQUENCY
EC	ELECTRICAL CONDUCTOR	RMC	RIGID METALLIC CONDUIT
EL	ELEVATION	RRH	REMOTE RADIO HEAD
ELEC	ELECTRICAL	RRU	REMOTE RADIO UNIT
EMT	ELECTRICAL METALLIC TUBING	RWY	RACEWAY
ENG	ENGINEER	SCH	SCHEDULE
EQ	EQUAL	SHT	SHEET
EXP	EXPANSION	SIAD	SMART INTEGRATED ACCESS DEVICE
EXT	EXTERIOR	SIM	SIMILAR
EW	EACH WAY	SPEC	SPECIFICATION
FAB	FABRICATION	SQ	SQUARE
FF	FINISH FLOOR	SS	STAINLESS STEEL
FG	FINISH GRADE	STD	STANDARD
FIF	FACILITY INTERFACE FRAME	STL	STEEL
FIN	FINISH(ED)	TEMP	TEMPORARY
FLR	FLOOR	THK	THICKNESS
FDN	FOUNDATION	TMA	TOWER MOUNTED AMPLIFIER
FOC	FACE OF CONCRETE	TN	TOE NAIL
FOM	FACE OF MASONRY	TOA	TOP OF ANTENNA
FOS	FACE OF STUD	TOC	TOP OF CURB
FOW	FACE OF WALL	TOF	TOP OF FOUNDATION
FS	FINISH SURFACE	TOP	TOP OF PLATE (PARAPET)
FT	FOOT	TOS	TOP OF STEEL
FTG	FOOTING	TOW	TOP OF WALL
GA	GAUGE	TVSS	TRANSIENT VOLTAGE SURGE SUPPRESSION
GEN	GENERATOR	TYP	TYPICAL
GFCI	GROUND FAULT CIRCUIT INTERRUPTER	UG	UNDERGROUND
GLB	GLUE LAMINATED BEAM	UL	UNDERWRITERS LABORATORY
GLV	GALVANIZED	UNO	UNLESS NOTED OTHERWISE
GPS	GLOBAL POSITIONING SYSTEM	UMTS	UNIVERSAL MOBILE TELECOMMUNICATIONS SYSTEM
GND	GROUND	UPS	UNINTERRUPTIBLE POWER SYSTEM (DC POWER PLANT)
GSM	GLOBAL SYSTEM FOR MOBILE	VIF	VERIFIED IN FIELD
HDG	HOT DIPPED GALVANIZED	W	WIDE
HDR	HEADER	W/	WITH
HGR	HANGER	WD	WOOD
HVAC	HEAT/VENTILATION/AIR CONDITIONING	WP	WEATHERPROOF
HT	HEIGHT	WT	WEIGHT
IGR	INTERIOR GROUND RING		

ABBREVIATIONS



5701 SOUTH SANTA FE DRIVE
 LITTLETON, CO 80120



45 BEECHWOOD DRIVE N. ANDOVER, MA 01845 TEL: (978) 557-5553 FAX: (978) 336-5586

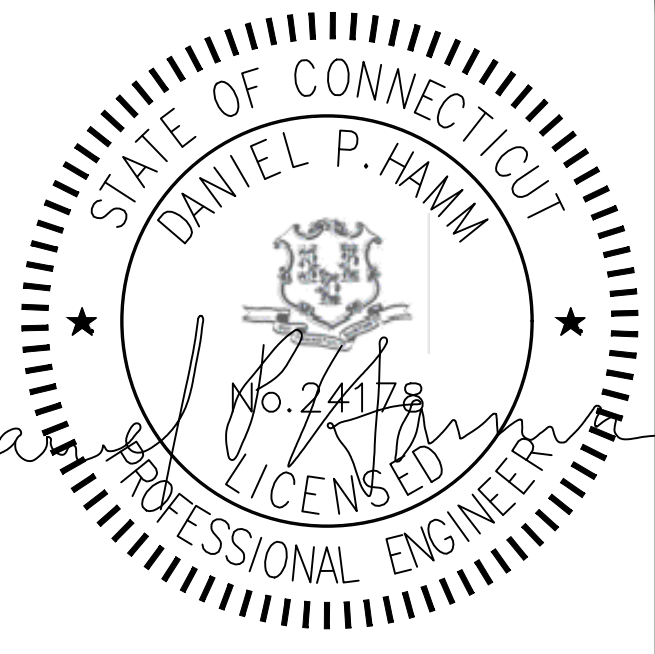

IT IS A VIOLATION OF LAW FOR ANY PERSON, UNLESS THEY ARE ACTING UNDER THE DIRECTION OF A LICENSED PROFESSIONAL ENGINEER, TO ALTER THIS DOCUMENT.

DRAWN BY: MRK CHECKED BY: SMA APPROVED BY: DPH

RFDS REV #: 4

PRELIMINARY DOCUMENT

SUBMITTALS		
REV	DATE	DESCRIPTION
A	11/16/2021	ISSUED FOR REVIEW
B	04/04/2022	ISSUED FOR REVIEW
C	06/06/2022	ISSUED FOR REVIEW

A&E PROJECT NUMBER
 BOBOS01000A

DISH Wireless L.L.C.
 PROJECT INFORMATION
 BOBOS01000A
 CROWN CASTLE BU#881533
 75 ROBERTS ROAD
 GROTON, CT 06340

SHEET TITLE
 LEGEND AND ABBREVIATIONS

SHEET NUMBER
GN-1

SITE ACTIVITY REQUIREMENTS:

1. NOTICE TO PROCEED – NO WORK SHALL COMMENCE PRIOR TO CONTRACTOR RECEIVING A WRITTEN NOTICE TO PROCEED (NTP) AND THE ISSUANCE OF A PURCHASE ORDER. PRIOR TO ACCESSING/ENTERING THE SITE YOU MUST CONTACT THE DISH Wireless L.L.C. AND TOWER OWNER NOC & THE DISH Wireless L.L.C. AND TOWER OWNER CONSTRUCTION MANAGER.
2. "LOOK UP" – DISH Wireless L.L.C. AND TOWER OWNER SAFETY CLIMB REQUIREMENT:
THE INTEGRITY OF THE SAFETY CLIMB AND ALL COMPONENTS OF THE CLIMBING FACILITY SHALL BE CONSIDERED DURING ALL STAGES OF DESIGN, INSTALLATION, AND INSPECTION. TOWER MODIFICATION, MOUNT REINFORCEMENTS, AND/OR EQUIPMENT INSTALLATIONS SHALL NOT COMPROMISE THE INTEGRITY OR FUNCTIONAL USE OF THE SAFETY CLIMB OR ANY COMPONENTS OF THE CLIMBING FACILITY ON THE STRUCTURE. THIS SHALL INCLUDE, BUT NOT BE LIMITED TO: PINCHING OF THE WIRE ROPE, BENDING OF THE WIRE ROPE FROM ITS SUPPORTS, DIRECT CONTACT OR CLOSE PROXIMITY TO THE WIRE ROPE WHICH MAY CAUSE FRICTIONAL WEAR, IMPACT TO THE ANCHORAGE POINTS IN ANY WAY, OR TO IMPEDE/BLOCK ITS INTENDED USE. ANY COMPROMISED SAFETY CLIMB, INCLUDING EXISTING CONDITIONS MUST BE TAGGED OUT AND REPORTED TO YOUR DISH Wireless L.L.C. AND DISH Wireless L.L.C. AND TOWER OWNER POC OR CALL THE NOC TO GENERATE A SAFETY CLIMB MAINTENANCE AND CONTRACTOR NOTICE TICKET.
3. PRIOR TO THE START OF CONSTRUCTION, ALL REQUIRED JURISDICTIONAL PERMITS SHALL BE OBTAINED. THIS INCLUDES, BUT IS NOT LIMITED TO, BUILDING, ELECTRICAL, MECHANICAL, FIRE, FLOOD ZONE, ENVIRONMENTAL, AND ZONING. AFTER ONSITE ACTIVITIES AND CONSTRUCTION ARE COMPLETED, ALL REQUIRED PERMITS SHALL BE SATISFIED AND CLOSED OUT ACCORDING TO LOCAL JURISDICTIONAL REQUIREMENTS.
4. ALL CONSTRUCTION MEANS AND METHODS; INCLUDING BUT NOT LIMITED TO, ERECTION PLANS, RIGGING PLANS, CLIMBING PLANS, AND RESCUE PLANS SHALL BE THE RESPONSIBILITY OF THE GENERAL CONTRACTOR RESPONSIBLE FOR THE EXECUTION OF THE WORK CONTAINED HEREIN, AND SHALL MEET ANSI/ASSE A10.48 (LATEST EDITION); FEDERAL, STATE, AND LOCAL REGULATIONS; AND ANY APPLICABLE INDUSTRY CONSENSUS STANDARDS RELATED TO THE CONSTRUCTION ACTIVITIES BEING PERFORMED. ALL RIGGING PLANS SHALL ADHERE TO ANSI/ASSE A10.48 (LATEST EDITION) AND DISH Wireless L.L.C. AND TOWER OWNER STANDARDS, INCLUDING THE REQUIRED INVOLVEMENT OF A QUALIFIED ENGINEER FOR CLASS IV CONSTRUCTION, TO CERTIFY THE SUPPORTING STRUCTURE(S) IN ACCORDANCE WITH ANSI/TIA-322 (LATEST EDITION).
5. ALL SITE WORK TO COMPLY WITH DISH Wireless L.L.C. AND TOWER OWNER INSTALLATION STANDARDS FOR CONSTRUCTION ACTIVITIES ON DISH Wireless L.L.C. AND TOWER OWNER TOWER SITE AND LATEST VERSION OF ANSI/TIA-1019-A-2012 "STANDARD FOR INSTALLATION, ALTERATION, AND MAINTENANCE OF ANTENNA SUPPORTING STRUCTURES AND ANTENNAS."
6. IF THE SPECIFIED EQUIPMENT CAN NOT BE INSTALLED AS SHOWN ON THESE DRAWINGS, THE CONTRACTOR SHALL PROPOSE AN ALTERNATIVE INSTALLATION FOR APPROVAL BY DISH Wireless L.L.C. AND TOWER OWNER PRIOR TO PROCEEDING WITH ANY SUCH CHANGE OF INSTALLATION.
7. ALL MATERIALS FURNISHED AND INSTALLED SHALL BE IN STRICT ACCORDANCE WITH ALL APPLICABLE CODES, REGULATIONS AND ORDINANCES. CONTRACTOR SHALL ISSUE ALL APPROPRIATE NOTICES AND COMPLY WITH ALL LAWS, ORDINANCES, RULES, REGULATIONS AND LAWFUL ORDERS OF ANY PUBLIC AUTHORITY REGARDING THE PERFORMANCE OF THE WORK. ALL WORK CARRIED OUT SHALL COMPLY WITH ALL APPLICABLE MUNICIPAL AND UTILITY COMPANY SPECIFICATIONS AND LOCAL JURISDICTIONAL CODES, ORDINANCES AND APPLICABLE REGULATIONS.
8. THE CONTRACTOR SHALL INSTALL ALL EQUIPMENT AND MATERIALS IN ACCORDANCE WITH MANUFACTURER'S RECOMMENDATIONS UNLESS SPECIFICALLY STATED OTHERWISE.
9. THE CONTRACTOR SHALL CONTACT UTILITY LOCATING SERVICES INCLUDING PRIVATE LOCATES SERVICES PRIOR TO THE START OF CONSTRUCTION.
10. ALL EXISTING ACTIVE SEWER, WATER, GAS, ELECTRIC AND OTHER UTILITIES WHERE ENCOUNTERED IN THE WORK, SHALL BE PROTECTED AT ALL TIMES AND WHERE REQUIRED FOR THE PROPER EXECUTION OF THE WORK, SHALL BE RELOCATED AS DIRECTED BY CONTRACTOR. EXTREME CAUTION SHOULD BE USED BY THE CONTRACTOR WHEN EXCAVATING OR DRILLING PIERS AROUND OR NEAR UTILITIES. CONTRACTOR SHALL PROVIDE SAFETY TRAINING FOR THE WORKING CREW. THIS WILL INCLUDE BUT NOT BE LIMITED TO A) FALL PROTECTION B) CONFINED SPACE C) ELECTRICAL SAFETY D) TRENCHING AND EXCAVATION E) CONSTRUCTION SAFETY PROCEDURES.
11. ALL SITE WORK SHALL BE AS INDICATED ON THE STAMPED CONSTRUCTION DRAWINGS AND DISH PROJECT SPECIFICATIONS, LATEST APPROVED REVISION.
12. CONTRACTOR SHALL KEEP THE SITE FREE FROM ACCUMULATING WASTE MATERIAL, DEBRIS, AND TRASH AT THE COMPLETION OF THE WORK. IF NECESSARY, RUBBISH, STUMPS, DEBRIS, STICKS, STONES AND OTHER REFUSE SHALL BE REMOVED FROM THE SITE AND DISPOSED OF LEGALLY.
13. ALL EXISTING INACTIVE SEWER, WATER, GAS, ELECTRIC AND OTHER UTILITIES, WHICH INTERFERE WITH THE EXECUTION OF THE WORK, SHALL BE REMOVED AND/OR CAPPED, PLUGGED OR OTHERWISE DISCONTINUED AT POINTS WHICH WILL NOT INTERFERE WITH THE EXECUTION OF THE WORK, SUBJECT TO THE APPROVAL OF DISH Wireless L.L.C. AND TOWER OWNER, AND/OR LOCAL UTILITIES.
14. THE CONTRACTOR SHALL PROVIDE SITE SIGNAGE IN ACCORDANCE WITH THE TECHNICAL SPECIFICATION FOR SITE SIGNAGE REQUIRED BY LOCAL JURISDICTION AND SIGNAGE REQUIRED ON INDIVIDUAL PIECES OF EQUIPMENT, ROOMS, AND SHELTERS.
15. THE SITE SHALL BE GRADED TO CAUSE SURFACE WATER TO FLOW AWAY FROM THE CARRIER'S EQUIPMENT AND TOWER AREAS.
16. THE SUB GRADE SHALL BE COMPACTED AND BROUGHT TO A SMOOTH UNIFORM GRADE PRIOR TO FINISHED SURFACE APPLICATION.
17. THE AREAS OF THE OWNERS PROPERTY DISTURBED BY THE WORK AND NOT COVERED BY THE TOWER, EQUIPMENT OR DRIVEWAY, SHALL BE GRADED TO A UNIFORM SLOPE, AND STABILIZED TO PREVENT EROSION AS SPECIFIED ON THE CONSTRUCTION DRAWINGS AND/OR PROJECT SPECIFICATIONS.
18. CONTRACTOR SHALL MINIMIZE DISTURBANCE TO EXISTING SITE DURING CONSTRUCTION. EROSION CONTROL MEASURES, IF REQUIRED DURING CONSTRUCTION, SHALL BE IN CONFORMANCE WITH THE LOCAL GUIDELINES FOR EROSION AND SEDIMENT CONTROL.
19. THE CONTRACTOR SHALL PROTECT EXISTING IMPROVEMENTS, PAVEMENTS, CURBS, LANDSCAPING AND STRUCTURES. ANY DAMAGED PART SHALL BE REPAIRED AT CONTRACTOR'S EXPENSE TO THE SATISFACTION OF OWNER.
20. CONTRACTOR SHALL LEGALLY AND PROPERLY DISPOSE OF ALL SCRAP MATERIALS SUCH AS COAXIAL CABLES AND OTHER ITEMS REMOVED FROM THE EXISTING FACILITY. ANTENNAS AND RADIOS REMOVED SHALL BE RETURNED TO THE OWNER'S DESIGNATED LOCATION.
21. CONTRACTOR SHALL LEAVE PREMISES IN CLEAN CONDITION. TRASH AND DEBRIS SHOULD BE REMOVED FROM SITE ON A DAILY BASIS.
22. NO FILL OR EMBANKMENT MATERIAL SHALL BE PLACED ON FROZEN GROUND. FROZEN MATERIALS, SNOW OR ICE SHALL NOT BE PLACED IN ANY FILL OR EMBANKMENT.

GENERAL NOTES:

- 1.FOR THE PURPOSE OF CONSTRUCTION DRAWING, THE FOLLOWING DEFINITIONS SHALL APPLY:
CONTRACTOR:GENERAL CONTRACTOR RESPONSIBLE FOR CONSTRUCTION
CARRIER:DISH Wireless L.L.C.
TOWER OWNER:TOWER OWNER
2. THESE DRAWINGS HAVE BEEN PREPARED USING STANDARDS OF PROFESSIONAL CARE AND COMPLETENESS NORMALLY EXERCISED UNDER SIMILAR CIRCUMSTANCES BY REPUTABLE ENGINEERS IN THIS OR SIMILAR LOCALITIES. IT IS ASSUMED THAT THE WORK DEPICTED WILL BE PERFORMED BY AN EXPERIENCED CONTRACTOR AND/OR WORKPEOPLE WHO HAVE A WORKING KNOWLEDGE OF THE APPLICABLE CODE STANDARDS AND REQUIREMENTS AND OF INDUSTRY ACCEPTED STANDARD GOOD PRACTICE. AS NOT EVERY CONDITION OR ELEMENT IS (OR CAN BE) EXPLICITLY SHOWN ON THESE DRAWINGS, THE CONTRACTOR SHALL USE INDUSTRY ACCEPTED STANDARD GOOD PRACTICE FOR MISCELLANEOUS WORK NOT EXPLICITLY SHOWN.
3. THESE DRAWINGS REPRESENT THE FINISHED STRUCTURE. THEY DO NOT INDICATE THE MEANS OR METHODS OF CONSTRUCTION. THE CONTRACTOR SHALL BE SOLELY RESPONSIBLE FOR THE CONSTRUCTION MEANS, METHODS, TECHNIQUES, SEQUENCES, AND PROCEDURES. THE CONTRACTOR SHALL PROVIDE ALL MEASURES NECESSARY FOR PROTECTION OF LIFE AND PROPERTY DURING CONSTRUCTION. SUCH MEASURES SHALL INCLUDE, BUT NOT BE LIMITED TO, BRACING, FORMWORK, SHORING, ETC. SITE VISITS BY THE ENGINEER OR HIS REPRESENTATIVE WILL NOT INCLUDE INSPECTION OF THESE ITEMS AND IS FOR STRUCTURAL OBSERVATION OF THE FINISHED STRUCTURE ONLY.
4. NOTES AND DETAILS IN THE CONSTRUCTION DRAWINGS SHALL TAKE PRECEDENCE OVER GENERAL NOTES AND TYPICAL DETAILS. WHERE NO DETAILS ARE SHOWN, CONSTRUCTION SHALL CONFORM TO SIMILAR WORK ON THE PROJECT, AND/OR AS PROVIDED FOR IN THE CONTRACT DOCUMENTS. WHERE DISCREPANCIES OCCUR BETWEEN PLANS, DETAILS, GENERAL NOTES, AND SPECIFICATIONS, THE GREATER, MORE STRICT REQUIREMENTS, SHALL GOVERN. IF FURTHER CLARIFICATION IS REQUIRED CONTACT THE ENGINEER OF RECORD.
5. SUBSTANTIAL EFFORT HAS BEEN MADE TO PROVIDE ACCURATE DIMENSIONS AND MEASUREMENTS ON THE DRAWINGS TO ASSIST IN THE FABRICATION AND/OR PLACEMENT OF CONSTRUCTION ELEMENTS BUT IT IS THE SOLE RESPONSIBILITY OF THE CONTRACTOR TO FIELD VERIFY THE DIMENSIONS, MEASUREMENTS, AND/OR CLEARANCES SHOWN IN THE CONSTRUCTION DRAWINGS PRIOR TO FABRICATION OR CUTTING OF ANY NEW OR EXISTING CONSTRUCTION ELEMENTS. IF IT IS DETERMINED THAT THERE ARE DISCREPANCIES AND/OR CONFLICTS WITH THE CONSTRUCTION DRAWINGS THE ENGINEER OF RECORD IS TO BE NOTIFIED AS SOON AS POSSIBLE.
6. PRIOR TO THE SUBMISSION OF BIDS, THE BIDDING CONTRACTOR SHALL VISIT THE CELL SITE TO FAMILIARIZE WITH THE EXISTING CONDITIONS AND TO CONFIRM THAT THE WORK CAN BE ACCOMPLISHED AS SHOWN ON THE CONSTRUCTION DRAWINGS. ANY DISCREPANCY FOUND SHALL BE BROUGHT TO THE ATTENTION OF CARRIER POC AND TOWER OWNER.
7. ALL MATERIALS FURNISHED AND INSTALLED SHALL BE IN STRICT ACCORDANCE WITH ALL APPLICABLE CODES, REGULATIONS AND ORDINANCES. CONTRACTOR SHALL ISSUE ALL APPROPRIATE NOTICES AND COMPLY WITH ALL LAWS, ORDINANCES, RULES, REGULATIONS AND LAWFUL ORDERS OF ANY PUBLIC AUTHORITY REGARDING THE PERFORMANCE OF THE WORK. ALL WORK CARRIED OUT SHALL COMPLY WITH ALL APPLICABLE MUNICIPAL AND UTILITY COMPANY SPECIFICATIONS AND LOCAL JURISDICTIONAL CODES, ORDINANCES AND APPLICABLE REGULATIONS.
8. UNLESS NOTED OTHERWISE, THE WORK SHALL INCLUDE FURNISHING MATERIALS, EQUIPMENT, APPURTENANCES AND LABOR NECESSARY TO COMPLETE ALL INSTALLATIONS AS INDICATED ON THE DRAWINGS.
9. THE CONTRACTOR SHALL INSTALL ALL EQUIPMENT AND MATERIALS IN ACCORDANCE WITH MANUFACTURER'S RECOMMENDATIONS UNLESS SPECIFICALLY STATED OTHERWISE.
10. IF THE SPECIFIED EQUIPMENT CAN NOT BE INSTALLED AS SHOWN ON THESE DRAWINGS, THE CONTRACTOR SHALL PROPOSE AN ALTERNATIVE INSTALLATION FOR APPROVAL BY THE CARRIER AND TOWER OWNER PRIOR TO PROCEEDING WITH ANY SUCH CHANGE OF INSTALLATION.
11. CONTRACTOR IS TO PERFORM A SITE INVESTIGATION, BEFORE SUBMITTING BIDS, TO DETERMINE THE BEST ROUTING OF ALL CONDUITS FOR POWER, AND TELCO AND FOR GROUNDING CABLES AS SHOWN IN THE POWER, TELCO, AND GROUNDING PLAN DRAWINGS.
12. THE CONTRACTOR SHALL PROTECT EXISTING IMPROVEMENTS, PAVEMENTS, CURBS, LANDSCAPING AND STRUCTURES. ANY DAMAGED PART SHALL BE REPAIRED AT CONTRACTOR'S EXPENSE TO THE SATISFACTION OF DISH Wireless L.L.C. AND TOWER OWNER
13. CONTRACTOR SHALL LEGALLY AND PROPERLY DISPOSE OF ALL SCRAP MATERIALS SUCH AS COAXIAL CABLES AND OTHER ITEMS REMOVED FROM THE EXISTING FACILITY. ANTENNAS REMOVED SHALL BE RETURNED TO THE OWNER'S DESIGNATED LOCATION.
14. CONTRACTOR SHALL LEAVE PREMISES IN CLEAN CONDITION. TRASH AND DEBRIS SHOULD BE REMOVED FROM SITE ON A DAILY BASIS.



5701 SOUTH SANTA FE DRIVE
LITTLETON, CO 80120



45 BEECHWOOD DRIVE N. ANDOVER, MA 01845 TEL: (978) 557-5553 FAX: (978) 336-5586



IT IS A VIOLATION OF LAW FOR ANY PERSON, UNLESS THEY ARE ACTING UNDER THE DIRECTION OF A LICENSED PROFESSIONAL ENGINEER, TO ALTER THIS DOCUMENT.

DRAWN BY:	CHECKED BY:	APPROVED BY:
MRK	SMA	DPH

RFDS REV #: 4

PRELIMINARY DOCUMENT

SUBMITTALS		
REV	DATE	DESCRIPTION
A	11/16/2021	ISSUED FOR REVIEW
B	04/04/2022	ISSUED FOR REVIEW
C	06/06/2022	ISSUED FOR REVIEW

A&E PROJECT NUMBER
BOBOS01000A

DISH Wireless L.L.C.
PROJECT INFORMATION
BOBOS01000A
CROWN CASTLE BU#881533
75 ROBERTS ROAD
GROTON, CT 06340

SHEET TITLE
GENERAL NOTES

SHEET NUMBER
GN-2

CONCRETE, FOUNDATIONS, AND REINFORCING STEEL:

1. ALL CONCRETE WORK SHALL BE IN ACCORDANCE WITH THE ACI 301, ACI 318, ACI 336, ASTM A184, ASTM A185 AND THE DESIGN AND CONSTRUCTION SPECIFICATION FOR CAST-IN-PLACE CONCRETE.
2. UNLESS NOTED OTHERWISE, SOIL BEARING PRESSURE USED FOR DESIGN OF SLABS AND FOUNDATIONS IS ASSUMED TO BE 1000 psf.
3. ALL CONCRETE SHALL HAVE A MINIMUM COMPRESSIVE STRENGTH (f'c) OF 3000 psi AT 28 DAYS, UNLESS NOTED OTHERWISE. NO MORE THAN 90 MINUTES SHALL ELAPSE FROM BATCH TIME TO TIME OF PLACEMENT UNLESS APPROVED BY THE ENGINEER OF RECORD. TEMPERATURE OF CONCRETE SHALL NOT EXCEED 90°F AT TIME OF PLACEMENT.
4. CONCRETE EXPOSED TO FREEZE-THAW CYCLES SHALL CONTAIN AIR ENTRAINING ADMIXTURES. AMOUNT OF AIR ENTRAINMENT TO BE BASED ON SIZE OF AGGREGATE AND F3 CLASS EXPOSURE (VERY SEVERE). CEMENT USED TO BE TYPE II PORTLAND CEMENT WITH A MAXIMUM WATER-TO-CEMENT RATIO (W/C) OF 0.45.
5. ALL STEEL REINFORCING SHALL CONFORM TO ASTM A615. ALL WELDED WIRE FABRIC (WWF) SHALL CONFORM TO ASTM A185. ALL SPLICES SHALL BE CLASS "B" TENSION SPLICES, UNLESS NOTED OTHERWISE. ALL HOOKS SHALL BE STANDARD 90 DEGREE HOOKS, UNLESS NOTED OTHERWISE. YIELD STRENGTH (Fy) OF STANDARD DEFORMED BARS ARE AS FOLLOWS:
 - #4 BARS AND SMALLER 40 ksi
 - #5 BARS AND LARGER 60 ksi
6. THE FOLLOWING MINIMUM CONCRETE COVER SHALL BE PROVIDED FOR REINFORCING STEEL UNLESS SHOWN OTHERWISE ON DRAWINGS:
 - CONCRETE CAST AGAINST AND PERMANENTLY EXPOSED TO EARTH 3"
 - CONCRETE EXPOSED TO EARTH OR WEATHER:
 - #6 BARS AND LARGER 2"
 - #5 BARS AND SMALLER 1-1/2"
 - CONCRETE NOT EXPOSED TO EARTH OR WEATHER:
 - SLAB AND WALLS 3/4"
 - BEAMS AND COLUMNS 1-1/2"
7. A TOOLED EDGE OR A 3/4" CHAMFER SHALL BE PROVIDED AT ALL EXPOSED EDGES OF CONCRETE, UNLESS NOTED OTHERWISE, IN ACCORDANCE WITH ACI 301 SECTION 4.2.4.

ELECTRICAL INSTALLATION NOTES:

1. ALL ELECTRICAL WORK SHALL BE PERFORMED IN ACCORDANCE WITH THE PROJECT SPECIFICATIONS, NEC AND ALL APPLICABLE FEDERAL, STATE, AND LOCAL CODES/ORDINANCES.
2. CONDUIT ROUTINGS ARE SCHEMATIC. CONTRACTOR SHALL INSTALL CONDUITS SO THAT ACCESS TO EQUIPMENT IS NOT BLOCKED AND TRIP HAZARDS ARE ELIMINATED.
3. WIRING, RACEWAY AND SUPPORT METHODS AND MATERIALS SHALL COMPLY WITH THE REQUIREMENTS OF THE NEC.
4. ALL CIRCUITS SHALL BE SEGREGATED AND MAINTAIN MINIMUM CABLE SEPARATION AS REQUIRED BY THE NEC.
 - 4.1. ALL EQUIPMENT SHALL BEAR THE UNDERWRITERS LABORATORIES LABEL OF APPROVAL, AND SHALL CONFORM TO REQUIREMENT OF THE NATIONAL ELECTRICAL CODE.
 - 4.2. ALL OVERCURRENT DEVICES SHALL HAVE AN INTERRUPTING CURRENT RATING THAT SHALL BE GREATER THAN THE SHORT CIRCUIT CURRENT TO WHICH THEY ARE SUBJECTED, 22,000 AIC MINIMUM. VERIFY AVAILABLE SHORT CIRCUIT CURRENT DOES NOT EXCEED THE RATING OF ELECTRICAL EQUIPMENT IN ACCORDANCE WITH ARTICLE 110.24 NEC OR THE MOST CURRENT ADOPTED CODE PRE THE GOVERNING JURISDICTION.
5. EACH END OF EVERY POWER PHASE CONDUCTOR, GROUNDING CONDUCTOR, AND TELCO CONDUCTOR OR CABLE SHALL BE LABELED WITH COLOR-CODED INSULATION OR ELECTRICAL TAPE (3M BRAND, 1/2" PLASTIC ELECTRICAL TAPE WITH UV PROTECTION, OR EQUAL). THE IDENTIFICATION METHOD SHALL CONFORM WITH NEC AND OSHA.
6. ALL ELECTRICAL COMPONENTS SHALL BE CLEARLY LABELED WITH LAMICOID TAGS SHOWING THEIR RATED VOLTAGE, PHASE CONFIGURATION, WIRE CONFIGURATION, POWER OR AMPACITY RATING AND BRANCH CIRCUIT ID NUMBERS (i.e. PANEL BOARD AND CIRCUIT ID'S).
7. PANEL BOARDS (ID NUMBERS) SHALL BE CLEARLY LABELED WITH PLASTIC LABELS.
8. TIE WRAPS ARE NOT ALLOWED.
9. ALL POWER AND EQUIPMENT GROUND WIRING IN TUBING OR CONDUIT SHALL BE SINGLE COPPER CONDUCTOR (#14 OR LARGER) WITH TYPE THHW, THWN, THWN-2, XHHW, XHHW-2, THW, THW-2, RHW, OR RHW-2 INSULATION UNLESS OTHERWISE SPECIFIED.
10. SUPPLEMENTAL EQUIPMENT GROUND WIRING LOCATED INDOORS SHALL BE SINGLE COPPER CONDUCTOR (#6 OR LARGER) WITH TYPE THHW, THWN, THWN-2, XHHW, XHHW-2, THW, THW-2, RHW, OR RHW-2 INSULATION UNLESS OTHERWISE SPECIFIED.
11. POWER AND CONTROL WIRING IN FLEXIBLE CORD SHALL BE MULTI-CONDUCTOR, TYPE SOOW CORD (#14 OR LARGER) UNLESS OTHERWISE SPECIFIED.
12. POWER AND CONTROL WIRING FOR USE IN CABLE TRAY SHALL BE MULTI-CONDUCTOR, TYPE TC CABLE (#14 OR LARGER), WITH TYPE THHW, THWN, THWN-2, XHHW, XHHW-2, THW, THW-2, RHW, OR RHW-2 INSULATION UNLESS OTHERWISE SPECIFIED.
13. ALL POWER AND GROUNDING CONNECTIONS SHALL BE CRIMP-STYLE, COMPRESSION WIRE LUGS AND WIRE NUTS BY THOMAS AND BETTS (OR EQUAL). LUGS AND WIRE NUTS SHALL BE RATED FOR OPERATION NOT LESS THAN 75° C (90° C IF AVAILABLE).
14. RACEWAY AND CABLE TRAY SHALL BE LISTED OR LABELED FOR ELECTRICAL USE IN ACCORDANCE WITH NEMA, UL, ANSI/IEEE AND NEC.
15. ELECTRICAL METALLIC TUBING (EMT), INTERMEDIATE METAL CONDUIT (IMC), OR RIGID METAL CONDUIT (RMC) SHALL BE USED FOR EXPOSED INDOOR LOCATIONS.

16. ELECTRICAL METALLIC TUBING (EMT) OR METAL-CLAD CABLE (MC) SHALL BE USED FOR CONCEALED INDOOR LOCATIONS.
17. SCHEDULE 40 PVC UNDERGROUND ON STRAIGHTS AND SCHEDULE 80 PVC FOR ALL ELBOWS/90s AND ALL APPROVED ABOVE GRADE PVC CONDUIT.
18. LIQUID-TIGHT FLEXIBLE METALLIC CONDUIT (LIQUID-TITE FLEX) SHALL BE USED INDOORS AND OUTDOORS, WHERE VIBRATION OCCURS OR FLEXIBILITY IS NEEDED.
19. CONDUIT AND TUBING FITTINGS SHALL BE THREADED OR COMPRESSION-TYPE AND APPROVED FOR THE LOCATION USED. SET SCREW FITTINGS ARE NOT ACCEPTABLE.
20. CABINETS, BOXES AND WIRE WAYS SHALL BE LABELED FOR ELECTRICAL USE IN ACCORDANCE WITH NEMA, UL, ANSI/IEEE AND THE NEC.
21. WIREWAYS SHALL BE METAL WITH AN ENAMEL FINISH AND INCLUDE A HINGED COVER, DESIGNED TO SWING OPEN DOWNWARDS (WIREMOLD SPECMATE WIREWAY).
22. SLOTTED WIRING DUCT SHALL BE PVC AND INCLUDE COVER (PANDUIT TYPE E OR EQUAL).
23. CONDUITS SHALL BE FASTENED SECURELY IN PLACE WITH APPROVED NON-PERFORATED STRAPS AND HANGERS. EXPLOSIVE DEVICES (i.e. POWDER-ACTUATED) FOR ATTACHING HANGERS TO STRUCTURE WILL NOT BE PERMITTED. CLOSELY FOLLOW THE LINES OF THE STRUCTURE, MAINTAIN CLOSE PROXIMITY TO THE STRUCTURE AND KEEP CONDUITS IN TIGHT ENVELOPES. CHANGES IN DIRECTION TO ROUTE AROUND OBSTACLES SHALL BE MADE WITH CONDUIT OUTLET BODIES. CONDUIT SHALL BE INSTALLED IN A NEAT AND WORKMANLIKE MANNER. PARALLEL AND PERPENDICULAR TO STRUCTURE WALL AND CEILING LINES. ALL CONDUIT SHALL BE FISHED TO CLEAR OBSTRUCTIONS. ENDS OF CONDUITS SHALL BE TEMPORARILY CAPPED FLUSH TO FINISH GRADE TO PREVENT CONCRETE, PLASTER OR DIRT FROM ENTERING. CONDUITS SHALL BE RIGIDLY CLAMPED TO BOXES BY GALVANIZED MALLEABLE IRON BUSHING ON INSIDE AND GALVANIZED MALLEABLE IRON LOCKNUT ON OUTSIDE AND INSIDE.
24. EQUIPMENT CABINETS, TERMINAL BOXES, JUNCTION BOXES AND PULL BOXES SHALL BE GALVANIZED OR EPOXY-COATED SHEET STEEL SHALL MEET OR EXCEED UL 50 AND BE RATED NEMA 1 (OR BETTER) FOR INTERIOR LOCATIONS AND NEMA 3 (OR BETTER) FOR EXTERIOR LOCATIONS.
25. METAL RECEPTACLE, SWITCH AND DEVICE BOXES SHALL BE GALVANIZED, EPOXY-COATED OR NON-CORRODING; SHALL MEET OR EXCEED UL 514A AND NEMA OS 1 AND BE RATED NEMA 1 (OR BETTER) FOR INTERIOR LOCATIONS AND WEATHER PROTECTED (WP OR BETTER) FOR EXTERIOR LOCATIONS.
26. NONMETALLIC RECEPTACLE, SWITCH AND DEVICE BOXES SHALL MEET OR EXCEED NEMA OS 2 (NEWEST REVISION) AND BE RATED NEMA 1 (OR BETTER) FOR INTERIOR LOCATIONS AND WEATHER PROTECTED (WP OR BETTER) FOR EXTERIOR LOCATIONS.
27. THE CONTRACTOR SHALL NOTIFY AND OBTAIN NECESSARY AUTHORIZATION FROM THE CARRIER AND/OR DISH Wireless L.L.C. AND TOWER OWNER BEFORE COMMENCING WORK ON THE AC POWER DISTRIBUTION PANELS.
28. THE CONTRACTOR SHALL PROVIDE NECESSARY TAGGING ON THE BREAKERS, CABLES AND DISTRIBUTION PANELS IN ACCORDANCE WITH THE APPLICABLE CODES AND STANDARDS TO SAFEGUARD LIFE AND PROPERTY.
29. INSTALL LAMICOID LABEL ON THE METER CENTER TO SHOW "DISH Wireless L.L.C.".
30. ALL EMPTY/SPARE CONDUITS THAT ARE INSTALLED ARE TO HAVE A METERED MULE TAPE PULL CORD INSTALLED.



5701 SOUTH SANTA FE DRIVE
LITTLETON, CO 80120



45 BEECHWOOD DRIVE TEL: (978) 557-5553
N. ANDOVER, MA 01845 FAX: (978) 336-5586



IT IS A VIOLATION OF LAW FOR ANY PERSON, UNLESS THEY ARE ACTING UNDER THE DIRECTION OF A LICENSED PROFESSIONAL ENGINEER, TO ALTER THIS DOCUMENT.

DRAWN BY:	CHECKED BY:	APPROVED BY:
MRK	SMA	DPH

RFDS REV #: 4

PRELIMINARY DOCUMENT

SUBMITTALS		
REV	DATE	DESCRIPTION
A	11/16/2021	ISSUED FOR REVIEW
B	04/04/2022	ISSUED FOR REVIEW
C	06/06/2022	ISSUED FOR REVIEW

A&E PROJECT NUMBER
BOBOS01000A

DISH Wireless L.L.C.
PROJECT INFORMATION
BOBOS01000A
CROWN CASTLE BU#881533
75 ROBERTS ROAD
GROTON, CT 06340

SHEET TITLE
GENERAL NOTES

SHEET NUMBER
GN-3

GROUNDING NOTES:

1. ALL GROUND ELECTRODE SYSTEMS (INCLUDING TELECOMMUNICATION, RADIO, LIGHTNING PROTECTION AND AC POWER GES'S) SHALL BE BONDED TOGETHER AT OR BELOW GRADE, BY TWO OR MORE COPPER BONDING CONDUCTORS IN ACCORDANCE WITH THE NEC.
2. THE CONTRACTOR SHALL PERFORM IEEE FALL-OF-POTENTIAL RESISTANCE TO EARTH TESTING (PER IEEE 1100 AND 81) FOR GROUND ELECTRODE SYSTEMS, THE CONTRACTOR SHALL FURNISH AND INSTALL SUPPLEMENTAL GROUND ELECTRODES AS NEEDED TO ACHIEVE A TEST RESULT OF 5 OHMS OR LESS.
3. THE CONTRACTOR IS RESPONSIBLE FOR PROPERLY SEQUENCING GROUNDING AND UNDERGROUND CONDUIT INSTALLATION AS TO PREVENT ANY LOSS OF CONTINUITY IN THE GROUNDING SYSTEM OR DAMAGE TO THE CONDUIT AND PROVIDE TESTING RESULTS.
4. METAL CONDUIT AND TRAY SHALL BE GROUNDED AND MADE ELECTRICALLY CONTINUOUS WITH LISTED BONDING FITTINGS OR BY BONDING ACROSS THE DISCONTINUITY WITH #6 COPPER WIRE UL APPROVED GROUNDING TYPE CONDUIT CLAMPS.
5. METAL RACEWAY SHALL NOT BE USED AS THE NEC REQUIRED EQUIPMENT GROUND CONDUCTOR. STRANDED COPPER CONDUCTORS WITH GREEN INSULATION, SIZED IN ACCORDANCE WITH THE NEC, SHALL BE FURNISHED AND INSTALLED WITH THE POWER CIRCUITS TO BTS EQUIPMENT.
6. EACH CABINET FRAME SHALL BE DIRECTLY CONNECTED TO THE MASTER GROUND BAR WITH GREEN INSULATED SUPPLEMENTAL EQUIPMENT GROUND WIRES, #6 STRANDED COPPER OR LARGER FOR INDOOR BTS; #2 BARE SOLID TINNED COPPER FOR OUTDOOR BTS.
7. CONNECTIONS TO THE GROUND BUS SHALL NOT BE DOUBLED UP OR STACKED BACK TO BACK CONNECTIONS ON OPPOSITE SIDE OF THE GROUND BUS ARE PERMITTED.
8. ALL EXTERIOR GROUND CONDUCTORS BETWEEN EQUIPMENT/GROUND BARS AND THE GROUND RING SHALL BE #2 SOLID TINNED COPPER UNLESS OTHERWISE INDICATED.
9. ALUMINUM CONDUCTOR OR COPPER CLAD STEEL CONDUCTOR SHALL NOT BE USED FOR GROUNDING CONNECTIONS.
10. USE OF 90° BENDS IN THE PROTECTION GROUNDING CONDUCTORS SHALL BE AVOIDED WHEN 45° BENDS CAN BE ADEQUATELY SUPPORTED.
11. EXOTHERMIC WELDS SHALL BE USED FOR ALL GROUNDING CONNECTIONS BELOW GRADE.
12. ALL GROUND CONNECTIONS ABOVE GRADE (INTERIOR AND EXTERIOR) SHALL BE FORMED USING HIGH PRESS CRIMPS.
13. COMPRESSION GROUND CONNECTIONS MAY BE REPLACED BY EXOTHERMIC WELD CONNECTIONS.
14. ICE BRIDGE BONDING CONDUCTORS SHALL BE EXOTHERMICALLY BONDED OR BOLTED TO THE BRIDGE AND THE TOWER GROUND BAR.
15. APPROVED ANTIOXIDANT COATINGS (i.e. CONDUCTIVE GEL OR PASTE) SHALL BE USED ON ALL COMPRESSION AND BOLTED GROUND CONNECTIONS.
16. ALL EXTERIOR GROUND CONNECTIONS SHALL BE COATED WITH A CORROSION RESISTANT MATERIAL.
17. MISCELLANEOUS ELECTRICAL AND NON-ELECTRICAL METAL BOXES, FRAMES AND SUPPORTS SHALL BE BONDED TO THE GROUND RING, IN ACCORDANCE WITH THE NEC.
18. BOND ALL METALLIC OBJECTS WITHIN 6 ft OF MAIN GROUND RING WITH (1) #2 BARE SOLID TINNED COPPER GROUND CONDUCTOR.
19. GROUND CONDUCTORS USED FOR THE FACILITY GROUNDING AND LIGHTNING PROTECTION SYSTEMS SHALL NOT BE ROUTED THROUGH METALLIC OBJECTS THAT FORM A RING AROUND THE CONDUCTOR, SUCH AS METALLIC CONDUITS, METAL SUPPORT CLIPS OR SLEEVES THROUGH WALLS OR FLOORS. WHEN IT IS REQUIRED TO BE HOUSED IN CONDUIT TO MEET CODE REQUIREMENTS OR LOCAL CONDITIONS, NON-METALLIC MATERIAL SUCH AS PVC CONDUIT SHALL BE USED. WHERE USE OF METAL CONDUIT IS UNAVOIDABLE (i.e., NONMETALLIC CONDUIT PROHIBITED BY LOCAL CODE) THE GROUND CONDUCTOR SHALL BE BONDED TO EACH END OF THE METAL CONDUIT.
20. ALL GROUNDS THAT TRANSITION FROM BELOW GRADE TO ABOVE GRADE MUST BE #2 BARE SOLID TINNED COPPER IN 3/4" NON-METALLIC, FLEXIBLE CONDUIT FROM 24" BELOW GRADE TO WITHIN 3" TO 6" OF CAD-WELD TERMINATION POINT. THE EXPOSED END OF THE CONDUIT MUST BE SEALED WITH SILICONE CAULK. (ADD TRANSITIONING GROUND STANDARD DETAIL AS WELL).
21. BUILDINGS WHERE THE MAIN GROUNDING CONDUCTORS ARE REQUIRED TO BE ROUTED TO GRADE, THE CONTRACTOR SHALL ROUTE TWO GROUNDING CONDUCTORS FROM THE ROOFTOP, TOWERS, AND WATER TOWERS GROUNDING RING, TO THE EXISTING GROUNDING SYSTEM, THE GROUNDING CONDUCTORS SHALL NOT BE SMALLER THAN 2/0 COPPER. ROOFTOP GROUNDING RING SHALL BE BONDED TO THE EXISTING GROUNDING SYSTEM, THE BUILDING STEEL COLUMNS, LIGHTNING PROTECTION SYSTEM, AND BUILDING MAIN WATER LINE (FERROUS OR NONFERROUS METAL PIPING ONLY). DO NOT ATTACH GROUNDING TO FIRE SPRINKLER SYSTEM PIPES.



5701 SOUTH SANTA FE DRIVE
LITTLETON, CO 80120



45 BEECHWOOD DRIVE TEL: (978) 557-5553
N. ANDOVER, MA 01845 FAX: (978) 336-5586

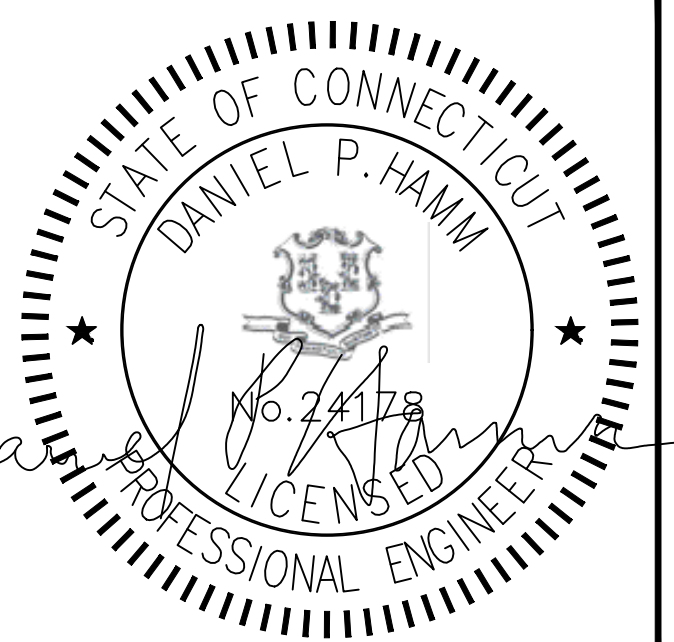

IT IS A VIOLATION OF LAW FOR ANY PERSON, UNLESS THEY ARE ACTING UNDER THE DIRECTION OF A LICENSED PROFESSIONAL ENGINEER, TO ALTER THIS DOCUMENT.

DRAWN BY:	CHECKED BY:	APPROVED BY:
MRK	SMA	DPH

RFDS REV #: 4

PRELIMINARY DOCUMENT

SUBMITTALS		
REV	DATE	DESCRIPTION
A	11/16/2021	ISSUED FOR REVIEW
B	04/04/2022	ISSUED FOR REVIEW
C	06/06/2022	ISSUED FOR REVIEW

A&E PROJECT NUMBER
BOBOS01000A

DISH Wireless L.L.C.
PROJECT INFORMATION
BOBOS01000A
CROWN CASTLE BU#881533
75 ROBERTS ROAD
GROTON, CT 06340

SHEET TITLE
GENERAL NOTES

SHEET NUMBER
GN-4

Exhibit D

Structural Analysis Report

Date: **October 27, 2021**



B+T Group
1717 S. Boulder, Suite 300
Tulsa, OK 74119
(918) 587-4630

Subject: **Structural Analysis Report**

Carrier Designation: **DISH Network Co-Locate**
Site Number: **BOBOS01000A**

Crown Castle Designation: **BU Number:** 881533
Site Name: Groton Tower
JDE Job Number: 675287
Work Order Number: 2013150
Order Number: 576662 Rev. 4

Engineering Firm Designation: **B+T Group Project Number:** 92739.019.01

Site Data: **75 Roberts Road, Groton, New London County, CT**
Latitude 41° 21' 36.8", Longitude -72° 2' 55.1"
144.5 Foot - Monopole

B+T Group is pleased to submit this “**Structural Analysis Report**” to determine the structural integrity of the above-mentioned tower.

The purpose of the analysis is to determine acceptability of the tower stress level. Based on our analysis we have determined the tower stress level for the structure and foundation, under the following load case, to be:

LC7: Proposed Equipment Configuration

Sufficient Capacity - 92.9%

This analysis utilizes an ultimate 3-second gust wind speed of 127 mph as required by the 2018 Connecticut State Building Code. Applicable Standard references and design criteria are listed in Section 2 - Analysis Criteria.

Structural analysis prepared by: Rose Denny

Respectfully submitted by: B+T Engineering, Inc.
COA: PEC.0001564; Expires: 02/10/2022



Chad E. Tuttle, P.E.

TABLE OF CONTENTS

1) INTRODUCTION

2) ANALYSIS CRITERIA

Table 1 - Proposed Equipment Configuration
Table 2 - Other Considered Equipment

3) ANALYSIS PROCEDURE

Table 3 - Documents Provided
3.1) Analysis Method
3.2) Assumptions

4) ANALYSIS RESULTS

Table 4 - Section Capacity (Summary)
Table 5 - Tower Component Stresses vs. Capacity - LC7
4.1) Recommendations

5) APPENDIX A

tnxTower Output

6) APPENDIX B

Base Level Drawing

7) APPENDIX C

Additional Calculations

1) INTRODUCTION

This tower is a 144.5 ft Monopole designed by Engineered Endeavors, Inc.
 This monopole has been modified multiple times to accommodate additional loading.

2) ANALYSIS CRITERIA

TIA-222 Revision:	TIA-222-H
Risk Category:	II
Wind Speed:	135 mph
Exposure Category:	C
Topographic Factor:	1
Ice Thickness:	1.5 in
Wind Speed with Ice:	50 mph
Service Wind Speed:	60 mph

Table 1 - Proposed Equipment Configuration

Mounting Level (ft)	Center Line Elevation (ft)	Number of Antennas	Antenna Manufacturer	Antenna Model	Number of Feed Lines	Feed Line Size (in)
98.0	98.0	3	Fujitsu	TA08025-B604	1	1-1/2
		3	Fujitsu	TA08025-B605		
		3	JMA Wireless	MX08FRO665-21		
		1	Raycap	RDIDC-9181-PF-48		
		1	--	Commscope MC-PK8-DSH		

Table 2 - Other Considered Equipment

Mounting Level (ft)	Center Line Elevation (ft)	Number of Antennas	Antenna Manufacturer	Antenna Model	Number of Feed Lines	Feed Line Size (in)
147.0	147.0	6	Ericsson	RRUS 11	12 6 2	1-5/8 3/4 3/8
		3	Ericsson	RRUS 32		
		3	Ericsson	RRUS 32 B2		
		3	Ericsson	RRUS 4478 B14		
		3	Ericsson	RRUS 4478 B5		
		6	Kaelus	DBCT108F1V92-1		
		6	Powerwave Tech	7020.00		
		3	Powerwave Tech	7770.00		
		6	Powerwave Tech	LGP21401		
		1	--	Platform Mount [LP 602-1_KCKR]		
	146.0	1	Andrew	SBNH-1D6565C		
		3	Kathrein	840370799		
		2	KMW Comm.	AM-X-CD-17-65-00T-RET		
		1	Raycap	DC6-48-60-0-8F		
2		Raycap	DC6-48-60-18-8F			
135.0	135.0	3	Andrew	LNx-6512DS-VTM	8	1-5/8
		6	JMA Wireless	MX06FRO660-02		
		2	Raycap	RVZDC-6627-PF-48		
		3	Samsung Telecom	RFV01U-D1A		

Mounting Level (ft)	Center Line Elevation (ft)	Number of Antennas	Antenna Manufacturer	Antenna Model	Number of Feed Lines	Feed Line Size (in)
		3	Samsung Telecom	RFV01U-D2A		
		1	--	Platform Mount [LP 601-1]		
		3	VZW	Sub6 Antenna - VZS01		
130.0	130.0	1	--	Miscellaneous [NA 507-1]	--	--
128.0	128.0	3	Ericsson	ERICSSON AIR 21 B2A B4P	4	1-5/8
		3	Ericsson	ERICSSON AIR 21 B4A B2P		
		3	Ericsson	KRY 112 144/1		
		3	Ericsson	RADIO 4449 B12/B71		
		3	RFS Celwave	APXVAARR24_43-U-NA20		
		1	--	Platform Mount [LP 601-1]		
118.0	118.0	3	Alcatel Lucent	TD-RRH8X20-25	3	1-1/4 5/8
		3	RFS Celwave	APXVSP18-C-A20		
		3	RFS Celwave	APXVTM14-C-120		
		1	--	Platform Mount [LP 601-1]		
108.0	108.0	3	Alcatel Lucent	TME-PCS 1900MHz 4x45W-65MHz		
		1	--	Side Arm Mount [SO 102-3]		
	106.0	3	Alcatel Lucent	TME-800MHz 2X50W RRH W/FILTER		
103.0	103.0	1	--	Platform Mount [LP 601-1]	--	--

3) ANALYSIS PROCEDURE

Table 3 - Documents Provided

Document	Reference	Source
Tower Manufacturer Drawing	1405782	CCI Sites
Tower Modification Drawing	2048224	CCI Sites
Post Modification Inspection	2304223	CCI Sites
Tower Modification Drawing	2353860	CCI Sites
Post Modification Inspection	2435103	CCI Sites
Tower Modification Drawing	4491288	CCI Sites
Post Modification Inspection	5246681	CCI Sites
Tower Modification Drawing	5795331	CCI Sites
Post Modification Inspection	6017666	CCI Sites
Tower Modification Drawing	5944786	CCI Sites
Post Modification Inspection	6089847	CCI Sites
Tower Modification Drawing	6708152	CCI Sites
Post Modification Inspection	7137178	CCI Sites
Tower Modification Drawing	7042669	CCI Sites
Post Modification Inspection	7262385	CCI Sites
Foundation Drawing	1405796	CCI Sites
Geotech Report	1406209	CCI Sites
Crown CAD Package	Date: 10/21/2021	CCI Sites

3.1) Analysis Method

tnxTower (version 8.1.1.0), a commercially available analysis software package, was used to create a three-dimensional model of the tower and calculate member stresses for various loading cases. Selected output from the analysis is included in Appendix A. When applicable, Crown Castle has calculated and provided the effective area for panel antennas using approved methods following the intent of the TIA-222 standard.

tnxTower was used to determine the loads on the modified structure. Additional calculations were performed to determine the stresses in the pole and in the reinforcing elements. These calculations are presented in Appendix C.

3.2) Assumptions

- 1) The tower and structures were maintained in accordance with the - TIA-222 standard.
- 2) The configuration of antennas, transmission cables, mounts and other appurtenances are as specified in Tables 1 and 2 and the referenced drawings.

This analysis may be affected if any assumptions are not valid or have been made in error. B+T Group should be notified to determine the effect on the structural integrity of the tower.

4) ANALYSIS RESULTS

Table 4 - Section Capacity (Summary)

Section No.	Elevation (ft)	Component Type	Size	Critical Element	P (K)	SF*P_allow (K)	% Capacity	Pass / Fail
L1	144.5 - 139.5	Pole	TP22.092x21x0.1875	1	-4.161	--	20.3	Pass
L2	139.5 - 134.5	Pole	TP23.184x22.092x0.1875	2	-7.042	--	33.2	Pass
L3	134.5 - 129.5	Pole	TP24.276x23.184x0.1875	3	-7.767	--	49.5	Pass
L4	129.5 - 124.5	Pole	TP25.368x24.276x0.1875	4	-11.032	--	68.1	Pass
L5	124.5 - 121.41	Pole	TP26.882x25.368x0.1875	5	-11.441	--	79.0	Pass
L6	121.41 - 116.41	Pole	TP26.737x25.668x0.25	6	-14.368	--	67.8	Pass
L7	116.41 - 112.58	Pole	TP27.555x26.737x0.25	7	-15.016	--	77.0	Pass
L8	112.58 - 112.33	Pole	TP27.608x27.555x0.25	8	-15.085	--	77.6	Pass
L9	112.33 - 107.33	Pole	TP28.677x27.608x0.25	9	-16.416	--	88.3	Pass
L10	107.33 - 106.92	Pole	TP28.765x28.677x0.25	10	-16.510	--	89.2	Pass
L11	106.92 - 106.67	Pole + Reinf.	TP28.818x28.765x0.5375	11	-16.580	--	74.3	Pass
L12	106.67 - 103.5	Pole + Reinf.	TP29.496x28.818x0.525	12	-17.359	--	80.1	Pass
L13	103.5 - 103.25	Pole + Reinf.	TP29.549x29.496x0.525	13	-17.435	--	80.5	Pass
L14	103.25 - 98.5	Pole + Reinf.	TP30.564x29.549x0.5125	14	-20.121	--	89.5	Pass
L15	98.5 - 98.25	Pole + Reinf.	TP30.618x30.564x0.675	15	-20.216	--	69.0	Pass
L16	98.25 - 97.58	Pole + Reinf.	TP30.761x30.618x0.675	16	-23.285	--	70.2	Pass
L17	97.58 - 97.33	Pole + Reinf.	TP30.815x30.761x0.5625	17	-23.363	--	79.9	Pass
L18	97.33 - 92.33	Pole + Reinf.	TP31.883x30.815x0.55	18	-24.787	--	88.7	Pass
L19	92.33 - 91.74	Pole + Reinf.	TP32.997x31.883x0.55	19	-24.968	--	89.7	Pass
L20	91.74 - 86.12	Pole	TP32.72x31.509x0.375	20	-27.221	--	83.6	Pass
L21	86.12 - 83	Pole	TP33.392x32.72x0.375	21	-28.047	--	86.5	Pass
L22	83 - 82.75	Pole	TP33.446x33.392x0.375	22	-28.140	--	86.7	Pass
L23	82.75 - 77.75	Pole	TP34.523x33.446x0.375	23	-29.476	--	90.6	Pass
L24	77.75 - 77.25	Pole	TP34.631x34.523x0.375	24	-29.631	--	91.0	Pass
L25	77.25 - 77	Pole + Reinf.	TP34.685x34.631x0.825	25	-29.748	--	67.4	Pass

Section No.	Elevation (ft)	Component Type	Size	Critical Element	P (K)	SF*P_allow (K)	% Capacity	Pass / Fail
L26	77 - 76.75	Pole + Reinf.	TP34.738x34.685x0.6375	26	-29.834	--	85.9	Pass
L27	76.75 - 71.75	Pole + Reinf.	TP35.816x34.738x0.625	27	-31.580	--	90.1	Pass
L28	71.75 - 69	Pole + Reinf.	TP36.408x35.816x0.625	28	-32.556	--	92.3	Pass
L29	69 - 68.75	Pole + Reinf.	TP36.462x36.408x0.8	29	-32.688	--	73.3	Pass
L30	68.75 - 63.75	Pole + Reinf.	TP37.539x36.462x0.7875	30	-34.807	--	76.6	Pass
L31	63.75 - 60	Pole + Reinf.	TP38.347x37.539x0.775	31	-36.426	--	78.9	Pass
L32	60 - 59.75	Pole + Reinf.	TP38.401x38.347x0.775	32	-36.553	--	79.0	Pass
L33	59.75 - 58.5	Pole + Reinf.	TP38.67x38.401x0.775	33	-37.082	--	79.7	Pass
L34	58.5 - 58.25	Pole + Reinf.	TP38.724x38.67x0.775	34	-37.209	--	79.9	Pass
L35	58.25 - 58	Pole + Reinf.	TP38.778x38.724x0.775	35	-37.319	--	80.0	Pass
L36	58 - 57.75	Pole + Reinf.	TP38.832x38.778x0.6125	36	-37.422	--	91.2	Pass
L37	57.75 - 56.75	Pole + Reinf.	TP39.047x38.832x0.6125	37	-37.824	--	91.8	Pass
L38	56.75 - 56.5	Pole + Reinf.	TP39.101x39.047x0.7375	38	-37.953	--	83.4	Pass
L39	56.5 - 51.5	Pole + Reinf.	TP40.178x39.101x0.725	39	-40.175	--	86.0	Pass
L40	51.5 - 47.82	Pole + Reinf.	TP42.216x40.178x0.7125	40	-41.841	--	87.8	Pass
L41	47.82 - 41.04	Pole + Reinf.	TP41.678x40.221x0.7875	41	-47.219	--	85.6	Pass
L42	41.04 - 36.04	Pole + Reinf.	TP42.753x41.678x0.7875	42	-49.690	--	87.4	Pass
L43	36.04 - 31.25	Pole + Reinf.	TP43.783x42.753x0.7625	43	-52.090	--	89.0	Pass
L44	31.25 - 31	Pole + Reinf.	TP43.836x43.783x0.65	44	-52.232	--	87.6	Pass
L45	31 - 27.75	Pole + Reinf.	TP44.535x43.836x0.65	45	-53.844	--	85.2	Pass
L46	27.75 - 27.5	Pole + Reinf.	TP44.589x44.535x0.65	46	-53.989	--	85.3	Pass
L47	27.5 - 27.25	Pole + Reinf.	TP44.642x44.589x0.65	47	-54.115	--	85.3	Pass
L48	27.25 - 27	Pole + Reinf.	TP44.696x44.642x0.725	48	-54.241	--	87.0	Pass
L49	27 - 22	Pole + Reinf.	TP45.771x44.696x0.7125	49	-56.743	--	88.3	Pass
L50	22 - 17	Pole + Reinf.	TP46.846x45.771x0.7125	50	-59.292	--	89.5	Pass
L51	17 - 12	Pole + Reinf.	TP47.921x46.846x0.7125	51	-61.872	--	90.6	Pass
L52	12 - 7	Pole + Reinf.	TP48.995x47.921x0.7125	52	-64.483	--	91.6	Pass
L53	7 - 2	Pole + Reinf.	TP50.07x48.995x0.7	53	-67.128	--	92.6	Pass
L54	2 - 0	Pole + Reinf.	TP50.5x50.07x0.7	54	-68.196	--	92.9	Pass
							Summary	
						Pole (L24)	91.0	Pass
						Reinforcement	92.9	Pass
						Rating =	92.9	Pass

Table 5 - Tower Component Stresses vs. Capacity - LC7

Notes	Component	Elevation (ft)	% Capacity	Pass / Fail
1,2	Anchor Rod Brackets	Base	53.2	Pass
1,2	Anchor Rods	Base	86.1	Pass
1,2	Base Plate	Base	84.5	Pass
1,2	Base Foundation (Structure)	Base	30.1	Pass
1,2	Base Foundation (Soil Interaction)	Base	61.7	Pass
1,2	Concrete Breakout	Base	89.1	Pass

Structure Rating (max from all components) =	92.9%
---	--------------

Notes:

- 1) See additional documentation in "Appendix C – Additional Calculations" for calculations supporting the % capacity consumed.
- 2) Rating per TIA-222-H Section 15.5.

4.1) Recommendations

The tower and its foundations have sufficient capacity to carry the proposed load configuration. No modifications are required at this time.

APPENDIX A
TNXTOWER OUTPUT

Section	Length (ft)	Number of Sides	Thickness (in)	Socket Length (ft)	Top Dia (in)	Bot Dia (in)	Grade	Weight (K)
1		18	0.188	3.841	50.07	50.50	A572-65	21.000
2		18	0.188	3.841	50.07	50.50	A572-65	22.092
3		18	0.188	3.841	50.07	50.50	A572-65	23.184
4		18	0.188	3.841	50.07	50.50	A572-65	24.276
5		18	0.188	3.841	50.07	50.50	A572-65	25.368
6		18	0.188	3.841	50.07	50.50	A572-65	26.460
7		18	0.188	3.841	50.07	50.50	A572-65	27.552
8		18	0.188	3.841	50.07	50.50	A572-65	28.644
9		18	0.188	3.841	50.07	50.50	A572-65	29.736
10		18	0.188	3.841	50.07	50.50	A572-65	30.828
11		18	0.188	3.841	50.07	50.50	A572-65	31.920
12		18	0.188	3.841	50.07	50.50	A572-65	33.012
13		18	0.188	3.841	50.07	50.50	A572-65	34.104
14		18	0.188	3.841	50.07	50.50	A572-65	35.196
15		18	0.188	3.841	50.07	50.50	A572-65	36.288
16		18	0.188	3.841	50.07	50.50	A572-65	37.380
17		18	0.188	3.841	50.07	50.50	A572-65	38.472
18		18	0.188	3.841	50.07	50.50	A572-65	39.564
19		18	0.188	3.841	50.07	50.50	A572-65	40.656
20		18	0.188	3.841	50.07	50.50	A572-65	41.748
21		18	0.188	3.841	50.07	50.50	A572-65	42.840
22		18	0.188	3.841	50.07	50.50	A572-65	43.932
23		18	0.188	3.841	50.07	50.50	A572-65	45.024
24		18	0.188	3.841	50.07	50.50	A572-65	46.116
25		18	0.188	3.841	50.07	50.50	A572-65	47.208
26		18	0.188	3.841	50.07	50.50	A572-65	48.300
27		18	0.188	3.841	50.07	50.50	A572-65	49.392
28		18	0.188	3.841	50.07	50.50	A572-65	50.484
29		18	0.188	3.841	50.07	50.50	A572-65	51.576
30		18	0.188	3.841	50.07	50.50	A572-65	52.668
31		18	0.188	3.841	50.07	50.50	A572-65	53.760
32		18	0.188	3.841	50.07	50.50	A572-65	54.852
33		18	0.188	3.841	50.07	50.50	A572-65	55.944
34		18	0.188	3.841	50.07	50.50	A572-65	57.036
35		18	0.188	3.841	50.07	50.50	A572-65	58.128
36		18	0.188	3.841	50.07	50.50	A572-65	59.220
37		18	0.188	3.841	50.07	50.50	A572-65	60.312
38		18	0.188	3.841	50.07	50.50	A572-65	61.404
39		18	0.188	3.841	50.07	50.50	A572-65	62.496
40		18	0.188	3.841	50.07	50.50	A572-65	63.588
41		18	0.188	3.841	50.07	50.50	A572-65	64.680
42		18	0.188	3.841	50.07	50.50	A572-65	65.772
43		18	0.188	3.841	50.07	50.50	A572-65	66.864
44		18	0.188	3.841	50.07	50.50	A572-65	67.956
45		18	0.188	3.841	50.07	50.50	A572-65	69.048
46		18	0.188	3.841	50.07	50.50	A572-65	70.140
47		18	0.188	3.841	50.07	50.50	A572-65	71.232
48		18	0.188	3.841	50.07	50.50	A572-65	72.324
49		18	0.188	3.841	50.07	50.50	A572-65	73.416
50		18	0.188	3.841	50.07	50.50	A572-65	74.508
51		18	0.188	3.841	50.07	50.50	A572-65	75.600
52		18	0.188	3.841	50.07	50.50	A572-65	76.692
53		18	0.188	3.841	50.07	50.50	A572-65	77.784
54		18	0.188	3.841	50.07	50.50	A572-65	78.876

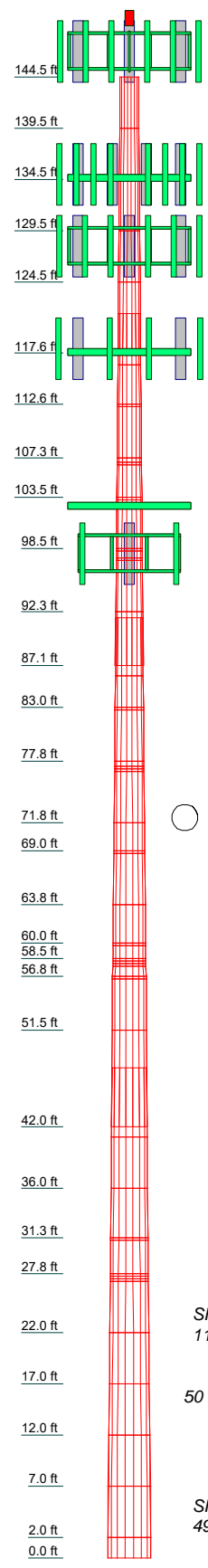

MATERIAL STRENGTH

GRADE	Fy	Fu	GRADE	Fy	Fu
A572-65	65 ksi	80 ksi			

TOWER DESIGN NOTES

1. Tower is located in New London County, Connecticut.
2. Tower designed for Exposure C to the TIA-222-H Standard.
3. Tower designed for a 135 mph basic wind in accordance with the TIA-222-H Standard.
4. Tower is also designed for a 50 mph basic wind with 1.50 in ice. Ice is considered to increase in thickness with height.
5. Deflections are based upon a 60 mph wind.
6. Tower Risk Category II.
7. Topographic Category 1 with Crest Height of 0.000 ft
8. TIA-222-H Annex S
9. TOWER RATING: 92.9%

ALL REACTIONS ARE FACTORED

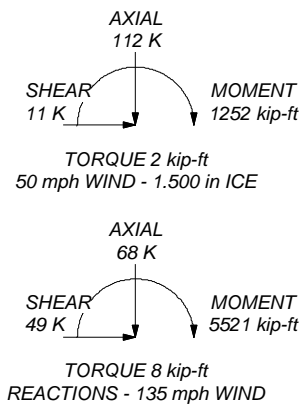

B+T Group
 1717 S. Boulder, Suite 300
 Tulsa, OK 74119
 Phone: (918) 587-4630
 FAX: (918) 295-0265

Job: 92739.019.01 - GROTON TOWER, CT (BU# 88153)		
Project:		
Client: Crown Castle	Drawn by: JD Prabhu	App'd:
Code: TIA-222-H	Date: 10/26/21	Scale: NTS
Path:	Dwg No: E-1	

©Users:RDP201/Design/92739_88153 Groton Tower - Jaydev - Raju/92739_019_01_CCI/01/10/26/21

Vx

Vz

Mx

Mz

Global Mast Shear (K)

Global Mast Moment (kip-ft)

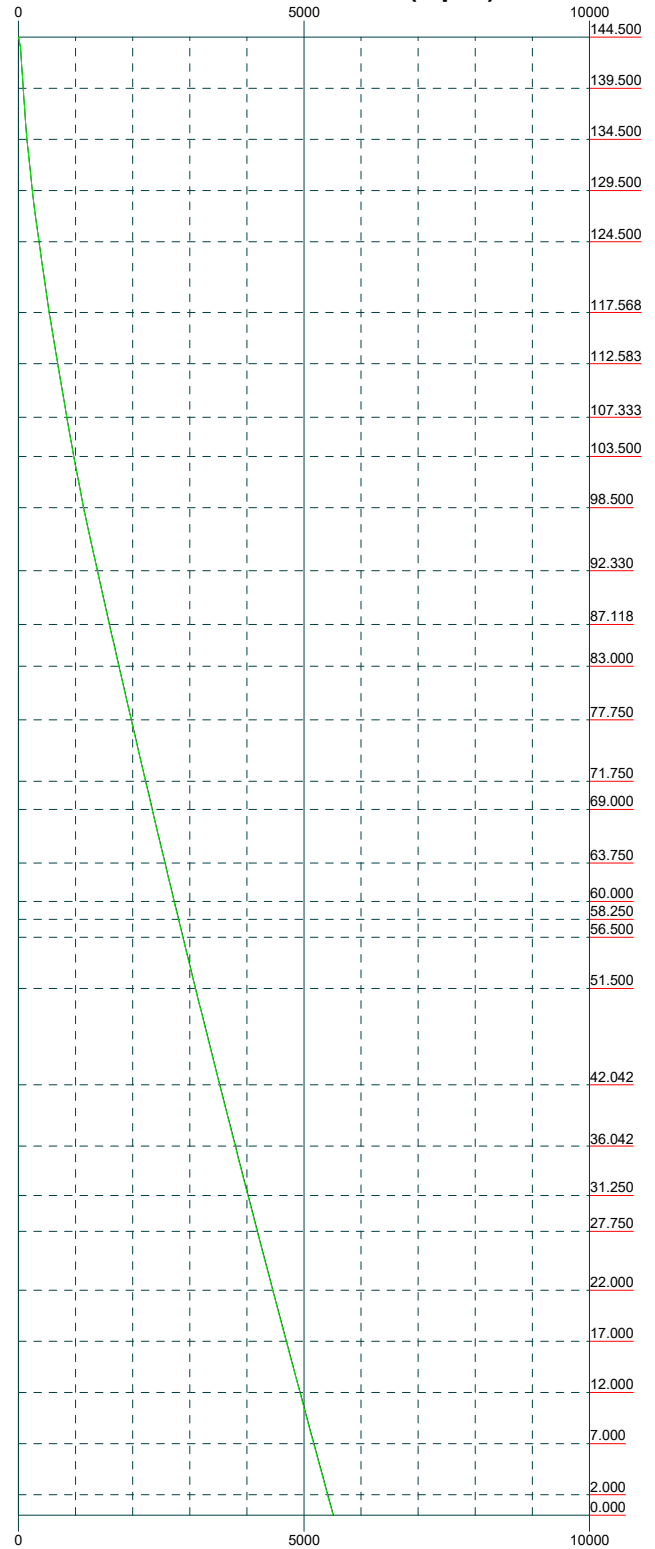
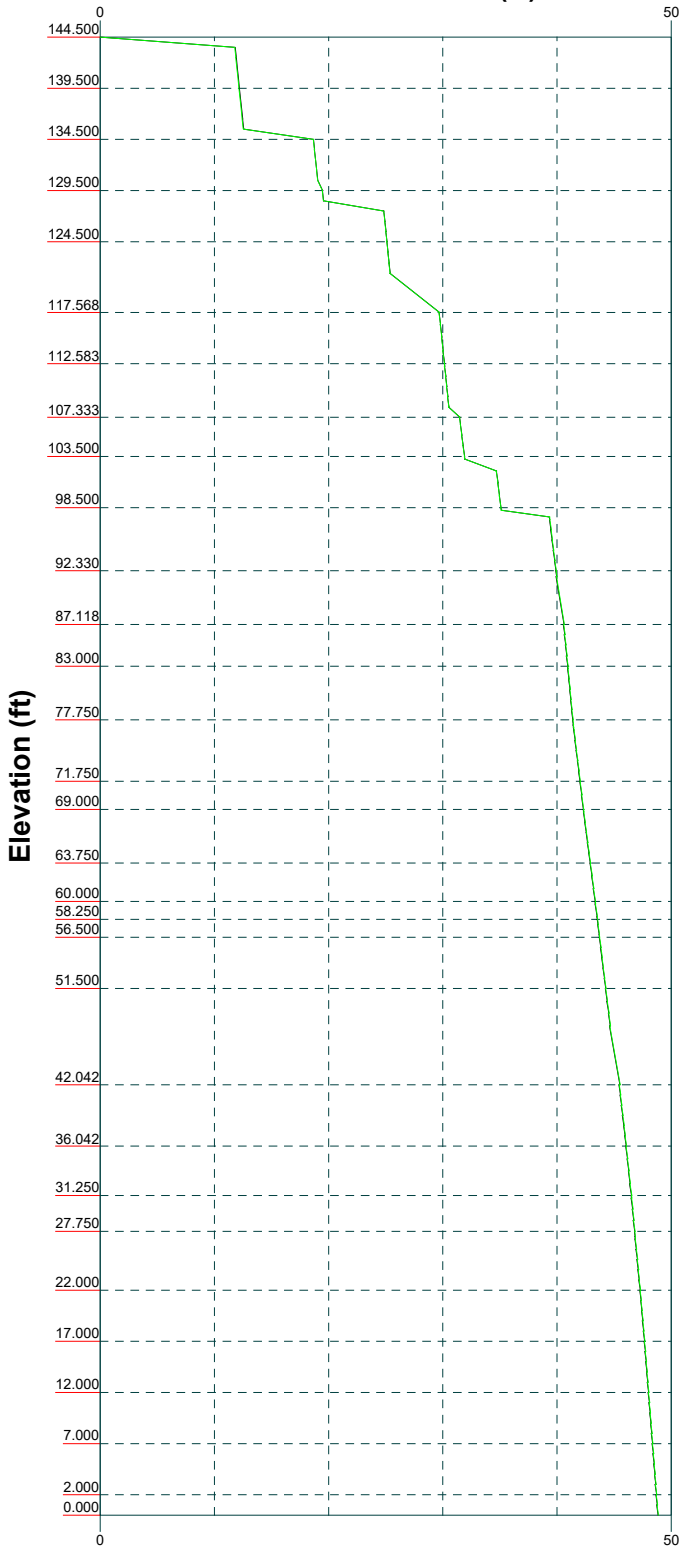

B+T Group
 1717 S. Boulder, Suite 300
 Tulsa, OK 74119
 Phone: (918) 587-4630
 FAX: (918) 295-0265

Job: 92739.019.01 - GROTON TOWER, CT (BU# 88153)		
Project:		
Client: Crown Castle	Drawn by: JD Prabhu	App'd:
Code: TIA-222-H	Date: 10/26/21	Scale: NTS
Path:	Dwg No: E-4	

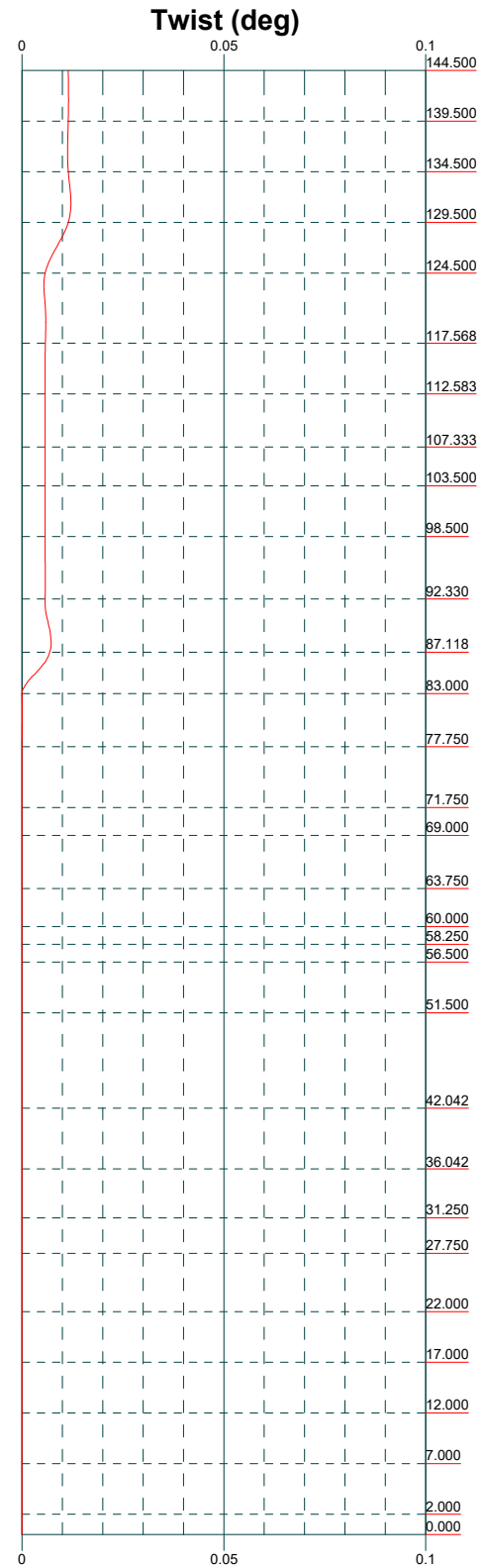
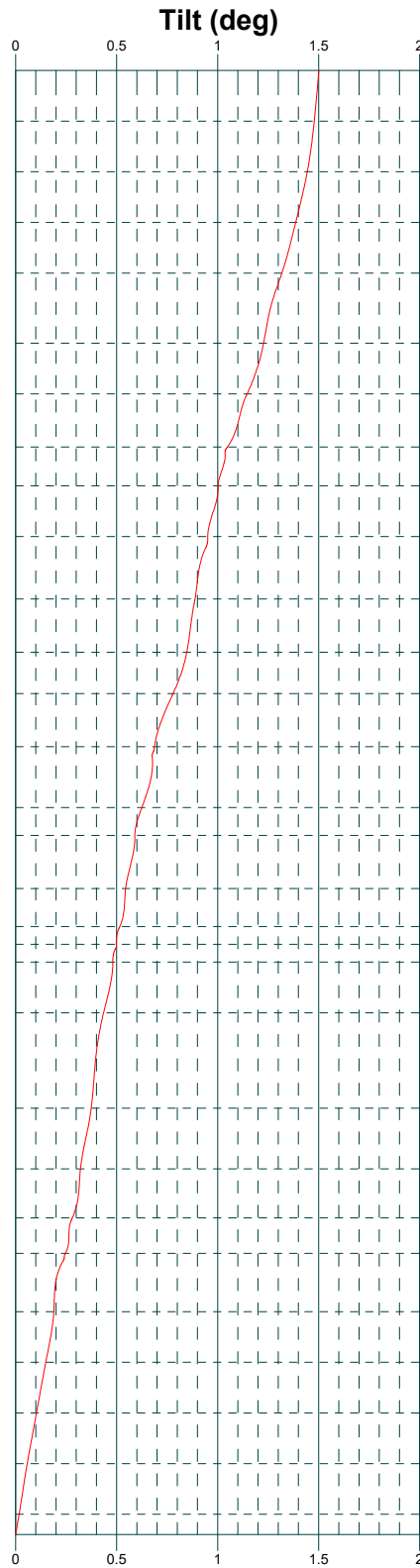
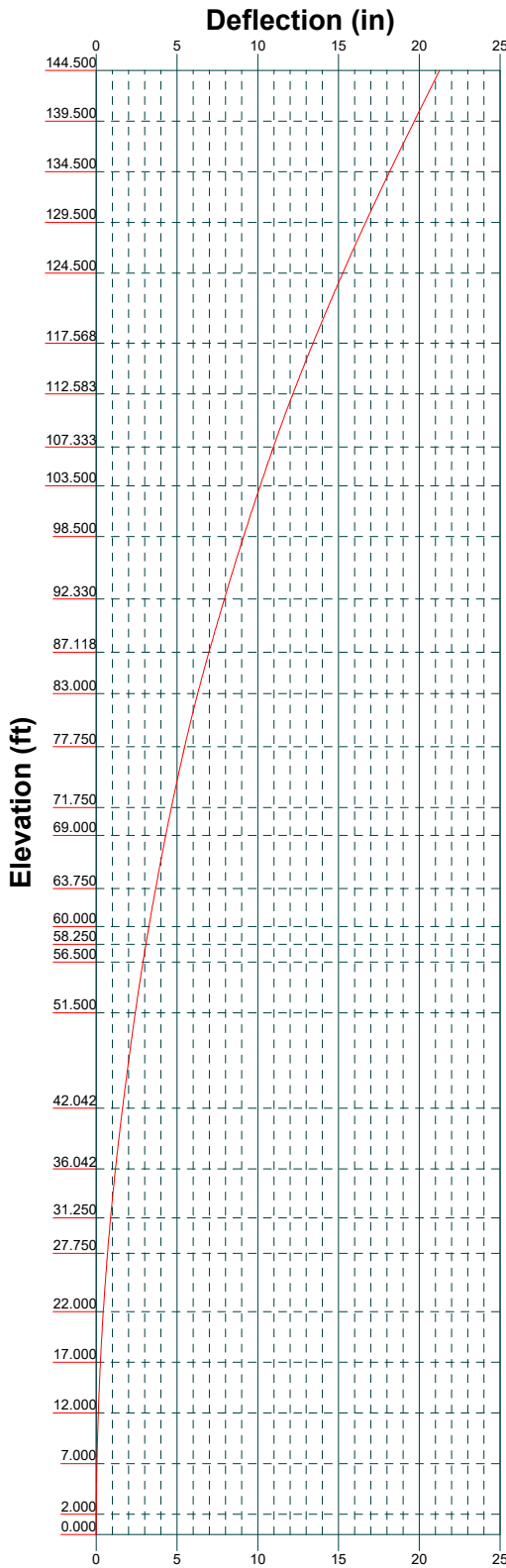

B+T Group
 1717 S. Boulder, Suite 300
 Tulsa, OK 74119
 Phone: (918) 587-4630
 FAX: (918) 295-0265

Job: 92739.019.01 - GROTON TOWER, CT (BU# 881533)		
Project:		
Client: Crown Castle	Drawn by: JD Prabhu	App'd:
Code: TIA-222-H	Date: 10/26/21	Scale: NTS
Path:	Dwg No: E-5	

C:\Users\BPC201\Desktop\92739_881533 Groton Tower - Jaydev - Path\92739_019_01_CCI\pvt\MCD\F10.dwg

Feed Line Distribution Chart

0' - 144'6"

— Round
 — Flat
 — App In Face
 — App Out Face
 — Truss Leg

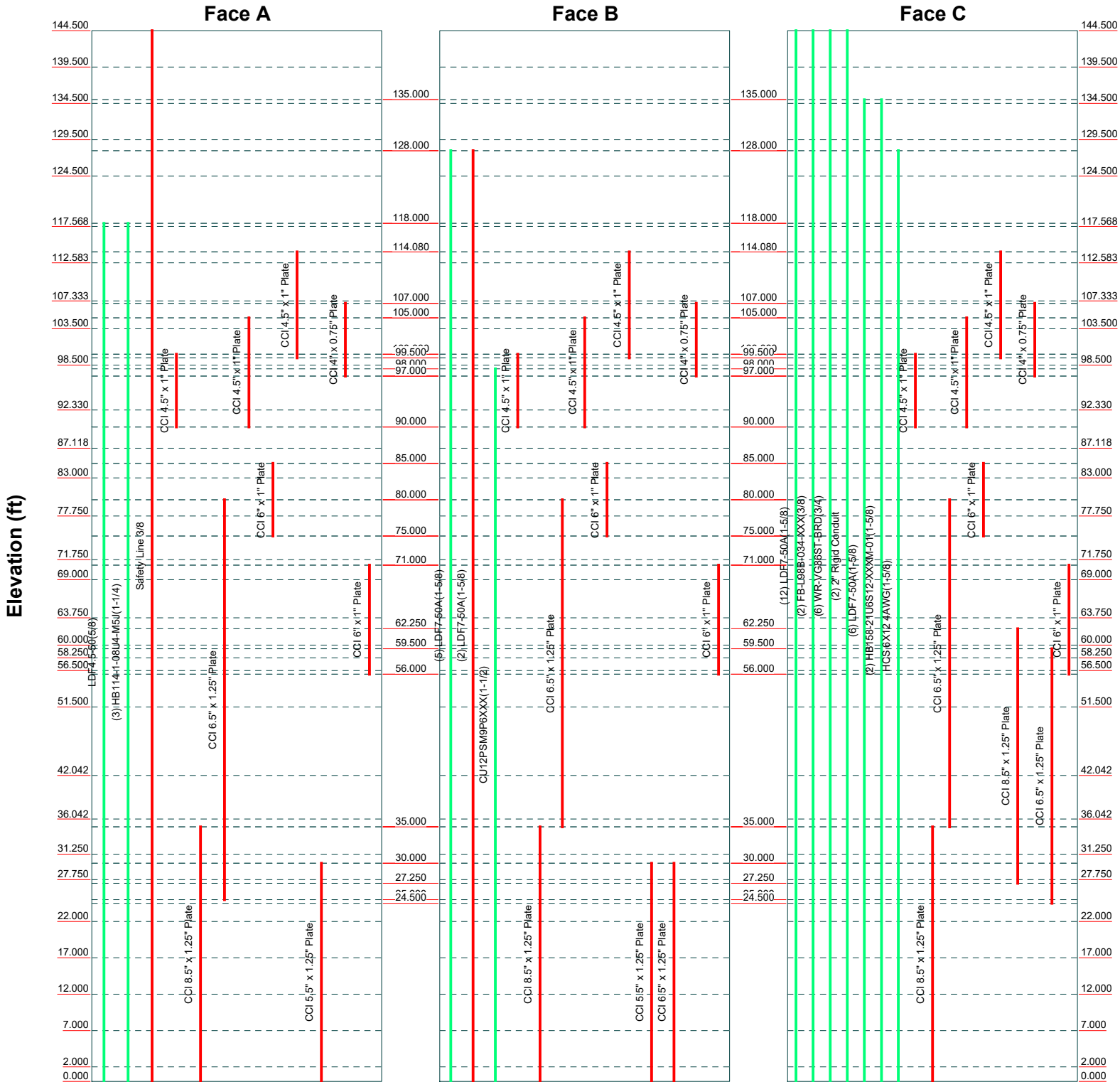

B+T Group
 1717 S. Boulder, Suite 300
 Tulsa, OK 74119
 Phone: (918) 587-4630
 FAX: (918) 295-0265

Job: 92739.019.01 - GROTON TOWER, CT (BU# 88153)		
Project:		
Client: Crown Castle	Drawn by: JD Prabhu	App'd:
Code: TIA-222-H	Date: 10/26/21	Scale: NTS
Path:		Dwg No: E-7

tnxTower B+T Group 1717 S. Boulder, Suite 300 Tulsa, OK 74119 Phone: (918) 587-4630 FAX: (918) 295-0265	Job 92739.019.01 - GROTON TOWER, CT (BU# 881533)	Page 1 of 62
	Project	Date 20:02:38 10/26/21
	Client Crown Castle	Designed by JD Prabhu

Tower Input Data

The tower is a monopole.

This tower is designed using the TIA-222-H standard.

The following design criteria apply:

Tower is located in New London County, Connecticut.

Tower base elevation above sea level: 128.000 ft.

Basic wind speed of 135 mph.

Risk Category II.

Exposure Category C.

Simplified Topographic Factor Procedure for wind speed-up calculations is used.

Topographic Category: 1.

Crest Height: 0.000 ft.

Nominal ice thickness of 1.500 in.

Ice thickness is considered to increase with height.

Ice density of 56.000 pcf.

A wind speed of 50 mph is used in combination with ice.

Temperature drop of 50.000 °F.

Deflections calculated using a wind speed of 60 mph.

TIA-222-H Annex S.

TOWER RATING: 92.9%.

A non-linear (P-delta) analysis was used.

Pressures are calculated at each section.

Stress ratio used in pole design is 1.

Tower analysis based on target reliabilities in accordance with Annex S.

Load Modification Factors used: $K_{es}(F_w) = 0.95$, $K_{es}(t_i) = 0.85$.

Maximum demand-capacity ratio is: 1.05.

Local bending stresses due to climbing loads, feed line supports, and appurtenance mounts are not considered.

Options

<ul style="list-style-type: none"> Consider Moments - Legs Consider Moments - Horizontals Consider Moments - Diagonals Use Moment Magnification √ Use Code Stress Ratios √ Use Code Safety Factors - Guys Escalate Ice Always Use Max Kz Use Special Wind Profile Include Bolts In Member Capacity Leg Bolts Are At Top Of Section Secondary Horizontal Braces Leg Use Diamond Inner Bracing (4 Sided) SR Members Have Cut Ends SR Members Are Concentric 	<ul style="list-style-type: none"> Distribute Leg Loads As Uniform Assume Legs Pinned √ Assume Rigid Index Plate √ Use Clear Spans For Wind Area Use Clear Spans For KL/r Retension Guys To Initial Tension √ Bypass Mast Stability Checks √ Use Azimuth Dish Coefficients √ Project Wind Area of Appurt. Autocalc Torque Arm Areas Add IBC .6D+W Combination Sort Capacity Reports By Component Triangulate Diamond Inner Bracing Treat Feed Line Bundles As Cylinder Ignore KL/ry For 60 Deg. Angle Legs 	<ul style="list-style-type: none"> Use ASCE 10 X-Brace Ly Rules Calculate Redundant Bracing Forces Ignore Redundant Members in FEA SR Leg Bolts Resist Compression All Leg Panels Have Same Allowable Offset Girt At Foundation √ Consider Feed Line Torque Include Angle Block Shear Check Use TIA-222-H Bracing Resist. Exemption Use TIA-222-H Tension Splice Exemption <li style="background-color: #e0e0e0;">Poles √ Include Shear-Torsion Interaction Always Use Sub-Critical Flow Use Top Mounted Sockets Pole Without Linear Attachments Pole With Shroud Or No Appurtenances Outside and Inside Corner Radii Are Known
--	---	--

tnxTower B+T Group 1717 S. Boulder, Suite 300 Tulsa, OK 74119 Phone: (918) 587-4630 FAX: (918) 295-0265	Job 92739.019.01 - GROTON TOWER, CT (BU# 881533)	Page 2 of 62
	Project	Date 20:02:38 10/26/21
	Client Crown Castle	Designed by JD Prabhu

Tapered Pole Section Geometry

Section	Elevation ft	Section Length ft	Splice Length ft	Number of Sides	Top Diameter in	Bottom Diameter in	Wall Thickness in	Bend Radius in	Pole Grade
L1	144.500-139.500	5.000	0.000	18	21.000	22.092	0.188	0.750	A572-65 (65 ksi)
L2	139.500-134.500	5.000	0.000	18	22.092	23.184	0.188	0.750	A572-65 (65 ksi)
L3	134.500-129.500	5.000	0.000	18	23.184	24.276	0.188	0.750	A572-65 (65 ksi)
L4	129.500-124.500	5.000	0.000	18	24.276	25.368	0.188	0.750	A572-65 (65 ksi)
L5	124.500-117.568	6.932	3.841	18	25.368	26.882	0.188	0.750	A572-65 (65 ksi)
L6	117.568-116.409	5.000	0.000	18	25.668	26.737	0.250	1.000	A572-65 (65 ksi)
L7	116.409-112.583	3.826	0.000	18	26.737	27.555	0.250	1.000	A572-65 (65 ksi)
L8	112.583-112.333	0.250	0.000	18	27.555	27.608	0.250	1.000	A572-65 (65 ksi)
L9	112.333-107.333	5.000	0.000	18	27.608	28.677	0.250	1.000	A572-65 (65 ksi)
L10	107.333-106.920	0.413	0.000	18	28.677	28.765	0.250	1.000	A572-65 (65 ksi)
L11	106.920-106.670	0.250	0.000	18	28.765	28.818	0.537	2.150	A572-65 (65 ksi)
L12	106.670-103.500	3.170	0.000	18	28.818	29.496	0.525	2.100	A572-65 (65 ksi)
L13	103.500-103.250	0.250	0.000	18	29.496	29.549	0.525	2.100	A572-65 (65 ksi)
L14	103.250-98.500	4.750	0.000	18	29.549	30.564	0.512	2.050	A572-65 (65 ksi)
L15	98.500-98.250	0.250	0.000	18	30.564	30.618	0.675	2.700	A572-65 (65 ksi)
L16	98.250-97.580	0.670	0.000	18	30.618	30.761	0.675	2.700	A572-65 (65 ksi)
L17	97.580-97.330	0.250	0.000	18	30.761	30.815	0.563	2.250	A572-65 (65 ksi)
L18	97.330-92.330	5.000	0.000	18	30.815	31.883	0.550	2.200	A572-65 (65 ksi)
L19	92.330-87.118	5.212	4.625	18	31.883	32.997	0.550	2.200	A572-65 (65 ksi)
L20	87.118-86.118	5.625	0.000	18	31.509	32.720	0.375	1.500	A572-65 (65 ksi)
L21	86.118-83.000	3.118	0.000	18	32.720	33.392	0.375	1.500	A572-65 (65 ksi)
L22	83.000-82.750	0.250	0.000	18	33.392	33.446	0.375	1.500	A572-65 (65 ksi)
L23	82.750-77.750	5.000	0.000	18	33.446	34.523	0.375	1.500	A572-65 (65 ksi)
L24	77.750-77.250	0.500	0.000	18	34.523	34.631	0.375	1.500	A572-65 (65 ksi)
L25	77.250-77.000	0.250	0.000	18	34.631	34.685	0.825	3.300	A572-65 (65 ksi)
L26	77.000-76.750	0.250	0.000	18	34.685	34.738	0.637	2.550	A572-65 (65 ksi)
L27	76.750-71.750	5.000	0.000	18	34.738	35.816	0.625	2.500	A572-65 (65 ksi)
L28	71.750-69.000	2.750	0.000	18	35.816	36.408	0.625	2.500	A572-65 (65 ksi)

tnxTower B+T Group 1717 S. Boulder, Suite 300 Tulsa, OK 74119 Phone: (918) 587-4630 FAX: (918) 295-0265	Job 92739.019.01 - GROTON TOWER, CT (BU# 881533)	Page 3 of 62
	Project	Date 20:02:38 10/26/21
	Client Crown Castle	Designed by JD Prabhu

Section	Elevation ft	Section Length ft	Splice Length ft	Number of Sides	Top Diameter in	Bottom Diameter in	Wall Thickness in	Bend Radius in	Pole Grade
L29	69.000-68.750	0.250	0.000	18	36.408	36.462	0.800	3.200	A572-65 (65 ksi)
L30	68.750-63.750	5.000	0.000	18	36.462	37.539	0.787	3.150	A572-65 (65 ksi)
L31	63.750-60.000	3.750	0.000	18	37.539	38.347	0.775	3.100	A572-65 (65 ksi)
L32	60.000-59.750	0.250	0.000	18	38.347	38.401	0.775	3.100	A572-65 (65 ksi)
L33	59.750-58.500	1.250	0.000	18	38.401	38.670	0.775	3.100	A572-65 (65 ksi)
L34	58.500-58.250	0.250	0.000	18	38.670	38.724	0.775	3.100	A572-65 (65 ksi)
L35	58.250-58.000	0.250	0.000	18	38.724	38.778	0.775	3.100	A572-65 (65 ksi)
L36	58.000-57.750	0.250	0.000	18	38.778	38.832	0.613	2.450	A572-65 (65 ksi)
L37	57.750-56.750	1.000	0.000	18	38.832	39.047	0.613	2.450	A572-65 (65 ksi)
L38	56.750-56.500	0.250	0.000	18	39.047	39.101	0.738	2.950	A572-65 (65 ksi)
L39	56.500-51.500	5.000	0.000	18	39.101	40.178	0.725	2.900	A572-65 (65 ksi)
L40	51.500-42.042	9.458	5.776	18	40.178	42.215	0.713	2.850	A572-65 (65 ksi)
L41	42.042-41.042	6.776	0.000	18	40.221	41.678	0.787	3.150	A572-65 (65 ksi)
L42	41.042-36.042	5.000	0.000	18	41.678	42.753	0.787	3.150	A572-65 (65 ksi)
L43	36.042-31.250	4.792	0.000	18	42.753	43.783	0.762	3.050	A572-65 (65 ksi)
L44	31.250-31.000	0.250	0.000	18	43.783	43.836	0.650	2.600	A572-65 (65 ksi)
L45	31.000-27.750	3.250	0.000	18	43.836	44.535	0.650	2.600	A572-65 (65 ksi)
L46	27.750-27.500	0.250	0.000	18	44.535	44.589	0.650	2.600	A572-65 (65 ksi)
L47	27.500-27.250	0.250	0.000	18	44.589	44.642	0.650	2.600	A572-65 (65 ksi)
L48	27.250-27.000	0.250	0.000	18	44.642	44.696	0.725	2.900	A572-65 (65 ksi)
L49	27.000-22.000	5.000	0.000	18	44.696	45.771	0.713	2.850	A572-65 (65 ksi)
L50	22.000-17.000	5.000	0.000	18	45.771	46.846	0.713	2.850	A572-65 (65 ksi)
L51	17.000-12.000	5.000	0.000	18	46.846	47.921	0.713	2.850	A572-65 (65 ksi)
L52	12.000-7.000	5.000	0.000	18	47.921	48.995	0.713	2.850	A572-65 (65 ksi)
L53	7.000-2.000	5.000	0.000	18	48.995	50.070	0.700	2.800	A572-65 (65 ksi)
L54	2.000-0.000	2.000		18	50.070	50.500	0.700	2.800	A572-65 (65 ksi)

Tapered Pole Properties

<p>tnxTower</p> <p>B+T Group 1717 S. Boulder, Suite 300 Tulsa, OK 74119 Phone: (918) 587-4630 FAX: (918) 295-0265</p>	Job	Page	
	92739.019.01 - GROTON TOWER, CT (BU# 881533)		4 of 62
	Project	Date	20:02:38 10/26/21
Client	Crown Castle	Designed by JD Prabhu	

Section	Tip Dia. in	Area in ²	I in ⁴	r in	C in	I/C in ³	J in ⁴	I/Q in ²	w in	w/t
L1	21.295	12.386	677.826	7.388	10.668	63.538	1356.544	6.194	3.366	17.952
	22.404	13.036	790.221	7.776	11.223	70.412	1581.483	6.519	3.558	18.977
L2	22.404	13.036	790.221	7.776	11.223	70.412	1581.483	6.519	3.558	18.977
	23.513	13.686	914.401	8.164	11.778	77.640	1830.006	6.844	3.750	20.002
L3	23.513	13.686	914.401	8.164	11.778	77.640	1830.006	6.844	3.750	20.002
	24.622	14.336	1050.954	8.551	12.332	85.220	2103.290	7.169	3.943	21.027
L4	24.622	14.336	1050.954	8.551	12.332	85.220	2103.290	7.169	3.943	21.027
	25.731	14.986	1200.465	8.939	12.887	93.153	2402.511	7.494	4.135	22.052
L5	25.731	14.986	1200.465	8.939	12.887	93.153	2402.511	7.494	4.135	22.052
	27.268	15.887	1430.295	9.477	13.656	104.736	2862.472	7.945	4.401	23.474
L6	27.268	15.887	1430.295	9.477	13.656	104.736	2862.472	7.945	4.401	23.474
	27.111	20.017	1862.865	9.403	13.582	137.153	3728.181	10.511	4.266	17.063
L7	27.111	20.017	1862.865	9.403	13.582	137.153	3728.181	10.511	4.266	17.063
	27.941	21.666	2040.766	9.693	13.998	145.792	4084.218	10.835	4.410	17.638
L8	27.941	21.666	2040.766	9.693	13.998	145.792	4084.218	10.835	4.410	17.638
	27.995	21.709	2052.770	9.712	14.025	146.366	4108.241	10.856	4.419	17.676
L9	27.995	21.709	2052.770	9.712	14.025	146.366	4108.241	10.856	4.419	17.676
	29.080	22.557	2302.832	10.091	14.568	158.077	4608.695	11.280	4.607	18.428
L10	29.080	22.557	2302.832	10.091	14.568	158.077	4608.695	11.280	4.607	18.428
	29.170	22.627	2324.350	10.123	14.613	159.065	4651.759	11.315	4.623	18.491
L11	29.170	22.627	2324.350	10.123	14.613	159.065	4651.759	11.315	4.623	18.491
	29.126	48.157	4847.716	10.021	14.613	331.749	9701.811	24.083	4.117	7.659
L12	29.126	48.157	4847.716	10.021	14.613	331.749	9701.811	24.083	4.117	7.659
	29.180	48.248	4875.296	10.040	14.640	333.018	9757.007	24.129	4.126	7.676
L13	29.180	48.248	4875.296	10.040	14.640	333.018	9757.007	24.129	4.126	7.676
	29.182	47.147	4768.234	10.044	14.640	325.705	9542.743	23.578	4.148	7.901
L14	29.182	47.147	4768.234	10.044	14.640	325.705	9542.743	23.578	4.148	7.901
	29.870	48.276	5119.035	10.285	14.984	341.636	10244.805	24.142	4.267	8.128
L15	29.870	48.276	5119.035	10.285	14.984	341.636	10244.805	24.142	4.267	8.128
	29.924	48.365	5147.410	10.304	15.011	342.908	10301.593	24.187	4.277	8.146
L16	29.924	48.365	5147.410	10.304	15.011	342.908	10301.593	24.187	4.277	8.146
	29.926	47.233	5031.348	10.308	15.011	335.176	10069.315	23.621	4.299	8.388
L17	29.926	47.233	5031.348	10.308	15.011	335.176	10069.315	23.621	4.299	8.388
	30.957	48.885	5577.727	10.668	15.527	359.233	11162.794	24.447	4.477	8.736
L18	30.957	48.885	5577.727	10.668	15.527	359.233	11162.794	24.447	4.477	8.736
	30.932	64.037	7227.748	10.611	15.527	465.503	14465.006	32.024	4.191	6.209
L19	30.932	64.037	7227.748	10.611	15.527	465.503	14465.006	32.024	4.191	6.209
	30.986	64.151	7266.578	10.630	15.554	467.187	14542.718	32.082	4.201	6.223
L20	30.986	64.151	7266.578	10.630	15.554	467.187	14542.718	32.082	4.201	6.223
	31.132	64.458	7371.329	10.681	15.627	471.716	14752.357	32.235	4.226	6.261
L21	31.132	64.458	7371.329	10.681	15.627	471.716	14752.357	32.235	4.226	6.261
	31.149	53.916	6211.940	10.721	15.627	397.523	12432.055	26.963	4.424	7.865
L22	31.149	53.916	6211.940	10.721	15.627	397.523	12432.055	26.963	4.424	7.865
	31.203	54.011	6244.971	10.739	15.654	398.943	12498.160	27.011	4.433	7.882
L23	31.203	54.011	6244.971	10.739	15.654	398.943	12498.160	27.011	4.433	7.882
	31.205	52.833	6113.766	10.744	15.654	390.562	12235.577	26.421	4.455	8.101
L24	31.205	52.833	6113.766	10.744	15.654	390.562	12235.577	26.421	4.455	8.101
	32.290	54.698	6784.514	11.123	16.197	418.884	13577.956	27.354	4.643	8.443
L25	32.290	54.698	6784.514	11.123	16.197	418.884	13577.956	27.354	4.643	8.443
	33.421	56.643	7534.158	11.519	16.763	449.464	15078.230	28.327	4.839	8.799
L26	33.421	56.643	7534.158	11.519	16.763	449.464	15078.230	28.327	4.839	8.799
	32.949	37.057	4538.007	11.052	16.006	283.512	9081.986	18.532	4.886	13.028
L27	32.949	37.057	4538.007	11.052	16.006	283.512	9081.986	18.532	4.886	13.028
	33.167	38.499	5088.777	11.483	16.622	306.148	10184.250	19.253	5.099	13.597
L28	33.167	38.499	5088.777	11.483	16.622	306.148	10184.250	19.253	5.099	13.597
	33.849	39.299	5412.411	11.721	16.963	319.068	10831.944	19.653	5.217	13.912
L29	33.849	39.299	5412.411	11.721	16.963	319.068	10831.944	19.653	5.217	13.912
	33.904	39.363	5438.940	11.740	16.991	320.116	10885.037	19.685	5.226	13.937
L30	33.904	39.363	5438.940	11.740	16.991	320.116	10885.037	19.685	5.226	13.937
	34.998	40.645	5987.880	12.123	17.538	341.429	11983.639	20.326	5.416	14.443
L31	34.998	40.645	5987.880	12.123	17.538	341.429	11983.639	20.326	5.416	14.443
	35.107	40.773	6044.721	12.161	17.592	343.598	12097.396	20.390	5.435	14.493
L32	35.107	40.773	6044.721	12.161	17.592	343.598	12097.396	20.390	5.435	14.493
	35.038	88.522	12781.159	12.001	17.592	726.515	25579.137	44.269	4.643	5.628
L33	35.038	88.522	12781.159	12.001	17.592	726.515	25579.137	44.269	4.643	5.628
	35.092	88.663	12842.342	12.020	17.620	728.859	25701.583	44.340	4.652	5.639
L34	35.092	88.663	12842.342	12.020	17.620	728.859	25701.583	44.340	4.652	5.639
	35.121	68.892	10089.401	12.087	17.620	572.618	20192.078	34.452	4.982	7.816
L35	35.121	68.892	10089.401	12.087	17.620	572.618	20192.078	34.452	4.982	7.816
	35.176	69.001	10137.356	12.106	17.647	574.447	20288.050	34.507	4.992	7.831
L36	35.176	69.001	10137.356	12.106	17.647	574.447	20288.050	34.507	4.992	7.831
	35.178	67.673	9949.517	12.110	17.647	563.803	19912.126	33.843	5.014	8.022
L37	35.178	67.673	9949.517	12.110	17.647	563.803	19912.126	33.843	5.014	8.022
	36.272	69.809	10922.052	12.493	18.194	600.300	21858.476	34.911	5.204	8.326
L38	36.272	69.809	10922.052	12.493	18.194	600.300	21858.476	34.911	5.204	8.326
	36.873	70.985	11482.996	12.703	18.495	620.861	22981.101	35.499	5.308	8.492
L39	36.873	70.985	11482.996	12.703	18.495	620.861	22981.101	35.499	5.308	8.492
	36.846	90.416	14483.639	12.641	18.495	783.100	28986.335	45.217	5.000	6.25
L40	36.846	90.416	14483.639	12.641	18.495	783.100	28986.335	45.217	5.000	6.25
	36.901	90.553	14549.457	12.660	18.523	785.496	29118.058	45.285	5.009	6.262
L41	36.901	90.553	14549.457	12.660	18.523	785.496	29118.058	45.285	5.009	6.262
	36.903	89.169	14337.187	12.664	18.523	774.036	28693.239	44.593	5.031	6.389
L42	36.903	89.169	14337.187	12.664	18.523	774.036	28693.239	44.593	5.031	6.389
	37.997	91.861	15675.454	13.047	19.070	822.004	31371.535	45.939	5.221	6.63
L43	37.997	91.861	15675.454	13.047	19.070	822.004	31371.535	45.939	5.221	6.63
	37.999	90.434	15442.384	13.051	19.070	809.782	30905.087	45.226	5.243	6.765
L44	37.999	90.434	15442.384	13.051	19.070	809.782	30905.087	45.226	5.243	6.765
	38.819	92.421	16482.901	13.338	19.480	846.136	32987.491	46.219	5.385	6.948

<p>tnxTower</p> <p>B+T Group 1717 S. Boulder, Suite 300 Tulsa, OK 74119 Phone: (918) 587-4630 FAX: (918) 295-0265</p>	<p>Job 92739.019.01 - GROTON TOWER, CT (BU# 881533)</p>	<p>Page 5 of 62</p>
	<p>Project</p>	<p>Date 20:02:38 10/26/21</p>
	<p>Client Crown Castle</p>	<p>Designed by JD Prabhu</p>

Section	Tip Dia. in	Area in ²	I in ⁴	r in	C in	I/C in ³	J in ⁴	It/Q in ²	w in	w/t
L32	38.819	92.421	16482.901	13.338	19.480	846.136	32987.491	46.219	5.385	6.948
	38.874	92.554	16553.884	13.357	19.508	848.588	33129.550	46.286	5.395	6.961
L33	38.874	92.554	16553.884	13.357	19.508	848.588	33129.550	46.286	5.395	6.961
	39.147	93.216	16911.855	13.453	19.644	860.902	33845.963	46.617	5.442	7.022
L34	39.147	93.216	16911.855	13.453	19.644	860.902	33845.963	46.617	5.442	7.022
	39.202	93.348	16984.063	13.472	19.672	863.375	33990.474	46.683	5.451	7.034
L35	39.202	93.348	16984.063	13.472	19.672	863.375	33990.474	46.683	5.451	7.034
	39.256	93.481	17056.476	13.491	19.699	865.852	34135.396	46.749	5.461	7.046
L36	39.281	74.196	13653.782	13.549	19.699	693.118	27325.531	37.105	5.747	9.383
	39.336	74.301	13711.666	13.568	19.726	695.091	27441.374	37.157	5.756	9.398
L37	39.336	74.301	13711.666	13.568	19.726	695.091	27441.374	37.157	5.756	9.398
	39.555	74.720	13944.837	13.644	19.836	703.011	27908.023	37.367	5.794	9.46
L38	39.536	89.676	16627.429	13.600	19.836	838.251	33276.738	44.846	5.574	7.558
	39.590	89.802	16697.654	13.619	19.863	840.632	33417.279	44.909	5.584	7.571
L39	39.592	88.309	16430.693	13.623	19.863	827.192	32883.006	44.163	5.606	7.732
	40.686	90.787	17853.412	14.006	20.410	874.721	35730.317	45.402	5.795	7.994
L40	40.688	89.250	17562.277	14.010	20.410	860.457	35147.663	44.634	5.817	8.165
	42.757	93.858	20425.266	14.734	21.445	952.428	40877.407	46.938	6.176	8.668
L41	41.981	98.566	19364.112	13.999	20.432	947.717	38753.704	49.292	5.693	7.229
	42.199	102.206	21590.086	14.516	21.172	1019.733	43208.582	51.113	5.949	7.555
L42	42.199	102.206	21590.086	14.516	21.172	1019.733	43208.582	51.113	5.949	7.555
	43.291	104.893	23337.694	14.898	21.718	1074.564	46706.096	52.456	6.138	7.795
L43	43.294	101.623	22637.224	14.906	21.718	1042.311	45304.234	50.821	6.182	8.108
	44.340	104.116	24344.325	15.272	22.242	1094.543	48720.684	52.068	6.364	8.346
L44	44.358	88.987	20915.773	15.312	22.242	940.392	41859.068	44.502	6.562	10.095
	44.412	89.098	20994.048	15.331	22.269	942.754	42015.721	44.557	6.571	10.11
L45	44.412	89.098	20994.048	15.331	22.269	942.754	42015.721	44.557	6.571	10.11
	45.122	90.539	22029.462	15.579	22.624	973.732	44087.911	45.278	6.694	10.299
L46	45.122	90.539	22029.462	15.579	22.624	973.732	44087.911	45.278	6.694	10.299
	45.176	90.650	22110.490	15.598	22.651	976.136	44250.073	45.334	6.704	10.313
L47	45.176	90.650	22110.490	15.598	22.651	976.136	44250.073	45.334	6.704	10.313
	45.231	90.761	22191.716	15.617	22.678	978.542	44412.632	45.389	6.713	10.328
L48	45.219	101.061	24625.918	15.591	22.678	1085.878	49284.240	50.540	6.581	9.077
	45.274	101.184	24716.429	15.610	22.706	1088.559	49465.381	50.602	6.591	9.09
L49	45.276	99.468	24311.005	15.614	22.706	1070.703	48653.999	49.743	6.613	9.281
	46.367	101.899	26137.107	15.996	23.252	1124.098	52308.605	50.959	6.802	9.546
L50	46.367	101.899	26137.107	15.996	23.252	1124.098	52308.605	50.959	6.802	9.546
	47.458	104.329	28052.436	16.377	23.798	1178.791	56141.785	52.174	6.991	9.812
L51	47.458	104.329	28052.436	16.377	23.798	1178.791	56141.785	52.174	6.991	9.812
	48.550	106.760	30059.123	16.759	24.344	1234.784	60157.798	53.390	7.180	10.077
L52	48.550	106.760	30059.123	16.759	24.344	1234.784	60157.798	53.390	7.180	10.077
	49.641	109.190	32159.294	17.140	24.890	1292.077	64360.904	54.606	7.369	10.343
L53	49.643	107.302	31619.641	17.145	24.890	1270.395	63280.888	53.661	7.391	10.559
	50.735	109.690	33778.008	17.526	25.436	1327.981	67600.462	54.856	7.580	10.829
L54	50.735	109.690	33778.008	17.526	25.436	1327.981	67600.462	54.856	7.580	10.829
	51.171	110.646	34668.132	17.679	25.654	1351.373	69381.881	55.333	7.656	10.937

Tower Elevation	Gusset Area (per face)	Gusset Thickness	Gusset Grade	Adjust. Factor A _f	Adjust. Factor A _r	Weight Mult.	Double Angle Stitch Bolt Spacing Diagonals	Double Angle Stitch Bolt Spacing Horizontals	Double Angle Stitch Bolt Spacing Redundants
ft	ft ²	in					in	in	in
L1 144.500-139.5 00				1	1	1			
L2 139.500-134.5 00				1	1	1			
L3 134.500-129.5 00				1	1	1			

tnxTower B+T Group 1717 S. Boulder, Suite 300 Tulsa, OK 74119 Phone: (918) 587-4630 FAX: (918) 295-0265	Job 92739.019.01 - GROTON TOWER, CT (BU# 881533)	Page 9 of 62
	Project	Date 20:02:38 10/26/21
	Client Crown Castle	Designed by JD Prabhu

Description	Sector	Exclude From Torque Calculation	Component Type	Placement ft	Total Number	Number Per Row	Start/End Position	Width or Diameter in	Perimeter in	Weight klf
CCI 8.5" x 1.25" Plate	C	No	Surface Af (CaAa)	62.250 - 27.250	1	1	0.250 0.250	8.500	19.500	0.000
*										
CCI 4" x 0.75" Plate	A	No	Surface Af (CaAa)	107.000 - 97.000	1	1	-0.250 -0.250	4.000	9.500	0.000
CCI 4" x 0.75" Plate	B	No	Surface Af (CaAa)	107.000 - 97.000	1	1	-0.250 -0.250	4.000	9.500	0.000
CCI 4" x 0.75" Plate	C	No	Surface Af (CaAa)	107.000 - 97.000	1	1	-0.250 -0.250	4.000	9.500	0.000
*										
CCI 6.5" x 1.25" Plate	C	No	Surface Af (CaAa)	59.500 - 24.500	1	1	0.000 0.000	6.500	15.500	0.000
*										
CCI 6" x 1" Plate	A	No	Surface Af (CaAa)	71.000 - 56.000	1	1	0.000 0.000	6.000	14.000	0.000
CCI 6" x 1" Plate	B	No	Surface Af (CaAa)	71.000 - 56.000	1	1	0.000 0.000	6.000	14.000	0.000
CCI 6" x 1" Plate	C	No	Surface Af (CaAa)	71.000 - 56.000	1	1	0.000 0.000	6.000	14.000	0.000
*										

Feed Line/Linear Appurtenances - Entered As Area

Description	Face or Leg	Allow Shield	Exclude From Torque Calculation	Component Type	Placement ft	Total Number		C _{AA} ft ² /ft	Weight klf
LDF7-50A(1-5/8)	C	No	No	Inside Pole	144.500 - 0.000	12	No Ice 1/2" Ice 1" Ice 2" Ice	0.000 0.000 0.000 0.000	0.001 0.001 0.001 0.001
FB-L98B-034-XXX(3/8)	C	No	No	Inside Pole	144.500 - 0.000	2	No Ice 1/2" Ice 1" Ice 2" Ice	0.000 0.000 0.000 0.000	0.000 0.000 0.000 0.000
WR-VG86ST-BRD(3/4)	C	No	No	Inside Pole	144.500 - 0.000	6	No Ice 1/2" Ice 1" Ice 2" Ice	0.000 0.000 0.000 0.000	0.001 0.001 0.001 0.001
2" Rigid Conduit	C	No	No	Inside Pole	144.500 - 0.000	2	No Ice 1/2" Ice 1" Ice 2" Ice	0.000 0.000 0.000 0.000	0.003 0.003 0.003 0.003
*									
LDF7-50A(1-5/8)	C	No	No	Inside Pole	135.000 - 0.000	6	No Ice 1/2" Ice 1" Ice 2" Ice	0.000 0.000 0.000 0.000	0.001 0.001 0.001 0.001
HB158-21U6S12-XXM-01(1-5/8)	C	No	No	Inside Pole	135.000 - 0.000	2	No Ice 1/2" Ice 1" Ice 2" Ice	0.000 0.000 0.000 0.000	0.002 0.002 0.002 0.002

*
**Previous 018
SA**
*
019 SA

tnxTower B+T Group 1717 S. Boulder, Suite 300 Tulsa, OK 74119 Phone: (918) 587-4630 FAX: (918) 295-0265	Job 92739.019.01 - GROTON TOWER, CT (BU# 881533)	Page 10 of 62
	Project	Date 20:02:38 10/26/21
	Client Crown Castle	Designed by JD Prabhu

Description	Face or Leg	Allow Shield	Exclude From Torque Calculation	Component Type	Placement ft	Total Number		C _{AA} ft ² /ft	Weight klf
LDF7-50A(1-5/8)	B	No	No	Inside Pole	128.000 - 0.000	5	No Ice	0.000	0.001
							1/2" Ice	0.000	0.001
							1" Ice	0.000	0.001
							2" Ice	0.000	0.001
HCS 6X12 4AWG(1-5/8)	C	No	No	Inside Pole	128.000 - 0.000	1	No Ice	0.000	0.002
							1/2" Ice	0.000	0.002
							1" Ice	0.000	0.002
							2" Ice	0.000	0.002
* LDF4.5-50(5/8)	A	No	No	Inside Pole	118.000 - 0.000	1	No Ice	0.000	0.000
							1/2" Ice	0.000	0.000
							1" Ice	0.000	0.000
							2" Ice	0.000	0.000
HB114-1-08U4-M5J (1-1/4)	A	No	No	Inside Pole	118.000 - 0.000	3	No Ice	0.000	0.001
							1/2" Ice	0.000	0.001
							1" Ice	0.000	0.001
							2" Ice	0.000	0.001
* CU12PSM9P6XXX(1-1/2)	B	No	No	Inside Pole	98.000 - 0.000	1	No Ice	0.000	0.002
							1/2" Ice	0.000	0.002
							1" Ice	0.000	0.002
							2" Ice	0.000	0.002

Feed Line/Linear Appurtenances Section Areas

Tower Section	Tower Elevation ft	Face	A _R ft ²	A _F ft ²	C _{AA} In Face ft ²	C _{AA} Out Face ft ²	Weight K
L1	144.500-139.500	A	0.000	0.000	0.188	0.000	0.001
		B	0.000	0.000	0.000	0.000	0.000
		C	0.000	0.000	0.000	0.000	0.095
L2	139.500-134.500	A	0.000	0.000	0.188	0.000	0.001
		B	0.000	0.000	0.000	0.000	0.000
		C	0.000	0.000	0.000	0.000	0.100
L3	134.500-129.500	A	0.000	0.000	0.188	0.000	0.001
		B	0.000	0.000	0.000	0.000	0.000
		C	0.000	0.000	0.000	0.000	0.139
L4	129.500-124.500	A	0.000	0.000	0.188	0.000	0.001
		B	0.000	0.000	1.386	0.000	0.020
		C	0.000	0.000	0.000	0.000	0.147
L5	124.500-117.568	A	0.000	0.000	0.260	0.000	0.003
		B	0.000	0.000	2.745	0.000	0.040
		C	0.000	0.000	0.000	0.000	0.209
L6	117.568-116.409	A	0.000	0.000	0.043	0.000	0.004
		B	0.000	0.000	0.459	0.000	0.007
		C	0.000	0.000	0.000	0.000	0.035
L7	116.409-112.583	A	0.000	0.000	1.266	0.000	0.014
		B	0.000	0.000	2.638	0.000	0.022
		C	0.000	0.000	1.123	0.000	0.115
L8	112.583-112.333	A	0.000	0.000	0.197	0.000	0.001
		B	0.000	0.000	0.286	0.000	0.001
		C	0.000	0.000	0.188	0.000	0.008
L9	112.333-107.333	A	0.000	0.000	3.938	0.000	0.018

<p>tnxTower</p> <p>B+T Group 1717 S. Boulder, Suite 300 Tulsa, OK 74119 Phone: (918) 587-4630 FAX: (918) 295-0265</p>	<p>Job 92739.019.01 - GROTON TOWER, CT (BU# 881533)</p>	<p>Page 11 of 62</p>
	<p>Project</p>	<p>Date 20:02:38 10/26/21</p>
	<p>Client Crown Castle</p>	<p>Designed by JD Prabhu</p>

Tower Section	Tower Elevation ft	Face	A _R ft ²	A _F ft ²	C _{AA} In Face ft ²	C _{AA} Out Face ft ²	Weight K
		B	0.000	0.000	5.730	0.000	0.029
		C	0.000	0.000	3.750	0.000	0.151
L10	107.333-106.920	A	0.000	0.000	0.379	0.000	0.001
		B	0.000	0.000	0.527	0.000	0.002
		C	0.000	0.000	0.363	0.000	0.012
L11	106.920-106.670	A	0.000	0.000	0.364	0.000	0.001
		B	0.000	0.000	0.453	0.000	0.001
		C	0.000	0.000	0.354	0.000	0.008
L12	106.670-103.500	A	0.000	0.000	5.735	0.000	0.011
		B	0.000	0.000	6.871	0.000	0.018
		C	0.000	0.000	5.616	0.000	0.096
L13	103.500-103.250	A	0.000	0.000	0.551	0.000	0.001
		B	0.000	0.000	0.641	0.000	0.001
		C	0.000	0.000	0.542	0.000	0.008
L14	103.250-98.500	A	0.000	0.000	10.845	0.000	0.017
		B	0.000	0.000	12.548	0.000	0.027
		C	0.000	0.000	10.667	0.000	0.143
L15	98.500-98.250	A	0.000	0.000	0.551	0.000	0.001
		B	0.000	0.000	0.641	0.000	0.001
		C	0.000	0.000	0.542	0.000	0.008
L16	98.250-97.580	A	0.000	0.000	1.477	0.000	0.002
		B	0.000	0.000	1.717	0.000	0.005
		C	0.000	0.000	1.452	0.000	0.020
L17	97.580-97.330	A	0.000	0.000	0.551	0.000	0.001
		B	0.000	0.000	0.641	0.000	0.002
		C	0.000	0.000	0.542	0.000	0.008
L18	97.330-92.330	A	0.000	0.000	7.907	0.000	0.018
		B	0.000	0.000	9.700	0.000	0.040
		C	0.000	0.000	7.720	0.000	0.151
L19	92.330-87.118	A	0.000	0.000	3.690	0.000	0.019
		B	0.000	0.000	5.559	0.000	0.042
		C	0.000	0.000	3.495	0.000	0.157
L20	87.118-86.118	A	0.000	0.000	0.037	0.000	0.004
		B	0.000	0.000	0.396	0.000	0.008
		C	0.000	0.000	0.000	0.000	0.030
L21	86.118-83.000	A	0.000	0.000	1.941	0.000	0.011
		B	0.000	0.000	3.059	0.000	0.025
		C	0.000	0.000	1.824	0.000	0.094
L22	83.000-82.750	A	0.000	0.000	0.237	0.000	0.001
		B	0.000	0.000	0.327	0.000	0.002
		C	0.000	0.000	0.228	0.000	0.008
L23	82.750-77.750	A	0.000	0.000	7.186	0.000	0.018
		B	0.000	0.000	8.978	0.000	0.040
		C	0.000	0.000	6.998	0.000	0.151
L24	77.750-77.250	A	0.000	0.000	1.016	0.000	0.002
		B	0.000	0.000	1.196	0.000	0.004
		C	0.000	0.000	0.998	0.000	0.015
L25	77.250-77.000	A	0.000	0.000	0.508	0.000	0.001
		B	0.000	0.000	0.598	0.000	0.002
		C	0.000	0.000	0.499	0.000	0.008
L26	77.000-76.750	A	0.000	0.000	0.508	0.000	0.001
		B	0.000	0.000	0.598	0.000	0.002
		C	0.000	0.000	0.499	0.000	0.008
L27	76.750-71.750	A	0.000	0.000	7.200	0.000	0.018
		B	0.000	0.000	8.993	0.000	0.040
		C	0.000	0.000	7.013	0.000	0.151
L28	71.750-69.000	A	0.000	0.000	5.082	0.000	0.010
		B	0.000	0.000	6.068	0.000	0.022
		C	0.000	0.000	4.979	0.000	0.083
L29	69.000-68.750	A	0.000	0.000	0.530	0.000	0.001
		B	0.000	0.000	0.620	0.000	0.002

Tower Section	Tower Elevation ft	Face	A _R ft ²	A _F ft ²	C _{AA} In Face ft ²	C _{AA} Out Face ft ²	Weight K
L30	68.750-63.750	C	0.000	0.000	0.521	0.000	0.008
		A	0.000	0.000	10.604	0.000	0.018
		B	0.000	0.000	12.397	0.000	0.040
L31	63.750-60.000	C	0.000	0.000	10.417	0.000	0.151
		A	0.000	0.000	7.953	0.000	0.014
		B	0.000	0.000	9.297	0.000	0.030
L32	60.000-59.750	C	0.000	0.000	11.000	0.000	0.113
		A	0.000	0.000	0.530	0.000	0.001
		B	0.000	0.000	0.620	0.000	0.002
L33	59.750-58.500	C	0.000	0.000	0.875	0.000	0.008
		A	0.000	0.000	2.651	0.000	0.005
		B	0.000	0.000	3.099	0.000	0.010
L34	58.500-58.250	C	0.000	0.000	5.458	0.000	0.038
		A	0.000	0.000	0.530	0.000	0.001
		B	0.000	0.000	0.620	0.000	0.002
L35	58.250-58.000	C	0.000	0.000	1.146	0.000	0.008
		A	0.000	0.000	0.530	0.000	0.001
		B	0.000	0.000	0.620	0.000	0.002
L36	58.000-57.750	C	0.000	0.000	1.146	0.000	0.008
		A	0.000	0.000	0.530	0.000	0.001
		B	0.000	0.000	0.620	0.000	0.002
L37	57.750-56.750	C	0.000	0.000	1.146	0.000	0.008
		A	0.000	0.000	2.121	0.000	0.004
		B	0.000	0.000	2.479	0.000	0.008
L38	56.750-56.500	C	0.000	0.000	4.583	0.000	0.030
		A	0.000	0.000	0.530	0.000	0.001
		B	0.000	0.000	0.620	0.000	0.002
L39	56.500-51.500	C	0.000	0.000	1.146	0.000	0.008
		A	0.000	0.000	6.104	0.000	0.018
		B	0.000	0.000	7.897	0.000	0.040
L40	51.500-42.042	C	0.000	0.000	18.417	0.000	0.151
		A	0.000	0.000	10.601	0.000	0.034
		B	0.000	0.000	13.992	0.000	0.077
L41	42.042-41.042	C	0.000	0.000	33.892	0.000	0.285
		A	0.000	0.000	1.121	0.000	0.004
		B	0.000	0.000	1.479	0.000	0.008
L42	41.042-36.042	C	0.000	0.000	3.583	0.000	0.030
		A	0.000	0.000	5.604	0.000	0.018
		B	0.000	0.000	7.397	0.000	0.040
L43	36.042-31.250	C	0.000	0.000	17.917	0.000	0.151
		A	0.000	0.000	10.683	0.000	0.017
		B	0.000	0.000	8.339	0.000	0.039
L44	31.250-31.000	C	0.000	0.000	18.421	0.000	0.145
		A	0.000	0.000	0.634	0.000	0.001
		B	0.000	0.000	0.453	0.000	0.002
L45	31.000-27.750	C	0.000	0.000	0.979	0.000	0.008
		A	0.000	0.000	10.309	0.000	0.012
		B	0.000	0.000	10.391	0.000	0.026
L46	27.750-27.500	C	0.000	0.000	12.729	0.000	0.098
		A	0.000	0.000	0.864	0.000	0.001
		B	0.000	0.000	0.953	0.000	0.002
L47	27.500-27.250	C	0.000	0.000	0.979	0.000	0.008
		A	0.000	0.000	0.864	0.000	0.001
		B	0.000	0.000	0.953	0.000	0.002
L48	27.250-27.000	C	0.000	0.000	0.979	0.000	0.008
		A	0.000	0.000	0.864	0.000	0.001
		B	0.000	0.000	0.953	0.000	0.002
L49	27.000-22.000	C	0.000	0.000	0.625	0.000	0.008
		A	0.000	0.000	14.021	0.000	0.018
		B	0.000	0.000	19.063	0.000	0.040
		C	0.000	0.000	9.792	0.000	0.151

tnxTower B+T Group 1717 S. Boulder, Suite 300 Tulsa, OK 74119 Phone: (918) 587-4630 FAX: (918) 295-0265	Job	Page		
	92739.019.01 - GROTON TOWER, CT (BU# 881533)		13 of 62	
	Project	Date	20:02:38 10/26/21	
Client	Crown Castle		Designed by	JD Prabhu

Tower Section	Tower Elevation ft	Face	A _R ft ²	A _F ft ²	C _{AA} In Face ft ²	C _{AA} Out Face ft ²	Weight K
L50	22.000-17.000	A	0.000	0.000	11.854	0.000	0.018
		B	0.000	0.000	19.063	0.000	0.040
		C	0.000	0.000	7.083	0.000	0.151
L51	17.000-12.000	A	0.000	0.000	11.854	0.000	0.018
		B	0.000	0.000	19.063	0.000	0.040
		C	0.000	0.000	7.083	0.000	0.151
L52	12.000-7.000	A	0.000	0.000	11.854	0.000	0.018
		B	0.000	0.000	19.063	0.000	0.040
		C	0.000	0.000	7.083	0.000	0.151
L53	7.000-2.000	A	0.000	0.000	11.854	0.000	0.018
		B	0.000	0.000	19.063	0.000	0.040
		C	0.000	0.000	7.083	0.000	0.151
L54	2.000-0.000	A	0.000	0.000	4.742	0.000	0.007
		B	0.000	0.000	7.625	0.000	0.016
		C	0.000	0.000	2.833	0.000	0.060

Feed Line/Linear Appurtenances Section Areas - With Ice

Tower Section	Tower Elevation ft	Face or Leg	Ice Thickness in	A _R ft ²	A _F ft ²	C _{AA} In Face ft ²	C _{AA} Out Face ft ²	Weight K
L1	144.500-139.500	A	1.475	0.000	0.000	1.663	0.000	0.018
		B		0.000	0.000	0.000	0.000	0.000
		C		0.000	0.000	0.000	0.000	0.095
L2	139.500-134.500	A	1.470	0.000	0.000	1.658	0.000	0.018
		B		0.000	0.000	0.000	0.000	0.000
		C		0.000	0.000	0.000	0.000	0.100
L3	134.500-129.500	A	1.465	0.000	0.000	1.652	0.000	0.018
		B		0.000	0.000	0.000	0.000	0.000
		C		0.000	0.000	0.000	0.000	0.139
L4	129.500-124.500	A	1.459	0.000	0.000	1.646	0.000	0.017
		B		0.000	0.000	3.009	0.000	0.051
		C		0.000	0.000	0.000	0.000	0.147
L5	124.500-117.568	A	1.452	0.000	0.000	2.273	0.000	0.025
		B		0.000	0.000	5.948	0.000	0.100
		C		0.000	0.000	0.000	0.000	0.209
L6	117.568-116.409	A	1.447	0.000	0.000	0.380	0.000	0.008
		B		0.000	0.000	0.994	0.000	0.017
		C		0.000	0.000	0.000	0.000	0.035
L7	116.409-112.583	A	1.444	0.000	0.000	2.793	0.000	0.040
		B		0.000	0.000	4.820	0.000	0.069
		C		0.000	0.000	1.545	0.000	0.129
L8	112.583-112.333	A	1.441	0.000	0.000	0.339	0.000	0.004
		B		0.000	0.000	0.472	0.000	0.006
		C		0.000	0.000	0.258	0.000	0.010
L9	112.333-107.333	A	1.438	0.000	0.000	6.780	0.000	0.080
		B		0.000	0.000	9.427	0.000	0.117
		C		0.000	0.000	5.155	0.000	0.197
L10	107.333-106.920	A	1.434	0.000	0.000	0.629	0.000	0.007
		B		0.000	0.000	0.847	0.000	0.010
		C		0.000	0.000	0.495	0.000	0.017
L11	106.920-106.670	A	1.434	0.000	0.000	0.554	0.000	0.006
		B		0.000	0.000	0.687	0.000	0.008
		C		0.000	0.000	0.473	0.000	0.012
L12	106.670-103.500	A	1.432	0.000	0.000	8.578	0.000	0.090
		B		0.000	0.000	10.255	0.000	0.114
		C		0.000	0.000	7.551	0.000	0.165
L13	103.500-103.250	A	1.429	0.000	0.000	0.812	0.000	0.008

<p>tnxTower</p> <p>B+T Group 1717 S. Boulder, Suite 300 Tulsa, OK 74119 Phone: (918) 587-4630 FAX: (918) 295-0265</p>	<p>Job 92739.019.01 - GROTON TOWER, CT (BU# 881533)</p>	<p>Page 14 of 62</p>
	<p>Project</p>	<p>Date 20:02:38 10/26/21</p>
	<p>Client Crown Castle</p>	<p>Designed by JD Prabhu</p>

Tower Section	Tower Elevation ft	Face or Leg	Ice Thickness in	A _R ft ²	A _F ft ²	C _{AA} In Face ft ²	C _{AA} Out Face ft ²	Weight K
		B		0.000	0.000	0.944	0.000	0.010
		C		0.000	0.000	0.731	0.000	0.014
L14	103.250-98.500	A	1.426	0.000	0.000	15.761	0.000	0.162
		B		0.000	0.000	18.272	0.000	0.198
		C		0.000	0.000	14.228	0.000	0.273
L15	98.500-98.250	A	1.422	0.000	0.000	0.782	0.000	0.008
		B		0.000	0.000	0.914	0.000	0.010
		C		0.000	0.000	0.701	0.000	0.014
L16	98.250-97.580	A	1.421	0.000	0.000	2.095	0.000	0.022
		B		0.000	0.000	2.449	0.000	0.028
		C		0.000	0.000	1.879	0.000	0.038
L17	97.580-97.330	A	1.421	0.000	0.000	0.782	0.000	0.008
		B		0.000	0.000	0.914	0.000	0.011
		C		0.000	0.000	0.701	0.000	0.014
L18	97.330-92.330	A	1.417	0.000	0.000	11.598	0.000	0.126
		B		0.000	0.000	14.240	0.000	0.175
		C		0.000	0.000	9.993	0.000	0.244
L19	92.330-87.118	A	1.409	0.000	0.000	6.184	0.000	0.077
		B		0.000	0.000	8.936	0.000	0.127
		C		0.000	0.000	4.520	0.000	0.199
L20	87.118-86.118	A	1.404	0.000	0.000	0.319	0.000	0.007
		B		0.000	0.000	0.847	0.000	0.016
		C		0.000	0.000	0.000	0.000	0.030
L21	86.118-83.000	A	1.401	0.000	0.000	3.112	0.000	0.042
		B		0.000	0.000	4.757	0.000	0.072
		C		0.000	0.000	2.122	0.000	0.115
L22	83.000-82.750	A	1.398	0.000	0.000	0.344	0.000	0.004
		B		0.000	0.000	0.476	0.000	0.007
		C		0.000	0.000	0.265	0.000	0.010
L23	82.750-77.750	A	1.393	0.000	0.000	9.947	0.000	0.111
		B		0.000	0.000	12.582	0.000	0.159
		C		0.000	0.000	8.366	0.000	0.228
L24	77.750-77.250	A	1.389	0.000	0.000	1.368	0.000	0.014
		B		0.000	0.000	1.631	0.000	0.019
		C		0.000	0.000	1.210	0.000	0.026
L25	77.250-77.000	A	1.388	0.000	0.000	0.684	0.000	0.007
		B		0.000	0.000	0.816	0.000	0.009
		C		0.000	0.000	0.605	0.000	0.013
L26	77.000-76.750	A	1.388	0.000	0.000	0.684	0.000	0.007
		B		0.000	0.000	0.816	0.000	0.009
		C		0.000	0.000	0.605	0.000	0.013
L27	76.750-71.750	A	1.383	0.000	0.000	10.223	0.000	0.107
		B		0.000	0.000	12.856	0.000	0.155
		C		0.000	0.000	8.653	0.000	0.225
L28	71.750-69.000	A	1.375	0.000	0.000	7.034	0.000	0.069
		B		0.000	0.000	8.481	0.000	0.095
		C		0.000	0.000	6.174	0.000	0.134
L29	69.000-68.750	A	1.372	0.000	0.000	0.722	0.000	0.007
		B		0.000	0.000	0.854	0.000	0.009
		C		0.000	0.000	0.644	0.000	0.013
L30	68.750-63.750	A	1.367	0.000	0.000	14.430	0.000	0.139
		B		0.000	0.000	17.060	0.000	0.186
		C		0.000	0.000	12.876	0.000	0.257
L31	63.750-60.000	A	1.358	0.000	0.000	10.805	0.000	0.103
		B		0.000	0.000	12.775	0.000	0.139
		C		0.000	0.000	13.445	0.000	0.221
L32	60.000-59.750	A	1.353	0.000	0.000	0.720	0.000	0.007
		B		0.000	0.000	0.851	0.000	0.009
		C		0.000	0.000	1.065	0.000	0.016
L33	59.750-58.500	A	1.352	0.000	0.000	3.598	0.000	0.034
		B		0.000	0.000	4.254	0.000	0.046

tnxTower B+T Group 1717 S. Boulder, Suite 300 Tulsa, OK 74119 Phone: (918) 587-4630 FAX: (918) 295-0265	Job	Page	
		92739.019.01 - GROTON TOWER, CT (BU# 881533)	15 of 62
	Project		Date
			20:02:38 10/26/21
	Client	Designed by	
	Crown Castle	JD Prabhu	

Tower Section	Tower Elevation ft	Face or Leg	Ice Thickness in	A _R ft ²	A _F ft ²	C _{AA} In Face ft ²	C _{AA} Out Face ft ²	Weight K
L34	58.500-58.250	C		0.000	0.000	6.676	0.000	0.091
		A	1.350	0.000	0.000	0.719	0.000	0.007
		B		0.000	0.000	0.851	0.000	0.009
		C		0.000	0.000	1.402	0.000	0.019
L35	58.250-58.000	A	1.349	0.000	0.000	0.719	0.000	0.007
		B		0.000	0.000	0.851	0.000	0.009
		C		0.000	0.000	1.402	0.000	0.019
L36	58.000-57.750	A	1.349	0.000	0.000	0.719	0.000	0.007
		B		0.000	0.000	0.850	0.000	0.009
		C		0.000	0.000	1.402	0.000	0.019
L37	57.750-56.750	A	1.347	0.000	0.000	2.876	0.000	0.027
		B		0.000	0.000	3.401	0.000	0.037
		C		0.000	0.000	5.608	0.000	0.075
L38	56.750-56.500	A	1.346	0.000	0.000	0.719	0.000	0.007
		B		0.000	0.000	0.850	0.000	0.009
		C		0.000	0.000	1.402	0.000	0.019
L39	56.500-51.500	A	1.339	0.000	0.000	8.891	0.000	0.091
		B		0.000	0.000	11.513	0.000	0.138
		C		0.000	0.000	22.543	0.000	0.327
L40	51.500-42.042	A	1.320	0.000	0.000	15.596	0.000	0.160
		B		0.000	0.000	20.547	0.000	0.249
		C		0.000	0.000	41.384	0.000	0.603
L41	42.042-41.042	A	1.305	0.000	0.000	1.649	0.000	0.017
		B		0.000	0.000	2.172	0.000	0.026
		C		0.000	0.000	4.375	0.000	0.064
L42	41.042-36.042	A	1.295	0.000	0.000	8.194	0.000	0.083
		B		0.000	0.000	10.805	0.000	0.129
		C		0.000	0.000	21.801	0.000	0.315
L43	36.042-31.250	A	1.277	0.000	0.000	14.090	0.000	0.123
		B		0.000	0.000	11.568	0.000	0.130
		C		0.000	0.000	22.093	0.000	0.307
L44	31.250-31.000	A	1.268	0.000	0.000	0.825	0.000	0.007
		B		0.000	0.000	0.621	0.000	0.007
		C		0.000	0.000	1.169	0.000	0.016
L45	31.000-27.750	A	1.260	0.000	0.000	13.334	0.000	0.111
		B		0.000	0.000	13.690	0.000	0.131
		C		0.000	0.000	15.187	0.000	0.208
L46	27.750-27.500	A	1.253	0.000	0.000	1.114	0.000	0.009
		B		0.000	0.000	1.244	0.000	0.011
		C		0.000	0.000	1.167	0.000	0.016
L47	27.500-27.250	A	1.251	0.000	0.000	1.114	0.000	0.009
		B		0.000	0.000	1.244	0.000	0.011
		C		0.000	0.000	1.167	0.000	0.016
L48	27.250-27.000	A	1.250	0.000	0.000	1.114	0.000	0.009
		B		0.000	0.000	1.244	0.000	0.011
		C		0.000	0.000	0.750	0.000	0.013
L49	27.000-22.000	A	1.238	0.000	0.000	18.228	0.000	0.152
		B		0.000	0.000	24.818	0.000	0.226
		C		0.000	0.000	11.648	0.000	0.233
L50	22.000-17.000	A	1.210	0.000	0.000	15.483	0.000	0.129
		B		0.000	0.000	24.699	0.000	0.221
		C		0.000	0.000	8.293	0.000	0.208
L51	17.000-12.000	A	1.174	0.000	0.000	15.377	0.000	0.125
		B		0.000	0.000	24.549	0.000	0.215
		C		0.000	0.000	8.258	0.000	0.206
L52	12.000-7.000	A	1.126	0.000	0.000	15.231	0.000	0.119
		B		0.000	0.000	24.342	0.000	0.206
		C		0.000	0.000	8.209	0.000	0.203
L53	7.000-2.000	A	1.044	0.000	0.000	14.988	0.000	0.110
		B		0.000	0.000	23.997	0.000	0.192
		C		0.000	0.000	8.128	0.000	0.199

tnxTower B+T Group 1717 S. Boulder, Suite 300 Tulsa, OK 74119 Phone: (918) 587-4630 FAX: (918) 295-0265	Job 92739.019.01 - GROTON TOWER, CT (BU# 881533)	Page 16 of 62
	Project	Date 20:02:38 10/26/21
	Client Crown Castle	Designed by JD Prabhu

Tower Section	Tower Elevation ft	Face or Leg	Ice Thickness in	A _R ft ²	A _F ft ²	C _{AA} In Face ft ²	C _{AA} Out Face ft ²	Weight K
L54	2.000-0.000	A	0.899	0.000	0.000	5.820	0.000	0.038
		B		0.000	0.000	9.351	0.000	0.067
		C		0.000	0.000	3.193	0.000	0.076

Feed Line Center of Pressure

Section	Elevation ft	CP _X in	CP _Z in	CP _X Ice in	CP _Z Ice in
L1	144.500-139.500	-0.003	-0.301	-0.014	-1.296
L2	139.500-134.500	-0.003	-0.301	-0.014	-1.306
L3	134.500-129.500	-0.003	-0.301	-0.014	-1.314
L4	129.500-124.500	1.847	-1.079	1.768	-1.787
L5	124.500-117.568	2.483	-1.349	2.316	-1.952
L6	117.568-116.409	2.490	-1.354	2.333	-1.968
L7	116.409-112.583	1.761	-0.958	1.877	-1.582
L8	112.583-112.333	1.218	-0.662	1.443	-1.217
L9	112.333-107.333	1.232	-0.670	1.460	-1.230
L10	107.333-106.920	1.146	-0.623	1.390	-1.172
L11	106.920-106.670	0.861	-0.468	1.120	-0.944
L12	106.670-103.500	0.746	-0.406	0.993	-0.837
L13	103.500-103.250	0.650	-0.354	0.883	-0.744
L14	103.250-98.500	0.642	-0.349	0.880	-0.742
L15	98.500-98.250	0.668	-0.363	0.929	-0.782
L16	98.250-97.580	0.669	-0.364	0.931	-0.784
L17	97.580-97.330	0.671	-0.365	0.932	-0.786
L18	97.330-92.330	0.861	-0.469	1.147	-0.966
L19	92.330-87.118	1.400	-0.762	1.672	-1.408
L20	87.118-86.118	2.557	-1.393	2.491	-2.097
L21	86.118-83.000	1.498	-0.816	1.812	-1.524
L22	83.000-82.750	1.223	-0.666	1.580	-1.329
L23	82.750-77.750	0.966	-0.526	1.314	-1.105
L24	77.750-77.250	0.772	-0.421	1.094	-0.920
L25	77.250-77.000	0.774	-0.422	1.097	-0.921
L26	77.000-76.750	0.775	-0.422	1.097	-0.922
L27	76.750-71.750	0.988	-0.538	1.321	-1.109
L28	71.750-69.000	0.851	-0.464	1.171	-0.983
L29	69.000-68.750	0.778	-0.424	1.090	-0.915
L30	68.750-63.750	0.786	-0.428	1.101	-0.923
L31	63.750-60.000	-0.827	0.659	-0.217	-0.018
L32	60.000-59.750	-1.769	1.294	-1.010	0.527
L33	59.750-58.500	-1.639	2.720	-0.947	1.810
L34	58.500-58.250	-1.614	3.050	-0.934	2.110
L35	58.250-58.000	-1.616	3.054	-0.936	2.112
L36	58.000-57.750	-1.617	3.056	-0.937	2.114
L37	57.750-56.750	-1.622	3.064	-0.939	2.120
L38	56.750-56.500	-1.626	3.073	-0.942	2.126
L39	56.500-51.500	-2.142	4.046	-1.187	2.674
L40	51.500-42.042	-2.278	4.297	-1.258	2.825
L41	42.042-41.042	-2.293	4.324	-1.266	2.842
L42	41.042-36.042	-2.317	4.369	-1.286	2.879
L43	36.042-31.250	-2.883	1.559	-1.951	0.825
L44	31.250-31.000	-3.025	0.926	-2.119	0.338
L45	31.000-27.750	-1.978	2.235	-1.316	1.645
L46	27.750-27.500	-1.616	2.706	-1.031	2.124
L47	27.500-27.250	-1.618	2.709	-1.032	2.127
L48	27.250-27.000	0.591	1.400	0.855	0.987

tnxTower B+T Group 1717 S. Boulder, Suite 300 Tulsa, OK 74119 Phone: (918) 587-4630 FAX: (918) 295-0265	Job 92739.019.01 - GROTON TOWER, CT (BU# 881533)	Page 17 of 62
	Project	Date 20:02:38 10/26/21
	Client Crown Castle	Designed by JD Prabhu

Section	Elevation	CP _x	CP _z	CP _x	CP _z
	ft	in	in	Ice in	Ice in
L49	27.000-22.000	1.994	-0.202	2.080	-0.422
L50	22.000-17.000	3.196	-1.925	3.099	-1.891
L51	17.000-12.000	3.247	-1.956	3.139	-1.914
L52	12.000-7.000	3.298	-1.986	3.175	-1.934
L53	7.000-2.000	3.348	-2.016	3.202	-1.947
L54	2.000-0.000	3.383	-2.036	3.199	-1.940

Note: For pole sections, center of pressure calculations do not consider feed line shielding.

Shielding Factor Ka

Tower Section	Feed Line Record No.	Description	Feed Line Segment Elev.	K _a No Ice	K _a Ice
L1	27	Safety Line 3/8	139.50 - 144.50	1.0000	1.0000
L2	27	Safety Line 3/8	134.50 - 139.50	1.0000	1.0000
L3	27	Safety Line 3/8	129.50 - 134.50	1.0000	1.0000
L4	18	LDF7-50A(1-5/8)	124.50 - 128.00	1.0000	1.0000
L4	27	Safety Line 3/8	124.50 - 129.50	1.0000	1.0000
L5	18	LDF7-50A(1-5/8)	117.57 - 124.50	1.0000	1.0000
L5	27	Safety Line 3/8	117.57 - 124.50	1.0000	1.0000
L6	18	LDF7-50A(1-5/8)	116.41 - 117.57	1.0000	1.0000
L6	27	Safety Line 3/8	116.41 - 117.57	1.0000	1.0000
L7	18	LDF7-50A(1-5/8)	112.58 - 116.41	1.0000	1.0000
L7	27	Safety Line 3/8	112.58 - 116.41	1.0000	1.0000
L7	49	CCI 4.5" x 1" Plate	112.58 - 114.08	1.0000	1.0000
L7	50	CCI 4.5" x 1" Plate	112.58 - 114.08	1.0000	1.0000
L7	51	CCI 4.5" x 1" Plate	112.58 - 114.08	1.0000	1.0000
L8	18	LDF7-50A(1-5/8)	112.33 - 112.58	1.0000	1.0000
L8	27	Safety Line 3/8	112.33 - 112.58	1.0000	1.0000
L8	49	CCI 4.5" x 1" Plate	112.33 - 112.58	1.0000	1.0000
L8	50	CCI 4.5" x 1" Plate	112.33 - 112.58	1.0000	1.0000
L8	51	CCI 4.5" x 1" Plate	112.33 - 112.58	1.0000	1.0000
L9	18	LDF7-50A(1-5/8)	107.33 - 112.33	1.0000	1.0000
L9	27	Safety Line 3/8	107.33 -	1.0000	1.0000

tnxTower

B+T Group
1717 S. Boulder, Suite 300
Tulsa, OK 74119
Phone: (918) 587-4630
FAX: (918) 295-0265

Job 92739.019.01 - GROTON TOWER, CT (BU# 881533)	Page 18 of 62
Project	Date 20:02:38 10/26/21
Client Crown Castle	Designed by JD Prabhu

Tower Section	Feed Line Record No.	Description	Feed Line Segment Elev.	K_a No Ice	K_a Ice
L9	49	CCI 4.5" x 1" Plate	112.33 107.33 - 112.33	1.0000	1.0000
L9	50	CCI 4.5" x 1" Plate	107.33 - 112.33	1.0000	1.0000
L9	51	CCI 4.5" x 1" Plate	107.33 - 112.33	1.0000	1.0000
L10	18	LDF7-50A(1-5/8)	106.92 - 107.33	1.0000	1.0000
L10	27	Safety Line 3/8	106.92 - 107.33	1.0000	1.0000
L10	49	CCI 4.5" x 1" Plate	106.92 - 107.33	1.0000	1.0000
L10	50	CCI 4.5" x 1" Plate	106.92 - 107.33	1.0000	1.0000
L10	51	CCI 4.5" x 1" Plate	106.92 - 107.33	1.0000	1.0000
L10	59	CCI 4" x 0.75" Plate	106.92 - 107.00	1.0000	1.0000
L10	60	CCI 4" x 0.75" Plate	106.92 - 107.00	1.0000	1.0000
L10	61	CCI 4" x 0.75" Plate	106.92 - 107.00	1.0000	1.0000
L11	18	LDF7-50A(1-5/8)	106.67 - 106.92	1.0000	1.0000
L11	27	Safety Line 3/8	106.67 - 106.92	1.0000	1.0000
L11	49	CCI 4.5" x 1" Plate	106.67 - 106.92	1.0000	1.0000
L11	50	CCI 4.5" x 1" Plate	106.67 - 106.92	1.0000	1.0000
L11	51	CCI 4.5" x 1" Plate	106.67 - 106.92	1.0000	1.0000
L11	59	CCI 4" x 0.75" Plate	106.67 - 106.92	1.0000	1.0000
L11	60	CCI 4" x 0.75" Plate	106.67 - 106.92	1.0000	1.0000
L11	61	CCI 4" x 0.75" Plate	106.67 - 106.92	1.0000	1.0000
L12	18	LDF7-50A(1-5/8)	103.50 - 106.67	1.0000	1.0000
L12	27	Safety Line 3/8	103.50 - 106.67	1.0000	1.0000
L12	41	CCI 4.5" x 1" Plate	103.50 - 105.00	1.0000	1.0000
L12	42	CCI 4.5" x 1" Plate	103.50 - 105.00	1.0000	1.0000
L12	43	CCI 4.5" x 1" Plate	103.50 - 105.00	1.0000	1.0000
L12	49	CCI 4.5" x 1" Plate	103.50 - 106.67	1.0000	1.0000
L12	50	CCI 4.5" x 1" Plate	103.50 - 106.67	1.0000	1.0000
L12	51	CCI 4.5" x 1" Plate	103.50 - 106.67	1.0000	1.0000
L12	59	CCI 4" x 0.75" Plate	103.50 - 106.67	1.0000	1.0000
L12	60	CCI 4" x 0.75" Plate	103.50 - 106.67	1.0000	1.0000
L12	61	CCI 4" x 0.75" Plate	103.50 - 106.67	1.0000	1.0000
L13	18	LDF7-50A(1-5/8)	103.25 -	1.0000	1.0000

Tower Section	Feed Line Record No.	Description	Feed Line Segment Elev.	K _a No Ice	K _a Ice
			103.50		
L13	27	Safety Line 3/8	103.25 - 103.50	1.0000	1.0000
L13	41	CCI 4.5" x 1" Plate	103.25 - 103.50	1.0000	1.0000
L13	42	CCI 4.5" x 1" Plate	103.25 - 103.50	1.0000	1.0000
L13	43	CCI 4.5" x 1" Plate	103.25 - 103.50	1.0000	1.0000
L13	49	CCI 4.5" x 1" Plate	103.25 - 103.50	1.0000	1.0000
L13	50	CCI 4.5" x 1" Plate	103.25 - 103.50	1.0000	1.0000
L13	51	CCI 4.5" x 1" Plate	103.25 - 103.50	1.0000	1.0000
L13	59	CCI 4" x 0.75" Plate	103.25 - 103.50	1.0000	1.0000
L13	60	CCI 4" x 0.75" Plate	103.25 - 103.50	1.0000	1.0000
L13	61	CCI 4" x 0.75" Plate	103.25 - 103.50	1.0000	1.0000
L14	18	LDF7-50A(1-5/8)	98.50 - 103.25	1.0000	1.0000
L14	27	Safety Line 3/8	98.50 - 103.25	1.0000	1.0000
L14	29	CCI 4.5" x 1" Plate	98.50 - 100.00	1.0000	1.0000
L14	30	CCI 4.5" x 1" Plate	98.50 - 100.00	1.0000	1.0000
L14	31	CCI 4.5" x 1" Plate	98.50 - 100.00	1.0000	1.0000
L14	41	CCI 4.5" x 1" Plate	98.50 - 103.25	1.0000	1.0000
L14	42	CCI 4.5" x 1" Plate	98.50 - 103.25	1.0000	1.0000
L14	43	CCI 4.5" x 1" Plate	98.50 - 103.25	1.0000	1.0000
L14	49	CCI 4.5" x 1" Plate	99.50 - 103.25	1.0000	1.0000
L14	50	CCI 4.5" x 1" Plate	99.50 - 103.25	1.0000	1.0000
L14	51	CCI 4.5" x 1" Plate	99.50 - 103.25	1.0000	1.0000
L14	59	CCI 4" x 0.75" Plate	98.50 - 103.25	1.0000	1.0000
L14	60	CCI 4" x 0.75" Plate	98.50 - 103.25	1.0000	1.0000
L14	61	CCI 4" x 0.75" Plate	98.50 - 103.25	1.0000	1.0000
L15	18	LDF7-50A(1-5/8)	98.25 - 98.50	1.0000	1.0000
L15	27	Safety Line 3/8	98.25 - 98.50	1.0000	1.0000
L15	29	CCI 4.5" x 1" Plate	98.25 - 98.50	1.0000	1.0000
L15	30	CCI 4.5" x 1" Plate	98.25 - 98.50	1.0000	1.0000
L15	31	CCI 4.5" x 1" Plate	98.25 - 98.50	1.0000	1.0000
L15	41	CCI 4.5" x 1" Plate	98.25 - 98.50	1.0000	1.0000
L15	42	CCI 4.5" x 1" Plate	98.25 - 98.50	1.0000	1.0000
L15	43	CCI 4.5" x 1" Plate	98.25 - 98.50	1.0000	1.0000
L15	59	CCI 4" x 0.75" Plate	98.25 - 98.50	1.0000	1.0000
L15	60	CCI 4" x 0.75" Plate	98.25 - 98.50	1.0000	1.0000
L15	61	CCI 4" x 0.75" Plate	98.25 - 98.50	1.0000	1.0000
L16	18	LDF7-50A(1-5/8)	97.58 - 98.25	1.0000	1.0000
L16	27	Safety Line 3/8	97.58 - 98.25	1.0000	1.0000
L16	29	CCI 4.5" x 1" Plate	97.58 - 98.25	1.0000	1.0000
L16	30	CCI 4.5" x 1" Plate	97.58 - 98.25	1.0000	1.0000
L16	31	CCI 4.5" x 1" Plate	97.58 - 98.25	1.0000	1.0000
L16	41	CCI 4.5" x 1" Plate	97.58 - 98.25	1.0000	1.0000
L16	42	CCI 4.5" x 1" Plate	97.58 - 98.25	1.0000	1.0000
L16	43	CCI 4.5" x 1" Plate	97.58 - 98.25	1.0000	1.0000
L16	59	CCI 4" x 0.75" Plate	97.58 - 98.25	1.0000	1.0000
L16	60	CCI 4" x 0.75" Plate	97.58 - 98.25	1.0000	1.0000
L16	61	CCI 4" x 0.75" Plate	97.58 - 98.25	1.0000	1.0000
L17	18	LDF7-50A(1-5/8)	97.33 - 97.58	1.0000	1.0000
L17	27	Safety Line 3/8	97.33 - 97.58	1.0000	1.0000
L17	29	CCI 4.5" x 1" Plate	97.33 - 97.58	1.0000	1.0000
L17	30	CCI 4.5" x 1" Plate	97.33 - 97.58	1.0000	1.0000
L17	31	CCI 4.5" x 1" Plate	97.33 - 97.58	1.0000	1.0000

tnxTower

B+T Group
1717 S. Boulder, Suite 300
Tulsa, OK 74119
Phone: (918) 587-4630
FAX: (918) 295-0265

Job 92739.019.01 - GROTON TOWER, CT (BU# 881533)	Page 20 of 62
Project	Date 20:02:38 10/26/21
Client Crown Castle	Designed by JD Prabhu

Tower Section	Feed Line Record No.	Description	Feed Line Segment Elev.	K _a No Ice	K _a Ice
L17	41	CCI 4.5" x 1" Plate	97.33 - 97.58	1.0000	1.0000
L17	42	CCI 4.5" x 1" Plate	97.33 - 97.58	1.0000	1.0000
L17	43	CCI 4.5" x 1" Plate	97.33 - 97.58	1.0000	1.0000
L17	59	CCI 4" x 0.75" Plate	97.33 - 97.58	1.0000	1.0000
L17	60	CCI 4" x 0.75" Plate	97.33 - 97.58	1.0000	1.0000
L17	61	CCI 4" x 0.75" Plate	97.33 - 97.58	1.0000	1.0000
L18	18	LDF7-50A(1-5/8)	92.33 - 97.33	1.0000	1.0000
L18	27	Safety Line 3/8	92.33 - 97.33	1.0000	1.0000
L18	29	CCI 4.5" x 1" Plate	92.33 - 97.33	1.0000	1.0000
L18	30	CCI 4.5" x 1" Plate	92.33 - 97.33	1.0000	1.0000
L18	31	CCI 4.5" x 1" Plate	92.33 - 97.33	1.0000	1.0000
L18	41	CCI 4.5" x 1" Plate	92.33 - 97.33	1.0000	1.0000
L18	42	CCI 4.5" x 1" Plate	92.33 - 97.33	1.0000	1.0000
L18	43	CCI 4.5" x 1" Plate	92.33 - 97.33	1.0000	1.0000
L18	59	CCI 4" x 0.75" Plate	97.00 - 97.33	1.0000	1.0000
L18	60	CCI 4" x 0.75" Plate	97.00 - 97.33	1.0000	1.0000
L18	61	CCI 4" x 0.75" Plate	97.00 - 97.33	1.0000	1.0000
L19	18	LDF7-50A(1-5/8)	87.12 - 92.33	1.0000	1.0000
L19	27	Safety Line 3/8	87.12 - 92.33	1.0000	1.0000
L19	29	CCI 4.5" x 1" Plate	90.00 - 92.33	1.0000	1.0000
L19	30	CCI 4.5" x 1" Plate	90.00 - 92.33	1.0000	1.0000
L19	31	CCI 4.5" x 1" Plate	90.00 - 92.33	1.0000	1.0000
L19	41	CCI 4.5" x 1" Plate	90.00 - 92.33	1.0000	1.0000
L19	42	CCI 4.5" x 1" Plate	90.00 - 92.33	1.0000	1.0000
L19	43	CCI 4.5" x 1" Plate	90.00 - 92.33	1.0000	1.0000
L20	18	LDF7-50A(1-5/8)	86.12 - 87.12	1.0000	1.0000
L20	27	Safety Line 3/8	86.12 - 87.12	1.0000	1.0000
L21	18	LDF7-50A(1-5/8)	83.00 - 86.12	1.0000	1.0000
L21	27	Safety Line 3/8	83.00 - 86.12	1.0000	1.0000
L21	45	CCI 6" x 1" Plate	83.00 - 85.00	1.0000	1.0000
L21	46	CCI 6" x 1" Plate	83.00 - 85.00	1.0000	1.0000
L21	47	CCI 6" x 1" Plate	83.00 - 85.00	1.0000	1.0000
L22	18	LDF7-50A(1-5/8)	82.75 - 83.00	1.0000	1.0000
L22	27	Safety Line 3/8	82.75 - 83.00	1.0000	1.0000
L22	45	CCI 6" x 1" Plate	82.75 - 83.00	1.0000	1.0000
L22	46	CCI 6" x 1" Plate	82.75 - 83.00	1.0000	1.0000
L22	47	CCI 6" x 1" Plate	82.75 - 83.00	1.0000	1.0000
L23	18	LDF7-50A(1-5/8)	77.75 - 82.75	1.0000	1.0000
L23	27	Safety Line 3/8	77.75 - 82.75	1.0000	1.0000
L23	37	CCI 6.5" x 1.25" Plate	77.75 - 80.00	1.0000	1.0000
L23	38	CCI 6.5" x 1.25" Plate	77.75 - 80.00	1.0000	1.0000
L23	39	CCI 6.5" x 1.25" Plate	77.75 - 80.00	1.0000	1.0000
L23	45	CCI 6" x 1" Plate	77.75 - 82.75	1.0000	1.0000
L23	46	CCI 6" x 1" Plate	77.75 - 82.75	1.0000	1.0000
L23	47	CCI 6" x 1" Plate	77.75 - 82.75	1.0000	1.0000
L24	18	LDF7-50A(1-5/8)	77.25 - 77.75	1.0000	1.0000
L24	27	Safety Line 3/8	77.25 - 77.75	1.0000	1.0000
L24	37	CCI 6.5" x 1.25" Plate	77.25 - 77.75	1.0000	1.0000
L24	38	CCI 6.5" x 1.25" Plate	77.25 - 77.75	1.0000	1.0000
L24	39	CCI 6.5" x 1.25" Plate	77.25 - 77.75	1.0000	1.0000
L24	45	CCI 6" x 1" Plate	77.25 - 77.75	1.0000	1.0000
L24	46	CCI 6" x 1" Plate	77.25 - 77.75	1.0000	1.0000
L24	47	CCI 6" x 1" Plate	77.25 - 77.75	1.0000	1.0000
L25	18	LDF7-50A(1-5/8)	77.00 - 77.25	1.0000	1.0000
L25	27	Safety Line 3/8	77.00 - 77.25	1.0000	1.0000
L25	37	CCI 6.5" x 1.25" Plate	77.00 - 77.25	1.0000	1.0000
L25	38	CCI 6.5" x 1.25" Plate	77.00 - 77.25	1.0000	1.0000
L25	39	CCI 6.5" x 1.25" Plate	77.00 - 77.25	1.0000	1.0000
L25	45	CCI 6" x 1" Plate	77.00 - 77.25	1.0000	1.0000
L25	46	CCI 6" x 1" Plate	77.00 - 77.25	1.0000	1.0000
L25	47	CCI 6" x 1" Plate	77.00 - 77.25	1.0000	1.0000
L26	18	LDF7-50A(1-5/8)	76.75 - 77.00	1.0000	1.0000

Job	92739.019.01 - GROTON TOWER, CT (BU# 881533)	Page	21 of 62
Project		Date	20:02:38 10/26/21
Client	Crown Castle	Designed by	JD Prabhu

Tower Section	Feed Line Record No.	Description	Feed Line Segment Elev.	K _a No Ice	K _a Ice
L26	27	Safety Line 3/8	76.75 - 77.00	1.0000	1.0000
L26	37	CCI 6.5" x 1.25" Plate	76.75 - 77.00	1.0000	1.0000
L26	38	CCI 6.5" x 1.25" Plate	76.75 - 77.00	1.0000	1.0000
L26	39	CCI 6.5" x 1.25" Plate	76.75 - 77.00	1.0000	1.0000
L26	45	CCI 6" x 1" Plate	76.75 - 77.00	1.0000	1.0000
L26	46	CCI 6" x 1" Plate	76.75 - 77.00	1.0000	1.0000
L26	47	CCI 6" x 1" Plate	76.75 - 77.00	1.0000	1.0000
L27	18	LDF7-50A(1-5/8)	71.75 - 76.75	1.0000	1.0000
L27	27	Safety Line 3/8	71.75 - 76.75	1.0000	1.0000
L27	37	CCI 6.5" x 1.25" Plate	71.75 - 76.75	1.0000	1.0000
L27	38	CCI 6.5" x 1.25" Plate	71.75 - 76.75	1.0000	1.0000
L27	39	CCI 6.5" x 1.25" Plate	71.75 - 76.75	1.0000	1.0000
L27	45	CCI 6" x 1" Plate	75.00 - 76.75	1.0000	1.0000
L27	46	CCI 6" x 1" Plate	75.00 - 76.75	1.0000	1.0000
L27	47	CCI 6" x 1" Plate	75.00 - 76.75	1.0000	1.0000
L28	18	LDF7-50A(1-5/8)	69.00 - 71.75	1.0000	1.0000
L28	27	Safety Line 3/8	69.00 - 71.75	1.0000	1.0000
L28	37	CCI 6.5" x 1.25" Plate	69.00 - 71.75	1.0000	1.0000
L28	38	CCI 6.5" x 1.25" Plate	69.00 - 71.75	1.0000	1.0000
L28	39	CCI 6.5" x 1.25" Plate	69.00 - 71.75	1.0000	1.0000
L28	65	CCI 6" x 1" Plate	69.00 - 71.00	1.0000	1.0000
L28	66	CCI 6" x 1" Plate	69.00 - 71.00	1.0000	1.0000
L28	67	CCI 6" x 1" Plate	69.00 - 71.00	1.0000	1.0000
L29	18	LDF7-50A(1-5/8)	68.75 - 69.00	1.0000	1.0000
L29	27	Safety Line 3/8	68.75 - 69.00	1.0000	1.0000
L29	37	CCI 6.5" x 1.25" Plate	68.75 - 69.00	1.0000	1.0000
L29	38	CCI 6.5" x 1.25" Plate	68.75 - 69.00	1.0000	1.0000
L29	39	CCI 6.5" x 1.25" Plate	68.75 - 69.00	1.0000	1.0000
L29	65	CCI 6" x 1" Plate	68.75 - 69.00	1.0000	1.0000
L29	66	CCI 6" x 1" Plate	68.75 - 69.00	1.0000	1.0000
L29	67	CCI 6" x 1" Plate	68.75 - 69.00	1.0000	1.0000
L30	18	LDF7-50A(1-5/8)	63.75 - 68.75	1.0000	1.0000
L30	27	Safety Line 3/8	63.75 - 68.75	1.0000	1.0000
L30	37	CCI 6.5" x 1.25" Plate	63.75 - 68.75	1.0000	1.0000
L30	38	CCI 6.5" x 1.25" Plate	63.75 - 68.75	1.0000	1.0000
L30	39	CCI 6.5" x 1.25" Plate	63.75 - 68.75	1.0000	1.0000
L30	65	CCI 6" x 1" Plate	63.75 - 68.75	1.0000	1.0000
L30	66	CCI 6" x 1" Plate	63.75 - 68.75	1.0000	1.0000
L30	67	CCI 6" x 1" Plate	63.75 - 68.75	1.0000	1.0000
L31	18	LDF7-50A(1-5/8)	60.00 - 63.75	1.0000	1.0000
L31	27	Safety Line 3/8	60.00 - 63.75	1.0000	1.0000
L31	37	CCI 6.5" x 1.25" Plate	60.00 - 63.75	1.0000	1.0000
L31	38	CCI 6.5" x 1.25" Plate	60.00 - 63.75	1.0000	1.0000
L31	39	CCI 6.5" x 1.25" Plate	60.00 - 63.75	1.0000	1.0000
L31	57	CCI 8.5" x 1.25" Plate	60.00 - 62.25	1.0000	1.0000
L31	65	CCI 6" x 1" Plate	60.00 - 63.75	1.0000	1.0000
L31	66	CCI 6" x 1" Plate	60.00 - 63.75	1.0000	1.0000
L31	67	CCI 6" x 1" Plate	60.00 - 63.75	1.0000	1.0000
L32	18	LDF7-50A(1-5/8)	59.75 - 60.00	1.0000	1.0000
L32	27	Safety Line 3/8	59.75 - 60.00	1.0000	1.0000
L32	37	CCI 6.5" x 1.25" Plate	59.75 - 60.00	1.0000	1.0000
L32	38	CCI 6.5" x 1.25" Plate	59.75 - 60.00	1.0000	1.0000
L32	39	CCI 6.5" x 1.25" Plate	59.75 - 60.00	1.0000	1.0000
L32	57	CCI 8.5" x 1.25" Plate	59.75 - 60.00	1.0000	1.0000
L32	65	CCI 6" x 1" Plate	59.75 - 60.00	1.0000	1.0000
L32	66	CCI 6" x 1" Plate	59.75 - 60.00	1.0000	1.0000
L32	67	CCI 6" x 1" Plate	59.75 - 60.00	1.0000	1.0000
L33	18	LDF7-50A(1-5/8)	58.50 - 59.75	1.0000	1.0000
L33	27	Safety Line 3/8	58.50 - 59.75	1.0000	1.0000
L33	37	CCI 6.5" x 1.25" Plate	58.50 - 59.75	1.0000	1.0000
L33	38	CCI 6.5" x 1.25" Plate	58.50 - 59.75	1.0000	1.0000
L33	39	CCI 6.5" x 1.25" Plate	58.50 - 59.75	1.0000	1.0000

tnxTower

B+T Group
1717 S. Boulder, Suite 300
Tulsa, OK 74119
Phone: (918) 587-4630
FAX: (918) 295-0265

Job

92739.019.01 - GROTON TOWER, CT (BU# 881533)

Page

22 of 62

Project

Date

20:02:38 10/26/21

Client

Crown Castle

Designed by

JD Prabhu

Tower Section	Feed Line Record No.	Description	Feed Line Segment Elev.	K_a No Ice	K_a Ice
L33	57	CCI 8.5" x 1.25" Plate	58.50 - 59.75	1.0000	1.0000
L33	63	CCI 6.5" x 1.25" Plate	58.50 - 59.50	1.0000	1.0000
L33	65	CCI 6" x 1" Plate	58.50 - 59.75	1.0000	1.0000
L33	66	CCI 6" x 1" Plate	58.50 - 59.75	1.0000	1.0000
L33	67	CCI 6" x 1" Plate	58.50 - 59.75	1.0000	1.0000
L34	18	LDF7-50A(1-5/8)	58.25 - 58.50	1.0000	1.0000
L34	27	Safety Line 3/8	58.25 - 58.50	1.0000	1.0000
L34	37	CCI 6.5" x 1.25" Plate	58.25 - 58.50	1.0000	1.0000
L34	38	CCI 6.5" x 1.25" Plate	58.25 - 58.50	1.0000	1.0000
L34	39	CCI 6.5" x 1.25" Plate	58.25 - 58.50	1.0000	1.0000
L34	57	CCI 8.5" x 1.25" Plate	58.25 - 58.50	1.0000	1.0000
L34	63	CCI 6.5" x 1.25" Plate	58.25 - 58.50	1.0000	1.0000
L34	65	CCI 6" x 1" Plate	58.25 - 58.50	1.0000	1.0000
L34	66	CCI 6" x 1" Plate	58.25 - 58.50	1.0000	1.0000
L34	67	CCI 6" x 1" Plate	58.25 - 58.50	1.0000	1.0000
L35	18	LDF7-50A(1-5/8)	58.00 - 58.25	1.0000	1.0000
L35	27	Safety Line 3/8	58.00 - 58.25	1.0000	1.0000
L35	37	CCI 6.5" x 1.25" Plate	58.00 - 58.25	1.0000	1.0000
L35	38	CCI 6.5" x 1.25" Plate	58.00 - 58.25	1.0000	1.0000
L35	39	CCI 6.5" x 1.25" Plate	58.00 - 58.25	1.0000	1.0000
L35	57	CCI 8.5" x 1.25" Plate	58.00 - 58.25	1.0000	1.0000
L35	63	CCI 6.5" x 1.25" Plate	58.00 - 58.25	1.0000	1.0000
L35	65	CCI 6" x 1" Plate	58.00 - 58.25	1.0000	1.0000
L35	66	CCI 6" x 1" Plate	58.00 - 58.25	1.0000	1.0000
L35	67	CCI 6" x 1" Plate	58.00 - 58.25	1.0000	1.0000
L36	18	LDF7-50A(1-5/8)	57.75 - 58.00	1.0000	1.0000
L36	27	Safety Line 3/8	57.75 - 58.00	1.0000	1.0000
L36	37	CCI 6.5" x 1.25" Plate	57.75 - 58.00	1.0000	1.0000
L36	38	CCI 6.5" x 1.25" Plate	57.75 - 58.00	1.0000	1.0000
L36	39	CCI 6.5" x 1.25" Plate	57.75 - 58.00	1.0000	1.0000
L36	57	CCI 8.5" x 1.25" Plate	57.75 - 58.00	1.0000	1.0000
L36	63	CCI 6.5" x 1.25" Plate	57.75 - 58.00	1.0000	1.0000
L36	65	CCI 6" x 1" Plate	57.75 - 58.00	1.0000	1.0000
L36	66	CCI 6" x 1" Plate	57.75 - 58.00	1.0000	1.0000
L36	67	CCI 6" x 1" Plate	57.75 - 58.00	1.0000	1.0000
L37	18	LDF7-50A(1-5/8)	56.75 - 57.75	1.0000	1.0000
L37	27	Safety Line 3/8	56.75 - 57.75	1.0000	1.0000
L37	37	CCI 6.5" x 1.25" Plate	56.75 - 57.75	1.0000	1.0000
L37	38	CCI 6.5" x 1.25" Plate	56.75 - 57.75	1.0000	1.0000
L37	39	CCI 6.5" x 1.25" Plate	56.75 - 57.75	1.0000	1.0000
L37	57	CCI 8.5" x 1.25" Plate	56.75 - 57.75	1.0000	1.0000
L37	63	CCI 6.5" x 1.25" Plate	56.75 - 57.75	1.0000	1.0000
L37	65	CCI 6" x 1" Plate	56.75 - 57.75	1.0000	1.0000
L37	66	CCI 6" x 1" Plate	56.75 - 57.75	1.0000	1.0000
L37	67	CCI 6" x 1" Plate	56.75 - 57.75	1.0000	1.0000
L38	18	LDF7-50A(1-5/8)	56.50 - 56.75	1.0000	1.0000
L38	27	Safety Line 3/8	56.50 - 56.75	1.0000	1.0000
L38	37	CCI 6.5" x 1.25" Plate	56.50 - 56.75	1.0000	1.0000
L38	38	CCI 6.5" x 1.25" Plate	56.50 - 56.75	1.0000	1.0000
L38	39	CCI 6.5" x 1.25" Plate	56.50 - 56.75	1.0000	1.0000
L38	57	CCI 8.5" x 1.25" Plate	56.50 - 56.75	1.0000	1.0000
L38	63	CCI 6.5" x 1.25" Plate	56.50 - 56.75	1.0000	1.0000
L38	65	CCI 6" x 1" Plate	56.50 - 56.75	1.0000	1.0000
L38	66	CCI 6" x 1" Plate	56.50 - 56.75	1.0000	1.0000
L38	67	CCI 6" x 1" Plate	56.50 - 56.75	1.0000	1.0000
L39	18	LDF7-50A(1-5/8)	51.50 - 56.50	1.0000	1.0000
L39	27	Safety Line 3/8	51.50 - 56.50	1.0000	1.0000
L39	37	CCI 6.5" x 1.25" Plate	51.50 - 56.50	1.0000	1.0000
L39	38	CCI 6.5" x 1.25" Plate	51.50 - 56.50	1.0000	1.0000
L39	39	CCI 6.5" x 1.25" Plate	51.50 - 56.50	1.0000	1.0000
L39	57	CCI 8.5" x 1.25" Plate	51.50 - 56.50	1.0000	1.0000
L39	63	CCI 6.5" x 1.25" Plate	51.50 - 56.50	1.0000	1.0000

tnxTower

B+T Group
1717 S. Boulder, Suite 300
Tulsa, OK 74119
Phone: (918) 587-4630
FAX: (918) 295-0265

Job

92739.019.01 - GROTON TOWER, CT (BU# 881533)

Page

23 of 62

Project

Date

20:02:38 10/26/21

Client

Crown Castle

Designed by

JD Prabhu

Tower Section	Feed Line Record No.	Description	Feed Line Segment Elev.	K_a No Ice	K_a Ice
L39	65	CCI 6" x 1" Plate	56.00 - 56.50	1.0000	1.0000
L39	66	CCI 6" x 1" Plate	56.00 - 56.50	1.0000	1.0000
L39	67	CCI 6" x 1" Plate	56.00 - 56.50	1.0000	1.0000
L40	18	LDF7-50A(1-5/8)	42.04 - 51.50	1.0000	1.0000
L40	27	Safety Line 3/8	42.04 - 51.50	1.0000	1.0000
L40	37	CCI 6.5" x 1.25" Plate	42.04 - 51.50	1.0000	1.0000
L40	38	CCI 6.5" x 1.25" Plate	42.04 - 51.50	1.0000	1.0000
L40	39	CCI 6.5" x 1.25" Plate	42.04 - 51.50	1.0000	1.0000
L40	57	CCI 8.5" x 1.25" Plate	42.04 - 51.50	1.0000	1.0000
L40	63	CCI 6.5" x 1.25" Plate	42.04 - 51.50	1.0000	1.0000
L41	18	LDF7-50A(1-5/8)	41.04 - 42.04	1.0000	1.0000
L41	27	Safety Line 3/8	41.04 - 42.04	1.0000	1.0000
L41	37	CCI 6.5" x 1.25" Plate	41.04 - 42.04	1.0000	1.0000
L41	38	CCI 6.5" x 1.25" Plate	41.04 - 42.04	1.0000	1.0000
L41	39	CCI 6.5" x 1.25" Plate	41.04 - 42.04	1.0000	1.0000
L41	57	CCI 8.5" x 1.25" Plate	41.04 - 42.04	1.0000	1.0000
L41	63	CCI 6.5" x 1.25" Plate	41.04 - 42.04	1.0000	1.0000
L42	18	LDF7-50A(1-5/8)	36.04 - 41.04	1.0000	1.0000
L42	27	Safety Line 3/8	36.04 - 41.04	1.0000	1.0000
L42	37	CCI 6.5" x 1.25" Plate	36.04 - 41.04	1.0000	1.0000
L42	38	CCI 6.5" x 1.25" Plate	36.04 - 41.04	1.0000	1.0000
L42	39	CCI 6.5" x 1.25" Plate	36.04 - 41.04	1.0000	1.0000
L42	57	CCI 8.5" x 1.25" Plate	36.04 - 41.04	1.0000	1.0000
L42	63	CCI 6.5" x 1.25" Plate	36.04 - 41.04	1.0000	1.0000
L43	18	LDF7-50A(1-5/8)	31.25 - 36.04	1.0000	1.0000
L43	27	Safety Line 3/8	31.25 - 36.04	1.0000	1.0000
L43	33	CCI 8.5" x 1.25" Plate	31.25 - 35.00	1.0000	1.0000
L43	34	CCI 8.5" x 1.25" Plate	31.25 - 35.00	1.0000	1.0000
L43	35	CCI 8.5" x 1.25" Plate	31.25 - 35.00	1.0000	1.0000
L43	37	CCI 6.5" x 1.25" Plate	31.25 - 36.04	1.0000	1.0000
L43	38	CCI 6.5" x 1.25" Plate	35.00 - 36.04	1.0000	1.0000
L43	39	CCI 6.5" x 1.25" Plate	35.00 - 36.04	1.0000	1.0000
L43	57	CCI 8.5" x 1.25" Plate	31.25 - 36.04	1.0000	1.0000
L43	63	CCI 6.5" x 1.25" Plate	31.25 - 36.04	1.0000	1.0000
L44	18	LDF7-50A(1-5/8)	31.00 - 31.25	1.0000	1.0000
L44	27	Safety Line 3/8	31.00 - 31.25	1.0000	1.0000
L44	33	CCI 8.5" x 1.25" Plate	31.00 - 31.25	1.0000	1.0000
L44	34	CCI 8.5" x 1.25" Plate	31.00 - 31.25	1.0000	1.0000
L44	35	CCI 8.5" x 1.25" Plate	31.00 - 31.25	1.0000	1.0000
L44	37	CCI 6.5" x 1.25" Plate	31.00 - 31.25	1.0000	1.0000
L44	57	CCI 8.5" x 1.25" Plate	31.00 - 31.25	1.0000	1.0000
L44	63	CCI 6.5" x 1.25" Plate	31.00 - 31.25	1.0000	1.0000
L45	18	LDF7-50A(1-5/8)	27.75 - 31.00	1.0000	1.0000
L45	27	Safety Line 3/8	27.75 - 31.00	1.0000	1.0000
L45	33	CCI 8.5" x 1.25" Plate	27.75 - 31.00	1.0000	1.0000
L45	34	CCI 8.5" x 1.25" Plate	27.75 - 31.00	1.0000	1.0000
L45	35	CCI 8.5" x 1.25" Plate	27.75 - 31.00	1.0000	1.0000
L45	37	CCI 6.5" x 1.25" Plate	27.75 - 31.00	1.0000	1.0000
L45	53	CCI 5.5" x 1.25" Plate	27.75 - 30.00	1.0000	1.0000
L45	54	CCI 5.5" x 1.25" Plate	27.75 - 30.00	1.0000	1.0000
L45	55	CCI 6.5" x 1.25" Plate	27.75 - 30.00	1.0000	1.0000
L45	57	CCI 8.5" x 1.25" Plate	27.75 - 31.00	1.0000	1.0000
L45	63	CCI 6.5" x 1.25" Plate	27.75 - 31.00	1.0000	1.0000
L46	18	LDF7-50A(1-5/8)	27.50 - 27.75	1.0000	1.0000
L46	27	Safety Line 3/8	27.50 - 27.75	1.0000	1.0000
L46	33	CCI 8.5" x 1.25" Plate	27.50 - 27.75	1.0000	1.0000
L46	34	CCI 8.5" x 1.25" Plate	27.50 - 27.75	1.0000	1.0000
L46	35	CCI 8.5" x 1.25" Plate	27.50 - 27.75	1.0000	1.0000
L46	37	CCI 6.5" x 1.25" Plate	27.50 - 27.75	1.0000	1.0000
L46	53	CCI 5.5" x 1.25" Plate	27.50 - 27.75	1.0000	1.0000
L46	54	CCI 5.5" x 1.25" Plate	27.50 - 27.75	1.0000	1.0000
L46	55	CCI 6.5" x 1.25" Plate	27.50 - 27.75	1.0000	1.0000

tnxTower

B+T Group
1717 S. Boulder, Suite 300
Tulsa, OK 74119
Phone: (918) 587-4630
FAX: (918) 295-0265

Job 92739.019.01 - GROTON TOWER, CT (BU# 881533)	Page 24 of 62
Project	Date 20:02:38 10/26/21
Client Crown Castle	Designed by JD Prabhu

Tower Section	Feed Line Record No.	Description	Feed Line Segment Elev.	K_a No Ice	K_a Ice
L46	57	CCI 8.5" x 1.25" Plate	27.50 - 27.75	1.0000	1.0000
L46	63	CCI 6.5" x 1.25" Plate	27.50 - 27.75	1.0000	1.0000
L47	18	LDF7-50A(1-5/8)	27.25 - 27.50	1.0000	1.0000
L47	27	Safety Line 3/8	27.25 - 27.50	1.0000	1.0000
L47	33	CCI 8.5" x 1.25" Plate	27.25 - 27.50	1.0000	1.0000
L47	34	CCI 8.5" x 1.25" Plate	27.25 - 27.50	1.0000	1.0000
L47	35	CCI 8.5" x 1.25" Plate	27.25 - 27.50	1.0000	1.0000
L47	37	CCI 6.5" x 1.25" Plate	27.25 - 27.50	1.0000	1.0000
L47	53	CCI 5.5" x 1.25" Plate	27.25 - 27.50	1.0000	1.0000
L47	54	CCI 5.5" x 1.25" Plate	27.25 - 27.50	1.0000	1.0000
L47	55	CCI 6.5" x 1.25" Plate	27.25 - 27.50	1.0000	1.0000
L47	57	CCI 8.5" x 1.25" Plate	27.25 - 27.50	1.0000	1.0000
L47	63	CCI 6.5" x 1.25" Plate	27.25 - 27.50	1.0000	1.0000
L48	18	LDF7-50A(1-5/8)	27.00 - 27.25	1.0000	1.0000
L48	27	Safety Line 3/8	27.00 - 27.25	1.0000	1.0000
L48	33	CCI 8.5" x 1.25" Plate	27.00 - 27.25	1.0000	1.0000
L48	34	CCI 8.5" x 1.25" Plate	27.00 - 27.25	1.0000	1.0000
L48	35	CCI 8.5" x 1.25" Plate	27.00 - 27.25	1.0000	1.0000
L48	37	CCI 6.5" x 1.25" Plate	27.00 - 27.25	1.0000	1.0000
L48	53	CCI 5.5" x 1.25" Plate	27.00 - 27.25	1.0000	1.0000
L48	54	CCI 5.5" x 1.25" Plate	27.00 - 27.25	1.0000	1.0000
L48	55	CCI 6.5" x 1.25" Plate	27.00 - 27.25	1.0000	1.0000
L48	63	CCI 6.5" x 1.25" Plate	27.00 - 27.25	1.0000	1.0000
L49	18	LDF7-50A(1-5/8)	22.00 - 27.00	1.0000	1.0000
L49	27	Safety Line 3/8	22.00 - 27.00	1.0000	1.0000
L49	33	CCI 8.5" x 1.25" Plate	22.00 - 27.00	1.0000	1.0000
L49	34	CCI 8.5" x 1.25" Plate	22.00 - 27.00	1.0000	1.0000
L49	35	CCI 8.5" x 1.25" Plate	22.00 - 27.00	1.0000	1.0000
L49	37	CCI 6.5" x 1.25" Plate	25.00 - 27.00	1.0000	1.0000
L49	53	CCI 5.5" x 1.25" Plate	22.00 - 27.00	1.0000	1.0000
L49	54	CCI 5.5" x 1.25" Plate	22.00 - 27.00	1.0000	1.0000
L49	55	CCI 6.5" x 1.25" Plate	22.00 - 27.00	1.0000	1.0000
L49	63	CCI 6.5" x 1.25" Plate	24.50 - 27.00	1.0000	1.0000
L50	18	LDF7-50A(1-5/8)	17.00 - 22.00	1.0000	1.0000
L50	27	Safety Line 3/8	17.00 - 22.00	1.0000	1.0000
L50	33	CCI 8.5" x 1.25" Plate	17.00 - 22.00	1.0000	1.0000
L50	34	CCI 8.5" x 1.25" Plate	17.00 - 22.00	1.0000	1.0000
L50	35	CCI 8.5" x 1.25" Plate	17.00 - 22.00	1.0000	1.0000
L50	53	CCI 5.5" x 1.25" Plate	17.00 - 22.00	1.0000	1.0000
L50	54	CCI 5.5" x 1.25" Plate	17.00 - 22.00	1.0000	1.0000
L50	55	CCI 6.5" x 1.25" Plate	17.00 - 22.00	1.0000	1.0000
L51	18	LDF7-50A(1-5/8)	12.00 - 17.00	1.0000	1.0000
L51	27	Safety Line 3/8	12.00 - 17.00	1.0000	1.0000
L51	33	CCI 8.5" x 1.25" Plate	12.00 - 17.00	1.0000	1.0000
L51	34	CCI 8.5" x 1.25" Plate	12.00 - 17.00	1.0000	1.0000
L51	35	CCI 8.5" x 1.25" Plate	12.00 - 17.00	1.0000	1.0000
L51	53	CCI 5.5" x 1.25" Plate	12.00 - 17.00	1.0000	1.0000
L51	54	CCI 5.5" x 1.25" Plate	12.00 - 17.00	1.0000	1.0000
L51	55	CCI 6.5" x 1.25" Plate	12.00 - 17.00	1.0000	1.0000
L52	18	LDF7-50A(1-5/8)	7.00 - 12.00	1.0000	1.0000
L52	27	Safety Line 3/8	7.00 - 12.00	1.0000	1.0000
L52	33	CCI 8.5" x 1.25" Plate	7.00 - 12.00	1.0000	1.0000
L52	34	CCI 8.5" x 1.25" Plate	7.00 - 12.00	1.0000	1.0000
L52	35	CCI 8.5" x 1.25" Plate	7.00 - 12.00	1.0000	1.0000
L52	53	CCI 5.5" x 1.25" Plate	7.00 - 12.00	1.0000	1.0000
L52	54	CCI 5.5" x 1.25" Plate	7.00 - 12.00	1.0000	1.0000
L52	55	CCI 6.5" x 1.25" Plate	7.00 - 12.00	1.0000	1.0000
L53	18	LDF7-50A(1-5/8)	2.00 - 7.00	1.0000	1.0000
L53	27	Safety Line 3/8	2.00 - 7.00	1.0000	1.0000
L53	33	CCI 8.5" x 1.25" Plate	2.00 - 7.00	1.0000	1.0000
L53	34	CCI 8.5" x 1.25" Plate	2.00 - 7.00	1.0000	1.0000
L53	35	CCI 8.5" x 1.25" Plate	2.00 - 7.00	1.0000	1.0000

tnxTower B+T Group 1717 S. Boulder, Suite 300 Tulsa, OK 74119 Phone: (918) 587-4630 FAX: (918) 295-0265	Job 92739.019.01 - GROTON TOWER, CT (BU# 881533)	Page 25 of 62
	Project	Date 20:02:38 10/26/21
	Client Crown Castle	Designed by JD Prabhu

Tower Section	Feed Line Record No.	Description	Feed Line Segment Elev.	K _a No Ice	K _a Ice
L53	53	CCI 5.5" x 1.25" Plate	2.00 - 7.00	1.0000	1.0000
L53	54	CCI 5.5" x 1.25" Plate	2.00 - 7.00	1.0000	1.0000
L53	55	CCI 6.5" x 1.25" Plate	2.00 - 7.00	1.0000	1.0000
L54	18	LDF7-50A(1-5/8)	0.00 - 2.00	1.0000	1.0000
L54	27	Safety Line 3/8	0.00 - 2.00	1.0000	1.0000
L54	33	CCI 8.5" x 1.25" Plate	0.00 - 2.00	1.0000	1.0000
L54	34	CCI 8.5" x 1.25" Plate	0.00 - 2.00	1.0000	1.0000
L54	35	CCI 8.5" x 1.25" Plate	0.00 - 2.00	1.0000	1.0000
L54	53	CCI 5.5" x 1.25" Plate	0.00 - 2.00	1.0000	1.0000
L54	54	CCI 5.5" x 1.25" Plate	0.00 - 2.00	1.0000	1.0000
L54	55	CCI 6.5" x 1.25" Plate	0.00 - 2.00	1.0000	1.0000

Effective Width of Flat Linear Attachments / Feed Lines

Tower Section	Attachment Record No.	Description	Attachment Segment Elev.	Ratio Calculation Method	Effective Width Ratio
L7	49	CCI 4.5" x 1" Plate	112.58 - 114.08	Auto	0.0263
L7	50	CCI 4.5" x 1" Plate	112.58 - 114.08	Auto	0.0263
L7	51	CCI 4.5" x 1" Plate	112.58 - 114.08	Auto	0.0263
L8	49	CCI 4.5" x 1" Plate	112.33 - 112.58	Auto	0.0190
L8	50	CCI 4.5" x 1" Plate	112.33 - 112.58	Auto	0.0190
L8	51	CCI 4.5" x 1" Plate	112.33 - 112.58	Auto	0.0190
L9	49	CCI 4.5" x 1" Plate	107.33 - 112.33	Auto	0.0039
L9	50	CCI 4.5" x 1" Plate	107.33 - 112.33	Auto	0.0039
L9	51	CCI 4.5" x 1" Plate	107.33 - 112.33	Auto	0.0039
L10	49	CCI 4.5" x 1" Plate	106.92 - 107.33	Auto	0.0000
L10	50	CCI 4.5" x 1" Plate	106.92 - 107.33	Auto	0.0000
L10	51	CCI 4.5" x 1" Plate	106.92 - 107.33	Auto	0.0000
L10	59	CCI 4" x 0.75" Plate	106.92 - 107.00	Auto	0.0000
L10	60	CCI 4" x 0.75" Plate	106.92 - 107.00	Auto	0.0000
L10	61	CCI 4" x 0.75" Plate	106.92 - 107.00	Auto	0.0000
L11	49	CCI 4.5" x 1" Plate	106.67 - 106.92	Auto	0.0841
L11	50	CCI 4.5" x 1" Plate	106.67 - 106.92	Auto	0.0841
L11	51	CCI 4.5" x 1" Plate	106.67 - 106.92	Auto	0.0841
L11	59	CCI 4" x 0.75" Plate	106.67 -	Auto	0.0000

Job 92739.019.01 - GROTON TOWER, CT (BU# 881533)	Page 26 of 62
Project	Date 20:02:38 10/26/21
Client Crown Castle	Designed by JD Prabhu

Tower Section	Attachment Record No.	Description	Attachment Segment Elev.	Ratio Calculation Method	Effective Width Ratio
L11	60	CCI 4" x 0.75" Plate	106.92 106.67 - 106.92	Auto	0.0000
L11	61	CCI 4" x 0.75" Plate	106.67 - 106.92	Auto	0.0000
L12	41	CCI 4.5" x 1" Plate	103.50 - 105.00	Auto	0.0580
L12	42	CCI 4.5" x 1" Plate	103.50 - 105.00	Auto	0.0580
L12	43	CCI 4.5" x 1" Plate	103.50 - 105.00	Auto	0.0580
L12	49	CCI 4.5" x 1" Plate	103.50 - 106.67	Auto	0.0650
L12	50	CCI 4.5" x 1" Plate	103.50 - 106.67	Auto	0.0650
L12	51	CCI 4.5" x 1" Plate	103.50 - 106.67	Auto	0.0650
L12	59	CCI 4" x 0.75" Plate	103.50 - 106.67	Auto	0.0000
L12	60	CCI 4" x 0.75" Plate	103.50 - 106.67	Auto	0.0000
L12	61	CCI 4" x 0.75" Plate	103.50 - 106.67	Auto	0.0000
L13	41	CCI 4.5" x 1" Plate	103.25 - 103.50	Auto	0.0507
L13	42	CCI 4.5" x 1" Plate	103.25 - 103.50	Auto	0.0507
L13	43	CCI 4.5" x 1" Plate	103.25 - 103.50	Auto	0.0507
L13	49	CCI 4.5" x 1" Plate	103.25 - 103.50	Auto	0.0507
L13	50	CCI 4.5" x 1" Plate	103.25 - 103.50	Auto	0.0507
L13	51	CCI 4.5" x 1" Plate	103.25 - 103.50	Auto	0.0507
L13	59	CCI 4" x 0.75" Plate	103.25 - 103.50	Auto	0.0000
L13	60	CCI 4" x 0.75" Plate	103.25 - 103.50	Auto	0.0000
L13	61	CCI 4" x 0.75" Plate	103.25 - 103.50	Auto	0.0000
L14	29	CCI 4.5" x 1" Plate	98.50 - 100.00	Auto	0.0113
L14	30	CCI 4.5" x 1" Plate	98.50 - 100.00	Auto	0.0113
L14	31	CCI 4.5" x 1" Plate	98.50 - 100.00	Auto	0.0113
L14	41	CCI 4.5" x 1" Plate	98.50 - 103.25	Auto	0.0249
L14	42	CCI 4.5" x 1" Plate	98.50 - 103.25	Auto	0.0249
L14	43	CCI 4.5" x 1" Plate	98.50 - 103.25	Auto	0.0249
L14	49	CCI 4.5" x 1" Plate	99.50 - 103.25	Auto	0.0291
L14	50	CCI 4.5" x 1" Plate	99.50 - 103.25	Auto	0.0291
L14	51	CCI 4.5" x 1" Plate	99.50 - 103.25	Auto	0.0291
L14	59	CCI 4" x 0.75" Plate	98.50 - 103.25	Auto	0.0000
L14	60	CCI 4" x 0.75" Plate	98.50 - 103.25	Auto	0.0000
L14	61	CCI 4" x 0.75" Plate	98.50 - 103.25	Auto	0.0000
L15	29	CCI 4.5" x 1" Plate	98.25 - 98.50	Auto	0.0675
L15	30	CCI 4.5" x 1" Plate	98.25 - 98.50	Auto	0.0675
L15	31	CCI 4.5" x 1" Plate	98.25 - 98.50	Auto	0.0675
L15	41	CCI 4.5" x 1" Plate	98.25 - 98.50	Auto	0.0675
L15	42	CCI 4.5" x 1" Plate	98.25 - 98.50	Auto	0.0675
L15	43	CCI 4.5" x 1" Plate	98.25 - 98.50	Auto	0.0675
L15	59	CCI 4" x 0.75" Plate	98.25 - 98.50	Auto	0.0000
L15	60	CCI 4" x 0.75" Plate	98.25 - 98.50	Auto	0.0000

tnxTower

B+T Group
1717 S. Boulder, Suite 300
Tulsa, OK 74119
Phone: (918) 587-4630
FAX: (918) 295-0265

Job

92739.019.01 - GROTON TOWER, CT (BU# 881533)

Page

27 of 62

Project

Date

20:02:38 10/26/21

Client

Crown Castle

Designed by

JD Prabhu

Tower Section	Attachment Record No.	Description	Attachment Segment Elev.	Ratio Calculation Method	Effective Width Ratio
L15	61	CCI 4" x 0.75" Plate	98.25 - 98.50	Auto	0.0000
L16	29	CCI 4.5" x 1" Plate	97.58 - 98.25	Auto	0.0637
L16	30	CCI 4.5" x 1" Plate	97.58 - 98.25	Auto	0.0637
L16	31	CCI 4.5" x 1" Plate	97.58 - 98.25	Auto	0.0637
L16	41	CCI 4.5" x 1" Plate	97.58 - 98.25	Auto	0.0637
L16	42	CCI 4.5" x 1" Plate	97.58 - 98.25	Auto	0.0637
L16	43	CCI 4.5" x 1" Plate	97.58 - 98.25	Auto	0.0637
L16	59	CCI 4" x 0.75" Plate	97.58 - 98.25	Auto	0.0000
L16	60	CCI 4" x 0.75" Plate	97.58 - 98.25	Auto	0.0000
L16	61	CCI 4" x 0.75" Plate	97.58 - 98.25	Auto	0.0000
L17	29	CCI 4.5" x 1" Plate	97.33 - 97.58	Auto	0.0159
L17	30	CCI 4.5" x 1" Plate	97.33 - 97.58	Auto	0.0159
L17	31	CCI 4.5" x 1" Plate	97.33 - 97.58	Auto	0.0159
L17	41	CCI 4.5" x 1" Plate	97.33 - 97.58	Auto	0.0159
L17	42	CCI 4.5" x 1" Plate	97.33 - 97.58	Auto	0.0159
L17	43	CCI 4.5" x 1" Plate	97.33 - 97.58	Auto	0.0159
L17	59	CCI 4" x 0.75" Plate	97.33 - 97.58	Auto	0.0000
L17	60	CCI 4" x 0.75" Plate	97.33 - 97.58	Auto	0.0000
L17	61	CCI 4" x 0.75" Plate	97.33 - 97.58	Auto	0.0000
L18	29	CCI 4.5" x 1" Plate	92.33 - 97.33	Auto	0.0012
L18	30	CCI 4.5" x 1" Plate	92.33 - 97.33	Auto	0.0012
L18	31	CCI 4.5" x 1" Plate	92.33 - 97.33	Auto	0.0012
L18	41	CCI 4.5" x 1" Plate	92.33 - 97.33	Auto	0.0012
L18	42	CCI 4.5" x 1" Plate	92.33 - 97.33	Auto	0.0012
L18	43	CCI 4.5" x 1" Plate	92.33 - 97.33	Auto	0.0012
L18	59	CCI 4" x 0.75" Plate	97.00 - 97.33	Auto	0.0000
L18	60	CCI 4" x 0.75" Plate	97.00 - 97.33	Auto	0.0000
L18	61	CCI 4" x 0.75" Plate	97.00 - 97.33	Auto	0.0000
L19	29	CCI 4.5" x 1" Plate	90.00 - 92.33	Auto	0.0000
L19	30	CCI 4.5" x 1" Plate	90.00 - 92.33	Auto	0.0000
L19	31	CCI 4.5" x 1" Plate	90.00 - 92.33	Auto	0.0000
L19	41	CCI 4.5" x 1" Plate	90.00 - 92.33	Auto	0.0000
L19	42	CCI 4.5" x 1" Plate	90.00 - 92.33	Auto	0.0000
L19	43	CCI 4.5" x 1" Plate	90.00 - 92.33	Auto	0.0000
L21	45	CCI 6" x 1" Plate	83.00 - 85.00	Auto	0.1368
L21	46	CCI 6" x 1" Plate	83.00 - 85.00	Auto	0.1368
L21	47	CCI 6" x 1" Plate	83.00 - 85.00	Auto	0.1368
L22	45	CCI 6" x 1" Plate	82.75 - 83.00	Auto	0.1297
L22	46	CCI 6" x 1" Plate	82.75 - 83.00	Auto	0.1297
L22	47	CCI 6" x 1" Plate	82.75 - 83.00	Auto	0.1297
L23	37	CCI 6.5" x 1.25" Plate	77.75 - 80.00	Auto	0.1733
L23	38	CCI 6.5" x 1.25" Plate	77.75 - 80.00	Auto	0.1733
L23	39	CCI 6.5" x 1.25" Plate	77.75 - 80.00	Auto	0.1733
L23	45	CCI 6" x 1" Plate	77.75 - 82.75	Auto	0.1131
L23	46	CCI 6" x 1" Plate	77.75 - 82.75	Auto	0.1131
L23	47	CCI 6" x 1" Plate	77.75 - 82.75	Auto	0.1131
L24	37	CCI 6.5" x 1.25" Plate	77.25 - 77.75	Auto	0.1653
L24	38	CCI 6.5" x 1.25" Plate	77.25 - 77.75	Auto	0.1653
L24	39	CCI 6.5" x 1.25" Plate	77.25 - 77.75	Auto	0.1653
L24	45	CCI 6" x 1" Plate	77.25 - 77.75	Auto	0.0957
L24	46	CCI 6" x 1" Plate	77.25 - 77.75	Auto	0.0957
L24	47	CCI 6" x 1" Plate	77.25 - 77.75	Auto	0.0957
L25	37	CCI 6.5" x 1.25" Plate	77.00 - 77.25	Auto	0.2850
L25	38	CCI 6.5" x 1.25" Plate	77.00 - 77.25	Auto	0.2850
L25	39	CCI 6.5" x 1.25" Plate	77.00 - 77.25	Auto	0.2850
L25	45	CCI 6" x 1" Plate	77.00 - 77.25	Auto	0.2254
L25	46	CCI 6" x 1" Plate	77.00 - 77.25	Auto	0.2254
L25	47	CCI 6" x 1" Plate	77.00 - 77.25	Auto	0.2254
L26	37	CCI 6.5" x 1.25" Plate	76.75 - 77.00	Auto	0.2327
L26	38	CCI 6.5" x 1.25" Plate	76.75 - 77.00	Auto	0.2327
L26	39	CCI 6.5" x 1.25" Plate	76.75 - 77.00	Auto	0.2327

Tower Section	Attachment Record No.	Description	Attachment Segment Elev.	Ratio Calculation Method	Effective Width Ratio
L26	45	CCI 6" x 1" Plate	76.75 - 77.00	Auto	0.1688
L26	46	CCI 6" x 1" Plate	76.75 - 77.00	Auto	0.1688
L26	47	CCI 6" x 1" Plate	76.75 - 77.00	Auto	0.1688
L27	37	CCI 6.5" x 1.25" Plate	71.75 - 76.75	Auto	0.2140
L27	38	CCI 6.5" x 1.25" Plate	71.75 - 76.75	Auto	0.2140
L27	39	CCI 6.5" x 1.25" Plate	71.75 - 76.75	Auto	0.2140
L27	45	CCI 6" x 1" Plate	75.00 - 76.75	Auto	0.1588
L27	46	CCI 6" x 1" Plate	75.00 - 76.75	Auto	0.1588
L27	47	CCI 6" x 1" Plate	75.00 - 76.75	Auto	0.1588
L28	37	CCI 6.5" x 1.25" Plate	69.00 - 71.75	Auto	0.1914
L28	38	CCI 6.5" x 1.25" Plate	69.00 - 71.75	Auto	0.1914
L28	39	CCI 6.5" x 1.25" Plate	69.00 - 71.75	Auto	0.1914
L28	65	CCI 6" x 1" Plate	69.00 - 71.00	Auto	0.1217
L28	66	CCI 6" x 1" Plate	69.00 - 71.00	Auto	0.1217
L28	67	CCI 6" x 1" Plate	69.00 - 71.00	Auto	0.1217
L29	37	CCI 6.5" x 1.25" Plate	68.75 - 69.00	Auto	0.2301
L29	38	CCI 6.5" x 1.25" Plate	68.75 - 69.00	Auto	0.2301
L29	39	CCI 6.5" x 1.25" Plate	68.75 - 69.00	Auto	0.2301
L29	65	CCI 6" x 1" Plate	68.75 - 69.00	Auto	0.1659
L29	66	CCI 6" x 1" Plate	68.75 - 69.00	Auto	0.1659
L29	67	CCI 6" x 1" Plate	68.75 - 69.00	Auto	0.1659
L30	37	CCI 6.5" x 1.25" Plate	63.75 - 68.75	Auto	0.2114
L30	38	CCI 6.5" x 1.25" Plate	63.75 - 68.75	Auto	0.2114
L30	39	CCI 6.5" x 1.25" Plate	63.75 - 68.75	Auto	0.2114
L30	65	CCI 6" x 1" Plate	63.75 - 68.75	Auto	0.1457
L30	66	CCI 6" x 1" Plate	63.75 - 68.75	Auto	0.1457
L30	67	CCI 6" x 1" Plate	63.75 - 68.75	Auto	0.1457
L31	37	CCI 6.5" x 1.25" Plate	60.00 - 63.75	Auto	0.1825
L31	38	CCI 6.5" x 1.25" Plate	60.00 - 63.75	Auto	0.1825
L31	39	CCI 6.5" x 1.25" Plate	60.00 - 63.75	Auto	0.1825
L31	57	CCI 8.5" x 1.25" Plate	60.00 - 62.25	Auto	0.3715
L31	65	CCI 6" x 1" Plate	60.00 - 63.75	Auto	0.1143
L31	66	CCI 6" x 1" Plate	60.00 - 63.75	Auto	0.1143
L31	67	CCI 6" x 1" Plate	60.00 - 63.75	Auto	0.1143
L32	37	CCI 6.5" x 1.25" Plate	59.75 - 60.00	Auto	0.1708
L32	38	CCI 6.5" x 1.25" Plate	59.75 - 60.00	Auto	0.1708
L32	39	CCI 6.5" x 1.25" Plate	59.75 - 60.00	Auto	0.1708
L32	57	CCI 8.5" x 1.25" Plate	59.75 - 60.00	Auto	0.3659
L32	65	CCI 6" x 1" Plate	59.75 - 60.00	Auto	0.1017
L32	66	CCI 6" x 1" Plate	59.75 - 60.00	Auto	0.1017
L32	67	CCI 6" x 1" Plate	59.75 - 60.00	Auto	0.1017
L33	37	CCI 6.5" x 1.25" Plate	58.50 - 59.75	Auto	0.1664
L33	38	CCI 6.5" x 1.25" Plate	58.50 - 59.75	Auto	0.1664
L33	39	CCI 6.5" x 1.25" Plate	58.50 - 59.75	Auto	0.1664
L33	57	CCI 8.5" x 1.25" Plate	58.50 - 59.75	Auto	0.3626
L33	63	CCI 6.5" x 1.25" Plate	58.50 - 59.50	Auto	0.1657
L33	65	CCI 6" x 1" Plate	58.50 - 59.75	Auto	0.0970
L33	66	CCI 6" x 1" Plate	58.50 - 59.75	Auto	0.0970
L33	67	CCI 6" x 1" Plate	58.50 - 59.75	Auto	0.0970
L34	37	CCI 6.5" x 1.25" Plate	58.25 - 58.50	Auto	0.1621
L34	38	CCI 6.5" x 1.25" Plate	58.25 - 58.50	Auto	0.1621
L34	39	CCI 6.5" x 1.25" Plate	58.25 - 58.50	Auto	0.1621
L34	57	CCI 8.5" x 1.25" Plate	58.25 - 58.50	Auto	0.3592
L34	63	CCI 6.5" x 1.25" Plate	58.25 - 58.50	Auto	0.1621
L34	65	CCI 6" x 1" Plate	58.25 - 58.50	Auto	0.0922
L34	66	CCI 6" x 1" Plate	58.25 - 58.50	Auto	0.0922
L34	67	CCI 6" x 1" Plate	58.25 - 58.50	Auto	0.0922
L35	37	CCI 6.5" x 1.25" Plate	58.00 - 58.25	Auto	0.1606
L35	38	CCI 6.5" x 1.25" Plate	58.00 - 58.25	Auto	0.1606
L35	39	CCI 6.5" x 1.25" Plate	58.00 - 58.25	Auto	0.1606
L35	57	CCI 8.5" x 1.25" Plate	58.00 - 58.25	Auto	0.3581

Tower Section	Attachment Record No.	Description	Attachment Segment Elev.	Ratio Calculation Method	Effective Width Ratio
L35	63	CCI 6.5" x 1.25" Plate	58.00 - 58.25	Auto	0.1606
L35	65	CCI 6" x 1" Plate	58.00 - 58.25	Auto	0.0906
L35	66	CCI 6" x 1" Plate	58.00 - 58.25	Auto	0.0906
L35	67	CCI 6" x 1" Plate	58.00 - 58.25	Auto	0.0906
L36	37	CCI 6.5" x 1.25" Plate	57.75 - 58.00	Auto	0.1151
L36	38	CCI 6.5" x 1.25" Plate	57.75 - 58.00	Auto	0.1151
L36	39	CCI 6.5" x 1.25" Plate	57.75 - 58.00	Auto	0.1151
L36	57	CCI 8.5" x 1.25" Plate	57.75 - 58.00	Auto	0.3233
L36	63	CCI 6.5" x 1.25" Plate	57.75 - 58.00	Auto	0.1151
L36	65	CCI 6" x 1" Plate	57.75 - 58.00	Auto	0.0414
L36	66	CCI 6" x 1" Plate	57.75 - 58.00	Auto	0.0414
L36	67	CCI 6" x 1" Plate	57.75 - 58.00	Auto	0.0414
L37	37	CCI 6.5" x 1.25" Plate	56.75 - 57.75	Auto	0.1115
L37	38	CCI 6.5" x 1.25" Plate	56.75 - 57.75	Auto	0.1115
L37	39	CCI 6.5" x 1.25" Plate	56.75 - 57.75	Auto	0.1115
L37	57	CCI 8.5" x 1.25" Plate	56.75 - 57.75	Auto	0.3206
L37	63	CCI 6.5" x 1.25" Plate	56.75 - 57.75	Auto	0.1115
L37	65	CCI 6" x 1" Plate	56.75 - 57.75	Auto	0.0374
L37	66	CCI 6" x 1" Plate	56.75 - 57.75	Auto	0.0374
L37	67	CCI 6" x 1" Plate	56.75 - 57.75	Auto	0.0374
L38	37	CCI 6.5" x 1.25" Plate	56.50 - 56.75	Auto	0.1417
L38	38	CCI 6.5" x 1.25" Plate	56.50 - 56.75	Auto	0.1417
L38	39	CCI 6.5" x 1.25" Plate	56.50 - 56.75	Auto	0.1417
L38	57	CCI 8.5" x 1.25" Plate	56.50 - 56.75	Auto	0.3436
L38	63	CCI 6.5" x 1.25" Plate	56.50 - 56.75	Auto	0.1417
L38	65	CCI 6" x 1" Plate	56.50 - 56.75	Auto	0.0702
L38	66	CCI 6" x 1" Plate	56.50 - 56.75	Auto	0.0702
L38	67	CCI 6" x 1" Plate	56.50 - 56.75	Auto	0.0702
L39	37	CCI 6.5" x 1.25" Plate	51.50 - 56.50	Auto	0.1230
L39	38	CCI 6.5" x 1.25" Plate	51.50 - 56.50	Auto	0.1230
L39	39	CCI 6.5" x 1.25" Plate	51.50 - 56.50	Auto	0.1230
L39	57	CCI 8.5" x 1.25" Plate	51.50 - 56.50	Auto	0.3293
L39	63	CCI 6.5" x 1.25" Plate	51.50 - 56.50	Auto	0.1230
L39	65	CCI 6" x 1" Plate	56.00 - 56.50	Auto	0.0641
L39	66	CCI 6" x 1" Plate	56.00 - 56.50	Auto	0.0641
L39	67	CCI 6" x 1" Plate	56.00 - 56.50	Auto	0.0641
L40	37	CCI 6.5" x 1.25" Plate	42.04 - 51.50	Auto	0.0774
L40	38	CCI 6.5" x 1.25" Plate	42.04 - 51.50	Auto	0.0774
L40	39	CCI 6.5" x 1.25" Plate	42.04 - 51.50	Auto	0.0774
L40	57	CCI 8.5" x 1.25" Plate	42.04 - 51.50	Auto	0.2945
L40	63	CCI 6.5" x 1.25" Plate	42.04 - 51.50	Auto	0.0774
L41	37	CCI 6.5" x 1.25" Plate	41.04 - 42.04	Auto	0.0876
L41	38	CCI 6.5" x 1.25" Plate	41.04 - 42.04	Auto	0.0876
L41	39	CCI 6.5" x 1.25" Plate	41.04 - 42.04	Auto	0.0876
L41	57	CCI 8.5" x 1.25" Plate	41.04 - 42.04	Auto	0.3023
L41	63	CCI 6.5" x 1.25" Plate	41.04 - 42.04	Auto	0.0876
L42	37	CCI 6.5" x 1.25" Plate	36.04 - 41.04	Auto	0.0702
L42	38	CCI 6.5" x 1.25" Plate	36.04 - 41.04	Auto	0.0702
L42	39	CCI 6.5" x 1.25" Plate	36.04 - 41.04	Auto	0.0702
L42	57	CCI 8.5" x 1.25" Plate	36.04 - 41.04	Auto	0.2890
L42	63	CCI 6.5" x 1.25" Plate	36.04 - 41.04	Auto	0.0702
L43	33	CCI 8.5" x 1.25" Plate	31.25 - 35.00	Auto	0.2597
L43	34	CCI 8.5" x 1.25" Plate	31.25 - 35.00	Auto	0.2597
L43	35	CCI 8.5" x 1.25" Plate	31.25 - 35.00	Auto	0.2597
L43	37	CCI 6.5" x 1.25" Plate	31.25 - 36.04	Auto	0.0349
L43	38	CCI 6.5" x 1.25" Plate	35.00 - 36.04	Auto	0.0458
L43	39	CCI 6.5" x 1.25" Plate	35.00 - 36.04	Auto	0.0458
L43	57	CCI 8.5" x 1.25" Plate	31.25 - 36.04	Auto	0.2620
L43	63	CCI 6.5" x 1.25" Plate	31.25 - 36.04	Auto	0.0349
L44	33	CCI 8.5" x 1.25" Plate	31.00 - 31.25	Auto	0.2275
L44	34	CCI 8.5" x 1.25" Plate	31.00 - 31.25	Auto	0.2275

Tower Section	Attachment Record No.	Description	Attachment Segment Elev.	Ratio Calculation Method	Effective Width Ratio
L44	35	CCI 8.5" x 1.25" Plate	31.00 - 31.25	Auto	0.2275
L44	37	CCI 6.5" x 1.25" Plate	31.00 - 31.25	Auto	0.0000
L44	57	CCI 8.5" x 1.25" Plate	31.00 - 31.25	Auto	0.2275
L44	63	CCI 6.5" x 1.25" Plate	31.00 - 31.25	Auto	0.0000
L45	33	CCI 8.5" x 1.25" Plate	27.75 - 31.00	Auto	0.2197
L45	34	CCI 8.5" x 1.25" Plate	27.75 - 31.00	Auto	0.2197
L45	35	CCI 8.5" x 1.25" Plate	27.75 - 31.00	Auto	0.2197
L45	37	CCI 6.5" x 1.25" Plate	27.75 - 31.00	Auto	0.0000
L45	53	CCI 5.5" x 1.25" Plate	27.75 - 30.00	Auto	0.0000
L45	54	CCI 5.5" x 1.25" Plate	27.75 - 30.00	Auto	0.0000
L45	55	CCI 6.5" x 1.25" Plate	27.75 - 30.00	Auto	0.0000
L45	57	CCI 8.5" x 1.25" Plate	27.75 - 31.00	Auto	0.2197
L45	63	CCI 6.5" x 1.25" Plate	27.75 - 31.00	Auto	0.0000
L46	33	CCI 8.5" x 1.25" Plate	27.50 - 27.75	Auto	0.2119
L46	34	CCI 8.5" x 1.25" Plate	27.50 - 27.75	Auto	0.2119
L46	35	CCI 8.5" x 1.25" Plate	27.50 - 27.75	Auto	0.2119
L46	37	CCI 6.5" x 1.25" Plate	27.50 - 27.75	Auto	0.0000
L46	53	CCI 5.5" x 1.25" Plate	27.50 - 27.75	Auto	0.0000
L46	54	CCI 5.5" x 1.25" Plate	27.50 - 27.75	Auto	0.0000
L46	55	CCI 6.5" x 1.25" Plate	27.50 - 27.75	Auto	0.0000
L46	57	CCI 8.5" x 1.25" Plate	27.50 - 27.75	Auto	0.2119
L46	63	CCI 6.5" x 1.25" Plate	27.50 - 27.75	Auto	0.0000
L47	33	CCI 8.5" x 1.25" Plate	27.25 - 27.50	Auto	0.2108
L47	34	CCI 8.5" x 1.25" Plate	27.25 - 27.50	Auto	0.2108
L47	35	CCI 8.5" x 1.25" Plate	27.25 - 27.50	Auto	0.2108
L47	37	CCI 6.5" x 1.25" Plate	27.25 - 27.50	Auto	0.0000
L47	53	CCI 5.5" x 1.25" Plate	27.25 - 27.50	Auto	0.0000
L47	54	CCI 5.5" x 1.25" Plate	27.25 - 27.50	Auto	0.0000
L47	55	CCI 6.5" x 1.25" Plate	27.25 - 27.50	Auto	0.0000
L47	57	CCI 8.5" x 1.25" Plate	27.25 - 27.50	Auto	0.2108
L47	63	CCI 6.5" x 1.25" Plate	27.25 - 27.50	Auto	0.0000
L48	33	CCI 8.5" x 1.25" Plate	27.00 - 27.25	Auto	0.2252
L48	34	CCI 8.5" x 1.25" Plate	27.00 - 27.25	Auto	0.2252
L48	35	CCI 8.5" x 1.25" Plate	27.00 - 27.25	Auto	0.2252
L48	37	CCI 6.5" x 1.25" Plate	27.00 - 27.25	Auto	0.0000
L48	53	CCI 5.5" x 1.25" Plate	27.00 - 27.25	Auto	0.0000
L48	54	CCI 5.5" x 1.25" Plate	27.00 - 27.25	Auto	0.0000
L48	55	CCI 6.5" x 1.25" Plate	27.00 - 27.25	Auto	0.0000
L48	63	CCI 6.5" x 1.25" Plate	27.00 - 27.25	Auto	0.0000
L49	33	CCI 8.5" x 1.25" Plate	22.00 - 27.00	Auto	0.2109
L49	34	CCI 8.5" x 1.25" Plate	22.00 - 27.00	Auto	0.2109
L49	35	CCI 8.5" x 1.25" Plate	22.00 - 27.00	Auto	0.2109
L49	37	CCI 6.5" x 1.25" Plate	25.00 - 27.00	Auto	0.0000
L49	53	CCI 5.5" x 1.25" Plate	22.00 - 27.00	Auto	0.0000
L49	54	CCI 5.5" x 1.25" Plate	22.00 - 27.00	Auto	0.0000
L49	55	CCI 6.5" x 1.25" Plate	22.00 - 27.00	Auto	0.0000
L49	63	CCI 6.5" x 1.25" Plate	24.50 - 27.00	Auto	0.0000
L50	33	CCI 8.5" x 1.25" Plate	17.00 - 22.00	Auto	0.1887
L50	34	CCI 8.5" x 1.25" Plate	17.00 - 22.00	Auto	0.1887
L50	35	CCI 8.5" x 1.25" Plate	17.00 - 22.00	Auto	0.1887
L50	53	CCI 5.5" x 1.25" Plate	17.00 - 22.00	Auto	0.0000
L50	54	CCI 5.5" x 1.25" Plate	17.00 - 22.00	Auto	0.0000
L50	55	CCI 6.5" x 1.25" Plate	17.00 - 22.00	Auto	0.0000
L51	33	CCI 8.5" x 1.25" Plate	12.00 - 17.00	Auto	0.1664
L51	34	CCI 8.5" x 1.25" Plate	12.00 - 17.00	Auto	0.1664
L51	35	CCI 8.5" x 1.25" Plate	12.00 - 17.00	Auto	0.1664
L51	53	CCI 5.5" x 1.25" Plate	12.00 - 17.00	Auto	0.0000
L51	54	CCI 5.5" x 1.25" Plate	12.00 - 17.00	Auto	0.0000
L51	55	CCI 6.5" x 1.25" Plate	12.00 - 17.00	Auto	0.0000
L52	33	CCI 8.5" x 1.25" Plate	7.00 - 12.00	Auto	0.1442
L52	34	CCI 8.5" x 1.25" Plate	7.00 - 12.00	Auto	0.1442

tnxTower B+T Group 1717 S. Boulder, Suite 300 Tulsa, OK 74119 Phone: (918) 587-4630 FAX: (918) 295-0265	Job 92739.019.01 - GROTON TOWER, CT (BU# 881533)	Page 31 of 62
	Project	Date 20:02:38 10/26/21
	Client Crown Castle	Designed by JD Prabhu

Tower Section	Attachment Record No.	Description	Attachment Segment Elev.	Ratio Calculation Method	Effective Width Ratio
L52	35	CCI 8.5" x 1.25" Plate	7.00 - 12.00	Auto	0.1442
L52	53	CCI 5.5" x 1.25" Plate	7.00 - 12.00	Auto	0.0000
L52	54	CCI 5.5" x 1.25" Plate	7.00 - 12.00	Auto	0.0000
L52	55	CCI 6.5" x 1.25" Plate	7.00 - 12.00	Auto	0.0000
L53	33	CCI 8.5" x 1.25" Plate	2.00 - 7.00	Auto	0.1193
L53	34	CCI 8.5" x 1.25" Plate	2.00 - 7.00	Auto	0.1193
L53	35	CCI 8.5" x 1.25" Plate	2.00 - 7.00	Auto	0.1193
L53	53	CCI 5.5" x 1.25" Plate	2.00 - 7.00	Auto	0.0000
L53	54	CCI 5.5" x 1.25" Plate	2.00 - 7.00	Auto	0.0000
L53	55	CCI 6.5" x 1.25" Plate	2.00 - 7.00	Auto	0.0000
L54	33	CCI 8.5" x 1.25" Plate	0.00 - 2.00	Auto	0.1037
L54	34	CCI 8.5" x 1.25" Plate	0.00 - 2.00	Auto	0.1037
L54	35	CCI 8.5" x 1.25" Plate	0.00 - 2.00	Auto	0.1037
L54	53	CCI 5.5" x 1.25" Plate	0.00 - 2.00	Auto	0.0000
L54	54	CCI 5.5" x 1.25" Plate	0.00 - 2.00	Auto	0.0000
L54	55	CCI 6.5" x 1.25" Plate	0.00 - 2.00	Auto	0.0000

Discrete Tower Loads

Description	Face or Leg	Offset Type	Offsets:		Azimuth Adjustment	Placement	C _{AA}		Weight	
			Horz	Vert			Front	Side		
			Lateral							
			ft	ft	°	ft	ft ²	ft ²	K	
			ft							
Lightning Rod 5/8" x 5'	C	None			0.000	147.000	No Ice	0.313	0.313	0.006
							1/2" Ice	0.826	0.826	0.010
							1" Ice	1.322	1.322	0.016
							2" Ice	1.957	1.957	0.040
Strobe	C	None			0.000	149.500	No Ice	4.500	3.000	0.020
							1/2" Ice	4.770	3.237	0.058
							1" Ice	5.048	3.481	0.100
							2" Ice	5.626	3.993	0.198
5' x 2" Pipe Mount	C	None			0.000	147.000	No Ice	1.188	1.188	0.018
							1/2" Ice	1.496	1.496	0.027
							1" Ice	1.807	1.807	0.040
							2" Ice	2.458	2.458	0.076
Top Hat	C	None			0.000	146.000	No Ice	3.000	3.000	0.081
							1/2" Ice	3.480	3.480	0.111
							1" Ice	3.960	3.960	0.141
							2" Ice	4.920	4.920	0.201
* 7770.00 w/ Mount Pipe	A	From Leg	4.000	0.000	0.000	147.000	No Ice	5.746	4.254	0.055
							1/2" Ice	6.179	5.014	0.103
							1" Ice	6.607	5.711	0.157
							2" Ice	7.488	7.155	0.287
7770.00 w/ Mount Pipe	B	From Leg	4.000	0.000	0.000	147.000	No Ice	5.746	4.254	0.055
							1/2" Ice	6.179	5.014	0.103
							1" Ice	6.607	5.711	0.157
							2" Ice	7.488	7.155	0.287
7770.00 w/ Mount Pipe	C	From Leg	4.000	0.000	0.000	147.000	No Ice	5.746	4.254	0.055
							1/2" Ice	6.179	5.014	0.103
							1" Ice	6.607	5.711	0.157
							2" Ice	7.488	7.155	0.287

tnxTower B+T Group 1717 S. Boulder, Suite 300 Tulsa, OK 74119 Phone: (918) 587-4630 FAX: (918) 295-0265	Job		92739.019.01 - GROTON TOWER, CT (BU# 881533)		Page		32 of 62	
	Project				Date		20:02:38 10/26/21	
	Client		Crown Castle		Designed by		JD Prabhu	

Description	Face or Leg	Offset Type	Offsets:		Azimuth Adjustment	Placement	C _{AA} Front	C _{AA} Side	Weight	
			Horz	Lateral						Vert
840370799 w/ Mount Pipe	A	From Leg	4.000	0.000	0.000	147.000	2" Ice	7.488	7.155	0.287
			0.000				No Ice	12.880	7.800	0.168
			-1.000				1/2" Ice	13.850	8.710	0.258
							1" Ice	14.840	9.640	0.361
840370799 w/ Mount Pipe	B	From Leg	4.000	0.000	0.000	147.000	2" Ice	16.860	11.560	0.610
			0.000				No Ice	12.880	7.800	0.168
			-1.000				1/2" Ice	13.850	8.710	0.258
							1" Ice	14.840	9.640	0.361
840370799 w/ Mount Pipe	C	From Leg	4.000	0.000	0.000	147.000	2" Ice	16.860	11.560	0.610
			0.000				No Ice	12.880	7.800	0.168
			-1.000				1/2" Ice	13.850	8.710	0.258
							1" Ice	14.840	9.640	0.361
SBNH-1D6565C w/ Mount Pipe	A	From Leg	4.000	0.000	0.000	147.000	2" Ice	16.860	11.560	0.610
			0.000				No Ice	5.560	4.470	0.085
			-1.000				1/2" Ice	6.070	4.970	0.167
							1" Ice	6.590	5.470	0.262
AM-X-CD-17-65-00T-RET w/ Mount Pipe	B	From Leg	4.000	0.000	0.000	147.000	2" Ice	7.650	6.520	0.495
			0.000				No Ice	6.090	4.310	0.092
			-1.000				1/2" Ice	6.660	4.860	0.170
							1" Ice	7.240	5.420	0.261
AM-X-CD-17-65-00T-RET w/ Mount Pipe	C	From Leg	4.000	0.000	0.000	147.000	2" Ice	8.430	6.570	0.484
			0.000				No Ice	6.090	4.310	0.092
			-1.000				1/2" Ice	6.660	4.860	0.170
							1" Ice	7.240	5.420	0.261
(2) RRUS 11	A	From Leg	4.000	0.000	0.000	147.000	2" Ice	8.430	6.570	0.484
			0.000				No Ice	2.784	1.187	0.048
			0.000				1/2" Ice	2.992	1.334	0.068
							1" Ice	3.207	1.490	0.092
(2) RRUS 11	B	From Leg	4.000	0.000	0.000	147.000	2" Ice	3.658	1.833	0.150
			0.000				No Ice	2.784	1.187	0.048
			0.000				1/2" Ice	2.992	1.334	0.068
							1" Ice	3.207	1.490	0.092
(2) RRUS 11	C	From Leg	4.000	0.000	0.000	147.000	2" Ice	3.658	1.833	0.150
			0.000				No Ice	2.784	1.187	0.048
			0.000				1/2" Ice	2.992	1.334	0.068
							1" Ice	3.207	1.490	0.092
RRUS 32	A	From Leg	4.000	0.000	0.000	147.000	2" Ice	3.658	1.833	0.150
			0.000				No Ice	2.857	1.777	0.055
			0.000				1/2" Ice	3.083	1.968	0.077
							1" Ice	3.316	2.166	0.103
RRUS 32	B	From Leg	4.000	0.000	0.000	147.000	2" Ice	3.805	2.583	0.165
			0.000				No Ice	2.857	1.777	0.055
			0.000				1/2" Ice	3.083	1.968	0.077
							1" Ice	3.316	2.166	0.103
RRUS 32	C	From Leg	4.000	0.000	0.000	147.000	2" Ice	3.805	2.583	0.165
			0.000				No Ice	2.857	1.777	0.055
			0.000				1/2" Ice	3.083	1.968	0.077
							1" Ice	3.316	2.166	0.103
RRUS 32 B2	A	From Leg	4.000	0.000	0.000	147.000	2" Ice	3.805	2.583	0.165
			0.000				No Ice	2.731	1.668	0.053
			0.000				1/2" Ice	2.953	1.855	0.074
							1" Ice	3.182	2.049	0.098
RRUS 32 B2	B	From Leg	4.000	0.000	0.000	147.000	2" Ice	3.663	2.458	0.157
			0.000				No Ice	2.731	1.668	0.053
			0.000				1/2" Ice	2.953	1.855	0.074
							1" Ice	3.182	2.049	0.098
						2" Ice	3.663	2.458	0.157	

tnxTower B+T Group 1717 S. Boulder, Suite 300 Tulsa, OK 74119 Phone: (918) 587-4630 FAX: (918) 295-0265	Job	92739.019.01 - GROTON TOWER, CT (BU# 881533)	Page	33 of 62
	Project		Date	20:02:38 10/26/21
	Client	Crown Castle		Designed by

Description	Face or Leg	Offset Type	Offsets:		Azimuth Adjustment	Placement	C _{AA} Front	C _{AA} Side	Weight	
			Horz	Lateral						°
RRUS 32 B2	C	From Leg	4.000	0.000	0.000	147.000	No Ice	2.731	1.668	0.053
			0.000	0.000			1/2" Ice	2.953	1.855	0.074
			0.000	0.000			1" Ice	3.182	2.049	0.098
			0.000	0.000			2" Ice	3.663	2.458	0.157
RRUS 4478 B5	A	From Leg	4.000	0.000	0.000	147.000	No Ice	1.843	1.059	0.060
			0.000	0.000			1/2" Ice	2.012	1.197	0.076
			0.000	0.000			1" Ice	2.190	1.342	0.094
			0.000	0.000			2" Ice	2.566	1.656	0.140
RRUS 4478 B5	B	From Leg	4.000	0.000	0.000	147.000	No Ice	1.843	1.059	0.060
			0.000	0.000			1/2" Ice	2.012	1.197	0.076
			0.000	0.000			1" Ice	2.190	1.342	0.094
			0.000	0.000			2" Ice	2.566	1.656	0.140
RRUS 4478 B5	C	From Leg	4.000	0.000	0.000	147.000	No Ice	1.843	1.059	0.060
			0.000	0.000			1/2" Ice	2.012	1.197	0.076
			0.000	0.000			1" Ice	2.190	1.342	0.094
			0.000	0.000			2" Ice	2.566	1.656	0.140
RRUS 4478 B14	A	From Leg	4.000	0.000	0.000	147.000	No Ice	1.843	1.059	0.060
			0.000	0.000			1/2" Ice	2.012	1.197	0.076
			0.000	0.000			1" Ice	2.190	1.342	0.094
			0.000	0.000			2" Ice	2.566	1.656	0.140
RRUS 4478 B14	B	From Leg	4.000	0.000	0.000	147.000	No Ice	1.843	1.059	0.060
			0.000	0.000			1/2" Ice	2.012	1.197	0.076
			0.000	0.000			1" Ice	2.190	1.342	0.094
			0.000	0.000			2" Ice	2.566	1.656	0.140
RRUS 4478 B14	C	From Leg	4.000	0.000	0.000	147.000	No Ice	1.843	1.059	0.060
			0.000	0.000			1/2" Ice	2.012	1.197	0.076
			0.000	0.000			1" Ice	2.190	1.342	0.094
			0.000	0.000			2" Ice	2.566	1.656	0.140
(2) 7020.00	A	From Leg	4.000	0.000	0.000	147.000	No Ice	0.102	0.175	0.002
			0.000	0.000			1/2" Ice	0.147	0.239	0.005
			0.000	0.000			1" Ice	0.199	0.311	0.009
			0.000	0.000			2" Ice	0.326	0.476	0.022
(2) 7020.00	B	From Leg	4.000	0.000	0.000	147.000	No Ice	0.102	0.175	0.002
			0.000	0.000			1/2" Ice	0.147	0.239	0.005
			0.000	0.000			1" Ice	0.199	0.311	0.009
			0.000	0.000			2" Ice	0.326	0.476	0.022
(2) 7020.00	C	From Leg	4.000	0.000	0.000	147.000	No Ice	0.102	0.175	0.002
			0.000	0.000			1/2" Ice	0.147	0.239	0.005
			0.000	0.000			1" Ice	0.199	0.311	0.009
			0.000	0.000			2" Ice	0.326	0.476	0.022
(2) LGP21401	A	From Leg	4.000	0.000	0.000	147.000	No Ice	1.104	0.207	0.014
			0.000	0.000			1/2" Ice	1.239	0.274	0.021
			0.000	0.000			1" Ice	1.381	0.348	0.030
			0.000	0.000			2" Ice	1.688	0.521	0.055
(2) LGP21401	B	From Leg	4.000	0.000	0.000	147.000	No Ice	1.104	0.207	0.014
			0.000	0.000			1/2" Ice	1.239	0.274	0.021
			0.000	0.000			1" Ice	1.381	0.348	0.030
			0.000	0.000			2" Ice	1.688	0.521	0.055
(2) LGP21401	C	From Leg	4.000	0.000	0.000	147.000	No Ice	1.104	0.207	0.014
			0.000	0.000			1/2" Ice	1.239	0.274	0.021
			0.000	0.000			1" Ice	1.381	0.348	0.030
			0.000	0.000			2" Ice	1.688	0.521	0.055
(2) DBCT108F1V92-1	A	From Leg	4.000	0.000	0.000	147.000	No Ice	0.637	0.604	0.029
			0.000	0.000			1/2" Ice	0.740	0.705	0.036
			0.000	0.000			1" Ice	0.850	0.813	0.045
			0.000	0.000			2" Ice	1.093	1.052	0.069
(2) DBCT108F1V92-1	B	From Leg	4.000	0.000	0.000	147.000	No Ice	0.637	0.604	0.029

tnxTower B+T Group 1717 S. Boulder, Suite 300 Tulsa, OK 74119 Phone: (918) 587-4630 FAX: (918) 295-0265	Job		92739.019.01 - GROTON TOWER, CT (BU# 881533)		Page		34 of 62	
	Project				Date		20:02:38 10/26/21	
	Client		Crown Castle		Designed by		JD Prabhu	

Description	Face or Leg	Offset Type	Offsets:		Azimuth Adjustment	Placement	C _{AA} Front	C _{AA} Side	Weight
			Horz	Lateral					
			ft	ft			ft ²	ft ²	K
			0.000			1/2" Ice	0.740	0.705	0.036
			0.000			1" Ice	0.850	0.813	0.045
						2" Ice	1.093	1.052	0.069
(2) DBCT108F1V92-1	C	From Leg	4.000	0.000	147.000	No Ice	0.637	0.604	0.029
			0.000			1/2" Ice	0.740	0.705	0.036
			0.000			1" Ice	0.850	0.813	0.045
						2" Ice	1.093	1.052	0.069
DC6-48-60-18-8F	A	From Leg	4.000	0.000	147.000	No Ice	1.212	1.212	0.033
			0.000			1/2" Ice	1.892	1.892	0.055
			-1.000			1" Ice	2.105	2.105	0.080
						2" Ice	2.570	2.570	0.138
DC6-48-60-0-8F	B	From Leg	4.000	0.000	147.000	No Ice	0.917	0.917	0.033
			0.000			1/2" Ice	1.458	1.458	0.051
			-1.000			1" Ice	1.643	1.643	0.071
						2" Ice	2.042	2.042	0.119
DC6-48-60-18-8F	C	From Leg	4.000	0.000	147.000	No Ice	1.212	1.212	0.033
			0.000			1/2" Ice	1.892	1.892	0.055
			-1.000			1" Ice	2.105	2.105	0.080
						2" Ice	2.570	2.570	0.138
8' x 2" Pipe Mount	A	From Leg	4.000	0.000	147.000	No Ice	1.900	1.900	0.029
			0.000			1/2" Ice	2.728	2.728	0.044
			0.000			1" Ice	3.401	3.401	0.063
						2" Ice	4.396	4.396	0.119
8' x 2" Pipe Mount	B	From Leg	4.000	0.000	147.000	No Ice	1.900	1.900	0.029
			0.000			1/2" Ice	2.728	2.728	0.044
			0.000			1" Ice	3.401	3.401	0.063
						2" Ice	4.396	4.396	0.119
8' x 2" Pipe Mount	C	From Leg	4.000	0.000	147.000	No Ice	1.900	1.900	0.029
			0.000			1/2" Ice	2.728	2.728	0.044
			0.000			1" Ice	3.401	3.401	0.063
						2" Ice	4.396	4.396	0.119
Platform Mount [LP 602-1_KCKR]	C	None		0.000	147.000	No Ice	42.300	42.300	1.618
						1/2" Ice	49.040	49.040	2.384
						1" Ice	55.870	55.870	3.267
						2" Ice	69.850	69.850	5.398
Transition Ladder	A	From Leg	3.000	0.000	147.000	No Ice	6.000	6.000	0.160
			0.000			1/2" Ice	8.000	8.000	0.240
			-2.000			1" Ice	10.000	10.000	0.320
						2" Ice	14.000	14.000	0.480
Miscellaneous [NA 507-1]	C	None		0.000	146.000	No Ice	4.560	4.560	0.245
						1/2" Ice	6.390	6.390	0.311
						1" Ice	8.180	8.180	0.402
						2" Ice	11.660	11.660	0.657
*									
(2) MX06FRO660-02 w/ Mount Pipe	A	From Leg	4.000	0.000	135.000	No Ice	6.540	5.540	0.082
			0.000			1/2" Ice	7.060	6.050	0.164
			0.000			1" Ice	7.600	6.570	0.256
						2" Ice	8.700	7.640	0.475
(2) MX06FRO660-02 w/ Mount Pipe	B	From Leg	4.000	0.000	135.000	No Ice	6.540	5.540	0.082
			0.000			1/2" Ice	7.060	6.050	0.164
			0.000			1" Ice	7.600	6.570	0.256
						2" Ice	8.700	7.640	0.475
(2) MX06FRO660-02 w/ Mount Pipe	C	From Leg	4.000	0.000	135.000	No Ice	6.540	5.540	0.082
			0.000			1/2" Ice	7.060	6.050	0.164
			0.000			1" Ice	7.600	6.570	0.256
						2" Ice	8.700	7.640	0.475
Sub6 Antenna - VZS01 w/	A	From Leg	4.000	0.000	135.000	No Ice	4.915	2.687	0.101

tnxTower B+T Group 1717 S. Boulder, Suite 300 Tulsa, OK 74119 Phone: (918) 587-4630 FAX: (918) 295-0265	Job		92739.019.01 - GROTON TOWER, CT (BU# 881533)		Page		35 of 62	
	Project				Date		20:02:38 10/26/21	
	Client		Crown Castle		Designed by		JD Prabhu	

Description	Face or Leg	Offset Type	Offsets:		Azimuth Adjustment °	Placement ft	C _{AA} Front ft ²	C _{AA} Side ft ²	Weight K
			Horz ft	Lateral ft					
Mount Pipe			0.000			1/2" Ice	5.264	3.151	0.141
			0.000			1" Ice	5.623	3.631	0.186
						2" Ice	6.371	4.639	0.294
Sub6 Antenna - VZS01 w/ Mount Pipe	B	From Leg	4.000	0.000	135.000	No Ice	4.915	2.687	0.101
			0.000			1/2" Ice	5.264	3.151	0.141
			0.000			1" Ice	5.623	3.631	0.186
						2" Ice	6.371	4.639	0.294
Sub6 Antenna - VZS01 w/ Mount Pipe	C	From Leg	4.000	0.000	135.000	No Ice	4.915	2.687	0.101
			0.000			1/2" Ice	5.264	3.151	0.141
			0.000			1" Ice	5.623	3.631	0.186
						2" Ice	6.371	4.639	0.294
RFV01U-D1A	A	From Leg	4.000	0.000	135.000	No Ice	1.875	1.250	0.084
			0.000			1/2" Ice	2.045	1.393	0.103
			0.000			1" Ice	2.223	1.543	0.124
						2" Ice	2.601	1.865	0.175
RFV01U-D1A	B	From Leg	4.000	0.000	135.000	No Ice	1.875	1.250	0.084
			0.000			1/2" Ice	2.045	1.393	0.103
			0.000			1" Ice	2.223	1.543	0.124
						2" Ice	2.601	1.865	0.175
RFV01U-D1A	C	From Leg	4.000	0.000	135.000	No Ice	1.875	1.250	0.084
			0.000			1/2" Ice	2.045	1.393	0.103
			0.000			1" Ice	2.223	1.543	0.124
						2" Ice	2.601	1.865	0.175
RFV01U-D2A	A	From Leg	4.000	0.000	135.000	No Ice	1.875	1.013	0.070
			0.000			1/2" Ice	2.045	1.145	0.087
			0.000			1" Ice	2.223	1.284	0.106
						2" Ice	2.601	1.585	0.153
RFV01U-D2A	B	From Leg	4.000	0.000	135.000	No Ice	1.875	1.013	0.070
			0.000			1/2" Ice	2.045	1.145	0.087
			0.000			1" Ice	2.223	1.284	0.106
						2" Ice	2.601	1.585	0.153
RFV01U-D2A	C	From Leg	4.000	0.000	135.000	No Ice	1.875	1.013	0.070
			0.000			1/2" Ice	2.045	1.145	0.087
			0.000			1" Ice	2.223	1.284	0.106
						2" Ice	2.601	1.585	0.153
RVZDC-6627-PF-48	A	From Leg	4.000	0.000	135.000	No Ice	3.792	2.514	0.032
			0.000			1/2" Ice	4.044	2.727	0.063
			0.000			1" Ice	4.303	2.947	0.099
						2" Ice	4.844	3.417	0.181
RVZDC-6627-PF-48	B	From Leg	4.000	0.000	135.000	No Ice	3.792	2.514	0.032
			0.000			1/2" Ice	4.044	2.727	0.063
			0.000			1" Ice	4.303	2.947	0.099
						2" Ice	4.844	3.417	0.181
LNX-6512DS-VTM w/ Mount Pipe	A	From Leg	4.000	0.000	135.000	No Ice	2.670	2.150	0.047
			0.000			1/2" Ice	2.940	2.420	0.091
			0.000			1" Ice	3.220	2.690	0.143
						2" Ice	3.810	3.250	0.272
LNX-6512DS-VTM w/ Mount Pipe	B	From Leg	4.000	0.000	135.000	No Ice	2.670	2.150	0.047
			0.000			1/2" Ice	2.940	2.420	0.091
			0.000			1" Ice	3.220	2.690	0.143
						2" Ice	3.810	3.250	0.272
LNX-6512DS-VTM w/ Mount Pipe	C	From Leg	4.000	0.000	135.000	No Ice	2.670	2.150	0.047
			0.000			1/2" Ice	2.940	2.420	0.091
			0.000			1" Ice	3.220	2.690	0.143
						2" Ice	3.810	3.250	0.272
Platform Mount [LP 601-1]	C	None		0.000	135.000	No Ice	28.500	28.500	1.122
						1/2" Ice	31.690	31.690	1.676

tnxTower B+T Group 1717 S. Boulder, Suite 300 Tulsa, OK 74119 Phone: (918) 587-4630 FAX: (918) 295-0265	Job		92739.019.01 - GROTON TOWER, CT (BU# 881533)		Page		36 of 62	
	Project				Date		20:02:38 10/26/21	
	Client		Crown Castle		Designed by		JD Prabhu	

Description	Face or Leg	Offset Type	Offsets:		Azimuth Adjustment °	Placement ft	C _{AA} Front ft ²	C _{AA} Side ft ²	Weight K
			Horz Lateral ft	Vert ft					
Transition Ladder	A	From Leg	3.000	0.000	135.000	1" Ice	34.870	34.870	2.282
						2" Ice	41.230	41.230	3.653
						No Ice	6.000	6.000	0.160
						1/2" Ice	8.000	8.000	0.240
						1" Ice	10.000	10.000	0.320
						2" Ice	14.000	14.000	0.480
* **Previous 018 SA** **019 SA**									
APXVAARR24_43-U-NA20 w/ Mount Pipe	A	From Leg	4.000	0.000	128.000	No Ice	14.690	6.870	0.186
						1/2" Ice	15.460	7.550	0.315
						1" Ice	16.230	8.250	0.458
						2" Ice	17.820	9.670	0.788
APXVAARR24_43-U-NA20 w/ Mount Pipe	B	From Leg	4.000	0.000	128.000	No Ice	14.690	6.870	0.186
						1/2" Ice	15.460	7.550	0.315
						1" Ice	16.230	8.250	0.458
						2" Ice	17.820	9.670	0.788
APXVAARR24_43-U-NA20 w/ Mount Pipe	C	From Leg	4.000	0.000	128.000	No Ice	14.690	6.870	0.186
						1/2" Ice	15.460	7.550	0.315
						1" Ice	16.230	8.250	0.458
						2" Ice	17.820	9.670	0.788
RADIO 4449 B12/B71	A	From Leg	4.000	0.000	128.000	No Ice	1.650	1.163	0.074
						1/2" Ice	1.810	1.301	0.090
						1" Ice	1.978	1.447	0.109
						2" Ice	2.336	1.762	0.155
RADIO 4449 B12/B71	B	From Leg	4.000	0.000	128.000	No Ice	1.650	1.163	0.074
						1/2" Ice	1.810	1.301	0.090
						1" Ice	1.978	1.447	0.109
						2" Ice	2.336	1.762	0.155
RADIO 4449 B12/B71	C	From Leg	4.000	0.000	128.000	No Ice	1.650	1.163	0.074
						1/2" Ice	1.810	1.301	0.090
						1" Ice	1.978	1.447	0.109
						2" Ice	2.336	1.762	0.155
ERICSSON AIR 21 B2A B4P w/ Mount Pipe	A	From Leg	4.000	0.000	128.000	No Ice	3.140	2.590	0.112
						1/2" Ice	3.450	2.880	0.164
						1" Ice	3.770	3.190	0.225
						2" Ice	4.430	3.840	0.375
ERICSSON AIR 21 B2A B4P w/ Mount Pipe	B	From Leg	4.000	0.000	128.000	No Ice	3.140	2.590	0.112
						1/2" Ice	3.450	2.880	0.164
						1" Ice	3.770	3.190	0.225
						2" Ice	4.430	3.840	0.375
ERICSSON AIR 21 B2A B4P w/ Mount Pipe	C	From Leg	4.000	0.000	128.000	No Ice	3.140	2.590	0.112
						1/2" Ice	3.450	2.880	0.164
						1" Ice	3.770	3.190	0.225
						2" Ice	4.430	3.840	0.375
ERICSSON AIR 21 B4A B2P w/ Mount Pipe	A	From Leg	4.000	0.000	128.000	No Ice	3.140	2.590	0.111
						1/2" Ice	3.450	2.880	0.163
						1" Ice	3.770	3.190	0.224
						2" Ice	4.430	3.840	0.374
ERICSSON AIR 21 B4A B2P w/ Mount Pipe	B	From Leg	4.000	0.000	128.000	No Ice	3.140	2.590	0.111
						1/2" Ice	3.450	2.880	0.163
						1" Ice	3.770	3.190	0.224
						2" Ice	4.430	3.840	0.374
ERICSSON AIR 21 B4A B2P w/ Mount Pipe	C	From Leg	4.000	0.000	128.000	No Ice	3.140	2.590	0.111
						1/2" Ice	3.450	2.880	0.163
						1" Ice	3.770	3.190	0.224
						2" Ice	4.430	3.840	0.374

tnxTower B+T Group 1717 S. Boulder, Suite 300 Tulsa, OK 74119 Phone: (918) 587-4630 FAX: (918) 295-0265	Job		92739.019.01 - GROTON TOWER, CT (BU# 881533)		Page		37 of 62	
	Project				Date		20:02:38 10/26/21	
	Client		Crown Castle		Designed by		JD Prabhu	

Description	Face or Leg	Offset Type	Offsets:		Azimuth Adjustment	Placement	C _{AA} Front	C _{AA} Side	Weight	
			Horz	Lateral						°
KRY 112 144/1	A	From Leg	4.000	0.000	0.000	128.000	No Ice	0.350	0.175	0.011
			0.000	0.000			1/2" Ice	0.426	0.234	0.014
			0.000	0.000			1" Ice	0.509	0.301	0.019
							2" Ice	0.698	0.456	0.032
KRY 112 144/1	B	From Leg	4.000	0.000	0.000	128.000	No Ice	0.350	0.175	0.011
			0.000	0.000			1/2" Ice	0.426	0.234	0.014
			0.000	0.000			1" Ice	0.509	0.301	0.019
							2" Ice	0.698	0.456	0.032
KRY 112 144/1	C	From Leg	4.000	0.000	0.000	128.000	No Ice	0.350	0.175	0.011
			0.000	0.000			1/2" Ice	0.426	0.234	0.014
			0.000	0.000			1" Ice	0.509	0.301	0.019
							2" Ice	0.698	0.456	0.032
Platform Mount [LP 601-1]	C	None		0.000	0.000	128.000	No Ice	28.500	28.500	1.122
							1/2" Ice	31.690	31.690	1.676
							1" Ice	34.870	34.870	2.282
							2" Ice	41.230	41.230	3.653
Transition Ladder	A	From Leg	3.000	0.000	0.000	128.000	No Ice	6.000	6.000	0.160
			0.000	0.000			1/2" Ice	8.000	8.000	0.240
			-2.000				1" Ice	10.000	10.000	0.320
							2" Ice	14.000	14.000	0.480
Miscellaneous [NA 507-1]	C	None		0.000	0.000	130.000	No Ice	4.560	4.560	0.245
							1/2" Ice	6.390	6.390	0.311
							1" Ice	8.180	8.180	0.402
							2" Ice	11.660	11.660	0.657
* APXVSP18-C-A20 w/ Mount Pipe	A	From Leg	4.000	0.000	0.000	118.000	No Ice	4.600	4.010	0.095
			0.000	0.000			1/2" Ice	5.050	4.450	0.160
			0.000	0.000			1" Ice	5.500	4.890	0.235
							2" Ice	6.440	5.820	0.419
APXVSP18-C-A20 w/ Mount Pipe	B	From Leg	4.000	0.000	0.000	118.000	No Ice	4.600	4.010	0.095
			0.000	0.000			1/2" Ice	5.050	4.450	0.160
			0.000	0.000			1" Ice	5.500	4.890	0.235
							2" Ice	6.440	5.820	0.419
APXVSP18-C-A20 w/ Mount Pipe	C	From Leg	4.000	0.000	0.000	118.000	No Ice	4.600	4.010	0.095
			0.000	0.000			1/2" Ice	5.050	4.450	0.160
			0.000	0.000			1" Ice	5.500	4.890	0.235
							2" Ice	6.440	5.820	0.419
APXVTM14-C-120 w/ Mount Pipe	A	From Leg	4.000	0.000	0.000	118.000	No Ice	4.090	2.860	0.077
			0.000	0.000			1/2" Ice	4.480	3.230	0.127
			0.000	0.000			1" Ice	4.880	3.610	0.185
							2" Ice	5.710	4.400	0.331
APXVTM14-C-120 w/ Mount Pipe	B	From Leg	4.000	0.000	0.000	118.000	No Ice	4.090	2.860	0.077
			0.000	0.000			1/2" Ice	4.480	3.230	0.127
			0.000	0.000			1" Ice	4.880	3.610	0.185
							2" Ice	5.710	4.400	0.331
APXVTM14-C-120 w/ Mount Pipe	C	From Leg	4.000	0.000	0.000	118.000	No Ice	4.090	2.860	0.077
			0.000	0.000			1/2" Ice	4.480	3.230	0.127
			0.000	0.000			1" Ice	4.880	3.610	0.185
							2" Ice	5.710	4.400	0.331
TD-RRH8X20-25	A	From Leg	4.000	0.000	0.000	118.000	No Ice	4.045	1.535	0.070
			0.000	0.000			1/2" Ice	4.298	1.714	0.097
			0.000	0.000			1" Ice	4.557	1.901	0.128
							2" Ice	5.098	2.295	0.201
TD-RRH8X20-25	B	From Leg	4.000	0.000	0.000	118.000	No Ice	4.045	1.535	0.070
			0.000	0.000			1/2" Ice	4.298	1.714	0.097
			0.000	0.000			1" Ice	4.557	1.901	0.128
							2" Ice	5.098	2.295	0.201

tnxTower B+T Group 1717 S. Boulder, Suite 300 Tulsa, OK 74119 Phone: (918) 587-4630 FAX: (918) 295-0265	Job		92739.019.01 - GROTON TOWER, CT (BU# 881533)		Page		38 of 62	
	Project				Date		20:02:38 10/26/21	
	Client		Crown Castle		Designed by		JD Prabhu	

Description	Face or Leg	Offset Type	Offsets:		Azimuth Adjustment	Placement	C _{AA} Front	C _{AA} Side	Weight	
			Horz	Lateral						Vert
TD-RRH8X20-25	C	From Leg	4.000	0.000	0.000	118.000	No Ice	4.045	1.535	0.070
			0.000				1/2" Ice	4.298	1.714	0.097
			0.000				1" Ice	4.557	1.901	0.128
							2" Ice	5.098	2.295	0.201
Platform Mount [LP 601-1]	C	None		0.000	0.000	118.000	No Ice	28.500	28.500	1.122
							1/2" Ice	31.690	31.690	1.676
							1" Ice	34.870	34.870	2.282
							2" Ice	41.230	41.230	3.653
Transition Ladder	A	From Leg	3.000	0.000	0.000	118.000	No Ice	6.000	6.000	0.160
			0.000				1/2" Ice	8.000	8.000	0.240
			-2.000				1" Ice	10.000	10.000	0.320
							2" Ice	14.000	14.000	0.480
* TME-PCS 1900MHz 4x45W-65MHz	A	From Leg	4.000	0.000	0.000	108.000	No Ice	2.322	2.238	0.060
			0.000				1/2" Ice	2.527	2.441	0.083
			0.000				1" Ice	2.739	2.651	0.110
							2" Ice	3.185	3.093	0.173
TME-PCS 1900MHz 4x45W-65MHz	B	From Leg	4.000	0.000	0.000	108.000	No Ice	2.322	2.238	0.060
			0.000				1/2" Ice	2.527	2.441	0.083
			0.000				1" Ice	2.739	2.651	0.110
							2" Ice	3.185	3.093	0.173
TME-PCS 1900MHz 4x45W-65MHz	C	From Leg	4.000	0.000	0.000	108.000	No Ice	2.322	2.238	0.060
			0.000				1/2" Ice	2.527	2.441	0.083
			0.000				1" Ice	2.739	2.651	0.110
							2" Ice	3.185	3.093	0.173
TME-800MHz 2X50W RRH W/FILTER	A	From Leg	4.000	0.000	0.000	108.000	No Ice	2.058	1.932	0.064
			0.000				1/2" Ice	2.240	2.109	0.086
			-2.000				1" Ice	2.429	2.293	0.111
							2" Ice	2.829	2.684	0.172
TME-800MHz 2X50W RRH W/FILTER	B	From Leg	4.000	0.000	0.000	108.000	No Ice	2.058	1.932	0.064
			0.000				1/2" Ice	2.240	2.109	0.086
			-2.000				1" Ice	2.429	2.293	0.111
							2" Ice	2.829	2.684	0.172
TME-800MHz 2X50W RRH W/FILTER	C	From Leg	4.000	0.000	0.000	108.000	No Ice	2.058	1.932	0.064
			0.000				1/2" Ice	2.240	2.109	0.086
			-2.000				1" Ice	2.429	2.293	0.111
							2" Ice	2.829	2.684	0.172
Side Arm Mount [SO 102-3]	C	None		0.000	0.000	108.000	No Ice	3.600	3.600	0.075
							1/2" Ice	4.180	4.180	0.105
							1" Ice	4.750	4.750	0.135
							2" Ice	5.900	5.900	0.195
* 6' x 2" Mount Pipe	A	From Leg	4.000	0.000	0.000	103.000	No Ice	1.425	1.425	0.022
			0.000				1/2" Ice	1.925	1.925	0.033
			0.000				1" Ice	2.294	2.294	0.048
							2" Ice	3.060	3.060	0.090
6' x 2" Mount Pipe	B	From Leg	4.000	0.000	0.000	103.000	No Ice	1.425	1.425	0.022
			0.000				1/2" Ice	1.925	1.925	0.033
			0.000				1" Ice	2.294	2.294	0.048
							2" Ice	3.060	3.060	0.090
6' x 2" Mount Pipe	C	From Leg	4.000	0.000	0.000	103.000	No Ice	1.425	1.425	0.022
			0.000				1/2" Ice	1.925	1.925	0.033
			0.000				1" Ice	2.294	2.294	0.048
							2" Ice	3.060	3.060	0.090
8' x 2" Mount Pipe	A	From Leg	4.000	0.000	0.000	103.000	No Ice	1.900	1.900	0.029
			0.000				1/2" Ice	2.728	2.728	0.044
			0.000				1" Ice	3.401	3.401	0.063

tnxTower B+T Group 1717 S. Boulder, Suite 300 Tulsa, OK 74119 Phone: (918) 587-4630 FAX: (918) 295-0265	Job		92739.019.01 - GROTON TOWER, CT (BU# 881533)		Page		39 of 62	
	Project				Date		20:02:38 10/26/21	
	Client		Crown Castle		Designed by		JD Prabhu	

Description	Face or Leg	Offset Type	Offsets:			Azimuth Adjustment	Placement	C _{AA} Front	C _{AA} Side	Weight
			Horz	Lateral	Vert					
8' x 2" Mount Pipe	B	From Leg	4.000	0.000	103.000	2" Ice	4.396	4.396	0.119	
			0.000			No Ice	1.900	1.900	0.029	
			0.000			1/2" Ice	2.728	2.728	0.044	
						1" Ice	3.401	3.401	0.063	
8' x 2" Mount Pipe	C	From Leg	4.000	0.000	103.000	2" Ice	4.396	4.396	0.119	
			0.000			No Ice	1.900	1.900	0.029	
			0.000			1/2" Ice	2.728	2.728	0.044	
						1" Ice	3.401	3.401	0.063	
Platform Mount [LP 601-1]	C	None		0.000	103.000	2" Ice	4.396	4.396	0.119	
						No Ice	28.500	28.500	1.122	
						1/2" Ice	31.690	31.690	1.676	
						1" Ice	34.870	34.870	2.282	
Transition Ladder	A	From Leg	3.000	0.000	103.000	2" Ice	41.230	41.230	3.653	
			0.000			No Ice	6.000	6.000	0.160	
			-2.000			1/2" Ice	8.000	8.000	0.240	
						1" Ice	10.000	10.000	0.320	
* MX08FRO665-21 w/ Mount Pipe	A	From Leg	4.000	0.000	98.000	2" Ice	14.000	14.000	0.480	
			0.000			No Ice	8.010	4.230	0.108	
			0.000			1/2" Ice	8.520	4.690	0.194	
						1" Ice	9.040	5.160	0.292	
MX08FRO665-21 w/ Mount Pipe	B	From Leg	4.000	0.000	98.000	2" Ice	10.110	6.120	0.522	
			0.000			No Ice	8.010	4.230	0.108	
			0.000			1/2" Ice	8.520	4.690	0.194	
						1" Ice	9.040	5.160	0.292	
MX08FRO665-21 w/ Mount Pipe	C	From Leg	4.000	0.000	98.000	2" Ice	10.110	6.120	0.522	
			0.000			No Ice	8.010	4.230	0.108	
			0.000			1/2" Ice	8.520	4.690	0.194	
						1" Ice	9.040	5.160	0.292	
TA08025-B604	A	From Leg	4.000	0.000	98.000	2" Ice	10.110	6.120	0.522	
			0.000			No Ice	1.964	0.981	0.064	
			0.000			1/2" Ice	2.138	1.112	0.081	
						1" Ice	2.320	1.250	0.100	
TA08025-B604	B	From Leg	4.000	0.000	98.000	2" Ice	2.705	1.548	0.148	
			0.000			No Ice	1.964	0.981	0.064	
			0.000			1/2" Ice	2.138	1.112	0.081	
						1" Ice	2.320	1.250	0.100	
TA08025-B604	C	From Leg	4.000	0.000	98.000	2" Ice	2.705	1.548	0.148	
			0.000			No Ice	1.964	0.981	0.064	
			0.000			1/2" Ice	2.138	1.112	0.081	
						1" Ice	2.320	1.250	0.100	
TA08025-B605	A	From Leg	4.000	0.000	98.000	2" Ice	2.705	1.548	0.148	
			0.000			No Ice	1.964	1.129	0.075	
			0.000			1/2" Ice	2.138	1.267	0.093	
						1" Ice	2.320	1.411	0.114	
TA08025-B605	B	From Leg	4.000	0.000	98.000	2" Ice	2.705	1.723	0.164	
			0.000			No Ice	1.964	1.129	0.075	
			0.000			1/2" Ice	2.138	1.267	0.093	
						1" Ice	2.320	1.411	0.114	
TA08025-B605	C	From Leg	4.000	0.000	98.000	2" Ice	2.705	1.723	0.164	
			0.000			No Ice	1.964	1.129	0.075	
			0.000			1/2" Ice	2.138	1.267	0.093	
						1" Ice	2.320	1.411	0.114	
RDIDC-9181-PF-48	A	From Leg	4.000	0.000	98.000	2" Ice	2.705	1.723	0.164	
			0.000			No Ice	2.012	1.168	0.022	
			0.000			1/2" Ice	2.189	1.311	0.040	
						1" Ice	2.373	1.461	0.060	

tnxTower B+T Group 1717 S. Boulder, Suite 300 Tulsa, OK 74119 Phone: (918) 587-4630 FAX: (918) 295-0265	Job 92739.019.01 - GROTON TOWER, CT (BU# 881533)	Page 40 of 62
	Project	Date 20:02:38 10/26/21
	Client Crown Castle	Designed by JD Prabhu

Description	Face or Leg	Offset Type	Offsets:		Azimuth Adjustment °	Placement ft	C _{AA} Front ft ²	C _{AA} Side ft ²	Weight K	
			Horz Lateral ft	Vert ft						
(2) 8' x 2" Mount Pipe	A	From Leg	4.000	0.000	0.000	98.000	2" Ice	2.763	1.784	0.110
			0.000	No Ice			1.900	1.900	0.029	
			0.000	1/2" Ice			2.728	2.728	0.044	
				1" Ice			3.401	3.401	0.063	
(2) 8' x 2" Mount Pipe	B	From Leg	4.000	0.000	0.000	98.000	2" Ice	4.396	4.396	0.119
			0.000	No Ice			1.900	1.900	0.029	
			0.000	1/2" Ice			2.728	2.728	0.044	
				1" Ice			3.401	3.401	0.063	
(2) 8' x 2" Mount Pipe	C	From Leg	4.000	0.000	0.000	98.000	2" Ice	4.396	4.396	0.119
			0.000	No Ice			1.900	1.900	0.029	
			0.000	1/2" Ice			2.728	2.728	0.044	
				1" Ice			3.401	3.401	0.063	
Commscope MC-PK8-DSH	C	None		0.000	0.000	98.000	2" Ice	4.396	4.396	0.119
				No Ice			34.240	34.240	1.749	
				1/2" Ice			62.950	62.950	2.099	
				1" Ice			91.660	91.660	2.450	
						2" Ice	149.080	149.080	3.151	
*										

Load Combinations

Comb. No.	Description
1	Dead Only
2	1.2 Dead+1.0 Wind 0 deg - No Ice
3	0.9 Dead+1.0 Wind 0 deg - No Ice
4	1.2 Dead+1.0 Wind 30 deg - No Ice
5	0.9 Dead+1.0 Wind 30 deg - No Ice
6	1.2 Dead+1.0 Wind 60 deg - No Ice
7	0.9 Dead+1.0 Wind 60 deg - No Ice
8	1.2 Dead+1.0 Wind 90 deg - No Ice
9	0.9 Dead+1.0 Wind 90 deg - No Ice
10	1.2 Dead+1.0 Wind 120 deg - No Ice
11	0.9 Dead+1.0 Wind 120 deg - No Ice
12	1.2 Dead+1.0 Wind 150 deg - No Ice
13	0.9 Dead+1.0 Wind 150 deg - No Ice
14	1.2 Dead+1.0 Wind 180 deg - No Ice
15	0.9 Dead+1.0 Wind 180 deg - No Ice
16	1.2 Dead+1.0 Wind 210 deg - No Ice
17	0.9 Dead+1.0 Wind 210 deg - No Ice
18	1.2 Dead+1.0 Wind 240 deg - No Ice
19	0.9 Dead+1.0 Wind 240 deg - No Ice
20	1.2 Dead+1.0 Wind 270 deg - No Ice
21	0.9 Dead+1.0 Wind 270 deg - No Ice
22	1.2 Dead+1.0 Wind 300 deg - No Ice
23	0.9 Dead+1.0 Wind 300 deg - No Ice
24	1.2 Dead+1.0 Wind 330 deg - No Ice
25	0.9 Dead+1.0 Wind 330 deg - No Ice
26	1.2 Dead+1.0 Ice+1.0 Temp
27	1.2 Dead+1.0 Wind 0 deg+1.0 Ice+1.0 Temp
28	1.2 Dead+1.0 Wind 30 deg+1.0 Ice+1.0 Temp

tnxTower B+T Group 1717 S. Boulder, Suite 300 Tulsa, OK 74119 Phone: (918) 587-4630 FAX: (918) 295-0265	Job 92739.019.01 - GROTON TOWER, CT (BU# 881533)	Page 41 of 62
	Project	Date 20:02:38 10/26/21
	Client Crown Castle	Designed by JD Prabhu

Comb. No.	Description
29	1.2 Dead+1.0 Wind 60 deg+1.0 Ice+1.0 Temp
30	1.2 Dead+1.0 Wind 90 deg+1.0 Ice+1.0 Temp
31	1.2 Dead+1.0 Wind 120 deg+1.0 Ice+1.0 Temp
32	1.2 Dead+1.0 Wind 150 deg+1.0 Ice+1.0 Temp
33	1.2 Dead+1.0 Wind 180 deg+1.0 Ice+1.0 Temp
34	1.2 Dead+1.0 Wind 210 deg+1.0 Ice+1.0 Temp
35	1.2 Dead+1.0 Wind 240 deg+1.0 Ice+1.0 Temp
36	1.2 Dead+1.0 Wind 270 deg+1.0 Ice+1.0 Temp
37	1.2 Dead+1.0 Wind 300 deg+1.0 Ice+1.0 Temp
38	1.2 Dead+1.0 Wind 330 deg+1.0 Ice+1.0 Temp
39	Dead+Wind 0 deg - Service
40	Dead+Wind 30 deg - Service
41	Dead+Wind 60 deg - Service
42	Dead+Wind 90 deg - Service
43	Dead+Wind 120 deg - Service
44	Dead+Wind 150 deg - Service
45	Dead+Wind 180 deg - Service
46	Dead+Wind 210 deg - Service
47	Dead+Wind 240 deg - Service
48	Dead+Wind 270 deg - Service
49	Dead+Wind 300 deg - Service
50	Dead+Wind 330 deg - Service

Maximum Member Forces

Section No.	Elevation ft	Component Type	Condition	Gov. Load Comb.	Axial K	Major Axis Moment kip-ft	Minor Axis Moment kip-ft
L1	144.5 - 139.5	Pole	Max Tension	26	0.000	0.000	-0.000
			Max. Compression	26	-13.784	0.066	1.799
			Max. Mx	20	-4.159	83.853	0.575
			Max. My	2	-4.161	-0.014	84.279
			Max. Vy	8	12.194	-83.852	0.569
			Max. Vx	2	-12.153	-0.014	84.279
			Max. Torque	8			1.641
L2	139.5 - 134.5	Pole	Max Tension	1	0.000	0.000	0.000
			Max. Compression	26	-22.853	-0.544	3.931
			Max. Mx	8	-7.041	-148.421	1.243
			Max. My	2	-7.037	-0.095	149.338
			Max. Vy	8	18.675	-148.421	1.243
			Max. Vx	2	-18.665	-0.095	149.338
			Max. Torque	8			3.349
L3	134.5 - 129.5	Pole	Max Tension	1	0.000	0.000	0.000
			Max. Compression	26	-24.120	-0.540	4.051
			Max. Mx	8	-7.776	-243.119	1.193
			Max. My	2	-7.772	0.042	243.989
			Max. Vy	8	19.466	-243.119	1.193
			Max. Vx	2	-19.456	0.042	243.989
			Max. Torque	8			3.348
L4	129.5 - 124.5	Pole	Max Tension	1	0.000	0.000	0.000
			Max. Compression	26	-32.820	-0.572	5.920
			Max. Mx	8	-11.042	-359.018	1.739
			Max. My	2	-11.038	0.174	360.606
			Max. Vy	8	25.117	-359.018	1.739
			Max. Vx	2	-25.108	0.174	360.606
			Max. Torque	9			4.770
L5	124.5 - 117.568	Pole	Max Tension	1	0.000	0.000	0.000
			Max. Compression	26	-33.336	-0.602	6.022

tnxTower B+T Group 1717 S. Boulder, Suite 300 Tulsa, OK 74119 Phone: (918) 587-4630 FAX: (918) 295-0265	Job	Page	
		92739.019.01 - GROTON TOWER, CT (BU# 881533)	42 of 62
	Project		Date
	Client	Crown Castle	20:02:38 10/26/21
			Designed by
			JD Prabhu

Section No.	Elevation ft	Component Type	Condition	Gov. Load Comb.	Axial K	Major Axis Moment kip-ft	Minor Axis Moment kip-ft
L6	117.568 - 116.409	Pole	Max. Mx	8	-11.451	-437.073	1.710
			Max. My	2	-11.446	0.254	438.631
			Max. Vy	8	25.398	-437.073	1.710
			Max. Vx	2	-25.389	0.254	438.631
			Max. Torque	9			4.766
			Max Tension	1	0.000	0.000	0.000
			Max. Compression	26	-40.599	-0.651	7.928
			Max. Mx	8	-14.379	-570.849	2.281
			Max. My	2	-14.374	0.384	573.148
			Max. Vy	8	29.804	-570.849	2.281
L7	116.409 - 112.583	Pole	Max. Vx	2	-29.796	0.384	573.148
			Max. Torque	8			6.265
			Max Tension	1	0.000	0.000	0.000
			Max. Compression	26	-41.395	-0.690	8.056
			Max. Mx	8	-15.026	-685.501	2.240
			Max. My	2	-15.022	0.484	687.765
			Max. Vy	8	30.156	-685.501	2.240
			Max. Vx	2	-30.148	0.484	687.765
			Max. Torque	8			6.263
			Max Tension	1	0.000	0.000	0.000
L8	112.583 - 112.333	Pole	Max. Compression	26	-41.452	-0.692	8.064
			Max. Mx	8	-15.096	-693.040	2.236
			Max. My	2	-15.091	0.491	695.301
			Max. Vy	8	30.166	-693.040	2.236
			Max. Vx	2	-30.158	0.491	695.301
			Max. Torque	8			6.258
			Max Tension	1	0.000	0.000	0.000
			Max. Compression	26	-43.674	-0.742	8.217
			Max. Mx	8	-16.426	-845.005	2.169
			Max. My	2	-16.422	0.622	847.218
L9	112.333 - 107.333	Pole	Max. Vy	8	31.495	-845.005	2.169
			Max. Vx	2	-31.486	0.622	847.218
			Max. Torque	8			6.257
			Max Tension	1	0.000	0.000	0.000
			Max. Compression	26	-43.772	-0.746	8.229
			Max. Mx	8	-16.520	-858.014	2.162
			Max. My	2	-16.516	0.633	860.224
			Max. Vy	8	31.523	-858.014	2.162
			Max. Vx	2	-31.514	0.633	860.224
			Max. Torque	8			6.249
L10	107.333 - 106.92	Pole	Max Tension	1	0.000	0.000	0.000
			Max. Compression	26	-43.859	-0.749	8.237
			Max. Mx	8	-16.590	-865.898	2.158
			Max. My	2	-16.586	0.639	868.105
			Max. Vy	8	31.547	-865.898	2.158
			Max. Vx	2	-31.539	0.639	868.105
			Max. Torque	8			6.249
			Max Tension	1	0.000	0.000	0.000
			Max. Compression	26	-45.010	-0.781	8.328
			Max. Mx	8	-17.370	-966.462	2.115
L11	106.92 - 106.67	Pole	Max. My	2	-17.366	0.723	968.639
			Max. Vy	8	31.908	-966.462	2.115
			Max. Vx	2	-31.899	0.723	968.639
			Max. Torque	8			6.248
			Max Tension	1	0.000	0.000	0.000
			Max. Compression	26	-43.859	-0.749	8.237
			Max. Mx	8	-16.590	-865.898	2.158
			Max. My	2	-16.586	0.639	868.105
			Max. Vy	8	31.547	-865.898	2.158
			Max. Vx	2	-31.539	0.639	868.105
L12	106.67 - 103.5	Pole	Max. Torque	8			6.249
			Max Tension	1	0.000	0.000	0.000
			Max. Compression	26	-45.010	-0.781	8.328
			Max. Mx	8	-17.370	-966.462	2.115
			Max. My	2	-17.366	0.723	968.639
			Max. Vy	8	31.908	-966.462	2.115
			Max. Vx	2	-31.899	0.723	968.639
			Max. Torque	8			6.248
			Max Tension	1	0.000	0.000	0.000
			Max. Compression	26	-45.010	-0.781	8.328
L13	103.5 - 103.25	Pole	Max. Mx	8	-17.370	-966.462	2.115
			Max. My	2	-17.366	0.723	968.639
			Max. Vy	8	31.908	-966.462	2.115
			Max. Vx	2	-31.899	0.723	968.639
			Max. Torque	8			6.248
			Max Tension	1	0.000	0.000	0.000
			Max. Compression	26	-45.010	-0.781	8.328
			Max. Mx	8	-17.370	-966.462	2.115
			Max. My	2	-17.366	0.723	968.639
			Max. Vy	8	31.908	-966.462	2.115

tnxTower B+T Group 1717 S. Boulder, Suite 300 Tulsa, OK 74119 Phone: (918) 587-4630 FAX: (918) 295-0265	Job	92739.019.01 - GROTON TOWER, CT (BU# 881533)	Page	43 of 62
	Project		Date	20:02:38 10/26/21
	Client	Crown Castle	Designed by	JD Prabhu

Section No.	Elevation ft	Component Type	Condition	Gov. Load Comb.	Axial K	Major Axis Moment kip-ft	Minor Axis Moment kip-ft
L14	103.25 - 98.5	Pole	Max. Compression	26	-45.105	-0.783	8.336
			Max. Mx	8	-17.445	-974.441	2.111
			Max. My	2	-17.441	0.729	976.616
			Max. Vy	8	31.930	-974.441	2.111
			Max. Vx	2	-31.922	0.729	976.616
			Max. Torque	8			6.246
			Max Tension	1	0.000	0.000	0.000
			Max. Compression	26	-50.931	-0.833	10.255
			Max. Mx	8	-20.134	-1138.538	2.718
			Max. My	2	-20.130	0.854	1141.477
L15	98.5 - 98.25	Pole	Max. Vy	8	35.104	-1138.538	2.718
			Max. Vx	2	-35.096	0.854	1141.477
			Max. Torque	8			7.724
			Max Tension	1	0.000	0.000	0.000
			Max. Compression	26	-51.041	-0.835	10.263
			Max. Mx	8	-20.229	-1147.315	2.714
			Max. My	2	-20.225	0.860	1150.252
			Max. Vy	8	35.124	-1147.315	2.714
			Max. Vx	2	-35.117	0.860	1150.252
			Max. Torque	8			7.720
L16	98.25 - 97.58	Pole	Max Tension	1	0.000	0.000	0.000
			Max. Compression	26	-57.153	-0.842	10.734
			Max. Mx	8	-23.302	-1172.604	2.819
			Max. My	2	-23.294	0.878	1175.690
			Max. Vy	8	39.326	-1172.604	2.819
			Max. Vx	2	-39.356	0.878	1175.690
			Max. Torque	8			8.000
			Max Tension	1	0.000	0.000	0.000
			Max. Compression	26	-57.255	-0.845	10.742
			Max. Mx	8	-23.379	-1182.438	2.816
L17	97.58 - 97.33	Pole	Max. My	2	-23.371	0.885	1185.531
			Max. Vy	8	39.350	-1182.438	2.816
			Max. Vx	2	-39.382	0.885	1185.531
			Max. Torque	8			8.000
			Max Tension	1	0.000	0.000	0.000
			Max. Compression	26	-59.174	-0.899	10.893
			Max. Mx	8	-24.803	-1380.551	2.745
			Max. My	2	-24.796	1.017	1383.794
			Max. Vy	8	39.907	-1380.551	2.745
			Max. Vx	2	-39.937	1.017	1383.794
L18	97.33 - 92.33	Pole	Max. Torque	8			7.999
			Max Tension	1	0.000	0.000	0.000
			Max. Compression	26	-59.384	-0.905	10.911
			Max. Mx	8	-24.984	-1403.997	2.736
			Max. My	2	-24.977	1.032	1407.258
			Max. Vy	8	39.965	-1403.997	2.736
			Max. Vx	2	-39.996	1.032	1407.258
			Max. Torque	8			7.994
			Max Tension	1	0.000	0.000	0.000
			Max. Compression	26	-62.315	-0.967	11.076
L19	92.33 - 87.1178	Pole	Max. Mx	8	-27.236	-1630.837	2.652
			Max. My	2	-27.230	1.181	1634.266
			Max. Vy	8	40.676	-1630.837	2.652
			Max. Vx	2	-40.706	1.181	1634.266
			Max. Torque	9			7.990
			Max Tension	1	0.000	0.000	0.000
			Max. Compression	26	-63.251	-1.000	11.163
			Max. Mx	8	-28.061	-1758.013	2.595
			Max. My	2	-28.055	1.263	1761.535
			Max. Vy	8	40.676	-1630.837	2.652
L20	87.1178 - 86.1178	Pole	Max. Vy	8	39.965	-1403.997	2.736
			Max. Vx	2	-39.996	1.032	1407.258
			Max. Torque	8			7.994
			Max Tension	1	0.000	0.000	0.000
			Max. Compression	26	-59.384	-0.905	10.911
			Max. Mx	8	-24.984	-1403.997	2.736
			Max. My	2	-24.977	1.032	1407.258
			Max. Vy	8	39.965	-1403.997	2.736
			Max. Vx	2	-39.996	1.032	1407.258
			Max. Torque	8			7.994
L21	86.1178 - 83	Pole	Max Tension	1	0.000	0.000	0.000
			Max. Compression	26	-62.315	-0.967	11.076
			Max. Mx	8	-27.236	-1630.837	2.652
			Max. My	2	-27.230	1.181	1634.266
			Max. Vy	8	40.676	-1630.837	2.652
			Max. Vx	2	-40.706	1.181	1634.266
			Max. Torque	9			7.990
			Max Tension	1	0.000	0.000	0.000
			Max. Compression	26	-63.251	-1.000	11.163
			Max. Mx	8	-28.061	-1758.013	2.595
Max. My	2	-28.055	1.263	1761.535			

tnxTower B+T Group 1717 S. Boulder, Suite 300 Tulsa, OK 74119 Phone: (918) 587-4630 FAX: (918) 295-0265	Job	92739.019.01 - GROTON TOWER, CT (BU# 881533)	Page	44 of 62
	Project		Date	20:02:38 10/26/21
	Client	Crown Castle	Designed by	JD Prabhu

Section No.	Elevation ft	Component Type	Condition	Gov. Load Comb.	Axial K	Major Axis Moment kip-ft	Minor Axis Moment kip-ft
L22	83 - 82.75	Pole	Max. Vy	8	40.946	-1758.013	2.595
			Max. Vx	2	-40.976	1.263	1761.535
			Max. Torque	9			7.988
			Max Tension	1	0.000	0.000	0.000
			Max. Compression	26	-63.330	-1.003	11.170
			Max. Mx	8	-28.154	-1768.247	2.589
			Max. My	2	-28.148	1.270	1771.776
			Max. Vy	8	40.949	-1768.247	2.589
			Max. Vx	2	-40.981	1.270	1771.776
L23	82.75 - 77.75	Pole	Max. Torque	9			7.984
			Max Tension	1	0.000	0.000	0.000
			Max. Compression	26	-64.991	-1.058	11.297
			Max. Mx	8	-29.489	-1974.028	2.491
			Max. My	2	-29.483	1.402	1977.705
			Max. Vy	8	41.389	-1974.028	2.491
			Max. Vx	2	-41.419	1.402	1977.705
			Max. Torque	9			7.983
			Max Tension	1	0.000	0.000	0.000
L24	77.75 - 77.25	Pole	Max. Compression	26	-65.168	-1.063	11.310
			Max. Mx	8	-29.644	-1994.722	2.480
			Max. My	2	-29.638	1.415	1998.414
			Max. Vy	8	41.418	-1994.722	2.480
			Max. Vx	2	-41.448	1.415	1998.414
			Max. Torque	9			7.976
			Max Tension	1	0.000	0.000	0.000
			Max. Compression	26	-65.300	-1.066	11.316
			Max. Mx	8	-29.760	-2005.078	2.475
L25	77.25 - 77	Pole	Max. My	2	-29.755	1.422	2008.777
			Max. Vy	8	41.439	-2005.078	2.475
			Max. Vx	2	-41.470	1.422	2008.777
			Max. Torque	9			7.975
			Max Tension	1	0.000	0.000	0.000
			Max. Compression	26	-65.413	-1.069	11.322
			Max. Mx	8	-29.846	-2015.441	2.470
			Max. My	2	-29.841	1.428	2019.147
			Max. Vy	8	41.467	-2015.441	2.470
L26	77 - 76.75	Pole	Max. Vx	2	-41.498	1.428	2019.147
			Max. Torque	9			7.975
			Max Tension	1	0.000	0.000	0.000
			Max. Compression	26	-67.592	-1.123	11.439
			Max. Mx	8	-31.591	-2224.106	2.370
			Max. My	2	-31.586	1.560	2227.958
			Max. Vy	8	42.015	-2224.106	2.370
			Max. Vx	2	-42.045	1.560	2227.958
			Max. Torque	9			7.974
L27	76.75 - 71.75	Pole	Max Tension	1	0.000	0.000	0.000
			Max. Compression	26	-68.838	-1.153	11.501
			Max. Mx	8	-32.567	-2340.011	2.313
			Max. My	2	-32.562	1.632	2343.944
			Max. Vy	8	42.314	-2340.011	2.313
			Max. Vx	2	-42.344	1.632	2343.944
			Max. Torque	9			7.970
			Max Tension	1	0.000	0.000	0.000
			Max. Compression	26	-68.972	-1.156	11.507
L28	71.75 - 69	Pole	Max. Mx	8	-32.699	-2350.588	2.307
			Max. My	2	-32.694	1.638	2354.528
			Max. Vy	8	42.324	-2350.588	2.307
			Max. Vx	2	-42.355	1.638	2354.528
			Max. Torque	9			7.968
			Max Tension	1	0.000	0.000	0.000
			Max. Compression	26	-71.662	-1.212	11.616
			Max. Mx	8	-32.699	-2350.588	2.307
			Max. My	2	-32.694	1.638	2354.528
L29	69 - 68.75	Pole	Max. Vy	8	42.324	-2350.588	2.307
			Max. Vx	2	-42.355	1.638	2354.528
			Max. Torque	9			7.968
			Max Tension	1	0.000	0.000	0.000
			Max. Compression	26	-71.662	-1.212	11.616
			Max. Mx	8	-32.699	-2350.588	2.307
			Max. My	2	-32.694	1.638	2354.528
			Max. Vy	8	42.324	-2350.588	2.307
			Max. Vx	2	-42.355	1.638	2354.528
L30	68.75 - 63.75	Pole	Max. Torque	9			7.968
			Max Tension	1	0.000	0.000	0.000
			Max. Compression	26	-71.662	-1.212	11.616

tnxTower B+T Group 1717 S. Boulder, Suite 300 Tulsa, OK 74119 Phone: (918) 587-4630 FAX: (918) 295-0265	Job 92739.019.01 - GROTON TOWER, CT (BU# 881533)	Page 45 of 62
	Project	Date 20:02:38 10/26/21
	Client Crown Castle	Designed by JD Prabhu

Section No.	Elevation ft	Component Type	Condition	Gov. Load Comb.	Axial K	Major Axis Moment kip-ft	Minor Axis Moment kip-ft
L31	63.75 - 60	Pole	Max. Mx	8	-34.817	-2563.644	2.203
			Max. My	2	-34.813	1.769	2567.729
			Max. Vy	8	42.912	-2563.644	2.203
			Max. Vx	2	-42.942	1.769	2567.729
			Max. Torque	9			7.968
			Max Tension	1	0.000	0.000	0.000
			Max. Compression	26	-73.730	-1.230	11.648
			Max. Mx	8	-36.435	-2725.319	2.122
			Max. My	2	-36.431	1.866	2729.513
			Max. Vy	8	43.343	-2725.319	2.122
L32	60 - 59.75	Pole	Max. Vx	2	-43.373	1.866	2729.513
			Max. Torque	9			7.964
			Max Tension	1	0.000	0.000	0.000
			Max. Compression	26	-73.870	-1.231	11.648
			Max. Mx	8	-36.562	-2736.154	2.116
			Max. My	2	-36.558	1.873	2740.355
			Max. Vy	8	43.357	-2736.154	2.116
			Max. Vx	2	-43.388	1.873	2740.355
			Max. Torque	9			7.962
			Max Tension	1	0.000	0.000	0.000
L33	59.75 - 58.5	Pole	Max. Compression	26	-74.583	-1.232	11.629
			Max. Mx	8	-37.091	-2790.437	2.090
			Max. My	2	-37.087	1.905	2794.674
			Max. Vy	8	43.513	-2790.437	2.090
			Max. Vx	2	-43.543	1.905	2794.674
			Max. Torque	9			7.962
			Max Tension	1	0.000	0.000	0.000
			Max. Compression	26	-74.726	-1.232	11.625
			Max. Mx	8	-37.218	-2801.314	2.083
			Max. My	2	-37.215	1.912	2805.559
L34	58.5 - 58.25	Pole	Max. Vy	8	43.526	-2801.314	2.083
			Max. Vx	2	-43.558	1.912	2805.559
			Max. Torque	9			7.962
			Max Tension	1	0.000	0.000	0.000
			Max. Compression	26	-74.869	-1.232	11.620
			Max. Mx	8	-37.328	-2812.199	2.078
			Max. My	2	-37.324	1.918	2816.451
			Max. Vy	8	43.555	-2812.199	2.078
			Max. Vx	2	-43.586	1.918	2816.451
			Max. Torque	9			7.961
L35	58.25 - 58	Pole	Max Tension	1	0.000	0.000	0.000
			Max. Compression	26	-75.005	-1.232	11.615
			Max. Mx	8	-37.432	-2823.091	2.072
			Max. My	2	-37.428	1.925	2827.350
			Max. Vy	8	43.582	-2823.091	2.072
			Max. Vx	2	-43.613	1.925	2827.350
			Max. Torque	9			7.961
			Max Tension	1	0.000	0.000	0.000
			Max. Compression	26	-75.549	-1.233	11.596
			Max. Mx	8	-37.833	-2866.722	2.050
L36	58 - 57.75	Pole	Max. My	2	-37.830	1.951	2871.009
			Max. Vy	8	43.699	-2866.722	2.050
			Max. Vx	2	-43.729	1.951	2871.009
			Max. Torque	9			7.961
			Max Tension	1	0.000	0.000	0.000
			Max. Compression	26	-75.694	-1.233	11.592
			Max. Mx	8	-37.962	-2877.646	2.044
			Max. My	2	-37.958	1.957	2881.941
			Max. Vy	8	43.712	-2877.646	2.044
			Max. Vx	2	-43.743	1.957	2881.941
L37	57.75 - 56.75	Pole	Max. Torque	9			7.960
			Max Tension	1	0.000	0.000	0.000
			Max. Compression	26	-75.694	-1.233	11.592
			Max. Mx	8	-37.962	-2877.646	2.044
			Max. My	2	-37.958	1.957	2881.941
			Max. Vy	8	43.712	-2877.646	2.044
			Max. Vx	2	-43.743	1.957	2881.941
			Max. Torque	9			7.960
			Max Tension	1	0.000	0.000	0.000
			Max. Compression	26	-75.694	-1.233	11.592
L38	56.75 - 56.5	Pole	Max. Mx	8	-37.962	-2877.646	2.044
			Max. My	2	-37.958	1.957	2881.941
			Max. Vy	8	43.712	-2877.646	2.044
			Max. Vx	2	-43.743	1.957	2881.941
			Max. Torque	9			7.960
			Max Tension	1	0.000	0.000	0.000
			Max. Compression	26	-75.694	-1.233	11.592
			Max. Mx	8	-37.962	-2877.646	2.044
			Max. My	2	-37.958	1.957	2881.941
			Max. Vy	8	43.712	-2877.646	2.044

tnxTower B+T Group 1717 S. Boulder, Suite 300 Tulsa, OK 74119 Phone: (918) 587-4630 FAX: (918) 295-0265	Job	92739.019.01 - GROTON TOWER, CT (BU# 881533)	Page	46 of 62
	Project		Date	20:02:38 10/26/21
	Client	Crown Castle	Designed by	JD Prabhu

Section No.	Elevation ft	Component Type	Condition	Gov. Load Comb.	Axial K	Major Axis Moment kip-ft	Minor Axis Moment kip-ft
L39	56.5 - 51.5	Pole	Max Tension	1	0.000	0.000	0.000
			Max. Compression	26	-78.452	-1.237	11.491
			Max. Mx	8	-40.183	-3097.560	1.932
			Max. My	2	-40.180	2.087	3101.999
			Max. Vy	8	44.270	-3097.560	1.932
			Max. Vx	2	-44.300	2.087	3101.999
			Max. Torque	9			7.960
			Max Tension	1	0.000	0.000	0.000
			Max. Compression	26	-80.494	-1.239	11.402
L40	51.5 - 42.0418	Pole	Max. Mx	8	-41.849	-3261.228	1.847
			Max. My	2	-41.845	2.182	3265.772
			Max. Vy	8	44.661	-3261.228	1.847
			Max. Vx	2	-44.690	2.182	3265.772
			Max. Torque	9			7.957
			Max Tension	1	0.000	0.000	0.000
			Max. Compression	26	-87.062	-1.237	11.202
			Max. Mx	8	-47.226	-3566.891	1.694
			Max. My	2	-47.223	2.357	3571.629
L41	42.0418 - 41.0418	Pole	Max. Vy	8	45.561	-3566.891	1.694
			Max. Vx	2	-45.590	2.357	3571.629
			Max. Torque	9			7.954
			Max Tension	1	0.000	0.000	0.000
			Max. Compression	26	-90.032	-1.236	11.054
			Max. Mx	8	-49.696	-3795.854	1.575
			Max. My	2	-49.693	2.485	3800.735
			Max. Vy	8	46.059	-3795.854	1.575
			Max. Vx	2	-46.088	2.485	3800.735
L42	41.0418 - 36.0418	Pole	Max. Torque	9			7.953
			Max Tension	1	0.000	0.000	0.000
			Max. Compression	26	-92.966	-1.186	10.966
			Max. Mx	8	-52.095	-4017.562	1.459
			Max. My	2	-52.093	2.608	4022.579
			Max. Vy	8	46.518	-4017.562	1.459
			Max. Vx	2	-46.547	2.608	4022.579
			Max. Torque	9			7.951
			Max Tension	1	0.000	0.000	0.000
L43	36.0418 - 31.25	Pole	Max. Compression	26	-93.118	-1.183	10.963
			Max. Mx	8	-52.238	-4029.188	1.452
			Max. My	2	-52.235	2.614	4034.212
			Max. Vy	8	46.520	-4029.188	1.452
			Max. Vx	2	-46.551	2.614	4034.212
			Max. Torque	9			7.949
			Max Tension	1	0.000	0.000	0.000
			Max. Compression	26	-95.157	-1.170	10.926
			Max. Mx	8	-53.849	-4180.810	1.372
L44	31.25 - 31	Pole	Max. My	2	-53.847	2.697	4185.925
			Max. Vy	8	46.813	-4180.810	1.372
			Max. Vx	2	-46.842	2.697	4185.925
			Max. Torque	9			7.949
			Max Tension	1	0.000	0.000	0.000
			Max. Compression	26	-95.317	-1.171	10.924
			Max. Mx	8	-53.993	-4192.509	1.365
			Max. My	2	-53.992	2.704	4197.632
			Max. Vy	8	46.813	-4192.509	1.365
L45	27.75 - 27.5	Pole	Max. Vx	2	-46.843	2.704	4197.632
			Max. Torque	9			7.948
			Max Tension	1	0.000	0.000	0.000
			Max. Compression	26	-95.477	-1.171	10.921

tnxTower B+T Group 1717 S. Boulder, Suite 300 Tulsa, OK 74119 Phone: (918) 587-4630 FAX: (918) 295-0265	Job	92739.019.01 - GROTON TOWER, CT (BU# 881533)	Page	47 of 62
	Project		Date	20:02:38 10/26/21
	Client	Crown Castle	Designed by	JD Prabhu

Section No.	Elevation ft	Component Type	Condition	Gov. Load Comb.	Axial K	Major Axis Moment kip-ft	Minor Axis Moment kip-ft
L48	27.25 - 27	Pole	Max. Mx	8	-54.120	-4204.214	1.359
			Max. My	2	-54.118	2.710	4209.343
			Max. Vy	8	46.833	-4204.214	1.359
			Max. Vx	2	-46.863	2.710	4209.343
			Max. Torque	9			7.948
			Max Tension	1	0.000	0.000	0.000
			Max. Compression	26	-95.634	-1.173	10.924
			Max. Mx	8	-54.246	-4215.924	1.352
			Max. My	2	-54.244	2.716	4221.060
			Max. Vy	8	46.854	-4215.924	1.352
L49	27 - 22	Pole	Max. Vx	2	-46.884	2.716	4221.060
			Max. Torque	9			7.947
			Max Tension	1	0.000	0.000	0.000
			Max. Compression	26	-98.719	-1.293	11.031
			Max. Mx	8	-56.747	-4451.217	1.227
			Max. My	2	-56.745	2.843	4456.493
			Max. Vy	8	47.287	-4451.217	1.227
			Max. Vx	2	-47.315	2.843	4456.493
			Max. Torque	9			7.947
			Max Tension	1	0.000	0.000	0.000
L50	22 - 17	Pole	Max. Compression	26	-101.781	-1.454	11.181
			Max. Mx	8	-59.295	-4688.507	1.099
			Max. My	2	-59.294	2.969	4693.921
			Max. Vy	8	47.672	-4688.507	1.099
			Max. Vx	2	-47.700	2.969	4693.921
			Max. Torque	9			7.946
			Max Tension	1	0.000	0.000	0.000
			Max. Compression	26	-104.858	-1.614	11.330
			Max. Mx	8	-61.874	-4927.636	0.970
			Max. My	2	-61.874	3.093	4933.187
L51	17 - 12	Pole	Max. Vy	8	48.023	-4927.636	0.970
			Max. Vx	2	-48.051	3.093	4933.187
			Max. Torque	9			7.945
			Max Tension	1	0.000	0.000	0.000
			Max. Compression	26	-107.942	-1.770	11.475
			Max. Mx	8	-64.485	-5168.515	0.838
			Max. My	2	-64.484	3.217	5174.202
			Max. Vy	8	48.373	-5168.515	0.838
			Max. Vx	2	-48.401	3.217	5174.202
			Max. Torque	9			7.944
L52	12 - 7	Pole	Max Tension	1	0.000	0.000	0.000
			Max. Compression	26	-111.010	-1.918	11.611
			Max. Mx	8	-67.128	-5411.123	0.705
			Max. My	2	-67.128	3.340	5416.944
			Max. Vy	8	48.716	-5411.123	0.705
			Max. Vx	2	-48.744	3.340	5416.944
			Max. Torque	9			7.943
			Max Tension	1	0.000	0.000	0.000
			Max. Compression	26	-112.212	-1.970	11.658
			Max. Mx	8	-68.196	-5508.645	0.651
L53	7 - 2	Pole	Max. My	2	-68.196	3.389	5514.520
			Max. Vy	8	48.853	-5508.645	0.651
			Max. Vx	2	-48.880	3.389	5514.520
			Max. Torque	9			7.943
			Max Tension	1	0.000	0.000	0.000
			Max. Compression	26	-112.212	-1.970	11.658
L54	2 - 0	Pole	Max. Mx	8	-68.196	-5508.645	0.651
			Max. My	2	-68.196	3.389	5514.520
			Max. Vy	8	48.853	-5508.645	0.651
			Max. Vx	2	-48.880	3.389	5514.520
			Max. Torque	9			7.943
			Max Tension	1	0.000	0.000	0.000

Maximum Reactions

tnxTower B+T Group 1717 S. Boulder, Suite 300 Tulsa, OK 74119 Phone: (918) 587-4630 FAX: (918) 295-0265	Job	92739.019.01 - GROTON TOWER, CT (BU# 881533)	Page	48 of 62
	Project		Date	20:02:38 10/26/21
	Client	Crown Castle	Designed by	JD Prabhu

Location	Condition	Gov. Load Comb.	Vertical K	Horizontal, X K	Horizontal, Z K
Pole	Max. Vert	26	112.212	-0.000	0.000
	Max. H _x	20	68.216	48.826	0.028
	Max. H _z	2	68.216	0.028	48.853
	Max. M _x	2	5514.520	0.028	48.853
	Max. M _z	8	5508.645	-48.826	-0.028
	Max. Torsion	9	7.943	-48.826	-0.028
	Min. Vert	5	51.162	-24.389	42.294
	Min. H _x	8	68.216	-48.826	-0.028
	Min. H _z	14	68.216	-0.028	-48.853
	Min. M _x	14	-5505.352	-0.028	-48.853
	Min. M _z	20	-5507.656	48.826	0.028
	Min. Torsion	21	-7.938	48.826	0.028

Tower Mast Reaction Summary

Load Combination	Vertical K	Shear _x K	Shear _z K	Overturning Moment, M _x kip-ft	Overturning Moment, M _z kip-ft	Torque kip-ft
Dead Only	56.846	0.000	-0.000	-3.734	-0.405	-0.000
1.2 Dead+1.0 Wind 0 deg - No Ice	68.216	-0.028	-48.853	-5514.520	3.389	0.439
0.9 Dead+1.0 Wind 0 deg - No Ice	51.162	-0.028	-48.853	-5455.107	3.472	0.443
1.2 Dead+1.0 Wind 30 deg - No Ice	68.216	24.389	-42.294	-4774.391	-2751.240	-3.586
0.9 Dead+1.0 Wind 30 deg - No Ice	51.162	24.389	-42.294	-4722.800	-2722.046	-3.584
1.2 Dead+1.0 Wind 60 deg - No Ice	68.216	42.271	-24.403	-2756.160	-4768.790	-6.655
0.9 Dead+1.0 Wind 60 deg - No Ice	51.162	42.271	-24.403	-2725.896	-4718.278	-6.654
1.2 Dead+1.0 Wind 90 deg - No Ice	68.216	48.826	0.028	-0.650	-5508.645	-7.941
0.9 Dead+1.0 Wind 90 deg - No Ice	51.162	48.826	0.028	0.505	-5450.320	-7.943
1.2 Dead+1.0 Wind 120 deg - No Ice	68.216	42.298	24.451	2753.777	-4772.596	-7.098
0.9 Dead+1.0 Wind 120 deg - No Ice	51.162	42.298	24.451	2725.841	-4722.051	-7.101
1.2 Dead+1.0 Wind 150 deg - No Ice	68.216	24.459	42.360	4773.098	-2760.206	-4.350
0.9 Dead+1.0 Wind 150 deg - No Ice	51.162	24.459	42.360	4723.849	-2730.927	-4.353
1.2 Dead+1.0 Wind 180 deg - No Ice	68.216	0.028	48.853	5505.352	-4.373	-0.434
0.9 Dead+1.0 Wind 180 deg - No Ice	51.162	0.028	48.853	5448.366	-4.199	-0.438
1.2 Dead+1.0 Wind 210 deg - No Ice	68.216	-24.389	42.294	4765.247	2750.209	3.596
0.9 Dead+1.0 Wind 210 deg - No Ice	51.162	-24.389	42.294	4716.077	2721.283	3.594
1.2 Dead+1.0 Wind 240 deg - No Ice	68.216	-42.271	24.403	2747.069	4767.757	6.659
0.9 Dead+1.0 Wind 240 deg - No Ice	51.162	-42.271	24.403	2719.212	4717.513	6.659
1.2 Dead+1.0 Wind 270 deg - No Ice	68.216	-48.826	-0.028	-8.412	5507.656	7.936

<p>tnxTower</p> <p>B+T Group 1717 S. Boulder, Suite 300 Tulsa, OK 74119 Phone: (918) 587-4630 FAX: (918) 295-0265</p>	<p>Job 92739.019.01 - GROTON TOWER, CT (BU# 881533)</p>	<p>Page 49 of 62</p>
	<p>Project</p>	<p>Date 20:02:38 10/26/21</p>
	<p>Client Crown Castle</p>	<p>Designed by JD Prabhu</p>

Load Combination	Vertical K	Shear _x K	Shear _z K	Overturning Moment, M _x kip-ft	Overturning Moment, M _z kip-ft	Torque kip-ft
0.9 Dead+1.0 Wind 270 deg - No Ice	51.162	-48.826	-0.028	-7.167	5449.588	7.938
1.2 Dead+1.0 Wind 300 deg - No Ice	68.216	-42.298	-24.451	-2762.862	4771.654	7.088
0.9 Dead+1.0 Wind 300 deg - No Ice	51.162	-42.298	-24.451	-2732.521	4721.355	7.092
1.2 Dead+1.0 Wind 330 deg - No Ice	68.216	-24.459	-42.360	-4782.237	2759.267	4.345
0.9 Dead+1.0 Wind 330 deg - No Ice	51.162	-24.459	-42.360	-4730.568	2730.232	4.349
1.2 Dead+1.0 Ice+1.0 Temp	112.212	0.000	-0.000	-11.658	-1.970	-0.000
1.2 Dead+1.0 Wind 0 deg+1.0 Ice+1.0 Temp	112.212	-0.004	-10.808	-1252.476	-1.388	0.063
1.2 Dead+1.0 Wind 30 deg+1.0 Ice+1.0 Temp	112.212	5.398	-9.358	-1085.960	-621.609	-1.006
1.2 Dead+1.0 Wind 60 deg+1.0 Ice+1.0 Temp	112.212	9.354	-5.400	-631.640	-1075.804	-1.805
1.2 Dead+1.0 Wind 90 deg+1.0 Ice+1.0 Temp	112.212	10.803	0.004	-11.256	-1242.271	-2.120
1.2 Dead+1.0 Wind 120 deg+1.0 Ice+1.0 Temp	112.212	9.358	5.408	608.961	-1076.408	-1.868
1.2 Dead+1.0 Wind 150 deg+1.0 Ice+1.0 Temp	112.212	5.405	9.362	1062.825	-622.661	-1.115
1.2 Dead+1.0 Wind 180 deg+1.0 Ice+1.0 Temp	112.212	0.004	10.808	1228.727	-2.610	-0.063
1.2 Dead+1.0 Wind 210 deg+1.0 Ice+1.0 Temp	112.212	-5.398	9.358	1062.214	617.604	1.005
1.2 Dead+1.0 Wind 240 deg+1.0 Ice+1.0 Temp	112.212	-9.354	5.400	607.903	1071.799	1.804
1.2 Dead+1.0 Wind 270 deg+1.0 Ice+1.0 Temp	112.212	-10.803	-0.004	-12.478	1238.272	2.119
1.2 Dead+1.0 Wind 300 deg+1.0 Ice+1.0 Temp	112.212	-9.358	-5.408	-632.699	1072.416	1.867
1.2 Dead+1.0 Wind 330 deg+1.0 Ice+1.0 Temp	112.212	-5.405	-9.362	-1086.571	618.669	1.114
Dead+Wind 0 deg - Service	56.846	-0.005	-9.093	-1024.384	0.305	0.082
Dead+Wind 30 deg - Service	56.846	4.539	-7.872	-887.297	-509.902	-0.681
Dead+Wind 60 deg - Service	56.846	7.867	-4.542	-513.485	-883.592	-1.262
Dead+Wind 90 deg - Service	56.846	9.087	0.005	-3.113	-1020.634	-1.505
Dead+Wind 120 deg - Service	56.846	7.873	4.551	507.066	-884.309	-1.345
Dead+Wind 150 deg - Service	56.846	4.552	7.884	881.093	-511.574	-0.824
Dead+Wind 180 deg - Service	56.846	0.005	9.093	1016.719	-1.131	-0.082
Dead+Wind 210 deg - Service	56.846	-4.539	7.872	879.632	509.075	0.682
Dead+Wind 240 deg - Service	56.846	-7.867	4.542	505.822	882.764	1.263
Dead+Wind 270 deg - Service	56.846	-9.087	-0.005	-4.549	1019.807	1.505
Dead+Wind 300 deg - Service	56.846	-7.873	-4.551	-514.729	883.483	1.344
Dead+Wind 330 deg - Service	56.846	-4.552	-7.884	-888.757	510.748	0.824

Solution Summary

Load Comb.	Sum of Applied Forces			Sum of Reactions			% Error
	PX K	PY K	PZ K	PX K	PY K	PZ K	
1	0.000	-56.846	0.000	0.000	56.846	0.000	0.000%
2	-0.028	-68.216	-48.853	0.028	68.216	48.853	0.000%
3	-0.028	-51.162	-48.853	0.028	51.162	48.853	0.000%
4	24.389	-68.216	-42.294	-24.389	68.216	42.294	0.000%
5	24.389	-51.162	-42.294	-24.389	51.162	42.294	0.000%

tnxTower B+T Group 1717 S. Boulder, Suite 300 Tulsa, OK 74119 Phone: (918) 587-4630 FAX: (918) 295-0265	Job	92739.019.01 - GROTON TOWER, CT (BU# 881533)	Page	50 of 62
	Project		Date	20:02:38 10/26/21
	Client	Crown Castle	Designed by	JD Prabhu

Load Comb.	Sum of Applied Forces			Sum of Reactions			% Error
	PX K	PY K	PZ K	PX K	PY K	PZ K	
6	42.271	-68.216	-24.403	-42.271	68.216	24.403	0.000%
7	42.271	-51.162	-24.403	-42.271	51.162	24.403	0.000%
8	48.826	-68.216	0.028	-48.826	68.216	-0.028	0.000%
9	48.826	-51.162	0.028	-48.826	51.162	-0.028	0.000%
10	42.298	-68.216	24.451	-42.298	68.216	-24.451	0.000%
11	42.298	-51.162	24.451	-42.298	51.162	-24.451	0.000%
12	24.459	-68.216	42.360	-24.459	68.216	-42.360	0.000%
13	24.459	-51.162	42.360	-24.459	51.162	-42.360	0.000%
14	0.028	-68.216	48.853	-0.028	68.216	-48.853	0.000%
15	0.028	-51.162	48.853	-0.028	51.162	-48.853	0.000%
16	-24.389	-68.216	42.294	24.389	68.216	-42.294	0.000%
17	-24.389	-51.162	42.294	24.389	51.162	-42.294	0.000%
18	-42.271	-68.216	24.403	42.271	68.216	-24.403	0.000%
19	-42.271	-51.162	24.403	42.271	51.162	-24.403	0.000%
20	-48.826	-68.216	-0.028	48.826	68.216	0.028	0.000%
21	-48.826	-51.162	-0.028	48.826	51.162	0.028	0.000%
22	-42.298	-68.216	-24.451	42.298	68.216	24.451	0.000%
23	-42.298	-51.162	-24.451	42.298	51.162	24.451	0.000%
24	-24.459	-68.216	-42.360	24.459	68.216	42.360	0.000%
25	-24.459	-51.162	-42.360	24.459	51.162	42.360	0.000%
26	0.000	-112.212	0.000	-0.000	112.212	0.000	0.000%
27	-0.004	-112.212	-10.808	0.004	112.212	10.808	0.000%
28	5.398	-112.212	-9.358	-5.398	112.212	9.358	0.000%
29	9.354	-112.212	-5.400	-9.354	112.212	5.400	0.000%
30	10.803	-112.212	0.004	-10.803	112.212	-0.004	0.000%
31	9.358	-112.212	5.408	-9.358	112.212	-5.408	0.000%
32	5.405	-112.212	9.362	-5.405	112.212	-9.362	0.000%
33	0.004	-112.212	10.808	-0.004	112.212	-10.808	0.000%
34	-5.398	-112.212	9.358	5.398	112.212	-9.358	0.000%
35	-9.354	-112.212	5.400	9.354	112.212	-5.400	0.000%
36	-10.803	-112.212	-0.004	10.803	112.212	0.004	0.000%
37	-9.358	-112.212	-5.408	9.358	112.212	5.408	0.000%
38	-5.405	-112.212	-9.362	5.405	112.212	9.362	0.000%
39	-0.005	-56.846	-9.093	0.005	56.846	9.093	0.000%
40	4.539	-56.846	-7.872	-4.539	56.846	7.872	0.000%
41	7.867	-56.846	-4.542	-7.867	56.846	4.542	0.000%
42	9.087	-56.846	0.005	-9.087	56.846	-0.005	0.000%
43	7.873	-56.846	4.551	-7.873	56.846	-4.551	0.000%
44	4.552	-56.846	7.884	-4.552	56.846	-7.884	0.000%
45	0.005	-56.846	9.093	-0.005	56.846	-9.093	0.000%
46	-4.539	-56.846	7.872	4.539	56.846	-7.872	0.000%
47	-7.867	-56.846	4.542	7.867	56.846	-4.542	0.000%
48	-9.087	-56.846	-0.005	9.087	56.846	0.005	0.000%
49	-7.873	-56.846	-4.551	7.873	56.846	4.551	0.000%
50	-4.552	-56.846	-7.884	4.552	56.846	7.884	0.000%

Non-Linear Convergence Results

Load Combination	Converged?	Number of Cycles	Displacement Tolerance	Force Tolerance
1	Yes	4	0.00000001	0.00000488
2	Yes	5	0.00000001	0.00026561
3	Yes	5	0.00000001	0.00009507
4	Yes	7	0.00000001	0.00004875
5	Yes	6	0.00000001	0.00031575
6	Yes	7	0.00000001	0.00005508

tnxTower B+T Group 1717 S. Boulder, Suite 300 Tulsa, OK 74119 Phone: (918) 587-4630 FAX: (918) 295-0265	Job 92739.019.01 - GROTON TOWER, CT (BU# 881533)	Page 51 of 62
	Project	Date 20:02:38 10/26/21
	Client Crown Castle	Designed by JD Prabhu

7	Yes	6	0.00000001	0.00035930
8	Yes	6	0.00000001	0.00015397
9	Yes	6	0.00000001	0.00004742
10	Yes	7	0.00000001	0.00004699
11	Yes	6	0.00000001	0.00030379
12	Yes	7	0.00000001	0.00005359
13	Yes	6	0.00000001	0.00034895
14	Yes	5	0.00000001	0.00033120
15	Yes	5	0.00000001	0.00012757
16	Yes	7	0.00000001	0.00005300
17	Yes	6	0.00000001	0.00034503
18	Yes	7	0.00000001	0.00004714
19	Yes	6	0.00000001	0.00030493
20	Yes	6	0.00000001	0.00015874
21	Yes	6	0.00000001	0.00004886
22	Yes	7	0.00000001	0.00005543
23	Yes	6	0.00000001	0.00036166
24	Yes	7	0.00000001	0.00004843
25	Yes	6	0.00000001	0.00031338
26	Yes	5	0.00000001	0.00022547
27	Yes	7	0.00000001	0.00014864
28	Yes	7	0.00000001	0.00018077
29	Yes	7	0.00000001	0.00018534
30	Yes	7	0.00000001	0.00014822
31	Yes	7	0.00000001	0.00017350
32	Yes	7	0.00000001	0.00017649
33	Yes	7	0.00000001	0.00014236
34	Yes	7	0.00000001	0.00017527
35	Yes	7	0.00000001	0.00017253
36	Yes	7	0.00000001	0.00014761
37	Yes	7	0.00000001	0.00018499
38	Yes	7	0.00000001	0.00018022
39	Yes	5	0.00000001	0.00004859
40	Yes	5	0.00000001	0.00026238
41	Yes	5	0.00000001	0.00035884
42	Yes	5	0.00000001	0.00015983
43	Yes	5	0.00000001	0.00024853
44	Yes	5	0.00000001	0.00032265
45	Yes	5	0.00000001	0.00004794
46	Yes	5	0.00000001	0.00031162
47	Yes	5	0.00000001	0.00024672
48	Yes	5	0.00000001	0.00016045
49	Yes	5	0.00000001	0.00036509
50	Yes	5	0.00000001	0.00026051

Maximum Tower Deflections - Service Wind

Section No.	Elevation ft	Horz. Deflection in	Gov. Load Comb.	Tilt °	Twist °
L1	144.5 - 139.5	21.250	39	1.500	0.012
L2	139.5 - 134.5	19.689	39	1.480	0.011
L3	134.5 - 129.5	18.158	39	1.443	0.011
L4	129.5 - 124.5	16.674	50	1.389	0.009
L5	124.5 - 117.568	15.256	50	1.317	0.008
L6	121.409 - 116.409	14.421	50	1.264	0.007
L7	116.409 - 112.583	13.121	50	1.212	0.007
L8	112.583 - 112.333	12.177	50	1.146	0.006
L9	112.333 - 107.333	12.117	50	1.141	0.006
L10	107.333 - 106.92	10.971	50	1.047	0.005

tnxTower B+T Group 1717 S. Boulder, Suite 300 Tulsa, OK 74119 Phone: (918) 587-4630 FAX: (918) 295-0265	Job 92739.019.01 - GROTON TOWER, CT (BU# 881533)	Page 52 of 62
	Project	Date 20:02:38 10/26/21
	Client Crown Castle	Designed by JD Prabhu

Section No.	Elevation ft	Horz. Deflection in	Gov. Load Comb.	Tilt °	Twist °
L11	106.92 - 106.67	10.881	50	1.039	0.005
L12	106.67 - 103.5	10.826	50	1.036	0.005
L13	103.5 - 103.25	10.149	50	1.005	0.004
L14	103.25 - 98.5	10.096	50	1.002	0.004
L15	98.5 - 98.25	9.124	50	0.952	0.004
L16	98.25 - 97.58	9.074	50	0.950	0.004
L17	97.58 - 97.33	8.942	50	0.944	0.004
L18	97.33 - 92.33	8.892	50	0.941	0.004
L19	92.33 - 87.1178	7.934	50	0.888	0.003
L20	91.7428 - 86.1178	7.825	50	0.882	0.003
L21	86.1178 - 83	6.809	50	0.834	0.003
L22	83 - 82.75	6.282	50	0.781	0.003
L23	82.75 - 77.75	6.241	50	0.776	0.003
L24	77.75 - 77.25	5.474	50	0.689	0.002
L25	77.25 - 77	5.402	50	0.680	0.002
L26	77 - 76.75	5.366	50	0.678	0.002
L27	76.75 - 71.75	5.331	50	0.676	0.002
L28	71.75 - 69	4.652	50	0.622	0.002
L29	69 - 68.75	4.302	50	0.592	0.002
L30	68.75 - 63.75	4.271	50	0.590	0.002
L31	63.75 - 60	3.676	50	0.546	0.001
L32	60 - 59.75	3.260	50	0.513	0.001
L33	59.75 - 58.5	3.233	50	0.511	0.001
L34	58.5 - 58.25	3.101	50	0.500	0.001
L35	58.25 - 58	3.075	50	0.498	0.001
L36	58 - 57.75	3.049	50	0.496	0.001
L37	57.75 - 56.75	3.023	50	0.493	0.001
L38	56.75 - 56.5	2.921	50	0.483	0.001
L39	56.5 - 51.5	2.895	50	0.480	0.001
L40	51.5 - 42.0418	2.417	50	0.434	0.001
L41	47.8178 - 41.0418	2.095	50	0.400	0.001
L42	41.0418 - 36.0418	1.550	50	0.365	0.001
L43	36.0418 - 31.25	1.191	50	0.322	0.001
L44	31.25 - 31	0.889	50	0.279	0.001
L45	31 - 27.75	0.875	50	0.277	0.001
L46	27.75 - 27.5	0.697	50	0.244	0.001
L47	27.5 - 27.25	0.685	50	0.241	0.001
L48	27.25 - 27	0.672	50	0.239	0.001
L49	27 - 22	0.660	50	0.237	0.001
L50	22 - 17	0.436	50	0.191	0.000
L51	17 - 12	0.259	50	0.147	0.000
L52	12 - 7	0.129	50	0.103	0.000
L53	7 - 2	0.044	50	0.060	0.000
L54	2 - 0	0.004	50	0.017	0.000

Critical Deflections and Radius of Curvature - Service Wind

Elevation ft	Appurtenance	Gov. Load Comb.	Deflection in	Tilt °	Twist °	Radius of Curvature ft
149.500	Strobe	39	21.250	1.500	0.012	9999
147.000	Lightning Rod 5/8" x 5'	39	21.250	1.500	0.012	9999
146.000	Top Hat	39	21.250	1.500	0.012	9999
135.000	(2) MX06FRO660-02 w/ Mount Pipe	39	18.309	1.448	0.011	6572
130.000	Miscellaneous [NA 507-1]	50	16.819	1.395	0.009	4721
128.000	APXVAARR24_43-U-NA20 w/	50	16.240	1.370	0.009	4112

tnxTower B+T Group 1717 S. Boulder, Suite 300 Tulsa, OK 74119 Phone: (918) 587-4630 FAX: (918) 295-0265	Job 92739.019.01 - GROTON TOWER, CT (BU# 881533)	Page 53 of 62
	Project	Date 20:02:38 10/26/21
	Client Crown Castle	Designed by JD Prabhu

Elevation	Appurtenance	Gov. Load Comb.	Deflection in	Tilt °	Twist °	Radius of Curvature ft
ft	Mount Pipe					
118.000	APXVSPPI18-C-A20 w/ Mount Pipe	50	13.528	1.230	0.007	4365
108.000	TME-PCS 1900MHz 4x45W-65MHz	50	11.118	1.061	0.005	3515
103.000	6' x 2" Mount Pipe	50	10.044	1.000	0.004	5456
98.000	MX08FRO665-21 w/ Mount Pipe	50	9.025	0.948	0.004	5610

Maximum Tower Deflections - Design Wind

Section No.	Elevation ft	Horz. Deflection in	Gov. Load Comb.	Tilt °	Twist °
L1	144.5 - 139.5	113.796	2	8.011	0.063
L2	139.5 - 134.5	105.486	2	7.907	0.059
L3	134.5 - 129.5	97.330	2	7.716	0.056
L4	129.5 - 124.5	89.429	24	7.432	0.050
L5	124.5 - 117.568	81.870	24	7.055	0.043
L6	121.409 - 116.409	77.411	24	6.774	0.038
L7	116.409 - 112.583	70.466	24	6.501	0.035
L8	112.583 - 112.333	65.413	24	6.150	0.030
L9	112.333 - 107.333	65.093	24	6.126	0.030
L10	107.333 - 106.92	58.957	24	5.622	0.025
L11	106.92 - 106.67	58.474	24	5.579	0.025
L12	106.67 - 103.5	58.183	24	5.566	0.024
L13	103.5 - 103.25	54.552	24	5.399	0.023
L14	103.25 - 98.5	54.271	24	5.385	0.023
L15	98.5 - 98.25	49.059	24	5.115	0.020
L16	98.25 - 97.58	48.792	24	5.104	0.020
L17	97.58 - 97.33	48.080	24	5.074	0.020
L18	97.33 - 92.33	47.815	24	5.061	0.020
L19	92.33 - 87.1178	42.674	24	4.777	0.018
L20	91.7428 - 86.1178	42.089	24	4.743	0.017
L21	86.1178 - 83	36.635	24	4.487	0.016
L22	83 - 82.75	33.803	24	4.199	0.014
L23	82.75 - 77.75	33.584	24	4.176	0.014
L24	77.75 - 77.25	29.461	24	3.709	0.011
L25	77.25 - 77	29.075	24	3.662	0.011
L26	77 - 76.75	28.884	24	3.651	0.011
L27	76.75 - 71.75	28.693	24	3.637	0.011
L28	71.75 - 69	25.041	24	3.347	0.010
L29	69 - 68.75	23.160	24	3.187	0.009
L30	68.75 - 63.75	22.994	24	3.176	0.009
L31	63.75 - 60	19.793	24	2.942	0.008
L32	60 - 59.75	17.554	24	2.765	0.007
L33	59.75 - 58.5	17.410	24	2.753	0.007
L34	58.5 - 58.25	16.697	24	2.695	0.007
L35	58.25 - 58	16.556	24	2.683	0.007
L36	58 - 57.75	16.416	24	2.671	0.007
L37	57.75 - 56.75	16.277	24	2.657	0.007
L38	56.75 - 56.5	15.727	24	2.598	0.007
L39	56.5 - 51.5	15.591	24	2.586	0.007
L40	51.5 - 42.0418	13.015	24	2.338	0.006
L41	47.8178 - 41.0418	11.284	24	2.153	0.005
L42	41.0418 - 36.0418	8.348	24	1.966	0.005
L43	36.0418 - 31.25	6.412	24	1.732	0.004
L44	31.25 - 31	4.789	24	1.505	0.003

tnxTower B+T Group 1717 S. Boulder, Suite 300 Tulsa, OK 74119 Phone: (918) 587-4630 FAX: (918) 295-0265	Job 92739.019.01 - GROTON TOWER, CT (BU# 881533)	Page 54 of 62
	Project	Date 20:02:38 10/26/21
	Client Crown Castle	Designed by JD Prabhu

Section No.	Elevation ft	Horz. Deflection in	Gov. Load Comb.	Tilt °	Twist °
L45	31 - 27.75	4.711	24	1.491	0.003
L46	27.75 - 27.5	3.756	24	1.314	0.003
L47	27.5 - 27.25	3.688	24	1.300	0.003
L48	27.25 - 27	3.620	24	1.287	0.003
L49	27 - 22	3.553	24	1.275	0.003
L50	22 - 17	2.347	24	1.030	0.002
L51	17 - 12	1.395	24	0.789	0.002
L52	12 - 7	0.692	24	0.553	0.001
L53	7 - 2	0.235	24	0.322	0.001
L54	2 - 0	0.019	24	0.091	0.000

Critical Deflections and Radius of Curvature - Design Wind

Elevation ft	Appurtenance	Gov. Load Comb.	Deflection in	Tilt °	Twist °	Radius of Curvature ft
149.500	Strobe	2	113.796	8.011	0.063	1986
147.000	Lightning Rod 5/8" x 5'	2	113.796	8.011	0.063	1986
146.000	Top Hat	2	113.796	8.011	0.063	1986
135.000	(2) MX06FRO660-02 w/ Mount Pipe	2	98.136	7.739	0.056	1301
130.000	Miscellaneous [NA 507-1]	24	90.206	7.464	0.050	929
128.000	APXVAARR24_43-U-NA20 w/ Mount Pipe	24	87.120	7.333	0.048	808
118.000	APXVSPP18-C-A20 w/ Mount Pipe	24	72.639	6.593	0.036	846
108.000	TME-PCS 1900MHz 4x45W-65MHz	24	59.745	5.699	0.026	674
103.000	6' x 2" Mount Pipe	24	53.990	5.372	0.023	1042
98.000	MX08FRO665-21 w/ Mount Pipe	24	48.526	5.093	0.020	1069

Compression Checks

Pole Design Data

Section No.	Elevation ft	Size	L ft	L _u ft	Kl/r	A in ²	P _u K	φP _n K	Ratio P _u / φP _n
L1	144.5 - 139.5	TP22.092x21x0.188	5.000	0.000	0.0	13.036	-4.161	762.603	0.005
L2	139.5 - 134.5	TP23.184x22.092x0.188	5.000	0.000	0.0	13.686	-7.042	800.623	0.009
L3	134.5 - 129.5	TP24.276x23.184x0.188	5.000	0.000	0.0	14.336	-7.767	838.642	0.009
L4	129.5 - 124.5	TP25.368x24.276x0.188	5.000	0.000	0.0	14.986	-11.032	876.662	0.013
L5	124.5 - 117.568	TP26.882x25.368x0.188	6.932	0.000	0.0	15.387	-11.441	900.167	0.013
L6	117.568 - 116.409	TP26.737x25.668x0.25	5.000	0.000	0.0	21.017	-14.368	1229.520	0.012
L7	116.409 -	TP27.555x26.737x0.25	3.826	0.000	0.0	21.666	-15.016	1267.470	0.012

tnxTower B+T Group 1717 S. Boulder, Suite 300 Tulsa, OK 74119 Phone: (918) 587-4630 FAX: (918) 295-0265	Job	92739.019.01 - GROTON TOWER, CT (BU# 881533)	Page	56 of 62
	Project		Date	20:02:38 10/26/21
	Client	Crown Castle		Designed by

Section No.	Elevation ft	Size	L ft	L _u ft	Kl/r	A in ²	P _u K	φP _n K	Ratio $\frac{P_u}{\phi P_n}$
L43	36.0418 (42) 36.0418 - 31.25 (43)	TP43.783x42.753x0.763	4.792	0.000	0.0	104.116	-52.090	6090.790	0.009
L44	31.25 - 31 (44)	TP43.836x43.783x0.65	0.250	0.000	0.0	89.098	-52.232	5212.210	0.010
L45	31 - 27.75 (45)	TP44.535x43.836x0.65	3.250	0.000	0.0	90.539	-53.844	5296.530	0.010
L46	27.75 - 27.5 (46)	TP44.589x44.535x0.65	0.250	0.000	0.0	90.650	-53.989	5303.020	0.010
L47	27.5 - 27.25 (47)	TP44.642x44.589x0.65	0.250	0.000	0.0	90.761	-54.115	5309.500	0.010
L48	27.25 - 27 (48)	TP44.696x44.642x0.725	0.250	0.000	0.0	101.184	-54.241	5919.280	0.009
L49	27 - 22 (49)	TP45.771x44.696x0.713	5.000	0.000	0.0	101.899	-56.743	5961.060	0.010
L50	22 - 17 (50)	TP46.846x45.771x0.713	5.000	0.000	0.0	104.329	-59.292	6103.250	0.010
L51	17 - 12 (51)	TP47.921x46.846x0.713	5.000	0.000	0.0	106.760	-61.872	6245.440	0.010
L52	12 - 7 (52)	TP48.995x47.921x0.713	5.000	0.000	0.0	109.190	-64.483	6387.640	0.010
L53	7 - 2 (53)	TP50.07x48.995x0.7	5.000	0.000	0.0	109.690	-67.128	6416.890	0.010
L54	2 - 0 (54)	TP50.5x50.07x0.7	2.000	0.000	0.0	110.646	-68.196	6472.770	0.011

Pole Bending Design Data

Section No.	Elevation ft	Size	M _{ux} kip-ft	φM _{ux} kip-ft	Ratio $\frac{M_{ux}}{\phi M_{ux}}$	M _{uy} kip-ft	φM _{uy} kip-ft	Ratio $\frac{M_{uy}}{\phi M_{uy}}$
L1	144.5 - 139.5 (1)	TP22.092x21x0.188	84.252	412.151	0.204	0.000	412.151	0.000
L2	139.5 - 134.5 (2)	TP23.184x22.092x0.188	149.316	447.433	0.334	0.000	447.433	0.000
L3	134.5 - 129.5 (3)	TP24.276x23.184x0.188	243.976	483.412	0.505	0.000	483.412	0.000
L4	129.5 - 124.5 (4)	TP25.368x24.276x0.188	360.626	519.990	0.694	0.000	519.990	0.000
L5	124.5 - 117.568 (5)	TP26.882x25.368x0.188	438.733	542.862	0.808	0.000	542.862	0.000
L6	117.568 - 116.409 (6)	TP26.737x25.668x0.25	573.279	825.969	0.694	0.000	825.969	0.000
L7	116.409 - 112.583 (7)	TP27.555x26.737x0.25	688.000	870.592	0.790	0.000	870.592	0.000
L8	112.583 - 112.333 (8)	TP27.608x27.555x0.25	695.543	873.533	0.796	0.000	873.533	0.000
L9	112.333 - 107.333 (9)	TP28.677x27.608x0.25	847.600	932.942	0.909	0.000	932.942	0.000
L10	107.333 - 106.92 (10)	TP28.765x28.677x0.25	860.617	937.892	0.918	0.000	937.892	0.000
L11	106.92 - 106.67 (11)	TP28.818x28.765x0.538	868.508	2061.800	0.421	0.000	2061.800	0.000
L12	106.67 - 103.5 (12)	TP29.496x28.818x0.525	969.150	2115.150	0.458	0.000	2115.150	0.000
L13	103.5 - 103.25 (13)	TP29.549x29.496x0.525	977.133	2123.033	0.460	0.000	2123.033	0.000
L14	103.25 - 98.5 (14)	TP30.564x29.549x0.513	1142.142	2224.100	0.514	0.000	2224.100	0.000
L15	98.5 - 98.25 (15)	TP30.618x30.564x0.675	1150.933	2892.475	0.398	0.000	2892.475	0.000
L16	98.25 - 97.58 (16)	TP30.761x30.618x0.675	1176.392	2920.508	0.403	0.000	2920.508	0.000
L17	97.58 - 97.33 (17)	TP30.815x30.761x0.563	1186.242	2469.958	0.480	0.000	2469.958	0.000

<p>tnxTower</p> <p>B+T Group 1717 S. Boulder, Suite 300 Tulsa, OK 74119 Phone: (918) 587-4630 FAX: (918) 295-0265</p>	<p>Job</p> <p>92739.019.01 - GROTON TOWER, CT (BU# 881533)</p>	<p>Page</p> <p>57 of 62</p>
	<p>Project</p>	<p>Date</p> <p>20:02:38 10/26/21</p>
	<p>Client</p> <p>Crown Castle</p>	<p>Designed by</p> <p>JD Prabhu</p>

Section No.	Elevation ft	Size	M_{ux} kip-ft	ϕM_{rx} kip-ft	Ratio $\frac{M_{ux}}{\phi M_{rx}}$	M_{uy} kip-ft	ϕM_{ry} kip-ft	Ratio $\frac{M_{uy}}{\phi M_{ry}}$
L18	97.33 - 92.33 (18)	TP31.883x30.815x0.55	1384.808	2593.417	0.534	0.000	2593.417	0.000
L19	92.33 - 87.1178 (19)	TP32.997x31.883x0.55	1408.308	2614.417	0.539	0.000	2614.417	0.000
L20	87.1178 - 86.1178 (20)	TP32.72x31.509x0.375	1635.658	1895.433	0.863	0.000	1895.433	0.000
L21	86.1178 - 83 (21)	TP33.392x32.72x0.375	1763.125	1975.433	0.893	0.000	1975.433	0.000
L22	83 - 82.75 (22)	TP33.446x33.392x0.375	1773.383	1981.917	0.895	0.000	1981.917	0.000
L23	82.75 - 77.75 (23)	TP34.523x33.446x0.375	1979.617	2113.875	0.936	0.000	2113.875	0.000
L24	77.75 - 77.25 (24)	TP34.631x34.523x0.375	2000.358	2127.300	0.940	0.000	2127.300	0.000
L25	77.25 - 77 (25)	TP34.685x34.631x0.825	2010.733	4512.550	0.446	0.000	4512.550	0.000
L26	77 - 76.75 (26)	TP34.738x34.685x0.638	2021.125	3556.550	0.568	0.000	3556.550	0.000
L27	76.75 - 71.75 (27)	TP35.816x34.738x0.625	2230.242	3716.608	0.600	0.000	3716.608	0.000
L28	71.75 - 69 (28)	TP36.408x35.816x0.625	2346.400	3843.908	0.610	0.000	3843.908	0.000
L29	69 - 68.75 (29)	TP36.462x36.408x0.8	2357.000	4863.200	0.485	0.000	4863.200	0.000
L30	68.75 - 63.75 (30)	TP37.539x36.462x0.788	2570.508	5089.233	0.505	0.000	5089.233	0.000
L31	63.75 - 60 (31)	TP38.347x37.539x0.775	2732.525	5238.642	0.522	0.000	5238.642	0.000
L32	60 - 59.75 (32)	TP38.401x38.347x0.775	2743.383	5253.825	0.522	0.000	5253.825	0.000
L33	59.75 - 58.5 (33)	TP38.67x38.401x0.775	2797.775	5330.058	0.525	0.000	5330.058	0.000
L34	58.5 - 58.25 (34)	TP38.724x38.67x0.775	2808.675	5345.367	0.525	0.000	5345.367	0.000
L35	58.25 - 58 (35)	TP38.778x38.724x0.775	2819.583	5360.708	0.526	0.000	5360.708	0.000
L36	58 - 57.75 (36)	TP38.832x38.778x0.613	2830.500	4303.483	0.658	0.000	4303.483	0.000
L37	57.75 - 56.75 (37)	TP39.047x38.832x0.613	2874.217	4352.517	0.660	0.000	4352.517	0.000
L38	56.75 - 56.5 (38)	TP39.101x39.047x0.738	2885.167	5204.558	0.554	0.000	5204.558	0.000
L39	56.5 - 51.5 (39)	TP40.178x39.101x0.725	3105.533	5415.617	0.573	0.000	5415.617	0.000
L40	51.5 - 42.0418 (40)	TP42.216x40.178x0.713	3269.533	5545.550	0.590	0.000	5545.550	0.000
L41	42.0418 - 41.0418 (41)	TP41.678x40.221x0.788	3575.800	6313.417	0.566	0.000	6313.417	0.000
L42	41.0418 - 36.0418 (42)	TP42.753x41.678x0.788	3805.217	6652.891	0.572	0.000	6652.891	0.000
L43	36.0418 - 31.25 (43)	TP43.783x42.753x0.763	4027.350	6776.591	0.594	0.000	6776.591	0.000
L44	31.25 - 31 (44)	TP43.836x43.783x0.65	4039.000	5836.825	0.692	0.000	5836.825	0.000
L45	31 - 27.75 (45)	TP44.535x43.836x0.65	4190.908	6028.617	0.695	0.000	6028.617	0.000
L46	27.75 - 27.5 (46)	TP44.589x44.535x0.65	4202.633	6043.500	0.695	0.000	6043.500	0.000
L47	27.5 - 27.25 (47)	TP44.642x44.589x0.65	4214.358	6058.400	0.696	0.000	6058.400	0.000
L48	27.25 - 27 (48)	TP44.696x44.642x0.725	4226.092	6739.541	0.627	0.000	6739.541	0.000
L49	27 - 22 (49)	TP45.771x44.696x0.713	4461.825	6959.567	0.641	0.000	6959.567	0.000
L50	22 - 17 (50)	TP46.846x45.771x0.713	4699.558	7298.191	0.644	0.000	7298.191	0.000
L51	17 - 12 (51)	TP47.921x46.846x0.713	4939.125	7644.858	0.646	0.000	7644.858	0.000
L52	12 - 7 (52)	TP48.995x47.921x0.713	5180.442	7999.575	0.648	0.000	7999.575	0.000
L53	7 - 2 (53)	TP50.07x48.995x0.7	5423.475	8221.867	0.660	0.000	8221.867	0.000
L54	2 - 0 (54)	TP50.5x50.07x0.7	5521.175	8366.667	0.660	0.000	8366.667	0.000

Pole Shear Design Data

Section No.	Elevation ft	Size	Actual V_u K	ϕV_n K	Ratio $\frac{V_u}{\phi V_n}$	Actual T_u kip-ft	ϕT_n kip-ft	Ratio $\frac{T_u}{\phi T_n}$
L1	144.5 - 139.5 (1)	TP22.092x21x0.188	12.163	228.781	0.053	0.882	438.868	0.002
L2	139.5 - 134.5 (2)	TP23.184x22.092x0.188	18.644	240.187	0.078	1.285	483.718	0.003
L3	134.5 - 129.5 (3)	TP24.276x23.184x0.188	19.484	251.593	0.077	2.053	530.751	0.004
L4	129.5 - 124.5 (4)	TP25.368x24.276x0.188	25.136	262.999	0.096	2.760	579.964	0.005
L5	124.5 - 117.568 (5)	TP26.882x25.368x0.188	25.417	270.050	0.094	2.757	611.482	0.005
L6	117.568 - 116.409 (6)	TP26.737x25.668x0.25	29.824	368.856	0.081	3.512	855.600	0.004
L7	116.409 - 112.583 (7)	TP27.555x26.737x0.25	30.176	380.242	0.079	3.508	909.233	0.004
L8	112.583 - 112.333 (8)	TP27.608x27.555x0.25	30.186	380.986	0.079	3.508	912.800	0.004
L9	112.333 - 107.333 (9)	TP28.677x27.608x0.25	31.517	395.868	0.080	3.503	985.500	0.004
L10	107.333 - 106.92 (10)	TP28.765x28.677x0.25	31.545	397.097	0.079	3.503	991.625	0.004
L11	106.92 - 106.67 (11)	TP28.818x28.765x0.538	31.569	846.750	0.037	3.502	2097.142	0.002
L12	106.67 - 103.5 (12)	TP29.496x28.818x0.525	31.938	847.237	0.038	3.501	2149.542	0.002
L13	103.5 - 103.25 (13)	TP29.549x29.496x0.525	31.962	848.799	0.038	3.501	2157.483	0.002
L14	103.25 - 98.5 (14)	TP30.564x29.549x0.513	35.162	857.928	0.041	4.238	2257.900	0.002
L15	98.5 - 98.25 (15)	TP30.618x30.564x0.675	35.182	1125.850	0.031	4.238	2952.267	0.001
L16	98.25 - 97.58 (16)	TP30.761x30.618x0.675	39.415	1131.240	0.035	4.378	2980.575	0.001
L17	97.58 - 97.33 (17)	TP30.815x30.761x0.563	39.440	947.897	0.042	4.377	2511.283	0.002
L18	97.33 - 92.33 (18)	TP31.883x30.815x0.55	40.001	959.955	0.042	4.375	2634.117	0.002
L19	92.33 - 87.1178 (19)	TP32.997x31.883x0.55	40.059	963.799	0.042	4.374	2655.258	0.002
L20	87.1178 - 86.1178 (20)	TP32.72x31.509x0.375	40.770	675.660	0.060	4.372	1913.908	0.002
L21	86.1178 - 83 (21)	TP33.392x32.72x0.375	41.039	689.690	0.060	4.369	1994.217	0.002
L22	83 - 82.75 (22)	TP33.446x33.392x0.375	41.043	690.815	0.059	4.368	2000.725	0.002
L23	82.75 - 77.75 (23)	TP34.523x33.446x0.375	41.482	713.315	0.058	4.364	2133.175	0.002
L24	77.75 - 77.25 (24)	TP34.631x34.523x0.375	41.511	715.565	0.058	4.364	2146.658	0.002
L25	77.25 - 77 (25)	TP34.685x34.631x0.825	41.532	1556.040	0.027	4.363	4614.050	0.001
L26	77 - 76.75 (26)	TP34.738x34.685x0.638	41.560	1210.960	0.034	4.363	3616.408	0.001
L27	76.75 - 71.75 (27)	TP35.816x34.738x0.625	42.108	1225.150	0.034	4.361	3775.700	0.001
L28	71.75 - 69 (28)	TP36.408x35.816x0.625	42.407	1245.780	0.034	4.360	3903.892	0.001
L29	69 - 68.75 (29)	TP36.462x36.408x0.8	42.416	1589.200	0.027	4.359	4963.208	0.001
L30	68.75 - 63.75 (30)	TP37.539x36.462x0.788	43.005	1612.170	0.027	4.358	5188.775	0.001
L31	63.75 - 60 (31)	TP38.347x37.539x0.775	43.436	1621.990	0.027	4.357	5336.925	0.001
L32	60 - 59.75 (32)	TP38.401x38.347x0.775	43.449	1624.320	0.027	4.356	5352.233	0.001
L33	59.75 - 58.5 (33)	TP38.67x38.401x0.775	43.606	1635.940	0.027	4.356	5429.117	0.001

<p>tnxTower</p> <p>B+T Group 1717 S. Boulder, Suite 300 Tulsa, OK 74119 Phone: (918) 587-4630 FAX: (918) 295-0265</p>	<p>Job</p> <p>92739.019.01 - GROTON TOWER, CT (BU# 881533)</p>	<p>Page</p> <p>59 of 62</p>
	<p>Project</p>	<p>Date</p> <p>20:02:38 10/26/21</p>
	<p>Client</p> <p>Crown Castle</p>	<p>Designed by</p> <p>JD Prabhu</p>

Section No.	Elevation ft	Size	Actual V_u K	ϕV_n K	Ratio $\frac{V_u}{\phi V_n}$	Actual T_u kip-ft	ϕT_n kip-ft	Ratio $\frac{T_u}{\phi T_n}$
L34	58.5 - 58.25 (34)	TP38.724x38.67x0.775	43.619	1638.270	0.027	4.356	5444.558	0.001
L35	58.25 - 58 (35)	TP38.778x38.724x0.775	43.647	1640.590	0.027	4.356	5460.025	0.001
L36	58 - 57.75 (36)	TP38.832x38.778x0.613	43.674	1303.980	0.033	4.356	4364.458	0.001
L37	57.75 - 56.75 (37)	TP39.047x38.832x0.613	43.792	1311.330	0.033	4.355	4413.792	0.001
L38	56.75 - 56.5 (38)	TP39.101x39.047x0.738	43.805	1576.020	0.028	4.355	5294.908	0.001
L39	56.5 - 51.5 (39)	TP40.178x39.101x0.725	44.362	1593.320	0.028	4.354	5505.050	0.001
L40	51.5 - 42.0418 (40)	TP42.216x40.178x0.713	44.753	1597.820	0.028	4.352	5633.375	0.001
L41	42.0418 - 41.0418 (41)	TP41.678x40.221x0.788	45.653	1793.720	0.025	4.351	6423.241	0.001
L42	41.0418 - 36.0418 (42)	TP42.753x41.678x0.788	46.151	1840.870	0.025	4.350	6765.341	0.001
L43	36.0418 - 31.25 (43)	TP43.783x42.753x0.763	46.610	1827.240	0.026	4.349	6884.083	0.001
L44	31.25 - 31 (44)	TP43.836x43.783x0.65	46.611	1563.660	0.030	4.349	5913.841	0.001
L45	31 - 27.75 (45)	TP44.535x43.836x0.65	46.905	1588.960	0.030	4.348	6106.725	0.001
L46	27.75 - 27.5 (46)	TP44.589x44.535x0.65	46.904	1590.910	0.029	4.348	6121.683	0.001
L47	27.5 - 27.25 (47)	TP44.642x44.589x0.65	46.924	1592.850	0.029	4.348	6136.675	0.001
L48	27.25 - 27 (48)	TP44.696x44.642x0.725	46.945	1775.780	0.026	4.348	6838.133	0.001
L49	27 - 22 (49)	TP45.771x44.696x0.713	47.378	1788.320	0.026	4.347	7056.691	0.001
L50	22 - 17 (50)	TP46.846x45.771x0.713	47.762	1830.980	0.026	4.346	7397.358	0.001
L51	17 - 12 (51)	TP47.921x46.846x0.713	48.113	1873.630	0.026	4.346	7746.050	0.001
L52	12 - 7 (52)	TP48.995x47.921x0.713	48.462	1916.290	0.025	4.345	8102.775	0.001
L53	7 - 2 (53)	TP50.07x48.995x0.7	48.805	1925.070	0.025	4.345	8323.191	0.001
L54	2 - 0 (54)	TP50.5x50.07x0.7	48.941	1941.830	0.025	4.345	8468.750	0.001

Pole Interaction Design Data

Section No.	Elevation ft	Ratio P_u ϕP_n	Ratio M_{ux} ϕM_{ux}	Ratio M_{uy} ϕM_{uy}	Ratio V_u ϕV_n	Ratio T_u ϕT_n	Comb. Stress Ratio	Allow. Stress Ratio	Criteria
L1	144.5 - 139.5 (1)	0.005	0.204	0.000	0.053	0.002	0.213	1.050	4.8.2 ✓
L2	139.5 - 134.5 (2)	0.009	0.334	0.000	0.078	0.003	0.349	1.050	4.8.2 ✓
L3	134.5 - 129.5 (3)	0.009	0.505	0.000	0.077	0.004	0.521	1.050	4.8.2 ✓
L4	129.5 - 124.5 (4)	0.013	0.694	0.000	0.096	0.005	0.716	1.050	4.8.2 ✓
L5	124.5 - 117.568 (5)	0.013	0.808	0.000	0.094	0.005	0.831	1.050	4.8.2 ✓
L6	117.568 - 116.409 (6)	0.012	0.694	0.000	0.081	0.004	0.713	1.050	4.8.2 ✓
L7	116.409 - 112.583 (7)	0.012	0.790	0.000	0.079	0.004	0.809	1.050	4.8.2 ✓
L8	112.583 - 112.333 (8)	0.012	0.796	0.000	0.079	0.004	0.815	1.050	4.8.2 ✓

tnxTower

B+T Group
1717 S. Boulder, Suite 300
Tulsa, OK 74119
Phone: (918) 587-4630
FAX: (918) 295-0265

Job
92739.019.01 - GROTON TOWER, CT (BU# 881533)

Page
60 of 62

Project

Date
20:02:38 10/26/21

Client

Crown Castle

Designed by
JD Prabhu

Section No.	Elevation ft	Ratio P_u	Ratio M_{ux}	Ratio M_{uy}	Ratio V_u	Ratio T_u	Comb. Stress Ratio	Allow. Stress Ratio	Criteria
L9	112.333 - 107.333 (9)	0.012	0.909	0.000	0.080	0.004	0.928	1.050	4.8.2 ✓
L10	107.333 - 106.92 (10)	0.012	0.918	0.000	0.079	0.004	0.937	1.050	4.8.2 ✓
L11	106.92 - 106.67 (11)	0.006	0.421	0.000	0.037	0.002	0.429	1.050	4.8.2 ✓
L12	106.67 - 103.5 (12)	0.006	0.458	0.000	0.038	0.002	0.466	1.050	4.8.2 ✓
L13	103.5 - 103.25 (13)	0.006	0.460	0.000	0.038	0.002	0.468	1.050	4.8.2 ✓
L14	103.25 - 98.5 (14)	0.007	0.514	0.000	0.041	0.002	0.522	1.050	4.8.2 ✓
L15	98.5 - 98.25 (15)	0.005	0.398	0.000	0.031	0.001	0.404	1.050	4.8.2 ✓
L16	98.25 - 97.58 (16)	0.006	0.403	0.000	0.035	0.001	0.410	1.050	4.8.2 ✓
L17	97.58 - 97.33 (17)	0.007	0.480	0.000	0.042	0.002	0.490	1.050	4.8.2 ✓
L18	97.33 - 92.33 (18)	0.008	0.534	0.000	0.042	0.002	0.544	1.050	4.8.2 ✓
L19	92.33 - 87.1178 (19)	0.008	0.539	0.000	0.042	0.002	0.548	1.050	4.8.2 ✓
L20	87.1178 - 86.1178 (20)	0.012	0.863	0.000	0.060	0.002	0.879	1.050	4.8.2 ✓
L21	86.1178 - 83 (21)	0.012	0.893	0.000	0.060	0.002	0.909	1.050	4.8.2 ✓
L22	83 - 82.75 (22)	0.012	0.895	0.000	0.059	0.002	0.911	1.050	4.8.2 ✓
L23	82.75 - 77.75 (23)	0.012	0.936	0.000	0.058	0.002	0.953	1.050	4.8.2 ✓
L24	77.75 - 77.25 (24)	0.012	0.940	0.000	0.058	0.002	0.956	1.050	4.8.2 ✓
L25	77.25 - 77 (25)	0.006	0.446	0.000	0.027	0.001	0.452	1.050	4.8.2 ✓
L26	77 - 76.75 (26)	0.007	0.568	0.000	0.034	0.001	0.577	1.050	4.8.2 ✓
L27	76.75 - 71.75 (27)	0.008	0.600	0.000	0.034	0.001	0.609	1.050	4.8.2 ✓
L28	71.75 - 69 (28)	0.008	0.610	0.000	0.034	0.001	0.619	1.050	4.8.2 ✓
L29	69 - 68.75 (29)	0.006	0.485	0.000	0.027	0.001	0.492	1.050	4.8.2 ✓
L30	68.75 - 63.75 (30)	0.006	0.505	0.000	0.027	0.001	0.512	1.050	4.8.2 ✓
L31	63.75 - 60 (31)	0.007	0.522	0.000	0.027	0.001	0.529	1.050	4.8.2 ✓
L32	60 - 59.75 (32)	0.007	0.522	0.000	0.027	0.001	0.530	1.050	4.8.2 ✓
L33	59.75 - 58.5 (33)	0.007	0.525	0.000	0.027	0.001	0.532	1.050	4.8.2 ✓
L34	58.5 - 58.25 (34)	0.007	0.525	0.000	0.027	0.001	0.533	1.050	4.8.2 ✓

tnxTower B+T Group 1717 S. Boulder, Suite 300 Tulsa, OK 74119 Phone: (918) 587-4630 FAX: (918) 295-0265	Job 92739.019.01 - GROTON TOWER, CT (BU# 881533)	Page 61 of 62
	Project	Date 20:02:38 10/26/21
	Client Crown Castle	Designed by JD Prabhu

Section No.	Elevation ft	Ratio P_u ϕP_n	Ratio M_{ux} ϕM_{nx}	Ratio M_{uy} ϕM_{ny}	Ratio V_u ϕV_n	Ratio T_u ϕT_n	Comb. Stress Ratio	Allow. Stress Ratio	Criteria
L35	58.25 - 58 (35)	0.007	0.526	0.000	0.027	0.001	0.534	1.050	4.8.2 ✓
L36	58 - 57.75 (36)	0.009	0.658	0.000	0.033	0.001	0.668	1.050	4.8.2 ✓
L37	57.75 - 56.75 (37)	0.009	0.660	0.000	0.033	0.001	0.670	1.050	4.8.2 ✓
L38	56.75 - 56.5 (38)	0.007	0.554	0.000	0.028	0.001	0.562	1.050	4.8.2 ✓
L39	56.5 - 51.5 (39)	0.008	0.573	0.000	0.028	0.001	0.582	1.050	4.8.2 ✓
L40	51.5 - 42.0418 (40)	0.008	0.590	0.000	0.028	0.001	0.598	1.050	4.8.2 ✓
L41	42.0418 - 41.0418 (41)	0.008	0.566	0.000	0.025	0.001	0.575	1.050	4.8.2 ✓
L42	41.0418 - 36.0418 (42)	0.008	0.572	0.000	0.025	0.001	0.581	1.050	4.8.2 ✓
L43	36.0418 - 31.25 (43)	0.009	0.594	0.000	0.026	0.001	0.604	1.050	4.8.2 ✓
L44	31.25 - 31 (44)	0.010	0.692	0.000	0.030	0.001	0.703	1.050	4.8.2 ✓
L45	31 - 27.75 (45)	0.010	0.695	0.000	0.030	0.001	0.706	1.050	4.8.2 ✓
L46	27.75 - 27.5 (46)	0.010	0.695	0.000	0.029	0.001	0.706	1.050	4.8.2 ✓
L47	27.5 - 27.25 (47)	0.010	0.696	0.000	0.029	0.001	0.707	1.050	4.8.2 ✓
L48	27.25 - 27 (48)	0.009	0.627	0.000	0.026	0.001	0.637	1.050	4.8.2 ✓
L49	27 - 22 (49)	0.010	0.641	0.000	0.026	0.001	0.651	1.050	4.8.2 ✓
L50	22 - 17 (50)	0.010	0.644	0.000	0.026	0.001	0.654	1.050	4.8.2 ✓
L51	17 - 12 (51)	0.010	0.646	0.000	0.026	0.001	0.657	1.050	4.8.2 ✓
L52	12 - 7 (52)	0.010	0.648	0.000	0.025	0.001	0.658	1.050	4.8.2 ✓
L53	7 - 2 (53)	0.010	0.660	0.000	0.025	0.001	0.671	1.050	4.8.2 ✓
L54	2 - 0 (54)	0.011	0.660	0.000	0.025	0.001	0.671	1.050	4.8.2 ✓

Section Capacity Table

Section No.	Elevation ft	Component Type	Size	Critical Element	P K	ϕP_{allow} K	% Capacity	Pass Fail
L1	144.5 - 139.5	Pole	TP22.092x21x0.188	1	-4.161	800.733	**	**
L2	139.5 - 134.5	Pole	TP23.184x22.092x0.188	2	-7.042	840.654	**	**
L3	134.5 - 129.5	Pole	TP24.276x23.184x0.188	3	-7.767	880.574	**	**
L4	129.5 - 124.5	Pole	TP25.368x24.276x0.188	4	-11.032	920.495	**	**

<p style="text-align: center;">tnxTower</p> <p style="text-align: center;">B+T Group 1717 S. Boulder, Suite 300 Tulsa, OK 74119 Phone: (918) 587-4630 FAX: (918) 295-0265</p>	<p>Job</p> <p style="text-align: center;">92739.019.01 - GROTON TOWER, CT (BU# 881533)</p>	<p>Page</p> <p style="text-align: center;">62 of 62</p>
	<p>Project</p>	<p>Date</p> <p style="text-align: center;">20:02:38 10/26/21</p>
	<p>Client</p> <p style="text-align: center;">Crown Castle</p>	<p>Designed by</p> <p style="text-align: center;">JD Prabhu</p>

Section No.	Elevation ft	Component Type	Size	Critical Element	P K	ϕP_{allow} K	% Capacity	Pass Fail
L5	124.5 - 117.568	Pole	TP26.882x25.368x0.188	5	-11.441	945.175	**	**
L6	117.568 - 116.409	Pole	TP26.737x25.668x0.25	6	-14.368	1290.996	**	**
L7	116.409 - 112.583	Pole	TP27.555x26.737x0.25	7	-15.016	1330.843	**	**
L8	112.583 - 112.333	Pole	TP27.608x27.555x0.25	8	-15.085	1333.447	**	**
L9	112.333 - 107.333	Pole	TP28.677x27.608x0.25	9	-16.416	1385.538	**	**
L10	107.333 - 106.92	Pole	TP28.765x28.677x0.25	10	-16.510	1389.843	**	**
L11	106.92 - 106.67	Pole	TP28.818x28.765x0.538	11	-16.580	2963.625	**	**
L12	106.67 - 103.5	Pole	TP29.496x28.818x0.525	12	-17.359	2965.326	**	**
L13	103.5 - 103.25	Pole	TP29.549x29.496x0.525	13	-17.435	2970.796	**	**
L14	103.25 - 98.5	Pole	TP30.564x29.549x0.513	14	-20.121	3002.748	**	**
L15	98.5 - 98.25	Pole	TP30.618x30.564x0.675	15	-20.216	3940.482	**	**
L16	98.25 - 97.58	Pole	TP30.761x30.618x0.675	16	-23.285	3959.329	**	**
L17	97.58 - 97.33	Pole	TP30.815x30.761x0.563	17	-23.363	3317.643	**	**
L18	97.33 - 92.33	Pole	TP31.883x30.815x0.55	18	-24.787	3359.842	**	**
L19	92.33 - 87.1178	Pole	TP32.997x31.883x0.55	19	-24.968	3373.293	**	**
L20	87.1178 - 86.1178	Pole	TP32.72x31.509x0.375	20	-27.221	2364.810	**	**
L21	86.1178 - 83	Pole	TP33.392x32.72x0.375	21	-28.047	2413.918	**	**
L22	83 - 82.75	Pole	TP33.446x33.392x0.375	22	-28.140	2417.856	**	**
L23	82.75 - 77.75	Pole	TP34.523x33.446x0.375	23	-29.476	2496.606	**	**
L24	77.75 - 77.25	Pole	TP34.631x34.523x0.375	24	-29.631	2504.481	**	**
L25	77.25 - 77	Pole	TP34.685x34.631x0.825	25	-29.748	5446.129	**	**
L26	77 - 76.75	Pole	TP34.738x34.685x0.638	26	-29.834	4238.367	**	**
L27	76.75 - 71.75	Pole	TP35.816x34.738x0.625	27	-31.580	4288.042	**	**
L28	71.75 - 69	Pole	TP36.408x35.816x0.625	28	-32.556	4360.230	**	**
L29	69 - 68.75	Pole	TP36.462x36.408x0.8	29	-32.688	5562.196	**	**
L30	68.75 - 63.75	Pole	TP37.539x36.462x0.788	30	-34.807	5642.584	**	**
L31	63.75 - 60	Pole	TP38.347x37.539x0.775	31	-36.426	5676.961	**	**
L32	60 - 59.75	Pole	TP38.401x38.347x0.775	32	-36.553	5685.099	**	**
L33	59.75 - 58.5	Pole	TP38.67x38.401x0.775	33	-37.082	5725.786	**	**
L34	58.5 - 58.25	Pole	TP38.724x38.67x0.775	34	-37.209	5733.924	**	**
L35	58.25 - 58	Pole	TP38.778x38.724x0.775	35	-37.319	5742.061	**	**
L36	58 - 57.75	Pole	TP38.832x38.778x0.613	36	-37.422	4563.919	**	**
L37	57.75 - 56.75	Pole	TP39.047x38.832x0.613	37	-37.824	4589.644	**	**
L38	56.75 - 56.5	Pole	TP39.101x39.047x0.738	38	-37.953	5516.080	**	**
L39	56.5 - 51.5	Pole	TP40.178x39.101x0.725	39	-40.175	5576.602	**	**
L40	51.5 - 42.0418	Pole	TP42.216x40.178x0.713	40	-41.841	5592.384	**	**
L41	42.0418 - 41.0418	Pole	TP41.678x40.221x0.788	41	-47.219	6278.013	**	**
L42	41.0418 - 36.0418	Pole	TP42.753x41.678x0.788	42	-49.690	6443.031	**	**
L43	36.0418 - 31.25	Pole	TP43.783x42.753x0.763	43	-52.090	6395.329	**	**
L44	31.25 - 31	Pole	TP43.836x43.783x0.65	44	-52.232	5472.820	**	**
L45	31 - 27.75	Pole	TP44.535x43.836x0.65	45	-53.844	5561.356	**	**
L46	27.75 - 27.5	Pole	TP44.589x44.535x0.65	46	-53.989	5568.171	**	**
L47	27.5 - 27.25	Pole	TP44.642x44.589x0.65	47	-54.115	5574.975	**	**
L48	27.25 - 27	Pole	TP44.696x44.642x0.725	48	-54.241	6215.244	**	**
L49	27 - 22	Pole	TP45.771x44.696x0.713	49	-56.743	6259.113	**	**
L50	22 - 17	Pole	TP46.846x45.771x0.713	50	-59.292	6408.412	**	**
L51	17 - 12	Pole	TP47.921x46.846x0.713	51	-61.872	6557.712	**	**
L52	12 - 7	Pole	TP48.995x47.921x0.713	52	-64.483	6707.022	**	**
L53	7 - 2	Pole	TP50.07x48.995x0.7	53	-67.128	6737.734	**	**
L54	2 - 0	Pole	TP50.5x50.07x0.7	54	-68.196	6796.408	**	**
							Summary	
							Pole (L24)	**
							RATING =	**

** Above stress ratios for reinforced sections are approximate. More exact calculations are presented in Appendix C.

APPENDIX B
BASE LEVEL DRAWING

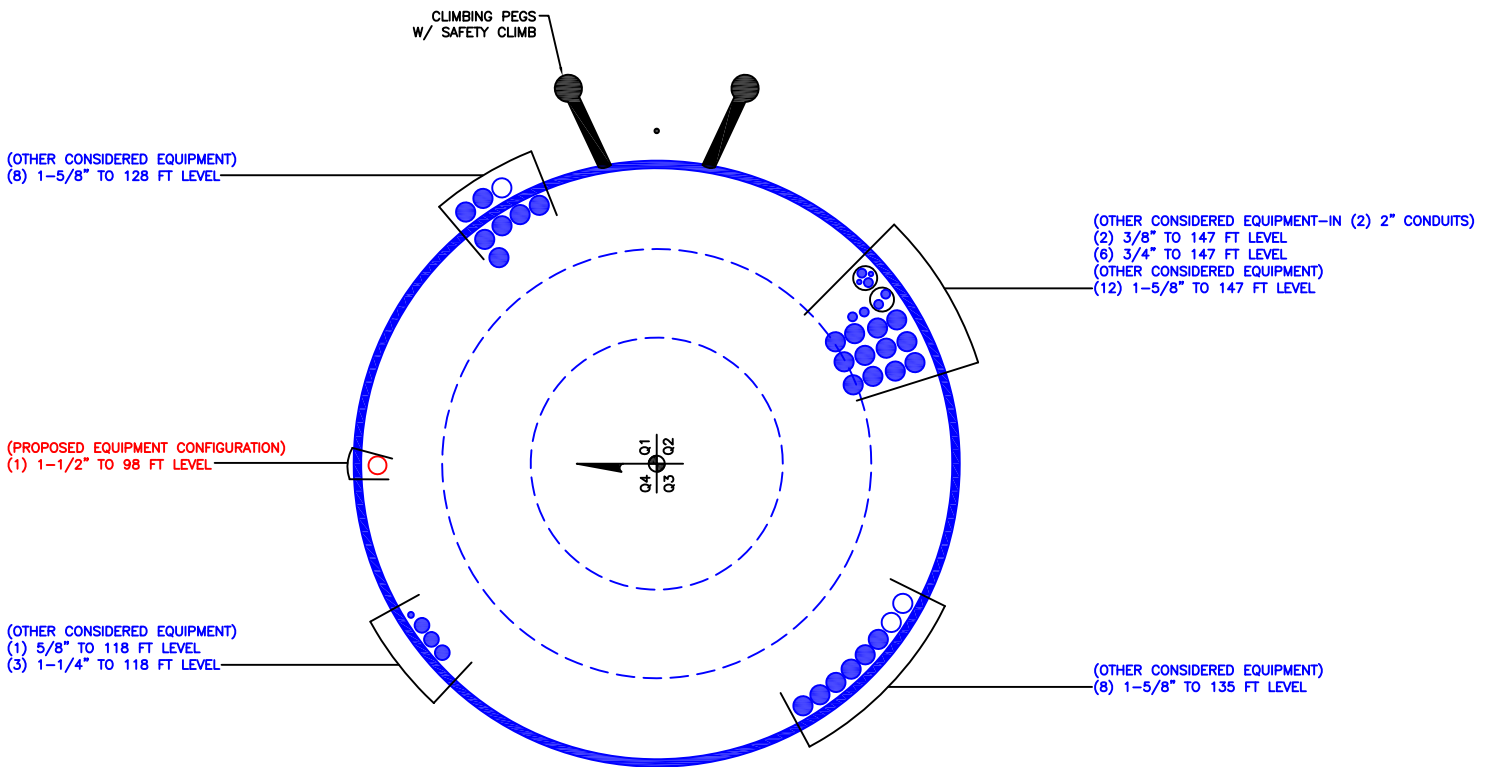

BUSINESS UNIT: 881533

APPENDIX C
ADDITIONAL CALCULATIONS

Site BU: 881533
Work Order: 2013150

Pole Geometry

Copyright © 2019 Crown Castle

	Pole Height Above Base (ft)	Section Length (ft)	Lap Splice Length (ft)	Number of Sides	Top Diameter (in)	Bottom Diameter (in)	Wall Thickness (in)	Bend Radius (in)	Pole Material
1	144.5	26.9323	3.8411	18	21	26.8823	0.1875	Auto	A572-65
2	121.4088	34.291	4.625	18	25.67	32.9971	0.25	Auto	A572-65
3	91.7428	49.701	5.776	18	31.51	42.2155	0.375	Auto	A572-65
4	47.8178	47.8178	0	18	40.22	50.5	0.4375	Auto	A572-65

Reinforcement Configuration

	Bottom Effective Elevation (ft)	Top Effective Elevation (ft)	Type	Model	Number																		
						1	2	3	4	5	6	7	8	9	10	11	12	13	14	15	16	17	18
1	91.48	98.5	plate	CCI-SFP-045100	3		E3						E3						E3				
2	0	31.25	plate	CCI-WSFP-085125	3		E4								E4						E4		
3	31.25	60	plate	CCI-SFP-065125	3				E4						E4						E4		
4	60	77.25	plate	CCI-SFP-065125	3				E4						E4						E4		
5	91.48	103.5	plate	CCI-SFP-045100	3			E4							E4						E4		
6	77	83	plate	CCI-SFP-060100	3		E5							E5						E5			
7	103.5	112.583	plate	CCI-SFP-045100	3						E5						E5					E5	
8	0	27.75	plate	WCFP-5.5x1.25	2					E6							E6						
9	0	27.25	plate	CCI-WSFP-065125	1															E6			
10	31.25	58.5	plate	CCI-SFP-085125	1							E6											
11	97.58	106.92	plate	CCI-SFP-040075	3	E6							E6							E6			
12	27.25	56.75	plate	CCI-SFP-065125	1													E7					
13	58	69	plate	CCI-SFP-060100	3						E7						E7					E7	
14																							

Reinforcement Details

	B (in)	H (in)	Gross Area (in ²)	Pole Face to Centroid (in)	Bottom Termination Type	Bottom Termination Length (in)	Top Termination Type	Top Termination Length (in)	Lu (in)	Net Area (in ²)	Bolt Hole Size (in)	Reinforcement Material
1	4.5	1	4.5	0.5	PC 8.8 - M20 (100)	18	PC 8.8 - M20 (100)	18.000	20.000	3.250	1.1875	A572-65
2	8.5	1.25	10.625	0.625	Welded	n/a	PC 8.8 - M20 (100)	45.000	17.000	9.063	1.1875	A572-65
3	6.5	1.25	8.125	0.625	PC 8.8 - M20 (100)	33	PC 8.8 - M20 (100)	33.000	19.000	6.563	1.1875	A572-65
4	6.5	1.25	8.125	0.625	PC 8.8 - M20 (100)	33	PC 8.8 - M20 (100)	33.000	19.000	6.563	1.1875	A572-65
5	4.5	1	4.5	0.5	PC 8.8 - M20 (100)	18	PC 8.8 - M20 (100)	18.000	20.000	3.250	1.1875	A572-65
6	6	1	6	0.5	PC 8.8 - M20 (100)	24	PC 8.8 - M20 (100)	24.000	16.000	4.750	1.1875	A572-65
7	4.5	1	4.5	0.5	PC 8.8 - M20 (100)	18	PC 8.8 - M20 (100)	18.000	20.000	3.250	1.1875	A572-65
8	5.5	1.25	6.875	0.625	Welded	n/a	PC 8.8 - M20 (100)	27.000	21.000	5.313	1.1875	A572-65
9	6.5	1.25	8.125	0.625	Welded	n/a	PC 8.8 - M20 (100)	33.000	19.000	6.563	1.1875	A572-65
10	8.5	1.25	10.625	0.625	PC 8.8 - M20 (100)	45	PC 8.8 - M20 (100)	45.000	17.000	9.063	1.1875	A572-65
11	4	0.75	3	0.375	PC 8.8 - M20 (100)	12	PC 8.8 - M20 (100)	12.000	16.000	2.063	1.1875	A572-65
12	6.5	1.25	8.125	0.625	PC 8.8 - M20 (100)	33	PC 8.8 - M20 (100)	33.000	19.000	6.563	1.1875	A572-65
13	6	1	6	0.5	PC 8.8 - M20 (100)	24	PC 8.8 - M20 (100)	24.000	16.000	4.750	1.1875	A572-65

Connection Details for Custom Reinforcements

Reinforcement	End	# Bolts	N or X	Bolt Spacing (in)	Edge Dist (in)	Weld Grade (ksi)	Transverse (Horiz.) Weld Type	Horiz. Weld Length (in)	Horiz. Groove Depth (in)	Horiz. Groove Angle (deg)	Horiz. Fillet Size (in)	Vertical Weld Length (in)	Vertical Fillet Size (in)	Rev H Connection Capacity (kip)
WCFP-5.5x1.25	Top	9	N	3	3	-	-	-	-	-	-	-	-	-
	Bottom	-	-	-	-	70	CJP Groove	5.5	1.25	45	0.25	-	-	-

TNX Geometry Input

Increment (ft): [Export to TNX](#)

	Section Height (ft)	Section Length (ft)	Lap Splice Length (ft)	Number of Sides	Top Diameter (in)	Bottom Diameter (in)	Wall Thickness (in)	Tapered Pole Grade	Weight Multiplier
1	144.5 - 139.5	5		18	21.000	22.092	0.1875	A572-65	1.000
2	139.5 - 134.5	5		18	22.092	23.184	0.1875	A572-65	1.000
3	134.5 - 129.5	5		18	23.184	24.276	0.1875	A572-65	1.000
4	129.5 - 124.5	5		18	24.276	25.368	0.1875	A572-65	1.000
5	124.5 - 121.4088	6.9323	3.8411	18	25.368	26.882	0.1875	A572-65	1.000
6	121.4088 - 116.4088	5		18	25.668	26.737	0.25	A572-65	1.000
7	116.4088 - 112.583	3.8258		18	26.737	27.555	0.25	A572-65	1.000
8	112.583 - 112.333	0.25		18	27.555	27.608	0.25	A572-65	1.000
9	112.333 - 107.333	5		18	27.608	28.677	0.25	A572-65	1.000
10	107.333 - 106.92	0.413		18	28.677	28.765	0.25	A572-65	1.000
11	106.92 - 106.67	0.25		18	28.765	28.818	0.5375	A572-65	0.936
12	106.67 - 103.5	3.17		18	28.818	29.496	0.525	A572-65	0.947
13	103.5 - 103.25	0.25		18	29.496	29.549	0.525	A572-65	0.946
14	103.25 - 98.5	4.75		18	29.549	30.564	0.5125	A572-65	0.952
15	98.5 - 98.25	0.25		18	30.564	30.618	0.675	A572-65	0.937
16	98.25 - 97.58	0.67		18	30.618	30.761	0.675	A572-65	0.934
17	97.58 - 97.33	0.25		18	30.761	30.815	0.5625	A572-65	0.949
18	97.33 - 92.33	5		18	30.815	31.883	0.55	A572-65	0.953
19	92.33 - 91.7428	5.2122	4.625	18	31.883	32.997	0.55	A572-65	0.951
20	91.7428 - 86.1178	5.625		18	31.509	32.720	0.375	A572-65	1.000
21	86.1178 - 83	3.1178		18	32.720	33.392	0.375	A572-65	1.000
22	83 - 82.75	0.25		18	33.392	33.446	0.375	A572-65	1.000
23	82.75 - 77.75	5		18	33.446	34.523	0.375	A572-65	1.000
24	77.75 - 77.25	0.5		18	34.523	34.631	0.375	A572-65	1.000
25	77.25 - 77	0.25		18	34.631	34.685	0.825	A572-65	0.939
26	77 - 76.75	0.25		18	34.685	34.738	0.6375	A572-65	0.946
27	76.75 - 71.75	5		18	34.738	35.816	0.625	A572-65	0.953
28	71.75 - 69	2.75		18	35.816	36.408	0.625	A572-65	0.948
29	69 - 68.75	0.25		18	36.408	36.462	0.8	A572-65	0.942
30	68.75 - 63.75	5		18	36.462	37.539	0.7875	A572-65	0.943
31	63.75 - 60	3.75		18	37.539	38.347	0.775	A572-65	0.948
32	60 - 59.75	0.25		18	38.347	38.401	0.775	A572-65	0.947
33	59.75 - 58.5	1.25		18	38.401	38.670	0.775	A572-65	0.944
34	58.5 - 58.25	0.25		18	38.670	38.724	0.775	A572-65	0.943
35	58.25 - 58	0.25		18	38.724	38.778	0.775	A572-65	0.942
36	58 - 57.75	0.25		18	38.778	38.832	0.6125	A572-65	1.087
37	57.75 - 56.75	1		18	38.832	39.047	0.6125	A572-65	1.084
38	56.75 - 56.5	0.25		18	39.047	39.101	0.7375	A572-65	0.994
39	56.5 - 51.5	5		18	39.101	40.178	0.725	A572-65	0.997
40	51.5 - 47.8178	9.4582	5.776	18	40.178	42.216	0.7125	A572-65	1.004
41	47.8178 - 41.0418	6.776		18	40.221	41.678	0.7875	A572-65	0.982
42	41.0418 - 36.0418	5		18	41.678	42.753	0.7875	A572-65	0.971
43	36.0418 - 31.25	4.7918		18	42.753	43.783	0.7625	A572-65	0.992
44	31.25 - 31	0.25		18	43.783	43.836	0.65	A572-65	1.125
45	31 - 27.75	3.25		18	43.836	44.535	0.65	A572-65	1.118
46	27.75 - 27.5	0.25		18	44.535	44.589	0.65	A572-65	1.118
47	27.5 - 27.25	0.25		18	44.589	44.642	0.65	A572-65	1.117
48	27.25 - 27	0.25		18	44.642	44.696	0.725	A572-65	1.003
49	27 - 22	5		18	44.696	45.771	0.7125	A572-65	1.010
50	22 - 17	5		18	45.771	46.846	0.7125	A572-65	1.001
51	17 - 12	5		18	46.846	47.921	0.7125	A572-65	0.992
52	12 - 7	5		18	47.921	48.995	0.7125	A572-65	0.984
53	7 - 2	5		18	48.995	50.070	0.7	A572-65	0.993
54	2 - 0	2		18	50.070	50.500	0.7	A572-65	0.990

TNX Section Forces

Increment (ft):		TNX Output		
	5	P _u	M _{ux} (kip-ft)	V _u
	Section Height (ft)	(K)		(K)
1	144.5 - 139.5	4.16	84.28	12.15
2	139.5 - 134.5	7.04	149.34	18.67
3	134.5 - 129.5	7.77	243.99	19.46
4	129.5 - 124.5	11.03	360.63	25.14
5	124.5 - 121.4088	11.44	438.73	25.42
6	121.4088 - 116.4088	14.37	573.28	29.82
7	116.4088 - 112.583	15.02	688.00	30.18
8	112.583 - 112.333	15.09	695.54	30.19
9	112.333 - 107.333	16.42	847.60	31.52
10	107.333 - 106.92	16.51	860.62	31.54
11	106.92 - 106.67	16.58	868.51	31.57
12	106.67 - 103.5	17.36	969.15	31.94
13	103.5 - 103.25	17.43	977.14	31.96
14	103.25 - 98.5	20.12	1142.14	35.16
15	98.5 - 98.25	20.22	1150.93	35.18
16	98.25 - 97.58	23.29	1176.39	39.41
17	97.58 - 97.33	23.36	1186.24	39.44
18	97.33 - 92.33	24.79	1384.81	40.00
19	92.33 - 91.7428	24.97	1408.31	40.06
20	91.7428 - 86.1178	27.22	1635.66	40.77
21	86.1178 - 83	28.05	1763.12	41.04
22	83 - 82.75	28.14	1773.38	41.04
23	82.75 - 77.75	29.48	1979.62	41.48
24	77.75 - 77.25	29.63	2000.36	41.51
25	77.25 - 77	29.75	2010.74	41.53
26	77 - 76.75	29.83	2021.12	41.56
27	76.75 - 71.75	31.58	2230.24	42.11
28	71.75 - 69	32.56	2346.40	42.41
29	69 - 68.75	32.69	2357.00	42.42
30	68.75 - 63.75	34.81	2570.51	43.00
31	63.75 - 60	36.43	2732.52	43.44
32	60 - 59.75	36.55	2743.38	43.45
33	59.75 - 58.5	37.08	2797.78	43.61
34	58.5 - 58.25	37.21	2808.68	43.62
35	58.25 - 58	37.32	2819.58	43.65
36	58 - 57.75	37.42	2830.50	43.67
37	57.75 - 56.75	37.82	2874.22	43.79
38	56.75 - 56.5	37.95	2885.17	43.80
39	56.5 - 51.5	40.18	3105.53	44.36
40	51.5 - 47.8178	41.84	3269.53	44.75
41	47.8178 - 41.0418	47.22	3575.80	45.65
42	41.0418 - 36.0418	49.69	3805.22	46.15
43	36.0418 - 31.25	52.09	4027.35	46.61
44	31.25 - 31	52.23	4039.00	46.61
45	31 - 27.75	53.84	4190.91	46.90
46	27.75 - 27.5	53.99	4202.63	46.90
47	27.5 - 27.25	54.12	4214.36	46.92
48	27.25 - 27	54.24	4226.09	46.95
49	27 - 22	56.74	4461.83	47.38
50	22 - 17	59.29	4699.56	47.76
51	17 - 12	61.87	4939.12	48.11
52	12 - 7	64.48	5180.44	48.46
53	7 - 2	67.13	5423.48	48.81
54	2 - 0	68.20	5521.17	48.94

Analysis Results

Elevation (ft)	Component Type	Size	Critical Element	% Capacity	Pass / Fail
144.5 - 139.5	Pole	TP22.092x21x0.1875	Pole	20.3%	Pass
139.5 - 134.5	Pole	TP23.184x22.092x0.1875	Pole	33.2%	Pass
134.5 - 129.5	Pole	TP24.276x23.184x0.1875	Pole	49.5%	Pass
129.5 - 124.5	Pole	TP25.368x24.276x0.1875	Pole	68.1%	Pass
124.5 - 121.41	Pole	TP26.882x25.368x0.1875	Pole	79.0%	Pass
121.41 - 116.41	Pole	TP26.737x25.668x0.25	Pole	67.8%	Pass
116.41 - 112.58	Pole	TP27.555x26.737x0.25	Pole	77.0%	Pass
112.58 - 112.33	Pole	TP27.608x27.555x0.25	Pole	77.6%	Pass
112.33 - 107.33	Pole	TP28.677x27.608x0.25	Pole	88.3%	Pass
107.33 - 106.92	Pole	TP28.765x28.677x0.25	Pole	89.2%	Pass
106.92 - 106.67	Pole + Reinf.	TP28.818x28.765x0.5375	Reinf. 11 Tension Rupture	74.3%	Pass
106.67 - 103.5	Pole + Reinf.	TP29.496x28.818x0.525	Reinf. 11 Tension Rupture	80.1%	Pass
103.5 - 103.25	Pole + Reinf.	TP29.549x29.496x0.525	Reinf. 11 Tension Rupture	80.5%	Pass
103.25 - 98.5	Pole + Reinf.	TP30.564x29.549x0.5125	Reinf. 11 Tension Rupture	89.5%	Pass
98.5 - 98.25	Pole + Reinf.	TP30.618x30.564x0.675	Reinf. 11 Tension Rupture	69.0%	Pass
98.25 - 97.58	Pole + Reinf.	TP30.761x30.618x0.675	Reinf. 11 Tension Rupture	70.2%	Pass
97.58 - 97.33	Pole + Reinf.	TP30.815x30.761x0.5625	Reinf. 1 Tension Rupture	79.9%	Pass
97.33 - 92.33	Pole + Reinf.	TP31.883x30.815x0.55	Reinf. 1 Tension Rupture	88.7%	Pass
92.33 - 91.74	Pole + Reinf.	TP32.997x31.883x0.55	Reinf. 1 Tension Rupture	89.7%	Pass
91.74 - 86.12	Pole	TP32.72x31.509x0.375	Pole	83.6%	Pass
86.12 - 83	Pole	TP33.392x32.72x0.375	Pole	86.5%	Pass
83 - 82.75	Pole	TP33.446x33.392x0.375	Pole	86.7%	Pass
82.75 - 77.75	Pole	TP34.523x33.446x0.375	Pole	90.6%	Pass
77.75 - 77.25	Pole	TP34.631x34.523x0.375	Pole	91.0%	Pass
77.25 - 77	Pole + Reinf.	TP34.685x34.631x0.825	Reinf. 6 Tension Rupture	67.4%	Pass
77 - 76.75	Pole + Reinf.	TP34.738x34.685x0.6375	Reinf. 4 Tension Rupture	85.9%	Pass
76.75 - 71.75	Pole + Reinf.	TP35.816x34.738x0.625	Reinf. 4 Tension Rupture	90.1%	Pass
71.75 - 69	Pole + Reinf.	TP36.408x35.816x0.625	Reinf. 4 Tension Rupture	92.3%	Pass
69 - 68.75	Pole + Reinf.	TP36.462x36.408x0.8	Reinf. 13 Tension Rupture	73.3%	Pass
68.75 - 63.75	Pole + Reinf.	TP37.539x36.462x0.7875	Reinf. 13 Tension Rupture	76.6%	Pass
63.75 - 60	Pole + Reinf.	TP38.347x37.539x0.775	Reinf. 13 Tension Rupture	78.9%	Pass
60 - 59.75	Pole + Reinf.	TP38.401x38.347x0.775	Reinf. 13 Tension Rupture	79.0%	Pass
59.75 - 58.5	Pole + Reinf.	TP38.67x38.401x0.775	Reinf. 13 Tension Rupture	79.7%	Pass
58.5 - 58.25	Pole + Reinf.	TP38.724x38.67x0.775	Reinf. 13 Tension Rupture	79.9%	Pass
58.25 - 58	Pole + Reinf.	TP38.778x38.724x0.775	Reinf. 13 Tension Rupture	80.0%	Pass
58 - 57.75	Pole + Reinf.	TP38.832x38.778x0.6125	Reinf. 3 Tension Rupture	91.2%	Pass
57.75 - 56.75	Pole + Reinf.	TP39.047x38.832x0.6125	Reinf. 3 Tension Rupture	91.8%	Pass
56.75 - 56.5	Pole + Reinf.	TP39.101x39.047x0.7375	Reinf. 3 Tension Rupture	83.4%	Pass
56.5 - 51.5	Pole + Reinf.	TP40.178x39.101x0.725	Reinf. 3 Tension Rupture	86.0%	Pass
51.5 - 47.82	Pole + Reinf.	TP42.216x40.178x0.7125	Reinf. 3 Tension Rupture	87.8%	Pass
47.82 - 41.04	Pole + Reinf.	TP41.678x40.221x0.7875	Reinf. 3 Tension Rupture	85.6%	Pass
41.04 - 36.04	Pole + Reinf.	TP42.753x41.678x0.7875	Reinf. 3 Tension Rupture	87.4%	Pass
36.04 - 31.25	Pole + Reinf.	TP43.783x42.753x0.7625	Reinf. 3 Tension Rupture	89.0%	Pass
31.25 - 31	Pole + Reinf.	TP43.836x43.783x0.65	Reinf. 2 Bolt Shear	87.6%	Pass
31 - 27.75	Pole + Reinf.	TP44.535x43.836x0.65	Reinf. 2 Compression	85.2%	Pass
27.75 - 27.5	Pole + Reinf.	TP44.589x44.535x0.65	Reinf. 2 Compression	85.3%	Pass
27.5 - 27.25	Pole + Reinf.	TP44.642x44.589x0.65	Reinf. 2 Compression	85.3%	Pass
27.25 - 27	Pole + Reinf.	TP44.696x44.642x0.725	Reinf. 2 Compression	87.0%	Pass
27 - 22	Pole + Reinf.	TP45.771x44.696x0.7125	Reinf. 2 Compression	88.3%	Pass
22 - 17	Pole + Reinf.	TP46.846x45.771x0.7125	Reinf. 2 Compression	89.5%	Pass
17 - 12	Pole + Reinf.	TP47.921x46.846x0.7125	Reinf. 2 Compression	90.6%	Pass
12 - 7	Pole + Reinf.	TP48.995x47.921x0.7125	Reinf. 2 Compression	91.6%	Pass
7 - 2	Pole + Reinf.	TP50.07x48.995x0.7	Reinf. 2 Compression	92.6%	Pass
2 - 0	Pole + Reinf.	TP50.5x50.07x0.7	Reinf. 2 Compression	92.9%	Pass
				Summary	
			Pole	91.0%	Pass
			Reinforcement	92.9%	Pass
			Overall	92.9%	Pass

Additional Calculations

Section Elevation (ft)	Moment of Inertia (in ⁴)			Area (in ²)			% Capacity*													
	Pole	Reinf.	Total	Pole	Reinf.	Total	Pole	R1	R2	R3	R4	R5	R6	R7	R8	R9	R10	R11	R12	R13
144.5 - 139.5	790	n/a	790	13.04	n/a	13.04	20.3%													
139.5 - 134.5	914	n/a	914	13.69	n/a	13.69	33.2%													
134.5 - 129.5	1051	n/a	1051	14.34	n/a	14.34	49.5%													
129.5 - 124.5	1200	n/a	1200	14.99	n/a	14.99	68.1%													
124.5 - 121.41	1299	n/a	1299	15.39	n/a	15.39	79.0%													
121.41 - 116.41	1862	n/a	1862	21.02	n/a	21.02	67.8%													
116.41 - 112.58	2040	n/a	2040	21.67	n/a	21.67	77.0%													
112.58 - 112.33	2052	n/a	2052	21.71	n/a	21.71	77.6%													
112.33 - 107.33	2302	n/a	2302	22.56	n/a	22.56	88.3%													
107.33 - 106.92	2324	n/a	2324	22.63	n/a	22.63	89.2%													
106.92 - 106.67	2337	2502	4839	22.67	22.50	45.17	42.6%							71.4%				74.3%		
106.67 - 103.5	2507	2617	5124	23.21	22.50	45.71	46.2%							76.9%				80.1%		
103.5 - 103.25	2521	2626	5146	23.25	22.50	45.75	46.5%					77.3%						80.5%		
103.25 - 98.5	2792	2803	5594	24.05	22.50	46.55	52.3%					85.9%						89.5%		
98.5 - 98.25	2807	4511	7318	24.10	36.00	60.10	40.4%	66.3%				66.3%						69.0%		
98.25 - 97.58	2846	4552	7398	24.21	36.00	60.21	41.2%	67.4%				67.4%						70.2%		
97.58 - 97.33	2861	3440	6301	24.25	27.00	51.25	48.9%	79.9%				79.9%								
97.33 - 92.33	3172	3673	6845	25.10	27.00	52.10	54.9%	88.7%				88.7%								
92.33 - 91.74	3210	3701	6911	25.20	27.00	52.20	55.6%	89.7%				89.7%								
91.74 - 86.12	5087	n/a	5087	38.50	n/a	38.50	83.6%													
86.12 - 83	5411	n/a	5411	39.30	n/a	39.30	86.5%													
83 - 82.75	5437	n/a	5437	39.36	n/a	39.36	86.7%													
82.75 - 77.75	5986	n/a	5986	40.64	n/a	40.64	90.6%													
77.75 - 77.25	6043	n/a	6043	40.77	n/a	40.77	91.0%													
77.25 - 77	6071	6872	12943	40.84	42.38	83.21	42.1%				66.5%		67.4%							
77 - 76.75	6100	3991	10091	40.90	24.38	65.27	54.4%				85.9%									
76.75 - 71.75	6692	4230	10922	42.18	24.38	66.56	57.1%				90.1%									
71.75 - 69	7033	4365	11398	42.89	24.38	67.26	58.7%				92.3%									
69 - 68.75	7064	7563	14627	42.95	42.38	85.33	46.1%				72.4%									73.3%
68.75 - 63.75	7716	7998	15714	44.23	42.38	86.61	48.5%				75.6%									76.6%
63.75 - 60	8230	8333	16563	45.19	42.38	87.57	50.2%				77.8%									78.9%
60 - 59.75	8265	8355	16621	45.26	42.38	87.63	50.3%			78.0%										79.0%
59.75 - 58.5	8442	8469	16911	45.58	42.38	87.95	50.9%			78.7%										79.7%
58.5 - 58.25	8478	8491	16969	45.64	42.38	88.02	51.0%			78.8%										79.9%
58.25 - 58	8514	8514	17028	45.71	42.38	88.08	51.1%			78.9%										80.0%
58 - 57.75	8571	5226	13797	45.77	35.00	80.77	66.2%			91.2%							64.9%			
57.75 - 56.75	8715	5281	13997	46.03	35.00	81.03	66.8%			91.8%							65.4%			
56.75 - 56.5	8809	7891	16700	46.09	43.13	89.22	57.4%			83.4%							65.6%		74.6%	
56.5 - 51.5	9562	8314	17876	47.37	43.13	90.50	59.7%			86.0%							67.8%		77.1%	
51.5 - 47.82	10144	8633	18776	48.32	43.13	91.44	61.3%			87.8%							69.4%		78.9%	
47.82 - 41.04	12369	9355	21724	57.27	43.13	100.39	57.0%			85.6%							69.1%		78.0%	
41.04 - 36.04	13359	9826	23185	58.76	43.13	101.88	58.5%			87.4%							70.7%		79.8%	
36.04 - 31.25	14356	10288	24644	60.19	43.13	103.31	60.0%			89.0%							75.1%		81.4%	
31.25 - 31	14751	6753	21504	60.26	40.00	100.26	73.4%		87.6%										82.5%	
31 - 27.75	15466	6968	22434	61.23	40.00	101.23	74.4%		85.2%										83.5%	
27.75 - 27.5	15522	6984	22506	61.31	40.00	101.31	74.4%		85.3%										83.5%	
27.5 - 27.25	15578	7001	22579	61.38	40.00	101.38	74.5%		85.3%										83.6%	
27.25 - 27	15256	9465	24721	61.46	40.00	101.46	63.1%		87.0%							84.2%				
27 - 22	16393	9909	26302	62.95	40.00	102.95	64.5%		88.3%								85.6%			
22 - 17	17556	10786	28342	64.44	40.00	104.44	64.9%		89.5%								86.9%			
17 - 12	18803	11269	30072	65.93	40.00	105.93	66.1%		90.6%								88.1%			
12 - 7	20108	11763	31871	67.43	40.00	107.43	67.3%		91.6%								89.2%			
7 - 2	21472	12268	33740	68.92	40.00	108.92	68.5%		92.6%								90.1%			
2 - 0	22035	12472	34507	69.52	40.00	109.52	68.9%		92.9%								90.5%			

Note: Section capacity checked using 5 degree increments.
Rating per TIA-222-H Section 15.5.

PROJECT	92739.019.01 - GROTON TOWER, CT
SUBJECT	Anchor Rod Bracket Analysis
DATE	10/26/21
v4.6.1	TIA-222 Rev. H Apply TIA-222-H Section 15.5? Yes



Analysis Criteria	
Design/Analysis	Analysis
Load Type	Current Load
Current load	139.11 kips
AR Capacity	227.3 kips

Tower Type	Monopole
------------	----------

Manufacturers Tower Prop.	
Pole Thickness	0.4375 in
Pole Grade	A572-65
Fy	65 ksi
Fu	80 ksi
Base Plate Gr.	A572-60
Fy	60 ksi
Fu	75 ksi

Post-Installed Adhesive AR Mod.	
ARB Type	Welded
Size	1.75 in
Grade	F1554-105
Fy	105 ksi
Fu	125 ksi

Anchor Rod Bracket Analysis Checks		
Tube Bearing	35.4%	-
Tube Compression	53.2%	-
Gusset Shear	12.3%	-
Gusset Flexure	N/A	-
Welds	Gusset to Tower and BP	30.8% -
	Gusset to Tube	39.7% -
	Geometry	N/A -
Tower Punching	13.3%	-
Tube Punching	10.6%	-
Utilization		53.2%

Bracket Properties		
Gusset	Pipe/Tube	Weld - Gusset to Pipe/Tube
Thickness	1.25 in	FEXX
Width at Tube	2.75 in	70 ksi
Height at Pole	30 in	Weld Type
Height at Tube	24 in	Double Fillet
Grade	A572-65	Fillet Size
Fy	65 ksi	5/16 in
Fu	80 ksi	
Weld - Gusset to Tower		Weld - Gusset to Base Plate
FEXX	70 ksi	FEXX
Weld Type	Double Fillet	70 ksi
Fillet Size	5/16 in	Weld Type
		CJP - Double Bevel
		Fillet Size
		9/16 in
		Bevel Depth
		9/16 in
		Gap
		0 in
		Notch (horiz)
		0.75 in
		Notch (vert)
		0.75 in
		Pipe/Tube Welded to Base/Footpad?
		Yes
		Fillet Size
		1/2 in

PROJECT **92739.019.01 - GROTON TOWER, CT**
 SUBJECT **Anchor Rod Bracket Analysis**
 DATE **10/26/21**
 v4.6.1

TIA-222 Rev. **H**
 Apply TIA-222-H Section 15.5? **Yes**



Analysis Criteria	
Design/Analysis	Analysis
Load Type	Current Load
Current load	139.11 kips
AR Capacity	227.3 kips

Tower Type	Monopole
------------	----------

Manufacturers Tower Prop.	
Pole Thickness	0.4375 in
Pole Grade	A572-65
Fy	65 ksi
Fu	80 ksi
Base Plate Gr.	A572-60
Fy	60 ksi
Fu	75 ksi

Post-Installed Adhesive AR Mod.	
ARB Type	Welded
Size	1.75 in
Grade	F1554-105
Fy	105 ksi
Fu	125 ksi

Anchor Rod Bracket Analysis Checks		
Tube Bearing	35.4%	-
Tube Compression	53.2%	-
Gusset Shear	12.3%	-
Gusset Flexure	N/A	-
Welds	Gusset to Tower and BP	29.2% -
	Gusset to Tube	39.7% -
	Geometry	N/A -
Tower Punching	16.8%	-
Tube Punching	10.6%	-
Utilization		53.2%

Bracket Properties			
Gusset	Pipe/Tube	Weld - Gusset to Pipe/Tube	
Thickness	1.25 in	FEXX	
Width at Tube	4 in	70 ksi	
Height at Pole	30 in	Weld Type	
Height at Tube	24 in	Double Fillet	
Grade	A572-65	Fillet Size	
Fy	65 ksi	5/16 in	
Fu	80 ksi		
Weld - Gusset to Tower		Weld - Gusset to Base Plate	
FEXX	70 ksi	FEXX	70 ksi
Weld Type	Double Fillet	Weld Type	CJP - Double Bevel
Fillet Size	5/16 in	Fillet Size	9/16 in
		Bevel Depth	9/16 in
		Gap	0 in
		Notch (horiz)	0.75 in
		Notch (vert)	0.75 in
		Pipe/Tube Welded to Base/Footpad?	Yes
		Fillet Size	1/2 in

Monopole Base Plate Connection



Site Info	
BU #	881533
Site Name	GROTON TOWER, CT
Order #	576662, Rev. 4

Analysis Considerations	
TIA-222 Revision	H
Grout Considered:	See Custom Sheet
l_{ar} (in)	See Custom Sheet

Applied Loads	
Moment (kip-ft)	5521.17
Axial Force (kips)	68.20
Shear Force (kips)	48.94

*TIA-222-H Section 15.5 Applied

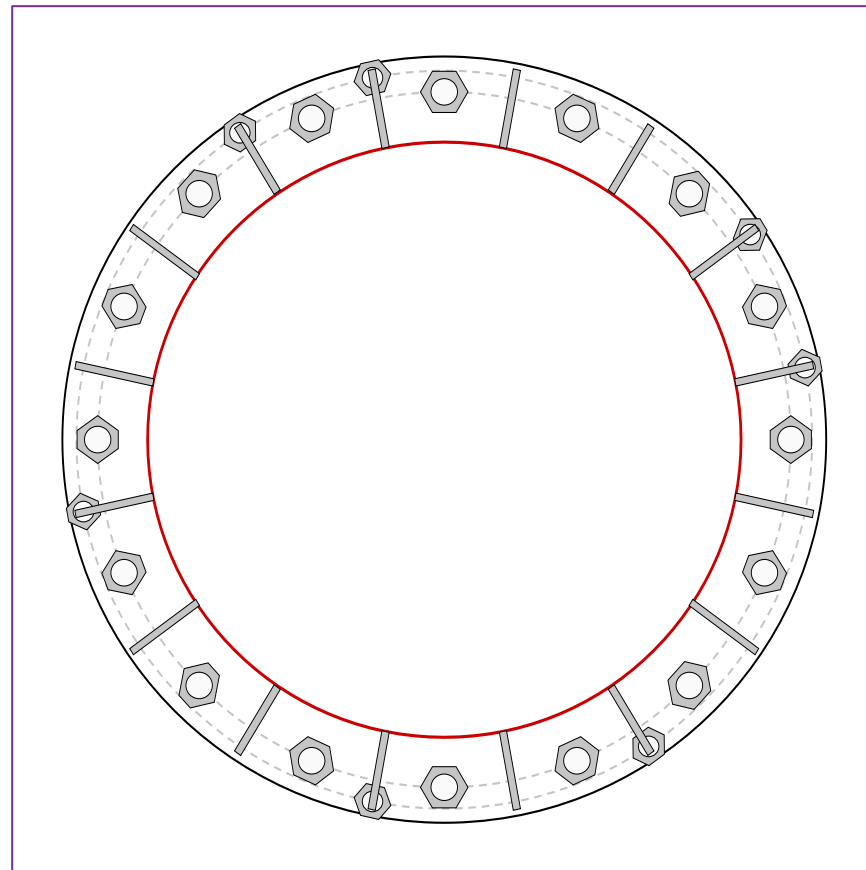

Connection Properties	Analysis Results
-----------------------	------------------

Anchor Rod Data
GROUP 1: (16) 2-1/4" ϕ bolts (A615-75 N; $F_y=75$ ksi, $F_u=100$ ksi) on 59" BC
GROUP 2: (7) 1-3/4" ϕ bolts (F1554-105 N; $F_y=105$ ksi, $F_u=125$ ksi) on 62.61" BC
pos. (deg): 11.2, 33.8, 101.2, 123.8, 191.2, 258.8, 303.8
Base Plate Data
65" OD x 2" Plate (A572-60; $F_y=60$ ksi, $F_u=75$ ksi)
Stiffener Data
(16) 17.75"H x 6.75"W x 0.625"T, Notch: 0.75"
plate: $F_y=50$ ksi ; weld: $F_y=70$ ksi
horiz. weld: 0.625" fillet
vert. weld: 0.375" fillet
Pole Data
50.5" x 0.4375" 18-sided pole (A572-65; $F_y=65$ ksi, $F_u=80$ ksi)

Anchor Rod Summary (units of kips, kip-in)		
GROUP 1:		
$P_{u,t} = 220.45$	$\phi P_{n,t} = 243.75$	Stress Rating
$V_u = 3.06$	$\phi V_n = 149.1$	86.1%
$M_u = n/a$	$\phi M_n = n/a$	Pass
GROUP 2:		
$P_{u,t} = 139.11$	$\phi P_{n,t} = 178.13$	Stress Rating
$V_u = 0$	$\phi V_n = 112.75$	74.4%
$M_u = n/a$	$\phi M_n = n/a$	Pass
Base Plate Summary		
Max Stress (ksi):	38.58	(Roark's Flexural)
Allowable Stress (ksi):	54	
Stress Rating:	68.0%	Pass
Stiffener Summary		
Horizontal Weld:	72.9%	Pass
Vertical Weld:	47.8%	Pass
Plate Flexure+Shear:	28.7%	Pass
Plate Tension+Shear:	80.0%	Pass
Plate Compression:	84.5%	Pass
Pole Summary		
Punching Shear:	12.1%	Pass

CCIplate

Elevation (ft) 0 (Base)

note: Bending interaction not considered when Grout Considered = "Yes"

Bolt Group	Resist Axial	Resist Shear	Induce Plate Bending	Grout Considered	Apply at BARB Elevation	BARB CL Elevation (ft)
1	Yes	Yes	Yes	No	No	
2	No	No	No	No	No	

Custom Bolt Connection

Bolt	Bolt Group ID	Location (deg.)	Diameter (in)	Material	Bolt Circle (in)	Eta Factor, η	I_{br} (in)	Thread Type	Area Override, in ²	Tension Only
1	1	0	2.25	A615-75	59	0.5	0	N-Included		No
2	1	22.5	2.25	A615-75	59	0.5	0	N-Included		No
3	1	45	2.25	A615-75	59	0.5	0	N-Included		No
4	1	67.5	2.25	A615-75	59	0.5	0	N-Included		No
5	1	90	2.25	A615-75	59	0.5	0	N-Included		No
6	1	112.5	2.25	A615-75	59	0.5	0	N-Included		No
7	1	135	2.25	A615-75	59	0.5	0	N-Included		No
8	1	157.5	2.25	A615-75	59	0.5	0	N-Included		No
9	1	180	2.25	A615-75	59	0.5	0	N-Included		No
10	1	202.5	2.25	A615-75	59	0.5	0	N-Included		No
11	1	225	2.25	A615-75	59	0.5	0	N-Included		No
12	1	247.5	2.25	A615-75	59	0.5	0	N-Included		No
13	1	270	2.25	A615-75	59	0.5	0	N-Included		No
14	1	292.5	2.25	A615-75	59	0.5	0	N-Included		No
15	1	315	2.25	A615-75	59	0.5	0	N-Included		No
16	1	337.5	2.25	A615-75	59	0.5	0	N-Included		No
17	2	11.25	1.75	F1554-105	62.61	0.5	0	N-Included		No
18	2	33.75	1.75	F1554-105	62.61	0.5	0	N-Included		No
19	2	101.25	1.75	F1554-105	62.61	0.5	0	N-Included		No
20	2	123.75	1.75	F1554-105	62.61	0.5	0	N-Included		No
21	2	191.25	1.75	F1554-105	62.61	0.5	0	N-Included		No
22	2	258.75	1.75	F1554-105	62.61	0.5	0	N-Included		No
23	2	303.75	1.75	F1554-105	62.61	0.5	0	N-Included		No

Custom Stiffener Connection

Stiffener	Stiffener Group ID	Location (deg.)	Width (in)	Height (in)	Thickness (in)	H. Notch (in)	V. Notch (in)	Grade (ksi)	Weld Type	Groove Depth (in)	Groove Angle (deg.)	H. Fillet Weld Size (in)	V. Fillet Weld Size (in)	Weld Strength (ksi)
1	1	11.25	6.75	17.75	0.625	0.75	0.75	50	Fillet			0.625	0.375	70
2	1	33.75	6.75	17.75	0.625	0.75	0.75	50	Fillet			0.625	0.375	70
3	1	56.25	6.75	17.75	0.625	0.75	0.75	50	Fillet			0.625	0.375	70
4	1	78.75	6.75	17.75	0.625	0.75	0.75	50	Fillet			0.625	0.375	70
5	1	101.25	6.75	17.75	0.625	0.75	0.75	50	Fillet			0.625	0.375	70
6	1	123.75	6.75	17.75	0.625	0.75	0.75	50	Fillet			0.625	0.375	70
7	1	146.25	6.75	17.75	0.625	0.75	0.75	50	Fillet			0.625	0.375	70
8	1	168.75	6.75	17.75	0.625	0.75	0.75	50	Fillet			0.625	0.375	70
9	1	191.25	6.75	17.75	0.625	0.75	0.75	50	Fillet			0.625	0.375	70
10	1	213.75	6.75	17.75	0.625	0.75	0.75	50	Fillet			0.625	0.375	70
11	1	236.25	6.75	17.75	0.625	0.75	0.75	50	Fillet			0.625	0.375	70
12	1	258.75	6.75	17.75	0.625	0.75	0.75	50	Fillet			0.625	0.375	70
13	1	281.25	6.75	17.75	0.625	0.75	0.75	50	Fillet			0.625	0.375	70
14	1	303.75	6.75	17.75	0.625	0.75	0.75	50	Fillet			0.625	0.375	70
15	1	326.25	6.75	17.75	0.625	0.75	0.75	50	Fillet			0.625	0.375	70
16	1	348.75	6.75	17.75	0.625	0.75	0.75	50	Fillet			0.625	0.375	70

Plot Graphic

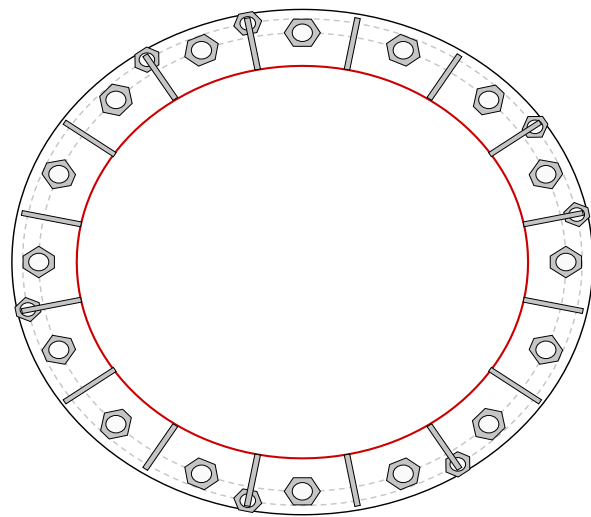

Pier and Pad Foundation



BU #: 881533
Site Name: GROTON TOWER
App. Number: 576662, Rev. 4

TIA-222 Revision: H
Tower Type: Monopole

Top & Bot. Pad Rein. Different?:
Block Foundation?:
Rectangular Pad?:

Superstructure Analysis Reactions		
Compression, P_{comp} :	68.2	kips
Base Shear, Vu_{comp} :	48.94	kips
Moment, M_u :	5521.17	ft-kips
Tower Height, H :	145	ft
BP Dist. Above Fdn, bp_{dist} :	3.25	in
Bolt Circle / Bearing Plate Width, BC :	59	in

Foundation Analysis Checks				
	Capacity	Demand	Rating*	Check
<i>Lateral (Sliding) (kips)</i>	257.26	48.94	18.1%	Pass
<i>Bearing Pressure (ksf)</i>	18.00	3.15	17.5%	Pass
<i>Overturning (kip*ft)</i>	9372.77	5779.12	61.7%	Pass
<i>Pad Flexure (kip*ft)</i>	8579.25	2712.73	30.1%	Pass
<i>Pad Shear - 1-way (kips)</i>	1861.32	281.40	14.4%	Pass
<i>Pad Shear - 2-way (Comp) (ksi)</i>	0.190	0.003	1.4%	Pass
<i>Flexural 2-way (Comp) (kip*ft)</i>	8603.29	0.00	0.0%	Pass

*Rating per TIA-222-H Section 15.5

Structural Rating*:	30.1%
Soil Rating*:	61.7%

Pad Properties		
Depth, D :	5	ft
Pad Width, W_1 :	30	ft
Pad Thickness, T :	5	ft
Pad Rebar Size (Bottom dir. 2), Sp_2 :	8	
Pad Rebar Quantity (Bottom dir. 2), mp_2 :	45	
Pad Clear Cover, cc_{pad} :	4	in

Material Properties		
Rebar Grade, F_y :	60	ksi
Concrete Compressive Strength, F'_c :	4	ksi
Dry Concrete Density, δ_c :	150	pcf

Soil Properties		
Total Soil Unit Weight, γ :	165	pcf
Ultimate Gross Bearing, Q_{ult} :	24.000	ksf
Cohesion, C_u :	0.000	ksf
Friction Angle, ϕ :	30	degrees
SPT Blow Count, N_{blows} :	0	
Base Friction, μ :		
Neglected Depth, N :	3.33	ft
Foundation Bearing on Rock?	Yes	
Groundwater Depth, gw :	N/A	ft

<--Toggle between Gross and Net

www.hilti.com

Company:	B+T Grp	Page:	1
Address:	1717 S. Boulder,Suite 300	Specifier:	Pavithra
Phone Fax:	918-587-4630	E-Mail:	
Design:	Drafts_92739.018.01 - GROTON TOWER, CT	Date:	10/26/2021
Fastening point:			

Specifier's comments:

1 Input data

Anchor type and diameter:	Heavy Hex Head 2.25 in dia AR	
Item number:	not available	
Effective embedment depth:	$h_{ef} = 56$ in	
Material:	ASTM F 1554	
Evaluation Service Report:	Hilti Technical Data	
Issued Valid:	- -	
Proof:	Design Method ACI 318-14 / CIP	
Stand-off installation:	without clamping (anchor); restraint level (anchor plate): 2.00; $e_b = 3.250$ in.; $t = 2.000$ in. Hilti Grout: CB-G EG, epoxy, $f_{c,Grout} = 14,939$ psi	
Anchor plate ^R :	$l_x \times l_y \times t = 65.000$ in. x 65.000 in. x 2.000 in.; (Recommended plate thickness: not calculated)	
Profile:	Steel pipe, ; (L x W x T) = 50.500 in. x 50.500 in. x 0.437 in.	
Base material:	cracked concrete, 4000, $f_c' = 4,000$ psi; $h = 60.000$ in.	
Reinforcement:	tension: condition B, shear: condition B; edge reinforcement: none or < No. 4 bar	

^R - The anchor calculation is based on a rigid anchor plate assumption.

Geometry [in.] & Loading [kip, ft.kip]

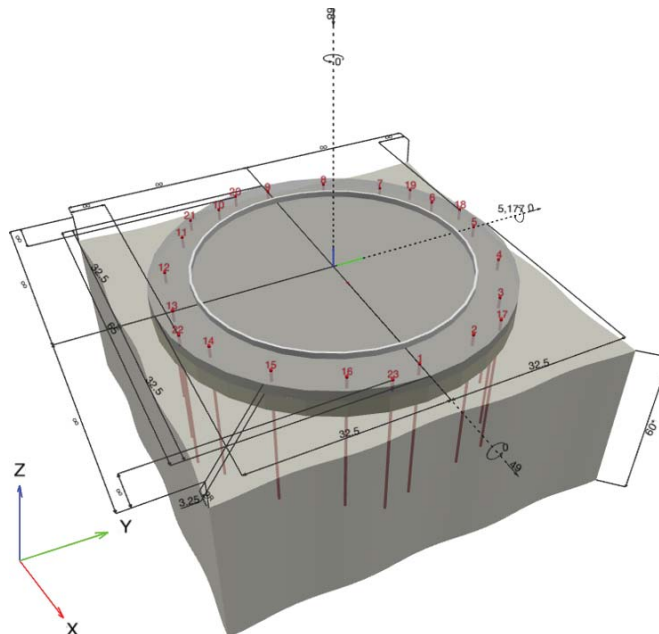



www.hilti.com

Company:	B+T Grp	Page:	2
Address:	1717 S. Boulder,Suite 300	Specifier:	Pavithra
Phone Fax:	918-587-4630	E-Mail:	
Design:	Drafts_92739.018.01 - GROTON TOWER, CT	Date:	10/26/2021
Fastening point:			

1.1 Design results

Case	Description	Forces [kip] / Moments [ft.kip]	Seismic	Max. Util. Anchor [%]
1	Combination 1	N = -68.000; V _x = 49.000; V _y = 0.000; M _x = 0.00000; M _y = 5,177.00000; M _z = 0.00000;	no	∞

2 Load case/Resulting anchor forces

Anchor reactions [kip]

Tension force: (+Tension, -Compression)

Anchor	Tension force	Shear force	Shear force x	Shear force y
1	0.000	2.132	2.131	0.043
2	0.000	2.115	2.115	0.040
3	8.665	2.102	2.101	0.031
4	28.730	2.092	2.092	0.017
5	52.494	2.089	2.089	0.001
6	76.341	2.092	2.092	-0.015
7	96.640	2.102	2.101	-0.029
8	110.300	2.115	2.115	-0.038
9	115.243	2.132	2.131	-0.041
10	110.715	2.148	2.148	-0.038
11	97.406	2.161	2.161	-0.029
12	77.341	2.171	2.170	-0.015
13	53.577	2.174	2.174	0.001
14	29.730	2.171	2.170	0.017
15	9.431	2.161	2.161	0.031
16	0.000	2.148	2.148	0.040
17	0.000	2.107	2.106	0.038
18	66.201	2.087	2.087	-0.008
19	89.483	2.094	2.094	-0.024
20	117.724	2.141	2.141	-0.043
21	108.078	2.157	2.156	-0.036
22	39.870	2.175	2.175	0.010
23	0.000	2.140	2.139	0.045

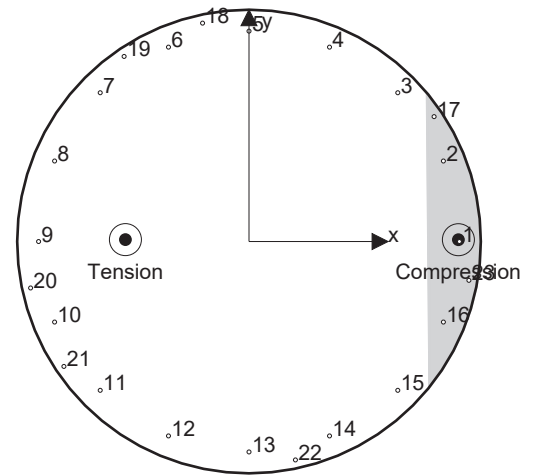

max. concrete compressive strain: 3.76 [%]
 max. concrete compressive stress: 16,371 [psi]
 resulting tension force in (x/y)=(-17.327/0.269): 1,287.969 [kip]
 resulting compression force in (x/y)=(29.358/0.255): 1,355.969 [kip]

Anchor forces are calculated based on the assumption of a rigid anchor plate.



www.hilti.com

Company:	B+T Grp	Page:	3
Address:	1717 S. Boulder,Suite 300	Specifier:	Pavithra
Phone Fax:	918-587-4630	E-Mail:	
Design:	Drafts_92739.018.01 - GROTON TOWER, CT	Date:	10/26/2021
Fastening point:			

3 Tension load

	Load N_{ua} [kip]	Capacity ϕN_n [kip]	Utilization $\beta_N = N_{ua}/\phi N_n$	Rev H
Steel Strength*	117.724	304.6875	38.63%	36.8%
Pullout Strength*	117.724	160.5	73.34%	69.86%
Concrete Breakout Failure**	1,287.969	1376.32	93.59%	89.12%

Governing rating

3.1 Steel Strength

$$N_{sa} = A_{se,N} f_{uta} \quad \text{ACI 318-14 Eq. (17.4.1.2)}$$

$$\phi N_{sa} \geq N_{ua} \quad \text{ACI 318-14 Table 17.3.1.1}$$

Variables

$A_{se,N}$ [in. ²]	f_{uta} [psi]
3.25	125000

Calculations

N_{sa} [kip]
406.25

Results

N_{sa} [kip]	ϕ_{steel}	ϕN_{sa} [kip]	N_{ua} [kip]
406.25	0.750	304.6875	117.724

3.2 Pullout Strength

$$N_{pn} = \psi_{c,p} N_p \quad \text{ACI 318-14 Eq. (17.4.3.1)}$$

$$N_p = 8 A_{brg} f'_c \quad \text{ACI 318-14 Eq. (17.4.3.4)}$$

$$\phi N_{pn} \geq N_{ua} \quad \text{ACI 318-14 Table 17.3.1.1}$$

Variables

$\psi_{c,p}$	A_{brg} [in. ²]	λ_a	f'_c [psi]
1.000	7.17	1.000	4,000

Calculations

N_p [kip]
229.2869

Results

N_{pn} [kip]	$\phi_{concrete}$	ϕN_{pn} [kip]	N_{ua} [kip]
229.2869	0.700	160.5	117.724



www.hilti.com

Company:	B+T Grp	Page:	4
Address:	1717 S. Boulder,Suite 300	Specifier:	Pavithra
Phone Fax:	918-587-4630	E-Mail:	
Design:	Drafts_92739.018.01 - GROTON TOWER, CT	Date:	10/26/2021
Fastening point:			

3.3 Concrete Breakout Failure

$$N_{cbg} = \left(\frac{A_{Nc}}{A_{Nc0}} \right) \psi_{ec,N} \psi_{ed,N} \psi_{c,N} \psi_{cp,N} N_b \quad \text{ACI 318-14 Eq. (17.4.2.1b)}$$

$$\phi N_{cbg} \geq N_{ua} \quad \text{ACI 318-14 Table 17.3.1.1}$$

$$A_{Nc} \text{ see ACI 318-14, Section 17.4.2.1, Fig. R 17.4.2.1(b)}$$

$$A_{Nc0} = 9 h_{ef}^2 \quad \text{ACI 318-14 Eq. (17.4.2.1c)}$$

$$\psi_{ec,N} = \left(\frac{1}{1 + \frac{2 e_N}{3 h_{ef}}} \right) \leq 1.0 \quad \text{ACI 318-14 Eq. (17.4.2.4)}$$

$$\psi_{ed,N} = 0.7 + 0.3 \left(\frac{c_{a,min}}{1.5 h_{ef}} \right) \leq 1.0 \quad \text{ACI 318-14 Eq. (17.4.2.5b)}$$

$$\psi_{cp,N} = \text{MAX} \left(\frac{c_{a,min}}{c_{ac}}, \frac{1.5 h_{ef}}{c_{ac}} \right) \leq 1.0 \quad \text{ACI 318-14 Eq. (17.4.2.7b)}$$

$$N_b = 16 \lambda_a \sqrt{f'_c} h_{ef}^{5/3} \quad \text{ACI 318-14 Eq. (17.4.2.2b)}$$

Variables

h_{ef} [in.]	$e_{c1,N}$ [in.]	$e_{c2,N}$ [in.]	$c_{a,min}$ [in.]	$\psi_{c,N}$
56	8.544	0.162	∞	1.000
c_{ac} [in.]	k_c	λ_a	f'_c [psi]	
-	16	1.000	4,000	

Calculations

A_{Nc} [in. ²]	A_{Nc0} [in. ²]	$\psi_{ec1,N}$	$\psi_{ec2,N}$	$\psi_{ed,N}$	$\psi_{cp,N}$	N_b [kip]
44795.83	28224	0.85	0.996	1.000	1.000	202.070

Results

N_{cbg} [kip]	$\phi_{concrete}$	ϕN_{cbg} [kip]	N_{ua} [kip]
1966.176	0.700	1376.32	1,287.969

*Please refer excel tool for calculation

ASCE 7 Hazards Report

Address:
No Address at This Location

Standard: ASCE/SEI 7-16
Risk Category: II
Soil Class: D - Default (see Section 11.4.3)

Elevation: 128.26 ft (NAVD 88)
Latitude: 41.360222
Longitude: -72.048639

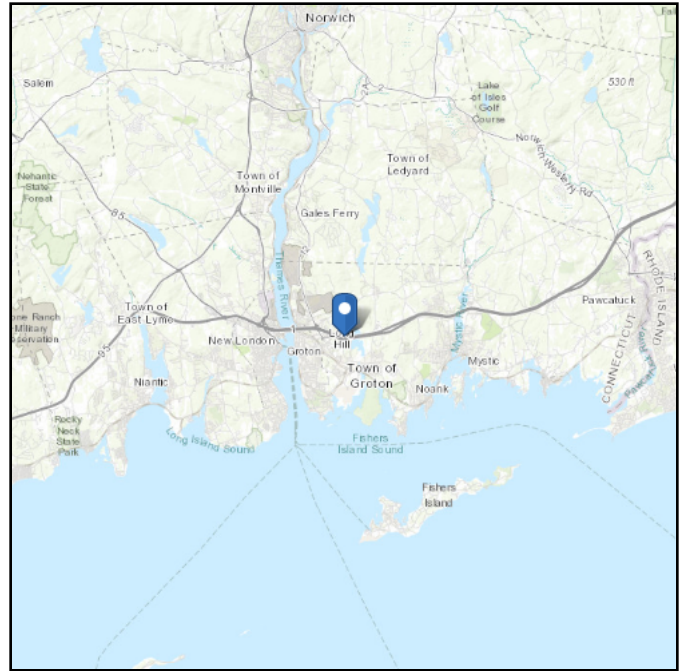
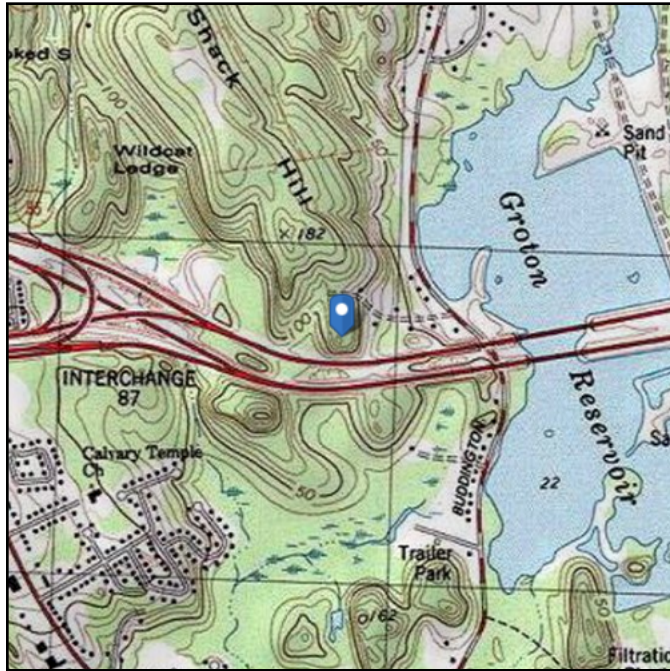

Wind

Results:

Wind Speed:	127 Vmph
10-year MRI	76 Vmph
25-year MRI	86 Vmph
50-year MRI	99 Vmph
100-year MRI	105 Vmph

Data Source: ASCE/SEI 7-16, Fig. 26.5-1B and Figs. CC.2-1–CC.2-4, and Section 26.5.2
Date Accessed: Tue Oct 26 2021

Value provided is 3-second gust wind speeds at 33 ft above ground for Exposure C Category, based on linear interpolation between contours. Wind speeds are interpolated in accordance with the 7-16 Standard. Wind speeds correspond to approximately a 7% probability of exceedance in 50 years (annual exceedance probability = 0.00143, MRI = 700 years).

Site is in a hurricane-prone region as defined in ASCE/SEI 7-16 Section 26.2. Glazed openings need not be protected against wind-borne debris.

Site Soil Class: D - Default (see Section 11.4.3)

Results:

S_s :	0.189	S_{D1} :	0.084
S_1 :	0.052	T_L :	6
F_a :	1.6	PGA :	0.104
F_v :	2.4	PGA _M :	0.165
S_{MS} :	0.302	F_{PGA} :	1.593
S_{M1} :	0.126	I_e :	1
S_{DS} :	0.201	C_v :	0.7

Seismic Design Category B

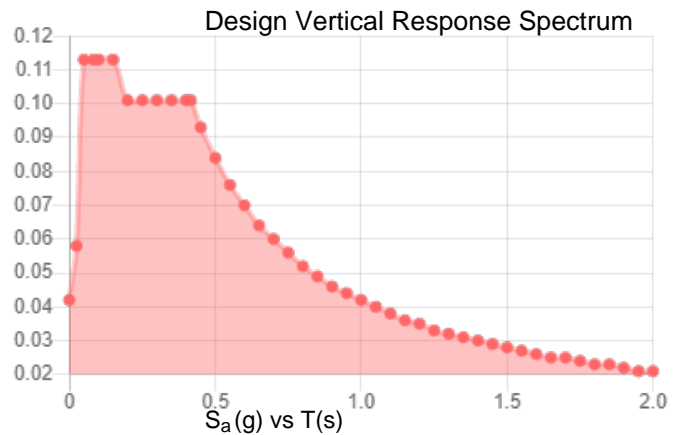
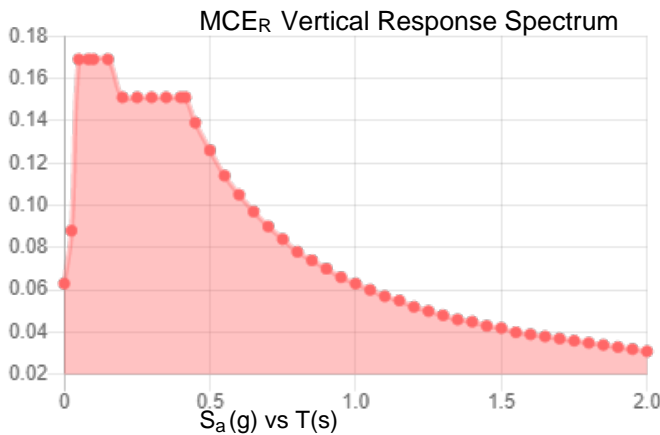
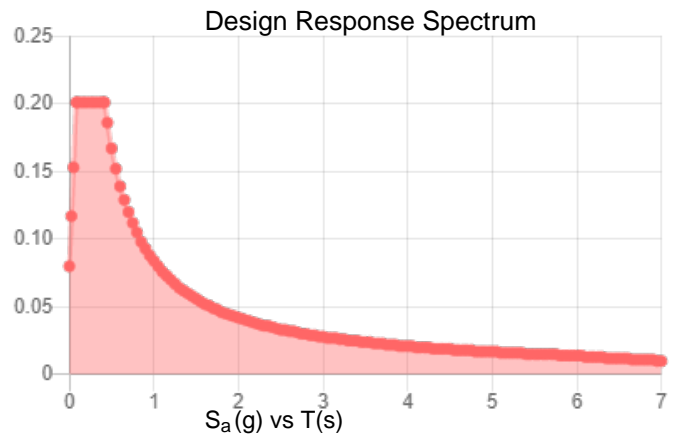
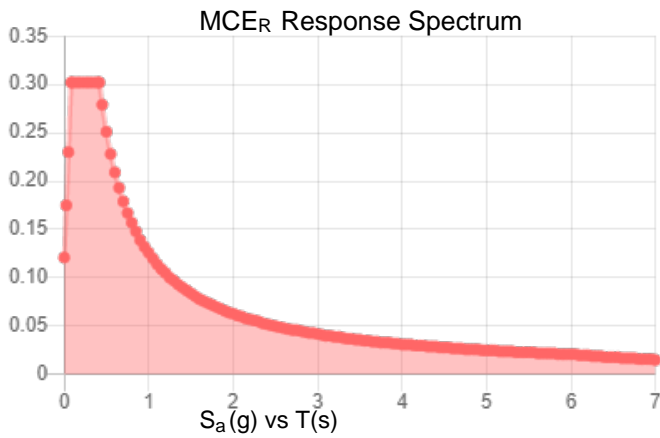

Data Accessed:

Tue Oct 26 2021

Date Source:

USGS Seismic Design Maps based on ASCE/SEI 7-16 and ASCE/SEI 7-16 Table 1.5-2. Additional data for site-specific ground motion procedures in accordance with ASCE/SEI 7-16 Ch. 21 are available from USGS.

Ice

Results:

Ice Thickness: 1.00 in.
Concurrent Temperature: 15 F
Gust Speed: 50 mph

Data Source: Standard ASCE/SEI 7-16, Figs. 10-2 through 10-8

Date Accessed: Tue Oct 26 2021

Ice thicknesses on structures in exposed locations at elevations higher than the surrounding terrain and in valleys and gorges may exceed the mapped values.

Values provided are equivalent radial ice thicknesses due to freezing rain with concurrent 3-second gust speeds, for a 500-year mean recurrence interval, and temperatures concurrent with ice thicknesses due to freezing rain. Thicknesses for ice accretions caused by other sources shall be obtained from local meteorological studies. Ice thicknesses in exposed locations at elevations higher than the surrounding terrain and in valleys and gorges may exceed the mapped values.

The ASCE 7 Hazard Tool is provided for your convenience, for informational purposes only, and is provided “as is” and without warranties of any kind. The location data included herein has been obtained from information developed, produced, and maintained by third party providers; or has been extrapolated from maps incorporated in the ASCE 7 standard. While ASCE has made every effort to use data obtained from reliable sources or methodologies, ASCE does not make any representations or warranties as to the accuracy, completeness, reliability, currency, or quality of any data provided herein. Any third-party links provided by this Tool should not be construed as an endorsement, affiliation, relationship, or sponsorship of such third-party content by or from ASCE.

ASCE does not intend, nor should anyone interpret, the results provided by this Tool to replace the sound judgment of a competent professional, having knowledge and experience in the appropriate field(s) of practice, nor to substitute for the standard of care required of such professionals in interpreting and applying the contents of this Tool or the ASCE 7 standard.

In using this Tool, you expressly assume all risks associated with your use. Under no circumstances shall ASCE or its officers, directors, employees, members, affiliates, or agents be liable to you or any other person for any direct, indirect, special, incidental, or consequential damages arising from or related to your use of, or reliance on, the Tool or any information obtained therein. To the fullest extent permitted by law, you agree to release and hold harmless ASCE from any and all liability of any nature arising out of or resulting from any use of data provided by the ASCE 7 Hazard Tool.

Exhibit E

Mount Analysis

Date: April 6, 2022



Trylon
1825 W. Walnut Hill Lane,
Suite 302
Irving, TX 75038
214-930-1730

Subject: Mount Analysis - Conditional Passing Report

Carrier Designation: DISH Network Equipment Change-Out
Carrier Site Number: BOBOS01000A
Carrier Site Name: --

Crown Castle Designation: **BU Number:** 881533
Site Name: GROTON TOWER
JDE Job Number: 675287
Order Number: 576662 Rev. 4

Engineering Firm Designation: **Trylon Report Designation:** 206811

Site Data: 75 Roberts Road, Groton, New London County, CT, 06340
Latitude 41°21'36.80" Longitude -72°2'55.10"

Structure Information: **Tower Height & Type:** 145.0 ft Monopole
Mount Elevation: 98.0 ft
Mount Width & Type: 8.0 ft Platform

Trylon is pleased to submit this "Mount Analysis - Conditional Passing Report" to determine the structural integrity of DISH Network's antenna mounting system with the proposed appurtenance and equipment addition on the abovementioned supporting tower structure. Analysis of the existing supporting tower structure is to be completed by others and therefore is not part of this analysis. Analysis of the antenna mounting system as a tie-off point for fall protection or rigging is not part of this document.

The purpose of the analysis is to determine acceptability of the mount stress level. Based on our analysis we have determined the mount stress level to be:

Platform

Sufficient*

***Sufficient upon completion of the changes listed in the 'Recommendations' section of this report.**

This analysis utilizes an ultimate 3-second gust wind speed of 135 mph as required by the 2018 Connecticut State Building Code. Applicable Standard references and design criteria are listed in Section 2 - Analysis Criteria.

Mount analysis prepared by: Vladimir Negoita

Respectfully Submitted by:
Cliff Abernathy, P.E.

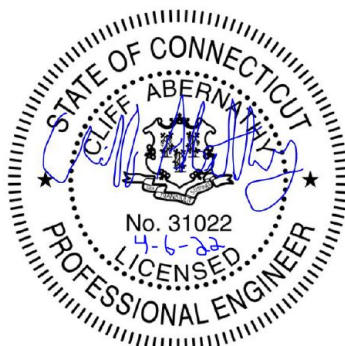

TABLE OF CONTENTS

1) INTRODUCTION

2) ANALYSIS CRITERIA

Table 1 - Proposed Equipment Configuration

3) ANALYSIS PROCEDURE

Table 2 - Documents Provided

3.1) Analysis Method

3.2) Assumptions

4) ANALYSIS RESULTS

Table 3 - Mount Component Stresses vs. Capacity

4.1) Recommendations

5) APPENDIX A

Wire Frame and Rendered Models

6) APPENDIX B

Software Input Calculations

7) APPENDIX C

Software Analysis Output

8) APPENDIX D

Additional Calculations

9) APPENDIX E

Supplemental Drawings

1) INTRODUCTION

This is a proposed 3 sector 8.0 ft Platform, designed by Commscope.

2) ANALYSIS CRITERIA

Building Code:	2015 IBC / 2018 Connecticut State Building Code
TIA-222 Revision:	TIA-222-H
Risk Category:	II
Ultimate Wind Speed:	135 mph
Exposure Category:	C
Topographic Factor at Base:	1.00
Topographic Factor at Mount:	1.00
Ice Thickness:	1.50 in
Wind Speed with Ice:	50 mph
Seismic S_s:	0.160
Seismic S₁:	0.058
Live Loading Wind Speed:	30 mph
Man Live Load at Mid/End-Points:	250 lb
Man Live Load at Mount Pipes:	500 lb

Table 1 - Proposed Equipment Configuration

Mount Centerline (ft)	Antenna Centerline (ft)	Number of Antennas	Antenna Manufacturer	Antenna Model	Mount / Modification Details
98.0	98.0	3	JMA WIRELESS	MX08FRO665-21	8.0 ft Platform [Commscope MC-PK8-DSH]
		3	FUJITSU	TA08025-B604	
		3	FUJITSU	TA08025-B605	
		1	RAYCAP	RDIDC-9181-PF-48	

3) ANALYSIS PROCEDURE

Table 2 - Documents Provided

Document	Remarks	Reference	Source
Crown Application	DISH Network Application	576662 Rev. 4	CCI Sites
Mount Manufacturer Drawings	Commscope	MC-PK8-DSH	Trylon

3.1) Analysis Method

RISA-3D (Version 19), a commercially available analysis software package, was used to create a three-dimensional model of the antenna mounting system and calculate member stresses for various loading cases.

A tool internally developed, using Microsoft Excel, by Trylon was used to calculate wind loading on all appurtenances, dishes, and mount members for various load cases. Selected output from the analysis is included in Appendix B.

This analysis was performed in accordance with Crown Castle's ENG-SOW-10208 *Tower Mount Analysis* (Revision B).

3.2) Assumptions

- 1) The antenna mounting system was properly fabricated, installed and maintained in good condition in accordance with its original design and manufacturer's specifications.
- 2) The configuration of antennas, mounts, and other appurtenances are as specified in Table 1 and the referenced drawings.
- 3) All member connections are assumed to have been designed to meet or exceed the load carrying capacity of the connected member unless otherwise specified in this report.
- 4) The analysis will be required to be revised if the existing conditions in the field differ from those shown in the above-referenced documents or assumed in this analysis. No allowance was made for any damaged, missing, or rusted members.
- 5) Prior structural modifications to the tower mounting system are assumed to be installed as shown per available data.
- 6) Steel grades have been assumed as follows, unless noted otherwise:

Channel, Solid Round, Angle, Plate	ASTM A36 (GR 36)
HSS (Rectangular)	ASTM A500 (GR B-46)
Pipe	ASTM A53 (GR 35)
Connection Bolts	ASTM A325

This analysis may be affected if any assumptions are not valid or have been made in error. Tylon should be notified to determine the effect on the structural integrity of the antenna mounting system.

4) ANALYSIS RESULTS

Table 3 - Mount Component Stresses vs. Capacity (Platform, All Sectors)

Notes	Component	Critical Member	Centerline (ft)	% Capacity	Pass / Fail
1, 2, 3	Mount Pipe(s)	MP4	98.0	59.1	Pass
	Horizontal(s)	H3		18.3	Pass
	Standoff(s)	M2		54.5	Pass
	Bracing(s)	M11		69.5	Pass
	Handrail(s)	M19		37.8	Pass
	Mount Connection(s)	--		23.1	Pass

Structure Rating (max from all components) =	69.5%
---	--------------

Notes:

- 1) See additional documentation in "Appendix C - Software Analysis Output" for calculations supporting the % capacity consumed.
- 2) See additional documentation in "Appendix D – Additional Calculations" for detailed mount connection calculations.
- 3) Rating per TIA-222-H, Section 15.5

4.1) Recommendations

The mount has sufficient capacity to carry the proposed loading configuration. In order for the results of the analysis to be considered valid, the structural modifications listed below must be completed.

1. Installation of a Commscope MC-PK8-DSH

No structural modifications are required at this time, provided that the above-listed changes are implemented.

APPENDIX A
WIRE FRAME AND RENDERED MODELS

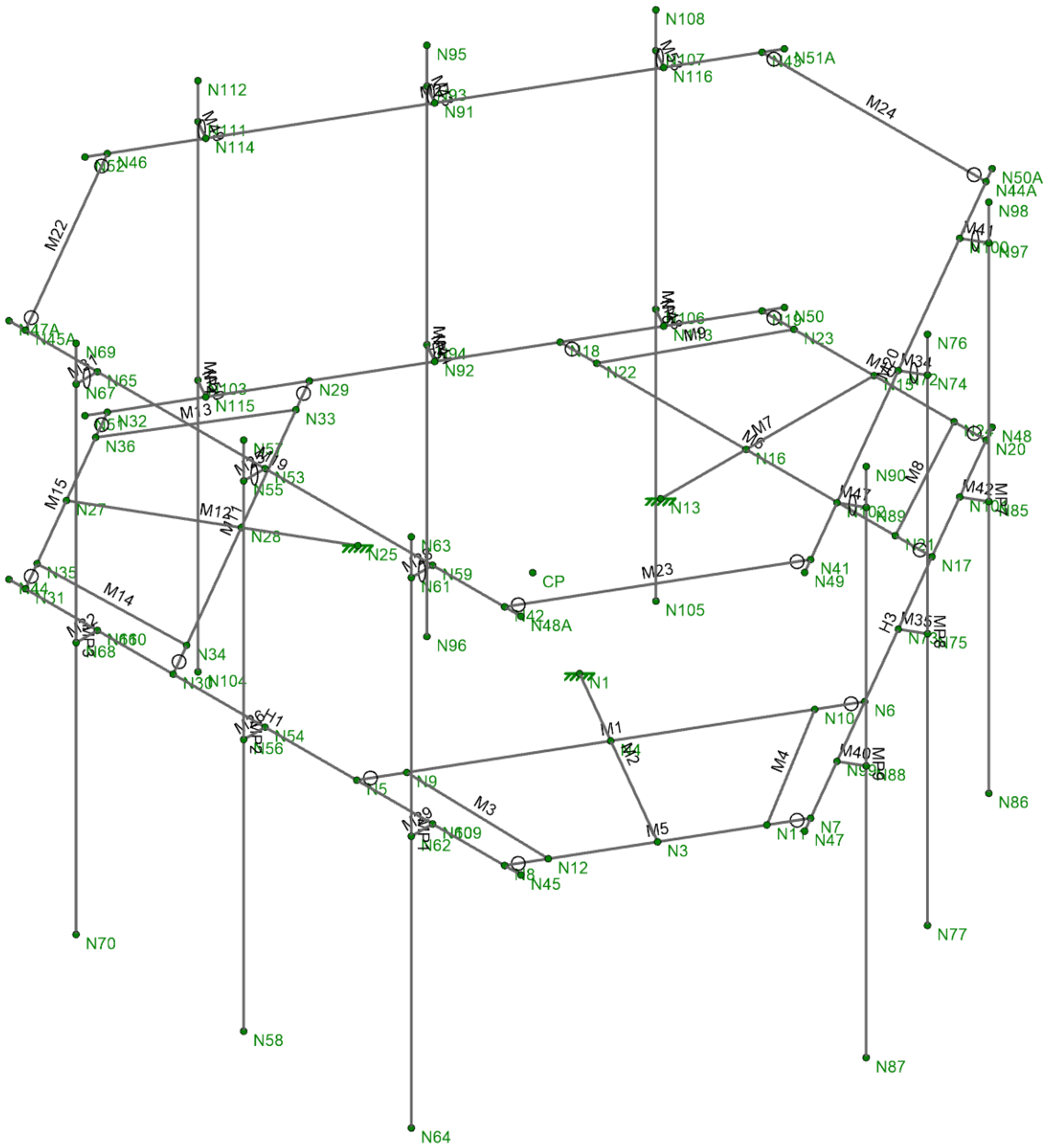

Trylon

VN

206811

881533_576662

SK-1

Apr 06, 2022

881533_576662_MC-PK8-DSH_...



Trylon
VN
206811

881533_576662

SK-2
Apr 06, 2022
881533_576662_MC-PK8-DSH_...

APPENDIX B
SOFTWARE INPUT CALCULATIONS

ASCE 7 Hazards Report

Address:
No Address at This Location

Standard: ASCE/SEI 7-10
Risk Category: II
Soil Class: D - Stiff Soil

Elevation: 128.26 ft (NAVD 88)
Latitude: 41.360222
Longitude: -72.048639

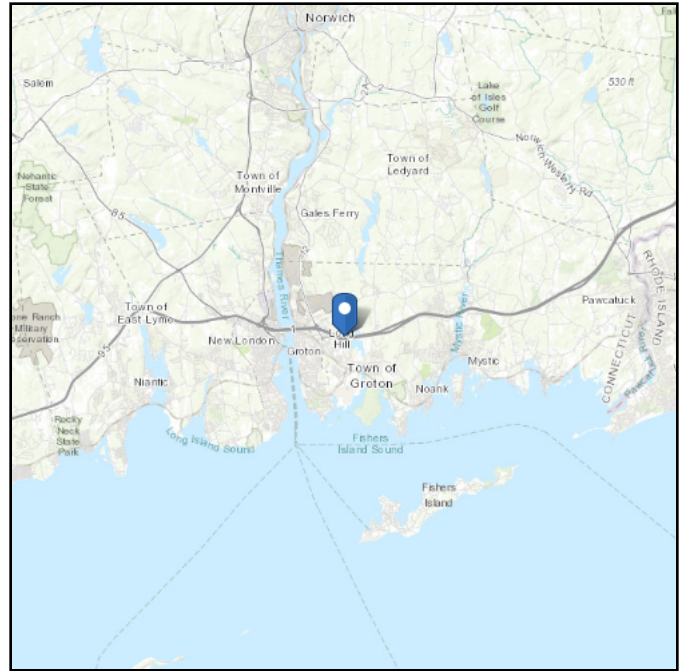
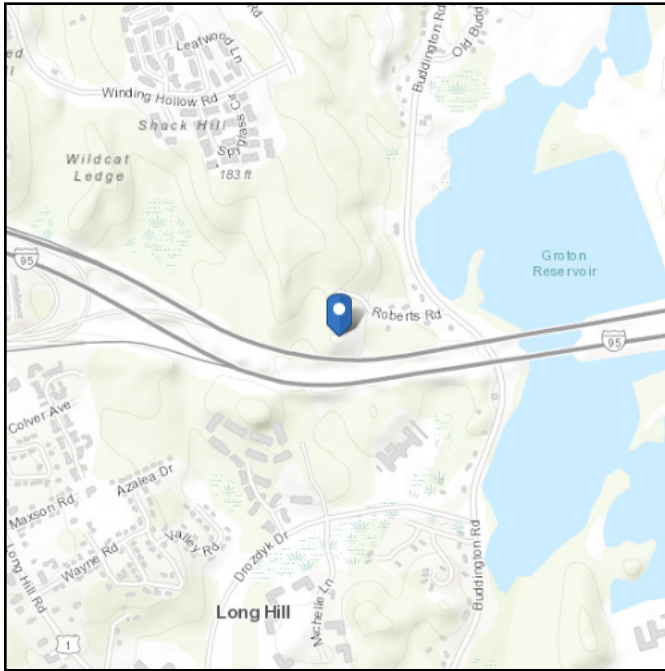

Wind

Results:

Wind Speed	135 Vmph
10-year MRI	80 Vmph
25-year MRI	90 Vmph
50-year MRI	99 Vmph
100-year MRI	109 Vmph

Data Source: ASCE/SEI 7-10, Fig. 26.5-1A and Figs. CC-1–CC-4, and Section 26.5.2, incorporating errata of March 12, 2014

Date Accessed: Wed Apr 06 2022

Value provided is 3-second gust wind speeds at 33 ft above ground for Exposure C Category, based on linear interpolation between contours. Wind speeds are interpolated in accordance with the 7-10 Standard. Wind speeds correspond to approximately a 7% probability of exceedance in 50 years (annual exceedance probability = 0.00143, MRI = 700 years).

Site is in a hurricane-prone region as defined in ASCE/SEI 7-10 Section 26.2. Glazed openings need not be protected against wind-borne debris.

Site Soil Class: D - Stiff Soil

Results:

S_S :	0.16	S_{DS} :	0.171
S_1 :	0.058	S_{D1} :	0.093
F_a :	1.6	T_L :	6
F_v :	2.4	PGA :	0.08
S_{MS} :	0.256	PGA_M :	0.128
S_{M1} :	0.139	F_{PGA} :	1.6
		I_e :	1

Seismic Design Category B

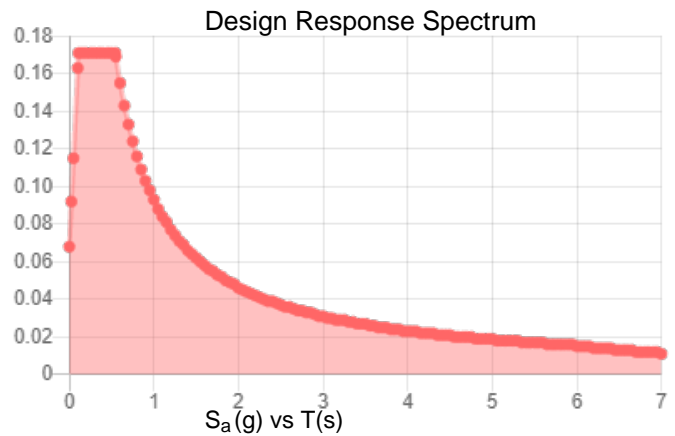
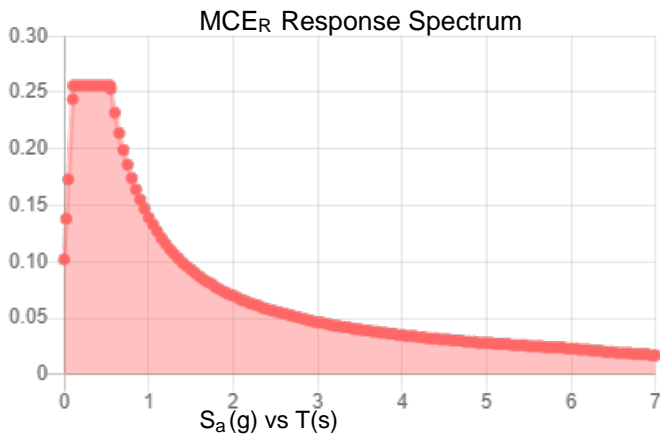

Data Accessed: Wed Apr 06 2022

Date Source:

USGS Seismic Design Maps based on ASCE/SEI 7-10, incorporating Supplement 1 and errata of March 31, 2013, and ASCE/SEI 7-10 Table 1.5-2. Additional data for site-specific ground motion procedures in accordance with ASCE/SEI 7-10 Ch. 21 are available from USGS.

Ice

Results:

Ice Thickness: 0.75 in.
Concurrent Temperature: 15 F
Gust Speed 50 mph

Data Source: Standard ASCE/SEI 7-10, Figs. 10-2 through 10-8

Date Accessed: Wed Apr 06 2022

Ice thicknesses on structures in exposed locations at elevations higher than the surrounding terrain and in valleys and gorges may exceed the mapped values.

Values provided are equivalent radial ice thicknesses due to freezing rain with concurrent 3-second gust speeds, for a 50-year mean recurrence interval, and temperatures concurrent with ice thicknesses due to freezing rain. Thicknesses for ice accretions caused by other sources shall be obtained from local meteorological studies. Ice thicknesses in exposed locations at elevations higher than the surrounding terrain and in valleys and gorges may exceed the mapped values.

The ASCE 7 Hazard Tool is provided for your convenience, for informational purposes only, and is provided “as is” and without warranties of any kind. The location data included herein has been obtained from information developed, produced, and maintained by third party providers; or has been extrapolated from maps incorporated in the ASCE 7 standard. While ASCE has made every effort to use data obtained from reliable sources or methodologies, ASCE does not make any representations or warranties as to the accuracy, completeness, reliability, currency, or quality of any data provided herein. Any third-party links provided by this Tool should not be construed as an endorsement, affiliation, relationship, or sponsorship of such third-party content by or from ASCE.

ASCE does not intend, nor should anyone interpret, the results provided by this Tool to replace the sound judgment of a competent professional, having knowledge and experience in the appropriate field(s) of practice, nor to substitute for the standard of care required of such professionals in interpreting and applying the contents of this Tool or the ASCE 7 standard.

In using this Tool, you expressly assume all risks associated with your use. Under no circumstances shall ASCE or its officers, directors, employees, members, affiliates, or agents be liable to you or any other person for any direct, indirect, special, incidental, or consequential damages arising from or related to your use of, or reliance on, the Tool or any information obtained therein. To the fullest extent permitted by law, you agree to release and hold harmless ASCE from any and all liability of any nature arising out of or resulting from any use of data provided by the ASCE 7 Hazard Tool.



Trylon

1825 W. Walnut Hill Lane Suite 120
Irving, TX 75038

TIA LOAD CALCULATOR 2.2

PROJECT DATA	
Job Code:	206811
Carrier Site ID:	BOBOS01000A
Carrier Site Name:	GROTON TOWER

CODES AND STANDARDS	
Building Code:	2015 IBC
Local Building Code:	0
Design Standard:	TIA-222-H

STRUCTURE DETAILS		
Mount Type:	Platform	--
Mount Elevation:	98.0	ft.
Number of Sectors:	3	--
Structure Type:	Monopole	--
Structure Height:	145.0	ft.

ANALYSIS CRITERIA		
Structure Risk Category:	II	--
Exposure Category:	C	--
Site Class:	D - Default	--
Ground Elevation:	128.26	ft.

TOPOGRAPHIC DATA		
Topographic Category:	1.00	--
Topographic Feature:	N/A	--
Crest Point Elevation:	0.00	ft.
Base Point Elevation:	0.00	ft.
Crest to Mid-Height (L/2):	0.00	ft.
Distance from Crest (x):	0.00	ft.
Base Topo Factor (K_{zt}):	1.00	--
Mount Topo Factor (K_{zt}):	1.00	--

WIND PARAMETERS		
Design Wind Speed:	135	mph
Wind Escalation Factor (K_s):	1.00	--
Velocity Coefficient (K_z):	1.26	--
Directionality Factor (K_d):	0.95	--
Gust Effect Factor (G _h):	1.00	--
Shielding Factor (K_a):	0.90	--
Velocity Pressure (q_z):	55.60	psf
Ground Elevation Factor (K_g):	1.00	--

ICE PARAMETERS		
Design Ice Wind Speed:	50	mph
Design Ice Thickness (t_i):	1.50	in
Importance Factor (I_i):	1.00	--
Ice Velocity Pressure (q_{zi}):	6.75	psf
Mount Ice Thickness (t_{iz}):	1.67	in

WIND STRUCTURE CALCULATIONS		
Flat Member Pressure:	100.08	psf
Round Member Pressure:	60.05	psf
Ice Wind Pressure:	7.29	psf

SEISMIC PARAMETERS		
Importance Factor (I_e):	1.00	--
Short Period Accel. (S_s):	0.16	g
1 Second Accel. (S_1):	0.06	g
Short Period Des. (S_{DS}):	0.17	g
1 Second Des. (S_{D1}):	0.09	g
Short Period Coeff. (F_a):	1.60	--
1 Second Coeff. (F_v):	2.40	--
Response Coefficient (C_s):	0.09	--
Amplification Factor (A_S):	1.20	--

LOAD COMBINATIONS [LRFD]

#	Description
1	1.4DL
2	1.2DL + 1WL 0 AZI
3	1.2DL + 1WL 30 AZI
4	1.2DL + 1WL 45 AZI
5	1.2DL + 1WL 60 AZI
6	1.2DL + 1WL 90 AZI
7	1.2DL + 1WL 120 AZI
8	1.2DL + 1WL 135 AZI
9	1.2DL + 1WL 150 AZI
10	1.2DL + 1WL 180 AZI
11	1.2DL + 1WL 210 AZI
12	1.2DL + 1WL 225 AZI
13	1.2DL + 1WL 240 AZI
14	1.2DL + 1WL 270 AZI
15	1.2DL + 1WL 300 AZI
16	1.2DL + 1WL 315 AZI
17	1.2DL + 1WL 330 AZI
18	0.9DL + 1WL 0 AZI
19	0.9DL + 1WL 30 AZI
20	0.9DL + 1WL 45 AZI
21	0.9DL + 1WL 60 AZI
22	0.9DL + 1WL 90 AZI
23	0.9DL + 1WL 120 AZI
24	0.9DL + 1WL 135 AZI
25	0.9DL + 1WL 150 AZI
26	0.9DL + 1WL 180 AZI
27	0.9DL + 1WL 210 AZI
28	0.9DL + 1WL 225 AZI
29	0.9DL + 1WL 240 AZI
30	0.9DL + 1WL 270 AZI
31	0.9DL + 1WL 300 AZI
32	0.9DL + 1WL 315 AZI
33	0.9DL + 1WL 330 AZI
34	1.2DL + 1DLi + 1WLi 0 AZI
35	1.2DL + 1DLi + 1WLi 30 AZI
36	1.2DL + 1DLi + 1WLi 45 AZI
37	1.2DL + 1DLi + 1WLi 60 AZI
38	1.2DL + 1DLi + 1WLi 90 AZI
39	1.2DL + 1DLi + 1WLi 120 AZI
40	1.2DL + 1DLi + 1WLi 135 AZI
41	1.2DL + 1DLi + 1WLi 150 AZI

#	Description
42	1.2DL + 1DLi + 1WLi 180 AZI
43	1.2DL + 1DLi + 1WLi 210 AZI
44	1.2DL + 1DLi + 1WLi 225 AZI
45	1.2DL + 1DLi + 1WLi 240 AZI
46	1.2DL + 1DLi + 1WLi 270 AZI
47	1.2DL + 1DLi + 1WLi 300 AZI
48	1.2DL + 1DLi + 1WLi 315 AZI
49	1.2DL + 1DLi + 1WLi 330 AZI
50	(1.2+0.2Sds) + 1.0E 0 AZI
51	(1.2+0.2Sds) + 1.0E 30 AZI
52	(1.2+0.2Sds) + 1.0E 45 AZI
53	(1.2+0.2Sds) + 1.0E 60 AZI
54	(1.2+0.2Sds) + 1.0E 90 AZI
55	(1.2+0.2Sds) + 1.0E 120 AZI
56	(1.2+0.2Sds) + 1.0E 135 AZI
57	(1.2+0.2Sds) + 1.0E 150 AZI
58	(1.2+0.2Sds) + 1.0E 180 AZI
59	(1.2+0.2Sds) + 1.0E 210 AZI
60	(1.2+0.2Sds) + 1.0E 225 AZI
61	(1.2+0.2Sds) + 1.0E 240 AZI
62	(1.2+0.2Sds) + 1.0E 270 AZI
63	(1.2+0.2Sds) + 1.0E 300 AZI
64	(1.2+0.2Sds) + 1.0E 315 AZI
65	(1.2+0.2Sds) + 1.0E 330 AZI
66	(0.9-0.2Sds) + 1.0E 0 AZI
67	(0.9-0.2Sds) + 1.0E 30 AZI
68	(0.9-0.2Sds) + 1.0E 45 AZI
69	(0.9-0.2Sds) + 1.0E 60 AZI
70	(0.9-0.2Sds) + 1.0E 90 AZI
71	(0.9-0.2Sds) + 1.0E 120 AZI
72	(0.9-0.2Sds) + 1.0E 135 AZI
73	(0.9-0.2Sds) + 1.0E 150 AZI
74	(0.9-0.2Sds) + 1.0E 180 AZI
75	(0.9-0.2Sds) + 1.0E 210 AZI
76	(0.9-0.2Sds) + 1.0E 225 AZI
77	(0.9-0.2Sds) + 1.0E 240 AZI
78	(0.9-0.2Sds) + 1.0E 270 AZI
79	(0.9-0.2Sds) + 1.0E 300 AZI
80	(0.9-0.2Sds) + 1.0E 315 AZI
81	(0.9-0.2Sds) + 1.0E 330 AZI
82-88	1.2D + 1.5 Lv1

#	Description
89	1.2D + 1.5Lm + 1.0Wm 0 AZI - MP1
90	1.2D + 1.5Lm + 1.0Wm 30 AZI - MP1
91	1.2D + 1.5Lm + 1.0Wm 45 AZI - MP1
92	1.2D + 1.5Lm + 1.0Wm 60 AZI - MP1
93	1.2D + 1.5Lm + 1.0Wm 90 AZI - MP1
94	1.2D + 1.5Lm + 1.0Wm 120 AZI - MP1
95	1.2D + 1.5Lm + 1.0Wm 135 AZI - MP1
96	1.2D + 1.5Lm + 1.0Wm 150 AZI - MP1
97	1.2D + 1.5Lm + 1.0Wm 180 AZI - MP1
98	1.2D + 1.5Lm + 1.0Wm 210 AZI - MP1
99	1.2D + 1.5Lm + 1.0Wm 225 AZI - MP1
100	1.2D + 1.5Lm + 1.0Wm 240 AZI - MP1
101	1.2D + 1.5Lm + 1.0Wm 270 AZI - MP1
102	1.2D + 1.5Lm + 1.0Wm 300 AZI - MP1
103	1.2D + 1.5Lm + 1.0Wm 315 AZI - MP1
104	1.2D + 1.5Lm + 1.0Wm 330 AZI - MP1
105	1.2D + 1.5Lm + 1.0Wm 0 AZI - MP2
106	1.2D + 1.5Lm + 1.0Wm 30 AZI - MP2
107	1.2D + 1.5Lm + 1.0Wm 45 AZI - MP2
108	1.2D + 1.5Lm + 1.0Wm 60 AZI - MP2
109	1.2D + 1.5Lm + 1.0Wm 90 AZI - MP2
110	1.2D + 1.5Lm + 1.0Wm 120 AZI - MP2
111	1.2D + 1.5Lm + 1.0Wm 135 AZI - MP2
112	1.2D + 1.5Lm + 1.0Wm 150 AZI - MP2
113	1.2D + 1.5Lm + 1.0Wm 180 AZI - MP2
114	1.2D + 1.5Lm + 1.0Wm 210 AZI - MP2
115	1.2D + 1.5Lm + 1.0Wm 225 AZI - MP2
116	1.2D + 1.5Lm + 1.0Wm 240 AZI - MP2
117	1.2D + 1.5Lm + 1.0Wm 270 AZI - MP2
118	1.2D + 1.5Lm + 1.0Wm 300 AZI - MP2
119	1.2D + 1.5Lm + 1.0Wm 315 AZI - MP2
120	1.2D + 1.5Lm + 1.0Wm 330 AZI - MP2

#	Description
121	1.2D + 1.5Lm + 1.0Wm 0 AZI - MP3
122	1.2D + 1.5Lm + 1.0Wm 30 AZI - MP3
123	1.2D + 1.5Lm + 1.0Wm 45 AZI - MP3
124	1.2D + 1.5Lm + 1.0Wm 60 AZI - MP3
125	1.2D + 1.5Lm + 1.0Wm 90 AZI - MP3
126	1.2D + 1.5Lm + 1.0Wm 120 AZI - MP3
127	1.2D + 1.5Lm + 1.0Wm 135 AZI - MP3
128	1.2D + 1.5Lm + 1.0Wm 150 AZI - MP3
129	1.2D + 1.5Lm + 1.0Wm 180 AZI - MP3
130	1.2D + 1.5Lm + 1.0Wm 210 AZI - MP3
131	1.2D + 1.5Lm + 1.0Wm 225 AZI - MP3
132	1.2D + 1.5Lm + 1.0Wm 240 AZI - MP3
133	1.2D + 1.5Lm + 1.0Wm 270 AZI - MP3
134	1.2D + 1.5Lm + 1.0Wm 300 AZI - MP3
135	1.2D + 1.5Lm + 1.0Wm 315 AZI - MP3
136	1.2D + 1.5Lm + 1.0Wm 330 AZI - MP3
137	1.2D + 1.5Lm + 1.0Wm 0 AZI - MP4
138	1.2D + 1.5Lm + 1.0Wm 30 AZI - MP4
139	1.2D + 1.5Lm + 1.0Wm 45 AZI - MP4
140	1.2D + 1.5Lm + 1.0Wm 60 AZI - MP4
141	1.2D + 1.5Lm + 1.0Wm 90 AZI - MP4
142	1.2D + 1.5Lm + 1.0Wm 120 AZI - MP4
143	1.2D + 1.5Lm + 1.0Wm 135 AZI - MP4
144	1.2D + 1.5Lm + 1.0Wm 150 AZI - MP4
145	1.2D + 1.5Lm + 1.0Wm 180 AZI - MP4
146	1.2D + 1.5Lm + 1.0Wm 210 AZI - MP4
147	1.2D + 1.5Lm + 1.0Wm 225 AZI - MP4
148	1.2D + 1.5Lm + 1.0Wm 240 AZI - MP4
149	1.2D + 1.5Lm + 1.0Wm 270 AZI - MP4
150	1.2D + 1.5Lm + 1.0Wm 300 AZI - MP4
151	1.2D + 1.5Lm + 1.0Wm 315 AZI - MP4
152	1.2D + 1.5Lm + 1.0Wm 330 AZI - MP4

*This page shows an example of maintenance loads for (4) pipes, the number of mount pipe LCs may vary per site

ELEVATION VIEW

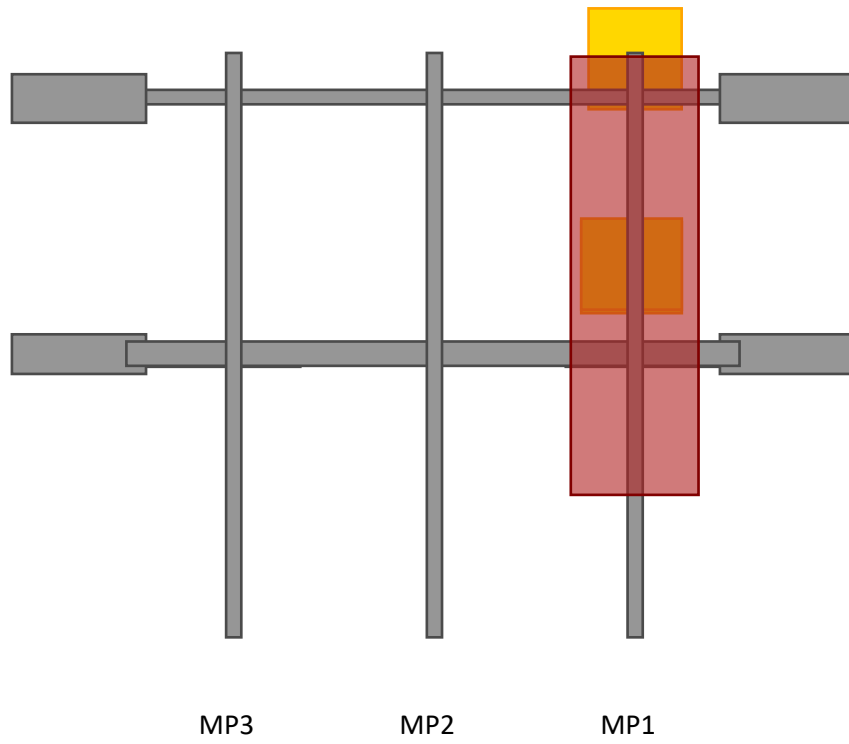

*Elevation View Shows Only One Sector

PLAN VIEW

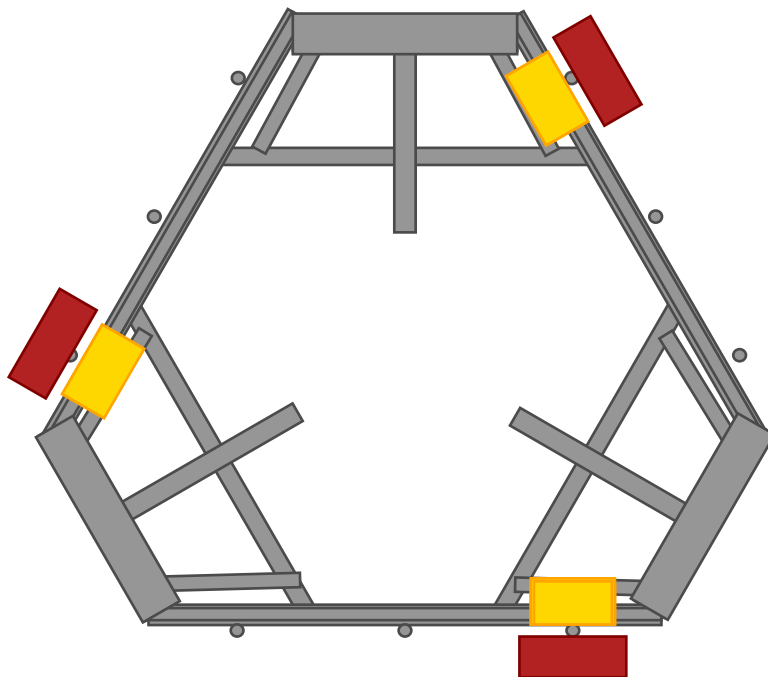

APPENDIX C
SOFTWARE ANALYSIS OUTPUT

Model Settings

Solution

Members

Number of Reported Sections	5
Number of Internal Sections	100
Member Area Load Mesh Size (in ²)	144
Consider Shear Deformation	Yes
Consider Torsional Warping	Yes

Wall Panels

Approximate Mesh Size (in)	24
Transfer Forces Between Intersecting Wood Walls	Yes
Increase Wood Wall Nailing Capacity for Wind Loads	Yes
Include P-Delta for Walls	Yes
Optimize Masonry and Wood Walls	Yes
Maximum Number of Iterations	3

Processor Core Utilization

Single	No
Multiple (Optimum)	Yes
Maximum	No

Axis

Vertical Global Axis

Global Axis corresponding to vertical direction	Y
Convert Existing Data	Yes

Default Member Orientation

Default Global Plane for z-axis	XZ
---------------------------------	----

Plate Axis

Plate Local Axis Orientation	Nodal
------------------------------	-------

Codes

Hot Rolled Steel	AISC 14th (360-10): LRFD
Stiffness Adjustment	Yes (Iterative)
Notional Annex	None
Connections	AISC 14th (360-10): LRFD
Cold Formed Steel	AISI S100-12: LRFD
Stiffness Adjustment	Yes (Iterative)
Wood	None
Temperature	< 100F
Concrete	None
Masonry	None
Aluminum	None
Structure Type	Building
Stiffness Adjustment	Yes (Iterative)
Stainless	AISC 14th (360-10): LRFD
Stiffness Adjustment	Yes (Iterative)

Concrete

Compression Stress Block	Rectangular Stress Block
Analyze using Cracked Sections	Yes
Leave room for horizontal rebar splices (2*d bar spacing)	No

Model Settings (Continued)

List forces which were ignored for design in the Detail Report	Yes
--	-----

Rebar

Column Min Steel	1
Column Max Steel	8
Rebar Material Spec	ASTM A615
Warn if beam-column framing arrangement is not understood	No

Shear Reinforcement

Number of Shear Regions	4
Region 2 & 3 Spacing Increase Increment (in)	4

Seismic

RISA-3D Seismic Load Options

Code	ASCE 7-10
Risk Category	I or II
Drift Cat	Other
Base Elevation (ft)	
Include the weight of the structure in base shear calcs	Yes

Site Parameters

S_1 (g)	1
SD_1 (g)	1
SD_s (g)	1
T_1 (sec)	5

Structure Characteristics

T Z (sec)	
T X (sec)	
C_x	0.02
$C_{Exp. Z}$	0.75
$C_{Exp. X}$	0.75
R Z	3
R X	3
Ω_z	1
Ω_x	1
$C_d Z$	1
$C_d X$	1
ρZ	1
ρX	1

Hot Rolled Steel Properties

	Label	E [ksi]	G [ksi]	Nu	Therm. Coeff. [$1e^{50}F^{-1}$]	Density [k/ft ³]	Yield [ksi]	Ry	Fu [ksi]	Rt
1	A992	29000	11154	0.3	0.65	0.49	50	1.1	65	1.1
2	A36 Gr.36	29000	11154	0.3	0.65	0.49	36	1.5	58	1.2
3	A572 Gr.50	29000	11154	0.3	0.65	0.49	50	1.1	65	1.1
4	A500 Gr.B RND	29000	11154	0.3	0.65	0.527	42	1.4	58	1.3
5	A500 Gr.B Rect	29000	11154	0.3	0.65	0.527	46	1.4	58	1.3
6	A53 Gr.B	29000	11154	0.3	0.65	0.49	35	1.6	60	1.2
7	A1085	29000	11154	0.3	0.65	0.49	50	1.4	65	1.3

Cold Formed Steel Properties

	Label	E [ksi]	G [ksi]	Nu	Therm. Coeff. [$1e^{50}F^{-1}$]	Density [k/ft ³]	Yield [ksi]	Fu [ksi]
1	A653 SS Gr33	29500	11346	0.3	0.65	0.49	33	45
2	A653 SS Gr50/1	29500	11346	0.3	0.65	0.49	50	65

Hot Rolled Steel Section Sets

	Label	Shape	Type	Design List	Material	Design Rule	Area [in ²]	Iyy [in ⁴]	Izz [in ⁴]	J [in ⁴]
1	Plates	6.5"x0.37" Plate	Beam	RECT	A53 Gr.B	Typical	2.405	0.027	8.468	0.106
2	Grating Bracing	L2x2x3	Beam	Single Angle	A36 Gr.36	Typical	0.722	0.271	0.271	0.009
3	Standoffs	PIPE 3.5	Beam	Pipe	A53 Gr.B	Typical	2.5	4.52	4.52	9.04
4	Standoff Bracing	C3X5	Beam	Channel	A36 Gr.36	Typical	1.47	0.241	1.85	0.043
5	Handrails	PIPE 2.0	Beam	Pipe	A53 Gr.B	Typical	1.02	0.627	0.627	1.25
6	Handrail Corners	L6 5/8x4 7/16x3/16	Beam	Single Angle	A36 Gr.36	Typical	2.039	3.593	9.575	0.023
7	Horizontalts	PIPE 3.5	Beam	Pipe	A53 Gr.B	Typical	2.5	4.52	4.52	9.04
8	Mount Pipes	PIPE 2.0	Beam	Pipe	A53 Gr.B	Typical	1.02	0.627	0.627	1.25

Cold Formed Steel Section Sets

	Label	Shape	Type	Design List	Material	Design Rule	Area [in ²]	Iyy [in ⁴]	Izz [in ⁴]	J [in ⁴]
1	CF1A	8CU1.25X057	Beam	None	A653 SS Gr33	Typical	0.581	0.057	4.41	0.00063

Node Boundary Conditions

	Node Label	X [k/in]	Y [k/in]	Z [k/in]	X Rot [k-ft/rad]	Y Rot [k-ft/rad]	Z Rot [k-ft/rad]
1	N25	Reaction	Reaction	Reaction	Reaction	Reaction	Reaction
2	N1	Reaction	Reaction	Reaction	Reaction	Reaction	Reaction
3	N13	Reaction	Reaction	Reaction	Reaction	Reaction	Reaction

Basic Load Cases

	BLC Description	Category	X Gravity	Y Gravity	Z Gravity	Point	Distributed	Area(Member)
1	Self Weight	DL		-1		13		3
2	Structure Wind Z	WLZ					51	
3	Structure Wind X	WLX					51	
4	Wind Load 0 AZI	WLZ				26		
5	Wind Load 30 AZI	None				26		
6	Wind Load 45 AZI	None				26		
7	Wind Load 60 AZI	None				26		
8	Wind Load 90 AZI	WLX				26		
9	Wind Load 120 AZI	None				26		
10	Wind Load 135 AZI	None				26		
11	Wind Load 150 AZI	None				26		
12	Ice Weight	OL1				13	51	3

Basic Load Cases (Continued)

	BLC Description	Category	X Gravity	Y Gravity	Z Gravity	Point	Distributed	Area(Member)
13	Ice Structure Wind Z	OL2					51	
14	Ice Structure Wind X	OL3					51	
15	Ice Wind Load 0 AZI	OL2				26		
16	Ice Wind Load 30 AZI	None				26		
17	Ice Wind Load 45 AZI	None				26		
18	Ice Wind Load 60 AZI	None				26		
19	Ice Wind Load 90 AZI	OL3				26		
20	Ice Wind Load 120 AZI	None				26		
21	Ice Wind Load 135 AZI	None				26		
22	Ice Wind Load 150 AZI	None				26		
23	Seismic Load Z	ELZ			-0.102	13		
24	Seismic Load X	ELX	-0.102			13		
25	Live Load 1 (Lv)	None				1		
26	Live Load 2 (Lv)	None				1		
27	Live Load 3 (Lv)	None				1		
28	Live Load 4 (Lv)	None				1		
29	Live Load 5 (Lv)	None				1		
30	Live Load 6 (Lv)	None				1		
31	Live Load 7 (Lv)	None				1		
32	Live Load 8 (Lv)	None				1		
33	Live Load 9 (Lv)	None				1		
34	Maintenance Load 1 (Lm)	None				1		
35	Maintenance Load 2 (Lm)	None				1		
36	Maintenance Load 3 (Lm)	None				1		
37	Maintenance Load 4 (Lm)	None				1		
38	Maintenance Load 5 (Lm)	None				1		
39	Maintenance Load 6 (Lm)	None				1		
40	Maintenance Load 7 (Lm)	None				1		
41	Maintenance Load 8 (Lm)	None				1		
42	Maintenance Load 9 (Lm)	None				1		
43	BLC 1 Transient Area Loads	None					9	
44	BLC 12 Transient Area Loads	None					9	

Load Combinations

	Description	Solve	P-Delta	BLC	Factor	BLC	Factor	BLC	Factor	BLC	Factor	BLC	Factor
1	1.4DL	Yes	Y	DL	1.4								
2	1.2DL + 1WL 0 AZI	Yes	Y	DL	1.2	2	1	3		4	1		
3	1.2DL + 1WL 30 AZI	Yes	Y	DL	1.2	2	0.866	3	0.5	5	1		
4	1.2DL + 1WL 45 AZI	Yes	Y	DL	1.2	2	0.707	3	0.707	6	1		
5	1.2DL + 1WL 60 AZI	Yes	Y	DL	1.2	2	0.5	3	0.866	7	1		
6	1.2DL + 1WL 90 AZI	Yes	Y	DL	1.2	2		3	1	8	1		
7	1.2DL + 1WL 120 AZI	Yes	Y	DL	1.2	2	-0.5	3	0.866	9	1		
8	1.2DL + 1WL 135 AZI	Yes	Y	DL	1.2	2	-0.707	3	0.707	10	1		
9	1.2DL + 1WL 150 AZI	Yes	Y	DL	1.2	2	-0.866	3	0.5	11	1		
10	1.2DL + 1WL 180 AZI	Yes	Y	DL	1.2	2	-1	3		4	-1		
11	1.2DL + 1WL 210 AZI	Yes	Y	DL	1.2	2	-0.866	3	-0.5	5	-1		
12	1.2DL + 1WL 225 AZI	Yes	Y	DL	1.2	2	-0.707	3	-0.707	6	-1		
13	1.2DL + 1WL 240 AZI	Yes	Y	DL	1.2	2	-0.5	3	-0.866	7	-1		
14	1.2DL + 1WL 270 AZI	Yes	Y	DL	1.2	2		3	-1	8	-1		
15	1.2DL + 1WL 300 AZI	Yes	Y	DL	1.2	2	0.5	3	-0.866	9	-1		
16	1.2DL + 1WL 315 AZI	Yes	Y	DL	1.2	2	0.707	3	-0.707	10	-1		
17	1.2DL + 1WL 330 AZI	Yes	Y	DL	1.2	2	0.866	3	-0.5	11	-1		
18	0.9DL + 1WL 0 AZI	Yes	Y	DL	0.9	2	1	3		4	1		
19	0.9DL + 1WL 30 AZI	Yes	Y	DL	0.9	2	0.866	3	0.5	5	1		
20	0.9DL + 1WL 45 AZI	Yes	Y	DL	0.9	2	0.707	3	0.707	6	1		

Load Combinations (Continued)

	Description	Solve	P-Delta	BLC	Factor	BLC	Factor	BLC	Factor	BLC	Factor	BLC	Factor
21	0.9DL + 1WL 60 AZI	Yes	Y	DL	0.9	2	0.5	3	0.866	7	1		
22	0.9DL + 1WL 90 AZI	Yes	Y	DL	0.9	2		3	1	8	1		
23	0.9DL + 1WL 120 AZI	Yes	Y	DL	0.9	2	-0.5	3	0.866	9	1		
24	0.9DL + 1WL 135 AZI	Yes	Y	DL	0.9	2	-0.707	3	0.707	10	1		
25	0.9DL + 1WL 150 AZI	Yes	Y	DL	0.9	2	-0.866	3	0.5	11	1		
26	0.9DL + 1WL 180 AZI	Yes	Y	DL	0.9	2	-1	3		4	-1		
27	0.9DL + 1WL 210 AZI	Yes	Y	DL	0.9	2	-0.866	3	-0.5	5	-1		
28	0.9DL + 1WL 225 AZI	Yes	Y	DL	0.9	2	-0.707	3	-0.707	6	-1		
29	0.9DL + 1WL 240 AZI	Yes	Y	DL	0.9	2	-0.5	3	-0.866	7	-1		
30	0.9DL + 1WL 270 AZI	Yes	Y	DL	0.9	2		3	-1	8	-1		
31	0.9DL + 1WL 300 AZI	Yes	Y	DL	0.9	2	0.5	3	-0.866	9	-1		
32	0.9DL + 1WL 315 AZI	Yes	Y	DL	0.9	2	0.707	3	-0.707	10	-1		
33	0.9DL + 1WL 330 AZI	Yes	Y	DL	0.9	2	0.866	3	-0.5	11	-1		
34	1.2DL + 1DLi + 1WLi 0 AZI	Yes	Y	DL	1.2	OL1	1	13	1	14		15	1
35	1.2DL + 1DLi + 1WLi 30 AZI	Yes	Y	DL	1.2	OL1	1	13	0.866	14	0.5	16	1
36	1.2DL + 1DLi + 1WLi 45 AZI	Yes	Y	DL	1.2	OL1	1	13	0.707	14	0.707	17	1
37	1.2DL + 1DLi + 1WLi 60 AZI	Yes	Y	DL	1.2	OL1	1	13	0.5	14	0.866	18	1
38	1.2DL + 1DLi + 1WLi 90 AZI	Yes	Y	DL	1.2	OL1	1	13		14	1	19	1
39	1.2DL + 1DLi + 1WLi 120 AZI	Yes	Y	DL	1.2	OL1	1	13	-0.5	14	0.866	20	1
40	1.2DL + 1DLi + 1WLi 135 AZI	Yes	Y	DL	1.2	OL1	1	13	-0.707	14	0.707	21	1
41	1.2DL + 1DLi + 1WLi 150 AZI	Yes	Y	DL	1.2	OL1	1	13	-0.866	14	0.5	22	1
42	1.2DL + 1DLi + 1WLi 180 AZI	Yes	Y	DL	1.2	OL1	1	13	-1	14		15	-1
43	1.2DL + 1DLi + 1WLi 210 AZI	Yes	Y	DL	1.2	OL1	1	13	-0.866	14	-0.5	16	-1
44	1.2DL + 1DLi + 1WLi 225 AZI	Yes	Y	DL	1.2	OL1	1	13	-0.707	14	-0.707	17	-1
45	1.2DL + 1DLi + 1WLi 240 AZI	Yes	Y	DL	1.2	OL1	1	13	-0.5	14	-0.866	18	-1
46	1.2DL + 1DLi + 1WLi 270 AZI	Yes	Y	DL	1.2	OL1	1	13		14	-1	19	-1
47	1.2DL + 1DLi + 1WLi 300 AZI	Yes	Y	DL	1.2	OL1	1	13	0.5	14	-0.866	20	-1
48	1.2DL + 1DLi + 1WLi 315 AZI	Yes	Y	DL	1.2	OL1	1	13	0.707	14	-0.707	21	-1
49	1.2DL + 1DLi + 1WLi 330 AZI	Yes	Y	DL	1.2	OL1	1	13	0.866	14	-0.5	22	-1
50	(1.2+0.2Sds)DL + 1E 0 AZI	Yes	Y	DL	1.234	23	1	24					
51	(1.2+0.2Sds)DL + 1E 30 AZI	Yes	Y	DL	1.234	23	0.866	24	0.5				
52	(1.2+0.2Sds)DL + 1E 45 AZI	Yes	Y	DL	1.234	23	0.707	24	0.707				
53	(1.2+0.2Sds)DL + 1E 60 AZI	Yes	Y	DL	1.234	23	0.5	24	0.866				
54	(1.2+0.2Sds)DL + 1E 90 AZI	Yes	Y	DL	1.234	23		24	1				
55	(1.2+0.2Sds)DL + 1E 120 AZI	Yes	Y	DL	1.234	23	-0.5	24	0.866				
56	(1.2+0.2Sds)DL + 1E 135 AZI	Yes	Y	DL	1.234	23	-0.707	24	0.707				
57	(1.2+0.2Sds)DL + 1E 150 AZI	Yes	Y	DL	1.234	23	-0.866	24	0.5				
58	(1.2+0.2Sds)DL + 1E 180 AZI	Yes	Y	DL	1.234	23	-1	24					
59	(1.2+0.2Sds)DL + 1E 210 AZI	Yes	Y	DL	1.234	23	-0.866	24	-0.5				
60	(1.2+0.2Sds)DL + 1E 225 AZI	Yes	Y	DL	1.234	23	-0.707	24	-0.707				
61	(1.2+0.2Sds)DL + 1E 240 AZI	Yes	Y	DL	1.234	23	-0.5	24	-0.866				
62	(1.2+0.2Sds)DL + 1E 270 AZI	Yes	Y	DL	1.234	23		24	-1				
63	(1.2+0.2Sds)DL + 1E 300 AZI	Yes	Y	DL	1.234	23	0.5	24	-0.866				
64	(1.2+0.2Sds)DL + 1E 315 AZI	Yes	Y	DL	1.234	23	0.707	24	-0.707				
65	(1.2+0.2Sds)DL + 1E 330 AZI	Yes	Y	DL	1.234	23	0.866	24	-0.5				
66	(0.9-0.2Sds)DL + 1E 0 AZI	Yes	Y	DL	0.866	23	1	24					
67	(0.9-0.2Sds)DL + 1E 30 AZI	Yes	Y	DL	0.866	23	0.866	24	0.5				
68	(0.9-0.2Sds)DL + 1E 45 AZI	Yes	Y	DL	0.866	23	0.707	24	0.707				
69	(0.9-0.2Sds)DL + 1E 60 AZI	Yes	Y	DL	0.866	23	0.5	24	0.866				
70	(0.9-0.2Sds)DL + 1E 90 AZI	Yes	Y	DL	0.866	23		24	1				
71	(0.9-0.2Sds)DL + 1E 120 AZI	Yes	Y	DL	0.866	23	-0.5	24	0.866				
72	(0.9-0.2Sds)DL + 1E 135 AZI	Yes	Y	DL	0.866	23	-0.707	24	0.707				
73	(0.9-0.2Sds)DL + 1E 150 AZI	Yes	Y	DL	0.866	23	-0.866	24	0.5				
74	(0.9-0.2Sds)DL + 1E 180 AZI	Yes	Y	DL	0.866	23	-1	24					
75	(0.9-0.2Sds)DL + 1E 210 AZI	Yes	Y	DL	0.866	23	-0.866	24	-0.5				

Load Combinations (Continued)

	Description	Solve	P-Delta	BLC	Factor	BLC	Factor	BLC	Factor	BLC	Factor	BLC	Factor
76	(0.9-0.2Sds)DL + 1E 225 AZI	Yes	Y	DL	0.866	23	-0.707	24	-0.707				
77	(0.9-0.2Sds)DL + 1E 240 AZI	Yes	Y	DL	0.866	23	-0.5	24	-0.866				
78	(0.9-0.2Sds)DL + 1E 270 AZI	Yes	Y	DL	0.866	23		24	-1				
79	(0.9-0.2Sds)DL + 1E 300 AZI	Yes	Y	DL	0.866	23	0.5	24	-0.866				
80	(0.9-0.2Sds)DL + 1E 315 AZI	Yes	Y	DL	0.866	23	0.707	24	-0.707				
81	(0.9-0.2Sds)DL + 1E 330 AZI	Yes	Y	DL	0.866	23	0.866	24	-0.5				
82	1.2DL + 1Lv1	Yes	Y	DL	1.2	25	1.5						
83	1.2DL + 1Lv2	Yes	Y	DL	1.2	26	1.5						
84	1.2DL + 1Lv3	Yes	Y	DL	1.2	27	1.5						
85	1.2DL + 1Lv4	Yes	Y	DL	1.2	28	1.5						
86	1.2DL + 1Lv5	Yes	Y	DL	1.2	29	1.5						
87	1.2DL + 1Lv6	Yes	Y	DL	1.2	30	1.5						
88	1.2DL + 1Lv7	Yes	Y	DL	1.2	31	1.5						
89	1.2DL + 1Lv8	Yes	Y	DL	1.2	32	1.5						
90	1.2DL + 1Lv9	Yes	Y	DL	1.2	33	1.5						
91	1.2DL + 1.5Lm + 1Wm 0 AZI - MP2	Yes	Y	DL	1.2	34	1.5	2	0.049	3		4	0.049
92	1.2DL + 1.5Lm + 1Wm 30 AZI - MP2	Yes	Y	DL	1.2	34	1.5	2	0.043	3	0.025	5	0.049
93	1.2DL + 1.5Lm + 1Wm 45 AZI - MP2	Yes	Y	DL	1.2	34	1.5	2	0.035	3	0.035	6	0.049
94	1.2DL + 1.5Lm + 1Wm 60 AZI - MP2	Yes	Y	DL	1.2	34	1.5	2	0.025	3	0.043	7	0.049
95	1.2DL + 1.5Lm + 1Wm 90 AZI - MP2	Yes	Y	DL	1.2	34	1.5	2		3	0.049	8	0.049
96	1.2DL + 1.5Lm + 1Wm 120 AZI - MP2	Yes	Y	DL	1.2	34	1.5	2	-0.025	3	0.043	9	0.049
97	1.2DL + 1.5Lm + 1Wm 135 AZI - MP2	Yes	Y	DL	1.2	34	1.5	2	-0.035	3	0.035	10	0.049
98	1.2DL + 1.5Lm + 1Wm 150 AZI - MP2	Yes	Y	DL	1.2	34	1.5	2	-0.043	3	0.025	11	0.049
99	1.2DL + 1.5Lm + 1Wm 180 AZI - MP2	Yes	Y	DL	1.2	34	1.5	2	-0.049	3		4	-0.049
100	1.2DL + 1.5Lm + 1Wm 210 AZI - MP2	Yes	Y	DL	1.2	34	1.5	2	-0.043	3	-0.025	5	-0.049
101	1.2DL + 1.5Lm + 1Wm 225 AZI - MP2	Yes	Y	DL	1.2	34	1.5	2	-0.035	3	-0.035	6	-0.049
102	1.2DL + 1.5Lm + 1Wm 240 AZI - MP2	Yes	Y	DL	1.2	34	1.5	2	-0.025	3	-0.043	7	-0.049
103	1.2DL + 1.5Lm + 1Wm 270 AZI - MP2	Yes	Y	DL	1.2	34	1.5	2		3	-0.049	8	-0.049
104	1.2DL + 1.5Lm + 1Wm 300 AZI - MP2	Yes	Y	DL	1.2	34	1.5	2	0.025	3	-0.043	9	-0.049
105	1.2DL + 1.5Lm + 1Wm 315 AZI - MP2	Yes	Y	DL	1.2	34	1.5	2	0.035	3	-0.035	10	-0.049
106	1.2DL + 1.5Lm + 1Wm 330 AZI - MP2	Yes	Y	DL	1.2	34	1.5	2	0.043	3	-0.025	11	-0.049
107	1.2DL + 1.5Lm + 1Wm 0 AZI - MP1	Yes	Y	DL	1.2	35	1.5	2	0.049	3		4	0.049
108	1.2DL + 1.5Lm + 1Wm 30 AZI - MP1	Yes	Y	DL	1.2	35	1.5	2	0.043	3	0.025	5	0.049
109	1.2DL + 1.5Lm + 1Wm 45 AZI - MP1	Yes	Y	DL	1.2	35	1.5	2	0.035	3	0.035	6	0.049
110	1.2DL + 1.5Lm + 1Wm 60 AZI - MP1	Yes	Y	DL	1.2	35	1.5	2	0.025	3	0.043	7	0.049
111	1.2DL + 1.5Lm + 1Wm 90 AZI - MP1	Yes	Y	DL	1.2	35	1.5	2		3	0.049	8	0.049
112	1.2DL + 1.5Lm + 1Wm 120 AZI - MP1	Yes	Y	DL	1.2	35	1.5	2	-0.025	3	0.043	9	0.049
113	1.2DL + 1.5Lm + 1Wm 135 AZI - MP1	Yes	Y	DL	1.2	35	1.5	2	-0.035	3	0.035	10	0.049
114	1.2DL + 1.5Lm + 1Wm 150 AZI - MP1	Yes	Y	DL	1.2	35	1.5	2	-0.043	3	0.025	11	0.049
115	1.2DL + 1.5Lm + 1Wm 180 AZI - MP1	Yes	Y	DL	1.2	35	1.5	2	-0.049	3		4	-0.049
116	1.2DL + 1.5Lm + 1Wm 210 AZI - MP1	Yes	Y	DL	1.2	35	1.5	2	-0.043	3	-0.025	5	-0.049
117	1.2DL + 1.5Lm + 1Wm 225 AZI - MP1	Yes	Y	DL	1.2	35	1.5	2	-0.035	3	-0.035	6	-0.049
118	1.2DL + 1.5Lm + 1Wm 240 AZI - MP1	Yes	Y	DL	1.2	35	1.5	2	-0.025	3	-0.043	7	-0.049
119	1.2DL + 1.5Lm + 1Wm 270 AZI - MP1	Yes	Y	DL	1.2	35	1.5	2		3	-0.049	8	-0.049
120	1.2DL + 1.5Lm + 1Wm 300 AZI - MP1	Yes	Y	DL	1.2	35	1.5	2	0.025	3	-0.043	9	-0.049
121	1.2DL + 1.5Lm + 1Wm 315 AZI - MP1	Yes	Y	DL	1.2	35	1.5	2	0.035	3	-0.035	10	-0.049
122	1.2DL + 1.5Lm + 1Wm 330 AZI - MP1	Yes	Y	DL	1.2	35	1.5	2	0.043	3	-0.025	11	-0.049
123	1.2DL + 1.5Lm + 1Wm 0 AZI - MP3	Yes	Y	DL	1.2	36	1.5	2	0.049	3		4	0.049
124	1.2DL + 1.5Lm + 1Wm 30 AZI - MP3	Yes	Y	DL	1.2	36	1.5	2	0.043	3	0.025	5	0.049
125	1.2DL + 1.5Lm + 1Wm 45 AZI - MP3	Yes	Y	DL	1.2	36	1.5	2	0.035	3	0.035	6	0.049
126	1.2DL + 1.5Lm + 1Wm 60 AZI - MP3	Yes	Y	DL	1.2	36	1.5	2	0.025	3	0.043	7	0.049
127	1.2DL + 1.5Lm + 1Wm 90 AZI - MP3	Yes	Y	DL	1.2	36	1.5	2		3	0.049	8	0.049
128	1.2DL + 1.5Lm + 1Wm 120 AZI - MP3	Yes	Y	DL	1.2	36	1.5	2	-0.025	3	0.043	9	0.049
129	1.2DL + 1.5Lm + 1Wm 135 AZI - MP3	Yes	Y	DL	1.2	36	1.5	2	-0.035	3	0.035	10	0.049
130	1.2DL + 1.5Lm + 1Wm 150 AZI - MP3	Yes	Y	DL	1.2	36	1.5	2	-0.043	3	0.025	11	0.049

Load Combinations (Continued)

	Description	Solve	P-Delta	BLC	Factor	BLC	Factor	BLC	Factor	BLC	Factor	BLC	Factor
131	1.2DL + 1.5Lm + 1Wm 180 AZI - MP3	Yes	Y	DL	1.2	36	1.5	2	-0.049	3		4	-0.049
132	1.2DL + 1.5Lm + 1Wm 210 AZI - MP3	Yes	Y	DL	1.2	36	1.5	2	-0.043	3	-0.025	5	-0.049
133	1.2DL + 1.5Lm + 1Wm 225 AZI - MP3	Yes	Y	DL	1.2	36	1.5	2	-0.035	3	-0.035	6	-0.049
134	1.2DL + 1.5Lm + 1Wm 240 AZI - MP3	Yes	Y	DL	1.2	36	1.5	2	-0.025	3	-0.043	7	-0.049
135	1.2DL + 1.5Lm + 1Wm 270 AZI - MP3	Yes	Y	DL	1.2	36	1.5	2		3	-0.049	8	-0.049
136	1.2DL + 1.5Lm + 1Wm 300 AZI - MP3	Yes	Y	DL	1.2	36	1.5	2	0.025	3	-0.043	9	-0.049
137	1.2DL + 1.5Lm + 1Wm 315 AZI - MP3	Yes	Y	DL	1.2	36	1.5	2	0.035	3	-0.035	10	-0.049
138	1.2DL + 1.5Lm + 1Wm 330 AZI - MP3	Yes	Y	DL	1.2	36	1.5	2	0.043	3	-0.025	11	-0.049
139	1.2DL + 1.5Lm + 1Wm 0 AZI - MP8	Yes	Y	DL	1.2	37	1.5	2	0.049	3		4	0.049
140	1.2DL + 1.5Lm + 1Wm 30 AZI - MP8	Yes	Y	DL	1.2	37	1.5	2	0.043	3	0.025	5	0.049
141	1.2DL + 1.5Lm + 1Wm 45 AZI - MP8	Yes	Y	DL	1.2	37	1.5	2	0.035	3	0.035	6	0.049
142	1.2DL + 1.5Lm + 1Wm 60 AZI - MP8	Yes	Y	DL	1.2	37	1.5	2	0.025	3	0.043	7	0.049
143	1.2DL + 1.5Lm + 1Wm 90 AZI - MP8	Yes	Y	DL	1.2	37	1.5	2		3	0.049	8	0.049
144	1.2DL + 1.5Lm + 1Wm 120 AZI - MP8	Yes	Y	DL	1.2	37	1.5	2	-0.025	3	0.043	9	0.049
145	1.2DL + 1.5Lm + 1Wm 135 AZI - MP8	Yes	Y	DL	1.2	37	1.5	2	-0.035	3	0.035	10	0.049
146	1.2DL + 1.5Lm + 1Wm 150 AZI - MP8	Yes	Y	DL	1.2	37	1.5	2	-0.043	3	0.025	11	0.049
147	1.2DL + 1.5Lm + 1Wm 180 AZI - MP8	Yes	Y	DL	1.2	37	1.5	2	-0.049	3		4	-0.049
148	1.2DL + 1.5Lm + 1Wm 210 AZI - MP8	Yes	Y	DL	1.2	37	1.5	2	-0.043	3	-0.025	5	-0.049
149	1.2DL + 1.5Lm + 1Wm 225 AZI - MP8	Yes	Y	DL	1.2	37	1.5	2	-0.035	3	-0.035	6	-0.049
150	1.2DL + 1.5Lm + 1Wm 240 AZI - MP8	Yes	Y	DL	1.2	37	1.5	2	-0.025	3	-0.043	7	-0.049
151	1.2DL + 1.5Lm + 1Wm 270 AZI - MP8	Yes	Y	DL	1.2	37	1.5	2		3	-0.049	8	-0.049
152	1.2DL + 1.5Lm + 1Wm 300 AZI - MP8	Yes	Y	DL	1.2	37	1.5	2	0.025	3	-0.043	9	-0.049
153	1.2DL + 1.5Lm + 1Wm 315 AZI - MP8	Yes	Y	DL	1.2	37	1.5	2	0.035	3	-0.035	10	-0.049
154	1.2DL + 1.5Lm + 1Wm 330 AZI - MP8	Yes	Y	DL	1.2	37	1.5	2	0.043	3	-0.025	11	-0.049
155	1.2DL + 1.5Lm + 1Wm 0 AZI - MP5	Yes	Y	DL	1.2	38	1.5	2	0.049	3		4	0.049
156	1.2DL + 1.5Lm + 1Wm 30 AZI - MP5	Yes	Y	DL	1.2	38	1.5	2	0.043	3	0.025	5	0.049
157	1.2DL + 1.5Lm + 1Wm 45 AZI - MP5	Yes	Y	DL	1.2	38	1.5	2	0.035	3	0.035	6	0.049
158	1.2DL + 1.5Lm + 1Wm 60 AZI - MP5	Yes	Y	DL	1.2	38	1.5	2	0.025	3	0.043	7	0.049
159	1.2DL + 1.5Lm + 1Wm 90 AZI - MP5	Yes	Y	DL	1.2	38	1.5	2		3	0.049	8	0.049
160	1.2DL + 1.5Lm + 1Wm 120 AZI - MP5	Yes	Y	DL	1.2	38	1.5	2	-0.025	3	0.043	9	0.049
161	1.2DL + 1.5Lm + 1Wm 135 AZI - MP5	Yes	Y	DL	1.2	38	1.5	2	-0.035	3	0.035	10	0.049
162	1.2DL + 1.5Lm + 1Wm 150 AZI - MP5	Yes	Y	DL	1.2	38	1.5	2	-0.043	3	0.025	11	0.049
163	1.2DL + 1.5Lm + 1Wm 180 AZI - MP5	Yes	Y	DL	1.2	38	1.5	2	-0.049	3		4	-0.049
164	1.2DL + 1.5Lm + 1Wm 210 AZI - MP5	Yes	Y	DL	1.2	38	1.5	2	-0.043	3	-0.025	5	-0.049
165	1.2DL + 1.5Lm + 1Wm 225 AZI - MP5	Yes	Y	DL	1.2	38	1.5	2	-0.035	3	-0.035	6	-0.049
166	1.2DL + 1.5Lm + 1Wm 240 AZI - MP5	Yes	Y	DL	1.2	38	1.5	2	-0.025	3	-0.043	7	-0.049
167	1.2DL + 1.5Lm + 1Wm 270 AZI - MP5	Yes	Y	DL	1.2	38	1.5	2		3	-0.049	8	-0.049
168	1.2DL + 1.5Lm + 1Wm 300 AZI - MP5	Yes	Y	DL	1.2	38	1.5	2	0.025	3	-0.043	9	-0.049
169	1.2DL + 1.5Lm + 1Wm 315 AZI - MP5	Yes	Y	DL	1.2	38	1.5	2	0.035	3	-0.035	10	-0.049
170	1.2DL + 1.5Lm + 1Wm 330 AZI - MP5	Yes	Y	DL	1.2	38	1.5	2	0.043	3	-0.025	11	-0.049
171	1.2DL + 1.5Lm + 1Wm 0 AZI - MP7	Yes	Y	DL	1.2	39	1.5	2	0.049	3		4	0.049
172	1.2DL + 1.5Lm + 1Wm 30 AZI - MP7	Yes	Y	DL	1.2	39	1.5	2	0.043	3	0.025	5	0.049
173	1.2DL + 1.5Lm + 1Wm 45 AZI - MP7	Yes	Y	DL	1.2	39	1.5	2	0.035	3	0.035	6	0.049
174	1.2DL + 1.5Lm + 1Wm 60 AZI - MP7	Yes	Y	DL	1.2	39	1.5	2	0.025	3	0.043	7	0.049
175	1.2DL + 1.5Lm + 1Wm 90 AZI - MP7	Yes	Y	DL	1.2	39	1.5	2		3	0.049	8	0.049
176	1.2DL + 1.5Lm + 1Wm 120 AZI - MP7	Yes	Y	DL	1.2	39	1.5	2	-0.025	3	0.043	9	0.049
177	1.2DL + 1.5Lm + 1Wm 135 AZI - MP7	Yes	Y	DL	1.2	39	1.5	2	-0.035	3	0.035	10	0.049
178	1.2DL + 1.5Lm + 1Wm 150 AZI - MP7	Yes	Y	DL	1.2	39	1.5	2	-0.043	3	0.025	11	0.049
179	1.2DL + 1.5Lm + 1Wm 180 AZI - MP7	Yes	Y	DL	1.2	39	1.5	2	-0.049	3		4	-0.049
180	1.2DL + 1.5Lm + 1Wm 210 AZI - MP7	Yes	Y	DL	1.2	39	1.5	2	-0.043	3	-0.025	5	-0.049
181	1.2DL + 1.5Lm + 1Wm 225 AZI - MP7	Yes	Y	DL	1.2	39	1.5	2	-0.035	3	-0.035	6	-0.049
182	1.2DL + 1.5Lm + 1Wm 240 AZI - MP7	Yes	Y	DL	1.2	39	1.5	2	-0.025	3	-0.043	7	-0.049
183	1.2DL + 1.5Lm + 1Wm 270 AZI - MP7	Yes	Y	DL	1.2	39	1.5	2		3	-0.049	8	-0.049
184	1.2DL + 1.5Lm + 1Wm 300 AZI - MP7	Yes	Y	DL	1.2	39	1.5	2	0.025	3	-0.043	9	-0.049
185	1.2DL + 1.5Lm + 1Wm 315 AZI - MP7	Yes	Y	DL	1.2	39	1.5	2	0.035	3	-0.035	10	-0.049

Load Combinations (Continued)

	Description	Solve	P-Delta	BLC	Factor	BLC	Factor	BLC	Factor	BLC	Factor	BLC	Factor
186	1.2DL + 1.5Lm + 1Wm 330 AZI - MP7	Yes	Y	DL	1.2	39	1.5	2	0.043	3	-0.025	11	-0.049
187	1.2DL + 1.5Lm + 1Wm 0 AZI - MP9	Yes	Y	DL	1.2	40	1.5	2	0.049	3		4	0.049
188	1.2DL + 1.5Lm + 1Wm 30 AZI - MP9	Yes	Y	DL	1.2	40	1.5	2	0.043	3	0.025	5	0.049
189	1.2DL + 1.5Lm + 1Wm 45 AZI - MP9	Yes	Y	DL	1.2	40	1.5	2	0.035	3	0.035	6	0.049
190	1.2DL + 1.5Lm + 1Wm 60 AZI - MP9	Yes	Y	DL	1.2	40	1.5	2	0.025	3	0.043	7	0.049
191	1.2DL + 1.5Lm + 1Wm 90 AZI - MP9	Yes	Y	DL	1.2	40	1.5	2		3	0.049	8	0.049
192	1.2DL + 1.5Lm + 1Wm 120 AZI - MP9	Yes	Y	DL	1.2	40	1.5	2	-0.025	3	0.043	9	0.049
193	1.2DL + 1.5Lm + 1Wm 135 AZI - MP9	Yes	Y	DL	1.2	40	1.5	2	-0.035	3	0.035	10	0.049
194	1.2DL + 1.5Lm + 1Wm 150 AZI - MP9	Yes	Y	DL	1.2	40	1.5	2	-0.043	3	0.025	11	0.049
195	1.2DL + 1.5Lm + 1Wm 180 AZI - MP9	Yes	Y	DL	1.2	40	1.5	2	-0.049	3		4	-0.049
196	1.2DL + 1.5Lm + 1Wm 210 AZI - MP9	Yes	Y	DL	1.2	40	1.5	2	-0.043	3	-0.025	5	-0.049
197	1.2DL + 1.5Lm + 1Wm 225 AZI - MP9	Yes	Y	DL	1.2	40	1.5	2	-0.035	3	-0.035	6	-0.049
198	1.2DL + 1.5Lm + 1Wm 240 AZI - MP9	Yes	Y	DL	1.2	40	1.5	2	-0.025	3	-0.043	7	-0.049
199	1.2DL + 1.5Lm + 1Wm 270 AZI - MP9	Yes	Y	DL	1.2	40	1.5	2		3	-0.049	8	-0.049
200	1.2DL + 1.5Lm + 1Wm 300 AZI - MP9	Yes	Y	DL	1.2	40	1.5	2	0.025	3	-0.043	9	-0.049
201	1.2DL + 1.5Lm + 1Wm 315 AZI - MP9	Yes	Y	DL	1.2	40	1.5	2	0.035	3	-0.035	10	-0.049
202	1.2DL + 1.5Lm + 1Wm 330 AZI - MP9	Yes	Y	DL	1.2	40	1.5	2	0.043	3	-0.025	11	-0.049
203	1.2DL + 1.5Lm + 1Wm 0 AZI - MP4	Yes	Y	DL	1.2	41	1.5	2	0.049	3		4	0.049
204	1.2DL + 1.5Lm + 1Wm 30 AZI - MP4	Yes	Y	DL	1.2	41	1.5	2	0.043	3	0.025	5	0.049
205	1.2DL + 1.5Lm + 1Wm 45 AZI - MP4	Yes	Y	DL	1.2	41	1.5	2	0.035	3	0.035	6	0.049
206	1.2DL + 1.5Lm + 1Wm 60 AZI - MP4	Yes	Y	DL	1.2	41	1.5	2	0.025	3	0.043	7	0.049
207	1.2DL + 1.5Lm + 1Wm 90 AZI - MP4	Yes	Y	DL	1.2	41	1.5	2		3	0.049	8	0.049
208	1.2DL + 1.5Lm + 1Wm 120 AZI - MP4	Yes	Y	DL	1.2	41	1.5	2	-0.025	3	0.043	9	0.049
209	1.2DL + 1.5Lm + 1Wm 135 AZI - MP4	Yes	Y	DL	1.2	41	1.5	2	-0.035	3	0.035	10	0.049
210	1.2DL + 1.5Lm + 1Wm 150 AZI - MP4	Yes	Y	DL	1.2	41	1.5	2	-0.043	3	0.025	11	0.049
211	1.2DL + 1.5Lm + 1Wm 180 AZI - MP4	Yes	Y	DL	1.2	41	1.5	2	-0.049	3		4	-0.049
212	1.2DL + 1.5Lm + 1Wm 210 AZI - MP4	Yes	Y	DL	1.2	41	1.5	2	-0.043	3	-0.025	5	-0.049
213	1.2DL + 1.5Lm + 1Wm 225 AZI - MP4	Yes	Y	DL	1.2	41	1.5	2	-0.035	3	-0.035	6	-0.049
214	1.2DL + 1.5Lm + 1Wm 240 AZI - MP4	Yes	Y	DL	1.2	41	1.5	2	-0.025	3	-0.043	7	-0.049
215	1.2DL + 1.5Lm + 1Wm 270 AZI - MP4	Yes	Y	DL	1.2	41	1.5	2		3	-0.049	8	-0.049
216	1.2DL + 1.5Lm + 1Wm 300 AZI - MP4	Yes	Y	DL	1.2	41	1.5	2	0.025	3	-0.043	9	-0.049
217	1.2DL + 1.5Lm + 1Wm 315 AZI - MP4	Yes	Y	DL	1.2	41	1.5	2	0.035	3	-0.035	10	-0.049
218	1.2DL + 1.5Lm + 1Wm 330 AZI - MP4	Yes	Y	DL	1.2	41	1.5	2	0.043	3	-0.025	11	-0.049
219	1.2DL + 1.5Lm + 1Wm 0 AZI - MP6	Yes	Y	DL	1.2	42	1.5	2	0.049	3		4	0.049
220	1.2DL + 1.5Lm + 1Wm 30 AZI - MP6	Yes	Y	DL	1.2	42	1.5	2	0.043	3	0.025	5	0.049
221	1.2DL + 1.5Lm + 1Wm 45 AZI - MP6	Yes	Y	DL	1.2	42	1.5	2	0.035	3	0.035	6	0.049
222	1.2DL + 1.5Lm + 1Wm 60 AZI - MP6	Yes	Y	DL	1.2	42	1.5	2	0.025	3	0.043	7	0.049
223	1.2DL + 1.5Lm + 1Wm 90 AZI - MP6	Yes	Y	DL	1.2	42	1.5	2		3	0.049	8	0.049
224	1.2DL + 1.5Lm + 1Wm 120 AZI - MP6	Yes	Y	DL	1.2	42	1.5	2	-0.025	3	0.043	9	0.049
225	1.2DL + 1.5Lm + 1Wm 135 AZI - MP6	Yes	Y	DL	1.2	42	1.5	2	-0.035	3	0.035	10	0.049
226	1.2DL + 1.5Lm + 1Wm 150 AZI - MP6	Yes	Y	DL	1.2	42	1.5	2	-0.043	3	0.025	11	0.049
227	1.2DL + 1.5Lm + 1Wm 180 AZI - MP6	Yes	Y	DL	1.2	42	1.5	2	-0.049	3		4	-0.049
228	1.2DL + 1.5Lm + 1Wm 210 AZI - MP6	Yes	Y	DL	1.2	42	1.5	2	-0.043	3	-0.025	5	-0.049
229	1.2DL + 1.5Lm + 1Wm 225 AZI - MP6	Yes	Y	DL	1.2	42	1.5	2	-0.035	3	-0.035	6	-0.049
230	1.2DL + 1.5Lm + 1Wm 240 AZI - MP6	Yes	Y	DL	1.2	42	1.5	2	-0.025	3	-0.043	7	-0.049
231	1.2DL + 1.5Lm + 1Wm 270 AZI - MP6	Yes	Y	DL	1.2	42	1.5	2		3	-0.049	8	-0.049
232	1.2DL + 1.5Lm + 1Wm 300 AZI - MP6	Yes	Y	DL	1.2	42	1.5	2	0.025	3	-0.043	9	-0.049
233	1.2DL + 1.5Lm + 1Wm 315 AZI - MP6	Yes	Y	DL	1.2	42	1.5	2	0.035	3	-0.035	10	-0.049
234	1.2DL + 1.5Lm + 1Wm 330 AZI - MP6	Yes	Y	DL	1.2	42	1.5	2	0.043	3	-0.025	11	-0.049

Envelope Node Reactions

Node Label		X [lb]	LC	Y [lb]	LC	Z [lb]	LC	MX [lb-ft]	LC	MY [lb-ft]	LC	MZ [lb-ft]	LC	
1	N25	max	1444.122	20	1896.142	39	1615.987	3	318.012	33	2741.018	3	-318.666	31
2		min	-1444.547	12	48.782	31	-1603.497	27	-2679.88	130	-2730.755	28	-3579.838	39
3	N1	max	1316.51	24	1934.128	45	2004.081	18	121.871	19	2831.243	25	3725.032	45

Envelope Node Reactions (Continued)

Node Label		X [lb]	LC	Y [lb]	LC	Z [lb]	LC	MX [lb-ft]	LC	MY [lb-ft]	LC	MZ [lb-ft]	LC	
4		min	-1318.38	16	58.443	21	-2011.057	10	-2713.19	117	-2848.434	17	56.771	21
5	N13	max	1728.869	6	1842.779	34	494.969	18	3921.491	34	1759.598	30	858.48	183
6		min	-1723.016	30	88.681	26	-505.987	10	-105.762	26	-1764.333	6	-800.617	223
7	N31	max	NC		NC		NC		NC		LOCKED		NC	
8		min	NC		NC		NC		NC		LOCKED		NC	
9	Totals:	max	3833.653	22	5466.643	41	4086.436	2						
10		min	-3833.658	14	1407.558	80	-4086.435	10						

Envelope AISC 14TH (360-10): LRFD Member Steel Code Checks

Member	Shape	Code Check	Loc[in]	LC	Shear Check	Loc[in]	Dir	LC	phi*Pnc [lb]	phi*Pnt [lb]	phi*Mn y-y [lb-ft]	phi*Mn z-z [lb-ft]	Cb	Eqn	
1	M11	C3X5	0.73	34.856	128	0.376	63.177	y	130	11202.931	47628	981.263	4104	1.463	H1-1b
2	M3	L2x2x3	0.651	27.295	11	0.052	0	y	12	18051.765	23392.8	557.717	1239.29	1.5	H2-1
3	M1	C3X5	0.645	34.856	12	0.365	6.536	z	3	11202.931	47628	981.263	4104	1.335	H1-1b
4	MP4	PIPE 2.0	0.621	48	11	0.157	48		3	14916.096	32130	1871.625	1871.625	1.681	H1-1b
5	M2	PIPE 3.5	0.572	0	44	0.221	16.25		114	75262.68	78750	7953.75	7953.75	1.965	H1-1b
6	M7	PIPE 3.5	0.494	0	34	0.177	0		184	75262.68	78750	7953.75	7953.75	2.086	H1-1b
7	M12	PIPE 3.5	0.492	0	41	0.295	0		130	75262.68	78750	7953.75	7953.75	2.128	H1-1b
8	MP9	PIPE 2.0	0.477	48	2	0.1	48		10	14916.096	32130	1871.625	1871.625	1.812	H1-1b
9	MP1	PIPE 2.0	0.466	48	17	0.365	48		10	14916.096	32130	1871.625	1871.625	1.564	H3-6
10	M13	L2x2x3	0.455	0	6	0.042	0	y	13	18051.765	23392.8	557.717	1239.29	1.5	H2-1
11	M5	6.5"x0.37" Plate	0.44	21	13	0.525	5.687	y	38	3513.807	75757.5	583.963	7052.369	1.306	H1-1b
12	M14	L2x2x3	0.435	0	15	0.065	27.295	y	127	18051.765	23392.8	557.717	1239.29	1.5	H2-1
13	M15	6.5"x0.37" Plate	0.413	21	6	0.186	36.312	y	82	3513.807	75757.5	583.963	7552.885	1.399	H1-1b
14	M19	PIPE 2.0	0.397	79	2	0.171	48		3	14916.036	32130	1871.625	1871.625	1.468	H1-1b
15	MP2	PIPE 2.0	0.389	48	6	0.08	48		135	14916.096	32130	1871.625	1871.625	1.604	H1-1b
16	M6	C3X5	0.368	34.856	49	0.13	6.536	y	40	37027.882	47628	981.263	4020.228	1	H1-1b
17	MP8	PIPE 2.0	0.366	48	10	0.081	48		10	14916.096	32130	1871.625	1871.625	1.891	H1-1b
18	MP5	PIPE 2.0	0.361	48	2	0.11	48		3	14916.096	32130	1871.625	1871.625	1.876	H1-1b
19	MP3	PIPE 2.0	0.342	48	6	0.083	7		2	14916.096	32130	1871.625	1871.625	1.603	H1-1b
20	MP6	PIPE 2.0	0.329	48	7	0.071	48		4	14916.096	32130	1871.625	1871.625	1.624	H1-1b
21	M4	L2x2x3	0.323	0	14	0.034	0	y	41	18051.765	23392.8	557.717	1239.29	1.5	H2-1
22	MP7	PIPE 2.0	0.315	48	10	0.048	48		10	14916.096	32130	1871.625	1871.625	2.039	H1-1b
23	M10	6.5"x0.37" Plate	0.292	21	2	0.092	5.688	y	39	3513.807	75757.5	583.963	6159.699	1.141	H1-1b
24	M8	L2x2x3	0.224	0	17	0.026	0	z	39	18051.765	23392.8	557.717	1239.29	1.5	H2-1
25	H3	PIPE 3.5	0.192	31	17	0.129	16		17	60666.044	78750	7953.75	7953.75	1.759	H1-1b
26	H2	PIPE 3.5	0.149	65	11	0.12	92		11	60666.044	78750	7953.75	7953.75	1.599	H1-1b
27	M21	PIPE 2.0	0.144	80	10	0.134	48		11	14916.036	32130	1871.625	1871.625	1.517	H1-1b
28	M20	PIPE 2.0	0.135	16	10	0.074	48		10	14916.036	32130	1871.625	1871.625	1.816	H1-1b
29	M9	L2x2x3	0.126	0	26	0.027	0	y	44	18051.765	23392.8	557.717	1239.29	1.5	H2-1
30	H1	PIPE 3.5	0.077	80	120	0.078	92		113	60666.044	78750	7953.75	7953.75	2.04	H1-1b
31	M24	L6 5/8x4 7/16x3/16	0.045	21	26	0.023	42	z	15	14361.786	66065.641	3407.114	3031.076	1.136	H2-1
32	M22	L6 5/8x4 7/16x3/16	0.038	21	32	0.038	42	y	10	14361.786	66065.641	3407.114	3031.076	1.136	H2-1
33	M23	L6 5/8x4 7/16x3/16	0.038	20.562	21	0.039	42	y	9	14361.786	66065.641	3407.114	3031.076	1.136	H2-1

Envelope AISI S100-12: LRFD Member Cold Formed Steel Code Checks

No Data to Print...														
---------------------	--	--	--	--	--	--	--	--	--	--	--	--	--	--

APPENDIX D
ADDITIONAL CALCULATIONS

BOLT TOOL 1.5.2

Project Data	
Job Code:	206811
Carrier Site ID:	BOBOS01000A
Carrier Site Name:	GROTON TOWER

Code	
Design Standard:	TIA-222-H
Slip Check:	No
Pretension Standard:	TIA-222-H

Bolt Properties		
Connection Type:	Bolt	
Diameter:	0.625	in
Grade:	A325	--
Yield Strength (Fy):	92	ksi
Ultimate Strength (Fu):	120	ksi
Number of Bolts:	4	--
Threads Included:	Yes	--
Double Shear:	No	--
Connection Pipe Size:	-	in

Connection Description
Mount to Collar Connection

Bolt Check*		
Tensile Capacity (ϕT_n):	20340.1	lbs
Shear Capacity (ϕV_n):	13805.8	lbs
Tension Force (T_u):	4935.0	lbs
Shear Force (V_u):	700.9	lbs
Tension Usage:	23.1%	--
Shear Usage:	4.8%	--
Interaction:	23.1%	Pass
Controlling Member:	M2	--
Controlling LC:	48	--

*Rating per TIA-222-H Section 15.5

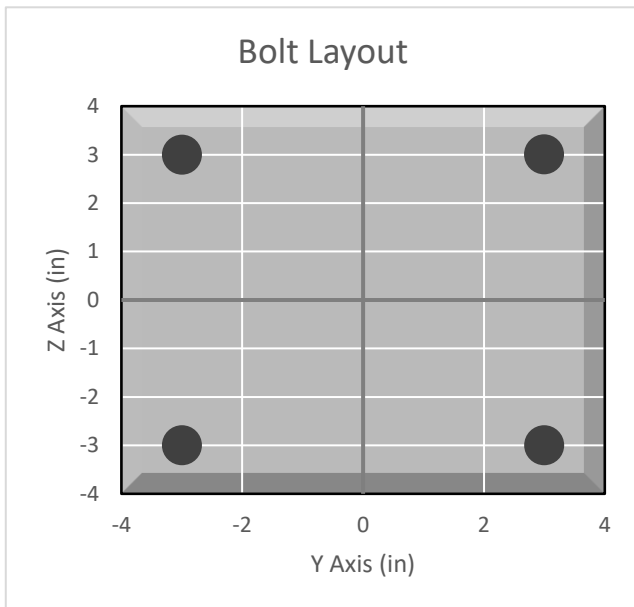

APPENDIX E
SUPPLEMENTAL DRAWINGS

4

3

2

1

NOTES:

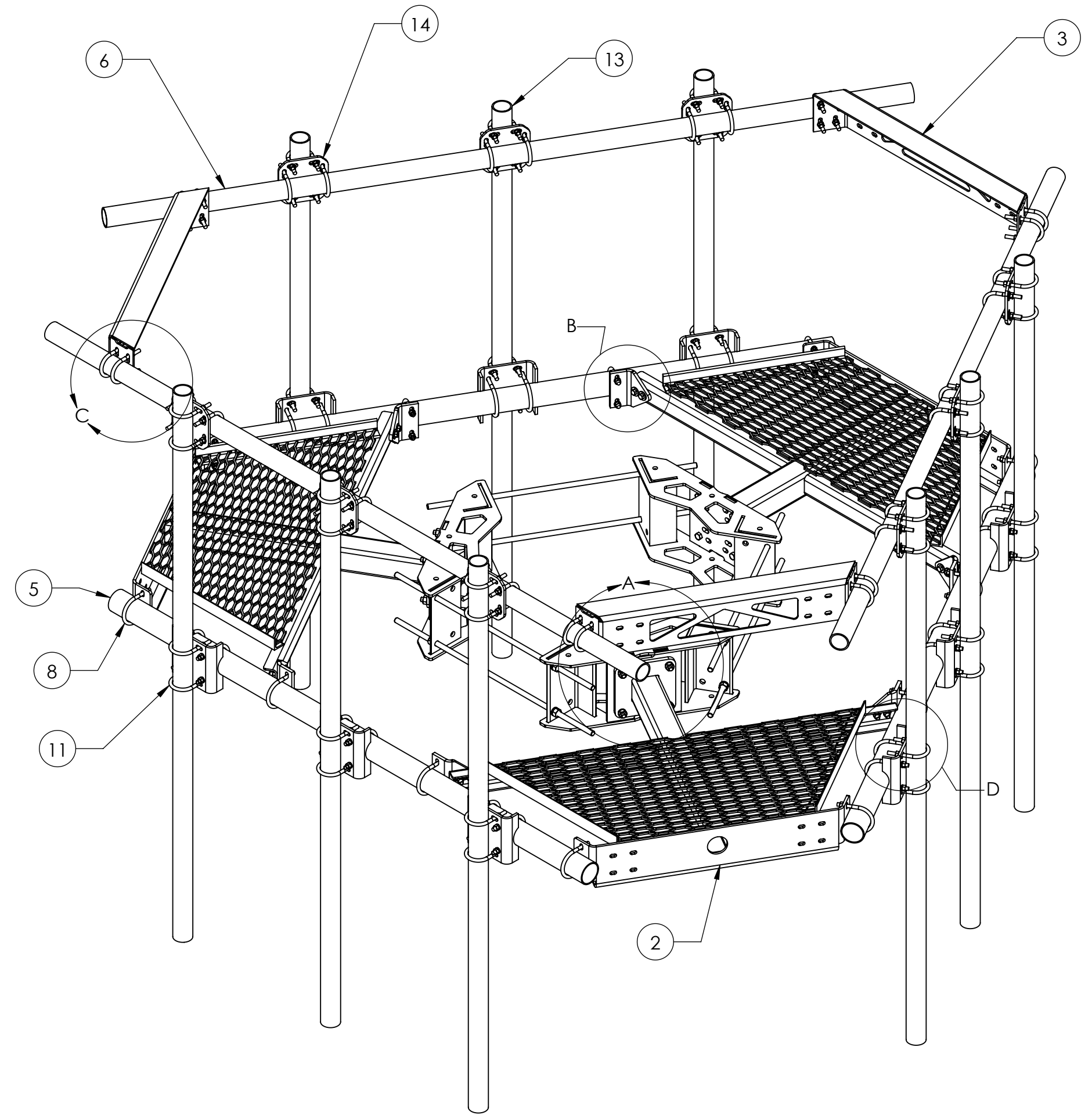
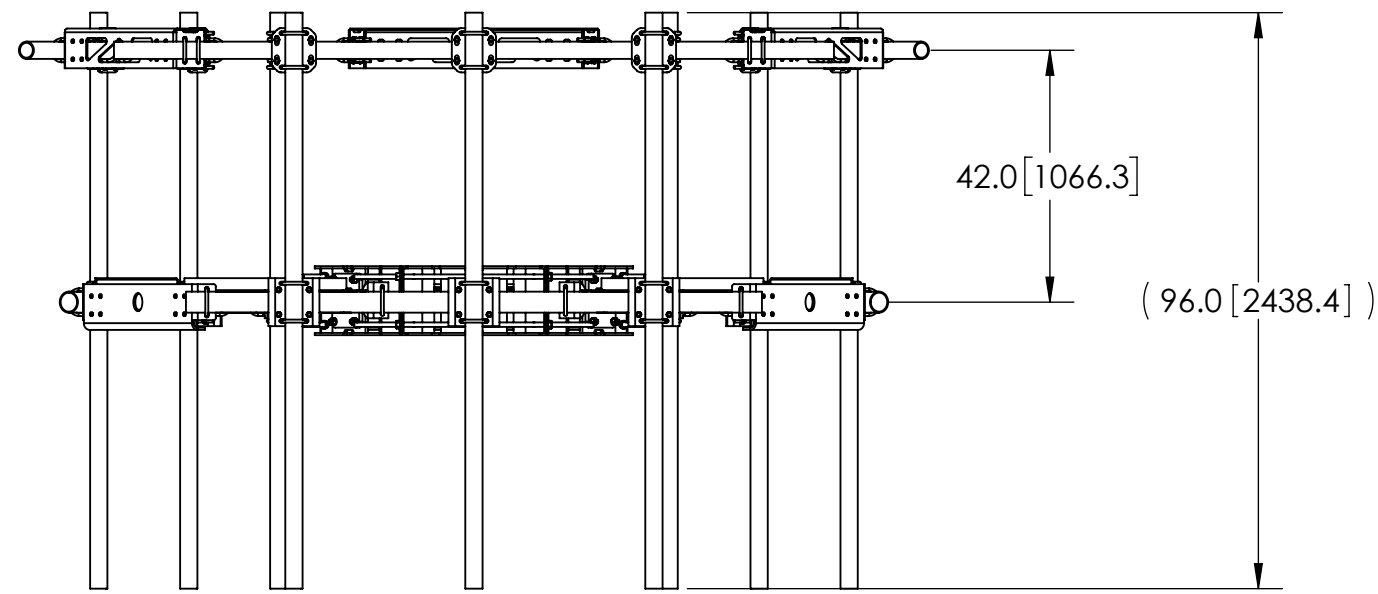
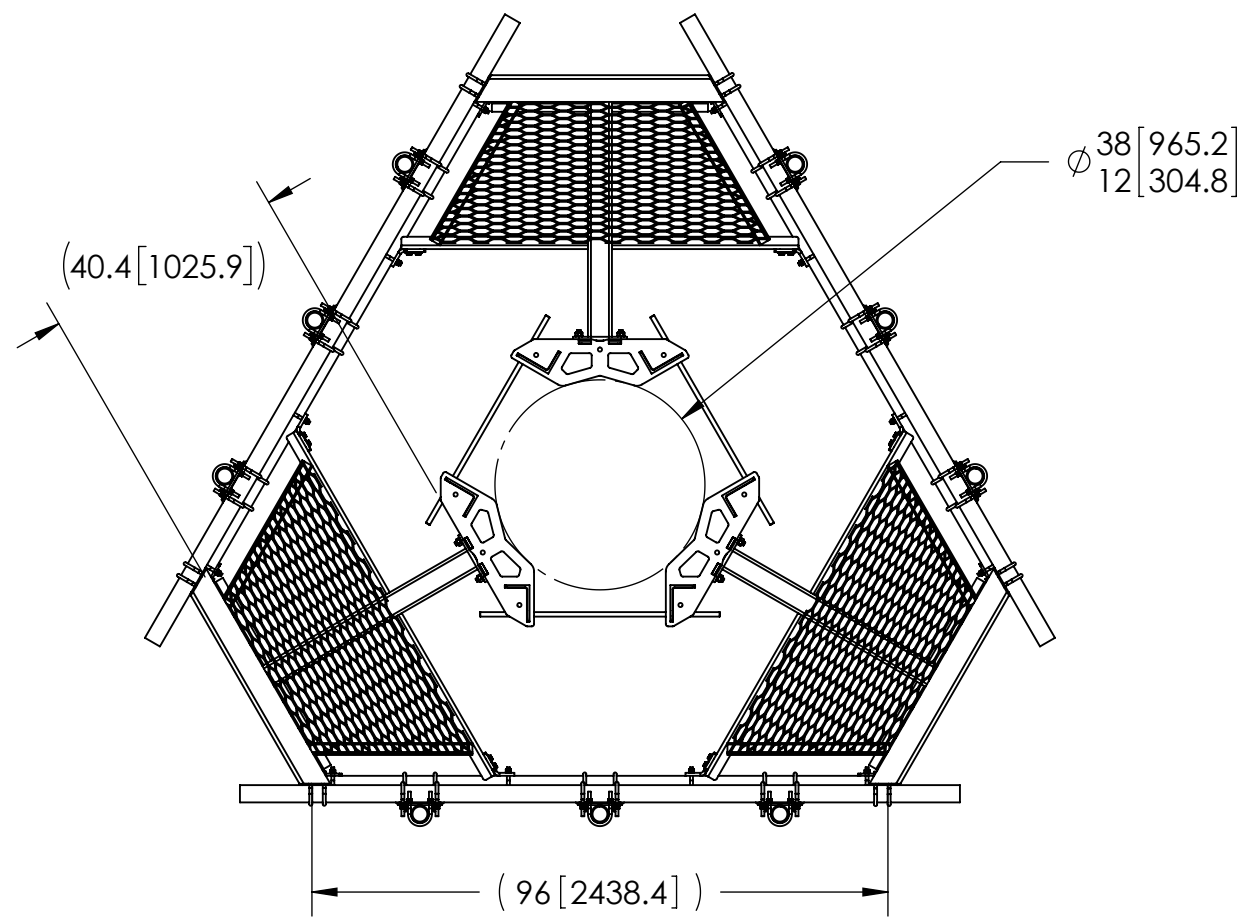

BOM IS FOR REFERENCE ONLY, PART NUMBER SUBSTITUTIONS MAY BE MADE

ITEM	PART NO.	DESCRIPTION	QTY.
1	MC-RM1550-3	12" - 50" OD RINGMOUNT	1
2	MTC300602	SECTOR WELDMENT FOR SNUB NOSE PLATFORM	3
3	MT195801	Corner Weldment Snub Nose Handrail	3
4	GB-0522A	5/8" X 2-1/4" GALV BOLT KIT (A325)	12
5	MT54796	3.50" OD X 96" GALV PIPE	3
6	MT546120	2.875" O.D. X 120" PIPE	3
7	GWF-04	1/2" GALV FLAT WASHER	12
8	GUB-4355	1/2" X 3-5/8" X 5" GALV U-BOLT	12
9	MTC300618	MOUNTING PLATE FOR MT-196	6
10	GB-04205	1/2" X 2" GALV BOLT KIT	12
11	MT-219M-H	3.5" OD X 2-7/8" OD CLAMP BRACKET ASSY	9
12	GUB-4352	1/2" X 3" X 5-1/4" GALV U-BOLT	12
13	MT54696	Ø 2.875" O.D. X 96" PIPE	9
14	XP-2525	CROSSOVER PLATE KIT, 2-7/8 OD X 2-7/8 OD	9

COMMSCOPE, INC. OF NORTH CAROLINA

TITLE
LOW PROFILE PLATFORM FACE

SIZE C SCALE 1:32 DOCUMENT NO. MC-PK8-DSH

DRAWING	SHEET		
	VERSION	STATUS	REVISION
02	RE	C	

© 2021 CommScope, Inc.

4

3

2

1

4

3

2

1

NOTES:

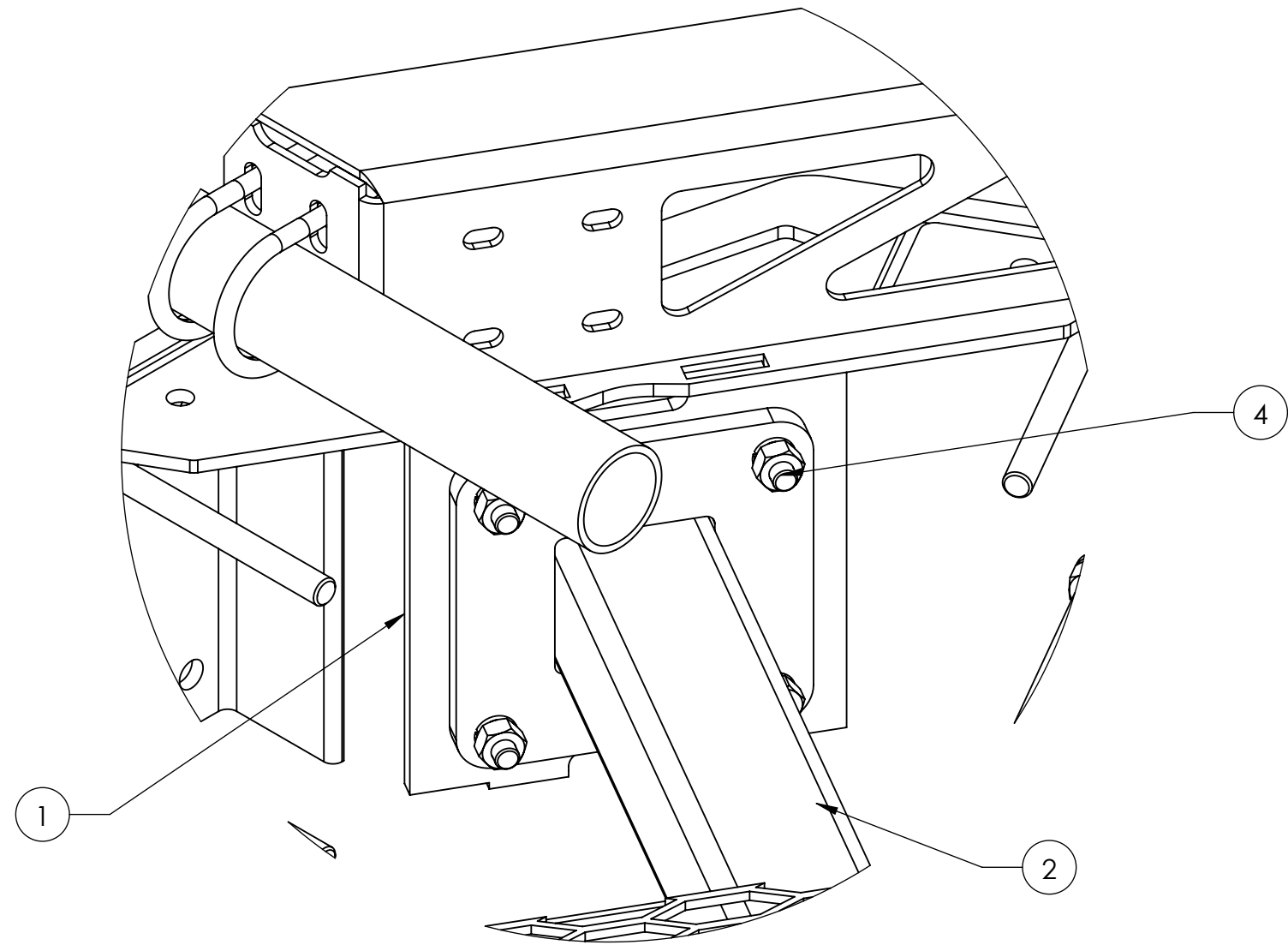

DETAIL A
SCALE 1 : 4

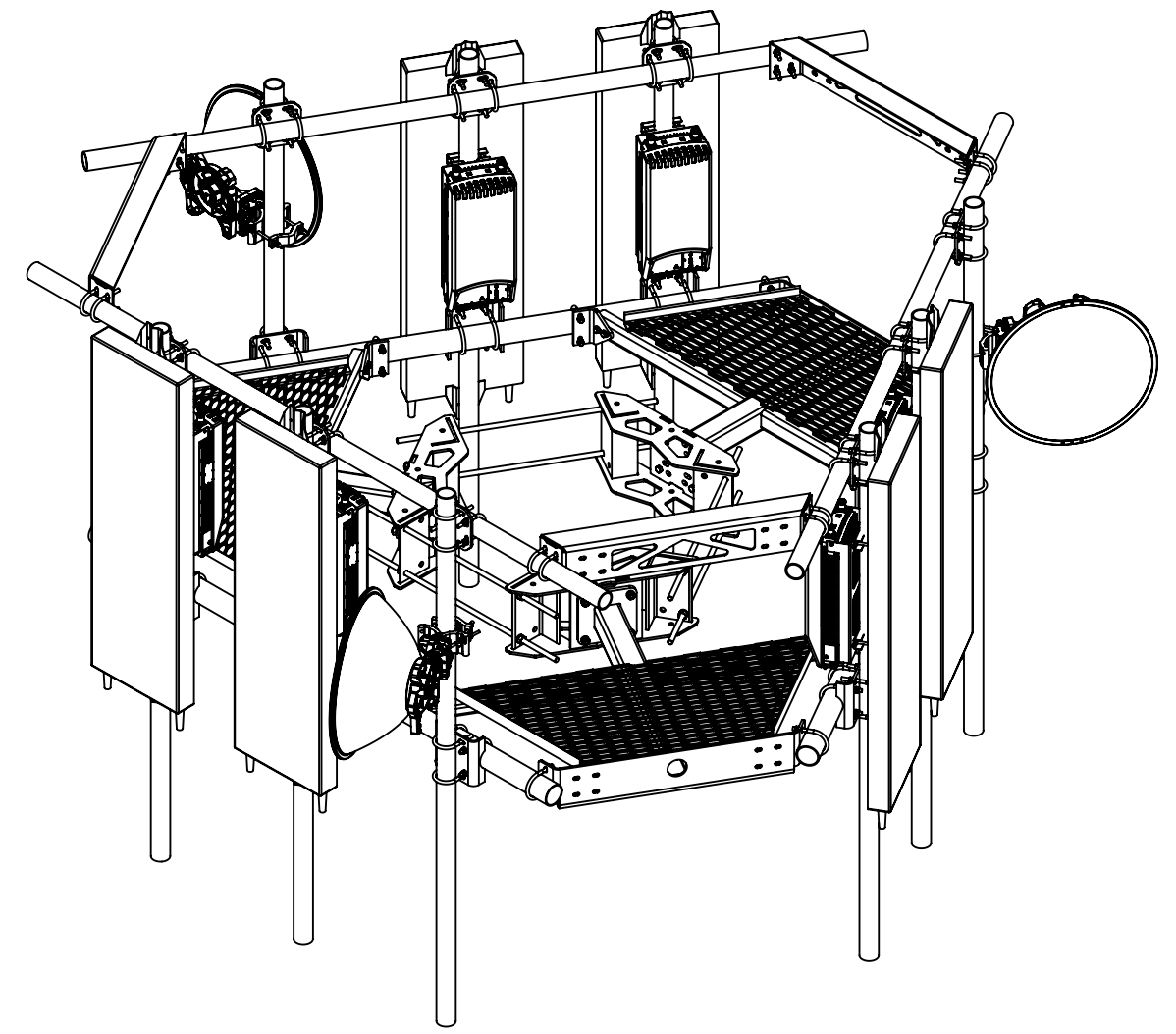

WITH ANTENNAS

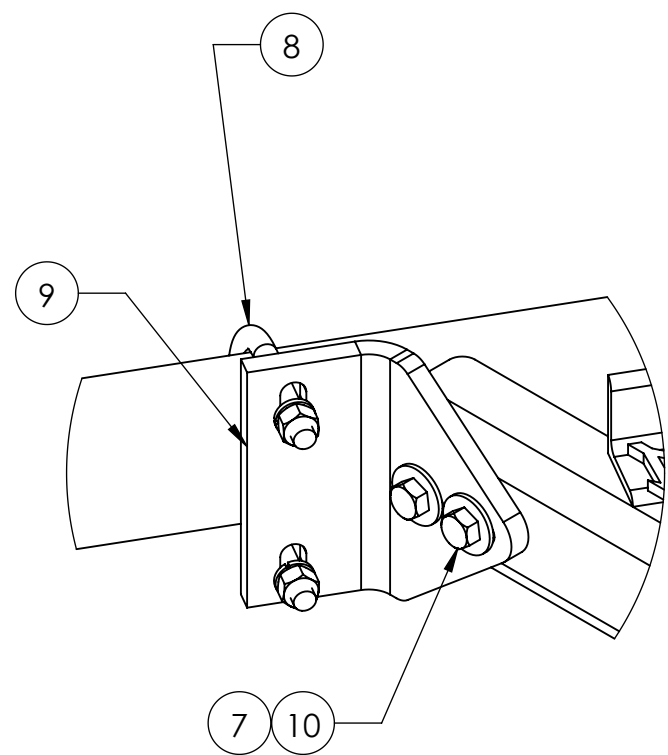

DETAIL B
SCALE 1 : 4

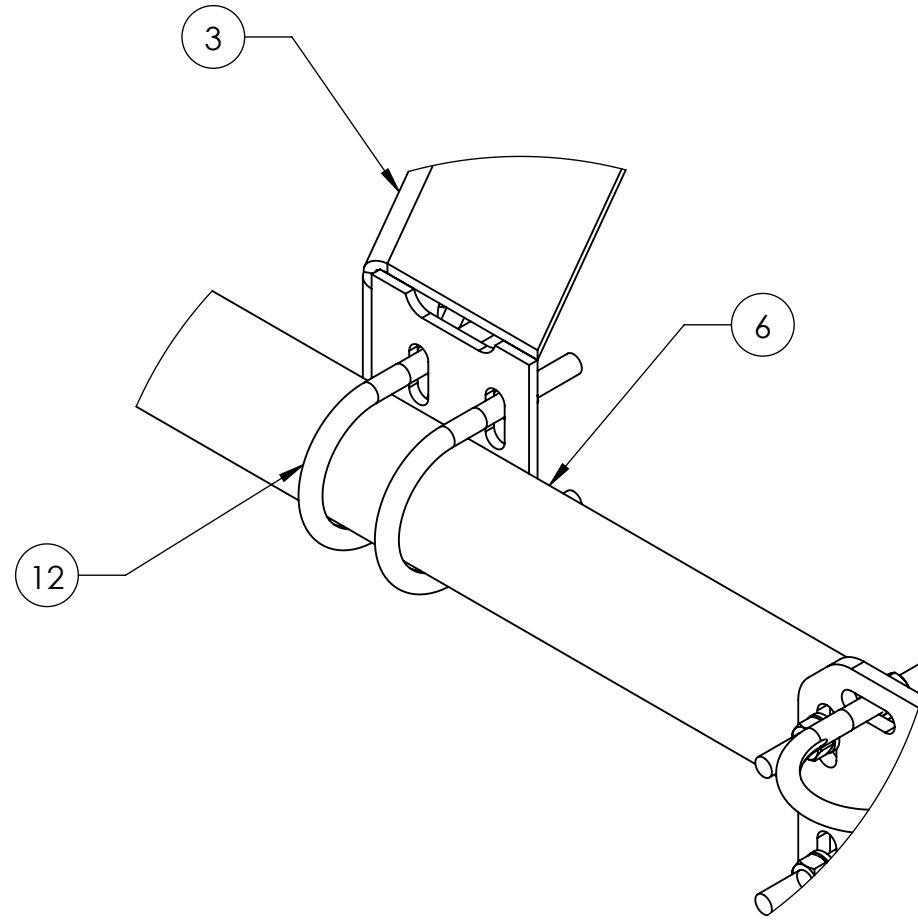

DETAIL C
SCALE 1 : 4

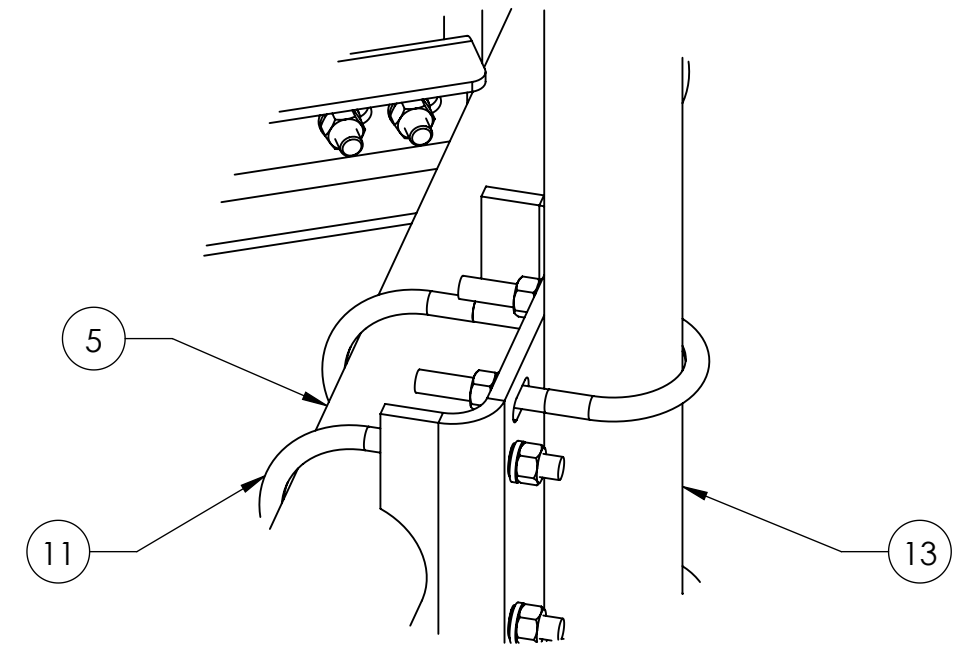

DETAIL D
SCALE 1 : 4

COMMSCOPE, INC. OF NORTH CAROLINA

TITLE
LOW PROFILE PLATFORM FACE

SIZE C	SCALE 1:24	DOCUMENT NO. MC-PK8-DSH
------------------	----------------------	-----------------------------------

DRAWING			SHEET 3 OF 3
VERSION 02	STATUS RE	REVISION C	

© 2021 CommScope, Inc.

4

3

2

1

D

D

C

C

B

B

A

A

Exhibit F

Power Density/RF Emissions Report

RADIO FREQUENCY EMISSIONS ANALYSIS REPORT
EVALUATION OF HUMAN EXPOSURE POTENTIAL
TO NON-IONIZING EMISSIONS

Dish Wireless Existing Facility

Site ID: 881533

BOBOS01000A
75 Roberts Road
Groton, Connecticut 06340

May 24, 2022

EBI Project Number: 6222001776

Site Compliance Summary	
Compliance Status:	COMPLIANT
Site total MPE% of FCC general population allowable limit:	30.52%

May 24, 2022

Attn: Dish Wireless

Emissions Analysis for Site: 881533 - BOBOS01000A

EBI Consulting was directed to analyze the proposed Dish Wireless facility located at **75 Roberts Road in Groton, Connecticut** for the purpose of determining whether the emissions from the Proposed Dish Wireless Antenna Installation located on this property are within specified federal limits.

All information used in this report was analyzed as a percentage of current Maximum Permissible Exposure (% MPE) as listed in the FCC OET Bulletin 65 Edition 97-01 and ANSI/IEEE Std C95.1. The FCC regulates Maximum Permissible Exposure in units of microwatts per square centimeter ($\mu\text{W}/\text{cm}^2$). The number of $\mu\text{W}/\text{cm}^2$ calculated at each sample point is called the power density. The exposure limit for power density varies depending upon the frequencies being utilized. Wireless Carriers and Paging Services use different frequency bands each with different exposure limits; therefore, it is necessary to report results and limits in terms of percent MPE rather than power density.

All results were compared to the FCC (Federal Communications Commission) radio frequency exposure rules, 47 CFR 1.1307(b)(1) – (b)(3), to determine compliance with the Maximum Permissible Exposure (MPE) limits for General Population/Uncontrolled environments as defined below.

General population/uncontrolled exposure limits apply to situations in which the general population may be exposed or in which persons who are exposed as a consequence of their employment may not be made fully aware of the potential for exposure or cannot exercise control over their exposure. Therefore, members of the general population would always be considered under this category when exposure is not employment related, for example, in the case of a telecommunications tower that exposes persons in a nearby residential area.

Public exposure to radio frequencies is regulated and enforced in units of microwatts per square centimeter ($\mu\text{W}/\text{cm}^2$). The general population exposure limits for the 600 MHz and 700 MHz frequency bands are approximately $400 \mu\text{W}/\text{cm}^2$ and $467 \mu\text{W}/\text{cm}^2$, respectively. The general population exposure limit for the 1900 MHz (PCS), 2100 MHz (AWS) and 11 GHz frequency bands is $1000 \mu\text{W}/\text{cm}^2$. Because each carrier will be using different frequency bands, and each frequency band has different exposure limits, it is necessary to report percent of MPE rather than power density.

Occupational/controlled exposure limits apply to situations in which persons are exposed as a consequence of their employment and in which those persons who are exposed have been made fully aware of the potential for exposure and can exercise control over their exposure.

Occupational/controlled exposure limits also apply where exposure is of a transient nature as a result of incidental passage through a location where exposure levels may be above general population/uncontrolled limits (see below), as long as the exposed person has been made fully aware of the potential for exposure and can exercise control over his or her exposure by leaving the area or by some other appropriate means.

Additional details can be found in FCC OET 65.

CALCULATIONS

Calculations were done for the proposed Dish Wireless Wireless antenna facility located at 75 Roberts Road in Groton, Connecticut using the equipment information listed below. All calculations were performed per the specifications under FCC OET 65. Since Dish Wireless is proposing highly focused directional panel antennas, which project most of the emitted energy out toward the horizon, all calculations were performed assuming a lobe representing the maximum gain of the antenna per the antenna manufacturer's supplied specifications, minus 20 dB for directional panel antennas and 20 dB for highly focused parabolic microwave dishes, was focused at the base of the tower. For this report, the sample point is the top of a 6-foot person standing at the base of the tower.

For all calculations, all equipment was calculated using the following assumptions:

- 1) 4 n71 channels (600 MHz Band) were considered for each sector of the proposed installation. These Channels have a transmit power of 30 Watts per Channel.
- 2) 4 n70 channels (PCS Band - 1900 MHz) were considered for each sector of the proposed installation. These Channels have a transmit power of 40 Watts per Channel.
- 3) All radios at the proposed installation were considered to be running at full power and were uncombined in their RF transmissions paths per carrier prescribed configuration. Per FCC OET Bulletin No. 65 - Edition 97-01 recommendations to achieve the maximum anticipated value at each sample point, all power levels emitting from the proposed antenna installation are increased by a factor of 2.56 to account for possible in-phase reflections from the surrounding environment. This is rarely the case, and if so, is never continuous.
- 4) For the following calculations, the sample point was the top of a 6-foot person standing at the base of the tower. The maximum gain of the antenna per the antenna manufacturer's supplied specifications, minus 20 dB for directional panel antennas and 20 dB for highly focused parabolic microwave dishes, was used in this direction. This value is a very conservative estimate as gain reductions for these particular antennas are typically much higher in this direction.

- 5) The antennas used in this modeling are the JMA MX08FRO665-21 for the 600 MHz / 1900 MHz channel(s) in Sector A, the JMA MX08FRO665-21 for the 600 MHz / 1900 MHz channel(s) in Sector B, the JMA MX08FRO665-21 for the 600 MHz / 1900 MHz channel(s) in Sector C. This is based on feedback from the carrier with regard to anticipated antenna selection. All Antenna gain values and associated transmit power levels are shown in the Site Inventory and Power Data table below. The maximum gain of the antenna per the antenna manufacturer's supplied specifications, minus 20 dB for directional panel antennas and 20 dB for highly focused parabolic microwave dishes, was used for all calculations. This value is a very conservative estimate as gain reductions for these particular antennas are typically much higher in this direction.
- 6) The antenna mounting height centerline of the proposed antennas is 98 feet above ground level (AGL).
- 7) Emissions values for additional carriers were taken from the Connecticut Siting Council active database. Values in this database are provided by the individual carriers themselves.
- 8) All calculations were done with respect to uncontrolled / general population threshold limits.

Dish Wireless Site Inventory and Power Data

Sector:	A	Sector:	B	Sector:	C
Antenna #:	1	Antenna #:	1	Antenna #:	1
Make / Model:	JMA MX08FRO665-21	Make / Model:	JMA MX08FRO665-21	Make / Model:	JMA MX08FRO665-21
Frequency Bands:	600 MHz / 1900 MHz	Frequency Bands:	600 MHz / 1900 MHz	Frequency Bands:	600 MHz / 1900 MHz
Gain:	11.35 dBd / 15.75 dBd	Gain:	11.35 dBd / 15.75 dBd	Gain:	11.35 dBd / 15.75 dBd
Height (AGL):	98 feet	Height (AGL):	98 feet	Height (AGL):	98 feet
Channel Count:	8	Channel Count:	8	Channel Count:	8
Total TX Power (W):	280.00 Watts	Total TX Power (W):	280.00 Watts	Total TX Power (W):	280.00 Watts
ERP (W):	1,424.17	ERP (W):	1,424.17	ERP (W):	1,424.17
Antenna AI MPE %:	0.89%	Antenna BI MPE %:	0.89%	Antenna CI MPE %:	0.89%

Site Composite MPE %	
Carrier	MPE %
Dish Wireless (Max at Sector A):	0.89%
Sprint	1.52%
Metro PCS	0.85%
T-Mobile	7.77%
AT&T	4.99%
Verizon	14.5%
Site Total MPE % :	30.52%

Dish Wireless MPE % Per Sector	
Dish Wireless Sector A Total:	0.89%
Dish Wireless Sector B Total:	0.89%
Dish Wireless Sector C Total:	0.89%
Site Total MPE % :	30.52%

Dish Wireless Maximum MPE Power Values (Sector A)							
Dish Wireless Frequency Band / Technology (Sector A)	# Channels	Watts ERP (Per Channel)	Height (feet)	Total Power Density ($\mu\text{W}/\text{cm}^2$)	Frequency (MHz)	Allowable MPE ($\mu\text{W}/\text{cm}^2$)	Calculated % MPE
Dish Wireless 600 MHz n71	4	110.82	98.0	1.88	600 MHz n71	400	0.47%
Dish Wireless 1900 MHz n70	4	245.22	98.0	4.17	1900 MHz n70	1000	0.42%
						Total:	0.89%

• NOTE: Totals may vary by approximately 0.01% due to summation of remainders in calculations.

Summary

All calculations performed for this analysis yielded results that were **within** the allowable limits for general population exposure to RF Emissions.

The anticipated maximum composite contributions from the Dish Wireless facility as well as the site composite emissions value with regards to compliance with FCC's allowable limits for general population exposure to RF Emissions are shown here:

Dish Wireless Sector	Power Density Value (%)
Sector A:	0.89%
Sector B:	0.89%
Sector C:	0.89%
Dish Wireless Maximum MPE % (Sector A):	0.89%
Site Total:	30.52%
Site Compliance Status:	COMPLIANT

The anticipated composite MPE value for this site assuming all carriers present is **30.52%** of the allowable FCC established general population limit sampled at the ground level. This is based upon values listed in the Connecticut Siting Council database for existing carrier emissions.

FCC guidelines state that if a site is found to be out of compliance (over allowable thresholds), that carriers over a 5% contribution to the composite value will require measures to bring the site into compliance. For this facility, the composite values calculated were well within the allowable 100% threshold standard per the federal government.

Exhibit G

Letter of Authorization



4545 E River Rd, Suite 320
West Henrietta, NY 14586

Phone: (585) 445-5896
Fax: (724) 416-4461
www.crowncastle.com

Crown Castle Letter of Authorization

CT - CONNECTICUT SITING COUNCIL

Melanie A. Bachman
Executive Director
Connecticut Siting Council
10 Franklin Square
New Britain, CT 06051

Re: Tower Share Application
Crown Castle telecommunications site at:
75 ROBERTS ROAD, GROTON, CT 06340

GLOBAL SIGNAL ACQUISITIONS IV LLC ("Crown Castle") hereby authorizes DISH Wireless LLC, including their Agent, to act as our Agent in the processing of all zoning applications, building permits and approvals through the CT - CONNECTICUT SITING COUNCIL for the existing wireless communications site described below:

Crown Site ID/Name: 881533/GROTON TOWER
Customer Site ID: BOBOS01000A/
Site Address: 75 Roberts Road, Groton, CT 06340

Crown Castle

By:  Date: 6/6/2022
Richard Zajac
Site Acquisition Specialist

Exhibit H

Recipient Mailings



RICH ZAJAC
CROWN CASTLE
4545 E RIVER RD
STE 320
W HENRIETTA NY 14586-9024

USPS TRACKING #

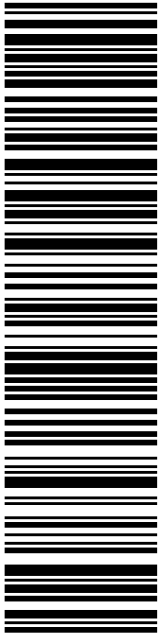

9405 5036 9930 0275 9667 65

P

USPS.com
US POSTAGE
Flat Rate Env
U.S. POSTAGE PAID
click-n-ship®

06/17/2022 Mailed from 01566

PRIORITY MAIL 2-DAY™

DEBORAH CHASE
NORTHEAST SITE SOLUTIONS
420 MAIN ST
STE 1
STURBRIDGE MA 01566-1359

Expected Delivery Date: 06/21/22
Ref#: DS-881533
0006

R013

Electronic Rate Approved #038555749



✂ ————— Cut on dotted line. —————

Instructions

1. Each Click-N-Ship® label is unique. Labels are to be used as printed and used only once. DO NOT PHOTO COPY OR ALTER LABEL.
2. Place your label so it does not wrap around the edge of the package.
3. Adhere your label to the package. A self-adhesive label is recommended. If tape or glue is used, DO NOT TAPE OVER BARCODE. Be sure all edges are secure.
4. To mail your package with PC Postage®, you may schedule a Package Pickup online, hand to your letter carrier, take to a Post Office™, or drop in a USPS collection box.
5. Mail your package on the "Ship Date" you selected when creating this label.

Click-N-Ship® Label Record

USPS TRACKING # :
9405 5036 9930 0275 9667 65

Trans. #: 565829729	Priority Mail® Postage: \$8.95
Print Date: 06/17/2022	Total: \$8.95
Ship Date: 06/17/2022	
Expected Delivery Date: 06/21/2022	

From: DEBORAH CHASE
NORTHEAST SITE SOLUTIONS
420 MAIN ST
STE 1
STURBRIDGE MA 01566-1359

Ref#: DS-881533

To: RICH ZAJAC
CROWN CASTLE
4545 E RIVER RD
STE 320
W HENRIETTA NY 14586-9024

* Retail Pricing Priority Mail rates apply. There is no fee for USPS Tracking® service on Priority Mail service with use of this electronic rate shipping label. Refunds for unused postage paid labels can be requested online 30 days from the print date.



Thank you for shipping with the United States Postal Service!
Check the status of your shipment on the USPS Tracking® page at usps.com



PATRICE GRANATOSKY
MAYOR
45 FORT HILL RD
GROTON CT 06340-4360

USPS TRACKING #

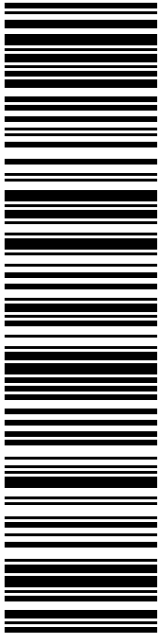

9405 5036 9930 0275 9667 72

P

USPS.com
US POSTAGE
Flat Rate Env
\$8.95

9405 5036 9930 0275 9667 72 0089 5000 0010 6340

U.S. POSTAGE PAID
click-n-ship®

06/17/2022 Mailed from 01566

PRIORITY MAIL 2-DAY™

Expected Delivery Date: 06/21/22
Ref#: DS-881533
0006

C012

DEBORAH CHASE
NORTHEAST SITE SOLUTIONS
420 MAIN ST
STE 1
STURBRIDGE MA 01566-1359

Electronic Rate Approved #038555749



✂ ————— Cut on dotted line. —————

Instructions

1. Each Click-N-Ship® label is unique. Labels are to be used as printed and used only once. DO NOT PHOTO COPY OR ALTER LABEL.
2. Place your label so it does not wrap around the edge of the package.
3. Adhere your label to the package. A self-adhesive label is recommended. If tape or glue is used, DO NOT TAPE OVER BARCODE. Be sure all edges are secure.
4. To mail your package with PC Postage®, you may schedule a Package Pickup online, hand to your letter carrier, take to a Post Office™, or drop in a USPS collection box.
5. Mail your package on the "Ship Date" you selected when creating this label.

Click-N-Ship® Label Record

USPS TRACKING # :
9405 5036 9930 0275 9667 72

Trans. #: 565829729	Priority Mail® Postage: \$8.95
Print Date: 06/17/2022	Total: \$8.95
Ship Date: 06/17/2022	
Expected Delivery Date: 06/21/2022	

From: DEBORAH CHASE Ref#: DS-881533
NORTHEAST SITE SOLUTIONS
420 MAIN ST
STE 1
STURBRIDGE MA 01566-1359

To: PATRICE GRANATOSKY
MAYOR
45 FORT HILL RD
GROTON CT 06340-4360

* Retail Pricing Priority Mail rates apply. There is no fee for USPS Tracking® service on Priority Mail service with use of this electronic rate shipping label. Refunds for unused postage paid labels can be requested online 30 days from the print date.

 Thank you for shipping with the United States Postal Service!
 Check the status of your shipment on the USPS Tracking® page at usps.com

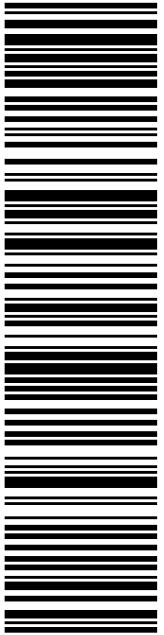

USPS TRACKING #
9405 5036 9930 0275 9668 02

Electronic Rate Approved #038555749



JOHN BURT
GROTON TOWN MANAGER
45 FORT HILL RD
GROTON CT 06340-4360

P

USPS.com
US POSTAGE
Flat Rate Env
\$8.95

9405 5036 9930 0275 9668 02 0089 5000 0010 6340

U.S. POSTAGE PAID
Click-N-Ship®

06/17/2022 Mailed from 01566

PRIORITY MAIL 2-DAY™

DEBORAH CHASE
NORTHEAST SITE SOLUTIONS
420 MAIN ST
STE 1
STURBRIDGE MA 01566-1359

Expected Delivery Date: 06/21/22
Ref#: DS-881533
0006

C012



Click-N-Ship®



Cut on dotted line.

Instructions

- Each Click-N-Ship® label is unique. Labels are to be used as printed and used only once. DO NOT PHOTO COPY OR ALTER LABEL.
- Place your label so it does not wrap around the edge of the package.
- Adhere your label to the package. A self-adhesive label is recommended. If tape or glue is used, DO NOT TAPE OVER BARCODE. Be sure all edges are secure.
- To mail your package with PC Postage®, you may schedule a Package Pickup online, hand to your letter carrier, take to a Post Office™, or drop in a USPS collection box.
- Mail your package on the "Ship Date" you selected when creating this label.

Click-N-Ship® Label Record

USPS TRACKING # :
9405 5036 9930 0275 9668 02

Trans. #: 565829729	Priority Mail® Postage: \$8.95
Print Date: 06/17/2022	Total: \$8.95
Ship Date: 06/17/2022	
Expected Delivery Date: 06/21/2022	

From: DEBORAH CHASE
NORTHEAST SITE SOLUTIONS
420 MAIN ST
STE 1
STURBRIDGE MA 01566-1359

Ref#: DS-881533

To: JOHN BURT
GROTON TOWN MANAGER
45 FORT HILL RD
GROTON CT 06340-4360

* Retail Pricing Priority Mail rates apply. There is no fee for USPS Tracking® service on Priority Mail service with use of this electronic rate shipping label. Refunds for unused postage paid labels can be requested online 30 days from the print date.



Thank you for shipping with the United States Postal Service!
Check the status of your shipment on the USPS Tracking® page at usps.com



JONATHAN REINER
DIRECTOR OF PLANNING
45 FORT HILL RD
GROTON CT 06340-4360

USPS TRACKING #

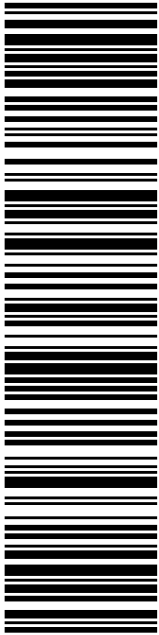

9405 5036 9930 0275 9668 19

P

USPS.com
US POSTAGE
Flat Rate Env
\$8.95

9405 5036 9930 0275 9668 19 0089 5000 0010 6340

U.S. POSTAGE PAID
Click-N-Ship®

06/17/2022 Mailed from 01566

PRIORITY MAIL 2-DAY™

DEBORAH CHASE
NORTHEAST SITE SOLUTIONS
420 MAIN ST
STE 1
STURBRIDGE MA 01566-1359

Expected Delivery Date: 06/21/22
Ref#: DS-881533
0006

C012

Electronic Rate Approved #038555749





Cut on dotted line.

Instructions

1. Each Click-N-Ship® label is unique. Labels are to be used as printed and used only once. DO NOT PHOTO COPY OR ALTER LABEL.
2. Place your label so it does not wrap around the edge of the package.
3. Adhere your label to the package. A self-adhesive label is recommended. If tape or glue is used, DO NOT TAPE OVER BARCODE. Be sure all edges are secure.
4. To mail your package with PC Postage®, you may schedule a Package Pickup online, hand to your letter carrier, take to a Post Office™, or drop in a USPS collection box.
5. Mail your package on the "Ship Date" you selected when creating this label.

Click-N-Ship® Label Record

USPS TRACKING # :
9405 5036 9930 0275 9668 19

Trans. #: 565829729	Priority Mail® Postage: \$8.95
Print Date: 06/17/2022	Total: \$8.95
Ship Date: 06/17/2022	
Expected Delivery Date: 06/21/2022	

From: DEBORAH CHASE
NORTHEAST SITE SOLUTIONS
420 MAIN ST
STE 1
STURBRIDGE MA 01566-1359

Ref#: DS-881533

To: JONATHAN REINER
DIRECTOR OF PLANNING
45 FORT HILL RD
GROTON CT 06340-4360

* Retail Pricing Priority Mail rates apply. There is no fee for USPS Tracking® service on Priority Mail service with use of this electronic rate shipping label. Refunds for unused postage paid labels can be requested online 30 days from the print date.



Thank you for shipping with the United States Postal Service!
Check the status of your shipment on the USPS Tracking® page at usps.com



DANIEL & STACEY PERROTTA
75 ROBERTS RD
GROTON CT 06340-3218

USPS TRACKING #

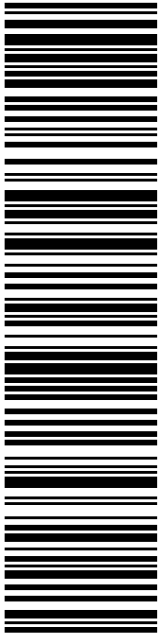

9405 5036 9930 0275 9668 26

P

USPS.com
US POSTAGE
Flat Rate Env

06/17/2022

Mailed from 01566

U.S. POSTAGE PAID
click-n-ship®

PRIORITY MAIL 2-DAY™

Expected Delivery Date: 06/21/22
Ref#: DS-881533
0006

R001

DEBORAH CHASE
NORTHEAST SITE SOLUTIONS
420 MAIN ST
STE 1
STURBRIDGE MA 01566-1359

Click-N-Ship®

9405 5036 9930 0275 9668 26 0089 5000 0010 6340

\$8.95

USPS.com

9405 5036 9930 0275 9668 26 0089 5000 0010 6340

\$8.95

US POSTAGE

Flat Rate Env

06/17/2022

Mailed from 01566

U.S. POSTAGE PAID

click-n-ship®

Electronic Rate Approved #038555749





Cut on dotted line.

Instructions

1. Each Click-N-Ship® label is unique. Labels are to be used as printed and used only once. DO NOT PHOTO COPY OR ALTER LABEL.
2. Place your label so it does not wrap around the edge of the package.
3. Adhere your label to the package. A self-adhesive label is recommended. If tape or glue is used, DO NOT TAPE OVER BARCODE. Be sure all edges are secure.
4. To mail your package with PC Postage®, you may schedule a Package Pickup online, hand to your letter carrier, take to a Post Office™, or drop in a USPS collection box.
5. Mail your package on the "Ship Date" you selected when creating this label.

Click-N-Ship® Label Record

USPS TRACKING # :
9405 5036 9930 0275 9668 26

Trans. #: 565829729	Priority Mail® Postage: \$8.95
Print Date: 06/17/2022	Total: \$8.95
Ship Date: 06/17/2022	
Expected Delivery Date: 06/21/2022	

From: DEBORAH CHASE
NORTHEAST SITE SOLUTIONS
420 MAIN ST
STE 1
STURBRIDGE MA 01566-1359

To: DANIEL & STACEY PERROTTA
75 ROBERTS RD
GROTON CT 06340-3218

Ref#: DS-881533

* Retail Pricing Priority Mail rates apply. There is no fee for USPS Tracking® service on Priority Mail service with use of this electronic rate shipping label. Refunds for unused postage paid labels can be requested online 30 days from the print date.



Thank you for shipping with the United States Postal Service!

Check the status of your shipment on the USPS Tracking® page at usps.com



FARMINGTON
 210 MAIN ST
 FARMINGTON, CT 06032-9998
 (800)275-8777

06/22/2022

10:39 AM

Product	Qty	Unit Price	Price
---------	-----	------------	-------

Prepaid Mail	1		\$0.00
West Henrietta, NY 14586			
Weight: 0 lb 1.90 oz			
Acceptance Date:			
Wed 06/22/2022			
Tracking #:			
9405 5036 9930 0275 9667 65			

Prepaid Mail	1		\$0.00
Groton, CT 06340			
Weight: 0 lb 10.00 oz			
Acceptance Date:			
Wed 06/22/2022			
Tracking #:			
9405 5036 9930 0275 9667 72			

Prepaid Mail	1		\$0.00
Groton, CT 06340			
Weight: 0 lb 9.90 oz			
Acceptance Date:			
Wed 06/22/2022			
Tracking #:			
9405 5036 9930 0275 9668 26			

Prepaid Mail	1		\$0.00
Groton, CT 06340			
Weight: 0 lb 9.90 oz			
Acceptance Date:			
Wed 06/22/2022			
Tracking #:			
9405 5036 9930 0275 9668 02			

Prepaid Mail	1		\$0.00
Groton, CT 06340			
Weight: 0 lb 9.90 oz			
Acceptance Date:			
Wed 06/22/2022			
Tracking #:			
9405 5036 9930 0275 9668 19			

Grand Total:			\$0.00
--------------	--	--	--------

 Every household in the U.S. is now
 eligible to receive a third set
 of 8 free test kits.
 Go to www.covidtests.gov

Preview your Mail
 Track your Packages
 Sign up for FREE @
<https://informedelivery.usps.com>

All sales final on stamps and postage.
 Refunds for guaranteed services only.
 Thank you for your business.

Tell us about your experience.
 Go to: <https://postalexperience.com/Pos>
 or scan this code with your mobile device.

